

ETSI TS 123 060 V11.10.0 (2014-07)



**Digital cellular telecommunications system (Phase 2+);
Universal Mobile Telecommunications System (UMTS);
General Packet Radio Service (GPRS);
Service description;
Stage 2
(3GPP TS 23.060 version 11.10.0 Release 11)**



Reference

RTS/TSGS-0223060vba0

Keywords

GSM,UMTS

ETSI

650 Route des Lucioles
F-06921 Sophia Antipolis Cedex - FRANCE

Tel.: +33 4 92 94 42 00 Fax: +33 4 93 65 47 16

Siret N° 348 623 562 00017 - NAF 742 C
Association à but non lucratif enregistrée à la
Sous-Préfecture de Grasse (06) N° 7803/88

Important notice

The present document can be downloaded from:

<http://www.etsi.org>

The present document may be made available in electronic versions and/or in print. The content of any electronic and/or print versions of the present document shall not be modified without the prior written authorization of ETSI. In case of any existing or perceived difference in contents between such versions and/or in print, the only prevailing document is the print of the Portable Document Format (PDF) version kept on a specific network drive within ETSI Secretariat.

Users of the present document should be aware that the document may be subject to revision or change of status. Information on the current status of this and other ETSI documents is available at

<http://portal.etsi.org/tb/status/status.asp>

If you find errors in the present document, please send your comment to one of the following services:

http://portal.etsi.org/chaicor/ETSI_support.asp

Copyright Notification

No part may be reproduced or utilized in any form or by any means, electronic or mechanical, including photocopying and microfilm except as authorized by written permission of ETSI.

The content of the PDF version shall not be modified without the written authorization of ETSI.

The copyright and the foregoing restriction extend to reproduction in all media.

© European Telecommunications Standards Institute 2014.

All rights reserved.

DECT™, **PLUGTESTS™**, **UMTS™** and the ETSI logo are Trade Marks of ETSI registered for the benefit of its Members. **3GPP™** and **LTE™** are Trade Marks of ETSI registered for the benefit of its Members and of the 3GPP Organizational Partners.

GSM® and the GSM logo are Trade Marks registered and owned by the GSM Association.

Intellectual Property Rights

IPRs essential or potentially essential to the present document may have been declared to ETSI. The information pertaining to these essential IPRs, if any, is publicly available for **ETSI members and non-members**, and can be found in ETSI SR 000 314: *"Intellectual Property Rights (IPRs); Essential, or potentially Essential, IPRs notified to ETSI in respect of ETSI standards"*, which is available from the ETSI Secretariat. Latest updates are available on the ETSI Web server (<http://ipr.etsi.org>).

Pursuant to the ETSI IPR Policy, no investigation, including IPR searches, has been carried out by ETSI. No guarantee can be given as to the existence of other IPRs not referenced in ETSI SR 000 314 (or the updates on the ETSI Web server) which are, or may be, or may become, essential to the present document.

Foreword

This Technical Specification (TS) has been produced by ETSI 3rd Generation Partnership Project (3GPP).

The present document may refer to technical specifications or reports using their 3GPP identities, UMTS identities or GSM identities. These should be interpreted as being references to the corresponding ETSI deliverables.

The cross reference between GSM, UMTS, 3GPP and ETSI identities can be found under <http://webapp.etsi.org/key/queryform.asp>.

Modal verbs terminology

In the present document "**shall**", "**shall not**", "**should**", "**should not**", "**may**", "**may not**", "**need**", "**need not**", "**will**", "**will not**", "**can**" and "**cannot**" are to be interpreted as described in clause 3.2 of the [ETSI Drafting Rules](#) (Verbal forms for the expression of provisions).

"**must**" and "**must not**" are **NOT** allowed in ETSI deliverables except when used in direct citation.

Contents

Intellectual Property Rights	2
Foreword.....	2
Modal verbs terminology.....	2
Foreword.....	12
1 Scope	13
2 References	13
3 Definitions, abbreviations and symbols	18
3.1 Definitions	18
3.2 Abbreviations	18
3.3 Symbols.....	21
4 Main Concept.....	22
5 General GPRS Architecture and Transmission Mechanism.....	23
5.1 GPRS Access Interfaces and Reference Points	23
5.2 Network Interworking	23
5.2.1 Internet (IP) Interworking.....	23
5.3 High-Level Functions.....	24
5.3.0 General.....	24
5.3.1 Network Access Control Functions	24
5.3.1.1 Registration Function	24
5.3.1.2 Authentication and Authorisation Function	24
5.3.1.3 Admission Control Function	24
5.3.1.4 Message Screening Function.....	24
5.3.1.5 Packet Terminal Adaptation Function.....	25
5.3.1.6 Charging Data Collection Function.....	25
5.3.1.7 Operator Determined Barring Function	25
5.3.2 Packet Routing and Transfer Functions	25
5.3.2.1 Relay Function	25
5.3.2.2 Routing Function.....	25
5.3.2.3 Address Translation and Mapping Function	25
5.3.2.4 Encapsulation Function.....	25
5.3.2.5 Tunneling Function	25
5.3.2.6 Compression Function	26
5.3.2.7 Ciphering Function.....	26
5.3.2.8 Domain Name Server Function.....	26
5.3.2.9 DHCP function.....	26
5.3.3 Mobility Management Functions	26
5.3.3.1 General	26
5.3.3.2 Idle Mode Signalling Reduction Function	26
5.3.4 Logical Link Management Functions (A/Gb mode).....	26
5.3.4.1 Logical Link Establishment Function	26
5.3.4.2 Logical Link Maintenance Functions.....	26
5.3.4.3 Logical Link Release Function	26
5.3.5 Radio Resource Management Functions.....	27
5.3.5.1 General	27
5.3.5.2 RAT/Frequency Selection Priority.....	27
5.3.5.3 Service identification for improved radio utilisation for GERAN	28
5.3.6 Network Management Functions	28
5.3.6.1 General	28
5.3.6.2 NAS level congestion control	29
5.3.6.2.1 General	29
5.3.6.2.2 APN based Session Management congestion control.....	29
5.3.6.2.3 APN based Mobility Management congestion control.....	30

5.3.6.2.4	General NAS level Mobility Management congestion control.....	31
5.3.6.3	GGSN control of overload	31
5.3.6.4	SGSN control of overload	32
5.3.6.5	S4-SGSN control of overload	32
5.3.7	Selection functions.....	33
5.3.7.1	SGW/PGW/GGSN selection function (3GPP accesses)	33
5.3.7.2	Serving GW selection function	33
5.3.7.3	SGSN selection function	33
5.3.8	IMS voice over PS Session Supported Indication.....	33
5.3.8A	Homogenous Support of IMS Voice over PS Sessions Indication	34
5.3.9	Closed Subscriber Group functions	34
5.3.10	UE Reachability function.....	35
5.3.11	Location Service functions	35
5.3.12	Selected IP Traffic Offload (SIPTO) function.....	35
5.3.12.1	SIPTO with GW Selection	35
5.3.12.2	Support for SIPTO at Iu-ps	35
5.3.13	Machine Type Communication (MTC)	35
5.3.13.1	General	35
5.3.13.2	Overview of Protection from Potential MTC Related Overload.....	36
5.3.13.3	MS configuration and usage of indicators.....	37
5.3.13.4	Void.....	39
5.3.13.5	Optimizing periodic RAU Signalling.....	39
5.3.13.6	Support of MSs configured for low access priority, Extended Access Barring and permission for override	40
5.3.14	Local IP Access (LIPA) function.....	40
5.3.15	Voice domain preference and UE's usage setting	40
5.3.16	Support for Application / Service Layer Rate Adaptation	41
5.3.17	Support for subscriptions without MSISDN.....	41
5.3.18	PS-only Service Provision and PS domain SMS support	41
5.3.19	Access and Mobility Restrictions	43
5.4	Logical Architecture.....	43
5.4.0	General.....	43
5.4.1	GPRS Core Network Nodes	45
5.4.1.1	General	45
5.4.1.2	Gateway GPRS Support Node	45
5.4.1.3	Serving GPRS Support Node	45
5.4.1.4	Serving Gateway	45
5.4.1.5	PDN Gateway	46
5.4.2	Packet Domain PLMN Backbone Networks	46
5.4.3	HLR/HSS.....	47
5.4.4	SMS-GMSC and SMS-IW MSC	47
5.4.5	Mobile Stations (A/Gb mode).....	47
5.4.6	Mobile Stations (Iu mode)	48
5.4.7	Charging Gateway Functionality	48
5.4.8	PCRF	48
5.4.9	HNB subsystem	48
5.4.10	CSG Subscriber Server	49
5.5	Assignment of Functions to General Logical Architecture	50
5.6	User and Control Planes	50
5.6.1	User Plane (A/Gb mode).....	50
5.6.1.1	MS – P-GW/GGSN.....	50
5.6.1.2	Core Network Node - Core Network Node.....	52
5.6.2	User Plane (Iu mode)	52
5.6.2.1	MS – GGSN user plane with GERAN in Iu mode	52
5.6.2.2	MS – P-GW/GGSN user plane with UTRAN	53
5.6.2.3	Core Network Node - Core Network Node.....	54
5.6.3	Control Plane	54
5.6.3.1	MS - SGSN (A/Gb mode).....	55
5.6.3.2	MS – SGSN (Iu mode).....	55
5.6.3.3	Gn/Gp-SGSN - HLR.....	56
5.6.3.4	SGSN - MSC/VLR.....	56
5.6.3.5	SGSN - EIR.....	56

5.6.3.5a	S4-SGSN - EIR	57
5.6.3.6	SGSN - SMS-GMSC or SMS-IWMSC.....	57
5.6.3.7	Core Network Node - Core Network Node.....	57
5.6.3.8	GGSN - HLR	58
5.6.3.8.1	MAP-based GGSN - HLR Signalling.....	58
5.6.3.8.2	GTP and MAP-based GGSN - HLR Signalling	58
5.6.3.9	S4-SGSN - HSS	59
5.6.3.10	Gn/Gp-SGSN - CSS.....	59
5.6.3.11	S4-SGSN - CSS	60
5.7	Functionality Needed for Mobile IPv4.....	60
5.8	Functionality for Intra Domain Connection of RAN Nodes to Multiple CN Nodes	60
5.9	Functionality for network sharing	61
5.10	IMS Emergency Session Support.....	61
5.10.1	Introduction.....	61
5.10.2	PS Domain Functions for IMS Emergency Session Support.....	61
5.10.2.1	General	61
5.10.2.2	Reachability Management for Emergency Attached MS in PMM-IDLE state	62
5.10.2.3	Mobility and Access Restrictions for Emergency Services.....	62
5.10.3	Attach handling.....	62
5.10.4	PDP Context Activation for emergency bearer services.....	63
5.10.5	Handling of PDN Connections for Emergency Bearer Services.....	63
6	Mobility Management Functionality	64
6.1	Definition of Mobility Management States	64
6.1.0	General.....	64
6.1.1	Mobility Management States (A/Gb mode).....	64
6.1.1.1	IDLE (GPRS) State	64
6.1.1.2	STANDBY State	64
6.1.1.3	READY State	65
6.1.1.4	State Transitions and Functions	66
6.1.2	Mobility Management States (Iu mode)	67
6.1.2.1	PMM-DETACHED State.....	67
6.1.2.2	PMM-IDLE State.....	67
6.1.2.3	PMM-CONNECTED State.....	67
6.1.2.4	State Transitions and Functions	68
6.1.2.4.1	Handling of Un-synchronous States in the UE and the Network	69
6.2	Mobility Management Timer Functions.....	70
6.2.1	READY Timer Function (A/Gb mode)	70
6.2.2	Periodic RA Update Timer Function	70
6.2.3	Mobile Reachable Timer Function	71
6.3	Interactions Between SGSN and MSC/VLR.....	71
6.3.0	General.....	71
6.3.1	Administration of the SGSN - MSC/VLR Association	72
6.3.2	Combined RA / LA Updating	73
6.3.3	CS Paging (A/Gb mode).....	74
6.3.3.1	Paging Co-ordination in A/Gb mode	75
6.3.4	CS Paging (Iu mode).....	76
6.3.4.1	Network Operation Modes for Iu mode	76
6.3.4a	CS Paging (in case Selective RA Update)	77
6.3.5	Non-GPRS Alert.....	77
6.3.6	MS Information Procedure	77
6.3.7	MM Information Procedure	78
6.4	MM Procedures	78
6.5	GPRS Attach Function	79
6.5.0	General.....	79
6.5.1	A/Gb mode GPRS Attach Procedure.....	79
6.5.2	Iu mode GPRS Attach Procedure	80
6.5.3	Combined GPRS / IMSI Attach procedure.....	81
6.5.3A	Combined GPRS / IMSI Attach procedure, Delete Bearer by the new SGSN, using S4.....	86
6.5.3B	Combined GPRS / IMSI Attach procedure, Delete Bearer by the old SGSN, using S4	87
6.6	Detach Function	88
6.6.1	MS-Initiated Detach Procedure.....	89

6.6.2	Network-Initiated Detach Procedure	90
6.6.2.1	SGSN-Initiated Detach Procedure	90
6.6.2.2	HLR-Initiated Detach Procedure.....	91
6.6.3	SGSN interaction during Detach Procedure when using S4	92
6.7	Purge Function	93
6.8	Security Function	93
6.8.0	General.....	93
6.8.1	Authentication.....	93
6.8.1.1	GSM Authentication procedure	94
6.8.1.2	UMTS Authentication procedure	94
6.8.2	User Identity Confidentiality	95
6.8.2.1	User Identity Confidentiality (A/Gb mode)	95
6.8.2.2	User Identity Confidentiality (Iu mode).....	95
6.8.2.3	P-TMSI Signature	96
6.8.2.4	P-TMSI Reallocation Procedure	96
6.8.3	User Data and GMM/SM Signalling Confidentiality	96
6.8.3.1	Scope of Ciphering.....	96
6.8.3.2	Ciphering Algorithm	97
6.8.3.3	Start of Ciphering.....	97
6.8.4	Identity Check Procedures	97
6.8.5	Data Integrity Procedure (Iu mode)	97
6.9	Location Management Function.....	98
6.9.0	General.....	98
6.9.1	Location Management Procedures (A/Gb mode)	98
6.9.1.1	Cell Update Procedure	99
6.9.1.2	Routeing Area Update Procedure.....	99
6.9.1.2.0	General	99
6.9.1.2.1	Intra SGSN Routeing Area Update.....	100
6.9.1.2.2	Inter SGSN Routeing Area Update.....	102
6.9.1.2.2a	Inter SGSN Routeing Area Update and Combined Inter SGSN RA / LA Update using S4.....	106
6.9.1.3	Combined RA / LA Update Procedure.....	108
6.9.1.3.0	General	108
6.9.1.3.1	Combined Intra SGSN RA / LA Update	109
6.9.1.3.2	Combined Inter SGSN RA / LA Update	112
6.9.2	Location Management Procedures (Iu-mode).....	117
6.9.2.1	Routeing Area Update Procedure.....	118
6.9.2.1a	Routeing Area Update Procedure using S4	127
6.9.2.2	Serving RNS Relocation Procedures.....	129
6.9.2.2.1	Serving RNS Relocation Procedure.....	129
6.9.2.2.1a	Serving RNS Relocation Procedure, Combined Hard Handover and SRNS Relocation Procedure, and Combined Cell / URA Update and SRNS Relocation Procedure Using S4	135
6.9.2.2.2	Combined Hard Handover and SRNS Relocation Procedure	137
6.9.2.2.3	Combined Cell / URA Update and SRNS Relocation Procedure	144
6.9.2.2.4	SRNS Relocation Cancel Procedure.....	149
6.9.2.2.4a	SRNS Relocation Cancel Procedure Using S4	151
6.9.2.2.5	Enhanced Serving RNS Relocation Procedure	151
6.9.2.2.5A	Enhanced Serving RNS Relocation Procedure using S4	153
6.9.3	Periodic RA and LA Updates	155
6.9.4	PS Handover Procedure	155
6.9.5	UE Radio Capability Match Request	156
6.10	Tunnelling of non-GSM Signalling Messages Function (A/Gb mode)	157
6.10.1	Uplink Tunnelling of non-GSM Signalling Messages Procedure	157
6.10.2	Downlink Tunnelling of non-GSM Signalling Messages Procedure	158
6.11	Subscriber Management Function.....	158
6.11.1	Subscriber Management Procedures	158
6.11.1.1	Insert Subscriber Data Procedure	158
6.11.1.2	Delete Subscriber Data Procedure.....	159
6.11.1.3	Insert CSG Subscriber Data Procedure	160
6.12	Service Request Procedure (Iu mode)	160
6.12.0	General.....	160
6.12.1	MS Initiated Service Request Procedure Using Gn/Gp	161
6.12.1A	UE Initiated Service Request Procedure Using S4	163

6.12.2	Network Initiated Service Request Procedure using Gn/Gp.....	164
6.12.2A	Void	166
6.13	Intersystem Change	166
6.13.1	Intra SGSN Intersystem Change	166
6.13.1.1	Iu mode to A/Gb mode Intra SGSN Change	166
6.13.1.1.1	Iu mode to A/Gb mode Intra SGSN Change using Gn/Gp.....	166
6.13.1.1.2	Iu mode to A/Gb mode Intra SGSN Change using S4.....	169
6.13.1.2	A/Gb mode to Iu mode Intra-SGSN Change.....	170
6.13.1.2.1	A/Gb mode to Iu mode Intra-SGSN Change using Gn/Gp.....	170
6.13.1.2.2	A/Gb mode to Iu mode Intra-SGSN Change using S4	173
6.13.1.3	Selective RA Update	174
6.13.1.3.1	Uplink Signalling or Data Transmission	174
6.13.1.3.2	Downlink Signalling or Data Transmission.....	174
6.13.2	Inter-SGSN Inter-system Change	175
6.13.2.1	Iu mode to A/Gb mode Inter-SGSN Change.....	175
6.13.2.1.1	Iu mode to A/Gb mode Inter-SGSN Change using Gn/Gp.....	175
6.13.2.1.2	Iu mode to A/Gb mode Inter-SGSN Change using S4	180
6.13.2.2	A/Gb mode to Iu mode Inter-SGSN Change.....	182
6.13.2.2.1	A/Gb mode to Iu mode Inter-SGSN Change using Gn/Gp.....	182
6.13.2.2.2	A/Gb mode to Iu mode Inter-SGSN Change using S4	187
6.14	Classmark Handling	189
6.14.1	Radio Access Classmark.....	189
6.14.1.1	MS Radio Access Capability (A/Gb mode)	189
6.14.1.2	UE Capability (Iu mode).....	190
6.14.2	Core Network Capability	190
6.15	UE Reachability procedures	191
6.16	Update CSG Location Procedure	192
7	Network Management Functionality	192
8	Radio Resource Functionality	192
8.1	Radio Resource Functionality (A/Gb mode)	192
8.1.1	Cell Selection and Reselection.....	192
8.1.2	Discontinuous Reception	192
8.1.3	Radio Resource Management	193
8.1.3.1	Layer Functions.....	193
8.1.3.2	Model of Operation	193
8.1.3.2.1	Dynamic Allocation of Radio Resources	193
8.1.3a	Ready to Standby state transition in S4 architecture.....	193
8.1.4	Paging for GPRS Downlink Transfer (A/Gb mode).....	194
8.1.4A	Paging response for GPRS Downlink Transfer with no established user plane on S4	195
8.1.5	RAN Information Management (RIM) procedures.....	196
8.1.5.1	General	196
8.1.5.2	Addressing, routing and relaying	196
8.1.5.2.1	Addressing.....	196
8.1.5.2.2	Routing	196
8.1.5.2.3	Relaying.....	196
8.1.5.3	Void.....	196
8.1.5.4	Void.....	197
8.1.5.5	Applications using the RIM Procedures.....	197
8.1.6	BSS Paging Co-ordination.....	197
8.2	Radio Resource Functionality (Iu mode).....	197
8.2.1	Radio Resource Management	197
8.2.2	RRC State Machine	197
8.2.3	Discontinuous Reception	198
8.2.4	Paging Initiated by CN	199
8.2.4.1	PS Paging Initiated by SGSN (Iu mode) without RRC Connection for CS	199
8.2.4.1A	Serving GW Triggered Paging (Iu mode) with S4.....	200
8.2.4.2	PS Paging Initiated by 3G-SGSN With RRC Connection for CS.....	200
8.2.5	Paging Initiated by RAN.....	201
9	Packet Routing and Transfer Functionality	202
9.1	Definition of Packet Data Protocol States	202

9.1.0	General.....	202
9.1.1	INACTIVE State	202
9.1.2	ACTIVE State.....	202
9.2	PDP Context Activation, Modification, Deactivation, and Preservation Functions	203
9.2.0	General.....	203
9.2.1A	Principles for mapping between PDP Contexts and EPS Bearers.....	206
9.2.1	Static and Dynamic PDP Addresses	207
9.2.1.1	Stateless IPv6 Address Autoconfiguration.....	209
9.2.1.2	IPv6 Prefix Delegation via DHCPv6.....	210
9.2.2	Activation Procedures.....	211
9.2.2.1	PDP Context Activation Procedure.....	211
9.2.2.1A	PDP Context Activation Procedure using S4.....	216
9.2.2.1.1	Secondary PDP Context Activation Procedure	220
9.2.2.1.1A	Secondary PDP Context Activation Procedure, PDP Creation part, using S4.....	223
9.2.2.1.1B	Void.....	225
9.2.2.2	Network-Requested PDP Context Activation Procedure	225
9.2.2.2.1	Successful Network-Requested PDP Context Activation Procedure.....	225
9.2.2.2.2	Unsuccessful Network-Requested PDP Context Activation Procedure	226
9.2.2.3	Network Requested Secondary PDP Context Activation Procedure using Gn	228
9.2.2.3A	Network Requested Secondary PDP Context Activation Procedure using S4.....	229
9.2.3	Modification Procedures.....	230
9.2.3.0	General	230
9.2.3.1	SGSN-Initiated PDP Context Modification Procedure	231
9.2.3.1A	Request part of SGSN-Initiated EPS Bearer Modification Procedure using S4.....	233
9.2.3.1B	Update part of SGSN-Initiated EPS Bearer Modification Procedure using S4.....	234
9.2.3.2	GGSN-Initiated PDP Context Modification Procedure	235
9.2.3.2A	PDN GW Initiated EPS Bearer Modification Procedure, using S4.....	237
9.2.3.3	MS-Initiated PDP Context Modification Procedure.....	238
9.2.3.3A	Request part of MS-Initiated EPS Bearer Modification Procedure using S4.....	240
9.2.3.3B	Execution part of MS-Initiated Modification Procedure using S4	244
9.2.3.3C	Response part of MS-Initiated Modification Procedure using S4.....	244
9.2.3.4	RNC/BSS-Initiated PDP Context Modification Procedure	245
9.2.3.5	RAB Release-Initiated Local PDP Context Modification Procedure.....	246
9.2.3.6	RAN-initiated RAB Modification Procedure (Iu mode).....	247
9.2.3.7	SGSN-initiated procedure on UE's CSG membership change	247
9.2.4	Deactivation Procedures	248
9.2.4.1	MS Initiated PDP Context Deactivation Procedure	248
9.2.4.1A	MS- and SGSN Initiated Bearer Deactivation Procedure using S4.....	249
9.2.4.1A.1	MS-and SGSN Initiated PDN connection Deactivation Procedure using S4	249
9.2.4.1A.2	MS-and SGSN Initiated Bearer Deactivation Procedure.....	250
9.2.4.2	SGSN-initiated PDP Context Deactivation Procedure.....	252
9.2.4.3	GGSN-initiated PDP Context Deactivation Procedure	253
9.2.4.3A	PDN GW initiated Bearer Deactivation Procedure using S4, part 1	254
9.2.4.3B	PDN GW initiated Bearer Deactivation Procedure using S4, part 2	254
9.2.5	Preservation Procedures.....	255
9.2.5.1	Release of RABs Triggered by an Iu mode RAN	255
9.2.5.1.1	RAB Release Procedure	255
9.2.5.1.2	Iu Release Procedure	255
9.2.5.2	Re-establishment of RABs.....	255
9.3	Packet Routing and Transfer Function	256
9.4	Relay Function	258
9.5	Packet Terminal Adaptation Function.....	258
9.6	Encapsulation Function	258
9.6.1	Encapsulation Between Core Network Nodes	258
9.6.2	Encapsulation Between SGSN and RAN in Iu mode	259
9.6.3	Encapsulation Between SGSN and MS in A/Gb mode.....	259
9.6.4	Encapsulation Between RAN and MS in Iu mode.....	259
9.7	Home NodeB Multicast Packet Forwarding Function.....	259
10	Message Screening Functionality.....	259
11	Compatibility Issues.....	259

11.1	Interaction between Releases 97/98 and 99	260
11.1.1	Interactions Between GTP v0 (R97) and GTP v1 (R99)	260
11.1.2	Interactions Between MS R97 and CN R99	260
11.1.3	Interactions Between SM R97 and SM R99	260
11.1.4	Interactions Between MAP R97 and MAP R99	260
11.1a	Interactions between Release 7 and earlier Releases	260
11.1a.1	Interactions Between CN (R7) and Iu-mode RAN (pre-R7)	260
11.1a.2	Interactions between CN and RAN to handle Rel-7 QoS extensions	260
11.2	Network Configuration for Interaction with E-UTRAN and S4-SGSNs	261
11.3	Interactions between CN and RAN to support higher bit rates	261
12	Transmission	261
12.1	Transmission Modes	261
12.1.1	GTP-U Transmission Modes	261
12.1.2	LLC Transmission Modes (A/Gb mode)	261
12.1.3	RLC Transmission Modes	262
12.2	Logical Link Control Functionality (A/Gb mode)	262
12.2.1	Addressing	262
12.2.2	Services	262
12.2.3	Functions	262
12.3	Subnetwork Dependent Convergence Functionality (A/Gb mode)	263
12.3.1	Services	263
12.3.2	Subfunctions	264
12.4	PDCP (Iu mode)	264
12.5	Point-to-Point Protocol Functionality	264
12.5.1	User Plane for PDP Type PPP	265
12.5.2	Functions	265
12.6	Gb Interface (A/Gb mode)	265
12.6.1	Physical Layer Protocol	266
12.6.2	Link Layer Protocols	266
12.6.3	BSS GPRS Protocol	266
12.6.3.1	Inter-dependency of the BSSGP and LLC Functions	267
12.6.3.2	BSSGP Addressing	267
12.6.3.3	BVCI Contexts in BSS and in SGSN	267
12.6.3.4	Flow Control Between SGSN and BSS over the Gb Interface	267
12.6.3.5	BSS Context	268
12.6.3.5.1	BSS Packet Flow Context Creation Procedure	269
12.6.3.5.2	SGSN-Initiated BSS Packet Flow Context Modification Procedure	270
12.6.3.5.3	BSS-Initiated BSS Packet Flow Context Modification Procedure	270
12.6.3.5.4	BSS Packet Flow Context Deletion Procedures	270
12.7	Iu Interface (Iu mode)	271
12.7.1	Consistent Sequence Numbering of PDUs on Iu and Gn Interfaces	271
12.7.2	RAB Release Procedure	271
12.7.2.1	RAB Release Procedure using Gn/Gp	271
12.7.2.2	RAB Release Procedure using S4	272
12.7.3	Iu Release Procedure	272
12.7.3.1	Iu Release Procedure Using Gn/Gp	272
12.7.3.2	Iu Release Procedure Using S4	274
12.7.4	RAB Assignment Procedure	274
12.7.4.1	RAB Assignment Procedure Using Gn/Gp	274
12.7.4.2	RAB Assignment Procedure Using S4	275
12.7.5	Location Reporting Procedure	276
12.8	Abis Interface (A/Gb mode)	277
12.8.1	Remote Packet Control Unit	278
12.9	Gn Interface (A/Gb mode)	278
13	Information Storage	278
13.1	HLR/HSS	278
13.2	SGSN	280
13.2.1	General	280
13.2.2	Parameter exchange between S4-SGSNs	281
13.2.3	Context fields for one MS	282

13.2.4	SGSN Emergency Configuration Data for Iu Mode	286
13.3	GGSN	287
13.3a	Serving GW	288
13.3b	PDN GW	288
13.4	MS	289
13.5	MSC/VLR	290
13.6	BSS in A/Gb mode	290
13.7	RNC/BSC for Iu mode	291
13.8	Direct Tunnel specific error handling	291
13.9	Void	291
13.10	CSS	291
14	Identities	292
14.1	IMSI	292
14.2	Packet TMSI	292
14.2A	GUTI	292
14.3	NSAPI and TLLI for A/Gb mode	292
14.4	NSAPI, RB Identity, and RAB ID for Iu mode	293
14.4A	EPS Bearer Identity	294
14.5	PDP Address	294
14.6	TEID	294
14.7	Routeing Area Identity	294
14.8	RAN Registration Area Identity (Iu mode)	295
14.9	Cell Identity	295
14.10	Service Area Identity (Iu mode)	295
14.11	CN Node Addresses	295
14.11.1	CN Node Address	295
14.11.2	GSN Number	295
14.12	RNC/BSC Addresses (Iu mode)	296
14.12.1	RNC/BSC Address	296
14.12.2	RNC/BSC Number	296
14.13	Access Point Name	296
14.14	Closed Subscriber Group ID	296
15	Operational Aspects	296
15.1	Charging	296
15.1.0	General	296
15.1.1	Charging Information	297
15.1.1a	General impacts of applying Flow Based Charging	298
15.1.2	Reverse Charging	299
15.1.3	Location and CSG dependent charging	299
15.1.3.1	Basic principles	299
15.1.3.2	Interaction with CGI / SAI / user CSG information reporting	299
15.1.3.2a	Interaction with CGI / SAI / user CSG information reporting using S4	300
15.2	Quality of Service Profile	301
15.2.0	General	301
15.2.1	Radio Priority Levels (A/Gb mode)	301
15.2.1a	APN-AMBR	301
15.2.2	UE-AMBR	302
15.3	Traffic Flow Template	302
15.3.0	General	302
15.3.1	Rules for Operations on TFTs	303
15.3.2	Packet Filter Attributes	304
15.3.2.0	General	304
15.3.2.1	Remote Address and Subnet Mask	304
15.3.2.2	Protocol Number / Next Header	305
15.3.2.2A	Local Address and Mask	305
15.3.2.3	Port Numbers	305
15.3.2.4	IPSec Security Parameter Index	305
15.3.2.5	Type of Service / Traffic Class and Mask	305
15.3.2.6	Flow Label	305
15.3.3	Example Usage of Packet Filters	305

15.3.3.0	General	305
15.3.3.1	IPv4 Multi-field Classification	305
15.3.3.2	IPv4 TOS-based Classification	306
15.3.3.3	IPv4 Multi-field Classification for IPSec Traffic	306
15.3.3.4	Services with IP flows in only one direction	306
15.4	APN Restriction	306
15.5	Automatic Device Detection	307
15.6	Direct Tunnel Functionality	307
15.7	HPLMN Notification with specific indication due to SGSN initiated Bearer removal	308
16	Interactions with Other Services	309
16.0	General	309
16.1	Point-to-point Short Message Service	309
16.1.1	Mobile-terminated SMS Transfer	309
16.1.1.1	Unsuccessful Mobile-terminated SMS Transfer	310
16.1.2	Mobile-originated SMS Transfer	312
16.2	Circuit-switched Services (A/Gb mode)	313
16.2.1	Suspension of GPRS Services	313
16.2.1.1	Suspend and Resume procedure (A/Gb mode)	313
16.2.1.1.1	Intra-SGSN Suspend and Resume procedure	313
16.2.1.1.2	Inter-SGSN Suspend and Resume procedure	314
16.2.1.2	Inter-System Suspend and Resume procedure	315
16.2.1.2.1	Intra-SGSN Suspend and Resume procedure	315
16.2.1.2.2	Inter-SGSN Suspend and Resume procedure	316
16.2.1.3	Inter System Resume procedure	318
16.2.1.3.1	Intra-SGSN Resume procedure	318
16.2.1.3.2	Inter-SGSN Resume procedure	318
16.2.2	GPRS and Dedicated Mode Priority Handling	318
16.3	Supplementary Services	318
16.4	CAMEL Services	319
Annex A (normative):	APN and P-GW/GGSN Selection	320
A.0	General	320
A.1	Definitions	320
A.2	Selection Rules	321
Annex B (informative):	Selected IP Traffic Offload at Iu-PS	331
B.1	SIPTO with Traffic Offload Function	331
B.2	Support for SIPTO at Iu-ps	332
Annex C (informative):	Link MTU considerations	333
Annex D (informative):	Change History	335
History		337

Foreword

This Technical Specification has been produced by the 3rd Generation Partnership Project (3GPP).

The contents of the present document are subject to continuing work within the TSG and may change following formal TSG approval. Should the TSG modify the contents of the present document, it will be re-released by the TSG with an identifying change of release date and an increase in version number as follows:

Version x.y.z

where:

- x the first digit:
 - 1 presented to TSG for information;
 - 2 presented to TSG for approval;
 - 3 or greater indicates TSG approved document under change control.
- y the second digit is incremented for all changes of substance, i.e. technical enhancements, corrections, updates, etc.
- z the third digit is incremented when editorial only changes have been incorporated in the document.

1 Scope

The present document defines the stage-2 service description for the General Packet Radio Service (GPRS) which is a packet bearer service and a main part of the packet domain. ITU-T Recommendation I.130 [29] describes a three-stage method for characterisation of telecommunication services, and ITU-T Recommendation Q.65 [31] defines stage 2 of the method. The GPRS described in the present document is also the description of the GERAN and UTRAN related functionality of the Evolved Packet System (EPS) according to TS 23.401 [89].

The present document does not cover the Radio Access Network functionality. TS 43.064 [11] contains an overall description of the GSM EDGE Radio Access Network (GERAN). TS 25.401 [53] contains an overall description of the Universal Terrestrial Radio Access Network (UTRAN). TS 43.051 [74] contains an overall description of GSM/EDGE Radio Access Network.

The present document does not cover the functionality of the GPRS enhancements for the Evolved Universal Terrestrial Radio Access Network (E-UTRAN). This functionality and also the interoperation functionality between E-UTRAN and GERAN/UTRAN accesses are described in TS 23.401 [89].

2 References

The following documents contain provisions, which, through reference in this text, constitute provisions of the present document.

- References are either specific (identified by date of publication, edition number, version number, etc.) or non-specific.
- For a specific reference, subsequent revisions do not apply.
- For a non-specific reference, the latest version applies. For a reference to a 3GPP document (including a GSM document), a non-specific reference implicitly refers to the latest version of that document *in the same Release as the present document*.

- [1] Void.
- [2] 3GPP TS 41.061: "General Packet Radio Service (GPRS); GPRS ciphering algorithm requirements".
- [3] 3GPP TS 22.060: "General Packet Radio Service (GPRS); Service description; Stage 1".
- [4] 3GPP TS 23.003: "Numbering, addressing and identification".
- [5] 3GPP TS 23.007: "Restoration procedures".
- [5b] 3GPP TS 23.016: "Subscriber data management; Stage 2".
- [6] 3GPP TS 43.020: "Security related network functions".
- [7] GSM 03.22: "Digital cellular telecommunications system (Phase 2+); Functions related to Mobile Station (MS) in idle mode and group receive mode".
- [7b] 3GPP TS 23.122: "Non-Access Stratum functions related to Mobile Station (MS) in idle mode".
- [8] 3GPP TS 23.040: "Technical realization of the Short Message Service (SMS)".
- [8b] 3GPP TS 23.078: "Customised Applications for Mobile network Enhanced Logic (CAMEL) Phase 3 - Stage 2".
- [9] 3GPP TR 21.905: "Vocabulary for 3GPP Specifications".
- [10] Void.
- [11] 3GPP TS 43.064: "General Packet Radio Service (GPRS); Overall description of the GPRS radio interface; Stage 2".

- [12] 3GPP TS 24.007: "Mobile radio interface signalling layer 3; General aspects".
- [13] 3GPP TS 24.008: "Mobile Radio Interface Layer 3 specification; Core Network Protocols; Stage 3".
- [13b] 3GPP TS 24.011: "Point to Point (PP) Short Message Service (SMS) support on mobile radio interface".
- [14] Void.
- [15] 3GPP TS 44.064: "General Packet Radio Service (GPRS); Mobile Station – Serving GPRS Support Node (MS-SGSN) Logical Link Control (LLC) layer specification".
- [16] 3GPP TS 44.065: "General Packet Radio Service (GPRS); Mobile Station (MS) – Serving GPRS Support Node (SGSN); Subnetwork Dependent Convergence Protocol (SNDTCP)".
- [16b] 3GPP TS 45.008: "Digital cellular telecommunications system (Phase 2+); Radio subsystem link control".
- [17] 3GPP TS 27.060: "Packet Domain; Mobile Station (MS) supporting Packet Switched services".
- [18] 3GPP TS 48.008: "Mobile-services Switching Centre - Base Station System (MSC-BSS) interface; Layer 3 specification".
- [19] 3GPP TS 48.014: "General Packet Radio Service (GPRS); Base Station System (BSS) - Serving GPRS Support Node (SGSN) interface; Gb interface layer 1".
- [20] 3GPP TS 48.016: "General Packet Radio Service (GPRS); Base Station System (BSS) - Serving GPRS Support Node (SGSN) interface; Network Service".
- [21] Void.
- [22] 3GPP TS 48.060: "In-band control of remote transcoders and rate adaptors for Enhanced Full Rate (EFR) and full rate traffic channels".
- [23] 3GPP TS 29.002: "Mobile Application Part (MAP) specification".
- [24] 3GPP TS 29.016: "General Packet Radio Service (GPRS); Serving GPRS Support Node (SGSN) - Visitors Location Register (VLR); Gs interface network service specification".
- [25] 3GPP TS 29.018: "General Packet Radio Service (GPRS); Serving GPRS Support Node (SGSN) - Visitors Location Register (VLR); Gs interface layer 3 specification".
- [26] 3GPP TS 29.060: "General Packet Radio Service (GPRS); GPRS Tunnelling Protocol (GTP) across the Gn and Gp Interface".
- [27] 3GPP TS 29.061: "Interworking between the Public Land Mobile Network (PLMN) supporting Packet Based services and Packet Data Networks (PDN)".
- [27b] Void.
- [28] 3GPP TS 51.011: "Specification of the Subscriber Identity Module - Mobile Equipment (SIM-ME) interface".
- [29] ITU-T Recommendations I.130: "Method for the characterization of telecommunication services supported by an ISDN and network capabilities of an ISDN".
- [30] ITU-T Recommendation E.164: "The international public telecommunication numbering plan".
- [31] ITU-T Recommendation Q.65: "The unified functional methodology for the characterization of services and network capabilities".
- [32] ITU-T Recommendation V.42bis: "Data compression procedures for data circuit-terminating equipment (DCE) using error correction procedures".
- [33] Void.

- [34] ITU-T Recommendation X.25: "Interface between Data Terminal Equipment (DTE) and Data Circuit-terminating Equipment (DCE) for terminals operating in the packet mode and connected to public data networks by dedicated circuit".
- [35] IETF RFC 4960: "Stream Control Transmission Protocol".
- [39] IETF RFC 768 (1980): "User Datagram Protocol" (STD 6).
- [40] IETF RFC 791 (1981): "Internet Protocol" (STD 5).
- [41] IETF RFC 792 (1981): "Internet Control Message Protocol" (STD 5).
- [42] Void.
- [43] IETF RFC 1034 (1987): "Domain names – concepts and facilities" (STD 13).
- [44] IETF RFC 1661 (1994): "The Point-to-Point Protocol (PPP)" (STD 51).
- [45] IETF RFC 1542 (1993): "Clarifications and Extensions for the Bootstrap Protocol".
- [46] IETF RFC 3344 (2002): "IP Mobility Support for IPv4".
- [47] IETF RFC 2131 (1997): "Dynamic Host Configuration Protocol".
- [48] IETF RFC 2460 (1998): "Internet Protocol, Version 6 (IPv6) Specification".
- [49] TIA/EIA-136 (1999): "TDMA Cellular / PCS"; Arlington: Telecommunications Industry Association.
- [50] 3GPP TS 25.301: "Radio Interface Protocol Architecture".
- [51] 3GPP TS 25.303: "Interlayer procedures in Connected Mode".
- [51b] 3GPP TS 25.304: "UE Procedures in Idle Mode and Procedures for Call Reselection in Connected Mode".
- [52] 3GPP TS 25.331: "RRC Protocol Specification".
- [53] 3GPP TS 25.401: "UTRAN Overall Description".
- [54] 3GPP TS 23.121: "Architectural Requirements for Release 1999".
- [55] 3GPP TS 25.322: "RLC protocol specification".
- [56] 3GPP TS 25.412: "UTRAN Iu interface signalling transport".
- [56b] 3GPP TS 25.413: "UTRAN Iu interface Radio Access Network Application Part (RANAP) signalling".
- [57] 3GPP TS 25.323: "Packet Data Convergence Protocol (PDCP) specification".
- [58] 3GPP TS 23.107: "Quality of Service (QoS) concept and architecture".
- [59] ITU-T Recommendation I.361: "B-ISDN ATM layer specification".
- [60] 3GPP TS 25.321: "Medium Access Control (MAC) protocol specification".
- [61] 3GPP TS 33.102: "3G Security; Security architecture".
- [62] Void.
- [63] 3GPP TS 25.411: "UTRAN Iu interface Layer 1".

- [64] 3GPP TS 25.414: "UTRAN Iu interface data transport & transport signalling".
- [65] 3GPP TS 23.271: "Functional stage 2 description of LCS".
- [66] 3GPP TS 23.015: "Technical realization of Operator Determined Barring (ODB)".
- [67] ITU-T Recommendation I.363.5: "B-ISDN ATM Adaptation Layer (AAL) specification: Type 5 AAL".
- [68] Void.
- [69] Void.
- [70] 3GPP TS 32.251: "Telecommunication management; Charging management; Packet Switched (PS) domain charging".
- [71] Void.
- [72] 3GPP TS 29.202: "Signalling System No. 7 (SS7) signalling transport in core network; Stage 3".
- [73] 3GPP TS 23.236: "Intra Domain Connection of RAN Nodes to Multiple CN Nodes".
- [74] 3GPP TS 43.051: "Radio Access Network; Overall description – Stage 2".
- [75] 3GPP TS 24.229: IP Multimedia Call Control Protocol based on SIP and SDP.
- [76] 3GPP TS 23.195: "Provision of UE Specific Behaviour Information to Network Entities".
- [77] 3GPP TS 44.060: General Packet Radio Service (GPRS); Mobile Station (MS) - Base Station System (BSS) interface; Radio Link Control/Medium Access Control (RLC/MAC) protocol".
- [78] 3GPP TS 48.018: "General Packet Radio Service (GPRS); Base Station System (BSS) - Serving GPRS Support Node (SGSN); BSS GPRS Protocol (BSSGP)".
- [79] 3GPP TS 23.008: "Organization of subscriber data".
- [80] 3GPP TS 23.221: "Architectural requirements".
- [81] 3GPP TS 23.012: "Location Management Procedures".
- [82] 3GPP TS 22.101: "Service Principles".
- [83] 3GPP TS 23.251: " Network Sharing; Architecture and Functional Description".
- [84] 3GPP TS 32.422: "Subscriber and equipment trace; Trace control and Configuration Management (CM)".
- [85] 3GPP TS 44.018: "Mobile radio interface layer 3 specification; Radio Resource Control (RRC) protocol".
- [86] Void.
- [87] 3GPP TS 43.129: "Packet-switched handover for GERAN A/Gb mode; Stage 2".
- [88] 3GPP TS 23.203: "Policy and charging control architecture; Stage 2".
- [89] 3GPP TS 23.401: "General Packet Radio Service (GPRS) enhancements for Evolved Universal Terrestrial Radio Access Network (E-UTRAN) access".
- [90] 3GPP TS 23.402: "Architecture enhancements for non-3GPP accesses".
- [91] 3GPP TS 33.401: "3GPP System Architecture Evolution: Security Architecture".
- [92] 3GPP TS 29.274: "3GPP Evolved Packet System; Evolved General Packet Radio Service (GPRS) Tunnelling Protocol for Control plane (GTPv2-C); Stage 3".
- [93] 3GPP TS 23.272: "Circuit Switched Fallback in Evolved Packet System; Stage 2".

- [94] 3GPP TS 32.240: "Charging architecture and principles".
- [95] 3GPP TS 25.423: "UTRAN Iur interface Radio Network Subsystem Application Part (RNSAP) signalling".
- [96] IETF RFC 3588: "Diameter Base Protocol" (STD 1).
- [97] Void.
- [98] IETF RFC 4861 (2007): "Neighbor Discovery for IP Version 6 (IPv6)".
- [99] IETF RFC 4862 (2007): "IPv6 Stateless Address Autoconfiguration".
- [100] 3GPP TS 29.303: "Domain Name System Procedures; Stage 3".
- [101] 3GPP TS 23.216: "Single Radio Voice Call Continuity (SRVCC); Stage 2".
- [102] 3GPP TS 24.301: "Non-Access-Stratum (NAS) protocol for Evolved Packet System (EPS); Stage 3".
- [103] 3GPP TS 25.467: "UTRAN architecture for 3G Home NodeB; Stage 2".
- [104] 3GPP TS 23.292: "IP Multimedia Subsystem (IMS) centralized services; Stage 2".
- [105] IETF RFC 3633: "IPv6 Prefix Options for Dynamic Host Configuration Protocol (DHCP) version 6".
- [106] IETF RFC 3376: "Internet Group Management Protocol, Version 3".
- [107] IETF RFC 3810: "Multicast Listener Discovery Version 2 (MLDv2) for IPv6".
- [108] IETF RFC 3927: "Dynamic Configuration of IPv4 Link-Local Addresses".
- [109] IETF RFC 4291: "IP Version 6 Addressing Architecture".
- [110] 3GPP TS 22.368: "Service requirements for Machine-Type Communications (MTC)".
- [111] 3GPP TS 24.368: "Non-Access Stratum (NAS) configuration Management Object (MO)".
- [112] 3GPP TS 22.011: "Service Accessibility".
- [113] IETF RFC 6603: "Prefix Exclude Option for DHCPv6-based Prefix Delegation".
- [114] 3GPP TS 33.210: "Network Domain Security (NDS); IP network layer security".
- [115] IETF RFC 3168: "The Addition of Explicit Congestion Notification (ECN) to IP".
- [116] 3GPP TS 26.114: "IP Multimedia Subsystem (IMS); Multimedia Telephony; Media handling and interaction".
- [117] IETF RFC 4039: "Rapid Commit Option for the Dynamic Host Configuration Protocol version 4 (DHCPv4)".
- [118] IETF RFC 3736: "Stateless Dynamic Host Configuration Protocol (DHCP) Service for IPv6".
- [119] 3GPP TS 23.682: "Architecture Enhancements to facilitate communications with Packet Data Networks and Applications".
- [120] 3GPP TS 29.281: "GPRS Tunnelling Protocol User Plane (GTPv1-U)".
- [121] 3GPP TS 22.173: "IP Multimedia Core Network Subsystem (IMS) Multimedia Telephony Service and supplementary services; Stage 1".

3 Definitions, abbreviations and symbols

3.1 Definitions

Definitions can be found in TS 22.060 [3] and TS 25.401 [53]. For the purposes of the present document, the following terms and definitions apply:

GERAN/UTRAN PS coverage: an MS is defined to be in GERAN/UTRAN PS coverage if it can access GPRS services via GERAN or UTRAN. These services may be provided in A/Gb mode or in Iu mode. According to this definition, an MS camped on an E-UTRAN cell is not in GERAN/UTRAN PS coverage.

GPRS: packet bearer service of the packet domain.

A/Gb mode: indicates that this clause or paragraph applies only to a system or sub-system which operate in A/Gb mode of operation, i.e. with a functional division that is in accordance with the use of an A or a Gb interface between the radio access network and the core network. This definition is consistent with the A/Gb mode definition for the RAN in TS 43.051 [74].

NOTE 1: A/Gb mode is independent of the support of both interfaces, e.g. an SGSN in A/Gb mode uses only the Gb interface.

Iu mode: indicates that this clause or paragraph applies only to a system or a sub-system which operates in Iu mode of operation, i.e. with a functional division that is in accordance with the use of an Iu-CS or Iu-PS interface between the radio access network and the core network. This definition is consistent with the Iu mode definition for the RAN in TS 43.051 [74]. Note that Iu mode is independent of the support of both parts of the Iu interface, e.g. an SGSN in Iu mode uses only the Iu-PS interface.

Inter-system change: change of an MS from A/Gb mode to Iu mode of operation and vice versa.

MS: this specification makes no distinction between MS and UE

2G- / 3G-: prefixes 2G- and 3G- refer to systems or sub-systems, that support A/Gb mode or Iu mode, respectively, e.g. 2G-SGSN refers to all functionality of an SGSN which serves an MS in A/Gb mode.

NOTE 2: When the prefix is omitted, reference is made independently from the A/Gb mode or Iu mode functionality.

Pool area: refers to a grouping of one or more RA(s) that, from a RAN perspective, are served by a certain group of CN nodes, as defined for the Intra Domain Connection of RAN Nodes to Multiple CN Nodes.

Emergency attached MS: An MS which only has PDP context(s) related to emergency bearer service.

NOTE 3: The above term is equivalent to the term "attached for emergency bearer services" as specified in 3GPP TS 24.008 [13].

LIPA PDN connection: a PDN connection for local IP access for a UE connected to a HNB.

Correlation ID: For a LIPA PDN connection, Correlation ID is a parameter that enables direct user plane path between the HNB and L-GW.

3.2 Abbreviations

Applicable abbreviations can be found in TR 21.905 [9]. For the purposes of the present document the following abbreviations apply:

AAL5	ATM Adaptation Layer type 5
ADD	Automatic Device Detection
APN	Access Point Name
APN-AMBR	APN-Aggregate Maximum Bit Rate
ATM	Asynchronous Transfer Mode
AUTN	Authentication Token
BCM	Bearer Control Mode

BG	Border Gateway
BSSAP+	Base Station System Application Part +
BSSGP	Base Station System GPRS Protocol
BVCI	BSSGP Virtual Connection Identifier
CCU	Channel Codec Unit
CDR	Call Detail Record
CGF	Charging Gateway Functionality
CGI	Cell Global Identification
CK	Cipher Key
CMM	Circuit Mobility Management
CS	Circuit Switched
CSG	Closed Subscriber Group
CSG ID	Closed Subscriber Group Identity
CSS	CSG Subscriber Server
DHCP	Dynamic Host Configuration Protocol
DNS	Domain Name System
DTI	Direct Tunnel Indicator
DTM	Dual Transfer Mode
EGPRS	Enhanced GPRS
EPS	Evolved Packet System
ESP	Encapsulating Security Payload
ETFTN	Extended TFT Support Network
ETFTU	Extended TFT Support UE
E-UTRAN	Evolved UTRAN
GCSI	GPRS CAMEL Subscription Information indicator
GEA	GPRS Encryption Algorithm
GERAN	GSM EDGE Radio Access Network
GGSN	Gateway GPRS Support Node
GMM/SM	GPRS Mobility Management and Session Management
GPRS-SSF	GPRS Service Switching Function
GPRS-CSI	GPRS CAMEL Subscription Information
GRA	GERAN Registration Area
GSM-SCF	GSM Service Control Function
GSIM	GSM Service Identity Module
GSN	GPRS Support Node
GTP	GPRS Tunnelling Protocol
GTP-C	GTP Control Plane
GTP-U	GTP User Plane
GW	Gateway
HNB	Home Node B
HNB GW	Home Node B Gateway
ICMP	Internet Control Message Protocol
IETF	Internet Engineering Task Force
IK	Integrity Key
IP	Internet Protocol
IPv4	Internet Protocol version 4
IPv6	Internet Protocol version 6
IPX	Internet Packet eXchange
ISP	Internet Service Provider
KSI	Key Set Identifier
L2TP	Layer-2 Tunnelling Protocol
L-GW	Local Gateway
LIPA	Local IP Access
LL-PDU	LLC PDU
LLC	Logical Link Control
MAC	Medium Access Control
MIP	Mobile IP
MNRF	Mobile station Not Reachable Flag
MNRG	Mobile station Not Reachable for GPRS flag
MNRR	Mobile station Not Reachable Reason
MOCN	Multi-Operator Core Network
MTC	Machine Type Communications

MTP2	Message Transfer Part layer 2
MTP3	Message Transfer Part layer 3
MTU	Maximum Transfer Unit
NACC	Network Assisted Cell Change
NGAF	Non-GPRS Alert Flag
N-PDU	Network Protocol Data Unit
NRSU	Network Request Support UE
NRSN	Network Request Support Network
NS	Network Service
NSAPI	Network layer Service Access Point Identifier
NSS	Network SubSystem
ODB	Operator Determined Barring
OFCS	Offline Charging System
P-TMSI	Packet TMSI
PCU	Packet Control Unit
PDCH	Packet Data CHannel
PDCP	Packet Data Convergence Protocol
PDN	Packet Data Network
PDN GW	Packet Data Network Gateway
PDP	Packet Data Protocol, e.g. IP
PDU	Protocol Data Unit
P-GW	PDN Gateway
PMM	Packet Mobility Management
PPF	Paging Proceed Flag
PPP	Point-to-Point Protocol
PTP	Point To Point
PVC	Permanent Virtual Circuit
RA	Routeing Area
RAB	Radio Access Bearer
RAC	Routeing Area Code
RAI	Routeing Area Identity
RANAP	Radio Access Network Application Protocol
RAU	Routeing Area Update
RLC	Radio Link Control
RNC	Radio Network Controller
RNS	Radio Network Subsystem
RNTI	Radio Network Temporary Identity
RRC	Radio Resource Control
SBSC	Serving Base Station Controller
SBSS	Serving BSS
SGSN	Serving GPRS Support Node
S-GW	Serving Gateway
SIPTO	Selected IP Traffic Offload
SM	Short Message
SM-SC	Short Message service Service Centre
SMS-GMSC	Short Message Service Gateway MSC
SMS-IWMSC	Short Message Service Interworking MSC
SN-PDU	SNDCP PDU
SNDC	SubNetwork Dependent Convergence
SNDCP	SubNetwork Dependent Convergence Protocol
SPI	Security Parameter Index
SRNC	Serving RNC
SRNS	Serving RNS
TCAP	Transaction Capabilities Application Part
TCP	Transmission Control Protocol
TFT	Traffic Flow Template
TEID	Tunnel Endpoint IDentifier
LLI	Temporary Logical Link Identity
TOM	Tunnelling Of Messages
TOS	Type of Service
TRAU	Transcoder and Rate Adaptor Unit
UDP	User Datagram Protocol

UE-AMBR	UE-Aggregate Maximum Bit Rate
UEA	UMTS Encryption Algorithm
UESBI-Iu	UE Specific Behaviour Information - Iu
UESBI-Uu	UE Specific Behaviour Information - Uu
UIA	UMTS Integrity Algorithm
URA	UTRAN Registration Area
URRP-SGSN	UE Reachability Request Parameter for SGSN
USIM	User Service Identity Module

3.3 Symbols

For the purposes of the present document, the following symbols apply:

Ga	Charging data collection interface between a CDR transmitting unit (e.g. an SGSN, S-GW, PDN GW or a GGSN) and a CDR receiving functionality (a CGF).
Gb	Interface between an SGSN and a BSS.
Gc	Interface between a GGSN and an HLR.
Gd	Interface between an SMS-GMSC and an SGSN, and between an SMS-IWMSC and an SGSN.
Gf	Interface between an SGSN and an EIR.
Gi	Reference point between a GGSN and a packet data network.
Gn	Interface between two SGSNs within the same or different PLMNs or between an SGSN and a GGSN within the same PLMN.
Gp	Interface between a SGSN and a P-GW/GGSN in different PLMNs. The Gp interface allows support of GPRS network services across areas served by the co-operating GPRS PLMNs.
Gr	Interface between an SGSN and an HLR.
Gs	Interface between an SGSN and an MSC/VLR.
Iu	Interface between the RNS and the core network. It is also considered as a reference point.
kbit/s	Kilobits per second.
Mbit/s	Megabits per second. 1 Mbit/s = 1 million bits per second.
R	Reference point between a non-ISDN compatible TE and MT. Typically this reference point supports a standard serial interface.
Reporting Area	The service area for which the location of an MS is reported.
Service Area	The location accuracy level needed for service management purposes in the 3G-SGSN, e.g. a routing area or a cell. The 3G-SGSN can request the SRNC to report: i) the MS's current service area; ii) when the MS moves into a given service area; or iii) when the MS moves out of a given service area.
S4	Interface between a SGSN and a S-GW within the same PLMN.
S5	Interface between a S-GW and a P-GW within the same PLMN.
S6d	Interface between a SGSN and a HSS.
S8	Interface between a S-GW and a P-GW in different PLMNs. The S8 interface allows support of GPRS network services across areas served by the co-operating GPRS PLMNs
S12	User plane interface between the RNS and a S-GW for Direct Tunnel.
S16	Interface between two SGSNs within the same or different PLMNs when those SGSNs support S4.
SGi	Reference point between a P-GW and a packet data network.
SGs	Interface between MME and an MSC/VLR.
Um	Interface between the mobile station (MS) and the A/Gb mode network. The Um interface is the MS to network interface for providing GPRS services over the GERAN radio to the MS in A/Gb mode.
Uu	Interface between the mobile station (MS) and the Iu mode network. The Uu interface is the Iu mode network interface for providing GPRS services over the UTRAN radio (and in Iu mode, over the GERAN radio) to the MS.
S13'	Interface between a SGSN and an EIR within the same or different PLMNs.

NOTE: Except where stated otherwise, this specification does not make an explicit assumption as to whether an interface is intra-PLMN or inter-PLMN.

4 Main Concept

The packet domain uses packet-mode techniques to transfer high-speed and low-speed data and signalling in an efficient manner. The packet domain optimises the use of network and radio resources. Strict separation between the radio subsystem and network subsystem is maintained, allowing the network subsystem to be reused with other radio access technologies.

A common packet domain Core Network is used for both Radio Access Networks (RAN) the GERAN and the UTRAN. This common Core Network provides together with these RANs GPRS services. It is designed to support several quality of service levels to allow efficient transfer of non real-time traffic (e.g. intermittent and bursty data transfers, occasional transmission of large volumes of data) and real-time traffic (e.g. voice, video). Applications based on standard data protocols and SMS are supported, and interworking is defined with IP networks. Charging should be flexible and allow to bill according to the amount of data transferred, the QoS supported, and the duration of the connection.

The Serving GPRS Support Node (SGSN) keeps track of the location of an individual MS and performs security functions and access control. The SGSN is connected to the GERAN base station system through the Gb or Iu interface and/or to the UTRAN through the Iu interface. The SGSN also interfaces via the GPRS Service Switching Function with the GSM Service Control Function for optional CAMEL session and cost control service support.

The Gateway Node (P-GW/GGSN) provides interworking with packet data networks, and is connected with other core network nodes via an IP-based packet domain PLMN backbone network.

The Serving Gateway is user plane node that provides a common anchor for interoperation between GERAN/UTRAN and E-UTRAN accesses and when S4 is used it permits Direct Tunnel usage in roaming scenarios.

The Offline Charging System (OFCS) collects charging records from SGSNs, S-GWs and P-GW/GGSNs.

The HSS/HLR contains subscriber information.

The SMS-GMSCs and SMS-IWMSCs support SMS transmission via the SGSN.

Optionally, the MSC/VLR can be enhanced for more-efficient co-ordination of packet-switched and circuit-switched services and functionality: e.g. combined GPRS and non-GPRS location updates.

In order to use GPRS services, an MS shall first make its presence known to the network by performing a GPRS attach. This makes the MS available for SMS over GPRS and SMS over IMS, paging via the SGSN, and notification of incoming packet data. If the UE is already PS-attached due to an attach via E-UTRAN it makes its presence known to an SGSN by a Routing Area Update.

In order to send and receive packet data by means of GPRS services, the MS shall activate the Packet Data Protocol context that it wants to use. This operation makes the MS known in the corresponding P-GW/GGSN, and interworking with data networks can commence.

User data are transferred transparently between the MS and the packet data networks with a method known as encapsulation and tunnelling: data packets are equipped with GPRS-specific protocol information and transferred between the MS and the P-GW/GGSN. This transparent transfer method lessens the requirement for the PLMN to interpret external data protocols, and it enables easy introduction of additional interworking protocols in the future.

Packet Switched (PS) handover is introduced in order to support real-time packet-switched service with strict QoS requirements on low latency and packet loss. PS handover reduces the service interruption of the user plane information at cell change compared to the cell-reselection and enables methods to improve buffer handling of user plane data in order to reduce packet loss at cell-change. PS handover is the handover between GERAN PS and UTRAN PS. The complete specification of the PS handover procedures for A/Gb mode and between Iu mode and A/Gb mode are described in TS 43.129 [87].

Earlier release versions of this specification described a Network Mode Operation III, which is not available for deployment as GERAN specifications forbid deploying Packet Common Control Channels since Release 9 in TS 44.060 [77].

5 General GPRS Architecture and Transmission Mechanism

5.1 GPRS Access Interfaces and Reference Points

Each PLMN has two access points to GPRS services, the radio interface (labelled Um in A/Gb mode and Uu in Iu mode) used for mobile access and the R reference point used for origination or reception of messages. The R reference point for the MSs is defined in TS 27.060 [17].

An interface differs from a reference point in that an interface is defined where specific information is exchanged and needs to be fully recognised.

There is an inter PLMN interface called Gp or S8, respectively that connects two independent GPRS packet domain networks for message exchange.

There is also a PLMN to packet data network reference point called Gi or SGi, respectively. Gi and SGi are defined in TS 29.061 [27].

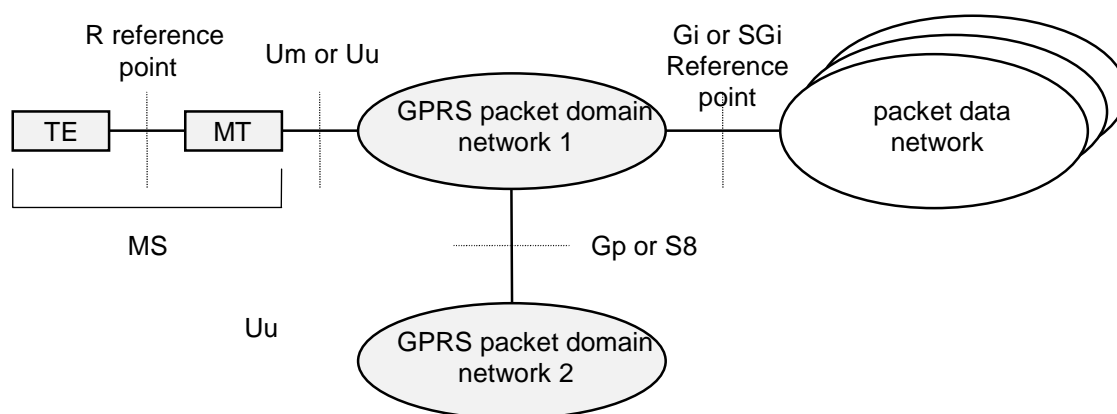

Figure 1: GPRS Access Interfaces and Reference Points

There may be more than a single network interface to several different packet data networks. These networks may both differ in ownership as well as in communications protocol (e.g. TCP/IP etc.). The network operator defines and negotiates interconnection with each interconnected packet data network.

5.2 Network Interworking

Network interworking is required whenever a packet domain PLMN and any other network are involved in the execution of a service request. With reference to Figure 1, interworking takes place through the Gi or SGi reference point and the Gp or S8 interface.

The internal mechanism for conveying the PDP PDU through the PLMN is managed by the PLMN network operator and is not apparent to the data user. The use of the GPRS service may have an impact on and increase the transfer time normally found for a message when communicated through a fixed packet data network.

5.2.1 Internet (IP) Interworking

GPRS shall support interworking with networks based on the Internet protocol (IP). IP is defined in RFC 791 [40]. The packet domain may provide compression of the TCP/IP header when an IP datagram is used within the context of a TCP connection.

Mobile terminals offered service by a service provider may be globally addressable through the network operator's addressing scheme.

5.3 High-Level Functions

5.3.0 General

The following list gives the logical functions performed within the packet domain network for GPRS with GERAN or UTRAN accesses. Several functional groupings (meta functions) are defined and each encompasses a number of individual functions:

- Network Access Control Functions.
- Packet Routing and Transfer Functions.
- Mobility Management Functions.
- Logical Link Management Functions (A/Gb mode).
- Radio Resource Management Functions.
- Network Management Functions.
- UE reachability function

5.3.1 Network Access Control Functions

Network access is the means by which a user is connected to a telecommunication network in order to use the services and/or facilities of that network. An access protocol is a defined set of procedures that enables the user to employ the services and/or facilities of the network.

User network access may occur from either the mobile side or the fixed side of the network. The fixed network interface may support multiple access protocols to packet data networks, for example IP. The set of access protocols to be supported is determined by the PLMN operator.

Individual PLMN administrations may require specific access-control procedures in order to limit the set of users permitted to access the network, or to restrict the capabilities of individual users, for example by limiting the type of service available to an individual subscriber. Such access control procedures are beyond the scope of the specifications.

5.3.1.1 Registration Function

Registration is the means by which a user's Mobile Id is associated with the user's packet data protocol(s) and address(es) within the PLMN, and with the user's access point(s) to the packet data network. The association can be static, i.e. stored in an HLR, or dynamic, i.e. allocated on a per need basis.

5.3.1.2 Authentication and Authorisation Function

This function performs the identification and authentication of the service requester, and the validation of the service request type to ensure that the user is authorised to use the particular network services. The authentication function is performed in association with the Mobility Management functions.

5.3.1.3 Admission Control Function

The purpose of admission control is to calculate which network resources are required to provide the quality of service (QoS) requested, determine if those resources are available, and then reserve those resources. Admission control is performed in association with the Radio Resource Management functions in order to estimate the radio resource requirements within each cell.

5.3.1.4 Message Screening Function

A screening function concerned with filtering out unauthorised or unsolicited messages is required. This should be supported through packet filtering functions. All types of message screening are left to the operators' control, e.g. by use of Internet firewalls.

5.3.1.5 Packet Terminal Adaptation Function

This function adapts data packets received / transmitted from/to terminal equipment to a form suitable for transmission by GPRS across the packet domain network.

5.3.1.6 Charging Data Collection Function

This function collects data necessary to support subscription and/or traffic fees.

5.3.1.7 Operator Determined Barring Function

The purpose of this function is to limit the service provider's financial risk with respect to new subscribers or to those who have not promptly paid their bills by restricting a particular packet switched service.

The functionality of ODB is described in the TS 23.015 [66].

5.3.2 Packet Routing and Transfer Functions

A route is an ordered list of nodes used for the transfer of messages within and between the PLMN(s). Each route consists of the originating node, zero or more relay nodes and the destination node. Routing is the process of determining and using, in accordance with a set of rules, the route for transmission of a message within and between the PLMN(s).

5.3.2.1 Relay Function

The relay function is the means by which a node forwards data received from one node to the next node in the route.

5.3.2.2 Routing Function

The routing function determines the core network node to which a message should be forwarded and the underlying service(s) used to reach that GPRS Support Node (GSN), S-GW or P-GW, using the destination address of the message. The routing function selects the transmission path for the "next hop" in the route.

Data transmission between core network nodes may occur across packet data networks that provide their own internal routing functions, for example ITU-T Recommendation X.25 [34], Frame Relay or ATM networks.

5.3.2.3 Address Translation and Mapping Function

Address translation is the conversion of one address to another address of a different type. Address translation may be used to convert an packet data network protocol address into an internal network address that can be used for routing packets within and between the PLMN(s).

Address mapping is used to map a network address to another network address of the same type for the routing and relaying of messages within and between the PLMN(s), for example to forward packets from one network node to another.

5.3.2.4 Encapsulation Function

Encapsulation is the addition of address and control information to a data unit for routing packets within and between the PLMN(s). Decapsulation is the removal of the addressing and control information from a packet to reveal the original data unit.

Encapsulation and decapsulation are performed between the core network nodes, and between the GPRS serving support node and the MS.

5.3.2.5 Tunnelling Function

Tunnelling is the transfer of encapsulated data units within and between the PLMN(s) from the point of encapsulation to the point of decapsulation. A tunnel is a two-way point-to-point path. Only the tunnel endpoints are identified.

5.3.2.6 Compression Function

The compression function optimises use of radio path capacity by transmitting as little of the SDU (i.e. the exterior PDP PDU) as possible while at the same time preserving the information contained within it. Only IP header compression is supported in Iu mode. The P-GW/GGSN may instruct the SGSN to negotiate no data compression for specific PDP contexts.

5.3.2.7 Ciphering Function

The ciphering function preserves the confidentiality of user data and signalling across the radio channels and inherently protects the PLMN from intruders.

5.3.2.8 Domain Name Server Function

The Domain Name Server function resolves logical network node names to addresses. This function is standard Internet functionality according to RFC 1034 [43], which allows resolution of any name for GSNs and other nodes within the GPRS packet domain PLMN backbone networks.

5.3.2.9 DHCP function

The Dynamic Host Configuration Function allows to deliver IP configuration information for UEs. This function is standard Internet functionality.

5.3.3 Mobility Management Functions

5.3.3.1 General

The mobility management functions are used to keep track of the current location of an MS within the PLMN or within another PLMN.

5.3.3.2 Idle Mode Signalling Reduction Function

The Idle mode Signalling Reduction (ISR) function provides a mechanism to limit signalling during cell-reselection in idle mode between GERAN and E-UTRAN or between UTRAN and E-UTRAN and is described in TS 23.401 [89].

NOTE: This function is not used in GERAN/UTRAN only network deployments.

5.3.4 Logical Link Management Functions (A/Gb mode)

Logical link management functions are concerned with the maintenance of a communication channel between an individual MS and the PLMN across the radio interface. These functions involve the co-ordination of link state information between the MS and the PLMN as well as the supervision of data transfer activity over the logical link.

Refer to TS 44.064 [15] for further information.

5.3.4.1 Logical Link Establishment Function

Logical link establishment is performed when the MS attaches to the PS services.

5.3.4.2 Logical Link Maintenance Functions

Logical link maintenance functions supervise the logical link status and control link state changes.

5.3.4.3 Logical Link Release Function

The logical link release function is used to de-allocate resources associated with the logical link connection.

5.3.5 Radio Resource Management Functions

5.3.5.1 General

Radio resource management functions are concerned with the allocation and maintenance of radio communication paths, and are performed by the Radio Access Network. Refer to TS 43.064 [11] and to TS 43.051 [74] for further information on GERAN. Refer to TS 25.301 [50] for further information on UTRAN.

5.3.5.2 RAT/Frequency Selection Priority

To support radio resource management in UTRAN/GERAN, the SGSN provides the parameter 'Index to RAT/Frequency Selection Priority' to RNC across Iu and to BSC across Gb. The RFSP Index is mapped by the RNC/BSC to locally defined configuration in order to apply specific RRM strategies. The RFSP Index is UE specific and applies to all the Radio Bearers. Examples of how this parameter may be used in UTRAN/GERAN:

- to derive UE specific cell reselection priorities to control idle mode camping.
- to decide on redirecting active mode UEs to different frequency layers or RATs.

The SGSN receives the subscribed RFSP Index from the HSS (e.g., during the Attach procedure). For non-roaming subscribers the SGSN chooses the RFSP Index in use according to one of the following procedures, depending on operator's configuration:

- the RFSP Index in use is identical to the subscribed RFSP Index, or
- the SGSN chooses the RFSP Index in use based on the subscribed RFSP Index, the locally configured operator's policies and the UE related context information available at the SGSN, including the UE's usage setting and voice domain preference for E-UTRAN, if received during Attach and Routing Area Update procedures (see clause 5.3.15).

NOTE 1: One example of how the SGSN can use the "UE voice capabilities and settings" is to select an RFSP value that enforces idle mode camping on 2G/3G for a UE acting in a "Voice centric" way and provisioned with "CS Voice preferred, IMS Voice as secondary", in order to minimize the occurrence of RAT changes. Another example is the selection of an RFSP value that prevents idle mode camping on 2G for a UE provisioned with "IMS PS voice preferred, CS Voice as secondary" if other RATs supporting IMS Voice are available, as the UE would in such case always select the CS domain for its voice calls.

For roaming subscribers the SGSN may alternatively choose the RFSP Index in use based on the visited network policy but can take input from HPLMN into account. (e.g. an RFSP Index value pre-configured per HPLMN, or a single RFSP Index value to be used for all roamers independent of the HPLMN).

NOTE 2: One example of how the SGSN can choose the RFSP Index in use for non-roaming or roaming subscribers with access restriction for E-UTRAN access due to access restriction in the subscription data or based on local configuration e.g. to reflect roaming restriction to E-UTRAN access, is to select an RFSP value that minimizes the risk of E-UTRAN cell reselection by a UE.

The SGSN forwards the RFSP Index in use to the RNC across Iu and to the BSC across Gb. The RFSP Index in use is also forwarded from source RNC to target RNC during the SRNS Relocation procedure for Intra-RAT handover.

The SGSN stores the subscribed RFSP Index value received from the HSS and the RFSP Index value in use. During the Routing Area Update procedure the SGSN may update the RFSP Index value in use and signal the updated value to the RNC across Iu and to the BSC across Gb, if the locally configured operator's policies indicate to do so (e.g. the SGSN may need to update the RFSP Index value in use if the UE related context information has changed). During inter-SGSN mobility procedures, the source SGSN forwards both RFSP Index values to the target SGSN. The target SGSN may replace the received RFSP Index value in use with a new RFSP Index value in use that is based on the operator's policies and the UE related context information available at the target SGSN.

The Iu messages that transfer the RFSP Index to the RNC are specified in TS 25.413 [56b].

The Gb messages that transfer the RFSP Index to the BSC are specified in TS 48.018 [78].

5.3.5.3 Service identification for improved radio utilisation for GERAN

The Service Class Indicator (SCI) (see TS 29.281 [120]) enables the GGSN/P-GW to provide the A/Gb mode GERAN access with an indication in the downlink user plane packet to assist the A/Gb mode GERAN access in providing specific RRM treatment in order to improve radio resource control and the overall performance of the GERAN.

NOTE 1: It is intended to standardize SCIs and relationship between SCIs and QoS classes in a future Release.

In the current specification, the SCI is only applicable for A/Gb mode GERAN access, and only for the Gn/Gp, S4 and the GTP based S5/S8 interfaces.

Support of SCI is optional in GERAN, A/Gb mode SGSN, and PGW/GGSN.

The GGSN/PGW is informed by the SGSN/MME of the UE's current RAT.

When the UE is using an A/Gb mode GERAN the GGSN/PGW determines the value of the SCI based on configuration. The SCI is included in the downlink user plane data packet (see TS 29.281 [120]).

NOTE 2: The 3GPP charging architecture does not take the SCI value into account.

There is no impact on the S-GW as part of this feature. If the SCI is received at the S-GW, the S-GW forwards them transparently.

NOTE 3: This feature has no impact on the RNC, eNodeB and Iu mode SGSN. If (unusually) the SCI is received, these entities behave according to the existing specifications for the treatment of GTP extension headers.

An eNodeB or RNC shall ignore the Service Class Indicator if received over the S1-U, S12 or other interface.

When the serving A/Gb mode SGSN receives SCI in a GTP-U packet, it copies it, without modifying its value, into a Gb interface information element that is sent by the SGSN in the downlink Gb interface user data packet to the GERAN access. In order to allow the GERAN to map the SCI into RRM behaviour, the downlink Gb interface user data packet also carries the HPLMN ID (in the IMSI parameter) and additional information, added by the SGSN, which indicates whether the SCI is assigned:

- by a GGSN/P-GW in the Home PLMN; or
- by a GGSN/P-GW in the Visited PLMN; or
- by a GGSN/P-GW for which the SCIs are coordinated across the different operator group PLMNs and the serving PLMN of the SGSN (Operator Group GGSN).

Absence of additional information is an indication of a VPLMN provided SCI.

NOTE 4: The SGSN determines and indicates "Operator Group GGSN" based on local configuration, which consists of a list of specific APN-NIs and associated PLMN-IDs.

The A/Gb mode GERAN uses the information from the SGSN to determine whether to map, and how to map, the SCI to the related RRM behaviour. If the GERAN is not configured with an SCI mapping for the SGSN provided information, then the GERAN shall treat the user plane packet normally, i.e. the GERAN ignores the SCI.

NOTE 5: When sending downlink GTP-U packets, there are some transient periods where the "current RAT" information for the user may be incorrect at the GGSN/P-GW e.g. after a handover from (E)UTRAN to GERAN, or if the MS is in idle mode with ISR active, or if the MS is in idle mode and located in a Routing Area comprising GERAN and UTRAN cells. In these cases, the A/Gb mode GERAN may receive the first downlink user plane packets without Service Class Indicator.

In network sharing configurations (MOCN or GWCN) the SCI can be supported as specified in TS 23.251 [83].

5.3.6 Network Management Functions

5.3.6.1 General

Network management functions provide mechanisms to support O&M functions related to GPRS.

5.3.6.2 NAS level congestion control

5.3.6.2.1 General

NAS level congestion control contains the functions: "APN based congestion control" and "General NAS level Mobility Management congestion control".

The use of the APN based MM and SM congestion control is for avoiding and handling of MM and SM signalling congestion associated with UEs with a particular APN. Both UEs and network shall support the functions to provide APN based MM and SM congestion control.

The SGSN may detect the NAS signalling congestion associated with the APN and start and stop performing the APN based congestion control based on criteria such as:

- Maximum number of active PDP contexts per APN;
- Maximum rate of PDP context activations per APN;
- One or multiple PDN GWs or GGSNs of an APN are not reachable or indicated congestion to the SGSN;
- Maximum rate of MM signalling requests associated with the devices with a particular subscribed APN; and/or
- Setting in network management.

The SGSN should not apply NAS level congestion control for emergency services.

The SGSN may also use the reject of NAS level Mobility Management signalling requests under general congestion conditions.

5.3.6.2.2 APN based Session Management congestion control

The APN based Session Management congestion control may be activated by SGSN due to e.g. congestion situation at SGSN, or by OAM at SGSN, or by a restart or recovery condition of a GGSN or PDN GW, or by a partial failure or recovery of a GGSN or PDN GW for a particular APN(s).

The SGSN may reject the Session Management (SM) requests from the MS (e.g. Activate PDP Context, Secondary PDP Context and Modify PDP Context Requests) with a Session Management back-off timer for congested APNs. If the MS provides no APN, then the SGSN uses the APN which is used in GGSN/PDN GW selection procedure.

The SGSN may deactivate PDP contexts belonging to a congested APN by sending the Deactivate PDP Context Request message to the MS with a Session Management back-off timer. If Session Management back-off timer is set in the Deactivate PDP Context Request message then the cause "reactivation requested" should not be set.

NOTE 1: MSs that do not support the Session Management back-off timer (including earlier release of MS) might contribute to increasing the signalling load in the SGSN by reattempting Session Management procedure.

The SGSN may store a Session Management back-off time per MS and APN when congestion control is active for an APN if a request without the low access priority indicator is rejected by the SGSN. The SGSN may immediately reject any subsequent request from the MS targeting to the APN before the stored Session Management back-off time is expired. If the SGSN stores the Session Management back-off time per MS and APN and the SGSN decides to send a Session Management Request message to a MS connected to the congested APN (e.g. due to decreased congestion situation), the SGSN shall clear the Session Management back-off time prior to sending any Session Management Request message to the MS.

NOTE 2: The above functionality is to diminish the performance advantage for MSs that do not support the NAS level back-off timer (e.g. pre-Rel-10 MSs) compared to MSs that do support it.

The SGSN should not apply APN based congestion control for emergency services.

Upon reception of the Session Management back-off timer in the Session Management reject message or in the Deactivate PDP Context Request message, the MS shall take the following actions until the timer expires:

- If APN is provided in the rejected Session Management Request message or if the Session Management back-off timer is received in the Deactivate PDP Context Request message, the MS shall not initiate any Session

Management procedures for the congested APN. The MS may initiate Session Management procedures for other APNs.

- If APN is not provided in the rejected Session Management Request message, the MS shall not initiate any Session Management requests without APN. The MS may initiate Session Management procedures for specific APN.
- Cell/RA/PLMN/RAT change do not stop the Session Management back-off timer.
- The MS is allowed to initiate the Session Management procedures when it is accessing the network with AC11-15 or for emergency services even when the Session Management back-off timer is running.
- If the MS receives a network initiated Session Management Request message for the congested APN while the Session Management back-off timer is running, the MS shall stop the Session Management back-off timer associated with this APN and respond to the SGSN.
- If the MS is configured with a permission for overriding low access priority and the Session Management back-off timer is running due to a reject message received in response to a request with low access priority, the upper layers in MS may request the initiation of Session Management procedures without low access priority.

The MS is allowed to initiate PDN disconnection procedure (e.g. sending Deactivate PDP Context Request) when the Session Management back off timer is running.

NOTE 3: The MS does not delete the related Session Management back-off timer when deactivating a PDP context.

The MS shall support a separate Session Management back-off timer for every APN that the MS may activate.

To avoid that large amounts of MSs initiate deferred requests (almost) simultaneously, the SGSN should select the Session Management back-off timer value so that deferred requests are not synchronized.

The APN based Session Management congestion control is applicable to the NAS SM signalling initiated from the MS in the control plane. The Session Management congestion control does not prevent the MS to send and receive data or initiate Service Request procedures for activating user plane bearers towards the APN(s) that are under SM congestion control.

5.3.6.2.3 APN based Mobility Management congestion control

The SGSN may perform APN based congestion control for MSs with a particular subscribed APN by rejecting Attach procedures with a Mobility Management back-off timer. If the subscription contains a wildcard APN, the SGSN should not reject the request.

When congestion control is active for MSs with a particular subscribed APN, a Mobility Management back-off timer may be sent by the SGSN to MS.

If SGSN maintains the MS context, the SGSN may store the back-off time per MS if a request without the low access priority indicator is rejected by the SGSN. The SGSN may immediately reject any subsequent request from the MS before the stored back-off time is expired.

NOTE 1: The above functionality is to diminish the performance advantage for MSs that do not support the NAS level back-off timer (e.g. pre-Rel-10 MSs) compared to MSs that do support it.

After rejecting Attach Requests, the SGSN should keep the subscriber data for some time. This allows for the rejection of subsequent requests without HSS signalling when the congestion situation resulting from MSs with a particular subscribed APN persists. Similarly the SGSN may reject Attach Requests based on subscriber data that the SGSN may store after the Detach procedure.

While the Mobility Management back-off timer is running, the UE shall not initiate any NAS request for Mobility Management procedures. However, the UE is allowed to initiate Mobility Management procedures when it is accessing the network with AC11-15 or for emergency services even when the Mobility Management back-off timer is running.

NOTE 2: When receiving the Mobility Management back-off timer the MS behaviour is not APN specific.

While the Mobility Management back-off timer is running, the MS configured with a permission for overriding low access priority is allowed to initiate Mobility Management procedures without low access priority if the Mobility Management back-off timer was started due to a reject message received in response to a request with low access

priority and the upper layers in MS request to activate a PDP context without low access priority or the MS has an activated PDP context that is without low access priority.

To avoid that large amounts of MSs initiate deferred requests (almost) simultaneously, the SGSN should select the Mobility Management back-off timer value so that deferred requests are not synchronized.

5.3.6.2.4 General NAS level Mobility Management congestion control

Under general overload conditions the SGSN may reject Mobility Management signalling requests from MSs. When a NAS request is rejected, a Mobility Management back-off timer may be sent by the SGSN. If SGSN maintains the MS context, the SGSN may store the back-off time per MS if a request without the low access priority indicator is rejected by the SGSN. The SGSN may immediately reject any subsequent request from the MS before the stored back-off time is expired. While the Mobility Management back-off timer is running, the MS shall not initiate any NAS request for Mobility Management procedures. While the Mobility Management back-off timer is running, the MS is allowed to access the network with AC11-15, perform Detach Procedure, perform mobile terminated services and initiate emergency services. While the Mobility Management back-off timer is running, the MS is allowed to perform Routing Area Update (or combined RA/LA update) if it is already in READY or PMM-CONNECTED state. After any such Detach procedure, the back-off timer continues to run. If the MS receives a paging request from the SGSN while the Mobility Management back-off timer is running, the MS shall stop the Mobility Management back-off timer and initiate the Service Request procedure or the Routing Area Update procedure as described in clause 6.9.2.1.

While the Mobility Management back-off timer is running, the MS configured with a permission for overriding low access priority is allowed to initiate Mobility Management procedures without low access priority if the Mobility Management back-off timer was started due to a reject message received in response to a request with low access priority and the upper layers in MS request to activate a PDP context without low access priority or the MS has an activated PDP context that is without low access priority.

The Mobility Management back-off timer shall not impact the UE's function to perform Cell/RAT and PLMN change. Cell/RAT and RA change do not stop the Mobility Management back-off timer. The Mobility Management back-off timer shall not be a trigger for PLMN reselection. The back-off timer is stopped as defined in TS 24.008 [13] when a new PLMN that is not an equivalent PLMN is accessed.

When the MS receives a handover command, the MS shall proceed with the handover procedure regardless of whether the Mobility Management back-off timer is running.

The SGSN should not reject Routing Area Update procedures that are performed when the MS is already in READY or PMM-CONNECTED state.

If the SGSN rejects a Routing Area Update Request or a Service Request with a Mobility Management back-off timer which is larger than the sum of the MS's periodic RA Update timer plus the implicit detach timer, the SGSN should adjust the mobile reachable timer and/or implicit detach timer such that the SGSN does not implicitly detach the MS while the Mobility Management back-off timer is running.

NOTE: This is to minimize unneeded signalling after the Mobility Management back-off timer expires.

To avoid that large amounts of MSs initiate deferred requests (almost) simultaneously, the SGSN should select the Mobility Management back-off timer value so that deferred requests are not synchronized.

5.3.6.3 GGSN control of overload

The GGSN may provide mechanisms for avoiding and handling overload situations. These include the rejection of PDP context requests from UEs.

The GGSN may detect congestion per APN and start and stop performing overload control based on criteria such as:

- Maximum number of active PDP contexts per APN and/or
- Maximum rate of PDP context activations per APN.

When performing overload control the GGSN rejects PDP context requests. When receiving the rejection from the GGSN, the SGSN rejects the UE's PDP context request as specified in clause 5.3.6.2. In addition the GGSN may indicate a "GGSN back-off time" for a specific APN to the SGSN. The SGSN should reject PDP context requests from UEs for the specific APN related to that GGSN during the "GGSN back-off time", by the means specified in clause 5.3.6.2. If a GGSN indicates APN congestion by the "GGSN back-off time" the SGSN may select another GGSN

of that APN instead of rejecting PDP context requests. unless there is already an existing PDP context to the same APN for the MS, in which case, the SGSN shall reject PDP context request

5.3.6.4 SGSN control of overload

The SGSN contains mechanisms for avoiding and handling overload situations. In an overload situation the SGSN can request the RNC to reduce any kind of signalling traffic as specified in TS 25.413 [56b].

In addition, the SGSN can request the BSC/RNC to reject the RR(C) connection establishments from MSs that access the network with low access priority that its connected BSCs/RNCs are generating on it.

A BSC/RNC supports rejecting of RR(C) connection establishments from MSs that access the network with low access priority. When rejecting an RR(C) connection request for overload reasons the BSC/RNC indicates to the MSs an appropriate timer value that limits further RR(C) connection requests.

If the network is operating in Network Mode of Operation II, then (because at a common LA/RA boundary Location Area Updates are initiated before Routing Area updates) MSs will often initiate signalling connections towards the SGSN while in RRC connected state. If the SGSN has indicated an overload situation to the RNC, then the RNC can use the Signalling Connection Release message to avoid establishing the signalling connection with the SGSN.

Additionally, a BSC/RNC provides support for the barring of MSs configured for Extended Access Barring, as described in TS 22.011 [112]. These mechanisms are further specified in TS 48.016 [20] and TS 44.018 [85] for GERAN, TS 25.331 [52] for UTRAN.

A BSC/RNC may initiate Extended Access Barring when:

- all the SGSNs (and all the MSCs) connected to a BSC/RNC request to restrict the load for MSs that access the network with low access priority; or
- requested by O&M.

If a SGSN requests a BSC/RNC to restrict the load for MSs that access the network with low access priority, the SGSN should select all the BSCs/RNCs with which the SGSN has Gb/Iu interface connections (so that Extended Access Barring can be triggered if all SGSNs within a pool area are experiencing the same overload situation). Alternatively, the selected BSCs/RNCs may be limited to a subset of the BSCs/RNCs with which the SGSN has Gb/Iu interface connections (e.g. particular location area or where MSs of the targeted type are registered).

For GERAN, subsequent initial access attempts by a previously barred MS through Extended Access Barring is described in TS 44.018 [85].

In addition, to protect the network from overload the SGSN has the option of rejecting NAS request messages which include the low access priority indicator before rejecting NAS request messages without the low access priority indicator (see clause 5.3.6.2 for more information).

5.3.6.5 S4-SGSN control of overload

Under unusual circumstances (e.g. when the S4-SGSN load exceeds an operator configured threshold), the S4-SGSN may restrict the signalling load that its SGWs are generating on it, if configured to do so.

The S4-SGSN can reject Downlink Data Notification requests for low priority traffic for UEs in idle mode or to further offload the S4-SGSN, the S4-SGSN can request the SGWs to selectively reduce the number of Downlink Data Notification requests it sends for downlink low priority traffic received for UEs in idle mode according to a throttling factor and for a throttling delay specified in the Downlink Data Notification Ack message.

SGW and S4-SGSN determine whether a bearer is for low priority traffic or not on the basis of the bearer's ARP priority level and operator policy (i.e. operator's configuration in the SGW and S4-SGSN of the ARP priority levels to be considered as priority or non-priority traffic). The S4-SGSN determines whether a Downlink Data Notification request is for low priority traffic or not on the basis of the ARP priority level that was received from the SGW and operator policy.

If ISR is not active for the UE, during the throttling delay, the SGW drops downlink packets received on all its low priority bearers for UEs known as not user plane connected (i.e. the SGW context data indicates no downlink user plane TEID) served by that S4-SGSN in proportion to the throttling factor, and sends a Downlink Data Notification message to the S4-SGSN only for the non throttled bearers.

If ISR is active for the UE, during the throttling delay, the SGW does not send DDN to the S4-SGSN and only sends the DDN to the MME. If both MME and SGSN are requesting load reduction, the SGW drops downlink packets received on all its low priority bearers for UEs known as not user plane connected (i.e. the SGW context data indicates no downlink user plane TEID) in proportion to the throttling factors.

The SGW resumes normal operations at the expiry of the throttling delay. The last received value of the throttling factor and throttling delay supersedes any previous values received from that S4-SGSN. The reception of a throttling delay restarts the SGW timer associated with that S4-SGSN.

5.3.7 Selection functions

5.3.7.1 SGW/PGW/GGSN selection function (3GPP accesses)

The SGSN supporting both S4 and Gn/Gp shall support selection of SGW/PGW and GGSN.

The Gn/Gp SGSN shall support selection of GGSN and may optionally support selection of PGW.

For a given UE, the SGSN shall select the same GGSN/PGW for all the PDP contexts belonging to the same APN.

At PDP Context activation, it shall be possible for SGSN to use:

- the UE capability (as indicated in the MS Network Capability); and
- the configuration about the roaming agreement for E-UTRAN with the HPLMN of the UE,

as input to select GGSN, or a SGW and PGW.

It shall be possible to configure the selection function on the SGSN to give priority towards SGW/PGW for E-UTRAN capable UEs, and GGSN for non E-UTRAN capable UE.

It shall also be possible to configure the selection function on the SGSN to select GGSN/PGW using Gp when there is no roaming agreement for E-UTRAN with the HPLMN of the UE.

NOTE: EPS-based mobility to non-3GPP accesses is only possible if the SGSN selects a PDN GW.

5.3.7.2 Serving GW selection function

The Serving GW selection function is described in the clause "Serving GW selection function" of TS 23.401 [89].

5.3.7.3 SGSN selection function

The SGSN selection function selects an available SGSN to serve a UE. The selection is based on network topology, i.e. the selected SGSN serves the UE's location and in case of overlapping SGSN service areas, the selection may prefer SGSNs with service areas that reduce the probability of changing the SGSN. Other criteria for SGSN selection may be load balancing between SGSNs.

5.3.8 IMS voice over PS Session Supported Indication

The serving PLMN, both in Iu mode and A/Gb mode, shall send an indication toward the UE during the Attach procedure and Routing Area Update procedures if an IMS voice over PS session is supported. The serving PLMN uses this indicator to indicate to the UE whether it can expect a successful IMS voice over PS session according to TS 22.173 [121] with a bearer that supports Conversational Voice as specified in TS 23.203 [88], when the UTRAN Iu mode is used. A UE with "IMS voice over PS" voice capability should take this indication into account when:

- establishing voice over PS sessions (as specified in TS 23.221 [80]);
- determining whether to deactivate ISR locally (as detailed in clauses 6.9.1.2.0 and 6.9.2.1); and
- determining whether to perform a Routing Area Update when changing between GERAN and UTRAN cells within a Routing Area with both GERAN and UTRAN cells (to inform about IMS voice over PS sessions support as detailed in clauses 6.9.1.2.0 and 6.9.2.1).

The serving PLMN provides this indication based e.g. on local policy, HPLMN, Voice Support Match Indicator, the SRVCC capability of the network and UE and/or level of UTRAN coverage. The serving PLMN shall indicate to the UE that the UE can expect a successful IMS voice over PS session according to TS 22.173 [121] with a bearer that supports Conversational Voice as specified in TS 23.203 [88] only if the SGSN is configured to know that the serving PLMN has a roaming agreement for IMS voice with the HPLMN of the UE. This indication is per RAI within the SGSN.

On request from the HSS, the SGSN shall indicate the following:

- whether or not an IMS voice over PS session is supported in the UE's current Routing Area ("IMS voice over PS Session Supported Indication"), together with the time of the last radio contact with the UE; and
- the current RAT type.

5.3.8A Homogenous Support of IMS Voice over PS Sessions Indication

The "Homogenous Support of IMS Voice over PS Sessions" indication is provided by the SGSN to the HSS/HLR, and can be used by the HSS/HLR to avoid requesting the serving nodes whether or not an IMS voice over PS session is supported. This indication is stored in the SGSN MM context.

The SGSN shall behave as follows whenever it sends a Update Location or a Notify Request message to the HLR/HSS:

- if "IMS Voice over PS Sessions" is supported homogeneously in all RAs in the serving SGSN for the UE, the SGSN shall include the "Homogenous Support of IMS Voice over PS Sessions" indication set to "Supported".
- if none of the RAs of the serving SGSN supports "IMS Voice over PS Sessions" for the UE, the SGSN shall include the "Homogenous Support of IMS Voice over PS Sessions" indication set to "Not supported".
- if "IMS Voice over PS Sessions" support is either non-homogeneous or unknown, the SGSN shall not include the "Homogenous Support of IMS Voice over PS Sessions" indication.

5.3.9 Closed Subscriber Group functions

A Closed Subscriber Group (CSG) identifies a group of subscribers who are permitted to access one or more CSG cells of the PLMN as a member of the CSG for a HNB. The following CSG related functions are defined:

- CSG subscription handling function stores and updates the user's CSG subscription data at the MS and the network.
- For closed mode, CSG access control function ensures a UE has valid subscription at a CSG where it performs an access.
- Admission and rate control function is used to provide different admission and rate control for CSG and non-CSG members for a hybrid cell.
- CSG charging function enables per CSG charging for a subscriber consuming network services via a CSG cell or a hybrid cell.
- Paging optimization function is optionally used to filter paging messages based on RAI/LAI, UE CSG capability, user's CSG subscription data and CSG access mode in order to avoid paging at CSG cells where the UE is not allowed to access. If the MS has emergency bearer service the paging optimization function shall not be performed.
- VPLMN Autonomous CSG roaming function is optionally supported whereby a VPLMN, if allowed by the HPLMN, stores and manages VPLMN specific CSG subscription information for roaming UEs without interaction with the HLR/HSS.

NOTE: The support of the Closed Subscriber Group functions is optional for an UTRAN MS.

5.3.10 UE Reachability function

One or several services can subscribe to the HSS in order to be notified when the UE becomes reachable at NAS layer. On request from the HSS, the SGSN notifies the HSS when the UE is detected at NAS level by the SGSN, and the HSS notifies the subscribed services. An example service is SMS over IP.

5.3.11 Location Service functions

LCS procedures are described in the LCS stage 2 specification, see TS 23.271 [65].

In addition, in the Detach and PDP Context Deactivation procedures, the SGSN shall inform the GGSN/S-GW of the last known location of the MS, and shall provide information to enable the determination of the time at which the MS was in that location. The S-GW shall (if necessary taking into account information from the MME) inform the PDN GW of the last known location of the MS, and shall provide information to enable the determination of the time at which the MS was in that location. If requested by the PCRF the GGSN/PDN GW shall indicate this information to the PCRF as defined in TS 23.203 [88]. The information can also be made available on the Gi interface as specified in TS 29.061 [27] and on the CDRs at the GGSN/PDN GW as specified in TS 32.251 [70].

5.3.12 Selected IP Traffic Offload (SIPTO) function

5.3.12.1 SIPTO with GW Selection

The SIPTO function enables an operator to offload certain types of traffic at a network node close to that UE's point of attachment to the access network.

SIPTO function specified in TS 23.401 [89] clause 4.3.15 is applicable, with the SGSN node providing the functions specified for the MME.

In order to fully utilise the benefit of the SIPTO with GW selection function, direct tunnel functionality as described in clause 15.6 should be applied.

In order to select a set of GWs (S-GW/P-GW or GGSN) that is most appropriate for that UE's current location (during the PDP Context Activation Procedure (clauses 9.2.2.1 and 9.2.2.1A)), the SGSN checks the APN status for SIPTO for the user during the GW Selection function procedure as described in clause 5.3.7 and Annex A.

As a result of UE mobility (e.g. detected by the SGSN at RAU), the target SGSN may allocate a different GW that is more appropriate for the UE's current location, e.g. the SGSN may know whether the UE's new location is served by the same GW as the old one. When the SGSN decides upon the need for GW relocation, the SGSN deactivates the impacted PDN connections indicating "reactivation requested" as specified in clause 9.2.4.2.

NOTE: If the above procedure for GW relocation is initiated while the UE has active applications, it may cause disruption of services that are affected if the IP address changes.

5.3.12.2 Support for SIPTO at Iu-ps

SIPTO can be achieved by adding an optional Traffic Offload Function at Iu interface as described in clause B.1. If implemented, and in order to activate SIPTO at Iu-ps, the SGSN shall send charging parameters including MSISDN, APN, Charging Characteristics in the RANAP messages whenever a RAB to be offloaded is requested to be setup as described in clause B.2.

5.3.13 Machine Type Communication (MTC)

5.3.13.1 General

This clause provides an overview about functionality for Machine Type Communications according to service requirements described in TS 22.368 [110]. The specific functionality is described in the affected procedures and features of this and other specifications. For discrepancies between this overview clause and the detailed procedure and function descriptions, the latter take precedence.

MTC functionality is provided by the visited and home networks when the networks are configured to support machine type communication. It applies to both the non-roaming case and the roaming case and some functionality may be dependent upon the existence of appropriate roaming agreements between the operators.

Some of the MTC functions are controlled by subscriber data. Other MTC functions are based on indicators sent by the UE to the network. MTC functionality is performed by UEs that are configured to support different options as described in clause 5.3.13.3.

Though motivated by scenarios and use cases defined in TS 22.368 [110], the functions added to support MTC have general applicability and are in no way constrained to any specific scenario or use case except where explicitly stated.

5.3.13.2 Overview of Protection from Potential MTC Related Overload

The number of Machine Type Communication devices may be several orders of magnitude greater than "traditional" devices. Many (but not all) MTC devices will be relatively stationary and/or generate low volumes of traffic. However, these MTC devices have the capability to generate normal quantities of signalling. As normal signalling from large numbers of MSs may cause overload independently whether the MS is used for MTC or not, generic functionality for overload and congestion control is required.

The total signalling from large numbers of MSs is a concern in at least two situations:

- when an application (running in many MSs) requests many MSs to do "something" at the same time; and/or
- when many MSs are roamers and their serving network fails, then they can all move onto the local competing networks, and potentially overload the not (yet) failed network(s).

To counter these potential problems, the following standardised indications and mechanisms are provided in a generic manner. These permit node specific features to be developed to protect the networks.

- a) Where applicable, MSs can be configured for enhancements as described in subsequent bullets. Post-manufacturing configuration can be performed remotely as described in clause 5.3.13.3.
- b) For mobile originated services, MSs configured for low access priority provide:
 - the UTRAN with information indicating that the RR(C) connection establishment request has low access priority (see clause 5.3.13.3); and
 - the GERAN with information indicating that the RR connection establishment request has low access priority (see clause 5.3.13.3), when accessing the network for the purpose of PS domain signalling.

In GERAN, "Implicit Reject" functionality permits the BSS to inhibit Random Access Channel signalling (see TS 44.018 [85]).

Clause 5.3.13.3 describes when low access priority is not applicable.

- c) RR and RRC signalling has the capability of providing 'extended wait timers' when rejecting messages.
- d) SGSN can initiate rejection of RR(C) connection establishment in the GERAN/UTRAN MSs that access the network with low access priority. In addition, SGSN signalling or GERAN/UTRAN O&M can trigger GERAN/UTRAN to initiate Extended Access Barring in the GERAN /UTRAN. These mechanisms are further described in clause 5.3.6.4.
- e) Overload messages from the SGSN to RNS/BSS are extended to aid the RAN in performing the functionality in bullets b, c and d above.
- f) MSs configured with a long minimum periodic PLMN search time limit (see TS 24.368 [111]) have an increased minimum time inbetween their searches for more preferred PLMNs.

NOTE 1: Following the failure of a more preferred PLMN, MSs configured as above might change to other local competing networks. Expiry of this search timer will lead to the MS re-attempting to access the failed network, and then, if that network has not yet recovered, reaccessing one of the local competing networks. Use of a too short timer for the more preferred PLMN search can both prevent the failed network from recovering, and, impose more load on the local competing networks.

- g) At PLMN change, MSs configured to perform Attach with IMSI at PLMN change (see TS 24.368 [111]) do this rather than an RA update with P-TMSI (thus avoiding the need to reject the RA update, and to request the IMSI following the subsequent Attach with P-TMSI).

NOTE 2: In the case of a network failure, this reduces the message processing load on a local competing network and hence makes that network more likely to survive the failure of the other network.

- h) For mobile originated services, MSs configured for low access priority (see TS 24.368 [111]) provide a low access priority indication to the SGSN in NAS signalling that permits the SGSN to undertake protective measures (e.g. to permit the SGSN to immediately command the MS to move to a state where it does not need to generate further signalling messages and/or does not reselect PLMNs), as described in clause 5.3.6.4. Clause 5.3.13.3 describes when low access priority is not applicable.
- i) Using periodic RAU timer information sent by the HSS and/or MS provided indication (bullet h above), the SGSN can allocate a long periodic RAU timer to the MS. A long periodic RAU timer is likely to slow down the rate at which an MS detects a network failure and thus it slows down the rate of movement of MSs from a failed network to other local competing networks (see clause 5.3.13.5).
- j) Mechanisms for the SGSN and GGSN/P-GW to detect congestion associated with a particular APN (see clauses 5.3.6.2 and 5.3.6.3 and TS 23.401 [89]).
- k) The addition of 'back off timers' to GMM and SM signalling messages (e.g. to rejection messages). These include some time randomisation to guard against a repeat of a load peak. The SGSN should be able to apply this behaviour on a per-APN basis as described in clause 5.3.6.2.
- l) Mechanisms that permit the GGSN/P-GW to handle per-APN congestion (see clause 5.3.6.3 and TS 23.401 [89]).
- m) When using the S4 architecture, an SGSN overload control mechanism to selectively limit the number of Downlink Data Notification requests the S-GW sends to the SGSN for downlink low priority traffic received for MSs in idle mode (see clause 5.3.6.5).
- n) The BSS and RNS are provided with indications from the MS that permit them to steer "new MTC entrants into a pool area" to specific SGSNs (e.g. to an SGSN optimised for MTC devices by having a larger subscriber data base, see TS 23.236 [73]).
- o) GERAN and/or UTRAN broadcast signalling can be used to command MSs configured to use the extended NMO I system information (see TS 24.368 [111]) to operate in Network Mode of Operation I while leaving other MSs operating in NMO II. This reduces the amount of signalling from MSs configured as above and may be particularly useful at times of the failure of another PLMN. Maintaining NMO II for existing MSs avoids changes to their existing service levels (see clause 6.3.3.1).

NOTE 3: It is assumed that the mechanisms described in this entire clause are designed by stage-3 in a manner that allows extensibility and forward compatibility.

- p) MS configured for specific handling of the invalid USIM state, the "forbidden PLMN list" and the "forbidden PLMNs for GPRS service list" remembers that the (U)SIM is invalid and keeps the PLMN forbidden lists even if the MS is switched off and then switched on.
- q) When the MS has an activated PDP context that is without low access priority or the MS is requested to activate such a PDP context and the MS is configured with a permission for overriding low access priority, then the MS does not provide a low access priority indication to the SGSN in MM NAS signalling and also not to the RAN in the RR(C) requests. In the NAS request for activating a PDP context, this MS always indicates what the upper layers requested, i.e. the MS indicates low access priority in that NAS request unless the upper layers request activation of a PDN connection without low access priority.
- r) When the MS has an activated PDP context that is without low access priority or the MS is requested to activate such a PDP context and the MS is configured with a permission for overriding Extended Access Barring, then the MS ignores any Extended Access Barring (if it is activated in the network) as defined in TS 22.011 [112].

5.3.13.3 MS configuration and usage of indicators

A subscriber can by agreement with its operator be required to use MSs that are configured (see TS 24.368 [111]) to support one or more of the following options:

- MS configured for low access priority; and/or
- MS configured with a permission for overriding low access priority, which is only applicable for an MS that is also configured for low access priority; and/or
- MS configured to use the extended NMO I system information; and/or
- MS configured to perform Attach with IMSI at PLMN change; and/or
- MS configured with a long minimum periodic PLMN search time limit; and/or
- MS configured for Extended Access Barring; and/or
- MS configured with a permission for overriding Extended Access Barring, which is only applicable for a UE that is also configured for Extended Access Barring; and/or
- MS configured for specific handling of the invalid (U)SIM state, the "forbidden PLMN list" and the "forbidden PLMNs for GPRS service list".

NOTE 1: When an MS is accessing the network with low access priority, the MS may be subject for longer backoff timers at overload and consequently need to be designed to be tolerant to delays when accessing the network.

MSs can be configured for one or more of the above options with the following restrictions:

- in this Release of the specification, an MS that is configured for low access priority shall also be configured for Extended Access Barring; and
- in this Release of the specification, an MS that is configured for Extended Access Barring shall be configured for low access priority.
- in this Release of the specification, an MS that is configured for overriding low access priority shall also be configured for overriding Extended Access Barring; and
- in this Release of the specification, an MS that is configured for overriding Extended Access Barring shall also be configured for overriding low access priority.

Post-manufacturing configuration of these options in the MS can be performed only by OMA DM or (U)SIM OTA procedures. MSs capable of the above options should support configuration of these options by both OMA DM and (U)SIM OTA procedures.

An MS configured for low access priority shall transmit the low access priority indicator to the SGSN during the appropriate NAS signalling procedures and transmit the corresponding low access priority to the UTRAN/GERAN during RR(C) connection establishment procedures, unless the MS is also configured with a permission for overriding low access priority where bullet q from clause 5.3.13.2 applies.

NOTE 2: The low access priority indicator in NAS signalling and the corresponding low access priority for RR(C) connection establishment are only used by the network to decide whether to accept the NAS request or the setup of the RR(C) connection, respectively.

Low access priority shall not be applicable in the following situations:

- for all procedures related to an emergency PDN connection; used for IMS Emergency sessions that are to be prioritized as per the requirements for IMS Emergency session procedures (see clause 5.10). When an emergency PDN connection gets established, the SGSN may, based on SGSN configuration, initiate the deactivation of any non-emergency PDN connection using the SGSN-initiated PDP Context Deactivation Procedure described in clause 9.2.4.2 and, in S4 mode, the SGSN Initiated PDN connection Deactivation Procedure described in clause 9.2.4.1A.1;
- for all procedures when preferential access to the network is provided to the MS by the Access Class 11-15 mechanism according to TS 48.018 [78], TS 25.331 [52] and TS 22.011 [112];

NOTE 3: The configuration of an MS for low access priority and Access Class 11-15 is configured independently of each other. However, the home operator can take care to prevent a subscription for Access Class 11-15 from being used in an MS configured for low access priority.

- for RRC connection establishment procedures when responding to paging;
- for an MS configured with a permission for overriding low access priority under conditions described by bullet q from clause 5.3.13.2; or
- other specific situations described in TS 24.008 [13].

If the NAS session management request message used to establish a new PDN connection contains a low access priority indication, the SGSN shall forward the low access priority indication in the Create PDP Context Request message to the GGSN and, in S4 mode, in the Create Session Request message to the S-GW/P-GW. The low priority indication gets associated with a PDN connection when it is established and it shall not change until the PDN connection is deactivated.

The low access priority indication may be included in charging records by the visited and home networks. In order to permit the S-GW and/or Gn/Gp SGSN to include the low access priority indicator in the charging records, the low access priority indicator should be stored in the SGSN EPS/PDP Bearer contexts and should be passed as part of these contexts to other SGSN/MME or S-GW nodes in mobility management procedures.

NOTE 4: In this release there is no other usage of storing the low access priority indicator in EPS/PDP Bearer contexts other than for the purpose to include it in charging records. Particularly, the low access priority indicator in EPS/PDP Bearer contexts is not used by the network to make overload control decisions.

A network node may invoke one or more of the following mechanisms based on the indicators received in signalling from MSs or forwarded by other network nodes:

- based on the low access priority indicator in NAS request messages, bullets e, h, i, k and l as defined in clause 5.3.13.2; and/or
- based on the low access priority for RR(C) connection establishment, bullets b and c as defined in clause 5.3.13.2.

An MS shall invoke one or more of the following mechanisms based on the configuration and capabilities of the MS:

- when MS is configured with a long minimum periodic PLMN search time limit, MS invokes actions as described in bullet f in clause 5.3.13.2; and/or
- when MS is configured to perform Attach with IMSI at PLMN change, MS invokes actions as described in bullet g in clause 5.3.13.2; and/or
- when MS is configured to use the extended NMO I system information, MS invokes actions as described in bullet o in clause 5.3.13.2; and/or
- when MS is configured for low access priority, MS invokes actions as described in bullets b and h in clause 5.3.13.2; and/or
- when MS is configured for Extended Access Barring, MS invokes actions as defined in bullet d in clause 5.3.13.2; and/or
- when MS is configured for specific handling of the invalid (U)SIM state, the "forbidden PLMN list" and the "forbidden PLMNs for GPRS service list", MS invokes actions as defined in bullet p in clause 5.3.13.2; and/or
- when MS is configured with a permission for overriding low access priority and Extended Access Barring, the MS invokes actions as described in bullets q and r in clause 5.3.13.2.

5.3.13.4 Void

5.3.13.5 Optimizing periodic RAU Signalling

To reduce network load from periodic RAU signalling and to increase the time until the MS detects a potential need for changing the RAT or PLMN (e.g. due to network problems) the longer values of the periodic RAU timer and Mobile Reachable timer shall be supported.

A long periodic RAU/TAU timer value may be locally configured at SGSN or may be stored as part of the subscription data in HSS. During Attach and RAU procedures the SGSN allocates the periodic RAU timer value as periodic RAU timer to the UE based on VPLMN operator policy, low access priority indication from the MS, and subscription information received from the HSS.

If SGSN receives a subscribed periodic RAU/TAU timer value from the HSS it allocates the subscribed value to the MS as periodic RAU timer. A visited PLMN SGSN may use subscribed periodic RAU/TAU timer value, if available, as an indication to decide for allocating a locally configured periodic RAU/TAU timer value to the MS.

5.3.13.6 Support of MSs configured for low access priority, Extended Access Barring and permission for override

An MS may be configured for low access priority and Extended Access Barring as defined in TS 22.011 [112]. This configuration is primarily for usage by applications or users that can tolerate being deferred when competing with other MSs for accessing network resources, e.g. during congestion situations. A subscriber can by agreement with its operator be required to use MSs that are configured for low access priority. The agreement may include a specific tariffing. CDRs show whether a PDN connections was activated for use with low access priority.

An MS that is configured for low access priority and Extended Access Barring may be also configured with a permission for an override of low access and Extended Access Barring priority restrictions. This configuration is primarily for usage by applications or users that most of the time can tolerate being deferred due to low access priority when competing with other MSs for accessing network resources, but occasionally the application or user needs access to the network also when the low access priority configuration would prevent getting access. For getting network access also during low priority access or Extended Access Barring restriction conditions, the user or application (upper layers in UE) may request the UE to initiate the activation of a PDN connection without low access priority.

The permission for overriding low access priority and Extended Access Barring restrictions by the application or user should be handled with care because as long as such a PDN connection without low access priority is active, the MS is not affected by any access restriction conditions that the network may set for access with low access priority. That is, after the activation of a PDN connection without low access priority, all further MM and RRC access requests of the UE are performed without low access priority as long as such a PDN connection is active.

A subscriber can, by agreement with its operator, be required to use MSs that are configured with a permission for overriding low access priority and Extended Access Barring. As the 3GPP system cannot determine whether any overriding of access restrictions by such MSs is justified, the agreement can include a specific tariffing to avoid excessive usage of overriding the low access priority. This can for example be a specific tariffing for the amount of activations and/or the duration of PDN connections that are not with low access priority. CDRs show whether the MS activated the PDN connection with or without low access priority, but not necessarily the access priority the MS uses for the individual data transfer requests.

5.3.14 Local IP Access (LIPA) function

The LIPA function enables an IP capable UE connected via a HNB to access other IP capable entities in the same residential/enterprise IP network without the user plane traversing the mobile operator's network except HNB subsystem.

LIPA is available for UTRAN access only.

For this Release of the specification there is no support for secondary PDP context on the PDN connection used for Local IP Access. The PDN GW/GGSN shall reject any MS initiated Secondary PDP Context Activation Procedure or any PDP Context Modification Procedure that is for the LIPA PDN Connection.

The LIPA function specified in TS 23.401 [89] clause 4.3.16 is applicable, with the SGSN node providing the functions specified for the MME and the HNB providing the functions specified for the HeNB.

The HNB supporting the LIPA function includes the Local GW address to the SGSN in every INITIAL UE MESSAGE and every UTRAN Originated DIRECT TRANSFER control message as specified in TS 25.413 [56b].

5.3.15 Voice domain preference and UE's usage setting

If the UE supports CS fallback, or the UE is configured to support IMS voice, or both, and the UE is E-UTRAN capable, the UE shall include the information element "Voice domain preference and UE's usage setting" in Attach

Request and Routing Area Update Request messages. The purpose of this information element is to signal to the network the UE's usage setting and voice domain preference for E-UTRAN. The UE's usage setting indicates whether the UE behaves in a voice centric or data centric way (as defined in TS 23.221 [80]). The voice domain preference for E-UTRAN indicates whether the UE is configured as CS Voice only, CS Voice preferred and IMS PS Voice as secondary, IMS PS Voice preferred and CS Voice as secondary, or IMS PS Voice only (as defined in TS 23.221 [80]).

NOTE: Depending on operator's configuration, the UE's usage setting and voice domain preference for E-UTRAN can be used by the network to choose the RFSP Index in use (see clause 5.3.5). As an example, this enables the enforcement of selective idle mode camping over GERAN/UTRAN for voice centric UEs relying on CS Fallback for voice support in E-UTRAN.

5.13.16 Support for Application / Service Layer Rate Adaptation

The UTRAN and the UE support of Explicit Congestion Notification (ECN) according to the RFC 3168 [115] are described in TS 23.401 [89], TS 25.401 [53] and TS 26.114 [116].

If the UTRAN cannot sustain the GBR of an active GBR bearer the RNC should initiate a RAB Release according to clause 12.7.2. In addition, in case of UTRAN with GPRS (Gn/Gp SGSN with GGSN) the deactivation of the bearer is handled differently. The GPRS supports RNC initiated "PDP Context modification" where bearers are preserved in the core network for certain cases as described in clause 9.2.3.5 for architecture variants using Gn/Gp based interaction with GGSN.

5.3.17 Support for subscriptions without MSISDN

GPRS shall allow for operation whereby a MSISDN is not allocated as part of the subscription data. For example this can be useful for devices supporting MTC applications, see TS 23.682 [119].

The following applies for a UE that operates without an MSISDN:

- a) Presence of the MSISDN in the HLR/HSS subscription is optional.
- b) The presence of the MSISDN in the SGSN MM context, PDP contexts and GGSN PDP contexts is dictated by its storage in HLR/HSS.
- c) GTP support for MSISDN optionality whereby MSISDN is included only if available.
- d) When the MSISDN is not available for CDR generation in the PS domain, the IMSI shall be used for CDR generation purposes.
- e) Delivery of SMS destined to an MS without MSISDN.

The following services have unresolved MSISDN dependencies and are not supported at operation without MSISDN:

- a) CAMEL Services.

NOTE: There may be additional problems with the following services: I-WLAN, SMS, IMS, LCS, MNP, Presence Services, MBMS, GUP, Charging, Remote Device Management and Over-the-Air configuration.

5.3.18 PS-only Service Provision and PS domain SMS support

The HSS allows an operator to configure a subscription, which is limited to only PS services and SMS services. This limitation is indicated in the PS subscription data as "PS and SMS only". With this subscription the SMS service can either be provided via the PS domain or via the CS domain.

The support of SMS services via SGSN is a network deployment option and may depend also on roaming agreements. Therefore a subscription profile intended for PS-only service provision is either a subscription profile that is PS-only without any CS subscriber data, or it is a subscription profile for PS domain services and allowing also for SMS services via CS domain by CS subscriber data. The latter option of configuring a subscription is for providing a UE with PS domain and SMS services in situations when serving node or the visited network does not support SMS via SGSN.

If the subscription profile does not contain any CS subscriber data the HSS indicates this by the Network Access Mode information in the subscriber data provided to the SGSN. This indicates to the SGSN that the SGSN shall not perform any combined MM procedures for the UE and shall not establish a Gs association.

NOTE 1: An operator should not configure a subscription profile without any CS subscription data when the UE/user shall be able to receive SMS services from an MME that uses SGs functionality for providing SMS services. It depends on (visited) network deployment or configuration whether the MME provides SMS services via "SMS in MME" or via SGs functionality. Further it should be noted that using PS-only service provision requires that the SMS-GMSC(s) deliver mobile terminating SMS via SGSN, which depends on network deployment or configuration (including a correct setting of the HSS "Transfer of SMS option" when the SMS-GMSC does not support two serving nodes addresses). For PS-only service provision it is therefore recommended that a home PLMN deploys an SMS-router and routes all terminating SMSs to its subscribers via the SMS-router. Especially when SMS-GMSCs from PLMNs other than the hPLMN are allowed to send mobile terminating SMS directly to the UE's serving CN node, but it cannot be ensured that all these SMS-GMSCs deliver SMS via SGSN.

The SGSN indicates that it offers SMS services via the PS domain to the HSS by an indication "SMS in SGSN offered" in the signalling with the HSS during the Attach/RAU procedure. In addition the SGSN may indicate a "Registration for SMS Request" according to the table below. The SGSN also forwards the capability indicated by the UE as an "SMS-only" indication to the HSS. When the subscription information indicates "PS and SMS only" the HSS shall respond to queries from SMS-GMSCs and SMS routers so that MT SMS gets routed to serving nodes in the PS domain when SMS via the PS domain are offered by these serving nodes.

Table 5.3.18-1: Registration For SMS Request values

SMS in SGSN Required	- The SGSN can be configured to use this value when the UE indicates "SMS only" or when known that the subscription is "PS and SMS only" for asking the HSS to cancel any registered MSC.
SMS in SGSN Not Preferred	- The SGSN can be configured to use this value for asking the HSS to not register the SGSN for SMS and to not cancel a registered MSC. This value can be requested regardless whether the UE indicates "SMS only" or the subscription is "PS and SMS only".
No Preference for SMS in SGSN	- The SGSN has no preference about cancelling or keeping a registered MSC.

NOTE 2: In earlier Releases, CS is considered as primary domain and PS optional and related UEs may try to always get CS registration. The SGSN should not request "SMS in SGSN Required" for UEs that assume a need for being always also CS attached when PS attached.

If the SGSN indicates "SMS in SGSN offered" and the PS subscriber data allow for SMS services and the home PLMN supports SMS services via SGSN, the HSS indicates "SMS in SGSN Support" in the subscriber data provided to the SGSN, unless the SGSN indicated "SMS in SGSN not Preferred" and the subscription allows for SMS via CS domain.

The HSS may be configured per visited PLMN whether SMS services via SGSN are supported and wanted, e.g. based on roaming agreement, for the specific visited PLMN. The HSS provision of CS subscriber data to any serving node requesting CS subscriber data follows regular procedures and is not affected.

When the HSS registers the SGSN for terminating SMS and the HSS has an old serving MSC registered, the HSS cancels the serving MSC for a UE if:

- The SGSN indicates no parameter "Registration for SMS Request" and the MS indicated "SMS-only"; or
- The SGSN indicated "SMS in SGSN Required" and the MS indicated "SMS-only"; or
- The SGSN indicated "SMS in SGSN Required" and the subscription is "PS and SMS only"; or
- The SGSN indicated "No Preference for SMS in SGSN" and the MS indicated "SMS-only".

A CS/PS enabled UE that needs only PS domain services and SMS services over NAS indicates this capability as "SMS-only" to the SGSN during combined GPRS / IMSI attach or combined RA/LA update procedures, i.e. the included CS registration is only requested for obtaining SMS services over NAS. Based on that UE provided information, based on preferences configured in SGSN and when the HSS provided subscription information indicates

"SMS in SGSN Support", the SGSN then decides not to establish an association with an MSC when requested by the UE by combined GPRS / IMSI attach or combined RA/LA update procedures.

When the subscription information indicates "SMS in SGSN Support", the SGSN signals to the UE "SMS-Supported" in every Attach/RAU procedures to inform the UE that it can obtain SMS services via PS domain NAS from the SGSN. Thereby also UEs with CS services other than SMS are informed that SMS services via PS domain NAS can be obtained from the SGSN. The subscription information "SMS in SGSN Support" indicates to the SGSN that the UE's home PLMN is able and willing to provide SMS services via SGSN.

A CS/PS enabled UE that needs only PS domain services and SMS services over NAS and that receives indications in Attach/RAU procedures that it can obtain SMS services via SGSN should not perform an IMSI Attach or LAU procedures with the CS domain. That UE shall however perform combined RAU/LAU procedures when required by the network operation mode (NMO) for being informed when the PS domain provided services change.

5.3.19 Access and Mobility Restrictions

S4-SGSNs and Gn/Gp-SGSNs determine mobility and access restrictions with LA granularity. Any time the UE performs a GPRS Attach or RAU the SGSN checks for access restrictions (see TS 23.221 [80] and TS 23.008 [79]).

If roaming restriction to E-UTRAN access needs to be enforced, a SGSN that is connected to RNCs or BSCs that may handover or invoke release with redirection to E-UTRAN is configured with a list of HPLMN IDs that are permitted to access E-UTRAN unless restricted by the UE individual access restriction information received from HLR/HSS. Also, the SGSN shall set the E-UTRAN Service Handover IE (in Iu mode) or the Service UTRAN CCO (in A/Gb mode) to an appropriate value to inform the RNC or BSC respectively about connected-mode mobility restriction to E-UTRAN.

The SGSN shall also determine a RAT/Frequency Selection Priority that minimizes the risk of cell reselection of RATs that have access restrictions for a UE and provides the RAT/Frequency Selection Priority to the RNC or BSC, see clause 5.3.5.2.

5.4 Logical Architecture

5.4.0 General

When based on Gn/Gp interfaces, the GPRS Core Network functionality is logically implemented on two network nodes, the Serving GPRS Support Node and the Gateway GPRS Support Node. When based on S4/S5/S8 interfaces, the GPRS Core Network functionality is logically implemented on three network nodes, the Serving GPRS Support Node, the Serving Gateway and the PDN Gateway. No inference should be drawn about the physical configuration on an interface from figure 2 or figure 2a.

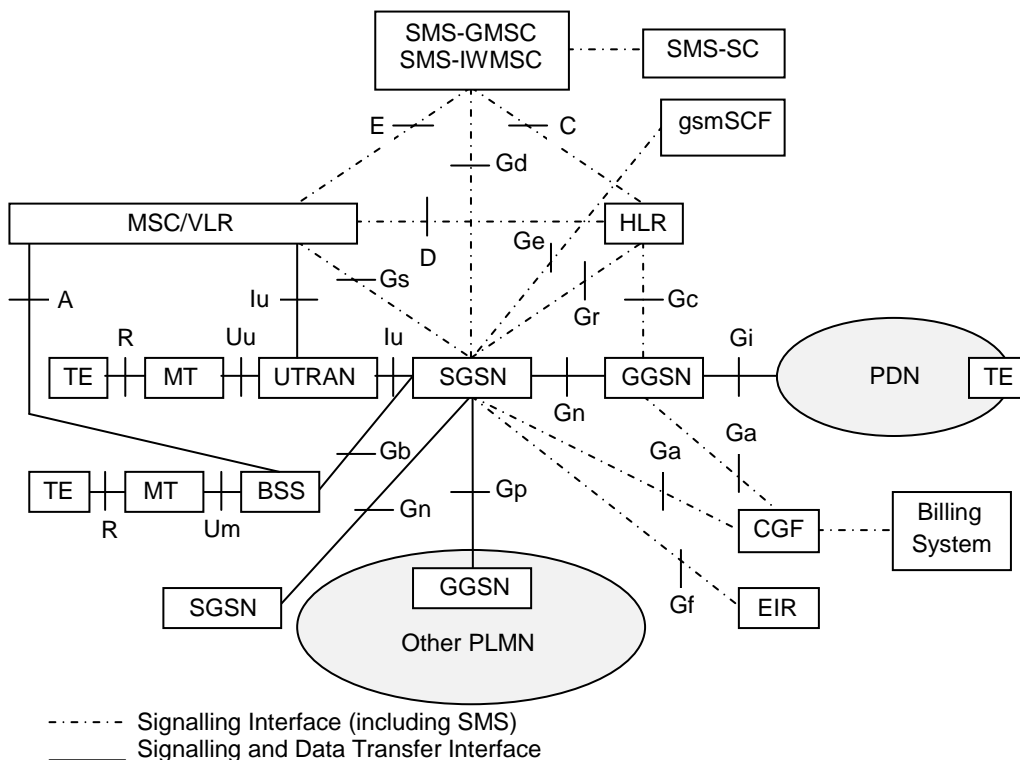
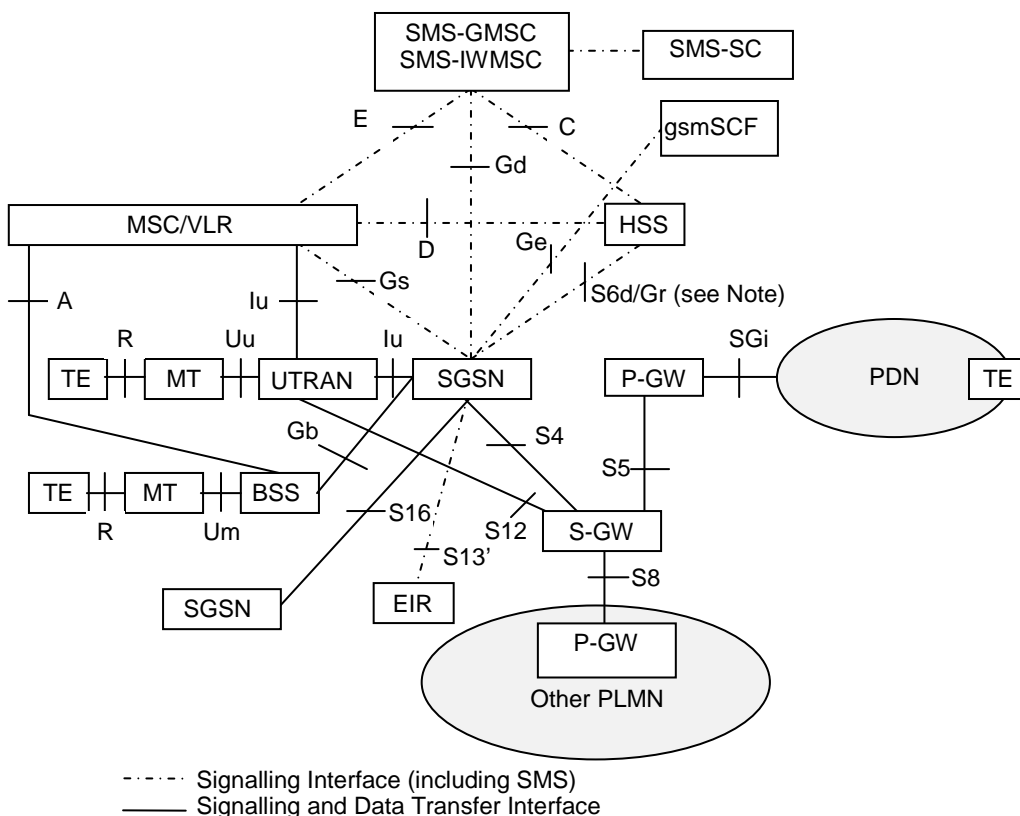

Figure 2: Overview of the GPRS Logical Architecture when based on Gn/Gp interfaces



NOTE: Between S4-SGSN and HSS, the interface is Diameter based (S6d). However, to assist with the SGSN transition the use of MAP based Gr between the S4-SGSN and the HSS is not precluded.

Figure 2a: Overview of the GPRS Logical Architecture when based on S4/S5/S8 interfaces

5.4.1 GPRS Core Network Nodes

5.4.1.1 General

A GPRS Support Node (GSN) contains functionality required to support GPRS functionality for GERAN and/or UTRAN. In one PLMN, there may be more than one GSN.

The SGSN and GGSN functionalities may be combined in the same physical node, or they may reside in different physical nodes. The SGSN and the GGSN contain IP or other (operator's selection, e.g. ATM-SVC) routing functionality, and they may be interconnected with IP routers.

5.4.1.2 Gateway GPRS Support Node

The Gateway GPRS Support Node (GGSN) is the node that is accessed by the packet data network due to evaluation of the PDP address. It contains routing information for PS-attached users. The routing information is used to tunnel N-PDUs to the MS's current point of attachment, i.e. the Serving GPRS Support Node. The GGSN may request location information from the HLR via the optional Gc interface. The GGSN is the first point of PDN interconnection with a PLMN supporting GPRS (i.e. the Gi reference point is supported by the GGSN). GGSN functionality is common for all types of RANs.

For emergency bearer service, the GGSN shall block any traffic that is not from/to addresses of network entities (e.g. P-CSCF) providing emergency service. The list of allowed addresses may be configured by the operator.

5.4.1.3 Serving GPRS Support Node

The Serving GPRS Support Node (SGSN) is the node that is serving the MS. The SGSN supports GPRS for A/Gb mode (i.e. the Gb interface is supported by the SGSN) and/or Iu-mode (i.e. the Iu interface is supported by the SGSN). At PS attach, the SGSN establishes a mobility management context containing information pertaining to e.g. mobility and security for the MS. At PDP Context Activation, the SGSN establishes a PDP context, to be used for routing purposes, with the GGSN that the subscriber will be using.

In Iu mode, the SGSN and RNC may be interconnected with one or more IP routers.

In Gn/Gp mode and when the SGSN and the GGSN are in different PLMNs, they are interconnected via the Gp interface. The Gp interface provides the functionality of the Gn interface, plus security functionality required for inter-PLMN communication. The security functionality is based on mutual agreements between operators.

In Gn/Gp mode, the SGSN interworks signalling on the Gn/Gp interface with Iu/Gb interface signalling. In S4 mode, the SGSN interworks signalling on the S4 interface with Iu/Gb interface signalling. One SGSN may have some MSs using Gn/Gp mode and other MSs using S4 mode.

The SGSN may send location information to the MSC/VLR via the optional Gs interface. The SGSN may receive paging requests from the MSC/VLR via the Gs interface.

The SGSN interfaces with the GSM-SCF for optional CAMEL control using Ge reference point. Depending on the result from the CAMEL interaction, the session and packet data transfer may proceed normally. Otherwise, interaction with the GSM-SCF continues as described in TS 23.078 [8b]. Only the GSM-SCF interworking points are indicated in the signalling procedures in this specification.

If there is already an emergency bearer activated, the SGSN shall reject any additional PDP context activation request by the MS for emergency services.

5.4.1.4 Serving Gateway

The functionality of the Serving Gateway is defined in TS 23.401 [89] with the following additions and exceptions:

The Serving Gateway:

- terminates the user plane interface towards the UTRAN when the Direct Tunnel feature is in use;
- is the local Mobility Anchor point for SRNS relocation when the Direct Tunnel feature is in use;
- is the local Mobility Anchor for inter-SGSN routing area update;

- if E-UTRAN is not in use in that PLMN, need not support functionality related to inter eNodeB mobility.

5.4.1.5 PDN Gateway

The functionality of the PDN Gateway is defined in TS 23.401 [89].

5.4.2 Packet Domain PLMN Backbone Networks

There are two kinds of backbone networks. These are called:

- intra-PLMN backbone network; and
- inter-PLMN backbone network.

The intra-PLMN backbone network is the IP network interconnecting SGSNs, GGSNs, Serving GWs and PDN GWs within the same PLMN and it interconnects GGSNs and Serving GWs with RNCs if Direct Tunnel functionality is supported.

The inter-PLMN backbone network is the IP network interconnecting SGSNs, GGSNs, Serving GWs and PDN GWs with intra-PLMN backbone networks in different PLMNs.

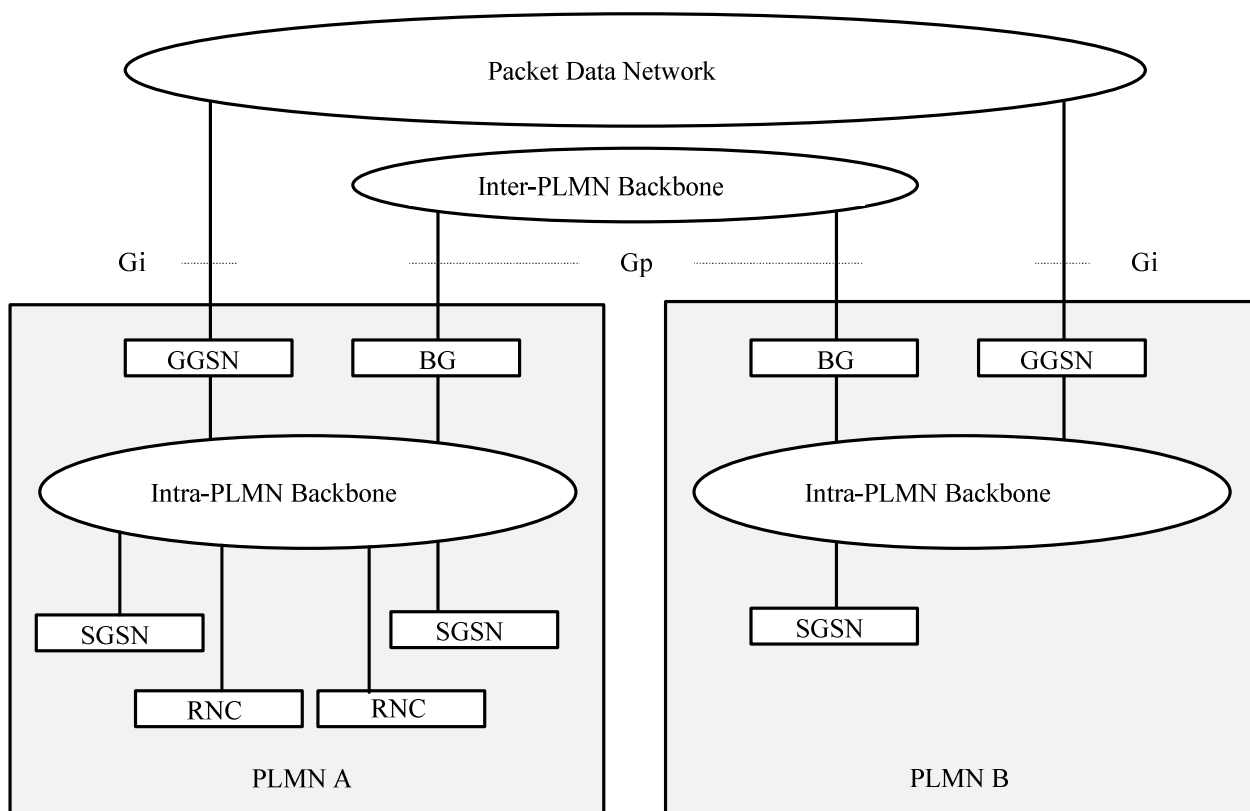

Figure 3: Intra- and Inter-PLMN Backbone Networks when based on Gn/Gp interfaces

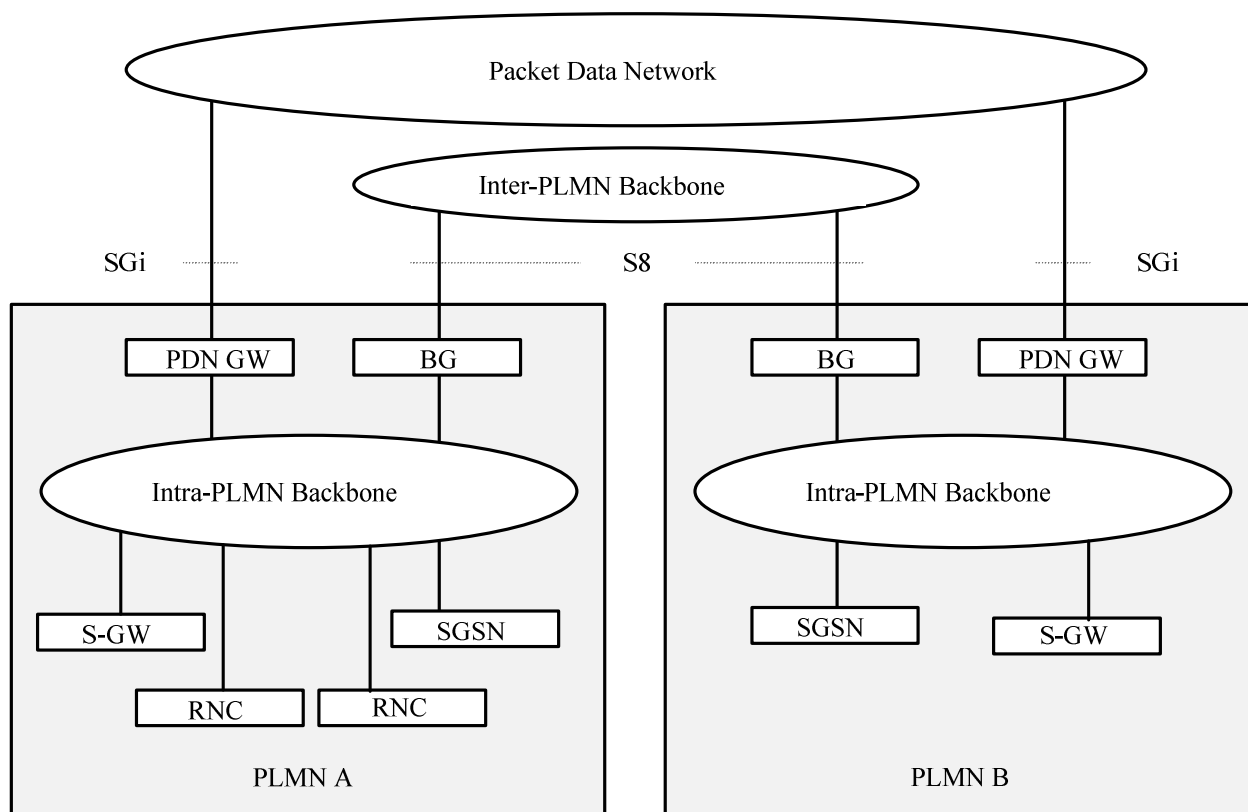

Figure 3a: Intra- and Inter-PLMN Backbone Networks when based on S5/S8 interfaces

Every intra-PLMN backbone network is a private IP network intended for GPRS packet domain data and signalling only. A private IP network is an IP network to which some access control mechanism is applied in order to achieve a required level of security. Two intra-PLMN backbone networks are connected via the Gp interface using Border Gateways (BGs) and an inter-PLMN backbone network. The inter-PLMN backbone network is selected by a roaming agreement that includes the BG security functionality. The BG is not defined within the scope of GPRS. The inter-PLMN backbone can be a Packet Data Network, e.g. the public Internet or a leased line.

5.4.3 HLR/HSS

The HLR/HSS contains GPRS and EPS subscription data and routing information. The HLR/HSS is accessible from the Gn/Gp SGSN via the Gr interface, from the S4-SGSN via the S6d interface and from the GGSN via the Gc interface. For roaming MSs, the HLR/HSS may be in a different PLMN than the current SGSN.

NOTE: As specified in clause 6.4, "between S4-SGSN and HSS, the interface is Diameter based (S6d); however, to assist with SGSN transition the use of MAP based Gr between the S4-SGSN and HSS is not precluded".

5.4.4 SMS-GMSC and SMS-IWMSC

The SMS-GMSC and SMS-IWMSC are connected to the SGSN via the Gd interface to enable the SGSN to support SMS.

5.4.5 Mobile Stations (A/Gb mode)

An A/Gb mode MS operates in one of three modes of operation. The mode of operation depends on the network domains that the MS is attached to, i.e. only PS or both PS and CS domain, and upon the MS's capabilities to operate PS and CS domain services simultaneously.

- Class-A mode of operation: The MS is attached to both PS and CS domain, and the MS supports simultaneous operation of PS and CS domain services.

- Class-B mode of operation: The MS is attached to both PS and CS domain, but the MS can only operate one set of services, PS or CS services, at a time.
- Class-C mode of operation: The MS is exclusively attached to the PS domain.

The three modes of operation are defined in TS 22.060 [3].

NOTE: Other technical specifications may refer to the MS modes of operation as GPRS class-A MS, GPRS class-B MS, and GPRS class-C MS.

5.4.6 Mobile Stations (Iu mode)

An Iu mode MS operates in one of three modes of operation. However, these operation modes are different from the ones of an A/Gb mode MS due to the capabilities of an Iu mode RAN to multiplex CS and PS connections, due to paging co-ordination for PS services and CS services that are offered by the CN or the UTRAN/GERAN-Iu, etc. The different Iu mode MS operation modes are defined as follows:

- CS/PS mode of operation: The MS is attached to both the PS domain and CS domain, and the MS is capable of simultaneously signalling with the PS and CS core network domains. This mode of operation is comparable to the class-A mode of operation defined for A/Gb mode. The ability to operate CS and PS services simultaneously depends on the MS capabilities (for example an A/Gb mode MS of class B, which can not operate simultaneously CS and PS services, may have the same limitations when changing to Iu mode and CS/PS mode of operation).
- PS mode of operation: The MS is attached to the PS domain only and may only operate services of the PS domain. However, this does not prevent CS-like services to be offered over the PS domain (e.g. VoIP). This mode of operation is equivalent to the A/Gb mode GPRS class-C mode of operation.
- CS mode of operation: The MS is attached to the CS domain only and may only operate services of the CS domain. However, this does not prevent PS-like service to be offered over the CS domain. The CS mode of operation is outside the scope of this specification.

All combinations of different operation modes as described for A/Gb mode and Iu mode MSs shall be allowed for GERAN and UTRAN multisystem terminals.

5.4.7 Charging Gateway Functionality

The Charging Gateway Functionality (CGF) described in TS 32.251 [70] is a function of the Offline Charging System (OFCS) which is described in TS 32.240 [94].

5.4.8 PCRF

The PCRF is the policy and charging control element. PCRF functions are described in more detail in TS 23.203 [88].

5.4.9 HNB subsystem

A HNB subsystem consists of a HNB, a HNB GW and optionally a Local GW.

The Local IP Access function is achieved using a Local GW (L-GW) co-located with the HNB.

Figure 5.4.9-1 and figure 5.4.9-2 illustrate LIPA for HNB connected to respectively EPC and Gn-based SGSN.

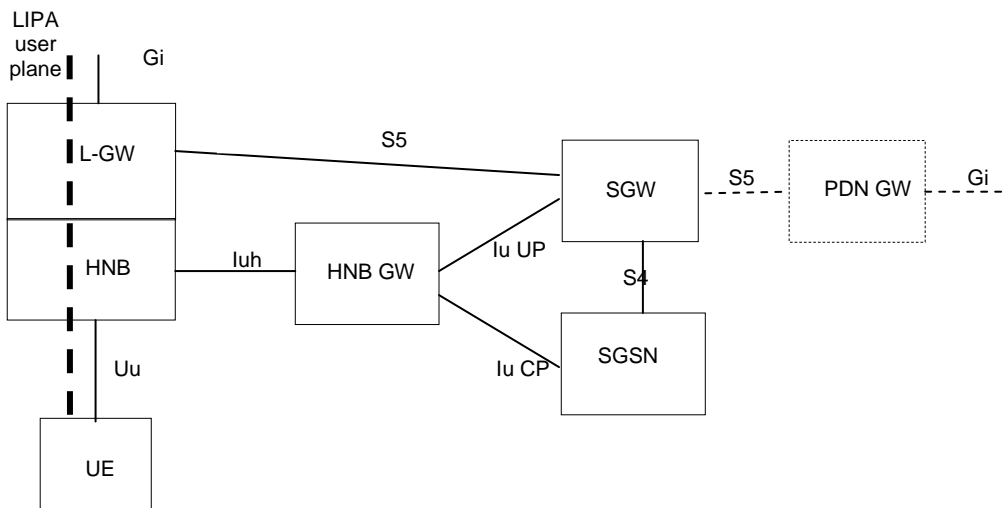

Figure 5.4.9-1: LIPA architecture for HNB subsystem connected to EPC

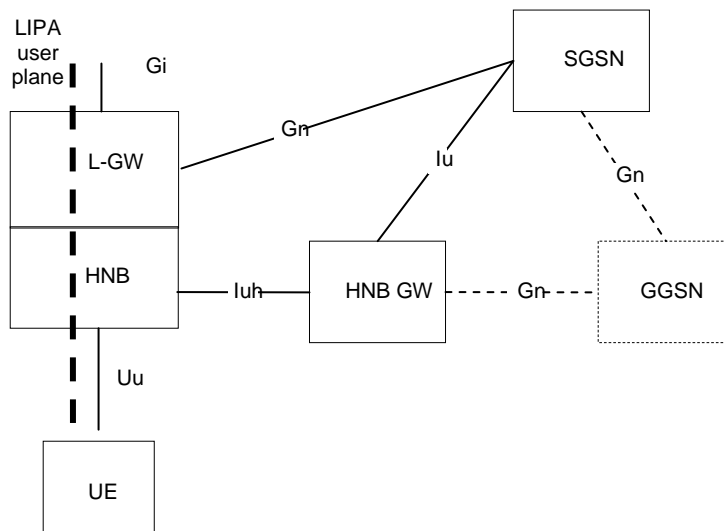

Figure 5.4.9-2: LIPA architecture for HNB connected to a Gn-based SGSN

The HNB Subsystem appears as an RNS to the core network and is connected by means of the Iu-CS interface to the MSC and by means of the Iu-PS interface to the SGSN. When LIPA is activated, the HNB subsystem also has following interface to the core network i.e.:

- For S4-SGSN, an S5 interface between the S-GW and the Local GW;
- For Gn-based SGSN, a Gn interface between the SGSN and the Local GW.

NOTE 1: In this specification and for simplification the term RNC (or RNS if used instead) refers to the HNB subsystem if the MS accesses the network via a HNB unless stated otherwise.

NOTE 2: Detailed functions of HNB and HNB GW are described in TS 25.467 [103].

The Local GW is the gateway towards the IP networks (e.g. residential/enterprise networks) associated with the HNB. The Local GW functions are described in TS 23.401 [89], clause 4.4.9:

5.4.10 CSG Subscriber Server

CSG Subscriber Server (CSS) is an optional element that stores CSG subscription data for roaming subscribers. The CSS stores and provides VPLMN specific CSG subscription information to the SGSN. The CSS is accessible from the Gn/Gp SGSN via the Ghv interface and from the S4-SGSN via the S7d interface. The CSS is always in the same PLMN as the current SGSN.

If the same CSG ID exists in both CSS subscription data and HLR/HSS subscription data, the CSG subscription data from HLR/HSS shall take precedence over the data from CSS.

Figure 5.4.10-1 illustrates CSS connected to SGSN and MSC/VLR.

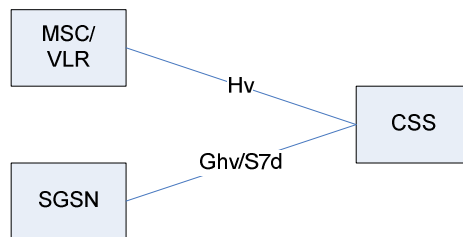

Figure 5.4.10-1: CSS connected to SGSN and MSC/VLR

5.5 Assignment of Functions to General Logical Architecture

The functions identified in the functional model are assigned to the logical architecture.

Table 1: Mapping of Functions to Logical Architecture

Function	A/Gb mode - MS	Iu mode MS	A/Gb mode RAN	Iu mode RAN	A/Gb mode SGSN	Iu mode SGSN	Serving GW	GGSN	P-GW	HLR
Network Access Control:										
Registration										X
Authentication and Authorisation	X	X			X	X				X
Admission Control	X	X	X	X	X	X	X	X	X	
Message Screening								X	X	
Packet Terminal Adaptation	X	X								
Charging Data Collection					X	X	X	X	X	
Operator Determined Barring					X	X				X
Packet Routing & Transfer:										
Relay	X	X	X	X	X	X	X	X	X	
Routing	X	X	X	X	X	X	X	X	X	
Address Translation and Mapping	X	X		X	X	X	X	X	X	
Encapsulation	X	X		X	X	X	X	X	X	
Tunnelling				X	X	X	X	X	X	
Compression	X	X		X	X					
Ciphering	X	X		X	X					X
Mobility Management:	X	X			X	X	X	X	X	X
Logical Link Management:										
Logical Link Establishment	X				X					
Logical Link Maintenance	X				X					
Logical Link Release	X				X					
Radio Resource Management:	X	X	X	X	X					

5.6 User and Control Planes

5.6.1 User Plane (A/Gb mode)

5.6.1.1 MS – P-GW/GGSN

The user plane consists of a layered protocol structure providing user information transfer, along with associated information transfer control procedures (e.g. flow control, error detection, error correction and error recovery). The user

plane independence of the Network Subsystem (NSS) platform from the underlying radio interface is preserved via the Gb interface. The following user plane is used in A/Gb mode.

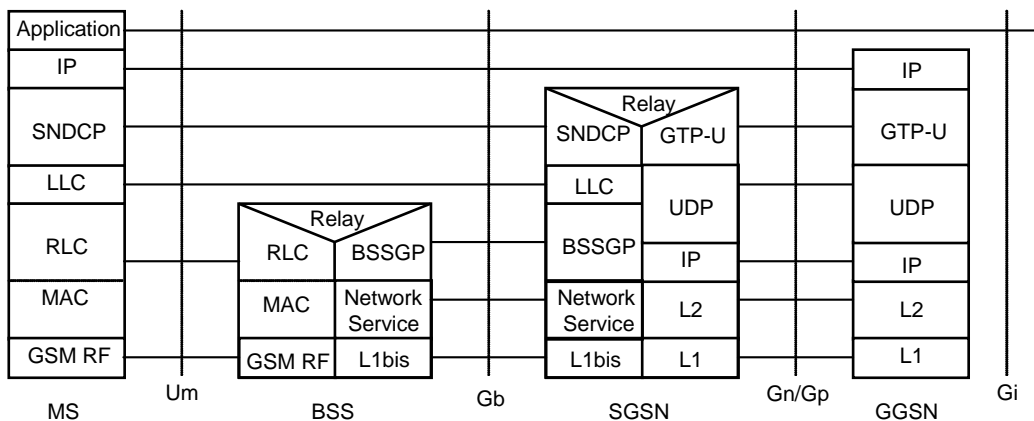

Figure 4: User Plane for A/Gb mode and for Gn/Gp

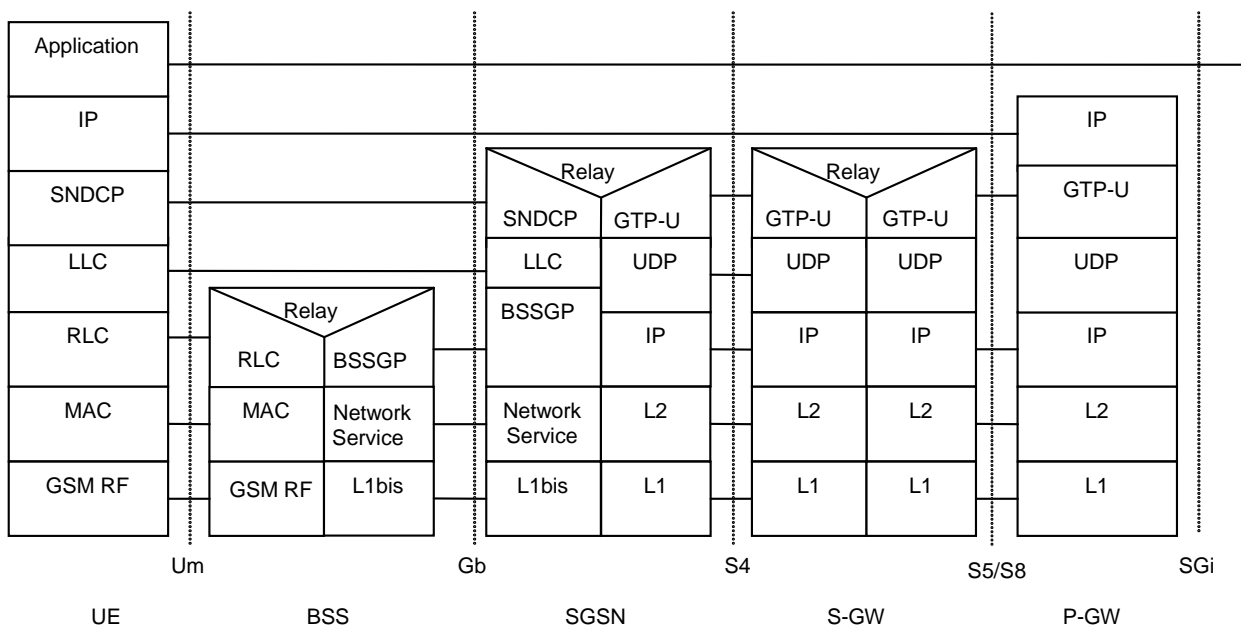

Figure 4a: User Plane for A/Gb mode and for GTP-based S5/S8

NOTE: Refer to TS 23.402 [90] for the S-GW - P-GW protocol stack with the PMIP-based S5/S8.

Legend:

- GPRS Tunnelling Protocol for the user plane (GTP-U): This protocol tunnels user data between core network nodes in the backbone network. The GPRS Tunnelling Protocol shall encapsulate all PDP PDUs. GTP is specified in TS 29.060 [26], or TS 29.274 [92].
- UDP carries GTP PDUs for protocols that do not need a reliable data link (e.g. IP), and provides protection against corrupted GTP PDUs. UDP is defined in RFC 768 [39].
- IP: This is the backbone network protocol used for routing user data and control signalling. The backbone network may initially be based on the IPv4. Ultimately, IPv6 shall be used. When IPv6 is used in the backbone, then IPv4 shall also be supported. IPv4 is defined in RFC 791 [40] and IPv6 is defined in RFC 2460 [48].
- Subnetwork Dependent Convergence Protocol (SNDCP): This transmission functionality maps network-level characteristics onto the characteristics of the underlying network. SNDCP is specified in TS 44.065 [16].

- Logical Link Control (LLC): This layer provides a highly reliable ciphered logical link. LLC shall be independent of the underlying radio interface protocols in order to allow introduction of alternative GPRS radio solutions with minimum changes to the NSS. LLC is specified in TS 44.064 [15].
- Relay: In the BSS, this function relays LLC PDUs between the Um and Gb interfaces. In the SGSN, this function relays PDP PDUs either between the Gb and Gn interfaces or between the Gb and S4 interfaces.
- Base Station System GPRS Protocol (BSSGP): This layer conveys routing- and QoS-related information between the BSS and the SGSN. BSSGP does not perform error correction. BSSGP is specified in TS 48.018 [78].
- Network Service (NS): This layer transports BSSGP PDUs. NS is specified in TS 48.016 [20].
- RLC/MAC: This layer contains two functions: The Radio Link Control function provides a radio-solution-dependent reliable link. The Medium Access Control function controls the access signalling (request and grant) procedures for the radio channel, and the mapping of LLC frames onto the GSM physical channel. RLC/MAC is defined in TS 44.060 [77].
- GSM RF: As defined in the 3GPP TS 45.xxx series of specifications.

5.6.1.2 Core Network Node - Core Network Node

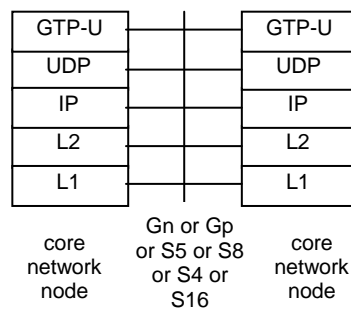

Figure 5: User Plane for GTP-based Interfaces between Core Network Nodes

NOTE: Refer to TS 23.402 [90] for the protocol stack with the PMIP-based S5 or S8.

Legend:

- GPRS Tunnelling Protocol for the user plane (GTP-U): This protocol tunnels user data between SGSNs and GGSNs (Gn or Gp), between SGSNs and S-GWs (S4), between S-GWs and P-GWs (S5 or S8) and between SGSNs in the backbone network (Gn or S16).
- User Datagram Protocol (UDP): This protocol transfers user data between GSNs. UDP is defined in RFC 768.

5.6.2 User Plane (Iu mode)

5.6.2.1 MS – GGSN user plane with GERAN in Iu mode

NOTE 1: The user plane for GERAN in Iu mode is described in TS 43.051 [74].

NOTE 2: The user plane for a HNB Subsystem in Iu mode is described in TS 25.467 [103].

5.6.2.2 MS – P-GW/GGSN user plane with UTRAN

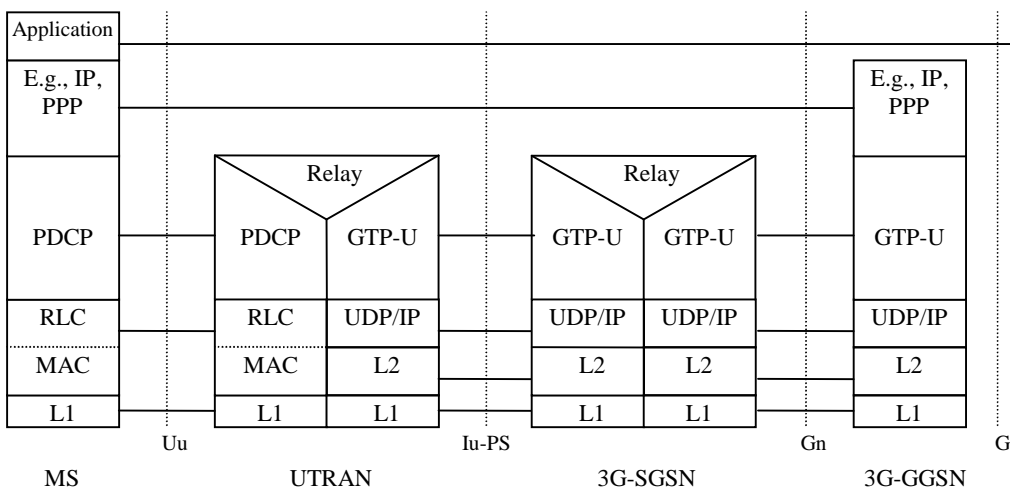

Figure 6a: User Plane with UTRAN for Gn/Gp

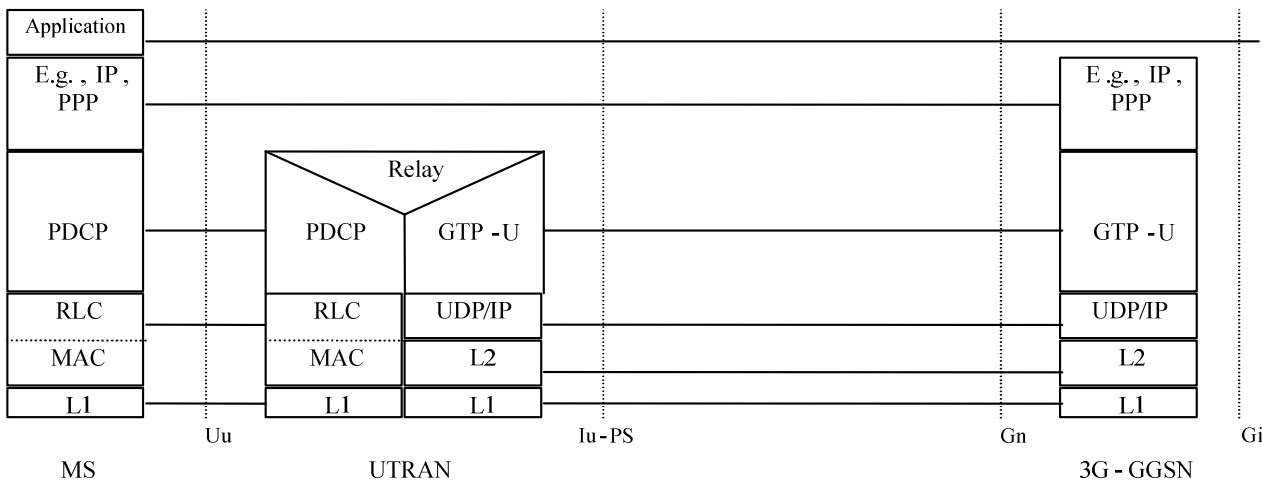

Figure 6b: User Plane with UTRAN for Gn/Gp and Direct Tunnel

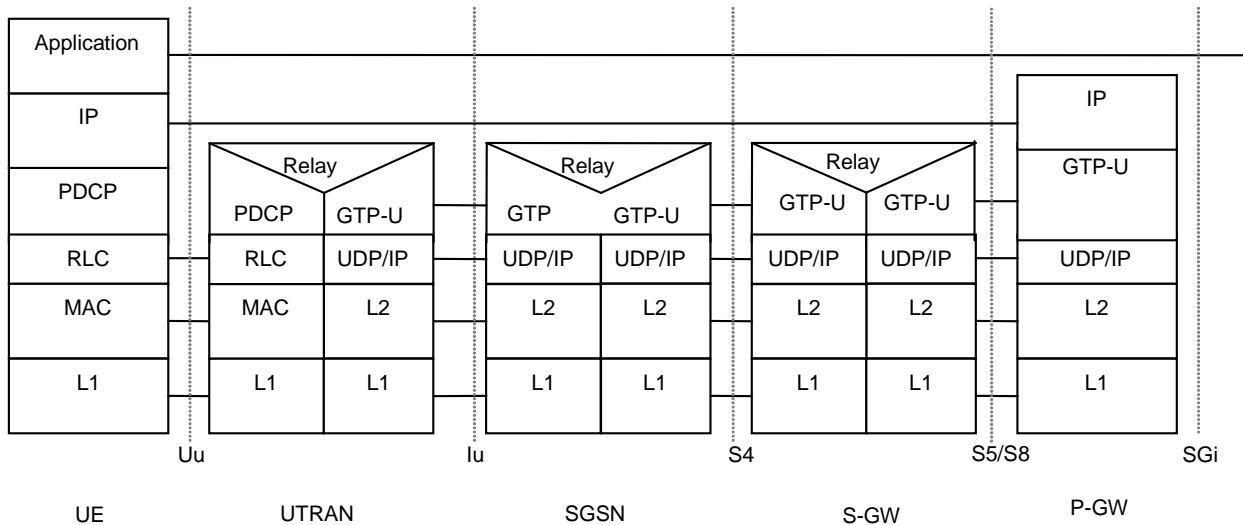

Figure 6c: User Plane with UTRAN for GTP-based S5/S8

NOTE: Refer to TS 23.402 [90] for the S-GW - P-GW protocol stack with the PMIP-based S5/S8.

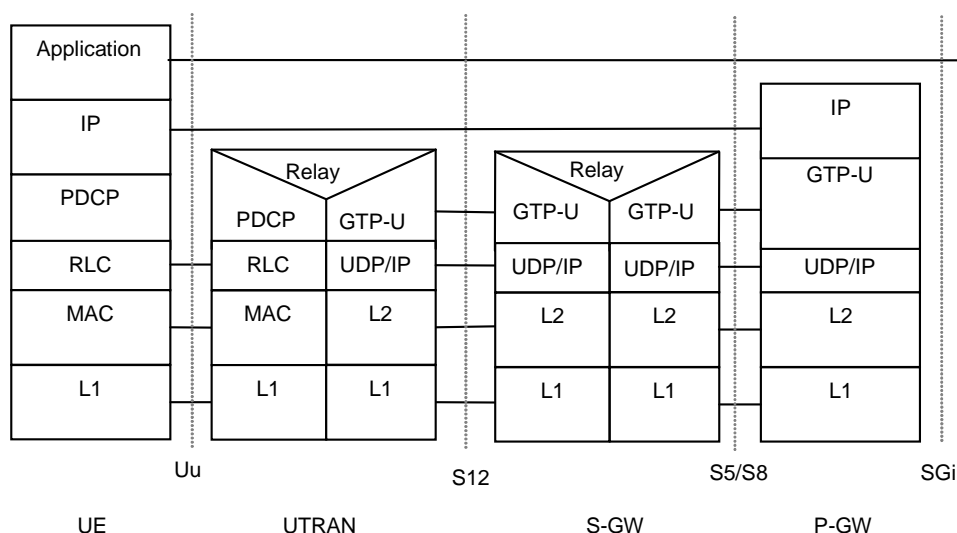

Figure 6d: User Plane with UTRAN for GTP-based S5/S8 and Direct Tunnel

NOTE: Refer to TS 23.402 [90] for the S-GW - P-GW protocol stack with the PMIP-based S5/S8.

Legend:

- Packet Data Convergence Protocol (PDCP): This transmission functionality maps higher-level characteristics onto the characteristics of the underlying radio-interface protocols. PDCP provides protocol transparency for higher-layer protocols. PDCP supports e.g. IPv4, PPP and IPv6. Introduction of new higher-layer protocols shall be possible without any changes to the radio-interface protocols. PDCP provides protocol control information compression. PDCP is specified in TS 25.323 [57].

NOTE: Unlike in A/Gb mode, user data compression is not supported in Iu mode, because the data compression efficiency depends on the type of user data, and because many applications compress data before transmission. It is difficult to check the type of data in the PDCP layer, and compressing all user data requires too much processing.

- GPRS Tunnelling Protocol for the user plane (GTP-U): This protocol tunnels user data between UTRAN and the 3G-SGSN, and between the GSN CN nodes in the backbone network. GTP shall encapsulate all PDP PDUs. GTP is specified in TS 29.060 [26].
- SGSN controls the user plane tunnel establishment and may establish a Direct Tunnel between UTRAN and GGSN as shown in Figure 6b or a Direct Tunnel between UTRAN and S-GW as shown in Figure 6d.
- UDP/IP: These are the backbone network protocols used for routing user data and control signalling.
- Radio Link Control (RLC): The RLC protocol provides logical link control over the radio interface. There may be several simultaneous RLC links per MS. Each link is identified by a Bearer Id. RLC is defined in TS 25.322 [55].
- Medium Access Control (MAC): The MAC protocol controls the access signalling (request and grant) procedures for the radio channel. MAC is specified in TS 25.321 [60].

5.6.2.3 Core Network Node - Core Network Node

This user plane is the same as for A/Gb mode, see clause "Core Network Node - Core Network Node" above.

5.6.3 Control Plane

The control plane consists of protocols for control and support of the user plane functions:

- controlling the GPRS network access connections, such as attaching to and detaching from GPRS;
- controlling the attributes of an established network access connection, such as activation of a PDP address;

- controlling the routing path of an established network connection in order to support user mobility; and
- controlling the assignment of network resources to meet changing user demands.

The following control planes are used in both A/Gb mode and Iu mode unless specifically indicated.

5.6.3.1 MS - SGSN (A/Gb mode)

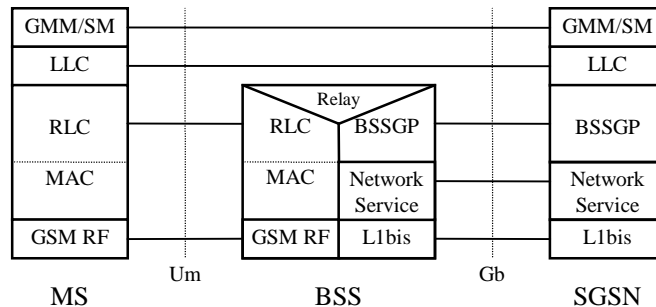

Figure 7: Control Plane MS - SGSN in A/Gb mode

Legend:

- GPRS Mobility Management and Session Management (GMM/SM): This protocol supports mobility management functionality such as GPRS attach, GPRS detach, security, routing area update, location update, PDP context activation, and PDP context deactivation, as described in clauses "Mobility Management Functionality" and "PDP Context Activation, Modification, Deactivation, and Preservation Functions".

5.6.3.2 MS – SGSN (Iu mode)

NOTE 1: The control plane for GERAN in Iu mode is described in TS 43.051 [74].

NOTE 2: The control plane for a HNB Subsystem in Iu mode is described in TS 25.467 [103].

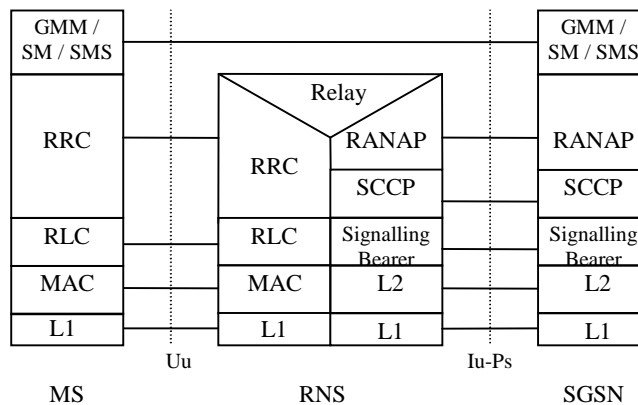

Figure 8: Control Plane MS - SGSN in Iu mode

Legend:

- Iu mode Mobility Management and Session Management (GMM/SM): GMM supports mobility management functionality such as attach, detach, security, and routing area update, as described in clause "Mobility Management Functionality". SM supports PDP context activation and PDP context deactivation, as described in clause "PDP Context Activation, Modification, Deactivation, and Preservation Functions".
- SMS supports the mobile-originated and mobile-terminated short message service described in TS 23.040 [8].
- Radio Access Network Application Protocol (RANAP): This protocol encapsulates and carries higher-layer signalling, handles signalling between the 3G-SGSN and Iu mode RAN, and manages the GTP connections on the Iu interface. RANAP is specified in TS 25.413 [56b]. The layers below RANAP are defined in TS 25.412 [56] and TS 25.414 [64].

- Radio Link Control (RLC): The RLC protocol offers logical link control over the radio interface for the transmission of higher layer-signalling messages and SMS. RLC is defined in TS 25.322 [55].

5.6.3.3 Gn/Gp-SGSN - HLR

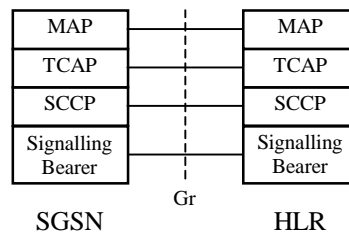

Figure 9: Control Plane Gn/Gp-SGSN - HLR

Legend:

- Mobile Application Part (MAP): This protocol supports signalling exchange with the HLR, as defined in TS 29.002 [23].
- TCAP and SCCP are the same protocols as used to support MAP in CS PLMNs.
- The Signalling Bearer is one of the signalling bearers specified in TS 29.202 [72].

5.6.3.4 SGSN - MSC/VLR

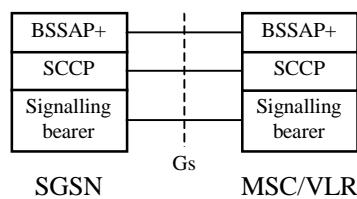

Figure 10: Control Plane SGSN - MSC/VLR

Legend:

- Base Station System Application Part + (BSSAP+): A subset of BSSAP procedures supports signalling between the SGSN and MSC/VLR, as described in clause "Mobility Management Functionality" and in TS 29.018 [25]. The requirements for the lower layers are specified in TS 29.016 [24].

5.6.3.5 SGSN - EIR

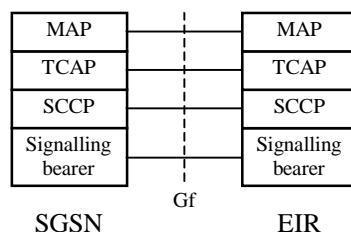
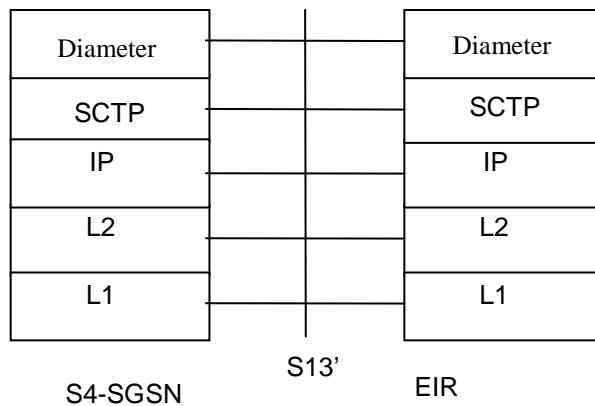

Figure 11: Control Plane SGSN - EIR

Legend:

- Mobile Application Part (MAP): This protocol supports signalling between the SGSN and the EIR, as described in clause "Identity Check Procedures".

5.6.3.5a S4-SGSN - EIR



Legend:

- **Diameter:** This protocol supports MS identity check procedure between S4-SGSN and EIR (S13'), as described in clause "Identity Check Procedures". Diameter is defined in RFC 3588 [96].
- **Stream Control Transmission Protocol (SCTP):** This protocol transfers signalling messages. SCTP is defined in RFC 4960 [35].

Figure 11A: Control Plane S4-SGSN - EIR

5.6.3.6 SGSN - SMS-GMSC or SMS-IWMSC

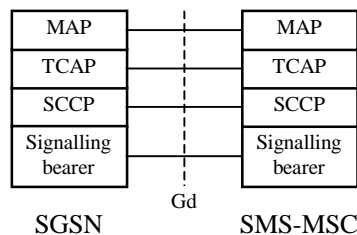

Figure 12: Control Plane SGSN - SMS-GMSC and SGSN - SMS-IWMSC

Legend:

- **Mobile Application Part (MAP):** This protocol supports signalling between the SGSN and SMS-GMSC or SMS-IWMSC, as described in clause "Point-to-point Short Message Service".

5.6.3.7 Core Network Node - Core Network Node

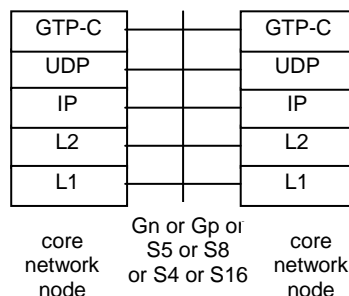

Figure 13: Control Plane for GTP-based Interfaces between Core Network Nodes

NOTE: Refer to TS 23.402 [90] for the S-GW - P-GW protocol stack with the PMIP-based S5 or S8.

Legend:

- GPRS Tunnelling Protocol for the control plane (GTP-C): This protocol tunnels signalling messages between SGSNs and GGSNs (Gn or Gp), between SGSNs and S-GWs (S4), between S-GWs and P-GWs (S5 or S8) and between SGSNs in the backbone network (Gn or S16).
- User Datagram Protocol (UDP): This protocol transfers signalling messages between GSNs. UDP is defined in RFC 768 [39].

5.6.3.8 GGSN - HLR

NOTE: This interface is not supported when UEs are served via S5/S8.

This optional signalling path allows a GGSN to exchange signalling information with an HLR. There are two alternative ways to implement this signalling path:

- If an SS7 interface is installed in the GGSN, the MAP protocol can be used between the GGSN and an HLR.
- If an SS7 interface is not installed in the GGSN, any GSN with an SS7 interface installed in the same PLMN as the GGSN can be used as a GTP-to-MAP protocol converter to allow signalling between the GGSN and an HLR.

5.6.3.8.1 MAP-based GGSN - HLR Signalling

Figure 14: Control Plane GGSN - HLR Using MAP

Legend:

- Mobile Application Part (MAP): This protocol supports signalling exchange with the HLR, as described in clause "Network-Requested PDP Context Activation Procedure".

5.6.3.8.2 GTP and MAP-based GGSN - HLR Signalling

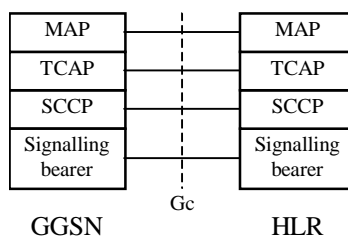
Figure 15: Control Plane GGSN - HLR Using GTP and MAP

Legend:

- GPRS Tunnelling Protocol for the control plane (GTP-C): This protocol tunnels signalling messages between the GGSN and the protocol-converting GSN in the backbone network.
- Interworking: This function provides interworking between GTP and MAP for GGSN - HLR signalling.

5.6.3.9 S4-SGSN - HSS

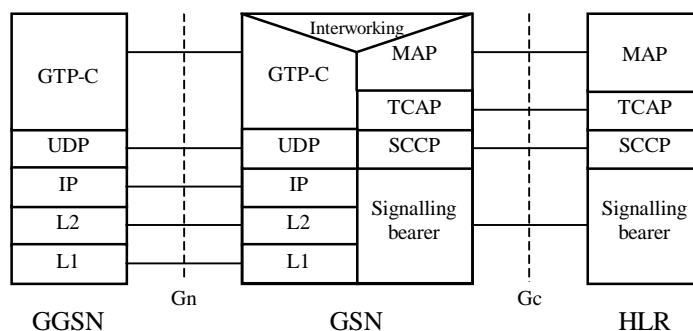
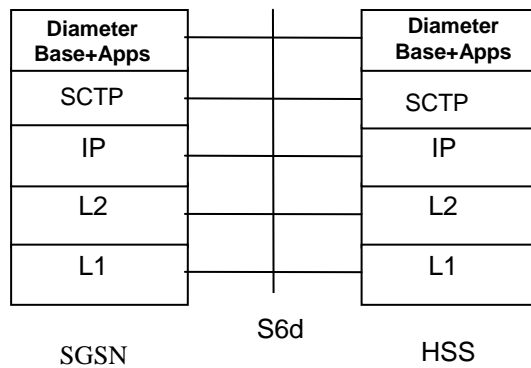

Legend:

- **Diameter Base+Apps:** Diameter Base Protocol as defined in RFC 3588 [96]. The Apps are various Diameter Applications as necessary for the operation between SGSN and HSS.
- **SCTP:** This protocol guarantees delivery of upper layer packets between SGSN and the HSS with built-in redundancy scheme. SCTP is defined in RFC 4960 [35].

Figure 15a: Control Plane S4-SGSN - HSS

NOTE: As specified in clause 6.4, between S4-SGSN and HSS, the interface is Diameter based (S6d); however, to assist with SGSN transition the use of MAP based Gr between the S4-SGSN and HSS is not precluded".

5.6.3.10 Gn/Gp-SGSN - CSS

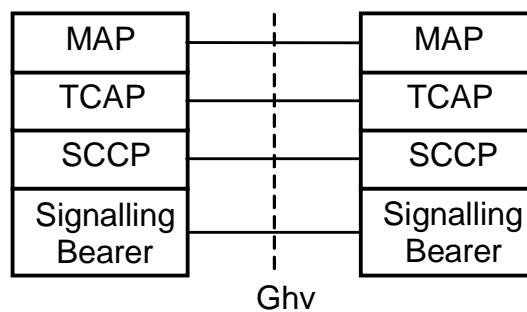

Legend:

- **Mobile Application Part (MAP):** This protocol supports signalling between Gn/Gp-SGSN and CSS, as defined in clause "Mobility Management Functionality".

Figure 5.6.3.10-1: Control Plane Gn/Gp-SGSN-CSS

5.6.3.11 S4-SGSN - CSS

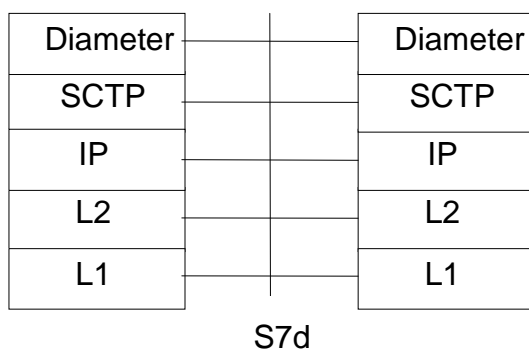

Legend:

- **Diameter:** This protocol supports signalling messages between S4-SGSN and CSS (S7d), as described in clause "Mobility Management Functionality". Diameter is defined in RFC 3588 [96].
- **Stream Control Transmission Protocol (SCTP):** This protocol transfers signalling messages. SCTP is defined in RFC 4960 [35].

Figure 5.6.3.11-1: Control Plane S4-SGSN-CSS

5.7 Functionality Needed for Mobile IPv4

To support the optional Mobile IP services, see TS 23.121 [54], efficiently by GPRS, Foreign Agent (FA) functionality needs to be provided in the GGSN. The interface between the GGSN and FA, including the mapping between the care of IP address and the GTP tunnel in the PLMN is not standardized as the GGSN and the FA are considered to be one integrated node.

Mobile IP service needs a Home Agent (HA) to anchor the IP session. The HA is a router that tunnels datagrams to/from an FA. The FA tunnels/de-tunnels the datagrams between the MS and the HA. In this case, the FA functionality resides in the GGSN. The location of the HA is outside the scope of the 3GPP specifications.

The FA and HA functionality is specified in RFC 3344 [46].

The Mobile IPv4 mobility management capabilities described in this clause are in addition to and distinct from the Mobile IP capabilities defined in TS 23.402 [90]. Support of Mobile IPv4 defined for the GGSN is retained in this specification for support of legacy terminals. Interworking between Mobile IPv4 support in the GGSN and MIPv4 as defined in TS 23.402 [90] is not defined for this release.

5.8 Functionality for Intra Domain Connection of RAN Nodes to Multiple CN Nodes

The Intra Domain Connection of RAN Nodes to Multiple CN Nodes overcomes the strict hierarchy that restricts the connection of a RAN node to just one CN node, and hence also to one SGSN. This implies that a RAN node must be able to determine which of the SGSNs, covering the area where an MS is located, should receive the signalling and user traffic sent from an MS. To avoid unnecessary signalling in the core network, an MS that has attached to one SGSN, should generally continue to be served by this SGSN as long as the MS is in the radio coverage of the pool area, to which the SGSN is associated. The concept of pool area is a RAN based definition that comprises one or more RA(s) that, from a RAN perspective, are served by a certain group of CN nodes. This does not exclude that one or more of the SGSNs in this group serve RAs outside the pool area. This group of SGSNs is also referred to as an SGSN pool.

To enable the RAN node to determine which SGSN to select when forwarding messages from an MS, Intra Domain Connection of RAN Nodes to Multiple CN Nodes defines a routing mechanism (and other related functionality). Another routing mechanism (and other related functionality) is defined for the SGSNs that support the Intra Domain Connection of RAN Nodes to Multiple CN Nodes. The routing mechanism is required to find the correct old SGSN (from the multiple SGSNs that are associated with a pool area). When an MS roams out of the pool area and into the area of one or more SGSNs that do not know about the internal structure of the pool area where the MS roamed from, the new SGSN will send the Identification Request message or the SGSN Context Request message to an SGSN that is

believed to be the old SGSN. This SGSN, which is associated with the same pool area as the actual old SGSN, resolves the ambiguity of multiple SGSNs in the pool area and determines the correct old SGSN from the P-TMSI (or the TLLI). The received message is then relayed to the correct old SGSN (unless it is itself the correct old SGSN). The routing mechanism in both the SGSNs and the RAN nodes utilises the fact that every SGSN that serves a pool area must have its own unique value range of the P-TMSI parameter within the pool area.

NOTE: Following idle mode mobility from E-UTRAN to GERAN/UTRAN, the new SGSN needs to find the "correct old MME" rather than the "correct old SGSN". As specified in TS 23.401 [89], E-UTRAN capable MSs process EPS IDs such that information in the RAI and P-TMSI or TLLI information elements enable the new SGSN to reuse the existing mechanism for "finding the correct old SGSN" to instead "find the correct old MME".

The requirements on, and the detailed functionality needed to support, the Intra Domain Connection of RAN Nodes to Multiple CN Nodes are defined in TS 23.236 [73] and additional functionality and requirements related to interworking with E-UTRAN are specified in TS 23.401 [89].

5.9 Functionality for network sharing

Network sharing allows multiple network operators to share a radio access network. In a shared network, an MS that supports network sharing selects one of the operators and indicates it to the network. This allows the network to provide services from the selected operator. For an MS that does not support network sharing, the network may select the network operator that provides the services.

The functionality needed to support network sharing is defined in TS 23.251 [83].

5.10 IMS Emergency Session Support

5.10.1 Introduction

Emergency bearer services are provided to support IMS emergency sessions. Emergency bearer services are functionalities provided by the serving network when the network is configured to support emergency services. Emergency bearer services are provided to normal attached UEs and to UEs that are in limited service state. Receiving emergency services in limited service state does not require a subscription. To provide emergency bearer services as a local service, node configuration parameters may be used to set service values that would otherwise be obtained from subscription data.

When a PLMN supports IMS emergency services in UTRAN, all SGSNs in that PLMN shall have the same capability to support emergency bearer services.

NOTE: IMS emergency session may be provided over GPRS without emergency procedures as specified from this release of specifications. In such a scenario, GPRS is unaware of the emergency session and thus provides no specific support explicitly required for such access.

5.10.2 PS Domain Functions for IMS Emergency Session Support

5.10.2.1 General

IMS emergency sessions over emergency access via packet core are supported for UTRAN access as well as inter-RAT handover between UTRAN and E-UTRAN. Support for Packet Core (GPRS and EPS) emergency bearer services over GERAN networks is not included in this Release and thus PS handover to GERAN access should not be performed when IMS emergency sessions over EPS or GPRS using emergency bearer services are active.

The MS shall signal a cause specific for emergency as defined in TS 25.331 [52] when it requests an RRC connection in relation to an emergency session. Specific situations that require setting the RRC establishment cause to emergency are described in TS 24.008 [13].

5.10.2.2 Reachability Management for Emergency Attached MS in PMM-IDLE state

An emergency attached MS when its periodic RA update timer expires shall not initiate a periodic RAU procedure but enter PMM- DETACHED state. The SGSN assigns the periodic RAU timer value to emergency attached MS. This timer keeps the MS emergency attached after change to PMM-IDLE state to allow for a subsequent emergency service without a need to emergency attach again. For emergency attached MS the SGSN runs a mobile reachable timer with a similar value to the MS's periodic RAU timer. Any time after expiry of this timer the SGSN may change the PMM state of an emergency attached MS to PMM- DETACHED.

5.10.2.3 Mobility and Access Restrictions for Emergency Services

When Emergency Services are supported and local regulation requires Emergency Sessions to be provided regardless of mobility or access restrictions, regional subscription restrictions or access restrictions (see TS 23.221 [80] and TS 23.008 [79]) e.g. CSG restrictions, should not be applied to MSs receiving emergency services. When the RABs for emergency bearers are established, the ARP value for emergency bearer services indicates the usage for emergency services to the UTRAN.

During handover, the source UTRAN and source SGSN ignore any MS related restrictions during handover evaluation when there are active emergency bearers. UTRAN shall not initiate handover to GERAN PS domain. During handover to a CSG cell, if the UE is not a CSG member of the target CSG cell and has emergency bearer services, the target RNC only accepts the emergency bearers and the target SGSN releases the non-emergency bearers that were not accepted by the target RNC according to clause 9.2.4.2. Such UEs behave as emergency attached.

During Routing Area Update procedures, including a RAU as part of a handover, the target SGSN ignores any mobility or access restrictions for MS with emergency bearer services where required by local regulation. Any non emergency bearer services are deactivated, according to clause 9.2.4.2, by the target SGSN when not allowed by the subscription for the target location. Such MSs behave as emergency attached. To allow the emergency attached MS to get access to normal services after the emergency session has ended and when it has moved to a new area that is not stored by the MS as a forbidden area, the MS may explicitly detach and reattach to normal services without waiting for the emergency PDN connection deactivation by the PDN GW or GGSN.

This functionality applies to all mobility procedures.

5.10.3 Attach handling

An MS in limited service state, as specified in TS 23.122 [7b], initiates the GPRS Attach procedure by indicating that the attach procedure is for emergency services. The Attach Request message for emergency attach purpose is indicated as Attach Type "GPRS Emergency Attach". Also MSs that had attached for normal service and do not have emergency bearers established and are camped on a cell, where the MS is in limited service state (e.g. because of change to a restricted Tracking Area or not allowed CSG), shall initiate this Attach procedure, indicating that the attach is to receive emergency services. The network which support emergency services for an MS in limited service state provides emergency attach service to this MS, according to regulatory requirements. The UEs in limited service state determine that the cell supports emergency bearer services for IMS based emergency services over UTRAN from a broadcast indicator in AS.

TS 23.401 [89] describes in clause "IMS Emergency Session Support" how the network provides emergency services according to different local regulations. Roaming or mobility restrictions are not applied when the network supports emergency services. Emergency Attach is supported only in UTRAN access.

An MS that camps normally on a cell, i.e. without any conditions that result in limited service state, initiates the normal GPRS attach procedure if not already attached. A normal attached IMS enabled MS is assumed to have a non-emergency PDN connection. A normal attached MS initiates the GPRS PDP Context Activation procedure by indicating emergency service to receive emergency bearer services. The UEs that camp normally on a cell are informed that the PLMN supports emergency bearer services for IMS based emergency services over UTRAN from the Emergency Service Support indicator in the Attach and RAU procedures. UEs that camp normally on a cell may also use the emergency attach procedure under conditions specified in TS 24.008 [13], e.g. when the MM back-off timer is running.

NOTE 1: Failure of the normal initial attach may occur e.g. when the network rejects the request with a back-off time.

NOTE 2: The establishment of the emergency bearer services may fail e.g. when the MS needs to perform a RAU procedure prior to the GPRS PDP Context Activation procedure, i.e. the MS moved into a non-registered Routing Area with the MM back-off timer running in the MS. Another example is when the MS needs to perform a Service Request procedure prior to the GPRS PDP Context Activation procedure, i.e. the MS is in PMM-IDLE state when the emergency service is triggered.

The details for Emergency Attach are included in the Combined GPRS/IMSI Attach procedure, see clause 6.5.3.

5.10.4 PDP Context Activation for emergency bearer services

The procedure is executed after the MS has successfully performed a GPRS attach and is valid for both normal and limited service state. The MS shall always activate a new PDP Context when emergency bearer services are invoked. When the MS detects a request for emergency service and it is required to establish a PDP context within the same network as the SGSN, the MS performs a PDP context activation with an indication of emergency usage so that emergency bearer services handling can be provided by the local network per configuration without subscription limitations. The request for emergency bearer services is indicated as Request Type "emergency" in the PDP Context Activation message.

MS request for emergency PDP context activation is added into the *PDP Context Activation Procedure* in clause 9.2.2.1.

The enhancements to support MS request for emergency PDP context activation are:

- a) The PDP Context Activation Request includes an indication of emergency usage.
- b) Configuration parameters in the network are used to override subscription limitations such as bearer QoS.

The PDN GW/GGSN selection function in the SGSN shall derive a PDN GW/GGSN identity in the visited PLMN by using the Emergency APN. The PDN GW/GGSN address is derived from the PDN GW/GGSN identity by using the Domain Name Service function. If the Domain Name Service function provides a list of PDN GW/GGSN addresses, one PDN GW/GGSN address is selected from this list. If the selected PDN GW/GGSN cannot be used, e.g. due to an error, then another PDN GW/GGSN is selected from the list. The specific interaction between the SGSN and the Domain Name Service function may include functionality to allow for the retrieval or provision of additional information regarding the PDN GW capabilities (e.g. whether the PDN GW supports PMIP based or GTP-based S5/S8, or both).

If there is already an emergency bearer activated, the SGSN shall reject any PDP context activation request for normal services if the mobility and access restrictions do not allow the MS to access normal services.

If the PDN GW/GGSN identity is statically configured in the SGSN, then it may be a FQDN or an IP Address[es].

5.10.5 Handling of PDN Connections for Emergency Bearer Services

The PDP contexts (described in clause 5.10.4) of a PDN Connection associated with the emergency APN shall be dedicated for IMS emergency sessions and shall not allow any other type of traffic. The Emergency PDP contexts shall not be changed to normal PDP contexts and vice versa.

The PDN GW/GGSN shall block any traffic that is not from or to addresses of network entities (e.g. P-CSCF) providing IMS emergency service. Dynamic PCC shall be deployed in order to support IMS emergency sessions, the procedures are as described in TS 23.203 [88]. If there is already an emergency PDN connection, the MS shall not request another emergency PDN Connection. The SGSN shall reject any additional emergency PDN Connection requests. The MS shall not initiate any Secondary PDP Context Activation Procedure or any PDP Context Modification Procedure for the emergency PDN connection. The PDN GW/GGSN shall reject any MS initiated Secondary PDP Context Activation Procedure or any PDP Context Modification Procedure that is for the emergency PDN Connection.

The ARP reserved for emergency bearer service shall only be assigned to bearers associated with an emergency PDN Connection.

For emergency attached MS, SGSN initiates an implicit detach based on an inactivity timeout specific to emergency.

NOTE: In case of IMS emergency services prior to this release of specification, dynamic PCC support was not required in the specifications. In such case if PCC is not used the PDN GW/GGSN provides static policy.

6 Mobility Management Functionality

6.1 Definition of Mobility Management States

6.1.0 General

The Mobility Management (MM) activities related to a subscriber are characterised by one of three different MM states. In A/Gb mode, the MM states for a GPRS subscriber are IDLE, STANDBY, and READY. In Iu mode, the MM states for a GPRS subscriber are PMM-DETACHED, PMM-IDLE, and PMM-CONNECTED. Each state describes a certain level of functionality and information allocated. The information sets held at the MS and the SGSN are denoted MM context.

The MM state relates only to GPRS MM activities of a subscriber. The MM state is independent of the number and state of PDP contexts for that subscriber.

NOTE: A GERAN/UTRAN MS that is also capable of E-UTRAN access has both MM states and EPS Mobility Management (EMM) states. The EMM states and the effects on the EMM and MM states of inter-RAT mobility between GERAN/UTRAN and E-UTRAN are described in TS 23.401 [89].

6.1.1 Mobility Management States (A/Gb mode)

6.1.1.1 IDLE (GPRS) State

In GPRS IDLE state, the subscriber is not attached to GPRS mobility management. The MS and SGSN contexts hold no valid location or routing information for the subscriber. The subscriber-related mobility management procedures are not performed.

The MS performs PLMN selection and cell selection and re-selection.

Data transmission to and from the mobile subscriber as well as the paging of the subscriber is not possible. The GPRS MS is seen as not reachable in this case.

In order to establish MM contexts in the MS and the SGSN, the MS shall perform the GPRS Attach procedure.

6.1.1.2 STANDBY State

In STANDBY state, the subscriber is attached to GPRS mobility management. The MS and SGSN have established MM contexts as described in clause "Information Storage".

Pages for data or signalling information transfers may be received. It is also possible to receive pages for the CS services via the SGSN. Data reception and transmission are not possible in this state.

The MS performs GPRS Routing Area (RA) and GPRS cell selection and re-selection locally. The MS executes mobility management procedures to inform the SGSN when it has entered a new RA. The MS does not inform the SGSN on a change of cell in the same RA. Therefore, the location information in the SGSN MM context contains only the GPRS RAI for MSs in STANDBY state.

The MS may initiate activation or deactivation of PDP contexts while in STANDBY state. A PDP context shall be activated before data can be transmitted or received for this PDP context.

The SGSN may have to send data or signalling information to an MS in STANDBY state. The SGSN then sends a Paging Request in the routing area where the MS is located if PPF is set. If PPF is cleared, then paging is not done. The MM state in the MS is changed to READY when the MS responds to the page, and in the SGSN when the page response is received. Also, the MM state in the MS is changed to READY when data or signalling information is sent from the MS and, accordingly, the MM state in the SGSN is changed to READY when data or signalling information is received from the MS.

The MS or the network may initiate the GPRS Detach procedure to move to the IDLE state. After expiry of the mobile reachable timer the SGSN may perform an implicit detach in order to return the MM contexts in the SGSN to IDLE state. The MM and PDP contexts may then be deleted.

For S4-SGSN, after expiry of the mobile reachable timer the SGSN should clear the PPF flag in the SGSN and start an Implicit Detach timer, with a relatively large value and if ISR is activated, at least slightly larger than the UE's GERAN/UTRAN Deactivate ISR timer. After the Implicit Detach timer expires, the S4-SGSN can perform an implicit detach in order to return the MM contexts in the SGSN to IDLE state.

6.1.1.3 READY State

In READY state, the SGSN MM context corresponds to the STANDBY MM context extended by location information for the subscriber on the cell level. The MS performs mobility management procedures to provide the network with the actual selected cell. GPRS cell selection and re-selection is done locally by the MS, or may optionally be controlled by the network.

An identifier of the cell, the Cell Global Identity including RAC and LAC, is included in the BSSGP header of the data packet from the MS; see TS 48.018 [78].

The MS may send and receive PDP PDUs in this state. The network initiates no GPRS pages for an MS in READY state. Pages for other services may be done via the SGSN. The SGSN transfers downlink data to the BSS responsible for the subscriber's actual GPRS cell.

The MS may activate or deactivate PDP contexts while in READY state.

Regardless if a radio resource is allocated to the subscriber or not, the MM context remains in the READY state even when there is no data being communicated. A timer supervises the READY state. An MM context moves from READY state to STANDBY state when the READY timer expires. In order to move from READY state to IDLE state, the MS initiates the GPRS Detach procedure.

6.1.1.4 State Transitions and Functions

The movement from one state to the next is dependent on the current state (IDLE, STANDBY, or READY) and the event that occurs (e.g. GPRS attach).

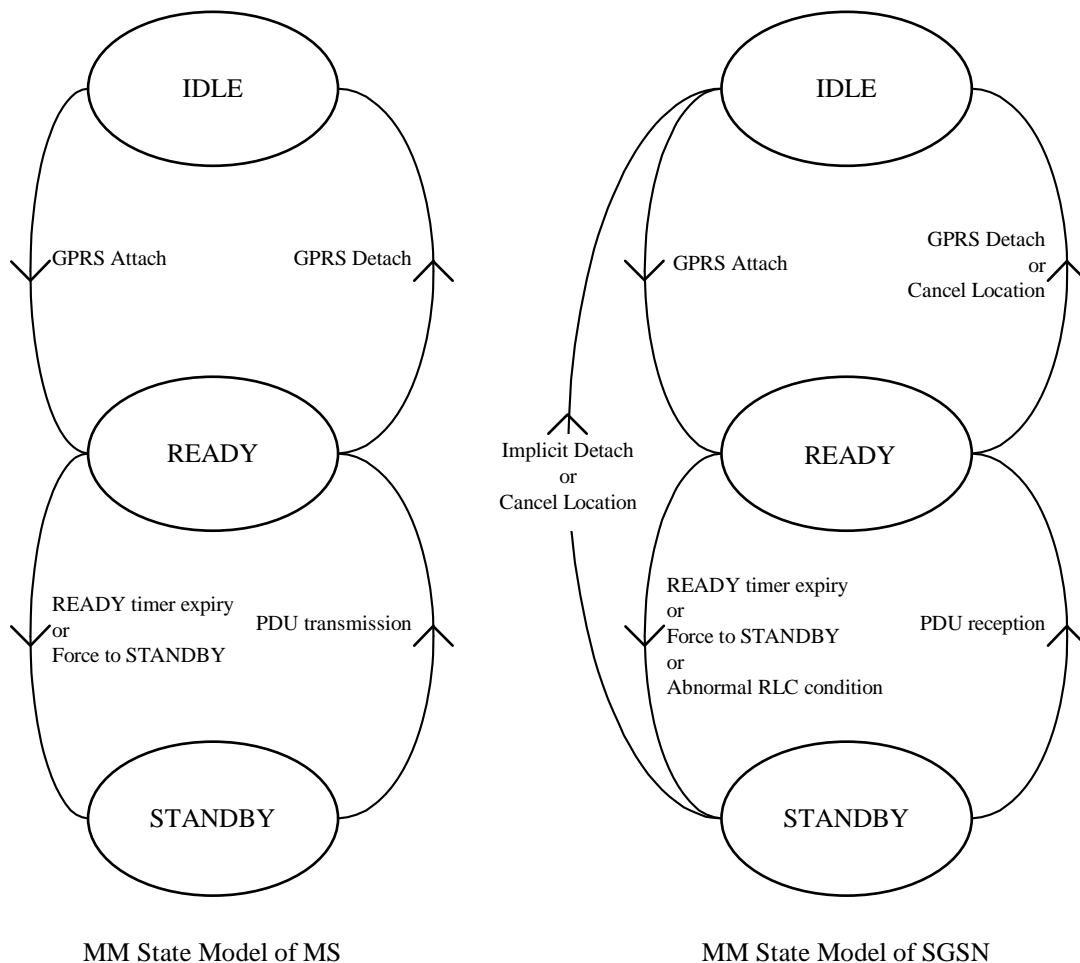

Figure 16: Functional Mobility Management State Model

Figure 16 describes the following state transitions:

Moving from IDLE to READY:

- GPRS Attach: The MS requests access and a logical link to an SGSN is initiated. MM contexts are established at the MS and SGSN.

Moving from STANDBY to IDLE:

- Implicit Detach: The MM and PDP contexts in the SGSN shall return to IDLE and INACTIVE state. The MM and PDP contexts in the SGSN may be deleted. The GGSN PDP contexts shall be deleted. If ISR is not activated, the P-GW and S-GW bearer contexts shall be deleted.
- Cancel Location: The SGSN receives a MAP Cancel Location message from the HLR, and removes the MM and PDP contexts.

Moving from STANDBY to READY:

- PDU transmission: The MS sends an LLC PDU to the SGSN, possibly in response to a page.
- PDU reception: The SGSN receives an LLC PDU from the MS.

Moving from READY to STANDBY:

- READY timer expiry: The MS and the SGSN MM contexts return to STANDBY state.

- Force to STANDBY: The SGSN indicates an immediate return to STANDBY state before the READY timer expires.
- Abnormal RLC condition: The SGSN MM context returns to STANDBY state in case of delivery problems on the radio interface or in case of irrecoverable disruption of a radio transmission.

Moving from READY to IDLE:

- GPRS Detach: The MS or the network requests that the MM contexts return to IDLE state and that the PDP contexts return to INACTIVE state. The SGSN may delete the MM and PDP contexts. The PDP contexts in the GGSN/P-GW and S-GW shall be deleted.
- Cancel Location: The SGSN receives a MAP Cancel Location message from the HLR, and removes the MM and PDP contexts.

6.1.2 Mobility Management States (Iu mode)

6.1.2.1 PMM-DETACHED State

In the PMM-DETACHED state there is no communication between the MS and the 3G-SGSN. The MS and SGSN contexts hold no valid location or routing information for the MS. The MS MM state machine does not react on system information related to the 3G-SGSN. The MS is not reachable by a 3G-SGSN, as the MS location is not known.

In order to establish MM contexts in the MS and the SGSN, the MS shall perform the GPRS Attach procedure. When the PS signalling connection is established between the MS and the 3G-SGSN for performing the GPRS attach, the state changes to PMM-CONNECTED in the 3G-SGSN and in the MS. The PS signalling connection is made up of two parts: an RRC connection and an Iu connection.

6.1.2.2 PMM-IDLE State

The MS location is known in the 3G-SGSN with an accuracy of a routing area. Paging is needed in order to reach the MS, e.g. for signalling. The MS and SGSN have established MM contexts as described in clause "Information Storage".

The MS shall perform a routing area update if the RA changes. Signalling towards the HLR is needed if the 3G-SGSN does not have an MM context for this MS.

The MS and 3G-SGSN shall enter the PMM-CONNECTED state when the PS signalling connection is established between the MS and the 3G-SGSN.

GPRS detach changes the state to PMM-DETACHED. The 3G-SGSN may perform an implicit GPRS detach any time after the MS reachable timer expiry. The MS's MM context is deleted, preferably after a certain (implementation dependent) time. The HLR may be informed about the deletion (see clause "Purge Function").

For S4-SGSN, after expiry of the mobile reachable timer the 3G-SGSN should clear the PPF flag in the SGSN and start an Implicit Detach timer, with a relatively large value and if ISR is activated, at least slightly larger than the UE's GERAN/UTRAN Deactivate ISR timer. After the Implicit Detach timer expires, the SGSN can perform an implicit detach in order to return the MM contexts in the SGSN to PMM-DETACHED state.

6.1.2.3 PMM-CONNECTED State

The MS location is known in the 3G-SGSN with an accuracy of a serving RNC. In the PMM-CONNECTED state, the location of the MS is tracked by the serving RNC. The MS performs the routing area update procedure when RAI in the MM system information changes.

When an MS and a 3G-SGSN are in the PMM-CONNECTED state, a PS signalling connection is established between the MS and the 3G-SGSN.

In the 3G-SGSN, PS signalling connection release or failed downlink transfer with cause "IMSI unknown in RNC" changes the state to PMM-IDLE.

The MS shall enter the PMM-IDLE state when its PS signalling connection to the 3G-SGSN has been released or broken. This release or failure is explicitly indicated by the RNC to the MS or detected by the MS (RRC connection

failure). The radio connection shall also be released if a URA update fails because of "RRC connection not established", or if the URA update timer expires while the MS is out of UTRAN (or Iu mode GERAN) coverage.

After a signalling procedure (e.g. routing area update), the 3G-SGSN may decide to release the PS signalling connection, after which the state is changed to PMM-IDLE.

GPRS detach changes the state to PMM-DETACHED.

6.1.2.4 State Transitions and Functions

Figure 17 introduces the MM states for a GPRS subscriber (PMM). The states and activations are further described below the figure.

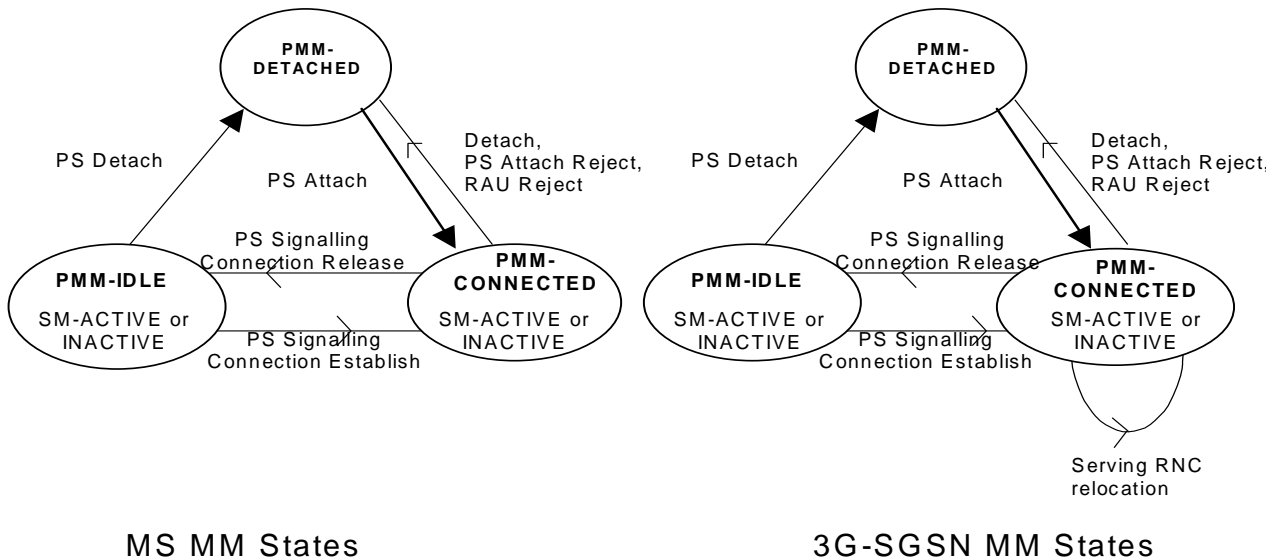

Figure 17: PMM State Model

NOTE: In both the PMM-IDLE and the PMM-CONNECTED states, session management may or may not have activated a PDP context. The consequence is that in PMM-CONNECTED state, only a signalling connection may be established. In PMM-IDLE state, a PDP context may be established, but no corresponding connection over the Iu interface nor the radio are established.

Moving from PMM-DETACHED to PMM-CONNECTED in the MS:

- GPRS Attach: The MM context shall move to the PMM-CONNECTED state when a PS signalling connection is established between the MS and the 3G-SGSN for performing a GPRS attach. If the GPRS attach is accepted an MM context is created in the MS.

Moving from PMM-CONNECTED to PMM-DETACHED in the MS:

- GPRS Detach: The MM context shall move to the PMM-DETACHED state when the PS signalling connection is released between the MS and the 3G-SGSN after the MS has performed a GPRS detach or after the network-initiated GPRS detach is performed. The MM context in the MS may be deleted.
- RAU Reject: The MM context shall move to the PMM-DETACHED state when the PS signalling connection is released between the MS and the 3G-SGSN after a RAU is rejected by the 3G-SGSN. The MM context may be deleted.
- GPRS Attach Reject: The MM context shall move to the PMM-DETACHED state when the PS signalling connection is released between the MS and the 3G-SGSN after a GPRS attach is rejected by the 3G-SGSN. The MM context may be deleted.

Moving from PMM-CONNECTED to PMM-IDLE in the MS:

- PS Signalling Connection Release: The MM context shall move to the PMM-IDLE state when the PS signalling connection is released.

Moving from PMM-IDLE to PMM-CONNECTED in the MS:

- PS Signalling Connection Establishment: The MM context shall move to the PMM-CONNECTED state when the PS signalling connection is established between the MS and the 3G-SGSN.

Moving from PMM-IDLE to PMM-DETACHED in the MS:

- Implicit GPRS Detach: The MM context shall locally move to the PMM-DETACHED state, e.g. in the case of removal of the battery, the USIM, or the SIM from the TE.

Moving from PMM-DETACHED to PMM-CONNECTED in the 3G-SGSN:

- GPRS Attach: The MM context shall move to the PMM-CONNECTED state when a PS signalling connection is established between the MS and 3G-SGSN for performing a GPRS attach. If the GPRS attach is accepted, an MM context is created in the 3G-SGSN.

Moving from PMM-CONNECTED to PMM-DETACHED in the 3G-SGSN:

- GPRS Detach: The MM context shall move to the PMM-DETACHED state when the PS signalling connection is released between the MS and the 3G-SGSN after the MS has performed a GPRS detach or after the network-initiated GPRS detach is performed. The MM context in the 3G-SGSN may be deleted.
- RAU Reject: The MM context shall move to the PMM-DETACHED state when the PS signalling connection is released between the MS and the 3G-SGSN after a RAU is rejected.
- GPRS Attach Reject: The MM context shall move to the PMM-DETACHED state when a PS signalling connection is released between the MS and the 3G-SGSN after a GPRS attach is rejected by the 3G-SGSN.

Moving from PMM-CONNECTED to PMM-IDLE in the 3G-SGSN:

- PS Signalling Connection Release: The MM context shall move to the PMM-IDLE state when the PS signalling connection is released.

Moving from PMM-IDLE to PMM-CONNECTED in the 3G-SGSN:

- PS Signalling Connection Establishment: The MM context shall move to the PMM-CONNECTED state when the PS signalling connection is established.

Moving from PMM-IDLE to PMM-DETACHED in the 3G-SGSN:

- Implicit GPRS Detach: The MM context may locally move to the PMM-DETACHED state after expiry of the MS Reachable timer. The MM and PDP context(s) in the 3G-SGSN may be deleted, preferably after an implementation-dependent time. For S4-SGSN, the MM context may locally move to the PMM-DETACHED state after expiry of the Implicit Detach timer.

6.1.2.4.1 Handling of Un-synchronous States in the UE and the Network**6.1.2.4.1.1 Un-synchronous PMM states in the UE and the SGSN**

In case of RRC connection release with cause "Directed Signalling connection re-establishment" or in case of an error, the PMM state of the MS and the 3G-SGSN may lose synchronisation. In this case the MS may be in the PMM-IDLE state while the 3G-SGSN is in the PMM-CONNECTED state.

NOTE 1: The opposite (MS in the PMM-CONNECTED state and SGSN in the PMM-IDLE state) shall never happen because the 3G-SGSN may not have the RAI where the MS is really located, so downlink transfer is impossible until the periodic URA update timer expires.

This situation is recovered by a successful MS initiated connection establishment, e.g. for a RAU or for data transfer, or by a failed downlink transfer with cause "IMSI unknown in RNC", triggering a paging procedure from the 3G-SGSN.

If the SGSN in PMM-CONNECTED state receives Iu connection establishment request from the MS, the SGSN shall ensure the new Iu connection and the existing one are for the same MS, and if so the SGSN shall process the new request and release existing Iu connection and all RABs associated with it. To ensure that the new Iu connection and the existing one are for the same MS, the SGSN may perform the security functions. If the Iu connection establishment request is for signalling only and if Direct Tunnel was established for the MS, the SGSN (in Gn/Gp mode) sends Update

PDP Context Request(s) to the GGSN(s) or the SGSN (in S4/S5/S8 mode) sends Update Bearer Request to the S-GW, to establish the GTP tunnels between SGSN and GGSN(s)/S-GW. If the Iu connection establishment request is for data transfer the SGSN may immediately establish a new direct tunnel and, in Gn/Gp mode, send Update PDP Context Request(s) to the GGSN(s) or, in S4/S5/S8 mode, send Update Bearer Request to the S-GW and include the RNC's Address for User Plane and, downlink TEID for data.

The UE shall also perform a RAU procedure immediately on entering PMM-IDLE state when it has received a RRC Connection Release message with cause "Directed Signalling connection re-establishment" even if the RA has not changed since the last update. The UE shall perform a subsequent Service request procedure after successful completion of the RA Update procedure to re-establish the radio access bearer when it has pending user data to send.

NOTE 2: The RNC will send a RRC CONNECTION RELEASE message with cause "Directed Signalling Connection re-establishment" when it is unable to contact the SRNC to validate the UE due to lack of Iur connection (see TS 25.331 [52]).

6.1.2.4.1.2 Unsynchronous states in the UE and the UTRAN

In abnormal cases, the UTRAN can believe the UE is in the RRC-CONNECTED state while the UE is actually in the RRC-IDLE state.

Symptoms of this condition are that the UTRAN has an Iu interface connection to the SGSN and the UTRAN pages with the RNTI but receives no answer from the UE.

For UTRAN paging triggered by CS domain pages, the RNC should take the responsibility to recover this situation by re-paging with the Core Network Identity in the cells of that RNC which are in the Location Area indicated by the CN. A consequence of this re-paging is that it may lead to the RNC having two RRC connections for one UE but different RNTIs. To resolve this, when the RNC receives the Common ID message from the MSC, the RNC may request the release of the Iu-PS connection associated with any different RNTI previously associated with that IMSI.

6.2 Mobility Management Timer Functions

6.2.1 READY Timer Function (A/Gb mode)

The READY timer function maintains the READY timer in the MS and SGSN. The READY timer controls the time an MS remains in READY state in the MS and the SGSN. The READY timer shall be reset and begin running in the MS when an LLC PDU is transmitted, and in the SGSN when an LLC PDU is correctly received. When the READY timer expires, the MS and SGSN MM contexts shall return to STANDBY state.

The length of the READY timer shall be the same in the MS and SGSN. The initial length of the READY timer shall be defined by a default value. The SGSN, and only the SGSN, may change the length of the READY timer by transmitting a new value in the Attach Accept or Routeing Area Update Accept messages.

If the READY timer length is set to zero, the MS shall immediately be forced into STANDBY state. If the timer length is set to all 1s (binary), the READY timer function shall be deactivated, i.e. the timer no longer runs and the MS remains in READY state.

6.2.2 Periodic RA Update Timer Function

The Periodic RA Update Timer function monitors the periodic RA update procedure in the MS. The length of the periodic RA update timer is sent in the Routeing Area Update Accept or Attach Accept message. The periodic RA update timer is unique within an RA. Upon expiry of the periodic RA update timer, the MS shall start a periodic routeing area update procedure.

The SGSN may allocate long periodic RAU timer value to the MS as per clause 5.3.13.5.

If the MS is in GERAN/UTRAN coverage but out of GERAN/UTRAN PS coverage when the periodic RA update timer expires, then, if the MS is IMSI-attached to a network in network operation mode I, the periodic location update procedure (or other appropriate location update procedure) shall be started immediately. In addition, and irrespective of whether or not the MS was IMSI-attached, regardless of the network operation mode, the periodic RA update procedure (or other appropriate update procedure) shall be started as soon as the MS returns to GERAN/UTRAN PS coverage.

If the MS is out of GERAN/UTRAN PS coverage or camps on E-UTRAN when the periodic RA update timer expires then:

- if the MS is both IMSI- and GPRS-attached and returns to GERAN/UTRAN coverage in a cell that supports packet-domain services in network operation mode I, then the combined RA / LA update procedure with IMSI attach requested shall be started as soon as the MS returns to GERAN/UTRAN coverage;
- if the MS is both IMSI- and GPRS-attached and returns to GERAN/UTRAN coverage in a cell that supports packet-domain services in network operation mode II, or if a GPRS only-attached MS returns to GERAN/UTRAN coverage in a cell that supports packet-domain services, then the periodic RA update procedure shall be started as soon as the MS returns to GERAN/UTRAN coverage; or
- if the MS returns to GERAN/UTRAN coverage in a cell that does not support packet-domain services, and if the MS is IMSI-attached, then the periodic location update procedure (or other appropriate location update procedure) shall be started as soon as the MS returns to GERAN/UTRAN coverage in that cell. In addition, and irrespective of whether or not the MS was IMSI-attached, the periodic RA update procedure (or other appropriate update procedure) shall be started as soon as the MS returns to GERAN/UTRAN PS coverage.

If the MS lost GERAN/UTRAN PS coverage or camped on E-UTRAN but the periodic RA update timer did not expire while not camping on a GERAN/UTRAN PS cell, then the MS shall not perform the periodic RA update procedure because of the MS's return to GERAN/UTRAN PS coverage.

If the MS lost GERAN/UTRAN coverage or camped on E-UTRAN but the periodic RA update timer did not expire while not camping on a GERAN/UTRAN cell, the MS shall not perform the periodic RA update procedure because of the MS's return to GERAN/UTRAN coverage.

If the MS's periodic RAU timer expires and ISR is activated the MS shall start the GERAN/UTRAN Deactivate ISR timer. After the GERAN/UTRAN Deactivate ISR timer expires the MS shall deactivate ISR by setting its TIN to "GUTI".

The GERAN/UTRAN Deactivate ISR timer is stopped when the MS performs a successful RAU.

6.2.3 Mobile Reachable Timer Function

The Mobile Reachable Timer function monitors the periodic RA update procedure in the SGSN. The mobile reachable timer shall be slightly longer than the periodic RA update timer used by an MS.

The mobile reachable timer is stopped when the READY state or PMM-CONNECTED state is entered. The mobile reachable timer is reset and started when the state returns to STANDBY or PMM-IDLE.

If the mobile reachable timer expires, the SGSN shall clear PPF. Typically, in GPRS, this causes the SGSN to stop sending GPRS paging or CS paging messages to the MS, but other features (e.g. MSC/VLR-based call forwarding) may happen immediately. PPF is set when the next activity from the MS is detected. The MM and PDP contexts shall be kept in the SGSN.

When an MS first registers in an SGSN, then PPF is set.

The PPF in the SGSN is specific to GERAN/UTRAN access.

TS 23.401 [89] specifies a separate PPF for E-UTRAN. If the SGSN is combined with an MME, the SGSN's PPF shall have no impact on whether or not the MME performs paging in E-UTRAN.

When the SGSN applies General NAS level Mobility Management Congestion Control to a MS, the SGSN may need to adjust the mobile reachable timer and/or implicit detach timer (as clause 5.3.6.2.4).

6.3 Interactions Between SGSN and MSC/VLR

6.3.0 General

The interactions described in this clause shall be supported if the optional Gs interface is installed. All functionality of this clause applies for A/Gb mode and Iu mode unless stated differently.

NOTE: The functionality described in this clause operates independently of whether or not the MS supports E-UTRAN access.

An association is created between SGSN and MSC/VLR to provide for interactions between SGSN and MSC/VLR. The association is created when the VLR stores the SGSN number and the SGSN stores the VLR number. The association is used for co-ordinating MSs that are both GPRS-attached and IMSI-attached.

The association supports the following actions:

- IMSI attach and detach via SGSN. This makes combined GPRS / IMSI attach and combined GPRS / IMSI detach possible, thus saving radio resources.
- Co-ordination of LA update and RA update, including periodic updates, thus saving radio resources. A combined RA / LA update is sent from the MS to the SGSN. The SGSN forwards the LA update to the VLR.
- Paging for a CS connection via the SGSN.
- Alert procedures for non-PS services.
- Identification procedure.
- MM Information procedure.
- CS and PS registration coordination in networks that support network sharing as defined in TS 23.251 [83] so that a UE is registered with the same core network operator in the CS and PS domain.

6.3.1 Administration of the SGSN - MSC/VLR Association

The SGSN - MSC/VLR association is created at the following occasions:

- Combined GPRS / IMSI attach.
- GPRS attach when the MS is already IMSI-attached.
- Combined RA / LA update when the MS performs IMSI attach and is already GPRS-attached.
- Combined RA / LA update when an IMSI and GPRS-attached MS changes from an area of network operation mode II to an area of network operation mode I.

The association is initiated by the SGSN. The SGSN creates an association by sending a BSSAP+ message concerning a particular MS to the VLR. An SGSN that does not provide functionality for Intra Domain Connection of RAN Nodes to Multiple CN Nodes uses the RAI to determine the VLR number. An SGSN that provides functionality for Intra Domain Connection of RAN Nodes to Multiple CN Nodes uses the RAI and a hash value from the IMSI to determine the VLR number. During a CS connection, an MS in class-B mode of operation (A/Gb mode) cannot perform GPRS attach nor routing area updates, only MSs in class-A mode of operation can perform these procedures. If a GPRS attach was made during a CS connection, the association shall be initiated by a combined RA / LA update after the CS connection has been released.

The association is updated on the following occasions:

- When an MS changes VLR.
- When an MS changes SGSN.

The association is not updated during a CS connection.

NOTE: When the Idle mode Signalling Reduction feature described in TS 23.401 [89] is active, the association is not impacted just because of mobility between GERAN/UTRAN and E-UTRAN, unless CS Fallback is in use (see TS 23.272 [93]).

When the MS is in idle mode (see GSM 03.22 [7] and TS 23.122 [7b]), the association is updated with the combined RA / LA updates procedure.

In relation to a CS connection, the association is managed in the following way:

MS in class-A or CS/PS mode of operation:

An MS in class-A or CS/PS mode of operation makes RA updates but no combined RA / LA updates during the CS connection. If the MS changes SGSN, the SGSN (according to normal RA update procedures, see clause "Inter SGSN Routeing Area Update") updates the HLR and the GGSN, but not the VLR, about the new SGSN number.

If the MS changes MSC during the CS connection, the subscriber data still remains in the old VLR until the CS connection is released and a combined RA / LA update or LA update is made. The association is also not updated during the CS connection.

After the CS connection has been released, a combined RA / LA update is performed (if there has been a change of RA, or if a GPRS attach was performed and the new cell indicates network operation mode I), and the association is updated according to combined RA / LA update procedures, see clause "Combined RA / LA Update Procedure". If the new cell indicates network operation mode II, then the MS performs an LA update.

MS in class-B mode of operation (A/Gb mode):

An MS in class-B mode of operation does not make any RA updates during a CS connection. The SGSN number therefore remains the same during the CS connection and does not need to be updated in the VLR. If the MS changes MSC during the CS connection, the subscriber data still remains in the old VLR until the CS connection has been released and a combined RA / LA update or LA update is made. Therefore, the VLR number remains the same during the CS connection. After the CS connection has been released, the MS performs an RA update and an LA update if the RA has changed and the new cell indicates network operation mode II, or a combined RA / LA update if the RA has changed and the new cell indicates network operation mode I. The association is updated according to the combined RA / LA update procedures, see clauses "Inter SGSN Routeing Area Update" and "Combined RA / LA Update Procedure".

The SGSN - MSC/VLR association is removed at the following occasions:

- At IMSI detach.
- At GPRS detach.
- SGs association establishment, see TS 23.272 [93].

When the MSC/VLR receives an LA update via the A or Iu interface from an MS or establishes a SGs association with an MME for which a Gs association exists for that MS, the MSC/VLR shall remove the association without notifying the SGSN. When the SGSN receives a (non-combined) RA update from an MS for which an association exists, the SGSN shall remove the association without notifying the MSC/VLR. When the MSC/VLR receives a BSSAP+ MS Unreachable message from the SGSN indicating that PPF is cleared, the state of the association shall not be changed at the MSC/VLR.

6.3.2 Combined RA / LA Updating

When the MS is both IMSI and GPRS-attached, the LA and RA updating is done in a co-ordinated way to save radio resources if supported by the network operation mode. When the MS enters a new RA in network operation mode I, the MS sends a Routeing Area Update Request message to the SGSN, as described in clause "Combined RA / LA Update Procedure". The LA update is included in the RA update. The SGSN then forwards the LA update to the MSC/VLR. The MSC/VLR optionally returns a new VLR TMSI that is sent to the MS via the SGSN.

An MS in class-A mode of operation involved in a CS connection makes only RA updates and no combined RA / LA updates to the SGSN.

An MS in CS/PS mode of operation involved in a CS connection makes only RA updates and no combined RA / LA updates to the SGSN.

An MS in class-B mode of operation involved in a CS connection does not make any updates during the CS connection.

An MS in class-C mode of operation never makes combined RA / LA updates. MSs in CS mode of operation and MSs in PS mode of operation never make combined RA / LA updates.

6.3.3 CS Paging (A/Gb mode)

When an MS is both IMSI and GPRS-attached in a network that operates in mode I, the MSC/VLR executes paging for circuit-switched services via the SGSN. If the MS is in STANDBY state, it is paged in the routing area and in the null routing area (see clause "Routing Area Identity"). If the MS is in READY state, it is paged in the cell. A paging timer in the MSC supervises the paging procedure. The SGSN converts the MSC paging message into an SGSN paging message.

The CS Paging procedure is illustrated in figure 18. Each step is explained in the following list.

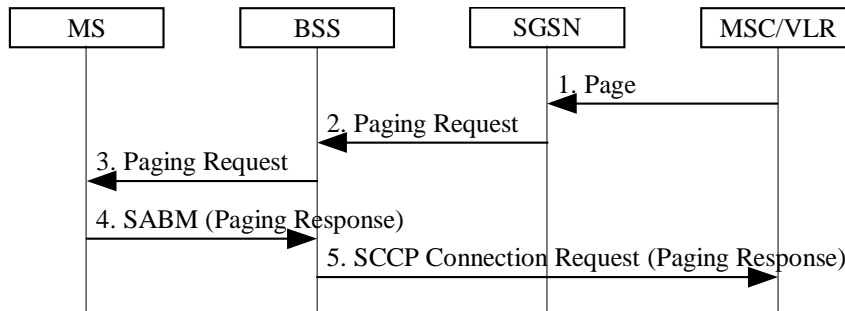

Figure 18: CS Paging Procedure in A/Gb mode

- 1) The SGSN receives a Page (IMSI, VLR TMSI, Channel Needed, Priority, Location Information) message from the MSC. Channel Needed is defined in TS 48.008 [18] and indicates to the MS which type of CS channel is needed to be requested in the response. VLR TMSI and Channel Needed are optional parameters. Priority is the circuit-switched paging priority parameter as defined in TS 48.008 [18].
- 2) The SGSN sends a BSSGP Paging Request (IMSI, TLLI, VLR TMSI, Area, Channel Needed, QoS) message to the BSS serving the MS. Area is derived from either the MS's MM context in the SGSN or, if no such information is available, from the Location Information received from the MSC/VLR. Area indicates a single cell for a READY state MS or a routing area for a STANDBY state MS. VLR TMSI and Channel Needed are included if received from the MSC. If Channel Needed was not received from the MSC, then a default Channel Needed parameter indicating circuit-switched paging is included by the SGSN. QoS indicates the priority of this Paging Request relative to other Paging Request messages buffered in the BSS. If the location area where the MS was last known to be located has an associated null routing area, then the SGSN shall send an additional BSSGP Paging Request message to each BSS serving this null RA.
- 3) The BSS translates the incoming BSSGP Paging Request message into one radio Paging Request message per cell. If a dedicated radio resource is assigned to the MS in a cell, then the BSS transmits one Paging Request (VLR TMSI or IMSI, Channel Needed) message on this radio resource, without stopping possibly ongoing data transfers for the MS. Otherwise, the BSS pages the MS with one Paging Request (VLR TMSI or IMSI, Channel Needed) message on the appropriate paging channel in each addressed cell. This is described in TS 43.064 [11].
- 4) Upon receipt of a Paging Request message for a circuit-switched service the MS may accept to respond to this request and shall follow the CS procedures for paging response (random access, immediate assignment, and paging response) as specified in TS 24.008 [13].
- 5) When received at the BSS, the Paging Response message is sent to the MSC, which shall stop the paging response timer.

6.3.3.1 Paging Co-ordination in A/Gb mode

The network may provide co-ordination of paging for circuit-switched and packet-switched services. Paging co-ordination means that the network sends paging messages for circuit-switched services on the same channel as used for packet-switched services, i.e. on the GPRS paging channel or on the GPRS traffic channel, and the MS needs only to monitor that channel. Three network operation modes are defined:

- Network operation mode I: the network sends a CS paging message for a GPRS-attached MS, either on the same channel as the GPRS paging channel (i.e. the packet paging channel or the CCCH paging channel), or on a GPRS traffic channel. This means that the MS needs only to monitor one paging channel, and that it receives CS paging messages on the packet data channel when it has been assigned a packet data channel.
- Network operation mode II: the network sends a CS paging message for a GPRS-attached MS on the CCCH paging channel, and this channel is also used for GPRS paging. This means that the MS needs only to monitor the CCCH paging channel, but that e.g. CS paging continues on this paging channel even if the MS has been assigned a packet data channel, unless BSS paging co-ordination as described in 8.1.6 is active.
- Network operation mode III: the network sends a CS paging message for a GPRS-attached MS on the CCCH paging channel, and sends a GPRS paging message on either the packet paging channel (if allocated in the cell) or on the CCCH paging channel. This means that an MS that wants to receive pages for both circuit-switched and packet-switched services shall monitor both paging channels in the cell, if the packet-paging channel is allocated. The core network performs no paging co-ordination. See, however, also 8.1.6 for description of paging co-ordination on BSS level.

Table 2: Paging Channel Configuration in different Network Operation Modes for A/Gb mode without BSS paging co-ordination

Mode	Circuit Paging Channel	GPRS Paging Channel	CN Paging co-ordination
I	Packet Paging Channel (NOTE 1)	Packet Paging Channel (NOTE 1)	Yes
	CCCH Paging Channel	CCCH Paging Channel	
	Packet Data Channel	Not Applicable	
II	CCCH Paging Channel	CCCH Paging Channel	No
III	CCCH Paging Channel	Packet Paging Channel (NOTE 1)	No
	CCCH Paging Channel	CCCH Paging Channel	
NOTE 1: Since Release 9 GERAN TS 44.060 [77] forbid deploying Packet Common Control Channels. This makes use of NMO-III and packet paging channel obsolete.			

For MSs with an SGSN – MSC/VLR association, which is established via the GS interface, all MSC-originated paging of GPRS-attached MSs shall go via the SGSN, thus allowing network co-ordination of paging. Paging co-ordination shall be made by the SGSN based on the IMSI, and is provided independently of whether the MS is in STANDBY or in READY state. The network operates in mode I.

When no SGSN – MSC/VLR association exists, all MSC-originated paging of GPRS-attached MSs shall go via the A interface, and co-ordination of paging cannot be performed by the core network. The network shall then operate in mode II, meaning that the packet common control channel shall not be allocated in the cell.

The network operation mode (mode I or II) shall be indicated as system information to MSs. Additional system information can indicate that MSs configured to use the extended NMO I system information (see TS 24.368 [111]) shall use NMO I, regardless of what NMO is indicated by system information for other MSs. If this additional system information is absent, MSs configured to use the extended NMO I system information shall use the system information that represents the network operation mode for other MSs. From these indications, the MS determines which mode applies to it. That mode shall be used when using the procedures described in other clauses of this specification.

For proper operation, the mode of operation should be the same in each cell of a routing area.

Based on the system information provided by the network, the MS can then choose, according to its capabilities, whether it can attach to GPRS services, to non-GPRS services, or to both.

6.3.4 CS Paging (Iu mode)

When an MS is both IMSI- and GPRS-attached in a network that operates in mode I, the MSC/VLR executes paging for circuit-switched services via the SGSN.

In the MSC, a paging timer supervises the paging procedure.

The CS Paging procedure is illustrated in Figure 19. Each step is explained in the following list.

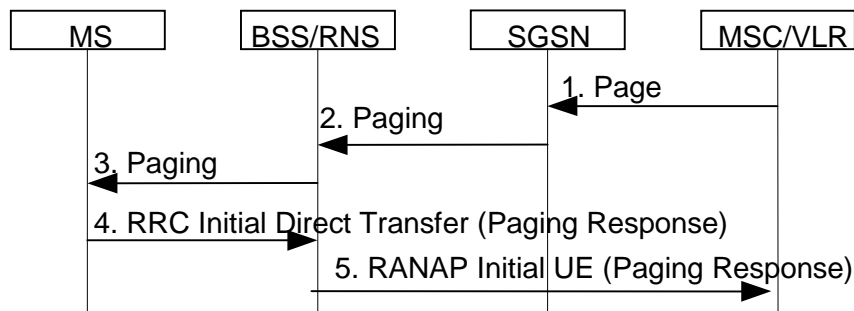

Figure 19: CS Paging Procedure in Iu mode

- 1) The SGSN receives a Page (IMSI, VLR TMSI, Location Information) message from the MSC. If VLR TMSI is omitted, the IMSI is used instead of the TMSI as a paging address at the radio interface. If location information is not included, the SGSN shall page the MS in all the cells served by the VLR and the SGSN, unless the SGSN has reliable information about the location of the MS.

NOTE 1: If the PS network support paging optimization and MS has Emergency Service in CS domain, CS paging procedure via SGSN may fail.

- 2) The 3G-SGSN sends a RANAP Paging (IMSI, TMSI, Area, CN Domain Indicator) message to each RNS. IMSI is needed by the RNS in order to calculate the MS paging group and to identify the paged MS. TMSI is included if received from the MSC. Area indicates the area in which the MS is paged, and is derived from either the MS's MM context in the SGSN or, if no such information is available, from the Location Information received from the MSC/VLR. CN Domain Indicator indicates which domain (CS or PS) initiated the paging message, and in this case it must be set to "CS" by the SGSN. The list of CSG IDs for paging is included when the SGSN is configured to support paging optimisation described in clause 5.3.9. For paging optimisation, the CSG IDs of expired CSG subscriptions and valid CSG subscriptions are both included in the list.

NOTE 2: An expired CSG subscription indicates that the MS is not allowed service in the CSG. However, since the removal of the CSG from the MS is pending, it is possible the MS will camp on that CSG and therefore the MS is still paged for the CSG.

- 3) For more details on the radio resource part of the paging procedure, see clause "Paging Initiated by CN".
- 4) Upon receipt of a Paging Request message for a circuit-switched service, the MS responds to this request and returns the paging response as specified in TS 44.018 [85] in an RRC Initial Direct Transfer message as specified in TS 25.331 [52]. CN Domain Indicator is set to "CS" in the Initial Direct Transfer message.
- 5) When received at the RNS, the Paging Response message is sent in an RANAP Initial UE message to the MSC, which shall then stop the paging response timer.

6.3.4.1 Network Operation Modes for Iu mode

The network operation mode is used to indicate whether the Gs interface is installed or not. When the Gs interface is present, MSs initiate combined procedures.

Table 3-1: Network Operation Modes for Iu mode

Mode	Network configuration	Combined procedure by MT
I	Gs interface is present	Yes
II	Gs interface is not present	No

The network operation mode (mode I or II) shall be indicated as system information to the MSs. Additional system information can indicate that MSs configured to use the extended NMO I system information shall use NMO I, regardless of what NMO is indicated by system information for other MSs. If this additional system information is absent, MSs configured to use the extended NMO I system information shall use the system information that represents the network operation mode for other MSs. From these indications, the MS determines which mode applies to it. That mode shall be used when using the procedures described in other clauses of this specification.

For proper operation, the mode of operation should be the same in each cell of a routing area.

Based on the system information provided by the network, the MS derives whether to initiate combined update procedures or separate update procedures.

NOTE: Network operation modes I and II for Iu mode correspond to modes I and II for A/Gb mode, respectively.

6.3.4a CS Paging (in case Selective RA Update)

When an MS is both IMSI- and GPRS-attached in a network that operates in mode I, and the MSC/VLR executes paging for circuit-switched services via the SGSN that support Selective RA Update Procedure, if the MS is in STANDBY or PMM-IDLE state, the SGSN shall cause the page to be sent in all cells in the routing area where the MS is located. This can include both A/Gb mode and Iu mode cells (see clause "Selective RA Update").

The CS Paging procedure in A/Gb mode is illustrated in figure 18 and the CS Paging procedure in Iu mode is illustrated in figure 19.

6.3.5 Non-GPRS Alert

The MSC/VLR may request an SGSN to report activity from a specific MS. In this case, the MSC/VLR shall send a BSSAP+ Alert Request (IMSI) message to the SGSN where the MS is currently GPRS-attached.

Upon reception of the Alert Request (IMSI) message, the SGSN shall set NGAF. If NGAF is set for an MS, the SGSN shall inform the MSC/VLR when the next activity from that MS (and the MS is both IMSI- and GPRS-attached) is detected, and shall clear NGAF.

If the activity detected by the SGSN leads to a procedure towards the MSC/VLR, the SGSN shall just follow this procedure. If the activity detected by the SGSN does not lead to any procedure towards the MSC/VLR, the SGSN shall send an MS Activity Indication (IMSI) message towards the MSC/VLR.

6.3.6 MS Information Procedure

When the MS is marked at the VLR as both IMSI- and GPRS-attached, the VLR may perform the MS Information procedure via the SGSN. If the information requested by the VLR in the MS Information procedure is known by the SGSN, then the SGSN shall return this information to the VLR without interrogating the MS.

If the information requested is MS identity information (e.g. IMEI) that is not known by the SGSN but is known by the MS, then the SGSN shall interrogate the MS in a similar manner to that described in clause "Identity Check Procedures".

In A/Gb mode, if the information requested is MS location information, then this indicates a request for Cell Global Identity and Cell Identity Age. In Iu mode, if the information requested is MS location information, then this indicates a request for Service Area Identity and Service Area Identity Age, and in this case if an Iu connection for the MS exists, then the SGSN shall use the Location Reporting procedure (see clause "Location Reporting Procedure") in order to retrieve the Service Area Identity.

The MS Information procedure is illustrated in Figure 20. Procedure steps are explained in the following list.

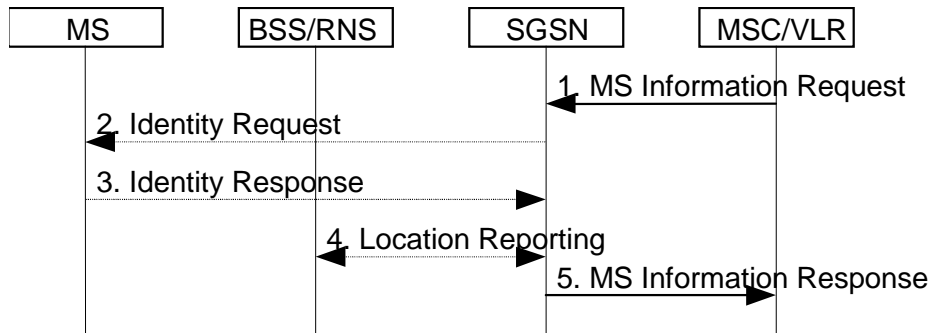

Figure 20: MS Information Procedure

- 1) The MSC/VLR sends an MS Information Request (IMSI, Information Type) message to the SGSN. Information Type indicates the information that the MSC/VLR is requesting for that IMSI.
- 2) If the information requested is not known by the SGSN but should be known by the MS, then the SGSN interrogates the MS in a similar manner to that described in the clause "Identity Check Procedures". The SGSN sends an Identity Request (Identity Type) message to the MS.
- 3) The MS responds with an Identity Response (Mobile Identity) message to the SGSN.
- 4) In Iu mode, if an Iu connection for the MS exists, then the SGSN shall use the Location Reporting procedure to retrieve the Service Area Identity. If the BSS/RNS cannot determine the current Service Area of the MS, it indicates in the Location Report message that the request could not be fulfilled and may report the Last Known Service Area with an indication of how long has past since the MS was known to be in the indicated Service Area.
- 5) The SGSN sends an MS Information Response (IMSI, Information) message to the MSC/VLR. Information contains the information requested by the MSC/VLR.
If an Iu connection for MS exist and RAN node cannot determine current Service Area and Last Known Service Area is not reported, the SGSN shall include in the MS Information Response message the last successfully received Service Area Identity with time elapsed since it was saved by SGSN.

6.3.7 MM Information Procedure

When the MS is marked at the VLR as both IMSI- and GPRS-attached, the VLR may perform the MM Information procedure via the SGSN. The MM Information procedure is typically used to inform the MS about such things as the network name and the local time zone of the mobile.

The MM Information procedure is illustrated in Figure 21.

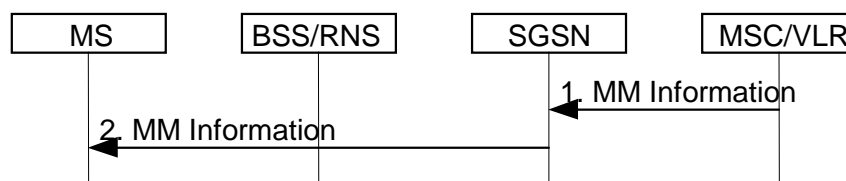

Figure 21: MM Information Procedure

- 1) The SGSN receives an MM Information (IMSI, Information) message from the MSC/VLR. Information is the information that the MSC/VLR is sending to the MS.
- 2) The SGSN sends an MM Information (Information) message to the MS including the information received by the MSC/VLR.

6.4 MM Procedures

In A/Gb mode, the MM procedures shall use the LLC and RLC/MAC protocols for message transmission across the Gb and Um interfaces. The MM procedures shall provide information to the underlying layers to enable reliable

transmission of MM messages on the Um interface. TS 43.064 [11] defines the mapping between LLC and the radio channels used.

In Iu mode, the MM procedures shall use the RANAP and RRC protocols for message transmission across the Iu and radio interfaces, respectively.

Furthermore, the MM procedures use MAP interfaces between Gn/Gp SGSN and HLR (Gr), and between SGSN and EIR (Gf), and a BSSAP+ interface between SGSN and MSC/VLR (Gs). Between S4-SGSN and HSS, the interface is Diameter based (S6d).

However, to assist with SGSN transition the use of MAP based Gr between the S4-SGSN and HSS is not precluded.

User data can in general be transmitted during MM signalling procedures. In A/Gb mode, user data transmitted during attach, authentication, and routing area update procedures may be lost and may therefore have to be retransmitted. In order to minimise the need for retransmission, the MS and SGSN should not transmit user data during attach and authentication procedures. In case of routing area update procedures, the user data transfer is allowed with restriction specified in description of these procedures in clauses 6.9.1.2 and 6.9.1.3.

6.5 GPRS Attach Function

6.5.0 General

An MS shall perform a GPRS Attach to the SGSN in order to obtain access to the GPRS services. If the MS is connected in A/Gb mode, it shall perform an A/Gb mode GPRS Attach procedure. If the MS is connected via Iu mode, it shall perform an Iu mode GPRS Attach procedure.

In the attach procedure, the MS shall provide its identity and an indication of which type of attach that is to be executed. The identity provided to the network shall be the MS's Packet TMSI (P-TMSI) or IMSI. The P-TMSI may be derived from a GUTI when the MS is E-UTRAN capable. If the MS does not have a valid P-TMSI or a valid GUTI, the MS shall provide its IMSI. For emergency attach, the IMEI shall be included when the MS has no IMSI, no valid GUTI and no valid P-TMSI.

In order to limit load on the network, only when performing a GPRS Attach with a new PLMN (i.e. not the registered PLMN or an equivalent PLMN of the registered PLMN), an MS configured to perform Attach with IMSI at PLMN change (see TS 24.368 [111]) shall identify itself with its IMSI instead of any stored temporary identifier.

During the Attach procedure, the MS provides its PS Handover and inter-RAT Handover capabilities in the Attach Request message. The SGSN uses the inter-RAT indicator and/or other indicators to ask the MS (using the Attach Accept message) to send the other RAT's Radio Access Capabilities in the Attach Complete message.

6.5.1 A/Gb mode GPRS Attach Procedure

A GPRS attach is made to the SGSN. A GPRS-attached MS makes IMSI attach via the SGSN with the combined RA / LA update procedure if the network operation mode is I. In network operation mode II, or if the MS is not GPRS-attached, the MS makes an IMSI attach as already defined in A/Gb mode. An IMSI-attached MS in class-A mode of operation engaged in a CS connection shall use the (non-combined) GPRS Attach procedures when it performs a GPRS attach.

The SGSN indicates "SMS-Supported" to the MS when the HSS has indicated "SMS in SGSN Support". It indicates to the MS that it can obtain SMS services via PS domain NAS from the SGSN. An MS that needs only PS services and SMS services via NAS should not perform any procedures via CS domain when it can obtain SMS services via PS domain NAS from SGSN.

At the RLC/MAC layer, the MS shall identify itself with a Local or Foreign TLLI if the MS is already GPRS-attached and is performing an IMSI attach. Otherwise, the MS shall identify itself with a Foreign TLLI, or a Random TLLI if a valid P-TMSI is not available. The Foreign or Random TLLI is used as an identifier during the attach procedure until a new P-TMSI is allocated.

After having executed the GPRS attach, the MS is in READY state and MM contexts are established in the MS and the SGSN. The MS may then activate PDP contexts as described in clause "Activation Procedures".

An IMSI-attached MS that can only operate in class-C mode of operation shall follow the normal IMSI detach procedure before it makes a GPRS attach. A GPRS-attached MS in class-C mode of operation shall always perform a GPRS detach before it makes an IMSI attach.

If the network operates in mode I (see clause "Paging Co-ordination in A/Gb mode"), then an MS that is both GPRS-attached and IMSI-attached shall perform the Combined RA / LA Update procedures.

If the network operates in mode II, then a GPRS-attached MS that has the capability to be simultaneously GPRS-attached and IMSI-attached shall perform the (non-combined) Routing Area Update procedures, and either:

- access the non-GPRS common control channels for CS operation (the way that CS operation is performed in parallel with GPRS operation is an MS implementation issue outside the scope of the present document); or
- if CS operation is not desired, depending on system information that defines whether or not explicit detach shall be used, either:
 - avoid all CS signalling (in which case the MS may be implicitly IMSI detached after a while); or
 - perform an explicit IMSI detach via the non-GPRS common control channels (if the MS was already IMSI-attached).

The Combined GPRS / IMSI Attach procedure is illustrated in Figure 22.

6.5.2 Iu mode GPRS Attach Procedure

A GPRS-attached MS makes an IMSI attach via the SGSN with the combined RA / LA update procedure if the network operates in mode I. If the network operates in mode II, or if the MS is not GPRS-attached, the MS makes a normal IMSI attach. An IMSI-attached MS engaged in a CS connection shall use the (non-combined) GPRS Attach procedure when it performs a GPRS attach.

The SGSN indicates "SMS-Supported" to the MS when the HSS has indicated "SMS in SGSN Support". It indicates to the MS that it can obtain SMS services via PS domain NAS from the SGSN. An MS that needs only PS services and SMS services via NAS should not perform any procedures via CS domain when it can obtain SMS services via PS domain NAS from SGSN.

After having executed the GPRS attach, the MS is in the PMM-CONNECTED state and MM contexts are established in the MS and the SGSN. The MS may then activate PDP contexts as described in clause "Activation Procedures".

An IMSI-attached MS that cannot operate in CS/PS mode of operation shall follow the normal IMSI detach procedure before it makes a GPRS attach. A GPRS-attached MS that cannot operate in CS/PS mode of operation shall perform a GPRS detach before it makes an IMSI attach.

In networks that support network sharing as defined in TS 23.251 [83], the SGSN may be informed by the RNS about the identity of the selected core network operator when receiving the Attach Request message. If available, this information is stored in the SGSN MM context.

During the GPRS Attach procedure, if the SGSN supports SRVCC and if any of the conditions described in step 7 in Figure 22 are satisfied, if the UE SRVCC capability has changed, it notifies the HSS with the UE SRVCC capability e.g. for further IMS registration.

For emergency attach handling, see clause 5.10.3.

For Emergency Attach only GPRS emergency attach is performed and no combined GPRS and IMSI attach is specified.

6.5.3 Combined GPRS / IMSI Attach procedure

The Combined GPRS / IMSI Attach procedure is illustrated in Figure 22.

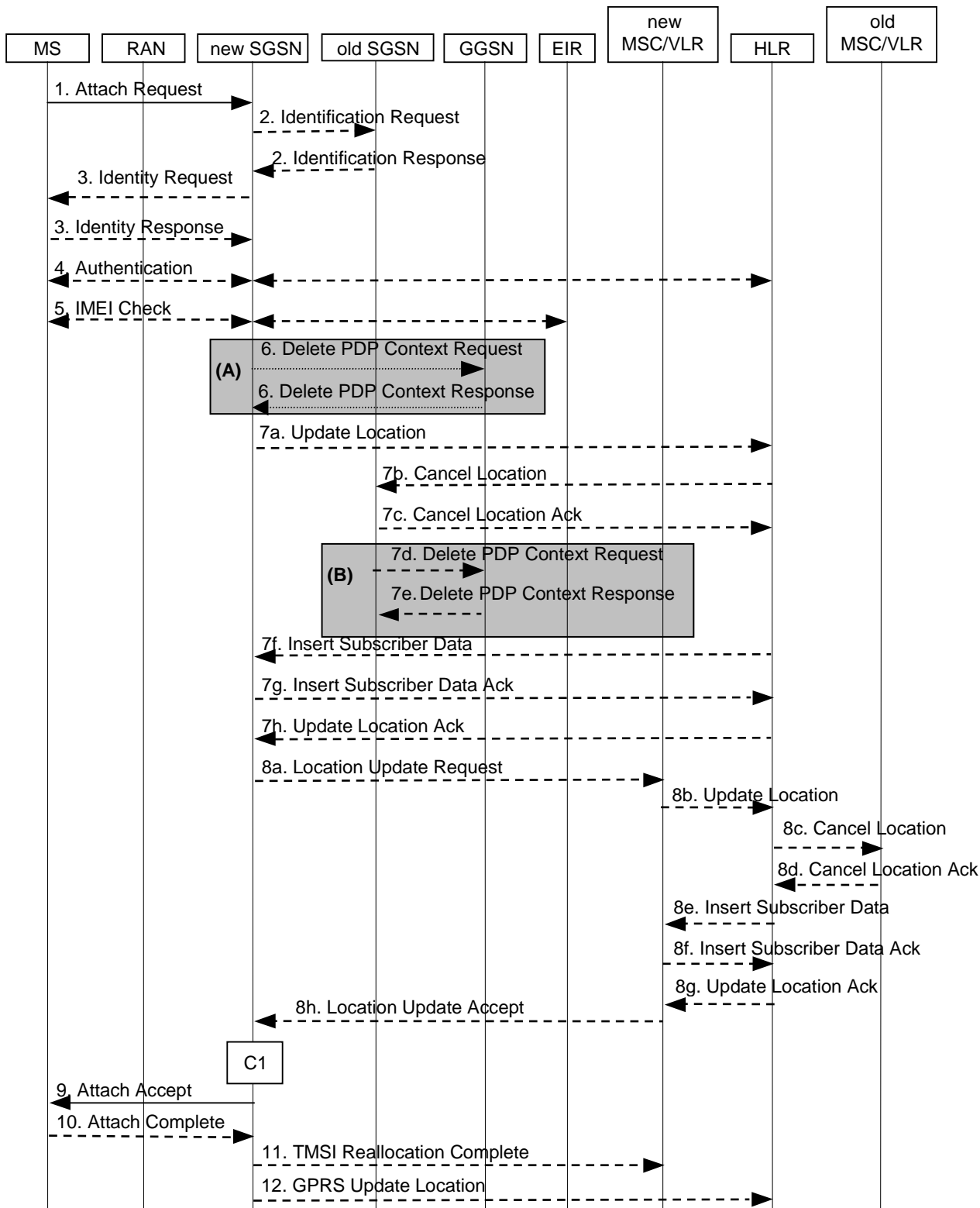

Figure 22: Combined GPRS / IMSI Attach Procedure

NOTE 1: All steps except steps 6 and 7d, 7e are common for architecture variants using Gn/Gp based interaction with GGSN and using S4-based interaction with S-GW and P-GW. For an S4-based interaction with S-GW and P-GW, procedure steps (A) are defined in clause 6.5.3A and procedure steps (B) are defined in clause 6.5.3B.

NOTE 2: For an Emergency Attach in which the MS was not successfully authenticated, steps 6, 7, 8 and 11 are not performed.

- 1) In A/Gb mode, the MS initiates the attach procedure by the transmission of an Attach Request (IMSI or P-TMSI and old RAI, MS Radio Access Capability, MS Network Capability, CKSN, Attach Type, DRX Parameters, old P-TMSI Signature, additional P-TMSI, Voice domain preference and UE's usage setting, SMS-only) message to the SGSN. IMSI shall be included if the MS does not have a valid P-TMSI available, or, if the MS is configured to perform Attach with IMSI at PLMN change and is accessing a new PLMN. If the MS has a valid P-TMSI or a valid GUTI, then P-TMSI and the old RAI associated with P-TMSI shall be included. MS Radio Access Capability contains the MS's GPRS multislots capabilities, frequency bands, etc. as defined in TS 24.008 [13]. Attach Type indicates which type of attach is to be performed, i.e. GPRS attach only, GPRS Attach while already IMSI attached, or combined GPRS / IMSI attach. If the MS uses P-TMSI for identifying itself and if it has also stored its old P-TMSI Signature, then the MS shall include the old P-TMSI Signature in the Attach Request message.

For Iu mode, the MS initiates the attach procedure by the transmission of an Attach Request (IMSI or P-TMSI and old RAI, Core Network Classmark, KSI, Attach Type, old P-TMSI Signature, Follow On Request, DRX Parameters, additional P-TMSI, SMS-only) message to the SGSN. IMSI shall be included if the MS does not have a valid P-TMSI available or a valid GUTI. If the MS uses P-TMSI for identifying itself and if it has also stored its old P-TMSI Signature, then the MS shall include the old P-TMSI Signature in the Attach Request message. If the MS has a valid P-TMSI, then P-TMSI and the old RAI associated with P-TMSI shall be included. KSI shall be included if the MS has valid security parameters. Core Network Classmark is described in clause "MS Network Capability". The MS shall set "Follow On Request" if there is pending uplink traffic (signalling or user data). The SGSN may use, as an implementation option, the follow on request indication to release or keep the Iu connection after the completion of the GPRS Attach procedure. Attach Type indicates which type of attach is to be performed, i.e. GPRS attach only, GPRS Attach while already IMSI attached, or combined GPRS / IMSI attach.

In both A/Gb and Iu mode, the DRX Parameters contain information about DRX cycle length for GERAN, UTRAN and possibly other RATs, e.g. E-UTRAN.

If the MS initiates the Attach procedure at a CSG cell or a hybrid cell, the RAN indicates the CSG ID of the cell with the Attach Request message sent to the new SGSN. If the MS attaches via a hybrid cell, the RAN indicates the CSG access mode to the new SGSN. If the CSG access mode is not indicated but the CSG ID is indicated, the SGSN shall consider the cell as a CSG cell.

The E-UTRAN capable MS stores the TIN in detached state. If the MS's TIN indicates "P-TMSI" or "RAT related TMSI" and the MS holds a valid P-TMSI then the "old P-TMSI" IE indicates this valid P-TMSI. If the MS's TIN indicates "GUTI" and the MS holds a valid GUTI then the "old P-TMSI" IE indicates a P-TMSI mapped from the GUTI. If the UE has a valid NAS token, the truncated NAS token shall be included in the "old P-TMSI signature" IE as described in TS 33.401 [91]. Otherwise, an empty NAS token shall be included in the "old P-TMSI Signature" IE.

Mapping a GUTI to P-TMSI/RAI is specified in TS 23.003 [4]. If the MS holds a valid P-TMSI then the MS indicates the P-TMSI as additional P-TMSI, regardless whether the "old P-TMSI" IE also indicates this P-TMSI or a P-TMSI mapped from a GUTI.

The UE sets the voice domain preference and UE's usage setting according to its configuration, as described in clause 5.3.15.

For an Emergency Attach the MS shall indicate emergency service and the IMSI shall be included if the MS does not have a valid P-TMSI or a valid GUTI available. The IMEI shall be included when the MS has no valid IMSI, no valid P-TMSI and no valid GUTI. The UE shall set the "Follow On Request" to indicate that there is pending uplink traffic and the UE shall initiate the activation of an emergency PDP context after successful Emergency Attach.

If the SGSN is not configured to support Emergency Attach the SGSN shall reject any Attach Request that indicates emergency service.

The MS indicates its "SMS-only" capability during a combined GPRS / IMSI attach when the MS is requesting IMSI attach only for obtaining SMS and not any other services from CS domain.

- 2) If the MS identifies itself with P-TMSI and the SGSN has changed since detach, the new SGSN sends an Identification Request (P-TMSI, old RAI, old P-TMSI Signature) to the old SGSN (this could be an old MME)

to request the IMSI. If the new SGSN provides functionality for Intra Domain Connection of RAN Nodes to Multiple CN Nodes, the new SGSN may derive the old SGSN from the old RAI and the old P-TMSI and send the Identification Request message to this old SGSN. Otherwise, the new SGSN derives the old SGSN from the old RAI. In any case the new SGSN will derive an SGSN that it believes is the old SGSN. This derived SGSN is itself the old SGSN, or it is associated with the same pool area as the actual old SGSN and it will determine the correct old SGSN from the P-TMSI and relay the message to that actual old SGSN. The old SGSN responds with Identification Response (IMSI, Authentication Triplets or Authentication Quintets). If the MS is not known in the old SGSN, the old SGSN responds with an appropriate error cause. The old SGSN also validates the old P-TMSI Signature and responds with an appropriate error cause if it does not match the value stored in the old SGSN. If the old SGSN is a MME and the truncated NAS token is included in the "old P-TMSI Signature" IE, this validation checks the NAS token as described in TS 33.401 [91].

For an Emergency Attach if the MS identifies itself with a temporary identity that is not known to the SGSN, the SGSN shall immediately request the IMSI from the MS. If the UE identifies itself with IMEI, the IMSI request shall be skipped.

- 3) If the MS is unknown in both the old and new SGSN, the SGSN sends an Identity Request (Identity Type = IMSI) to the MS. The MS responds with Identity Response (IMSI).
- 4) The authentication functions are defined in the clause "Security Function". If no MM context for the MS exists anywhere in the network, then authentication is mandatory. Ciphering procedures are described in clause "Security Function". If P-TMSI allocation is going to be done and the network supports ciphering, the network shall set the ciphering mode.

If the SGSN is configured to support Emergency Attach for unauthenticated IMSIs and the MS indicated emergency service, the SGSN skips the authentication and security setup or the SGSN accepts that the authentication may fail and continues the attach procedure. If the MS is emergency attached and not successfully authenticated, integrity protection and ciphering shall not be performed.

- 5) The equipment checking functions are defined in the clause "Identity Check Procedures". Equipment checking is optional.

For an Emergency Attach, the MS may have included the IMEI in the Attach Request message. If not, and the IMSI cannot be authenticated, the SGSN shall retrieve the IMEI from the MS.

For an Emergency Attach, the IMEI check to the EIR may be performed. If the IMEI is blocked, operator policies determine whether the Emergency Attach procedure continues or is stopped.

- 6) If there are active PDP contexts in the new SGSN for this particular MS (i.e. the MS re-attaches to the same SGSN without having properly detached before), the new SGSN deletes these PDP contexts by sending Delete PDP Context Request (TEID) messages to the GGSNs involved. The GGSNs acknowledge with Delete PDP Context Response (TEID) messages.
- 7) If the SGSN number has changed since the GPRS detach, or if it is the very first attach, or if the Automatic Device Detection (ADD) function is supported and the IMEISV has changed (see TS 22.101 [82] for ADD functional requirement), or if the MS provides an IMSI or the MS provides an old P-TMSI/RAI which doesn't point to a valid context in the SGSN, or for some network sharing scenario (e.g. GWCN) if the PLMN-ID of the RAI supplied by the RNC is different from that of the RAI in the UE's context, then the SGSN informs the HLR:
 - a) The SGSN sends an Update Location (SGSN Number, SGSN Address, IMSI, IMEISV, Update Type, Homogenous Support of IMS Voice over PS Sessions, UE SRVCC capability, equivalent PLMN list, Registration For SMS Request, SMS in SGSN offered) to the HLR. IMEISV is sent if the ADD function is supported. Update Type indicates an initial attach via initial attach indicator as this is an Attach procedure. The inclusion of the equivalent PLMN list indicates that the SGSN supports the inter-PLMN handover to a CSG cell in an equivalent PLMN using the subscription information of the target PLMN. If the S6d interface is used between S4-SGSN and HSS, a parameter "SMS in SGSN offered" is included in the Update Location message. When Gr is used, this parameter is included in the Insert Subscriber Data Ack (Step 7g). "SMS in SGSN offered" indicates that the SGSN supports SMS services via SGSN.

The "Homogenous Support of IMS Voice over PS Sessions" indication (see clause 5.3.8A) shall not be included unless the SGSN has completed its evaluation of the support of "IMS voice over PS Session" as specified in clause 5.3.8.

NOTE 3: At this step, the SGSN may not have all the information needed to determine the setting of the IMS voice over PS Session Supported indication for this MS (see clause 5.3.8). Hence the SGSN can send the "Homogenous Support of IMS Voice over PS Sessions" later on in this procedure.

If the SGSN determines that only the UE SRVCC capability has changed, the SGSN sends a GPRS Update Location to the HSS to inform about the changed UE SRVCC capability.

- b) The HLR sends Cancel Location (IMSI, Cancellation Type) to the old SGSN. Also, because the Update Type indicates an initial attach via initial attach indicator, if the HSS has the MME registration, the HSS sends Cancel Location (IMSI, Cancellation Type) to the old MME. The Cancellation Type indicates the old MME or SGSN to release the old Serving GW / PDN GW resource.
- c) The old SGSN acknowledges with Cancel Location Ack (IMSI). If there are any ongoing procedures for that MS, the old SGSN shall wait until these procedures are finished before removing the MM and PDP contexts.
- d) If there are active PDP contexts in the old SGSN for this particular MS, the old SGSN deletes these PDP contexts by sending Delete PDP Context Request (TEID) messages to the GGSNs involved.
- e) The GGSNs acknowledge with Delete PDP Context Response (TEID) messages.
- f) The HLR sends Insert Subscriber Data (IMSI, Subscription Data) to the new SGSN. If the S6d interface is used between an S4-SGSN and HSS the message "Insert Subscriber Data" is not used. Instead, the Subscription Data is sent by HSS in the message Update Location Ack. (Step 7h). The subscription data may contain the CSG subscription data for the PLMN.

If the MS initiates the Attach procedure at a CSG cell, the new SGSN shall check whether the CSG ID and associated PLMN is contained in the CSG subscription and is not expired. If the CSG ID and associated PLMN is not present or expired, the SGSN shall send an Attach Reject message to the MS with an appropriate cause value. The MS shall remove the CSG ID and associated PLMN from its Allowed CSG list, if present.

- g) The new SGSN validates the MS's presence in the (new) RA. If due to regional subscription restrictions or access restrictions (see clause 5.3.19) e.g. CSG restrictions, the MS is not allowed to attach in the RA, the SGSN rejects the Attach Request with an appropriate cause, and may return an Insert Subscriber Data Ack (IMSI, SGSN Area Restricted) message to the HLR. If subscription checking fails for other reasons, the SGSN rejects the Attach Request with an appropriate cause and returns an Insert Subscriber Data Ack (IMSI, Cause) message to the HLR. If the network supports the MOCN configuration for network sharing, the SGSN may, if the MS is not a 'Network Sharing Supporting MS', in this case decide to initiate redirection by sending a Reroute Command to the RNS, as described in TS 23.251 [83] instead of rejecting the Attach Request message. If all checks are successful then the SGSN constructs an MM context for the MS and returns an Insert Subscriber Data Ack (IMSI, SMS in SGSN offered) message to the HLR. The "SMS in SGSN offered" indicates that the SGSN supports SMS services via SGSN. If the S6d interface is used between S4-SGSN and HSS the message "Insert Subscriber Data Ack" is not used. Instead the subscription data check performed by S4-SGSN is done when the S4-SGSN has received the message "Update Location Ack" from HSS (Step 7h).
- h) The HLR acknowledges the Update Location message by sending an Update Location Ack to the SGSN after the cancelling of old MM context and insertion of new MM context are finished. If the S6d interface is used the Update Location Ack messages includes the subscription Data. If the Update Location is rejected by the HLR, the SGSN rejects the Attach Request from the MS with an appropriate cause. If the network supports the MOCN configuration for network sharing, the SGSN may, if the MS is not a 'Network Sharing Supporting MS', in this case decide to initiate redirection by sending a Reroute Command to the RNS, as described in TS 23.251 [83] instead of rejecting the Attach Request message.

If the HLR accepts to register the SGSN identity for terminating SMS services, the MS has indicated "SMS-only", then the HLR cancels the serving MSC if there is a serving MSC.

If the MS performs the attach procedure in a VPLMN supporting Autonomous CSG Roaming and the HPLMN has enabled Autonomous CSG Roaming in the VPLMN (via Service Level Agreement) and the SGSN needs to retrieve the CSG subscription information of the MS from the CSS, the SGSN initiates the Update CSG Location Procedure with CSS as described in clause 6.16.

For an Emergency Attach in which the MS was not successfully authenticated, the SGSN shall not send an Update Location Request to the HLR.

For an Emergency Attach, the SGSN shall ignore any unsuccessful Update Location Ack from HLR and continue with the Attach procedure.

- 8) If Attach Type in step 1 indicated GPRS Attach while already IMSI attached, or combined GPRS / IMSI attached, then the VLR shall be updated if the Gs interface is installed. This step is not performed if:
- Subscription Data indicate by the Network Access Mode information that the subscription has no CS subscriber data; or
 - Subscription Data have an HSS indication of "SMS in SGSN Support" and only SMS services are used in CS domain (the MS indicated "SMS-only" or the subscription is PS and SMS only) and the SGSN is configured to not establish Gs under that conditions.

When the SGSN does not provide functionality for the Intra Domain Connection of RAN Nodes to Multiple CN Nodes, the VLR number is derived from the RAI. When the SGSN provides functionality for Intra Domain Connection of RAN Nodes to Multiple CN Nodes, the SGSN uses the RAI and a hash value from the IMSI to determine the VLR number. The SGSN starts the location update procedure towards the new MSC/VLR upon receipt of the first Insert Subscriber Data message from the HLR in step 6d). This operation marks the MS as GPRS-attached in the VLR.

- a) The SGSN sends a Location Update Request (new LAI, IMSI, SGSN Number, Location Update Type) message to the VLR. Location Update Type shall indicate IMSI attach if Attach Type indicated combined GPRS / IMSI attach. Otherwise, Location Update Type shall indicate normal location update. The VLR creates an association with the SGSN by storing SGSN Number. In networks that support network sharing, the Location Update Request includes the identity of the selected core network operator if the SGSN has received this information from the RAN, as described in TS 23.251 [83].
- b) If the LA update is inter-MSC, the new VLR sends Update Location (IMSI, new VLR, equivalent PLMN list) to the HLR. The inclusion of the equivalent PLMN list indicates that the SGSN supports the inter-PLMN handover to a CSG cell in an equivalent PLMN using the subscription information of the target PLMN.
- c) If the LA update is inter-MSC, the HLR sends a Cancel Location (IMSI) to the old VLR.
- d) The old VLR acknowledges with Cancel Location Ack (IMSI).
- e) If the LA update is inter-MSC, the HLR sends Insert Subscriber Data (IMSI, subscriber data) to the new VLR. The subscriber data may contain the CSG subscription data for the PLMNs.
- f) The VLR acknowledges with Insert Subscriber Data Ack (IMSI).
- g) After finishing the inter-MSC location update procedures, the HLR responds with Update Location Ack (IMSI) to the new VLR.
- h) The VLR responds with Location Update Accept (VLR TMSI) to the SGSN.

If the MS performs the attach procedure in a VPLMN supporting Autonomous CSG Roaming and the HPLMN has enabled Autonomous CSG Roaming in the VPLMN (via Service Level Agreement) and the VLR needs to retrieve the CSG subscription information of the MS from the CSS, the VLR initiates the Update CSG Location Procedure with CSS as described in clause 6.16.

If the SGSN requires the RAN to check whether the UE capabilities are compatible with the network configuration to be able to set the IMS voice over PS Session Supported Indication (see clause 5.3.8) then the SGSN sends a UE Radio Capability Match Request to the RAN as defined in clause 6.9.5.

- 9) The SGSN selects Radio Priority SMS, and sends an Attach Accept (P-TMSI, VLR TMSI, P-TMSI Signature, Radio Priority SMS, IMS voice over PS Session Supported Indication, Emergency Service Support indicator, SMS-Supported, Cause) message to the MS. P-TMSI is included if the SGSN allocates a new P-TMSI. The IMS voice over PS Session Supported Indication is set as described in clause 5.3.8.

If new SGSN has not received, from Step 8, Voice Support Match Indicator for the UE from the RAN then, based on implementation, the SGSN may set IMS Voice over PS session supported Indication and update it at a later stage.

The Emergency Service Support indicator informs the MS that Emergency PDP contexts are supported, i.e. the MS is allowed to request activation of emergency PDP contexts when needed.

"SMS-Supported" is indicated to the MS when the HSS has indicated "SMS in SGSN Support". It indicates to the MS that it can obtain SMS services via PS domain NAS from the SGSN. An MS that needs only PS services and SMS services via NAS should not perform any procedures via CS domain when it can obtain SMS services via PS domain NAS from SGSN. If step 8 was not performed, e.g. due to Subscription Data indicate by the Network Access Mode information that the subscription has no CS subscriber data, then SGSN indicates that the Attach was successful for GPRS only and a Cause indicates why the IMSI attach was not performed.

When receiving the Attach Accept message the E-UTRAN capable UE shall set its TIN to "P-TMSI" as no ISR Activated is indicated at Attach.

If the attach is initiated by manual CSG selection via a CSG cell, the MS upon receiving the Attach Accept message at a CSG cell shall add the CSG ID and associated PLMN of the cell where the MS has sent the Attach Request message to its Allowed CSG list if it is not already present. Manual CSG selection is not supported when an emergency service has been initiated.

If the MS initiates the Attach procedure at a hybrid mode CSG cell, the SGSN shall check whether the CSG ID is contained in the CSG subscription and is not expired. The SGSN shall send an indication whether the UE is a CSG member to the RAN along with the RANAP message. Based on this information the RAN may perform differentiated treatment for CSG and non-CSG members.

NOTE 4: If the MS receives a Attach Accept message via a hybrid cell, the MS does not add the corresponding CSG ID and associated PLMN to its Allowed CSG list. Adding a CSG ID and associated PLMN to the MS's Allowed CSG list for a hybrid cell is performed only by OTA or OMA DM procedures.

- 10) If P-TMSI or VLR TMSI was changed, the MS acknowledges the received TMSI(s) by returning an Attach Complete message to the SGSN.
- 11) If VLR TMSI was changed, the SGSN confirms the VLR TMSI re-allocation by sending a TMSI Reallocation Complete message to the VLR.
- 12) After step 7a, and in parallel to any of the preceding steps, the SGSN shall send either a GPRS Update Location (Homogeneous Support of IMS Voice over PS Sessions) to the HLR or, when the S6d interface is used, a Notify Request (Homogeneous Support of IMS Voice over PS Sessions) message to the HSS:
 - if the SGSN has evaluated the support of IMS Voice over PS Sessions, see clause 5.3.8; and
 - if the SGSN determines that it needs to update the Homogeneous Support of IMS Voice over PS Sessions, see clause 5.3.8A.

For an Emergency Attach the SGSN shall not check for access restrictions, regional restrictions, subscription restrictions (e.g. CSG restrictions) or perform CSG access control.

If the Attach Request cannot be accepted, the SGSN returns an Attach Reject (IMSI or IMEI, Cause) message to the MS. IMEI shall be sent if it is an Emergency Attach and no valid IMSI exists. If the network supports the MOCN configuration for network sharing, the SGSN may, if the MS is not a 'Network Sharing Supporting MS', in this case decide to initiate redirection by sending a Reroute Command to the RNS, as described in TS 23.251 [83] instead of returning an Attach Reject (IMSI, Cause) message to the MS.

The CAMEL procedure call shall be performed, see referenced procedure in TS 23.078 [8b]:

- C1) CAMEL_GPRS_Attach and CAMEL_PS_Notification.

They are called in the following order:

- The procedure CAMEL_GPRS_Attach is called. In Figure 22, the procedure returns as result "Continue".
- Then the procedure CAMEL_PS_Notification is called. The procedure returns as result "Continue".

6.5.3A Combined GPRS / IMSI Attach procedure, Delete Bearer by the new SGSN, using S4

The procedure described in figures 22A shows only the steps, due to use of S4, that are different from the Gn/Gp variant of the procedure given in clause 6.5.3.

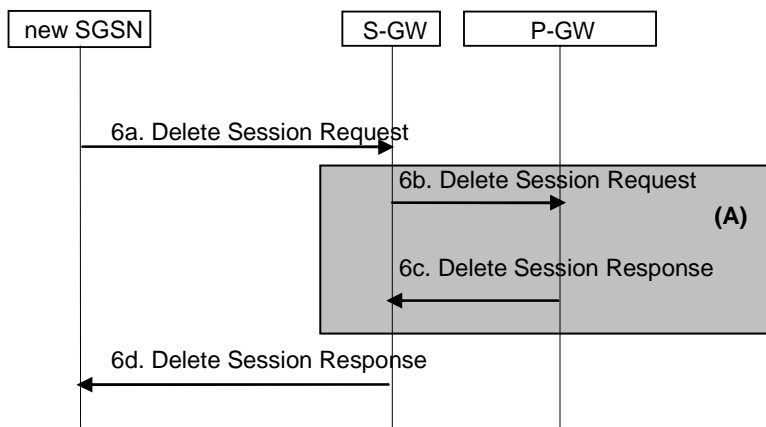

Figure 22A: Combined GPRS / IMSI Attach Procedure

NOTE: Steps 6a and 6d are common for architecture variants with GTP based S5/S8 and PMIP-based S5/S8. For a PMIP-based S5/S8, procedure step (A) is defined in TS 23.402 [90]. Steps 6b and 6c concern GTP based S5/S8

- 6) If there are active PDP contexts in the new SGSN for this particular MS (i.e. the MS re-attaches to the same SGSN without having properly detached before), the new SGSN deletes these PDP contexts by sending Delete Session Request (Cause, Operation Indication) messages to the GWs involved. If ISR is activated the Cause indicates that the old S-GW shall delete the bearer resources on the other old CN node by sending Delete Session Request message to the other CN node. The Operation Indication flag is set by the new SGSN. This indicates to the S-GW that the S-GW shall initiate a delete procedure towards the PDN GW. The GWs acknowledges with Delete Session Response messages. If a PCRF is deployed, the PDN GW employs an IP-CAN Session Termination procedure interacts with the PCRF to indicate that resources have been released.

6.5.3B Combined GPRS / IMSI Attach procedure, Delete Bearer by the old SGSN, using S4

The procedure described in figure 22B shows only the steps, due to use of S4, that are different from the Gn/Gp variant of the procedure given by clause 6.5.3.

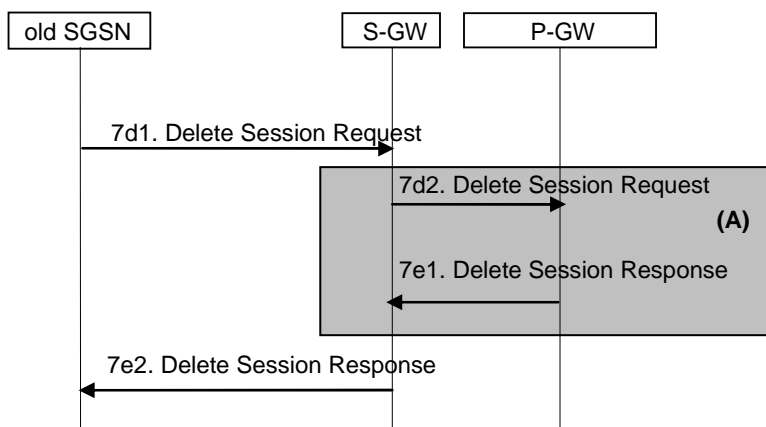

Figure 22B: Combined GPRS / IMSI Attach Procedure

NOTE: Steps 7d1 and 7e2 are common for architecture variants with GTP based S5/S8 and PMIP-based S5/S8. For a PMIP-based S5/S8, procedure step (A) is defined in TS 23.402 [90]. Steps 7d2 and 7e1 concern GTP based S5/S8.

- 7)
 - d) If there are active PDP contexts in the old SGSN for this particular MS, the old SGSN deletes these PDP contexts by sending Delete Session Request (Cause, Operation Indication) messages to the GWs involved. If ISR is activated the Cause indicates that the old S-GW shall delete the bearer resources on the other old CN

node by sending Delete Bearer Request message to the other CN node. The Operation Indication flag is set by the old SGSN. This indicates to the S-GW that the S-GW shall initiate a delete procedure towards the PDN GW. The GWs return Delete Session Response message to the old SGSN. If a PCRF is deployed, the PDN GW employs an IP-CAN Session Termination procedure.

- e) The GWs acknowledge with Delete Session Response messages.

6.6 Detach Function

The GPRS Detach procedure allows:

- an MS to inform the network that it does not want to access the SGSN-based services any longer; and
- the network to inform an MS that it does not have access to the SGSN-based services any more.

The Detach function allows an MS to inform the network that it wants to make a GPRS and/or IMSI detach, and it allows the network to inform an MS that it has been GPRS-detached or IMSI-detached by the network.

The different types of detach are:

- IMSI detach;
- GPRS detach; and
- combined GPRS / IMSI detach (MS-initiated only).

The MS is detached either explicitly or implicitly:

- Explicit detach: The network or the MS explicitly requests detach.
- Implicit detach: The network detaches the MS, without notifying the MS, a configuration-dependent time after the mobile reachable timer expired, or after an irrecoverable radio error causes disconnection of the logical link.

In the explicit detach case, a Detach Request (Cause) is sent by the SGSN to the MS, or by the MS to the SGSN.

The MS can make an IMSI detach in one of two ways depending on whether it is GPRS-attached or not:

- A GPRS-attached MS sends a Detach Request message to the SGSN, indicating an IMSI detach. This can be made in combination with GPRS detach.
- An MS that is not GPRS-attached makes the IMSI detach as already defined in A/Gb mode or Iu mode.

In the Mobile-originated Detach Request message there is an indication to tell if the detach is due to switch off or not. The indication is needed to know whether a Detach Accept message should be returned or not.

In the network-originated Detach Request message there may be an indication to tell the MS that it is requested to initiate GPRS Attach and PDP Context Activation procedures for the previously activated PDP contexts.

6.6.1 MS-Initiated Detach Procedure

The MS-Initiated Detach procedure when initiated by the MS is illustrated in Figure 23.

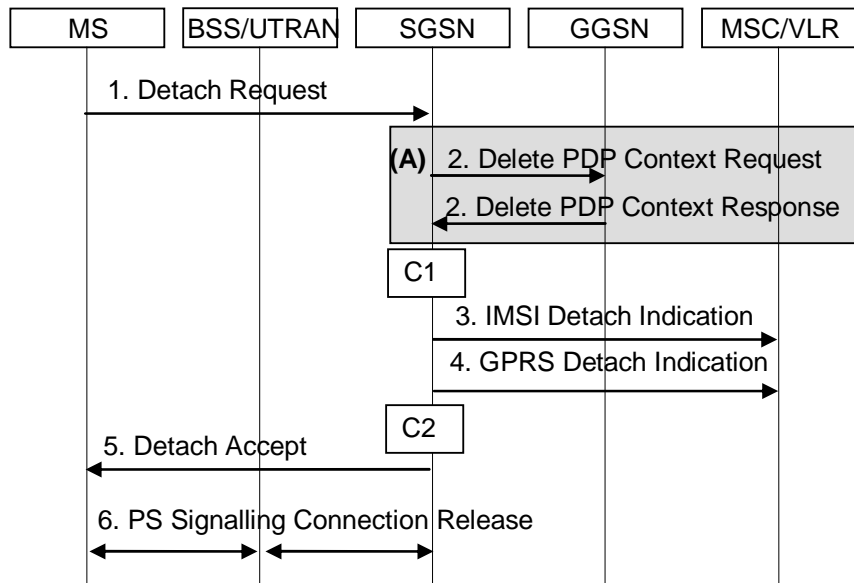

Figure 23: MS-Initiated Combined GPRS / IMSI Detach Procedure

NOTE: All steps except step 2 are common for architecture variants using Gn/Gp based interaction with GGSN and using S4 based interaction with S-GW and P-GW. For an S4 based interaction with S-GW and P-GW, procedure steps (A) are defined in clause 6.6.3.

- 1) The MS detaches by sending Detach Request (Detach Type, P-TMSI, P-TMSI Signature, Switch Off) to the SGSN. Detach Type indicates which type of detach is to be performed, i.e., GPRS Detach only, IMSI Detach only or combined GPRS and IMSI Detach. Switch Off indicates whether detach is due to a switch off situation or not. The Detach Request message includes P-TMSI and P-TMSI Signature. P-TMSI Signature is used to check the validity of the Detach Request message. If P-TMSI Signature is not valid or is not included, the authentication procedure should be performed.

If the SGSN receives a Detach Request via a CSG cell with Switch Off parameter indicating that detach is not due to a switch off situation, and the CSG subscription for this CSG ID and associated PLMN is absent or expired, the SGSN shall trigger a SGSN-initiated Detach procedure as specified in clause 6.6.2.1.

- 2) If GPRS detach, the active PDP contexts in the GGSNs regarding this particular MS are deactivated by the SGSN sending Delete PDP Context Request (TEID, CGI/SAI) to the GGSNs. The GGSNs acknowledge with Delete PDP Context Response (TEID). The GGSN may interact with PCRF (refer to TS 23.203 [88]), e.g. to deliver User Location Information and/or UE Time Zone if it was requested by the PCRF.
- 3) If IMSI detach, the SGSN sends an IMSI Detach Indication (IMSI) message to the VLR.
- 4) If the MS wants to remain IMSI-attached and is doing a GPRS detach, the SGSN sends a GPRS Detach Indication (IMSI) message to the VLR. The VLR removes the association with the SGSN and handles paging and location update without going via the SGSN.
- 5) If Switch Off indicates that detach is not due to a switch off situation, the SGSN sends a Detach Accept to the MS.
- 6) If the MS was GPRS detached, then the 3G-SGSN releases the PS signalling connection.

The CAMEL procedure calls shall be performed; see referenced procedures in TS 23.078 [8b]:

- C1) CAMEL_GPRS_PDP_Context_Disconnection.

This procedure is called several times: once per PDP context. The procedure returns as result "Continue".

- C2) CAMEL_GPRS_Detach and CAMEL_PS_Notification.

They are called in the following order:

- The procedure CAMEL_GPRS_Detach is called. The procedure returns as result "Continue".
- Then the procedure CAMEL_PS_Notification is called. The procedure returns as result "Continue".

6.6.2 Network-Initiated Detach Procedure

6.6.2.1 SGSN-Initiated Detach Procedure

The SGSN-Initiated Detach procedure when initiated by the SGSN is illustrated in Figure 24.

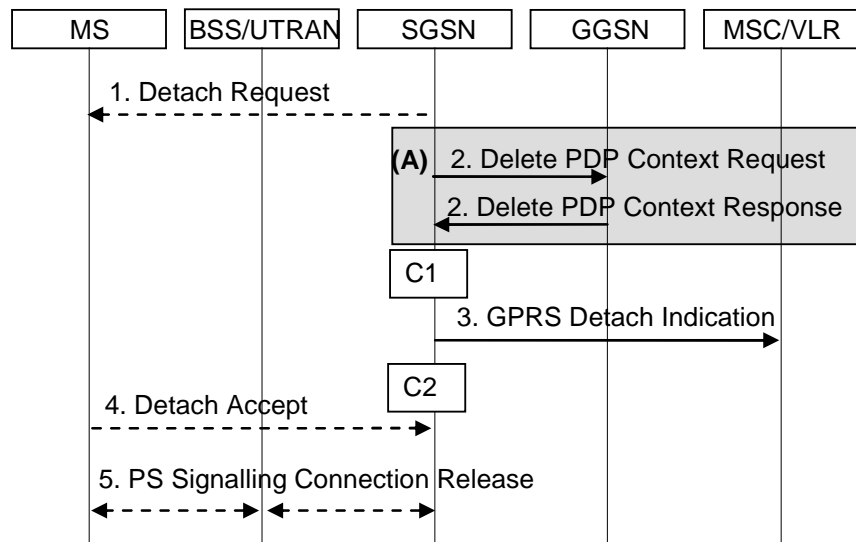

Figure 24: SGSN-Initiated GPRS Detach Procedure

NOTE: All steps except step 2 are common for architecture variants using Gn/Gp based interaction with GGSN and using S4 based interaction with S-GW and P-GW. For an S4 based interaction with S-GW and P-GW, procedure steps (A) are defined in clause 6.6.3.

- 1) The SGSN informs the MS that it has been detached, by sending Detach Request (Detach Type) to the MS. Detach Type indicates if the MS is requested to make a new attach and PDP context activation for the previously activated PDP contexts. If so, the attach procedure shall be initiated when the detach procedure is completed.

If this Detach procedure is due to the MS's Detach Request via a CSG cell which the MS is not allowed to access, i.e. the CSG subscription for this CSG ID and associated PLMN is absent or expired, the SGSN shall send a Detach Request to MS with an appropriate cause indicating the MS is not allowed to access this CSG.

- 2) The active PDP contexts in the GGSNs regarding this particular MS are deactivated by the SGSN sending Delete PDP Context Request (TEID, CGI/SAI) messages to the GGSNs. The GGSNs acknowledge with Delete PDP Context Response (TEID) messages. The GGSN may interact with PCRF (refer to TS 23.203 [88]), e.g. to deliver User Location Information and/or UE Time Zone if it was requested by the PCRF.
- 3) If the MS was both IMSI- and GPRS-attached, the SGSN sends a GPRS Detach Indication (IMSI) message to the VLR. The VLR removes the association with the SGSN and handles paging and location update without going via the SGSN.
- 4) The MS sends a Detach Accept message to the SGSN any time after step 1. If the MS receives Detach Request from the SGSN via a CSG cell with the cause indicating the MS is not allowed to access this CSG, the MS shall remove this CSG ID and associated PLMN from its Allowed CSG list, if present.
- 5) After receiving the Detach Accept message, if Detach Type did not request the MS to make a new attach, then the 3G SGSN releases the PS signalling connection.

The CAMEL procedure calls shall be performed, see referenced procedure in TS 23.078 [8b]:

C1) CAMEL_GPRS_PDP_Context_Disconnection.

This procedure is called several times: once per PDP context. The procedure returns as result "Continue".

C2) CAMEL_GPRS_Detach and CAMEL_PS_Notification.

They are called in the following order:

- The procedure CAMEL_GPRS_Detach is called. The procedure returns as result "Continue".
- Then the procedure CAMEL_PS_Notification is called. The procedure returns as result "Continue".

6.6.2.2 HLR-Initiated Detach Procedure

The HLR-Initiated Detach procedure is initiated by the HLR. The HLR uses this procedure for operator-determined purposes to request the removal of a subscriber's MM and PDP contexts at the SGSN. The HLR-Initiated Detach Procedure is illustrated in Figure 25.

For MS with emergency PDP Context, the SGSN shall not send detach message to MS. Instead the SGSN shall deactivate all the non emergency PDP Contexts.

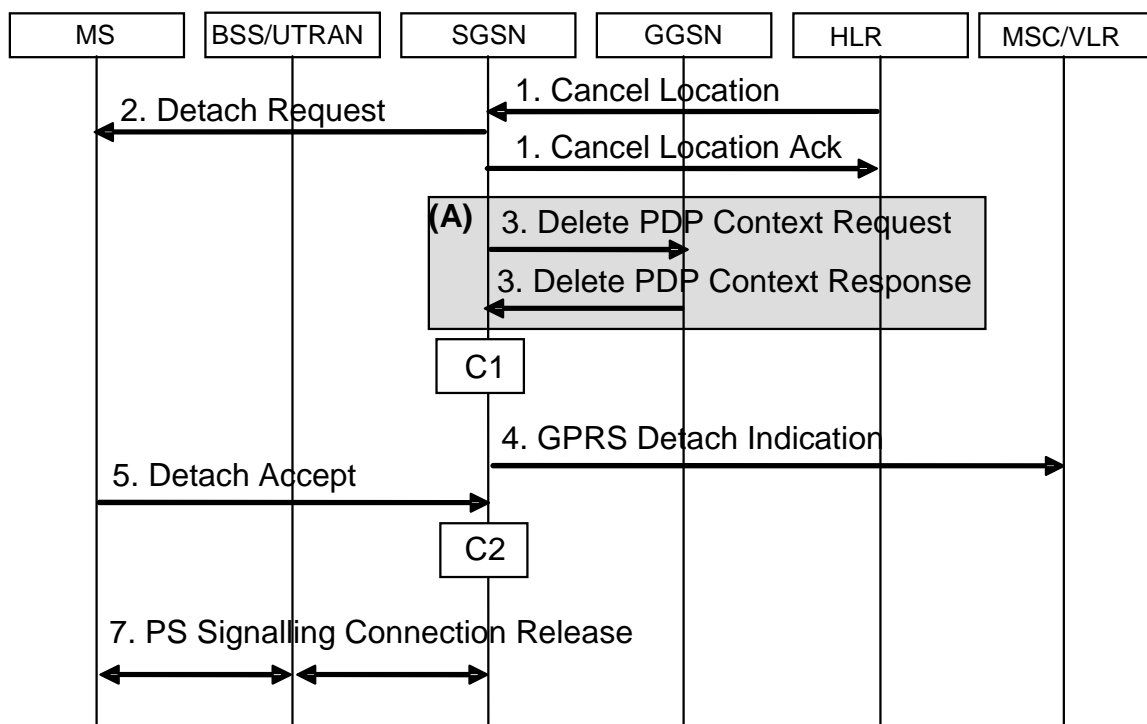

Figure 25: HLR-Initiated GPRS Detach Procedure

NOTE: All steps except step 2 are common for architecture variants using Gn/Gp based interaction with GGSN and using S4 based interaction with S-GW and P-GW. For an S4 based interaction with S-GW and P-GW, procedure steps (A) are defined in clause 6.6.3.

- 1) If the HLR wants to request the immediate deletion of a subscriber's MM and PDP contexts from the SGSN, the HLR shall send a Cancel Location (IMSI, Cancellation Type) message to the SGSN with Cancellation Type set to Subscription Withdrawn. When receiving the Cancel Location Message the SGSN acknowledges with a Cancel Location Ack (IMSI) message to the HLR.
- 2) The SGSN informs the MS that it has been detached by sending Detach Request (Detach Type) to the MS. Detach Type shall indicate that the MS is not requested to make a new attach and PDP context activation.

- 3) The active PDP contexts in the GGSNs regarding this particular MS are deactivated by the SGSN sending Delete PDP Context Request (TEID, CGI/SAI) messages to the GGSNs. The GGSNs acknowledge with Delete PDP Context Response (TEID) messages. The GGSN may interact with PCRF (refer to TS 23.203 [88]), e.g. to deliver User Location Information and/or UE Time Zone if it was requested by the PCRF.
- 4) If the MS was both IMSI- and GPRS-attached, the SGSN sends a GPRS Detach Indication (IMSI) message to the VLR. The VLR removes the association with the SGSN and handles paging and location update without going via the SGSN.
- 5) The MS sends a Detach Accept message to the SGSN any time after step 2.
- 6) Void.
- 7) After receiving the Detach Accept message, if Detach Type did not request the MS to make a new attach, then the 3G-SGSN releases the PS signalling connection.

The CAMEL procedure calls shall be performed, see referenced procedures in TS 23.078 [8b]:

C1) CAMEL_GPRS_PDP_Context_Disconnection.

This procedure is called several times: once per PDP context. The procedure returns as result "Continue".

C2) CAMEL_GPRS_Detach and CAMEL_PS_Notification.

They are called in the following order:

- The procedure CAMEL_GPRS_Detach is called. The procedure returns as result "Continue".
- Then the procedure CAMEL_PS_Notification is called. The procedure returns as result "Continue".

6.6.3 SGSN interaction during Detach Procedure when using S4

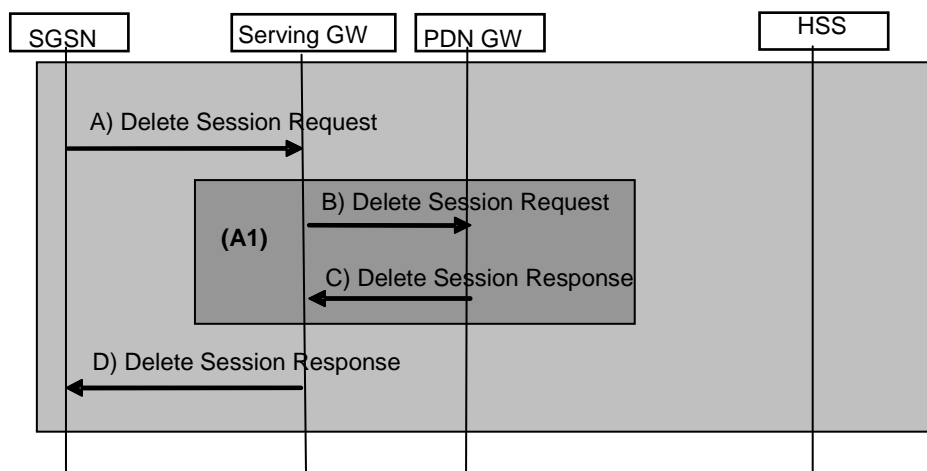

Figure 25A: SGSN interaction when using S4

NOTE 1: Steps A and D are common for architecture variants with GTP based S5/S8 and PMIP-based S5/S8. For a PMIP-based S5/S8, procedure step (A1) is defined in TS 23.402 [90]. Steps B and C concern GTP based S5/S8.

- A) For each PDN connection, the EPS Bearer(s) in the Serving GW regarding this particular MS are deactivated by the SGSN by sending Delete Session Request to the Serving GW. This message indicates that all bearers belonging to that PDN connection shall be released. User Location Information is also reported in this message.
- B) The Serving GW sends Delete Session Request to the PDN GW, including User Location Information. The PDN GW may interact with PCRF (refer to TS 23.203 [88]), e.g. to deliver User Location Information and/or UE Time Zone if it was requested by the PCRF.
- C) The PDN GW acknowledges the bearer deactivation to the S-GW by sending a Delete Session Response.

D) The SGW acknowledges with Delete Session Response.

Further messages due to ISR and messages between S-GW and P-GW are described in clause 5.3.8 "Detach procedure" of TS 23.401 [89].

6.7 Purge Function

The Purge function allows an SGSN to inform the HLR that it has deleted the MM and PDP contexts of a detached MS. The SGSN may, as an implementation option, delete the MM and PDP contexts of an MS immediately after the implicit or explicit detach of the MS. Alternatively, the SGSN may keep for some time the MM and PDP contexts and the authentication triplets of the detached MS, so that the contexts can be reused at a later GPRS attach without accessing the HLR.

When the SGSN deletes the MM and PDP contexts, it shall initiate the Purge procedure as illustrated in Figure 26.

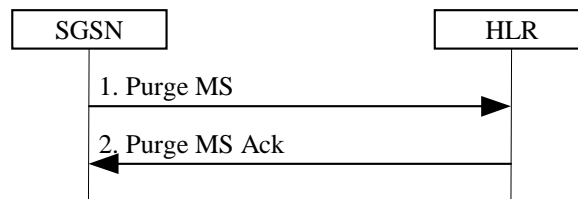

Figure 26: Purge Procedure

- 1) After deleting the MM and PDP contexts of a detached MS, the SGSN sends a Purge MS (IMSI) message to the HLR.
- 2) The HLR sets the MS Purged for GPRS flag and acknowledges with a Purge MS Ack message.

6.8 Security Function

6.8.0 General

The GERAN/UTRAN Security function:

- Guards against unauthorised packet-domain service usage (authentication of the MS by the network and service request validation).
- Provides user identity confidentiality (temporary identification and ciphering).
- Provides user data and signalling confidentiality (ciphering).
- Provides, for Iu mode only, data integrity and origin authentication of signalling data (integrity protection).
- Provides, by UMTS authentication (USIM) only, authentication of the network by the MS.

GERAN/UTRAN security-related network functions are described in TS 43.020 [6] and in TS 33.102 [61].

NOTE: The security functions related to mobility between GERAN/UTRAN access and E-UTRAN access are described in TS 33.401 [91] and TS 23.401 [89].

6.8.1 Authentication

The Authentication function includes two types of authentication: "UMTS authentication" and "GSM authentication". These procedures are independent of the RAN modes, i.e. each procedure may be executed in A/Gb mode or in Iu mode. UMTS authentication requires a USIM for the MS and Authentication Quintets in the SGSN. GSM authentication bases on a SIM for the MS and Authentication Triplets in the SGSN or it bases on a GSM capable USIM for the MS and parameters derived from Authentication Quintets in the SGSN.

"UMTS authentication" implies mutual authentication, i.e. authentication of the MS by the network and authentication of the network by the MS. It also implies establishment of a new UMTS ciphering key (CK) and integrity key (IK) agreement between the SGSN and the MS.

"GSM authentication" implies authentication of the MS by the network and establishment of a new GSM ciphering key (Kc) agreement between the SGSN and the MS.

6.8.1.1 GSM Authentication procedure

The GSM Authentication procedure performs subscriber authentication, or selection of the ciphering algorithm, or both. In A/Gb mode it performs in addition the synchronisation of the start of ciphering. Authentication triplets are stored in the SGSN. The MSC/VLR shall not authenticate the MS via the SGSN upon IMSI attach, nor location update, but may authenticate the MS during CS connection establishment. Security-related network functions are described in TS 43.020 [6].

The GSM Authentication procedure is illustrated in Figure 27.

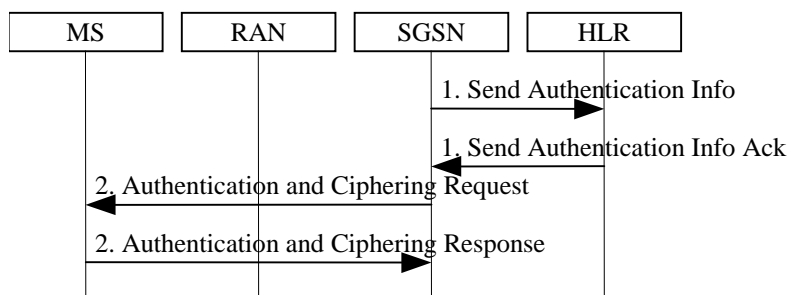

Figure 27: GSM Authentication Procedure

- 1) If the SGSN does not have a previously stored authentication vector, a Send Authentication Info (IMSI) message is sent to the HLR. The HLR responds with a Send Authentication Info Ack (Authentication Triplets or quintets) message.
- 2) The SGSN sends an Authentication and Ciphering Request (RAND, CKSN, Ciphering Algorithm) message to the MS. The MS responds with an Authentication and Ciphering Response (SRES) message.

In A/Gb mode, the MS starts ciphering after sending the Authentication and Ciphering Response message as described in clause "Start of Ciphering".

Change of the ciphering algorithm during PS Handover procedure is described in TS 43.129 [87].

In Iu mode, the SGSN and the MS shall generate the UMTS CK and IK from the GSM Kc using the standardised conversion functions specified for this purpose in TS 33.102 [61].

In Iu mode, the start of ciphering is controlled by the security mode procedure described in TS 33.102 [61].

If the SGSN cannot determine the HLR address to establish the Send Authentication Info dialogue, the GSM Authentication of Procedure fails.

6.8.1.2 UMTS Authentication procedure

The UMTS authentication procedure is described in TS 33.102 [61]. The UMTS authentication procedure executed from the SGSN performs both the mutual authentication and security keys agreement. Authentication quintets are stored in the SGSN. The MSC/VLR shall not authenticate the MS via the SGSN upon IMSI attach nor upon location update, but may authenticate the MS during CS connection establishment.

The UMTS Authentication procedure is illustrated in Figure 28.

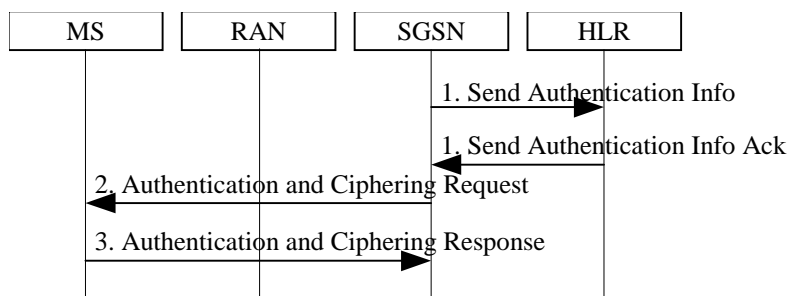

Figure 28: UMTS Authentication

- 1) If the SGSN does not have previously stored UMTS Authentication Vectors (quintets), a Send Authentication Info (IMSI) message is sent to the HLR. Upon receipt of this message, the HLR responds with a Send Authentication Info Ack message including an ordered array of quintets to the SGSN. Each quintet contains RAND, XRES, AUTN, CK, and IK. The generation of quintets in HLR is performed as specified in TS 33.102 [61].
- 2) At authentication, the SGSN selects the next in-order quintet and transmits the RAND and AUTN, that belong to this quintet, to the MS in the Authentication and Ciphering Request (RAND, AUTN, KSI) message. The SGSN also selects a Key Set Identifier, KSI, and includes this in the message.
- 3) At reception of this message, the USIM in the MS verifies AUTN and, if accepted, the USIM computes the signature of RAND, RES, in accordance with TS 33.102 [61]. If the USIM considers the authentication as being successful, the MS returns an Authentication and Ciphering Response (RES) message to the SGSN. During generation of authentication vectors, the USIM in the MS also computes a new Ciphering Key, CK, and a new Integrity Key, IK. These keys are stored together with the KSI until KSI is updated at the next authentication.

If the USIM considers the authentication being unsuccessful, e.g., in case of an authentication synchronisation failure, the MS returns the Authentication and Ciphering Failure message to the SGSN. The actions then taken are described in TS 33.102 [61].

In A/Gb mode, the SGSN and the MS shall generate the Kc from the UMTS CK and IK using the standardised conversion function specified for this purpose in TS 33.102 [61].

In A/Gb mode, the MS starts ciphering after sending the Authentication and Ciphering Response message as described in clause "Start of Ciphering".

In Iu mode, the start of ciphering is controlled by the security mode procedure described in TS 33.102 [61].

If the SGSN cannot determine the HLR address to establish the Send Authentication Info dialogue, the UMTS Authentication Procedure fails.

6.8.2 User Identity Confidentiality

6.8.2.1 User Identity Confidentiality (A/Gb mode)

A Temporary Logical Link Identity (TLLI) identifies a user in A/Gb mode. The relationship between TLLI and IMSI is known only in the MS and in the SGSN. TLLI is derived from the P-TMSI allocated by the SGSN or built by the MS as described in clause "NSAPI and TLLI for A/Gb mode".

NOTE: Following inter-RAT mobility from E-UTRAN, the MS will use values for the TLLI and P-TMSI as instructed by the old MME.

6.8.2.2 User Identity Confidentiality (Iu mode)

A Radio Network Temporary Identity (RNTI) identifies a user between the MS and an Iu mode RAN. The relationship between RNTI and IMSI is known only in the MS and in the RAN. A P-TMSI identifies a user between the MS and the SGSN. The relationship between P-TMSI and IMSI is known only in the MS and in the SGSN.

NOTE: Following inter-RAT mobility from E-UTRAN, the MS will use a value for the P-TMSI as instructed by the old MME.

6.8.2.3 P-TMSI Signature

P-TMSI Signature is optionally sent by the SGSN to the MS in Attach Accept and Routing Area Update Accept messages. If the P-TMSI Signature has been sent by the SGSN to the MS since the current P-TMSI was allocated, then the MS shall include the P-TMSI Signature in the next Routing Area Update Request, Detach Request, and Attach Request for identification checking purposes. If the P-TMSI Signature was sent, then the SGSN shall compare the P-TMSI Signature sent by the MS with the signature stored in the SGSN. If the values do not match, the SGSN should use the security functions to authenticate the MS. If the values match or if the P-TMSI Signature is missing, the SGSN may use the security functions to authenticate the MS. The P-TMSI Signature parameter has only local significance in the SGSN that allocated the signature.

NOTE: Following inter-RAT mobility from E-UTRAN, the P-TMSI signature is also used for a different function and may carry other information from the MS to the old MME (see TS 23.401 [89]) without modification by the new SGSN.

If the network supports ciphering, the SGSN shall send the P-TMSI Signature ciphered to the MS. Routing Area Update Request and Attach Request, into which the MS includes the P-TMSI Signature, are not ciphered.

6.8.2.4 P-TMSI Reallocation Procedure

The SGSN may attempt to reallocate the P-TMSI at any time that the MS is in GERAN/UTRAN PS coverage. The reallocation procedure can be performed by the P-TMSI Reallocation procedure, or it can be included in the Attach or Routing Area Update procedures. The P-TMSI reallocation during PS Handover procedure is described in TS 43.129 [87].

The P-TMSI Reallocation procedure is illustrated in Figure 29.

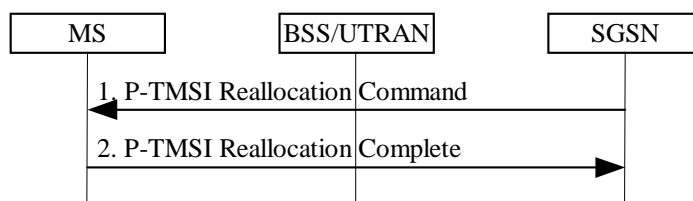

Figure 29: P-TMSI Reallocation Procedure

- 1) The SGSN sends a P-TMSI Reallocation Command (new P-TMSI, P-TMSI Signature, RAI) message to the MS. P-TMSI Signature is an optional parameter that the MS, if received, shall return to the SGSN in the next Attach and Routing Area Update procedures.
- 2) The MS returns a P-TMSI Reallocation Complete message to the SGSN.

6.8.3 User Data and GMM/SM Signalling Confidentiality

6.8.3.1 Scope of Ciphering

In A/Gb mode, the scope of ciphering is from the ciphering function in the SGSN to the ciphering function in the MS. Ciphering is done in the LLC layer, and from the perspective of the A/Gb mode MS-BTS radio path, an LLC PDU is transmitted as plain text.

In Iu mode, the scope of ciphering is from the ciphering function in the RAN to the ciphering function in the MS.

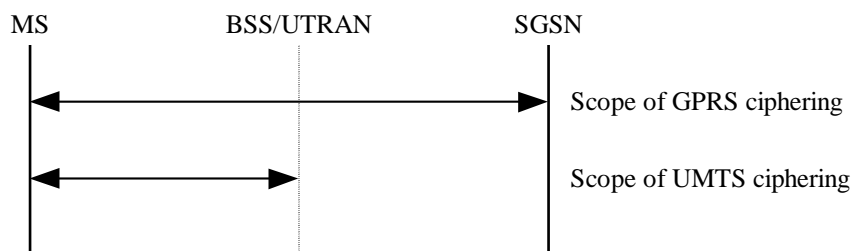

Figure 30: Scope of Ciphering

6.8.3.2 Ciphering Algorithm

TS 41.061 [2] contains the requirements for the GPRS Encryption Algorithm (GEA) for A/Gb mode. The A/Gb mode ciphering key K_c is an input to the algorithm. The standard key management procedures for the K_c shall be used.

In Iu mode ciphering is performed with the UMTS Encryption Algorithm (UEA). The Iu mode Ciphering Key CK is an input to the algorithm.

6.8.3.3 Start of Ciphering

In A/Gb mode, the MS starts ciphering after sending the Authentication and Ciphering Response message. The SGSN starts ciphering when a valid Authentication and Ciphering Response message is received from the MS. In the routing area update case, if ciphering was used before the routing area update, and if the authentication procedure is omitted, then the SGSN shall resume ciphering with the same algorithm when a ciphered Routing Area Update Accept message is sent, and the MS shall resume ciphering when a ciphered Routing Area Update Accept message is received.

In Iu mode, the start of ciphering is controlled by the security mode procedure described in TS 33.102 [61].

6.8.4 Identity Check Procedures

The Identity Check procedure is illustrated in Figure 31.

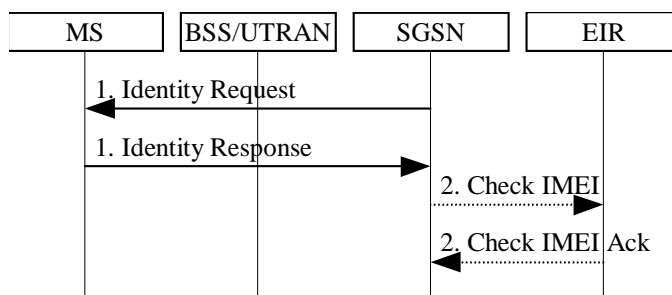

Figure 31: Identity Check Procedure

- 1) The SGSN sends Identity Request (Identity Type) to the MS. The MS responds with Identity Response (Mobile Identity).
- 2) If the SGSN decides to check the IMEI against the EIR, it sends Check IMEI (IMEI) to EIR. The EIR responds with Check IMEI Ack (IMEI).

6.8.5 Data Integrity Procedure (Iu mode)

The Data Integrity procedure is performed between the MS and the RAN. It is applicable only to radio signalling. The Iu mode integrity check is made with the UMTS Integrity Algorithm (UIA). The UMTS Integrity Key IK is an input to the algorithm. The start of the data integrity procedure is controlled by the security mode procedure as described in TS 33.102 [61].

6.9 Location Management Function

6.9.0 General

The Location Management function provides:

- mechanisms for cell and PLMN selection;
- a mechanism for the network to know the Routeing Area for MSs in STANDBY, PMM-IDLE, READY, and PMM-CONNECTED states;
- a mechanism for the 2G-SGSN to know the cell identity for MSs in READY state;
- a mechanism for the Iu mode RAN to know the RAN registration area identity or cell identity for MSs in PMM-CONNECTED state;
- a mechanism for the Iu mode RAN to indicate to an MS in RRC Connected mode when a Routeing Area Update procedure shall be performed by providing the RAI; and
- a mechanism for the network in Iu mode to know the address of the serving BSC/RNC handling an MS in PMM-CONNECTED state. This mechanism is the serving RNC relocation procedure.

NOTE 1: The SGSN may not know the Routeing Area where the Iu mode MS is physically located for an MS is in RRC Connected mode. An MS in PMM-CONNECTED state is necessarily in RRC Connected mode. An MS in PMM-IDLE state is in RRC Connected mode only if the MS is in CS MM-CONNECTED state.

In Iu mode, the tracking of the location of the MS is on three levels (cell, RAN area, or RA); see TS 23.121 [54].

In A/Gb mode, the tracking of the location of the MS is on two levels (cell or RA).

Routing Area Update procedure may be triggered by a PS Handover procedure as described in TS 43.129 [87].

Routing Area Update procedure may be triggered by an Inter RAT Handover from EUTRAN to GERAN/UTRAN as described in TS 23.401 [89].

Routing Area Update procedure may be triggered by the ISR function as described in TS 23.401 [89].

Other specified events may also trigger the Routing Area Update procedure.

Routeing Area (RA) is defined in clause "Routeing Area Identity".

Emergency bearer service is not supported in GERAN PS domain. Relocation to A/Gb mode shall be prevented if an MS in UTRAN with emergency bearer services tries to handover to GERAN PS domain.

If SIPTO using GW selection is enabled for a PDN connection, the SGSN should re-evaluate whether the PGW/GGSN location is still acceptable. If the SGSN determines that GW relocation is needed, the SGSN may initiate PDN deactivation with reactivation requested according to clause 9.2.4.2 at the end of the routing area update procedure.

NOTE 2: It depends on the operator's configuration in the SGSN whether to use the deactivation with reactivation request or allow the continued usage of the already connected GW.

6.9.1 Location Management Procedures (A/Gb mode)

The PLMN shall provide information for the MS to be able to:

- detect when it has entered a new cell or a new RA; and
- determine when to perform periodic RA updates.

The MS detects that it has entered a new cell by comparing the cell's identity with the cell identity stored in the MS's MM context. The MS detects that a new RA has been entered by periodically comparing the RAI stored in its MM context with that received from the new cell. The MS shall consider hysteresis in signal strength measurements.

When the MS camps on a new cell, possibly in a new RA, this indicates one of three possible scenarios:

- a cell update is required;
- a routeing area update is required; or
- a combined routeing area and location area update is required.

In all three scenarios the MS stores the cell identity in its MM context.

If the MS enters a new PLMN, the MS shall perform a routeing area update, unless it is not allowed to do so for the reasons specified in TS 24.008 [13] and TS 23.122 [7b], or it is an MS configured to perform Attach with IMSI at PLMN change.

In network mode of operation II, whenever an MS that needs only PS services and SMS services over NAS determines that it shall perform both an LA update/IMSI attach and an RA update/GPRS attach, the MS shall complete the RA update / GPRS attach first before initiating the LA update/ IMSI attach. If the GPRS Attach or RA update procedure indicates that SMS services via PS domain NAS is supported, such an MS determines that no LA update / IMSI Attach is required.

In network mode of operation II, whenever an MS that needs PS services and CS services other than SMS over NAS determines that it shall perform both an LA update and an RA update:

1. It shall initiate the LA update and then initiate the RA update, if the MS is in class A mode of operation.
2. It shall perform the LA update first if the MS is not in class A mode of operation.

Routeing Area Update Request messages shall be sent unciphered, since in the inter-SGSN routeing area update case the new SGSN shall be able to process the request.

6.9.1.1 Cell Update Procedure

A cell update takes place when the MS enters a new cell inside the current RA and the MS is in READY state. If the RA has changed, a routeing area update is executed instead of a cell update.

If the network does not support the Cell Notification which is an optimised Cell Update Procedure (see TS 24.008 [13]), the MS performs the cell update procedure by sending an uplink LLC frame of any type except the LLC NULL frame (see TS 44.064 [15]) containing the MS's identity to the SGSN. If the network and the MS support the Cell Notification, then the MS shall use the LLC NULL frame containing the MS's identity in order to perform a cell update. The support of Cell Notification is mandatory for the MS the network, but the network and the MS have to support the Cell Update Procedure without using the LLC NULL frame for backward compatibility reasons.

In the direction towards the SGSN, the BSS shall add the Cell Global Identity including RAC and LAC to all BSSGP frames, see TS 48.018 [78]. A cell update is any correctly received and valid LLC PDU carried inside a BSSGP PDU containing a new identifier of the cell.

The SGSN records this MS's change of cell and further traffic towards the MS is conveyed over the new cell. If requested by the GGSN according to charging requirements in clause 15.1.1a, the SGSN shall forward the new CGI to the GGSN based on the procedures defined in clause 15.1.3.2. If requested by the S-GW/P-GW according to charging requirements in clause 15.1.0, the SGSN shall forward the new CGI to the S-GW/P-GW based on the procedures defined in clause 15.1.3.2a.

6.9.1.2 Routeing Area Update Procedure

6.9.1.2.0 General

A Routeing Area Update takes place when a GPRS-attached MS detects:

- that it has entered a new RA (except for the case of an MS configured to perform GPRS Attach with IMSI when entering an RA in a new non-equivalent PLMN in RRC-IDLE mode);
- when the periodic RA update timer has expired;
- when the MS has to indicate changed access capabilities or DRX parameters to the network;

- for a UE supporting CS fallback, or configured to support IMS voice, or both, a change of the UE's usage setting or voice domain preference for E-UTRAN;
- for an SR-VCC capable MS, the MS has changed its MS Classmark 2, or MS Classmark 3, or Supported Codec information;
- for A/Gb mode, when a suspended MS is not resumed by the BSS (see clause "Suspension of GPRS Services");
- when the MS reselects GERAN/UTRAN with the TIN indicating "GUTI";
- when the MS moves from E-UTRAN-connected to GERAN via Cell Change Order that is not for CS fallback. If the TIN indicates "RAT-related TMSI" the MS shall set the TIN to "GUTI" before initiating the RA update procedure;
- the RRC layer in an E-UTRAN capable UE informs the UE's NAS layer that an RRC connection failure occurred in E-UTRAN and this led the MS to select a GERAN/UTRAN cell;
- when the UE Network Capability and/or MS Network Capability are changed; or
- that it is registered for IMS voice and has moved from a RAT that supports IMS voice over PS sessions (see clause 5.3.8 for more information) to one that does not, or vice versa. It shall be possible using Device Management or initial provisioning to configure the UE to apply/not apply this particular exception.

NOTE: A UE moving between RATs that both support IMS voice over PS sessions, or, both that do not support IMS voice over PS sessions, is unaffected by the above.

The SGSN detects that it is an intra-SGSN routeing area update by noticing that it also handles the old RA. In this case, the SGSN has the necessary information about the MS and there is no need to inform the S-GW/P-GWs or GGSNs or the HLR/HSS about the new MS location. A periodic RA update is always an intra SGSN routeing area update.

During the Routeing Area Update procedure, the MS provides its PS Handover inter-RAT Handover capabilities in the Routeing Area Update Request message. The SGSN uses the inter-RAT indicator and/or other indicators to ask the MS (using the Routeing Area Update Accept message) to send the other RAT's Radio Access Capabilities in the Routeing Area Update Complete message.

During the Routeing Area Update procedure, if the SGSN supports SRVCC and if the UE SRVCC capability has changed, it notifies the HSS with the UE SRVCC capability e.g. for further IMS registration.

6.9.1.2.1 Intra SGSN Routeing Area Update

The Intra SGSN Routeing Area Update procedure is illustrated in Figure 32. This procedure applies for S4-SGSNs and for Gn/Gp SGSNs.

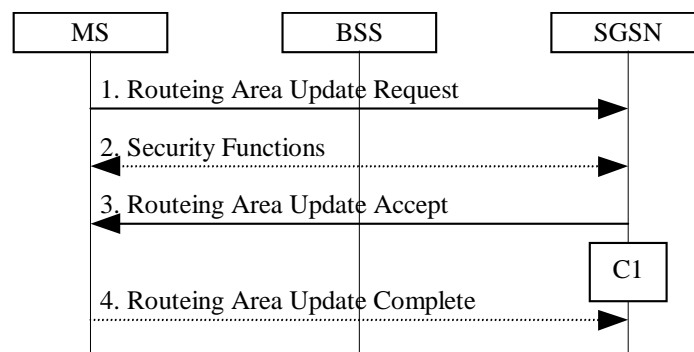

Figure 32: Intra SGSN Routeing Area Update Procedure

- 1) The MS sends a Routeing Area Update Request (P-TMSI, old RAI, old P-TMSI Signature, Update Type, MS Radio Access Capability, DRX parameters, MS Network Capability, additional P-TMSI/RAI, Voice domain preference and UE's usage setting) to the SGSN. Update Type shall indicate RA update or periodic RA update. The BSS shall add the Cell Global Identity including the RAC and LAC of the cell where the message was received before passing the message to the SGSN, see TS 48.018 [78]. MS Radio Access Capability contains the MS GPRS multislot capabilities, supported frequency bands, etc as defined in TS 24.008 [13]. DRX Parameters are included if the MS has altered its DRX Parameters.

If the E-UTRAN capable UE's TIN indicates "GUTI" and the UE holds a valid GUTI then the UE indicates the GUTI as the old P-TMSI and old RAI. If the UE's TIN indicates "P-TMSI" or "RAT-related TMSI" and the UE holds a valid P-TMSI and related RAI then these two elements are indicated as old P-TMSI and old RAI. Mapping a GUTI to a P-TMSI and an RAI is specified in TS 23.401 [89]. In this scenario of intra SGSN RAU, the TIN indicates "P-TMSI" or "RAT-related TMSI".

If the E-UTRAN capable UE holds a valid P-TMSI and related RAI then the UE indicates these parameters as additional P-TMSI/RAI, regardless whether the old P-TMSI and old RAI indicate the same parameters or parameters mapped from a GUTI.

The Gn/Gp SGSN shall ignore this additional P-TMSI/RAI.

The UE sets the voice domain preference and UE's usage setting according to its configuration, as described in clause 5.3.15.

- 2) Security functions may be executed. These procedures are defined in clause "Security Function".
- 3) The SGSN validates the MS's presence in the new RA. If, due to regional subscription restrictions, the MS is not allowed to be attached in the RA, or if subscription checking fails, the SGSN rejects the routing area update with an appropriate cause. If all checks are successful, the SGSN updates the MM context for the MS. A new P-TMSI may be allocated. A Routing Area Update Accept (P-TMSI, P-TMSI Signature, IMS voice over PS Session Supported Indication, SMS-Supported) is returned to the MS. The IMS voice over PS Session Supported Indication is set as described in clause 5.3.8.

If ISR is activated for the MS when the S4-SGSN receives the Routing Area Update Request in the intra SGSN scenario, the S4-SGSN should maintain ISR by indicating ISR Activated in the Routing Area Update Accept message.

"SMS-Supported" is indicated to the MS when the HSS has indicated "SMS in SGSN Support". It indicates to the MS that it can obtain SMS services via PS domain NAS from the SGSN. An MS that needs only PS services and SMS services over NAS should not perform any procedures via CS domain when it can obtain SMS services via PS domain NAS from SGSN.

- 4) If P-TMSI was reallocated, the MS acknowledges the new P-TMSI by returning a Routing Area Update Complete message to the SGSN.

For some network sharing scenario (e.g. GWCN) if the PLMN-ID of the RAI supplied by the RNC is different from that of the RAI in the UE's context, then the SGSN shall inform the HLR.

If the routing area update procedure fails a maximum allowable number of times, or if the SGSN returns a Routing Area Update Reject (Cause) message, the MS shall enter IDLE state.

The CAMEL procedure calls shall be performed, see referenced procedure in TS 23.078 [8b] C1:

- C1) CAMEL_GPRS_Routing_Area_Update_Session, CAMEL_PS_Notification and CAMEL_GPRS_Routing_Area_Update_Context.

They are called in the following order:

- The procedure CAMEL_GPRS_Routing_Area_Update_Session is called once per session. It returns as a result "Continue".
- Then the procedure CAMEL_PS_Notification is called once per session. It returns as a result "Continue".
- Then the procedure CAMEL_GPRS_Routing_Area_Update_Context is called once per PDP context. It returns as a result "Continue".

6.9.1.2.2 Inter SGSN Routing Area Update

The Inter SGSN Routing Area Update procedure is illustrated in Figure 33 for mobility between two Gn/Gp SGSNs and for mobility from S4-SGSN to Gn/Gp SGSN. The Inter SGSN Routing Area Update procedure between two S4-SGSNs shows differences for the steps in the boxes (A) and (B). The Inter SGSN Routing Area Update procedure from Gn/Gp SGSN to S4-SGSN shows differences for the steps in the box (B). These different step descriptions of the boxes are described in clause "Inter SGSN Routing Area Update and Combined Inter SGSN RA / LA Update using S4".

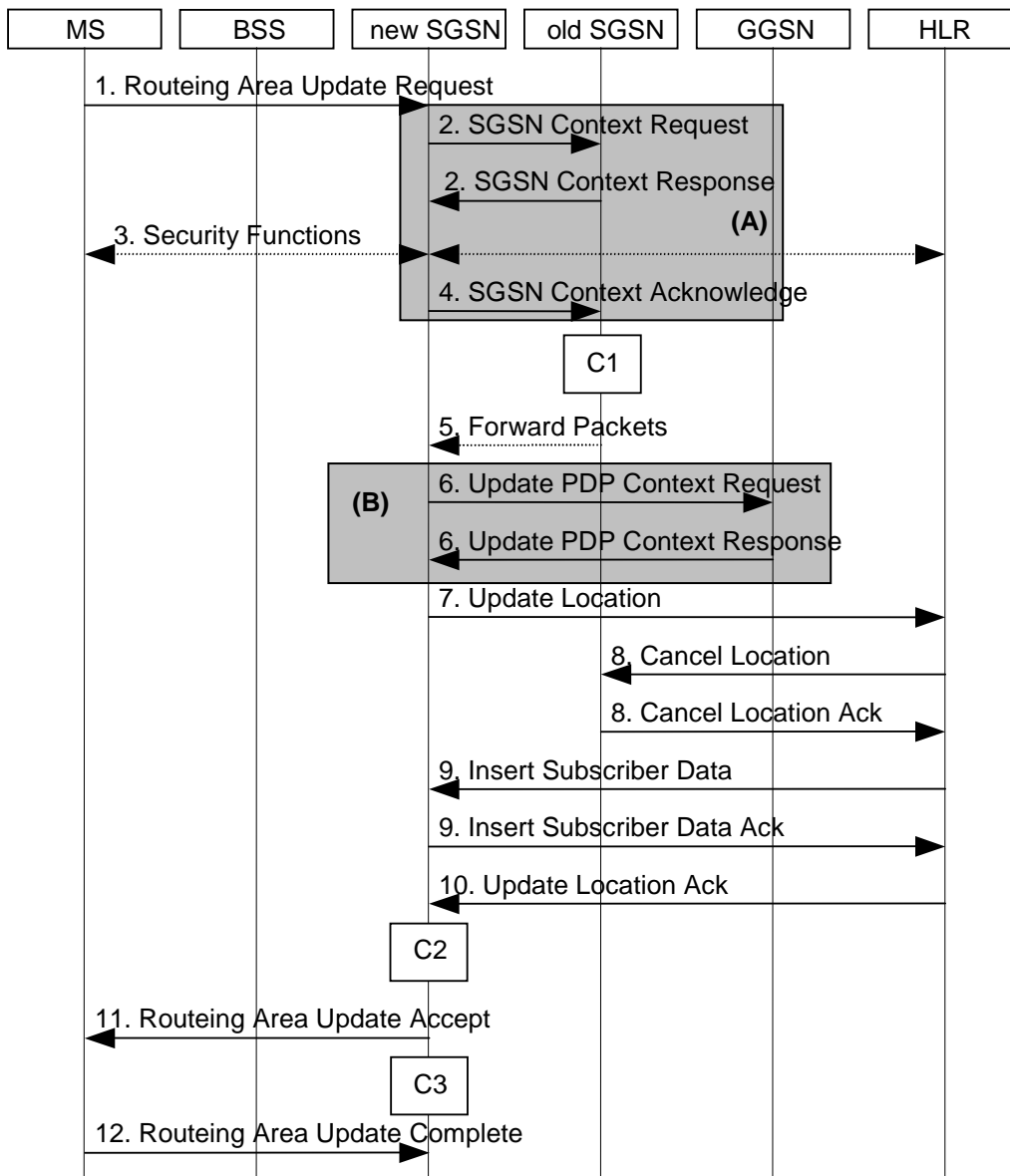

Figure 33: Inter SGSN Routing Area Update Procedure

NOTE 1: All steps in figure 33, except steps 2, 4, and 6, are common for architecture variants using Gn/Gp based and S4 based SGSN. For specific interaction with S4 based SGSN, procedure steps (A) and (B) are defined in the clause 6.9.1.2.2a.

- 1) The MS sends a Routing Area Update Request (old RAI, old P-TMSI Signature, Update Type, MS Radio Access Capability, DRX parameters, MS Network Capability, additional P-TMSI/RAI, Voice domain preference and UE's usage setting) to the new SGSN. Update Type shall indicate RA update or periodic RA update. The BSS shall add the Cell Global Identity including the RAC and LAC of the cell where the message was received before passing the message to the SGSN. MS Radio Access Capability contains the MS GPRS multislot capabilities, supported frequency bands, etc. as defined in TS 24.008 [13]. DRX Parameters are included if the MS has altered its DRX Parameters.

If the E-UTRAN capable UE's TIN indicates "GUTI" and the UE holds a valid GUTI then the UE indicates the GUTI as the old P-TMSI and old RAI. If the UE's TIN indicates "P-TMSI" or "RAT-related TMSI" and the UE holds a valid P-TMSI and related RAI then these two elements are indicated as old P-TMSI and old RAI. Mapping a GUTI to a P-TMSI and an RAI is specified in TS 23.401 [89]. In this scenario of inter SGSN RAU, the TIN indicates "P-TMSI" or "RAT-related TMSI".

If the E-UTRAN capable UE holds a valid P-TMSI and related RAI then the UE indicates these parameters as additional P-TMSI/RAI, regardless whether the old P-TMSI and old RAI indicate the same parameters or parameters mapped from a GUTI.

The Gn/Gp SGSN shall ignore this additional P-TMSI/RAI.

The UE sets the voice domain preference and UE's usage setting according to its configuration, as described in clause 5.3.15.

- 2) The new SGSN sends SGSN Context Request (old RAI, TLLI, old P-TMSI Signature, New SGSN Address) to the old SGSN to get the MM and PDP contexts for the MS. If the new SGSN provides functionality for Intra Domain Connection of RAN Nodes to Multiple CN Nodes, the new SGSN may derive the old SGSN from the old RAI and the old P-TMSI (or TLLI) and send the SGSN Context Request message to this old SGSN. Otherwise, the new SGSN derives the old SGSN from the old RAI. In any case the new SGSN will derive an SGSN that it believes is the old SGSN. This derived SGSN is itself the old SGSN, or it is associated with the same pool area as the actual old SGSN and it will determine the correct old SGSN from the P-TMSI (or TLLI) and relay the message to that actual old SGSN. The old SGSN validates the old P-TMSI Signature and responds with an appropriate error cause if it does not match the value stored in the old SGSN. This should initiate the security functions in the new SGSN. If the security functions authenticate the MS correctly, the new SGSN shall send an SGSN Context Request (old RAI, TLLI, MS Validated, New SGSN Address) message to the old SGSN. MS Validated indicates that the new SGSN has authenticated the MS. If the old P-TMSI Signature was valid or if the new SGSN indicates that it has authenticated the MS, the old SGSN stops assigning SDCP N-PDU numbers to downlink N-PDUs received, and responds with SGSN Context Response (MM Context, PDP Contexts, Negotiated Evolved ARP). If the MS is not known in the old SGSN, the old SGSN responds with an appropriate error cause. The old SGSN stores New SGSN Address, to allow the old SGSN to forward data packets to the new SGSN. Each PDP Context includes the SDCP Send N-PDU Number for the next downlink N-PDU to be sent in acknowledged mode to the MS, the SDCP Receive N-PDU Number for the next uplink N-PDU to be received in acknowledged mode from the MS, the GTP sequence number for the next downlink N-PDU to be sent to the MS and the GTP sequence number for the next uplink N-PDU to be tunnelled to the GGSN. The old SGSN starts a timer and stops the transmission of N-PDUs to the MS. The new SGSN shall ignore the MS Network Capability contained in MM Context of SGSN Context Response only when it has previously received an MS Network Capability in the Routing Area Request.

SDCP and GTP sequence numbers are not relevant for a new S4-SGSN if provided by an old Gn/Gp SGSN and need not to be provided by an old S4-SGSN as the EPS network shall not configure usage of "delivery order required" and no acknowledged mode NSAPIs (SDCP) as described in clause "Network Configuration for Interaction with E-UTRAN and S4-SGSNs".

- 3) Security functions may be executed. These procedures are defined in clause "Security Function". Ciphering mode shall be set if ciphering is supported. If the SGSN Context Response message did not include IMEISV and ADD is supported by the SGSN, the SGSN retrieves the IMEISV from the MS.

If the security functions fail (e.g. because the SGSN cannot determine the HLR address to establish the Send Authentication Info dialogue), the Inter SGSN RAU Update procedure fails. A reject shall be returned to the MS with an appropriate cause.

- 4) The new SGSN sends an SGSN Context Acknowledge message to the old SGSN. This informs an old Gn/Gp SGSN that the new SGSN is ready to receive data packets belonging to the activated PDP contexts. Only old Gn/Gp SGSNs may forward data to a new Gn/Gp or S4-SGSN.

The old SGSN marks in its context that the MSC/VLR association and the information in the GGSNs and the HLR are invalid. This triggers the MSC/VLR, the GGSNs, and the HLR to be updated if the MS initiates a routing area update procedure back to the old SGSN before completing the ongoing routing area update procedure. If the security functions do not authenticate the MS correctly, then the routing area update shall be rejected, and the new SGSN shall send a reject indication to the old SGSN. The old SGSN shall continue as if the SGSN Context Request was never received.

- 5) Only old Gn/Gp SGSNs may forward data to a new SGSN. An old Gn/Gp SGSN duplicates the buffered N-PDUs and starts tunnelling them to the new SGSN. Additional N-PDUs received from the GGSN before the timer described in step 2 expires are also duplicated and tunneled to the new SGSN. N-PDUs that were already sent to the MS in acknowledged mode and that are not yet acknowledged by the MS are tunneled together with the SNDCP N-PDU number. No N-PDUs shall be forwarded to the new SGSN after expiry of the timer described in step 2.

SNDCP N-PDU numbers are not relevant for S4-SGSNs as the network shall not configure usage of acknowledged mode NSAPIs (SNDCP) as described in clause "Network Configuration for Interaction with E-UTRAN and S4-SGSNs". A new S4-SGSN indicates reserved TEID and IP address parameters from an SGW to an old Gn/Gp SGSN so that the old Gn/Gp SGSN can forward data packets when needed. The SGW discards any packets received from old Gn/Gp SGSN.

- 6) The new SGSN sends Update PDP Context Request (new SGSN Address, TEID, QoS Negotiated, Negotiated Evolved ARP, serving network identity, CGI/SAI, User CSG Information, RAT type, MS Info Change Reporting support indication, NRSN) to the GGSNs concerned. The SGSN shall send the serving network identity to the GGSN. NRSN indicates SGSN support of the network requested bearer control. The inclusion of the Negotiated Evolved ARP IE indicates that the SGSN supports the Evolved ARP feature. If the new SGSN did not receive a Negotiated Evolved ARP IE in the SGSN Context Response message from the old SGSN then the new SGSN shall derive this value from the Allocation/Retention Priority of the QoS profile negotiated according to Annex E of TS 23.401 [89]. The GGSNs update their PDP context fields and return Update PDP Context Response (TEID, Prohibit Payload Compression, APN Restriction, MS Info Change Reporting Action, CSG Information Reporting Action, BCM, Negotiated Evolved ARP). The GGSN sets the Negotiated Evolved ARP based on local policy or PCC. The Allocation/Retention Priority of the QoS Profile Negotiated is derived from the Evolved ARP according to the mapping principles of TS 23.401 [89] Annex E. The Prohibit Payload Compression indicates that the SGSN should negotiate no data compression for this PDP context. User CSG Information includes CSG ID, access mode and CSG membership indication. The SGSN shall apply the Negotiated Evolved ARP if received from the GGSN.
- 7) The new SGSN informs the HLR of the change of SGSN by sending Update Location (SGSN Number, SGSN Address, IMSI, IMEISV, UE SRVCC capability, Registration For SMS Request) to the HLR. IMEISV is sent if the ADD function is supported. If the S6d interface is used between S4-SGSN and HSS, a parameter "SMS in SGSN offered" is included in the Update Location message, otherwise this parameter is included in the Insert Subscriber Data Ack (Step 9). "SMS in SGSN offered" indicates that the SGSN supports SMS services via SGSN.

If the MS performs the Routing Area Update procedure in a VPLMN supporting Autonomous CSG Roaming and the HPLMN has enabled Autonomous CSG Roaming in the VPLMN (via Service Level Agreement) and the SGSN needs to retrieve the CSG subscription information of the MS from the CSS, the SGSN initiates the Update CSG Location Procedure with CSS as described in clause 6.16.

- 8) The HLR sends Cancel Location (IMSI, Cancellation Type) to the old SGSN with Cancellation Type set to Update Procedure. If the timer described in step 2 is not running, the old SGSN removes the MM and PDP contexts/EPS Bearer Contexts and an old S4-SGSN releases in addition the S-GW resources when the new SGSN is a Gn/Gp SGSN or when an S-GW change is performed. GTPv1 SGSN context transfer signalling indicates to the old S4-SGSN that the new SGSN is a Gn/Gp SGSN, which does not signal any S-GW change. When the timer described in step 2 is running, the MM and PDP/EPS Bearer Contexts and any affected S-GW resources are removed when the timer expires and the SGSN received a Cancel Location. The old S4-SGSN deletes S-GW bearer resources by sending Delete Session Request (Cause, Operation Indication) messages to the SGW. If ISR is activated the Cause indicates that the old S-GW shall delete the bearer resources on the other old CN node by sending Delete Bearer Request message to the other CN node. The Operation Indication flag is not

set by the old S4-SGSN. This indicates to the S-GW that the S-GW shall not initiate a delete procedure towards the PDN GW.

When the timer described in step 2 expires and no Cancel Location was received the S4-SGSN removes the PDP contexts/EPS Bearer Contexts but preserves the MM context.

The timer started in step 2 allows the old SGSN to complete the forwarding of N-PDUs. It also ensures that the MM and PDP contexts/EPS Bearer Contexts are kept in the old SGSN in case the MS initiates another inter-SGSN routing area update before completing the ongoing routing area update to the new SGSN. The old SGSN acknowledges with Cancel Location Ack (IMSI).

- 9) The HLR sends Insert Subscriber Data (IMSI, Subscription Data) to the new SGSN. The new SGSN validates the MS's presence in the (new) RA. If due to regional subscription restrictions or access restrictions the MS is not allowed to be attached in the RA, the SGSN rejects the Routing Area Update Request with an appropriate cause, and may return an Insert Subscriber Data Ack (IMSI, SGSN Area Restricted) message to the HLR. If all checks are successful, the SGSN constructs an MM context for the MS and returns an Insert Subscriber Data Ack (IMSI, SMS in SGSN offered) message to the HLR. The "SMS in SGSN offered" indicates that the SGSN supports SMS services via SGSN. If the S6d interface is used between S4-SGSN and HSS the messages "Insert Subscriber Data" and "Insert Subscriber Data Ack" are not used. Instead, the Subscription Data is sent by HSS in the message Update Location Ack (Step 10).
- 10) The HLR acknowledges the Update Location by sending Update Location Ack (IMSI, GPRS Subscriber Data (only if S6d interface is used)) to the new SGSN.
- 11) The new SGSN validates the MS's presence in the new RA. If due to roaming restrictions or access restrictions the MS, is not allowed to be attached in the SGSN, or if subscription checking fails, the new SGSN rejects the routing area update with an appropriate cause. If all checks are successful, the new SGSN constructs MM and PDP contexts/EPS Bearer Contexts for the MS. A logical link is established between the new SGSN and the MS. The new SGSN responds to the MS with Routing Area Update Accept (P-TMSI, P-TMSI Signature, Receive N-PDU Number, IMS voice over PS Session Supported Indication, SMS-Supported). Receive N-PDU Number contains the acknowledgements for each acknowledged-mode NSAPI used by the MS, thereby confirming all mobile-originated N-PDUs successfully transferred before the start of the update procedure. The IMS voice over PS Session Supported Indication is set as described in clause 5.3.8.

ISR Activated is never indicated to the MS in case of inter SGSN RAU as described in TS 23.401 [89]. The E-UTRAN capable UE sets its TIN to "P-TMSI" or "RAT-related TMSI" as described for Routing Area Update procedures in TS 23.401 [89].

"SMS-Supported" is indicated to the MS when the HSS has indicated "SMS in SGSN Support". It indicates to the MS that it can obtain SMS services via PS domain NAS from the SGSN.

- 12) The MS acknowledges the new P-TMSI by returning a Routing Area Update Complete (Receive N-PDU Number) message to the SGSN. Receive N-PDU Number contains the acknowledgements for each acknowledged-mode NSAPI used by the MS, thereby confirming all mobile-terminated N-PDUs successfully transferred before the start of the update procedure. If Receive N-PDU Number confirms reception of N-PDUs that were forwarded from the old SGSN, these N-PDUs shall be discarded by the new SGSN. LLC and SNDPCP in the MS are reset.

For a rejected routing area update operation, due to regional subscription, roaming restrictions, access restrictions (see TS 23.221 [80] and TS 23.008 [79]) or because the SGSN cannot determine the HLR address to establish the locating updating dialogue, the new SGSN should not construct an MM context. In the case of receiving the subscriber data from HLR, the new SGSN may construct an MM context and store the subscriber data for the MS to optimize signalling between the SGSN and the HLR. A reject shall be returned to the MS with an appropriate cause. Upon return to idle, the MS shall act according to TS 23.122 [7b].

If the new SGSN is unable to update the PDP context/EPS Bearer Context in one or more GGSNs/P-GWs, the new SGSN shall deactivate the corresponding PDP contexts/EPS Bearer Contexts as described in clause "SGSN-initiated PDP Context Deactivation Procedure". This shall not cause the SGSN to reject the routing area update.

The PDP Contexts/EPS Bearer Contexts shall be sent from old to new SGSN in a prioritized order, i.e. the most important PDP Context/EPS Bearer Context first in the SGSN Context Response message. (The prioritization method is implementation dependent, but should be based on the current activity).

The new SGSN shall determine the Maximum APN restriction based on the received APN Restriction of each PDP context/EPS Bearer Context from the GGSN/P-GW or old S4-SGSN and then store the new Maximum APN restriction value.

If the new SGSN is unable to support the same number of active PDP contexts as received from old SGSN, the new SGSN should use the prioritisation sent by old SGSN as input when deciding which PDP contexts/EPS Bearer Contexts to maintain active and which ones to delete. In any case, the new SGSN shall first update all contexts in one or more GGSNs/P-GWs and then deactivate the context(s) that it cannot maintain as described in clause "SGSN-initiated PDP Context Deactivation Procedure". This shall not cause the SGSN to reject the routeing area update.

If the timer described in step 2 expires and no Cancel Location (IMSI) was received from the HLR, the old SGSN stops forwarding N-PDUs to the new SGSN.

If the routeing area update procedure fails a maximum allowable number of times, or if the SGSN returns a Routeing Area Update Reject (Cause) message, the MS shall enter IDLE state.

If "SMS-Supported" is indicated to the MS, the MS should not initiate Location Update or IMSI attach with the MSC for only obtaining SMS services as SMS services via PS domain NAS are provided by the SGSN.

The CAMEL procedure calls shall be performed, see referenced procedures in TS 23.078 [8b]:

C1) CAMEL_GPRS_PDP_Context_Disconnection, CAMEL_GPRS_Detach and CAMEL_PS_Notification.

They are called in the following order:

- The CAMEL_GPRS_PDP_Context_Disconnection procedure is called several times: once per PDP context. The procedure returns as result "Continue".
- Then the CAMEL_GPRS_Detach procedure is called once. The procedure returns as result "Continue".
- Then the CAMEL_PS_Notification procedure is called once. The procedure return as result "Continue".

C2) CAMEL_GPRS_Routeing_Area_Update_Session and CAMEL_PS_Notification.

They are called in the following order:

- The CAMEL_GPRS_Routeing_Area_Update_Session procedure is called. The procedure returns as result "Continue".
- Then the CAMEL_PS_Notification procedure is called. The procedure returns as result "Continue".

C3) CAMEL_GPRS_Routeing_Area_Update_Context.

This procedure is called several times: once per PDP context. It returns as result "Continue".

6.9.1.2.2a Inter SGSN Routeing Area Update and Combined Inter SGSN RA / LA Update using S4

The procedures described in figures 33a and 33b show only the steps 2 and 4 for the case when new and old SGSNs are S4-SGSNs and step 6 when the new SGSN is an S4-SGSN. These steps are different from the Gn/Gp variant of the procedure given by clauses 6.9.1.2.2 and 6.9.1.3.2. The ISR function is deactivated in Inter SGSN RAU as defined in TS 23.401 [89].

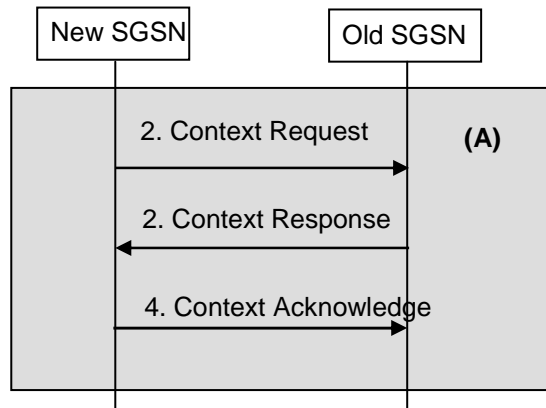

Figure 33a: Step 2 and 4 for Inter SGSN Routing Area Update Procedure and Combined Inter SGSN RA / LA Update between S4-SGSNs

2. The new SGSN sends a Context Request (old RAI, TLLI, old P TMSI Signature, New SGSN Address) to the old SGSN to get the MM and EPS Bearer contexts for the MS. If the new SGSN provides functionality for Intra Domain Connection of RAN Nodes to Multiple CN Nodes, the new SGSN may derive the old SGSN from the old RAI and the old P-TMSI (or TLLI) and send the Context Request message to this old SGSN. Otherwise, the new SGSN derives the old SGSN from the old RAI. In any case the new SGSN will derive an SGSN that it believes is the old SGSN. This derived SGSN is itself the old SGSN, or it is associated with the same pool area as the actual old SGSN and it will determine the correct old SGSN from the P-TMSI (or TLLI) and relay the message to that actual old SGSN. The old SGSN validates the old P TMSI Signature and responds with an appropriate error cause if it does not match the value stored in the old SGSN. This should initiate the security functions in the new SGSN. If the security functions authenticate the MS correctly, the new SGSN shall send a Context Request (old RAI, TLLI, MS Validated) message to the old SGSN. MS Validated indicates that the new SGSN has authenticated the MS. If the old P TMSI Signature was valid or if the new SGSN indicates that it has authenticated the MS, the old SGSN responds with a Context Response (MM Context, EPS Bearer Contexts). MM Context and EPS Bearer Context when used at the S16 interface are defined by clause 13.2.2. If the MS is not known in the old SGSN, the old SGSN responds with an appropriate error cause. The old SGSN starts a timer and stops the transmission of N-PDUs to the MS. The new SGSN shall ignore the MS Network Capability contained in MM Context of Context Response only when it has previously received an MS Network Capability in the Routing Area Request.

For RAU between two S4-SGSNs, the old SGSN shall include the Change Reporting Action and CGI/SAI/RAI change support indication in the Context Response message.

4. The new SGSN sends a Context Acknowledge message to the old SGSN. The old SGSN marks in its context that the MSC/VLR association and the information in the GWs and the HSS are invalid. This triggers the MSC/VLR, the S-GW, the P-GW and the HSS to be updated if the MS initiates a routeing area update procedure back to the old SGSN before completing the ongoing routeing area update procedure. If the security functions do not authenticate the MS correctly, then the routeing area update shall be rejected, and the new SGSN shall send a reject indication to the old SGSN. The old SGSN shall continue as if the Context Request was never received.

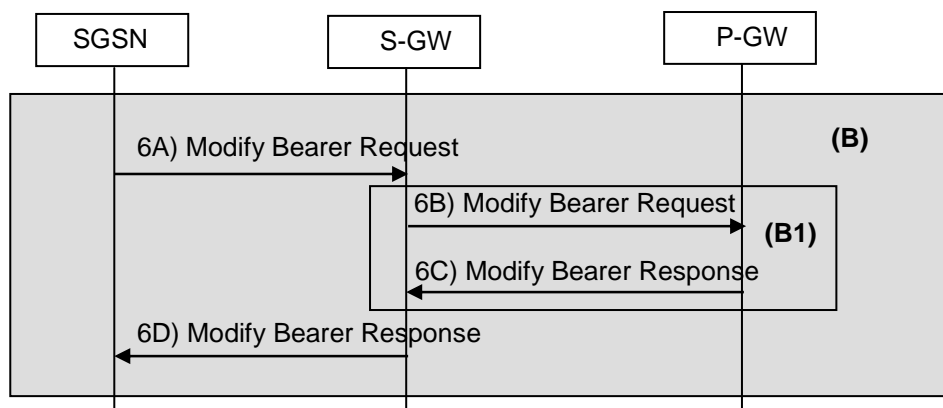

Figure 33b: Step 6 for Inter SGSN Routing Area Update Procedure and Combined Inter SGSN RA / LA Update to S4-SGSNs

NOTE: Steps A) and D) are common for architecture variants with GTP based S5/S8 and PMIP-based S5/S8. For a PMIP-based S5/S8, procedure steps (B1) are defined in TS 23.402 [90]. Steps B) and C) concern GTP based S5/S8.

6A) If the S-GW does not change, the new SGSN updates these EPS Bearer contexts by sending Modify Bearer Request (SGSN Tunnel Endpoint Identifier for Control Plane, EPS Bearer ID(s), SGSN Address for Control Plane, SGSN Address(es) and TEID(s), PDN GW addresses and TEIDs (for GTP-based S5/S8) or GRE keys (for PMIP-based S5/S8) at the PDN GW(s) for uplink traffic, serving network identity, CGI/SAI, User CSG Information, RAT type, MS Info Change Reporting support indication). The SGSN puts the according NSAPI in the field of EPS Bearer ID. If ISR is activated on the S-GW that is updated by a new SGSN then this S-GW deletes the bearer resources on the other old CN node by sending Delete Session Request message(s) to that CN node.

If the S-GW changes or if an S-GW needs to be allocated (Gn/Gp to S4-SGSN RAU) the SGSN selects an S-GW and sends a Create Session Request message (APN-AMBR) with the content as described for the Modify Bearer Request message to the S-GW.

For Gn/Gp to S4-SGSN RAU, the new S4-SGSN provides APN-AMBR to the Serving GW. Details on mapping MBR to APN-AMBR are specified in Annex E of TS 23.401 [89].

6B) If the S-GW has changed, or if an S GW needs to be allocated (Gn/Gp to S4-SGSN RAU), or the RAT type has changed, or the S-GW received CGI/SAI from the S4-SGSN, the S-GW sends Modify Bearer Request (EPS Bearer ID(s), serving network identity, CGI/SAI, User CSG Information, RAT type, MS Info Change Reporting support indication, APN-AMBR) messages to the P-GWs involved.

6C) The P-GWs acknowledge by sending Modify Bearer Response (TEID, Prohibit Payload Compression, MS Info Change Reporting Action, CSG Information Reporting Action, Default bearer id, APN-AMBR) messages to S-GW. The Prohibit Payload Compression indicates that the SGSN should negotiate no data compression for this PDP/EPS Bearer context. The default bearer id is included if the UE moves from a Gn/Gp SGSN to an S4-SGSN.

6D) The S-GW acknowledges the user plane switch to the new SGSN via the message Modify Bearer Response (Cause, Serving GW Tunnel Endpoint Identifier for Control Plane, Serving GW Address for Control Plane, PDN GW addresses and TEIDs (for GTP-based S5/S8) or GRE keys (for PMIP-based S5/S8) at the PDN GW(s) for uplink traffic, Prohibit Payload Compression, MS Info Change Reporting Action, CSG Information Reporting Action, default bearer id, APN-AMBR). If the SGSN sent a Create Session Request message the S-GW sends a Create Session Response message with the content as described for the Modify Bearer Response message to the SGSN.

If there are active GBR bearers with maximum bit rate set to 0, the S4-SGSN should use the SGSN-initiated PDP Context Deactivation Procedure using S4 (as defined in clause 9.2.4.2) to deactivate the PDP Context.

6.9.1.3 Combined RA / LA Update Procedure

6.9.1.3.0 General

A combined RA / LA update takes place in network operation mode I when:

- the MS enters a new RA (except for the case of an MS configured to perform GPRS Attach with IMSI when entering an RA in a new non-equivalent PLMN in RRC-IDLE mode, in which case, a Combined GPRS Attach shall be performed) or
- when a GPRS-attached MS performs an IMSI attach or
- when the MS has to indicate changed access capabilities or DRX parameters to the network, or
- for a UE supporting CS fallback, or configured to support IMS voice, or both, a change of the UE's usage setting or voice domain preference for E-UTRAN, or
- for an SR-VCC capable MS, the MS has changed its MS Classmark 2, or MS Classmark 3, or Supported Codec information, or
- when a suspended MS is not resumed by the BSS (see clause "Suspension of GPRS Services"), or

- when the MS reselects GERAN/UTRAN with the TIN indicating "GUTI", or
- when the MS moves from E-UTRAN-connected to GERAN via Cell Change Order that is not for CS fallback. If the TIN indicates "RAT-related TMSI" the MS shall set the TIN to "GUTI" before initiating the RA update procedure;
- the RRC layer in an E-UTRAN capable UE informs the UE's NAS layer that an RRC connection failure occurred in E-UTRAN and this led the MS to select a GERAN/UTRAN cell.
- when a EPS and IMSI attached MS camps on GERAN/UTRAN and the E-UTRAN periodic TAU timer expires and the TIN indicates "RAT Related TMSI".
- the UE Network Capability and/or MS Network Capability are changed.

The MS sends a Routing Area Update Request indicating that an LA update may also need to be performed, in which case the SGSN forwards the LA update to the VLR. This concerns only idle mode (see TS 23.122 [7b]), as no combined RA / LA updates are performed during a CS connection.

6.9.1.3.1 Combined Intra SGSN RA / LA Update

The Combined RA / LA Update (intra SGSN) procedure is illustrated in Figure 34. This procedure applies for S4-SGSNs and for Gn/Gp SGSNs.

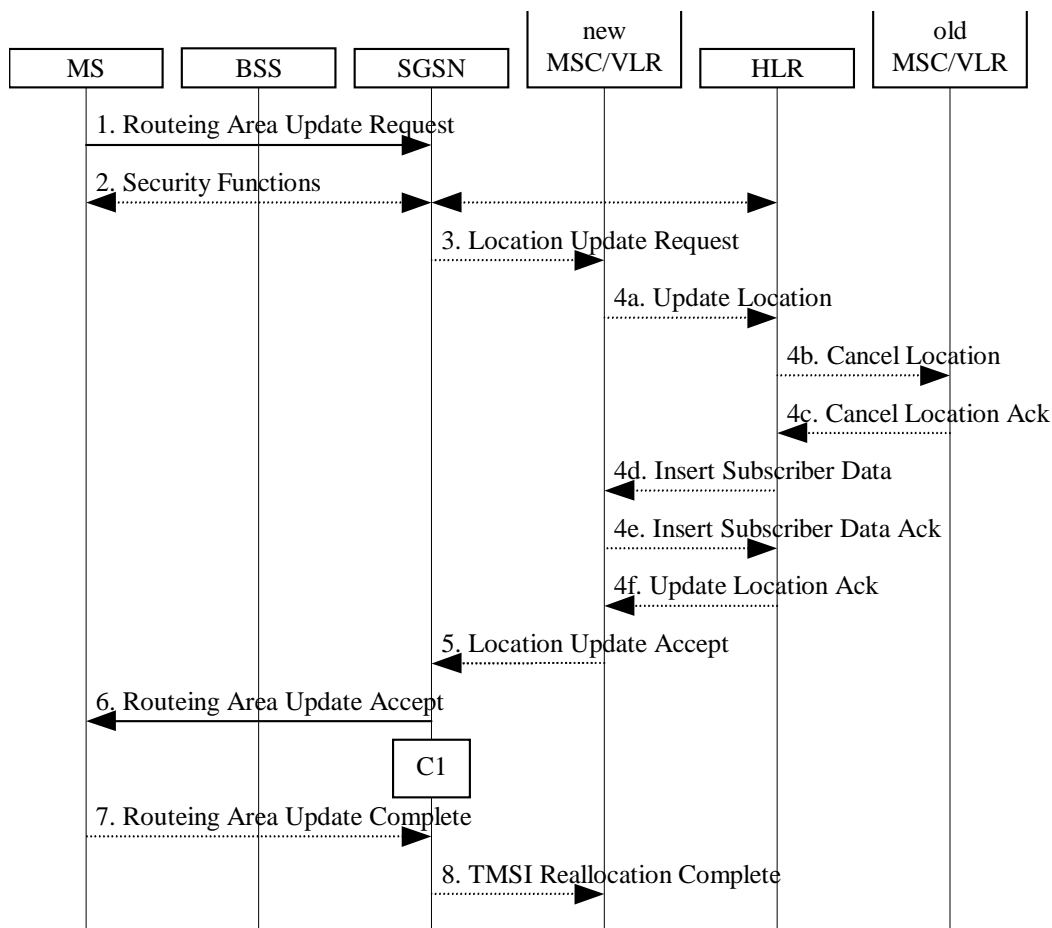

Figure 34: Combined RA / LA Update in the Case of Intra SGSN RA Update Procedure

- 1) The MS sends a Routing Area Update Request (old RAI, old P-TMSI Signature, Update Type, MS Radio Access Capability, DRX parameters, MS Network Capability, additional P-TMSI/RAI, Voice domain preference and UE's usage setting, SMS-only) to the SGSN. Update Type shall indicate combined RA / LA update, or, if the MS wants to perform an IMSI attach, combined RA / LA update with IMSI attach requested. The BSS shall add the Cell Global Identity including the RAC and LAC of the cell where the message was received before passing the message to the SGSN. MS Radio Access Capability contains the MS GPRS multislot capabilities, supported

frequency bands, etc as defined in TS 24.008 [13]. DRX Parameters are included if the MS has altered its DRX Parameters.

If the E-UTRAN capable UE's TIN indicates "GUTI" and the UE holds a valid GUTI then the UE indicates the GUTI as the old P-TMSI and old RAI. If the UE's TIN indicates "P-TMSI" or "RAT-related TMSI" and the UE holds a valid P-TMSI and related RAI then these two elements are indicated as old P-TMSI and old RAI. Mapping a GUTI to a P-TMSI and an RAI is specified in TS 23.401 [89]. In this scenario of Combined RA/LA Update in the Case of Intra SGSN RAU, the TIN indicates "P-TMSI" or "RAT-related TMSI".

If the E-UTRAN capable UE holds a valid P-TMSI and related RAI then the UE indicates these parameters as additional P-TMSI/RAI, regardless whether the old P-TMSI and old RAI indicate the same parameters or parameters mapped from a GUTI.

The Gn/Gp SGSN shall ignore this additional P-TMSI/RAI.

The UE sets the voice domain preference and UE's usage setting according to its configuration, as described in clause 5.3.15.

The MS indicates its "SMS-only" capability during a combined RA/LA update when the MS is requesting the LA update or IMSI attach only for obtaining SMS and not any other services from CS domain.

- 2) Security functions may be executed. This procedure is defined in clause "Security Function". If the security functions fail (e.g. because the SGSN cannot determine the HLR address to establish the Send Authentication Info dialogue), the Inter SGSN RAU Update procedure fails. A reject shall be returned to the MS with an appropriate cause.
- 3) If the association has to be established, if Update Type indicates combined RA / LA update with IMSI attach requested, or if Update Type indicates combined RA / LA update without IMSI attach and the the MS Network Capability IE indicates that EMM Combined procedure is supported, or if the LA changed with the routing area update, the SGSN sends a Location Update Request (new LAI, IMSI, SGSN Number, Location Update Type) to the VLR. Location Update Type shall indicate IMSI attach if Update Type in step 1 indicated combined RA / LA update with IMSI attach requested. Otherwise, Location Update Type shall indicate normal location update. When the SGSN does not provide functionality for the Intra Domain Connection of RAN Nodes to Multiple CN Nodes, the VLR number is derived from the RAI. When the SGSN provides functionality for Intra Domain Connection of RAN Nodes to Multiple CN Nodes, the SGSN uses the RAI and a hash value from the IMSI to determine the VLR number. The VLR creates or updates the association with the SGSN by storing SGSN Number.

This step is not performed if:

- Subscription Data indicate by the Network Access Mode information that the subscription has no CS subscriber data; or
 - Subscription Data have an HSS indication of "SMS in SGSN Support" and the subscription allows SMS services and the MS indicated "SMS-only" and the SGSN provides SMS services via PS domain NAS.
- 4) If the subscriber data in the VLR is marked as not confirmed by the HLR, the new VLR informs the HLR. The HLR cancels the data in the old VLR and inserts subscriber data in the new VLR:
 - a) The new VLR sends an Update Location (new VLR) to the HLR.
 - b) The HLR cancels the data in the old VLR by sending Cancel Location (IMSI) to the old VLR.
 - c) The old VLR acknowledges with Cancel Location Ack (IMSI).
 - d) The HLR sends Insert Subscriber Data (IMSI, subscriber data) to the new VLR.
 - e) The new VLR acknowledges with Insert Subscriber Data Ack (IMSI).
 - f) The HLR responds with Update Location Ack (IMSI) to the new VLR.

If the MS performs the Combined RA / LA Update procedure in a VPLMN supporting Autonomous CSG Roaming and the HPLMN has enabled Autonomous CSG Roaming in the VPLMN (via Service Level Agreement) and the VLR needs to retrieve the CSG subscription information of the MS from the CSS, the VLR initiates the Update CSG Location Procedure with CSS as described in clause 6.16.

- 5) The new VLR allocates a new VLR TMSI and responds with Location Update Accept (VLR TMSI) to the SGSN. VLR TMSI is optional if the VLR has not changed.
- 6) The SGSN validates the MS's presence in the new RA. If due to regional subscription restrictions the MS is not allowed to be attached in the RA, or if subscription checking fails, the SGSN rejects the routing area update with an appropriate cause. If all checks are successful, the SGSN updates the MM context for the MS. A new P-TMSI may be allocated. The SGSN responds to the MS with Routing Area Update Accept (P-TMSI, VLR TMSI, P-TMSI Signature, IMS voice over PS Session Supported Indication, SMS-Supported, Cause). The IMS voice over PS Session Supported Indication is set as described in clause 5.3.8.

For using S4 variant, if ISR is activated for the MS when the S4-SGSN receives the Routing Area Update Request in the intra SGSN scenario, the S4-SGSN should maintain ISR by indicating ISR Activated in the Routing Area Update Accept message.

"SMS-Supported" is indicated to the MS when the subscription data indicate "SMS in SGSN Support". It indicates to the MS that it can obtain SMS services via PS domain NAS from the SGSN. An MS that needs only PS and SMS services via NAS should not perform any procedures via CS domain when it can obtain SMS services via PS domain NAS from SGSN. If step 3 was not performed, e.g. due to Subscription Data indicate by the Network Access Mode information that the subscription has no CS subscriber data, then the SGSN indicates that the Attach was successful for GPRS only and a Cause indicates why the IMSI attach was not performed.

- 7) If a new P-TMSI or VLR TMSI was received, the MS confirms the reallocation of the TMSIs by returning a Routing Area Update Complete message to the SGSN.
- 8) The SGSN sends a TMSI Reallocation Complete message to the VLR if the MS confirms the VLR TMSI.

For some network sharing scenario (e.g. GWCN) if the PLMN-ID of the RAI supplied by the RNC is different from that of the RAI in the UE's context, then the SGSN shall inform the HLR.

If the routing area update procedure fails a maximum allowable number of times, or if the SGSN returns a Routing Area Update Reject (Cause) message, the MS shall enter IDLE state.

If the Location Update Accept message indicates a reject, this should be indicated to the MS, and the MS shall not access non-GPRS services until a successful Location Update is performed. If "SMS-Supported" is indicated to the MS the MS should not initiate Attach or Location Update with the MSC for only obtaining SMS services as SMS services via PS domain NAS are provided by the SGSN.

The CAMEL procedure calls shall be performed, see referenced procedures in TS 23.078 [8b]:

- C1) CAMEL_GPRS_Routing_Area_Update_Session, CAMEL_PS_Notification and CAMEL_GPRS_Routing_Area_Update_Context.

They are called in the following order:

- The procedure CAMEL_GPRS_Routing_Area_Update_Session is called once per session. In Figure 34, the procedure returns as result "Continue".
- Then the procedure CAMEL_PS_Notification is called. The procedure returns as result "Continue".
- Then the procedure CAMEL_GPRS_Routing_Area_Update_Context is called once per PDP context. In Figure 34, the procedure returns as result "Continue".

6.9.1.3.2 Combined Inter SGSN RA / LA Update

The Combined RA / LA Update (inter-SGSN) procedure is illustrated in Figure 35 for mobility between two Gn/Gp SGSNs and for mobility from S4-SGSN to Gn/Gp SGSN. The Inter SGSN Routeing Area Update procedure between two S4-SGSNs shows differences for the steps in the boxes (A) and (B). The Inter SGSN Routeing Area Update procedure from Gn/Gp SGSN to S4-SGSN shows differences for the steps in the box (B). These different step descriptions of the boxes are described in clause "Inter SGSN Routeing Area Update and Combined Inter SGSN RA / LA Update using S4".

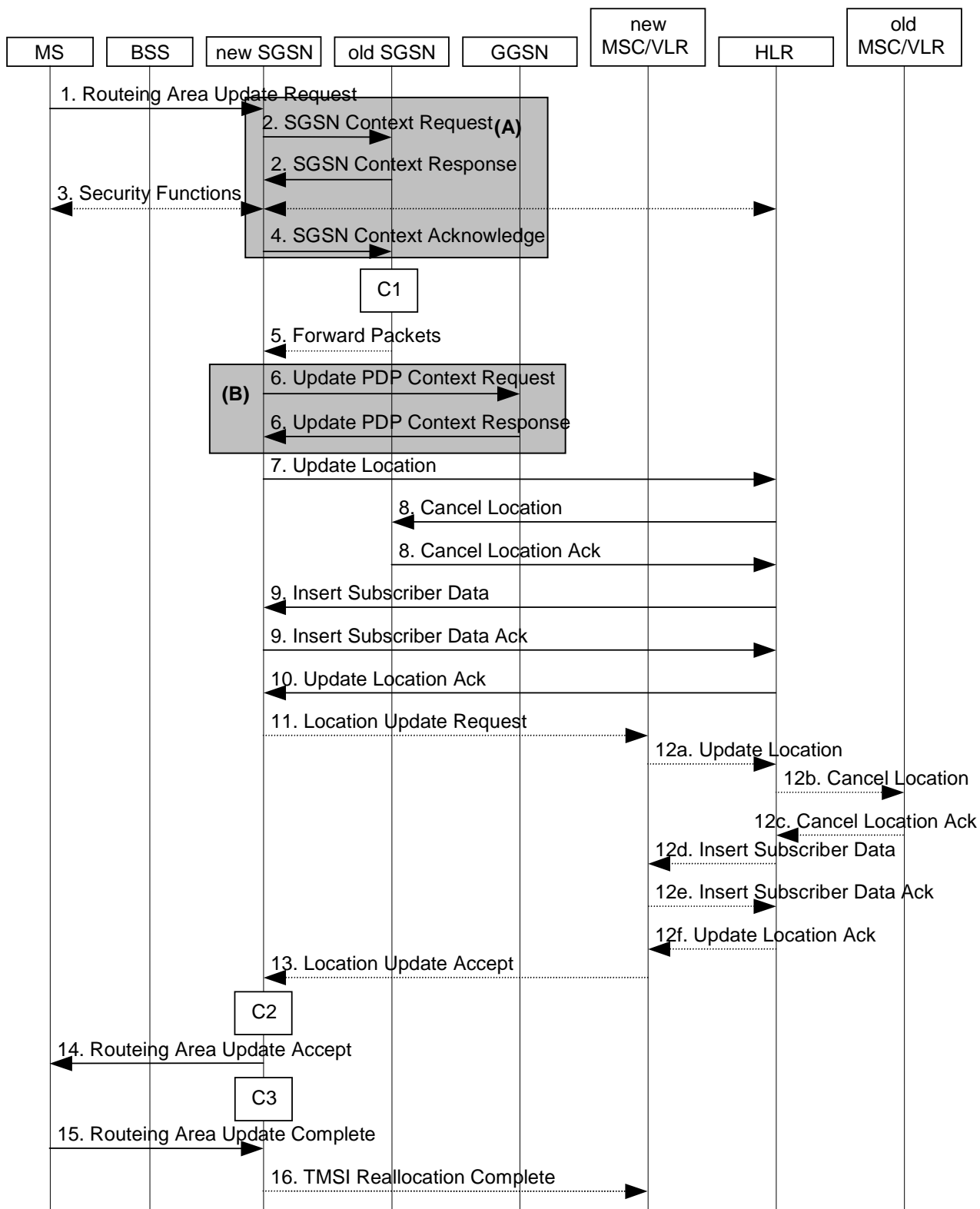

Figure 35: Combined RA / LA Update in the Case of Inter SGSN RA Update Procedure

NOTE 1: All steps in figure 35, except steps 2, 4 and 6, are common for architecture variants using Gn/Gp based and S4 based SGSN. For specific interactions with S4 based SGSNs, procedure steps (A) and (B) are defined in the clause 6.9.1.2.2a.

- 1) The MS sends a Routeing Area Update Request (old RAI, old P-TMSI Signature, Update Type, MS Radio Access Capability, DRX parameters, MS Network Capability, additional P-TMSI/RAI, Voice domain preference and UE's usage setting, SMS-only) to the new SGSN. Update Type shall indicate combined RA / LA update, or, if the MS wants to perform an IMSI attach, combined RA / LA update with IMSI attach requested. The BSS shall add the Cell Global Identity including the RAC and LAC of the cell where the message was received before passing the message to the SGSN. MS Radio Access Capability contains the MS GPRS multislot capabilities, supported frequency bands, etc. as defined in TS 24.008 [13]. DRX Parameters are included if the MS has altered its DRX Parameters.

If the E-UTRAN capable UE's TIN indicates "GUTI" and the UE holds a valid GUTI then the UE indicates the GUTI as the old P-TMSI and old RAI. If the UE's TIN indicates "P-TMSI" or "RAT-related TMSI" and the UE holds a valid P-TMSI and related RAI then these two elements are indicated as old P-TMSI and old RAI. Mapping a GUTI to a P-TMSI and an RAI is specified in TS 23.401 [89]. In this scenario of Combined RA/LA Update in the case of inter SGSN RAU, the TIN indicates "P-TMSI" or "RAT-related TMSI".

If the E-UTRAN capable UE holds a valid P-TMSI and related RAI then the UE indicates these parameters as additional P-TMSI/RAI, regardless whether the old P-TMSI and old RAI indicate the same parameters or parameters mapped from a GUTI.

The Gn/Gp SGSN shall ignore this additional P-TMSI/RAI.

The UE sets the voice domain preference and UE's usage setting according to its configuration, as described in clause 5.3.15.

The MS indicates its "SMS-only" capability during a combined RA / LA update when the MS is requesting the LA update or IMSI attach only for obtaining SMS and not any other services from CS domain.

- 2) The new SGSN sends SGSN Context Request (old RAI, TLLI, old P-TMSI Signature, New SGSN Address) to the old SGSN to get the MM and PDP contexts for the MS. If the new SGSN provides functionality for Intra Domain Connection of RAN Nodes to Multiple CN Nodes, the new SGSN may derive the old SGSN from the old RAI and the old P-TMSI (or TLLI) and send the SGSN Context Request message to this old SGSN. Otherwise, the new SGSN derives the old SGSN from the old RAI. In any case the new SGSN will derive an SGSN that it believes is the old SGSN. This derived SGSN is itself the old SGSN, or it is associated with the same pool area as the actual old SGSN and it will determine the correct old SGSN from the P-TMSI (or TLLI) and relay the message to that actual old SGSN. The old SGSN validates the old P-TMSI Signature and responds with an appropriate error cause if it does not match the value stored in the old SGSN. This should initiate the security functions in the new SGSN. If the security functions authenticate the MS correctly, the new SGSN shall send an SGSN Context Request (old RAI, TLLI, MS Validated, New SGSN Address) message to the old SGSN. MS Validated indicates that the new SGSN has authenticated the MS. If the old P-TMSI Signature was valid or if the new SGSN indicates that it has authenticated the MS, the old SGSN stops assigning SMDCP N-PDU numbers to downlink N-PDUs received, and responds with SGSN Context Response (MM Context, PDP Contexts, Negotiated Evolved ARP). If the MS is not known in the old SGSN, the old SGSN responds with an appropriate error cause. The old SGSN stores New SGSN Address until the old MM context is cancelled, to allow the old SGSN to forward data packets to the new SGSN. Each PDP Context includes the SMDCP Send N-PDU Number for the next downlink N-PDU to be sent in acknowledged mode to the MS, the SMDCP Receive N-PDU Number for the next uplink N-PDU to be received in acknowledged mode from the MS, the GTP sequence number for the next downlink N-PDU to be sent to the MS and the GTP sequence number for the next uplink N-PDU to be tunnelled to the GGSN. The old SGSN starts a timer and stops the downlink transfer. The new SGSN shall ignore the MS Network Capability contained in MM Context of SGSN Context Response only when it has previously received an MS Network Capability in the Routeing Area Request.

For RAU between two S4-SGSNs, the old SGSN shall include the Change Reporting Action in the Context Response message.

SMDCP and GTP sequence numbers are not relevant for a new S4-SGSN if provided by an old Gn/Gp SGSN and need not to be provided by an old S4-SGSN as the EPS network shall not configure usage of "delivery order required" and no acknowledged mode NSAPIs (SMDCP) as described in clause "Network Configuration for Interaction with E-UTRAN and S4-SGSNs".

- 3) Security functions may be executed. These procedures are defined in clause "Security Function". Ciphering mode shall be set if ciphering is supported. If the SGSN Context Response message did not include IMEISV and ADD is supported, the SGSN retrieves the IMEISV from the MS. If the security functions fail (e.g. because the SGSN cannot determine the HLR address to establish the Send Authentication Info dialogue), the Inter SGSN RAU Update procedure fails. A reject shall be returned to the MS with an appropriate cause.
- 4) The new SGSN sends an SGSN Context Acknowledge message to the old SGSN. This informs an old Gn/Gp SGSN that the new SGSN is ready to receive data packets belonging to the activated PDP contexts. Only old Gn/Gp SGSNs may forward data to a new Gn/Gp or S4-SGSN.

The old SGSN marks in its context that the MSC/VLR association and the information in the GGSNs and the HLR are invalid. This triggers the MSC/VLR, the GGSNs, and the HLR to be updated if the MS initiates a routing area update procedure back to the old SGSN before completing the ongoing routing area update procedure. If the security functions do not authenticate the MS correctly, the routing area update shall be rejected, and the new SGSN shall send a reject indication to the old SGSN. The old SGSN shall continue as if the SGSN Context Request was never received.

- 5) Only old Gn/Gp SGSNs may forward data to a new SGSN. An old Gn/Gp SGSN duplicates the buffered N-PDUs and starts tunnelling them to the new SGSN. Additional N-PDUs received from the GGSN before the timer described in step 2 expires are also duplicated and tunnelled to the new SGSN. N-PDUs that were already sent to the MS in acknowledged mode and that are not yet acknowledged by the MS are tunnelled together with the SNDCP N-PDU number. No N-PDUs shall be forwarded to the new SGSN after expiry of the timer described in step 2.

SNDCP N-PDU numbers are not relevant for S4-SGSNs as the network shall not configure usage of acknowledged mode NSAPIs (SNDCP) as described in clause "Network Configuration for Interaction with E-UTRAN and S4-SGSNs". A new S4-SGSN indicates reserved TEID and IP address parameters from an SGW to an old Gn/Gp SGSN so that the old Gn/Gp SGSN can forward data packets when needed. The SGW discards any packets received from old Gn/Gp SGSN.

- 6) The new SGSN sends Update PDP Context Request (new SGSN Address, TEID, QoS Negotiated, Negotiated Evolved ARP, serving network identity, CGI/SAI, User CSG Information, RAT type, MS Info Change Reporting support indication, NRSN) to the GGSNs concerned. The SGSN shall send the serving network identity to the GGSN. NRSN indicates SGSN support of the network requested bearer control. The inclusion of the Negotiated Evolved ARP IE indicates that the SGSN supports the Evolved ARP feature. If the new SGSN did not receive a Negotiated Evolved ARP IE in the SGSN Context Response message from the old SGSN then the new SGSN shall derive this value from the Allocation/Retention Priority of the QoS profile negotiated according to Annex E of TS 23.401 [89]. The GGSNs update their PDP context fields and return an Update PDP Context Response (TEID, Prohibit Payload Compression, APN Restriction, MS Info Change Reporting Action, CSG Information Reporting Action, BCM, Negotiated Evolved ARP). The GGSN sets the Negotiated Evolved ARP based on local policy or PCC. The Allocation/Retention Priority of the QoS Profile Negotiated is derived from the Evolved ARP according to the mapping principles of TS 23.401 [89] Annex E. The Prohibit Payload Compression indicates that the SGSN should negotiate no data compression for this PDP context. The SGSN shall apply the Negotiated Evolved ARP if received from the GGSN.
- 7) The new SGSN informs the HLR of the change of SGSN by sending Update Location (SGSN Number, SGSN Address, IMSI, IMEISV, Homogenous Support of IMS Voice over PS Sessions, UE SRVCC capability, Registration For SMS Request) to the HLR. IMEISV is sent if the ADD function is supported. If the S6d interface is used between S4-SGSN and HSS, a parameter "SMS in SGSN offered" is included in the Update Location message, otherwise this parameter is included in the Insert Subscriber Data Ack (Step 9). "SMS in SGSN offered" indicates that the SGSN supports SMS services via SGSN.

For "Homogenous Support of IMS Voice over PS Sessions", see clause 5.3.8A.

NOTE 2: As this is an A/Gb mode RAU procedure, and the T-ADS feature requires distinct GERAN and UTRAN Routing Areas, per-MS checking of the support of "IMS voice over PS Session" is not needed in this procedure.

If the MS performs the Routing Area Update procedure in a VPLMN supporting Autonomous CSG Roaming and the HPLMN has enabled Autonomous CSG Roaming in the VPLMN (via Service Level Agreement) and the SGSN needs to retrieve the CSG subscription information of the MS from the CSS, the SGSN initiates the Update CSG Location Procedure with CSS as described in clause 6.16.

- 8) The HLR sends Cancel Location (IMSI, Cancellation Type) to the old SGSN with Cancellation Type set to Update Procedure. If the timer described in step 2 is not running, the old SGSN removes the MM and PDP contexts/EPS Bearer Contexts and an old S4-SGSN releases in addition the S-GW resources when the new SGSN is a Gn/Gp SGSN or when an S-GW change is performed. GTPv1 SGSN context transfer signalling indicates to the old S4-SGSN that the new SGSN is a Gn/Gp SGSN, which does not signal any S-GW change. When the timer described in step 2 is running, the MM and PDP/EPS Bearer Contexts and any affected S-GW resources are removed when the timer expires. The old S4-SGSN deletes S-GW bearer resources by sending Delete Session Request (Cause, Operation Indication) messages to the SGW. If ISR is activated the Cause indicates that the old S-GW shall delete the bearer resources on the other old CN node by sending Delete Bearer Request message to the other CN node. The Operation Indication flag is not set by the old S4-SGSN. This indicates to the S-GW that the S-GW shall not initiate a delete procedure towards the PDN GW.

The timer started in step 2 allows the old SGSN to complete the forwarding of N-PDUs. It also ensures that the MM and PDP contexts/EPS Bearer Contexts are kept in the old SGSN in case the MS initiates another inter SGSN routing area update before completing the ongoing routing area update to the new SGSN. The old SGSN acknowledges with Cancel Location Ack (IMSI).

- 9) The HLR sends Insert Subscriber Data (IMSI, Subscription Data) to the new SGSN. The new SGSN validates the MS's presence in the (new) RA. If due to regional subscription restrictions or access restrictions the MS is not allowed to be attached in the RA, the SGSN rejects the Routing Area Update Request with an appropriate cause, and may return an Insert Subscriber Data Ack (IMSI, SGSN Area Restricted) message to the HLR. If all checks are successful, the SGSN constructs an MM context for the MS and returns an Insert Subscriber Data Ack (IMSI, SMS in SGSN offered) message to the HLR. The "SMS in SGSN offered" indicates if the SGSN supports SMS services via NAS. If the S6d interface is used between S4-SGSN and HSS the messages "Insert Subscriber Data" and "Insert Subscriber Data Ack" are not used. Instead the Subscription Data is sent by HSS in the message Update Location Ack (Step 10).
- 10) The HLR acknowledges the Update Location by sending Update Location Ack (IMSI, GPRS Subscriber Data (only if S6d interface is used)) to the new SGSN. If the HLR accepts to register the SGSN identity for terminating SMS services, then the HLR cancels the serving MSC if there is a serving MSC.
- 11) If the association has to be established, if Update Type indicates combined RA / LA update with IMSI attach requested, or if the LA changed with the routing area update, the new SGSN sends a Location Update Request (new LAI, IMSI, SGSN Number, Location Update Type) to the VLR. Location Update Type shall indicate IMSI attach if Update Type in step 1 indicated combined RA / LA update with IMSI attach requested. Otherwise, Location Update Type shall indicate normal location update. When the SGSN does not provide functionality for the Intra Domain Connection of RAN Nodes to Multiple CN Nodes, the VLR number is derived from the RAI. When the SGSN provides functionality for Intra Domain Connection of RAN Nodes to Multiple CN Nodes, the SGSN uses the RAI and a hash value from the IMSI to determine the VLR number. The SGSN starts the location update procedure towards the new MSC/VLR upon receipt of the first Insert Subscriber Data message from the HLR in step 9). The VLR creates or updates the association with the SGSN by storing SGSN Number.

This step is not performed if:

- Subscription Data indicate by the Network Access Mode information that the subscription has no CS subscriber data; or
- Subscription Data have an HSS indication of "SMS in SGSN Support" and the subscription allows SMS services and the MS indicated SMS-only and the SGSN provides SMS services via PS domain NAS.

- 12) If the subscriber data in the VLR is marked as not confirmed by the HLR, the new VLR informs the HLR. The HLR cancels the old VLR and inserts subscriber data in the new VLR:
- a) The new VLR sends an Update Location (new VLR) to the HLR.
 - b) The HLR cancels the data in the old VLR by sending Cancel Location (IMSI) to the old VLR.
 - c) The old VLR acknowledges with Cancel Location Ack (IMSI).
 - d) The HLR sends Insert Subscriber Data (IMSI, subscriber data) to the new VLR.
 - e) The new VLR acknowledges with Insert Subscriber Data Ack (IMSI).
 - f) The HLR responds with Update Location Ack (IMSI) to the new VLR.

If the MS performs the Combined RA / LA Update procedure in a VPLMN supporting Autonomous CSG Roaming and the HPLMN has enabled Autonomous CSG Roaming in the VPLMN (via Service Level Agreement) and the VLR needs to retrieve the CSG subscription information of the MS from the CSS, the VLR initiates the Update CSG Location Procedure with CSS as described in clause 6.16.

- 13) The new VLR allocates a new TMSI and responds with Location Update Accept (VLR TMSI) to the SGSN. VLR TMSI is optional if the VLR has not changed.
- 14) The new SGSN validates the MS's presence in the new RA. If due to roaming restrictions or access restrictions the MS is not allowed to be attached in the RA, or if subscription checking fails, the SGSN rejects the routing area update with an appropriate cause. If all checks are successful, the new SGSN establishes MM and PDP contexts/EPS Bearer Contexts for the MS. A logical link is established between the new SGSN and the MS. The new SGSN responds to the MS with Routing Area Update Accept (P-TMSI, VLR TMSI, P-TMSI Signature, Receive N-PDU Number, IMS voice over PS Session Supported Indication, SMS-Supported, Cause). Receive N-PDU Number contains the acknowledgements for each acknowledged-mode NSAPI used by the MS, thereby confirming all mobile-originated N-PDUs successfully transferred before the start of the update procedure. The IMS voice over PS Session Supported Indication is set as described in clause 5.3.8.

ISR Activated is never indicated in case of inter SGSN RAU as described in TS 23.401 [89]. The E-UTRAN capable UE sets its TIN to "P-TMSI" or "RAT-related TMSI" as described for Routing Area Update procedures in TS 23.401 [89].

"SMS-Supported" is indicated to the MS when the HSS has indicated "SMS in SGSN Support". It indicates to the MS that it can obtain SMS services via PS domain NAS from the SGSN. An MS that needs only PS and SMS services via NAS should not perform any procedures via CS domain when it can obtain SMS services via PS domain NAS from SGSN. If step 11 was not performed, e.g. due to Subscription Data indicate by the Network Access Mode information that the subscription has no CS subscriber data, then SGSN indicates that the Attach was successful for GPRS only and a Cause indicates why the IMSI attach was not performed.

- 15) The MS confirms the reallocation of the TMSIs by returning a Routing Area Update Complete (Receive N-PDU Number) message to the SGSN. Receive N-PDU Number contains the acknowledgements for each acknowledged-mode NSAPI used by the MS, thereby confirming all mobile-terminated N-PDUs successfully transferred before the start of the update procedure. If Receive N-PDU Number confirms reception of N-PDUs that were forwarded from the old SGSN, these N-PDUs shall be discarded by the new SGSN. LLC and SNDPCP in the MS are reset.
- 16) The new SGSN sends a TMSI Reallocation Complete message to the new VLR if the MS confirms the VLR TMSI.

For a rejected routing area update operation, due to regional subscription, roaming restrictions, access restrictions (see clause 5.3.19) or because the SGSN cannot determine the HLR address to establish the locating updating dialogue, the new SGSN should not construct an MM context. In the case of receiving the subscriber data from HLR, the new SGSN may construct an MM context and store the subscriber data for the MS to optimize signalling between the SGSN and the HLR. A reject shall be returned to the MS with an appropriate cause. Upon return to idle, the MS shall act according to TS 23.122 [7b].

If the new SGSN is unable to update the PDP context/EPS Bearer Context in one or more GGSNs/P-GWs, the new SGSN shall deactivate the corresponding PDP contexts/EPS Bearer Contexts as described in clause "SGSN-initiated PDP Context Deactivation Procedure". This shall not cause the SGSN to reject the routing area update.

The PDP Contexts/EPS Bearer Contexts shall be sent from old to new SGSN in a prioritized order, i.e. the most important PDP Context/EPS Bearer Context first in the SGSN Context Response message. (The prioritization method is implementation dependent, but should be based on the current activity).

The new SGSN shall determine the Maximum APN restriction based on the received APN Restriction of each PDP context/EPS Bearer Context for using S4 from the GGSN/P-GW or old S4-SGSN and then store the new Maximum APN restriction value.

If the new SGSN is unable to support the same number of active PDP contexts/EPS Bearer Contexts as received from old SGSN, the new SGSN should use the prioritisation sent by old SGSN as input when deciding which PDP contexts/EPS Bearer Contexts to maintain active and which ones to delete. In any case, the new SGSN shall first update all contexts in one or more GGSNs/EPS Bearer Context and then deactivate the context(s) that it cannot maintain as described in clause "SGSN-initiated PDP Context Deactivation Procedure". This shall not cause the SGSN to reject the routing area update.

If the routing area update procedure fails a maximum allowable number of times, or if the SGSN returns a Routing Area Update Reject (Cause) message, the MS shall enter IDLE state.

If the timer described in step 2 expires and no Cancel Location (IMSI) was received from the HLR, the old SGSN shall stop forwarding N-PDUs to the new SGSN.

If the Location Update Accept message indicates a reject, this should be indicated to the MS, and the MS shall not access non-GPRS services until a successful location update is performed. If "SMS-Supported" is indicated to the MS the MS should not initiate Location Update or IMSI attach with the MSC for only obtaining SMS services as SMS services via PS domain NAS are provided by the SGSN.

The CAMEL procedure calls shall be performed, see referenced procedures in TS 23.078 [8b]:

C1) CAMEL_GPRS_PDP_Context_Disconnection, CAMEL_GPRS_Detach and CAMEL_PS_Notification.

They are called in the following order:

- The CAMEL_GPRS_PDP_Context_Disconnection procedure is called several times: once per PDP context. The procedure returns as result "Continue".

- Then the CAMEL_GPRS_Detach procedure is called once. The procedure returns as result "Continue".

- Then the CAMEL_PS_Notification procedure is called once. The procedure returns as result "Continue".

C2) CAMEL_GPRS_Routeing_Area_Update_Session and CAMEL_PS_Notification.

They are called in the following order:

- The CAMEL_GPRS_Routeing_Area_Update_Session procedure is called. The procedure returns as result "Continue".

- Then the CAMEL_PS_Notification procedure is called. The procedure returns as result "Continue".

C3) CAMEL_GPRS_Routeing_Area_Update_Context.

This procedure is called several times: once per PDP context. It returns as result "Continue".

6.9.2 Location Management Procedures (Iu-mode)

In the context of this specification, the terms RNS or RNC refer also to a GERAN BSS or BSC (respectively) when serving an MS in Iu mode.

Refer to TS 25.301 [50] for further information on the location management procedures for the UTRAN.

The PLMN shall provide information for the MS to be able to:

- detect when it has entered a new cell or a new RA; and
- determine when to perform periodic RA updates.

In this specification, only the Location Management procedures related to the CN are described. These procedures are:

- a routing area update procedure; and
- Serving RNC relocation procedure.

An MS detects entering a new cell by comparing the cell's identity with the cell identity stored in the MS. By comparing the RAI stored in the MS's MM context with the RAI received from the network, the MS detects that an RA update shall be performed. In RRC-CONNECTED mode (PMM-CONNECTED state or CS MM CONNECTED state), the MS is informed of RAI and Cell Identity by the serving RNC via an "MM information" message at the RRC layer. In RRC-IDLE state, the MS is informed of RAI and Cell Identity by the broadcast system information at the RRC layer.

If the MS enters a new PLMN, the MS shall perform a routing area update, unless it is not allowed to do so for the reasons specified in TS 24.008 [13] and TS 23.122 [7b], or it is an MS configured to perform Attach with IMSI at PLMN change.

In network mode of operation II, whenever an MS that needs only PS and NAS based SMS services determines that it shall perform both an LA update/IMSI attach and an RA update/GPRS attach, the MS shall complete the RA update / GPRS attach first before initiating the LA update/ IMSI attach. If the GPRS Attach or RA update procedure indicates that NAS based SMS is supported by the PS domain, such an MS determines that no LA update / IMSI Attach is required.

In network mode of operation II, whenever an MS that needs PS services and CS services other than NAS based SMS determines that it shall perform both an LA update and an RA update, the MS shall start the LA update first. The MS should start the RA update procedure before the LA update is completed.

6.9.2.1 Routeing Area Update Procedure

A Routeing Area Update takes place when an attached MS detects:

- that it has entered a new RA (except for the case of an MS configured to perform GPRS Attach with IMSI when entering an RA in a new non-equivalent PLMN in RRC-IDLE mode, in which case, a GPRS Attach shall be performed);
- when the periodic RA update timer has expired;
- when RRC connection is released with cause "Directed Signalling connection re-establishment";
- when the MS has to indicate changed access capabilities or new DRX parameters to the network;
- for a UE supporting CS fallback, or configured to support IMS voice, or both, a change of the UE's usage setting or voice domain preference for E-UTRAN;
- for an SR-VCC capable MS, the MS has changed its MS Classmark 2, or MS Classmark 3, or Supported Codec information;
- when the MS reselects GERAN/UTRAN with the TIN indicating "GUTI";
- the RRC layer in an E-UTRAN capable UE informs the UE's NAS layer that an RRC connection failure occurred in E-UTRAN and this led the MS to select a GERAN/UTRAN cell;
- that it has manually selected a CSG cell whose CSG ID and associated PLMN is absent from both the MS's Allowed CSG list and the MS's Operator CSG list; or
- that it is registered for IMS voice and has moved from a RAT that supports IMS voice over PS sessions (see clause 5.3.8 for more information) to one that does not, or vice versa. It shall be possible, using Device Management or initial provisioning to configure the UE to apply/not apply this particular exception.

NOTE 1: A UE moving between RATs that both support IMS voice over PS sessions, or, both that do not support IMS voice over PS sessions, is unaffected by the above.

- MS receives a paging request from the SGSN while the Mobility Management back off timer is running and the MS's TIN indicates "GUTI".

The SGSN detects that it is an intra-SGSN routeing area update by noticing that it also handles the old RA. In this case, the SGSN has the necessary information about the MS and there is no need to inform the GGSNs or the HLR about the new MS location. A periodic RA update is always an intra-SGSN routeing area update. If the network operates in mode I, an MS that is in CS/PS mode of operation shall perform the Combined RA / LA Update procedures except this CS/PS mode MS is engaged in a CS connection, then it shall perform (non combined) RA Update procedures. When a EPS and IMSI attached MS camps on UTRAN/GERAN and the E-UTRAN periodic TAU timer expires and the TIN indicates "RAT Related TMSI", the MS shall perform combined RA/LA update procedure.

In Iu mode, an RA update is either an intra-SGSN or inter-SGSN RA update, either combined RA / LA update or only RA update, either initiated by an MS in PMM-CONNECTED or in PMM-IDLE state. The SRNC may provide a PMM-CONNECTED state MS with MM information like RAI by dedicated signalling. Typically, the SRNC should not provide a RAI to an MS in PMM-CONNECTED state. An exception is after an SRNS relocation, in which case the new SRNC shall indicate the RAI to the MS.

During the Routing Area Update procedure, the MS provides its PS Handover capabilities as defined in TS 24.008 [13].

During the Routing Area Update procedure, if the SGSN supports SRVCC and if the UE SRVCC capability has changed, it notifies the HSS with the UE SRVCC capability via Update Location Request or Notify Request message, and the HSS stores this information e.g. for further IMS registration.

All the RA update cases are contained in the procedure illustrated in Figure 36.

Figure 36 illustrates mobility between two Gn/Gp SGSNs and mobility from S4-SGSN to Gn/Gp SGSN. The Inter SGSN Routing Area Update procedure between two S4-SGSNs shows differences for the steps in the boxes (A) and (B). The Inter SGSN Routing Area Update procedure from Gn/Gp SGSN to S4-SGSN shows differences for the steps in the box (B). These different step descriptions of the boxes are described in clause 6.9.2.1a "Routing Area Update Procedure using S4".

NOTE 2: The network may receive an RA update from a UE in PMM-CONNECTED state over a new Iu signalling connection. This could happen when the UE enters PMM-IDLE state on receipt of RRC Connection Release with cause "Directed Signalling connection re-establishment" and initiates an RA or Combined RA update procedure (see clause 6.1.2.4.1).

If LIPA is active for a PDN connection of the MS, the source Gn-SGSN shall not include LIPA bearer(s) in the PDP context during Routing Area Update procedure and shall release the core network resources of the LIPA PDN connections by performing the SGSN-initiated PDP Context Deactivation according to step A of clause 9.2.4.2 subsequent to the completion of the routing area update procedure. If LIPA is active for a PDN connection of the MS, the source S4-SGSN shall release the core network resources of the LIPA PDN connection by performing the SGSN-initiated PDP Context Deactivation according to step A of clause 9.2.4.2 before sending the Context Response.

NOTE 3: The source S4-SGSN may not be able to release the LIPA PDN connection after the Context Response is sent as the SGW will assign the S4 control plane tunnel of the UE to the new S4-SGSN.

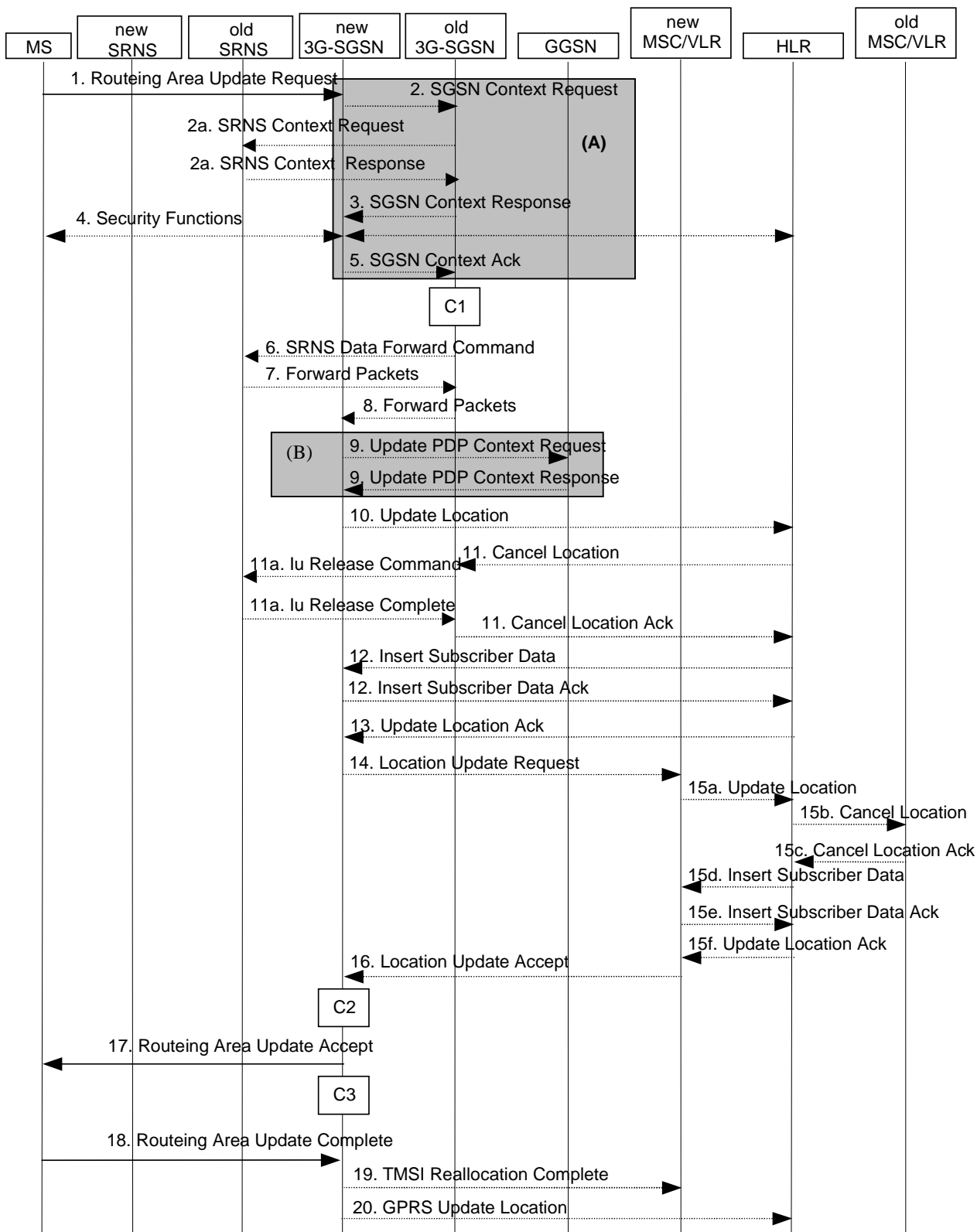

Figure 36: Iu mode RA Update Procedure

NOTE 1: All steps in figure 36, except steps 2, 3, 5 and 9, are common for architecture variants using Gn/Gp based and S4 based SGSNs. For specific interactions with S4 based SGSNs, procedure steps (A) and (B) are defined in the clause 6.9.2.1a.

NOTE 2: For Emergency Attach, an MS which is not successfully authenticated, steps 10, 11, 12, 13 and 14 are not performed.

- 1) The RRC connection is established, if not already done. The MS sends a Routeing Area Update Request message (P-TMSI, old RAI, old P-TMSI Signature, Update Type, follow on request, MS Radio Access Capability, DRX Parameters, MS Network Capability, additional P-TMSI/RAI, Voice domain preference and UE's usage setting, SMS-only) to the new SGSN. The MS shall set a follow-on request if there is pending uplink traffic (signalling or user data). The SGSN may use, as an implementation option, the follow-on request indication to release or keep the Iu connection after the completion of the RA update procedure. Update Type shall indicate:
- RA Update if the RA Update is triggered by a change of RA;
 - Periodic RA Update if the RA update is triggered by the expiry of the Periodic RA Update timer;
 - Combined RA / LA Update if the MS is also IMSI-attached and the LA update shall be performed in network operation mode I (see clause "Interactions Between SGSN and MSC/VLR"); or
 - Combined RA / LA Update with IMSI attach requested if the MS wants to perform an IMSI attach in network operation mode I.

The SRNC shall add the Routeing Area Identity before forwarding the message to the 3G-SGSN. This RA identity corresponds to the RAI in the MM system information sent by the SRNC to the MS. CSG ID is indicated if the MS sends the RAU Request message via a CSG cell or a hybrid cell. CSG access mode is provided if the MS sends the RAU Request message via a hybrid cell. If the CSG access mode is not provided but the CSG ID is provided, the SGSN shall consider the cell as a CSG cell.

MS Radio Access Capability is described in clause "MS Network Capability". The DRX Parameters contain information about DRX cycle length for GERAN, UTRAN and possibly other RATs, e.g. E-UTRAN.

If the E-UTRAN capable UE's TIN indicates "GUTI" and the UE holds a valid GUTI then the UE indicates the GUTI as the old P-TMSI and old RAI. If the UE's TIN indicates "P-TMSI" or "RAT-related TMSI" and the UE holds a valid P-TMSI and related RAI then these two elements are indicated as old P-TMSI and old RAI. Mapping a GUTI to a P-TMSI and an RAI is specified in TS 23.401 [89]. In this scenario of Iu mode RAU, the TIN indicates "P-TMSI" or "RAT-related TMSI".

If the E-UTRAN capable UE holds a valid P-TMSI and related RAI then the UE indicates these parameters as additional P-TMSI/RAI, regardless whether the old P-TMSI and old RAI indicate the same parameters or parameters mapped from a GUTI.

The Gn/Gp SGSN shall ignore this additional P-TMSI/RAI.

The UE sets the voice domain preference and UE's usage setting according to its configuration, as described in clause 5.3.15.

The MS indicates its "SMS-only" capability during a combined RA/LA update when the MS is requesting LA update or IMSI attach only for obtaining SMS and not any other services from CS domain.

NOTE 3: Sending the Routeing Area Update Request message to the SGSN triggers the establishment of a signalling connection between RAN and SGSN for the concerned MS.

- 2) If the RA update is an Inter-SGSN Routeing area update and if the MS was in PMM-IDLE state, the new SGSN sends an SGSN Context Request message (old P-TMSI, old RAI, old P-TMSI Signature) to the old SGSN to get the MM and PDP contexts for the MS. If the new SGSN provides functionality for Intra Domain Connection of RAN Nodes to Multiple CN Nodes, the new SGSN may derive the old SGSN from the old RAI and the old P-TMSI and send the SGSN Context Request message to this old SGSN. Otherwise, the new SGSN derives the old SGSN from the old RAI. In any case the new SGSN will derive an SGSN that it believes is the old SGSN. This derived SGSN is itself the old SGSN, or it is associated with the same pool area as the actual old SGSN and it will determine the correct old SGSN from the P-TMSI and relay the message to that actual old SGSN. The old SGSN validates the old P-TMSI Signature and responds with an appropriate error cause if it does not match the value stored in the old SGSN. This should initiate the security functions in the new SGSN. If the security functions authenticate the MS correctly, the new SGSN shall send an SGSN Context Request (IMSI, old RAI, MS Validated) message to the old SGSN. MS Validated indicates that the new SGSN has authenticated the MS. If the old P-TMSI Signature was valid or if the new SGSN indicates that it has authenticated the MS, the old SGSN starts a timer. If the MS is not known in the old SGSN, the old SGSN responds with an appropriate error cause.

If the UE with emergency bearers is not authenticated in the old SGSN (in a network supporting unauthenticated UEs) the old SGSN continues the procedure with sending a Context Response and starting the timer also when it cannot validate the Context Request.

- 2a) If the MS is PMM-CONNECTED state in the old 3G-Gn/Gp-SGSN or, in case of an intra-Gn/Gp-SGSN RA update, if the MS is in the PMM-CONNECTED state and the RAU was received over another Iu connection than the established one, the old Gn/Gp SGSN sends an SRNS Context Request message to the old SRNS to retrieve the sequence numbers for the PDP context for inclusion in the SGSN Context Response message. Upon reception of this message, the SRNS buffers and stops sending downlink PDUs to the MS and returns an SRNS Context Response (IMSI, GTP-SNDs, GTP-SNUs, PDCP-SNUs) message. The SRNS shall include for each PDP context the next in-sequence GTP sequence number to be sent to the MS and the GTP sequence number of the next uplink PDU to be tunnelled to the GGSN. For each active PDP context which uses lossless PDCP, the SRNS also includes the uplink PDCP sequence number (PDCP-SNU). PDCP-SNU shall be the next in-sequence PDCP sequence number expected from the MS (per each active radio bearer). No conversion of PDCP sequence numbers to SNDCP sequence numbers shall be done in the 3G-SGSN.

SNDCP, GTP and PDCP sequence numbers are not relevant for the S4-SGSN as the network shall not configure usage of "delivery order required", no acknowledged mode NSAPIs (SNDCP) and also not loss less UTRAN PDCP as described in clause "Network Configuration for Interaction with E-UTRAN and S4-SGSNs".

- 3) The old 3G-SGSN responds with an SGSN Context Response (MM Context, PDP Contexts, Negotiated Evolved ARP) message. For each PDP context the old 3G-SGSN shall include the GTP sequence number for the next uplink GTP PDU to be tunnelled to the GGSN and the next downlink GTP sequence number for the next PDU to be sent to the MS. Each PDP Context also includes the PDCP sequence numbers if PDCP sequence numbers are received from the old SRNS. The new 3G-SGSN shall ignore the MS Network Capability contained in MM Context of SGSN Context Response only when it has previously received an MS Network Capability in the Routeing Area Request. The GTP sequence numbers received from the old 3G-SGSN are only relevant if delivery order is required for the PDP context (QoS profile).

If the UE receives emergency services from the old 3G Gn/Gp-SGSN and the UE is UICCless, IMSI can not be included in the MM and PDP contexts in SGSN Context Response message. For emergency attached UEs if the IMSI cannot be authenticated then the IMSI shall be marked as unauthenticated.

For RAU between two S4-SGSNs, the old SGSN shall include the Change Reporting Action in the Context Response message.

- 4) Security functions may be executed. These procedures are defined in clause "Security Function". If the SGSN Context Response message did not include IMEISV and ADD is supported, the SGSN retrieves the IMEISV from the MS. If the security functions do not authenticate the MS correctly, the routeing area update shall be rejected, and the new SGSN shall send a reject indication to the old SGSN. The old SGSN shall continue as if the SGSN Context Request was never received.

If the new SGSN is configured to allow emergency services for unauthenticated MS the new SGSN behave as follows:

- where a MS has only emergency bearer services, the SGSN either skips the authentication and security setup or accepts that the authentication may fail and continues the Routeing area update procedure, or.
- where a MS has both emergency and non emergency bearer services and authentication fails, the SGSN continues the Routing Area Update procedure and deactivates all the non-emergency PDP contexts as specified in clause 9.2.4.2.

- 5) If the RA update is an Inter-SGSN Routeing area update, the new SGSN sends an SGSN Context Acknowledge message to the old SGSN. This informs an old Gn/Gp SGSN that the new SGSN is ready to receive data packets belonging to the activated PDP contexts. Only old Gn/Gp SGSNs may forward data to a new Gn/Gp or S4-SGSN. A new S4-SGSN indicates reserved TEID and IP address parameters from an SGW to an old Gn/Gp SGSN so that the old Gn/Gp SGSN can forward data packets when needed. The SGW discards any packets received from old Gn/Gp SGSN.

The old SGSN marks in its context that the MSC/VLR association and the information in the GGSNs and the HLR are invalid. This triggers the MSC/VLR, the GGSNs, and the HLR to be updated if the MS initiates a routeing area update procedure back to the old SGSN before completing the ongoing routeing area update procedure.

- 6) If the MS is in PMM-CONNECTED state in the old 3G-Gn/Gp-SGSN or, in case of an intra-Gn/Gp-SGSN RA update, if the MS is PMM connected and the RAU was received over another Iu connection than the established one, the old 3G-Gn/Gp-SGSN sends an SRNS Data Forward Command (RAB ID, Transport Layer Address, Iu Transport Association) message to the SRNS. Upon receipt of the SRNS Data Forward Command message from the 3G-SGSN, the SRNS shall start the data-forwarding timer.
- 7) For each indicated RAB the SRNS starts duplicating and tunnelling the buffered GTP PDUs to the old 3G-Gn/Gp-SGSN. For each radio bearer which uses lossless PDCP the SRNS shall start tunnelling the partly transmitted and the transmitted but not acknowledged PDCP-PDUs together with their related PDCP sequence numbers and start duplicating and tunnelling the buffered GTP PDUs to the old 3G-Gn/Gp-SGSN. Upon receipt of the SRNS Data Forward Command message from the 3G-Gn/Gp-SGSN, the SRNS shall start the data-forwarding timer.
- 8) If the RA update is an Inter-SGSN RA Update, the old 3G-SGSN tunnels the GTP PDUs to the new 3G-SGSN. No conversion of PDCP sequence numbers to SMDCP sequence numbers shall be done in the 3G-SGSN.
- 9) If the RA update is an Inter-SGSN RA Update and if the MS was not in PMM-CONNECTED state in the new 3G-SGSN, the new SGSN sends Update PDP Context Request (new SGSN Address, QoS Negotiated, Negotiated Evolved ARP, Tunnel Endpoint Identifier, serving network identity, CGI/SAI, RAT type, MS Info Change Reporting support indication, NRSN) to the GGSNs concerned. The SGSN shall send the serving network identity to the GGSN. NRSN indicates SGSN support of the network requested bearer control. The inclusion of the Negotiated Evolved ARP IE indicates that the SGSN supports the Evolved ARP feature. If the new SGSN did not receive a Negotiated Evolved ARP IE in the SGSN Context Response message from the old SGSN then the new SGSN shall derive this value from the Allocation/Retention Priority of the QoS profile negotiated according to Annex E of TS 23.401 [89]. The GGSNs update their PDP context fields and return an Update PDP Context Response (Tunnel Endpoint Identifier, Prohibit Payload Compression, APN Restriction, MS Info Change Reporting Action, CSG Information Reporting Action, BCM, Negotiated Evolved ARP). The GGSN sets the Negotiated Evolved ARP based on local policy or PCC. The Allocation/Retention Priority of the QoS Profile Negotiated is derived from the Evolved ARP according to the mapping principles of TS 23.401 [89], Annex E. The Prohibit Payload Compression indicates that the SGSN should negotiate no data compression for this PDP context. The SGSN shall apply the Negotiated Evolved ARP if received from the GGSN.

NOTE 4: If the RA update is an Inter-SGSN routing area update initiated by an MS in PMM-CONNECTED state in the new 3G-SGSN, the Update PDP Context Request message is sent as described in clause "Serving RNS Relocation Procedures".

- 10) If the RA update is an Inter-SGSN RA Update, the new SGSN informs the HLR of the change of SGSN by sending Update Location (SGSN Number, SGSN Address, IMSI, IMEISV, Homogenous Support of IMS Voice over PS Sessions, UE SRVCC capability, Registration For SMS Request) to the HLR. IMEISV is sent if the ADD function is supported. The "Homogenous Support of IMS Voice over PS Sessions" indication (see clause 5.3.8A) shall not be included unless the SGSN has completed its evaluation of the support of "IMS voice over PS Session" as specified in clause 5.3.8. If the S6d interface is used between S4-SGSN and HSS, a parameter "SMS in SGSN offered" is included in the Update Location message, otherwise this parameter is included in the Insert Subscriber Data Ack (Step 12). "SMS in SGSN offered" indicates that the SGSN supports SMS services via SGSN.

NOTE 5: At this step, the SGSN may not have all the information needed to determine the setting of the IMS voice over PS Session Supported indication for this MS (see clause 5.3.8). Hence the SGSN can send the "Homogenous Support of IMS Voice over PS Sessions" later on in this procedure.

If the MS performs the Routing Area Update procedure in a VPLMN supporting Autonomous CSG Roaming and the HPLMN has enabled Autonomous CSG Roaming in the VPLMN (via Service Level Agreement) and the SGSN needs to retrieve the CSG subscription information of the MS from the CSS, the SGSN initiates the Update CSG Location Procedure with CSS as described in clause 6.16.

- 11) If the RA update is an Inter-SGSN RA Update, the HLR sends Cancel Location (IMSI, Cancellation Type) to the old SGSN with Cancellation Type set to Update Procedure. If the timer described in step 2 is not running, the old SGSN removes the MM and PDP context/EPS Bearer Contexts and an old S4-SGSN releases in addition the S-GW resources when the new SGSN is a Gn/Gp SGSN or when an S-GW change is performed. GTPv1 SGSN context transfer signalling indicates to the old S4-SGSN that the new SGSN is a Gn/Gp SGSN, which does not signal any S-GW change. When the timer described in step 2 is running the MM and PDP/EPS Bearer Contexts and any affected S-GW resources are removed when the timer expires and the SGSN received a Cancel Location. The old S4-SGSN deletes S-GW bearer resources by sending Delete Session Request (Cause,

Operation Indication) messages to the SGW. If ISR is activated the Cause indicates that the old S-GW shall delete the bearer resources on the other old CN node by sending Delete Bearer Request message to the other CN node. The Operation Indication flag is not set by the old S4-SGSN. This indicates to the S-GW that the S-GW shall not initiate a delete procedure towards the PDN GW.

When the timer described in step 2 expires and no Cancel Location was received the S4-SGSN removes the PDP contexts/EPS Bearer Contexts but preserves the MM context.

The timer started in step 2 ensures that the MM and PDP contexts/EPS Bearer Contexts are kept in the old SGSN in case the MS initiates another inter SGSN routing area update before completing the ongoing routing area update to the new SGSN. The old SGSN acknowledges with Cancel Location Ack (IMSI).

- 11a) On receipt of Cancel Location, if the MS is PMM-CONNECTED in the old 3G-SGSN, the old 3G-SGSN sends an Iu Release Command message to the old SRNC. When the data-forwarding timer has expired, the SRNS responds with an Iu Release Complete message.
- 12) If the RA update is an inter-SGSN RA Update, the HLR sends Insert Subscriber Data (IMSI, subscription data) to the new SGSN. The new SGSN validates the MS's presence in the (new) RA. If due to regional subscription restrictions or access restrictions (e.g. CSG restrictions) the MS is not allowed to be attached in the RA, the SGSN rejects the Routing Area Update Request with an appropriate cause, and may return an Insert Subscriber Data Ack (IMSI, SGSN Area Restricted) message to the HLR. If the network supports the MOCN configuration for network sharing, the SGSN may, if the MS is not a 'Network Sharing Supporting MS', in this case decide to initiate redirection by sending a Reroute Command to the RNS, as described in TS 23.251 [83] instead of rejecting the Routing Area Update Request. If all checks are successful, the SGSN constructs an MM context for the MS and returns an Insert Subscriber Data Ack (IMSI, SMS in SGSN offered) message to the HLR. The "SMS in SGSN offered" indicates that the SGSN supports SMS services via NAS. If the S6d interface is used between S4-SGSN and HSS the messages "Insert Subscriber Data" and "Insert Subscriber Data Ack" are not used. Instead the Subscription Data is sent by HSS in the message Update Location Ack (Step 13). The subscription data may contain the CSG subscription data for the PLMN.

If the MS initiates the RAU procedure at a CSG cell, the new SGSN shall check whether the CSG ID and associated PLMN and associated PLMN is contained in the CSG subscription and is not expired. If the CSG ID and associated PLMN is not present or expired, the SGSN shall send a RAU reject message to the MS with an appropriate cause value. The MS shall remove the CSG ID and associated PLMN from its Allowed CSG list, if present.

- 13) If the RA update is an Inter-SGSN RA Update, the HLR acknowledges the Update Location by sending Update Location Ack (IMSI, GPRS Subscriber Data (only if S6d interface is used)) to the new SGSN. If the HLR accepts to register the SGSN identity for terminating SMS services, then the HLR cancels the serving MSC if there is a serving MSC.
- 14) If Update Type indicates combined RA / LA update with IMSI attach requested, or if the LA changed with the routing area update, the association has to be established, and the new SGSN sends a Location Update Request (new LAI, IMSI, SGSN Number, Location Update Type) to the VLR. Location Update Type shall indicate IMSI attach if Update Type in step 1 indicated combined RA / LA update with IMSI attach requested. Otherwise, Location Update Type shall indicate normal location update. When the SGSN does not provide functionality for the Intra Domain Connection of RAN Nodes to Multiple CN Nodes, the VLR number is derived from the RAI. When the SGSN provides functionality for Intra Domain Connection of RAN Nodes to Multiple CN Nodes, the SGSN uses the RAI and a hash value from the IMSI to determine the VLR number. The SGSN starts the location update procedure towards the new MSC/VLR upon receipt of the first Insert Subscriber Data message from the HLR in step 8). The VLR creates or updates the association with the SGSN by storing SGSN Number. In networks that support network sharing, the Location Update Request includes the identity of the selected core network operator if the SGSN has received this information from the RNS, as described in TS 23.251 [83].

This step is not performed if:

- Subscription Data indicate by the Network Access Mode information that the subscription has no CS subscriber data; or
- Subscription Data have an HSS indication of "SMS in SGSN Support" and the subscription allows SMS services and the MS indicated SMS-only and the SGSN provides SMS services via PS domain NAS.

- 15) If the subscriber data in the VLR is marked as not confirmed by the HLR, the new VLR informs the HLR. The HLR cancels the old VLR and inserts subscriber data in the new VLR:

- a) The new VLR sends an Update Location (new VLR) to the HLR.
- b) The HLR cancels the data in the old VLR by sending Cancel Location (IMSI) to the old VLR.
- c) The old VLR acknowledges with Cancel Location Ack (IMSI).
- d) The HLR sends Insert Subscriber Data (IMSI, subscriber data) to the new VLR.
- e) The new VLR acknowledges with Insert Subscriber Data Ack (IMSI).
- f) The HLR responds with Update Location Ack (IMSI) to the new VLR.

If the MS performs the Routing Area Update procedure in a VPLMN supporting Autonomous CSG Roaming and the HPLMN has enabled Autonomous CSG Roaming in the VPLMN (via Service Level Agreement) and the VLR needs to retrieve the CSG subscription information of the MS from the CSS, the VLR initiates the Update CSG Location Procedure with CSS as described in clause 6.16.

- 16) The new VLR allocates a new TMSI and responds with Location Update Accept (VLR TMSI) to the SGSN. VLR TMSI is optional if the VLR has not changed.
- 17) The new SGSN validates the MS's presence in the new RA. If due to roaming restrictions or access restrictions (e.g. CSG restrictions) the MS is not allowed to be attached in the RA, or if subscription checking fails, the SGSN rejects the routing area update with an appropriate cause. If the network supports the MOCN configuration for network sharing, the SGSN may, if the MS is not a 'Network Sharing Supporting MS', in this case decide to initiate redirection by sending a Reroute Command to the RNS, as described in TS 23.251 [83] instead of rejecting the routing area update. If all checks are successful, the new SGSN establishes MM and PDP contexts/EPS Bearer Contexts for the MS. The new SGSN responds to the MS with Routing Area Update Accept (P-TMSI, VLR TMSI, P-TMSI Signature, IMS voice over PS Session Supported Indication, Emergency Service Support, SMS-Supported, Cause). The IMS voice over PS Session Supported Indication is set as described in clause 5.3.8.

If the SGSN did not receive the Voice Support Match Indicator in the MM Context, then the SGSN sends a UE Radio Capability Match Request to the RAN as described in clause 6.9.5. If the SGSN has not received Voice Support Match Indicator from the RAN then, based on implementation, SGSN may set IMS Voice over PS session supported Indication and update it at a later stage.

ISR Activated is never indicated in case of inter SGSN RAU as described in TS 23.401 [89]. The E-UTRAN capable UE sets its TIN to "P-TMSI" or "RAT-related TMSI" as described for Routing Area Update procedures in TS 23.401 [89].

If ISR is activated for the MS when the S4-SGSN receives the Routing Area Update Request in the intra SGSN scenario, the S4-SGSN should maintain ISR by indicating ISR Activated in the Routing Area Update Accept message.

If RAU procedure is initiated by manual CSG selection and occurs via a CSG cell, the MS upon receiving the RAU Accept message shall add the CSG ID and associated PLMN to its Allowed CSG list if it is not already present. Manual CSG selection is not supported if the MS has emergency bearers established.

If the user plane setup is performed in conjunction with the RAU Accept message and the RAU is performed via a hybrid cell, then the SGSN shall send an indication whether the UE is a CSG member to the RAN along with the RANAP message. Based on this information the RAN may perform differentiated treatment for CSG and non-CSG members.

NOTE 6: If the UE receives a RAU Accept message via a hybrid cell, the UE does not add the corresponding CSG ID and associated PLMN to its Allowed CSG list. Adding a CSG ID and associated PLMN to the UE's local Allowed CSG list for a hybrid cell is performed only by OTA or OMA DM procedures.

The Emergency Service Support indicator informs the MS that Emergency PDP contexts are supported, i.e. the MS is allowed to request activation of emergency PDP context when needed.

If due to regional subscription restrictions, or not allowed CSG, an MS with ongoing emergency bearer service is not allowed to access the RA or CSG cell the SGSN shall accept the Routing Area Update Request and deactivate the non-emergency PDP context as specified in clause 9.2.4.2. If the Routing Area Update procedure is initiated in PMM-IDLE/STANDBY state, all non-emergency PDP Contexts are deactivated by the Routing

Area Update procedure without PDP Context deactivation signalling between the SGSN and the MS. The MS shall be prevented from accessing GERAN in case of emergency bearer services.

"SMS-Supported" is indicated to the MS when the HSS has indicated "SMS in SGSN Support". It indicates to the MS that it can obtain SMS services via PS domain NAS from the SGSN. An MS that needs only PS and SMS services via NAS should not perform any procedures via CS domain when it can obtain SMS services via PS domain NAS from SGSN. If step 14 was not performed, e.g. due to Subscription Data indicate by the Network Access Mode information that the subscription has no CS subscriber data, then SGSN indicates that the Attach was successful for GPRS only and a Cause indicates why the IMSI attach was not performed.

- 18) The MS confirms the reallocation of the TMSIs by returning a Routeing Area Update Complete message to the SGSN.
- 19) The new SGSN sends a TMSI Reallocation Complete message to the new VLR if the MS confirms the VLR TMSI.
- 20) After step 10, and in parallel to any of the preceding steps, the SGSN shall send either a GPRS Update Location (Homogeneous Support of IMS Voice over PS Sessions) to the HLR or, when the S6d interface is used, a Notify Request (Homogeneous Support of IMS Voice over PS Sessions) message to the HSS:
 - if the SGSN has evaluated the support of IMS Voice over PS Sessions, see clause 5.3.8, and
 - if the SGSN determines that it needs to update the Homogeneous Support of IMS Voice over PS Sessions, see clause 5.3.8A.

NOTE 7: Steps 15, 16, and 19 are performed only if step 14 is performed.

NOTE 8: The new SGSN may initiate RAB establishment after execution of the security functions (step 4), or wait until completion of the RA update procedure. For the MS, RAB establishment may occur anytime after the RA update request is sent (step 1).

For of a rejected routeing area update operation, due to regional subscription, roaming restrictions, or access restrictions (see clause 5.3.19) the new SGSN should not construct an MM context. In the case of receiving the subscriber data from HLR, the new SGSN may construct an MM context and store the subscriber data for the MS to optimize signalling between the SGSN and the HLR. A reject shall be returned to the MS with an appropriate cause and the PS signalling connection shall be released. Upon return to idle, the MS shall act according to TS 23.122 [7b]. If the network supports the MOCN configuration for network sharing, the SGSN may, if the MS is not a 'Network Sharing Supporting MS', in this case decide to initiate redirection by sending a Reroute Command to the RNS, as described in TS 23.251 [83] instead of rejecting the routeing area update.

If the new SGSN is unable to update the PDP context/EPS Bearer Context in one or more GGSNs/P-GWs, the new SGSN shall deactivate the corresponding PDP contexts/EPS Bearer Contexts as described in clause "SGSN-initiated PDP Context Deactivation Procedure". This shall not cause the SGSN to reject the routeing area update.

The PDP Contexts/EPS Bearer Contexts shall be sent from old to new SGSN in a prioritized order, i.e. the most important PDP Context/EPS Bearer Context first in the SGSN Context Response message. (The prioritization method is implementation dependent, but should be based on the current activity).

The new SGSN shall determine the Maximum APN restriction based on the received APN Restriction of each PDP context/EPS Bearer Context for using S4 from the GGSN/P-GW or old S4-SGSN and then store the new Maximum APN restriction value.

If the new SGSN is unable to support the same number of active PDP contexts/EPS Bearer Contexts as received from old SGSN, the new SGSN should use the prioritisation sent by old SGSN as input when deciding which PDP contexts/EPS Bearer Contexts to maintain active and which ones to delete. In any case, the new SGSN shall first update all contexts in one or more GGSNs/P-GWs and then deactivate the context(s) that it cannot maintain as described in clause "SGSN-initiated PDP Context Deactivation Procedure". This shall not cause the SGSN to reject the routeing area update.

NOTE 9: If the MS was in PMM-CONNECTED state the PDP Contexts are sent already in the Forward Relocation Request message as described in clause "Serving RNS relocation procedures".

If the routeing area update procedure fails a maximum allowable number of times, or if the SGSN returns a Routeing Area Update Reject (Cause) message, the MS shall enter PMM-DETACHED state.

If the Location Update Accept message indicates a reject, this should be indicated to the MS, and the MS shall not access non-PS services until a successful location update is performed. If SMS-Supported is indicated to the MS the MS should not initiate Location Update or IMSI attach with the MSC for only obtaining SMS services as SMS services via NAS are provided by the SGSN.

The CAMEL procedure calls shall be performed, see referenced procedures in TS 23.078 [8b]:

C1) CAMEL_GPRS_PDP_Context_Disconnection, CAMEL_GPRS_Detach and CAMEL_PS_Notification.

They are called in the following order:

- The CAMEL_GPRS_PDP_Context_Disconnection procedure is called several times: once per PDP context. The procedure returns as result "Continue".

- Then the CAMEL_GPRS_Detach procedure is called once. The procedure returns as result "Continue".

- Then the CAMEL_PS_Notification procedure is called once. The procedure returns as result "Continue".

C2) CAMEL_GPRS_Routeing_Area_Update_Session and CAMEL_PS_Notification.

They are called in the following order:

- The CAMEL_GPRS_Routeing_Area_Update_Session procedure is called. The procedure returns as result "Continue".

- Then the CAMEL_PS_Notification procedure is called. The procedure returns as result "Continue".

C3) CAMEL_GPRS_Routeing_Area_Update_Context.

This procedure is called several times: once per PDP context. It returns as result "Continue".

6.9.2.1a Routeing Area Update Procedure using S4

The procedures described in figures 36a and 36b show only the steps 2, 3, 5 and 9, due to use of S4, which are different from the Gn/Gp variant of the procedure given by clause 6.9.2.1. The ISR function is deactivated in Inter-SGSN Routeing Area Update Procedures as defined in TS 23.401 [89].

NOTE 1: If the RA update is an Inter-SGSN routing area update initiated by an MS in PMM CONNECTED state in the new 3G-SGSN, step 9 is described as the step 13 in clause 6.9.2.2.1a.

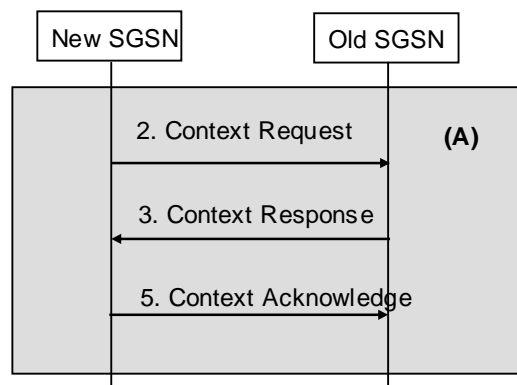

Figure 36a: Step 2, 3 and 5 for lu Mode Routeing Area Update Procedure between S4-SGSNs

2) If the RA update is an Inter-SGSN Routeing area update and if the MS was in PMM IDLE state, the new SGSN sends a Context Request message (old P TMSI, old RAI, old P TMSI Signature) to the old SGSN to get the MM and EPS Bearer contexts for the MS. If the new SGSN provides functionality for Intra Domain Connection of RAN Nodes to Multiple CN Nodes, the new SGSN may derive the old SGSN from the old RAI and the old P-TMSI and send the Context Request message to this old SGSN. Otherwise, the new SGSN derives the old SGSN from the old RAI. In any case the new SGSN will derive an SGSN that it believes is the old SGSN. This derived SGSN is itself the old SGSN, or it is associated with the same pool area as the actual old SGSN and it will determine the correct old SGSN from the P-TMSI and relay the message to that actual old SGSN. The old SGSN validates the old P TMSI Signature and responds with an appropriate error cause if it does not match the

value stored in the old SGSN. This should initiate the security functions in the new SGSN. If the security functions authenticate the MS correctly, the new SGSN shall send a Context Request (IMSI, old RAI, MS Validated) message to the old SGSN. MS Validated indicates that the new SGSN has authenticated the MS. If the old P TMSI Signature was valid or if the new SGSN indicates that it has authenticated the MS, the old SGSN starts a timer. If the MS is not known in the old SGSN, the old SGSN responds with an appropriate error cause.

If the UE with emergency bearers is not authenticated in the old MME (in a network supporting unauthenticated UEs) the old MME continues the procedure with sending a Context Response and starting the timer also when it cannot validate the Context Request.

- 3) The old 3G SGSN responds with a Context Response (MM Context, EPS Bearer Contexts) message. MM Context and EPS Bearer Context when used at the S16 interface are defined by clause 13.2.2. The new 3G-SGSN shall ignore the MS Network Capability contained in MM Context of Context Response only when it has previously received an MS Network Capability in the Routing Area Request.

If the UE receives only emergency services from the old S4-SGSN and the UE is UICCless, IMSI can not be included in the MM and PDP contexts in SGSN Context Response message. For emergency attached UEs if the IMSI cannot be authenticated then the IMSI shall be marked as unauthenticated.

For RAU between two S4-SGSNs, the old SGSN shall include the Change Reporting Action and CGI/SAI/RAI change support indication in the Context Response message.

- 5) If the RA update is an Inter-SGSN Routing area update, the new SGSN sends a Context Acknowledge message to the old SGSN. The old SGSN marks in its context that the MSC/VLR association and the information in the S-GW and the HLR are invalid. This triggers the MSC/VLR, the S-GWs, and the HLR to be updated if the MS initiates a routing area update procedure back to the old SGSN before completing the ongoing routing area update procedure.

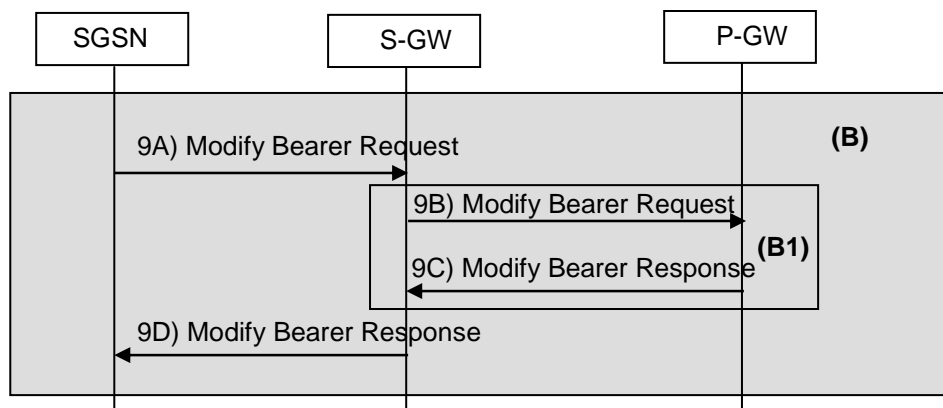

Figure 36b: Step 9 for lu Mode Routing Area Update Procedure using S4

NOTE 2: Steps 9A) and 9D) are common for architecture variants with GTP based S5/S8 and PMIP-based S5/S8. For a PMIP-based S5/S8, procedure step (B1) is defined in TS 23.402 [90]. Steps 9B) and 9C) concern GTP based S5/S8.

- 9A) If the S-GW does not change, the new SGSN update these EPS Bearer contexts by sending Modify Bearer Request (SGSN Tunnel Endpoint Identifier for Control Plane, EPS Bearer ID(s), SGSN Address for Control Plane, SGSN Address(es) and TEID(s), PDN GW addresses and TEIDs (for GTP-based S5/S8) or GRE keys (for PMIP-based S5/S8) at the PDN GW(s) for uplink traffic, serving network identity, CGI/SAI, User CSG Information, RAT type, MS Info Change Reporting support indication). The SGSN puts the according NSAPI in the field of EPS Bearer ID. If ISR is activated on the S-GW that is updated by a new SGSN then this S-GW deletes the bearer resources on the other old CN node by sending Delete Session Request message(s) to that CN node.

If ISR Activated is indicated or SGSN and SGW are configured to release S4 U-Plane when EPS Bearer Contexts associated with the released RABs are to be preserved, the SGSN does not send SGSN address and TEID for U-Plane in Modify Bearer Request. If the S-GW changes or if an S-GW needs to be allocated (Gn/Gp to S4-SGSN RAU) the SGSN selects an S-GW and sends a Create Session Request message (APN-AMBR) with the content as described for the Modify Bearer Request message to the S-GW.

For Gn/Gp to S4-SGSN RAU, the new S4-SGSN provides APN-AMBR to the Serving GW. Details on mapping MBR to APN-AMBR are specified in Annex E of TS 23.401 [89].

- 9B) If the S-GW has changed, or if an S-GW needs to be allocated (Gn/Gp to S4-SGSN RAU), or the RAT type has changed, or the S-GW received CGI/SAI from the S4-SGSN, the S-GW sends Modify Bearer Request (EPS Bearer ID(s), serving network identity, CGI/SAI, User CSG Information, RAT type, MS Info Change Reporting support indication, APN-AMBR) messages to the P-GWs involved.
- 9C) The P-GWs acknowledge with sending Modify Bearer Response (TEID, Prohibit Payload Compression, MS Info Change Reporting Action, CSG Information Reporting Action, Default Bearer id, APN-AMBR) messages to S-GW. The Prohibit Payload Compression indicates that the SGSN should negotiate no data compression for this PDP context. The default bearer id is included if the UE moves from a Gn/Gp SGSN to an S4-SGSN.
- 9D) The S-GW acknowledges the connection establishment to the new SGSN via the message Modify Bearer Response (Cause, Serving GW Tunnel Endpoint Identifier for Control Plane, Serving GW Address for Control Plane, PDN GW addresses and TEIDs (for GTP-based S5/S8) or GRE keys (for PMIP-based S5/S8) at the PDN GW(s) for uplink traffic, Prohibit Payload Compression, MS Info Change Reporting Action, CSG Information Reporting Action, Default Bearer id, APN-AMBR). If the SGSN sent a Create Session Request message the S-GW sends a Create Session Response message with the content as described for the Modify Bearer Response message to the SGSN.

6.9.2.2 Serving RNS Relocation Procedures

In the context of this specification, the terms RNS or RNC refer also to a GERAN BSS or BSC (respectively) when serving an MS in Iu mode.

Serving RNS relocation procedures move the RAN to CN connection point at the RAN side of the source RNC to the target RNC. The Serving RNS Relocation Procedures, described in the following clauses, may be performed as "Lossless SRNS Relocation", which means packet loss during the SRNS change is eliminated. For this purpose, the RNS and the MS have to provide PDCP layer functionality, which in the subsequent description is referred as the lossless PDCP. The source RNC decides to perform the Serving RNS Relocation Procedure as "Lossless SRNS Relocation" based on capabilities of the UE and the RNS and based on QoS parameters (e.g. SDU error ratio).

For "Lossless SRNS Relocation", both the MS and the source RNS have to support and to use the lossless PDCP. When the SRNS changes, the old RNS forwards all received and not yet transferred downlink GTP-PDUs to the target RNS. GTP-PDUs forwarded to the target RNS indicate a PDCP sequence number if the contained N-PDUs were sent to the MS as a PDCP-SDUs, but are not yet acknowledged by lossless PDCP. The target RNS and the MS exchange respective sequence numbers of next expected PDCP-PDUs. This process indicates PDCP-PDUs that were already successfully transferred between the MS and the source RNS for downlink and uplink directions, respectively. This also confirms all N-PDUs (PDCP-SDUs) successfully transferred before the change of the SRNS. These N-PDUs are discarded by the MS and the target RNS, respectively. The target RNS identifies the forwarded GTP-PDUs containing confirmed N-PDUs by the PDCP sequence number in the GTP-PDU. All other N-PDUs have to be transmitted via the new MS – RNS link.

For inter-PLMN handover to a CSG cell, if the source SGSN has the CSG-ID list of the target PLMN, the source SGSN shall use it to validate the CSG membership of the MS in the target CSG cell. Otherwise, based on configuration the source SGSN may allow the handover by validating the CSG membership of the MS in the target CSG cell using the CSG-ID list of the registered PLMN-ID. If neither the CSG-ID lists of the target PLMN nor the operator's configuration permission, the source SGSN shall reject the handover due to no CSG membership information of the target PLMN-ID.

NOTE 1: Inter-PLMN handover to a CSG cell in a PLMN which is not an equivalent PLMN for the UE is not supported.

NOTE 2: Inter-PLMN handover to a CSG cell of an equivalent PLMN is only supported if the CSG-ID of the cell is in the CSG-ID list of both equivalent PLMNs.

6.9.2.2.1 Serving RNS Relocation Procedure

This procedure is only performed for an MS in PMM-CONNECTED state where the Iur interface carries both the control signalling and the user data. This procedure is not applicable for GERAN.

The Serving SRNS Relocation procedure is used to move the RAN to CN connection point at the RAN side from the source SRNC to the target RNC, from a "standing still position". In the procedure, the Iu links are relocated. If the

target RNC is connected to the same SGSN as the source SRNC, an Intra-SGSN SRNS Relocation procedure is performed. If the routing area is changed, this procedure is followed by an Intra-SGSN Routing Area Update procedure. The SGSN detects an Intra-SGSN routing area update by noticing that it also handles the old RA. In this case, the SGSN has the necessary information about the MS and there is no need to inform the HLR about new location of the MS.

Figure 37 shows user data routing before SRNS relocation when source SRNC and target RNC are connected to different SGSNs. Figure 38 shows the user data routing after SRNS Relocation procedure and Routing Area Update procedure is completed. In case depicted in Figure 37 and Figure 38, the MS is in state PMM-CONNECTED.

NOTE 1: The figures showing S-GW/P-GW instead of GGSN are omitted since they are similar to figures 37 and 38.

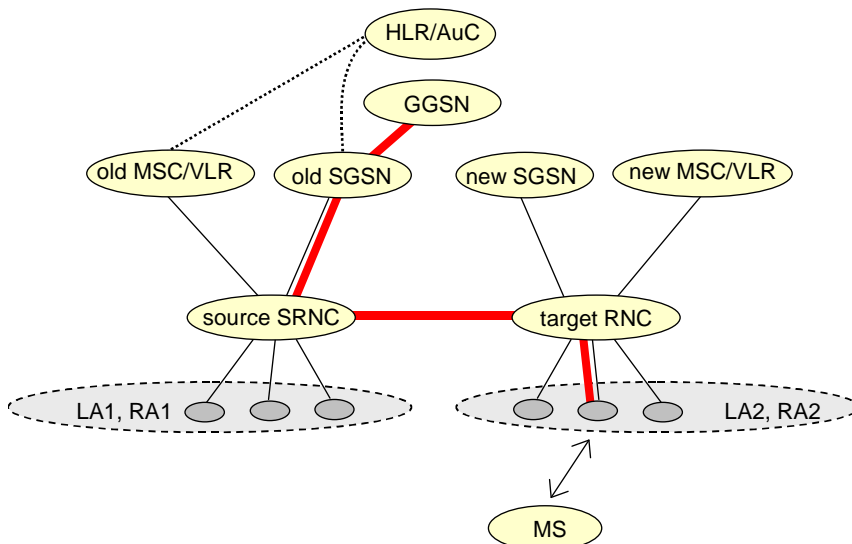

Figure 37: Before SRNS Relocation and Routing Area Update

Before the SRNS Relocation procedure and RA update, the MS is registered in the old SGSN. The source RNC is acting as a serving RNC (SRNC).

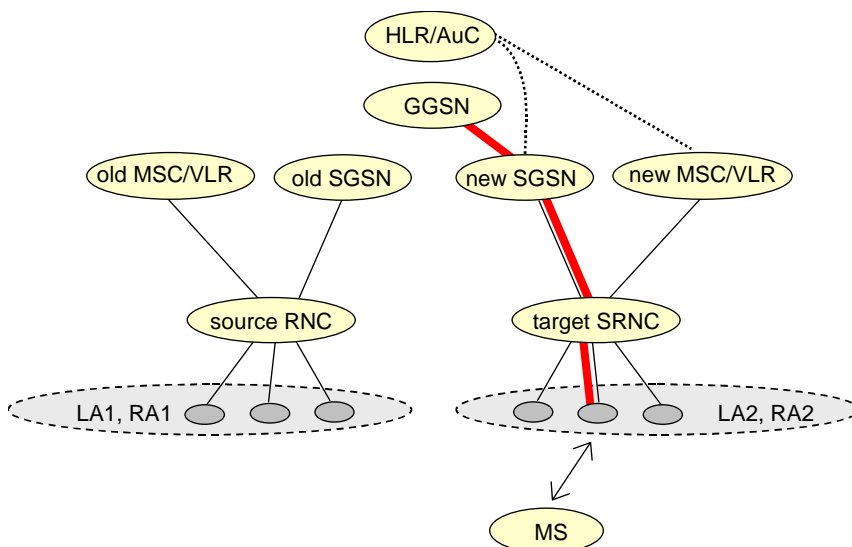

Figure 38: After SRNS Relocation and Routing Area Update

After the SRNS Relocation procedure and RA update, the MS is registered in the new SGSN. The MS is in the state PMM-CONNECTED towards the new SGSN, and the target RNC is acting as the serving RNC.

The Serving SRNS Relocation procedure is illustrated in Figure 39. The sequence is valid for both intra-SGSN SRNS relocation and inter-SGSN SRNS relocation.

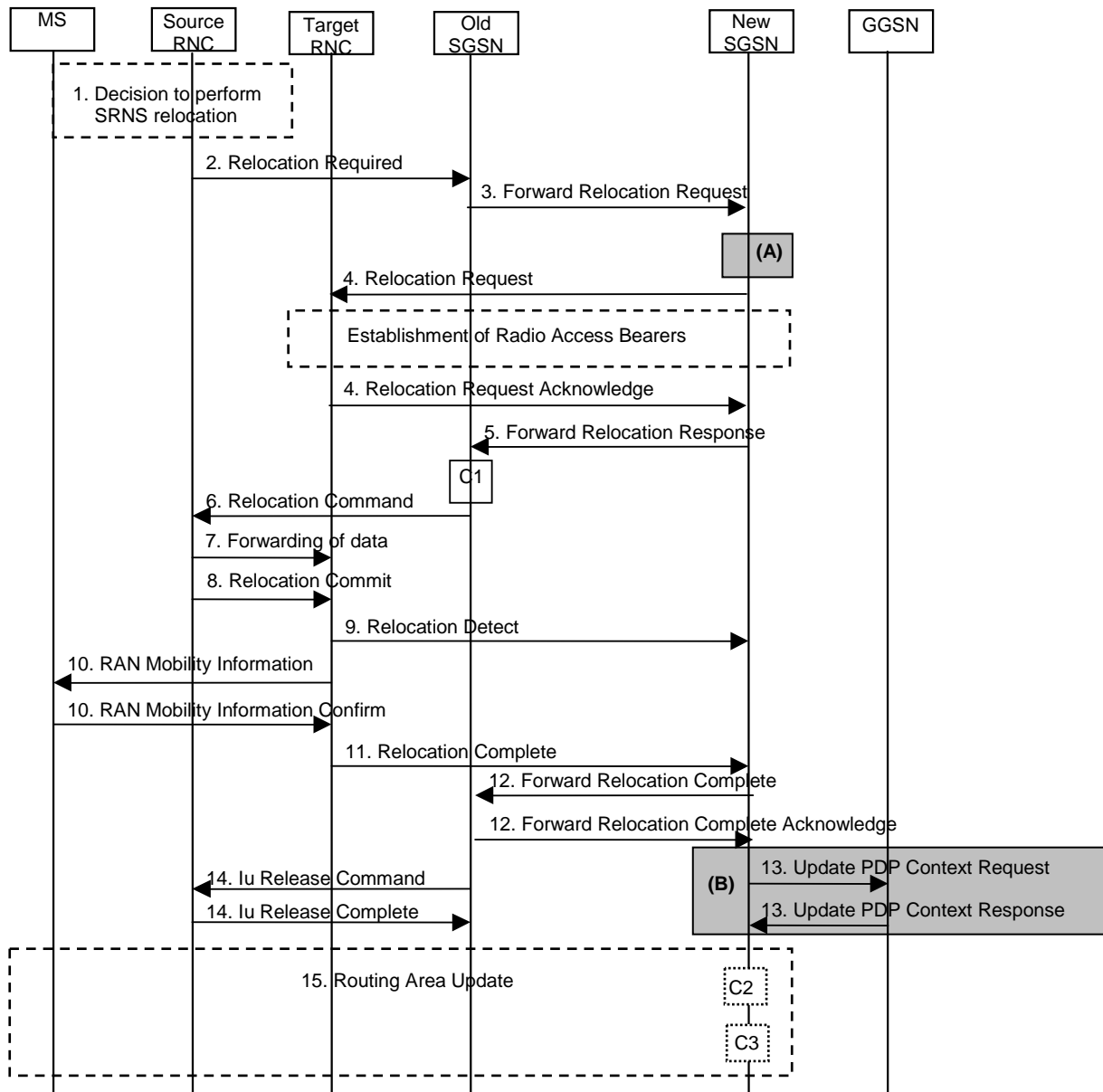

Figure 39: SRNS Relocation Procedure

NOTE 2: All steps in figure 39, except steps (A) and 13, are common for architecture variants using Gn/Gp based interaction with GGSN and using S4 based interaction with S-GW and P-GW. For an S4 based interaction with S-GW and P-GW, procedure steps (A) and (B) are defined in the clause 6.9. 2.2.1a.

- 1) The source SRNC decides to perform/initiate SRNS relocation. At this point both uplink and downlink user data flows via the following tunnel(s): Radio Bearer between MS and source SRNC (data flows via the target RNC, which acts as a drift RNC); GTP-U tunnel(s) between source SRNC and old-SGSN; GTP-U tunnel(s) between old-SGSN and GGSN. (for using S4: GTP-U tunnel(s) between old-SGSN and S-GW; GTP-U tunnel(s) between S-GW and P-GW)
- 2) The source SRNC sends a Relocation Required message (Relocation Type, Cause, Source ID, Target ID, Source RNC to target RNC transparent container) to the old SGSN. The source SRNC shall set the Relocation Type to "UE not involved". The Source SRNC to Target RNC Transparent Container includes the necessary information for Relocation co-ordination, security functionality and RRC protocol context information (including MS Capabilities).

- 3) The old SGSN determines from the Target ID if the SRNS Relocation is intra-SGSN SRNS relocation or inter-SGSN SRNS relocation. In case of inter-SGSN SRNS relocation, the old SGSN initiates the relocation resource allocation procedure by sending a Forward Relocation Request message (IMSI, Tunnel Endpoint Identifier Signalling, MM Context, PDP Context/EPS Bearer Context, Negotiated Evolved ARP, Target Identification, RAN transparent container, RANAP Cause, GCSI) to the new SGSN. If this message is sent between two S4-SGSNs, the old SGSN shall include APN Restriction and Change Reporting Action in this message. MM Context and EPS Bearer Context when used at the S16 interface are defined by clause 13.2.2. For relocation to an area where Intra Domain Connection of RAN Nodes to Multiple CN Nodes is used, the old SGSN may – if it provides Intra Domain Connection of RAN Nodes to Multiple CN Nodes have multiple target SGSNs for each relocation target in a pool area, in which case the old SGSN will select one of them to become the new SGSN, as specified in TS 23.236 [73].

If at least one of the two SGSNs is a Gn/Gp SGSN then PDP context is indicated. An S4-SGSN derives from GTPv1 Forward Relocation signalling that the other SGSN is a Gn/Gp SGSN, which also does not signal any S-GW change. The PDP context contains GGSN Address for User Plane and Uplink TEID for Data (to this GGSN Address and Uplink TEID for Data the old SGSN and the new SGSN send uplink packets).

At the same time a timer is started on the MM and PDP contexts/EPS Bearer Contexts in the old SGSN (see the Routing Area Update procedure in clause "Location Management Procedures (Iu mode)"). The Forward Relocation Request message is applicable only in the case of inter-SGSN SRNS relocation. The old SGSN 'sets' the GCSI flag if the MM context contains GPRS CAMEL Subscription Information.

If the UE receives only emergency services from the old SGSN and the UE is UICCless, IMSI can not be included in Forward Relocation Request message. For emergency attached UEs if the IMSI cannot be authenticated then the IMSI shall be marked as unauthenticated.

- 4) The new SGSN sends a Relocation Request message (Permanent NAS UE Identity (if available), MSISDN, Cause, CN Domain Indicator, Source-RNC to target RNC transparent container, RABs to be setup (APN, Charging characteristics), UE-AMBR, Service Handover related info) to the target RNC. Only the Iu Bearers of the RABs are setup between the target RNC and the new-SGSN as the existing Radio Bearers will be reallocated between the MS and the target RNC when the target RNC takes the role of the serving RNC. For each requested RAB, the RABs to be setup information elements shall contain information such as RAB ID, RAB parameters, Transport Layer Address, and Iu Transport Association. SGSN shall not establish RABs for PDP contexts/EPS Bearer Contexts for using S4 with maximum bit rate for uplink and downlink of 0 kbit/s. . The list of RABs requested by the new SGSN may differ from list of RABs established in the Source RNC contained in the Source-RNC to target RNC transparent container. The target RNC shall not establish the RABs (as identified from the Source-RNC to target RNC transparent container) that did not exist in the source RNC prior to the relocation. The RAB ID information element contains the NSAPI value, and the RAB parameters information element gives the QoS profile. The Transport Layer Address is the SGSN Address for user data, and the Iu Transport Association corresponds to the uplink Tunnel Endpoint Identifier Data. The new SGSN may decide to establish Direct Tunnel unless it has received a 'set' GCSI flag from the old SGSN. If the new SGSN decides to establish Direct Tunnel, it provides to the target RNC the GGSN's Address for User Plane and TEID for Uplink data. For using S4, if the new SGSN decides to establish Direct Tunnel, it provides to the target RNC the S-GW's Address for User Plane and TEID for Uplink data. If the Access Restriction is present in the MM context, the Service Handover related information shall be included by new S4-SGSN for the Relocation Request message in order for RNC to restrict the UE in connected mode to handover to the RAT prohibited by the Access Restriction. MSISDN, APN and Charging characteristics are optional parameters and only transferred if SGSN supports SIPTO at Iu-ps.

After all necessary resources for accepted RABs including the Iu user plane are successfully allocated; the target RNC shall send the Relocation Request Acknowledge message (RABs setup, RABs failed to setup) to the new SGSN. Each RAB to be setup is defined by a Transport Layer Address, which is the target RNC Address for user data, and an Iu Transport Association, which corresponds to the downlink Tunnel Endpoint Identifier for user data. For each RAB to be set up, the target RNC may receive simultaneously downlink user packets both from the source SRNC and from the new SGSN.

- 5) When resources for the transmission of user data between the target RNC and the new SGSN have been allocated and the new SGSN is ready for relocation of SRNS, the Forward Relocation Response message (Cause, RANAP Cause, and RAB Setup Information) is sent from the new SGSN to old SGSN. This message indicates that the target RNC is ready to receive from source SRNC the forwarded downlink PDUs, i.e. the relocation resource allocation procedure is terminated successfully. RANAP Cause is information from the target RNC to be forwarded to the source SRNC. The RAB Setup Information, one information element for each RAB, contains the RNC Tunnel Endpoint Identifier and the RNC IP address for data forwarding from the source SRNC

to the target RNC. If the target RNC or the new SGSN failed to allocate resources, the RAB Setup Information element contains only NSAPI indicating that the source SRNC shall release the resources associated with the NSAPI. The Forward Relocation Response message is applicable only in case of inter-SGSN SRNS relocation.

- 6) The old SGSN continues the relocation of SRNS by sending a Relocation Command message (RABs to be released, and RABs subject to data forwarding) to the source SRNC. The old SGSN decides the RABs to be subject for data forwarding based on QoS, and those RABs shall be contained in RABs subject to data forwarding. For each RAB subject to data forwarding, the information element shall contain RAB ID, Transport Layer Address, and Iu Transport Association. These are the same Transport Layer Address and Iu Transport Association that the target RNC had sent to new SGSN in Relocation Request Acknowledge message, and these are used for forwarding of downlink N-PDU from source SRNC to target RNC. The source SRNC is now ready to forward downlink user data directly to the target RNC over the Iu interface. This forwarding is performed for downlink user data only.
- 7) The source SRNC may, according to the QoS profile, begin the forwarding of data for the RABs to be subject for data forwarding. The data forwarding at SRNS relocation shall be carried out through the Iu interface, meaning that the data exchanged between the source SRNC and the target RNC are duplicated in the source SRNC and routed at IP layer towards the target RNC. For each radio bearer which uses lossless PDCP the GTP-PDUs related to transmitted but not yet acknowledged PDCP-PDUs are duplicated and routed at IP layer towards the target RNC together with their related downlink PDCP sequence numbers. The source RNC continues transmitting duplicates of downlink data and receiving uplink data. Before the serving RNC role is not yet taken over by target RNC and when downlink user plane data starts to arrive to target RNC, the target RNC may buffer or discard arriving downlink GTP-PDUs according to the related QoS profile.

NOTE 3: The order of steps, starting from step 7 onwards, does not necessarily reflect the order of events. For instance, source RNC may start data forwarding (step 7) and send Relocation Commit message (step 8) almost simultaneously except in the delivery order required case where step 7 triggers step 8. Target RNC may send Relocation Detect message (step 9) and RAN Mobility Information message (step 10) at the same time. Hence, target RNC may receive RAN Mobility Information Confirm message (step 10) while data forwarding (step 7) is still underway, and before the new SGSN receives Update PDP Context Response message (step 11).

- 8) Before sending the Relocation Commit the uplink and downlink data transfer in the source, SRNC shall be suspended for RABs, which require delivery order. The source RNC shall start the data-forwarding timer. When the source SRNC is ready, the source SRNC shall trigger the execution of relocation of SRNS by sending a Relocation Commit message (SRNS Contexts) to the target RNC over the Iur interface. The purpose of this procedure is to transfer SRNS contexts from the source RNC to the target RNC, and to move the SRNS role from the source RNC to the target RNC. SRNS contexts are sent for each concerned RAB and contain the sequence numbers of the GTP-PDUs next to be transmitted in the uplink and downlink directions and the next PDCP sequence numbers that would have been used to send and receive data from the MS. For PDP context(s) using delivery order not required (QoS profile), the sequence numbers of the GTP-PDUs next to be transmitted are not used by the target RNC. PDCP sequence numbers are only sent by the source RNC for radio bearers, which used lossless PDCP (see TS 25.323 [57]). The use of lossless PDCP is selected by the RNC when the radio bearer is set up or reconfigured.

If delivery order is required (QoS profile), consecutive GTP-PDU sequence numbering shall be maintained throughout the lifetime of the PDP context(s). Therefore, during the entire SRNS relocation procedure for the PDP context(s) using delivery order required (QoS profile), the responsible GTP-U entities (RNCs and GGSN) shall assign consecutive GTP-PDU sequence numbers to user packets belonging to the same PDP context for uplink and downlink, respectively.

- 9) The target RNC shall send a Relocation Detect message to the new SGSN when the relocation execution trigger is received. For SRNS relocation type "UE not involved", the relocation execution trigger is the reception of the Relocation Commit message from the Iur interface. When the Relocation Detect message is sent, the target RNC shall start SRNC operation.
- 10) The target SRNC sends a RAN Mobility Information message. This message contains UE information elements and CN information elements. The UE information elements include among others new SRNC identity and S-RNTI. The CN information elements contain among others Location Area Identification and Routing Area Identification. The procedure shall be co-ordinated in all Iu signalling connections existing for the MS.

The target SRNC establishes and/or restarts the RLC, and exchanges the PDCP sequence numbers (PDCP-SNU, PDCP-SND) between the target SRNC and the MS. PDCP-SND is the PDCP sequence number for the next expected in-sequence downlink packet to be received in the MS per radio bearer, which used lossless PDCP in the source RNC. PDCP-SND confirms all mobile-terminated packets successfully transferred before the SRNC relocation. If PDCP-SND confirms reception of packets that were forwarded from the source SRNC, the target SRNC shall discard these packets. PDCP-SNU is the PDCP sequence number for the next expected in-sequence uplink packet to be received in the RNC per radio bearer, which used lossless PDCP in the source RNC. PDCP-SNU confirms all mobile originated packets successfully transferred before the SRNC relocation. If PDCP-SNU confirms reception of packets that were received in the source SRNC, the MS shall discard these packets.

Upon reception of the RAN Mobility Information message the MS may start sending uplink user data to the target SRNC. When the MS has reconfigured itself, it sends the RAN Mobility Information Confirm message to the target SRNC. This indicates that the MS is also ready to receive downlink data from the target SRNC.

If new the SGSN has already received the Update PDP Context Response message from the GGSN, it shall forward the uplink user data to GGSN over this new GTP-U tunnel. Otherwise, the new SGSN shall forward the uplink user data to that GGSN IP address and TEID(s), which the new SGSN had received earlier by the Forward Relocation Request message.

For using S4, if new the SGSN has already received the Modify Bearer Response message from the S-GW, it shall forward the uplink user data to S-GW over this new GTP-U tunnel. Otherwise, the new SGSN shall forward the uplink user data to that S-GW IP address and TEID(s), which the new SGSN had received earlier by the Forward Relocation Request message.

For all RABs, the target RNC should:

- start uplink reception of data and start transmission of uplink GTP-PDUs towards the new SGSN;
- start processing the already buffered and the arriving downlink GTP-PDUs and start downlink transmission towards the MS.

- 11) When the target SRNC receives the RAN Mobility Information Confirm message, i.e. the new SRNC—ID + S-RNTI are successfully exchanged with the MS by the radio protocols, the target SRNC shall initiate the Relocation Complete procedure by sending the Relocation Complete message to the new SGSN. The purpose of the Relocation Complete procedure is to indicate by the target SRNC the completion of the relocation of the SRNS to the CN.
- 12) Upon receipt of Relocation Complete message, if the SRNS Relocation is an inter SGSN SRNS relocation, the new SGSN signals to the old SGSN the completion of the SRNS relocation procedure by sending a Forward Relocation Complete message.
- 13) Upon receipt of the Relocation Complete message, the CN shall switch the user plane from the source RNC to the target SRNC. If the SRNS Relocation is an inter-SGSN SRNS relocation or if Direct Tunnel was established in intra-SGSN SRNS relocation, the new SGSN sends Update PDP Context Request messages (new SGSN Address, SGSN Tunnel Endpoint Identifier, QoS Negotiated, Negotiated Evolved ARP, serving network identity, CGI/SAI, RAT type, MS Info Change Reporting support indication, NRSN, DTI) to the GGSNs concerned. The SGSN shall send the serving network identity to the GGSN. If Direct Tunnel is established the SGSN provides to GGSN the RNC's Address for User Plane and TEID for Downlink data and shall include the DTI to instruct the GGSN to apply Direct Tunnel specific error handling procedure as described in clause 13.8. NRSN indicates SGSN support of the network requested bearer control. The inclusion of the Negotiated Evolved ARP IE indicates that the SGSN supports the Evolved ARP feature. If the new SGSN did not receive a Negotiated Evolved ARP IE in the SGSN Forward Relocation Request message from the old SGSN then the new SGSN shall derive this value from the Allocation/Retention Priority of the QoS profile negotiated according to Annex E of TS 23.401 [89]. The GGSNs update their PDP context fields and return an Update PDP Context Response (GGSN Tunnel Endpoint Identifier, Prohibit Payload Compression, APN Restriction, MS Info Change Reporting Action, CSG Information Reporting Action, BCM, and Negotiated Evolved ARP) message. The GGSN sets the Negotiated Evolved ARP based on local policy or PCC. The Allocation/Retention Priority of the QoS Profile Negotiated is derived from the Evolved ARP according to the mapping principles of TS 23.401 [89], Annex E. The Prohibit Payload Compression indicates that the SGSN should negotiate no data compression for this PDP context. The SGSN shall apply the Negotiated Evolved ARP if received from the GGSN.

- 14) Upon receiving the Relocation Complete message or if it is an inter-SGSN SRNS relocation; the Forward Relocation Complete message, the old SGSN sends an Iu Release Command message to the source RNC. When the RNC data-forwarding timer has expired the source RNC responds with an Iu Release Complete.

An old S4-SGSN starts a timer to supervise when resources in old Serving GW (in case of Serving GW change or in case of S4 to Gn/Gp SGSN change) shall be released. When this timer expires the old S4-SGSN releases the S-GW resources. The old S4-SGSN deletes S-GW bearer resources by sending Delete Session Request (Cause, Operation Indication) messages to the SGW. If ISR is activated the Cause indicates that the old S-GW shall delete the bearer resources on the other old CN node by sending Delete Bearer Request message to the other CN node. The Operation Indication flag is not set by the old S4-SGSN. This indicates to the S-GW that the S-GW shall not initiate a delete procedure towards the PDN GW.

- 15) After the MS has finished the RNTI reallocation procedure and if the new Routing Area Identification is different from the old one, the MS initiates the Routing Area Update procedure. See clause "Location Management Procedures (Iu mode)". Note that it is only a subset of the RA update procedure that is performed, since the MS is in PMM-CONNECTED mode.

The new SGSN shall determine the Maximum APN restriction based on the received APN Restriction of each PDP context/EPS Bearer context for using S4 from the GGSN/P-GW or old S4-SGSN for using S4 and then store the new Maximum APN restriction value.

If the SRNS Relocation is inter-SGSN, then the following CAMEL procedure calls shall be performed (see referenced procedures in TS 23.078 [8b]):

- C1) CAMEL_GPRS_PDP_Context_Disconnection, CAMEL_GPRS_Detach and CAMEL_PS_Notification.

They are called in the following order:

- The CAMEL_GPRS_PDP_Context_Disconnection procedure is called several times: once per PDP context. The procedure returns as result "Continue".
- Then the CAMEL_GPRS_Detach procedure is called once. The procedure returns as result "Continue".
- Then the CAMEL_PS_Notification procedure is called once. The procedure returns as result "Continue".

If the SRNS Relocation is intra-SGSN, then the above mentioned CAMEL procedures calls shall not be performed.

If Routing Area Update occurs, the SGSN shall determine whether Direct Tunnel can be used based on the received GPRS CAMEL Subscription Information. If Direct Tunnel can not be maintained the SGSN shall re-establish RABs and initiate the Update PDP Context procedure to update the IP Address and TEID for Uplink and Downlink data.

If Routing Area Update occurs, then the following CAMEL procedure calls shall be performed (see referenced procedures in TS 23.078 [8b]):

- C2) CAMEL_GPRS_Routing_Area_Update_Session and CAMEL_PS_Notification.

They are called in the following order:

- The CAMEL_GPRS_Routing_Area_Update_Session procedure is called. The procedure returns as result "Continue".
- Then, the CAMEL_PS_Notification procedure is called. The procedure returns as result "Continue".

- C3) CAMEL_GPRS_Routing_Area_Update_Context.

This procedure is called several times: once per PDP context. It returns as result ""Continue"".

For C2 and C3: refer to Routing Area Update procedure description for detailed message flow.

6.9.2.2.1a Serving RNS Relocation Procedure, Combined Hard Handover and SRNS Relocation Procedure, and Combined Cell / URA Update and SRNS Relocation Procedure Using S4

The procedures described in figures 39a and 39b shows only the steps (A) and 13, due to use of S4, which are different from the Gn/Gp variant of the procedure given by clauses 6.9.2.2.1, 6.9.2.2.2 and 6.9.2.2.3.

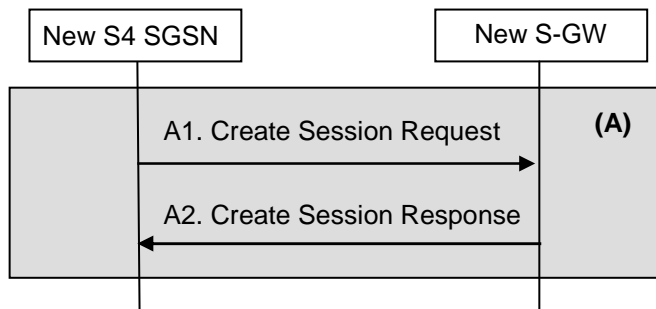

Figure 39a: Steps 9A) for Serving RNS Relocation Procedure, Combined Hard Handover and SRNS Relocation Procedure, and Combined Cell / URA Update and SRNS Relocation Procedure Using S4

A1. The new S4-SGSN determines if the Serving GW is to be allocated or relocated, e.g., due to PLMN change or due to change from Gn/Gp to S4-SGSN. If a new Serving GW is needed or if the Serving GW changes, the new SGSN selects the new Serving GW as described in TS 23.401 [89] under clause 4.3.8.2 on "Serving GW selection function", and sends a Create Session Request message (IMSI, SGSN Tunnel Endpoint Identifier for Control Plane, SGSN Address for Control plane, PDN GW address(es) for user plane, PDN GW UL TEID(s) for user plane, PDN GW address(es) for control plane, and PDN GW TEID(s) for control plane, the Protocol Type over S5/S8, APN-AMBR, DTI) to the new Serving GW. The Protocol Type over S5/S8 is provided to Serving GW which protocol should be used over S5/S8 interface. SGSN User Plane TEID shall not be sent if the SGSN decides to establish the Direct Tunnel between RNC and Serving GW. DTI is used to instruct the Serving GW that the Direct Tunnel shall be established between RNC and Serving GW.

The new S4-SGSN establishes the EPS Bearer Context(s) in the indicated order. The new S4-SGSN deactivates the PDP Contexts/EPS Bearer Contexts which cannot be established.

For relocation from an old Gn/Gp SGSN, the new S4-SGSN provides APN-AMBR to the Serving GW. Details on mapping of MBR to APN-AMBR are specified in Annex E of TS 23.401 [89].

A2. The new Serving GW allocates its local resources and returns a Create Session Response (Serving GW address(es) for user plane, Serving GW UL TEID(s) for user plane, Serving GW Address for control plane, Serving GW TEID for control plane) message to the new SGSN.

13. Box (B):

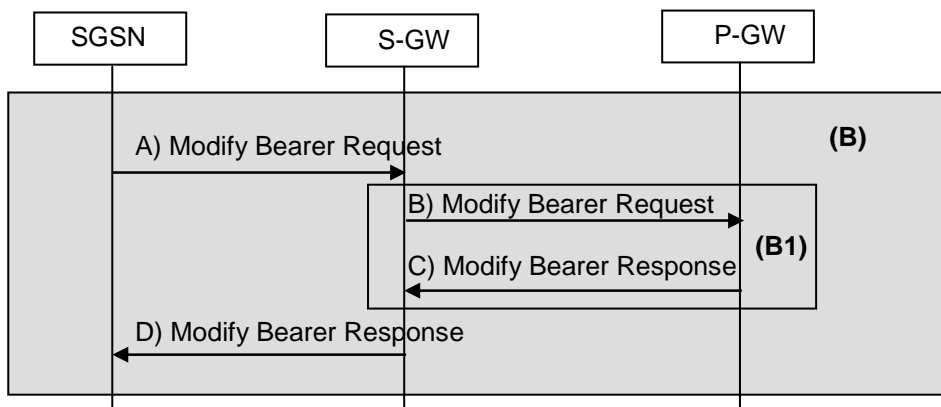

Figure 39b: Step 13 for Serving RNS Relocation Procedure, Combined Hard Handover and SRNS Relocation Procedure, and Combined Cell / URA Update and SRNS Relocation Procedure Using S4

NOTE: Steps A) and D) are common for architecture variants with GTP based S5/S8 and PMIP-based S5/S8. For a PMIP-based S5/S8, procedure step (B1) are defined in TS 23.402 [90]. Steps B) and C) concern GTP based S5/S8.

A) If the SRNS Relocation is an inter-SGSN SRNS relocation or if Direct Tunnel was established in intra-SGSN SRNS relocation or the Serving GW is changed, the new SGSN update these EPS Bearer contexts by sending Modify Bearer Request (SGSN Tunnel Endpoint Identifier for Control Plane, EPS Bearer ID(s), SGSN Address for Control Plane, SGSN Address(es) and TEID(s) (if Direct Tunnel is not used) or RNC Address(es) and TEID(s) for User Traffic (if Direct Tunnel is used), PDN GW addresses and TEIDs (for GTP-based S5/S8) or

GRE keys (for PMIP-based S5/S8) at the PDN GW(s) for uplink traffic, serving network identity, CGI/SAI, RAT type, MS Info Change Reporting support indication, DTI, APN-AMBR). If Direct Tunnel is established the SGSN shall include the DTI to instruct the S-GW to apply Direct Tunnel specific error handling procedure as described in clause 13.8. The SGSN puts the according NSAPI in the field of EPS Bearer ID.

For relocation from an old Gn/Gp SGSN, the new S4-SGSN provides APN-AMBR to the Serving GW. Details on mapping of MBR to APN-AMBR are specified in Annex E of TS 23.401 [89].

- B) If the S-GW changes, or if an S-GW needs to be allocated (Gn/Gp to S4-SGSN RAU), or the RAT type has changed, or the S-GW received CGI/SAI from the S4-SGSN, the S-GW sends Modify Bearer Request (EPS Bearer ID(s), serving network identity, CGI/SAI, RAT type, MS Info Change Reporting support indication, APN-AMBR) messages to the P-GWs involved.
- C) The P-GWs acknowledge with sending Modify Bearer Response (TEID, Prohibit Payload Compression, MS Info Change Reporting Action, CSG Information Reporting Action, Default bearer id) messages to S-GW. The Prohibit Payload Compression indicates that the SGSN should negotiate no data compression for this EPS Bearer context. The default bearer id is included if the UE moves from a Gn/Gp SGSN to an S4-SGSN.
- D) The Serving GW acknowledges the user plane switch to the new SGSN via the message Modify Bearer Response (Cause, Serving GW Tunnel Endpoint Identifier for Control Plane, Serving GW Address for Control Plane, Protocol Configuration Options, PDN GW addresses and TEIDs (for GTP-based S5/S8) or GRE keys (for PMIP-based S5/S8) at the PDN GW(s) for uplink traffic, Prohibit Payload Compression, MS Info Change Reporting Action, CSG Information Reporting Action, Default bearer id, APN-AMBR). At this stage the user plane path is established for all EPS Bearer contexts between the UE, target RNC, new SGSN in case Direct Tunnel is not used, Serving GW (for Serving GW relocation this will be the Target Serving GW) and PDN GW.

6.9.2.2.2 Combined Hard Handover and SRNS Relocation Procedure

This procedure is only performed for an MS in PMM-CONNECTED state in case the Iur interface is not available. In the context of this specification, the terms RNS or RNC refer also to a GERAN BSS or BSC (respectively) when serving a mobile in Iu mode.

The Combined Hard Handover and SRNS Relocation procedure is used to move the RAN to CN connection point at the RAN side from the source SRNC to the target RNC, while performing a hard handover decided by the RAN. In the procedure, the Iu links are relocated. If the target RNC is connected to the same SGSN as the source SRNC, an Intra-SGSN SRNS Relocation procedure is performed. If the routeing area is changed, this procedure is followed by an Intra-SGSN Routeing Area Update procedure. The SGSN detects that it is an intra-SGSN routeing area update by noticing that it also handles the old RA. In this case, the SGSN has the necessary information about the MS and there is no need to inform the HLR about the new MS location.

If the target RNC is connected to a different SGSN than the source SRNC, an Inter-SGSN SRNS Relocation procedure is performed. This procedure is followed by an Inter-SGSN Routeing Area Update procedure.

Figure 40 shows the situation before a Combined Hard Handover and SRNS Relocation procedure when source and target RNC are connected to different SGSNs. Figure 41 shows the situation after the Combined Hard Handover and SRNS Relocation procedure and RA update procedure have been completed. In the case described in Figure 40 and Figure 41 the MS is in PMM-CONNECTED state. Both figures are also applicable to BSS to RNS relocation and vice-versa, as well as for BSS to BSS relocation.

NOTE 1: The figures showing S-GW/P-GW instead of GGSN are omitted since they are similar with Figures 40 and 41.

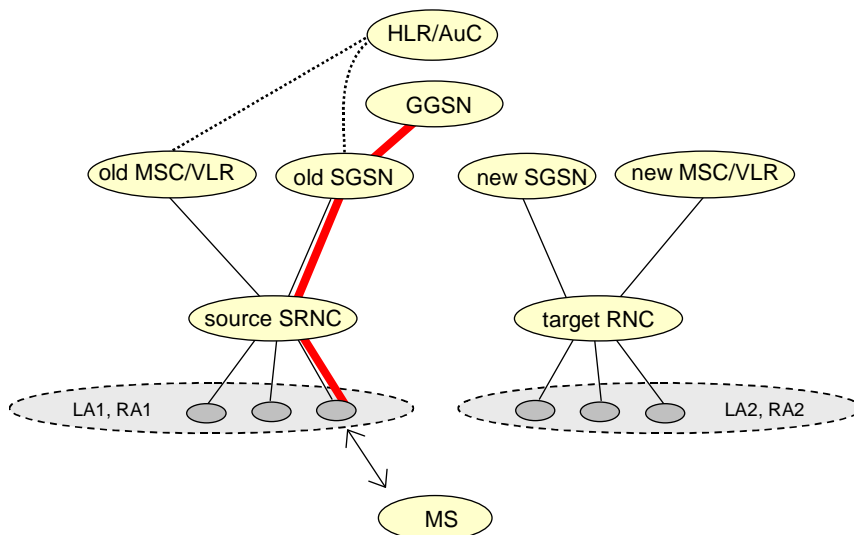

Figure 40: Before Combined Hard Handover and SRNS Relocation and Routeing Area Update

Before the SRNS Relocation and Routeing Area Update the MS is registered in the old SGSN and in the old MSC/VLR. The source RNC is acting as serving RNC.

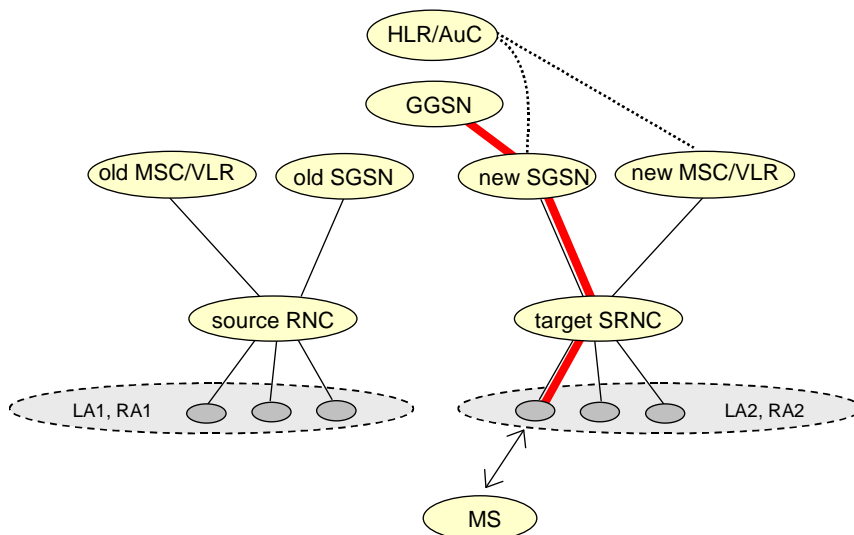

Figure 41: After Combined Hard Handover and SRNS Relocation and Routeing Area Update

After the SRNS relocation and RA update, the MS is registered in the new SGSN and in the new MSC/VLR. The MS is in state PMM-CONNECTED towards the new SGSN and in MM IDLE state towards the new MSC/VLR. The target RNC is acting as serving RNC.

The Combined Hard Handover and SRNS Relocation procedure for the PS domain is illustrated in Figure 42. The sequence is valid for both intra-SGSN SRNS relocation and inter-SGSN SRNS relocation. Furthermore, this signalling flow is also applicable for BSS to RNS relocation and vice-versa, as well as BSS to BSS relocation.

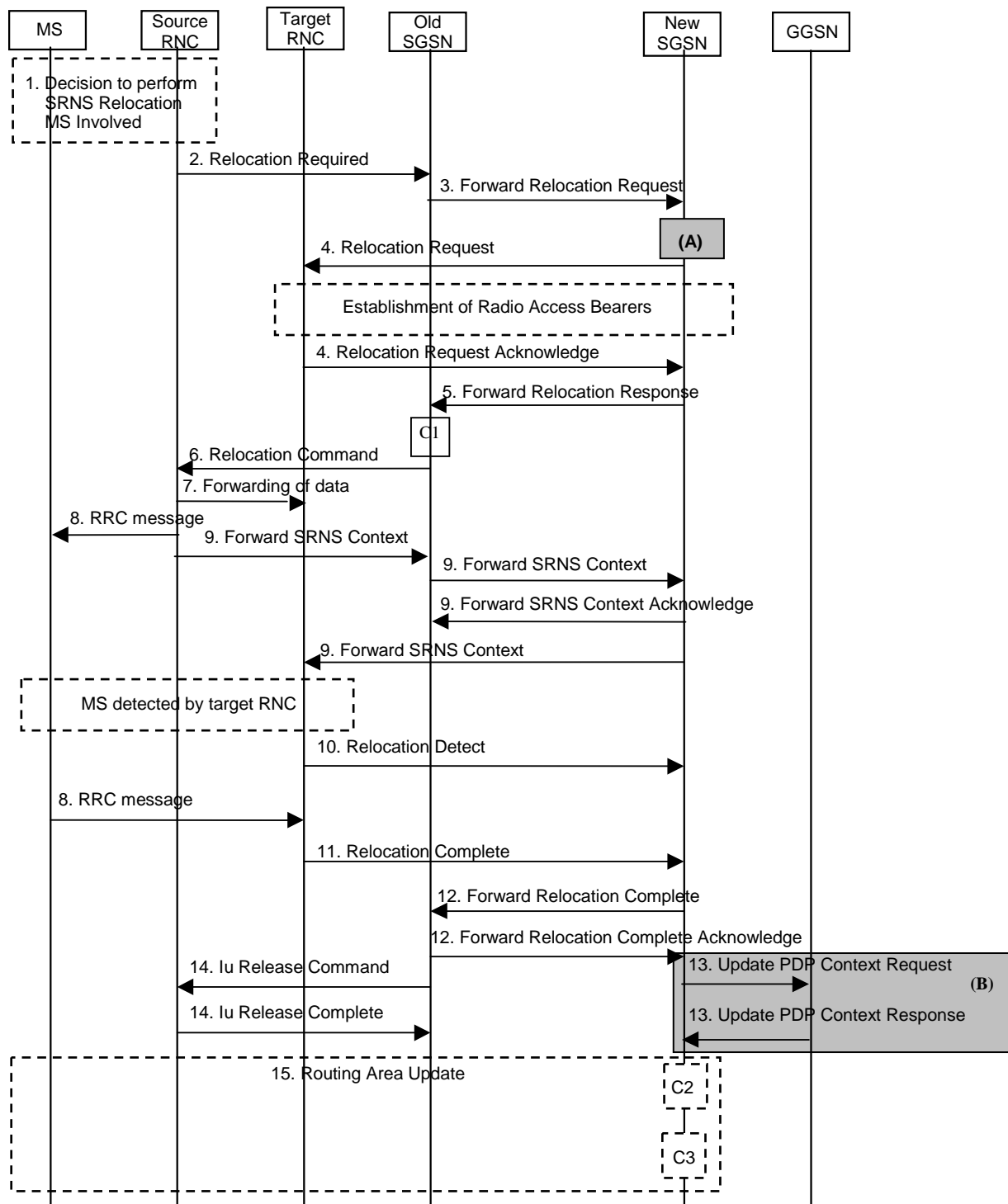

Figure 42: Combined Hard Handover and SRNS Relocation Procedure

NOTE 2: All steps in figure 42, except steps (A) and 13, are common for architecture variants using Gn/Gp based interaction with GGSN and using S4 based interaction with S-GW and P-GW. For an S4 based interaction with S-GW and P-GW, procedure steps (A) and (B) are defined in the clause 6.9. 2.2.1a.

- 1) Based on measurement results and knowledge of the RAN topology, the source SRNC decides to initiate a combined hard handover and SRNS relocation. At this point both uplink and downlink user data flows via the following tunnel(s): Radio Bearer between the MS and the source SRNC (no drift RNC available); GTP-U

tunnel(s) between the source SRNC and the old SGSN; GTP-U tunnel(s) between the old SGSN and the GGSN (for using S4: GTP-U tunnel(s) between old-SGSN and S-GW; GTP-U tunnel(s) between S-GW and P-GW).

If the UE has an ongoing emergency bearer service the source SRNC shall not initiate relocation from UTRAN to GERAN.

- 2) The source SRNC sends a Relocation Required message (Relocation Type, Cause, Source ID, Target ID, CSG ID, CSG access mode, Source RNC To Target RNC Transparent Container) to the old SGSN. The source SRNC shall set Relocation Type to "UE Involved". Source RNC To Target RNC Transparent Container includes the necessary information for relocation co-ordination, security functionality and RRC protocol context information (including MS Capabilities). The source SRNC shall include the CSG ID of the target cell when the target cell is a CSG cell or a hybrid cell. The source SRNC shall indicate the CSG access mode of the target cell when the target cell is a hybrid cell.
- 3) The old SGSN determines from the Target ID if the SRNS relocation is intra-SGSN SRNS relocation or inter-SGSN SRNS relocation. In case of inter-SGSN SRNS relocation the old SGSN initiates the relocation resource allocation procedure by sending a Forward Relocation Request message (IMSI, Tunnel Endpoint Identifier Signalling, MM Context, PDP Context/EPS Bearer Context, Negotiated Evolved ARP, Target Identification, CSG ID, CSG Membership Indication, RAN Transparent Container, RANAP Cause, GCSI) to the new SGSN. If this message is sent between two S4-SGSNs then the old SGSN shall include APN restriction and Change Reporting Action in this message. For relocation to an area where Intra Domain Connection of RAN Nodes to Multiple CN Nodes is used, the old SGSN may – if it provides Intra Domain Connection of RAN Nodes to Multiple CN Nodes have multiple target SGSNs for each relocation target in a pool area, in which case the old SGSN will select one of them to become the new SGSN, as specified in TS 23.236 [73].

If the CSG ID is provided by the source SRNC, the old SGSN shall check whether the CSG ID is contained in the CSG subscription and is not expired. If the CSG ID is not present or is expired and the target cell is a CSG cell, the old SGSN shall reject the handover with an appropriate cause unless the UE has emergency bearer services.

If the CSG ID was received in the Relocation Required message, the old SGSN includes the CSG ID in the Forward Relocation Request message. If the CSG access mode was received in the Relocation Required message indicating the target cell is a hybrid cell, or if there are one or several emergency bearers and the target cell is a CSG cell, the old SGSN shall include the CSG Membership Indication indicating whether the UE is a CSG member in the Forward Relocation Request message.

If at least one of the two SGSNs is a Gn/Gp SGSN then PDP context is indicated. An S4-SGSN derives from GTPv1 Forward Relocation signalling that the other SGSN is a Gn/Gp SGSN, which also does not signal any S-GW change. PDP context contains GGSN Address for User Plane and Uplink TEID for Data (to this GGSN Address and Uplink TEID for Data, the old SGSN and the new SGSN send uplink packets).

Between two S4-SGSNs EPS Bearer Context is indicated. The Bearer context contains S-GW Address for User Plane and Uplink TEID for Data (to this S-GW Address and Uplink TEID for Data the old SGSN and the new SGSN send uplink packets) and P-GW Address for User Plane and Uplink TEID for Data.

At the same time a timer is started on the MM and PDP contexts/EPS Bearer Contexts in the old SGSN (see Routing Area Update procedure in clause "Location Management Procedures (Iu mode)"). The Forward Relocation Request message is applicable only in case of inter-SGSN SRNS relocation. The old SGSN 'sets' the GCSI flag if the MM context contains GPRS CAMEL Subscription Information.

If the UE receives only emergency services from the old SGSN and the UE is UICCless, IMSI can not be included in Forward Relocation Request message. For emergency attached UEs if the IMSI cannot be authenticated then the IMSI shall be marked as unauthenticated.

- 4) The new SGSN sends a Relocation Request message (Permanent NAS UE Identity (if available), MSISDN, Cause, CN Domain Indicator, CSG ID, CSG Membership Indication, Source RNC To Target RNC Transparent Container, RAB To Be Setup (APN, Charging characteristics), UE-AMBR, Service Handover related information) to the target RNC. For each RAB requested to be established, RABs To Be Setup shall contain information such as RAB ID, RAB parameters, Transport Layer Address, and Iu Transport Association. SGSN shall not establish RABs for PDP contexts with maximum bit rate for uplink and downlink of 0 kbit/s. The list of RABs requested by the new SGSN may differ from list of RABs established in the Source RNC contained in the Source-RNC to target RNC transparent container. The target RNC should not establish the RABs (as identified from the Source-RNC to target RNC transparent container) that did not exist in the source RNC prior to the relocation. The RAB ID information element contains the NSAPI value, and the RAB parameters information

element gives the QoS profile. The Transport Layer Address is the SGSN Address for user data, and the Iu Transport Association corresponds to the uplink Tunnel Endpoint Identifier Data. The new SGSN may decide to establish Direct Tunnel unless it has received a 'set' GCSI flag from the old SGSN. If the new SGSN decides to establish Direct Tunnel, it provides to the target RNC the GGSN's Address for User Plane and TEID for Uplink data. For using S4, if the new SGSN decides to establish Direct Tunnel, it provides to the target RNC the S-GW's Address for User Plane and TEID for Uplink data. If the Access Restriction is present in the MM context, the Service Handover related information shall be included by new S4-SGSN for the Relocation Request message in order for RNC to restrict the UE in connected mode to handover to the RAT prohibited by the Access Restriction. MSISDN, APN and Charging characteristics are optional parameters and only transferred if SGSN supports SIPTO at Iu-ps.

The new SGSN shall include the CSG ID and CSG Membership Indication when provided by the old SGSN in the Forward Relocation Request message.

The target RNC shall verify the CSG ID provided by the source SRNC, and reject the handover with an appropriate cause if it does not match the CSG ID and the target cell is a CSG cell. If the target cell is a hybrid cell and differentiated treatment of CSG and non-CSG members is performed then the CSG membership status is used to differentiate CSG and non-CSG members. If the target cell is a CSG cell, and if the CSG Membership Indication is "non member", the target RNC only accepts the emergency bearers.

After all the necessary resources for accepted RABs including the Iu user plane are successfully allocated, the target RNC shall send the Relocation Request Acknowledge message (Target RNC To Source RNC Transparent Container, RABs Setup, RABs Failed To Setup) to the new SGSN. Each RAB to be setup is defined by a Transport Layer Address, which is the target RNC Address for user data, and the Iu Transport Association, which corresponds to the downlink Tunnel Endpoint Identifier for user data. The transparent container contains all radio-related information that the MS needs for the handover, i.e., a complete RRC message (e.g., Physical Channel Reconfiguration in UTRAN case, or Handover From UTRAN, or Handover Command in GERAN Iu mode case) to be sent transparently via CN and source SRNC to the MS. For each RAB to be set up, the target RNC may receive simultaneously downlink user packets both from the source SRNC and from the new SGSN.

- 5) When resources for the transmission of user data between target RNC and new SGSN have been allocated and the new SGSN is ready for relocation of SRNS, the Forward Relocation Response (Cause, RAN Transparent Container, RANAP Cause, Target-RNC Information) message is sent from the new SGSN to the old SGSN. This message indicates that the target RNC is ready to receive from source SRNC the forwarded downlink PDUs, i.e., the relocation resource allocation procedure is terminated successfully. RAN transparent container and RANAP Cause are information from the target RNC to be forwarded to the source SRNC. The Target RNC Information, one information element for each RAB to be set up, contains the RNC Tunnel Endpoint Identifier and RNC IP address for data forwarding from the source SRNC to the target RNC. The Forward Relocation Response message is applicable only in case of inter-SGSN SRNS relocation.
- 6) The old SGSN continues the relocation of SRNS by sending a Relocation Command message (Target RNC To Source RNC Transparent Container, RABs To Be Released, RABs Subject To Data Forwarding) to the source SRNC. The old SGSN decides the RABs to be subject for data forwarding based on QoS, and those RABs shall be contained in RABs subject to data forwarding. For each RAB subject to data forwarding, the information element shall contain RAB ID, Transport Layer Address, and Iu Transport Association. These are the same Transport Layer Address and Iu Transport Association that the target RNC had sent to new SGSN in Relocation Request Acknowledge message, and these are used for forwarding of downlink N-PDU from the source SRNC to the target RNC. The source SRNC is now ready to forward downlink user data directly to the target RNC over the Iu interface. This forwarding is performed for downlink user data only.
- 7) The source SRNC may, according to the QoS profile, begins the forwarding of data for the RABs to be subject for data forwarding.

NOTE 3: The order of steps, starting from step 7 onwards, does not necessarily reflect the order of events. For instance, source RNC may start data forwarding (step 7), send the RRC message to MS (step 8) and forward SRNS Context message to the old SGSN (step 9) almost simultaneously.

The data forwarding at SRNS relocation shall be carried out through the Iu interface, meaning that the GTP-PDUs exchanged between the source SRNC and the target RNC are duplicated in the source SRNC and routed at the IP layer towards the target RNC. For each radio bearer which uses lossless PDCP the GTP-PDUs related to transmitted but not yet acknowledged PDCP-PDUs are duplicated and routed at IP layer towards the target RNC together with their related downlink PDCP sequence numbers. The source RNC continues transmitting duplicates of downlink data and receiving uplink data.

Before the serving RNC role is not yet taken over by target RNC and when downlink user plane data starts to arrive to target RNC, the target RNC may buffer or discard arriving downlink GTP-PDUs according to the related QoS profile.

- 8) Before sending the RRC message the uplink and downlink data transfer shall be suspended in the source SRNC for RABs, which require delivery order. The RRC message is for example Physical Channel Reconfiguration for RNS to RNS relocation, or Intersystem to UTRAN Handover for BSS to RNS relocation, or Handover from UTRAN Command for BSS relocation, or Handover Command for BSS to BSS relocation. When the source SRNC is ready, the source RNC shall trigger the execution of relocation of SRNS by sending to the MS the RRC message provided in the Target RNC to source RNC transparent container, e.g., a Physical Channel Reconfiguration (UE Information Elements, CN Information Elements) message. UE Information Elements include among others new SRNC identity and S-RNTI. CN Information Elements contain among others Location Area Identification and Routing Area Identification.

When the MS has reconfigured itself, it sends an RRC message e.g., a Physical Channel Reconfiguration Complete message to the target SRNC. If the Forward SRNS Context message with the sequence numbers is received, the exchange of packets with the MS may start. If this message is not yet received, the target RNC may start the packet transfer for all RABs, which do not require maintaining the delivery order.

- 9) The source SRNC continues the execution of relocation of SRNS by sending a Forward SRNS Context (RAB Contexts) message to the target RNC via the old and the new SGSN. The Forward SRNS Context message is acknowledged by a Forward SRNS Context Acknowledge message, from new to old SGSN. The purpose of this procedure is to transfer SRNS contexts from the source RNC to the target RNC, and to move the SRNS role from the source RNC to the target RNC. SRNS contexts are sent for each concerned RAB and contain the sequence numbers of the GTP PDUs next to be transmitted in the uplink and downlink directions and the next PDCP sequence numbers that would have been used to send and receive data from the MS. PDCP sequence numbers are only sent by the source RNC for the radio bearers which used lossless PDCP (see TS 25.323 [57]). The use of lossless PDCP is selected by the RNC when the radio bearer is set up or reconfigured.

When using Gn/Gp, for PDP context(s) using delivery order not required (QoS profile), the sequence numbers of the GTP-PDUs next to be transmitted are not used by the target RNC.

When using Gn/Gp, if delivery order is required (QoS profile), consecutive GTP-PDU sequence numbering shall be maintained throughout the lifetime of the PDP context(s). Therefore, during the entire SRNS relocation procedure for the PDP context(s) using delivery order required (QoS profile), the responsible GTP-U entities (RNCs and SGSN) shall assign consecutive GTP-PDU sequence numbers to user packets belonging to the same PDP context uplink and downlink, respectively.

The target RNC establishes and/or restarts the RLC and exchanges the PDCP sequence numbers (PDCP-SNU, PDCP-SND) between the target RNC and the MS. PDCP-SND is the PDCP sequence number for the next expected in-sequence downlink packet to be received by the MS per radio bearer, which used lossless PDCP in the source RNC. PDCP-SND confirms all mobile terminated packets successfully transferred before the SRNC relocation. If PDCP-SND confirms reception of packets that were forwarded from the source SRNC, then the target SRNC shall discard these packets. PDCP-SNU is the PDCP sequence number for the next expected in-sequence uplink packet to be received in the RNC per radio bearer, which used lossless PDCP in the source RNC. PDCP-SNU confirms all mobile originated packets successfully transferred before the SRNC relocation. If PDCP-SNU confirms reception of packets that were received in the source SRNC, the MS shall discard these packets.

- 10) The target RNC shall send a Relocation Detect message to the new SGSN when the relocation execution trigger is received. For SRNS relocation type "UE Involved", the relocation execution trigger may be received from the Uu interface; i.e., when target RNC detects the MS on the lower layers. When the Relocation Detect message is sent, the target RNC shall start SRNC operation.
- 11) When the target SRNC receives the appropriate RRC message, e.g. Physical Channel Reconfiguration Complete message or the Radio Bearer Release Complete message in UTRAN case, or the Handover To UTRAN Complete message or Handover Complete message in GERAN case, i.e. the new SRNC-ID + S-RNTI are successfully exchanged with the MS by the radio protocols, the target SRNC shall initiate a Relocation Complete procedure by sending the Relocation Complete message to the new SGSN. The purpose of the Relocation Complete procedure is to indicate by the target SRNC the completion of the relocation of the SRNS to the CN.
- 12) Upon receipt of Relocation Complete message, if the SRNS Relocation is an inter SGSN SRNS relocation, the new SGSN signals to the old SGSN the completion of the SRNS relocation procedure by sending a Forward Relocation Complete message.

- 13) Upon receipt of the Relocation Complete message, the CN shall switch the user plane from the source RNC to the target SRNC. If the SRNS Relocation is an inter-SGSN SRNS relocation or if Direct Tunnel was established in intra-SGSN SRNS relocation, the new SGSN sends Update PDP Context Request messages (new SGSN Address, SGSN Tunnel Endpoint Identifier, QoS Negotiated, Negotiated Evolved ARP, serving network identity, CGI/SAI, User CSG Information, RAT type, MS Info Change Reporting support indication, NRSN, DTI) to the GGSNs concerned. The SGSN shall send the serving network identity to the GGSN. If Direct Tunnel is established the SGSN provides to GGSN the RNC's Address for User Plane and TEID for Downlink data and shall include the DTI to instruct the GGSN to apply Direct Tunnel specific error handling procedure as described in clause 13.8. NRSN indicates SGSN support of the network requested bearer control. The inclusion of the Negotiated Evolved ARP IE indicates that the SGSN supports the Evolved ARP feature. If the new SGSN did not receive a Negotiated Evolved ARP IE in the SGSN Forward Relocation Request message from the old SGSN then the new SGSN shall derive this value from the Allocation/Retention Priority of the QoS profile negotiated according to Annex E of TS 23.401 [89]. The GGSNs update their PDP context fields and return an Update PDP Context Response (GGSN Tunnel Endpoint Identifier, Prohibit Payload Compression, APN Restriction, MS Info Change Reporting Action, CSG Information Reporting Action, BCM, Negotiated Evolved ARP) message. The GGSN sets the Negotiated Evolved ARP based on local policy or PCC. The Allocation/Retention Priority of the QoS Profile Negotiated is derived from the Evolved ARP according to the mapping principles of TS 23.401 [89], Annex E. The Prohibit Payload Compression indicates that the SGSN should negotiate no data compression for this PDP context. The SGSN shall apply the Negotiated Evolved ARP if received from the GGSN.
- 14) Upon receiving the Relocation Complete message or, if it is an inter-SGSN SRNS relocation, the Forward Relocation Complete message, the old SGSN sends an Iu Release Command message to the source RNC. When the RNC data-forwarding timer has expired, the source RNC responds with an Iu Release Complete message.
- An old S4-SGSN starts a timer to supervise when resources in old Serving GW (in case of Serving GW change or in case of S4 to Gn/Gp SGSN change) shall be released. When this timer expires the old S4-SGSN releases the S-GW resources. The old S4-SGSN deletes S-GW bearer resources by sending Delete Session Request (Cause, Operation Indication) messages to the SGW. If ISR is activated the Cause indicates that the old S-GW shall delete the bearer resources on the other old CN node by sending Delete Bearer Request message to the other CN node. The Operation Indication flag is not set by the old S4-SGSN. This indicates to the S-GW that the S-GW shall not initiate a delete procedure towards the PDN GW.
- 15) After the MS has finished the reconfiguration procedure and if the new Routing Area Identification is different from the old one, the MS initiates the Routing Area Update procedure. See clause "Location Management Procedures (Iu mode)". Note that it is only a subset of the RA update procedure that is performed, since the MS is in PMM-CONNECTED state.

If the SRNS Relocation is inter-SGSN, then the following CAMEL procedure calls shall be performed (see referenced procedures in TS 23.078 [8b])

- C1) CAMEL_GPRS_PDP_Context_Disconnection, CAMEL_GPRS_Detach and CAMEL_PS_Notification.

They are called in the following order:

- The CAMEL_GPRS_PDP_Context_Disconnection procedure is called several times: once per PDP context. The procedure returns as result "Continue".
- Then the CAMEL_GPRS_Detach procedure is called once. The procedure returns as result "Continue".
- Then the CAMEL_PS_Notification procedure is called once. The procedure returns as result "Continue".

The new SGSN shall determine the Maximum APN restriction based on the received APN Restriction of each PDP context/EPS Bearer Context for using S4 from the GGSN/P-GW or old S4-SGSN for using S4 and then store the new Maximum APN restriction value.

If the SRNS Relocation is intra-SGSN, then the above mentioned CAMEL procedures calls shall not be performed.

If Routing Area Update occurs, the SGSN shall determine whether Direct Tunnel can be used based on the received GPRS CAMEL Subscription Information. If Direct Tunnel can not be maintained the SGSN shall re-establish RABs and initiate the Update PDP Context procedure to update the IP Address and TEID for Uplink and Downlink data.

If Routing Area Update occurs, then the following CAMEL procedure calls shall be performed (see referenced procedures in TS 23.078 [8b]):

- C2) CAMEL_GPRS_Routing_Area_Update_Session and CAMEL_PS_Notification.

They are called in the following order:

- The CAMEL_GPRS_Routeing_Area_Update_Session procedure is called. In Figure 42, the procedure returns as result "Continue".
- Then the CAMEL_PS_Notification procedure is called. The procedure returns as result "Continue".

C3) CAMEL_GPRS_Routeing_Area_Update_Context.

This procedure is called several times: once per PDP context. It returns as result "Continue".

For C2 and C3: refer to Routing Area Update procedure description for detailed message flow.

6.9.2.2.3 Combined Cell / URA Update and SRNS Relocation Procedure

This procedure is only performed for an MS in PMM-CONNECTED state, where the Iur/Iur-g interface carries control signalling but no user data. In the context of this specification, the terms RNS or RNC refer also to a GERAN BSS or BSC (respectively) when serving an MS in Iu mode.

The Combined Cell / URA Update and SRNS Relocation or Combined Cell/GRA Update and SBSS Relocation procedure is used to move the RAN to CN connection point at the RAN side from the source SRNC to the target RNC, while performing a cell re-selection in the RAN. In the procedure, the Iu links are relocated. If the target RNC is connected to the same SGSN as the source SRNC, an Intra-SGSN SRNS Relocation procedure is performed. If the routing area is changed, this procedure is followed by an Intra-SGSN Routing Area Update procedure. The SGSN detects that it is an intra-SGSN routing area update by noticing that it also handles the old RA. In this case, the SGSN has the necessary information about the MS and there is no need to inform the HLR about the new MS location.

Before the Combined Cell / URA Update and SRNS Relocation or Combined Cell/GRA Update and SBSS Relocation and before the Routing Area Update, the MS is registered in the old SGSN. The source RNC is acting as serving RNC or serving BSS.

After the Combined Cell / URA Update and SRNS Relocation or Combined Cell/GRA Update and SBSS Relocation and after the Routing Area Update, the MS is registered in the new SGSN. The MS is in state PMM-CONNECTED towards the new SGSN, and the target RNC is acting as serving RNC.

The Combined Cell / URA Update and SRNS Relocation or Combined Cell/GRA Update and SBSS relocation procedure for the PS domain is illustrated in Figure 43. The sequence is valid for both intra-SGSN SRNS relocation and inter-SGSN SRNS relocation. This signalling flow is also applicable to BSS to RNS relocation and vice-versa, as well as for BSS to BSS relocation.

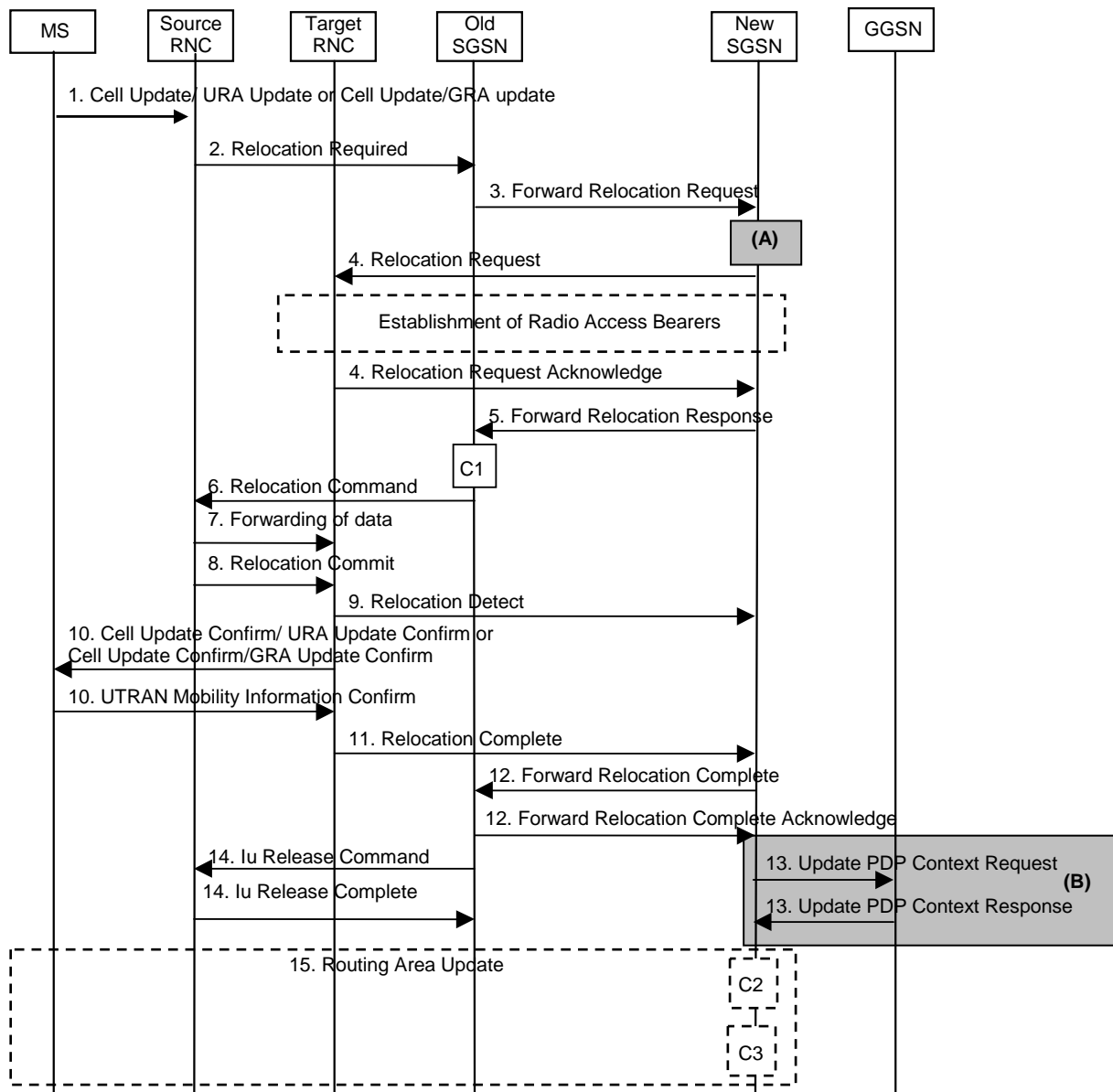

Figure 43: Combined Cell / URA Update and SRNS Relocation Procedure

NOTE 1: All steps in figure 43, except steps (A) and 13, are common for architecture variants using Gn/Gp based interaction with GGSN and using S4 based interaction with S-GW and P-GW. For an S4 based interaction with S-GW and P-GW, procedure steps (A) and (B) are defined in clause 6.9.2.2.1a.

- 1) The MS sends a Cell Update / URA Update or a Cell Update / GRA Update message to the source SRNC (if the cell is located under another RNC the message is routed via the DRNC to SRNC over the Iur). The source SRNC decides whether or not to perform a combined cell / URA update and SRNS relocation towards the target RNC. The rest of this clause describes the case where a combined cell / URA update and SRNS relocation applies. In this case no radio bearer is established between the source SRNC and the UE. Nonetheless the following tunnel(s) are established: GTP-U tunnel(s) between source SRNC and old-SGSN; GTP-U tunnel(s) between old-SGSN and GGSN (for using S4: GTP-U tunnel(s) between old-SGSN and S-GW; GTP-U tunnel(s) between S-GW and P-GW).

If the UE has an ongoing emergency bearer service the source SRNC shall not initiate relocation from UTRAN to GERAN.

- 2) The source SRNC sends a Relocation Required message (Relocation Type, Cause, Source ID, Target ID, Source RNC to Target RNC Transparent Container) to the old SGSN. The source SRNC shall set Relocation Type to "UE not involved". Source RNC to Target RNC Transparent Container includes the necessary information for Relocation co-ordination, security functionality, and RRC protocol context information (including MS Capabilities).
- 3) The old SGSN determines from the Target ID if the SRNS Relocation is intra-SGSN SRNS relocation or inter-SGSN SRNS relocation. In the case of inter-SGSN SRNS relocation the old SGSN initiates the relocation resource allocation procedure by sending a Forward Relocation Request (IMSI, Tunnel Endpoint Identifier Signalling, MM Context, PDP Context/EPS Bearer Context, Negotiated Evolved ARP, Target Identification, RAN Transparent Container, RANAP Cause, GCSI) message to the new SGSN. If this message is sent between two S4-SGSNs then the old SGSN shall include APN restriction and Change Reporting Action in this message. For relocation to an area where Intra Domain Connection of RAN Nodes to Multiple CN Nodes is used, the old SGSN may – if it provides Intra Domain Connection of RAN Nodes to Multiple CN Nodes have multiple target SGSNs for each relocation target in a pool area, in which case the old SGSN will select one of them to become the new SGSN, as specified in TS 23.236 [73].

If at least one of the two SGSNs is a Gn/Gp SGSN then PDP context is indicated. An S4-SGSN derives from GTPv1 Forward Relocation signalling that the other SGSN is a Gn/Gp SGSN, which also does not signal any S-GW change. PDP context contains GGSN Address for User Plane and Uplink TEID for Data (to this GGSN Address and Uplink TEID for Data, the old SGSN and the new SGSN send uplink packets).

Between two S4-SGSNs EPS Bearer Context is indicated. The Bearer context contains S-GW Address for User Plane and Uplink TEID for Data (to this S-GW Address and Uplink TEID for Data the old SGSN and the new SGSN send uplink packets) and P-GW Address for User Plane and Uplink TEID for Data.

At the same time a timer is started on the MM and PDP contexts/EPS Bearer Context in the old SGSN, see Routing Area Update procedure in clause "Location Management Procedures (Iu mode)". The Forward Relocation Request message is applicable only in case of inter-SGSN SRNS relocation. The old SGSN 'sets' the GCSI flag if the MM context contains GPRS CAMEL subscription information.

If the UE receives only emergency services from the old SGSN and the UE is UICCless, IMSI can not be included in Forward Relocation Request message. For emergency attached UEs if the IMSI cannot be authenticated then the IMSI shall be marked as unauthenticated.

- 4) The new SGSN sends a Relocation Request message (Permanent NAS UE Identity (if available), MSISDN, Cause, CN Domain Indicator, Source RNC to Target RNC Transparent Container, RABs To Be Setup (APN, Charging characteristics), UE-AMBR, Service Handover related information) to the target RNC. For each requested RAB, RABs To Be Setup shall contain information such as RAB ID, RAB parameters, Transport Layer Address, and Iu Transport Association. SGSN shall not establish RABs for PDP contexts with maximum bit rate for uplink and downlink of 0 kbit/s. The list of RABs requested by the SGSN may differ from list of RABs available in the Source RNC. The target RNC should not establish the RABs (as identified from the Source-RNC to target RNC transparent container) that did not exist in the source RNC prior to the relocation. The RAB ID information element contains the NSAPI value, and the RAB parameters information element gives the QoS profile. The Transport Layer Address is the SGSN Address for user data, and the Iu Transport Association corresponds to the uplink Tunnel Endpoint Identifier Data. The new SGSN may decide to establish Direct Tunnel unless it has received a 'set' GCSI flag from the old SGSN. If the new SGSN decides to establish Direct Tunnel, it provides to the target RNC the GGSN's Address for User Plane and TEID for Uplink data. For using S4, if the new SGSN decides to establish Direct Tunnel, it provides to the target RNC the S-GW's Address for User Plane and TEID for Uplink data. If the Access Restriction is present in the MM context, the Service Handover related information shall be included by new S4-SGSN for the Relocation Request message in order for RNC to restrict the UE in connected mode to handover to the RAT prohibited by the Access Restriction. MSISDN, APN and Charging characteristics are optional parameters and only transferred if SGSN supports SIPTO at Iu-ps.

After all necessary resources for accepted RABs including the Iu user plane are successfully allocated, the target RNC shall send the Relocation Request Acknowledge message (RABs setup, RABs failed to setup) to the new SGSN. Each RAB to be setup is defined by a Transport Layer Address, which is the target RNC Address for user data, and a Iu Transport Association which corresponds to the downlink Tunnel Endpoint Identifier for user data.

After the new SGSN receives the Relocation Request Acknowledge message, the GTP-U tunnels are established between the target RNC and the new-SGSN.

The target-RNC may simultaneously receive for each RAB to be set up downlink user packets both from the source SRNC and from the new SGSN.

- 5) When resources for the transmission of user data between the target RNC and the new SGSN have been allocated and the new SGSN is ready for relocation of SRNS, the Forward Relocation Response message (Cause, RANAP Cause, and Target RNC Information) is sent from the new SGSN to the old SGSN. This message indicates that the target RNC is ready to receive from the source SRNC the forwarded downlink packets, i.e., the relocation resource allocation procedure is terminated successfully. RANAP Cause is information from the target RNC to be forwarded to the source SRNC. The RAB Setup Information, one information element for each RAB, contains the RNC Tunnel Endpoint Identifier and RNC IP address for data forwarding from the source SRNC to the target RNC. If the target RNC or the new SGSN failed to allocate resources, the RAB Setup Information element contains only NSAPI indicating that the source SRNC shall release the resources associated with the NSAPI. The Forward Relocation Response message is applicable only in case of inter-SGSN SRNS relocation.
- 6) The old SGSN continues the relocation of SRNS by sending a Relocation Command (RABs to be released, and RABs subject to data forwarding) message to the source SRNC. The old SGSN decides the RABs subject to data forwarding based on QoS, and those RABs shall be contained in RABs subject to data forwarding. For each RAB subject to data forwarding, the information element shall contain RAB ID, Transport Layer Address, and Iu Transport Association. These are the same Transport Layer Address and Iu Transport Association that the target RNC had sent to new SGSN in Relocation Request Acknowledge message, and these are used for forwarding of downlink N-PDU from the source SRNC to the target RNC. The source SRNC is now ready to forward downlink data directly to the target RNC over the Iu interface. This forwarding is performed for downlink user data only.
- 7) The source SRNC may, according to the QoS profile, begin the forwarding of data for the RABs subject to data forwarding and starts the data-forwarding timer. The data forwarding at SRNS relocation shall be carried out through the Iu interface, meaning that the data exchanged between the source SRNC and the target RNC are duplicated in the source SRNC and routed at the IP layer towards the target RNC. For each radio bearer which uses lossless PDCP the GTP-PDUs related to transmitted but not yet acknowledged PDCP-PDUs are duplicated and routed at IP layer towards the target RNC together with their related downlink PDCP sequence numbers. The source RNC continues transmitting duplicates of downlink data and receiving uplink data.

NOTE 2: The order of steps, starting from step 7 onwards, does not necessarily reflect the order of events. For instance, source RNC may send data forwarding (step 7) and start Relocation Commit message (step 8) almost simultaneously. Target RNC may send Relocation Detect message (step 9) and Cell Update Confirm/URA Update Confirm (or Cell Update Confirm/GRA Update Confirm) message (step 10) at the same time. Hence, target RNC may receive the UTRAN or GERAN Mobility Information Confirm message from MS (step 10) while data forwarding (step 8) is still underway, and before the new SGSN receives Update PDP Context Response message (step 11).

Before the serving RNC role is not yet taken over by target RNC and when downlink user plane data starts to arrive to target RNC, the target RNC may buffer or discard arriving downlink GTP-PDUs according to the related QoS profile.

- 8) Before sending the Relocation Commit the uplink and downlink data transfer in the source, SRNC shall be suspended for RABs, which require delivery order.

When the source SRNC is ready, the source SRNC shall trigger the execution of relocation of SRNS by sending a Relocation Commit message (SRNS Contexts) to the target RNC over the UTRAN Iur interface or over the GERAN Iur-g interface, respectively. The purpose of this procedure is to transfer SRNS contexts from the source RNC to the target RNC, and to move the SRNS role from the source RNC to the target RNC. SRNS contexts are sent for each concerned RAB and contain the sequence numbers of the GTP-PDUs next to be transmitted in the uplink and downlink directions and the next PDCP sequence numbers that would have been used to send and receive data from the MS. . PDCP sequence numbers are only sent by the source RNC for radio bearers, which used lossless PDCP (see TS 25.323 [57]). The use of lossless PDCP is selected by the RNC when the radio bearer is set up or reconfigured. For PDP context(s) using delivery order not required (QoS profile), the sequence numbers of the GTP-PDUs next to be transmitted are not used by the target RNC.

If delivery order is required (QoS profile), consecutive GTP-PDU sequence numbering shall be maintained throughout the lifetime of the PDP context(s). Therefore, during the entire SRNS relocation procedure for the PDP context(s) using delivery order required (QoS profile), the responsible GTP-U entities (RNCs and GGSN) shall assign consecutive GTP-PDU sequence numbers to user packets belonging to the same PDP context for uplink and downlink respectively.

- 9) The target RNC shall send a Relocation Detect message to the new SGSN when the relocation execution trigger is received. For SRNS relocation type "UE not involved", the relocation execution trigger is the reception of the Relocation Commit message from the Iur interface. When the Relocation Detect message is sent, the target RNC shall start SRNC operation.
- 10) The target SRNC sends a Cell Update Confirm / URA Update Confirm or Cell Update Confirm / GRA Update Confirm message. This message contains UE information elements and CN information elements. The UE information elements include among others new SRNC identity and S-RNTI. The CN information elements contain among others Location Area Identification and Routeing Area Identification. The procedure shall be coordinated in all Iu signalling connections existing for the MS.

Upon reception of the Cell Update Confirm / URA Update Confirm or Cell Update Confirm / GRA Update Confirm message the MS may start sending uplink user data to the target SRNC. When the MS has reconfigured itself, it sends the RAN Mobility Information Confirm message to the target SRNC. This indicates that the MS is also ready to receive downlink data from the target SRNC.

If the new SGSN has already received the Update PDP Context Response message from the GGSN, it shall forward the uplink user data to the GGSN over this new GTP-U tunnel. Otherwise, the new SGSN shall forward the uplink user data to that GGSN IP address and TEID(s), which the new SGSN had received earlier by the Forward Relocation Request message.

For using S4, if new the SGSN has already received the Modify Bearer Context Response message from the S-GW, it shall forward the uplink user data to S-GW over this new GTP-U tunnel. Otherwise, the new SGSN shall forward the uplink user data to that S-GW IP address and TEID(s), which the new SGSN had received earlier by the Forward Relocation Request message.

The target SRNC and the MS exchange the PDCP sequence numbers; PDCP-SNU and PDCP-SND. PDCP-SND is the PDCP sequence number for the next expected in-sequence downlink packet to be received in the MS per radio bearer, which used lossless PDCP in the source RNC. PDCP-SND confirms all mobile terminated packets successfully transferred before the SRNC relocation procedure. . If PDCP-SND confirms the reception of packets that were forwarded from the source SRNC, the target SRNC shall discard these packets. PDCP-SNU is the PDCP sequence number for the next expected in-sequence uplink packet to be received in the RNC per radio bearer, which used lossless PDCP in the source RNC. PDCP-SNU confirms all mobile originated packets successfully transferred before the SRNC relocation. If PDCP-SNU confirms reception of packets that were received in the source SRNC, the target SRNC shall discard these packets.

- 11) When the target SRNC receives the RAN Mobility Information Confirm message, i.e. the new SRNC-ID + S-RNTI are successfully exchanged with the MS by the radio protocols, the target SRNC shall initiate the Relocation Complete procedure by sending the Relocation Complete message to the new SGSN. The purpose of the Relocation Complete procedure is to indicate by the target SRNC the completion of the relocation of the SRNS to the CN.
- 12) Upon receipt of Relocation Complete message, if the SRNS Relocation is an inter SGSN SRNS relocation, the new SGSN signals to the old SGSN the completion of the SRNS relocation procedure by sending a Forward Relocation Complete message.
- 13) Upon receipt of the Relocation Complete message, the CN shall switch the user plane from the source RNC to the target SRNC. If the SRNS Relocation is an inter-SGSN SRNS relocation or if Direct Tunnel was established in intra-SGSN SRNS relocation, the new SGSN sends Update PDP Context Request messages (new SGSN Address, SGSN Tunnel Endpoint Identifier, QoS Negotiated, Negotiated Evolved ARP, serving network identity, CGI/SAI, RAT type, MS Info Change Reporting support indication, NRSN, DTI) to the GGSNs concerned. The SGSN shall send the serving network identity to the GGSN. If Direct Tunnel is established the SGSN provides to GGSN the RNC's Address for User Plane and TEID for Downlink data and shall include the DTI to instruct the GGSN to apply Direct Tunnel specific error handling procedure as described in clause 13.8. NRSN indicates SGSN support of the network requested bearer control. The inclusion of the Negotiated Evolved ARP IE indicates that the SGSN supports the Evolved ARP feature. If the new SGSN did not receive a Negotiated Evolved ARP IE in the SGSN Forward Relocation Request message from the old SGSN then the new SGSN shall derive this value from the Allocation/Retention Priority of the QoS profile negotiated according to Annex E of TS 23.401 [89]. The GGSNs update their PDP context fields and return an Update PDP Context Response (GGSN Tunnel Endpoint Identifier, Prohibit Payload Compression, APN Restriction, MS Info Change Reporting Action, CSG Information Reporting Action, BCM, Negotiated Evolved ARP) message. The GGSN sets the Negotiated Evolved ARP based on local policy or PCC. The Allocation/Retention Priority of the QoS Profile Negotiated is derived from the Evolved ARP according to the mapping principles of TS 23.401 [89],

Annex E. The Prohibit Payload Compression indicates that the SGSN should negotiate no data compression for this PDP context. The SGSN shall apply the Negotiated Evolved ARP if received from the GGSN.

- 14) Upon receiving the Relocation Complete message or if it is an inter-SGSN SRNS relocation, the Forward Relocation Complete message, the old SGSN sends an Iu Release Command message to the source RNC. When the RNC data-forwarding timer has expired the source RNC responds with an Iu Release Complete.

An old S4-SGSN starts a timer to supervise when resources in old Serving GW (in case of Serving GW change or in case of S4 to Gn/Gp SGSN change) shall be released. When this timer expires the old S4-SGSN releases the S-GW resources. The old S4-SGSN deletes S-GW bearer resources by sending Delete Session Request (Cause, Operation Indication) messages to the SGW. If ISR is activated the Cause indicates that the old S-GW shall delete the bearer resources on the other old CN node by sending Delete Bearer Request message to the other CN node. The Operation Indication flag is not set by the old S4-SGSN. This indicates to the S-GW that the S-GW shall not initiate a delete procedure towards the PDN GW.

- 15) After the MS has finished the Cell / URA update or the Cell / GRA update and RNTI reallocation procedure and if the new Routing Area Identification is different from the old one, the MS initiates the Routing Area Update procedure. See clause "Location Management Procedures (Iu mode)". Note that it is only a subset of the RA update procedure that is performed, since the MS is in PMM-CONNECTED state.

If the SRNS Relocation is inter-SGSN, then the following CAMEL procedure calls shall be performed (see referenced procedures in TS 23.078 [8b])

- C1) CAMEL_GPRS_PDP_Context_Disconnection, CAMEL_GPRS_Detach and CAMEL_PS_Notification.

They are called in the following order:

- The CAMEL_GPRS_PDP_Context_Disconnection procedure is called several times: once per PDP context. The procedure returns as result "Continue".
- Then the CAMEL_GPRS_Detach procedure is called once. The procedure returns as result "Continue".
- Then the CAMEL_PS_Notification procedure is called once. The procedure returns as result "Continue".

The new SGSN shall determine the Maximum APN restriction based on the received APN Restriction of each PDP context/EPS Bearer Context for using S4 from the GGSN/P-GW or old S4-SGSN and then store the new Maximum APN restriction value.

If the SRNS Relocation is intra-SGSN, then the above mentioned CAMEL procedures calls shall not be performed.

If Routing Area Update occurs, the SGSN shall determine whether Direct Tunnel can be used based on the received GPRS CAMEL Subscription Information. If Direct Tunnel, can not be maintained the SGSN shall re-establish RABs and initiate the Update PDP Context procedure to update the IP Address and TEID for Uplink and Downlink data.

If Routing Area Update occurs, then the following CAMEL procedure calls shall be performed (see referenced procedures in TS 23.078 [8b]):

- C2) CAMEL_GPRS_Routing_Area_Update_Session and CAMEL_PS_Notification.

They are called in the following order:

- The CAMEL_GPRS_Routing_Area_Update_Session procedure is called. The procedure returns as result "Continue".
- Then, the CAMEL_PS_Notification procedure is called. The procedure returns as result "Continue".

- C3) CAMEL_GPRS_Routing_Area_Update_Context.

This procedure is called several times: once per PDP context/EPS Bearer Context for using S4. It returns as result "Continue". For C2 and C3: refer to Routing Area Update procedure description for detailed message flow.

6.9.2.2.4 SRNS Relocation Cancel Procedure

The purpose of the SRNS Relocation Cancel procedure is to cancel an ongoing SRNS relocation. The SRNS Relocation Cancel procedure may be initiated during or after the Relocation Preparation procedure and may be initiated by the source RNC.

The SRNS Relocation Cancel procedure is illustrated in Figure 44. The sequence is valid for cancelling both an intra-SGSN SRNS relocation and an inter-SGSN SRNS relocation.

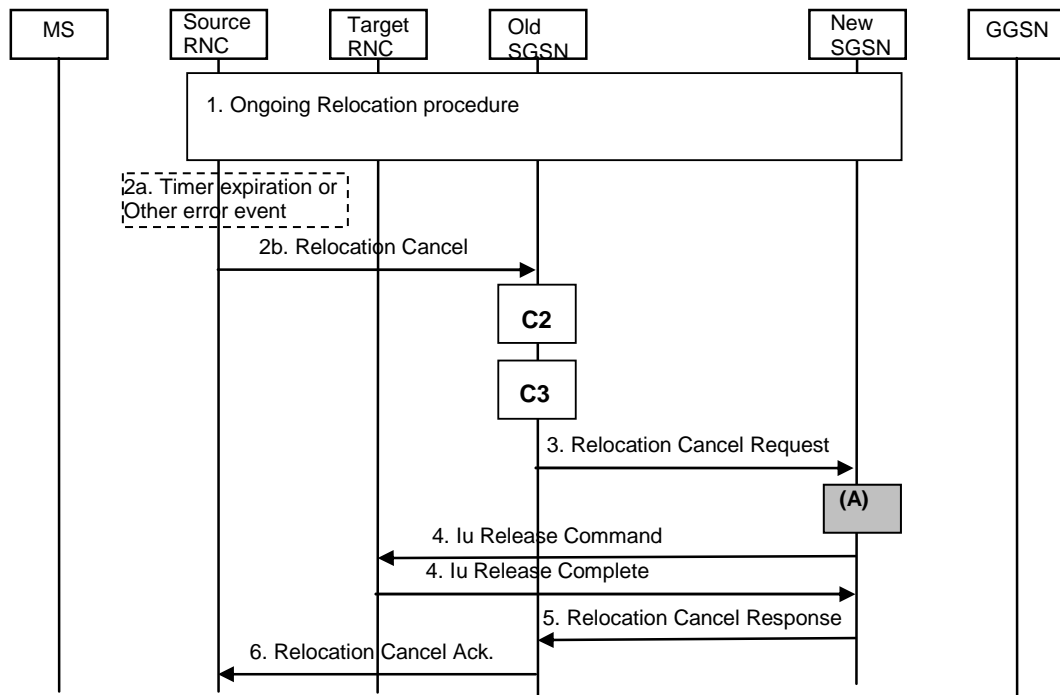

Figure 44: SRNS Cancel Relocation Procedure

NOTE: All steps in figure 44, except steps (A), are common for architecture variants using Gn/Gp based SGSN and using S4 based interaction with S-GW. For an S4 based interaction with S-GW, procedure steps (A) are defined in the clause 6.9.2.2.4a.

- 1) An SRNS Relocation procedure has started, as specified in clause 6.9.2.2.1.
- 2a) The SRNS Cancel Relocation may be initiated by a timer expiry or by an error event in the source RNC.
- 2b) When one of conditions in 2a is satisfied, the source RNC sends a Relocation Cancel (Cause) to the old SGSN. Cause indicates the reason for cancelling the ongoing SRNS relocation.
- 3) The old SGSN sends a Relocation Cancel Request (RANAP Cause) to the new SGSN to indicate that the ongoing SRNS relocation should be cancelled. RANAP Cause contains the cause value received by the source RNC in the Relocation Cancel message.
- 4) The new SGSN sends an Iu Release Command (Cause) to request from the target RNC to release the Iu resources already allocated for the SRNS relocation, or to cancel the ongoing allocation of Iu resources for the SRNS relocation. Cause is set equal to RANAP Cause, i.e. to whatever cause value was included in the Relocation Cancel Request received from old SGSN. The target RNC releases the requested Iu resources and responds with an Iu Release Complete.
- 5) The new SGSN acknowledges the cancellation of the ongoing SRNS Relocation by sending a Relocation Cancel Response to the old SGSN.
- 6) The old SGSN responds to the source RNC with a Relocation Cancel Ack message.

If the SRNS Relocation is inter-SGSN, then the following CAMEL procedure calls shall be performed (see referenced procedures in TS 23.078 [8b]):

C2) CAMEL_GPRS_Routeing_Area_Update_Session and CAMEL_PS_Notification.

They are called in the following order:

- The procedure CAMEL_GPRS_Routeing_Area_Update_Session is called. The procedure returns as result "Continue".
- Then the procedure CAMEL_PS_Notification is called. The procedure returns as result "Continue".

C3) CAMEL_GPRS_Routeing_Area_Update_Context.

The procedure is called several times: once per PDP context. It returns as result "Continue".

For C2 and C3: refer to Routing Area Update procedure description for detailed message flow.

6.9.2.2.4a SRNS Relocation Cancel Procedure Using S4

The procedures described in figures 44a shows only the steps (A) due to use of S4, which are different from the Gn/Gp variant of the procedure given by clauses 6.9.2.2.4.

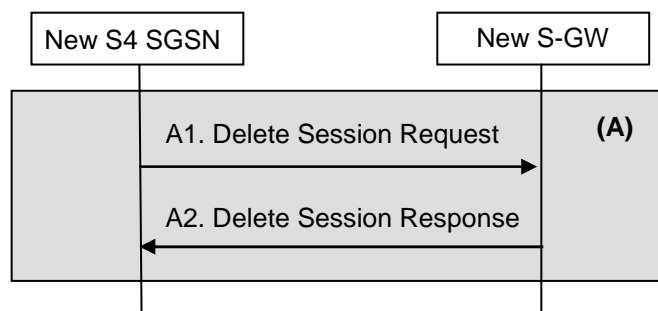

Figure 44a1: A) for SRNS Relocation Cancel Procedure Using S4

A1. This step is only performed in case of handover from S4-SGSN to S4-SGSN with Serving GW relocation or handover from Gn/Gp SGSN to S4-SGSN. The New S4-SGSN deletes the EPS bearer resources by sending Delete Session Request (Cause) messages to the New S-GW.

A2. The New S-GW acknowledges with Delete Session Response messages.

6.9.2.2.5 Enhanced Serving RNS Relocation Procedure

The procedure can be used for relocation when source SRNC and target RNC are connected to same SGSN.

NOTE 1: If the MS is both MM-CONNECTED and PMM-CONNECTED, then this procedure can only be used if the source RNC and target RNC are connected to same MSC.

This procedure is only performed for an MS in PMM CONNECTED state where the Iur interface is available between a serving RNC and a drifting RNC. This procedure is not applicable for GERAN.

In Enhanced Serving RNS Relocation the SRNS functionality is prepared at RAN side and the SGSN is not informed until the preparation and execution of the relocation has taken place, the preparation and execution phases are performed as specified in TS 25.423 [95]. The completion phase is illustrated in Figure 44a below.

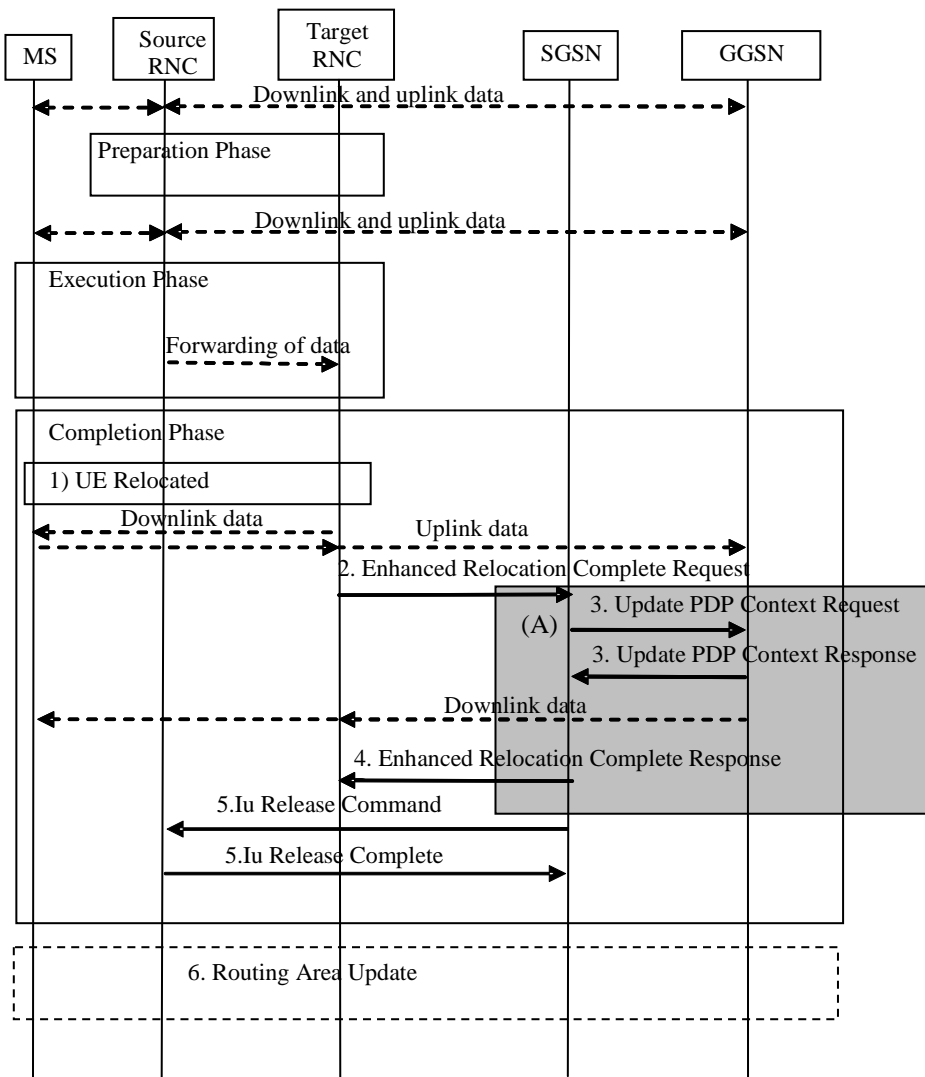

Figure 44a2: Enhanced Serving RNS Relocation

NOTE 2: The figure shows the user plane connections when Direct Tunnel is established. If Direct Tunnel is not established only the user plane between RNC and SGSN is impacted due relocation.

There are three phases for the Enhanced Serving RNS Relocation.

Preparation Phase:

- The Source RNC decides to relocate the UE to a neighbouring RNC (Target RNC).
- The Source RNC triggers the RNSAP: Enhanced Relocation procedure.

Execution Phase:

- The RNC triggers the relocation to MS.
- The Source RNC may start data forwarding.

Completion Phase:

1. The MS has been relocated to the Target RNC.

2. The Target RNC sends Enhanced Relocation Complete Request message to the SGSN to indicate that the MS was relocated to the Target RNC. The Target RNC indicates successfully relocated, modified or released RABs to the SGSN.
3. Upon receipt of the enhanced Relocation Complete message, the SGSN shall switch the user plane from the source RNC to the target SRNC. If Direct Tunnel was established, the SGSN sends Update PDP Context Request messages (SGSN Address, SGSN Tunnel Endpoint Identifier, QoS Negotiated, Negotiated Evolved ARP, serving network identity, CGI/SAI, RAT type, MS Info Change Reporting support indication, NRSN, DTI) to the GGSNs concerned. The SGSN shall send the serving network identity to the GGSN. If Direct Tunnel is established the SGSN provides to GGSN the RNC's Address for User Plane and TEID for Downlink data and shall include the DTI to instruct the GGSN to apply Direct Tunnel specific error handling procedure as described in clause 13.8. NRSN indicates SGSN support of the network requested bearer control. The GGSNs update their PDP context fields and return an Update PDP Context Response (GGSN Tunnel Endpoint Identifier, Prohibit Payload Compression, APN Restriction, MS Info Change Reporting Action, CSG Information Reporting Action, BCM, Negotiated Evolved ARP) message. The GGSN sets the Negotiated Evolved ARP based on local policy or PCC. The Allocation/Retention Priority of the QoS Profile Negotiated is derived from the Evolved ARP according to the mapping principles of TS 23.401 [89], Annex E. The Prohibit Payload Compression indicates that the SGSN should negotiate no data compression for this PDP context. The SGSN shall apply the Negotiated Evolved ARP if received from the GGSN.

For an S4 based interaction with S-GW and P-GW procedure step (A) is defined in clause 6.9.2.2.5A.

4. The SGSN configures the necessary Iu resources for the Target RNC and responds with Enhanced Relocation Complete Response.
5. After sending the Enhanced Relocation Complete Response message to the Target RNC the SGSN sends an Iu Release Command message to the source RNC and the source RNC responds with an Iu Release Complete.
6. If the Routing Area Identification is different from the old one the MS initiates the Routing Update procedure. See clause 6.9.2. Like after the relocation procedures described in clauses above e.g. clause 6.9.2.2.1, only a subset of the RA update is performed, since the MS is in PMM-CONNECTED state.

6.9.2.2.5A Enhanced Serving RNS Relocation Procedure using S4

Two procedures are defined depending on whether the Serving GW is unchanged or relocated, figures 44b and 44c show only the steps 3 and 4 due to use of S4, which is different from the Gn/Gp variant defined in clause 6.9.2.2.5.

A1) Procedure using S4 without Serving GW relocation

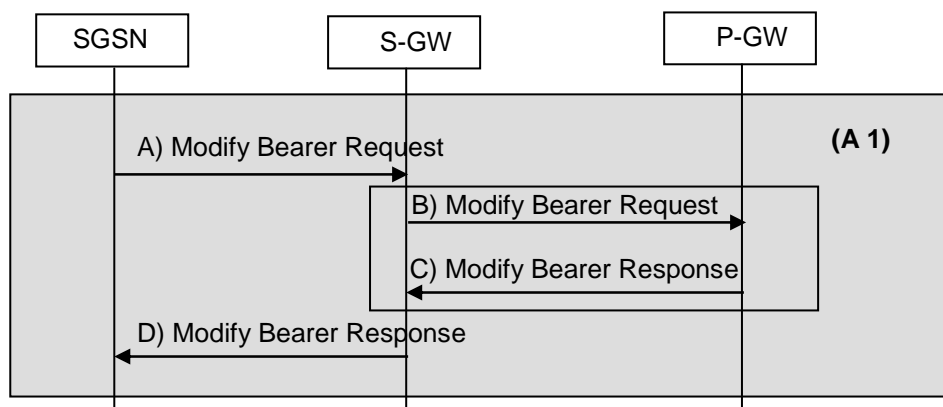

Figure 44b1: Step 3 for Enhanced Serving RNS Relocation without Serving GW relocation using S4

NOTE 1: Steps A) and B) are common for architecture variants with GTP based S5/S8 and PMIP-based S5/S8.

- A) If Direct Tunnel was established the SGSN update these EPS Bearer contexts by sending Modify Bearer Request (SGSN Tunnel Endpoint Identifier for Control Plane, EPS Bearer ID(s), SGSN Address for Control Plane, SGSN Address(es) and TEID(s) (if Direct Tunnel is not used) or RNC Address(es) and TEID(s) for User Traffic (if Direct Tunnel is used), PDN GW addresses and TEIDs (for GTP based S5/S8) or GRE keys (for PMIP based S5/S8) at the PDN GW(s) for uplink traffic, serving network identity, CGI/SAI, RAT type, MS Info Change Reporting support indication, DTI). If Direct Tunnel is established the SGSN shall include the DTI to instruct the

S-GW to apply Direct Tunnel specific error handling procedure as described in clause 13.8. The SGSN puts the according NSAPI in the field of EPS Bearer ID.

- B) If MS Info Change Reporting is started, the S-GW sends Modify Bearer Request (EPS Bearer ID(s), serving network identity, CGI/SAI, RAT type, MS Info Change Reporting support indication) messages to the P-GWs involved.
- C) The P-GWs acknowledge with sending Modify Bearer Response (TEID, Prohibit Payload Compression, MS Info Change Reporting Action, CSG Information Reporting Action) messages to S-GW. The Prohibit Payload Compression indicates that the SGSN should negotiate no data compression for this EPS Bearer context.
- D) The Serving GW acknowledges the user plane switch to the SGSN via the message Modify Bearer Response (Cause, Serving GW Tunnel Endpoint Identifier for Control Plane, Serving GW Address for Control Plane, Protocol Configuration Options, PDN GW addresses and TEIDs (for GTP based S5/S8) or GRE keys (for PMIP based S5/S8) at the PDN GW(s) for uplink traffic, Prohibit Payload Compression, MS Info Change Reporting Action, CSG Information Reporting Action). At this stage the user plane path is established for all EPS Bearer contexts between the UE, target RNC, SGSN in case Direct Tunnel is not used, Serving GW and PDN GW.

A2) Procedure using S4 with Serving GW relocation and Direct Tunnel

This procedure is used if the SGSN determines the Serving Gateway is to be relocated.

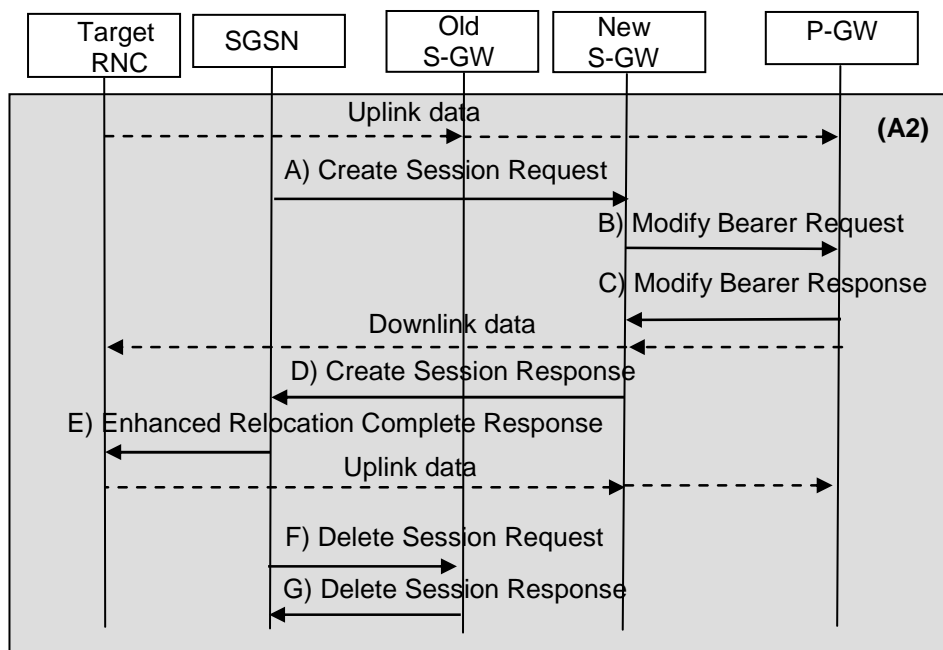

Figure 44b2: Step 3 for Enhanced Serving RNS Relocation with Serving GW relocation using S4

NOTE 2: Steps A) and B) are common for architecture variants with GTP based S5/S8 and PMIP-based S5/S8.

- A) The SGSN selects the new Serving GW as described in TS 23.401 [89] under clause 4.3.8.2 on "Serving GW selection function", and sends a Create Session Request message (SGSN Tunnel Endpoint Identifier for Control Plane, EPS Bearer ID(s), SGSN Address for Control Plane, SGSN Address(es) and TEID(s) (if Direct Tunnel is not used) or RNC Address(es) and TEID(s) for User Traffic (if Direct Tunnel is used), PDN GW addresses and TEIDs (for GTP based S5/S8) or GRE keys (for PMIP based S5/S8) at the PDN GW(s) for uplink traffic, serving network identity, CGI/SAI, RAT type, MS Info Change Reporting support indication, DTI). If Direct Tunnel is established the SGSN shall include the DTI to instruct the S-GW to apply Direct Tunnel specific error handling procedure as described in clause 13.8.
- B) The new S-GW sends Modify Bearer Request (EPS Bearer ID(s), serving network identity, CGI/SAI, RAT type, MS Info Change Reporting support indication) messages to the P-GWs involved.
- C) The P-GWs acknowledge with sending Modify Bearer Response (TEID, Prohibit Payload Compression, MS Info Change Reporting Action, CSG Information Reporting Action) messages to new S-GW. The Prohibit Payload Compression indicates that the SGSN should negotiate no data compression for this EPS Bearer context.

- D) The new Serving GW acknowledges the user plane switch to the SGSN via the message Create Session Response (Cause, Serving GW Tunnel Endpoint Identifier for Control Plane, Serving GW Address for Control Plane, Protocol Configuration Options, PDN GW addresses and TEIDs (for GTP based S5/S8) or GRE keys (for PMIP based S5/S8) at the PDN GW(s) for uplink traffic, Prohibit Payload Compression, MS Info Change Reporting Action, CSG Information Reporting Action). The SGSN starts timer, to be used in step F.
- E) The SGSN configures the necessary Iu resources for the Target RNC and responds with Enhanced Relocation Complete Response. The SGSN provides to the target RNC the new S-GW's Address for user Plane and TEID(s) for Uplink data. The target RNC starts using the new Serving GW address and TEID(s) for forwarding subsequent uplink packets.
- F) When the timer has expired after step D, the SGSN releases the bearer(s) in old S-GW by sending a Delete Session Request message.
- G) The old S-GW acknowledge bearer deletion.

6.9.3 Periodic RA and LA Updates

All GPRS-attached MSs, except A/Gb mode MSs in class-B mode of operation engaged in CS communication, shall perform periodic RA updates. MSs that are IMSI-attached and not GPRS-attached shall perform periodic LA updates. Periodic RA updates are equivalent to intra SGSN routing area updates as described in clause "Intra SGSN Routing Area Update", with Update Type indicating periodic RA update. For MSs that are both IMSI-attached and GPRS-attached, the periodic updates depend on the mode of operation of the network:

- If the network operates in mode I, periodic RA updates shall be performed, and periodic LA updates shall not be performed. In this case, the MSC/VLR shall disable implicit detach for GPRS-attached MSs and instead rely on the SGSN to receive periodic RA updates. If periodic RA updates are not received in the SGSN and the SGSN detaches the MS, the SGSN shall notify the MSC/VLR by sending an IMSI Detach Indication message.
- If the network operates in mode II, both periodic RA updates and periodic LA updates shall be performed independently. RA updates are performed towards the SGSN, and LA updates are performed towards the MSC/VLR.

In A/Gb mode, the periodic RA update timer in the MS is stopped when an LLC PDU is sent since all sent LLC PDUs set the MM context state to READY. The periodic RA update timer is reset and started when the state returns to STANDBY.

In Iu mode, the periodic RA update timer in the MS is stopped when the MM context enters the PMM-CONNECTED state. The periodic RA update timer is reset and started when the state returns to PMM-IDLE state.

If the MS could not successfully complete the periodic RA update procedure after a retry scheme while the MS was in GERAN/UTRAN PS coverage, the MS shall wait a back-off time equal to the periodic LA update timer broadcast by the network before restarting the periodic RA update procedure.

NOTE: If ISR is activated, additional handling in MS and SGSN is described in TS 23.401 [89].

6.9.4 PS Handover Procedure

The PS Handover procedure is used to handover an MS with one or more packet flows from a source cell to a target cell, when at least one of the cells is a GERAN cell. The source and target cells can be located within either the same BSS (Intra BSS HO), different BSSs within the same SGSN (Intra SGSN HO) or belonging to different SGSNs (Inter SGSN HO), or systems with different radio access types (Inter RAT HO, Inter mode HO).

While the MS is still in the source cell:

- Radio resources in the target cell are allocated and signalled to the MS.
- System information of the target cell needed for access in the target cell is signalled to the MS.

After handover between GERAN and UTRAN is complete, the RAU procedure is performed even if the RAI has not changed.

The complete PS Handover procedures are defined in TS 43.129 [87].

The complete Inter RAT HO between E-UTRAN and GERAN procedures are defined in TS 23.401 [89].

6.9.5 UE Radio Capability Match Request

If the SGSN requires more information on the UE capabilities support to be able to set the IMS voice over PS Session Supported Indication (see clause 5.3.8), then the SGSN may send a UE Radio Capability Match Request to the RAN. This procedure is typically used during the Initial Attach procedure, during Routing Area Update procedure for the "first RAU following GERAN/E-UTRAN Attach" or for "UE Capability update" or when SGSN has not received the Voice Support Match Indicator (as part of the MM Context).

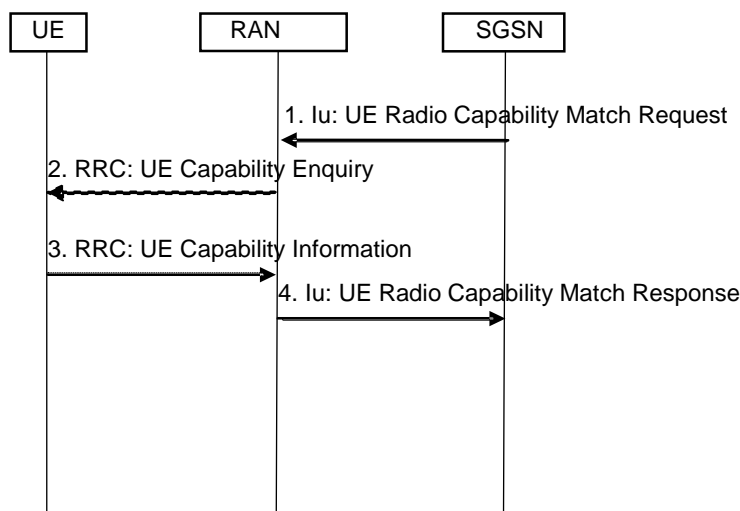

Figure 6.9.5-1: UE Radio Capability Match Request

1. The SGSN indicates whether the SGSN wants to receive Voice support match indicator.
2. Upon receiving a UE Radio Capability Match Request from the SGSN, if the RAN has not already received the UE capabilities from the MS the RAN requests the MS to upload the UE Capability information by sending the RRC UE Capability Enquiry.
3. The MS provides the RAN with its UE capabilities sending the RRC UE Capability Information.
4. Upon receiving a UE Radio Capability Match Request from the SGSN, the RAN checks whether the UE capabilities are compatible with the network configuration. The RAN provides a Voice Support Match Indicator to the SGSN to indicate whether the UE capabilities and networks configuration are compatible.

For determining the appropriate UE Radio Capability Match Response, the RAN is configured by the operator to check whether the MS supports certain capabilities required for IMS PS Voice continuity. In a shared network, the RAN keeps a configuration separately per PLMN.

NOTE: What checks to perform depends on network configuration, i.e. following are some examples of MS capabilities to be taken into account:

- the SRVCC, and UTRAN/E-UTRAN Voice over PS capabilities;
- the Radio capabilities for UTRAN/E-UTRAN FDD and/or TDD; and/or
- the support of UTRAN/E-UTRAN frequency bands.

The SGSN stores the received Voice support match indicator in the MM Context and uses it as an input for setting the IMS voice over PS Session Supported Indication.

6.10 Tunnelling of non-GSM Signalling Messages Function (A/Gb mode)

Tunnelling of Messages (TOM) is an optional protocol layer that uses the LLC unacknowledged mode procedures to tunnel messages between the MS and the SGSN (see TS 44.064 [15]). TOM uses two LLC SAPs for communication between the MS and the SGSN; one for high-priority messages and one for low-priority messages. A network that supports TIA/EIA-136 [49] shall support the TOM protocol and the Gs interface.

Upon receiving a non-GSM signalling message from an MS via the TOM protocol, the SGSN forwards the message to a non-GSM MSC/VLR using the BSSAP+ protocol (see GSM 09.18). The specific Gs interface used by the SGSN is determined by the:

- RAI associated with the current location of the MS when the SGSN does not provide functionality for the Intra Domain Connection of RAN Nodes to Multiple CN Nodes. When the SGSN provides functionality for Intra Domain Connection of RAN Nodes to Multiple CN Nodes, the SGSN uses the RAI and a hash value from the IMSI to determine the Gs interface; and
- information in the TOM protocol header.

Upon receiving a non-GSM signalling message from a non-GSM MSC/VLR via the BSSAP+ protocol, the SGSN forwards the message to a specific MS using the TOM protocol. The specific MS is determined by the SGSN based on the content of the BSSAP+ header.

The control plane between an MS and a non-GSM MSC/VLR that uses tunnelling procedures for non-GSM signalling is shown in Figure 45.

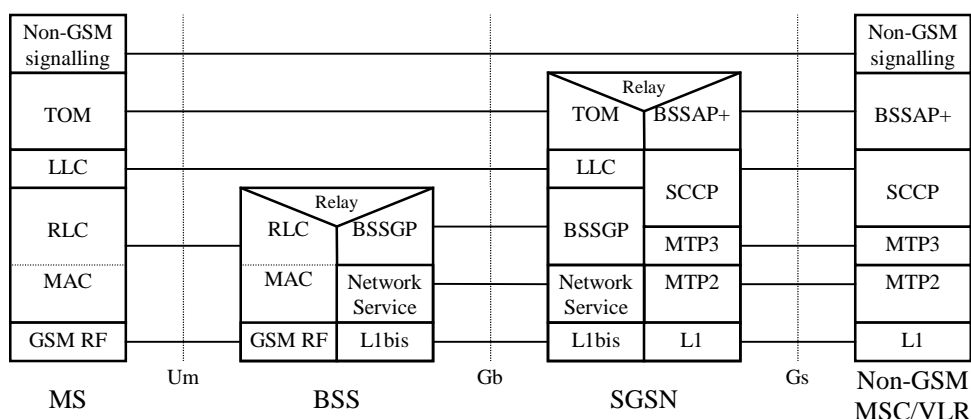

Figure 45: Control Plane MS - Non-GSM MSC/VLR

6.10.1 Uplink Tunnelling of non-GSM Signalling Messages Procedure

The Uplink Tunnelling of non-GSM Signalling Messages procedure is illustrated in Figure 46.

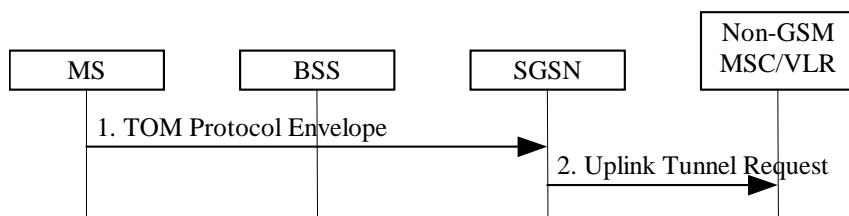

Figure 46: Uplink Tunnelling of non-GSM Signalling Messages Procedure

- 1) The MS sends a TOM Protocol Envelope (Non-GSM Signalling Message) to the SGSN either in ciphered or clear mode. The TOM protocol header contains information about the application using the TOM facility and any other TOM Protocol Discriminator-specific information. The TOM Protocol Envelope is received on one of the two LLC SAPs used for tunnelling of messages.

- 2) The SGSN identifies the non-GSM MSC/VLR to which to forward the non-GSM signalling message. It then sends a BSSAP+ Uplink Tunnel Request (IMSI, SGSN Address, TOM Priority, Cipher, Non-GSM Signalling Message) message to the identified non-GSM MSC/VLR. The Cipher parameter is set to cipher if the TOM Protocol Envelope was received in ciphered form by the LLC layer. Otherwise, it is set to not cipher. TOM Priority is set to high priority if the TOM Protocol Envelope was received on the high-priority LLC SAP, Otherwise, it is set to low priority.

6.10.2 Downlink Tunnelling of non-GSM Signalling Messages Procedure

The Downlink Tunnelling of non-GSM Signalling Messages procedure is illustrated in Figure 47.

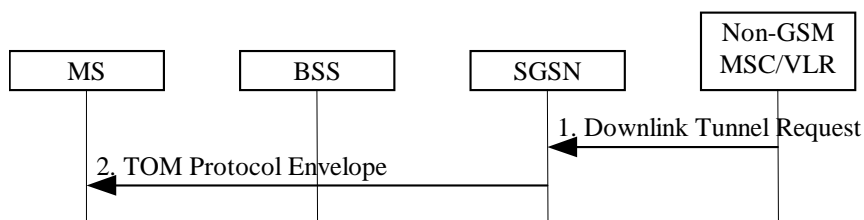

Figure 47: Downlink Tunnelling of non-GSM Signalling Messages Procedure

- 1) The non-GSM MSC/VLR sends a BSSAP+ Downlink Tunnel Request (IMSI, VLR Address, TOM Priority, Cipher, Non-GSM Signalling Message) message to the SGSN associated with the MS. TOM Priority indicates whether the SGSN shall select the high-priority or low-priority LLC SAP when forwarding the non-GSM signalling message to the MS. Cipher indicates whether or not the SGSN shall cipher the non-GSM signalling message before forwarding it to the MS.
- 2) The SGSN sends a TOM Protocol Envelope (Non-GSM Signalling Message) to the MS using the selected LLC SAP.

6.11 Subscriber Management Function

The Subscriber Management function provides a mechanism to inform the nodes about changes of the subscription data for a specific subscriber.

6.11.1 Subscriber Management Procedures

Whenever the GPRS subscription data is changed for a subscriber in the HLR/HSS, and the changes affect the GPRS subscription data stored in the SGSN, the SGSN node shall be informed about these changes by means of the following procedures:

- Insert Subscriber Data procedure, used to add or modify subscription data in the SGSN; or Delete Subscriber Data procedure, used to remove PS subscription data in the SGSN.
- Delete Subscriber Data procedure, used to remove subscription data from the SGSN.

6.11.1.1 Insert Subscriber Data Procedure

In addition to the insertion and modification of general subscription data for a PS subscriber, see TS 29.002 [23], the HLR may request the insertion or modification of one or several new or existing PDP subscription contexts in the SGSN. It should be noted that the modification may trigger a PDP Context Modification procedure as described in clause "Modification Procedures". In particular, the following PDP context parameters may be modified by the HLR:

- QoS Profile Subscribed;
- Subscribed Evolved ARP; and
- VPLMN Address Allowed.

The Insert Subscriber Data procedure is illustrated in Figure 48.

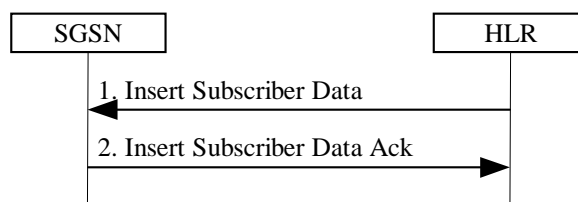

Figure 48: Insert Subscriber Data Procedure

- 1) The HLR sends an Insert Subscriber Data (IMSI, Subscription Data) message to the SGSN.
- 2) The SGSN updates its GPRS subscription data and acknowledges the Insert Subscriber Data message by returning an Insert Subscriber Data Ack (IMSI) message. For each PDP context that is included in Subscription Data the SGSN shall check whether it is a new, an active, or an inactive PDP context:

For architecture variants using Gn/Gp based interaction with GGSN the PDP contexts are handled as follows:

- For a new or inactive PDP context, no further action is required except storage in the SGSN.
- For an active PDP context, the SGSN shall in addition compare the new QoS Subscribed with QoS Negotiated, new Subscribed Evolved ARP with the previously stored Subscribed Evolved ARP, respectively and shall, if necessary and MS is in the READY or PMM CONNECTED State, initiate a PDP Context Modification procedure as described in clause "Modification Procedures". If modification is necessary, when MS is not in the READY or PMM CONNECTED State, or the modification is not successful when MS is in the READY or PMM CONNECTED State, the SGSN shall directly delete the concerned PDP context(s). PDP Context Modification due to changes in Subscribed Evolved ARP may be skipped if there is no previously stored value for Subscribed Evolved ARP.
- For an MS in PMM-CONNECTED State and connected via a CSG or hybrid cell, the SGSN shall check the received CSG subscription data. If the SGSN detects that the UE's CSG membership to that cell has changed or expired, the SGSN initiates the procedure in clause 9.2.3.7.

For architecture variants using S4 based interaction with S-GW and P-GW, the PDP contexts are handled as follows:

- For a new or inactive PDP context, no further action is required except storage in the SGSN.
- For an active PDP context, the SGSN shall in addition compare the new QoS Subscribed with bearer QoS and shall, if necessary and MS is in the READY or PMM CONNECTED State, initiate a PDP Context Modification procedure as described in clause "Modification Procedures". If modification is necessary, when MS is not in the READY or PMM CONNECTED State, or the modification is not successful when MS is in the READY or PMM CONNECTED State:
 - a) If ISR is activated when the next activity from MS is detected the S4-SGSN shall compare the stored updated subscription data with the existing data for that PDP context and initiate modification procedure.
 - b) If ISR is not activated, the SGSN shall directly delete the concerned PDP context.
- For an MS in PMM-CONNECTED State and connected via a CSG or hybrid cell, the SGSN shall check the received CSG subscription data. If the SGSN detects that the UE's CSG membership to that cell has changed or expired, the SGSN initiates the procedure in clause 9.2.3.7.

Furthermore, if VPLMN Address Allowed is changed, the SGSN shall, if necessary (e.g., if the PDP context is currently routed via a GGSN in the VPLMN and VPLMN Address Allowed is changed to not allowed), initiate a PDP Context Deactivation procedure as explained in clause 9.2.4.

6.11.1.2 Delete Subscriber Data Procedure

In addition to the deletion of general subscription data for a subscriber, see TS 29.002 [23], the HLR may request the deletion of one or several PDP contexts from the SGSN.

The Delete Subscriber Data procedure is illustrated in Figure 49.

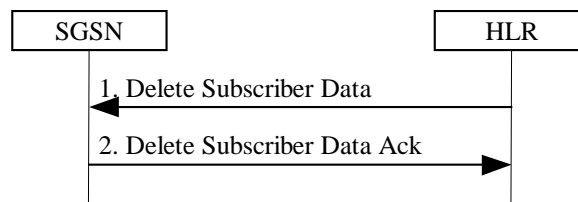

Figure 49: Delete Subscriber Data Procedure

- 1) The HLR sends a Delete Subscriber Data (IMSI, PDP Context Identifiers List) message to the SGSN.
- 2) The SGSN acknowledges the Delete Subscriber Data message by returning a Delete Subscriber Data Ack (IMSI) message. For each PDP context identifier included in PDP Context Identifiers List, the SGSN shall check whether it belongs to an active or an inactive PDP context:
 - For an inactive PDP context no further action is required except deletion of the PDP context.
 - For an active PDP context, the SGSN shall initiate the PDP Context Deactivation Initiated by the SGSN procedure as explained in clause "Deactivation Procedures" before the PDP context is deleted.

6.11.1.3 Insert CSG Subscriber Data Procedure

The CSS may request insertion of new or modification of existing CSG subscription data in the SGSN. Whenever the CSG subscription data is changed for a user in the CSS, and the changes affect the CSG subscription data stored in the SGSN, the CSS shall inform the SGSN about these changes by the means of the Insert CSG Subscriber Data procedure.

The CSS Subscription data is stored and managed in the SGSN independently from the CSG Subscription Data received from the HLR/HSS. The Insert CSG Subscriber Data procedure only affects the CSS Subscription data.

The Insert CSG Subscriber Data procedure for the CSS is illustrated in Figure 49a.

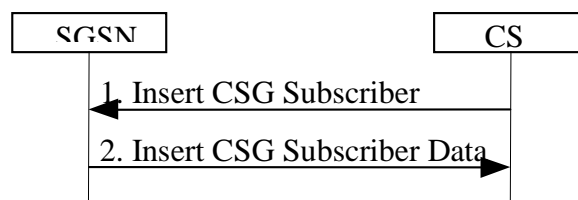

Figure 49a: Insert CSG Subscriber Data Procedure

- 1) The CSS sends an Insert CSG Subscriber Data (IMSI, CSG Subscription Data) message to the SGSN.
- 2) The SGSN updates the stored CSG Subscription Data and acknowledges the Insert CSG Subscriber Data message by returning an Insert CSG Subscriber Data Ack (IMSI) message to the CSS. The update result should be contained in the Ack message.

For an MS in PMM-CONNECTED State and connected via a CSG or hybrid cell, the SGSN shall check the received CSG subscription data. If the SGSN detects that the UE's CSG membership to that cell has changed or expired, the SGSN initiates the procedure in clause 9.2.3.7.

6.12 Service Request Procedure (Iu mode)

6.12.0 General

The Service Request procedure is used by a 3G-MS in PMM-IDLE state to request the establishment of a secure connection to a 3G-SGSN. The MS in PMM-IDLE state initiates this procedure in order to send uplink signalling messages (e.g. Activate PDP Context Request), user data, or as paging response, or after the MS has regained UTRAN (or Iu mode GERAN) radio coverage. This procedure is also used by an MS in PMM-CONNECTED state to request resource reservation for active PDP contexts.

In the context of this specification, the terms RNC refer also to a GERAN BSC when serving an MS in Iu mode.

6.12.1 MS Initiated Service Request Procedure Using Gn/Gp

The MS in PMM-IDLE state sends the Service Request message to the 3G-SGSN in order to establish the PS signalling connection for the upper layer signalling or for the resource reservation for active PDP context(s). After receiving the Service Request message, the 3G-SGSN may perform authentication, and it shall perform the security mode procedure. After the establishment of the secure PS signalling connection to a 3G-SGSN, the MS may send signalling messages, e.g. Activate PDP Context Request, to the 3G-SGSN, or the 3G-SGSN may start the resource reservation for the active PDP contexts depending on the requested service in the Service Request message. An MS in PMM-CONNECTED state also requests the resource reservation for the active PDP contexts through this procedure. An MS in PMM-CONNECTED state also requests the resource reservation for preserved active PDP contexts that need to transfer data but have not been allocated resources in a previous Service Request.

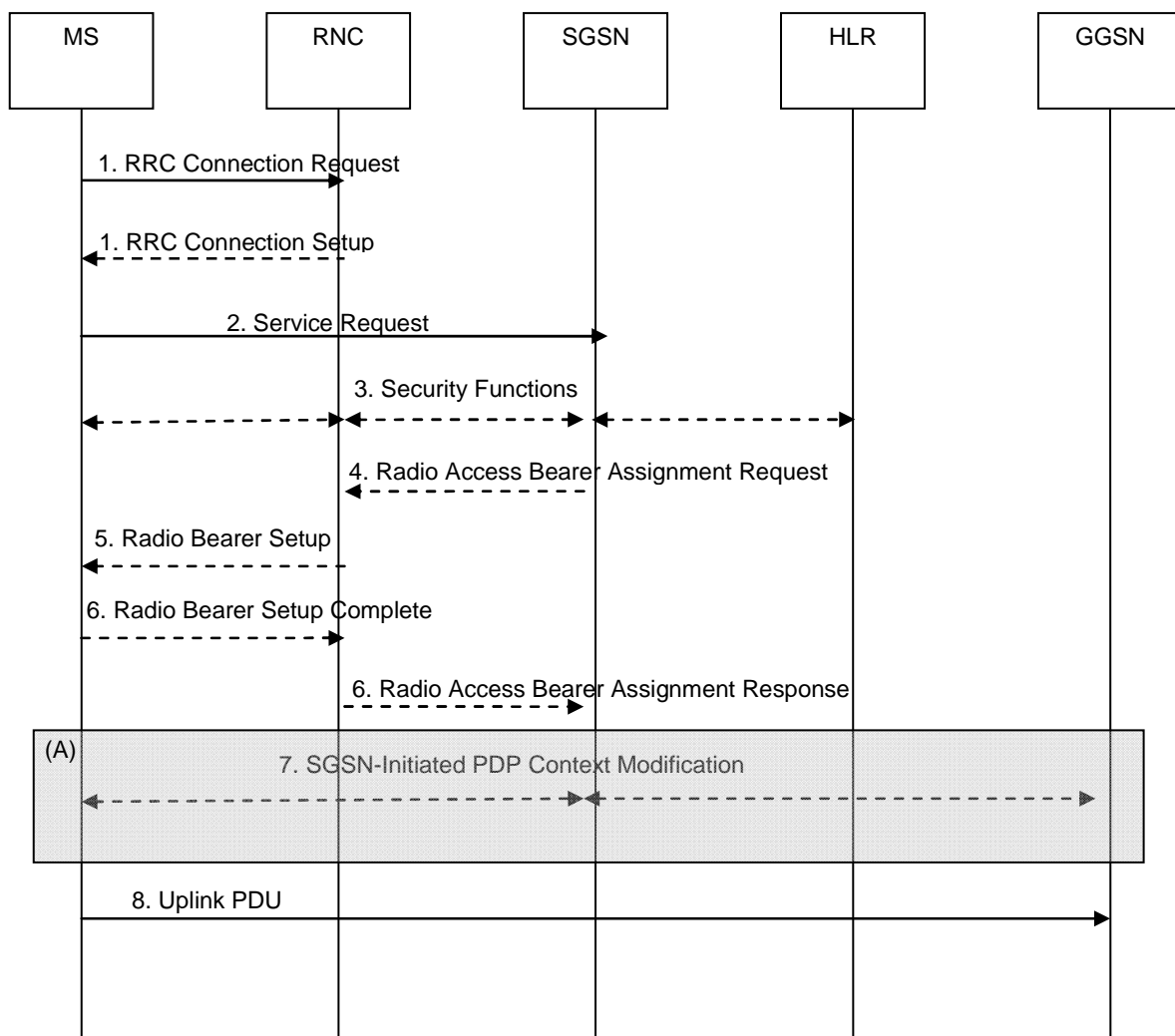

Figure 50: MS Initiated Service Request Procedure using Gn/Gp

NOTE 1: All steps in Figure 50 and 50a, except steps 6, 7 and 8, are common for architecture variants using Gn/Gp based interaction with GGSN and using S4 based interaction with S-GW and P-GW. For an S4 based interaction with S-GW and P-GW, procedure steps (A) are defined in clause 6.12.1A.

- 1) The MS establishes an RRC connection, if none exists for CS traffic.

The MS shall signal a cause that indicates emergency when it requests an RRC connection for PS emergency services, as defined in TS 25.331 [52].

- 2) The MS sends a Service Request (P-TMSI, RAI, CKSN, Service Type) message to the SGSN. Service Type specifies the requested service. Service Type shall indicate one of the following: Data or Signalling. When the

Service Type indicates Data, the UE may also include PDP context activity information to indicate which PDP contexts need to transfer data. At this point, the SGSN may perform the authentication procedure.

If Service Type indicates Data, a signalling connection is established between the MS and the SGSN, and resources for active PDP context(s) are allocated, i.e. RAB establishment for the activated PDP context(s).

If Service Type indicates Signalling, the signalling connection is established between the MS and the SGSN for sending upper-layer signalling messages, e.g. Activate PDP Context Request. The resources for active PDP context(s) are not allocated.

CSG ID is provided if the MS sends the Service Request message via a CSG cell or hybrid cell. CSG access mode is provided if the MS sends the Service Request message via a hybrid cell. If the CSG access mode is not provided but the CSG ID is provided, the SGSN shall consider the cell as a CSG cell.

If a CSG ID is indicated and CSG access mode is "closed" or CSG access mode is not provided, and there is no subscription data for this CSG ID and associated PLMN or the CSG subscription is expired, the SGSN rejects the Service Request with an appropriate cause. The UE shall remove the CSG ID and associated PLMN of the cell where the UE has initiated the service request procedure from the Allowed CSG list, if present.

For MSs with emergency PDP contexts, i.e. at least one PDP Context has an ARP value reserved for emergency services, and if CSG access restrictions do not allow the MS to get normal services, the SGSN shall deactivate all non-emergency PDP contexts and accept the Service Request.

If LIPA is active for a PDP context and if the cell accessed by the MS does not link to the L-GW where the MS initiated the LIPA PDP context, the SGSN shall not request the establishment of the bearers of the LIPA PDP context from the RNC in step 4 and shall disconnect the LIPA PDP context by means of the SGSN-initiated PDP Context Deactivation Procedure according to clause 9.2.4.2.

- 3) The SGSN shall perform the security functions if the MS in PMM-IDLE state initiated the service request.
- 4) If the network is in PMM-CONNECTED state and the Service Type indicates Data, the SGSN shall respond with a Service Accept message towards the MS, in case the service request can be accepted. In case Service Type indicates Data, the SGSN sends a Radio Access Bearer Assignment Request (NSAPIRAB ID(s), TEID(s), QoS Profile(s), SGSN IP Address(es), UE-AMBR, CSG Membership Indication, MSISDN, APN, Charging characteristics) message to re-establish radio access bearers for PDP contexts which do not have maximum bit rates for uplink and downlink of 0 kbit/s. If Direct Tunnel is established the SGSN provides to the RNC the GGSN's User Plane Address(es) and TEID(s) for uplink data instead of the SGSN's IP Address(es) and TEID(s). The SGSN may in addition use PDP context activity information provided by the UE in the Service Request to decide which RABs to set up. MSISDN, APN and Charging characteristics are optional parameters and only transferred if SGSN supports SIPTO at Iu-ps. For RABs belonging to a PDP context/PDN connection for Local IP Access the RAB Assignment Request message includes a Correlation ID for enabling the direct user plane path between the HNB and the L-GW.

NOTE 1: In this release of the 3GPP specification the Correlation ID is set equal to the user plane GGSN TEID that the Gn-SGSN has received in step 4 of clause 9.2.2.1 or the user plane PDN GW TEID that the S4-SGSN has received from the PDN GW.

NOTE 2: When using Gn-SGSN, the direct user plane path between the HNB and the L-GW is enabled with the direct tunnel functionality described in clause 15.6.

If the Service Request is performed via a hybrid cell, the CSG Membership Indication indicating whether the UE is a CSG member shall be included. Based on this information, the RAN can perform differentiated treatment for CSG and non-CSG members.

If the MS is not allowed to access the cell where the MS initiated the service request due to CSG access restriction, the SGSN shall only request to establish radio access bearers for Emergency PDP contexts.

- 5) The RNC indicates to the MS the new Radio Bearer Identity established and the corresponding RAB ID with the RRC radio bearer setup procedure.
- 6) SRNC responds with the Radio Access Bearer Assignment Response (RAB ID(s), TEID(s), QoS Profile(s), RNC IP Address(es)) message. The GTP tunnel(s) are established on the Iu interface.
- 7) If the RNC returns a Radio Access Bearer Assignment Response message with a cause indicating that the requested QoS profile(s) can not be provided, e.g. "Requested Maximum Bit Rate not Available", the SGSN may

send a new Radio Access Bearer Assignment Request message with different QoS profile(s). The number of re-attempts, if any, as well as how the new QoS profile(s) values are determined is implementation dependent. For each RAB re-established with a modified QoS profile, the SGSN initiates a PDP Context Modification procedure to inform the MS and the GGSN of the new negotiated QoS profile for the corresponding PDP context. If the SGSN established Direct Tunnel in step 4) it shall initiate a PDP Context Modification procedure to the GGSN and provide to the GGSN the RNC's Address for User Plane and TEID for Downlink data and shall include the DTI to instruct the GGSN to apply Direct Tunnel specific error handling procedure as described in clause 13.8.

8) The MS sends the uplink packet.

For Service Type = Signalling, the MS knows that the Service Request message was successfully received in the SGSN when the MS receives the RRC Security Mode Control Command message.

For Service Type = Data, in PMM-IDLE, the MS knows that the Service Request was successfully received when the MS receives the RRC Security Mode Control Command message from the RNC; in PMM-CONNECTED state, the MS knows that the Service Request was successfully received when the MS receives the Service Accept message.

NOTE 2: The reception of the Service Accept message does not imply the successful re-establishment of the RAB(s).

For any Service Type, in case the service request cannot be accepted, the network returns a Service Reject message to the MS with an appropriate cause value.

For Service Type = Data, in case the SGSN fails to re-establish RAB(s) for the PDP context(s), the SGSN determines if an SM procedure, such as SGSN-Initiated PDP Context Modification or PDP Context Deactivation, should be initiated. The appropriate action depends on the QoS profile of the PDP context and is an operator choice.

For each PDP context using streaming or conversational traffic class with maximum bit rate for uplink and downlink of 0 kbit/s the MS starts the MS-Initiated PDP Context Modification procedure or the MS-Initiated PDP Context Deactivation procedure to inform the SGSN whether to re-activate or to delete the PDP contexts. If the PDP context has been deactivated locally in the MS, the MS shall not perform the PDP context deactivation procedure for this PDP context because the list of active and inactive PDP contexts is included in the Service Request Message sent prior to the network.

6.12.1A UE Initiated Service Request Procedure Using S4

The procedures described in figure 50a shows only the steps, which are different from the Gn/Gp variant of the procedure described in clause 6.12.1. due to the use of S4.

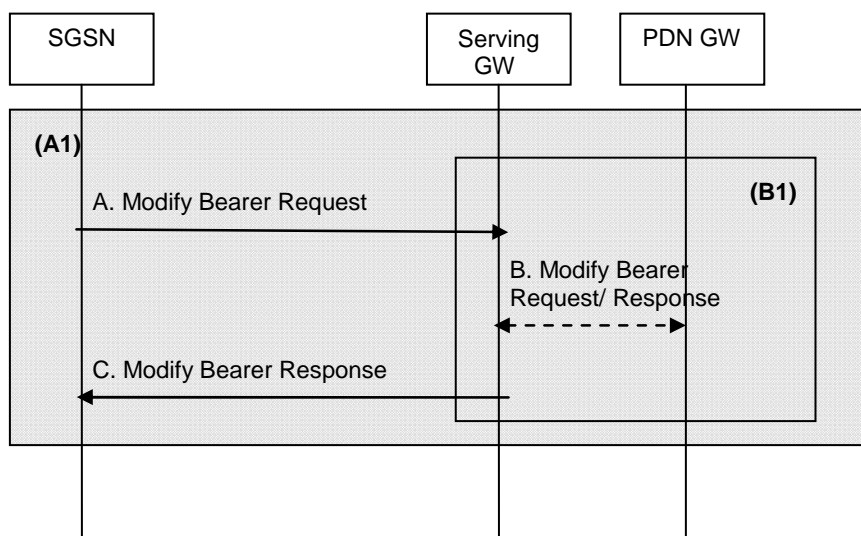

Figure 50a: UE Initiated Service Request Procedure using S4

NOTE 1: All steps in figures 50a and 51a, are common for UE and Network initiated procedure using S4. For a PMIP-based S5/S8, procedure steps (B1) are defined in TS 23.402 [90].

A) If the RNC returns a Radio Access Bearer Assignment Response message with a cause indicating that the requested QoS profile(s) can not be provided, e.g. "Requested Maximum Bit Rate not Available", the SGSN does not send any new Radio Access Bearer Assignment Request message with different QoS profile(s), the RAB is not established. For each established RABs, the SGSN sends Modify Bearer Request messages to the Serving GW (Downlink S4/S12 TEID). If the S-GW receives a DL packet for an unaccepted bearer, the S-GW drops the DL packet and does not send a Downlink Data Notification to the MME. For the established RABs, if the SGSN established Direct Tunnel it includes the RNC's Address for User Plane TEID for downlink data and DTI. If Direct Tunnel is not used, the SGSN includes SGSN Address for User Plane and TEID for downlink data. The Serving GW is now able to transmit downlink data towards the UE. If there is no Direct Tunnel the SGSN sends downlink packet.

If any EPS bearers are to be released the SGSN triggers the bearer release procedure as specified in clause 9.2.4.2.

B) If the RAT Type has changed compared to the last reported RAT Type, the Serving GW shall send the Modify Bearer Request message (RAT Type) to the PDN GW. The PDN GW sends the Modify Bearer Response to the Serving GW.

NOTE 2: PCC interactions between the PDN GW and the PCRF are documented in TS 23.401 [89]

C) The Serving GW acknowledges by sending Modify Bearer Response (SGW address for user plane and uplink S4 GTP-U TEID) to the SGSN.

6.12.2 Network Initiated Service Request Procedure using Gn/Gp

When the 3G-SGSN receives a downlink packet (e.g. Request PDP Context Activation, Mobile-terminated SMS, user data) for an MS in PMM-IDLE state, the 3G-SGSN sends a paging request to RAN. The paging request triggers the Service Request procedure in the MS.

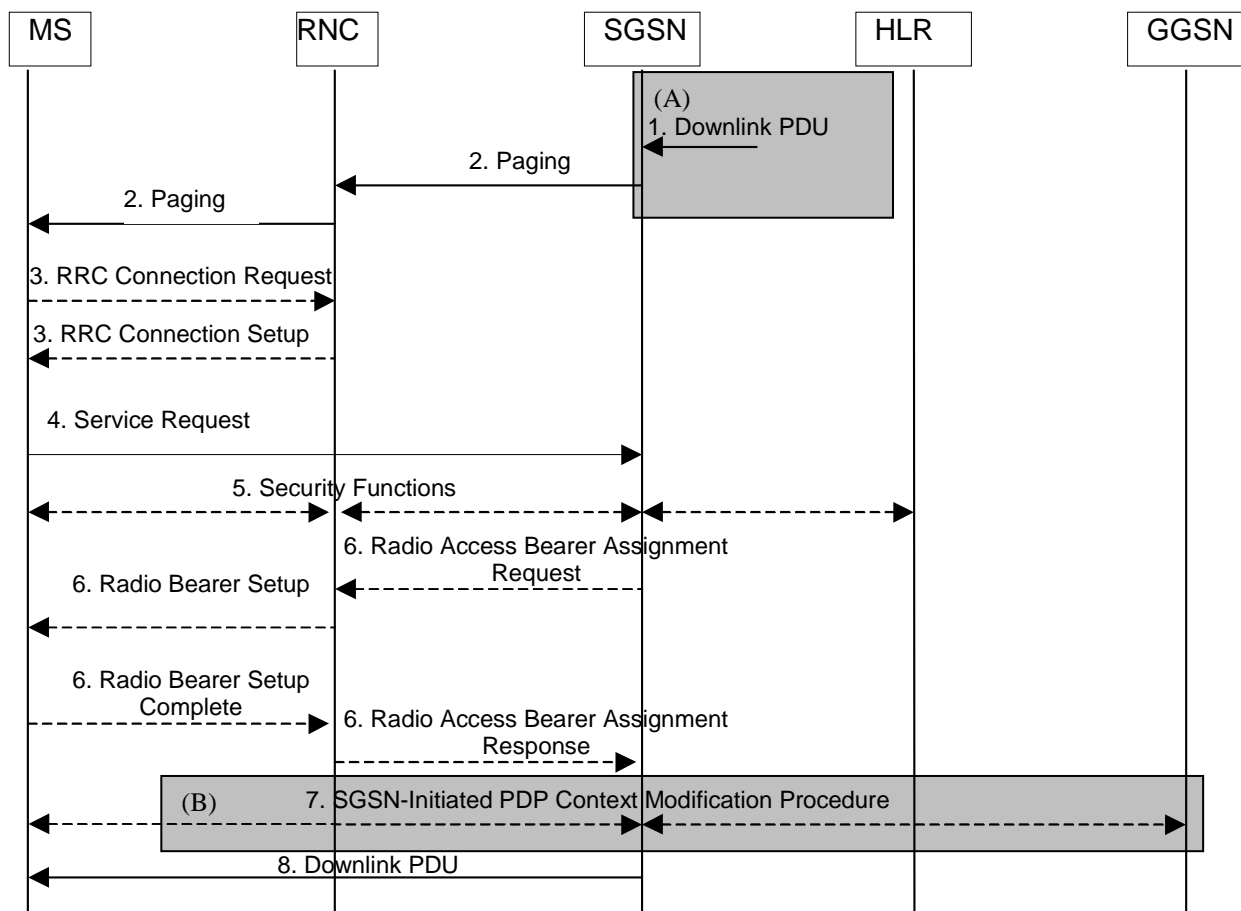

Figure 51: Network Initiated Service Request Procedure

NOTE 1: All steps in figure 51, except Procedure steps (A) and (B), are common for architecture variants using Gn/Gp based interaction with GGSN and using S4 based interaction with S-GW and P-GW.

NOTE 2: Procedure steps B (step 7) in figure 51 above are common for MS and Network initiated service request using S4 and are described in clause 6.12.1A. Procedure steps (A) are defined in clause 8.2.4.1A when S4 is used.

If a LIPA PDP context exists, when the L-GW receives the downlink data for an MS in PMM-IDLE state, the L-GW sends the first downlink user packet to the SGSN and buffers all other downlink user packets. When S4 is used, the L-GW sends the first downlink user packet to Serving GW and the Serving GW will trigger the SGSN to page the UE.

- 1) The SGSN receives a downlink PDP PDU for an MS in PMM-IDLE state.
- 2) The SGSN sends a Paging message to the RNC. The RNC pages the MS by sending a Paging message to the MS. See clause "PS Paging Initiated by 3G-SGSN without RRC Connection for CS" for details.
- 3) The MS establishes an RRC connection if none exists for CS traffic.
- 4) The MS sends a Service Request (P-TMSI, RAI, CKSN, Service Type) message to the SGSN. Service Type specifies Paging Response. The Service Request is carried over the radio in an RRC Direct Transfer message and over the Iu interface in the RANAP Initial MS message. At this point, the SGSN may perform the authentication procedure. The SGSN knows whether the downlink packet requires RAB establishment (e.g. downlink PDU) or not (e.g. Request PDP Context Activation or Mobile-terminated SMS).

CSG ID is provided if the MS attaches via a CSG cell or hybrid cell. CSG access mode is provided if the MS sends the Service Request message via a hybrid cell. If the CSG access mode is not provided but the CSG ID is provided, the SGSN shall consider the cell as a CSG cell.

If a CSG ID is indicated and CSG access mode is "closed" or CSG access mode is not provided, and there is no subscription data for this CSG ID and associated PLMN or the CSG subscription is expired, the SGSN rejects the Service Request with an appropriate cause. The MS shall remove the CSG ID and associated PLMN of the cell where the MS has initiated the service request procedure from the Allowed CSG list, if present.

For MSs with emergency PDP contexts, i.e. at least one PDP Context has an ARP value reserved for emergency services, and if CSG access restrictions do not allow the MS to get normal services, the SGSN shall deactivate all non-emergency PDP contexts and accept the Service Request.

- 5) The SGSN shall perform the security mode procedure.
- 6) If resources for the PDP contexts are re-established, the SGSN sends a Radio Access Bearer Assignment Request (RAB ID(s), TEID(s), QoS Profile(s), SGSN IP Address(es), UE-AMBR, CSG Membership Indication, MSISDN, APN, Charging characteristics) message to the RNC. If Direct Tunnel is established the SGSN provides to the RNC the GGSN's User Plane Address and TEID for uplink data. The RNC sends a Radio Bearer Setup (RAB ID(s)) to the MS. The MS responds by returning a Radio Bearer Setup Complete message to the RNC. The RNC sends a Radio Access Bearer Assignment Response (RAB ID(s), TEID(s), RNC IP Address(es)) message to the SGSN in order to indicate that GTP tunnels are established on the Iu interface and radio access bearers are established between the RNC and the MS. If the RNC returns a Radio Access Bearer Assignment Response message with a cause indicating that the requested QoS profile(s) can not be provided, e.g. "Requested Maximum Bit Rate not Available", the SGSN may send a new Radio Access Bearer Assignment Request message with different QoS profile(s). The number of re-attempts, if any, as well as how the new QoS profile(s) values are determined is implementation dependent. MSISDN, APN and Charging characteristics are optional parameters and only transferred if SGSN supports SIPTO at Iu-ps. For RABs belonging to a PDP context/PDN connection for Local IP Access the RAB Assignment Request message includes a Correlation ID for enabling the direct user plane path between the HNB and the L-GW.

If the Service Request is performed via a hybrid cell, the CSG Membership Indication indicating whether the UE is a CSG member shall be included. Based on this information the RAN can perform differentiated treatment for CSG and non-CSG members.

If the MS is not allowed to access the cell where the MS initiated the service request due to CSG access restriction, the SGSN shall only request to establish radio access bearers for Emergency PDP contexts.

NOTE 3: In this Release of the 3GPP specification the Correlation ID is set equal to the user plane GGSN TEID that the Gn-SGSN has received in step 4 of clause 9.2.2.1 or the user plane PDN GW TEID that the S4-SGSN has received from the PDN GW.

- 7) For each RAB re-established with a modified QoS profile, the SGSN initiates a PDP Context Modification procedure to inform the MS and the GGSN of the new negotiated QoS profile for the corresponding PDP context. If SGSN established Direct Tunnel in step 6) it shall initiate a PDP Context Update procedure to the GGSN and provide to the GGSN the RNC's Address for User Plane and TEID for Downlink data and shall include the DTI to instruct the GGSN to apply Direct Tunnel specific error handling procedure as described in clause 13.8.
- 8) The SGSN sends the downlink packet. For a LIPA PDP context, after the MS enters connected mode, the packets buffered in the L-GW are forwarded to the HNB on the direct path. If the MS enters connected mode at a different cell than the one where the L-GW is collocated, the SGSN shall deactivate the LIPA PDP context as defined in clause 6.12.1, step 2.

For Service Type = Page Response, the MS knows that the Service Request message was successfully received in the SGSN when the MS receives the RRC Security Mode Control Command message.

If the SGSN fails to re-establish RAB(s) for the PDP context(s), the SGSN determines if an SM procedure, such as SGSN-Initiated PDP Context Modification or PDP Context Deactivation, should be initiated. The appropriate action depends on the QoS profile of the PDP context and is an operator choice.

6.12.2A Void

6.13 Intersystem Change

An intersystem change takes place when an MS changes between Iu mode and A/Gb mode of operation by the Routing Area Update procedure or by PS handover. A prerequisite for an intersystem change is that the MS is GPRS-attached. The transition of the mobility management states is as specified for the corresponding mobility management procedures.

There is no transition of the session management states at an intersystem change.

6.13.1 Intra SGSN Intersystem Change

An SGSN that supports both the Gb and Iu-PS interfaces may support an intra-SGSN intersystem change if the radio access technology nodes serving the MS before and after the intersystem change are both served by this SGSN.

6.13.1.1 Iu mode to A/Gb mode Intra SGSN Change

6.13.1.1.1 Iu mode to A/Gb mode Intra SGSN Change using Gn/Gp

The intersystem change from Iu mode to A/Gb mode takes place when an MS changes from UTRAN or GERAN Iu mode to A/Gb mode. Depending on the PMM state before the intersystem change and whether the RA is changed or not, one of the following procedures is initiated by the MS:

- When an MS in PMM-IDLE state changes to the A/Gb mode without changing the RA, the MS shall follow the selective RA update procedures, see clause "Selective RA Update".
- When an MS in PMM-IDLE state changes to the A/Gb mode and the RA changes, the MS shall initiate the GPRS RA update procedure, see clause "Intra SGSN Routing Area Update".
- When an MS in PMM-CONNECTED state changes to the A/Gb mode, the MS shall initiate the GPRS RA update procedure independent of whether the RA has changed or not. The RA update procedure is either combined RA / LA update or only RA update.

A combined RA / LA update takes place in network operation mode I when the MS enters a new RA or when a GPRS-attached MS performs IMSI attach. The MS sends a Routing Area Update Request message indicating that an LA update may also need to be performed, in which case the SGSN forwards the LA update to the VLR. This concerns only idle mode (see TS 23.122 [7b]), as no combined RA / LA updates are performed during a CS connection. In the context of this specification, the terms RNS or RNC refer also to a GERAN BSS or BSC (respectively) when serving an MS in Iu mode.

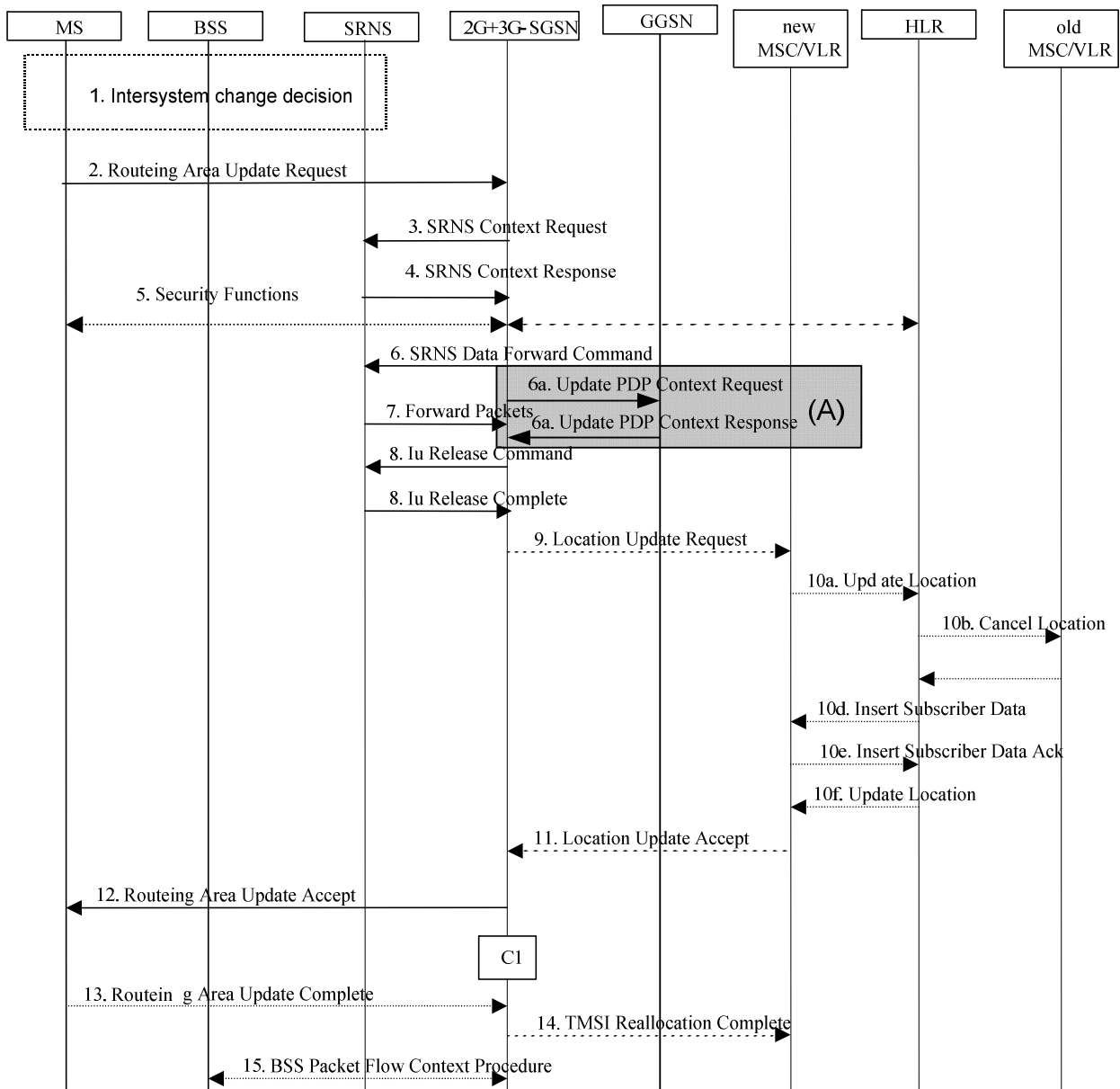

Figure 52: Iu mode to A/Gb mode Intra SGSN Change

NOTE: All steps in figure 52 are common for architecture variants using Gn/Gp based interaction with a GGSN and using S4 based interactions with an S-GW and P-GW. For S4 based interaction with an S-GW and P-GW, procedure step (A) is defined in clause 6.13.1.1.2.

- 1) The MS or RAN decides to perform an intersystem change which makes the MS switch to a new cell where A/Gb mode has to be used, and stops transmission to the network.
- 2) The MS sends a Routing Area Update Request (old RAI, old P-TMSI Signature, Update Type, Voice domain preference and UE's usage setting) message to the 2G+3G-SGSN. Update Type shall indicate RA update or combined RA / LA-update or, if the MS wants to perform an IMSI attach, combined RA / LA update with IMSI attached requested. The BSS shall add the Cell Global Identity including the RAC and LAC of the cell where the message was received before passing the message to the 2G+3G-SGSN. The UE sets the voice domain preference and UE's usage setting according to its configuration, as described in clause 5.3.15.

If there is an ongoing emergency bearer service and a Routing Area Update Request is received the Routing Area Update shall be rejected with a cause code indicating that access to GERAN is not allowed.

- 3) If the MS is PMM-CONNECTED state, the 2G+3G-SGSN sends an SRNS Context Request (IMSI) message to the SRNS.

Upon reception of the SRNS Context Request message, the SRNS starts buffering and stops sending downlink PDUs to the MS. The SRNS responds with an SRNS Context Response (GTP-SNDs, GTP-SNUs, PDCP-SNDs, PDCP-SNUs) message. The GTP sequence numbers are included for each PDP context indicating the next in-sequence downlink GTP-PDU to be sent to the MS and the next in-sequence GTP PDU to be tunnelled to the GGSN. For each active PDP context, which uses lossless PDCP, the SRNS also includes the uplink PDCP sequence number (PDCP-SNU) and the downlink PDCP sequence number (PDCP-SND). PDCP-SNU is the PDCP sequence number for the next expected in-sequence uplink packet to be received from the MS. PDCP-SND is the PDCP sequence number for the first downlink packet for which successful transmission has not been confirmed. The 2G+3G-SGSN shall strip off the eight most significant bits of the passed PDCP sequence numbers, thus converting them to SMDCP N-PDU numbers of the respective 2G GPRS PDP contexts.

- 5) Security functions may be executed.
- 6) If the MS is PMM-CONNECTED, the 2G+3G-SGSN sends an SRNS Data Forward Command (RAB ID, Transport Layer Address, Iu Transport Association) message to the SRNS. This informs the SRNS that the 2G+3G-SGSN is ready to receive data packets. Upon reception of SRNS Data Forward Command message from the 2G+3G-SGSN the SRNS shall start the data-forwarding timer.
 - 6a) If Direct Tunnel was established in Iu mode the SGSN sends Update PDP Context Request to the GGSN(s) concerned to establish the GTP tunnel between SGSN and GGSN. The GGSN(s) update the address for User Plane and downlink TEID for data and return an Update PDP Context Response. Otherwise, if there were changes of for example the RAT type that e.g. can be used for charging, the SGSN sends Update PDP Context Request (SGSN Address and TEID, QoS Negotiated, RAT type) message to the GGSN.
- 7) For each RAB indicated by the SRNS Data Forward Command the SRNS starts duplicating and tunnelling the buffered GTP-PDUs back to the 2G+3G-SGSN. For each radio bearer which uses lossless PDCP the GTP-PDUs related to transmitted but not yet acknowledged PDCP-PDUs are duplicated and tunnelled back to the 2G+3G-SGSN together with their related downlink PDCP sequence numbers. The 2G+3G-SGSN converts the PDCP sequence numbers to SMDCP sequence number (by stripping off the eight most significant bits of the PDCP sequence numbers).
- 8) The 2G+3G-SGSN sends an Iu Release Command message to the SRNS. When the RNC data-forwarding timer has expired, the SRNS responds with an Iu Release Complete message.
- 9) If the association has to be established i.e. if Update Type indicates combined RA / LA update with IMSI attach requested, or if the LA changed with the routing area update, then the 2G+3G-SGSN sends a Location Update Request (new LAI, IMSI, SGSN Number, Location Update Type) to the VLR. Location Update Type shall indicate IMSI attach if Update Type in step 1 indicated combined RA / LA update with IMSI attach requested. Otherwise, Location Update Type shall indicate normal location update. When the SGSN does not provide functionality for the Intra Domain Connection of RAN Nodes to Multiple CN Nodes, the VLR number is derived from the RAI. When the SGSN provides functionality for Intra Domain Connection of RAN Nodes to Multiple CN Nodes, the SGSN uses the RAI and a hash value from the IMSI to determine the VLR number. The VLR creates or updates the association with the 2G+3G-SGSN by storing the SGSN Number.
- 10) If the subscriber data in the VLR is marked as not confirmed by the HLR, the new VLR informs the HLR. The HLR cancels the data in the old VLR and inserts subscriber data in the new VLR:
 - a) The new VLR sends an Update Location (new VLR) to the HLR.
 - b) The HLR cancels the data in the old VLR by sending Cancel Location (IMSI) to the old VLR.
 - c) The old VLR acknowledges with Cancel Location Ack (IMSI).
 - d) The HLR sends Insert Subscriber Data (IMSI, subscriber data) to the new VLR.
 - e) The new VLR acknowledges with Insert Subscriber Data Ack (IMSI).
 - f) The HLR responds with Update Location Ack (IMSI) to the new VLR.
- 11) The new VLR allocates a new VLR TMSI and responds with Location Update Accept (VLR TMSI) to the 2G+3G-SGSN. VLR TMSI is optional if the VLR has not changed.

- 12) The 2G+3G-SGSN validates the MS's presence in the new RA. If due to roaming restrictions or access restrictions the MS is not allowed to be attached in the RA, or if subscription checking fails, the 2G+3G-SGSN rejects the routing area update with an appropriate cause. If all checks are successful, the 2G+3G-SGSN updates MM and PDP contexts for the MS. A new P-TMSI may be allocated. A logical link is established between the new 2G+3G-SGSN and the MS. 2G+3G-SGSN initiates the establishment procedure. A Routing Area Update Accept (P-TMSI, P-TMSI Signature, Receive N-PDU Number (= converted PDCP-SNU), IMS voice over PS Session Supported Indication) message is returned to the MS. Receive N-PDU Number contains the acknowledgements for each NSAPI which used lossless PDCP before the start of the update procedure, thereby confirming all mobile-originated N-PDUs successfully transferred before the start of the update procedure. If Receive N-PDU Number confirms the reception of N-PDUs, these N-PDUs shall be discarded by the MS. The IMS voice over PS Session Supported Indication is set as described in clause 5.3.8.
- 13) The MS acknowledges the new P-TMSI by returning a Routing Area Update Complete (Receive N-PDU Number) message to the SGSN. Receive N-PDU Number (= converted PDCP-SND) contains the acknowledgements for each NSAPI which used lossless PDCP before the start of the update procedure, thereby confirming all mobile-terminated N-PDUs successfully transferred before the start of the update procedure. If Receive N-PDU Number confirms the reception of N-PDUs, these N-PDUs shall be discarded by the 2G+3G-SGSN. The MS deducts Receive N-PDU Number from PDCP-SND by stripping off the eight most significant bits. PDCP-SND is the PDCP sequence number for the next expected in-sequence downlink packet to be received in the MS per radio bearer, which used lossless PDCP. The new 2G-SGSN negotiates with the MS for each NSAPI the use of acknowledged or unacknowledged SNDCP regardless whether the SRNS used lossless PDCP or not.
- 14) The 2G+3G-SGSN sends a TMSI Reallocation Complete message to the VLR if the MS confirms the VLR TMSI.
- 15) The 2G+3G-SGSN and the BSS may execute the BSS Packet Flow Context procedure.

For some network sharing scenario (e.g. GWCN) if the PLMN-ID of the RAI supplied by the RNC is different from that of the RAI in the UE's context, then the SGSN shall inform the HLR.

The CAMEL procedure calls shall be performed, see referenced procedure in TS 23.078 [8b]:

- C1) CAMEL_GPRS_Routeing_Area_Update_Session, CAMEL_PS_Notification and CAMEL_GPRS_Routeing_Area_Update_Context.
- The procedure CAMEL_GPRS_Routeing_Area_Update_Session is called once per session. In Figure 52, the procedure returns as result "Continue".
 - Then the procedure CAMEL_PS_Notification is called once per session. The procedure returns as result "Continue".
 - Then, the procedure CAMEL_GPRS_Routeing_Area_Update_Context is called once per PDP context. In Figure 52, the procedure returns as result "Continue".

6.13.1.1.2 lu mode to A/Gb mode Intra SGSN Change using S4

In this case, clause 6.13.1.1.1 applies except for steps 6a and 7, as well as section specific general statements stated below.

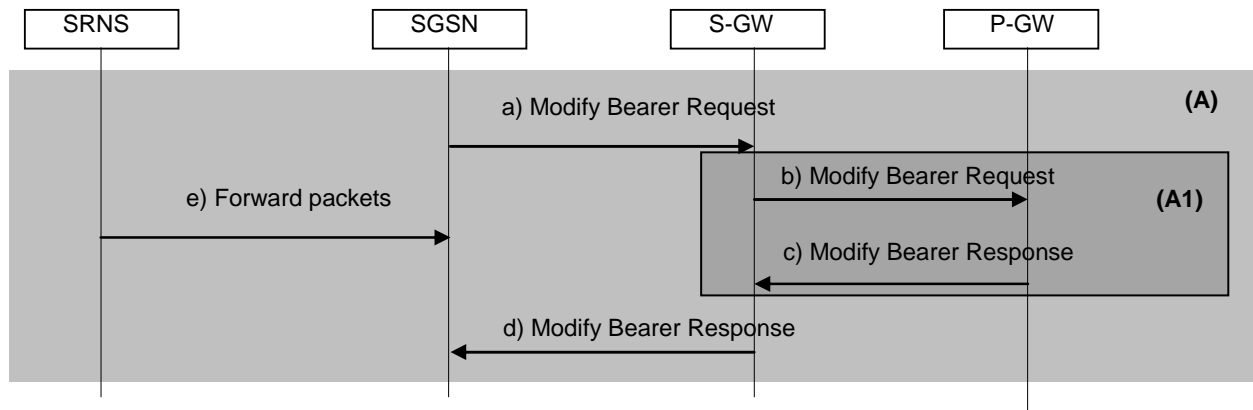

Figure 52-2: step 6a for Iu mode to A/Gb mode Intra SGSN Change using S4

NOTE: Steps a) and d) are common for architecture variants with GTP-based S5/S8 and PMIP-based S5/S8. For a PMIP-based S5/S8, procedure step (A1) is defined in TS 23.402 [90]. Steps b) and c) in Figure 52-2 concern GTP-based S5/S8.

- In this procedure flow the Serving GW is not relocated. If Direct Tunnel was established in Iu mode or if there were changes of for example the RAT type that e.g. can be used for charging, the SGSN sends Modify Bearer Request (SGSN Address and TEID, serving network identity, RAT type) message to the Serving GW.
- The Serving GW informs the P-GW(s) about the change of for example the RAT type that e.g. can be used for charging, by sending the message Modify Bearer Request (Serving GW Address and TEID, RAT type) to the concerned P-GW(s). If dynamic PCC is deployed, and RAT type information needs to be conveyed from the P-GW to the PCRF, then the P-GW sends RAT type information to the PCRF as defined in TS 23.203 [88].
- Each P-GW updates its context field and returns a Modify Bearer Response (MSISDN, P-GW address and TEID) message to the Serving GW. MSISDN is included if available in the stored UE context.
- The Serving GW updates the address for User Plane and downlink TEID for data and return a Modify Bearer Response (Serving GW address and TEID, P-GW address and TEIDs (for GTP-based S5/S8) or GRE keys (for PMIP-based S5/S8) at the PDN GW(s) for uplink traffic) message.
- In case Direct Tunnel in Iu mode was not established, for each RAB indicated by the SRNS Data Forward Command the SRNS starts duplicating and tunnelling the buffered GTP-PDUs back to the 2G+3G SGSN. For each radio bearer which uses lossless PDCP the GTP-PDUs related to transmitted but not yet acknowledged PDCP PDUs are duplicated and tunneled back to the 2G+3G SGSN together with their related downlink PDCP sequence numbers. The 2G+3G SGSN converts the PDCP sequence numbers to SDCP sequence number (by stripping off the eight most significant bits of the PDCP sequence numbers).

In case Direct Tunnel in Iu mode was established, the packets are forwarded via the S-GW.

6.13.1.2 A/Gb mode to Iu mode Intra-SGSN Change

6.13.1.2.1 A/Gb mode to Iu mode Intra-SGSN Change using Gn/Gp

The intersystem change from A/Gb mode to Iu mode takes place when a GPRS-attached MS changes from A/Gb mode to GERAN or UTRAN Iu mode. Depending on the GPRS mobility management state before the intersystem change and whether the RA is changed or not, one of the following procedures is initiated by the MS:

- When an MS in STANDBY state changes to Iu mode inside the current RA, the MS shall follow the selective RA update procedures, see clause "Selective RA Update".
- When an MS in STANDBY state changes to Iu mode and the RA changes, the MS shall initiate the Iu mode RA update procedure, see clause "Routing Area Update Procedure".
- When an MS in READY state changes to Iu mode independent of whether the RA has changed or not, the MS shall initiate the Iu mode RA update procedure and afterwards initiate the RABs by the Service Request procedure, see clause "MS Initiated Service Request Procedure". The RA update procedure is either combined RA / LA update or only RA update.

If the network operates in mode I, an MS that is both PS-attached and CS-attached shall perform the Combined RA / LA Update procedure. This concerns only idle mode (see TS 23.122 [7b]), as no combined RA / LA updates are performed during a CS connection. In the context of this specification, the terms RNS or RNC refer also to a GERAN BSS or BSC (respectively) when serving an MS in Iu mode.

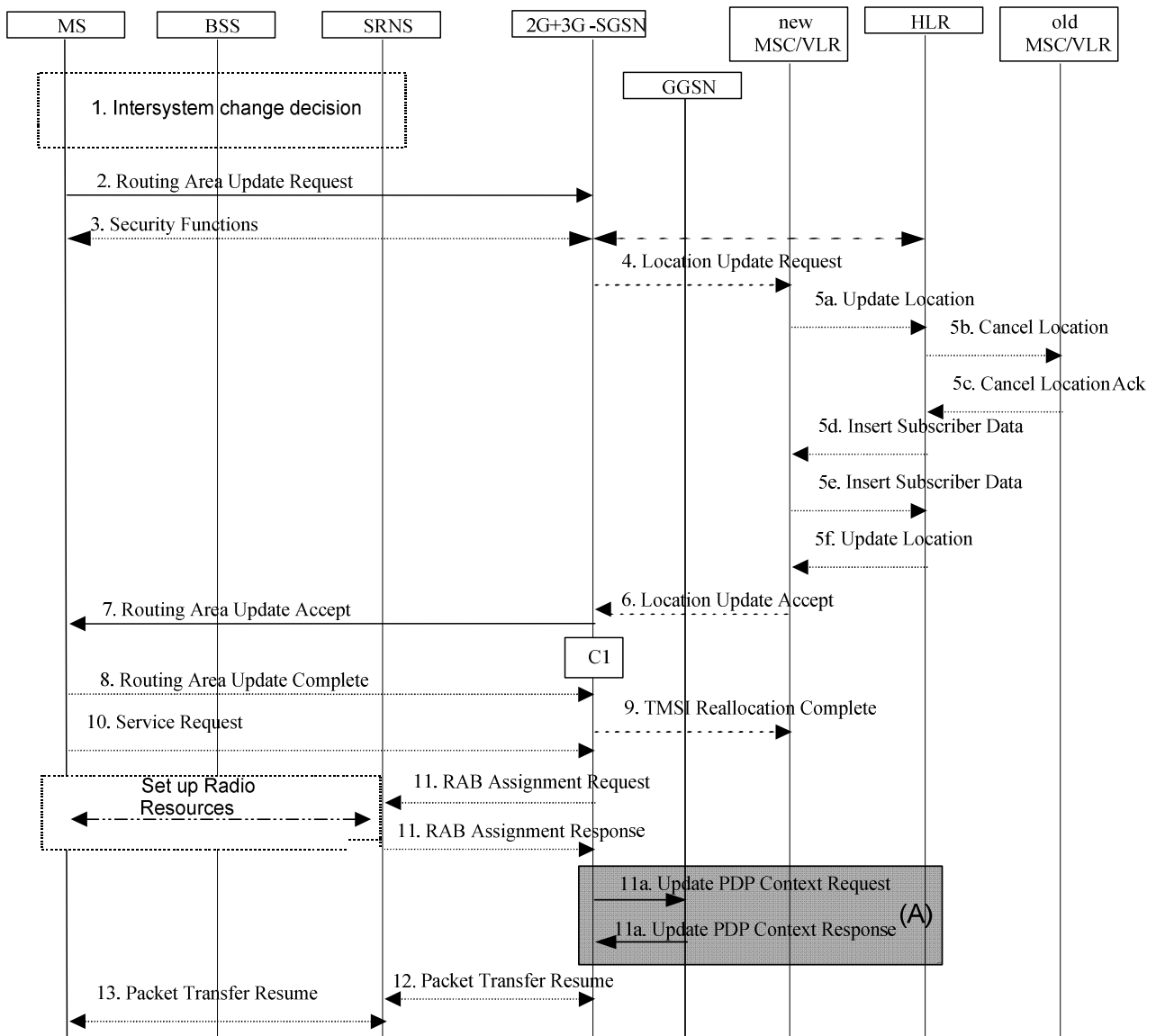

Figure 53: A/Gb mode to Iu mode Intra SGSN Change

- 1) The MS or the RAN decides to perform an intersystem change which makes the MS switch to a new cell where Iu mode has to be used, and stops transmission to the network.
- 2) The MS initiates an RRC connection establishment and sends a Routing Area Update Request (P-TMSI, Old RA, Old P-TMSI Signature, Update Type, CM, Voice domain preference and UE's usage setting) message to the combined 2G+3G-SGSN. Update Type shall indicate RA update or combined RA / LA update or, if the MS wants to perform an IMSI attach, combined RA / LA update with IMSI attach requested and also if the MS has a follow on request, i.e. if there is pending uplink traffic (signalling or data). The SGSN may use, as an implementation option, the follow-on request indication to release or keep the Iu connection after the completion of the RA update procedure. The SRNS shall add an identifier of the area where the message was received before passing the message to the 2G+3G-SGSN. The 2G+3G-SGSN stops transmission of N-PDUs to the MS. The UE sets the voice domain preference and UE's usage setting according to its configuration, as described in clause 5.3.15.
- 3) Security functions may be executed.

- 4) If the association has to be established i.e. if Update Type indicates combined RA / LA update with IMSI attach requested, or if the LA changed with the routing area update, the 2G+3G-SGSN sends a Location Update Request (new LAI, IMSI, SGSN Number, Location Update Type) to the VLR. Location Update Type shall indicate IMSI attach if Update Type in step 1 indicated combined RA / LA update with IMSI attach requested. Otherwise, Location Update Type shall indicate normal location update. When the SGSN does not provide functionality for the Intra Domain Connection of RAN Nodes to Multiple CN Nodes, the VLR number is derived from the RAI. When the SGSN provides functionality for Intra Domain Connection of RAN Nodes to Multiple CN Nodes, the SGSN uses the RAI and a hash value from the IMSI to determine the VLR number. The VLR creates or updates the association with the 2G+3G-SGSN by storing SGSN Number. In networks that support network sharing, the Location Update Request includes the identity of the selected core network operator if the SGSN has received this information from the RNS, as described in TS 23.251 [83].
- 5) If the subscriber data in the VLR is marked as not confirmed by the HLR, the new VLR informs the HLR. The HLR cancels the data in the old VLR and inserts subscriber data in the new VLR:
 - a) The new VLR sends an Update Location (new VLR) to the HLR.
 - b) The HLR cancels the data in the old VLR by sending Cancel Location (IMSI) to the old VLR.
 - c) The old VLR acknowledges with Cancel Location Ack (IMSI).
 - d) The HLR sends Insert Subscriber Data (IMSI, subscriber data) to the new VLR.
 - e) The new VLR acknowledges with Insert Subscriber Data Ack (IMSI).
 - f) The HLR responds with Update Location Ack (IMSI) to the new VLR.
- 6) The new VLR allocates a new VLR TMSI and responds with Location Update Accept (VLR TMSI) to the 2G+3G-SGSN. VLR TMSI is optional if the VLR has not changed.
- 7) The 2G+3G-SGSN validates the MS's presence in the new RA. If due to roaming restrictions or access restrictions the MS is not allowed to be attached in the RA, or if subscription checking fails, the 2G+3G-SGSN rejects the routing area update with an appropriate cause. If the network supports the MOCN configuration for network sharing, the SGSN may, if the MS is not a 'Network Sharing Supporting MS', in this case decide to initiate redirection by sending a Reroute Command to the RNS, as described in TS 23.251 [83] instead of rejecting the routing area update. If all checks are successful, the 2G+3G-SGSN updates MM and PDP contexts for the MS. A new P-TMSI may be allocated. A Routing Area Update Accept (P-TMSI, P-TMSI Signature, IMS voice over PS Session Supported Indication, Emergency Service Support) message is returned to the MS. The 2G+3G-SGSN derives for this intersystem change the corresponding PDCP sequence numbers from the N-PDU sequence numbers stored in the SGSN PDP contexts by adding eight most significant bits "1". These PDCP sequence numbers are stored in the SGSN PDP contexts. The IMS voice over PS Session Supported Indication is set as described in clause 5.3.8.

The Emergency Service Support indicator shall be included when going to UTRAN to inform the MS that Emergency PDP contexts are supported, i.e. the MS is allowed to request activation of emergency PDP context when needed.
- 8) The MS acknowledges the new P-TMSI by returning a Routing Area Update Complete message to the SGSN.
- 9) The 2G+3G-SGSN sends a TMSI Reallocation Complete message to the VLR if the MS confirms the VLR TMSI.
- 10) If the MS has pending uplink data or signalling, it shall send a Service Request (P-TMSI, RAI, CKSN, Service Type) message to the SGSN. Service Type specifies the requested service. Service Type shall indicate one of the following: Data or Signalling.
- 11) The 2G+3G-SGSN requests the SRNS to establish a radio access bearer by sending a RAB Assignment Request (RAB ID(s), QoS Profile(s), GTP-SNDs, GTP-SNU, PDCP-SNU, UE-AMBR, MSISDN, APN, Charging characteristics) message to the SRNS. If Direct Tunnel is established the SGSN provides to the RNC the SGSN's Address for User Plane and TEID for uplink data. The PDCP sequence numbers are derived from the N-PDU sequence numbers and stored in the PDP contexts in step 7). The SRNS sends a Radio Bearer Setup Request (PDCP-SNUs) message to the MS. The MS responds with a Radio Bearer Setup Complete (PDCP-SNDs) message. The SRNS responds with a RAB Assignment Response message. MSISDN, APN and Charging characteristics are optional parameters and only transferred if SGSN supports SIPTO at Iu-ps.

NOTE: The NSAPI value is carried in the RAB ID IE.

11a) If the SGSN established Direct Tunnel it shall send Update PDP Context Request to the GGSN(s) concerned and include the RNC's Address for User Plane, downlink TEID for data and DTI to instruct the GGSN(s) to apply Direct Tunnel specific error handling as described in clause 13.8. The GGSN(s) update the Address for User Plane and TEID for downlink data and return an Update PDP Context Response. Otherwise, if there were changes of for example the RAT type that e.g. can be used for charging, the SGSN sends Update PDP Context Request (SGSN Address and TEID, QoS Negotiated, RAT type) message to the GGSN.

12) Traffic flow is resumed between the 2G+3G-SGSN and the SRNS. N-PDUs that were already sent to the MS in acknowledged mode SNDCP and that are not yet acknowledged by the MS are tunnelled by the 2G+3G-SGSN to the SRNS together with their related N-PDU number (SNDCP sequence number). No PDCP sequence numbers shall be indicated for these N-PDUs. The SRNS shall discard all N-PDUs with N-PDU sequence numbers older than the eight least significant bits of PDCP-SND received from the MS. Other N-PDUs shall be transmitted to the MS. The MS shall discard all N-PDUs with sequence numbers older than the eight least significant bits of the PDCP-SNU received from the SRNS. All other N-PDUs shall be transmitted to the SRNS. The SRNS negotiates with the MS for each radio bearer the use of lossless PDCP or not regardless whether the old 2G-SGSN used acknowledged or unacknowledged SNDCP for the related NSAPI or not.

13) The traffic flow is resumed between the SRNS and the MS.

For some network sharing scenario (e.g. GWCN) if the PLMN-ID of the RAI supplied by the RNC is different from that of the RAI in the UE's context, then the SGSN shall inform the HLR.

The CAMEL procedure calls shall be performed, see referenced procedure in TS 23.078 [8b]:

C1) CAMEL_GPRS_Routeing_Area_Update_Session, CAMEL_PS_Notification and CAMEL_GPRS_Routeing_Area_Update_Context.

- The procedure CAMEL_GPRS_Routeing_Area_Update_Session is called once relative to the session. In Figure 53, the procedure returns as result "Continue".
- Then the procedures CAMEL_PS_Notification is called once relative to the session. The procedure returns as result "Continue".
- Then the procedure CAMEL_GPRS_Routeing_Area_Update_Context is called once per PDP context. In Figure 53, the procedure returns as result "Continue".

6.13.1.2.2 A/Gb mode to lu mode Intra-SGSN Change using S4

In this case, clause 6.13.1.2.1 applies except for step 11, as well as clause-specific general statements stated below.

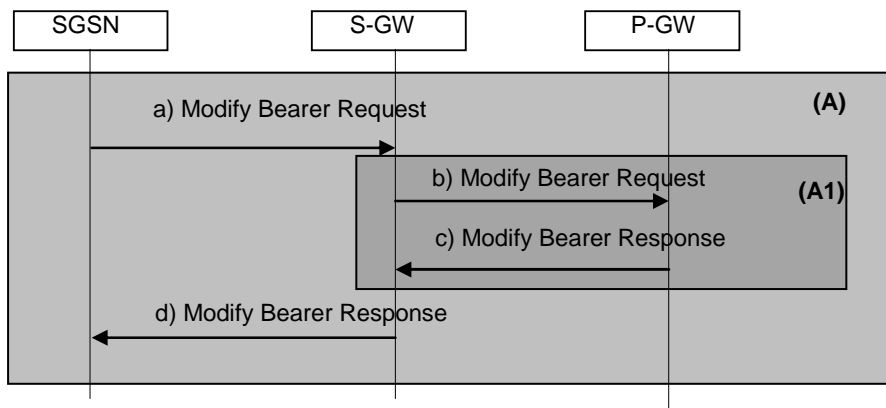

Figure 53-2: step 11 for A/Gb mode to lu mode Intra-SGSN Change using S4

NOTE: Steps a) and d) are common for architecture variants with GTP-based S5/S8 and PMIP-based S5/S8. For a PMIP-based S5/S8, procedure step (A1) is defined in TS 23.402 [90]. Steps b) and c) in Figure 53-2 concern GTP-based S5/S8.

- a) If the SGSN established Direct Tunnel it shall send Modify Bearer Request (RNC Address and TEID, serving network identity, RAT type) message to the Serving GW and include the RNC's Address for User Plane, downlink TEID for data and DTI to instruct the Serving GW to apply Direct Tunnel specific error handling as described in clause 13.8. Otherwise, if there were changes of for example the RAT type that e.g. can be used for charging, the SGSN shall send Modify Bearer Request (SGSN Address and TEID, serving network identity, RAT type) message to the Serving GW and include the SGSN's Address for User Plane, downlink TEID for data.
- b) The Serving GW informs the P-GW(s) about the change of for example the RAT type that e.g. can be used for charging, by sending the message Modify Bearer Request (Serving GW Address and TEID, RAT type) to the concerned P-GW(s). If dynamic PCC is deployed, and RAT type information needs to be conveyed from the P-GW to the PCRF, then the P-GW sends RAT type information to the PCRF as defined in TS 23.203 [88].
- c) Each P-GW updates its context field and returns a Modify Bearer Response (MSISDN, P-GW address and TEID) message to the Serving GW. MSISDN is included if available in the stored UE context.
- d) The Serving GW updates the Address for User Plane and TEID for downlink data and return a Modify Bearer Response (Serving GW address and TEID, P-GW address and TEIDs (for GTP-based S5/S8) or GRE keys (for PMIP-based S5/S8) at the PDN GW(s) for uplink traffic) message.

6.13.1.3 Selective RA Update

The MS shall use the following procedures when in STANDBY or PMM-IDLE state.

Note that upon expiry of the periodic RA update timer, the MS shall carry out the periodic routing area update procedure.

6.13.1.3.1 Uplink Signalling or Data Transmission

In STANDBY or PMM-IDLE state the MS shall not perform an RA update procedure until uplink data or signalling information is to be sent from the MS.

If the MS is in the same mode (A/Gb mode or Iu mode) as when it last sent data or signalling, the procedures defined for that mode shall be followed. This shall be the sending of an LLC PDU in A/Gb mode, or for example sending of a Service Request message in Iu mode.

If the MS is in a different mode (A/Gb mode or Iu mode) as when it last sent data or signalling, the RA update procedure shall be performed before the sending of data or signalling. The RA update procedure needs not be performed if the signalling message is a power-off detach.

6.13.1.3.2 Downlink Signalling or Data Transmission

If the SGSN receives data for an MS in STANDBY or PMM-IDLE state or, if the SGSN uses S4 and receives a Downlink Data Notification from the S-GW, the SGSN shall page in the RA where the MS is located. This may include both A/Gb mode and Iu mode cells.

If the MS receives this page in the same mode (A/Gb mode or Iu mode) as when it last sent data or signalling, the procedures defined for that mode shall be followed. This shall be the sending of an LLC PDU in a cell where the MS has to use A/Gb mode or, for example, sending of a Service Request message in a cell where the MS has to use Iu mode. When receiving such trigger from the RAN, if the S4-SGSN has no S4/S12 downlink user plane TEIDs for the UE, it sends Modify Bearer Request (S4/S12 downlink user plane TEIDs and IP address) to the S-GW, which establishes the downlink user plane towards the S4-SGSN or S12 RNC.

If the MS receives this page in a different mode (A/Gb mode or Iu mode) as when it last sent data or signalling, the RA update procedure shall be performed. The SGSN shall accept this RAU as a valid response.

6.13.2 Inter-SGSN Inter-system Change

6.13.2.1 Iu mode to A/Gb mode Inter-SGSN Change

6.13.2.1.1 Iu mode to A/Gb mode Inter-SGSN Change using Gn/Gp

An inter-SGSN inter-system change from Iu mode to A/Gb mode takes place when an MS in PMM-IDLE or PMM-CONNECTED state changes from UTRAN or GERAN Iu mode to A/Gb mode and the A/Gb mode radio access node serving the MS is served by a different SGSN. In this case, the RA changes. Therefore, the MS shall initiate a A/Gb mode RA update procedure. The RA update procedure is either combined RA / LA update or only RA update. These RA update cases are illustrated in Figure 54. In the context of this specification, the terms RNS or RNC refer also to a GERAN BSS or BSC (respectively) when serving an MS in Iu mode.

A combined RA / LA update takes place in network operation mode I when the MS enters a new RA or when a GPRS-attached MS performs IMSI attach. The MS sends a Routing Area Update Request indicating that an LA update may also need to be performed, in which case the SGSN forwards the LA update to the VLR. This concerns only idle mode (see TS 23.122 [7b]), as no combined RA / LA updates are performed during a CS connection.

NOTE: Direct Tunnel requires no additional functionality.

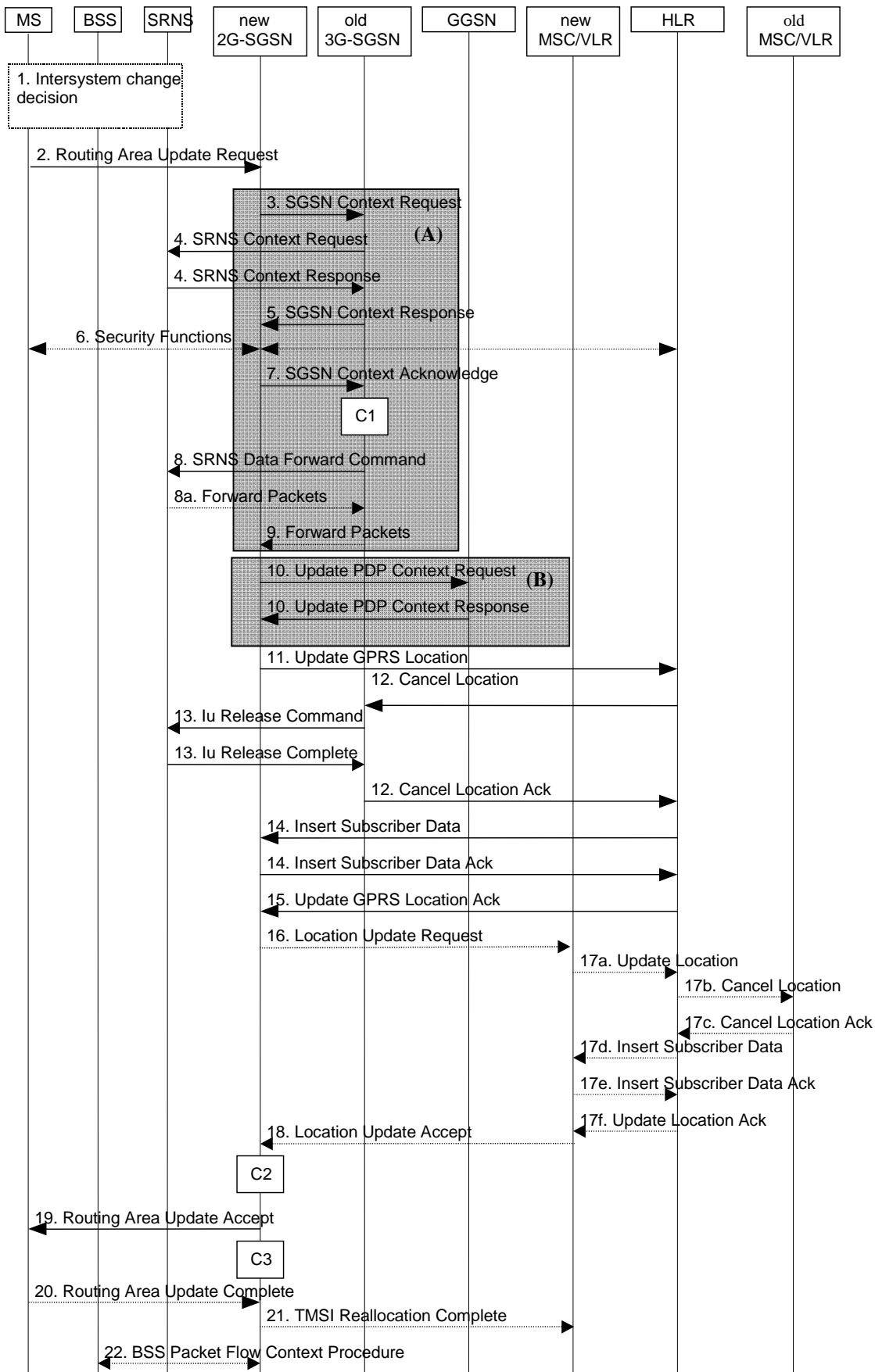

Figure 54: Iu mode to A/Gb mode Inter-SGSN Change

- 1) The MS or RAN decides to perform an inter-system change, which makes the MS switch to a new cell where A/Gb mode has to be used, and stops transmission to the network.

- 2) The MS sends a Routing Area Update Request (old RAI, old P-TMSI Signature, Update Type, MS Network Capability, Voice domain preference and UE's usage setting) message to the new 2G-SGSN. Update Type shall indicate RA update or combined RA / LA update, or, if the MS wants to perform an IMSI attach, combined RA / LA update with IMSI attach requested. The BSS shall add the Cell Global Identity including the RAC and LAC of the cell where the message was received before passing the message to the new 2G-SGSN. The UE sets the voice domain preference and UE's usage setting according to its configuration, as described in clause 5.3.15.

If there is an ongoing emergency bearer service and a Routing Area Update Request is received the Routing Area Update shall be rejected with a cause code indicating that access to GERAN is not allowed.

- 3) The new 2G-SGSN sends an SGSN Context Request (old RAI, TLLI, old P-TMSI Signature, New SGSN Address) message to the old 3G-SGSN to get the MM and PDP contexts for the MS. If the new SGSN provides functionality for Intra Domain Connection of RAN Nodes to Multiple CN Nodes, the new SGSN may derive the old SGSN from the old RAI and the old P-TMSI (or TLLI) and send the SGSN Context Request message to this old SGSN. Otherwise, the new SGSN derives the old SGSN from the old RAI. In any case the new SGSN will derive an SGSN that it believes is the old SGSN. This derived SGSN is itself the old SGSN, or it is associated with the same pool area as the actual old SGSN and it will determine the correct old SGSN from the P-TMSI (or TLLI) and relay the message to that actual old SGSN. The old 3G-SGSN validates the old P-TMSI Signature and responds with an appropriate error cause if it does not match the value stored in the old 3G-SGSN. If the received old P-TMSI Signature does not match the stored value, the security functions in the new 2G-SGSN should be initiated. If the security functions authenticate the MS correctly, the new 2G-SGSN shall send an SGSN Context Request (old RAI, TLLI, MS Validated, New SGSN Address) message to the old 3G-SGSN. MS Validated indicates that the new 2G-SGSN has authenticated the MS. If the old P-TMSI Signature was valid or if the new 2G-SGSN indicates that it has authenticated the MS correctly, the old 3G-SGSN starts a timer. If the MS is not known in the old 3G-SGSN, the old 3G-SGSN responds with an appropriate error cause.
- 4) If the MS is PMM-CONNECTED the old 3G-SGSN sends an SRNS Context Request (IMSI) message to the SRNS. Upon receipt of this message the SRNS buffers and stops sending downlink PDUs to the MS and returns an SRNS Context Response (GTP-SNDs, GTP-SNUs, PDCP-SNDs, PDCP-SNUs) message. The SRNS shall include for each PDP context the next in-sequence GTP sequence number to be sent to the MS and the GTP sequence number of the next uplink PDU to be tunnelled to the GGSN. For each active PDP context, which uses lossless PDCP, the SRNS also includes the uplink PDCP sequence number (PDCP-SNU) downlink PDCP sequence number (PDCP-SND). PDCP-SNU shall be the next in-sequence PDCP sequence number expected from the MS. PDCP-SND is the PDCP sequence number for the first downlink packet for which successful transmission has not been confirmed. The 3G-SGSN shall strip off the eight most significant bits of the passed PDCP sequence numbers, thus converting them to SMDCP N-PDU numbers and stores the N-PDU numbers in its PDP contexts..
- 5) The old 3G-SGSN responds with an SGSN Context Response (MM Context, PDP Contexts, Negotiated Evolved ARP) message. For each PDP context the old 3G-SGSN shall include the GTP sequence number for the next uplink GTP PDU to be tunnelled to the GGSN and the next downlink GTP sequence number for the next in-sequence N-PDU to be sent to the MS. Each PDP Context also includes the SMDCP Send N-PDU Number (the value is 0) for the next in-sequence downlink N-PDU to be sent in SMDCP acknowledged mode to the MS and the SMDCP Receive N-PDU Number (= converted PDCP-SNU) for the next in-sequence uplink N-PDU to be received in SMDCP acknowledged mode from the MS. The new 3G-SGSN shall ignore the MS Network Capability contained in MM Context of SGSN Context Response only when it has previously received an MS Network Capability in the Routing Area Request.
- 6) Security functions may be executed. If the SGSN Context Response message did not include IMEISV and the ADD function is supported by the new 2G-SGSN, then the IMEISV shall be retrieved from the MS.
- 7) The new 2G-SGSN sends an SGSN Context Acknowledge message to the old 3G-SGSN. This informs the old 3G-SGSN that the new 2G-SGSN is ready to receive data packets belonging to the activated PDP contexts. The old SGSN marks in its context that the MSC/VLR association and the information in the GGSNs and the HLR are invalid. This triggers the MSC/VLR, the GGSNs, and the HLR to be updated if the MS initiates a RA update procedure back to the old SGSN before completing the ongoing RA update procedure.
- 8) If the MS is in the PMM-CONNECTED state, the old 3G-SGSN sends an SRNS Data Forward Command (RAB ID, Transport Layer Address, Iu Transport Association) message to the SRNS. For each indicated RAB the SRNS starts duplicating and tunnelling the buffered GTP PDUs to the old 3G-SGSN. For each radio bearer which uses lossless PDCP the SRNS shall start tunnelling the GTP-PDUs related to transmitted but not yet acknowledged PDCP-PDUs to the old 3G-SGSN together with their related downlink PDCP sequence numbers.

Upon receipt of the SRNS Data Forward Command message from the 3G-SGSN, the SRNS shall start the data-forwarding timer.

- 9) The old 3G-SGSN tunnels the GTP PDUs to the new 2G-SGSN. For GTPv1, the conversion of PDCP sequence numbers to SNDCP sequence numbers (the eight most significant bits shall be stripped off) shall be done in the new SGSN. No N-PDU sequence numbers shall be indicated for these N-PDUs.
- 10) The new 2G-SGSN sends an Update PDP Context Request (new SGSN Address, TEID, QoS Negotiated, Negotiated Evolved ARP, serving network identity, CGI/SAI, User CSG Information, RAT type, MS Info Change Reporting support indication, NRSN) message to each GGSN concerned. The SGSN shall send the serving network identity to the GGSN. NRSN indicates SGSN support of the network requested bearer control. The inclusion of the Negotiated Evolved ARP IE indicates that the SGSN supports the Evolved ARP feature. If the new SGSN did not receive a Negotiated Evolved ARP IE in the SGSN Context Response message from the old SGSN then the new SGSN shall derive this value from the Allocation/Retention Priority of the QoS profile negotiated according to Annex E of TS 23.401 [89]. Each GGSN updates its PDP context fields and returns an Update PDP Context Response (TEID, Prohibit Payload Compression, APN Restriction, MS Info Change Reporting Action, CSG Information Reporting Action, BCM, Negotiated Evolved ARP) message. The GGSN sets the Negotiated Evolved ARP based on local policy or PCC. The Allocation/Retention Priority of the QoS Profile Negotiated is derived from the Evolved ARP according to the mapping principles of TS 23.401 [89], Annex E. The Prohibit Payload Compression indicates that the SGSN should negotiate no data compression for this PDP context. The SGSN shall apply the Negotiated Evolved ARP if received from the GGSN.
- 11) The new 2G-SGSN informs the HLR of the change of SGSN by sending an Update GPRS Location (SGSN Number, SGSN Address, IMSI, IMEISV, Homogenous Support of IMS Voice over PS Sessions) message to the HLR. IMEISV is sent if the ADD function is supported. For "Homogenous Support of IMS Voice over PS Sessions", see clause 5.3.8A.
- 12) The HLR sends a Cancel Location (IMSI) message to the old 3G-SGSN. The old 3G-SGSN acknowledges with a Cancel Location Ack (IMSI) message. The old 3G-SGSN removes the MM and PDP contexts if the timer described in step 3 is not running. If the timer is running, the MM and PDP contexts shall be removed when the timer expires.
- 13) When the MS is PMM-CONNECTED, the old 3G-SGSN sends an Iu Release Command message to the SRNS. When the RNC data-forwarding timer has expired, the SRNS responds with an Iu Release Complete message.
- 14) The HLR sends an Insert Subscriber Data (IMSI, Subscription Data) message to the new 2G-SGSN. The 2G-SGSN constructs an MM context and PDP contexts for the MS and returns an Insert Subscriber Data Ack (IMSI) message to the HLR. If the S6d interface is used between S4-SGSN and HSS the messages "Insert Subscriber Data" and "Insert Subscriber Data Ack" are not used. Instead the Subscription Data is sent by HSS in the message Update Location Ack (Step 15).
- 15) The HLR acknowledges the Update GPRS Location by returning an Update GPRS Location Ack (IMSI, GPRS Subscriber Data (only if S6d interface is used)) message to the new 2G-SGSN.
- 16) If the association has to be established i.e. if Update Type indicates combined RA / LA update with IMSI attach requested, or if the LA changed with the routing area update, the new 2G-SGSN sends a Location Update Request (new LAI, IMSI, SGSN Number, Location Update Type) to the VLR. Location Update Type shall indicate IMSI attach if Update Type in step 1 indicated combined RA / LA update with IMSI attach requested. Otherwise, Location Update Type shall indicate normal location update. When the SGSN does not provide functionality for the Intra Domain Connection of RAN Nodes to Multiple CN Nodes, the VLR number is derived from the RAI. When the SGSN provides functionality for Intra Domain Connection of RAN Nodes to Multiple CN Nodes, the SGSN uses the RAI and a hash value from the IMSI to determine the VLR number. The 2G-SGSN starts the location update procedure towards the new MSC/VLR upon receipt of the first Insert Subscriber Data message from the HLR in step 14). The VLR creates or updates the association with the 2G-SGSN by storing SGSN Number.
- 17) If the subscriber data in the VLR is marked as not confirmed by the HLR, the new VLR informs the HLR. The HLR cancels the old VLR and inserts subscriber data in the new VLR:
 - a) The new VLR sends an Update Location (new VLR) to the HLR.
 - b) The HLR cancels the data in the old VLR by sending Cancel Location (IMSI) to the old VLR.
 - c) The old VLR acknowledges with Cancel Location Ack (IMSI).

- d) The HLR sends Insert Subscriber Data (IMSI, subscriber data) to the new VLR.
 - e) The new VLR acknowledges with Insert Subscriber Data Ack (IMSI).
 - f) The HLR responds with Update Location Ack (IMSI) to the new VLR.
- 18) The new VLR allocates a new TMSI and responds with Location Update Accept (VLR TMSI) to the 2G-SGSN. VLR TMSI is optional if the VLR has not changed.
- 19) The new 2G-SGSN validates the MS's presence in the new RA. If due to roaming restrictions or access restrictions the MS is not allowed to be attached in the RA, or if subscription checking fails, the new 2G-SGSN rejects the routing area update with an appropriate cause. If all checks are successful, the new 2G-SGSN constructs MM and PDP contexts for the MS. A logical link is established between the new 2G-SGSN and the MS. 2G-SGSN initiates the establishment procedure. The new 2G-SGSN responds to the MS with a Routing Area Update Accept (P-TMSI, P-TMSI Signature, Receive N-PDU Number (= converted PDCP-SNU), IMS voice over PS Session Supported Indication) message. Receive N-PDU Number contains the acknowledgements for each NSAPI which used lossless PDCP before the start of the update procedure, thereby confirming all mobile-originated N-PDUs successfully transferred before the start of the update procedure. If Receive N-PDU Number confirms the reception of N-PDUs, the MS shall discard these N-PDUs. The IMS voice over PS Session Supported Indication is set as described in clause 5.3.8.
- 20) The MS acknowledges the new P-TMSI by returning a Routing Area Update Complete (Receive N-PDU Number (= converted PDCP-SND)) message to the SGSN. Receive N-PDU Number contains the acknowledgements for each lossless PDCP used by the MS before the start of the update procedure, thereby confirming all mobile-terminated N-PDUs successfully transferred before the start of the update procedure. If Receive N-PDU Number confirms the reception of N-PDUs that were forwarded from the old 3G-SGSN, the new 2G-SGSN shall discard these N-PDUs. The MS deducts Receive N-PDU number from PDCP-SND by stripping off the eight most significant bits. PDCP-SND is the PDCP sequence number for the next expected in-sequence downlink packet to be received in the MS per radio bearer, which used lossless PDCP. The new 2G-SGSN negotiates with the MS for each NSAPI the use of acknowledged or unacknowledged SNDCP regardless whether the SRNS used lossless PDCP or not.
- 21) The new 2G-SGSN sends TMSI Reallocation Complete message to the new VLR if the MS confirms the VLR TMSI.
- 22) The 2G-SGSN and the BSS may execute the BSS Packet Flow Context procedure.

If the new SGSN is unable to update the PDP context in one or more GGSN(s), the new SGSN shall deactivate the corresponding PDP contexts as described in clause "SGSN-initiated PDP Context Deactivation Procedure". This shall not cause the SGSN to reject the routing area update.

The PDP Contexts shall be sent from old to new SGSN in a prioritized order, i.e. the most important PDP Context first in the SGSN Context Response message. (The prioritization method is implementation dependent, but should be based on the current activity).

The new SGSN shall determine the Maximum APN restriction based on the received APN Restriction of each PDP context from the GGSN and then store the new Maximum APN restriction value.

If the new SGSN is unable to support the same number of active PDP contexts as received from old SGSN, the new SGSN should use the prioritisation sent by old SGSN as input when deciding which PDP contexts to maintain active and which ones to delete. In any case, the new SGSN shall first update all contexts in one or more GGSNs and then deactivate the context(s) that it cannot maintain as described in clause "SGSN-initiated PDP Context Deactivation Procedure". This shall not cause the SGSN to reject the routing area update.

The CAMEL procedure calls shall be performed, see referenced procedures in TS 23.078 [8b]:

- C1) CAMEL_GPRS_PDP_Context_Disconnection, CAMEL_GPRS_Detach and CAMEL_PS_Notification.

They are called in the following order:

- The CAMEL_GPRS_PDP_Context_Disconnection procedure is called several times: once per PDP context. The procedure returns as result "Continue".
- Then the CAMEL_GPRS_Detach procedure is called once. The procedure returns as result "Continue".

- Then the CAMEL_PS_Notification procedure is called once. The procedure returns as result "Continue".

C2) CAMEL_GPRS_Routeing_Area_Update_Session and CAMEL_PS_Notification.

They are called in the following order:

- The CAMEL_GPRS_Routeing_Area_Update_Session procedure is called. The procedure returns as result "Continue".
- Then the CAMEL_PS_Notification procedure is called. The procedure returns as result "Continue".

C3) CAMEL_GPRS_Routeing_Area_Update_Context.

This procedure is called several times once per PDP context. It returns as result "Continue".

6.13.2.1.2 Iu mode to A/Gb mode Inter-SGSN Change using S4

In this case, clause 6.13.2.1.1 applies except for steps 3, 5, 7, 9 and 10, as well as clause-specific general statements stated below.

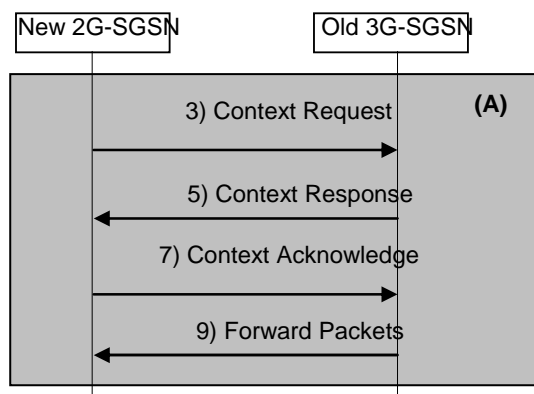

Figure 54-2: steps 3, 5, 7, 9 for Iu mode to A/Gb mode Inter-SGSN Change using S4

Steps 3, 5 and 7 are identical to the Gn/Gp case in clause 6.13.2.2.1, except that:

- Message SGSN Context Request is replaced by message Context Request;
- Parameter PDP Contexts is replaced by parameter EPS Bearer Contexts.

MM Context and EPS Bearer Context when used at the S16 interface are defined by clause 13.2.2. For RAU between two S4-SGSNs, the old SGSN shall include the APN Restriction, CGI/SAI/RAI change support indication and Change Reporting Action in the Context Response message.

- 9) In case Direct Tunnel in Iu mode was not established, the old 3G SGSN tunnels the GTP PDUs to the new 2G-SGSN. For GTPv2 or GTPv1 user plane, the conversion of PDCP sequence numbers to SNDCP sequence numbers (the eight most significant bits shall be stripped off) shall be done in the new SGSN. No N-PDU sequence numbers shall be indicated for these N-PDUs.

In case Direct Tunnel in Iu mode was established, the packets are forwarded via the S-GW.

10) Box (B)

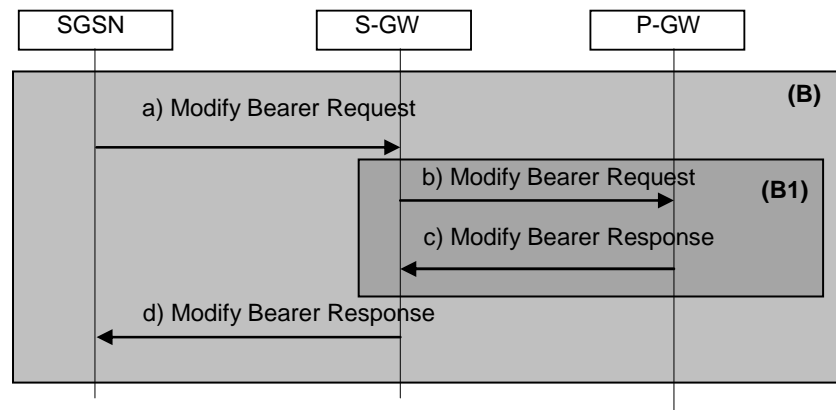

Figure 54-3: step 10 for lu mode to A/Gb mode Inter-SGSN Change using S4

NOTE: Steps a) and d) are common for architecture variants with GTP-based S5/S8 and PMIP-based S5/S8. For a PMIP-based S5/S8, procedure step (A1) is defined in TS 23.402 [90]. Steps b) and c) in Figure 54-3 concern GTP-based S5/S8.

- a) The new 2G-SGSN sends a Modify Bearer Request (new SGSN Address, TEID, serving network identity, CGI/SAI, User CSG Information, RAT type, MS Info Change Reporting support indication) message to the Serving GW. The SGSN shall send the serving network identity to the Serving GW.
- b) The Serving GW informs the P-GW(s) about the change of Serving GW Address and TEID, as well as about RAT type that e.g. can be used for charging, by sending the message Modify Bearer Request (Serving GW Address and TEID, RAT type) to the concerned P-GW(s). If dynamic PCC is deployed, and RAT type information needs to be conveyed from the P-GW to the PCRF, then the P-GW shall send RAT type information to the PCRF as defined in TS 23.203 [88].
- c) Each P-GW updates its context fields and returns a Modify Bearer Response (MSISDN, P-GW address and TEID, Prohibit Payload Compression, MS Info Change Reporting Action, CSG Information Reporting Action) message. The Prohibit Payload Compression indicates that the SGSN should negotiate no data compression for this EPS Bearer context. MSISDN is included if available in the stored UE context.
- d) The Serving GW updates the Address for User Plane and TEID for downlink data and return a Modify Bearer Response (Serving GW address and TEID, P-GW address and TEIDs (for GTP-based S5/S8) or GRE keys (for PMIP-based S5/S8) at the PDN GW(s) for uplink traffic, CSG Information Reporting Action) message.

If the new SGSN is unable to update the Bearer context in the S-GW or in one or more P-GW(s), the new SGSN shall deactivate the corresponding Bearer contexts as described in clause "SGSN-initiated PDP Context Deactivation Procedure". This shall not cause the SGSN to reject the routing area update.

The Bearer Contexts shall be sent from old to new SGSN in a prioritized order, i.e. the most important Bearer Context first in the Context Response message. (The prioritization method is implementation dependent, but should be based on the current activity).

The new SGSN shall determine the Maximum APN restriction based on the received APN Restriction of each Bearer context from the P-GW(s) or old S4-SGSN and then store the new Maximum APN restriction value.

The bearer contexts shall be prioritized by the new SGSN. If the new SGSN is unable to support the same number of active Bearer contexts as received from old SGSN, the new SGSN should use the prioritisation when deciding which Bearer contexts to maintain active and which ones to delete. In any case, the new SGSN shall first update all contexts in the S-GW and in one or more P-GW(s) and then deactivate the context(s) that it cannot maintain as described in clause "SGSN-initiated PDP Context Deactivation Procedure". This shall not cause the SGSN to reject the routing area update.

6.13.2.2 A/Gb mode to Iu mode Inter-SGSN Change

6.13.2.2.1 A/Gb mode to Iu mode Inter-SGSN Change using Gn/Gp

The inter-system change from A/Gb mode to Iu mode takes place when a GPRS-attached MS changes from A/Gb mode to UTRAN or GERAN Iu mode and the new RAN node serving the MS is served by a different SGSN. In this case the RA changes. Therefore, the MS shall initiate a Iu mode RA update procedure by establishing an RRC connection and initiating the RA update procedure. The RA update procedure is either combined RA / LA update or only RA update, these RA update cases are illustrated in Figure 55. In the context of this specification, the terms RNS or RNC refer also to a GERAN BSS or BSC (respectively) when serving an MS in Iu mode.

If the network operates in mode I, then an MS, that is both PS-attached and CS-attached, shall perform the Combined RA / LA Update procedures. This concerns only idle mode (see TS 23.122 [7b]), as no combined RA / LA updates are performed during a CS connection.

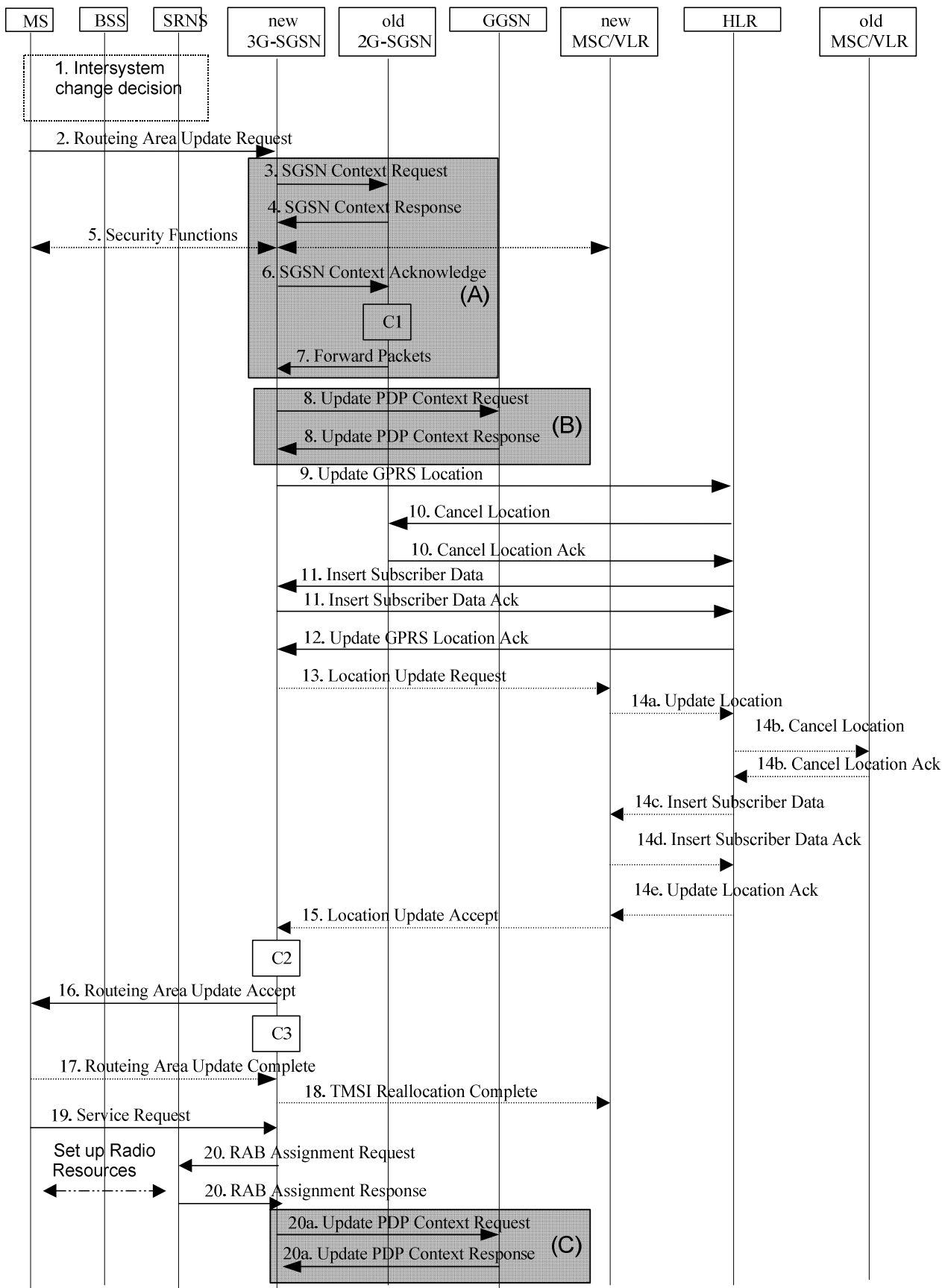

Figure 55: A/Gb mode to Iu mode Inter SGSN Change

- 1) The MS or RAN decides to perform an inter-system change, which makes the MS switch to a new cell where Iu mode has to be used, and stops transmission to the network.

- 2) The MS sends a Routing Area Update Request (P-TMSI, old RAI, old P-TMSI Signature, Update Type, CM, MS Network Capability, Voice domain preference and UE's usage setting) message to the new 3G-SGSN. Update Type shall indicate RA update or combined RA / LA update, or, if the MS wants to perform an IMSI attach, combined RA / LA update with IMSI attach requested, and also if the MS has a follow-on request, i.e. if there is pending uplink traffic (signalling or data). The SGSN may use, as an implementation option, the follow-on request indication to release or keep the Iu connection after the completion of the RA update procedure. The SRNC shall add the Routing Area Identity before forwarding the message to the 3G-SGSN. This RA identity corresponds to the RAI in the MM system information sent by the SRNC to the MS. The UE sets the voice domain preference and UE's usage setting according to its configuration, as described in clause 5.3.15.
- 3) The new 3G-SGSN uses the old RAI received from the MS to derive the old 2G-SGSN address, and sends an SGSN Context Request (old RAI, old P-TMSI, New SGSN Address) message to the old 2G-SGSN to get the MM and PDP contexts for the MS. If the new SGSN provides functionality for Intra Domain Connection of RAN Nodes to Multiple CN Nodes, the new SGSN may derive the old SGSN from the old RAI and the old P-TMSI and send the SGSN Context Request message to this old SGSN. Otherwise, the new SGSN derives the old SGSN from the old RAI. In any case the new SGSN will derive an SGSN that it believes is the old SGSN. This derived SGSN is itself the old SGSN, or it is associated with the same pool area as the actual old SGSN and it will determine the correct old SGSN from the P-TMSI and relay the message to that actual old SGSN. The old 2G-SGSN validates the old P-TMSI Signature and responds with an appropriate error cause if it does not match the value stored in the old 2G-SGSN. If the received old P-TMSI Signature does not match the stored value, the old 2G-SGSN should initiate the security functions in the new 3G-SGSN. If the security functions authenticate the MS correctly, the new 3G-SGSN shall send an SGSN Context Request (old RAI, IMSI, MS Validated, New SGSN Address) message to the old 2G-SGSN. MS Validated indicates that the new 3G-SGSN has authenticated the MS. If the old P-TMSI Signature was valid or if the new 3G-SGSN indicates that it has authenticated the MS correctly, the old 2G-SGSN starts a timer and stops the transmission of N-PDUs to the MS.
- 4) The old 2G-SGSN responds with an SGSN Context Response (MM Context, PDP Contexts, Negotiated Evolved ARP) message. Each PDP Context includes the GTP sequence number for the next downlink N-PDU to be sent to the MS and the GTP sequence number for the next uplink N-PDU to be tunnelled to the GGSN. Each PDP Context also includes the SMDCP Send N-PDU Number for the next downlink N-PDU to be sent in acknowledged mode SMDCP to the MS and the SMDCP Receive N-PDU Number for the next uplink N-PDU to be received in acknowledged mode SMDCP from the MS. The new 3G-SGSN derives the corresponding PDCP sequence numbers from these N-PDU sequence numbers by adding eight most significant bits "1". These PDCP sequence numbers are stored in the 3G-SGSN PDP contexts. The new 3G-SGSN shall ignore the MS Network Capability contained in MM Context of SGSN Context Response only when it has previously received an MS Network Capability in the Routing Area Request.
- 5) Security functions may be executed. If the SGSN Context Response message did not include IMEISV and the ADD function is supported by the new 3G-SGSN, then the IMEISV shall be retrieved from the MS.
- 6) The new 3G-SGSN sends an SGSN Context Acknowledge message to the old 2G-SGSN. This informs the old 2G-SGSN that the new 3G-SGSN is ready to receive data packets belonging to the activated PDP contexts. The old SGSN marks in its context that the MSC/VLR association and the information in the GGSNs and the HLR are invalid. This triggers the MSC/VLR, the GGSNs, and the HLR to be updated if the MS initiates a routing area update procedure back to the old SGSN before completing the ongoing routing area update procedure.
- 7) The old 2G-SGSN duplicates the buffered N-PDUs and starts tunnelling them to the new 3G-SGSN. Additional N-PDUs received from the GGSN before the timer described in step 3 expires are also duplicated and tunnelled to the new 3G-SGSN. N-PDUs that were already sent to the MS in acknowledged mode SMDCP and that are not yet acknowledged by the MS are tunnelled together with their related SMDCP N-PDU sequence number. No PDCP sequence numbers shall be indicated for these N-PDUs. No N-PDUs shall be forwarded to the new 3G-SGSN after expiry of the timer described in step 3.
- 8) The new 3G-SGSN sends an Update PDP Context Request (new SGSN Address, TEID, QoS Negotiated, Negotiated Evolved ARP, serving network identity, CGI/SAI, User CSG Information, RAT type, MS Info Change Reporting support indication, NRSN) message to each GGSN concerned. The SGSN shall send the serving network identity to the GGSN. NRSN indicates SGSN support of the network requested bearer control. The inclusion of the Negotiated Evolved ARP IE indicates that the SGSN supports the Evolved ARP feature. If the new SGSN did not receive a Negotiated Evolved ARP IE in the SGSN Context Response message from the old SGSN then the new SGSN shall derive this value from the Allocation/Retention Priority of the QoS profile negotiated according to Annex E of TS 23.401 [89]. Each GGSN updates its PDP context fields and returns an Update PDP Context Response (TEID, Prohibit Payload Compression, APN Restriction, MS Info Change Reporting Action, CSG Information Reporting Action, BCM, Negotiated Evolved ARP) message. The GGSN

sets the Negotiated Evolved ARP based on local policy or PCC. The Allocation/Retention Priority of the QoS Profile Negotiated is derived from the Evolved ARP according to the mapping principles of TS 23.401 [89], Annex E. The Prohibit Payload Compression indicates that the SGSN should negotiate no data compression for this PDP context. The SGSN shall apply the Negotiated Evolved ARP if received from the GGSN.

- 9) The new 3G-SGSN informs the HLR of the change of SGSN by sending an Update GPRS Location (SGSN Number, SGSN Address, IMSI, IMEISV, Homogenous Support of IMS Voice over PS Sessions) message to the HLR. IMEISV is sent if the ADD function is supported. For "Homogenous Support of IMS Voice over PS Sessions", see clause 5.3.8A.
- 10) The HLR sends a Cancel Location (IMSI, Cancellation Type) message to the old 2G-SGSN. The old 2G-SGSN removes the MM and PDP contexts if the timer described in step 3 is not running. If the timer is running, the MM and PDP contexts are removed when the timer expires. The old 2G-SGSN acknowledges with a Cancel Location Ack (IMSI) message.
- 11) The HLR sends an Insert Subscriber Data (IMSI, Subscription Data) message to the new 3G-SGSN. The 3G-SGSN constructs an MM context for the MS and returns an Insert Subscriber Data Ack (IMSI) message to the HLR. If the S6d interface is used between S4-SGSN and HSS the messages "Insert Subscriber Data" and "Insert Subscriber Data Ack" are not used. Instead the Subscription Data is sent by HSS in the message Update Location Ack (Step 15).
- 12) The HLR acknowledges the Update GPRS Location by returning an Update GPRS Location Ack (IMSI, GPRS Subscriber Data (only if S6d interface is used)) message to the new 3G-SGSN.
- 13) If the association has to be established, if Update Type indicates combined RA / LA update with IMSI attach requested, or if the LA changed with the routing area update, the new SGSN sends a Location Update Request (new LAI, IMSI, SGSN Number, Location Update Type) to the VLR. Location Update Type shall indicate IMSI attach if Update Type in step 1 indicated combined RA / LA update with IMSI attach requested. Otherwise, Location Update Type shall indicate normal location update. When the SGSN does not provide functionality for the Intra Domain Connection of RAN Nodes to Multiple CN Nodes, the VLR number is derived from the RAI. When the SGSN provides functionality for Intra Domain Connection of RAN Nodes to Multiple CN Nodes, the SGSN uses the RAI and a hash value from the IMSI to determine the VLR number. The 3G-SGSN starts the location update procedure towards the new MSC/VLR upon receipt of the first Insert Subscriber Data message from the HLR in step 12). The VLR creates or updates the association with the 3G-SGSN by storing SGSN Number. In networks that support network sharing, the Location Update Request includes the identity of the selected core network operator if the new 3G-SGSN has received this information from the RNS, as described in TS 23.251 [83].
- 14) If the subscriber data in the VLR is marked as not confirmed by the HLR, the new VLR informs the HLR. The HLR cancels the old VLR and inserts subscriber data in the new VLR:
 - a) The new VLR sends an Update Location (new VLR) to the HLR.
 - b) The HLR cancels the data in the old VLR by sending Cancel Location (IMSI) to the old VLR.
 - c) The old VLR acknowledges with Cancel Location Ack (IMSI).
 - d) The HLR sends Insert Subscriber Data (IMSI, subscriber data) to the new VLR.
 - e) The new VLR acknowledges with Insert Subscriber Data Ack (IMSI).
 - f) The HLR responds with Update Location Ack (IMSI) to the new VLR.
- 15) The new VLR allocates a new TMSI and responds with Location Update Accept (VLR TMSI) to the 3G-SGSN. VLR TMSI is optional if the VLR has not changed.
- 16) The new 3G-SGSN validate the MS's presence in the new RA. If due to roaming restrictions or access restrictions the MS is not allowed to be attached in the RA, or if subscription checking fails, the new 3G-SGSN rejects the routing area update with an appropriate cause. If the network supports the MOCN configuration for network sharing, the SGSN may, if the MS is not a 'Network Sharing Supporting MS', in this case decide to initiate redirection by sending a Reroute Command to the RNS, as described in TS 23.251 [83] instead of rejecting the routing area update. If all checks are successful, the new 3G-SGSN constructs MM and PDP contexts for the MS. The new 3G-SGSN responds to the MS with a Routing Area Update Accept (P-TMSI, P-TMSI signature, IMS voice over PS Session Supported Indication, Emergency Service Support) message. The IMS voice over PS Session Supported Indication is set as described in clause 5.3.8.

The Emergency Service Support indicator shall be included when going to UTRAN to inform the MS that Emergency PDP contexts are supported, i.e. the MS is allowed to request activation of emergency PDP context when needed.

- 17) The MS acknowledges the new P-TMSI by returning a Routeing Area Update Complete message to the SGSN.
- 18) The new 3G-SGSN sends TMSI Reallocation Complete message to the new VLR, if the MS confirms the VLR TMSI.
- 19) If the MS has uplink data or signalling pending it shall send a Service Request (P-TMSI, RAI, CKSN, Service Type) message to the SGSN. Service Type specifies the requested service. Service Type shall indicate one of the following: Data or Signalling.
- 20) If the MS has sent the Service Request, the new 3G-SGSN requests the SRNS to establish a radio access bearer by sending a RAB Assignment Request (RAB ID(s), QoS Profile(s), GTP-SNDs, GTP-SNUs, PDCP-SNUs, UE-AMBR, MSISDN, APN, Charging characteristics) message to the SRNS. If Direct Tunnel is established the SGSN provides to the RNC the GGSN's Address for User Plane and TEID for uplink data. The PDCP sequence numbers are derived from the N-PDU sequence numbers in step 4) and stored in the SGSN PDP contexts. The SRNS sends a Radio Bearer Setup Request (PDCP-SNUs) message to the MS. The MS responds with a Radio Bearer Setup Complete (PDCP-SNDs) message. The MS deducts PDCP-SND from its Receive N-PDU Number by adding eight most significant bits "1". The SRNS responds with a RAB Assignment Response message. The SRNS shall discard all N-PDUs tunnelled from the SGSN with N-PDU sequence numbers older than the eight least significant bits of the PDCP-SNDs received from the MS. Other N-PDUs shall be transmitted to the MS. The MS shall discard all N-PDUs with SNDCP sequence numbers older than the eight least significant bits of the PDCP-SNUs received from the SRNS. Other N-PDUs shall be transmitted to the SRNS. The SRNS negotiates with the MS for each radio bearer the use of lossless PDCP or not regardless whether the old 2G-SGSN used acknowledged or unacknowledged SNDCP for the related NSAPI or not. MSISDN, APN and Charging characteristics are optional parameters and only transferred if SGSN supports SIPTO at Iu-ps.
- 20a) If the SGSN established Direct Tunnel in step 20) it shall send Update PDP Context Request to the GGSN(s) concerned and include the RNC's Address for User Plane, downlink TEID for data and DTI to instruct the GGSN to apply Direct Tunnel specific error handling as described in clause 13.8. The GGSN(s) update the Address for User Plane and TEID for downlink data and return an Update PDP Context Response.

NOTE 1: The NSAPI value is carried in the RAB ID IE.

NOTE 2: The new SGSN may initiate RAB establishment after execution of the security functions (step 5), or wait until completion of the RA update procedure. For the MS, RAB establishment may occur anytime after the RA update request is sent (step 2).

If the new SGSN is unable to update the PDP context in one or more GGSNs, the new SGSN shall deactivate the corresponding PDP contexts as described in clause "SGSN-initiated PDP Context Deactivation Procedure". This shall not cause the SGSN to reject the routeing area update.

The PDP Contexts shall be sent from old to new SGSN in a prioritized order, i.e. the most important PDP Context first in the SGSN Context Response message. (The prioritization method is implementation dependent, but should be based on the current activity).

The new SGSN shall determine the Maximum APN restriction based on the received APN Restriction of each PDP context from the GGSN and then store the new Maximum APN restriction value.

If the new SGSN is unable to support the same number of active PDP contexts as received from old SGSN, the new SGSN should use the prioritisation sent by old SGSN as input when deciding which PDP contexts to maintain active and which ones to delete. In any case, the new SGSN shall first update all contexts in one or more GGSNs and then deactivate the context(s) that it cannot maintain as described in clause "SGSN-initiated PDP Context Deactivation Procedure". This shall not cause the SGSN to reject the routeing area update.

The CAMEL procedure calls shall be performed, see referenced procedures in TS 23.078 [8b]:

- C1) CAMEL_GPRS_PDP_Context_Disconnection, CAMEL_GPRS_Detach and CAMEL_PS_Notification.

They are called in the following order:

- The CAMEL_GPRS_PDP_Context_Disconnection procedure is called several times: once per PDP context. The procedure returns as result "Continue".

- Then the CAMEL_GPRS_Detach procedure is called once. It returns as result "Continue".
- Then the CAMEL_PS_Notification procedure is called once. It returns as result "Continue".

C2) CAMEL_GPRS_Routeing_Area_Update_Session and CAMEL_PS_Notification.

They are called in the following order:

- The CAMEL_GPRS_Routeing_Area_Update_Session procedure is called. The procedure returns as result "Continue".
- Then the CAMEL_PS_Notification procedure is called. The procedure returns as result "Continue".

C3) CAMEL_GPRS_Routeing_Area_Update_Context

This procedure is called several times: once per PDP context. It returns as result "Continue".

6.13.2.2.2 A/Gb mode to lu mode Inter-SGSN Change using S4

In this case, clause 6.13.2.2.1 applies except for steps 3, 4, 6, 7, 8 and 20, as well as clause-specific general statements stated below.

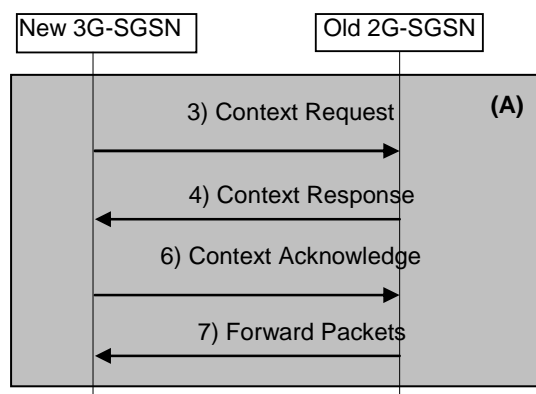

Figure 55-2: steps 3, 4, 6, 7 for A/Gb mode to lu mode Inter-SGSN Change using S4

Steps 3, 4, 6 and 7 are identical to the Gn/Gp case in clause 6.13.2.2.1, except that:

- Message SGSN Context Request is replaced by message Context Request;
- Parameter PDP Contexts is replaced by parameter EPS Bearer Contexts.
- MM Context and EPS Bearer Context when used at the S16 interface are defined by clause 13.2.2. For RAU between two S4-SGSNs, the old SGSN shall include the APN Restriction, CGI/SAI/RAI change support indication and Change Reporting Action in the Context Response message.

8. Box (B).

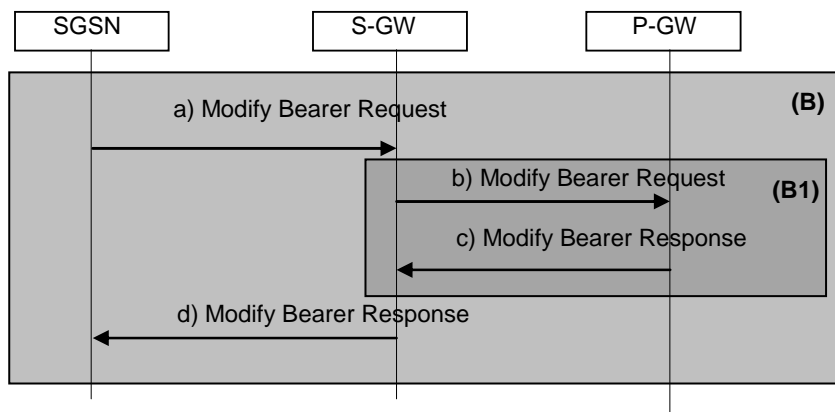

Figure 55-3: step 8 for A/Gb mode to lu mode Inter-SGSN Change using S4

NOTE: Steps a) and d) are common for architecture variants with GTP-based S5/S8 and PMIP-based S5/S8. For a PMIP-based S5/S8, procedure step (A1) is defined in TS 23.402 [90]. Steps b) and c) in Figure 55-3 concern GTP-based S5/S8.

- a) The new 3G SGSN sends a Modify Bearer Request (new SGSN Address, TEID, serving network identity, CGI/SAI, User CSG Information, RAT type, MS Info Change Reporting support indication) message to the Serving GW. The SGSN shall send the serving network identity to the Serving GW.
- b) The Serving GW informs the P-GW(s) about the change of Serving GW Address and TEID, as well as about the RAT type that e.g. can be used for charging, by sending the message Modify Bearer Request (Serving GW Address and TEID, RAT type) to the concerned P-GW(s). If dynamic PCC is deployed, and RAT type information needs to be conveyed from the P-GW to the PCRF, then the P-GW shall send RAT type information to the PCRF as defined in TS 23.203 [88].
- c) Each P-GW updates its context fields and returns a Modify Bearer Response (MSISDN, P-GW address and TEID, Prohibit Payload Compression, MS Info Change Reporting Action, CSG Information Reporting Action) message. The Prohibit Payload Compression indicates that the SGSN should negotiate no data compression for this EPS Bearer context. MSISDN is included if available in the stored UE context.
- d) The Serving GW updates the Address for User Plane and TEID for downlink data and return a Modify Bearer Response (Serving GW address and TEID, P-GW address and TEIDs (for GTP-based S5/S8) or GRE keys (for PMIP-based S5/S8) at the PDN GW(s) for uplink traffic, CSG Information Reporting Action) message.

20. Box (C).

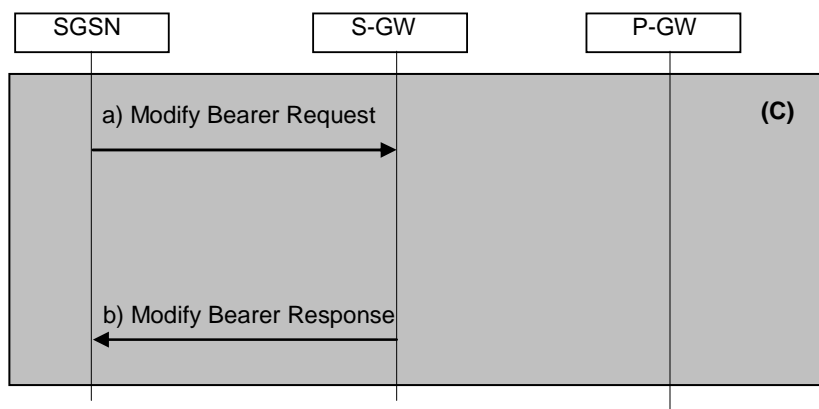

Figure 55-4: step 10 for A/Gb mode to lu mode Inter-SGSN Change using S4

Step 10 is identical to the Gn/Gp case in clause 6.13.2.2.1, except that:

- Message SGSN Context Request is replaced by message Context Request;
- Parameter PDP Contexts is replaced by parameter EPS Bearer Contexts.

MM Context and EPS Bearer Context when used at the S16 interface are defined by clause 13.2.2.

6.14 Classmark Handling

To support efficient radio interface usage in GPRS, the MS Classmark is handled differently for SGSN-based services than for MSC-based services. In particular, the Classmark information is sent in MM and Iu mode RRC messages to the network and stored in the network as long as the MS is attached, avoiding redundant Classmark retransmissions over the radio interface. This is sometimes called the "idle-mode Classmark" principle.

In order to allow introduction of new radio access technologies in the future, the MS Classmark is split into distinct and independent information sets, the radio access Classmark, and the core network capability. The radio access Classmark is split into two information elements, the MS radio access capability (A/Gb mode) and the UE capability (Iu mode). The core network capability is split into two distinct information elements, the MS network capability IE (which shall be common for A/Gb mode and Iu mode) and for E-UTRAN capable MSs, the UE Network Capability IE.

6.14.1 Radio Access Classmark

The MS shall send the MS radio access capability in the GPRS Attach Request message to the SGSN regardless, if the MS is about to attach to A/Gb mode or to Iu mode network, as defined in TS 24.008 [13]. Both the MS radio access capability and the MS network capability contain some information on the UE's support for other RATs. The SGSN uses the information from the MS network capability, and knowledge about the support of Inter-RAT Handover, to request the MS to send information on the MS's other radio capabilities in the Attach Complete/RA Update Complete.

If the MS supports SRVCC to GERAN (TS 23.216 [101]), the MS sends the CS domain's Classmark 2 and Classmark 3 information elements to the SGSN in the Attach Request/Routeing Area Update Request messages in both Iu mode and A/Gb mode.

If the MS supports SRVCC to UTRAN (TS 23.216 [101]), the MS sends the CS domain's Classmark 2 information element to the SGSN in the Attach Request/Routeing Area Update Request messages in both Iu mode and A/Gb mode.

6.14.1.1 MS Radio Access Capability (A/Gb mode)

The MS radio access capability information element contains the A/Gb mode radio capabilities of the MS (e.g. multislots capability, power class), and more generally all the information that should be known by the BSS in order to handle radio resources for that MS with GERAN. The Inter RAT handover information that can be sent in the Attach Complete/RA Update Complete contains the information that the BSS needs for inter-RAT handover to other RATs.

The MS radio access capability is a container for a multiplicity of radio access technology-dependent information, i.e. within the MS radio access capability there are independent sub-fields for various technologies such as GSM 900 and GSM 1800. The coding shall allow a BSS to extract only the sub-fields relevant to it without interpreting the other sub-fields. This ensures that the MS radio access capability does not need to be interpreted by the NSS, and the full MS radio access capability is always sent by the MS to the SGSN, and thereafter provided to the BSS irrespective of the actual BSS capabilities.

The SGSN shall provide the MS radio access capability as an information element on the Gb interface. It is the responsibility of the SGSN to provide the BSS with the most recent MS radio access capability received from the MS. The MS radio access capability information element can be included in a downlink transfer request, or be sent in a specific message that updates the MS radio access capability information in the BSS. The BSS may at any time request the MS radio access capability for a given MS to be transmitted from the SGSN to the BSS.

Together with the MS radio access capability, the SGSN shall provide the IMSI of the MS when this is known. For a BSS supporting DTM, the IMSI is stored at the BSS and used for radio resource co-ordination; e.g. for a DTM MS.

A specific optimisation allows the BSS to receive a reduced MS radio access capability at initial access directly from the MS. This enables the BSS not to wait for the full MS radio access capability to be provided by the SGSN, and is therefore quicker for the initial MS-originated transmission. The reduced MS radio access capability can be carried in several RR messages depending on the access method, e.g. in the initial random access message, or in the first uplink radio block. Details are provided in TS 24.008 [13] and TS 44.060 [77].

If stored, the SGSN shall provide the Inter RAT handover information and MS Classmark 2 and MS Classmark 3 as information elements on the Gb interface when a Packet Flow Context is established. MS Classmark 2 and 3 are

included to support the case that a SRVCC handover is needed following PS domain handover from GERAN to UTRAN/E-UTRAN.

When the MS performs a Routeing Area Update (e.g. at GERAN-UTRAN change with change of RA in idle mode, and, GERAN-UTRAN Handover) the MS radio access capability shall be sent to the SGSN in the Routeing Area Update Request message. The SGSN then provides the BSS with the MS radio access capability.

At inter-RAT Handover, the source, target and all other RATs' MS/UE radio capability are exchanged within the container information elements. To support subsequent connections, an A/Gb mode SGSN supporting inter-RAT handover requests the MS to send the Inter RAT handover information in the RA Update Complete message.

To allow for the addition of future radio technologies, frequency bands, and other enhancements, the SGSN shall store the Inter RAT handover information even if it is larger than specified in TS 24.008 [13], up to a maximum size of 255 octets.

To allow for the addition of future radio technologies, frequency bands, and other enhancements, the SGSN shall store the MS radio access capability even if it is larger than specified in TS 24.008 [13], up to a maximum size of 255 octets.

NOTE: The 255 octet value comes from the information element encoding rules described in TS 24.007 [12].

6.14.1.2 UE Capability (Iu mode)

The UE capability information element contains all the radio capabilities of the MS (power control, code resource, UE mode, ciphering, PDCP capabilities, etc.) that the RNC has to know in order to handle radio resources for this MS.

The MS sends the UE capability information element to the serving RNC upon RRC connection establishment, and the RNC stores it. This is done before the Attach Request or Routeing Area Update Request message is sent.

At SRNC relocation the source RNC sends the UE capability transparently through the core network to the target RNC. If the RNC has not received the UE capability information it can request the MS to send the information.

At inter-system change the UE capability is transferred from the MS to the serving RNC on RRC connection establishment before the Routeing Area Update Request message is sent.

Details are provided in TS 25.331 [52] and TS 25.413 [56b].

The SGSN may also request for Voice Support Match Indicator. If requested, the RAN shall then derive and provide an indication to the SGSN whether the UE capabilities are compatible with the network configuration as defined in clause 6.9.5.

6.14.2 Core Network Capability

The MS network capability IE contains mostly non radio-related capabilities (e.g. the GSM GPRS ciphering, UMTS authentication, and TI extension capabilities) related to GERAN and UTRAN access. In the coding of the information element certain capabilities may be grouped together in a single indicator.

The UE network capability IE mostly contains information related to the MS's E-UTRAN core network capabilities.

The SGSN stores the MS network capability and UE network capability, which is used both by the local SGSN and for transfer to the new SGSN/MME for any type of inter SGSN/inter-RAT mobility. To avoid interoperability problems when roaming between A/Gb mode and Iu mode, the MS network capability shall be included in the routeing area update request sent by the MS. At inter-SGSN RA update, the network shall use this MS Network Capability and ignore the same IE received in MM Context from the old SGSN/old MME.

If the MS's MS network capability and/or UE network capability information changes (including cases of being in E-UTRAN coverage and having ISR activated), the UE shall perform a Routeing Area Update ('type' different to 'periodic') when it next returns to GERAN/UTRAN coverage.

To allow for the addition of future features, the SGSN shall store the UE Network Capability and the MS Network Capability even if either or both is larger than specified in TS 24.008 [13]/TS 24.301 [102], up to a maximum size of 32 octets for each IE.

An E-UTRAN capable MS notifies the SGSN of its E-UTRAN capability using the MS Network Capability.

NOTE: The MS Network Capability can contain information relating to the MS's non-E-UTRAN EPS capabilities.

6.15 UE Reachability procedures

There are two procedures necessary for any service related entity that would need to be notified on the reachability of the UE at NAS level:

- UE Reachability Notification Request procedure, and
- UE Activity Notification procedure.

The UE Reachability Notification Request procedure is illustrated in Figure 6.15-1.



Figure 6.15-1: UE Reachability Notification Request Procedure

- 1) If a service-related entity requests the HSS to provide an indication regarding UE reachability, the HSS stores the request in the URRP-SGSN parameter. If the value of URRP-SGSN parameter has changed from "not set" to "set", the HSS sends a UE-REACHABILITY-NOTIFICATION-REQUEST (URRP-SGSN) to the SGSN. If the SGSN has an MM context for that user, the SGSN stores URRP-SGSN to indicate the need to report to the HSS information regarding changes in UE reachability, e.g. when the next NAS activity with that UE is detected.

The UE Activity Notification procedure is illustrated in Figure 6.15-2.

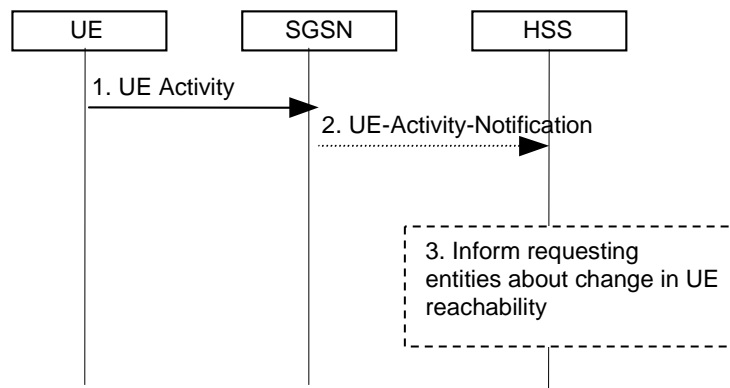

Figure 6.15-2: UE Activity Procedure

- 1) The SGSN receives an indication regarding UE reachability, e.g. an Routing Area Update Request message from the UE.
- 2) If the SGSN contains an MM context of the UE and if URRP-SGSN for that UE is configured to report once that the UE is reachable, the SGSN shall send a UE-Activity-Notification (IMSI, UE-Reachable) message to the HSS and clears the corresponding URRP-SGSN for that UE.
- 3) When the HSS receives the UE-Activity-Notification (IMSI, UE-Reachable) message or the Update Location message for an UE that has URRP-SGSN set, it triggers appropriate notifications to the entities that have subscribed to the HSS for this notification.

6.16 Update CSG Location Procedure

The Update CSG Location procedure takes place when the SGSN/VLR needs to retrieve the CSG subscription information of the MS from the CSS.

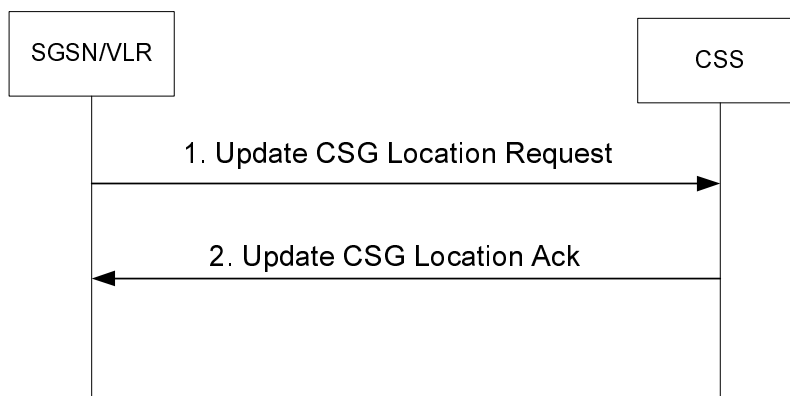

Figure 6.16-1: Update CSG Location Procedure

1. The SGSN/VLR sends an Update CSG Location Request (SGSN/VLR Number, IMSI, MSISDN) to the CSS. The MSISDN is included if available.
2. The CSS acknowledges the Update CSG Location message by sending an Update CSG Location Ack (IMSI, CSG Subscription data) message to the SGSN/VLR.

7 Network Management Functionality

The Network Management function provides mechanisms to support O&M functions related to GPRS.

8 Radio Resource Functionality

8.1 Radio Resource Functionality (A/Gb mode)

8.1.1 Cell Selection and Reselection

An MS (in any mode of operation - A, B, or C) cannot camp on more than one cell. If the MS is in idle mode, see TS 23.122 [7b], it shall use cell selection and reselection procedures as described in TS 43.064 [11] and specified in TS 23.122 [7b] and TS 45.008 [16b].

8.1.2 Discontinuous Reception

In A/Gb mode an MS may use discontinuous reception (DRX) or not. If using DRX, the MS shall also be able to specify other DRX parameters that indicate the delay for the network to send a page request or a channel assignment to the MS (see TS 43.064 [11]).

The DRX parameters shall be indicated by the MS in the attach procedure. The SGSN shall then send these parameters in each page request to the BSS that uses this information and the IMSI to calculate the correct paging group.

DRX usage is independent of the MM states IDLE, STANDBY and READY. When a GPRS MS in READY state uses DRX, DRX has to be considered when assigning a packet data channel for downlink transfer. The SGSN shall therefore indicate the DRX parameters for the MS in all packet transmission requests to the BSS.

In A/Gb mode an MS shall not apply DRX in READY state during the GPRS attach and routing area update procedures.

At inter SGSN change to an SGSN operating in A/Gb mode, the DRX parameters are sent from the old SGSN to the new SGSN as part of the MM context information. Hence, unless the DRX parameters have been altered, the UE should not include the DRX parameters in the Routing Area Update message sent to an A/Gb mode SGSN.

If the UE wishes to alter its GERAN or UTRAN/E-UTRAN DRX Parameters while in A/Gb mode, then it shall send a Routing Area Update Request message to the SGSN containing its new DRX Parameters. If ISR had been activated for the MS, then the MS shall deactivate ISR by setting its TIN to "P-TMSI" so that the MS performs a Tracking Area Update when it next enters E-UTRAN coverage. When the UE performs that Tracking Area Update, the MME will receive the updated DRX parameters within the MM context information sent by the old SGSN and hence the UE should not include them again in the Tracking Area Update.

8.1.3 Radio Resource Management

A/Gb mode Radio Resource Management functions are defined in TS 24.007 [12]. The radio interface layer 3 protocol is specified in TS 24.008 [13].

8.1.3.1 Layer Functions

GPRS radio resource management procedures are required for the following functions:

- allocation and release of physical resources (i.e. timeslots) associated with a GPRS channel;
- monitoring GPRS channel utilisation to detect under-utilised or congested GPRS channels;
- initiating congestion control procedures; and
- distribution of GPRS channel configuration information for broadcasting to the MSs.

The radio resource management features that are required for PS handover are detailed in TS 43.129 [87].

8.1.3.2 Model of Operation

8.1.3.2.1 Dynamic Allocation of Radio Resources

AnA/Gb mode cell may or may not support GPRS.

A cell supporting GPRS may have GPRS radio resources allocated at a given instance. If no GPRS radio resources are allocated, an MS can request allocation of such resources. MSs may then use these radio resources. The PLMN may dynamically increase, to a PLMN operator-defined maximum, or, decrease to an operator-defined minimum, the radio resources allocated.

The network broadcasts GPRS system information on the common control channels.

A/Gb mode radio resources are dynamically shared between GPRS and CS domain services.

8.1.3a Ready to Standby state transition in S4 architecture

When idle mode packet buffering is performed in the S-GW, the SGSN needs to inform the S-GW each time that the MS changes from READY state to STANDBY state. The following figure illustrates the procedure between SGSN and S-GW.

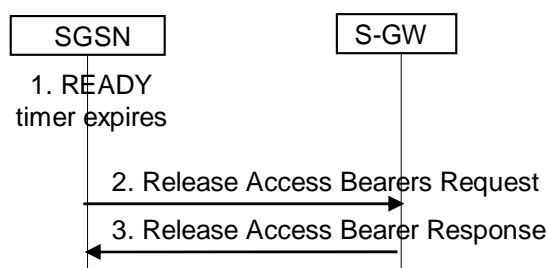

Figure 55-5: READY to STANDBY transition within the network using S4

1. The READY timer expires in the SGSN.
2. If PDP Contexts associated are to be preserved:
 - if ISR is activated for that MS, the SGSN shall send a Release Access Bearers Request to the S-GW to remove the SGSN address for user plane and downlink S4 GTP-U TEID;
 - if ISR is not activated for that MS, the SGSN may send a Release Access Bearers Request to the S-GW to remove the SGSN address for user plane and downlink S4 GTP-U TEID.
3. If the S-GW received a Release Access Bearers Request, the S-GW returns a Release Access Bearers Response to SGSN.

8.1.4 Paging for GPRS Downlink Transfer (A/Gb mode)

An MS in STANDBY state is paged by the SGSN before a downlink transfer to that MS. The paging procedure shall move the MM state to READY to allow the SGSN to forward downlink data to the radio resource. Therefore, any uplink data from the MS that moves the MM context at the SGSN to READY state is a valid response to paging.

The SGSN supervises the paging procedure with a timer. If the SGSN receives no response from the MS to the Paging Request message, it shall repeat the paging. The repetition strategy is implementation dependent.

The MS shall accept pages also in READY state if no radio resource is assigned. This supports recovery from inconsistent MM states in the MS and the SGSN.

The GPRS Paging procedure in A/Gb mode is illustrated in Figure 56.

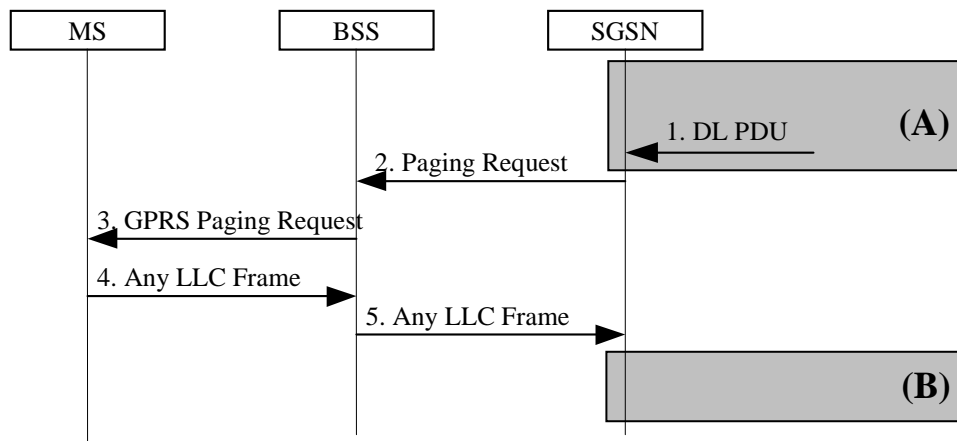

Figure 56: GPRS Paging Procedure (A/Gb mode)

NOTE: The procedure describes the flow when there is an established user plane between SGSN and GGSN with Gn/Gp based SGSN, or between SGSN and S-GW with S4 based SGSN. In case of an S4 based SGSN, when the S-GW has no downlink user plane TEIDs, procedure steps (A) and (B) are defined in clause 8.1.4A.

- 1) The SGSN receives a DL PDU for an MS in STANDBY state. Downlink signalling to a STANDBY state MS initiates paging as well.
- 2) The SGSN sends a BSSGP Paging Request (IMSI, P-TMSI, Area, Channel Needed, QoS, DRX Parameters) message to the BSS serving the MS. IMSI is needed by the BSS in order to calculate the MS paging group. P-TMSI is the identifier by which the MS is paged. Area indicates the routeing area in which the MS is paged. Channel Needed indicates GPRS paging. QoS is the negotiated QoS for the PDP context that initiates the paging procedure, and indicates the priority of this Paging Request relative to other Paging Request messages buffered in the BSS. DRX Parameters indicates whether the MS uses discontinuous reception or not. If the MS uses discontinuous reception, DRX Parameters in combination with the IMSI indicate when the MS is in a non-sleep mode able to receive paging requests.
- 3) The BSS pages the MS with one Paging Request (P-TMSI, Channel Needed) message in each cell belonging to the addressed routeing area. This is described in TS 43.064 [11].

- 4) Upon receipt of a GPRS Paging Request message, the MS shall respond with either any single valid LLC frame (e.g. a Receive Ready or Information frame) that implicitly is interpreted as a page response message by the SGSN. The MS shall not use the LLC NULL frame as a page response. When responding, the MS changes MM state to READY. The Packet Channel Request precedes the response and Packet Immediate Assignment procedures as described in TS 43.064 [11].
- 5) Upon reception of the LLC frame, the BSS adds the Cell Global Identity including the RAC and LAC of the cell and sends the LLC frame to the SGSN. The SGSN shall then consider the LLC frame to be an implicit paging response message and stop the paging response timer.

8.1.4A Paging response for GPRS Downlink Transfer with no established user plane on S4

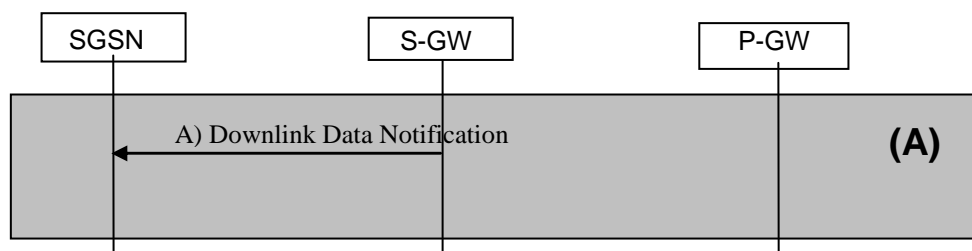

Figure 56a: Paging with no established user plane on S4

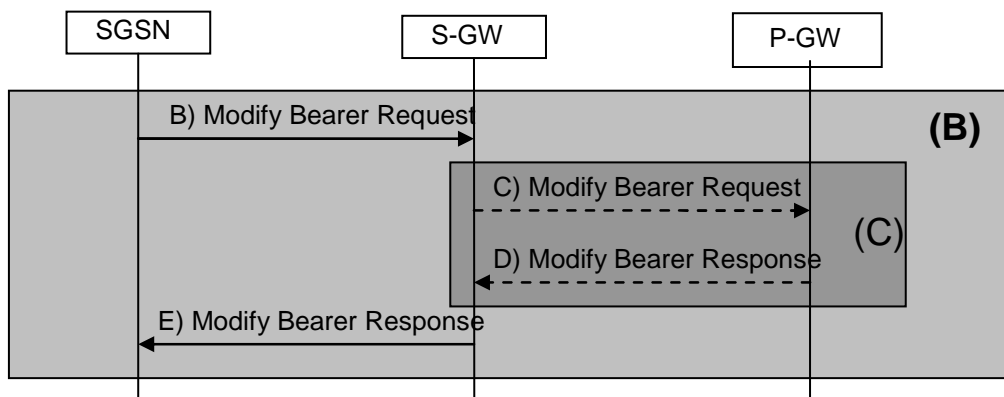

Figure 56b: Paging Response with no established user plane on S4

NOTE: Steps A, B and E are common for architecture variants with GTP based S5/S8 and PMIP-based S5/S8. For a PMIP-based S5/S8, procedure steps (C) are defined in TS 23.402 [90]. Steps C and D concern GTP based S5/S8.

- A) When the S-GW receives a downlink PDU and no downlink user plane exists for the UE at S4, the S-GW buffers the downlink data packet and identifies which SGSN is serving that UE.

If that SGSN has requested the S-GW to throttle downlink low priority traffic and if the downlink data packet is received on a low priority bearer to be throttled (see clause 5.3.6.5), the SGW drops the downlink data packet. The steps below are not executed.

Otherwise the S-GW sends a Downlink Data Notification message to the SGSN.

Steps between A and B are described in clause 8.1.4.

- B) Upon reception of the LLC frame in STANDBY state and if the user plane tunnel does not exist, the SGSN shall indicate the paging response from GERAN by sending a Modify Bearer Request (SGSN user plane address, RAT Type, TEID) to the Serving GW. The S-GW is now able to transmit downlink data towards the UE.
- C) If the RAT Type has changed compared to the last reported RAT Type, the S-GW shall send the Modify Bearer Request message (RAT Type) to the PDN GW.

D) The PDN GW sends the Modify Bearer Response to the S-GW.

E) The S-GW sends a Modify Bearer Response to the SGSN.

8.1.5 RAN Information Management (RIM) procedures

8.1.5.1 General

The RAN Information Management (RIM) procedures provide a generic mechanism for the exchange of arbitrary information between applications belonging to the RAN nodes. The RAN information is transferred via the SGSN core network node(s). In order to make the RAN information transparent for the Core Network, the RAN information is included in a RIM container that shall not be interpreted by the Core Network nodes.

The RIM procedures are optional both in the RAN node and in the SGSN. For the Gb interface the use of RIM procedures is negotiated at start/restart of the Gb link. For the Iu interface there is no negotiation of using RIM procedures or not at Iu link start/restart.

The RAN information is transferred in RIM containers from the source RAN node to the destination RAN node by use of messages. Each message carrying the RIM container is routed and relayed independently by the SGSN(s). Any relation between messages is transparent for the SGSN, i.e. a request/response exchange between RIM applications, for example, is routed and relayed as two independent messages by the SGSN.

The interfaces which will be used are the Gb (BSSGP), the Iu (RANAP), the Gn (GTPv1) and the S16 (GTPv2) interfaces. The RAN information in the RIM container shall be transparent for the Core Network. An SGSN supporting the RIM procedures provides addressing, routing and relay functions.

8.1.5.2 Addressing, routing and relaying

8.1.5.2.1 Addressing

All the messages used for the exchange of RAN information contain the addresses of the source and destination RAN nodes. A BSS is addressed by Routing Area Identity (RAI) + Cell Identity (CI) of one of its cells. An RNC is addressed by Global RNC-Id.

8.1.5.2.2 Routing

The following description applies to all the messages used for the exchange of RAN information.

The source RAN node sends a message to its SGSN including the source and destination addresses. An RNC sends in addition a RIM routing address, which is a copy of the destination address. From the destination address or from the RIM routing address, the SGSN shall decide whether or not it is connected to the destination RAN node.

If the SGSN is not connected to the destination RAN node, then it shall use the destination address or the RIM routing address to route the message encapsulated in a GTP message to the correct SGSN via the Gn interface. If the destination address or RIM routing address identifies an RNC the SGSN includes the RIM routing address in the GTP message. If the SGSN received the message from a BSC it copies the destination address from the message into the RIM routing address.

The SGSN connected to the destination RAN node decides which RAN node to send the message to based on the destination address or on the RIM routing address.

8.1.5.2.3 Relaying

The SGSN performs relaying between BSSGP messages, RANAP messages and GTP messages as described in TS 48.018 [78], TS 25.413 [56b] and TS 29.060 [26].

8.1.5.3 Void

8.1.5.4 Void

8.1.5.5 Applications using the RIM Procedures

The RAN node applications, which use the RIM procedures, are fully transparent for the SGSN. These applications are described in RAN specifications. An example is the Network Assisted Cell Change described in TS 48.018 [78] and TS 25.413 [56b].

8.1.6 BSS Paging Co-ordination

In Network Operation Mode II, paging from one CN domain is done independently from the state of the MS in the other CN domain, i.e. no paging co-ordination on core network level is done.

It is, however, possible to do paging co-ordination on BSS level in these cases. This means that for each paging request received from one CN domain, the BSC determines whether the MS is engaged with the other CN domain or not. In order to achieve this, the context that is prepared within the BSC for an MS engaged with one of the CN domains must contain the IMSI, which is the common MS identity for the two CN domains.

If the BSC determines that the MS is engaged with the PS domain, the CS paging will be done on a packet data channel for the MS in question.

If the BSC determines that the MS is engaged with the CS domain, the PS paging (packet notification) will be done on a CS dedicated channel for the MS in question.

If no context is found for the MS, "normal CS paging" is performed on the CCCH paging channel and "normal PS paging" is performed on the CCCH paging channel or the packet paging channel (PCCCH shall not be used, see clause 6.3.3.1), as applicable.

If BSS paging co-ordination for CS paging is active in a cell or not, shall be indicated as system information to the MSs. For proper operation, the mode should be the same in each cell of a routing area.

BSS paging co-ordination for PS paging shall always be active in a cell where DTM is supported and is applicable to MSs supporting DTM.

8.2 Radio Resource Functionality (Iu mode)

8.2.1 Radio Resource Management

UTRAN functions are defined in TS 25.401 [53]. The radio interface protocol architecture is specified in TS 25.301 [50], and the Radio Resource Control protocol is specified in TS 25.331 [52]. TS 43.051 [74] contains an overall description of GSM/EDGE Radio Access Network.

In the context of this specification, the term URA refers also to GRA (GERAN Registration Area) when the RAN serving an MS in Iu mode is a GERAN.

8.2.2 RRC State Machine

The RRC state machine is a description model of how the MS and the Iu mode RAN co-operate regarding RRC functionality. The RRC state describes the MS state in the Iu mode RAN. This clause contains a brief description of the RRC state machine, for more information see TS 25.303 [51].

The RRC state machine exists as two peer entities, one in the MS and one in the Iu mode RAN. Apart from transient situations and error cases the two peer entities are synchronised. Figure 57 illustrates the main modes and states of the RRC state machine.

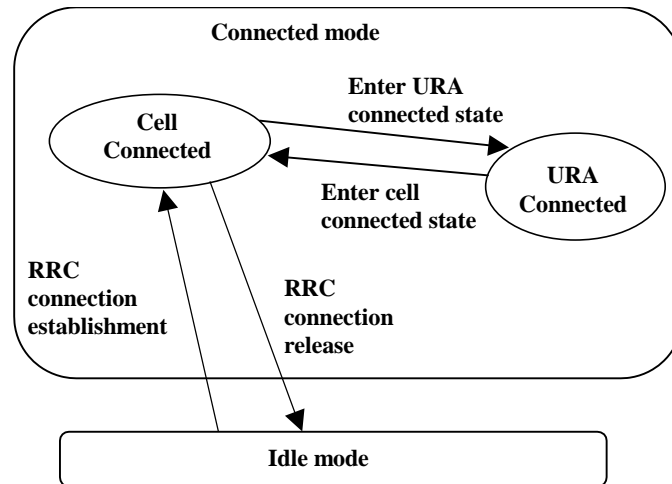

Figure 57: RRC Modes, Main RRC States and Main Mode and State Transition

RRC Idle mode: In the Idle mode there is no connection established between the MS and the Iu mode RAN. There is no signalling between RAN and the MS except for system information that is sent from RAN on a broadcast channel to the MS. The MS can also receive paging messages with a CN identity on the PCH. There is no information of the MS stored in RAN in this mode.

RRC Connected mode: In the Connected mode the main states are Cell Connected state and URA Connected state. In this mode there is one RNC/BSC that is acting as serving RNC/BSC, and an RRC connection is established between the MS and this SRNC/SBSC.

- When the MS position is known at the cell level, the MS is in the Cell Connected state. When in Cell Connected state, the RRC connection mobility is handled by handover and cell update procedures.
- When the MS position is known at the URA level, the MS is in the URA Connected state. URA updating procedures provide the mobility functionality in this state. No dedicated radio resources are used in the URA Connected state.

8.2.3 Discontinuous Reception

An MS can set the DRX cycle length that is specific to the PS domain. TS 25.304 [51b] describes how the MS shall select which DRX cycle length to use with respect to DRX cycle length requirements set by the RAN, CN PS domain and CN CS domain.

The DRX parameter information shall be indicated by the MS in the attach procedure and when changing from A/Gb mode to Iu mode also in the routing area update procedure. The SGSN shall then in each page request send these parameters to the RNC/BSC that uses this information, and the IMSI, to calculate the correct paging group.

At inter-SGSN change (either RA update or SRNS relocation), the DRX parameters are sent from the old SGSN to the new SGSN as part of the MM context information. Hence, unless the DRX parameters have been altered, the UE should not include the DRX parameters in the Routing Area Update message. There is one other exception to this: in order to support mobility from pre-Release 99 SGSNs, the MS shall include the DRX Parameter IE in a Routing Area Update Request message sent at RA update from GERAN to UTRAN.

At inter-SGSN RA update (e.g. from GERAN), if the network receives a DRX parameters IE from the MS in the routing area update request message, the new SGSN shall use the information provided by the MS and shall ignore the same IE received in MM Context from the old SGSN.

If the UE wishes to alter its GERAN or UTRAN/E-UTRAN DRX Parameters while in Iu mode, then it shall send a Routing Area Update Request message to the SGSN containing its new DRX Parameters. If ISR had been activated for the MS, then the MS shall deactivate ISR by setting its TIN to "P-TMSI" so that the MS performs a Tracking Area Update when it next enters E-UTRAN coverage. When the UE performs that Tracking Area Update, the MME will receive the updated DRX parameters within the MM context information sent by the old SGSN and hence the UE should not include them again in the Tracking Area Update.

8.2.4 Paging Initiated by CN

A CN node requests paging only for MSs in CMM-IDLE state or PMM-IDLE state. In the separate CN architecture, paging from a CN node is done independently from the state of the MS in the other CN service domain.

In the context of this specification, the terms RNS or RNC refer also to a GERAN BSS or BSC (respectively) when serving an MS in Iu mode.

In this alternative with paging co-ordination in the RAN, the MS does not need to listen to the PCH (Paging Channel) in the RRC Connected mode, at least not when MS is allocated a dedicated channel.

For each paging request received from a CN node, the RNC determines whether the MS has an established RRC connection or not. In order to achieve this, the context that is prepared within the SRNC for MS in RRC Connected mode must contain the IMSI, which is the common MS identity for the two CN domains.

If no context is found for the MS, "normal PCH paging" is performed. The paging message is transferred on the paging channel, and it includes the MS paging identity received from the CN and a CN service domain type indication.

If a context is found, a "CN paging message" is transferred using the existing RRC connection. This message includes a CN service domain type indication. If, potentially after repetition, this transfer is unsuccessful and if the CS domain originally triggered the paging, the RNC should decide whether to attempt "normal PCH paging" as described in clause "Unsynchronous states in the UE and the UTRAN".

8.2.4.1 PS Paging Initiated by SGSN (Iu mode) without RRC Connection for CS

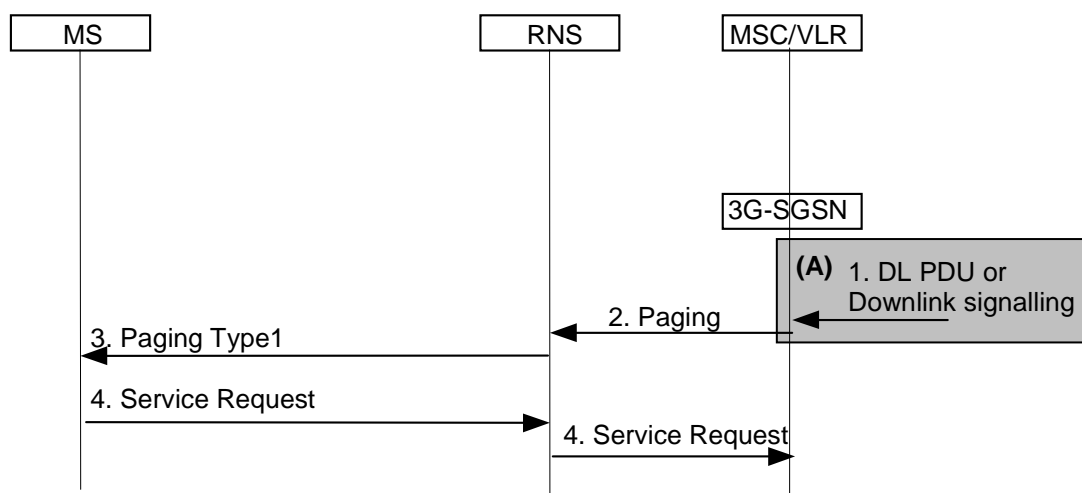

Figure 58: PS Paging by SGSN (Iu mode) Without RRC Connection for CS

NOTE 1: Steps 2-4 are common for architecture variants using Gn/Gp based interaction with GGSN. For an S4 based interaction with S-GW and P-GW, procedure steps (A) are defined in clause 8.2.4.1A.

- 1) The 3G-SGSN receives a DL PDU or downlink signalling for an MS in PMM Idle state.
- 2) The 3G-SGSN sends a RANAP Paging (IMSI, P-TMSI, Area, CN Domain Indicator, DRX parameters, list of CSG IDs for paging) message to each RNS belonging to the routing area in which the MS is located. IMSI is needed by the RNS in order to calculate the MS paging group, and to identify the paged MS. If 3G-SGSN assigned the P-TMSI to the MS, P-TMSI is also included. Area indicates the routing area in which the MS is paged. CN Domain Indicator indicates which domain (MSC or 3G-SGSN) initiated the paging message, and it represents "SGSN" in this case. DRX Parameters indicates the MS's preferred DRX cycle length. The list of CSG IDs for paging is included when the 3G SGSN is configured to support paging optimisation described in clause 5.3.9. For paging optimisation, the CSG IDs of expired CSG subscriptions and valid CSG subscriptions are both included in the list. If the MS has emergency bearer service the 3G SGSN shall not perform paging optimization.

NOTE 2: An expired CSG subscription indicates that the MS is not allowed service in the CSG. However, since the removal of the CSG from the MS is pending, it is possible the MS will camp on that CSG and therefore the MS is still paged for the CSG.

- 3) The RNS controls whether the MS has an established RRC connection or not. In this case, MS has no RRC connection, so a "normal PCH paging" is performed. Paging Type 1 (IMSI or P-TMSI, Paging originator, CN domain ID) is transferred on the Paging channel, IMSI or P-TMSI identifies the MS. Paging originator indicates whether this is core network originated paging or RAN originated paging, so it represents "CN" in this case. And CN domain ID indicates whether this paging message is for CS service or PS service, so it represents "PS" in this case.
- 4) The paging request triggers the Service Request procedures in the MS. The service request procedures are described in clause "Service Request Procedure (Iu mode)".

Optionally, 3G-SGSN may include "Non Searching Indication" in RANAP Paging message in this case. If a "Non Searching Indication" parameter is present, the RNC will not search the established RRC connection, and just initiate "normal PCH paging".

8.2.4.1A Serving GW Triggered Paging (Iu mode) with S4

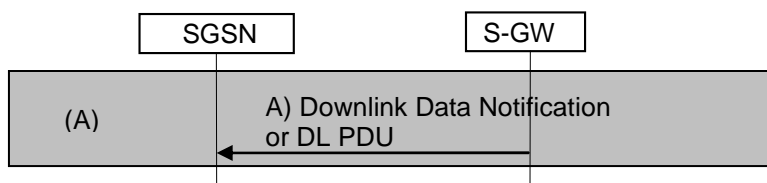

Figure 58a: Serving GW triggered paging with S4

- A) If the S-GW has no downlink user plane TEIDs for S4 and S12, the S-GW buffers the DL PDUs and identifies which SGSN is serving that UE.

If that SGSN has requested the S-GW to throttle downlink low priority traffic and if the downlink data packet is received on a low priority bearer to be throttled (see clause 5.3.6.5), the S-GW drops the downlink data packet. The steps below are not executed.

Otherwise the S-GW sends a Downlink Data Notification to the SGSN. If the S-GW has downlink user plane TEIDs for S4 the DL PDUs are transferred to SGSN.

8.2.4.2 PS Paging Initiated by 3G-SGSN With RRC Connection for CS

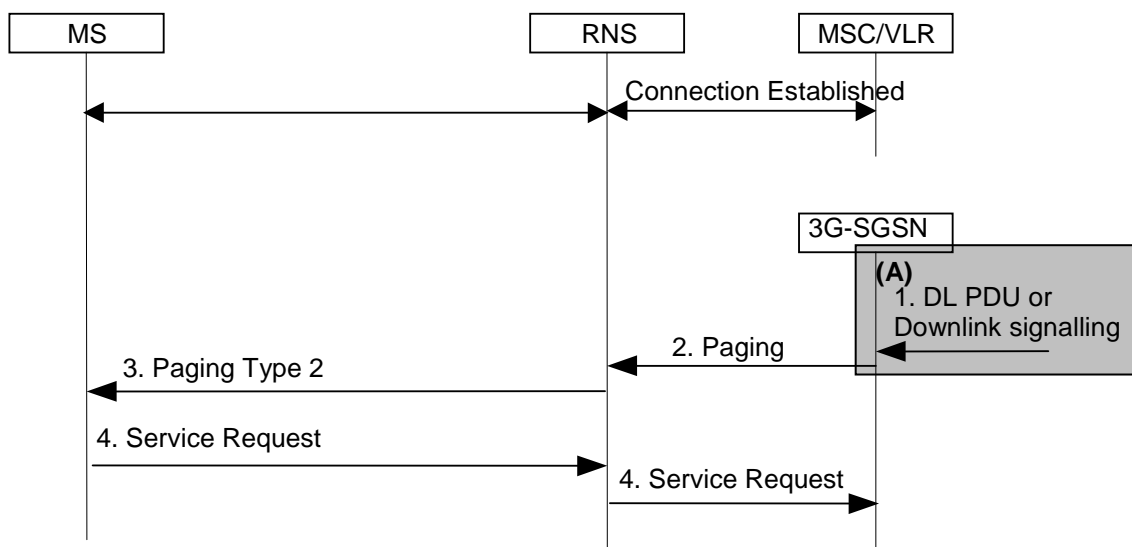

Figure 59: PS Paging by SGSN (Iu mode) With RRC Connection for CS

NOTE 1: Steps 2-4 are common for architecture variants using Gn/Gp based interaction with GGSN and using S4 based interaction with S-GW and P-GW. For an S4 based interaction with S-GW and P-GW, procedure steps (A) are defined in clause 8.2.4.1A.

- 1) The 3G-SGSN receives a DL PDU or downlink signalling for an MS in PMM Idle state.
- 2) The 3G-SGSN sends a RANAP Paging (IMSI, P-TMSI, Area, CN Domain Indicator, DRX parameters, list of CSG IDs for paging) message to each RNS belonging to the routing area in which the MS is located. IMSI is needed by the RNS in order to calculate the MS paging group. If 3G-SGSN assigned the P-TMSI to the MS, P-TMSI is included, and it identifies the MS is paged. Area indicates the routing area in which the MS is paged. CN Domain Indicator indicates to which domain (MSC or 3G-SGSN) the paging was initiated, and it represents "3G-SGSN" in this case. DRX Parameters indicates whether or not the MS uses discontinuous reception and the DRX cycle length. The list of CSG IDs for paging is included when the 3G SGSN is configured to support paging optimisation described in clause 5.3.9. For paging optimisation, the CSG IDs of expired CSG subscriptions and valid CSG subscriptions are both included in the list. If the MS has emergency bearer service the 3G SGSN shall not perform paging optimization.

NOTE 2: An expired CSG subscription indicates that the MS is not allowed service in the CSG. However, since the removal of the CSG from the MS is pending, it is possible the MS will camp on that CSG and therefore the MS is still paged for the CSG.

- 3) The RNS controls whether the MS has an established RRC connection or not. In this case, MS has an established RRC connection for CS service, so RNS sends an RRC Paging Type 2 (CN domain ID) message to the MS on established RRC connection. CN Domain ID indicates to which domain (CS or PS) the paging shall be directed, so it represents "PS" in this case.
- 4) The paging request triggers the Service Request procedures in the MS. The service request procedures are described in clause "Service Request Procedure (Iu mode)".

8.2.5 Paging Initiated by RAN

An MS in RRC URA/GRA connected state is paged by the RAN before a downlink transfer to that MS. The URA/GRA paging procedure shall move the RRC state to Cell Connected to allow the RAN to forward downlink data or signalling message to the radio resource. Therefore, the RRC: Cell Update message from the MS that moves the RRC State at the RAN to Cell Connected state is a valid response to URA/GRA paging.

The RAN supervises the paging procedure with a timer. If the RAN receives no response from the MS to the URA or GRA Paging Request message, it shall repeat the paging. The repetition strategy is implementation dependent. If it is unsuccessful and if the paging was originally triggered by the CS domain, it is the RNC's responsibility to recover this situation by following the "normal PCH paging" mechanism (see clause "Paging Initiated by CN"). For more information see TS 25.303 [51].

The URA/GRA Paging procedure is illustrated in Figure 60.

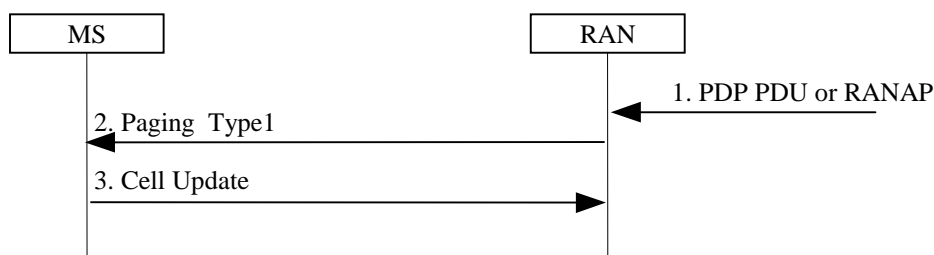

Figure 60: URA/GRA Paging Procedure

- 1) The RAN receives a downlink PDP PDU for an MS in RRC URA/GRA connected state. Downlink signalling to an MS in RRC URA/GRA connected state initiates URA/GRA paging as well.
- 2) The RAN pages the MS with one Paging Type 1 (RNTI, Paging originator) message in each cell belonging to the URA/GRA where the MS exists. RNTI is the identifier by which the MS is paged. Paging originator indicates whether this is the core network originated paging or RAN originated paging, so it represents "RAN" in this case.
- 3) The paging request triggers the Cell Update procedures in the MS. The Cell Update procedures are described in TS 25.331 [52].

9 Packet Routing and Transfer Functionality

9.1 Definition of Packet Data Protocol States

9.1.0 General

A PS subscription contains the subscription of one or more PDP addresses. Each PDP address is an element of a PDP context. The same PDP address may appear in one or more PDP contexts in the MS, the SGSN, the S-GW, the P-GW and the GGSN. Each PDP context may be associated with a TFT. At most one PDP context associated with the same PDP address may exist at any time with no TFT assigned to it. Every PDP context exists independently in one of two PDP states. The PDP state indicates whether data transfer is enabled for that PDP address and TFT or not. In case all PDP contexts associated with the same PDP address are deactivated, data transfer for that PDP address is disabled. Activation and deactivation are described in clause "PDP Context Activation, Modification, Deactivation, and Preservation Functions". All PDP contexts of a subscriber are associated with the same MM context for the IMSI of that subscriber.

9.1.1 INACTIVE State

The INACTIVE state characterises the data service for a certain PDP address of the subscriber as not activated. The PDP context contains no routing or mapping information to process PDP PDUs related to that PDP address. No data can be transferred. A changing location of a subscriber causes no update for the PDP context in INACTIVE state even if the subscriber is GPRS-attached.

Mobile-terminated PDP PDUs received in INACTIVE state by the GGSN may initiate the Network-Requested PDP Context Activation procedure if the GGSN is allowed to initiate the activation of the PDP context for that PDP address. Otherwise, mobile-terminated PDP PDUs received in INACTIVE state invoke error procedures in the P-GW or GGSN relevant to the packet data network protocol, for example, an IP packet is discarded and an ICMP (see RFC 792 [41]) packet (error notification) is returned to the source of the received packet. Other error procedures may be introduced on the application level, but this is outside the scope of the present document.

The MS initiates the movement from INACTIVE to ACTIVE state by initiating the PDP Context Activation procedure.

9.1.2 ACTIVE State

In ACTIVE state, the PDP context for the PDP address in use is activated in the MS, SGSN and GGSN when using Gn/Gp, or in the MS, SGSN, S-GW and P-GW when using S4. The PDP context contains mapping and routing information for transferring PDP PDUs for that particular PDP address between the MS and the P-GW or GGSN. The PDP state ACTIVE is permitted only when the mobility management state of the subscriber is STANDBY, READY, PMM-IDLE, or PMM-CONNECTED. The Iu interface radio access bearer may or may not be established for an active PDP context.

An active PDP context for an MS is moved to INACTIVE state when the deactivation procedure is initiated.

All active PDP contexts for an MS are moved to INACTIVE state when the MM state changes to IDLE or PMM-DETACHED.

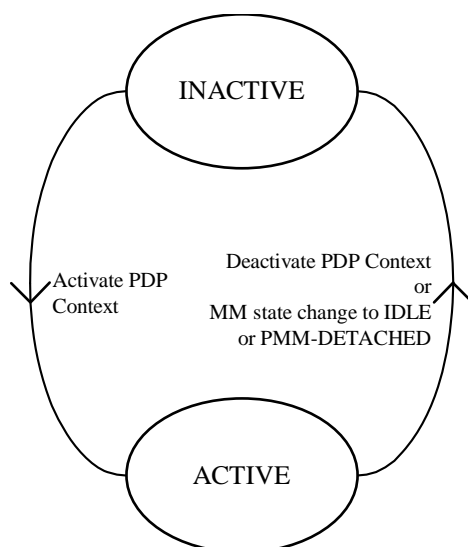

Figure 61: Functional PDP State Model

9.2 PDP Context Activation, Modification, Deactivation, and Preservation Functions

9.2.0 General

This clause describes the procedures to enable a GPRS-attached MS to initiate the activation, modification, and deactivation functions for a PDP context in the MS, the SGSN, the S-GW and the P-GW or GGSN. In addition procedures to enable a P-GW or GGSN to request the activation, modification and deactivation of a PDP context to a GPRS-attached subscriber are described.

NOTE 1: If the MS is in PMM-IDLE state, it needs to perform a service request procedure to enter the PMM-CONNECTED state before initiating these procedures.

NOTE 2: There are two procedures specified for GGSN initiated PDP Context Activation; the Network Requested PDP Context Activation Procedure and the Network Requested Secondary PDP Context Activation Procedure. P-GWs support only the Network Requested Secondary PDP Context Activation Procedure. The network requested bearer control makes use of the Network Requested Secondary PDP Context Activation Procedure only.

Upon receiving an Activate PDP Context Request message or an Activate Secondary PDP Context Request message, the SGSN shall initiate procedures to set up PDP contexts. The first procedure includes subscription checking, APN selection, and host configuration, while the latter procedure excludes these functions and reuses PDP context parameters including the PDP address but except the QoS parameters. Once activated, all PDP contexts that share the same PDP address and APN shall be managed equally. At least one PDP context shall be activated for a PDP address before a Secondary PDP Context Activation procedure may be initiated. When the MS performs an RA update procedure to change from a release 99 to a release 97 or 98 system, only one active PDP context per PDP address and APN shall be preserved. This PDP context is selected taking the QoS profile and NSAPI value into account.

When the SGSN is using the S4-interface to an S-GW for a PDP Context, EPS Bearer procedures will be used.

The EPS subscription context includes a mandatory EPS subscribed QoS profile for the default bearer of each subscribed APN. If the S4-SGSN has received an EPS subscribed QoS profile and the first PDP context to a given APN is activated, the S4-SGSN disregards the QoS requested by the MS and sends the EPS subscribed QoS profile for this APN to the S-GW. For MSs, for which the S4-SGSN has not received an EPS subscribed QoS profile per APN, the S4-SGSN treats MS originated QoS requests the same as the Gn/Gp SGSN. For MSs, for which the S4-SGSN has not received a subscribed APN-AMBR per APN, the S4-SGSN provides APN-AMBR to the Serving GW and PDN GW. Details on mapping MBR to APN-AMBR are specified in Annex E of TS 23.401 [89].

The E-UTRAN capable MS shall not deactivate the PDP context created by the PDP Context Activation Procedure unless all PDP contexts for the same PDN connection are to be deactivated. The MS shall not modify the QoS of the PDP context created by the PDP Context Activation Procedure.

When the E-UTRAN capable MS is activating the first PDP context with the PDP Context Activation Procedure, the MS shall request for the subscribed QoS profile, but the MS may request for subscribed, interactive or background traffic class. If the EPS subscribed QoS profile information is available to the PDN GW (e.g. if PCC is deployed) and the PDN GW is connected to an Gn/Gp SGSN, the PDN GW shall modify the requested QoS according to the EPS subscribed QoS profile during the PDP Context Activation Procedure.

NOTE 3: As the Gn/Gp SGSN is not capable of allocating the EPS subscribed QoS profile, the MS and the PDN GW are responsible for this.

The non E-UTRAN capable MS should not deactivate the PDP context created by the PDP Context Activation Procedure unless all PDP contexts for the same PDN connection are to be deactivated. The MS should not modify the QoS of the PDP context created by the PDP Context Activation Procedure as long as the MS can achieve the same result using a different PDP context than the PDP context created by the PDP Context Activation Procedure.

During the PDP Context Activation Procedure the bearer control mode, applicable to all PDP Contexts within the activated PDP Address/APN pair, is negotiated. The Bearer Control Mode (BCM) is one of 'MS_only' or 'MS/NW':

- When 'MS_only' the MS shall request any additional PDP contexts for the PDP Address/APN pair through the Secondary PDP Context Activation Procedure. Session Management procedures described in 9.2 apply with the following restrictions:
 - The P-GW or GGSN shall not initiate any Network Requested Secondary PDP Context Activation.
 - The P-GW or GGSN shall not initiate any TFT operation.
 - The P-GW shall reject any MS request for a secondary PDP context activation that is received without a TFT.
 - For a TFT, when the MS uses the direction attribute, the MS shall ensure that there is at least one packet filter for the uplink direction.
- When 'MS/NW' both the MS and the P-GW or GGSN may request additional PDP contexts for the PDP Address/APN pair. The MS shall use the Secondary PDP Context Activation Procedure. The P-GW or GGSN shall use the Network Requested Secondary PDP Context Activation Procedure. The MS shall, when modifying the QoS of a PDP context, include a TFT with at least packet filter identifiers to indicate which packet filters in the TFT are associated with the QoS change.

NOTE 4: The MS indicates the packet filters in the TFT so that the network can perform the appropriate authorization, i.e. in-line with a valid state for the TFT settings (as defined in clause 15.3.0).

For 'MS/NW' the session Management procedures described in clause 9.2 apply with the following restrictions:

- The MS shall not modify the QoS of a PDP context until this PDP context is associated with a TFT containing packet filters set by the MS. If the TFT also contains packet filters set by the P-GW/GGSN, the MS is only allowed to modify the bit rate parameters in the QoS profile of that PDP Context;
- The MS shall not initiate any Secondary PDP Context Activation without sending a TFT containing at least one packet filter for the uplink direction;
- The P-GW/GGSN shall not initiate any Network Requested Secondary PDP Context Activation without sending a TFT containing at least one packet filter for the uplink direction;
- The MS shall not add a TFT to a PDP context that was established without a TFT;
- The MS shall not delete the TFT from a PDP context that is associated with a TFT;
- Only the entity that sets a packet filter in the TFT (either MS or P-GW/GGSN) is allowed to modify or delete this packet filter;
- For each TFT, the MS and the network shall ensure that among the packet filters under own control there is at least one packet filter for the uplink direction, or no own packet filter at all;

- For each packet filter the MS and the network shall indicate whether it corresponds to uplink, downlink or bi-directional traffic flow(s).

NOTE 5: The restriction below may be relaxed in a future Release. In the restriction below, packet filters without a declared direction are considered to be bi-directional.

- The P-GW/GGSN shall ensure that for all PDP contexts of the same APN/PDP address pair, a valid state for the TFT settings (as defined in clause 15.3.0) is maintained.

NOTE 6: If a PDP context is to be used for services having downlink IP flows only, then the TFT needs to include a packet filter for the uplink direction that effectively disallows any useful uplink packet flows (see clause 15.3.3.4 for an example of such a packet filter).

NOTE 7: If the PDP context is to be used for services having uplink IP flows only, the TFT needs no packet filter for the downlink direction.

The MS indicates support of the network requested bearer control through the Network Request Support UE (NRSU) parameter, which is applicable to all PDP contexts within the same PDP address / APN pair. The SGSN indicates support of the network requested bearer control through the Network Request Support Network (NRSN) parameter.

If the NRSN is not included in the Update PDP Context Request message from the SGSN, or the SGSN does not indicate support of the network requested bearer control, the GGSN or P-GW shall, following a SGSN-Initiated PDP Context Modification (triggered by SGSN change), perform a GGSN or P-GW-Initiated PDP Context Modification to change the BCM to 'MS-Only' for all PDP-Address/APN-pairs for which the current BCM is 'MS/NW'.

NOTE 8: An MS is informed of the change in BCM, by SGSN, via Protocol Configuration Options IE in Modify PDP Context Request. The support for PCO IE in Modify PDP Context Request was introduced during Release 5. Hence, the communication of change in BCM, for some pre-Release 6 deployments which do not support PCO IE in Modify PDP Context Request, to an MS may not be possible.

NOTE 9: Change of BCM from 'MS-Only' to 'MS/NW' has not been supported by the MS and the network since introduction of MS/NW BCM mode in Rel-7.

An S4-based SGSN shall apply the BCM 'MS/NW' whenever the S4 is selected for a certain MS.

NOTE 10: The S4-SGSN needs to support the network requested bearer control due to the nature of the procedures and thus a dynamic signalling of NRSN and BCM is not necessary.

NOTE 11: There may be cases where BCM mode in an S4-SGSN is "MS/NW" but BCM mode in MS and P-GW is "MS-Only", e.g. when the MS does not send NRSU in PCO IE.

The MS indicates support of the extended TFT filter format through the Extended TFT Support UE (ETFTU) parameter, which is applicable to all PDP contexts within the same PDP address / APN pair. The network indicates the support of the extended TFT filter format for all PDP contexts within the same PDP address / APN pair through the Extended TFT Support Network (ETFTN) parameter.

Upon receiving a Deactivate PDP Context Request message, the SGSN shall initiate procedures to deactivate the PDP context. When the last PDP context associated with a PDP address is deactivated, N-PDU transfer for this PDP address is disabled.

An MS does not have to receive the (De-) Activate PDP Context Accept message before issuing another (De-)Activate PDP Context Request. However, only one request can be outstanding for every TI.

By sending a RAB Release Request or Iu Release Request message to the SGSN, the RAN initiates the release of one or more RABs. The preservation function allows the active PDP contexts associated with the released RABs to be preserved in the CN, and the RABs can then be re-established at a later stage.

An S4-based SGSN shall for all active PDN Connections for a certain MS use either S4 or Gn/Gp. This is achieved by the SGSN rejecting a PDP Context activation violating this:

- If an MS is sending an Activate PDP Context Request for an APN using Gn, the activation will be rejected by the SGSN if a PDP Context using S4 already exists for this MS;
- If an MS is sending an Activate PDP Context Request for an APN using S4, the activation will be rejected by the SGSN if a PDP Context using Gn already exists for this MS.

In a roaming scenario, based on local configuration, the S4-SGSN may downgrade the ARP or APN-AMBR and/or remap QCI parameter values received from HSS to the value locally configured in S4-SGSN (e.g. when the values received from HSS do not comply with services provided by the visited PLMN). The PCEF may change the QoS parameter values received from the S4-SGSN based on interaction with the PCRF or based on local configuration. Alternatively, the PCEF may reject the bearer establishment.

NOTE 12: For certain APNs (e.g. the IMS APN defined by the GSMA) the QCI value is strictly defined and therefore remapping of QCI is not permitted.

NOTE 13: In roaming scenarios, the ARP/APN-AMBR/QCI values provided by the S4-SGSN for a default bearer may deviate from the subscribed values depending on the roaming agreement. If the PCEF (based on interaction with the PCRF or based on local configuration) upgrades the ARP/APN-AMBR/QCI parameter values received from the S4-SGSN, the default bearer establishment may be rejected by the S4-SGSN.

If case S4 is selected for a certain MS the SGSN shall not modify the EPS bearer level QoS parameters received from the PDN GW during establishment or modification of a default or dedicated bearer (except when the conditions described in NOTE 14 apply). Based on local configuration, the SGSN may reject the establishment or modification of a default or dedicated bearer in the case of roaming when the bearer level QoS parameter values do not comply with a roaming agreement.

NOTE 14: The S4-SGSN, based on local policies, can downgrade the ARP pre-emption vulnerability and/or pre-emption capability, APN-AMBR or MBR (for GBR bearers) parameters received over S8 and allow the bearer establishment or modification of a default or dedicated bearer. The HPLMN is expected to set EPS QoS parameters compliant with roaming agreements, therefore the HPLMN is not informed about any downgrade of EPS bearer QoS parameters. The consequences of such a downgrade are that APN-AMBR and MBR enforcement at the HPLMN and at the UE will not be aligned.

9.2.1A Principles for mapping between PDP Contexts and EPS Bearers

The following text describes the general principles used by an SGSN using S4 when mapping between PDP Contexts and EPS Bearers.

The MS is using PDP Context Activation, Modification and Deactivation functions, and PDP Contexts are therefore used between MS and SGSN. An SGSN using Gn/Gp only will use these procedures towards GGSNs as well. An SGSN using S4 will for a specific PDP Context towards an MS map these procedures into equivalent procedures using EPS Bearer towards S-GW and P-GW. EPS Bearer procedures will not be used between MS and SGSN.

The following principles are to be used:

- 1:1 mapping between one PDP context and one EPS Bearer;
- 1:1 mapping between NSAPI and EPS Bearer ID;
- The P-GW treats an MS-initiated request, e.g. a Secondary PDP Context Activation Request, according to the UE requested bearer resource modification procedures in TS 23.401 [89];
- PDN GW and Serving GW need to be RAT aware to allow for 2G/3G specific handling of EPS bearers, e.g. MS initiated secondary PDP Context activation must make the P-GW to activate a new EPS bearer.
- The QoS profiles of the PDP context and EPS bearer are mapped as specified in TS 23.401 [89].
- If the S4-SGSN receives the EPS subscribed QoS profile per subscribed APN from the HSS, the S4-SGSN enforces this QoS for the first PDP context which is activated to the given APN. Otherwise the S4-SGSN restricts requested QoS according to the QoS Profile Subscribed which defines the maximum QoS per subscribed APN.

9.2.1 Static and Dynamic PDP Addresses

PDP addresses can be allocated to an MS in four different ways:

- the HPLMN operator assigns a PDP address permanently to the MS (static PDP address);
- the HPLMN operator assigns a PDP address to the MS when a PDP context is activated (dynamic HPLMN PDP address);
- the VPLMN operator assigns a PDP address to the MS when a PDP context is activated (dynamic VPLMN PDP address); or
- the PDN operator or administrator assigns a permanent or dynamic PDP address to the MS (External PDN Address Allocation).

NOTE 1: A PDP address consists of an IPv4 address and/or IPv6 prefix as described in clause 14.5.

It is the HPLMN operator that defines in the subscription whether a dynamic HPLMN or VPLMN PDP address can be used. The HPLMN operator may assign a static PDP address in the PDP context subscription record. An MS implemented according to this version of the protocol does not support static PDP addresses, which are permanently configured in the MS and sent by the MS within the PDP context activation request. The handling of static addresses, which are sent by the MS, is retained in the SGSN in order to ensure backwards compatibility for MSs implemented according to earlier protocol releases.

For every IMSI, zero, one, or more dynamic PDP addresses per PDP type can be assigned. For every IMSI, zero, one, or more static PDP addresses per PDP type can be subscribed to.

When dynamic addressing from the HPLMN or the VPLMN is used, it is the responsibility of the GGSN or P-GW to allocate and release the dynamic PDP address.

When External PDN Address Allocation is used, the following applies for GGSN:

- the PLMN may obtain a PDP address from the PDN and provide it to the MS during PDP context activation, or the MS may directly negotiate a PDP address with the PDN after the PDP context activation procedure is executed. If the PLMN provides the address during PDP context activation in case of External PDN Address Allocation, then it is the responsibility of the GGSN and PDN to allocate, renew and release the dynamic PDP address by means of protocols such as DHCP or RADIUS. If DHCPv4/v6 is used, the GGSN provides the function of a DHCPv4/v6 Client. If RADIUS is used, the GGSN provides the function of a RADIUS Client. If the MS negotiates a PDP address with the PDN after PDP context activation in case of External PDN Address Allocation, it is the responsibility of the MS and the PDN to allocate and release the PDP address by means of protocols such as DHCP or MIP. In case of DHCPv4, the GGSN provides the function of a DHCP Relay Agent as defined in RFC 2131 [47] and RFC 1542 [45]. In case of MIP, the GGSN provides the function of a Foreign Agent as defined in RFC 3344 [46].

External PDN Address Allocation (including DHCP functionality) in P-GW is specified in TS 23.401 [89].

Only static PDP addressing is applicable in the network-requested PDP context activation case.

PDP types IPv4, IPv6 and IPv4v6 are supported. A PDP Context of PDP type IPv4v6 may be associated with one IPv6 prefix only or with both one IPv4 address and one IPv6 prefix. PDP types IPv4 and IPv6 are utilised in case the MS and/or the GGSN or P-GW support IPv4 addressing only or IPv6 addressing only; or operator preferences dictate the use of a single IP version type only, or the subscription is limited to IPv4 only or IPv6 only. In addition, PDP types IPv4 and IPv6 are utilised for interworking with nodes of earlier releases.

The way that the MS sets the requested PDP type may be pre-configured in the device per APN. Unless otherwise configured (including when the MS does not send any APN), PDP types are set by the MS as follows:

- An MS, which is IPv6 and IPv4 capable, shall request for PDP type IPv4v6.
- An MS, which supports IPv4 addressing only, shall request for PDP type IPv4.
- An MS, which supports IPv6 addressing, shall request for PDP type IPv6.
- When the IP addressing capability of the MS is not known in the MS (as in the case when the MT and TE are separated and the capability of the TE is not known in the MT), the MS shall request for PDP type IPv4v6.

During the PDP Context Activation procedure the SGSN compares the requested PDP type to the PDP type in the subscription records for the given APN and sets the PDP type as follows:

- If the requested PDP type is allowed by subscription, the S4-SGSN sets the PDP type as requested.
- If the requested PDP type is allowed by subscription and if the requested PDP type is IPv4v6, the Gn/Gp SGSN sets the PDP type as requested if the GGSN supports PDP type IPv4v6. Otherwise, the SGSN shall set the PDP type to IPv4 or IPv6 where the selection between IPv4 and IPv6 is based on the result of the check.

NOTE 2: The check for PDP type IPv4v6 is implementation specific and configuration may be shared in roaming agreements.

NOTE 3: A Gn/Gp SGSN assumes coherent support for PDP type IPv4v6 across all SGSNs in a PLMN.

- If the requested PDP type is IPv4v6 and subscription data only allows PDP type IPv4 or only allows PDP type IPv6, the SGSN sets the PDP type according to the subscribed value. A reason cause shall be returned to the UE indicating that only the assigned PDP type is allowed. In this case the UE shall not request for another PDP context to the same APN for the other IP version.
- If the requested PDP type is IPv4 or IPv6, and either the requested PDP type or PDP type IPv4v6 are subscribed, the SGSN sets the PDP type as requested. Otherwise the PDP context activation request is rejected.
- If the requested PDP type is IPv4v6, and both IPv4 and IPv6 PDP types are allowed by subscription but not IPv4v6, the SGSN shall set the PDP type to IPv4 or IPv6 where the selection between IPv4 and IPv6 is implementation specific. The MS should then initiate another PDP Context Activation procedure to this APN in order to activate a second PDP context with the other single address PDP type which was not allocated by the network.

The GGSN / PDN GW may restrict the usage of PDP type IPv4v6 as follows:

- If the MS requests PDP type IPv4v6, but the operator preferences dictate the use of a single IP version only, the PDP type shall be changed to a single address PDP type (IPv4 or IPv6) and a reason cause shall be returned to the MS indicating that only the assigned PDP type is allowed. In this case, the MS should not request another PDP context for the other PDP type.
- If the MS requests PDP type IPv4v6, but the operator uses single addressing per PDP context due to interworking with nodes of earlier releases, the PDP type shall be changed to a single address PDP type and a reason cause of "single address bearers only" shall be returned to the MS. In this case the MS should request another PDP context for the other PDP type to the same APN with a single address PDP type (IPv4 or IPv6) other than the one already activated.

NOTE 4: If the MT and TE are separated, the MS might not be able to use reason cause "single address bearers only" as a trigger for activating a second single-stack PDP context.

An MS of this release may request for PDP type IPv4v6 from a SGSN which does not support this PDP type. The SGSN treats a request for PDP type IPv4v6 as if it were a request for PDP type IPv4. To enable dual-stack connectivity for this case, the MS should request another PDP context for PDP type IPv6 to the same APN.

NOTE 5: If the MS requests PDP type IPv4v6, and the PDP context is rejected due to "unknown PDP type", the MS can attempt to establish dual-stack connectivity by performing two PDP context request procedures to activate an IPv4 PDP context and an IPv6 PDP context, both to the same APN.

The mechanism used to allocate an IPv4 address to an MS depends on the MS and the network capabilities. The MS may indicate to the network within the Protocol Configuration Options element that the MS wants to obtain the IPv4 address with DHCPv4 as defined in RFC 2131 [47]:

- the MS may indicate that it prefers to obtain an IPv4 address as part of the PDP context activation procedure. In such a case, the MS relies on the network to provide an IPv4 address to the MS as part of the PDP context activation procedure.
- the MS may indicate that it prefers to obtain the IPv4 address after the PDP Context Activation by DHCPv4. That is, the network does not provide the IPv4 address for the MS as part of the PDP context activation procedures but sets the PDP address as 0.0.0.0. After the PDP Context establishment procedure is completed, the MS initiates the IPv4 address allocation by using DHCPv4 (see details in TS 29.061 [27] and RFC 2131 [47]).

If the MS does not send such an indication of address allocation preference, the network selects the IPv4 address allocation method based on per APN configuration.

Both the network elements and MS may support:

- a. IPv4 address allocation and IPv4 parameter configuration after the attach procedure via DHCPv4 according to RFC 2131 [47] and RFC 4039 [117];
- b. IPv6 parameter configuration via Stateless DHCPv6 according to RFC 3736 [118].

9.2.1.1 Stateless IPv6 Address Autoconfiguration

IPv6 address configuration is somewhat different from the IPv4 address configuration procedure. The address of an IPv6 node is allocated by stateless autoconfiguration.

The GGSN informs the MS that it shall perform stateless address autoconfiguration by means of the Router Advertisements, as defined in RFC 4861 [98]. For this purpose, the GGSN shall automatically and periodically send Router Advertisement messages towards the MS after a PDP context of type IPv4v6 or IPv6 is activated.

In order to support the standard IPv6 stateless address autoconfiguration mechanism, as defined by the IETF, within the particular context of UMTS (point-to-point connections, radio resource efficiency, etc.), the GGSN shall assign a prefix that is unique within its scope to each PDP context applying IPv6 stateless address autoconfiguration. The size of the prefix is according to the maximum prefix length for a global IPv6 address. This avoids the necessity to perform duplicate address detection at the network level for every address built by the MS. The GGSN shall not use the prefix advertised to the MS to configure an address on any of its interfaces.

To ensure that the link-local address generated by the MS does not collide with the link-local address of the GGSN, the GGSN shall provide an interface identifier (see RFC 4862 [99]) to the MS and the MS shall use this interface identifier to configure its link-local address. For stateless address autoconfiguration however, the MS can choose any interface identifier to generate addresses other than link-local, without involving the network. However, the UE shall not use any identifiers defined in TS 23.003 [4] as the basis for generating the interface identifier. For privacy, the UE may change the interface identifier used to generate full IPv6 address as defined in TS 23.221 [80], without involving the network. In particular, the SGSN and the GGSN are not updated with the actual address used by the MS, as the prefix alone identifies the PDP context.

Figure 62 illustrates the IPv6 stateless autoconfiguration procedure. The figure and its description show only the messages and actions specific to the IPv6 stateless address autoconfiguration procedure. For a complete description of the PDP Context Activation Procedure, refer to the corresponding clause.

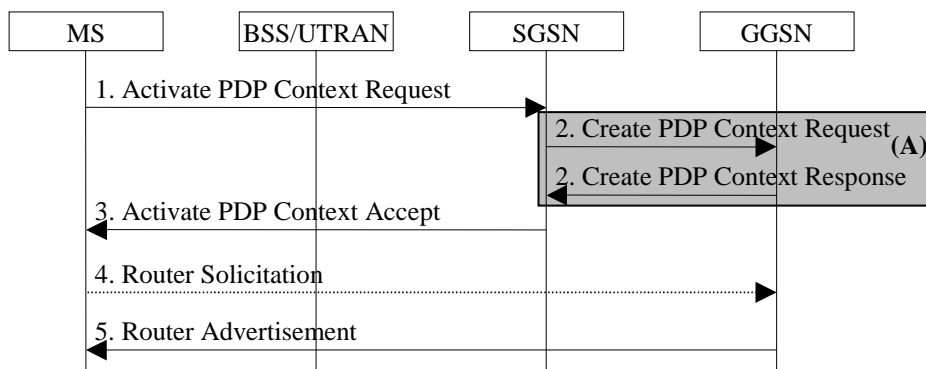

Figure 62: IPv6 Stateless Address Autoconfiguration Procedure

NOTE 1: All steps in Figure 62 except step 2 are common for architecture variants using Gn/Gp based interaction with Gn/Gp-based interaction with a GGSN and using S4-based interaction with an S-GW and a P-GW. For a S4-based interaction with a S-GW and P-GW, procedure step (A) is defined in clause 9.2.2.1A.

- 1) The MS sends an Activate PDP Context Request message to the SGSN as defined in clause "PDP Context Activation Procedure". The MS shall leave PDP Address empty and set PDP Type to IPv6 or IPv4v6.
- 2) Upon reception of the Create PDP Context Request, the GGSN creates an IPv6 address composed of the prefix allocated to the PDP context and an interface identifier generated by the GGSN. This address is then returned in

the PDP Address information element in the Create PDP Context Response message. The processing of the Create PDP Context Request and Create PDP Context Response, in both the SGSN and the GGSN, is otherwise as specified in clause "PDP Context Activation Procedure".

NOTE 2: Since the MS is considered to be alone on its link towards the GGSN, the interface identifier does not need to be unique across all PDP contexts on any APN.

- 3) The MS receives the IPv6 address produced by the GGSN in the Activate PDP Context Accept. The MS extracts the interface identifier from the address received and stores it. The MS shall use this interface identifier to build its link-local address and may also use it for building its full IPv6 address, as describe in step 5. The MS shall ignore the prefix contained in the address received in the Activate PDP Context Accept. The processing of the Activate PDP Context Accept is otherwise as specified in clause "PDP Context Activation Procedure".
- 4) The MS may send a Router Solicitation message to the GGSN to activate the sending of the Router Advertisement message.
- 5) The GGSN sends a Router Advertisement message. The Router Advertisement messages shall contain the same prefix as the one provided in step 2. A given prefix shall not be advertised on more than one PDP context on a given APN, or set of APNs, within the same addressing scope. The GGSN shall be configured to advertise only one prefix per PDP context.

After the MS has received the Router Advertisement message, it constructs its full IPv6 address by concatenating the interface identifier received in step 3, or a locally generated interface identifier, and the prefix received in the Router Advertisement. If the Router Advertisement contains more than one prefix option, the MS shall only consider the first one and silently discard the others.

NOTE 3: The MS can at any time change the interface identifier used to generate full IPv6 addresses, without involving the network, i.e. without updating the PDP context in the SGSN and the GGSN.

Because any prefix that the GGSN advertises in a PDP context is unique within the scope of the prefix (i.e. site-local or global), there is no need for the MS to perform Duplicate Address Detection for this IPv6 address. Therefore, the GGSN shall silently discard Neighbor Solicitation messages that the MS may send to perform Duplicate Address Detection. It is possible for the MS to perform Neighbor Unreachability Detection towards the GGSN, as defined in RFC 4861 [98]; therefore if the GGSN receives a Neighbor Solicitation as part of this procedure, the GGSN shall provide a Neighbor Advertisement as described in RFC 4862 [99].

9.2.1.2 IPv6 Prefix Delegation via DHCPv6

Optionally, a single network prefix shorter than the default /64 prefix may be assigned to a PDN connection. In this case, the /64 default prefix used for IPv6 stateless autoconfiguration will be allocated from this network prefix; the remaining address space from the network prefix can be delegated to the PDN connection using prefix delegation after the PDP context activation and IPv6 prefix allocation via IPv6 stateless address autoconfiguration as defined in clause 9.2.1.1. When PLMN based parameter configuration is used, the GGSN provides the requested IPv6 prefix from a locally provisioned pool. When external PDN based IPv6 prefix allocation is used, the GGSN obtains the prefix from the external PDN.

NOTE 1: Allocation of IPv6 prefixes with flexible prefix length can leverage e.g. local configuration on the GGSN or interaction with the AAA server.

The address space provided is maintained as an IPv6 address space pool available to the PDN connection for DHCPv6 IPv6 prefix requests with the exclusion of the IPv6 prefix that is allocated to the PDP context during PDP context activation as defined in clause 9.2.1.1. The total IPv6 address space available for the PDP connection (the /64 default prefix and the remaining IPv6 address space pool) shall be possible to aggregate into one IPv6 prefix that will represent all IPv6 addresses that the MS may use. If the MS had indicated that it supports prefix exclusion and the prefix to be delegated to the UE includes the /64 prefix that was allocated to the PDN Connection, the GGSN shall utilise the prefix exclusion feature as specified for DHCPv6 Prefix Delegation in RFC 6603 [113].

The MS uses DHCPv6 to request additional IPv6 prefixes (i.e. prefixes in addition to the default prefix) from the GGSN after completing stateless IPv6 address autoconfiguration procedures. The MS acts as a "Requesting Router" as described in RFC 3633 [105] and inserts one or more IA_PD option(s) into a DHCPv6 Solicit message sent from the MS to the GGSN. The GGSN acts as the DHCP server and fulfils the role of a "Delegating Router" according to RFC 3633 [105]. The MS optionally includes the RAPID_COMMIT option in the DHCPv6 Solicit message to trigger two-message DHCPv6 procedure instead of the four-message DHCPv6 procedure. The MS shall include OPTION_PD_EXCLUDE option code in an OPTION_ORO option to indicate support for prefix exclusion. In response

to the DHCPv6 Solicit message, the MS receives a DHCPv6 Reply message with one or more IA_PD prefix(es) for every IA_PD option that it sent in the DHCPv6 Solicit message. The GGSN delegates a prefix excluding the default prefix with help of OPTION_PD_EXCLUDE. Prefix exclusion procedures shall follow RFC 6603 [113].

9.2.2 Activation Procedures

9.2.2.1 PDP Context Activation Procedure

The PDP Context Activation procedure is illustrated in Figure 63 and Figure 64.

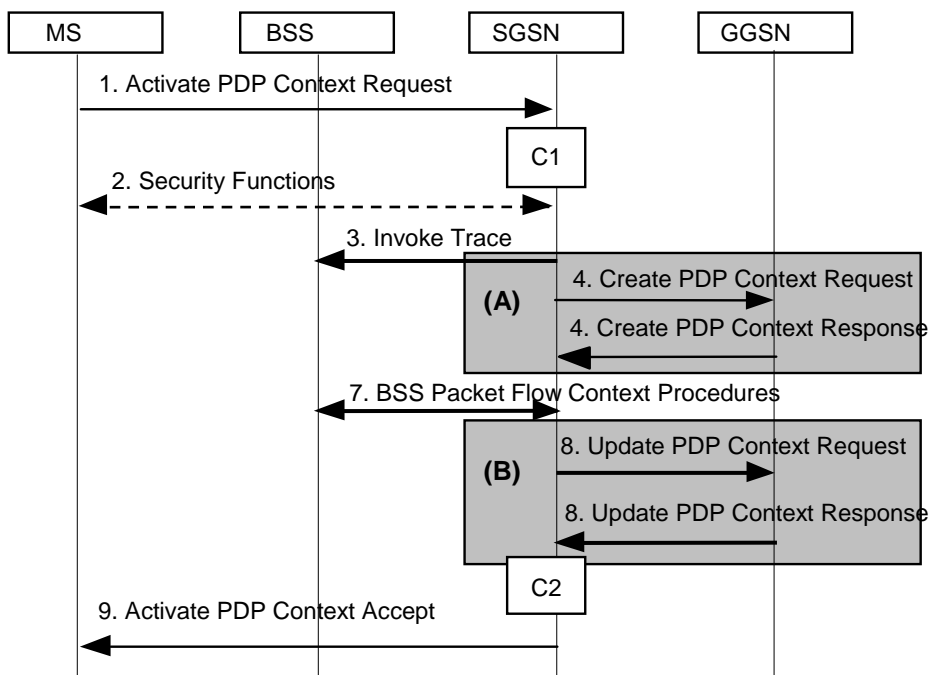

Figure 63: PDP Context Activation Procedure for A/Gb mode

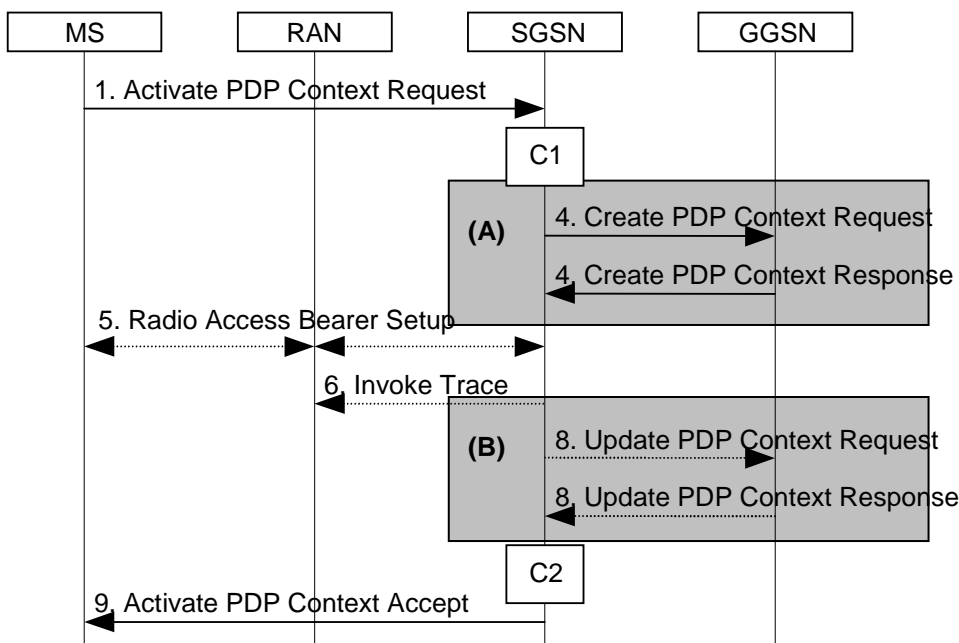

Figure 64: PDP Context Activation Procedure for Iu mode

NOTE 1: All steps in figures 63 and 64, except steps 4 and 8, are common for architecture variants using Gn/Gp based interaction with GGSN and using S4 based interaction with S-GW and P-GW. For an S4-based interaction with S-GW and P-GW, procedure steps (A) and (B) are defined in clause 9.2.2.1A.

If Emergency Service is required and an emergency PDP Context is not already active the MS shall request a PDP Context for emergency services via emergency indication in the Activate PDP Context Request message when initiating the PDP Context Request Procedure. An emergency attached MS shall initiate the PDP Context Request procedure directly after the Attach procedure is completed. Any additional emergency PDP Context Activation by an MS shall be rejected by the SGSN if there is already an emergency PDP context activated.

- 1) The MS sends an Activate PDP Context Request (NSAPI, TI, PDP Type, PDP Address, Access Point Name, QoS Requested, Protocol Configuration Options, Request Type) message to the SGSN. In this version of the protocol, the MS shall leave PDP Address empty. The MS may use Access Point Name to select a reference point to a certain packet data network and/or to select a service. Access Point Name is a logical name referring to the packet data network and/or to a service that the subscriber wishes to connect to. QoS Requested indicates the desired QoS profile. For an E-UTRAN capable UE, the QoS requested shall indicate subscribed, interactive or background traffic class in this message. If the UE is not E-UTRAN capable, in this release the QoS requested should indicate subscribed, interactive or background traffic class in this message. If the request is as a result of a Network-Requested PDP context activation procedure, the MS shall not set the PDP Type to IPv4v6, but to the value received in the Request PDP Context Activation message: see clause 9.2.2.1.

NOTE 2: In case an S4-SGSN is used in the network the QoS Requested information element shall be ignored in the network.

Protocol Configuration Options is used to transfer the NRSU, ETFTU and Address Allocation Preference to the GGSN and may be used to transfer the BCM as well as optional PDP parameters and/or request to the GGSN (see TS 29.060 [26] and TS 24.229 [75]). Protocol Configuration Options is sent transparently through the SGSN. NRSU indicates MS support of the network requested bearer control. ETFTU indicates MS support of the extended TFT filter format. The Protocol Configuration Options may include the Address Allocation Preference indicating that the MS prefers to obtain an IPv4 address only after the PDP Context Accept by means of DHCPv4 as defined in RFC 2131 [47].

If the SGSN has stored a value for the Maximum APN restriction and the value indicates the most restrictive type, then the SGSN shall reject any Activate PDP Context requests to a different APN, using the PDP Context Activation Reject message including an appropriate error cause.

If the SGSN decides to establish Direct Tunnel between RNC and GGSN, the SGSN provides to the RNC the Direct Tunnel specific parameters in step 5 "RAB Assignment Procedure" and shall initiate PDP Context Update procedure in step 8 to update IP Address and TEID for Downlink data.

Request Type indicates "Handover" when the MS has already an activated PDN GW/HA due to mobility with non-3GPP accesses, and is only interpreted by SGSNs using S4.

The PDP context activation for emergency services shall be exempted from the Maximum APN restriction control. If there is already an emergency bearer activated, the SGSN shall reject any PDP context activation request for normal services if the mobility and access restrictions do not allow the MS to access normal services.

If the message is being sent via a HNB which has a collocated L-GW, it includes the L-GW address in the Direct Transfer message to the SGSN.

- 2) In A/Gb mode, security functions may be executed. These procedures are defined in clause "Security Function".
- 3) In A/Gb mode and if BSS trace is activated, the SGSN shall send an Invoke Trace (Trace Reference, Trace Type, Trigger Id, OMC Identity) message to the BSS. Trace Reference, and Trace Type are copied from the trace information received from the HLR or OMC.
- 4) The SGSN validates the Activate PDP Context Request using PDP Type (optional), PDP Address (optional), and Access Point Name (optional) provided by the MS and the PDP context subscription records. The SGSN shall use the CSG Subscription Data to authorize the LIPA connection to the APN provided by the MS. A PDP Address may only be sent by an MS implemented according to an earlier protocol release. The validation criteria, the APN selection criteria, and the mapping from APN to a GGSN are described in annex A.

For an emergency PDP Context Activation the SGSN applies the parameters from SGSN Emergency Configuration Data for the emergency bearer establishment performed in this step and any potentially stored IMSI related subscription data are ignored by the SGSN.

If no GGSN address can be derived or if the SGSN has determined that the Activate PDP Context Request is not valid according to the rules described in annex A, the SGSN rejects the PDP context activation request.

If a GGSN address can be derived, the SGSN creates a TEID for the requested PDP context. If the MS requests a dynamic address, the SGSN lets a GGSN allocate the dynamic address. The SGSN may restrict the requested QoS attributes given its capabilities and the current load, and it shall restrict the requested QoS attributes according to the subscribed QoS profile. If the UE requests the subscribed MBR and the subscribed MBR is larger than 16 Mbps, the SGSN should restrict the requested MBR to 16 Mbps or lower, if the "Higher bitrates than 16 Mbps flag" in the MM Context is set to "not allowed".

The SGSN sends a Create PDP Context Request (PDP Type, PDP Address, Access Point Name, QoS Negotiated, Negotiated Evolved ARP, TEID, NSAPI, MSISDN, Selection Mode, Charging Characteristics, Trace Reference, Trace Type, Trigger Id, OMC Identity, Protocol Configuration Options, serving network identity, Maximum APN Restriction IMEISV, CGI/SAI, User CSG Information, RAT type, S-CDR CAMEL information, MS Info Change Reporting support indication, NRSN, Dual Address Bearer Flag, APN-AMBR) message to the affected GGSN. MSISDN is included if available in the stored UE context otherwise IMSI is included. The Negotiated Evolved ARP IE shall contain the Subscribed Evolved ARP value. If the SGSN did not receive a Subscribed Evolved ARP value in subscription data from the HLR the SGSN shall derive this value from the Allocation/Retention Priority of the QoS profile negotiated according to Annex E in TS 23.401 [89]. The inclusion of the Negotiated Evolved ARP IE indicates that the SGSN supports the Evolved ARP feature. The SGSN shall send the serving network identity to the GGSN. Access Point Name shall be the APN Network Identifier of the APN selected according to the procedure described in Annex A. PDP Address shall be empty if a dynamic address is requested. The GGSN may use Access Point Name to find a packet data network and optionally to activate a service for this APN. Selection Mode indicates whether a subscribed APN was selected, or whether a non-subscribed APN sent by an MS or a non-subscribed APN chosen by the SGSN was selected. Selection Mode is set according to Annex A. The GGSN may use Selection Mode when deciding whether to accept or reject the PDP context activation. For example, if an APN requires subscription, the GGSN is configured to accept only the PDP context activation that requests a subscribed APN as indicated by the SGSN with Selection Mode. Charging Characteristics indicates which kind of charging the PDP context is liable for. The charging characteristics on the subscription and individually subscribed APNs as well as the way the SGSN handles Charging Characteristics and chooses to send them or not to the GGSN is defined in TS 32.251 [70]. The SGSN shall include Trace Reference, Trace Type, Trigger Id, and OMC Identity if GGSN trace is activated. The SGSN shall copy Trace Reference, Trace Type, and OMC Identity from the trace information received from the HLR or OMC. The Maximum APN Restriction denotes the most stringent restriction as required by any already active PDP contexts. If there are no already active PDP contexts, this value is set to the least restrictive type (see clause 15.4). If the GGSN receives the Maximum APN Restriction, then the GGSN shall check if the Maximum APN Restriction value does not conflict with the APN Restriction value associated with this PDP context request. If there is no conflict the request shall be allowed, otherwise the request shall be rejected with the SGSN sending a PDP Context Activation Reject Message to the MS including an appropriate error cause. NRSN indicates SGSN support of the network requested bearer control. The Dual Address Bearer Flag shall be set when the MS requests PDN type IPv4v6 and all SGSNs, which the MS may be handed over to, are Release 8 or above supporting dual addressing, which is determined based on node pre configuration by the operator.

For emergency attached UEs IMSI is included if available and if the IMSI cannot be authenticated the IMSI is included and marked as unauthenticated.

The GGSN creates a new entry in its PDP context table and generates a Charging Id. The new entry allows the GGSN to route PDP PDUs between the SGSN and the packet data network, and to start charging. The way the GGSN handles Charging Characteristics that it may have received from the SGSN is defined in TS 32.251 [70]. The GGSN may restrict QoS Negotiated given its capabilities and the current load or increase the QoS Negotiated based on any external input (e.g. policy control). The GGSN then returns a Create PDP Context Response (TEID, PDP Type, PDP Address, Protocol Configuration Options, QoS Negotiated, Negotiated Evolved ARP, Charging Id, Prohibit Payload Compression, APN Restriction, Cause, MS Info Change Reporting Action, CSG Information Reporting Action, BCM, APN-AMBR) message to the SGSN. The GGSN sets the Negotiated Evolved ARP based on local policy or PCC. The Allocation/Retention Priority of the QoS Profile Negotiated is derived from the Evolved ARP according to the mapping principles of TS 23.401 [89], Annex E. The Prohibit Payload Compression indicates that the SGSN should negotiate no data compression for this PDP context. The SGSN shall apply the Negotiated Evolved ARP if received from the GGSN. If the MS has requested PDP type IPv4v6 and both IPv4 and IPv6 addressing is possible in the PDN but the Dual Address

Bearer Flag is not set, or only single IP version addressing is possible in the PDN, the GGSN selects a single IP version (either IPv4 or IPv6). If the MS has requested PDP type IPv4 or IPv6, the GGSN uses the PDP type supplied by the MS in case it is supported in the PDN, otherwise an appropriate error cause will be returned. The GGSN allocates a PDP Address according to the selected PDP type. If the GGSN has selected a PDN type different from the one sent by the MS, the GGSN indicates, together with the PDP type IE, a reason cause to the MS why the PDP type has been modified as described in clause 9.2.1. PDP Address is included if the GGSN allocated a PDP address. If the GGSN has been configured by the operator to use External PDN Address Allocation for the requested APN, PDP Address shall be set to 0.0.0.0, indicating that the PDP address shall be negotiated by the MS with the external PDN after completion of the PDP Context Activation procedure. The GGSN shall relay, modify and monitor these negotiations as long as the PDP context is in ACTIVE state, and use the GGSN-Initiated PDP Context Modification procedure to transfer the currently used PDP address to the SGSN and the MS. However, the MS cannot rely on always getting a session management level update of the IP address, which it has negotiated with the external PDN. This is because the P-GW does not update the IP address within the EPS bearer modification procedure, see clause 9.2.3.2A. Protocol Configuration Options contains the BCM, ETFTN as well as optional PDP parameters that the GGSN may transfer to the MS. BCM shall also be sent as a separate IE to the SGSN. These optional PDP parameters may be requested by the MS in the Activate PDP Context Request message, or may be sent unsolicited by the GGSN. Protocol Configuration Options is sent transparently through the SGSN. The Create PDP Context messages are sent over the backbone network. The BCM is used by the SGSN to handle unexpected session management signalling.

If QoS Negotiated received from the SGSN is incompatible with the PDP context being activated, the GGSN rejects the Create PDP Context Request message. The GGSN operator configures the compatible QoS profiles.

If an APN Restriction is received from the GGSN for this PDP Context, then the SGSN shall store this value for the PDP Context and the SGSN shall check this received value with the stored value for the Maximum APN Restriction to ensure there are no conflicts between values. If the consequence of this check results in the PDP context being rejected, the SGSN shall initiate a PDP Context Deactivation and return an appropriate error cause. If the PDP Context is accepted, it shall determine a (new) value for the Maximum APN Restriction. If there is no previously stored value for Maximum APN Restriction, then the Maximum APN Restriction shall be set to the value of the received APN Restriction.

The emergency PDP context activation shall be exempted from the Maximum APN restriction control.

If the MS Info Change Reporting Action and/or the CSG Information Reporting Action are received from the GGSN for this PDP context, then the SGSN shall store this for the PDP context and the SGSN shall report to that GGSN whenever a CGI/SAI/RAI or user CSG information change occurs that meets the GGSN request, as described in clause 15.1.1a.

The GGSN derives the BCM based on NRSU, NRSN and operator policy if previously received in the Create PDP Context Request message. The derived BCM is sent to the MS indicating the Bearer Control Mode applicable to all PDP Contexts within the activated PDP Address/APN pair.

The GGSN derives the ETFTN based on ETFTU and operator policy if ETFTU was previously received in the Create PDP Context Request message. The derived ETFTN is sent to the MS indicating that the extended TFT filter format can be used on all PDP Contexts within the activated PDP Address/APN pair.

The SGSN shall re-verify and may restrict the QoS Negotiated received in the response from the GGSN against the subscribed QoS profile and additionally restrict the QoS negotiated based on its capabilities and current load. The SGSN shall use this updated QoS Negotiated for the subsequent steps.

The SGSN shall apply a Negotiated Evolved ARP even if it is different from the Subscribed Evolved ARP.

The SGSN determines the UE AMBR to be used by the RAN based on the subscribed UE-AMBR and the APN AMBR for active APNs, see clause 15.2.2.

- 5) In Iu mode, RAB setup is done by the RAB Assignment procedure, see clause "RAB Assignment Procedure".
- 6) In Iu mode and if BSS trace is activated, the SGSN shall send an Invoke Trace (Trace Reference, Trace Type, Trigger Id, OMC Identity) message to the RAN. Trace Reference, and Trace Type are copied from the trace information received from the HLR or OMC.

NOTE 3: Step 6 is applied when the trace activation is triggered by means of signalling. Another alternative is the triggering of trace activation by the OMC. The details of both Trace Activation procedures are described in TS 32.422 [84].

- 7) In A/Gb mode, BSS packet flow context procedures may be executed. These procedures are defined in clause "BSS Context".
- 8) In case the QoS attributes, used as input to step 5 for Iu mode or step 7 for A/Gb mode, have been downgraded during those steps, the SGSN may inform the GGSN about the downgraded QoS attributes by sending an Update PDP Context Request to the affected GGSN. The GGSN shall not attempt to renegotiate the QoS attributes. The No QoS negotiation indication is set in Update PDP Context Request to indicate to the GGSN that the SGSN does not upgrade the previously negotiated QoS attributes and that the GGSN shall accept the provided QoS attributes without negotiation. The GGSN confirms the new QoS attributes by sending an Update PDP Context Response to the SGSN. If the SGSN established Direct Tunnel in step 5 it shall send Update PDP Context Request and include the RNC's Address for User Plane, TEID for downlink data, No QoS negotiation indication and the DTI. DTI is used to instruct the GGSN to apply Direct Tunnel specific error handling as described in clause 13.8. The GGSN(s) shall not include a PCO in the Update PDP Context Response if the No QoS negotiation indication is set. If the No QoS negotiation indication is not set, e.g. by a pre-Rel-7 SGSN and the GGSN includes a PCO in the Update PDP Context Response, it shall contain same information as the Protocol Configuration Options IE sent in the Create PDP Context Response in step 4 above.

If the SGSN does not receive PCO in this step and it has received PCO in step 4, then the SGSN shall forward the PCO received in step 4 to the UE.

- 9) The SGSN inserts the NSAPI along with the GGSN address in its PDP context. The PDP address received from the GGSN or from HSS subscription records is inserted in the PDP context. The SGSN selects Radio Priority and Packet Flow Id based on QoS Negotiated, and returns an Activate PDP Context Accept (PDP Type, PDP Address, TI, QoS Negotiated, Radio Priority, Packet Flow Id, Protocol Configuration Options) message to the MS. If the MS indicated in the MS Network Capability it does not support BSS packet flow procedures, then the SGSN shall not include the Packet Flow Id. In A/Gb mode, the QoS Negotiated shall take into account the Aggregate BSS QoS Profile, if any, returned from the BSS. Protocol Configuration Options are used to transfer the BCM and ETFTN to the UE and may be used to transfer optional PDP parameters to the UE (see TS 29.060 [26] and TS 24.229 [75]). Protocol Configuration Options is sent transparently through the SGSN. The BCM indicates the Bearer Control Mode applicable to all PDP Contexts within the activated PDP Address/APN pair. If the BCM parameter is not included in the message then the MS shall set the Bearer Control Mode to 'MS_Only' for the PDP Address/APN pair (see clause 9.2). If the ETFTN is included in the message then the MS may use the extended TFT filter format in subsequent MS requests. The SGSN is now able to route PDP PDUs between the GGSN and the MS, and to start charging.

If the MS is incapable of accepting the new QoS Negotiated, the MS should initiate application level signalling to lower the QoS requirements for the concerned application(s). If this is not possible then the MS shall instead de-activate the PDP context with the PDP Context Deactivation Initiated by the MS procedure.

For each PDP Context a different quality of service (QoS) profile may be requested. For example, some PDP contexts may be associated with E-mail that can tolerate lengthy response times. Other applications cannot tolerate delay and demand a very high level of throughput, interactive applications being one example. These different requirements are reflected in the QoS profile. The QoS profile is defined in clause "Quality of Service Profile". If a QoS requirement is beyond the capabilities of a PLMN, the PLMN negotiates the QoS profile as close as possible to the requested QoS profile. The MS either accepts the negotiated QoS profile, or deactivates the PDP context.

After an SGSN has successfully updated the GGSN, the PDP contexts associated with an MS is distributed as shown in clause "Information Storage".

If the PDP Context Activation Procedure fails or if the SGSN returns an Activate PDP Context Reject (Cause, Protocol Configuration Options) message, the MS may attempt another activation to the same APN up to a maximum number of attempts.

If the MS requested for a dual address PDP type (IPv4v6) to a given APN and was granted a single address PDP type (IPv4 or IPv6) by the network with a reason cause 'single address bearers only', the MS should request for the activation of a parallel PDP Context to the same APN with a single address PDP type (IPv4 or IPv6) other than the one already activated.

If the MS requested for a PDP type IPv4v6 to a given APN and was granted PDP type IPv4 with no reason cause indicating that only the assigned PDP type is allowed, the MS should request for the activation of a parallel PDP Context to the same APN with PDP type IPv6.

If the MS receives no reason cause in response to an IPv4v6 PDP type and it receives an IPv6 prefix and Interface Identifier apart from the IPv4 address or 0.0.0.0 in the PDP Address field, it considers that the request for a dual address

PDP was successful. It can wait for the Router Advertisement from the network with the IPv6 prefix information or it may send Router Solicitation if necessary.

The CAMEL procedure calls shall be performed, see referenced procedures in TS 23.078 [8b]:

C1) CAMEL_GPRS_PDP_Context_Establishment.

In Figure 63 and Figure 64, procedures return as result "Continue".

C2) CAMEL_GPRS_PDP_Context_Establishment_Acknowledgement.

In Figure 63 and Figure 64, procedures return as result "Continue".

9.2.2.1A PDP Context Activation Procedure using S4

The procedures described in figures 64a and 64b show only the steps, due to use of S4, which are different from the Gn/Gp variant of the procedure given by clause 9.2.2.1.

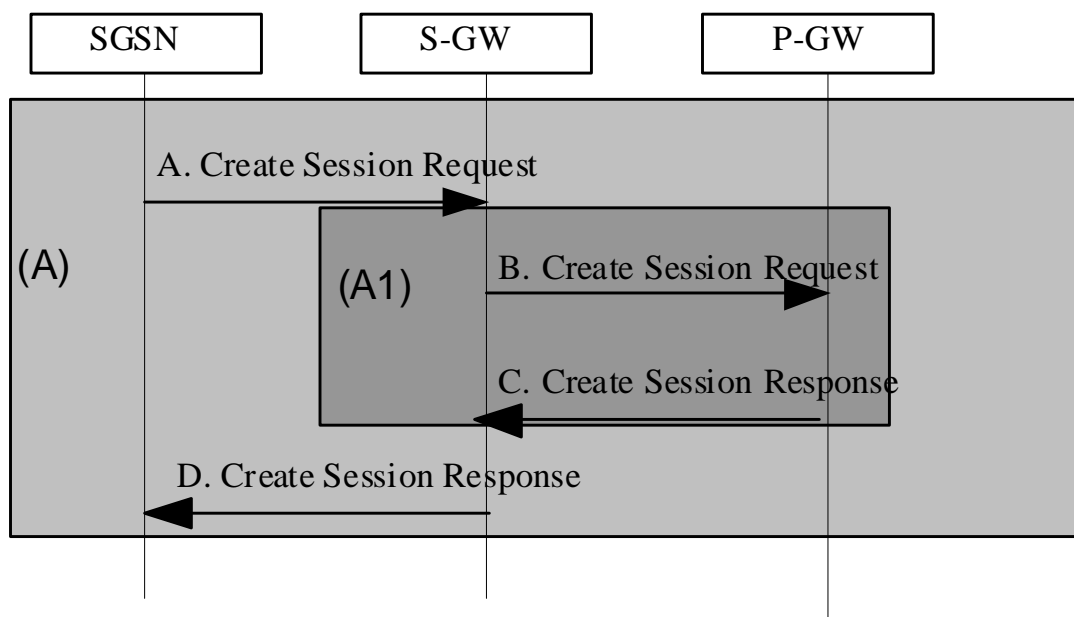

Figure 64a: PDP Context Activation Procedure steps (A) using S4

NOTE 1: Steps A and D are common for architecture variants with GTP based S5/S8 and PMIP-based S5/S8. For a PMIP-based S5/S8, procedure steps (A1) are defined in TS 23.402 [90]. Steps B and C concern GTP based S5/S8.

If there is already an emergency bearer activated, the SGSN shall reject any PDP context activation request for normal services if the mobility and access restrictions do not allow the MS to access normal services.

A) The SGSN shall use the HSS provided default APN if no APN is provided by the UE. If the PDN subscription context contains no PDN GW identity for this APN, or the APN has a LIPA permission of "LIPA Only" or "LIPA Conditional", the SGSN selects a PDN GW as described in clause PDN GW selection function. If the PDN subscription context profile contains a dynamically allocated PDN GW identity and the Request Type does not indicate "Handover" the SGSN may select a new PDN GW as described in clause PDN GW selection function, e.g. to allocate a PDN GW that allows for more efficient routing. If a Serving GW is not yet selected for this MS, the SGSN selects a Serving GW as described in clause Serving GW selection function. The SGSN sets the EPS Bearer Identity to an equivalent value as the NSAPI for the Bearer associated with the MS. Then the SGSN shall send a Create Session Request (IMSI, MSISDN, SGSN Control Plane TEID, PDN GW address, APN, RAT type, Default Bearer QoS, PDN Type, APN-AMBR, PDN Address, EPS Bearer Identity, Protocol Configuration Options, Handover Indication, ME Identity, User Location Information, Serving Network, SGSN User Plane TEID, Dual Address Bearer Flag, Protocol Type over S5/S8, Selection Mode, Charging Characteristics, Trace Reference, Trace Type, Trigger Id, OMC Identity, Maximum APN Restrictions, CGI/SAI, User CSG Information, MS Info Change Reporting support indication, DTI) message to the selected Serving

GW. MSISDN is included if available in the stored UE context. The RAT type is provided in this message for the later PCC decision. The SGSN may change the requested PDP type according to the subscription data for this APN as described in clause 9.2.1. The Dual Address Bearer Flag shall be set when the MS requests PDN type IPv4v6 and all SGSNs, which the MS may be handed over to, are release 8 or above supporting dual addressing, which is determined based on node pre-configuration by the operator. SGSN User Plane TEID shall not be sent if the SGSN decides to establish the Direct Tunnel between RNC and Serving GW. DTI is used to instruct the Serving GW that the Direct Tunnel shall be established between RNC and Serving GW.

For an emergency PDP Context Activation the SGSN applies the parameters from SGSN Emergency Configuration Data for the emergency bearer establishment performed in this step and any potentially stored IMSI related subscription data are ignored by the SGSN. For emergency attached UEs IMSI is included if available and if the IMSI cannot be authenticated the IMSI is included and marked as unauthenticated.

The Protocol Type over S5/S8 is provided to Serving GW which protocol should be used over S5/S8 interface. Handover Indication is included if the Request type indicates handover. Selection Mode indicates whether a subscribed APN was selected, or whether a non-subscribed APN chosen by the SGSN was selected. Selection Mode is set according to Annex A. The P-GW may use Selection Mode when deciding whether to accept or reject the default bearer activation. For example, if an APN requires subscription, the P-GW is configured to accept only the default bearer activation that requests a subscribed APN as indicated by Selection Mode. Charging Characteristics indicates which kind of charging the bearer context is liable for. If there is an EPS subscription context available for the MS, the SGSN shall ignore the QoS requested parameter sent by the MS, and use the EPS subscribed QoS profile as received from the HSS. For MSs, for which the S4-SGSN has not received an EPS subscribed QoS profile, the S4-SGSN treats MS originated QoS requests the same as the Gn/Gp SGSN, i.e. the requested QoS is used when deriving the Default Bearer QoS and the APN-AMBR from the QoS requested parameter sent by the MS. If the "Higher bitrates than 16 Mbps flag" in the MM Context of the UE is set to "not allowed", the S4-SGSN shall restrict the APN-AMBR in the EPS QoS profile to within 16 Mbps.

The ARP of the PDP context activated with this procedure should be set appropriately to minimize the risk of unnecessary release.

The charging characteristics for the PS subscription and individually subscribed APNs as well as the way of handling Charging Characteristics and whether to send them or not to the P-GW is defined in TS 32.251 [70]. The SGSN shall include Trace Reference, Trace Type, Trigger Id, and OMC Identity if S-GW and/or P-GW trace is activated. The SGSN shall copy Trace Reference, Trace Type, and OMC Identity from the trace information received from the HLR or OMC.

The Maximum APN Restriction parameter is used as described for the equivalent step in clause 9.2.2.1.

- B) The Serving GW creates a new entry in its EPS Bearer table and sends a Create Session Request (IMSI, MSISDN, APN, Serving GW Address for the user plane, Serving GW TEID of the user plane, Serving GW TEID of the control plane, RAT type, Default Bearer QoS, PDN Type, PDN Address, APN-AMBR, EPS Bearer Identity, Protocol Configuration Options, Handover Indication, ME Identity, User Location Information, Serving Network, Dual Address Bearer Flag, Selection Mode, Charging Characteristics, Trace Reference, Trace Type, Trigger Id, OMC Identity, Maximum APN Restriction, CGI/SAI, User CSG Information, MS Info Change Reporting support indication) message to the PDN GW indicated by the PDN GW address received in the previous step. MSISDN is included if available in the stored UE context. The PDN GW may interact with PCRF (refer to TS 23.203 [88]).

For emergency attached UEs IMSI is included if available and if the IMSI cannot be authenticated the IMSI is included and marked as unauthenticated.

- C) The P-GW creates a new entry in its EPS bearer context table and generates a Charging Id. The new entry allows the P-GW to route user plane PDUs between the S-GW and the packet data network, and to start charging. The way the P-GW handles Charging Characteristics that it may have received is defined in TS 32.251 [70].

The PDN GW may restrict or increase Default Bearer QoS based on external input e.g. PCRF.

The PDN GW returns a Create Session Response (PDN GW Address for the user plane, PDN GW TEID of the user plane, PDN GW Address for the control plane, PDN GW TEID of the control plane, PDN Type, PDN Address, APN-AMBR, EPS Bearer Identity, EPS Bearer QoS, Protocol Configuration Options, Charging Id, Prohibit Payload Compression, APN Restriction, Cause, MS Info Change Reporting Action, CSG Information Reporting Action) message to the Serving GW. The PDN GW takes into account the PDN type sent by the MS, the Dual Address Bearer Flag and the policies of operator when the PDN GW selects the PDN type to be used as follows. If the MS has requested PDN type IPv4v6 and both IPv4 and IPv6 addressing is possible in the PDN but

the Dual Address Bearer Flag is not set, or only single IP version addressing is possible in the PDN, the PDN GW selects a single IP version (either IPv4 or IPv6). If the MS has requested PDN type IPv4 or IPv6, the PDN GW uses the PDN type supplied by the MS in case it is supported in the PDN, otherwise an appropriate error cause will be returned. The PDN GW allocates a PDN Address according to the selected PDN type. In case the PDN GW has selected a PDN type different from the one sent by the MS, the PDN GW indicates together with the PDN type IE a reason cause to the MS why the PDN type has been modified as described in clause 9.2.1. PDN Address is included if the P-GW allocated a PDN Address. If the PDN has been configured by the operator so that the PDN addresses for the requested APN shall be allocated by usage of DHCPv4 only, or if the PDN GW allows the MS to use DHCPv4 for address allocation according to the Address Allocation Preference received from the MS, the PDN Address shall be set to 0.0.0.0, indicating that the IPv4 PDN address shall be negotiated by the MS with DHCPv4 after completion of the PDP Context Activation procedure. In case of external PDN addressing for IPv6, the PDN GW obtains the IPv6 prefix from the external PDN using either RADIUS or Diameter client function. In the PDN Address field of the Create Session Response, the PDN GW includes the Interface Identifier and IPv6 prefix. The PDN GW sends Router Advertisement to the UE after default bearer establishment with the IPv6 prefix information for all cases. The IP address allocation details are described in the clause "Static and Dynamic PDP Addresses".

When the MS negotiates the IPv4 address with DHCPv4, the PDN GW shall relay, modify and monitor these negotiations. However, in contrast to the GGSN procedures, the PDN GW shall not update the IPv4 address to the SGSN nor to the MS.

The P-GW derives the BCM based on NRSU and operator policy if previously received in the Create Default Bearer Request message. The derived BCM is sent to the MS indicating the Bearer Control Mode applicable to all PDP Contexts within the activated PDP Address/APN pair.

The P-GW derives the ETFTN based on ETFTU, if received in the Create PDP Context Request message, and operator policy. The derived ETFTN is sent to the MS indicating whether the extended TFT filter format can be used on all PDP Contexts within the activated PDP Address/APN pair.

Protocol Configuration Options contains the BCM, ETFTN as well as optional PDN parameters that the P-GW may transfer to the MS. These optional PDN parameters may be requested by the MS, or may be sent unsolicited by the P-GW. Protocol Configuration Options are sent transparently through the S-GW and SGSN.

When the Handover Indication is present, the PDN GW does not yet send downlink packets to the SGW; the downlink path is to be switched at step A1 of Figure 64b.

- D) If the MS Info Change Reporting Action and/or the CSG Information Reporting Action are received for this bearer context, then the SGSN shall store this for the bearer context and the SGSN shall report to that P-GW via the S-GW whenever a CGI/SAI/RAI or user CSG information change occurs that meets the P-GW request, as described in clause 15.1.1a.

The Serving GW returns a Create Session Response (PDN Type, PDN Address, Serving GW address for User Plane, Serving GW TEID for User Plane, Serving GW TEID for Control Plane, APN-AMBR, EPS Bearer Identity, EPS Bearer QoS, PDN GW addresses and TEIDs (GTP-based S5/S8) or GRE keys (PMIP-based S5/S8) at the PDN GW(s) for uplink traffic, PDN GW Address for Control Plane, PDN GW TEID for Control Plane, Protocol Configuration Options, Charging Id, Prohibit Payload Compression, APN Restriction, Cause, MS Info Change Reporting Action, CSG Information Reporting Action) message to the SGSN. The Prohibit Payload Compression indicates that the SGSN should negotiate no data compression for this PDP context.

If an APN Restriction is received from the P-GW for this PDP Context, then the SGSN shall store this value for the PDP Context and the SGSN shall check this received value with the stored value for the Maximum APN Restriction to ensure there are no conflicts between values. If the consequence of this check results in the PDP Context being rejected, the SGSN shall initiate a PDP Context deactivation and return an appropriate error cause. If the PDP Context is accepted, it shall determine a (new) value for the Maximum APN Restriction. If there is no previously stored value for Maximum APN Restriction, then the Maximum APN Restriction shall be set to the value of the received APN Restriction.

When the PDN GW has changed Default Bearer QoS the SGSN shall use the new QoS parameter values during establishment of the PDP Context. However, if the "Higher bit rates than 16 Mbps flag" in the MM Context of the UE is set to "not allowed", the S4-SGSN shall, for non-GBR bearers, restrict the MBR sent to the UE to within 16 Mbps.

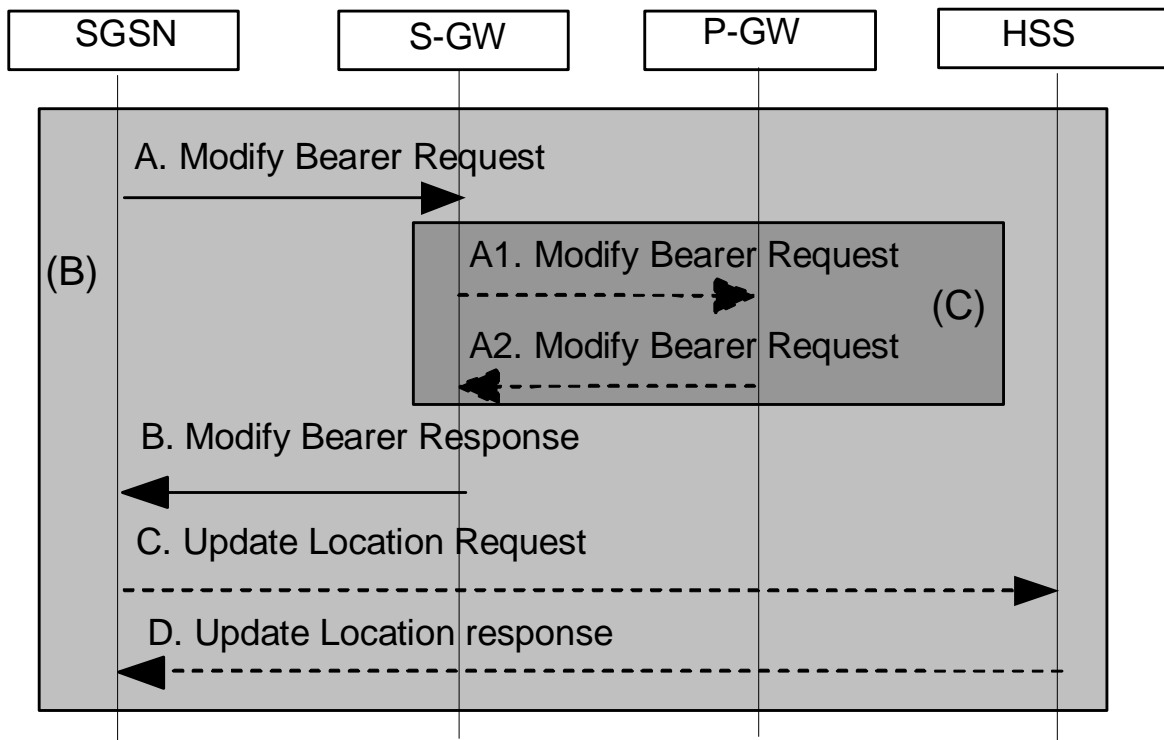

Figure 64b: PDP Context Activation Procedure steps (B) using S4

NOTE 3: Steps A and B are common for architecture variants with GTP based S5/S8 and PMIP-based S5/S8.

NOTE 4: The steps A1 and A2 are executed only upon handover from non-3GPP access.

A) In case the QoS attributes, used as input to step 5 for Iu mode or step 7 for A/Gb mode, have been downgraded during those steps, the SGSN rejects the PDP Context Activation and terminates the procedure. If the SGSN established Direct Tunnel in step 5 it shall send Modify Bearer Request and include the RNC's Address for User Plane, TEID for downlink data and DTI. DTI is used to instruct the S-GW to apply Direct Tunnel specific error handling as described in clause 13.8. An Update Bearer Request shall also be sent to the S-GW if the UE has indicated Request type "Handover" in the Activate PDP Context Request message, and in that case the Handover Indicator shall be included in the message.

A1) If the Handover Indication is included in step A, the Serving GW sends a Modify Bearer Request(Handover Indication) message to the PDN to prompt the PDN GW to tunnel packets from non 3GPP IP access to 3GPP access system and immediately start routing packets to the Serving GW for the default and any dedicated EPS bearers established.

A2) The PDN GW acknowledges by sending Modify Bearer Response to the Serving GW.

B) The Serving GW acknowledges by sending Modify Bearer Response to the SGSN. The Serving GW can then send its buffered downlink packets.

C) After the SGSN receives Modify Bearer Response in step B, if an EPS bearer was established and if the subscription data indicates that the user is allowed to perform handover to non-3GPP accesses and if the SGSN selected a PDN GW that is different from the PDN GW identity which was indicated by the HSS in the PDN subscription context, the SGSN shall send an Update Location Request including the PDN GW identity, the APN and information identifying the PLMN in which the PDN GW is located to the HSS for mobility with non-3GPP accesses.

If the MS is emergency Attached, SGSN shall not send any Update Location Request to an HSS.

D) The HSS stores the PDN GW identity and the associated APN, and sends an Update Location Response to the SGSN.

If the S6d interface is used between an S4-SGSN and HSS, the messages "Update Location Request" and "Update Location Response" shall be replaced with "Notify Request" and "Notify Response".

If the MS requested for a dual address PDP type (IPv4v6) to a given APN and was granted a single address PDP type (IPv4 or IPv6) by the network with a reason cause 'single address bearers only', the MS should request for the activation of a parallel PDP Context to the same APN with a single address PDP type (IPv4 or IPv6) other than the one already activated. If the MS receives no reason cause in response to an IPv4v6 PDP type and it receives an IPv6 prefix and Interface Identifier apart from the IPv4 address or 0.0.0.0 in the PDN Address field, it considers that the request for a dual address PDP was successful. The MS shall ignore the IPv6 prefix as described in the step 3 in clause 9.2.1.1. It can wait for the Router Advertisement from the network with the IPv6 prefix information or it may send Router Solicitation if necessary.

9.2.2.1.1 Secondary PDP Context Activation Procedure

The Secondary PDP Context Activation procedure may be used to activate a PDP context while reusing the PDP address and other PDP context information from an already active PDP context, but with a different QoS profile. Procedures for APN selection and PDP address negotiation are not executed. A unique TI and a unique NSAPI shall identify each PDP context sharing the same PDP address and APN.

Any emergency secondary PDP context activation procedure shall be initiated by the network. An MS with an active emergency PDP context shall not initiate the Secondary PDP Context Activation procedure for the emergency PDN connection unless triggered by the Network Requested Secondary PDP Context Procedure.

The Secondary PDP Context Activation procedure may be executed without providing a Traffic Flow Template (TFT) to the newly activated PDP context if all other active PDP contexts for this PDP address and APN already have an associated TFT. Otherwise a TFT shall be provided. The TFT contains attributes that specify an IP header filter that is used to route downlink N-PDUs to the newly activated PDP context (as described in clause 9.3). The TFT may also contain attributes that specify an IP header filter that is used to identify uplink IP flow(s) to apply policy control functionality as described in TS 23.203 [88].

The Secondary PDP Context Activation procedure may only be initiated after a PDP context is already activated for the same PDP address and APN. The procedure is illustrated in Figure 65 and Figure 66.

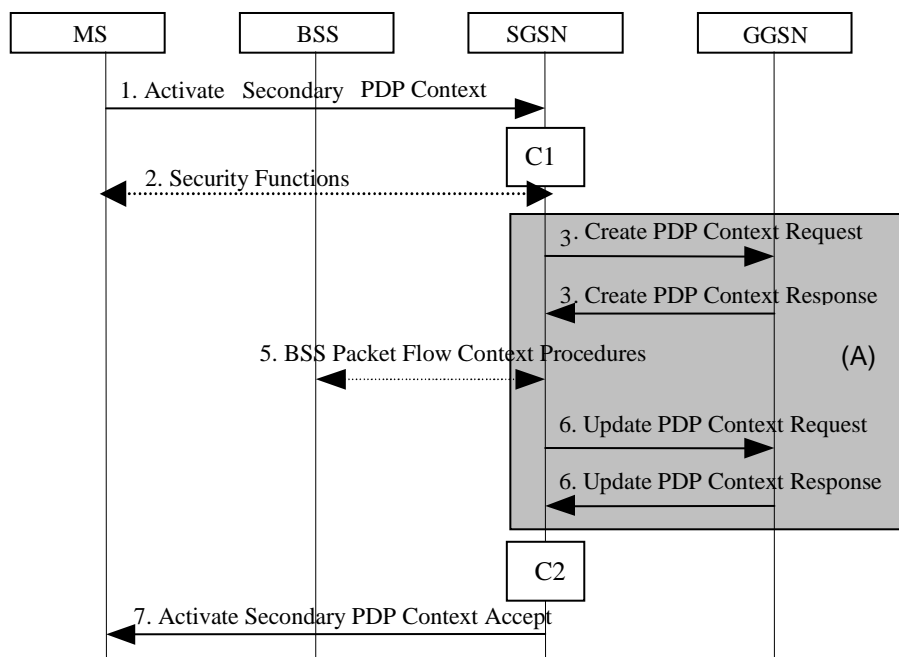

Figure 65: Secondary PDP Context Activation Procedure for A/Gb mode

NOTE 1: Steps 1, 2, 5 and 7 are common for architecture variants using Gn/Gp based interaction with GGSN and using S4 based interaction with S-GW and P-GW. For an S4 based interaction with S-GW and P-GW, procedure steps (A) are defined in clause 9.2.2.1.1A and procedure steps (B) are defined in clause 9.2.2.1.1B.

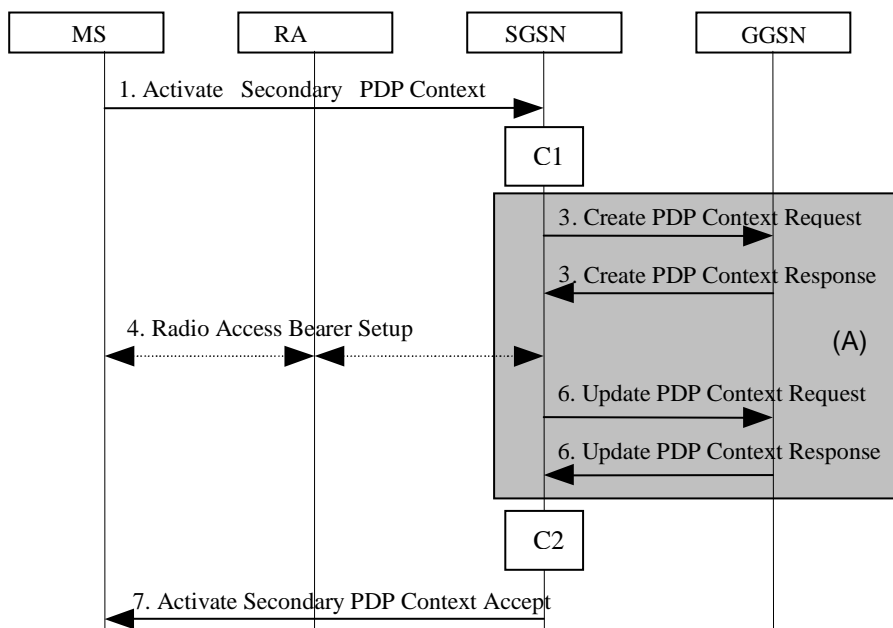

Figure 66: Secondary PDP Context Activation Procedure for Iu mode

NOTE 2: Steps 1, 4 and 7 are common for architecture variants using Gn/Gp based interaction with GGSN and using S4 based interaction with S-GW and P-GW. For an S4 based interaction with S-GW and P-GW, procedure part (A) is defined in clause 9.2.2.1.1A.

- 1) The MS sends an Activate Secondary PDP Context Request (Linked TI, NSAPI, TI, QoS Requested, TFT, Protocol Configuration Options) message to the SGSN. Linked TI indicates the TI value assigned to any one of the already activated PDP contexts for this PDP address and APN. QoS Requested indicates the desired QoS profile. TFT is sent transparently through the SGSN to the GGSN to enable packet classification for downlink data transfer. TI and NSAPI contain values not used by any other activated PDP context. Protocol Configuration Options may be used to transfer optional PDP parameters and/or requests to the GGSN (see TS 29.060 [26] and TS 24.229 [75]). Protocol Configuration Options is sent transparently through the SGSN.

If the SGSN decides to establish Direct Tunnel between RNC and GGSN, the SGSN provides to the RNC the Direct Tunnel specific parameters in step 4 "RAB Assignment Procedure" and shall initiate PDP Context Update procedure in step 6 to update IP Address and TEID for Downlink data.

- 2) In A/Gb mode, security functions may be executed. These procedures are defined in clause "Security Function".
- 3) The SGSN validates the Activate Secondary PDP Context Request using the TI indicated by Linked TI. The same GGSN address is used by the SGSN as for the already-activated PDP context(s) for that TI and PDP address.

The SGSN may restrict the requested QoS attributes given its capabilities and the current load, and it shall restrict the requested QoS attributes according to the subscribed QoS profile, which represents the maximum QoS per PDP context to the associated APN. The GGSN may restrict or increase, and negotiate the requested QoS as specified in clause "PDP Context Activation Procedure". The SGSN sends a Create PDP Context Request (QoS Negotiated, TEID, NSAPI, Primary NSAPI, TFT, Protocol Configuration Options, serving network identity, IMEISV, CGI/SAI, RAT type, S-CDR CAMEL information, CGI/SAI/RAI change support indication, Correlation-ID) message to the affected GGSN. The SGSN shall send the serving network identity to the GGSN. Primary NSAPI indicates the NSAPI value assigned to any one of the already activated PDP contexts for this PDP address and APN. TFT is included only if received in the Activate Secondary PDP Context Request message. Protocol Configuration Options is sent transparently through the SGSN if received in the Activate secondary PDP Context Request message. If the Secondary PDP Context Activation Procedure is performed as part of the Network Requested Secondary PDP Context Activation Procedure (clause 9.2.2.3) and if the GGSN included Negotiated Evolved ARP in the Initiate PDP Context Activation then the SGSN shall include the provided negotiated Evolved ARP in the Create PDP Context Request. The Correlation-ID shall only be included if the Secondary PDP Context Activation is performed as part of the Network Requested Secondary PDP Context Activation Procedure (clause 9.2.2.3), and shall be linked to the TI as described in clause 9.2.2.3.

The GGSN uses the same packet data network as used by the already-activated PDP context(s) for that PDP address, generates a new entry in its PDP context table, and stores the TFT. The new entry will allow the GGSN to route PDP PDUs via different GTP tunnels between the SGSN and the packet data network. The GGSN returns a Create PDP Context Response (TEID, QoS Negotiated, Negotiated Evolved ARP, Cause, Protocol Configuration Options, Prohibit Payload Compression, APN Restriction, CGI/SAI/RAI change report required) message to the SGSN. The GGSN sets the Negotiated Evolved ARP based on local policy or PCC. The Allocation/Retention Priority of the QoS Profile Negotiated is derived from the Evolved ARP according to the mapping principles of TS 23.401 [89], Annex E. Protocol Configuration Options may be used to transfer optional PDP parameters to the UE (see TS 29.060 [26] and TS 24.229 [75]). The Prohibit Payload Compression indicates that the SGSN should negotiate no data compression for this PDP context. If an APN Restriction is received from the GGSN for this PDP Context, then the SGSN shall store this value for the PDP Context.

If the CGI/SAI/RAI report required is received from the GGSN for this PDP context, then the SGSN shall store this for the PDP context and the SGSN shall report to that GGSN whenever a CGI/SAI/RAI change occurs that meets the GGSN request.

The SGSN shall re-verify and may restrict the QoS Negotiated received from the GGSN against the subscribed QoS profile and additionally restrict the QoS negotiated based on its capabilities and current load. The SGSN shall use this updated QoS Negotiated for the subsequent steps.

The SGSN shall apply a Negotiated Evolved ARP even if it is different from the Subscribed Evolved ARP.

The GGSN may interact with PCRF (refer to TS 23.203 [88]), e.g. to deliver User Location Information and/or UE Time Zone Information if it was requested by the PCRF.

- 4) In Iu mode, RAB setup is done by the RAB Assignment procedure.
- 5) In A/Gb mode, BSS packet flow context procedures may be executed. These procedures are defined in clause "BSS Context".
- 6) The SGSN sends an Update PDP Context Request message to the GGSN, including the QoS attributes that have been accepted by the RAN. In case the QoS attributes have been downgraded in step 5 for A/Gb mode or in step 4 for Iu mode, the SGSN may inform the GGSN about the downgraded QoS. The GGSN shall not attempt to renegotiate the QoS attributes. A RAN Procedures Ready flag is included in the Update PDP Context Request. A GGSN that receives an Update PDP Context Request with a RAN Procedures Ready flag set, should start to route downlink PDP PDUs immediately. The No QoS negotiation indication is set in Update PDP Context Request to indicate to the GGSN that the SGSN does not upgrade the previously negotiated QoS attributes and that the GGSN shall accept the provided QoS attributes without negotiation. The GGSN confirms the reception of the message and the potentially downgraded QoS attributes by sending an Update PDP Context Response to the SGSN. If the SGSN established Direct Tunnel in step 4 it shall send Update PDP Context Request and include the RNC's Address for User Plane and downlink TEID for data, the No QoS negotiation indication and DTI. DTI is used to instruct the GGSN to apply Direct Tunnel specific error handling as described in clause 13.8. The GGSN(s) shall not include a PCO in the Update PDP Context Response if the No QoS negotiation indication is set. If the No QoS negotiation indication is not set, e.g. by a pre-Rel-7 SGSN and the GGSN includes a PCO in the Update PDP Context Response, it shall contain same information as the Protocol Configuration Options IE sent in the Create PDP Context Response in step 3 above.

If the SGSN does not receive PCO in this step and it has received PCO in step 3, then the SGSN shall forward the PCO received in step 3 to the UE.

- 7) The SGSN selects Radio Priority and Packet Flow Id based on QoS Negotiated, and returns an Activate Secondary PDP Context Accept (TI, QoS Negotiated, Radio Priority, Packet Flow Id, Protocol Configuration Options) message to the MS. If the MS indicated in the MS Network Capability it does not support BSS packet flow procedures, then the SGSN shall not include the Packet Flow Id. In A/Gb mode, the QoS Negotiated shall take into account the Aggregate BSS QoS Profile, if any, returned from the BSS. Protocol Configuration Options is sent transparently through the SGSN if received in the Create PDP Context Response message. The SGSN is now able to route PDP PDUs between the GGSN and the MS via different GTP tunnels and possibly different LLC links.

If the MS is incapable of accepting the new QoS Negotiated, the MS should initiate application level signalling to lower the QoS requirements for the concerned application(s). If this is not possible then the MS shall instead de-activate the PDP context with the PDP Context Deactivation Initiated by the MS procedure.

For each additionally activated PDP context a QoS profile and TFT may be requested.

If the secondary PDP context activation procedure fails or if the SGSN returns an Activate Secondary PDP Context Reject (Cause, Protocol Configuration Options) message, the MS may attempt another activation with a different TFT, depending on the cause.

The CAMEL procedure calls shall be performed, see referenced procedures in TS 23.078 [8b]:

- C1) CAMEL_GPRS_PDP_Context_Establishment.

In Figure 65 and in Figure 66, procedures return as result "Continue".

- C2) CAMEL_GPRS_PDP_Context_Establishment_Acknowledgement.

In Figure 65 and in Figure 66, procedures return as result "Continue".

9.2.2.1.1A Secondary PDP Context Activation Procedure, PDP Creation part, using S4

The procedure described in figure 66a shows only the steps, due to use of S4, that are different from the Gn/Gp variant of the procedure given by clause 9.2.2.1.1.

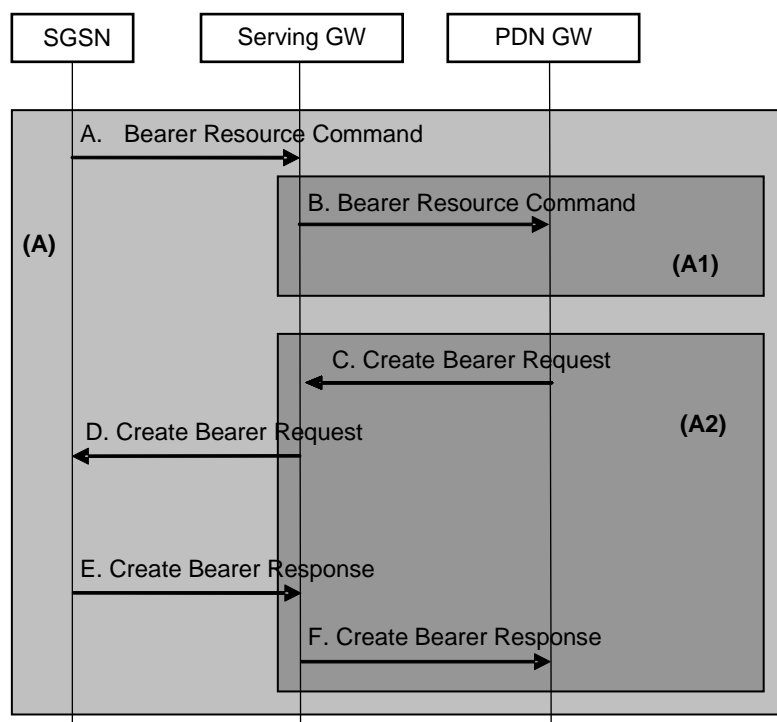

Figure 66a: Secondary PDP Context Activation Procedure using S4

NOTE 1: Steps A, D and E are common for architecture variants with GTP based S5/S8 and PMIP-based S5/S8. For a PMIP-based S5/S8, procedure parts (A1) and (A2) are defined in TS 23.402 [90]. Steps B, C and F concern GTP-based S5/S8.

A) The SGSN validates the Activate Secondary PDP Context Request using the TI indicated by Linked TI. The same P-GW and S-GW addresses are used by the SGSN as for the already-activated PDP context(s) for that TI and PDP address.

NOTE 2: The EPS Bearer QoS parameters for the traffic flow aggregate are derived from the QoS Release 99 profile.

The Procedure Transaction Id, PTI, is dynamically allocated by the SGSN for the Activate Secondary PDP Context procedure when using S4. The SGSN should ensure as far as possible that previously used PTI values are not immediately reused for the same MS. The SGSN shall store the relationship between the assigned PTI and the received Linked TI during the lifetime of the procedure. The PTI is released when the procedure is completed.

The SGSN sends the Bearer Resource Command (LBI, PTI, EPS Bearer QoS (excluding ARP), TFT, RAT type, Protocol Configuration Options) message to the selected Serving GW. The same Serving GW is used by the SGSN as for the PDP Context identified by the Linked TI received in the Activate Secondary PDP Context Request message.

B) The Serving GW sends the Bearer Resource Command (LBI, PTI, EPS Bearer QoS (excluding ARP), TFT, RAT type, Protocol Configuration Options) message to the PDN GW. The Serving GW sends the message to the same PDN GW as for the EPS Bearer identified by the Linked Bearer Id. The PDN GW derives from the RAT type indicating GERAN or UTRAN and the absence of the EPS Bearer Id that a new EPS Bearer needs to be established. The PDN GW may interact with PCRF (refer to TS 23.203 [88]) and provides to the PCRF the TFT operation add together with the new filter(s) and the QCI and/or GBR, if available. The PDN GW shall accept packet filter identifiers specified by the MS in the TFT.

C) If the request is accepted, the Dedicated Bearer Activation Procedure is invoked to establish a new EPS Bearer by the PDN GW and the PDN GW sends the Create Bearer Request (PTI, EPS Bearer QoS, TFT, S5/S8-TEID, LBI, Protocol Configuration Options) message to the Serving GW. The PTI allocated by the SGSN is used as a parameter in the invoked Dedicated Bearer Activation Procedure to correlate it to the Activate Secondary PDP Context Procedure. The PDN GW shall assign packet filter identifiers as specified in the TFT received with the Bearer Resource Command for the corresponding TFT filters. The PDN GW/PCRF may restrict or increase, and negotiate the requested QoS as specified in clause "PDP Context Activation Procedure". If the PCRF was contacted, the EPS Bearer QoS is updated according to the QoS of the received PCC rules. In addition, the PDN GW uses the SDF filter(s) in the PCC rule(s) received from the PCRF to generate the TFT. The PDN GW maintains the relation between the SDF filter identifier in the PCC rule and the packet filter identifier of the TFT.

If the request for a specific QoS is not accepted or the request does not include a TFT, or the PCC rule(s) received from the PCRF include any SDF filter (that is to be provided to the MS) that was not requested by the MS, the PDN GW sends a reject indication, which shall be delivered to the MS. A cause indicates the reason why the request was rejected.

D) The Serving GW sends the Create Bearer Request (PTI, EPS Bearer QoS, TFT, UL TEID, LBI, Protocol Configuration Options) message to the SGSN. If the "Higher bit rates than 16 Mbps flag" in the MM Context of the UE is set to "not allowed", the S4-SGSN shall, for non-GBR bearers, restrict the MBR sent to the UE to within 16 Mbps.

E) The SGSN acknowledges the bearer activation to the Serving GW by sending a Create Bearer Response (EPS Bearer Identity, DL TEID, User Location Information) message. The SGSN sets the EPS Bearer Identity to the same value as the NSAPI for the Bearer associated with the MS. The DL TEID value can be either the SGSN user plane TEID (2G or non-DT 3G) or the RNC user plane TEID.

F) The Serving GW acknowledges the bearer activation to the PDN GW by sending a Create Bearer Response (EPS Bearer Identity, S5/S8-TEID, User Location Information) message. The PDN GW may interact with PCRF (refer to TS 23.203 [88]). The PDN GW may deliver User Location Information and/or UE Time Zone Information if it was requested by the PCRF (refer to TS 23.203 [88]).

NOTE 3: The Serving GW determines that a Create Dedicated Bearer Response belongs to a previously sent Create Dedicated Bearer Request based on protocol specific details as described in TS 29.274 [92].

9.2.2.1.1B Void

9.2.2.2 Network-Requested PDP Context Activation Procedure

NOTE: These procedures only apply for SGSNs using Gn/Gp

The Network-Requested PDP Context Activation procedure allows the GGSN to initiate the activation of a PDP context. When receiving a PDP PDU the GGSN checks if a PDP context is established for that PDP address. If no PDP context has been previously established, the GGSN may try to deliver the PDP PDU by initiating the Network-Requested PDP Context Activation procedure. The criteria used by the GGSN to determine whether trying to deliver the PDP PDU to the MS may be based on subscription information are outside the scope of GPRS standardisation.

To support Network-Requested PDP Context Activation, the GGSN has to have static PDP information about the PDP address. To determine whether Network-Requested PDP Context Activation is supported for a PDP address, the GGSN checks if there is static PDP information for that PDP address.

Once these checks have been performed the GGSN may initiate the Network-Requested PDP Context Activation procedure.

The network operator may implement the following techniques to prevent unnecessary enquires to the HLR:

- Implementation of the Mobile station Not Reachable for GPRS flag (MNRG) technique in GGSN, SGSN, and HLR (see clause "Unsuccessful Network-Requested PDP Context Activation Procedure").
- The GGSN may reject or discard PDP PDUs after a previous unsuccessful delivery attempt. This systematic rejection of PDP PDUs would be performed during a certain time after the unsuccessful delivery.
- The GGSN may store the address of the SGSN with which the GGSN established the last PDP context. This would prevent an enquiry to the HLR. This SGSN address would be considered as valid during a certain time.

9.2.2.2.1 Successful Network-Requested PDP Context Activation Procedure

The Successful Network-Requested PDP Context Activation procedure is illustrated in Figure 67.

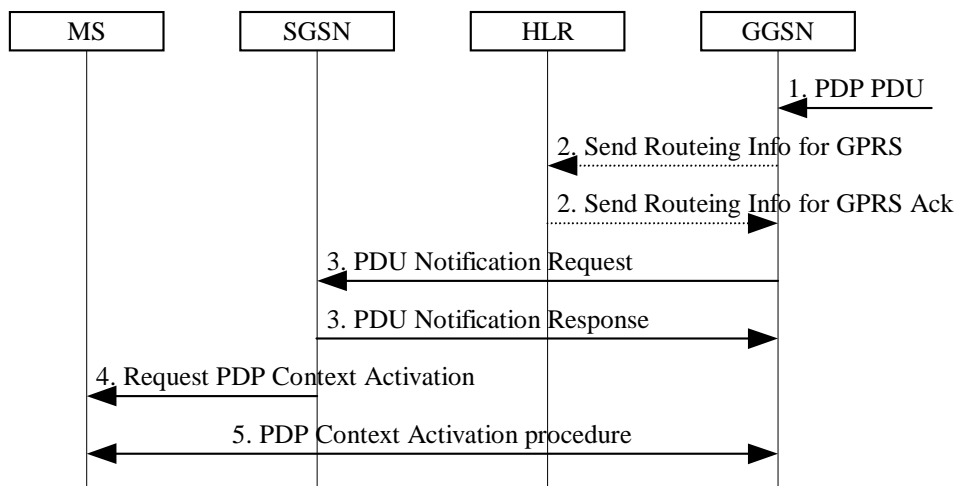

Figure 67: Successful Network-Requested PDP Context Activation Procedure

- 1) When receiving a PDP PDU the GGSN determines if the Network-Requested PDP Context Activation procedure has to be initiated. The GGSN may store subsequent PDP PDUs received for the same PDP address.
- 2) The GGSN may send Send Routeing Information for GPRS (IMSI) message to the HLR. If the HLR determines that the request can be served, it returns Send Routeing Information for GPRS Ack (IMSI, SGSN Address, Mobile Station Not Reachable Reason) message to the GGSN. The Mobile Station Not Reachable Reason parameter is included if the MNRG flag is set in the HLR. The Mobile Station Not Reachable Reason parameter indicates the reason for the setting of the MNRG flag as stored in the MNRR record (see GSM 03.40). If the

MNRR record indicates a reason other than "No Paging Response", the HLR shall include the GGSN number in the GGSN-list of the subscriber.

If the HLR determines that the request cannot be served (e.g. IMSI unknown in HLR), the HLR shall send a Send Routing Information for GPRS Ack (IMSI, MAP Error Cause) message. Map Error Cause indicates the reason for the negative response.

- 3) If the SGSN address is present and either Mobile Station Not Reachable Reason is not present or Mobile Station Not Reachable Reason indicates "No Paging Response", the GGSN shall send a PDU Notification Request (IMSI, PDP Type, PDP Address, APN) message to the SGSN indicated by the HLR. Otherwise, the GGSN shall set the MNRG flag for that MS. The GGSN shall not use PDP Type IPv4v6. The SGSN returns a PDU Notification Response (Cause) message to the GGSN in order to acknowledge that it shall request the MS to activate the PDP context indicated with PDP Address.
- 4) The SGSN sends a Request PDP Context Activation (TI, PDP Type, PDP Address, APN) message to request the MS to activate the indicated PDP context.
- 5) The PDP context is activated with the PDP Context Activation procedure (see clause "PDP Context Activation Procedure").

9.2.2.2.2 Unsuccessful Network-Requested PDP Context Activation Procedure

If the PDP context requested by the GGSN cannot be established, the SGSN sends a PDU Notification Response (Cause) or a PDU Notification Reject Request (IMSI, PDP Type, PDP Address, Cause) message to the GGSN depending on if the context activation fails before or after the SGSN has sent a Request PDP Context Activation message to the MS. Cause indicates the reason why the PDP context could not be established:

- "IMSI Not Known". The SGSN has no MM context for that IMSI (Cause in PDU Notification Response).
- "MS GPRS Detached". The MM state of the MS is IDLE (Cause in PDU Notification Response).
- "MS Not GPRS Responding". The MS is GPRS-attached to the SGSN but the MS does not respond. This may be due to the lack of a response to a GPRS Paging Request, due to an Abnormal RLC condition, or due to no Activate PDP Context Request message received within a certain time after the Request PDP Context Activation message was delivered to the MS (Cause in PDU Notification Reject Request).
- "MS Refuses". The MS refuses explicitly the network-requested PDP context (Cause in PDU Notification Reject Request).

When receiving the PDU Notification Response or the PDU Notification Reject Request message, the GGSN may reject or discard the PDP PDU depending on the PDP type.

After an unsuccessful Network-Requested PDP Context Activation procedure the network may perform some actions to prevent unnecessary enquires to the HLR. The actions taken depend on the cause of the delivery failure.

- If the MS is not reachable or if the MS refuses the PDP PDU (Cause value "MS Not GPRS Responding" or "MS Refuses"), the SGSN shall not change the setting of MNRG for this MS. The GGSN may refuse any PDP PDU for that PDP address during a certain period. The GGSN may store the SGSN address during a certain period and send subsequent PDU Notification Request messages to that SGSN.
- If the MS is GPRS-detached or if the IMSI is not known in the SGSN (Cause value "MS GPRS Detached" or "IMSI Not Known"), the SGSN, the GGSN, and the HLR may perform the Protection and Mobile User Activity procedures.

The Protection procedure is illustrated in Figure 68.

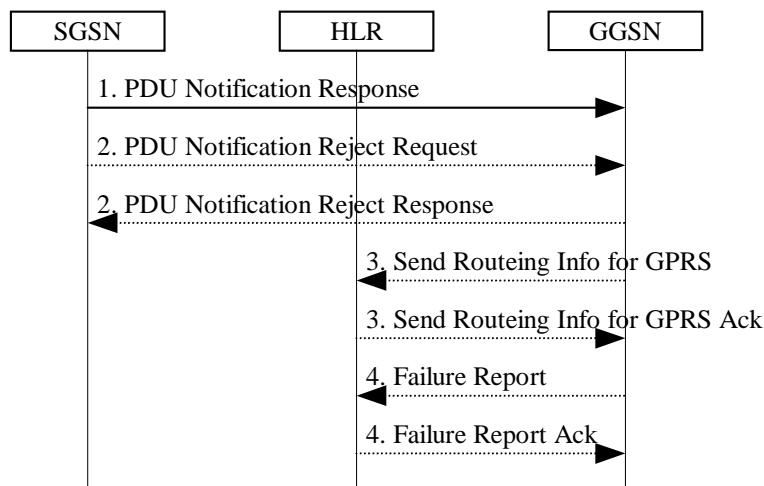

Figure 68: Protection Procedure

- 1) If the MM context of the mobile is IDLE or if the SGSN has no information about that user, the SGSN returns a PDU Notification Response (Cause) message to the GGSN with Cause equal to "MS GPRS Detached" or "IMSI Not Known". Otherwise, the Cause shall be "Activation Proceeds". If the Cause is "MS GPRS Detached" or "IMSI Not Known" and if the SGSN has an MM context for that user, the SGSN sets MNRG to indicate the need to report to the HLR when the next contact with that MS is performed.
- 2) If the MS does not respond or refuses the activation request, the SGSN sends a PDU Notification Reject Request (IMSI, PDP Type, PDP Address, Cause) message to the GGSN with Cause equal to "MS Not GPRS Responding" or "MS Refuses". The GGSN returns a PDU Notification Reject Response message to the SGSN.
- 3) If Cause equals "IMSI Not Known", the GGSN may send Send Routeing Information for GPRS (IMSI) message to the HLR. The HLR returns Send Routeing Information for GPRS Ack (IMSI, SGSN Address, Cause) message to the GGSN indicating the address of the SGSN that currently serves the MS. If SGSN Address is different from the one previously stored by the GGSN, then steps 3, 4, and 5 in Figure 67 are followed.
- 4) If SGSN Address is the same as the one previously stored in the GGSN, or if the Cause value returned in step 1 equals "MS GPRS Detached", then the GGSN sets MNRG for all PDP address(es) for that MS and sends a Failure Report (IMSI, GGSN Number, GGSN Address) message to the HLR to request MNRG to be set in the HLR. The HLR sets (if not already set) MNRG for the IMSI and adds GGSN Number and GGSN Address to the list of GGSNs to report to when activity from that IMSI is detected. GGSN Number is either the number of the GGSN, or, if a protocol-converting GSN is used as an intermediate node, the number of the protocol-converting GSN. GGSN Address is an optional parameter that shall be included if a protocol-converting GSN is used.

The Mobile User Activity procedure is illustrated in Figure 69.

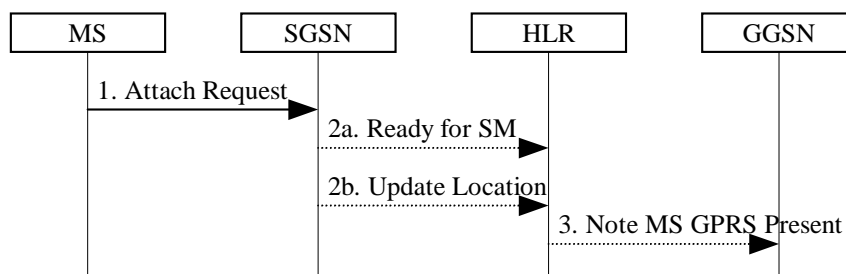

Figure 69: Mobile User Activity Procedure

- 1) The SGSN receives an indication that an MS is reachable, e.g., an Attach Request message from the MS.
- 2a) If the SGSN contains an MM context of the MS and MNRG for that MS is set, the SGSN shall send a Ready for SM (IMSI, MS Reachable) message to the HLR and clears MNRG for that MS.

- 2b) If the SGSN does not keep the MM context of the MS, the SGSN shall send an Update Location message (see clause "GPRS Attach Function") to the HLR.
- 3) When the HLR receives the Ready for SM message or the Update Location message for an MS that has MNRG set, it clears MNRG for that MS and sends a Note MS GPRS Present (IMSI, SGSN Address) message to all the GGSNs in the list of the subscriber. (The Ready for SM message also triggers the SMS alert procedure as described in clause "Unsuccessful Mobile-terminated SMS Transfer".) SGSN Address field is the address of the SGSN that currently serves the MS. Upon reception of Note MS Present each GGSN shall clear MNRG.

9.2.2.3 Network Requested Secondary PDP Context Activation Procedure using Gn

The Network Requested Secondary PDP Context Activation Procedure allows the GGSN to initiate the Secondary PDP Context Activation Procedure (see clause 9.2.2.1.1). The Network Requested Secondary PDP Context Activation Procedure when using Gn is illustrated in figure 69b.

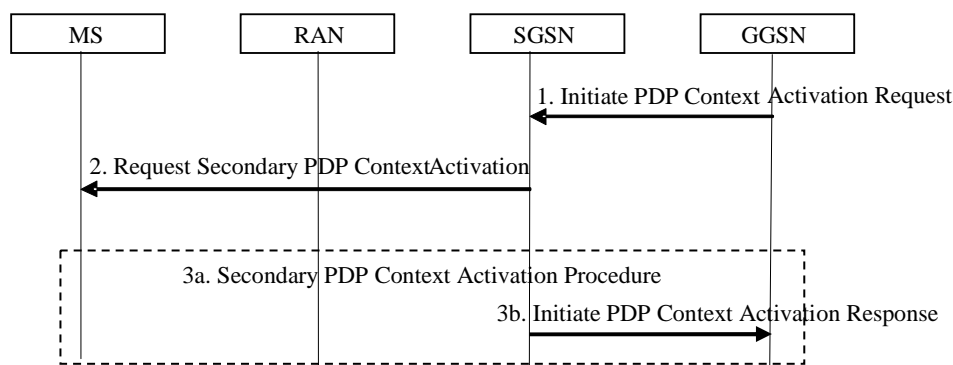

Figure 69b: Network Requested Secondary PDP Context Activation Procedure using Gn

- 1) The GGSN sends an Initiate PDP Context Activation (Linked NSAPI, QoS Requested, TFT, Protocol Configuration Options, Correlation-ID, Negotiated Evolved ARP) message to the SGSN. The QoS Requested, TFT, and Protocol Configuration Options are sent transparently through the SGSN. The TFT shall contain uplink packet filter(s) and should contain downlink packet filter(s). The Correlation-ID is used by the GGSN to correlate the subsequent Secondary PDP Context Activation Procedure (as described below) with this message. The Negotiated Evolved ARP may be included if the GGSN supports this IE and if the support of Evolved ARP has been indicated by the SGSN.
- 2) The SGSN sends a Request Secondary PDP Context Activation (Linked TI, TI, QoS Requested, TFT, Protocol Configuration Options) message to the MS. The Linked TI indicates the TI value assigned to the Active PDP Context corresponding to the Linked NSAPI previously received as described in step 1 above. The SGSN shall store a linkage between the TI value assigned to the new PDP Context, and the Correlation-ID received from the GGSN in the Initiate PDP Context Activation message.
- 3) The MS sends an Activate Secondary PDP Context Request:
 - a) That initiates the Secondary PDP Context activation procedure as described in 9.2.2.1.1. The Linked TI, TI, QoS Requested, and Protocol Configuration Options sent in the Activate secondary PDP Context Request shall be the same as previously received in step 2 above. The TFT shall contain the packet filters received in the Request Secondary PDP Context Activation message. The MS shall apply the uplink packet filters in the TFT on any uplink traffic, only packets conforming to any of the uplink packet filters in the TFT may be sent on the PDP context. If the MS did not receive a TFT in the Request Secondary PDP Context Activation message (which can only happen in case of a pre-Release 11 GGSN), the MS shall send the Activate secondary PDP Context Request without a TFT. The MS shall apply for this PDP context an uplink packet filter with the lowest possible evaluation precedence which allows any kind of uplink traffic to be sent on this PDP context.
 - b) The SGSN returns an Initiate PDP Activation Response (Cause) message to the GGSN. This acknowledges the PDP context activation request towards the GGSN.

9.2.2.3A Network Requested Secondary PDP Context Activation Procedure using S4

The Network Requested Secondary PDP Context Activation Procedure allows the P-GW to initiate the Secondary PDP Context Activation Procedure towards the MS. The Network Requested Secondary PDP Context Activation Procedure when using S4 is illustrated in figure 69c.

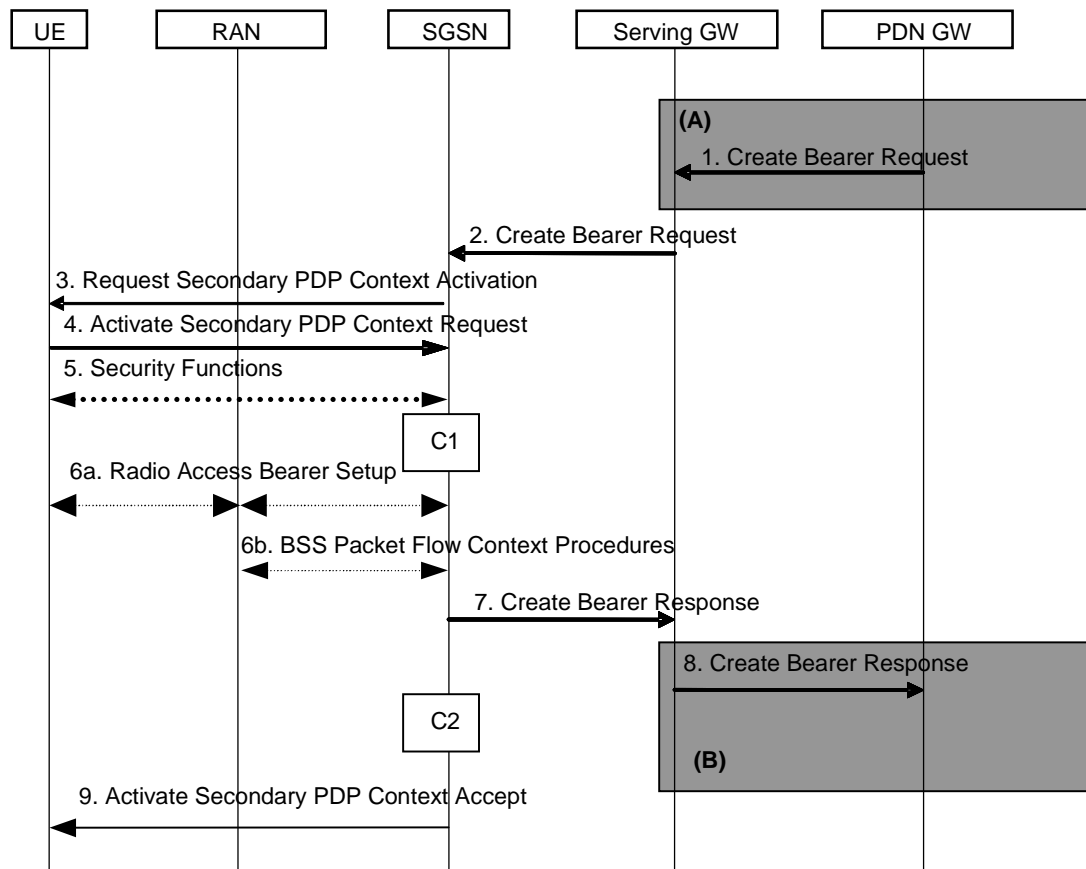

Figure 69c: Network Requested Secondary PDP Context Activation Procedure using S4

NOTE: Steps 2-7 and 9 are common for architecture variants with GTP based S5/S8 and PMIP-based S5/S8. For a PMIP-based S5/S8, procedure steps (A) and (B) are defined in TS 23.402 [90]. Steps 1 and 8 concern GTP based S5/S8.

1. The PDN GW uses the QoS policy to assign the EPS Bearer QoS, i.e., it assigns the values to the bearer level QoS parameters QCI, ARP, GBR and MBR; see TS 23.401 [89]. The PDN GW may have interacted with PCRF beforehand (refer to TS 23.203 [88]). The PDN GW sends a Create Bearer Request message (Bearer QoS, TFT, S5/S8 TEID, LBI, Protocol Configuration Options) to the Serving GW, the Linked EPS Bearer Identity (LBI) is the EPS Bearer Identity of a bearer for this MS and PDN connection.
2. The Serving GW sends the Create Bearer Request (EPS Bearer QoS, TFT, UL TEID, LBI, CGI/SAI/RAI change report required, Protocol Configuration Options) message to the SGSN.
3. Same as step 2 in clause 9.2.2.3, where Linked NSAPI equals LBI. The LBI is received from the S-GW in the Create Bearer Request message.
4. The MS initiates the Secondary PDP Context activation procedure as described in clause 9.2.2.1.1.

The SGSN validates the Activate Secondary PDP Context Request using the TI indicated by Linked TI. The same S-GW and P-GW addresses are used by the SGSN as for the already-activated PDP context(s) for that TI and PDP address.

5. In A/Gb mode, security functions may be executed. These procedures are defined in clause "Security Function".
- 6a. In Iu mode, RAB setup is done by the RAB Assignment procedure.

- 6b. In A/Gb mode, BSS packet flow context procedures may be executed. These procedures are defined in clause "BSS Context".
7. The SGSN acknowledges the bearer activation to the Serving GW by sending a Create Bearer Response (EPS Bearer Identity, UL TEID, DL TEID, User Location Information) message. The SGSN sets the EPS Bearer Identity to an equivalent value as the NSAPI for the Bearer associated with the MS. The DL TEID value can be either the SGSN user plane TEID (2G or non-DT 3G) or the RNC user plane TEID.
8. The Serving GW acknowledges the bearer activation to the PDN GW by sending a Create Bearer Response (EPS Bearer Identity, S5/S8-TEID, User Location Information) message. The PDN GW may interact with PCRF (refer to TS 23.203 [88], e.g. to deliver User Location Information and/or UE Time Zone Information if it was requested by the PCRF).
9. Same as step 7 in clause 9.2.2.1.1.

9.2.3 Modification Procedures

9.2.3.0 General

Modification procedures modify parameters that were negotiated during an activation procedure for one or several PDP contexts. An MS, a GGSN, a P-GW, an SGSN, a PCRF, or an RNC can request or initiate a modification procedure. The Modification procedures may possibly be triggered by the HLR as explained in clause "Insert Subscriber Data Procedure" or by an RNC in a RAB Release or an RNC-initiated RAB Modification procedure. An MS and SGSN can also decide about modification procedures after an RNC-initiated Iu release.

The following parameters can be modified:

- QoS Negotiated;
- Negotiated Evolved ARP;
- Radio Priority;
- Packet Flow Id;
- PDP Address (in case of the GGSN-initiated modification procedure);
- TFT (in case of MS- or GGSN or PDN GW-initiated modification procedure);
- Protocol Configuration Options (in case of MS and GGSN-initiated modification procedure);
- BCM (in case of GGSN-initiated or PDN GW-initiated modification procedure);
- Usage of Direct Tunnel; and
- APN-AMBR.

The SGSN can request the modification of parameters by sending a Modify PDP Context Request message to the MS.

A GGSN can request the modification of parameters by sending an Update PDP Context Request message to the SGSN.

A P-GW can request the modification of parameters by sending an Update Bearer Request message to the S-GW.

An MS can request the modification of parameters by sending a Modify PDP Context Request message to the SGSN.

An RNC can request an Iu release by sending an Iu Release Request message to the SGSN. After Iu release the MS and SGSN shall modify the PDP contexts according to the rules defined in clause "RNC-Initiated PDP Context Modification Procedure".

An RNC can request the release of a radio access bearer. After RAB release the MS and the SGSN shall locally modify the corresponding PDP context according to rules defined in the clause "RAB Release-Initiated Local PDP Context Modification Procedure".

A trace may be activated while a PDP context is active. To enable trace activation in a GGSN, the SGSN shall send an Update PDP Context Request message to the GGSN. To enable trace activation in a P-GW, the SGSN shall send an

Update Bearer Request message to the S-GW. If PDP context modification is performed only to activate a trace, the SGSN shall not send a Modify PDP Context Request message to the MS.

When the APN restriction value configured in the GGSN/P-GW is modified, the GGSN/P-GW applies the new APN restriction value to new PDP contexts/EPS bearers. Existing PDP contexts/EPS bearers continue to use the previous APN restriction value.

If the GGSN has stored information that the current SGSN supports the reporting of CGI/SAI/RAI and/or user CSG information changes, to enable or disable CGI/SAI/RAI and/or user CSG information change reporting for an already active PDP context, the GGSN shall send an Update PDP Context Request message to the SGSN. The SGSN shall behave according to clause 15.1.1a.

If the P-GW has stored information that the current S4-SGSN supports the reporting of CGI/SAI/RAI and/or user CSG information changes, to enable or disable CGI/SAI/RAI and/or user CSG information change reporting for an already active EPS Bearer, the P-GW shall send an Update Bearer Request message to the S-GW. The S4-SGSN shall behave according to clause 15.1.1a.

An RNC may request the modification of some negotiated RAB related QoS parameters by sending a RAB Modify Request.

For S4-based SGSNs the SGSN-Initiated PDP Context Modification can be used in the following use case:

- HSS initiated subscribed QoS modification, where typically QoS related parameters are changed. The parameters that may be modified are EPS Bearer QoS of the default bearer and APN-AMBR.
- A handover or RAU from Gn/Gp SGSN to S4-SGSN, if the S4-SGSN detects that the mapped EPS subscribed QoS profile (i.e. the subscribed QoS profile mapped according to TS 23.401 [89], Annex E) of the default bearer is different from the EPS Subscribed QoS profile received from the HSS.

9.2.3.1 SGSN-Initiated PDP Context Modification Procedure

The SGSN-Initiated PDP Context Modification procedure is illustrated in Figures 70a and 70b.

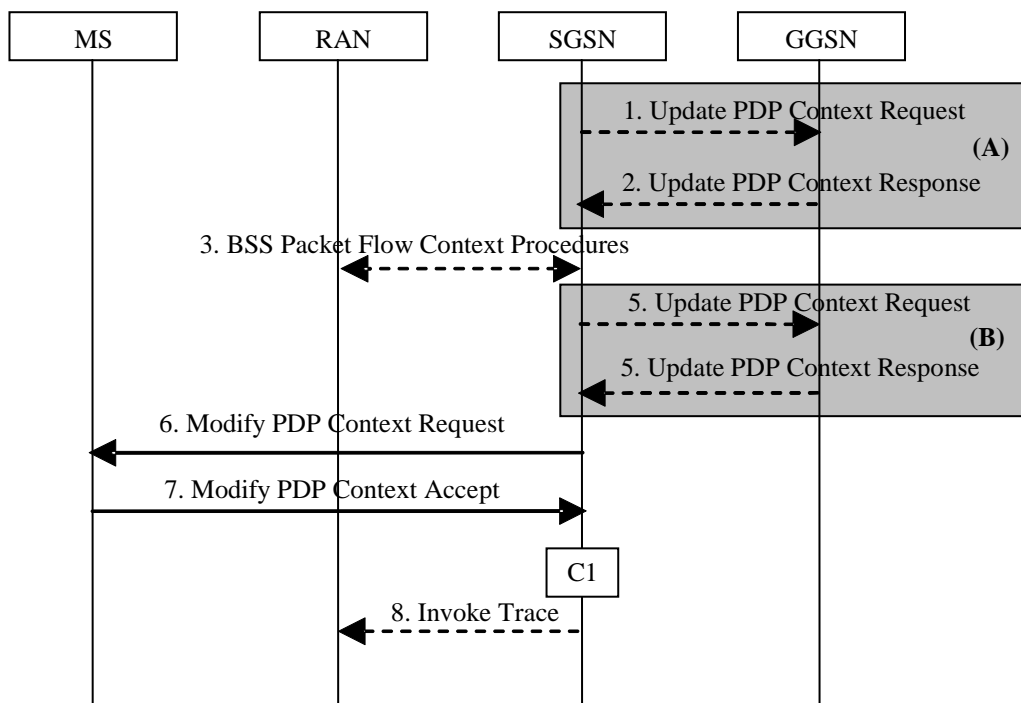

Figure 70a: SGSN-Initiated PDP Context Modification Procedure, A/Gb mode

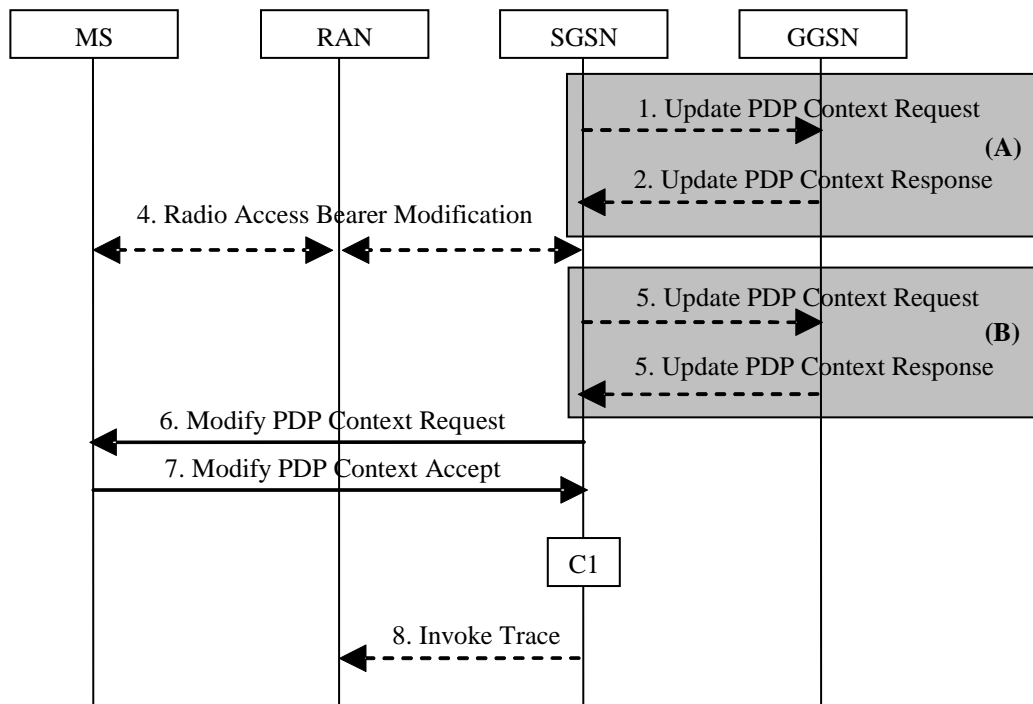

Figure 70b: SGSN-Initiated PDP Context Modification Procedure, Iu mode

NOTE 1: Steps 3, 4, 6, 7 and 8 are common for architecture variants using Gn/Gp based interaction with GGSN and using S4 based interaction with S-GW and P-GW. For an S4 based interaction with S-GW and P-GW, procedure steps (A) are defined in clause 9.2.3.1A and procedure steps (B) are defined in clause 9.2.3.1B.

- 1) The SGSN may send an Update PDP Context Request (TEID, NSAPI, QoS Negotiated, Negotiated Evolved ARP, Trace Reference, Trace Type, Trigger Id, OMC Identity, serving network identity, MS Info Change Reporting support indication, DTI, APN-AMBR, CGI/SAI) message to the GGSN. If the Subscribed Evolved ARP value is changed then it shall be provided to the GGSN in the Negotiated Evolved ARP IE. If Direct Tunnel is established the SGSN provides to the GGSN the RNC's Address for User Plane and TEID for downlink data and shall include the DTI to instruct the GGSN to apply Direct Tunnel specific error handling as described in clause 13.8. The QoS Negotiated may be equal to, an upgrade or a downgrade compared to the current QoS of the PDP context. The SGSN shall send the serving network identity to the GGSN. If QoS Negotiated received from the SGSN is incompatible with the PDP context being modified, the GGSN rejects the Update PDP Context Request. The GGSN operator configures the compatible QoS profiles. The SGSN shall include Trace Reference, Trace Type, Trigger Id, and OMC Identity in the message if GGSN trace is activated while the PDP context is active. The SGSN shall copy Trace Reference, Trace Type, and OMC Identity from the trace information received from the HLR or OMC. If the modification is triggered by a change of the subscribed APN-AMBR only, then only one PDP context associated with that APN shall be modified.
- 2) The GGSN may restrict QoS Negotiated given its capabilities and the current load or increase the QoS Negotiated based on any external input (e.g. policy control). The GGSN stores QoS Negotiated and returns an Update PDP Context Response (TEID, QoS Negotiated, Negotiated Evolved ARP, Prohibit Payload Compression, APN Restriction, Cause, MS Info Change Reporting Action, CSG Information Reporting Action, APN-AMBR) message. The GGSN sets the Negotiated Evolved ARP based on local policy or PCC. The Allocation/Retention Priority of the QoS Profile Negotiated is derived from the Evolved ARP according to the mapping principles of TS 23.401 [89], Annex E. The Prohibit Payload Compression indicates that the SGSN should negotiate no data compression for this PDP context. The SGSN shall re-verify and may restrict the QoS Negotiated received from the GGSN against the subscribed QoS profile and additionally restrict the QoS negotiated based on its capabilities and current load. The SGSN shall use this updated QoS Negotiated for the subsequent steps. The SGSN shall apply a Negotiated Evolved ARP even if it is different from the Subscribed Evolved ARP. The SGSN recalculates the UE-AMBR if the APN-AMBR was received from the GGSN: see clause 15.2.2.
- 3) In A/Gb mode, BSS packet flow context procedures may be executed. These procedures are defined in clause "BSS Context".
- 4) In Iu mode, radio access bearer modification may be performed by the RAB Assignment procedure.

- 5) In case the QoS profile, used as input to step 4 for Iu mode and step 3 for A/Gb mode, have been downgraded during those steps, the SGSN may inform the GGSN about the downgraded QoS profile by sending an Update PDP Context Request to the affected GGSN. The GGSN shall not attempt to renegotiate the QoS profile. The No QoS negotiation indication is set in Update PDP Context Request to indicate to the GGSN that the SGSN does not upgrade the previously negotiated QoS profile and that the GGSN shall accept the provided QoS profile without negotiation. The GGSN confirms the new QoS profile by sending an Update PDP Context Response to the SGSN. If the SGSN established Direct Tunnel in step 4 it shall send Update PDP Context Request and include the RNC's Address for User Plane, TEID for downlink data, No QoS negotiation indication and the DTI. DTI is used to instruct the GGSN to apply Direct Tunnel specific error handling as described in clause 13.8. The GGSN(s) shall not include a PCO in the Update PDP Context Response if the No QoS negotiation indication is set. If the No QoS negotiation indication is not set, e.g. by a pre-Rel-7 SGSN and the GGSN includes a PCO in the Update PDP Context Response, it shall contain same information as the Protocol Configuration Options IE sent in the Update PDP Context Response in step 2 above.

If the SGSN does not receive PCO in this step and it has received PCO in step 2, then the SGSN shall forward the PCO received in step 2 to the UE.

- 6) The SGSN selects Radio Priority and Packet Flow Id based on QoS Negotiated, and may send a Modify PDP Context Request (TI, QoS Negotiated, Radio Priority, Packet Flow Id) message to the MS. If the MS indicated in the MS Network Capability it does not support BSS packet flow procedures, then the SGSN shall not include the Packet Flow Id. In A/Gb mode, the QoS Negotiated shall take into account the Aggregate BSS QoS Profile, if any, returned from the BSS.
- 7) The MS should accept the PDP context modification requested by the network if it is capable of supporting the modified QoS Negotiated. For a successful modification the MS acknowledges by returning a Modify PDP Context Accept message. If the MS is incapable of accepting the new QoS Negotiated, the MS should initiate application level signalling to lower the QoS requirements for the concerned application(s). If this is not possible then the MS shall instead de-activate the PDP context with the PDP Context Deactivation Initiated by the MS procedure.

An E-UTRAN capable MS shall set its TIN to "P-TMSI" if the modified PDP context was established before ISR activation.

NOTE 2: In order to facilitate operator control of the QoS an MS should accept a new QoS being assigned by the network even if the QoS is different from the one that the MS uses by default for a particular service type. One reason why the MS may not accept the modified QoS is if it has insufficient internal resources available to support the new QoS.

- 8) If BSS trace is activated while the PDP context is active, the SGSN shall send an Invoke Trace (Trace Reference, Trace Type, Trigger Id, OMC Identity) message to the RAN. Trace Reference, and Trace Type are copied from the trace information received from the HLR or OMC.

NOTE 3: Step 7 is applied when the trace activation is triggered by means of signalling. Another alternative is the triggering of trace activation by the OMC. The details of both Trace Activation procedures are described in TS 32.422 [84].

If an APN Restriction is received from the GGSN for this PDP Context, then the SGSN shall store this value for the PDP Context, replacing any previously stored value for this PDP context. The SGSN shall determine a (new) value for the Maximum APN Restriction using any stored APN Restriction and the received APN Restriction.

The GGSN may interact with PCRF (refer to TS 23.203 [88], e.g. to deliver User Location Information and/or UE Time Zone Information if it was requested by the PCRF.

The CAMEL procedure calls shall be performed, see referenced procedure in TS 23.078 [8b]:

- C1) CAMEL_GPRS_Change_Of_QoS.

The procedure returns as result "Continue".

9.2.3.1A Request part of SGSN-Initiated EPS Bearer Modification Procedure using S4

The procedure described in Figure 70c shows only the steps, due to use of S4, that are different from the Gn/Gp variant of the procedures given by clause 9.2.3.1.

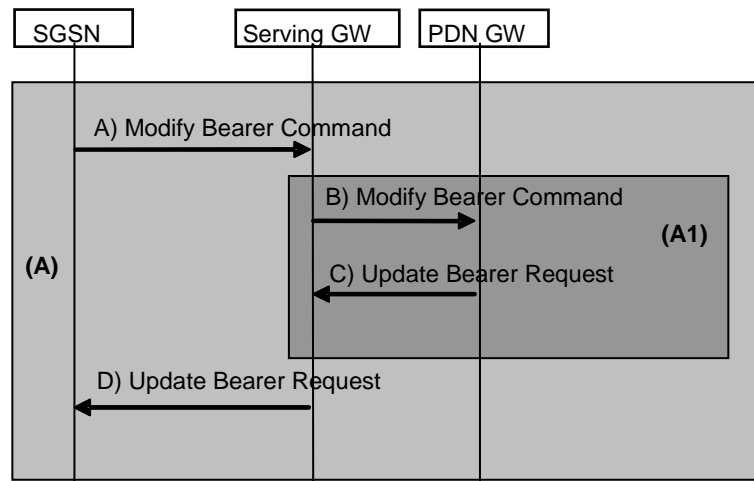

Figure 70c: Request part of SGSN-Initiated EPS Bearer Modification Procedure using S4

NOTE: Step A and B are common for architecture variants with GTP based S5/S8 and PMIP-based S5/S8. For a PMIP-based S5/S8, procedure step (A1) is defined in TS 23.402 [90]. Step B and C concern GTP based S5/S8.

- A) The SGSN sends the Modify Bearer Command (TEID, EPS Bearer Identity, PTI, EPS Bearer QoS, APN AMBR, RAT type, Trace Reference, Trace Type, Trigger Id, OMC Identity, serving network identity, MS Info Change Reporting support indication, DTI, CGI/SAI) message to the Serving GW. The EPS Bearer Identity identifies the default bearer. The EPS Bearer QoS contains the EPS subscribed QoS profile to be updated. The Procedure Transaction Id, PTI, is dynamically allocated by the SGSN. The SGSN should ensure as far as possible that previously used PTI values are not immediately reused for the same UE. PTI is used to differentiate between Update Bearer Requests triggered by this procedure, and any Update Bearer Requests initiated by the P-GW. The PTI is released when the procedure is completed. If Direct Tunnel is established the S4-SGSN provides to the Serving GW the RNC's Address for User Plane and TEID for downlink data and shall include the DTI to instruct the Serving GW to apply Direct Tunnel specific error handling as described in clause 13.8.
- B) The Serving GW sends the Modify Bearer Command (TEID, EPS Bearer Identity, PTI, EPS Bearer QoS, APN AMBR, RAT type, Trace Reference, Trace Type, Trigger Id, OMC Identity, serving network identity, MS Info Change Reporting support indication, CGI/SAI) message to the PDN GW. The PDN GW may interact with PCRF (refer to TS 23.203 [88]), e.g. to deliver User Location Information and/or UE Time Zone Information if it was requested by the PCRF.
- C) The PDN GW sends the Update Bearer Request (TEID, EPS Bearer Identity, PTI, EPS Bearer QoS, TFT, APN AMBR, Prohibit Payload Compression, MS Info Change Reporting Action, CSG Information Reporting Action) message to the Serving GW.
- D) The Serving GW sends the Update Bearer Request (TEID, EPS Bearer Identity, PTI, EPS Bearer QoS, TFT, APN AMBR, Prohibit Payload Compression, MS Info Change Reporting Action, CSG Information Reporting Action) message to the SGSN. If the "Higher bit rates than 16 Mbps flag" in the MM Context of the UE is set to "not allowed", then the S4-SGSN shall, for non-GBR bearers, restrict the MBR sent to the UE to within 16 Mbps.

9.2.3.1B Update part of SGSN-Initiated EPS Bearer Modification Procedure using S4

The procedure described in Figure 70d shows only the steps, due to use of S4, which are different from the Gn/Gp variant of the procedures given by clause 9.2.3.1.

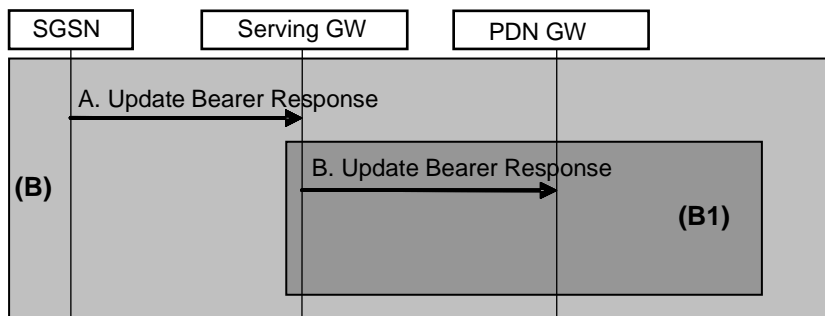

Figure 70d: Update part of SGSN-Initiated EPS Bearer Modification Procedure using S4

NOTE: Step A is common for architecture variants with GTP based S5/S8 and PMIP-based S5/S8. For a PMIP-based S5/S8, procedure step (B1) is defined in TS 23.402 [90]. Step B concern GTP based S5/S8.

A) The SGSN acknowledges the bearer modification to the Serving GW by sending an Update Bearer Response (TEID, EPS Bearer Identity, RAT type, DL TEID and DL Address, DTI) message. If the S4-SGSN established Direct Tunnel in step 4 it shall send Update Bearer Response and include the RNC's Address for User Plane, TEID for downlink data. DTI is used to instruct the Serving GW to apply Direct Tunnel specific error handling as described in clause 13.8.

B) The Serving GW acknowledges the bearer modification to the PDN GW by sending an Update Bearer Response (TEID, EPS Bearer Identity, RAT type) message. The PDN GW may interact with PCRF (refer to TS 23.203 [88]).

9.2.3.2 GGSN-Initiated PDP Context Modification Procedure

The GGSN-Initiated PDP Context Modification procedure is illustrated in Figures 71a and 71b.

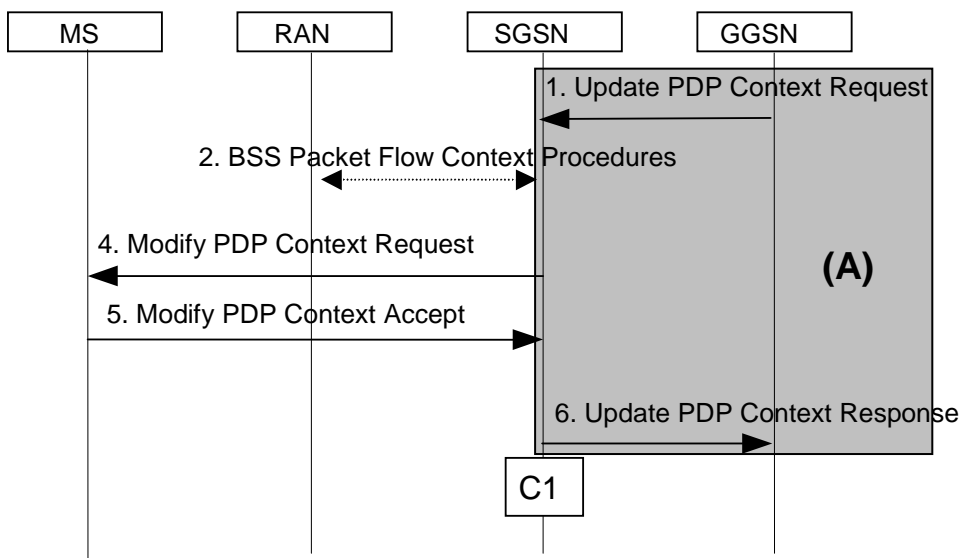

Figure 71a: GGSN-Initiated PDP Context Modification Procedure, A/Gb mode

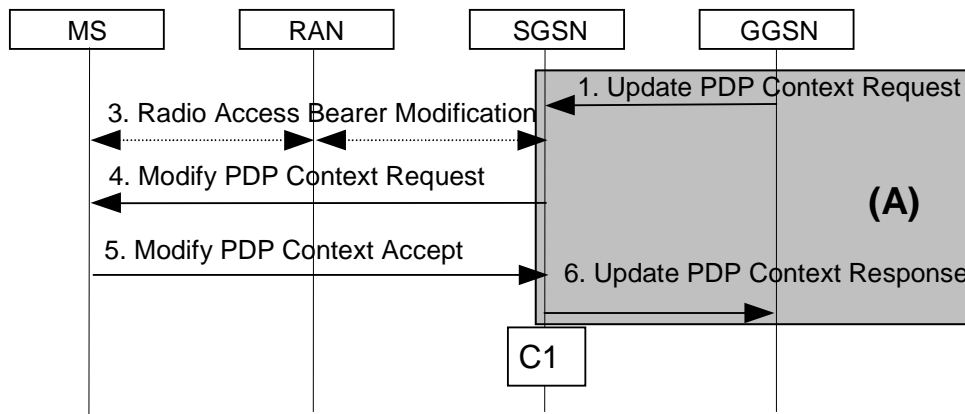

Figure 71b: GGSN-Initiated PDP Context Modification Procedure, Iu mode

NOTE 1: Steps 2-5 are common for architecture variants using Gn/Gp based interaction with GGSN and using S4 based interaction with S-GW and P-GW. For an S4 based interaction with S-GW and P-GW, procedure steps (A) are defined in clause 9.2.3.2A.

- 1) The GGSN sends an Update PDP Context Request (TEID, NSAPI, PDP Address, QoS Requested, Negotiated Evolved ARP, Prohibit Payload Compression, APN Restriction, MS Info Change Reporting Action, CSG Information Reporting Action, TFT, Protocol Configuration Options, BCM, APN-AMBR, Retrieve Location) message to the SGSN. The GGSN sets the Negotiated Evolved ARP based on local policy or PCC. The Allocation/Retention Priority of the QoS Profile Negotiated is derived from the Evolved ARP according to the mapping principles of TS 23.401 [89], Annex E. QoS Requested indicates the desired QoS profile. The QoS Requested may be equal to, an upgrade or a downgrade compared to the current QoS of the PDP context. PDP Address is optional. The Prohibit Payload Compression indicates that the SGSN should negotiate no data compression for this PDP context. If the Bearer Control Mode is set to 'MS/NW', the TFT may be included in order to add, modify or delete the TFT related to the PDP Context. Protocol Configuration Options may contain the BCM as well as optional PDP parameters that the GGSN may transfer to the MS. BCM shall also be sent as a separate IE to the SGSN. BCM indicates the Bearer Control Mode applicable to all PDP Contexts within the activated PDP Address/APN pair. The GGSN shall only indicate Bearer Control Modes allowed according to the NRSN and NRSU previously indicated by the SGSN and MS respectively. The SGSN may restrict a desired QoS profile given its capabilities, the current load, the current QoS profile, and the subscribed QoS profile. The SGSN shall apply a Negotiated Evolved ARP even if it is different from the Subscribed Evolved ARP. The BCM is used by the SGSN to handle unexpected session management signalling. If the GGSN determines the active APN-AMBR needs to be modified, the APN-AMBR is included in the request message. If the modification is triggered by a change of the APN-AMBR only, then only one PDP context associated with that APN shall be modified. The SGSN recalculates the UE-AMBR if the APN-AMBR was received from the GGSN: see clause 15.2.2. "Retrieve Location" is indicated if requested by the PCRF.
- 2) In A/Gb mode, BSS packet flow context procedures may be executed. These procedures are defined in clause "BSS Context".
- 3) In Iu mode, radio access bearer modification may be performed by the RAB Assignment procedure.
- 4) The SGSN selects Radio Priority and Packet Flow Id based on QoS Negotiated, and sends a Modify PDP Context Request (TI, PDP Address, QoS Negotiated, Radio Priority, Packet Flow Id, TFT, PCO) message to the MS. PDP Address is optional. If the MS indicated in the MS Network Capability it does not support BSS packet flow procedures, then the SGSN shall not include the Packet Flow Id. In A/Gb mode, the QoS Negotiated shall be included if modified and take into account the Aggregate BSS QoS Profile, if any, returned from the BSS. The TFT is included only if it was received from the GGSN in the Update PDP Context Request message. Protocol Configuration Options contains the BCM as well as optional PDP parameters that the GGSN may transfer to the MS. Protocol Configuration Options is sent transparently through the SGSN. BCM indicates the Bearer Control Mode applicable to all PDP Contexts within the activated PDP Address/APN pair.

If only QoS parameter ARP is modified Steps 4, 5 may be skipped unless ISR is activated.

If the procedure is performed without steps 4 and 5 and location retrieval is requested and the UE is PMM_CONNECTED and unless the SGSN is configured not to retrieve CGI/SAI from the RNC under this condition, the SGSN uses the Location Reporting Procedure described in clause 12.7.5 to retrieve the SAI from the RNC.

NOTE 2: Based on operator policy and local regulation the SGSN is configured to either use the Location Reporting Procedure described in clause 12.7.5 for retrieving the CGI/SAI from the RNC, or to use the last known User Location information obtained from e.g. GPRS attach procedure, routing area update procedure, etc.

5) The MS should accept the PDP context modification requested by the network if it is capable of supporting any modified QoS Negotiated as well as any modified TFT. For a successful modification the MS acknowledges by returning a Modify PDP Context Accept message. If the MS is incapable of accepting a new QoS Negotiated it shall instead de-activate the PDP context with the PDP Context Deactivation Initiated by MS procedure.

An E-UTRAN capable MS shall set its TIN to "P-TMSI" if the modified PDP context was established before ISR activation.

NOTE 3: In order to facilitate operator control of the QoS an MS should accept a new QoS being assigned by the network even if the QoS is different from the one that the MS uses by default for a particular service type. One reason why the MS may not accept the modified QoS is if it has insufficient internal resources available to support the new QoS.

If the BCM parameter is not included in the Modify PDP Context Request message then the MS shall set the Bearer Control Mode to 'MS_only' for the PDP Address/APN pair (see clause 9.2).

6) Upon receipt of the Modify PDP Context Accept message, or upon completion of the RAB modification procedure, the SGSN returns an Update PDP Context Response (TEID, QoS Negotiated, CGI/SAI) message to the GGSN. If the SGSN receives a Deactivate PDP Context Request message, it shall instead follow the PDP Context Deactivation Initiated by MS procedure. The SGSN includes the last known location information.

The GGSN may interact with PCRF (refer to TS 23.203 [88], e.g. to deliver User Location Information and/or UE Time Zone Information if it was requested by the PCRF).

If an APN Restriction is received from the GGSN for this PDP Context, then the SGSN shall store this value for the PDP Context, replacing any previously stored value for this PDP context. The SGSN shall determine a (new) value for the Maximum APN Restriction using any stored APN Restriction and the received APN Restriction.

The CAMEL procedure calls shall be performed, see referenced procedure in TS 23.078 [8b]:

C1) CAMEL_GPRS_Change_Of_QoS.

The procedure returns as result "Continue".

9.2.3.2A PDN GW Initiated EPS Bearer Modification Procedure, using S4

The procedure described in figure 71c shows only the steps, due to use of S4, that are different from the Gn/Gp variant of the procedure given by clause 9.2.3.2.

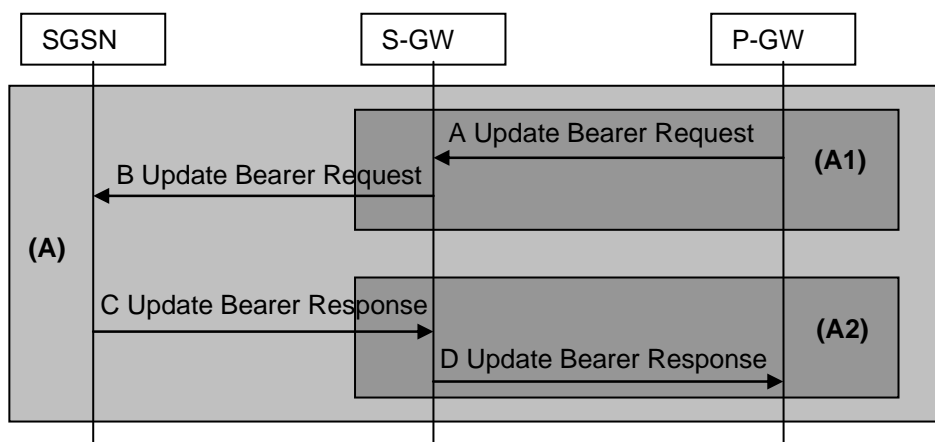

Figure 71c: PDN GW-Initiated EPS Bearer Modification Procedure

NOTE: Steps B) and C) are common for architecture variants with GTP based S5/S8 and PMIP-based S5/S8. For a PMIP-based S5/S8, procedure steps (A1) and (A2) are defined in TS 23.402 [90]. Steps A and D concern GTP based S5/S8.

A) The P-GW sends the Update Bearer Request (TEID, EPS Bearer Identity, EPS Bearer QoS, APN-AMBR, Prohibit Payload Compression, MS Info Change Reporting Action, CSG Information Reporting Action, TFT, Protocol Configuration Options, Retrieve Location) message to the S-GW.

PDN Address Information is included if it was provided by the P-GW. The Prohibit Payload Compression indicates that the SGSN should negotiate no data compression for this EPS Bearer. The TFT is optional and included in order to add, modify or delete the TFT related to the PDP Context. Protocol Configuration Options optional EPS Bearer parameters that the P-GW/PCRF may transfer to the MS. The PDN GW may have interacted with PCRF beforehand (refer to TS 23.203 [88]). "Retrieve Location" is indicated if requested by the PCRF.

B) If ISR is activated and UE is in PMM_IDLE or STANDBY state, S-GW shall first trigger the Network Triggered Service Request procedure (refer to TS 23.401 [89]).

The S-GW sends the Update Bearer Request (TEID, EPS Bearer Identity, EPS Bearer QoS, APN-AMBR, Prohibit Payload Compression, MS Info Change Reporting Action, CSG Information Reporting Action, TFT, Protocol Configuration Options, Retrieve Location) message to the SGSN. If the "Higher bit rates than 16 Mbps flag" in the MM Context of the UE is set to "not allowed", then the S4-SGSN shall, for non-GBR bearers, restrict the MBR sent to the UE to within 16 Mbps.

C) The SGSN acknowledges the bearer modification to the S-GW by sending an Update Bearer Response (EPS Bearer Identity, User Location Information) message to the S-GW. If there is no signalling with the MS, e.g. because the MS is in PMM_IDLE or STANDBY state, the SGSN provides the last known location information.

D) The S-GW acknowledges the bearer modification to the P-GW by sending an Update Bearer Response (EPS Bearer Identity, User Location Information) message. The PDN GW may interact with PCRF (refer to TS 23.203 [88]). The P-GW may interact with PCRF (refer to TS 23.203 [88]), e.g. to deliver User Location Information and/or UE Time Zone Information if it was requested by the PCRF.

9.2.3.3 MS-Initiated PDP Context Modification Procedure

The MS-Initiated PDP Context Modification procedure is illustrated in Figures 72a and 72b.

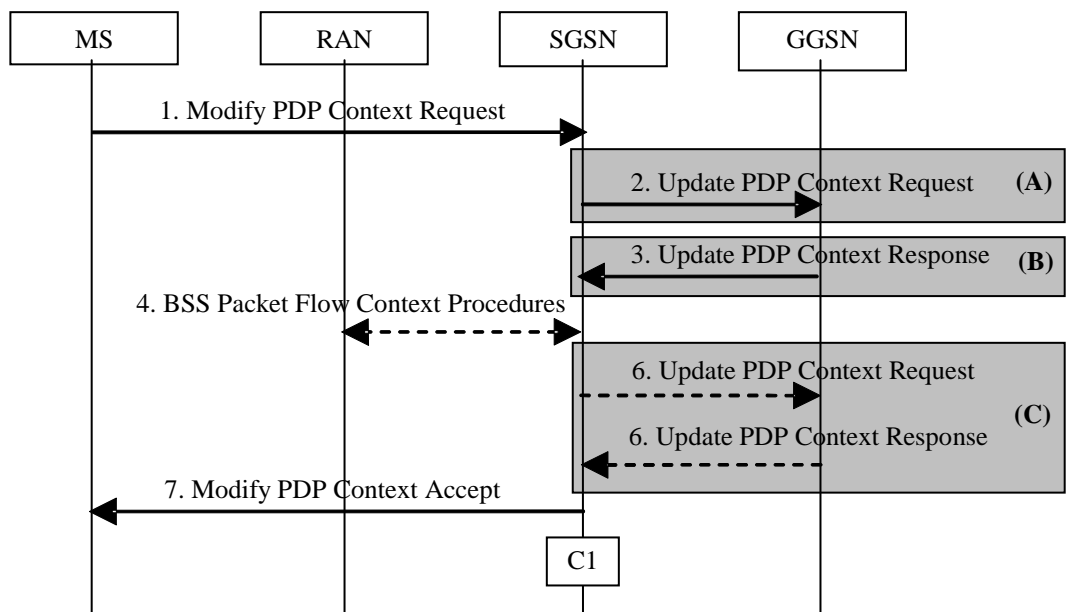

Figure 72a: MS-Initiated PDP Context Modification Procedure, A/Gb mode

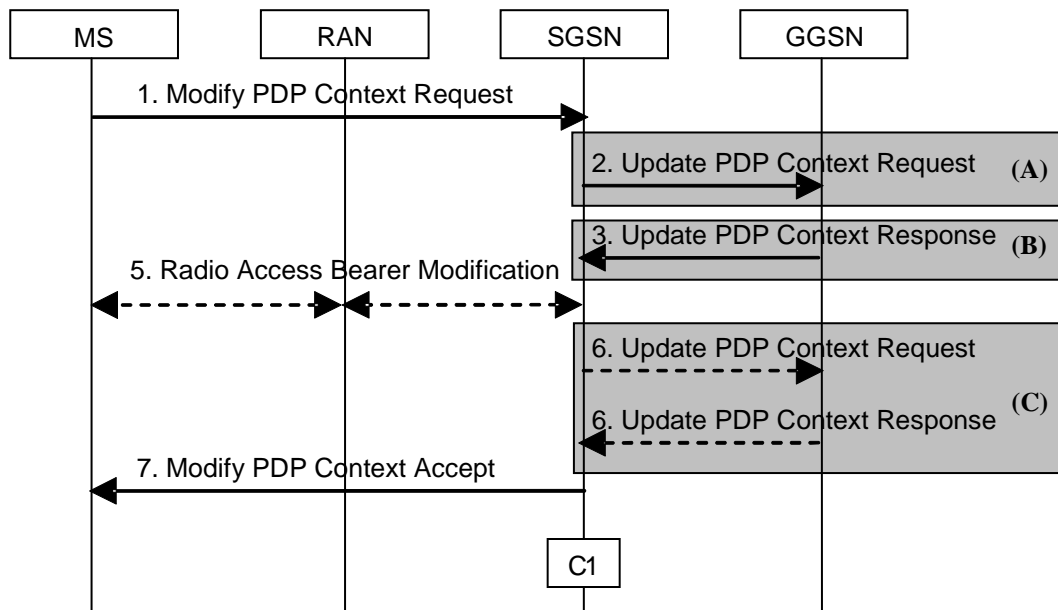

Figure 72b: MS-Initiated PDP Context Modification Procedure, Iu mode

NOTE 1: Steps 1, 4, 5 and 7 are common for architecture variants using Gn/Gp based interaction with GGSN and using S4 based interaction with S-GW and P-GW. For an S4 based interaction with S-GW and P-GW, procedure steps (A) are defined in clause 9.2.3.3A, procedure steps (B) are defined in clause 9.2.3.3B and procedure steps (C) are defined in clause 9.2.3.3C.

- 1) The MS sends a Modify PDP Context Request (TI, QoS Requested, TFT, Protocol Configuration Options) message to the SGSN. Either QoS Requested or TFT or both may be included. QoS Requested indicates the desired QoS profile, while TFT indicates the TFT that is to be added or modified or deleted from the PDP context. An E-UTRAN capable UE shall not modify the QoS for the first PDP context that was established within the PDN connection. A UE in this release that is not E-UTRAN capable should not modify the QoS for the first PDP context that was established within the PDN connection. Protocol Configuration Options may be used to transfer optional PDP parameters and/or requests to the GGSN.
- 2) The SGSN may restrict the desired QoS profile given its capabilities, the current load, and the subscribed QoS profile. The SGSN sends an Update PDP Context Request (TEID, NSAPI, QoS Negotiated, TFT, Protocol Configuration Options, serving network identity, CGI/SAI, MS Info Change Reporting support indication, DTI, CGI/SAI, User CSG Information) message to the GGSN. If Direct Tunnel is established the SGSN provides to the GGSN the RNC's Address for User Plane and TEID for downlink data and shall include the DTI to instruct the GGSN to apply Direct Tunnel specific error handling as described in clause 13.8. The SGSN shall send the serving network identity to the GGSN. If QoS Negotiated and/or TFT received from the SGSN is incompatible with the PDP context being modified (e.g., TFT contains inconsistent packet filters), the GGSN rejects the Update PDP Context Request. The GGSN operator configures the compatible QoS profile. Protocol Configuration Options is sent transparently through the SGSN if received in Modify PDP Context Request message. The GGSN may interact with the PCRF (refer to TS 23.203 [88]), e.g. to deliver User Location Information and/or UE Time Zone Information if it was requested by the PCRF.
- 3) The GGSN may further restrict QoS Negotiated given its capabilities, operator policies and the current load or increase QoS Negotiated based on any external input (e.g. policy control). The GGSN stores QoS Negotiated, stores, modifies, or deletes TFT of that PDP context as indicated in TFT, and returns an Update PDP Context Response (TEID, QoS Negotiated, Negotiated Evolved ARP, Protocol Configuration Options, Prohibit Payload Compression, APN Restriction, MS Info Change Reporting Action, CSG Information Reporting Action) message. The GGSN sets the Negotiated Evolved ARP based on local policy or PCC. The Allocation/Retention Priority of the QoS Profile Negotiated is derived from the Evolved ARP according to the mapping principles of TS 23.401 [89], Annex E. Protocol Configuration Options may be used to transfer optional PDP parameters to the UE. The Prohibit Payload Compression indicates that the SGSN should negotiate no data compression for this PDP context. The SGSN shall re-verify and may restrict the QoS Negotiated received from the GGSN against the subscribed QoS profile and additionally restrict the QoS negotiated based on its capabilities and current load. The SGSN shall use this updated QoS Negotiated for the subsequent steps. The SGSN shall apply a Negotiated Evolved ARP even if it is different from the Subscribed Evolved ARP.

- 4) In A/Gb mode, BSS packet flow context procedures may be executed. These procedures are defined in clause "BSS Context".
- 5) In Iu mode, radio access bearer modification may be performed by the RAB Assignment procedure. In case the radio access bearer does not exist the RAB setup is done by the RAB Assignment procedure.
- 6) In case the QoS profile, used as input to step 5 for Iu mode and step 4 for A/Gb mode, have been downgraded during those steps, the SGSN may inform the GGSN about the downgraded QoS profile by sending an Update PDP Context Request to the affected GGSN. The GGSN shall not attempt to renegotiate the QoS profile. The No QoS negotiation indication is set in Update PDP Context Request to indicate to the GGSN that the SGSN does not upgrade the previously negotiated QoS profile and that the GGSN shall accept the provided QoS profile without negotiation. The GGSN confirms the new QoS profile by sending an Update PDP Context Response to the SGSN. If the SGSN established Direct Tunnel in step 5 it shall send Update PDP Context Request and include the RNC's Address for User Plane, TEID for downlink data, No QoS negotiation indication and the DTI. DTI is used to instruct the GGSN to apply Direct Tunnel specific error handling as described in clause 13.8. The GGSN(s) shall not include a PCO in the Update PDP Context Response if the No QoS negotiation indication is set. If the No QoS negotiation indication is not set, e.g. by a pre-Rel-7 SGSN and the GGSN includes a PCO in the Update PDP Context Response, it shall contain same information as the Protocol Configuration Options IE sent in the Update PDP Context Response in step 3 above.

If the SGSN does not receive PCO in this step and it has received PCO in step 3, then the SGSN shall forward the PCO received in step 3 to the UE.

- 7) The SGSN selects Radio Priority and Packet Flow Id based on QoS Negotiated, and returns a Modify PDP Context Accept (TI, QoS Negotiated, Radio Priority, Packet Flow Id, Protocol Configuration Options) message to the MS. If the MS indicated in the MS Network Capability it does not support BSS packet flow procedures, then the SGSN shall not include the Packet Flow Id. In A/Gb mode, the QoS Negotiated shall take into account the Aggregate BSS QoS Profile, if any, returned from the BSS. Protocol Configuration Options is sent transparently through the SGSN if received in Modify PDP Context Response message.

If the MS is incapable of accepting the new QoS Negotiated, the MS should initiate application level signalling to lower the QoS requirements for the concerned application(s). If this is not possible then the MS shall instead de-activate the PDP context with the PDP Context Deactivation Initiated by the MS procedure.

An E-UTRAN capable MS shall set its TIN to "P-TMSI" if the modified PDP context was established before ISR activation.

NOTE 2: If the SGSN does not accept QoS Requested, then steps 2 and 3 of this procedure are skipped, and the existing QoS Negotiated is returned to the MS in step 4.

NOTE 3: In this release of the standards no procedure is defined that uses the Protocol Configuration Options in the PDP context modification procedure.

If an APN Restriction is received from the GGSN for this PDP Context, then the SGSN shall store this value for the PDP Context, replacing any previously stored value for this PDP context. The SGSN shall determine a (new) value for the Maximum APN Restriction using any stored APN Restriction and the received APN Restriction.

The CAMEL procedure calls shall be performed, see referenced procedure in TS 23.078 [8b]:

- C1) CAMEL_GPRS_Change_Of_QoS.

The procedure returns as result "Continue".

9.2.3.3A Request part of MS-Initiated EPS Bearer Modification Procedure using S4

The procedure described in Figure 72c shows only the steps, due to use of S4, which are different from the Gn/Gp variant of the procedures given by clause 9.2.3.3.

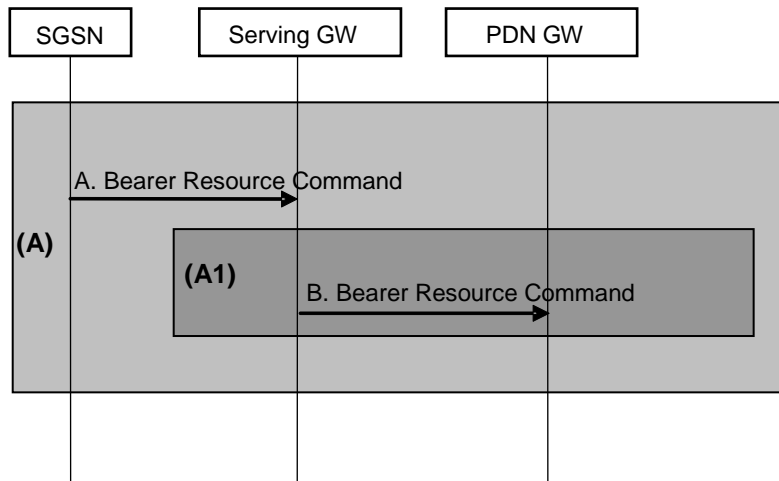

Figure 72c: Request part of MS-Initiated Modification Procedure using S4

NOTE 1: Step A is common for architecture variants with GTP based S5/S8 and PMIP-based S5/S8. For a PMIP-based S5/S8, procedure step (A1) is defined in TS 23.402 [90]. Step B concern GTP based S5/S8.

- A) The SGSN identifies the bearer modification scenario that applies and sends the Bearer Resource Command (TEID, LBI, PTI, EPS Bearer QoS (excluding ARP), TFT, RAT type, Protocol Configuration Options, serving network identity, CGI/SAI, User CSG Information, MS Info Change Reporting support indication, DL TEID and DL Address, DTI) message to the selected Serving GW. If Direct Tunnel is established the S4-SGSN provides to the Serving GW the RNC's Address for User Plane and TEID for downlink data and shall include the DTI to instruct the Serving GW to apply Direct Tunnel specific error handling as described in clause 13.8.

The Procedure Transaction Id, PTI, is dynamically allocated by the SGSN. The SGSN should ensure as far as possible that previously used PTI values are not immediately reused for the same UE. The SGSN stores the relationship between the assigned PTI and the received Linked TI during the lifetime of the procedure. PTI is used to differentiate between Update Bearer Requests triggered by this procedure, and any Update Bearer Requests initiated by the PDN GW. The PTI is released when the procedure is completed.

Bearer modification scenarios are described by table 3-3 (MS_only mode) and table 3-4 (MS/NW mode).

- B) The Serving GW sends the Bearer Resource Command (LBI, PTI, EPS Bearer Id, EPS Bearer QoS (excluding ARP), TFT, RAT type, Protocol Configuration Options, serving network identity, CGI/SAI, User CSG Information, MS Info Change Reporting support indication) message. The Serving GW sends the message to the same PDN GW as for the EPS Bearer identified by the Linked Bearer Id. The EPS Bearer Id identifies the EPS Bearer, for which the modification was requested.

The PDN GW may interact with PCRF (refer to TS 23.203 [88]), e.g. to deliver User Location Information and/or UE Time Zone Information if it was requested by the PCRF.

When interacting with PCRF, the PDN GW provides to the PCRF;

- the interpretation of the TFT, i.e.:
 - the filter operation;
 - the filter definitions for filters to be added or modified;
 - the SDF filter identifier(s) for filters to be modified or deleted;
 - the SDF filter identifier(s) for unchanged filters targeted with a QoS change;
 - the requested QCI; and
- for a GBR QCI, the total requested GBR pertaining to (a) the filters added and (b) the set of PCC rules that have one or more SDF filter identifier(s) forwarded to the PCRF in the Gx request.

The PDN GW shall calculate the total requested GBR for Gx from the current Bearer GBR, the requested Bearer GBR from the MS and the QoS for the targeted PCC rules. The PDN GW identifies the targeted PCC

rules based on the SDF filter identifier(s) corresponding to the packet filter identifier(s) provided by the MS in the parameter list of the TFT. If the MS did not provide any packet filter identifiers, the PDN GW shall use all SDF filter identifier(s), previously assigned on Gx, for this EPS bearer to identify the PCC rules. The total requested GBR is calculated by the following formula:

total requested GBR for Gx = max(0, sum(GBR[targeted PCC rules]) + (requested Bearer GBR - current Bearer GBR))

EXAMPLE: The targeted GBR bearer has GBR=500 and the MS requests to increase the bearer GBR to 750. The TFT operation is "No TFT operation", so the PDN GW considers all the MS-created TFT filters to be targeted and calculates the sum of the GBR values for the targeted PCC rules. The sum is 400 in this example. The formula yields a requested GBR=400+(750-500)=650. The list of targeted SDF filters, the QCI and GBR=650 is provided with the Gx request.

The TFT definition includes an operation, a list of packet filter identifiers and conditionally their packet filter definitions as well as an optional parameter list. The PDN GW shall assign packet filter identifiers as specified in the TFT received with the Bearer Resource Command for the corresponding packet filters. The MS use of the TFT parameter list is not specified in this Release for BCM MS-only. Valid combinations are shown in Table 3-2. The absence of the TFT IE is treated as "No TFT operation".

The PDN GW shall forward, over Gx, an MS request to change the QCI only if the following prerequisites are fulfilled:

- there is no NW-initiated TFT filter on the same bearer; and
- the Gx request includes at least one SDF filter identifier from each of the PCC rules on the same bearer.

Table 3-2: TFT filter information elements per TFT operation

TFT operation	Packet filter(s)		Parameter list	Precondition
	identifier	definition		
Create new TFT	M	M	N/A	No previous TFT on the same bearer
Delete existing TFT	N/A	N/A	N/A	Previous TFT on all bearers
Add packet filters to existing TFT	M	M	N/A	Previous TFT on the same bearer
Replace packet filters in existing TFT	M	M	N/A	Previous TFT on the same bearer
Delete packet filters from existing TFT	M	N/A	N/A	Previous TFT on the same bearer
No TFT operation	N/A	N/A	C1	
C1: If the BCM is MS/NW, then the parameter list shall include the TFT filter identifiers, created by the MS, targeted with a QoS change.				

If the TFT operation is "Replace packet filters in existing TFT", then the PDN GW provides to the PCRF the Gx operation "modify filters" and the modified filter(s) and their respective SDF filter identifier(s), previously assigned on Gx, that correspond to the received packet filter identifiers of the EPS bearer together with the requested QCI and/or GBR for the targeted resources, if available.

If the TFT operation is "Delete packet filters from existing TFT", then the PDN GW provides to the PCRF the Gx operation "delete filters" and the SDF filter identifier(s), previously assigned on Gx, that correspond to the received packet filter identifiers of the EPS bearer together with the requested QCI and/or GBR for the targeted resources, if available.

If the TFT operation is "Add packet filters to existing TFT", then the PDN GW provides to the PCRF the Gx operation "add filters" and the new filter(s) together with the requested QCI and/or GBR for the targeted resources, if available. The PDN GW also includes all SDF filter identifier(s), previously assigned on Gx, for this EPS bearer.

If the TFT operation is "Create new TFT", then the PDN GW provides to the PCRF the Gx operation "add filters" and the new filter(s) together with the requested QCI and/or GBR for the targeted resources, if available.

If the TFT operation is "Delete existing TFT", then the PDN GW provides to the PCRF the Gx operation "delete filters" together with the SDF filter identifier(s), previously assigned on Gx, for the filters in the TFT to be deleted together with the requested QCI and/or GBR for the targeted resources, if available.

NOTE 2: The sending of the QCI/GBR change triggers the PCRF to perform an appropriate PCC rule operation to enable the continuation of the EPS bearer after the removal of the TFT by the UE.

If the TFT operation is "No TFT operation" or the TFT is missing (allowed in BCM MS-only only) in the Bearer Resource Command, then the PDN GW provides to the PCRF no Gx filter operation together with the requested QCI and/or GBR for the targeted resources. The PDN GW also includes, if BCM is MS-only, all SDF filter identifier(s), previously assigned on Gx, for this EPS bearer. If the BCM is MS/NW, the TFT shall contain packet filter identifiers and PDN GW shall include the SDF filter identifier(s) that correspond to the packet filter identifier(s) in the parameter list of the TFT.

NOTE 3: The requested modification being translatable to a Gx request is required but not the only condition for the procedure being successful.

Table 3-3: MS-initiated EPS bearer modification, MS_only mode

	PDP context modification use case	Information provided by UE and NAS signalling	Information provided by SGSN at S4 signalling (refer to TS 23.401 [89])
1	Add TFT filters and increase QoS	TFT filters added, New QoS of the PDP context (NOTE 1), Linked TI / NSAPI	QoS related to EPS Bearer, TFT filters added, TEID, EPS Bearer ID
2	Increase of QoS, TFT filters not specified	New QoS of the PDP context (NOTE 1), Linked TI / NSAPI	QoS related to EPS Bearer, TEID, EPS Bearer ID
3	Add/remove TFT filters, no QoS change	TFT filters added/removed, Linked TI / NSAPI	TFT filters added/removed, TEID, EPS Bearer ID
4	Remove TFT filters and decrease QoS	New QoS of the PDP context (NOTE 1), TFT filters removed, Linked TI / NSAPI	QoS related to EPS Bearer, TFT filters removed, TEID, EPS Bearer ID
5	Decrease of QoS, TFT filters not specified	New QoS of the PDP context (NOTE 1), Linked TI / NSAPI	QoS related to EPS Bearer, TEID, EPS Bearer ID

NOTE 1: Only the modified QCI and/or GBR parameters are forwarded by the SGSN.

Table 3-4: MS-initiated EPS bearer modification, MS/NW mode

	PDP context modification use case	Information provided by UE and NAS signalling	Information provided by SGSN at S4 signalling (refer to TS 23.401 [89])
1	Add TFT filters and increase QoS	TFT filters added, New QoS of the PDP context (NOTE 1), Linked TI / NSAPI	QoS related to EPS Bearer, TFT filters added, TEID, EPS Bearer ID
2	Increase of QoS related to one or more TFT filter(s)	New QoS of the PDP context (NOTE 1), Impacted TFT filter(s), Linked TI / NSAPI	QoS related to EPS Bearer filters, Impacted TFT filters, TEID, EPS Bearer ID
3	Increase of QoS, TFT filters not specified	Not allowed in MS/NW mode	Not allowed in MS/NW mode
4	Add/remove TFT filters, no QoS change	TFT filters added/removed, Linked TI / NSAPI	TFT filters added/removed, TEID, EPS Bearer ID
5	Decrease QoS related to one or more TFT filter(s)	New QoS of the PDP context (NOTE 1), Impacted TFT filter(s), Linked TI / NSAPI	QoS related to EPS Bearer filters, Impacted TFT filters, TEID, EPS Bearer ID
6	Remove TFT filters and decrease QoS	New QoS of the PDP context (NOTE 1) TFT filters removed, Linked TI / NSAPI	QoS related to EPS Bearer, TFT filters removed, TEID, EPS Bearer ID
7	Decrease of QoS, TFT filters not specified	Not allowed in MS/NW mode	Not allowed in MS/NW mode

NOTE 1: Only the modified QCI and/or GBR parameters are forwarded by the SGSN.

9.2.3.3B Execution part of MS-Initiated Modification Procedure using S4

The procedure described in Figure 72d shows only the steps, due to use of S4, that are different from the Gn/Gp variant of the procedures given by clause 9.2.3.3.

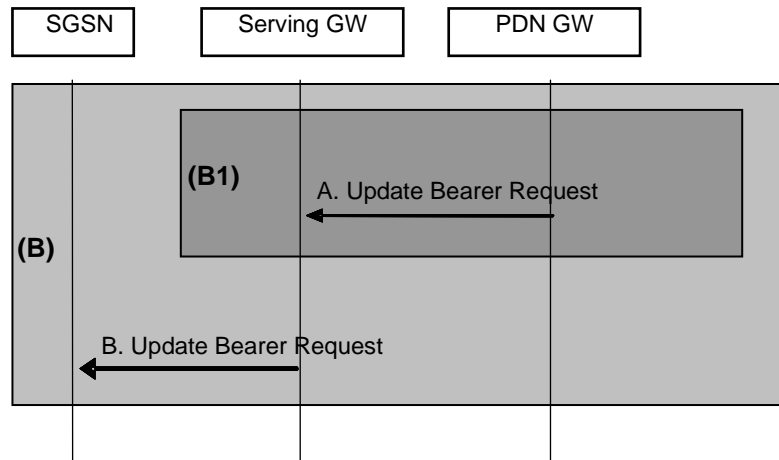

Figure 72d: Execution part of MS-Initiated Modification Procedure using S4

NOTE: Step B is common for architecture variants with GTP based S5/S8 and PMIP-based S5/S8. For a PMIP-based S5/S8, procedure step (B1) is defined in TS 23.402 [90]. Step A concern GTP based S5/S8.

A) If the request is accepted, the PDN GW Initiated Bearer Modification Procedure is invoked by the PDN GW to modify the EPS Bearer indicated by the TEID.

The PDN GW updates the TFT and the EPS Bearer QoS to match the aggregated set of service data flows. If the PCRF was contacted, the PDN GW uses the SDF filter(s) in the PCC rule(s) received from the PCRF to update the TFT. The PDN GW maintains the relation between the SDF filter identifier in the PCC rule received from the PCRF and the packet filter identifier of the TFT.

The PDN GW sends an Update Bearer Request (TEID, EPS Bearer Identity, PTI, EPS Bearer QoS, APN-AMBR, TFT, Protocol Configuration Options, Prohibit Payload Compression, MS Info Change Reporting Action, CSG Information Reporting Action) message to the Serving GW. The Procedure Transaction Id (PTI) parameter is used to link this message to the Request Bearer Resource Modification message received from the Serving GW.

If the request for specific QoS is not accepted, or the PCC rule(s) received from the PCRF include any SDF filter (that is to be provided to the MS) that was not introduced by the MS request or which the MS requested to remove, the PDN GW sends a reject indication, which shall be delivered to the MS.

B) The Serving GW sends an Update Bearer Request (PTI, EPS Bearer Identity, EPS Bearer QoS, TFT, APN-AMBR, Protocol Configuration Options, Prohibit Payload Compression, MS Info Change Reporting Action, CSG Information Reporting Action) message to the SGSN. If the "Higher bit rates than 16 Mbps flag" in the MM Context of the UE is set to "not allowed", the S4-SGSN shall, for non-GBR bearers, restrict the MBR sent to the UE to within 16 Mbps.

9.2.3.3C Response part of MS-Initiated Modification Procedure using S4

The procedure described in Figure 72e shows only the steps, due to use of S4, that are different from the Gn/Gp variant of the procedures given by clause 9.2.3.3.

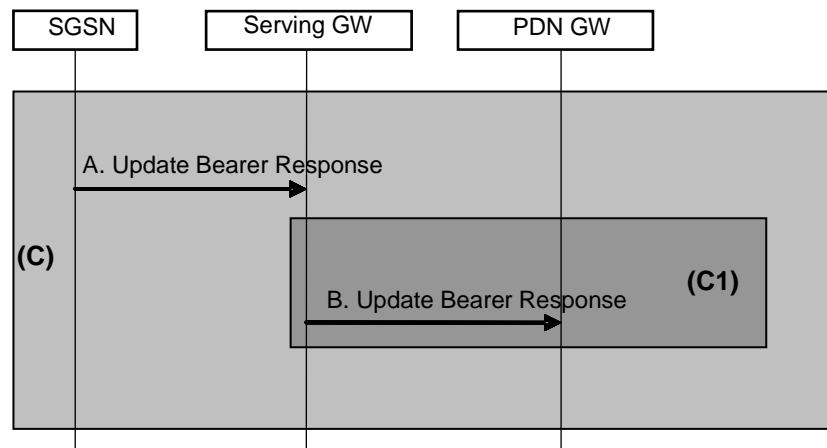

Figure 72e: Response part of MS-Initiated Modification Procedure using S4

NOTE: Steps A is common for architecture variants with GTP based S5/S8 and PMIP-based S5/S8. For a PMIP-based S5/S8, procedure step (C1) is defined in TS 23.402 [90]. Step B concern GTP based S5/S8.

- A) The SGSN acknowledges the bearer modification by sending an Update Bearer Response (TEID, EPS Bearer Identity, DL TEID and DL Address, DTI) message to the Serving GW. If the S4-SGSN established Direct Tunnel in step 5 it shall send Update Bearer Response and include the RNC's Address for User Plane, TEID for downlink data and the DTI. DTI is used to instruct the Serving GW to apply Direct Tunnel specific error handling as described in clause 13.8.
- B) The Serving GW acknowledges the bearer modification by sending an Update Bearer Response (TEID, EPS Bearer Identity) message to the PDN GW. The PDN GW may interact with PCRF (refer to TS 23.203 [88]).

9.2.3.4 RNC/BSS-Initiated PDP Context Modification Procedure

The RNC can request the release of the Iu connection (see clause "Iu Release Procedure"). The BSS may terminate the downlink data transfer to a MS by the Suspend procedure (which is triggered by the MS) or by the Radio Status procedure with cause "Radio contact lost with MS" or "Radio link quality insufficient to continue communication" both defined in TS 48.018 [78].

After Iu Release in Iu mode, or after termination of the downlink data transfer in A/Gb mode, the PDP contexts for architecture variants using Gn/Gp based interaction with GGSN are handled as follows:

- In the SGSN, for a PDP context using background or interactive traffic class, the PDP context is preserved with no modifications.
- In the SGSN, for a PDP context using streaming or conversational traffic class, the PDP context is preserved, but the maximum bit rate is downgraded to 0 kbit/s (for both uplink and downlink). The SGSN sends an Update PDP Context Request (TEID, QoS Negotiated) message to the GGSN to set the maximum bit rate to 0 kbit/s in the GGSN. The value of 0 kbit/s for the maximum bit rate indicates to the GGSN to stop sending packets to the SGSN for this PDP context. For the Iu mode the value of 0 kbit/s for the maximum bit rate for both uplink and downlink indicates to the SGSN that a RAB shall not be re-established for this PDP Context in subsequent Service Request Procedure. For the A/Gb mode the value of 0 kbit/s for the maximum bit rate for both uplink and downlink indicates that the SGSN shall not send any downlink data for this PDP Context. In Iu and A/Gb mode CAMEL procedure calls shall be performed, see referenced procedure in TS 23.078 [8b]: CAMEL_GPRS_Change_Of_QoS. The procedure returns as result "Continue".

For architecture variants using S4 based interaction with S-GW and P-GW, the PDP contexts are handled as follows:

- In the SGSN, for a PDP context using streaming or conversational traffic class, the PDP context is deactivated by the SGSN using the SGSN-initiated PDP Context Deactivation procedure.
- In the SGSN, for all other cases, the PDP context is preserved with no modifications.

In Iu mode the following procedures shall be performed in the MS when radio coverage is lost:

- For a PDP context using background or interactive traffic class, the PDP context is preserved even if RRC re-establishment procedures have failed.
- For a PDP context using streaming or conversational traffic class and only for the PDP context(s) that have a TFT that includes packet filter(s) set by the MS, the PDP context may be preserved, but the maximum bit rate is downgraded to 0 kbit/s (for both uplink and downlink) when the RRC re-establishment procedure has failed. The PDP contexts that are not preserved are all locally deactivated.

After coverage is regained on the GERAN or the UTRAN and if the MS did not deactivate the PDP Context locally the MS should start MS-initiated PDP Context Modification procedure or the PDP Context Deactivation procedure. The MS shall use the PDP Context Modification procedure to re-activate the PDP context and re-establish the RAB .

In A/Gb mode the following procedures shall be performed in the MS when radio coverage is lost, when the radio link quality is insufficient or when the MS suspends GPRS:

- For a PDP context using background or interactive traffic class, the PDP context is preserved.
- For a PDP context using streaming or conversational traffic class and only for the PDP context(s) that have a TFT that includes packet filter(s) set by the MS, the PDP context may be preserved, but the maximum bit rate is downgraded to 0 kbit/s (for both uplink and downlink). The PDP Contexts that are not preserved are all locally deactivated.

After coverage or radio link quality is regained on the GERAN or the UTRAN or when GPRS services shall resume and if the MS did not deactivate the PDP Context locally the MS should start MS initiated PDP Context Modification procedure or the PDP Context Deactivation procedure. The MS shall use the PDP Context Modification procedure to re-activate the PDP context.

9.2.3.5 RAB Release-Initiated Local PDP Context Modification Procedure

The RNC can request a RAB to be released through the RAB Release procedure without releasing the Iu connection.

After the RAB(s) release the SGSN shall handle the PDP context for architecture variants using Gn/Gp based interaction with GGSN as follows:

- In the SGSN, for a PDP context using background or interactive traffic class, the PDP context is preserved with no modifications.
- In the SGSN, for a PDP context using streaming or conversational traffic class, the PDP context is preserved, but the maximum bit rate is downgraded to 0 kbit/s (for both uplink and downlink) when the associated RAB is released. The SGSN sends an Update PDP Context Request (TEID, QoS Negotiated) message to the GGSN to set the maximum bit rate to 0 kbit/s in the GGSN. The value of 0 kbit/s for the maximum bit rate indicates to the GGSN to stop sending packets to the SGSN on this PDP context. The value of 0 kbit/s for the maximum bit rate for both uplink and downlink indicates to the SGSN that a RAB shall not be re-established for this PDP Context in subsequent Service Request Procedure. CAMEL procedure calls shall be performed, see referenced procedure in TS 23.078 [8b]: CAMEL_GPRS_Change_Of_QoS. The procedure returns as result "Continue".

For architecture variants using S4 based interaction with S-GW and P-GW, the PDP contexts are handled as follows:

- In the SGSN, for a PDP context using background or interactive traffic class, the PDP context is preserved with no modifications.
- In the SGSN, for a PDP context using streaming or conversational traffic class, the PDP context is deactivated by the SGSN using the SGSN-initiated PDP Context Deactivation procedure.

The following procedures shall be performed in the MS when the RRC layer indicate to higher layer that a RAB has been released and the RAB release was not initiated due to a PDP Context Deactivation Procedure:

- For a PDP context using background or interactive traffic class, the PDP context is be preserved with no modifications.
- For a PDP context using streaming or conversational traffic class and if the TFT include packet filter(s) set by the MS, the PDP context may be preserved, but the maximum bit rate is downgraded to 0 kbit/s (for both uplink

and downlink). If the TFT only include packet filter(s) set by the network, or if the TFT include packet filter(s) set by the MS and the PDP context was not preserved, the PDP context is locally deactivated in the MS.

At this point or at a later stage (for preserved PDP contexts), the MS may start a PDP Context Deactivation procedure or PDP Context Modification procedure. The MS shall use the PDP context modification procedure to re-activate the PDP context and to re-establish the RAB.

9.2.3.6 RAN-initiated RAB Modification Procedure (Iu mode)

The RNC-initiated RAB Modification procedure permits an Iu mode RAN to propose modifications to any negotiable RAB parameter for an MS after RAB establishment, TS 25.413 [56b]. RAB parameters are equivalent to RAB attributes as defined in TS 23.107 [58] for each QoS class. The procedure is depicted in the figure below.

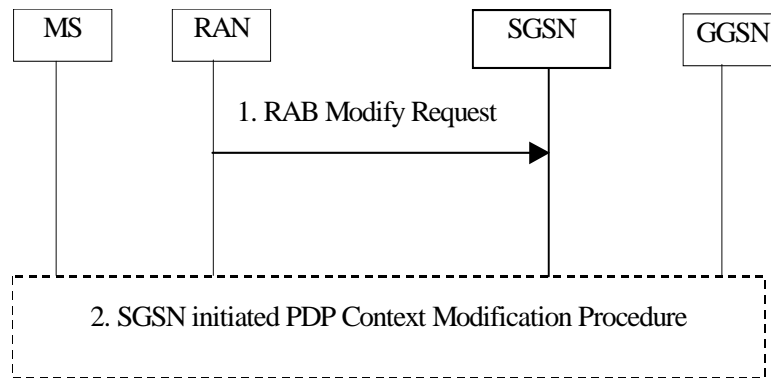

Figure 73: RAN-initiated RAB Modification Procedure

- 1) The RAN sends a RAB Modify Request (RAB ID, RAB Parameter Values) message to the SGSN.
- 2) The SGSN may decide to ignore the message or to invoke the PDP Context Modification procedure as described in clause 9.2.3.1, which includes the SGSN RAB Modification procedure. For architecture variants using S4 based interaction with S-GW and P-GW, the SGSN shall always ignore the message.

9.2.3.7 SGSN-initiated procedure on UE's CSG membership change

For an MS in PMM-CONNECTED State and connected via a CSG cell, if the SGSN detects that the UE's CSG membership to that cell has expired, the SGSN shall send an appropriate Iu message to the RAN which includes an indication that the CSG membership of the UE has expired. The RAN receiving this indication may initiate a handover to another cell. If the UE is not handed over the RAN should initiate the release of the Iu connection with an appropriate cause. The SGSN initiates Iu release after a configurable time if the UE is not handed over or released by the CSG cell. If the CSG membership expires for a MS with ongoing emergency bearer services, no indication that the CSG membership of the UE has expired is sent to the RAN and the SGSN shall initiate deactivation of all non-emergency PDP connections.

For an MS in PMM-CONNECTED State and connected via a hybrid cell, if the SGSN detects that the UE's CSG membership to that cell has changed or expired, the SGSN shall send an appropriate Iu message to the RAN which includes an indication that the CSG membership of the UE has changed. Based on this information the RAN may perform differentiated treatment for CSG and non-CSG members. If the SGSN has been requested to report user CSG information changes to the GGSN/PDN GW for the MS, the Gn/Gp-SGSN shall send the change notification message to the GGSN with user CSG Information to indicate the CSG membership change and a S4-SGSN shall send the change notification message to the Serving GW with user CSG Information to indicate the CSG membership change. The Serving GW shall send the change notification message with the user CSG Information to the PDN GW. The SGSN shall release the impacted LIPA PDN connection if the LIPA CSG authorization data for this CSG cell is no longer valid due to UE's CSG membership changed or expired.

9.2.4 Deactivation Procedures

9.2.4.1 MS Initiated PDP Context Deactivation Procedure

The PDP Context Deactivation Initiated by MS procedures for A/Gb mode and Iu mode are illustrated in Figure 74 and Figure 75, respectively.

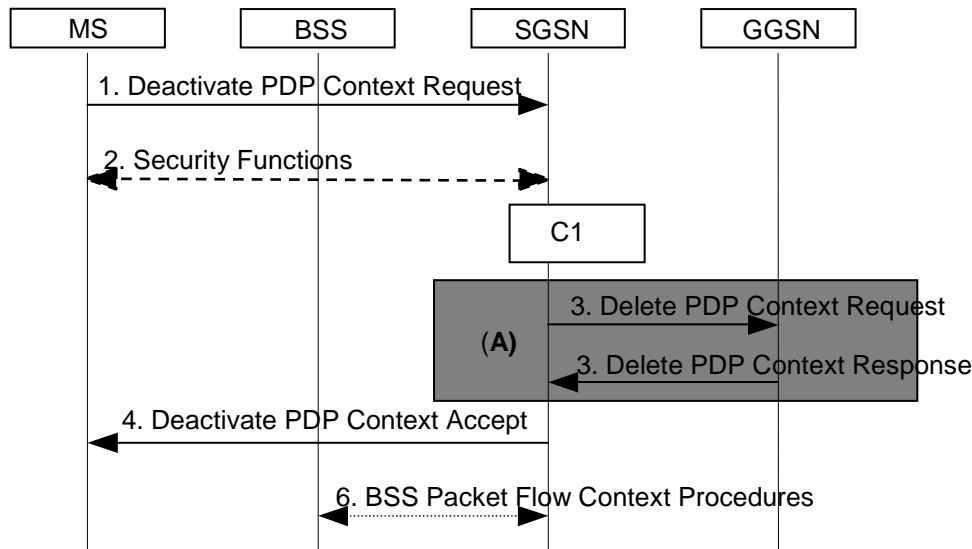

Figure 74: MS Initiated PDP Context Deactivation Procedure for A/Gb mode

NOTE 1: Steps 1, 2, 4 and 6 are common for architecture variants using Gn/Gp based interaction with GGSN and using S4 based interaction with S-GW and P-GW. For an S4 based interaction with S-GW and P-GW, procedure step (A) is defined in clause 9.2.4.1A.

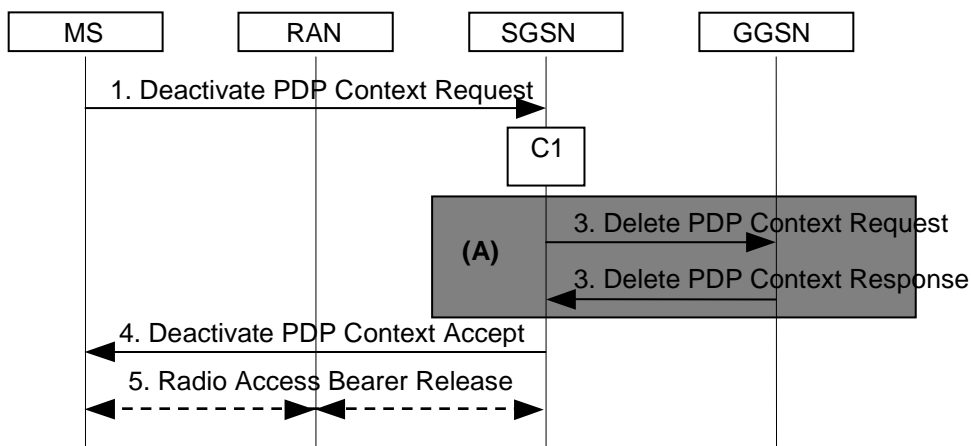

Figure 75: MS Initiated PDP Context Deactivation Procedure for Iu mode

NOTE 2: Steps 1, 4 and 5 are common for architecture variants using Gn/Gp based interaction with GGSN and using S4 based interaction with S-GW and P-GW. For an S4 based interaction with S-GW and P-GW, procedure step (A) is defined in clause 9.2.4.1A.

- 1) The MS sends a Deactivate PDP Context Request (TI, Teardown Ind) message to the SGSN. If the MS deactivates the PDP context created by the PDP Context Activation Procedure, the Teardown Ind shall be sent.
- 2) In A/Gb mode security functions may be executed. These procedures are defined in clause "Security Function".

- 3) The SGSN sends a Delete PDP Context Request (TEID, NSAPI, Teardown Ind, CGI/SAI Information) message to the GGSN. If the MS in the Deactivate PDP Context Request message included Teardown Ind, then the SGSN deactivates all PDP contexts associated with this PDP address and the same APN by including Teardown Ind in the Delete PDP Context Request message. The GGSN removes the PDP context(s) and returns a Delete PDP Context Response (TEID) message to the SGSN. If the MS was using a dynamic PDP address allocated by the GGSN, and if the context being deactivated is the last PDP context associated with this PDP address, then the GGSN releases this PDP address and makes it available for subsequent activation by other MSs. The Delete PDP Context messages are sent over the backbone network. The GGSN may interact with the PCRF (refer to TS 23.203 [88]), e.g. to deliver User Location Information and/or UE Time Zone Information if it was requested by the PCRF.
- 4) The SGSN returns a Deactivate PDP Context Accept (TI) message to the MS. If this deactivates the last PDP context of the UE then an E-UTRAN capable MS shall set its TIN to "P-TMSI". If PDP contexts remain for the MS, the SGSN recalculates the UE-AMBR and updates the RAN accordingly.
- 5) In Iu mode, radio access bearer release is done by the RAB Assignment procedure, if a RAB exists for this PDP context.
- 6) In A/Gb mode, BSS packet flow context procedures may be executed. These procedures are defined in clause "BSS Context".

At GPRS detach, all PDP contexts for the MS are implicitly deactivated.

If the SGSN receives a Deactivate PDP Context Request (TI) message for a PDP context that is currently being activated, the SGSN shall stop the PDP Context Activation procedure without responding to the MS, and continue with the PDP Context Deactivation initiated by MS procedure.

The SGSN determines the Maximum APN Restriction for the remaining PDP contexts and stores this new value for the Maximum APN Restriction.

The CAMEL procedure call shall be performed, see referenced procedure in TS 23.078 [8b]:

- C1) CAMEL_GPRS_PDP_Context_Disconnection.

The procedure returns as result "Continue".

9.2.4.1A MS- and SGSN Initiated Bearer Deactivation Procedure using S4

When MS- and SGSN initiates Bearer Deactivation procedure,

- If the Tear Down Indicator (Teardown Ind) is set, the procedure in clause 9.2.4.1A.1 is used.
- Otherwise, the procedure in clause 9.2.4.1A.2 is used.

The procedures described in figures 74a and figure 74b show only the steps, due to use of S4, that are different from the Gn/Gp variant of the procedure given by clauses 9.2.4.1 and 9.2.4.2.

9.2.4.1A.1 MS-and SGSN Initiated PDN connection Deactivation Procedure using S4

The procedure described in figure 74a is used when the MS/SGSN initiates PDN connection deactivation.

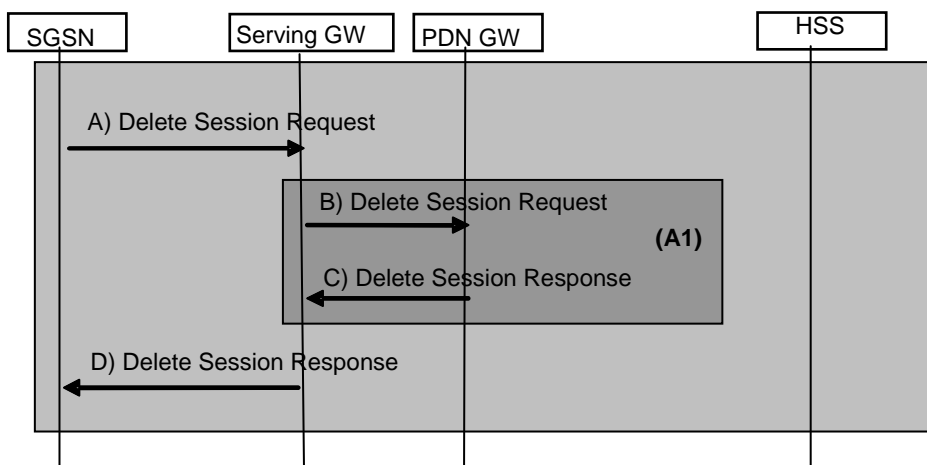

Figure 74a: MS- and SGSN Initiated PDN connection Deactivation Procedure using S4

NOTE 1: Steps A) and D) are common for architecture variants with GTP based S5/S8 and PMIP-based S5/S8. For a PMIP-based S5/S8, procedure step (A1) is defined in TS 23.402 [90]. Steps B and C concern GTP based S5/S8.

A) The EPS Bearer in the Serving GW regarding this particular MS and the PDN are deactivated by the SGSN by sending Delete Session Request (TEID, EPS Bearer Identity, Teardown Ind, User Location Information), to the Serving GW. This message indicates that all bearers belonging to that PDN connection shall be released.

NOTE 2: The SGSN does not modify the ISR status even if the last PDP context is deactivated.

B) The Serving GW sends Delete Session Request (TEID, EPS Bearer Identity, Teardown Ind, User Location Information, User CSG Information) to the PDN GW. This message includes an indication that all bearers belonging to that PDN connection shall be released, i.e. the Teardown Ind. The PDN GW may interact with PCRF (refer to TS 23.203 [88]), e.g. to deliver User Location Information and/or UE Time Zone Information if it was requested by the PCRF.

C) The PDN GW acknowledges the bearer deactivation to the S-GW by sending a Delete Session Response (TEID).

D) The Serving GW acknowledges the bearer deactivation to the SGSN with Delete Session Response (TEID).

9.2.4.1A.2 MS-and SGSN Initiated Bearer Deactivation Procedure

The procedure described in figure 74b is used when the MS/SGSN initiates Bearer Deactivation procedure.

In case of RNC Failure, SGSN may based on operator policy either preserve all bearers or initiate the Dedicated Bearer Deactivation procedure, as shown in Figure 74b below. In deactivating the GBR bearers, SGSN may take the EPS bearer QoS into account.

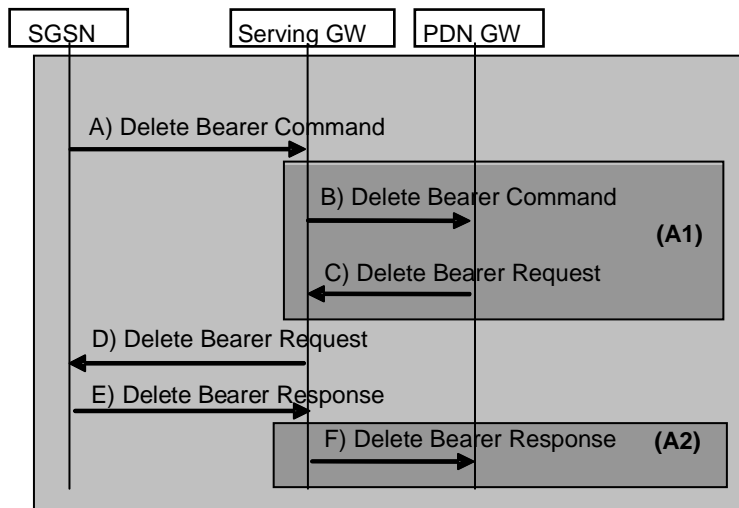

Figure 74b: MS- and SGSN Initiated Bearer Deactivation Procedure using S4

NOTE 1: Steps A), D) and E) are common for architecture variants with GTP based S5/S8 and PMIP-based S5/S8. For a PMIP-based S5/S8, procedure steps (A1) and (A2) are defined in TS 23.402 [90]. Steps B, C and F concern GTP based S5/S8.

A) The SGSN sends the Delete Bearer Command (EPS Bearer Identity) message to the Serving GW to deactivate the selected EPS bearer.

NOTE 2: The SGSN does not modify the ISR status.

B) The Serving GW sends the Delete Bearer Command (EPS Bearer Identity) message to the PDN GW.

C) The PDN GW sends a Delete Bearer Request (TEID, EPS Bearer Identity) message to the Serving GW. The PDN GW may have interacted with PCRF beforehand (refer to TS 23.203 [88]).

If the bearer deleted is the default bearer (i.e. the UE is not supporting the default bearer concept) it is implementation specific whether the PDN GW keeps the rest of the EPS bearer(s) for the PDN connection or whether the PDN GW initiates a deactivation of the PDN connection.

D) The Serving GW sends the Delete Bearer Request (TEID, EPS Bearer Identity) message to the SGSN.

E) The SGSN deletes the bearer contexts related to the deactivated EPS bearer and acknowledges the bearer deactivation to the Serving GW by sending a Delete Bearer Response (TEID, EPS Bearer Identity, User Location Information) message.

F) The Serving GW deletes the bearer context related to the deactivated EPS bearer and acknowledges the bearer deactivation to the PDN GW by sending a Delete Bearer Response (TEID, EPS Bearer Identity, User Location Information, User CSG Information) message. The PDN GW may interact with the PCRF (refer to TS 23.203 [88]), e.g. to deliver User Location Information and/or UE Time Zone Information if it was requested by the PCRF.

9.2.4.2 SGSN-initiated PDP Context Deactivation Procedure

The PDP Context Deactivation Initiated by SGSN procedure is illustrated in Figure 76.

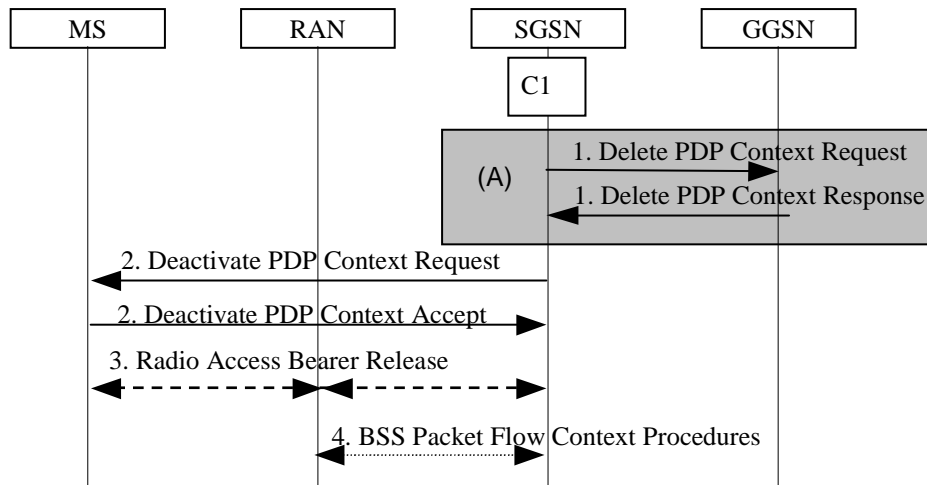

Figure 76: SGSN-initiated PDP Context Deactivation Procedure

NOTE 1: Steps 2-4 are common for architecture variants using Gn/Gp based interaction with GGSN and using S4 based interaction with S-GW and P-GW. For an S4 based interaction with S-GW and P-GW, procedure step (A) is defined in clause 9.2.4.1A.

This procedure is also used as part of the SIPTO using GW selection function when the SGSN determines that GW relocation is desirable. In this situation the SGSN deactivates the relevant PDN connection(s) using the "reactivation requested" cause value, and the UE should then re-establish those PDN connection(s) towards the same APN(s).

- 1) The SGSN sends a Delete PDP Context Request (TEID, NSAPI, Teardown Ind, CGI/SAI) message to the GGSN. If Teardown Ind is included by the SGSN, the GGSN deactivates all PDP contexts associated with this PDP address and the same APN. The GGSN removes the PDP context and returns a Delete PDP Context Response (TEID) message to the SGSN. If the MS was using a dynamic PDP address allocated by the GGSN, and if the context being deactivated is the last PDP context associated with this PDP address, the GGSN releases this PDP address and makes it available for subsequent activation by other MSs. The Delete PDP Context messages are sent over the backbone network. The SGSN may not wait for the response from the GGSN before sending the Deactivate PDP Context Request message.

NOTE 2: The CGI/SAI may be outdated as the interaction with MS and RAN happen after step 1.

The GGSN may interact with PCRF (refer to TS 23.203 [88]), e.g. to deliver User Location Information and/or UE Time Zone Information if it was requested by the PCRF.

- 2) The SGSN sends a Deactivate PDP Context Request (TI, Teardown Ind, Cause) message to the MS. If Teardown Ind is included, all PDP contexts associated with this PDP address and the same APN are deactivated. The MS removes the PDP context(s) and returns a Deactivate PDP Context Accept (TI) message to the SGSN. If this deactivates the last PDP context of the UE then an E-UTRAN capable MS shall set its TIN to "P-TMSI". If PDP contexts remain for the MS, the SGSN recalculates the UE-AMBR and updates the RAN accordingly.

If the request is deactivation with reactivation from SGSN, the UE starts MS initiated PDP context Activation Procedure as specified in clauses 9.2.2.1 and 9.2.2.1A by using the same APN of the released PDN connection.

- 3) In Iu mode, radio access bearer release is done by the RAB Assignment procedure.
- 4) In A/Gb mode, BSS packet flow context procedures may be executed. These procedures are defined in clause "BSS Context".

The SGSN determines the Maximum APN Restriction for the remaining PDP contexts and stores this new value for the Maximum APN Restriction.

The CAMEL procedure call shall be performed, see referenced procedure in TS 23.078 [8b]:

C1) CAMEL_GPRS_PDP_Context_Disconnection

The procedure returns as result "Continue".

9.2.4.3 GGSN-initiated PDP Context Deactivation Procedure

The PDP Context Deactivation Initiated by GGSN procedure is illustrated in Figure 77.

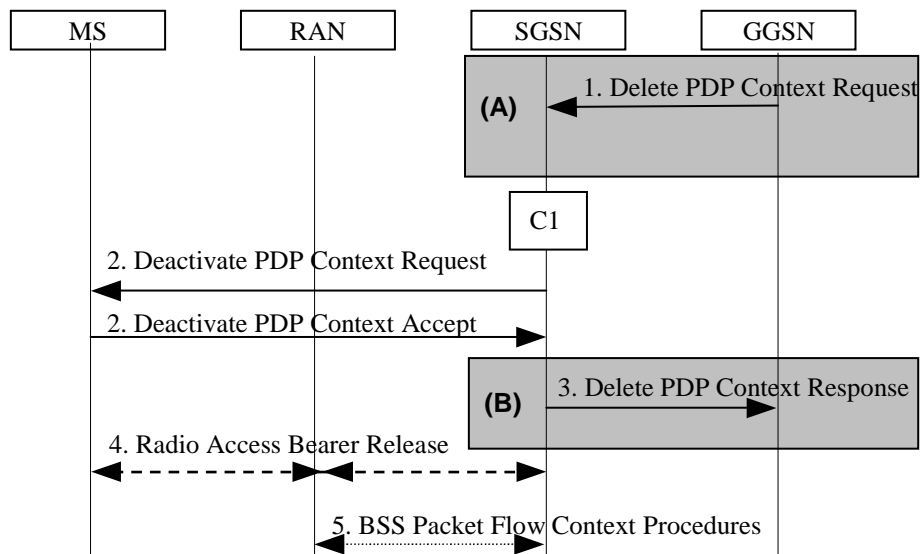

Figure 77: GGSN-initiated PDP Context Deactivation Procedure

NOTE: Steps 2, 4 and -5 are common for architecture variants using Gn/Gp based interaction with GGSN and using S4 based interaction with S-GW and P-GW. For an S4 based interaction with S-GW and P-GW, procedure step (A) is defined in clause 9.2.4.3A and step (B) is defined in clause 9.2.4.3B.

- 1) The GGSN sends a Delete PDP Context Request (TEID, NSAPI, Teardown Ind) message to the SGSN. Teardown Ind indicates whether or not all PDP contexts associated with this PDP address and the same APN shall be deactivated.

For an emergency call related PDP address, the GGSN initiates the deactivation of all PDP contexts related to that emergency PDP address when the PDP context is inactive (i.e. not transferring any packets) for a configured period of time or when triggered by dynamic PCC.

- 2) The SGSN sends a Deactivate PDP Context Request (TI, Teardown Ind, Cause) message to the MS. If Teardown Ind was included by the SGSN, then all PDP contexts associated with this PDP address and the same APN are deactivated. The MS removes the PDP context(s) and returns a Deactivate PDP Context Accept (TI) message to the SGSN. If this deactivates the last PDP context of the UE then an E-UTRAN capable MS shall set its TIN to "P-TMSI".
- 3) The SGSN returns a Delete PDP Context Response (TEID, CGI/SAI) message to the GGSN. If the MS was using a dynamic PDP address allocated by the GGSN, and if the context being deactivated is the last PDP context associated with this PDP address, the GGSN releases this PDP address and makes it available for subsequent activation by other MSs. The Delete PDP Context messages are sent over the backbone network. The SGSN may not wait for the response from the MS before sending the Delete PDP Context Response message. If PDP contexts remain for the MS, the SGSN recalculates the UE-AMBR and updates the RAN accordingly. If there is no signalling with the MS, e.g. because the MS is in PMM_IDLE or STANDBY state, the SGSN provides the last known CGI/SAI.

The GGSN may interact with PCRF (refer to TS 23.203 [88]), e.g. to deliver User Location Information and/or UE Time Zone Information if it was requested by the PCRF.

- 4) In Iu mode, radio access bearer release is done by the RAB Assignment procedure.
- 5) In A/Gb mode, BSS packet flow context procedures may be executed. These procedures are defined in clause "BSS Context".

The SGSN determines the Maximum APN Restriction for the remaining PDP contexts and stores this new value for the Maximum APN Restriction.

The CAMEL procedure call shall be performed, see referenced procedure in TS 23.078 [8b]:

- C1) CAMEL_GPRS_PDP_Context_Disconnection.

The procedure returns as result "Continue".

9.2.4.3A PDN GW initiated Bearer Deactivation Procedure using S4, part 1

The procedure described in figures 77 shows only the steps, due to use of S4, that are different from the Gn/Gp variant of the procedure given by clause 9.2.4.3.

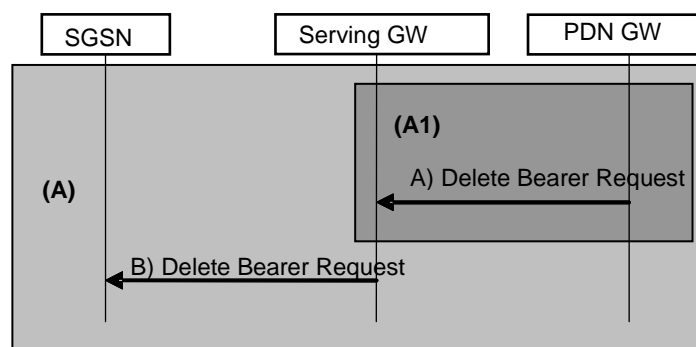

Figure 77a: PDN GW initiated Bearer Deactivation Procedure using S4, part 1

NOTE: Step B) is common for architecture variants with GTP based S5/S8 and PMIP-based S5/S8. For a PMIP-based S5/S8, procedure step (A1) is defined in TS 23.402 [90]. Step A) concern GTP based S5/S8.

- A) The PDN GW sends a Delete Bearer Request (TEID, EPS Bearer Identity, Cause) message to the Serving GW. This message may include an indication that all bearers belonging to that PDN connection shall be released. If the PDN GW deactivates the PDP context created by the PDP Context Activation Procedure, the Teardown Ind shall be sent. The PDN GW may have interacted with PCRF beforehand (refer to TS 23.203 [88]).

If the Delete Bearer Request message is sent due to "handover without optimization from 3GPP to non-3GPP" then the PDN GW includes the 'Cause' IE set to 'RAT changed from 3GPP to Non-3GPP'.

For an emergency PDN connection the PDN GW initiates the deactivation of all bearers of that emergency PDN connection when the PDN connection is inactive (i.e. not transferring any packets) for a configured period of time or when triggered by dynamic PCC.

- B) The Serving GW sends the Delete Bearer Request (TEID, EPS Bearer Identity, Cause) message to the SGSN. This message can include an indication that all bearers belonging to that PDN connection shall be released.

If all the bearers belonging to a UE are released due to "handover without optimization from 3GPP to non-3GPP", the SGSN changes the MM state of the UE to IDLE (GERAN network) or PMM-DETACHED (UTRAN network).

9.2.4.3B PDN GW initiated Bearer Deactivation Procedure using S4, part 2

The procedure described in figures 77b shows only the steps, due to use of S4, that are different from the Gn/Gp variant of the procedure given by clause 9.2.4.3

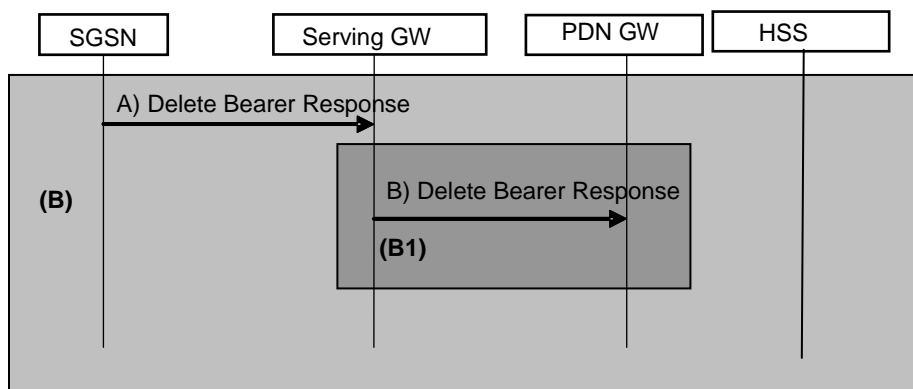

Figure 77b: PDN GW initiated Bearer Deactivation Procedure using S4, part 2

NOTE 1: Step A) is common for architecture variants with GTP based S5/S8 and PMIP-based S5/S8. For a PMIP-based S5/S8, procedure step (B1) is defined in TS 23.402 [90]. Step B) concerns GTP-based S5/S8.

A) The SGSN deletes the bearer context related to the deactivated EPS bearer and acknowledges the bearer deactivation to the Serving GW by sending a Delete Bearer Response (TEID, EPS Bearer Identity, User Location Information) message. If there is no signalling with the MS, e.g. because the MS is in PMM_IDLE or STANDBY state, the SGSN provides the last known CGI/SAI.

The SGSN does not modify the ISR status unless the bearer deactivation occurs for the last PDN connection in which case the SGSN deactivates ISR.

B) The Serving GW deletes the bearer context related to the deactivated EPS bearer and acknowledges the bearer deactivation to the PDN GW by sending a Delete Bearer Response (TEID, EPS Bearer Identity, User Location Information) message. The PDN GW may interact with PCRF (refer to TS 23.203 [88]), e.g. to deliver User Location Information and/or UE Time Zone Information if it was requested by the PCRF.

9.2.5 Preservation Procedures

By sending a RAB Release Request or Iu Release Request message to the SGSN, an Iu mode RAN initiates the release of one or more RABs. The preservation procedure allows the active PDP contexts associated with the released RABs to be preserved in the CN, and the RABs can then be re-established at a later stage, see clause 9.2.5.2 and clause 9.2.3.5.

An Iu mode RAN uses the Iu Release Request to request release of all RABs of an MS, and the RAB Release Request in other cases.

9.2.5.1 Release of RABs Triggered by an Iu mode RAN

9.2.5.1.1 RAB Release Procedure

An Iu mode RAN initiates a RAB release procedure to release one or several RABs. The RAB Release procedure is described in clause 12.7.2.

9.2.5.1.2 Iu Release Procedure

An Iu mode RAN initiates an Iu release procedure to release all RABs of an MS and the Iu connection. The Iu Release procedure is described in clause 12.7.3.

9.2.5.2 Re-establishment of RABs

The procedure for re-establishment of RABs allows the SGSN to re-establish RABs for active PDP contexts that don't have an associated RAB.

The MS initiates the re-establishment of RABs by using the Service Request (Service Type = Data) message. This is described in the clause "MS Initiated Service Request Procedure". SGSN shall not establish RABs for PDP contexts with maximum bit rate for uplink and downlink of 0 kbit/s. For these PDP contexts including a TFT with packet filter(s) set by the MS, the MS shall perform a MS-initiated PDP Context Modification or Deactivation procedure. For PDP

contexts including a TFT with packet filter(s) set by the network only, the MS does not re-establish the RABs (see clauses 9.2.3.4 and 9.2.3.5).

When RABs for an MS that has no RRC connection needs to be re-established, the CN must first page the MS. The clause "Network Initiated Service Request Procedure" describes this.

When RAB(s) are released in S4 SGSN, the received downlink data packet(s) for the preserved EPS bearer(s) may be buffered in the Serving GW. In this case, at reception of the first downlink data packet for one of those EPS bearers, the Serving GW sends a Downlink Data Notification message to the S4 SGSN. When RABs for a UE in PMM-IDLE needs to be re-established, the S4 SGSN must first page the UE. When RAB(s) need to be re-established for a UE that already has an active RRC connection, the S4 SGSN initiates the re-establishment of RABs for all the preserved PDN connections by using the RAB assignment procedure.

9.3 Packet Routeing and Transfer Function

The packet routeing and transfer function:

- routes and transfers packets between a mobile TE and a packet data network, i.e. between reference point R and reference points Gi or SGi;
- routes and transfers packets between mobile TE across different PLMNs, i.e.:
 - between reference point R and reference point Gi via interface Gp;
 - between reference point R and reference point SGi via interface S8;
- routes and transfers packets between TEs, i.e. between the R reference point in different MSs; and
- optionally supports IP Multicast routeing of packets via a relay function in the GGSN and P-GW.

The PDP PDUs shall be routed and transferred between the MS and the GGSN or P-GW as N-PDUs. In order to avoid IP layer fragmentation between the MS and the GGSN or P-GW, the link MTU size in the MS should be set to the value provided by the network as a part of the IP configuration. The link MTU size for IPv4 is sent to the MS by including it in the PCO (see TS 24.008 [13]). The link MTU size for IPv6 is sent to the MS by including it in the IPv6 Router Advertisement message (see RFC 4861 [98])

NOTE 1: Ideally the network configuration ensures that for PDP type IPv4v6 the link MTU values provided to the UE via PCO and in the IPv6 Router Advertisement message are the same. In cases where this condition cannot be met, the MTU size selected by the UE is unspecified.

When the MT and the TE are separated, e.g. a dongle based MS, it is not always possible to set the MTU value by means of information provided by the network. The network shall have the capability of transferring N-PDUs containing PDP PDUs, where the PDP PDUs are of 1500 octets, between the MS and GGSN/P-GW.

NOTE 2: The TE when it is separated from the MT can perform MTU configuration itself and this is out of scope of 3GPP standardization. Thus, when the MT component in the terminal obtains MTU configuration from the network, this does not imply that the behavior of the MS considered as a whole will always employ this MTU. In many terminals having a separated TE, the TE component configured by default to use an MTU of 1500 octets.

NOTE 3: In network deployments that have MTU size of 1500 octets in the transport network, providing a link MTU value of 1358 octets to the MS as part of the IP configuration information from the network will prevent the IP layer fragmentation within the transport network between the MS and the GGSN/P-GW. Link MTU considerations are discussed further in Annex C.

NOTE 4: As the link MTU value is provided as a part of the IP configuration information, a link MTU value can be provided during each PDN connection establishments.

NOTE 5: PDP type PPP is supported only when data is routed over a GGSN employing the Gn/Gp interfaces. A P-GW supports PDP type IPv4, IPv6 and IPv4/v6 only.

Between the 2G-SGSN and the MS, PDP PDUs are transferred with SMDCP. Between the 3G-SGSN and the MS, PDP PDUs are transferred with GTP-U and PDCP.

Between the SGSN and the GGSN when using Gn/Gp, or between the SGSN and the S-GW when using S4, PDP PDUs are routed and transferred with the UDP/IP protocols. The GPRS Tunnelling Protocol (GTP) transfers data through tunnels. A tunnel endpoint identifier (TEID) and an IP address identify a GTP tunnel. When a Direct Tunnel is established, PDP PDUs are routed and transferred directly between the UTRAN and the GGSN using Gn or between UTRAN and the S-GW using S12. On S5/S8 interfaces PMIP may be used instead of GTP (see TS 23.402 [90]).

When multiple PDP contexts exist for the same PDP address/APN pair of an MS, the GGSN routes downlink N-PDUs to the different GTP tunnels based on the downlink packet filters in the TFTs assigned to the PDP contexts. Upon reception of a PDP PDU, the GGSN evaluates for a match, first the downlink packet filter amongst all TFTs that has the smallest evaluation precedence index and, in case no match is found, proceeds with the evaluation of downlink packet filters in increasing order of their evaluation precedence index. This procedure shall be executed until a match is found, in which case the N-PDU is tunnelled to the SGSN via the PDP context that is associated with the TFT of the matching downlink packet filter. If no match is found, the N-PDU shall be sent via the PDP context that does not have a TFT assigned to it; if all PDP contexts have a TFT assigned, the GGSN shall silently discard the PDP PDU.

When multiple PDP contexts exist for the same PDP address/APN pair of an MS, the MS routes uplink PDP-PDUs to the different PDP contexts based on either MS-local mapping for 'MS_only' mode, or both MS-local mapping and uplink packet filters in the TFTs assigned to these PDP contexts for 'MS/NW' mode.

For 'MS_only' mode, upon transmission of a PDP PDU, the MS shall apply local mapping. The MS is responsible for creating or modifying PDP contexts and their QoS. The MS should define TFTs in such a way that downlink PDP PDUs are routed to a PDP context that best matches the QoS requested by the receiver of this PDU (e.g. an application supporting QoS). For each uplink PDP PDU, the MS should choose the PDP context that best matches the QoS requested by the sender of this PDP PDU (e.g. an application supporting QoS). Packet classification and routing within the MS is an MS-local matter. The GGSN shall not match uplink N-PDUs against TFTs.

NOTE 6: If the network applies enforcements of uplink PDP PDUs the network might expect the uplink PDP PDUs to be sent on the same PDP contexts as the corresponding downlink N-PDUs of the same traffic flow i.e. traffic flows might be expected to be bi-directional.

For 'MS/NW' mode, upon transmission of a PDP PDU, the MS evaluates for a match, first the uplink packet filter amongst all TFTs that has the smallest evaluation precedence index and, in case no match is found, proceeds with the evaluation of uplink packet filters in increasing order of their evaluation precedence index. This procedure shall be executed until a match is found, or all uplink packet filters have been evaluated. If a match is found, the PDP PDU is transmitted on the PDP context that is associated with the TFT of the matching uplink packet filter. If no match is found, the MS shall evaluate whether the PDP PDU belongs to an application for which the MS applied a local mapping to a PDP context. If this is the case, the relevant PDP context shall be used. Otherwise, the PDP PDU shall be sent via the PDP context that has not been assigned any uplink packet filter. If all PDP contexts have been assigned uplink packet filter(s), the MS shall silently discard the PDP PDU.

NOTE 7: Some MS implementations may expect that during the lifetime of a PDN connection (PDP contexts for the same PDP address/APN pair) where only the network has provided TFT packet filters, at most one PDP context exists without uplink packet filters. The requirements in clause 9.2.0 ensure that this PDP context cannot have any TFT and thus that it is unique. If the PDP context for services having downlink IP flows only, then the corresponding TFT needs to include an uplink packet filter that effectively disallows any useful uplink packet flows (see clause 15.3.3.4 for an example of such a packet filter).

TFTs are used for PDP types IPv4, IPv6, IPv4/v6 and PPP only. For PDP type PPP a TFT is applicable only when PPP is terminated in the GGSN (i.e. GGSN does not provide PDN interworking by means of tunnelled PPP, e.g. by the Layer Two Tunnelling Protocol (L2TP)) and IP traffic is carried over PPP. To support roaming subscribers, and for forward compatibility, the SGSN is not required to know the tunnelled PDP. Every SGSN shall have the capability to transfer PDUs belonging to PDPs not supported in the PLMN of the SGSN.

If packet routing and transfer takes place between the SGSN and the S-GW using S4, or between the UTRAN and the S-GW using S12, PDP contexts need to be mapped into EPS bearer contexts and vice versa. Context mapping is handled by the SGSN when using S4. This is transparent to the MS.

The GGSN and P-GW could also optionally support IP Multicast: this allows the MSs to join multicast groups and start receiving multicast packets. The GGSN duplicates the incoming multicast packets and relays them to the already active TEIDs. These TEIDs are those of MSs that have joined a multicast group.

9.4 Relay Function

The relay function of a network node transfers the PDP PDUs received from the incoming link to the appropriate outgoing link. At the RNC, the SGSN, the S-GW, and the GGSN or P-GW the relay function stores all valid PDP PDUs until they are forwarded to the next network node or until the maximum holding time of the PDP PDUs is reached. The PDP PDUs are discarded when buffering is longer than their maximum holding time. This maximum holding time is implementation dependent and can be influenced by the PDP type, the QoS of the PDP PDU, the resource load status, and by buffer conditions. The discarding protects resources from useless transfer attempts, especially the radio resource. Impacts on user protocol operation by too short holding time shall be avoided.

In A/Gb mode, the SGSN and GGSN or P-GW relay functions add sequence numbers to PDP PDUs received from SNDSCP and from the Gi or SGi reference points, respectively. In Iu mode, the RNC and GGSN or P-GW relay functions add sequence numbers to PDP PDUs received from PDCP and from the Gi or SGi reference points, respectively.

PDP PDUs may be re-sequenced in the RNC, the SGSN, and/or in the GGSN depending on the setting of the delivery order attribute in the QoS profile. In A/Gb mode, the SGSN relay function may perform re-sequencing of PDP PDUs before passing the PDP PDUs to SNDSCP. In Iu mode, the SGSN relay function may optionally perform re-sequencing of PDP PDUs before passing the PDP PDUs to Iu GTP-U and before passing the PDP PDUs to Gn GTP-U. The GGSN relay function may perform re-sequencing of PDP PDUs before passing the PDP PDUs to the Gi reference point. The RNC may perform re-sequencing of PDP PDUs before passing the PDP PDUs to PDCP.

9.5 Packet Terminal Adaptation Function

The Packet Terminal Adaptation function adapts packets received from and transmitted to the Terminal Equipment to a form suitable for transmission within the PLMN.

A range of MT versions providing different standard interfaces towards the TE can be used, e.g.:

- MT with asynchronous serial interface and PAD (Packet Assembly / Disassembly) support. If the PAD function does not exist in the MT, it exists in the TE.
- "Embedded MT" integrated with the TE, possibly via an industry-standard application program interface.
- MT with synchronous serial interface.

9.6 Encapsulation Function

GPRS transparently transports PDP PDUs between packet data networks and MSs. All PDP PDUs are encapsulated and decapsulated for routing purposes. Encapsulation functionality exists at the MS, at the RNC, at the Iu mode BSC, at the SGSN, at the S-GW, and at the GGSN/P-GW. Encapsulation allows PDP PDUs to be delivered to and associated with the correct PDP context in the MS, the SGSN, or the GGSN/P-GW. Two different encapsulation schemes are used; one for the backbone network between two GSNs, between SGSNs and S-GWs, and between an SGSN and an RNC, and one for the A/Gb mode connection between the SGSN and the MS or for the Iu mode RRC connection between the RAN and the MS.

Encapsulation requires that the MS is attached to GPRS, and that the PDP Context Activation procedure has been executed. If the GPRS Attach or PDP Context Activation procedures cannot be successfully executed, then uplink PDP PDUs are discarded in the MS. If these procedures have not been executed when a downlink PDP PDU arrives in the GGSN/P-GW, then the downlink PDP PDU shall be discarded, rejected, or the Network-Requested PDP Context Activation procedure shall be initiated. Network-Requested PDP Context Activation is not supported for connectivity over S4.

9.6.1 Encapsulation Between Core Network Nodes

Core network nodes encapsulate a PDP PDU with a GPRS Tunnelling Protocol header, and insert this GTP PDU in a UDP PDU that again is inserted in an IP PDU. The IP and GTP PDU headers contain the core network node addresses and tunnel endpoint identifier necessary to uniquely address a PDP context.

For connectivity between SGSNs and between SGSNs and GGSNs based on Gn/Gp, the GTP encapsulation header is defined in TS 29.060 [26]. For connectivity between SGSNs and between SGSNs and S-GWs based on S16 and S4, respectively, the GTP encapsulation header is defined in TS 29.274 [92].

9.6.2 Encapsulation Between SGSN and RAN in Iu mode

On the Iu interface, a PDP PDU is encapsulated with a GPRS Tunnelling Protocol header as specified in TS 29.060 [26].

9.6.3 Encapsulation Between SGSN and MS in A/Gb mode

Between an SGSN and an MS in A/Gb mode, an SGSN or MS PDP context is uniquely addressed with a temporary logical link identity and a network layer service access point identifier pair. TLLI is derived from the P-TMSI. An NSAPI is assigned when the MS initiates the PDP Context Activation function. The relationship between TLLI / NSAPI and LLC / SDCP is illustrated in Figure 94. TLLI and NSAPI are described in clause "NSAPI and TLLI for A/Gb mode".

9.6.4 Encapsulation Between RAN and MS in Iu mode

On the Uu interface, a PDP PDU is encapsulated with PDCP.

9.7 Home NodeB Multicast Packet Forwarding Function

A Home NodeB L-GW should receive and process multicast group membership report messages (e.g. according to RFC 3376 [106] / RFC 3810 [107]) sent either by the network accessed by LIPA or by the UE. Based upon these messages, the L-GW should forward multicast IP datagrams messages sent by the UE to the network accessed by LIPA, or from the network accessed by LIPA to the UE, as appropriate.

The UE may implement RFC 3376 [106] or RFC 3810 [107] to report multicast groups that the UE seeks to receive.

To make UPnP/DLNA service advertisements sent with an IP TTL=1 available to UEs that employ LIPA, a proxying function in the L-GW may be implemented, e.g. to retransmit UPnP service advertisements to UEs after changing the source address. This proxying to the UE shall not be performed if the multicast packet is transmitted with an IPv4 or IPv6 link-local source address, RFC 3927 [108], RFC 4291 [109].

10 Message Screening Functionality

This screening mechanism may be performed by routers and firewalls, and performs the selection of which packets to allow and which to deny.

Only network-controlled message screening shall be supported. Network-controlled screening is used to protect the GPRS packet domain PLMN from known security problems, and the screening provided by a certain PLMN is applied independently of the MS user. Network-controlled screening is outside the scope of this specification.

11 Compatibility Issues

Non-GPRS MSs in A/Gb mode PLMNs that support GPRS shall, without changes, be able to continue operation.

PLMNs that do not support GPRS shall, without changes, be able to continue interworking with PLMNs that do support GPRS.

An A/Gb mode MS shall be able to access GPRS services with GPRS-aware SIMs, and with SIMs that are not GPRS-aware. A GPRS-aware SIM is able to store information in the elementary files EF_{KcGPRS} and $EF_{LOCIGPRS}$, as defined in TS 51.011 [28].

The compatibility of SIMs and USIMs with A/Gb mode MSs or Iu mode MSs is defined in TS 22.102.

11.1 Interaction between Releases 97/98 and 99

NOTE: Unless specifically indicated, references to release 97 in this clause refer to both release 97 and release 98.

11.1.1 Interactions Between GTP v0 (R97) and GTP v1 (R99)

Support for GTPv0 is removed from 3GPP Rel-8 GTPv1 specification. Therefore, the interactions between GTPv0 (R99) and GTPv1(R99) is not defined and supported, for protocol details see "Removing support for GTPv1 to GTPv0" in TS 29.060 [26].

11.1.2 Interactions Between MS R97 and CN R99

When an R97 MS activates a PDP context and both the SGSN and the GGSN support R99, the QoS profile shall not be converted to R99.

11.1.3 Interactions Between SM R97 and SM R99

The SM protocol shall be backwards compatible.

11.1.4 Interactions Between MAP R97 and MAP R99

The MAP protocol shall be backwards compatible to allow interworking between HLRs and SGSNs that support different releases.

11.1a Interactions between Release 7 and earlier Releases

11.1a.1 Interactions Between CN (R7) and Iu-mode RAN (pre-R7)

A Gn/Gp SGSN supporting R7 or later shall be configured with knowledge of the Release supported by the Iu-mode RAN. In addition to the QoS profile negotiation mechanism defined in clause "Activation Procedures", the Gn/Gp SGSN shall further select specific values of the QoS profile to be compliant with the Release supported by the Iu-mode RAN, as specified in TS 23.107 [58] for that Release, before contacting the GGSN/P-GW, if appropriate, and performing RAB assignment procedures.

11.1a.2 Interactions between CN and RAN to handle Rel-7 QoS extensions

To avoid that bit rates exceeding 16 Mbps are assigned to UEs potentially not capable of handling NAS QoS extensions introduced in Rel-7, the RNC indicates a "Higher bitrates than 16 Mbps flag" in the RANAP Initial UE Message, RANAP Relocation Complete, or RANAP Enhanced Relocation Complete as defined in TS 25.413 [56b] to the SGSN. This flag is set depending on the "Access stratum release indicator" defined in TS 25.331 [52]. The "Higher bitrates than 16 Mbps flag" is set to "allowed" if the "Access stratum release indicator" is set to a release of Rel-7 or higher. Otherwise, it shall be set to "not allowed".

If the SGSN receives the "Higher bitrates than 16 Mbps flag" in RANAP Initial UE Message, RANAP Relocation Complete, or RANAP Enhanced Relocation Complete, it stores it as received in the MM Context of the UE, unless, based on implementation specific logic, the SGSN derives from other information that the UE either supports bitrates higher than 16 MBit/s or not. If "Higher bitrates than 16 Mbps flag" is not included by RANAP (since the employed version of the RANAP protocol does not support this feature), the SGSN sets the corresponding flag in the MM Context of the UE depending on implementation.

NOTE: If the employed RANAP version does not provide the information the SGSN can infer information that the UE is capable of handling NAS QoS extensions introduced in Rel-7 from MS network capability information, e.g. from information that the UE supports LTE/EPC.

If the "Higher bitrates than 16 Mbps flag" in the MM Context of the UE is set to "not allowed" and if the authorized APN-AMBR is higher than 16 Mbps, the S4-SGSN shall, for non-GBR bearers, restrict the MBR sent to the UE to

within 16 Mbps. For GBR bearers, the request shall be rejected if the authorized GBR/MBR is higher than 16 Mbps in the activation and modification procedures.

11.2 Network Configuration for Interaction with E-UTRAN and S4-SGSNs

GPRS idle mode mobility procedures performed by Gn/Gp SGSNs specify a set of sequence number handling functions, e.g. the exchange of sequence numbers during Routing Area Update procedure. E-UTRAN based and S4-SGSN based idle mode mobility procedures don't specify any such sequence number mappings for mobility scenarios. To avoid interoperation issues a network that deploys E-UTRAN and/or S4-SGSNs shall not configure usage of the feature "delivery order required" for PDP contexts of PDP type IPv4, IPv6 or IPv4v6. Also the network shall not configure usage of lossless PDCP of UTRAN and the GERAN SGSN shall not configure usage of acknowledged mode LLC/NSAPI/SNDCP.

11.3 Interactions between CN and RAN to support higher bit rates

A Gn/Gp SGSN or S4-SGSN supporting QoS extensions available from this release of specification shall be configured with knowledge of the Maximum Bit Rate and Guaranteed Bit Rate supported by the Iu-mode RAN. In addition to the QoS profile negotiation mechanism defined in clause 9.2.2 "Activation Procedures", the Gn/Gp SGSN or S4-SGSN shall further select specific values of the QoS profile to be compliant with the Maximum Bit Rate supported by the Iu-mode RAN, as specified in TS 23.107 [58] for that release, before performing RAB assignment procedures.

For GBR bearers, the Gn/Gp SGSN shall restrict the Guaranteed Bit Rate in the same way as described for the Maximum Bit Rate above. For GBR bearers, the S4-SGSN shall reject an EPS Bearer Activation or Modification including a Guaranteed Bit Rate that is not supported by the Iu-mode RAN. RAB Assignment procedures shall not be initiated in this case.

12 Transmission

12.1 Transmission Modes

In A/Gb mode, the LLC and RLC protocols offer various transmission modes. The combinations of the LLC and RLC transmission modes define the QoS attributes SDU error ratio and residual bit error ratio.

In Iu mode, the RLC protocol provides various transmission modes to support user data transmission with different QoS.

The RLC protocol for A/Gb mode and the RLC protocol for Iu mode are distinct protocols.

12.1.1 GTP-U Transmission Modes

One mode of operation of the GTP-U layer is supported for information transfer between the GGSN and SGSN, unacknowledged (UDP/IP). This is also used between SGSN and S-GW, between S-GW and P-GW, and between RNC and S-GW. In Iu mode, GTP-U is also used on the Iu interface for user data transport. Only the unacknowledged mode (UDP/IP) is supported on the Iu interface.

12.1.2 LLC Transmission Modes (A/Gb mode)

Two modes of operation of the LLC layer are defined for information transfer; unacknowledged and acknowledged. The LLC layer shall support both modes simultaneously.

- In acknowledged mode, the receipt of LL-PDUs is confirmed. The LLC layer retransmits LL-PDUs if confirmation has not been received within a timeout period.
- In unacknowledged mode, there is no confirmation required for LL-PDUs.

Signalling and SMS shall be transferred in unacknowledged mode.

In unacknowledged mode, the LLC layer shall offer the following two options:

- transport of "protected" information, such that errors within the LLC information field result in the frame being discarded; and
- transport of "unprotected" information, such that errors within the LLC information field do not result in the frame being discarded.

The LLC layer shall support several different QoS traffic classes with different transfer delay characteristics.

12.1.3 RLC Transmission Modes

Two modes of operation of the RLC layer are defined for information transfer; unacknowledged and acknowledged. The RLC layer shall support both modes simultaneously.

The RLC for A/Gb mode is described in TS 44.060 [77], and for Iu mode in TS 25.322 [55].

12.2 Logical Link Control Functionality (A/Gb mode)

The Logical Link Control (LLC) protocol provides a reliable logical link between the MS and its SGSN. As shown in clause "User and Control Planes", the LLC layer is situated below the SNDC layer.

12.2.1 Addressing

TLLI is used for addressing at the LLC layer. TLLI is described in clause "NSAPI and TLLI for A/Gb mode".

12.2.2 Services

LLC provides the services necessary to maintain a ciphered data link between an MS and an SGSN. The LLC layer does not support direct communication between two MSs.

The LLC connection is maintained as the MS moves between cells served by the same SGSN. When the MS moves to a cell being served by a different SGSN, the existing connection is released and a new logical connection is established with the new SGSN.

LLC shall be independent of the underlying radio interface protocols. In order to allow LLC to operate with a variety of different radio interface protocols, and to ensure optimum performance, it may be necessary to adjust e.g. the maximum LLC PDU length and the LLC protocol timer values. Such adjustments can be made through negotiation between the MS and the SGSN. The maximum length of an LLC PDU shall not be greater than 1 600 octets minus the BSSGP protocol control information.

12.2.3 Functions

The Logical Link Control layer supports:

- service primitives allowing the transfer of SNDCP Protocol Data Units (SN-PDUs) between the Subnetwork Dependent Convergence layer and the Logical Link Control layer;
- procedures for transferring LL-PDUs between the MS and SGSN, including:
 - procedures for unacknowledged delivery of LL-PDUs between the MS and the SGSN; and
 - procedures for acknowledged, reliable delivery of LL-PDUs between the MS and SGSN;
- procedures for detecting and recovering from lost or corrupted LL-PDUs;
- procedures for flow control of LL-PDUs between the MS and the SGSN; and
- procedures for ciphering of LL-PDUs. The procedures are applicable to both unacknowledged and acknowledged LL-PDU delivery.

The layer functions are organised in such a way that ciphering resides immediately above the RLC/MAC layer in the MS, and immediately above the BSSGP layer in the SGSN.

12.3 Subnetwork Dependent Convergence Functionality (A/Gb mode)

The Subnetwork Dependent Convergence (SNDC) protocol is situated below the network layer and above the Logical Link Control layer in the MS and the SGSN, as shown in clause "User and Control Planes". A variety of network layers are supported; e.g. IP. The network-layer packet data protocols share the same SNDCP, which performs multiplexing of data coming from the different sources to be sent across the LLC. This is illustrated in Figure 80.

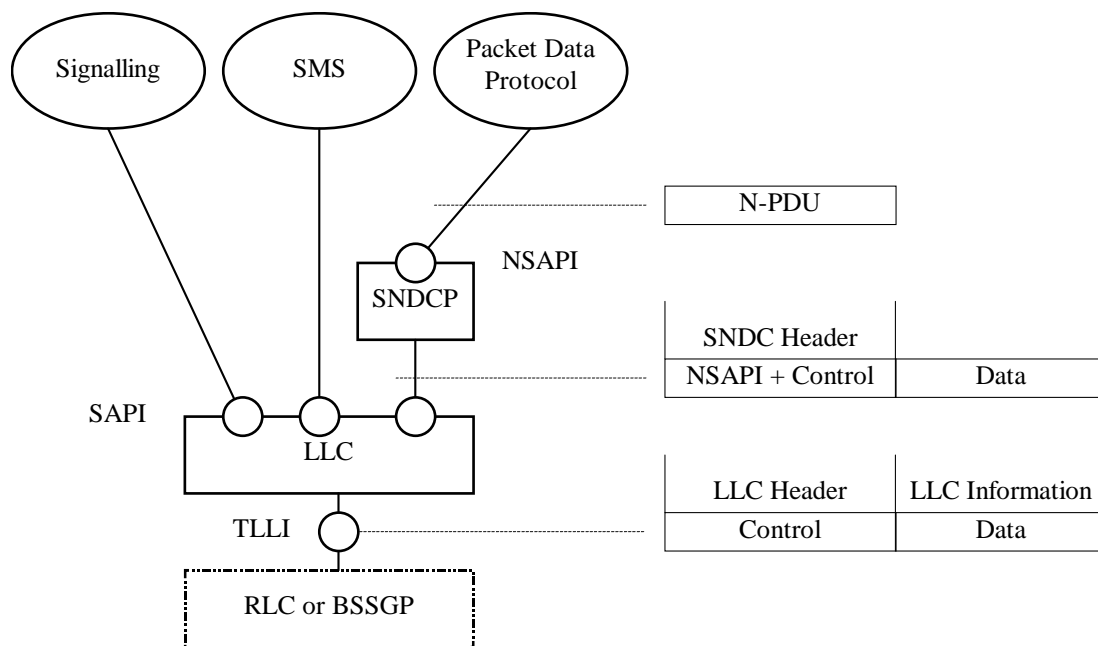

Figure 80: Multiplexing of Network Protocols

The following identities and control information is needed:

- NSAPI identifies the network layer. The SNDCP control part contains compression information.
- TLLI identifies the MS. The LLC control part contains the rest of the LLC protocol header including ciphering information.

The Subnetwork Dependent Convergence function is defined in terms of offered services and sub-functions.

12.3.1 Services

The SNDC function provides the following services to the network layer:

- Transmission and reception of N-PDUs in acknowledged and unacknowledged LLC mode. In acknowledged mode, the receipt of data shall be confirmed at the LLC layer, and the data shall be transmitted and received in order per NSAPI. In unacknowledged mode, the receipt of data shall not be confirmed at the SNDCP layer nor at the LLC layer.
- Transmission and reception between the MS and SGSN of variable-length N-PDUs.
- Transmission and reception of N-PDUs between the SGSN and MS according to the negotiated QoS profile.
- Transfer of the minimum amount of data possible between the SGSN and MS through compression techniques.

The SNDC function requires the following services from the LLC layer:

- Acknowledged and unacknowledged data transfer.

- Ciphered transmission of SN-PDUs.
- In-order delivery of SN-PDUs per LLC SAPI.
- Support for variable-length SN-PDUs.

12.3.2 Subfunctions

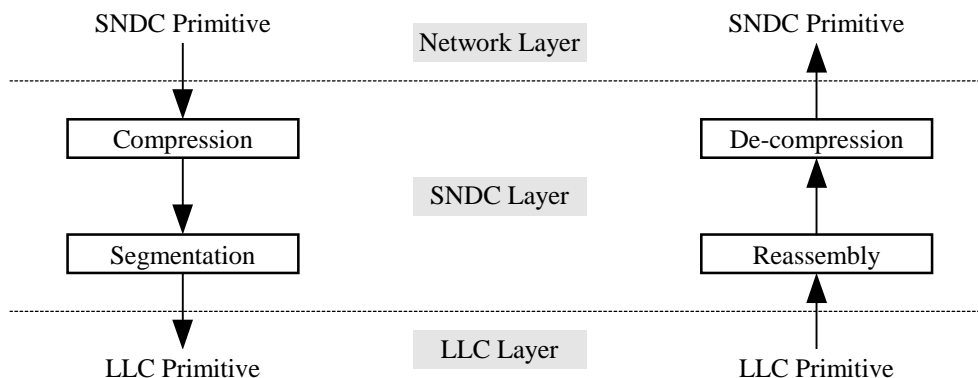

Figure 81: Sequential Invocation of SNDC Functionality

SNDCP performs the following subfunctions:

- Mapping of SNDC primitives received from the network layer into corresponding LLC primitives to be passed to the LLC layer, and vice versa.
- Multiplexing of N-PDUs from one or several NSAPIs onto one LLC SAPI. NSAPIs that are multiplexed onto the same SAPI shall use the same radio priority level, and traffic class. In case BSS packet flow contexts are created all NSAPIs that are multiplexed onto the same LLC SAPI shall share the same BSS packet flow context.
- Compression of redundant protocol control information and user data. This may include e.g. TCP/IP header compression and V.42 bis [32] data compression. Compression may be performed independently for each QoS traffic handling priority and traffic class. If several network layers use the same QoS traffic handling priority and traffic class, one common compressor may be used for these network layers. The relationship between NSAPIs, compressors, and SAPIs is defined in TS 44.065 [16]. Compression parameters are negotiated between the MS and the SGSN. Compression is an optional SNDC function. The GGSN may indicate to the SGSN during PDP Context Activation and during Update PDP Context to negotiate no data compression for the PDP context.
- Segmentation and reassembly. The output of the compression subfunctions are segmented to maximum-length LLC frames.

12.4 PDCP (lu mode)

The Packet Data Compatibility Protocol (PDCP) transmission functionality maps network-level characteristics onto the characteristics of the underlying network. PDCP can support several network layer protocols by providing protocol transparency for the users of the service. PDCP provides protocol control information compression. PDCP is located in the MS and the RAN and is described in TS 25.323 [57].

12.5 Point-to-Point Protocol Functionality

The PPP protocol is specified in RFC 1661 [44].

PDP Type PPP is only supported when using Gn/Gp.

12.5.1 User Plane for PDP Type PPP

The user plane for the PDP type PPP consists of a PPP protocol stack above SNDCP for A/Gb mode or above PDCP for Iu mode in the MS, and above GTP in the GGSN. The GGSN may either terminate the PPP protocol and access the packet data network at the IP level, or further tunnel PPP PDUs via e.g. L2TP.

In case the application above PPP uses a different protocol than IP (e.g. IPX or AppleTalk), the interconnection to the packet data network is outside the scope of this specification.

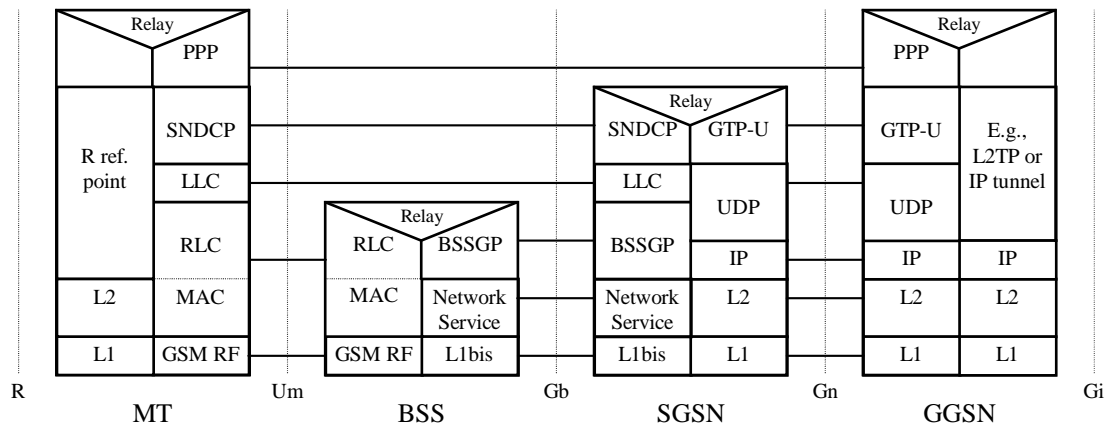

Figure 82: A/Gb mode User Plane for PDP Type PPP

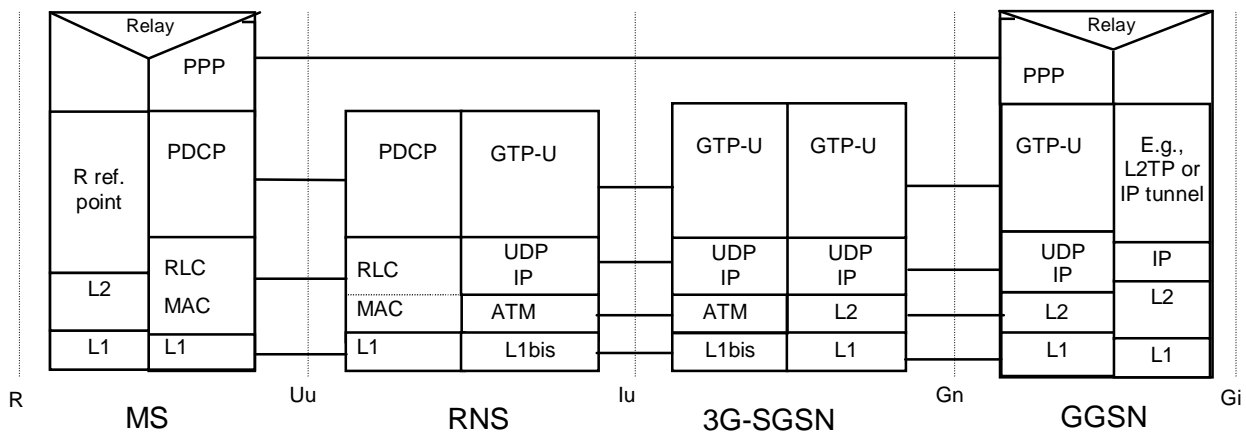

Figure 83: Iu mode User Plane for PDP Type PPP

12.5.2 Functions

The PPP peers at the MS and the GGSN handle the PPP protocol as specified in RFC 1661 [44]. PPP requires in-sequence packet delivery by the underlying protocols. Concerning GTP, this shall be achieved by negotiation of the delivery order attribute in the QoS profile upon PDP context activation. In A/Gb mode, concerning SNDCP, out-of-sequence packets, that may be present if LLC operates in unacknowledged mode, shall be discarded. SNDCP for A/Gb mode, and PDCP for Iu mode, shall not use TCP/IP header compression because PPP may not carry IP packets at all, or because PPP may carry IP packets with already compressed TCP/IP headers. These PPP options are negotiated during the RFC 1661 [44] Network Control Protocol establishment phase.

12.6 Gb Interface (A/Gb mode)

The Gb interface connects the BSS and the SGSN, allowing the exchange of signalling information and user data. The Gb interface shall allow many users to be multiplexed over the same physical resource. Resources are given to a user upon activity (when data is sent or received) and are reallocated immediately thereafter. This is in contrast to the A

interface where a single user has the sole use of a dedicated physical resource throughout the lifetime of a call irrespective of activity.

A/Gb mode signalling and user data are sent in the same user plane. No dedicated physical resources are required to be allocated for signalling purposes.

Access rates per user may vary without restriction from zero data to the maximum possible line rate (e.g. 1 984 kbit/s for the available bit rate of an E1 trunk).

12.6.1 Physical Layer Protocol

Several physical layer configurations and protocols are possible, as defined in TS 48.014 [19].

The physical resources shall be allocated by O&M procedures.

12.6.2 Link Layer Protocols

Several Gb interface link layer configurations and protocols are possible as defined in TS 48.016 [20].

12.6.3 BSS GPRS Protocol

The primary function of BSSGP is to provide the radio-related, QoS, and routing information that is required to transmit user data between a BSS and an SGSN. In the BSS, it acts as an interface between LLC frames and RLC/MAC blocks. In the SGSN, it forms an interface between RLC/MAC-derived information and LLC frames. A secondary function is to enable two physically distinct nodes, the SGSN and the BSS, to operate node management control functions.

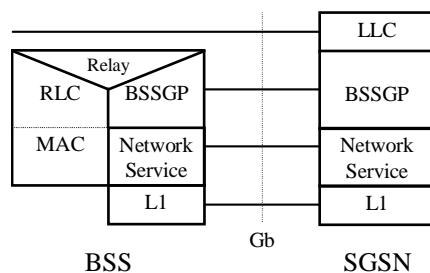

Figure 84: BSSGP Protocol Position

There is a one-to-one relationship between the BSSGP protocol in the SGSN and in the BSS. If one SGSN handles multiple BSSs, the SGSN has to have one BSSGP protocol machine for each BSS. If the BSS applies Intra Domain Connection of RAN Nodes to Multiple CN Nodes, the BSS must have one BSSGP protocol machine for each SGSN to which it applies Intra Domain Connection of RAN Nodes to Multiple CN Nodes.

The main functions of the BSSGP protocol are to:

- provide a connection-less link between the SGSN and the BSS;
- transfer data unconfirmed between the SGSN and the BSS;
- provide tools for bi-directional control of the flow of data between the SGSN and the BSS;
- handle paging requests from the SGSN to the BSS;
- give support for flushing of old messages in the BSS e.g. when an MS changes BSS;
- support multiple layer 2 links between the SGSN and one BSS; and
- Provide tools for control of the flow of data between the SGSN and the BSS during PS Handover procedures, as defined in TS 48.018 [78].

BSSGP is defined in TS 48.018 [78].

12.6.3.1 Inter-dependency of the BSSGP and LLC Functions

The functions of the BSSGP shall be defined in the context of the LLC function in order to avoid duplication of functions and information flows. The following functional model indicates each layer's functional responsibilities.

Table 4: Mapping of High-level Functions Across the Gb Architecture

Network Node and Function	MS	BSS	SGSN
LLC: TS 44.064 [15]	Same as for the SGSN.		Provides transfer of frames between the SGSN and MS.
BSSGP: TS 48.018 [78]		<p>MS←PLMN: Using BSSGP information, RLC/MAC operations are invoked.</p> <p>MS→PLMN: Using RLC/MAC-derived information, a BSSGP PDU is constructed. An identifier of the cell including RAC and LAC in which an LLC frame was received is inserted into the BSSGP PDU.</p> <p>Same as for SGSN.</p>	<p>Individual MS radio-related information is used by the BSS to transfer LLC frames across the Gb and Um.</p> <p>Provides flow control and unconfirmed data delivery services across the Gb interface (not the Um – this is the function of the LLC and RLC/MAC function).</p> <p>Provides SGSN-BSS node management functions.</p>
Network Service: TS 48.016 [20]		Same as for SGSN	Provides a multiplexing, variable-bandwidth, frame-based, link layer transport mechanism across the Gb interface, and load balancing.

12.6.3.2 BSSGP Addressing

For information transfer between the SGSN and the BSS, the BSSGP is using a BSSGP Virtual Connection Identifier (BVCI) for addressing. Additionally, QoS profile, and the MS identification, e.g. TLLI, may be used to create queues and contexts in both the SGSN and the BSS. The flow control mechanism is then based on these queues and contexts.

12.6.3.3 BVCI Contexts in BSS and in SGSN

A BVCI context in the BSS consists of at least one queue for LLC PDUs and of the radio resource capacity that is available on a radio cell for one SGSN. If the BSS applies Intra Domain Connection of RAN Nodes to Multiple CN Nodes, the BSS must share the total available radio resource capacity for a radio cell between all the BVCI contexts representing this radio cell, where each of these BVCI contexts represents the radio cell for one SGSN.

The BVCI context in the BSS is allocated for each cell supporting GPRS. For each new GPRS cell introduced in the BSS area, a new BVCI context shall be allocated. If the BSS applies Intra Domain Connection of RAN Nodes to Multiple CN Nodes, the BSS must have for each cell supporting GPRS and belonging to one pool area, one BVCI context for each of the SGSNs associated with this pool area.

In the SGSN, the BVCI context consists of at least one queue for LLC PDUs and the allowed throughput on BSSGP. The allowed throughput is updated by BSSGP flow control messages.

12.6.3.4 Flow Control Between SGSN and BSS over the Gb Interface

The flow control mechanism controls the loading of the BSS LLC PDU queues per BVCI, per MS and optionally per one or more PFCs between the SGSN and the BSS in the downlink direction. No flow control is performed in the uplink direction. Buffers and link capacity shall be dimensioned to avoid loss of uplink data.

The downlink flow control mechanism is based on the following principles:

- In the SGSN, queues for LLC PDUs are provided per BVCI. These queues may be split further, e.g. per MS or per packet flow. The SGSN shall pass LLC PDUs to LLC via BSSGP to the BSS as long as the allowed BSSGP throughput is not exceeded. The allowed BSSGP throughput is given per BVCI, for a single MS on that BVCI and optionally for one or more PFCs of a single MS on a certain BVCI. The SGSN schedules the BSSGP downlink traffic of all MSs of a BVCI and, optionally of all PFCs of an MS, according to the maximum and guaranteed bit rate attributes and to the QoS profile related to each LLC PDU. The scheduling algorithm is implementation dependent.
- In the BSS, queues per BVCI context are provided at the BSSGP level. These queues may be split further, e.g. per MS or per packet flow. Depending on the queuing conditions and the available radio resource capacity in the cell, the BSS indicates the allowed BSSGP throughput per BVCI context and the default allowed BSSGP throughput for each individual MS of that BVCI context by BSSGP flow control messages to the SGSN. Additionally, the BSS may change the allowed BSSGP throughput for one or more PFCs of an individual MS or for an individual MS by a BSSGP flow control message. As more than one SGSN may send downlink data at the same time for a radio cell when the BSS applies Intra Domain Connection of RAN Nodes to Multiple CN Nodes, the BSS has to share the total possible downlink traffic between the SGSNs that can access a radio cell. The BSS should use the existing flow control procedure on BVCI level to control each of the SGSNs in a way not to violate the total possible traffic for the radio cell. How the BSS decides to share the downlink traffic between each of the SGSNs is an implementation specific issue.

12.6.3.5 BSS Context

The SGSN may provide a BSS with information related to ongoing user data transmission in A/Gb mode. The information is given as BSS packet flow contexts, which describe QoS characteristics for the data transmission. Network support of BSS packet flow procedures is indicated in the system information as specified in TS 44.060 [77], the MS support is indicated in MS network capability as specified in TS 24.008 [13].

All BSS packet flow contexts related to one MS are stored in an MS specific BSS context. The BSS may contain BSS contexts for several MSs. Within a BSS context the BSS packet flow contexts are identified by a packet flow identifier, which is assigned by the SGSN. A BSS packet flow context is shared by one or more LLC SAPIs of the same MS with identical or similar negotiated QoS profiles. The data transfers related to LLC SAPIs that share the same BSS packet flow context constitute one packet flow.

Four packet flows are pre-defined, and identified by four reserved packet flow identifier values. The BSS shall not negotiate BSS packet flow contexts for these pre-defined packet flows with the SGSN. One pre-defined packet flow is used for best-effort service, one is used for SMS, one is used for TOM (Tunnelling of Messages) and one is used for signalling. The SGSN can assign the best-effort or SMS packet flow identifier to any PDP context. In the SMS case, the BSS shall handle the packet flow for the PDP context with the same QoS with which it handles SMS. A non-reserved packet flow identifier value is only significant for an MS when the SGSN provided the BSS with a packet flow context for this packet flow identifier value for this MS.

The combined BSS QoS profile for the PDP contexts that share the same packet flow is called the aggregate BSS QoS profile. The aggregate BSS QoS profile is considered to be a single parameter with multiple data transfer attributes as defined in clause "Quality of Service Profile". It defines the QoS that must be provided by the BSS for a given packet flow between the MS and the SGSN, i.e. for the Um and Gb interfaces combined. The aggregate BSS QoS profile is negotiated between the SGSN and the BSS. In order to control UE-AMBR, the SGSN shall group all non-GBR PDP contexts for an MS into a single aggregate BSS QoS profile and set the MBR parameter of that profile to equal the UE-AMBR.

NOTE: In order to maintain relative priority, associated with PDP contexts, of packets, implementation should ensure that packets are prioritised/scheduled appropriately before being passed into the BSS packet flow context.

A BSS packet flow timer indicates the maximum time that the BSS may store the BSS packet flow context. The BSS packet flow timer shall not exceed the value of the READY timer for this MS. The BSS packet flow timer is started when the BSS packet flow context is stored in the BSS and when an LLC frame is received from the MS. When the BSS packet flow timer expires, the BSS shall delete the BSS packet flow context.

When a PDP context is activated, modified or deactivated, the SGSN may create, modify, or delete BSS packet flow contexts.

PS Handover procedure is used to handover an MS with one or more packet flows from a source cell to a target cell. Handling of the BSS packet flows during PS Handover procedures over the BSSGP are described in TS 43.129 [87] and TS 48.018 [78].

12.6.3.5.1 BSS Packet Flow Context Creation Procedure

On receiving a request to transmit an uplink or downlink LLC PDU for which no BSS packet flow context exists in the BSS, the BSS may request the download of the BSS packet flow context from the SGSN.

If MS and BSS supports BSS packet flow procedures the SGSN may at any time request the creation of a BSS packet flow context, e.g. due to the activation of a PDP context.

If a request to create a BSS Packet Flow is received in the BSS for an MS during the ongoing PS Handover procedure, then the BSS shall ignore the request and apply the procedures as described in TS 48.018 [78].

The BSS Packet Flow Context Creation procedure is illustrated in Figure 85.

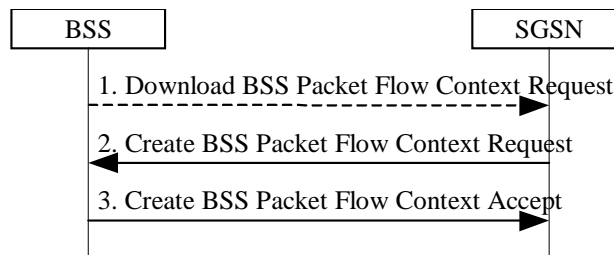

Figure 85: BSS Packet Flow Context Creation Procedure

- 1) The BSS receives a request to transfer an uplink or downlink user data LLC PDU for which it currently does not have a BSS packet flow context. In the uplink case, TLLI, Radio Priority, and Packet Flow Id are received from the MS as defined in TS 44.060 [77]. In the downlink case, TLLI and Packet Flow Id are received from the SGSN as defined in TS 48.018 [78]. If Packet Flow Id does not indicate a pre-defined value the BSS sends a Download BSS Packet Flow Context Request (RAI, TLLI, Packet Flow Id) message to the SGSN. Until the BSS receives the BSS packet flow context, the BSS shall handle uplink and downlink transfers according to a default aggregate BSS QoS profile. For uplink transfers, the default profile is specific to the radio priority level.
- 2) The SGSN sends a Create BSS Packet Flow Context Request (IMSI, TLLI, Packet Flow Id, Aggregate BSS QoS Profile Requested, BSS Packet Flow Timer) message to the associated BSS. The SGSN derives Aggregate BSS QoS Profile Requested from the QoS profile negotiated for the PDP contexts that share a packet flow as follows: The SGSN shall divide the transfer delay attribute in the QoS profile in one core network part and one BSS part. The SGSN estimates the transfer delay in the core network and subtracts this from the GPRS bearer service transfer delay. The result only covers the delay in the MS to SGSN segment of the GPRS PLMN. Since the BSS transports LLC PDUs obtained after segmentation of SDUs by the SMDCP layer, the SGSN shall convert the values of the GPRS bearer service attributes maximum SDU size, SDU error ratio, residual bit error ration, maximum bit rate, guaranteed bit rate and the resulting transfer delay to values applicable to the LLC PDUs. All other attributes in Aggregate BSS QoS Profile shall be the same as the corresponding GPRS bearer service attribute, see TS 23.107 [58]. The SGSN may also include the Allocation / Retention Priority Information Element in the Create BSS Packet Flow Context Request.
- 3) The BSS may restrict the requested aggregate BSS QoS profile given its capabilities and the current load. If the Allocation / Retention Priority Information Element is included by the SGSN in the Create BSS Packet Flow Context Request, the BSS may use it to perform queuing of the packet flow context creation or to pre-empt other packet flow contexts. The BSS creates a BSS packet flow context and inserts the parameters in its BSS context. The BSS returns a Create BSS Packet Flow Context Accept (IMSI, Packet Flow Id, Aggregate BSS QoS Profile Negotiated) message to the SGSN. The BSS uses the negotiated aggregate BSS QoS profile when allocating radio resources and other resources such as buffer capacity. The detailed operation is defined in TS 48.018 [78]. If the SGSN Aggregate BSS QoS Profile requested by the SGSN was restricted by the BSS, the SGSN takes the BSS restriction into account when indicating to the MS the negotiated QoS of the associated PDP context(s).

12.6.3.5.2 SGSN-Initiated BSS Packet Flow Context Modification Procedure

The SGSN may at any time request the modification of the contents of an existing BSS packet flow context, e.g. due to the activation, modification, or deactivation of a PDP context, or modification of the UE-AMBR value. The BSS Packet Flow Context Creation procedure shall be used in this case, and the BSS shall instead of creating a BSS packet flow context overwrite the existing parameters with the modified parameters.

The BSS Packet Flow Context Modification procedure will never be initiated for an MS during the ongoing PS Handover procedure as described in TS 48.018 [78].

12.6.3.5.3 BSS-Initiated BSS Packet Flow Context Modification Procedure

The BSS can at any time request modification of the contents of an existing BSS packet flow context, e.g. due to a change in the resource availability at the BSS.

The BSS-Initiated BSS Packet Flow Context Modification procedure is illustrated in Figure 86.

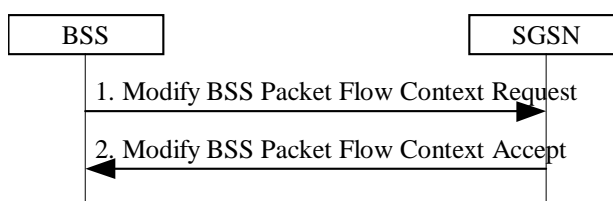

Figure 86: BSS-Initiated BSS Packet Flow Context Modification Procedure

- 1) The BSS sends a Modify BSS Packet Flow Context Request (IMSI, Packet Flow Id, Aggregate BSS QoS Profile Requested) message to the SGSN.
- 2) The SGSN may restrict the requested aggregate BSS QoS profile given its capabilities and the current load. The SGSN returns a Modify BSS Packet Flow Context Accept (IMSI, TLLI, Packet Flow Id, Aggregate BSS QoS Profile Negotiated, BSS Packet Flow Timer) message to the BSS. The BSS inserts the modified parameters in its BSS context.

12.6.3.5.4 BSS Packet Flow Context Deletion Procedures

The BSS may, due to e.g. memory restrictions or user inactivity, at any time delete a BSS packet flow context without notifying the SGSN.

If the BSS is no longer able to support the aggregate BSS QoS profile of a BSS packet flow context, it may, especially for conversational or streaming traffic class, request the SGSN to delete or modify the BSS packet flow context. The SGSN should either modify or delete the BSS packet flow context. In addition the SGSN may need to initiate the PDP Context Modification or PDP Context Deletion procedure.

If a Delete BSS Packet Flow Context Request is received for an MS during the ongoing PS Handover procedure, the procedures applied are described in TS 48.018 [78].

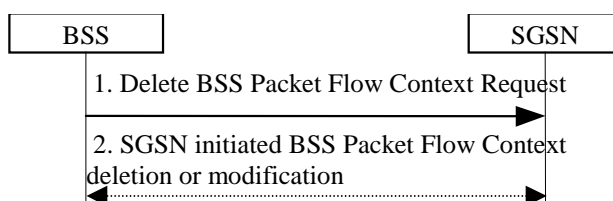

Figure 86a: BSS-Initiated BSS Packet Flow Context Deletion Procedure

- 1) The BSS sends a Delete BSS Packet Flow Context Request (TLLI, Packet Flow Id, Cause) to the SGSN.
- 2) The SGSN should start either the SGSN-initiated BSS packet flow context modification procedure or the deletion of the BSS packet flow context. In addition the SGSN may need to initiate the PDP Context Modification or PDP Context Deletion procedure.

The SGSN may request the deletion of a BSS packet flow context with the SGSN-Initiated BSS Packet Flow Context Deletion procedure, as illustrated in Figure 87.

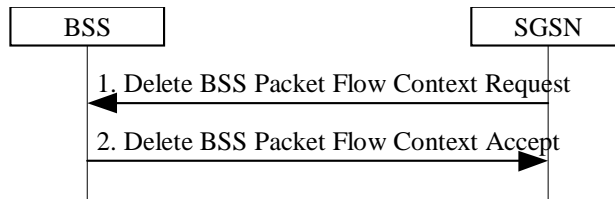

Figure 87: SGSN-Initiated BSS Packet Flow Context Deletion Procedure

- 1) The SGSN sends a Delete BSS Packet Flow Context Request (TLLI , Packet Flow Id) message to the BSS. The BSS deletes the corresponding BSS packet flow context from its BSS context.
- 2) The BSS returns a Delete BSS Packet Flow Context Accept (TLLI, Packet Flow Id) message to the SGSN.

12.7 Iu Interface (Iu mode)

The Iu interface connects the UTRAN or Iu mode GERAN and the Core Network allowing the exchange of signalling information and user data. The user plane of the Iu interface shall allow user data from many users to be multiplexed over the same physical resource. Resources are given to a user upon activity (when data is sent or received) and are reallocated immediately thereafter.

In Iu mode only user data is transmitted on this shared physical medium. Signalling data is transferred via an SCCP connection. Two different options exist for the transport of signalling and user data over Iu: the ATM transport option and the IP transport option. The different protocol stacks applicable to the Iu interface are described in TS 25.412 [56] for the control plane and TS 25.414 [64] for the user plane.

12.7.1 Consistent Sequence Numbering of PDUs on Iu and Gn Interfaces

The GTP-U PDU sequence numbers allocated by the GGSN (downlink) and SRNS/SBSS (uplink) are kept unchanged irrespective of the number of GTP tunnels the PDU is transferred over. Therefore, SGSN shall use on the Iu interface for downlink PDUs the GTP-U sequence number received from the GGSN, and shall use on the Gn interface for uplink PDUs the GTP-U sequence number received from the SRNS/SBSS. In case of SRNS/SBSS relocation and inter-system change, the SRNS/SBSS and SGSN shall tunnel PDUs without changing the GTP-U sequence numbers.

12.7.2 RAB Release Procedure

12.7.2.1 RAB Release Procedure using Gn/Gp

UTRAN initiates a RAB release procedure to release one or several RABs. The RAB Release procedure is illustrated in Figure 88a.

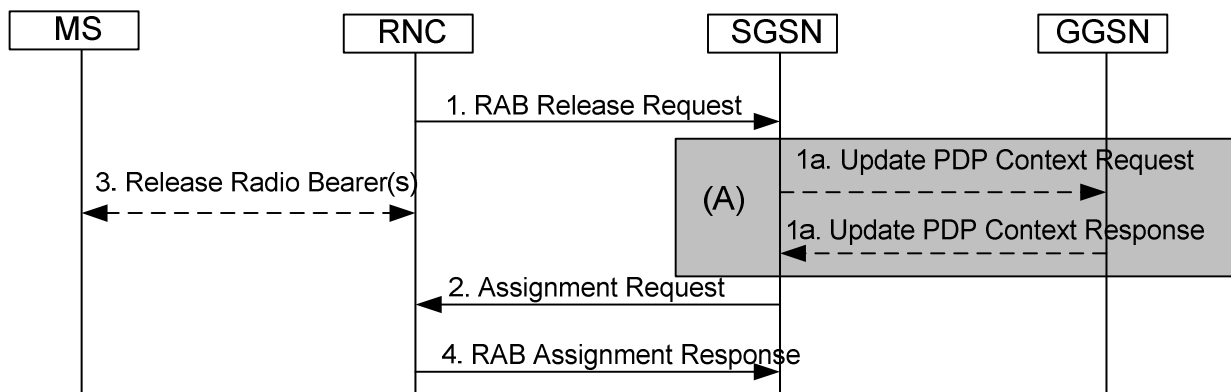

Figure 88a: RAB Release Procedure Using Gn/Gp

- 1) UTRAN initiates the procedure by sending a RAB Release Request (For each RAB to be released: RAB ID, Cause) message to the SGSN.
- 1a) If PDP Contexts associated with the released RABs are using streaming or conversational traffic class and to be preserved, or Direct Tunnel was established the SGSN sends Update PDP Context Request to the GGSN(s) concerned to establish the GTP tunnel between SGSN and GGSN. The GGSN(s) update the Address for User Plane and TEID for downlink data and return an Update PDP Context Response. The No QoS negotiation indication is set in Update PDP Context Request to indicate to the GGSN that the SGSN does not upgrade the previously negotiated QoS attributes and that the GGSN shall not negotiate the QoS attributes. The GGSN(s) shall not include a PCO in the Update PDP Context Response if the No QoS negotiation indication is set. See clause 12.7.2.2 when S4 interface is used.
- 2) The SGSN sends a RAB Assignment Request (For each RAB to be released: RAB ID, Cause) to the UTRAN.
- 3) The Radio Bearer(s) are released if still existing.
- 4) UTRAN sends a RAB Assignment Response (For each released RAB: RAB ID, GTP SND, GTP SNU) to the SGSN. GTP SND and GTP SNU enable the SGSN to restore the values in case the PDP context is maintained and the RAB is re-established at a later stage.

If the RAB for the LIPA PDP Context is released, the HNB informs the collocated L-GW by internal signalling to release the direct user plane path between the L-GW and HNB of the LIPA PDP context.

12.7.2.2 RAB Release Procedure using S4

The following illustrates the procedure between SGSN and S-GW when RAB Release Procedures takes place over S4. The procedure between MS and SGSN is same as specified in clause 12.7.2.1.

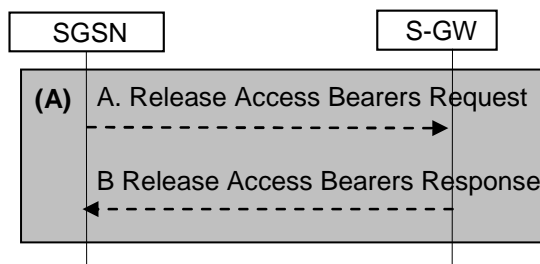

Figure 88b: RAB Release Procedure Using S4

- A. The SGSN deactivates affected PDP context using streaming or conversational traffic class as specified in clause 9.2.4.2. For all other traffic classes, the SGSN preserves the affected PDP context.

If PDP Contexts associated with the released RAB is to be preserved and Direct Tunnel is established the SGSN sends Release Access Bearers Request to the S-GW concerned to remove RNC address and TEID.

- B. S-GW sends Release Access Bearers Response to SGSN. The SGSN update the Address for User Plane and TEID for downlink data.

12.7.3 Iu Release Procedure

12.7.3.1 Iu Release Procedure Using Gn/Gp

This procedure is used to release the Iu interface. This procedure also triggers the release of all the Iu connections and changes the 3G-SGSN PMM state to PMM-IDLE. Both RAN-initiated and SGSN-initiated Iu release procedures are shown in Figure 89a.

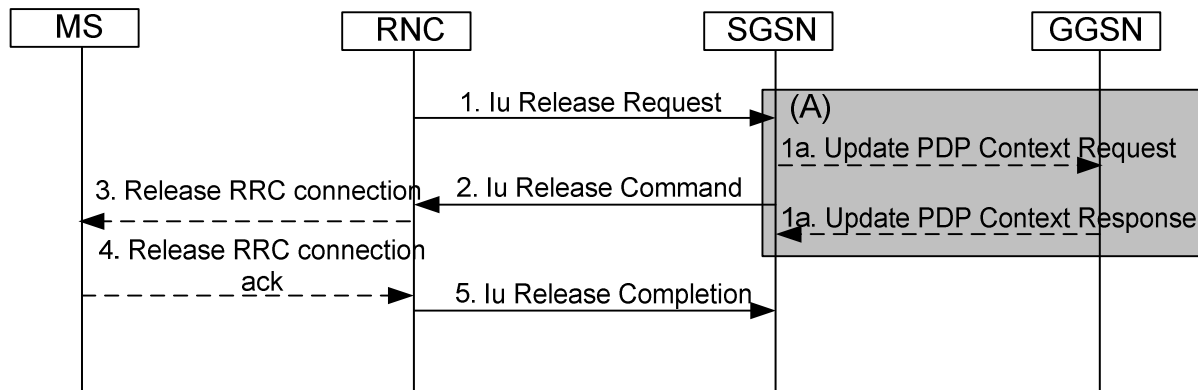

NOTE 1: Message 1 is only sent when the RAN-initiated Iu release procedure is considered.

NOTE 2: Message 1 is not sent but message 2 is sent when the SGSN-initiated Iu release procedure is considered.

Figure 89a: Iu Release Procedure Using Gn/Gp

- 1) The RAN notices that the RRC connection has been released or detects a need to release the radio resources. It sends an Iu Release Request (Cause) message to the SGSN. Cause indicates the reason for the release (e.g. O&M Intervention, Unspecified Failure, User Inactivity, Repeated Integrity Checking Failure, or Release due to UE generated signalling connection release). User Inactivity means that the RAN decided to release an MS that shows no more activity, in the case where the MS has only non real-time RABs established, in order to optimise the radio usage after the RRC-Connection-Release timer expired.
 - 1a) If PDP Contexts associated with the released RABs are using streaming or conversational traffic class and to be preserved, or Direct Tunnel was established the SGSN sends Update PDP Context Request to the GGSN(s) concerned to establish the GTP tunnel between SGSN and GGSN. The No QoS negotiation indication is set in Update PDP Context Request to indicate to the GGSN that the SGSN does not upgrade the previously negotiated QoS attributes and that the GGSN(s) shall not negotiate the QoS attributes. The GGSN(s) update the Address for User Plane and TEID for downlink data and return an Update PDP Context Response. The GGSN(s) shall not include a PCO in the Update PDP Context Response if the No QoS negotiation indication is set. See clause 12.7.3.2 when S4 interface is used.
- 2) The SGSN releases the Iu by sending the Iu Release Command (Cause) message to the RAN. This message may be triggered either by an Iu Release Request message, or by another SGSN event (e.g. authentication failure, detach or the subscription to the CSG ID expires). The SGSN shall take the responsibility to release the Iu interface when the UE has no active PDP context, either immediately or after some timeout. It is optional for the SGSN to send the Iu Release Command message after an Iu Release Request message with Cause set to User Inactivity is received from the RAN.
- 3) If the RRC connection is not already released (Cause = User Inactivity), the RAN sends a Release RRC Connection message to the MS.
- 4) The MS returns a Release RRC Connection Acknowledge message to the RAN.
- 5) The RAN confirms the Iu release by returning an Iu Release Completion (for each released RAB: RAB ID, GTP SND, GTP SNU) message to the SGSN. GTP SND and GTP SNU enable the SGSN to restore the values in case the PDP context is maintained and the RAB is re-established at a later stage.

If the RNC does not receive the Release RRC Connection Acknowledge message and if Cause is different from Authentication Failure or Detach, it should send a failure message to the SGSN, and the SGSN should stay in the MM-CONNECTED state.

If LIPA is active for a PDN connection, the HNB informs the collocated L-GW by internal signalling to release the direct user plane path between the L-GW and the HNB.

After Iu release, the MS and the SGSN shall modify PDP context(s) that use streaming or conversational traffic class according to the rules in clause "RNC-Initiated PDP Context Modification Procedure".

12.7.3.2 Iu Release Procedure Using S4

The following illustrates the procedure between SGSN and S-GW when Iu Release Procedures takes place over S4. The procedure between MS and SGSN is same as specified in clause 12.7.3.1.

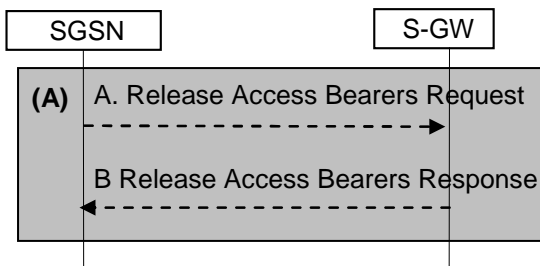

Figure 89b: Iu Release Procedure Using S4

- A. The SGSN deactivates the PDP contexts using streaming or conversational traffic class as specified in clause 9.2.4.2. For all other cases, the SGSN preserves the PDP contexts.

In case of RNC Failure, SGSN may based on operator policy either preserve all bearers or initiate the Dedicated Bearer Deactivation procedure. See clause 9.2.4.1A.2.

If PDP Contexts associated with the released RABs are to be preserved and:

- if ISR is activated or Direct tunnel is established, the SGSN shall send Release Access Bearers Request to the S-GW. For Direct Tunnel, the S-GW removes RNC address for user plane and downlink S12 GTP-U TEID. Otherwise the S-GW removes the SGSN addresses for user plane and downlink S4 GTP-U TEIDs.
- in other cases the SGSN can optionally send a Release Access Bearers Request to the SGW to remove the downlink user plane on S4.

- B. The S-GW returns a Release Access Bearers Response to SGSN.

12.7.4 RAB Assignment Procedure

12.7.4.1 RAB Assignment Procedure Using Gn/Gp

The purpose of the RAB Assignment procedure is to enable establishment of new RABs for a given MS and/or modification and/or release of already established RABs. When this procedure is executed and if there is any PDP context without radio access bearer assigned, the SGSN will decide which RABs to re-establish. The same messages are used for the three mentioned actions and it is only the content carried by the messages that is different. The RAB Assignment procedure, which is shown below, is specified in TS 25.413 [56b]. The RRC protocol is specified in TS 25.331 [52].

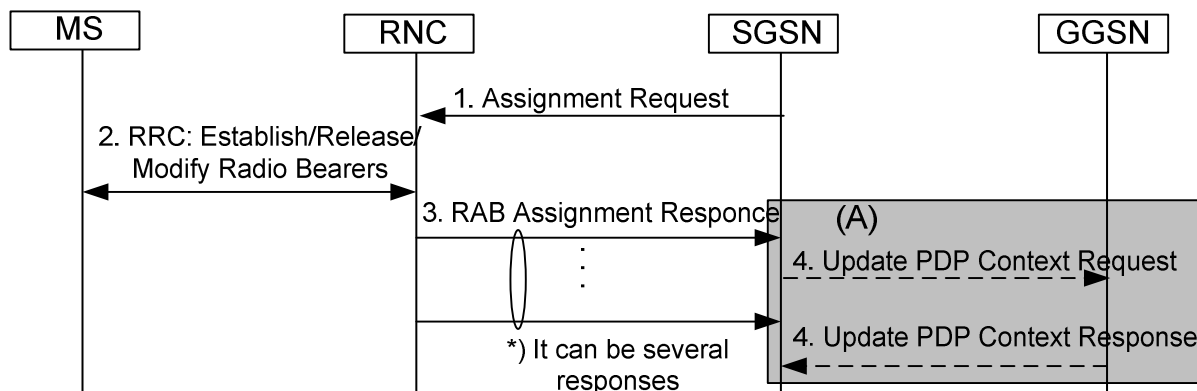

Figure 90a: RAB Assignment Procedure Using Gn/Gp

For LIPA PDN connection, when the L-GW receives the downlink data for an MS after the direct user plane path between the HNB and L-GW is released for a LIPA PDP context as defined in clause 12.7.2, the L-GW sends the first downlink user packet to the SGSN and buffers all other downlink user packets.

- 1) The SGSN sends a RAB Assignment Request (MSISDN, APN, Charging characteristics) message to the RAN to establish, modify, or release one or several RABs. For each requested RAB or modified, if the RAB is allowed for queuing and the resource situation requires it, the RAN may place the RAB in the establishment queue. If Direct Tunnel is used the SGSN provides to the RNC the GGSN's Address(es) for User Plane and TEID(s) for Uplink data. If any Release 7 new QoS IEs i.e. extended maximum bitrate and/or extended guaranteed bitrate are requested, QoS negotiation should be allowed. For RABs belonging to a PDP context/PDN connection for local IP access the RAB Assignment Request message includes a Correlation ID for enabling the direct user plane path between the HNB and the L-GW.

NOTE 1: In this release of the 3GPP specification the Correlation ID is set equal to the user plane GGSN TEID that the Gn-SGSN has received in step 4 of clause 9.2.2.1 or the user plane PDN GW TEID that the S4-SGSN has received in step D of clause 9.2.2.1A. For more detailed description on the usage of Correlation ID refer to TS 23.401 [89].

The SGSN may add, modify or remove the UE-AMBR in parallel to any requested RAB procedures. If the Access Restriction is present in the MM context, the Service Handover related information shall be included by S4-SGSN for the RAB Assignment Request message in order for RNC to restrict the UE in connected mode to handover to the RAT prohibited by the Access Restriction. MSISDN, APN and Charging characteristics are optional parameters and only transferred if SGSN supports SIPTO at Iu-ps.

- 2) The RAN establishes, modifies, or releases the appropriate radio bearers.
- 3) The RAN returns a RAB Assignment Response message to the SGSN. If the request to establish or modify one or several RABs has been queued, the RAN will report the outcome of the establishment or modification in subsequent RAB Assignment Response messages. The RAN returned MBR and/or GBR shall not exceed the maximum value corresponding to the 3GPP release the UE supports. If the SGSN receives a RAB Assignment Response message with a cause indicating that the requested QoS profile(s) can not be provided (e.g. "Requested Maximum Bit Rate not Available"), then the SGSN may send a new RAB Assignment Request message with different QoS profile(s). The number of re-attempts, if any, as well as how the new QoS profile(s) values are determined is implementation dependent. If the LIPA PDP context is requested in the RAB Assignment, the internal direct user plane path is established between the HNB and L-GW. The downlink packet in the SGSN is forwarded to the HNB and the packets buffered in the L-GW are forwarded to the HNB on the direct user plane path.
- 4) If the SGSN established Direct Tunnel it shall send Update PDP Context Request to the GGSN(s) concerned and include the RNC's Address for User Plane, downlink TEID for data, No QoS negotiation indication and the DTI. DTI is used to instruct the GGSN to apply Direct Tunnel specific error handling as described in clause 13.8, The No QoS negotiation indication is set in Update PDP Context Request to indicate to the GGSN that the SGSN does not upgrade the previously negotiated QoS attributes and that the GGSN(s) shall not negotiate the QoS attributes. The GGSN(s) update the Address for User Plane and TEID for downlink data and return an Update PDP Context Response. The GGSN(s) shall not include a PCO in the Update PDP Context Response if the No QoS negotiation indication is set. See clause 12.7.4.2 when S4 interface is used.

12.7.4.2 RAB Assignment Procedure Using S4

The following illustrates the procedure between SGSN and S-GW when RAB Assignment Procedures takes place over S4. The procedure between MS and SGSN is same as specified in clause 12.7.4.1.

For LIPA PDN connection, the downlink data handling in the L-GW as described in clause 12.7.4.1 is applied with one difference: If the SGSN established direct tunnel, the L-GW sends the first downlink user packet to the Serving GW. Otherwise, if the SGSN did not establish the direct tunnel, the L-GW sends the first downlink user packet to the SGSN.

If the SGSN receives a RAB Assignment Response message with a cause indicating that the requested QoS profile(s) can not be provided, the SGSN shall not re-attempt to send a new RAB Assignment Request message with different QoS profile(s) and also the step A and B below shall not be performed for the non-established RABs.

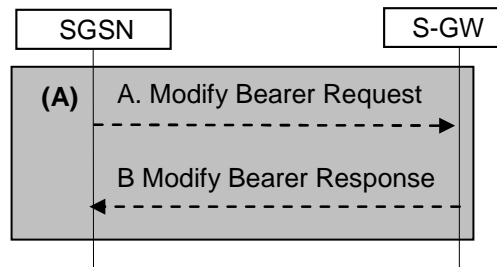

Figure 90b: RAB Assignment Procedure Using S4

- A. If the SGSN established Direct Tunnel it shall send Modify Bearer Request to the S-GW concerned and include the RNC's Address for User Plane, downlink TEID for data, No QoS negotiation indication and the DTI. DTI is used to instruct the S-GW to apply Direct Tunnel specific error handling as described in clause 13.8.
- B. The S-GW update the Address for User Plane and TEID for downlink data and return a Modify Bearer Response to S-GW.

12.7.5 Location Reporting Procedure

This procedure is used by an SGSN to request the RAN to report where the MS is currently located, or to report when the MS moves into or out of a given service area. This procedure is defined for Iu mode and may be used for services that require location information (e.g. CAMEL and emergency calls).

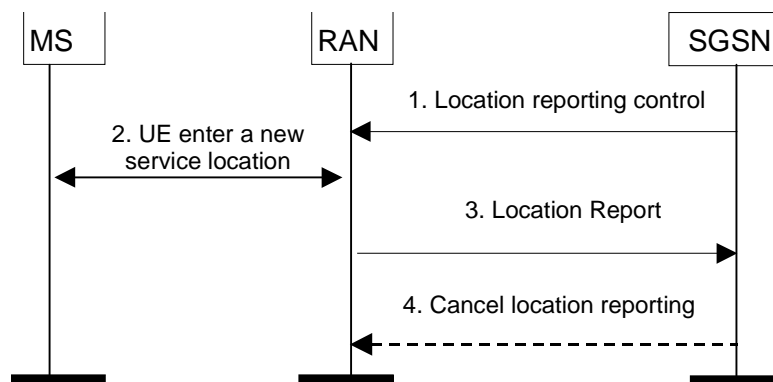

Figure 91: Location Reporting Procedure

- 1) The SGSN detects from the subscriber data the need to monitor in which service area an MS in the PMM-CONNECTED state with an Iu interface connection is located. The SGSN sends a Location Reporting Control (Service Area Code(s), Reporting Type) message to the RAN. The RAN stores the Service Area Code(s) as reporting area(s) for this MS. For example, a service area may be a location area with restricted access. Reporting Type indicates whether the message is intended to start a reporting period or trigger a stand-alone report about the current location of the MS.
- 2) The RAN detects that the MS moves into or out of a reporting area. Alternatively, the RAN derives the current location of the MS if this was requested by the SGSN.
- 3) The RAN sends a Location Report message informing the SGSN about where the MS is located. When the SGSN has requested the current location of the MS, the RAN shall include the requested location information, i.e. the Service Area Indication, in the Location Report message, if the RAN cannot determine current Service Area of the mobile, it indicates that the request could not be fulfilled, and may report Last Known Service Area with an indication of how long has past since the mobile was known to be in the indicated Service Area. The SGSN may then perform specific actions.
- 4) The SGSN can send a Cancel Location Reporting message to inform the RAN that it should terminate location reporting for a given MS. This message is needed only when the reporting was requested for a reporting period.

The procedure is implicitly cancelled at SRNC/SBSC relocation. If the service is still required in the new SRNC/SBSC or new SGSN, a new Location Reporting Control message shall be sent.

12.8 Abis Interface (A/Gb mode)

When the MAC and RLC layer functions are positioned remote to the BTS, the information between the Channel Codec Unit (CCU) and the remote Packet Control Unit (PCU) is transferred in frames with a fixed length of 320 bits (20 ms). In the present document these frames are denoted "PCU Frames" and are an extension to the "TRAU frames" defined in TS 48.060 [22]. Within these frames both GPRS data and the RLC/MAC associated control signals are transferred.

The Abis interface should be the same if the PCU is positioned at the BSC site (option B in Figure 92) or at the SGSN site (option C in Figure 92). In option B, the PCU could be implemented as an adjunct unit to the BSC. In option C, the BSC should be considered as transparent for 16 kbit/s channels. In configurations B and C the PCU is referred to as being a remote PCU.

The remote PCU is considered a part of the BSC, and using BSC internal signals may provide the signalling between the BSC and the PCU. The in-band signalling between the CCU and the PCU functions, using PCU frames is required when the Abis interface is applied (options B and C in Figure 92).

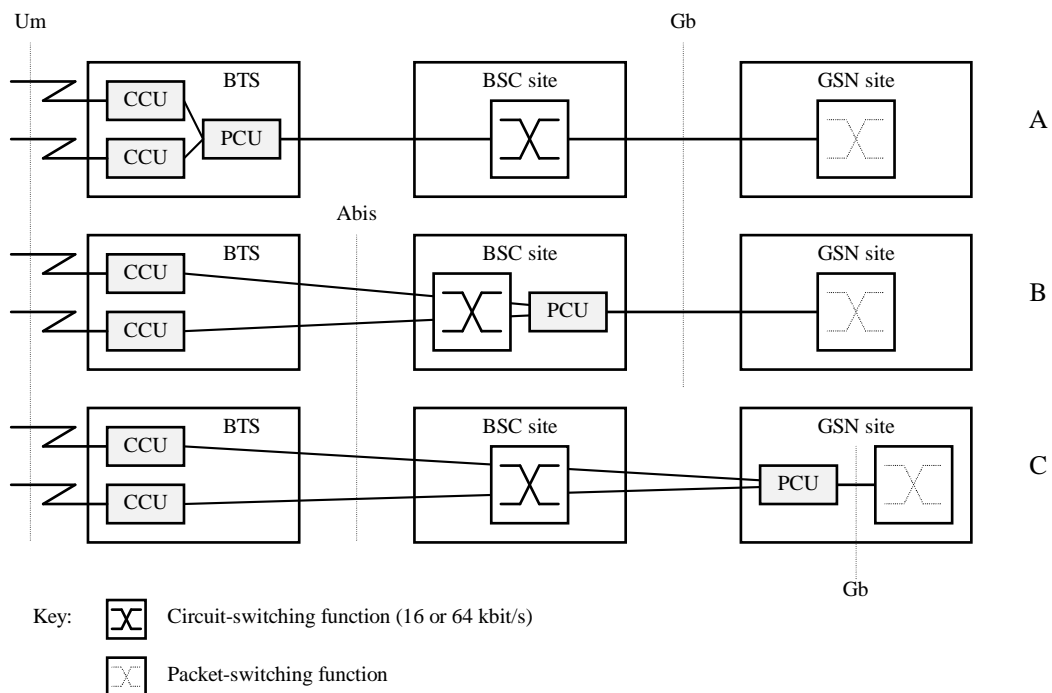

Figure 92: Remote Packet Control Unit (PCU) Positions

The PCU is responsible for the following MAC and RLC layer functions as defined in TS 43.064 [11]:

- LLC layer PDU segmentation into RLC blocks for downlink transmission;
- LLC layer PDU reassembly from RLC blocks for uplink transmissions;
- PDCH scheduling functions for the uplink and downlink data transfers;
- PDCH uplink ARQ functions, including RLC block Ack / Nack;
- PDCH downlink ARQ function, including buffering and retransmission of RLC blocks;
- channel access control functions, e.g. access requests and grants; and
- radio channel management functions, e.g. power control, congestion control, broadcast control information, etc.

The functions inside the Channel Codec Unit (CCU) are:

- the channel coding functions, including FEC and interleaving;
- radio channel measurement functions, including received quality level, received signal level and information related to timing advance measurements; and

- for EGPRS, in case of incremental redundancy mode of operation, enhanced channel coding functions.

The BSS is responsible for allocation and de-allocation of radio resources. A PCU frame shall be transferred between the PCU and the CCU every 20 ms.

12.8.1 Remote Packet Control Unit

When the Packet Control Unit (PCU) is remote to the BTS, the Channel Codec Unit (CCU) in the BTS may control some of the functions in the remote PCU in the BSC. As well, the PCU may control some of the functions of the CCU. Inband signalling provides the remote control by using the control bits (C-bits) in each PCU frame.

12.9 Gn Interface (A/Gb mode)

During the PS handover procedure the PS Handover Request Context containing packet flow specific information needs to be transferred between SGSNs. The detailed description of the procedures used during PS handover from GERAN A/Gb mode to GERAN A/Gb mode or GERAN A/Gb mode to Iu mode and vice-versa are described in TS 29.060 [26].

13 Information Storage

This clause describes information storage structures required for GPRS, and the recovery and restoration procedures needed to maintain service if inconsistencies in databases and lost or invalid database information occur.

13.1 HLR/HSS

IMSI is the prime key to the subscription data stored in the HLR/HSS. There may be several sets of PS subscription data per IMSI. This is illustrated in Figure 93.

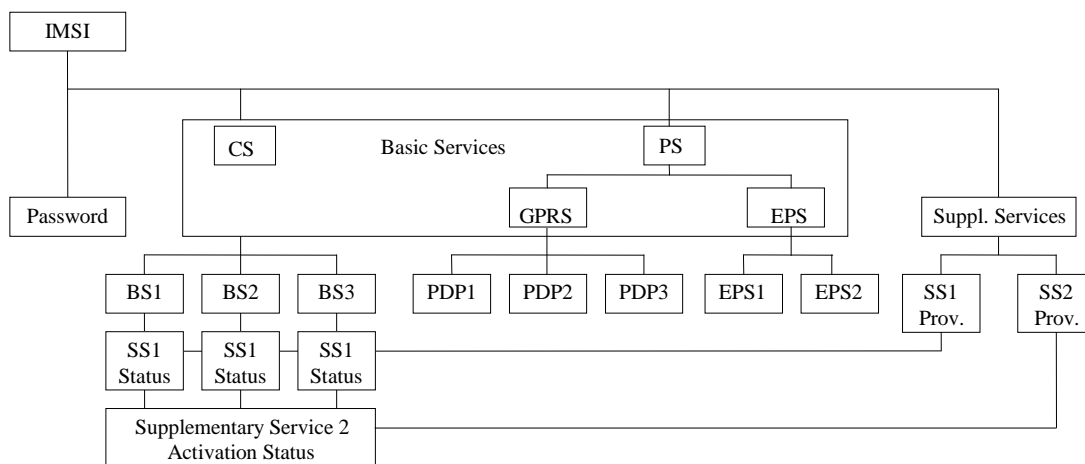

Figure 93: Subscription Data

As Figure 93 indicates, the PS subscription data is at the same level as basic services. Each PDP subscription is seen as a basic service. Supplementary services are provisioned as part of the overall subscription. Activation of SSs is either at the basic service level (SS1) or at the overall subscription level (SS2).

Table 5 shows the GPRS/EPS subscription data contained in the HLR/HSS.

Table 5: HLR/HSS GPRS/EPS Subscription Data

Field	Description
IMSI	IMSI is the main reference key.
MSISDN	The basic MSISDN of the MS. (Presence of the MSISDN is optional).
SGSN Number	The SS7 number of the SGSN currently serving this MS.
SGSN Address	The IP address of the SGSN currently serving this MS.
Subscribed Charging Characteristics	The charging characteristics for the MS, e.g. normal, prepaid, flat-rate, and/or hot billing subscription.
Trace Reference	Identifies a record or a collection of records for a particular trace.
Trace Type	Indicates the type of trace, e.g. MSC/BSS trace, HLR trace, and/or SGSN/GGSN/BSS trace.
OMC Identity	Identifies the OMC that shall receive the trace record(s).
SMS Parameters	SMS-related parameters, e.g. operator-determined barring.
MS PS Purged for GPRS	Indicates that the MM and PDP contexts of the MS are deleted from the SGSN.
MNRG	Indicates that the MS is not reachable through an SGSN, and that the MS is marked as not reachable at the SGSN and possibly at the GGSN.
GGSN-list	The GSN number and optional IP address pair related to the GGSN that shall be contacted when activity from the MS is detected and MNRG is set. The GSN number shall be either the number of the GGSN or the protocol-converting GSN as described in the clauses "MAP-based GGSN-HLR Signalling" and "GTP and MAP-based GGSN-HLR Signalling".
GPRS-CSI	Optional GPRS CAMEL subscription information, see TS 23.016 [5b]
MG-CSI	Optional Mobility Management for GPRS CAMEL subscription information, see TS 23.016 [5b].
APN-OI Replacement	Indicates the domain name to replace the APN-OI when constructing the GGSN/PDN GW FQDN upon which to perform a DNS resolution. This replacement applies for all the APNs in the subscriber's profile. See TS 23.003 [4] clause 9.1.2 for more information on the format of domain names that are allowed in this field.
ODB for PS parameters	Indicates that the status of the operator determined barring for packet oriented services.
Access Restriction	Indicates the access restriction subscription information. (Note, the access restriction applies to both packet and circuit oriented services).
IMEI	International Mobile Equipment Identity
SVN	Software Version Number
RFSP Index	An index to specific RRM configuration in the UTRAN/GERAN
CSG Subscription Data	The CSG Subscription Data is a list of CSG IDs per PLMN and for each CSG ID optionally an associated expiration date which indicates the point in time when the subscription to the CSG ID expires; an absent expiration date indicates unlimited subscription. For a CSG ID that can be used to access specific PDNs via Local IP Access, the CSG ID entry includes the corresponding APN(s).
VPLMN LIPA Allowed	Specifies per PLMN whether the UE is allowed to use LIPA.
Subscribed UE-AMBR	The Maximum Aggregated uplink and downlink MBRs to be shared across all Non-GBR PDP contexts according to the subscription of the user.
URRP-SGSN UE	Reachability Request Parameter indicating that UE activity notification from SGSN has been requested by the HLR/HSS.
Homogenous Support of IMS Voice over PS Sessions for SGSN	Indicates per UE and SGSN if "IMS Voice over PS Sessions" is homogeneously supported in all RAs in the serving SGSN or homogeneously not supported, or, support is non-homogeneous/unknown, see clause 5.3.8A.
Subscribed periodic RAU/TAU Timer	Indicates a subscribed periodic RAU/TAU timer value.
UE-SRVCC-Capability	Indicates whether the UE is UTRAN/GERAN SRVCC capable or not.
<i>Each subscription profile may also contain one or more APN configurations:</i>	
PDP/EPS Bearer Context Identifier	Index of the PDP/EPS Bearer context.
PDP Type	PDP type, e.g. PPP or IP (IPv4, IPv6, IPv4v6).

Field	Description
PDP Address	PDP address, e.g., an IP address. This field shall be empty if dynamic addressing is allowed.
APN-OI Replacement	APN level APN-OI Replacement which has the same role as the UE level APN-OI Replacement but with higher priority than UE level APN-OI Replacement. This is an optional parameter. When available, it shall be used to construct the GGSN/PDN GW FQDN instead of UE level APNOI Replacement. See TS 23.003 [4] clause 9.1.2 for more information on the format of domain names that are allowed in this field.
Access Point Name	A label according to DNS naming conventions describing the access point to the packet data network. For S4-SGSN the APN to be used as default APN is indicated.
SIPTO permissions	Indicates whether the traffic associated with this APN is allowed or prohibited for SIPTO
LIPA permissions	Indicates whether the PDN can be accessed via Local IP Access. Possible values are: LIPA-prohibited, LIPA-only and LIPA-conditional.
QoS Profile Subscribed	The quality of service profile subscribed. QoS Profile Subscribed is the default level if a particular QoS profile is not requested. . QoS Profile Subscribed is also the maximum QoS per PDP context to the associated APN.
Subscribed Evolved ARP	The Subscribed Evolved ARP for PDP contexts associated with the APN.
VPLMN Address Allowed	Specifies per VPLMN whether the MS is allowed to use the APN in the domain of the HPLMN only, or additionally the APN in the domain of the VPLMN.
PDP/EPS Bearer context Charging Characteristics	The charging characteristics of this PDP/EPS Bearer context, e.g. normal, prepaid, flat-rate, and/or hot billing.
EPS subscribed QoS profile	The EPS bearer level QoS parameter values for that APN's default bearer (QCI and ARP)
APN-AMBR	The maximum aggregated uplink and downlink MBR values to be shared across all Non-GBR EPS bearers, which are established for this APN.
P-GW/GGSN address	The address currently used for the P-GW/GGSN supporting this APN

NOTE: IMEI and SVN are stored in HLR/HSS when the Automatic Device Detection feature is supported, see clause 15.5.

An expired CSG subscription should not be removed from the HLR/HSS subscription data before it is removed from the MS's Allowed CSG list or Operator CSG list. When a CSG subscription is cancelled it should be handled as an expired subscription in HLR/HSS subscription data to allow for removing it from MS's Allowed CSG list or Operator CSG list first.

If the LIPA permission and SIPTO permission flags are both included for a particular APN, they shall be set in a consistent manner, e.g. if the LIPA permission is set to LIPA-only or LIPA-conditional, the SIPTO permission shall be set to SIPTO-prohibited. Conversely, if the SIPTO permission is set to SIPTO-allowed, the LIPA permission shall be set to LIPA-prohibited.

13.2 SGSN

13.2.1 General

SGSN maintains MM context and PDP/EPS bearer context information for MSs in the STANDBY, READY, PMM-IDLE, and PMM-CONNECTED states. Table 6 shows the context fields for one MS.

During the Intersystem Change, when new Authentication and Key Agreement is not performed, the KSI in the new 3G-SGSN shall be assigned the value of the CKSN, which has been sent by the MS. Similarly, in the new 2G-SGSN, when AKA does not take place, the CKSN shall be assigned the value of the KSI, which has been sent by the MS.

13.2.2 Parameter exchange between S4-SGSNs

The S4-SGSN also maintains parameters related to MME use without interpreting them.

For that reason the MM Context and PDP/EPS Bearer Context also includes information that is used by MME but only stored and forwarded by SGSN.

13.2.3 Context fields for one MS

Table 6: SGSN MM and PDP/EPS Bearer Contexts

Field	Description	A/Gb mode	lu mode
IMSI	IMSI is the main reference key.	X	X
IMSI-unauthenticated-indicator	This is an IMSI indicator to show the IMSI is unauthenticated.		X
MM State	Mobility management state, IDLE, STANDBY, READY, PMM-DETACHED, PMM-IDLE, or PMM-CONNECTED.	X	X
P-TMSI	Packet Temporary Mobile Subscriber Identity.	X	X
P-TMSI Signature	A signature used for identification checking purposes.	X	X
IMEI	International Mobile Equipment Identity	X	X
SVN	Software Version Number (stored by SGSNs supporting the "Provision of UE Specific Behaviour Information to Network Entities" feature as defined in TS 23.195 [76].) or the "Automatic Device Detection" feature, see clause 15.5.	3)	X
MSISDN	The basic MSISDN of the MS. The presence is dictated by its storage in the HLR/HSS.	X	X
Routing Area	Current routing area.	X	X
Cell Identity	Current cell in READY state, last known cell in STANDBY or IDLE state.	X	
Cell Identity Age	Time elapsed since the last LLC PDU was received from the MS at the SGSN.	X	
Service Area Code	Last known SAC when initial UE message was received or Location Reporting procedure was executed.		X
Service Area Code Age	Time elapsed since the last SAC was received at the 3G-SGSN.		X
CSG ID	Last known CSG ID when the UE was active.		X
CSG membership	Last known CSG membership of the MS when the UE was active.		X
Access mode	Access mode of last known Cell Identity when the UE was active.		X
VLR Number	The VLR number of the MSC/VLR currently serving this MS.	X	X
New SGSN Address	The IP address of the new SGSN where buffered and not sent N-PDUs should be forwarded to.	X	X
Authentication Vectors	Authentication and ciphering parameters (authentication triplets or quintets).	X	X
Kc	Currently used A/Gb mode ciphering key.	X	2)
CKSN	Ciphering key sequence number of Kc.	X	2)
Ciphering algorithm	Selected ciphering algorithm.	X	X
CK	Currently used lu mode ciphering key.	1)	X
IK	Currently used lu mode integrity key.	1)	X
KSI	Key Set Identifier.	1)	X
MS Radio Access Capability	MS, mostly GERAN, radio access capabilities.	X	
MS Radio Access Capabilities for other RATs	MS's Radio access capabilities for UTRAN, E-UTRAN, etc (needed only for PS handover support)	X	
MS Classmark 2	GERAN/UTRAN CS domain core network Classmark (used if the MS supports SRVCC to GERAN or UTRAN)	X	X
MS Classmark 3	GERAN CS domain radio network Classmark (used if the MS supports SRVCC to GERAN)	X	X
Supported Codecs	List of codecs supported in the CS domain (used if the MS supports SRVCC to GERAN or UTRAN, see TS 23.216 [101])	X	X
MS Network Capability	MS network capabilities.	X	X
UE Network Capability	Core network capabilities (stored if the UE supports E-UTRAN)	X	X
Higher bitrates than 16 Mbps flag	Indicates whether assignment of higher bitrates than 16 Mbps is "allowed" (for UE supporting Rel-7 or higher release) or "not allowed" (for UE supporting Rel-6 or lower release)	X	X
DRX Parameters	Discontinuous reception parameters.	X	X
MNRG	Indicates whether activity from the MS shall be reported to the HLR.	X	X
NGAF	Indicates whether activity from the MS shall be reported to the MSC/VLR.	X	X
PPF	Indicates whether paging for PS and CS services can be initiated.	X	X
Subscribed Charging Characteristics	The charging characteristics for the MS, e.g. normal, prepaid, flat-rate, and/or hot billing subscription.	X	X

Field	Description	A/Gb mode	lu mode
Selected CN operator id	Selected core network operator identity (to support network sharing as defined in TS 23.251 [83]).		4)
Trace Reference	Identifies a record or a collection of records for a particular trace.	X	X
Trace Type	Indicates the type of trace.	X	X
Trigger Id	Identifies the entity that initiated the trace.	X	X
OMC Identity	Identifies the OMC that shall receive the trace record(s).	X	X
SMS Parameters	SMS-related parameters, e.g. operator-determined barring.	X	X
Recovery	Indicates if HLR/HSS or VLR is performing database recovery.	X	X
Radio Priority SMS	The RLC/MAC radio priority level for uplink SMS transmission.	X	
Access Restriction	The access restriction subscription information.	X	X
GPRS-CSI	Optional GPRS CAMEL subscription information, see TS 23.016 [5b]	X	X
MG-CSI	Optional Mobility Management for GPRS CAMEL subscription information, see TS 23.016 [5b].	X	X
ODB for PS parameters	Indicates that the status of the operator determined barring for packet oriented services.	X	X
APN-OI Replacement	Indicates the domain name to replace the APN-OI when constructing the GGSN/PDN GW FQDN upon which to perform a DNS resolution. See TS 23.003 [4] clause 9.1.2 for more information on the format of domain names that are allowed in this field.	X	X
Subscribed UE-AMBR	The Maximum Aggregated uplink and downlink MBR values to be shared across all Non-GBR PDP contexts/bearers according to the subscription of the user.	X	X
UE-AMBR	The currently used Maximum Aggregated uplink and downlink MBR values to be shared across all Non-GBR PDP context/bearers.	X	X
APN Subscribed	The APN received from the HLR/HSS. For S4-SGSN the APN to be used as default APN is indicated.	X	X
CSG Subscription Data	The CSG Subscription Data is associated lists of CSG IDs for the visiting PLMN and the equivalent PLMNs of the visiting PLMN and for each CSG ID optionally an associated expiration date which indicates the point in time when the subscription to the CSG ID expires; an absent expiration date indicates unlimited subscription. For a CSG ID that can be used to access specific PDNs via Local IP Access, the CSG ID entry includes the corresponding APN(s).		X
LIPA Allowed	Specifies whether the UE is allowed to use LIPA in this PLMN.		X
MME IP Address for S3	IP address of the MME for the MS when connected via E-UTRAN (used if ISR is activated for the MS).	X	X
MME TEID for S3	Tunnel Endpoint Identifier of the MME for the MS when connected via E-UTRAN (used if ISR is activated for the MS).	X	X
URRP-SGSN	URRP-SGSN indicating that the HSS has requested the SGSN to notify the HSS regarding UE reachability at the SGSN	X	X
Subscribed RFSP Index	An index to specific RRM configuration in the UTRAN/GERAN that is received from the HSS.	X	5)
RFSP Index in Use	An index to specific RRM configuration in the UTRAN/GERAN that is currently in use.	X	5)
Subscribed Periodic RAU/TAU Timer	Indicates a subscribed periodic RAU/TAU timer value.	X	5)
Voice Support Match Indicator	An indication whether the UE radio capabilities are compatible with the network configuration for PS voice continuity. The SGSN uses it as an input for setting the IMS voice over PS Session Supported Indication.		X
Homogenous Support of IMS Voice over PS Sessions	Indicates per UE if "IMS Voice over PS Sessions" is homogeneously supported in all RAs in the serving SGSN or homogeneously not supported, or, support is non-homogeneous/unknown, see clause 5.3.8A.	X	X
<i>> For each active PDN connection with GGSN (using Gn/Gp) or with S-GW (using S4):</i>			
APN in Use	The APN currently used. This APN shall be composed of the APN Network Identifier and the default APN Operator Identifier as specified in TS 23.003 [4], clause 9.1.2. Any received value in the APN-OI Replacement field in the subscription data is not applied here.	X	X

Field	Description	A/Gb mode	lu mode
APN Restriction	Denotes the restriction on the combination of types of APN for the APN associated with this PDP Context. (See Note)	X	X
APN-OI Replacement	APN level APN-OI Replacement which has the same role as the UE level APN-OI Replacement but with higher priority than UE level APN-OI Replacement. This is an optional parameter. When available, it shall be used to construct the GGSN/PDN GW FQDN instead of UE level APN-OI Replacement. See TS 23.003 [4] clause 9.1.2 for more information on the format of domain names that are allowed in this field.	X	X
SIPTO permissions	Indicates whether the traffic associated with this APN is allowed or prohibited for SIPTO		X
LIPA permissions	Indicates whether the PDN can be accessed via Local IP Access. Possible values are: LIPA-prohibited, LIPA-only and LIPA-conditional.		X
Subscribed APN-AMBR	The maximum aggregated uplink and downlink MBRs to be shared across all Non-GBR PDP contexts/EPS Bearers established for this APN according to the subscription of the user.	X	X
Negotiated APN-AMBR	The maximum aggregated uplink and downlink MBRs to be shared across all Non-GBR PDP contexts/EPS Bearers established for this APN according to the GGSN/PGW decision.	X	X
VPLMN Address Allowed	Specifies whether the MS is allowed to use the APN in the domain of the HPLMN only, or additionally the APN in the domain of the VPLMN.	X	X
EPS subscribed QoS profile	The bearer level QoS parameter values for that APN's default bearer	X	X
Subscribed Evolved ARP	The Evolved ARP for this PDN connection according to the subscription of the user	X	X
GGSN or P-GW TEID on Gn/Gp or S5/S8 (control plane)	Tunnel Endpoint Identifier at the GGSN or P-GW on the Gn/Gp or S5/S8 interfaces for control plane signalling	X	X
GGSN or P-GW IP Address in Use (control plane)	The IP address of the GGSN (using Gn/Gp) or P-GW (when using S4) for control plane signalling	X	X
SGSN IP address for Gn/Gp or S4 (control plane)	SGSN IP address for the Gn/Gp (used by GGSN) or S4 (used by S-GW) for control plane signalling	X	X
SGSN TEID for Gn/Gp or S4 (control plane)	SGSN Tunnel Endpoint Identifier for the Gn/Gp used by GGSN) or S4 (used by S-GW) for control plane signalling.	X	X
S-GW IP address for S11/S4 (control plane)	S-GW IP address for the S11 and S4 interfaces	X	X
S-GW TEID for S11/S4 (control plane)	S-GW Tunnel Endpoint Identifier for the S11 and S4 interfaces.	X	X
low access priority	Indicates that the UE requested low access priority when the PDN connection was opened (see Note 6).	X	X
<i>> For each active PDN connection with S-GW (using S4):</i>			
Default bearer	Identifies the NSAPI of the default bearer, corresponding to the PDP context which was first established within the given PDN connection.	X	X
PDN GW GRE Key for uplink traffic (user plane)	PDN GW assigned GRE Key for the S5/S8 interface for the user plane for uplink traffic. (For PMIP-based S5/S8 only)	X	X
<i>Each MM context contains zero or more of the following PDP/EPS bearer contexts within the PDN connection.:</i>			
PDP/EPS bearer Context Identifier	Index of the PDP/EPS bearer context.	X	X
PDP State	Packet data protocol state, INACTIVE or ACTIVE.	X	X
PDP/PDN Type	PDP type (e.g., PPP) or PDN type (e.g., IPv4, IPv6, or IPv4v6)	X	X
PDP/PDN Address	PDP/PDN address, e.g., an IP address.	X	X
NSAPI/EPS bearer ID	Network layer Service Access Point Identifier. There is a 1:1 mapping between the NSAPI and the EPS bearer ID.	X	X
TI	Transaction Identifier.	X	X
TEID for lu	Tunnel Endpoint Identifier for the lu interface.		X
GGSN or P-GW TEID (user plane)	Tunnel Endpoint Identifier of the GGSN or P-GW for user-plane traffic. (NOTE 4)	X	X
GGSN or P-GW IP address (user plane)	The IP address of the GGSN or P-GW for user-plane traffic. (NOTE 5)	X	X

Field	Description	A/Gb mode	lu mode
S-GW IP address (user plane)	S-GW IP address for user plane.	X	X
S-GW TEID (user plane)	S-GW Tunnel Endpoint Identifier for user plane.	X	X
SGSN IP address (user plane)	SGSN IP address used by GGSN for Gn/Gp or by S-GW for S4 for user plane downlink traffic.	X	X
SGSN TEID (user plane)	SGSN Tunnel Endpoint Identifier used by GGSN for Gn/Gp or by S-GW for S4 for user plane downlink traffic.	X	X
QoS Profile Subscribed	The quality of service profile subscribed.	X	X
QoS Profile Requested	The quality of service profile requested.	X	X
QoS Profile Negotiated	The quality of service profile negotiated. This also represents the EPS Bearer QoS parameters QCI and ARP and optionally GBR and MBR in case of GBR bearer	X	X
Negotiated Evolved ARP	The evolved ARP to be used for this PDP context as authorized by the GGSN	X	X
Radio Priority	The RLC/MAC radio priority level for uplink user data transmission.	X	
Packet Flow Id	Packet flow identifier.	X	
Aggregate BSS QoS Profile Negotiated	The aggregate BSS quality of service profile negotiated for the packet flow that this PDP context belongs to.	X	
Send N-PDU Number	SNDCP sequence number of the next downlink N-PDU to be sent to the MS.	X	
Receive N-PDU Number	SNDCP sequence number of the next uplink N-PDU expected from the MS.	X	
GTP-SND	GTP-U sequence number of the next downlink N-PDU to be sent to the MS.	X	X
GTP-SNU	GTP-U sequence number of the next uplink N-PDU to be sent to the GGSN.	X	X
PDCP-SND	Sequence number of the next downlink in-sequence PDCP-PDU to be sent to the MS.		X
PDCP-SNU	Sequence number of the next uplink in-sequence PDCP-PDU expected from the MS.		X
Charging Id	Charging identifier, identifies charging records generated by SGSN, S-GW and P-GW/GGSN. (NOTE 3)	X	X
PDP/EPS bearer Context Charging Characteristics	The charging characteristics of this PDP/EPS bearer context, e.g. normal, prepaid, flat-rate, and/or hot billing.	X	X
RNC Address in Use	The IP address of the RNC/BSC currently used.		X
Prohibit Payload Compression	Indicates that the SGSN should negotiate no data compression for this PDP context.	X	
DTI	Indicates whether SGSN has established direct user plane tunnel between RNC and GGSN (using Gn/Gp) or between RNC and S-GW (using S12) for this PDP context.		X
MS Info Change Reporting Action	Denotes the need to send changes in CGI/SAI or RAI to the GGSN (using Gn/Gp) or S-GW (using S4) associated with this PDP Context. (See Note 2).	X	X
CSG Information Reporting Action	Denotes the need to send changes in User CSG Information to the GGSN (using Gn/Gp) or S-GW (using S4) associated with this PDP Context. (See Note 2). This field denotes separately whether the SGSN is requested to send changes in User CSG Information for (a) CSG cells, (b) hybrid cells in which the subscriber is a CSG member, and (c) hybrid cells in which the subscriber is not a CSG member, or any combination of the above.	X	X
CGI/SAI/RAI change support indication	Denotes the indicated level of support to the GGSN (using Gn/Gp) or S-GW (using S4) associated with this PDP Context (See Note 2).	X	X
BCM	The negotiated BCM.	X	X
<i>> For each PDP/EPS bearer context with S-GW (using S4):</i>			
DL TFT	Downlink Traffic Flow Template. (For PMIP-based S5/S8 only)	X	X
UL TFT	Uplink Traffic Flow Template. (For PMIP-based S5/S8 only)	X	X

Field	Description	A/Gb mode	Iu mode
NOTE 1:	The SGSN might not have information on the allocated IPv4 address. Alternatively, following mobility involving a pre-Release 8 SGSN, this IPv4 address might not be the one allocated to the MS.		
NOTE 2:	APN Restriction, CGI/SAI/RAI change support indication, MS Info Change Reporting Action and CSG Information Reporting Action shall not be transferred between SGSNs during mobility management, unless the connectivity between the SGSNs is based on S16..		
NOTE 3:	When the SGSN is connected with a S-GW through S4, then the Charging Id is only applicable for online charging with CAMEL as specified in clause 15.1.0.		
NOTE 4:	The PDN GW TEID is needed in SGSN context as S-GW relocation is triggered without interaction with the source S-GW. The Target S GW requires this Information Element, so it must be stored by the SGSN.		
NOTE 5:	The PDN GW IP address is needed in SGSN context as S-GW relocation is triggered without interaction with the source. The Target S-GW requires this Information Element, so it must be stored by the SGSN.		
NOTE 6:	The low access priority indicator is only stored for the purpose to be included in charging records.		

The information marked with a "1)" in table 6 may be maintained if authentication is performed by the UMTS authentication procedure.

The information marked with a "2)" in table 6 may be maintained if authentication is performed by the GSM authentication procedure.

The information marked with a "3)" in table 6 is optional. It can be sent to a new SGSN at RA update.

The information marked with a "4)" in table 6 is used in networks that support network sharing as defined in TS 23.251 [83].

The information marked with a "5)" in table 6 is used in UTRAN only.

13.2.4 SGSN Emergency Configuration Data for Iu Mode

The SGSN Emergency Configuration Data is used instead of UE subscription data received from the HSS or the parameters provided by UE in the PDP context created by the PDP Context Activation Procedure for emergency service.

Table 6A: SGSN Emergency Configuration Data

Field	Description
Emergency Access Point Name (em APN)	A label according to DNS naming conventions describing the access point used for Emergency Bearers (wild card not allowed).
Emergency QoS profile	The bearer level QoS parameter values for Emergency APN's PDP context created by the PDP Context Activation Procedure.
Emergency Evolved ARP	The Evolved ARP value to be used for Emergency APN's PDP context created by the PDP Context Activation Procedure
Emergency APN-AMBR (only for S4-SGSN)	The Maximum Aggregated uplink and downlink MBR values to be shared across all Non-GBR bearers, which are established for the Emergency APN, as decided by the PDN GW.
Emergency PDN GW/GGSN identity	The statically configured identity of the PDN GW/GGSN used for emergency APN. The PDN GW/GGSN identity may be either an FQDN or an IP address.

If the S4-SGSN is used, the Emergency EPS QoS profile (QCI and ARP) is configured. The ARP is an ARP value reserved for emergency bearers. The QCI for Emergency APN's PDP context created by the PDP Context Activation Procedure is set per operator configuration.

If Gn/Gp SGSN is used, the Emergency GPRS QoS profile (Traffic class, Signalling Indication) and Emergency Evolved ARP is used. The Traffic class and Signalling Indication is set per operator configurations. The Emergency Evolved ARP is an Evolved ARP value reserved for emergency bearers.

13.3 GGSN

GGSN maintains activated PDP contexts. Table 7 shows the PDP context fields.

Table 7: GGSN PDP Context

Field	Description
IMSI	International Mobile Subscriber Identity.
IMSI-unauthenticated-indicator	This is an IMSI indicator to show the IMSI is unauthenticated
ME Identity	Mobile Equipment Identity (e.g. IMEI/IMEISV)
NSAPI	Network layer Service Access Point Identifier.
MSISDN	The basic MSISDN of the MS. The presence is dictated by its storage in the HLR/HSS.
PDP Type	PDP type; e.g. PPP or IP.
PDP Address	PDP address(es); e.g. an IP address.
Dynamic Address	Indicates whether PDP Address is static or dynamic.
APN in Use	The APN Network Identifier currently used, as received from the SGSN.
Negotiated APN-AMBR	The maximum aggregated uplink and downlink MBRs to be shared across all Non-GBR PDP contexts/EPS Bearers established for this APN according to the GGSN/PGW decision.
TEID	Tunnel Endpoint Identifier.
TFT	Traffic flow template.
QoS Profile Negotiated	The quality of service profile negotiated.
Negotiated Evolved ARP	The evolved ARP authorized by the GGSN
SGSN Address	The IP address of the SGSN currently serving this MS.
MNRG	Indicates whether the MS is marked as not reachable for PS at the HLR.
Recovery	Indicates if the SGSN is performing database recovery.
GTP-SND	GTP-U sequence number of the next downlink N-PDU to be sent to the SGSN.
GTP-SNU	GTP-U sequence number of the next uplink N-PDU to be received from the SGSN.
Charging Id	Charging identifier, identifies charging records generated by SGSN and GGSN.
Charging Characteristics	The charging characteristics for this PDP context, e.g. normal, prepaid, flat-rate, and/or hot billing.
Trace Reference	Identifies a record or a collection of records for a particular trace.
Trace Type	Indicates the type of trace.
Trigger Id	Identifies the entity that initiated the trace.
OMC Identity	Identifies the OMC that shall receive the trace record(s).
Prohibit Payload Compression	Indicates that the SGSN should negotiate no data compression for this PDP context.
SGSN support for MS Info Change Reporting	Indicated that the SGSN serving the MS supports procedures for reporting CGI/SAI/RAI and/or User CSG Information changes according to clause 15.1.1a.
MS Info Change Reporting Action	Denotes whether the SGSN is requested to send changes in CGI/SAI or RAI to the GGSN (using Gn/Gp) or S-GW (using S4) associated with this PDP Context.
CSG Information Reporting Action	Denotes whether the SGSN is requested to send changes in User CSG Information to the GGSN (using Gn/Gp) or S-GW (using S4) associated with this PDP Context. This field denotes separately whether the SGSN is requested to send changes in User CSG Information for (a) CSG cells, (b) hybrid cells in which the subscriber is a CSG member, and (c) hybrid cells in which the subscriber is not a CSG member, or any combination of the above.
BCM	The negotiated Bearer Control Mode.
DTI	Indicates whether SGSN has established direct user plane tunnel between RNC and GGSN for this PDP Context.

If a PDP context is enabled for network-requested PDP context activation, then IMSI, PDP Type, PDP Address, SGSN Address and MNRG contain valid information also when the PDP context is inactive and when the MS is GPRS-detached.

For emergency attached UEs which are not authenticated, IMEI is stored in context.

13.3a Serving GW

The information storage for the Serving GW to support MS access to the EPC via UTRAN or GERAN is described in TS 23.401 [89].

13.3b PDN GW

The information storage for the PDN GW to support MS access to the EPC via UTRAN or GERAN is described in TS 23.401 [89].

13.4 MS

Each MS supporting GPRS maintains MM and PDP context information in IDLE, STANDBY, READY, PMM-DETACHED, PMM-IDLE, and PMM-CONNECTED states. The information may be contained in the MS and the TE. Table 8 shows the MS context fields. An E-UTRAN capable MS maintains additional information, e.g. a TIN. The additional information is described in TS 23.401 [89].

Table 8: MS MM and PDP Contexts

Field	SIM	Description	A/Gb mode	Iu mode
IMSI	G, U	International Mobile Subscriber Identity.	X	X
MM State		Mobility management state, IDLE, STANDBY, READY, PMM-DETACHED, PMM-IDLE, or PMM-CONNECTED.	X	X
P-TMSI	G, U	Packet Temporary Mobile Subscriber Identity.	X	X
P-TMSI Signature	G, U	A signature used for identification checking purposes.	X	X
Routeing Area	G, U	Current routeing area.	X	X
Cell Identity		Current cell.	X	
Kc	G	Current A/Gb mode ciphering key.	X	2)
KSI / CKSN	G, U	Key Set Identifier for IK Next, CK Next / key sequence number of Kc.	X	X
Ciphering algorithm		Selected ciphering algorithm.	X	X
CK		Currently used Iu mode ciphering key.	1)	X
CK Next	U	Iu mode ciphering key to be used after the next security mode command.	1)	X
IK		Currently used Iu mode integrity key.	1)	X
IK Next	U	Integrity key to be used after the next security mode command.	1)	X
MS Radio Access Capability		MS radio access capabilities.	X	X
UE Capability		UE radio capabilities.		X
MS Network Capability		MS network capabilities.	X	X
DRX Parameters		Discontinuous reception parameters.	X	X
Radio Priority SMS		The RLC/MAC radio priority level for uplink SMS transmission.	X	
Allowed CSG list		The Allowed CSG list, which is under both user and operator control, indicates the list of CSG IDs and the associated PLMN where the MS is a member.		X
Operator CSG list		The Operator CSG list, which is under exclusive Operator control, indicates the list of CSG IDs and the associated PLMN where the MS is a member.		X
Each MM context contains zero or more of the following PDP contexts:				
PDP Type		PDP type, e.g. PPP or IP.	X	X
PDP Address		PDP address; e.g. an IP address.	X	X
PDP State		Packet data protocol state, INACTIVE or ACTIVE.	X	X
Dynamic Address Allowed		Specifies whether the MS is allowed to use a dynamic address.	X	X
APN Requested		The APN requested.	X	X
NSAPI		Network layer Service Access Point Identifier.	X	X
TI		Transaction Identifier.	X	X
QoS Profile Requested		The quality of service profile requested.	X	X
QoS Profile Negotiated		The quality of service profile negotiated.	X	X
TFT		Traffic flow template.	X	X
Radio Priority		The RLC/MAC radio priority level for uplink user data transmission.	X	
Packet Flow Id		Packet flow identifier.	X	
Send N-PDU Number		SNDCP sequence number of the next uplink N-PDU to be sent to the SGSN.	X	X
Receive N-PDU Number		SNDCP sequence number of the next downlink N-PDU expected from the SGSN.	X	X
PDCP-SND		Sequence number of the next downlink in-sequence PDCP-PDU expected from the RNC.		X
PDCP-SNU		Sequence number of the next uplink in-sequence PDCP-PDU to be sent to the RNC.		X
BCM		The negotiated Bearer Control Mode	X	X

The information marked with a "1)" in table 8 may be maintained if authentication is performed by the UMTS authentication procedure.

The information marked with a "2)" in table 8 may be maintained if authentication is performed by the GSM authentication procedure.

The information marked with a "U" in table 8 shall be stored in the USIM.

The information marked with a "G" in table 8:

- shall be stored in the GSIM if the connected SIM is GPRS-aware; and
- may be stored in the ME after GPRS detach if the connected GSIM is not GPRS-aware.

If the GSIM is GPRS service-aware, then the IMSI, P-TMSI, P-TMSI Signature, Routeing Area, Kc, and CKSN stored in the GSIM shall be used for GPRS services.

If the GSIM is not GPRS service-aware, the P-TMSI, P-TMSI Signature, Routeing Area, Kc, and CKSN stored in the ME shall be used if and only if the IMSI stored in the GSIM is identical to the IMSI image maintained in the ME. If the IMSI stored in the GSIM is different from the IMSI image in the ME, the IMSI image in the ME shall not be used, and the MS shall identify itself with the IMSI stored in the SIM when performing a GPRS attach. IMSI, P-TMSI, P-TMSI Signature, Routeing Area, Kc, and CKSN may be stored in the ME after the GPRS attach has been successfully performed.

When using a USIM, the IMSI, P-TMSI, P-TMSI Signature, Routeing Area, Kc, CK Next, IK Next, and CKSN / KSI stored in the USIM, and the CK and IK stored in the ME, shall be used for GPRS services.

13.5 MSC/VLR

The MSC/VLR may store the SGSN number of GPRS-attached MSs that are also IMSI-attached. Table 9 shows the MSC/VLR association for one MS.

Table 9: MSC/VLR Association

Field	Description
IMSI	IMSI is the main reference key.
SGSN Number	The SGSN number of the SGSN currently serving this MS.

13.6 BSS in A/Gb mode

Table 10 shows the BSS context fields for one MS.

Table 10: BSS Context

Field	Description
IMSI	IMSI is the main reference key.
TLLI	Temporary Logical Link Identity.
Trace Reference	Identifies a record or a collection of records for a particular trace.
Trace Type	Indicates the type of trace.
Trigger Id	Identifies the entity that initiated the trace.
OMC Identity	Identifies the OMC that shall receive the trace record(s).
RFSP Index	An index to specific RRM configuration in GERAN
Each BSS context contains one or more BSS Packet Flow contexts:	
Packet Flow Id	Packet flow identifier.
Aggregate BSS QoS Profile Negotiated	The aggregate BSS quality of service profile negotiated for this packet flow.
BSS Packet Flow Timer	BSS packet flow context inactivity timer.

13.7 RNC/BSC for Iu mode

RNC/BSC maintains RNC/BSC Context for CN-related information in PMM-CONNECTED state. RNC/BSC also contains RAB contexts for activated RABs. Table 11 shows the context fields for one MS.

For emergency attached UEs which are not authenticated, IMEI is stored in context.

Table 11: RNC/BSC Context

Field	Description
IMSI	IMSI is the main reference key.
ME Identity	Mobile Equipment Identity (e.g. IMEI/IMEISV).
UE Capability	UE radio capabilities.
UESBI-Iu	Stored by an RNC which supports the "Provision of UE Specific Behaviour Information to Network Entities" feature defined in TS 23.195 [76].
UESBI-Uu	Stored by an RNC which supports the "Provision of UE Specific Behaviour Information to Network Entities" feature defined in TS 23.195 [76].
SAI	Current or last known SAI
SAI age	Time elapsed since the RNC last established the UE's last known SAI
Trace Reference	Identifies a record or a collection of records for a particular trace.
Trace Type	Indicates the type of trace.
Trigger Id	Identifies the entity that initiated the trace.
OMC Identity	Identifies the OMC that shall receive the trace record(s).
UE-AMBR	The currently used Maximum Aggregated uplink and downlink MBR values to be shared across all Non-GBR bearers.
RFSP Index	An index to specific RRM configuration in UTRAN (not defined in GERAN Iu mode)
Each RNC context contains zero or more RNC RAB contexts:	
RAB ID	Radio Access Bearer Identifier.
PDP Type	PDP type, e.g. PPP or IP.
TEID	Tunnel Endpoint Identifier.
SGSN (or GGSN) Address in Use	The IP address of the SGSN currently used if Direct Tunnel is not established (or GGSN in case of Direct Tunnel).
QoS Profile Negotiated	The quality of service profile negotiated for this RAB.
GTP-SND	GTP-U sequence number of the next downlink in-sequence N-PDU to be sent to the MS.
GTP-SNU	GTP-U sequence number of the next uplink in-sequence N-PDU to be sent to the GGSN.
PDCCP-SND	Sequence number of the next downlink in-sequence PDCCP-PDU to be sent to the MS.
PDCCP-SNU	Sequence Number of the next uplink in-sequence PDCCP-PDU expected from the MS.

13.8 Direct Tunnel specific error handling

Like other restoration procedures Direct Tunnel specific error handling is described in TS 23.007 [5].

13.9 Void

13.10 CSS

Please refer to TS 23.008 [79] for the content of the information storage for the CSS.

14 Identities

14.1 IMSI

A unique International Mobile Subscriber Identity (IMSI) shall be allocated to each packet-domain subscriber. This is also the case for GPRS-only subscribers. IMSI is defined in TS 23.003 [4].

14.2 Packet TMSI

A Packet Temporary Mobile Subscriber Identity shall be allocated to each GPRS-attached MS. P-TMSI is defined in TS 23.003 [4].

14.2A GUTI

Globally Unique Temporary Identity (GUTI) is defined in TS 23.401 [89].

14.3 NSAPI and TLLI for A/Gb mode

The Network layer Service Access Point Identifier (NSAPI) and Temporary Logical Link Identity (TLLI) are used for network layer routing. An NSAPI / TLLI pair is unambiguous within a routing area.

In the MS, NSAPI identifies the PDP-SAP. In the SGSN and GGSN, NSAPI identifies the PDP context associated with a PDP address. Between the MS and the SGSN, TLLI unambiguously identifies the logical link. The NSAPI may be related to either one IP address or two IP addresses (one IPv4 and one IPv6 if PDP Type IPv4v6 is supported and used).

When the MS requests the activation of a PDP context, the MS selects one of its unused NSAPIs.

For example (shown figuratively below), the MS receives an IP packet from a connected TE at the IP address A SAP. The IP PDU is encapsulated and NSAPI is initialised to NSAPI-1. TLLI is set to the MS's TLLI before the encapsulated IP packet is passed to the SNDC function. After the IP PDU is received, the SGSN analyses TLLI and NSAPI-1 and determines that the IP PDU shall be sent to the GGSN associated with IP address A.

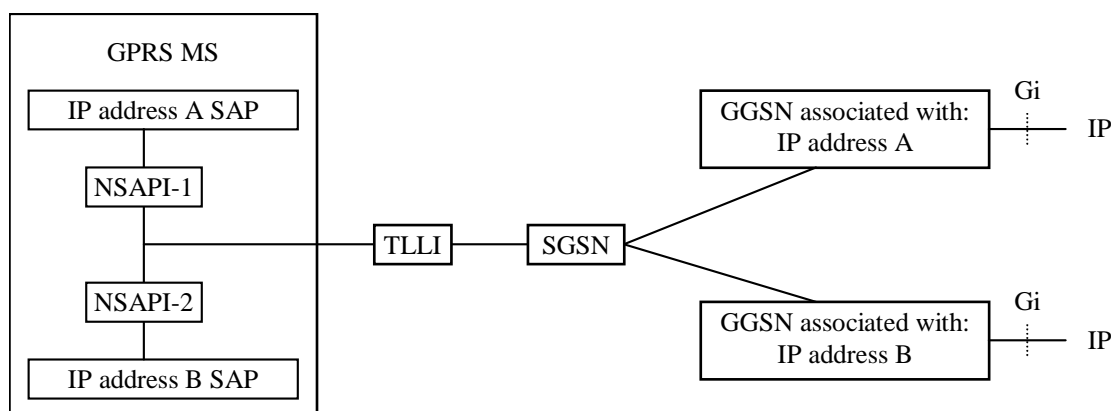

Figure 94: Use of NSAPI and TLLI

Within a routing area, there is a one-to-one correspondence between TLLI and IMSI that is only known in the MS and SGSN. If it is not clear from the context which routing area a TLLI belongs to, then TLLI is used together with RAI. TLLI is derived from a P-TMSI, and does then provide user identity confidentiality as described in clause "User Identity Confidentiality (A/Gb mode)".

The TLLI address range is divided into four ranges: Local, Foreign, Random, and Auxiliary. The TLLI structure allows the MS and SGSN to deduce the range that a TLLI belongs to. A Local TLLI is derived from the P-TMSI allocated by the SGSN, and is valid only in the RA associated with the P-TMSI. A Foreign TLLI is derived from a P-TMSI allocated

in another RA. A Random TLLI is selected randomly by the MS, and is used when the MS does not have a valid P-TMSI available. An Auxiliary TLLI is selected by the SGSN, but is not used in this release of the specifications.

If the MS has a valid P-TMSI associated with the RA where the MS is currently located, the MS shall use a Local TLLI derived from its P-TMSI, unless the MS performs a GPRS attach.

If the MS does not have a valid P-TMSI associated with the current RA, or if the MS performs a GPRS attach, it shall derive a Foreign TLLI from its P-TMSI, or allocate a Random TLLI if no valid P-TMSI is available.

When a TLLI is exchanged between the MS and an SGSN, the TLLI is transmitted at the RLC/MAC layer within the Um protocol stack, and at the BSSGP layer within the Gb protocol stack. NSAPI is transmitted within the SNDCP layer in the user plane, and within the GMM/SM layer in the control plane. In some SM signalling messages, transaction identifier (TI) represents NSAPI. The TI is dynamically allocated by the MS for MS-requested PDP context activation, and by the network for network-requested PDP context activation. The TI is deallocated when a PDP context has been deactivated. TI usage is defined in TS 24.007 [12] and TS 24.008 [13].

By default, unless explicitly specified in the procedures, the TLLI transmitted at the RLC/MAC and BSSGP layers shall be used to identify the MS.

14.4 NSAPI, RB Identity, and RAB ID for Iu mode

The Network layer Service Access Point Identifier (NSAPI) and IMSI are used for network layer routing. An NSAPI / IMSI pair is used to assign a Tunnel Endpoint Identifier (TEID).

In the MS, NSAPI identifies the PDP-SAP. In the SGSN and GGSN, NSAPI identifies the PDP context associated with an MM context.

In the context of this specification, the term RNC refer also to a GERAN BSC when serving an MS in Iu mode.

In communication with the RNC across the Iu-PS and Uu interfaces, the RAB ID is used to identify the radio access bearer and that information element shall be set identical to the NSAPI value. In the RNC, RAB ID identifies the RAB context. Radio Bearer Identity (RB Identity) is used to identify the Uu interface radio bearer(s) associated with the radio access bearer. The RAB ID shall uniquely identify the RAB for a specific CN domain and a particular MS.

There is a one-to-one relationship between NSAPI, Radio Access Bearer, and PDP context. In the packet domain, there is also a one-to-one relationship with Radio Bearer Identity. The NSAPI may be related to either one IP address or two IP addresses (one IPv4 and one IPv6 if PDP Type IPv4v6 is supported and used).

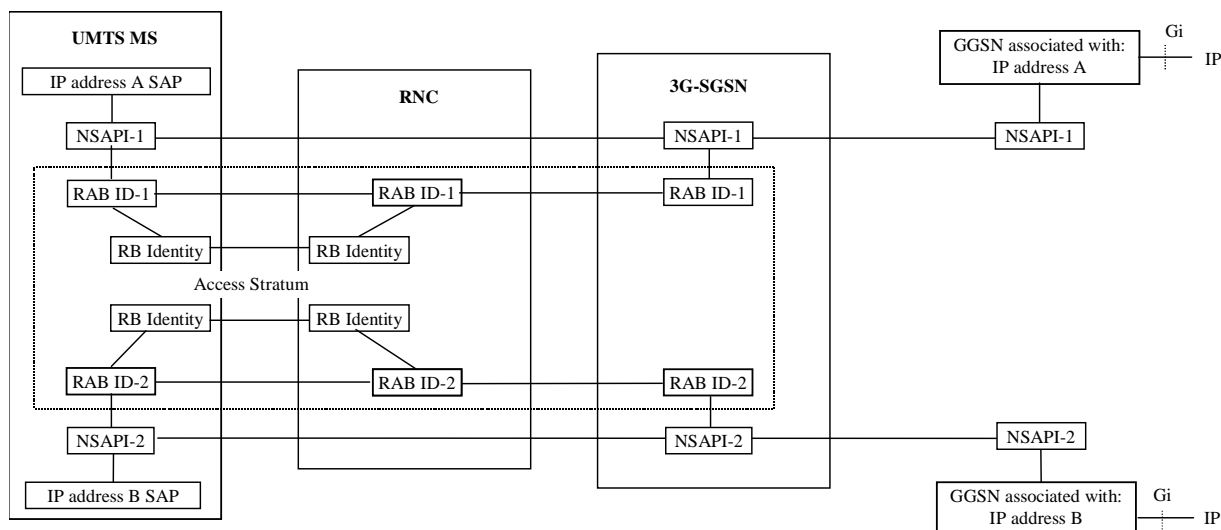

Figure 95: Use of NSAPI, RB Identity, and RAB ID

When the MS initiates activation of a PDP context, the MS selects one of its unused NSAPIs. When the SGSN initiates a RAB assignment procedure, the SGSN shall include the NSAPI(s) in the RAB ID information element(s).

14.4A EPS Bearer Identity

An EPS bearer identity uniquely identifies an EPS bearer for one UE. When there is a mapping between an EPS bearer and a PDP context, the same identity value is used for the EPS bearer ID and the NSAPI/RAB ID. The EPS Bearer Identity is defined in TS 23.401 [89].

14.5 PDP Address

A packet-domain subscriber identified by an IMSI, shall have one or more network layer addresses, i.e. PDP addresses, temporarily and/or permanently associated with it that conforms to the standard addressing scheme of the respective network layer service used, e.g.:

- an IP version 4 address; or
- an IP version 6 prefix; or
- an IP version 4 address and an IP version 6 prefix.

PDP addresses are activated and deactivated through MM procedures described in clause "PDP Context Activation, Modification, Deactivation, and Preservation Functions".

A corresponding identity "PDN Address" is used over S-based interfaces using GTP.

14.6 TEID

A Tunnel Endpoint Identifier (TEID) is used by the GPRS tunnelling protocol between GSNs, between SGSNs and S-GWs and P-GWs and between RNCs/BSCs and SGSNs, to identify a tunnel endpoint in the receiving GTP-C or GTP-U protocol entity and to identify an EPS Bearer and/or a PDP context (or in the Iu case a Radio Access Bearer). The receiving end side of a GTP-U tunnel locally assigns the TEID value that the transmitting side has to use. The TEID values are exchanged between tunnel endpoints using GTP-C (or RANAP in the Iu case) messages.

The TEID is a unique identifier within one IP address of a logical node, i.e. RNC, BSC, SGSN, S-GW, P-GW or GGSN, which has meaning only within the GTP protocol. For the user plane, i.e. GTP-U, each PDP context has a one-to-one relationship between the TEID on one hand and NSAPI and IMSI on the other hand, or in the Iu reference point case, between the TEID and RAB ID and IMSI. When a node releases an EPS Bearer/PDP context, the corresponding TEID shall not be re-used within a significant period of time to ensure a low probability of the TEID being still assigned to an existing EPS Bearer/PDP context in a peer node. However, the algorithm for computing the value of the TEID and the period of time until the re-use of a TEID are implementation dependent.

The TEID is forwarded to the S-GW and P-GW or GGSN upon PDP Context Activation and it is used in subsequent tunnelling of user data between the GGSN or S-GW and P-GW and the SGSN to identify the MS's PDP contexts in the SGSN and GGSN or S-GW and P-GW. The TEID is also used to forward N-PDUs from the old SGSN to the new SGSN at and after an inter-SGSN routing area update. In Iu mode, the TEID is also forwarded to the RNC upon RAB assignment and it is used in subsequent tunnelling of user data between the SGSN and the RNC/BSC in order to identify the MS's PDP contexts in the SGSN and the MS's RAB contexts in the RNC/BSC. It is also used to forward N-PDUs from the SRNC/SBSC to the target RNC/BSC at SRNS/SBSS relocation.

14.7 Routing Area Identity

Routing Area Identity (RAI), defined by an operator, identifies one or several cells.

In A/Gb mode, RAI is broadcast as system information.

In Iu mode, RAI is broadcast to MSs in RRC Idle mode, and is notified to MSs in RRC Connected mode on established RRC connections as MM system information.

The location of an MS in STANDBY or PMM-IDLE state is known in the SGSN on an RA level. Cells that do not support packet-domain services within an LA are grouped into a null RA. The MS is paged for packet services in the RA where the MS is located when mobile-terminated traffic arrives in the SGSN. The MS is paged for circuit-switched services by the SGSN in the last known RA plus in the null RA.

NOTE: Cells not supporting GPRS and served by a BSC without a Gb interface should not be included in the same location area as cells not supporting GPRS and served by a BSC with a Gb interface.

A Routing Area is a subset of one, and only one, Location Area (LA), meaning that an RA cannot span more than one LA. An RA is served by only one SGSN.

The following rules apply for the Routing Area Identity:

- RAC is only unique when presented together with LAI.
- CI is only unique when presented together with LAI or RAI (A/Gb mode only).
- LAI = MCC + MNC + LAC.
- RAI = MCC + MNC + LAC + RAC.
- CGI = LAI + CI (A/Gb mode only).

14.8 RAN Registration Area Identity (Iu mode)

The UTRAN/GERAN Registration Area Identity (URA/GRA Id) identifies a UTRAN/GERAN Registration Area (URA/GRA) and is defined in TS 25.331 [52]. URA/GRA Id can be used to indicate to the MS which URA/GRA it shall use in case of overlapping URA/GRAs.

14.9 Cell Identity

In A/Gb mode, Cell Identity (CI) identifies one cell. In Iu mode, Cell Identifier (C-Id) uniquely identifies a cell within an RNS. CI and C-Id are defined in TS 23.003 [4].

14.10 Service Area Identity (Iu mode)

The Service Area Identity (SAI) is used to uniquely identify an area consisting of one or more cells belonging to the same location area. Such an area is called a Service Area and can be used for indicating the location of an MS to the CN.

The Service Area Code (SAC) together with the PLMN identity and the LAC constitutes the Service Area Identity:

- SAI = MCC + MNC + LAC + SAC.

14.11 CN Node Addresses

14.11.1 CN Node Address

Each SGSN, S-GW, P-GW and GGSN shall have one or more IP addresses of type IPv4, and optionally of type IPv6, for inter-communication over the backbone network. When an SGSN, S-GW, P-GW or a GGSN supports IPv6 in the backbone network, then it shall also support IPv4. The IP addresses of GSNs and other backbone nodes of all PLMNs build a private address space that is not accessible from the public Internet. For the GGSN, S-GW, P-GW and SGSN, each of these IP addresses may also correspond to one or more DNS-type logical GSN names.

14.11.2 GSN Number

Each SGSN shall have an SGSN number for communication with e.g. HLR and EIR.

Each GGSN that supports the optional SS7-based Gc interface shall have a GGSN number for communication with HLRs.

14.12 RNC/BSC Addresses (Iu mode)

14.12.1 RNC/BSC Address

Each RNC or BSC shall have one or more IP addresses for inter-communication over the Iu interface. When the ATM transport option is applied on the Iu interface, each RNC or BSC shall be able to support addresses of type IPv4 and optionally of type IPv6. When the IP transport option is applied on the Iu interface, each RNC or BSC shall be able to support both IPv6 addresses and IPv4 addresses.

NOTE: These statements refer to RNC and BSC implementation requirements. When both IP versions are required to be supported in the RNC or BSC, it is still an operational choice whether to configure and use both or only one of the address types in a particular network set-up (i.e. in a network where it is known that all interconnected RNCs and SGSNs support the same IP version, it is legitimate to operate IPv4 only or IPv6 only).

14.12.2 RNC/BSC Number

Each RNC or BSC shall have an RNC/BSC number for inter-communication over the Iu interface.

14.13 Access Point Name

In the backbone, Access Point Name is a reference to the GGSN or P-GW to be used. In addition, Access Point Name may, in the GGSN or P-GW, identify the packet data network and optionally a service to be offered. Access Point Name is composed of two parts as defined in TS 23.003 [4].

The APN stored in the HLR shall not contain the APN Operator Identifier. A wild card may be stored in the HLR instead of the APN. This wild card indicates that the user may select an APN that is not stored in the HLR. The use of the wild card is described in Annex A.

14.14 Closed Subscriber Group ID

A CSG ID is a unique identifier within the scope of PLMN defined in TS 23.003 [4] which identifies a Closed Subscriber Group (CSG) in the PLMN associated with a CSG cell or group of CSG cells.

15 Operational Aspects

15.1 Charging

15.1.0 General

GPRS charging information is collected for each MS by SGSNs, S-GWs and P-GWs/GGSNs that are serving the MS. When based on Gn/Gp, the operator can control whether charging information shall be collected in the SGSN and the GGSN on an individual MS and/or PDP context basis by appropriately setting the Subscribed Charging Characteristics and/or PDP context Charging Characteristics in the HLR.

NOTE 1: The charging requirements for the S-GW, including connectivity through S4, and the P-GW are as defined in TS 23.401 [89].

The charging characteristics on the subscription and individually subscribed APNs are specified in TS 32.251 [70].

The information that the operator uses to generate a bill to a subscriber is operator-specific. Billing aspects, e.g. a regular fee for a fixed period, are outside the scope of the present document.

Every operator collects and processes his own charging information.

The SGSN, for connectivity through Gn/Gp, collects charging information for each MS related to the radio network usage while the P-GW/GGSN collect charging information for each MS related to the packet data network usage. All core network nodes also collect charging information on usage of the network resources.

If the SGSN is connected through Gn/Gp with a GGSN/P-GW, charging may be also realised by a CAMEL server using CAMEL interaction procedures, see referenced procedures in TS 23.078 [8b]. Prepaid charging may also be realised by a CAMEL server, which do not rely on receiving a valid Charging Id, when the SGSN is connected through S4 with a P-GW.

NOTE 2: A network configuration may ensure that the Charging Id is valid, when the SGSN is connected with a S-GW through S4 and GTP is in use on S5/S8.

NOTE 3: When using CAMEL for prepaid charging, the GGSN/P-GW should not be used for the same purpose.

Charging may be also realised by Flow Based Charging procedures at the GGSN, see referenced procedures in TS 23.203 [88] and TS 32.251 [70].

15.1.1 Charging Information

Charging information is collected for the GPRS subscriber.

As a minimum, the SGSN, when connected through Gn/Gp or through S4 for non-E-UTRAN CAMEL enabled subscribers, shall collect the following charging information for MSs and/or individual PDP contexts that are subject to charging:

- usage of the radio interface: the charging information shall describe the amount of data transmitted in Mobile-originated and Mobile-terminated directions categorised with QoS and user protocols;
- usage of the general GPRS resources: the charging information shall describe the usage of other GPRS-related resources and the MS's network activity (e.g. mobility management); and
- location of MS: HPLMN, VPLMN, plus optional higher-accuracy location information.

When connected through Gn/Gp, the SGSN shall in addition collect the following charging information for MSs and/or individual PDP contexts that are subject to charging:

- usage of the packet data protocol addresses: the charging information shall describe how long the MS has used the packet data protocol addresses.

When CSG is deployed in the network, the SGSN shall also collect the following charging information for MSs and/or individual PDP contexts that are subject to charging:

- User CSG information: CSG ID and access mode of the cell which the MS is accessing, and CSG membership indication of whether the MS is a CSG member in this cell.

The valid CSG information shall be available in the SGSN and GGSN in connected mode.

The PCRF shall, if deployed, provide User CSG Information reporting rules to the GGSN at Attach and PDP context activation procedure. The GGSN sets the CSG Information Reporting Action IE according to the User CSG Information reporting rules and sends it to SGSN.

As a minimum, the GGSN shall collect the following charging information for MSs and/or individual PDP contexts that are subject to charging:

- destination and source: the charging information shall describe the destination and source addresses with a level of accuracy as defined by the GPRS operator;
- usage of the packet data networks: the charging information shall describe the amount of data sent and received to and from the packet data network; and
- usage of the packet data protocol addresses: the charging information shall describe how long the MS has used the PDP addresses.

Additionally, the GGSN may collect the location of an MS: HPLMN, VPLMN, plus optional information i.e. RAI/CGI/SAI and/or CSG information if required for individual MSs.

When the SGSN is connected through Gn/Gp or through S4 for non-E-UTRAN CAMEL enabled subscribers, the RNC and the Iu mode BSC shall collect the following charging information for an MS's RABs when instructed by the SGSN:

- amount of not transferred downlink data, i.e. data that the RNC/BSC has either discarded or forwarded to an SGSN or to another RNC/BSC. Partially transferred packets shall be handled as not transferred. The collected charging information shall be sent by the RNC/BSC to the SGSN when a RAB is released, or when explicitly requested by the SGSN. The SGSN shall indicate at RAB setup whether data volume collection and reporting for the particular RAB is required or not.

When the SGSN is connected through S4, the S-GW collects charging information for MSs and/or individual EPS bearers as described in TS 23.401 [89].

15.1.1a General impacts of applying Flow Based Charging

TS 23.203 [88] and TS 32.251 [70] define means for providing online and offline charging with IP flow granularity for GPRS based on functionality in the GGSN. If Flow Based Charging functionality is deployed in an operator's GPRS network, end-user charging functionalities are provided by the GGSN.

NOTE: When Flow Based Charging is deployed, charging functions in the SGSN and S-GW are expected to still be used for inter-operator accounting purposes for the scenario where the SGSN or S-GW (for connectivity through S4) and the GGSN are in different networks. When the SGSN or S-GW and the GGSN are in the same network and Flow Based Charging is deployed, then the operator may decide to disable the charging functions in the SGSN or S-GW.

In order to allow for disabling of the charging functions in the SGSN, the SGSN shall be able to include extra information in the signalling messages sent to the GGSN/P-GW, as follows:

- a) in the Create PDP Context Request message, the IMEISV, the RAT type and the S-CDR CAMEL information shall be sent by the SGSN to the GGSN;
- b) in the Update PDP Context Request messages sent due to SGSN change, the RAT type shall be sent by the SGSN to the GGSN; and
- c) dependent upon the identity of the GGSN's operator, the SGSN shall send (or omit) the CGI/SAI and User CSG Information in:
 - i) the Create PDP Context Request message,
 - ii) the Update PDP Context Request message sent as part of the MS-Initiated PDP Context Modification procedure
 - iii) the Update PDP Context Request message sent due to SGSN change.
 - iv) an Change Notification sent when requested to report changes in CGI/SAI and User CSG Information of the MS by the GGSN, see clause 15.1.3.
- d) The SGSN shall send a Change Notification as part of the intra-SGSN Routeing Area Update procedures when requested to report changes in Routeing Area by the GGSN, see clause 15.1.3.

In addition:

- e) the SGSN shall send an Update PDP Context Request to the GGSN when the Radio Access Technology changes during an intra SGSN routing area update, if the SGSN is not already reporting changes in RAI, SAI, CGI or User CSG Information, as defined in clause 15.1.3 to that GGSN.

The RAT type indicates whether the SGSN serves the UE by GERAN or UTRAN Radio Access Technology.

As an implementation option, the SGSN may include these parameters in other situations that cause the Update PDP Context Request message to be sent.

The above information elements shall be handled by the GGSN in a transparent manner, i.e. the GGSN copies the information elements without modification into the charging information (see TS 32.251 [70]) and/or (if RADIUS

accounting is applied in the operator's network) without modification into the RADIUS accounting messages (see TS 29.061 [27]).

15.1.2 Reverse Charging

It shall be possible to provide reverse charging as a subscription option. However, reverse charging may not be applicable to certain packet data network protocols.

15.1.3 Location and CSG dependent charging

15.1.3.1 Basic principles

The GGSN or P-GW may request for each PDP context independently using the "MS info change report required" and/or the "CSG information change report required" parameter that the SGSN shall report changes at CGI/SAI/RAI level and/or changes of user CSG information to the GGSN. This may be controlled through the Policy and Charging Control architecture as defined in TS 23.203 [88]. If CGI/SAI and/or user CSG information are permitted to be sent to the GGSN operator according to SGSN operator's policy, the SGSN shall include an indication for the support of reporting changes in CGI/SAI/RAI and/or user CSG information when signalling to the GGSN during both mobility management and session management. If the level of support changes during a mobility management procedure then the S4-SGSN shall indicate the current level of support to the S-GW and shall in addition provide CGI/SAI even if the P-GW has not requested this information. This could for example happen during SGSN change when the level of support indicated by the old SGSN is not the same as in the new SGSN.

NOTE 1: The inclusion of CGI/SAI will trigger a Modify Bearer Request message from S-GW to the P-GW and therefore this will make sure that the new level of support reaches the P-GW.

The GGSN/P-GW shall not request the SGSN to report CGI/SAI/RAI and/or user CSG information changes if it has not received the indication for support from the SGSN. In Iu-mode, the SGSN uses the Location Reporting procedures in clause 12.7.5 to request the RNC to report changes in SAI to the SGSN.

The SGSN should report to the GGSN/P-GW per MS in the Change notification message where the report is not combined with other mobility management or session management signalling. The GGSN/P-GW may also request the SGSN to stop reporting CGI/SAI/RAI and/or user CSG information changes. The SGSN obeys the last explicit instruction from the GGSN/P-GW.

NOTE 2: Due to the increased signalling load, it is recommended that such reporting is only applied for a limited number of subscribers.

15.1.3.2 Interaction with CGI / SAI / user CSG information reporting

The following procedures in figures 15.1.3-1, and 15.1.3-2 represent the notification of the CGI and SAI changes respectively to the GGSN.

The procedures only apply when the SGSN has been explicitly requested to report CGI or SAI and/or user CSG information changes.

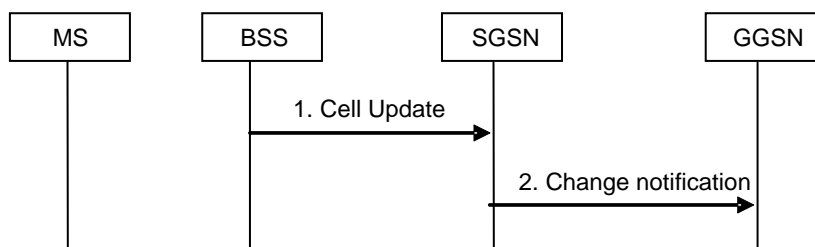

Figure 15.1.3-1: Cell Update triggering a report of change in CGI

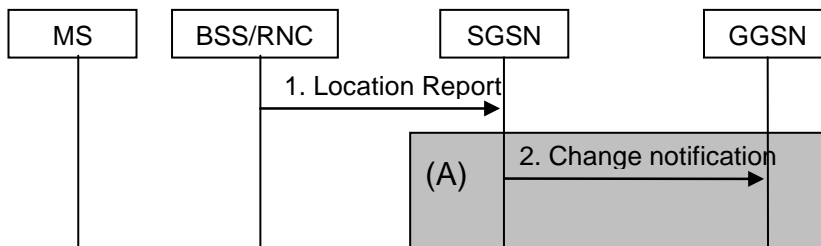

Figure 15.1.3-2: Iu-mode Location report triggering a report of change in SAI

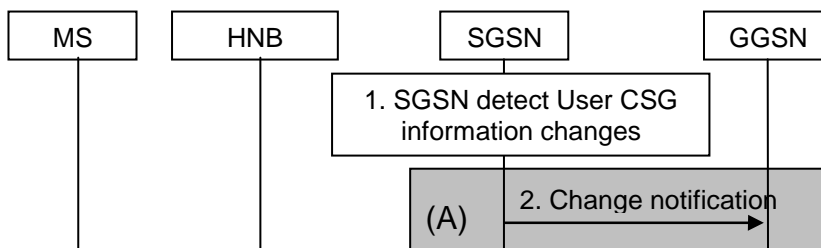

Figure 15.1.3-3: User CSG Information Changes triggering a report of change in user CSG information

NOTE: Step 1 is common for architecture variants using Gn/Gp based interaction with GGSN and using S4 based interaction with S-GW and P-GW. For an S4 based interaction with S-GW and P-GW, procedure steps (A) are defined in clause 15.1.3.2B.

1. In Gb-mode, the SGSN receives a Cell Update indication via the mechanisms described in clause 6.9.1.1.

In Iu-mode, the SGSN receive a location report message (as per the location reporting procedures in clause 12.7.5)

The SGSN detects that the user CSG information has changed by comparing with the SGSN stored user CSG information.

2. If the SGSN has been requested to report the CGI or SAI and/or user CSG information changes to the GGSN for the MS, the SGSN shall send the change notification to the GGSN indicating the new cell and/or new user CSG information. The SGSN stores the notified user CSG information. If dynamic PCC is deployed, and CGI or SAI changes need to be conveyed to the PCRF, then the GGSN shall send this information to the PCRF as defined in TS 23.203 [88].

15.1.3.2a Interaction with CGI / SAI / user CSG information reporting using S4

The procedures described in figure 15.1.3-3 shows only the steps, due to use of S4, which are different from the Gn/Gp variant of the procedure given by clause 15.1.3.2.

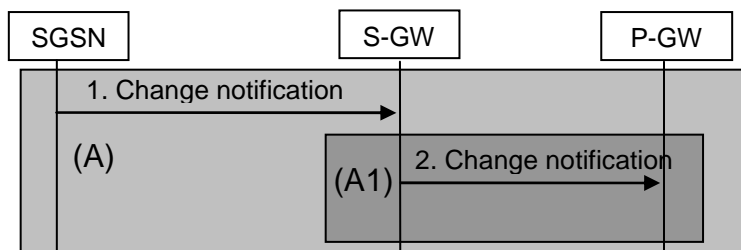

Figure 15.1.3-3: Cell Update triggering a report of change in CGI, Iu-mode Location report triggering a report of change in SAI and User CSG information change triggering a report of change in user CSG information

NOTE: Step 1 is common for architecture variants with GTP based S5/S8 and PMIP-based S5/S8. For a PMIP-based S5/S8, procedure step (A1) is defined in TS 23.402 [90]. Step 2 concerns GTP based S5/S8.

1. If the SGSN has been requested to report the CGI or SAI and/or user CSG information changes to the P-GW (via the S-GW) for the MS, the SGSN shall send the change notification to the S-GW indicating the new cell and/or new user CSG information. The SGSN stores the notified user CSG information.
2. The S-GW forwards the change notification to the P-GW. If dynamic PCC is deployed, and CGI or SAI changes need to be conveyed to the PCRF, then the PGW shall send this information to the PCRF as defined in TS 23.203 [88].

15.2 Quality of Service Profile

15.2.0 General

A QoS profile is associated with each PDP context. The QoS profile is considered to be a single parameter with multiple data transfer attributes. The definition of the QoS attributes for Gn/Gp can be found in TS 23.107 [58], which also defines the mapping between the Release 99 QoS attributes and the QoS attributes for GPRS Releases 97 and 98. In addition the Evolved ARP is introduced over Gn/Gp from Release 9. If the network supports the Evolved ARP then this parameter shall be used instead of the Allocation/Retention Priority parameter of the QoS profile during resource allocation/modification towards the RAN. The EPS Bearer QoS parameters are defined in TS 23.203 [88] and the mapping between the EPS Bearer QoS parameters and the Release 99 QoS attributes in TS 23.401 [89].

At any given time, there should be a maximum of one PDP context, for a particular PDP address, that is not associated with a TFT.

During the QoS profile negotiation defined in clause "Activation Procedures", it shall be possible for the MS to request a value for each of the QoS attributes, including the HLR-stored subscribed default values. However if the MS requests the traffic class as 'subscribed', the SGSN will assume a request for Interactive class. When the MS requests a QoS, the HLR-stored subscribed default values shall be interpreted as the maximum QoS per PDP context to the associated APN. However the Evolved ARP shall be interpreted as the default value and an SGSN shall accept to receive a Negotiated Evolved ARP from the GGSN even if it is different from the subscribed Evolved ARP received from the HLR. When the application in the MS requires streaming or conversational QoS, then the MS shall at least explicitly request the traffic class and should explicitly request the guaranteed bit rate and the maximum bit rate.

For architecture variants using Gn/Gp based interaction with GGSN, the network shall negotiate each attribute to a level that is in accordance with the available GPRS resources and the known capabilities of the rest of the system. For architecture variants using S4 based interaction with SGW, the network shall not negotiate (either accept or reject) the EPS QoS attributes.

The network shall always attempt to provide adequate resources to support the negotiated QoS profiles.

15.2.1 Radio Priority Levels (A/Gb mode)

The RLC/MAC layer supports four radio priority levels and an additional level for signalling messages as defined in TS 43.064 [11] and TS 44.060 [77]. Upon uplink access the MS can indicate one of the four priority levels, and whether the cause for the uplink access is user data or signalling message transmission. This information is used by the BSS to determine the radio access precedence (i.e. access priority) and the service precedence (i.e. transfer priority under congested situation), see TS 44.060 [77]. The radio priority levels to be used for transmission of Mobile-originated SMS shall be determined by the SGSN and delivered to the MS in the Attach Accept message. The radio priority level to be used for user data transmission shall be determined by the SGSN based on the negotiated QoS profile and shall be delivered to the MS during the PDP Context Activation and PDP Context Modification procedures.

15.2.1a APN-AMBR

APN-AMBR limits the aggregate bit rate that can be expected to be provided across all non GBR PDP Contexts/bearers and across all PDN connections of the same APN (e.g. excess traffic may get discarded by a rate shaping function). GBR PDP Contexts/bearers are outside the scope of APN AMBR. It has an uplink and a downlink component. The GGSN/PDN-GW enforces the APN AMBR. Each APN configuration, stored in the HSS subscription profile may contain a subscribed APN-AMBR value. The APN-AMBR is signalled from the HSS via SGSN to the GGSN/PDN-GW. If no APN-AMBR is received from the HSS, the SGSN shall set the APN-AMBR according to implementation specific policies (e.g. a preconfigured maximum APN-AMBR). The SGSN shall set the negotiated APN-AMBR to the value of the APN-AMBR received from the GGSN/PDN-GW.

The APN-AMBR is a parameter of PDP Context/PDN Connection information and is transferred over the Gn/Gp, S10 or S3 interface.

15.2.2 UE-AMBR

The UE-AMBR denote bit rates of traffic per group of bearers and as such the UE-AMBR is considered outside the scope of the Quality of Service profile. It has an uplink and a downlink component. The UE-AMBR is limited by a subscription parameter stored in the HSS. The SGSN shall set the UE-AMBR to the sum of the APN-AMBR of all active APNs, up to the value of the subscribed UE-AMBR. If no values of UE-AMBR are received from the HSS, the SGSN shall set the UE-AMBR according to implementation specific policies (e.g. a preconfigured maximum UE-AMBR). The UE-AMBR limits the aggregate bit rate that can be expected to be provided across all Non-GBR PDP contexts of a UE (e.g. excess traffic may get discarded by a rate shaping function). Each of those Non-GBR PDP contexts could potentially utilize the entire UE-AMBR, e.g. when the other Non-GBR PDP contexts do not carry any traffic. GBR (real-time) PDP contexts are outside the scope of UE-AMBR. The RAN enforces the UE-AMBR in uplink and downlink.

The operation of UE-AMBR in A/Gb mode is described in clause 12.6.3.5 and in Iu mode is described in clause 12.7.4.

The UE-AMBR is a parameter of MM Context information and is transferred over the Gn/Gp, S10 or S3 interface.

15.3 Traffic Flow Template

15.3.0 General

A TFT consists of one or more packet filters, each identified by a unique packet filter identifier. The maximum number of packet filters is specified in TS 24.008 [13]. A packet filter also has an evaluation precedence index that is unique among all packet filters that are associated with the PDP contexts that share the same PDP address and APN. This evaluation precedence index is in the range of 255 (lowest evaluation precedence) down to 0 (highest evaluation precedence). The MS manages packet filter identifiers and their evaluation precedence indexes, and creates the packet filter contents for those packet filters that are created by the MS. In 'MS/NW' mode, the GGSN/PGW manages packet filter identifiers and their evaluation precedence indexes for those packet filters that are created by the network. A packet filter has a direction attribute, which indicates the direction of the traffic flow(s), i.e. whether they are uplink, downlink or bi-directional. A packet filter from the MS where the direction attribute is not provided describes desired downlink traffic mapping and the network shall interpret such filter as valid for both directions. For services having no downlink IP flows, the MS shall provide packet filters for uplink IP flows to enable policy control functionality as described in TS 23.203 [88].

NOTE 1: Packet filter direction was introduced together with the support for Network Requested Secondary PDP Context Activation procedure.

The state for the TFT and packet filter settings amongst all the PDP Contexts associated with one PDP address/prefix and APN pair is valid if all of the following conditions are fulfilled:

- there is at most one PDP Context with no associated TFT; and
- for 'MS/NW' mode or when the MS uses the direction attribute in 'MS_only' mode, the PDP Context established with the Secondary PDP Context Activation Procedure always has an associated TFT with at least one packet filter for the uplink direction.

NOTE 2: The above conditions for the valid TFT and packet filter setting is intended for use with bearers in all types of 3GPP accesses.

NOTE 3: A TFT that does not have any packet filter for the uplink direction is not considered valid (except for the PDP context established with the PDP Context Activation Procedure). By not considering the TFT valid a non-backward compatible change is introduced, but it would otherwise introduce unnecessary complexity to the system and it would still remain ambiguous whether such a TFT would be considered as allowing or not allowing uplink flows from an MS perspective, e.g. if the MS sends uplink packets on such PDP context the network might drop such packets due to lack of PCC rules with matching filters.

The network shall, after conducting any action necessary to recover from a detected TFT status misalignment between the MS and the network, reject any request from the MS that would violate any of these conditions.

NOTE 4: The network action to recover from a detected TFT status misalignment sometimes include deactivating outdated bearer information remaining after MS and network getting out of synchronization.

For each TFT, the MS and the network shall ensure that the subset of their own packet filters, if any, fulfils the conditions above.

NOTE 5: Ensuring that the own packet filters alone fulfils the conditions also ensures that the TFT setting for the PDP Contexts associated with one PDP address/prefix and APN pair remains valid, still allowing the MS and the network manipulating their own packet filters independently.

The MS may associate a TFT with a PDP context in the Secondary PDP Context Activation procedure or the MS-Initiated PDP Context Modification procedure. The network associates a TFT with a PDP context in the Network Requested Secondary PDP Context Activation Procedure or the GGSN-Initiated PDP Context Modification procedure (if in 'MS/NW' mode). A PDP context can never have more than one associated TFT.

In 'MS_only' mode the MS may modify any TFT through the MS-Initiated PDP Context Modification procedure.

In 'MS/NW' mode the GGSN and the MS may modify any TFT through the PDP Context Modification Procedure in accordance with the restrictions described in clause 9.2.0.

A TFT associated with a PDP context is always deleted at PDP context deactivation.

Among the PDP contexts that share the same PDP address and APN pair there shall be a maximum of one PDP context without an associated TFT. If every established PDP context of a PDP address and APN pair is associated with a TFT a new PDP context, for the same PDP address and APN pair, may be established without a TFT by means of the Secondary PDP Context Activation procedure in accordance with the restrictions described in clause 9.2.0.

The UE may use the TFT to associate the Network Requested Secondary PDP Context Activation Procedure and the GGSN-Initiated PDP Context Modification Procedure to an application and to traffic flow aggregates of the application. Therefore the GGSN shall (in the Network Requested Secondary PDP Context Activation Procedure and the GGSN-Initiated PDP Context Modification Procedure) and the P-GW shall (in the Create Dedicated Bearer Request and the Update Bearer Request messages) provide all available traffic flow description information applicable for the same EPS Bearer/PDP context (e.g. source and destination IP address and port numbers and the protocol information).

15.3.1 Rules for Operations on TFTs

The MS and GGSN shall use the TFT and packet filter identifiers in each operation for handling of the TFTs and packet filters in accordance with the restrictions described in clause 9.2.0.

When the MS or GGSN creates a new TFT, or modifies an existing TFT, it has to include at least one valid packet filter. If no valid packet filter is included in the newly created or modified TFT, the procedure used for the creation or modification of the TFT shall fail, and an error code shall be returned to the MS or GGSN respectively.

During the modification of a TFT, one or more existing packet filters can be modified or deleted, or a new packet filter can be created. In order to modify an existing packet filter, the new values for the packet filter attributes along with the packet filter identifier is sent from the MS to the GGSN, or from the GGSN to the MS. The MS may also modify the evaluation precedence index only of one or several packet filters by means of the MS-Initiated PDP Context Modification procedure. The GGSN may also modify the evaluation precedence index only of one or several packet filters by means of the GGSN-Initiated PDP Context Modification procedure.

A TFT is deleted when the associated PDP context is deactivated. A TFT can also be deleted by means of the MS-Initiated PDP Context Modification procedure. At any time there may exist only one PDP context with no associated TFT amongst all the PDP contexts associated with one PDP address. An attempt by the MS to delete a TFT, which would violate this rule, shall be rejected by the GGSN.

15.3.2 Packet Filter Attributes

15.3.2.0 General

Each valid downlink- and uplink-packet filter contains a unique identifier within a given TFT, an evaluation precedence index that is unique among all packet filters for one PDP address and APN pair, and at least one of the following attributes:

- Remote Address and Subnet Mask.
- Protocol Number (IPv4) / Next Header (IPv6).
- Local Address and Mask.
- Local Port Range.
- Remote Port Range.
- IPSec Security Parameter Index (SPI).
- Type of Service (TOS) (IPv4) / Traffic class (IPv6) and Mask.
- Flow Label (IPv6).

In the list of attributes above 'Remote' refers to the external network entity, and 'Local' to the MS.

Some of the above-listed attributes may coexist in a packet filter while others mutually exclude each other. In table 12 below, the possible combinations are shown. Only those attributes marked with an "X" may be specified for a single packet filter. All marked attributes may be specified, but at least one shall be specified.

If the parameters of the header of a received PDP PDU match all specified attribute values in a packet filter, then it is considered that a match is found for this packet filter. In this case, the evaluation procedure is aborted. Other packet filters in increasing order of their evaluation precedence index are evaluated until such match is found.

There may be potential conflicts if attribute values are combined in such a way that the defined filter can never achieve a match to a valid IP packet header. However, the determination of such conflicts is outside the scope of GPRS standardization.

Table 12: Valid Packet Filter Attribute Combinations

Packet filter attribute	Valid combination types		
	I	II	III
Remote Address and Subnet Mask	X	X	X
Protocol Number (IPv4) / Next Header (IPv6)	X	X	
Local Address and Mask	X	X	X
Local Port Range	X		
Remote Port Range	X		
IPSec SPI		X	
TOS (IPv4) / Traffic Class (IPv6) and Mask	X	X	X
Flow Label (IPv6)			X

15.3.2.1 Remote Address and Subnet Mask

The Remote Address and Subnet Mask attribute of a valid packet filter shall contain an IPv4 or IPv6 address along with a subnet mask.

As an example, the remote address and subnet mask attribute to classify packets coming from all hosts within the IPv4 domain A.B.C.0/24 is {A.B.C.0 [255.255.255.0]}.

15.3.2.2 Protocol Number / Next Header

The Protocol Number / Next Header attribute of a valid packet filter shall contain either an IPv4 Protocol Number or an IPv6 Next Header value. The value range is from 0 to 255.

15.3.2.2A Local Address and Mask

The Local Address and Mask attribute of a valid packet filter shall contain an IP address along with a mask.

The Local Address and Mask attribute is optional for both the MS and the network and can be used in case both the MS and network has declared support for the extended TFT filter format in the Protocol Configuration Options.

NOTE: For IPv4, there is only one local address associated with the bearer. Therefore an IPv4 local address in the TFT filter would be redundant.

15.3.2.3 Port Numbers

The Local Port Range and Remote Port Range attributes of a valid packet filter shall each contain one port number, or a range of port numbers. Port numbers range between 0 and 65 535.

15.3.2.4 IPSec Security Parameter Index

The IPSec SPI attribute of a valid packet filter shall contain one SPI which is a 32-bit field.

15.3.2.5 Type of Service / Traffic Class and Mask

The Type of Service / Traffic Class and Mask attribute of a valid packet filter shall contain either an IPv4 TOS octet or an IPv6 Traffic Class octet along with a mask defining which of the 8 bits should be used for matching.

15.3.2.6 Flow Label

The Flow Label attribute of a valid packet filter shall contain an IPv6 flow label, which is a 20-bit field.

15.3.3 Example Usage of Packet Filters

15.3.3.0 General

Based on the type of traffic or the packet data network QoS capabilities, different types of packet filters can be used to classify a given PDP PDU in order to determine the right PDP context. Some examples are given below.

15.3.3.1 IPv4 Multi-field Classification

For multi-field classification, the packet filter consists of a number of packet header fields. For example, to classify TCP/IPv4 packets originating from 172.168.8.0/24 destined to port 5 003 at the TE, the following packet filter can be used:

- Packet Filter Identifier = 1;
- IPv4 Source Address = {172.168.8.0 [255.255.255.0]};
- Protocol Number for TCP = 6; and
- Destination Port = 5 003.

15.3.3.2 IPv4 TOS-based Classification

For TOS-based classification, the packet filter consists of only the TOS octet coding. For example to classify IPv4 packets marked with TOS coding 001010xx, the following packet filter can be used:

- Packet Filter Identifier = 3;
- Type of Service / Traffic Class = 00101000 and Mask = 11111100.

NOTE: The TOS-based classification can always be augmented with the source address attribute if it is known that different source domains use different TOS octet codings for the same traffic class.

15.3.3.3 IPv4 Multi-field Classification for IPSec Traffic

For multi-field classification of IPSec traffic, the packet filter contains the SPI instead of the port numbers that are not available due to encryption. If IPSec (ESP) was used with an SPI of 0x0F80F000, then the following packet filter can be used:

- Packet Filter Identifier = 4;
- Protocol Number for ESP = 50; and
- SPI = 0x0F80F000.

15.3.3.4 Services with IP flows in only one direction

For services with no uplink IP flows, a dummy uplink packet filter can be provided by the network to avoid that the UE uses the PDP context for uplink traffic that is expected on the PDP context without any uplink packet filter. For example that can be done by assigning the remote port "9", which is the "discard" port, i.e. the following packet filter can be used:

- Packet Filter Identifier = 5;
- Packet Filter Direction = uplink only; and
- Remote port = 9 (the discard port).

15.4 APN Restriction

The support for APN Restriction and Maximum APN Restriction at the SGSN is optional and an APN Restriction value may be configured for each APN in the GGSN or PGW. The support for reception, storage, and transfer of APN Restriction is required for an S4-SGSN. It is used to determine, on a per MS basis, whether it is allowed to establish PDP Contexts or EPS bearers to other APNs.

Table 13: Valid Combinations of APN Restriction

Maximum APN Restriction Value	Type of APN	Application Example	APN Restriction Value allowed to be established
0	No Existing Contexts or Restriction		All
1	Public-1	WAP or MMS	1, 2, 3
2	Public-2	Internet or PSPDN	1, 2
3	Private-1	Corporate (e.g. who use MMS)	1
4	Private-2	Corporate (e.g. who do not use MMS)	None

During the PDP Context Activation procedure or the default bearer activation (for connectivity through S4), the GGSN or PGW may compare the APN Restriction of the PDP Context being set up with the Maximum APN Restriction received from the SGSN to decide whether this activation is accepted. The Maximum APN Restriction is the most restrictive value of the APN Restriction (highest number) from all already active PDP Contexts. The APN Restriction is transferred at PDP Context activation to the SGSN.

The APN Restriction for each PDP context, if available, shall be transferred either from the GGSN or PGW to the new SGSN during inter-SGSN changes (e.g. SRNS Relocation and Routing Area Update) or from the old SGSN in case both SGSNs use S16 for connectivity. The new SGSN determines the maximum APN Restriction using the APN Restriction contained in the Update PDP Context Response message(s) received from the GGSN(s) or PGW(s).

During the PDP Context Modification procedure (via the APN Restriction received from the GGSN or PGW) and inter-SGSN changes, the SGSN shall verify if there are PDP contexts to different APNs that violate valid combinations based on the APN Restriction. If a violation is detected, the SGSN shall release PDP contexts until a valid combination results and shall send appropriate error causes to the MS. Which PDP contexts are released is network operator configurable and the SGSN may perform one of the following actions, using the SGSN-Initiated PDP Context Deactivation procedures in clause 9.2.4.2, until a valid combination remains or no further actions are possible:

1. Deactivate the most restrictive, as dictated by the APN Restriction value, PDP Context sending an appropriate error cause to the MS,
2. Deactivate the least restrictive, as dictated by the APN Restriction value, PDP Context sending an appropriate error cause to the MS,
3. Deactivate PDP Contexts in no particular order sending an appropriate error cause to the MS.

During PDP Context Activation procedure or default bearer activation (for connectivity through S4) for emergency, GGSN or PGW shall ignore APN Restriction. During PDP Context Modification procedure (via the APN Restriction received from the GGSN or PGW) and inter SGSN changes, the SGSN shall not deactivate bearer(s) with emergency ARP, if any, to maintain valid APN combination. Same restriction also applies to procedures in TS 23.401 [89].

15.5 Automatic Device Detection

The Automatic Device Detection (ADD) function is an optional feature that allows the network to be updated with the current User Equipment identity (IMEISV). This, for example, enables the network to configure the subscriber's equipment. A device management system can retrieve the IMEISV either from SGSN or from HLR, or be triggered by a changed IMEISV in either SGSN or HLR. However, the device management system and the mechanism to send the configuration to the terminal are outside the scope of 3GPP specifications.

When the ADD function is supported, the SGSN obtains and stores the IMEISV from the MS at GPRS Attach and at Inter-SGSN Routing Area Update procedures when the old SGSN does not provide the IMEISV. The SGSN uses either the GMM Identification procedure or the GMM Authentication and Ciphering procedure to obtain the IMEISV (TS 24.008 [13]). Equipment checking is independent from IMEISV retrieval for ADD. If the IMSI was not previously registered in the SGSN, the SGSN includes the IMEISV in the Update Location message to the HLR. If the IMSI was already registered, the SGSN compares the IMEISV retrieved from the UE with the one stored in SGSN MM context and sends the IMEISV in the Update Location to the HLR if these are different. The MAP parameter Skip Subscriber Data Update should be included in this case to avoid unnecessary signalling, i.e. Cancel Location and Insert Subscriber Data unnecessarily being sent to SGSN.

For the purposes of ADD the IMEISV is transferred on the Gs interface as part of the combined GPRS/IMSI attach procedure.

For further information on the Automatic Device Detection function, please refer to TS 22.101 [82] and TS 23.012 [81].

15.6 Direct Tunnel Functionality

Direct Tunnel is an optional function in Iu mode that allows the SGSN to establish a direct user plane tunnel between RAN and GGSN (for connectivity with GGSN through Gn/Gp) or S-GW (for connectivity through S4) within the PS domain.

A Direct Tunnel capable SGSN shall have the capability to be configured on a per RNC and per GGSN or S-GW basis whether or not it can use a direct user plane connection.

The SGSN handles the control plane signalling and makes the decision when to establish Direct Tunnel. When the RAB assigned for a PDP context is released (i.e. the PDP context is preserved) the GTP-U tunnel is established between the GGSN (for connectivity with GGSN through Gn/Gp) and SGSN in order to be able to handle the downlink packets.

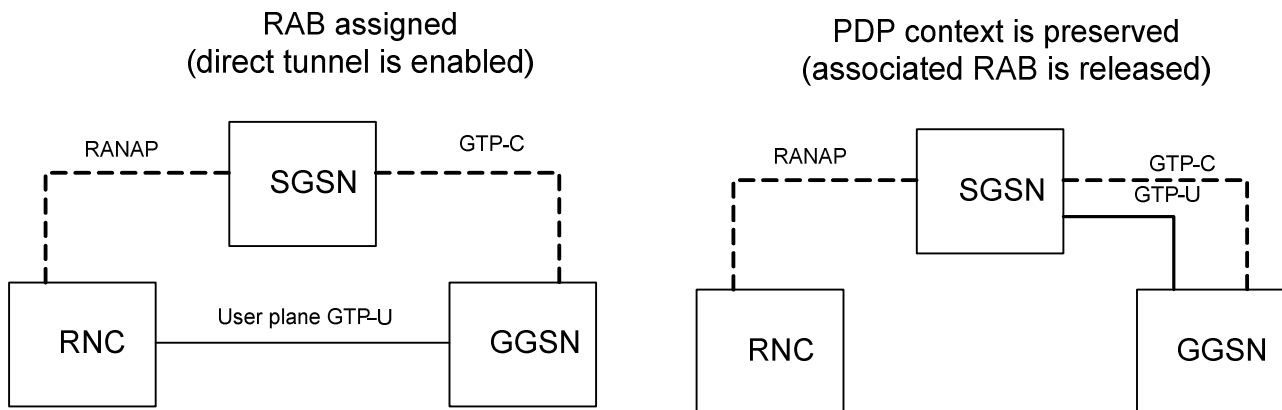

Figure 15.6-1: IDLE mode handling for Gn/Gp connectivity

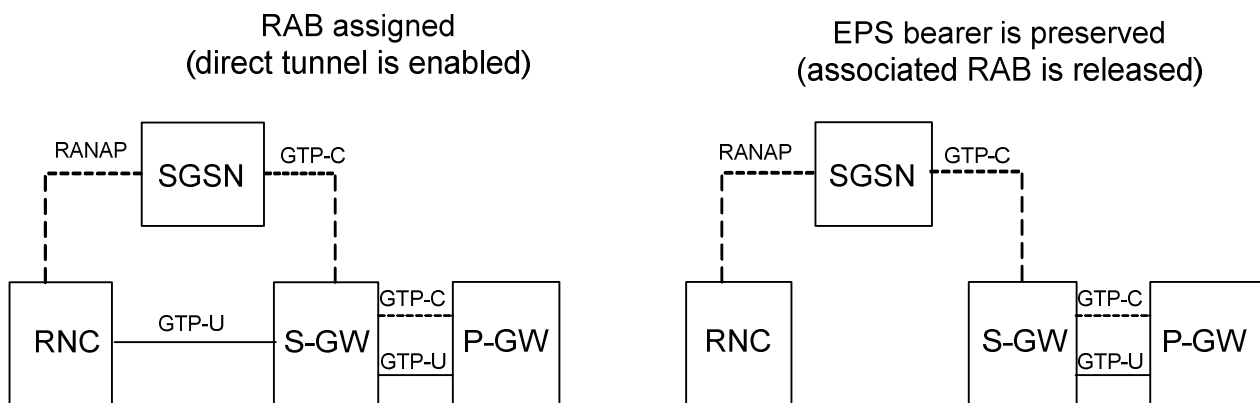

Figure 15.6-1: IDLE mode handling for S4 connectivity

Direct Tunnel shall not be used in following traffic cases:

- 1) In roaming case for connectivity with GGSN through Gn/Gp only
 - The SGSN needs to know whether the GGSN is in the same or different PLMN.
- 2) If the SGSN is connected with a GGSN through Gn/Gp and the SGSN has received CAMEL Subscription Information in the subscriber profile from the HLR.
 - If Direct Tunnel is established then volume reporting from SGSN is not possible as the SGSN no longer has visibility of the User Plane. Since a CAMEL server can invoke volume reporting at anytime during the life time of a PDP Context, the use of Direct Tunnel shall be prohibited for a subscriber whose profile contains CAMEL Subscription Information.
- 3) GGSN does not support GTP protocol version 1.

15.7 HPLMN Notification with specific indication due to SGSN initiated Bearer removal

When initiating a Delete PDP context procedure, the SGSN should add an appropriate cause code facilitating the operator of the GGSN/P-GW to take appropriate action (e.g. Alarm, O&M action by operator's management network) if needed.

NOTE: This is for the HPLMN operator to be able to differentiate Delete PDP context procedures due to a failure case (e.g. due to a QoS parameter mismatch at Initial Attach) from Delete PDP context procedures that are executed in cases not related to any failure conditions (e.g. due to a Routing Area Update). Action taken by the HPLMN operator is outside the scope of 3GPP specification.

16 Interactions with Other Services

16.0 General

This clause describes the interaction between packet-domain services and the following other services for a GPRS-attached MS which is in GERAN/UTRAN PS coverage:

- point-to-point Short Message Service (SMS);
- circuit-switched services;
- supplementary services; and
- CAMEL services.

16.1 Point-to-point Short Message Service

It shall be possible for a GPRS-attached MS to send and receive short messages over the PS domain when it is in GERAN/UTRAN PS coverage. An MS that is GPRS-attached and not IMSI-attached shall transfer SMs over the PS domain. MSs that are both GPRS-attached and IMSI-attached shall transfer SMs over the PS domain or over the CS domain (if the CS domain is used, then paging for Mobile-terminated SMS may go through the SGSN).

The following two clauses define the operation of mobile-terminated and mobile-originated SMS routing and transfer over the PS domain. More detailed definitions are contained in TS23.040 [8].

16.1.1 Mobile-terminated SMS Transfer

Figure 96 and the description below show an example of a successful delivery of an SM to an MS in GERAN/UTRAN PS coverage over the PS domain.

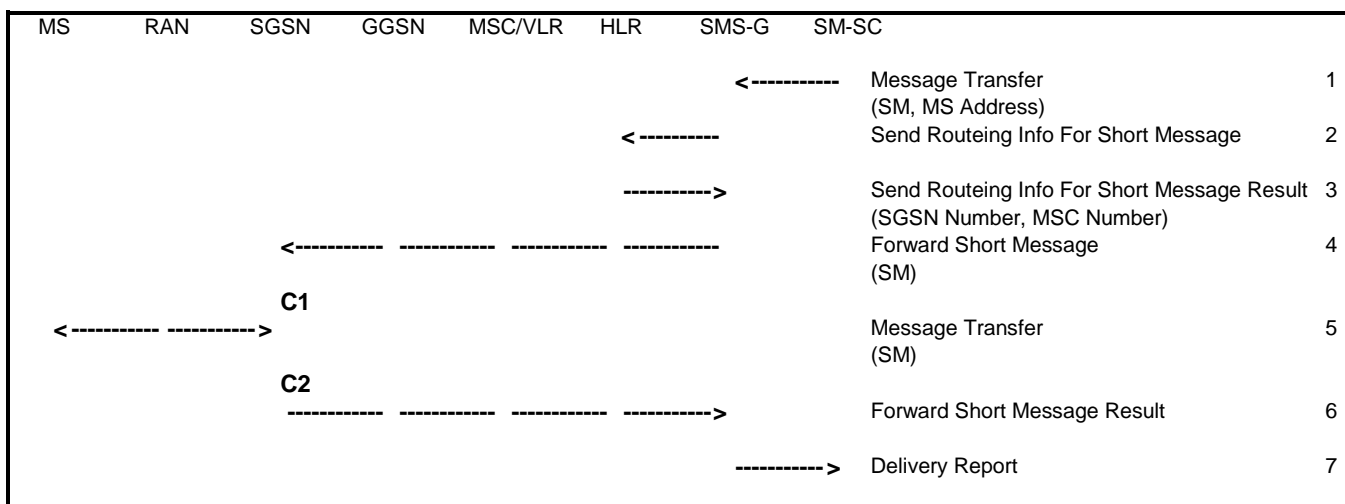

Figure 96: Mobile-terminated SMS Transfer, Successful

- 1) The short message service centre determines it shall send an SM to an MS. SM-SC forwards the SM to an SMS gateway MSC (SMS-GMSC).

- 2) SMS-GMSC examines the destination MS Address, and sends a Send Routeing Info For Short Message message to the relevant HLR.
- 3) HLR checks the subscriber data (e.g. ODB data and Call Barring Info) for the MS and determines that the MS is allowed to receive the SMS. The HLR returns a Send Routeing Info For Short Message Result message to the SMS-GMSC. The result may contain the MS's current SGSN Number, the MSC Number, or both. If the result does not contain an SGSN Number (i.e., the HLR knows that the MS is not reachable via an SGSN), and if the result does contain an MSC Number, non-GPRS SMS delivery procedures are followed. If the result contains an SGSN Number, the SMS transfer proceeds according to the following events.

NOTE: SMS delivery via the SGSN is normally more radio resource efficient than SMS delivery via the MSC/VLR. The preferred delivery path is selected by SMS-GMSC operator-specific action.

- 4) SMS-GMSC forwards the SM to the SGSN.
- 5) SGSN transfers the SM to the MS on the RP and CP layers, as defined in TS 24.011 [13b].
- 6) SGSN returns a Forward Short Message Result message to the SMS-GMSC indicating successful delivery of the SM.
- 7) SMS-GMSC returns a Delivery Report to the SM-SC indicating successful delivery of the SM.

CAMEL procedure calls shall be performed, see referenced procedures in TS 23.078 [8b]:

C1) CAMEL_T_SMS_INIT.

The procedure returns as result "Continue".

C2) CAMEL_T_SMS_DELIVERED.

This procedure does not return a result.

16.1.1.1 Unsuccessful Mobile-terminated SMS Transfer

The SGSN or the HLR may not be able to deliver the SM to the MS. This may for example happen when the MS is not attached to GPRS, when the radio channel conditions are bad, or when the Mobile-terminated SMS is barred.

When the SGSN cannot deliver the SM to the MS, the SGSN sets the Mobile station Not Reachable for GPRS flag (MNRG), and returns a failure report to the SMS-GMSC. Based on the routeing information received from the HLR, the SMS-GMSC shall do one of the following:

- If an MSC/VLR is available for the MS, the SM is forwarded to the MS via the MSC/VLR. A successful delivery report shall be returned to the SM-SC.
- If an MSC/VLR is not available for the MS, the Message Waiting Indication information in the HLR shall be updated and an unsuccessful delivery report shall be returned to the SM-SC.

Figure 97 illustrates one possible traffic scenario when neither the SGSN nor the MSC is able to deliver the SM.

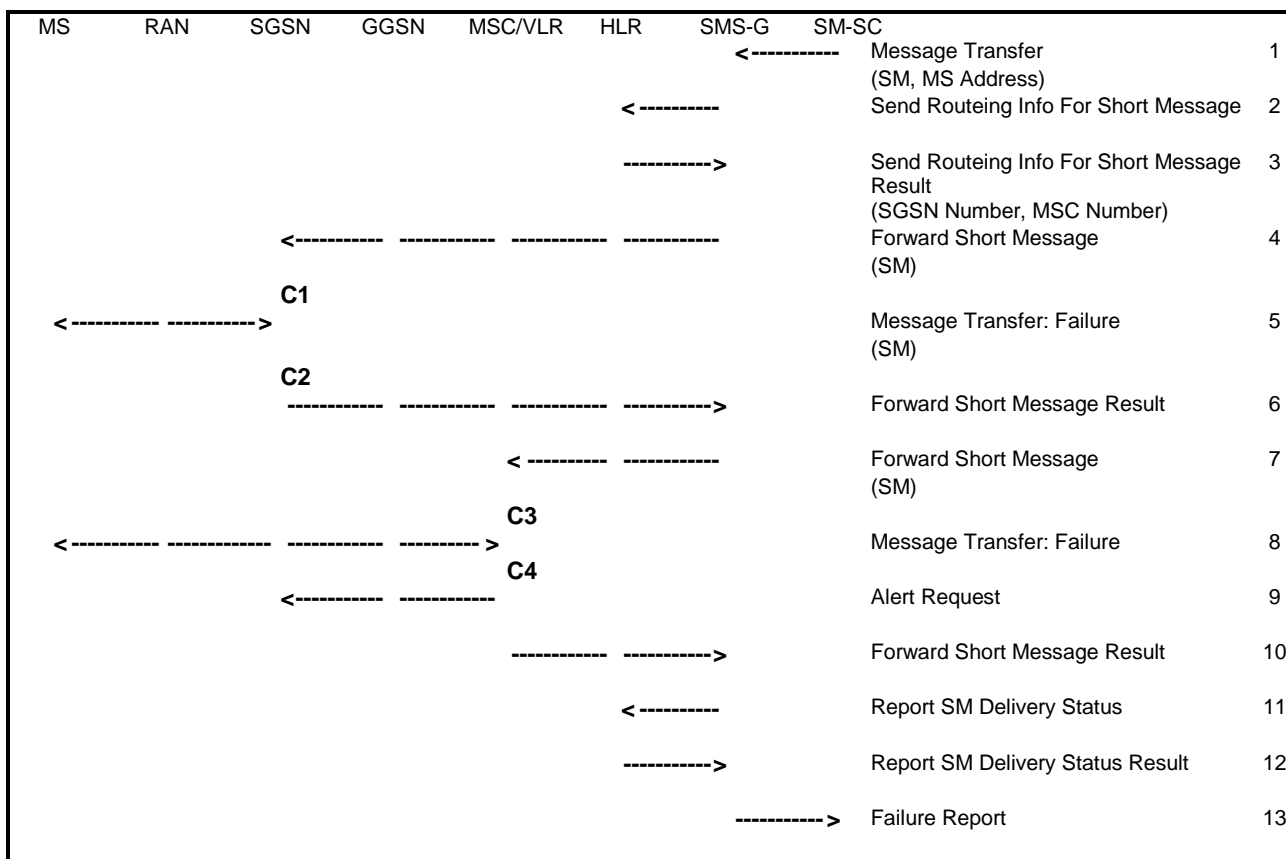

Figure 97: Mobile-terminated SMS Transfer, Unsuccessful

- 1) The short message service centre determines it shall send an SM to an MS. SM-SC forwards the SM to a SMS-GMSC.
- 2) SMS-GMSC examines the destination MS Address, and sends a Send Routing Info For Short Message message to the relevant HLR.
- 3) HLR checks the subscriber data (e.g. ODB data and Call Barring Info) for the MS to determine whether the MS is allowed to receive the SMS. If the Mobile-terminated SMS is barred, the HLR returns a Send Routing Info for Short Message Error message with an appropriate cause. If the Mobile-terminated SMS is not barred, the HLR returns a Send Routing Info For Short Message Result message to the SMS-GMSC. The Result contains an SGSN Number and an MSC Number.
- 4) SMS-GMSC forwards the SM to the SGSN.
- 5) SGSN attempts to transfer the SM to the MS, but fails.
- 6) SGSN sets MNRG and returns a Forward Short Message Result message to SMS-GMSC indicating unsuccessful delivery of the SM.
- 7) SMS-GMSC selects an alternative route for the SMS, and forwards the SM to the MSC/VLR.
- 8) MSC/VLR attempts to transfer the SM to the MS, but fails.
- 9) The MSC/VLR requests the setting of the NGAF at the SGSN.
- 10) VLR sets MNRF and returns a Forward Short Message Result message to the SMS-GMSC indicating unsuccessful delivery of the SM.
- 11) SMS-GMSC sends a Report SM Delivery message to the HLR.

12)HLR updates its Message Waiting Indication fields and returns a Report SM Delivery Result message to the SMS-GMSC.

13)SMS-GMSC returns a Failure Report to the SM-SC indicating unsuccessful delivery of the SM.

CAMEL procedure calls shall be performed, see referenced procedures in TS 23.078 [8b]:

C1) CAMEL_T_SMS_INIT.

The procedure returns as result "Continue".

C2) CAMEL_T_SMS_FAILURE.

This procedure does not return a result.

C3) CAMEL_T_SMS_INIT.

The procedure returns as result "Continue".

C4) CAMEL_T_SMS_FAILURE.

This procedure does not return a result.

Figure 69 shows that the SGSN sends a Ready for SM (MS Reachable) message to the HLR when the MS becomes reachable and MNRG is set in the SGSN. The SGSN indicates also to the MSC/VLR when the MS becomes reachable and NGAF is set in the SGSN. If the MNRF is set at the MSC/VLR, the MSC/VLR sends a Ready for SM (MS Reachable) message to the HLR. Reception of a Ready for SM message or Update Location message when MNRG is set in the HLR shall trigger the SMS alert procedure as defined in TS 23.040 [8].

MNRG remains set in the SGSN independently of whether the MSC/VLR was successful in delivering the SM or not. This means that the SGSN in certain cases sends a Ready for SM message to the HLR when an MS becomes reachable via the SGSN, even if no SM is waiting. This causes a small amount of duplicate signalling between the SGSN and the HLR only.

16.1.2 Mobile-originated SMS Transfer

Figure 98 and the description below explain the steps involved in sending an SM from an MS in GERAN/UTRAN PS coverage over the PS domain.

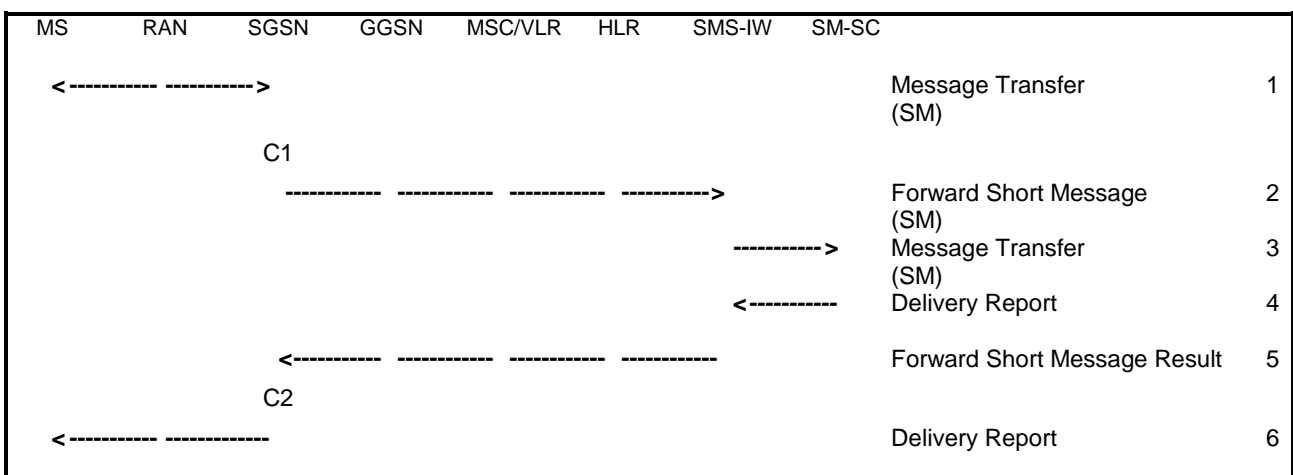

Figure 98: Mobile-originated SMS Transfer, Successful

- 1) The MS has an SM to send, and transfers the SM to the SGSN via RP and CP.
- 2) SGSN checks the MS subscription data (e.g. ODB data and Call Barring Info), and determines that the MS is allowed to originate the SMS. SGSN forwards the SM to a SMS interworking MSC (SMS-IWMSC). If the MS is not allowed to originate the SMS, the SGSN returns an RP Error message with an appropriate cause.
- 3) SMS-IWMSC passes the SM to the addressed SM-SC.

- 4) SM-SC returns a Delivery Report to the SMS-IW MSC indicating successful delivery of the SM.
- 5) SMS-IW MSC returns a Forward Short Message Result message to the SGSN indicating successful delivery of the SM.
- 6) SGSN returns a Delivery Report to the MS indicating successful delivery of the SM.

CAMEL procedure calls shall be performed, see referenced procedures in TS 23.078 [8b].

C1) CAMEL_O_SMS_INIT.

The procedure returns as result "Continue".

C2) CAMEL_O_SMS_SUBMITTED

This procedure does not return a result.

16.2 Circuit-switched Services (A/Gb mode)

The ability for a GPRS user to access circuit-switched services depends on the subscription held, the network capabilities, and the MS capabilities. Interaction between GPRS and circuit-switched services is described in clause "Interactions Between SGSN and MSC/VLR".

16.2.1 Suspension of GPRS Services

The MS shall request the network for suspension of GPRS services when the MS or the network limitations make it unable to communicate on GPRS channels in one or more of the following scenarios:

- 1 When a GPRS-attached MS enters dedicated mode and the support of Class A mode of operation is not possible (e.g. the MS only supports DTM (see TS 43.064 [11]) and the network only supports independent CS and PS).
- 2 During CS connection, the MS performs handover from Iu mode to A/Gb mode, and the MS or the network limitations make it unable to support CS/PS mode of operation, e.g. an MS in CS/PS mode of operation in Iu mode during a CS connection reverts to class-B mode of operation in A/Gb mode.
- 3 When an MS in class A mode of operation is handed over to a cell where the support of Class A mode of operation is not possible (e.g. a DTM mobile station entering a cell not supporting DTM).

16.2.1.1 Suspend and Resume procedure (A/Gb mode)

In the following procedures, when a suspended MS is resumed, the MS should either deactivate the PDP context of streaming or conversational traffic class, or the MS should modify the PDP context of streaming or conversational traffic class to reset the maximum bit rate to a proper value (see clause "RNC/BSS-Initiated PDP Context Modification Procedure").

16.2.1.1.1 Intra-SGSN Suspend and Resume procedure

The Suspend and Resume procedure for intra-SGSN is illustrated in Figure 99.

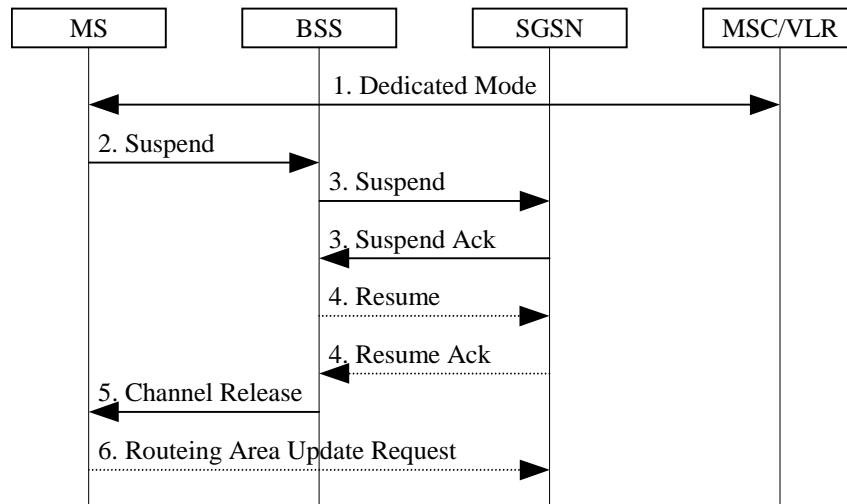

Figure 99: Suspend and Resume Procedure for intra SGSN

- 1) The MS enters dedicated mode and the MS or the network limitations make it unable to support Class A mode of operation, or during CS connection, a DTM MS performs handover from a cell supporting DTM to a cell not supporting DTM.
- 2) The MS sends an RR Suspend (TLLI, RAI) message to the BSS. The BSS may terminate any ongoing GPRS traffic for this TLLI.
- 3) The BSS sends a Suspend (TLLI, RAI) message to the SGSN, and the SGSN acknowledges by returning Suspend Ack. The BSS shall store TLLI and RAI in order to be able to request the SGSN to resume GPRS services when the MS leaves dedicated mode.
- 4) Eventually, the BSS may determine that the conditions for the GPRS suspension have disappeared. If the BSS is able to request the SGSN to resume GPRS services, the BSS shall send a Resume (TLLI, RAI) message to the SGSN. The SGSN acknowledges the successful outcome of the resume by returning Resume Ack.
- 5) If the circuit switched radio channel is to be released, the BSS sends an RR Channel Release (Resume) message to the MS. The Resume message indicates whether the BSS has successfully requested the SGSN to resume GPRS services for the MS, i.e., whether Resume Ack was received in the BSS before the RR Channel Release message was transmitted. The MS leaves dedicated mode.
- 6) The MS shall resume GPRS services by sending a Routeing Area Update Request message to the SGSN:
 - if the BSS did not successfully request the SGSN to resume GPRS services,
 - if the RR Channel Release message was not received before the MS left dedicated mode,
 - if the MS locally determines that the conditions for the GPRS suspension have disappeared

The Update Type depends on the mode of operation of the network in use e.g. in mode I Combined RA/LA Update is made and in mode II Routeing Area Update is made.

The full handling of suspended MSs in the BSS and the SGSN is implementation dependent. Typically, the SGSN should not page suspended MSs.

If the MS performs an inter-BSC handover while suspended, the TLLI and RAI should be transferred as BSC-to-BSC information in the Handover Required and Handover Request messages, see TS 48.008 [18]. This allows the new BSC to initiate the Resume request procedure to the SGSN. If the BSC-to-BSC information was not transferred or not understood, the MS doesn't receive an indication that resumption has been successful, and the MS shall resume GPRS services by initiating a Routeing Area Update or Combined RA/LA Updating procedure as described in step 6.

16.2.1.1.2 Inter-SGSN Suspend and Resume procedure

The Suspend and Resume procedure for inter-SGSN is illustrated in Figure 100.

This describes the scenario where the old cell and the new cell are handled by different SGSN's, i.e. suspend message is received in an SGSN that is different from the SGSN currently handling the packet data transmission.

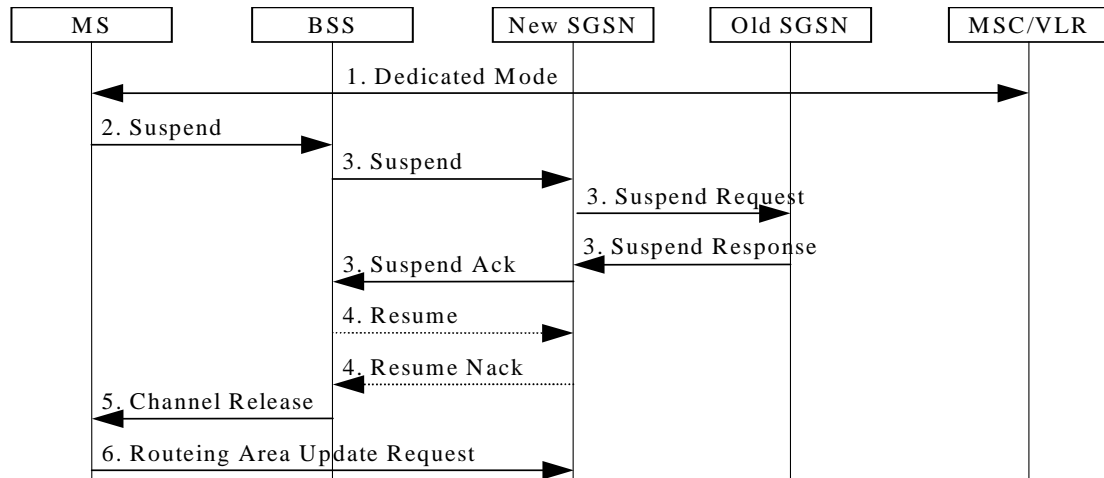

Figure 100: Suspend and Resume Procedure for inter-SGSN

- 1) During CS connection, a DTM MS performs handover from a cell supporting DTM to a cell not supporting DTM.
- 2) The MS sends an RR Suspend (TLLI, RAI) message to the BSS.
- 3) The BSS sends a Suspend (TLLI, RAI) message to the SGSN.
 - Since the SGSN that receives the Suspend message is not the one currently handling the packet data transmission, an indication to perform suspend will be sent to the old SGSN by means of a SUSPEND REQUEST message on the Gn interface. The address of the old SGSN is derived by "old RAI" received in Suspend message. If the SGSN that receives the Suspend message provides functionality for Intra Domain Connection of RAN Nodes to Multiple CN Nodes, the SGSN that receives the Suspend message from the BSS may derive the old SGSN from the old RAI and the old TLLI and send the Suspend Request message to this old SGSN. Otherwise, the SGSN that receives the Suspend message from the BSS derives the old SGSN from the old RAI. In any case the SGSN that receives the Suspend message from the BSS will derive an SGSN that it believes is the old SGSN. This derived SGSN is itself the old SGSN, or it is associated with the same pool area as the actual old SGSN and it will determine the correct old SGSN from the TLLI and relay the Suspend Request message to that actual old SGSN.
 - The Old SGSN returns a SUSPEND RESPONSE.
 - The new SGSN then returns Suspend Ack to the BSS.
- 4) After CS connection is terminated, the BSS may send a Resume (TLLI, RAI) message to the new SGSN, but since resume is not needed against the old SGSN, the new SGSN acknowledges the resume by Resume Nack. (Resume is not needed against the old SGSN since the MS in this case always will perform an RA Update for updating of GPRS services when the CS connection is terminated and the MM context will be moved from the old to the new SGSN.)
- 5) The BSS sends an RR Channel Release message to the MS, indicating that the BSS has not successfully requested the SGSN to resume GPRS services for the MS. The MS leaves dedicated mode.
- 6) The MS shall resume GPRS services by sending a Routeing Area Update Request message to the SGSN. The Update Type depends on the mode of operation of the network in use e.g. in mode I Combined RA/LA Update is made and in mode II Routeing Area Update is made.

16.2.1.2 Inter-System Suspend and Resume procedure

16.2.1.2.1 Intra-SGSN Suspend and Resume procedure

The Suspend and Resume procedure for intra SGSN is illustrated in Figure 101.

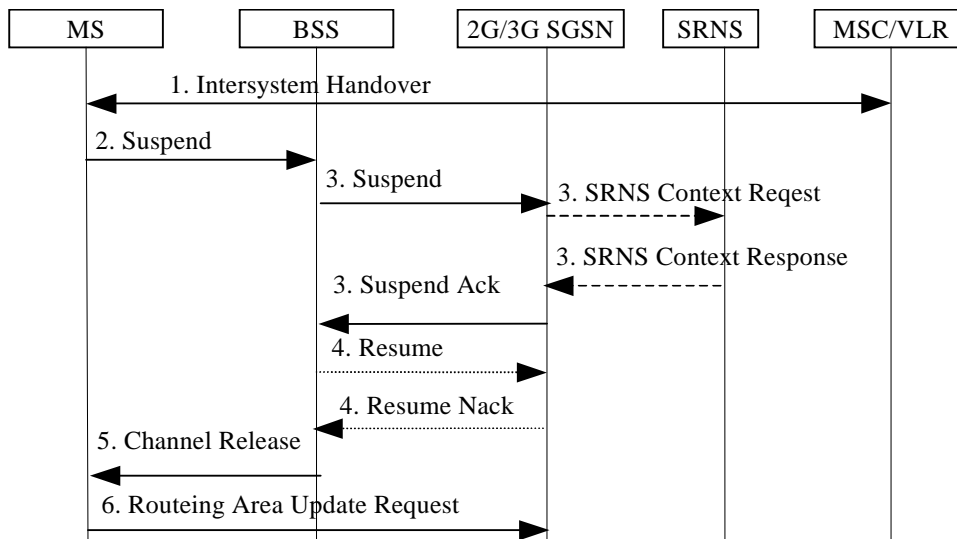

Figure 101: Suspend and Resume Procedure for intra-SGSN

- 1) During CS connection, the MS performs handover from Iu mode to A/Gb mode and the MS or the network limitations are unable to support CS/PS mode of operation.
- 2) The MS sends an RR Suspend (TLLI, RAI) message to the BSS.
- 3) The BSS sends a Suspend (TLLI, RAI) message to the SGSN and:
 - The SGSN may request the SRNS to stop sending downlink PDU's by the SRNS Context Request message. The SRNS then starts buffering the downlink PDUs.
 - The SRNS responds with an SRNS Context Response message.
 - The SGSN then returns Suspend Ack to the BSS.
- 4) After CS connection is terminated, the BSS may send a Resume (TLLI, RAI) message to the SGSN, but resume is not possible since the MS has changed the radio system, so the SGSN acknowledges the resume by Resume Nack.
- 5) The BSS sends an RR Channel Release message to the MS, indicating that the BSS has not successfully requested the SGSN to resume GPRS services for the MS.
- 6) The MS shall resume GPRS services by sending a Routeing Area Update Request message to the SGSN. The Update Type depends on the mode of operation of the network in use e.g. in mode I Combined RA/LA Update is made and in mode II Routeing Area Update is made.

16.2.1.2.2 Inter-SGSN Suspend and Resume procedure

The Suspend and Resume procedure for inter SGSN is illustrated in Figure 102.

This describes the scenario when the suspend message is received in an SGSN that is different from the SGSN currently handling the packet data transmission and would be valid for at least the following cases:

- MS performs inter-system handover from Iu mode to A/Gb mode during CS connection and the SGSN handling the A/Gb mode cell is different from the SGSN handling the Iu mode cell, i.e. the 2G and 3G SGSNs are separated.

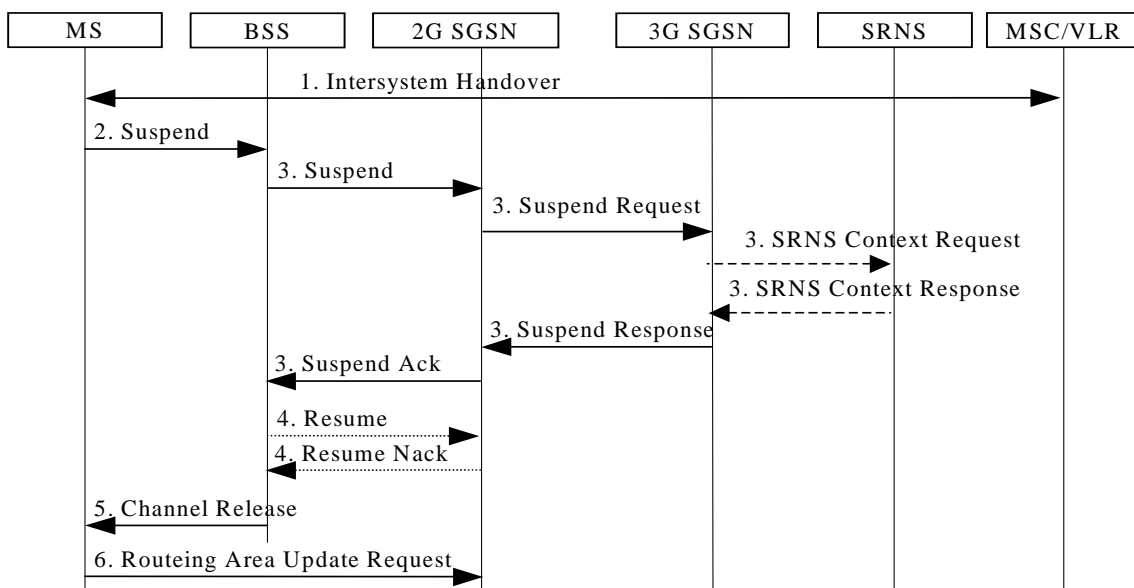

Figure 102: Suspend and Resume Procedure for inter-SGSN

- 1) During CS connection, the MS performs handover from Iu mode to A/Gb mode, and the MS or the network limitations make it unable to support CS/PS mode of operation.
- 2) The MS sends an RR Suspend (TLLI, RAI) message to the BSS.
- 3) The BSS sends a Suspend (TLLI, RAI) message to the SGSN.
 - Since the SGSN that receives the Suspend message is not the one currently handling the packet data transmission, an indication to perform suspend will be sent to the 3G SGSN by means of a SUSPEND REQUEST message on the Gn interface. The address of the old SGSN is derived by "old RAI" received in the Suspend message. If the SGSN that receives the Suspend message provides functionality for Intra Domain Connection of RAN Nodes to Multiple CN Nodes, the SGSN that receives the Suspend message from the BSS may derive the old SGSN from the old RAI and the old TLLI and send the Suspend Request message to this old SGSN. Otherwise, the SGSN that receives the Suspend message from the BSS derives the old SGSN from the old RAI. In any case the SGSN that receives the Suspend message from the BSS will derive an SGSN that it believes is the old SGSN. This derived SGSN is itself the old SGSN, or it is associated with the same pool area as the actual old SGSN and it will determine the correct old SGSN from the TLLI and relay the Suspend Request message to that actual old SGSN.
 - The 3G SGSN may request the SRNS to stop sending downlink PDU's by the SRNS Context Request message. Upon reception of the SRNS Context Request message, the SRNS starts buffering the downlink PDU's.
 - The SRNS responds with an SRNS Context Response message.
 - The 3G SGSN return a SUSPEND RESPONSE.
 - The 2G SGSN then returns Suspend Ack to the BSS.
- 4) After CS connection is terminated, the BSS may send a Resume (TLLI, RAI) message to the 2G SGSN, but since resume is not needed against the 3G SGSN the 2G SGSN acknowledges the resume by Resume Nack. (Resume is not needed in this case since the MS always will perform an RA Update for updating of GPRS services when the CS connection is terminated and the MM context will be moved from 3G to 2G SGSN.)
- 5) The BSS sends an RR Channel Release message to the MS, indicating that the BSS has not successfully requested the SGSN to resume GPRS services for the MS.
- 6) The MS shall resume GPRS services by sending a Routeing Area Update Request message to the SGSN. The Update Type depends on the mode of operation of the network in use e.g. in mode I Combined RA/LA Update is made and in mode II Routeing Area Update is made.

16.2.1.3 Inter System Resume procedure

The resume procedure is only applicable in case of A/Gb mode to Iu mode handover.

16.2.1.3.1 Intra-SGSN Resume procedure

The procedure for resume of GPRS traffic at intra SGSN case is illustrated in Figure 103.

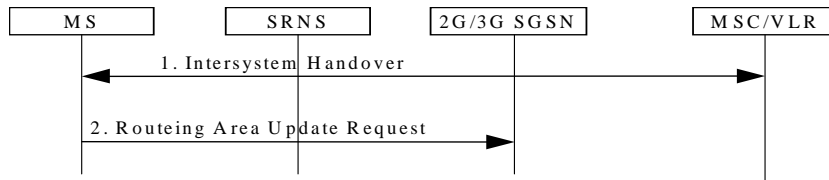

Figure 103: Resume of GPRS traffic at intra SGSN

- 1) The MS in A/Gb mode class-B mode of operation during CS connection performs handover to CS/PS mode of operation in Iu mode;
or the MS in class-A mode of operation capable of DTM performs handover during CS connection from an A/Gb mode cell not supporting DTM to an Iu mode cell.
- 2) The MS shall resume GPRS services, directly after the CS handover is completed, by sending a Routeing Area Update Request message to the SGSN, as described in clause " Inter System Change Procedure".

16.2.1.3.2 Inter-SGSN Resume procedure

The procedure for resuming GPRS traffic at inter-SGSN case is illustrated in Figure 104.

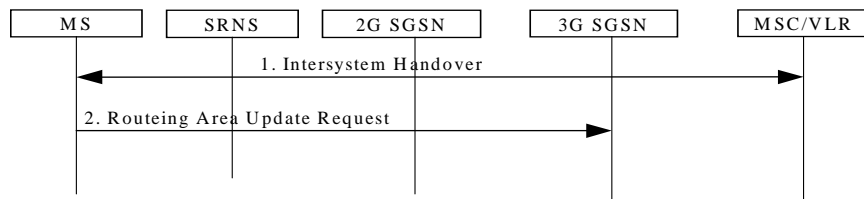

Figure 104: Resume of GPRS traffic at inter SGSN

- 1) The MS in A/Gb mode class-B mode of operation during CS connection performs a handover to CS/PS mode of operation in Iu mode;
or the MS in class-A mode of operation capable of DTM performs a handover during CS connection from an A/Gb mode cell not supporting DTM to an Iu mode cell.

The MS shall resume GPRS services, directly after the CS handover is completed, by sending a Routeing Area Update Request message to the SGSN, as described in clause " Inter System Change Procedure".

16.2.2 GPRS and Dedicated Mode Priority Handling

An MS in class-B mode of operation that communicates on GPRS radio channels when a dedicated channel is needed, shall immediately abort the GPRS communication and trigger the Suspend and Resume procedure.

Response to circuit-switched paging, non-emergency Mobile-originated circuit-switched calls, Mobile-originated SMS, and Mobile-originated supplementary services are exceptions to the above rule. In these cases, it is an implementation choice whether to immediately abort GPRS communication or to delay the dedicated mode establishment.

16.3 Supplementary Services

For SMS over GPRS, only the invocation of Call Barring Supplementary Service is supported. The user control by using the Supplementary Service protocol is not supported over GPRS.

Other supplementary services are not defined for GPRS. Supplementary services may be available in the interworked packet data networks, but this is outside the scope of this specification.

16.4 CAMEL Services

CAMEL may be used for session and cost control. It may also be used for other operator-specific services. Subscription data received over Gr, as described in TS 23.078 [8b], enables CAMEL interactions. In this Release of the specification CAMEL Services are not applicable to subscriptions without MSISDN as existing messages have unresolved MSISDN references.

NOTE: Cost control with ability to correlate, using the Charging Id, with charging information from a GGSN/P-GW depends on GGSN (Gn/Gp) or S-GW (S4) providing a Charging Id that is unique for the PDP context. For S4, such uniqueness requires the S5/S8 to be GTP.

Annex A (normative): APN and P-GW/GGSN Selection

A.0 General

This annex contains the rules applied by the SGSN upon PDP context activation to determine the APN and the corresponding P-GW/GGSN.

The selection process used by the SGSN to select P-GW and GGSN is described in clause 5.3.7.1. The procedures specified in TS 29.303 [100] apply to DNS-based P-GW selection.

APN selection refers to the process of selection and construction of the full APN (APN-NI + APN-OI). This full APN is then employed for interrogation of the DNS server to obtain the GGSN or P-GW address.

A.1 Definitions

The SGSN knows from the subscription data the following parameters (S for Subscribed): PDP type (S), PDP address (S), APN (S), and VPLMN address allowed. In addition, the S4-SGSN and MME receive a PDN subscription context that is marked as default (and associated default APN) for E-UTRAN UEs.

The SGSN may know from configuration the Local APN supporting a given PDP type. This APN is called APN (SGSN) and does not include an APN Operator Identifier. APN (SGSN) shall not be an APN with LIPA permissions set to "LIPA-only" or "LIPA-conditional".

The SGSN knows the parameters requested by the MS (R for Requested): PDP type (R), PDP address (R), and APN (R). APN (R) is the APN Network Identifier requested by the MS.

In case of "an APN chosen by the SGSN" the activated PDP context is always linked with a dynamic PDP address.

An MS may have multiple subscription records for the same PDP type and the same PDP address, but with different APNs.

An MS may have one or two subscription records with the same PDP type and the same APN: one with a static PDP address, one with a dynamic PDP address.

An MS may have multiple subscription records with the same APN, but with different PDP types.

When the MS is in its HPLMN, if the MS requests an APN that does not correspond to any GGSN or P-GW of its HPLMN, the request shall be rejected by the SGSN. When the MS is in a VPLMN, if the MS requests an APN that does not correspond to any GGSN or P-GW of its HPLMN nor of this VPLMN or any of its associated PLMNs when the VPLMN is a shared network, the request shall be rejected by the SGSN.

If APN (S) = wild card (see TS 23.003 [4]), it means either:

- that a Local APN (a locally defined PDN) has to be chosen by the SGSN (APN (SGSN)) if no APN (R) has been provided; or
- that a PDP context with dynamic PDP address may be activated towards any APN requested by the MS.

The PDN subscription context that is marked as default for the default bearer activation, defines a Default APN that takes precedence over the locally defined APN for the S4-SGSN and MME.

In order to derive APN (R) from the APN sent by the MS, the SGSN shall check if the APN sent by the user ends with ".gprs". If not, then APN (R) is equal to APN sent by the MS. If yes, then APN (R) is the APN sent by the MS without the three last labels.

NOTE 1: If yes, then the APN-OI shall be saved for later use, see Figure A.4.

NOTE 2: If the APN OI Replacement field in the subscriber's profile is present, then the default APN-OI is overwritten before performing a DNS look-up on the full APN.

NOTE 3: The APN as constructed by the SGSN for GGSN resolution takes into account the APN-OI Replacement field. This differs from the APN that is provided in charging data and to another SGSN and MME over the Gn, S3 and S16 interfaces as well as to the Serving GW and PDN GW over the S4 and S5/S8 interface, in that the APN-OI Replacement field is not applied. See clause 13.2 of the present document for more details.

NOTE 4: The UE should not be provisioned with the APN-OI Replacement FQDN, otherwise APN resolution might fail.

For deriving a GGSN by the procedure defined in the SDL Diagram, PDPtype(R) shall be assumed equal to PDPtype(S) if PDPtype(R) is IPv4 or IPv6 and PDPtype(S) is IPv4v6.

A.2 Selection Rules

The SGSN shall select the APN to be used to derive the GGSN or P-GW address, and set the selection mode parameter according to the rules in the SDL diagrams in this clause. The following definitions apply to the SDL diagrams:

AddrMode: Addressing Mode, temporary parameter set in the selection process to either of:

AddrMode := static

AddrMode := dynamic

APN-OI: APN Operator Identifier.

HPLMN AP: HPLMN Access Point.

HPLMN OI-1: HPLMN APN Operator Identifier type 1 (derived from the APN OI Replacement field in the subscriber's profile).

HPLMN-OI-2: HPLMN APN Operator Identifier type 2 (derived from IMSI).

Number <condition>: determines the PDP context subscription records that satisfy the given condition.

ODB parameter: Operator Determined Barring parameter configured in subscriber data to one of:

All Packet Oriented Services barred

Roamer Access to HPLMN-AP barred

Roamer Access to VPLMN-AP barred

PDPaddr: PDP address.

SelMode: APN selection mode, temporary parameter set in the selection process to either of:

SelMode := ChosenBySGSN: Network-provided APN, subscription not verified.

SelMode := SentByMS: MS-provided APN, subscription not verified.

SelMode := Subscribed: MS or Network-provided APN, subscription verified.

VPLMN AP: VPLMN Access Point.

VPLMN-OI: VPLMN APN Operator Identifier or the APN Operator Identifier of an associated PLMN when the VPLMN is a shared network.

PDN GW allocation type: PDN GW allocation type is not for the GGSN selection but only for the PDN GW selection. It is either static or dynamic.

Static: for the determined APN, the selected PDN GW has been statically allocated.

Dynamic: for the determined APN, the selected PDN GW can be dynamically allocated.

+: concatenation operation.

The subscription data may contain the information whether SIPTO is allowed or prohibited for each subscribed APN or the SGSN may know from configuration whether SIPTO is allowed or prohibited for a given APN. An indication that SIPTO is allowed or prohibited for the wild card APN allows or prohibits SIPTO for any APN that is not present in the subscription data. When a PDP context for SIPTO is established, the SGSN uses either the RAI (Routing Area Identity) and/or the serving RNC identifier depending on the operator's configuration during the DNS interrogation as specified in TS 29.303 [100]. In roaming scenario the GW selection for a PDP context with SIPTO is only possible when a GGSN or a P-GW in the visited PLMN is selected. Therefore in a roaming scenario with home routed traffic, GW selection for SIPTO is not performed. When the UE is in a network with A/Gb mode and SIPTO is allowed for the given APN, the RAI may also be used for PGW/GGSN selection. In this way when the UE enters UTRAN or E-UTRAN the PDP context deactivation with reactivation request to find an optimal PGW/GGSN for SIPTO may not be needed.

The subscription data may also contain the information on whether:

- a) an APN is LIPA-conditional, LIPA-prohibited, or LIPA-only;
- b) a CSG in the UE's CSG subscription data supports APN(s) that are LIPA-only or LIPA-conditional; and
- c) LIPA is allowed in a list of VPLMNs when roaming.

When a PDP context for a LIPA APN is established, the SGSN uses the L-GW address included by HNB in RANAP messages as the GGSN/PGW address to be used, instead of DNS interrogation for GGSN/PGW selection. If no collocated L-GW address is included by the HNB and the UE requested a LIPA only APN, the request shall be rejected. If no collocated L-GW address is included by the HNB and the UE requested a LIPA conditional APN, the SGSN uses DNS interrogation for GGSN/PGW selection to establish a non-LIPA PDP context. The subscription data for an APN with LIPA permissions set to "LIPA-only" shall not contain a statically configured PDP address or a statically allocated PDN GW. A static PDP address or a static PDN GW address, if configured by HSS for an APN with LIPA permissions set to "LIPA-conditional", is ignored by SGSN when the APN is established as a LIPA PDP context. When establishing a PDP context for a LIPA APN, the VPLMN Address Allowed flag is not considered.

In the procedure denoted "Interface and protocol selection" in Figure A.8, the SGSN shall select one of the configurations listed in Table A.1.

The SGSN may use the UE capability (indicated as part of the MS Network Capability) and roaming agreement as indicated in clause 5.3.7.1 as input to select between configurations using GGSN or P-GW as well as the interface type (Gp or S4/S8). The SGSN may give priority for a configuration using P-GW for E-UTRAN capable UEs, and GGSN for non E-UTRAN capable UE.

If the SGSN supports Gn/Gp only, selection between the configurations indexed 1 and 2 are applicable. If the SGSN supports both Gn/Gp and S4, any of the configurations in Table A.1 apply. In case of P-GW selection, the service parameter shall be set as given in the respective column of Table A.1 and applied as defined in TS 29.303 [100].

If the HLR/HSS provides a subscription context that allows for allocation of a GGSN/PGW from the visited PLMN for this APN and, optionally, the SGSN is configured to know that the visited VPLMN has a suitable roaming agreement with the HPLMN of the UE, the GGSN/PGW selection function derives a GGSN/PGW from the VPLMN. If a visited GGSN/PGW cannot be derived, the APN is used to derive a GGSN/PGW from the HPLMN.

DNS interrogation in Figure A.8 shall be performed based on the full APN (APN-NI +APN-OI). For index of 2, 3, or 4 DNS interrogation procedure is defined by TS 29.303 [100]. For index 1 the DNS interrogation is a DNS A query and/or DNS AAAA query at the full APN exactly as in pre-Release 8 networks. Fall back to the legacy procedure (i.e. index 1) is required for indexes 2, 3, and 4 if they fail since the APN may represent a pre-Release 8 network.

Table A.1: Gateway interface and protocol configurations

Index	Gateway node	Interface type	Protocol on S5/S8	Service parameter
1	GGSN	Gn/Gp	n.a.	no
2	P-GW	Gn/Gp	n.a.	yes
3	P-GW	S4	GTPv2	yes
4	P-GW	S4	PMIP	yes

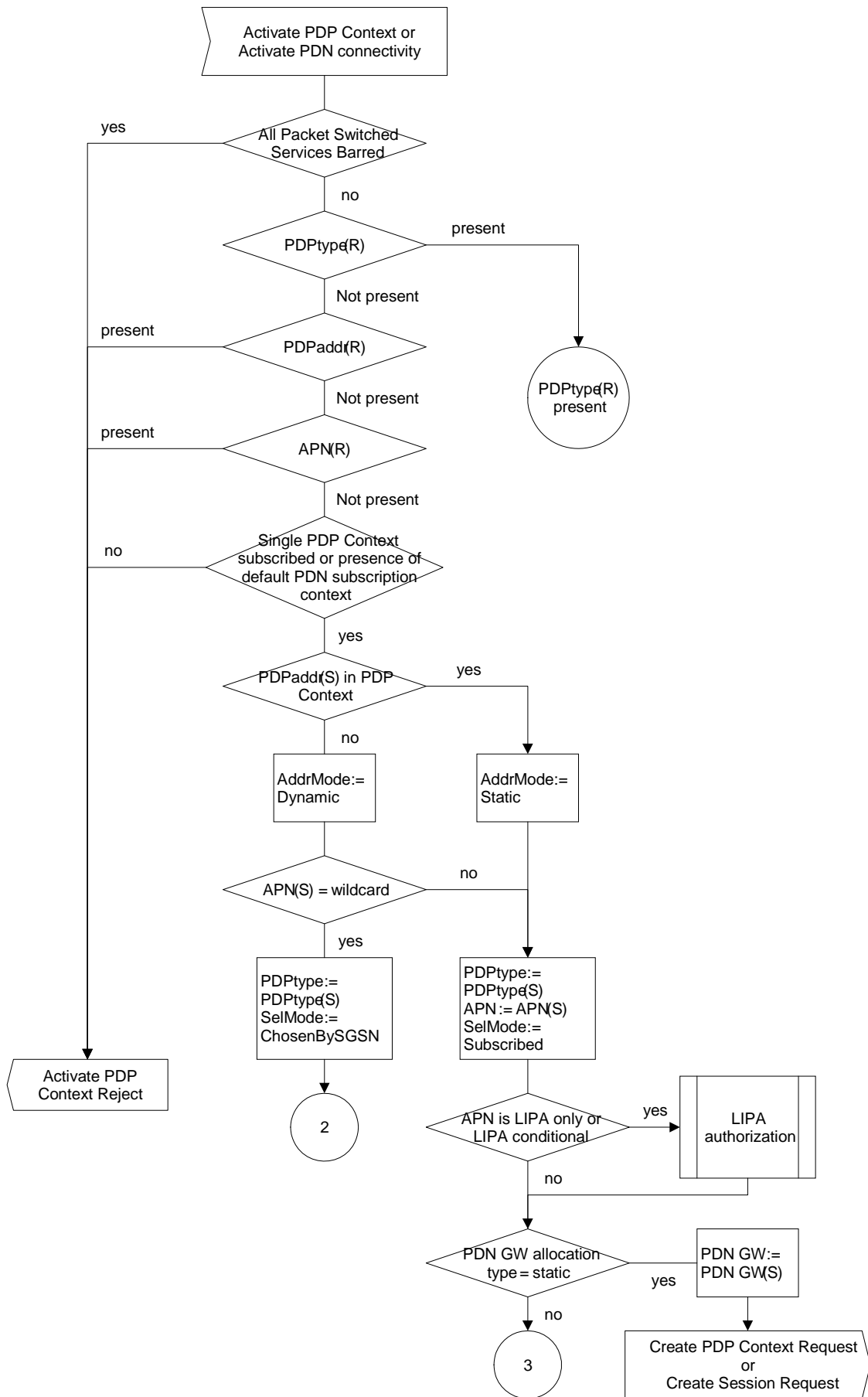

Figure A.1: APN selection-Null Parameter present

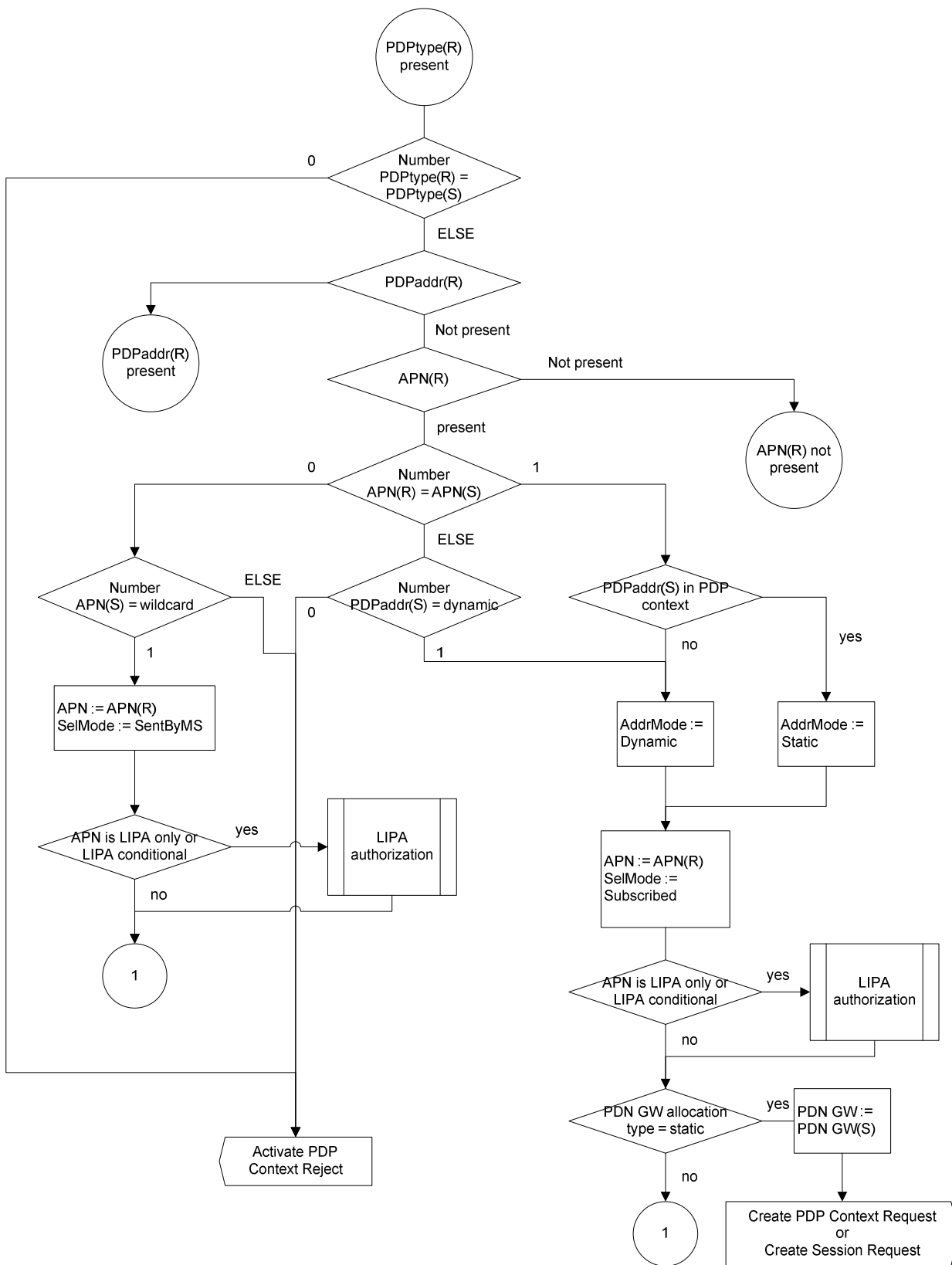

Figure A.2: APN selection-PDType(R) present

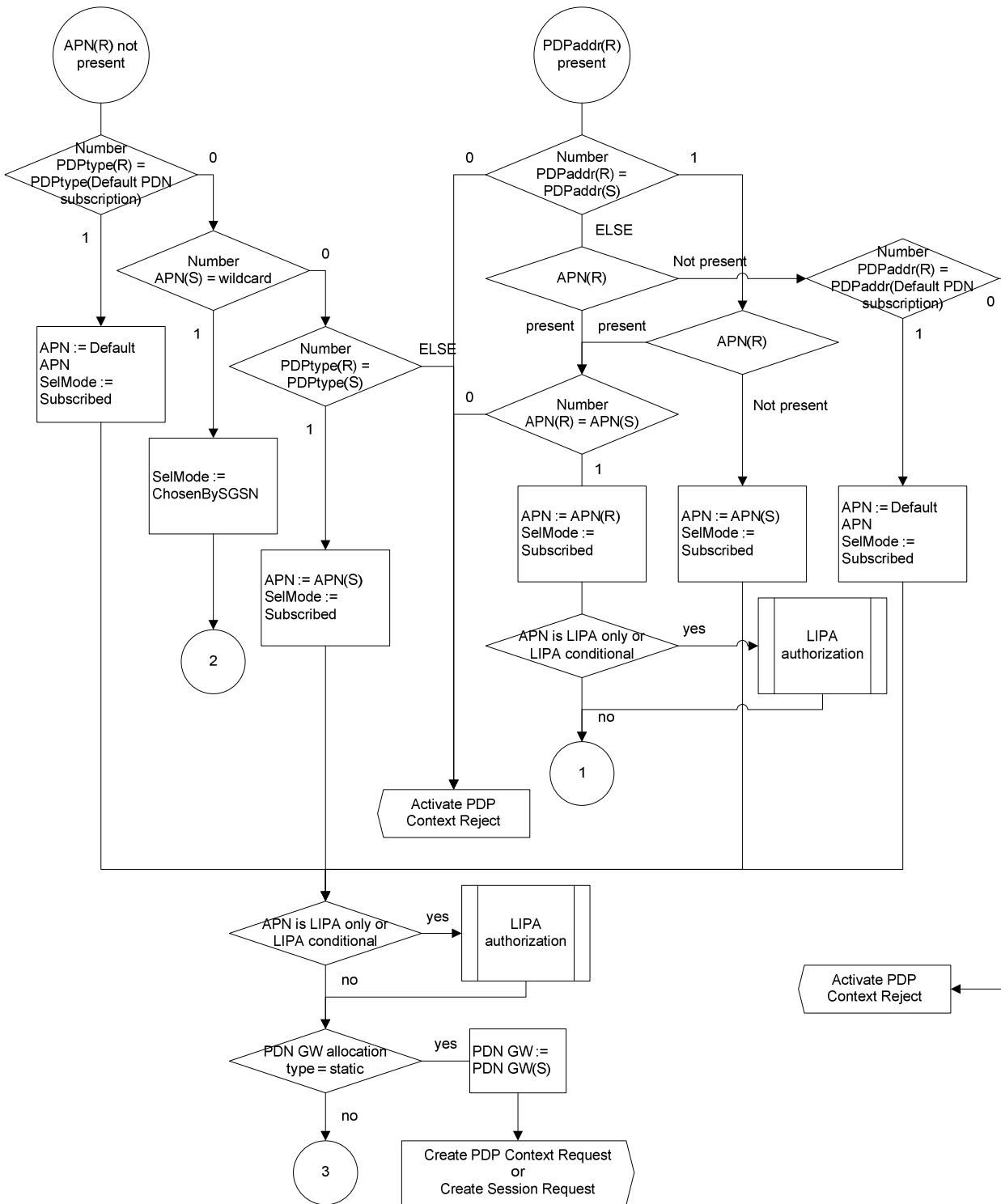

Figure A.3: APN selection- APN(R) not present or PDPAddr(R) present

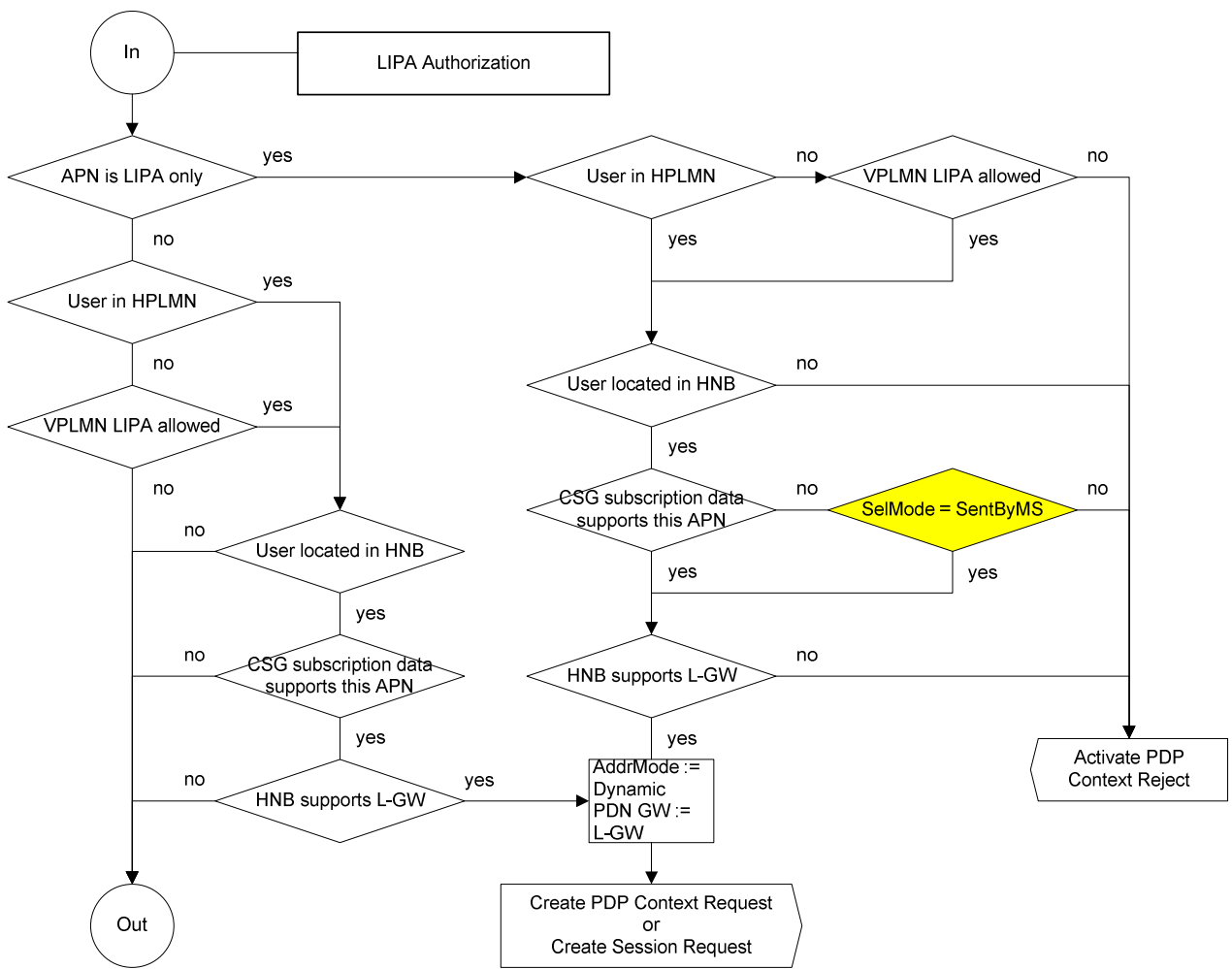

Figure A.4: LIPA authorization

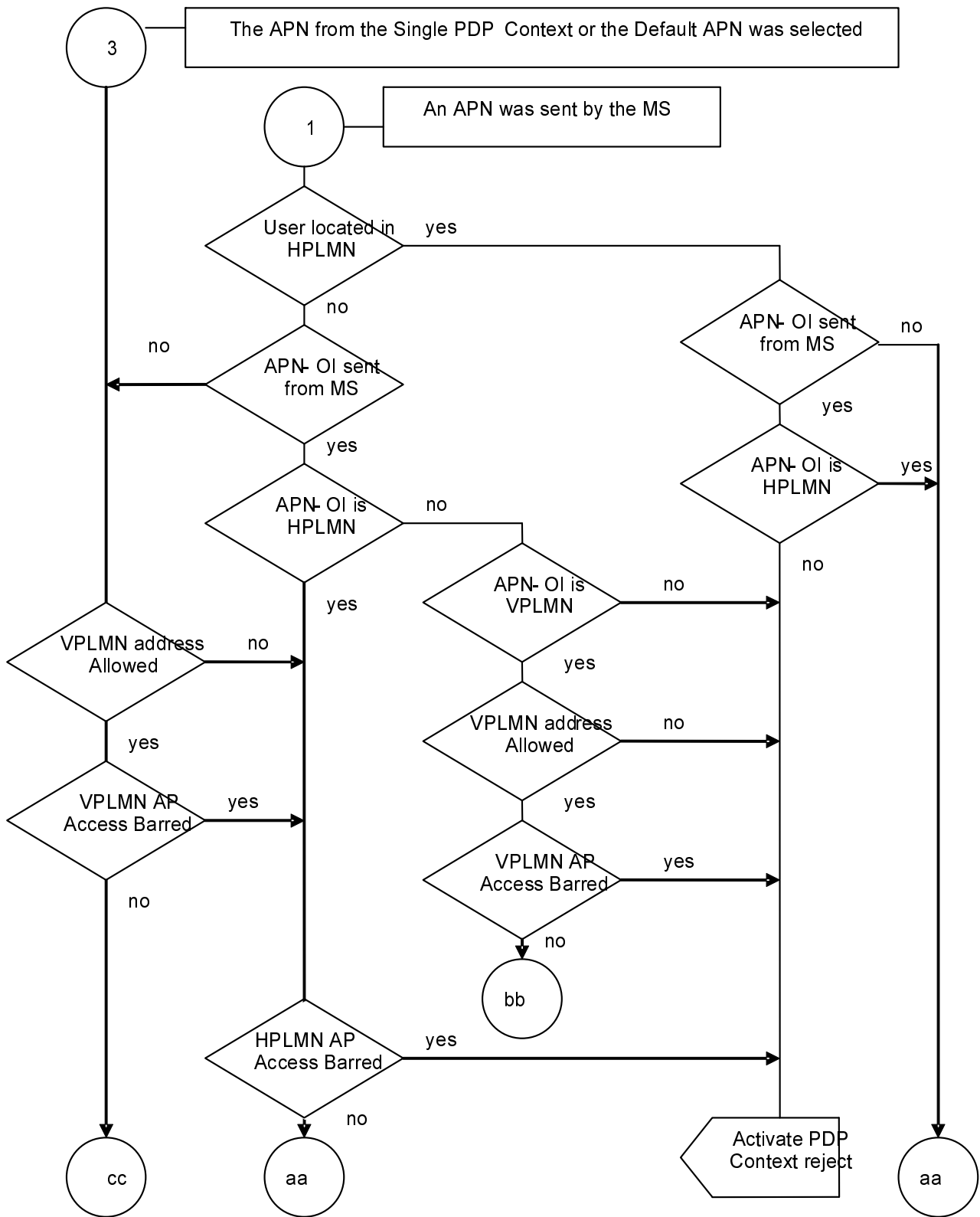

Figure A.5: APN PLMN selection-APN from subscription or MS

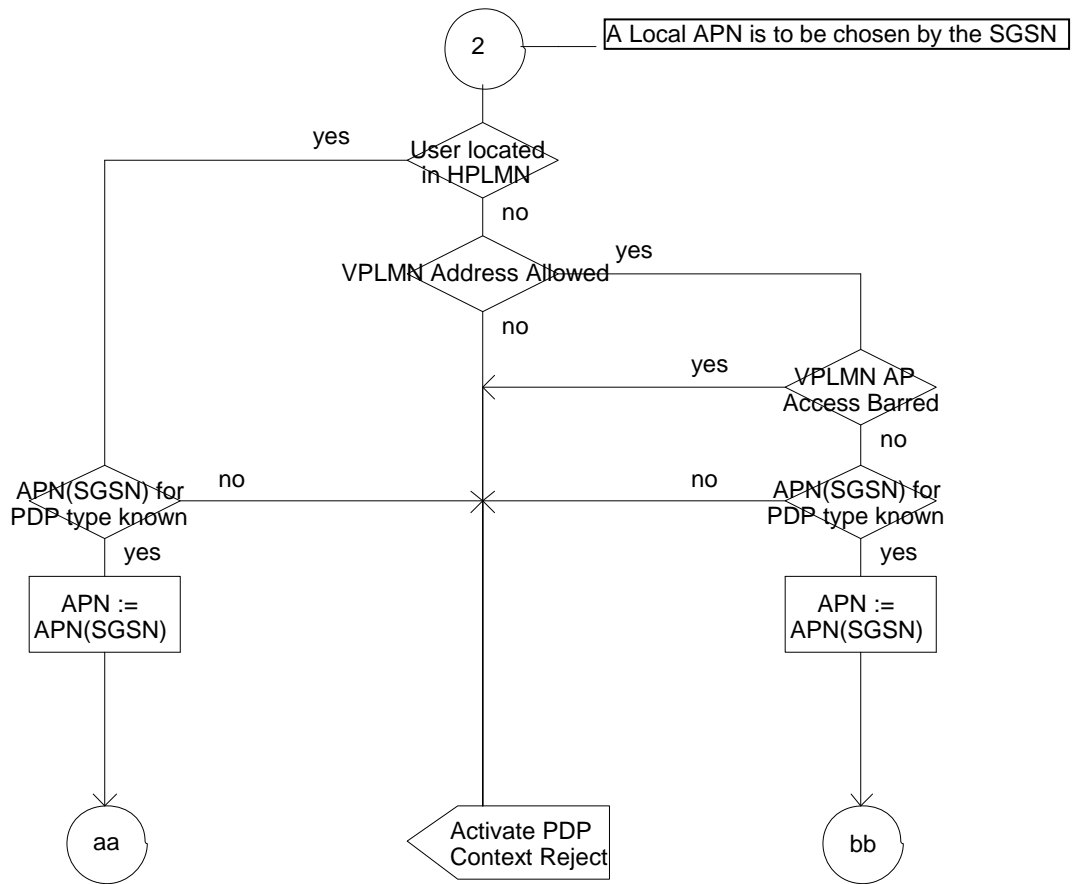
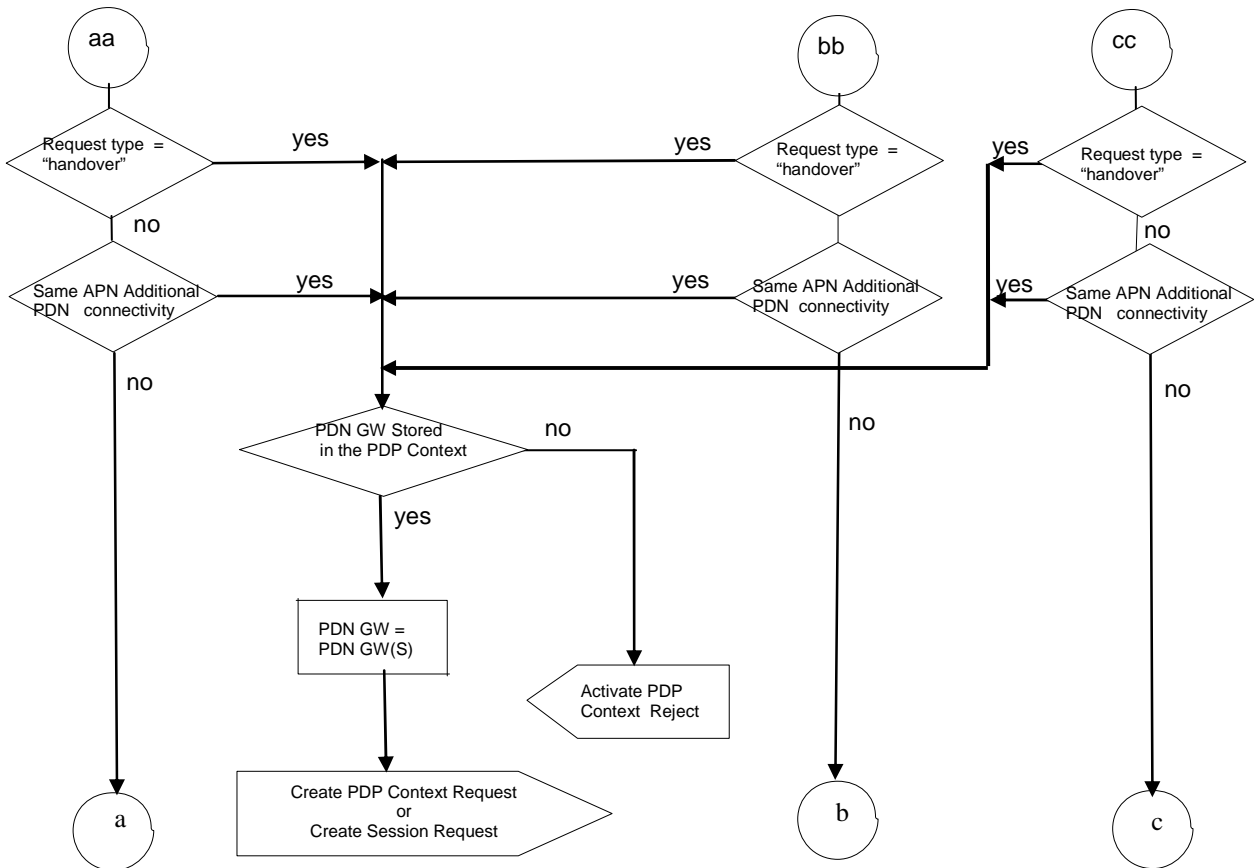

Figure A.6: APN PLMN selection-APN chosen by SGSN



NOTE: This process is only applied by an SGSN when S4 is used.

Figure A.7: APN selection-Dynamic stored PGW selection

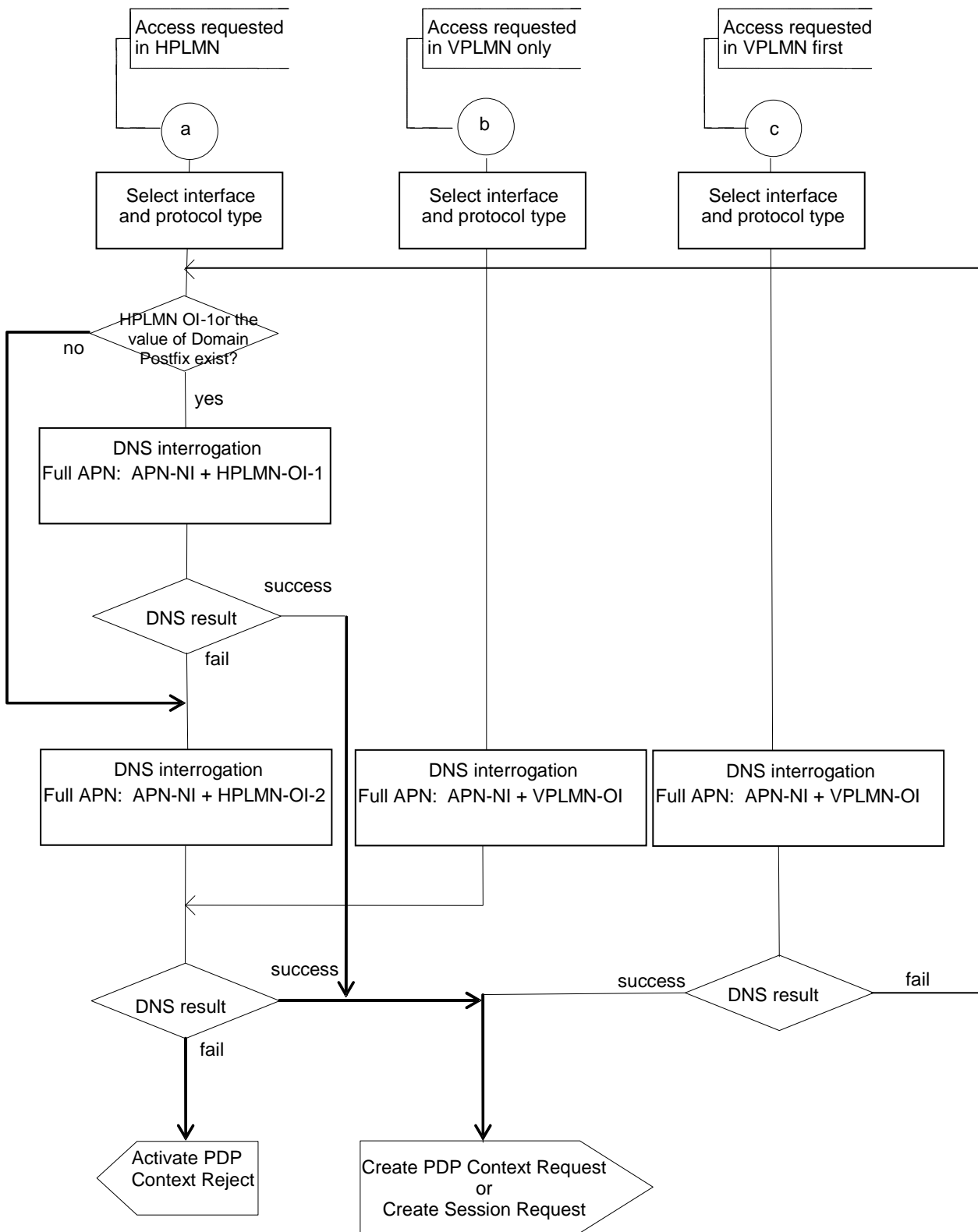

Figure A.8: APN DNS query

Annex B (informative): Selected IP Traffic Offload at Iu-PS

B.1 SIPTO with Traffic Offload Function

This clause describes one way to perform Selected IP Traffic Offload by the Traffic Offload Function at Iu-PS for UMTS network.

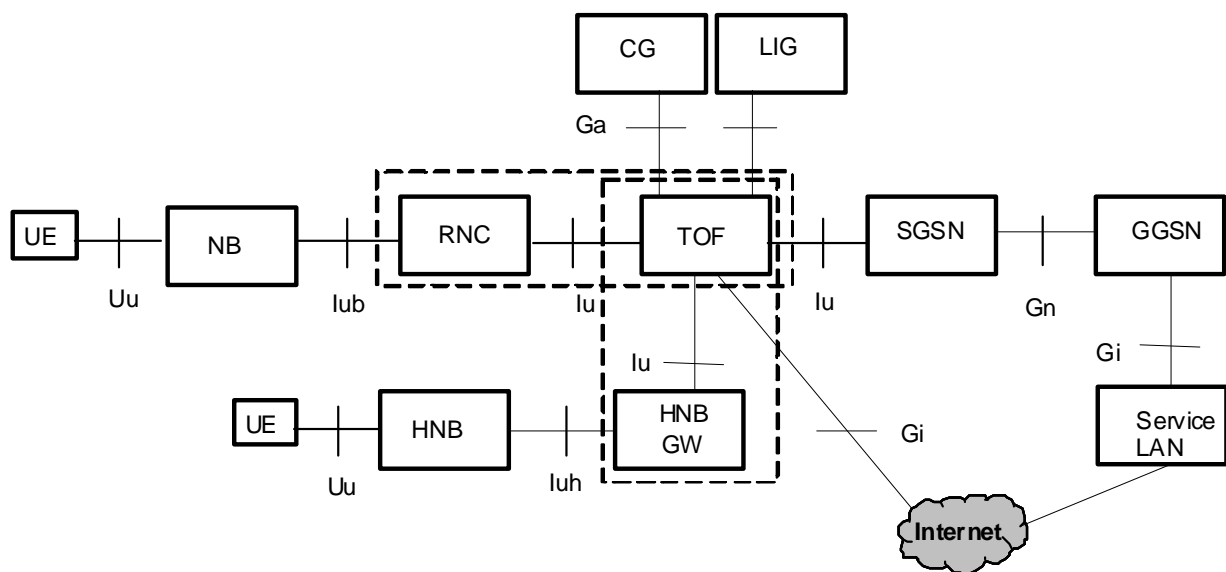

Figure B.1: Selected IP Traffic Offload from Traffic Offload Function (TOF) deployed at Iu-PS

TOF may include the following functions:

- NAS and RANAP message inspection to build/remove local UE context and local session context;
- Packet Inspection and Selected IP Traffic Offload enforcement;
- Uplink traffic offloaded by removing GTP-U header and performing IPv4-IPv4 Network Address Translation;
- Downlink traffic offloaded by reverse IPv4-IPv4 Network Address Translation and adding GTP-U header;
- Charging for offloaded traffic;
- LI for offloaded traffic;
- Offload traffic service continuity during intra-TOF mobility;
- Paging.

In this implementation example a deployment is needed that assures that all PS domain signalling from a UE goes through the same TOF instance. The TOF inspects the NAS and RANAP messages to build the local UE context and local session context. When a RAB is requested to be set up and should be offloaded, the SGSN includes the MSISDN, APN and the Charging Characteristics for the requested RAB to enable Iu-ps offload. The details of how the SGSN transfers these RANAP parameters to the TOF are described in the following clause B.2. The TOF records any necessary information e.g. the RAB ID/NSAPI, uplink TEID and downlink TEID, APN, etc. in its local context.

During the data transfer procedure, the TOF performs IPv4-IPv4 Network Address Translation for uplink offload traffic which matches the offload policies, and transparently transfers the non-offload traffic to the CN. The TOF adds the

corresponding GTP-U header to the downlink offload traffic which has no GTP-U header, and then sends the downlink traffic to the RNC/HNB GW in the same way as would an SGSN.

When the TOF detects an Iu release message it could start an inactivity timer, which is longer than the RAU Timer. When this inactivity timer expires and the Iu connection is not re-established, the TOF deletes related UE context. The inactivity timer is stopped when the Iu connection is re-established for the UE.

When the TOF is configured to perform paging, the TOF pages a UE in idle mode for downlink offload traffic arriving at the TOF, and when the UE sends a Service Request message as the paging response, the TOF modifies the Service type IE in the Service Request message to indicate "Data" and sends it to the SGSN. When the TOF is configured not to perform paging, the TOF discards the received downlink offload packets for a UE in idle mode.

B.2 Support for SIPTO at Iu-ps

This clause describes the functionality that an SGSN provides if the SGSN supports the "SIPTO at Iu-ps" function. Support for the "SIPTO at Iu-ps" function is optional in the SGSN.

During the SRNS Relocation Procedures (in clauses 6.9.2.2.1, 6.9.2.2.2 and 6.9.2.2.3):

- If the SGSN has valid subscriber data before it sends Relocation Request message to the target RNC, and SIPTO function should be activated for the APN of the RAB to be setup according to the subscriber data and operator policies, the SGSN shall include the MSISDN in the Relocation Request message (in step 4), and include the APN and the Charging characteristics in the RABs to be setup IE for the RAB to be offloaded to enable Iu-ps traffic offload and charging for the offload traffic.
- If the SRNS Relocation is inter-SGSN and the new SGSN does not have valid subscriber data before it sends Relocation Request message to the target RNC, and SIPTO function should be activated for the APN of the RAB to be setup according to the subscriber data and operator policies, the new SGSN shall initiate a RAB assignment procedure after Routing Area Update procedure (after step 15) to enable Iu-ps offload and transfer the charging parameters to the Traffic Offload Function. The SGSN includes MSISDN in the RAB Assignment Request message, and includes the APN and the Charging characteristics in the RABs to be setup IE for the RAB to be offloaded.

During Service Request Procedures (in clauses 6.12.1 and 6.12.2):

- If SIPTO function should be activated for the APN of the RAB to be setup according to the subscriber data and operator policies, the SGSN shall include the MSISDN in the RAB Assignment Request message (in step 4 of clause 6.12.1, step 6 of clause 6.12.2), and include the APN and the Charging characteristics in the RABs to be setup IE for the RAB to be offloaded to enable Iu-ps traffic offload and charging for the offload traffic.

During the intersystem change procedures from A/Gb mode to Iu mode (in clauses 6.13.1.2.1 and 6.13.2.2.1):

- If SIPTO function should be activated for the APN of the RAB to be setup according to the subscriber data and operator policies, the SGSN shall include the MSISDN in the RAB Assignment Request message (step 11 of clause 6.13.1.2.1, step 20 of clause 6.13.2.2.1), and include the APN and the Charging characteristics in the RABs to be setup IE for the RAB to be offloaded to enable Iu-ps traffic offload and charging for the offload traffic.

During RAB Assignment procedure (in clause 12.7.4.1):

- If SIPTO function should be activated for the APN of the RAB to be setup according to the subscriber data and operator policies, the SGSN shall include the MSISDN in the RAB Assignment Request message (step 1), and include the APN and the Charging characteristics in the RABs to be setup IE for the RAB to be offloaded to enable Iu-ps traffic offload and charging for the offload traffic.

Annex C (informative): Link MTU considerations

According to clause 9.3 networks can provide link MTU size for MSs. A purpose of the link MTU size provisioning is to limit the size of the packets sent by the MS to avoid packet fragmentation in the backbone network between the MS and the GGSN/PGW when some of the backbone links does not support packets larger than 1500 octets. Fragmentation within the backbone network creates a significant overhead. Therefore, operators might desire to avoid it. This Annex presents an overhead calculation that can be used by operators to set the link MTU size provided by the network. A MS may not employ the provided link MTU size, e.g. when the MT and TE are separated, as discussed in clause 9.3. Therefore, providing an MTU size does not guarantee that there will be no packets larger than the provided value. However if MSs follow the provided link MTU value operators will benefit from reduced transmission overhead within backbone networks.

One of the worst case scenarios is when GTP packets, e.g., between a RAN node and the core network, are transferred over IPsec tunnel in an IPv6 deployment. In that case the user packet first encapsulated in a GTP tunnel which results the following overhead:

- IPv6 header, which is 40 octets;
- UDP overhead, which is 8 octets;
- Extended GTP-U header, which is 16 octets.

NOTE: The sending of SCI in the GTP-U header will increase the GTP-U header size (see TS 29.281 [120]).

In this scenario the GTP packet then further encapsulated to an IPsec tunnel. The actual IPsec tunnel overhead depends on the used encryption and integrity protection algorithms. TS 33.210 [114] mandates the support of AES-CBC with a key length of 128 bits and the use of HMAC_SHA-1 for integrity protection. Therefore the overhead with those algorithms is calculated in this Annex:

- IPv6 header, which is 40 octets;
- IPsec Security Parameter Index and Sequence Number overhead, which is 4+4 octets;
- Initialization Vector for the encryption algorithm, which is 16 octets;
- Padding to make the size of the encrypted payload a multiple of 16;
- Padding Length and Next Header octets (2 octets);
- Integrity Check Value, which is 12 octets.

In order to make the user packet size as large as possible a padding of 0 octet is assumed. With this zero padding assumption the total overhead is 144 octets, which results a maximum user packet size of 1358 octets. Note that this user packet size will result in a 1424 octets payload length to be ciphered, which is a multiple of 16, thus the assumption that no padding is needed is correct (see Figure C.1).

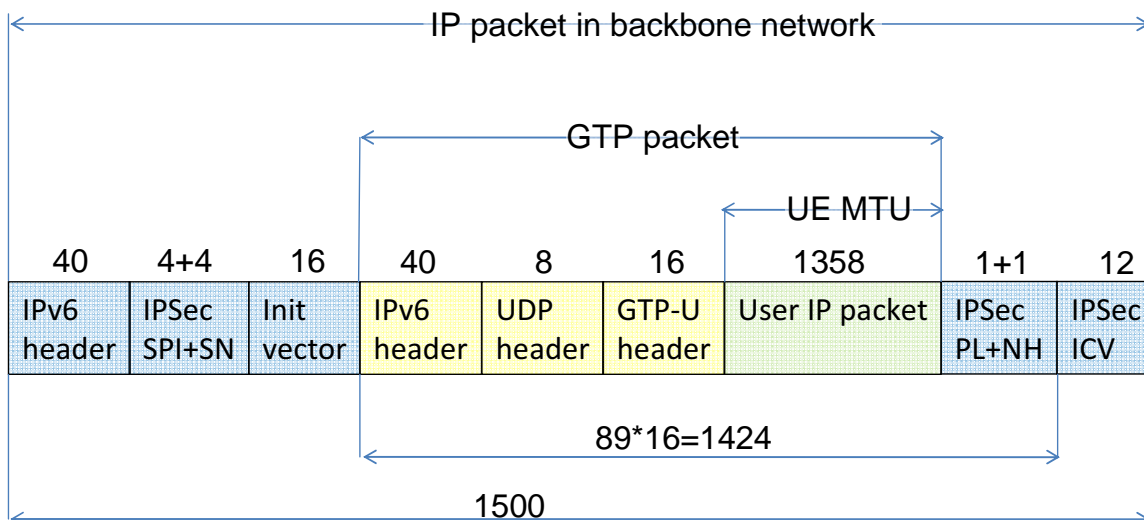

Figure C.1: Overhead for MTU calculation

The link MTU value that can prevent fragmentation in the backbone network between the MS and GGSN/PGW depends on the actual deployment. Based on the above calculation a link MTU value of 1358 is small enough in most of the network deployments.

Note that using a link MTU value smaller than necessary would decrease the efficiency in the network. Moreover a UE may also apply some tunnelling (e.g., DSMIPv6 or VPN). and it is desired to use a link MTU size that assures at least 1280 octets, which is the minimum MTU size in case of IPv6, within the UE tunnel to avoid the fragmentation of the user packets within the tunnel applied in the UE.

Another aspect of the dynamic link MTU provisioning is that in the future when all network links support larger packet sizes than 1500 octets, operators can send a value larger than 1500 octets as a link MTU size to MSs. This option is useful for operators as if an MS uses large packets then it will increase the transport efficiency in the network.

Annex D (informative): Change History

Change history								
Date	TSG #	TSG Doc.	CR	Rev	Cat	Subject/Comment	Old	New
12/2011	SA#54	SP-110734	1502	2	F	Relationship between LIPA permissions and SIPTO permissions	10.5.0	10.6.0
12/2011	SA#54	SP-110732	1508	1	A	Pre-Rel-7 QoS description correction	10.5.0	10.6.0
12/2011	SA#54	SP-110737	1509	-	F	PDP Context Activation of pre-Rel-7 UEs	10.5.0	10.6.0
12/2011	SA#54	SP-110736	1510	1	F	Throttling of Downlink Data Notification Request when ISR is activated	10.5.0	10.6.0
12/2011	SA#54	SP-110732	1514	1	A	Restriction on inter-PLMN handover to a CSG cell	10.5.0	10.6.0
12/2011	SA#54	SP-110736	1519	1	F	MS initiates detach procedure when MM backoff timer is running	10.5.0	10.6.0
12/2011	SA#54	SP-110736	1520	2	F	APN based Session Management congestion control correction	10.5.0	10.6.0
12/2011	SA#54	SP-110737	1522	2	F	ISR handling at SGSN	10.5.0	10.6.0
12/2011	SA#54	SP-110736	1537	1	F	Emergency attach when MM back-off timer is running	10.5.0	10.6.0
12/2011	SA#54	SP-110736	1548	2	F	Back-off timer handling in READY or PMM-CONNECTED state	10.5.0	10.6.0
12/2011	SA#54	SP-110732	1563	2	A	Handover to CSG cell with emergency bearer	10.5.0	10.6.0
12/2011	SA#54	SP-110749	1469	2	B	Introducing CSS for VPLMN autonomous CSG roaming	10.6.0	11.0.0
12/2011	SA#54	SP-110749	1470	2	B	CSS information storage	10.6.0	11.0.0
12/2011	SA#54	SP-110749	1471	2	B	Insert CSG subscriber data procedure in 23.060	10.6.0	11.0.0
12/2011	SA#54	SP-110749	1482	2	B	Retrieval of VPLMN CSG subscription information during MM procedures	10.6.0	11.0.0
12/2011	SA#54	SP-110748	1515	1	C	Inter-PLMN Handover to a CSG cell based on the associated CSG white lists	10.6.0	11.0.0
03/2012	SA#55	SP-120066	1571	2	A	S4-SGSN procedure clarifications	11.0.0	11.1.0
03/2012	SA#55	SP-120074	1576	1	A	Alignment of the clause on MTC with GERAN specifications	11.0.0	11.1.0
03/2012	SA#55	SP-120075	1588	1	A	Clarify reference point used inter-PLMN and intra-PLMN	11.0.0	11.1.0
03/2012	SA#55	SP-120075	1600	1	A	PS Domain Overload Control when using Network Mode of Operation II	11.0.0	11.1.0
03/2012	SA#55	SP-120073	1618	-	A	LIPA PDN connection handling when the UE's CSG membership changes	11.0.0	11.1.0
03/2012	SA#55	SP-120090	1467	2	F	Correct the behaviour upon receipt of Teardown Indication	11.0.0	11.1.0
03/2012	SA#55	SP-120089	1506	4	B	SM-Backoff timer for NW initiated bearer deactivation	11.0.0	11.1.0
03/2012	SA#55	SP-120090	1564	1	F	Indication of Change in BCM by GGSN/PDN-GW to UE	11.0.0	11.1.0
03/2012	SA#55	SP-120090	1565	1	F	Alignment of S4-SGSN behaviour for PDP Ctx involving streaming or conversational traffic class	11.0.0	11.1.0
03/2012	SA#55	SP-120089	1566	1	D	Editorial corrections to 23.060	11.0.0	11.1.0
03/2012	SA#55	SP-120089	1567	1	F	IETF references update for 23.060	11.0.0	11.1.0
03/2012	SA#55	SP-120090	1582	1	D	Minor Corrections - References and Abbreviations	11.0.0	11.1.0
03/2012	SA#55	SP-120089	1583	-	F	Barring sub-categories	11.0.0	11.1.0
03/2012	SA#55	SP-120090	1593	2	F	Correction on Update Location at Attachment	11.0.0	11.1.0
03/2012	SA#55	SP-120090	1599	1	F	RAU trigger upon receipt of paging in congestion	11.0.0	11.1.0
03/2012	SA#55	SP-120090	1602	3	F	Support BCM Upgrade from MS-Only to MS/NW	11.0.0	11.1.0
03/2012	SA#55	SP-120080	1607	1	C	Include support of other media for IMS Emergency Session	11.0.0	11.1.0
03/2012	SA#55	SP-120090	1608	1	B	Local address and IP address type in the TFT filter	11.0.0	11.1.0
03/2012	SA#55	SP-120089	1609	1	B	Declaring support for extended TFT filter format	11.0.0	11.1.0
03/2012	SA#55	SP-120081	1613	2	B	Network Provided Location Information Retrieval via Session Management Procedures	11.0.0	11.1.0
03/2012	SA#55	SP-120089	1614	2	B	EAB for UTRAN	11.0.0	11.1.0
03/2012	SA#55	SP-120086	1616	3	B	Normative documentation for PS Only subscriptions in GPRS Service Description	11.0.0	11.1.0
03/2012	SA#55	SP-120090	1617	2	F	QoS for default bearer	11.0.0	11.1.0
03/2012	SA#55	SP-120086	1620	4	B	Support of PS-only service provision	11.0.0	11.1.0
06/2012	SA#56	SP-120236	1603	3	A	Fix wrong statement for the Reporting Action related storage	11.1.0	11.2.0
06/2012	SA#56	SP-120250	1635	2	F	Correction of the wrong description about emergency ARP value	11.1.0	11.2.0
06/2012	SA#56	SP-120239	1639	4	F	Correction of PS-only Feature Description	11.1.0	11.2.0
06/2012	SA#56	SP-120243	1640	1	F	Correction of Procedures for Netloc Location Retrieval by Modification Procedure	11.1.0	11.2.0
06/2012	SA#56	SP-120250	1645	2	F	EAB overload control from CN to RAN for UTRAN	11.1.0	11.2.0
06/2012	SA#56	SP-120250	1646	3	F	UE AS capability request over lu	11.1.0	11.2.0

Change history								
Date	TSG #	TSG Doc.	CR	Rev	Cat	Subject/Comment	Old	New
06/2012	SA#56	SP-120243	1649	-	F	Removal of CSG ID as a network provided location information parameter	11.1.0	11.2.0
06/2012	SA#56	SP-120236	1659	1	A	ISR deactivation for PGW-initiated Bearer Deactivation Procedure	11.1.0	11.2.0
06/2012	SA#56	SP-120243	1671	-	F	Correction of Network Provided Location Information Retrieval on GGSN-Initiated PDP Context Modification Procedure	11.1.0	11.2.0
06/2012	SA#56	SP-120252	1680	2	B	Introduction of SIRIG	11.1.0	11.2.0
09/2012	SA#57	SP-120485	1684	5	F	Appropriate Cause value from the SGSN in roaming case	11.2.0	11.3.0
09/2012	SA#57	SP-120485	1688	1	F	RA update after Cell Change Order (CCO) to GERAN	11.2.0	11.3.0
09/2012	SA#57	SP-120485	1689	2	F	Clarification on handling of Homogenous Support of IMS Over PS Sessions	11.2.0	11.3.0
09/2012	SA#57	SP-120482	1693	4	F	Correction of PS-only Feature Description	11.2.0	11.3.0
09/2012	SA#57	SP-120485	1703	3	C	Removing NMO-III	11.2.0	11.3.0
09/2012	SA#57	SP-120483	1707	3	F	Correction of SIRIG to cope with mix of standardised/non-standardised SCIs, and, roamers using V-GGSN, while avoiding impact to LTE/UMTS users	11.2.0	11.3.0
09/2012	SA#57	SP-120477	1685	2	F	Interactions between SGSN and RAN not supporting bit rates higher than 256 Mbps	11.2.0	11.3.0
09/2012	SA#57	SP-120477	1709	1	A	Removal of Maximum MBR/APN-AMBR	11.2.0	11.3.0
12/2012	SA#58	SP-120717	1654	3	F	Clarification of UE behaviour that needs PS only services and NAS based SMS	11.3.0	11.4.0
12/2012	SA#58	SP-120710	1666	4	A	Restriction of Inter RAT handover/release with redirection between E-UTRAN and UTRAN/GERAN	11.3.0	11.4.0
12/2012	SA#58	SP-120726	1676	4	F	Secondary PDP context activation without TFT	11.3.0	11.4.0
12/2012	SA#58	SP-120717	1691	7	F	Correction of indication of "SMS support"	11.3.0	11.4.0
12/2012	SA#58	SP-120715	1699	2	A	Correction on existence of uplink packet filter in TFT	11.3.0	11.4.0
12/2012	SA#58	SP-120717	1702	6	B	MS supporting dual priority	11.3.0	11.4.0
12/2012	SA#58	SP-120721	1716	-	F	Roaming support in SIRIG	11.3.0	11.4.0
12/2012	SA#58	SP-120726	1719	1	F	Correction of priority services	11.3.0	11.4.0
12/2012	SA#58	SP-120717	1722	2	F	Correction of network stored back-off after addition of Dual priority	11.3.0	11.4.0
12/2012	SA#58	SP-120726	1731	-	F	Remove the RAN3 reference for EAB	11.3.0	11.4.0
03/2013	SA#59	SP-130083	1733	4	F	User Location Information Age	11.4.0	11.5.0
03/2013	SA#59	SP-130078	1743	-	A	Restricting Inter RAT handover and release-with-redirection from GERAN to E-UTRAN	11.4.0	11.5.0
03/2013	SA#59	SP-130088	1744	2	F	Alignment with Stage 3 of 3G DT handling at PDP Context Activation to avoid IOT problem	11.4.0	11.5.0
06/2013	SA#60	SP-130320	1738	3	F	Correction on the definition of packet filter evaluation precedence index	11.5.0	11.6.0
06/2013	SA#60	SP-130225	1761	1	F	Clarification that IMSVoPS is MMTEL	11.5.0	11.6.0
06/2013	SA#60	SP-130225	1763	2	F	Immediate Cancel Location ACK during HSS-initiated detach procedure	11.5.0	11.6.0
06/2013	SA#60	SP-130213	1767	2	A	Consistent description of allowed packet filter configurations	11.5.0	11.6.0
06/2013	SA#60	SP-130225	1772	1	C	Gateway selection by SGSN depending on E-UTRAN roaming agreement	11.5.0	11.6.0
06/2013	SA#60	SP-130319	1778	4	F	Introduction of Operator Group GGSN	11.5.0	11.6.0
06/2013	SA#60	SP-130222	1784	2	F	Incomplete specification text on link MTU size for IPv6	11.5.0	11.6.0
09/2013	SA#61	SP-130374	1803	2	F	Clarifications on QoS and roaming	11.6.0	11.7.0
12/2013	SA#62	SP-130524	1800	8	F	Definition for a valid state of the TFT setting	11.7.0	11.8.0
03/2014	SA#63	SP-140100	1831	1	F	Corrections to TFT packet filter related descriptions	11.8.0	11.9.0
06/2014	SA#64	SP-140251	1844	-	A	Correction of IETF reference on prefix delegation	11.9.0	11.10.0
06/2014	SA#64	SP-140256	1846	2	F	Corrections to TFT packet filter related descriptions	11.9.0	11.10.0
06/2014	SA#64	SP-140256	1865	2	F	Clarification on SGSN behaviour on roaming situation	11.9.0	11.10.0

History

Document history		
V11.3.0	November 2012	Publication
V11.4.0	January 2013	Publication
V11.5.0	April 2013	Publication
V11.6.0	June 2013	Publication
V11.7.0	September 2013	Publication
V11.8.0	January 2014	Publication
V11.9.0	March 2014	Publication
V11.10.0	July 2014	Publication