

# ETSI TS 123 066 V3.1.0 (2000-01)

---

*Technical Specification*

**Digital cellular telecommunications system (Phase 2+) (GSM);  
Universal Mobile Telecommunications System (UMTS);  
Support of Mobile Number Portability (MNP);  
Technical Realisation;  
Stage 2  
(3G TS 23.066 version 3.1.0 Release 1999)**

---



Reference

---

DTS/TSGN-0223066U

Keywords

---

GSM, UMTS

**ETSI**

Postal address

---

F-06921 Sophia Antipolis Cedex - FRANCE

Office address

---

650 Route des Lucioles - Sophia Antipolis  
Valbonne - FRANCE  
Tel.: +33 4 92 94 42 00 Fax: +33 4 93 65 47 16  
Siret N° 348 623 562 00017 - NAF 742 C  
Association à but non lucratif enregistrée à la  
Sous-Préfecture de Grasse (06) N° 7803/88

Internet

---

secretariat@etsi.fr  
Individual copies of this ETSI deliverable  
can be downloaded from  
<http://www.etsi.org>  
If you find errors in the present document, send your  
comment to: editor@etsi.fr

---

**Important notice**

This ETSI deliverable may be made available in more than one electronic version or in print. In any case of existing or perceived difference in contents between such versions, the reference version is the Portable Document Format (PDF). In case of dispute, the reference shall be the printing on ETSI printers of the PDF version kept on a specific network drive within ETSI Secretariat.

---

**Copyright Notification**

No part may be reproduced except as authorized by written permission.  
The copyright and the foregoing restriction extend to reproduction in all media.

© European Telecommunications Standards Institute 2000.  
All rights reserved.

---

## Intellectual Property Rights

IPRs essential or potentially essential to the present document may have been declared to ETSI. The information pertaining to these essential IPRs, if any, is publicly available for **ETSI members and non-members**, and can be found in SR 000 314: "*Intellectual Property Rights (IPRs); Essential, or potentially Essential, IPRs notified to ETSI in respect of ETSI standards*", which is available from the ETSI Secretariat. Latest updates are available on the ETSI Web server (<http://www.etsi.org/ipr>).

Pursuant to the ETSI IPR Policy, no investigation, including IPR searches, has been carried out by ETSI. No guarantee can be given as to the existence of other IPRs not referenced in SR 000 314 (or the updates on the ETSI Web server) which are, or may be, or may become, essential to the present document.

---

## Foreword

This Technical Specification (TS) has been produced by the ETSI 3<sup>rd</sup> Generation Partnership Project (3GPP).

The present document may refer to technical specifications or reports using their 3GPP identities or GSM identities. These should be interpreted as being references to the corresponding ETSI deliverables. The mapping of document identities is as follows:

For 3GPP documents:

3G TS | TR nn.nnn "<title>" (with or without the prefix 3G)

is equivalent to

ETSI TS | TR 1nn nnn "[Digital cellular telecommunications system (Phase 2+) (GSM);] Universal Mobile Telecommunications System; <title>

For GSM document identities of type "GSM xx.yy", e.g. GSM 01.04, the corresponding ETSI document identity may be found in the Cross Reference List on [www.etsi.org/key](http://www.etsi.org/key)

# Contents

Foreword.....	6
1 Scope.....	7
2 References.....	7
2.1 References.....	7
3 Definitions and abbreviations .....	8
3.1 Definitions .....	8
3.2 Abbreviations.....	9
4 General.....	9
4.1 Overview.....	9
4.2 Compatibility .....	10
4.3 Common Functionality of the MNP-SRF .....	11
5 Common Architecture for call setup.....	14
<b>Annex A (normative): IN Call-Related Technical Realization .....</b>	<b>16</b>
A.1 Architecture .....	16
A.1.1 Network Options.....	16
A.1.2 No NP Query required – Number is not subject for portability .....	16
A.1.3 NP Query in Number Range Owner Network .....	17
A.1.3.1 TQoD – Number is not ported.....	17
A.1.3.2 TQoD – Number is ported.....	18
A.1.3.3 QoHR – Number is ported .....	19
A.1.4 NP Query in Originating Network.....	20
A.1.4.1 OQoD – Number is not ported .....	20
A.1.4.2 OQoD – Number is ported .....	21
A.2 Information flows .....	23
A.3 Functional requirements of network entities.....	29
A.3.1 Functional requirement of GMSC .....	29
A.3.1.1 Procedure MOBILE_NUMBER_PORTABILITY_IN_QoHR.....	29
A.3.1.2 Procedure MOBILE_NUMBER_PORTABILITY_IN_TQoD.....	31
A.3.2 Functional requirement of MSC .....	33
A.3.2.1 Procedure MOBILE_NUMBER_PORTABILITY_IN_OQoD .....	33
A.3.3 Functional requirement of NPDB .....	35
A.3.3.1 Process IDP_NPDB .....	35
A.4 Contents of messages.....	37
A.4.1 Messages on the ISUP interface .....	37
A.4.1.1 IAM.....	37
A.4.2 Messages on the MSC - NPDB interface.....	37
A.4.2.1 INITIAL DP .....	37
A.4.2.2 INITIAL DP negative response.....	37
A.4.2.3 CONNECT.....	37
A.4.2.4 CONTINUE .....	37
<b>Annex B (normative): Handling of Non-Call Related Signalling.....</b>	<b>38</b>
B.1 Handling of Non-call Related Signalling.....	38
B.1.1 Routeing Conventions.....	38
B.1.2 Network Architecture .....	38
B.2 Signalling Scenarios .....	40
B.2.1 Non-call Related Signalling Message for a Non-ported Number – Indirect Routeing .....	40
B.2.2 Non-call Related Signalling Message for a Ported or Non-ported Number – Direct Routeing .....	41
B.2.3 Non-call Related Signalling Message for a Ported Number – Indirect Routeing .....	42

B.3	Functional Requirements of Network Entities.....	43
B.3.1	Procedure MNP_SRF_Non_Call_Related.....	43
B.4	Signalling Scenarios (informative).....	45
B.4.1	Delivery of SMS to a Non-porting Number – Direct Routing – MNP-SRF acts as SCCP Relay.....	45
B.4.2	Delivery of SMS to a Non-porting Number - Direct Routing – MNP-SRF acts as Higher-level Relay.....	46
B.4.3	Delivery of SMS to a Porting Number – Indirect Routing.....	47
B.4.4	Delivery of SMS to a Porting Number – Direct Routing.....	48
B.4.5	International SOR for a Non-porting Number.....	49
B.4.6	SOR for a Porting Number – Indirect Routing.....	50
B.4.7	Any Time Interrogation for a Porting Number – Indirect Routing.....	51
B.4.8	Any Time Interrogation for a Porting Number – Direct Routing.....	52
B.4.9	CCBS where the Busy Subscriber is a Porting Subscriber – Direct Routing.....	53
<b>Annex C (normative): MNP Signalling Relay Function - Call Related Signalling.....</b>		<b>54</b>
C.1	Handling of Call Related Signalling.....	54
C.2	Functional Requirements of Network Entities.....	55
C.2.1	Procedure MNP_SRF_MATF_Call_Related.....	55
C.2.2	Process SRI_NPLR.....	55
C.3	Call Scenarios.....	59
C.3.1	Call to a Non-Porting Number or Number Porting into the Network.....	59
C.3.2	Call to a Porting Number – Originating Network = Subscription Network – Direct Routing.....	60
C.3.3	Mobile Originated Call to a Porting or not known to be Porting Number – Originating Network ≠Subscription Network– Direct Routing.....	61
C.3.4	Call to a Porting Number – Indirect Routing.....	62
C.3.5	Call to a Porting Number – Indirect Routing with Reference to Subscription Network.....	63
C.4	Information Flows.....	64
C.5	Contents of the messages.....	70
C.5.1	Send Routing Info.....	70
C.5.2	Send Routing Info ack.....	70
C.6	Handling of MAP to ISUP mapping (informative).....	70
C.6.1	Mapping direction: ISUP to MAP.....	70
C.6.2	Mapping direction: MAP to ISUP.....	70
<b>Annex D: Change history.....</b>		<b>72</b>
History.....		73

---

# Foreword

This Technical Specification has been produced by the 3GPP.

The present document specifies alternatives for the realisation of Mobile Number Portability within the digital cellular telecommunications system.

The contents of the present document are subject to continuing work within the TSG and may change following formal TSG approval. Should the TSG modify the contents of this TS, it will be re-released by the TSG with an identifying change of release date and an increase in version number as follows:

Version x.y.z

where:

- x the first digit:
  - 1 presented to TSG for information;
  - 2 presented to TSG for approval;
  - 3 Indicates TSG approved document under change control.
- y the second digit is incremented for all changes of substance, i.e. technical enhancements, corrections, updates, etc.
- z the third digit is incremented when editorial only changes have been incorporated in the specification;

---

# 1 Scope

The present document describes several alternatives for the realisation of Mobile Number Portability.

The present document includes information applicable to network operators, service providers, switch and database manufacturers and national regulators.

It is left to operator and implementation decisions which option, or combination of options, is used, taking into account the regulatory and architectural constraints that may prevail. The possible implications of these options on internal node functions and on signalling performance are not covered in the present document.

Normative Annex A of the present document describes the technical realisation of the handling of calls to ported GSM mobile subscribers using IN technology.

Normative Annex C of the present document describes the technical realisation of the handling of calls to ported GSM mobile subscribers using Signalling Relay technology.

Normative Annex A and Normative Annex C describe alternative solutions. The network operator may choose the solution to be used in his network.

Normative Annex B of the present document describes the technical realisation of the handling of non-call related SCCP signalling for ported GSM mobile subscribers using Signalling Relay technology.

The present document does not specify the porting process.

---

# 2 References

## 2.1 References

The following documents contain provisions which, through reference in this text, constitute provisions of the present document.

- References are either specific (identified by date of publication, edition number, version number, etc.) or non-specific.
- For a specific reference, subsequent revisions do not apply.
- For a non-specific reference, the latest version applies.
- A non-specific reference to an ETS shall also be taken to refer to later versions published as an EN with the same number.
- For this Release 1998 document, references to GSM documents are for Release 1998 versions (version 7.x.y).

- [1] GSM 01.04: (ETR 350) "Digital cellular telecommunications system (Phase 2+); Abbreviations and acronyms".
- [2] ETS 300 009 (December 1991): "Integrated Services Digital Network (ISDN); CCITT Signalling System No. 7 – Signalling Connection Control Part (SCCP) [connectionless services] to support international interconnection".
- [3] GSM 02.66: "Digital cellular telecommunications system (Phase 2+); Support of Mobile Number Portability (MNP); Service description. Stage 1".
- [4] GSM 03.18: "Digital cellular telecommunications system (Phase 2+); Basic call handling ; Technical realisation".
- [5] GSM 09.02 (ETS 300 974): "Digital cellular telecommunications system (Phase 2+); Mobile Application Part (MAP) specification".

- [6] ETS 300 374-1: "Intelligent Network (IN); Intelligent Network Capability Set 1 (CS1); Core Intelligent Network Application Protocol (INAP); Part 1: protocol specification".
- [7] draft EN 302 097 V1.1.2 (1999-01): "Integrated Services Digital Network (ISDN); Signalling System No.7; ISDN User Part (ISUP); Enhancements for support of Number Portability (NP)".

---

## 3 Definitions and abbreviations

### 3.1 Definitions

For the purposes of the present document, the following definitions apply:

**donor network:** the subscription network from which a number is ported in the porting process. This may or may not be the number range owner network.

**interrogating network entity:** the entity that submits a non-call related signalling message to interrogate the HLR;

**interrogating network:** the network in which the interrogating network entity resides;

**mobile number portability:** the ability for a mobile subscriber to change GSM subscription network within the same country whilst retaining their original MSISDN(s).

**network operator:** a GSM PLMN operator.

**non-call related signalling message:** all signalling messages where the MSISDN is used to route the message on SCCP level except MAP SRI without OR parameter set (i.e. SRI\_SMS, SRI for SOR, Send\_IMSI, CCBS\_Request etc);

**number range owner network:** the network to which the number range containing the ported number has been allocated.

**originating network:** the network where the calling party is located.

**portability cluster:** a set of GSM PLMNs in a country between which MSISDNs may be ported.

**portable number:** an E.164 number that can be ported between networks in one nation.

**ported number:** a portable number that has undergone the porting process.

**ported subscriber:** the subscriber of a ported number.

**porting process:** a description of the transfer of a number between network operators.

**recipient network:** the network which receives the number in the porting process. This network becomes the subscription network when the porting process is complete.

**routing number:** the routing number is the data stored against the ported number in the Number Portability Database.

**service key:** the Service Key can identify to the entity holding the Number Portability Database that the service logic for Mobile Number Portability should apply. The Service Key value for Mobile Number Portability is administered in the MSC, and is passed transparently to the entity holding the Number Portability Database.

**service provider:** an entity which offers service subscriptions to individual subscribers and contracts with a network operator to implement services for a specific MSISDN. A service provider may contract with more than one network operator.

**service provider portability:** the transfer of numbers between two unique Service Providers.

**subscription network:** the network with which the customer's Service Provider has a contract to implement the customer's services for a specific MSISDN.

NOTE: The term "recipient network" is used during the porting process. The recipient network becomes the "subscription network" after the completion of the porting process.



## 3.2 Abbreviations

Abbreviations used in the present document are listed in GSM 01.04 ([1]).

For the purposes of the present document, the following abbreviations apply:

GMSC	Gateway MSC
GMSCB	The GMSC in HPLMNB
HLR	Home Location Register
HPLMNB	The subscription network of the B subscriber
IDP	Initial Detection Point
IE	Information Element
INE	Interrogating Network Entity
IF	Information Flow
IPLMN	Interrogating PLMN
MATF	MAP application Terminating Function
MNP	Mobile Number Portability
MNP-SRF	Signalling Relay Function for support of MNP
MSA	Mobile Station of the A subscriber
MSB	Mobile Station of the B subscriber
MSC	Mobile service Switching Centre
NPDB	Number Portability Database
NPLMN	The number range owner network of the B subscriber
OQoD	Originating call Query on Digit Analysis
PLMN	Public Land Mobile Network
QoHR	Query on HLR Release
RN	Routing Number
SMS	Short Message Service
SOR	Support of Optimal Routeing
SRI	Send Routeing Information
TQoD	Terminating call Query on Digit Analysis
TT	Translation Type
VMSC	The Visited MSC
VMSCB	The VMSC of the B subscriber

Further GSM related abbreviations are given in GSM 01.04.

---

## 4 General

### 4.1 Overview

Mobile Number Portability (MNP) is the ability for a mobile subscriber to change the GSM subscription network within a portability cluster whilst retaining her original MSISDN or MSISDNs.

As part of the porting process administrative actions have to be performed by the GSM network operators of the number range owner network, donor network, recipient network and, as an option, by operators of other national GSM networks as follows:

a) if the number range owner network is identical with the donor network:

Recipient network:	add an entry in the HLR; add an entry in the Number Portability Database.
Donor network:	add an entry in the Number Portability Database; delete the entry related to the ported MSISDNs in the HLR.
Other networks in the portability cluster:	add an entry in the Number Portability Database (if direct routeing is used).

b) if the number range owner network is identical with the recipient network:

Recipient network:	add an entry in the HLR; delete any entry related to the ported MSISDN in the Number Portability Database.
Donor network:	delete any entry related to the ported MSISDN in the Number Portability Database; delete the entry related to the ported MSISDNs in the HLR.
Other networks in the portability cluster:	delete any entry related to the ported MSISDN in the Number Portability Database.

c) if the number range owner network is different from both the recipient and the donor network:

Recipient network:	add an entry in the HLR; add an entry in the Number Portability Database.
Number range owner network:	update the Number Portability Database
Donor network:	delete (or update) the entry in the Number Portability Database; delete the entry related to the ported MSISDNs in the HLR.
Other networks in the portability cluster:	update the Number Portability Database (if an entry for the ported MSISDN exists ).

Note that the order of sequence for the administrative actions to be performed both within a network and by different network operators is significant with respect to prevention of disruption in service to the mobile subscriber and prevention of looping calls between networks during the porting process.

Termination of a subscription for a ported number results in the deletion of any entry in an HLR and NPDB of that number.

If a call fails because databases are not correctly synchronised, the network entity which detects the inconsistency will raise an MNP specific alarm to the operation and maintenance subsystem.

The present document does not specify the porting process; it specifies the functionality needed to set-up calls to both ported and non ported subscribers (Normative Annex A and Normative Annex C) and the functionality needed to relay non-call related signalling messages to the HLR in the subscription network (Normative Annex B).

## 4.2 Compatibility

The IAM sent to the subscription network may contain additional routing information. Within a portability cluster the method how to convey the Routing Number in the IAM between 2 PLMNs shall be agreed upon by the 2 network operators involved (see also [7]).

In general, IN-based and MNP-SRF (call-related) solutions are compatible and may coexist in the same portability cluster. The only restriction refers to the case where the number range owner network relays call-related MAP messages (i.e. SRI for national calls) to the subscription network. If this solution is selected by at least one network operator within a portability cluster, all the PLMNs and transit networks affected must fulfil the following requirements:

1. The SCCP interfaces between networks in a portability cluster must be agreed. This refers to the SCCP addressing mechanism being used (e.g. number lengths, natures of address and translation types for call-related MAP messages).  
For messages which do not cross network boundaries the SCCP addressing mechanism is a choice of the network operator.
2. The subscription network must be able to generate the SRI ack to allow the onward routing of the call from the number range owner network to the subscription network.

In the rest of the possible architectures for MNP, no interworking problems have been identified. In these cases, network architectures used within one PLMN (e.g. IN, MNP-SRF) are regarded as operator dependent.

In order to avoid loops and incompatibility situations, all the networks within a portability cluster shall use the same routing convention either direct routing, indirect routing or indirect routing with reference to the Subscription network. As an alternative, indirect routing can interwork successfully with direct routing if the routing number is transferred in the IAM or if dedicated traffic connections are used.

### 4.3 Common Functionality of the MNP-SRF

In a PLMN which supports mobile number portability, SCCP messages sent to an HLR may be relayed by an MNP-SRF. Depending on the implemented solution (IN-based or MNP-SRF-based), on the type of message (call-related or non-call-related) and on the porting status of the called subscriber the MNP-SRF may modify the SCCP called party address and route the message to a different HLR or to the subscription network, or terminate the dialogue and response to the INE.

Figure 1 shows the general steering functionality for SCCP message routing. It shows the SCCP routing principle for mobile number portability within a network.

Note that call related messages in the IN-based solution are not routed to the MNP-SRF. Therefore Normative Annex A of the present document does not mention the MNP-SRF.

However, the usage of the IN-based solution for the call-related messages should allow operators to have the routing of the non call-related messages determined in the same database. See [8] for the description of the access of the MNP-SRF (node with relay capability) to the NPDB (external database).

In order to guard against the possibility that the porting data for an MSISDN is inconsistent between PLMNs in a porting cluster, the SCCP hop counter may be used to prevent indefinite looping of messages between PLMNs. The MNP-SRF would then decrement the SCCP hop counter for every message that is relayed. It should be noted that the use of the SCCP hop counter requires the use of unsegmented SCCP XUDT messages as defined in ITU-T 1996 SCCP recommendations.

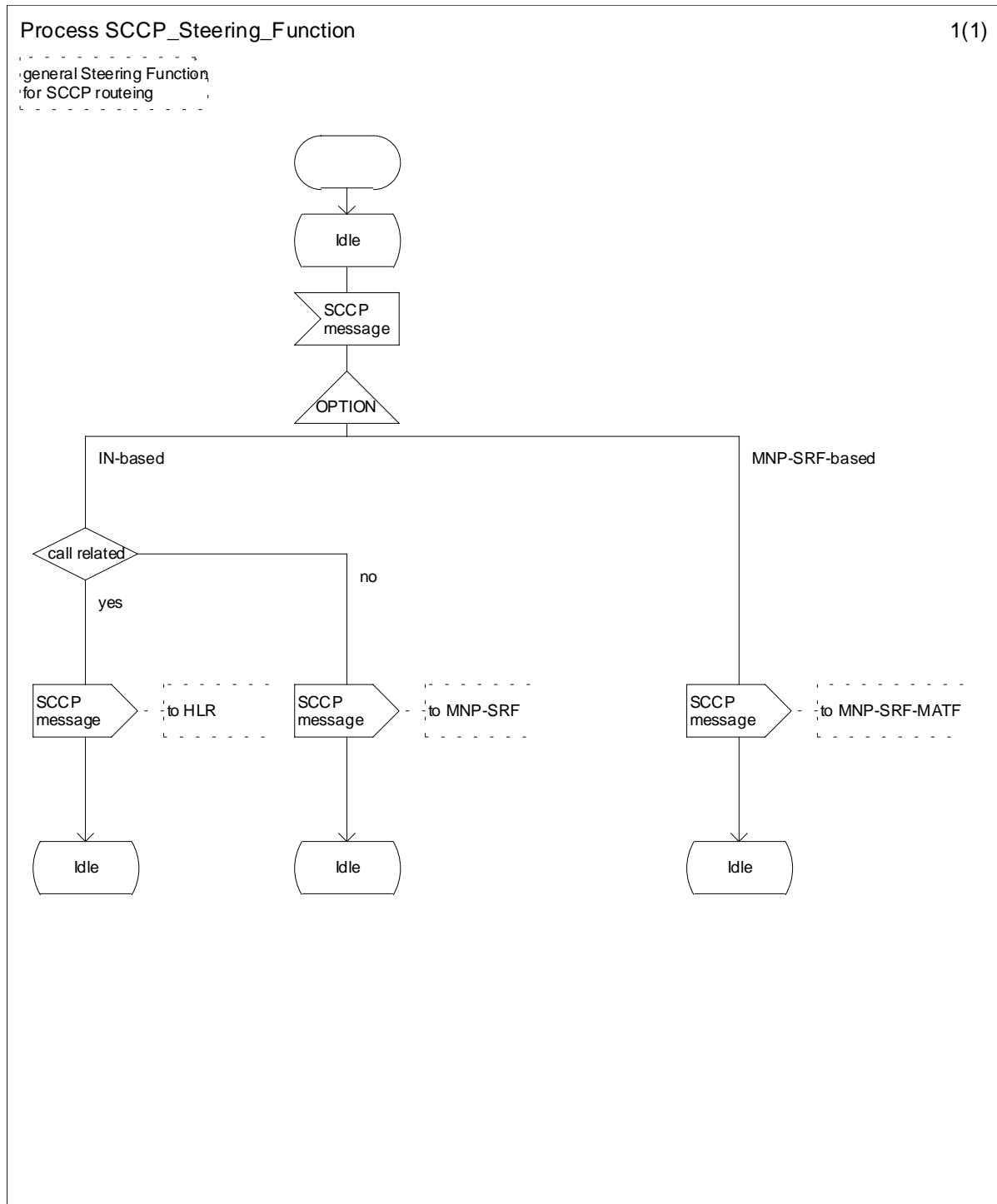

**Figure 1: Steering Function for SCCP Message routing**

Figure 2 shows the process MNP\_SRF in the MNP-SRF. The procedures MNP\_SRF\_MATF\_Call\_Related and MNP\_SRF\_Non\_Call\_Related are described in Normative Annex C and Normative Annex B of the present document. Note that in networks which support the IN-based solution for call related signalling, a distinction on SCCP level for call related and non-call related messages is needed and that the MNP-SRF does not require to include a MATF since call related messages are not routed to the MNP-SRF.

The test "call-related" is a test on the SCCP Translation Type if a dedicated Translation Type value for call related messages is used in the network. The handling of SCCP messages in the MNP-SRF in networks which do not make use of a dedicated Translation Type value for call related messages is for further study.

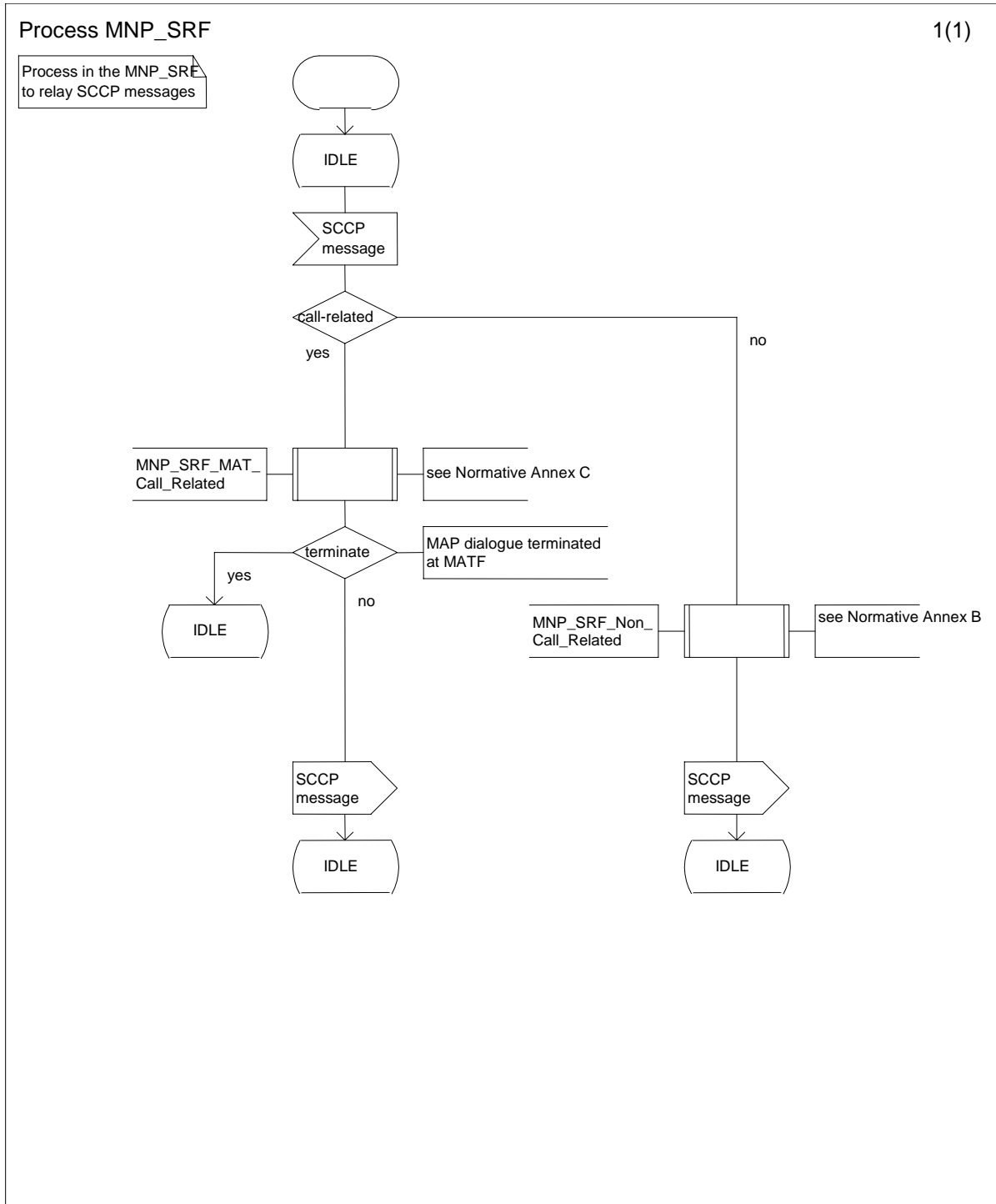
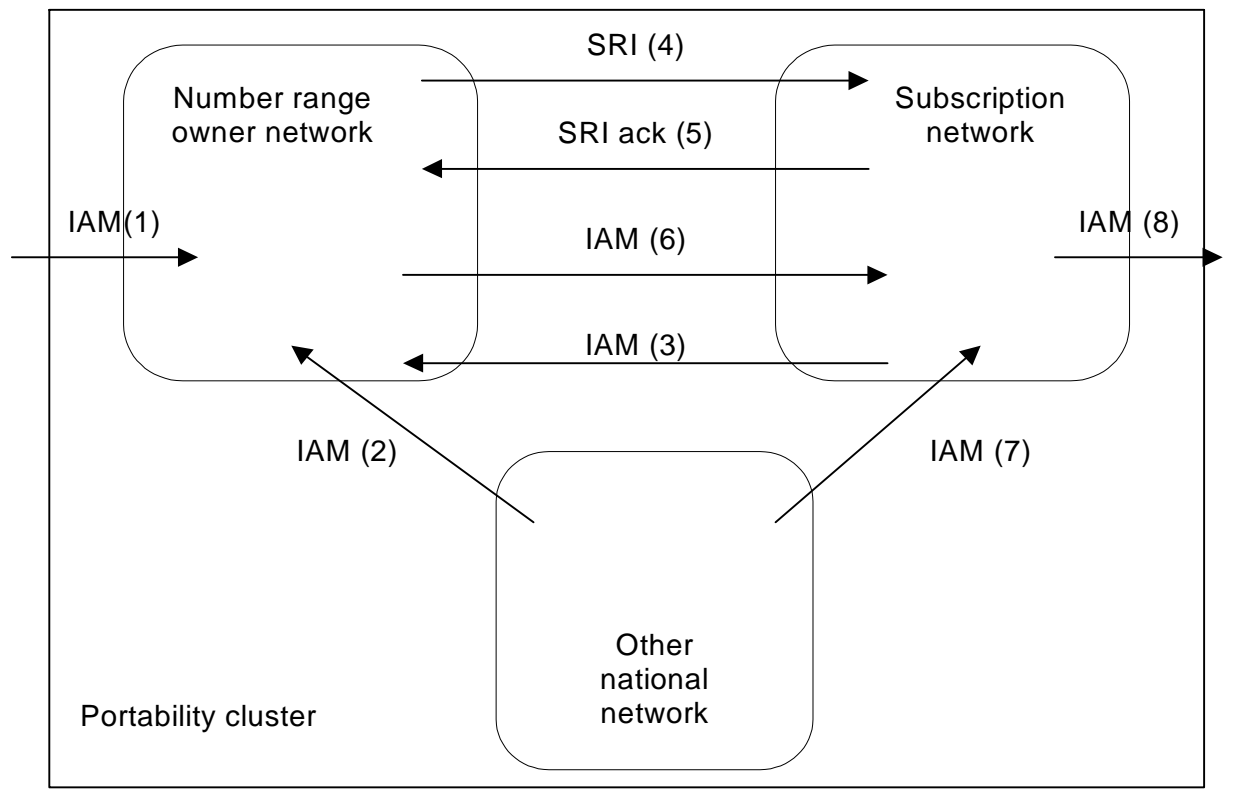

Figure 2: Process MNP\_SRF

## 5 Common Architecture for call setup

Figure 3 shows the general architecture of a portability cluster for routing of calls. The more detailed architecture within the networks depends on the chosen solution (IN-based or MNP/SRF-based) and options and is described in Normative Annex A and Normative Annex C of the present document.

The architecture for non-call related signalling is described in Normative Annex B of the present document.



**Figure 3 General architecture of a portability cluster for routing of calls**

The following routing conventions are identified:

1. Direct Routing of calls is a PLMN option which allows to route calls directly from the PLMN supporting this option to the ported subscriber's subscription network.
2. Indirect Routing of calls is a PLMN option which allows to route calls from the PLMN supporting this option via the number range owner network to the ported subscriber's subscription network.
3. Indirect Routing of calls with reference to the subscription network is a PLMN option for PLMN operators having chosen the MNP-SRF solution for call related signalling described in Normative Annex C. If all PLMNs within a portability cluster support this option, calls are routed from the originating network to the number range owner network. The number range owner network obtains onward routing information from the subscription network and routes the call onward to the ported subscriber's subscription network.

The following action in the different networks can be identified:

1. If the call is originated outside the portability cluster, the IAM(1) is received by the number range owner network.
- 2a. If the call is originated in another national network and the other national network does not support originating call query (i.e. Indirect Routing of calls is applicable), the IAM(2) is received by the number range owner network.

- 2b. If the call is originated in another national network and the other national network supports originating call query (i.e. Direct Routeing of calls is applicable), the IAM(7) containing the routeing number is sent to the subscription network. If the routeing number is not used in the IAM sent from the national originating network to the subscription network, all transit networks involved are required to look up an NPDB in order to retrieve routeing information to route the call to the subscription network without looping.
- 3a. If the call is originated in the subscription network and the subscription network does not support originating call query (i.e. Indirect Routeing of calls is applicable), the IAM(3) is received by the number range owner network.
- 3b. If the call is originated in the subscription network and the subscription network supports originating call query (i.e. Direct Routeing of calls is applicable), it sends an IAM(8) containing the MSRN to the visited network of the called subscriber.
- 3c. If the subscription network receives IAM(6 or 7) containing the routeing number, it sends an IAM(8) containing the MSRN to the visited network of the called subscriber.
- 4a. If the call is routed via the number range owner network, and the number range owner network supports the MNP-SRF/MATF solution with the option 'MATF in subscription network' described in Normative Annex C of the present document (i.e. Indirect Routeing of calls with reference to the subscription network is applicable), the number range owner network sends SRI(4) to the subscription network. The subscription network returns SRI ack (5) containing the routeing number. The number range owner network then sends IAM(6) containing the routeing number to the subscription network. If the routeing number is not used in the IAM sent from the number range owner network to the subscription network, all transit networks involved are required to look up an NPDB in order to retrieve routeing information to route the call to the subscription network without looping.
- 4b. If the call is routed via the number range owner network, and the number range owner network supports the IN solution described in Normative Annex A of the present document or the MNP-SRF/MATF solution with the option 'MATF inside number range owner network' described in Normative Annex C of the present document, the number range owner network sends IAM(6) containing the routeing number to the subscription network.

---

## Annex A (normative): IN Call-Related Technical Realization

### A.1 Architecture

#### A.1.1 Network Options

The following network operator options are defined for the MT calls in the GMSC:

- Terminating call Query on Digit Analysis (TQoD),
- Query on HLR Release (QoHR).

In a GSM network which supports the IN-based approach for call related MNP, each GMSC shall support at least one of these options.

The following network operator option is defined for MO calls in VMSCA and for forwarded calls in the GMSC and VMSCB:

- Originating call Query on Digit Analysis (OQoD).

In a GSM network which supports the IN-based approach for call related MNP, it is a network operator decision, taking into account the regulatory and architectural constraints that may prevail, whether or not VMSCs and GMSCs support this option.

The use of OQoD in transit switches in a PLMN while avoiding multiple database interrogations is for further study.

The interworking between the CCF and the SSF for MNP is for further study.

Note that for different number ranges different options may be chosen.

#### A.1.2 No NP Query required – Number is not subject for portability

Figure A.1.2 shows the architecture for a call to a number that is not subject for portability. This can be for several reasons like for example:

- the national regulator has stipulated some number series as being non-portable or;
- in an initial phase only a limited amount of subscribers might port in certain number blocks and some operators might want to treat the call routing according to traditional routing plans without any change.



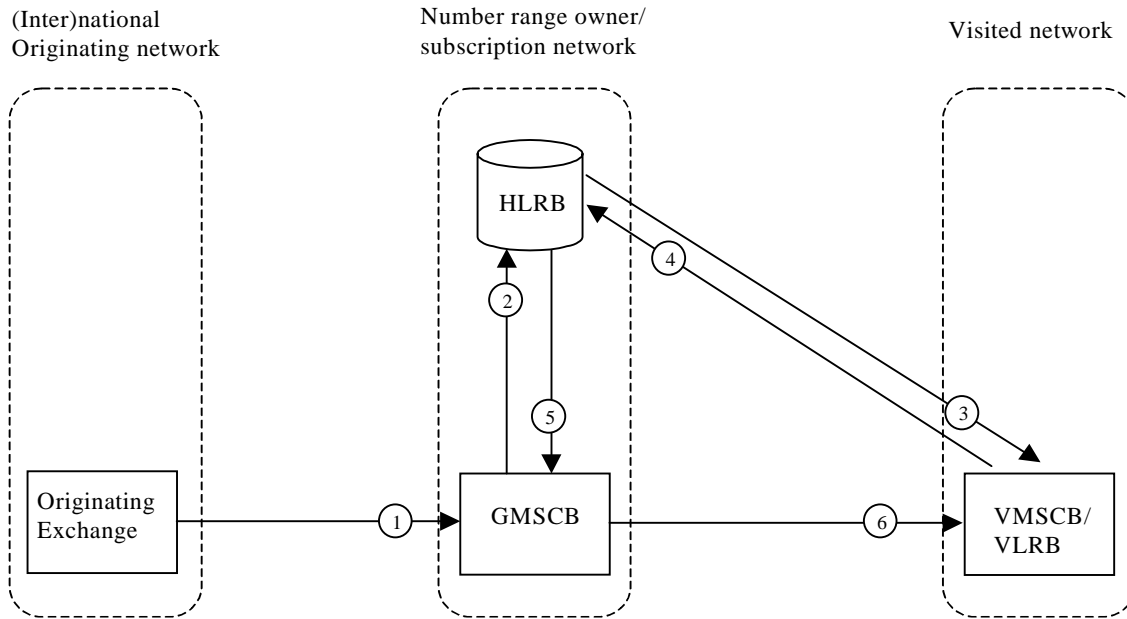

**Figure A.1.2: Call to a non-ported number, no NP query required**

- 1 From an Originating Exchange a call is set up to MSISDN. The call is routed to the Number range owner network being the Subscription network;
- 2 When GMSCB receives the ISUP IAM, it requests routing information by submitting a MAP SRI to the HLRB including the MSISDN in the request;
- 3 The HLRB requests an MSRN from the MSC/VLRB where the mobile subscriber currently is registered;
- 4 The MSC/VLRB returns an MSRN back to the HLRB;
- 5 The HLRB responds to the GMSCB by sending an SRI ack with an MSRN;
- 6 GMSCB uses the MSRN to route the call to VMSCB.

## A.1.3 NP Query in Number Range Owner Network

### A.1.3.1 TQoD – Number is not ported

Figure A.1.3.1 shows the architecture for a call where the Originating network has no knowledge whether the MSISDN is ported or not and uses the traditional routing plans for routing the call to the Number range owner network for further routing decisions.

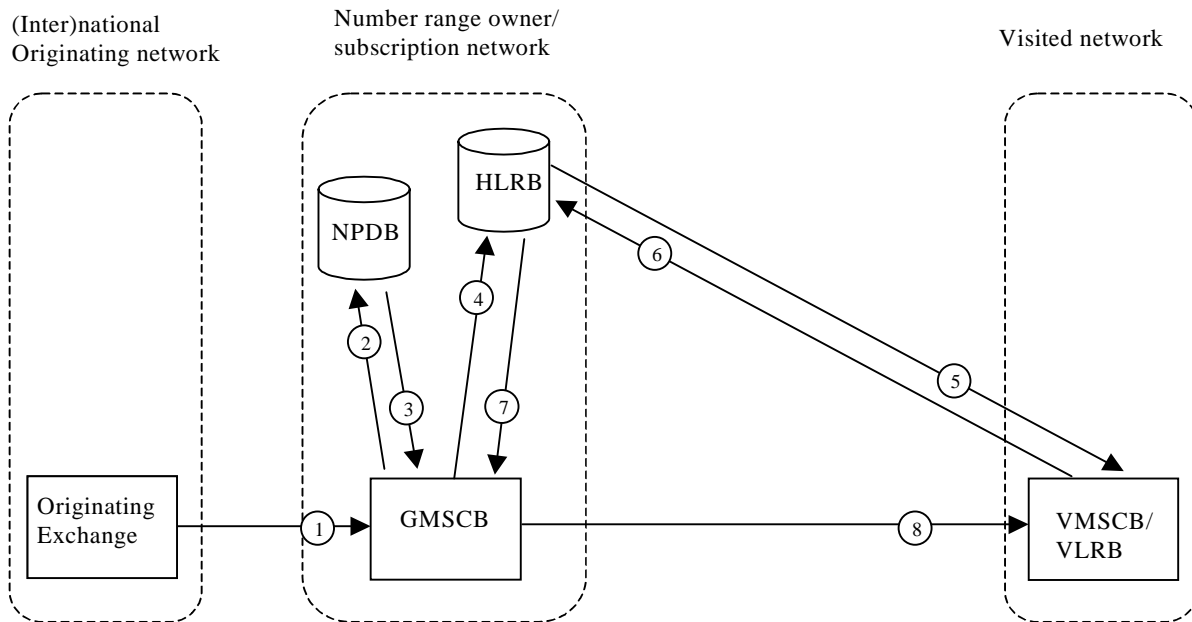

**Figure A.1.3.1: Call to a non-ported number using TQoD procedure**

1. From an Originating Exchange a call is set up to MSISDN. The call is routed to the Number range owner network being the Subscription network;
2. When GMSCB receives the ISUP IAM, it will send a database query to the NPDB as a result of analysis of the received MSISDN. The MSISDN is included in the query to the NPDB;
3. The NPDB detects that the MSISDN is not ported and responds back to the GMSCB to continue the normal call setup procedure for MT calls;
4. The GMSCB requests routing information by submitting a MAP SRI to the HLRB, including the MSISDN in the request;
5. The HLRB requests an MSRN from the MSC/VLRB where the mobile subscriber owning the MSISDN currently is registered;
6. The MSC/VLRB returns an MSRN back to the HLRB;
7. The HLRB responds to the GMSCB by sending an SRI ack with an MSRN;
8. GMSCB uses the MSRN to route the call to VMSCB.

Note that the NPDB may be outside the number range owner network if a shared NPDB is used.

### A.1.3.2 TQoD – Number is ported

Figure A.1.3.2 shows the architecture for a call where the Originating network has no knowledge whether the MSISDN is ported or not and uses the traditional routing plans for routing the call to the Number range owner network for further routing decisions.

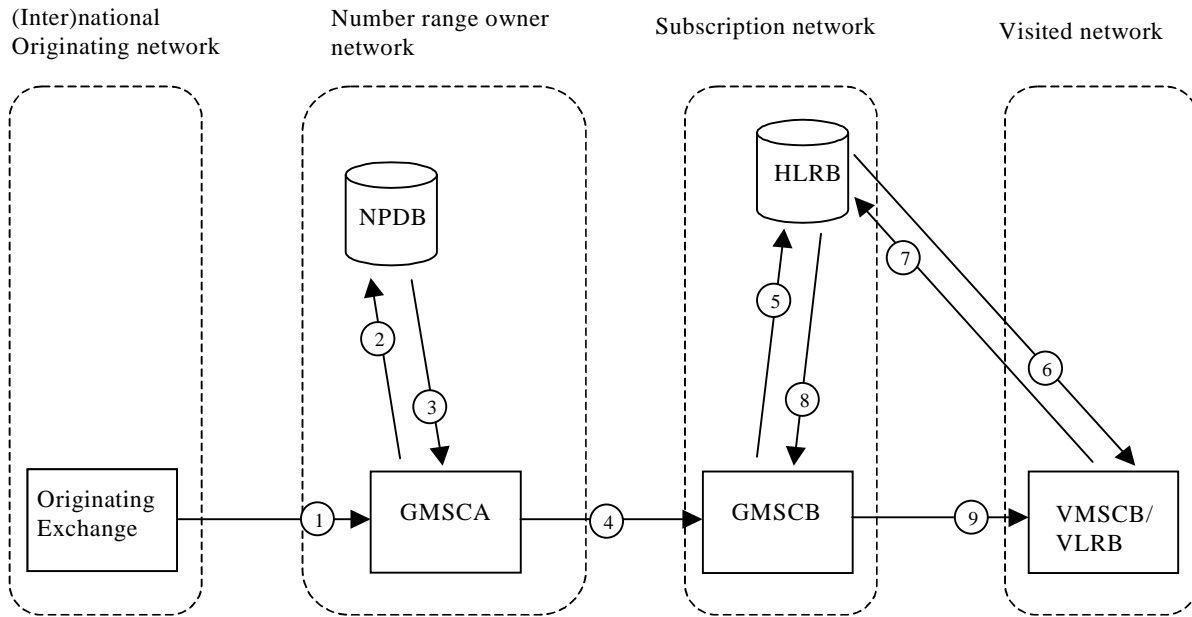

**Figure A.1.3.2: Call to a ported number using TQoD procedure**

- 1 From an Originating Exchange a call is set up to MSISDN. The call is routed to the Number range owner network;
- 2 When GMSCA receives the ISUP IAM, it will send a database query, including the MSISDN, to the NPDB as a result of analysis of the received MSISDN;
- 3 The NPDB detects that the MSISDN is ported and responds back to the GMSCA with a Routing Number pointing out the Subscription network;
- 4 The call is routed to the Subscription network based on the Routing Number carried in ISUP IAM message; also the MSISDN is included in IAM.
- 5 The GMSCB requests routing information by submitting a MAP SRI to the HLRB, including the MSISDN in the request. The capability to route messages to the correct HLR is required.
- 6 The HLRB requests an MSRN from the MSC/VLRB where the mobile subscriber currently is registered;
- 7 The MSC/VLRB returns an MSRN back to the HLRB;
- 8 The HLRB responds to the GMSCB by sending an SRI ack with an MSRN;
- 9 GMSCB uses the MSRN to route the call to VMSCB.

Note that the NPDB may be outside the number range owner network if a shared NPDB is used.

### A.1.3.3 QoHR – Number is ported

Figure A.1.3.3 shows the architecture for a call where the Originating network has no knowledge whether the MSISDN is ported or not and uses the traditional routing plans for routing the call to the Number range owner network for further routing decisions.

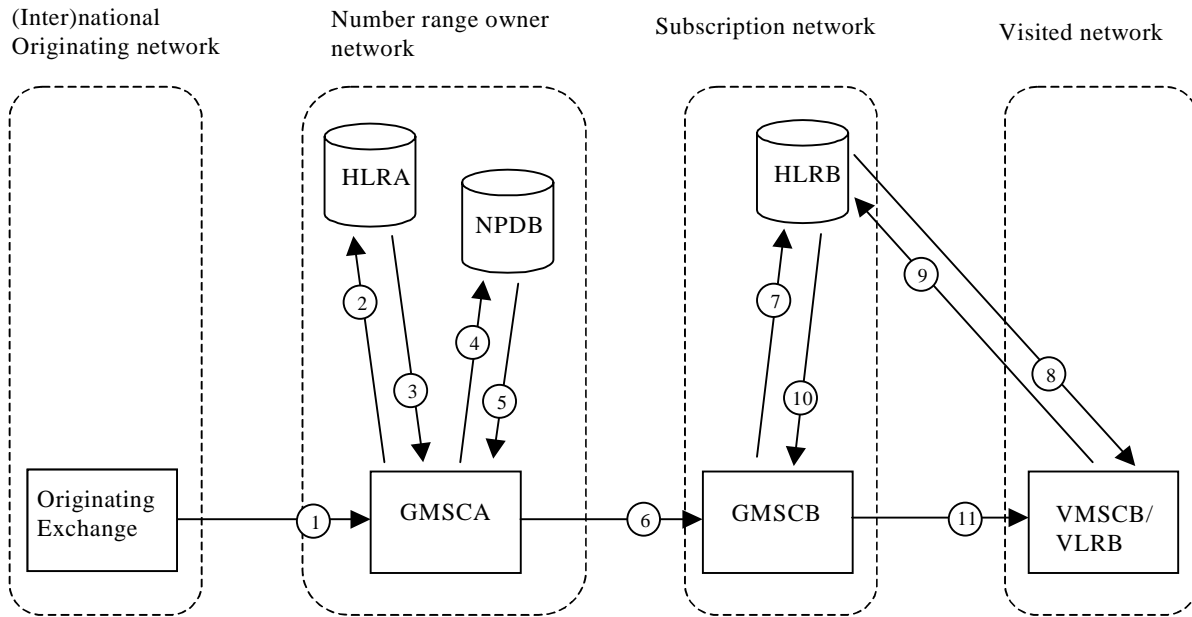

**Figure A.1.3.3: Call to a ported number using QoHR procedure**

1. From an Originating Exchange a call is set up to MSISDN. The call is routed to the number range owner network;
2. When GMSCA receives the ISUP IAM, it requests routing information by submitting a MAP SRI to the HLRA including the MSISDN in the request;
3. The HLRA returns a MAP SRI ack with an “Unknown Subscriber” error since no record was found for the subscriber in the HLRA;
4. When GMSCA receives the error indication form the HLRA, this will trigger the sending of a database query to the NPDB, including the MSISDN in the query;
5. The NPDB detects that the MSISDN is ported and responds back to the GMSCA with a Routing Number pointing out the Subscription network;
6. The call is routed to the Subscription network based on the Routing Number carried in ISUP IAM message; also the MSISDN is included in IAM.
7. The GMSCB requests routing information by submitting a MAP SRI to the HLRB, including the MSISDN in the request. The capability to route messages to the correct HLR is required.
8. The HLRB requests an MSRN from the MSC/VLRB where the mobile subscriber currently is registered;
9. The MSC/VLRB returns an MSRN back to the HLRB;
10. The HLRB responds to the GMSCB by sending an SRI ack with an MSRN;
11. GMSCB uses the MSRN to route the call to VMSCB.

Note that the NPDB may be outside the number range owner network if a shared NPDB is used.

## A.1.4 NP Query in Originating Network

### A.1.4.1 OQoD – Number is not ported

Figure A.1.4.1 shows the architecture for a call where already the Originating network has the knowledge whether the MSISDN is ported or not and can route the call directly to the Subscription network that in this case is the same as the Number range owner network.

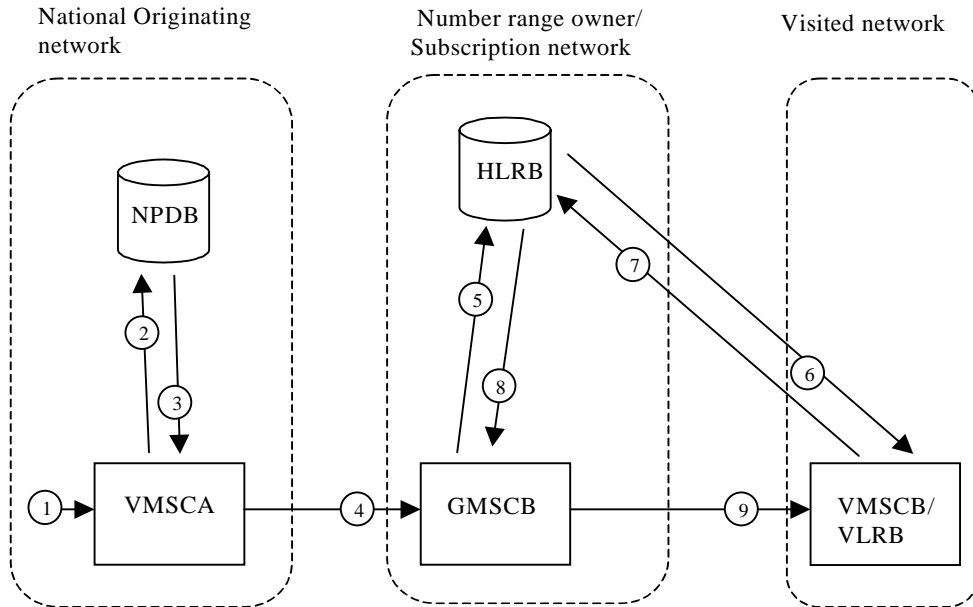

**Figure A.1.4.1: Call to a non-ported number using OQoD procedure**

- 1 A call is initiated by Mobile Subscriber A towards Mobile Subscriber B, using MSISDN of the called subscriber;
- 2 When VMSCA receives the call setup indication, it will send a database query to the NPDB as a result of analysis of the received MSISDN, including the MSISDN in the query;
- 3 The NPDB detects that the MSISDN is not ported and responds back to the VMSCA to continue the normal call setup procedure for MO calls. Depending on database configuration option, the NPDB could either return a Routing Number on not ported calls, as done for ported calls, or the call is further routed using the MSISDN number only towards the Number range owner network;
- 4 The call is routed to the Number range owner/Subscription network based on the MSISDN or Routing Number carried in ISUP IAM message;
- 5 The GMSCB requests routing information by submitting a MAP SRI to the HLRB, including the MSISDN in the request;
- 6 The HLRB requests an MSRN from the MSC/VLRB where the mobile subscriber currently is registered;
- 7 The MSC/VLRB returns an MSRN back to the HLRB;
- 8 The HLRB responds to the GMSCB by sending an SRI ack with an MSRN;
- 9 GMSCB uses the MSRN to route the call to VMSCB.

Note that the NPDB may be outside the national originating network if a shared NPDB is used.

#### A.1.4.2 OQoD – Number is ported

Figure A.1.4.2 shows the architecture for a call where already the Originating network has the knowledge that the MSISDN is ported and can route the call directly to the Subscription network without involving the Number range owner network.

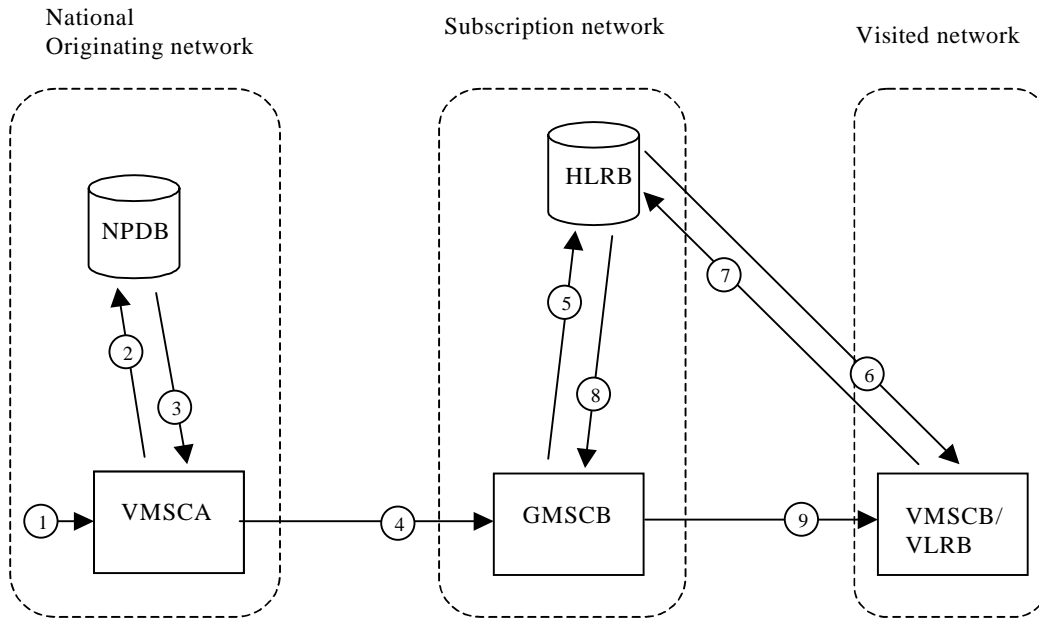

**Figure A.1.4.2: Call to a ported number using OQoD procedure**

- 1 A call is initiated by Mobile Subscriber A towards Mobile Subscriber B, using MSISDN of the called subscriber;
- 2 When VMSCA receives the call setup indication, it will send a database query to the NPDB as a result of analysis of the received MSISDN including the MSISDN in the query;
- 3 The NPDB detects that the MSISDN is ported and responds back to the VMSCA with a Routing Number pointing out the Subscription network;
- 4 The call is routed to the Subscription network based on the Routing Number carried in ISUP IAM message; also the MSISDN is included in IAM.
- 5 The GMSCB requests routing information by submitting a MAP SRI to the HLRB, including the MSISDN in the request. The capability to route messages to the correct HLR is required.
- 6 The HLRB requests an MSRN from the MSC/VLRB where the mobile subscriber currently is registered;
- 7 The MSC/VLRB returns an MSRN back to the HLRB;
- 8 The HLRB responds to the GMSCB by sending an SRI ack with an MSRN;
- 9 GMSCB uses the MSRN to route the call to VMSCB.

Note that the NPDB may be outside the national originating network if a shared NPDB is used.

## A.2 Information flows

In the following figures the NPDB is shown as belonging to the number range owner network or to the national originating network. However, the NPDB may be shared within one portability cluster i.e. nation-wide.

Figure A.2.1 shows the information flow for successful QoHR.

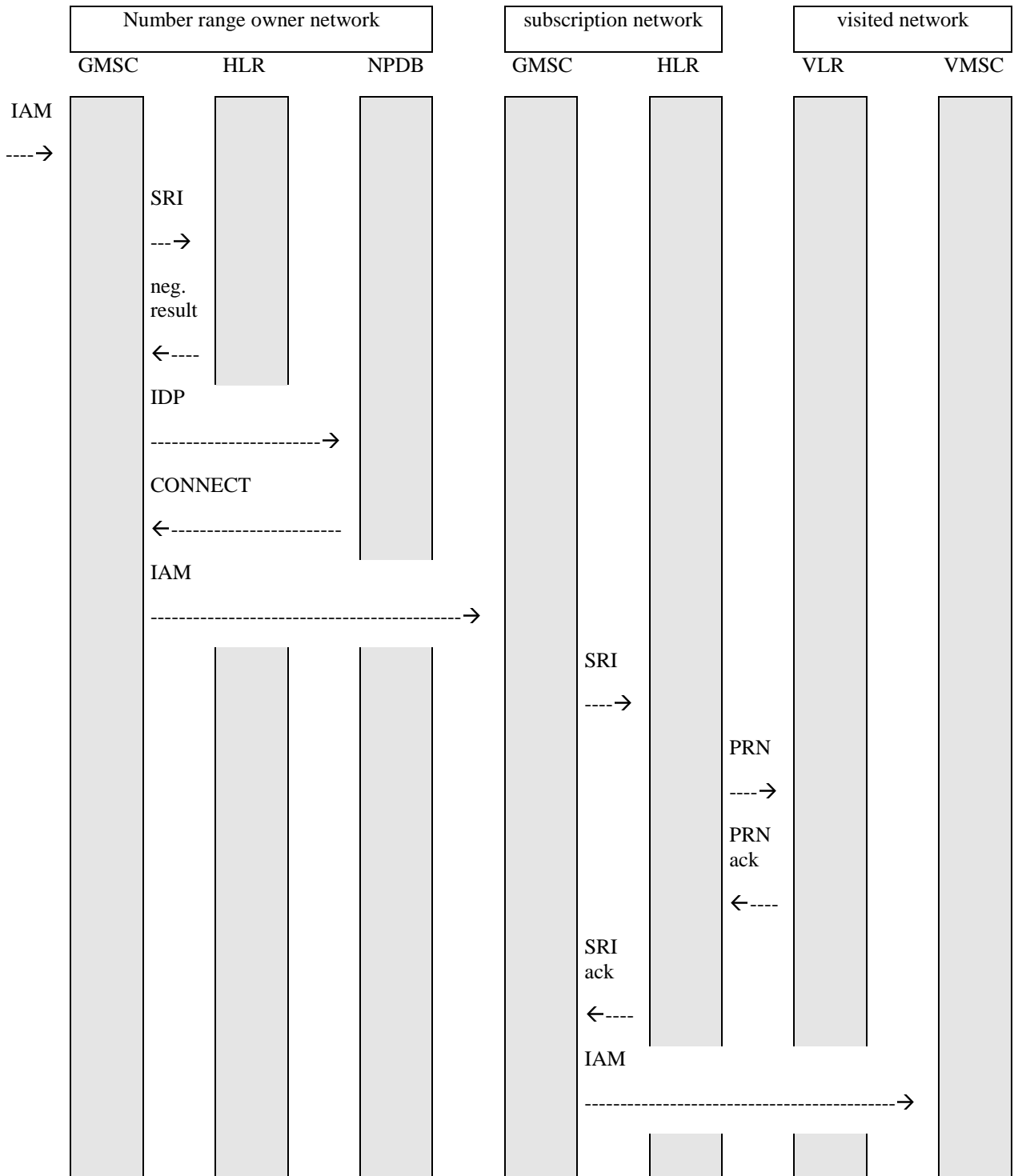

Figure A.2.1

Figure A.2.2 shows the information flow for unsuccessful QoHR (misdialed unallocated number).

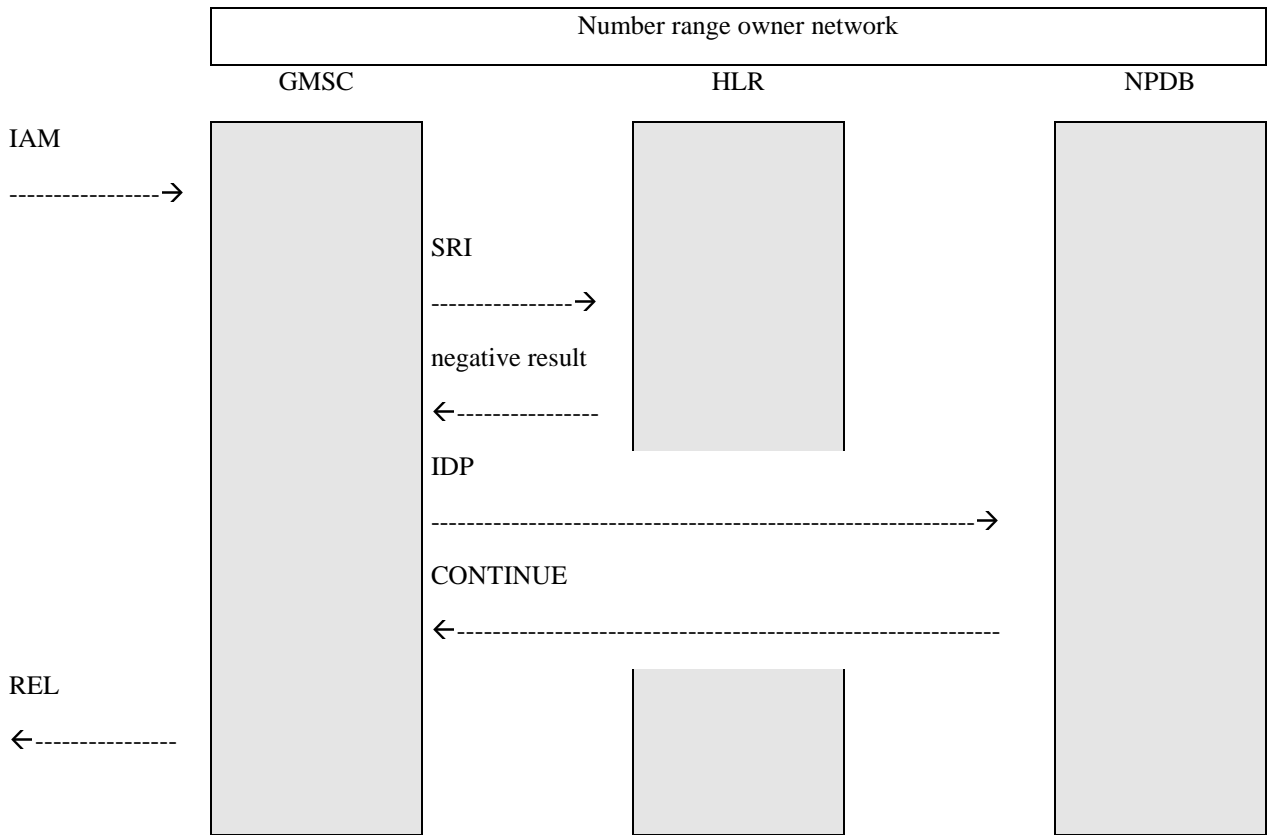

Figure A.2.2



Figure A.2.3 shows the information flow for successful TQoD.

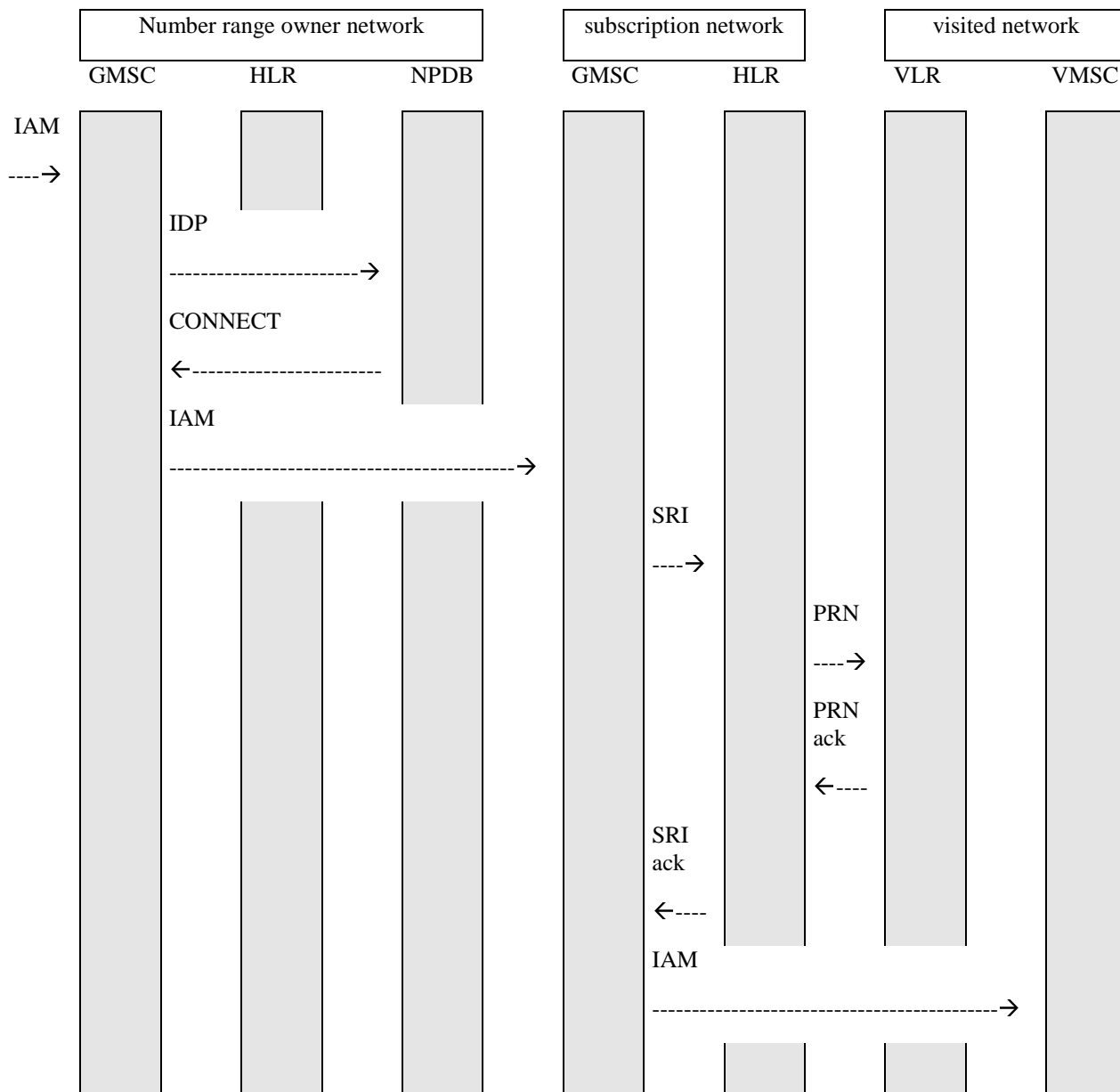

Figure A.2.3

Figure A.2.4 shows the information flow for unsuccessful TQoD (number not ported).

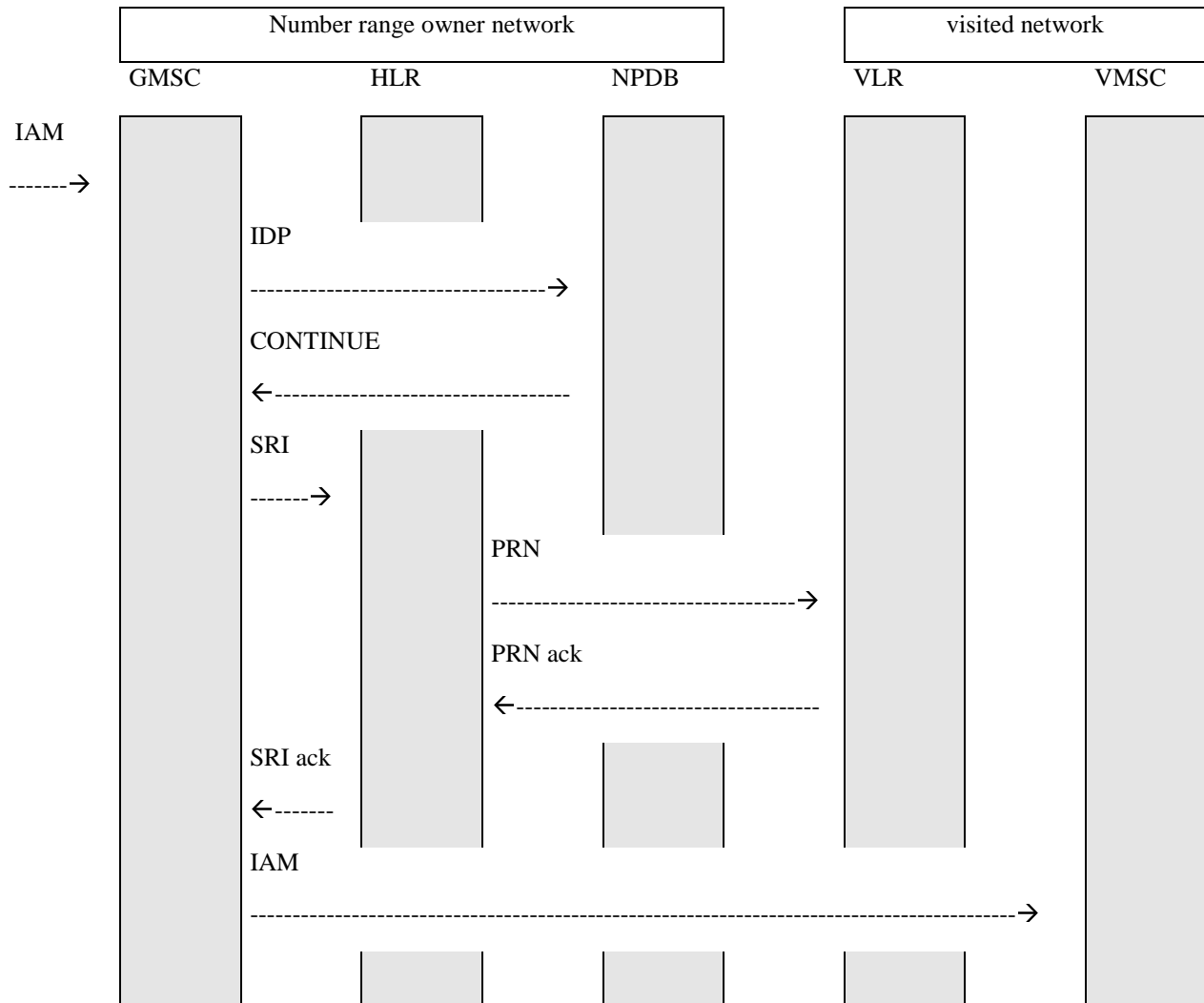

Figure A.2.4

Figure A.2.5 shows the information flow for successful OQoD (number ported ).

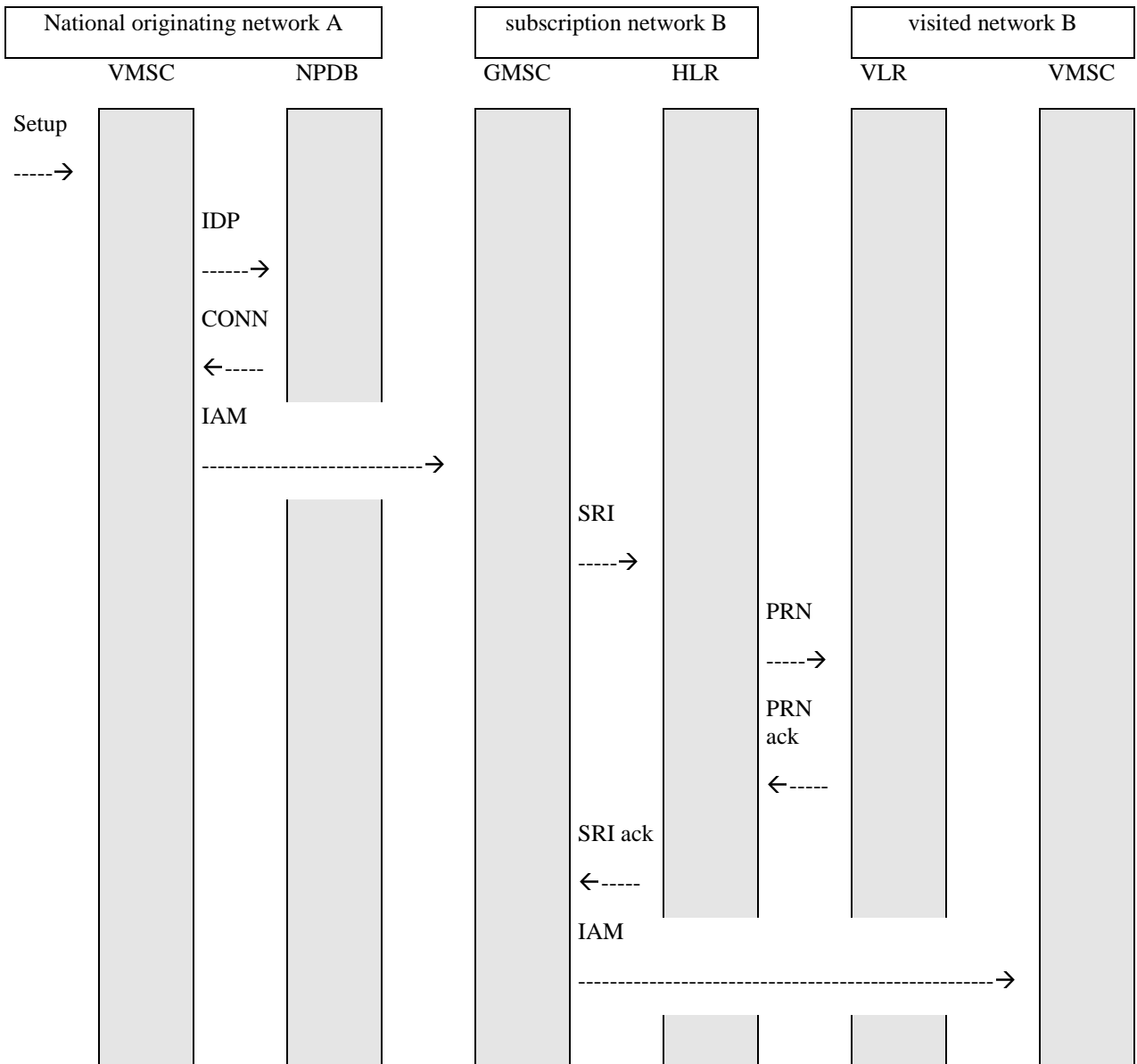

Figure A.2.5

Figure A.2.6 shows the information flow for unsuccessful OQoD (number not ported in).

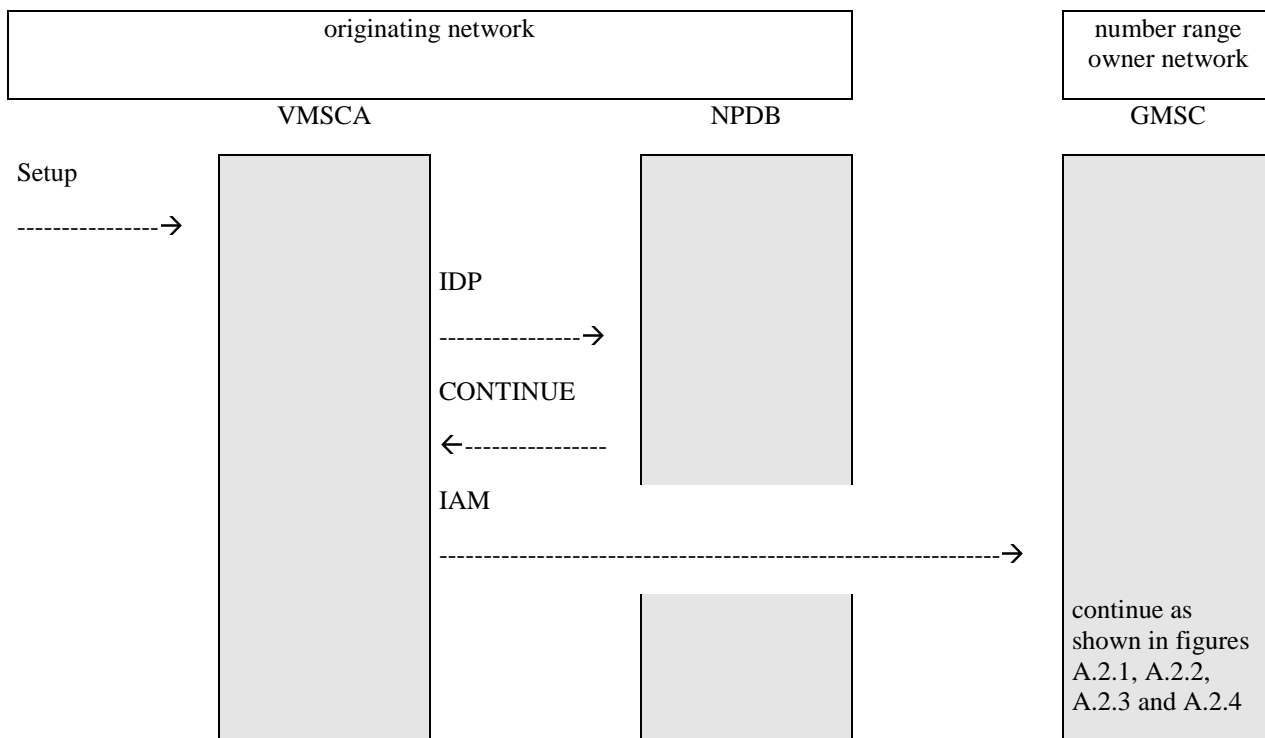

Figure A.2.6

---

## A.3 Functional requirements of network entities

### A.3.1 Functional requirement of GMSC

#### A.3.1.1 Procedure MOBILE\_NUMBER\_PORTABILITY\_IN\_QoHR

The procedure MOBILE\_NUMBER\_PORTABILITY\_IN\_QoHR is shown in figure A.1.3. It is called from the procedure Obtain\_Routing\_Address defined in GSM 03.18 [4].

The text in this clause is a supplement to the definition in the SDL diagrams; it does not duplicate the information in the SDL diagrams.

The IDP message contains the service key for MNP query and the called party's MSISDN.

Procedure MOBILE\_NUMBER\_PORTABILITY\_IN\_QoHR

1(1)

Procedure in the GMSC to handle Query on HLR Release for Mobile Number Portability

Signals to/from the right are to/from the NPDB

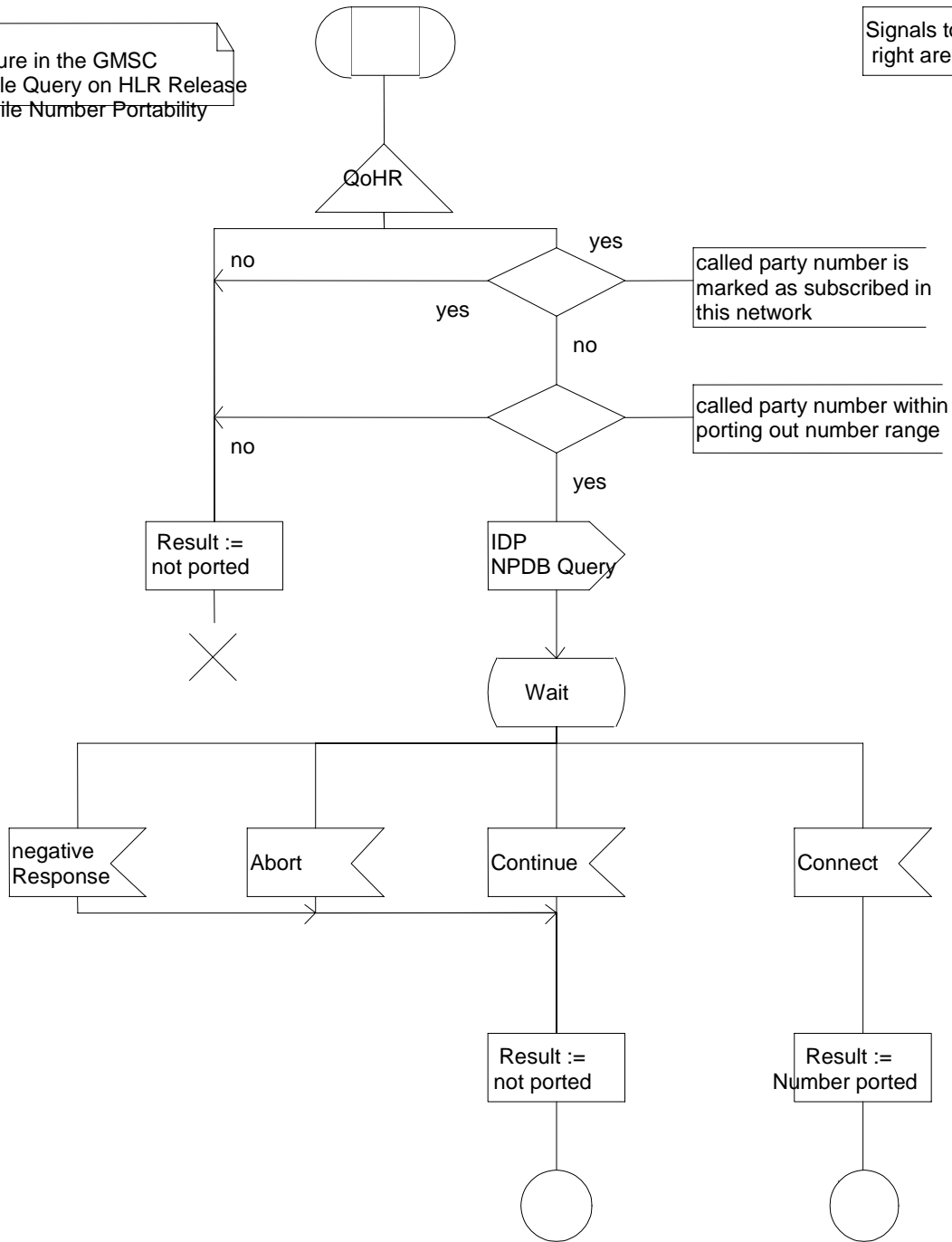

Figure A.13: Procedure MOBILE\_NUMBER\_PORTABILITY\_IN\_QoHR

### A.3.1.2 Procedure MOBILE\_NUMBER\_PORTABILITY\_IN\_TQoD

The procedure MOBILE\_NUMBER\_PORTABILITY\_IN\_TQoD is shown in figure A.14. It is called from the procedure Obtain\_Routing\_Address defined in GSM 03.18 [4].

The text in this clause is a supplement to the definition in the SDL diagrams; it does not duplicate the information in the SDL diagrams.

The IDP message contains the service key for MNP query and the called party's MSISDN.

Procedure MOBILE\_NUMBER\_PORTABILITY\_IN\_TQoD

1(1)

Procedure in the GMSC to handle Terminating call Query on Digit Analysis for Mobile Number Portability

Signals to/from the right are to/from the NPDB

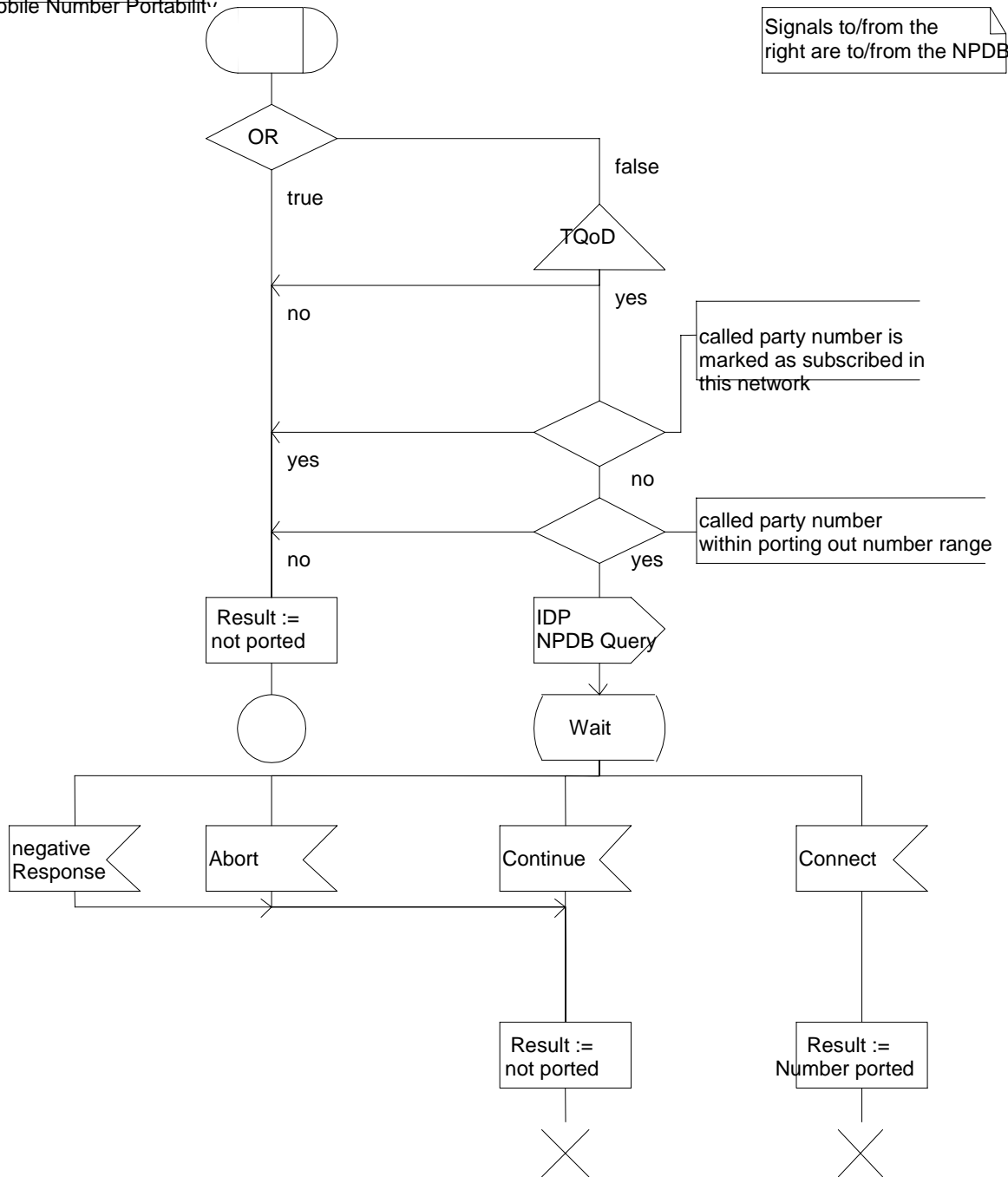

Figure A.14: Procedure MOBILE\_NUMBER\_PORTABILITY\_IN\_TQoD



## A.3.2 Functional requirement of MSC

### A.3.2.1 Procedure MOBILE\_NUMBER\_PORTABILITY\_IN\_OQoD

The procedure MOBILE\_NUMBER\_PORTABILITY\_IN\_OQoD is shown in figure A.15. It is called from the procedure Outgoing\_Call\_Setup\_MSC and from the process MT\_CF\_MSC defined in GSM 03.18 [4].

The text in this clause is a supplement to the definition in the SDL diagrams; it does not duplicate the information in the SDL diagrams.

The MSC may recognise own numbers as not being within the ported number range. For foreign numbers however, the MSC will not in general know whether the number is portable. The test “called party number is a portable national MSISDN” takes the “yes” exit if the number is a foreign national MSISDN or an own portable MSISDN.

The IDP message contains the service key for MNP query and the called party’s MSISDN.

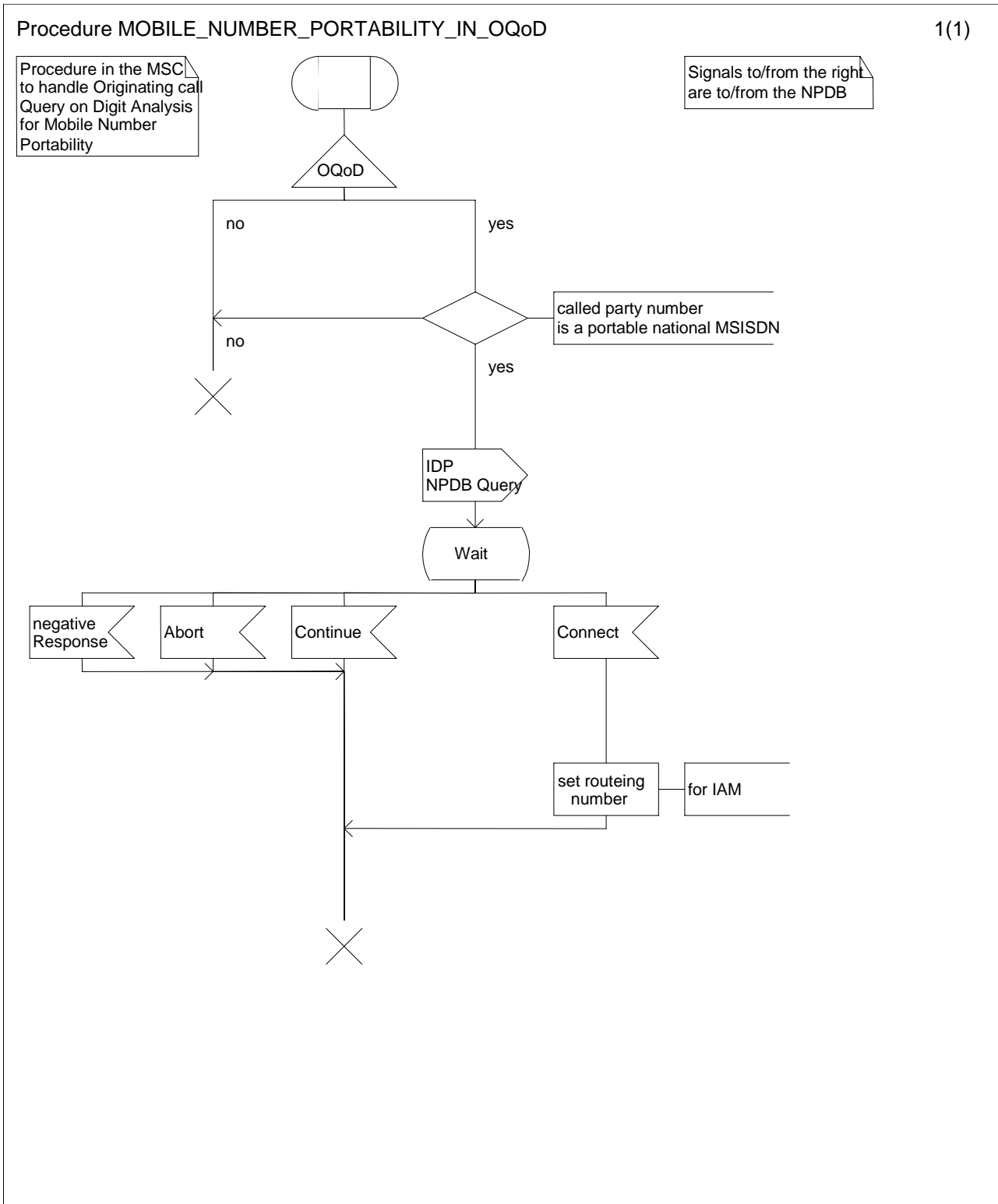

Figure A.15: Procedure MOBILE\_NUMBER\_PORTABILITY\_IN\_OQoD

## A.3.3 Functional requirement of NPDB

### A.3.3.1 Process IDP\_NPDB

The process IDP\_NPDB is shown in figure A.16.

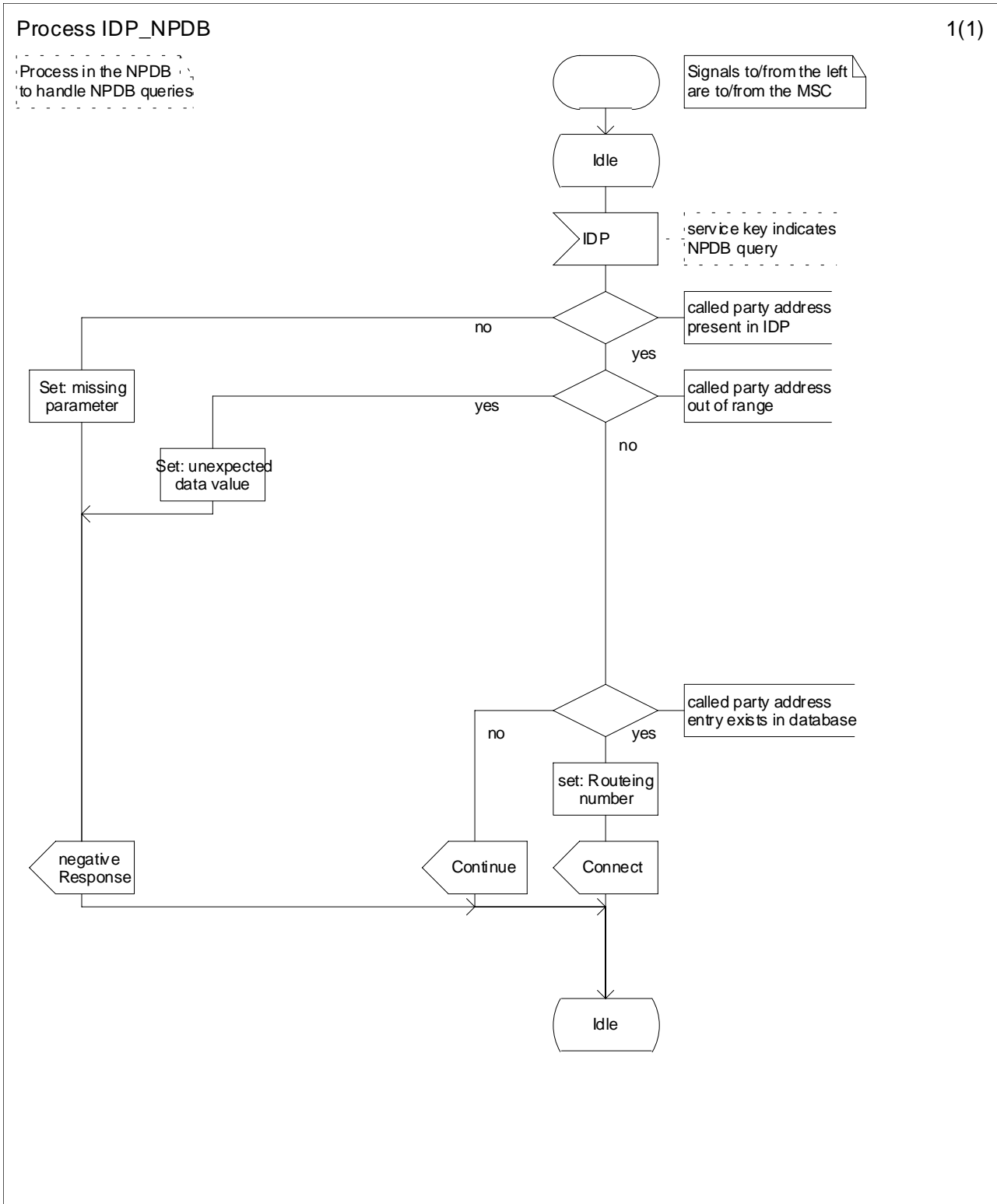

Figure A.16: Process IDP\_NPDB

## A.4 Contents of messages

This clause specifies the content of the following messages:

On the ISUP interface:

IAM;

On the MSC - NPDB interface:

INITIAL DP

CONTINUE

CONNECT;

In the tables which follow, information elements are shown as mandatory (M), conditional © or optional (O). A mandatory information element shall always be present. A conditional information element shall be present if certain conditions are fulfilled; if those conditions are not fulfilled it shall be absent. An optional element may be present or absent, at the discretion of the application at the sending entity.

### A.4.1 Messages on the ISUP interface

#### A.4.1.1 IAM

This message is specified in [7]. It is necessary for the IAM to contain the information needed to route the call to the subscription network of the ported subscriber. The ways in which this may be coded are shown in [7].

### A.4.2 Messages on the MSC - NPDB interface

#### A.4.2.1 INITIAL DP

This message is specified in [6]. The following information elements are required:

Information element name	Required	Description
Service Key	M	Identifies the requested IN service (MNP query).
Called Party Number	M	The possibly ported MSISDN

#### A.4.2.2 INITIAL DP negative response

This message is specified in [6]. The negative response information element can take the following values:

1. missing parameter;
2. unexpected data value.

#### A.4.2.3 CONNECT

This message is specified in [6]. It shall be ensured that the information in the Connect message shall be aligned with the coding supported in the ISUP signalling.

#### A.4.2.4 CONTINUE

This message does not contain any information element.

## Annex B (normative): Handling of Non-Call Related Signalling

### B.1 Handling of Non-call Related Signalling

#### B.1.1 Routing Conventions

Figure B.1.1 illustrates the routing of non-call related signalling messages between networks in a number portability environment.

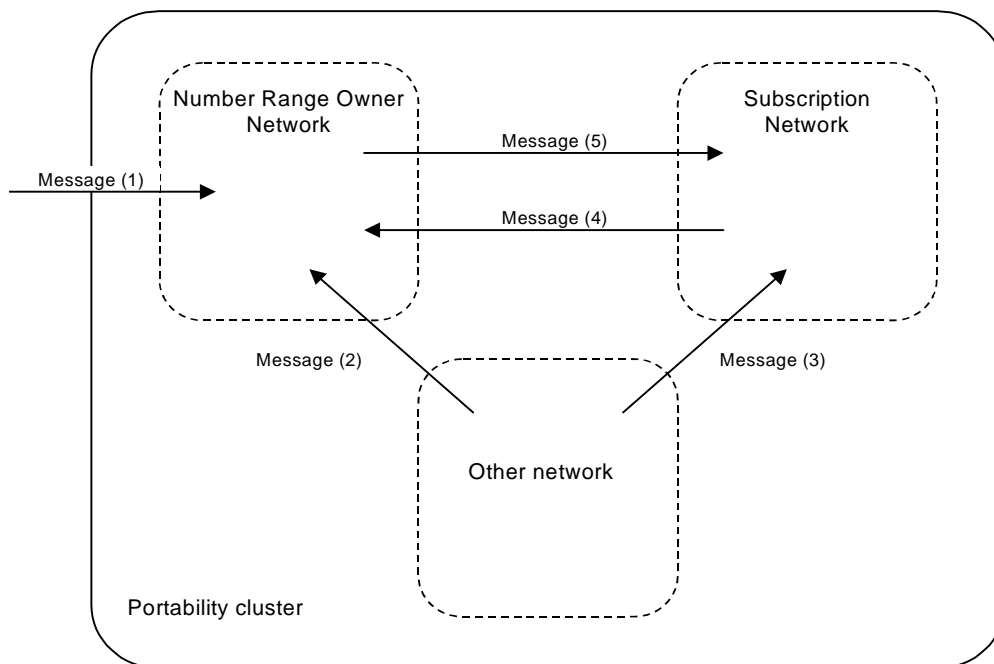

**Figure B.1.1: Routing of non-call related signalling messages in a number portability environment**

If a non-call related signalling message is originated outside the portability cluster, this message (1) is received by the number range owner network. The number range owner network routes the message (5) onward to the subscription network.

If a non-call related signalling message is originated in a network inside the portability cluster and this network supports direct routing, this message (3) is routed to the subscription network.

If a non-call related signalling message is originated in a network inside the portability cluster and this network does not support direct routing, the message (2, 4) is routed to the number range owner network. The number range owner network routes the message (5) onward to the subscription network. This is referred to as indirect routing.

#### B.1.2 Network Architecture

In a PLMN which supports MNP, non-call related signalling messages as mentioned in section B.1.1 are relayed by an MNP-Signalling Relay Function (MNP-SRF). The MNP-SRF provides re-routing capability for signalling messages addressed using the MSISDN. The MNP-SRF obtains routing information from the NP database to identify the subscription network associated with a particular national MSISDN. The interface between the MNP-SRF and the NP database is considered implementation dependent and is not detailed further. For further details see clause 4.3. For further details of the signalling relay function, the reader is referred to [9].

From the perspective of the PLMN in which the MNP-SRF resides, the MSISDN in the CdPA represents either:

- 1 An own number ported out;
- 2 An own number not ported out;
- 3 A foreign number ported in;
- 4 A foreign number ported to a foreign network;
- 5 A foreign number not known to be ported.

When a PLMN supports direct routing (clause B.1.1), all non-call related signalling messages where the MSISDN in the CdPA belongs to a number range owned by a PLMN in the portability cluster and all non-call related signalling messages which are relayed towards the network, are routed to the PLMN's MNP-SRF for treatment.

In case 2 and 3 the MNP-SRF relays the message to the HLR.

In case 1, 4 and 5 the MNP-SRF relays the message to subscription network.

When a PLMN does not support direct routing, only non-call related signalling messages where the MSISDN in the CdPA belongs to a number range owned by the PLMN itself and all non-call related signalling messages which are relayed towards the network are routed to the PLMN's MNP-SRF for treatment. All other messages are routed to the number range owner network.

For this routing convention, only cases 1, 2 and 3 are applicable:

In case 2 and 3 the MNP-SRF relays the message to the HLR.

In case 1 the MNP-SRF relays the message to the subscription network.

## B.2 Signalling Scenarios

### B.2.1 Non-call Related Signalling Message for a Non-ported Number – Indirect Routeing

Figure B.2.1 shows the MNP-SRF operation for routing a non-call related signalling message for a non-ported number where the interrogating network is inside the portability cluster and indirect routeing is used or the interrogating network is outside the portability cluster.

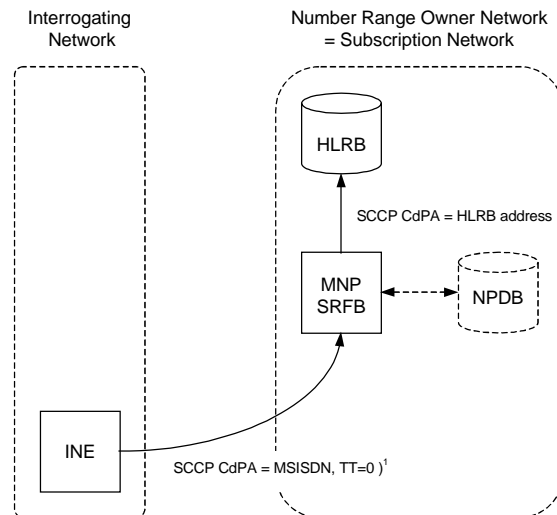

**Figure B.2.1: MNP-SRF operation for routing a non-call related signalling message for a non-ported number where the interrogating network is inside the portability cluster and indirect routeing is used or the interrogating network is outside the portability cluster.**

<sup>1</sup> Note that the TT may have a different value, e.g. TT=17 in the case of CCBS Requests.

The Interrogating Network Entity (INE) submits a non-call related signalling message. When MNP-SRFB receives the message, MNP-SRF operation is triggered. The MNP-SRF functionality analyses the MSISDN in the CdPA and identifies the MSISDN as being non-ported using information which may be retrieved from an NP database. The MNP-SRF function then reroutes the message to HLRB.



## B.2.2 Non-call Related Signalling Message for a Ported or Non-ported Number – Direct Routing

Figure B.2.2 shows the MNP-SRF operation for routing a non-call related signalling message for a ported or non-ported number where the interrogating network supports direct routing. If the interrogating network is the subscription network, MNP-SRFA and MNP-SRFB coincide, i.e. the signalling message passes the MNP-SRF only once.

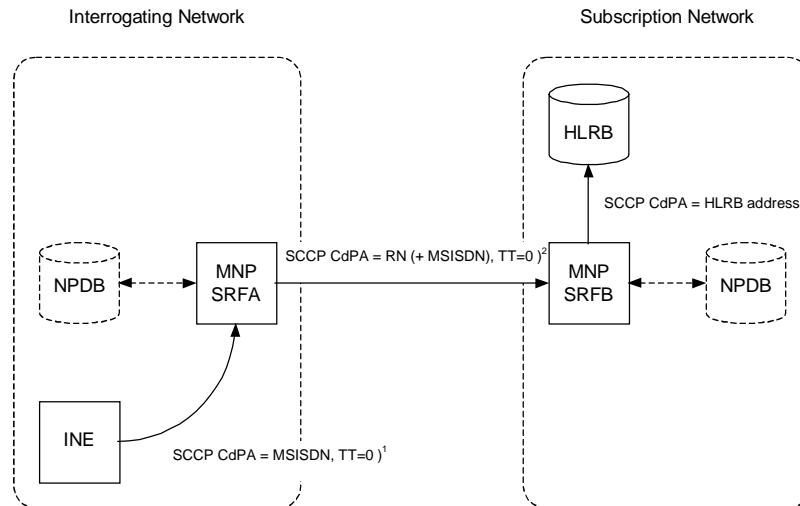

**Figure B.2.2: MNP-SRF operation for routing a non-call related signalling message for a ported or non-ported number where the interrogating network supports direct routing.**

- <sup>1</sup> Note that the TT may have a different value, e.g. TT=17 in the case of CCBS Requests.
- <sup>2</sup> The CdPA may have different values in the GT address and the nature of address fields.

The Interrogating Network Entity (INE) submits a non-call related signalling message. When MNP-SRFA receives the message, MNP-SRF operation is triggered. The MNP-SRF functionality analyses the MSISDN in the CdPA and identifies the subscription network using information which may be retrieved from an NP database. The MNP-SRF function then modifies the CdPA according to the rules agreed for the portability cluster and routes the message to MNP-SRFB in the subscription network.

When MNP-SRFB receives the message, MNP-SRF operation is triggered. The MNP-SRF functionality analyses the MSISDN in the CdPA and identifies the MSISDN as being ported into the network using information which may be retrieved from an NP database. The MNP-SRF function then re-routes the message to HLRB.

## B.2.3 Non-call Related Signalling Message for a Ported Number – Indirect Routeing

Figure B.2.3 shows the MNP-SRF operation for indirectly routeing (i.e. via the number range owner network) a non-call related signalling message for a ported subscriber.

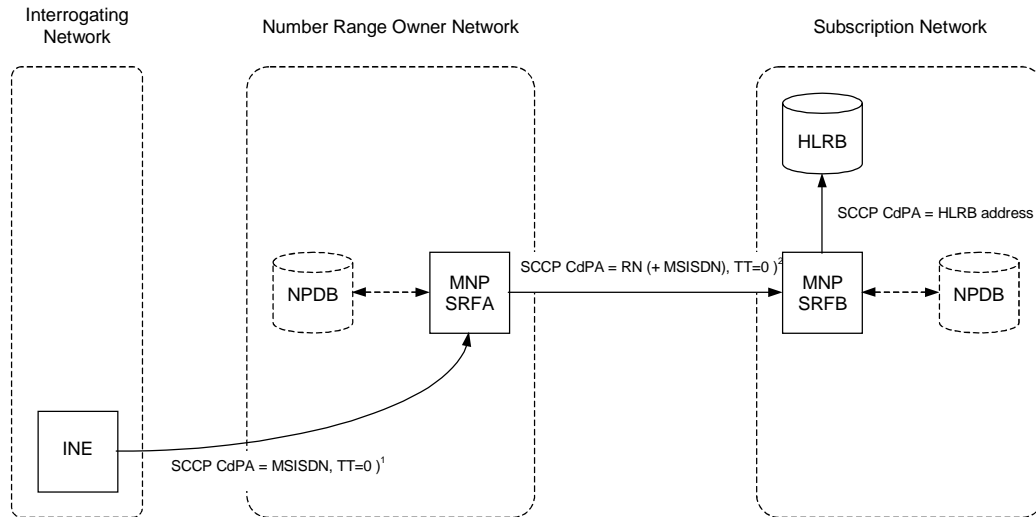

**Figure B.2.3: MNP-SRF operation for indirectly routeing (i.e. via the number range owner network) a non-call related signalling message for a ported subscriber.**

- 1 Note that the TT may have a different value, e.g. TT=17 in the case of CCBS Requests.
- 2 The CdPA may have different values in the GT address and the nature of address fields.

The Interrogating Network Entity (INE) submits a non-call related signalling message. This message is routed on MSISDN global title to MNP-SRFA in the number range owner network.

When MNP-SRFA receives the message, MNP-SRF operation is triggered. The MNP-SRF functionality analyses the MSISDN in the CdPA and identifies the subscription network using information which may be retrieved from an NP database. The MNP-SRF function then modifies the CdPA according to the rules agreed for the portability cluster and routes the message to MNP-SRFB in the subscription network.

When MNP-SRFB receives the message, MNP-SRF operation is triggered. The MNP-SRF functionality analyses the MSISDN in the CdPA and identifies the MSISDN as being ported into the network using information which may be retrieved from an NP database. The MNP-SRF function then reroutes the message to HLRB.

---

## B.3 Functional Requirements of Network Entities

### B.3.1 Procedure MNP\_SRF\_Non\_Call\_Related

Figure B.3.1 shows the procedure MNP\_SRF\_Non\_Call\_Related. This procedure handles non-call related signalling messages. It is called from the process MNP\_SRF (see chapter 4.3).

The check “CdPA contains own number ported out?” identifies all mobile numbers from number ranges allocated to the network the MNP-SRF is located in and which are ported to other networks. In this case the message is relayed to the subscription network.

The check “CdPA contains own number not ported out?” identifies all mobile numbers from the number ranges allocated to the network the MNP-SRF is located in and which are still served by the network the MNP-SRF is located in, i.e. the numbers are not ported out. In this case the message is relayed to the HLR in the network.

The check “CdPA contains foreign number ported in?” identifies all mobile numbers from the number ranges not allocated to the network the MNP-SRF is located in and which are served by the network the MNP-SRF is located in, i.e. the numbers are ported in. In this case the message is relayed to the HLR in the network.

The check “CdPA contains foreign number ported to a foreign network?” identifies all mobile numbers from the number ranges not allocated to the network the MNP-SRF is located in and which are not served by the MNP-SRF is located in and not served by the network the number range is allocated to, i.e. the numbers are ported to a foreign network. In this case the message is relayed to the subscription network.

The remaining numbers “CdPA contains number not known to be ported ?” are mobile numbers from the number ranges not allocated to the network the MNP-SRF is located in and which are also not served by the network the MNP-SRF is located in. In this case the message is relayed to the number range owner network.

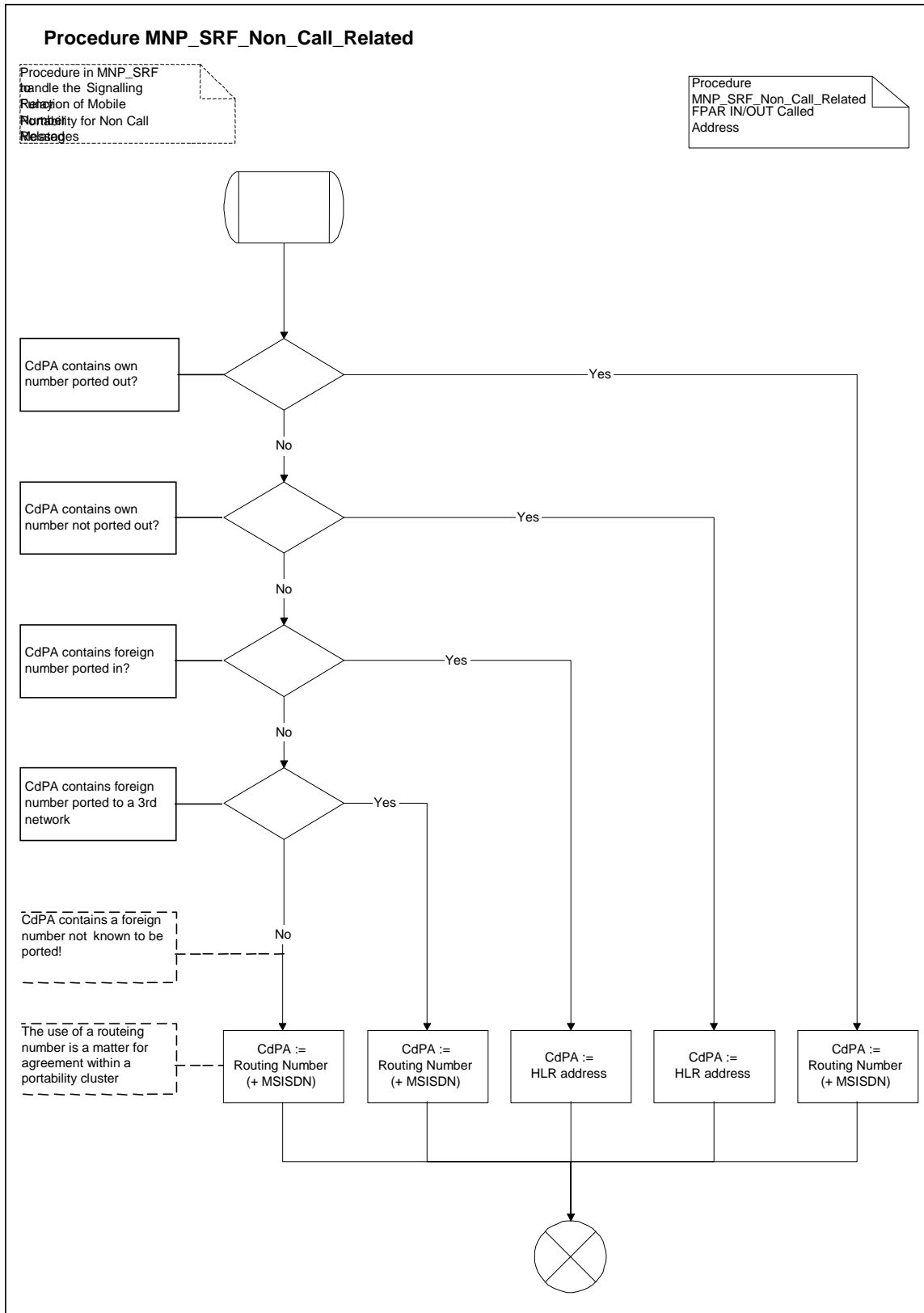

Figure B.3.1: Procedure MNP\_SRF\_Non\_Call\_Related

## B.4 Signalling Scenarios (informative)

This chapter (informative) contains examples of signalling scenarios.

### B.4.1 Delivery of SMS to a Non-ported Number – Direct Routeing – MNP-SRF acts as SCCP Relay

Figure B.4.1 shows the MNP-SRF operation for delivering an SMS message to a non-ported number.

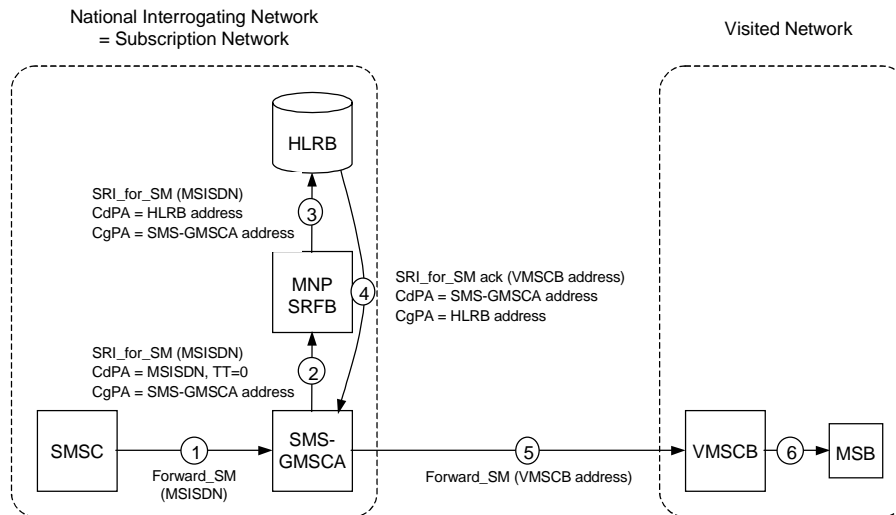
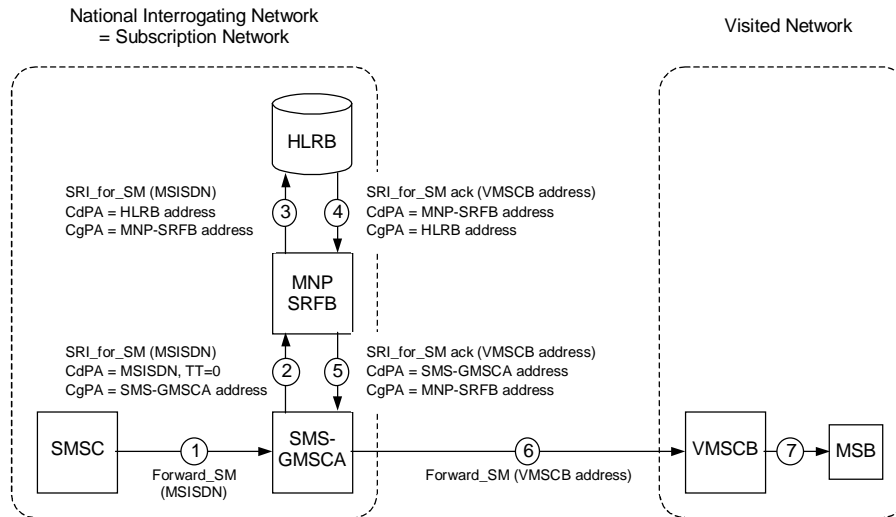

**Figure B.4.1: SRF operation for delivering an SMS message to a non-ported number where the SRI\_for\_SM message is submitted by a national interrogating network**

1. The SMSC forwards a SM to the SMS-GMSCA via a proprietary interface;
2. The SMS-GMSCA generates a routing enquiry for SM delivery. The MAP SRI\_for\_SM message is routed to the network's MNP-SRF;
3. When MNP-SRFB receives the message, MNP-SRF operation is triggered. The MNP-SRF functionality analyses the MSISDN in the CdPA and identifies the MSISDN as being non-ported using information which may be retrieved from an NP database. The MNP-SRF function then populates the CdPA with an HLRB address. After modifying the CdPA, the message is routed to HLRB;
4. HLRB responds to the routing enquiry by sending back an SRI\_for\_SM ack with the address of the VMSCB;
5. The SMS-GMSCA can now deliver the message to the VMSCB using a Forward\_SMS message.
6. VMSCB further delivers the message to MSB.

## B.4.2 Delivery of SMS to a Non-ported Number - Direct Routing – MNP-SRF acts as Higher-level Relay

Figure B.4.2 shows the MNP-SRF operation for delivering an SMS message to a non-ported number where the SRI\_for\_SM message is submitted by a national interrogating network.



**Figure B.4.2: SRF operation for delivering an SMS message to a non-ported number where the SRI\_for\_SM message is submitted by a national interrogating network**

1. The SMSC forwards a SM to the SMS-GMSCA via a proprietary interface;
2. The SMS-GMSCA generates a routing enquiry for SM delivery. The MAP SRI\_for\_SM message is routed to the network's MNP-SRF;
3. When MNP-SRFB receives the message it terminates the TCAP dialogue and an MNP-SRF operation is triggered. The MNP-SRF functionality analyses the MSISDN in the TCAP portion of the message and identifies the MSISDN as being non-ported using information which may be retrieved from an NP database. The MNP-SRF function then initiates a new dialogue and routes the message to HLRB;
4. HLRB responds to the routing enquiry by sending back an SRI\_for\_SM ack with the address of the VMSCB;
5. MNP-SRFB responds to the routing enquiry by sending back an SRI\_for\_SM ack with the address of the VMSC to the SMS-GMSCA
6. The SMS-GMSCA can now deliver the message to the VMSCB using a Forward\_SMS message.
7. VMSCB further delivers the message to MSB.

### B.4.3 Delivery of SMS to a Ported Number – Indirect Routing

Figure B.4.3 shows the MNP-SRF operation for delivering an SMS message to a ported number where the interrogating network does not support direct routing.

The message flows for this scenario are based on the use of an SCCP-relay function in the MNP-SRF(s). If the MNP-SRF(s) use(s) a higher-level relay function (e.g. TC-relay), then the response message will go via the MNP-SRF as shown in B.4.2. For further details of the signalling relay functions, the reader is referred to [8].

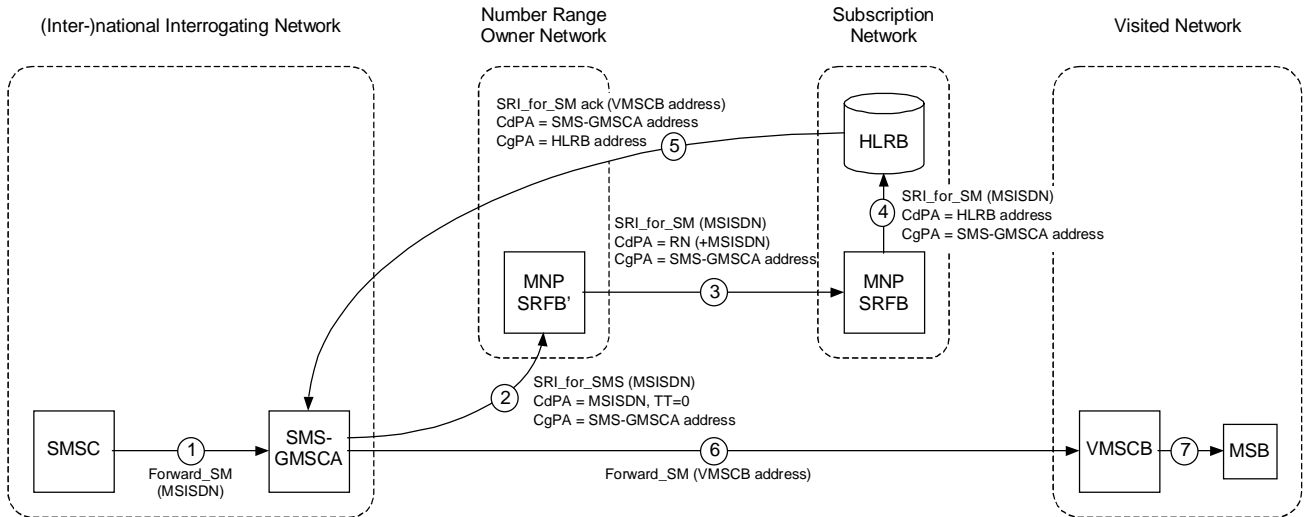

**Figure B.4.3: SRF operation for delivering an SMS message to a ported number where the interrogating network does not support direct routing**

1. The SMSC forwards a SM to the SMS-GMSCA via a proprietary interface;
2. The SMS-GMSCA generates a routing enquiry for SM delivery. The MAP SRI\_for\_SM message is routed to the number range owner network's MNP-SRFB';
3. When MNP-SRFB' receives the message, MNP-SRF operation is triggered. The MNP-SRF functionality analyses the MSISDN in the CdPA and identifies the MSISDN as being ported using information which may be retrieved from an NP database. As the message is non-call related, the MNP-SRF function then populates the CdPA with either a routing number or a concatenation of a routing number and MSISDN. After modifying the CdPA, the message is routed to MNP-SRFB in the subscription network;
4. When MNP-SRFB receives the message, MNP-SRF operation is triggered. The MNP-SRF functionality analyses the MSISDN in the CdPA and identifies the MSISDN as being ported into the network using information which may be retrieved from an NP database. The MNP-SRF function then populates the CdPA with an HLRB address. After modifying the CdPA, the message is routed to HLRB;
5. HLRB responds to the routing enquiry by sending back an SRI\_for\_SM ack with the address of the VMSC;
6. The SMS-GMSCA can now deliver the message to the VMSCB using a Forward\_SMS message.
7. VMSCB further delivers the message to MSB.

## B.4.4 Delivery of SMS to a Ported Number – Direct Routing

Figure B.4.4 shows the MNP-SRF operation for delivering an SMS message to a ported number where the interrogating network supports direct routing.

The message flows for this scenario are based on the use of an SCCP-relay function in the MNP-SRFs. If the MNP-SRFs use a higher-level relay function (e.g. TC-relay), then the response message will go via the MNP-SRF as shown in B.4.2. For further details of the signalling relay functions, the reader is referred to [8].

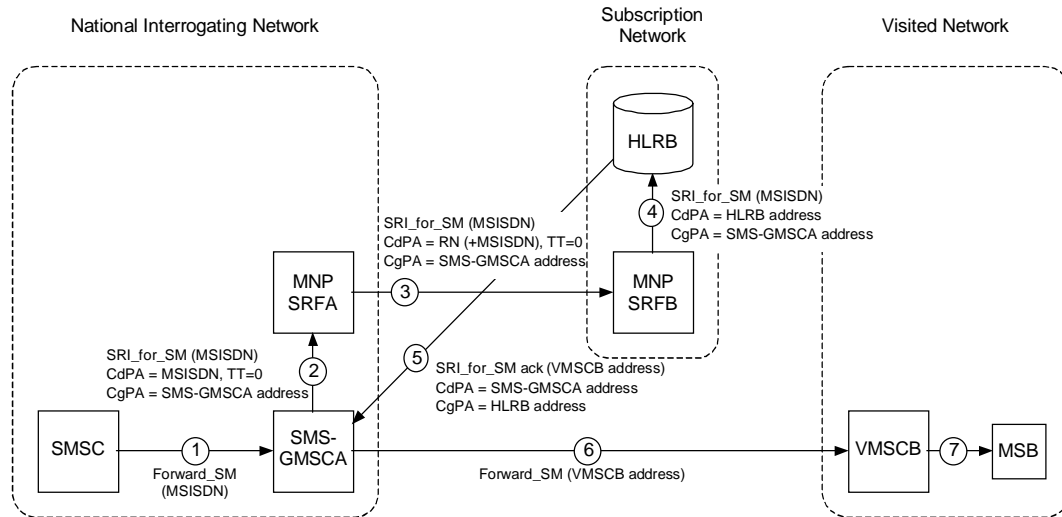

**Figure B.4.4: SRF operation for delivering an SMS message to a ported number where the interrogating network supports direct routing**

1. The SMSC forwards a SM to the SMS-GMSC via a proprietary interface;
2. The SMS-GMSC generates a routing enquiry for SM delivery. The MAP *SRI\_for\_SM* message is routed to the network's MNP-SRF;
3. When MNP-SRFA receives the message, MNP-SRF operation is triggered. The MNP-SRF functionality analyses the MSISDN in the CdPA and identifies the MSISDN as being ported using information which may be retrieved from an NP database. As the message is non-call related, the MNP-SRF function then populates the CdPA with either a routing number or a concatenation of a routing number and MSISDN. After modifying the CdPA, the message is routed to MNP-SRFB in the subscription network;
4. When MNP-SRFB receives the message, MNP-SRF operation is triggered. The MNP-SRF functionality analyses the MSISDN in the CdPA and identifies the MSISDN as being ported into the network using information which may be retrieved from an NP database. The MNP-SRF function then populates the CdPA with an HLRB address. After modifying the CdPA, the message is routed to HLRB;
5. HLRB responds to the routing enquiry by sending back an *SRI\_for\_SM ack* with the address of the VMSC;
6. The SMS-GMSC can now deliver the message to the VMSCB using a *Forward\_SMS* message.
7. VMSCB further delivers the message to MSB.



## B.4.5 International SOR for a Non-ported Number

Figure B.4.5 shows the MNP-SRF operation for optimally routing an international call to a non-ported number.

The message flows for this scenario are based on the use of an SCCP-relay function in the MNP-SRF. If the MNP-SRF uses a higher-level relay function (e.g. TC-relay), then the response message will go via the MNP-SRF as shown in B.4.2. For further details of the signalling relay functions, the reader is referred to [8].

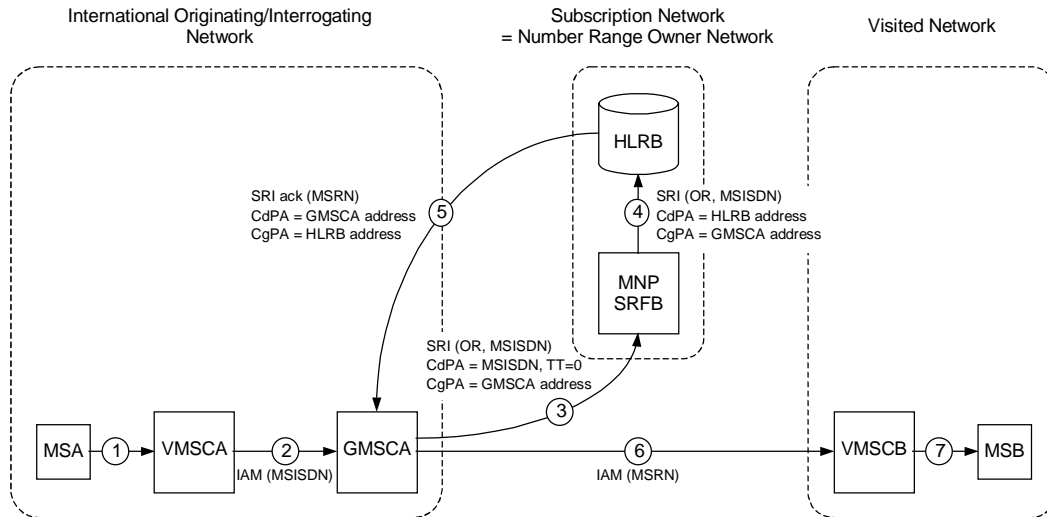

**Figure B.4.5: SRF operation for optimally routing an international call to a non-ported number**

1. MSA originates a call to MSISDN;
2. VMSCA routes the call to the originating network's GMSCA;
3. When GMSCA receives the ISUP IAM, it requests routing information by submitting a MAP SRI with SOR parameter set to the number range owner network of the dialled MSISDN. Within the number range owner network, the message is routed to the network's MNP-SRF;
4. When MNP-SRFB receives the message, MNP-SRF operation is triggered. The MNP-SRF functionality analyses the MSISDN in the CdPA and identifies the MSISDN as being non-ported using information which may be retrieved from an NP database. The MNP-SRF function then populates the CdPA with an HLRB address. After modifying the CdPA, the message is routed to HLRB;
5. When HLRB receives the SRI, it responds to the GMSCA by sending back an SRI ack with a MSRN;
6. GMSCA uses the MSRN to route the call to VMSCB;
7. VMSCB further establishes a traffic channel to MSB.

## B.4.6 SOR for a Ported Number – Indirect Routing

Figure B.4.6 shows the MNP-SRF operation for optimally routing a call (using SOR) to a ported number where the interrogating network does not support direct routing.

The message flows for this scenario are based on the use of an SCCP-relay function in the MNP-SRFs. If the MNP-SRFs use a higher-level relay function (e.g. TC-relay), then the response message will go via the MNP-SRF as shown in B.4.2. For further details of the signalling relay functions, the reader is referred to [8].

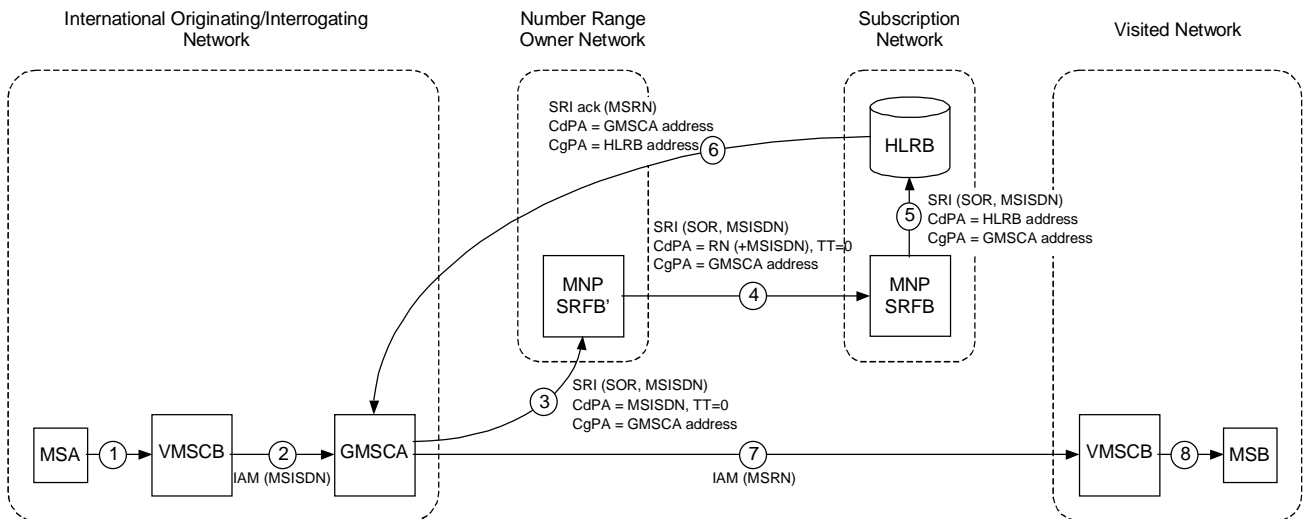

**Figure B.4.6: MNP-SRF operation for optimally routing a call (using SOR) to a ported number where the interrogating network does not support direct routing**

1. MSA originates a call to MSISDN;
2. VMSCA routes the call to the network's GMSCA;
3. When GMSCA receives the ISUP IAM, it requests routing information by submitting a MAP SRI with SOR parameter set to the number range owner network of the dialled MSISDN. Within the number range owner network, the message is routed to the network's MNP-SRF;
4. When MNP-SRFB' receives the message, MNP-SRF operation is triggered. The MNP-SRF functionality analyses the MSISDN in the CdPA and identifies the MSISDN as being ported using information which may be retrieved from an NP database. As the message is non-call related, the MNP-SRF function then populates the CdPA with either a routing number or a concatenation of a routing number and MSISDN. After modifying the CdPA, the message is routed to MNP-SRFB in the subscription network;
5. When MNP-SRFB receives the message, MNP-SRF operation is triggered. The MNP-SRF functionality analyses the MSISDN in the CdPA and identifies the MSISDN as being ported into the network using information which may be retrieved from an NP database. The MNP-SRF function then populates the CdPA with an HLRB address. After modifying the CdPA, the message is routed to HLRB;
6. When HLRB receives the SRI, it responds to the GMSCA by sending back an SRI ack with a MSRN;
7. GMSCA uses the MSRN to route the call to VMSCB;
8. VMSCB further establishes a traffic channel to MSB.

## B.4.7 Any Time Interrogation for a Ported Number – Indirect Routing

Figure B.4.7 shows the MNP-SRF operation for routing an Any\_Time\_Interrogation message for a ported number where the interrogating network does not support direct routing.

The message flows for this scenario are based on the use of an SCCP-relay function in the MNP-SRFs. If the MNP-SRFs use a higher-level relay function (e.g. TC-relay), then the response message will go via the MNP-SRF as shown in B.4.2. For further details of the signalling relay functions, the reader is referred to [8].

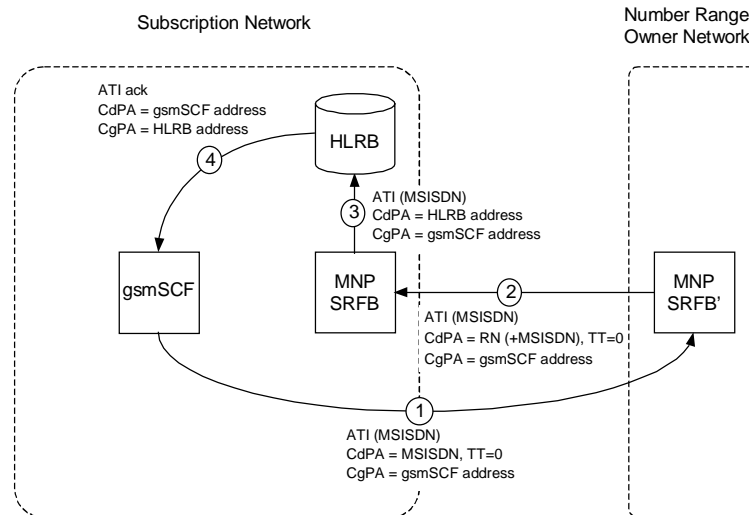

**Figure B.4.7: MNP-SRF operation for routing an Any\_Time\_Interrogation message for a ported number where the interrogating network does not support direct routing**

1. The gsmSCF generates an Any\_Time\_Interrogation (ATI) message. The message is routed to the number range owner network's MNP-SRF;
2. When MNP-SRFB' receives the message, MNP-SRF operation is triggered. The MNP-SRF functionality analyses the MSISDN in the CdPA and identifies the MSISDN as being ported using information which may be retrieved from an NP database. As the message is non-call related, the MNP-SRF function then populates the CdPA with either a routing number or a concatenation of a routing number and MSISDN. After modifying the CdPA, the message is routed to MNP-SRFB in the subscription network;
3. When MNP-SRFB receives the message, MNP-SRF operation is triggered. The MNP-SRF functionality analyses the MSISDN in the CdPA and identifies the MSISDN as being ported into the network using information which may be retrieved from an NP database. The MNP-SRF function then populates the CdPA with an HLRB address. After modifying the CdPA, the message is routed to HLRB;
4. HLRB responds to the ATI by sending back an ATI ack with the requested information;

## B.4.8 Any Time Interrogation for a Ported Number – Direct Routing

Figure B.4.8 shows the MNP-SRF operation for routing an Any\_Time\_Interrogation message for a ported number where the interrogating network supports direct routing.

The message flows for this scenario are based on the use of an SCCP-relay function in the MNP-SRF. If the MNP-SRF uses a higher-level relay function (e.g. TC-relay), then the response message will go via the MNP-SRF as shown in B.4.2. For further details of the signalling relay functions, the reader is referred to [8].

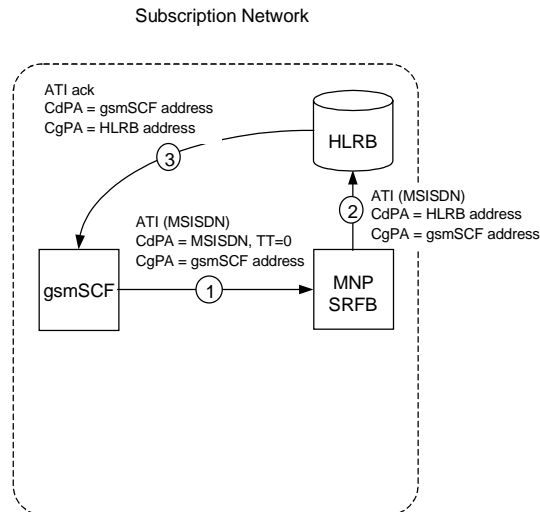

**Figure B.4.8: MNP-SRF operation for routing an Any\_Time\_Interrogation message for a ported number where the interrogating network supports direct routing**

1. The gsmSCF generates an Any\_Time\_Interrogation (ATI) message. The message is routed to the network's MNP-SRF;
2. When MNP-SRFB receives the message, MNP-SRF operation is triggered. The MNP-SRF functionality analyses the MSISDN in the CdPA and identifies the MSISDN as being ported into the network using information which may be retrieved from an NP database. The MNP-SRF function then populates the CdPA with an HLRB address. After modifying the CdPA, the message is routed to HLRB;
3. HLRB responds to the ATI by sending back an ATI ack with the requested information;

## B.4.9 CCBS where the Busy Subscriber is a Ported Subscriber – Direct Routeing

Figure B.4.9 shows the MNP-SRF operation for routing a CCBS Request for a ported number where the interrogating network supports direct routing.

The message flows for this scenario are based on the use of an SCCP-relay function in the MNP-SRFs. If the MNP-SRFs use a higher-level relay function (e.g. TC-relay), then the response message will go via the MNP-SRF as shown in B.4.2. For further details of the signalling relay functions, the reader is referred to [8].

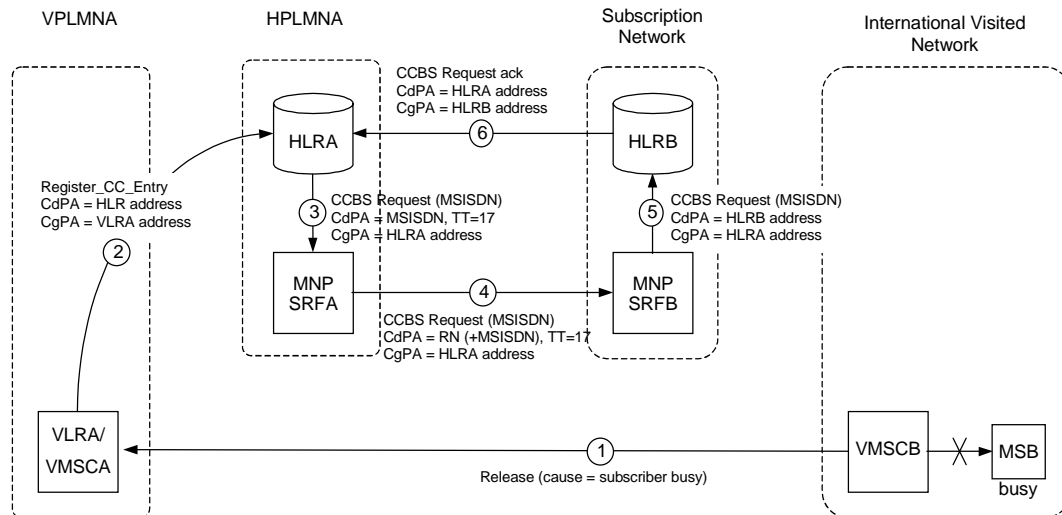

**Figure B.4.9: MNP-SRF operation for routing a CCBS Request for a ported number where the interrogating network supports direct routing**

1. The VMSCA receives a ISUP Release message with cause value 'subscriber busy' from VMSCB;
2. VLRA/VMSCA sends a Register\_CC\_Entry to HLRA using the HLRA address as CdPA on SCCP;
3. The HLRA sends a CCBS Request message to the networks MNP-SRFA;
4. When MNP-SRFA receives the message, MNP-SRF operation is triggered. The MNP-SRF functionality analyses the MSISDN in the CdPA and identifies the MSISDN as being ported using information which may be retrieved from an NP database. As the message is non-call related, the MNP-SRF function then populates the CdPA with either a routeing number or a concatenation of a routeing number and MSISDN. After modifying the CdPA, the message is routed to MNP-SRFB in the subscription network;
5. When MNP-SRFB receives the message, MNP-SRF operation is triggered. The MNP-SRF functionality analyses the MSISDN in the CdPA and identifies the MSISDN as being ported into the network using information which may be retrieved from an NP database. The MNP-SRF function then populates the CdPA with an HLRB address. After modifying the CdPA, the message is routed to HLRB;
6. HLRB can now respond to HLRA by sending back a CCBS ack message;

---

## Annex C (normative): MNP Signalling Relay Function - Call Related Signalling

### C.1 Handling of Call Related Signalling

The only call related MAP message affected by MNP is the MAP SEND\_ROUTEING\_INFORMATION (SRI) message without OR parameter set sent to the HLR.

In a PLMN supporting MNP with direct routeing using signalling relay, all incoming calls and calls originating in the network for which the called party number is within the ranges owned by any network in the portability cluster, the gateway MSCs will send an SRI such that it will be handled by the MNP-SRF in that network.

In a PLMN supporting MNP with indirect routeing using signalling relay, all incoming calls and calls originating in the network for which the called party number is within the range owned by the network, the gateway MSCs will send SRI such that it will be handled by the MNP-SRF in that network.

The MNP-SRF obtains routeing information from the NP database to identify the subscription network associated with a particular national MSISDN. The interface between the MNP-SRF and the NP database is considered implementation dependent and is not detailed further.

From the perspective of the PLMN in which the MNP-SRF resides, the CdPA represents one of:

1. An own number ported out;
2. An own number not ported out;
3. A foreign number ported in;
4. A foreign number ported to a foreign network;
5. A foreign number not known to be ported.

Cases 4 and 5 are applicable only for direct routeing.

In case 1, the MNP-SRF may perform one of the following depending on agreements within the number portability cluster.

- a. An SRI response is sent containing the necessary routeing information to route the call to the subscription network. This is performed by an internal MAP Application Termination Function (MATF) known as the Number Portability Location Register (NPLR).
- b. If indirect routeing of calls with reference to the subscription network is used, the message is relayed to the MNP-SRF in the subscription network, whose NPLR provides the necessary routeing information in an SRI response. The use of an NPLR in the subscription network can only be by agreement within the number portability cluster.

In cases 2 and 3, the MNP-SRF relays the message to the HLR. For further details of the signalling relay function, the reader is referred to [8].

In case 4, an SRI response is sent, containing the necessary routeing information to route the call to the subscription network.

In case 5, an SRI response is sent, containing the necessary routeing information to route the call to the number range owner network.

---

## C.2 Functional Requirements of Network Entities

### C.2.1 Procedure MNP\_SRF\_MATF\_Call\_Related

Figure C.2.1.1 shows the procedure MNP\_SRF\_MATF\_Call\_Related. This procedure handles call-related signalling messages. It is called from the process MNP\_SRF (see clause 4.3).

The check “message has been relayed” identifies all call related signalling messages which are relayed from the number range owner network towards the subscription network in the case of Indirect Routeing with reference to subscription network implementation. These messages only refer to numbers ported into the network.

The check “own number not ported out” identifies all mobile numbers from number ranges allocated to the network the MNP-SRF/MATF is located in and which are not ported to other networks. In this case the call related message is relayed to the HLR in the network

The check “foreign number ported in” identifies all mobile numbers from the number ranges not allocated to the network the MNP-SRF/MATF is located in and which are served by the network the MNP-SRF/MATF is located in. In this case the call related message is relayed to the HLR in the network.

The check “foreign number not known to be ported” identifies all mobile numbers from the number ranges not allocated to the network the MNP-SRF/MATF is located in and which are also not served by the network the MNP-SRF/MATF is located in. In this case the call is sent to the SRF\_MATF procedure for handling.

The check “foreign number ported to foreign network” identifies all mobile numbers from the number ranges not allocated to the network the MNP-SRF/MATF is located in and which are not served by the network the MNP-SRF is located in and not served by the network the number range is allocated to, i.e. the number is ported between two other networks. In this case the call related message is sent to the SRF\_MATF procedure for handling.

The remaining cases “own number ported out” are mobile numbers allocated to the network the MNP-SRF/MATF is located in and which are served by other networks, i.e. the number is ported out to another network. In this case the call is relayed to the MATF in the subscription network if this option is the one used by the operator, or sent to the SRF\_MATF procedure for handling if not.

### C.2.2 Process SRI\_NPLR

Figure C.2.2 shows the process SRI\_NPLR.

The check “unknown subscriber” identifies a subscriber without any associated available information.

If the GMSC is in the database own network then a routeing number is provided to route to the number range owner network.

If the GMSC is not in the database own network then the enquiry has been routed from the number range owner network, so the call should fail.

The database query uses the MSISDN received at the application level in the SRI, rather than the CdPA of the SCCP level.

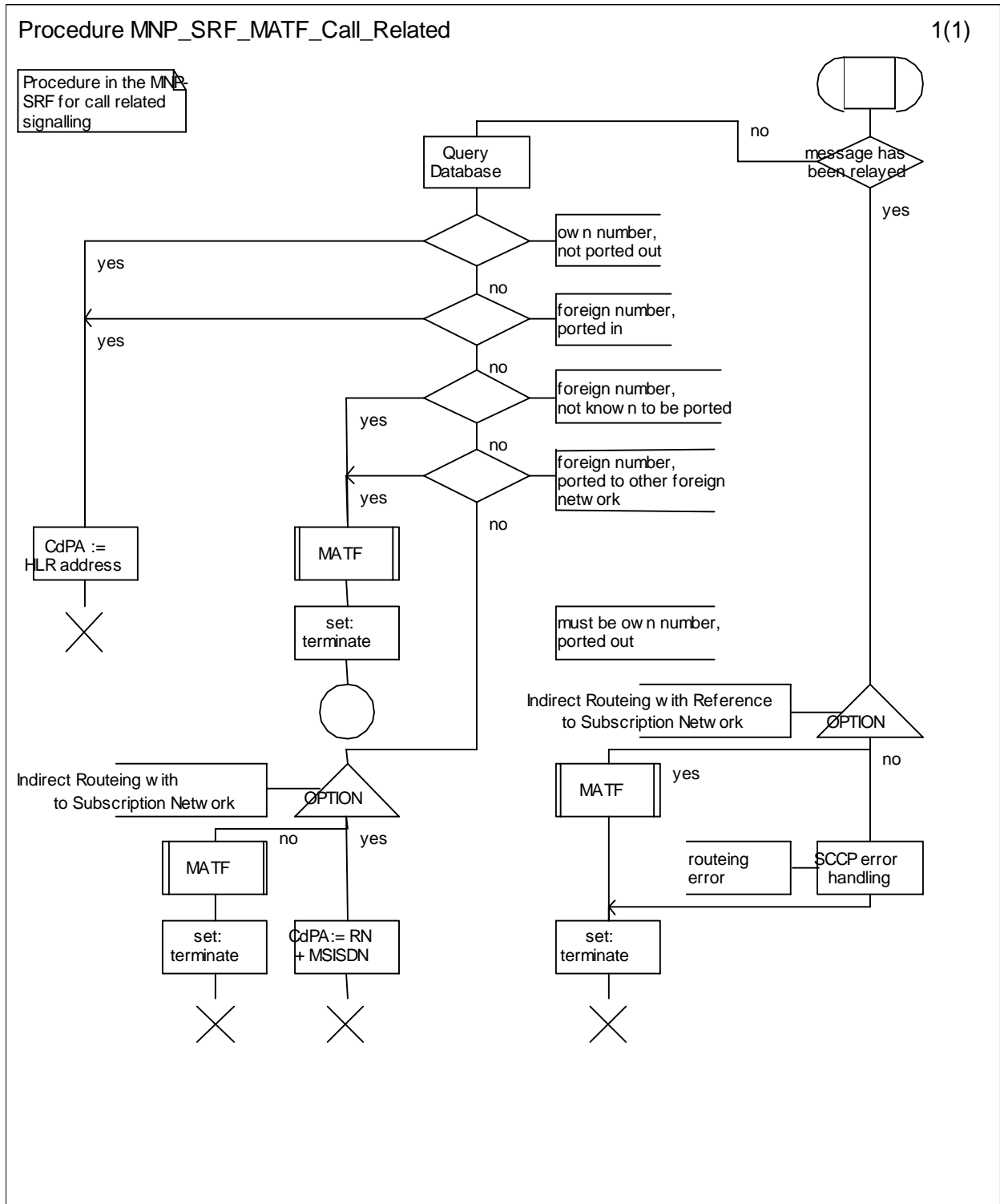

Figure C.2.1.1: Procedure MNP\_SRF\_MATF\_Call\_Related



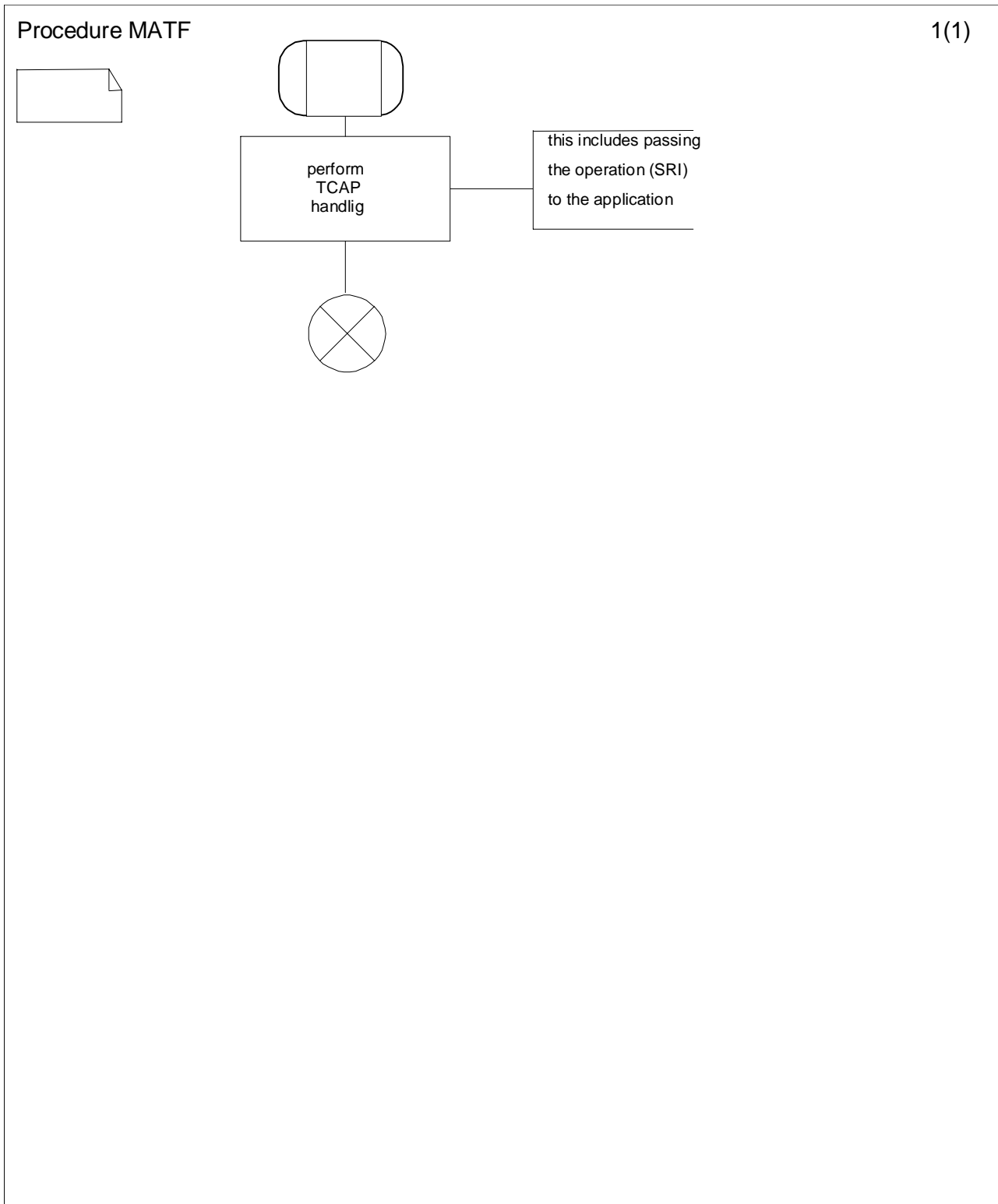

Figure C.2.1.2: Procedure MATF

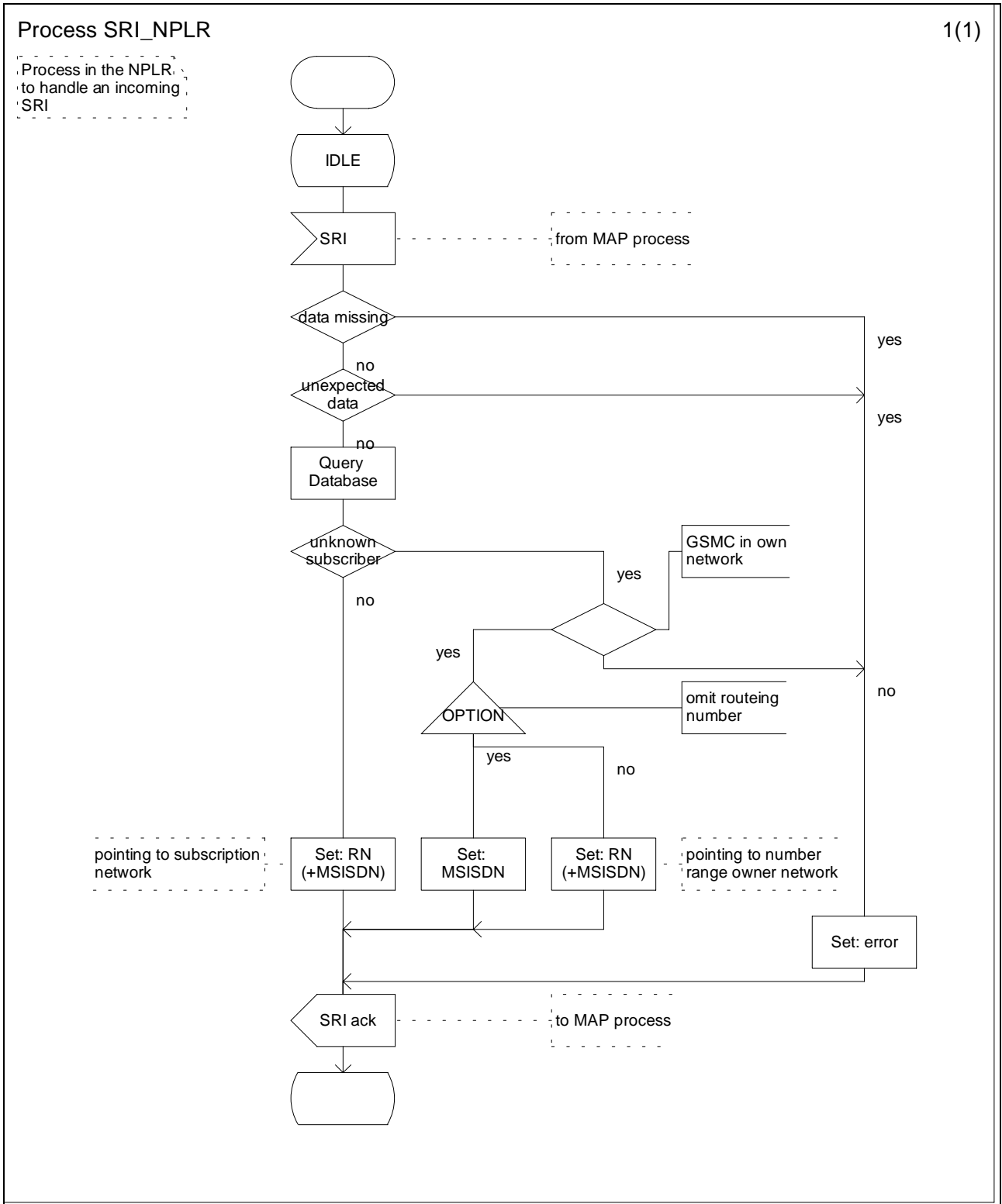

Figure C.2.2: Process SRI\_NPLR

## C.3 Call Scenarios

The notation TT=SRI in diagrams in this section assumes that SRI=CRMNP. The use of other translation types is for further study. The message flows for the following scenarios are based on the use of an SCCP relay function in MNP-SRF(s). The message flows for the higher level relay function (e.g. TC relay) in MNP-SRF are not covered here, but the principle can be found in C.5.2. For further details of the signalling relay function, the reader is referred to [8].

### C.3.1 Call to a Non-Ported Number or Number Ported into the Network

Figure C.3.1 shows the signalling involved for a call to a non-ported number or number ported into the network (see GSM 03.18 [4]).

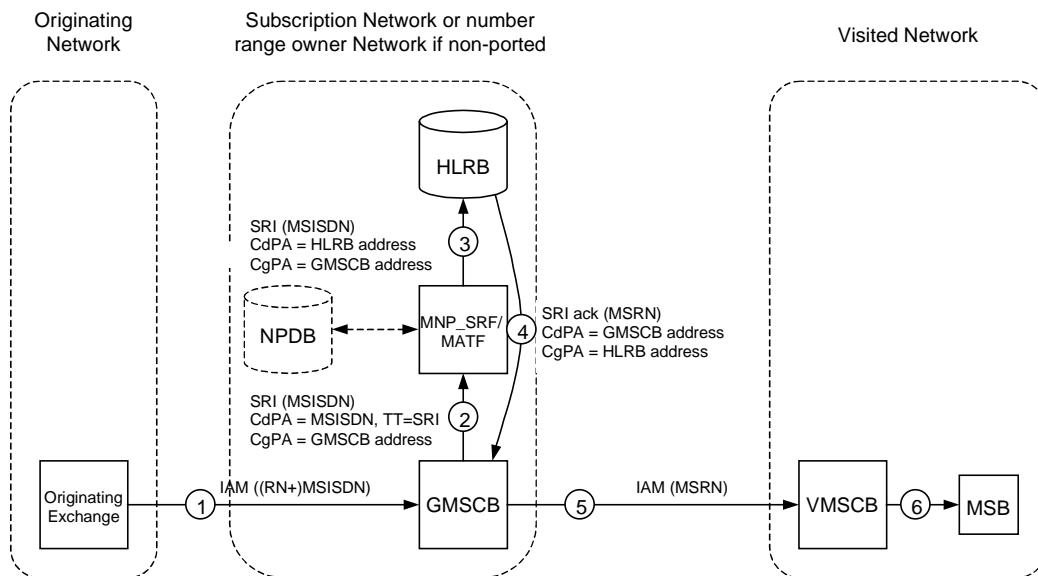
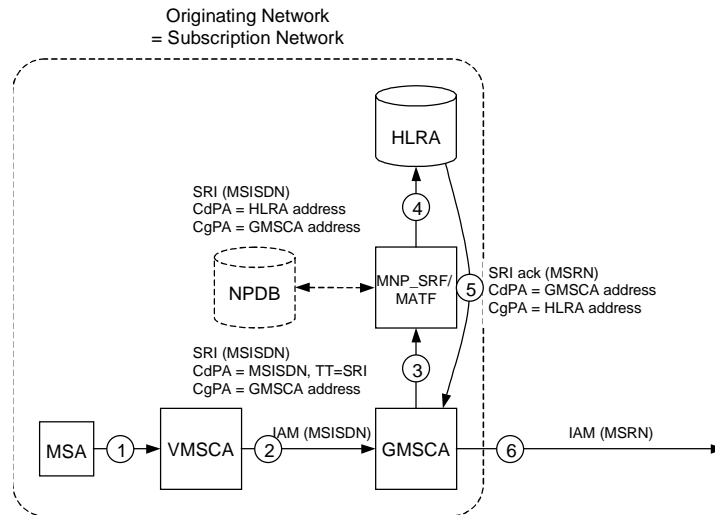

**Figure C.3.1: Call to a non-ported number**

1. From an Originating Exchange a call is set up to MSISDN. The call is routed to the subscription network being the number range owner network, if the number is non-ported.
2. When GMSCB receives the ISUP IAM, it requests routing information by submitting a MAP SRI to the MNP\_SRF/MATF. The TT on SCCP may be set to 'SRI'.
3. When the MNP\_SRF/MATF receives the message, the MNP\_SRF/MATF analyses the MSISDN in the CdPA and identifies the MSISDN as being non-ported. The MNP\_SRF/MATF function then replaces the CdPA by an HLRB address. After modifying the CdPA, the message is routed to HLRB.
4. When HLRB receives the SRI, it responds to the GMSCB by sending an SRI ack with an MSRN that identifies the MSB in the VMSCB;
5. GMSCB uses the MSRN to route the call to VMSCB

### C.3.2 Call to a Ported Number – Originating Network = Subscription Network – Direct Routing

Figure C.3.2 shows the signalling involved for a call to a ported number via direct routing where the call is originated in the subscription network.

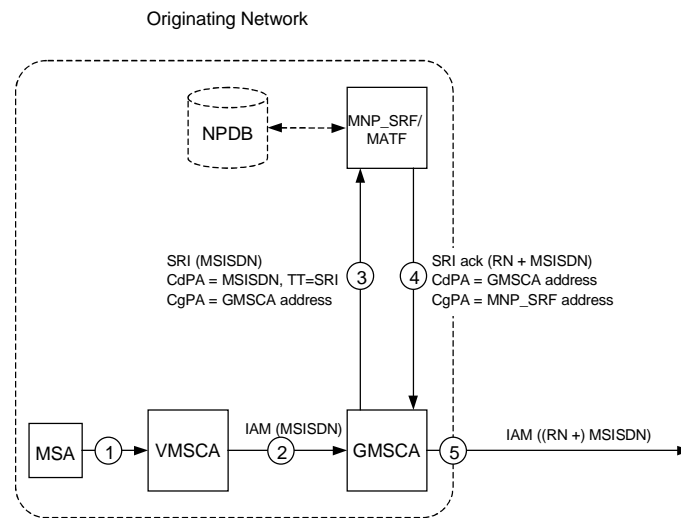

**Figure C.3.2: Call to a ported number via direct routing where the call is originated in the subscription network**

1. MSA originates a call to MSISDN;
2. VMSCA routes the call to the network's GMSCA;
3. When GMSCA receives the ISUP IAM, it requests routing information by submitting a MAP SRI to the MNP\_SRF/MATF. The TT on SCCP may be set to 'SRI';
4. When the MNP\_SRF/MATF receives the message, it analyses the MSISDN in the CdPA and identifies the MSISDN as being ported into the network. The MNP\_SRF/MATF function then replaces the CdPA by an HLRA address. After modifying the CdPA, the message is routed to HLRA.
5. When HLRA receives the SRI, it responds to the GMSCA by sending an SRI ack with an MSRN that identifies the MSB in the VMSCB;
6. GMSCA uses the MSRN to route the call to VMSCB.

### C.3.3 Mobile Originated Call to a Ported or not known to be Ported Number – Originating Network $\neq$ Subscription Network – Direct Routeing

Figure C.3.3 shows the signalling involved for a national mobile originated call to a number not Subscribed in the originating network via direct routeing. The scenario describes signalling in the originating network using direct routing in the cases when an own number is ported out, a foreign number is not known to be ported or a foreign number is ported to other foreign network.

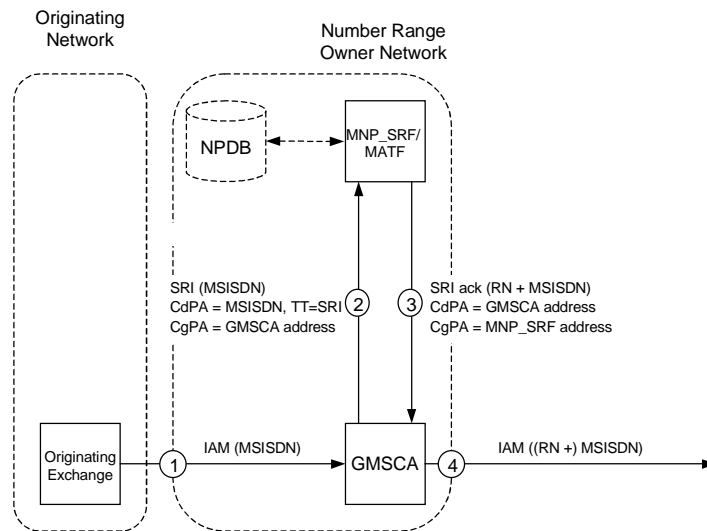

**Figure C.3.3: National mobile originated call to a ported number via direct routing**

1. MSA originates a call to MSISDN;
2. VMSCA routes the call to the network's GMSCA;
3. When GMSCA receives the ISUP IAM, it requests routing information by submitting a MAP SRI to the MNP\_SRF/MATF. The TT on SCCP may be set to 'SRI';
4. When the MNP\_SRF/MATF receives the message, it analyses the MSISDN in the CdPA and identifies the MSISDN as not known to be ported or being ported to another network. As the message is a SRI message, the MNP\_SRF/MATF responds to the GMSCA by sending an SRI ack with a RN + MSISDN; For the case the number is not known to be ported the routing number may be omitted.
5. GMSCA uses the (RN +) MSISDN to route the call to GMSCB in the subscription network. Depending on the interconnect agreement, the RN will be added in the IAM or not.

### C.3.4 Call to a Ported Number – Indirect Routeing

Figure C.3.4 shows the signalling involved for a call to a ported number via indirect routeing.

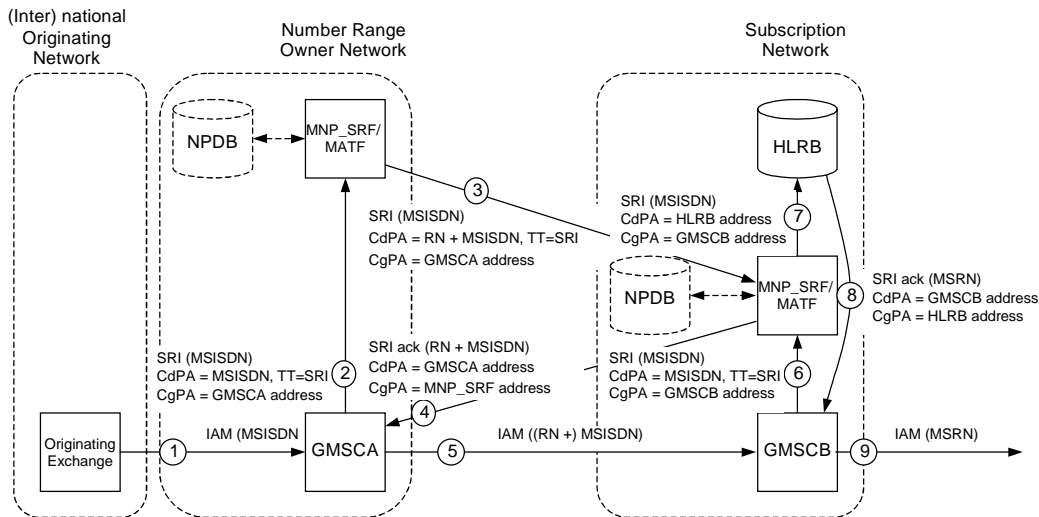

**Figure C.3.4: Call to a ported number via indirect routeing**

1. From an Originating Exchange a call is set up to MSISDN. The call is routed to the number range owner network;
2. When GMSCA in the number range owner network receives the ISUP IAM, it requests routing information by submitting a MAP SRI to MNP\_SRF/MATF. The TT on SCCP may be set to 'SRI';
3. When the MNP\_SRF/MATF receives the message, it analyses the MSISDN in the CdPA and identifies the MSISDN as being ported to another network. As the message is an SRI message, the MNP\_SRF/MATF responds to the GMSCA by sending an SRI ack with a RN + MSISDN;
4. GMSCA uses the RN + MSISDN to route the call to GMSCB in the subscription network. Depending on the interconnect agreement, the RN will be added in the IAM or not.

## C.3.5 Call to a Ported Number – Indirect Routing with Reference to Subscription Network

Figure C.3.5 shows the signalling involved for a call to a ported number where indirect routing with reference to the subscription network is used.



**Figure C.3.5: National or international originated call to a ported number where indirect routing with reference to the subscription network is used**

1. From an Originating Exchange a call is set up to MSISDN. The call is routed to the number range owner network;
2. When GMSCA in the number range owner network receives the ISUP IAM, it requests routing information by submitting a MAP SRI to the MNP\_SRF/MATF. The TT on SCCP may be set to 'SRI';
3. When MNP\_SRF/MATF receives the message, MNP\_SRF/MATF operation is triggered. The MNP\_SRF/MATF functionality analyses the MSISDN in the CdPA and identifies the MSISDN as being ported to another network. As the message is a SRI message, the MNP\_SRF/MATF function relays the message to the subscription network by adding a routing number to the CdPA which information may be retrieved from a database. After modifying the CdPA, the message is routed to the subscription network;
4. When MNP\_SRF/MATF in the subscription network receives the SRI, it responds to the GMSCA in the number range owner network by sending a SRI ack with a RN + MSISDN;
5. GMSCA uses the (RN +) MSISDN to route the call to GMSCB in the subscription network; Depending on the interconnect agreement, the RN will be added in the IAM or not.
6. When GMSCB in the subscription network receives the ISUP IAM, it requests routing information by submitting a MAP SRI to MNP\_SRF/MATF. The TT on SCCP may be set to 'SRI';
7. When MNP\_SRF/MATF receives the message, MNP\_SRF/MATF operation is triggered. The MNP\_SRF/MATF functionality analyses the MSISDN in the CdPA and identifies the MSISDN as being ported into the network. The MNP\_SRF/MATF function then replaces the CdPA by an HLRB address which information may be retrieved from a database. After modifying the CdPA, the message is routed to HLRB;
8. When HLRB receives the SRI, it responds to the GMSCB by sending an SRI ack with an MSRN that identifies the MSB in the VMSCB;
9. GMSCB uses the MSRN to route the call to VMSCB.

**NOTE:** The MNP\_SRF/MATF in this scenario has only information about all ported numbers to one subscription network, except those for which subscription information is held in the subscription networks HLR. In this scenario the routing depends always on the number range owner and the subscription network.

## C.4 Information Flows

Figure C.4.1 shows the information flow for a successful delivery of a call to a non-ported number or number ported into the network. The figure is related to figure C.3.1.

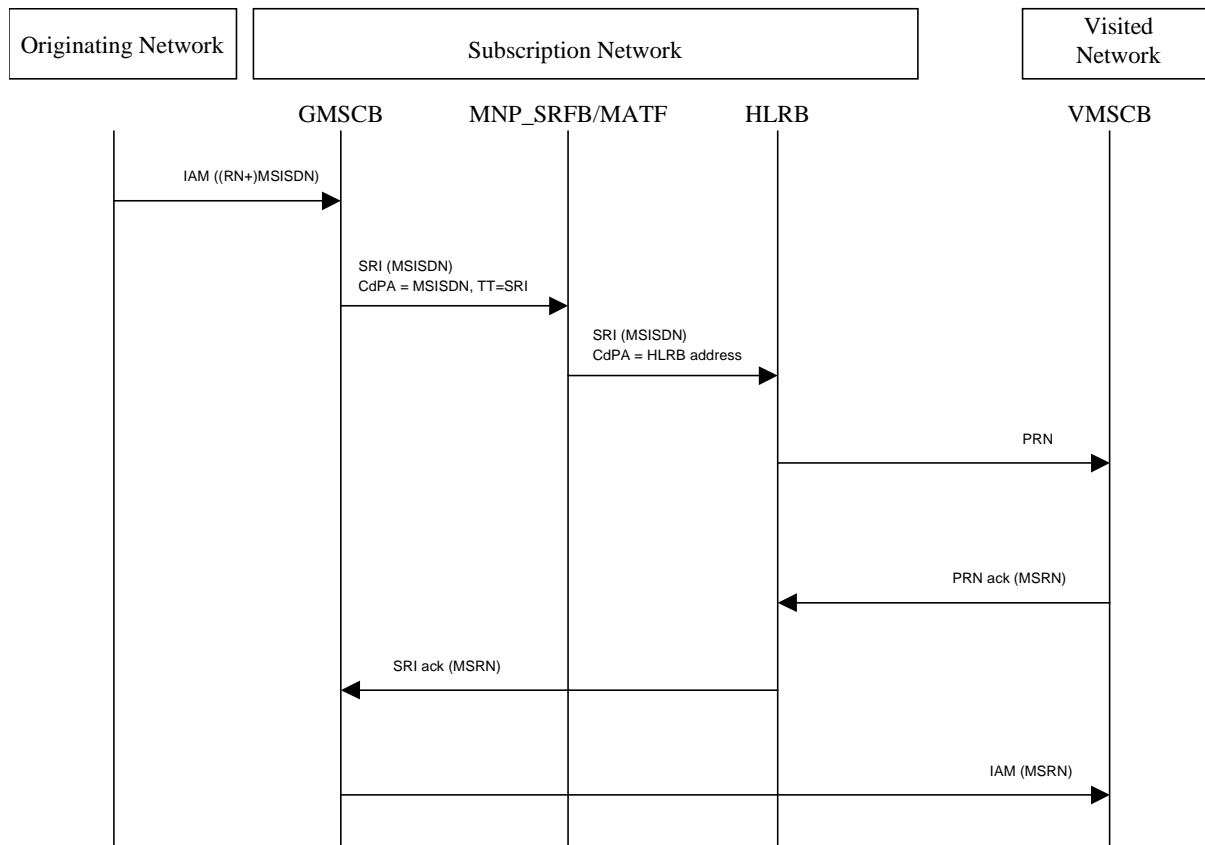

**Figure C.4.1: Successful delivery of a call to a non-ported subscriber or number ported into the network**



Figure C.4.2 shows the signalling involved for a call to a ported number via direct routing where the call is originated in the subscription network. The figure is related to figure C.3.2.

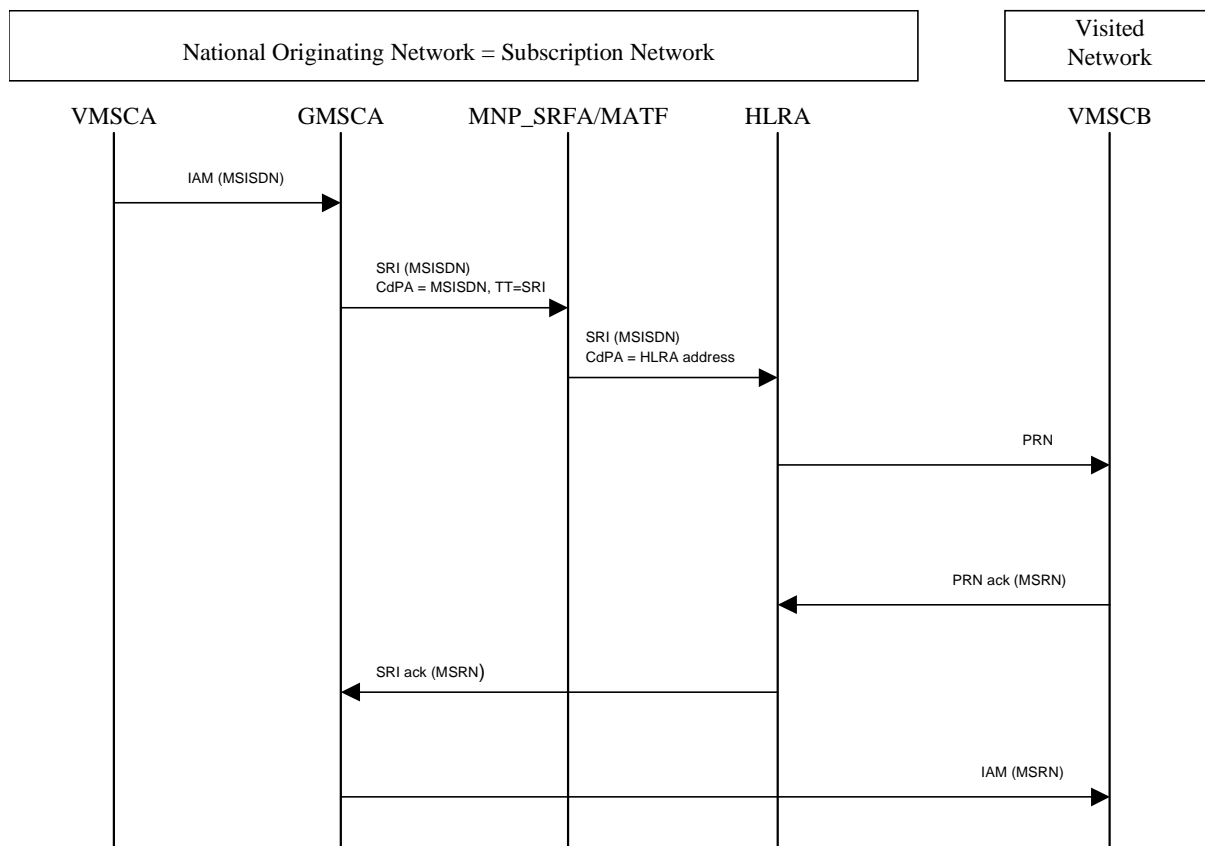

**Figure C.4.2: Successful delivery of a call to a ported number via direct routing where the call is originated in the subscription network**

Figure C.4.3 shows the signalling involved for a national mobile originated call to a ported number via direct routing. The figure is related to figure C.3.3

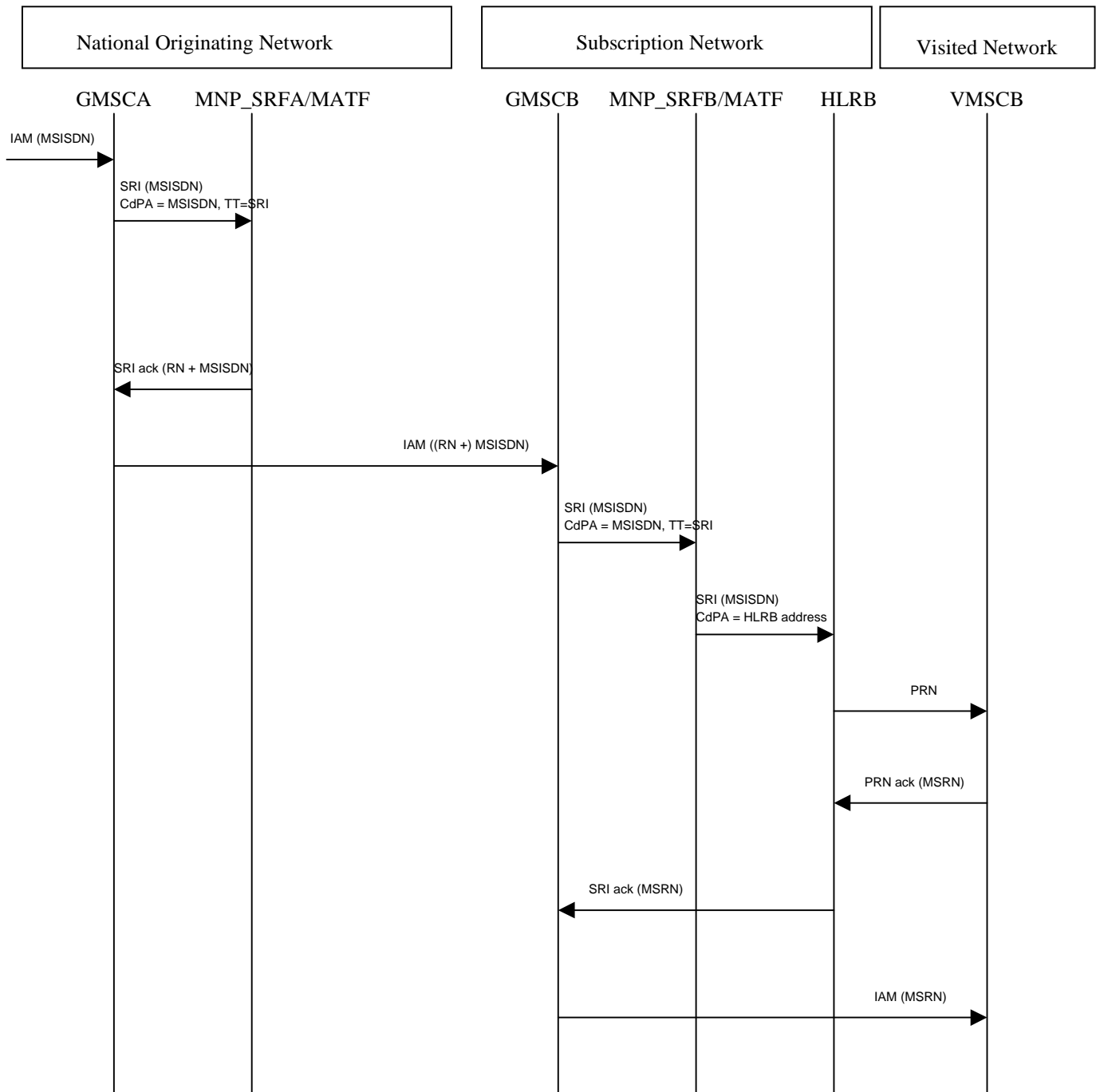
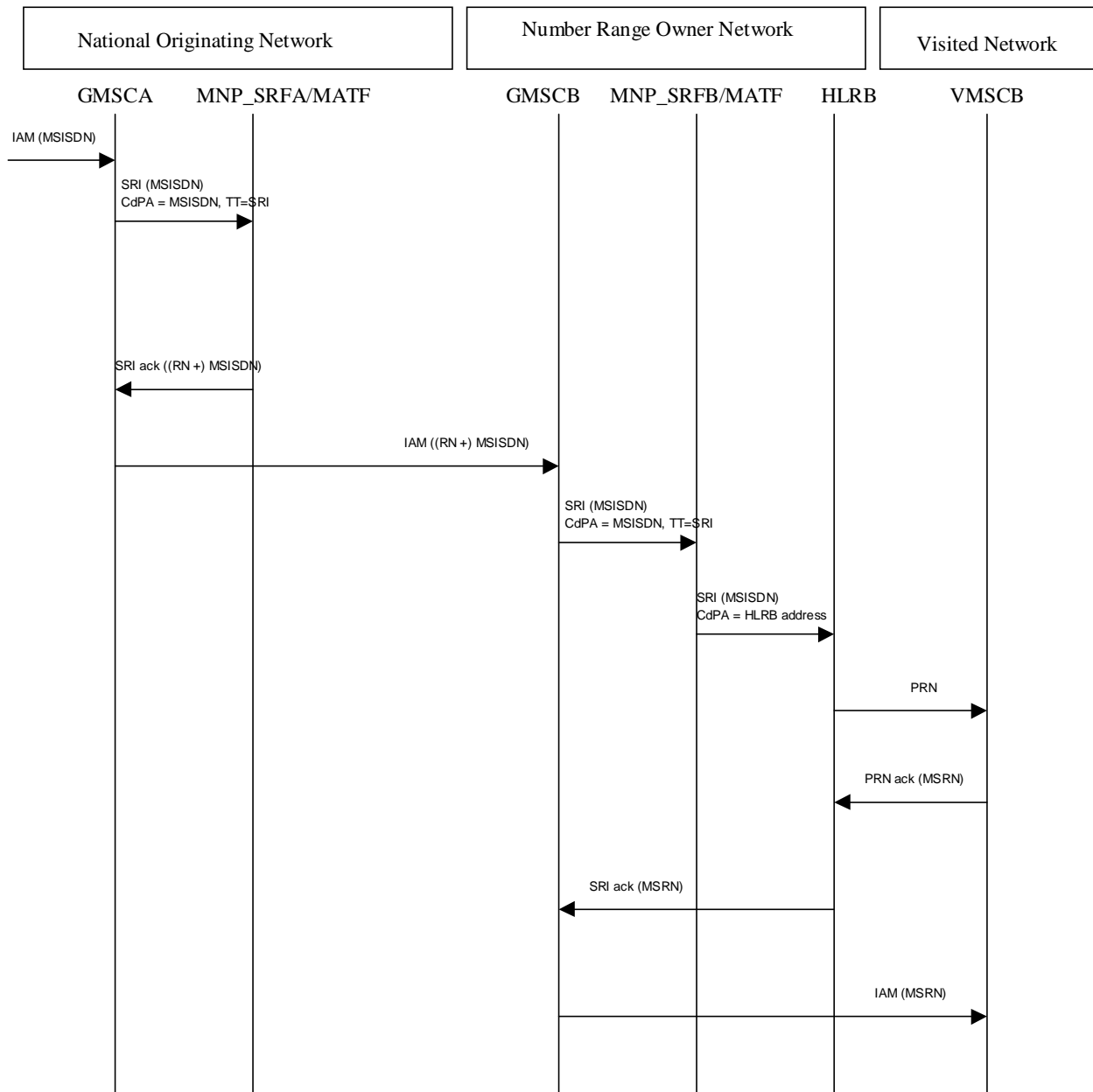

Figure C.4.3: Successful delivery of a national mobile originated call to a ported number via direct routing

Figure C.4.4 shows the signalling involved for a national mobile originated call to a not known to be ported number via direct routing. The figure is related to figure C.3.3.



**Figure C.4.4: Successful delivery of a national mobile originated call to a not known to be ported number via direct routing**

Figure C.4.5 shows the signalling involved for a call to a ported number via indirect routing. The figure is related to figure C.3.4

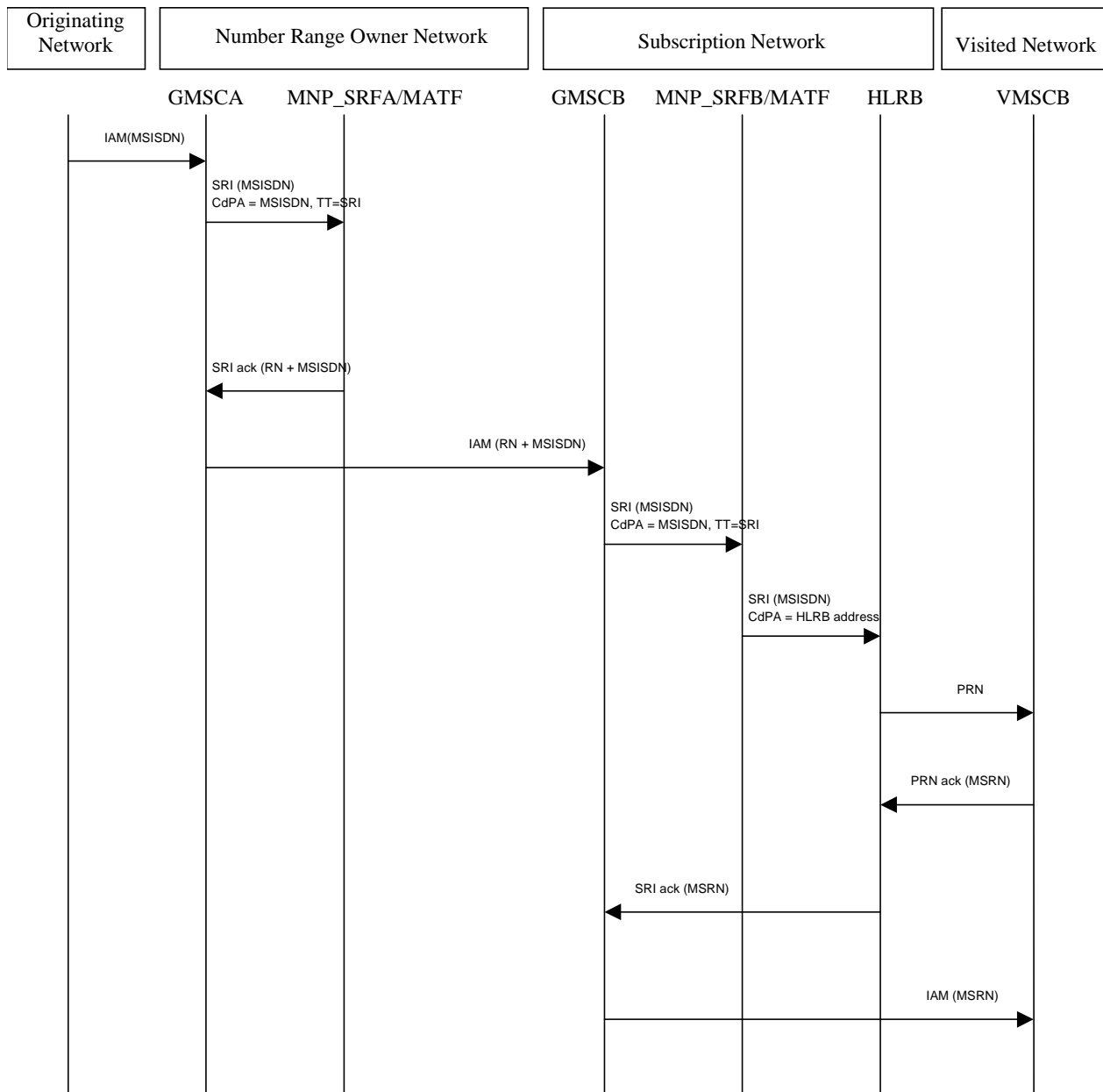
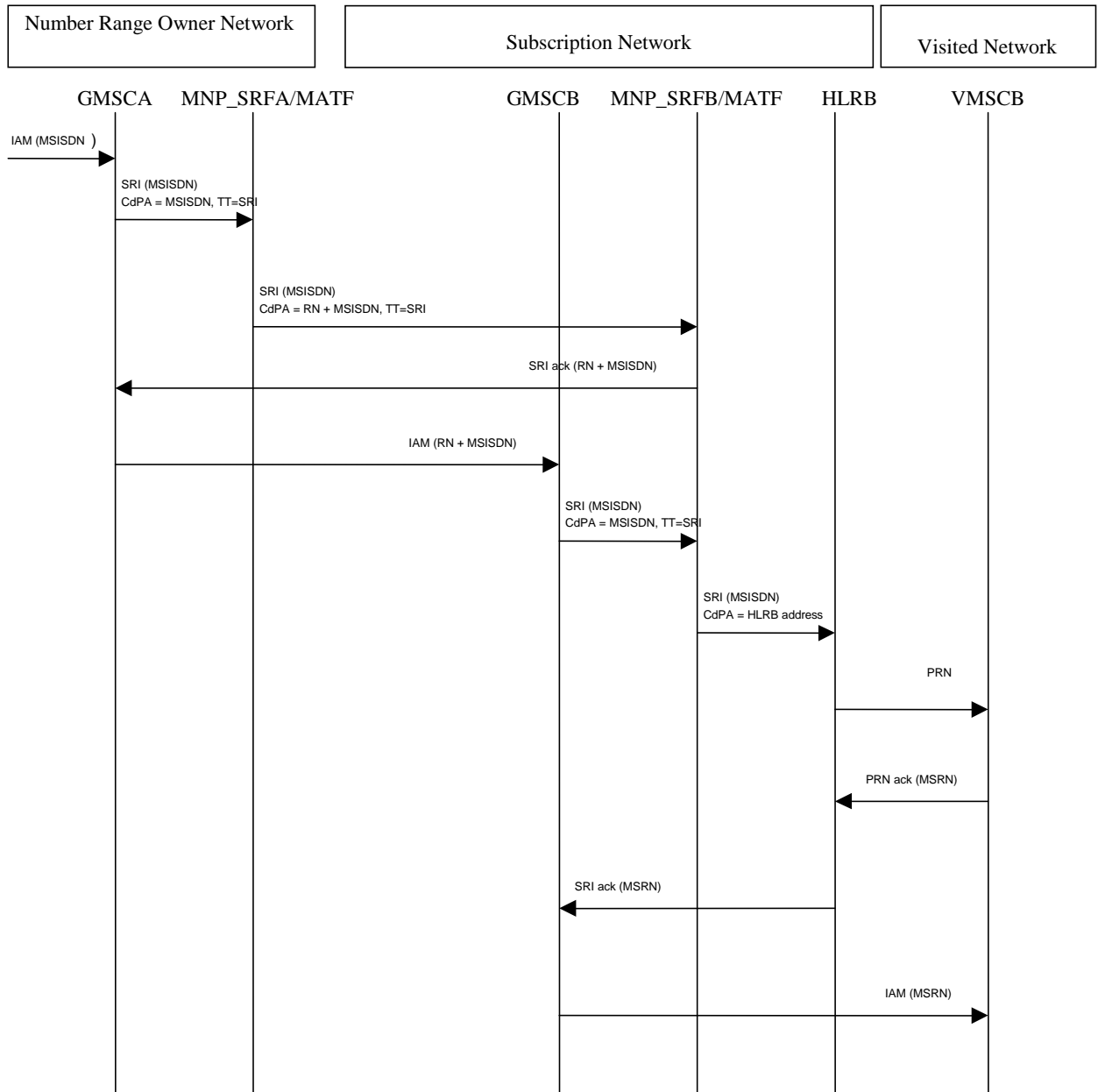

Figure C.4.5: Successful delivery of a call to a ported number via indirect routing

Figure C.4.6 shows the signalling involved for a call to a ported number where indirect routing with reference to the subscription network is used. The figure is related to figure C.3.5.



**Figure C.4.6: Successful delivery for a call to a ported number where indirect routing with reference to the subscription network is used**

---

## C.5 Contents of the messages

This clause contains detailed description of the messages shown in this part B of the specification.

### C.5.1 Send Routeing Info

The contents of this message are specified in GSM 03.18 [4].

### C.5.2 Send Routeing Info ack

The contents of this message are specified in GSM 03.18 [4]. In the case that the message is sent from the NPLR to the GMSC, the following MNP specific information is defined:

Information element name	Required	Description
Imsi	M	The IMSI returned by an NPLR is a generic IMSI, i.e. it is not tied necessarily to the Subscriber. MCC and MNC values in this IMSI shall point to the Subscription Network of the B Subscriber
Msrn	C	When returned from the NPLR, this parameter contains a Routeing Number that points to Subscription Network. If concatenate addressing is used, it also contains the MSISDN in addition to the Routeing Number. In the case of a number which is not known to be ported, the Routeing Number may be omitted as an operator option. If the routeing number is omitted, this parameter contains only the MSISDN.
Msisdn	C	MSISDN of the B subscriber. This information element shall be present if MSRN contains the routing number to reach the subscription network for B subscriber and the MSISDN is not contained in the MSRN information element.
MNP Indicator	U	Indicates the number portability status of the subscriber.

---

## C.6 Handling of MAP to ISUP mapping (informative)

Different configurations can be possible within a portability cluster depending on the versions of MAP and ISUP protocols being used. The following sections describe possible interworking scenarios.

### C.6.1 Mapping direction: ISUP to MAP

The GMSC always constructs the Send Routeing Info message using the MSISDN. If the incoming IAM corresponds to a ported number the GMSC shall retrieve the MSISDN from the corresponding parameter in the IAM.

### C.6.2 Mapping direction: MAP to ISUP

In MAP SRIack messages from NPLR, MAP versions 1 and 2 only support concatenate addressing for MNP. If MSISDN parameter is present in the SRIack, this means that separate addressing is used in MAP; this is only possible if MAP version 3 is used. MAP version 3 can also support concatenate addressing. In all cases, when a Routeing Number is returned, it is included in the MSRN parameter of the SRIack.

Regardless of how MAP is established, the possible mappings of the parameters in ISUP IAM message is one of these 4 options (see also [7]):

1. CdPN parameter includes only the MSISDN

2. CdPN parameter includes both RN and MSISDN concatenated
3. CdPN parameter includes the MSISDN and NRN parameter includes the Routeing Number
4. CdPN parameter includes the Routeing Number and CDN parameter includes the MSISDN

In all cases, the method to transport the routing number in the IAM depends on the interfaces agreed by the operators in the portability cluster.

## Annex D: Change history

TSG CN#	Spec	Version	CR	<Phase>	New Version	Subject/Comment
03	GSM 03.66	7.1.0				Transferred to 3GPP CN1
Aug 1999	23.066	3.0.0				
Oct 1999	23.066	3.0.0	001		3.1.0	Harmonisation of terminology <b>interrogating</b>
Oct 1999	23.066	3.0.0	002		3.1.0	Proposed changes to B.4.2 Delivery of SMS to a Non-ported Number - Direct Routeing – MNP-SRF acts as Higher-level Relay
Oct 1999	23.066	3.0.0	003		3.1.0	Clarification of NPLR functionality in not known to be ported case



---

# History

<b>Document history</b>		
V3.1.0	January 2000	Publication