

ETSI TS 123 073 V3.0.0 (2000-01)

Technical Specification

**Digital cellular telecommunications system (Phase 2+) (GSM);
Universal Mobile Telecommunications System (UMTS);
Support of Localized Service Area (SoLSA);
Stage 2
(3G TS 23.073 version 3.0.0 Release 1999)**



Reference

DTS/TSGN-SS23073U

Keywords

GSM, UMTS

ETSI

Postal address

F-06921 Sophia Antipolis Cedex - FRANCE

Office address

650 Route des Lucioles - Sophia Antipolis
Valbonne - FRANCE
Tel.: +33 4 92 94 42 00 Fax: +33 4 93 65 47 16
Siret N° 348 623 562 00017 - NAF 742 C
Association à but non lucratif enregistrée à la
Sous-Préfecture de Grasse (06) N° 7803/88

Internet

secretariat@etsi.fr
Individual copies of this ETSI deliverable
can be downloaded from
<http://www.etsi.org>
If you find errors in the present document, send your
comment to: editor@etsi.fr

Important notice

This ETSI deliverable may be made available in more than one electronic version or in print. In any case of existing or perceived difference in contents between such versions, the reference version is the Portable Document Format (PDF). In case of dispute, the reference shall be the printing on ETSI printers of the PDF version kept on a specific network drive within ETSI Secretariat.

Copyright Notification

No part may be reproduced except as authorized by written permission.
The copyright and the foregoing restriction extend to reproduction in all media.

© European Telecommunications Standards Institute 2000.
All rights reserved.

Intellectual Property Rights

IPRs essential or potentially essential to the present document may have been declared to ETSI. The information pertaining to these essential IPRs, if any, is publicly available for **ETSI members and non-members**, and can be found in SR 000 314: "*Intellectual Property Rights (IPRs); Essential, or potentially Essential, IPRs notified to ETSI in respect of ETSI standards*", which is available from the ETSI Secretariat. Latest updates are available on the ETSI Web server (<http://www.etsi.org/ipr>).

Pursuant to the ETSI IPR Policy, no investigation, including IPR searches, has been carried out by ETSI. No guarantee can be given as to the existence of other IPRs not referenced in SR 000 314 (or the updates on the ETSI Web server) which are, or may be, or may become, essential to the present document.

Foreword

This Technical Specification (TS) has been produced by the ETSI 3rd Generation Partnership Project (3GPP).

The present document may refer to technical specifications or reports using their 3GPP identities or GSM identities. These should be interpreted as being references to the corresponding ETSI deliverables. The mapping of document identities is as follows:

For 3GPP documents:

3G TS | TR nn.nnn "<title>" (with or without the prefix 3G)

is equivalent to

ETSI TS | TR 1nn nnn "[Digital cellular telecommunications system (Phase 2+) (GSM);] Universal Mobile Telecommunications System; <title>

For GSM document identities of type "GSM xx.yy", e.g. GSM 01.04, the corresponding ETSI document identity may be found in the Cross Reference List on www.etsi.org/key

Contents

Foreword	5
1 Scope.....	5
2 References.....	5
2.1 Normative references.....	5
2.2 Informative references	6
3 Definitions and abbreviations	6
3.1 Definitions	6
3.2 Abbreviations.....	6
4 Main concepts	7
4.1 Localised Service Area definition.....	7
4.2 Subscriber information for Localised Service Area.....	7
4.3 Localised Service Area support in idle mode	7
4.3.1 Cell selection and reselection	7
4.3.2 Localised service area indication	7
4.3.3 Exclusive access.....	7
4.3.4 LSA only access.....	8
4.4 Localised Service Area support in active mode.....	8
4.4.1 Localised service area indication	8
4.4.2 Resource handling	8
4.5 Localised Service Area support in access control.....	8
4.5.1 Emergency Call setup.....	8
4.5.2 Mobile Originating and Mobile Terminating Call setup	8
4.5.3 Location Registration	9
4.5.4 Call unrelated services (Short message transfer, USSD, Supplementary Service management)	9
4.5.5 Routing Area Update.....	9
5 General architecture	9
6 Compatibility issues.....	9
6.1 Handling of mobiles in exclusive access cells	10
7 Transmission.....	10
8 Information storage.....	10
8.1 Information managed per subscriber	10
8.1.1 Stored in the HLR	10
8.1.2 Stored in the VLR	11
8.1.3 Stored in the SIM	11
8.1.4 Stored in the SGSN.....	11
8.2 Information managed per LSA	12
8.2.1 Stored in the MSC.....	12
8.2.2 Stored in the BSS	12
9 Identities	12
9.1 Identities for LSA	12
9.1.1 LSA ID.....	12
9.1.2 LSA name	12
10 Operation and maintenance aspects.....	13
11 Function and information flows.....	13
11.1 LSA management	13
11.2 Subscription management.....	13
11.3 Update of LSA data in SIM	13
11.4 Functions related to MS in idle mode for support of LSA.....	13
11.4.1 Broadcast information	13
11.4.2 Cell selection and reselection.....	14

11.4.3	Location Updating.....	14
11.4.4	Routing Area Update.....	14
11.5	Transfer of information from HLR to VLR.....	14
11.6	Transfer of information from HLR to SGSN.....	14
11.7	Functions related to active mode support of LSA.....	14
11.7.1	MS connection establishment.....	14
11.7.1.1	Indication of current LSA to the MSC.....	14
11.7.1.2	Indication of allowed LSA to the BSS.....	15
11.7.1.3	Indication of allowed LSA to the BSS.....	15
11.7.2	Handover.....	15
11.7.2.1	Indication of allowed LSA to the target BSS	15
11.7.2.2	Indication of current LSA to the MSC.....	15
11.7.2.3	Indication of current LSA to the SGSN.....	15
11.8	LSA indication procedures	15
11.8.1	Indication for mobile stations in idle mode.....	15
11.8.2	Indications for mobile stations in active mode.....	16
11.9	Overview of signalling.....	16
12	Charging.....	20
12.1	General principles	20
12.2	Toll ticketing.....	20
Annex A (informative): SoLSA interworking with CAMEL		21
A.1	Subscriber information for Localised Service Area.....	21
A.2	Network Architecture	21
A.3	Signalling Interworking	22
Annex B (informative): Change history		24
History.....		25

Foreword

This Technical Specification has been produced by the 3GPP.

This TS specifies the stage 2 description of the SoLSA service within the 3GPP system.

The contents of the present document are subject to continuing work within the TSG and may change following formal TSG approval. Should the TSG modify the contents of this TS, it will be re-released by the TSG with an identifying change of release date and an increase in version number as follows:

Version 3.y.z

where:

- x the first digit:
 - 1 presented to TSG for information;
 - 2 presented to TSG for approval;
 - 3 Indicates TSG approved document under change control.
- y the second digit is incremented for all changes of substance, i.e. technical enhancements, corrections, updates, etc.
- z the third digit is incremented when editorial only changes have been incorporated in the specification;

1 Scope

This document specifies the stage 2 description of the SoLSA service, which gives the network operator the basis to offer subscribers or group of subscribers different services, different tariffs and different access rights depending on the geographical location of the subscriber, according to GSM 02.43.

2 References

The following documents contain provisions which, through reference in this text, constitute provisions of the present document.

- References are either specific (identified by date of publication, edition number, version number, etc.) or non-specific.
- For a specific reference, subsequent revisions do not apply.
- For a non-specific reference, the latest version applies.

2.1 Normative references

- [1] GSM 02.43: “Digital cellular telecommunications system (Phase 2+); Support of Localised Service Area (SoLSA), Stage 1”.
- [2] GSM 03.03: “Digital cellular telecommunications system (Phase 2+); Numbering, Addressing and Identification”.
- [3] GSM 03.22: “Digital cellular telecommunications system (Phase 2+); Functions Related to Mobile Station (MS) in Idle Mode”.
- [4] GSM 04.08: “Digital cellular telecommunications system (Phase 2+); Mobile Radio Interface – Layer 3 Specification”.

- [5] GSM 04.60: “Digital cellular telecommunications system (Phase 2+); Mobile Station (MS) – Base Station System (BSS) interface; Radio Link Control/ Medium Access Control (RLC/MAC) protocol (GPRS)”.
- [6] GSM 05.02: “ Digital cellular telecommunications system (Phase 2+); Multiplexing and Multiple Access on the Radio Path”.
- [7] GSM 05.08: “Digital cellular telecommunications system (Phase 2+); Radio subsystem link control”.
- [8] GSM 08.08: “Digital cellular telecommunications system (Phase 2+); Mobile Switching Centre – Base Station System (MSC – BSS) interface Layer 3 specification”.
- [9] GSM 08.18: “Digital cellular telecommunications system (Phase 2+); General Packet Radio Service (GPRS); Base Station System (BSS) – Serving GPRS Support Node (SGSN); BSS GPRS Protocol (BSSGP)”.
- [10] GSM 08.58: “Digital cellular telecommunications system (Phase 2+); BSC-BTS Interface – Layer 3 Specification”.
- [11] GSM 11.11: “Digital cellular telecommunications system (Phase 2+); Specification of the Subscriber Identity Module – Mobile Equipment (SIM-ME) Interface”.
- [12] GSM 11.14: “Digital cellular telecommunications system (Phase 2+); Specification of the SIM Application Toolkit for the Subscriber Identity Module – Mobile Equipment”.

2.2 Informative references

- [13] GSM 10.43: “Digital cellular telecommunications system; SoLSA, Work item status”.

3 Definitions and abbreviations

3.1 Definitions

For the purposes of the present document, the following definitions apply:

Allowed localised service area: A Localised Service Area where the subscriber has allowed service.

Current localised service area: The Localised Service Area of the serving cell to which the mobile station has subscription.

Escape PLMN: A specific PLMN code that may be broadcast for non SoLSA compatible mobile stations that do not understand the exclusive access indicator.

Localised Service Area: A Localised Service Area consists of a cell or a number of cells. The cells constituting a LSA may not necessarily provide continuous coverage.

Network operator: Entity that provides the network operating elements and resources for the execution of the LSA service.

Service provider: Entity that offers the LSA services for subscription. The network operator may be the service provider.

Service subscriber: Mobile subscriber, which subscribes to the LSA service. In principle, if a network provides LSA service, all users are able to subscribe to this service.

3.2 Abbreviations

For the purposes of the present document, the following abbreviations apply:

LSA	Localised Service Area
LSA ID	Localised Service Area Identity
CSE	Camel Service Environment

4 Main concepts

4.1 Localised Service Area definition

The network operator can define a Localised Service Area, LSA, consisting of a cell or a number of cells. It is possible for the network operator to set certain characteristics/attributes per LSA. Some LSA related attributes may be managed as part of cell management, e.g. exclusive access.

The LSA is identified by a LSA ID. It shall be possible for the service subscriber to define a name on each of her allowed LSAs.

4.2 Subscriber information for Localised Service Area

For a subscriber, the network operator or the service provider can define one or more LSA(s) as allowed LSA(s). It shall be possible to establish an order of priority between the allowed LSAs for a given subscriber and if the subscriber shall have preferential access within these LSAs. It shall also be possible to define whether access outside the allowed LSA(s) is allowed for a subscriber.

Subscriber specific LSA information is stored and managed in the HLR. Application related LSA information is stored in appropriate service platform, e.g. in the CAMEL Service Environment (see annex A).

In addition to subscriber details in the HLR server, it is also necessary for subscriber specific LSA information to be stored and managed in the SIM.

Subscribers may receive SIM cards with the initial LSA data stored. The management of LSA data on SIM may be performed manually (in which case SIM has to be returned to the network operator or service provider for updating), or over the air interface as described in subclause 11.3.

4.3 Localised Service Area support in idle mode

4.3.1 Cell selection and reselection

A cell reselection mechanism as defined in subclause 11.4.2 shall be used so that when camping on a cell in idle mode, the subscriber's mobile station favours the cells belonging to her LSA(s). The mobile station shall always attempt to reselect a cell in a higher priority LSA. Cells outside the allowed LSA(s) shall have the lowest priority.

4.3.2 Localised service area indication

The service subscriber can define a name (alphanumeric name, icon, etc) for each of her allowed LSAs. The MS will, in idle mode and if required by the user, indicate to the user the current LSA. The indication may be the name of the current LSA, as set by the user. The form of display and indication are left to manufacturer's choice.

4.3.3 Exclusive access

An exclusive access cell is a cell belonging to one or more LSAs and with allowed access only for users having this exclusive access cell included in his/her allowed LSAs. Other user's mobile stations must be prevented from using the cell to obtain any service, other than TS12 (Emergency Calls).

4.3.4 LSA only access

It shall be BSS-controlled functionality to prevent terminated and/or originated calls outside the subscriber's allowed LSA(s). Emergency calls are however always allowed.

4.4 Localised Service Area support in active mode

4.4.1 Localised service area indication

As a network option, service subscribers may be notified at change of current LSA. This notification shall be performed as described in subclause 11.7. The form of display and indication are left to manufacturer's choice.

4.4.2 Resource handling

As a network operator option it shall be possible to allow or prohibit connection set-up and handover depending on the subscriber's LSA information.

Information to be made available to the radio resource allocation function and the handover function are as depicted in subclause 8.2.2.

NOTE: For the handling of an established connection, it is out of scope of this document to describe how the network shall perform the resource allocation, handover, etc. depending on the subscriber's LSA information. The following shall only be seen as examples.

Assignment of traffic resources in preferential access LSA's may (network option) be favoured for subscribers having this cell as part of their allowed LSAs.

When the subscriber sets up a call in one of her LSAs, the cells belonging to that LSA can (network option) be favoured when handovers are carried out.

Handovers to exclusive access cells can (network option) be prevented for users not having the cell as part of their allowed LSA.

For a user with LSA only access, handovers as well as new originating and terminating calls may (network option) be allowed outside the allowed LSAs. Emergency calls are however always allowed

4.5 Localised Service Area support in access control

4.5.1 Emergency Call setup

The Emergency Call setup shall always be accepted by the MSC.

4.5.2 Mobile Originating and Mobile Terminating Call setup

The MSC receives the LSA ID(s) of the current cell from the BSC before the call setup. The current LSA can be selected on the basis of the allowed LSA(s) in the subscriber data. Depending on the current LSA, the network may continue as follows:

- The MSC accepts the setup without Active mode support, if the active mode indicator flag for selected LSA is not set.
- The MSC accepts the setup with Active mode support, if the active mode indicator flag for selected LSA is set.
- The MSC starts charging activities for the current LSA

4.5.3 Location Registration

The MSC/VLR shall reject a location registration if the cell is used for exclusive access and none of the LSA IDs of current cell corresponds to the LSA ID(s) stored in the subscriber record.

4.5.4 Call unrelated services (Short message transfer, USSD, Supplementary Service management)

The MSC receives the LSA ID(s) of the current cell from the BSC in the COMPLETE_L3_INFO. The current LSA can be selected on the basis of the allowed LSA(s) in the subscriber data and it can be used e.g. for the charging purposes. However, the service request is always accepted. Also, no active mode support is applied for the call unrelated services.

4.5.5 Routing Area Update

SGSN shall reject a routing area update if the cell is used for exclusive access and none of the LSA IDs of current cell corresponds to the LSA ID(s) stored in the subscriber record.

5 General architecture

No specific requirements are identified. The general architecture of GSM is maintained.

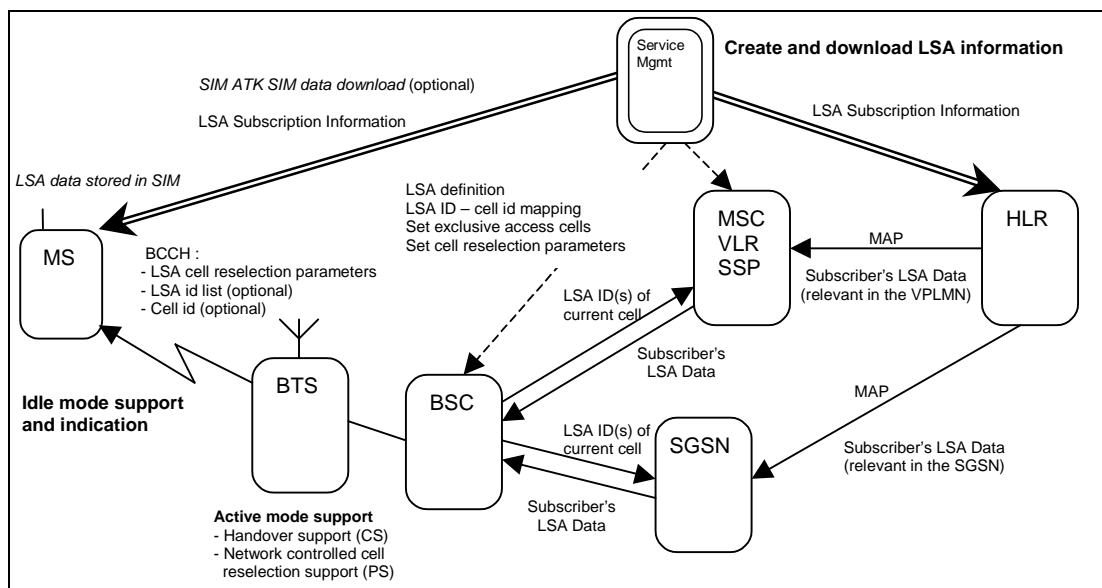

Figure 1: General architecture

6 Compatibility issues

LSA can not be used with standard phase 1 or phase 2 mobile stations (or with non-compatible phase 2+ mobile stations) with all service aspects. A dedicated mobile station with LSA capability is required.

A compatible mobile station shall provide the following specific functions:

3. cell reselection in case of a LSA subscription;
3. notification of the current LSA.

A mobile station with LSA capability shall also provide the complete functionality in order to allow the use of phase 2 services.

Standard phase 1 and phase 2 mobile stations in a network shall not be impacted by the presence of LSA services in that network due to LSA signalling, also if the mobile station is operated with a SIM that contains SoLSA fields.

However, if LSA is provided in a network, it can be applied to non-compatible mobile stations in the following way:

3. For a user with a LSA service subscription and with LSA only access, support is given for LSA only access, with exception of the notification (LSA indication).
3. For a user with a LSA service subscription, support is given for LSAs in active mode, with exception of the notification (LSA indication).

6.1 Handling of mobiles in exclusive access cells

An escape PLMN may be included for old MSs that do not understand the exclusive access indicator. Such an MS will consider the cell as belonging to another PLMN. If the escape PLMN is broadcast and the subscriber is not allowed within the cell, the receiving MSC/VLR/SGSN shall reject the location update with the cause PLMN not allowed. The escape PLMN will be added to the list of forbidden PLMNs and not accessed again. SoLSA compatible mobile stations will however read the correct PLMN in the system information and treat the cell as normal.

7 Transmission

No specific requirements are identified.

8 Information storage

8.1 Information managed per subscriber

8.1.1 Stored in the HLR

The following mandatory information shall be stored in the HLR for each service subscriber:

3. a list of all the LSA Ids for the service subscriber;
3. the priority for each LSA;
3. the preferential access indicator for each LSA;
3. the LSA only access indicator.

The following optional information may be stored in the HLR for each service subscriber:

3. LSA only access indication text (text to be displayed when out of LSA).

The following optional information may also be stored for each subscribed LSA:

3. LSA name (A text string describing area and/or service. For example "ETSI BUILDING");
3. LSA indication for idle mode (flag to activate/deactivate LSA indication in idle mode);
3. LSA indication for active mode (flag to activate/deactivate LSA indication in active mode);
- - idle mode support (flag to activate/deactivate idle mode support in LSA);
3. active mode support (flag to activate/deactivate active mode support in LSA).

The LSA Ids are defined in subclause 9.1.1.

A service subscriber shall not be provided with more than 20 LSAs per PLMN (including universal LSA's).

8.1.2 Stored in the VLR

The following mandatory information, which is relevant in the VPLMN, shall be stored in the VLR for each service subscriber:

- 3. a list of all the LSA Ids for the service subscriber;
- 3. the priority for each LSA;
- 3. the preferential access indicator for each LSA;
- 3. the LSA only access indicator.

The following optional information may also be stored for each subscribed LSA:

- 3. LSA indication for active mode (flag to activate/deactivate LSA indication in active mode);
-  active mode support (flag to activate/deactivate active mode support in LSA).

This information shall be brought forward to the VLR at the same time as other subscriber information is copied from HLR. VLR entries shall be modified when corresponding HLR records are changed.

8.1.3 Stored in the SIM

The following mandatory information shall be stored in the SIM for each service subscriber:

- 3. a list of all the LSA Ids for the service subscriber;
- 3. the priority for each LSA;
- 3. the LSA only access indicator.

The following optional information may be stored in the SIM for each service subscriber:

- 3. LSA only access indication text (text to be displayed when out of LSA).

The following optional information may also be stored for each subscribed LSA:

- 3. a list of all the cell identities for the subscribed LSA;
- 3. LSA name (A text string describing area and / or service. For example "ETSI BUILDING");
- 3. LSA indication for idle mode (flag to activate/deactivate LSA indication in idle mode);
- - idle mode support (flag to activate/deactivate idle mode support in LSA);

The information shall be modified when corresponding HLR and BSS records are changed.

8.1.4 Stored in the SGSN

The following mandatory information, which is relevant in the VPLMN, shall be stored in the SGSN for each service subscriber:

- 3. a list of all the LSA Ids for the service subscriber;
- 3. the priority for each LSA;
- 3. the preferential access indicator for each LSA;
- 3. the LSA only access indicator.

The following optional information may also be stored for each subscribed LSA:

- 3. LSA indication for active mode (flag to activate/deactivate LSA indication in active mode);
- 3. active mode support (flag to activate/deactivate active mode support in LSA).

This information shall be brought forward to the SGSN at the same time as other subscriber information is copied from HLR. SGSN entries shall be modified when corresponding HLR records are changed.

8.2 Information managed per LSA

The LSA is defined as a list of cells inside the network. The cells shall be defined by their cell identification consisting of the Location Area Code and the Cell Identity as defined in GSM 08.08 and are therefore uniquely identified in the network.

8.2.1 Stored in the MSC

The information stored in the MSC (network option) is the network specific service configuration of each LSA defined by the network operator and relevant for the MSC.

The network specific configuration of each LSA may also include specific rules for e.g. the priority handling and the mapping between LSA information for the subscriber (VLR data) and the LSA information sent to BSS and when to notify MS about a service area change.

NOTE: For the handling of call establishment, it is out of scope of this document to describe how the network shall perform e.g. mapping between LSA information for the subscriber (VLR data) and the LSA information sent to BSS. The network specific service configuration information shall only be seen as an example.

8.2.2 Stored in the BSS

The information stored in the BSS is the network specific service configuration of each LSA defined by the network operator and relevant for the BSS.

For each LSA relevant for the BSS in case of internal and external handover support, the LSA ID and the cells belonging to the LSA shall be stored. The BSS must also have knowledge about in which LSA cells that the exclusive access shall be indicated.

The network specific configuration of each LSA may also include rules for e.g. handover and resource allocation.

9 Identities

9.1 Identities for LSA

9.1.1 LSA ID

The LSA ID shall either be a PLMN significant number or a universal identity, indicated by one bit in the LSA ID.

PLMN significant number: The LSA ID shall be a binary number uniquely assigned to an area in one network. The identity consists of 3 octets.

Universal identity: The LSA ID shall be a globally unique identity assigned to a specific company or organization. A suitable Assigning and Registration Authority is required.

9.1.2 LSA name

It shall be possible to assign a subscriber-defined identifier to each LSA. The LSA name can e.g. be an icon or an alphanumeric text up to 10 characters.

10 Operation and maintenance aspects

The operators have the possibility to:

- Define LSAs consisting of a cell or a number of cells.
- Set parameters for prioritised LSA cell reselection.
- Set the parameter for exclusive access.

11 Function and information flows

11.1 LSA management

The LSA attributes, as given in subclause 8.2 shall be entered and modified by the network operator or the service provider.

11.2 Subscription management

When the subscriber record is created in the HLR, the list of allowed LSAs, priority of each LSA, the preferential access indicator of each LSA and information about access rights outside these LSAs shall be included.

The network operator can change the LSA information for a subscription at any time. A change of subscription shall not affect any on-going calls at the moment of change.

The update of SIM with user LSA information is done as depicted in subclause 11.3.

11.3 Update of LSA data in SIM

SIM Application Toolkit (SAT) SIM Data Download procedure, as specified in GSM 11.14, can be used to download LSA data to SIM over the air interface. SAT class 1 supports SMS as the bearer for LSA data.

When using over the air interface for updating LSA information on the SIM card the GSM 03.48 specifies Standardised SIM toolkit commands for Remote File Management:

- 3.1 GSM 03.48 contains a standard format for remote file handling based on the instruction set from GSM 11.11. Operators have possibility to use and update SIMs from different vendors.
- 3.2 The parameter(s) in the SIM Data Download Message is either a single command, or a list of commands, and each command is coded according to the generalised structure defined in GSM 03.48.
- 3.3 Data field to be used in commands will be specified in GSM 11.11 for SoLSA

GSM Rec. 03.48 also specifies various security mechanisms (e.g. various derivatives of DES) that can be used to protect the remote file management commands.

New SIMs for SoLSA are needed to cater for SIM related security issues. Unauthorised modification of SoLSA data in SIM, either by users or by any other entity, is to be prohibited.

11.4 Functions related to MS in idle mode for support of LSA

11.4.1 Broadcast information

In cells belonging to a LSA, the LSA ID(s) and/or cell identity is broadcast.

Further, in cells belonging to a LSA, which shall give exclusive access to a subscriber group, an exclusive access indication is broadcast.

To be able to favour the LSA cells at cell reselection new LSA reselection parameters are broadcast.

11.4.2 Cell selection and reselection.

The definition of a “suitable cell”, as defined in GSM 03.22, is modified with the following criterion:

A SoLSA exclusive access cell is “suitable” only if the LSA of the cell is one of the allowed LSA according to the SIM. Emergency calls are always allowed if no cells are found suitable.

An MS with SIM indicating LSA subscription shall always try to reselect the cell with the highest LSA priority according to the information stored on the SIM. The LSA reselection parameters broadcast on the BCCH shall be used to calculate the reselection criteria. The broadcasting mechanism is as described in GSM 04.08 and GSM 04.60. The MS shall follow the reselection procedures defined in GSM 05.08.

NOTE: The text above covers also the case when the MS is using GPRS together with SoLSA.

11.4.3 Location Updating

If the escape PLMN is broadcast the BSS shall, at location updating, inform the MSC/VLR about the LSA ID(s) of the cell where the location updating request message was received. *This is done by adding the LSA ID(s) of current cell to the complete layer 3 information message for the exclusive access cell.*

11.4.4 Routing Area Update

If the escape PLMN is broadcast the BSS shall, at routing area update, inform the SGSN about the LSA ID(s) of the cell where the routing area update request message was received. *This is done by adding the LSA ID(s) of current cell to the UL UNITDATA message for the exclusive access cell.*

11.5 Transfer of information from HLR to VLR

If the subscription contain LSA information then, when the subscriber registers on a VLR, the HLR shall send the LSA subscription data to that VLR, which is relevant in the VPLMN. This is done by adding the LSA information to the MAP_INSERT_SUBSCRIBER_DATA and for deletion in MAP_DELETE_SUBSCRIBER_DATA.

When there is a change in the LSA information the HLR shall include at least the new and/or modified LSA data. When there is a change in the access right outside the LSA(s) the HLR shall include the LSA only access indicator.

11.6 Transfer of information from HLR to SGSN

If the subscription contain LSA information then, when the subscriber registers on a SGSN, the HLR shall send the LSA subscription data to that SGSN, which is relevant in the VPLMN. This is done by adding the LSA information to the MAP_INSERT_SUBSCRIBER_DATA and for deletion in MAP_DELETE_SUBSCRIBER_DATA.

When there is a change in the LSA information the HLR shall include at least the new and/or modified LSA data. When there is a change in the access right outside the LSA(s) the HLR shall include the LSA only access indicator.

11.7 Functions related to active mode support of LSA

11.7.1 MS connection establishment

11.7.1.1 Indication of current LSA to the MSC

At initial connection establishment the BSS shall inform the MSC about the LSA ID(s) of the cell where the initial layer 3 message was received. *This is done by adding the LSA ID(s) of current cell to the complete layer 3 message.*

11.7.1.2 Indication of allowed LSA to the BSS

The MSC sends the LSA information message to the BSS including the A-interface LSA information of the connection *as defined in GSM 08.08*. The MSC maps the subscription LSA information on to the A-interface LSA information for LSAs requiring 'active mode support'. The LSA information sent to the BSS indicates the allowed area for the MS connection. The BSS shall store the LSA information in order to use it on later actions, e.g. at handover.

The LSA information for the MS connection shall be used in the BSS at assignment of radio resources in order to e.g. prioritise cells in the allowed LSA(s) and to prevent allocating resources in cells outside the allowed area for the MS connection.

11.7.1.3 Indication of allowed LSA to the BSS

The SGSN may send the LSA information message to the BSS for a mobile station in ready mode *as defined in GSM 08.18*. The SGSN sends the subscription LSA information for LSAs requiring 'active mode support'. The LSA information sent to the BSS indicates the allowed area for the MS connection. The BSS shall store the LSA information in order to use it on later actions, e.g. when determine specific cell selection parameters.

The LSA information for the MS connection shall be used in the BSS to e.g. prioritise cells in the allowed LSA(s) and to prevent allocating resources in cells outside the allowed area for the MS connection.

11.7.2 Handover

11.7.2.1 Indication of allowed LSA to the target BSS

In case of BSS external handover, the LSA information for the connection shall be included in the handover request message.

11.7.2.2 Indication of current LSA to the MSC

In case of BSS external handover, the BSS informs the MSC about the LSA ID of current cell. *This is done by adding the LSA ID of the current/new cell to the handover request acknowledge message.*

In case of BSS internal handover, the BSS informs the MSC when a change of LSA has occurred for a connection. This is done by adding the LSA ID of the current/new cell to the handover performed message or assignment complete message (if handover performed during assignment).

11.7.2.3 Indication of current LSA to the SGSN

In case of cell change, the BSS may inform the SGSN about the LSA ID(s) of current cell. This is done by adding the LSA ID(s) of the current/new cell to the UL UNITDATA message.

11.8 LSA indication procedures

Different indication procedures shall be applied in relation to the mode of the mobile station as presented in clause 4 and defined in the following sections.

11.8.1 Indication for mobile stations in idle mode

In addition to indicate the registered PLMN, an MS with subscription for a LSA in the registered PLMN shall indicate this LSA when it is available. The indication towards the user is optional and may be done by displaying the stored LSA name that corresponds to the ID of the current LSA.

An MS with LSA only access subscription may also give an indication towards the user, when the no subscribed LSAs are available to the user. The indication is optional and may be done by displaying the LSA only access text stored in the SIM.

11.8.2 Indications for mobile stations in active mode

The network decides when to send a notification to the MS about a change of current LSA. The information will be sent from the MSC to the MS and will contain the LSA ID. This is done by adding the LSA ID of the current cell to the MM Information message. If no LSA ID is included in the MM Information message the MS shall assume that the current cell does not belong to any of the allowed LSAs for the subscriber.

The indication towards the user is optional and can be heard as e.g. a beep in the receiver or by displaying the stored LSA name that corresponds to the received LSA ID.

11.9 Overview of signalling

In this overview, the messages required to implement the specified concept are identified and brief details are given of each message. These signalling flows are not normative, but provided as an illustration on possible signalling interworking (note that only those parts of the procedures that are relevant for the LSA service are included).

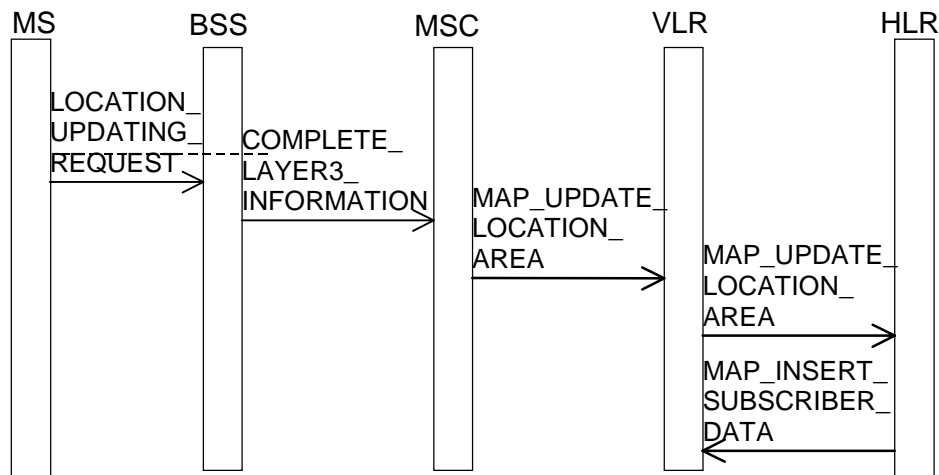

Figure 2: Signalling information required at location registration

LOCATION_UPDATING_REQUEST: Standard message.

COMPLETE_LAYER3_INFORMATION: If the escape PLMN is broadcast, the MSC is provided with location updating information together with the LSA ID(s) of current cell.

MAP_UPDATE_LOCATION_AREA: Standard message.

MAP_INSERT_SUBSCRIBER_DATA: The VLR is provided with the subscriber information including the allowed LSA ID(s), priority of each LSA, the preferential access indicator for each LSA and the LSA only access indicator of current PLMN.

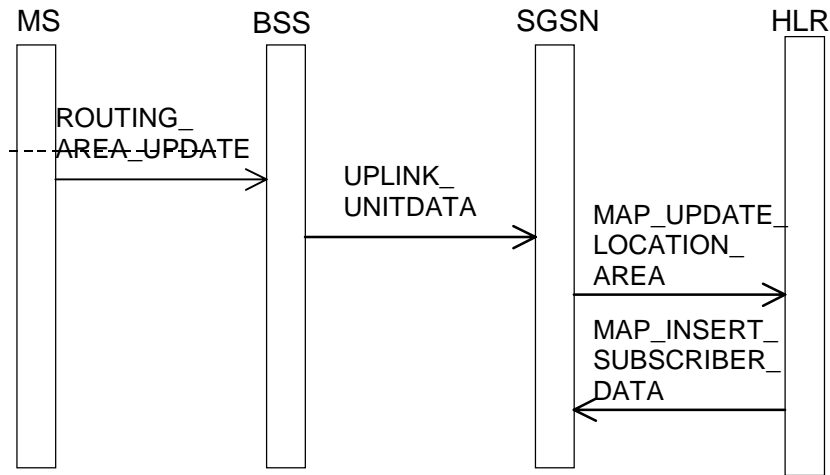

Figure 3: Signalling information required at routing area update

ROUTING_AREA_UPDATE_REQUEST: Standard message.

UPLINK_UNITDATA: If the escape PLMN is broadcast, the SGSN is provided with routing area update information together with the LSA ID(s) of current cell.

MAP_UPDATE_LOCATION_AREA: Standard message.

MAP_INSERT_SUBSCRIBER_DATA: The SGSN is provided with the subscriber information including the allowed LSA ID(s), priority of each LSA and the LSA only access indicator of current PLMN.

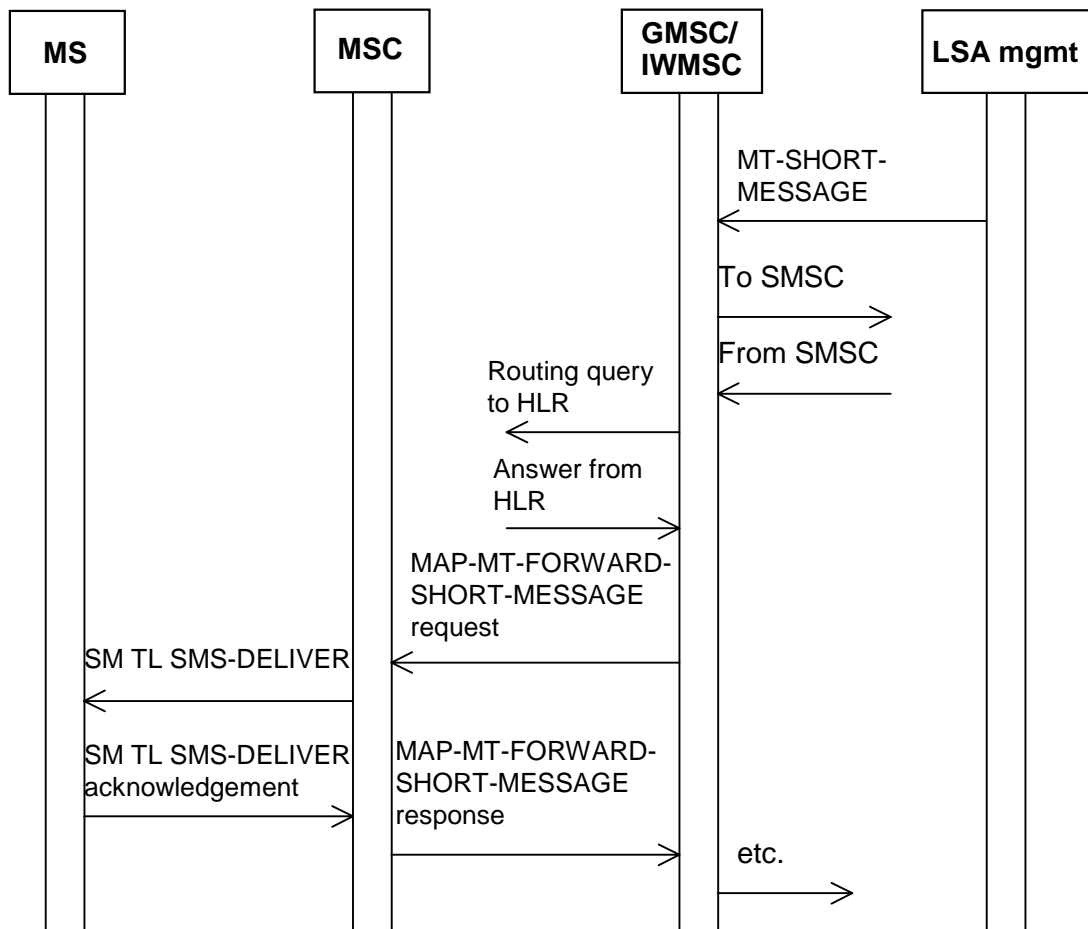

Figure 4: Signalling information required at updating of the subscriber's LSA information by using SMS

MT-SHORT-MESSAGE, MAP-MT-FORWARD-SHORT-MESSAGE request, SM TP SMS-DELIVER:

Standard messages containing subscriber's LSA information and are parts of SIM data download.

SM TP SMS-DELIVER acknowledgement, MAP-MT-FORWARD-SHORT-MESSAGE response: Standard messages containing result of the operation.

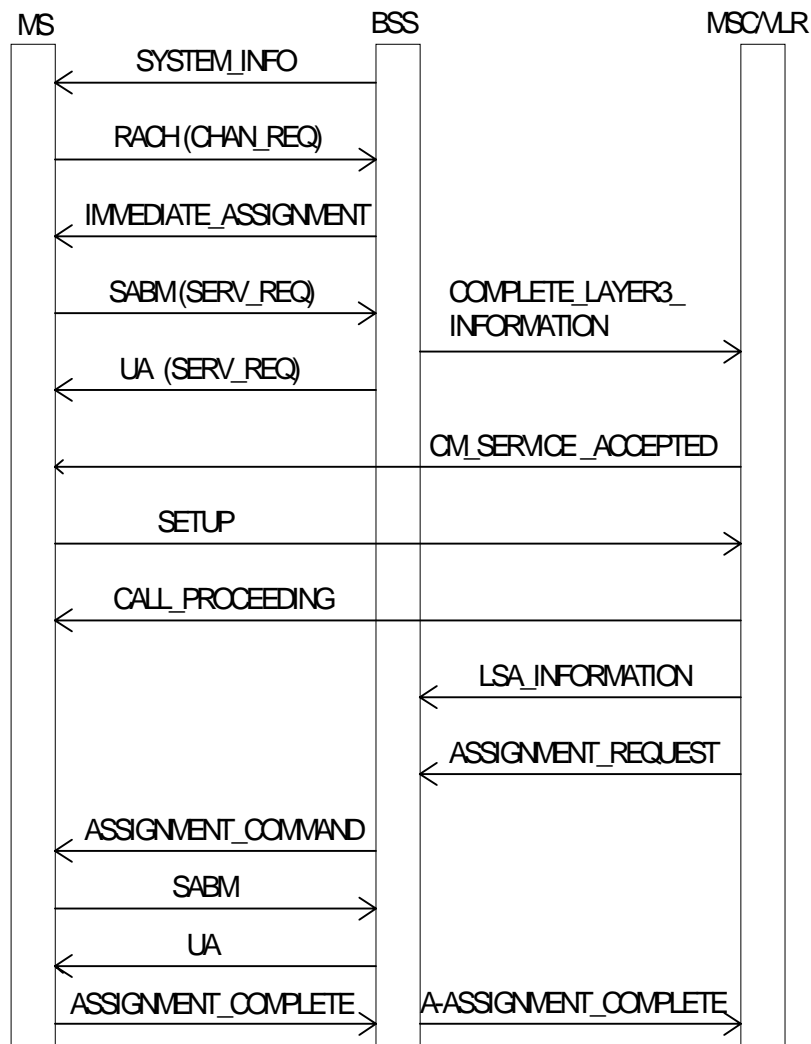

Figure 5: Signalling information required for mobile originating call establishment

SYSTEM_INFO: The network provides the cell identity and/or LSA ID(s) of the cell, LSA cell reselection parameters and the exclusive access indication.

Initial RACH CHANNEL_REQUEST: Standard message.

IMMEDIATE_ASSIGNMENT: Standard message.

SABM (SERV_REQ): Standard message.

UA (SERV_REQ): Standard message.

COMPLETE_LAYER3_INFORMATION: The MSC is provided with initial information about the requested service together with the LSA ID(s) of current cell.

CM_SERVICE_ACCEPT: Standard message. The service request is acknowledged. Acknowledgement of the service can also be performed by invocation of ciphering mode setting.

SETUP: Standard message.

CALL_PROCEEDING: Standard message.

LSA INFO: New message including the allowed LSA ID(s), priority of each LSA, the preferential access indicator for each LSA and an indication about the access rights outside these LSA(s) for the service subscriber. This message needs to be sent before Assignment request. Additional messages may be sent anytime during the lifetime of a call.

ASSIGNMENT_REQUEST: Standard message.

ASSIGNMENT_COMMAND: Standard message.

SABM: Standard message.

UA: Standard message.

ASSIGNMENT_COMPLETE: Standard message.

A_ASSIGNMENT_COMPLETE: Modified assignment complete including the LSA ID of current cell.

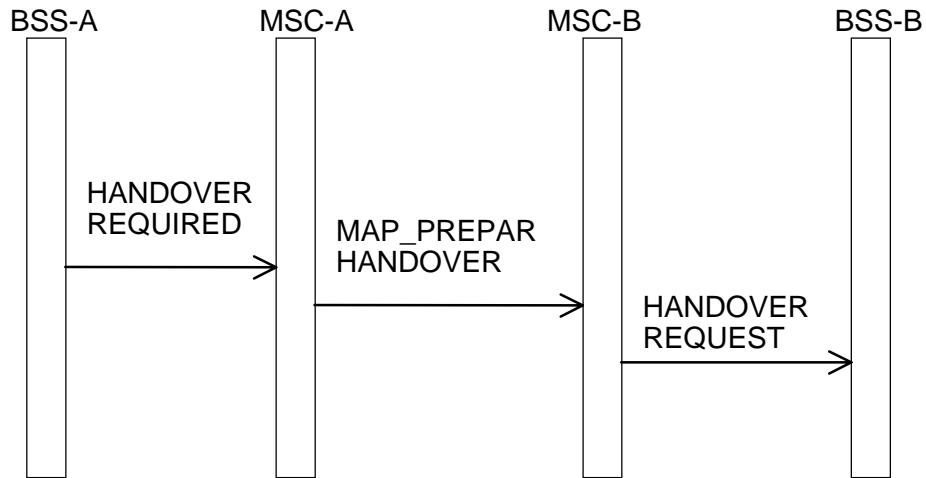

Figure 6: Signalling information required at BSS external handover initiation

HANDOVER REQUIRED: Standard message.

MAP_PREPARE_HANDOVER: Standard message. Including the modified handover request.

HANDOVER_REQUEST: Modified handover request including the allowed LSA ID(s), priority of each LSA, the preferential access indicator of each LSA and an indication about the access rights outside these LSA(s).

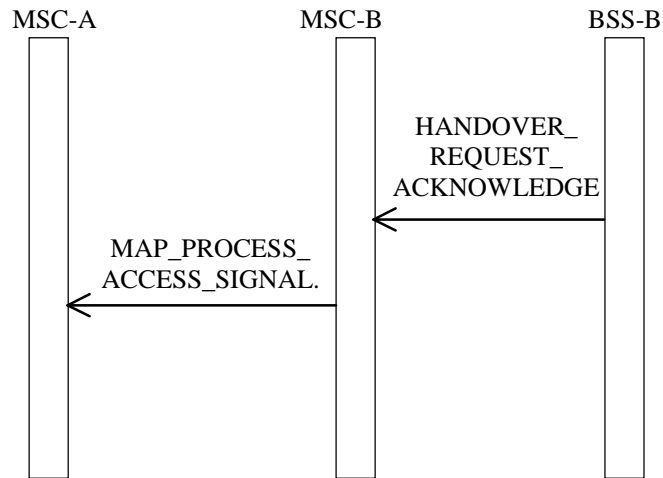

Figure 7: Signalling information required at BSS external handover acknowledgement

HANDOVER_REQUEST_ACKNOWLEDGE: Modified handover request acknowledge including the LSA ID of current cell.

MAP_PROCESS_ACCESS_SIGNALING request: Standard message. Including the modified handover request acknowledge.

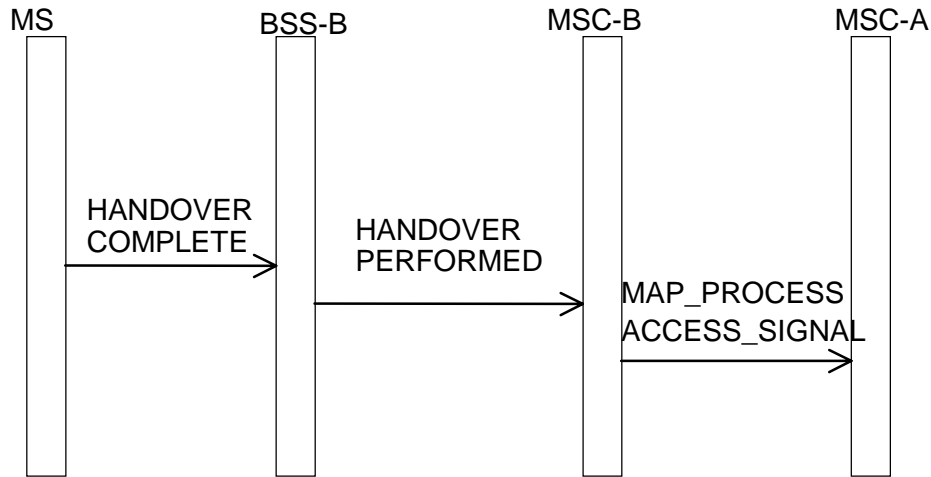

Figure 8: Signalling information required at BSS internal handover

HANDOVER_COMPLETE: Standard message.

HANDOVER_PERFORMED: Modified handover performed including the LSA ID of current cell.

MAP_PROCESS_ACCESS_SIGNALLING request: Standard message. Including the modified handover performed.

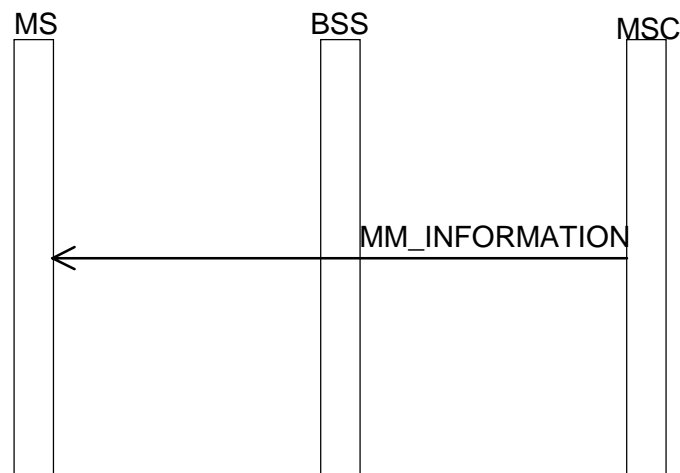

Figure 9: Signalling information required at notification of LSA change in active mode

MM_INFORMATION: Modified MM-INFORMATION message including the LSA ID of current cell.

12 Charging

12.1 General principles

Using LSA as a location based charging can be realised. Different charging can be applied with respect to different LSAs, which shall also include the possibility to change charging when moving between LSAs with different tariffs associated. LSAs with higher priority may be associated with different tariffs.

12.2 Toll ticketing

Appropriate information concerning the change of charging due to the LSA change shall also be included in the charging record (toll ticket).

Annex A (informative): SoLSA interworking with CAMEL

This Annex is informative.

Regarding the SoLSA network architecture SMG12 has decided that:

- *the HLR solution is chosen for SoLSA*
- *CAMEL phase 3 will be improved in the 99 release so that it fully utilises the SoLSA benefits.*

This annex collects the optional functional enhancements for CAMEL required to enable CAMEL interworking with SoLSA. These enhancements are expected to be included in CAMEL phase3 in Release 99.

A.1 Subscriber information for Localised Service Area

Subscriber specific information LSA information is stored and managed in the HLR. Application related LSA information is stored in appropriate service platform, e.g. in the CAMEL Service Environment.

A.2 Network Architecture

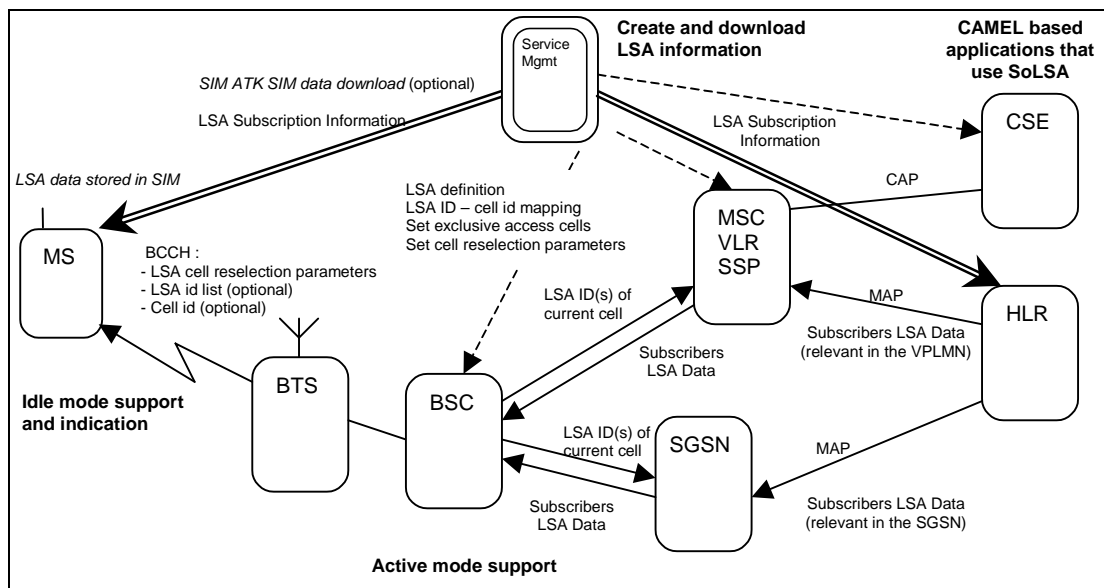

Figure A1: NW architecture including SoLSA related enhancements on CAMEL Service Environment

A.3 Signalling Interworking

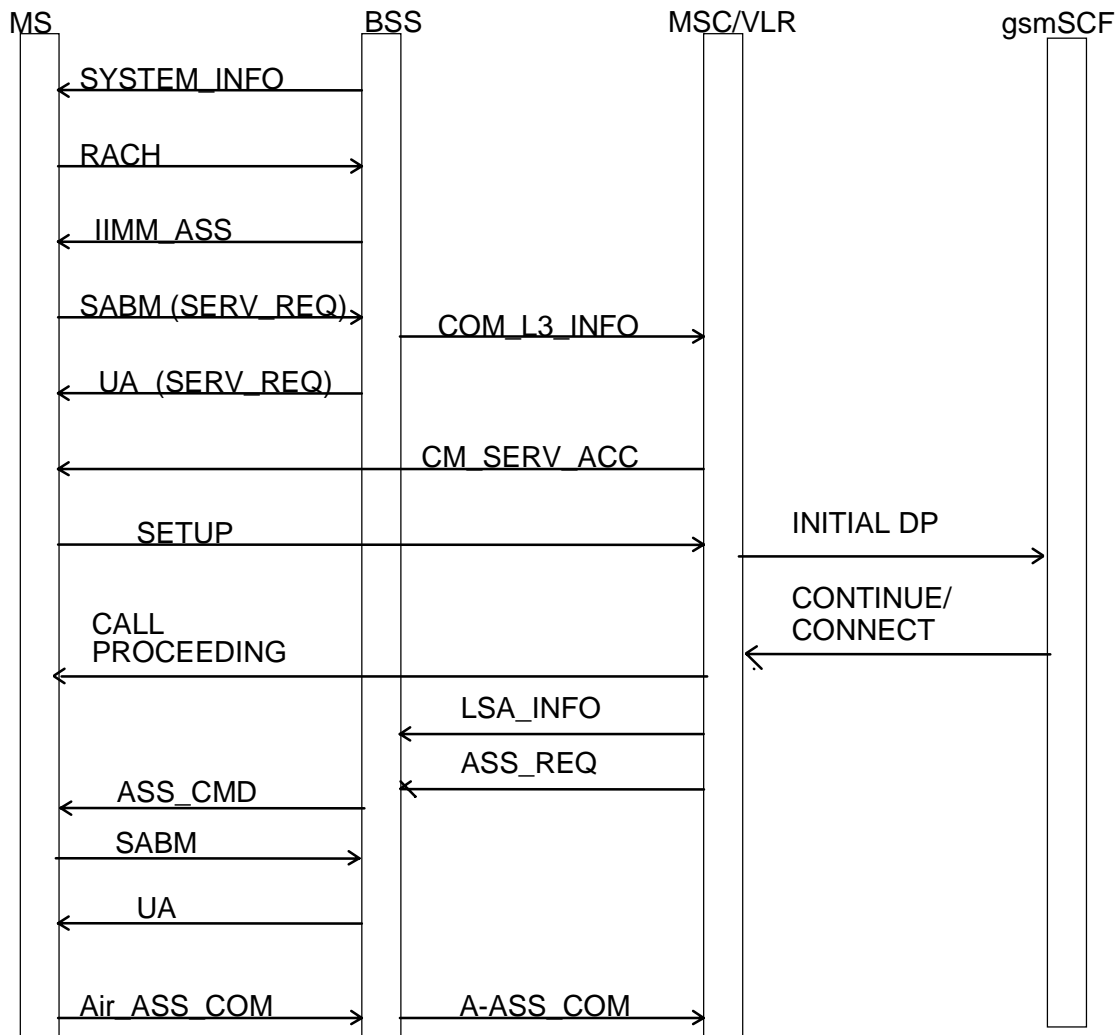

Figure A2: Signalling interworking at Mobile Originating Call Establishment with applications on CAMEL Service Environment

SYSTEM_INFO: The network provides the cell identity and/or LSA ID(s) of the cell, LSA cell reselection parameters and the exclusive access indication.

Initial RACH CHAN_REQ: Standard message.

IMM_ASS: Standard message.

SABM (SERV_REQ): Standard message.

UA (SERV_REQ): Standard message.

COM_L3_INFO: The MSC is provided with initial information about the requested service together with the LSA ID(s) of current cell.

CM_SERV_ACC: Standard message. The service request is acknowledged. Acknowledgement of the service can also be performed by invocation of ciphering mode setting.

SETUP: Standard message.

INITIALDP: Modified CAP message indicating that the CAMEL TDP has been met. Additionally the LSA ID(s) of the current cell are sent to the gsmSCF.

CONTINUE: Modified CAP message indicating that the call continues without modifications.

CONNECT: Modified CAP message indicating that the gsmSCF has modified e.g. the destination number.

CALL_PROCEEDING: Standard message.

LSA INFO: New message including the LSA ID(s), priority of each LSA, the preferential access indicator of each LSA and an indication about the access rights outside these LSA(s) for the service subscriber. This message need to be sent before Assignment Request message. Additional messages may be sent at anytime during the lifetime of a call.

ASS_REQ: Standard message.

ASS_CMD: Standard message.

SABM: Standard message.

UA: Standard message.

Air_ASS_COM: Standard message.

A_ASS_COM: Modified assignment complete including the LSA ID of current cell.

Annex B (informative): Change history

Change history						
TSG SA#	Spec	Version	CR	<Phase>	New Version	Subject/Comment
Jun 1999	GSM 03.73	7.1.0				Transferred to 3GPP CN
CN#04	23.073				3.0.0	

History

Document history		
V3.0.0	January 2000	Publication