

# ETSI TS 123 110 V3.3.0 (2000-01)

---

*Technical Specification*

**Digital cellular telecommunications system (Phase 2+) (GSM);  
Universal Mobile Telecommunications System (UMTS);  
UMTS Access Stratum  
Services and Functions  
(3G TS 23.110 version 3.3.0 Release 1999)**

---



Reference

---

DTS/TSGS-0223110U

Keywords

---

GSM, UMTS

**ETSI**

Postal address

---

F-06921 Sophia Antipolis Cedex - FRANCE

Office address

---

650 Route des Lucioles - Sophia Antipolis  
Valbonne - FRANCE  
Tel.: +33 4 92 94 42 00 Fax: +33 4 93 65 47 16  
Siret N° 348 623 562 00017 - NAF 742 C  
Association à but non lucratif enregistrée à la  
Sous-Préfecture de Grasse (06) N° 7803/88

Internet

---

secretariat@etsi.fr  
Individual copies of this ETSI deliverable  
can be downloaded from  
<http://www.etsi.org>  
If you find errors in the present document, send your  
comment to: editor@etsi.fr

---

**Important notice**

This ETSI deliverable may be made available in more than one electronic version or in print. In any case of existing or perceived difference in contents between such versions, the reference version is the Portable Document Format (PDF). In case of dispute, the reference shall be the printing on ETSI printers of the PDF version kept on a specific network drive within ETSI Secretariat.

---

**Copyright Notification**

No part may be reproduced except as authorized by written permission.  
The copyright and the foregoing restriction extend to reproduction in all media.

© European Telecommunications Standards Institute 2000.  
All rights reserved.

---

## Intellectual Property Rights

IPRs essential or potentially essential to the present document may have been declared to ETSI. The information pertaining to these essential IPRs, if any, is publicly available for **ETSI members and non-members**, and can be found in SR 000 314: *"Intellectual Property Rights (IPRs); Essential, or potentially Essential, IPRs notified to ETSI in respect of ETSI standards"*, which is available from the ETSI Secretariat. Latest updates are available on the ETSI Web server (<http://www.etsi.org/ipr>).

Pursuant to the ETSI IPR Policy, no investigation, including IPR searches, has been carried out by ETSI. No guarantee can be given as to the existence of other IPRs not referenced in SR 000 314 (or the updates on the ETSI Web server) which are, or may be, or may become, essential to the present document.

---

## Foreword

This Technical Specification (TS) has been produced by the ETSI 3<sup>rd</sup> Generation Partnership Project (3GPP).

The present document may refer to technical specifications or reports using their 3GPP identities or GSM identities. These should be interpreted as being references to the corresponding ETSI deliverables. The mapping of document identities is as follows:

For 3GPP documents:

3G TS | TR nn.nnn "<title>" (with or without the prefix 3G)

is equivalent to

ETSI TS | TR 1nn nnn "[Digital cellular telecommunications system (Phase 2+) (GSM);] Universal Mobile Telecommunications System; <title>

For GSM document identities of type "GSM xx.yy", e.g. GSM 01.04, the corresponding ETSI document identity may be found in the Cross Reference List on [www.etsi.org/key](http://www.etsi.org/key)

# Contents

|  |    |
|--|----|
| Foreword.....  | 5  |
| 1 Scope.....   | 6  |
| 2 References.....  | 6  |
| 3 Definitions and abbreviations .....  | 6  |
| 3.1 Definitions .....  | 6  |
| 3.2 Abbreviations.....   | 7  |
| 4 Basic Assumptions.....   | 7  |
| 4.1 Boundaries of the Access Stratum .....   | 7  |
| 4.2 Main design guidelines .....   | 7  |
| 5 Functions location inside/outside Access Stratum.....                                  | 8  |
| 5.1 Call Control .....   | 9  |
| 5.2 (Connection) Bearer Control .....  | 9  |
| 5.3 Supplementary Services (CLIP, CF etc.) .....   | 10 |
| 5.4 Location Management .....  | 10 |
| 5.5 Attach/ Detach .....   | 10 |
| 5.6 Resource management .....  | 10 |
| 5.7 Handover .....   | 10 |
| 5.7.1 Handover - outside Access Stratum .....  | 10 |
| 5.7.2 Handover - inside Access Stratum .....   | 10 |
| 5.7.3 Handover scenarios supported by the Iu interface.....                              | 10 |
| 5.7.3.1 Classification A .....   | 10 |
| 5.7.3.2 Classification B .....   | 11 |
| 5.7.3.3 Classification C .....   | 11 |
| 5.7.3.4 Classification D .....   | 12 |
| 5.8 Macrodiversity.....  | 12 |
| 5.9 Encryption.....  | 12 |
| 5.10 Authentication of Subscriber .....  | 12 |
| 5.11 (Non source dependent coding) Compression .....                                     | 12 |
| 5.12 Source (e.g. voice or video) Coding .....   | 12 |
| 5.13 Radio Channel Coding.....   | 12 |
| 5.14 UE Location Identification .....  | 12 |
| 5.15 Charging .....  | 13 |
| 6 Access Stratum services.....   | 13 |
| 6.1 Service Access Points (SAPs).....  | 13 |
| 6.1.1 General Control SAPs .....   | 15 |
| 6.1.2 Notification SAPs.....   | 15 |
| 6.1.3 Dedicated Control SAPs.....  | 15 |
| 6.2 Operations.....  | 15 |
| 6.2.1 General .....  | 15 |
| 6.2.2 Common operations .....  | 16 |
| 6.2.2.1 General Control SAP .....  | 16 |
| 6.2.2.1.1 Information broadcast .....  | 16 |
| 6.2.2.2 Notification SAPs .....  | 16 |
| 6.2.2.2.1 Paging Request, IF side.....   | 16 |
| 6.2.2.2.2 Notification Broadcast Request, IF side.....                                   | 17 |
| 6.2.2.2.3 Notification Indication, UE side .....   | 17 |
| 6.2.2.3 Dedicated Control SAPs.....  | 17 |
| 6.2.2.3.1 UE Side Initiated Connection Establishment .....                               | 18 |
| 6.2.2.3.2 Connection Release.....  | 19 |
| 6.2.2.3.3 Information Transfer.....  | 19 |
| 6.2.2.3.4 IF Side Initiated Radio Access Bearer Establishment.....                       | 20 |
| 6.2.2.3.4.1 IF Side Initiated Radio Access Bearer Establishment Request, IF Side.....    | 21 |
| 6.2.2.3.4.2 IF Side Initiated Radio Access Bearer Establishment Indication, UE Side..... | 21 |

|  |  |           |
|--|--|-----------|
| 6.2.2.3.4.3  | IF Side Initiated Radio Access Bearer Establishment Response, UE Side..... | 21        |
| 6.2.2.3.4.4  | IF Side Initiated Radio Access Bearer Establishment Confirm, IF Side ..... | 21        |
| 6.2.2.3.5  | IF Side Initiated Radio Access Bearer Release .....                        | 21        |
| 6.2.2.3.5.1  | IF Side Initiated Radio Access Bearer Release Request, IF Side .....       | 21        |
| 6.2.2.3.5.2  | IF Side Initiated Radio Access Bearer Release Indication, UE Side.....     | 22        |
| 6.2.3  | IF side only operations .....  | 22        |
| 6.2.3.1  | Dedicated control SAPs.....  | 22        |
| 6.2.3.1.1  | Position update indication.....  | 22        |
| 6.2.3.1.2  | Connection loss indication .....   | 22        |
| 6.2.3.1.3  | Streamlining required indication.....                                      | 22        |
| 6.2.3.1.4  | Branch establishment request.....  | 22        |
| 6.2.3.1.5  | Branch establishment confirm .....   | 22        |
| 6.2.3.1.6  | UE location information request .....                                      | 22        |
| 6.2.3.1.7  | UE location information confirm .....                                      | 23        |
| 6.2.4  | UE side only operations .....  | 23        |
| 6.2.4.1  | Dedicated control SAPs.....  | 23        |
| 6.2.4.1.1  | Connection loss indication .....   | 23        |
| 6.3  | Parameters structure.....  | 23        |
| 6.3.1  | Local.....   | 23        |
| 6.3.2  | Bit string.....  | 23        |
| 6.3.3  | Enumerated .....   | 23        |
| 6.3.4  | Geographical description.....  | 23        |
| 6.3.5  | QoS .....  | 24        |
| 6.3.6  | Route .....  | 24        |
| 6.3.7  | Transaction identifier .....   | 24        |
| 6.3.8  | Transaction list.....  | 24        |
| 6.3.9  | Transmission mode .....  | 24        |
| 6.3.10   | AN/CN Point List.....  | 24        |
| 6.3.11   | Localisation .....   | 24        |
| <b>Annex A (informative): Change History .....</b> |  | <b>24</b> |
| History.....                                       |  | 27        |

---

# Foreword

This Technical Specification has been produced by the 3GPP.

The contents of the present document are subject to continuing work within the TSG and may change following formal TSG approval. Should the TSG modify the contents of this TS, it will be re-released by the TSG with an identifying change of release date and an increase in version number as follows:

Version 3.y.z

where:

- x the first digit:
  - 1 presented to TSG for information;
  - 2 presented to TSG for approval;
  - 3 Indicates TSG approved document under change control.
- y the second digit is incremented for all changes of substance, i.e. technical enhancements, corrections, updates, etc.
- z the third digit is incremented when editorial only changes have been incorporated in the specification;

---

# 1 Scope

This document specifies the services provided by the Access Stratum to the rest of the system. The adopted architecture is given by UMTS 23.01 "General Architecture"[2].

This document describes the main functions visible at the boundary between the Access Stratum and the rest of the system, it describes in general terms the information flows, both control and user data, over this boundary and relevant for the Access Stratum.

This document shall be the basis of the detailed specifications of the protocols which rule the information flows, both control and user data, between the Access Stratum and the parts of UMTS outside the Access Stratum, and of the detailed specifications of the UTRAN. These detailed specifications are to be found in other Technical Specifications.

---

# 2 References

The following documents contain provisions which, through reference in this text, constitute provisions of the present document.

- References are either specific (identified by date of publication, edition number, version number, etc.) or non-specific.
- For a specific reference, subsequent revisions do not apply.
- For a non-specific reference, the latest version applies.
- A non-specific reference to an ETS shall also be taken to refer to later versions published as an EN with the same number.

- [1] 3G TS 22.101: "Universal Mobile Telecommunications System (UMTS): Service aspects; Service principles".
- [2] 3G TS 23.101: "Universal Mobile Telecommunications System (UMTS): General UMTS Architecture"
- [3] 3G TS 23.105: "Universal Mobile Telecommunications System (UMTS): Network Principles"
- [4] ITU-T X.210: "Information Technology - Open Systems Interconnection - Basic Reference Model: Conventions for the Definition of OSI Services"; November 1993.
- [5] 3G TS 23.107: "QoS Concept and Architecture".

---

# 3 Definitions and abbreviations

## 3.1 Definitions

For the purposes of the present document, the following definitions apply:

For the purposes of the present document, the following definitions from other documents are referred to:

**Access Stratum:** defined in [2].

**Access Network:** defined in [2].

**Edge-Node:** a core network node which is connected to the URAN at a particular instance

**URAN:** defined in [TBD].

## 3.2 Abbreviations

For the purposes of the present document, the following abbreviations apply:

|       |  |
|-------|--|
| AN    | Access Network                             |
| AS    | Access Stratum                             |
| CC    | Call Control                               |
| DC    | Dedicated Control SAP                      |
| CN    | Core Network                               |
| GC    | General Control (SAP)                      |
| GPRS  | General Packet Radio Service               |
| GSM   | Global System for Mobile communications    |
| HPLMN | Home Public Land Mobile Network            |
| IF    | Infrastructure                             |
| ME    | Mobile Equipment                           |
| MM    | Mobility Management                        |
| MS    | Mobile Station                             |
| NAS   | Non Access Stratum                         |
| Nt    | Notification (SAP)                         |
| PDN   | Packet Data Network                        |
| PTM   | Point to Multipoint                        |
| RAN   | Radio Access Network                       |
| SAP   | Service Access Point                       |
| SAPI  | Service Access Point Identifier [??]       |
| SIM   | Subscriber Identity Module                 |
| SMS   | Short Message Service                      |
| SS    | Supplementary Services                     |
| UE    | User Equipment                             |
| UMTS  | Universal Mobile Telecommunications System |
| URAN  | UMTS Radio Access Network                  |
| USIM  | UMTS Subscriber Identity Module            |
| USSD  | Unstructured Supplementary Service Data    |
| UTRA  | UMTS Terrestrial Radio Access              |
| UTRAN | UMTS Terrestrial Radio Access Network      |
| VBS   | Voice Broadcast Service                    |
| VGCS  | Voice Group Call Service                   |
| VPLMN | Visited Public Land Mobile Network         |

---

## 4 Basic Assumptions

### 4.1 Boundaries of the Access Stratum

The Access Stratum (AS) is defined in [2]. It consists of a functional grouping which includes all the layers embedded in the URAN; and part of the layers in the User Equipment (UE) and the infrastructure (IF); i.e. the edge-node. Its boundary is the frontier between the layers which are independent of the access technique and the ones which are dependent on it. This frontier is located in the UE (mobile boundary) and in an edge-node (fixed boundary). There is a direct or "transparent" dialogue (i.e. not interpreted by the AS) between the UE and the edge-node for the Non-Access Stratum layers.

### 4.2 Main design guidelines

- 1) The Access Stratum contains all access specific functionality, e.g. all mode specific functionality in case of the UTRAN.
- 2) Reconfiguration of the AN, or changes in the AN domain functionality shall have minimal impact on Core Network functions, and vice-versa.
- 3) A given Access Network (e.g., the UTRAN) may provide access to different type of Core Networks via the  $I_u$  reference point.



- 4) The services, access signalling, mobility and subscriber management specific to each Core Network are completely outside the Access Stratum, and are transferred transparently by the Access Stratum.
- 5) The Access Stratum provides flexible radio access bearers characterised by parameters describing the type of information and QoS transported over the radio interface (i.e. not the actual radio resources). Some radio access bearers may be asymmetric, i.e., have different parameters on uplink and downlink.
- 6) There are radio access bearers for both connection oriented packet-switched services, connectionless (store-and-forward) services, and circuit-switched traffic.
- 7) Parameters for connection-oriented radio access bearers may change during connection (bandwidth on demand, quality management).
- 8) Whether a terminal can be registered and have connections to several Core Networks simultaneously (i.e., over different instances of Iu) is FFS.
- 9) The Access Stratum can provide several parallel and independent radio access bearers to one user equipment each with its own characteristics.
- 10) Multimedia is handled outside the Access Stratum by multiplexing several streams onto one radio access bearer or by requesting several parallel radio access bearers. In the latter case, the possibly needed synchronisation is handled outside the Access Stratum.
- 11) Connection of a user equipment to several URAN at a time has to be studied.
- 12) Handover and if applied macrodiversity within one Access Network is handled within the Access Stratum.
- 13) Handover between two Access Networks (e.g., two UTRANs, or between UTRAN and GSM BSS) may use support from the Core Network.
- 14) The Access Stratum should hide all access -specific parameters, e.g., location data provided to the Core Networks should be independent from the actual configuration of the Access Network.
- 15) The user equipment can be connected to different AN/CN points via a single Access Network. The Access Stratum should be able to provide a flexible routing to the appropriate AN/CN point.

---

## 5 Functions location inside/outside Access Stratum

Following table shows the functional split between Access Stratum and the rest of the system.

Table 1: Functions inside/outside the Access Stratum

| FUNCTION   | LOCATION | Outside the Access Stratum | Inside the Access Stratum         |
|--|----------|----------------------------|-----------------------------------|
| Call set up/release  |          | yes                        | no                                |
| (Connection) Bearer Set-Up<br>Release  |          | CN bearer [tbd]            | Radio Access Bearer [tbd]         |
| Supplementary Services   |          | yes                        | no                                |
| Location management  |          | yes (IWF/CN related)       | yes (Radio related)               |
| Attach/ Detach   |          | yes                        | FFS, Contr expected               |
| Resource Management  |          | yes (for NAS resource)     | yes (for AS resource incl. radio) |
| Handover   |          | yes*                       | yes                               |
| Macrodiversity [ffs]   |          | yes*                       | yes                               |
| Encryption   |          | yes                        | yes**                             |
| Authentication   |          | yes                        | no                                |
| compression (non source<br>dependent)  |          | yes                        | yes                               |
| source dependent coding  |          | yes                        | no                                |
| radio channel coding (could be<br>many)  |          | no                         | yes (could be many)               |
| UE location identification   |          | may be supported           | yes                               |
| Charging   |          | yes                        | no                                |
| NOTE *: Optionally execution. In some CNs, it may not be present but not full service will be supported (e.g. limited to RLL type of service). |          |                            |                                   |
| NOTE **: Contributions expected to clarify the role between encryption and subscriber data.  |          |                            |                                   |

## 5.1 Call Control

This Functionality is placed in the NAS, since it manipulates the call state machine. An example is termination of Q.931 message and sending of ISUP.

Not part of AS. NAS specific signalling messages, e.g. Q.931, Q.2931 and ISUP.

## 5.2 (Connection) Bearer Control

It is distinguished between the bearers used in the NAS and the common bearer used in the AS (radio access bearer).

Basic principles for radio access bearers are:

- 1) Radio access bearers provide information transport between the non-access stratum parts of the infrastructure side (i.e. the edge node) and the user equipment side. Radio access bearers shall support real time as well as non real time user traffic.
- 2) Radio access bearers must be flexible enough to support different traffic types, activity levels, throughput rates, transfer delays and bit error rates. Attributes allowing efficient use of radio resources are crucial.
- 3) Efficient mapping from the traffic attributes used by non-UMTS applications, given by dominating external network technologies, to the attributes of the radio access bearer layer of the access stratum is essential. Complexity in mapping procedures should be avoided.
- 4) Definitions of traffic attributes and traffic management for radio access bearers shall be consistent with the predominant networking technology on the market (e.g. N-ISDN and IP networks for UMTS phase 1). As networking technologies emerge, adapted radio access bearer attributes and types shall gradually be added.
- 5) Radio access bearer definitions must allow for straightforward and efficient traffic management and resource handling of the radio resources in the access stratum.

This procedure is part of the NAS. Example are 13.0 kbit/s (for GSM speech) and 2B+D (for ISDN BRI).

The protocols required in AS to provide a radio access bearer should be able to describe both packet switch and circuit

switch types of connections.

## 5.3 Supplementary Services (CLIP, CF etc.)

Supplementary services are part of the NAS, since they manipulate the Call state machine.

Supplementary services are not part of AS since they manipulate the call state machine.

## 5.4 Location Management

"Location Updating Management" and "Paging" is an existing example of Location Management.

Location Management may be supported in the NAS

Radio related Location Management may be part of the AS.

## 5.5 Attach/ Detach

If the Attach/ Detach procedures are supported in the NAS they use CN specific identifiers to mark the attached/detached subscriber. As an example in GSM, the attach/detach procedure is performed on the IMSI flag, and therefore it is a NAS functionality.

Attach/Detach may be performed in the AS using the URAN unique identifiers. This is FFS.

## 5.6 Resource management

This function allocates resources for a given information stream, as to allow to convey it with a given QoS. This information stream may support either signalling data (CC, MM, ...) or user data.

Both circuit switched and packet access are supported, offering both connection oriented and connectionless services.

The AS resource management is transparent for the NAS and vice versa.

## 5.7 Handover

### 5.7.1 Handover - outside Access Stratum

Handover may be a NAS functionality, but it can not be expected that all CNs will support handover therefore the IWF may take care of any required handover functionality. The AN may leave certain parameters, e.g. the address to a new IWF/CN-AN connection point, to which the IWF/CN may switch if it has the capabilities.

### 5.7.2 Handover - inside Access Stratum

Handover is performed in the AS, to hide all radio specific details from the NAS.

### 5.7.3 Handover scenarios supported by the Iu interface

The following sections describe which functions will be supported by the Iu interface. Some functions have no impact on the Iu interface and therefore will be supported de-facto, nevertheless they are explicitly mentioned for completeness of the scenarios.

#### 5.7.3.1 Classification A

Classification A describes the way the handover is prepared :

HO A1: the network has informed the target cell before the MS changes cell;

HO A2: the network has not informed the target cell before the MS changes cell;

HO A3: the mobile has informed the target cell before it leaves the source cell.

HO A1 is typical of the existing handover in GSM.

HO A2 reflects the call re-establishment in GSM, mobile directed handovers in general, or even GPRS to some extent (although the GPRS vocabulary is different).

HO A1, HO A2 and HO A3 shall be supported by the service primitives of the Iu interface.

### 5.7.3.2 Classification B

Classification B describes the way the decision to initiate a handover is taken:

HO B1: decision is taken by the terminal;

HO B2: decision is taken by the network.

When the network takes the decision, it can be either in the RAN (HO B2a), or in the CN (probably based on information provided by the RAN and/or the MS) (HO B2b).

In order to keep the radio independence from the CN, it would be desirable that the decision be taken only in the RAN. This means that a communication mechanism is needed between URANs, that interface being logically different from the Iu interface.

HO B1 and HO B2 shall be supported by the service primitives of the Iu interface.

NOTE 1: FFS: For HO B2 cases, handover initiation/decisions shall be taken by the source URAN.

NOTE 2: FFS: There is a URAN to URAN signalling mechanism transparent to the CN. A standardised protocol will be implemented across that interface to allow handover decisions by the URAN in HO B2 cases.

### 5.7.3.3 Classification C

Classification C concerns the kind of handover performed:

- 1) intra-cell handover;
- 2) intra-URAN handover;
- 3) inter-URAN handover (without change of CN access point);
- 4) intra-CN handover with same URAN type;
- 5) intra-CN handover with different URAN type;
- 6) inter-CN handover with same URAN type and same CN type;
- 7) inter-CN handover with different URAN type and same CN type;
- 8) inter-CN handover with same URAN type and different CN type;
- 9) inter-CN handover with different URAN type and different CN type;
- 10) inter-CN handover without change of URAN.

The type of URAN type should be relatively transparent to the Iu interface.

Regarding handovers across multiple CN, it is proposed that this is supported (and this is already possible with GSM).

C1 to C7 scenarios shall be supported by the service primitives of the Iu interface.

NOTE: FFS: scenarios C8 to C10 shall be supported by the service primitives of the Iu interface.

#### 5.7.3.4 Classification D

Regarding how a handover is performed, there is the possibility to either have the notion of anchor point, or not to have it. Example is circuit switched GSM, using anchor points, and GPRS, not using that notion.

Furthermore, the notion of anchor point may be handled differently for the signalling plane and the transmission plane.

The notion of anchor point shall be supported by the service primitives of the Iu interface.

NOTE1: FFS: the notion of transmission plane anchor point is supported by the service primitives of the Iu interface.

NOTE2: FFS: the notion of signalling plane anchor point is supported by the service primitives of the Iu interface.

NOTE3: FFS: the anchor points for the signalling plane and transmission plane need not necessarily be the same or even exist simultaneously. The flexibility should be left in UMTS by the Iu service principles.

### 5.8 Macrodiversity

(if needed, dependent of the choice of multiple access technology)

Not all IWF/CNs will support macrodiversity.

Macrodiversity may be supported in the AS, dependent on the choice of multiple access technology.

### 5.9 Encryption

The NAS may support encryption to protect the transmitted data.

The AS needs to support encryption to prevent from eavesdropping at the radio interface.

### 5.10 Authentication of Subscriber

Subscriber data is stored in the NAS and therefore authentication should be considered a NAS functionality.

NAS data is not stored in the URAN, and subscriber authentication can therefore not be a URAN functionality.

### 5.11 (Non source dependent coding) Compression

NAS may support compression.

The AS should support compression to optimise usage of radio resources.

### 5.12 Source (e.g. voice or video) Coding

Source coding is different dependent on IWF/CN and is therefore a NAS functionality.

### 5.13 Radio Channel Coding

Radio Channel coding is needed due to the radio interface and could therefore be considered a radio functionality.

Radio Channel coding is not a NAS functionality.

Radio Channel coding is supported by URAN.

### 5.14 UE Location Identification

The UE location identification may be supported by the UE and/or the access network side of the AS; i.e., URAN; e.g.,

as defined in the GSM LCS (Location Services) specifications or by some other means. The UE location identification is provided to identify the likely location of specific UEs. This is meant to be used for charging, location-based services, lawful interception, emergency calls, etc., as well as the positioning services.

When location identification is supported by URAN, the following apply,

- 1) URAN obtains 'Area ID' and/or geographic co-ordinates with uncertainty parameters for identification of the likely location of UE, to be sent to the NAS entity side of the CN (i.e., edge node) 'Area ID' represents either a radio access cell/sector or a geographic area. 'Area ID' is coded in the same format as Cell Global Identification (CGI), for compatibility to GSM.
- 2) Location information is categorised to two levels of accuracy. The Basic Level of information is what URAN obtains without extra signalling with the UE. The advanced level is obtained through extra signalling for positioning. Both levels can be used for both, Positioning services and other applications.
- 3) Location information is always at least obtained from URAN by the appropriate edge node(s) at the activation of a Call/PDP Context. Mechanism to make it possible to obtain the location information at the release of a Call/PDP Context should be specified. Location information sent to the edge node at other occasions is on the basis of asynchronous requests from the edge node to URAN. An edge node can request URAN to send the location information with the two types of requests, Type 1 (Direct request) where URAN sends location information only once at the request and Type 2 (Event request) where URAN sends location information at each specified event (e.g. Cell Update) requested by the edge node.

## 5.15 Charging

The functions related to charging are not part of the AS. These functions are mainly:

- charging information generation;
- charging processing.

---

## 6 Access Stratum services

The modelling of the services follow the basic principles as set by ITU-T X.210 [4]. In this recommendation the following figure is given as an example for peer-to-peer connection-mode services.

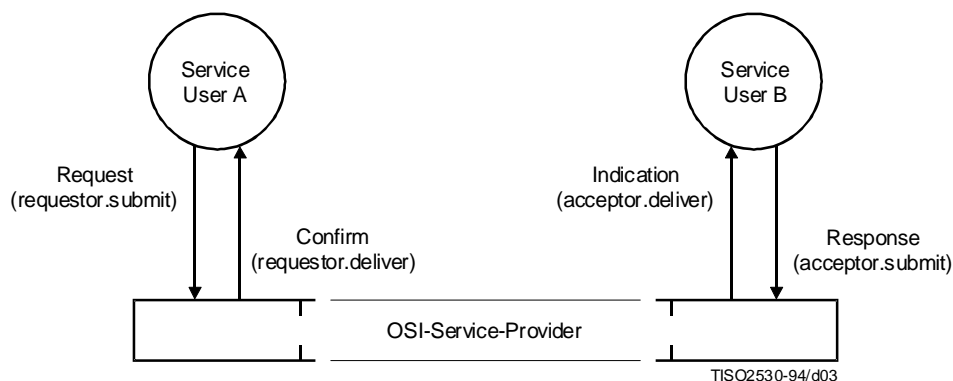
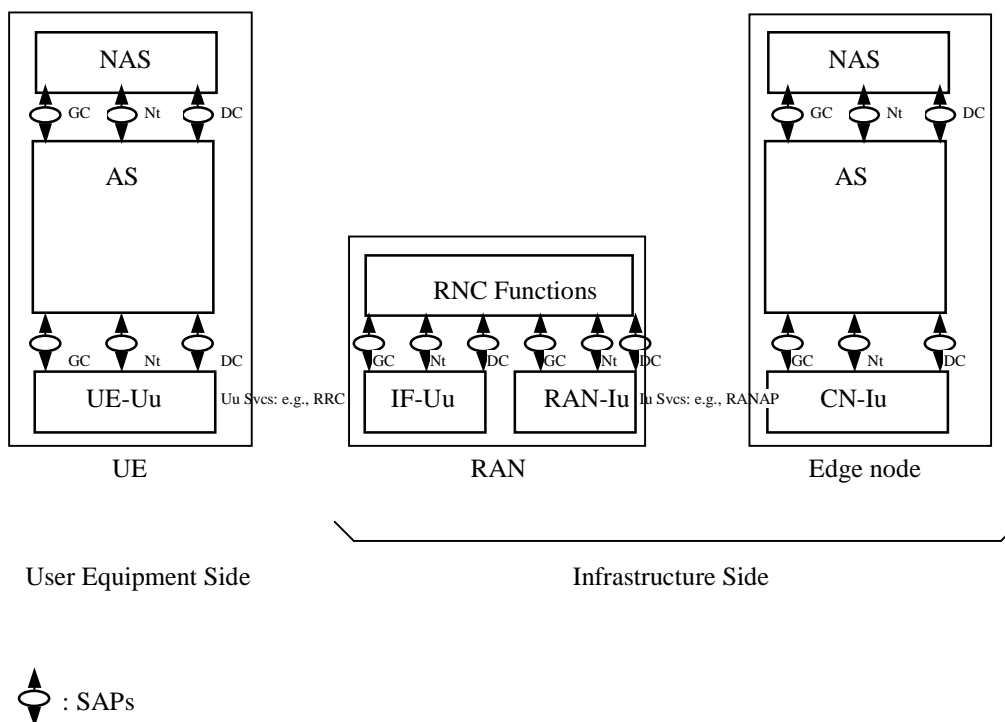

**Figure 1: Example of a peer-to-peer connection-mode service [4]**

For connectionless-mode services the basic primitives are "request" and "indication".

### 6.1 Service Access Points (SAPs)

The SAPs offered by the Access Stratum (AS) to the rest of the system (Non Access Stratum: NAS) are reflected in the following figure.



**Figure 2: Service Access Points (SAPs) offered by the Access Stratum (AS)**

For the time being, the SAPs offered by the AS are symmetric, i.e. the same SAPs are offered on the infrastructure side (CN-AS) and on the user equipment side (UE-AS). These SAPs are:

GC: General Control (see 6.1.1 for a general presentation and 6.2.2.1 for a detailed information).

Nt: Notification (see 6.1.2 for a general presentation and 6.2.2.2 for a detailed information).

DC: Dedicated Control (see 6.1.3 for a general presentation and 6.2.2.3 for a detailed information).

Note:

Broadcast and Multicast services can not be described using the services and functions defined so far in this TS. The nature of Broadcast and Multicast services, like Cell Broadcast Service (CBS), is very different from other specified services. The following model characteristics are missing to fulfil the CBS requirements, namely:

1. CBS uses two segments with different QoS requirements to deliver CB messages to the UE:

1a. From Cell Broadcast Center (CBC) to RNC, a SAP is required where for instance, 1 second turnaround time, interactive class, with a reliable transport is required.

1b. From RNC to UE, a SAP is required where for instance, a maximum delay of 10 seconds and a background class is required.

2. Because of (item 1), the service primitives used by each of the segments may also be different; i.e., the related SAPs to those primitives may differ in the two segments and a combination of GC, Nt, and DC SAPs requires study.

3. CBS traffic is asymmetric in nature. The communication flow is only in one direction from the CBC to the UE. There is no uplink channel needed and the UE can not initiate a communication or request specific information.

At least two changes are envisaged and thus detailed contributions are expected:

i. Introduce a new SAP type.

ii. Mapping example between the two communication segments.

Figure 2 shows also, as an example, some details of the AS architecture. The details are out of the scope of this document and are further specified in the 25-series.

This model does not exclude, nor imply, which protocol is specified between the UE-AS entity and the CN-AS entity. These protocols are 'transparent' for the AN, but participate in the service provided by the AS.

## 6.1.1 General Control SAPs

These SAPs are used to enable the Core Network to provide information and to give commands that do not relate to specific users or specific [sessions] (group calls, conference). There is typically one General Control SAP per AN/CN connection point. On the UE side, a possible model is to consider that there is a single General Control SAP in an MS.

## 6.1.2 Notification SAPs

These SAPs are used to broadcast data to identified Users. The typical use is for initiating paging in the AN. There is typically one Notification SAP per AN/CN connection point. On the UE side, a possible model is to consider that there is a single Notification SAP (a Paging SAP) in an MS.

## 6.1.3 Dedicated Control SAPs

These SAPs are used to establish, release connections with specific User Equipment, and to exchange information related to these connections. A connection is a relationship between temporary contexts respectively in the AN and in the CN. The context in the AN is initiated at the establishment of the connection, and erased when the connection is released. Several types of connections are identified, such as point connection (single user) and group connections.

There are typically a great number of Dedicated Control SAPs per AN/CN connection point. SAPs are identified by a SAPI at the AS boundary. During the lifetime of a connection, the connection can be identified unambiguously by the SAPI of the associated SAP, and the SAPI is used as a reference in the exchanges at the AS boundary on the infrastructure side.

A SAPI is used as a connection identifier allocated unambiguously to each connection during its lifetime, and used in the exchanges at the AS boundary on the infrastructure side.

On the UE side, a possible modelling is to consider that there is a single dedicated control SAP in an MS.

NOTE: On the UE side, an open issue is whether simultaneous services from distinct ANs can be provided to an MS. Settling this issue may lead to a different model, for instance with the possibility to have several Dedicated Control SAPs, one per AN with which an active context exists. Another issue, visible when analysing Point-to-Multipoint services in GSM, is the SAP modelling for those PTM services.

NOTE: The model is limited in this version to the cases where all the activity between a User Equipment and the infrastructure pertains to the same subscriber. Extension to cases with several subscriber sharing a User Equipment requires further study.

# 6.2 Operations

## 6.2.1 General

The operations are described both for the AS boundary on the Infrastructure side and on the User Equipment side. The description of the operations on the Infrastructure side is given with sufficient details to develop on this basis a concrete control protocol at the AN/CN inter-connection. The description of the operations on the User Equipment side may be used [to be discussed] for developing a concrete API, allowing an open modular design of the User Equipment software.

The operations are described in three sections, one for operations that involve both the IF side and the UE side, one for operations local to the IF and finally one for operations local to the UE side. In each sections, operations are sorted per SAP category.

Request and confirm primitives are always toward the Access Stratum. Indication and response primitives are always from the Access Stratum.



## 6.2.2 Common operations

### 6.2.2.1 General Control SAP

#### 6.2.2.1.1 Information broadcast

This operation consists in the broadcast from IF toward User Equipment of some information in some geographical area. This information is to be used by the User Equipment for instance to choose among access points or to be taken into account during initial access. The information can also be destined to an application.

NOTE: This concerns only information to be broadcasted on behalf of Non Access Strata. Other information may be broadcasted for the internal use of the Access Stratum.

##### 6.2.2.1.1.1 Information broadcast request, IF side

The parameters are:

|                          |  |
|--------------------------|--|
| Category                 | enumerated (access point selection, initial access, application) |
| Geographical area        | geographical area  |
| Information to broadcast | bit string   |

The size of the information to broadcast is not bound by this description, but may be constrained by the access system.

The geographical area is used by the AN to determine which access points are concerned. The rules are not specified in the external specification of the AS, but must exist and must be consistent with other translations between geographical descriptions and access points (e.g., in the connection establishment).

The category is used by the AN to determine priority and more generally the parameters governing information repetition over time.

NOTE: The category field could be enhanced, e.g., to allow a more precise control of priorities and repetitions.

##### 6.2.2.1.1.2 Information Broadcast Indication, UE Side

The parameters are

|                        |            |
|------------------------|------------|
| Access point reference | local      |
| Broadcast information  | bit string |

The access point reference identifies the point on the access boundary (e.g., the cell) where the information was received.

NOTE: The access point reference is a local reference, to be used in other primitives at the AS/NAS boundary in the same UE.

### 6.2.2.2 Notification SAPs

Notification operations consists of sending information to a dedicated user/terminal, or a group of users/terminals over a defined geographic area.

Typically the request is forwarded to the user/terminal on a broadcast resource. If the AN knows of an existing signalling relation to the user/terminal, the information might be sent through the existing relation, according to Access Stratum specifications.

#### 6.2.2.2.1 Paging Request, IF side

The parameters are the following:

|                                      |                            |
|--------------------------------------|----------------------------|
| User/terminal Identity               | pageable identity          |
| Geographical area where to broadcast | geographical area          |
| Paging resource parameters           | paging resource parameters |
| Information to send                  | bit string                 |

The user/terminal identity is provided to determine if a signalling relation with the user/terminal exists. The geographical area indicates the area in which the Core Network knows the User/terminal(s) to be.

The size of the information to send is not bound by this description, but may be constrained by the access system.

The paging resource parameters are used to determine which paging resource to be used when several are available. The organisation of paging resources is known in advance by the User Equipment, and are used by the User Equipment to choose the paging resources to listen to. The exact use of the paging resource parameters is specified as part of Access Stratum specifications.

**NOTE:** This function is typically used for paging, i.e., to trigger an access from the User/terminal. However, this is not relevant to the Access Stratum, and other uses can be envisaged without impacting the Access Stratum. The action required from the MS, if any, is indicated, implicitly or explicitly, in the information to send, the content of which being part of the Non Access Strata specifications and not of the Access Stratum specifications.

#### 6.2.2.2.2 Notification Broadcast Request, IF side

The parameters are the following:

|                                      |                            |
|--------------------------------------|----------------------------|
| Geographical area where to broadcast | geographical area          |
| Notification resource parameters     | paging resource parameters |
| Information to broadcast             | bit string                 |

The size of the information to broadcast is not bound by this description, but may be constrained by the access system.

The paging resource parameters are used to determine which paging resource to be used when several are available. The organisation of paging resources is known in advance by the User Equipment, and are used by the User Equipment to choose the paging resources to listen to. The exact use of the paging resource parameters is specified as part of Access Stratum specifications.

**NOTE:** This operation is used typically to inform all MSes of some starting or on-going activities, such as group calls.

#### 6.2.2.2.3 Notification Indication, UE side

Parameters

|                        |            |
|------------------------|------------|
| Access point reference | local      |
| Broadcast information  | bit string |

**NOTE:** This primitive applies both for a paging sent on broadcast resources and for the reception of an information broadcast to many users.

#### 6.2.2.3 Dedicated Control SAPs

Dedicated Control operations are done within the scope of a connection, embodied by corresponding SAPs on the UE and IF sides. This scope is determined by local references (respectively on the UE side and on the IF side). All operations contain such a local reference, and, at a given AN/CN interconnection point, all operations with the same local reference from the establishment event to the release event pertain to the same connection. The correspondence between Dedicated Control SAPs on the UE and IF side is dynamic, and established through the connection establishment operations.

The local connection references have only a local scope, and their values do not necessarily have any predictable

relationship with the corresponding reference local to the other side, or with a reference used over some interface to multiplex the messages pertaining to the connection with messages pertaining to other connections.

### 6.2.2.3.1 UE Side Initiated Connection Establishment

This operation consists in the establishment of a new connection at the initiative of NAS on the User Equipment side.

#### 6.2.2.3.1.1 UE Side Initiated Connection Establishment Request, UE side

Parameters

|                            |                    |
|----------------------------|--------------------|
| Local connection reference | local              |
| Routing parameters         | routing parameters |
| Initial message            | bit string         |

The routing parameters are to be used by the AS on the Infrastructure side to choose the AN/CN connection point through which the connection is to be established.

The initial message is to be forwarded to the non-access strata. The size of the initial message should not be constrained by the access system.

#### 6.2.2.3.1.2 UE Side Initiated Connection Establishment Indication, IF side

Parameters

|                            |                   |
|----------------------------|-------------------|
| Local connection reference | local             |
| Initial message            | bit string        |
| Localisation data          | localisation data |

The localisation data indicate the knowledge the AN has of the localisation of the initiating User Equipment. It includes typically a geographical area and some accuracy indication.

#### 6.2.2.3.1.3 UE Side Initiated Connection Establishment Confirm, IF Side

Parameters

|                            |  |
|----------------------------|--|
| Local connection reference | local                                    |
| Status                     | enumerated (terminated by NAS, going on) |
| Initial answer             | bit string                               |

The NAS can choose not to pursue the connection (status = terminated by NAS). Reasons can be that the information provided by the User Equipment did not require more than a single message answer (e.g., store-and-forward service), or some exception conditions prevented the CN to pursue the connection.

The initial answer is to be provided to the requesting part in the non-access strata.

#### 6.2.2.3.1.4 UE Side Initiated Connection Establishment Response, UE side

Parameters

|                            |  |
|----------------------------|--|
| Local connection reference | local  |
| Status                     | enumerated (terminated by NAS, terminated by AS, going on) |
| Initial answer             | bit string   |

The initial answer is not provided in the case the status is 'terminated by AS'. The status 'going on' and 'terminated by NAS' indicates that the initial message was delivered to the NAS; on the other hand, the status 'terminated by AS' can happen whether or not the initial message was delivered to the NAS.

### 6.2.2.3.2 Connection Release

This operation is the termination of a connection, at the request of non-access strata on the Infrastructure side. The use of this operation may lead to the non-completion of other previously started operations in the same connection (e.g., transparent data transfer).

#### 6.2.2.3.2.1 IF Initiated Connection Release Request, IF Side

Parameter

|                            |       |
|----------------------------|-------|
| Local connection reference | local |
|----------------------------|-------|

#### 6.2.2.3.2.2 IF Initiated Connection Release Indication UE side

Parameter

|                            |       |
|----------------------------|-------|
| Local connection reference | local |
|----------------------------|-------|

### 6.2.2.3.3 Information Transfer

These operations allow the transfer of messages between Non-Access Strata elements on each side of the access interface.

The service is essentially that of a transport layer, with multiplexing, and possibly guarantee of order and correct transmission (transmission difficulties lead to connection loss), including the effect of user movements. The operation caters only for transmission from AS boundary to access boundary. Upper layers of protocol are typically added for addressing and routing beyond this boundary.

Several independent streams can exist simultaneously on the same connection, as distinguished by a routing and transaction identifiers. Message order is guaranteed, if applicable, on a stream basis. Routing identifiers are typically used to indicate originator and destination (e.g., USIM to Home, ME to Serving, and also distinctions such as GSM between MM and CC for instance...). Transaction identifiers are used to distinguish streams with the same originator and destination. Messages can be sent within a transaction or not. Transactions are explicitly set up and released, either in-band (i.e., together with information transfer) or out-band. Transaction identifiers have only a local significance.

**NOTE:** There is a difficulty behind the message order. In some cases it may be important to keep message order in a combination of streams, e.g., within a route, or even involving two routes. The model presented so far is too simple to cope with such cases.

A quality of service indication is present in sending requests. This covers such aspects as message order, effect on other on-going traffic (e.g., speech pre-emption), delay. A finite number of quality of service classes will be identified, and the one to apply to a message indicated.

With each transaction is associated a default quality of service, established at transaction establishment or by a subsequent modification request.

A transmission mode indication is present in reception indications. This gives information from the Access Stratum on the aspects of the transmission related to service quality of service (e.g., speech has been pre-empted).

**NOTE:** This covers circuit data transport, including cases where each message is very small (down to 1 bit or other information quantum). Obviously, in such cases these primitives are a model not to be followed in implementations.

#### 6.2.2.3.3.1 Data Transfer Request, IF Side

Parameters

|                               |  |
|-------------------------------|--|
| Local connection reference    | local  |
| Route                         | route  |
| Transaction identification    | local  |
| Transaction management        | enumerated (single, first, subsequent, last) |
| Quality of Service indication | QoS  |
| Message                       | bit string                                   |

The transaction management field indicates if the message is independent from transactions (single), is the first of the transaction and hence initialises the transaction (first), is the last of the transaction and hence releases the transaction (last), or is in the middle of a transaction.

The primitive can be used with an empty message for transaction management alone (value 'single' is then meaningless).

#### 6.2.2.3.3.2 Data Transfer Indication, UE Side

Parameters

|                              |  |
|------------------------------|--|
| Local connection reference   | local  |
| Route                        | route  |
| Transaction identification   | local  |
| Transaction management       | enumerated (single, first, subsequent, last) |
| Transmission mode indication | transmission mode                            |
| Message                      | bit string                                   |

#### 6.2.2.3.3.3 Data Transfer Request, UE Side

Parameters

|                               |  |
|-------------------------------|--|
| Local connection reference    | local  |
| Route                         | route  |
| Transaction identification    | local  |
| Transaction management        | enumerated (single, first, subsequent, last) |
| Quality of Service indication | QoS  |
| Message                       | bit string                                   |

#### 6.2.2.3.3.4 Data Transfer Indication, IF Side

Parameters

|                              |  |
|------------------------------|--|
| Local connection reference   | local  |
| Route                        | route  |
| Transaction identification   | local  |
| Transaction management       | enumerated (single, first, subsequent, last) |
| Transmission mode indication | transmission mode                            |
| Message                      | bit string                                   |

#### 6.2.2.3.4 IF Side Initiated Radio Access Bearer Establishment

These operations allow the transfer of control messages for radio access bearer establishment between non-access strata elements on each side of the access interface. The operations pertain to the connection identified by the local connection reference parameter. The operations allow the IF side to initialise a radio access bearer. The operation also implies a request to the AS to allocate transmission resources to the radio access bearer.

A radio access bearer identification uniquely identifies the radio access bearer. It is used in all primitives that pertain to the radio access bearer. The radio access bearer identification has only local significance.

A NAS reference is provided in the radio access bearer establishment primitives. It contains application specific information, to be used by the remote NAS entity at the UE side. It may, for example, serve as the binding to a NAS call.

A quality of service request specifies the bearer characteristics that apply to the radio access bearer.

#### 6.2.2.3.4.1 IF Side Initiated Radio Access Bearer Establishment Request, IF Side

Parameters

|                                    |            |
|------------------------------------|------------|
| Local connection reference         | local      |
| Radio access bearer identification | local      |
| NAS reference                      | bit string |
| Quality of Service request         | QoS        |

#### 6.2.2.3.4.2 IF Side Initiated Radio Access Bearer Establishment Indication, UE Side

Parameters

|                                    |            |
|------------------------------------|------------|
| Local connection reference         | local      |
| Radio access bearer identification | local      |
| NAS reference                      | bit string |

#### 6.2.2.3.4.3 IF Side Initiated Radio Access Bearer Establishment Response, UE Side

Parameters

|                                    |  |
|------------------------------------|--|
| Local connection reference         | local                                    |
| Radio access bearer identification | local                                    |
| Status                             | enumerated (terminated by NAS, going on) |

#### 6.2.2.3.4.4 IF Side Initiated Radio Access Bearer Establishment Confirm, IF Side

Parameters

|                                    |  |
|------------------------------------|--|
| Local connection reference         | local  |
| Radio access bearer identification | local  |
| Status                             | enumerated (terminated by NAS, terminated by AS, going on) |

#### 6.2.2.3.5 IF Side Initiated Radio Access Bearer Release

These operations allow the transfer of radio access bearer release messages between non-access strata elements on each side of the access interface. The operations pertain to the connection identified by the local connection reference parameter. The operations allow IF side to release a radio access bearer.

NOTE: A radio access bearer release procedure is normally initiated by the IF side. Abnormal cases such as termination by the AS are FFS.

#### 6.2.2.3.5.1 IF Side Initiated Radio Access Bearer Release Request, IF Side

Parameters

|                                    |       |
|------------------------------------|-------|
| Local connection reference         | local |
| Radio access bearer identification | local |

#### 6.2.2.3.5.2 IF Side Initiated Radio Access Bearer Release Indication, UE Side

Parameters

|                                    |       |
|------------------------------------|-------|
| Local connection reference         | local |
| Radio access bearer identification | local |

### 6.2.3 IF side only operations

#### 6.2.3.1 Dedicated control SAPs

##### 6.2.3.1.1 Position update indication

Parameters

|                            |          |
|----------------------------|----------|
| Local connection reference | local    |
| Position                   | position |

##### 6.2.3.1.2 Connection loss indication

Parameters

|                            |       |
|----------------------------|-------|
| Local connection reference | local |
|----------------------------|-------|

##### 6.2.3.1.3 Streamlining required indication

This operation is used by the AS to indicate that the connection runs the risk to be aborted unless a streamlining is done.

Parameters

|   |                  |
|---|------------------|
| Local connection reference                | local            |
| Proposed list of alternative AN/CN points | AN/CN point list |

##### 6.2.3.1.4 Branch establishment request

This operation establishes a new branch supporting dedicated mode transport for a given UE.

Parameters

|                            |                  |
|----------------------------|------------------|
| Local connection reference | local            |
| Transaction list           | transaction list |

The transaction list describes the transactions for which the establishment prior the first transmission of data is required.

##### 6.2.3.1.5 Branch establishment confirm

This indicates that the branch is successfully established up to the UE and can then be used for transmission. As a result, the NAS may decide to remove the old branch.

Parameters

|                            |       |
|----------------------------|-------|
| Local connection reference | local |
|----------------------------|-------|

##### 6.2.3.1.6 UE location information request

This operation is sent from the NAS entity inside the CN (i.e. edge node) to the access network side of AS (i.e. URAN) to request the location information of a specific UE.

Parameters:

|                            |                                 |
|----------------------------|---------------------------------|
| Local connection reference | local                           |
| Level of accuracy          | basic level or advanced level   |
| Type of request            | direct request or event request |
| Event                      | conditions to send information  |

The level of accuracy describes the granularity required on the UE location information, either basic or advanced. The type of request describes whether the request is to get the current UE location or to get the location when some conditions specified by event are satisfied.

#### 6.2.3.1.7 UE location information confirm

This operation is sent in response to the UE location information request operation.

Parameters:

|                            |   |
|----------------------------|---|
| Local connection reference | local   |
| Area ID                    | UE location information in terms of CGI format  |
| Geographic coordinates     | UE location information in terms of coordinates |
| Event                      | conditions met                                  |

The Area ID is to be formatted in accordance with the CGI (Cell Global Identity). The geographic co-ordinates represents the physical co-ordinates on the earth and uncertainty parameters.

*[To be completed]*

### 6.2.4 UE side only operations

#### 6.2.4.1 Dedicated control SAPs

##### 6.2.4.1.1 Connection loss indication

Parameters

|                            |       |
|----------------------------|-------|
| Local connection reference | local |
|----------------------------|-------|

*[To be completed]*

## 6.3 Parameters structure

### 6.3.1 Local

The structure is not relevant in the scope of this document, and can be decided on an implementation basis.

### 6.3.2 Bit string

A finite ordered sequence of bit values.

### 6.3.3 Enumerated

The parameter can take one value out of a list explicitly given.

### 6.3.4 Geographical description

TBI



### 6.3.5 QoS

This section describes the radio access bearer (RAB) by referencing a list of attributes related to the QoS. The radio access bearers are divided into two categories:

- Restricted radio access bearers
- Unrestricted radio access bearers

An unrestricted radio access bearer is meant for data requiring bit sequence integrity (e.g., N-ISDN data transport), whereas a restricted radio access bearer contains a description of the nature of the information (e.g., encoded voice). For a restricted radio access bearer, the characteristics are implicitly given.

The characterisation of a radio access bearer is made by using a set of attributes. A radio access bearer attribute is a specific characteristic that distinguishes it from other radio access bearer services. Refer to ref. [5] for a list of these QoS attributes. Particular values are also indicated in that specification for different services.

In order to describe the desired radio access bearer service, QoS attributes are defined at the SAP. Note that it is not necessary, nor meaningful to support all possible combinations of parameter settings.

NOTE: In case of an unrestricted radio access bearer, for every SDU provided at the SAP, bit sequence integrity should be maintained.

### 6.3.6 Route

TBI

### 6.3.7 Transaction identifier

Local.

### 6.3.8 Transaction list

A list of transactions, each described by a transaction identifier (local) and by QoS parameters.

### 6.3.9 Transmission mode

TBI

### 6.3.10 AN/CN Point List

TBI

### 6.3.11 Localisation

TBI

---

## Annex A (informative): Change History

| Document history |          |   |
|------------------|----------|---|
| 0.0.0            | 04.04.97 | Initial Draft; preliminarily indicated as 23.yy |
| 0.1.0            | 19.05.97 | Second Draft; major improvements in clause 4.2  |

|             |          |  |
|-------------|----------|--|
| 0.1.1       | 12.06.97 | Revised version according to<br>- decisions during the meeting 20-22.05.97, Sophia Antipolis<br>- ETSI drafting rules,<br>renamed as "23.10"   |
| 0.2.0       | 07.07.97 | Revised version according to decisions during the meeting 30.06.-04.07.97, Sophia Antipolis. Major improvements in clause 5.   |
| 0.2.1       | 28.08.97 | Revised version according to decisions during the meeting 30.06.-04.07.97, Sophia Antipolis. Some changes in clause 5.   |
| 0.3.0       | 22.09.97 | Renumbered due to ETSI Drafting Rules, no changes since 0.2.1  |
| 0.3.1       | 12.11.97 | Some editorial changes, in particular adding notes to invite contributions in order to align "older parts" of the document and "scope"   |
| 0.4.0       | 08.01.98 | Revised version according to decisions during the meeting 17.-21.11.97, Kista:<br>- adoption of document incl. title to the scope<br>- improvements in clauses 4, 4.3.6 and 5.2.2.2.   |
| 0.5.0       | 23.01.98 | Revised version according to decisions during the meeting 19.-21.01.98, Malmö:<br>- figure 1 in clause 5.1 added   |
| 0.6.0       | 1998-04  | Revised version according to decisions during the meeting 23.-27.03.98, Bad Aibling:<br>- chapter 4 restructured (=> new chapter 5)<br>- table on functions in-/outside Access stratum revised<br>- some improvements in new chapter 5.6 |
| 0.6.1       | 1998-06  | No changes since 0.6.0 but deletion of revision marks and reformatting to paper size "LETTER" instead of "A4"  |
| 0.7.0       | 1998-08  | Revisions as agreed on TD 98s357 in June meeting (Chicago).<br><br>NOTE: Other agreed revisions could not be inserted as the relevant documents were not electronically available (TDocs 466, 467, 469, 476)                             |
| 0.7.1       | 1998-08  | Editorial changes:<br>- Some information from X.210 added.<br>- some further textual alignment to the current state of 23.01   |
| 0.8.0       | 1998-08  | Revisions as agreed in August meeting (Sophia Antipolis).<br><br>NOTE: Revisions according to TDocs 466, 467, 469, 476 are integrated also.  |
| 0.8.1       | 1998-09  | Editorial alignment due to rapporteur's notes on revisions as provided by TD 98s654 and additional text alignment.   |
| 1.0.0       | 1998-09  | Version 1.0.0 for presentation for information to SMG#27   |
| 1.0.1 draft | 1998-11  | Editorial updates from ver. 0.8.0 to ver. 0.8.1, and text alignments.<br><br>Addition of primitives, sections 6.2.2.3.4 and 6.2.2.3.5, for Control messages (Dedicated Control SAP) - RAB control procedures, Tdoc 98S720 (Rome).        |
| 1.0.1       | 1998-12  | Addition of editorial comments from November (Castle Combe) meeting.   |
| 1.1.0       | 1999-01  | Replacement of previous Section 5.14, Terminal Positioning, by new Section: UE Location Identification. With two enumerated bullet items, as agreed in the San Francisco meeting.  |

|       |         |   |
|-------|---------|---|
| 1.2.0 | 1999-02 | Addition of third enumerated item into section 5.14. In same section, an editor's note was inserted, regarding the need of primitives and operations, when the location services item is finalized. Title of section 5.4, replaced from 'MS Tracking' to 'Location Management'. In Table 1, replacement of 'UE positioning' to 'UE location identification' and 'UE Tracking' to 'UE location management'. Remove superfluous editor's notes throughout the specification.  |
| 2.0.0 | 1999-02 | Update in revision numbering for presentation to SMG#28 and provision to 3GPP for their baseline documentation.   |
| 3.0.0 | 1999-02 | Approved at SMG#28. Document for Transfer to TSG-SA   |
| 3.1.0 | 1999-03 | Addition of background information on UE location identification to section 5.14. Addition of primitives related to UE location information, sections 6.2.3.1.6-7: UE location information request and confirm, respectively. Both updates approved in S2#3, Nynaeshamn.<br><br>Update related to transcoder location at the core network and source depending coding belonging to the non-access stratum. Updates agreed in Ad hoc in February in Paris and approved in S2#3. Table 1, editorial section 5.12, section 6.3.5, QoS, and Table A.1 - speech codec in access stratum. |
| 3.2.0 | 1999-11 | Inclusion of CR 002 (editorial) and CR003 (removal of the QoS parameters) as agreed by TSG SA#5.  |
| 3.3.0 | 2000-01 | Inclusion of CR004 (note on CBS functions) and introduction of the figure in CR 003 (removal of the QoS parameters) not introduced by error in v.3.2.0, as approved by TSG SA#6.  |

---

# History

| <b>Document history</b> |              |             |
|-------------------------|--------------|-------------|
| V3.3.0                  | January 2000 | Publication |
|                         |              |             |
|                         |              |             |
|                         |              |             |
|                         |              |             |