

ETSI TS 123 122 V15.4.0 (2018-06)



**Digital cellular telecommunications system (Phase 2+) (GSM);  
Universal Mobile Telecommunications System (UMTS);  
LTE;  
Non-Access-Stratum (NAS) functions related to  
Mobile Station (MS) in idle mode  
(3GPP TS 23.122 version 15.4.0 Release 15)**



---

Reference

RTS/TSGC-0123122vf40

---

Keywords

GSM,LTE,UMTS

**ETSI**

650 Route des Lucioles  
F-06921 Sophia Antipolis Cedex - FRANCE

Tel.: +33 4 92 94 42 00 Fax: +33 4 93 65 47 16

Siret N° 348 623 562 00017 - NAF 742 C  
Association à but non lucratif enregistrée à la  
Sous-Préfecture de Grasse (06) N° 7803/88

---

**Important notice**

The present document can be downloaded from:

<http://www.etsi.org/standards-search>

The present document may be made available in electronic versions and/or in print. The content of any electronic and/or print versions of the present document shall not be modified without the prior written authorization of ETSI. In case of any existing or perceived difference in contents between such versions and/or in print, the only prevailing document is the print of the Portable Document Format (PDF) version kept on a specific network drive within ETSI Secretariat.

Users of the present document should be aware that the document may be subject to revision or change of status.

Information on the current status of this and other ETSI documents is available at

<https://portal.etsi.org/TB/ETSIDeliverableStatus.aspx>

If you find errors in the present document, please send your comment to one of the following services:

<https://portal.etsi.org/People/CommiteeSupportStaff.aspx>

---

**Copyright Notification**

No part may be reproduced or utilized in any form or by any means, electronic or mechanical, including photocopying and microfilm except as authorized by written permission of ETSI.

The content of the PDF version shall not be modified without the written authorization of ETSI.

The copyright and the foregoing restriction extend to reproduction in all media.

© ETSI 2018.

All rights reserved.

**DECT™**, **PLUGTESTS™**, **UMTS™** and the ETSI logo are trademarks of ETSI registered for the benefit of its Members.

**3GPP™** and **LTE™** are trademarks of ETSI registered for the benefit of its Members and of the 3GPP Organizational Partners.

**oneM2M** logo is protected for the benefit of its Members.

**GSM®** and the GSM logo are trademarks registered and owned by the GSM Association.

---

# Intellectual Property Rights

## Essential patents

IPRs essential or potentially essential to normative deliverables may have been declared to ETSI. The information pertaining to these essential IPRs, if any, is publicly available for **ETSI members and non-members**, and can be found in ETSI SR 000 314: *"Intellectual Property Rights (IPRs); Essential, or potentially Essential, IPRs notified to ETSI in respect of ETSI standards"*, which is available from the ETSI Secretariat. Latest updates are available on the ETSI Web server (<https://ipr.etsi.org/>).

Pursuant to the ETSI IPR Policy, no investigation, including IPR searches, has been carried out by ETSI. No guarantee can be given as to the existence of other IPRs not referenced in ETSI SR 000 314 (or the updates on the ETSI Web server) which are, or may be, or may become, essential to the present document.

## Trademarks

The present document may include trademarks and/or tradenames which are asserted and/or registered by their owners. ETSI claims no ownership of these except for any which are indicated as being the property of ETSI, and conveys no right to use or reproduce any trademark and/or tradename. Mention of those trademarks in the present document does not constitute an endorsement by ETSI of products, services or organizations associated with those trademarks.

---

# Foreword

This Technical Specification (TS) has been produced by ETSI 3rd Generation Partnership Project (3GPP).

The present document may refer to technical specifications or reports using their 3GPP identities, UMTS identities or GSM identities. These should be interpreted as being references to the corresponding ETSI deliverables.

The cross reference between GSM, UMTS, 3GPP and ETSI identities can be found under <http://webapp.etsi.org/key/queryform.asp>.

---

# Modal verbs terminology

In the present document "**shall**", "**shall not**", "**should**", "**should not**", "**may**", "**need not**", "**will**", "**will not**", "**can**" and "**cannot**" are to be interpreted as described in clause 3.2 of the [ETSI Drafting Rules](#) (Verbal forms for the expression of provisions).

"**must**" and "**must not**" are **NOT** allowed in ETSI deliverables except when used in direct citation.

# Contents

|  |    |
|--|----|
| Intellectual Property Rights .....                                       | 2  |
| Foreword.....  | 2  |
| Modal verbs terminology.....   | 2  |
| Foreword.....  | 5  |
| 1 Scope .....  | 6  |
| 1.1 References .....   | 6  |
| 1.2 Definitions and abbreviations.....                                   | 9  |
| 2 General description of idle mode .....                                 | 11 |
| 3 Requirements and technical solutions .....                             | 12 |
| 3.1 PLMN selection and roaming.....                                      | 13 |
| 3.1A CSG selection / restriction.....                                    | 16 |
| 3.1B PLMN selection triggered by ProSe direct communication .....        | 16 |
| 3.1C PLMN selection triggered by V2X communication over PC5 .....        | 18 |
| 3.2 Regional provision of service.....                                   | 20 |
| 3.3 Borders between registration areas.....                              | 20 |
| 3.4 Access control .....   | 21 |
| 3.4.1 Access control.....  | 21 |
| 3.4.2 Forbidden LA or TA for regional provision of service .....         | 21 |
| 3.5 No suitable cell (limited service state) .....                       | 22 |
| 3.6 CTS fixed part selection (A/Gb mode only).....                       | 22 |
| 3.7 NAS behaviour configuration.....                                     | 22 |
| 4 Overall process structure .....  | 23 |
| 4.1 Process goal.....  | 23 |
| 4.2 States description.....  | 23 |
| 4.3 List of states .....   | 23 |
| 4.3.1 List of states for the PLMN selection process .....                | 23 |
| 4.3.1.1 List of states for automatic mode (figure 2a) .....              | 23 |
| 4.3.1.2 List of states for manual mode (figure 2b).....                  | 23 |
| 4.3.2 Void .....   | 23 |
| 4.3.3 List of states for location registration (figure 3) .....          | 23 |
| 4.4 PLMN selection process.....  | 25 |
| 4.4.1 Introduction.....  | 25 |
| 4.4.2 Registration on a PLMN .....                                       | 25 |
| 4.4.3 PLMN selection .....   | 25 |
| 4.4.3.1 At switch-on or recovery from lack of coverage.....              | 26 |
| 4.4.3.1.1 Automatic Network Selection Mode Procedure .....               | 26 |
| 4.4.3.1.2 Manual Network Selection Mode Procedure.....                   | 28 |
| 4.4.3.1.3 Manual CSG selection.....                                      | 29 |
| 4.4.3.1.3.1 General.....   | 29 |
| 4.4.3.1.3.2 Manual CSG selection within the RPLMN.....                   | 30 |
| 4.4.3.1.3.3 Manual CSG selection in a PLMN different from the RPLMN..... | 30 |
| 4.4.3.2 User reselection.....  | 31 |
| 4.4.3.2.1 Automatic Network Selection Mode .....                         | 31 |
| 4.4.3.2.2 Manual Network Selection Mode.....                             | 31 |
| 4.4.3.2.3 Manual CSG selection.....                                      | 31 |
| 4.4.3.3 In VPLMN .....   | 32 |
| 4.4.3.3.1 Automatic and manual network selection modes .....             | 32 |
| 4.4.3.3.2 Manual CSG selection.....                                      | 33 |
| 4.4.3.4 Investigation Scan for higher prioritized PLMN.....              | 33 |
| 4.4.4 Abnormal cases.....  | 33 |
| 4.4.5 Roaming not allowed in this LA or TA .....                         | 33 |
| 4.4.6 Steering of roaming .....  | 33 |
| 4.5 Location registration process.....                                   | 34 |
| 4.5.1 General.....   | 34 |

|                               |  |           |
|-------------------------------|--|-----------|
| 4.5.2                         | Initiation of Location Registration.....                               | 34        |
| 4.5.3                         | Periodic Location Registration .....                                   | 36        |
| 4.5.4                         | IMSI attach/detach operation.....                                      | 36        |
| 4.5.5                         | No Suitable Cells In Location Area .....                               | 36        |
| 4.6                           | Service indication (A/Gb mode only).....                               | 37        |
| 4.7                           | Pageability of the mobile subscriber .....                             | 37        |
| 4.8                           | MM Restart Procedure .....   | 37        |
| 5                             | Tables and Figures .....   | 38        |
| 6                             | MS supporting access technologies defined both by 3GPP and 3GPP2 ..... | 44        |
| 6.1                           | General .....  | 44        |
| <b>Annex A (normative):</b>   | <b>HPLMN Matching Criteria .....</b>                                   | <b>46</b> |
| <b>Annex B (normative):</b>   | <b>PLMN matching criteria to be of same country as VPLMN .....</b>     | <b>50</b> |
| <b>Annex C (normative):</b>   | <b>Control plane solution for steering of roaming in 5GS .....</b>     | <b>51</b> |
| C.1                           | General .....  | 51        |
| C.2                           | Stage-2 flow for steering of UE in VPLMN during registration.....      | 51        |
| C.3                           | Stage-2 flow for steering of UE in VPLMN after registration .....      | 54        |
| <b>Annex D (informative):</b> | <b>Change history .....</b>  | <b>56</b> |
| History .....                 |  | 62        |

---

# Foreword

This Technical Specification (TS) has been produced by the 3<sup>rd</sup> Generation Partnership Project (3GPP).

The present document specifies functions related to Mobile Station (MS) in idle mode and within the 3GPP system.

The contents of the present document are subject to continuing work within the TSG and may change following formal TSG approval. Should the TSG modify the contents of the present document, it will be re-released by the TSG with an identifying change of release date and an increase in version number as follows:

Version x.y.z where:

- x the first digit:
  - 1 presented to TSG for information;
  - 2 presented to TSG for approval;
  - 3 or greater indicates TSG approved document under change control.
- y the second digit is incremented for all changes of substance, i.e. technical enhancements, corrections, updates, etc.
- z the third digit is incremented when editorial only changes have been incorporated in the document.

# 1 Scope

The present document gives an overview of the tasks undertaken by the Core network protocols of a Mobile Station (MS) when in idle mode, that is, switched on but typically not having a dedicated channel allocated. It also describes the corresponding network functions. The idle mode functions are also performed by a GPRS MS as long as no dedicated channel is allocated to the MS. The conditions when the idle mode functions are performed by an MS in the UTRA RRC connected mode states are specified in 3GPP TS 25.331 [33]. The conditions when the idle mode functions are performed by an MS in the E-UTRAN are specified in 3GPP TS 36.304 [43]. The conditions when the idle mode functions are performed by an MS in the NG-RAN are specified in 3GPP TS 38.304 [61].

The present document defines the PLMN selection for a multi mode MS that supports both 3GPP and 3GPP2 systems. The common PLMN selection logic covers also PLMNs that are available in 3GPP2 system, but the present document makes no changes on the cdma2000<sup>®</sup> signalling towards networks that are available via 3GPP2 system.

The present document gives procedures for using the CSG cells, whenever such use is permitted.

This 3GPP TS outlines how the requirements of the 22 series Technical Specifications (especially 3GPP TS 22.011 [9]) on idle mode operation shall be implemented. Further details are given in 3GPP TS 24.008 [23].

Clause 2 of this 3GPP TS gives a general description of the idle mode process. Clause 3 outlines the main requirements and technical solutions of those requirements. Clause 4 describes the processes used in idle mode. There is inevitably some overlap between these clauses.

NOTE: cdma2000<sup>®</sup> is a registered trademark of the Telecommunications Industry Association (TIA-USA).

The present document describes the procedures for control plane solution of steering of roaming in 5GS in annex C.

Annex C is applicable to the MS, the AMF and the UDM in the 5GS.

The present document does not consider GERAN Iu mode.

## 1.1 References

The following documents contain provisions which, through reference in this text, constitute provisions of the present document.

- References are either specific (identified by date of publication, edition number, version number, etc.) or non-specific.
- For a specific reference, subsequent revisions do not apply.
- For a non-specific reference, the latest version applies. In the case of a reference to a 3GPP document (including a GSM document), a non-specific reference implicitly refers to the latest version of that document *in the same Release as the present document*.

- |      |  |
|------|--|
| [1]  | Void.                                    |
| [2]  | Void.                                    |
| [3]  | Void.                                    |
| [4]  | Void.                                    |
| [5]  | Void.                                    |
| [6]  | Void.                                    |
| [7]  | Void.                                    |
| [8]  | Void.                                    |
| [9]  | 3GPP TS 22.011: "Service accessibility". |
| [10] | Void.                                    |

- [11] Void.
- [12] Void.
- [13] Void.
- [14] Void.
- [15] Void.
- [16] Void.
- [17] Void.
- [18] Void.
- [19] Void.
- [20] Void.
- [21] Void.
- [22] Void.
- [22A] 3GPP TS 23.003: "Numbering, addressing and identification".
- [23] 3GPP TS 24.008: "Mobile Radio Interface Layer 3 specification, Core Network Protocols - Stage 3".
- [23A] 3GPP TS 24.301: "Non-Access-Stratum (NAS) protocol for Evolved Packet System (EPS); Stage 3".
- [24] 3GPP TS 45.002: "Multiplexing and multiple access on the radio path".
- [25] 3GPP TS 45.008: "Radio subsystem link control".
- [26] Void.
- [27] 3GPP TS 23.060: "General Packet Radio Service (GPRS); Service description; Stage 2".
- [27A] 3GPP TS 23.682: "Architecture enhancements to facilitate communications with packet data networks and applications".
- [28] Void.
- [29] Void.
- [30] Void.
- [31] Void.
- [32] 3GPP TS 25.304: "UE Procedures in Idle Mode and Procedures for Cell Reselection in Connected Mode".
- [33] 3GPP TS 25.331: "RRC Protocol Specification".
- [34] 3GPP TS 44.018: "Mobile radio interface layer 3 specification, Radio Resource Control Protocol".
- [35] 3GPP TS 43.022: "Functions related to Mobile Station (MS) in idle mode and group receive mode".
- [35A] 3GPP TS 43.318: "Generic Access Network (GAN); Stage 2".
- [35B] 3GPP TS 44.318: "Generic Access Network (GAN); Mobile GAN interface layer 3 specification; Stage 3".
- [36] 3GPP TR 21.905: "Vocabulary for 3GPP Specifications".



- [37] Void.
- [38] 3GPP TS 21.111: "USIM and IC card requirements".
- [39] 3GPP TS 44.060: "General Packet Radio Service (GPRS); Mobile Station (MS) - Base Station System (BSS) interface; Radio Link Control/Medium Access Control (RLC/MAC) protocol".
- [40] 3GPP TS 31.102: "Characteristics of the USIM Application".
- [41] 3GPP TS 31.111: "Universal Subscriber Identity Module (USIM), Application Toolkit (USAT)".
- [42] 3GPP TS 36.331: "Evolved Universal Terrestrial Radio Access (E-UTRA) Radio Resource Control (RRC); Protocol specification".
- [43] 3GPP TS 36.304: "Evolved Universal Terrestrial Radio Access (E-UTRA); User Equipment (UE) procedures in idle mode".
- [44] 3GPP2 C.S0016-D v1.0: "Over-the-Air Service Provisioning of Mobile Stations in Spread Spectrum Standards".
- [45] 3GPP2 C.S0011-C v2.0: "Recommended Minimum Performance Standards for cdma2000 Spread Spectrum Mobile Stations".
- [46] 3GPP2 C.S0033-A v2.0: "Recommended Minimum Performance Standards for cdma2000 High Rate Packet Data Access Terminal".
- [47] 3GPP TS 24.285: "Allowed Closed Subscriber Group (CSG) List Management Object (MO)".
- [48] Void.
- [49] 3GPP TS 22.220: "Service requirements for Home Node B (HNB) and Home eNode B (HeNB)".
- [50] 3GPP TS 24.368: "Non-Access Stratum (NAS) configuration Management Object (MO)".
- [51] 3GPP TS 24.334: "Proximity-services (ProSe) User Equipment (UE) to Proximity-services (ProSe) Function Protocol aspects; Stage 3".
- [52] 3GPP TS 24.333: "Proximity-services (ProSe) Management Objects (MO)".
- [53] 3GPP TS 24.105: "Application specific Congestion control for Data Communication (ACDC) Management Object (MO)".
- [54] 3GPP TS 36.306: "Evolved Universal Terrestrial Radio Access (E-UTRA); User Equipment (UE) radio access capabilities".
- [55] 3GPP TS 43.064: "Overall description of the GPRS Radio Interface; Stage 2".
- [56] 3GPP TS 36.300: "Evolved Universal Terrestrial Radio Access (E-UTRA) and Evolved Universal Terrestrial Radio Access Network (E-UTRAN); Overall description".
- [57] 3GPP TS 23.167: "IP Multimedia Subsystem (IMS) emergency sessions".
- [58] 3GPP TS 23.401: "GPRS enhancements for E-UTRAN access".
- [59] 3GPP TS 24.386: "User Equipment (UE) to V2X control function; protocol aspects; Stage 3".
- [60] 3GPP TS 24.385: "V2X services Management Object (MO)".
- [61] 3GPP TS 38.304: "New Generation Radio Access Network; User Equipment (UE) procedures in Idle mode".
- [62] 3GPP TS 23.501: "System Architecture for the 5G System; Stage 2".
- [63] 3GPP TS 23.502: "Procedures for the 5G System; Stage 2".
- [64] 3GPP TS 24.501: "Non-Access-Stratum (NAS) protocol for 5G System (5GS); Stage 3".

## 1.2 Definitions and abbreviations

For the purposes of the present document, the abbreviations defined in 3GPP TR 21.905 [36] apply.

**(A/Gb mode only):** Indicates this clause applies only to a GSM system which operates in A/Gb mode. For multi system case this is determined by the current serving radio access network.

**(Iu mode only):** Indicates this clause applies only to UMTS. For multi system case this is determined by the current serving radio access network.

**NOTE:** In accordance with the description of packet services in Iu mode in 3GPP TS 24.008 [23], the terms 'CS/PS mode of operation' and 'PS mode of operation' are not used in the present document. Instead the terms 'MS operation mode A' and 'MS operation mode C' are used.

**(S1 mode only):** Indicates this clause applies only to an EPS. For multi system case this is determined by the current serving radio access network.

**Acceptable Cell:** This is a cell that the MS may camp on to make emergency calls. It must satisfy criteria which are defined for A/Gb mode in 3GPP TS 43.022 [35], for Iu mode in 3GPP TS 25.304 [32], for S1 mode in 3GPP TS 36.304 [43], and for N1 mode in 3GPP TS 38.304 [61]. For an MS in eCall only mode, an acceptable cell must further satisfy the criteria defined in subclause 4.4.3.1.1.

**Access Technology:** The access technology associated with a PLMN. The MS uses this information to determine what type(s) of radio carrier to search for when attempting to select a specific PLMN (e.g., GSM, UTRAN, GSM COMPACT, E-UTRAN or NG-RAN). A PLMN may support more than one access technology.

**ACDC:** Application specific Congestion control for Data Communication, see 3GPP TS 22.011 [9].

**Allowable PLMN:** In the case of an MS operating in MS operation mode A or B, this is a PLMN which is not in the list of "forbidden PLMNs" in the MS. In the case of an MS operating in MS operation mode C or an MS not supporting A/Gb mode and not supporting Iu mode, this is a PLMN which is not in the list of "forbidden PLMNs" and not in the list of "forbidden PLMNs for GPRS service" in the MS.

**Allowable PLMN/access technology combination:** For an MS operating in MS operation mode C or an MS not supporting A/Gb mode and not supporting Iu mode, this is an allowable PLMN in any specific access technology. For an MS operating in MS operation mode A or B, this is a PLMN/access technology combination where:

- the PLMN is an allowable PLMN and the specific access technology is supporting non-GPRS services; or
- the PLMN is not in the list of "forbidden PLMNs" and not in the list of "forbidden PLMNs for GPRS service" in the MS and the specific access technology is only supporting GPRS services.

**EXAMPLE:** E-UTRAN and NG-RAN are access technologies that are only supporting GPRS services.

**Available PLMN:** For GERAN A/Gb mode see 3GPP TS 43.022 [35]. For UTRAN see 3GPP TS 25.304 [32]. For E-UTRAN see 3GPP TS 36.304 [43]. For NG-RAN see 3GPP TS 38.304 [61]. For cdma2000<sup>®</sup> 1xRTT and cdma2000<sup>®</sup> HRPD see 3GPP2 C.S0016 [44].

**Available PLMN/access technology combination:** This is an available PLMN in a specific access technology.

**Camped on a cell:** The MS (ME if there is no SIM) has completed the cell selection/reselection process and has chosen a cell from which it plans to receive all available services. Note that the services may be limited, and that the PLMN may not be aware of the existence of the MS (ME) within the chosen cell.

**Country:** A country is identified by a single MCC value, with the exception that MCC values 310 through 316 identify a single country (USA) and MCC values 404 through 406 identify a single country (India).

**CSG whitelist:** See 3GPP TS 36.304 [43].

**Current serving cell:** This is the cell on which the MS is camped.

**CTS MS:** An MS capable of CTS services is a CTS MS.

**EAB:** Extended Access Barring, see 3GPP TS 22.011 [9].

**Extended Coverage in GSM for Internet of Things (EC-GSM-IoT):** Extended coverage in GSM for IoT is a feature which enables extended coverage operation. See 3GPP TS 43.064 [55].

**EHPLMN:** Any of the PLMN entries contained in the Equivalent HPLMN list.

**Equivalent HPLMN list:** To allow provision for multiple HPLMN codes, PLMN codes that are present within this list shall replace the HPLMN code derived from the IMSI for PLMN selection purposes. This list is stored on the USIM and is known as the EHPLMN list. The EHPLMN list may also contain the HPLMN code derived from the IMSI. If the HPLMN code derived from the IMSI is not present in the EHPLMN list then it shall be treated as a Visited PLMN for PLMN selection purposes.

**Generic Access Network (GAN):** See 3GPP TS 43.318 [35A].

**GAN mode:** See 3GPP TS 43.318 [35A].

**GPRS MS:** An MS capable of GPRS services is a GPRS MS.

**MS operation mode:** See 3GPP TS 23.060 [27].

**High quality signal:** The high quality signal limit is used in the PLMN selection procedure. It is defined in the appropriate AS specification: 3GPP TS 43.022 [35] for the GSM radio access technology, 3GPP TS 25.304 [32] for the UMTS radio access technology (FDD or TDD mode), 3GPP TS 36.304 [43] for the E-UTRAN radio access technology, 3GPP TS 38.304 [61] for the NG-RAN radio access technology. For 3GPP2 access technologies the high quality signal limit is defined in 3GPP2 C.S0011 [45] for cdma2000<sup>®</sup> 1xRTT and in 3GPP2 C.S0033 [46] for cdma2000<sup>®</sup> HRPD. A mobile station attempting to find a cell that supports EC-GSM-IoT (see 3GPP TS 43.064 [55]) does not use high quality signal limit in the PLMN selection procedure, i.e. for the purpose of PLMN selection, when attempting to find a cell that supports EC-GSM-IoT, any found cell supporting EC-GSM-IoT is considered to be received with high quality signal.

**Home PLMN:** This is a PLMN where the MCC and MNC of the PLMN identity match the MCC and MNC of the IMSI. Matching criteria are defined in Annex A.

**In A/Gb mode,...:** Indicates this clause applies only to a GSM system which operates in A/Gb mode. For multi system case this is determined by the current serving radio access network.

**In Iu mode,...:** Indicates this clause applies only to UMTS. For multi system case this is determined by the current serving radio access network.

**In N1 mode,...:** Indicates this clause applies only to an 5GS. For multi system case this is determined by the current serving radio access network.

**In S1 mode,...:** Indicates this clause applies only to an EPS. The S1 mode includes WB-S1 mode and NB-S1 mode. For multi system case this is determined by the current serving radio access network.

**In NB-S1 mode:** Indicates this paragraph applies only to a system which operates in NB-S1 mode. For a multi-access system this case applies if the current serving radio access network provides access to network services via E-UTRA by NB-IoT (see 3GPP TS 36.300 [56], 3GPP TS 36.331 [22], 3GPP TS 36.306 [54]).

**In WB-S1 mode:** Indicates this paragraph applies only to a system which operates in WB-S1 mode. For a multi-access system this case is applies if the system operates in S1 mode, but not in NB-S1 mode.

**Localised Service Area (LSA):** A localised service area consists of a cell or a number of cells. The cells constituting a LSA may not necessarily provide contiguous coverage.

**Location Registration (LR):** An MS which is IMSI attached to non-GPRS services only performs location registration by the Location Updating procedure. A GPRS MS which is IMSI attached to GPRS services or to GPRS and non-GPRS services performs location registration by the Routing Area Update procedure only when in a network of network operation mode I. Both location updating and routing area update procedures are performed independently by the GPRS MS when it is IMSI attached to GPRS and non-GPRS services in a network of network operation mode II (see 3GPP TS 23.060 [27]). An MS which is attached via the E-UTRAN performs location registration by the tracking area update procedure. An MS which is registered via the NG-RAN performs location registration by the mobility registration update procedure.

**MS:** Mobile Station. The present document makes no distinction between MS and UE.

**NarrowBand Internet of Things (NB-IoT):** NB-IoT is a non-backward compatible variant of E-UTRAN supporting a reduced set of functionality. NB-IoT allows access to network services via E-UTRA with a channel bandwidth limited to 180 kHz (see 3GPP TS 36.300 [20], 3GPP TS 36.331 [42], 3GPP TS 36.306 [44]).

**Network Type:** The network type associated with HPLMN or a PLMN on the PLMN selector (see 3GPP TS 31.102 [40]). The MS uses this information to determine what type of radio carrier to search for when attempting to select a specific PLMN. A PLMN may support more than one network type.

**Registered PLMN (RPLMN):** This is the PLMN on which certain LR outcomes have occurred (see table 1). In a shared network the RPLMN is the PLMN defined by the PLMN identity of the CN operator that has accepted the LR.

**Registration:** This is the process of camping on a cell of the PLMN and doing any necessary LRs.

**Registration Area:** A registration area is an area in which mobile stations may roam without a need to perform location registration. The registration area corresponds to location area (LA) for performing location updating procedure, to routing area for performing the GPRS attach or routing area update procedures, and to list of tracking areas (TAs) for performing the EPS attach, tracking area update, or 5GS registration procedure.

The PLMN to which a cell belongs (PLMN identity) is given in the system information transmitted on the BCCH (MCC + MNC part of LAI) or on the EC-BCCH (see 3GPP TS 44.018 [34]). In a shared network a cell belongs to all PLMNs given in the system information transmitted on the BCCH or on the EC-BCCH.

**Selected PLMN:** This is the PLMN that has been selected according to subclause 3.1, either manually or automatically.

**Shared Network:** An MS considers a cell to be part of a shared network, when multiple PLMN identities are received on the BCCH or on the EC-BCCH.

**SIM:** Subscriber Identity Module (see 3GPP TS 21.111 [38]). The present document makes no distinction between SIM and USIM.

**SoLSA exclusive access:** Cells on which normal camping is allowed only for MS with Localised Service Area (LSA) subscription.

**Suitable Cell:** This is a cell on which an MS may camp. It must satisfy criteria which are defined for GERAN A/Gb mode in 3GPP TS 43.022 [35], for UTRAN in 3GPP TS 25.304 [32], for E-UTRAN in 3GPP TS 36.304 [43] and for NG-RAN see 3GPP TS 38.304 [61]. For 3GPP2 access technologies the criteria are defined in 3GPP2 C.S0011 [45] for cdma2000<sup>®</sup> 1xRTT and in 3GPP2 C.S0033 [46] for cdma2000<sup>®</sup> HRPD. For an MS in eCall only mode, a suitable cell must further satisfy the criteria defined in subclause 4.4.3.1.1.

**Steering of Roaming:** A technique whereby a roaming UE is encouraged to roam to a preferred roamed-to network by the HPLMN.

**Visited PLMN:** This is a PLMN different from the HPLMN (if the EHPLMN list is not present or is empty) or different from an EHPLMN (if the EHPLMN list is present).

For the purposes of the present document, the following terms and definitions given in TS 23.167 [57] apply:

#### **eCall over IMS**

For the purposes of the present document, the following terms and definitions given in TS 23.401 [58] apply:

#### **eCall only mode**

For the purposes of the present document, the following terms and definitions given in 3GPP TS 23.501 [62] apply:

#### **NG-RAN**

---

## 2 General description of idle mode

When an MS is switched on, it attempts to make contact with a public land mobile network (PLMN). The particular PLMN to be contacted may be selected either automatically or manually.

The MS looks for a suitable cell of the chosen PLMN and chooses that cell to provide available services, and tunes to its control channel. This choosing is known as "camping on the cell". The MS will then register its presence in the

registration area of the chosen cell if necessary, by means of a location registration (LR), GPRS attach or IMSI attach procedure.

If the MS loses coverage of a cell, or find a more suitable cell, it reselects onto the most suitable cell of the selected PLMN and camps on that cell. If the new cell is in a different registration area, an LR request is performed.

If the MS loses coverage of a PLMN, either a new PLMN is selected automatically, or an indication of which PLMNs are available is given to the user, so that a manual selection can be made.

Registration is not performed by MSs only capable of services that need no registration.

The purpose of camping on a cell in idle mode is fourfold:

- a) It enables the MS to receive system information from the PLMN.
- b) If the MS wishes to initiate a call, it can do this by initially accessing the network on the control channel of the cell on which it is camped.
- c) If the PLMN receives a call for the MS, it knows (in most cases) the registration area of the cell in which the MS is camped. It can then send a "paging" message for the MS on control channels of all the cells in the registration area. The MS will then receive the paging message because it is tuned to the control channel of a cell in that registration area, and the MS can respond on that control channel.
- d) It enables the MS to receive cell broadcast messages.

If the MS is unable to find a suitable cell to camp on, or the SIM is not inserted, or if it receives certain responses to an LR request (e.g., "illegal MS"), it attempts to camp on a cell irrespective of the PLMN identity, and enters a "limited service" state in which it can only attempt to make emergency calls. An MS operating in NB-S1 mode, never attempts to make emergency calls.

If the MS is in eCall only mode, it attempts to camp on a suitable cell and enters an "eCall inactive" state in which it can only attempt an eCall over IMS, or a call to a non-emergency MSISDN or URI for test or terminal reconfiguration services as specified in 3GPP TS 31.102 [40].

If the MS is in eCall only mode and is unable to find a suitable cell to camp on, it attempts to camp on an acceptable cell in limited service state, and enters an "eCall inactive" state in which it can only attempt an eCall over IMS.

While in eCall inactive state, the MS does not perform LR with the PLMN of the cell on which the MS is camped.

In A/Gb mode, if the CTS MS is in CTS mode only or in automatic mode with CTS preferred, it will start by attempting to find a CTS fixed part on which it is enrolled.

The idle mode tasks can be subdivided into five processes:

- PLMN selection;
- CSG selection (Iu mode and S1 mode only);
- Cell selection and reselection;
- Location registration; and
- CTS fixed part selection (A/Gb mode only).

In A/Gb mode, to make this initial CTS fixed part selection, the MS shall be enrolled on at least one fixed part.

The relationship between these processes is illustrated in figure 1 in clause 5. The states and state transitions within each process are shown in figure 2a, figure 2b, and figure 3 in clause 5.

---

## 3 Requirements and technical solutions

The following clauses list the main requirements of idle mode operation and give an outline of the technical solution.

## 3.1 PLMN selection and roaming

The MS normally operates on its home PLMN (HPLMN) or equivalent home PLMN (EHPLMN). However, a visited PLMN (VPLMN) may be selected, e.g., if the MS loses coverage. There are two modes for PLMN selection:

- i) Automatic mode - This mode utilizes a list of PLMN/access technology combinations in priority order. The highest priority PLMN/access technology combination which is available and allowable is selected.
- ii) Manual mode - Here the MS indicates to the user which PLMNs are available. Only when the user makes a manual selection does the MS try to obtain normal service on the VPLMN.

To prevent repeated attempts to have roaming service on a not allowed area (i.e. LA or TA), when the MS is informed that an area is forbidden, the LA or TA is added to a list of "forbidden location areas for roaming" or "forbidden tracking areas for roaming" respectively which is stored in the MS. These lists, if existing, are deleted when the MS is switched off or when the SIM is removed. LA area restrictions are always valid for complete location areas independent of possible subdivision into GPRS routing areas. The structure of the routing area identifier (see 3GPP TS 23.003 [22A]) supports area restriction on LA basis.

If a message with cause value #15 (see 3GPP TS 24.008 [23] and 3GPP TS 24.301 [23A]) is received by an MS, then the MS shall take the following actions depending on the access technology in which the message was received:

GSM, GSM COMPACT or UTRAN:

The location area is added to the list of "forbidden location areas for roaming" which is stored in the MS. The MS shall then search for a suitable cell in the same PLMN but belonging to an LA or TA which is not in the "forbidden location areas for roaming" or "forbidden tracking areas for roaming" list respectively.

E-UTRAN:

The tracking area is added to the list of "forbidden tracking areas for roaming" which is stored in the MS. The MS shall then search for a suitable cell in the same PLMN but belonging to a TA or LA which is not in the "forbidden tracking areas for roaming" or "forbidden location areas for roaming" list respectively

NG-RAN:

**Editor's note: Whether cause value #15 can be received over NG-RAN is FFS.**

A VPLMN is added to a list of "forbidden PLMNs" in the SIM and thereafter that VPLMN will not be accessed by the MS when in automatic mode if a message with cause value "PLMN not allowed" or "Requested service option not authorized in this PLMN" is received by an MS in response to an LR request from that VPLMN and:

- the MS is configured to use timer T3245 as defined in 3GPP TS 24.008 [23] and 3GPP TS 24.301 [23A];
- the MS is not configured to use timer T3245 and the message is integrity-protected;
- the MS is not configured to use timer T3245, the message is not integrity-protected and the MS does not maintain a list of PLMN-specific attempt counters; or
- the MS is not configured to use timer T3245, the message is not integrity-protected, the MS maintains a list of PLMN-specific attempt counters and the value of the PLMN-specific attempt counter for that VPLMN is equal to the MS implementation specific maximum value as defined in 3GPP TS 24.008 [23] and 3GPP TS 24.301 [23A].

A PLMN is removed from the "forbidden PLMNs" list if, after a subsequent manual selection of that PLMN, there is a successful LR or upon expiry of timer T3245 if the MS is configured to use timer T3245. This list is retained when the MS is switched off or the SIM is removed. The HPLMN (if the EHPLMN list is not present or is empty) or an EHPLMN (if the EHPLMN list is present) shall not be stored on the list of "forbidden PLMNs".

In A/Gb mode, an ME not supporting SoLSA may consider a cell with the escape PLMN code (see 3GPP TS 23.073) to be a part of a PLMN belonging to the list of "forbidden PLMNs".

Optionally the ME may store in its memory an extension of the "forbidden PLMNs" list. The contents of the extension of the list shall be deleted when the MS is switched off or the SIM is removed.

If a message with cause value "GPRS services not allowed in this PLMN" or "EPS services not allowed in this PLMN" is received by an MS in response to an GPRS attach, routing area update, EPS attach or tracking area update request or received in a network initiated GPRS detach or EPS detach request (see 3GPP TS 24.008 [23] and 3GPP TS 24.301 [23A]) from a VPLMN, that VPLMN is added to a list of "forbidden PLMNs for GPRS service" which is stored in the MS and thereafter that VPLMN will not be accessed by the MS for GPRS service when in automatic mode. This list is deleted when the MS is switched off or when the SIM is removed. A PLMN is removed from the list of "forbidden PLMNs for GPRS service" if:

- after a subsequent manual selection of that PLMN, there is a successful GPRS attach, Routing Area Update, EPS attach or Tracking Area Update;
- the MS is configured to use timer T3245 and timer T3245 expires; or
- the MS is not configured to use timer T3245, the MS maintains a list of PLMN-specific PS-attempt counters as specified in 3GPP TS 24.008 [23] and 3GPP TS 24.301 [23A], the value of the PLMN-specific PS-attempt counter for that PLMN has a value greater than zero and less than the MS implementation-specific maximum value as defined in clause 5.3.7b in 3GPP TS 24.301 [23A], and T3247 expires.

The maximum number of possible entries in this list is implementation dependant, but must be at least one entry. The HPLMN (if the EHPLMN list is not present or is empty) or an EHPLMN (if the EHPLMN list is present) shall not be stored on the list of "forbidden PLMNs for GPRS service".

An MS that is attaching for emergency bearer services or is attached for emergency bearer services may access PLMNs in the list of "forbidden PLMNs" or the list of "forbidden PLMNs for GPRS service". The MS shall not remove any entry from the list of "forbidden PLMNs" or the list of "forbidden PLMNs for GPRS service" as a result of such accesses.

A UE capable of S101 mode maintains a list "forbidden PLMNs for attach in S101 mode"; the properties and handling in NAS signalling is defined in subclause 5.3.3 of 3GPP TS 24.301 [23A].

If the MS is in GAN mode and a "Location not allowed" message is received (see 3GPP TS 44.318 [35B]), then the MS may attempt to select another PLMN so that further GAN registrations may again be attempted. The selection of the PLMN either automatically or manually is implementation dependent.

If MS that has disabled its E-UTRA capability re-enables it when PLMN selection is performed, then:

- the MS should, for duration of timer TD, memorize the PLMNs where E-UTRA capability was disabled as PLMNs where voice service was not possible in E-UTRAN. The number of PLMNs where voice service was not possible in E-UTRAN that the MS can store is implementation specific, but it shall be at least one. The value of timer TD is MS implementation specific, but shall not exceed the maximum possible value of background scanning timer T as specified in subclause 4.4.3.3.1.
- in automatic PLMN selection the MS shall not consider PLMNs where voice service was not possible in E-UTRAN as PLMN selection candidates for E-UTRA access technology, unless no other PLMN is available. This does not prevent selection of such a PLMN if it is available in GERAN or UTRAN; and
- the MS shall delete stored information on PLMNs where voice service was not possible in E-UTRAN when the MS is switched off, the USIM is removed, timer TD expires or MS voice domain configuration changes so that E-UTRA capability disabling is no longer necessary.

The MS may support "E-UTRA Disabling for EMM cause #15" as specified in 3GPP TS 24.301 [23A]. If the MS supports "E-UTRA Disabling for EMM cause #15" and the "E-UTRA Disabling Allowed for EMM cause #15" parameter as specified in 3GPP TS 24.368 [50] or 3GPP TS 31.102 [40] is present and set to enabled:

- the MS shall maintain a list of "PLMNs with E-UTRAN not allowed";
- when the MS disables its E-UTRA capability on a PLMN due to E-UTRAN not allowed, it shall add the PLMN to the "PLMNs with E-UTRAN not allowed" list, and start timer TE if timer TE is not already running;
- the number of PLMNs that the MS can store in the "PLMNs with E-UTRAN not allowed" list is implementation specific, but it shall be at least one;
- the value of timer TE is MS implementation specific, but it shall not exceed the maximum possible value of background scanning timer T (8 hours or 240 hours for MSs supporting EC-GSM-IoT, Category M1 or Category NB1 as defined in 3GPP TS 36.306 [54]) as specified in subclause 4.4.3.3.1;

- in automatic PLMN selection the MS shall not consider PLMNs included in the "PLMNs with E-UTRAN not allowed" list as PLMN selection candidates for E-UTRAN access technology, unless no other PLMN is available. This does not prevent selection of such a PLMN if it is available in GERAN or UTRAN; and
- the MS shall delete stored information in the "PLMNs with E-UTRAN not allowed" list when the MS is switched off, the USIM is removed or timer TE expires.

The MS should maintain a list of PLMNs where the N1 mode capability was disabled due to IMS voice not available and the MS's usage setting was "voice centric" as PLMNs where voice service was not possible in N1 mode. When the MS disables its N1 mode capability due to IMS voice not available and the MS's usage setting was "voice centric":

- the MS should add the identity of the PLMN to the list of PLMNs where voice service was not possible in N1 mode and should start timer TF if timer TF is not already running. The number of PLMNs that the MS can store where voice services is not possible is implementation specific, but it shall be at least one. The value of timer TF is MS implementation specific, but shall not exceed the maximum possible value of background scanning timer T as specified in subclause 4.4.3.3.1;
- in automatic PLMN selection the MS shall not consider PLMNs where voice service was not possible in N1 mode as PLMN selection candidates for NG-RAN access technology, unless no other PLMN is available. This does not prevent selection of such a PLMN if it is available in another RAT; and
- the MS shall delete stored information on PLMNs where voice service was not possible in N1 mode when the MS is switched off, the USIM is removed, timer TF expires or the MS's usage setting changes so that N1 mode capability disabling is no longer necessary.

The MS should maintain a list of PLMNs where the N1 mode capability was disabled due to receipt of a reject from the network with 5GMM cause #27 "N1 mode not allowed", as PLMNs where N1 mode is not allowed. When the MS disables its N1 mode capability due to receipt of a reject from the network with 5GMM cause #27 "N1 mode not allowed":

- the MS should add the identity of the PLMN to the list of PLMNs where N1 mode is not allowed and should start timer TG if timer TG is not already running. The number of PLMNs that the MS can store where N1 mode is not allowed is implementation specific, but it shall be at least one. The value of timer TG is MS implementation specific, but shall not exceed the maximum possible value of background scanning timer T as specified in subclause 4.4.3.3.1;
- in automatic PLMN selection the MS shall not consider PLMNs where N1 mode is not allowed as PLMN selection candidates for NG-RAN access technology, unless no other PLMN is available. This does not prevent selection of such a PLMN if it is available in another RAT; and
- the MS shall delete stored information on PLMNs where N1 mode is not allowed when the MS is switched off, the USIM is removed or timer TG expires.

The MS in NB-S1 mode may maintain a list of "PLMNs with NB-IoT not allowed" where the NB-IoT capability was disabled due to receipt of a reject from the network with EMM cause #15 "no suitable cells in tracking area" and an Extended EMM cause IE with value "NB-IoT not allowed", as PLMNs where NB-S1 mode is not allowed. When the MS disables its NB-IoT capability due to receipt of a reject from the network with EMM cause #15 "no suitable cells in tracking area" and an Extended EMM cause IE with value "NB-IoT not allowed":

- the MS may add the identity of the PLMN to the list of "PLMNs with NB-IoT not allowed" and start timer TH if timer TH is not already running. The number of PLMNs that the MS can store in the "PLMNs with NB-IoT not allowed" list is implementation specific, but it shall be at least one. The value of timer TH is MS implementation specific, but shall not exceed the maximum possible value of background scanning timer T as specified in subclause 4.4.3.3.1;
- in automatic PLMN selection the MS shall not consider PLMNs included in the "PLMNs with NB-IoT not allowed" list as PLMN selection candidates for NB-IoT access technology, unless no other PLMN is available. This does not prevent selection of such a PLMN if it is available in another RAT; and
- the MS shall delete stored information in the "PLMNs with NB-IoT not allowed" list when the MS is switched off, the USIM is removed or timer TH expires.



## 3.1A CSG selection / restriction

If the MS supports CSG, it is provisioned with an Allowed CSG list and an Operator CSG list and associated PLMN identities. Both lists can be retrieved either from the USIM if the lists are available in the USIM, or as described in 3GPP TS 24.285 [47] if the lists are not available in the USIM. These lists have zero or more entries.

NOTE 1: The network also updates the Allowed CSG list in the same updating operation if one or more entries are removed from the Operator CSG list. This avoids an entry removed from the Operator CSG list remaining in the Allowed CSG list.

There are two modes of CSG selection:

- Automatic mode: This mode utilizes the Allowed CSG list and the Operator CSG list. After a PLMN is selected, the MS camps on a cell in that PLMN only if the cell is either not a CSG cell or it is a CSG cell with a CSG identity that is in the Allowed CSG list or in the Operator CSG List. The idle mode procedures of NAS are not impacted by this mode.
- Manual mode: In this mode, the MS indicates to the user a list of available CSGs and the associated PLMNs. Based on configuration by the HPLMN, the list of CSGs provided to the user for a certain PLMN is either:
  - not restricted by the Allowed CSG list and the Operator CSG List stored in the MS; or
  - restricted to entries in the Operator CSG List only.

After the user makes a selection, the MS camps on a cell with the selected CSG identity and may attempt to register with the associated PLMN (see 3GPP TS 24.008 [23] and 3GPP TS 24.301 [23A]).

The CSG whitelist is a combination of Operator CSG list and the Allowed CSG list. NAS shall provide the CSG whitelist to the AS. If the contents of the CSG whitelist have changed, NAS shall provide an updated CSG whitelist to the AS.

NOTE 2: The same CSG ID and its associated PLMN can exist in both the Operator CSG list and the Allowed CSG list. Such duplicates can be removed when combining these lists to form the CSG whitelist.

If an integrity protected message with cause value #25 (see 3GPP TS 24.008 [23] and 3GPP TS 24.301 [23A]) is received by an MS for a CSG ID and associated PLMN identity present in the Operator CSG list, then for an implementation dependent time which is not shorter than 60 minutes, or until the MS is switched off, or the SIM/USIM is removed, or the Operator CSG list is updated:

- a) The NAS shall not include this CSG ID and the associated PLMN identity in the CSG whitelist provided to the AS; and
- b) In CSG manual mode selection, the MS shall not indicate to the user that this CSG ID and the associated PLMN identity is in the Operator CSG List stored in the MS.

NOTE 3: As an implementation option, the user can be informed that the MS has not been authorized for a CSG included in the Operator CSG list.

## 3.1B PLMN selection triggered by ProSe direct communication

If the MS supports ProSe direct communication and needs to perform PLMN selection for ProSe direct communication as specified in 3GPP TS 24.334 [51], then the MS shall proceed as follows:

- i) the MS shall store a duplicate value of the RPLMN and a duplicate of the PLMN selection mode that were in use before PLMN selection due to ProSe direct communication was initiated, unless this PLMN selection due to ProSe direct communication follows another PLMN selection due to ProSe direct communication or a manual CSG selection as specified in subclause 4.4.3.1.3.3;
- ii) the MS shall enter into Automatic mode of PLMN selection as specified in subclause 4.4 taking into account the additional requirements in items iii) to x) below;
- iii) Among the PLMNs advertised by the E-UTRA cell operating in the radio resources provisioned to the MS for ProSe direct communication as specified in 3GPP TS 24.333 [52] or 3GPP TS 31.102 [40], the MS shall choose one allowable PLMN which:

- 1) provides radio resources for ProSe direct communication;
- 2) is in the list of authorised PLMNs for ProSe direct communication as specified in 3GPP TS 24.334 [51]; and
- 3) is not in the list of "PLMNs with E-UTRAN not allowed" as specified in subclause 3.1;

if conditions 1) through 3) above are met then the MS shall attempt to register on that PLMN. If none of the PLMNs meet conditions 1) through 3) above, the MS shall return to the stored duplicate PLMN selection mode and use the stored duplicate value of RPLMN for further action;

- iv) if the registration fails due to "PLMN not allowed" or "EPS services not allowed" as specified in 3GPP TS 24.334 [51], then the MS shall update the appropriate list of forbidden PLMNs as specified in subclause 3.1, and shall either:
  - A) if the PLMN provides common radio resources needed by the MS to do ProSe direct communication as specified in 3GPP TS 36.331 [42], perform ProSe direct communication on the selected PLMN in limited service state. In this case the MS shall not search for available and allowable PLMNs during the duration of ProSe direct communication;
  - B) return to the stored duplicate PLMN selection mode and use the stored duplicate value of RPLMN for further action; or
  - C) perform the action described in iii) again with the choice of PLMNs further excluding the PLMNs on which the MS has failed to register.

Whether the MS performs A), B) or C) above is left up to MS implementation.

- v) if the registration fails due to causes other than "PLMN not allowed" or "EPS services not allowed", the MS shall:
  - if the handling of the failure requires updating a list of forbidden PLMNs, update the appropriate list (as specified in 3GPP TS 24.301 [23A]); and
  - if the handling of the failure does not require updating a list of forbidden PLMNs (as specified in 3GPP TS 24.301 [23A]), remember the PLMN as a PLMN on which the MS has failed to register;

NOTE 1: How long the MS memorizes the PLMNs on which it has failed to register is implementation dependent.

and the MS shall either:

- A1) return to the stored duplicate PLMN selection mode and use the stored duplicate value of RPLMN for further action;
- B1) perform the action described in iii) again with the choice of PLMNs further excluding the PLMNs on which the MS has failed to register; or
- C1) perform ProSe direct communication in limited service state on a PLMN advertised by the cell operating in the radio resources provisioned to the MS for ProSe direct communication as specified in 3GPP TS 24.333 [52] or 3GPP TS 31.102 [40], if registration on this PLMN has previously failed due to "PLMN not allowed" or "EPS services not allowed" as specified in 3GPP TS 24.334 [51] and if this PLMN provides common radio resources needed by the MS to do ProSe direct communication as specified in 3GPP TS 36.331 [42]. In this case the MS shall not search for available and allowable PLMNs during the duration of ProSe direct communication;

Whether the MS performs A1), B1) or C1) above is left up to MS implementation.

- vi) if the MS is no longer in the coverage of the selected PLMN, then the MS shall either:

- A2) perform ProSe direct communication procedures for MS to use provisioned radio resources as specified in 3GPP TS 24.334 [51]; or
- B2) return to the stored duplicate PLMN selection mode and use the stored duplicate value of RPLMN for further action.

Whether the MS performs A2) or B2) above is left up to MS implementation.

vii) if the MS is unable to find a suitable cell on the selected PLMN as specified in 3GPP TS 24.334 [51], then the MS shall either:

- A3) if the PLMN provides common radio resources needed by the MS to do ProSe direct communication as specified in 3GPP TS 36.331 [42], perform ProSe direct communication on the selected PLMN in limited service state. In this case the MS shall not search for available and allowable PLMNs during the duration of ProSe direct communication; or
- B3) return to the stored duplicate PLMN selection mode and use the stored duplicate value of RPLMN for further action.

Whether the MS performs A3) or B3) above is left up to MS implementation.

- viii) if the MS is switched off while on the selected PLMN and switched on again, the MS shall use the stored duplicate value of RPLMN as RPLMN and behave as specified in subclause 4.4.3.1;
- ix) if the user initiates a PLMN selection while on the selected cell, the MS shall delete the stored duplicate value of PLMN selection mode, use the stored duplicate value of RPLMN as RPLMN and follow the procedures (as specified for switch-on or recovery from lack of coverage) in subclause 4.4.3.1. The MS shall delete the stored duplicate value of RPLMN once the MS has successfully registered to the selected PLMN; and
- x) if the MS no longer needs to perform ProSe direct communication, the MS shall return to the stored duplicate PLMN selection mode and use the stored duplicate value of RPLMN for further action.

NOTE 2: If the MS returns to the RPLMN due to a failure to register in the selected PLMN, the upper layers of the MS can trigger PLMN selection again to initiate ProSe direct communication.

If the PLMN selected for ProSe direct communication is a VPLMN, the MS shall not periodically scan for higher priority PLMNs during the duration of ProSe direct communication.

The solution to prevent potential ping-pong between the RPLMN and the PLMN selected for ProSe direct communication is MS implementation specific.

### 3.1C PLMN selection triggered by V2X communication over PC5

If the MS supports V2X communication over PC5 and needs to perform PLMN selection for V2X communication over PC5 as specified in 3GPP TS 24.386 [59], then the MS shall proceed as follows:

- i) the MS shall store a duplicate value of the RPLMN and a duplicate of the PLMN selection mode that were in use before PLMN selection due to V2X communication over PC5 was initiated, unless this PLMN selection due to V2X communication over PC5 follows another PLMN selection due to V2X communication over PC5 or a manual CSG selection as specified in subclause 4.4.3.1.3.3;
- ii) the MS shall enter into Automatic mode of PLMN selection as specified in subclause 4.4 taking into account the additional requirements in items iii) to x) below;
- iii) Among the PLMNs advertised by the E-UTRA cell operating in the radio resources provisioned to the MS for V2X communication over PC5 as specified in 3GPP TS 24.385 [60] or 3GPP TS 31.102 [40], the MS shall choose one allowable PLMN which:
  - 1) provides radio resources for V2X communication over PC5;
  - 2) is in the list of authorised PLMNs for V2X communication over PC5 as specified in 3GPP TS 24.386 [59]; and
  - 3) is not in the list of "PLMNs with E-UTRAN not allowed" as specified in subclause 3.1;

if conditions 1) through 3) above are met then the MS shall attempt to register on that PLMN. If none of the PLMNs meet conditions 1) through 3) above, the MS shall return to the stored duplicate PLMN selection mode and use the stored duplicate value of RPLMN for further action;
- iv) if the registration fails due to "PLMN not allowed" or "EPS services not allowed" as specified in 3GPP TS 24.386 [59], then the MS shall update the appropriate list of forbidden PLMNs as specified in subclause 3.1, and shall either:

- A) if the PLMN provides common radio resources needed by the MS to do V2X communication over PC5 as specified in 3GPP TS 36.331 [42], perform V2X communication over PC5 on the selected PLMN in limited service state. In this case the MS shall not search for available and allowable PLMNs during the duration of V2X communication over PC5;
- B) return to the stored duplicate PLMN selection mode and use the stored duplicate value of RPLMN for further action; or
- C) perform the action described in iii) again with the choice of PLMNs further excluding the PLMNs on which the MS has failed to register.

Whether the MS performs A), B) or C) above is left up to MS implementation.

v) if the registration fails due to causes other than "PLMN not allowed" or "EPS services not allowed", the MS shall:

- if the handling of the failure requires updating a list of forbidden PLMNs, update the appropriate list (as specified in 3GPP TS 24.301 [23A]); and
- if the handling of the failure does not require updating a list of forbidden PLMNs (as specified in 3GPP TS 24.301 [23A]), remember the PLMN as a PLMN on which the MS has failed to register;

NOTE 1: How long the MS memorizes the PLMNs on which it has failed to register is implementation dependent.

and the MS shall either:

- A1) return to the stored duplicate PLMN selection mode and use the stored duplicate value of RPLMN for further action;
- B1) perform the action described in iii) again with the choice of PLMNs further excluding the PLMNs on which the MS has failed to register; or
- C1) perform V2X communication over PC5 in limited service state on a PLMN advertised by the cell operating in the radio resources provisioned to the MS for V2X communication over PC5 as specified in 3GPP TS 24.385 [60] or 3GPP TS 31.102 [40], if registration on this PLMN has previously failed due to "PLMN not allowed" or "EPS services not allowed" as specified in 3GPP TS 24.386 [59] and if this PLMN provides common radio resources needed by the MS to do V2X communication over PC5 as specified in 3GPP TS 36.331 [42]. In this case the MS shall not search for available and allowable PLMNs during the duration of V2X communication over PC5;

Whether the MS performs A1), B1) or C1) above is left up to MS implementation.

vi) if the MS is no longer in the coverage of the selected PLMN, then the MS shall either:

- A2) perform V2X communication over PC5 procedures for MS to use provisioned radio resources as specified in 3GPP TS 24.386 [59]; or
- B2) return to the stored duplicate PLMN selection mode and use the stored duplicate value of RPLMN for further action.

Whether the MS performs A2) or B2) above is left up to MS implementation.

vii) if the MS is unable to find a suitable cell on the selected PLMN as specified in 3GPP TS 24.386 [59], then the MS shall either:

- A3) if the PLMN provides common radio resources needed by the MS to do V2X communication over PC5 as specified in 3GPP TS 36.331 [42], perform V2X communication over PC5 on the selected PLMN in limited service state. In this case the MS shall not search for available and allowable PLMNs during the duration of V2X communication over PC5; or
- B3) return to the stored duplicate PLMN selection mode and use the stored duplicate value of RPLMN for further action.

Whether the MS performs A3) or B3) above is left up to MS implementation.

- viii) if the MS is switched off while on the selected PLMN and switched on again, the MS shall use the stored duplicate value of RPLMN as RPLMN and behave as specified in subclause 4.4.3.1;
- ix) if the user initiates a PLMN selection while on the selected cell, the MS shall delete the stored duplicate value of PLMN selection mode, use the stored duplicate value of RPLMN as RPLMN and follow the procedures (as specified for switch-on or recovery from lack of coverage) in subclause 4.4.3.1. The MS shall delete the stored duplicate value of RPLMN once the MS has successfully registered to the selected PLMN; and
- x) if the MS no longer needs to perform V2X communication over PC5, the MS shall return to the stored duplicate PLMN selection mode and use the stored duplicate value of RPLMN for further action.

NOTE 2: If the MS returns to the RPLMN due to a failure to register in the selected PLMN, the upper layers of the MS can trigger PLMN selection again to initiate V2X communication over PC5.

If the PLMN selected for V2X communication over PC5 is a VPLMN, the MS shall not periodically scan for higher priority PLMNs during the duration of V2X communication over PC5.

The solution to prevent potential ping-pong between the RPLMN and the PLMN selected for V2X communication over PC5 is MS implementation specific.

## 3.2 Regional provision of service

An MS may have a "regionally restricted service" where it can only obtain service on certain areas (i.e. LAs or TAs). If such an MS attempts to camp on a cell of an area for which it does not have service entitlement, when it does an LR request, it will receive a message with cause value #12 (see 3GPP TS 24.008 [23] and 3GPP TS 24.301 [23A]). In this case, the MS shall take the following actions depending on the access technology in which the message was received:

GSM, GSM COMPACT or UTRAN:

- The MS stores the forbidden LA identity (LAI) in a list of "forbidden location areas for regional provision of service", to prevent repeated access attempts on a cell of the forbidden LA. This list is deleted when the MS is switched off or the SIM is removed. The MS enters the limited service state.

E-UTRAN:

The MS stores the forbidden TA identity (TAI) in a list of "forbidden tracking areas for regional provision of service", to prevent repeated access attempts on a cell of the forbidden TA. This list is deleted when the MS is switched off or the SIM is removed. The MS enters the limited service state.

NG-RAN:

The MS stores the forbidden TA identity (TAI) in a list of "5GS forbidden tracking areas for regional provision of service", to prevent repeated access attempts on a cell of the forbidden TA. This list is deleted when the MS is switched off or the SIM is removed. The MS enters the limited service state.

In A/Gb mode, a cell may be reserved for SoLSA exclusive access (see 3GPP TS 24.008 [23] and 3GPP TS 44.060 [39]). An MS is only allowed to camp normally on such a cell if it has a Localised Service Area subscription to the cell. Other MS may enter the limited service state.

NOTE: In A/Gb mode, in a SoLSA exclusive cell the MCC+MNC code is replaced by a unique escape PLMN code (see 3GPP TS 23.073), not assigned to any PLMN, in SI3 and SI4. An MS not supporting SoLSA may request for location update to an exclusive access cell. In this case the location attempt is rejected with the cause "PLMN not allowed" and the escape PLMN code is added to the list of the "forbidden PLMNs".

## 3.3 Borders between registration areas

If the MS is moving in a border area between registration areas, it might repeatedly change between cells of different registration areas. Each change of registration area would require an LR, which would cause a heavy signalling load and increase the risk of a paging message being lost. The access stratum shall provide a mechanism to limit this effect.

## 3.4 Access control

### 3.4.1 Access control

Due to problems in certain areas, network operators may decide to restrict access from some MSs (e.g., in case of congestion), and for this reason, a mechanism for common access control is provided. In A/Gb mode and Iu mode a mechanism for domain specific access control is also provided (see 3GPP TS 43.022 [35], 3GPP TS 44.018 [34] and 3GPP TS 25.304 [32]).

A mechanism to restrict access is provided via EAB. A network operator can restrict network access of those MSs that are configured for EAB in addition to common access control and domain specific access control.

The MS can be configured for EAB in the USIM (see 3GPP TS 31.102 [40]) or in the ME (see 3GPP TS 24.368 [50]). An MS that supports EAB shall follow the EAB mechanism (see 3GPP TS 24.008 [23], 3GPP TS 24.301 [23A], 3GPP TS 44.018 [34], 3GPP TS 25.331 [33], 3GPP TS 36.331 [42]) when configured for EAB.

The MS can be configured for ACDC in the USIM (see 3GPP TS 31.102 [40]) or in the ME (see 3GPP TS 24.105 [53]). An MS that supports ACDC shall follow the ACDC mechanism (see 3GPP TS 24.008 [23], 3GPP TS 24.301 [23A], 3GPP TS 25.331 [33], 3GPP TS 36.331 [42]) when configured for ACDC.

The MS can be configured in the USIM (see 3GPP TS 31.102 [40]) or in the ME (see 3GPP TS 24.368 [50]) to override EAB. An MS that supports overriding EAB shall follow the overriding EAB mechanism (see 3GPP TS 24.008 [23], 3GPP TS 24.301 [23A]) when configured to allow overriding EAB.

In the case that a network operator decides to restrict access they may as an option allow restricted MSs to respond to paging messages and/or to perform location registrations. Mechanisms to allow this optional access are provided (see 3GPP TS 25.304 [32]).

A network operator can also restrict some MSs to access the network for location registration, although via common access class control or domain specific access class control the MSs are permitted to access the network for other purposes.

If the MS is accessing the network with a special access class (Access classes 11 to 15), then the MS shall ignore EAB and ACDC.

NOTE: The conditions when the MS is allowed to access the network with access class 11 – 15 are specified in 3GPP TS 22.011 [138].

If an MS configured for EAB is initiating an emergency call, then the MS shall ignore EAB.

If an MS configured for EAB is responding to paging, then the MS shall ignore EAB.

If an MS configured for ACDC is responding to paging, then the MS shall ignore ACDC.

If an MS configured for ACDC is initiating an emergency call, then the MS shall ignore ACDC.

If an MS configured for ACDC and the MO MMTEL voice call is started, the MO MMTEL video call is started or the MO SMSoIP is started (see 3GPP TS 24.008 [23], 3GPP TS 24.301 [23A]), then the MS shall ignore ACDC.

### 3.4.2 Forbidden LA or TA for regional provision of service

The MS is not allowed to initiate establishment of a CM connection except for an emergency call when camped on a cell of an LA or TA of which belongs to the list of "forbidden location areas for regional provision of service" or "forbidden tracking areas for regional provision of service". The MS may respond to paging.

The MS is not allowed to request GPRS services except for an emergency bearer services when camped on a cell of an LA or TA of which belongs to the list of "forbidden location areas for regional provision of service" or "forbidden tracking areas for regional provision of service".

The MS is not allowed to request 5GS services except emergency services when camped on a cell of a TA of which belongs to the list of "5GS forbidden tracking areas for regional provision of service".

### 3.5 No suitable cell (limited service state)

There are a number of situations in which the MS is unable to obtain normal service from a PLMN. These include:

- a) Failure to find a suitable cell of the selected PLMN;
- b) No SIM in the MS;
- c) A "PLMN not allowed" response when an LR is received;
- d) An "illegal MS" or "illegal ME" response when an LR is received (Any SIM in the ME is then considered "invalid");
- e) An "IMSI unknown in HLR" response when an LR is received (Any SIM in the ME is then considered "invalid" for non-GPRS services);
- f) A "GPRS services not allowed" response when an LR of a GPRS MS attached to GPRS services only is received (The cell selection state of GPRS MSs attached to GPRS and non-GPRS depends on the outcome of the location updating), or an "EPS services not allowed" response is received when an EPS attach, tracking area update or service request is performed; or
- g) Power saving mode (PSM) is activated (see 3GPP TS 23.682 [27A]).

(In automatic PLMN selection mode, items a, c and f would normally cause a new PLMN selection, but even in this case, the situation may arise when no PLMNs are available and allowable for use).

For the items a to f, the MS attempts to camp on an acceptable cell, irrespective of its PLMN identity, so that emergency calls can be made if necessary, with the exception that an MS operating in NB-S1 mode, shall never attempt to make emergency calls. When in the limited service state with a valid SIM, the MS shall search for available and allowable PLMNs in the manner described in subclause 4.4.3.1 and when indicated in the SIM also as described in subclause 4.4.3.4. For an MS that is not in eCall only mode, with the exception of performing GPRS attach or EPS attach for emergency bearer services, or performing 5GS registration for emergency services, no LR requests are made until a valid SIM is present and either a suitable cell is found or a manual network reselection is performed. For an MS in eCall only mode, no LR requests are made except for performing EPS attach for emergency bearer services or 5GS registration for emergency services. When performing GPRS attach or EPS attach for emergency bearer services, or 5GS registration for emergency services, the PLMN of the current serving cell is considered as the selected PLMN for the duration the MS is attached for emergency bearer services or registered for emergency services. In the limited service state the presence of the MS need not be known to the PLMN on whose cell it has camped.

There are also other conditions under which only emergency calls may be made. These are shown in table 2 in clause 5. ProSe direct communication and ProSe direct discovery for public safety use can be initiated if necessary (see 3GPP TS 24.334 [51]) when in the limited service state due to items a) or c) or f). V2X communication over PC5 can be initiated if necessary (see 3GPP TS 24.386 [59]) when in the limited service state due to items a) or c) or f).

### 3.6 CTS fixed part selection (A/Gb mode only)

In CTS mode only or in automatic mode with CTS preferred, the CTS MS normally operates on a CTS fixed part on which the mobile station is already enrolled. If the CTS MS loses CTS coverage in these modes, it shall attempt periodically to select again a CTS fixed part.

To select a CTS fixed part, the CTS MS shall listen to the CTSBCH frequencies of all the fixed parts on which the MS is currently enrolled.

If the CTS MS is moving in a border area between one area with CTS coverage and one without it, it might repeatedly require CTS attachments and LU on the PLMN. To prevent this, the criteria C1\_CTS and C2\_CTS (defined in 3GPP TS 45.008 [25] subclause 11.1) are used. To attach to a CTS FP, the C1\_CTS criterion shall be greater than zero. When the C2\_CTS criterion falls below zero, the CTS MS shall consider itself to be no more under CTS coverage.

### 3.7 NAS behaviour configuration

NAS behaviour can be operator configurable using parameters in the USIM (see 3GPP TS 31.102 [40]) or in the ME (see 3GPP TS 24.368 [50]). For parameters available in both the USIM and the ME, precedence is specified in 3GPP TS 31.102 [40] subclause 5.2.29.

---

## 4 Overall process structure

### 4.1 Process goal

The aim of the idle mode processes is to ensure that the registered PLMN is the selected PLMN.

### 4.2 States description

Each of the processes of PLMN selection, cell selection and location registration can be described by a set of states. The overall state of the mobile is thus a composite of the states of the three processes. In some cases, an event which causes a change of state in one process may trigger a change of state in another process, e.g., camping on a cell in a new registration area triggers an LR request. The relationship between the processes is illustrated in figure 1 in clause 5.

The states in which the MS may be, for each of the processes, are described below and illustrated in figures 2a, 2b and 3 in clause 5. For many of the states, a fuller description can be found in other Technical Specifications, and a reference to the Technical Specification is given after the state description.

In the event of any conflict between the diagrams and the text in the present document, the text takes precedence.

### 4.3 List of states

#### 4.3.1 List of states for the PLMN selection process

##### 4.3.1.1 List of states for automatic mode (figure 2a)

- A1 Trying RPLMN - The MS is trying to perform a Location Registration on the registered PLMN.
- A2 On PLMN - The MS has successfully registered on a PLMN.
- A3 Trying PLMN - The MS is trying to register on a PLMN in the ordered list of PLMNs.
- A4 Wait for PLMNs to appear - There are no allowable and available PLMNs at present and the MS is waiting for one to appear.
- A5 HPLMN search in progress - The MS is trying to find if the HPLMN is available.
- A6 No SIM - There is no SIM in the MS, or certain LR responses have been received.

##### 4.3.1.2 List of states for manual mode (figure 2b)

- M1 Trying registered PLMN - The MS is trying to perform a Location Registration on the registered PLMN.
- M2 On PLMN - The MS has successfully registered on a PLMN.
- M3 Not on PLMN - The MS has failed to register on the selected PLMN.
- M4 Trying PLMN - The MS is trying to register on a user selected PLMN.
- M5 No SIM - There is no SIM in the MS, or certain LR responses have been received.

#### 4.3.2 Void

#### 4.3.3 List of states for location registration (figure 3)

The states are entered depending on responses to location registration (LR) requests. Independent update states exist for GPRS and for non-GPRS operation in MSs capable of GPRS and non-GPRS services.

- L0 Null – The MS is considered in this state when switched off.



- L1 Updated - The MS enters this state if an LR request is accepted. The update status is set to "UPDATED". The GPRS and the non-GPRS update state of a MS may enter "Updated" as a result of combined signalling or as a result of individual signalling depending on the capabilities of the network.
- L2 Idle, No IMSI - The MS enters this state if an LR request is rejected with cause:
- a) IMSI unknown in HLR;
  - b) illegal ME;
  - c) illegal MS;
  - d) GPRS services not allowed,
  - e) GPRS services and non-GPRS services not allowed,
- or if there is no SIM. All update states of a MS enter this state regardless whether received by individual or combined signalling for events b) and c). Event a) has no influence on the GPRS update state. Events b) and c) result in "ROAMING NOT ALLOWED" for the GPRS and/or non-GPRS update status depending on the specific location registration procedure. Event d) results in "ROAMING NOT ALLOWED" for the GPRS update status. Event e) results in "ROAMING NOT ALLOWED" for the GPRS update status and non-GPRS update status.
- If a SIM is present, the non-GPRS update status of the SIM is set to "ROAMING NOT ALLOWED".
- L3 Roaming not allowed - The MS enters this state if it receives an LR reject message with the cause:
- a) PLMN not allowed;
  - b) Location area not allowed;
  - c) Tracking area not allowed;
  - d) Roaming not allowed in this location area;
  - e) Roaming not allowed in this tracking area;
  - f) GPRS services not allowed in this PLMN;
  - g) No suitable cells in location area;
  - h) No suitable cells in tracking area;
  - i) Not authorized for this CSG.
- Except from event f) all update states of the MS are set to "Roaming not allowed" regardless whether received by individual or combined signalling. Event f) results in "Roaming not allowed" for the GPRS update state only. Event f) has no influence on the non-GPRS update state. The behaviour of the MS in the roaming not allowed state is dependent on the LR reject cause as shown in table 2 in clause 5. Additionally:
- in automatic mode, "PLMN not allowed", "Roaming not allowed in this location area" and "Roaming not allowed in this tracking area" cause the Automatic Network Selection procedure of subclause 4.4.3.1.1 to be started; it is also caused by "GPRS services not allowed in this PLMN" when received by a GPRS MS operating in MS operation mode C;
  - in manual mode, "PLMN not allowed" and "Roaming not allowed" cause the Manual Network Selection procedure of subclause 4.4.3.1.2 to be started; it is also caused by "GPRS services not allowed in this PLMN" when received by a GPRS MS operating in MS operation mode C.
- L4 Not updated - The MS enters this state if any LR failure not specified for states L2 or L3 occurs, in which cases the MS is not certain whether or not the network has received and accepted the LR attempt. The non-GPRS update status on the SIM and/or the GPRS update status are set to "NOT UPDATED" depending on the specific location registration procedure and their outcome.

- L5 LR request – The MS enters this state when determining that a LR request is to be made.
- L6 LR pending – The MS enters this state after having started the LR, waiting for the outcome (response message from the network).

NOTE This clause does not describe all the cases. For more details refer to 3GPP TS 24.008 [23]

## 4.4 PLMN selection process

### 4.4.1 Introduction

There are two modes for PLMN selection, automatic and manual. These are described in subclauses 4.4.3 below and illustrated in figures 2a to 2b in clause 5.

### 4.4.2 Registration on a PLMN

The MS shall perform registration on the PLMN if the MS is capable of services which require registration. In both automatic and manual modes, the concept of registration on a PLMN is used. An MS successfully registers on a PLMN if:

- a) The MS has found a suitable cell of the PLMN to camp on; and
- b) An LR request from the MS has been accepted in the registration area of the cell on which the MS is camped (see table 1).

### 4.4.3 PLMN selection

The registration on the selected PLMN and the location registration are only necessary if the MS is capable of services which require registration. Otherwise, the PLMN selection procedures are performed without registration.

The ME shall utilise all the information stored in the SIM related to the PLMN selection; e.g. "HPLMN Selector with Access Technology", "Operator controlled PLMN Selector with Access Technology", "User Controlled PLMN Selector with Access Technology", "Forbidden PLMNs", "Equivalent HPLMN", see 3GPP TS 31.102 [40].

The "HPLMN Selector with Access Technology", "User Controlled PLMN Selector with Access Technology" and "Operator Controlled PLMN Selector with Access Technology" data files in the SIM include associated access technologies for each PLMN entry, see 3GPP TS 31.102 [40]. The PLMN/access technology combinations are listed in priority order. If an entry indicates more than one access technology, then no priority is defined for the access technologies within this entry and the priority applied to each access technology within this entry is an implementation issue. If no particular access technology is indicated in an entry, it shall be assumed that all access technologies supported by the ME apply to the entry. If an entry only indicates access technologies not supported by the ME, the entry shall be ignored. If an entry indicates at least one access technology supported by the ME, the entry shall be used in the PLMN selection procedures if the other criteria defined for the specific PLMN selection procedures are fulfilled.

The Mobile Equipment stores a list of "equivalent PLMNs". This list is replaced or deleted at the end of each location update procedure, routing area update procedure, GPRS attach procedure, tracking area update procedure, EPS attach procedure, and 5GS registration procedure. The list is deleted by an MS attached for emergency bearer services after detach. The stored list consists of a list of equivalent PLMNs as downloaded by the network plus the PLMN code of the registered PLMN that downloaded the list. All PLMNs in the stored list, in all access technologies supported by the PLMN, are regarded as equivalent to each other for PLMN selection, cell selection/re-selection and handover.

When the MS reselects to a cell in a shared network, and the cell is a suitable cell for multiple PLMN identities received on the BCCH or on the EC-BCCH the AS indicates these multiple PLMN identities to the NAS according to 3GPP TS 44.018 [34], 3GPP TS 44.060 [39], 3GPP TS 25.304 [32] and 3GPP TS 36.304 [43]. The MS shall choose one of these PLMNs. If the registered PLMN is available among these PLMNs, the MS shall not choose a different PLMN.

The MS shall not use the PLMN codes contained in the "HPLMN Selector with Access Technology" data file.

It is possible for the home network operator to identify alternative Network IDs as the HPLMN. If the EHPLMN list is present, and not empty, the entries in the EHPLMN list are used in the network selection procedures. When attempting to select a network the highest priority EHPLMN that is available shall be selected. If the EHPLMN list is present and is empty or if the EHPLMN list is not present, the HPLMN derived from the IMSI is used for network selection procedures.

NOTE 1: The "HPLMN Selector with Access Technology" data file is only used by the MS to get the HPLMN access technologies related to the HPLMN code which corresponds to the PLMN code included in the IMSI if the EHPLMN list is not present or is empty. If the EHPLMN list is present then this data field is applicable to all the entries within the EHPLMN list.

NOTE 2: Different GSM frequency bands (e.g. 900, 1800, 1900, 400) are all considered GSM access technology. An MS supporting more than one band should scan all the bands it's supports when scanning for GSM frequencies. However GSM COMPACT systems which use GSM frequency bands but with the CBPCCH broadcast channel are considered as a separate access technology from GSM.

NOTE 3: The inclusion of the HPLMN derived from the IMSI in the EHPLMN list is allowed. The priority of the HPLMN derived from the IMSI is given by its position in the EHPLMN list, see 3GPP TS 31.102 [40]

#### 4.4.3.1 At switch-on or recovery from lack of coverage

At switch on, or following recovery from lack of coverage, the MS selects the registered PLMN or equivalent PLMN (if it is available) using all access technologies that the MS is capable of and if necessary (in the case of recovery from lack of coverage, see subclause 4.5.2) attempts to perform a Location Registration.

NOTE 1: The MS in automatic network selection mode can end the PLMN search procedure once the registered PLMN or equivalent PLMN is found on an access technology.

NOTE 2: An MS in automatic network selection mode can use location information to determine which PLMNs can be available in its present location.

EXCEPTION: As an alternative option to this, if the MS is in automatic network selection mode and it finds coverage of an EHPLMN, the MS may register to that EHPLMN and not return to the registered PLMN or equivalent PLMN. If the EHPLMN list is not present or is empty, and the HPLMN is available, the MS may register on the HPLMN and not return to the registered PLMN or equivalent PLMN. The operator shall be able to control by SIM configuration whether an MS that supports this option is permitted to perform this alternative behaviour.

EXCEPTION: In A/Gb mode an MS with voice capability, shall not search for CPBCCCH carriers. In A/Gb mode an MS not supporting packet services shall not search for CPBCCCH carriers.

If successful registration is achieved, the MS indicates the selected PLMN.

If there is no registered PLMN, or if registration is not possible due to the PLMN being unavailable or registration failure, the MS follows one of the following two procedures depending on its PLMN selection operating mode. At switch on, if the MS provides the optional feature of user preferred PLMN selection operating mode at switch on then this operating mode shall be used. Otherwise, the MS shall use the PLMN selection mode that was used before switching off.

EXCEPTION: At switch on, if the MS is in manual mode and neither registered PLMN nor PLMN that is equivalent to it is available but EHPLMN is available, then instead of performing the manual network selection mode procedure of subclause 4.4.3.1.2 the MS may select and attempt registration on the highest priority EHPLMN. If the EHPLMN list is not available or is empty and the HPLMN is available, then the MS may select and attempt registration on the HPLMN. The MS shall remain in manual mode.

NOTE 3: If successful registration is achieved, then the current serving PLMN becomes the registered PLMN and the MS does not store the previous registered PLMN for later use.

EXCEPTION: If registration is not possible on recovery from lack of coverage due to the registered PLMN being unavailable, an MS attached to GPRS services may, optionally, continue looking for the registered PLMN for an implementation dependent time.

NOTE 4: An MS attached to GPRS services should use the above exception only if one or more PDP contexts are currently active.

##### 4.4.3.1.1 Automatic Network Selection Mode Procedure

The MS selects and attempts registration on other PLMN/access technology combinations, if available and allowable, in the following order:

- i) either the HPLMN (if the EHPLMN list is not present or is empty) or the highest priority EHPLMN that is available (if the EHPLMN list is present) ;

- ii) each PLMN/access technology combination in the "User Controlled PLMN Selector with Access Technology" data file in the SIM (in priority order);
- iii) each PLMN/access technology combination in the "Operator Controlled PLMN Selector with Access Technology" data file in the SIM (in priority order);
- iv) other PLMN/access technology combinations with received high quality signal in random order;
- v) other PLMN/access technology combinations in order of decreasing signal quality.

When following the above procedure the following requirements apply:

- a) An MS with voice capability shall ignore PLMNs for which the MS has identified at least one GSM COMPACT.
- b) In A/Gb mode or GSM COMPACT, an MS with voice capability, or an MS not supporting packet services shall not search for CPBCCCH carriers.
- c) In ii and iii, the MS should limit its search for the PLMN to the access technology or access technologies associated with the PLMN in the appropriate PLMN Selector with Access Technology list (User Controlled or Operator Controlled selector list).

An MS using a SIM without access technology information storage (i.e. the "User Controlled PLMN Selector with Access Technology" and the "Operator Controlled PLMN Selector with Access Technology" data files are not present) shall instead use the "PLMN Selector" data file, for each PLMN in the "PLMN Selector" data file, the MS shall search for all access technologies it is capable of. The priority ordering amongst the access technologies is implementation dependent.

- d) In iv and v, the MS shall search for all access technologies it is capable of, before deciding which PLMN to select.
- e) In ii, and iii, a packet only MS which supports GSM COMPACT, but using a SIM without access technology information storage (i.e. the "User Controlled PLMN Selector with Access Technology" and the "Operator Controlled PLMN Selector with Access Technology" data files are not present) shall instead use the "PLMN Selector" data file, for each PLMN in the "PLMN Selector" data file, the MS shall search for all access technologies it is capable of and shall assume GSM COMPACT access technology as the lowest priority radio access technology.
- f) In i, the MS shall search for all access technologies it is capable of. No priority is defined for the preferred access technology and the priority is an implementation issue, but "HPLMN Selector with Access Technology" data file on the SIM may be used to optimise the procedure.
- g) In i, an MS using a SIM without access technology information storage (i.e. the "HPLMN Selector with Access Technology" data file is not present) shall search for all access technologies it is capable of. The priority ordering amongst the access technologies is implementation dependent. A packet only MS which supports GSM COMPACT using a SIM without access technology information storage shall also assume GSM COMPACT access technology as the lowest priority radio access technology.

NOTE 1: For f) and g), the MS in automatic network selection mode can end the PLMN search procedure once the HPLMN or the highest priority EHPLMN is found on an access technology.

NOTE 2: For i, ii and iii, the MS can use location information to determine which PLMNs can be available in its present location.

- h) In v, the MS shall order the PLMN/access technology combinations in order of decreasing signal quality within each access technology. The order between PLMN/access technology combinations with different access technologies is an MS implementation issue.

NOTE 3: Requirements a) and b) apply also to requirement d), so a GSM voice capable MS should not search for GSM COMPACT PLMNs, even if capable of GSM COMPACT.

NOTE 4: Requirements a) and b) apply also to requirement f), so a GSM voice capable MS should not search for GSM COMPACT PLMNs, even if this is the only access technology on the "HPLMN Selector with Access Technology" data file on the SIM.

NOTE 5: High quality signal is defined in the appropriate AS specification.

- i) In i to v, the MS shall not consider PLMNs where voice service was not possible as PLMN selection candidate, unless such PLMN is available in GERAN or UTRAN or no other allowed PLMN is available.
- j) In i to v, if the MS only supports EMM-REGISTERED without PDN connection (see 3GPP TS 24.301 [23A]), the MS shall not consider PLMNs which do not advertise support of EMM-REGISTERED without PDN connection.
- k) In i to v, if the MS only supports control plane CIoT EPS optimization (see 3GPP TS 24.301 [23A]) and the UE camps on a E-UTRA cell which is not NB-IoT cell (see 3GPP TS 36.304 [43], 3GPP TS 36.331 [22]), the MS shall not consider PLMNs which do not advertise support of EPS services with control plane CIoT EPS optimization.
- l) In i to v, if the MS is in eCall only mode, the MS shall not consider PLMNs which do not advertise support for eCall over IMS, unless such PLMNs are available in GERAN or UTRAN.

NOTE 6: As an implementation option, an MS in eCall only mode that was not able to select any PLMN according to l) can perform a second iteration of i to v with no restriction.

If successful registration is achieved, the MS indicates the selected PLMN.

If registration cannot be achieved because no PLMNs are available and allowable, the MS indicates "no service" to the user, waits until a new PLMN is available and allowable and then repeats the procedure.

If there were one or more PLMNs which were available and allowable, but an LR failure made registration on those PLMNs unsuccessful or an entry in any of the lists "forbidden location areas for roaming", "forbidden tracking areas for roaming", "5GS forbidden tracking areas for roaming", "forbidden location areas for regional provision of service", "forbidden tracking areas for regional provision of service" or "5GS forbidden tracking areas for regional provision of service" prevented a registration attempt, the MS selects the first such PLMN again and enters a limited service state.

#### 4.4.3.1.2 Manual Network Selection Mode Procedure

The MS indicates whether there are any PLMNs, which are available using all supported access technologies. This includes PLMNs in the "forbidden PLMNs" list, "forbidden PLMNs for GPRS service" list and PLMNs which only offer services not supported by the MS. An MS which supports GSM COMPACT shall also indicate GSM COMPACT PLMNs (which use PBCCH).

If displayed, PLMNs meeting the criteria above are presented in the following order:

- i)- either the HPLMN (if the EHPLMN list is not present or is empty) or, if one or more of the EHPLMNs are available then based on an optional data field on the SIM either only the highest priority available EHPLMN is to be presented to the user or all available EHPLMNs are presented to the user in priority order. If the data field is not present on the SIM, then only the highest priority available EHPLMN is presented;
- ii)- PLMN/access technology combinations contained in the " User Controlled PLMN Selector with Access Technology " data file in the SIM (in priority order);
- iii)- PLMN/access technology combinations contained in the "Operator Controlled PLMN Selector with Access Technology" data file in the SIM (in priority order);
- iv)- other PLMN/access technology combinations with received high quality signal in random order;
- v)- other PLMN/access technology combinations in order of decreasing signal quality.

In ii and iii, an MS using a SIM without access technology information storage (i.e. the "User Controlled PLMN Selector with Access Technology" and the "Operator Controlled PLMN Selector with Access Technology" data files are not present) shall instead present the PLMNs contained in the "PLMN Selector" data file in the SIM (in priority order).

In v, requirement h) in subclause 4.4.3.1.1 applies.

In i to v, requirements j), k) and l) in subclause 4.4.3.1.1 apply.

In GSM COMPACT, the non support of voice services shall be indicated to the user.

The HPLMN may provide on the SIM additional information on the available PLMNs. If this information is provided then the MS shall indicate it to the user. This information, provided as free text may include:

- preferred partner,
- roaming agreement status,
- supported services

Furthermore, the MS may indicate whether the available PLMNs are present on the EHPLMN list, the Forbidden list, the User Controlled PLMN List or the Operator Controlled PLMN List. The MS may also indicate that the PLMN is not present on any of these lists.

The user may select his desired PLMN and the MS then initiates registration on this PLMN using the access technology chosen by the user for that PLMN or using the highest priority available access technology for that PLMN, if the associated access technologies have a priority order. (This may take place at any time during the presentation of PLMNs). For such a registration, the MS shall ignore the contents of the "forbidden location areas for roaming", "forbidden tracking areas for roaming", "5GS forbidden tracking areas for roaming", "forbidden location areas for regional provision of service", "forbidden tracking areas for regional provision of service", "5GS forbidden tracking areas for regional provision of service", "forbidden PLMNs for GPRS service" and "forbidden PLMNs" lists.

NOTE 1: It is an MS implementation option whether to indicate access technologies to the user. If the MS does display access technologies, then the access technology selected by the user is only used for initial registration on the selected PLMN. If the MS does not display access technologies, then the access technology chosen for a particular PLMN should be the highest priority available access technology for that PLMN, if the associated access technologies have a priority order, and is only used for initial registration.

Once the MS has registered on a PLMN selected by the user, the MS shall not automatically register on a different PLMN unless:

- i) the new PLMN is declared as an equivalent PLMN by the registered PLMN;
- ii) the user selects automatic mode; or
- iii) the user initiates an emergency call while the MS is in limited service state and either the network does not broadcast the indication of support of emergency calls in limited service state or the attach request for emergency bearer services is rejected by the network.

NOTE 2: If case iii) occurs, the MS can provide an indication to the upper layers that the MS has exited manual network selection mode.

If the user does not select a PLMN, the selected PLMN shall be the one that was selected before the PLMN selection procedure started. If no such PLMN was selected or that PLMN is no longer available, then the MS shall attempt to camp on any acceptable cell and enter the limited service state.

NOTE 3: High quality signal is defined in the appropriate AS specification.

#### 4.4.3.1.3 Manual CSG selection

##### 4.4.3.1.3.1 General

The HPLMN may configure the MS whether to provide to the user CSGs for a certain PLMN without any restriction or to provide to the user only CSGs in the Operator CSG List for that PLMN. This configuration may be done either:

- in the USIM if the Operator CSG list is available in the USIM; or
- as described in 3GPP TS 24.285 [47].

In the absence of such configuration from the HPLMN for a certain PLMN, the MS shall by default provide to the user CSGs for that PLMN without any restriction.

For PLMNs where no restriction is configured, the MS provides to the user the CSGs that are available and the associated PLMNs using all access technologies which support CSGs (see 3GPP TS 23.003 [22A]) and which are supported by the MS. For each entry in the list, an indication is provided whether that CSG identity is in the Allowed CSG list or in the Operator CSG list stored in the MS for this PLMN.

For PLMNs where the MS is configured to provide to the user only CSGs in the Operator CSG List, the MS provides to the user the CSGs that are available and in the Operator CSG list, using all access technologies which support CSGs

(see 3GPP TS 23.003 [22A]) and which are supported by the MS. For each entry in the list, the MS provides to the user the associated PLMN and an indication that the CSG identity is in the Operator CSG List stored in the MS for this PLMN.

Additional requirements for the display, including for the display of HNB name, can be found in 3GPP TS 22.220 [49].

The user may select a CSG from the indicated CSGs.

If the MS has a PDN connection for emergency bearer services, manual CSG selection shall not be performed.

#### 4.4.3.1.3.2 Manual CSG selection within the RPLMN

If the user selects a CSG whose CSG identity is not included in the Allowed CSG list or Operator CSG list, then the MS shall attempt to register on a cell that corresponds to the CSG. For such a registration, the MS shall ignore the contents of the "forbidden location areas for roaming", "forbidden tracking areas for roaming", "forbidden location areas for regional provision of service", "forbidden tracking areas for regional provision of service" and "forbidden PLMNs for GPRS service" lists.

Manual CSG selection within the RPLMN does not affect the current PLMN selection mode.

#### 4.4.3.1.3.3 Manual CSG selection in a PLMN different from the RPLMN

If the user selects a CSG in a PLMN that is different from the RPLMN, then the following applies:

- i) The MS shall store a duplicate of the RPLMN and a duplicate of the PLMN selection mode that were in use before the manual CSG selection was initiated, unless this manual CSG selection follows another manual CSG selection or a PLMN selection triggered by ProSe direct communication as specified in subclause 3.1B or a PLMN selection triggered by V2X communication over PC5 as specified in subclause 3.1x;
- ii) The MS shall enter into Manual mode of PLMN selection in state M4 (Trying PLMN) as defined in subclause 4.3.1.2;
- iii) The MS shall select the PLMN corresponding to the CSG and attempt to register on the selected CSG cell in the PLMN. For such a registration, the MS shall ignore the contents of the "forbidden location areas for roaming", "forbidden tracking areas for roaming", "forbidden location areas for regional provision of service", "forbidden tracking areas for regional provision of service", "forbidden PLMNs for GPRS service" and "forbidden PLMNs" lists;
- iv) If the registration fails or the MS is no longer in the coverage of the selected CSG, then the MS shall return to the stored duplicate PLMN selection mode and use the stored duplicate value of RPLMN for further action;
- v) If the MS is switched off while on the selected CSG and switched on again, the MS should return to the stored duplicate PLMN selection mode, unless the MS provides the optional feature of user preferred PLMN selection operating mode at switch on. Additionally, the MS shall use the stored duplicate value of RPLMN for further action;
- vi) If the user initiates a PLMN selection while on the selected CSG, the MS shall delete the stored duplicate PLMN selection mode, use the stored duplicate value of RPLMN as RPLMN and follow the procedures (as specified for switch-on or recovery from lack of coverage) in subclause 4.4.3.1. The MS shall delete the stored duplicate value of RPLMN once the PLMN selection has been completed successfully ;
- vii) If the MS's E-UTRA capability is disabled as a result of successful registration (as described in 3GPP TS 24.301 [23A] subclauses 5.5.1.3.4.2, 5.5.1.3.4.3, 5.5.3.3.4.2 and 5.5.3.3.4.3) and the selected CSG is not available on UTRAN radio access technology, the MS shall re-enable the E-UTRA capability, return to the stored duplicate PLMN selection mode and use the stored duplicate value of RPLMN for further action; and
- viii) If the MS's E-UTRA capability is disabled as a result of performing the service request procedure (as described in 3GPP TS 24.301 [23A] subclause 5.6.1.5), the selected CSG is not available on UTRAN radio access technology and the MS performed a CS call, then after the end of the call, the MS shall re-enable the E-UTRA capability, return to the stored duplicate PLMN selection mode and use the stored duplicate value of RPLMN for further action.

#### 4.4.3.2 User reselection

At any time the user may request the MS to initiate reselection and registration onto an available PLMN, according to the following procedures, dependent upon the operating mode.

##### 4.4.3.2.1 Automatic Network Selection Mode

The MS selects and attempts registration on PLMN/access technology combinations, if available and allowable, in all of its bands of operation in accordance with the following order:

- i) the HPLMN (if the EHPLMN list is not present or is empty) or the highest priority EHPLMN that is available (if the EHPLMN list is present);
- ii) PLMN/access technology combinations contained in the "User Controlled PLMN Selector with Access Technology" data file in the SIM (in priority order) excluding the previously selected PLMN/access technology combination;
- iii) PLMN/access technology combinations contained in the "Operator Controlled PLMN Selector with Access Technology" data file in the SIM (in priority order) excluding the previously selected PLMN/access technology combination;
- iv) other PLMN/access technology combinations with the received high quality signal in random order excluding the previously selected PLMN/access technology combination;
- v) other PLMN/access technology combinations, excluding the previously selected PLMN/access technology combination in order of decreasing signal quality or, alternatively, the previously selected PLMN/access technology combination may be chosen ignoring its signal quality;
- vi) The previously selected PLMN/access technology combination.

The previously selected PLMN/access technology combination is the PLMN/access technology combination which the MS has selected prior to the start of the user reselection procedure.

NOTE 1: If the previously selected PLMN is chosen, and registration has not been attempted on any other PLMNs, then the MS is already registered on the PLMN, and so registration is not necessary.

The equivalent PLMNs list shall not be applied to the user reselection in Automatic Network Selection Mode.

When following the above procedure the requirements a), b), c), e), f), g), h), j), k) and l) in subclause 4.4.3.1.1 apply: Requirement d) shall apply as shown below:

- d) In iv, v, and vi, the MS shall search for all access technologies it is capable of before deciding which PLMN/access technology combination to select.

NOTE 2: High quality signal is defined in the appropriate AS specification.

##### 4.4.3.2.2 Manual Network Selection Mode

The Manual Network Selection Mode Procedure of subclause 4.4.3.1.2 is followed.

##### 4.4.3.2.3 Manual CSG selection

The procedure of subclause 4.4.3.1.3 is followed.



### 4.4.3.3 In VPLMN

#### 4.4.3.3.1 Automatic and manual network selection modes

If the MS is in a VPLMN, the MS shall periodically attempt to obtain service on its HPLMN (if the EHPLMN list is not present or is empty) or one of its EHPLMNs (if the EHPLMN list is present) or a higher priority PLMN/access technology combinations listed in "user controlled PLMN selector" or "operator controlled PLMN selector" by scanning in accordance with the requirements that are applicable to i), ii) and iii) as defined in the Automatic Network Selection Mode in subclause 4.4.3.1.1. In the case that the mobile has a stored "Equivalent PLMNs" list the mobile shall only select a PLMN if it is of a higher priority than those of the same country as the current serving PLMN which are stored in the "Equivalent PLMNs" list. For this purpose, a value of timer T may be stored in the SIM. The interpretation of the stored value depends on the radio capabilities supported by the MS:

- For an MS that does not only support any of the following or a combination of EC-GSM-IoT or Category M1 or Category NB1 (as defined in 3GPP TS 36.306 [54]): T is either in the range 6 minutes to 8 hours in 6 minute steps or it indicates that no periodic attempts shall be made. If no value for T is stored in the SIM, a default value of 60 minutes is used for T.
- For an MS that only supports any of the following or a combination of EC-GSM-IoT or Category M1 or Category NB1 (as defined in 3GPP TS 36.306 [54]): T is either in the range 2 hours to 240 hours, using 2 hour steps from 2 hours to 80 hours and 4 hour steps from 84 hours to 240 hours, or it indicates that no periodic attempts shall be made. If no value for T is stored in the SIM, a default value of 72 hours is used.

If the MS is configured with the MinimumPeriodicSearchTimer as specified in 3GPP TS 24.368 [50] or 3GPP TS 31.102 [40], the MS shall not use a value for T that is less than the MinimumPeriodicSearchTimer. If the value stored in the SIM, or the default value for T (when no value is stored in the SIM), is less than the MinimumPeriodicSearchTimer, then T shall be set to the MinimumPeriodicSearchTimer.

The MS does not stop timer T, as described in 3GPP TS 24.008 [23] and 3GPP TS 24.301 [23A], when it activates power saving mode (PSM) (see 3GPP TS 23.682 [27A]).

The MS can be configured for Fast First Higher Priority PLMN search as specified in 3GPP TS 31.102 [40] or 3GPP TS 24.368 [50]. Fast First Higher Priority PLMN search is enabled if the corresponding configuration parameter is present and set to enabled. Otherwise, Fast First Higher Priority PLMN search is disabled.

The attempts to access the HPLMN or an EHPLMN or higher priority PLMN shall be as specified below:

- a) The periodic attempts shall only be performed in automatic mode when the MS is roaming, and not while the MS is attached for emergency bearer services or has a PDN connection for emergency bearer services;
- b) The MS shall make the first attempt after a period of at least 2 minutes and at most T minutes:
  - only after switch on if Fast First Higher Priority PLMN search is disabled; or
  - after switch on or upon selecting a VPLMN if Fast First Higher Priority PLMN search is enabled.
- c) The MS shall make the following attempts if the MS is on the VPLMN at time T after the last attempt;
- d) Periodic attempts shall only be performed by the MS while in idle mode;
- d1) periodic attempts may be postponed while the MS is in power saving mode (PSM) (see 3GPP TS 23.682 [27A]).
- e) If the HPLMN (if the EHPLMN list is not present or is empty) or a EHPLMN (if the list is present) or a higher priority PLMN is not found, the MS shall remain on the VPLMN.
- f) In steps i), ii) and iii) of subclause 4.4.3.1.1 the MS shall limit its attempts to access higher priority PLMN/access technology combinations to PLMN/access technology combinations of the same country as the current serving VPLMN, as defined in Annex B.
- g) Only the priority levels of Equivalent PLMNs of the same country as the current serving VPLMN, as defined in Annex B, shall be taken into account to compare with the priority level of a selected PLMN.
- h) If the PLMN of the highest priority PLMN/access technology combination available is the current VPLMN, or one of the PLMNs in the "Equivalent PLMNs" list, the MS shall remain on the current PLMN/access technology combination.

#### 4.4.3.3.2 Manual CSG selection

The procedure of subclause 4.4.3.1.3 is followed.

#### 4.4.3.4 Investigation Scan for higher prioritized PLMN

The support of this procedure is mandatory if the ME supports GSM COMPACT and otherwise optional.

A MS capable of both GSM voice and packet service shall, when indicated in the SIM, investigate if there is service from a higher prioritized PLMN not offering GSM voice service, either HPLMN (if the EHPLMN list is not present or is empty) or one of its EHPLMNs (if the EHPLMN list is present) or a PLMN in a "PLMN Selector with Access Technology" data file on the SIM.

The MS shall scan for PLMNs in accordance with the requirements described for automatic network selection mode in subclause 4.4.3.1.1 that are applicable to i), ii) and iii) with the exception of requirement a) and b) in subclause 4.4.3.1. Requirement a) and b) that are specified for automatic network selection mode in subclause 4.4.3.1 shall be ignored during the investigation scan.

If indicated on the SIM, the investigation scan shall be performed:

- i) After each successful PLMN selection and registration is completed, when the MS is in idle mode. This investigation scan may rely on the information from the already performed PLMN selection and may not necessarily require a rescan
- ii) When the MS is unable to obtain normal service from a PLMN, (limited service state) see subclause 3.5.

The investigation scan is restricted to automatic selection mode and shall only be performed by an MS that is capable of both voice and packet data. It shall only be performed if the selected PLMN is not already the highest prioritized PLMN in the current country. (HPLMN in home country, otherwise according to PLMN selector lists)

The MS shall return to RPLMN after the investigation scan is performed.

If a higher prioritized PLMN not offering GSM voice service is found, this shall be indicated to the user. The MS shall not select the PLMN unless requested by the user.

#### 4.4.4 Abnormal cases

If there is no SIM in the MS, if there is an authentication failure, or if the MS receives an "IMSI unknown in HLR", "illegal ME" or "illegal MS" response to an LR request, then effectively there is no selected PLMN ("No SIM" state). In these cases, the states of the cell selection process are such that no PLMN selection information is used. Except when performing GPRS attach or EPS attach for emergency bearer services, no further attempts at registration on any PLMN are made until the MS is switched off and on again, or a SIM is inserted. When performing GPRS attach or EPS attach for emergency bearer services, the PLMN of the current serving cell is temporarily considered as the selected PLMN.

When in Automatic Network Selection mode and the MS is in the "not updated" state with one or more suitable cells to camp on; then after the maximum allowed unsuccessful LR requests (controlled by the specific attempt counters) the MS may continue (or start if it is not running) the user reselection procedure of subclause 4.4.3.2 1.

A multi mode MS that also supports 3GPP2 access technology may fall back to 3GPP2 mode if no SIM is inserted.

#### 4.4.5 Roaming not allowed in this LA or TA

If in either PLMN selection mode the LR response "Roaming not allowed in this LA" or "Roaming not allowed in this TA" is received:

The PLMN Automatic or Manual Mode Selection Procedure of subclause 4.4.3.1 are followed, depending on whether the MS is in automatic or manual mode.

#### 4.4.6 Steering of roaming

If the MS receives a USAT REFRESH command qualifier (3GPP TS 31.111 [41]) of type "Steering of Roaming", the MS shall:

- a) replace the highest priority entries in the "Operator Controlled PLMN Selector with Access Technology" list stored in the ME with the list provided in the REFRESH command;

- b) delete the PLMNs identified by the list in the REFRESH command from the Forbidden PLMN list and from the Forbidden PLMNs for GPRS service list, if they are present in these lists. This includes any information stored in the SIM and the ME internal memory;
- c) take the new information into account in subsequent attempts to access a higher priority PLMN; and
- d) attempt to obtain service on a higher priority PLMN as specified in subclause 4.4.3.3 by acting as if timer T that controls periodic attempts has expired.

In order to avoid unnecessary signalling, the network operator should avoid repeatedly using steering of roaming of a particular MS.

## 4.5 Location registration process

### 4.5.1 General

When the MS is switched on and capable of services requiring registration, the action taken by the location registration process is as follows:

- a) SIM present and no LR needed (because of the status of the stored registration area identity and "attach" flag): The MS is in the update state "Updated";
- b) SIM present and LR needed: A LR request is made;
- c) No SIM present: The MS enters the update state "Idle, No IMSI".

In case b) above, and subsequently whenever a LR request is made, the MS enters a state depending on the outcome of the LR request, as listed in subclause 4.3.3 above. In case c) the GPRS and the non-GPRS update state enters "Idle, No IMSI".

Whenever the MS goes to connected mode and then returns to idle mode again, the MS selects the appropriate state.

A multi mode MS that also supports 3GPP2 access technology may fall back to 3GPP2 mode if no SIM is inserted.

### 4.5.2 Initiation of Location Registration

An LR request indicating Normal Updating is made when, in idle mode,

- the MS changes cell while the update status is "NOT UPDATED"; (for MS capable of GPRS and non-GPRS services when at least one of both update statuses is "NOT UPDATED")
- the MS detects that it has entered a new registration area, i.e., when the received registration area identity differs from the one stored in the MS, and the LAI, TAI or PLMN identity is not contained in any of the lists of "forbidden location areas for roaming", "forbidden tracking areas for roaming", "5GS forbidden tracking areas for roaming", "forbidden location areas for regional provision of service", "forbidden tracking areas for regional provision of service", "5GS forbidden tracking areas for regional provision of service", "forbidden PLMNs for GPRS service" or "forbidden PLMNs" respectively, while being in one of the following update statuses:
  - UPDATED;
  - NOT UPDATED;
  - ROAMING NOT ALLOWED.
- the MS detects that it has entered a registration area that has the same identity as the one stored in the MS, while the update status is "ROAMING NOT ALLOWED", and the LAI, TAI or PLMN identity is not contained in any of the lists of "forbidden location areas for roaming", "forbidden tracking areas for roaming", "5GS forbidden tracking areas for roaming", "forbidden location areas for regional provision of service", "forbidden tracking areas for regional provision of service", "5GS forbidden tracking areas for regional provision of service", "forbidden PLMNs for GPRS service" or "forbidden PLMNs" respectively.
- the Periodic Location Updating Timer expires while the non-GPRS update status is "NOT UPDATED" (triggers Location Updating);

- the Periodic Routing Area Update timer expires while the GPRS update status is "NOT UPDATED" (triggers Routing Area Update);
- the Periodic Tracking Area Update timer expires while the EPS update status is "NOT UPDATED" (triggers Tracking Area Update);
- a manual network reselection has been performed, an acceptable cell of the selected PLMN is present, and the MS is not in the update status "UPDATED" on the selected PLMN; or
- emergency bearer services over packet services are requested by upper layers.

An MS which is attached for PS services and enters a new PLMN shall perform a routing area update or a tracking area update if the following conditions are fulfilled:

- if the MS is in S1 mode, the currently stored TAI list does not contain the TAI of the current serving cell;
- the LAI, TAI or PLMN identity of the current serving cell is not contained in any of the lists "forbidden location areas for roaming", "forbidden tracking areas for roaming", "5GS forbidden tracking areas for roaming", "forbidden location areas for regional provision of service", "forbidden tracking areas for regional provision of service", "5GS forbidden tracking areas for regional provision of service", "forbidden PLMNs for GPRS service" or "forbidden PLMNs", or the MS has a PDN connection for emergency bearer services;
- the current update state is different from "Idle, No IMSI"; and
  - the MS is configured to perform the attach procedure with IMSI at PLMN change (see "AttachWithIMSI" leaf of the NAS configuration MO in 3GPP TS 24.368 [50] or USIM file NAS<sub>CONFIG</sub> in 3GPP TS 31.102 [40]) and the new PLMN is the registered PLMN or an equivalent PLMN; or
  - the MS is not configured to perform the attach procedure with IMSI at PLMN change.

If the new PLMN the MS has entered is neither the registered PLMN nor an equivalent PLMN, an MS which is attached for PS services and configured to perform the attach procedure with IMSI at PLMN change (see "AttachWithIMSI" leaf of the NAS configuration MO in 3GPP TS 24.368 [50] or USIM file NAS<sub>CONFIG</sub> in 3GPP TS 31.102 [40]) shall perform an attach procedure using IMSI as mobile identity.

An LR request indicating Periodic Location Updating is made when, in idle mode, the Periodic Location Updating timer expires while the non-GPRS update status is "UPDATED".

An LR request indicating Periodic Routing Area Update is made when the Periodic Routing Area Update timer expires while the GPRS update status is "UPDATED", except when the MS is attached for emergency bearer services.

An LR request indicating Periodic Tracking Area Update is made when the Periodic Tracking Area Update timer expires while the EPS update status is "UPDATED", except when the MS is attached for emergency bearer services.

An LR request indicating IMSI attach is made when the MS is activated in the same location area in which it was deactivated while the non-GPRS update status is "UPDATED", and the system information indicates that IMSI attach/detach shall be used.

A GPRS attach is made by a GPRS MS when activated and capable of services which require registration. A GPRS attach may only be performed if the selected PLMN is not contained in the list of "forbidden PLMNs for GPRS service". Depending on system information about GPRS network operation mode MSs operating in MS operation mode A or B perform combined or non-combined location registration procedures. When the combined routing area update or GPRS attach is accepted with indication "MSC not reachable" or is not answered the MS performs also the corresponding location updating procedure or falls back to a GPRS only MS. When the combined routing area update or GPRS attach is rejected with cause "GPRS not allowed" the GPRS update status is "ROAMING NOT ALLOWED" and the MS performs the corresponding location updating procedure.

Furthermore, an LR request indicating Normal Location Updating is also made when the response to an outgoing request shows that the MS is unknown in the VLR or SGSN, respectively.

Table 2 in clause 5 summarizes the events in each state that trigger a new LR request. The actions that may be taken while being in the various states are also outlined in table 2.

A GPRS MS which is both IMSI attached for GPRS and non-GPRS services and which is capable of simultaneous operation of GPRS and non-GPRS services shall perform Routing Area Update in connected mode when it has entered

a new routing area which is not part of a LA contained in the list of "forbidden location areas for roaming" or "forbidden location areas for regional provision of service".

### 4.5.3 Periodic Location Registration

A Periodic Location Updating timer (for non-GPRS operation), a Periodic Routing Area Update timer (for GPRS operation) and a Periodic Tracking Area Update timer (for EPS operation) with the following characteristics shall be implemented in the MS (MS shall implement all timers corresponding to supported operations):

- i) Upon switch on of the MS or when the system information indicates that periodic location registration shall be applied, and the timer is not running, the timer shall be loaded with a random value between 0 and the broadcast or signalled time-out value and started.
- ii) The time-out value for the Periodic Location Updating timer shall be within the range of 1 deci-hour to 255 deci-hours with a granularity of 1 deci-hour.
- iii) When the timer reaches its expiry value, it shall be initiated with respect to the relevant time-out value, and the MS shall initiate the Periodic Location Registration corresponding to the expired timer. If the MS is attached for emergency bearer services, the MS shall locally detach instead of performing Periodic Location Registration.
- iv) The Periodic Location Updating timer shall be prevented from triggering Periodic Location Updating during connected mode. When the MS returns to idle mode, the Periodic Location Updating timer shall be initiated with respect to the broadcast time-out value, then started. Thereafter, the procedure in iii) shall be followed.
- v) The Periodic Routing Area Update timer shall be prevented from triggering the Periodic Routing Area Update during Ready state. At transition from Ready to Standby state the Periodic Routing Area Update timer shall be initiated with respect to its time-out value, then started. Thereafter, the procedure in iii) shall be followed.
- vi) If the MS performs a successful combined Routing Area Update the Periodic Location Updating timer shall be prevented from triggering the Periodic Location Updating until the MS starts using Location Updating procedure, for example because of a changed network operation mode or the MS uses non-GPRS services only.
- vii) When a change in the time-out value occurs (at a change of serving cell or a change in the broadcast time-out value or a change in the signalled time-out value), the related timer shall be reloaded so that the new time to expiry will be: "old time to expiry" modulo "new time-out value".

### 4.5.4 IMSI attach/detach operation

The system information will contain an indicator indicating whether or not IMSI attach/detach operation is mandatory to use in the cell. The MS shall operate in accordance with the received value of the indicator.

A GPRS MS shall perform GPRS attach/detach procedures independent of the value of the IMSI attach/detach indicator. When a GPRS MS has to perform IMSI attach/detach independent of GPRS procedures (for example GPRS network operation mode 2) the handling described in the clause above applies.

When IMSI attach/detach operation applies, a MS shall send the IMSI detach message to the network when the MS is powered down or the SIM is removed while the update status is "UPDATED". The IMSI detach message will not be acknowledged by the network.

When the MS returns to the active state, the MS shall perform an LR request indicating IMSI attach, provided that the MS still is in the same registration area. If the registration area has changed, an LR request indicating Normal Location Updating according to subclause 4.5.2 shall be performed.

### 4.5.5 No Suitable Cells In Location Area

If during location registration the LR response "No Suitable Cells In Location Area" or "No Suitable Cells In Tracking Area" is received:

- The MS shall attempt to find another LA or TA of the same PLMN on which it received the LR response. If the MS is able to find another LA or TA it shall attempt registration. If the MS is unable to find an LA or TA, the PLMN Automatic or Manual Mode Selection Procedure of subclause 4.4.3.1 shall be followed, depending on whether the MS is in automatic or manual mode.

## 4.6 Service indication (A/Gb mode only)

This is an indication to the user that service or CTS service is available.

The service indication should be set if the following conditions are all satisfied:

- a) Cell Selection: Camped on a suitable cell and in updated state, or in connected mode having been camped on a suitable cell.
- b) Location registration: In updated state, for MSs capable of services requiring registration.

A specific CTS service indication should be set when the CTS MS is attached to a CTS FP.

However due to the fact that there may be some transitory changes of state, the service indication is permitted to continue to be set for up to 10 seconds after the above conditions cease to be met. Also the service indication is permitted to take up to 1 second to be set after the above conditions are met.

## 4.7 Pageability of the mobile subscriber

An MS is required to listen to all paging messages that could address it (see 3GPP TS 45.002 [24]), when the following conditions are all satisfied:

- A SIM is inserted;
- The MS is camped on a cell;
- The MS is not in state "Idle, No IMSI"; and
- The MS is not performing the task to search for available PLMNs. (Whenever possible during this task, the MS should listen for paging.). However, when the MS is camped on a cell, is registered in a PLMN and is performing its regular search for a higher priority PLMN, as specified in 3GPP TS 22.011 [9], then it shall listen to all paging messages that could address it.

**NOTE:** In A/Gb mode, during cell reselection there is a certain period when the MS is no longer camped on the old cell but must decode the full BCCH, CPBCCH or EC-BCCH before camping on the new cell. This leads to a period of slightly more than 8 51 frame multiframes when the MS will not necessarily be pageable (full BCCH or CPBCCH is decoded) or up to 32 51 frame multiframes when the MS will not necessarily be pageable (full EC-BCCH is decoded).

## 4.8 MM Restart Procedure

In some cases, e.g. on change of SIM data, there is a need for the MM to be restarted without the need for user intervention.

To perform the procedure the MS shall behave as if the SIM is removed and afterwards a new SIM is inserted.

# 5 Tables and Figures

**Table 1: Effect of LR Outcomes on PLMN Registration**

| Location Registration Task State   | Registration Status | Registered PLMN is                                 |
|--|---------------------|--|
| Updated  | Successful          | Indicated in the stored registration area identity |
| Idle, No IMSI  | Unsuccessful        | No registered PLMN (3) (4)                         |
| Roaming not allowed:   | Unsuccessful        | No registered PLMN (4)                             |
| a) PLMN not allowed<br>b) LA not allowed or TA not allowed   | Indeterminate(1)    | No registered PLMN                                 |
| c) Roaming not allowed in this LA or Roaming not allowed in this TA  | Indeterminate (2)   | No registered PLMN (4)                             |
| d) No suitable cells in location area or No suitable cells in tracking area  | Indeterminate (5)   | No registered PLMN                                 |
| e) Not authorized for this CSG   | Indeterminate (6)   | No registered PLMN                                 |
| Not updated  | Unsuccessful        | No registered PLMN (4)                             |
| <p>1) The MS will perform a cell selection and will eventually either enter a different state when the registration status will be determined, or fail to be able to camp on a new cell, when registration status will be unsuccessful.</p> <p>2) The MS will select the HPLMN (if the EHPLMN list is not present or is empty) or an EHPLMN (if the EHPLMN list is present) if in automatic mode and will enter Automatic Network Selection Mode Procedure of subclause 4.4.3.1. If in manual mode, the MS will display the list of available PLMNs and follow the Manual Network Selection Mode Procedure of subclause 4.4.3.1.2 If the appropriate process does not result in registration, the MS will eventually enter the limited service state.</p> <p>3) An MS may have different update states for GPRS and non-GPRS. A PLMN is registered when at least one of both update states is updated.</p> <p>4) The stored list of equivalent PLMNs is invalid and can be deleted.</p> <p>5) The MS will attempt registration on another LA or TA of the same PLMN, or equivalent PLMN if available. Otherwise it will enter either the Automatic Network Selection Mode procedure of subclause 4.4.3.1 or follow the Manual Network Selection Mode procedure of subclause 4.4.3.1.2. If the appropriate process does not result in registration, the MS will eventually enter the limited service state.</p> <p>6) The MS will attempt registration on another cell of the same PLMN, or equivalent PLMN if available. Otherwise it will enter either the Automatic Network Selection Mode procedure of subclause 4.4.3.1 or follow the Manual Network Selection Mode procedure of subclause 4.4.3.1.2. If the appropriate process does not result in registration, the MS will eventually enter the limited service state.</p> <p>NOTE 1: MSs capable of GPRS and non-GPRS services may have different registration status for GPRS and for non-GPRS.</p> <p>NOTE 2: The registered PLMN is determined by looking at the stored registration area identity and stored location registration status.</p> |                     |  |

**Table 2: LR Process States and Allowed Actions**

| Location Registration<br><br>Task State  | New LR request when |                                  |                  |         | Normal Calls<br>Supported (1) | Paging<br>responded<br>to |
|--|---------------------|----------------------------------|------------------|---------|-------------------------------|---------------------------|
|  | Changing<br>Cell    | Changing<br>registration<br>area | Changing<br>PLMN | Other   |                               |                           |
| Null (4)   | No                  | Yes                              | Yes              | No      | No                            | No                        |
| Updated, (5)   | No                  | Yes                              | Yes              | (2)     | Yes                           | Yes                       |
| Idle, No IMSI (7)  | No                  | No                               | No               | No      | No                            | No                        |
| Roaming not allowed:   |                     |                                  |                  |         |                               |                           |
| a) Idle, PLMN not allowed  | No                  | No                               | Yes              | No      | No                            | Optional if with IMSI     |
| b) Idle, LA not allowed or TA not allowed  | No                  | Yes(6)                           | Yes              | No      | No                            | Optional if with IMSI     |
| c) Idle, Roaming not allowed in this LA or Roaming not allowed in this TA  | No                  | Yes(6,8)                         | Yes              | No      | No                            | Optional if with IMSI     |
| d) No suitable cells in location area or No suitable cells in tracking area  | No                  | Yes(6,8)                         | Yes              | No      | No                            | Optional if with IMSI     |
| e) Not authorized for this CSG   | No                  | Yes (6,8)                        | Yes              | No      | No                            | Optional if with IMSI     |
| Not updated  | Yes                 | Yes                              | Yes              | (2)&(3) | (3)                           | Yes if with IMSI          |
| 1): Emergency calls may always be made, subject to access control permitting it.<br>2): A new LR is made when the periodic registration timer expires.<br>3): If a normal call request is made, an LR request is made. If successful the updated state is entered and the call may be made.<br>4): The MS is in the null state from switch on until it has camped on a cell and either made an LR attempt or decided that no LR attempt is needed.<br>5): In this state, IMSI detach is performed if the MS is deactivated and the BCCH indicates that IMSI attach/detach shall be used. An LR request indicating IMSI attach is performed if the MS is activated in the same registration area in which it was deactivated while being in this state.<br>6): An MS shall not perform a new LR when the new routing area is part of an LA or TA contained in any of the lists "forbidden location areas for roaming", "forbidden tracking areas for roaming", "5GS forbidden tracking areas for roaming", "forbidden location areas for regional provision of service", "forbidden tracking areas for regional provision of service", "5GS forbidden tracking areas for regional provision of service" or the new cell is a CSG cell which is not part of any of the lists "Allowed CSG list", "Operator CSG list".<br>7): The conditions in which the GPRS and/or non-GPRS registration status "Idle, No IMSI" is entered are specified in subclause 4.3.3.<br>8): A MS shall perform a LR if it has entered a registration area whatever the registration area stored in the MS. |                     |                                  |                  |         |                               |                           |



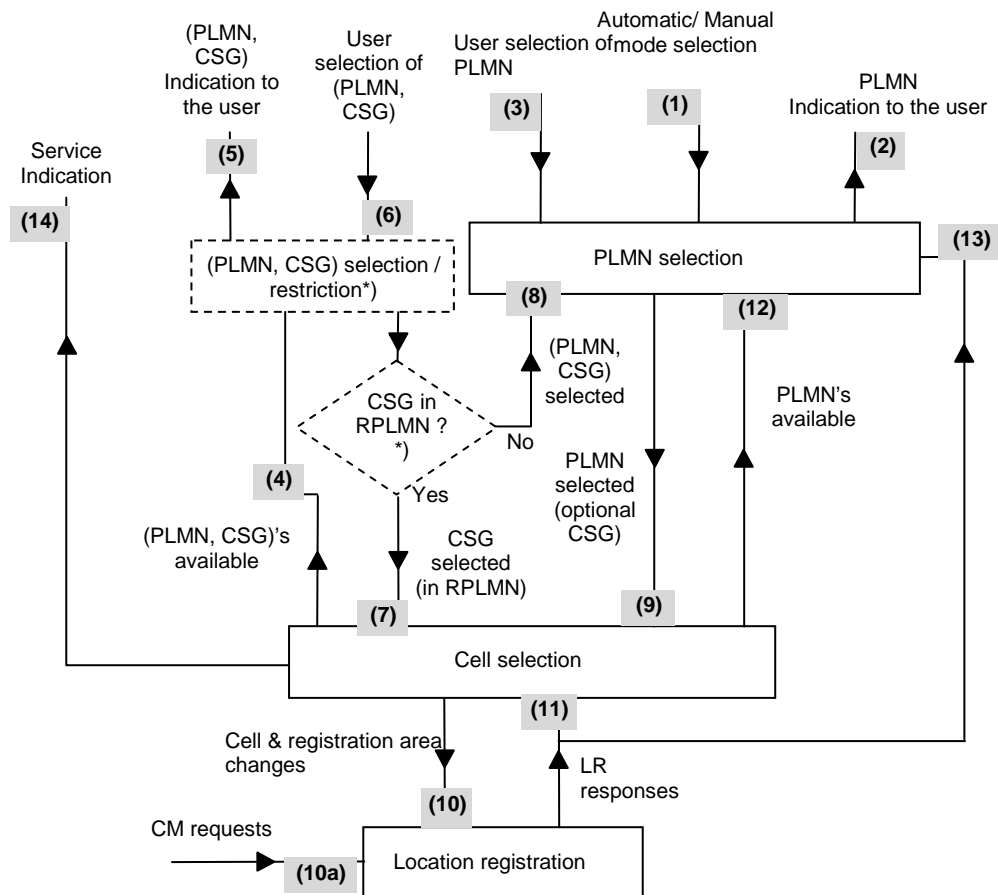

\*) dashed parts apply only for MEs supporting CSGs and are executed for manual CSG selection

**Figure 1: Overall Idle Mode process**

The individual steps are the following (they are not necessarily executed in the number sequence):

- (1) The PLMN selection mode is set (e.g. by the user via the user interface or by AT command).
- (2) The list of available PLMNs is presented to the user, according to the rules given in subclause 4.4.3.1.2.
- (3) In manual PLMN selection mode the user selects from the available PLMNs.
- (4) If the MS supports CSGs, the list of available PLMNs and CSGs, together with an indication as to which of the available CSGs is in the Allowed or Operator CSG list, is presented to the user upon request. The detailed rules are defined in subclause 5.5.4 of 3GPP TS 22.220 [49].
- (5) Only for MSs supporting CSGs: when camping on a cell, the available CSGs (with PLMN information) are conveyed to the CSG selection/restriction procedure (see subclause 3.1A).
- (6) Only for MSs supporting CSGs: in manual CSG selection mode the user selects from the available CSGs.
- (7) Only for MSs supporting CSGs: if the selected CSG is associated with the RPLMN, the MS performs selection of a cell belonging to this CSG.
- (8) Only for MSs supporting CSGs: if the selected CSG is associated with a PLMN different from the RPLMN, the MS enters the PLMN selection process and performs the parts applicable after manual selection of a PLMN.
- (9) After it has selected a PLMN, the MS performs selection of a cell belonging to this PLMN; this selection is additionally restricted by the selected CSG, if the PLMN selection was triggered by a manual CSG selection.
- (10) After having selected a new cell and the registration area has changed, the MS shall enter the LR process (see figure 3).

- (10a) A MS's CM requests may lead to a registration request.
- (11) If the LR is not successful, and if the cause received from the network does not exclude the RPLMN, the MS performs another cell selection (i.e. cell re-selection) within the RPLMN.
- (12) The information on available PLMNs, as detected by the cell selection process from detectable broadcast information, is made available to the PLMN selection process.
- (13) If the LR is not successful, and if the cause received from the network excludes the RPLMN, the MS performs PLMN selection.
- (14) The positive result of cell selection (suitable cell and in updated state, or in connected mode having been camped on a suitable cell) and location registration (updated, for MSs capable of services requiring registration) is indicated to the user.

Possible sequences of steps are e.g.:

- 1) 1 → 2 → 3 → 9 → 10 → 11 (manual PLMN selection, MS is not CSG capable)
- 2) 1 → 9 → 4 → 5 → 6 → 8 → 9 → 10 → 11 (automatic PLMN selection, MS is CSG capable, manual CSG selection);

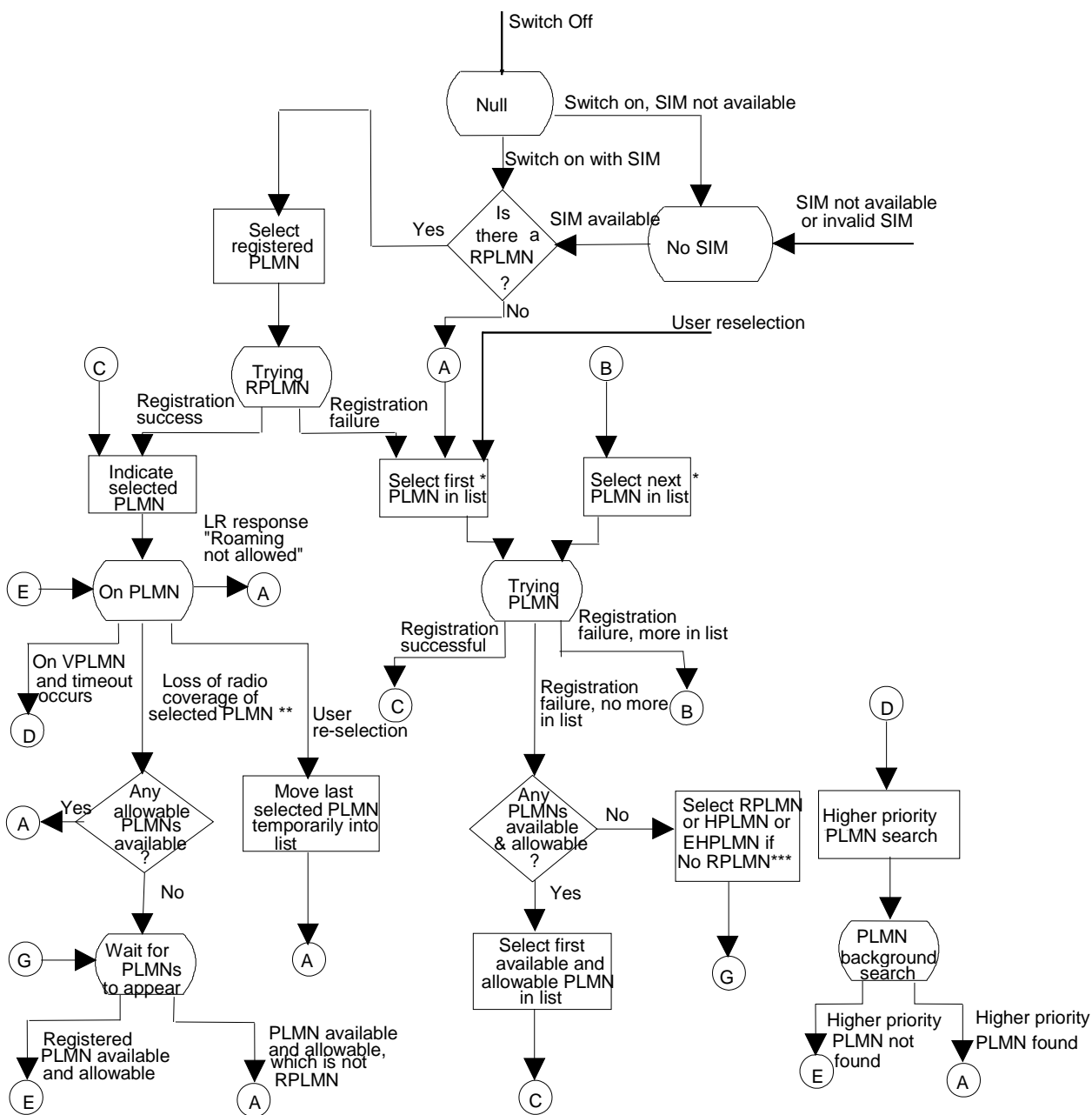

\* "List" consists of points i) to v) as defined in section 4.4.3.1.1 except in case of a user re-selection in which case "list" consists of points i) to v) as defined in section 4.4.3.2.1

\*\* Includes effective loss of coverage due to LAs/TAs being forbidden in all potentially suitable cells

\*\*\* HPLMN (if the EHPLMN list is not present or is empty) or EHPLMN (if the list is present)

Figure 2a: PLMN Selection State diagram (automatic mode)

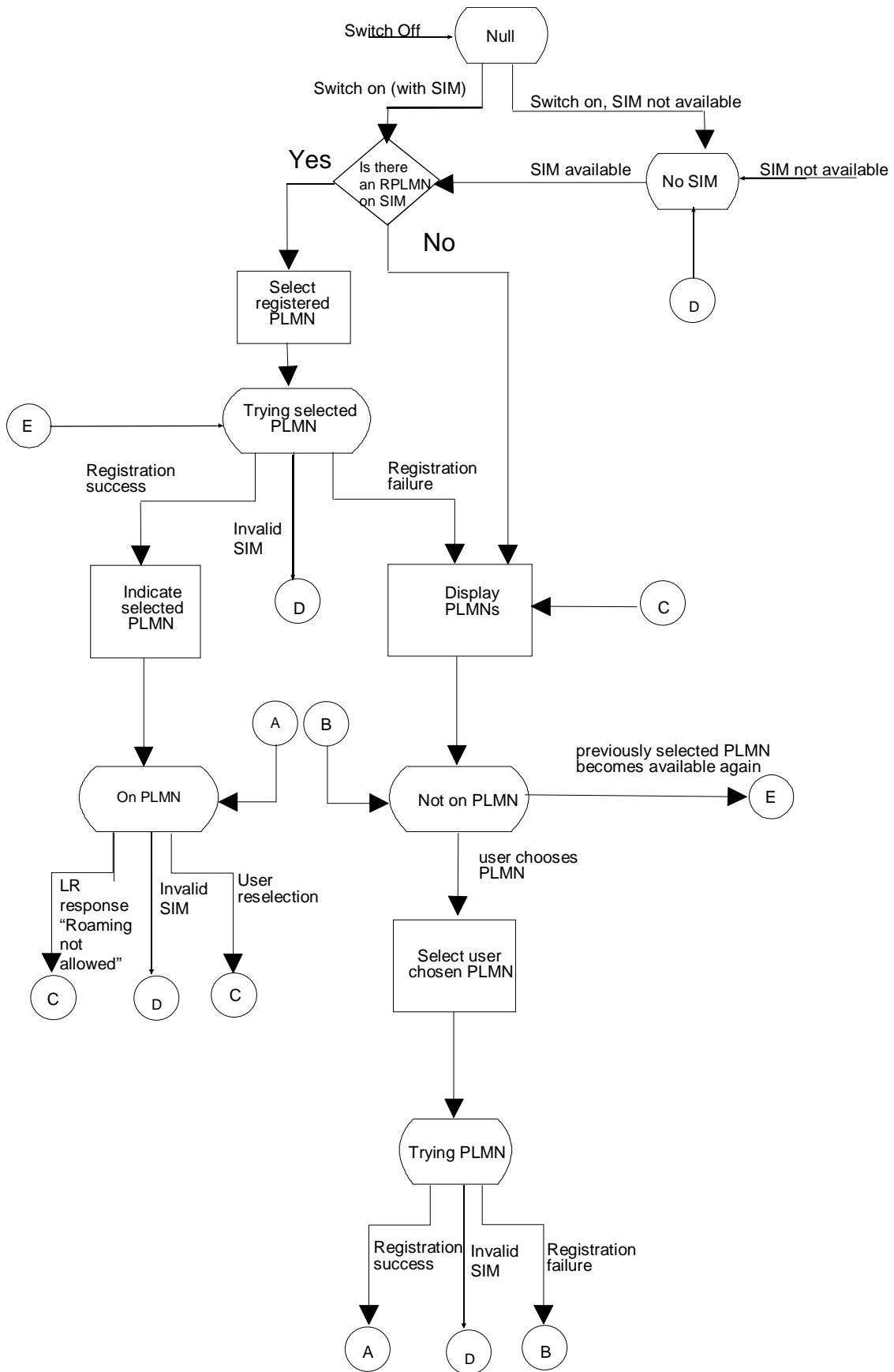
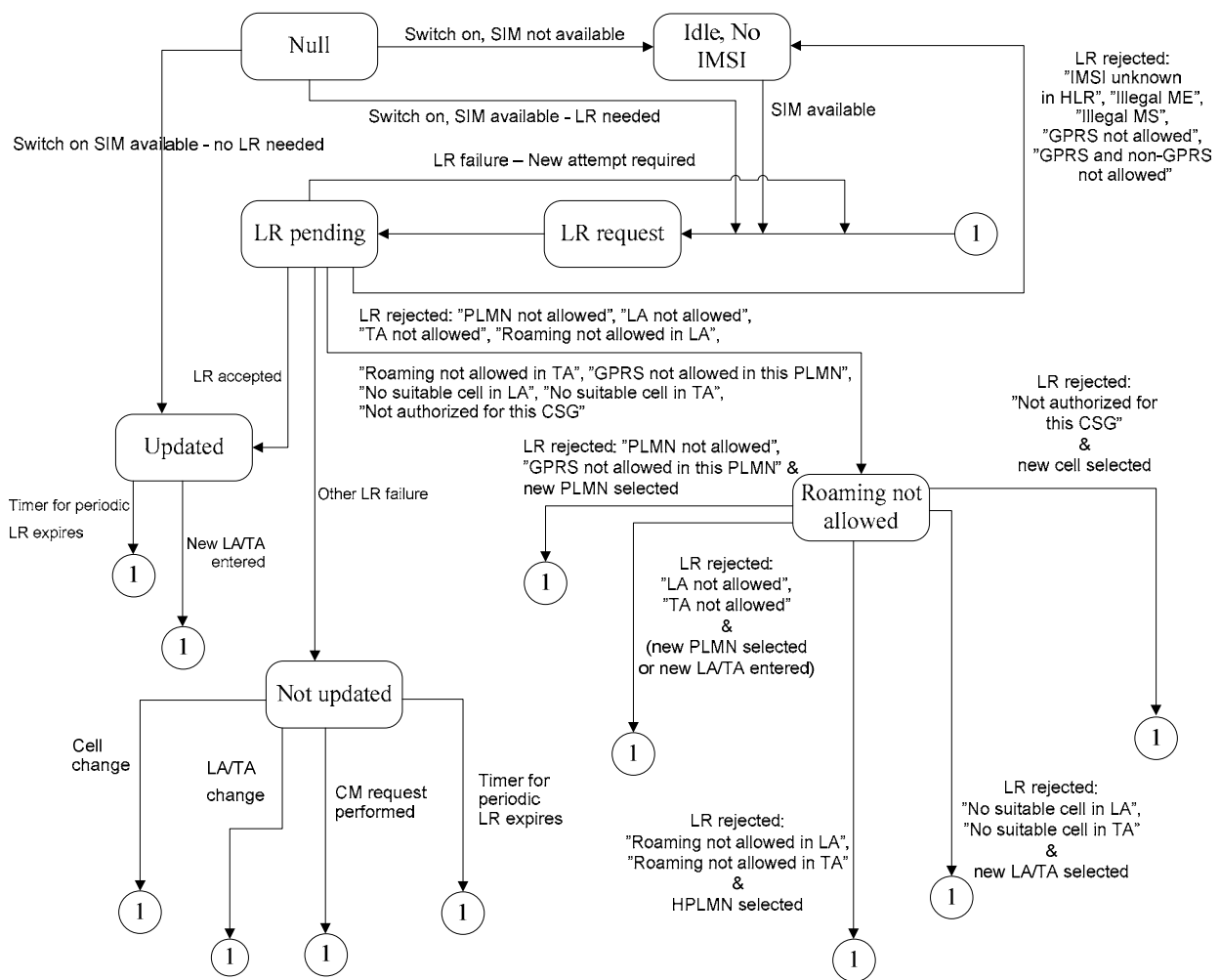

Figure 2b: PLMN Selection State diagram (manual mode)



NOTE 1: Whenever the MS goes to connected mode and then returns to idle mode again the MS selects appropriate state.

NOTE 2: A MS capable of GPRS and non-GPRS services has two Task State machines one for GPRS and one for non-GPRS operation.

Figure 3: Location Registration Task State diagram

## 6 MS supporting access technologies defined both by 3GPP and 3GPP2

### 6.1 General

An MS that supports access technologies defined both by 3GPP and 3GPP2 (see 3GPP TS 31.102 [40]) shall consider all supported access technologies in all supported bands when performing PLMN selection.

The goal of the PLMN selection process for such a multi mode MS is to find the highest priority PLMN and to attempt to register to it.

A multi mode MS shall follow the requirements in the present document for the PLMN selection procedures across both 3GPP and 3GPP2 access technologies. Additionally, the MS shall follow the requirements of the present document in its signalling procedures towards any 3GPP network. If the common PLMN selection procedure leads to selection of a 3GPP2 network, then the MS shall follow 3GPP2 specifications in meeting any 3GPP2 specific system selection constraints and in all signalling procedures towards the 3GPP2 network.

While registered to VPLMN via 3GPP2 access, the MS shall follow the 3GPP2 specifications for scan of higher priority PLMNs. Additionally to the requirements specified for 3GPP2 system, a multi mode MS while registered to a 3GPP2 VPLMN shall follow the requirements specified in subclause 4.4.3.3.

NOTE: It is assumed that the MS can determine the PLMN identity of networks supporting 3GPP2 technologies from the information broadcast over the air.

## Annex A (normative): HPLMN Matching Criteria

With the introduction of PCS1900 with the regulatory mandate to allocate 3-digit MNC codes, additional functionality is required to identify the HPLMN.

### Assumptions

An MNC code shall consist of 2 or 3 decimal digits. In NA PCS1900, all SIMs shall store 3 digit MNCs.

Any network using a 2 digit MNC code shall broadcast the hexadecimal code "F" in place of the 3<sup>rd</sup> digit.

For PCS1900 for North America, regulations mandate that a 3-digit MNC shall be used; however during a transition period, a 2 digit MNC may be broadcast by the Network and, in this case, the 3<sup>rd</sup> digit of the SIM is stored as 0 (this is the 0 suffix rule).

With the exception of North America during the transition period:

- a) Within a single country (or area identified by a MCC) all networks shall broadcast a 2 digit MNC code, or all networks shall broadcast a 3 digit MNC code. A mixture of broadcast 2 and 3 digit MNC codes is not permitted within a single country (or area identified by a MCC).
- b) A network which broadcasts a 2 digit MNC code, will issue SIMs with a 2 digit MNC code in the IMSI on the SIM. A network which broadcasts a 3 digit MNC code, will issue SIMs with a 3 digit MNC code in the IMSI on the SIM.

### Definitions and abbreviations

|                 |  |
|-----------------|--|
| <b>BCCH-MCC</b> | The MCC part of the LAI read from System Information type 3 messages broadcast on the BCCH by the network. |
| <b>BCCH-MNC</b> | The MNC part of the LAI read from System Information type 3 messages broadcast on the BCCH by the network. |
| <b>SIM-MCC</b>  | The MCC part of the IMSI or of additional entries in the EHPLMN list read from the SIM.                    |
| <b>SIM-MNC</b>  | The MNC part of the IMSI or of additional entries in the EHPLMN list read from the SIM.                    |

### HPLMN Matching Criteria in mobiles which don't support PCS1900 for NA:

Figure A.1 illustrates the logic flow described below. The text below is normative. Figure A.1 is informative.

- (1) The MS shall compare using all 3 digits of the SIM-MCC with the BCCH-MCC. If the values do not match, then the HPLMN match fails.

NOTE: If the MCC codes match, then the number of digits used for the SIM-MNC must be the same as the number of digits used for the BCCH-MNC.

- (2) The MS shall read the 3<sup>rd</sup> digit of the BCCH-MNC. If the 3<sup>rd</sup> digit is Hex F, then proceed to step (4).
- (3) The MS shall compare using all 3 digits of the SIM-MNC with the BCCH-MNC. If the values match, then the HPLMN match succeeds, otherwise the HPLMN match fails.
- (4) The MS shall compare using just the 1<sup>st</sup> 2 digits the SIM-MNC with the BCCH-MNC. If the values match, then the HPLMN match succeeds, otherwise the HPLMN match fails.

If the EHPLMN list is present and is empty or if the EHPLMN list is not present, the matching procedure shall be done for the MCC/MNC of the IMSI.

If the EHPLMN list is present and is not empty, the matching procedure shall be done for all entries in the EHPLMN list until a match is found or all matches fail.

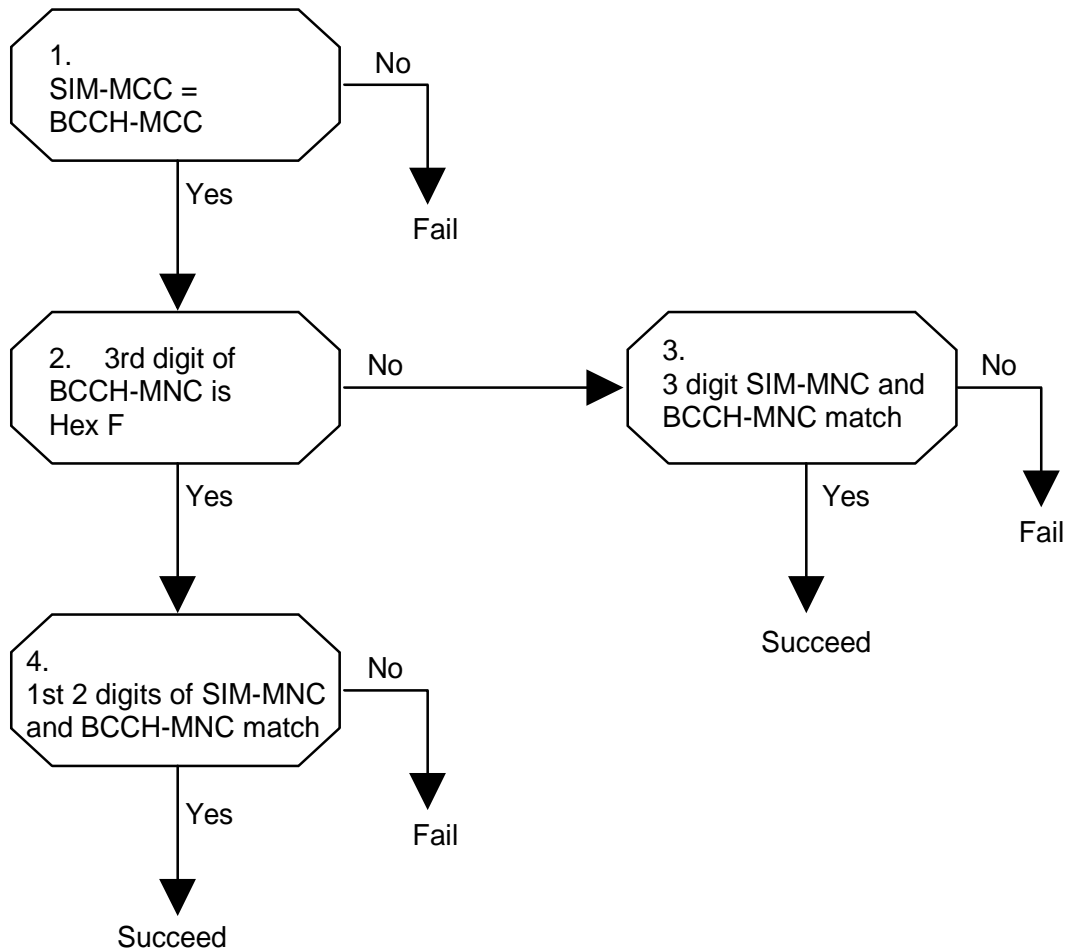

**Figure A.1: HPLMN Matching Criteria Logic Flow for mobiles which support GSM and DCS1800 (informative)**

HPLMN Matching Criteria for mobiles which support PCS1900 for NA:

Figure A.2 illustrates the logic flow described below. The text below is normative. Figure A.2 is informative.

- (1) The MS shall compare using all 3 digits the SIM-MCC with the BCCH-MCC. If the values do not match, then the HPLMN match fails.
- (2) The MS shall read the 3<sup>rd</sup> digit of the BCCH-MNC. If the 3<sup>rd</sup> digit is Hex F, then proceed to step (4).
- (3) The MS shall compare using all 3 digits the SIM-MNC with the BCCH-MNC. If the values match, then the HPLMN match succeeds, otherwise the HPLMN match fails.

NOTE: These rules (1) – (3) are the same as for mobiles which don't support PCS1900 for NA, except step (4) is different.

- (4) The MS shall determine if the BCCH-MCC lies in the range 310-316 (i.e., whether this network is a PCS1900 for NA network). If the BCCH-MCC lies outside the range 310-316, then proceed to step (6).

- (5) The MS shall compare the 3<sup>rd</sup> digit of the SIM-MNC with '0'. If the 3<sup>rd</sup> digit is not '0' then the HPLMN match fails.

NOTE: This is the '0' suffix rule.

- (6) The MS shall compare using just the 1<sup>st</sup> 2 digits of the SIM-MNC with the BCCH-MNC. If the values match, then the HPLMN match succeeds, otherwise the HPLMN match fails.

NOTE: When PCS1900 for NA switches over to broadcasting 3 digit MNCs in **all** networks, then the additional requirements for PCS1900 for NA can be deleted.



If the EHPLMN list is present and is empty or if the EHPLMN list is not present, the matching procedure shall be done for the MCC/MNC of the IMSI.

If the EHPLMN list is present and is not empty, the matching procedure shall be done for all entries in the EHPLMN list until a match is found or all matches fail.

#### Guidance for Networks in PCS1900 for NA

There may be some problems in the transition period from broadcasting 2 MNC digits to broadcasting 3 MNC digits. Here are some guidelines to avoid these problems.

- (1) Existing network codes. Operators who currently use a 2 digit BCCH-MNC **xy** should use the new code **xy0**.
- (2) New operators allocated 3 digit MNC codes with the same 1<sup>st</sup> 2 digits as an existing operator shall not use a 3<sup>rd</sup> digit of 0.

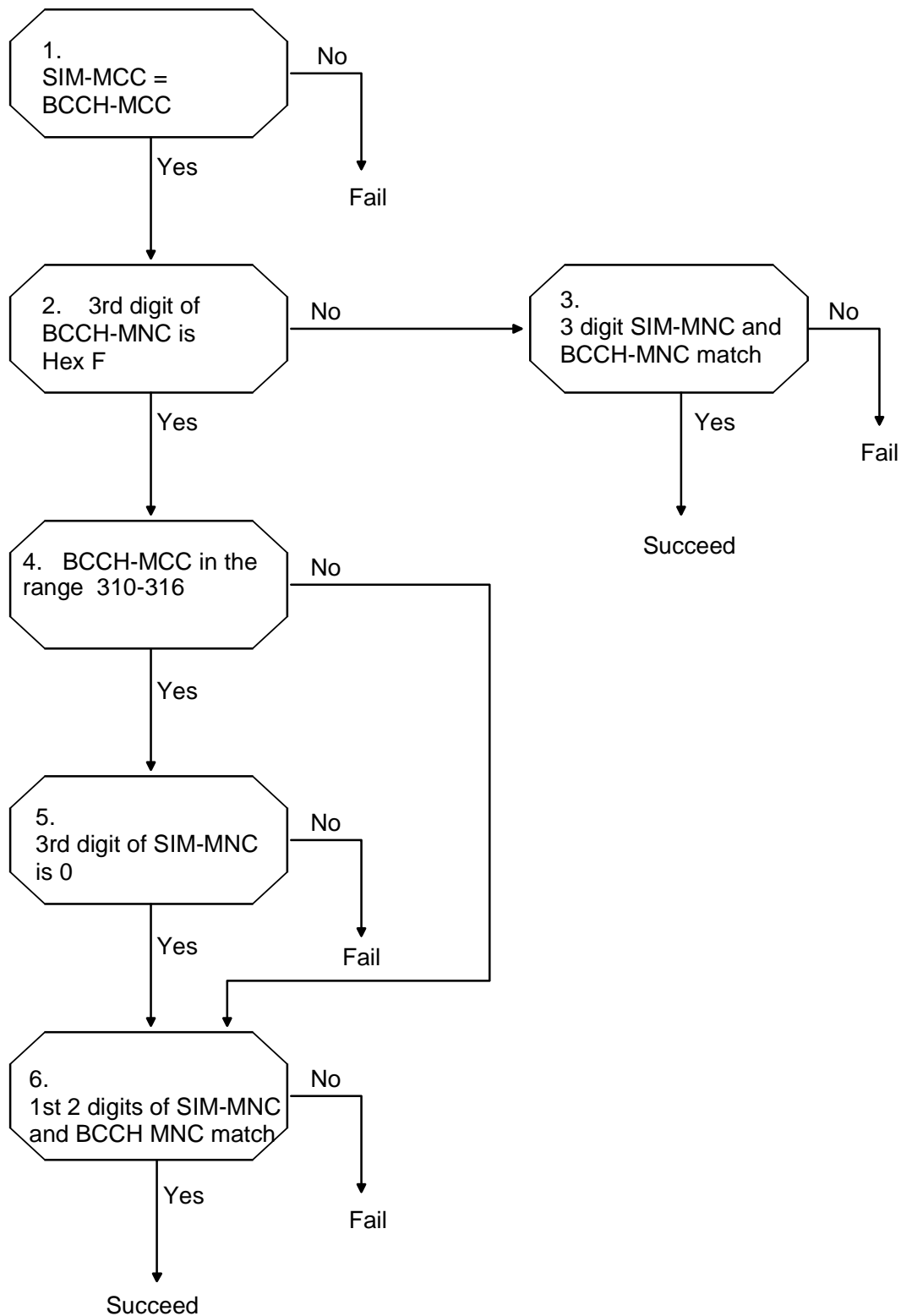

Figure A.2: HPLMN Matching Criteria Logic Flow for mobiles which support PCS1900 for NA (informative)

---

## Annex B (normative): PLMN matching criteria to be of same country as VPLMN

While a MS is roaming on a VPLMN, the VPLMN and a PLMN are of the same country only if their MCC values identify the same country. See subclause 1.2 for the definition of country.

---

# Annex C (normative): Control plane solution for steering of roaming in 5GS

## C.1 General

The purpose of the control plane solution for steering of roaming in 5GS procedure is to allow the HPLMN to update the "Operator Controlled PLMN Selector with Access Technology" list in the UE by providing the HPLMN protected list of preferred PLMN/access technology combinations via NAS signalling. The HPLMN updates the "Operator Controlled PLMN Selector with Access Technology" based on the operator policies, which can be based on the registered VPLMN, the location of the UE, etc.

The HPLMN may configure their subscribed UE's USIM to indicate that the UE is expected to receive the list of preferred PLMN/access technology combinations (or HPLMN indication that 'no change of the "Operator Controlled PLMN Selector with Access Technology" list stored in the UE is needed and thus no list of preferred PLMN/access technology combinations is provided') due to initial registration in a VPLMN. At the same time the HPLMN will mark the UE is expected to receive the list of preferred PLMN/access technology combinations (or HPLMN indication that 'no change of the "Operator Controlled PLMN Selector with Access Technology" list stored in the UE is needed and thus no list of preferred PLMN/access technology combinations is provided') due to initial registration in a VPLMN, in the subscription information in the UDM. In this case, it is mandatory for the HPLMN to provide the list of preferred PLMN/access technology combinations (or HPLMN indication that 'no change of the "Operator Controlled PLMN Selector with Access Technology" list stored in the UE is needed and thus no list of preferred PLMN/access technology combinations is provided') to the UE during initial registration, otherwise if such configuration is not provided in the USIM then it is optional for the HPLMN to provide the list of preferred PLMN/access technology combinations information to the UE during initial registration (based on operator policy). In addition, the HPLMN can request the UE to provide an acknowledgement of successful reception of the list of preferred PLMN/access technology combinations (or HPLMN indication that 'no change of the "Operator Controlled PLMN Selector with Access Technology" list stored in the UE is needed and thus no list of preferred PLMN/access technology combinations is provided').

The procedure in this annex for steering of UE in VPLMN can be initiated by the network while the UE is trying to register onto the VPLMN as described in subclause C.1, or after the UE has registered onto the VPLMN as described in subclause C.2.

**Editor's note:** The requirements for the case that steering of UE information is received while the UE is accessing the network for the purpose of establishing an IMS emergency session or IMS eCall is FFS.

**Editor's note:** As part of acknowledgement whether UE should also indicate current mode of operation (manual mode or automatic mode) and coverage status of priority PLMN to HPLMN is FFS.

---

## C.2 Stage-2 flow for steering of UE in VPLMN during registration

The stage-2 flow for the case when the UE registers with VPLMN AMF is described below in figure C.2.1:

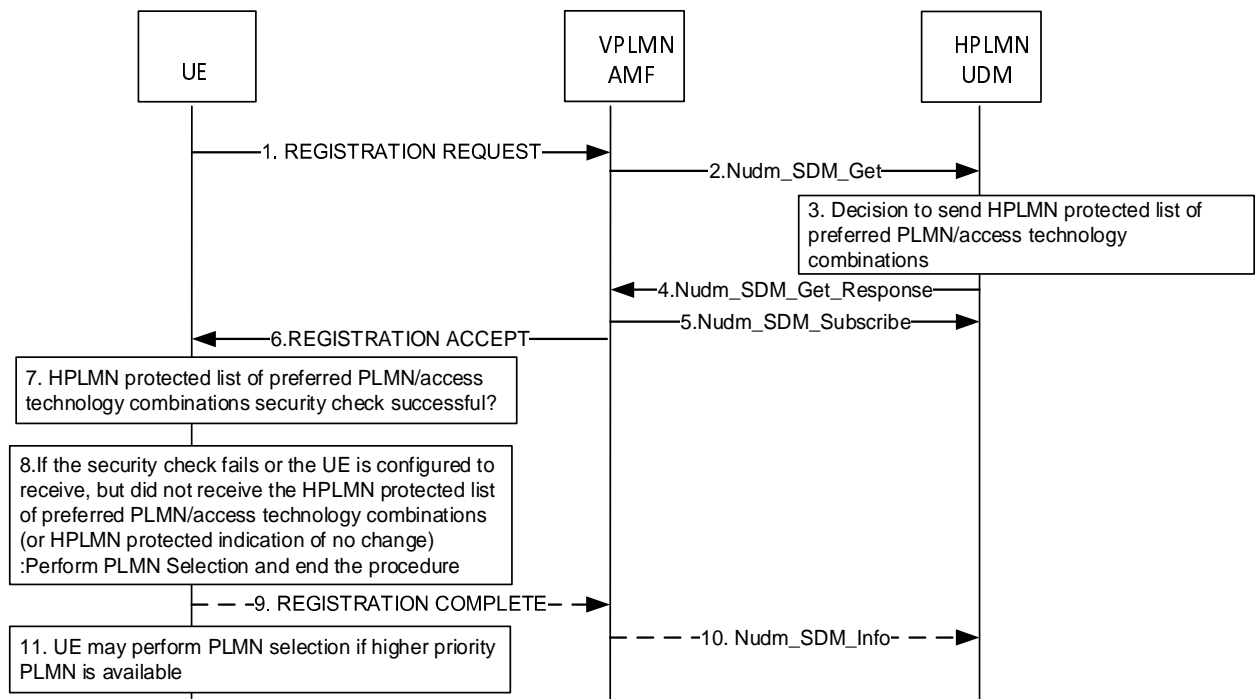

**Figure C.2.1: Procedure for providing list of preferred PLMN/access technology combinations**

- 1) The UE to the VPLMN AMF: The UE initiates registration by sending REGISTRATION REQUEST message to the VPLMN AMF;
- 2) The VPLMN AMF to the HPLMN UDM: The VPLMN AMF executes the registration procedure as defined in subclause 4.2.2.2.2 of 3GPP TS 23.502 [63]. As part of the registration procedure, the VPLMN AMF invokes Nudm\_SDM\_Get service operation message to the HPLMN UDM to get amongst other information the Access and Mobility Subscription data for the UE (see step 14b in subclause 4.2.2.2.2 of 3GPP TS 23.502 [63]);
- 3) If the user subscription information indicates to send the list of preferred PLMN/access technology combinations (or HPLMN indication that 'no change of the "Operator Controlled PLMN Selector with Access Technology" list stored in the UE is needed and thus no list of preferred PLMN/access technology combinations is provided') due to initial registration in a VPLMN, then HPLMN UDM shall provide the HPLMN protected list of preferred PLMN/access technology combinations (or HPLMN indication that 'no change of the "Operator Controlled PLMN Selector with Access Technology" list stored in the UE is needed and thus no list of preferred PLMN/access technology combinations is provided') to the UE, otherwise the HPLMN UDM may provide the HPLMN protected list of preferred PLMN/access technology combinations (or HPLMN indication that 'no change of the "Operator Controlled PLMN Selector with Access Technology" list stored in the UE is needed and thus no list of preferred PLMN/access technology combinations is provided') to the UE, based on operator policy;
- 4) The HPLMN UDM to the VPLMN AMF: The HPLMN UDM sends a response to the Nudm\_SDM\_Get service operation to the VPLMN AMF, which includes the list of preferred PLMN/access technology combinations (or HPLMN indication that 'no change of the "Operator Controlled PLMN Selector with Access Technology" list stored in the UE is needed and thus no list of preferred PLMN/access technology combinations is provided') within the Access and Mobility Subscription data. The Access and Mobility Subscription data type is defined in subclause 5.2.3.3.1 of 3GPP TS 23.502 [63]). The HPLMN may also request the UE to acknowledge the successful security check of the received list of preferred PLMN/access technology combinations (or HPLMN indication that 'no change of the "Operator Controlled PLMN Selector with Access Technology" list stored in the UE is needed and thus no list of preferred PLMN/access technology combinations is provided'), by providing the indication in the Nudm\_SDM\_Get response service operation;

- 5) The VPLMN AMF to the HPLMN UDM: As part of the registration procedure, the VPLMN AMF also invokes Nudm\_SDM\_Subscribe service operation to the HPLMN UDM to subscribe to notification of changes of the subscription data received in step 4) including notification of updates in the HPLMN list of preferred PLMN/access technology combinations included in the Access and Mobility Subscription data (see step 14c in subclause 4.2.2.2.2 of 3GPP TS 23.502 [63]);
- 6) The VPLMN AMF to the UE: The VPLMN AMF transparently sends the list of preferred PLMN/access technology combinations (or HPLMN indication that 'no change of the "Operator Controlled PLMN Selector with Access Technology" list stored in the UE is needed and thus no list of preferred PLMN/access technology combinations is provided') and the indication that the UDM requests an acknowledgement from the UE (if included by the HPLMN UDM) and the AV(s) to the UE in the REGISTRATION ACCEPT message;
- 7) If the list of preferred PLMN/access technology combinations is received and the security check is successful, then the UE shall replace the highest priority entries in the "Operator Controlled PLMN Selector with Access Technology" list stored in the UE with the received list of preferred PLMN/access technology combinations; and

Additionally, if the UDM has not requested an acknowledgement from the UE and if the UE has a list of available and allowable PLMNs in the area and based on this list the UE determines that there is a higher priority PLMN than the currently camped chosen VPLMN and the UE is in automatic network selection mode, then the UE may release the current N1 NAS signalling connection locally and abort the ongoing registration procedure before performing PLMN selection, and steps 8 to 11 are skipped; Alternatively, if the UE does not release the current N1 NAS signalling connection locally, then the UE completes the registration procedure as specified in 3GPP TS 24.501 [64] and steps 8 to 10 are skipped;

- 8) if:
  - a) the UE's USIM is configured with indication that the UE is to receive the list of preferred PLMN/access technology combinations (or HPLMN indication that 'no change of the "Operator Controlled PLMN Selector with Access Technology" list stored in the UE is needed and thus no list of preferred PLMN/access technology combinations is provided') due to initial registration in a VPLMN, but neither the list of preferred PLMN/access technology combinations nor the HPLMN indication that 'no change of the "Operator Controlled PLMN Selector with Access Technology" list stored in the UE is needed and thus no list of preferred PLMN/access technology combinations is provided' is received in the REGISTRATION ACCEPT message, or if the list of preferred PLMN/access technology combinations (or HPLMN indication that 'no change of the "Operator Controlled PLMN Selector with Access Technology" list stored in the UE is needed and thus no list of preferred PLMN/access technology combinations is provided') is received but the security check is not successful; and
  - b) the current chosen VPLMN is not contained in the list of "PLMNs where registration was aborted due to SOR", not part of "User Controlled PLMN Selector with Access Technology" list and the UE is not in manual mode of operation;

then the UE shall release the current N1 NAS signalling connection locally, store the PLMN identity in the list of "PLMNs where registration was aborted due to SOR" and attempt to obtain service on another PLMN by acting as if timer T that controls periodic attempts has expired, with an exception that the current PLMN is considered as lowest priority, and steps 9 to 12 are skipped;

NOTE: When the UE is in the manual mode of operation or the current chosen VPLMN is part of the "User Controlled PLMN Selector with Access Technology" list, the UE stays on the VPLMN.

- 9) The UE to the VPLMN AMF: If the UDM has requested an acknowledgement from the UE and the UE verified that the list of preferred PLMN/access technology combinations (or HPLMN indication that 'no change of the "Operator Controlled PLMN Selector with Access Technology" list stored in the UE is needed and thus no list of preferred PLMN/access technology combinations is provided') has been provided by the HPLMN in step 6, the UE sends the REGISTRATION COMPLETE message to the serving AMF with a transparent container including the UE acknowledgement;
- 10) The AMF to the UDM: The AMF sends a Nudm\_SDM\_Info request message. If a transparent container with a UE acknowledgement was received in the REGISTRATION COMPLETE message, the AMF includes the transparent container in the Nudm\_SDM\_Info request message. If the HPLMN decided that the UE is to acknowledge successful the security check of the received list of preferred PLMN/access technology combinations (or HPLMN indication that 'no change of the "Operator Controlled PLMN Selector with Access Technology" list stored in the UE is needed and thus no list of preferred PLMN/access technology combinations is provided') in step 4, the UDM verifies that the acknowledgement is provided by the UE; and

11) If the UE has a list of available PLMNs in the area and based on this list the UE determines that there is a higher priority PLMN than the currently camped chosen VPLMN and the UE is in automatic network selection mode, then the UE may perform PLMN selection after the release of the N1 NAS signalling connection. If the N1 NAS signalling connection is not released after implementation dependent time, the UE may locally release the N1 signalling connection.

12) The UE deletes the list of "PLMNs where registration was aborted due to SOR".

The list of "PLMNs where registration was aborted due to SOR" is deleted when the UE is switched off.

**Editor's note:** In order to guarantee end-to-end security between HPLMN and roaming UEs, CT1 in close coordination with SA3 will work further on this procedure.

**Editor's note:** The list of preferred PLMN/access technology combinations provided by HPLMN to VPLMN can be a secured packet (e.g. based on ETSI TS 102 225 V12.1.0: "Smart Cards; Secured packet structure for UICC based applications") or a plain non secured packet. It has to be decided by SA3, CT1 will align this aspect after SA3 defines the security mechanism.

## C.3 Stage-2 flow for steering of UE in VPLMN after registration

The stage-2 flow for the steering of UE in VPLMN after registration is indicated in figure C.3.1.

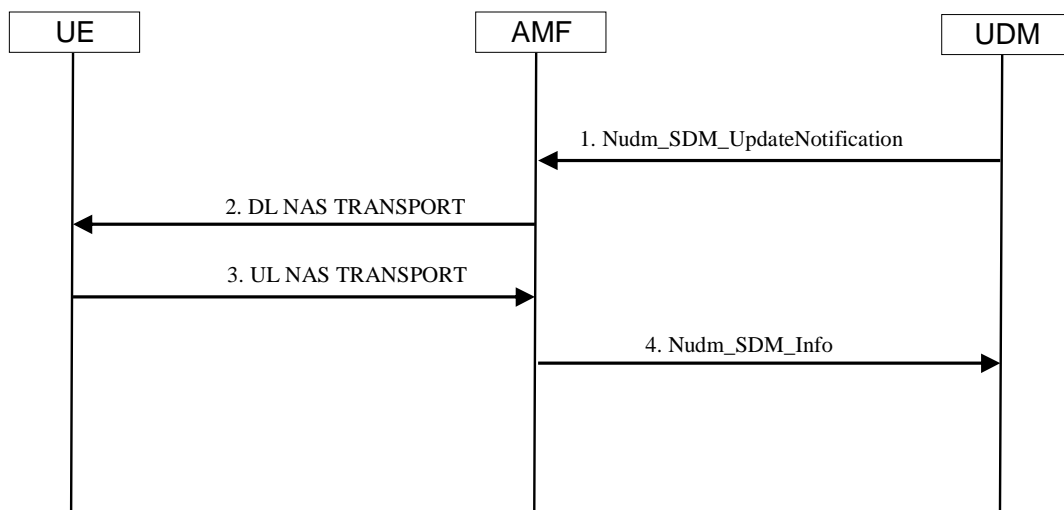

**Figure C.3.1: Procedure for providing list of preferred PLMN/access technology combinations after registration**

1. The UDM to the AMF: The UDM notifies the changes of the user profile to the affected AMF by the means of invoking Nudm\_SDM\_UpdateNotification service operation. The Nudm\_SDM\_UpdateNotification service operation contains the list of preferred PLMN/access technology combinations that needs to be delivery transparently to the UE over NAS within the Access and Mobility Subscription data. If the HPLMN decided that the UE is to acknowledge successful security check of the received list of preferred PLMN/access technology combinations, the Nudm\_SDM\_UpdateNotification service operation also contains an indication that the UDM requests an acknowledgement from the UE.
2. The AMF to the UE: the AMF sends a DL NAS TRANSPORT message to the served UE. The AMF includes in the DL NAS TRANSPORT message the transparent container received from the UDM. If the UE verifies that the list of preferred PLMN/access technology combinations included in the DL NAS TRANSPORT message is provided by HPLMN, the UE shall replace the highest priority entries in the "Operator Controlled PLMN

Selector with Access Technology" list stored in the UE with the received list of preferred PLMN/access technology combinations.

**Editor's note: How the need for the UE to provide an acknowledgment is encoded in the DL NAS TRANSPORT is FFS.**

3. The UE to the AMF: if the UDM has requested an acknowledgement from the UE in the DL NAS TRANSPORT message and the UE verified that the list of preferred PLMN/access technology combinations has been provided by HPLMN, the UE sends an UL NAS TRANSPORT message to the serving AMF with a transparent container including the UE acknowledgement.
4. The AMF to the UDM: the AMF sends a Nudm\_SDM\_Info request message to the UDM. If a transparent container with a UE acknowledgement was received in the UL NAS TRANSPORT message, the AMF includes the transparent container in the Nudm\_SDM\_Info request message. If the HPLMN decided that the UE is to acknowledge successful security check of the received list of preferred PLMN/access technology combinations in step 1, the UDM verifies that the acknowledgement is provided by the UE.

**Editor's note: Further messages and further entities might be involved in order to secure the solution.**



## Annex D (informative): Change history

| TSG#  | Tdoc                    | SPEC   | VERS  | CR  | REV | PHASE | CAT | N_VER | SUBJECT  | comment   |
|-------|-------------------------|--------|-------|-----|-----|-------|-----|-------|--|---|
|       |                         | 03.22  | 8.2.0 |     |     | R99   |     |       | Split of 03.22/R99 to 03.22 and 23.122   |   |
| #6    |                         | 23.122 | 0.0.0 |     |     | R99   |     | 3.0.0 |  | Was approved in the TSGN#6 plenary  |
| #4    | N1-99573                | 23.102 | 3.0.0 | 001 |     | R99   | F   | 3.1.0 | PLMN selection for GPRS mobiles  | Mirrored from CRA032r2 REMOVED in V3.1.1, where it is not approved by SMG2  |
| #6    | N1-99D13                | 23.122 | 3.0.0 | 002 |     | R99   | A   | 3.1.0 | Correction of Figure A.2 in Annex A  | Mirrored from CR006r1for 23.022   |
| #7    | N1-000546               | 23.122 | 3.1.1 | 004 | 1   | R99   | D   | 3.2.0 | UMTS references in 23.122  | Correction of references  |
| #8    | N1-000796               | 23.122 | 3.2.0 | 003 | 5   | R99   | F   | 3.3.0 | Modification of PLMN Selection Procedures to support UMTS+COMPACT Network Selection  | WI: GSM/UMTS interworking<br><b>Note</b> As a result of two conflicting CRs N1-000796 is merged with the existing text in V.3.2.0 by the rapporteur |
| #9    | NP-000443/<br>N1-001020 | 23.122 | 3.3.0 | 009 | 2   | R99   | F   | 3.4.0 | Clarifications of the PLMN Selection procedures for UMTS and COMPACT.  |   |
|       |                         | 23.122 | 3.4.0 |     |     |       |     | 3.4.1 | Correction of text in version3.4.0 (There was text to be deleted in clause 4.4.3.2.1 bullet point 2)   | 23.Oct.2000<br>Implementation correction  |
|       |                         | 23.122 | 3.4.1 |     |     |       |     | 3.4.2 | Correction of a systematic search for "TS" and replace it with "3GPP TS" has gone wrong as much more than the TSs for Technical Specifications have been changed also. | 1 Nov..2000<br>Implementation correction  |
| #10   | NP-000674/<br>N1-001415 | 23.122 | 3.4.2 | 010 | 1   | R99   | F   | 3.5.0 | Correction of terminology "In UMTS", "In GSM"  | Cat F/ WI=TEI   |
| #10   | NP-000671/<br>N1-001236 | 23.122 | 3.4.2 | 012 |     | R99   | F   | 3.5.0 | Restoration of figure A.1  | Cat F/ WI=GSM - UMTS Interworking   |
| #10   | NP-000671/<br>N1-001237 | 23.122 | 3.4.2 | 013 |     | R99   | F   | 3.5.0 | Alignment of figure 2a with PLMN selection for UMTS  | Cat F/ WI=GSM - UMTS Interworking   |
| #11   | NP-010207/<br>N1-010472 | 23.122 | 3.5.0 | 014 | 3   | R99   | F   | 3.6.0 | Clarification of the PLMN selection for UMTS regarding high quality signal   | GSM - UMTS Interworking   |
| #11   | NP-010168/<br>N1-010224 | 23.122 | 3.5.0 | 016 | 1   | R99   | F   | 3.6.0 | Roaming restrictions for GPRS service  | GSM - UMTS Interworking   |
| #11   | NP-010205/<br>N1-010334 | 23.122 | 3.5.0 | 017 |     | R99   | F   | 3.6.0 | remove use of GSM as default access technology in PLMN search  | T.E.I   |
| #11   | NP-01089/<br>N1-010443  | 23.122 | 3.5.0 | 018 |     | R99   | F   | 3.6.0 | Requirement of priority on High Quality Signal cell concerning Acceptable cell (for limited service as emergency call)   | T.E.I   |
| #11   | NP-010186/<br>N1-010489 | 23.122 | 3.5.0 | 019 | 4   | R99   | F   | 3.6.0 | Clarifications to PLMN search  | T.E.I   |
| #11   | NP-010186/<br>N1-010490 | 23.122 | 3.5.0 | 020 | 1   | R99   | F   | 3.6.0 | Clarifications to PLMN search  | T.E.I   |
| #11   | NP-010180               | 23.122 | 3.5.0 | 022 | 1   | R99   | F   | 3.6.0 | Equivalent handling of PLMNs with different PLMN codes   | GSM - UMTS Interworking   |
| #11   |                         |        | 3.6.0 |     |     |       |     | 4.0.0 | Upgraded to Release 4.   |   |
| #12   | NP-010352               | 23.122 | 4.0.0 | 024 | 1   | Rel-4 | A   | 4.1.0 | Stored list of equivalent PLMNs and error/abnormal cases   | GSM-UMTS INTERWORKING   |
| #12   | NP-010276               | 23.122 | 4.0.0 | 027 | 1   | Rel-4 | A   | 4.1.0 | Corrections and clarifications to PLMN Selection   | GSM-UMTS INTERWORKING   |
| #12   | NP-010275               | 23.122 | 4.0.0 | 030 | 3   | Rel-4 | A   | 4.1.0 | Partial Roaming – restriction by location area   | TEI   |
| #12   | NP-010276               | 23.122 | 4.0.0 | 032 |     | Rel-4 | A   | 4.1.0 | Removal of 'Requirement of priority on High Quality Signal cell concerning Acceptable cell   | TEI   |
| #12   | NP-010276               | 23.122 | 4.0.0 | 034 |     | Rel-4 | A   | 4.1.0 | Alignment with stage 1 specification on PLMN background search   | TEI   |
| NP-16 | NP-020243               | 23.122 | 4.1.0 | 048 |     | Rel-5 | F   | 5.0.0 | Role of the equivalent PLMNs list in the PLMN user reselection   | TEI5  |
| NP-17 | NP-020369               | 23.122 | 5.0.0 | 051 |     | Rel-5 | A   | 5.1.0 | Removal of CBQ2  | COMPACT   |
| NP-17 | NP-020383               | 23.122 | 5.0.0 | 052 | 1   | Rel-5 | F   | 5.1.0 | Applicability of the lists of "forbidden LAs"  | TEI5  |
| NP-17 | NP-020367               | 23.122 | 5.0.0 | 055 |     | Rel-5 | A   | 5.1.0 | Routing Area Update at network change  | TEI   |
| NP-18 | NP-020549               | 23.122 | 5.1.0 | 058 |     | Rel-5 | A   | 5.2.0 | Correction of references   | TEI   |
|       |                         |        | 5.1.0 |     |     | Rel-5 |     | 5.2.0 | Additional cleanup done to references by ETSI/MCC  |   |
| NP-21 | NP-030405               | 23.122 | 5.2.0 | 061 |     | Rel-5 | A   | 5.3.0 | Removal of RPLMNAct field  | TEI   |
| NP-23 | NP-040037               | 23.122 | 5.3.0 | 067 | 1   | Rel-6 | F   | 6.0.0 | Definition of MS idle mode   | TEI6  |
| NP-23 | NP-040037               | 23.122 | 5.3.0 | 068 |     | Rel-6 | F   | 6.0.0 | Usage of HPLMNAct by the UE  | TEI6  |

| TSG#  | Tdoc      | SPEC   | VERS   | CR   | REV | PHASE | CAT | N_VER  | SUBJECT  | comment               |
|-------|-----------|--------|--------|------|-----|-------|-----|--------|--|-----------------------|
| NP-24 | NP-040202 | 23.122 | 6.0.0  | 069  | 5   | Rel-6 | F   | 6.1.0  | Clarification on the use of the RAT during background scanning.                                  | TEI6                  |
| NP-24 | NP-040202 | 23.122 | 6.0.0  | 071  | 1   | Rel-6 | F   | 6.1.0  | Role of ePLMN list in manual PLMN selection mode   | TEI6                  |
| NP-24 | NP-040202 | 23.122 | 6.0.0  | 072  | 1   | Rel-6 | F   | 6.1.0  | Roaming not allowed for GPRS update state  | TEI6                  |
| NP-24 | NP-040202 | 23.122 | 6.0.0  | 073  |     | Rel-6 | D   | 6.1.0  | Data field -> data file  | TEI6                  |
| NP-25 | NP-040375 | 23.122 | 6.1.0  |      |     | Rel-6 | B   | 6.2.0  | Clarification on the registered PLMN for UEs that support network sharing in a shared network    | NTShar                |
|       |           |        |        | 76   | 2   |       |     |        |  |                       |
| NP-25 | NP-040378 | 23.122 | 6.1.0  |      |     | Rel-6 | F   | 6.2.0  | Correction of definitions of PLMNs in the same country   | TEI6                  |
|       |           |        |        | 77   | 1   |       |     |        |  |                       |
| NP-26 | NP-040513 | 23.122 | 6.2.0  |      |     | Rel-6 | B   | 6.3.0  | Clarification of PLMN selection in shared networks   | NTShar                |
|       |           |        |        | 086  | 1   |       |     |        |  |                       |
| NP-26 | NP-040514 | 23.122 | 6.2.0  |      |     | Rel-6 | F   | 6.3.0  | Clarification on the use of the RAT during background scanning                                   | TEI6                  |
|       |           |        |        | 084  | 1   |       |     |        |  |                       |
| NP-26 | NP-040516 | 23.122 | 6.2.0  | 082  | 7   | Rel-7 | C   | 7.0.0  | Support of multiple HPLMN codes  | TEI7                  |
| NP-27 |           | 23.122 | 7.0.0  |      |     | Rel-7 |     | 7.1.0  | Addition of domain specific access control description   | ACBOP                 |
|       | NP-050083 |        |        | 089  |     |       | A   |        |  |                       |
| NP-27 |           | 23.122 | 7.0.0  |      |     | Rel-7 |     | 7.1.0  | Minor Clarifications to EHPLMN handling  | TEI7                  |
|       | NP-050086 |        |        | 087  | 1   |       | F   |        |  |                       |
| CP-28 |           | 23.122 | 7.1.0  |      |     | Rel-7 |     | 7.2.0  | Correction of the PLMN Selection State diagram (automatic mode)                                  | TEI6                  |
|       | CP-050068 |        |        | 91   |     |       | A   |        |  |                       |
| CP-29 |           | 23.122 | 7.2.0  |      |     | Rel-7 |     | 7.3.0  | Enhancement of the EHPLMN feature to allow load balancing  | TEI7                  |
|       | CP-050366 |        |        | 93   | 1   |       | C   |        |  |                       |
| CP-31 |           | 23.122 | 7.3.0  |      |     | Rel-7 |     | 7.4.0  | EPLMN list is not invalid on receipt of reject cause values #12 and #15                          | TEI7                  |
|       | CP-060126 |        |        | 0094 | -   |       | F   |        |  |                       |
| CP-31 |           | 23.122 | 7.3.0  |      |     | Rel-7 |     | 7.4.0  | EHPLMN in automatic network selection mode   | TEI7                  |
|       | CP-060126 |        |        | 0095 | -   |       | F   |        |  |                       |
| CP-31 |           | 23.122 | 7.3.0  |      |     | Rel-7 |     | 7.4.0  | First higher priority PLMN scan in VPLMN   | TEI7                  |
|       | CP-060175 |        |        | 0096 | 4   |       | C   |        |  |                       |
| CP-32 | CP-060359 | 23.122 | 7.4.0  | 0098 | 2   | Rel-7 | B   | 7.5.0  | ME capability for Network Selection  | TEI7                  |
| CP-33 | CP-060460 | 23.122 | 7.5.0  | 0099 | 1   | Rel-7 | C   | 7.6.0  | Manual PLMN selection power-on   | NSP-CR                |
| CP-34 | CP-060668 | 23.122 | 7.6.0  | 0101 | 1   | Rel-7 | C   | 7.7.0  | Presentation of EHPLMN   | NSP-CR                |
| CP-34 |           | 23.122 | 7.6.0  |      |     | Rel-7 |     | 7.7.0  | Presentation of Additional Information in Manual Mode  | NSP-CR                |
|       | CP-060668 |        |        | 0102 | 2   |       | C   |        |  |                       |
| CP-34 |           | 23.122 | 7.6.0  |      |     | Rel-7 |     | 7.7.0  | Correction to the definition of national roaming and international roaming to include the EHPLMN | TEI7                  |
|       | CP-060670 |        |        | 0103 | 1   |       | F   |        |  |                       |
| CP-34 |           | 23.122 | 7.6.0  |      |     | Rel-7 |     | 7.7.0  | Correction of the PLMN Selection state diagram (automatic mode)                                  | TEI7                  |
|       | CP-060670 |        |        | 0104 | -   |       | F   |        |  |                       |
| CP-35 | CP-070152 | 23.122 | 7.7.0  | 0111 | 3   | Rel-7 | B   | 7.8.0  | Last RPLMN   | NSP-CR                |
| CP-35 |           | 23.122 | 7.7.0  |      |     | Rel-7 |     | 7.8.0  | Optional network selection mode at switch-on   | NSP-CR                |
|       | CP-070152 |        |        | 0113 | 1   |       | B   |        |  |                       |
| CP-35 |           | 23.122 | 7.7.0  |      |     | Rel-7 |     | 7.8.0  | Pingpong avoidance on PLMN change for search for higher priority PLMNs                           | TEI7                  |
|       | CP-070173 |        |        | 0106 | 2   |       | C   |        |  |                       |
| CP-36 | CP-070477 | 23.122 | 7.8.0  | 0114 | 4   | Rel-7 | B   | 7.9.0  | PLMN selection for steering of roaming   | NSP-CR                |
| CP-37 |           | 23.122 | 7.9.0  |      |     | Rel-7 |     | 7.10.0 |  |                       |
|       | CP-070597 |        |        | 0115 | 1   |       | C   |        | Steering of Roaming procedure  | NSP-CR                |
| CP-38 |           | 23.122 | 7.10.0 |      |     | Rel-7 |     | 7.11.0 | Single EHPLMN Display Name in Manual Mode  | TEI7                  |
|       | CP-070802 |        |        | 0117 |     |       | F   |        |  |                       |
| CP-38 | CP-070813 | 23.122 | 7.11.0 | 0118 | 1   | Rel-8 | B   | 8.0.0  | PPACR CR to 23.122   | PPACR-CT1             |
| CP-39 |           | 23.122 | 8.0.0  |      |     | Rel-8 |     | 8.1.0  | Inclusion of EHPLMN in the optimisation for automatic network selection                          | NSP-CR                |
|       | CP-080125 |        |        | 0120 | 1   |       | A   |        |  |                       |
| CP-40 |           | 23.122 | 8.1.0  |      |     | Rel-8 |     | 8.2.0  | PLMN Selection on receipt of GAN cause Location not allowed                                      | TEI8                  |
|       | CP-080361 |        |        | 0119 | 3   |       | B   |        |  |                       |
| CP-41 |           | 23.122 | 8.2.0  |      |     | Rel-8 |     | 8.3.0  | Clarifications for RAT usage in manual network selection mode                                    | TEI8                  |
|       | CP-080536 |        |        | 0121 | 0   |       | F   |        |  |                       |
| CP-41 |           | 23.122 | 8.2.0  |      |     | Rel-8 |     | 8.3.0  | Clarification on MS behavior further to LU Reject causes #13 and #15                             | TEI8                  |
|       | CP-080536 |        |        | 0122 | 1   |       | F   |        |  |                       |
| CP-42 | CP-080866 | 23.122 | 8.3.0  | 0124 | 1   | Rel-8 | B   | 8.4.0  | Multi system PLMN selection  | SAES                  |
| CP-42 | CP-080860 | 23.122 | 8.3.0  | 0125 | 1   | Rel-8 | B   | 8.4.0  | CR on description of PPAC  | PPACR-CT1             |
| CP-42 | CP-080866 | 23.122 | 8.3.0  | 0126 | 1   | Rel-8 | B   | 8.4.0  | 3GPP2 system selection   | SAES                  |
| CP-42 |           | 23.122 | 8.3.0  |      |     | Rel-8 |     | 8.4.0  | CSG selection – NAS aspects  | HomeNB-3G, HomeNB-LTE |
|       | CP-080966 |        |        | 0128 | 2   |       | B   |        |  |                       |
| CP-42 |           | 23.122 | 8.3.0  |      |     | Rel-8 |     | 8.4.0  | Editorial cleanup by MCC   |                       |
| CP-43 |           | 23.122 | 8.4.0  |      |     | Rel-8 |     | 8.5.0  | Correction on CSG related NAS requirement  | HomeNB-LTE, HomeNB-3G |
|       | CP-090157 |        |        | 0129 | 1   |       |     |        |  |                       |
| CP-43 |           | 23.122 | 8.4.0  |      |     | Rel-8 |     | 8.5.0  | CSG selection process in idle mode   | HomeNB-LTE, HomeNB-3G |
|       | CP-090222 |        |        | 0130 | 2   |       |     |        |  |                       |

| TSG#  | Tdoc      | SPEC   | VERS   | CR   | REV | PHASE  | CAT | N_VER  | SUBJECT   | comment               |
|-------|-----------|--------|--------|------|-----|--------|-----|--------|---|-----------------------|
| CP-43 | CP-090157 | 23.122 | 8.4.0  | 0132 | 1   | Rel-8  |     | 8.5.0  | Introduction of cause#25 handling in LR state diagram   | HomeNB-3G             |
| CP-44 | CP-090413 | 23.122 | 8.5.0  | 0131 | 1   | Rel-8  | F   | 8.6.0  | Addition of missing requirements for tracking area updating   | SAES                  |
| CP-45 | CP-090679 | 23.122 | 8.6.0  | 0133 | 2   | Rel-8  | F   | 8.7.0  | RAT selection when "HPLMN selector with access technology" data file is missing in the SIM or "PLMN selector" data file is used | TEI8                  |
| CP-45 | CP-090694 | 23.122 | 8.7.0  | 0139 | 1   | Rel-9  | B   | 9.0.0  | Introduction of Operator CSG List   | EHNB-CT1              |
| CP-45 | CP-090694 | 23.122 | 8.7.0  | 0140 | 1   | Rel-9  | F   | 9.0.0  | Manual CSG selection across PLMN  | EHNB-CT1              |
| CP-46 | CP-090930 | 23.122 | 9.0.0  | 0142 | 2   | Rel-9  | F   | 9.1.0  | PLMN selection during emergency attach  | IMS_EMER_GPRS_EPS     |
| CP-46 | CP-090935 | 23.122 | 9.0.0  | 0143 |     | Rel-9  | F   | 9.1.0  | Correct definitions related to CSG  | EHNB-CT1              |
| CP-46 | CP-090922 | 23.122 | 9.0.0  | 0146 |     | Rel-9  | F   | 9.1.0  | Correction of condition for tracking area updating  | TEI9                  |
| CP-46 | CP-090900 | 23.122 | 9.0.0  | 0148 |     | Rel-9  | A   | 9.1.0  | Adding missing requirements for PLMN selection in EPS   | SAES                  |
| CP-47 | CP-100148 | 23.122 | 9.1.0  | 0144 | 4   | Rel-9  | F   | 9.2.0  | Support for Operator CSG List   | EHNB-CT1              |
| CP-47 | CP-100144 | 23.122 | 9.1.0  | 0149 | 1   | Rel-9  | F   | 9.2.0  | Manual CSG selection during emergency   | IMS_EMER_GPRS_EPS     |
| CP-47 | CP-100130 | 23.122 | 9.1.0  | 0151 | 1   | Rel-9  | A   | 9.2.0  | Clarification to LR state when rejected for cause value #25.  | HomeNB-LTE, HomeNB-3G |
| CP-47 | CP-100148 | 23.122 | 9.1.0  | 0152 | 1   | Rel-9  | F   | 9.2.0  | Clarification to the LR Process States and Allowed Actions  | EHNB-CT1              |
| CP-47 | CP-100130 | 23.122 | 9.1.0  | 0156 | 1   | Rel-9  | A   | 9.2.0  | Clarify manual CSG selection across technologies  | HomeNB-LTE, HomeNB-3G |
| CP-47 | CP-100144 | 23.122 | 9.1.0  | 0160 | 1   | Rel-9  | F   | 9.2.0  | Correct definition of "acceptable cell" to include criteria for E-UTRAN (S1-mode)   | IMS_EMER_GPRS_EPS     |
| CP-47 | CP-100148 | 23.122 | 9.1.0  | 0161 |     | Rel-9  | F   | 9.2.0  | Correction to the manual CSG ID selection in Release 9  | EHNB-CT1              |
| CP-47 | CP-100134 | 23.122 | 9.1.0  | 0162 | 1   | Rel-9  | F   | 9.2.0  | Corrections/clarifications for equivalent and forbidden PLMN handling, state descriptions and overall idle mode procedure       | TEI9                  |
| CP-48 | CP-100362 | 23.122 | 9.2.0  | 0165 |     | Rel-9  | F   | 9.3.0  | Deleting editor's note related manual CSG selection   | EHNB-CT1              |
| CP-48 | CP-100339 | 23.122 | 9.2.0  | 0168 | 1   | Rel-9  | A   | 9.3.0  | Reference Update  | SAES                  |
| CP-48 | CP-100370 | 23.122 | 9.3.0  | 0166 | 1   | Rel-10 | F   | 10.0.0 | Manual CSG Selection using CSG Identities not in Allowed CSG List and Operator CSG List   | TEI10                 |
| CP-49 | CP-100521 | 23.122 | 10.0.0 | 0171 | 2   | Rel-10 | A   | 10.1.0 | Definition of CSG whitelist   | EHNB-CT1              |
| CP-49 | CP-100498 | 23.122 | 10.0.0 | 0176 | 1   | Rel-10 | A   | 10.1.0 | HeNB name for manual CSG selection  | HomeNB-LTE, HomeNB-3G |
| CP-49 | CP-100518 | 23.122 | 10.0.0 | 0178 | 1   | Rel-10 | F   | 10.1.0 | Correction to Initiation of Location Registration   | TEI10                 |
| CP-49 | CP-100518 | 23.122 | 10.0.0 | 0179 |     | Rel-10 | F   | 10.1.0 | Adding Reference for PLMN selection   | TEI10                 |
| CP-50 | CP-100748 | 23.122 | 10.1.0 | 0182 | 3   | Rel-10 | A   | 10.2.0 | Support for displaying only CSGs in the Operator CSG List for manual selection  | EHNB-CT1              |
| CP-50 | CP-100747 | 23.122 | 10.1.0 | 0184 | 1   | Rel-10 | A   | 10.2.0 | Inter PLMN mobility for emergency bearer services   | IMS_EMER_GPRS_EPS     |
| CP-50 | CP-100747 | 23.122 | 10.1.0 | 0186 | 2   | Rel-10 | A   | 10.2.0 | Handling forbidden PLMN list for emergency bearer services  | IMS_EMER_GPRS_EPS     |
| CP-50 | CP-100747 | 23.122 | 10.1.0 | 0188 | 1   | Rel-10 | A   | 10.2.0 | Handling of equivalent PLMN list when attached for emergency bearer services only   | IMS_EMER_GPRS_EPS     |
| CP-50 | CP-100887 | 23.122 | 10.1.0 | 0192 | 3   | Rel-10 | C   | 10.2.0 | MTC/Low-Priority PLMN Reselection Timer value   | NIMTC                 |
| CP-50 | CP-100748 | 23.122 | 10.1.0 | 0195 |     | Rel-10 | A   | 10.2.0 | Removing the CSG ID from ACL and OCL simultaneously   | EHNB-CT1              |
| CP-50 | CP-100664 | 23.122 | 10.1.0 | 0190 | 3   | Rel-10 | F   | 10.2.0 | Location Registration when entering new PLMN  | NIMTC, TEI10          |
| CP-51 | CP-110193 | 23.122 | 10.2.0 | 0196 | 1   | Rel-10 | F   | 10.3.0 | UEs configured with long minimum periodic PLMN search time limit  | NIMTC                 |
| CP-51 | CP-110193 | 23.122 | 10.2.0 | 0198 | 5   | Rel-10 | B   | 10.3.0 | EAB support   | NIMTC                 |
| CP-52 | CP-110446 | 23.122 | 10.3.0 | 0205 | 1   | Rel-10 | A   | 10.4.0 | Aligning NAS and AS on CSG  | HomeNB-3G, HomeNB-LTE |
| CP-52 | CP-110462 | 23.122 | 10.3.0 | 0206 | 1   | Rel-10 | B   | 10.4.0 | Reference to NAS configuration in USIM  | NIMTC                 |
| CP-53 | CP-110680 | 23.122 | 10.4.0 | 0210 | 1   | Rel-10 | F   | 10.5.0 | Correction to EAB   | NIMTC                 |
| CP-53 | CP-110695 | 23.122 | 10.5.0 | 0207 | 4   | Rel-11 | B   | 11.0.0 | Support for multiple MCC countries  | TEI11                 |
| CP-53 | CP-110737 | 23.122 | 10.5.0 | 0208 | 2   | Rel-11 | B   | 11.0.0 | EAB references  | SIMTC-RAN_OC          |

| TSG#  | Tdoc      | SPEC   | VERS   | CR   | REV | PHASE  | CAT | N_VER  | SUBJECT   | comment                |
|-------|-----------|--------|--------|------|-----|--------|-----|--------|---|------------------------|
| CP-54 | CP-110888 | 23.122 | 11.0.0 | 0211 | 1   | Rel-11 | F   | 11.1.0 | Clarification to the manual PLMN selection procedure  | SAES2                  |
| CP-56 | CP-120309 | 23.122 | 11.1.0 | 0212 |     | Rel-11 | F   | 11.2.0 | Correction on location registration task state  | TEI11                  |
| CP-56 | CP-120315 | 23.122 | 11.1.0 | 0213 |     | Rel-11 | F   | 11.2.0 | EAB configuration   | SIMTC-RAN_OC           |
| CP-56 | CP-120315 | 23.122 | 11.1.0 | 0214 | 1   | Rel-11 | F   | 11.2.0 | UE configured for EAB accessing with access class 11-15 or initiating emergency call                              | SIMTC-RAN_OC           |
| CP-56 | CP-120315 | 23.122 | 11.1.0 | 0215 |     | Rel-11 | F   | 11.2.0 | Applicability of EAB when the UE is responding to paging  | SIMTC-RAN_OC           |
| CP-56 | CP-120309 | 23.122 | 11.1.0 | 0217 |     | Rel-11 | F   | 11.2.0 | Handling of forbidden PLMNs for GPRS service list   | TEI11                  |
| CP-57 | CP-120595 | 23.122 | 11.2.0 | 0216 | 4   | Rel-11 | F   | 11.3.0 | PLMN selection timer for E-UTRA disabling   | SAES2, SAES2-CSFB      |
| CP-57 | CP-120589 | 23.122 | 11.2.0 | 0219 | 2   | Rel-11 | F   | 11.3.0 | EAB overriding handling   | SIMTC-Reach            |
| CP-57 | CP-120584 | 23.122 | 11.2.0 | 0220 |     | Rel-11 | F   | 11.3.0 | Removing NMO III  | TEI11                  |
| CP-58 | CP-120794 | 23.122 | 11.3.0 | 0218 | 2   | Rel-11 | F   | 11.4.0 | Correction on cause #2 in response to an LR   | TEI11                  |
| CP-58 | CP-120807 | 23.122 | 11.3.0 | 0221 | 3   | Rel-11 | F   | 11.4.0 | E-UTRA disabling stored information deletion criteria correction  | SAES2                  |
| CP-58 | CP-120794 | 23.122 | 11.3.0 | 0222 |     | Rel-11 | F   | 11.4.0 | Corrections to steps in subclause 5 related to CSG selection  | TEI11                  |
| CP-58 | CP-120797 | 23.122 | 11.3.0 | 0223 | 3   | Rel-11 | B   | 11.4.0 | Access control and DSAC for shared networks   | GDSAC, FULL_MOCN-GERAN |
| CP-58 | CP-120794 | 23.122 | 11.3.0 | 0224 | 1   | Rel-11 | F   | 11.4.0 | Ignoring Forbidden Lists During Manual CSG Selection  | TEI11                  |
| CP-58 | CP-120794 | 23.122 | 11.3.0 | 0225 | 3   | Rel-11 | F   | 11.4.0 | HPLMN or RPLMN selection clarification  | TEI11                  |
| CP-58 | CP-120807 | 23.122 | 11.3.0 | 0226 | 1   | Rel-11 | F   | 11.4.0 | Clean-up the confusion between the term update state and update status  | SAES2, TEI11           |
| CP-59 | CP-130129 | 23.122 | 11.4.0 | 0229 | 2   | Rel-12 | F   | 12.0.0 | EHPLMN selection clarification  | TEI12                  |
| CP-60 | CP-130264 | 23.122 | 12.0.0 | 0230 | 2   | Rel-12 | F   | 12.1.0 | Corrections to manual CSG selection   | TEI12                  |
| CP-60 | CP-130264 | 23.122 | 12.0.0 | 0231 | 2   | Rel-12 | F   | 12.1.0 | GERAN lu mode   | TEI12                  |
| CP-60 | CP-130264 | 23.122 | 12.0.0 | 0232 | 1   | Rel-12 | F   | 12.1.0 | Missing reference for GERAN specification   | TEI12                  |
| CP-61 | CP-130510 | 23.122 | 12.1.0 | 0234 | 1   | Rel-12 | F   | 12.2.0 | Last PLMN selection mode at switch on   | TEI12                  |
| CP-61 | CP-130510 | 23.122 | 12.1.0 | 0235 | 1   | Rel-12 | F   | 12.2.0 | Switch off after manual CSG selection in a PLMN different from the RPLMN  | TEI12                  |
| CP-61 | CP-130510 | 23.122 | 12.1.0 | 0237 |     | Rel-12 | F   | 12.2.0 | Clarifying requirement for steering of roaming  | TEI12                  |
| CP-61 | CP-130510 | 23.122 | 12.1.0 | 0238 |     | Rel-12 | F   | 12.2.0 | Handling the received error cause #25   | TEI12                  |
| CP-62 | CP-130762 | 23.122 | 12.2.0 | 0236 | 4   | Rel-12 | C   | 12.3.0 | Fast higher priority PLMN search upon entering VPLMN  | TEI12                  |
| CP-62 | CP-130762 | 23.122 | 12.2.0 | 0241 | 1   | Rel-12 | F   | 12.3.0 | Terminology Alignment for name of forbidden lists between Stage 2 and Stage 3                                     | TEI12                  |
| CP-62 | CP-130762 | 23.122 | 12.2.0 | 0242 |     | Rel-12 | F   | 12.3.0 | Duplicate entries in ACL and OCL when forming CSG Whitelist   | TEI12                  |
| CP-62 | CP-130762 | 23.122 | 12.2.0 | 0243 | 4   | Rel-12 | F   | 12.3.0 | User initiated PLMN selection after manual CSG selection and registration on a CSG cell.                          | TEI12                  |
| CP-62 | CP-130762 | 23.122 | 12.2.0 | 0244 |     | Rel-12 | D   | 12.3.0 | Clean-up of references  | TEI12                  |
| CP-62 | CP-130762 | 23.122 | 12.2.0 | 0246 |     | Rel-12 | F   | 12.3.0 | HPLMN criteria matching correction  | TEI12                  |
| CP-63 | CP-140144 | 23.122 | 12.3.0 | 0250 | 2   | Rel-12 | F   | 12.4.0 | Incorrect combination of stored duplicate of RPLMN and current PLMN selection mode due to multiple CSG selections | TEI12                  |
| CP-63 | CP-140144 | 23.122 | 12.3.0 | 0251 | 1   | Rel-12 | F   | 12.4.0 | No CSG cell and re-enable E-UTRA  | TEI12                  |
| CP-64 | CP-140331 | 23.122 | 12.4.0 | 0249 | 4   | Rel-12 | F   | 12.5.0 | PLMN selection timer for enhanced EMM cause #15   | TEI12                  |
| CP-64 | CP-140323 | 23.122 | 12.4.0 | 0253 | 1   | Rel-12 | F   | 12.5.0 | Updates due to power saving mode  | MTCe-UEPCOP-CT         |
| CP-64 | CP-140331 | 23.122 | 12.4.0 | 0255 |     | Rel-12 | F   | 12.5.0 | Clarification regarding cause #25 received by the UE  | TEI12                  |
| CP-64 | CP-140328 | 23.122 | 12.4.0 | 0257 | 2   | Rel-12 | F   | 12.5.0 | Triggering a CS call from the selected CSG  | SAES3-CSFB             |
| CP-66 | CP-140862 | 23.122 | 12.5.0 | 0262 | 5   | Rel-13 | F   | 13.0.0 | Correct Automatic Network Selection Mode Procedure for UE supporting E-UTRAN                                      | SAES4                  |
| CP-67 | CP-150205 | 23.122 | 13.0.0 | 0272 | 2   | Rel-13 | A   | 13.1.0 | Clarification on limited service state  | ProSe-CT               |
| CP-67 | CP-150206 | 23.122 | 13.0.0 | 0273 | 2   | Rel-13 | A   | 13.1.0 | Clarification on limited service state  | TEI12                  |
| CP-68 | CP-150316 | 23.122 | 13.1.0 | 0269 | 8   | Rel-13 | A   | 13.2.0 | PLMN selection triggered by ProSe direct communication  | ProSe-CT               |

| TSG#  | Tdoc      | SPEC   | VERS   | CR   | REV | PHASE  | CAT | N_VER  | SUBJECT   | comment            |
|-------|-----------|--------|--------|------|-----|--------|-----|--------|---|--------------------|
| CP-68 | CP-150323 | 23.122 | 13.1.0 | 0274 |     | Rel-13 | F   | 13.2.0 | Correct Automatic Network Selection Mode Procedure for UE supporting E-UTRA                             | SAES4              |
| CP-68 | CP-150316 | 23.122 | 13.1.0 | 0280 |     | Rel-13 | A   | 13.2.0 | Correction of limited service state for ProSe direct communication                                      | ProSe-CT           |
| CP-69 | CP-150534 | 23.122 | 13.2.0 | 0278 | 3   | Rel-13 | B   | 13.3.0 | Introduction of ACDC for access control   | ACDC-CT            |
| CP-69 | CP-150517 | 23.122 | 13.2.0 | 0282 | 1   | Rel-13 | A   | 13.3.0 | Correction of limited service state for ProSe direct communication                                      | ProSe-CT           |
| CP-69 | CP-150529 | 23.122 | 13.2.0 | 0283 | 1   | Rel-13 | F   | 13.3.0 | Inconsistency where PLMN selection in automatic mode is performed while GPRS services are not available | TEI13              |
| CP-71 | CP-160157 | 23.122 | 13.3.0 | 0289 | 1   | Rel-13 | F   | 13.4.0 | ProSe direct discovery for public safety use in limited service state                                   | eProSe-Ext-CT      |
| CP-72 | CP-160309 | 23.122 | 13.4.0 | 0293 | 2   | Rel-13 | C   | 13.5.0 | Disabling emergency calls for NB-IoT devices in limited service state                                   | CloT-CT            |
| CP-72 | CP-160318 | 23.122 | 13.4.0 | 0295 | 1   | Rel-13 | F   | 13.5.0 | Handling of PLMN background scan during PSM   | TEI13              |
| CP-72 | CP-160302 | 23.122 | 13.4.0 | 0300 | 1   | Rel-13 | A   | 13.5.0 | PLMN selection triggered by ProSe communication in manually selected CSG cell                           | ProSe-CT, TEI12    |
| CP-72 | CP-160309 | 23.122 | 13.4.0 | 0292 | 7   | Rel-13 | C   | 13.5.0 | Extend search cycle for higher priority PLMN  | CloT-CT            |
| CP-72 | CP-160318 | 23.122 | 13.4.0 | 0297 | 2   | Rel-13 | B   | 13.5.0 | Addition of EC-GSM-IoT access to PLMN selection   | TEI13, CloT_EC_GSM |
| CP-72 | CP-160309 | 23.122 | 13.4.0 | 0298 | 3   | Rel-13 | B   | 13.5.0 | PLMN selection when the network and UE capabilities for CloT do not match                               | CloT-CT            |

## Change history

| Date    | Meeting | TDoc      | CR   | Rev | Cat | Subject/Comment   | New version |
|---------|---------|-----------|------|-----|-----|---|-------------|
| 2016-09 | CP-73   | CP-160486 | 0302 |     | F   | Addition of NB-S1 mode to PLMN selection  | 13.6.0      |
| 2016-09 | CP-73   | CP-160487 | 0304 |     | F   | Corrections due to added CloT requirements  | 13.6.0      |
| 2016-09 | CP-73   | CP-160519 | 0301 | 1   | F   | Minor corrections for EC GPRS   | 14.0.0      |
| 2016-09 | CP-73   | CP-160512 | 0303 | 1   | B   | PLMN selection for eCall over IMS   | 14.0.0      |
| 2016-12 | CP-74   | CP-160739 | 0305 |     | F   | MS in eCall only mode   | 14.1.0      |
| 2016-12 | CP-74   | CP-160739 | 0306 | 1   | B   | Update of requirements on limited service state for MS in eCall only mode   | 14.1.0      |
| 2016-12 | CP-74   | CP-160753 | 0308 | 1   | F   | Skip ACDC for emergency call, MO MMTEL voice/video and MO SMSoIP  | 14.1.0      |
| 2016-12 | CP-74   | CP-160754 | 0310 | 1   | F   | V2X communication over PC5 is used for UEs in limited service state   | 14.1.0      |
| 2017-03 | CP-75   | CP-170138 | 0315 |     | F   | PLMN selection triggered by V2X communication over PC5  | 14.2.0      |
| 2017-06 | CP-76   | CP-171092 | 0321 |     | F   | Correction in handling of cause value "GPRS services not allowed in this PLMN" or "EPS services not allowed in this PLMN" | 14.3.0      |
| 2017-06 | CP-76   | CP-171094 | 0318 | 1   | F   | Adding a NOTE for HPLMN and RPLMN selection   | 15.0.0      |
| 2017-09 | CP-77   | CP-172122 | 0322 | 1   | F   | Clarification to network selection procedures   | 15.1.0      |
| 2017-09 | CP-77   | CP-172132 | 0326 |     | A   | Corrections to handling of EFFPLMN file in the SIM and of "forbidden PLMNs for GPRS service" list                         | 15.1.0      |
| 2017-12 | CP-78   | CP-173067 | 0327 |     | A   | Max length of timer TE for IoT devices  | 15.2.0      |
| 2017-12 | CP-78   | CP-173079 | 0328 |     | D   | Editorial correction: wrong color   | 15.2.0      |
| 2017-12 | CP-78   | CP-173079 | 0329 |     | F   | Correction for classification of EC-GSM-IoT high quality signal   | 15.2.0      |
| 2017-12 | CP-78   | CP-173079 | 0332 | 1   | F   | Allow exiting manual PLMN selection mode due to emergency call  | 15.2.0      |
| 2018-03 | CP-79   | CP-180076 | 0333 | 4   | B   | Addition of NG-RAN  | 15.3.0      |
| 2018-03 | CP-79   | CP-180089 | 0334 | 1   | F   | Informing user of exit from manual network selection mode   | 15.3.0      |
| 2018-03 | CP-79   | CP-180076 | 0335 | 1   | B   | Addition of 5GS forbidden TA lists  | 15.3.0      |
| 2018-03 | CP-79   | CP-180076 | 0337 | 1   | B   | N1 mode disabling - use of PLMN id in subsequent PLMN selections  | 15.3.0      |
| 2018-03 | CP-79   | CP-180076 | 0339 | 2   | B   | 5GS forbidden TA for regional provision of service  | 15.3.0      |
| 2018-03 | CP-79   | CP-180157 | 0340 | 5   | B   | Stage 2 solution of Steering Of Roaming (SOR)   | 15.3.0      |
| 2018-06 | CP-80   | CP-181057 | 0343 | 1   | F   | Terminology correction in handling of PLMNs where N1 mode was disabled  | 15.4.0      |
| 2018-06 | CP-80   | CP-181057 | 0344 |     | B   | Adding support for eCall over IMS in 5GS  | 15.4.0      |
| 2018-06 | CP-80   | CP-181057 | 0345 | 3   | B   | Alignment: replacing the highest priority entries in the "Operator Controlled PLMN Selector with Access Technology" list  | 15.4.0      |
| 2018-06 | CP-80   | CP-181058 | 0347 | 6   | B   | Updates to Stage 2 solution of Steering Of Roaming (SOR)  | 15.4.0      |
| 2018-06 | CP-80   | CP-181058 | 0348 | 1   | F   | Disabling and re-enabling capabilities in the NAS layer   | 15.4.0      |
| 2018-06 | CP-80   | CP-181076 | 0349 | 2   | B   | PLMN selection for disabling NB-IoT   | 15.4.0      |
| 2018-06 | CP-80   | CP-181058 | 0350 | 1   | B   | Updating terms in definitions and abbreviations due to 5GS  | 15.4.0      |
| 2018-06 | CP-80   | CP-181053 | 0352 |     | A   | Forbidden PLMN operation for cause value "Requested service option not authorized in this PLMN"                           | 15.4.0      |
| 2018-06 | CP-80   | CP-181058 | 0356 | 1   | C   | Updates due to network sharing for 5GS  | 15.4.0      |

---

# History

| <b>Document history</b> |           |             |
|-------------------------|-----------|-------------|
| V15.4.0                 | June 2018 | Publication |
|                         |           |             |
|                         |           |             |
|                         |           |             |
|                         |           |             |