

ETSI TS 123 135 V15.0.0 (2018-07)



**Universal Mobile Telecommunications System (UMTS);
LTE;
Multicall supplementary service;
Stage 2
(3GPP TS 23.135 version 15.0.0 Release 15)**



Reference

RTS/TSGC-0423135vf00

Keywords

LTE,UMTS

ETSI

650 Route des Lucioles
F-06921 Sophia Antipolis Cedex - FRANCE

Tel.: +33 4 92 94 42 00 Fax: +33 4 93 65 47 16

Siret N° 348 623 562 00017 - NAF 742 C
Association à but non lucratif enregistrée à la
Sous-Préfecture de Grasse (06) N° 7803/88

Important notice

The present document can be downloaded from:

<http://www.etsi.org/standards-search>

The present document may be made available in electronic versions and/or in print. The content of any electronic and/or print versions of the present document shall not be modified without the prior written authorization of ETSI. In case of any existing or perceived difference in contents between such versions and/or in print, the only prevailing document is the print of the Portable Document Format (PDF) version kept on a specific network drive within ETSI Secretariat.

Users of the present document should be aware that the document may be subject to revision or change of status.

Information on the current status of this and other ETSI documents is available at

<https://portal.etsi.org/TB/ETSIDeliverableStatus.aspx>

If you find errors in the present document, please send your comment to one of the following services:

<https://portal.etsi.org/People/CommiteeSupportStaff.aspx>

Copyright Notification

No part may be reproduced or utilized in any form or by any means, electronic or mechanical, including photocopying and microfilm except as authorized by written permission of ETSI.

The content of the PDF version shall not be modified without the written authorization of ETSI.

The copyright and the foregoing restriction extend to reproduction in all media.

© ETSI 2018.

All rights reserved.

DECT™, **PLUGTESTS™**, **UMTS™** and the ETSI logo are trademarks of ETSI registered for the benefit of its Members.
3GPP™ and **LTE™** are trademarks of ETSI registered for the benefit of its Members and of the 3GPP Organizational Partners.

oneM2M logo is protected for the benefit of its Members.

GSM® and the GSM logo are trademarks registered and owned by the GSM Association.

Intellectual Property Rights

Essential patents

IPRs essential or potentially essential to normative deliverables may have been declared to ETSI. The information pertaining to these essential IPRs, if any, is publicly available for **ETSI members and non-members**, and can be found in ETSI SR 000 314: *"Intellectual Property Rights (IPRs); Essential, or potentially Essential, IPRs notified to ETSI in respect of ETSI standards"*, which is available from the ETSI Secretariat. Latest updates are available on the ETSI Web server (<https://ipr.etsi.org/>).

Pursuant to the ETSI IPR Policy, no investigation, including IPR searches, has been carried out by ETSI. No guarantee can be given as to the existence of other IPRs not referenced in ETSI SR 000 314 (or the updates on the ETSI Web server) which are, or may be, or may become, essential to the present document.

Trademarks

The present document may include trademarks and/or tradenames which are asserted and/or registered by their owners. ETSI claims no ownership of these except for any which are indicated as being the property of ETSI, and conveys no right to use or reproduce any trademark and/or tradename. Mention of those trademarks in the present document does not constitute an endorsement by ETSI of products, services or organizations associated with those trademarks.

Foreword

This Technical Specification (TS) has been produced by ETSI 3rd Generation Partnership Project (3GPP).

The present document may refer to technical specifications or reports using their 3GPP identities, UMTS identities or GSM identities. These should be interpreted as being references to the corresponding ETSI deliverables.

The cross reference between GSM, UMTS, 3GPP and ETSI identities can be found under <http://webapp.etsi.org/key/queryform.asp>.

Modal verbs terminology

In the present document "**shall**", "**shall not**", "**should**", "**should not**", "**may**", "**need not**", "**will**", "**will not**", "**can**" and "**cannot**" are to be interpreted as described in clause 3.2 of the [ETSI Drafting Rules](#) (Verbal forms for the expression of provisions).

"**must**" and "**must not**" are **NOT** allowed in ETSI deliverables except when used in direct citation.

Contents

Intellectual Property Rights	2
Foreword.....	2
Modal verbs terminology.....	2
Foreword.....	5
1 Scope	5
2 References	5
3 Definitions and abbreviations.....	6
3.1 Definitions	6
3.2 Abbreviations	6
4 Descriptions.....	6
4.1 Handling of Multicall	6
4.1.1 Provision.....	6
4.1.2 Withdrawal	6
4.1.3 Registration.....	6
4.1.4 Erasure	7
4.1.5 Activation	7
4.1.6 Deactivation.....	8
4.1.7 Interrogation	8
4.2 Call related procedures.....	10
4.2.1 MO call	10
4.2.2 MT call	10
4.3 Messages and their contents	12
4.3.1 Messages between MS and MSC.....	12
4.3.2 Messages on B interface (MSC-VLR).....	13
4.3.2.1 Send Info For Outgoing Call.....	13
4.3.2.2 Send Info For Outgoing Call negative response.....	13
4.3.2.3 Send Info For Incoming Call.....	13
4.3.2.4 Send Info For Incoming Call ack	13
4.3.2.5 Send Info For Incoming Call negative response	13
4.3.2.6 Complete Call	13
4.3.2.7 Complete Call ack.....	13
4.3.2.8 Page MS	13
4.3.2.9 Page MS negative response.....	14
4.3.2.10 Process Access Request	14
4.3.2.11 Process Access Request ack.....	14
4.3.2.12 Process Access Request negative response	14
4.3.2.13 Search For MS	14
4.3.2.14 Search For MS ack.....	14
4.3.2.15 Search For MS negative response	14
5 Network entity functions	15
5.1 General	15
5.2 MO call.....	15
5.2.1 Functional requirements of serving MSC	15
5.2.2 Functional requirements of VLR	16
5.3 MT call.....	17
5.3.1 Functional requirements of serving MSC	17
5.3.2 Functional requirements of VLR	22
6 Interaction with telecommunication services	23
6.1 Speech	23
6.2 Short message service	23
6.3 Facsimile service	23
6.4 Data circuit asynchronous	23
6.5 Data circuit synchronous	23

6.6	Void.....	23
6.7	GPRS.....	23
7	Interaction with other supplementary services.....	23
7.1	Line Identification services.....	23
7.2	Call forwarding unconditional (CFU).....	23
7.3	Call forward on busy (CFB).....	23
7.4	Call forwarding on no reply (CFNRy).....	23
7.5	Call forwarding on MS not reachable (CFNRc).....	24
7.6	Call Hold (CH).....	24
7.7	Call Waiting (CW).....	24
7.8	Multiparty service (MPTY).....	24
7.9	Closed user group (CUG).....	24
7.10	Advice Of Charge (AoC).....	24
7.11	Call Barring services.....	24
7.12	Explicit call transfer (ECT).....	24
7.13	Call Deflection (CD).....	24
7.14	Completion of calls to busy subscriber (CCBS).....	24
8	Interaction with network features.....	24
8.1	Customised Applications for Mobile network Enhanced Logic (CAMEL).....	24
8.2	Support of Optimal Routeing (SOR).....	24
8.3	Operator Determined Barring (ODB).....	24
9	Information stored in the HLR.....	25
10	State transition model.....	25
11	Transfer of information from HLR to VLR.....	25
12	Information stored in VLR.....	25
13	Handover.....	26
Annex A (informative):	Examples.....	27
Annex B (informative):	Change history.....	31
History.....		32

Foreword

This Technical Specification (TS) has been produced by the 3rd Generation Partnership Project (3GPP).

The present document gives the stage 2 description of the Multicall service within the 3GPP system.

The contents of the present document are subject to continuing work within the TSG and may change following formal TSG approval. Should the TSG modify the contents of the present document, it will be re-released by the TSG with an identifying change of release date and an increase in version number as follows:

Version x.y.z

where:

- x the first digit:
 - 1 presented to TSG for information;
 - 2 presented to TSG for approval;
 - 3 or greater indicates TSG approved document under change control.
- y the second digit is incremented for all changes of substance, i.e. technical enhancements, corrections, updates, etc.
- z the third digit is incremented when editorial only changes have been incorporated in the document.

1 Scope

The present document gives the stage 2 description of the Multicall supplementary service.

2 References

The following documents contain provisions which, through reference in this text, constitute provisions of the present document.

- References are either specific (identified by date of publication, edition number, version number, etc.) or non-specific.
- For a specific reference, subsequent revisions do not apply.
- For a non-specific reference, the latest version applies.

- [1] 3GPP TR 21.905: "3GPP Vocabulary".
- [2] 3GPP TS 22.100: "UMTS Phase 1".
- [3] 3GPP TS 22.105: "Services & Service capabilities".
- [4] 3GPP TS 22.135: "Multicall Stage 1".
- [5] 3GPP TS 23.009: "Handover procedures".
- [6] 3GPP TS 23.011: "Technical realisation of supplementary services".
- [7] 3GPP TS 23.018: "Basic call handling; Technical realization".
- [8] 3GPP TS 23.083: "Call Waiting (CW) and Call Hold (HOLD) Supplementary Service - Stage 2".
- [9] 3GPP TS 24.008: "Mobile radio interface layer 3 specification Core Network Protocol – Stage 3".

3 Definitions and abbreviations

3.1 Definitions

For the purposes of the present document, the terms and definitions given in TS 22.135 and the following apply.

Speech Call: speech call means one of TS11 (Telephony), TS12 (Emergency call), TS61 (Alternate speech and facsimile group 3).

3.2 Abbreviations

Abbreviations used in the present document are listed in TR 21.905.

4 Descriptions

4.1 Handling of Multicall

4.1.1 Provision

No special signalling procedures apply.

4.1.2 Withdrawal

No special signalling procedures apply.

4.1.3 Registration

The information flow for registration is shown in figure 1. The registration process is shown in figure 2.

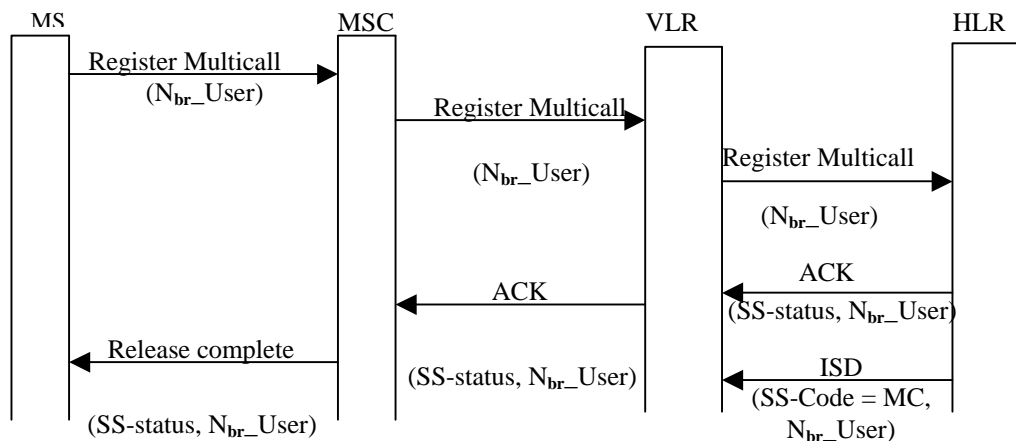

Figure 1: Registration of Multicall

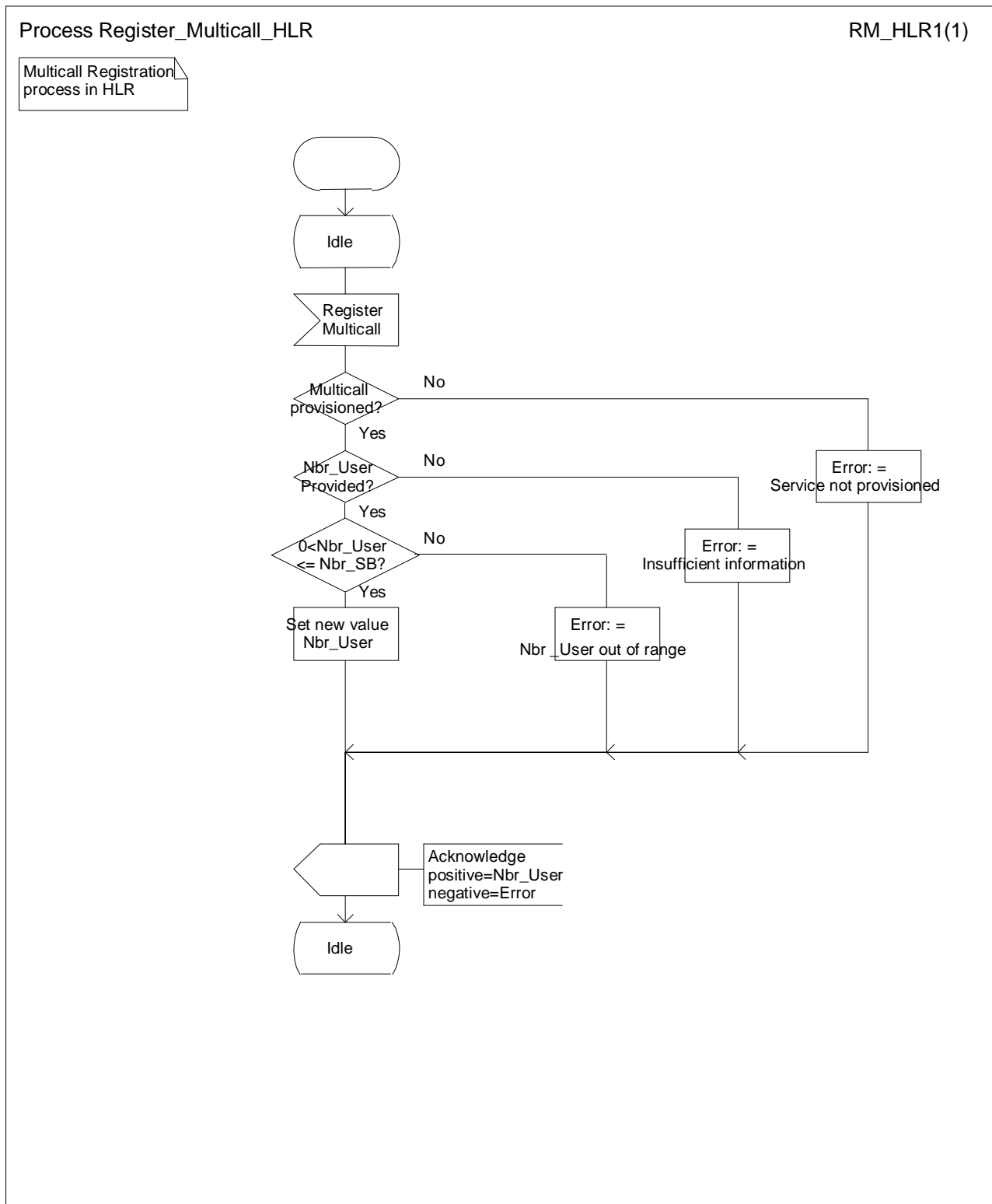

Figure 2: Process Register_Multicall_HLR

4.1.4 Erasure

No special signalling procedures apply.

4.1.5 Activation

The service provider shall provide an initial value for Nbr_User when activating the service. No special signalling procedures apply.

4.1.6 Deactivation

No special signalling procedures apply.

4.1.7 Interrogation

The information flow for interrogation is shown in figure 3. The interrogation process is shown in figure 4.

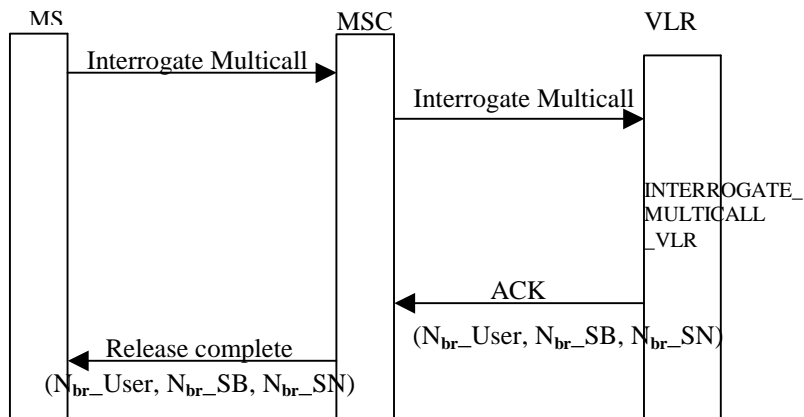

Figure 3: Interrogation of Multicall

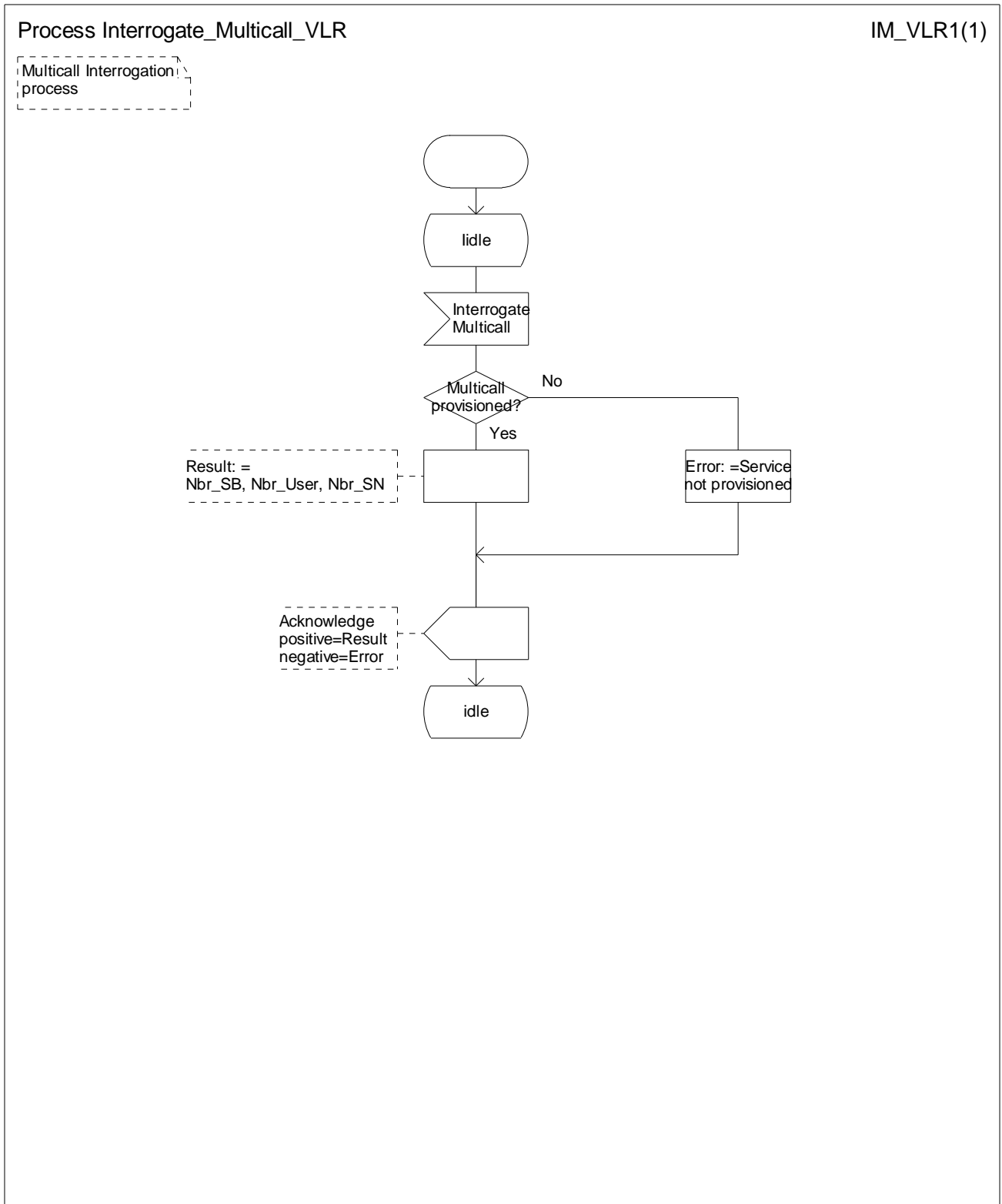

Figure 4: Process Interrogate_Multicall_VLR

4.2 Call related procedures

The procedures for basic call handling are specified in 3GPP TS 23.018. These shall also be used for Multicall.

4.2.1 MO call

Figure 5 shows the flow of information between network elements for an MO call:

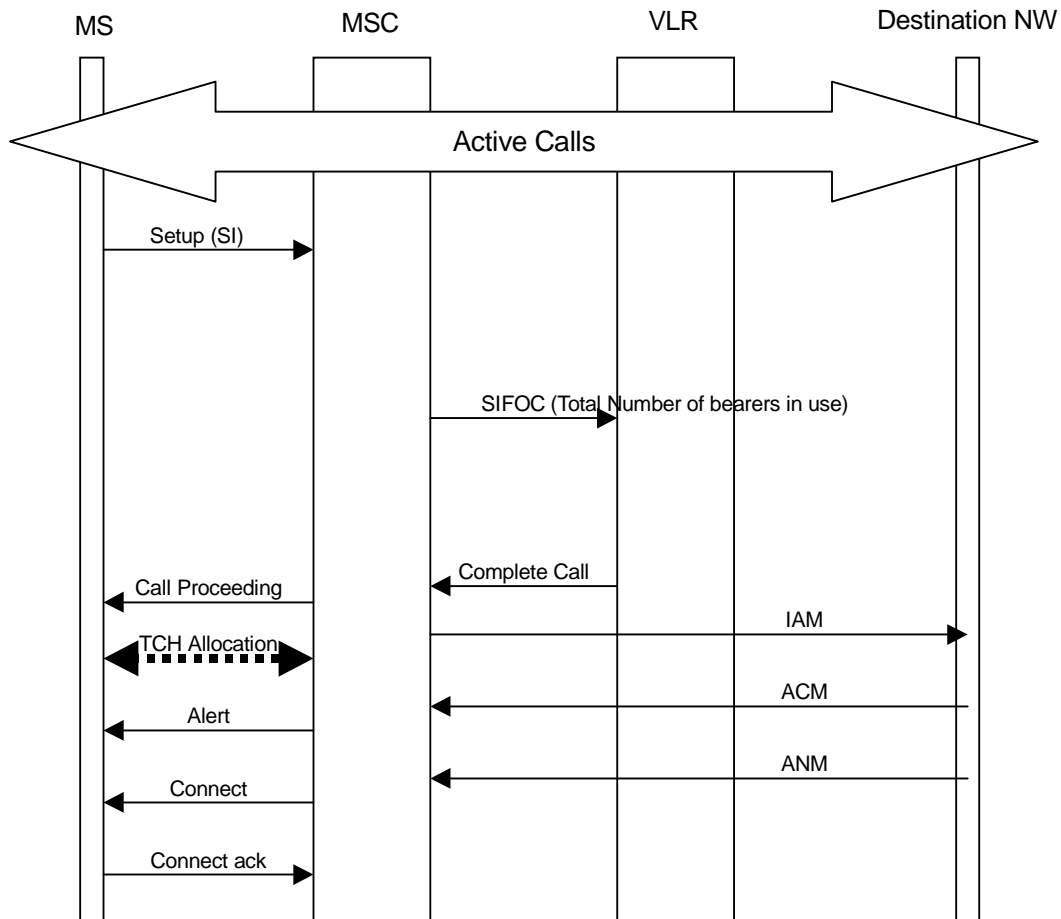

Figure 5: Information flow for mobile originating call

4.2.2 MT call

Figure 6 and Figure 7 show the flow of information between network elements for an MT call:

- Case 1: When the MS requests a new bearer in call confirmed. (Figure 6).
- Case 2: When the MS requests a new bearer in Connect. (Figure 7).

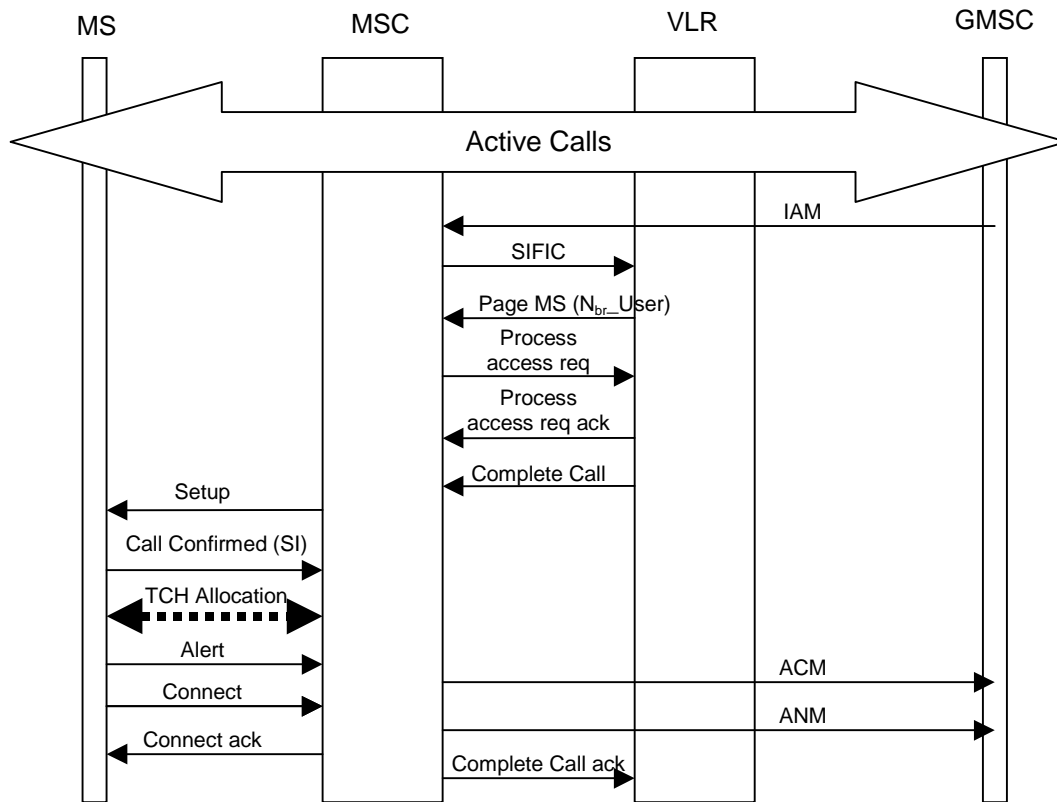

Figure 6: Information flow for mobile terminating call (Case1)

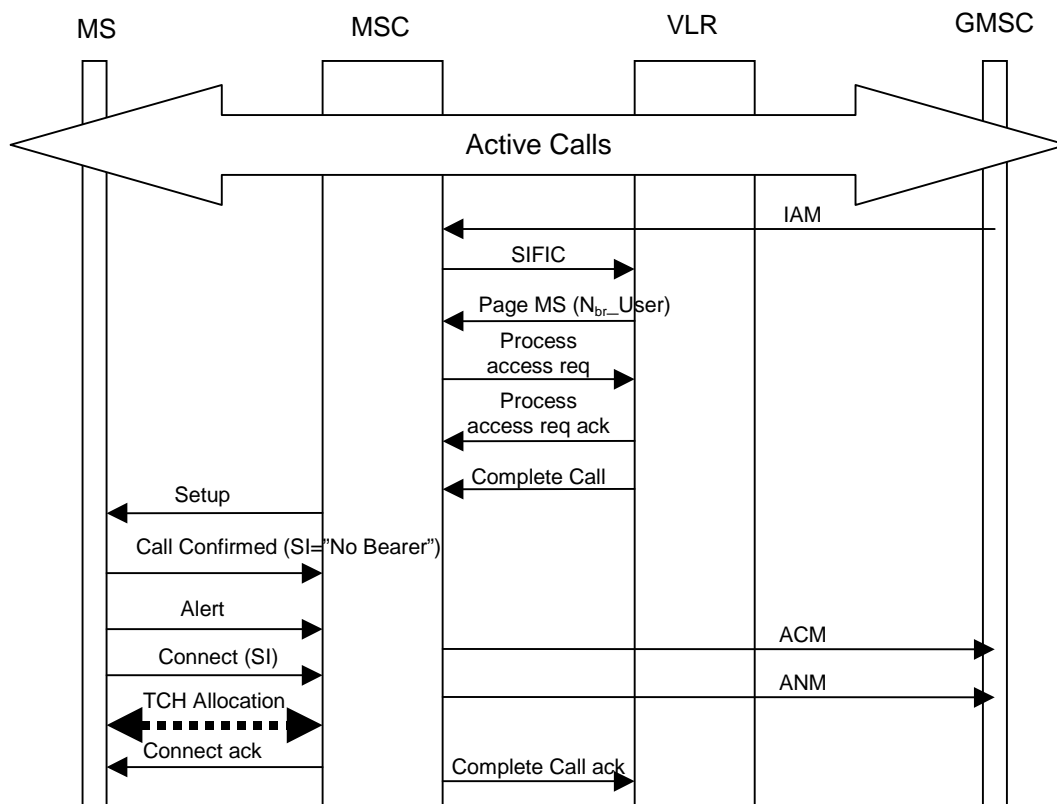

Figure 7: Information flow for mobile terminating call (Case2)

4.3 Messages and their contents

This clause contains the detailed description of the information flows used by Multicall.

Each Information Element, IE, is marked as (M) Mandatory, (C) Conditional or (O) Optional. A mandatory information element shall always be present. A conditional information shall be present if certain conditions are fulfilled; if those conditions are not fulfilled it shall be absent. An optional information element may be present or absent, at the discretion of the application at the sending entity. This categorisation is a functional classification, i.e., stage 2 information and not a stage 3 classification to be used for the protocol.

The stage 2 and stage 3 message and information element names are not necessarily identical.

4.3.1 Messages between MS and MSC

Table 1 indicates messages between the MS and the MSC for mobile originating calls and mobile terminating calls. (Refer to TS 24.008).

The MS shall indicate the maximum number of bearers supported by the MS in the CC capabilities IE. The MS shall also indicate the maximum number of simultaneous speech bearers supported by the MS for future compatibility. For Release 99, the maximum number of simultaneous speech bearers is 1. If the MS does not indicate the maximum number of bearers the network shall assume it does not support Multicall.

The network supporting Multicall shall indicate the capability in the NW CC capabilities IE. If the NW CC capabilities IE is not sent from the network, the MS supporting Multicall shall assume that the network doesn't support Multicall. If an MS initiating an emergency call is located in a network that does not support Multicall, the MS shall release one or more existing call to ensure that the emergency call can be established.

Table 1: Messages between MS and MSC

Message	Message sender	Information element name	Information element Required	Information element description
Setup (MO)	MS	Stream Identifier	M	This information element indicates which bearer (new or existing) shall be used for the call.
		CC Capabilities	C	For the first call, this information element shall be included to indicate the maximum number of bearers supported by the MS.
Emergency Setup	MS	Stream Identifier	M	This information element indicates which bearer (new or existing) shall be used for the call.
Call Confirmed	MS	Stream Identifier	M	This information element indicates whether a new bearer is requested, i.e. SI=value which is not used by any of the existing bearers , or no bearer is requested at that point in time, i.e. SI="no bearer".
		CC Capabilities	C	For the first call, this information element shall be included to indicate the maximum number of bearers supported by the MS.
Connect (MT)	MS	Stream Identifier	C	This IE shall be present in the Connect message if the SI contained "No bearer" in the Call Confirmed message, otherwise shall be absent.
Setup (MT)	NW	NW CC Capabilities	C	This information element shall be present for the first call.
Call Proceeding	NW	NW CC Capabilities	C	

4.3.2 Messages on B interface (MSC-VLR)

4.3.2.1 Send Info For Outgoing Call

This message is specified in 3GPP TS 23.018. The following additional information element is required:

Information element name	Required	Description
Total number of bearers in use	M	Total number includes the new bearer if requested for the call.

4.3.2.2 Send Info For Outgoing Call negative response

This message is specified in 3GPP TS 23.018. The following additional information element is required:

Information element name	Required	Description
Negative response information element	M	<p>If the VLR detects that the OG call can not be permitted because Multicall limit set by the user is exceeded, it shall indicate " N_{br}_User is exceeded" as the negative response information element value.</p> <p>If the VLR detects that the OG call can not be permitted because the user is not provisioned with Multicall, it shall indicate "Multicall not provisioned" as the negative response information element value.</p>

4.3.2.3 Send Info For Incoming Call

This message is specified in TS 23.018.

4.3.2.4 Send Info For Incoming Call ack

This message is specified in TS 23.018.

4.3.2.5 Send Info For Incoming Call negative response

This message is specified in TS 23.018.

4.3.2.6 Complete Call

This message is specified in TS 23.018.

4.3.2.7 Complete Call ack

This message is specified in TS 23.018.

4.3.2.8 Page MS

This message is specified in 3GPP TS 23.018. The following additional information element is required:

Information element name	Required	Description
N _{br} _User	M	Shall be present if the subscriber is provisioned with Multicall.

4.3.2.9 Page MS negative response

This message is specified in 3GPP TS 23.018. The following additional information element is required:

Information element name	Required	Description
Basic service list	C	If the MSC detects subscriber busy (More Calls Possible), the Basic service list shall be included, see Table 2.

Table 2: Basic Service List setting

Condition		Setting
The terminating call type is speech	There exists an active or held speech call	Basic service of active call via the same bearer as the existing speech call. If an active call does not exist via the same bearer as the existing speech call "speech" shall be indicated.
	There exists no speech call	All basic services of ongoing calls
The terminating call type is not speech		All basic services of ongoing calls

4.3.2.10 Process Access Request

This message is specified in TS 23.018.

4.3.2.11 Process Access Request ack

This message is specified in TS 23.018.

4.3.2.12 Process Access Request negative response

This message is specified in TS 23.018.

4.3.2.13 Search For MS

This message is specified in 3GPP TS 23.018. The following additional information element is required:

Information element name	Required	Description
N _{br} _User	M	Shall be present if the subscriber is provisioned with Multicall.

4.3.2.14 Search For MS ack

This message is specified in 3GPP TS 23.018.

4.3.2.15 Search For MS negative response

This message is specified in 3GPP TS 23.018. The following additional information element is required:

Information element name	Required	Description
Basic service list	C	If the MSC detects subscriber busy (More Calls Possible), the Basic service list shall be included, see Table 2.

5 Network entity functions

The following SDL diagrams describe the procedures within individual network entities for handling Multicall.

5.1 General

The MSC shall check whether the maximum number of bearers has been reached for both MO and MT call. In counting of the current number of bearers for the target subscriber, the following situations are counted as an active bearer.

- Call in set-up.
- Established call.
- Call on hold.
- Call on hold and established call on the same bearer.
- Call on hold and MO call in Setup on the same bearer.

5.2 MO call

5.2.1 Functional requirements of serving MSC

Figure 8: Procedure Check_OG_Multicall_MSC.

This procedure is called when the MSC receives a Setup message from the MS. After handover procedure completion to another MSC, N_{br_SN} as defined for the target MSC shall overwrite the previous N_{br_SN} .

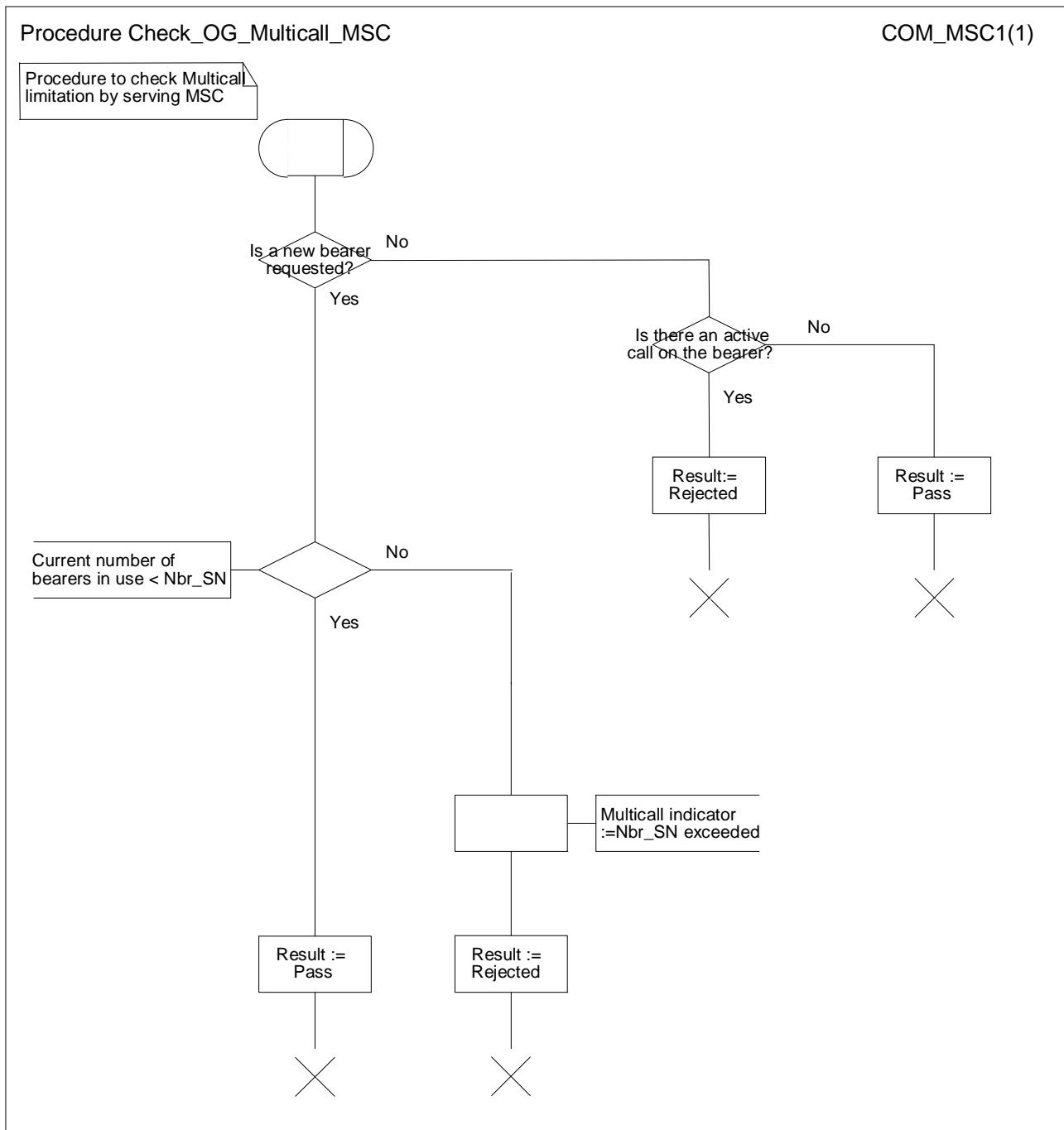

Figure 8: Procedure Check_OG_Multicall_MSC

5.2.2 Functional requirements of VLR

Figure 9: Procedure Check_OG_Multicall_VLR.

This procedure is called when the VLR receives a Send Info For Outgoing Call message from the MSC.

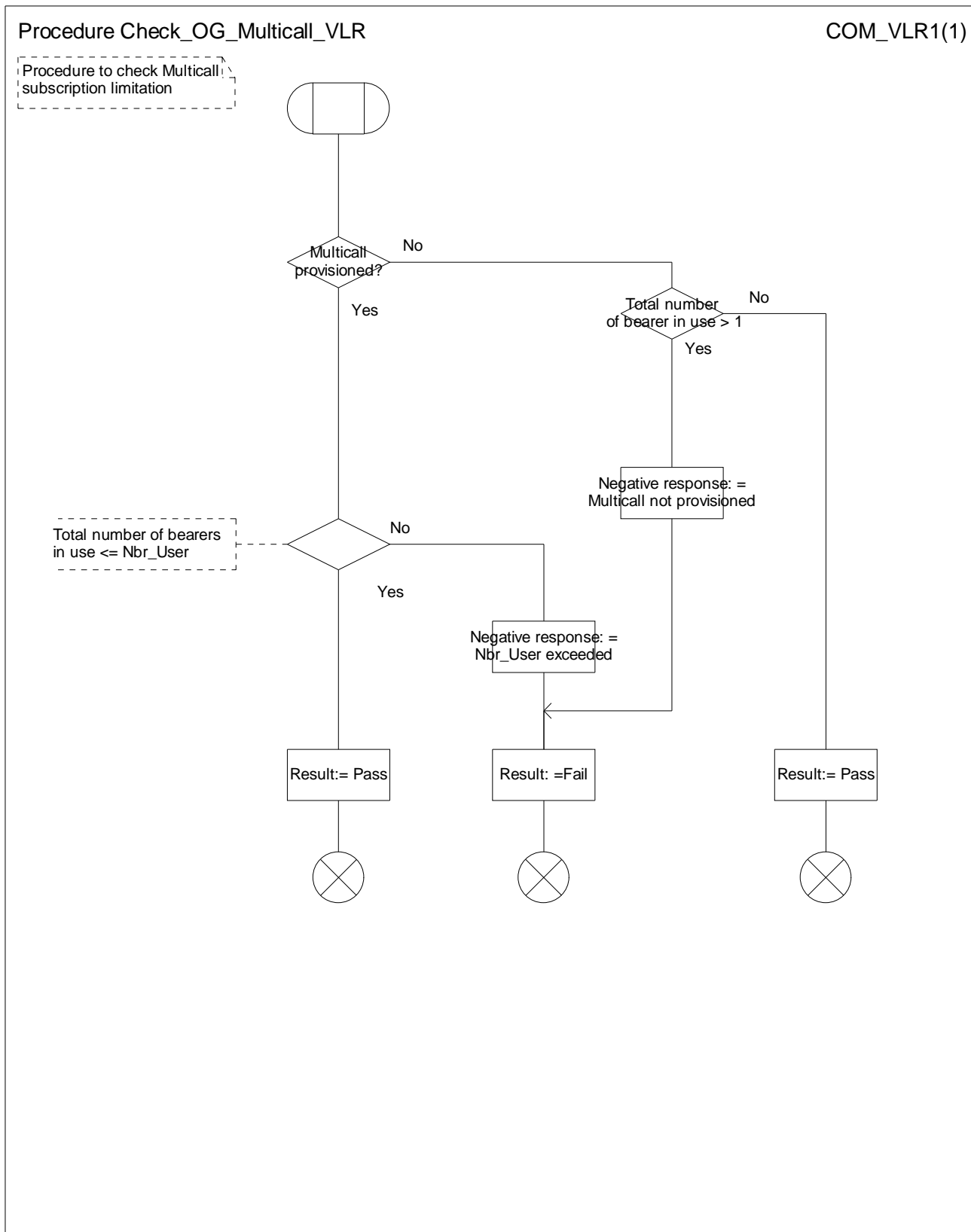

Figure 9: Procedure Check_OG_Multicall_VLR

5.3 MT call

5.3.1 Functional requirements of serving MSC

Figure 10: Procedure Check_MT_Multicall_MSC.

This procedure is called when the MSC receives a Page MS message or a Search For MS message from the VLR. The maximum number of bearers (N_{br}) indicates the minimum value of N_{br_User} , N_{br_SN} and N_{br_UE} . After handover to another MSC is completed, N_{br_SN} , as defined for the target MSC, shall overwrite the previous N_{br_SN} .

"Call in Setup" means that the MS is engaged in at least one call that has not reached the established phase (called party answer).

The test "Call waiting" takes the "Yes" exit if a waiting call has been offered to the subscriber but the outcome of offering the call has not been determined.

Figure 11: Procedure Establish_Terminating_TCH_Multicall.

This procedure is called when the MSC receives a Call Confirmed or a Connect message from the MS. If the MS indicates "No bearer" as the value of the Stream Identifier in the Call Confirmed message the test "Bearer allocation pending" takes the "Yes" exit.

Figure 12: Procedure MC_TCH_Check

This procedure is called when the MSC needs to establish a terminating TCH.

Procedure Check_MT_Multicall_MSC

CMM_MSC1(1)

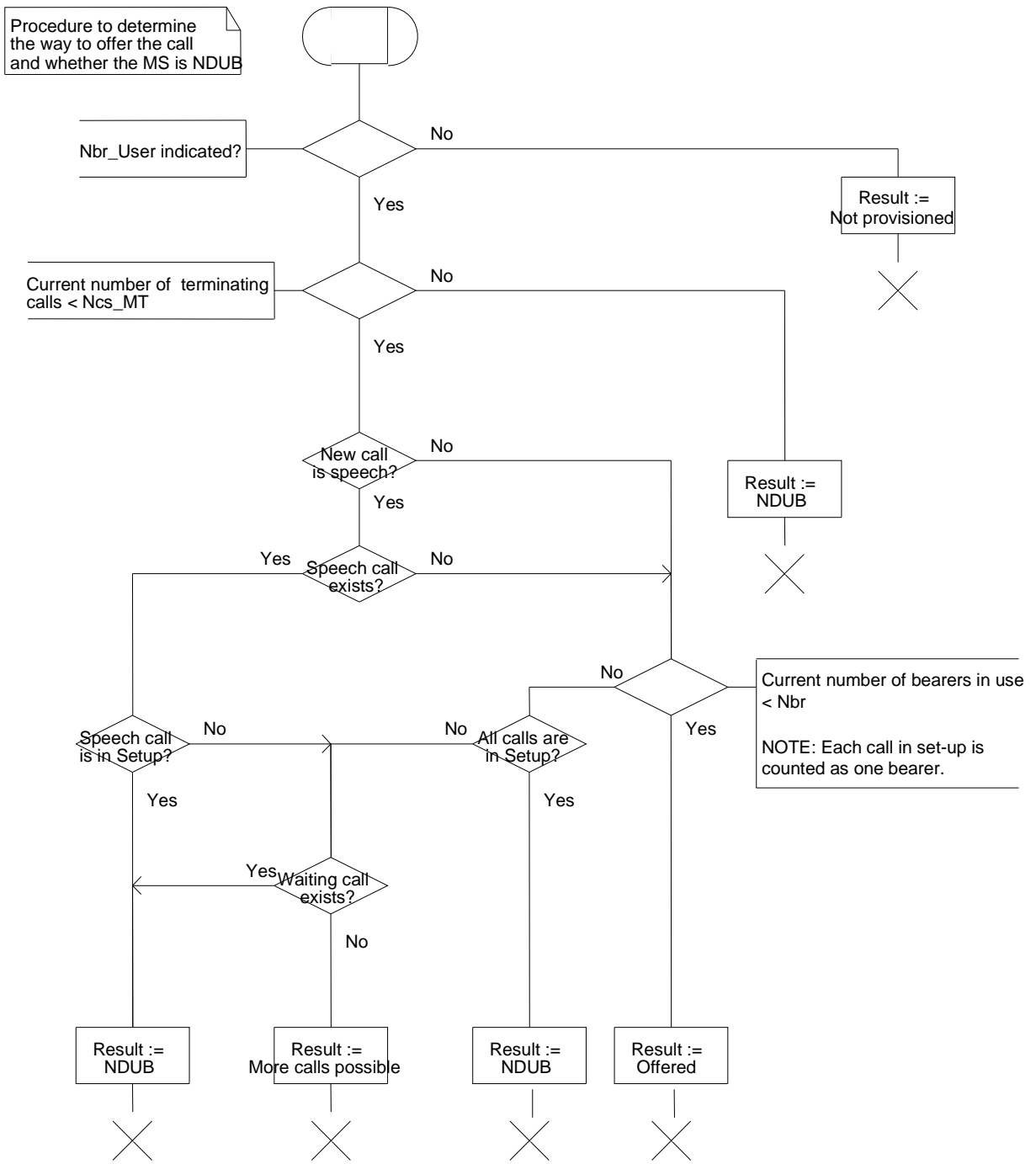

Figure 10: Procedure Check_MT_Multicall_MSC

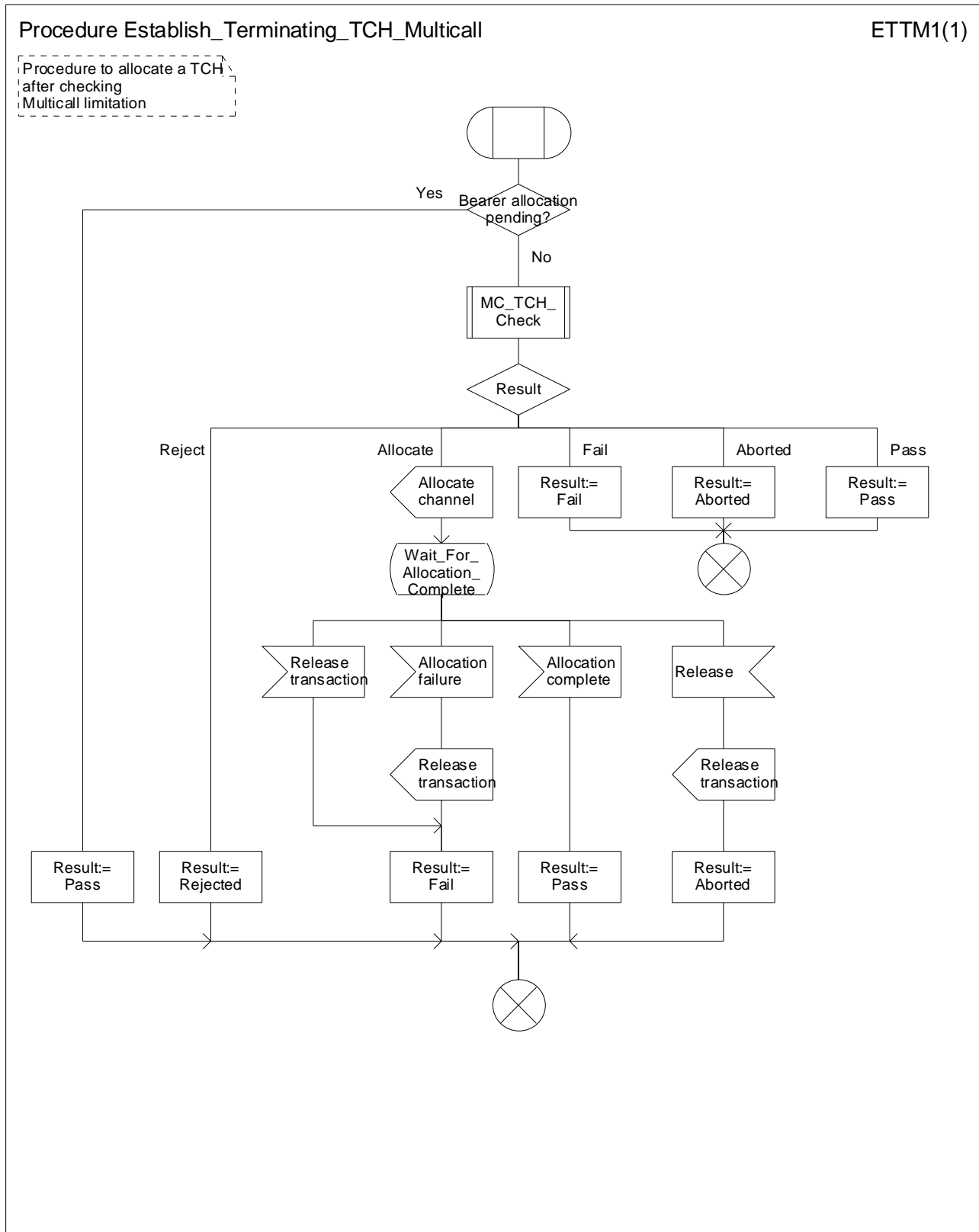

Figure 11: Procedure Establish_Terminating_TCH_Multicall

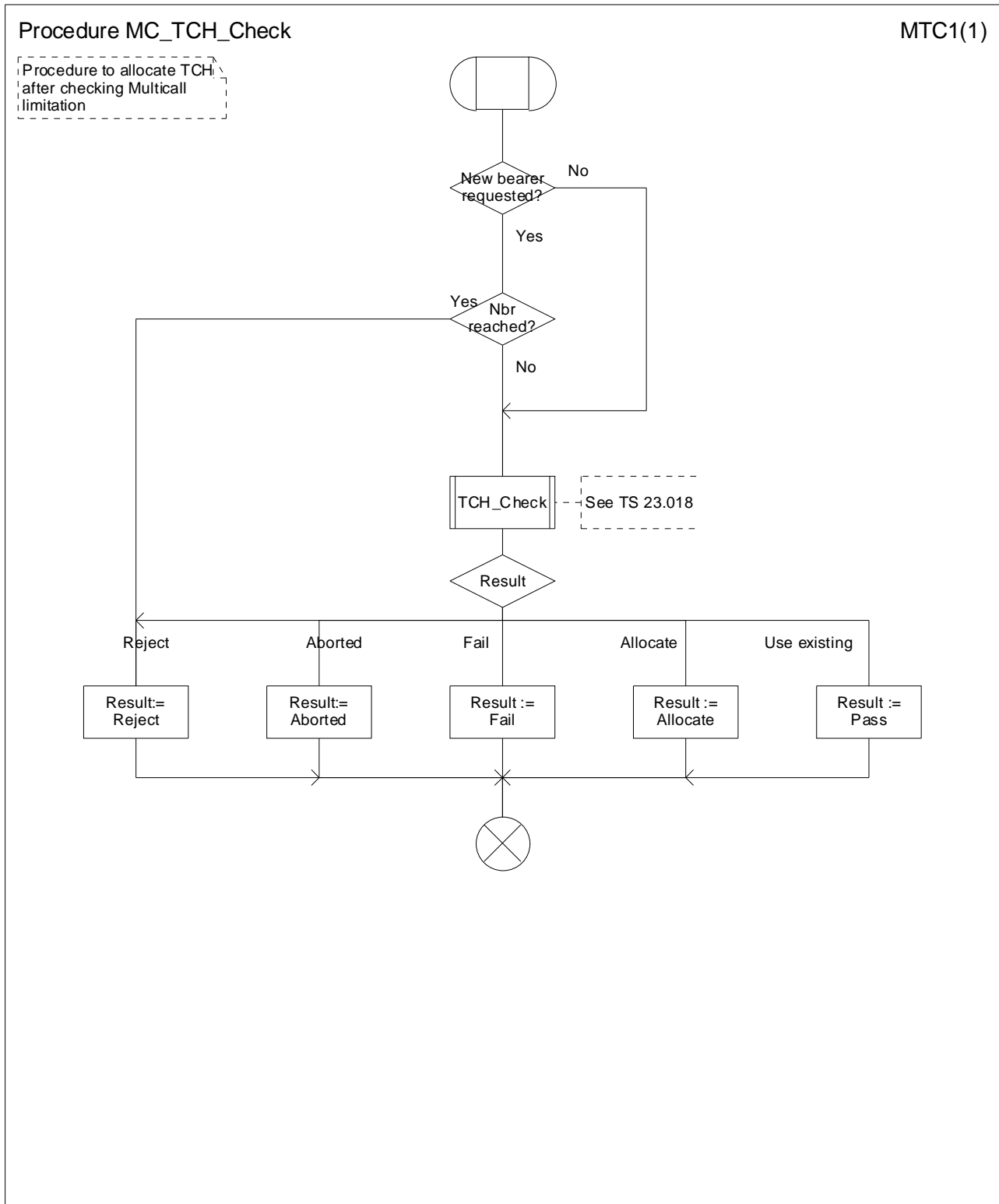

Figure 12: Procedure MC_TCH_Check

5.3.2 Functional requirements of VLR

Figure 13: Procedure Get_CW_Subscription_Info_Multicall_VLR.

This procedure is called when the VLR receives a Page MS negative response message or a Search For MS negative response message with the negative response IE set to "Busy (More Calls Possible)".

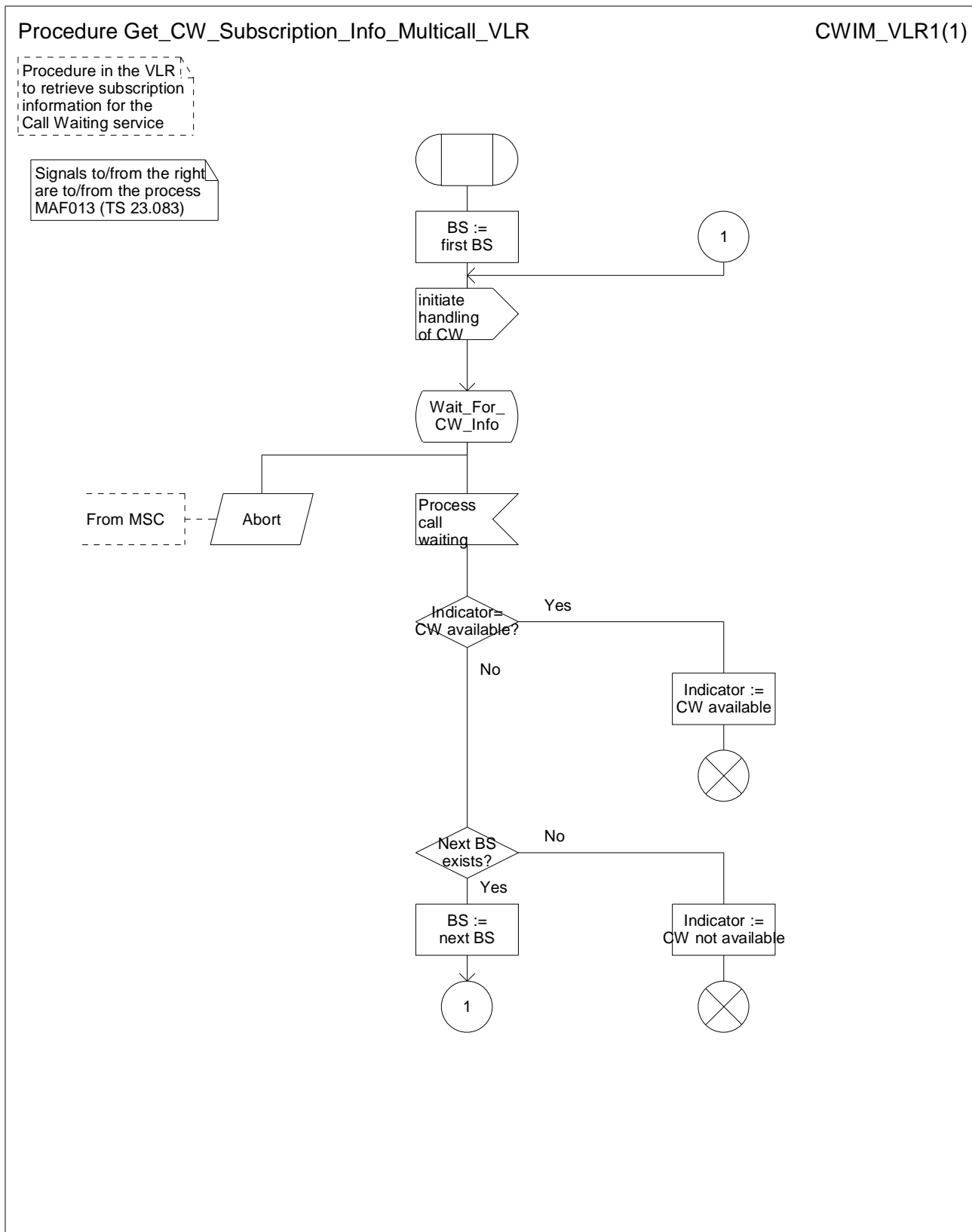

Figure 13: Procedure Get_CW_Subscription_Info_Multicall_VLR

6 Interaction with telecommunication services

6.1 Speech

The Multicall supplementary service does not provide multiple traffic channels for speech calls. Refer to Procedure Check_OG_Multicall_MSC and Procedure Check_MT_Multicall_MSC.

If N_{br_UE} is greater than N_{br_SN} , the mobile station may initiate an Emergency call even if N_{br_SN} has been reached. When the network receives an Emergency call Setup message from the mobile station:

- if N_{br_SN} has not been reached, the network shall accept it regardless of N_{br_SB} or N_{br_User} ;
- if N_{br_SN} has been reached, the network shall reject the emergency call setup attempt. The MS shall release one or more existing calls and it shall re-initiate an Emergency call.

The MS shall ensure that an emergency call Setup request is acceptable to a serving network which does not support multicall, if necessary by releasing one or more existing calls.

6.2 Short message service

No impact.

6.3 Facsimile service

The Multicall supplementary service provides multiple traffic channels for facsimile service except for alternate speech and facsimile group 3.

6.4 Data circuit asynchronous

The Multicall supplementary service provides multiple traffic channels for data circuit asynchronous.

6.5 Data circuit synchronous

The Multicall supplementary service provides multiple traffic channels for data circuit synchronous.

6.6 Void

6.7 GPRS

No impact.

7 Interaction with other supplementary services

7.1 Line Identification services

No impact.

7.2 Call forwarding unconditional (CFU)

No impact.

7.3 Call forward on busy (CFB)

The condition NDUB occurs in accordance with the definition for multicall. (See TS 22.135).

7.4 Call forwarding on no reply (CFNRy)

No impact.

7.5 Call forwarding on MS not reachable (CFNRc)

No impact.

7.6 Call Hold (CH)

No impact.

7.7 Call Waiting (CW)

Call Waiting SS will be invoked under the conditions described in TS 22.135.

7.8 Multiparty service (MPTY)

No impact.

7.9 Closed user group (CUG)

No impact.

7.10 Advice Of Charge (AoC)

No impact.

7.11 Call Barring services

No impact.

7.12 Explicit call transfer (ECT)

No impact.

7.13 Call Deflection (CD)

No impact.

7.14 Completion of calls to busy subscriber (CCBS)

The NDUB condition occurs in accordance with the definition for multicall. (See 3GPP TS 22.135).

A subscriber provisioned with multicall is in the idle state when the subscriber has no ongoing (active or held) calls. CCBS requests in the destination B CCBS queue shall be processed if destination B is idle.

8 Interaction with network features

8.1 Customised Applications for Mobile network Enhanced Logic (CAMEL)

No impact.

8.2 Support of Optimal Routeing (SOR)

No impact.

8.3 Operator Determined Barring (ODB)

No impact.

9 Information stored in the HLR

The following logical states are applicable for Multicall (refer to TS 23.011 for an explanation of the notation):

Provisioning State	Registration State	Activation State	HLR Induction State
(Not Provisioned,	Not Applicable,	Not Active,	Not Induced)
(Provisioned,	Registered,	Active and Operative,	Not Induced)

The HLR shall store:

- The state of Multicall (which shall be one of the valid states listed above) per subscriber.
- The subscription option "maximum number of bearers N_{br_SB} " per subscriber:
 - This subscription option takes a value in the range (2 – 7).
- The subscription option "maximum number of bearers N_{br_User} " per subscriber:
 - This subscription option takes a value in the range (1 – N_{br_SB}).

10 State transition model

Figure 14 shows the successful cases of transition between the applicable logical states of Multicall. The state changes are caused by actions of the service provider.

Note that error cases are not shown in the diagram, as they normally do not cause a state change. Additionally, some successful requests may not cause a state change. Hence they are not shown in the diagram.

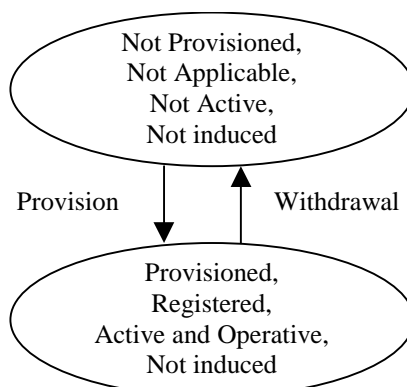

Figure 14: State transition model for Multicall

11 Transfer of information from HLR to VLR

If the provisioning state for Multicall is "Provisioned" then when the subscriber registers on a VLR the HLR shall send that VLR information about the logical state of Multicall, N_{br_User} and N_{br_SB} .

If the logical state of Multicall, the subscription options N_{br_SB} or N_{br_User} are changed while a subscriber is registered on a VLR then the HLR shall inform the VLR of the new logical state of Multicall, the new N_{br_User} or the new N_{br_SB} .

12 Information stored in VLR

The VLR shall store the service state information, N_{br_SB} and N_{br_User} as received from the HLR.

13 Handover

In the case that the network supports Multicall, it shall be possible to handover multiple bearers (See TS 23.009).

Annex A (informative): Examples

The following table shows some examples:

1 Mobile Originating Call (MO call).

As an example: $N_{br}=2$.

Current Status				Additional MO call	
No	Status	Number of bearers	Number of calls	Speech	Data
1	None	0	0	Acceptable	Acceptable
2	1 Speech call(active)	1	1	Rejected	Acceptable
3	1 Speech call(on hold)	1	1	Acceptable (with same SI) Rejected (with another SI)	Acceptable
4	1 Data call(active)	1	1	Acceptable	Acceptable
5	1 Speech call(on hold) 1 Speech call(active)	1	2	Rejected	Acceptable
6	1 Speech call(on hold) 1 Data call(active)	1	2	Rejected	Acceptable
7	Multiparty (2-5 remote parties: active)	1	2 - 5	Rejected	Acceptable
8	Multiparty (2-5 remote parties: on hold)	1	2 - 5	Acceptable (with same SI) Rejected (with another SI)	Acceptable
9	1 Speech call(active) 1 Data call(active)	2	2	Rejected	Rejected
10	1 Speech call(on hold) 1 Data call(active)	2	2	Acceptable (with same SI as speech call) Rejected (with another SI)	Acceptable (with same SI as speech call) Rejected (with another SI)
11	1 Speech call(on hold) 1 Speech call(active) 1 Data call(active)	2	3	Rejected	Rejected
12	2 Data call(active)	2	2	Rejected	Rejected
13	1 Speech call(on hold) 2 Data call(active)	2	3	Rejected	Rejected
14	Multiparty (2-5 remote parties: active) 1 Data call(active)	2	3 - 6	Rejected	Rejected
15	Multiparty (2-5 remote parties: on hold) 1 Data call(active)	2	3 - 6	Acceptable (with same SI as speech call) Rejected (with another SI)	Acceptable (with same SI as speech call) Rejected (with another SI)

2 Mobile Terminated Call (MT call).

As an example: $N_{br}=2$ (CW is not active).

Current Status				Additional MT call	
No	Status	Number of bearers	Number of calls	Speech	Data
1	None	0	0	Offered	Offered
2	1 Speech call(active)	1	1	Busy	Offered
3	1 Speech call(on hold)	1	1	Busy	Offered
4	1 Data call(active)	1	1	Offered	Offered
5	1 Speech call(on hold) 1 Speech call(active)	1	2	Busy	Offered
6	1 Speech call(on hold) 1 Data call(active)	1	2	Busy	Offered
7	Multiparty (2-5 remote parties: active)	1	2 - 5	Busy	Offered
8	Multiparty (2-5 remote parties: on hold)	1	2 - 5	Busy	Offered
9	1 Speech call(active) 1 Data call(active)	2	2	Busy	Busy
10	1 Speech call(on hold) 1 Data call(active)	2	2	Busy	Busy
11	1 Speech call(on hold) 1 Speech call(active) 1 Data call(active)	2	3	Busy	Busy
12	2 Data call(active)	2	2	Busy	Busy
13	1 Speech call(on hold) 2 Data call(active)	2	3	Busy	Busy
14	Multiparty (2-5 remote parties: active) 1 Data call(active)	2	3 - 6	Busy	Busy
15	Multiparty (2-5 remote parties: on hold) 1 Data call(active)	2	3 - 6	Busy	Busy

3 Call Waiting (CW).

As an example: $N_{br}=2$ (CW is provisioned).

Current Status				Additional MT call	
No	Status	CW status for speech	CW status for data	Speech	Data
1	None	-	-	-	-
2	1 Speech call(active)	active	-	CW offered	MT offered
		Not active	-	busy	MT offered
3	1 Speech call(on hold)	active	-	CW offered	MT offered
		Not active		busy	MT offered
4	1 Data call(active)	-	active	MT offered	MT offered
			Not active	MT offered	MT offered
5	1 Speech call(on hold) via bearer A 1 Speech call(active) via bearer A	active	active	CW offered	MT offered
		active	Not active	CW offered	MT offered
		Not active	active	busy	MT offered
		Not active	Not active	busy	MT offered
6	1 Speech call(on hold) via bearer A 1 Data call(active) via bearer A	active	active	CW offered	MT offered
		active	Not active	busy	MT offered
		Not active	active	CW offered	MT offered
		Not active	Not active	busy	MT offered
7	Multiparty via bearer A (2-5 remote parties: active)	active	-	CW offered	MT offered
		Not active	-	Busy	MT offered
8	Multiparty via bearer A (2-5 remote parties: on hold)	active	-	CW offered	MT offered
		Not active	-	busy	MT offered
9	1 Speech call(active) via bearer A 1 Data call(active) via bearer B	active	active	CW offered	CW offered
		active	Not active	CW offered	CW offered
		Not active	active	busy	CW offered
		Not active	Not active	busy	busy
10	1 Speech call(on hold) via bearer A 1 Data call(active) via bearer B	active	active	CW offered	CW offered
		active	Not active	CW offered	CW offered
		Not active	active	busy	CW offered
		Not active	Not active	busy	busy
11	1 Speech call(on hold) via bearer A 1 Speech call(active) via bearer A 1 Data call(active) via bearer B	active	active	CW offered	CW offered
		active	Not active	CW offered	CW offered
		Not active	active	busy	CW offered
		Not active	Not active	busy	busy
12	2 Data call(active)	-	active	CW offered	CW offered
		-	Not active	busy	busy

Current Status				Additional MT call	
No	Status	CW status for speech	CW status for data	Speech	Data
13	1 Speech call(on hold) via bearer A 2 Data call(active) via bearer A and B	-	active	CW offered	CW offered
		-	Not active	Busy	Busy
14	Multiparty via bearer A (2-5 remote parties: active) 1 Data call(active) via bearer B	active	active	CW offered	CW offered
		active	Not active	CW offered	CW offered
		Not active	active	busy	CW offered
		Not active	Not active	busy	busy
15	Multiparty via bearer A (2-5 remote parties: on hold) 1 Data call(active) via bearer B	active	active	CW offered	CW offered
		active	Not active	CW offered	CW offered
		Not active	active	busy	CW offered
		Not active	Not active	busy	busy

Annex B (informative): Change history

Change history						
TSG CN#	Spec	Version	CR	<Phase>	New Version	Subject/Comment
CN#07	23.135	1.0.0		R99	3.0.0	Approved at TSGN#07
CN#08	23.135	3.0.0	001r1	R99	3.1.0	Clean-up and corrections for Multicall Stage 2
CN#09	23.135	3.1.0	002r4	R99	3.2.0	Requirement on Network to Tear Down Calls to Accept EC in Multicall
CN#09	23.135	3.1.0	004r1	R99	3.2.0	Correction to MT_Multicall SDL
CN#09	23.135	3.2.0	003r1	Rel-4	4.0.0	Inclusion of call hold in basic call handling
CN#16	23.135	4.0.0		Rel-5	5.0.0	Release 5 after CN#16
CN#26	23.135	5.0.0		Rel-6	6.0.0	Release 6 after CN#26
CT#36	23.135	6.0.0		Rel-7	7.0.0	Upgraded unchanged from Rel-6
CT#42	23.135	7.0.0		Rel-8	8.0.0	Upgraded unchanged from Rel-7
CT#46	23.135	8.0.0	-	Rel-9	9.0.0	Update to Rel-9 version (MCC)
2011-03	23.135	9.0.0	-	Rel-10	10.0.0	Update to Rel-10 version (MCC)
2012-09	23.135	10.0.0	-	Rel-11	11.0.0	Update to Rel-11 version (MCC)
2014-09	23.135	11.0.0	-	Rel-12	12.0.0	Update to Rel-12 version (MCC)
2015-12	23.135	12.0.0		Rel-13	13.0.0	Update to Rel-13 version (MCC)
2017-03	23.135	13.0.0	-	Rel-14	14.0.0	Update to Rel-14 version (MCC)
2018-06	23.135	14.0.0	-	Rel-15	15.0.0	Update to Rel-15 version (MCC)

History

Document history		
V15.0.0	July 2018	Publication