

# ETSI TS 123 153 V4.13.0 (2005-06)

---

*Technical Specification*

**Universal Mobile Telecommunications System (UMTS);  
Out of Band Transcoder Control;  
Stage 2  
(3GPP TS 23.153 version 4.13.0 Release 4)**



---

**Reference**

RTS/TSGC-0423153v4d0

---

**Keywords**

UMTS

**ETSI**

650 Route des Lucioles  
F-06921 Sophia Antipolis Cedex - FRANCE

---

Tel.: +33 4 92 94 42 00 Fax: +33 4 93 65 47 16

Siret N° 348 623 562 00017 - NAF 742 C  
Association à but non lucratif enregistrée à la  
Sous-Préfecture de Grasse (06) N° 7803/88

---

**Important notice**

---

Individual copies of the present document can be downloaded from:

<http://www.etsi.org>

The present document may be made available in more than one electronic version or in print. In any case of existing or perceived difference in contents between such versions, the reference version is the Portable Document Format (PDF). In case of dispute, the reference shall be the printing on ETSI printers of the PDF version kept on a specific network drive within ETSI Secretariat.

Users of the present document should be aware that the document may be subject to revision or change of status. Information on the current status of this and other ETSI documents is available at

<http://portal.etsi.org/tb/status/status.asp>

If you find errors in the present document, please send your comment to one of the following services:

[http://portal.etsi.org/chaicor/ETSI\\_support.asp](http://portal.etsi.org/chaicor/ETSI_support.asp)

---

**Copyright Notification**

---

No part may be reproduced except as authorized by written permission.  
The copyright and the foregoing restriction extend to reproduction in all media.

© European Telecommunications Standards Institute 2005.  
All rights reserved.

**DECT**<sup>TM</sup>, **PLUGTESTS**<sup>TM</sup> and **UMTS**<sup>TM</sup> are Trade Marks of ETSI registered for the benefit of its Members.  
**TIPHON**<sup>TM</sup> and the **TIPHON logo** are Trade Marks currently being registered by ETSI for the benefit of its Members.  
**3GPP**<sup>TM</sup> is a Trade Mark of ETSI registered for the benefit of its Members and of the 3GPP Organizational Partners.

---

## Intellectual Property Rights

IPRs essential or potentially essential to the present document may have been declared to ETSI. The information pertaining to these essential IPRs, if any, is publicly available for **ETSI members and non-members**, and can be found in ETSI SR 000 314: "*Intellectual Property Rights (IPRs); Essential, or potentially Essential, IPRs notified to ETSI in respect of ETSI standards*", which is available from the ETSI Secretariat. Latest updates are available on the ETSI Web server (<http://webapp.etsi.org/IPR/home.asp>).

Pursuant to the ETSI IPR Policy, no investigation, including IPR searches, has been carried out by ETSI. No guarantee can be given as to the existence of other IPRs not referenced in ETSI SR 000 314 (or the updates on the ETSI Web server) which are, or may be, or may become, essential to the present document.

---

## Foreword

This Technical Specification (TS) has been produced by ETSI 3rd Generation Partnership Project (3GPP).

The present document may refer to technical specifications or reports using their 3GPP identities, UMTS identities or GSM identities. These should be interpreted as being references to the corresponding ETSI deliverables.

The cross reference between GSM, UMTS, 3GPP and ETSI identities can be found under <http://webapp.etsi.org/key/queryform.asp>.

# Contents

Intellectual Property Rights .....	2
Foreword.....	2
Foreword.....	5
1 Scope .....	6
2 References .....	6
3 Definitions and abbreviations.....	7
3.1 Definitions .....	7
3.2 Abbreviations .....	9
4 Out-of-Band Transcoder control functionality.....	9
4.1 OoBTC Requirements .....	9
4.2 Relationship between OoBTC and In-band TFO .....	10
4.3 Lawful interception .....	11
5 General Principles .....	11
5.1 Network Model .....	11
5.2 Simple call set-up .....	12
5.3 Media Gateway Control for Codec Handling .....	13
5.4 UP Framing Protocol Handling for TrFO.....	13
5.4.1 Framing Protocol Initialisation .....	13
5.4.2 RFCI Storage .....	15
5.4.3 RFCI Value Correction .....	16
5.4.4 TrFO Break .....	16
5.4.5 TrFO Break Recovery.....	16
5.4.6 MGW Control Protocol Iu Framing Package properties.....	17
5.5 TrFO/TFO Codec Negotiation Harmonisation.....	17
5.6 CN Node handling of Codec Types & Codec Modes.....	19
5.6.1 Signalling between UE and MSC .....	19
5.6.2 Node originating the OoBTC codec negotiation.....	19
5.6.3 Intermediate node .....	20
5.6.4 Node terminating the OoBTC codec negotiation.....	21
5.6.5 Signalling between server and MGW .....	22
5.6.6 Signalling between MSC and UTRAN .....	22
5.7 Inband Rate Control .....	22
5.8 Modification Procedures .....	23
5.8.1 Modification of Selected Codec.....	23
5.8.2 Modification of Available Codecs List.....	25
5.8.3 Mid-call Codec negotiation.....	25
5.8.4 Detailed Procedures For Iu Framing Protocol & Codec Modification .....	26
5.8.5 Unsuccessful Codec Modification .....	29
5.9 DTMF Handling For TrFO Connections.....	33
6 Detailed Call Procedures .....	34
6.1 Mobile to Mobile TrFO Call Establishment.....	34
6.2 SRNS Relocation during TrFO .....	37
6.3 IN and Call Forward SS .....	40
6.3.1 TrFO interworking with SS (VMSC = service interworking node).....	41
6.3.2 IN interworking (VMSC ≠ service interworking node).....	43
6.4 Information flow for interaction with Multiparty SS .....	44
6.5 Information flow for handover from UMTS to GSM after TrFO establishment.....	45
6.6 Call Hold/Call Wait.....	46
6.7 External Network to Mobile TrFO Call Establishment.....	51
6.8 Mobile to External Network TrFO Call Establishment.....	52
7 Interactions with supplementary services.....	52

7.1	Call Deflection service (GSM 23.072) .....	52
7.2	Line identification services (GSM 23.081) .....	53
7.2.1	Calling Line Identification Presentation (CLIP) .....	53
7.2.2	Calling Line Identification Restriction (CLIR) .....	53
7.2.3	Connected Line Identification Presentation (COLP) .....	53
7.2.4	Connected Line Identification Restriction (COLR) .....	53
7.3	Call forwarding services (GSM 23.082) .....	53
7.3.1	Call Forwarding Unconditional (CFU) .....	53
7.3.2	Call Forwarding on mobile subscriber Busy (CFB) .....	53
7.3.3	Call Forwarding on No Reply (CFNRy) .....	53
7.3.4	Call Forwarding on mobile subscriber Not Reachable (CFNRc) .....	53
7.4	Call wait (GSM 23.083) .....	53
7.5	Call hold (GSM 23.083) .....	53
7.6	Multiparty (GSM 23.084) .....	53
7.7	Closed user group (GSM 23.085) .....	54
7.8	Advice of charge (GSM 23.086) .....	54
7.9	User-to-user signalling (GSM 23.087) .....	54
7.10	Call barring (GSM 23.088) .....	54
7.10.1	Barring of outgoing calls .....	54
7.10.2	Barring of incoming calls .....	54
7.11	Explicit Call Transfer (GSM 23.091) .....	54
7.12	Completion of Calls to Busy Subscriber (3G TS 23.093) .....	54
8	Charging .....	54
<b>Annex A (informative):</b>	<b>Codec Re-negotiation .....</b>	<b>55</b>
<b>Annex B (informative):</b>	<b>Status of Technical Specification 23.153 .....</b>	<b>56</b>
History .....		58

---

# Foreword

This Technical Specification has been produced by the 3<sup>rd</sup> Generation Partnership Project (3GPP).

The contents of the present document are subject to continuing work within the TSG and may change following formal TSG approval. Should the TSG modify the contents of the present document, it will be re-released by the TSG with an identifying change of release date and an increase in version number as follows:

Version x.y.z

where:

- x the first digit:
  - 1 presented to TSG for information;
  - 2 presented to TSG for approval;
  - 3 or greater indicates TSG approved document under change control.
- y the second digit is incremented for all changes of substance, i.e. technical enhancements, corrections, updates, etc.
- z the third digit is incremented when editorial only changes have been incorporated in the document.

---

# 1 Scope

The present document specifies the stage 2 description of the Out-of-Band Transcoder Control for speech services. It describes the principles and procedures to support Transcoder Free Operation, Tandem Free Operation and the interworking between TrFO and TFO. Transcoder at the edge is also part of the present document.

---

# 2 References

The following documents contain provisions which, through reference in this text, constitute provisions of the present document.

- References are either specific (identified by date of publication, edition number, version number, etc.) or non-specific.
- For a specific reference, subsequent revisions do not apply.
- For a non-specific reference, the latest version applies. In the case of a reference to a 3GPP document (including a GSM document), a non-specific reference implicitly refers to the latest version of that document *in the same Release as the present document*.

- [1] 3GPP TS 23.107: "QoS Concept and Architecture".
- [2] 3GPP TS 24.008: "Mobile radio interface layer 3 specification Core Network Protocols –Stage 3".
- [3] 3GPP TS 25.413: "UTRAN Iu Interface RANAP Signalling".
- [4] 3GPP TS 25.415: "UTRAN Iu Interface User Plane Protocols".
- [5] 3GPP TS 26.103: "Speech codec list for GSM and UMTS".
- [6] 3GPP TS 29.205: "3rd Generation Partnership Project; Technical Specification Group CoreNetwork; Application of Q.1900 series to Bearer Independent circuit-switched core Network architecture; Stage 3".
- [7] ITU-T Recommendation Q.765.5: "Signalling system No. 7; Application transport mechanism: Bearer Independent Call Control (BICC)".
- [8] 3GPP TS 23.205: "Bearer-independent CS Core Network".
- [9] 3GPP TS 33.106: "3GPP Security; Lawful Interception Requirements".
- [10] 3GPP TS 28.062: "Inband Tandem Free Operation (TFO) of Speech Codecs; Service Description; Stage 3".
- [11] 3GPP TS 23.009: "Handover Procedures".
- [12] 3GPP TS 29.232: "Media Gateway Controller (MGC) – Media Gateway (MGW) interface; Stage 3".
- [13] ITU-T H.248: "Gateway Control Protocol".
- [14] 3GPP TS 29.415: "Customised Applications for Mobile network Enhanced Logic (CAMEL) Phase 3; CAMEL Application Part (CAP) specification".
- [15] 3GPP TS 34.108: "Common test environments for User Equipment (UE) conformance testing".

## 3 Definitions and abbreviations

### 3.1 Definitions

For the purposes of the present document, the following definition apply:

**Codec:** device to encode information from its original representation into an encoded form and to decode encoded information into its original representation

**Codec Lists, Selected Codecs:** The OoBTC procedures pass a number of codec lists created by comparing the capabilities of the different nodes or equipment involved. For the different interfaces involved during call setup, handover, and relocation, the following codec lists and selected codecs need to be distinguished:

- i) Supported Codecs List (DTAP) – this is the list of codecs supported by the UE. It is subdivided into codecs supported for the currently used radio access and codecs that can be used for other radio accesses supported by the UE. The list contains only the codec types, but not the individual configuration, as the UE is mandated to support all configurations for a given codec type.
- ii) Supported Codecs List (BICC) – this list is used on NNI (BICC) OoBTC signalling. At call setup it is sent forward by the node originating the OoBTC signalling and contains the default PCM codec and a set of codecs that is common to the nodes and the equipment involved in setting up the call. For a mobile originating call, these are the UE and the MGWs involved in the connection and, for UTRAN and GERAN Iu-mode, also the originating radio access. At inter-MS-C relocation and inter-MS-C handover, the Supported Codecs List (BICC) is sent forward by the anchor MS-C towards the target MS-C and contains the default PCM codec and a set of codecs that is common to the anchor MS-C and the nodes involved in setting up the new call leg towards the target MS-C. For UDI/RDI multimedia calls with fallback and service change according to 3GPP TS 23.172 [17], the multimedia dummy codec will be included (see 3GPP TS 26.103 [5]).
- iii) Available Codecs List (BICC) – this is the list of codecs available for the NNI connection. It is returned in the backward signalling to the node that originated the OoBTC and is a subset of the Supported Codecs List (BICC) sent forward. At call setup the Available Codecs List (BICC) contains the default PCM codec and a common set of codecs that can be supported by all nodes and, if Transcoder Free Operation has been achieved end-to-end, also by the UEs and the radio access networks that are involved in the call. At inter-MS-C relocation and inter-MS-C handover to UMTS, the Available Codecs List (BICC) contains the default PCM codec and a set of codecs that can be supported by all nodes involved in setting up the new call leg towards the target MS-C and, if Transcoder Free Operation can be maintained end-to-end after the handover or relocation, also by the UE and the target radio access network.
- iv) Selected Codec (BICC) – this is the codec selected to be used on the NNI connection. It is one of the codecs contained in the Available Codecs List (BICC) and may be different from the codec that is used on the radio interface, but if end-to-end Transcoder Free Operation has been achieved, this will be the common codec for all nodes, the UEs, and the radio accesses.
- v) Iu-Supported Codecs List (MAP) – this list is used for MAP signalling from the anchor MS-C to the target MS-C. It is subdivided into lists for UTRAN and GERAN Iu-mode and contains the codecs common to the UE and to the anchor MGW for each radio access supported by the UE. The codec capabilities of the serving radio access, i.e. the radio access used prior to the inter-MS-C handover or relocation, are not taken into account. Codecs that are only applicable to the NNI, e.g. the default PCM codec or the multimedia dummy codec (see 3GPP TS 26.103 [5]), are not included.
- vi) Iu-Available Codecs List (MAP) – this is the list of codecs available for the target Iu interface. When returned by the target MS-C to the anchor MS-C in response to an initial Prepare Handover message it is the Iu-Supported Codecs List (MAP) reduced according to the capabilities of the target MGW and the target radio access. After a subsequent intra-MS-C handover or relocation, the target MS-C may update the Iu-Available Codecs List (MAP) according to the capabilities of its associated MGW and the new target radio access, if necessary.
- vii) Iu-Selected Codec (MAP) – this is the codec selected for the target Iu interface. It is one of the codecs contained in the Iu-Available Codecs List (MAP). In response to a Prepare Handover request message this is the codec selected by the target MS-C and indicated back to the anchor MS-C. When sent from the anchor MS-C in a Forward Access Signalling request message during a codec modification, it contains the codec type and configuration chosen by the anchor MS-C.



- viii) Iu-Currently Used Codec (MAP) – this is the codec in use on the serving Iu interface prior to an inter-MSC handover.
- ix) TFO Codec List (H.248) – this is the list of codecs for use by the MGW during TFO in-band negotiations with a distant node. The list is passed via the Mc interface from the server to the MGW. The first entry of the TFO Codec List (H.248) is to be used by the MGW as the 'local used codec' (see [10]).
- x) Distant Codec List (H.248) – this is the list of codecs received by the MGW from a distant node during TFO in-band negotiations. The list is passed via the Mc interface from the MGW to the server. The first entry of the Distant Codec List (H.248) is the 'distant used codec' received by the MGW (see [10]).
- xi) Codec (H.248) – this is the codec for use on a certain MGW termination. It is passed via the Mc interface from the server to the MGW.

For the codecs in the Supported Codecs List (DTAP), no order of priority is defined. Within the lists ii and v, the codecs are ordered in decreasing order of priority, the first entry in the list being the highest priority codec (preferred codec).

**Tandem Free Operation:** configuration of a connection with two transcoders that support TFO protocol and whose external coding schemes are compatible, thus enabling compressed speech to pass between them

NOTE 1: When the TFO protocol is not supported by both transcoders or the coding schemes are not compatible then normal "Tandem" operation occurs and PCM encoded speech is passed between them.

**Transcoder:** device to change the encoding of information from one particular encoding scheme to a different one, most commonly to/from a compressed speech algorithm from/to PCM.

**Transcoder Free Operation:** configuration of a speech or multimedia call for which no transcoder device is physically present in the communication path and hence no control or conversion or other functions can be associated with it

**Out of Band Transcoder Control:** capability of a system to negotiate the types of codecs and codec modes on a call per call basis through out-of-band signalling, required to establish Transcoder Free Operation.

**Default PCM Codec:** network default 64kb/s codec for speech in PCM domain

NOTE 2: For example ITU G.711 A-law.

**Transcoding free link (TrFL):** bearer link, where compressed voice is being carried between bearer endpoints

NOTE 3: Within the UMTS network, the compressed voice is transmitted in Iu/ Nb User Plane format, depending on the related interface.

**Tandem free link (TFOL):** bearer link between transcoders that are operating in Tandem Free Operation mode, i.e. bypassing the transcoding functions

NOTE 4: The involved transcoders can be a UMTS transcoder or a GSM TRAU with TFO functionality.

**Transcoder free operation (TrFO):** calls that have no transcoders involved in the connection between the source codecs

NOTE 5: For mobile to mobile calls this is UE to UE, although the connection could be UE to another type of terminal. TrFO operation is considered a concatenation of TrFLs between RNCs.

NOTE 6: In case of mobile to fixed network calls the term "Transcoder free operation" is applicable for the TrFLs carrying compressed speech. The TrFO usually ends at the Gateway to the PSTN where the speech is transcoded e.g. to G.711.

**Tandem free and Transcoding free operation (TaTrFO):** concatenation of "transcoding free links" and "tandem free links"

**Iu Framing:** framing protocol used for the speech packets on both the Iu User Plane interface and the Nb User Plane interface

NOTE 7: The Iu framing protocol is specified by [4].

In addition, the definitions of ACS, SCS, OM, and MACS provided in [5] apply.

## 3.2 Abbreviations

For the purposes of the present document, the abbreviations defined in 3GPP TS 21.905 and the following apply:

ACS	Active Codec mode Set
APM	Application Transport Mechanism
BC	Bearer Control
BICC	Bearer Independent Call Control
CC	Call Control
CCD	Conference Call Device
CFNRc	Call Forward Not Reachable
CFNRy	Call Forward on No Reply
IN	Intelligent Network
IuFP	Iu Framing Protocol
MACS	Maximal number of codec modes in the ACS
OM	Optimization Mode
OoBTC	Out-of-Band Transcoder Control
QoS	Quality of Service
RAB	Radio Access Bearer
SCS	Supported Codec mode Set
TFO	Tandem Free Operation
TICC	Transport Independent Call Control
TrFO	Transcoder Free Operation
UP	User Plane

---

## 4 Out-of-Band Transcoder control functionality

Cellular networks depend heavily on codecs to provide their services. Codecs are necessary to compress speech in order to utilise efficiently the expensive bandwidth resources both in the radio interface and in the transmission networks.

Unnecessary transcoding of speech significantly degrades quality and, therefore, cellular systems try to avoid it for mobile-to-mobile calls when both UEs and the network support a common codec type.

Although the main reason for avoiding transcoding in mobile-to-mobile calls has been speech quality, the transmission of compressed information in the CN and CN-CN interface of the cellular network also offers the possibility of bandwidth savings. Therefore Out-of-Band Transcoder Control is not limited to mobile-to-mobile calls but can be applied for calls to or from an external network as well.

Digital cellular systems support an increasing number of codec types. As a result, in order to allocate transcoders for a call inside the network, and to select the appropriate codec type inside the UEs, signalling procedures are defined to convey the codec type selected for a call to all the affected nodes (UEs and (potential) transcoding points inside the network). Also, codec negotiation capabilities are being defined to enable the selection of a codec type supported in all the affected nodes, i.e. to resolve codec mismatch situations. This codec negotiation maximises the chances of operating in compressed mode end-to-end for mobile-to-mobile calls.

To allow transport of information in a compressed way in transmission networks, these networks make use of the transport -independent call control protocol as specified in [8] that provides means for signalling codec information, negotiation and selection of codecs end-to-end.

### 4.1 OoBTC Requirements

The OoBTC mechanism shall support the following:

- The capability to negotiate the preferred codec type to be used between two end nodes and to avoid the use of transcoders in the network at call set-up.

The originating UE indicates the list of its supported codec types for codec negotiation. This list shall be conveyed to the terminating MSC. The terminating UE indicates its list of supported codec types to the terminating MSC. The terminating MSC shall convey the selected codec to the originating MSC, which then indicates the selected codec to the originating UE.

Where no compatible codec type can be selected between the UEs then the default PCM coding shall be selected. Therefore, the default PCM codec shall always be included in the codec list for OoBTC. The originating MSC shall insert a transcoder in the path from the originating UE. Codec selection for the terminating UE is then performed within the terminating MSC, independently of the originating MSC.

NOTE: For a codec type supporting various modes, the described functionality shall also be applicable to negotiate the set of codec modes common to originating and terminating UEs. Other negotiations such as Initialisation and Rate control are performed at a later point in time by the Iu framing protocol.

- The capability to control the presence of transcoders in the network after call set-up.

Where a change to the call state of a transcoder free connection occurs, such that compressed speech cannot be maintained, it shall be possible to insert a transcoder or pair of transcoders where needed in the path. If this results in change to the encoding of the speech in other nodes then it shall be possible to inform the end points of this segment that the speech coding is changed. Such examples where this could occur are:

- SS interruptions (e.g. A to B call connection becomes to multiparty call connection.)
- Handover to an incompatible partner.
- Synchronisation loss

Where a change in call state as described above is temporary then it shall be possible to return to a transcoder free connection by removing the inserted transcoders and informing the endpoints that the connection has resumed to compressed speech encoding.

- The codec types comprise codecs for speech in the first phase of the present document. The transcoder control should have enough expandability to support future enhancements of codec types.
- The transcoder control procedure shall not cause a perceivable time lag in the cases of establishing transcoder free connection and reverting to normal (double transcoded) call connection in the cases described above for control of the presence of transcoders.
- The capability to insert transcoder (in cases where a TrFO connection is not possible) at the most appropriate location, i.e. to save bandwidth it should be located at the CN edge between an ATM or IP transport network and a STM network. When Transcoders are inserted, the OoBTC procedures shall provide support for TFO for inband codec negotiation and transmission of compressed speech.

When a transport network cannot maintain compressed voice then reversion to the default PCM coding shall occur. A transcoder shall be inserted at that point and OoBTC procedures terminated. TrFO link is then possible between that point and the preceding nodes.

When a Non-TrFO call reaches the UMTS CN then OoBTC procedures are initiated from that point and after codec negotiation has been performed, if compressed voice can be supported through the CN then a transcoder is inserted at the edge of the CN.

- The OoBTC signalling procedures shall be supported by the call control protocol on the Nc interface, for example codec negotiation, codec modification, codec list modification, codec renegotiation, and codec list renegotiation. BICC CS2 (see 3GPP TS 29.205 [6]) supports such a mechanism, through the APM procedures defined by [7].
- If TMR = 3.1Khz Audio is set for incoming calls, this shall be kept if OoBTC is initiated at the edge of the PLMN.
- For mobile originating calls, TMR=speech shall be used for speech calls with OoBTC. For other TMR values OoBTC shall not be used.
- The OoBTC signalling procedures shall be supported by the bearer control protocol on the Iu and Nb interfaces, for example to increase the bandwidth of the bearer (if needed) in the procedures for the codec modification.

## 4.2 Relationship between OoBTC and In-band TFO

OoBTC is used before call set-up to attempt to establish an UE-UE transcoder free connection. If successful the result is a saving of transcoding equipment in the path and provides a cost efficient transmission.

The In-band TFO protocol (described in [10]) is activated after call set-up only if transcoders are inserted in the path. In case two transcoders in tandem (a pair of transcoders with PCM coding between them) are able to communicate to each other (both support TFO), then the inband TFO protocol allows the transcoders to compare coding schemes. If compatible codec types exist, the transcoders are able to overwrite the PCM coding with the pure compressed speech (effectively bypassing the transcoding functions). In-band TFO provides fast fallback mechanisms in case the TFO connection can not be maintained (insertion of CCD, DTMF, tones, etc). In-band TFO provides no direct saving of transmission costs.

If the OoBTC fails to establish the TrFO and transcoders are required, then in-band TFO may be used after call set-up. Inband TFO shall be the fallback mechanism when transcoders cannot be avoided, either at set-up or during the communication phase. In-band TFO shall be used for interworking with the 2G systems (e.g. GSM).

## 4.3 Lawful interception

The TrFO shall be maintained if the interception is made due to the lawful interception. Two decoders are needed to monitor the TrFO call.

Lawful interception shall not have any influence on the establishment or maintenance of the TrFO connection in order to avoid any audible effect in speech quality or noticeable effect in speech delay to the end users.

The existing requirements for lawful interception shall be considered, these are described in [9].

---

# 5 General Principles

## 5.1 Network Model

The codec negotiation mechanism (OoBTC) is designed to work in the general situation where more than two call control (CC) nodes need to participate in the codec negotiation. The codec negotiation mechanism works as follows:

- Originating CC node: sends its list of supported codec types and options, listed in order of preference.
- Transit CC nodes: if needed, analyse the received list of options, delete unsupported options from the list and forward the list. No modification is done to the preference levels of any of the listed codecs.
- Terminating CC node: analyse the received list of options with their associated priorities and selects the supported option with highest indicated priority appropriate for the call.

Figure 5.1/1 illustrates the architecture for Rel-4 for UMTS to UMTS TrFO connection. The transit network may exist for calls between PLMNs or between islands of mobile CNs separated by transit networks. This figure is a basic illustration, OoBTC shall apply to other access technologies where the OoBTC procedures are supported, i.e. not limited to this figure. The negotiation occurs at call set-up phase, and possibly later on in the call due to other changes such as handover or relocation. *However, as described in the next clause, it shall be possible to modify the selected codec at any moment during the active phase of the call.*

Further detail of the Call & Bearer Separation for 3GPP is described in [8].

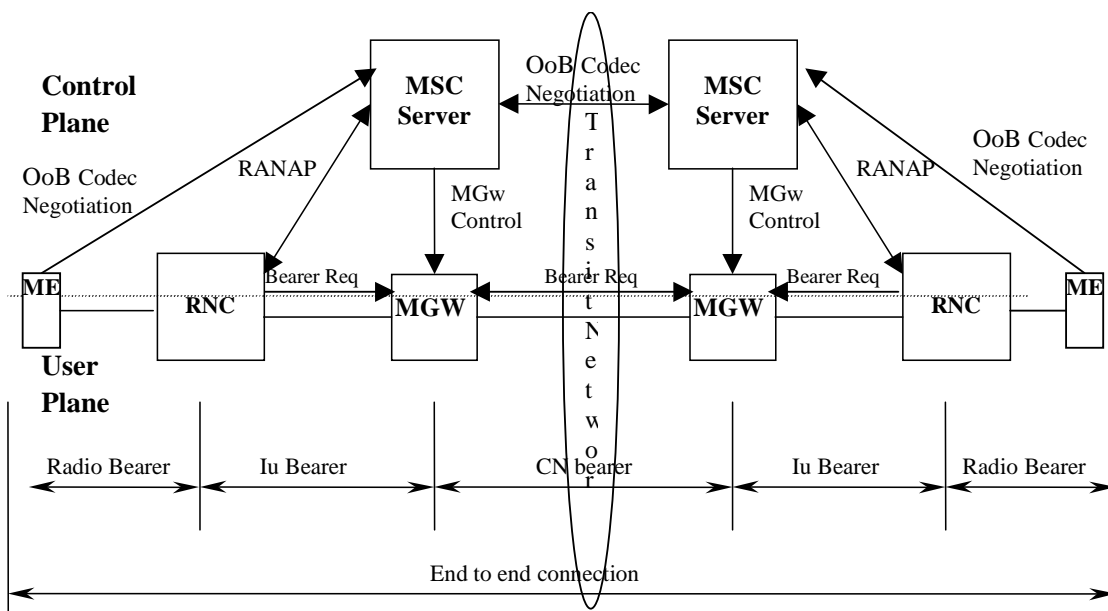

Figure 5.1/1. Basic Architecture for UMTS to UMTS TrFO Connection

The following clauses describe successful call establishment scenarios using the codec negotiation mechanism.

## 5.2 Simple call set-up

The signalling flow for the simple call set-up case is illustrated in figure 5.2/1. Codec negotiation is done prior to the establishment of bearer connections, so that appropriate bearer resources are committed to the call. In the proposed sequence, the codec negotiation starts with the IAM message containing the list of supported codec types (in this example v, w, x, y, z), sent by the Originating MSC (O-MSC). Transit nodes may puncture out (i.e. delete) codec types from the list (in this example y). The terminating MSC (T-MSC) selects the codec type (here v). The selected codec is conveyed in an APM message, together with the remaining list of alternative, but currently not selected codec types (here v, x, z).

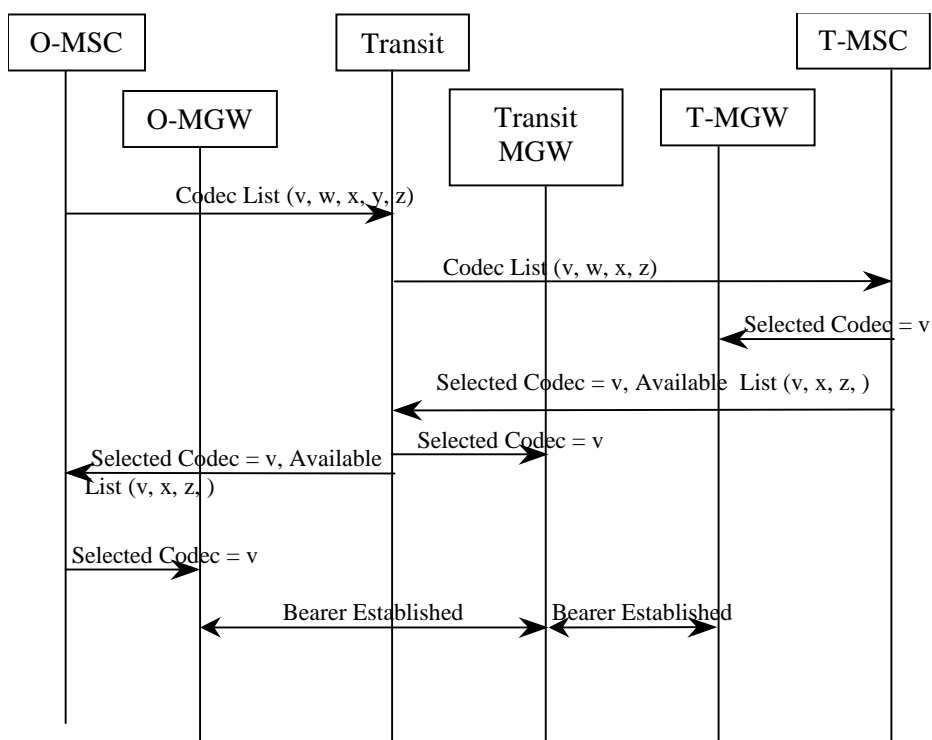
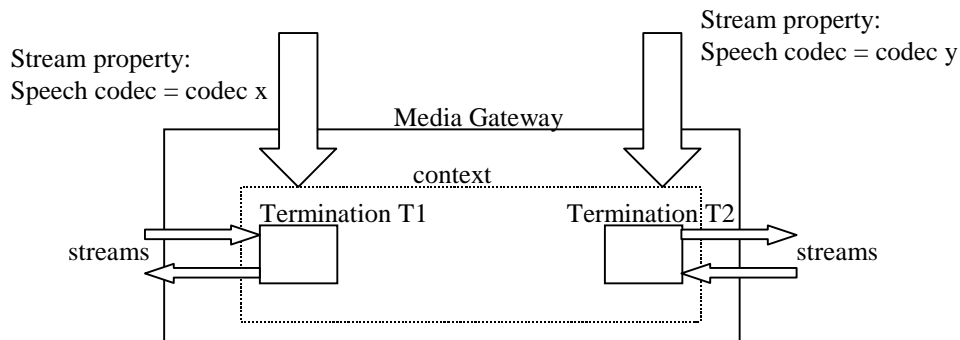

Figure 5.2/1. Basic Codec Negotiation Sequence

The codec list for BICC is specified according to [7], where each 3GPP codec entry is defined according to [5].

## 5.3 Media Gateway Control for Codec Handling

The general handling of MGW control procedures are detailed in [8]. Specific handling related to the control of the speech encoding is detailed in Figure. 5.3/1. The terms context, termination, streams and stream properties are described in the ITU-T H.248 "Media Gateway Control Protocol" [13].



**Figure 5.3/1. MGW control for speech codec**

The handling of transcoding between one codec type (media stream property applied at one termination) and another codec type (media stream property at other termination) is a function of the MGW. The media stream property for Audio Codec Type is defined in Annex C of the ITU-T MGW control protocol, H.248.

If TFO-incompatible codec types are applied at different terminations of the same context, the MGW shall insert a transcoder. For the definition of TFO-compatibility between 3GPP codec types and codec configurations see [10], clauses 11 and 12.

Between codecs of the AMR codec family, the MGW need not insert a transcoder, if the codec types are TFO-compatible according to [10], table 11-1, and

- the codecs use the same ACS; or
- the ACSs are TFO-compatible and the use of codec modes is restricted to a common subset of the ACSs by means of maximum rate control. In this case the MGW shall coordinate the rate control request.

## 5.4 UP Framing Protocol Handling for TrFO

### 5.4.1 Framing Protocol Initialisation

For TrFO calls the compressed speech is carried end to end (RNC to RNC or between RNC and other compressed voice terminal). In 3GPP Core Networks compressed voice framing protocol shall be specified by the Nb User Plane specification. The specification for Iu interface is defined in [4], the specification for the Nb interface is defined in [12]. The framing protocol for these interfaces is the same, Iu framing and is thus described as such, for both the Iu interface and the Nb interface. For compressed voice only the support mode is used, thus for TrFO the UP Initialisation procedure defined for the Nb UP shall be supported by the CN, when a CN MGW is required to establish a connection.

When negotiating TrFO OoB, a given serving MSC server shall consider the capabilities of the RNCs and MGWs, which are candidates to handle the TrFO call and which are controlled by this MSC server via an Iu/Mc interface. For TrFO, the selected RNC and MGW have to be able to support at least one Iu/Nb UP version with TrFO capabilities. Each MGW and RNC that supports TrFO shall support Iu/Nb UP version 2. If an RNC only supports Iu UP version 1 without TrFO capabilities, the MSC server shall insert a transcoder at the MGW that is connected to this RNC. For a TrFO call, each MSC server shall indicate in the "RAB assignment"/"Add request" only UP versions with TrFO

capabilities. In the inband UP framing protocol version negotiation during framing protocol initialisation, the informed RNCs/MGW shall only offer and/or accept UP version listed in the "RAB assignment"/"Add request".

The Iu framing Protocol is established through the CN in a forward direction, independently of the bearer establishment direction. The Notify message to indicate bearer establishment shall not be sent until the Iu framing has been initialised. The continuity message (COT) shall not be sent forward until the Notify message has been received from the MGW and also the COT from the previous server has been received. The sequences for mobile originated calls are shown in figures 5.4/1 and 5.4/2 for forward bearer and backward bearer establishment, respectively. The parameters in the Add Request messages in the Figures are described in further detail in clause 5.4.5.

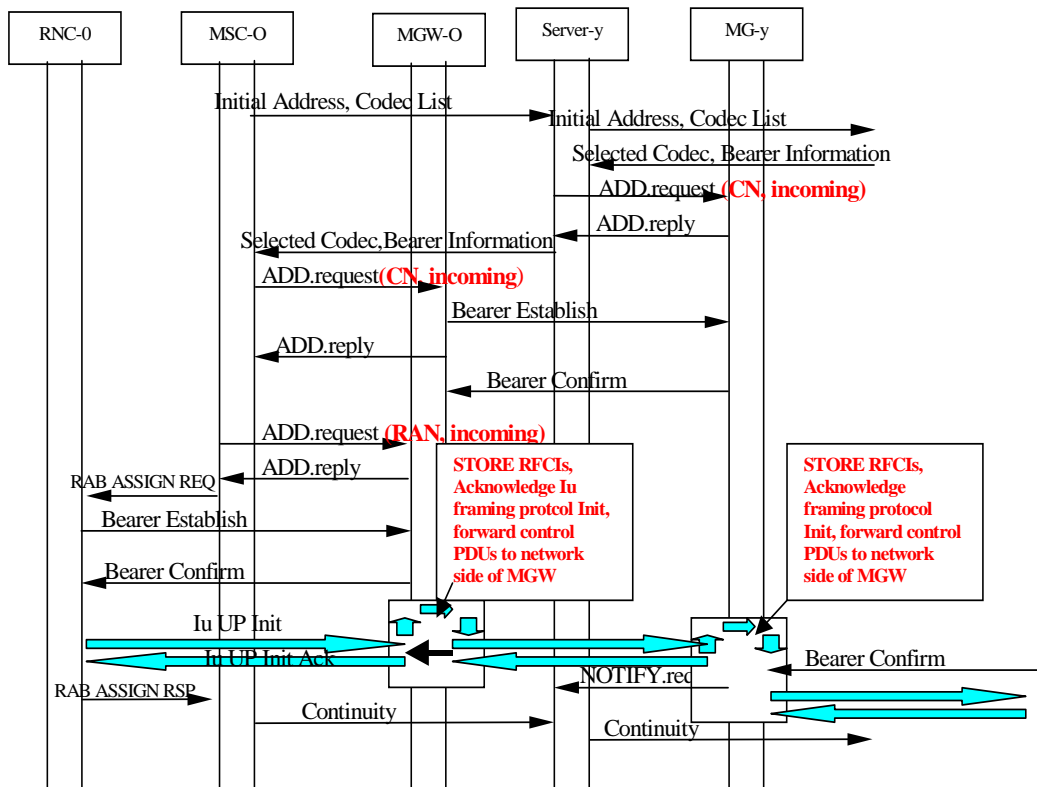

Figure 5.4.1/1: Iu Framing Protocol Establishment, Forward Bearer

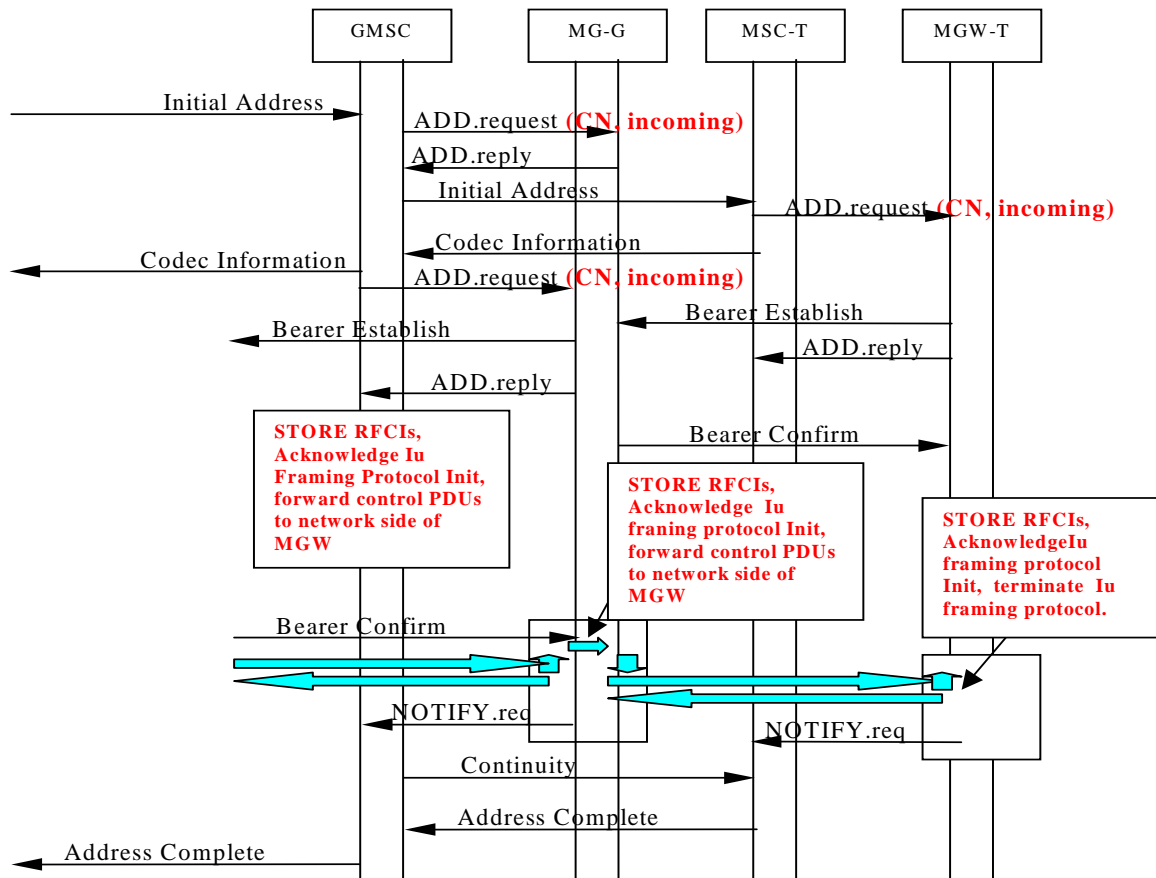

Figure 5.4.1/2: Iu Framing Protocol Establishment, backward bearer.

The transport independent call control procedures in [8] shall support a continuity mechanism, as described above.

### 5.4.2 RFCI Storage

The RNC shall allocate RAB Subflow Combination Indicators to the SDU formats (SDU formats sent to the RNC by the MSC in the RAB Assignment). This allocation is then sent in the Iu Framing Initialisation PDU by the RNC in the User Plane. For further details see [3] and [4].

During the TrFO call establishment each MGW linked into the call shall store the RFCIs received from Iu Framing PDU Type 14. The first subflow combination in the initialisation frame corresponds to an Initial Rate Control, i.e. indicates the highest rate for the first speech mode to be used in the direction of the Initialisation Acknowledgement frame.

After the out of band codec negotiation has been performed, if the originating side is a UTRAN, then on request from the MSC for a RAB Assignment, it shall initiate the Iu user plane. If the originating side is a network that does not support Iu Framing then the Iu Framing initialisation is initiated by the GMSC, as described in detail in Clause 6.7. An Initialisation Protocol Data Unit (PDU) shall be sent to the first MGW in the call connection. Each initialisation leg is acknowledged per TrFO Link, i.e. per MGW-MGW interface. The subsequent initialisation is performed using the same RFCI set as received from the preceding node, independently of the Stream mode directions (i.e. if the terminations are not through connected).

This is shown figure 5.4.2/1.

Figure 5.4.2/1: RFCI Storage and subsequent initialisation in MGW

When the MGW terminations are through-connected and the RFCIs at both terminations are matching, then the MGW may revert to transparent mode; the RNCs shall not perform any subsequent Iu Framing initialisations without explicit request by the serving MSCs.



All succeeding MGWs in the path shall behave in a similar way as described above.

### 5.4.3 RFCI Value Correction

At the terminating end of a TrFO connection with Iu Framing initialised to the terminating MGW, the originating RFCI allocation is stored. The terminating RNC is then requested to perform a RAB Assignment towards the terminating MGW. This results in an Iu Framing initialisation, where the allocation of the RFCI values is independent from the Originating RNC's allocation. These values may then be different to the originating RNC's set.

The terminating MGW shall acknowledge the Iu Framing Initialisation and compare the RFCI values stored from the originating side. If the allocated index values do not match, then the MGW shall perform one of the following procedures:

- 1) initiate an Iu Framing Initialisation PDU towards the terminating RNC with the RFCI allocation as defined by the preceding node (previously stored in the MGW. This behavior is shown in figure 5.4.3/1 and termed 'RFCI value correction') As the first Subflow combination received from the terminating RNC corresponds to an initial (maximum) rate control the MGW shall send a Rate Control PDU indicating this maximum speech mode back to the preceding node in the core-network.
- 2) map the RFCI indices of the incoming side to the corresponding RFCI indices at the outgoing side for all SDUs passed between the Iu Framing protocol terminations. As the first Subflow combination in the IuUP initialisation corresponds to an initial rate control, i.e. indicates maximum rate for the mode to be used (in direction of Initialisation acknowledgement frame) it is treated as the initial maximum rate control (see [4]) the MGW shall initiate a Rate Control PDU indicating this maximum speech mode toward the terminating RNC. Similarly as the first Subflow combination received from the terminating RNC corresponds to an initial (maximum) rate control the MGW shall send a Rate Control PDU indicating this maximum speech mode back to the preceding node in the core-network. For further details on the rate control see clause 5.7.

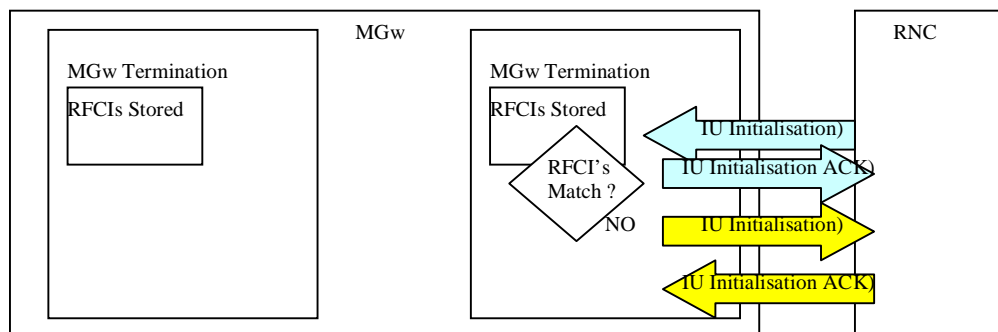

Figure 5.4.3/1:RFCI Value Correction

Further details of the TrFO call establishment are described in clause 6.

This resolution handling is required also during RNC relocation; further details are described in clause 6.

### 5.4.4 TrFO Break

The event and procedure when a TrFO connection must be interrupted at a certain point in the path, e.g. due to a supplementary service invocation or for handover/relocation, is termed "TrFO Break". A TrFO Break may occur at a MGW as a consequence of a command directed by the associated Server. During this period the Iu User Plane protocol is terminated by this MGW, in general at both sides of the MGW. This means that it must respond to new Initialisation PDUs and Inband Rate Control PDUs. The MGW inserts a TrFO Break Function, which then makes use of the stored RFCI values, in order to perform the required Iu Framing protocol functions and interpret the payload. Further call scenarios for specific services that incur a TrFO break are described in clause 6..

### 5.4.5 TrFO Break Recovery

During the TrFO break situation the individual connections are free to change, the RFCIs may have changed and also the rate control (maximum rate, current rate). After the service that caused the TrFO break is complete, the MGW shall

check if TrFO can be re-established. If the coding schemes are matching but the RFCI's have changed then RFCI value correction can be performed at the RNC side. In order to correct any changes in rate control between two RNCs, the MGW shall send a rate control request from each Termination, with the current rate and maximum rate applied at the other Termination. This will then result in the Distributed Rate Decision between the two RNCs in the call.

## 5.4.6 MGW Control Protocol Iu Framing Package properties

The following is a summary of the Iu Framing H.248 requirements; the procedures are described in [12] and are valid for Iu Framing in Support Mode:

### Additional Package Properties:

Iu Framing Termination Type: Values - Iu-RAN (Iu Framing Protocol on Iu Interface)

- Iu-CN (Iu Framing Protocol on Nb Interface)

Iu Framing Initialisation Procedure: Values – Incoming (For Iu-CN: the Iu Framing Protocol initialisation is received by the media gateway and used for subsequent initialisation from this MGW. For Iu-RAN this indicates the originating RNC interface).

- Outgoing (For Iu-CN the Iu Framing Protocol is generated by the core network MGW, i.e. initialised on the Nb Interface. For the Iu-RAN interface this specifies the terminating RNC Interface)

## 5.5 TrFO/TFO Codec Negotiation Harmonisation

When OoBTC procedures are initiated to a node where compressed voice cannot be supported (either at the node or to the preceding node) then a transcoder is inserted. This can be due to the transport technology (e.g. TDM) or due to the access technology (e.g. GSM). The OoBTC procedures can result in the following call scenarios:

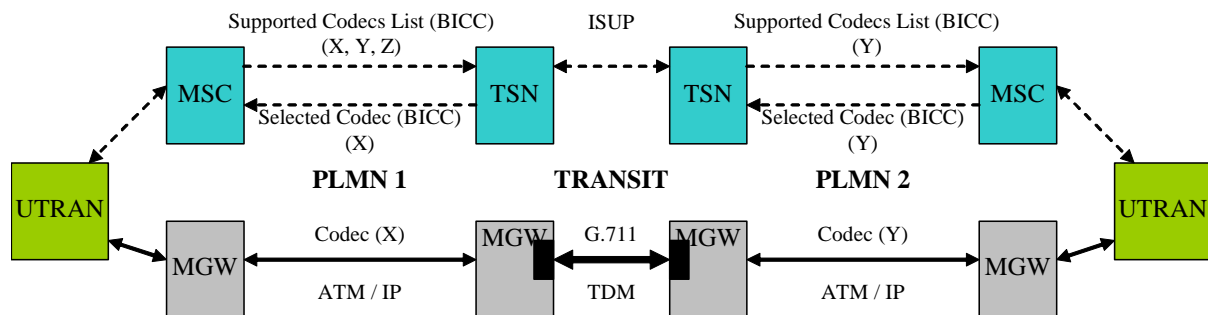

Figure 5.5/1: Cascaded TrFO & Transcoding

In Figure 5.5/ 1 the OoBTC cannot proceed as the call crosses a transit network that does not support compressed voice. The same could occur if the transit network did not support out of band codec negotiation (Support in BICC is optional).

In Figure 5.5/2 the OoBTC procedures result in the call terminating to a GSM access. As the GSM radio access transcodes to default PCM codec, the OoBTC results in default PCM selected. The reply is passed back to the originating network, which then inserts a transcoder from default PCM to AMR for the UMTS radio access.

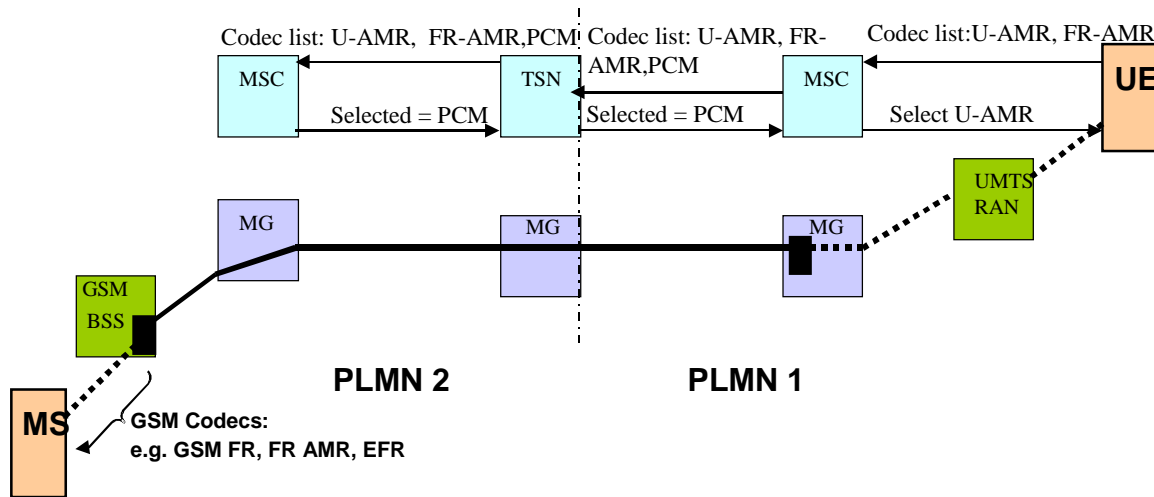

Figure 5.5/2: UMTS to GSM interworking

In a similar situation to that described in Figure 5.5/2, it is also possible that the OoBTC procedures result in UMTS\_AMR as the selected codec. In this case, the transcoder shall be inserted at the terminating MGW in order to transcode between PCM and UMTS\_AMR (as an example), and UMTS\_AMR shall be signalled back to the originating UE. Bandwidth savings and avoiding degradation in speech quality are then achieved in the core network.

For TFO to establish between the transcoders in the above scenarios, each TRAU must send a codec list inband after the call has been established. If a common codec type is available (determined by pre-defined rules, described in TFO specification [10]) then the OoBTC procedures need to be informed so that a codec modification can be performed. This is shown in Figure 5.5/3. Note – a modification could also be required when a common codec type has been selected but the ACS is not common.

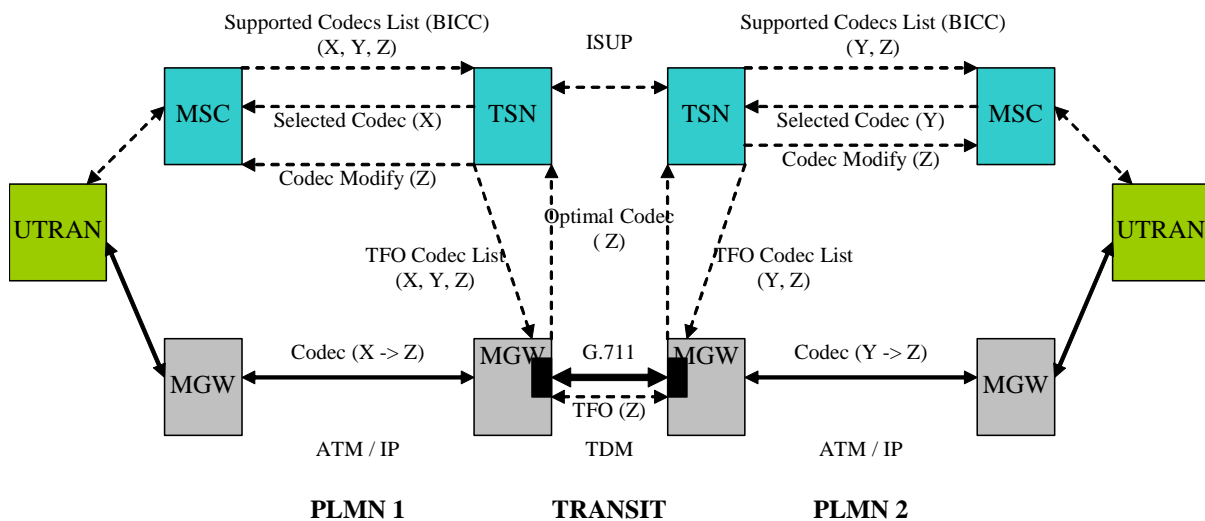

Figure 5.5/3: TFO support by OoBTC signalling

In H.248, the vertical MG control protocol, the coding types are specified by Media Stream Property, as defined by Annex C of H.248 specification. A specific package is used for TFO (see [12]).

The basic requirements are listed below:

- i) Property for TFO Codec List (same format as for [5])
- ii) Event for Optimal Codec, as determined by TFO in-band protocol
- iii) Event for Distant Codec List sent by the distant TFO partner
- iv) Procedures to define and enable TFO

The TFO package allows the Server to request the MGW to initiate the TFO in-band protocol towards a far end transcoder. The package includes a property to turn on/off the TFO (tfoenable); this may be required prior to TrFO break situations such as handover.

The TFO Codec List (H.248) is passed via the Mc interface from the Server to the MGW. The first entry of the TFO Codec List (H.248) shall be used by the MGW as the 'Local Used Codec'. The other entries of the TFO Codec List (H.248) shall be used by the MGW as '(Local) Codec List' in the TFO in-band negotiation (see [10]). For adaptive multi-rate codecs (AMR codecs) some control of the level of negotiation is performed by the "Optimization Mode" parameter in the respective Single Codec information element in the TFO Codec List (H.248) (see [5] and [12]). This allows a node to indicate if the offered ACS may be modified or not during TFO procedures, and this is mapped to the appropriate parameter in the TFO protocol by the MGW. If for a Single Codec information element in the TFO Package from the Server to the MGW the OM is set to "Optimization of the ACS not supported", then the TFO Negotiation shall not change the offered ACS of the respective Single Codec information element.

The MGW returns Notification Events for the Distant Codec List sent by the far end and the Optimal Codec Type as selected by the Codec Selection mechanism in TFO. The first entry of the Distant Codec List (H.248) is the 'Distant Used Codec' as received by the MGW during TFO in-band negotiations. The other entries of the Distant Codec List (H.248) are the entries of the '(Distant) Codec List' as received by the MGW from the distant TFO Partner (see [10]). The Server then compares the Distant Codec List (H.248) with its previously negotiated Available Codec List (BICC). If the lists are not the same then an OoBTC Codec List Modification or Mid-call Codec Negotiation may be performed. If for a Single Codec information element in the TFO Package from the MGW to the Server the OM is set to "Optimization of the ACS not supported", then the offered ACS of the respective Single Codec information element shall not be changed during OoBTC procedures.

## 5.6 CN Node handling of Codec Types & Codec Modes

### 5.6.1 Signalling between UE and MSC

The default Codec Type for 'R99 UMTS only' terminals is UMTS\_AMR, the default Codec Type for all terminals supporting GSM and UMTS radio access is UMTS\_AMR\_2, see [5] for the detailed description. The UMTS\_AMR\_2 is a superset of the UMTS\_AMR. It behaves as a FR\_AMR codec in the UL and as a UMTS\_AMR codec in the DL. This allows all UMTS terminals, except R99 UMTS only terminals, to operate in TFO with GSM terminals. The UMTS\_AMR\_2 is fully compatible with R99 CN nodes (TC in MGW). In any multi-mode configuration the UMTS\_AMR shall be treated as only TFO and TrFO compatible to itself, not to any other AMR codec Type, to avoid incompatibilities in TFO-TrFO-TFO interworking scenarios. In single mode configuration, UMTS\_AMR and UMTS\_AMR\_2 are TFO and TrFO compatible, when both codec types use the same single rate ACS, (see [10]).

During call setup, a UE supporting Rel-4 or later releases will indicate to the MSC the codecs supported by the UE in the Supported Codecs List (DTAP) (see [2]). For the codecs in this Supported Codecs List (DTAP), no order of priority is defined. If no Supported Codecs List (DTAP) is received from the UE and the UE is "UMTS only", then the MSC shall assume UMTS\_AMR as supported Codec Type. If no Supported Codecs List (DTAP) is received, but the UE is 'dual system', then the MSC shall assume UMTS\_AMR\_2 as the supported codec type. The MSC shall assume 'dual system' support only if the UE indicates at least one GSM speech version in Octet 3a etc. of the Bearer Capability.

### 5.6.2 Node originating the OoBTC codec negotiation

The node originating the OoBTC codec negotiation shall implement the procedures described in Q.1902.4, subclause 8.3.1 [6]. Additionally, the following applies:

In UTRAN, when constructing the codec configurations for AMR codecs in the Supported Codecs List (BICC), the MSC Server should take the codec types and codec configurations supported by the RNC or BSC into account (see subclause 5.6.6). The MSC may include more than one Single codec element indicating the same codec type, but different configurations, in the Supported Codecs List (BICC) (see [5]).

**NOTE:** This may be necessary if the RNC supports for an AMR codec different sets of codec modes, e.g., (a, b, c, d) and (e, f, g), which are not subsets of each other, and the RNC does not support combinations of these sets, e.g. (a, b, c, d, e, f, g).

For AMR codecs the originating CN node shall use the "Optimization Mode" parameter in the Single Codec information element in the Supported Codecs List (BICC) (see [5]) to indicate whether or not other nodes may change the offered ACS.

**EXAMPLE:** An RNC implementing only the prioritised RABs for interoperability testing specified in [15] will support for the UMTS\_AMR\_2 codec e.g. the set of codec modes (12.2, 7.4, 5.9, 4.75), but none of its subsets containing 2 or 3 codec modes. If the MSC Server connected to this RNC includes the codec configuration (12.2, 7.4, 5.9, 4.75) in the Supported Codecs List (BICC), it will therefore set the OM parameter of the respective Single Codec information element to "Optimization of the ACS not supported".

For AMR codecs, if the OM is set to "Optimization of the ACS supported", the originating CN node shall indicate the maximum number of codec modes (MACS) that may be selected for the ACS during speech codec negotiation. This maximum number of codec modes may depend on optimization strategies applied by the originating CN node. The recommended value is 4 (see [10]).

In order to support interworking with 2G systems it is recommended that MGWs support 2G EFR codecs (GSM\_EFR, PDC\_EFR, TDMA\_EFR). In order to avoid modifications during handover between 2G and 3G systems the MSC nodes may give preference to a suitable 2G codec.

Whenever one or several TrFO links have been already established and initialised, the CN node (e.g. the serving CN in case of Call Hold scenarios, the visited CN node in case of Call Forwarding scenarios, etc.) initiating a subsequent codec negotiation on a new call leg or a mid-call codec negotiation on an established and initialised TrFO link, should give the already negotiated Selected Codec (BICC), including its ACS, highest preference to reduce the probability of having to perform a bearer re-establishment or UP re-initialisation of the already established and initialised TrFO links.

### 5.6.3 Intermediate node

An intermediate node taking part in an OoBTC codec negotiation shall implement the procedures described in Q.1902.4, subclause 8.3.2 [6]. Additionally, the following applies:

If a Single Codec information element for an AMR codec is included in the Supported Codecs List (BICC), with the OM set to "Optimization of the ACS not supported", the intermediate node shall delete the Single Codec information element

- i) if the codec type is not supported; or
- ii) if one or more codec modes of the offered ACS are not supported.

If a Single Codec information element for an AMR codec is included in the Supported Codecs List (BICC), with the OM set to "Optimization of the ACS supported", the intermediate node

- i) shall delete the Single Codec information element, if the codec type is not supported;
- ii) shall delete codec modes from the offered SCS and ACS, if they are not supported. If the last codec mode is deleted from the offered SCS, the Single Codec information element shall be deleted from the Supported Codecs List (BICC);
- iii) shall reduce MACS to a locally supported value, if necessary;
- iv) may change the ACS to a different ACS within the offered SCS; and
- v) shall change the OM parameter from "Optimization of the ACS supported" to "not supported", if necessary.

NOTE: In interworking scenarios with TFO, step (iv) may prevent the establishment of an end-to-end tandem free and transcoder free connection; therefore, the intermediate node should not do this without a good reason.

During the processing of a Single Codec information element of an AMR codec with the OM set to "Optimization of the ACS supported", the intermediate node may replace the original Single Codec information element by two or more new Single Codec information elements, which can be derived from the original Single Codec information element by the steps (i) to (v) listed above.

#### 5.6.4 Node terminating the OoBTC codec negotiation

The node terminating the OoBTC codec negotiation shall implement the procedures described in Q.1902.4, subclause 8.3.3 [6]. Additionally, the following procedures apply:

The terminating node shall process the Supported Codecs List (BICC) as described for the intermediate note in subclause 5.6.3.

In UTRAN, when processing the codec configurations for AMR codecs in the Supported Codecs List (BICC), the terminating MSC Server should take the codec types and codec configurations supported by the terminating RNC into account (see subclause 5.6.6).

For the selection of the Selected Codec (BICC) from the Supported Codecs List (BICC), the following additional procedures apply:

If an adaptive multi-rate codec is selected, then the decision about the actual codec modes to be included in the selected ACS shall also be made by the terminating CN node. If the OM of the offered configuration is set to "Optimization of the ACS supported", the selected ACS may be different from the offered ACS, but it shall be a subset of the offered SCS and be consistent with MACS.

In order to provide harmonisation of out of band codec negotiation (for TrFO) and inband codec negotiation (for TFO) similar codec type and codec configuration selection mechanisms as those being defined for TFO should be applied for TrFO (see [10]).

NOTE: For TrFO codec negotiation, besides the speech quality additional aspects may be considered which are not applicable to TFO, e.g. the location of the transcoder that may need to be inserted or possible bandwidth savings in the core network.

If an adaptive multi-rate codec is selected, the terminating MSC Server shall exactly specify the ACS in the Selected Codec (BICC) and set the OM to "Optimization of the ACS not supported".

In the Available Codecs List (BICC), sent back to the originating node, the terminating MSC server may include more than one Single Codec information element indicating the same codec type, but different configurations. Single Codec information elements for adaptive multi-rate codecs may also be included with the OM set to "Optimization of the ACS supported" and the ACS being a subset of the SCS.

According to Q.1902.4, subclause 8.3.3 [6], the terminating node shall include the Selected Codec (BICC) in the Available Codecs List (BICC). For AMR codecs, the following applies:

If the Selected Codec (BICC) is an AMR codec, it shall be considered as included in the Available Codecs List (BICC), if the Available Codecs List (BICC) contains a Single Codec information element with the same codec type and

- exactly the same configuration, i.e. the same ACS and the OM set to "Optimization of the ACS not supported";  
or
- the Selected Codec (BICC) is consistent with the Single Codec information element, i.e. the selected ACS is a subset of the SCS of the Single Codec information element, the Number of codec modes in the selected ACS is less or equal to the MACS parameter of the Single Codec information element, and the OM of the Single Codec information element is set to "Optimization of the ACS supported".

## 5.6.5 Signalling between server and MGW

According to Q.1902.4, subclause 8.3 [6], during the OoBTC codec negotiation a server can provide its associated MGW with the preferred codec from the Supported Codecs List (BICC), and as a result of the negotiation the server will provide its associated MGW with the Selected Codec (BICC). The information is sent via the Mc interface as Codec (H.248).

If the Codec (H.248) is an adaptive multi-rate codec, the server shall exactly specify the ACS in the respective Single Codec information element and set the OM to "Optimization of the ACS not supported", both for the preferred codec and the Selected Codec (BICC).

For the Single Codec information elements of adaptive multi-rate codecs in the TFO Codec List (H.248), the OM may be set to "Optimization of the ACS supported", and the ACS may be a subset of the SCS. This applies also to the first entry in the TFO Codec List (H.248), the Local Used Codec.

NOTE: In some scenarios the flexible configuration of the Local Used Codec may be used for a faster TFO establishment (see [10]).

## 5.6.6 Signalling between MSC and UTRAN

The MSC Server shall know the codec types and codec mode configurations supported by the RNC. The MSC Server shall select only from these configurations for the RAB assignment.

When the MSC node requests a RAB assignment the Subflow Combinations provided shall either all be initialised by the RNC or all rejected with appropriate cause code.

The MSC shall always assume "Discontinuous Transmission (DTX)" as mandatory and shall define 'SID' SDUs in addition to the negotiated speech codec modes. This is because for TrFO the RAB requested by one RNC must match that requested by the peer RNC – they are effectively the same RAB. If one MSC requires DTX support then the RAB requested by the far end MSC must also support DTX (even if it is not desired by that MSC). As no Out Of Band negotiation for DTX is supported nor DTX control to the UE, DTX shall be mandatory for TrFO connections.

Once an adaptive multi-rate codec with an ACS has been selected as Selected Codec (BICC), the MSCs shall indicate in the RAB Assignment parameters [3] for the Guaranteed Bitrate the lowest speech mode in the ACS (assuming any SID frames are smaller than the SDU for lowest speech mode, otherwise the Guaranteed Bitrate shall be set to the largest SID frame). The Maximum bitrate shall correspond to the highest mode in the ACS.

## 5.7 Inband Rate Control

Inband rate control shall only allow the RNCs to set the maximum codec mode (maximum bitrate) from the set of codec modes that have been negotiated out of band. This procedure is called Maximum Rate Control. The final maximum mode selected results from a rate control request from one side and the maximum rate supported at the receiving side; the lower rate of these is selected. This is known as Distributed Rate Decision. In TrFO maximum rate control shall be supported through the Iu Framing protocol and through transit networks supporting compressed voice. The maximum rate control procedures are further defined within the Iu Framing protocol [4].

When the MSC requests for a RAB to be assigned, it shall always define 1 speech mode SDU (lowest rate), and DTX SDU as non-rate controllable. Other SDU formats for higher rates shall be defined as rate controllable. The first subflow combination in the IuUP initialisation shall be treated as an initial maximum rate control. Where a node is in TrFO break (e.g. the terminating MGW) this initial maximum rate control received at a given MGW/IuUP termination shall be signalled to the other TrFO link using the IuUP Rate Control PDU unless the IuUP Initialisation frame is to be sent on to the next link as in RFCI Value Correction (see clause 5.4.3).

At SRNS relocation the new RNC shall send a rate control frame at Relocation Detect indicating its current maximum rate, it will receive in the acknowledgement the current maximum rate from the far end. This procedure is called Immediate Rate Control. Again the distributed rate decision means both RNCs will operate within a common limit.

## 5.8 Modification Procedures

The OoBTC procedures shall support the following modification mechanisms:

- i) Modification of Selected Codec.  
(The codec type of the Selected Codec (BICC) may be switched to another type within the Available Codecs List (BICC), and/or the Active Codec mode Set of the Selected Codec (BICC) may be modified, and/or the Supported Codec mode Set of the Selected Codec (BICC) may be reduced.)
- ii) Modification of Available Codecs List  
(The Available Codecs List (BICC) may be reduced by removing codec types and modes)
- iii) Mid-call Codec Negotiation  
(The Available Codecs List (BICC) is re-negotiated, allowing the addition and removal of codec types and modes compared to the previous Available Codecs List (BICC), and a new Selected Codec (BICC) is chosen out of the new Available Codecs List (BICC))

The specific call flows when such procedures may be required are detailed in Clause 6. Further information on the Available Codecs List (BICC) and the Selected Codec (BICC) is provided in Section 5.2. Further information on codec types, codec modes, a Supported Codec mode Set and an Active Codec mode Set is provided in TS 26.103 [5]. The basic codec negotiation principles are defined by the BICC Call Control Procedures (see [6]) but the explicit Mc interface procedures are added.

### 5.8.1 Modification of Selected Codec

The codec modification procedures shall support the following changes:

- i) change of the codec type or codec configuration of the current Selected Codec (BICC) to another codec type or codec configuration within the Available Codecs List (BICC);
- ii) modification of the Available Codecs List (BICC) according to subclause 5.8.2, (i) to (v), in combination with any change of the codec type or codec configuration of the current Selected Codec (BICC) to another codec type or codec configuration within the new Available Codecs List (BICC). The modification of the Available Codecs List (BICC) may include removal of the current Selected Codec (BICC) from the list.

The procedures described in Q.1902.4, clauses 10.4.1 to 10.4.3 [6] shall apply.

The new codec type and codec configuration may be selected freely from the Available Codecs List (BICC). For an AMR codec, a codec configuration may be selected if it is considered to be included in the Available Codecs List (BICC) according to the criteria specified at the end of subclause 5.6.4.

For the coding of the new Selected Codec (BICC), the new Available Codecs List (BICC), and the new Codec (H.248), the same rules apply as specified in subclauses 5.6.4 and 5.6.5.

In Figure 5.8.1/1 and 5.8.1/2 the basic codec modification procedure is shown. This Figure is an example; the codec modification procedure may be initiated by any node within the call.

Upon Reception of a Modify Codec message (action 5 and 9 in Figure 5.8.1/1), a server node shall check if the Selected Codec is altered according to the criteria above. If the Selected Codec is not altered, the procedures in Section 5.8.2 (Modification of the Available Codec List) apply, otherwise the server node shall send a 'Reserve Characteristics' procedure to the attached MGW for the corresponding termination (action 6 and 10 in Figure 5.8.1/1)

To perform a modification of the selected codec at an Iu interface, the MSC server shall send a 'Modify Bearer Characteristics' procedure to the attached MGW (action 1 and 12 in Figure 5.8.1/1). Upon completion of the 'Modify Bearer Characteristics' procedure, the server node shall send a 'RAB Assignment Request' to the radio access network (action 2 and 13 in Figure 5.8.1/1). The MSC server shall then wait to receive a corresponding 'RAB Assignment Response' message from the radio access network (action 3 and 14 in Figures 5.8.1/2 and 5.8.1/3) before continuing the modification procedure.



An MSC server shall use the 'Reserve Characteristic' procedure for the termination towards the preceding node (with respect to the Modify Codec message) to perform the necessary bearer level modification. The MGW shall respond for that termination with the 'Bearer Modified' procedure to indicate that the possible bearer modification to increase bandwidth was successful. The MGW shall not wait until the Iu UP initialisation is complete before replying with the 'Bearer Modified' procedure. Each server shall not send forward the modify request to the succeeding node until the indication from its MGW that any necessary bearer level modification has been completed (BNC\_Modified notification). The MSC server shall use the 'Confirm Characteristics' procedure to confirm the modification at that termination.

An MSC server shall use the 'Modify Characteristic' procedure for the termination towards the succeeding node (with respect to the Modify Codec message) to confirm the codec modification.

The specific handling of the Iu UP initialisation is described in Section 5.8.4.

Error Cases are described in Section 5.8.5.

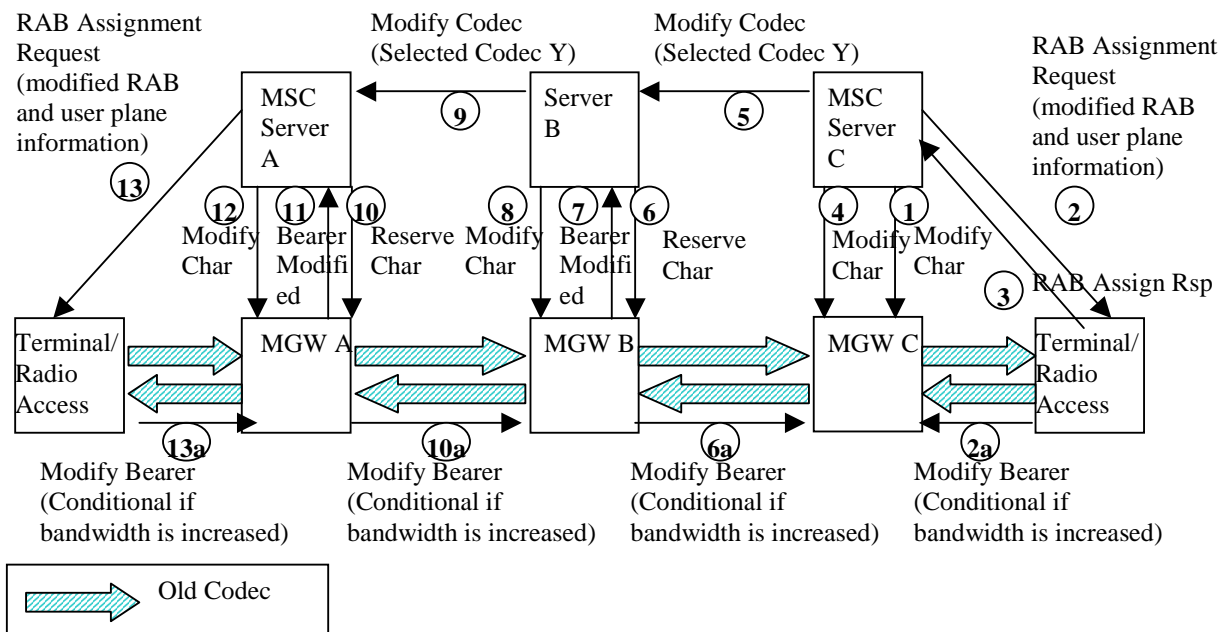

Figure 5.8.1/1: Codec Modification Control Procedures

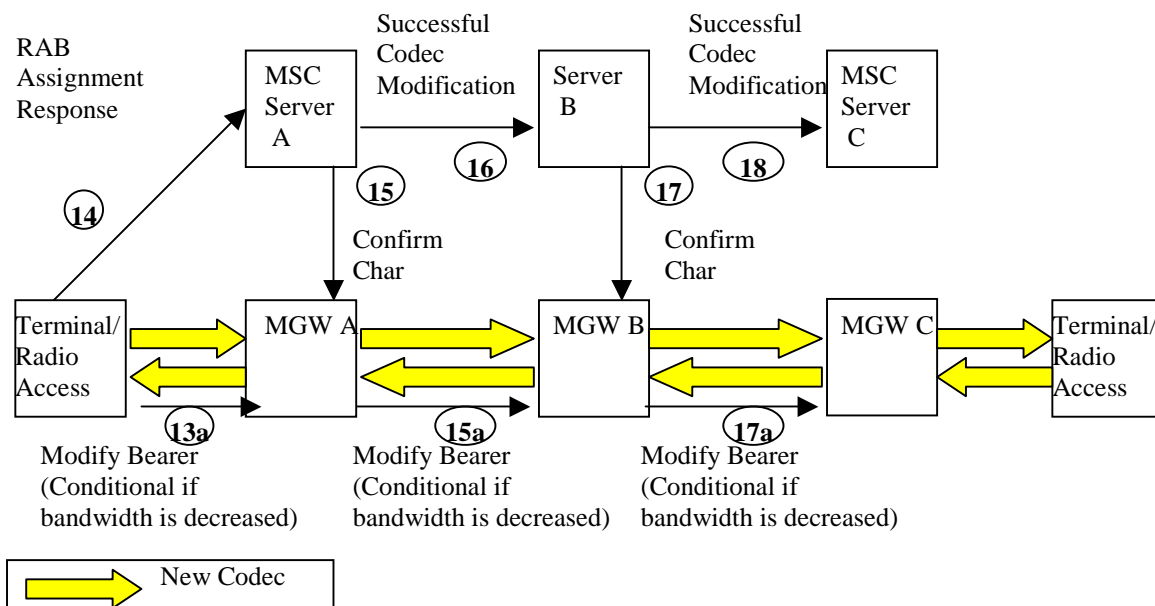

Figure 5.8.1/2: Codec Modification acknowledgement

## 5.8.2 Modification of Available Codecs List

The modification of the Available Codecs List (BICC) shall support the following changes:

- i) reduction of the ACS of any Single Codec information element in the Available Codecs List (BICC) for which OM is set to "Optimisation of the ACS supported";
- ii) reduction of the SCS of any Single Codec information element in the Available Codecs List (BICC) for which OM is set to "Optimisation of the ACS supported";
- iii) reduction of the MACS of any Single Codec information element in the Available Codecs List (BICC) for which OM is set to "Optimisation of the ACS supported";
- iv) change of the OM of any Single Codec information element in the Available Codecs List (BICC) from "Optimisation of the ACS supported" to "not supported"; and
- v) deletion of one or more Single Codec information elements from the Available Codecs List (BICC).

This shall not include the removal of the Selected Codec (BICC) or of modes from the ACS of the Selected Codec (BICC), as this would require a Modification of Selected Codec as described in 5.8.1.

The procedures described in Q.1902.4, clauses 10.4.1 to 10.4.3 [6] shall apply.

For the coding of the new Available Codecs List (BICC), the same rules apply as specified in subclause 5.6.4.

No modification of the user plane and signalling towards the MGWs and radio access network is required.

In Figure 5.8.2/1 the basic 'modification of available codec list' procedure is shown. This Figure is an example; the codec modification procedure may be initiated by any node within the call.

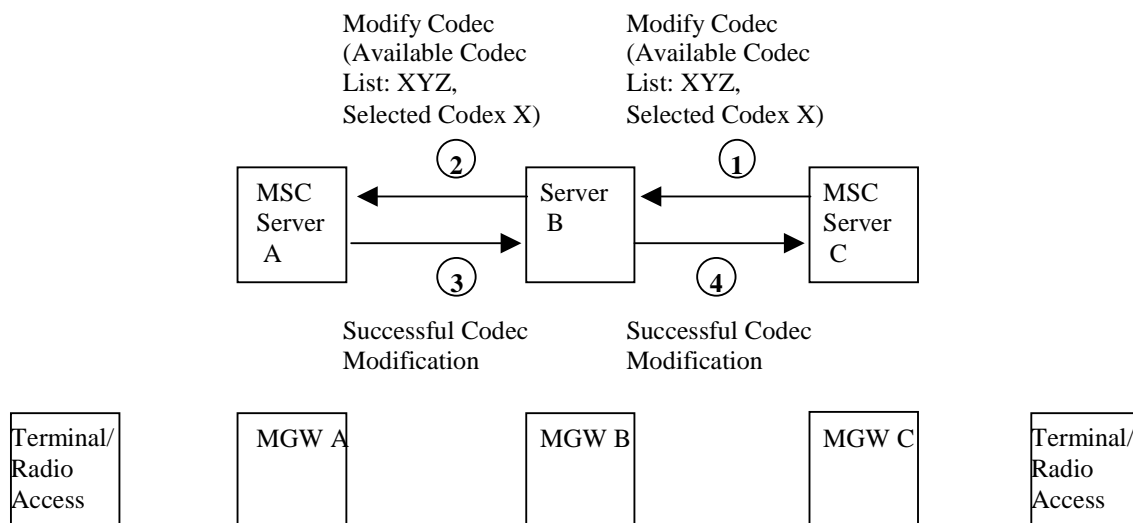

Figure 5.8.2/1: Modification of Available Codec List

## 5.8.3 Mid-call Codec negotiation

The Selected Codec (BICC) and the Available Codecs List (BICC) can be (re-) negotiated during the call using the 'Mid Call Codec Negotiation' mechanism. The Mid-Call Codec Negotiation mechanism results in a new Available Codecs List (BICC), where new codec types or modes not within the previous Available Codecs List (BICC) may be included. The codec negotiation procedure is performed as for call set-up.

The procedures described in Q.1902.4, clauses 10.4.4 to 10.4.6 [6] shall apply.

The sequence is shown in Figure 5.8.3/1. Starting with the Modify to Selected Codec message, the remaining sequence is the same as for the Codec Modification in Section 5.8.1 except that the message name for the modify request is 'Modify To Selected Codec' (instead of 'Modify Codec') in order to allow collisions between the two procedures to be resolved. Everything stated in Section 5.8.1 shall also apply for the Mid-Call Codec Negotiation procedure.

The node initiating the 'Mid Call Codec Negotiation' mechanism (MSC Server A in Figure 5.8.3/1) shall select a Preferred Codec and a Supported Codecs List (BICC), which may contain new codecs and also may not contain codecs from the previous Available Codecs List (BICC). If the list no longer contains the previous Selected Codec (BICC), then a new codec shall be selected as Preferred Codec. If the previous Selected Codec (BICC) exists within the Supported Codecs List (BICC), this codec should be selected as the Preferred Codec.

If a server node removes the Preferred Codec, from the Supported Codecs List (BICC), the node shall select a new Preferred Codec.

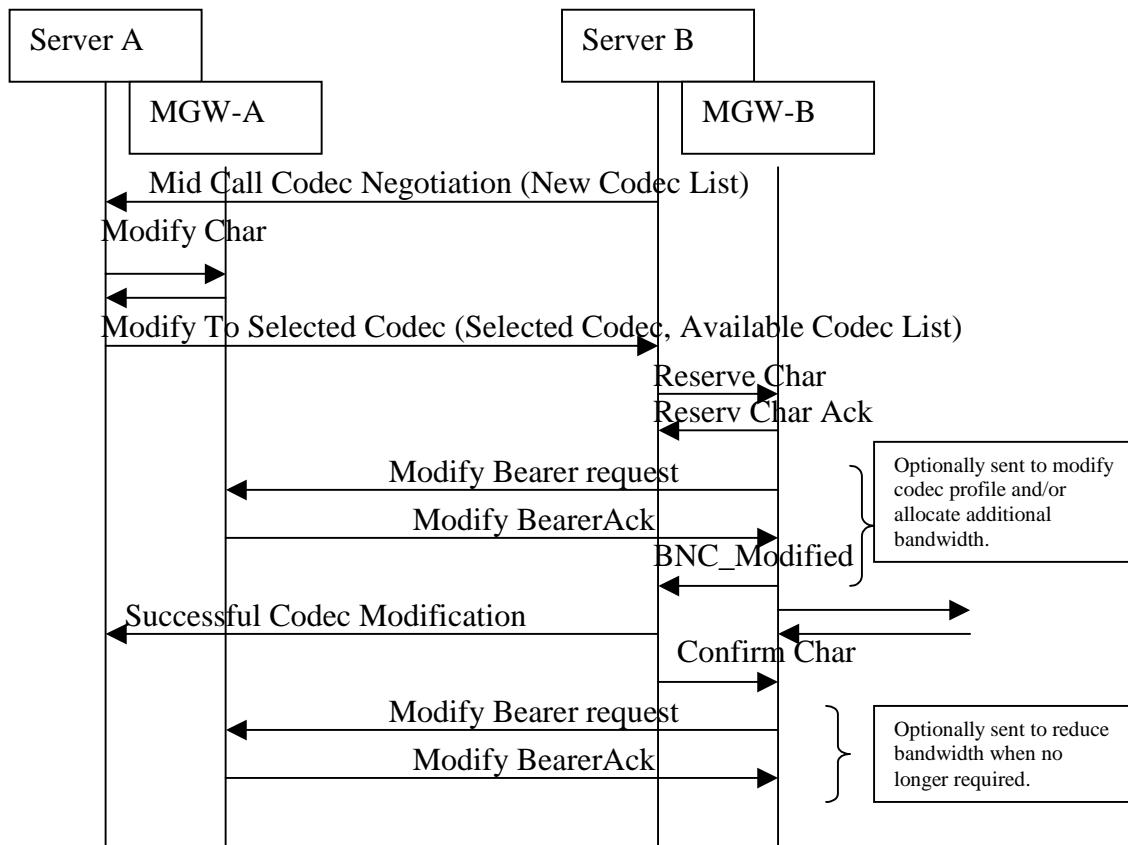
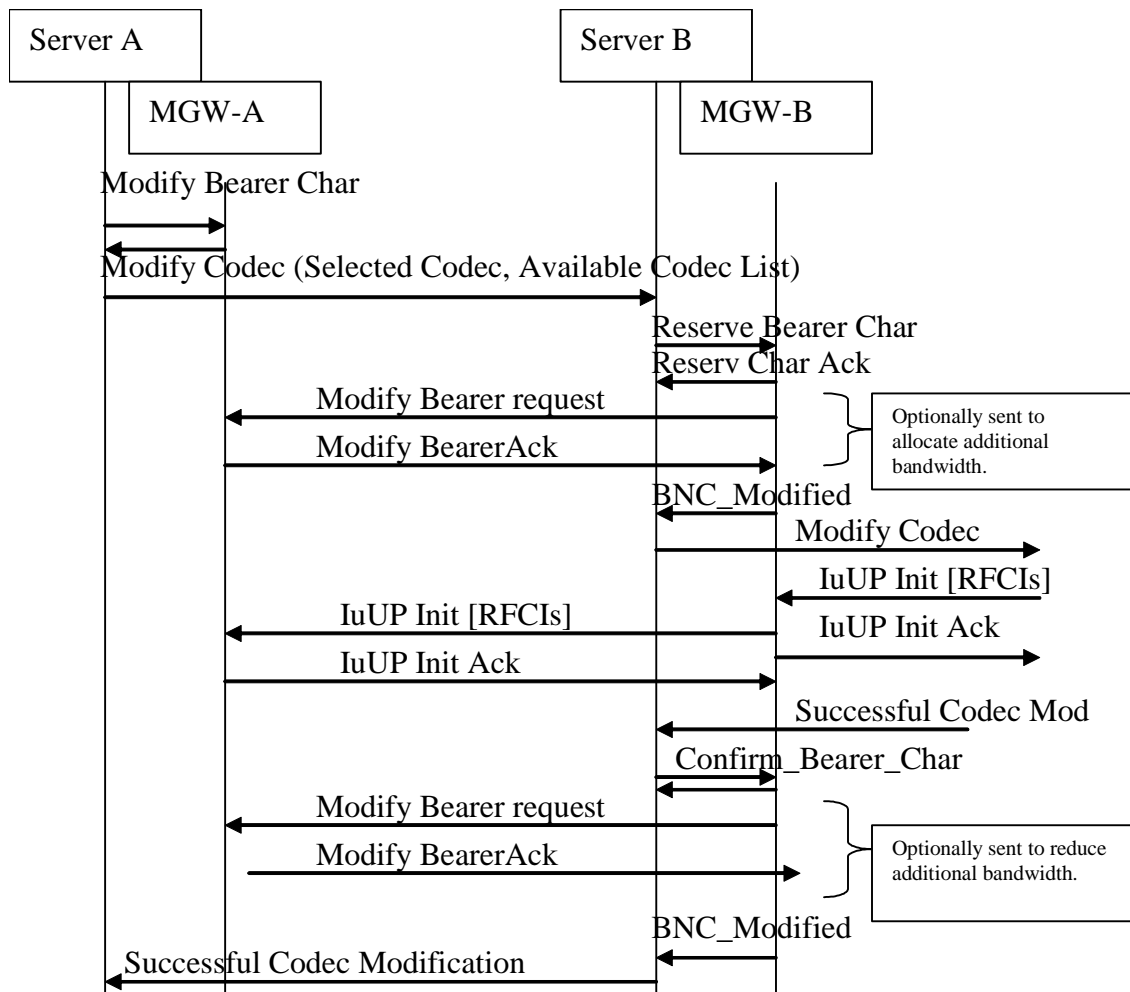

Figure 5.8.3/1: Mid Call Codec Negotiation

### 5.8.4 Detailed Procedures For Iu Framing Protocol & Codec Modification

The IuFP must be initialised sequentially from one end to the other in order to store new RFCIs in each node to allow TrFO to resume. The IuFP shall be initialised in the backward direction with respect to the Codec Modification/Modify To Selected Codec message as shown in Figure 5.8.4/1.



**Figure 5.8. 4/1: Successful Codec Modification including IuFP**

A MGW receiving a Modify Bearer Characteristics procedure shall be prepared to receive an incoming modify bearer procedure, this may be to increase the bandwidth prior to IuUP Initialisation or to reduce the bandwidth after the IuUP Initialisation. The new codec indicated in the Modify Bearer Characteristics procedure shall always result in the MGW being prepared to receive an Iu UP initialisation for the new codec, even if the SDU format is unchanged. The MSC shall send the RAB Parameters IE and NAS Synchronisation Indicator IE to the RNC to indicate that the codec has changed and IuUP Initialisation shall be generated.

Each termination receiving a Reserve\_Char will initiate bearer level modification to the preceding node if needed - i.e. if the bandwidth needs to be increased to support the new IuUP. No IuUP initialisation occurs at this point in time. If the Codec Modification Request is terminated by a MGW the IuUP init through the core-network is triggered by the setting of the 3GUP package property 'initialisation direction' to 'OUT' in either the Reserve\_Char or the Confirm\_Char procedure; the MGW shall then start the IuUP Initialisation out from that Termination. If the node terminating the modification is an RNC then it will generate a new IuUP Initialisation toward its access MGW, each Termination shall have the initialisation direction set to 'IN'. Each MGW shall in turn acknowledge the IuUP Init to the succeeding node (with respect to the modification request) and forward the RFCIs in an IuUP Initialisation to the preceding MGW (as for call set-up). After completing the Iu UP initialisation and receiving the 'Confirm Characteristics' procedure, the MGW may decrease the bandwidth of the corresponding bearer performing the 'Modify Bearer' procedure (if needed) - no bearer bandwidth reduction shall be initiated while the UP is still initialised for the old codec.

An example call sequence is shown in Figures 5.8.4/2 and 5.8.4/3.

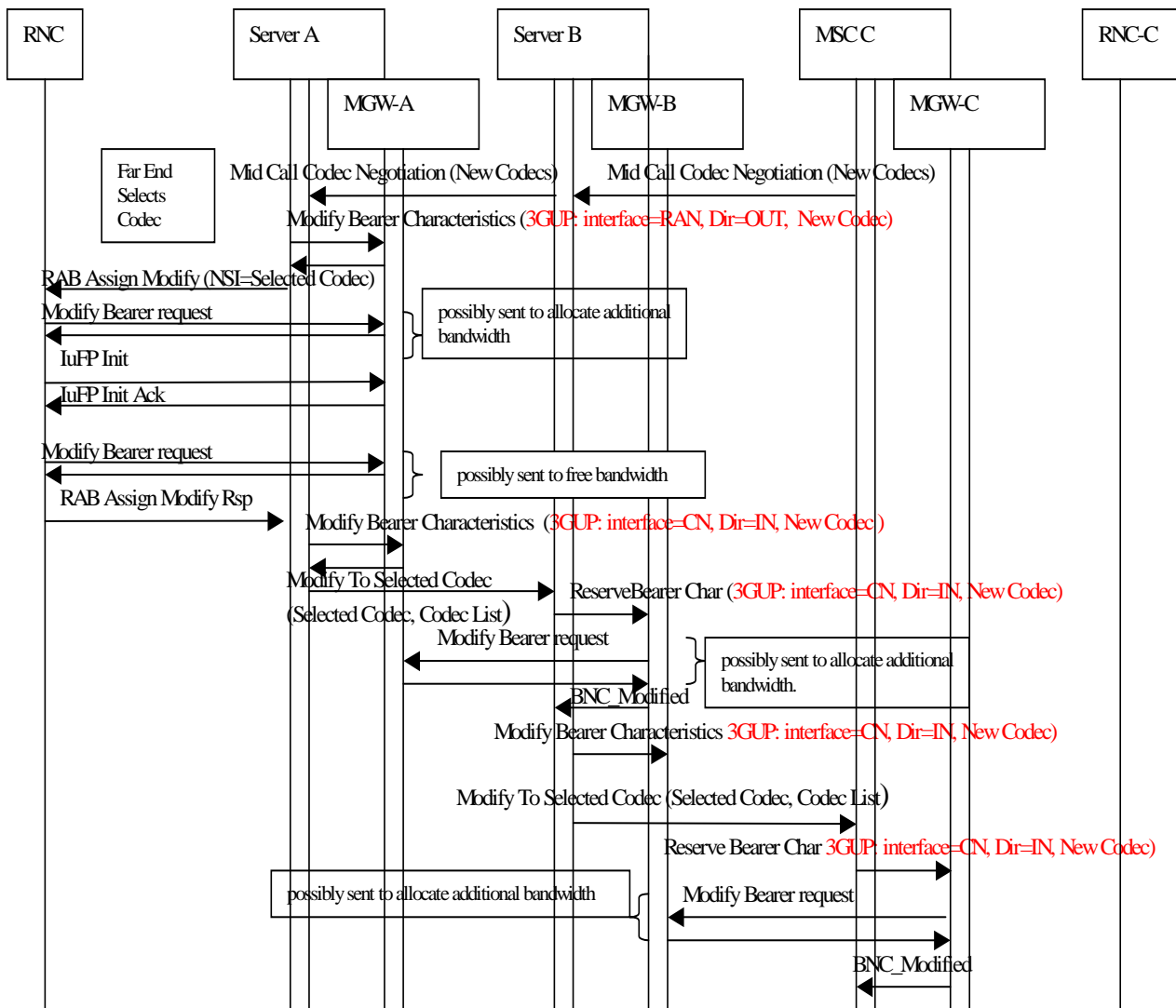

Figure 5.8.4/2: Mid Call Codec Negotiation Call Sequence. Call Flow Part 1

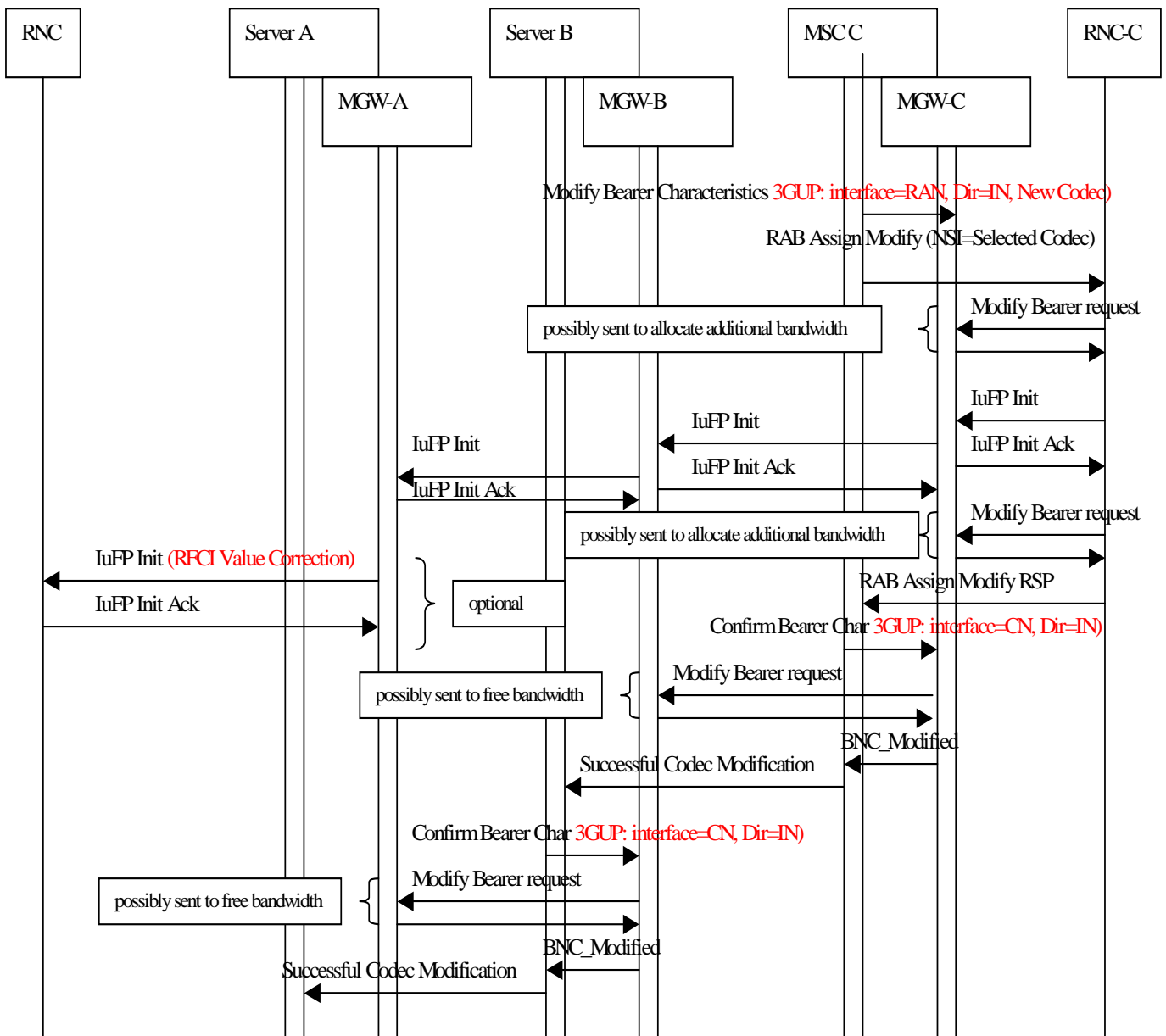

Figure 5.8.4/3: Mid Call Codec Negotiation Call Sequence. Call Flow Part 2

### 5.8.5 Unsuccessful Codec Modification

If the Codec Modification is unsuccessful at a certain node in the connection (due to the MGW rejecting a request to reserve the resources or a server rejecting the request to modify the codec) the Confirm\_Char message shall be sent to a termination that previously performed a successful Reserve\_Char Procedure to change the bearer back to its original bandwidth (if needed) and free up any reserved resources. However as the IuUP has not been modified, the Confirm\_Char shall not trigger an IuFP re-initialisation. The basic sequence is shown in Figure 5.8.5/1 and a detailed call flow is described in Figure 5.8.5/2. A server that performed a Modify Bearer Characteristics procedure to a termination with the new codec shall perform a subsequent Modify Bearer Characteristics procedure to that termination with the old codec in the failure case. As no IuFP initialisation occurs in the unsuccessful case the IuFP currently initialised will then match the old codec restored by the subsequent Modify Bearer Char; the MGW then knows that it can return to TrFO.

The Codec Modification Failure message shall not be returned to a preceding node until notification of the bearer level modification (BNC\_Modified).

#### RAB Assignment Modification Failure

If the reason for failed codec modification is due to an unsuccessful RAB Modification Request then the MSC shall assume that the old RAB is resumed and thus shall restore the old codec.

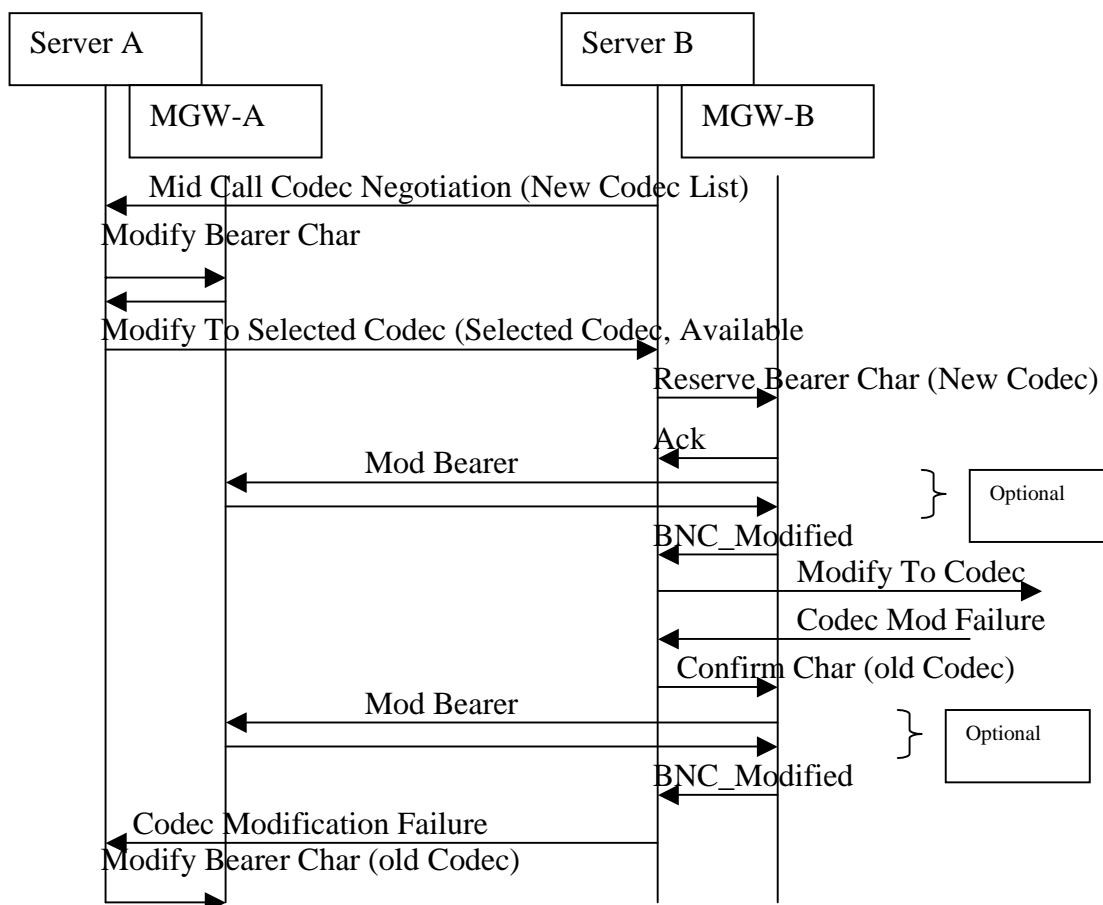

Figure 5.8.5/1: Unsuccessful Codec Modification

**IuUP Initialisation Unsuccessful**

If the IuUP initialisation fails (this must be due to some protocol error or transmission error because the resources have already been successfully reserved) then the UP protocol is cleared by the peers (see TS 25.415) and therefore the MGW shall notify the Server with a Bearer\_Released notification, the call shall be cleared (normal MGW initiated call clearing applies – see TS 23.205 clause 7.4 [8]).

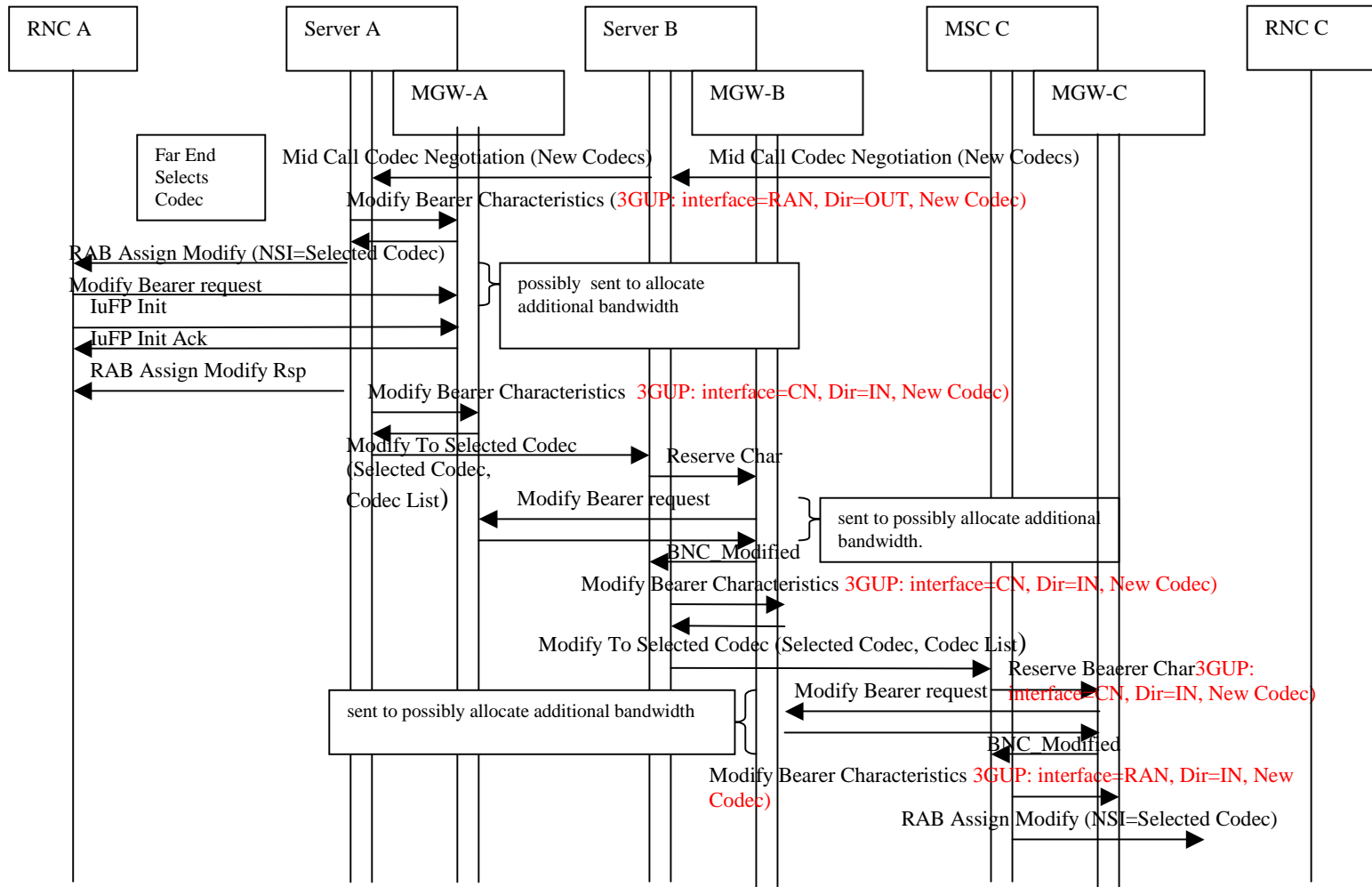

Figure 5.8.5/2: Call Sequence for Unsuccessful Modification. Call Flow Part 1



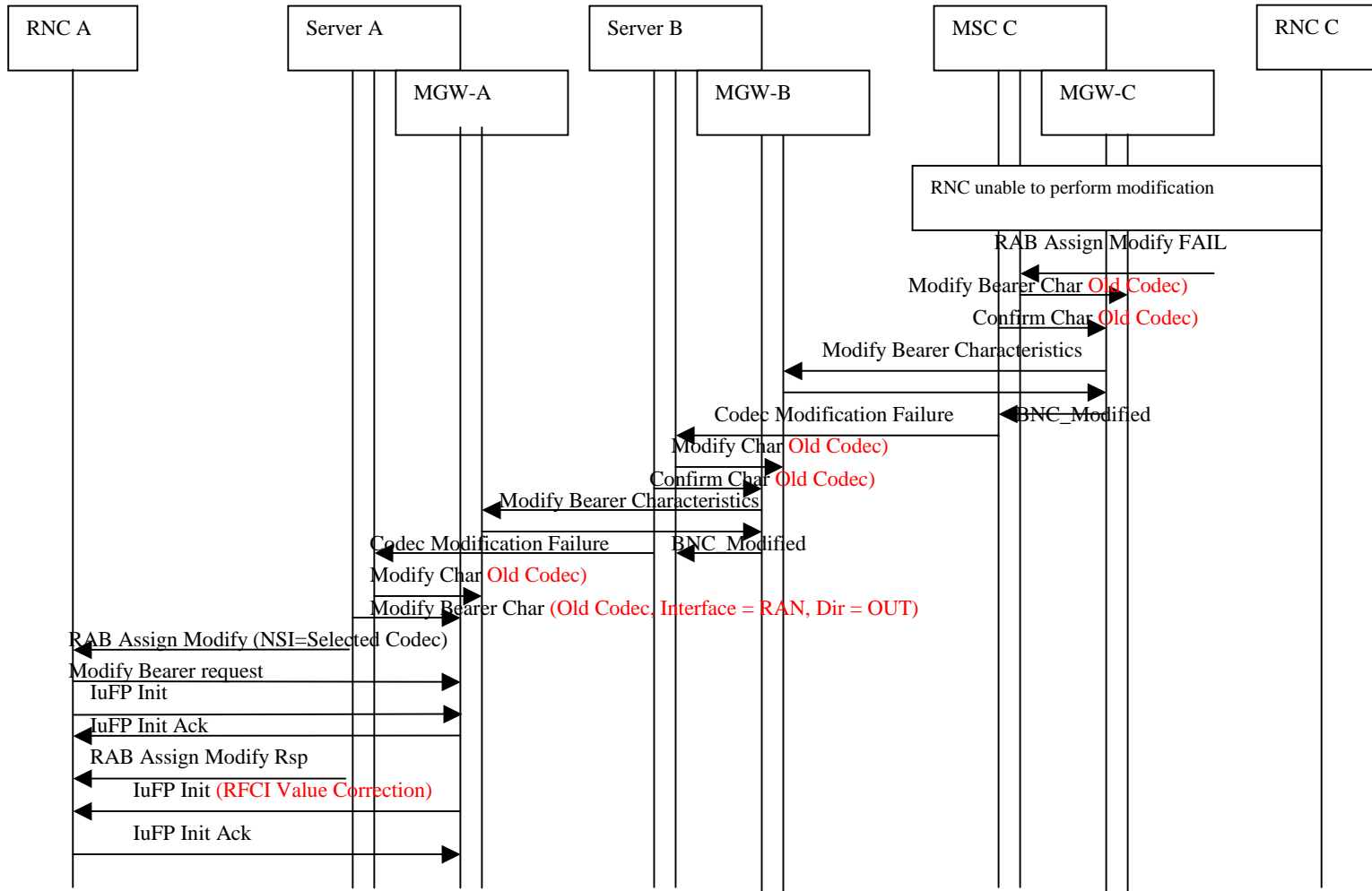

Figure5.8.5/2: Call Sequence for Unsuccessful Modification. Call Flow Part 2

## 5.9 DTMF Handling For TrFO Connections

DTMF from the UE is sent via DTAP procedures out-band. For a TrFO call the Originating MSC shall use an out-band DTMF procedure, all CN nodes shall support this procedure in their call control protocol. The out-band DTMF procedure shall also be used when TrFO is not achieved in order that TFO is possible. Insertion of DTMF in the PCM payload can result in the break of the TFO connection.

For terminating calls DTMF may need to be received by the core network (for voice-prompted services, voicemail control procedures etc). If the DTMF is received out-band then out-band procedures shall be maintained in core network.

If the DTMF is received for a TrFO call from an external network inband, in I.366.2 profile or RTP payload type, then the gateway MGW which interworks between Iu Framing and the external framing protocol shall report the DTMF tones via H.248 procedures to its server. The server shall then use out-band procedures to pass the DTMF through the CN. See Figure 5.9/1.

The same shall apply if a DTMF tone is received for a TrFO call from an external network inband in a PCM coded stream. The DTMF tone shall be detected by the MGW and reported via H.248 procedures to its server. In order to prevent duplication of DTMF tones due to subsequent PCM legs in the call, when encoding to compressed codecs the detected tones shall not be allowed to continue in the compressed stream; the DTMF Digits shall be deleted by the MGW before entering the speech encoding stage.

The MGW may also optionally pass DTMF inband where such an option exists for the Nb interface, and is supported by the proceeding MGW.

Transcoding to default PCM to send DTMF tones shall be avoided for TrFO connections.

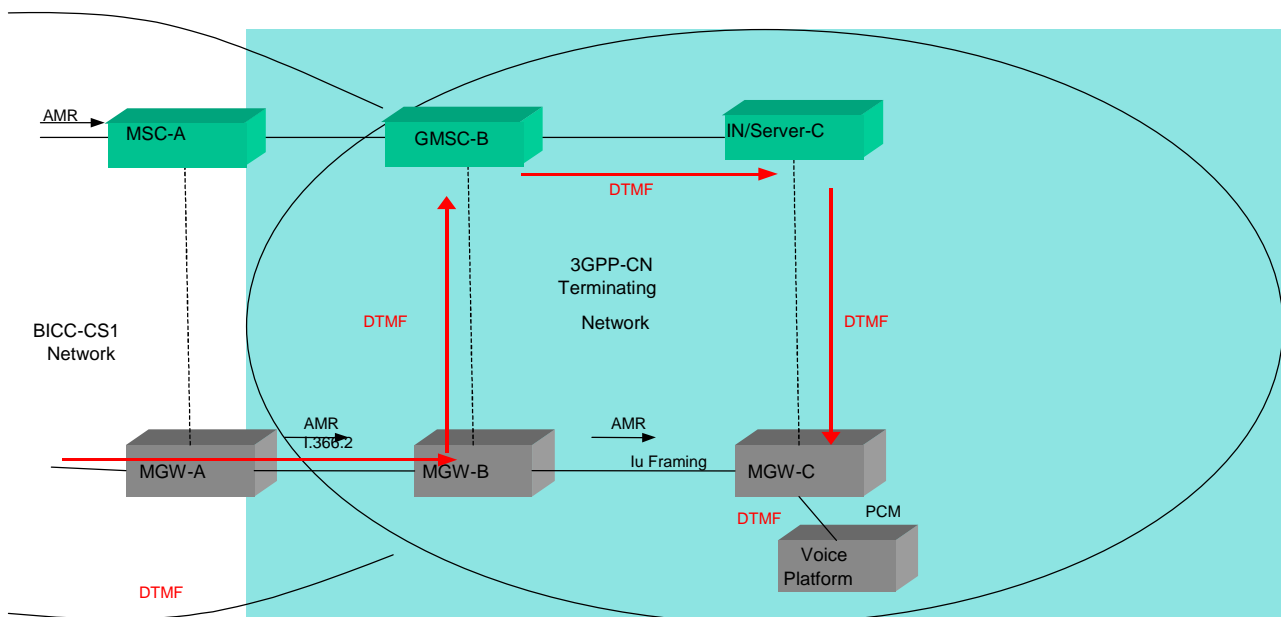

Figure 5.9/1:DTMF received inband from external network

## 6 Detailed Call Procedures

### 6.1 Mobile to Mobile TrFO Call Establishment

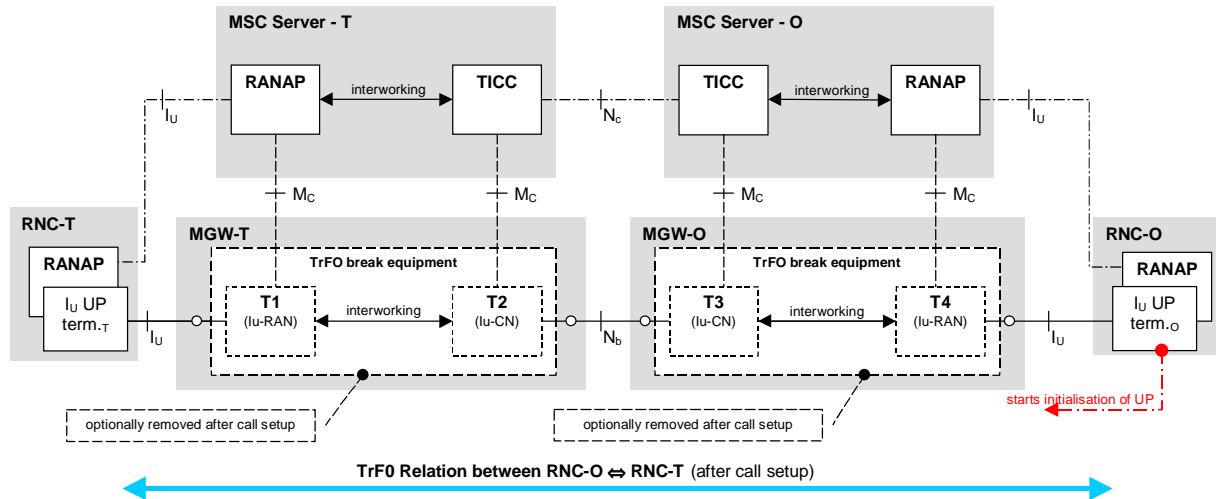

Figure 6.1/1: Configuration during Call Setup of a Mobile to Mobile Call

Following network and protocol entities are involved in the scenario, outlined in Figure 6.1/1:

**RNC-T, RNC-O:** terminating/originating RNCs.

**MSC Server-T, MSC Server-O:** MSC Servers, performing service, i.e. codec negotiation.

**MGW-T, MGW-O:** terminating/originating MGWs with the optional capability to insert/remove so called.

**TrFO break equipment (TBEs),** i.e. contexts containing an UTRAN- and a CN side I<sub>U</sub> Framing termination (**T1** – **T4**), inter-working in a distinct manner on control level. [Note: *context* is meant to be the H.248 specific throughout the document]. It is aimed to design protocols for TrFO in a way, that these pieces of HW can be removed after call setup phase to allow to revert to "simple" AAL2 switching in case of ATM transport.

**I<sub>U</sub> FP term.<sub>T</sub>, I<sub>U</sub> FP term.<sub>O</sub>:** Terminating- and originating-side TrFO peers (I<sub>U</sub> Framing terminations in RNC's in Figure 6.1/1).

**RANAP, TICC:** C-plane protocol incarnations, responsible for codec negotiation, controlling the respective interfaces (I<sub>U</sub>, N<sub>C</sub>), creating, modifying, removing etc. terminations and contexts.

The final configuration is (at least logically) an end to end TrFO relation between RNC-T and RNC-O with the option to remove the TBEs from the user data path, i.e. to revert to pure AAL2 switching in case of ATM Transport.

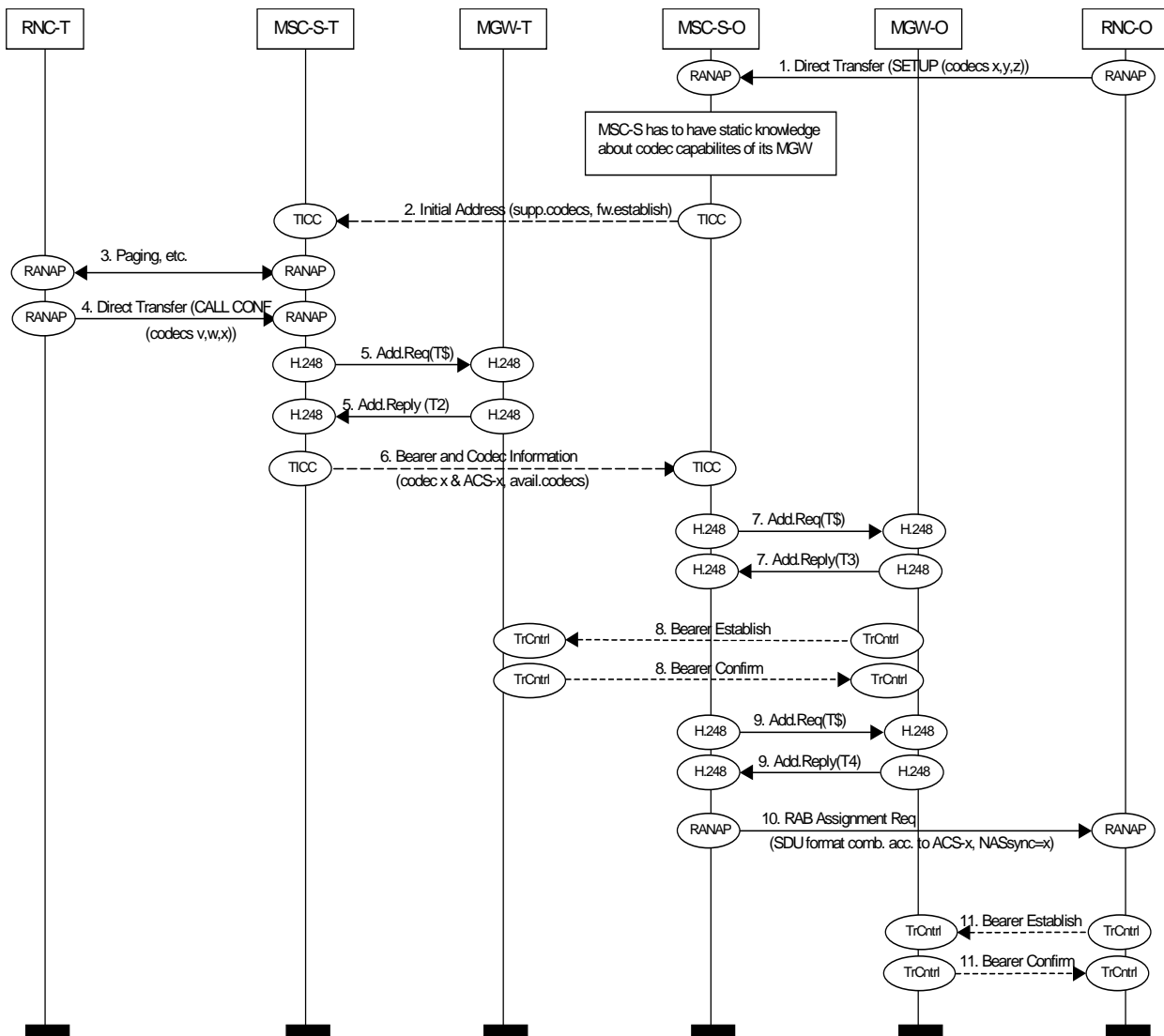

Figure 6.1/2: Call Setup. Mobile to Mobile Call. Message Flow part 1

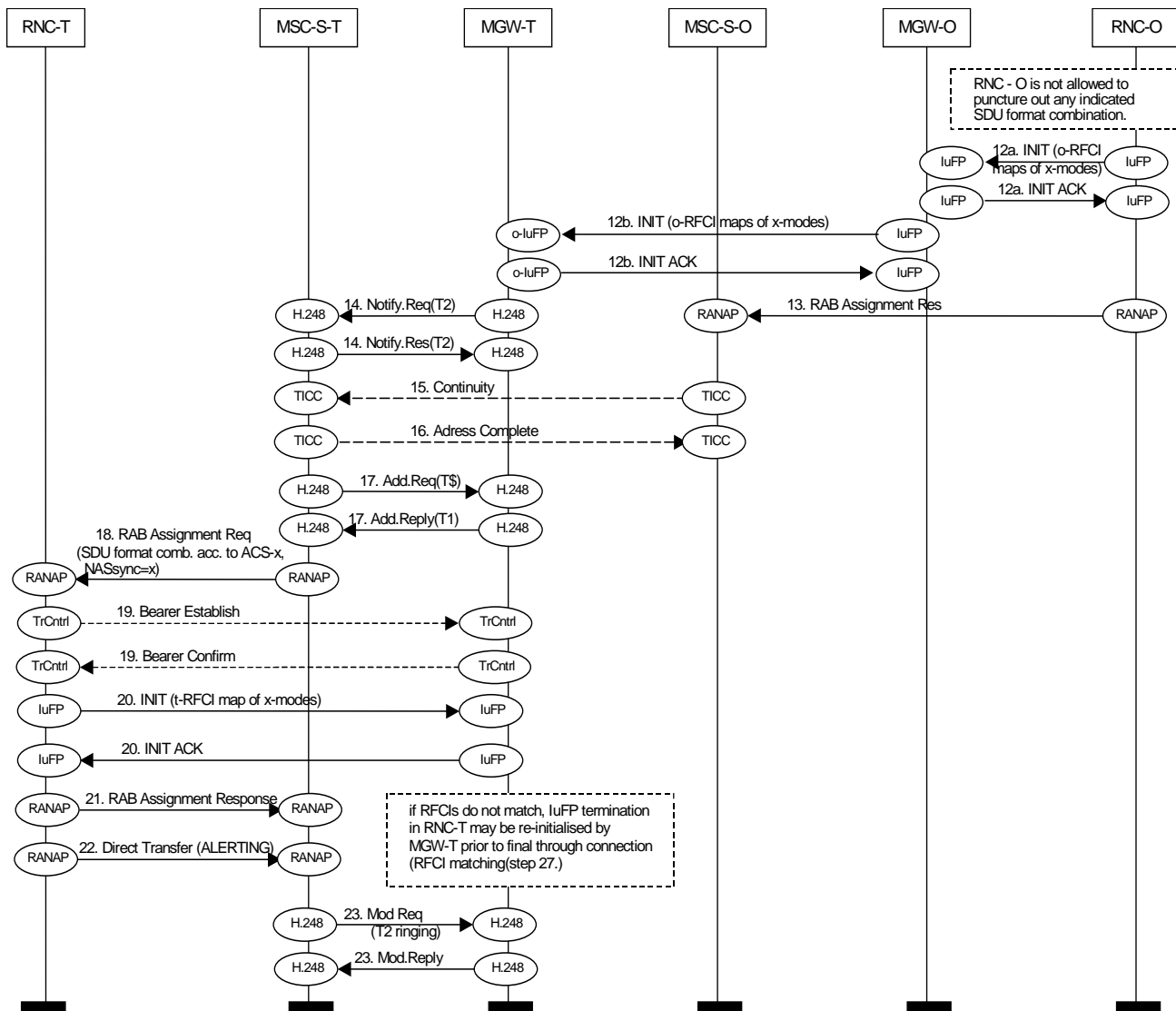

Figure 6.1/3: Call Setup. Mobile to Mobile Call. Message Flow part 2

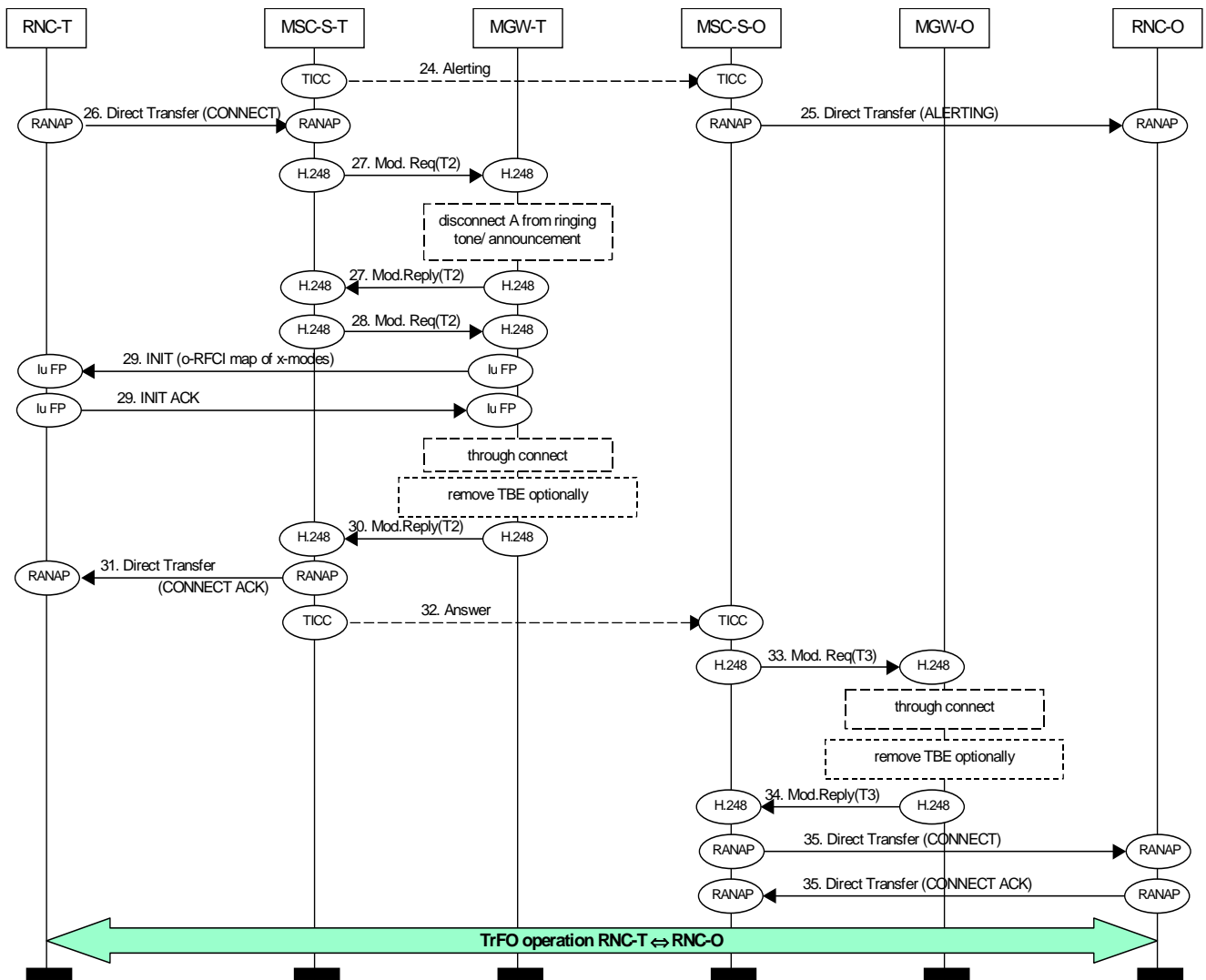

Figure 6.1/4: Call Setup. Mobile to Mobile Call. Message Flow part 3

**Codec negotiation**

Steps 1. to 6. give the codec negotiation phase. The mobiles inform the network about their capabilities (1. and 4.). Afterwards the MSC-Server performs codec negotiation according to clause 5.6.

**Network side bearer establishment**

MSC-T/MSC-O shall request seizure of network side bearer terminations with IuFP properties (see steps 5. and 7.). Intermediate CN nodes that may perform certain service interactions (e.g. IN nodes) have to seize terminations with IuFP properties as well.

**RAB Assignment**

RAN side terminations with IuFP property have to be seized (9. and 17.) before sending RAB Assignment (steps 10. and 18.), that contains RAB parameters according to the selected codec and the negotiated ACS. In addition, the respective NAS synchronisation indicator shall be included.

**6.2 SRNS Relocation during TrFO**

In order to maintain TrFO connection in SRNS Relocation, procedures specified in [8] and [11] for "Intra-MSC SRNS Relocation" shall be followed. Note that the "Intra-MSC SRNS Relocation" procedure can also be used for relocation between RNCs connected to different 3G MS's.

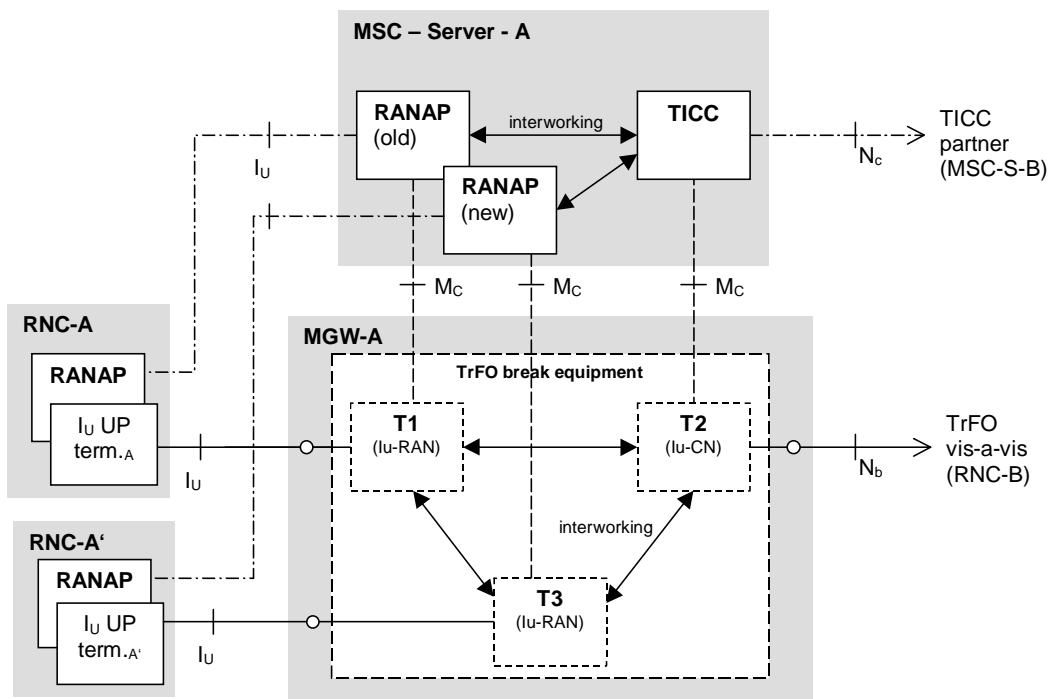

**Figure 6.2/1: Configuration during SRNS Relocation**

Figure 6.1/1 shows the configuration during relocation. After setting up the new I<sub>U</sub> interface (towards RNC-A') until releasing the old one, the original TrFO relation (A↔B) and the target TrFO relation (A'↔B) exist in parallel. Within the respective context (TBE) interworking between T1, T2 and T3 is necessary:

T3 will perform initialisation towards RNC-A'.

T2 will hide initialisation performed on I<sub>U,A'</sub> from RNC-B.

If the option to remove the TBE was applied after call setup, the whole context (TBE) needs to be inserted prior to performing SRNS Relocation. Initialisation data need to be available within MGW-A. After Relocation, the context (TBE) may be removed again, i.e. the MGW-A again acts as a pure AAL2 switch.

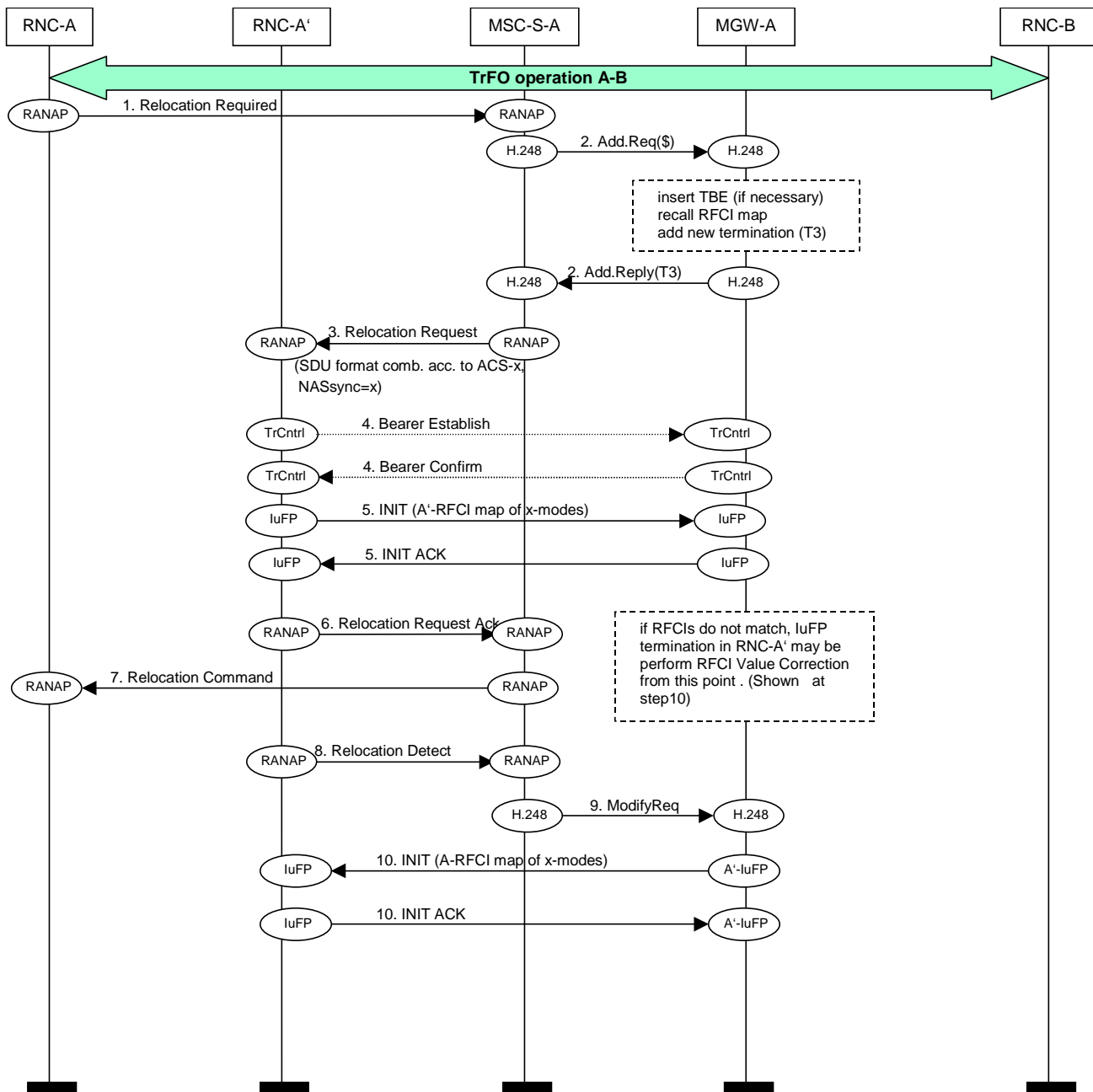

Figure 6.2/2:SRNS Relocation and TrFO. Flow chart part 1



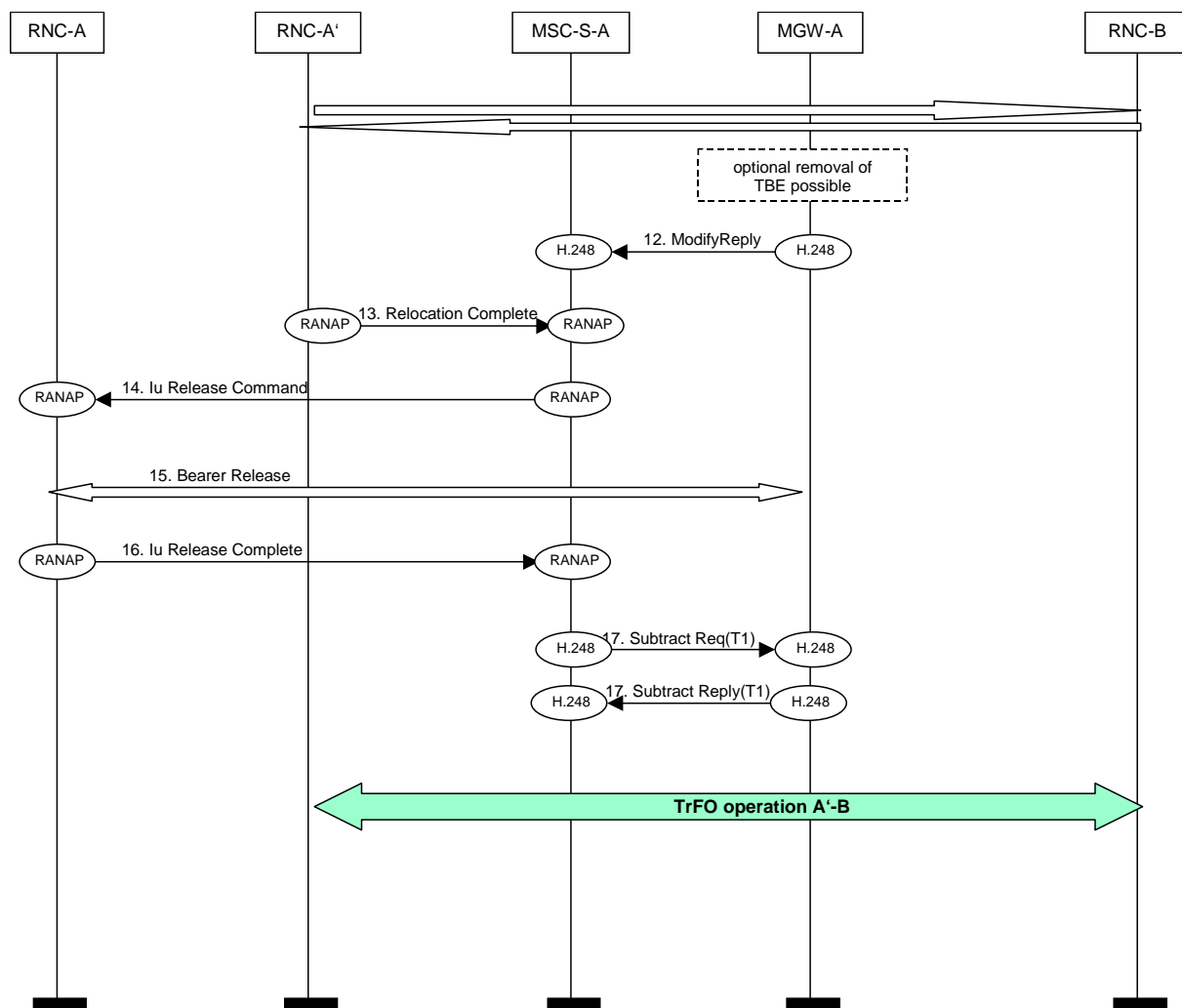

Figure 6.2/3 SRNS Relocation and TrFO. Flow chart part 2

**RAB Assignment on the new Iu leg:**

A RAN side terminations with IuFP property (T3) has to be added to the already seized call context (step 2.) before sending Relocation Request (4.), that contains all the RAB parameters already applied on the Iu leg towards RNC-A.

**UP initialisation**

RNC-A' shall accept the requested set of codec modes and is not allowed to puncture out any negotiated mode. The INIT frames shall be according to the RAB parameters received.

At reception of an INIT frame from the new RNC, the termination at MGW-A shall not perform forwarding of the IuFP initialisation. The MGW shall check whether the received RFCI allocations match the stored RFCI allocation. If it does not match, it may re-initialise the IuFP towards RNC-A' at this point in time.

**Removal of TrFO Break Equipment (TBE)**

If the MGW supports the removal of TBEs, it shall insert the TBE before seizing the additional termination. It may again remove the TBE after performing RFCI matching and through-connection of the new termination and the termination to the far end party.

**6.3 IN and Call Forward SS**

In some cases, IN services (e.g. voice prompting) are triggered at CC-IN nodes that require the establishment of an UP bearer for tones or announcements to be sent to the calling party. In order to establish this bearer, it is necessary that the CC-IN node temporarily selects one codec from the codec list sent from the initiating node, and informs the initiating node about the selected codec. Afterwards, the call may continue its establishment to the another node, which may not support the selected codec but requests that another one in the list be selected instead.

A similar situation arises with the CFNRy supplementary service. A UP connection needs to be established between the originating and "provisional" terminating CC nodes to enable ringing tones to be sent to the calling party. The type of codec must be agreed prior to the establishment of the bearer connection. Afterwards, the call is redirected to another node that may not support the selected code but requests the selection of another one.

### 6.3.1 TrFO interworking with SS (VMSC = service interworking node)

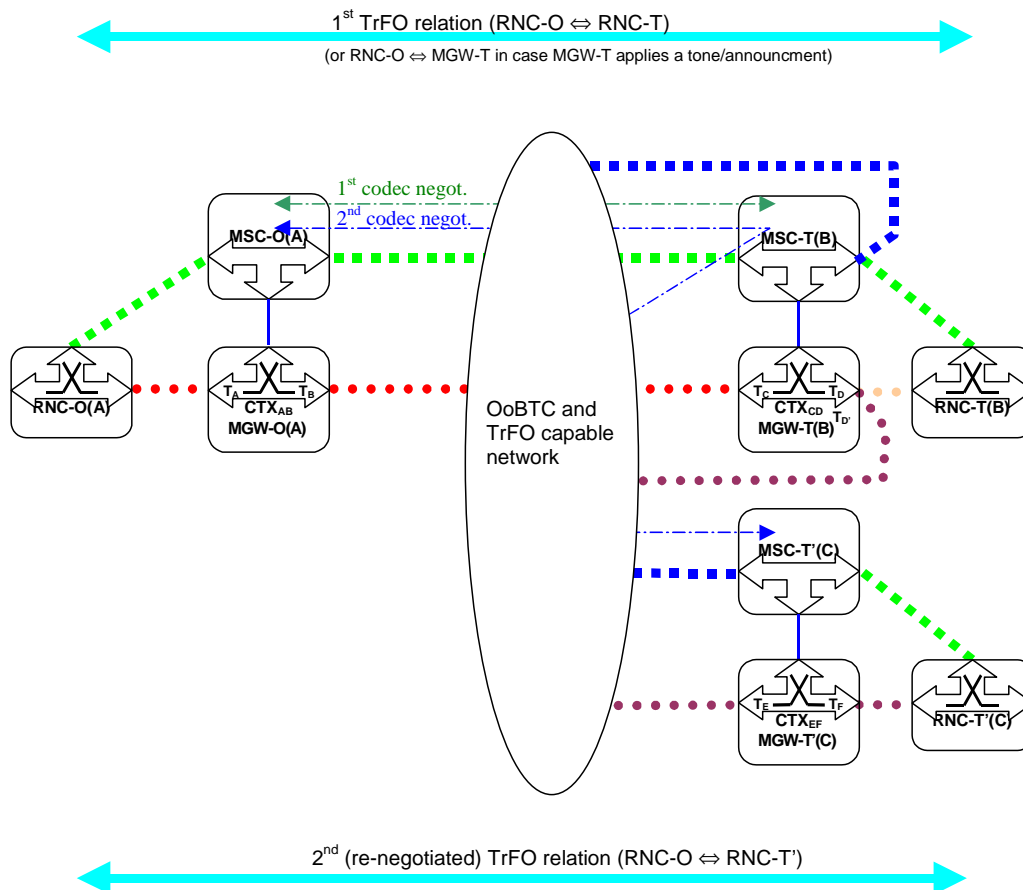

**Figure 6.3.1/1. Codec Modification in case of SS interworking**

In case of supplementary service interworking, it may become necessary to apply codec modification out of band. Figure 6.3.1/1 shows the network model, that may apply for a certain set of SS's (call deflection (CD), call forwarding on no reply (CFNRy), CF on user determined busy (CFUB), etc.). Common to these scenarios is:

- the service interworking is controlled by the VMSC (this is common to all SSs).
- MSC-T extends the call towards MSC-T' according to the forwarded-/deflected-to-number.

An intermediate TrFO relation will in general already exist between two RNC's (RNC-O and RNC-T in figure 6.3.1/1) before the call is diverted to another node, as the ringing tone was applied in backward direction.

In order to perform codec negotiation with the third node (MSC-T') as well it is necessary to forward the supported codec list from MSC-O. MSC-T' signals back the codec it selected and the available codec list. If the codec negotiation result is different from the previously performed codec negotiation between MSC-O and MSC-T, MSC-O shall be informed. MSC-O shall be able to decide based on the received modified codec type whether In Framing re-initialisation and bearer modification is required. This scenario is depicted in Figure 6.3.1/2 below. If no codec modification has to be applied, MSC-T(B) shall extend the UP initialisation towards MSC-T'(C), i.e. MSC-T(B) shall initialise a termination (TC) with the property Initialisation Procedure = incoming. MSC-T' (C) shall also initialise a termination TC with the property Initialisation Procedure = incoming. Further call handling follows the mobile to mobile call establishment (see clause 6.1).

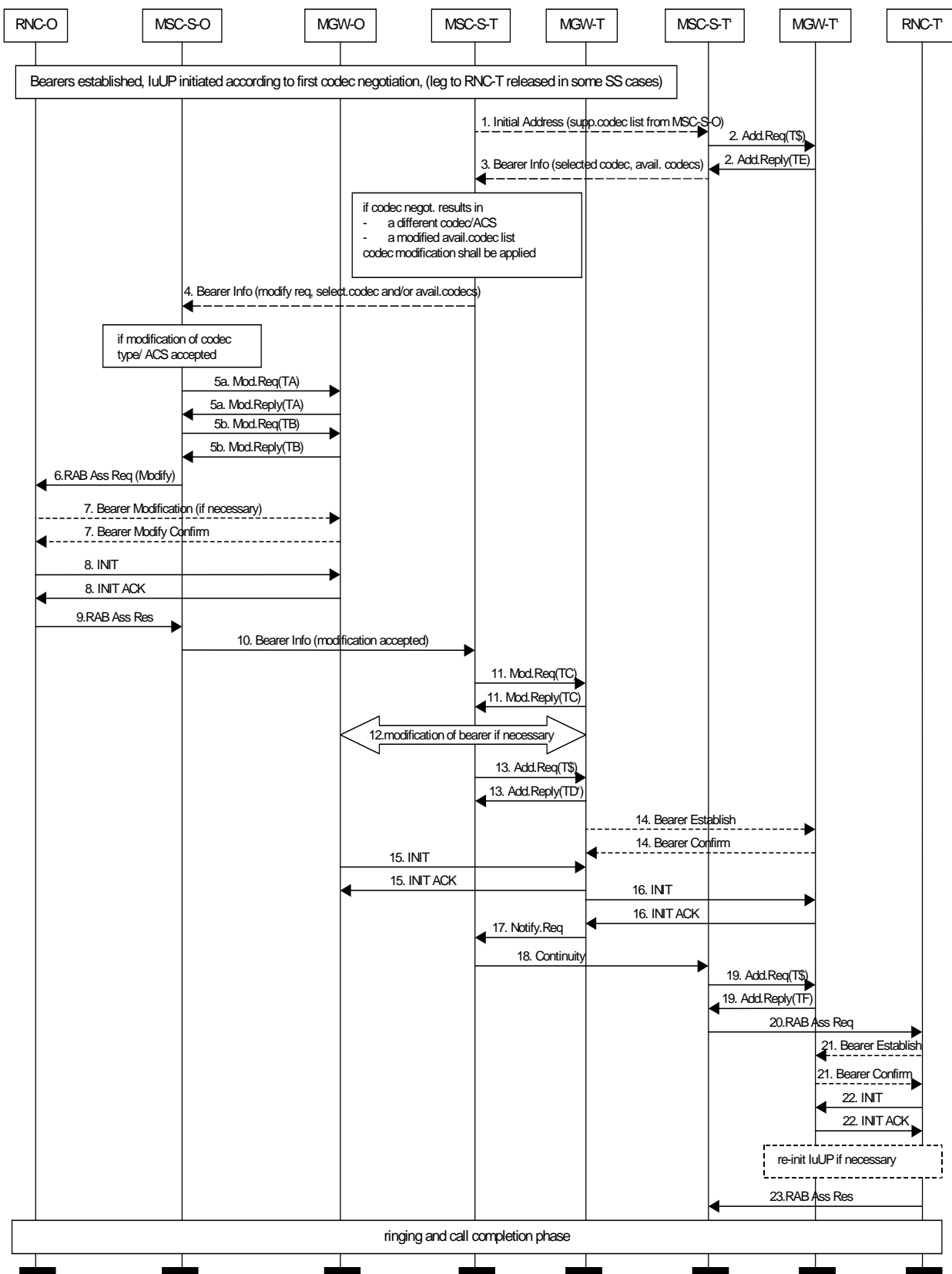
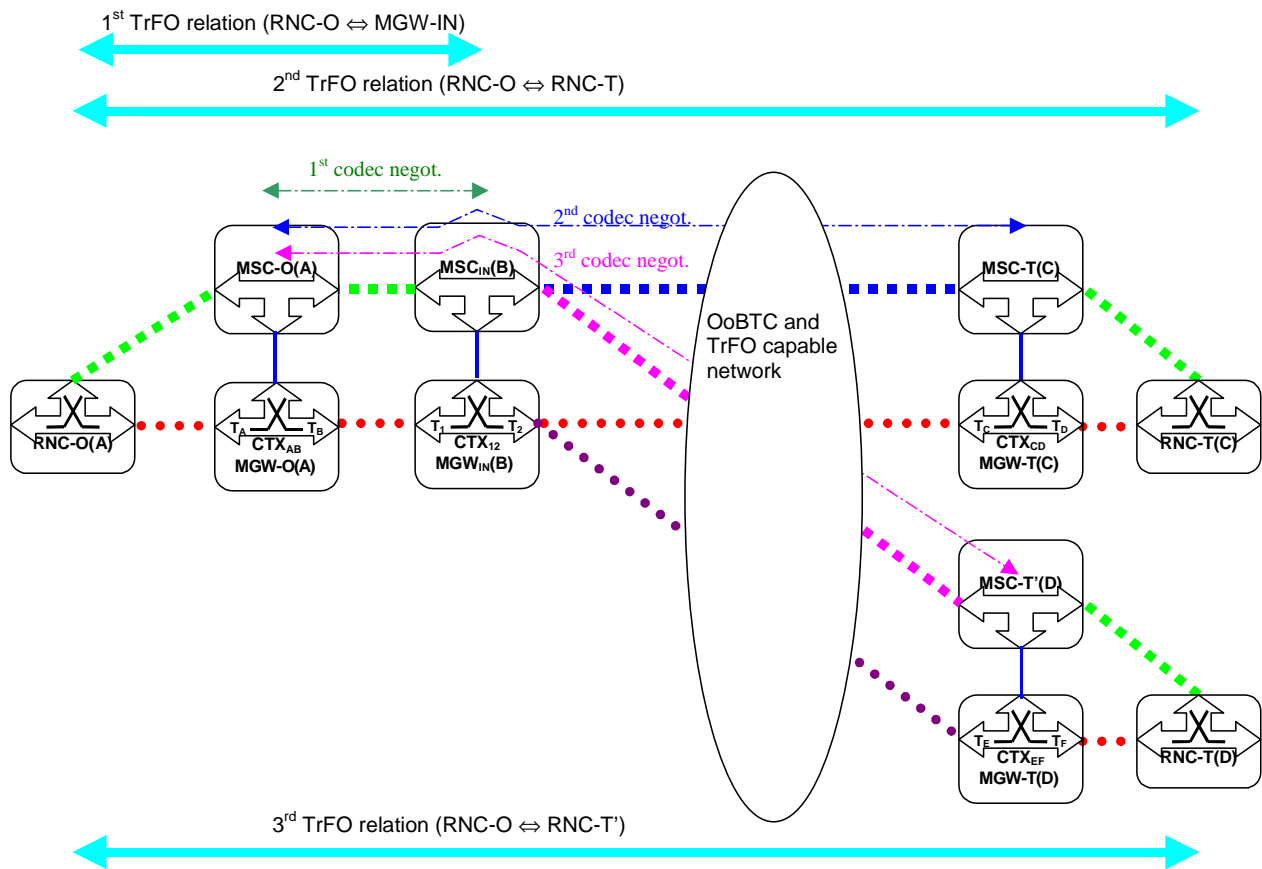

Figure 6.3.1/2: Codec Modification for SS-interworking & UP re-initialisation

### 6.3.2 IN interworking (VMSC ≠ service interworking node)



**Figure 6.3.2/1. Codec Modification in case of IN interworking**

Common to IN interworking scenarios is that service interworking is controlled by an IN service node that is generally not the VMSC.

IN interworking (i.e. in case of a separate IN service node, this is often a Gateway-MSC) may interrupt call establishment and apply an intermediate announcement back to the originating side. This means, that codec negotiation was in fact performed between the IN service node and the MSC-O.

When performing further call establishment, it is necessary to proceed with codec negotiation towards MSC-T. The codec negotiation process shall consider the capabilities of MGW-IN.

IN services, similar to call forwarding SS, are possible. The fact that this service interworking is controlled by an IN service node, may cause, that the leg towards MSC-T has to be released and a new leg towards MSC-T' will be established. Codec negotiation is again necessary from MSC-IN on.

The sequence chart given in figure 6.3.1/2 applies in principle for the 1<sup>st</sup> and the 2<sup>nd</sup> negotiation scenarios with following modifications:

- as MSC-IN may be involved in subsequent service interworking again, the capabilities of MGW-IN shall be taken into account during codec negotiation with MSC-T or MSC-T'. This means, that the codec list forwarded to the succeeding nodes is in fact the available codec list of the 1<sup>st</sup> negotiation.
- For the 3<sup>rd</sup> negotiation scenario, the leg between MSC-IN(B) and MSC-T (C) has to be released and a new leg toward MSC-T'(D) has to be setup.

## 6.4 Information flow for interaction with Multiparty SS

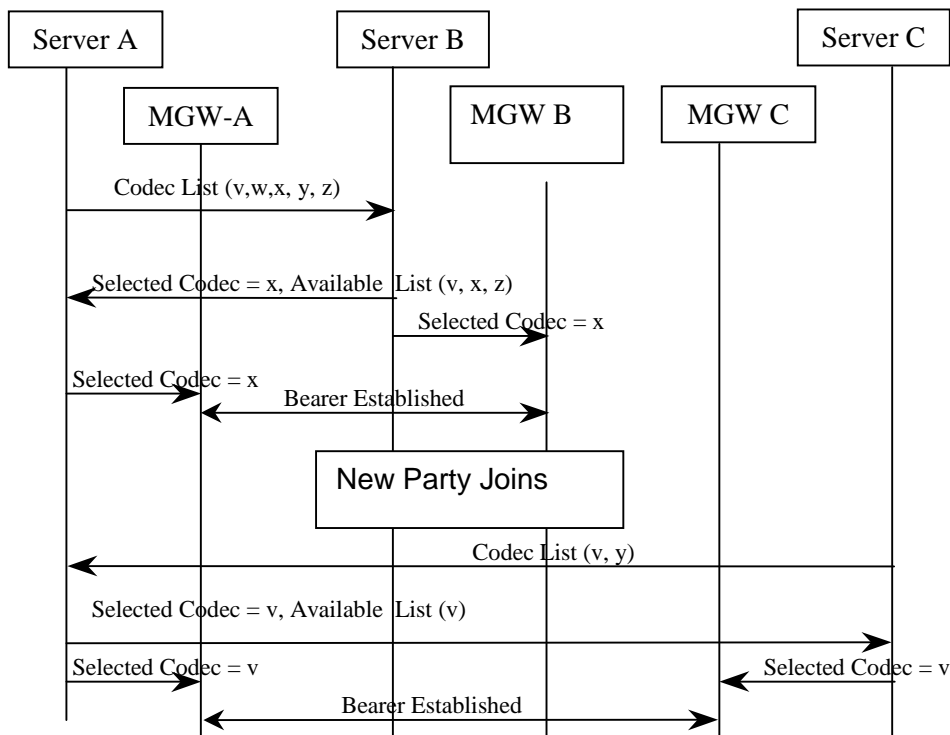

**Figure 6.4/1: Multi-party Call**

The operation of the MGW for conference calls is implementation dependent. The sequence in Figure 6.4/1 shows three connections to the MGW, where two were configured TrFO and have matching codecs but the third connection could not be made with the same codec type.

The Iu Framing connections for each multi-party call leg shall be terminated in the MGW where the multi-party call is controlled. The MGW shall control each connection independently during the multi-party call.

When the multi-party call is released, if two parties remain in the connection it shall be possible to either revert directly to a TrFO connection if both codecs match or OoBTC procedures could be performed to modify one or both of the codec types to achieve a TrFO connection. However, if the Server does not perform this then the MGW shall continue to resolve the difference in codecs by internal transcoding procedures.

Codec modification procedures may be employed (see clause 5.8.1) if a common codec exists, this is shown in Figure 6.4/2, where codec v is common to all parties.

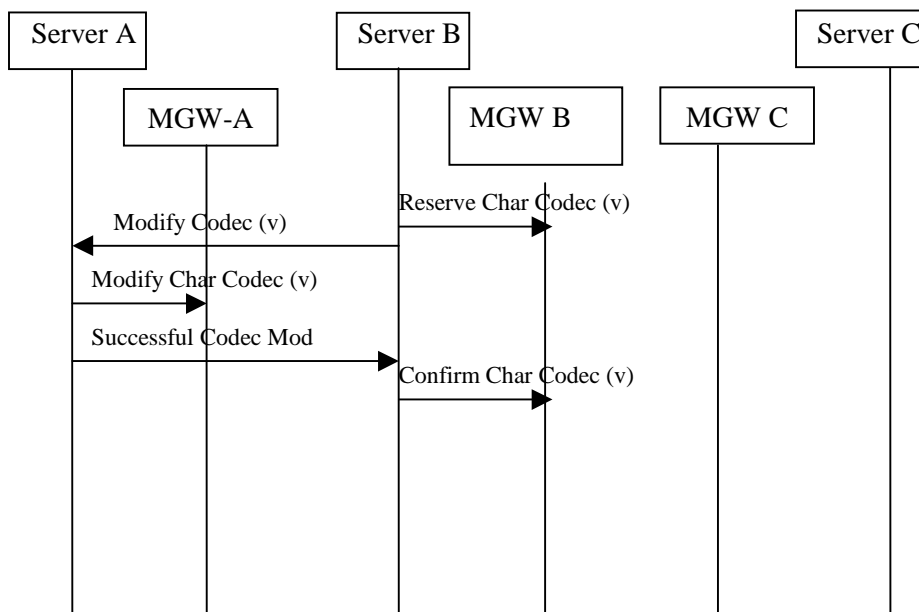

Figure 6.4/2: Multi-party Call, with codec modification

## 6.5 Information flow for handover from UMTS to GSM after TrFO establishment

Inter-system handover procedures are described at call control level in [11] and details for bearer independent architecture is described in [8]. For TrFO connected UMTS call, when a handover occurs to GSM radio access, by definition the A-interface to the BSC shall be default PCM. Prior to receipt of Handover Detect the Anchor MGW has one leg (A-interface) stream mode as default PCM and two terminations with compressed voice codec properties. It is recommended that after the Handover Complete procedure, the network property is maintained as compressed. Thus the Anchor MGW inserts a "TFO Partner" transcoder. Thus no modification to the compressed bearer to 64k PCM is required. TFO procedures may then ensure that speech quality is maintained by avoiding transcoding.

In the Intra-MSC case shown in Figure 6.5/1 the MSC controlling the handover has both codec lists for each radio access. The codec negotiation for the UMTS call was performed end to end with UMTS list. If this negotiation resulted in a codec being selected that is also included in the GSM list then at handover the MSC shall indicate this codec as the current speech version to the BSC and TFO can be achieved. If the selected codec is not supported for the GSM radio access but the GSM list contains a codec that is also in the Available Codecs list then the MSC has the option to perform codec modification to ensure TFO can be achieved. The MSC may also perform codec list modification by sending forward the GSM list to update nodes in the network of the change to the Available Codecs List.

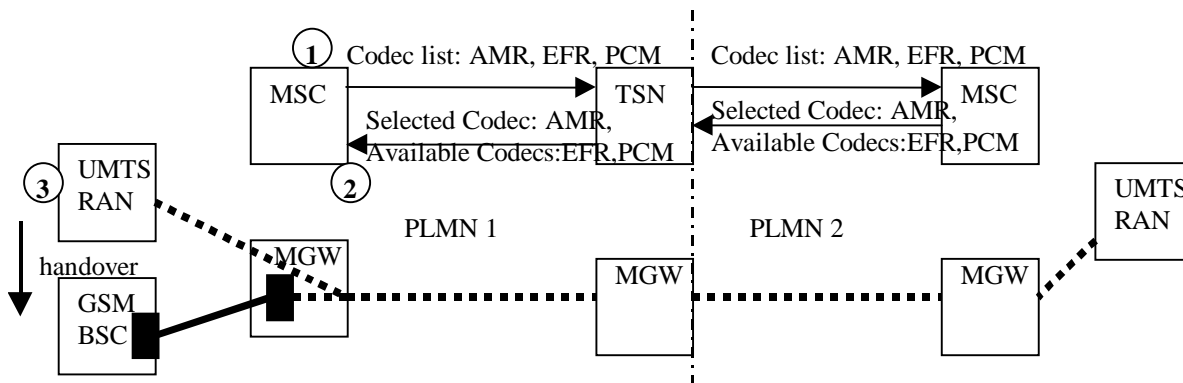

Figure 6.5/1: UMTS to GSM Inter-System Handover

If the Inter-system handover is an inter-MSC handover then the Anchor MSC sends the current speech version and the supported speech versions in the Prepare Handover Request message to the MSC-B. If the current speech version (codec selected for UMTS call) is not included in the GSM list then the MSC-A shall indicate a preferred codec in the current speech version parameter. The speech version for the GSM access that is finally selected by the MSC-B's BSS, is returned to MSC-A in the Prepare Handover Response message. The MSC-A can then decide if codec modification or codec re-negotiation shall be performed as described for the intra-MSC case. The MSC-B shall always assume default PCM across the E-interface, as there is no possibility to perform codec negotiation prior to performing the handover. The connections are shown in Figure 6.5/2.

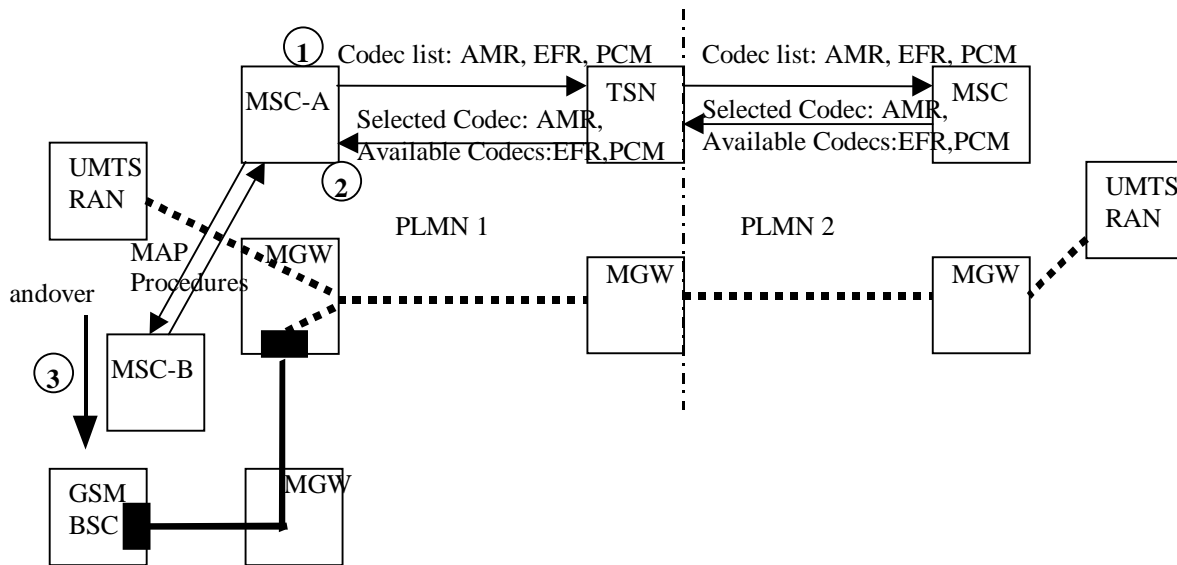

Figure 6.5/2: Inter-MSC, UMTS to GSM handover

## 6.6 Call Hold/Call Wait

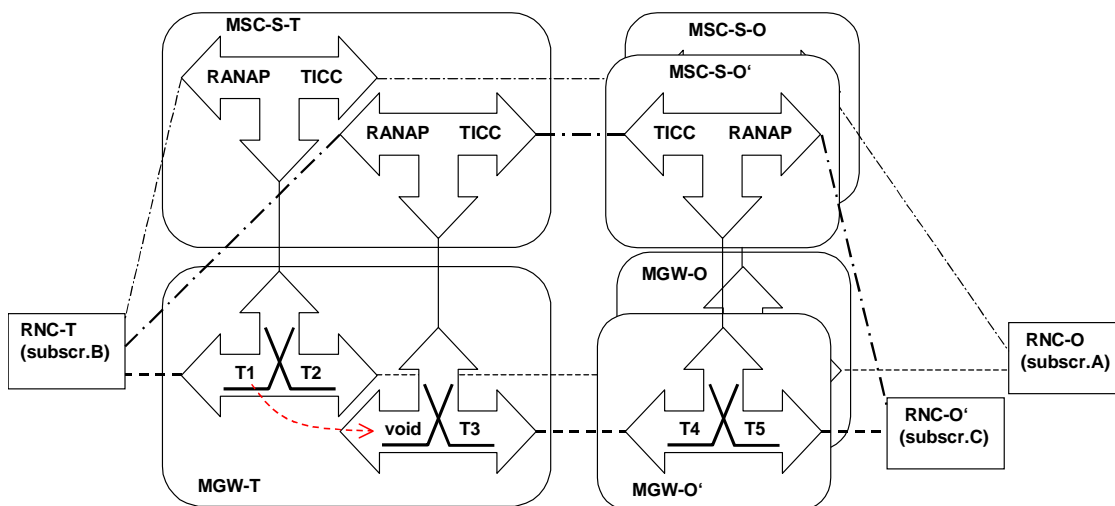

Figure 6.6/1: Configuration during Call Hold/Call Wait scenario

This scenario assumes subscriber C (served by RNC-O') calls subscriber B (served by RNC-T), currently in communication with subscriber A. Subscriber C receives a tone/announcement, applied by terminating side. Then subscriber B puts subscriber A on Hold and A receives an announcement (applied again by terminating side.)

MGW-O has to establish an originating side call context (T4, T5), MGW-T the respective terminating one (T3 only, T1 from subscriber will be moved to it during the scenario), the B party context has to be inserted into path again (if TBE was removed).

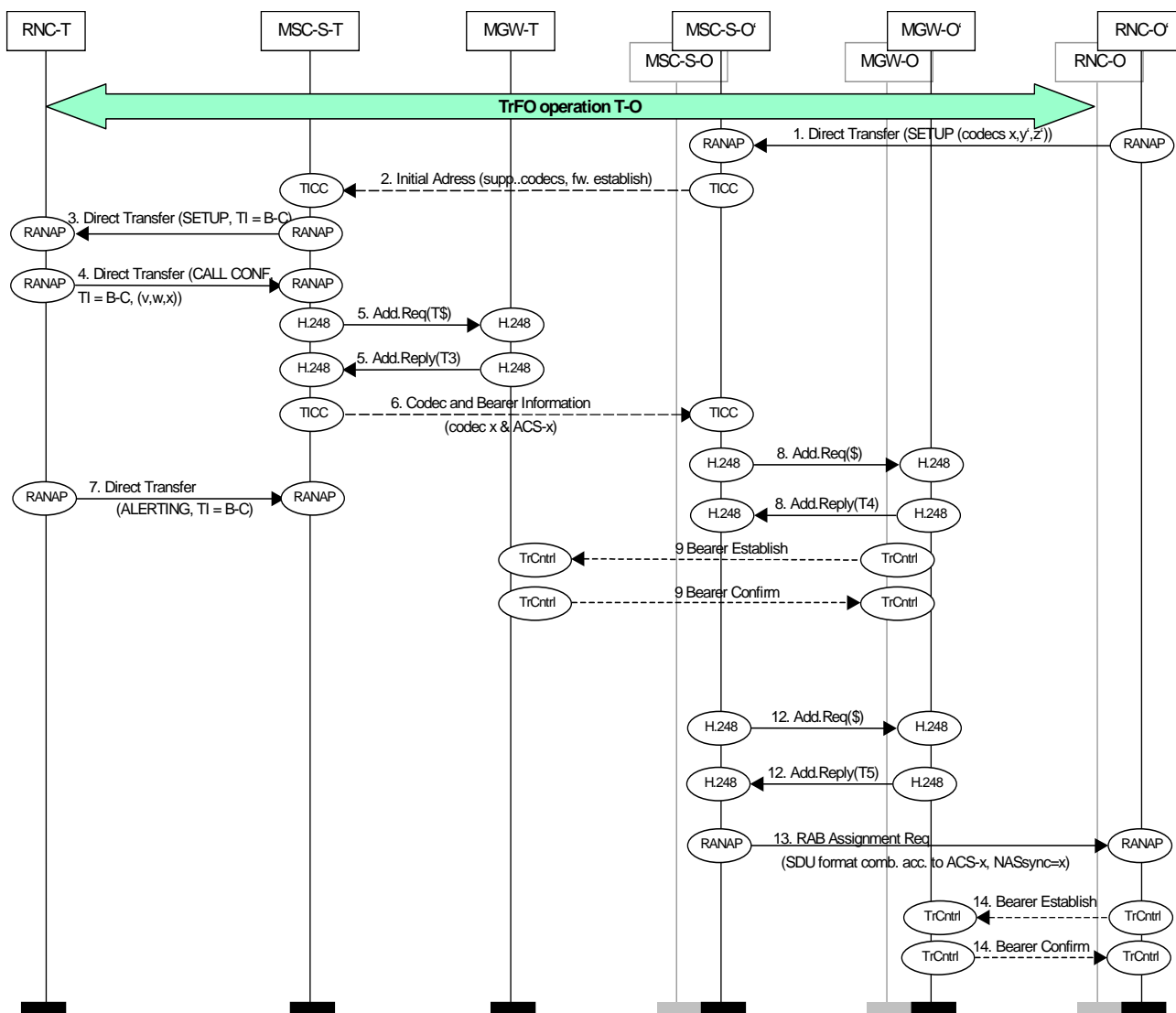

Figure 6.6/2: Call Hold/Call Wait and TrFO. Message flow part 1



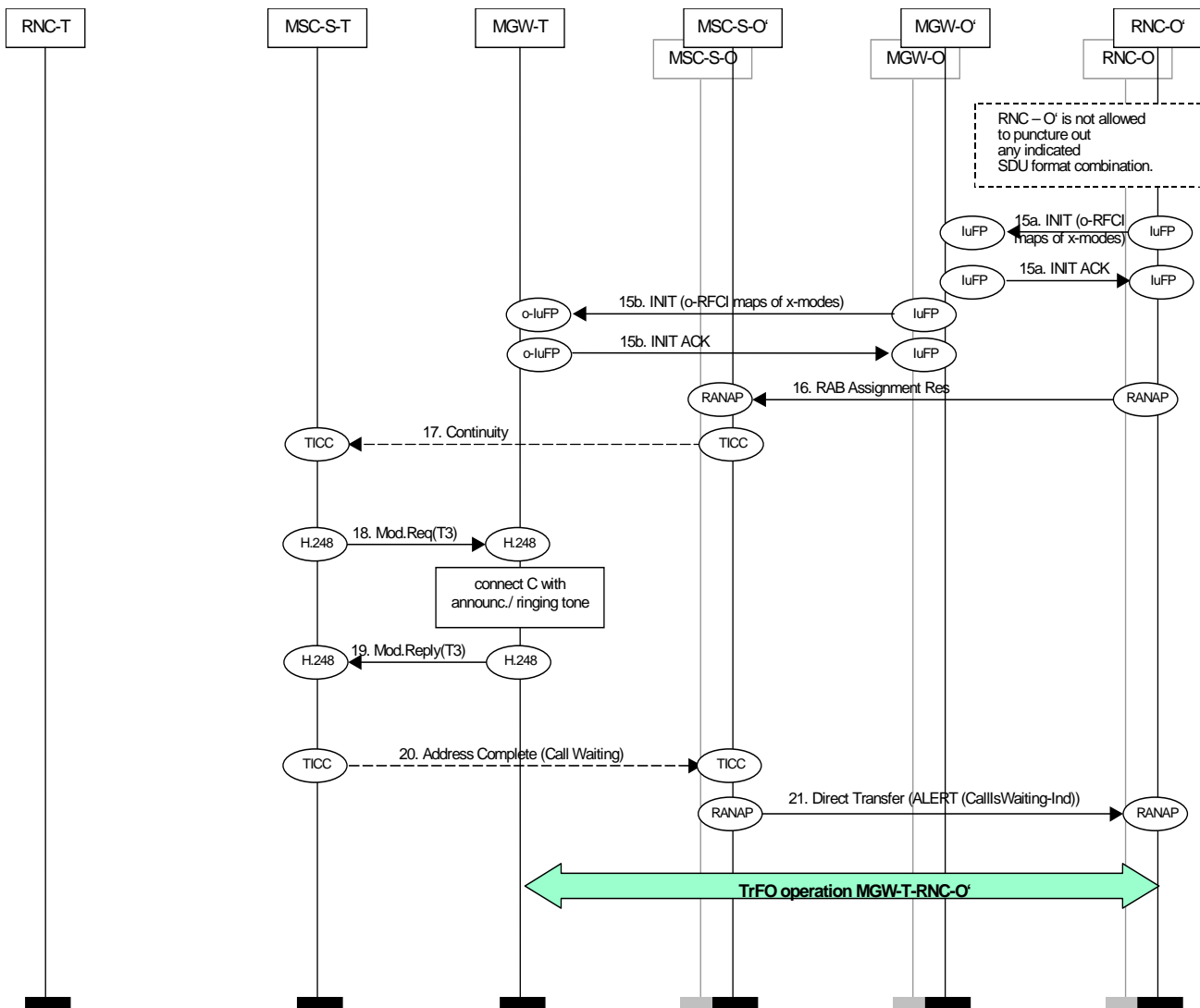

Figure 6.6/3: Call Hold/Call Wait and TrFO. Message flow part 2

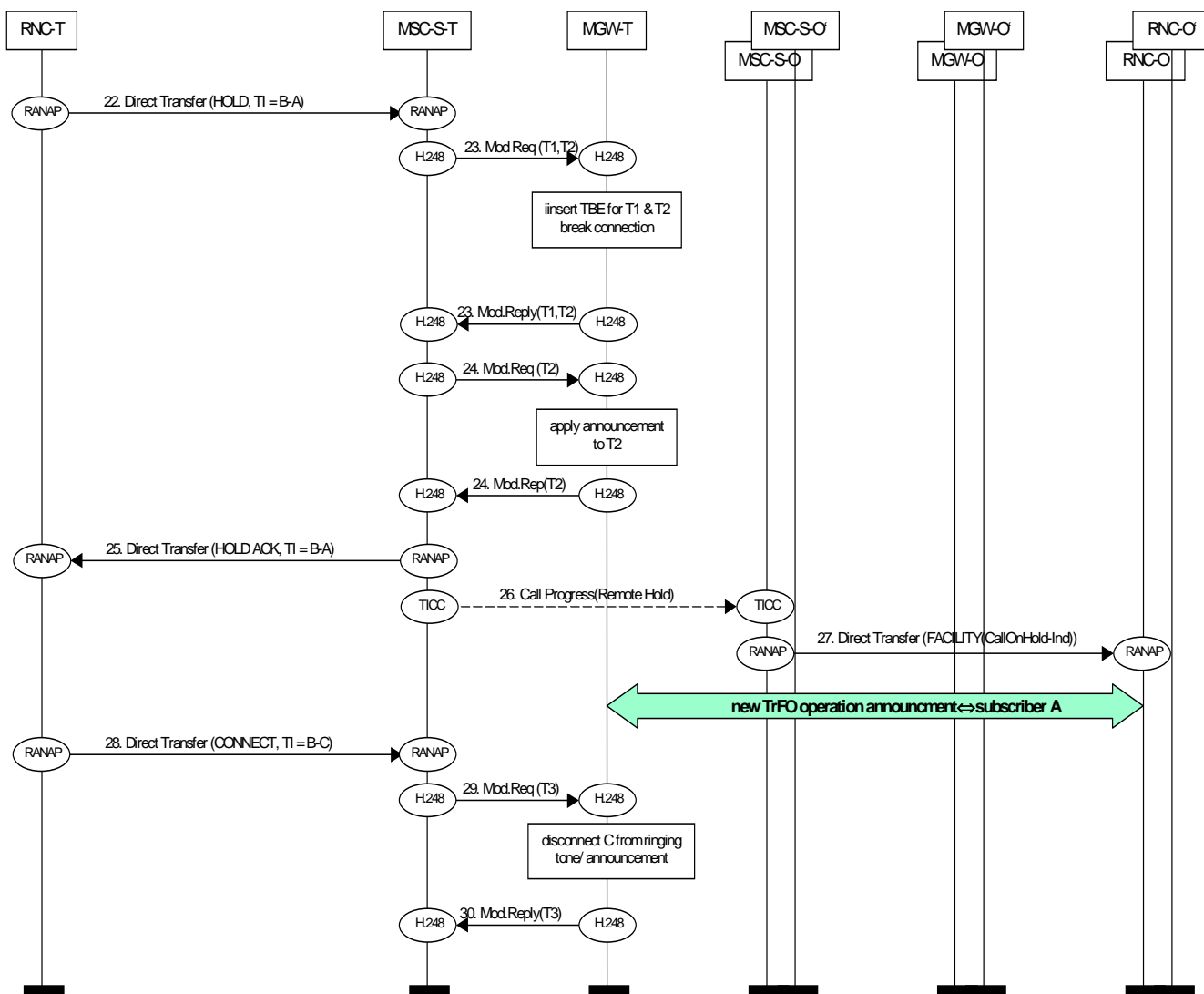

Figure 6.6/4: Call Hold/Call Wait and TrFO. Message flow part 3

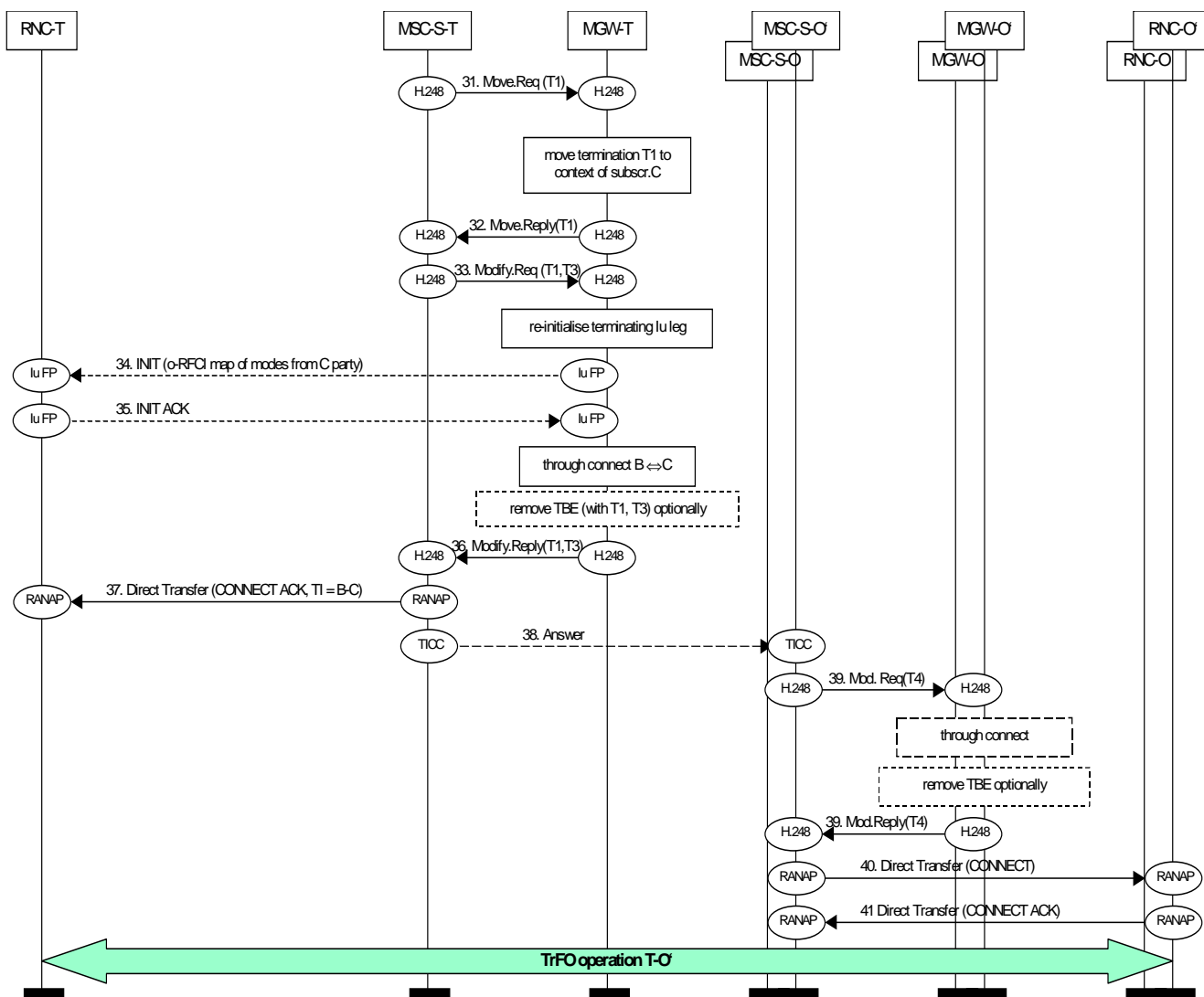
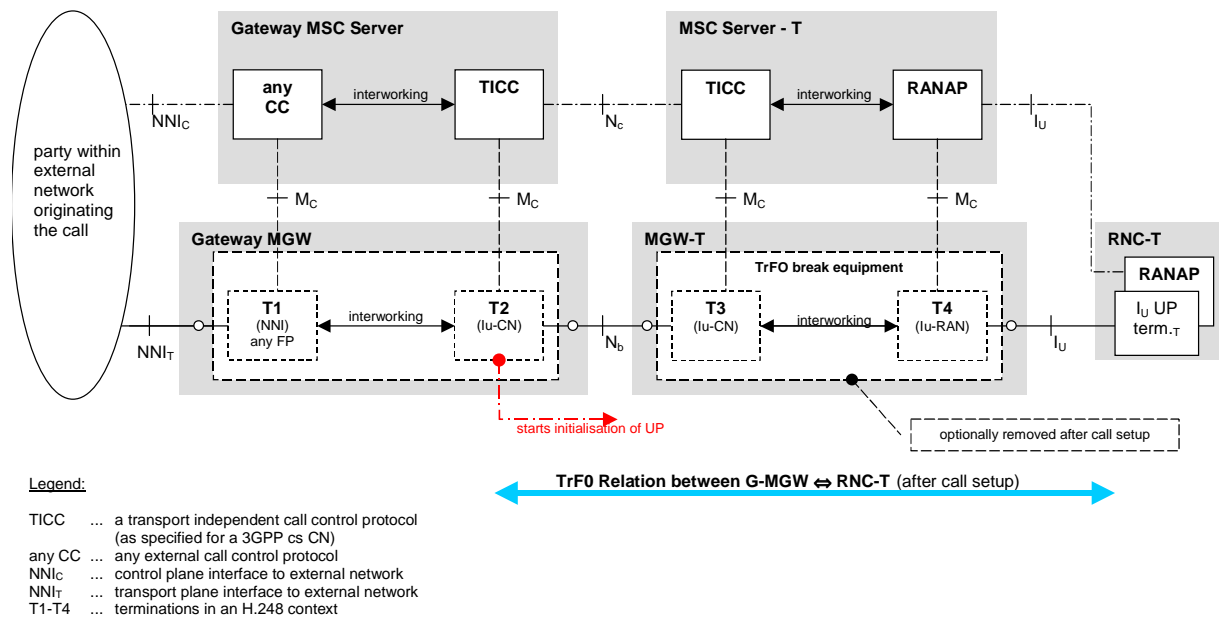

Figure 6.6/5: Call Hold/Call Wait and TrFO. Message flow part 4

## 6.7 External Network to Mobile TrFO Call Establishment



**Figure 6.7/1. Configuration during Call Setup of an External Network to Mobile Call**

The description of Figure 6.1/1 (Configuration during Call Setup of a Mobile to Mobile Call) within clause 6.1 applies for the network and protocol entities involved in the External Network to Mobile Call scenario with following modifications:

No RNC-O is present – a party served by an external network originates the call instead.

The originating CN nodes are Gateway nodes (Gateway MSC Server/Gateway MGW).

The Gateway MGW call context is no TrFO break equipment in general, i.e. T1 in general do not support the IuFP framing protocol. Appropriate interworking (in some cases transcoding) has to be performed between T1 and T2.

Therefore Figures 6.1/2 to 6.1/4. (the respective message flows for mobile to mobile call setup) apply in principle as well with appropriate modifications outlined below:

### Codec negotiation

Step 1. Until 6., that give the codec negotiation phase in Figure 6.1/2, shall be applied with following modifications:

There is no originating UE involved in this negotiation phase

If the preceding node of the Gateway MSC-Server doesn't support OoBTC procedures for compressed voice types, the Gateway MSC-Server shall initiate OoBTC procedures in order to enable transcoders placement at the edge gateway node.

The edge gateway node shall always send the complete list of the codec types and modes it supports for this type of call setup.

### UP initialisation

The main difference compared to the Mobile to Mobile call setup is, that the CN side termination of the Gateway MGW (T2 in figure 6.7/1) shall start the initialisation of the IuFP according to the result of the codec negotiation. The forward initialisation principle shall be followed in any setup scenario.

## 6.8 Mobile to External Network TrFO Call Establishment

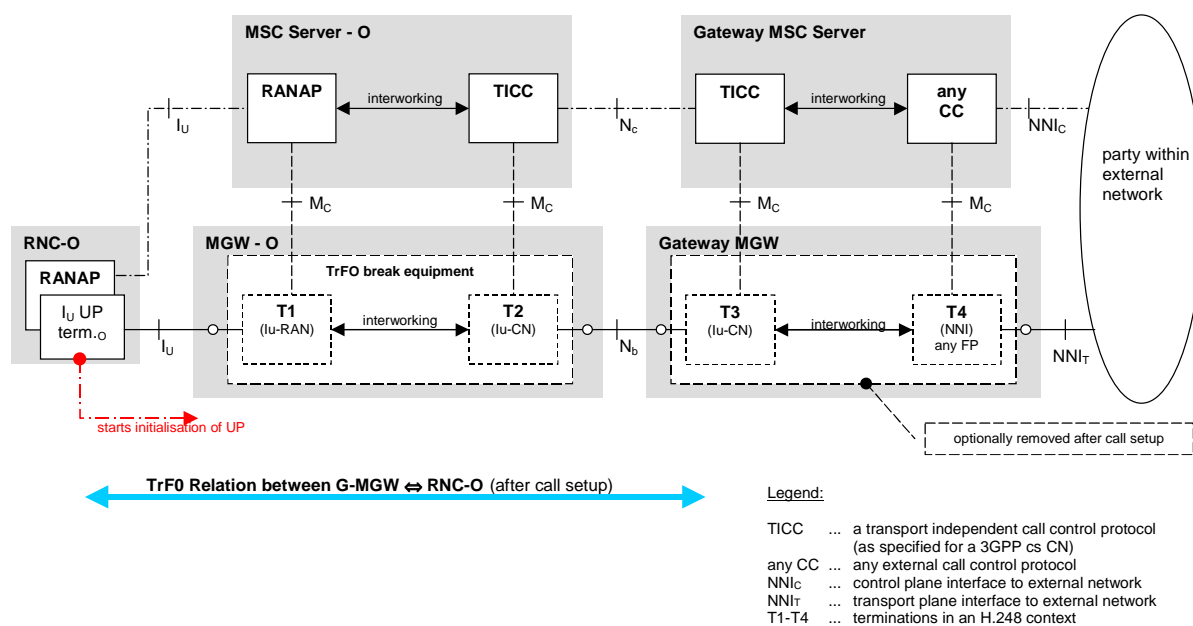

**Figure 6.8/1. Configuration during Call Setup of a Mobile to External Network Call**

The description of Figure 6.1/1 (Configuration during Call Setup of a Mobile to Mobile Call) within clause 6.1 applies for the network and protocol entities involved in the External Network to Mobile Call scenario with following modifications:

No RNC-T is present – a party served by an external network is the terminating side of the call instead.

The terminating side CN nodes are Gateway nodes (Gateway MSC Server/Gateway MGW).

The Gateway MGW call context is no TrFO break equipment in general, i.e. T4 in general do not support the IuFP framing protocol. Appropriate interworking (in some cases transcoding) has to be performed between T3 and T4.

Therefore Figures 6.1/2 to 6.1/4. (the respective message flows for mobile to mobile call setup) apply in principle as well with appropriate modifications outlined below:

### Codec negotiation

Step 1. Until 6., that give the codec negotiation phase in Figure 6.1/2, shall be applied with following modifications:

There is no terminating UE involved in this negotiation phase.

If the succeeding node of the Gateway MSC-Server doesn't support OoBTC procedures for compressed voice types, the Gateway MSC-Server terminates the OoBTC procedures in order to enable transcoders placement at the edge gateway node.

The edge gateway node shall accept the codec MSC-O prefers and shall not puncture out any codec mode.

## 7 Interactions with supplementary services

### 7.1 Call Deflection service (GSM 23.072)

In order to apply the confirmation tone to the originating party, the speech insertion procedure described in clause 6.3 is applied.

## 7.2 Line identification services (GSM 23.081)

### 7.2.1 Calling Line Identification Presentation (CLIP)

No impact.

### 7.2.2 Calling Line Identification Restriction (CLIR)

No impact.

### 7.2.3 Connected Line Identification Presentation (COLP)

No impact.

### 7.2.4 Connected Line Identification Restriction (COLR)

No impact.

## 7.3 Call forwarding services (GSM 23.082)

### 7.3.1 Call Forwarding Unconditional (CFU)

In order to apply the confirmation tone to the originating party, the speech insertion procedure described in clause 6.3 is applied.

### 7.3.2 Call Forwarding on mobile subscriber Busy (CFB)

In order to apply the confirmation tone to the originating party, the speech insertion procedure described in clause 6.3 is applied.

### 7.3.3 Call Forwarding on No Reply (CFNRy)

In order to apply the confirmation tone to the originating party, the speech insertion procedure described in clauses 6.3 is applied.

### 7.3.4 Call Forwarding on mobile subscriber Not Reachable (CFNRc)

In order to apply the confirmation tone to the originating party, the speech insertion procedure described in clauses 6.3 is applied.

## 7.4 Call wait (GSM 23.083)

In order to apply the notice tone to the interjected party, the speech insertion procedure described in clause 6.4 is applied.

## 7.5 Call hold (GSM 23.083)

In order to apply the notice tone to the held party, the speech insertion procedure described in clause 6.4 is applied.

## 7.6 Multiparty (GSM 23.084)

In order to mix calls, the speech insertion procedure described in clause 6.4 is applied.

## 7.7 Closed user group (GSM 23.085)

No impact.

## 7.8 Advice of charge (GSM 23.086)

No impact.

## 7.9 User-to-user signalling (GSM 23.087)

No impact.

## 7.10 Call barring (GSM 23.088)

### 7.10.1 Barring of outgoing calls

No impact.

### 7.10.2 Barring of incoming calls

No impact.

## 7.11 Explicit Call Transfer (GSM 23.091)

In case that a call A-B is transferred to C by B (A-C as result), A-B may use codec x, A-C may use codec y, the procedure described in clause 6.3 is applied.

## 7.12 Completion of Calls to Busy Subscriber (3G TS 23.093)

Within CCBS there exists an option for CCBS calls where a bearer can be established before setup in the state "CC-establishment confirmed". If the selected codec after setup is different to the one which was used to establish the bearer, RAB assignment (modify) may be required when RAB parameters are different.

---

# 8 Charging

The selected codec shall be included in all the call data records of the call legs involved in out-band codec negotiation belonging to a particular subscriber.

---

## Annex A (informative): Codec Re-negotiation

A node may perform a procedure (e.g. handover) that results in a completely new list from that which was originally negotiated. Assuming that the current Selected Codec is still common (no Selected Codec Modification or re-negotiation) then the node shall send a Re-negotiation Request with the new Supported Codec List. The Supported codec list may then be punctured by nodes in the network in the same way as for the basic Codec Negotiation procedure and a new Available Codecs List returned.

If a node performs a procedure (e.g. handover) that results in both a completely new list and also the need for a new codec then Codec Re-negotiation may be performed with a request for a new codec selection. The procedure is then the same as for an initial codec negotiation.



## Annex B (informative): Status of Technical Specification 23.153

Change history							
Date	TSG #	TSG Doc.	CR	Rev	Subject/Comment	Old	New
Sep 1999					First draft prepared by the rapporteur		0.0.0
Oct 1999					2nd draft prepared by the rapporteur (Updated version from Abiko.)	0.0.0	0.1.0
Nov 1999					3rd draft prepared by the rapporteur	0.1.0	0.2.0
Dec 1999					Submitted to CN#06 for information	0.2.0	1.0.0
Feb 2000					4th draft prepared by the rapporteur	1.0.0	1.1.0
Feb 2000					5th draft prepared by the rapporteur (Updated version from Milan.)	1.1.0	1.2.0
Feb 2000					6th draft prepared by the rapporteur (Updated version from Milan.)	1.2.0	1.3.0
Feb 2000					7th draft prepared by the rapporteur (Updated version from Milan.)	1.3.0	1.4.0
Feb 2000					8th draft prepared by the rapporteur (Updated version from Milan.)	1.4.0	1.5.0
Mar 2000					Submitted to TSG CN#07 for approval	1.5.0	2.0.0
Oct 2000					9th draft prepared by the rapporteur (Updated version from Windsor)	2.0.0	2.0.3
Nov 2000					10th draft accepted, input to TrFO workshop #5, Stockholm	2.0.3	2.1.0
Nov 2000					11th draft, workshop #5 interim editors document.	2.1.0	2.1.1
Nov 2000					Final Draft for approval at CN4 WG #5 (Paris)	2.1.1	2.2.0
Nov 2000					Final Clean version for Approval CN TSG (Bangkok)	2.2.0	2.3.0
Dec 2000	CN#10	NP-000653			TS 23.153 Out of Band Transcoder Control - Stage 2 approved as version 4.0.0	2.3.0	4.0.0
Mar 2001	CN#11	NP-010084	001	1	Correct wording of Nb/lU UP protocol	4.0.0	4.1.0
Mar 2001	CN#11	NP-010084	003	1	Alignment of codec modification procedures with current BICC CS2 procedures	4.0.0	4.1.0
Mar 2001	CN#11	NP-010084	004	1	Alignment of codec modification procedures with current BICC CS2 procedures	4.0.0	4.1.0
Mar 2001	CN#11	NP-010084	005	1	Alignment of codec modification procedures with current BICC CS2 procedures	4.0.0	4.1.0
Mar 2001	CN#11	NP-010084	006	1	Interaction with CCBS	4.0.0	4.1.0
Mar 2001	CN#11	NP-010084	007	2	Clause 5.6, establishment of additional calls	4.0.0	4.1.0
Mar 2001	CN#11	NP-010084	009	1	Editorials and minor corrections	4.0.0	4.1.0
Mar 2001	CN#11	NP-010084	012	2	Change of terminology from "Node X" to "MSC Server X"	4.0.0	4.1.0
Mar 2001	CN#11	NP-010084	014	1	Alignment of codec modification procedures with current BICC CS2 procedures	4.0.0	4.1.0
Mar 2001	CN#11	NP-010084	015		Alignment of SRNS Relocation with 3G TS 23.205	4.0.0	4.1.0
Mar 2001	CN#11	NP-010084	016		Inter-MSC Serving Area SRNS Relocation	4.0.0	4.1.0
Mar 2001	CN#11	NP-010084	017	1	General Improvements	4.0.0	4.1.0
Mar 2001	CN#11	NP-010084	020		Reference to Q.2630 in certain diagrams should be bearer	4.0.0	4.1.0

Change history							
Date	TSG #	TSG Doc.	CR	Rev	Subject/Comment	Old	New
					independent		
Mar 2001	CN#11	NP-010084	021	1	Initialisation Issues	4.0.0	4.1.0
Mar 2001	CN#11	NP-010084	022	2	Avoiding double description of lu framing package procedure	4.0.0	4.1.0
Jun 2001	CN#12	NP-010284	024	1	Role of MSC server in FP UP version negotiation for TrFO	4.1.0	4.2.0
Jun 2001	CN#12	NP-010297	025		Default Codec For UMTS & GSM dual systems	4.1.0	4.2.0
Sep 2001	CN#13	NP-010457	026		Optional FRCI value Correction	4.2.0	4.3.0
Sep 2001	CN#13	NP-010532	027	1	Default Codec Types For 'UMTS only' and 'UMTS & GSM dual system' UEs	4.2.0	4.3.0
Sep 2001	CN#13				Editorial clean up	4.2.0	4.3.0
Dec 2001	CN#14	NP-010620	028		Removal of "No Data" SDUs	4.3.0	4.4.0
Dec 2001	CN#14	NP-010620	029		Clarification for Codec Modification in case of SS/IN interworking	4.3.0	4.4.0
Sep 2002	CN#17	NP-020444	040		Initial Bitrate For TrFO	4.4.0	4.5.0
Sep 2002	CN#17	NP-020444	042	1	Handling of UMTS_AMR & UMTS_AMR_2 codecs in OoBTC	4.4.0	4.5.0
Dec 2002	CN#18	NP-020578	038	2	Correction/clarification to Codec Modification Procedures	4.5.0	4.6.0
Dec 2002	CN#18	NP-020578	048	2	Alignment on the optionality on usage of Global Titel Translation in case of relocation between RNC"s connected to different 3G MSC"s	4.5.0	4.6.0
Mar 2003	CN#19	NP-030097	052		Guaranteed Bitrate & Maximum Bitrate settings for TrFO	4.6.0	4.7.0
Jun 2003	CN#20	NP-030211	054	2	Clarification of use of Default PCM codec and handling of the Codec List	4.7.0	4.8.0
Jun 2003	CN#20	NP-030211	056		Clarification of handling of DTMF in TrFO	4.7.0	4.8.0
Jun 2003	CN#20	NP-030211	058		Clarification of use of TMR for codec negotiation	4.7.0	4.8.0
Sep 2003	CN#21	NP-030380	062	1	Clarification on codec modification	4.8.0	4.9.0
Sep 2003	CN#21	NP-030380	066	1	Clarification of luUP Initialisation during codec modification	4.8.0	4.9.0
Jun 2004	CN#24	NP-040214	070	1	Correction of Codec Negotiation and supported codec mode configurations	4.9.0	4.10.0
Dec 2004	CN#26	NP-040520	075		TFO/TrFO compatibility of UMTS_AMR and UMTS_AMR2	4.10.0	4.11.0
Dec 2004	CN#26	NP-040520	077	1	Detailed description of the handling of codec negotiation parameters	4.10.0	4.11.0
Dec 2004	CN#26	NP-040520	079	3	Addition of missing condition for transcoder free operation in the MGW	4.10.0	4.11.0
Mar 2005	CN#27	NP-050028	087		Removal of AMR-WB codec	4.11.0	4.12.0
Jun 2005	CT#28	CP-050079	0090	1	Codec Selection at Terminating Call Control Node for OoBTC	4.12.0	4.13.0

---

## History

<b>Document history</b>		
V4.1.0	March 2001	Publication
V4.2.0	July 2001	Publication
V4.3.0	October 2001	Publication
V4.4.0	December 2001	Publication
V4.5.0	September 2002	Publication
V4.6.0	December 2002	Publication
V4.7.0	March 2003	Publication
V4.8.0	June 2003	Publication
V4.9.0	September 2003	Publication
V4.10.0	June 2004	Publication
V4.11.0	December 2004	Publication
V4.12.0	March 2005	Publication
V4.13.0	June 2005	Publication