

# ETSI TS 123 286 V16.5.0 (2021-01)



**LTE;**  
**Application layer support**  
**for Vehicle-to-Everything (V2X) services;**  
**Functional architecture and information flows**  
**(3GPP TS 23.286 version 16.5.0 Release 16)**



---

Reference

RTS/TSGS-0623286vg50

---

Keywords

LTE

**ETSI**

650 Route des Lucioles  
F-06921 Sophia Antipolis Cedex - FRANCE

Tel.: +33 4 92 94 42 00 Fax: +33 4 93 65 47 16

Siret N° 348 623 562 00017 - NAF 742 C  
Association à but non lucratif enregistrée à la  
Sous-Préfecture de Grasse (06) N° 7803/88

---

**Important notice**

The present document can be downloaded from:

<http://www.etsi.org/standards-search>

The present document may be made available in electronic versions and/or in print. The content of any electronic and/or print versions of the present document shall not be modified without the prior written authorization of ETSI. In case of any existing or perceived difference in contents between such versions and/or in print, the prevailing version of an ETSI deliverable is the one made publicly available in PDF format at [www.etsi.org/deliver](http://www.etsi.org/deliver).

Users of the present document should be aware that the document may be subject to revision or change of status.

Information on the current status of this and other ETSI documents is available at

<https://portal.etsi.org/TB/ETSIDeliverableStatus.aspx>

If you find errors in the present document, please send your comment to one of the following services:

<https://portal.etsi.org/People/CommitteeSupportStaff.aspx>

---

**Copyright Notification**

No part may be reproduced or utilized in any form or by any means, electronic or mechanical, including photocopying and microfilm except as authorized by written permission of ETSI.

The content of the PDF version shall not be modified without the written authorization of ETSI.

The copyright and the foregoing restriction extend to reproduction in all media.

© ETSI 2021.

All rights reserved.

**DECT™**, **PLUGTESTS™**, **UMTS™** and the ETSI logo are trademarks of ETSI registered for the benefit of its Members.

**3GPP™** and **LTE™** are trademarks of ETSI registered for the benefit of its Members and of the 3GPP Organizational Partners.

**oneM2M™** logo is a trademark of ETSI registered for the benefit of its Members and of the oneM2M Partners.

**GSM®** and the GSM logo are trademarks registered and owned by the GSM Association.

---

## Intellectual Property Rights

### Essential patents

IPRs essential or potentially essential to normative deliverables may have been declared to ETSI. The information pertaining to these essential IPRs, if any, is publicly available for **ETSI members and non-members**, and can be found in ETSI SR 000 314: "*Intellectual Property Rights (IPRs); Essential, or potentially Essential, IPRs notified to ETSI in respect of ETSI standards*", which is available from the ETSI Secretariat. Latest updates are available on the ETSI Web server (<https://ipr.etsi.org/>).

Pursuant to the ETSI IPR Policy, no investigation, including IPR searches, has been carried out by ETSI. No guarantee can be given as to the existence of other IPRs not referenced in ETSI SR 000 314 (or the updates on the ETSI Web server) which are, or may be, or may become, essential to the present document.

### Trademarks

The present document may include trademarks and/or tradenames which are asserted and/or registered by their owners. ETSI claims no ownership of these except for any which are indicated as being the property of ETSI, and conveys no right to use or reproduce any trademark and/or tradename. Mention of those trademarks in the present document does not constitute an endorsement by ETSI of products, services or organizations associated with those trademarks.

---

## Legal Notice

This Technical Specification (TS) has been produced by ETSI 3rd Generation Partnership Project (3GPP).

The present document may refer to technical specifications or reports using their 3GPP identities. These shall be interpreted as being references to the corresponding ETSI deliverables.

The cross reference between 3GPP and ETSI identities can be found under <http://webapp.etsi.org/key/queryform.asp>.

---

## Modal verbs terminology

In the present document "**shall**", "**shall not**", "**should**", "**should not**", "**may**", "**need not**", "**will**", "**will not**", "**can**" and "**cannot**" are to be interpreted as described in clause 3.2 of the [ETSI Drafting Rules](#) (Verbal forms for the expression of provisions).

"**must**" and "**must not**" are **NOT** allowed in ETSI deliverables except when used in direct citation.

# Contents

Intellectual Property Rights .....	2
Legal Notice .....	2
Modal verbs terminology.....	2
Foreword.....	8
Introduction .....	8
1 Scope .....	9
2 References .....	9
3 Definitions and abbreviations.....	10
3.1 Definitions .....	10
3.2 Abbreviations .....	10
4 Architectural requirements .....	10
4.1 General .....	10
4.1.1 Description.....	10
4.1.2 Requirements .....	11
4.2 V2X group communication .....	11
4.2.1 Description.....	11
4.2.2 Requirements .....	11
4.3 V2X dynamic groups.....	11
4.3.1 Description.....	11
4.3.2 Requirements .....	11
4.4 File distribution capability.....	12
4.4.1 Description.....	12
4.4.2 Requirements .....	12
4.5 V2X application message distribution.....	12
4.5.1 Description.....	12
4.5.2 Requirements .....	12
4.6 Service continuity.....	12
4.6.1 Description.....	12
4.6.2 Requirements .....	12
5 Involved business relationships.....	12
6 Functional model .....	13
6.1 General .....	13
6.2 Functional model description .....	13
6.3 Functional entities description.....	15
6.3.1 General.....	15
6.3.2 V2X application specific client.....	16
6.3.3 V2X application specific server.....	16
6.3.4 VAE client .....	16
6.3.5 VAE server .....	16
6.3.6 SEAL client .....	17
6.3.7 SEAL server.....	17
6.4 Reference points description .....	17
6.4.1 General.....	17
6.4.2 V1-AE.....	17
6.4.3 V1-APP.....	17
6.4.4 V5-AE.....	18
6.4.5 V5-APP.....	18
6.4.6 Vs.....	18
6.4.7 Vc.....	18
6.4.8 SEAL-C .....	18
6.4.9 SEAL-S.....	18
6.4.10 SEAL-PC5 .....	18

6.4.11	SEAL-UU .....	19
6.4.12	VAE-E .....	19
6.5	External reference points.....	19
6.5.1	General.....	19
6.5.2	V2 .....	19
6.5.3	Rx.....	19
6.5.4	MB2-C .....	19
6.5.5	MB2-U.....	19
6.5.6	xMB-C.....	20
6.5.7	xMB-U.....	20
6.5.8	T8.....	20
7	Deployment models.....	20
7.1	General .....	20
7.2	Deployment of VAE server .....	20
7.2.1	Centralized deployments.....	20
7.2.2	Distributed deployment.....	22
8	Identities .....	24
8.1	V2X user identity (V2X user ID) .....	24
8.2	V2X UE identity (V2X UE ID).....	25
8.3	V2X service identity (V2X service ID).....	25
8.4	V2X group identity (V2X group ID).....	25
8.5	Geographical area identity (GEO ID).....	25
9	Procedures and information flows.....	25
9.1	Usage of SEAL services.....	25
9.1.1	Group management service.....	25
9.1.1.1	General .....	25
9.1.1.2	Information flows.....	25
9.1.1.3	Procedures .....	27
9.1.2	Configuration management service .....	27
9.1.2.1	General .....	27
9.1.2.2	Information flows.....	28
9.1.2.3	Procedures.....	28
9.1.3	Location management service.....	28
9.1.3.1	General .....	28
9.1.3.2	Information flows.....	28
9.1.3.3	Procedures .....	29
9.1.4	Identity management service .....	29
9.1.4.1	General .....	29
9.1.4.2	Information flows.....	29
9.1.4.3	Procedures .....	29
9.1.5	Key management service .....	29
9.1.5.1	General .....	29
9.1.5.2	Information flows.....	29
9.1.5.3	Procedures.....	29
9.1.6	Network resource management service .....	30
9.1.6.1	General .....	30
9.1.6.2	Information flows.....	30
9.1.6.3	Procedures.....	30
9.2	V2X UE registration.....	31
9.2.1	General.....	31
9.2.2	Information flows .....	31
9.2.2.1	Registration request.....	31
9.2.2.2	Registration response .....	31
9.2.2.3	Deregistration request .....	31
9.2.2.4	Deregistration response.....	31
9.2.3	V2X UE registration for receiving V2X messages .....	32
9.2.3.1	General .....	32
9.2.3.2	Procedure .....	32
9.2.4	V2X UE deregistration from receiving V2X messages .....	32
9.2.4.1	General .....	32

9.2.4.2	Procedure .....	32
9.3	Application level location tracking.....	33
9.3.1	General.....	33
9.3.2	Information flows .....	33
9.3.2.1	Subscription request .....	33
9.3.2.2	Subscription response.....	33
9.3.2.3	Unsubscription request.....	33
9.3.2.4	Unsubscription response .....	33
9.3.3	Tracking geographical location at the VAE server .....	34
9.3.3.1	General .....	34
9.3.3.2	Procedure .....	34
9.4	V2X message delivery.....	34
9.4.1	General.....	34
9.4.2	Information flows .....	35
9.4.2.1	V2X message .....	35
9.4.2.2	V2X message reception report .....	35
9.4.2.3	V2X group message .....	35
9.4.2.4	V2X uplink message .....	35
9.4.2.5	V2X uplink message reception report .....	36
9.4.2.6	Subscribe V2X message delivery request .....	36
9.4.2.7	Subscribe V2X message delivery response.....	36
9.4.2.8	Unsubscribe V2X message delivery request.....	37
9.4.2.9	Unsubscribe V2X message delivery response.....	37
9.4.3	Message delivery to target geographical areas from the VAE server .....	37
9.4.3.1	General .....	37
9.4.3.2	Procedure .....	37
9.4.4	V2X group message distribution .....	38
9.4.4.1	General .....	38
9.4.4.2	Procedure .....	38
9.4.5	Uplink V2X message delivery .....	38
9.4.5.1	General .....	38
9.4.5.2	Procedure for uplink message delivery .....	38
9.4.6	Procedure for subscription to message delivery.....	39
9.5	File Distribution .....	40
9.5.1	General.....	40
9.5.2	Use of MBMS "files" session type .....	40
9.6	Provisioning 3GPP system information by VAE server.....	40
9.6.1	General.....	40
9.6.2	Information flows .....	40
9.6.2.1	V2X USD announcement.....	40
9.6.2.2	Set PC5 parameters request.....	41
9.6.2.3	Set PC5 parameters response .....	41
9.6.3	V2X USD provisioning .....	41
9.6.3.1	General .....	41
9.6.3.2	Procedure .....	41
9.6.4	PC5 parameters provisioning .....	42
9.6.4.1	General .....	42
9.6.4.2	Procedure .....	42
9.7	Network monitoring by the V2X UE .....	42
9.7.1	General.....	42
9.7.2	Information flows .....	43
9.7.2.1	Network monitoring information subscription request .....	43
9.7.2.2	Network monitoring information subscription response.....	43
9.7.2.3	Network monitoring information notification .....	43
9.7.3	V2X UE subscription for network monitoring information.....	44
9.7.3.1	General .....	44
9.7.3.2	Procedure .....	44
9.7.4	Notifications for network monitoring information .....	44
9.7.4.1	General .....	44
9.7.4.2	Procedure .....	44
9.8	Switching modes of operations for V2V communications .....	45
9.9	V2X service discovery .....	45

9.9.1	General.....	45
9.9.2	Information flows .....	45
9.9.2.1	Get V2X UE service discovery request.....	45
9.9.2.2	Get V2X UE service discovery response .....	46
9.9.3	V2X UE service discovery .....	46
9.9.3.1	General .....	46
9.9.3.2	Procedure .....	46
9.10	V2X service continuity.....	47
9.10.1	General.....	47
9.10.2	Information flows .....	47
9.10.2.1	Service continuity request.....	47
9.10.2.2	Service continuity response.....	47
9.10.2.3	Local service information request .....	47
9.10.2.4	Local service information response.....	47
9.10.3	V2X service continuity management.....	48
9.10.3.1	General .....	48
9.10.3.2	Procedure .....	48
9.10.4	Dynamic local service information.....	48
9.10.4.1	General .....	48
9.10.4.2	Procedure .....	49
9.11	V2X application resource management.....	49
9.11.1	General.....	49
9.11.2	Information flows .....	50
9.11.2.1	V2X application requirement request.....	50
9.11.2.2	V2X application requirement response .....	50
9.11.2.3	V2X application requirement notification.....	50
9.11.3	V2X application resource adaptation.....	50
9.11.3.1	General .....	50
9.11.3.2	Procedure .....	50
9.12	Dynamic group management.....	51
9.12.1	General.....	51
9.12.2	Information flows .....	51
9.12.2.1	Push Layer-2 group ID mapping.....	51
9.12.2.2	Configure dynamic group request .....	52
9.12.2.3	Configure dynamic group response.....	52
9.12.2.4	Configure dynamic group notification .....	52
9.12.2.5	Identity list notification .....	52
9.12.3	On-network dynamic group creation .....	53
9.12.3.1	General .....	53
9.12.3.2	Procedure .....	53
9.12.4	Off-network dynamic group creation.....	54
9.12.4.1	General .....	54
9.12.4.2	Procedure .....	54
9.12.5	On-network dynamic group notification.....	54
9.12.5.1	General .....	54
9.12.5.2	Procedure .....	55
9.13	Network situation and QoS monitoring and reporting.....	55
9.13.1	General.....	55
9.13.2	Information flows .....	55
9.13.2.1	Monitoring request.....	55
9.13.2.2	Monitoring response.....	55
9.13.2.3	Monitoring report.....	55
9.13.3	Procedure .....	56
9.14	Service negotiation with underlying 3GPP network .....	56
9.14.1	General.....	56
9.14.2	Information flows .....	56
9.14.2.1	On-demand QoS request .....	56
9.14.2.2	On-demand QoS response.....	56
9.14.2.3	Background data transfer request.....	56
9.14.2.4	Background data transfer response .....	56
9.14.2.5	Network Status Request .....	56
9.14.2.6	Network Status Response.....	56

9.14.2.7	Network Status Report .....	56
9.14.2.8	Network Status Acknowledgment .....	57
9.14.3	Communication of service requirements from the VAE server .....	57
9.14.4	Notification generation by the SCEF function .....	57
10	VAE layer APIs .....	57
10.1	General .....	57
10.2	VAE server APIs .....	57
10.2.1	General .....	57
10.2.2	VAE_MessageDelivery API .....	58
10.2.2.1	General .....	58
10.2.2.2	Deliver_DL_Message operation .....	58
10.2.2.3	Deliver_UL_Message operation .....	58
10.2.2.4	V2X_MessageDelivery_Subscribe operation .....	58
10.2.2.5	V2X_MessageDelivery_Unsubscribe operation .....	59
10.2.3	VAE_FileDistribution API .....	59
10.2.3.1	General .....	59
10.2.3.2	Distribute_File operation .....	59
10.2.4	VAE_ApplicationRequirement API .....	59
10.2.4.1	General .....	59
10.2.4.2	Reserve_NetworkResource operation .....	59
10.2.4.3	Notify_NetworkResource operation .....	59
10.2.5	VAE_DynamicGroup API .....	60
10.2.5.1	General .....	60
10.2.5.2	Configure_DynamicGroup operation .....	60
10.2.5.3	Notify_DynamicGroup operation .....	60
10.2.6	VAE_ServiceContinuity API .....	60
10.2.6.1	General .....	60
10.2.6.2	Query_ServiceContinuity operation .....	60
<b>Annex A (informative):</b>	<b>Detailed V2X application layer functional model .....</b>	<b>61</b>
<b>Annex B (informative):</b>	<b>Functionalities with SA2 dependency .....</b>	<b>62</b>
B.1	Service negotiation with underlying 3GPP network .....	62
B.1.1	General .....	62
B.1.2	Information flows .....	62
B.1.2.1	Supporting information request .....	62
B.1.2.2	Supporting information response .....	62
B.1.2.3	Void .....	62
B.1.2.4	Void .....	62
B.1.3	Void .....	63
B.1.4	Void .....	63
B.2	Void .....	63
<b>Annex C (normative):</b>	<b>V2X application enabler related configuration data .....</b>	<b>64</b>
C.1	General .....	64
C.2	VAE client configuration data .....	64
C.3	VAE server configuration data .....	64
<b>Annex D:</b>	<b>Change history .....</b>	<b>65</b>
History .....		66



---

# Foreword

This Technical Report has been produced by the 3rd Generation Partnership Project (3GPP).

The contents of the present document are subject to continuing work within the TSG and may change following formal TSG approval. Should the TSG modify the contents of the present document, it will be re-released by the TSG with an identifying change of release date and an increase in version number as follows:

Version x.y.z

where:

- x the first digit:
  - 1 presented to TSG for information;
  - 2 presented to TSG for approval;
  - 3 or greater indicates TSG approved document under change control.
- y the second digit is incremented for all changes of substance, i.e. technical enhancements, corrections, updates, etc.
- z the third digit is incremented when editorial only changes have been incorporated in the document.

---

# Introduction

In order to ensure efficient use and deployment of V2X applications on 3GPP networks an architecture for V2X application layer consisting of V2X application enabler is specified in this document.

The V2X application enabler capabilities takes into consideration the study in 3GPP TR 23.795 [9], the existing stage 1 and stage 2 work within 3GPP related to V2X in 3GPP TS 22.185 [2], 3GPP TS 22.186 [3] and 3GPP TS 23.285 [5], as well as V2X application standards defined outside 3GPP (e.g. ETSI, SAE).

---

# 1 Scope

The present document specifies the functional architecture, procedures and information flows for V2X application enabler layer. This specification includes the capabilities of the application layer support for V2X services that are necessary to ensure efficient use and deployment of V2X services over 3GPP systems. The VAE capabilities applies to EPS.

---

# 2 References

The following documents contain provisions which, through reference in this text, constitute provisions of the present document.

- References are either specific (identified by date of publication, edition number, version number, etc.) or non-specific.
- For a specific reference, subsequent revisions do not apply.
- For a non-specific reference, the latest version applies. In the case of a reference to a 3GPP document (including a GSM document), a non-specific reference implicitly refers to the latest version of that document *in the same Release as the present document*.

- [1] 3GPP TR 21.905: "Vocabulary for 3GPP Specifications".
- [2] 3GPP TS 22.185: "Service requirements for V2X services; Stage 1".
- [3] 3GPP TS 22.186: "Enhancement of 3GPP support for V2X scenarios; Stage 1".
- [4] 3GPP TS 23.280: "Common functional architecture to support mission critical services".
- [5] 3GPP TS 23.285: "Architecture enhancements for V2X services".
- [6] 3GPP TS 23.434: "Service enabler architecture layer for verticals; Functional architecture and information flows".
- [7] 3GPP TS 23.468: "Group Communication System Enablers for LTE (GCSE\_LTE); Stage 2".
- [8] 3GPP TS 23.682: "Architecture enhancements to facilitate communications with packet data networks and applications".
- [9] 3GPP TR 23.795: "Study on application layer support for V2X services".
- [10] 3GPP TS 26.346: "Multimedia Broadcast/Multicast Service (MBMS); Protocols and codecs".
- [11] 3GPP TS 26.348: "Northbound Application Programming Interface (API) for Multimedia Broadcast/Multicast Service (MBMS) at the xMB reference point".
- [12] 3GPP TS 29.214: "Policy and Charging Control over Rx reference point".
- [13] 3GPP TS 29.468: "Group Communication System Enablers for LTE (GCSE\_LTE); MB2 Reference Point; Stage 3".
- [14] 3GPP TS 36.300: " Evolved Universal Terrestrial Radio Access (E-UTRA) and Evolved Universal Terrestrial Radio Access Network (E-UTRAN); Overall description; Stage 2".
- [15] ETSI EN 302 637-3 (V1.3.1): "Intelligent Transport Systems (ITS); Vehicular Communications; Basic Set of Applications; Part 3: Specifications of Decentralized Environmental Notification Basic Service".
- [16] ETSI TS 102 894-2 (V1.2.1): "Intelligent Transport Systems (ITS); Users and applications requirements; Part 2: Applications and facilities layer common data dictionaryMultimedia Broadcast/Multicast Service (MBMS); Protocols and codecs".

- [17] ETSI TS 102 965 (V1.4.1): "Intelligent Transport Systems (ITS); Application Object Identifier (ITS-AID); Registration".
- [18] ISO TS 17419: "Intelligent Transport Systems - Cooperative systems - Classification and management of ITS applications in a global context".

## 3 Definitions and abbreviations

### 3.1 Definitions

For the purposes of the present document, the terms and definitions given in 3GPP TR 21.905 [1] and the following apply. A term defined in the present document takes precedence over the definition of the same term, if any, in 3GPP TR 21.905 [1].

**V2X group:** A defined set of V2X UEs configured for specific purpose in V2X service.

**V2X dynamic group:** A V2X group where the V2X UEs are determined dynamically corresponding to a group criteria (e.g. proximity).

**V2X service:** A service offered by a V2X application which supports the related communications between two entities (e.g. V2X UE and V2X UE, V2X UE and V2X application server).

### 3.2 Abbreviations

For the purposes of the present document, the abbreviations given in 3GPP TR 21.905 [1] and the following apply. An abbreviation defined in the present document takes precedence over the definition of the same abbreviation, if any, in 3GPP TR 21.905 [1].

AS	Application Server
AID	Application Object Identifier
E-UTRAN	Evolved Universal Terrestrial Radio Access Network
EPS	Evolved Packet System
ETSI	European Telecommunications Standards Institute
LTE	Long-Term Evolution
MBMS	Multimedia Broadcast Multicast Service
PSID	Provider Service Identifier
SAE	Society of Automotive Engineers
SCEF	Service Capability Exposure Function
SCS	Services Capability Server
UE	User Equipment
USD	User Service Description
V2I	Vehicle-to-Infrastructure
V2N	Vehicle-to-Network
V2P	Vehicle-to-Pedestrian
V2V	Vehicle-to-Vehicle
V2X	Vehicle-to-Everything
VAE	V2X Application Enabler

## 4 Architectural requirements

### 4.1 General

#### 4.1.1 Description

This subclause specifies the general requirements for V2X application layer functional architecture.

## 4.1.2 Requirements

[AR-4.1.2-a] The VAE client and the VAE server shall support one or more V2X applications.

[AR-4.1.2-b] The VAE capabilities should be offered as APIs to the V2X applications.

[AR-4.1.2-c] The VAE capabilities shall enable V2X UEs to obtain the address of available V2X application servers associated with served geographical area information.

[AR-4.1.2-d] The VAE capabilities shall enable V2X UEs to obtain the information of available V2X services (e.g. identified by V2X service ID).

[AR-4.1.2-e] The VAE capabilities shall support obtaining information of the available V2X services (e.g. identified by V2X service ID) from the V2X application.

[AR-4.1.2-f] The VAE capabilities shall support obtaining information of the associated geographical area from the V2X application.

[AR-4.1.2-g] The VAE client shall be able to communicate to multiple VAE servers.

## 4.2 V2X group communication

### 4.2.1 Description

This subclause specifies the V2X group communication related requirements.

### 4.2.2 Requirements

[AR-4.2.2-a] The VAE capabilities shall enable configuring ProSe group communication parameters to the VAE clients.

[AR-4.2.2-b] The VAE capabilities shall enable broadcast of the group communication parameters.

[AR-4.2.2-c] The VAE capabilities shall enable VAE clients to generate the group communication parameters.

[AR-4.2.2-d] The VAE capabilities shall enable to prevent overlapping of group communication.

## 4.3 V2X dynamic groups

### 4.3.1 Description

This subclause specifies the V2X dynamic groups related requirements.

### 4.3.2 Requirements

[AR-4.3.2-a] The VAE capabilities shall enable V2X dynamic groups formation.

[AR-4.3.2-b] The VAE capabilities shall enable configuring dynamic group communication parameters to the VAE client.

[AR-4.3.2-c] The VAE capabilities shall enable switching from Uu to PC5-based communication.

[AR-4.3.2-d] The VAE capabilities shall enable determining V2X UEs in the proximity.

[AR-4.3.2-e] The VAE capabilities shall enable V2X dynamic group management (e.g. joining, adding or removing V2X UEs, split or merge).

## 4.4 File distribution capability

### 4.4.1 Description

This subclause specifies the architectural requirements for file distribution.

### 4.4.2 Requirements

[AR-4.4.2-a] The VAE capabilities shall also be able to support delivery of large files using unicast.

[AR-4.4.2-b] The VAE capabilities shall also be able to support delivery of large files using MBMS.

[AR-4.4.2-c] The VAE server shall enable the re-use of MBMS capabilities for file distribution.

## 4.5 V2X application message distribution

### 4.5.1 Description

This subclause specifies the V2X (e.g. ETSI ITS, SAE) message distribution requirements.

### 4.5.2 Requirements

[AR-4.5.2-a] The VAE server shall provide a mechanism to distribute V2X messages to all registered receivers in targeted geographical areas.

[AR-4.5.2-b] The VAE server shall enable the delivery of several V2X messages over the same connection.

[AR-4.5.2-c] The VAE client shall have the capability to register to V2X messages within one or more geographical area.

[AR-4.5.2-d] The VAE server shall have the capability to only forward V2X messages to authorized V2X UEs in target geographical areas.

[AR-4.5.2-e] The VAE server shall provide a mechanism for priority support of different V2X messages (e.g. safety message).

[AR-4.5.2-f] The VAE capabilities shall support the transmission of V2X messages from the V2X UE to the V2X application server.

## 4.6 Service continuity

### 4.6.1 Description

This subclause specifies the V2X service continuity related requirements.

### 4.6.2 Requirements

[AR-4.6.2-a] The VAE capabilities shall enable V2X UEs to continue receiving V2X service when changing geographical area.

---

## 5 Involved business relationships

Figure 5-1 shows the business relationships that exist and that are needed to support a single V2X user.

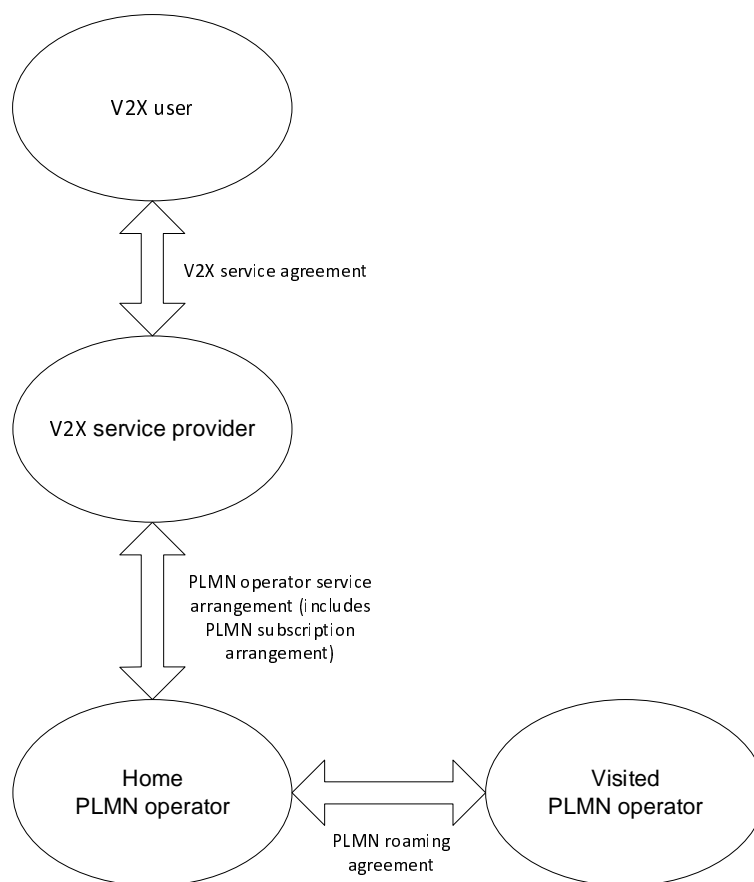

**Figure 5-1: Business relationships for V2X services**

The V2X user belongs to a V2X service provider based on a V2X service agreement between the V2X user and the V2X service provider. The V2X service provider can have V2X service agreements with several V2X users. The V2X user can have V2X service agreements with several V2X service providers.

The V2X service provider and the home PLMN operator can be part of the same organization, in which case the business relationship between the two is internal to a single organization.

The home PLMN operator can have PLMN operator service arrangements with multiple V2X service providers and the V2X service provider can have PLMN operator service arrangements with multiple home PLMN operators. As part of the PLMN operator service arrangement between the V2X service provider and the home PLMN operator, PLMN subscription arrangements can be provided which allows the V2X UEs to register with home PLMN operator network.

The home PLMN operator can have PLMN roaming agreements with multiple visited PLMN operators and the visited PLMN operator can have PLMN roaming agreements with multiple home PLMN operators.

---

## 6 Functional model

### 6.1 General

The functional model for the V2X application layer is organized into functional entities to describe a functional architecture which addresses the application layer support aspects for V2X applications.

### 6.2 Functional model description

Figure 6.2-1 illustrates the simplified architectural model for the V2X application layer. It utilizes the architectural reference model specified in subclause 4.2 in 3GPP TS 23.285 [5] which have impact on the application layer support aspects.

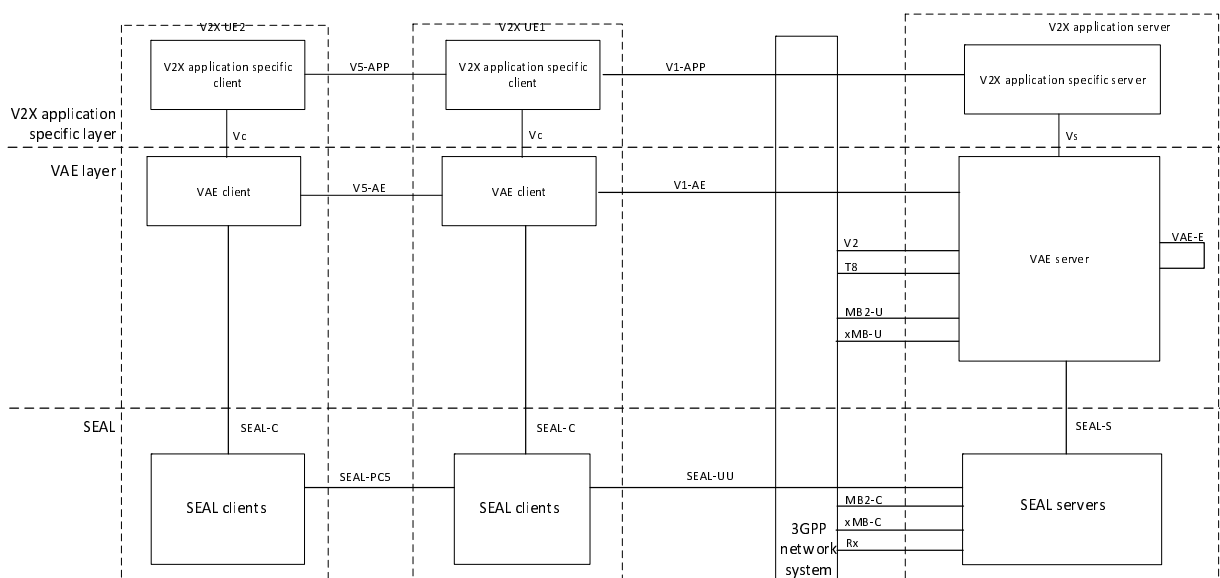

**Figure 6.2-1: Simplified architectural model for the V2X application layer**

The V2X UE1 communicates with V2X application server over V1 reference point. The V2X UE1 and V2X UE2 communicate over V5 reference point. V2X UE1 can also act as a UE-to-network relay, to enable V2X UE2 to access the V2X application server over V1 reference point.

The reference point V1 supports the V2X application related interactions between V2X UE and V2X AS and is specified in 3GPP TS 23.285 [5]. This reference point is supported for both unicast and multicast delivery modes. The reference point V5 supports the interactions between the V2X UEs and is specified in 3GPP TS 23.285 [5].

Figure 6.2-2 illustrates the detailed V2X application layer functional model. It enhances the simplified architectural model for the V2X application layer by specifying the functional entities at the V2X application layer.



**Figure 6.2-2: V2X application layer functional model**

The V2X application layer functional entities for the V2X UE and the V2X application server are grouped into the V2X application specific layer and the VAE layer. The VAE layer offers the VAE capabilities to the V2X application specific layer. The V2X application layer functional model utilizes the SEAL services as specified in 3GPP TS 23.434 [6].

The VAE server is located in the VAE layer. The SEAL services utilized by VAE layer are location management, group management, configuration management, identity management, key management and network resource management. The V2X application specific layer consists of the V2X application specific functionalities.

NOTE 1: The functionalities of the V2X application specific layer are out of scope of the present document.

The V2X application server consists of the VAE server, the SEAL servers and the V2X application specific server. The VAE server provides the V2X application layer support functions to the V2X application specific server over Vs reference point.

The V2X UEs consist of the VAE client, the SEAL clients and the V2X application specific client. The VAE client provides the V2X application layer support functions to the V2X application specific client over Vc reference point.

NOTE 2: In some deployments, the client and server entities of SEAL can be part of VAE client and VAE server respectively.

The VAE client acts as a VAL client for its interaction with the SEAL clients as specified in 3GPP TS 23.434 [6]. The VAE server acts as a VAL server for its interaction with the SEAL servers as specified in 3GPP TS 23.434 [6].

In the VAE layer, the VAE client communicates with the VAE server over V1-AE reference point. In the V2X application specific layer, the V2X application specific client communicates with V2X application specific server over V1-APP reference point.

NOTE 3: The V1-APP reference point is out of scope of the present document.

In the VAE layer, the VAE client of V2X UE2 communicates with VAE client of V2X UE1 over V5-AE reference point. In the V2X application specific layer, the V2X application specific client of V2X UE2 communicates with VAE client of V2X UE1 over V5-APP reference point.

NOTE 4: The V5-APP reference point is out of scope of the present document.

The following SEAL services for V2X applications are supported:

- Location management as specified in 3GPP TS 23.434 [6];
- Group management as specified in 3GPP TS 23.434 [6];
- Configuration management as specified in 3GPP TS 23.434 [6];
- Identity management as specified in 3GPP TS 23.434 [6];
- Key management as specified in 3GPP TS 23.434 [6]; and
- Network resource management as specified in 3GPP TS 23.434 [6].

The VAE client interacts with SEAL clients over the SEAL-C reference point specified for each SEAL service. The VAE server interacts with SEAL servers over the SEAL-S reference point specified for each SEAL service. The interaction between the SEAL clients is supported by SEAL-PC5 reference point specified for each SEAL service. The interaction between a SEAL client and the corresponding SEAL server is supported by SEAL-UU reference point specified for each SEAL service.

NOTE 5: The SEAL-C, SEAL-S, SEAL-PC5, SEAL-UU reference points for each SEAL service is specified in 3GPP TS 23.434 [6].

To support distributed VAE server deployments, the VAE server interacts with another VAE server over VAE-E reference point.

V2X UE1 can also act as a UE-to-network relay,

- to enable VAE client on V2X UE2 to access VAE server over V1-AE reference point; and
- to enable V2X application specific client on V2X UE2 to access V2X application specific server over V1-APP reference point.

A V1-AE message can be sent over unicast, transparent multicast via xMB, transparent multicast via MB2. The non-transparent multicast via xMB (as specified in 3GPP TS 26.348 [11]) is triggered by a V1-AE message. Multicast distribution can be supported by both transparent and non-transparent multicast modes.

The VAE server interacts with the 3GPP network system over V2, MB2, xMB, Rx and T8 reference points. The EPS is considered as the 3GPP network system.

## 6.3 Functional entities description

### 6.3.1 General

Each subclause is a description of a functional entity corresponding to V2X application layer and does not imply a physical entity.



### 6.3.2 V2X application specific client

The V2X application specific client provides the client side functionalities corresponding to the V2X applications (e.g. platooning client). The V2X application specific client utilizes the VAE client for the V2X application layer support functions.

NOTE: The details of the V2X application specific client is out of scope of the present document.

### 6.3.3 V2X application specific server

The V2X application specific server provides the server side functionalities corresponding to the V2X applications (e.g. platooning server). The V2X application specific server utilizes the VAE server for the V2X application layer support functions.

NOTE: The details of the V2X application specific server is out of scope of the present document.

### 6.3.4 VAE client

The VAE client provides the client side V2X application layer support functions as below:

- registration of VAE clients for receiving V2X messages;
- receiving V2X messages from the VAE server and the delivery to V2X application specific client(s) according to the V2X service ID;
- perform the role of the MBMS client for multicast file transfer using xMB APIs;
- receiving network monitoring reports from the VAE server;
- supports switching the modes of operations for V2V communications (e.g. between direct and in-direct V2V communications);
- providing application level locations to the VAE server (e.g. tile, geo-fence);
- receiving 3GPP system configuration information (e.g. V2X USD, PC5 parameters) from the VAE server; and
- supporting dynamic group management.

The VAE client supports interactions with the V2X application specific client(s).

### 6.3.5 VAE server

The VAE server acts as a GCS AS as described in 3GPP TS 23.468 [7] or acts as a content provider as described in 3GPP TS 26.346 [10].

The VAE server provides the server side V2X application layer support functions as below:

- communicating with the underlying 3GPP network system (EPS) for unicast and multicast network resource management;
- receiving monitoring reports/events from the underlying 3GPP network system (EPS) regarding network situation corresponding to RAN and core network;
- supporting registration of V2X UEs;
- tracking the application level geographic location of the V2X UEs;
- supporting V2X message distribution for the V2X applications;
- supporting provisioning of 3GPP system configuration information (e.g. V2X USD, PC5 parameters);
- perform the role of content provider for multicast file transfer using xMB APIs;
- providing network monitoring reports to the V2X UEs;

- communicating V2X service requirements to the underlying 3GPP network system (EPS);
- maintaining the mapping between the V2X user ID and the V2X UE ID;
- providing V2X service discovery;
- supporting V2X service continuity; and
- supporting V2X application resource adaptation.

### 6.3.6 SEAL client

The following SEAL clients for V2X applications are supported:

- Location management client as specified in 3GPP TS 23.434 [6];
- Group management client as specified in 3GPP TS 23.434 [6];
- Configuration management client as specified in 3GPP TS 23.434 [6];
- Identity management client as specified in 3GPP TS 23.434 [6];
- Key management client as specified in 3GPP TS 23.434 [6]; and
- Network resource management client as specified in 3GPP TS 23.434 [6].

### 6.3.7 SEAL server

The following SEAL servers for V2X applications are supported:

- Location management server as specified in 3GPP TS 23.434 [6];
- Group management server as specified in 3GPP TS 23.434 [6];
- Configuration management server as specified in 3GPP TS 23.434 [6];
- Identity management server as specified in 3GPP TS 23.434 [6];
- Key management server as specified in 3GPP TS 23.434 [6]; and
- Network resource management server as specified in 3GPP TS 23.434 [6].

## 6.4 Reference points description

### 6.4.1 General

The reference points for the V2X application layer are described in the following subclauses.

### 6.4.2 V1-AE

The interactions related to V2X application layer support functions between VAE client and VAE server are supported by V1-AE reference point. This reference point is an instance of V1 reference point as described in 3GPP TS 23.285 [5]. This reference point is supported for both unicast and multicast delivery modes.

### 6.4.3 V1-APP

The interactions related to V2X applications between V2X application specific client and V2X application specific server are supported by V1-APP reference point. This reference point is an instance of V1 reference point described in 3GPP TS 23.285 [5]. The details of V1-APP reference point is out of scope of the present document.

#### 6.4.4 V5-AE

The interactions related to V2X application layer support functions between the VAE clients are supported by V5-AE reference point. This reference point is an instance of V5 reference point as described in 3GPP TS 23.285 [5].

#### 6.4.5 V5-APP

The interactions related to V2X applications between V2X application specific clients are supported by V5-APP reference point. This reference point is an instance of V5 reference point described in 3GPP TS 23.285 [5]. The details of V5-APP reference point is out of scope of the present document.

#### 6.4.6 Vs

The interactions related to V2X application layer support functions between the VAE server and the V2X application specific server are supported by Vs reference point.

#### 6.4.7 Vc

The interactions related to V2X application layer support functions between the VAE client and the V2X application specific client are supported by Vc reference point.

#### 6.4.8 SEAL-C

The following SEAL-C reference points for V2X applications are supported:

- LM-C reference point for location management as specified in 3GPP TS 23.434 [6];
- GM-C reference point for group management as specified in 3GPP TS 23.434 [6];
- CM-C reference point for configuration management as specified in 3GPP TS 23.434 [6];
- IM-C reference point for identity management as specified in 3GPP TS 23.434 [6];
- KM-C reference point for key management as specified in 3GPP TS 23.434 [6]; and
- NRM-C reference point for network resource management as specified in 3GPP TS 23.434 [6].

#### 6.4.9 SEAL-S

The following SEAL-S reference points for V2X applications are supported:

- LM-S reference point for location management as specified in 3GPP TS 23.434 [6];
- GM-S reference point for group management as specified in 3GPP TS 23.434 [6];
- CM-S reference point for configuration management as specified in 3GPP TS 23.434 [6];
- IM-S reference point for identity management as specified in 3GPP TS 23.434 [6];
- KM-S reference point for key management as specified in 3GPP TS 23.434 [6]; and
- NRM-S reference point for network resource management as specified in 3GPP TS 23.434 [6].

#### 6.4.10 SEAL-PC5

The following SEAL-PC5 reference points for V2X applications are supported:

- LM-PC5 reference point for location management as specified in 3GPP TS 23.434 [6];
- GM-PC5 reference point for group management as specified in 3GPP TS 23.434 [6];
- CM-PC5 reference point for configuration management as specified in 3GPP TS 23.434 [6];

- IM-PC5 reference point for identity management as specified in 3GPP TS 23.434 [6];
- KM-PC5 reference point for key management as specified in 3GPP TS 23.434 [6]; and
- NRM-PC5 reference point for network resource management as specified in 3GPP TS 23.434 [6].

### 6.4.11 SEAL-UU

The following SEAL-UU reference points for V2X applications are supported:

- LM-UU reference point for location management as specified in 3GPP TS 23.434 [6];
- GM-UU reference point for group management as specified in 3GPP TS 23.434 [6];
- CM-UU reference point for configuration management as specified in 3GPP TS 23.434 [6];
- IM-UU reference point for identity management as specified in 3GPP TS 23.434 [6];
- KM-UU reference point for key management as specified in 3GPP TS 23.434 [6]; and
- NRM-UU reference point for network resource management as specified in 3GPP TS 23.434 [6].

### 6.4.12 VAE-E

The interactions related to V2X application supports functions between the VAE servers in a distributed deployment are supported by VAE-E reference point.

## 6.5 External reference points

### 6.5.1 General

The reference points between the V2X application layer and the 3GPP network system (EPS) are described in the following subclauses.

### 6.5.2 V2

The reference point V2 supports the interactions between V2X AS and the V2X control function of the EPS and is specified in 3GPP TS 23.285 [5].

### 6.5.3 Rx

The reference point Rx supports the interactions between the V2X AS and the PCRF and is specified in 3GPP TS 29.214 [12]. The functions for Rx reference point are supported by the network resource management server of the SEAL.

### 6.5.4 MB2-C

The reference point MB2-C supports the control plane interactions between the V2X AS and the BM-SC and is specified in 3GPP TS 29.468 [13]. The functions for MB2-C reference point are supported by the network resource management server of the SEAL.

### 6.5.5 MB2-U

The reference point MB2-U supports the user plane interactions between the V2X AS and the BM-SC and is specified in 3GPP TS 29.468 [13]. The functions for MB2-U reference point are supported by the VAE server.

## 6.5.6 xMB-C

The reference point xMB-C supports the control plane interactions between the V2X AS and the BM-SC and is specified in 3GPP TS 26.346 [10]. The functions for xMB reference point are supported by the network resource management server of the SEAL.

## 6.5.7 xMB-U

The reference point xMB-U supports the user plane interactions between the V2X AS and the BM-SC and is specified in 3GPP TS 26.346 [10]. The functions for xMB-U reference point are supported by the VAE server.

## 6.5.8 T8

The reference point T8 supports the interactions between the V2X AS and the SCEF and is specified in 3GPP TS 23.682 [8]. The functions of T8 interface are supported by VAE server and the functions related to location management of T8 are supported by the location management server.

---

# 7 Deployment models

## 7.1 General

This clause describes deployments of the functional model specified in clause 6.

NOTE: The representation of SEAL functionalities in the vertical deployment is specified in 3GPP TS 23.434 [6].

## 7.2 Deployment of VAE server

The VAE server deployments can be centralized and distributed.

### 7.2.1 Centralized deployments

A centralized deployment is where a single VAE server offers the VAE capabilities to one or more V2X application specific server. The VAE server and the V2X application specific server may be co-located in a single physical entity. The VAE server may be deployed either in the PLMN operator domain or deployed in the V2X service provider domain. The VAE server connects with the 3GPP network system (EPS) in one or more PLMN operator domain. When VAE server and V2X application specific server are co-located in a single physical entity, the Vs reference point between the VAE server and the V2X application enabler server may not be used.

Figure 7.2.1-1 illustrates a deployment of the VAE server and the V2X application specific server in a single physical entity and deployed in V2X service provider domain. The VAE server may be deployed in a separate physical entity from the V2X application specific server in the V2X service provider domain. In such deployments, the Vs reference point is used for the communication between the VAE server and the V2X application specific server.

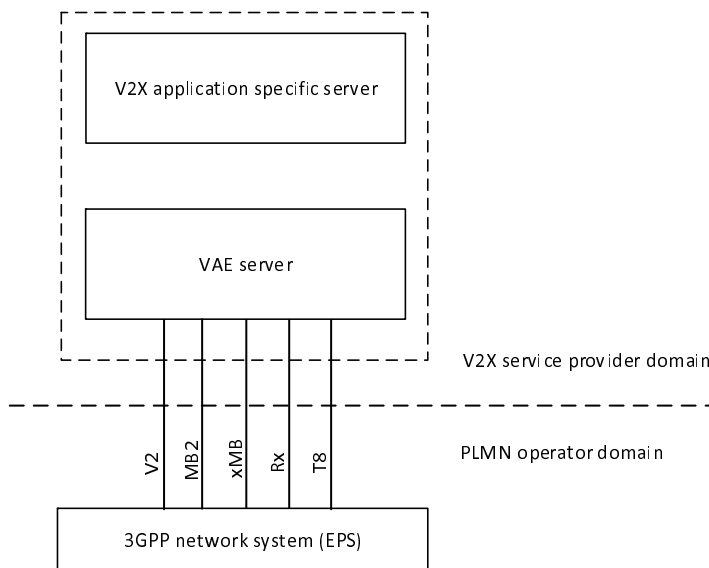

**Figure 7.2.1-1: VAE server co-located with V2X application specific server in a single physical entity**

Figure 7.2.1-2 illustrates a deployment of the VAE server in the PLMN operator domain and the V2X application specific server in the V2X service provider domain. The Vs reference point is used for the communication between V2X application specific server and the VAE server. The VAE server may support multiple V2X application specific servers.

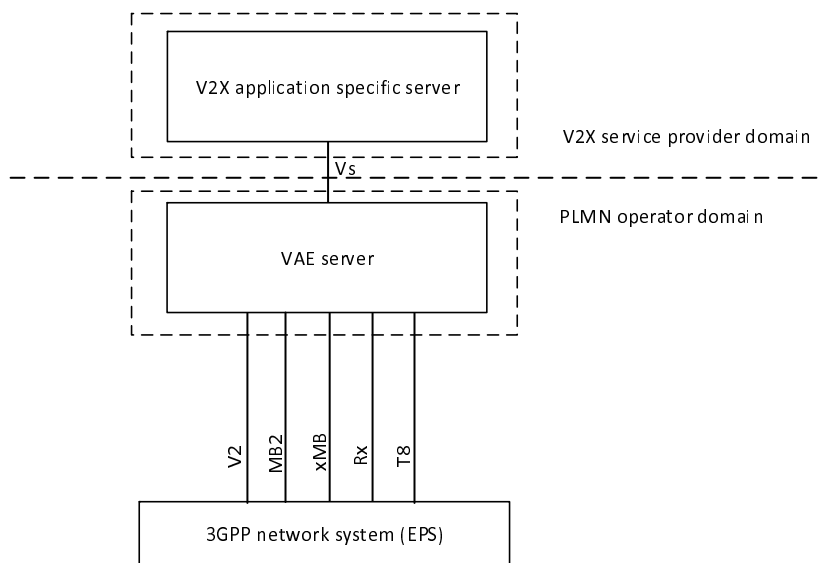

**Figure 7.2.1-2: VAE server deployed in the PLMN operator domain**

Figure 7.2.1-3 illustrates a deployment of the VAE server which connects to the 3GPP network system (EPS) in multiple PLMN operator domain. The VAE server may be co-located with the V2X application specific server in a single physical entity or deployed in different physical entities.

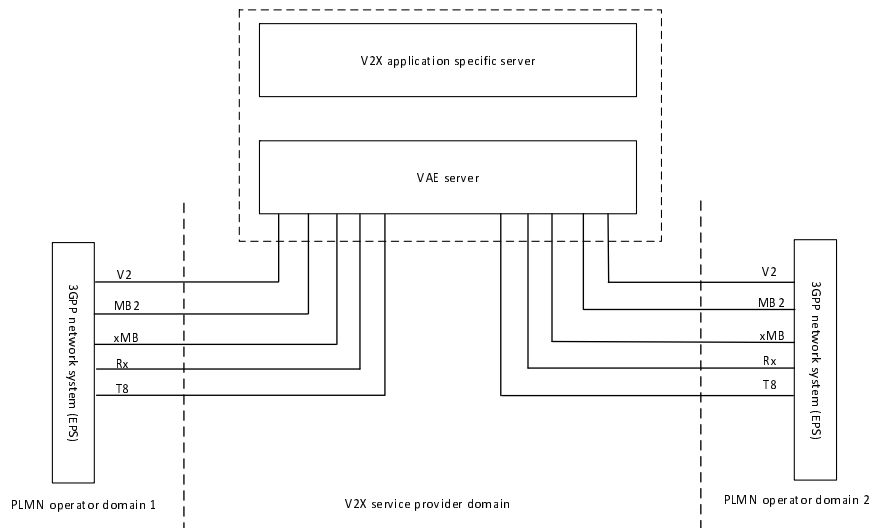

**Figure 7.2.1-3: Deployment of VAE server with connections to 3GPP network system (EPS) in multiple PLMN operator domains**

Figure 7.2.1-4 illustrates a deployment of the VAE server which provides VAE capabilities to multiple V2X application specific servers over Vs reference point and connects to the 3GPP network system (EPS) in multiple PLMN operator domain.

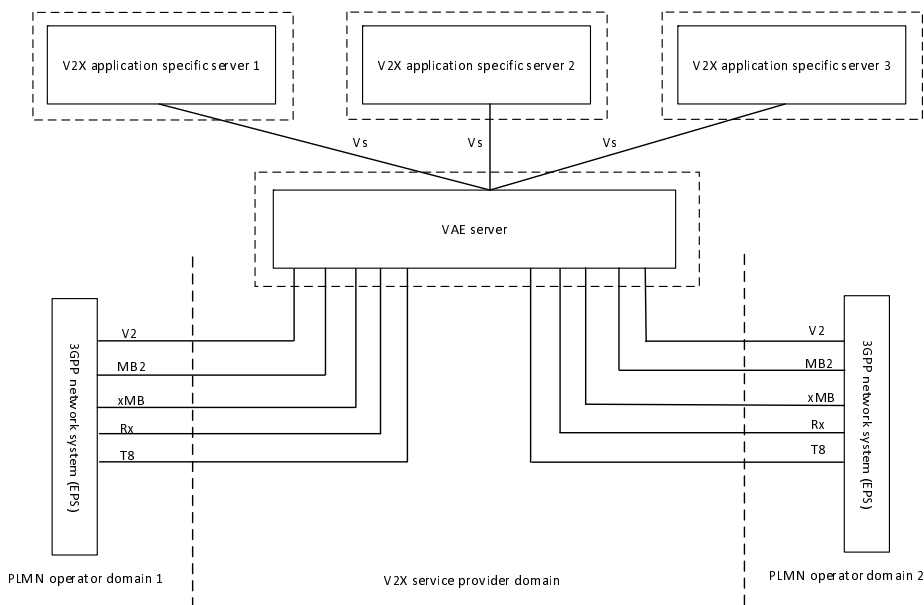
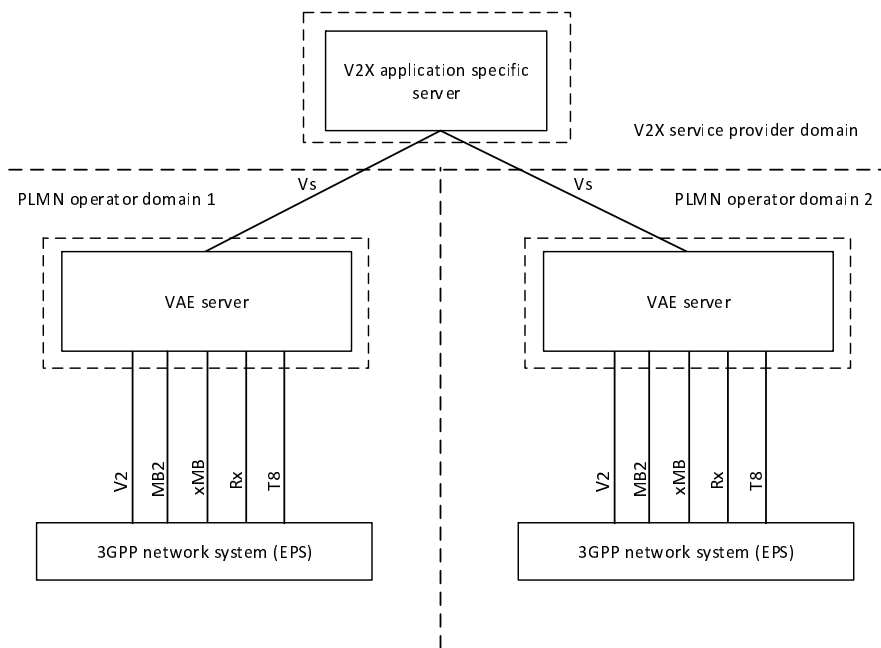

**Figure 7.2.1-4: Deployment of VAE server with connections to multiple V2X application specific servers**

## 7.2.2 Distributed deployment

The distributed deployment is where multiple VAE servers are deployed either in the V2X service provider domain or in the PLMN operator domain. The distributed deployment of the VAE servers provide geographical coverage or support multiple PLMN operator domains in a geographical location. The VAE servers interconnect via VAE-E and the Vs reference point is used for interaction between V2X application specific server and the VAE server.

Figure 7.2.2-1 illustrates the deployment of VAE servers in multiple PLMN operator domain and provides VAE capabilities to the V2X application specific server deployed in the V2X service provider domain. The V2X application specific server connects via Vs to the VAE servers.



**Figure 7.2.2-1: Distributed deployment of VAE servers in multiple PLMN operator domain without interconnection between VAE servers**

Figure 7.2.2-2 illustrates the deployment of multiple VAE servers deployed in multiple PLMN operator domains. The V2X application specific server connects via Vs to the VAE server. The interconnection between VAE servers is via VAE-E and supports the V2X applications for the V2X UEs connected to the VAE servers in multiple PLMN operator domains.

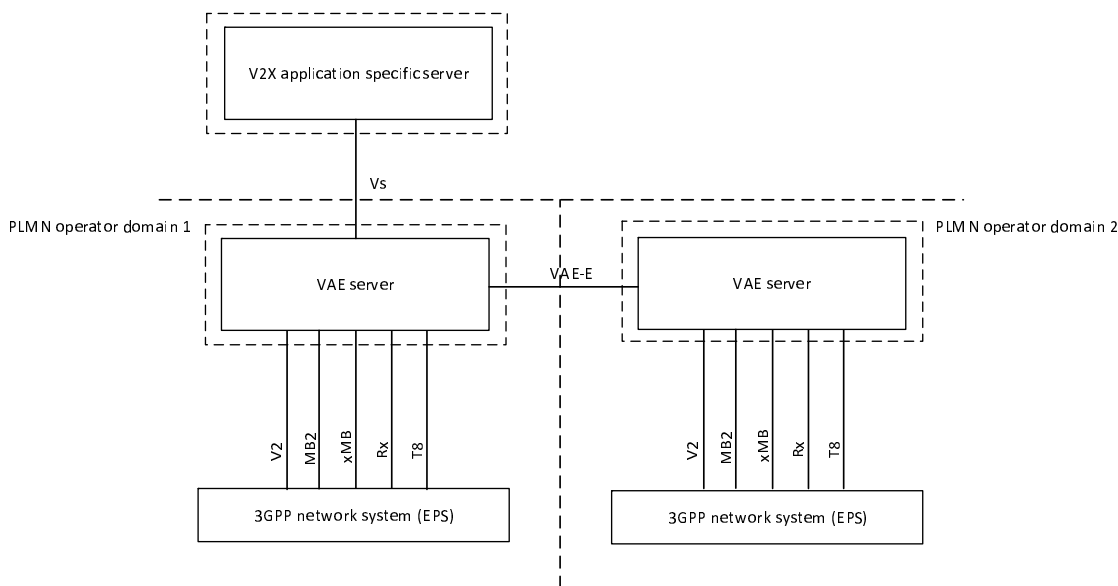

**Figure 7.2.2-2: Distributed deployment of VAE servers in multiple PLMN operator domain with interconnection between VAE servers**

Figure 7.2.2-3 illustrates the deployment of multiple VAE servers in PLMN operator domain based on geographical coverage. The V2X application specific server connects via Vs to the VAE server 1. The VAE servers interconnect via VAE-E and support the V2X communications to the V2X UEs connected to the VAE servers.



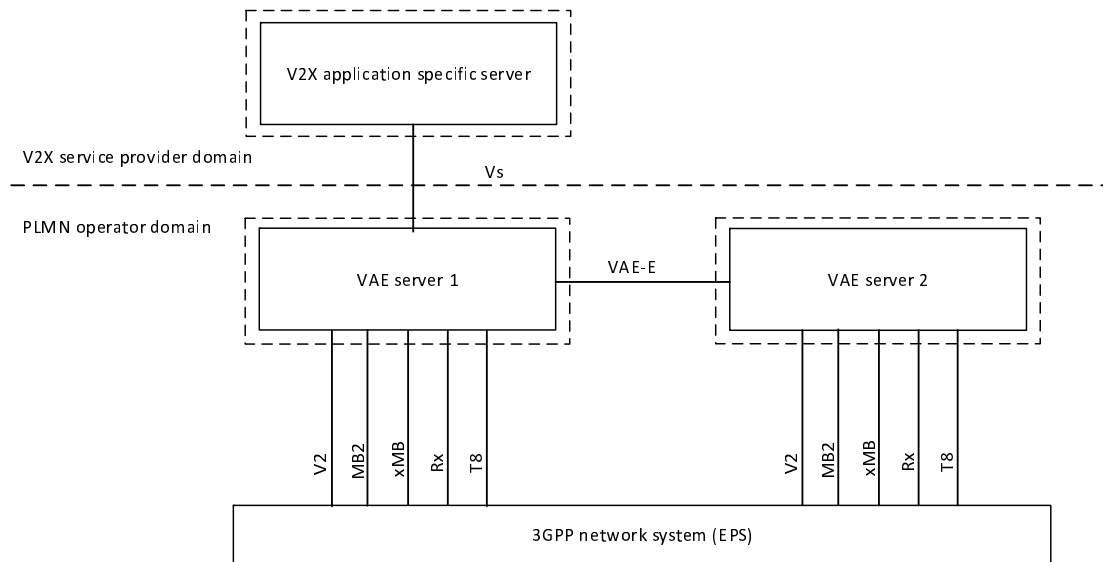

**Figure 7.2.2-3: Distributed deployment of VAE servers in PLMN operator domain**

Figure 7.2.2-4 illustrates the deployment of multiple VAE servers in the V2X service provider domain where VAE server 1 and VAE server 2 connect with 3GPP network system of PLMN operator domain 1 and PLMN operator domain 2 respectively. The PLMN operator domains provide coverage to different geographical areas. The V2X application specific server connects via Vs to the VAE server 1. The VAE servers interconnect via VAE-E and support the V2X applications for the V2X UEs connected via both the PLMN operator domains.

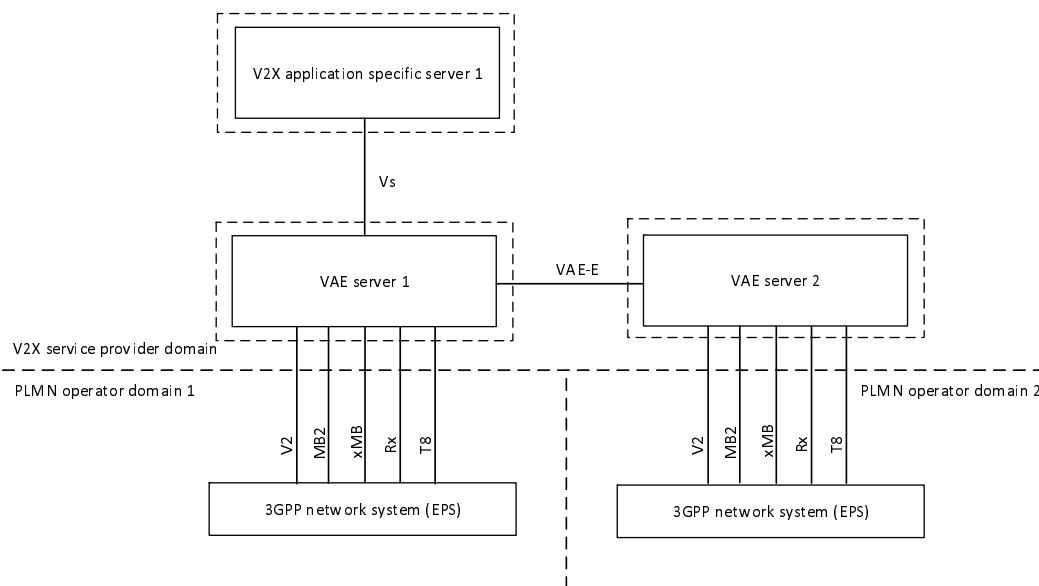

**Figure 7.2.2-4: Distributed deployment of VAE servers in V2X service provider domain**

## 8 Identities

### 8.1 V2X user identity (V2X user ID)

The V2X user ID can be an instance of the VAL user ID as specified in 3GPP TS 23.434 [6]. The V2X user ID is a globally unique identifier within the V2X service that represents the V2X user. The V2X user ID shall be a URI. The V2X user ID is used for authentication and authorization purposes for providing the V2X service towards the V2X user via the V2X UE. The V2X user ID also indicates the V2X service provider with whom the V2X user has a V2X service agreement. The V2X user may have V2X service agreement with several V2X service providers and thus will have obtained unique V2X user ID per V2X service provider.

Based on the service agreement, each V2X user ID is mapped to a V2X UE ID.

## 8.2 V2X UE identity (V2X UE ID)

The V2X UE ID can be an instance of the VAL UE ID as specified in 3GPP TS 23.434 [6]. The V2X UE ID is a unique identifier within the V2X service that represents the V2X UE. The V2X UE ID is mapped to an application specific UE identity (e.g. StationID as specified in ETSI TS 102 894-2 [16]). Due to privacy considerations, the V2X UE ID may be changed. The V2X UE ID is used to address the V2X UE in order to send V2X messages.

## 8.3 V2X service identity (V2X service ID)

The V2X service ID can be an instance of the VAL service ID as specified in 3GPP TS 23.434 [6]. The V2X service ID is a globally unique identifier that represents the V2X service. A V2X application server provides a list of V2X services towards the V2X UE. Each V2X service is uniquely identified by a V2X service ID, which is an identifier of the V2X application. The V2X service ID can be used for policy mapping, QoS handling for V2X communication and V2X message distribution, as specified in 3GPP TS 23.285 [5]. An identifier of a V2X service, e.g. ITS-AID or PSID specified in ETSI TS 102 965 [17] and ISO TS 17419 [18], can be used as a V2X service ID.

## 8.4 V2X group identity (V2X group ID)

The V2X group ID is a globally unique identifier within the V2X service that represents a set of V2X users and the corresponding V2X UE. The set of V2X users may belong to the same or different V2X service provider. It indicates the V2X application server where the group is defined.

## 8.5 Geographical area identity (GEO ID)

The V2X service provider defined identity of a geographical area. The GEO ID supports different representations of geographical area (e.g. geo-fence, tile identifiers). The VAE server maintains the mapping of the GEO ID with the location corresponding to one or more V2X UE IDs.

The GEO ID may support the format of a URI.

---

# 9 Procedures and information flows

## 9.1 Usage of SEAL services

### 9.1.1 Group management service

#### 9.1.1.1 General

The VAE capabilities (VAE client and VAE server) utilize the group management service procedures (e.g. creation, join, leave) of SEAL based on the group configuration information (e.g. group join policy, group leader) provided by the V2X application specific layer. The decisions and corresponding triggers (e.g. group creation, join, leave) for group management are responsibility of the V2X application specific layer and the details of the group management are abstracted by the VAE capabilities. The group management service of SEAL provides support for platooning groups and pre-arranged groups for V2X communications.

#### 9.1.1.2 Information flows

The following information flows of group management service of SEAL as specified in 3GPP TS 23.434 [6] are applicable for the V2X applications:

- Group creation request specified in subclause 10.3.2.1;

- Group creation response specified in subclause 10.3.2.2;
- Group creation notification specified in subclause 10.3.2.3;
- Group information query request specified in subclause 10.3.2.4;
- Group information query response specified in subclause 10.3.2.5;
- Group membership update request specified in subclause 10.3.2.6;
- Group membership update response specified in subclause 10.3.2.7;
- Group membership notification specified in subclause 10.3.2.8;
- Group deletion request specified in subclause 10.3.2.9;
- Group deletion response specified in subclause 10.3.2.10;
- Group deletion notification specified in subclause 10.3.2.11;
- Group information request specified in subclause 10.3.2.12;
- Group information response specified in subclause 10.3.2.13;
- Group information subscribe request specified in subclause 10.3.2.14;
- Group information subscribe response specified in subclause 10.3.2.15;
- Group information notify request specified in subclause 10.3.2.16;
- Group information notify response specified in subclause 10.3.2.17;
- Store group configuration request specified in subclause 10.3.2.18;
- Store group configuration response specified in subclause 10.3.2.19;
- Get group configuration request specified in subclause 10.3.2.20;
- Get group configuration response specified in subclause 10.3.2.21;
- Subscribe group configuration request specified in subclause 10.3.2.22;
- Subscribe group configuration response specified in subclause 10.3.2.23;
- Notify group configuration request specified in subclause 10.3.2.24;
- Notify group configuration response specified in subclause 10.3.2.25;
- Configure VAL group request specified in subclause 10.3.2.26;
- Configure VAL group response specified in subclause 10.3.2.27;
- Group announcement specified in subclause 10.3.2.28;
- Group registration request specified in subclause 10.3.2.29;
- Group registration response specified in subclause 10.3.2.30;
- Identity list notification specified in subclause 10.3.2.31;
- Group de-registration request specified in subclause 10.3.2.32;
- Group de-registration response specified in subclause 10.3.2.33;

The usage of the above information flows are clarified as below:

- The identity list is the list of V2X UE IDs.

- During group creation the identity list contains the list of V2X UE IDs that are part of the group to be created. If the group member list is empty, an empty group is created; and
- The VAL service ID list is the list of V2X service IDs whose service communications are to be enabled on the group.
- Table 9.1.1.2.1-1 describes the VAL service specific information corresponding to the V2X applications.

**Table 9.1.1.2.1-1: V2X service specific information for group creation request**

Information element	Status	Description
V2X group ID	O	The group ID to be used for the V2X group. If group ID is not provided then the group ID should be allocated by group management server.
Group join policy	O (NOTE)	The policy information to be enforced by the group management server for members joining the group.
Group leader ID	O (NOTE)	The identity information of the V2X user to be used for user controlled group join.
NOTE: If the information elements, identity list specified in 3GPP TS 23.434 [6] is empty and group leader ID is not included, then group join policy information element must be included.		

- The VAL group ID is the V2X group ID.
- The identity is the V2X UE ID;
- The VAL server is the VAE server;
- The VAL group configuration information is the V2X group configuration information;
- The VAL group configuration data is the V2X group configuration information;
- The VAL group information reference is the V2X group information reference; and
- The VAL services requested is the V2X service IDs.

### 9.1.1.3 Procedures

The following procedures of group management service of SEAL as specified in 3GPP TS 23.434 [6] are applicable for the V2X applications:

- Group creation specified in subclause 10.3.3;
  - Group creation support is provided for the V2X applications (e.g. platooning and cooperative short distance grouping) to provide a dedicated group for the V2X UEs to communicate with each other. The group creation supports group without any group members to enable group member joining.
- Group information query specified in subclause 10.3.4;
- Group membership specified in subclause 10.3.5;
- Group configuration management specified in subclause 10.3.6;
- Group announcement and join specified in subclause 10.3.8;

## 9.1.2 Configuration management service

### 9.1.2.1 General

The VAE capabilities (VAE client and VAE server) utilize configuration management service procedures of SEAL to support V2X services for unicast and multicast delivery over LTE-Uu. The configuration management service of SEAL is utilized for offline configuration (before the V2X UE is receiving the V2X service from the V2X application specific server) and online configuration (during the V2X UE is receiving the V2X service from the V2X application specific server).

### 9.1.2.2 Information flows

The following information flows of configuration management service are applicable for the V2X applications:

- Get VAL UE configuration request specified in subclause 11.3.2.1 of 3GPP TS 23.434 [6];
- Get VAL UE configuration response specified in subclause 11.3.2.2 of 3GPP TS 23.434 [6];

The usage of the above information flows are clarified as below:

- The VAL UE ID is the V2X UE ID;
- VAL service ID is the V2X service ID; and
- VAL UE configuration data is the V2X UE configuration data. The V2X UE configuration data includes:
  - V2X server USD information as specified in 3GPP TS 23.285 [5]; and
  - V2X application server address information as specified in 3GPP TS 23.285 [5] and transport port for unicast.

### 9.1.2.3 Procedures

The following procedures of configuration management service are applicable for the V2X applications:

- VAL UE configuration data specified in subclause 11.3.3 of 3GPP TS 23.434 [6].
  - Once the V2X UEs are connected to the serving PLMN, the V2X UE is configured with configuration data (e.g. local service information) for receiving V2X services.

## 9.1.3 Location management service

### 9.1.3.1 General

The VAE capabilities (VAE client and VAE server) utilize location management (e.g. network location of UEs) service procedures of SEAL to support V2X services.

### 9.1.3.2 Information flows

The following information flows of location management service of SEAL as specified in 3GPP TS 23.434 [6] are applicable for the V2X applications:

- Location reporting configuration request specified in subclause 9.3.2.0;
- Location reporting configuration response specified in subclause 9.3.2.1;
- Location information report specified in subclause 9.3.2.2;
- Location information request specified in subclause 9.3.2.3;
- Location reporting trigger specified in subclause 9.3.2.4;
- Location information subscription request specified in subclause 9.3.2.5;
- Location information subscription response specified in subclause 9.3.2.6;
- Location information notification specified in subclause 9.3.2.7;

The usage of the above information flows are clarified as below:

- The identity is the V2X UE ID or V2X group ID;
- The set of identities is the V2X UE ID;
- The identity list or identities list is the list of V2X UE IDs; and

- The VAL server is the VAE server.

### 9.1.3.3 Procedures

The following procedures of location management service of SEAL as specified in 3GPP TS 23.434 [6] are applicable for the V2X applications:

- Event-triggered location reporting procedure specified in subclause 9.3.3;
- On-demand location reporting procedure specified in subclause 9.3.4;
- Location reporting event triggers configuration cancel specified in subclause 9.3.6;
- Location information subscription procedure specified in subclause 9.3.7;
- Event-trigger location information notification procedure specified in subclause 9.3.8;
- On-demand usage of location information procedure specified in subclause 9.3.9;

## 9.1.4 Identity management service

### 9.1.4.1 General

The VAE capabilities (VAE client and VAE server) utilizes identity management service procedures (e.g. authentication and authorization of UEs) of SEAL to support V2X services.

### 9.1.4.2 Information flows

The following information flows of identity management service specified in subclause 12.3.2 of 3GPP TS 23.434 [6] are applicable for the V2X applications:

**Editor's note: The information flows of identity management service utilized by V2X services is FFS.**

### 9.1.4.3 Procedures

The following procedures of identity management service are applicable for the V2X applications:

- General user authentication and authorization for VAL services specified in subclause 12.3.3 of 3GPP TS 23.434 [6].

## 9.1.5 Key management service

### 9.1.5.1 General

The VAE capabilities (VAE client and VAE server) utilizes key management service procedures of SEAL to support V2X services.

### 9.1.5.2 Information flows

The following information flows of key management service specified in subclause 13.3.2 of 3GPP TS 23.434 [6] are applicable for the V2X applications:

**Editor's note: The information flows of key management service utilized by V2X services is FFS.**

### 9.1.5.3 Procedures

The following procedures of key management service specified in subclause 13.3 of 3GPP TS 23.434 [6] are applicable for the V2X applications:

**Editor's note: The procedures of key management service utilized by V2X services is FFS.**

## 9.1.6 Network resource management service

### 9.1.6.1 General

The VAE capabilities (VAE client and VAE server) utilizes network resource management service procedures of SEAL to support V2X services.

### 9.1.6.2 Information flows

The following information flows of network resource management service of SEAL specified in 3GPP TS 23.434 [6] are applicable for the V2X applications:

- Network resource adaptation request specified in subclause 14.3.2.1;
- Network resource adaptation response specified in subclause 14.3.2.2;
- MBMS bearer announcement specified in subclause 14.3.2.3;
- MBMS listening status report specified in subclause 14.3.2.4;
- MBMS suspension reporting instruction specified in subclause 14.3.2.5;
- Resource request specified in subclause 14.3.2.6;
- Resource response specified in subclause 14.3.2.7;
- Resource modification request specified in subclause 14.3.2.8;
- Resource modification response specified in subclause 14.3.2.9;
- MBMS bearers request specified in subclause 14.3.2.10;
- MBMS bearers response specified in subclause 14.3.2.11; and
- User plane delivery mode specified in subclause 14.3.2.12;

### 9.1.6.3 Procedures

The following procedures of network resource management service of SEAL specified 3GPP TS 23.434 [6] are applicable for the V2X applications:

- Request for unicast resources at VAL service communication establishment specified in subclause 14.3.3.2.1;
- Request for modification of unicast resources specified in subclause 14.3.3.2.2;
- Network resource adaptation specified in subclause 14.3.3.3.1;
- Use of pre-established MBMS bearers specified in subclause 14.3.4.2;
- Use of dynamic MBMS bearer establishment specified in subclause 14.3.4.3;
- MBMS bearer announcement over MBMS bearer specified in subclause 14.3.4.4;
- MBMS bearer quality detection specified in subclause 14.3.4.5;
- Service continuity in MBMS scenarios specified in subclause 14.3.4.6;
- MBMS suspension notification specified in subclause 14.3.4.7;
- MBMS bearer event notification specified in subclause 14.3.4.8; and
- Switching between MBMS bearer and unicast bearer specified in subclause 14.3.4.9.

## 9.2 V2X UE registration

### 9.2.1 General

The VAE capabilities provide support for registering V2X UEs at the VAE server. The VAE server uses the registration information to distribute V2X messages to the appropriate V2X UEs.

### 9.2.2 Information flows

#### 9.2.2.1 Registration request

Table 9.2.2.1-1 describes the information flow for a VAE client to register for specific V2X messages at the VAE server.

**Table 9.2.2.1-1: Registration request**

Information element	Status	Description
V2X UE ID	M	Identifier of the V2X UE (e.g. StationID specified in ETSI TS 102 894-2 [16])
V2X service ID	M	V2X service ID, the V2X UE is interested in receiving (e.g. PSID or ITS AID of ETSI ITS DENM, ETSI ITS CAM)

#### 9.2.2.2 Registration response

Table 9.2.2.2-1 describes the information flow for VAE server to respond for registration request from the VAE client.

**Table 9.2.2.2-1: Registration response**

Information element	Status	Description
Result	M	Result from the VAE server in response to registration request indicating success or failure

#### 9.2.2.3 Deregistration request

Table 9.2.2.3-1 describes the information flow for a VAE client to deregister from receiving specific V2X messages from the VAE server.

**Table 9.2.2.3-1: Deregistration request**

Information element	Status	Description
V2X UE ID	M	Identifier of the V2X UE
V2X service ID	M	V2X service ID the V2X UE is no longer interested in receiving (e.g. PSID or ITS AID of ETSI ITS DENM, ETSI ITS CAM)

#### 9.2.2.4 Deregistration response

Table 9.2.2.4-1 describes the information flow for VAE server to respond for deregistration request from the VAE client.

**Table 9.2.2.4-1: Deregistration response**

Information element	Status	Description
Result	M	Result from the VAE server in response to the deregistration request



## 9.2.3 V2X UE registration for receiving V2X messages

### 9.2.3.1 General

This subclause describes the procedures for V2X UE to register for receiving V2X messages from the V2X AS. The process is triggered by the V2X UE who is interested in receiving certain V2X messages.

### 9.2.3.2 Procedure

Pre-condition:

- The VAE client has discovered the VAE server and is aware of the address of the VAE server (e.g. FDQN).

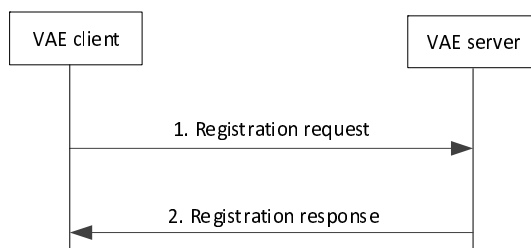

**Figure 9.2.3.2-1: Procedure for registering the VAE client at the VAE server**

1. The VAE client sends a registration request to the VAE server.
2. The VAE server sends an acknowledgement to the VAE client.

## 9.2.4 V2X UE deregistration from receiving V2X messages

### 9.2.4.1 General

This subclause describes the procedures for V2X UE to deregister from receiving V2X messages from the V2X AS. The process is triggered by the V2X UE who is no longer interested in receiving certain V2X messages.

### 9.2.4.2 Procedure

Pre-condition:

- The VAE client has already registered with the VAE server as described in subclause 9.2.3.

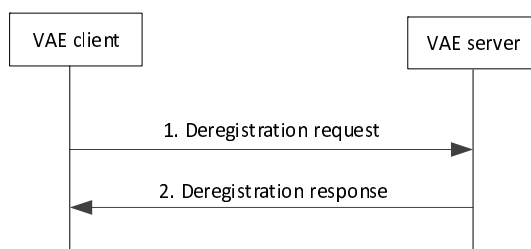

**Figure 9.2.4.2-1: Procedure for deregistering the VAE client at the VAE server**

1. The VAE client sends a deregistration request to the VAE server.
2. The VAE server sends a deregistration response to the VAE client.

## 9.3 Application level location tracking

### 9.3.1 General

The VAE capabilities provide support for location tracking of the VAE client(s) as per the geographical information provided by the V2X application specific layer.

### 9.3.2 Information flows

#### 9.3.2.1 Subscription request

Table 9.3.2.1-1 describes the information flow for a VAE client to subscribe to a geographical area at the VAE server.

**Table 9.3.2.1-1: Subscription request**

Information element	Status	Description
V2X UE ID	M	Identifier of the V2X UE
GEO ID	M	Geographical area identifier (e.g. URI, tile identifier, geo-fence tile identifier)

#### 9.3.2.2 Subscription response

Table 9.3.2.2-1 describes the information flow for VAE server to respond for geographical area subscription request from the VAE client.

**Table 9.3.2.2-1: Subscription response**

Information element	Status	Description
Result	M	Result from the VAE server in response to subscription request indicating success or failure

#### 9.3.2.3 Unsubscription request

Table 9.3.2.3-1 describes the information flow for a VAE client to unsubscribe from a geographical area at the VAE server.

**Table 9.3.2.3-1: Unsubscription request**

Information element	Status	Description
V2X UE ID	M	Identifier of the V2X UE
GEO ID	M	Geographical area identifier (e.g. URI, tile identifier, geo-fence tile identifier)

#### 9.3.2.4 Unsubscription response

Table 9.3.2.4-1 describes the information flow for VAE server to respond for geographical area unsubscription request from the VAE client.

**Table 9.3.2.4-1: Unsubscription response**

Information element	Status	Description
Result	M	Result from the VAE server in response to unsubscription request

## 9.3.3 Tracking geographical location at the VAE server

### 9.3.3.1 General

This subclause describes the procedures for tracking V2X UEs geographical location at the VAE server. The V2X UE provides geographical area information to the VAE server upon moving to a new geographical area. This information is used by the VAE server to create and update the mapping between the geographical location and the identification of the V2X UE.

### 9.3.3.2 Procedure

Pre-conditions:

1. The VAE client is provisioned with GEO ID information;
2. The VAE client has registered with the VAE server as described in subclause 9.2.3; and
3. The VAE client has subscribed to a certain geographical area identifier (GEO ID A) in order to receive V2X messages for this area.

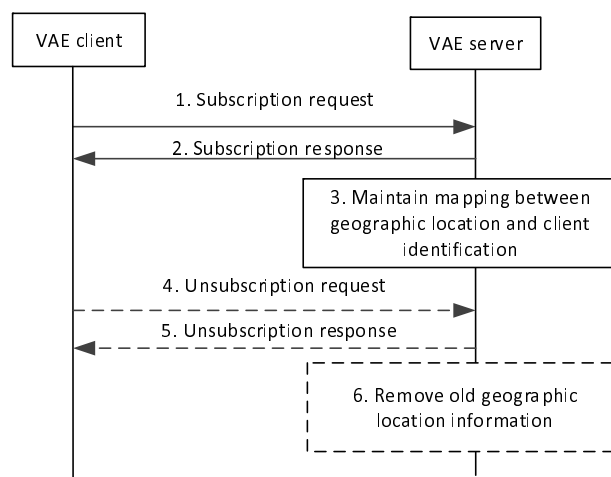

**Figure 9.3.3.2-1: Procedure for tracking the client geographical area at the VAE server**

1. Upon entering a new geographical area, the client subscribes to the geographic area Geo ID B.
2. The VAE server sends a subscription response to the VAE client.
3. The VAE server stores the new geographical area information GEO ID B with the client identification information V2X UE ID.
4. The client unsubscribes from the old geographical area GEO ID A.
5. The VAE server sends an unsubscription response to the VAE client.
6. The VAE server removes the old geographical area information GEO ID A associated with the client identification information V2X UE ID.

## 9.4 V2X message delivery

### 9.4.1 General

The VAE capabilities provide support for V2X message distribution originated from the V2X application specific layer. The message communication corresponding V2X applications and services are the responsibility of the V2X application specific layer entities. The VAE capabilities abstract the message distribution aspects from the V2X application specific layer.

## 9.4.2 Information flows

### 9.4.2.1 V2X message

Table 9.4.2.1-1 describes the information flow for a VAE server to deliver a V2X message to the VAE client.

**Table 9.4.2.1-1: V2X message**

Information element	Status	Description
V2X UE ID	M	Identifier of the destination V2X UE
V2X message payload (see NOTE)	M	V2X message payload carried by the V2X message (e.g. ETSI ITS DENM [15])
V2X service ID	M	The V2X service ID to which the V2X message belongs to
GEO ID	O	Geographical area identifier
Reception report required	O	Indicates whether a reception report is required for the V2X message
NOTE: The V2X message is V2X application/service specific and is not specified in this specification.		

### 9.4.2.2 V2X message reception report

Table 9.4.2.2-1 describes the information flow for VAE client to respond to reception of a V2X message from the VAE server.

**Table 9.4.2.2-1: V2X message reception report**

Information element	Status	Description
Result	M	Result from the VAE client in response to V2X message reception indicating success or failure

### 9.4.2.3 V2X group message

Table 9.4.2.3-1 describes the information flow for a VAE server to deliver a V2X message to a group of VAE clients.

**Table 9.4.2.3-1: V2X group message**

Information element	Status	Description
V2X group ID	M	The group ID for which the V2X message is addressed.
V2X message payload (see NOTE)	M	V2X message payload carried by the V2X message (e.g. ETSI ITS DENM [15]).
V2X service ID	M	The V2X service ID to which the V2X group message belongs to.
Geo ID	O	Geographical area identifier
Reception report required	O	Indicates whether a reception report is required for the V2X group message
NOTE: The V2X message is V2X application/service specific and is not specified in this specification.		

### 9.4.2.4 V2X uplink message

Table 9.4.2.4-1 describes the information flow for a VAE client to transmit a V2X message to the VAE server.

**Table 9.4.2.4-1: V2X uplink message**

Information element	Status	Description
V2X UE ID	M	Identifier of the sender V2X UE
V2X message payload (see NOTE)	M	V2X message payload carried by the V2X uplink message (e.g. ETSI ITS DENM [15])
V2X service ID	M	V2X service ID, the V2X UE is sending to the V2X AS
GEO ID (s)	O	Geographical area identifier of the originating V2X message from the V2X UE
Reception report required	O	Indicates whether a reception report is required for the uplink V2X message
NOTE: The V2X message payload is V2X application/service specific and is not specified in this specification.		

#### 9.4.2.5 V2X uplink message reception report

Table 9.4.2.5-1 describes the information flow for a VAE server in response to a received V2X message from the VAE client.

**Table 9.4.2.5-1: V2X uplink message reception report**

Information element	Status	Description
Result	M	Result from the VAE server in response to V2X message indicating success or failure

#### 9.4.2.6 Subscribe V2X message delivery request

Table 9.4.2.6-1 describes the information flow for a V2X application specific server to subscribe with VAE server for V2X messages.

**Table 9.4.2.6-1: Subscribe V2X message delivery request**

Information element	Status	Description
V2X application specific server identity information	M	Identity information of the V2X application specific server.
V2X service ID	M	The V2X service ID to which the V2X application-specific server registers to
GEO ID	O	The geographical area identifier to which the V2X application-specific server registers to
Endpoint information	M	Information of the endpoint of the V2X application specific server to which the uplink messages have to be sent.

#### 9.4.2.7 Subscribe V2X message delivery response

Table 9.4.2.7-1 describes the information flow for a VAE server to provide a response to the V2X application specific server for subscription request for V2X uplink message delivery.

**Table 9.4.2.7-1: Subscribe V2X uplink message delivery response**

Information element	Status	Description
Subscription identifier (NOTE)	M	The subscription identifier corresponding to the request
Result	M	Result from the VAE server indicating subscription success or failure.
NOTE: If Result indicates failure, the value of the subscription identifier in the response is ignored.		

### 9.4.2.8 Unsubscribe V2X message delivery request

Table 9.4.2.8-1 describes the information flow for a V2X application specific server to unsubscribe with VAE server for V2X messages.

**Table 9.4.2.8-1: Unsubscribe V2X message delivery request**

Information element	Status	Description
Subscription identifier	M	The subscription identifier provided by the VAE server.

### 9.4.2.9 Unsubscribe V2X message delivery response

Table 9.4.2.9-1 describes the information flow for a VAE server to provide a response to the V2X application specific server for unsubscription request for V2X uplink message delivery.

**Table 9.4.2.9-1: Unsubscribe V2X uplink message delivery response**

Information element	Status	Description
Result	M	Result from the VAE server indicating unsubscription success or failure.

## 9.4.3 Message delivery to target geographical areas from the VAE server

### 9.4.3.1 General

This subclause describes the procedures for delivering V2X messages to registered V2X UEs at the VAE server in targeted geographical areas.

### 9.4.3.2 Procedure

Pre-conditions:

1. One or more VAE clients have registered with the VAE server as described in subclause 9.2.3;
2. One or more VAE clients have subscribed to geographical area GEO ID;
3. The VAE server has created a mapping between geographical area information and client identification as described in subclause 9.3.3; and
4. The V2X application-specific server has subscribed with the VAE server as described in subclause 9.4.6.

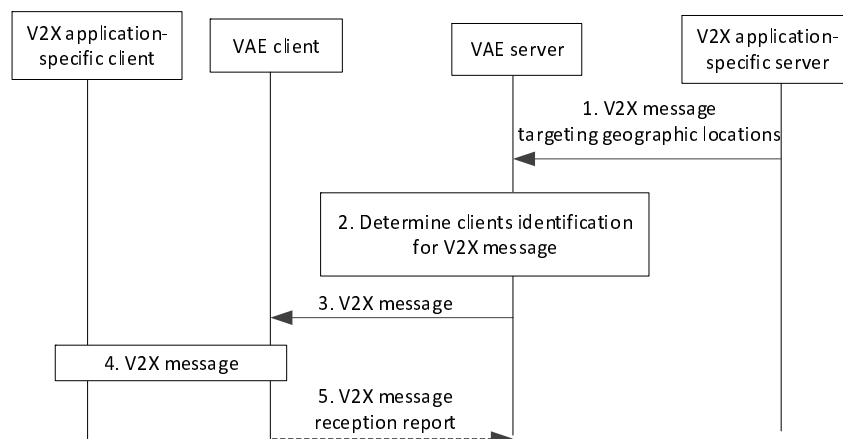

**Figure 9.4.3.2-1: Procedure for delivering messages to target geographical areas from the VAE server**

1. The application-specific server sends a V2X message of a service with V2X Service ID (e.g. ETSI ITS DENM, ETSI ITS CAM) with target geographical area GEO ID.
2. The VAE server retrieves the list of registered and subscribed clients for the V2X message targeting geographical area GEO ID and determines the clients' identification V2X UE ID.
3. The VAE server transmits the message to each VAE client using the client identification.
4. The VAE client provides the V2X message to the application-specific client.
5. The VAE client provides a V2X message reception report to the VAE server if indicated in the V2X message.

## 9.4.4 V2X group message distribution

### 9.4.4.1 General

This subclause describes the procedures for V2X group delivery from the VAE server to the VAE clients.

### 9.4.4.2 Procedure

Pre-conditions:

1. The VAE client has registered for receiving V2X group messages as described in in subclause 10.3.8 of 3GPP TS 23.434 [6].
2. The V2X application-specific server has subscribed with the VAE server as described in subclause 9.4.6.

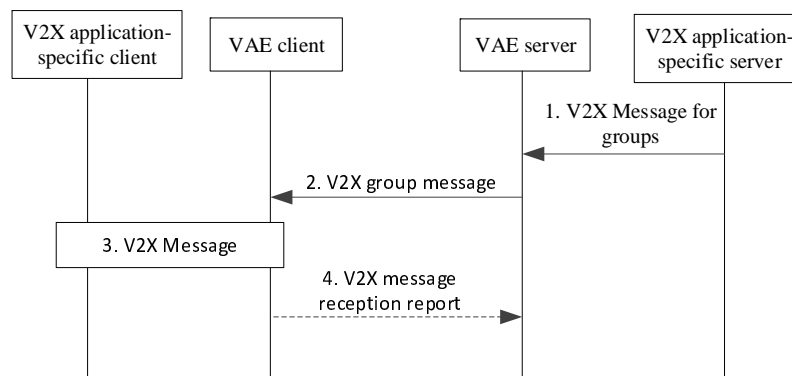

**Figure 9.4.4.2-1: Procedure for delivering V2X group messages to VAE clients**

1. The V2X application-specific server provides a V2X message for distribution to V2X group with V2X Group ID.
2. The VAE server delivers the V2X message to all registered VAE clients with V2X Group ID.
3. The VAE client provides the V2X message to the V2X application-specific client.
4. The VAE client may provide a V2X message reception report to the VAE server.

## 9.4.5 Uplink V2X message delivery

### 9.4.5.1 General

This subclause describes the procedures for delivering V2X messages from the V2X UE to the V2X application server.

### 9.4.5.2 Procedure for uplink message delivery

Pre-conditions:

1. The VAE client has discovered the VAE server as described in subclause 9.1.2.
2. The VAE client has registered to a V2X service identified by a V2X Service ID as described in subclause 9.2.
3. The V2X application specific server has performed the subscription as specified in clause 9.4.6.

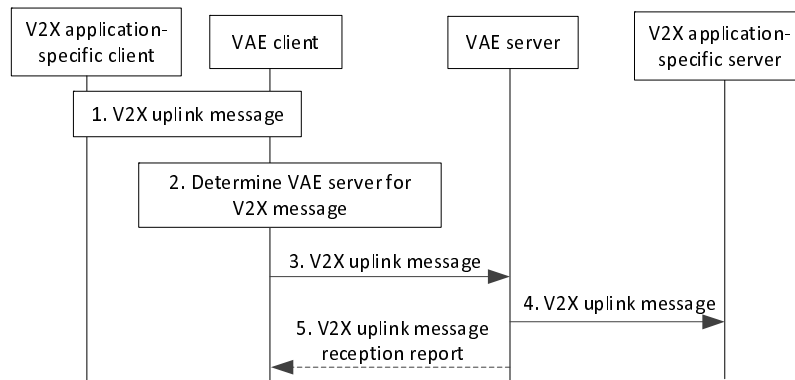

**Figure 9.4.5.2-1: Procedure for delivering messages from V2X UE to the V2X application server**

1. The V2X application-specific client sends a V2X uplink message to the VAE client.
2. The VAE client determines the VAE server for receiving the V2X uplink message with V2X Service ID.
3. The VAE client transmits the V2X uplink message to the VAE server.
4. The VAE server provides the V2X uplink message to the endpoint of V2X application-specific server(s).
5. The VAE server may provide a V2X uplink message reception report to the VAE client if indicated in the V2X uplink message.

### 9.4.6 Procedure for subscription to message delivery

Pre-condition:

- The V2X application specific server is configured with the VAE server information.

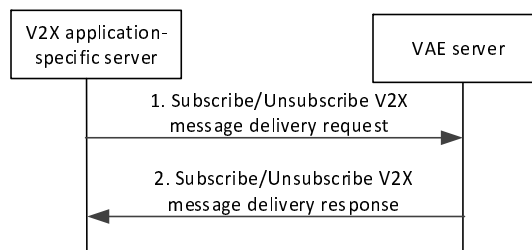

**Figure 9.4.6-1: Procedure for subscription to message delivery**

1. The V2X application-specific server sends a subscribe V2X message delivery request to the VAE server including the information of V2X service ID, GEO ID and the end point address at which the uplink messages from the V2X UE to the V2X application specific server are to be delivered.
2. The VAE server stores the subscription information and provides an acknowledgement via a subscribe V2X message delivery response message to the V2X application specific server.



## 9.5 File Distribution

### 9.5.1 General

The VAE capabilities provide support for file distribution to the V2X application specific layer. The VAE capabilities abstract the aspects like file chunking, QoE management, file delivery from the V2X application specific layer.

### 9.5.2 Use of MBMS "files" session type

The VAE server acts as a content provider and the VAE client acts as an MBMS client in the xMB reference model (subclause 4.1 in 3GPP TS 26.348 [11]).

The VAE server makes use of the xMB procedures from 3GPP TS 26.348 [11] to create MBMS sessions whose type is set to "files" and to request the delivery of files over these sessions. Before provisioning files to the BM-SC, the VAE server prepares the file for distribution, which may include partition of large files into smaller files or encryption.

The VAE server is responsible for translating the parameters related to the V2X application triggering the file delivery into corresponding xMB parameters. Table 9.5.2-1 describes the mapping between the V2X parameters and the xMB API properties specified in 3GPP TS 26.348 [11].

**Table 9.5.2-1: Mapping between V2X parameters and xMB APIs**

V2X parameter	Corresponding xMB API property
File transfer session indicator	Session Type: Files
List of files to be sent by the VAE server and their locations	File List
Target geographical area for the V2X Ues	Geographical Area
Information about the V2X application (e.g., software update, HD map download)	Service Class
Maximum bitrate for the V2X application	Max Bitrate
Maximum delay for the V2X application	Max Delay
QoE metrics the VAE server is interested in receiving about the V2X application	QoE Reporting

NOTE: The list of V2X parameters needed for file delivery is not exhaustive and can be updated based on the specific V2X application requirements.

## 9.6 Provisioning 3GPP system information by VAE server

### 9.6.1 General

The VAE server can provision network related information like multicast (e.g. V2X USD) to the V2X UE to further enable V2X UE to consume V2X service based on the location and connection with the VAE server.

### 9.6.2 Information flows

#### 9.6.2.1 V2X USD announcement

Table 9.6.2.1-1 describes the information flow V2X USD announcement from the VAE server to the VAE client.

**Table 9.6.2.1-1: V2X USD announcement**

Information element	Status	Description
V2X UE ID	O	Identity of the V2X UE to which the configuration is required
V2X USD configuration data	M	The V2X USD configuration data as specified in 3GPP TS 23.285 [5]

### 9.6.2.2 Set PC5 parameters request

Table 9.6.2.2-1 describes the information flow set PC5 parameters request from the VAE server to the VAE client.

**Table 9.6.2.2-1: Set PC5 parameters request**

Information element	Status	Description
V2X UE ID	O	Identity of the V2X UE to which the configuration is required
PC5 parameters configuration data	M	The PC5 parameters configuration data as specified in 3GPP TS 23.285 [5]

### 9.6.2.3 Set PC5 parameters response

Table 9.6.2.3-1 describes the information flow set PC5 parameters response from the VAE client to the VAE server.

**Table 9.6.2.3-1: Set PC5 parameters response**

Information element	Status	Description
Result	M	The result whether setting the PC5 parameters received by the VAE server was successful or not.

## 9.6.3 V2X USD provisioning

### 9.6.3.1 General

This subclause describes the procedure for VAE server provisioning the V2X USD information to V2X UE via V1-AE reference point for V2X communication using MBMS.

### 9.6.3.2 Procedure

Figure 9.6.3.2-1 illustrates the procedure for provisioning V2X USD to the V2X UE via V1-AE reference point.

Pre-conditions:

1. The V2X UE has connected to the VAE server.
2. If multicast delivery mode is used, the MBMS bearer being used is activated by the VAE server.

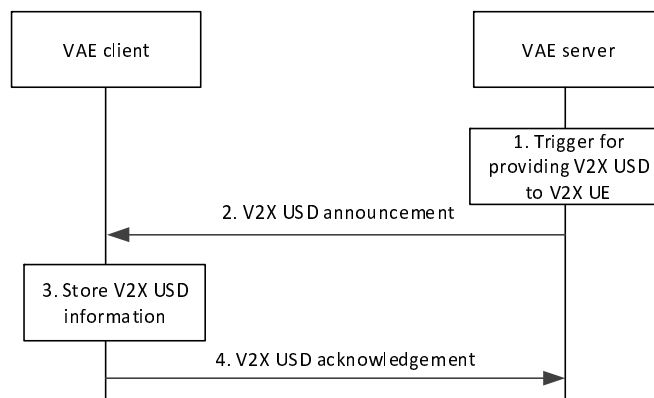

**Figure 9.6.3.2-1: V2X USD provisioning**

1. The VAE server is triggered for providing V2X USD to V2X UE.
2. The VAE server sends the V2X USD announcement to the VAE client in the V2X UE with the information of the V2X USDs corresponding to the V2X applications. The V2X USD information consists of TMGI, list of

SAIs, frequency and SDP information for V2X applications' communication using MBMS. The details of V2X USD are specified in subclause 4.4.7.2 in 3GPP TS 23.285 [5]. This message can be sent via unicast or multicast.

3. Upon receiving the V2X USD announcement, the VAE client of the V2X UE stores the received V2X USDs.

NOTE: The principles for storing and applying precedence when V2X USD is configured via different mechanisms (e.g. MBMS service announcement or pre-configuration or by VAE server via V1-AE reference point) is as per V2X service provider's policy.

4. The VAE client of the V2X UE provides an acknowledgement to the VAE server of the V2X AS. This step is optional when the announcement is sent via multicast.

## 9.6.4 PC5 parameters provisioning

### 9.6.4.1 General

This subclause describes the procedure for the VAE server provisioning the PC5 parameter provisioning information to the V2X UE via V1-AE reference point for V2X communication on PC5. The configuration information includes the configuration parameters specified in 3GPP TS 23.285 [5] and additional application related configuration parameters.

### 9.6.4.2 Procedure

Figure 9.6.4.2-1 illustrates the procedure for provisioning PC5 parameters to the V2X UE via V1 reference point.

Pre-conditions:

1. The V2X UE has discovered and connected to the VAE server.
2. If multicast delivery mode is used, the MBMS bearer being used is activated by the VAE server.

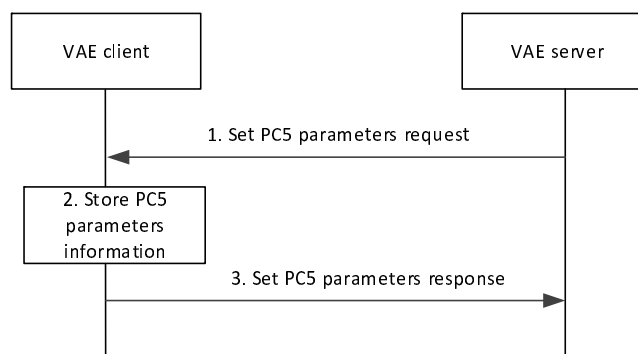

**Figure 9.6.4.2-1: PC5 parameters provisioning**

1. The VAE server sends the set PC5 parameters request to the VAE client with the information of the PC5 parameters. The PC5 parameters information are specified in subclause 4.4.1.1.2 in 3GPP TS 23.285 [5]. This message can be sent via unicast or multicast.
2. Upon receiving the set PC5 parameters request, the VAE client stores the received PC5 parameters in the V2X UE.
3. The VAE client provides an acknowledgement by sending the set PC5 parameters response to the VAE server.

## 9.7 Network monitoring by the V2X UE

### 9.7.1 General

The V2X UE subscribes for network monitoring information from the VAE server. Such network monitoring information may be used by the V2X UE for network connectivity adaptations (e.g. switching between different modes of operations for V2V communications).

## 9.7.2 Information flows

### 9.7.2.1 Network monitoring information subscription request

Table 9.7.2.1-1 describes the information flow network monitoring information subscription request from the VAE client to the VAE server.

**Table 9.7.2.1-1: Network monitoring information subscription request**

Information element	Status	Description
V2X UE ID	M	Identity of the V2X UE subscribing for the network monitoring information
Subscription event	M	Identify one or multiple network monitoring events (e.g. uplink degradation, congestion, overload, coverage)
Triggering criteria	M	Identify when the VAE server will send the monitoring reports to the VAE client.

### 9.7.2.2 Network monitoring information subscription response

Table 9.7.2.2-1 describes the information flow network monitoring information subscription response from the VAE server to the VAE client.

**Table 9.7.2.2-1: Network monitoring information subscription response**

Information element	Status	Description
V2X UE ID	M	Identity of the V2X UE
Result	M	Indicates success or failure

### 9.7.2.3 Network monitoring information notification

Table 9.7.2.3-1 describes the information flow network monitoring information notification from the VAE server to the VAE client.

**Table 9.7.2.3-1: Network monitoring information notification**

Information element	Status	Description
V2X UE ID	M	Identity of the subscribed V2X UE
Network monitoring information	M	This includes information on network status for the triggering criteria, and may include the following parameters: <ul style="list-style-type: none"> <li>- Uplink quality level</li> <li>- Congestion information</li> <li>- Geographical Area (cell area or TA for which the monitoring applies)</li> <li>- Time Validity (the period for which the monitoring applies)</li> <li>- Coverage level and bearer level events (optionally, for MBMS)</li> </ul>

## 9.7.3 V2X UE subscription for network monitoring information

### 9.7.3.1 General

This subclause describes the procedure for V2X UE subscription for network monitoring information.

### 9.7.3.2 Procedure

Figure 9.7.3.2-1 illustrates the procedure where the V2X UE subscribes for the network monitoring information from the VAE server.

Pre-condition:

- The VAE client of the V2X UE is connected to the VAE server and is authorized to access the network monitoring information.

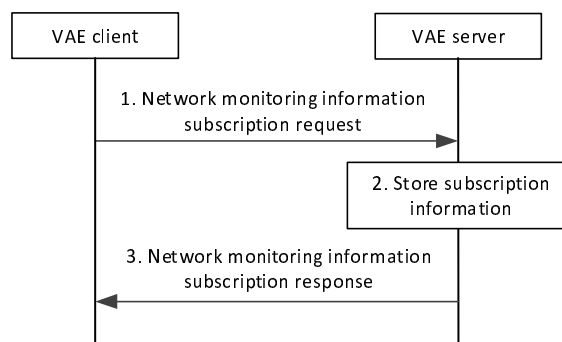

**Figure 9.7.3.2-1: V2X UE subscription for network monitoring information**

1. The VAE client sends a network monitoring information subscription request to the VAE server.
2. The VAE server checks for the authorization of the VAE client to access the network monitoring information and if allowed, stores the subscription information corresponding to the V2X UE.
3. The VAE server sends a network monitoring information subscription response to the VAE client including the result of the subscription (i.e. success or failure).

## 9.7.4 Notifications for network monitoring information

### 9.7.4.1 General

This subclause describes the procedure for notification of network monitoring information from the VAE server.

### 9.7.4.2 Procedure

Figure 9.7.4.2-1 illustrates the procedure where the VAE server sends notification of the network monitoring information to the V2X UEs.

Pre-conditions:

1. The VAE server acting as a SCS/AS is configured with the SCEF information and is authorized to exchange information with the SCEF as specified in subclause 4.9 in 3GPP TS 23.682 [8];
2. The V2X UE1 and V2X UE2 have subscribed for the network monitoring information at the VAE server.

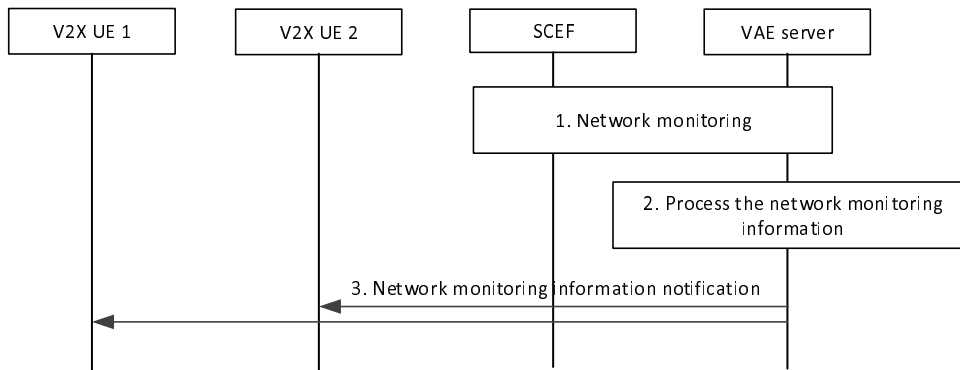

**Figure 9.7.4.2-1: Notifications for network monitoring information**

1. The VAE server communicates with the SCEF to receive network monitoring information as per the procedure in subclause 4.9 of 3GPP TS .23.682 [8].
2. The monitoring information (e.g. uplink or downlink link degradations, congestions, overload) available at the VAE server about the on-going V2V session(s) is based on the original network monitoring information provided by the SCEF in step 1.
3. The monitoring information is sent to the subscribed V2X UEs via network monitoring information notification.

## 9.8 Switching modes of operations for V2V communications

The V2X services need to support different modes of operation for V2V (PC5 and Uu) communications. The V2X UE makes the decision to switch between different modes of operation for V2V communications considering the V2V service KPIs as specified in 3GPP TS 22.186 [3]. The V2X application layer may provide the network monitoring information to assist the V2X UE in making the switching decision for the operation modes selection.

The V2X UE determines switching of the mode of operation for V2V sessions based on several factors including the received network monitoring information as specified in subclause 9.7 and the PC5 communication quality information. The V2X UE switches the mode of operation and engages in either direct (PC5) or indirect (Uu) session as specified in subclause 23.14 of 3GPP TS 36.300 [14].

## 9.9 V2X service discovery

### 9.9.1 General

The VAE server provides service information (e.g. available V2X services) to the V2X UE to enable the V2X UE to register and receive V2X services over LTE-Uu. The V2X services are identified by V2X service IDs.

### 9.9.2 Information flows

#### 9.9.2.1 Get V2X UE service discovery request

Table 9.9.2.1-1 describes the information flow get V2X UE service discovery request from the VAE client to the VAE server.

**Table 9.9.2.1-1: Get V2X UE service discovery request**

Information element	Status	Description
V2X UE ID	M	Identity of the V2X UE requesting the service discovery information.

### 9.9.2.2 Get V2X UE service discovery response

Table 9.9.2.2-1 describes the information flow get V2X UE service discovery response from the VAE server to the VAE client.

**Table 9.9.2.2-1: Get V2X UE service discovery response**

Information element	Status	Description
Result	M	Indicates the success or failure of getting the service discovery information
V2X UE service discovery information	O (NOTE)	The V2X UE service discovery data includes: - List of available V2X services identified by V2X service IDs  - Mapping of the V2X services to V2X application server address as specified in 3GPP TS 23.285 [5]
NOTE: If the Result information element indicates failure then V2X UE service discovery information element is not included.		

## 9.9.3 V2X UE service discovery

### 9.9.3.1 General

This subclause describes the procedure for providing V2X service information to the V2X UE via V1-AE reference point for unicast V2X communication over LTE-Uu.

### 9.9.3.2 Procedure

The procedure for V2X UE obtaining the V2X UE service discovery information is illustrated in figure 9.9.3.2-1.

Pre-conditions:

1. The V2X UE has connected to the VAE server.
2. The VAE server has received information about available V2X services from the V2X application-specific server.

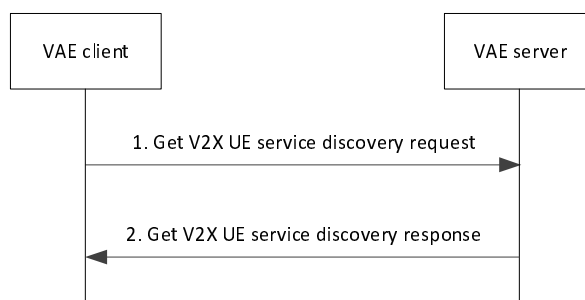

**Figure 9.9.3.2-1: V2X UE obtains the service discovery information**

1. The VAE client sends a get V2X UE service discovery request to the VAE server for obtaining V2X UE service discovery information.
2. The VAE server sends get V2X UE service discovery response to the VAE client. This message carries the V2X UE service discovery information.

## 9.10 V2X service continuity

### 9.10.1 General

The VAE server supports V2X service continuity by making available the local service information based on geographical areas to the V2X UEs.

### 9.10.2 Information flows

#### 9.10.2.1 Service continuity request

Table 9.10.2.1-1 describes the information flow from a VAE server to issue a service continuity request to other VAE servers.

**Table 9.10.2.1-1: Service continuity request**

Information element	Status	Description
GEO ID	M	Geographical area identifier (e.g. URI, tile identifier, geo-fence tile identifier)
V2X service ID	M	PSID or ITS-AID the V2X UE is interested in receiving (e.g. ETSI ITS DENM, ETSI ITS CAM)

#### 9.10.2.2 Service continuity response

Table 9.10.2.2-1 describes the information flow for a VAE server to respond to a service continuity request from other VAE server.

**Table 9.10.2.2-1: Service continuity response**

Information element	Status	Description
VAE server ID	M	Identifier of the VAE server (e.g., FQDN)
Result	M	The result whether the VAE server can serve the requested GEO ID and V2X Service ID

#### 9.10.2.3 Local service information request

Table 9.10.2.3-1 describes the information flow local service information request from the VAE client to the VAE server.

**Table 9.10.2.3-1: Local service information request**

Information element	Status	Description
V2X UE ID	M	Identity of the V2X UE requesting the service discovery information.
GEO ID	M	Geographical area identifier for which the local service information is requested

#### 9.10.2.4 Local service information response

Table 9.10.2.4-1 describes the information flow local service information response from the VAE server to the VAE client.



**Table 9.10.2.4-1: Local service information response**

Information element	Status	Description
Result	M	Indicates the success or failure of getting the local service information
Local service information	O (NOTE)	The local service information: <ul style="list-style-type: none"> <li>- V2X server USD information as specified in 3GPP TS 23.285 [5]</li> <li>- V2X application server address information as specified in 3GPP TS 23.285 [5] and transport port for unicast</li> <li>- V2X USD information as specified in 3GPP TS 23.285 [5]</li> </ul>
NOTE: If the Result information element indicates failure then local service information IE is not included.		

### 9.10.3 V2X service continuity management

#### 9.10.3.1 General

This subclause describes the procedure to determine the VAE server for serving a VAE client when moving to a new geographical area.

#### 9.10.3.2 Procedure

Pre-conditions:

1. The VAE servers have been configured with the information of the other VAE servers.
2. The VAE servers have obtained information of the available V2X services (e.g. identified by PSID or ITS-AIDs) and their corresponding geographical area association from the V2X application.
3. The VAE server 1 has received a geographic location update for a geographic area outside its coverage, with GEO ID, from a VAE client as described in subclause 9.3.

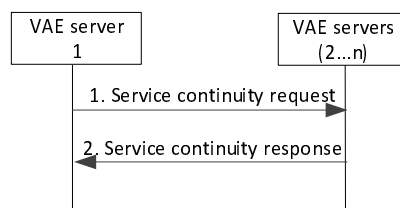
**Figure 9.10.3.2-1: Procedure for V2X service continuity management**

1. VAE server 1 sends a service continuity request to other VAE servers (2 ... n).

NOTE: The VAE server may send the service continuity request to all VAE servers it is connected to or to a subset of VAE servers, e.g. within the same PLMN.

2. The VAE servers provide a service continuity response to VAE server 1.

### 9.10.4 Dynamic local service information

#### 9.10.4.1 General

For the V2X scenarios like extended sensors, platooning, the V2X UEs may be connected to the serving PLMN, but the V2X application server information may change as per the geographical location. Also it is not practically feasible to

provide all the V2X server USDs to the V2X UE via the initial V2X UE configuration by the PLMN. It is hence required that the V2X server USDs may be provided considering the mobility of the V2X UE. This subclause describes the procedure for obtaining the local service information by the V2X UE via V1-AE.

### 9.10.4.2 Procedure

Figure 9.10.4.2-1 illustrates the procedure for obtaining the dynamic local service information by the V2X UE via V1-AE.

Pre-conditions:

1. The V2X UE is connected to the VAE server in geographical area A.
2. The V2X UE has no local service information for geographical area B.
3. If multicast delivery mode is used, the MBMS bearer being used is activated by the VAE server.

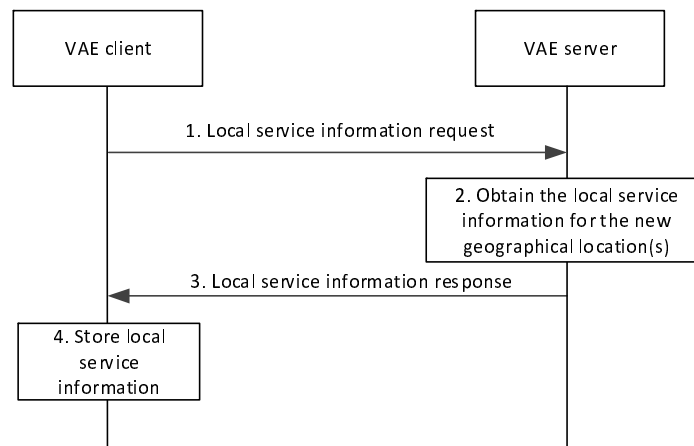

**Figure 9.10.4.2-1: Obtaining dynamic local service information by V2X UE via V1-AE**

1. The VAE client sends a local service information request to the VAE server (responsible for geographic location A) which may include mobility information like the geographic locations (geographic location B).
2. The VAE server determines the local service information (e.g. V2X server USD(s), V2X USD) corresponding to the geographic locations information received in step 1.
3. The VAE server provides the local service information (e.g. V2X server USD(s), V2X USD) with the corresponding geographic locations information to the VAE client via a local service information response. The V2X USD information consists of TMGI, list of SAIs, frequency and SDP information with the local service information for local V2X application server discovery. The details of V2X server USD are specified in subclause 4.4.7.3 in 3GPP TS 23.285 [5]. This message can be sent via unicast or multicast.
4. Upon receiving the local service information in step 3, the VAE client stores the received information.

**Editor's note:** The impact of edge application enabler study (FS\_EDGEAPP) on this procedure is FFS.

## 9.11 V2X application resource management

### 9.11.1 General

The VAE server utilizes the NRM server of the SEAL to support the network resource management aspects towards the V2X applications. The VAE server supports the V2X UEs connected to EPS networks of different PLMN operators.

## 9.11.2 Information flows

### 9.11.2.1 V2X application requirement request

Table 9.11.2.1-1 describes the information flow V2X application requirement request from the V2X application specific server to the VAE server.

**Table 9.11.2.1-1: V2X application requirement request**

Information element	Status	Description
V2X UE ID	M (NOTE)	Identity of the V2X UE for which V2X application requirement is initiated.
V2X group ID	M (NOTE)	Identity of the V2X group for which the V2X application requirement is initiated.
V2X service ID	M	The V2X service ID for which application requirement corresponds to.
V2X application requirement	M	The requirement for application change. E.g. service levels for application service.
End point information	M	The end point information to which the notification shall be sent.
NOTE: Either of the information element should be present.		

### 9.11.2.2 V2X application requirement response

Table 9.11.2.2-1 describes the information flow V2X application requirement response from the VAE server to the V2X application specific server.

**Table 9.11.2.2-1: V2X application requirement response**

Information element	Status	Description
Result	M	The result of the V2X application requirement request.

### 9.11.2.3 V2X application requirement notification

Table 9.11.2.3-1 describes the information flow V2X application requirement notification from the VAE server to the V2X application specific server.

**Table 9.11.2.3-1: V2X application requirement notification**

Information element	Status	Description
Result	M	The result of the network resource adaptation corresponding to the V2X application requirement.

## 9.11.3 V2X application resource adaptation

### 9.11.3.1 General

This subclause describes the procedure for V2X application resource adaptation where the VAE server maps the V2X application requirement to network resource request for single or groups of V2X UEs.

### 9.11.3.2 Procedure

Figure 9.11.3.2-1 illustrates the procedure where the VAE server supports V2X application resource adaptation.

Pre-conditions:

1. The VAE server has the KPI information for the V2X services.

2. The VAE server is provided with the network monitoring information as per the subclause A.3.
3. The VAE server is configured with the NRM server information.

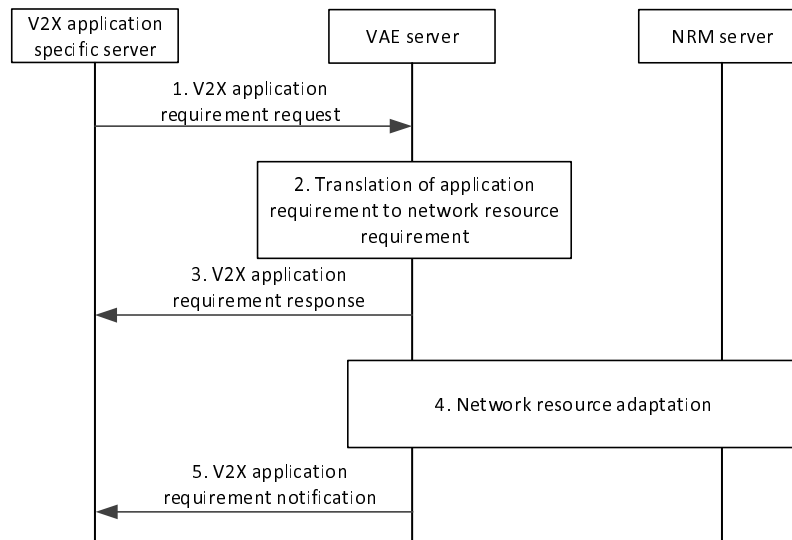

**Figure 9.11.3.2-1: V2X application resource adaptation**

1. The V2X application specific server sends a V2X application requirement request to the VAE server for an adaptation of the V2X service operation per V2X UE or per group of UEs.
2. The VAE server translates the V2X application requirement to different network resource requirement for group of users, which may be a subset of V2X UEs within the V2X group that will be affected by application adaptation.
3. If the V2X application requirement is successfully translated to the network resource requirement, the VAE server sends a V2X application requirement response to the V2X application specific server.
4. The VAE server performs network resource adaptation by interacting with the NRM server as specified in the 3GPP TS 23.434 [6] for the V2X application requirement received in step 1.
5. Based on the result of the network resource adaptation in step 4 corresponding to step 1, the VAE server sends a V2X application requirement notification to the V2X application specific server.

## 9.12 Dynamic group management

### 9.12.1 General

Some of the V2X scenarios require group-based communication (e.g. platooning). Unlike V2X communication for safety scenarios where all V2X UEs in the communication range receive broadcasted communication, the group-based communication is expected to be received only by the V2X UEs of the members of that group. However in some scenarios the V2X UEs are required to be determined dynamically (with the assistance of the V2X application server or independently by the V2X UEs when they are not connected to the network) during the operation. Also each V2X application group has to be mapped to a ProSe Layer-2 group ID in order to avoid any interference during PC5 communications for the V2X application groups. The ProSe Layer-2 Group ID is only used in PC5 V2X group communication (without the involvement of the V2X application server).

### 9.12.2 Information flows

#### 9.12.2.1 Push Layer-2 group ID mapping

Table 9.12.2.1-1 describes the information flow push layer-2 group ID mapping from the VAE server to the VAE client and between the VAE clients.

Editor's note: Whether the procedures and information flows for dynamic group management are to be moved to SEAL is FFS.

**Table 9.12.2.1-1: Push Layer-2 group ID mapping**

Information element	Status	Description
Dynamic group information	M	Group information including dynamic group ID, group definition, group leader ID
ProSe Layer-2 Group ID	M	ProSe Layer-2 Group ID corresponding to the dynamic group information

### 9.12.2.2 Configure dynamic group request

Table 9.12.2.2-1 describes the information flow for configure dynamic group request from the V2X application specific sever to the VAE server.

**Table 9.12.2.2-1: Configure dynamic group request**

Information element	Status	Description
Dynamic group information	M	Group information including dynamic group ID, group definition, group leader ID
Endpoint information	M	End point information to which the configure dynamic group notification has to be sent

### 9.12.2.3 Configure dynamic group response

Table 9.12.2.3-1 describes the information flow for configure dynamic group response from the VAE server to the V2X application specific sever.

**Table 9.12.2.3-1: Configure dynamic group response**

Information element	Status	Description
Result	M	Result from the VAE server in response to the configure dynamic group request.

### 9.12.2.4 Configure dynamic group notification

Table 9.12.2.4-1 describes the information flow for configure dynamic group notification from the VAE server to the V2X application specific sever.

**Table 9.12.2.4-1: Configure dynamic group notification**

Information element	Status	Description
Dynamic group information	M	Group information including dynamic group ID, UE ID (joined or left UE(s))

### 9.12.2.5 Identity list notification

Table 9.12.2.5-1 describes the information flow identity list notification from the VAE client to the VAE server.

**Table 9.12.2.5-1: Identity list notification**

Information element	Status	Description
Dynamic group information	M	Group information including dynamic group ID, UE ID (joined or left UE(s))

## 9.12.3 On-network dynamic group creation

### 9.12.3.1 General

The V2X application specific server is responsible for V2X dynamic group formation (including information like group ID assignment, group definition), membership management (e.g. user authorization). VAE layer supports V2X UEs in the Uu communication range assigning a ProSe Layer-2 Group ID for application layer V2X dynamic group formation.

### 9.12.3.2 Procedure

The procedure for on-network dynamic group creation is illustrated in figure 9.12.3.2-1.

Pre-condition:

1. V2X application dynamic group is defined at the V2X application specific server with V2X UE assigned as dynamic group leader.
2. VAE server has a pool of the ProSe Layer-2 Group IDs that can be assigned to dynamic groups

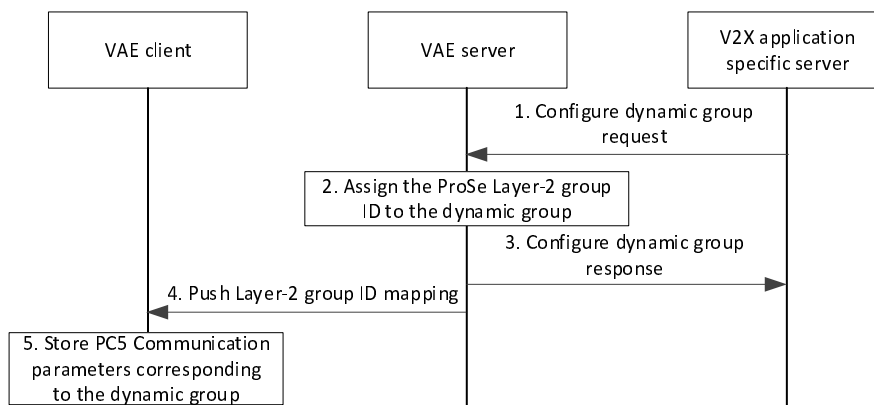

**Figure 9.12.3.2-1: On-network dynamic group creation**

1. The V2X application specific server requests the VAE server to configure dynamic group corresponding to the dynamic group information (e.g. dynamic group ID, group definition, group leader).
2. To enable PC5 communication, the VAE server assigns ProSe Layer-2 Group ID to the received dynamic group information from the available ProSe Layer-2 Group ID pool.
3. The VAE server responds to the V2X application specific server for the request to configure dynamic group.
4. The VAE server triggers a push request including ProSe Layer-2 Group ID corresponding to the dynamic group information to the VAE client.
5. The VAE client stores the received PC5 communication parameters corresponding to the dynamic group information received from the VAE server.

NOTE 1: The VAE client may further announce the dynamic group information including the corresponding ProSe Layer-2 Group ID to the other VAE clients within the PC5 communication proximity on a PC5 channel dedicated for V5-AE communications, enabling more V2X UEs to join the dynamic group.

NOTE 2: When there is loss of connectivity with the network by the V2X UEs, service continuity is ensured by the V2X UEs switching to PC5 communication using the VAE server assigned ProSe Layer-2 Group ID corresponding to the dynamic group formation.

## 9.12.4 Off-network dynamic group creation

### 9.12.4.1 General

The V2X application specific client is responsible for V2X dynamic group information (including information like group ID assignment, group definition). VAE layer on the client supports assigning a ProSe Layer-2 Group ID for application layer V2X dynamic group formation.

### 9.12.4.2 Procedure

The procedure for off-network dynamic group creation is illustrated in figure 9.12.4.2-1.

Pre-condition:

1. VAE clients are provisioned ProSe Layer-2 Group ID(s) generation rules corresponding to the group information or
2. VAE client(s) are configured with the unique pool of ProSe Layer-2 Group IDs, when they are in coverage area of the VAE server.

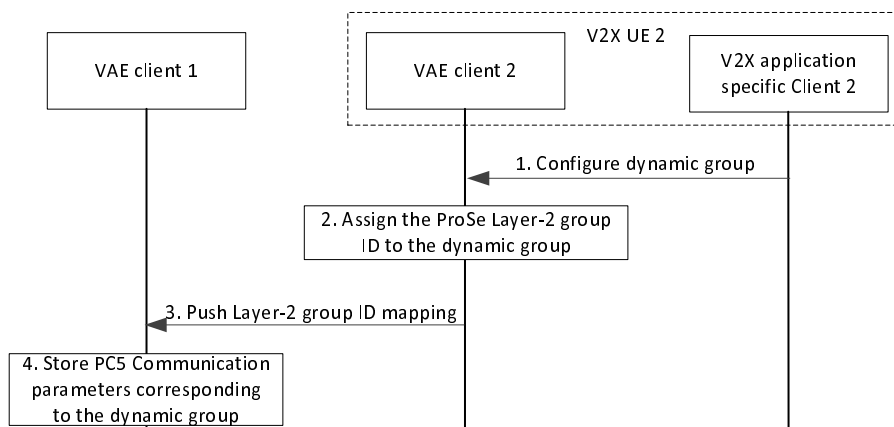

**Figure 9.12.4.2-1: Off-network dynamic group creation**

1. The V2X application specific client 2 requests the VAE client 2 to configure dynamic group corresponding to the dynamic group information (e.g. dynamic group ID, group definition, group leader).
2. Each VAE client generates ProSe Layer-2 Group ID independently based on the provisioned ProSe Layer-2 Group ID(s) generation rules for its group information or the VAE client 2 assigns ProSe Layer-2 Group ID from the pool of configured ProSe Layer-2 Group IDs.
3. VAE client may further announce the dynamic group information including the corresponding ProSe Layer-2 Group ID to the other VAE clients within the PC5 communication proximity on a PC5 channel dedicated for V5-AE communications, enabling more V2X UEs to join the dynamic group.
4. The VAE client stores the PC5 communication parameters corresponding to the dynamic group information received from another VAE client.

## 9.12.5 On-network dynamic group notification

### 9.12.5.1 General

Once the on-network dynamic group is created as defined in subclause 9.12.3, the VAE client notifies the VAE server about changes in the group (i.e. UE joins or leaves the group) and finally the V2X application specific server is notified with such information.

### 9.12.5.2 Procedure

The procedure for on-network dynamic group notification is illustrated in figure 9.12.5.2-1.

Pre-condition:

1. V2X application dynamic group is created as defined in subclause 9.12.3.

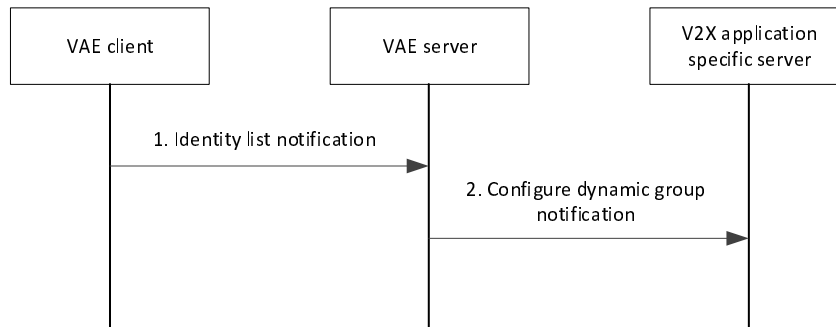

**Figure 9.12.5.2-1: On-network dynamic group notification**

1. The VAE client sends identity list notification to the VAE server about group member changes.
2. Upon receipt of the identity list notification from the VAE client, the VAE server further notifies the V2X application specific server about the newly joined or left group member(s).

## 9.13 Network situation and QoS monitoring and reporting

### 9.13.1 General

The VAE server supports monitoring of 3GPP systems' network situation for V2X services. The VAE server receives and processes access network-related monitoring events/reports from SCEF (EPS entity of the 3GPP network system) as specified in 3GPP TS 23.682 [8]. The monitoring events/report may also include RAN-related resource/traffic situation information and QoS related notifications per UE or group of UEs. The VAE server initiates monitoring of the QoS for single or aggregately for groups of vehicles (supporting a V2X service and being in proximity) having ongoing sessions. The information from V2X UE related to monitoring events (e.g. location, groups, resource usage) can be available at the VAE server using the network resource management and location management services of the SEAL.

### 9.13.2 Information flows

#### 9.13.2.1 Monitoring request

The information flow monitoring request from VAE server (acting as SCS/AS) to SCEF over T8 reference point is specified in clause 5.6 and clause 5.8 (when monitoring request comprises Network Status Request) in 3GPP TS 23.682 [8].

#### 9.13.2.2 Monitoring response

The information flow monitoring response from SCEF to VAE server (acting as SCS/AS) over T8 reference point is specified in clause 5.6 and clause 5.8 (when monitoring request comprises Network Status Response) in 3GPP TS 23.682 [8].

#### 9.13.2.3 Monitoring report

The information flow monitoring report from the SCEF to the VAE server over T8 reference point is specified in clause 5.6, clause 5.8 (when monitoring report comprises Network Status Information Report) and clause 5.11 (when monitoring report comprises notification of QoS/bearer level events) in 3GPP TS 23.682 [8].



### 9.13.3 Procedure

The VAE server acts as SCS/AS and initiates the procedure for monitoring with the SCEF as specified in the clause 5.6 and clause 5.8 in 3GPP TS 23.682 [8] by including the V2X application information corresponding to one or many V2X UEs.

The SCEF provides the monitoring reports (including the RAN related network situation information and QoS notification information for the corresponding V2X application, V2X UE or group of V2X UEs) to the VAE server as specified in the clause 5.6, clause 5.8 and clause 5.11 in 3GPP TS 23.682 [8].

## 9.14 Service negotiation with underlying 3GPP network

### 9.14.1 General

This subclause describes the procedures for the VAE server to provide service requirements to the 3GPP network system. The Service Capability Exposure Function (SCEF) can be used for this purpose. As described in 3GPP TS 23.682 [8], the SCEF provides a means to expose the services and capabilities provided by 3GPP network interfaces and provides a means for the discovery of the exposed services and capabilities.

### 9.14.2 Information flows

#### 9.14.2.1 On-demand QoS request

The information flow On-demand QoS request from VAE server (acting as SCS/AS) to SCEF over T8 reference point is specified in clause 5.11 (when setting up a session with required QoS) in 3GPP TS 23.682 [8].

#### 9.14.2.2 On-demand QoS response

The information flow On-demand QoS response from SCEF to VAE server (acting as SCS/AS) over T8 reference point is specified in clause 5.11 in 3GPP TS 23.682 [8].

#### 9.14.2.3 Background data transfer request

The information flow Background data transfer request from VAE server (acting as SCS/AS) to SCEF over T8 reference point is specified in clause 5.9 (resource management for background data transfer) in 3GPP TS 23.682 [8].

#### 9.14.2.4 Background data transfer response

The information flow Background data transfer response from SCEF to VAE server (acting as SCS/AS) over T8 reference point is specified in clause 5.9 in 3GPP TS 23.682 [8].

#### 9.14.2.5 Network Status Request

The information flow Network Status Request from VAE server (acting as SCS/AS) to SCEF over T8 reference point is specified in clause 5.8 in 3GPP TS 23.682 [8].

#### 9.14.2.6 Network Status Response

The information flow Network Status Response from SCEF to VAE server (acting as SCS/AS) over T8 reference point is specified in clause 5.8 in 3GPP TS 23.682 [8].

#### 9.14.2.7 Network Status Report

The information flow Network Status Report from SCEF to VAE server (acting as SCS/AS) over T8 reference point is specified in clause 5.8 in 3GPP TS 23.682 [8].

### 9.14.2.8 Network Status Acknowledgment

The information flow Network Status Acknowledgment from VAE server (acting as SCS/AS) to SCEF over T8 reference point is specified in clause 5.8 in 3GPP TS 23.682 [8].

### 9.14.3 Communication of service requirements from the VAE server

The procedure uses the APIs defined in subclauses 5.8, 5.9 and 5.11 in 3GPP TS 23.682 [8] for setting up an AS session with required QoS procedure. This procedure defines the information elements that need to be exchanged between the VAE server (acting as SCS/AS) and the SCEF function during service negotiation.

### 9.14.4 Notification generation by the SCEF function

The procedure notification generation by the SCEF function in response to the service requirements from the VAE server. The SCEF function notifies the VAE server if the service requirements can be satisfied. This procedure uses the APIs defined in subclause 5.8 in 3GPP TS 23.682 [8] for informing about potential network issues.

---

## 10 VAE layer APIs

### 10.1 General

The following VAE capabilities are offered as APIs:

- VAE server APIs;

The following SEAL service APIs are specified in 3GPP TS 23.434 [6]:

- Group management server APIs;
- Location management server APIs;
- Configuration management server APIs;
- Identity management server APIs; and
- Key management server APIs.

### 10.2 VAE server APIs

#### 10.2.1 General

Table 10.2.1-1 illustrates the VAE server APIs.

**Table 10.2.1-1: List of VAE server APIs**

API Name	API Operations	Known Consumer(s)	Communication Type
VAE_MessageDelivery API	Deliver_DL_Message	V2X application specific server	Request/ Response
	Deliver_UL_Message	V2X application specific server	Subscribe/notify
VAE_FileDistribution API	Distribute_File	V2X application specific server	Request/ Response
VAE_ApplicationRequirement API	Reserve_NetworkResource	V2X application specific server	Subscribe/notify
	Notify_NetworkResource		
VAE_DynamicGroup API	Configure_DynamicGroup	V2X application specific server	Request/Response
	Notify_DynamicGroup		
VAE_ServiceContinuity API	Query_ServiceContinuity	VAE server	Request/Response

The SEAL server(s) APIs available via SEAL-S reference point as specified in 3GPP TS 23.434 [6] are consumed by the V2X application specific server via the VAE server (acting as a VAL server) over the Vs reference point. When V2X application specific server invokes a SEAL server API via the VAE server over the Vs reference point, the VAE server shall interact with the corresponding SEAL server over the SEAL-S reference point for the API invocation request and response.

**NOTE:** When V2X application specific server invokes a SEAL server API directly, the V2X application specific server acting as VAL server shall interact with the corresponding SEAL server over the SEAL-S reference point for the API invocation request and response as specified in 3GPP TS 23.434 [6].

Editor's note: Whether the VAE\_DynamicGroup API is to be moved to SEAL is FFS.

## 10.2.2 VAE\_MessageDelivery API

### 10.2.2.1 General

**API description:** This API enables the V2X application specific server to subscribe/unsubscribe to the VAE server and communicate with the VAE server to send and receive V2X messages to and from the V2X UEs (including V2X groups).

#### 10.2.2.2 Deliver\_DL\_Message operation

**API operation name:** Deliver\_DL\_Message

**Description:** Delivers the V2X messages to the V2X UEs.

**Known Consumers:** V2X application specific server.

**Inputs:** Refer subclause 9.4.2.1, 9.4.2.3.

**Outputs:** None.

See subclause 9.4.3 and subclause 9.4.4 for the details of usage of this API operation.

#### 10.2.2.3 Deliver\_UL\_Message operation

**API operation name:** Deliver\_UL\_Message

**Description:** Delivers the uplink V2X messages from the V2X UEs to the V2X application specific server.

**Known Consumers:** V2X application specific server.

**Inputs:** None

**Outputs:** Refer subclause 9.4.2.4.

See subclause 9.4.5 for the details of usage of this API operation.

#### 10.2.2.4 V2X\_MessageDelivery\_Subscribe operation

**API operation name:** V2X\_MessageDelivery\_Subscribe

**Description:** Subscribe to the VAE server for sending and receiving V2X messages.

**Known Consumers:** V2X application specific server.

**Inputs:** Refer subclause 9.4.2.6.

**Outputs:** Refer subclause 9.4.2.7.

See subclause 9.4.6 for the details of usage of this API operation.

### 10.2.2.5 V2X\_MessageDelivery\_Unsubscribe operation

**API operation name:** V2X\_MessageDelivery\_Unsubscribe

**Description:** Unsubscribe to the VAE server for sending and receiving V2X messages.

**Known Consumers:** V2X application specific server.

**Inputs:** Refer subclause 9.4.2.8.

**Outputs:** Refer subclause 9.4.2.9.

See subclause 9.4.6 for the details of usage of this API operation.

## 10.2.3 VAE\_FileDistribution API

### 10.2.3.1 General

**API description:** This API enables the V2X application specific server to communicate with the VAE server to initiate file distribution to the V2X UEs.

### 10.2.3.2 Distribute\_File operation

**API operation name:** Distribute\_File

**Description:** Distributes files to the V2X UEs.

**Known Consumers:** V2X application specific server.

**Inputs:** Refer subclause 9.5.2.

**Outputs:** Refer subclause 9.5.2.

See subclause 9.5.2 for the details of usage of this API operation.

## 10.2.4 VAE\_ApplicationRequirement API

### 10.2.4.1 General

**API description:** This API enables the V2X application specific server to communicate with the VAE server to provide V2X application requirement to the underlying 3GPP network.

### 10.2.4.2 Reserve\_NetworkResource operation

**API operation name:** Reserve\_NetworkResource

**Description:** Provides V2X application requirement to underlying 3GPP network.

**Known Consumers:** V2X application specific server.

**Inputs:** Refer subclause 9.11.2.1

**Outputs:** Refer subclause 9.11.2.2

See subclause 9.11.3 for the details of usage of this API operation.

### 10.2.4.3 Notify\_NetworkResource operation

**API operation name:** Notify\_NetworkResource

**Description:** Notify the result of network resource adaptation corresponding to the V2X application requirement.

**Known Consumers:** V2X application specific server.

**Inputs:** Refer subclause 9.11.2.3

**Outputs:** None

See subclause 9.11.3 for the details of usage of this API operation.

## 10.2.5 VAE\_DynamicGroup API

### 10.2.5.1 General

**API description:** This API enables the V2X application specific server to communicate with the VAE server to configure dynamic group information.

### 10.2.5.2 Configure\_DynamicGroup operation

**API operation name:** Configure\_DynamicGroup

**Description:** Configures the dynamic group information at the VAE server.

**Known Consumers:** V2X application specific server.

**Inputs:** Refer subclause 9.12.2.2.

**Outputs:** Refer subclause 9.12.2.3.

See subclause 9.12.3 for the details of usage of this API operation.

### 10.2.5.3 Notify\_DynamicGroup operation

**API operation name:** Notify\_DynamicGroup

**Description:** Notify the dynamic group information (i.e. group member joins or leaves) at the VAE server.

**Known Consumers:** V2X application specific server.

**Inputs:** Refer subclause 9.12.2.4.

**Outputs:** None.

See subclause 9.12.5 for the details of usage of this API operation.

## 10.2.6 VAE\_ServiceContinuity API

### 10.2.6.1 General

**API description:** This API enables the VAE server to query whether the target VAE server can serve the GEO ID and V2X Service ID for service continuity.

### 10.2.6.2 Query\_ServiceContinuity operation

**API operation name:** Query\_ServiceContinuity

**Description:** Query the service continuity information.

**Known Consumers:** VAE server.

**Inputs:** Refer subclause 9.10.2.1.

**Outputs:** Refer subclause 9.10.2.2.

See subclause 9.10.3 for the details of usage of this API operation.

# Annex A (informative): Detailed V2X application layer functional model

Figure A-1 illustrates the detailed V2X application layer functional model including all the functional entities of the VAE layer and the functional entities of the SEAL as specified in 3GPP TS 23.434 [6].

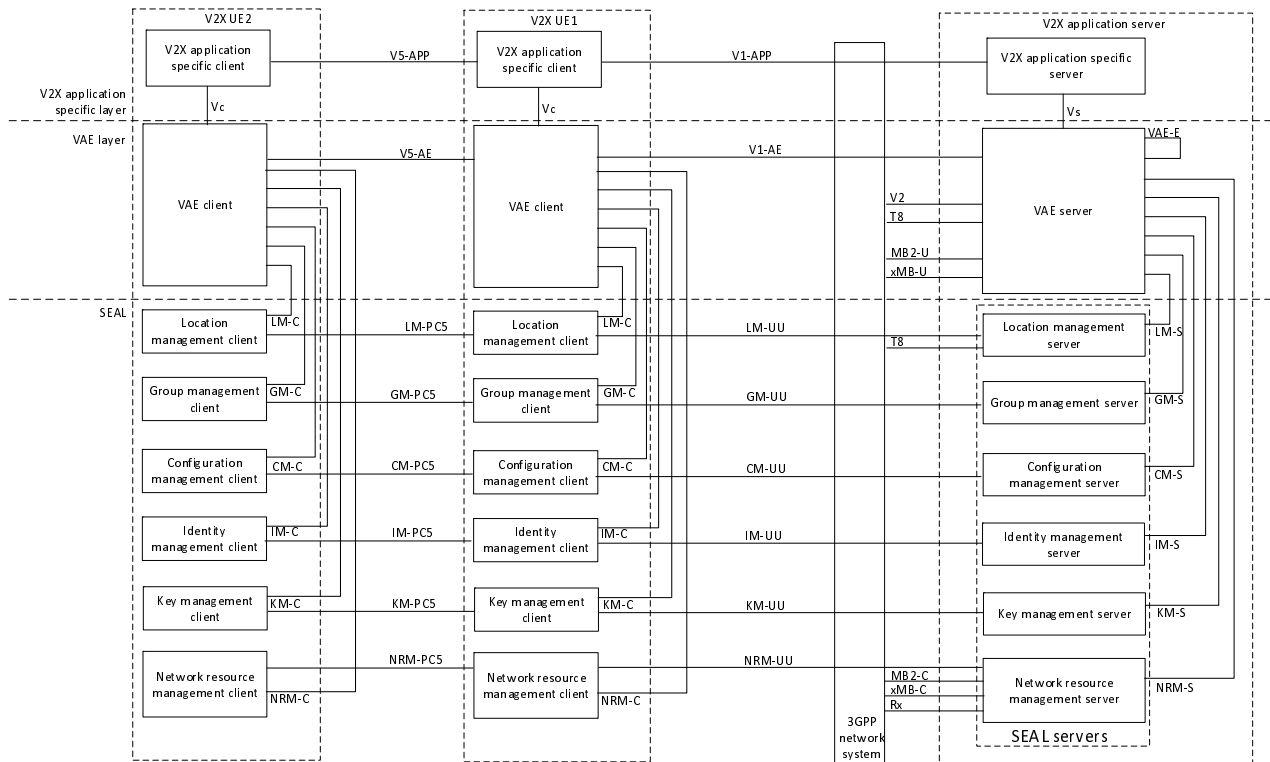

Figure A-1: Detailed V2X application layer functional model

## Annex B (informative): Functionalities with SA2 dependency

### B.1 Service negotiation with underlying 3GPP network

#### B.1.1 General

The following information flows for service negotiation with the 3GPP network are not supported in 3GPP TS 23.682 [8].

#### B.1.2 Information flows

##### B.1.2.1 Supporting information request

Table B.1.2.1-1 describes the information flow for a VAE server to provide the network with supporting information for service negotiation with the 3GPP network.

**Table B.1.2.1-1: Supporting information request**

Information element	Status	Description
Supporting Information	O	Indicating supporting information by the VAE server to increase the network awareness related to the service. Example of supporting information is planned/expected UE trajectory, which can be provided in the form of waypoints (GPS coordinates) and associated timestamps.

*Editor's note: Reference to the appropriate SA2 specification is needed and corresponding information flow table can be removed.*

*Editor's note: Need to verify with SA2 specifications on the exact support provided to this feature.*

##### B.1.2.2 Supporting information response

Table B.1.2.2-1 describes the information flow for a network to provide a response associated to a supporting information request.

**Table B.1.2.2-1: Supporting information response**

Information element	Status	Description
Result	M	Response from the network if supporting information is supported by the 3GPP network.

*Editor's note: Reference to the appropriate SA2 specification is needed and corresponding information flow table can be removed.*

##### B.1.2.3 Void

##### B.1.2.4 Void

B.1.3 Void

B.1.4 Void

B.2 Void



## Annex C (normative): V2X application enabler related configuration data

### C.1 General

This Annex provides information about the static data needed for configuration for the V2X application enabler service, which belongs to one of the following categories:

- VAE client configuration data (see subclause C.2); and
- VAE server configuration data (see subclause C.3).

### C.2 VAE client configuration data

The procedure of VAE client related configuration are specified in 3GPP TS 23.434 [6]. Data in tables C.2-1 has to be known by the VAE client.

Data in table C.2-1 can be configured using the CM-UU reference point as specified in 3GPP TS 23.434 [6].

**Table C.2-1: VAE client related configuration data**

Reference	Parameter description
Clause 8.1 and clause 9.1.2.2	V2X user/UE identity
Clause 9.1.2.2	V2X service ID
Clause 9.1.2.2	V2X server USD
Clause 9.2.3 and Clause 9.1.2.3	IP address and port information of the initial VAE server serving the VAE client
Clause 9.3.3	GEO ID information

### C.3 VAE server configuration data

The procedure of VAE server related configuration are specified in 3GPP TS 23.434 [6]. Data in tables C.3-1 has to be known by the VAE server.

Data in table C.3-1 can be configured using the CM-S reference point as specified in 3GPP TS 23.434 [6].

**Table C.3-1: VAE server related configuration data**

Reference	Parameter description
Clause 8.1	List of V2X user identities
Clause 9.7.4.2	IP address of the EPS entity SCEF
Clause 9.10.3.2	List of IP addresses of the neighboring VAE servers
Clause 9.11.3.2	IP address of the NRM server
Clause 9.12.3.2	Unique pool of ProSe Layer-2 Group IDs
Clause 9.5.2	BM-SC information

## Annex D: Change history

Change history							
Date	Meeting	TDoc	CR	Rev	Cat	Subject/Comment	New version
2018-10	SA6#26					TS skeleton	0.0.0
2018-10	SA6#26					Implementation of the following pCRs approved by SA6: S6-181488, S6-181489, S6-181490, S6-181548, S6-181549, S6-181554, S6-181555, S6-181556, S6-181575, S6-181576, S6-181583, S6-181589, S6-181591	0.1.0
2018-12	SA6#27					Implementation of the following pCRs approved by SA6: S6-181693, S6-181777, S6-181779, S6-181781, S6-181783, S6-181785, S6-181836, S6-181837, S6-181838, S6-181839	0.2.0
2019-01	SA6#28					Implementation of the following pCRs approved by SA6: S6-190137, S6-190144, S6-190219, S6-190221, S6-190222, S6-190223, S6-190224, S6-190271, S6-190298	0.3.0
2019-03	SA6#29					Implementation of the following pCRs approved by SA6: S6-190364, S6-190368, S6-190372, S6-190460, S6-190461, S6-190462, S6-190463, S6-190464, S6-190465, S6-190466, S6-190467, S6-190508	0.4.0
2019-03	SA#83	SP-190062				Presentation for information at SA#83	1.0.0
2019-04	SA6#30					Implementation of the following pCRs approved by SA6: S6-190641, S6-190643, S6-190644, S6-190651, S6-190652, S6-190755, S6-190756, S6-190757, S6-190758, S6-190760, S6-190762, S6-190827, S6-190828, S6-190829, S6-190830, S6-190831	1.1.0
2019-05	SA6#31					Implementation of the following pCRs approved by SA6: S6-191020, S6-191021, S6-191030, S6-191032, S6-191126, S6-191028, S6-191129, S6-191130, S6-191131, S6-191191133, S6-191136, S6-191138, S6-191139, S6-191194, S6-191195, S6-191196	1.2.0
2019-05	SA#84	SP-190472				Presentation for Approval at SA#84	2.0.0
2019-06	SA#84	SP-190472				MCC Editorial update for publication after TSG SA approval (SA#84)	16.0.0
2019-09	SA#85	SP-190734	0001	2	F	Remove EN GeolDs	16.1.0
2019-09	SA#85	SP-190734	0002	3	F	Functionalities with SA2 dependency	16.1.0
2019-09	SA#85	SP-190734	0003		F	Update to functional model	16.1.0
2019-09	SA#85	SP-190734	0004	1	F	Update to network QoS and situation monitoring aligned with SA2	16.1.0
2019-09	SA#85	SP-190734	0005	2	F	Dynamic group API	16.1.0
2019-09	SA#85	SP-190734	0006	1	F	Correction to push layer-2 group ID mapping information flow	16.1.0
2019-09	SA#85	SP-190734	0007	4	F	Corrections on notifications for network monitoring procedure	16.1.0
2019-09	SA#85	SP-190734	0008	1	F	Addition of missing VAE server APIs	16.1.0
2019-09	SA#85	SP-190734	0009	1	F	Update the configurations information	16.1.0
2019-12	SA#86	SP-191112	0010	2	F	CR Message Delivery	16.2.0
2019-12	SA#86	SP-191112	0011		F	Update API names	16.2.0
2019-12	SA#86	SP-191112	0012	3	F	Update to uplink message delivery procedure	16.2.0
2020-03	SA#87-E	SP-200115	0013		F	Add VAE application requirement notification	16.3.0
2020-03	SA#87-E	SP-200115	0014	1	F	Add VAE service continuity API	16.3.0
2020-03	SA#87-E	SP-200115	0015	1	F	Correct Group Management procedure	16.3.0
2020-03	SA#87-E	SP-200115	0016	1	F	Align with TS 23.434	16.3.0
2020-03	SA#87-E	SP-200115	0017	1	F	Clarifications on V2X USD	16.3.0
2020-03	SA#87-E	SP-200115	0018	1	F	Correction of the usage of SEAL services by the V2X application specific server	16.3.0
2020-09	SA#89-E	SP-200842	0019		F	Correct Geo id	16.4.0
2020-09	SA#89-E	SP-200842	0020	1	F	Correction to de-registration procedure	16.4.0
2020-12	SA#90-E	SP-200992	0033	1	F	Clarifications for network monitoring information notification	16.5.0

---

# History

<b>Document history</b>		
V16.3.0	October 2020	Publication
V16.4.0	October 2020	Publication
V16.5.0	January 2021	Publication