

ETSI TS 123 327 V8.2.2 (2009-01)

Technical Specification

**Digital cellular telecommunications system (Phase 2+);
Universal Mobile Telecommunications System (UMTS);
Mobility between 3GPP-Wireless Local Area Network (WLAN)
interworking and 3GPP systems
(3GPP TS 23.327 version 8.2.2 Release 8)**



Reference

RTS/TSGS-0223327v822

Keywords

GSM, UMTS

ETSI

650 Route des Lucioles
F-06921 Sophia Antipolis Cedex - FRANCE

Tel.: +33 4 92 94 42 00 Fax: +33 4 93 65 47 16

Siret N° 348 623 562 00017 - NAF 742 C
Association à but non lucratif enregistrée à la
Sous-Préfecture de Grasse (06) N° 7803/88

Important notice

Individual copies of the present document can be downloaded from:

<http://www.etsi.org>

The present document may be made available in more than one electronic version or in print. In any case of existing or perceived difference in contents between such versions, the reference version is the Portable Document Format (PDF). In case of dispute, the reference shall be the printing on ETSI printers of the PDF version kept on a specific network drive within ETSI Secretariat.

Users of the present document should be aware that the document may be subject to revision or change of status. Information on the current status of this and other ETSI documents is available at

<http://portal.etsi.org/tb/status/status.asp>

If you find errors in the present document, please send your comment to one of the following services:

http://portal.etsi.org/chaicor/ETSI_support.asp

Copyright Notification

No part may be reproduced except as authorized by written permission.
The copyright and the foregoing restriction extend to reproduction in all media.

© European Telecommunications Standards Institute 2009.
All rights reserved.

DECTTM, **PLUGTESTS**TM, **UMTS**TM, **TIPHON**TM, the TIPHON logo and the ETSI logo are Trade Marks of ETSI registered for the benefit of its Members.

3GPPTM is a Trade Mark of ETSI registered for the benefit of its Members and of the 3GPP Organizational Partners.

LTETM is a Trade Mark of ETSI currently being registered

for the benefit of its Members and of the 3GPP Organizational Partners.

GSM[®] and the GSM logo are Trade Marks registered and owned by the GSM Association.

Intellectual Property Rights

IPRs essential or potentially essential to the present document may have been declared to ETSI. The information pertaining to these essential IPRs, if any, is publicly available for **ETSI members and non-members**, and can be found in ETSI SR 000 314: *"Intellectual Property Rights (IPRs); Essential, or potentially Essential, IPRs notified to ETSI in respect of ETSI standards"*, which is available from the ETSI Secretariat. Latest updates are available on the ETSI Web server (<http://webapp.etsi.org/IPR/home.asp>).

Pursuant to the ETSI IPR Policy, no investigation, including IPR searches, has been carried out by ETSI. No guarantee can be given as to the existence of other IPRs not referenced in ETSI SR 000 314 (or the updates on the ETSI Web server) which are, or may be, or may become, essential to the present document.

Foreword

This Technical Specification (TS) has been produced by ETSI 3rd Generation Partnership Project (3GPP).

The present document may refer to technical specifications or reports using their 3GPP identities, UMTS identities or GSM identities. These should be interpreted as being references to the corresponding ETSI deliverables.

The cross reference between GSM, UMTS, 3GPP and ETSI identities can be found under <http://webapp.etsi.org/key/queryform.asp>.

Contents

Intellectual Property Rights	2
Foreword.....	2
Foreword.....	5
1 Scope	6
2 References	6
3 Definitions and Abbreviations.....	7
3.1 Definitions	7
3.2 Abbreviations	7
4 High-Level Requirements and Principles.....	7
4.1 General Requirements	7
4.2 Architecture Requirements	7
4.3 Mobility Requirements	8
4.4 Roaming Requirements	8
4.5 Charging Requirements	8
4.6 Security Requirements	8
5 Concepts and Architecture Model	8
5.1 General Concepts	8
5.2 Architecture Reference Model	8
5.2.1 Home Mobility Service Architecture	8
5.2.2 Visited Mobility Service Architecture	9
5.3 High Level Functions	10
5.3.1 General.....	10
5.3.2 Home Agent Discovery	10
5.3.3 Home Link Detection.....	10
5.4 Network Elements	11
5.5 Reference Points	11
6 Functional Description and Information Flows.....	12
6.1 H1 PDN Attach	12
6.2 H1 PDN Detach.....	13
6.2.1 UE Initiated Detach	13
6.2.2 HA Initiated Detach	14
6.2.3 AAA Initiated Detach	14
6.3 Handover	15
6.3.1 H1 Reference Point Procedure.....	15
6.3.2 Handover Signalling Flows	16
6.3.2.1 Handover from 3GPP I-WLAN to 3GPP access.....	16
6.3.2.2 Handover from 3GPP access to 3GPP I-WLAN access.....	16
6.4 Accounting	17
6.5 Interactions with Other Services	17
6.6 IPv4 Home Address Release Procedure	18
Annex A (Normative): EPS Migration Considerations.....	19
Annex B (Normative): Information on implementation options	20
B.1 Co-located HA and GGSN functions	20
B.1.1 I-WLAN Mobility System Architecture with Co-located HA-GGSN	20
B.1.2 Home Link Discovery for the Co-located HA and GGSN	20
B.1.3 3GPP Attachment.....	21
B.1.4 I-WLAN Attachment.....	22
B.1.5 Handover from 3GPP access to I-WLAN	24
B.1.6 Handover from I-WLAN to 3GPP Access	25

B.2 Co-located HA and PDG functions26
B.2.1 H1 PDN Attach26
Annex C (Informative): Change History27
History28

Foreword

This Technical Specification has been produced by the 3rd Generation Partnership Project (3GPP).

The contents of the present document are subject to continuing work within the TSG and may change following formal TSG approval. Should the TSG modify the contents of the present document, it will be re-released by the TSG with an identifying change of release date and an increase in version number as follows:

Version x.y.z

where:

- x the first digit:
 - 1 presented to TSG for information;
 - 2 presented to TSG for approval;
 - 3 or greater indicates TSG approved document under change control.
- y the second digit is incremented for all changes of substance, i.e. technical enhancements, corrections, updates, etc.
- z the third digit is incremented when editorial only changes have been incorporated in the document.

1 Scope

This document specifies the stage 2 system description for providing mobility between 3GPP Wireless Local Area Network Interworking (I-WLAN) and 3GPP Systems. It is to define a technical solution based on the working principles of DSMIPv6 [7] with necessary enhancement of the I-WLAN architecture for supporting mobility and roaming between 3GPP-WLAN Interworking system and 3GPP Systems so that ongoing 3GPP PS based services can be maintained with minimal impact on the end-user's perceived quality on the services at a change of the access network (between I-WLAN and 3GPP Access Systems).

The specification includes both non-roaming and roaming scenarios and covers all aspects, including mobility between 3GPP Systems and I-WLAN with access authentication and charging.

2 References

The following documents contain provisions which, through reference in this text, constitute provisions of the present document.

- References are either specific (identified by date of publication, edition number, version number, etc.) or non-specific.
- For a specific reference, subsequent revisions do not apply.
- For a non-specific reference, the latest version applies. In the case of a reference to a 3GPP document (including a GSM document), a non-specific reference implicitly refers to the latest version of that document *in the same Release as the present document*.

- [1] 3GPP TR 21.905: "Vocabulary for 3GPP Specifications".
- [2] 3GPP TS 23.234: "3GPP Systems to Wireless Local Area Network (WLAN) Interworking; System Description".
- [3] 3GPP TS 23.060: "General Packet Radio Service (GPRS); Service Description; Stage 2".
- [4] 3GPP TS 23.203: "Policy and Charging Control Architecture".
- [5] 3GPP TS 33.234: "3G security; Wireless Local Area Network (WLAN) interworking security".
- [6] 3GPP TS23.402: "Architecture Enhancements for non-3GPP accesses".
- [7] IETF Internet-Draft, draft-ietf-mip6-nemo-v4traversal-03.txt: "Mobile IPv6 support for dual stack Hosts and Routers (DSMIPv6)".
- [8] IETF RFC 3775: "Mobility Support in IPv6".
- [9] IETF RFC 4306, "Internet Key Exchange Protocol Version 2".
- [10] IETF RFC 3748: "Extensible Authentication Protocol (EAP)".
- [11] IETF RFC 4877: "Mobile IPv6 Operation with IKEv2 and the Revised IPsec Architecture".
- [12] IETF RFC 4739: "Multiple Authentication Exchanges in the Internet Key Exchange (IKEv2) Protocol".
- [13] 3GPP TS 29.061: "Interworking between the Public Land Mobile Network (PLMN) supporting Packet Based Services and Packet Data Networks (PDN)".

3 Definitions and Abbreviations

3.1 Definitions

For the purposes of the present document, the definition given in TR 21.905 [1] and the following apply. A definition given in the present document takes precedence over the same definition, if any, in TR 21.905 [1].

Home Agent Access Point Name (HA-APN): Is used to identify a specific PDN and a point of interconnection to that network (Home Agent).

3.2 Abbreviations

For the purposes of the present document, the abbreviations given in TR 21.905 [1] and the following apply. An abbreviation defined in the present document takes precedence over the definition of the same abbreviation, if any, in TR 21.905 [1].

APN	Access Point Name
CoA	Care-of-address
DHCP	Dynamic Host Configuration Protocol
DNS	Domain Name System
DSMIPv6	Dual-Stack MIPv6
EPS	Evolved Packet Systems
GGSN	Gateway GPRS Support Node
GTP	GPRS Tunnelling Protocol
HA	Home Agent
I-WLAN	Interworking WLAN
MIP	Mobile IP
MIPv6	Mobile IP version 6
MN	Mobile Node
PDP	Packet Data Protocol, e.g. IP
SGSN	Serving GPRS Support Node
UE	User Equipment

4 High-Level Requirements and Principles

4.1 General Requirements

- Access to 3GPP and internet services shall be supported.
- Smooth migration from legacy network with minimal impacts on dual mode UEs, I-WLAN and 3GPP systems shall be possible.
- Architecture, functions and procedures described in I-WLAN interworking TS 23.234 [2] and GPRS TS 23.060 [3] shall be re-used as basis.

4.2 Architecture Requirements

- Mobility for PDG based I-WLAN architecture shall be supported.
- Both IPv4 and IPv6 addresses shall be supported
- Quality of service shall be supported when the UE moves between I-WLAN and 3GPP systems
- I-WLAN and 3GPP QoS mechanisms defined in TS 23.234 [2] TS 23.060 [3] and TS 23.203 [4] shall be re-used. Additionally, the Home Agent shall be able to provide transport IP QoS e.g. DiffServ support similarly as defined for PDG in TS 23.234 [2].

4.3 Mobility Requirements

- Service continuity between 3GPP packet switched network and I-WLAN with IP address (es) preservation shall be supported.
- Multiple parallel sessions under the same APN shall be maintained when the UE moves between 3GPP PS network and I-WLAN. Also the mobility for the UE with multiple PDN connectivity should be supported.
- Interruption time of the operators' services or applications being provided to the end user shall be minimized.
- It shall be possible to notify to the user the change of the access networks, 3GPP PS system or I-WLAN.
- It shall be possible to disable the mobility function where applicable to the operators' needs.

4.4 Roaming Requirements

- Mobility with re-use of roaming architecture interface(s) and protocol(s) in a visited PLMN shall be possible.

4.5 Charging Requirements

- It shall be possible to re-use existing policy control and charging (PCC) rules and mechanisms as defined in TS 23.203 [4].
- Charging differentiation capability based on radio access type shall be enabled.
- Use of common billing system for 3GPP PS system and the I-WLAN access shall be possible.

4.6 Security Requirements

- Existing security measures taken by the end users and the operators shall not be compromised.
- It shall be possible for operators to apply common access control based on TS 33.234 [5] regardless of the change of the accesses by the UEs.
- The operators shall be able to apply legal interception.

5 Concepts and Architecture Model

This specification is based on the architectural/functional/procedural definitions described in (WLAN Interworking) TS 23.234 [5] and (GPRS) TS 23.060 [3].

I-WLAN Mobility solution shall allow the operator to configure a type of access (e.g. 3GPP access) as the "home link" for DSMIPv6 purposes.

5.1 General Concepts

5.2 Architecture Reference Model

5.2.1 Home Mobility Service Architecture

The *Home Mobility Service architecture* refers to the case where the Home Agent function locates at HPLMN. Whether the user is roaming or not roaming in the underlying access system and/or whether the illustrated H3 reference point spans across different administrative domains is not relevant for this specification.

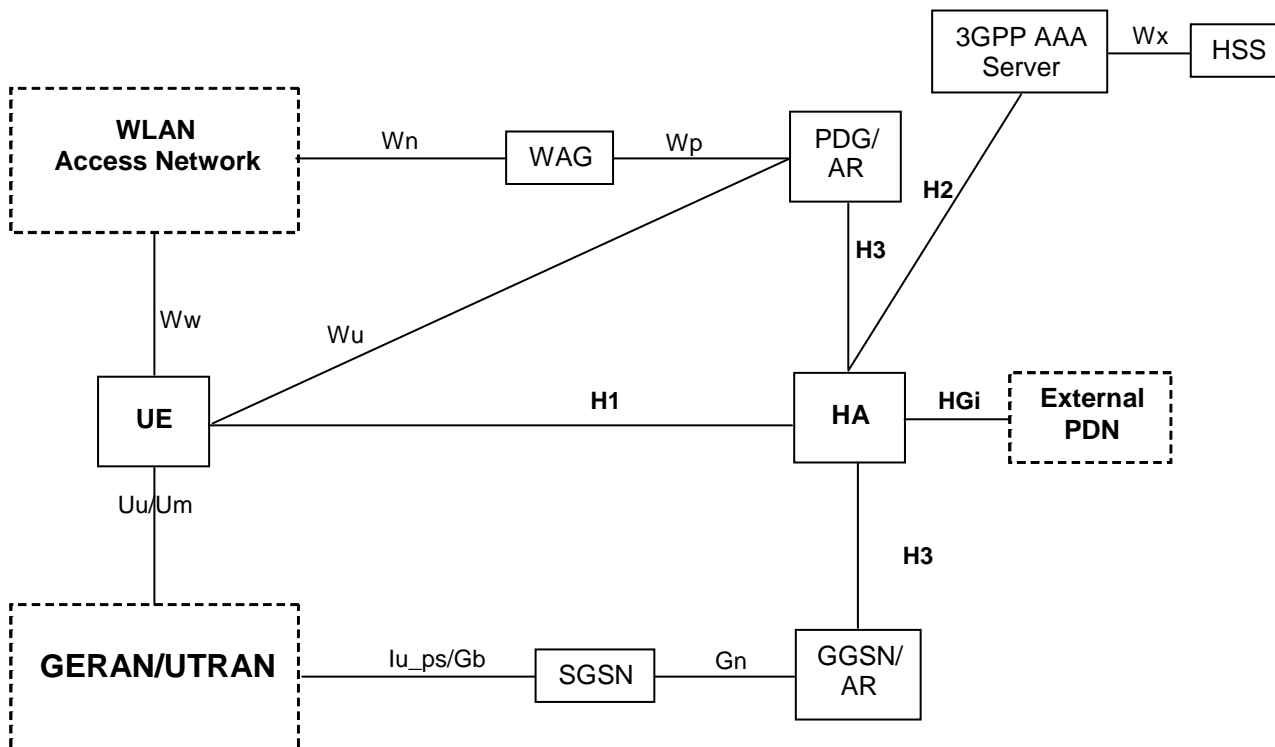

Figure 5.2.1-1: Home Mobility Service Architecture for I-WLAN Mobility

NOTE: The architecture is compatible with pre-Release 8 PDG and GGSN.

5.2.2 Visited Mobility Service Architecture

The Visited Mobility service *architecture* refers to the case where the Home Agent function locates outside of the HPLMN. Whether the user is roaming or not roaming in the underlying access system and/or whether the illustrated H3 reference point spans across different administrative domains is not relevant for this specification.

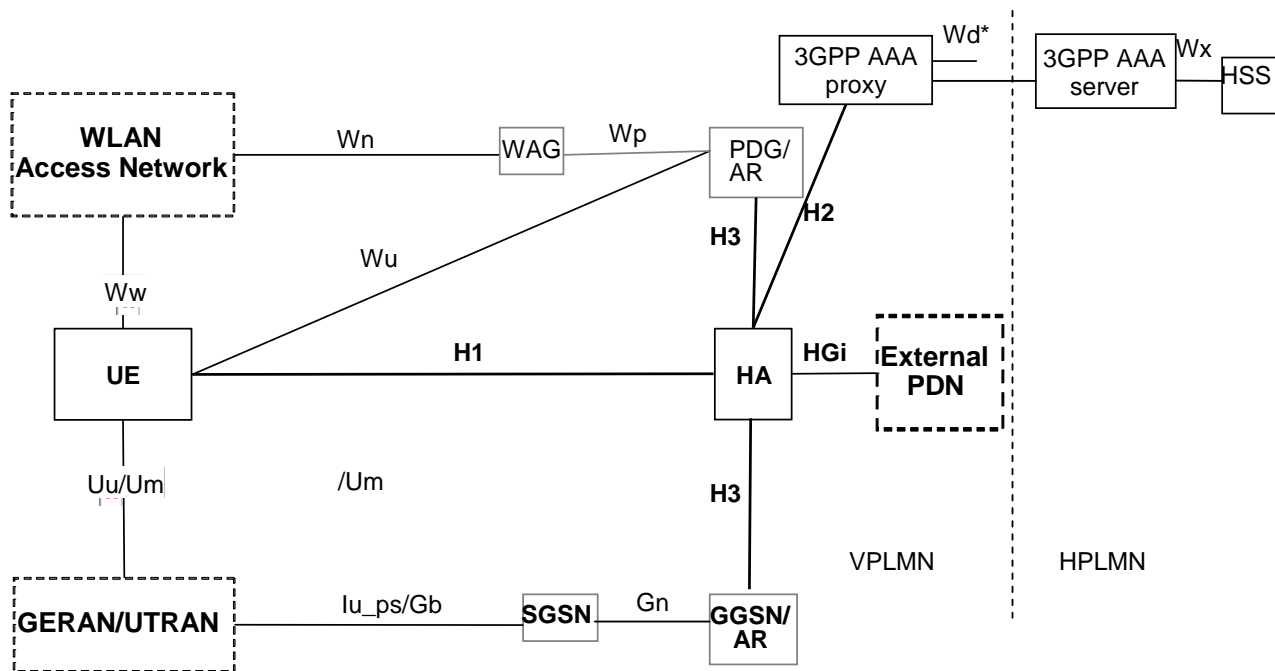

Figure 5.2.2-1: Visited Mobility Service Architecture for I-WLAN Mobility

5.3 High Level Functions

5.3.1 General

The WLAN Interworking Mobility solution described in this TS provides a DSMIPv6 [7] based inter-system mobility solution on top of 3GPP I-WLAN, TS 23.234 [2] and 3GPP PS domain, TS 23.060 [3]. The inter-system mobility solution is compatible with pre-Release 8 TS 23.060 [3] systems and with pre-Release 8 TS 23.234 [2] systems.

The inter-system mobility solution provides the following functions:

- HA discovery.
- Security association establishment between UE and HA, including the required AAA interactions.
- DSMIPv6 signalling and user data transfer between UE and HA.

The inter-system mobility solution has the following limitations:

- No support for Network Initiated Service Request procedures.
- No support for PCRF -HA interactions.
- No updates to the existing PCRFs.
- No updates to the existing PCC signalling.
- No updates to the existing PCEF functionality in GGSN and PDG.

NOTE: This means that the PCEF in GGSN and PDG can not operate on service data flows inside the tunnel between UE and HA.

Extending DSMIPv6 based inter-system mobility, to avoid the above limitations, requires deployment of EPS PDN GW. EPS PDN GW and its interactions with other 3GPP system nodes are specified in TS 23.402 [6].

Further EPS migration aspects are described in Annex A of this specification.

5.3.2 Home Agent Discovery

DSMIPv6 requires that the UE knows the HA IP address in order to establish the security association with home agent and then, to proceed to binding updates. This address is made known to the UE with one of the following ways:

- 1) The IP address of the home agent is statically configured in UE, typically through a manual method, and is permanent until manually changed.
- 2) The IP address of the home agent can be retrieved from DNS.
- 3) The IP address of the home agent can be delivered to the UE via PCO.
- 4) The PDG may return the IP address of the home agent in IKEv2 configuration payload to the UE.

NOTE: The underlying IP access network may support other ways of configuring the HA IP address to the UE, but this is out of the scope of this specification.

5.3.3 Home Link Detection

The DSMIPv6 Home Link Detection Function is used by the UE to detect, if for a specific PDN, an access interface is the Home Link from DSMIPv6 perspective.

It is up to the UE's configuration to decide when to trigger the home link detection function for a specific PDN connection. Before performing DSMIPv6 registration over any PDN connection, the UE must determine that it is not on its home link.

The home link detection function compares:

- IPv6 prefix associated with a specific access interface of the UE; and
- Home Network Prefix (HNP) allocated to the PDN connection.

If the two prefixes match, the UE detects it is in the home link for this specific PDN over the access interface. Otherwise, the UE detects it is not in the home link for this specific PDN over the access interface.

NOTE 1: The UE knows the IPv6 prefix associated with a specific access system interface via IP address allocation mechanisms applied in that access system.

The UE knows the HNP allocated to the PDN connection from:

- the IPsec security association bootstrap with the HA; or
- the PCO delivered to UE at 3GPP attach during the PDP context creation procedure to the GGSN in 2G/3G; or
- from the IKEv2 sent to the UE during the IPsec tunnel establishment to the PDG in I-WLAN.

The GGSN and PDG can get the HNP of the UE by means such as DHCP or AAA.

NOTE 2: The HNP may also be pre-configured in the UE.

5.4 Network Elements

Home Agent (HA):

The Home Agent communicates with the UE and exchanges DSMIPv6 related signalling to keep track of the access network the UE is recently camping on. This signalling is transparent to the Access Routers (AR) (GGSN and PDG).

HA functionality may be implemented as a stand-alone HA entity, or co-located with GGSN or PDG. The special considerations of the HA-GGSN and HA-PDG co-location are described in Annex B of this specification. Configuring the GPRS system as the home link also for a standalone HA is not precluded. The home link is the link on which the UE's home subnet prefix is defined (see RFC 3775 [8]).

UE:

The UE contains a DSMIPv6 Client to enable the DSMIPv6 based signalling and user data transfer towards the Home Agent.

5.5 Reference Points

HGi: This reference point defines the interface from the HA to external PDN

H1: This is the reference point for signalling and user data transfer between UE and HA.

NOTE: H1 may be transported over IP connectivity provided by I-WLAN or 3GPP access system.

H2: This reference point defines the interface between HA and 3GPP AAA infrastructure (3GPP AAA server or 3GPP AAA proxy) and is used to transport authentication, authorization and charging-related information in a secure manner.

H3: This is the IP transport reference point to carry the end-to-end UE-HA signalling and user data between Access Router and HA. Since there is no direct signalling messages between these two entities this is simple IP transport reference point, which does not require additional specification.

6 Functional Description and Information Flows

6.1 H1 PDN Attach

H1 PDN Attach is triggered by the UE to initialize the I-WLAN Mobility service towards a specific PDN. For each PDN connection, the H1 PDN Attach has to be performed separately.

NOTE 1: The H1 PDN Attach is creating a PDN specific H1 instance between a UE and a HA.

NOTE 2: To execute H1 PDN Attach via GPRS, the UE shall have Primary PDP context to GGSN from which the discovered HA can be reached via H3.

When connected over the UE home link (e.g. 3GPP access), the UE may be configured not to trigger the establishment of IKEv2 SA. In this case, H1 PDN Attach is triggered when the UE moves to I-WLAN. During the Handover the UE keeps using the source 2G/3G access (i.e. make-before-break).

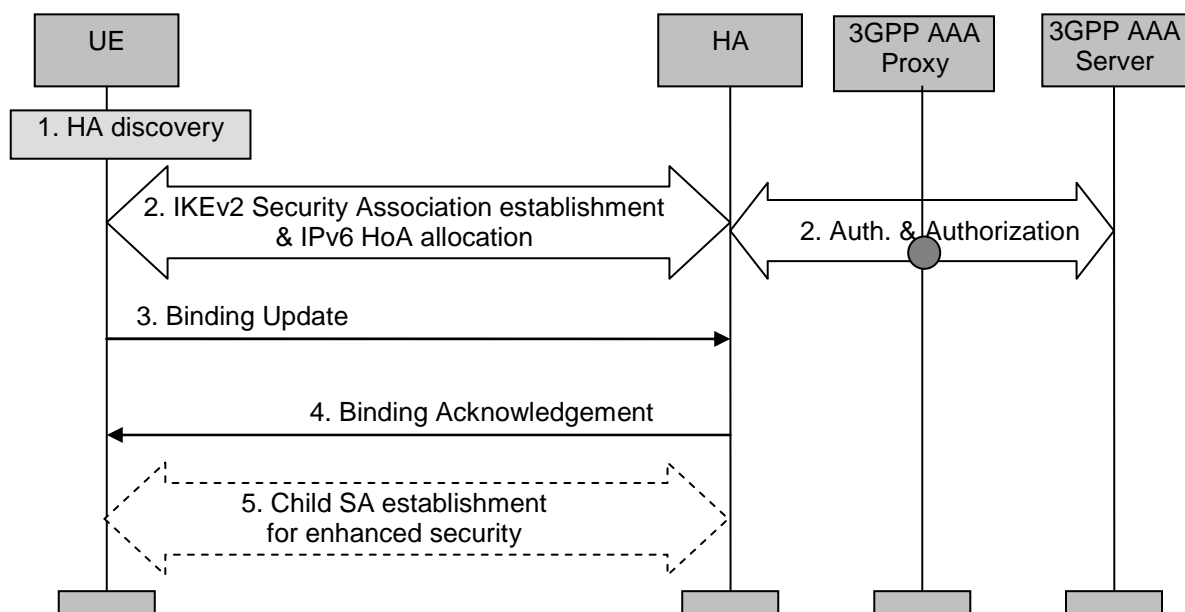

Figure 6.1: H1 PDN Attach

1. The UE discovers the Home Agent as defined in the clause 5.3.2, *Home Agent Discovery*.
2. A security association is established between UE and HA to secure the DSMIPv6 messages related to this PDN connection between the UE and the HA. The UE initiates the establishment of the security association using IKEv2 [9]; EAP [10] is used over IKEv2 for authentication purposes. The HA communicates with the AAA infrastructure in order to complete the authentication.

During this step an IPv6 home network prefix is assigned by the HA to the UE as defined in RFC 4877 [11] and RFC 4306 [9]. During this step the UE may include the APN of the PDN it wants to access (in the IKE AUTH message using the IDr payload in similar manner as specified for I-WLAN in TS 23.234 [2]) and it can also request a specific IPv6 home network prefix as defined in RFC 4877 [11] in order to influence the IP network prefix assignment procedure. After the IPv6 home network prefix is assigned, UE constructs a home address from it via auto-configuration.

In this step, the HA may be either in the HPLMN or in the VPLMN. When the HA is in the VPLMN, the interaction between the HA in the VPLMN with the AAA/HSS in the HPLMN may involve a 3GPP AAA Proxy in the VPLMN as specified in TS 23.234 [2].

If the PDN requires an additional authentication and authorization with an external AAA Server additional authentication is executed in this step. Details on these multiple authentications are specified in RFC 4739 [12] and in TS 23.234 [2] for I-WLAN (Private Network Access (PNA)).

3. In case a Binding Update is required to establish the desired PDN connectivity (e.g. UE is not at its home link), the UE sends the DSMIPv6 Binding Update message to the HA as specified in draft-ietf-mip6-nemo-v4traversal [7]. The UE shall inform the HA that IP address preservation shall be maintained for the whole home network prefix.

The HA processes the Binding Update. During the processing the HA performs local authentication and authorization of the message using the IPsec security association established in step 2. If the UE does not have an IPv4 HoA already, it may request for the IPv4 home address from the HA as defined in draft-ietf-mip6-nemo-v4traversal [7] in this step. This request for the IPv4 home address may alternatively be done in any subsequent Binding Update.

4. The HA sends the DSMIPv6 Binding Ack to the UE. In this step the HA may include an IPv4 home address as specified in draft-ietf-mip6-nemo-v4traversal [7] if requested by the UE in step 3. In case GPRS is configured to act as the home link for the PDN connection, the HA should also include an APN through which it is possible for the UE to gain GPRS home link connectivity.
5. The HA may additionally trigger the creation of a child IPsec Security Association for protecting the traffic sent via the H1 reference point. The child SA is created as specified in RFC 4877 [22]. Child SA can be used for H1 IP flow integrity protection and may be used also for H1 IP flow encryption.

NOTE 1: The child SA can be established and/or released by HA at any time after the IKEv2 bootstrap and not only just after step 4.

NOTE 2: In a roaming scenario, the usage of the child SA for H1 IP flow encryption by HPLMN HA may be restricted by the policies in the roaming agreement between the VPLMN and the HPLMN.

6.2 H1 PDN Detach

The H1 PDN Detach is clearing the PDN specific H1 instance between a UE and a HA. This H1 PDN detach has no impact to the status of possibly existing other H1 based PDN connections nor to the underlying IP access connectivity state e.g. within GPRS system.

6.2.1 UE Initiated Detach

The Detach procedure when initiated by the UE is illustrated below.

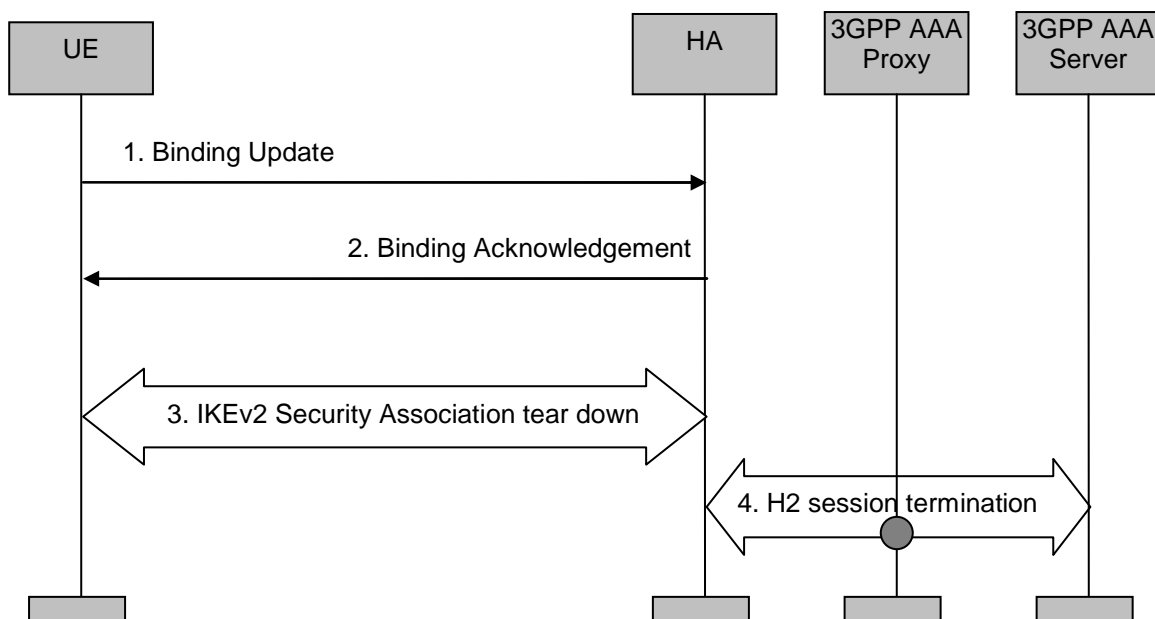

Figure 6.2-1: UE Initiated Detach Procedure

1. If a Binding exists, the UE sends the DSMIPv6 Binding Update message to the HA as specified in draft-ietf-mip6-nemo-v4traversal [7]. UE indicates Binding Lifetime as 0. The HA processes the Binding Update. During

the processing the HA performs local authentication and authorization of the message using the existing IPsec security association.

2. The HA sends the DSMIPv6 Binding Ack to the UE.
3. UE triggers the tear down of the security association between UE and HA using IKEv2 [9]. The HA acknowledges the security association removal.
4. The HA communicates with the AAA infrastructure in order to tear down the H2 session (unless needed to be maintained for other purposes).

In this step, the HA may be either in the HPLMN or in the VPLMN. When the HA is in the VPLMN, the interaction between the HA in the VPLMN with the AAA/HSS in the HPLMN may involve a 3GPP AAA Proxy in the VPLMN as specified in TS 23.234 [2].

6.2.2 HA Initiated Detach

The detach procedure when initiated by the HA is illustrated below.

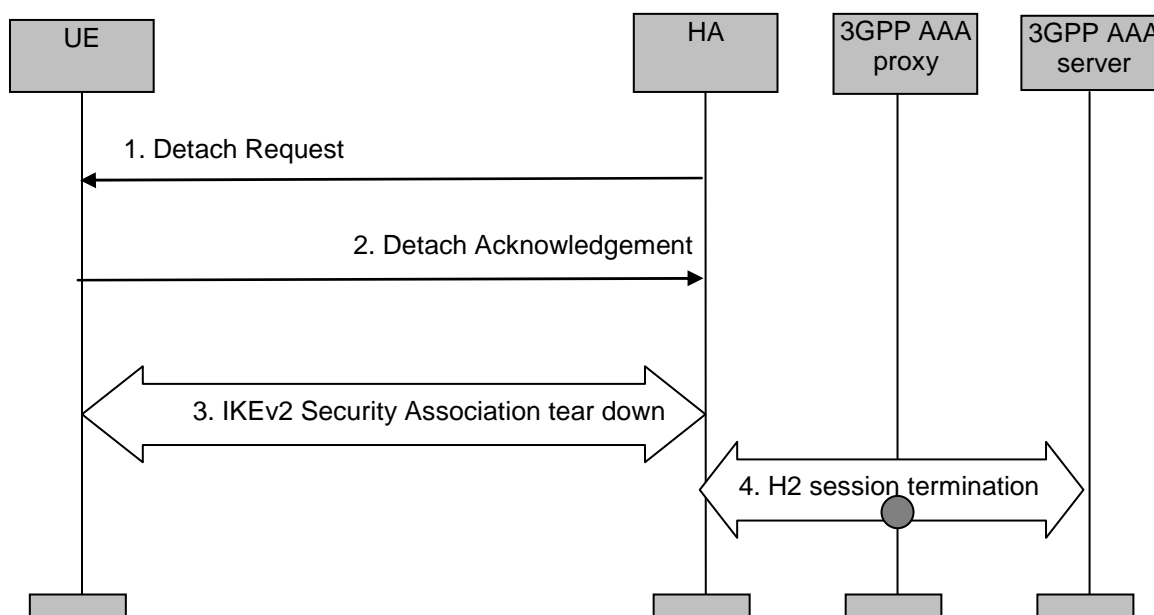

Figure 6.2-2: HA Initiated Detach Procedure

1. In the explicit detach procedure the HA shall send a detach request message as specified. In the implicit detach procedure this step is omitted.
2. In the explicit detach procedure, the UE shall acknowledge the detach request. In the implicit detach procedure this step is omitted.

NOTE: How the detach request and acknowledge messages are implemented is a stage 3 detail.

3. UE triggers the tear down of the security association between UE and HA using IKEv2 [9]. The HA acknowledges the security association removal.
4. The HA communicates with the AAA infrastructure in order to tear down the H2 session (unless needed to be maintained for other purposes).

In this step, the HA may be either in the HPLMN or in the VPLMN. When the HA is in the VPLMN, the interaction between the HA in the VPLMN with the AAA/HSS in the HPLMN may involve a 3GPP AAA Proxy in the VPLMN as specified in TS 23.234 [2].

6.2.3 AAA Initiated Detach

The Detach procedure when initiated by the AAA is illustrated below.

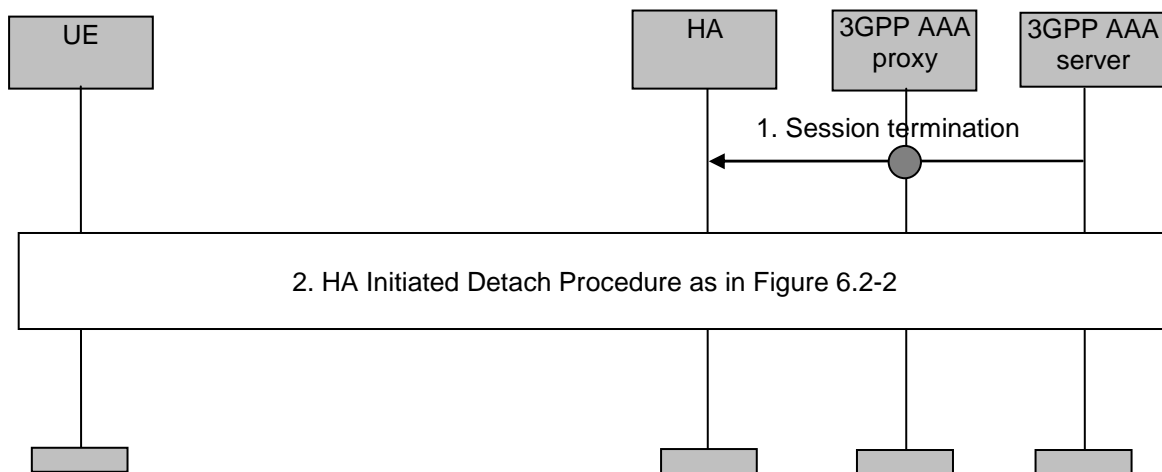

Figure 6.2-3: AAA Initiated Detach Procedure

1. If the AAA wants to request the immediate termination of an H1 session for a given UE, it shall send a Session Termination message to the HA. In the roaming case signalling may be routed via a 3GPP AAA Proxy in the VPLMN.
2. The HA initiated detach procedure is performed as defined in clause 6.2.2, Figure 6.2-2.

6.3 Handover

6.3.1 H1 Reference Point Procedure

This procedure is used to bind access specific Care-of Address with the Home Address. This procedure is performed to either refresh an existing binding or to change the binding from one Care-of Address to another when the Care-of Address changes e.g., due to movement between GPRS and I-WLAN. When this procedure is triggered it is assumed that the UE already has an IP address from the underlying IP access system.

In this procedure it is assumed that the UE is already H1 PDN Attached.

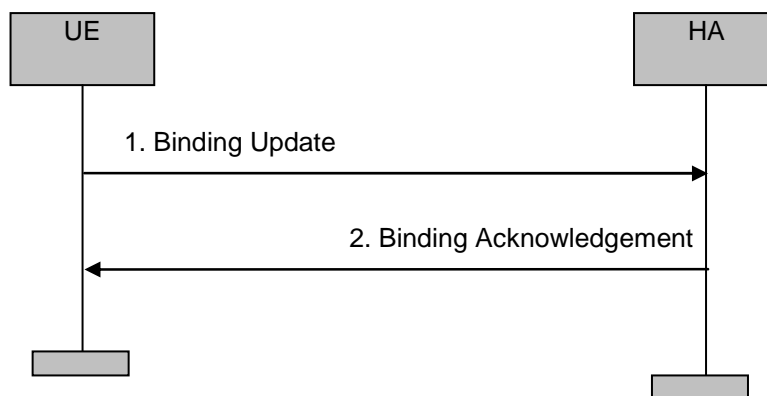

Figure 6.3.1-1: Binding Update Procedure

1. The UE sends the DSMIPv6 Binding Update message to the HA as specified in draft-ietf-mip6-nemo-v4traversal-03 [7]. HA performs local authentication and authorization of the Binding Update message using the existing IPsec security association. The UE shall inform the HA that IP address preservation shall be maintained for the whole home network prefix.
2. The HA sends the DSMIPv6 Binding Ack to the UE as specified in draft-ietf-mip6-nemo-v4traversal-03 [7].

6.3.2 Handover Signalling Flows

6.3.2.1 Handover from 3GPP I-WLAN to 3GPP access

The information flow represents a handover scenario from 3GPP I-WLAN access to 3GPP access for both the home mobility service and the visited mobility service cases (HSS and 3GPP AAA server are left out for simplicity).

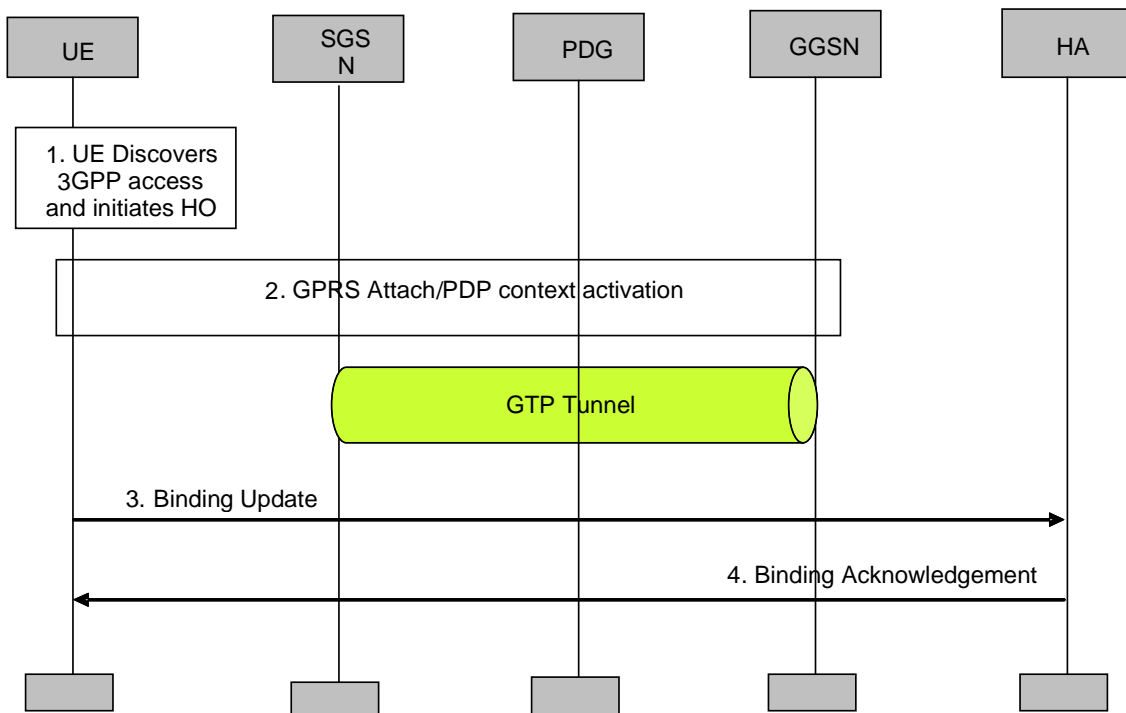

Figure 6.3.2.1-1: Handover from 3GPP I-WLAN access to 3GPP access

1. While connected over I-WLAN, the UE discovers the 3GPP GPRS coverage and determines to transfer its current sessions from the currently used 3GPP I-WLAN access to the discovered 3GPP access system.
2. The GPRS attach procedure including GGSN selection, IP address assignment to the UE, etc., is involved as specified in TS 23.060 [3]. The GTP tunnel between UE and GGSN is finally established and the UE can transfer data via 3GPP access.
3. The UE sends the DSMIPv6 Binding Update message to the HA as specified in draft-ietf-mip6-nemo-v4traversal [7].
 - A. If the UE is on the home link, the UE sends a BU with LIFETIME==0. The UE shall inform the HA that IP address preservation shall be maintained for the whole home network prefix.
 - B. If the UE is not on the home link, the UE sends a regular BU. The UE shall inform the HA that IP address preservation shall be maintained for the whole home network prefix.
4. The HA sends the DSMIPv6 Binding Ack to the UE as specified in draft-ietf-mip6-nemo-v4traversal [7]. The DSMIPv6 tunnelling is modified accordingly.

6.3.2.2 Handover from 3GPP access to 3GPP I-WLAN access

The information flow represents a handover scenario from 3GPP access to 3GPP I-WLAN access for both the home mobility service and the visited mobility service cases (HSS and 3GPP AAA server are left out for simplicity).

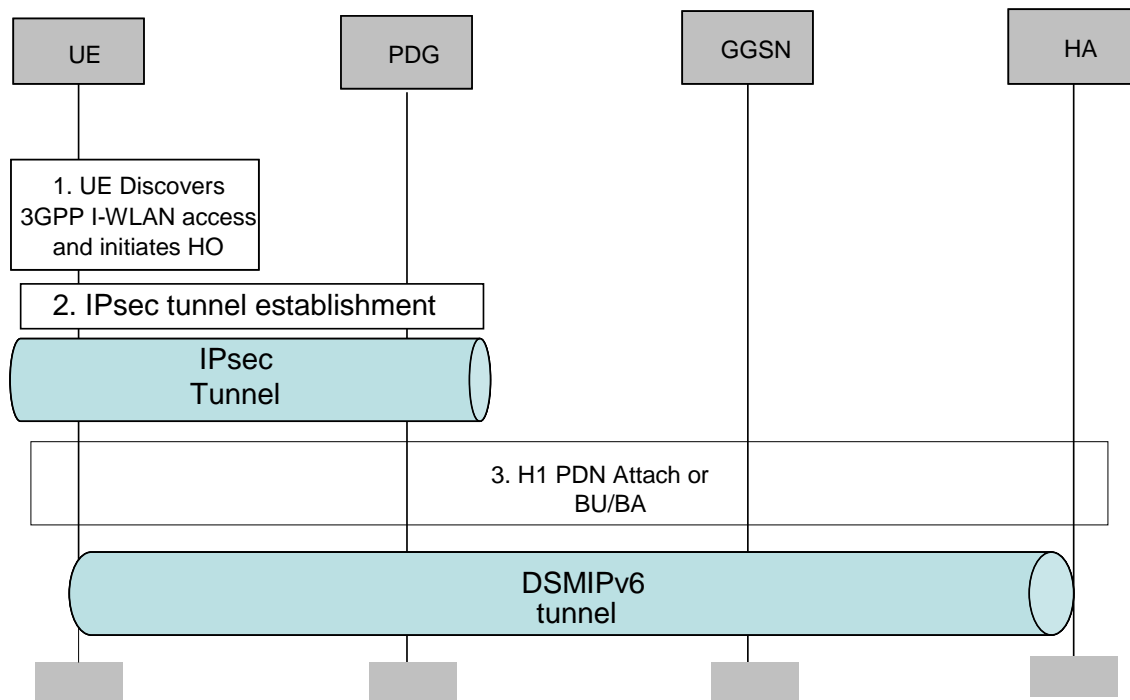

Figure 6.3.2.2-1: Handover from 3GPP access to 3GPP I-WLAN access

1. The UE discovers the 3GPP I-WLAN coverage and determines to transfer its current sessions from the currently used 3GPP GPRS access to the discovered 3GPP I-WLAN access system.
2. The UE establishes an IPsec tunnel with PDG according to TS 23.234 [2].
3. If H1 PDN attach is not already executed, UE triggers H1 PDN attach via I-WLAN. If H1 PDN attach is already executed the UE triggers a Binding Update via I-WLAN. The UE shall inform the HA that IP address preservation shall be maintained for the whole home network prefix.
4. As the result of H1 PDN attach or Binding Update, DSMIPv6 tunnel is established/re-established between UE and HA, and UE can transfer data via 3GPP I-WLAN access.

6.4 Accounting

H2 reference point supports transfer of accounting related information between the HA and 3GPP AAA infrastructure. The accounting related functionality in H2 reference point is based on accounting functionality for the Wa reference point specified in TS 23.234 [2].

As stated in the requirement section, It should be possible to perform charging differentiation based on radio access type the user is connected for collocated GGSN/HA and for separate GGSN and HA based architecture. The charging system may use the UE IP address to correlate the IP session between GPRS and I-WLAN and the NAS ID / NAS-IP address which correspond either to the GGSN or PDG or HA to derive the radio access type the user is connected to.

NOTE: How the charging differentiation based on radio access type the user is implemented is a stage 3 detail.

6.5 Interactions with Other Services

When the UE moves between I-WLAN and GPRS network, as the same IP address is kept, there is no need to re-register with the IMS network. There is no impact to the IMS services.

NOTE 1: A new registration to inform the network of changes of the access radio link (e.g. different capability) may be needed. In this case, because the P-CSCF has already been discovered in source access system, the re-registration in from the target access system is according to standard IMS registration.

NOTE 2: Current P-CSCF discovery mechanisms described in TS 23.228 are re-used.

6.6 IPv4 Home Address Release Procedure

This procedure is initiated by the UE to release an IPv4 Home Address previously registered at the HA.

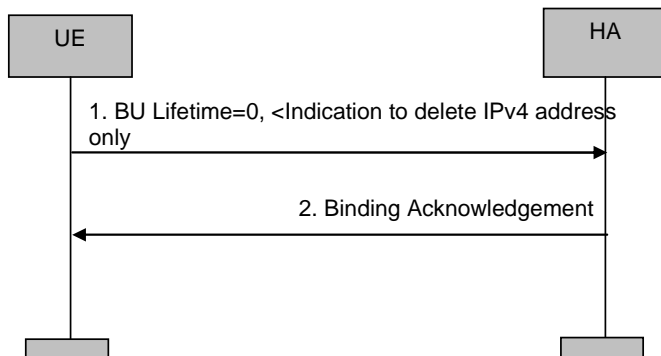

Figure 6.6-1: IPv4 Home Address Release Procedure

1. The UE sends a Binding Update (IPv6 HoA, IPv4 HoA, lifetime=0, IPv4 only indication) message to the HA with lifetime value set to zero, indicating de-registration for the IPv4 Home Address only. The indication for IPv4 only informs the UE that only the IPv4 address from BCE is to be deleted.
2. The PDN GW modifies the existing entry to delete the IPv4 home address implied in the Binding Update message from its Binding Cache and releases all associated resources, and then sends a Binding Ack (lifetime=0, IPv4 only indicator) message to the UE.

Annex A (Normative): EPS Migration Considerations

Extension of the DSMIPv6 based inter-system mobility with additional functionality, such as PCRF interactions, requires deployment of EPS PDNGW, containing the HA functionality. EPS PDN GW and its interactions with other 3GPP system nodes are specified in TS 23.402 [6].

The intention is not to extend the introduced HA entity to support these additional release 8 functions of PDN GW. Thus enabling these additional functions requires migration to EPS.

Figure A-1. illustrates a possible migration path to EPS.

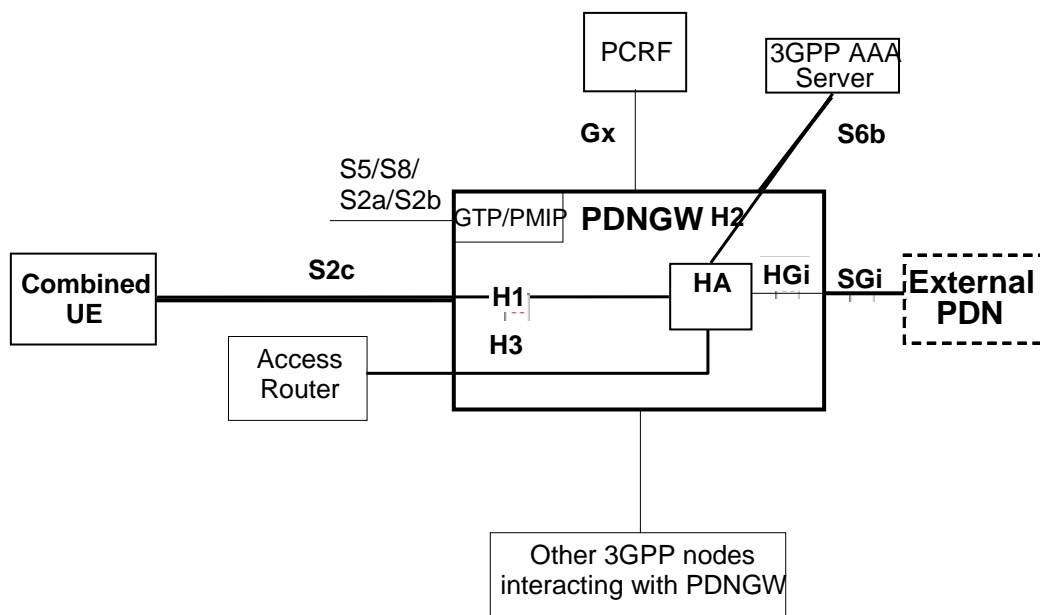

Figure A-1: A possible migration to EPS

Reference point considerations:

- The H1 should be a subset of S2c.
- The HG_i should be a subset of SG_i.
- The H2 should be a subset of S6b.

Annex B (Normative): Information on implementation options

B.1 Co-located HA and GGSN functions

It shall be possible to configure the GPRS access system as the DSMIPv6 "home link". In this case the IP address allocated to the UE by the GPRS system (as specified in TS 23.060 [3]) is used as the Home Address for DSMIPv6 and so, DSMIPv6 user plane encapsulation is not used over the GPRS system.

B.1.1 I-WLAN Mobility System Architecture with Co-located HA-GGSN

The *I-WLAN mobility architecture* in integrated scenario refers to the case where the Home Agent function logically locates within the GGSN.

The UE access the operator's PS Services via the radio interface labelled Um in A/Gb mode and Uu in Iu mode for mobile access.

The UE access the operator PS Services via the radio interface labelled Ww for I-WLAN access.

PDP contexts each of them using one unique PDP address are independent to each other. The terminating access points of these different primary PDP contexts could be located in the same or in different GGSN/HA's.

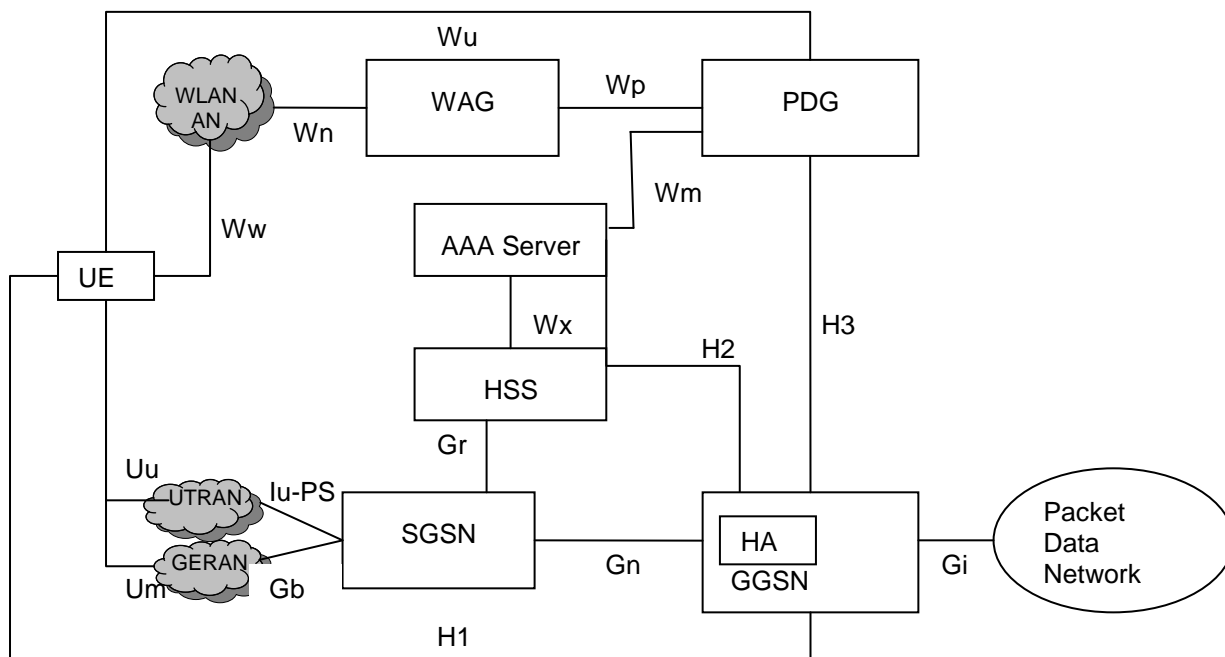

Figure B-1: Co-located HA and GGSN architecture

B.1.2 Home Link Discovery for the Co-located HA and GGSN

This section introduces the usage of Protocol Configuration Options (PCO) for the home link discovery when UE attaches to GPRS which is configured as UE's home link. PCO may be used to transfer IP address of Home Agent and Home Network Prefix from the GGSN to between the UE.

B.1.3 3GPP Attachment

In the collocated GGSN/HA I-WLAN mobility architecture, the Mobile Node is in the home link in 2G/3G. In this case, it does not need to use mobile IP signalling and encapsulation and it will use the PDP Address as the Home Address (HoA).

The 3GPP attachment procedure is unchanged. The 2G/3G network is assumed to be the home link therefore H1 PDN-Attach is not performed.

The following procedure describes the attach procedure over 2G/3G for the GGSN and HA collocated scenario.

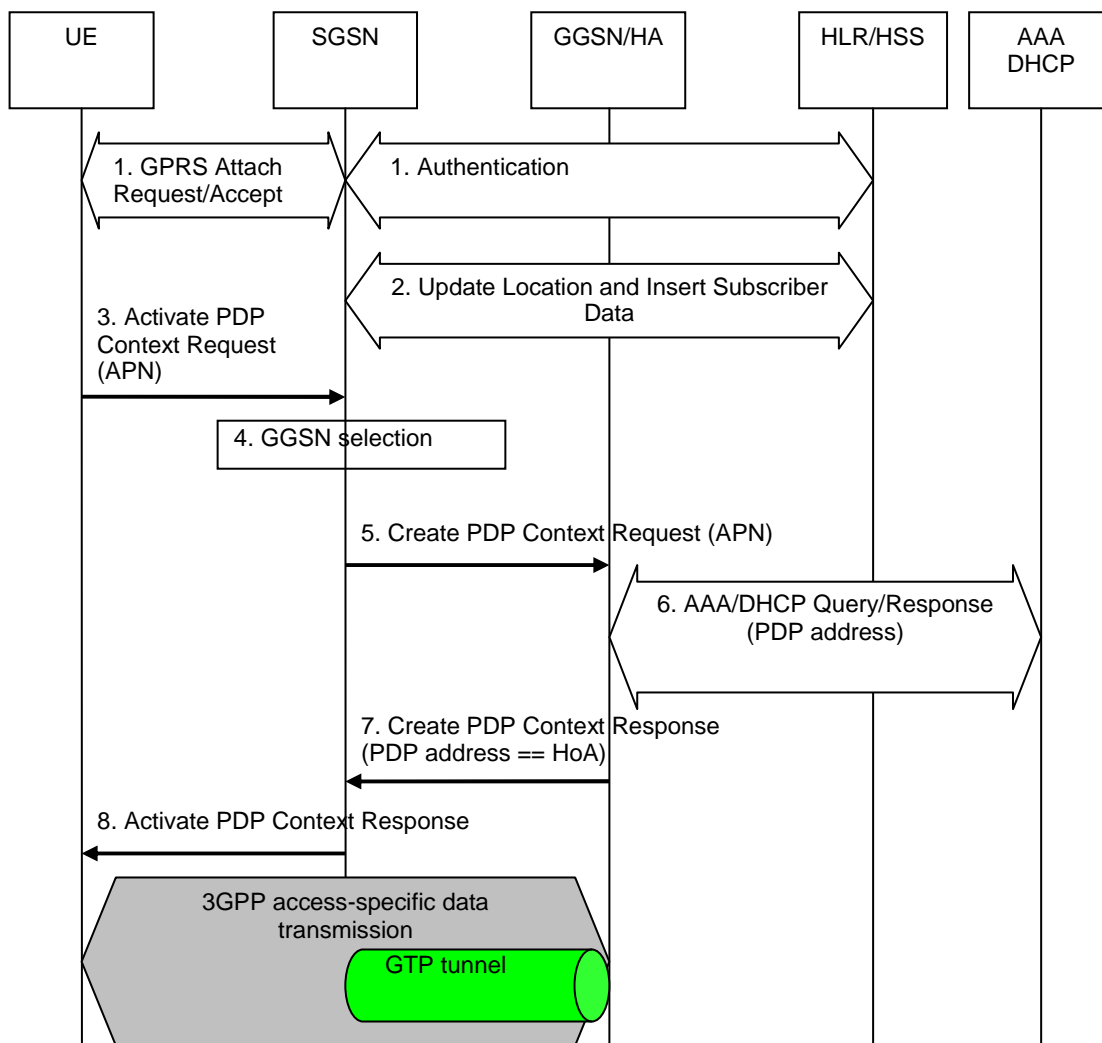

Figure B-2: PDP Context Activation with mobility

1. The UE initiates the attach procedure at power on. The UE is authenticated and authorized to access the 2G/3G network according to TS 23.060 [3]. SGSN may interact with the HLR for Authentication.
2. The SGSN interacts with the HLR and updates the mobile node's location area as it is specified in TS 23.060 [3]. SGSN receives the Subscriber Data from HLR.
3. The UE initiates the PDP context activation procedure as it is specified in TS 23.060 [3] to obtain the IP address. The Access Point Name (APN) specified by the service provider may be passed as a parameter. The UE shall leave the PDP Address empty to request a dynamic PDP address.
4. The SGSN performs the GGSN selection as it is specified in TS 23.060 [3].
5. The SGSN requests the selected GGSN to set up a PDP context for the UE as it is specified in TS 23.060 [3].

6. If the GGSN can assign an address for the UE locally, it assigns the address and the GGSN creates a TEID for the requested PDP context. Otherwise the GGSN uses External PDN Address Allocation mechanism as it is specified in TS 23.060 [3] and in TS 29.061 [13]. The GGSN obtain a PDP address from the PDN by means of protocols such as DHCP or RADIUS and creates a TEID for the requested PDP context.
7. The GGSN responds back to the SGSN, indicating completion of the PDP context activation procedure as it is specified in TS 23.060 [3]. The PDP address, which is sent back to the UE, is the Home Address. In addition to the GPRS specification TS 23.060 [3] the GGSN may return the Home Link information including the HA address via the PCO to the UE.
8. The SGSN replies back to the UE as it is specified in TS 23.060 [3]. This signals completion of the PDP context activation and the IP address allocated corresponds also to its HoA. The UE stores the information for future use.

NOTE 1: As the UE is on the home link, H1 PDN-Attach is not performed. How the UE detects that it is on the home link is described in Home link discovery section.

NOTE 2: The HA address may be returned to the UE in PCO.

B.1.4 I-WLAN Attachment

The UE powers on over I-WLAN and performs I-WLAN attach procedure according to TS 23.234 [2] and H1 PDN Attach to the HA according to this specification. The DSMIPv6 BU/BA to the Home Agent is triggered by the UE.

NOTE: How the UE discovers the HA is defined in HA discovery section (see clause 5.3.2 Home Agent Discovery).

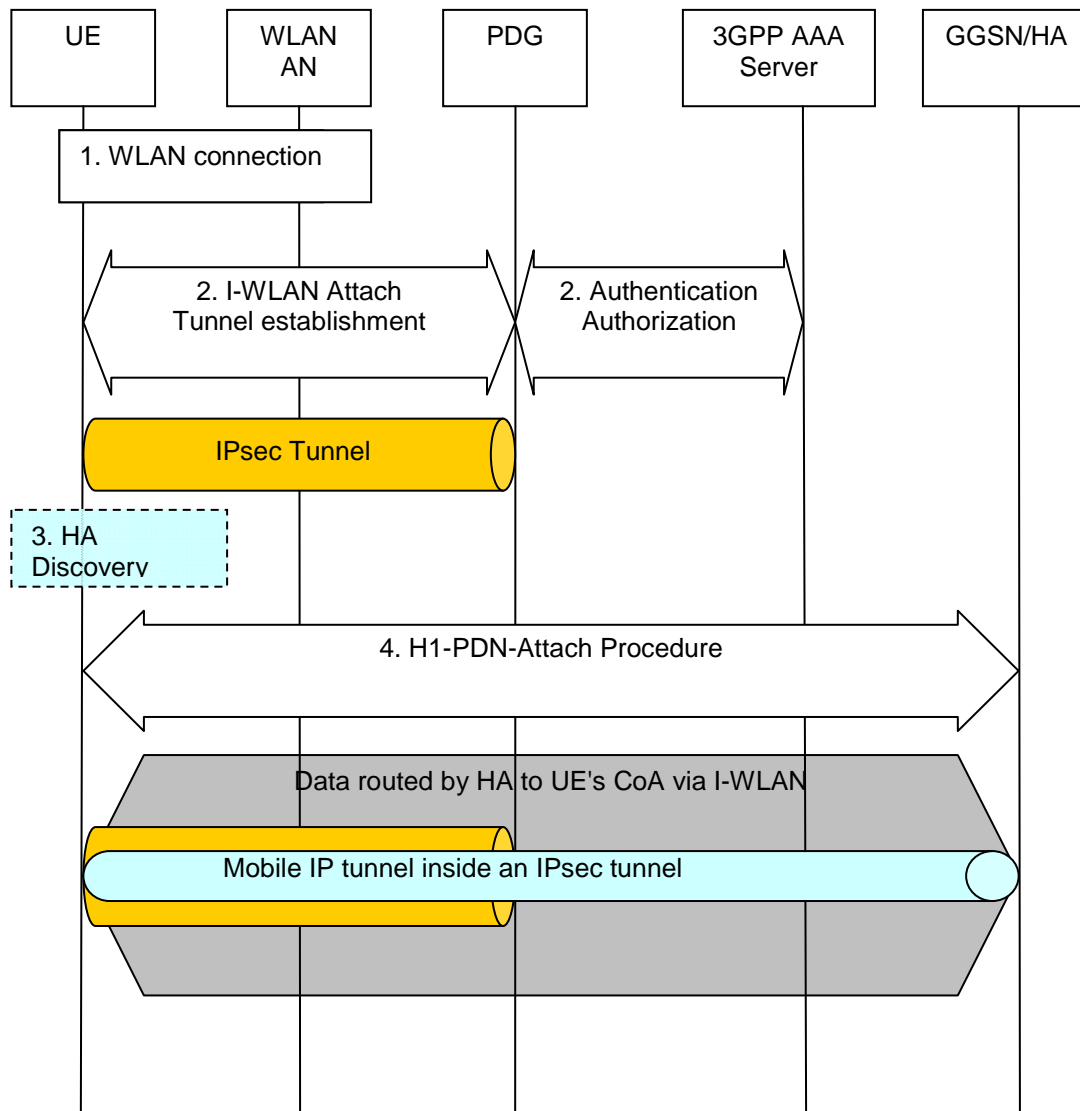

Figure B-3: I-WLAN Attach with mobility service

1. The WLAN UE selects a WLAN Access Network and establishes the WLAN connection with a WLAN technology specific procedure. The UE gets allocated a local IP address and optionally WLAN Access Authentication and Authorization which may depend on the home operator policy as well as the policy of the provider of the WLAN AN according to TS 23.234 [2].
2. I-WLAN attachment and IPsec tunnel setup is executed according to TS 23.234 [2]. In addition to the procedure defined in TS 23.234 [2]. The PDG may return the HA address in IKEv2 configuration payload to the UE.
3. The method by which HA is known to the UE is defined in HA discovery clause 5.3.2 The UE must know the HA in order to perform BU/BA. This step is required only if HA address was not discovered via IKEv2 configuration payload in the previous steps.
4. H1 PDN-Attach procedure is performed as it is specified in clause 6.1.
5. The UE can send and receive packet.

B.1.5 Handover from 3GPP access to I-WLAN

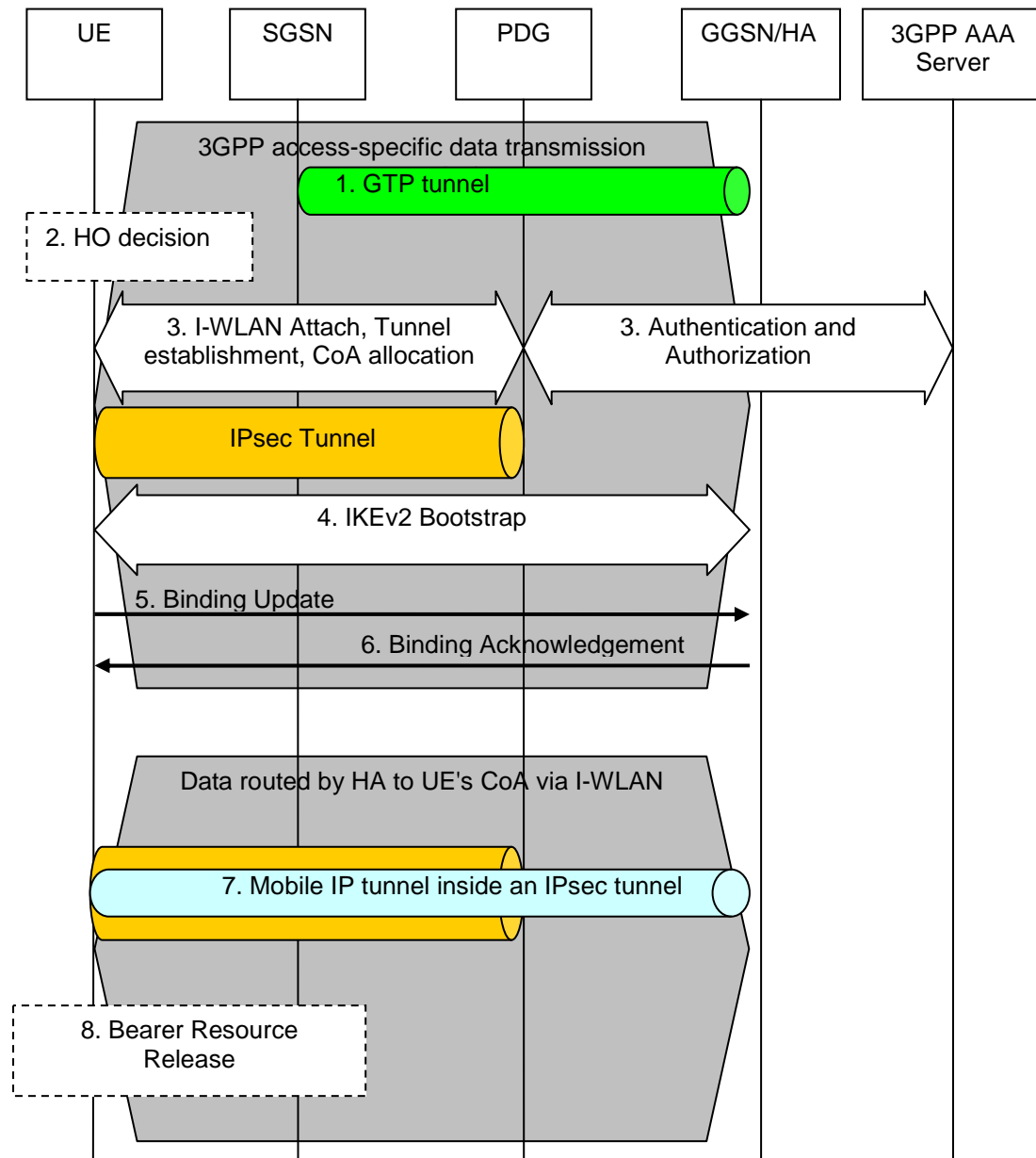

Figure B-4: Handover from 3GPP access to I-WLAN

1. The precondition of this flow is that the UE is attached to a 3GPP access and has active PDP context(s) with a GGSN/HA node. There is a GTP tunnel between the SGSN and the GGSN.
2. The UE needs to handover to a WLAN access network. The HO decision mechanism could be based on local policy in the UE.
3. I-WLAN attachment and IPsec tunnel setup is executed according to TS 23.234 [2]. In addition to the procedure defined in TS 23.234 [2] the UE may also obtain the Home Agent information via IKEv2 configuration payload if not already available in the UE.
4. The UE perform IKEv2/IPsec security association setup procedure with the Home Agent for DSMIPv6.
5. The UE sends a binding update to its home agent to update the binding cache entry at the home agent. The UE will use its IP address used in 3GPP access as its Home Address. This address will be preserved unless further indication from the 3GPP access. The UE uses the address configured from the PDG as the care-of address. The care-of address may be an IPv4 or IPv6 address.

6. The Home Agent responds with a binding acknowledgement if the binding update process was successful. The Home Agent also creates the binding cache entry with the new care-of address of the UE. In this message, the HA also includes the APN corresponding to the home link for the UE to store.
7. The successful exchange of binding update and binding acknowledgement results in a Mobile IP tunnel between the UE and the home agent over the IPsec tunnel between the UE and the PDG. Data packets are now routed by Home Agent to UE's Care-of-Address via I-WLAN.
8. During this procedure, bearer resources reserved for the UE are released.

B.1.6 Handover from I-WLAN to 3GPP Access

The handover may take place when the source network is no longer able to provide the required user-to-PDN connection service or based on operator policies.

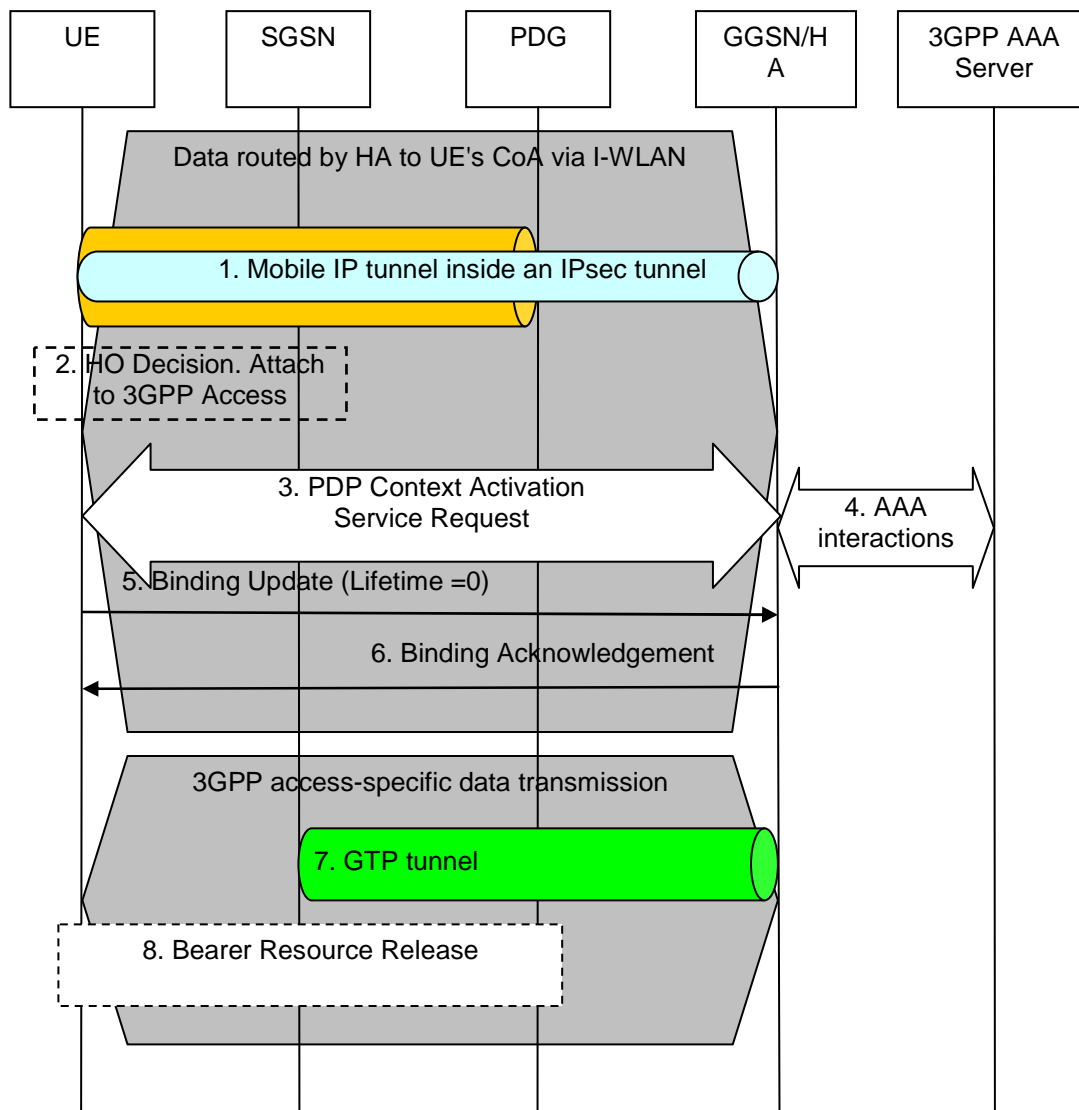

Figure B-5: Handover from I-WLAN to 3GPP Access

1. The precondition of this flow is that the UE is attached over I-WLAN with mobility support. There is a Mobile IP tunnel between the UE and the Home Agent over an IPsec tunnel between the UE and the PDG.
2. The UE may need to handover to 3GPP access network because I-WLAN is no longer able to provide the required user-to-PDN connection service or based on operator policies. The UE attaches to 3GPP access according to TS 23.060 [3].

In order to generate an APN to be used when activating a PDP context in the GPRS access, the UE uses the APN information received in the BA during H1 PDN attach as described in clause 1.6. If no APN is received in the Binding Acknowledgement message during H1 PDN attach, the UE shall use the pre-configured APN, if available

3. The UE initiates PDP context setup according to TS 23.060 [3]. The UE provides an APN corresponding to the combined GGSN/HA used in the source access. This results in a PDP context setup with a GTP tunnel between the SGSN and the GGSN. GGSN returns a PDP address to the UE which is same as the HoA the UE used in WLAN access in step 1. In case of IPv6, the prefix associated with the PDP context is the same as the one for HoA (i.e. HNP).
4. The GGSN/HA interacts with the AAA server for mobility service authentication and authorization according to TS 29.061 [13].
5. The UE detects that the HoA and the PDP address are same, so the UE considers itself in home link. The UE sends a Binding Update to its home agent with lifetime=0, and CoA=HoA to delete the binding cache entry at the home agent.
6. The Home Agent responds with a Binding Acknowledgement if the binding update process (binding deletion) was successful.
7. With the Binding Update and binding acknowledgement exchange the HA recognizes that the UE has returned home and deletes the binding cache. There is no Mobile IP tunnel between the UE and the home agent however a GTP tunnel is established between the SGSN and the GGSN.
8. Bearer Resources on the I-WLAN access system are released according to TS 23.234 [2]. For that the UE detaches from I-WLAN if it has not happened before.

B.2 Co-located HA and PDG functions

It shall be possible to co-locate the HA and PDG. The GERAN/UTRAN may still acts as the home link. In this case the IP address allocated to the UE by the GPRS system is used as HoA for DSMIPv6.

B.2.1 H1 PDN Attach

The H1- PDN Attach procedure for co-located PDG and HA is based on the attach procedure described in clause 6.1. When attached to the co-located PDG+HA, the UE may be on the home link. How the UE finds it's in the home link is described in clause 5.3.3 Home Link Detection.

Annex C (Informative): Change History

Change history								
Date	TSG #	TSG Doc.	CR	Rev	Cat	Subject/Comment	Old	New
2008-06	SP-40	SP-080358	-	-	-	Approved at TSG SA#40 and updated to version 8.0.0	1.0.0	8.0.0
2008-09	SP-41	SP-080577	0001	1	F	Essential corrections for TS 23.327	8.0.0	8.1.0
2008-09	SP-41	SP-080577	0002	1	F	Correction and Cleanup to IWLAN Mobility TS 23.327	8.0.0	8.1.0
2008-09	SP-41	SP-080577	0003	-	F	Correction and Cleanup of Annex A – IWLAN Mobility TS 23.327	8.0.0	8.1.0
2008-09	SP-41	SP-080577	0004	1	F	Correction and Cleanup of Annex B – IWLAN_Mob	8.0.0	8.1.0
2008-12	SP-42	SP-080810	0005	-	F	APN in IDr payload	8.1.0	8.2.0
2008-12	SP-42	SP-080810	0006	1	F	APN discovery for HO to GPRS	8.1.0	8.2.0
2008-12	SP-42	SP-080810	0007	1	F	Alignment of PDN address handling for H1	8.1.0	8.2.0
2008-12	SP-42	SP-080810	0008	1	F	IPv4 Home Address release procedure for H1	8.1.0	8.2.0
2008-12	SP-42	SP-080810	0010	3	F	I-WLAN Mobility- cleanups	8.1.0	8.2.0
2009-01						LTE logo and keyword removed	8.2.0	8.2.1
2009-01						Typo in previous entry of history box corrected	8.2.1	8.2.2

History

Document history		
V8.0.0	November 2008	Publication
V8.1.0	November 2008	Publication
V8.2.2	January 2009	Publication