

ETSI TS 123 468 V12.3.0 (2015-01)



**LTE;
Group Communication System Enablers for LTE (GCSE_LTE);
Stage 2
(3GPP TS 23.468 version 12.3.0 Release 12)**



Reference

RTS/TSGS-0223468vc30

Keywords

LTE

ETSI

650 Route des Lucioles
F-06921 Sophia Antipolis Cedex - FRANCE

Tel.: +33 4 92 94 42 00 Fax: +33 4 93 65 47 16

Siret N° 348 623 562 00017 - NAF 742 C
Association à but non lucratif enregistrée à la
Sous-Préfecture de Grasse (06) N° 7803/88

Important notice

The present document can be downloaded from:

<http://www.etsi.org>

The present document may be made available in electronic versions and/or in print. The content of any electronic and/or print versions of the present document shall not be modified without the prior written authorization of ETSI. In case of any existing or perceived difference in contents between such versions and/or in print, the only prevailing document is the print of the Portable Document Format (PDF) version kept on a specific network drive within ETSI Secretariat.

Users of the present document should be aware that the document may be subject to revision or change of status. Information on the current status of this and other ETSI documents is available at

<http://portal.etsi.org/tb/status/status.asp>

If you find errors in the present document, please send your comment to one of the following services:

http://portal.etsi.org/chaicor/ETSI_support.asp

Copyright Notification

No part may be reproduced or utilized in any form or by any means, electronic or mechanical, including photocopying and microfilm except as authorized by written permission of ETSI.

The content of the PDF version shall not be modified without the written authorization of ETSI.

The copyright and the foregoing restriction extend to reproduction in all media.

© European Telecommunications Standards Institute 2015.

All rights reserved.

DECT™, **PLUGTESTS™**, **UMTS™** and the ETSI logo are Trade Marks of ETSI registered for the benefit of its Members. **3GPP™** and **LTE™** are Trade Marks of ETSI registered for the benefit of its Members and of the 3GPP Organizational Partners.

GSM® and the GSM logo are Trade Marks registered and owned by the GSM Association.

Intellectual Property Rights

IPRs essential or potentially essential to the present document may have been declared to ETSI. The information pertaining to these essential IPRs, if any, is publicly available for **ETSI members and non-members**, and can be found in ETSI SR 000 314: *"Intellectual Property Rights (IPRs); Essential, or potentially Essential, IPRs notified to ETSI in respect of ETSI standards"*, which is available from the ETSI Secretariat. Latest updates are available on the ETSI Web server (<http://ipr.etsi.org>).

Pursuant to the ETSI IPR Policy, no investigation, including IPR searches, has been carried out by ETSI. No guarantee can be given as to the existence of other IPRs not referenced in ETSI SR 000 314 (or the updates on the ETSI Web server) which are, or may be, or may become, essential to the present document.

Foreword

This Technical Specification (TS) has been produced by ETSI 3rd Generation Partnership Project (3GPP).

The present document may refer to technical specifications or reports using their 3GPP identities, UMTS identities or GSM identities. These should be interpreted as being references to the corresponding ETSI deliverables.

The cross reference between GSM, UMTS, 3GPP and ETSI identities can be found under <http://webapp.etsi.org/key/queryform.asp>.

Modal verbs terminology

In the present document "**shall**", "**shall not**", "**should**", "**should not**", "**may**", "**may not**", "**need**", "**need not**", "**will**", "**will not**", "**can**" and "**cannot**" are to be interpreted as described in clause 3.2 of the [ETSI Drafting Rules](#) (Verbal forms for the expression of provisions).

"**must**" and "**must not**" are **NOT** allowed in ETSI deliverables except when used in direct citation.

Contents

Intellectual Property Rights	2
Foreword.....	2
Modal verbs terminology.....	2
Foreword.....	5
1 Scope	6
2 References	6
3 Definitions and abbreviations.....	6
3.1 Definitions	6
3.2 Abbreviations	7
4 Architecture Model and Concepts.....	7
4.1 General Concept	7
4.2 Architectural Reference Model	8
4.2.1 General.....	8
4.2.2 Non-roaming architecture	9
4.2.3 Roaming architecture	9
4.3 Reference points	11
4.3.1 General.....	11
4.3.2 List of Reference Points.....	11
4.3.2.1 GC1 reference point	11
4.3.2.2 MB2 reference point	11
4.3.2.3 SGmb/SGi-mb/M1/M3 reference points	11
4.3.2.4 Rx reference point.....	11
4.4 High level functions	11
4.4.1 Unicast Delivery	11
4.4.2 MBMS Delivery	12
4.4.3 Service continuity	12
4.5 Network Elements	12
4.5.1 GCS AS	12
4.5.2 UE.....	12
4.5.3 PCRF	12
4.5.4 BM-SC.....	13
5 Functional Description and Information Flow	13
5.1 MB2: Interface between GCS AS and BM-SC	13
5.1.1 General.....	13
5.1.2 MB2 Procedures	13
5.1.2.1 General	13
5.1.2.2 TMGI Management.....	14
5.1.2.2.1 General	14
5.1.2.2.2 TMGI Allocation Procedure.....	14
5.1.2.2.3 TMGI Deallocation Procedure	15
5.1.2.2.4 TMGI allocation period expiry.....	15
5.1.2.3 Activating and Deactivating an MBMS bearer	15
5.1.2.3.1 General	15
5.1.2.3.2 Activate MBMS Bearer Procedure	16
5.1.2.3.3 Deactivate MBMS Bearer Procedure	16
5.1.2.4 Modify MBMS Bearer Procedure	17
5.1.2.5 MBMS Delivery Status Indication Procedure.....	18
5.2 Specific Usage of EPS Bearers for GCS	18
5.3 Service Continuity	19
5.3.1 General.....	19
5.3.2 Switching from Unicast Delivery to MBMS Delivery.....	19
5.3.3 Switching from MBMS Delivery to Unicast Delivery	20

5.3.3.1	General	20
5.3.3.2	MBMS Delivery to Unicast Delivery (make-before-break)	20
5.3.3.3	MBMS Delivery to Unicast Delivery (break-before-make)	21
5.4	Priority and Pre-emption for Group Communication	22
5.5	Charging	22
5.6	Security	22
Annex A (Informative): Utilisation of the Group Communication Service.....		23
A.1	General	23
A.2	Downlink Media path setup for MBMS Delivery	23
A.2.1	General	23
A.2.2	Use of Pre-established MBMS bearers.....	23
A.2.3	Use of Dynamic MBMS bearer establishment	24
Annex B (Informative): Change history		26
History		27

Foreword

This Technical Specification has been produced by the 3rd Generation Partnership Project (3GPP).

The contents of the present document are subject to continuing work within the TSG and may change following formal TSG approval. Should the TSG modify the contents of the present document, it will be re-released by the TSG with an identifying change of release date and an increase in version number as follows:

Version x.y.z

where:

- x the first digit:
 - 1 presented to TSG for information;
 - 2 presented to TSG for approval;
 - 3 or greater indicates TSG approved document under change control.
- y the second digit is incremented for all changes of substance, i.e. technical enhancements, corrections, updates, etc.
- z the third digit is incremented when editorial only changes have been incorporated in the document.

1 Scope

The present document provides the stage 2 description for the 3GPP system provided enablers to support group communication services using EUTRAN access. The corresponding stage 1 requirements are defined in TS 22.468 [2].

The group communication system is represented by an Application Server (GCS AS) using the 3GPP system provided enablers for transferring its application signalling and for delivering application data, e.g. media data, to a group of UEs either (i) over MBMS Bearer Services using the Broadcast Mode of MBMS (TS 23.246 [3]); or (ii) over EPS Bearers; or (iii) over both MBMS and EPS bearer services.

The specification covers both roaming and non-roaming scenarios and also includes support for service continuity, i.e. support for continuous reception of application data when a UE changes between reception of application data via EPS and MBMS Bearer Services.

Application level interactions between the UE and the GCS Application Server are out of scope of this specification.

2 References

The following documents contain provisions which, through reference in this text, constitute provisions of the present document.

- References are either specific (identified by date of publication, edition number, version number, etc.) or non-specific.
- For a specific reference, subsequent revisions do not apply.
- For a non-specific reference, the latest version applies. In the case of a reference to a 3GPP document (including a GSM document), a non-specific reference implicitly refers to the latest version of that document *in the same Release as the present document*.

- [1] 3GPP TR 21.905: "Vocabulary for 3GPP Specifications".
- [2] 3GPP TS 22.468: "Group Communication System Enablers for LTE (GCSE_LTE)".
- [3] 3GPP TS 23.246: "Multimedia Broadcast/Multicast Service (MBMS); Architecture and functional description".
- [4] 3GPP TS 29.214: "Policy and charging control over Rx reference point".
- [5] 3GPP TS 23.401: "General Packet Radio Service (GPRS) enhancements for Evolved Universal Terrestrial Radio Access Network (E-UTRAN) access".
- [6] 3GPP TS 23.203: "Policy and charging control architecture".
- [7] 3GPP TS 26.346: "Multimedia Broadcast/Multicast Service (MBMS); Protocols and codecs".
- [8] 3GPP TS 33.246: "3G Security; Security of Multimedia Broadcast/Multicast Service (MBMS)".

3 Definitions and abbreviations

3.1 Definitions

For the purposes of the present document, the terms and definitions given in TR 21.905 [1] and the following apply. A term defined in the present document takes precedence over the definition of the same term, if any, in TR 21.905 [1].

MBMS Delivery: A mechanism by which application data and signaling are delivered using MBMS bearer service over EUTRAN as defined in TS 23.246 [3].

Unicast Delivery: A mechanism by which application data and signaling are delivered using EPS bearer service over EUTRAN as defined in TS 23.401 [5].

3.2 Abbreviations

For the purposes of the present document, the abbreviations given in TR 21.905 [1] and the following apply. An abbreviation defined in the present document takes precedence over the definition of the same abbreviation, if any, in TR 21.905 [1].

AS	Application Server
ARP	Allocation and Retention Priority
DRX	Discontinuous Reception
FQDN	Fully Qualified Domain Name
GCS	Group Communication Service
GCS AS	Group Communication Service Application Server
GCSE_LTE	Group Communication Service Enabler over LTE
MBMS	Multimedia Broadcast/Multicast Service
MCH	Multicast Channel
MCCH	Multicast Control Channel
MTCH	Multicast Traffic Channel
QCI	QoS Class Identifier
UDP	User Datagram Protocol
vPCRF	visited Policy and Charging Rules Function

4 Architecture Model and Concepts

4.1 General Concept

This specification describes how a GCS Application Server (GCS AS) may use the enablers offered by the 3GPP system for providing a Group Communication Service (GCS). These enablers are denoted as Group Communication System Enablers (GCSE).

The GCS AS uses EPS bearer services and may use in addition MBMS bearer services for transferring application signalling and data between the GCS AS and the UEs. In uplink direction, the UE uses an EPS bearer service to exchange application signalling with the GCS AS or when it wants to send data to the GCS AS. In downlink direction the GCS AS may transfer application signalling and data via the UE individual EPS bearer services and/or via MBMS bearer service. The GCS UEs register with their GCS AS using application signalling for participating in one or multiple GCS groups.

NOTE 1: GCS application signalling (e.g. for group admission and floor control) and GCS group management aspects (such as group creation, deletion, modification, group membership control, etc) are out of scope of this specification.

When an MBMS bearer service is used, its broadcast service area may be pre-configured for use by the GCS AS. Alternatively, the GCS AS may dynamically decide to use an MBMS bearer service when it determines that the number of UE for a GCS group is sufficiently large within an area (e.g. within a cell or a collection of cells).

When MBMS bearer service is used, GCS AS may transfer data from different GCS groups over a single MBMS broadcast bearer. The application signalling and data transferred via MBMS bearer(s) are transparent to BM-SC and the MBMS bearer service. The GCS AS provides the UEs via GCS application signalling with all configuration information that the UE needs to receive application data via MBMS bearer services and to handle that data appropriately.

When a GCS UE moves between areas where its MBMS broadcast bearers are available or not, the UE informs the GCS AS via application signalling that it changes from MBMS broadcast bearer reception to non-reception, or vice versa, the GCS AS activates or deactivates the downlink application signalling and data transfer via the UE individual EPS bearer(s) as appropriate. To accomplish service continuity, a UE may temporarily receive the same GCS application signalling and data in parallel via EPS bearer(s) and MBMS service(s). The GCS UE application discards any received application signalling or data duplicates.

The following diagram shows an example of a scenario where a combination of Unicast and MBMS Delivery is used for a particular media, belonging to a single group, by the GCS AS on the DL to different UEs. Here, UE-1 and UE-2 receive DL traffic over unicast whereas UEs 3-6 receive DL traffic over MBMS.

NOTE 2: Even though UE-2, UE-3 and UE-4 are connected to the same eNB (eNB-2), the UEs may be using different delivery modes. For example, UE-2 is using unicast since it may be in an area where the MBMS signal strength is weak.

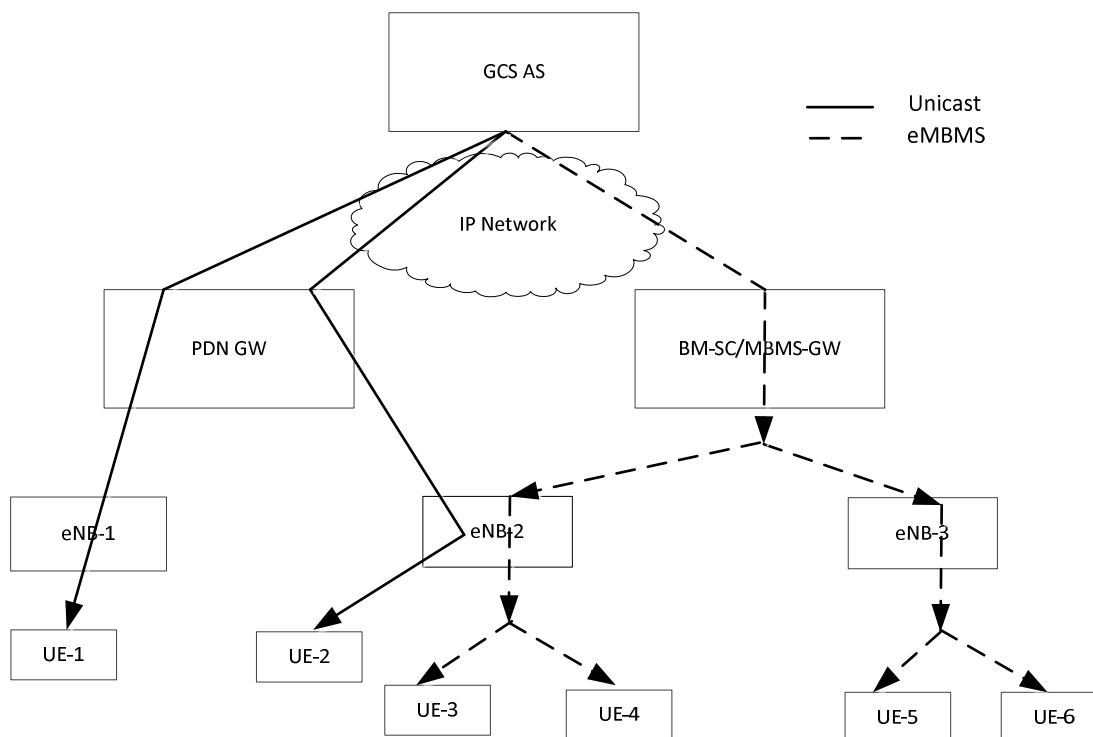

Figure 4.1-1: Media traffic with unicast and MBMS on DL

NOTE 3: During service continuity procedures a UE may simultaneously receive traffic from both unicast and MBMS.

4.2 Architectural Reference Model

4.2.1 General

This model assumes that the GCS AS is not associated with any PLMN (regardless of the subscription of the UEs that use it). The GCS AS is merely perceived as a third party application server by each serving PLMN. In addition:

- When the group communication service is provided using Unicast Delivery, there are no additional requirements in order to provide GCS in roaming other than enabling normal EPS roaming and the ability of the GCS AS to access QoS control capabilities via Rx interface in the HPLMN (for the non-roaming case and the roaming Home routed case). For the Local breakout scenario, QoS control may be established via hPCRF and the S9 interface towards the vPCRF directly to the vPCRF as specified in TS 23.203 [6]. The GCS AS shall provide information to enable session binding as defined in clause 6.1.1.2 of TS 23.203 [6].
- When MBMS Delivery to particular regions of the serving PLMN is required, the GCS AS needs to have access to an MB2 interface offered by the serving PLMN.

Since the GCS AS is a third party application server, the GCS AS can access the required network resources to deliver the group communication service, whether the serving PLMN is the Home PLMN or a different VPLMN, based on operator agreement.

The PLMN selection process is according to the existing 3GPP procedures. When a PLMN is selected, the UE should, in order to enable group communication services, register or re-register with the GCS AS and report to it the PLMN ID of the current serving network as well as its HPLMN ID. The GCS AS may then, based on this information, determine if it has an MB2 connection agreement for the serving PLMN, and if so report to the UE the MBMS related service data required to use the service via MBMS Delivery in that PLMN.

Both the Home and serving PLMN ID(s) are needed to identify the contact point for the Rx interface, in addition to existing parameters as defined in TS 23.203 [6] in order to accurately identify the UE and the session. The GCS AS finds the entry point at the HPLMN using the home PLMN ID, the GCS AS finds the entry point at the VPLMN using the serving PLMN ID. Within the PLMN, the information listed in TS 23.203 [6] is used to find the PCRF.

If no MB2 connection agreement with the GCS AS is available in the serving PLMN, then the GCS AS may deliver the group communication data using Unicast Delivery.

NOTE: In the architecture figures shown in clauses 4.2.2 and 4.2.3, "GCS AS" is being shown as one entity for simplicity. It may be comprised of different functional entities to handle user and control plane. A BM-SC may be connected to multiple GCS AS, and a UE may be served simultaneously by multiple GCS AS (via separate GC1 connections).

The GCS AS provides the Service Information to the PCRF and the BM-SC. The Service Information is mapped by the PCRF and the BM-SC to the QoS parameters under the consideration of the respective EPS network.

4.2.2 Non-roaming architecture

Figure 4.2.2-1 shows a high level view of the architecture for the non-roaming scenario.

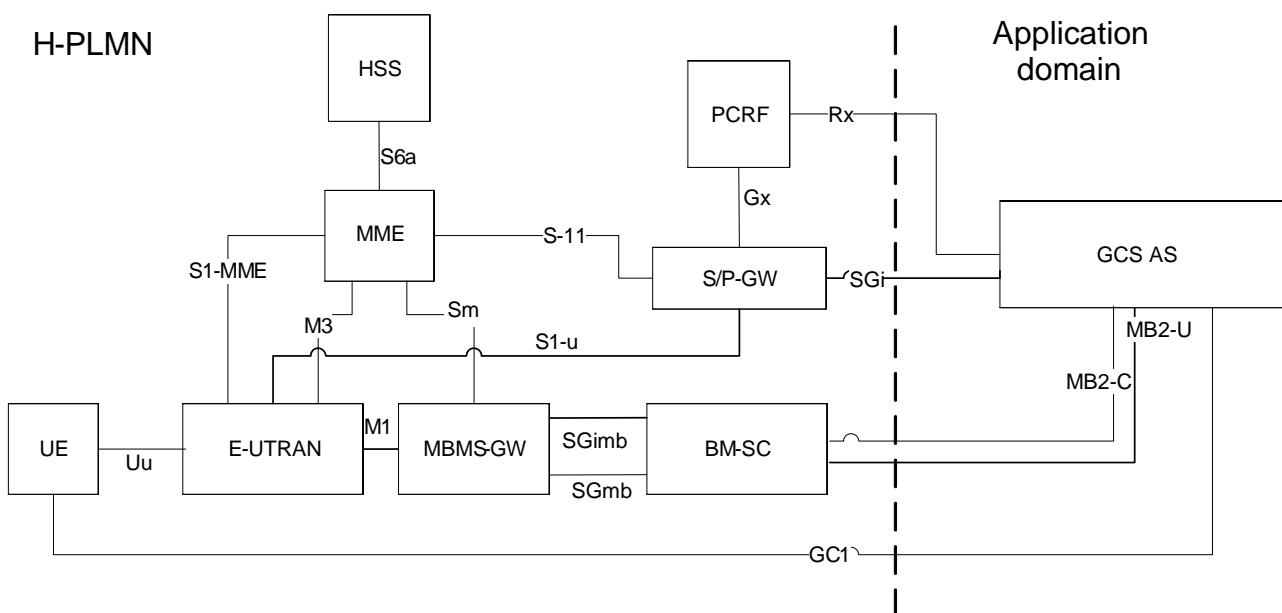

Figure 4.2.2-1: Non-roaming architecture model for GCSE_LTE

4.2.3 Roaming architecture

Figure 4.2.3-1 shows a high level view of the architecture applicable for the Home routed roaming model for Unicast Delivery. For MBMS Delivery, BM-SC in the V-PLMN has a direct MB2 connection with the GCS AS.

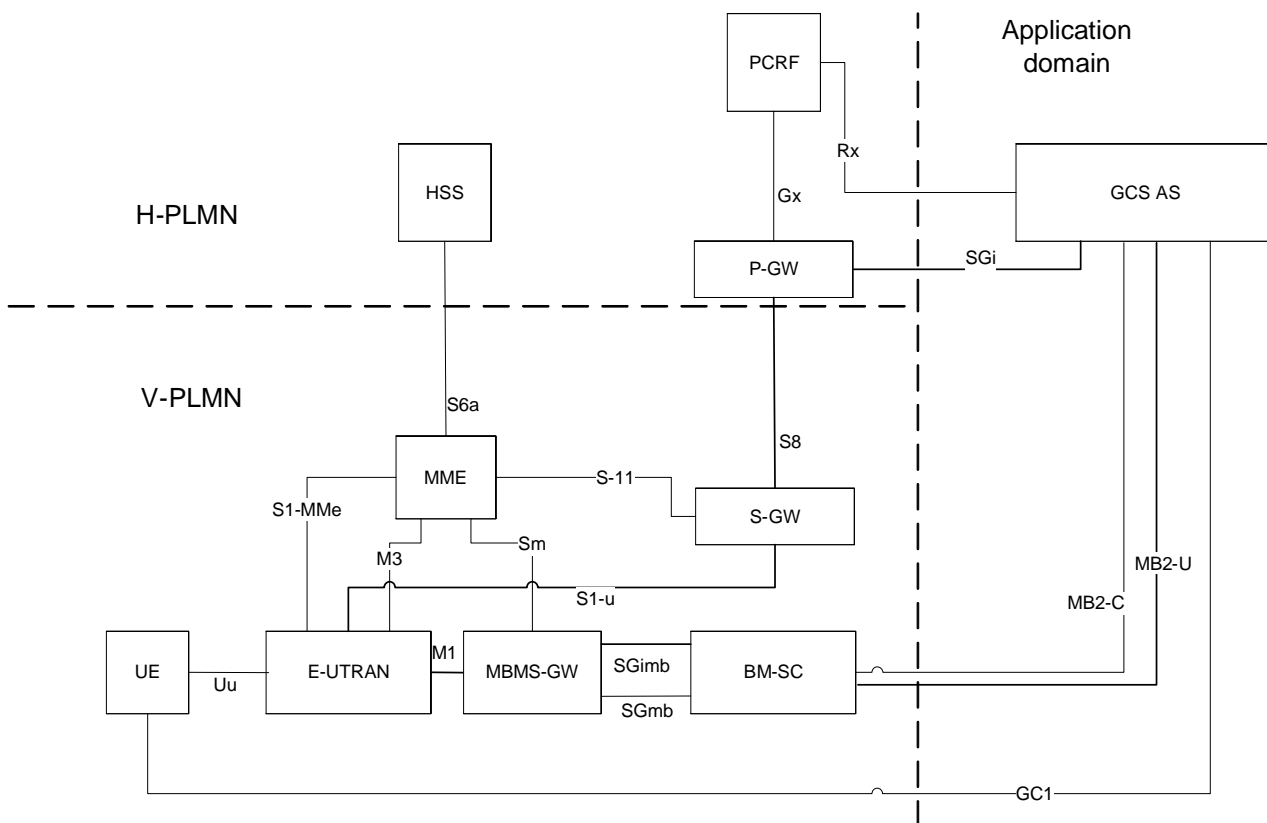

Figure 4.2.3-1: Home routed roaming model

Figure 4.2.3-2 shows a high level view of the architecture applicable for the Local Breakout roaming model for Unicast Delivery. For MBMS Delivery, BM-SC in the V-PLMN has a direct MB2 connection with the GCS AS.

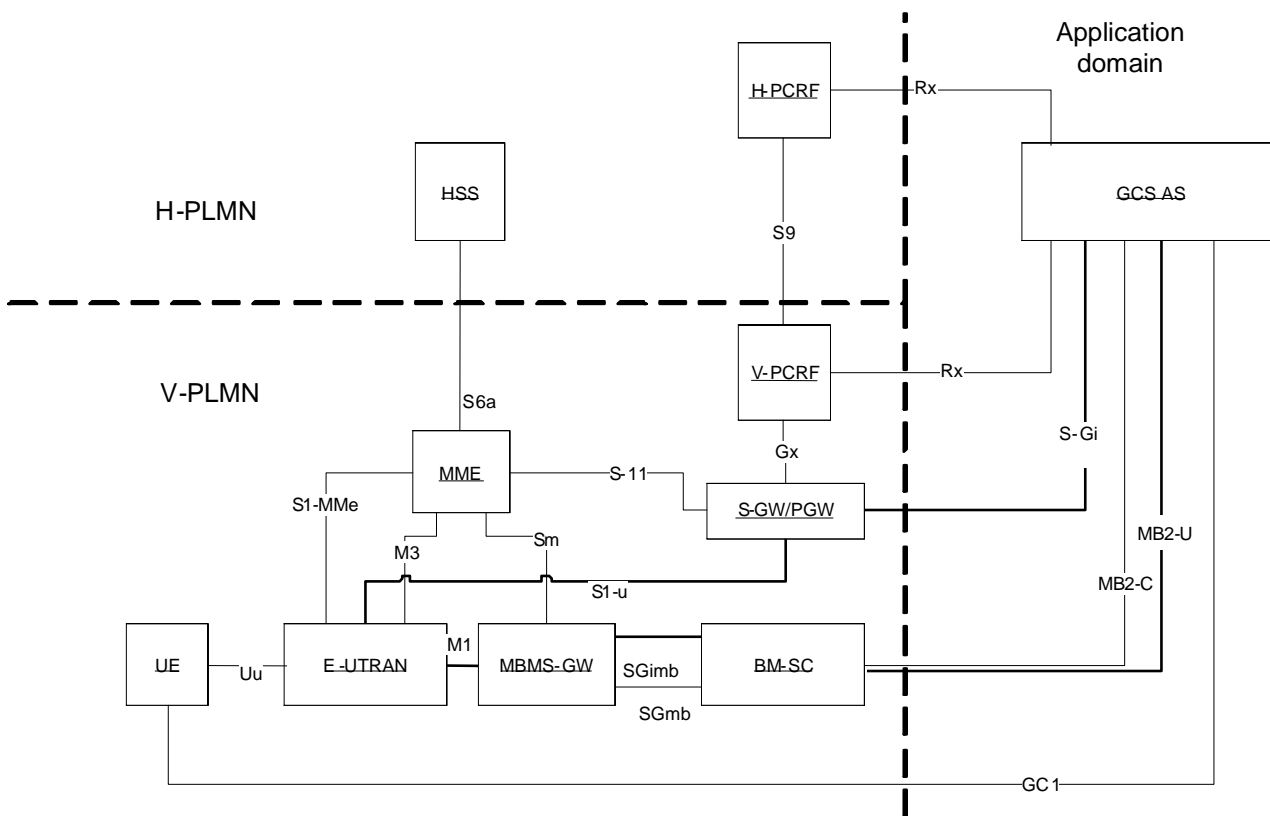

Figure 4.2.3-2: Local Break Out model

The GCS AS is configured with mapping information which contains an IP address range and the corresponding PLMN which is responsible for this IP address range {(IPx..IPy) -> PLMN ID}.

In roaming scenarios, the GCS AS receives the UE IP address, the HPLMN ID and the VPLMN ID via GC1 signalling from the UE. If the configured PLMN entry corresponding to the UE's IP address matches the HPLMN ID sent by the UE, the GCS AS selects a PCRF from the UE's HPLMN (hPCRF) using the procedures defined in TS 23.203 [6]. Otherwise, the GCS AS may select a PCRF from either the HPLMN or the VPLMN using the procedures defined in TS 23.203 [6]. The GCS AS makes this selection based on agreements with HPLMN/VPLMN operators.

4.3 Reference points

4.3.1 General

The reference points used to support group communications are listed in the following clauses.

4.3.2 List of Reference Points

4.3.2.1 GC1 reference point

The GC1 reference point exists between the GCS AS and the application client on the UE, and is not specified in this release of this specification. However, this specification includes high level descriptions of interactions on the GC1 reference point, which are necessary in order to convey certain information (e.g. PLMN ID) and perform certain functions (e.g. register or re-register with serving PLMN ID) in order for the EPS and MBMS bearer services to be delivered accurately. Some of these aspects are specified in clauses 4.2.1, 4.4.1, 4.4.2, 4.5.1, 4.5.2, 5.3.2 and 5.3.3 of this specification.

4.3.2.2 MB2 reference point

The MB2 reference point exists between the GCS AS and the BM-SC.

The MB2 reference point provides the ability for the application to:

- Request the allocation/deallocation of a set of TMGIs,
- Request to activate, deactivate, and modify an MBMS bearer.

The MB2 reference point provides the ability for the BM-SC to:

- Notify the application of the status of an MBMS bearer.

NOTE: The ability to indicate failure to deliver content is limited to current functionality.

4.3.2.3 SGmb/SGi-mb/M1/M3 reference points

The SGmb/SGi-mb/M1/M3 reference points are internal to the MBMS system and are defined in TS 23.246 [3].

4.3.2.4 Rx reference point

The Rx reference point is defined in TS 29.214 [4]. The GCS AS uses the Rx interface to manage unicast resources.

4.4 High level functions

4.4.1 Unicast Delivery

The UE and GCS AS use the EPS bearers defined in TS 23.401 [5] for Unicast Delivery. The EPS bearers are used for the following:

- Exchanging GC1 signalling between UE and GCS AS.

- Transport of data on the uplink from UE to the GCS AS.
- Transport of data on the downlink from GCS AS to UE when MBMS Delivery is not desirable or possible.

The GCS AS uses the Rx interface to specify and modify the priority level of the EPS bearers used for the group communication session (see clause 5.4).

4.4.2 MBMS Delivery

The GCS AS uses the MBMS bearers defined in TS 23.246 [3] for MBMS Delivery. The MBMS bearer is used to transport data on the downlink from the GCS AS to the UE. The MBMS bearer(s) used for MBMS Delivery can be pre-established before the group communication session is setup or can be dynamically established after the group communication session is setup.

NOTE: Downlink data from the same or different group communication sessions may be multiplexed on the same MBMS bearer as required by the GCS AS. The multiplexing of such data is transparent to the BM-SC.

4.4.3 Service continuity

The UE uses the service continuity procedures defined in clause 5.3 for switching between Unicast Delivery and MBMS Delivery.

4.5 Network Elements

4.5.1 GCS AS

The GCS AS shall support the following functionality:

- Exchanging GC1 signalling (including GCS session and group management aspects) with the UE.
- Receiving uplink data from the UE over unicast
- Delivery of data to all the UEs belonging to a group using Unicast Delivery and/or MBMS Delivery.
- Transport of application level session information via Rx interface towards PCRF.
- Support for service continuity procedures for a UE to switch between Unicast Delivery and MBMS Delivery as specified in clause 5.3.

4.5.2 UE

The GCS capable UE shall support the following functionality:

- Exchanging GC1 signalling (including GCS session and group management aspects) with the GCS AS.
- Provision of a UE specific IDLE MODE DRX cycle length to the core network as specified in TS 23.401 [5] clause 5.13.
- Receiving data from a GCS AS using either Unicast Delivery or MBMS Delivery, or both simultaneously.
- Sending data on the uplink to the GCS AS using unicast.
- Support for service continuity procedures to switch between Unicast Delivery and MBMS Delivery as specified in clause 5.3.
- Simultaneous monitoring and reception of one or more MBMS bearer(s).

4.5.3 PCRF

The PCRF supports the functionality defined in TS 23.203 [6].

4.5.4 BM-SC

The BM-SC shall support the following functionality:

- MBMS Broadcast Mode procedures defined in TS 23.246 [3].
- MB2 procedures defined in clause 5.1 for activating, deactivating and modifying an MBMS bearer.

5 Functional Description and Information Flow

5.1 MB2: Interface between GCS AS and BM-SC

5.1.1 General

MB2 offers access to the MBMS bearer service from a GCS AS. MB2 carries control plane signalling (MB2-C) and user plane (MB2-U) between GCS AS and BM-SC. MB2 has the following properties:

- MB2 is used by the GCS AS to interact with the BM-SC for MBMS bearer management.
- The GCS AS may use the MBMS service from multiple BM-SCs, each with a separate MB2 interface.
- The BM-SC shall provide service to multiple GCS ASs via a separate MB2 interface.
- Within one PLMN, an MBMS session is supported by exactly one BM-SC and provided for only one GCS AS.
- The data transferred via MBMS bearer(s) by the GCS AS is transparent to the BM-SC. A GCS AS may transfer data from one or multiple GCS groups via a single MBMS bearer.
- MB2 is a standardized secured interface to an AS.
- The GCS AS needs to be configured with the IP addresses or a FQDN of the contact points of MB2-C. The MB2-C contact points need to be configured per PLMN ID.
- The user plane transport information (e.g. IP address/UDP port) for delivering group communication data flow from the GCS AS to the BM-SC over MB2-U shall be exchanged over MB2-C.

NOTE 1: The GCS AS is not associated to any specific PLMN from an ownership standpoint.

NOTE 2: It is up to stage 3 to define the protocol stack and security requirements for MB2-C/U, and any additional parameters that may be needed by the MBMS procedure as defined in TS 23.246 [3].

5.1.2 MB2 Procedures

5.1.2.1 General

The MB2 interface provides the ability for the application to use the functionality of the MBMS system to deliver data to group members over MBMS. The procedures supported include:

- allocation of a set of TMGIs (TS 23.246 [3]) by the BM-SC at the request of the GCS AS, (see clause 5.1.2.2.2),
- deallocation of a set of TMGIs by the BM-SC at the request of the GCS AS, (see clause 5.1.2.2.3),
- activating an MBMS bearer, (see clause 5.1.2.3.2),
- deactivating an active MBMS bearer, (see clause 5.1.2.3.3),
- modifying characteristics of an active MBMS bearer, (see clause 5.1.2.4), and
- reporting of MBMS delivery status from the BM-SC to the GCS AS, (see clause 5.1.2.5).

The MB2 interface between the GCS AS and the BM-SC is established before any MB2 messages are sent between these two entities, and carries all MB2 messages between the two entities for all MBMS bearers used by the GCS AS. The TMGI/FlowID (see TS 23.246 [3]) is the unique identifier used by the GCS AS and BM-SC to refer to the MBMS bearer.

5.1.2.2 TMGI Management

5.1.2.2.1 General

TMGIs are managed between the GCS AS and the BM-SC using the following explicit allocation and deallocation procedures upon request from the GCS AS.

TMGIs may also be allocated automatically by the BM-SC at bearer activation as described in clause 5.1.2.3.2.

Each TMGI is allocated by the BM-SC for a given period of time determined by the BM-SC. If the GCS AS wants to retain access to a TMGI for an extended period of time the GCS AS needs to request extension of the allocation period. The GCS AS may request an extension of the allocation period at any time prior to expiry of the time period. The actions consequent upon expiry of a TMGI allocation period are described in clause 5.1.2.2.4.

5.1.2.2.2 TMGI Allocation Procedure

The TMGI Allocation procedure is used by the GCS AS to request a set of TMGIs. This procedure may also be used to renew the expiration time for already allocated TMGIs.

Figure 5.1.2.2.1-1 provides the procedure used between the GCS AS and the BM-SC to allocate a set of TMGIs to the GCS AS.

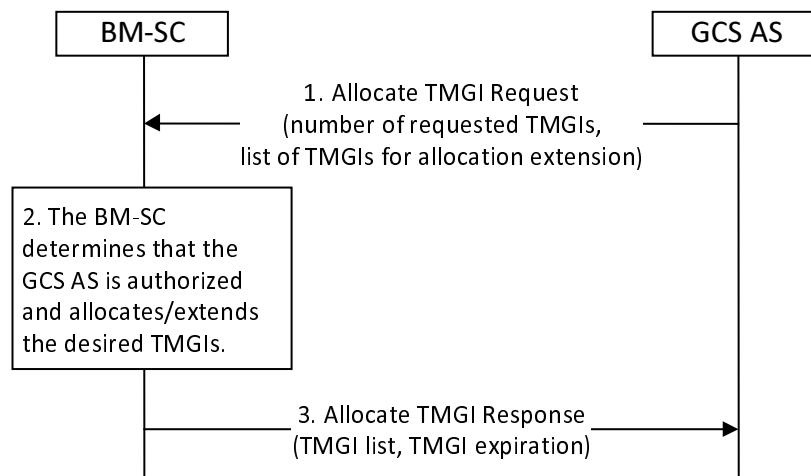

Figure 5.1.2.2.1-1: TMGI Allocation Procedure

1. When the GCS AS wishes to have the BM-SC allocate one or more TMGIs to it, the GCS AS sends an Allocate TMGI Request message to the BM-SC, including the number of requested TMGIs. The GCS AS may include a list of TMGIs that are already allocated to the GCS AS, and for which the GCS AS wishes to obtain a later expiration time. The number of TMGIs requested may be zero, if this procedure is used only to renew the expiration time for already allocated TMGIs.
2. The BM-SC shall determine whether the GCS AS is authorized to receive the TMGIs and allocates a set of TMGIs. The BM-SC determines an expiration time for the TMGIs. If a list of TMGIs has been received in the Allocate TMGI Request message, the BM-SC also determines whether the TMGIs are allocated to the requesting GCS AS and if yes, whether the expiration time for those TMGIs can be set to the new expiration time.
3. The BM-SC shall send an Allocate TMGI Response message to the GCS AS indicating the list of allocated TMGIs, and an expiration time for those TMGIs.

5.1.2.2.3 TMGI Deallocation Procedure

The TMGI Deallocation procedure is used by the GCS AS to immediately release a set of TMGIs, irrespective of their expiration times.

Figure 5.1.2.2.2-1 provides the procedure used between the GCS AS and the BM-SC to deallocate TMGIs.

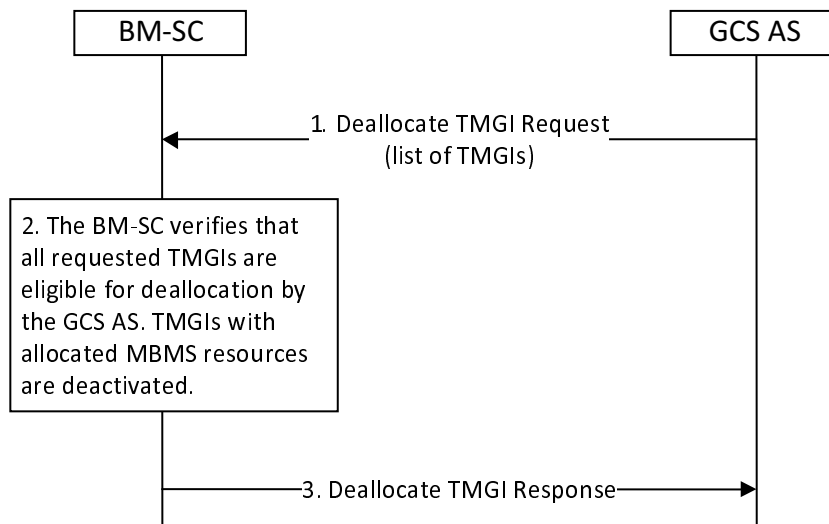

Figure 5.1.2.2.2-1: TMGI Deallocation Procedure

1. When the GCS AS decides that it no longer needs one or more TMGIs that are allocated to it, the GCS AS shall send a Deallocate TMGI Request message to the BM-SC with the list of TMGIs to be deallocated. Absence of the list of TMGIs implies that all TMGIs currently allocated by the BM-SC to the GCS AS are to be deallocated.
2. The BM-SC shall determine that the GCS AS is authorized to deallocate the indicated TMGIs, and shall then deallocate the TMGIs. If MBMS resources are in use for any of the deallocated TMGIs, those resources are released using the Session Stop procedure defined in TS 23.246 [3] and the BM-SC shall release any corresponding MB2 resources.
3. The BM-SC sends a Deallocate TMGI Response message to the GCS AS.

5.1.2.2.4 TMGI allocation period expiry

When the allocation period for a TMGI expires the TMGI and its associated Flow ID are no longer available for use by the GCS AS.

If, at the time of expiry, the TMGI is associated with a previously activated MBMS bearer (clause 5.1.2.3.2) the BM-SC shall autonomously take whatever actions are needed to stop broadcast of the MBMS bearer to the agreed MBMS service area, and shall release the MBMS resources used for the MBMS bearer using the Session Stop procedure defined in TS 23.246 [3]. The BM-SC shall send an MBMS Delivery Status Indication message to the GCS AS and shall release any corresponding MB2 resources.

At any time prior to expiry, the allocation period for a TMGI(s) may be extended as described in clause 5.1.2.2.2. A GCS AS wanting to ensure that it retains access to a TMGI should request extension of the allocation period at an adequate time before expiry, e.g. halfway through the allocation period.

5.1.2.3 Activating and Deactivating an MBMS bearer

5.1.2.3.1 General

Activating and deactivating an MBMS bearer involves the allocation/deallocation of MBMS resources, based on the MBMS bearer configuration provided by the GCS AS, using the following explicit activation and deactivation procedures upon request from the GCS AS.

MBMS bearer resources may also be deallocated autonomously by the BM-SC, upon expiry of the allocation period of the TMGI associated with the MBMS bearer, as described in clause 5.1.2.2.4.

5.1.2.3.2 Activate MBMS Bearer Procedure

The Activate MBMS Bearer procedure is used by the GCS AS to cause allocation of resources for an MBMS bearer.

Figure 5.1.2.3.1-1 provides the procedure used between the GCS AS and the BM-SC to activate an MBMS bearer.

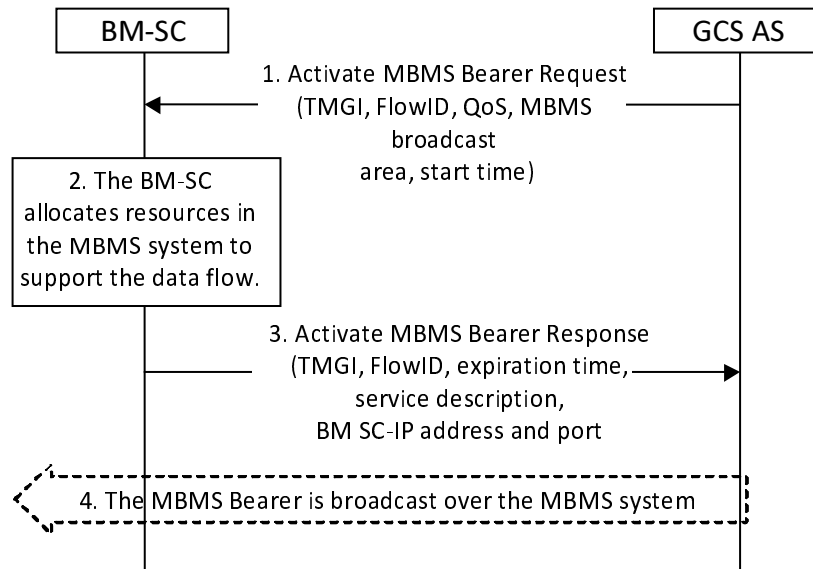

Figure 5.1.2.3.1-1: Activate MBMS Bearer Procedure

1. When the GCS AS wishes to activate an MBMS bearer over MB2, the GCS AS sends an Activate MBMS Bearer Request message to the BM-SC, including the TMGI which represents the MBMS bearer to be started, FlowID, QoS, MBMS broadcast area, and start time. The TMGI is optional. The FlowID may be included only if the TMGI is included. If the FlowID is included in the request, the BM-SC associates it to the TMGI in the request, for the MBMS broadcast area. The QoS shall be mapped into appropriate QoS parameters of the MBMS bearer. The MBMS broadcast area parameter shall carry an MBMS service area.
2. If the TMGI was included, the BM-SC shall determine whether the GCS AS is authorized to use the TMGI. The BM-SC shall reject the request if the TMGI is not authorized. If the TMGI was not included in the request, the BM-SC shall assign an unused value for the TMGI. If the FlowID was not included in the request, the BM-SC allocates a FlowID value corresponding to this TMGI and MBMS broadcast area. If another MBMS bearer with the same TMGI and FlowID, but different MBMS broadcast area, is already activated, BM-SC shall reject the request. If another MBMS bearer with the same TMGI but different FlowID is already activated, BM-SC shall ensure this MBMS broadcast area is not overlapping with any of the MBMS broadcast areas corresponding to existing MBMS bearer(s) of the same TMGI. The BM-SC shall allocate MBMS resources to support content delivery of the MBMS bearer to the requested MBMS broadcast area using the Session Start procedure defined in TS 23.246 [3].
3. The BM-SC shall send an Activate MBMS Bearer Response message to the GCS AS, including the TMGI, the FlowID (echoed back if initially included in the request, or allocated by BM-SC), service description, BM-SC IP address and port number for the user-plane, and an expiration time. The service description contains MBMS bearer related configuration information as defined in TS 26.346 [7] (e.g. infoBinding element containing *serviceArea* and *radiofrequency*). The expiration time is included only if the BM-SC has allocated a TMGI as a result of this procedure.

NOTE: The GCS AS may use the service description to provide information to the UE to access the MBMS bearer.

5.1.2.3.3 Deactivate MBMS Bearer Procedure

The Deactivate MBMS Bearer procedure is used by the GCS AS to cause deallocation of resources for an MBMS bearer.

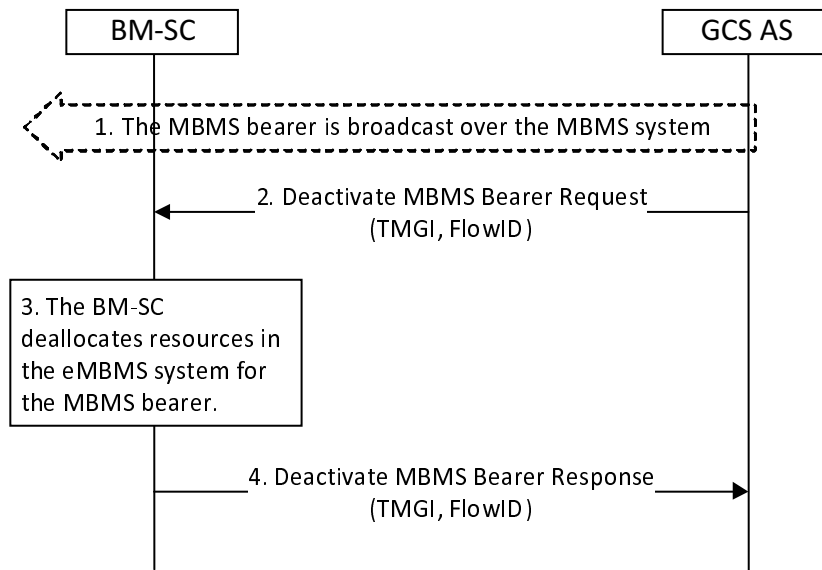

Figure 5.1.2.3.2-1: Deactivate MBMS Bearer Procedure

1. The MBMS bearer is being broadcast over the MBMS system.
2. When the GCS AS determines that the MBMS bearer is no longer needed, it shall send a Deactivate MBMS Bearer Request message to the BM-SC, including the TMGI and FlowID representing the MBMS bearer to be deactivated.
3. The BM-SC shall determine whether the GCS AS is authorized to use the TMGI and shall take whatever actions are needed to stop broadcast of the MBMS bearer to the agreed MBMS service area, and to deallocate MBMS resources used for the MBMS bearer using the Session Stop procedure defined in TS 23.246 [3].
4. The BM-SC shall send a Deactivate MBMS Bearer Response message to the application, including the TMGI, the FlowID, and a result.

5.1.2.4 Modify MBMS Bearer Procedure

The Modify MBMS Bearer procedure is used by the GCS AS to cause modification of the priority and preemption values for an MBMS bearer, the MBMS broadcast area, or both.

Figure 5.1.2.4-1 provides a description of the procedure used between the GCS AS and the BM-SC to modify an activated MBMS bearer.

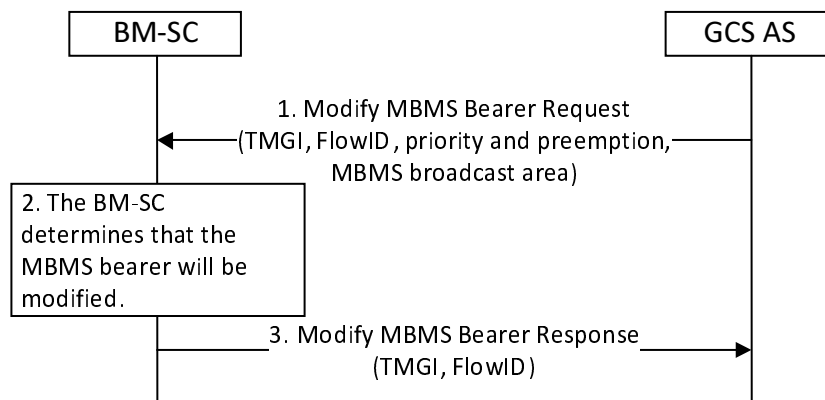

Figure 5.1.2.4-1: Modify MBMS Bearer Procedure

1. When the GCS AS determines that an activated MBMS bearer needs to be modified, it shall send a Modify MBMS Bearer Request message to the BM-SC, including the TMGI, FlowID, any new priority and preemption

characteristics to be used, and the MBMS broadcast area. The priority and preemption characteristics and the MBMS broadcast area are optional parameters but one of them needs to be included in the Modify MBMS Bearer request.

2. If the MBMS broadcast area is being modified, the BM-SC shall ensure that the new MBMS broadcast area is not overlapping with the MBMS broadcast area of any other existing MBMS bearer(s) with the same TMGI, in accordance with TS 23.246 [3]. The BM-SC shall modify the characteristics of the MBMS bearer using the Session Update procedure defined in TS 23.246 [3].
3. The BM-SC shall send a Modify MBMS Bearer Response message to the GCS AS, including the TMGI, FlowID, and the result.

5.1.2.5 MBMS Delivery Status Indication Procedure

The MB2 interface allows the BM-SC to notify the GCS AS of conditions affecting the delivery of services that use MBMS Delivery. The occurrence of the indicated condition may have been detected at the BM-SC or may have been reported to the BM-SC by other entities involved in the MBMS delivery.

The BM-SC sends the MBMS Delivery Status Indication message which includes an identification of the condition whose occurrence triggered the sending of the message and may include other information.

Figure 5.1.2.5-1 illustrates the MBMS Delivery Status Indication procedure.

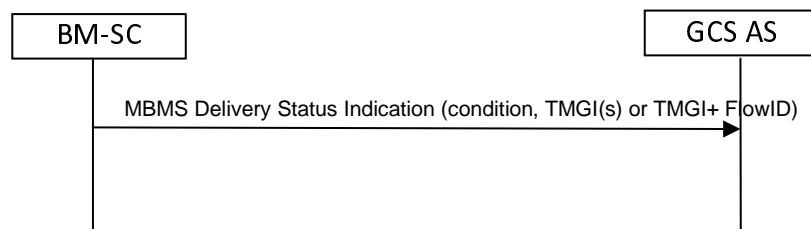

Figure 5.1.2.5-1: MBMS Delivery Status Indication procedure

5.2 Specific Usage of EPS Bearers for GCS

Each UE participating in the Group Communication Service uses one or multiple EPS bearers for exchanging application signaling and data with the GCS AS. The EPS bearer services are specified in TS 23.401 [5] and TS 23.203 [6].

In order to enable GCS, a PDN connection needs to be established that can be used for GC1 signaling exchange. When the PDN connection gets established the PCC functionality determines a QCI and an ARP for the default bearer, which may be used for GC1 signaling. Alternatively, during PDN connection establishment a dedicated bearer may be established for GC1 signaling by configuring PCC rules accordingly.

A GCS UE may join multiple GCS groups, which are served by one or more EPS bearers. The GCS AS determines the service characteristics of a specific Group Communication Service, e.g. media or flow description and priority, which is used by the PCRF to determine the EPS bearer configuration appropriate for GCS. The GCS AS updates the PCRF with service characteristics to initiate any required update of the EPS bearer configuration, e.g. when the UE joins or leaves a GCS group or when a GCS data exchange starts or stops.

Whenever the UE's bearer configuration needs to be updated, the GCS AS provides the updated or new service characteristics to the PCRF. From service characteristics PCRF determines the required bearer configuration, including QCI and ARP, and requests the PCEF amendment of the UE's EPS bearers accordingly. If the priority of the application Group Communication session changes, the GCS AS provides an update of the service characteristics towards the PCRF via the Rx interface. The PCRF translates the service characteristics to PCC policies and forwards its policy decision to the PCEF. The PCEF determines, based on policies provided by the PCRF, whether the PCEF modifies already established bearers or whether the PCEF establishes dedicated bearer(s) with the determined bearer characteristics.

The PCRF is not aware of the GCS group(s).

To obtain the responsiveness desired for GCS the GCS UE shall signal the Idle Mode DRX value to the MME, using the procedures described in TS 23.401 [5]. The EUTRAN derives from the QCI the configuration for delivering an equivalent responsiveness in Connected Mode.

5.3 Service Continuity

5.3.1 General

This clause provides flows & procedures for switching from Unicast Delivery to MBMS Delivery and vice-versa. In the flows, the need for service continuity is determined and executed by the UE. In the make-before-break flows, the UE may simultaneously receive the same DL data on both Unicast and MBMS bearers. In such scenarios, it is up to the application to manage duplicate detection.

5.3.2 Switching from Unicast Delivery to MBMS Delivery

Figure 5.3.2-1 shows the procedures for service continuity when a UE which is receiving DL data over unicast moves into MBMS coverage. During the switching process, the UE simultaneously receives data from both unicast and MBMS, so there is no service interruption.

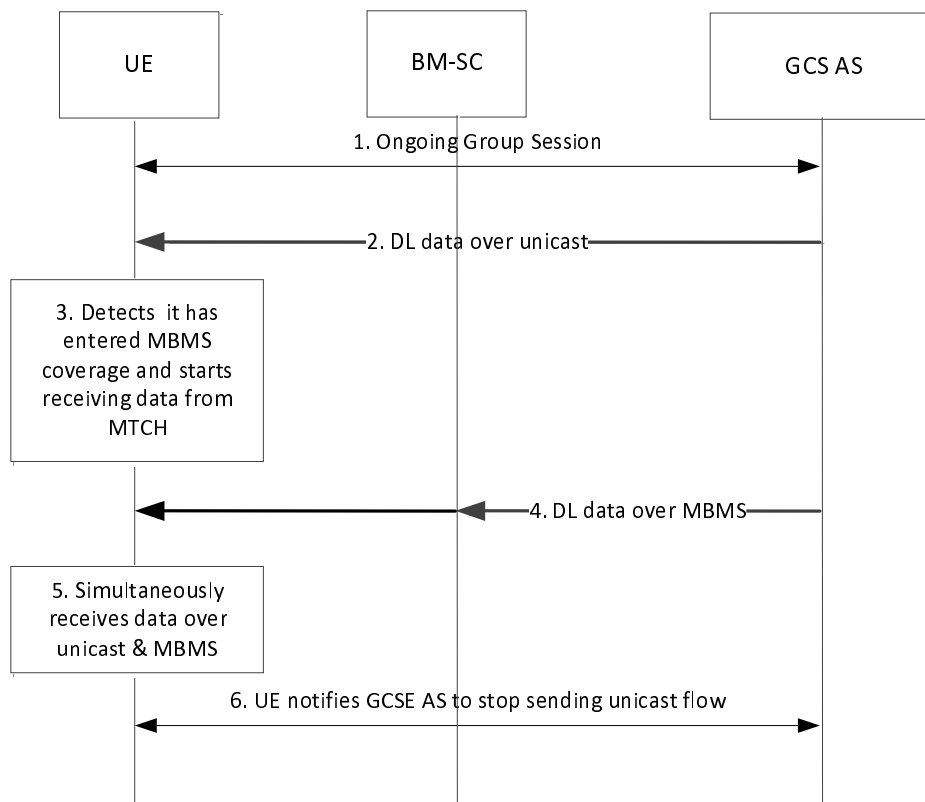

Figure 5.3.2-1: Switching from Unicast Delivery to MBMS Delivery

1. The UE has an on going group communication and the GCS AS informs the UE, over GC1, of the availability of MBMS delivery and of the corresponding TMGI of the MBMS bearer service.
2. The UE is receiving downlink data by Unicast Delivery.
3. The UE detects it has entered MBMS coverage and starts receiving MBMS Scheduling Information over MCH and the data from the MBMS bearer corresponding to the TMGI over MTCH.
4. The UE receives DL data by MBMS Delivery.
5. The UE simultaneously receives data by Unicast Delivery and MBMS Delivery.

6. The UE notifies the GCS AS via GC1 that it is in MBMS coverage and receiving the MBMS bearer service corresponding to the TMGI. The GCS AS stops sending the data over by Unicast Delivery to this UE. The UE now receives the content only by MBMS Delivery.

5.3.3 Switching from MBMS Delivery to Unicast Delivery

5.3.3.1 General

This clause defines the following two procedures for service continuity for switching from MBMS Delivery to Unicast Delivery:

- MBMS Delivery to Unicast Delivery (make-before-break).
- MBMS Delivery to Unicast Delivery (break-before-make).

5.3.3.2 MBMS Delivery to Unicast Delivery (make-before-break)

Figure 5.3.3.2-1 shows the procedure for service continuity when a UE is about to move out of MBMS coverage. In this procedure, the UE detects that it is about to move out of MBMS coverage and elects to receive data over unicast while still within MBMS coverage. During the switching process, the UE simultaneously receives data from both unicast and MBMS, so there is no service interruption.

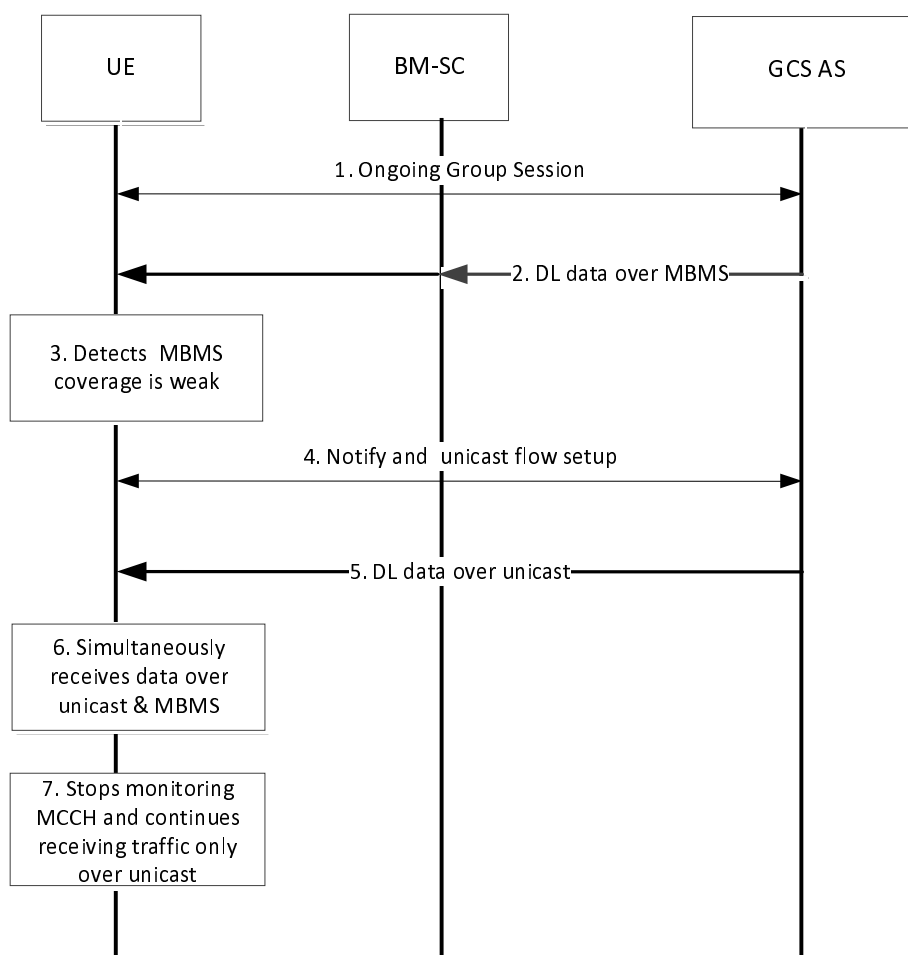

Figure 5.3.3.2-1: Switching from MBMS Delivery to Unicast Delivery (make-before-make)

1. The UE has an ongoing group communication.
2. The UE is receiving downlink data by MBMS Delivery.

3. The UE detects that it is about to move out from MBMS coverage, for the corresponding MBMS bearer service, through implementation-specific methods. For example, the UE can determine it is about to move out of MBMS coverage by detecting poor MBSFN signal quality.
4. The UE notifies the GCS AS that it may move out of MBMS coverage via GC1 and the GCS AS sets up a unicast flow.
5. The GCS AS now sends the downlink data by Unicast Delivery to this UE.
6. The UE simultaneously receives DL data by Unicast Delivery and by MBMS Delivery.
7. The UE stops monitoring MCCH and ceases to receive the downlink data by MBMS Delivery but continues receiving data by Unicast Delivery.

5.3.3.3 MBMS Delivery to Unicast Delivery (break-before-make)

Figure 5.3.3.3-1 shows the procedure for service continuity when a UE has moved out of MBMS coverage. Here the UE starts receiving DL data over unicast after it has stopped receiving data over MBMS, so there may be some service interruption.

This procedure is used by the UE to handle loss of MBMS Delivery due to MBMS resource congestion in E-UTRAN resulting in pre-emption of the MBMS bearer service as described in clause 5.4.

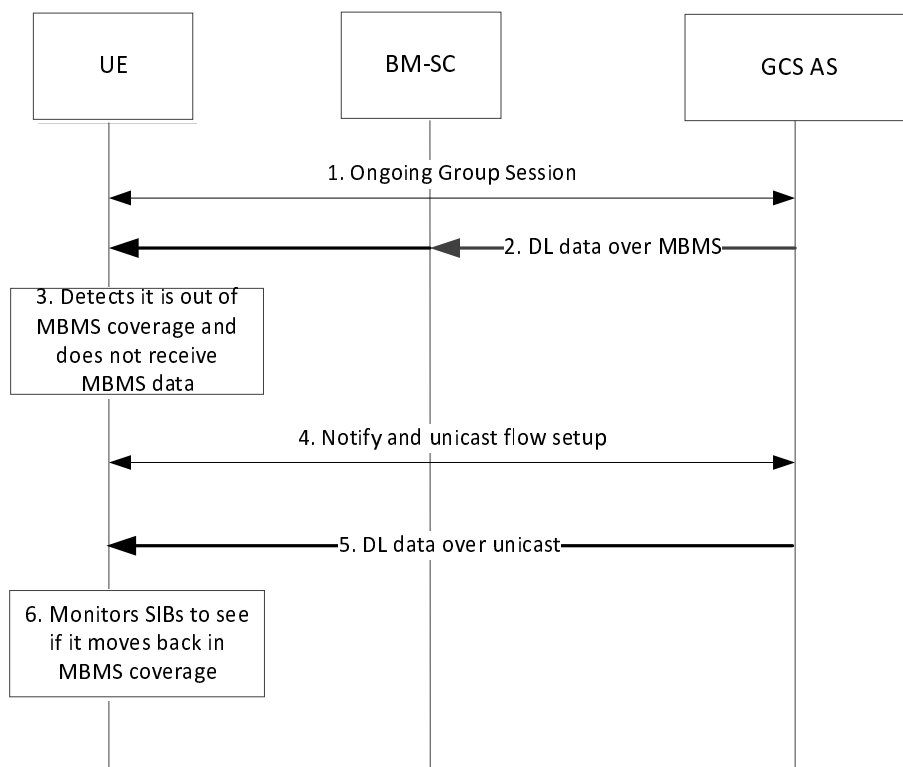

Figure 5.3.3.3-1: Switching from MBMS Delivery to Unicast Delivery (break-before-make)

1. The UE has an ongoing group communication.
2. The UE is receiving downlink data by MBMS Delivery for an MBMS bearer service is identified by a TMGI.
3. The UE detects it is out of MBMS coverage for that TMGI and, therefore, is unable to receive any data by MBMS Delivery for the corresponding MBMS bearer service.
4. The UE notifies the GCS AS via GC1 that it has moved out of MBMS coverage for the MBMS bearer service corresponding to the TMGI and the GCS AS sets up a unicast flow.
5. The GCS AS sends the downlink data by Unicast Delivery.

6. The UE monitors the SIBs in order to detect the TMGI on MCCH and thus determine that it is back in MBMS coverage for the MBMS bearer service.

5.4 Priority and Pre-emption for Group Communication

A Group Communication Session that requires to be prioritized over other Group Communication Sessions or non-Group Communication Sessions includes both the priority level and the GCS identifier in a service authorization request to the PCRF and to the BM-SC.

The priority level and the GCS identifier are defined at the application layer for priority and pre-emption purposes. The GCS AS provides the priority level and the GCS identifier to the PCRF and the BM-SC. It is mapped by the PCRF and the BM-SC to the ARP priority level, pre-emption capability and pre-emption vulnerability indication under the consideration of the respective EPS network.

In the case of Unicast Delivery, the PCRF translates the service characteristics to PCC policies and forwards its policy decision to the PCEF. The PCEF determines, based on policies provided by the PCRF, whether the PCEF modifies already established bearers or whether the PCEF establishes dedicated bearer(s) with the determined bearer characteristics. If the priority of a particular application Group Communication session changes, the GCS AS provides an update of the service characteristics towards the PCRF via the Rx interface. The PCRF updates the PCC policies and forwards them to the PCEF. The PCEF modifies already established bearers or establishes dedicated bearer(s) accordingly.

The PCRF shall, at the reception of service authorization from the GCS AS including an indication that is a prioritized GC Session and priority level, ensure that the ARP priority level of the default bearer is assigned a prioritized value which is at least as high as the highest priority of all Group Communication Sessions within the same IP-CAN session. The PCRF shall also ensure that the ARP pre-emption capability and pre-emption vulnerability indication of the default bearer satisfies the strongest requirements of all Group Communication Sessions within the same IP-CAN session.

When the PCRF detects that all prioritized Group Communication Sessions within the same IP-CAN session are released, the PCRF shall assign the ARP of the default bearer as appropriate.

In the case of MBMS Delivery, if the priority of an MBMS bearer needs to be changed, based upon a GCS AS decision to change the priority level, the GCS AS performs either:

- The Modify MBMS Bearer procedure in clause 5.1.2.4; or
- A new Activate MBMS Bearer procedure and a Deactivate MBMS Bearer procedure replacing the old MBMS bearer service with a new one.

In certain network conditions such as congestion, the bearer used for group communication service may be pre-empted.

- In the case of Unicast Delivery, the GCS AS is notified by the PCRF of unicast bearer release.
- In the case of MBMS Delivery, the related MBMS bearer may be 'suspended' by E-UTRAN, i.e. packets are dropped at the eNB without any message sent from eNB to BM-SC. The UE can detect that MBMS delivery is no longer available when the related TMGI is removed from MCCH. The UE shall treat this scenario in the manner as defined in clause 5.3.3.3.

5.5 Charging

For MBMS Delivery, the architecture requirement for charging defined for MBMS broadcast service for E-UTRAN in TS 23.246 [3] shall apply.

For Unicast Delivery, the architecture requirement for charging defined for EPS bearer services in TS 23.401 [5] shall apply.

5.6 Security

Security requirements for supporting the MB2 reference point for GCS are defined in TS 33.246 [8].

No additional security requirement is defined for supporting GCS with Unicast Delivery.

Annex A (Informative): Utilisation of the Group Communication Service

A.1 General

This annex provides informative call flows for how a GCS AS can use the Unicast Delivery and MBMS Delivery mechanisms defined in this specification to deliver data to group(s) of users.

A.2 Downlink Media path setup for MBMS Delivery

A.2.1 General

This clause describes two procedures for establishing MBMS Delivery on the downlink:

- using pre-established MBMS bearers, or
- using dynamic establishment of MBMS bearers

A.2.2 Use of Pre-established MBMS bearers

In this scenario, the GCS AS pre-establishes MBMS bearer(s) in certain pre-configured areas before the start of the group communication session. When a UE originates a request for group communication for one of these areas, the pre-established MBMS bearer(s) is used for the DL traffic.

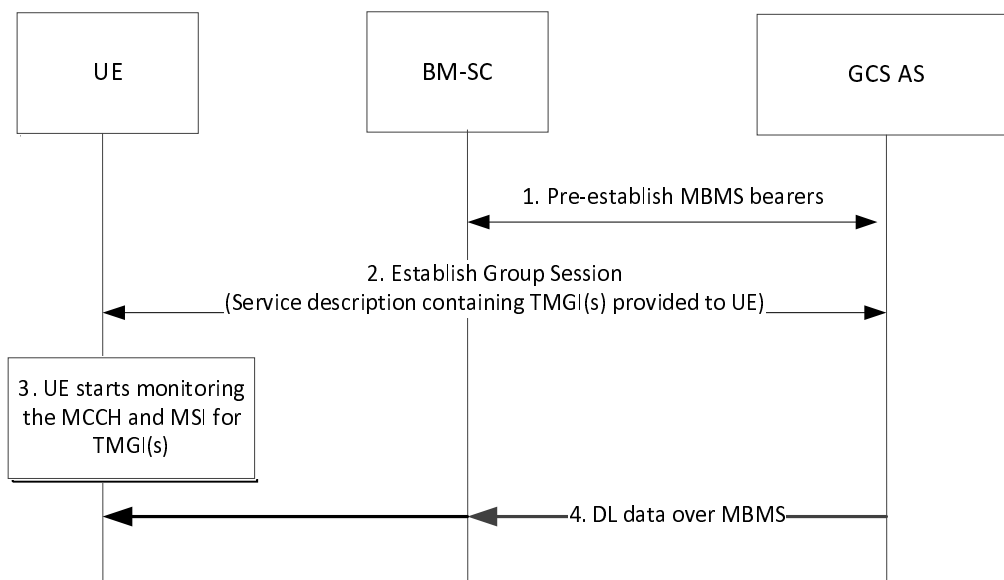

Figure A.2.2-1: Use of Pre-established MBMS Bearers

1. The GCS AS pre-establishes the MBMS bearers for the group communication session according to the procedures defined in clause 5.1.2.3.1. The BM-SC returns the MBMS service description associated with the MBMS bearer(s) to the GCS AS.
2. The UE establishes a group communication session with the GCS AS. The GCS AS passes the service description associated with the MBMS bearer service to the UE. The UE obtains the TMGI(s), identifying the MBMS bearer (s), from the service description.

3. The UE starts monitoring the MSI and MCCH of received MBSFN broadcast(s) for the TMGI(s).
4. Having detected a TMGI on MCCH the UE monitors the MSI and receives the DL data on the MTCH corresponding to the TMGI.

A.2.3 Use of Dynamic MBMS bearer establishment

In this scenario, the GCS AS uses a unicast bearer for communication with the UE on the DL at the start of the group communication session. When the GCS AS decides to use an MBMS bearer for the DL data, the GCS AS establishes one using the procedures defined in clause 5.1.2.3.1. The GCS AS provides the service description associated with MBMS bearer(s), obtained from the BM-SC, to the UE. The UE starts using the MBMS bearer(s) to receive DL data and stops using the unicast bearer for the DL data.

NOTE: The GCS AS logic for determining when to establish the new MBMS Delivery bearer is implementation specific. For example, the GCS AS could decide to establish the MBMS delivery based on the location of the UE's that are a part of the group communication session.

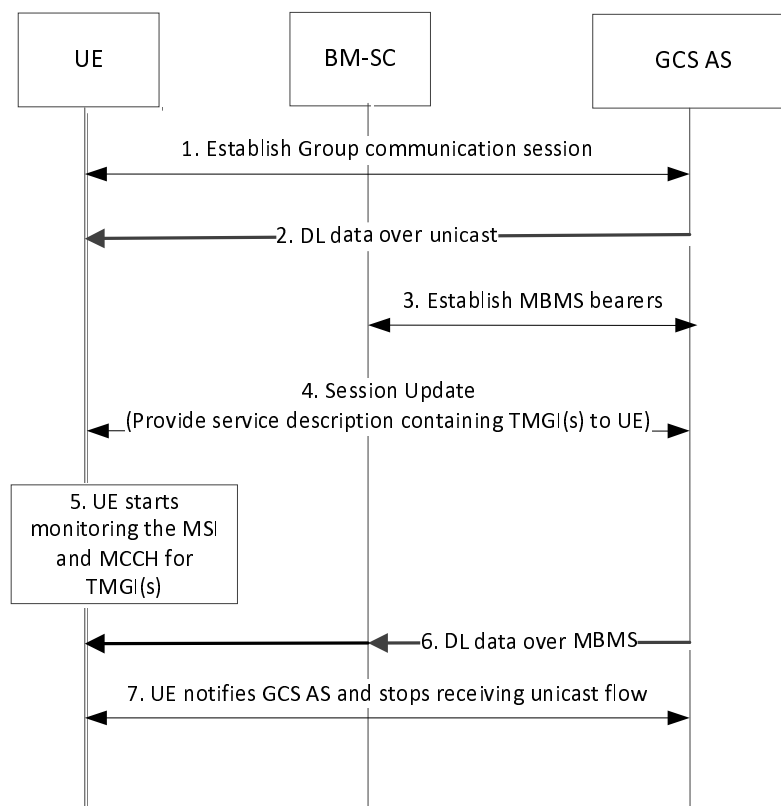

Figure A.2.3-1: Use of Dynamic MBMS Bearer Establishment

1. The UE establishes a group communication session with the GCS AS.
2. The downlink data is sent by Unicast Delivery.
3. The GCS AS establishes the MBMS bearer(s) for the group communication session according to the procedures defined in clause 5.1.2.3.1. The BM-SC returns the service description associated with the MBMS bearer(s) to the GCS AS.
4. The GCS AS provides the service description associated with the MBMS bearer(s) to the UE. The UE obtains the TMGI(s) from the service description.
5. The UE starts monitoring the MSI and MCCH of received MBSFN broadcast(s) for the TMGI(s).
6. Having detected a TMGI on MCCH the UE monitors the MSI and receives the DL data on the MTCH corresponding to the TMGI.

7. The UE notifies the GCS AS that it is receiving the data over MBMS for the given TMGI. The GCS AS stops sending DL data over unicast to the UE.

Annex B (Informative): Change history

Change history								
Date	TSG #	TSG Doc.	CR	Rev	Cat	Subject/Comment	Old	New
2014-02	SP-63	SP-140118	-	-	-	MCC Editorial Update for Presentation to TSG SA for Approval	0.1.1	1.0.0
2014-02	SP-63	-	-	-	-	MCC Editorial update for publication after TSG SA approval	1.0.0	12.0.0
2014-06	SP-64	SP-140259	0007	1	F	Update sections 5.2 & 5.4 for GCSE	12.0.0	12.1.0
2014-06	SP-64	SP-140259	0008	2	F	Update clause 4.2.1 for GCSE	12.0.0	12.1.0
2014-06	SP-64	SP-140259	0009	1	F	Update clause 4.2.3 for GCSE	12.0.0	12.1.0
2014-06	SP-64	SP-140259	0010	2	F	Update of GC1 reference point for GCSE	12.0.0	12.1.0
2014-06	SP-64	SP-140259	0016	1	F	Fix misleading text on uplink bearer	12.0.0	12.1.0
2014-06	SP-64	SP-140259	0017	1	F	Corrections to the TMGI allocation and deallocation procedures	12.0.0	12.1.0
2014-06	SP-64	SP-140259	0018	2	F	Proposed change of terminology for used TMGIs over MB2	12.0.0	12.1.0
2014-06	SP-64	SP-140259	0019	2	F	Charging requirements for GCSE_LTE	12.0.0	12.1.0
2014-06	SP-64	SP-140259	0021	2	F	Clarifications to service description from BM-SC	12.0.0	12.1.0
2014-06	SP-64	SP-140259	0032	1	F	Clarification of actions consequent upon TMGI expiry	12.0.0	12.1.0
2014-06	SP-64	SP-140259	0035	1	F	Deactivate the MBMS bearer procedure	12.0.0	12.1.0
2014-06	SP-64	SP-140259	0037	2	F	Priority and Pre-emption for GCS	12.0.0	12.1.0
2014-06	SP-64	SP-140259	0038	1	F	Clarifications to security requirements	12.0.0	12.1.0
2014-06	SP-64	SP-140259	0039	1	F	Flow ID allocation by BM-SC only	12.0.0	12.1.0
2014-09	SP-65	SP-140420	0022	2	F	Clarifications to roaming models and MBMS Delivery media flow in the figures	12.1.0	12.2.0
2014-09	SP-65	SP-140420	0044	1	F	Requirements for MB2 and GC1	12.1.0	12.2.0
2014-12	SP-66	SP-140678	0050	1	F	Clarifications for priority related PCRF actions	12.2.0	12.3.0
2014-12	SP-66	SP-140678	0055	1	F	Add missing FlowID parameter to 'Activate MBMS Bearer Request'	12.2.0	12.3.0

History

Document history		
V12.2.0	September 2014	Publication
V12.3.0	January 2015	Publication