

ETSI TS 124 182 V8.4.0 (2010-01)

Technical Specification

**Digital cellular telecommunications system (Phase 2+);
Universal Mobile Telecommunications System (UMTS);
LTE;
IP Multimedia Subsystem (IMS)
Customized Alerting Tones (CAT);
Protocol specification
(3GPP TS 24.182 version 8.4.0 Release 8)**



Reference

RTS/TSGC-0124182v840

Keywords

GSM, LTE, UMTS

ETSI

650 Route des Lucioles
F-06921 Sophia Antipolis Cedex - FRANCE

Tel.: +33 4 92 94 42 00 Fax: +33 4 93 65 47 16

Siret N° 348 623 562 00017 - NAF 742 C
Association à but non lucratif enregistrée à la
Sous-Préfecture de Grasse (06) N° 7803/88

Important notice

Individual copies of the present document can be downloaded from:

<http://www.etsi.org>

The present document may be made available in more than one electronic version or in print. In any case of existing or perceived difference in contents between such versions, the reference version is the Portable Document Format (PDF). In case of dispute, the reference shall be the printing on ETSI printers of the PDF version kept on a specific network drive within ETSI Secretariat.

Users of the present document should be aware that the document may be subject to revision or change of status. Information on the current status of this and other ETSI documents is available at

<http://portal.etsi.org/tb/status/status.asp>

If you find errors in the present document, please send your comment to one of the following services:

http://portal.etsi.org/chaicor/ETSI_support.asp

Copyright Notification

No part may be reproduced except as authorized by written permission.
The copyright and the foregoing restriction extend to reproduction in all media.

© European Telecommunications Standards Institute 2010.
All rights reserved.

DECT™, **PLUGTESTS™**, **UMTS™**, **TIPHON™**, the TIPHON logo and the ETSI logo are Trade Marks of ETSI registered for the benefit of its Members.

3GPP™ is a Trade Mark of ETSI registered for the benefit of its Members and of the 3GPP Organizational Partners.

LTE™ is a Trade Mark of ETSI currently being registered

for the benefit of its Members and of the 3GPP Organizational Partners.

GSM® and the GSM logo are Trade Marks registered and owned by the GSM Association.

Intellectual Property Rights

IPRs essential or potentially essential to the present document may have been declared to ETSI. The information pertaining to these essential IPRs, if any, is publicly available for **ETSI members and non-members**, and can be found in ETSI SR 000 314: "*Intellectual Property Rights (IPRs); Essential, or potentially Essential, IPRs notified to ETSI in respect of ETSI standards*", which is available from the ETSI Secretariat. Latest updates are available on the ETSI Web server (<http://webapp.etsi.org/IPR/home.asp>).

Pursuant to the ETSI IPR Policy, no investigation, including IPR searches, has been carried out by ETSI. No guarantee can be given as to the existence of other IPRs not referenced in ETSI SR 000 314 (or the updates on the ETSI Web server) which are, or may be, or may become, essential to the present document.

Foreword

This Technical Specification (TS) has been produced by ETSI 3rd Generation Partnership Project (3GPP).

The present document may refer to technical specifications or reports using their 3GPP identities, UMTS identities or GSM identities. These should be interpreted as being references to the corresponding ETSI deliverables.

The cross reference between GSM, UMTS, 3GPP and ETSI identities can be found under <http://webapp.etsi.org/key/queryform.asp>.

Contents

Intellectual Property Rights	2
Foreword.....	2
Foreword.....	5
1 Scope	6
2 References	6
3 Definitions and abbreviations.....	7
3.1 Definitions	7
3.2 Abbreviations	7
4 Customized Alerting Tones (CAT)	7
4.1 Introduction	7
4.2 Description	7
4.2.1 General description	7
4.3 Operational requirements	7
4.3.1 Provision/withdrawal	7
4.3.1.1 CAT provision/withdrawal.....	7
4.3.1.2 Requirements on the originating network side	8
4.3.1.3 Requirements on the terminating network side	8
4.4 Syntax requirements	8
4.5 Signalling procedures	8
4.5.1 General.....	8
4.5.2 Activation/deactivation	8
4.5.3 Registration/erasure	8
4.5.4 Interrogation	8
4.5.5 Invocation and operation	8
4.5.5.1 Actions at the originating UE.....	8
4.5.5.2 Actions at the AS serving the originating UE	9
4.5.5.3 Actions at the AS serving the terminating UE	9
4.5.5.3.1 General	9
4.5.5.3.2 AS actions for forking model	9
4.5.5.3.3 AS Actions for early session model.....	10
4.6 Interaction with other services.....	11
4.6.1 Communication session Hold (HOLD).....	11
4.6.2 Termination Identification Presentation (TIP).....	11
4.6.3 Termination Identification Restriction (TIR).....	11
4.6.4 Originating Identification Presentation (OIP).....	11
4.6.5 Originating Identification Restriction (OIR).....	12
4.6.6 Conference (CONF).....	12
4.6.7 Communication DIVersion services (CDIV).....	12
4.6.7.1 General	12
4.6.7.2 CFNR	13
4.6.8 Message Waiting Indication (MWI)	13
4.6.9 Communication Barring (CB).....	13
4.6.10 Explicit Call Transfer (ECT)	13
4.6.11 Communication Wait.....	13
4.6.12 Completion of Communications to Busy Subscriber.....	13
4.7 Parameter values (timers).....	14
4.8 Service configuration	14
Annex A (informative): Signalling flows	15
A.1 Scope of signalling flows	15
A.2 Introduction	15
A.3 CAT forking model signalling flows.....	15

A.3.1	Introduction	15
A.3.2	CAT when UE#1 and UE#2 have resources available	15
A.3.3	CAT when UE#1 does not have required resources available while UE#2 has resources available	19
A.3.4	CAT when UE#1 has resources available while UE#2 does not have required resources available	25
A.4	CAT early session model signalling flows	30
A.4.1	Introduction	30
A.4.2	CAT when UE#1 and UE#2 have resources available	30
A.4.3	CAT when UE#1 does not have required resources available while UE#2 has resources available	35
A.4.4	CAT when UE#1 has resources available while UE#2 does not have required resources available	45
A.5	CAT Gateway model signalling flows	51
A.5.1	Introduction	51
A.5.2	CAT when UE#1 and UE#2 have resources available	51
A.5.3	CAT when UE#1 does not have required resources available while UE#2 has resources available	56
A.5.4	CAT when UE#1 has resources available while UE#2 does not have required resources available	65
A.6	Interworking with CS domain	70
A.6.1	Introduction	70
A.6.2	CAT provided by the terminating CS domain	71
A.6.3	CAT provided to the originating CS domain with the CAT forking model	74
A.6.4	CAT provided to the originating CS domain with the CAT early session model	77
Annex B (informative):	Change history	83
History		84

Foreword

This Technical Specification has been produced by the 3rd Generation Partnership Project (3GPP).

The contents of the present document are subject to continuing work within the TSG and may change following formal TSG approval. Should the TSG modify the contents of the present document, it will be re-released by the TSG with an identifying change of release date and an increase in version number as follows:

Version x.y.z

where:

- x the first digit:
 - 1 presented to TSG for information;
 - 2 presented to TSG for approval;
 - 3 or greater indicates TSG approved document under change control.
- y the second digit is incremented for all changes of substance, i.e. technical enhancements, corrections, updates, etc.
- z the third digit is incremented when editorial only changes have been incorporated in the document.

1 Scope

The present document provides the protocol details for the Customized Alerting Tones (CAT) service in the IP Multimedia (IM) Core Network (CN) subsystem based on the requirements from 3GPP TS 22.182 [2].

The CAT service is an operator specific service by which an operator enables the subscriber to customize the media which is played to the calling party during alerting of the called party.

The present document is applicable to User Equipment (UE) and Application Servers (AS) which are intended to support the CAT service.

2 References

The following documents contain provisions which, through reference in this text, constitute provisions of the present document.

- References are either specific (identified by date of publication, edition number, version number, etc.) or non-specific.
- For a specific reference, subsequent revisions do not apply.
- For a non-specific reference, the latest version applies. In the case of a reference to a 3GPP document (including a GSM document), a non-specific reference implicitly refers to the latest version of that document *in the same Release as the present document*.

- [1] 3GPP TR 21.905: "Vocabulary for 3GPP Specifications".
- [2] 3GPP TS 22.182: "Customized Alerting Tones (CAT) Requirements; Stage 1".
- [3] 3GPP TS 24.238: "Session Initiation Protocol (SIP) based user configuration; Stage 3".
- [4] 3GPP TS 24.229: "Internet Protocol (IP) multimedia call control protocol based on Session Initiation Protocol (SIP) and Session Description Protocol (SDP); Stage 3".
- [5] RFC 3262: "Reliability of Provisional Responses in the Session Initiation Protocol (SIP)".
- [6] 3GPP TS 24.623: "Extensible Markup Language (XML) Configuration Access Protocol (XCAP) over the Ut interface for Manipulating Supplementary Services".
- [7] RFC 3959: "The Early Session Disposition Type for the Session Initiation Protocol (SIP)".
- [8] RFC 3960: "Early Media and Ringing Tone Generation in the Session Initiation Protocol (SIP)".
- [9] RFC 5009 (September 2007): "Private Header (P-Header) Extension to the Session Initiation Protocol (SIP) for Authorization of Early Media".
- [10] 3GPP TS 24.607: "Originating Identification Presentation (OIP) and Originating Identification Restriction (OIR) using IP Multimedia (IM) Core Network (CN) subsystem; Protocol specification".

3 Definitions and abbreviations

3.1 Definitions

For the purposes of the present document, the terms and definitions given in 3GPP TR 21.905 [1] and the following apply. A term defined in the present document takes precedence over the definition of the same term, if any, in 3GPP TR 21.905 [1].

3.2 Abbreviations

For the purposes of the present document, the abbreviations given in 3GPP TR 21.905 [1] and the following apply. An abbreviation defined in the present document takes precedence over the definition of the same abbreviation, if any, in 3GPP TR 21.905 [1].

CAT	Customized Alerting Tones
MRF	Media Resource Function

4 Customized Alerting Tones (CAT)

4.1 Introduction

The CAT service is an operator specific service by which an operator enables the subscriber to customize the media which is played to the calling party during alerting of the called party. The media can consist of favourable songs, multi-media clips or other customized alerting tones. CAT service should not negatively affect the conversation between calling and called parties.

4.2 Description

4.2.1 General description

The service user is able to subscribe to the CAT service, activate (or de-activate) the service, and update the settings, e.g., to change by configuration the active CAT media. The media can consist of favourable songs, multimedia clips or other customized alerting tones. The CAT subscriber is able to refine the CAT media selection behaviour with configured rules, e.g. time, calling party's location, called party's location, the identity of the calling and called party. The CAT service is able to select the appropriate CAT media according to the rules.

CAT is a terminating network service which enables subscriber configured CAT media to be selected on behalf of the called subscriber for playback to the calling party.

The start of playback of the selected CAT media toward the calling party occurs some time following the initiation of a session, but prior to session answer. When the called party answers, playback of the CAT media either stops or continues to play during the conversation, depending on operator or user preferences. When the CAT media is playing, the calling party is able to stop (e.g. mute) it.

4.3 Operational requirements

4.3.1 Provision/withdrawal

4.3.1.1 CAT provision/withdrawal

The CAT service may be provided after prior arrangement with the service provider.

The CAT service may be withdrawn at the subscriber's request or for administrative reasons.

4.3.1.2 Requirements on the originating network side

The originating network side may support the "early-session" extension as described in RFC 3959 [7].

NOTE: the CAT service implementing the early-session model needs the early-session extension to be supported by intermediate entities and the originating UE, else CAT media cannot not be provided to the caller.

The CAT service implementing the forking model and gateway model add no additional requirements on the originating network side.

4.3.1.3 Requirements on the terminating network side

An MRF in the terminating network is required to be controlled by the CAT AS that is acting on behalf of a called subscriber who has activated CAT.

4.4 Syntax requirements

There are no special SIP syntax requirements for the CAT service.

4.5 Signalling procedures

4.5.1 General

Configuration of supplementary services by the user should:

- take place over the Ut interface using XCAP as enabling protocol as described in 3GPP TS 24.623 [6]; or
- use SIP based user configuration as described in 3GPP TS 24.238 [3];

NOTE: Other possibilities for user configuration, such as web-based provisioning or pre-provisioning by the operator are outside the scope of the present document, but are not precluded.

The details of the Ut interface based user configuration of CAT service are not specified in this version of the document.

4.5.2 Activation/deactivation

The CAT service is activated at provisioning and deactivated at withdrawal.

When a CAT service is activated a subscriber can specify which CAT a calling user should experience, or use the operator"s default setting.

After a subscriber has activated their CAT service a calling user experiences the CAT that was chosen by the subscriber.

4.5.3 Registration/erasure

The CAT service requires no registration. Erasure is not applicable.

4.5.4 Interrogation

For CAT, interrogation is not applicable.

4.5.5 Invocation and operation

4.5.5.1 Actions at the originating UE

The UE shall follow the procedures specified in 3GPP TS 24.229 [4] for session initiation and termination.

If the originating UE supports the early session mechanism then the UE shall make use of the procedures as specified in RFC 3959 [7].

4.5.5.2 Actions at the AS serving the originating UE

No requirements at the AS serving the originating UE are specified in this version of the document.

4.5.5.3 Actions at the AS serving the terminating UE

4.5.5.3.1 General

The procedures specified in 3GPP TS 24.229 [4] for an AS acting as a routing B2BUA apply with additions described in the subclauses below.

If the initial INVITE destined to served user includes a Supported header with "early-session" option-tag and the AS supports the "early-session" extension as described in RFC 3959 [7], the AS shall based on operator policy follow the procedures in subclause 4.5.5.3.3 to provide CAT service. The procedures in subclause 4.5.5.3.3 shall not be used if there are intermediates in the network that do not understand the procedures.

Depending on the operator policy, it shall also be possible for the AS to perform the actions specified as Gateway model in RFC 3960 [8].

The AS shall follow procedures specified in subclause 4.6 for any services where interaction shall be considered.

4.5.5.3.2 AS actions for forking model

Upon receiving an initial SIP INVITE request destined to the served user, the AS shall:

- if the AS supports the P-Early-Media header [9], based on local policy remove the P-Early-Media header, if present;
- forward the initial SIP INVITE request to the served user;
- contact the MRF to request CAT resource;
- send a reliable SIP 183 (Session Progress) response to the originating UE. The SIP 183 (Session Progress) provisional response shall:
 - include a P-Asserted-Identity header containing the public user identity of the served user;
 - include a To header with a To tag locally generated by the AS;
 - if the AS supports the P-Early-Media header, include a P-Early-Media header with a "sendrecv" value or a "sendonly value";
 - include an SDP answer, based on information received from the MRF; and
 - if preconditions are used, indicate in the SDP answer that the local preconditions are fulfilled.

If preconditions are used, the AS shall not instruct the MRF to start applicable media for the CAT service before the originating UE has indicated that preconditions are fulfilled. The point when the AS instructs the MRF to start applicable media for the CAT service is based on local policy.

NOTE 1: The AS can, based on local policy, wait to send the SIP 183 (Session Progress) response to the originating UE until the AS has received a SIP 180 (Ringing) provisional response from the served UE.

NOTE 2: The AS can, based on local policy, wait to instruct the MRF to start CAT media until the AS has received a SIP 180 (Ringing) provisional response from the served UE.

NOTE 3: The interaction between the AS and MRF is not specified for the CAT service but can use the Cr reference point as described in 3GPP TS 24.229 [4].

NOTE 4: If the AS does not want to remain in the signalling path between the originating UE and the terminating UE, the AS does not need to add its own SIP-URI to the SIP Record-Route header.

NOTE 5: The AS can, if it supports the P-Early-Media header, based on local policy choose to not provide the CAT service to the originating UE if the initial INVITE request does not contain a P-Early-Media header with a "supported" value.

Upon receiving a reliable provisional response from a served UE containing an SDP answer to the original SIP INVITE request, the AS:

- may forward the provisional response to the originating UE reliably after changing the Status-Line to SIP 183 (Session Progress) response;
- if the AS supports the P-Early-Media header, the AS shall insert a P-Early-Media header with an "inactive" value before forwarding the provisional response;
- shall, if the reliable provisional response is not forwarded to the originating UE, acknowledge the received provisional response by sending a SIP PRACK request as defined in RFC 3262 [5] to the served UE; and
- shall, if the reliable provisional response contained an SDP answer and the provisional response is not forwarded to the originating UE, save the SDP answer contained in the reliable provisional response for that particular early dialog. If forking has occurred toward the served user, the AS may save SDP answers from several different UEs;

If precondition procedures are used between the originating UE and the served UE, the AS shall forward reliable provisional responses which contain SDP to the originating UE, in order to allow the UEs to exchange additional SDP offers and answers associated with the precondition procedures.

Upon receiving an unreliable provisional response from a served UE to the original SIP INVITE request, the AS may forward the provisional response to the originating UE after changing the Status-Line to SIP 183 (Session Progress) response.

If the AS supports the P-Early-Media header, the AS shall insert a P-Early-Media header with an "inactive" value before forwarding the provisional response.

Upon receiving a SIP 200 (OK) response to the initial SIP INVITE request from a served UE indicating that the served user has answered the call, the AS shall:

- instruct the MRF to stop the media for the CAT service;
- forward the SIP 200 (OK) response to the originating UE; and
- if the AS has saved the SDP answer associated with the dialog confirmed by the SIP 200 (OK) response and if the AS has not forwarded the SDP answer to the originating UE, the AS shall include the saved SDP answer in the SIP 200 (OK) response.

Upon receiving a SIP 4xx, 5xx or 6xx response from a served UE the AS shall:

- instruct the MRF to stop the media for the CAT service; and
- forward the final response to the originating UE.

4.5.5.3.3 AS Actions for early session model

Upon receiving an initial INVITE request destined to the served user including a Supported header with "early-session" tag, as described in RFC 3959 [7], the AS:

- may contact the MRF to request CAT resource if session SDP preconditions are not used, or local preconditions are fulfilled;
- shall forward the initial INVITE request to the served user.

Upon receiving the first SIP 18x response to the initial INVITE request, the AS shall:

- if session SDP preconditions are not used in the initial INVITE request, or local preconditions in the initial INVITE request are fulfilled, then contact the MRF to request CAT resource if it has not been requested;
- send a reliable SIP 18x response to the originating UE. The SIP 18x response shall:

- include a P-Asserted-Identity header containing the public user identity of the served user;
- include a Require header with option tag "early-session";
- include the SDP content for CAT as early-session SDP offer and if preconditions are used, and CAT resource has been requested, indicate the local preconditions are fulfilled;

Upon receiving additional SIP 18x response to the initial INVITE request, the AS shall forward it to the originating UE.

Upon receiving a SIP request containing an early-session SDP offer that indicates the local preconditions are fulfilled, the AS shall:

- contact the MRF to request CAT resource;
- generate an early-session SDP answer based on the information from the MRF and, if preconditions are used, indicate that the local preconditions are fulfilled; and
- after receiving a SIP 200 (OK) response to the request, include the early-session SDP answer in the SIP 200 (OK) response, and forwards it to the originator.

If preconditions are used, the AS should not instruct the MRF to start applicable media for the CAT service before the originating UE indicates that early-session SDP local preconditions are fulfilled. Whether to start applicable media for the CAT service before or after receiving the SIP 180 (Ringing) response from the served UE is based on local policy.

If a SIP message from served UE containing an SDP offer related to an early session is received, the AS shall send an SDP answer to the SDP offer related to the early-session sent by the served UE and set all port numbers of the media types to "0".

Upon receiving a SIP 200 (OK) response from the served UE to the initial INVITE request, the AS shall instruct the MRF to stop media for the CAT service and forward the SIP 200 (OK) response to the originating UE.

NOTE 1: The interaction between the AS and MRF is not specified for the CAT service but can use the Cr reference point as described in 3GPP TS 24.229 [4].

Upon receiving a SIP 4xx, 5xx or 6xx response from a served UE the AS shall:

- instruct the MRF to stop the media for the CAT service; and
- forward the final response to the originating UE.

4.6 Interaction with other services

4.6.1 Communication session Hold (HOLD)

No impact, i.e. neither service shall affect the operation of the other service.

4.6.2 Termination Identification Presentation (TIP)

No impact, i.e. neither service shall affect the operation of the other service.

4.6.3 Termination Identification Restriction (TIR)

The TIR service takes precedence over the CAT service subscribed by the called party. If the TIR service prevents CAT media from being played to the calling party, then the AS providing CAT service shall not apply the CAT service to the session.

4.6.4 Originating Identification Presentation (OIP)

The order of the services in the filter criteria list should be configured so that CAT service appears before OIP service, in order for the CAT service to provide CAT media associated with the calling party's identity (i.e., the called party may play one type of CAT media to a particular caller and other types of CAT media to other callers depending on the called party's subscription).

NOTE: If the called party does not subscribe to OIP service, the AS providing OIP service will remove P-Asserted-Identity according to 3GPP TS 24.607 [10], and it will not be possible to provide CAT service based on calling party's identity if the OIP service was applied prior to CAT service in this given case. Unless the network operator can assure that such scenario do not occur based on their service configuration, as CAT service cannot be aware of whether OIP service is subscribed by the user, and OIP service cannot be aware of how CAT service is to be performed, CAT service will always need to be performed prior to OIP service.

4.6.5 Originating Identification Restriction (OIR)

The OIR service takes precedence over the CAT service subscribed by the called party. The behaviour of the CAT service is dependent on whether if the called party has a CAT service associated with the calling party's identity (i.e., the called party may play one type of CAT media to a particular caller and other types of CAT media to other callers depending on the called party's subscription) and whether OIR service is requested.

The AS providing CAT service shall:

- 1) if the called party has CAT service associated with that specific calling party's identity, the AS shall:
 - inspect the priv-value set in the Privacy header field in the request; and
 - if the Privacy header field is set to either "id", "header", or "user", i.e. OIR service is requested, then the AS shall not apply CAT service to the session.
- 2) in all other cases (i.e. except for the case if the called party has CAT service associated with that specific calling party's identity, and OIR service is requested), the AS shall process CAT service based on the called party's subscription.

NOTE: OIR service itself is independent from CAT service, as the identities that need to be restricted towards the terminating user will be handled, i.e. restricted, appropriately by other functional entities as specified in 3GPP TS 24.229 [4], e.g. at the boundary of trust domain which may be the terminating P-CSCF.

4.6.6 Conference (CONF)

No impact, i.e. neither service shall affect the operation of the other service.

4.6.7 Communication DIVersion services (CDIV)

4.6.7.1 General

If the diverting party has both CAT service and CDIV active, and the diverted-to party has CAT service active, based on operator policy, either:

- 1) the CAT service of the diverted-to party shall be applied to the session by the AS providing the CAT service of diverted-to party, except in the case of CFNR. The interaction of CAT service with CFNR is described in subclause 4.6.7.2; or
- 2) the CAT service of the diverting party shall be applied to the session by the AS providing CAT service for the diverting party, without the CAT service for the diverted-to party applied to the session.

NOTE 1: the above network operator option can be deployed in cases where diversion of the call is hidden from the calling party.

If the diverting party has both CAT service and CDIV active, and the diverted-to party does not have an active service, based on operator policy, either:

- 1) no CAT service shall be applied to the session when CDIV is invoked; or
- 2) the CAT service of the diverting party shall be applied to the session by the AS providing CAT service for the diverting party, without the CAT service for the diverted-to party applied to the session.

NOTE 2: the above network operator option can be deployed in cases where diversion of the call is hidden from the calling party.

4.6.7.2 CFNR

If the diverting party has both CAT service and CFNR active, and the diverted-to party has CAT service active, based on operator policy, either:

- 1) the CAT service of the diverting party shall be applied to the session by the AS providing CAT service for the diverting party until the CFNR timer expires. Upon the CFNR timer expiring, the AS providing CAT service for the diverting party shall stop applying the CAT for the diverting user and the AS providing CAT service for the diverted-to party shall apply the CAT service of the diverted-to party; or
- 2) the CAT service of the diverting party shall be applied to the session by the AS providing CAT service for the diverting party, without the CAT service for the diverted-to party applied to the session.

NOTE 1: the above network operator option can be deployed in cases where diversion of the call is hidden from the calling party.

If the diverting party has CAT service and CFNR active, and the diverted-to party does not have an active service, based on operator policy, either:

- 1) the CAT service of the diverting party shall be applied to the session by the AS providing CAT service for the diverting party until the CFNR timer expires; or
- 2) the CAT service of the diverting party shall be applied to the session by the AS providing CAT service for the diverting party, without the CAT service for the diverted-to party applied to the session, until reception of a final SIP response to the INVITE.

NOTE 2: the above network operator option can be deployed in cases where diversion of the call is hidden from the calling party.

4.6.8 Message Waiting Indication (MWI)

No impact, i.e. neither service shall affect the operation of the other service.

4.6.9 Communication Barring (CB)

No impact, i.e. neither service shall affect the operation of the other service.

4.6.10 Explicit Call Transfer (ECT)

If the transfer target has CAT service active, the AS providing CAT service shall apply the transfer target's CAT in the case of blind transfer. The AS providing CAT service shall not apply the transfer target's CAT in the case of consultative transfer while the call is transferring to the transfer target.

The CAT service of the transferor shall not be applied when ECT is invoked.

4.6.11 Communication Wait

In the case that the called party has Communication Waiting and CAT services active, the AS providing the CAT service for the called party shall apply the called party's CAT to the session if the called party is considered 'approaching network determined user busy' as a network operator option. Alternatively, the AS providing the call party's CAT shall not apply the CAT service and the Communication Waiting alert shall be applied.

4.6.12 Completion of Communications to Busy Subscriber

No impact, i.e. neither service shall affect the operation of the other service.

4.7 Parameter values (timers)

No timers for CAT service are defined

4.8 Service configuration

User configuration of CAT service is not specified in this version of the document.

Annex A (informative): Signalling flows

A.1 Scope of signalling flows

This annex gives examples of signalling flows for the CAT service within the IP Multimedia (IM) Core Network (CN) subsystem based on the Session Initiation Protocol (SIP).

A.2 Introduction

A.3 CAT forking model signalling flows

A.3.1 Introduction

The following flows show establishment of a session between UE#1 and UE#2, using the forking model described in subclause 4.5.5.3.2 to provide CAT to UE#1. The following flows are included:

- subclause A.3.2 shows CAT, using the forking, model, when UE#1 and UE#2 have resources available;
- subclause A.3.3 shows CAT, using the forking, model, when UE#1 does not have resources available;
- subclause A.3.4 shows CAT, using the forking, model, when UE#2 does not have resources available;

A.3.2 CAT when UE#1 and UE#2 have resources available

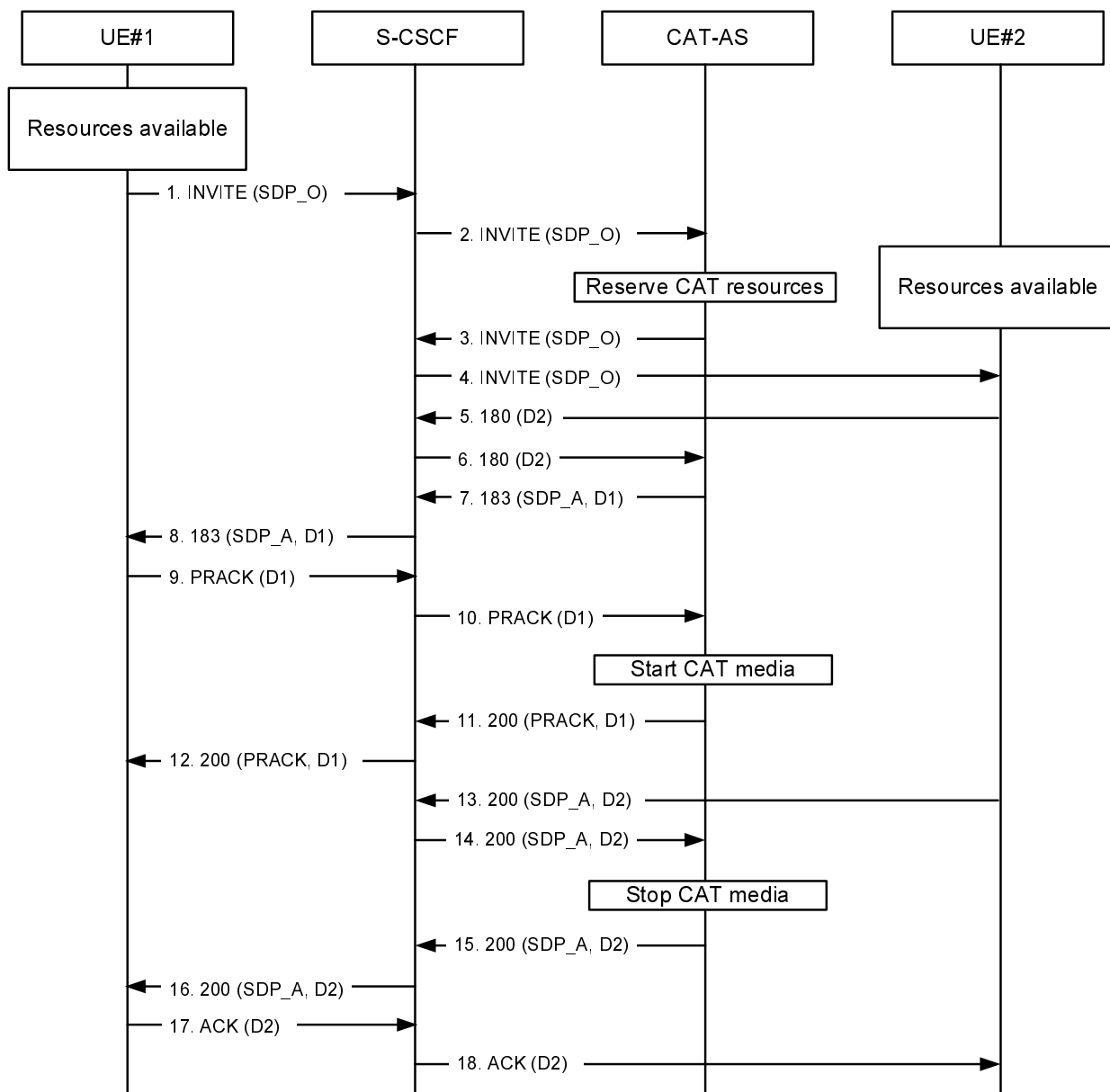

Figure A.3.2-1: CAT, no resource reservation

1 INVITE request (UE#1 to S-CSCF) see example in table A.3.2-1

UE#1 sends a SIP INVITE request to the intermediate IM CN subsystem.

Table A.3.2-1: INVITE request (UE#1 to CAT-AS)

```

INVITE tel:+1-212-555-2222 SIP/2.0
Via: SIP/2.0/UDP [5555::aaa:bbb:ccc:ddd]:1357;comp=sigcomp;branch=z9hG4bKnashds7
Max-Forwards: 70
Route: <sip:pcscf1.visited1.net:7531;lr;comp=sigcomp>, <sip:scscf1.home1.net;lr>
P-Preferred-Identity: "John Doe" <sip:user1_public1@home1.net>
P-Access-Network-Info: IEEE-802.11a
P-Preferred-Service: urn:urn-7:3gpp-service.ims.icsi.mmtel
Accept-Contact: *;+g.3gpp.icsi_ref="urn%3Aurn-7%3gpp-service.ims.icsi.mmtel"
Privacy: none
P-Early-Media: supported
From: <sip:user1_public1@home1.net>;tag=171828
To: <tel:+1-212-555-2222>
Call-ID: cb03a0s09a2sdfglkj490333
Cseq: 127 INVITE
Require: sec-agree
Supported: precondition, 100rel, gruu, 199
Proxy-Require: sec-agree
Security-Verify: ipsec-3gpp; q=0.1; alg=hmac-sha-1-96; spi-c=98765432; spi-s=87654321;
port-c=8642; port-s=7531
Contact:<sip:sip:user1_public1@home1.net;gr=urn:uuid:f81d4fae-7dec-11d0-a765-
00a0c91e6bf6>;+g.3gpp.icsi_ref="urn%3Aurn-7%3gpp-service.ims.icsi.mmtel"
Accept:application/sdp, application/3gpp-ims+xml
Allow: INVITE, ACK, CANCEL, BYE, PRACK, UPDATE, REFER, MESSAGE
Content-Type: application/sdp
Content-Length: (...)

v=0
o=- 2987933615 2987933615 IN IP6 6666::aaa:bbb:ccc:ddd
s=-
c=IN IP6 6666::aaa:bbb:ccc:ddd
t=0 0
m=video 3400 RTP/AVP 98
b=AS:75
a=crr:qos local sendrecv
a=crr:qos remote none
a=des:qos mandatory local sendrecv
a=des:qos none remote sendrecv
a=rtpmap:98 H263
a=fmtp:98 profile-level-id=0
m=audio 3456 RTP/AVP 97 96
b=AS:25.4
a=crr:qos local sendrecv
a=crr:qos remote none
a=des:qos mandatory local sendrecv
a=des:qos none remote sendrecv
a=rtpmap:97 AMR
a=fmtp:97 mode-set=0,2,5,7; maxframes=2
a=rtpmap:96 telephone-event

```

Supported: The UE indicates support for preconditions, reliable provisional responses, gruu and the 199 provisional response.

P-Early-Media: The UE indicates support for the P-Early-Media header.

SDP: The SDP offer (SDP_O) contains a set of codecs supported by UE#1 and desired by the calling user for this session. The local preconditions are indicated as fulfilled.

2 INVITE request (S-CSCF to CAT-AS)

The S-CSCF forwards the SIP INVITE request to the CAT-AS.

The CAT-AS instructs the MRF to reserve CAT resources.

3-4 INVITE request (CAT-AS to UE#2)

The CAT-AS forwards the request to UE#2.

5-6 180 (Ringing) provisional response (UE#2 to CAT-AS)

The called party is alerted. UE#2 sends a SIP 180 (Ringing) provisional response for the INVITE request to the CAT-AS.

The CAT-AS terminates the provisional response.

7-8 183 (Session Progress) provisional response (CAT-AS to UE#1) see example in table A.3.2-2

The CAT-AS sends a reliable SIP 183 (Session Progress) provisional response to UE#1.

An early dialog (D1) is established between UE#1 and the CAT-AS.

NOTE: As an alternative, the CAT-AS can send the SIP 183 (Session Progress) provisional response when the initial SIP INVITE request is received from UE#1.

Table A.3.2-2: 183 (Session Progress) response (CAT-AS to UE#1)

```
SIP/2.0 183 Session Progress
Via: SIP/2.0/UDP scscf2.home2.net;branch=z9hG4bK764z87.1, SIP/2.0/UDP
    icscf2_s.home2.net;branch=z9hG4bK871y12.1, SIP/2.0/UDP
    scscf1.home1.net;branch=z9hG4bK332b23.1pcscf1.visited1.net;branch=z9hG4bK240f34.1,
    SIP/2.0/UDP pcscf1.visited1.net;branch=z9hG4bK240f34.1, SIP/2.0/UDP
    [5555::aaa:bbb:ccc:ddd]:1357;comp=sigcomp;branch=z9hG4bKnashds7
Record-Route: <sip:pcscf2.visited2.net:5088;lr;comp=sigcomp>
From:
To: <tel:+1-212-555-2222>;tag=2236
Call-ID:
Cseq:
Require: 100rel
Allow: INVITE, ACK, CANCEL, BYE, PRACK, UPDATE, REFER, MESSAGE
RSeq: 9022
P-Early-Media: sendrecv
Contact: <sip:cat-as.home1.net>;+g.3gpp.icsi_ref="urn%3Aurn-7%3gpp-service.ims.icsi.mmtel"
Content-Type: application/sdp
Content-Length: (...)

v=0
o=- 2987933615 2987933615 IN IP6 6666::eee:fff:bbb:aaa
s=-
c=IN IP6 6666::eee:fff:bbb:aaa
t=0 0
m=video 3400 RTP/AVP 98
b=AS:75
a=crr:qos local sendrecv
a=crr:qos remote sendrecv
a=des:qos mandatory local sendrecv
a=des:qos mandatory remote sendrecv
a=rtpmap:98 H263
a=fmtp:98 profile-level-id=0
m=audio 3456 RTP/AVP 97 96
b=AS:25.4
a=crr:qos local sendrecv
a=crr:qos remote sendrecv
a=des:qos mandatory local sendrecv
a=des:qos mandatory remote sendrecv
a=rtpmap:97 AMR
a=fmtp:97 mode-set=0,2,5,7; maxframes
```

P-Early-Media: The CAT-AS requests authorization for early media.

SDP: The SDP answer (SDP_A) contains a set of codecs supported to be used for CAT. The SDP content is based on information received from the MRF. The local preconditions are indicated as fulfilled.

9-10 PRACK request (UE#1 to CAT-AS)

UE#1 sends a SIP PRACK request, which acknowledges the SIP 183 (Session Progress) provisional response, to the CAT-AS.

The CAT-AS instructs the MRF to play CAT media.

11-12 200 (OK) response to PRACK (CAT-AS to UE#1)

The CAT-AS sends a SIP 200 (OK) response for the SIP PRACK request to UE#1.

13-14 200 (OK) response to INVITE (UE#2 to CAT-AS) see example in table A.3.2-3

The called party answers the call. UE#2 sends a SIP 200 (OK) final response for the SIP INVITE request to the CAT-AS.

The CAT-AS instructs the MRF to stop CAT media.

Table A.3.2-3: 200 (OK) response (UE#2 to CAT-AS)

```
SIP/2.0 200 OK
Via: SIP/2.0/UDP pcscf2.visited2.net:5088;comp=sigcomp;branch=z9hG4bK361k21.1, SIP/2.0/UDP
scscf2.home2.net;branch=z9hG4bK764XC12.1, SIP/2.0/UDP
catas.home2.net;branch=z9hG4bK764Q32.1, SIP/2.0/UDP
scscf2.home2.net;branch=z9hG4bK764z87.1, SIP/2.0/UDP
icscf2_s.home2.net;branch=z9hG4bK871y12.1, SIP/2.0/UDP
scscf1.home1.net;branch=z9hG4bK332b23.1, SIP/2.0/UDP
pcscf1.visited1.net;branch=z9hG4bK240f34.1, SIP/2.0/UDP
[5555::aaa:bbb:ccc:ddd]:1357;comp=sigcomp;branch=z9hG4bKnashds7
Record-Route: <sip:pcscf2.visited2.net:5088;lr;comp=sigcomp>, <sip:scscf2.home2.net;lr>,
<sip:scscf1.home1.net;lr>, <sip:pcscf1.visited1.net;lr>
From:
To: <tel:+1-212-555-2222>;tag=6322
Call-ID:
Cseq:
Allow: INVITE, ACK, CANCEL, BYE, PRACK, UPDATE, REFER, MESSAGE
Contact: <sip:user2_public1@home2.net;gr=urn:uuid:2ad8950e-48a5-4a74-8d99-
ad76cc7fc74>;+g.3gpp.icsi_ref="urn%3Aurn-7%3gpp-service.ims.icsi.mmtel"
Content-Type: application/sdp
Content-Length: (...)

v=0
o=- 2987933615 2987933615 IN IP6 6666::eee:fff:aaa:bbb
s=-
c=IN IP6 6666::eee:fff:aaa:bbb
t=0 0
m=video 3400 RTP/AVP 98
b=AS:75
a=curr:qos local sendrecv
a=curr:qos remote sendrecv
a=des:qos mandatory local sendrecv
a=des:qos mandatory remote sendrecv
a=rtpmap:98 H263
a=fmtp:98 profile-level-id=0
m=audio 3456 RTP/AVP 97 96
b=AS:25.4
a=curr:qos local sendrecv
a=curr:qos remote sendrecv
a=des:qos mandatory local sendrecv
a=des:qos mandatory remote sendrecv
a=rtpmap:97 AMR
a=fmtp:97 mode-set=0,2,5,7; maxframes
```

SDP: The SDP answer (SDP_A) contains a set of codecs to be used for the session. If preconditions are used, they are indicated as fulfilled.

15-16 200 (OK) response to INVITE (CAT-AS to UE#1)

The CAT-AS forwards the SIP 200 (OK) response to UE#1.

A dialog (D2) is established between UE#1 and UE#2.

The early dialog (D1) between UE#1 and the CAT-AS is terminated.

17-18 ACK request (UE#1 to UE#2)

UE#1 sends a SIP ACK request, which acknowledges the SIP 200 (OK) final response, to UE#2.

A.3.3 CAT when UE#1 does not have required resources available while UE#2 has resources available

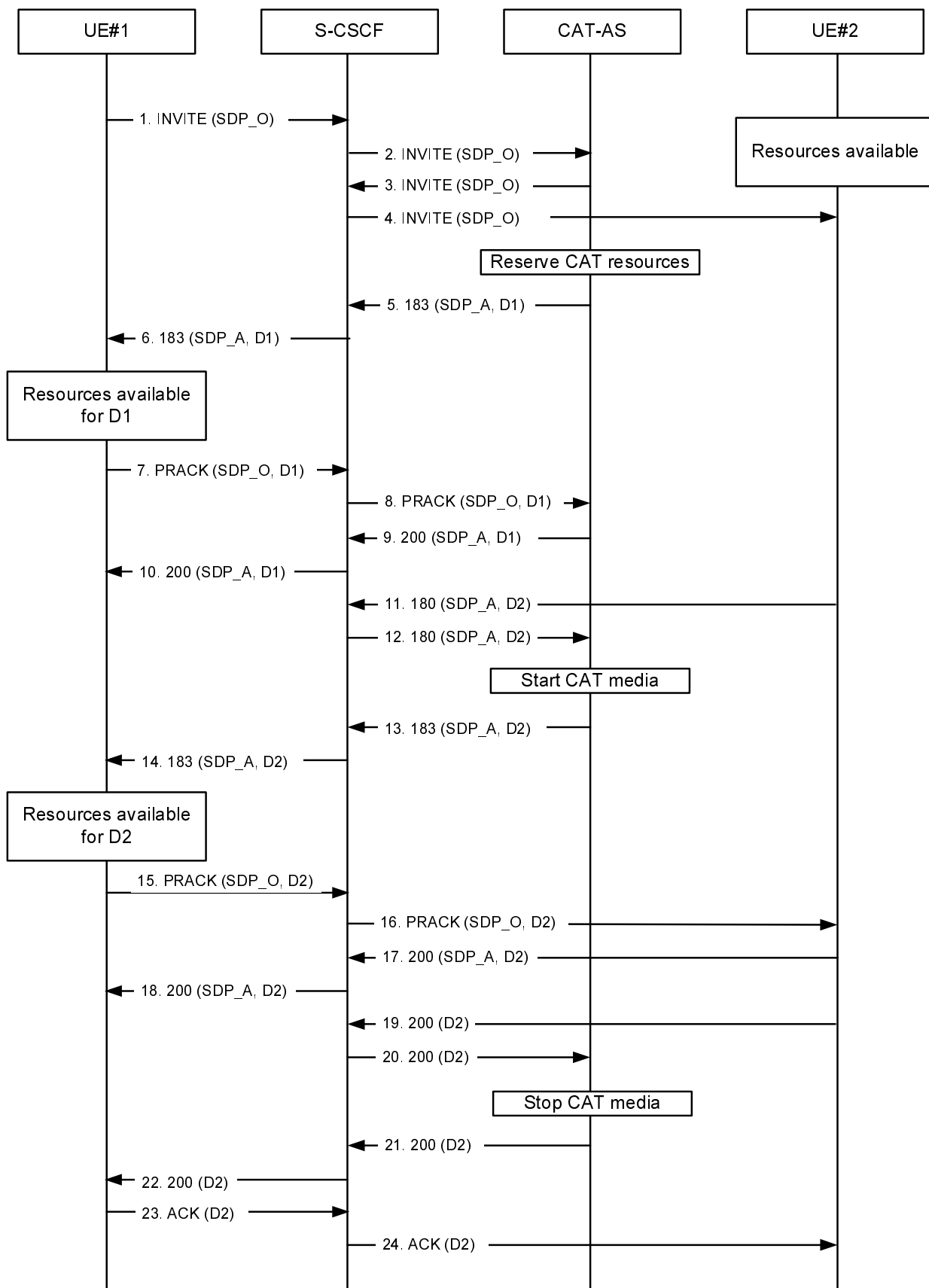

Figure A.3.3-1: CAT, UE#1 does not have required resources available

1 INVITE request (UE#1 to CAT-AS) see example in table A.3.3-1

UE#1 sends a SIP INVITE request to the intermediate IM CN subsystem.

Table A.3.3-1: INVITE request (UE#1 to CAT-AS)

```

INVITE tel:+1-212-555-2222 SIP/2.0
Via: SIP/2.0/UDP [5555::aaa:bbb:ccc:ddd]:1357;comp=sigcomp;branch=z9hG4bKnashds7
Max-Forwards: 70
Route: <sip:pcscf1.visited1.net:7531;lr;comp=sigcomp>, <sip:scscf1.home1.net;lr>
P-Preferred-Identity: "John Doe" <sip:user1_public1@home1.net>
P-Access-Network-Info: 3GPP-UTRAN-TDD; utran-cell-id-3gpp=234151D0FCE11
P-Preferred-Service: urn:urn-7:3gpp-service.ims.icsi.mmtel
Accept-Contact: *;+g.3gpp.icsi_ref="urn%3Aurn-7%3gpp-service.ims.icsi.mmtel"
Privacy: none
P-Early-Media: supported
From: <sip:user1_public1@home1.net>;tag=171828
To: <tel:+1-212-555-2222>
Call-ID: cb03a0s09a2sdfglkj490333
Cseq: 127 INVITE
Require: sec-agree
Supported: precondition, 100rel, gruu, 199
Proxy-Require: sec-agree
Security-Verify: ipsec-3gpp; q=0.1; alg=hmac-sha-1-96; spi-c=98765432; spi-s=87654321;
port-c=8642; port-s=7531
Contact: <sip:user1_public1@home1.net;gr=urn:uuid:f81d4fae-7dec-11d0-a765-
00a0c91e6bf6>;+g.3gpp.icsi_ref="urn%3Aurn-7%3gpp-service.ims.icsi.mmtel"
Accept: application/sdp, application/3gpp-ims+xml
Allow: INVITE, ACK, CANCEL, BYE, PRACK, UPDATE, REFER, MESSAGE
Content-Type: application/sdp
Content-Length: (...)

v=0
o=- 2987933615 2987933615 IN IP6 6666::aaa:bbb:ccc:ddd
s=-
c=IN IP6 6666::aaa:bbb:ccc:ddd
t=0 0
m=video 3400 RTP/AVP 98
b=AS:75
a=curr:qos local none
a=curr:qos remote none
a=des:qos mandatory local sendrecv
a=des:qos none remote sendrecv
a=inactive
a=rtpmap:98 H263
m=audio 3456 RTP/AVP 97 96
b=AS:25.4
a=curr:qos local none
a=curr:qos remote none
a=des:qos mandatory local sendrecv
a=des:qos none remote sendrecv
a=inactive
a=rtpmap:97 AMR
a=fmtp:97 mode-set=0,2,5,7; maxframes=2
a=rtpmap:96 telephone-event

```

Supported: The UE indicates support for preconditions, reliable provisional responses, gruu and the 199 provisional response.

P-Early-Media: The UE indicates support for the P-Early-Media header.

SDP: The SDP offer (SDP_O) contains a set of codecs supported by UE#1 and desired by the user at UE#1 for this session. The local preconditions are indicated as not fulfilled, and media are set to "inactive".

2 INVITE request (S-CSCF to CAT-AS)

The S-CSCF forwards the SIP INVITE request to the CAT-AS.

The CAT-AS instructs the MRF to reserve CAT resources.

3-4 INVITE request (CAT-AS to UE#2)

The CAT-AS forwards the SIP INVITE request to UE#2.

5-6 183 (Session Progress) provisional response (CAT-AS to UE#1) see example in table A.3.3-2

The CAT-AS sends a reliable SIP 183 (Session Progress) provisional response to UE#2.

An early dialog (D1) is established between UE#1 and the CAT-AS.

NOTE: As an alternative, the CAT-AS can send the SIP 183 (Session Progress) provisional response when a SIP 180 (Ringing) provisional response is received from UE#2.

Table A.3.3-2: 183 (Session Progress) response (CAT-AS to UE#1)

```
SIP/2.0 183 Session Progress
Via: SIP/2.0/UDP scscf2.home2.net;branch=z9hG4bK764z87.1, SIP/2.0/UDP
    icscf2_s.home2.net;branch=z9hG4bK871y12.1, SIP/2.0/UDP
    scscf1.home1.net;branch=z9hG4bK332b23.1pcscf1.visited1.net;branch=z9hG4bK240f34.1,
    SIP/2.0/UDP pcscf1.visited1.net;branch=z9hG4bK240f34.1, SIP/2.0/UDP
    [5555::aaa:bbb:ccc:ddd]:1357;comp=sigcomp;branch=z9hG4bKnashds7
Record-Route: <sip:pcscf2.visited2.net:5088;lr;comp=sigcomp>
From:
To: <tel:+1-212-555-2222>;tag=2236
Call-ID:
Cseq:
Require: 100rel
Allow: INVITE, ACK, CANCEL, BYE, PRACK, UPDATE, REFER, MESSAGE
RSeq: 9022
P-Early-Media: sendrecv
Contact: <sip:cat-as.home1.net;+g.3gpp.icsi_ref="urn%3Aurn-7%3gpp-service.ims.icsi.mmtel">
Content-Type: application/sdp
Content-Length: (...)

v=0
o=- 2987933615 2987933615 IN IP6 6666::eee:fff:bbb:aaa
s=-
c=IN IP6 6666::eee:fff:bbb:aaa
t=0 0
m=video 3400 RTP/AVP 98
b=AS:75
a=curr:qos local sendrecv
a=curr:qos remote none
a=des:qos mandatory local sendrecv
a=des:qos mandatory remote sendrecv
a=rtptime:98 H263
a=fmtp:98 profile-level-id=0
m=audio 3456 RTP/AVP 97 96
b=AS:25.4
a=curr:qos local sendrecv
a=curr:qos remote none
a=des:qos mandatory local sendrecv
a=des:qos mandatory remote sendrecv
a=rtptime:97 AMR
a=fmtp:97 mode-set=0,2,5,7; maxframes
```

P-Early-Media: The CAT-AS requests authorization for early media.

SDP: The SDP answer (SDP_A) contains a set of codecs supported to be used for CAT. The SDP content is based on information received from the MRF. The local preconditions are indicated as fulfilled.

7-8 PRACK request (UE#1 to CAT-AS) see example in table A.1.3-4

UE#1 sends a SIP PRACK request, which acknowledges the SIP 183 (Session Progress) provisional response, to the CAT-AS.

Table A.3.3-3: PRACK request (UE#1 to CAT-AS)

```

PRACK sip:cat-as.home1.net
Via: SIP/2.0/UDP [5555::aaa:bbb:ccc:ddd]:1357;comp=sigcomp;branch=z9hG4bKnashds7
Max-Forwards: 70
Route: <sip:pcscf1.visited1.net:7531;lr;comp=sigcomp>, <sip:orig@scscf1.home1.net;lr>
From:
To: <tel:+12125552222> tag=314159
Call-ID:
Cseq: 129 PRACK
Rack: 9022
Require: sec-agree
Proxy-Require: sec-agree
Security-Verify: ipsec-3gpp; q=0.1; alg=hmac-sha-1-96; ealg=aes-cbc; spi-c=98765432; spi-
s=87654321; port-c=8642; port-s=7531
Contact: <sip:user1_public1@home1.net;gr=urn:uuid:f81d4fae-7dec-11d0-a765-
00a0c91e6bf6>;+g.3gpp.icsi_ref="urn%3Aurn-7%3gpp-service.ims.icsi.mmtel"
Content-Type: application/sdp
Content-Length: (...)

v=0
o=- 2987933615 2987933669 IN IP6 6666::aaa:bbb:ccc:ddd
s=-
c=IN IP6 6666::aaa:bbb:ccc:ddd
t=0 0
m=video 3400 RTP/AVP 98
b=AS:75
a=curr:qos local sendrecv
a=curr:qos remote sendrecv
a=des:qos mandatory local sendrecv
a=des:qos mandatory remote sendrecv
a=sendrecv
a=rtpmap:98 H263
a=fmtp:98 profile-level-id=0
m=audio 3456 RTP/AVP 97 96
b=AS:25.4
a=curr:qos local sendrecv
a=curr:qos remote sendrecv
a=des:qos mandatory local sendrecv
a=des:qos mandatory remote sendrecv
a=sendrecv
a=rtpmap:97 AMR
a=fmtp:97 mode-set=0,2,5,7; maxframes

```

SDP: The local preconditions are indicated as fulfilled, and media are set to "sendrecv".

9-10 200 (OK) response to PRACK (CAT-AS to UE#1)

The CAT-AS sends a SIP 200 (OK) response for the SIP PRACK request to UE#1.

11-12 180 (Ringing) provisional response (UE#2 to CAT-AS) see example in table A.3.3-4

The called party is alerted. UE#2 sends an unreliable SIP 180 (Ringing) provisional response for the INVITE request to the CAT-AS.

The CAT-AS instructs the MRF to start CAT media.

Table A.3.3-4: 180 (Ringing) response (UE#2 to CAT-AS)

```

SIP/2.0 180 Ringing
Via: SIP/2.0/UDP pcscf2.visited2.net:5088;comp=sigcomp;branch=z9hG4bK361k21.1, SIP/2.0/UDP
scscf2.home2.net;branch=z9hG4bK764XC12.1, SIP/2.0/UDP
catas.home2.net;branch=z9hG4bK764Q32.1, SIP/2.0/UDP
scscf2.home2.net;branch=z9hG4bK764z87.1, SIP/2.0/UDP
icscf2_s.home2.net;branch=z9hG4bK871y12.1, SIP/2.0/UDP
scscf1.home1.net;branch=z9hG4bK332b23.1, SIP/2.0/UDP
pcscf1.visited1.net;branch=z9hG4bK240f34.1, SIP/2.0/UDP
[5555::aaa:bbb:ccc:ddd]:1357;comp=sigcomp;branch=z9hG4bKnashds7
Record-Route: <sip:pcscf2.visited2.net:5088;lr;comp=sigcomp>, <sip:scscf2.home2.net;lr>,
<sip:scscf1.home1.net;lr>, <sip:pcscf1.visited1.net;lr>
From:
To: <tel:+1-212-555-2222>;tag=6322
Call-ID:
Cseq:
Require: 100rel, precondition
Allow: INVITE, ACK, CANCEL, BYE, PRACK, UPDATE, REFER, MESSAGE
RSeq: 9021
Contact: <sip:user2_public1@home2.net;gr=urn:uuid:2ad8950e-48a5-4a74-8d99-
ad76cc7fc74>;+g.3gpp.icsi_ref="urn%3Aurn-7%3gpp-service.ims.icsi.mmtel"
Content-Type: application/sdp
Content-Length: (...)

v=0
o=- 2987933615 2987933615 IN IP6 6666::eee:fff:aaa:bbb
s=-
c=IN IP6 6666::eee:fff:aaa:bbb
t=0 0
m=video 3400 RTP/AVP 98
b=AS:75
a=curr:qos local sendrecv
a=curr:qos remote none
a=des:qos mandatory local sendrecv
a=des:qos mandatory remote sendrecv
a=rtpmap:98 H263
a=fmtp:98 profile-level-id=0
m=audio 3456 RTP/AVP 97 96
b=AS:25.4
a=curr:qos local sendrecv
a=curr:qos remote none
a=des:qos mandatory local sendrecv
a=des:qos mandatory remote none
a=rtpmap:97 AMR
a=fmtp:97 mode-set=0,2,5,7; maxframes

```

SDP: The SDP answer (SDP_A) contains a set of codecs to be used for the session. The local preconditions are indicated as fulfilled.

13-14 183 (Session Progress) provisional response (CAT-AS to UE#1)

The CAT-AS changes the response code to SIP 183 (Session Progress) and forwards the SIP provisional response to UE#1.

An early dialog (D2) is established between UE#1 and UE#2.

15-16 PRACK request (UE#1 to UE#2)

UE#1 sends a SIP PRACK request, which acknowledges the SIP 183 (Session Progress) provisional response, to UE#2.

SDP: The local preconditions are indicated as fulfilled, and media are set to "sendrecv".

17-18 200 (OK) response to PRACK (UE#2 to UE#1)

UE#2 sends a SIP 200 (OK) response for the SIP PRACK request to UE#1.

19-20 200 (OK) response to INVITE (UE#2 to CAT-AS)

The called party answers the call. UE#2 sends a SIP 200 (OK) final response for the SIP INVITE request to the CAT-AS.

21-22 200 (OK) response to INVITE (CAT-AS to UE#1)

The CAT-AS forwards the SIP 200 (OK) response to UE#1.

The CAT-AS instructs the MRF to stop CAT media.

The early dialog (D1) between UE#1 and the CAT-AS is terminated.

23-24 ACK request (UE#1 to UE#2)

UE#1 sends a SIP ACK request, which acknowledges the SIP 200 (OK) final response, to UE#2.

A.3.4 CAT when UE#1 has resources available while UE#2 does not have required resources available

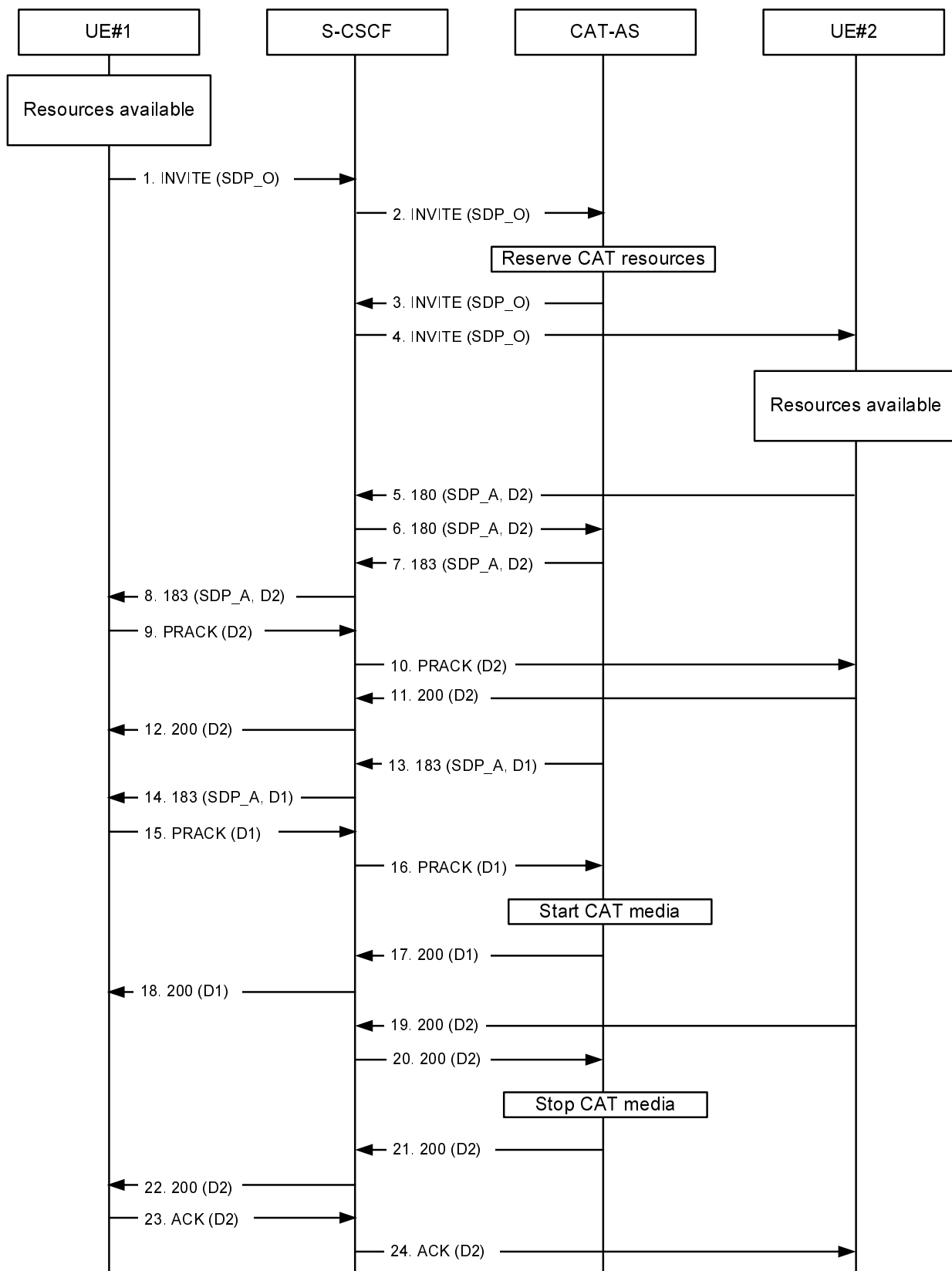

Figure A.3.4-1: CAT, UE#2 does not have required resources available

1 INVITE request (UE#1 to CAT-AS) see example in table A.3.4-1

UE#1 sends a SIP INVITE request to the intermediate IM CN subsystem.

Table A.3.4-1: INVITE request (UE#1 to CAT-AS)

```

INVITE tel:+1-212-555-2222 SIP/2.0
Via: SIP/2.0/UDP [5555::aaa:bbb:ccc:ddd]:1357;comp=sigcomp;branch=z9hG4bKnashds7
Max-Forwards: 70
Route: <sip:pcscf1.visited1.net:7531;lr;comp=sigcomp>, <sip:scscf1.home1.net;lr>
P-Preferred-Identity: "John Doe" <sip:user1_public1@home1.net>
P-Access-Network-Info: IEEE-802.11a
P-Preferred-Service: urn:urn-7:3gpp-service.ims.icsi.mmtel
Accept-Contact: *;+g.3gpp.icsi_ref="urn%3Aurn-7%3gpp-service.ims.icsi.mmtel"
Privacy: none
P-Early-Media: supported
From: <sip:user1_public1@home1.net>;tag=171828
To: <tel:+1-212-555-2222>
Call-ID: cb03a0s09a2sdfglkj490333
Cseq: 127 INVITE
Require: sec-agree
Supported: precondition, 100rel, gruu, 199
Proxy-Require: sec-agree
Security-Verify: ipsec-3gpp; q=0.1; alg=hmac-sha-1-96; spi-c=98765432; spi-s=87654321;
port-c=8642; port-s=7531
Contact:<sip:user1_public1@home1.net;gr=urn:uuid:f81d4fae-7dec-11d0-a765-
00a0c91e6bf6>;+g.3gpp.icsi_ref="urn%3Aurn-7%3gpp-service.ims.icsi.mmtel"
Accept:application/sdp, application/3gpp-ims+xml
Allow: INVITE, ACK, CANCEL, BYE, PRACK, UPDATE, REFER, MESSAGE
Content-Type: application/sdp
Content-Length: (...)

v=0
o=- 2987933615 2987933615 IN IP6 6666::aaa:bbb:ccc:ddd
s=-
c=IN IP6 6666::aaa:bbb:ccc:ddd
t=0 0
m=video 3400 RTP/AVP 98
b=AS:75
a=curr:qos local sendrecv
a=curr:qos remote none
a=des:qos mandatory local sendrecv
a=des:qos none remote sendrecv
a=inactive
a=rtpmap:98 H263
m=audio 3456 RTP/AVP 97 96
b=AS:25.4
a=curr:qos local sendrecv
a=curr:qos remote none
a=des:qos mandatory local sendrecv
a=des:qos none remote sendrecv
a=inactive
a=rtpmap:97 AMR
a=fmtp:97 mode-set=0,2,5,7; maxframes=2
a=rtpmap:96 telephone-event

```

Supported: The UE indicates support for preconditions, reliable provisional responses, gruu and the 199 provisional response.

P-Early-Media: The UE indicates support for the P-Early-Media header.

SDP: The SDP offer (SDP_O) contains a set of codecs supported by UE#1 and desired by the user at UE#1 for this session. The SDP contains an indication that the local preconditions are fulfilled.

2 INVITE request (S-CSCF to CAT-AS)

The S-CSCF forwards the SIP INVITE request to the CAT-AS.

The CAT-AS instructs the MRF to reserve CAT resources.

3-4 INVITE request (CAT-AS to UE#2)

The CAT-AS forwards the SIP INVITE request to UE#2.

5-6 180 (Ringing) provisional response (UE#2 to CAT-AS) see example in table A.3.4-2

The called party is alerted. UE#2 sends a SIP 180 (Ringing) provisional response for the INVITE request to the CAT-AS.

Table A.3.4-2: 180 (Ringing) response (UE#2 to CAT-AS)

```
SIP/2.0 180 Ringing
Via: SIP/2.0/UDP pcscf2.visited2.net:5088;comp=sigcomp;branch=z9hG4bK361k21.1, SIP/2.0/UDP
scscf2.home2.net;branch=z9hG4bK764XC12.1, SIP/2.0/UDP
catas.home2.net;branch=z9hG4bK764Q32.1, SIP/2.0/UDP
scscf2.home2.net;branch=z9hG4bK764z87.1, SIP/2.0/UDP
icscf2_s.home2.net;branch=z9hG4bK871y12.1, SIP/2.0/UDP
scscf1.home1.net;branch=z9hG4bK332b23.1, SIP/2.0/UDP
pcscf1.visited1.net;branch=z9hG4bK240f34.1, SIP/2.0/UDP
[5555::aaa:bbb:ccc:ddd]:1357;comp=sigcomp;branch=z9hG4bKnashds7
Record-Route: <sip:pcscf2.visited2.net:5088;lr;comp=sigcomp>, <sip:scscf2.home2.net;lr>,
<sip:scscf1.home1.net;lr>, <sip:pcscf1.visited1.net;lr>
From:
To: <tel:+1-212-555-2222>;tag=6322
Call-ID:
Cseq:
Require: 100rel, precondition
Allow: INVITE, ACK, CANCEL, BYE, PRACK, UPDATE, REFER, MESSAGE
RSeq: 9021
Contact: <sip:user2_public1@home2.net;gr=urn:uuid:2ad8950e-48a5-4a74-8d99-
ad76cc7fc74>;+g.3gpp.icsi_ref="urn%3Aurn-7%3gpp-service.ims.icsi.mmtel"
Content-Type: application/sdp
Content-Length: (...)

v=0
o=- 2987933615 2987933615 IN IP6 6666::eee:fff:aaa:bbb
s=-
c=IN IP6 6666::eee:fff:aaa:bbb
t=0 0
m=video 3400 RTP/AVP 98
b=AS:75
a=curr:qos local sendrecv
a=curr:qos remote sendrecv
a=des:qos mandatory local sendrecv
a=des:qos mandatory remote sendrecv
a=rtptime:98 H263
a=fmtp:98 profile-level-id=0
m=audio 3456 RTP/AVP 97 96
b=AS:25.4
a=curr:qos local sendrecv
a=curr:qos remote sendrecv
a=des:qos mandatory local sendrecv
a=des:qos mandatory remote none
a=rtptime:97 AMR
a=fmtp:97 mode-set=0,2,5,7; maxframes
```

SDP: The SDP answer (SDP_A) contains a set of codecs to be used for the session. The local preconditions are indicated as fulfilled.

7-8 183 (Session Progress) provisional response (CAT-AS to UE#1)

The CAT-AS changes the response code to 183 (Session Progress), and forwards the SIP provisional response to UE#1.

An early dialog (D2) is established between UE#1 and UE#2.

9-10 PRACK request (UE#1 to UE#2)

UE#1 sends a SIP PRACK request, which acknowledges the 183 (Session Progress) provisional response, to UE#2.

11-12 200 (OK) response to PRACK (UE#2 to UE#1)

UE#2 sends a SIP 200 (OK) response for the SIP PRACK request to UE#1.

13-14 183 (Session Progress) provisional response (CAT-AS to UE#1) see example in table A.3.3-3

The CAT-AS sends a reliable SIP 183 (Session Progress) provisional response to UE#2.

An early dialog (D1) is established between UE#1 and the CAT-AS.

NOTE: As an alternative, the CAT-AS can send the SIP 183 (Session Progress) provisional response when the initial SIP INVITE request is received from UE#1.

Table A.3.3-4: 183 (Session Progress) response (CAT-AS to UE#1)

```
SIP/2.0 183 Session Progress
Via: SIP/2.0/UDP scscf2.home2.net;branch=z9hG4bK764z87.1, SIP/2.0/UDP
    icscf2_s.home2.net;branch=z9hG4bK871y12.1, SIP/2.0/UDP
    scscf1.home1.net;branch=z9hG4bK332b23.1pcscf1.visited1.net;branch=z9hG4bK240f34.1,
    SIP/2.0/UDP pcscf1.visited1.net;branch=z9hG4bK240f34.1, SIP/2.0/UDP
    [5555::aaa:bbb:ccc:ddd]:1357;comp=sigcomp;branch=z9hG4bKnashds7
Record-Route: <sip:pcscf2.visited2.net:5088;lr;comp=sigcomp>
From:
To: <tel:+1-212-555-2222>;tag=2236
Call-ID:
Cseq:
Require: 100rel
Allow: INVITE, ACK, CANCEL, BYE, PRACK, UPDATE, REFER, MESSAGE
RSeq: 9022
P-Early-Media: sendrecv
Contact: <sip:cat-as.home1.net>;+g.3gpp.icsi_ref="urn%3Aurn-7%3gpp-service.ims.icsi.mmtel"
Content-Type: application/sdp
Content-Length: (...)

v=0
o=- 2987933615 2987933615 IN IP6 6666::eee:fff:bbb:aaa
s=-
c=IN IP6 6666::eee:fff:bbb:aaa
t=0 0
m=video 3400 RTP/AVP 98
b=AS:75
a=crr:qos local sendrecv
a=crr:qos remote sendrecv
a=des:qos mandatory local sendrecv
a=des:qos mandatory remote sendrecv
a=rtmpmap:98 H263
a=fmtp:98 profile-level-id=0
m=audio 3456 RTP/AVP 97 96
b=AS:25.4
a=crr:qos local sendrecv
a=crr:qos remote sendrecv
a=des:qos mandatory local sendrecv
a=des:qos mandatory remote sendrecv
a=rtmpmap:97 AMR
a=fmtp:97 mode-set=0,2,5,7; maxframes
```

P-Early-Media: The CAT-AS requests authorization for early media.

SDP: The SDP answer (SDP_A) contains a set of codecs supported to be used for CAT. The SDP content is based on information received from the MRF. The SDP contains an indication that the local preconditions are fulfilled.

15-16 PRACK request (UE#1 to CAT-AS)

UE#1 sends a SIP PRACK request, which acknowledges the SIP 183 (Session Progress) provisional response, to the CAT-AS.

The CAT-AS instructs the MRF to start CAT media.

17-18 200 (OK) response to PRACK (CAT-AS to UE#1)

The CAT-AS sends a SIP 200 (OK) response for the SIP PRACK request to UE#1.

19-20 200 (OK) response to INVITE (UE#2 to CAT-AS)

The called party answers the call. UE#2 sends a SIP 200 (OK) final response for the SIP INVITE request to the CAT-AS.

The CAT-AS instructs the MRF to stop CAT media.

21-22 200 (OK) response to INVITE (CAT-AS to UE#1)

The CAT-AS forwards the SIP 200 (OK) response to UE#1.

The early dialog (D1) between UE#1 and the CAT-AS is terminated.

23-24 ACK request (UE#1 to UE#2)

UE#1 sends a SIP ACK request, which acknowledges the 200 (OK) final response, to UE#2.

A.4 CAT early session model signalling flows

A.4.1 Introduction

The following flows show establishment of a session between UE#1 and UE#2, using the early session model described in subclause 4.5.5.3.3 to provide CAT to UE#1. The following flows are included:

- subclause A.4.2 shows CAT, using the early session model, when UE#1 and UE#2 have resources available;
- subclause A.4.3 shows CAT, using the early session model, when UE#1 does not have resources available;
- subclause A.4.4 shows CAT, using the early session model, when UE#2 does not have resources available;

A.4.2 CAT when UE#1 and UE#2 have resources available

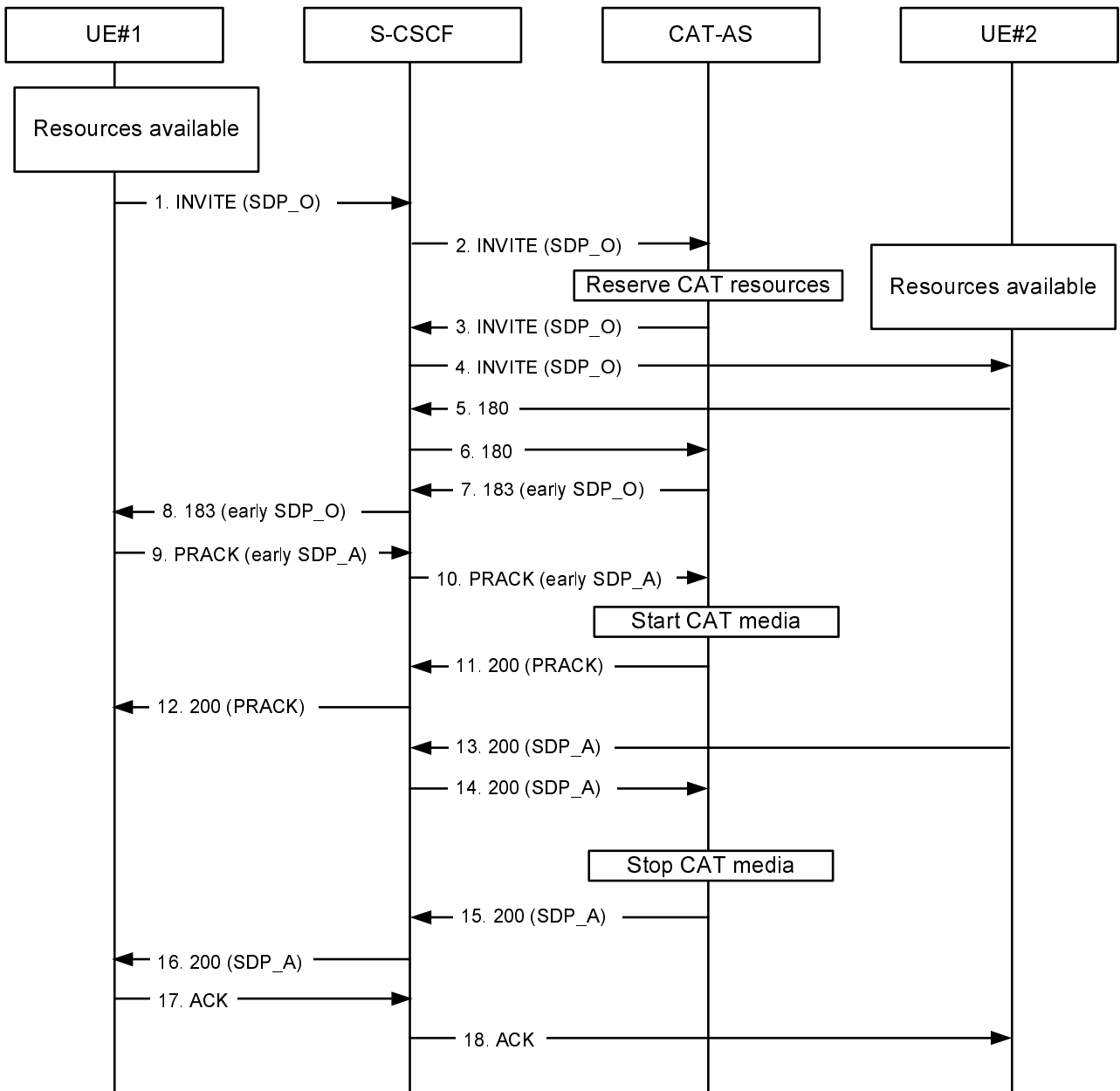

Figure A.4.2-1: CAT, no resource reservation

1 INVITE request (UE#1 to S-CSCF) see example in table A.4.2-1

UE#1 sends a SIP INVITE request to the intermediate IM CN subsystem.

Table A.4.2-1: INVITE request (UE#1 to S-CSCF)

```

INVITE tel:+1-212-555-2222 SIP/2.0
Via: SIP/2.0/UDP [5555::aaa:bbb:ccc:ddd]:1357;comp=sigcomp;branch=z9hG4bKnashds7
Max-Forwards: 70
Route: <sip:pcscf1.visited1.net:7531;lr;comp=sigcomp>, <sip:orig@scscf1.home1.net;lr>
P-Preferred-Identity: "John Doe" <sip:user1_public1@home1.net>
P-Access-Network-Info: 3GPP-UTRAN-TDD; utran-cell-id-3gpp=234151D0FCE11
Privacy: none
From: <sip:user1_public1@home1.net>;tag=171828
To: <tel:+1-212-555-2222>
Call-ID: cb03a0s09a2sdfg1kj490333
Cseq: 127 INVITE
Supported: precondition, 100rel, early-session
Security-Verify: ipsec-3gpp; q=0.1; alg= hmac-sha-1-96; spi-c=98765432; spi-s=87654321;
    port-c=8642; port-s=7531
Contact: <sip:user1_public1@home1.net;gr=urn:uuid:f81d4fae-7dec-11d0-a765-
    00a0c91e6bf6>;+g.3gpp.icsi_ref="urn%3Aurn-7%3gpp-service.ims.icsi.mmtel"
Accept:application/sdp, application/3gpp-ims+xml
Content-Type: application/sdp
Content-Disposition: session
Content-Length: (...)

v=0
o=- 2987933615 2987933615 IN IP6 5555::aaa:bbb:ccc:ddd
s=-
c=IN IP6 5555::aaa:bbb:ccc:ddd
t=0 0
m=audio 3456 RTP/AVP 97 96
b=AS:25.4
a=crr:qos local sendrcv
a=crr:qos remote none
a=des:qos mandatory local sendrcv
a=des:qos none remote sendrcv
a=rtpmap:97 AMR
a=fmtp:97 mode-set=0,2,5,7; maxframes=2
a=rtpmap:96 telephone-event

```

Supported: The UE indicates support for preconditions, reliable provisional responses, and early-session SDP.

SDP: The SDP offer (SDP_O) contains a set of codecs supported by UE#1 and desired by the calling user for this session. If preconditions are used, the local preconditions are indicated as fulfilled.

2 INVITE request (S-CSCF to CAT-AS)

The S-CSCF forwards the SIP INVITE request to the CAT-AS.

The CAT-AS instructs the MRF to reserve CAT resources.

3-4 INVITE request (CAT-AS to UE#2)

The CAT-AS forwards the request to UE#2.

5-6 Reliable 180 (Ringing) provisional response (UE#2 to CAT-AS) see example in table A.4.2-5

The called party is alerted. UE#2 sends a SIP 180 (Ringing) provisional response for the INVITE request to the CAT-AS.

The CAT-AS terminates the provisional response.

Table A.4.2-5: 180 (Ringing) response (UE#2 to CAT-AS)

```

SIP/2.0 180 Ringing
Via: SIP/2.0/UDP pcscf2.visited2.net;branch=z9hG4bK472a32.1, SIP/2.0/UDP
    scscf2.home2.net;branch=z9hG4bK764z87.2, SIP/2.0/UDP
    catas.home2.net;branch=z9hG4bK871y12.1, SIP/2.0/UDP
    scscf2.home2.net;branch=z9hG4bK764z87.1, SIP/2.0/UDP
    scscf1.home1.net;branch=z9hG4bK332b23.1, SIP/2.0/UDP
    pcscf1.visited1.net;branch=z9hG4bK240f34.1, SIP/2.0/UDP
    [5555::aaa:bbb:ccc:ddd]:1357;comp=sigcomp;branch=z9hG4bKnashds7
From:
To: <tel:+1-212-555-2222>;tag=2236
Call-ID:
Cseq:
Rseq: 9022
Contact: <sip:user2_public1@home2.net;gr=urn:uuid:2ad8950e-48a5-4a74-8d99-
    ad76cc7fc74>;+g.3gpp.icsi_ref="urn%3Aurn-7%3gpp-service.ims.icsi.mmtel"
Content-Length: 0

```

7-8 183 (Session Progress) provisional response (CAT-AS to UE#1) see example in table A.4.2-7

The CAT-AS sends a reliable SIP 183 (Session Progress) provisional response to UE#1.

An early-session SDP is sent to the UE#1 via the 183 provisional response.

Table A.4.2-7: 183 (Session Progress) response (CAT-AS to UE#1)

```

SIP/2.0 183 Session Progress
Via: SIP/2.0/UDP scscf2.home2.net;branch=z9hG4bK764z87.1, SIP/2.0/UDP
    scscf1.home1.net;branch=z9hG4bK332b23.1, SIP/2.0/UDP
    pcscf1.visited1.net;branch=z9hG4bK240f34.1, SIP/2.0/UDP
    [5555::aaa:bbb:ccc:ddd]:1357;comp=sigcomp;branch=z9hG4bKnashds7
From:
To:
Call-ID:
Cseq:
Require: precondition, 100rel, early-session
Rseq: 9022
Contact: <sip:cat-as.home1.net>;+g.3gpp.icsi_ref="urn%3Aurn-7%3gpp-service.ims.icsi.mmtel"
Content-Type: application/sdp
Content-Disposition: early-session
Content-Length: (...)

v=0
o=- 2987933616 2987933616 IN IP6 5555::eee:fff:aaa:bbb
s=-
c=IN IP6 5555::ccc:aaa:bbb:acc
t=0 0
m=audio 3456 RTP/AVP 97
b=AS:25.4
a=curr:qos local sendrecv
a=curr:qos remote none
a=des:qos mandatory local sendrecv
a=des:qos mandatory remote sendrecv
a=rtptime:97 AMR
a=fmtp:97 mode-set=0,2,5,7; maxframes

```

early SDP The early-session SDP offer (early SDP_O) contains a set of codecs supported to be used for CAT. The early-session SDP content is based on information received from the MRF. The local preconditions are indicated as fulfilled.

9-10 PRACK request (UE#1 to CAT-AS) see example in table A.4.2-9

UE#1 sends a SIP PRACK request with a early-session SDP answer, which acknowledges the SIP 183 (Session Progress) provisional response, towards UE#2.

The CAT-AS instructs the MRF to play CAT media.

Table A.4.2-9: PRACK request (UE#1 to CAT-AS)

```

PRACK sip:cat-as.home1.net SIP/2.0
Via: SIP/2.0/UDP [5555::aaa:bbb:ccc:ddd]:1357;comp=sigcomp;branch=z9hG4bKnashds7
Max-Forwards: 70
Route: <sip:pcscf1.visited1.net:7531;lr;comp=sigcomp>, <sip:orig@scscf1.home1.net;lr>
P-Preferred-Identity: "John Doe" <sip:user1_public1@home1.net>
P-Access-Network-Info: 3GPP-UTRAN-TDD; utran-cell-id-3gpp=234151D0FCE11
Privacy: none
From:
To:
Call-ID:
Cseq: 128 PRACK
Contact:
Content-Type: application/sdp
Content-Disposition: early-session
Content-Length: (...)

v=0
o=- 2987933616 2987933616 IN IP6 5555::aaa:bbb:ccc:ddd
s=-
c=IN IP6 5555::aaa:bbb:ccc:ddd
t=0 0
m=audio 3466 RTP/AVP 97
b=AS:25.4
a=curr:qos local sendrecv
a=curr:qos remote sendrecv
a=des:qos mandatory local sendrecv
a=des:qos none remote sendrecv
a=rtpmap:97 AMR
a=fmtp:97 mode-set=0,2,5,7; maxframes

```

early SDP The early-session SDP answer (early SDP_A) contains a set of codecs supported by UE#1 to be used for CAT. The local preconditions are indicated as fulfilled.

11-12 200 (OK) response to PRACK (CAT-AS to UE#1)

The CAT-AS sends a SIP 200 (OK) response for the SIP PRACK request to UE#1.

13-14 200 (OK) response to INVITE (UE#2 to CAT-AS) see example in table A.4.2-13

The called party answers the call. UE#2 sends a SIP 200 (OK) final response for the SIP INVITE request towards UE#1.

The CAT-AS instructs the MRF to stop CAT media.

Table A.4.2-13: 200 (OK) response (UE#2 to CAT-AS)

```

SIP/2.0 200 OK
Via: SIP/2.0/UDP pcscf2.visited2.net;branch=z9hG4bK361k21.1, SIP/2.0/UDP
scscf2.home2.net;branch=z9hG4bK764XC12.1, SIP/2.0/UDP
catas.home2.net;branch=z9hG4bK764Q32.1, SIP/2.0/UDP
scscf2.home2.net;branch=z9hG4bK764z87.1, SIP/2.0/UDP
scscf1.home1.net;branch=z9hG4bK332b23.1, SIP/2.0/UDP
pcscf1.visited1.net;branch=z9hG4bK240f34.1, SIP/2.0/UDP
[5555::aaa:bbb:ccc:ddd]:1357;comp=sigcomp;branch=z9hG4bKnashds7
From:
To:
Call-ID:
Cseq:
Contact: <sip:user2_public1@home2.net;gr=urn:uuid:2ad8950e-48a5-4a74-8d99-ad76cc7fc74
>;+g.3gpp.icsi_ref="urn%3Aurn-7%3gpp-service.ims.icsi.mmstel"
Content-Type: application/sdp
Content-Disposition: session
Content-Length: (...)

v=0
o=- 2987933615 2987933615 IN IP6 5555::eee:fff:aaa:bbb
s=-
c=IN IP6 6666::eee:fff:aaa:bbb
t=0 0
m=audio 3456 RTP/AVP 97 96
b=AS:25.4
a=curr:gosp local sendrecv
a=curr:gosp remote sendrecv
a=des:gosp mandatory local sendrecv
a=des:gosp mandatory remote sendrecv
a=rtpmap:97 AMR
a=fmtp:97 mode-set=0,2,5,7; maxframes=2
a=rtpmap:96 telephone-event

```

SDP The SDP answer (SDP_A) contains a set of codecs to be used for the session. If preconditions are used, they are indicated as fulfilled.

15-16 200 (OK) response to INVITE (CAT-AS to UE#1)

The CAT-AS forwards the SIP 200 (OK) response to UE#1.

A regular session is established between UE#1 and UE#2.

The early session between UE#1 and the CAT-AS is terminated.

17-19 ACK request (UE#1 to UE#2)

UE#1 sends a SIP ACK request, which acknowledges the SIP 200 (OK) final response, to UE#2.

A.4.3 CAT when UE#1 does not have required resources available while UE#2 has resources available

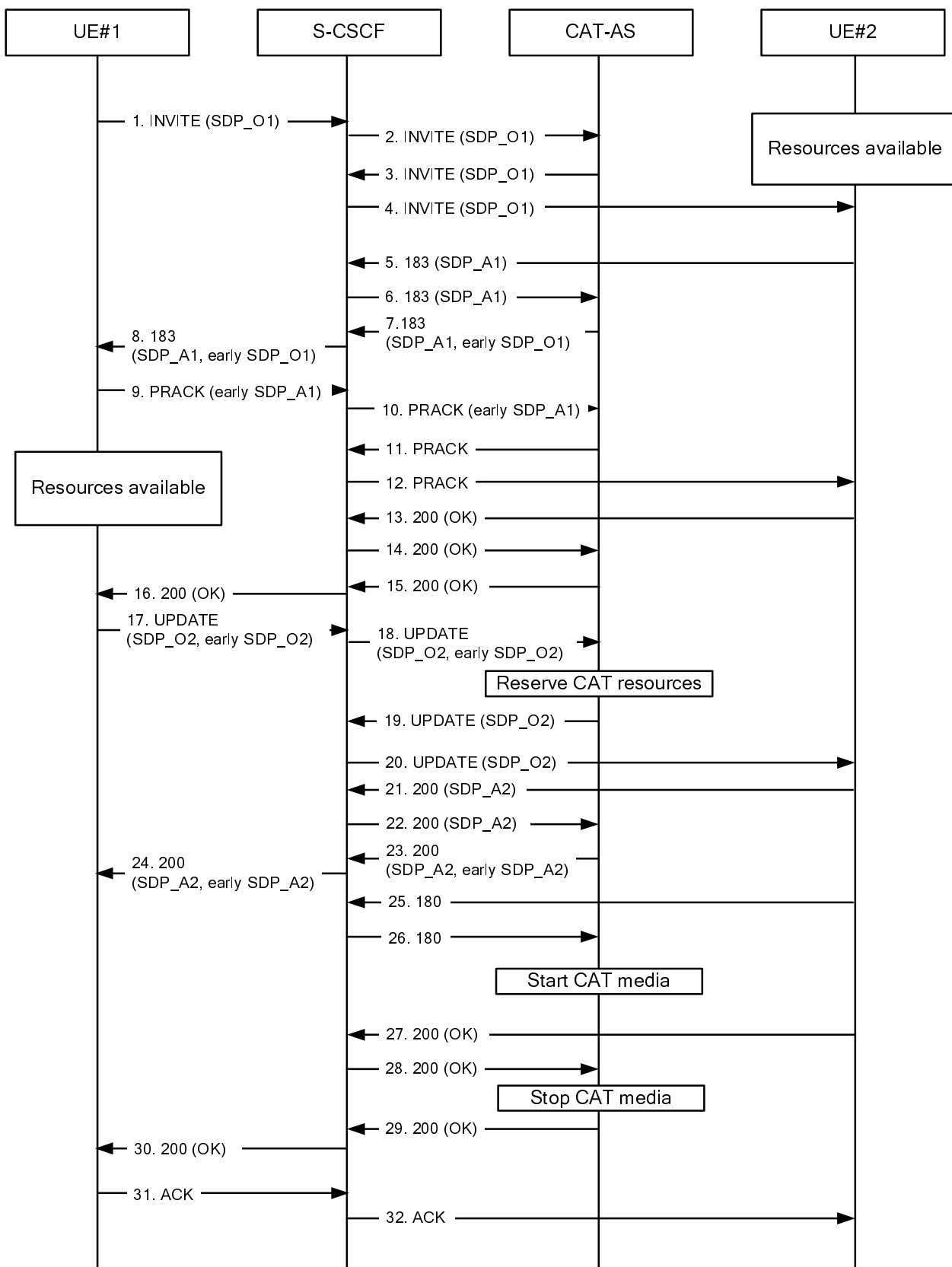

Figure A.4.3-1: CAT, UE#1 does not have resources available

1-2 INVITE request (UE#1 to CAT-AS) see example in table A.4.3-1

UE#1 sends a SIP INVITE request to the intermediate IM CN subsystem.

Table A.4.3-1: INVITE request (UE#1 to S-CSCF)

```

INVITE tel:+1-212-555-2222 SIP/2.0
Via: SIP/2.0/UDP [5555::aaa:bbb:ccc:ddd]:1357;comp=sigcomp;branch=z9hG4bKnashds7
Max-Forwards: 70
Route: <sip:pcscf1.visited1.net:7531;lr;comp=sigcomp>, <sip:orig@scscf1.home1.net;lr>
P-Preferred-Identity: "John Doe" <sip:user1_public1@home1.net>
P-Access-Network-Info: 3GPP-UTRAN-TDD; utran-cell-id-3gpp=234151D0FCE11
Privacy: none
From: <sip:user1_public1@home1.net>;tag=171828
To: <tel:+1-212-555-2222>
Call-ID: cb03a0s09a2sdfglkj490333
Cseq: 127 INVITE
Supported: precondition, 100rel, early-session
Security-Verify: ipsec-3gpp; q=0.1; alg= hmac-sha-1-96; spi-c=98765432; spi-s=87654321;
    port-c=8642; port-s=7531
Contact: <sip:user1_public1@home1.net;gr=urn:uuid:f81d4fae-7dec-11d0-a765-
    00a0c91e6bf6>;+g.3gpp.icsi_ref="urn%3Aurn-7%3gpp-service.ims.icsi.mm1tel"
Accept:application/sdp, application/3gpp-ims+xml
Content-Type: application/sdp
Content-Disposition: session
Content-Length: (...)

v=0
o=- 2987933615 2987933615 IN IP6 5555::aaa:bbb:ccc:ddd
s=-
c=IN IP6 5555::aaa:bbb:ccc:ddd
t=0 0
m=video 3400 RTP/AVP 98
b=AS:75
a=curr:qos local none
a=curr:qos remote none
a=des:qos mandatory local sendrecv
a=des:qos none remote sendrecv
a=inactive
a=rtpmap:98 H263
m=audio 3456 RTP/AVP 97 96
b=AS:25.4
a=curr:qos local none
a=curr:qos remote none
a=des:qos mandatory local sendrecv
a=des:qos none remote sendrecv
a=inactive
a=rtpmap:97 AMR
a=fmtp:97 mode-set=0,2,5,7; maxframes=2
a=rtpmap:96 telephone-event

```

Supported: The UE indicates support for preconditions, reliable provisional responses, and early-session SDP.

SDP The SDP offer (SDP_O1) contains a set of codecs supported by UE#1 and desired by the user at UE#1 for this session. The SDP contains an indication that the local preconditions are not fulfilled.

2 INVITE request (S-CSCF to CAT-AS)

The S-CSCF forwards the SIP INVITE request to the CAT-AS.

3-4 INVITE request (CAT-AS to UE#2)

The CAT-AS forwards the SIP INVITE request to UE#2.

5-6 183 (Session Progress) provisional response (UE#2 to CAT-AS) see example in table A.4.3-5

UE#2 sends a SIP 183 (Session Progress) provisional response for the INVITE request to the CAT-AS.

Table A.4.3-5: 183 (Session Progress) response (UE#2 to CAT-AS)

```

SIP/2.0 183 Session Progress
Via: SIP/2.0/UDP pcscf2.visited2.net;branch=z9hG4bK361k21.1, SIP/2.0/UDP
    scscf2.home2.net;branch=z9hG4bK764XC12.1, SIP/2.0/UDP
    catas.home2.net;branch=z9hG4bK764Q32.1, SIP/2.0/UDP
    scscf2.home2.net;branch=z9hG4bK764z87.1, SIP/2.0/UDP
    scscf1.home1.net;branch=z9hG4bK332b23.1, SIP/2.0/UDP

```

```

pcscf1.visited1.net;branch=z9hG4bK240f34.1, SIP/2.0/UDP
[5555::aaa:bbb:ccc:ddd]:1357;comp=sigcomp;branch=z9hG4bKnashds7
From:
To: <tel:+1-212-555-2222>;tag=6322
Call-ID:
Cseq:
Require: 100rel, precondition
RSeq: 9021
Contact: <sip:user2_public1@home2.net;gr=urn:uuid:2ad8950e-48a5-4a74-8d99-
ad76cc7fc74>;+g.3gpp.icsi_ref="urn:3Aurn-7%3gpp-service.ims.icsi.mmtel"
Content-Type: application/sdp
Content-Disposition: session
Content-Length: (...)

v=0
o=- 2987933615 2987933615 IN IP6 5555::eee:fff:aaa:bbb
s=-
c=IN IP6 5555::eee:fff:aaa:bbb
t=0 0
m=video 3400 RTP/AVP 98
b=AS:75
a=crr:qos local sendrecv
a=crr:qos remote none
a=des:qos mandatory local sendrecv
a=des:qos mandatory remote sendrecv
a=rtpmap:98 H263
a=fmtp:98 profile-level-id=0
m=audio 3456 RTP/AVP 97 96
b=AS:25.4
a=crr:qos local sendrecv
a=crr:qos remote none
a=des:qos mandatory local sendrecv
a=des:qos mandatory remote sendrecv
a=rtpmap:97 AMR
a=fmtp:97 mode-set=0,2,5,7; maxframes=2
a=rtpmap:96 telephone-event

```

SDP The SDP answer (SDP_A1) contains a set of codecs to be used for the session. The local preconditions are indicated as fulfilled.

7-8 183 (Session Progress) provisional response (CAT-AS to UE#1) see example in table A.4.3-7

The CAT-AS forwards the SIP 183 provisional response with early-session SDP for CAT to UE#1.

Table A.4.3-7: 183 (Session Progress) response (CAT-AS to UE#1)

```

SIP/2.0 183 Session Progress
Via: SIP/2.0/UDP scscf2.home2.net;branch=z9hG4bK764z87.1, SIP/2.0/UDP
    scscf1.home1.net;branch=z9hG4bK332b23.1, SIP/2.0/UDP
    pcscf1.visited1.net;branch=z9hG4bK240f34.1, SIP/2.0/UDP
    [5555::aaa:bbb:ccc:ddd]:1357;comp=sigcomp;branch=z9hG4bKnashds7
From:
To:
Call-ID:
Cseq:
Require: 100rel, precondition, early-session
RSeq: 9021
Contact:
Content-Type: multipart/mixed; boundary="boundary1"
Content-Length: (...)

--boundary1
Content-Type: application/sdp
Content-Disposition: session

v=0
o=- 2987933615 2987933615 IN IP6 5555::eee:fff:aaa:bbb
s=-
c=IN IP6 6666::eee:fff:aaa:bbb
t=0 0
m=video 3400 RTP/AVP 98
b=AS:75
a=curr:qos local sendrecv
a=curr:qos remote none
a=des:qos mandatory local sendrecv
a=des:qos mandatory remote sendrecv
a=rtpmap:98 H263
a=fmtp:98 profile-level-id=0
m=audio 3456 RTP/AVP 97 96
b=AS:25.4
a=curr:qos local sendrecv
a=curr:qos remote none
a=des:qos mandatory local sendrecv
a=des:qos mandatory remote sendrecv
a=rtpmap:97 AMR
a=fmtp:97 mode-set=0,2,5,7; maxframes=2
a=rtpmap:96 telephone-event

--boundary1
Content-Type: application/sdp
Content-Disposition: early-session

v=0
o=- 2987933616 2987933616 IN IP6 5555::ccc:aaa:bbb:acc
s=-
c=IN IP6 5555::ccc:aaa:bbb:acc
t=0 0
m=video 3400 RTP/AVP 98
b=AS:75
a=curr:qos local none
a=curr:qos remote none
a=des:qos mandatory local sendrecv
a=des:qos mandatory remote sendrecv
a=rtpmap:98 H263
a=fmtp:98 profile-level-id=0
m=audio 3456 RTP/AVP 97
b=AS:25.4
a=curr:qos local none
a=curr:qos remote none
a=des:qos mandatory local sendrecv
a=des:qos mandatory remote sendrecv
a=rtpmap:97 AMR
a=fmtp:97 mode-set=0,2,5,7; maxframes

--boundary1

```

early SDP The early-session SDP offer (early SDP_O1) contains a set of codecs to be used for CAT. The preconditions are indicated as not fulfilled.

9-10 PRACK request (UE#1 to CAT-AS) see example in table A.4.3-9

UE#1 sends a SIP PRACK request with early-session SDP answer, which acknowledges the 183 (Session Progress) provisional response, towards UE#2.

Table A.4.3-9: PRACK request (UE#1 to CAT-AS)

```
PRACK sip:user2_public1@home2.net;gr=urn:uuid:2ad8950e-48a5-4a74-8d99-ad76cc7fc74 SIP/2.0
Via: SIP/2.0/UDP [5555::aaa:bbb:ccc:ddd]:1357;comp=sigcomp;branch=z9hG4bKna234s7
Max-Forwards: 70
Route: <sip:pcscf1.visited1.net:7531;lr;comp=sigcomp>, <sip:orig@scscf1.home1.net;lr>
P-Preferred-Identity: "John Doe" <sip:user1_public1@home1.net>
P-Access-Network-Info: 3GPP-UTRAN-TDD; utran-cell-id-3gpp=234151D0FCE11
Privacy: none
From:
To:
Call-ID:
Cseq: 128 PRACK
Contact:
Content-Type: application/sdp
Content-Disposition: early-session
Content-Length: (...)

v=0
o=- 2987933616 2987933616 IN IP6 5555::aaa:bbb:ccc:ddd
s=-
c=IN IP6 5555::aaa:bbb:ccc:ddd
t=0 0
m=video 3500 RTP/AVP 98
b=AS:75
a=curr:qos local none
a=curr:qos remote none
a=des:qos mandatory local sendrecv
a=des:qos none remote sendrecv
a=rtpmap:98 H263
m=audio 3556 RTP/AVP 97
b=AS:25.4
a=curr:qos local none
a=curr:qos remote none
a=des:qos mandatory local sendrecv
a=des:qos none remote sendrecv
a=rtpmap:97 AMR
a=fmtp:97 mode-set=0,2,5,7; maxframes
```

early SDP The early-session SDP answer (early SDP_A1) contains a set of codecs supported by UE#1 to be used for CAT. The preconditions are indicated as not fulfilled.

11-12 PRACK request (CAT-AS to UE#2) see example in table A.4.3-11

CAT-AS forwards the SIP PRACK request without early-session SDP answer to UE#2.

Table A.4.3-11: PRACK request (CAT-AS to UE#2)

```
PRACK sip:user1_public1@home1.net;gr=urn:uuid:f81d4fae-7dec-11d0-a765-00a0c91e6bf6 SIP/2.0
Via: SIP/2.0/UDP catas.home2.net;branch=z9hG4bK614Q63.1, SIP/2.0/UDP
scscf2.home2.net;branch=z9hG4bK464z73.1, SIP/2.0/UDP
scscf1.home1.net;branch=z9hG4bK351b51.1, SIP/2.0/UDP
pcscf1.visited1.net;branch=z9hG4bK582f12.1, SIP/2.0/UDP
[5555::aaa:bbb:ccc:ddd]:1357;comp=sigcomp;branch=z9hG4bKna234s7
Max-Forwards: 66
Privacy:
From:
To:
Call-ID:
Cseq: 128 PRACK
Contact:
Content-Length: 0
```

13-16 200 (OK) response to PRACK (UE#2 to UE#1)

UE#2 sends a SIP 200 (OK) response for the SIP PRACK request to UE#1.

17-18 UPDATE request (UE#1 to CAT-AS) see example in table A.4.3-17

UE#1 reserved resources for regular session and early session, it sends an SIP UPDATE request with session SDP offer and early-session SDP offer towards UE#2.

Table A.4.3-17: UPDATE request (UE#1 to CAT-AS)

```

UPDATE sip:user2_public1@home2.net;gr=urn:uuid:2ad8950e-48a5-4a74-8d99-ad76cc7fc74 SIP/2.0
Via: SIP/2.0/UDP [5555::aaa:bbb:ccc:ddd]:1357;comp=sigcomp;branch=z9hG4bKna234s7
Max-Forwards: 70
Route: <sip:pcscf1.visited1.net:7531;lr;comp=sigcomp>, <sip:orig@scscf1.home1.net;lr>
P-Preferred-Identity: "John Doe" <sip:user1_public1@home1.net>
P-Access-Network-Info: 3GPP-UTRAN-TDD; utran-cell-id-3gpp=234151D0FCE11
Privacy: none
From:
To:
Call-ID:
Cseq: 129 UPDATE
Contact:
Content-Type: multipart/mixed; boundary="boundary1"
Content-Length: (...)

--boundary1
Content-Type: application/sdp
Content-Disposition: session

v=0
o=- 2987933615 2987933615 IN IP6 5555::aaa:bbb:ccc:ddd
s=-
c=IN IP6 5555::aaa:bbb:ccc:ddd
t=0 0
m=video 3400 RTP/AVP 98
b=AS:75
a=curr:qos local sendrecv
a=curr:qos remote sendrecv
a=des:qos mandatory local sendrecv
a=des:qos mandatory remote sendrecv
a=rtptime:98 H263
a=fmtp:98 profile-level-id=0
m=audio 3456 RTP/AVP 97 96
b=AS:25.4
a=curr:qos local sendrecv
a=curr:qos remote sendrecv
a=des:qos mandatory local sendrecv
a=des:qos mandatory remote sendrecv
a=rtptime:97 AMR
a=fmtp:97 mode-set=0,2,5,7; maxframes=2
a=rtptime:96 telephone-event

--boundary1
Content-Type: application/sdp
Content-Disposition: early-session

v=0
o=- 2987933616 2987933616 IN IP6 5555::aaa:bbb:ccc:ddd
s=-
c=IN IP6 5555::aaa:bbb:ccc:ddd
t=0 0
m=video 3500 RTP/AVP 98
b=AS:75
a=curr:qos local sendrecv
a=curr:qos remote none
a=des:qos mandatory local sendrecv
a=des:qos mandatory remote sendrecv
a=rtptime:98 H263
a=fmtp:98 profile-level-id=0
m=audio 3556 RTP/AVP 97
b=AS:25.4
a=curr:qos local sendrecv
a=curr:qos remote none
a=des:qos mandatory local sendrecv
a=des:qos mandatory remote sendrecv
a=rtptime:97 AMR
a=fmtp:97 mode-set=0,2,5,7; maxframes

--boundary1

```

SDP The offer (SDP_O2) contains a set of codecs supported by UE#1 and desired by the user at UE#1 for this session. The SDP contains an indication that the preconditions are fulfilled.

early SDP The early-session SDP offer (early SDP_O2) contains a set of codecs supported by UE#1 to be used for CAT. The local preconditions are indicated as fulfilled.

19-20 UPDATE request (CAT-AS to UE#2) see example in table A.4.3-19

CAT-AS forwards the SIP UPDATE request towards UE#2 without early-session SDP.

The CAT-AS instructs the MRF to reserve CAT resources.

Table A.4.3-19: UPDATE request (CAT-AS to UE#2)

```
UPDATE sip:user2_public1@home2.net;gr=urn:uuid:2ad8950e-48a5-4a74-8d99-ad76cc7fc74 SIP/2.0
Via: SIP/2.0/UDP catas.home2.net;branch=z9hG4bK164Q63.1, SIP/2.0/UDP
    scscf2.home2.net;branch=z9hG4bK442z73.1, SIP/2.0/UDP
    scscf1.home1.net;branch=z9hG4bK514b51.1, SIP/2.0/UDP
    pcscf1.visited1.net;branch=z9hG4bK812f12.1, SIP/2.0/UDP
    [5555::aaa:bbb:ccc:ddd]:1357;comp=sigcomp;branch=z9hG4bKna234s7
Max-Forwards: 66
Privacy:
From:
To:
Call-ID:
Cseq: 129 UPDATE
Contact:
Content-Type: application/sdp
Content-Disposition: session
Content-Length: (...)

v=0
o=- 2987933615 2987933615 IN IP6 5555::aaa:bbb:ccc:ddd
s=-
c=IN IP6 5555::aaa:bbb:ccc:ddd
t=0 0
m=video 3400 RTP/AVP 98
b=AS:75
a=curr:qos local sendrecv
a=curr:qos remote sendrecv
a=des:qos mandatory local sendrecv
a=des:qos mandatory remote sendrecv
a=rtpmap:98 H263
a=fmtp:98 profile-level-id=0
m=audio 3456 RTP/AVP 97 96
b=AS:25.4
a=curr:qos local sendrecv
a=curr:qos remote sendrecv
a=des:qos mandatory local sendrecv
a=des:qos mandatory remote sendrecv
a=rtpmap:97 AMR
a=fmtp:97 mode-set=0,2,5,7; maxframes=2
a=rtpmap:96 telephone-event
```

21-22 200 (OK) response to UPDATE (UE#2 to CAT-AS) see example in table A.4.3-21

UE#2 sends a SIP 200 (OK) for the SIP UPDATE request to the CAT-AS.

Table A.4.3-21: 200 (OK) response (UE#2 to CAT-AS)

```

SIP/2.0 200 OK
Via: SIP/2.0/UDP pcscf2.visited2.net;branch=z9hG4bK611k21.1, SIP/2.0/UDP
    scscf2.home2.net;branch=z9hG4bK764KS12.1, SIP/2.0/UDP
    catas.home2.net;branch=z9hG4bK164Q63.1, SIP/2.0/UDP
    scscf2.home2.net;branch=z9hG4bK442z73.1, SIP/2.0/UDP
    scscf1.home1.net;branch=z9hG4bK514b51.1, SIP/2.0/UDP
    pcscf1.visited1.net;branch=z9hG4bK812f12.1, SIP/2.0/UDP
    [5555::aaa:bbb:ccc:ddd]:1357;comp=sigcomp;branch=z9hG4bKna234s7
From:
To:
Call-ID:
Cseq:
Contact:
Content-Type: application/sdp
Content-Disposition: session
Content-Length: (...)

v=0
o=- 2987933615 2987933615 IN IP6 5555::eee:fff:aaa:bbb
s=-
c=IN IP6 5555::eee:fff:aaa:bbb
t=0 0
m=video 3400 RTP/AVP 98
b=AS:75
a=crr:qos local sendrecv
a=crr:qos remote sendrecv
a=des:qos mandatory local sendrecv
a=des:qos mandatory remote sendrecv
a=rtpmap:98 H263
a=fmtp:98 profile-level-id=0
m=audio 3456 RTP/AVP 97 96
b=AS:25.4
a=crr:qos local sendrecv
a=crr:qos remote sendrecv
a=des:qos mandatory local sendrecv
a=des:qos mandatory remote sendrecv
a=rtpmap:97 AMR
a=fmtp:97 mode-set=0,2,5,7; maxframes=2
a=rtpmap:96 telephone-event

```

SDP The SDP answer (SDP_A2) contains a set of codecs to be used for the session. The preconditions are indicated as fulfilled.

23-24 200 (OK) response to UPDATE (CAT-AS to UE#1) see example in table A.4.3-23

CAT-AS forwards the SIP 200 (OK) for the SIP UPDATE request to UE#1.

Table A.4.3-23: 200 (OK) response (CAT-AS to UE#1)

```

SIP/2.0 200 OK
Via: SIP/2.0/UDP catas.home2.net;branch=z9hG4bK164Q63.1, SIP/2.0/UDP
    scscf2.home2.net;branch=z9hG4bK442z73.1, SIP/2.0/UDP
    scscf1.home1.net;branch=z9hG4bK514b51.1, SIP/2.0/UDP
    pcscf1.visited1.net;branch=z9hG4bK812f12.1, SIP/2.0/UDP
    [5555::aaa:bbb:ccc:ddd]:1357;comp=sigcomp;branch=z9hG4bKna234s7
From:
To:
Call-ID:
Cseq:
Contact:
Content-Type: multipart/mixed; boundary="boundary1"
Content-Length: (...)

--boundary1
Content-Type: application/sdp
Content-Disposition: session

v=0
o=- 2987933615 2987933615 IN IP6 5555::eee:fff:aaa:bbb
s=-
c=IN IP6 5555::eee:fff:aaa:bbb
t=0 0
m=video 3400 RTP/AVP 98
b=AS:75
a=curr:qos local sendrecv
a=curr:qos remote sendrecv
a=des:qos mandatory local sendrecv
a=des:qos mandatory remote sendrecv
a=rtpmap:98 H263
a=fmtp:98 profile-level-id=0
m=audio 3456 RTP/AVP 97 96
b=AS:25.4
a=curr:qos local sendrecv
a=curr:qos remote sendrecv
a=des:qos mandatory local sendrecv
a=des:qos mandatory remote sendrecv
a=rtpmap:97 AMR
a=fmtp:97 mode-set=0,2,5,7; maxframes=2
a=rtpmap:96 telephone-event

--boundary1
Content-Type: application/sdp
Content-Disposition: early-session

v=0
o=- 2987933616 2987933616 IN IP6 5555::ccc:aaa:bbb:acc
s=-
c=IN IP6 5555::ccc:aaa:bbb:acc
t=0 0
m=video 3400 RTP/AVP 98
b=AS:75
a=curr:qos local sendrecv
a=curr:qos remote sendrecv
a=des:qos mandatory local sendrecv
a=des:qos mandatory remote sendrecv
a=rtpmap:98 H263
a=fmtp:98 profile-level-id=0
m=audio 3456 RTP/AVP 97
b=AS:25.4
a=curr:qos local sendrecv
a=curr:qos remote sendrecv
a=des:qos mandatory local sendrecv
a=des:qos mandatory remote sendrecv
a=rtpmap:97 AMR
a=fmtp:97 mode-set=0,2,5,7; maxframes

--boundary1

```

early SDP

The early-session SDP answer (early SDP_A2) contains a set of codecs supported by UE#1 to be used for CAT. The early-session SDP content is based on information received from the MRF. The preconditions are indicated as fulfilled.

25-26 180 (Ringing) response to INVITE (UE#2 to CAT-AS)

The called party is alerted. UE#2 sends a SIP 180 (Ringing) provisional response for the INVITE request towards UE#1.

The CAT-AS terminates the provisional response.

The CAT-AS instructs the MRF to play CAT media.

27-28 200 (OK) response to INVITE (UE#2 to CAT-AS)

The called party answers the call. UE#2 sends a SIP 200 (OK) final response for the SIP INVITE request towards UE#1.

The CAT-AS instructs the MRF to stop CAT media.

29-30 200 (OK) response to INVITE (CAT-AS to UE#1)

The CAT-AS forwards the SIP 200 (OK) response to UE#1.

A regular session is established between UE#1 and UE#2.

The early session between UE#1 and the CAT-AS is terminated.

31-32 ACK request (UE#1 to UE#2)

UE#1 sends a SIP ACK request, which acknowledges the 200 (OK) final response, to UE#2.

A.4.4 CAT when UE#1 has resources available while UE#2 does not have required resources available

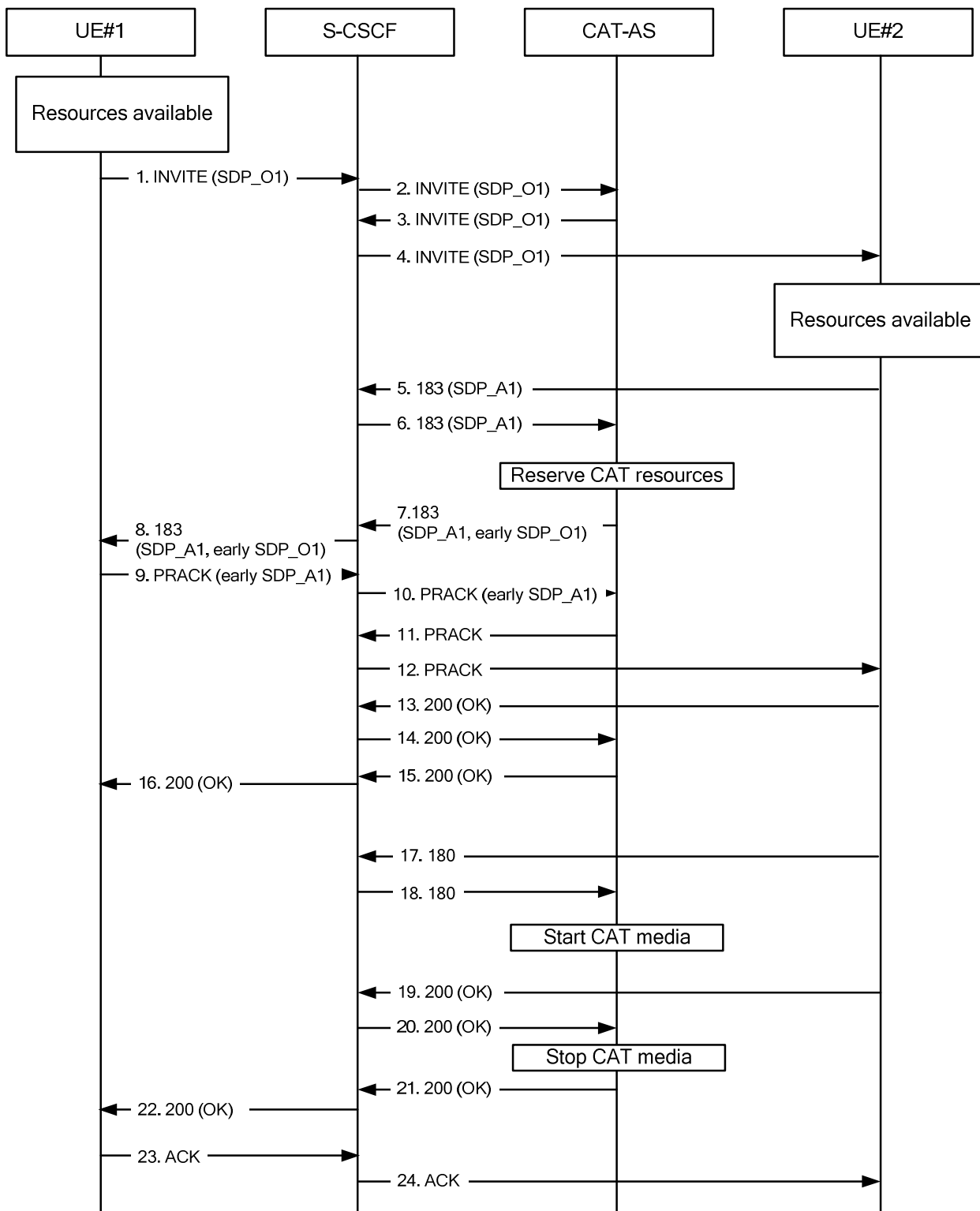

Figure A.4.4-1: CAT, UE#2 does not have resources available

1-2 INVITE request (UE#1 to CAT-AS) see example in table A.4.4-1

UE#1 sends a SIP INVITE request to the intermediate IM CN subsystem.

Table A.4.4-1: INVITE request (UE#1 to S-CSCF)

```

INVITE tel:+1-212-555-2222 SIP/2.0
Via: SIP/2.0/UDP [5555::aaa:bbb:ccc:ddd]:1357;comp=sigcomp;branch=z9hG4bKnashds7
Max-Forwards: 70
Route: <sip:pcscf1.visited1.net:7531;lr;comp=sigcomp>, <sip:orig@scscf1.home1.net;lr>
P-Preferred-Identity: "John Doe" <sip:user1_public1@home1.net>
P-Access-Network-Info: 3GPP-UTRAN-TDD; utran-cell-id-3gpp=234151D0FCE11
Privacy: none
From: <sip:user1_public1@home1.net>;tag=171828
To: <tel:+1-212-555-2222>
Call-ID: cb03a0s09a2sdfglkj490333
Cseq: 127 INVITE
Supported: precondition, 100rel, early-session
Security-Verify: ipsec-3gpp; q=0.1; alg= hmac-sha-1-96; spi-c=98765432; spi-s=87654321;
port-c=8642; port-s=7531
Contact: <sip:user1_public1@home1.net;gr=urn:uuid:f81d4fae-7dec-11d0-a765-00a0c91e6bf6>
>;+g.3gpp.icsi_ref="urn%3Aurn-7%3gpp-service.ims.icsi.mmstel"
Accept:application/sdp, application/3gpp-ims+xml
Content-Type: application/sdp
Content-Disposition: session
Content-Length: (...)

v=0
o=- 2987933615 2987933615 IN IP6 5555::aaa:bbb:ccc:ddd
s=-
c=IN IP6 5555::aaa:bbb:ccc:ddd
t=0 0
m=video 3400 RTP/AVP 98
b=AS:75
a=curr:qos local sendrecv
a=curr:qos remote none
a=des:qos mandatory local sendrecv
a=des:qos none remote sendrecv
a=inactive
a=rtpmap:98 H263
m=audio 3456 RTP/AVP 97 96
b=AS:25.4
a=curr:qos local sendrecv
a=curr:qos remote none
a=des:qos mandatory local sendrecv
a=des:qos none remote sendrecv
a=inactive
a=rtpmap:97 AMR
a=fmtp:97 mode-set=0,2,5,7; maxframes=2
a=rtpmap:96 telephone-event

```

Supported: The UE indicates support for preconditions, reliable provisional responses, and early-session SDP.

SDP The SDP offer (SDP_O1) contains a set of codecs supported by UE#1 and desired by the user at UE#1 for this session. The SDP contains an indication that the local preconditions are fulfilled.

2 INVITE request (S-CSCF to CAT-AS)

The S-CSCF forwards the SIP INVITE request to the CAT-AS.

3-4 INVITE request (CAT-AS to UE#2)

The CAT-AS forwards the SIP INVITE request to UE#2.

5-6 183 (Session Progress) provisional response (UE#2 to CAT-AS) see example in table A.4.4-5

UE#2 sends a SIP 183 (Session Progress) provisional response for the INVITE request to the CAT-AS.

Table A.4.4-5: 183 (Session Progress) response (UE#2 to CAT-AS)

```

SIP/2.0 183 Session Progress
Via: SIP/2.0/UDP pcscf2.visited2.net;branch=z9hG4bK361k21.1, SIP/2.0/UDP
scscf2.home2.net;branch=z9hG4bK764XC12.1, SIP/2.0/UDP
catas.home2.net;branch=z9hG4bK764Q32.1, SIP/2.0/UDP
scscf2.home2.net;branch=z9hG4bK764z87.1, SIP/2.0/UDP
scscf1.home1.net;branch=z9hG4bK332b23.1, SIP/2.0/UDP

```



```

pcscf1.visited1.net;branch=z9hG4bK240f34.1, SIP/2.0/UDP
[5555::aaa:bbb:ccc:ddd]:1357;comp=sigcomp;branch=z9hG4bKnashds7
From:
To: <tel:+1-212-555-2222>;tag=6322
Call-ID:
Cseq:
Require: 100rel, precondition
RSeq: 9021
Contact: <sip:user2_public1@home2.net;gr=urn:uuid:2ad8950e-48a5-4a74-8d99-
ad76cc7fc74>;+g.3gpp.icsi_ref="urn:3Aurn-7%3gpp-service.ims.icsi.mmtel"
Content-Type: application/sdp
Content-Disposition: session
Content-Length: (...)

v=0
o=- 2987933615 2987933615 IN IP6 5555::eee:fff:aaa:bbb
s=-
c=IN IP6 5555::eee:fff:aaa:bbb
t=0 0
m=video 3400 RTP/AVP 98
b=AS:75
a=crr:qos local sendrcv
a=crr:qos remote sendrcv
a=des:qos mandatory local sendrcv
a=des:qos mandatory remote sendrcv
a=rtpmap:98 H263
a=fmtp:98 profile-level-id=0
m=audio 3456 RTP/AVP 97 96
b=AS:25.4
a=crr:qos local sendrcv
a=crr:qos remote sendrcv
a=des:qos mandatory local sendrcv
a=des:qos mandatory remote sendrcv
a=rtpmap:97 AMR
a=fmtp:97 mode-set=0,2,5,7; maxframes=2
a=rtpmap:96 telephone-event

```

SDP The SDP answer (SDP_A1) contains a set of codecs to be used for the session. The preconditions are indicated as fulfilled.

7-8 183 (Session Progress) provisional response (CAT-AS to UE#1) see example in table A.4.4-7

The CAT-AS forwards the SIP 183 provisional response with early-session SDP for CAT to UE#1.

Table A.4.4-7: 183 (Session Progress) response (CAT-AS to UE#1)

```

SIP/2.0 183 Session Progress
Via: SIP/2.0/UDP scscf2.home2.net;branch=z9hG4bK764z87.1, SIP/2.0/UDP
    scscf1.home1.net;branch=z9hG4bK332b23.1, SIP/2.0/UDP
    pcscf1.visited1.net;branch=z9hG4bK240f34.1, SIP/2.0/UDP
    [5555::aaa:bbb:ccc:ddd]:1357;comp=sigcomp;branch=z9hG4bKnashds7
From:
To:
Call-ID:
Cseq:
Require: 100rel, precondition, early-session
RSeq: 9021
Contact:
Content-Type: multipart/mixed; boundary="boundary1"
Content-Length: (...)

--boundary1
Content-Type: application/sdp
Content-Disposition: session

v=0
o=- 2987933615 2987933615 IN IP6 5555::eee:fff:aaa:bbb
s=-
c=IN IP6 6666::eee:fff:aaa:bbb
t=0 0
m=video 3400 RTP/AVP 98
b=AS:75
a=curr:qos local sendrecv
a=curr:qos remote sendrecv
a=des:qos mandatory local sendrecv
a=des:qos mandatory remote sendrecv
a=rtptime:98 H263
a=fmtp:98 profile-level-id=0
m=audio 3456 RTP/AVP 97 96
b=AS:25.4
a=curr:qos local sendrecv
a=curr:qos remote sendrecv
a=des:qos mandatory local sendrecv
a=des:qos mandatory remote sendrecv
a=rtptime:97 AMR
a=fmtp:97 mode-set=0,2,5,7; maxframes=2
a=rtptime:96 telephone-event

--boundary1
Content-Type: application/sdp
Content-Disposition: early-session

v=0
o=- 2987933616 2987933616 IN IP6 5555::ccc:aaa:bbb:acc
s=-
c=IN IP6 5555::ccc:aaa:bbb:acc
t=0 0
m=video 3400 RTP/AVP 98
b=AS:75
a=curr:qos local sendrecv
a=curr:qos remote none
a=des:qos mandatory local sendrecv
a=des:qos mandatory remote sendrecv
a=rtptime:98 H263
a=fmtp:98 profile-level-id=0
m=audio 3456 RTP/AVP 97
b=AS:25.4
a=curr:qos local sendrecv
a=curr:qos remote none
a=des:qos mandatory local sendrecv
a=des:qos mandatory remote sendrecv
a=rtptime:97 AMR
a=fmtp:97 mode-set=0,2,5,7; maxframes

--boundary1

```

early SDP The early-session SDP offer (early SDP_O1) contains a set of codecs to be used for CAT. The local preconditions are indicated as fulfilled.

9-10 PRACK request (UE#1 to CAT-AS) see example in table A.4.4-9

UE#1 sends a SIP PRACK request with early-session SDP answer, which acknowledges the 183 (Session Progress) provisional response, towards UE#2.

Table A.4.4-9: PRACK request (UE#1 to CAT-AS)

```
PRACK sip:user2_public1@home2.net;gr=urn:uuid:2ad8950e-48a5-4a74-8d99-ad76cc7fc74 SIP/2.0
Via: SIP/2.0/UDP [5555::aaa:bbb:ccc:ddd]:1357;comp=sigcomp;branch=z9hG4bKna234s7
Max-Forwards: 70
Route: <sip:pcscf1.visited1.net:7531;lr;comp=sigcomp>, <sip:orig@scscf1.home1.net;lr>
P-Preferred-Identity: "John Doe" <sip:user1_public1@home1.net>
P-Access-Network-Info: 3GPP-UTRAN-TDD; utran-cell-id-3gpp=234151D0FCE11
Privacy: none
From:
To:
Call-ID:
Cseq: 128 PRACK
Contact:
Content-Type: application/sdp
Content-Disposition: early-session
Content-Length: (...)

v=0
o=- 2987933616 2987933616 IN IP6 5555::aaa:bbb:ccc:ddd
s=-
c=IN IP6 5555::aaa:bbb:ccc:ddd
t=0 0
m=video 3500 RTP/AVP 98
b=AS:75
a=crr:qos local sendrecv
a=crr:qos remote sendrecv
a=des:qos mandatory local sendrecv
a=des:qos none remote sendrecv
a=rtpmap:98 H263
m=audio 3556 RTP/AVP 97
b=AS:25.4
a=crr:qos local sendrecv
a=crr:qos remote sendrecv
a=des:qos mandatory local sendrecv
a=des:qos none remote sendrecv
a=rtpmap:97 AMR
a=fmtp:97 mode-set=0,2,5,7; maxframes
```

early SDP The early-session SDP answer (early SDP_A1) contains a set of codecs supported by UE#1 to be used for CAT. The preconditions are indicated as fulfilled.

11-12 PRACK request (CAT-AS to UE#2) see example in table A.4.4-11

CAT-AS forwards the SIP PRACK request without early-session SDP answer to UE#2.

Table A.4.4-11: PRACK request (CAT-AS to UE#2)

```
PRACK sip:user2_public1@home2.net;gr=urn:uuid:2ad8950e-48a5-4a74-8d99-ad76cc7fc74SIP/2.0
Via: SIP/2.0/UDP catas.home2.net;branch=z9hG4bK614Q63.1, SIP/2.0/UDP
scscf2.home2.net;branch=z9hG4bK464z73.1, SIP/2.0/UDP
scscf1.home1.net;branch=z9hG4bK351b51.1, SIP/2.0/UDP
pcscf1.visited1.net;branch=z9hG4bK582f12.1, SIP/2.0/UDP
[5555::aaa:bbb:ccc:ddd]:1357;comp=sigcomp;branch=z9hG4bKna234s7
Max-Forwards: 66
Privacy:
From:
To:
Call-ID:
Cseq: 128 PRACK
Contact:
Content-Length: 0
```

13-16 200 (OK) response to PRACK (UE#2 to UE#1)

UE#2 sends a SIP 200 (OK) response for the SIP PRACK request to UE#1.

17-18 180 (Ringing) response to INVITE (UE#2 to CAT-AS)

The called party is alerted. UE#2 sends a SIP 180 (Ringing) provisional response for the INVITE request towards UE#1.

The CAT-AS terminates the provisional response.

The CAT-AS instructs the MRF to play CAT media.

19-20 200 (OK) response to INVITE (UE#2 to CAT-AS)

The called party answers the call. UE#2 sends a SIP 200 (OK) final response for the SIP INVITE request towards UE#1.

The CAT-AS instructs the MRF to stop CAT media.

21-22 200 (OK) response to INVITE (CAT-AS to UE#1)

The CAT-AS forwards the SIP 200 (OK) response to UE#1.

A regular session is established between UE#1 and UE#2.

The early session between UE#1 and the CAT-AS is terminated.

23-24 ACK request (UE#1 to UE#2)

UE#1 sends a SIP ACK request, which acknowledges the 200 (OK) final response, to UE#2.

A.5 CAT Gateway model signalling flows

A.5.1 Introduction

The following flows show establishment of a session between UE#1 and UE#2, using the gateway model as defined in RFC 3960 [8] to provide CAT to UE#1. The following flows are included:

- subclause A.5.2 shows CAT, using the gateway model, when UE#1 and UE#2 have resources available;
- subclause A.5.3 shows CAT, using the gateway model, when UE#1 does not have resources available;
- subclause A.5.4 shows CAT, using the gateway model, when UE#2 does not have resources available;

A.5.2 CAT when UE#1 and UE#2 have resources available

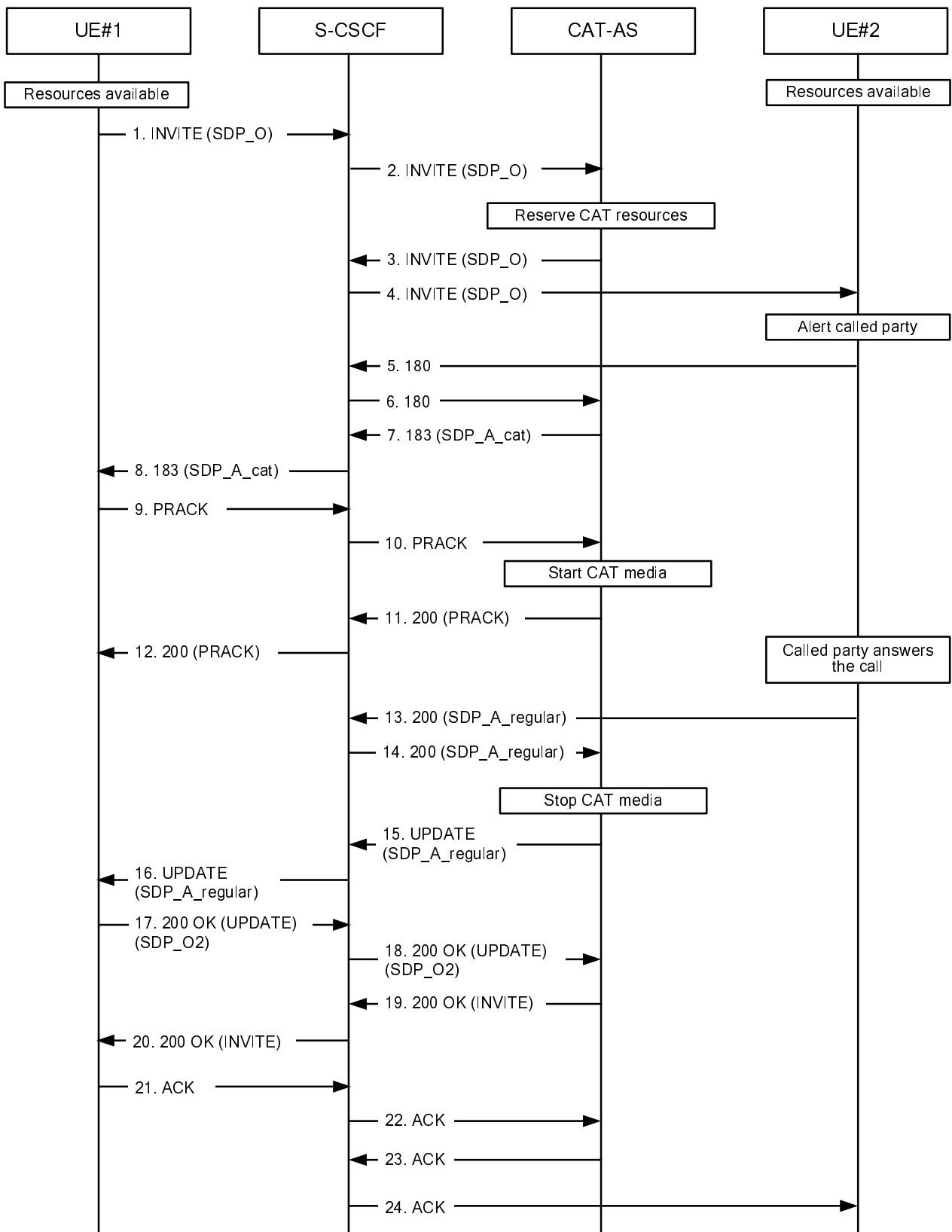

Figure A.5.1-1: CAT, no resource reservation

1 INVITE request (UE#1 to CAT-AS) see example in table A.5.2-1

UE#1 sends a SIP INVITE request to the intermediate IM CN subsystem.

Table A.5.2-1: INVITE request (UE#1 to CAT-AS)

```

INVITE tel:+1-212-555-2222 SIP/2.0
Via: SIP/2.0/UDP [5555::aaa:bbb:ccc:ddd]:1357;comp=sigcomp;branch=z9hG4bKnashds7
Max-Forwards: 70
Route: <sip:pcscf1.visited1.net:7531;lr;comp=sigcomp>, <sip:scscf1.home1.net;lr>
P-Preferred-Identity: "John Doe" <sip:user1_public1@home1.net>
P-Access-Network-Info: 3GPP-UTRAN-TDD; utran-cell-id-3gpp=234151D0FCE11
P-Preferred-Service: urn:urn-7:3gpp-service.ims.icsi.mmtel
Accept-Contact: *;+g.3gpp.icsi_ref="urn%3Aurn-7%3gpp-service.ims.icsi.mmtel"
Privacy: none
P-Early-Media: supported
From: <sip:user1_public1@home1.net>;tag=171828
To: <tel:+1-212-555-2222>
Call-ID: cb03a0s09a2sdfglkj490333
Cseq: 127 INVITE
Require: sec-agree
Supported: precondition, 100rel, gruu, 199
Proxy-Require: sec-agree
Security-Verify: ipsec-3gpp; q=0.1; alg=hmac-sha-1-96; spi-c=98765432; spi-s=87654321;
port-c=8642; port-s=7531
Contact: <sip: user1_public1@home1.net;gr=urn:uuid:f81d4fae-7dec-11d0-a765-
00a0c91e6bf6>;+g.3gpp.icsi-ref="urn%3Aurn-7%3gpp-service.ims.icsi.mmtel"
Allow: INVITE, ACK, CANCEL, BYE, PRACK, UPDATE, REFER, MESSAGE
Accept:application/sdp, application/3gpp-ims+xml
Content-Type: application/sdp
Content-Length: (...)

v=0
o=- 2987933615 2987933615 IN IP6 5555::aaa:bbb:ccc:ddd
s=-
c=IN IP6 5555::aaa:bbb:ccc:ddd
t=0 0
m=video 3400 RTP/AVP 98
a=tcap:1 RTP/AVPF
a=pcfg:1 t=1
b=AS:75
a=curr:qos local sendrecv
a=curr:qos remote none
a=des:qos mandatory local sendrecv
a=des:qos none remote sendrecv
a=rtpmap:98 H263
a=fmtp:98 profile-level-id=0
m=audio 3456 RTP/AVP 97 96
a=tcap:1 RTP/AVPF
a=pcfg:1 t=1
b=AS:25.4
a=curr:qos local sendrecv
a=curr:qos remote none
a=des:qos mandatory local sendrecv
a=des:qos none remote sendrecv
a=rtpmap:97 AMR
a=fmtp:97 mode-set=0,2,5,7; maxframes=2
a=rtpmap:96 telephone-event

```

Supported: The UE indicates support for GRUU, 199 responses, reliable provisional responses and preconditions.

P-Early-Media: The UE indicates support for the P-Early-Media header.

SDP The SDP offer (SDP_O) contains a set of codecs supported by UE#1 and desired by the calling user for this session. The local preconditions are indicated as fulfilled.

2 INVITE request (S-CSCF to CAT-AS)

The S-CSCF forwards the SIP INVITE request to the CAT-AS.

The CAT-AS instructs the MRF to reserve CAT resources.

3-4 INVITE request (CAT-AS to UE#2)

The CAT-AS forwards the request to UE#2.

5-7 180 (Ringing) provisional response (UE#2 to CAT-AS)

The called party is alerted. UE#2 sends a SIP 180 (Ringing) provisional response for the INVITE request to the CAT-AS.

The CAT-AS terminates the provisional response.

7-8 183 (Session Progress) provisional response (CAT-AS to UE#1) see example in table A.5.2-2

The CAT-AS sends a reliable SIP 183 (Session Progress) provisional response to UE#1.

Table A.5.2-2: 183 (Session Progress) response (CAT-AS to UE#1)

```
SIP/2.0 183 Session Progress
Via: SIP/2.0/UDP scscf2.home2.net;branch=z9hG4bK764z87.1, SIP/2.0/UDP
    icscf2_s.home2.net;branch=z9hG4bK871y12.1, SIP/2.0/UDP
    scscf1.home1.net;branch=z9hG4bK332b23.1, SIP/2.0/UDP
    pcscf1.visited1.net;branch=z9hG4bK240f34.1, SIP/2.0/UDP
    [5555::aaa:bbb:ccc:ddd]:1357;comp=sigcomp;branch=z9hG4bKnashds7
Record-Route: <sip:scscf2.home2.net;lr>, <sip:scscf1.home1.net;lr>,
    <sip:pcscf1.visited1.net;lr>
From:
To: <tel:+1-212-555-2222>;tag=2236
Call-ID:
Cseq:
Require: 100rel
Allow: INVITE, ACK, CANCEL, BYE, PRACK, UPDATE, REFER, MESSAGE
RSeq: 9022
P-Early-Media: sendrecv
Contact: <sip:catas.home2.net>;+g.3gpp.icsi-ref="urn%3Aurn-7%3gpp-service.ims.icsi.mmtel"
Content-Type: application/sdp
Content-Length: (...)

v=0
o=- 29879336156 29879336156 IN IP6 5555::ccc:aaa:abc:abc
s=-
c=IN IP6 5555::ccc:aaa:abc:abc
t=0 0
m=video 340051372 RTP/AVPF 98
a=acfg:1 t=1
b=AS:75
a=curr:qos local sendrecv
a=curr:qos remote sendrecv
a=des:qos mandatory local sendrecv
a=des:qos mandatory remote sendrecv
a=rtptime:98 H263
a=fmtp:98 profile-level-id=0
m=audio 49170 RTP/AVPF 97 96
a=acfg:1 t=1
b=AS:25.4
a=curr:qos local sendrecv
a=curr:qos remote sendrecv
a=des:qos mandatory local sendrecv
a=des:qos mandatory remote sendrecv
a=rtptime:97 AMR
a=fmtp:97 mode-set=0,2,5,7; maxframes
a=rtptime:96 telephone-event
```

P-Early-Media: The CAT-AS requests authorization for early media.

SDP The SDP answer (SDP_A_cat) contains a set of codecs supported to be used for CAT. The SDP content is based on information received from the MRF. The local preconditions are indicated as fulfilled.

9-10 PRACK request (UE#1 to CAT-AS)

UE#1 sends a SIP PRACK request, which acknowledges the SIP 183 (Session Progress) provisional response, to the CAT-AS.

The CAT-AS instructs the MRF to play CAT media.

11-12 200 (OK) response to PRACK (CAT-AS to UE#1)

The CAT-AS sends a SIP 200 (OK) response for the SIP PRACK request to UE#1.

13-14 200 (OK) response to INVITE (UE#2 to CAT-AS) see example in table A.5.2-3

The called party answers the call. UE#2 sends a SIP 200 (OK) final response for the SIP INVITE request to the CAT-AS.

The CAT-AS instructs the MRF to stop CAT media.

Table A.5.2-3: 200 (OK) response (UE#2 to CAT-AS)

```
SIP/2.0 200 OK
Via: SIP/2.0/UDP pcscf2.visited2.net:5088;comp=sigcomp;branch=z9hG4bK361k21.1, SIP/2.0/UDP
scscf2.home2.net;branch=z9hG4bK764XC12.1, SIP/2.0/UDP
catas.home2.net;branch=z9hG4bK764Q32.1, SIP/2.0/UDP
scscf2.home2.net;branch=z9hG4bK764z87.1, SIP/2.0/UDP
icscf2_s.home2.net;branch=z9hG4bK871y12.1, SIP/2.0/UDP
scscf1.home1.net;branch=z9hG4bK332b23.1, SIP/2.0/UDP
pcscf1.visited1.net;branch=z9hG4bK240f34.1, SIP/2.0/UDP
[5555::aaa:bbb:ccc:ddd]:1357;comp=sigcomp;branch=z9hG4bKnashds7
Record-Route: <sip:pcscf2.visited2.net:5088;lr>, <sip:scscf2.home2.net;lr>,
<sip:catas.home2.net;lr>, <sip:scscf2.home2.net;lr>, <sip:scscf1.home1.net;lr>,
<sip:pcscf1.visited1.net;lr>
From:
To: <tel:+1-212-555-2222>;tag=2236
Call-ID:
Cseq:
Allow: INVITE, ACK, CANCEL, BYE, PRACK, UPDATE, REFER, MESSAGE
Contact: <sip:user2_public1@home2.net;gr=urn:uuid:2ad8950e-48a5-4a74-8d99-
ad76cc7fc74>;+g.3gpp.icsi-ref="urn%3Aurn-7%3gpp-service.ims.icsi.mmstel"
Content-Type: application/sdp
Content-Length: (...)

v=0
o=- 29879336157 29879336157 IN IP6 6666::eee:fff:aaa:bbb
s=-
c=IN IP6 6666::eee:fff:aaa:bbb
t=0 0
m=video 7398 RTP/AVPF 98
b=AS:75
a=curr:qos local sendrecv
a=curr:qos remote sendrecv
a=des:qos mandatory local sendrecv
a=des:qos mandatory remote sendrecv
a=rtptime:98 H263
a=fmtp:98 profile-level-id=0
m=audio 8386 RTP/AVPF 97 96
b=AS:25.4
a=curr:qos local sendrecv
a=curr:qos remote sendrecv
a=des:qos mandatory local sendrecv
a=des:qos mandatory remote sendrecv
a=rtptime:97 AMR
a=fmtp:97 mode-set=0,2,5,7; maxframes
a=rtptime:96 telephone-event
```

SDP The SDP answer (SDP_A_regular) contains a set of codecs to be used for the session. If preconditions are used, they are indicated as fulfilled.

15-16 UPDATE request (CAT-AS to UE#1) see example in table A.5.2-4

The CAT-AS sends an UPDATE request containing values received in the 200 OK from UE#2.

Session between UE#1 and CAT-AS is replaced with session between UE#1 and UE#2.

Table A.5.2-4: UPDATE request (CAT-AS to UE#1)

```

UPDATE sip:user1_public1@home1.net;gr=urn:uuid:f81d4fae-7dec-11d0-a765-00a0c91e6bf6 SIP/2.0
Via: SIP/2.0/UDP [5555::ccc:aaa:abc:abc]:8805;branch=z9hG4bK182D87.1
Max-Forwards: 70
Route: <sip:scscf1.home1.net;lr>, <sip:pcscf1.visited1.net;lr>
From: <tel:+1-212-555-2222>;tag=2236
To: <sip:user1_public1@home1.net>;tag=171828
Call-ID:
Cseq: 12814111 UPDATE
Require:
Contact: <sip:user2_public1@home2.net;gr=urn:uuid:2ad8950e-48a5-4a74-8d99-
ad76cc7fc74>;g.3gpp.icsi-ref="urn%3Aurn-7%3gpp-service.ims.icsi.mmstel"
Content-Type: application/sdp
Content-Length: (...)

v=0
o=- 2987933617 2987933617 IN IP6 5555::ccc:aaa:abc:abc
s=-
c=IN IP6 6666::eee:fff:aaa:bbb
t=0 0
m=video 7398 RTP/AVPF 98
b=AS:75
a=curr:qos local sendrecv
a=curr:qos remote sendrecv
a=des:qos mandatory local sendrecv
a=des:qos mandatory remote sendrecv
a=rtpmap:98 H263
a=fmtp:98 profile-level-id=0
m=audio 8386 RTP/AVPF 97 96
b=AS:25.4
a=curr:qos local sendrecv
a=curr:qos remote sendrecv
a=des:qos mandatory local sendrecv
a=des:qos mandatory remote sendrecv
a=rtpmap:97 AMR
a=fmtp:97 mode-set=0,2,5,7; maxframes
a=rtpmap:96 telephone-event

```

SDP The SDP answer (SDP_A_regular) contains a set of codecs to be used for the session. The SDP content is based on information received from previous 200 (OK) response. The local preconditions are indicated as fulfilled.

17-18 200 (OK) response (UE#1 to CAT-AS)

UE#1 sends a SIP 200 (OK) response for the SIP UPDATE request to CAT-AS. UE#1 includes a SDP answer (SDP_O2) in the 200 (OK) response to the corresponding SIP UPDATE request.

19-20 200 (OK) response to INVITE (CAT-AS to UE#1)

The CAT-AS sends the SIP 200 (OK) response for the (initial) SIP INVITE request to UE#1.

21-22 ACK request (UE#1 to CAT-AS)

UE#1 sends a SIP ACK request, which acknowledges the SIP 200 (OK) final response, to CAT-AS.

23-24 ACK request (CAT-AS to UE#2)

CAT-AS sends a SIP ACK request, which acknowledges the SIP 200 (OK) final response, to UE#2.

NOTE 2: The ACK request from CAT-AS towards UE#2 may be sent after receiving 200 OK from UE#2 in step 14.

A.5.3 CAT when UE#1 does not have required resources available while UE#2 has resources available

Figure A.5.3-1 shows an example call flow for CAT when UE#1 does not have required resources available and UE#2 have resources available.

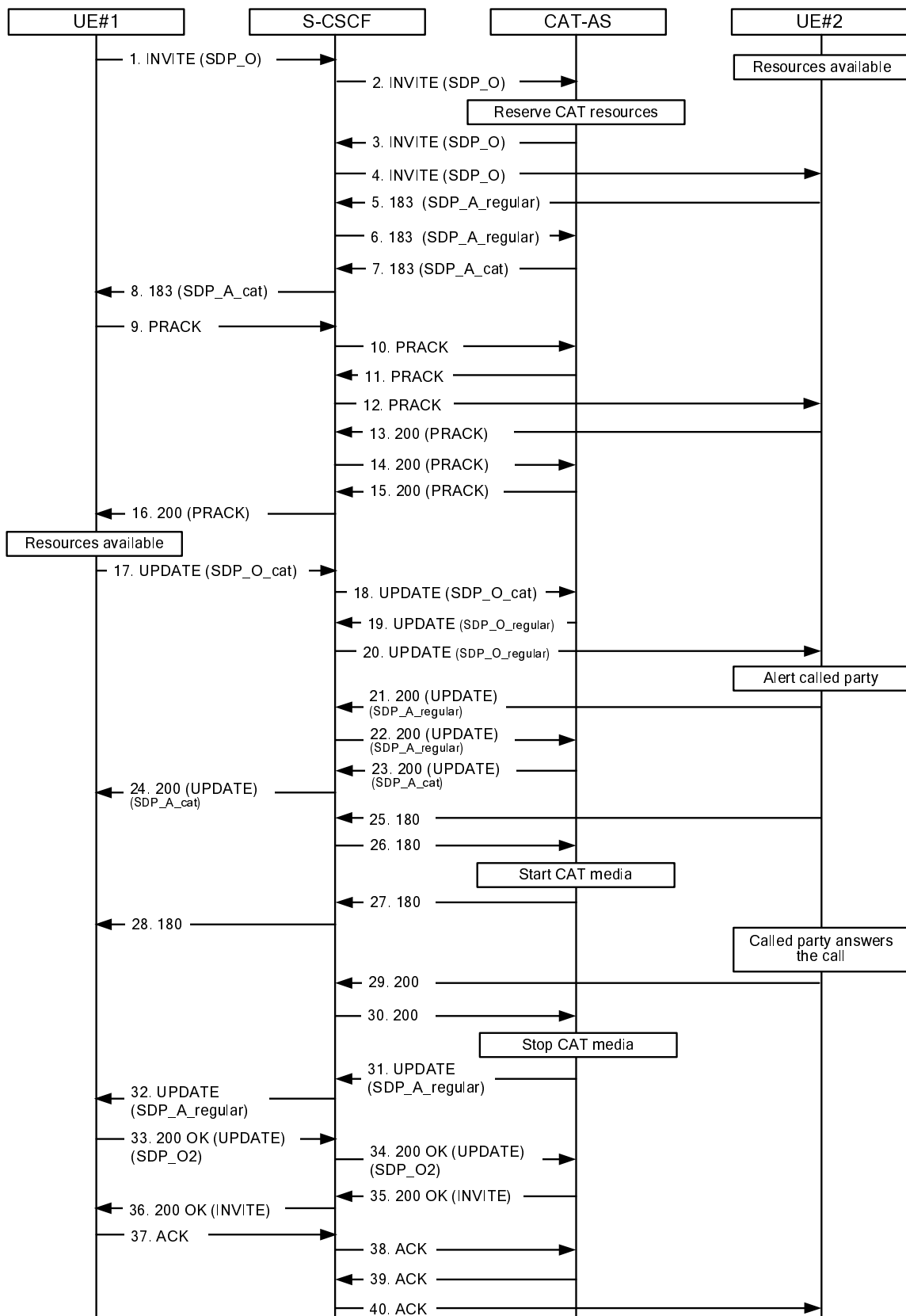

Figure A.5.3-1: CAT, UE#1 does not have required resources available

1 INVITE request (UE#1 to CAT-AS) see example in table A.5.3-1

UE#1 sends a SIP INVITE request to the intermediate IM CN subsystem.

Table A.5.3-1: INVITE request (UE#1 to CAT-AS)

```

INVITE tel:+1-212-555-2222 SIP/2.0
Via: SIP/2.0/UDP [5555::aaa:bbb:ccc:ddd]:1357;comp=sigcomp;branch=z9hG4bKnashds7
Max-Forwards: 70
Route: <sip:pcscf1.visited1.net:7531;lr;comp=sigcomp>, <sip:scscf1.home1.net;lr>
P-Preferred-Identity: "John Doe" <sip:user1_public1@home1.net>
P-Access-Network-Info: 3GPP-UTRAN-TDD; utran-cell-id-3gpp=234151D0FCE11
P-Preferred-Service: urn:urn-7:3gpp-service.ims.icsi.mmtel
Accept-Contact: *;+g.3gpp.icsi-ref="urn%3Aurn-7%3gpp-service.ims.icsi.mmtel"
Privacy: none
P-Early-Media: supported
From: <sip:user1_public1@home1.net>;tag=171828
To: <tel:+1-212-555-2222>
Call-ID: cb03a0s09a2sdfglkj490333
Cseq: 127 INVITE
Require: sec-agree
Supported: precondition, 100rel, gruu, 199
Proxy-Require: sec-agree
Security-Verify: ipsec-3gpp; q=0.1; alg=hmac-sha-1-96; spi-c=98765432; spi-s=87654321;
port-c=8642; port-s=7531
Contact: <sip:user1_public1@home1.net;gr=urn:uuid:f81d4fae-7dec-11d0-a765-00a0c91e6bf6
>;+g.3gpp.icsi-ref="urn%3Aurn-7%3gpp-service.ims.icsi.mmtel"
Allow: INVITE, ACK, CANCEL, BYE, PRACK, UPDATE, REFER, MESSAGE
Accept: application/sdp, application/3gpp-ims+xml
Content-Type: application/sdp
Content-Length: (...)

v=0
o=- 2987933615 2987933615 IN IP6 5555::aaa:bbb:ccc:ddd
s=-
c=IN IP6 5555::aaa:bbb:ccc:ddd
t=0 0
m=video 3400 RTP/AVP 98
a=tcap:1 RTP/AVPF
a=pcfg:1 t=1
b=AS:75
a=curr:qos local none
a=curr:qos remote none
a=des:qos mandatory local sendrecv
a=des:qos none remote sendrecv
a=inactive
a=rtptime:98 H263
a=fmtp:98 profile-level-id=0
m=audio 3456 RTP/AVP 97 96
a=tcap:1 RTP/AVPF
a=pcfg:1 t=1
b=AS:25.4
a=curr:qos local none
a=curr:qos remote none
a=des:qos mandatory local sendrecv
a=des:qos none remote sendrecv
a=inactive
a=rtptime:97 AMR
a=fmtp:97 mode-set=0,2,5,7; maxframes=2
a=rtptime:96 telephone-event

```

Supported: The UE indicates support for GRUU, 199 responses, reliable provisional responses and preconditions.

P-Early-Media: The UE indicates support for the P-Early-Media header.

SDP The SDP offer (SDP_O) contains a set of codecs supported by UE#1 and desired by the calling user for this session. The local preconditions are indicated as not fulfilled, and media are set to "inactive".

2 INVITE request (S-CSCF to CAT-AS)

The S-CSCF forwards the SIP INVITE request to the CAT-AS.

The CAT-AS instructs the MRF to reserve CAT resources.

3-4 INVITE request (CAT-AS to UE#2)

The CAT-AS forwards the request to UE#2.

5-6 183 (Session Progress) provisional response (UE#2 to CAT-AS) see example in table A.5.3-2

UE#2 sends a reliable SIP 183 (Session Progress) provisional response for the INVITE request to the CAT-AS.

The CAT-AS terminates the provisional response.

Table A.5.3-2: 183 (Session Progress) provisional response (UE#2 to CAT-AS)

```
SIP/2.0 183 Session Progress
Via: SIP/2.0/UDP pcscf2.visited2.net:5088;comp=sigcomp;branch=z9hG4bK361k21.1, SIP/2.0/UDP
scscf2.home2.net;branch=z9hG4bK764XC12.1, SIP/2.0/UDP
catas.home2.net;branch=z9hG4bK764Q32.1, SIP/2.0/UDP
scscf2.home2.net;branch=z9hG4bK764z87.1, SIP/2.0/UDP
icscf2_s.home2.net;branch=z9hG4bK871y12.1, SIP/2.0/UDP
scscf1.home1.net;branch=z9hG4bK332b23.1, SIP/2.0/UDP
pcscf1.visited1.net;branch=z9hG4bK240f34.1, SIP/2.0/UDP
[5555::aaa:bbb:ccc:ddd]:1357;comp=sigcomp;branch=z9hG4bKnashds7
Record-Route: <sip:pcscf2.visited2.net:5088;lr;comp=sigcomp>, <sip:scscf2.home2.net;lr>,
<sip:catas.home2.net;lr>, <sip:scscf2.home2.net;lr>, <sip:scscf1.home1.net;lr>,
<sip:pcscf1.visited1.net;lr>
From:
To: <tel:+1-212-555-2222>;tag=2236
Call-ID:
Cseq:
Require: 100rel
RSeq: 9022
P-Early-Media: sendrecv
Allow: INVITE, ACK, CANCEL, BYE, PRACK, UPDATE, REFER, MESSAGE
Contact: <sip:user2_public1@home2.net;gr=urn:uuid:2ad8950e-48a5-4a74-8d99-
ad76cc7fc74>;+g.3gpp.icsi-ref="urn%3Aurn-7%3gpp-service.ims.icsi.mmmtel"
Content-Type: application/sdp
Content-Length: (...)

v=0
o=- 29879336157 29879336157 IN IP6 6666::eee:fff:aaa:bbb
s=-
c=IN IP6 6666::eee:fff:aaa:bbb
t=0 0
m=video 7398 RTP/AVPF 98
a=acfg:1 t=1
b=AS:75
a=crr:qos local sendrecv
a=crr:qos remote none
a=des:qos mandatory local sendrecv
a=des:qos mandatory remote sendrecv
a=inactive
a=rtpmap:98 H263
a=fmtp:98 profile-level-id=0
m=audio 8386 RTP/AVPF 97 96
a=acfg:1 t=1
b=AS:25.4
a=crr:qos local sendrecv
a=crr:qos remote none
a=des:qos mandatory local sendrecv
a=des:qos mandatory remote sendrecv
a=inactive
a=rtpmap:97 AMR
a=fmtp:97 mode-set=0,2,5,7; maxframes
a=rtpmap:96 telephone-event
```

SDP The SDP answer (SDP_A_regular) contains a set of codecs to be used for the session. The local preconditions are indicated as not fulfilled, and media are set to "inactive".

7-8 183 (Session Progress) provisional response (CAT-AS to UE#1) see example in table A.5.3-3

The CAT-AS sends a reliable SIP 183 (Session Progress) provisional response to UE#1. The CAT-AS shall take into account, when creating the SDP message, the media indicated by UE#2 in the previously received 183 provisional response and the one used by MRF for the media for CAT.

Table A.5.3-3: 183 (Session Progress) response (CAT-AS to UE#1)

```

SIP/2.0 183 Session Progress
Via: SIP/2.0/UDP scscf2.home2.net;branch=z9hG4bK764z87.1, SIP/2.0/UDP
    icscf2_s.home2.net;branch=z9hG4bK871y12.1, SIP/2.0/UDP
    scscf1.home1.net;branch=z9hG4bK332b23.1, SIP/2.0/UDP
    pcscf1.visited1.net;branch=z9hG4bK240f34.1, SIP/2.0/UDP
    [5555::aaa:bbb:ccc:ddd]:1357;comp=sigcomp;branch=z9hG4bKnashds7
Record-Route: <sip:scscf2.home2.net;lr>, <sip:scscf1.home1.net;lr>,
    <sip:pcscf1.visited1.net;lr>
From:
To: <tel:+1-212-555-2222>;tag=2236
Call-ID:
Cseq:
Require: 100rel
Allow: INVITE, ACK, CANCEL, BYE, PRACK, UPDATE, REFER, MESSAGE
RSeq: 9022
P-Early-Media: sendrecv
Contact: <sip:catas.home2.net>;+g.3gpp.icsi-ref="urn%3Aurn-7%3gpp-service.ims.icsi.mmtel"
Content-Type: application/sdp
Content-Length: (...)

v=0
o=- 29879336156 29879336156 IN IP6 5555::ccc:aaa:abc:abc
s=-
c=IN IP6 5555::ccc:aaa:abc:abc
t=0 0
m=video 51372 RTP/AVPF 98
a=acfg:1 t=1
b=AS:75
a=curr:qos local sendrecv
a=curr:qos remote none
a=des:qos mandatory local sendrecv
a=des:qos mandatory remote sendrecv
a=inactive
a=rtpmap:98 H263
a=fmtp:98 profile-level-id=0
m=audio 49170 RTP/AVPF 97 96
a=acfg:1 t=1
b=AS:25.4
a=curr:qos local sendrecv
a=curr:qos remote none
a=des:qos mandatory local sendrecv
a=des:qos mandatory remote sendrecv
a=inactive
a=rtpmap:97 AMR
a=fmtp:97 mode-set=0,2,5,7; maxframes
a=rtpmap:96 telephone-event

```

P-Early-Media: The CAT-AS requests authorization for early media.

SDP The SDP answer (SDP_A_cat) contains a set of codecs supported to be used for CAT. The SDP content is based on information received from the MRF and information in the previously received 183 provisional response from UE#2. The local preconditions are indicated as not fulfilled, and media are set to "inactive".

9-12 PRACK request (UE#1 to CAT-AS, and to UE#2)

UE#1 sends a SIP PRACK request, which acknowledges the SIP 183 (Session Progress) provisional response, to the CAT-AS, which is further sent to UE#2.

13-16 200 (OK) response to PRACK (UE#2 to CAT-AS, and to UE#1)

UE#2 sends a SIP 200 (OK) response for the SIP PRACK request to CAT-AS, which is further sent to UE#1.

17-18 UPDATE request (UE#1 to CAT-AS) - see example in table A.5.3-4

UE#1 indicates that it can send and receive media as the necessary resources are available.

Table A.5.3-4: UPDATE request (UE#1 to CAT-AS)

```

UPDATE sip:user2_public1@home2.net;gr=urn:uuid:2ad8950e-48a5-4a74-8d99-ad76cc7fc74 SIP/2.0
Via: SIP/2.0/UDP [5555::aaa:bbb:ccc:ddd]:1357;comp=sigcomp;branch=z9hG4bKnashds7

```

```

Max-Forwards: 70
Route: <sip:pcscf1.visited1.net;lr>, <sip:scscf1.home1.net;lr>, <sip:scscf2.home2.net;lr>
From: <sip:user1_public1@home1.net>;tag=171828
To: <tel:+1-212-555-2222>;tag=2236
Call-ID:
Cseq: 129 UPDATE
Require: sec-agree
Proxy-Require: sec-agree
Security-Verify: ipsec-3gpp; q=0.1; alg= hmac-sha-1-96; ealg=aes-cbc; spi-c=98765432; spi-
s=87654321; port-c=8642; port-s=7531
Contact: <sip:user1_public1@home1.net;gr=urn:uuid:f81d4fae-7dec-11d0-a765-
00a0c91e6bf6>;+g.3gpp.icsi-ref="urn%3Aurn-7%3gpp-service.ims.icsi.mmtel"
Content-Type: application/sdp
Content-Length: (...)

v=0
o=- 2987933615 2987933616 IN IP6 5555::aaa:bbb:ccc:ddd
s=-
c=IN IP6 5555::aaa:bbb:ccc:ddd
t=0 0
m=video 3400 RTP/AVPF 98
b=AS:75
a=curr:qos local sendrecv
a=curr:qos remote sendrecv
a=des:qos mandatory local sendrecv
a=des:qos none remote sendrecv
a=rtpmap:98 H263
a=fmtp:98 profile-level-id=0
m=audio 3456 RTP/AVPF 97 96
b=AS:25.4
a=curr:qos local sendrecv
a=curr:qos remote sendrecv
a=des:qos mandatory local sendrecv
a=des:qos none remote sendrecv
a=rtpmap:97 AMR
a=fmtp:97 mode-set=0,2,5,7; maxframes=2
a=rtpmap:96 telephone-event

```

SDP The SDP answer (SDP_O_cat) contains a set of codecs supported to be used for CAT. The SDP content is based on information received from the MRF. The local preconditions are indicated as fulfilled.

19-20 UPDATE request (CAT-AS to UE#2) - see example in table A.5.3-5

CAT-AS indicates to UE#2 that UE#1 can send and receive media as the necessary resources are available.

Table A.5.3-5: UPDATE request (CAT-AS to UE#2)

```

UPDATE sip:user2_public1@home2.net;gr=urn:uuid:2ad8950e-48a5-4a74-8d99-
ad76cc7fc74;comp=sigcomp SIP/2.0
Via: SIP/2.0/UDP scscf2.home2.net;branch=z9hG4bK764z87.1, SIP/2.0/UDP
icscf2_s.home2.net;branch=z9hG4bK871y12.1, SIP/2.0/UDP
scscf1.home1.net;branch=z9hG4bK332b23.1, SIP/2.0/UDP
pcscf1.visited1.net;branch=z9hG4bK240f34.1, SIP/2.0/UDP
[5555::aaa:bbb:ccc:ddd]:1357;comp=sigcomp;branch=z9hG4bKnashds7
Max-Forwards: 66
Route: <sip:scscf2.home2.net;lr>
From: <sip:user1_public1@home1.net>;tag=171828
To: <tel:+1-212-555-2222>;tag=2236
Call-ID:
Cseq: 56101 UPDATE
Require: sec-agree
Proxy-Require: sec-agree
Security-Verify: ipsec-3gpp; q=0.1; alg= hmac-sha-1-96; ealg=aes-cbc; spi-c=98765432; spi-
s=87654321; port-c=8642; port-s=7531
Contact: <sip:user1_public1@home1.net;gr=urn:uuid:f81d4fae-7dec-11d0-a765-
00a0c91e6bf6>;+g.3gpp.icsi-ref="urn%3Aurn-7%3gpp-service.ims.icsi.mmtel"
Content-Type: application/sdp
Content-Length: (...)

v=0
o=- 2987933615 2987933616 IN IP6 5555::ccc:aaa:abc:abc
s=-
c=IN IP6 5555::aaa:bbb:ccc:ddd
t=0 0

```

```

m=video 3400 RTP/AVPF 98
b=AS:75
a=curr:qos local sendrecv
a=curr:qos remote sendrecv
a=des:qos mandatory local sendrecv
a=des:qos none remote sendrecv
a=rtpmap:98 H263
a=fmtp:98 profile-level-id=0
m=audio 3456 RTP/AVPF 97 96
b=AS:25.4
a=curr:qos local sendrecv
a=curr:qos remote sendrecv
a=des:qos mandatory local sendrecv
a=des:qos none remote sendrecv
a=rtpmap:97 AMR
a=fmtp:97 mode-set=0,2,5,7; maxframes=2
a=rtpmap:96 telephone-event

```

SDP The SDP answer (SDP_O_regular) contains a set of codecs supported to be used for CAT. The SDP content is based on information received from the MRF. The local preconditions are indicated as fulfilled.

21-22 200 (OK) response (UE#2 to CAT-AS) - see example in table A.5.3-6

UE#2 sends a SIP 200 (OK) response for the SIP UPDATE request to CAT-AS. The SDP shall contain information relevant to the media that will be used after the session is established.

CAT-AS shall store the relevant information in SDP for later use in step 31.

Table A.5.3-6: 200 (OK) response (UE#2 to CAT-AS)

```

SIP/2.0 200 OK
Via: SIP/2.0/UDP pcscf2.visited2.net:5088;comp=sigcomp;branch=z9hG4bK361k21.1, SIP/2.0/UDP
scscf2.home2.net;branch=z9hG4bK764XC12.1, SIP/2.0/UDP
catas.home2.net;branch=z9hG4bK764Q32.1, SIP/2.0/UDP
scscf2.home2.net;branch=z9hG4bK764z87.1, SIP/2.0/UDP
icscf2_s.home2.net;branch=z9hG4bK871y12.1, SIP/2.0/UDP
scscf1.home1.net;branch=z9hG4bK332b23.1, SIP/2.0/UDP
pcscf1.visited1.net;branch=z9hG4bK240f34.1, SIP/2.0/UDP
[5555:aaa:bbb:ccc:ddd]:1357;comp=sigcomp;branch=z9hG4bKnashds7
Record-Route: <sip:pcscf2.visited2.net:5088;lr;comp=sigcomp>, <sip:scscf2.home2.net;lr>,
<sip:catas.home2.net;lr>, <sip:scscf2.home2.net;lr>, <sip:scscf1.home1.net;lr>,
<sip:pcscf1.visited1.net;lr>
From:
To: <tel:+1-212-555-2222>;tag=2236
Call-ID:
Cseq:
Allow: INVITE, ACK, CANCEL, BYE, PRACK, UPDATE, REFER, MESSAGE
Contact: <sip:user2_public1@home2.net;gr=urn:uuid:2ad8950e-48a5-4a74-8d99-
ad76cc7fc74>;+g.3gpp.icsi-ref="urn%3Aurn-7%3gpp-service.ims.icsi.mmtel"
Content-Type: application/sdp
Content-Length: (...)

v=0
o=- 29879336157 29879336157 IN IP6 6666::eee:fff:aaa:bbb
s=-
c=IN IP6 6666::eee:fff:aaa:bbb
t=0 0
m=video 7398 RTP/AVPF 98
b=AS:75
a=curr:qos local sendrecv
a=curr:qos remote sendrecv
a=des:qos mandatory local sendrecv
a=des:qos mandatory remote sendrecv
a=rtpmap:98 H263
a=fmtp:98 profile-level-id=0
m=audio 8386 RTP/AVPF 97 96
b=AS:25.4
a=curr:qos local sendrecv
a=curr:qos remote sendrecv
a=des:qos mandatory local sendrecv
a=des:qos mandatory remote sendrecv
a=rtpmap:97 AMR
a=fmtp:97 mode-set=0,2,5,7; maxframes

```

```
a=rtpmap:96 telephone-event
```

SDP The SDP answer (SDP_A_regular) contains a set of codecs to be used for the session. The local preconditions are indicated as fulfilled.

23-24 200 (OK) response (CAT-AS to UE#1) - see example in table A.5.3-7

CAT-AS sends a SIP 200 (OK) response for the SIP UPDATE request to UE#1. The SDP shall contain information relevant to the media for CAT used by the MRF.

Table A.5.3-7: 200 (OK) response (CAT-AS to UE#1)

```
SIP/2.0 200 OK
Via: SIP/2.0/UDP scscf2.home2.net;branch=z9hG4bK764z87.1, SIP/2.0/UDP
    icscf2_s.home2.net;branch=z9hG4bK871y12.1, SIP/2.0/UDP
    scscf1.home1.net;branch=z9hG4bK332b23.1, SIP/2.0/UDP
    pcscf1.visited1.net;branch=z9hG4bK240f34.1, SIP/2.0/UDP
    [5555::aaa:bbb:ccc:ddd]:1357;comp=sigcomp;branch=z9hG4bKnashds7
Record-Route: <sip:scscf2.home2.net;lr>, <sip:scscf1.home1.net;lr>,
    <sip:pcscf1.visited1.net;lr>
From:
To: <tel:+1-212-555-2222>;tag=2236
Call-ID:
Cseq:
Allow: INVITE, ACK, CANCEL, BYE, PRACK, UPDATE, REFER, MESSAGE
Contact: <sip:catas.home2.net>;+g.3gpp.icsi-ref="urn%3Aurn-7%3gpp-service.ims.icsi.mmtel"
Content-Type: application/sdp
Content-Length: (...)

v=0
o=- 29879336156 29879336157 IN IP6 5555::ccc:aaa:abc:abc
s=-
c=IN IP6 5555::ccc:aaa:abc:abc
t=0 0
m=video 7398 RTP/AVPF 98
b=AS:75
a=curr:qos local sendrecv
a=curr:qos remote sendrecv
a=des:qos mandatory local sendrecv
a=des:qos mandatory remote sendrecv
a=rtpmap:98 H263
a=fmtp:98 profile-level-id=0
m=audio 8386 RTP/AVPF 97 96
b=AS:25.4
a=curr:qos local sendrecv
a=curr:qos remote sendrecv
a=des:qos mandatory local sendrecv
a=des:qos mandatory remote sendrecv
a=rtpmap:97 AMR
a=fmtp:97 mode-set=0,2,5,7; maxframes
a=rtpmap:96 telephone-event
```

SDP The SDP answer (SDP_A_cat) contains a set of codecs to be used for the session. The local preconditions are indicated as fulfilled.

25-26 180 (Ringing) provisional response (UE#2 to CAT-AS)

UE#2 sends a SIP 180 (Ringing) provisional response for the INVITE request to the CAT-AS.

The CAT-AS instructs the MRF to play CAT media upon receipt of 180.

27-28 180 (Ringing) provisional response (CAT-AS to UE#1)

CAT-AS sends a SIP 180 (Ringing) provisional response for the INVITE request to the UE#1.

29-30 200 (OK) response to INVITE (UE#2 to CAT-AS)

The called party answers the call. UE#2 sends a SIP 200 (OK) final response for the SIP INVITE request to the CAT-AS.

The CAT-AS instructs the MRF to stop CAT media.

31-32 UPDATE request (CAT-AS to UE#1) see example in table A.5.3-8

The CAT-AS sends an UPDATE request containing values received in the 200 OK for UPDATE from UE#2 in step 22.

Session between UE#1 and CAT-AS is replaced with session between UE#1 and UE#2.

NOTE 1: The AS will remain in the signalling path, i.e. work as a B2BUA, in order to align and maintain information in SDP for further exchanged messages between UE#1 and UE#2.

Table A.5.3-8: UPDATE request (CAT-AS to UE#1)

```
UPDATE sip:user1_public1@home1.net;gr=urn:uuid:f81d4fae-7dec-11d0-a765-00a0c91e6bf6 SIP/2.0
Via: SIP/2.0/UDP [5555::ccc:aaa:abc:abc]:8805;branch=z9hG4bK182D87.1
Max-Forwards: 70
Route: <sip:scscf1.home1.net;lr>, <sip:pcscf1.visited1.net;lr>
From: <tel:+1-212-555-2222>;tag=2236
To: <sip:user1_public1@home1.net>;tag=171828
Call-ID:
Cseq: 12814111 UPDATE
Require:
Contact: <sip:user2_public1@home2.net;gr=urn:uuid:2ad8950e-48a5-4a74-8d99-
ad76cc7fc74>;g.3gpp.icsi-ref="urn%3Aurn-7%3gpp-service.ims.icsi.mmtel"
Content-Type: application/sdp
Content-Length: (...)

v=0
o=- 29879336156 29879336158 IN IP6 5555::ccc:aaa:abc:abc
s=-
c=IN IP6 6666::eee:fff:aaa:bbb
t=0 0
m=video 7398 RTP/AVPF 98
b=AS:75
a=curr:qos local sendrecv
a=curr:qos remote sendrecv
a=des:qos mandatory local sendrecv
a=des:qos mandatory remote sendrecv
a=rtptime:98 H263
a=fmtp:98 profile-level-id=0
m=audio 8386 RTP/AVPF 97 96
b=AS:25.4
a=curr:qos local sendrecv
a=curr:qos remote sendrecv
a=des:qos mandatory local sendrecv
a=des:qos mandatory remote sendrecv
a=rtptime:97 AMR
a=fmtp:97 mode-set=0,2,5,7; maxframes
a=rtptime:96 telephone-event
```

SDP The SDP answer (SDP_A_regular) contains a set of codecs to be used for the session. The SDP content is based on information received from previous 200 (OK) response.

33-34 200 (OK) response (UE#1 to CAT-AS)

UE#1 sends a SIP 200 (OK) response for the SIP UPDATE request to CAT-AS. If the resources indicated for the media cannot be reused by the one reserved for the CAT media, UE#1 shall reserve necessary resources prior to sending the response. UE#1 includes a SDP answer (SDP_O2) in the 200 (OK) response to the corresponding SIP UPDATE request.

35-36 200 (OK) response to INVITE (CAT-AS to UE#1)

The CAT-AS sends the SIP 200 (OK) response for the (initial) SIP INVITE request to UE#1.

37-38 ACK request (UE#1 to CAT-AS)

UE#1 sends a SIP ACK request, which acknowledges the SIP 200 (OK) final response, to CAT-AS.

39-40 ACK request (CAT-AS to UE#2)

CAT-AS sends a SIP ACK request, which acknowledges the SIP 200 (OK) final response, to UE#2.

NOTE 3: The ACK request from CAT-AS towards UE#2 may be sent after receiving 200 OK from UE#2 in step 18.

A.5.4 CAT when UE#1 has resources available while UE#2 does not have required resources available

Figure A.5.4-1 shows an example call flow for CAT when UE#1 has resources available while UE#2 does not have required resources available.

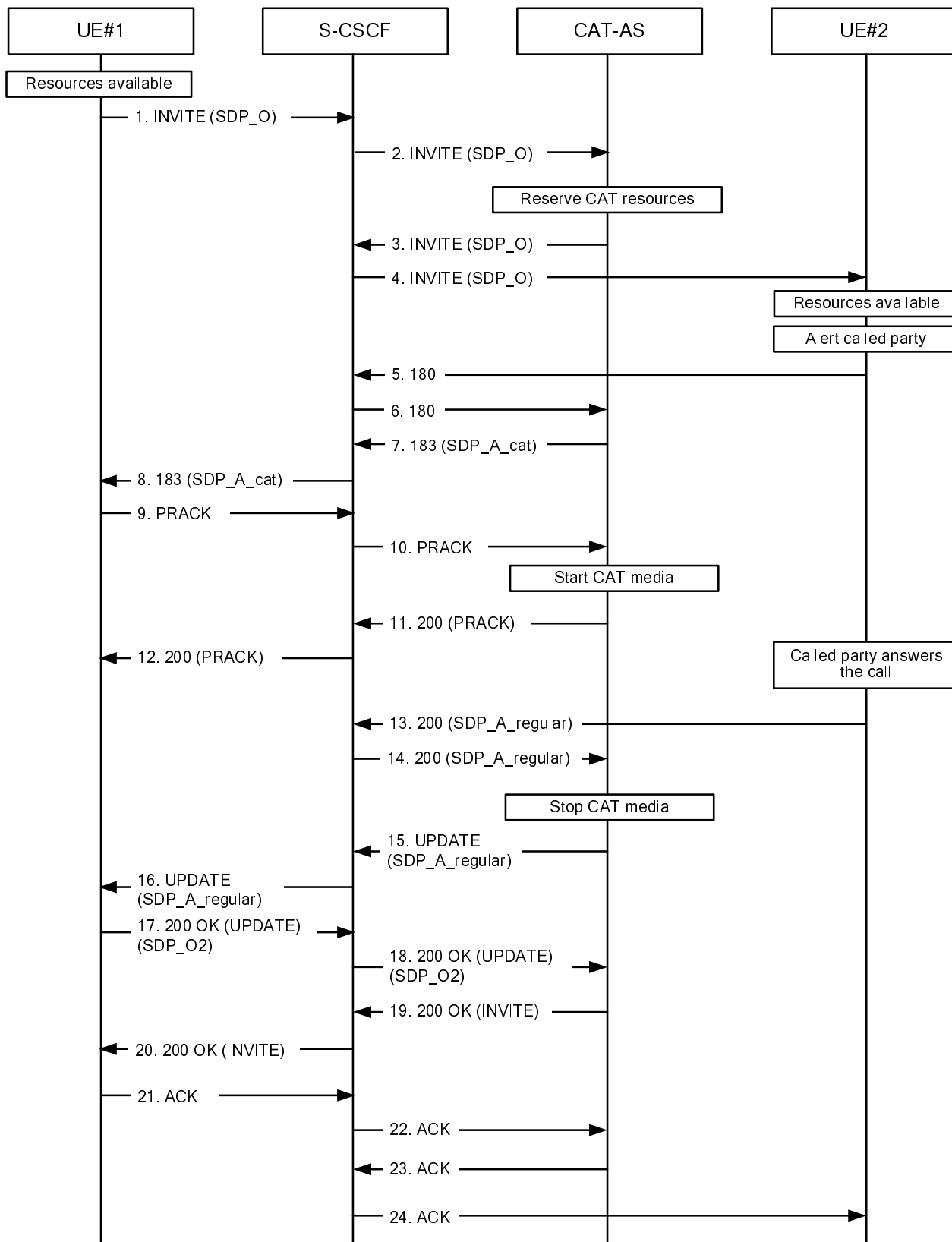

Figure A.5.4-1: CAT, UE#2 does not have required resources available

1 INVITE request (UE#1 to CAT-AS) see example in table A.5.4-1

UE#1 sends a SIP INVITE request to the intermediate IM CN subsystem.

Table A.5.4-1: INVITE request (UE#1 to CAT-AS)

```

INVITE tel:+1-212-555-2222 SIP/2.0
Via: SIP/2.0/UDP [5555::aaa:bbb:ccc:ddd]:1357;comp=sigcomp;branch=z9hG4bKnashds7
Max-Forwards: 70
Route: <sip:pcscf1.visited1.net:7531;lr;comp=sigcomp>, <sip:scscf1.home1.net;lr>
P-Preferred-Identity: "John Doe" <sip:user1_public1@home1.net>
P-Access-Network-Info: 3GPP-UTRAN-TDD; utran-cell-id-3gpp=234151D0FCE11
P-Preferred-Service: urn:urn-7:3gpp-service.ims.icsi.mmtel
Accept-Contact: *;+g.3gpp.icsi-ref="urn%3Aurn-7%3gpp-service.ims.icsi.mmtel"
Privacy: none
P-Early-Media: supported
From: <sip:user1_public1@home1.net>;tag=171828
To: <tel:+1-212-555-2222>
Call-ID: cb03a0s09a2sdfglkj490333
Cseq: 127 INVITE
Require: sec-agree
Supported: precondition, 100rel, gruu, 199
Proxy-Require: sec-agree
Security-Verify: ipsec-3gpp; q=0.1; alg=hmac-sha-1-96; spi-c=98765432; spi-s=87654321;
port-c=8642; port-s=7531
Contact: <sip: user1_public1@home1.net;gr=urn:uuid:f81d4fae-7dec-11d0-a765-
00a0c91e6bf6>;+g.3gpp.icsi-ref="urn%3Aurn-7%3gpp-service.ims.icsi.mmtel"
Allow: INVITE, ACK, CANCEL, BYE, PRACK, UPDATE, REFER, MESSAGE
Accept:application/sdp, application/3gpp-ims+xml
Content-Type: application/sdp
Content-Length: (...)

v=0
o=- 2987933615 2987933615 IN IP6 5555::aaa:bbb:ccc:ddd
s=-
c=IN IP6 5555::aaa:bbb:ccc:ddd
t=0 0
m=video 3400 RTP/AVP 98
a=tcap:1 RTP/AVPF
a=pcfg:1 t=1
b=AS:75
a=curr:qos local sendrecv
a=curr:qos remote none
a=des:qos mandatory local sendrecv
a=des:qos none remote sendrecv
a=rtptime:98 H263
a=fmtp:98 profile-level-id=0
m=audio 3456 RTP/AVP 97 96
a=tcap:1 RTP/AVPF
a=pcfg:1 t=1
b=AS:25.4
a=curr:qos local sendrecv
a=curr:qos remote none
a=des:qos mandatory local sendrecv
a=des:qos none remote sendrecv
a=rtptime:97 AMR
a=fmtp:97 mode-set=0,2,5,7; maxframes=2
a=rtptime:96 telephone-event

```

Supported: The UE indicates support for GRUU, 199 responses, reliable provisional responses and preconditions.

P-Early-Media: The UE indicates support for the P-Early-Media header.

SDP The SDP offer (SDP_O) contains a set of codecs supported by UE#1 and desired by the calling user for this session. The local preconditions are indicated as fulfilled.

2 INVITE request (S-CSCF to CAT-AS)

The S-CSCF forwards the SIP INVITE request to the CAT-AS.

The CAT-AS instructs the MRF to reserve CAT resources.

3-4 INVITE request (CAT-AS to UE#2)

The CAT-AS forwards the request to UE#2.

5-6180 (Ringing) provisional response (UE#2 to CAT-AS)

The called party is alerted. UE#2 sends a SIP 180 (Ringing) provisional response for the INVITE request to the CAT-AS.

The CAT-AS terminates the provisional response.

7-8 183 (Session Progress) provisional response (CAT-AS to UE#1) see example in table A.5.4-2

The CAT-AS sends a reliable SIP 183 (Session Progress) provisional response to UE#1.

Table A.5.4-2: 183 (Session Progress) response (CAT-AS to UE#1)

```
SIP/2.0 183 Session Progress
Via: SIP/2.0/UDP scscf2.home2.net;branch=z9hG4bK764z87.1, SIP/2.0/UDP
    icscf2_s.home2.net;branch=z9hG4bK871y12.1, SIP/2.0/UDP
    scscf1.home1.net;branch=z9hG4bK332b23.1, SIP/2.0/UDP
    pcscf1.visited1.net;branch=z9hG4bK240f34.1, SIP/2.0/UDP
    [5555::aaa:bbb:ccc:ddd]:1357;comp=sigcomp;branch=z9hG4bKnashds7
Record-Route: <sip:scscf2.home2.net;lr>, <sip:scscf1.home1.net;lr>,
    <sip:pcscf1.visited1.net;lr>
From:
To: <tel:+1-212-555-2222>;tag=2236
Call-ID:
Cseq:
Require: 100rel
Allow: INVITE, ACK, CANCEL, BYE, PRACK, UPDATE, REFER, MESSAGE
RSeq: 9022
P-Early-Media: sendrecv
Contact: <sip:catas.home2.net>;+g.3gpp.icsi-ref="urn:3Aurn-7%3gpp-service.ims.icsi.mmtel"
Content-Type: application/sdp
Content-Length: (...)

v=0
o=- 29879336156 29879336156 IN IP6 5555::ccc:aaa:abc:abc
s=-
c=IN IP6 5555::ccc:aaa:abc:abc
t=0 0
m=video 51372 RTP/AVPF 98
a=acfg:1 t=1
b=AS:75
a=curr:qos local sendrecv
a=curr:qos remote sendrecv
a=des:qos mandatory local sendrecv
a=des:qos mandatory remote sendrecv
a=rtptime:98 H263
a=fmtp:98 profile-level-id=0
m=audio 49170 RTP/AVPF 97 96
a=acfg:1 t=1
b=AS:25.4
a=curr:qos local sendrecv
a=curr:qos remote sendrecv
a=des:qos mandatory local sendrecv
a=des:qos mandatory remote sendrecv
a=rtptime:97 AMR
a=fmtp:97 mode-set=0,2,5,7; maxframes
a=rtptime:96 telephone-event
```

P-Early-Media: The CAT-AS requests authorization for early media.

SDP The SDP answer (SDP_A_cat) contains a set of codecs supported to be used for CAT. The SDP content is based on information received from the MRF. The local preconditions are indicated as fulfilled.

9-10 PRACK request (UE#1 to CAT-AS)

UE#1 sends a SIP PRACK request, which acknowledges the SIP 183 (Session Progress) provisional response, to the CAT-AS.

The CAT-AS instructs the MRF to play CAT media.

11-12 200 (OK) response to PRACK (CAT-AS to UE#1)

The CAT-AS sends a SIP 200 (OK) response for the SIP PRACK request to UE#1.

13-14 200 (OK) response to INVITE (UE#2 to CAT-AS) see example in table A.5.4-3

The called party answers the call. UE#2 sends a SIP 200 (OK) final response for the SIP INVITE request to the CAT-AS.

The CAT-AS instructs the MRF to stop CAT media.

Table A.5.4-3: 200 (OK) response (UE#2 to CAT-AS)

```
SIP/2.0 200 OK
Via: SIP/2.0/UDP pcscf2.visited2.net:5088;comp=sigcomp;branch=z9hG4bK361k21.1, SIP/2.0/UDP
scscf2.home2.net;branch=z9hG4bK764XC12.1, SIP/2.0/UDP
catas.home2.net;branch=z9hG4bK764Q32.1, SIP/2.0/UDP
scscf2.home2.net;branch=z9hG4bK764z87.1, SIP/2.0/UDP
icscf2_s.home2.net;branch=z9hG4bK871y12.1, SIP/2.0/UDP
scscf1.home1.net;branch=z9hG4bK332b23.1, SIP/2.0/UDP
pcscf1.visited1.net;branch=z9hG4bK240f34.1, SIP/2.0/UDP
[5555::aaa:bbb:ccc:ddd]:1357;comp=sigcomp;branch=z9hG4bKnashds7
Record-Route: <sip:pcscf2.visited2.net:5088;lr>, <sip:scscf2.home2.net;lr>,
<sip:catas.home2.net;lr>, <sip:scscf2.home2.net;lr>, <sip:scscf1.home1.net;lr>,
<sip:pcscf1.visited1.net;lr>
From:
To: <tel:+1-212-555-2222>;tag=2236
Call-ID:
Cseq:
Allow: INVITE, ACK, CANCEL, BYE, PRACK, UPDATE, REFER, MESSAGE
Contact: <sip:user2_public1@home2.net;gr=urn:uuid:2ad8950e-48a5-4a74-8d99-
ad76cc7fc74>;+g.3gpp.icsi-ref="urn%3Aurn-7%3gpp-service.ims.icsi.mmstel"
Content-Type: application/sdp
Content-Length: (...)

v=0
o=- 29879336157 29879336157 IN IP6 6666::eee:fff:aaa:bbb
s=-
c=IN IP6 6666::eee:fff:aaa:bbb
t=0 0
m=video 7398 RTP/AVPF 98
b=AS:75
a=crr:qos local sendrecv
a=crr:qos remote sendrecv
a=des:qos mandatory local sendrecv
a=des:qos mandatory remote sendrecv
a=rtmp:98 H263
a=fmtp:98 profile-level-id=0
m=audio 8386 RTP/AVPF 97 96
b=AS:25.4
a=crr:qos local sendrecv
a=crr:qos remote sendrecv
a=des:qos mandatory local sendrecv
a=des:qos mandatory remote sendrecv
a=rtmp:97 AMR
a=fmtp:97 mode-set=0,2,5,7; maxframes
a=rtmp:96 telephone-event
```

SDP The SDP answer (SDP_A_regular) contains a set of codecs to be used for the session. If preconditions are used, they are indicated as fulfilled.

15-16 UPDATE request (CAT-AS to UE#1) see example in table A.5.4-4

The CAT-AS sends an UPDATE request containing values received in the 200 OK from UE#2.

Session between UE#1 and CAT-AS is replaced with session between UE#1 and UE#2.

Table A.5.4-4: UPDATE request (CAT-AS to UE#1)

```
UPDATE sip:user1_public1@home1.net;gr=urn:uuid:f81d4fae-7dec-11d0-a765-00a0c91e6bf6 SIP/2.0
Via: SIP/2.0/UDP [5555::ccc:aaa:abc:abc]:8805;branch=z9hG4bK182D87.1
Max-Forwards: 70
Route: <sip:scscf1.home1.net;lr>, <sip:pcscf1.visited1.net;lr>
From: <tel:+1-212-555-2222>;tag=2236
To: <sip:user1_public1@home1.net>;tag=171828
Call-ID:
Cseq: 12814111 UPDATE
```

```

Require:
Contact: <sip:user2_public1@home2.net;gr=urn:uuid:2ad8950e-48a5-4a74-8d99-
ad76cc7fc74>;+g.3gpp.icsi-ref="urn%3Aurn-7%3gpp-service.ims.icsi.mmtel"
Content-Type: application/sdp
Content-Length: (...)

v=0
o=- 2987933617 2987933617 IN IP6 5555::ccc:aaa:abc:abc
s=-
c=IN IP6 6666::eee:fff:aaa:bbb
t=0 0
m=video 7398 RTP/AVPF 98
b=AS:75
a=curr:qos local sendrecv
a=curr:qos remote sendrecv
a=des:qos mandatory local sendrecv
a=des:qos mandatory remote sendrecv
a=rtpmap:98 H263
a=fmtp:98 profile-level-id=0
m=audio 8386 RTP/AVPF 97 96
b=AS:25.4
a=curr:qos local sendrecv
a=curr:qos remote sendrecv
a=des:qos mandatory local sendrecv
a=des:qos mandatory remote sendrecv
a=rtpmap:97 AMR
a=fmtp:97 mode-set=0,2,5,7; maxframes
a=rtpmap:96 telephone-event

```

SDP The SDP answer (SDP_A_regular) contains a set of codecs to be used for the session. The SDP content is based on information received from previous 200 (OK) response.

17-18 200 (OK) response (UE#1 to CAT-AS)

UE#1 sends a SIP 200 (OK) response for the SIP UPDATE request to CAT-AS. If the resources indicated for the media cannot be reused by the one reserved for the CAT media, UE#1 shall reserve necessary resources prior to sending the response. UE#1 includes a SDP answer (SDP_O2) in the 200 (OK) response to the corresponding SIP UPDATE request.

19-20 200 (OK) response to INVITE (CAT-AS to UE#1)

The CAT-AS sends the SIP 200 (OK) response for the (initial) SIP INVITE request to UE#1.

21-22 ACK request (UE#1 to CAT-AS)

UE#1 sends a SIP ACK request, which acknowledges the SIP 200 (OK) final response, to CAT-AS.

23-24 ACK request (CAT-AS to UE#2)

CAT-AS sends a SIP ACK request, which acknowledges the SIP 200 (OK) final response, to UE#2.

NOTE 2: The ACK request from CAT-AS towards UE#2 may be sent after receiving 200 OK from UE#2 in step 14.

A.6 Interworking with CS domain

A.6.1 Introduction

The following signalling flows show interworking with the CS domain, when CAT is provided by the terminating CS domain to the IMS, and when CAT is provided to the originating CS domain from the IMS. The following flows are included:

- subclause A.6.2 shows CAT when CAT is provided by the terminating CS domain;
- subclause A.6.3 shows CAT, using the forking model, when CAT is provided to the originating CS domain;

- subclause A.6.4 shows CAT, using the early session, model, when CAT is provided to the originating CS domain;

The signalling flow in subclause A.6.2 is not dependent on which CAT model is used.

A.6.2 CAT provided by the terminating CS domain

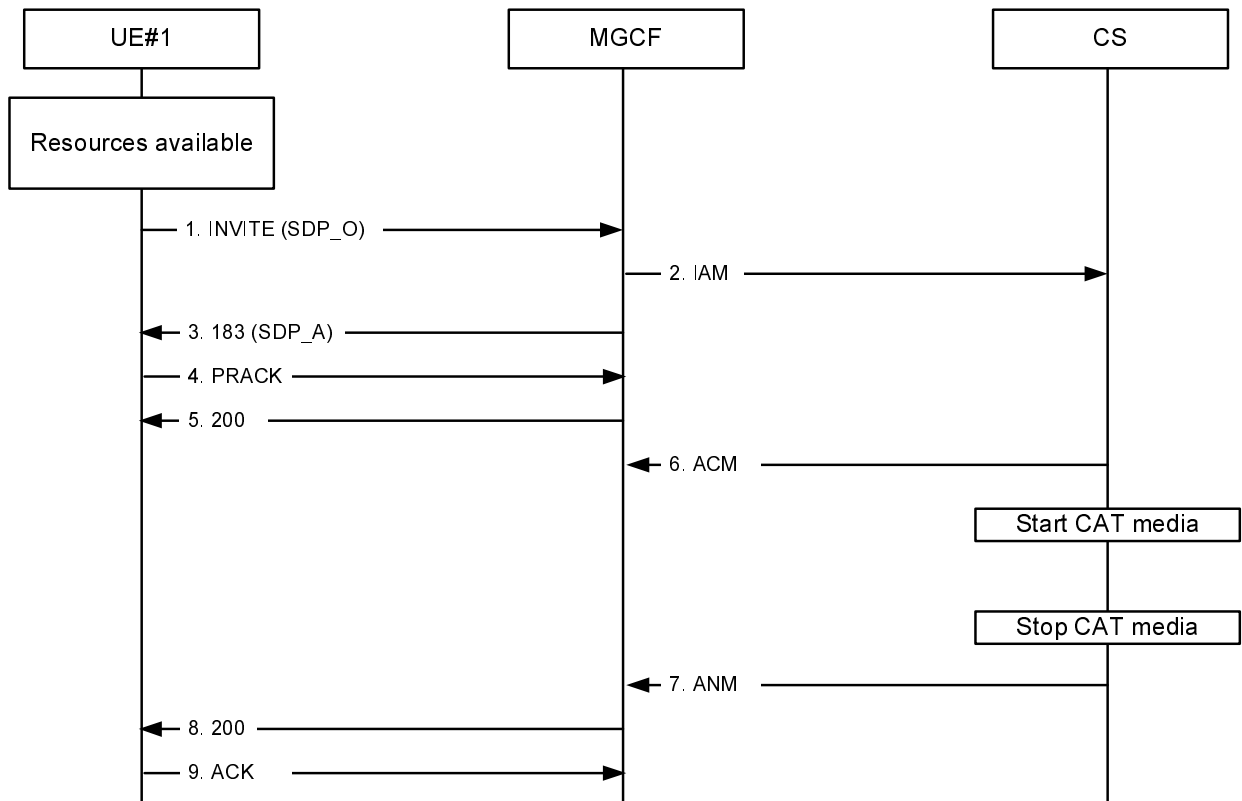

Figure A.6.2-1: CAT provided by terminating CS system

1-2 INVITE request (UE#1 to MGCF) see example in table A.6.2-1

UE#1 sends a SIP INVITE request to the MGCF.

The MGCF sends an ISUP IAM message to CS.

Table A.6.2-1: INVITE request (UE#1 to MGCF)

```

INVITE tel:+1-212-555-2222 SIP/2.0
Via: SIP/2.0/UDP [5555::aaa:bbb:ccc:ddd]:1357;comp=sigcomp;branch=z9hG4bKnashds7
Max-Forwards: 70
Route: <sip:pcscf1.visited1.net:7531;lr;comp=sigcomp>, <sip:scscf1.home1.net;lr>
P-Preferred-Identity: "John Doe" <sip:user1_public1@home1.net>
P-Access-Network-Info: IEEE-802.11a
P-Preferred-Service: urn:urn-7:3gpp-service.ims.icsi.mmtel
Accept-Contact: *;+g.3gpp.icsi_ref="urn%3Aurn-7%3gpp-service.ims.icsi.mmtel"
Privacy: none
From: <sip:user1_public1@home1.net>;tag=171828
To: <tel:+1-212-555-2222>
Call-ID: cb03a0s09a2sdfglkj490333
Cseq: 127 INVITE
Require: sec-agree
Supported: precondition, 100rel, gruu, 199
Proxy-Require: sec-agree
Security-Verify: ipsec-3gpp; q=0.1; alg=hmac-sha-1-96; spi-c=98765432; spi-s=87654321;
port-c=8642; port-s=7531
Contact: <sip:user1_public1@home1.net;;gr=urn:uuid:f81d4fae-7dec-11d0-a765-
00a0c91e6bf6>;+g.3gpp.icsi_ref="urn%3Aurn-7%3gpp-service.ims.icsi.mmtel"
Allow: INVITE, ACK, CANCEL, BYE, PRACK, UPDATE, REFER, MESSAGE
Accept:application/sdp, application/3gpp-ims+xml
Content-Type: application/sdp
Content-Length: (...)

v=0
o=- 2987933615 2987933615 IN IP6 6666::aaa:bbb:ccc:ddd
s=-
c=IN IP6 6666::aaa:bbb:ccc:ddd
t=0 0
m=video 3400 RTP/AVP 98
b=AS:75
a=crr:qos local sendrecv
a=crr:qos remote none
a=des:qos mandatory local sendrecv
a=des:qos none remote sendrecv
a=rtpmap:98 H263
a=fmtp:98 profile-level-id=0
m=audio 3456 RTP/AVP 97 96
b=AS:25.4
a=crr:qos local sendrecv
a=crr:qos remote none
a=des:qos mandatory local sendrecv
a=des:qos none remote sendrecv
a=rtpmap:97 AMR
a=fmtp:97 mode-set=0,2,5,7; maxframes=2
a=rtpmap:96 telephone-event

```

Supported: The UE indicates support for preconditions, reliable provisional responses, gruu and the 199 provisional response.

SDP: The SDP offer (SDP_O) contains a set of codecs supported by UE#1 and desired by the calling user for this session. The local preconditions are indicated as fulfilled.

3 183 (Session Progress) provisional response (MGCF to UE#1) see example in table A.6.2-2

The MGCF sends a reliable SIP 183 (Session Progress) provisional response to UE#1.

An early dialog is established between UE#1 and the MGCF.

CAT media is received from CS.

Table A.6.2-2: 183 (Session Progress) response (MGCF to UE#1)

```

SIP/2.0 183 Session Progress
Via: SIP/2.0/UDP scscf2.home2.net;branch=z9hG4bK764z87.1, SIP/2.0/UDP
    icscf2_s.home2.net;branch=z9hG4bK871y12.1, SIP/2.0/UDP
    scscf1.home1.net;branch=z9hG4bK332b23.1pcscf1.visited1.net;branch=z9hG4bK240f34.1,
    SIP/2.0/UDP pcscf1.visited1.net;branch=z9hG4bK240f34.1, SIP/2.0/UDP
    [5555::aaa:bbb:ccc:ddd]:1357;comp=sigcomp;branch=z9hG4bKnashds7
Record-Route: <sip:pcscf2.visited2.net:5088;lr;comp=sigcomp>
From:
To: <tel:+1-212-555-2222>;tag=2236
Call-ID:
Cseq:
Require: 100rel
Allow: INVITE, ACK, CANCEL, BYE, PRACK, UPDATE, REFER, MESSAGE
RSeq: 9022
P-Early-Media: sendonly
Contact: <sip:mgcf1.home1.net;gr>;+g.3gpp.icsi_ref="urn%3Aurn-7%3gpp-
    service.ims.icsi.mmtel"
Content-Type: application/sdp
Content-Length: (...)

v=0
o=- 2987933615 2987933615 IN IP6 6666::eee:fff:aaa:bbb
s=-
c=IN IP6 6666::eee:fff:aaa:bbb
t=0 0
m=video 0 RTP/AVP 98
m=audio 3456 RTP/AVP 97 96
b=AS:25.4
a=curr:qos local sendrecv
a=curr:qos remote sendrecv
a=des:qos mandatory local sendrecv
a=des:qos mandatory remote sendrecv
a=rtpmap:97 AMR
a=fmtp:97 mode-set=0,2,5,7; maxframes

```

P-Early-Media: The MGCF requests authorization for early media.

SDP: The SDP answer (SDP_A) contains a set of codecs to be used for the session. The video stream is rejected. The local preconditions are indicated as fulfilled.

4 PRACK request (UE#1 to MGCF)

UE#1 sends a SIP PRACK request, which acknowledges the SIP 183 (Session Progress) provisional response, to the MGCF.

5 200 (OK) response to PRACK (MGCF to UE#1)

The MGCF sends a SIP 200 (OK) response for the SIP PRACK request to UE#1.

6 ACM message (CS to MGCF)

The MGCF receives an ISUP ACM message from CS.

7-8 200 (OK) response to INVITE (MGCF to UE#1)

The MGCF receives an ISUP ANM message from CS.

The MGCF sends a SIP 200 (OK) response for the SIP INVITE request to UE#1.

9 ACK request (UE#1 to MGCF)

UE#1 sends a SIP ACK request, which acknowledges the SIP 200 (OK) final response, to the MGCF.

A.6.3 CAT provided to the originating CS domain with the CAT forking model

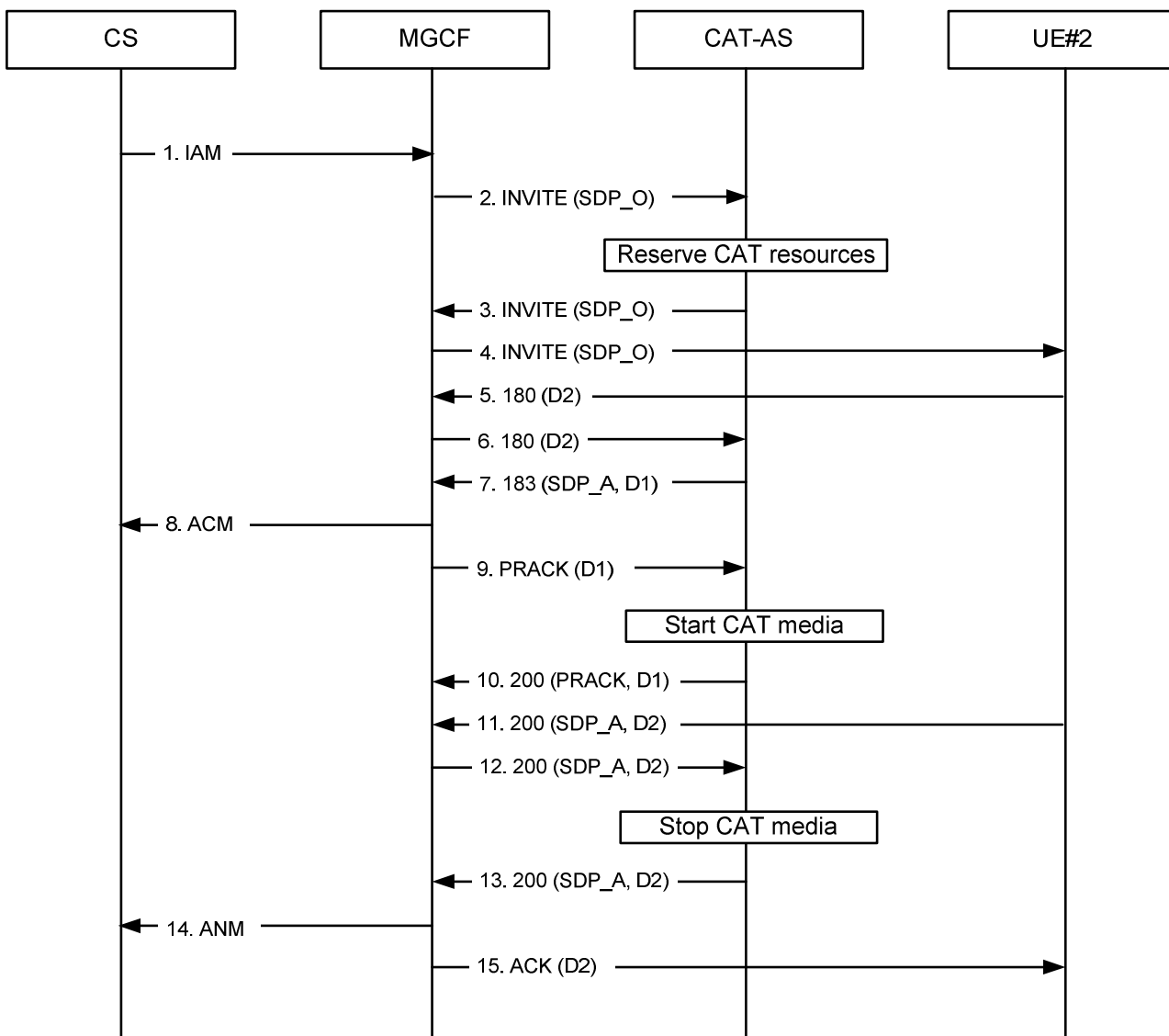

Figure A.6.3-1: CAT provided to originating CS system

1-2 INVITE request (MGCF to CAT-AS) see example in table A.6.3-1

The MGCF receives an ISUP IAM message from CS.

The MGCF sends a SIP INVITE request to the CAT-AS.

The CAT-AS instructs the MRF to reserve CAT resources.

Table A.6.3-1: INVITE request (MGCF to CAT-AS)

```

INVITE tel:+1-212-555-2222 SIP/2.0
Via: SIP/2.0/UDP [5555::aaa:bbb:ccc:ddd]:1357;comp=sigcomp;branch=z9hG4bKnashds7
Max-Forwards: 70
Privacy: none
P-Early-Media: supported
P-Asserted-Service: urn:urn-7:3gpp-service.ims.icsi.mmtel
Accept-Contact: *;+g.3gpp.icsi_ref="urn%3Aurn-7%3gpp-service.ims.icsi.mmtel"
From: <sip:user1_public1@home1.net>;tag=171828
To: <tel:+1-212-555-2222>
Call-ID: cb03a0s09a2sdfgkjkj490333
Cseq: 127 INVITE
Supported: precondition, 100rel, gruu, 199
Contact: <sip:mgcf1.home1.net;gr>;+g.3gpp.icsi_ref="urn%3Aurn-7%3gpp-
service.ims.icsi.mmtel"
Allow: INVITE, ACK, CANCEL, BYE, PRACK, UPDATE
Content-Type: application/sdp
Content-Length: (...)

v=0
o=- 2987933615 2987933615 IN IP6 6666::aaa:bbb:ccc:ddd
s=-
c=IN IP6 6666::aaa:bbb:ccc:ddd
t=0 0
m=audio 3456 RTP/AVP 97 96
b=AS:25.4
a=curr:goss local sendrecv
a=curr:goss remote none
a=des:goss mandatory local sendrecv
a=des:goss none remote sendrecv
a=rtpmap:97 AMR
a=fmtp:97 mode-set=0,2,5,7; maxframes=2
a=rtpmap:96 telephone-event

```

Supported: The UE indicates support for preconditions, reliable provisional responses, gruu and the 199 provisional response.

P-Early-Media: The MGCF indicates support for the P-Early-Media header.

Supported: The MGCF indicates support for reliable provisional responses.

SDP: The SDP offer (SDP_O) contains a set of codecs supported by the MGCF and desired by the calling user for this session. The local preconditions are indicated as fulfilled.

3-5 INVITE request (CAT-AS to UE#2)

The CAT-AS forwards the SIP INVITE request to UE#2.

5-8 180 (Ringing) provisional response (UE#2 to CAT-AS)

The called party is alerted. UE#2 sends a SIP 180 (Ringing) provisional response for the SIP INVITE request to the CAT-AS.

The CAT-AS terminates the SIP 180 (Ringing) provisional response.

7-8 183 (Session Progress) provisional response (CAT-AS to MGCF) see example in table A.6.3-2

The CAT-AS sends a reliable SIP 183 (Session Progress) provisional response to the MGCF.

An early dialog (D1) is established between the MGCF and the CAT-AS.

The MGCF sends an ISUP ACM message to CS.

Table A.6.3-2: 183 (Session Progress) response (CAT-AS to MGCF)

```

SIP/2.0 183 Session Progress
Via: SIP/2.0/UDP scscf2.home2.net;branch=z9hG4bK764z87.1, SIP/2.0/UDP
    icscf2_s.home2.net;branch=z9hG4bK871y12.1, SIP/2.0/UDP
    [5555::aaa:bbb:ccc:ddd]:1357;comp=sigcomp;branch=z9hG4bKnashds7
Record-Route: <sip:pcscf2.visited2.net:5088;lr;comp=sigcomp>
From:
To: <tel:+1-212-555-2222>;tag=2236
Call-ID:
Cseq:
Require: 100rel
Allow: INVITE, ACK, CANCEL, BYE, PRACK, UPDATE, REFER, MESSAGE
RSeq: 9022
P-Early-Media: sendrecv
Contact: <sip:cat-as.home1.net>;+g.3gpp.icsi_ref="urn%3Aurn-7%3gpp-service.ims.icsi.mmstel"
Content-Type: application/sdp
Content-Length: (...)

v=0
o=- 2987933615 2987933615 IN IP6 5555::eee:fff:bbb:aaa
s=-
c=IN IP6 5555::eee:fff:bbb:aaa
t=0 0
m=audio 3456 RTP/AVP 97 96
b=AS:25.4
a=crr:qos local sendrecv
a=crr:qos remote sendrecv
a=des:qos mandatory local sendrecv
a=des:qos mandatory remote sendrecv
a=rtmap:97 AMR
a=fmtp:97 mode-set=0,2,5,7; maxframes

```

P-Early-Media: The CAT-AS requests authorization for early media.

SDP: The SDP answer (SDP_A) contains a set of codecs supported to be used for CAT. The SDP content is based on information received from the MRF. The local preconditions are indicated as fulfilled.

9 PRACK request (MGCF to CAT-AS)

The MGCF sends a SIP PRACK request, which acknowledges the SIP 183 (Session Progress) provisional response, to the CAT-AS.

The CAT-AS instructs the MRF to play CAT media.

10 200 (OK) response to PRACK (CAT-AS to MGCF)

The CAT-AS sends a SIP 200 (OK) response for the SIP PRACK request to the MGCF.

11-12 200 (OK) response to INVITE (UE#2 to CAT-AS) see example in table A.6.3-3

The called party answers the call. UE#2 sends a SIP 200 (OK) final response for the SIP INVITE request to the CAT-AS.

The CAT-AS instructs the MRF to stop CAT media.

Table A.6.3-3: 200 (OK) response (UE#2 to CAT-AS)

```

SIP/2.0 200 OK
Via: SIP/2.0/UDP pcscf2.visited2.net:5088;comp=sigcomp;branch=z9hG4bK361k21.1, SIP/2.0/UDP
scscf2.home2.net;branch=z9hG4bK764XC12.1, SIP/2.0/UDP
catas.home2.net;branch=z9hG4bK764Q32.1, SIP/2.0/UDP
scscf2.home2.net;branch=z9hG4bK764z87.1, SIP/2.0/UDP
icscf2_s.home2.net;branch=z9hG4bK871y12.1, SIP/2.0/UDP
[5555::aaa:bbb:ccc:ddd]:1357;comp=sigcomp;branch=z9hG4bKnashds7
Record-Route: <sip:pcscf2.visited2.net:5088;lr;comp=sigcomp>, <sip:scscf2.home2.net;lr>,
<sip:scscf1.home1.net;lr>, <sip:pcscf1.visited1.net;lr>
From:
To: <tel:+1-212-555-2222>;tag=6322
Call-ID:
Cseq:
Allow: INVITE, ACK, CANCEL, BYE, PRACK, UPDATE, REFER, MESSAGE
Contact: <sip:user2_public1@home2.net;gr=urn:uuid:2ad8950e-48a5-4a74-8d99-
ad76cc7fc74>;+g.3gpp.icsi_ref="urn%3Aurn-7%3gpp-service.ims.icsi.mmtel"
Content-Type: application/sdp
Content-Length: (...)

v=0
o=- 2987933615 2987933615 IN IP6 6666::eee:fff:aaa:bbb
s=-
c=IN IP6 6666::eee:fff:aaa:bbb
t=0 0
m=audio 3456 RTP/AVP 97 96
b=AS:25.4
a=curr:qos local sendrecv
a=curr:qos remote sendrecv
a=des:qos mandatory local sendrecv
a=des:qos mandatory remote sendrecv
a=rtptime:97 AMR
a=fmtp:97 mode-set=0,2,5,7; maxframes

```

SDP: The SDP answer (SDP_A) contains a set of codecs to be used for the session. If preconditions are used, they are indicated as fulfilled.

13-14 200 (OK) response to INVITE (CAT-AS to MGCF)

The CAT-AS forwards the SIP 200 (OK) response to the MGCF.

A dialog (D2) is established between the MGCF and UE#2.

The early dialog (D1) between the MGCF and the CAT-AS is terminated.

The MGCF sends an ISUP ANM message to CS.

15 ACK request (MGCF to UE#2)

The MGCF sends a SIP ACK request, which acknowledges the SIP 200 (OK) final response, to UE#2.

A.6.4 CAT provided to the originating CS domain with the CAT early session model

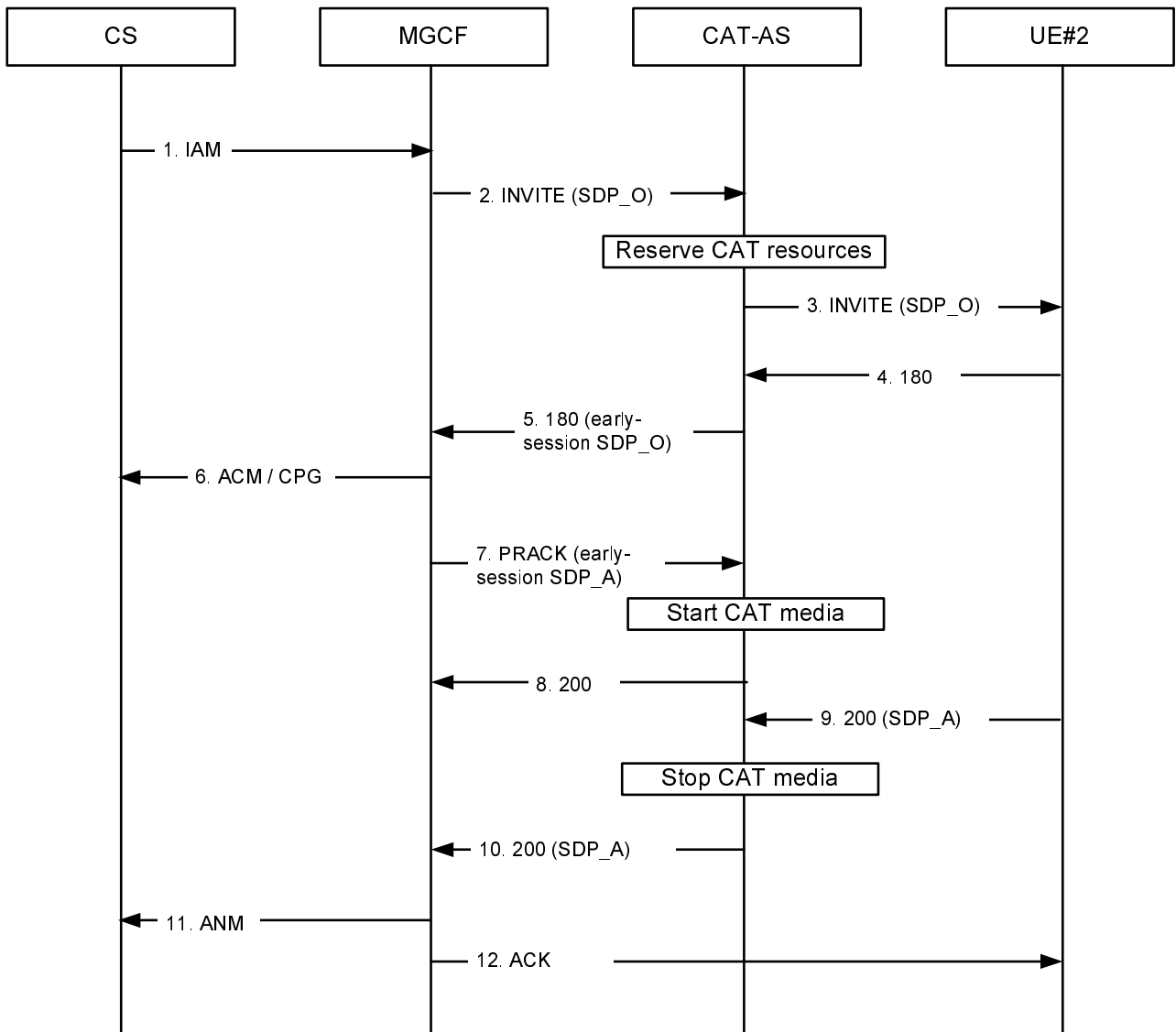

Figure A.6.4-1: CAT provided to originating CS domain with the CAT early-session model

1-2. INVITE request (MGCF to CAT-AS) see example in table A.6.4-2

The MGCF receives an ISUP IAM message from CS domain.

The MGCF sends a SIP INVITE request to the CAT-AS.

The CAT-AS instructs the MRF to reserve CAT resources.

Table A.6.4-2: INVITE request (MGCF to CAT-AS)

```

INVITE tel:+1-212-555-2222 SIP/2.0
Via: SIP/2.0/UDP [5555::aaa:bbb:ccc:ddd]:1357;comp=sigcomp;branch=z9hG4bKnashds7
Max-Forwards: 70
Privacy: none
P-Asserted-Service: urn:urn-7:3gpp-service.ims.icsi.mmtel
Accept-Contact: *;+g.3gpp.icsi_ref="urn%3Aurn-7%3gpp-service.ims.icsi.mmtel"
From: <sip:user1_public1@home1.net>;tag=171828
To: <tel:+1-212-555-2222>
Call-ID: cb03a0s09a2sdfglkj490333
Cseq: 127 INVITE
Supported: precondition, 100rel, gruu, early-session
Contact: <sip:mgcf1.home1.net;gr>;+g.3gpp.icsi_ref="urn%3Aurn-7%3gpp-
service.ims.icsi.mmtel"
Allow: INVITE, ACK, CANCEL, BYE, PRACK, UPDATE
Content-Type: application/sdp
Content-Length: (...)

v=0
o=- 2987933615 2987933615 IN IP6 5555::aaa:bbb:ccc:ddd
s=-
c=IN IP6 5555::aaa:bbb:ccc:ddd
t=0 0
m=video 3400 RTP/AVP 98 99
b=AS:75
a=curr:qos local none
a=curr:qos remote none
a=des:qos mandatory local sendrecv
a=des:qos none remote sendrecv
a=rtpmap:98 H263
a=fmtp:98 profile-level-id=0
a=rtpmap:99 MP4V-ES
m=audio 3456 RTP/AVP 97 96
b=AS:25.4
a=curr:qos local none
a=curr:qos remote none
a=des:qos mandatory local sendrecv
a=des:qos none remote sendrecv
a=rtpmap:97 AMR
a=fmtp:97 mode-set=0,2,5,7; mode-change-period=2
a=rtpmap:96 telephone-event
a=maxptime:20

```

Supported: The UE indicates support for preconditions, reliable provisional responses, gruu and early-session disposition type.

SDP The SDP offer (SDP_O) contains a set of codecs supported by the MGCF and desired by the calling user for this session. The local preconditions are indicated as fulfilled.

3 INVITE request (CAT-AS to UE#2)

The CAT-AS forwards the SIP INVITE request to UE#2.

4 180 (Ringing) provisional response (UE#2 to CAT-AS)

The called party is alerted. UE#2 sends a SIP 180 (Ringing) provisional response for the SIP INVITE request to the CAT-AS.

5 180 (Ringing) provisional response (CAT-AS to MGCF) see example in table A.6.4-5

The CAT-AS sends a reliable SIP 180 (Ringing) provisional response to the MGCF.

Table A.6.4-5: SIP 180 (Ringing) responses (CAT-AS to MGCF)

```

SIP/2.0 180 Ringing
Via: SIP/2.0/UDP scscf2.home2.net;branch=z9hG4bK764z87.1, SIP/2.0/UDP
    icscf2_s.home2.net;branch=z9hG4bK871y12.1, SIP/2.0/UDP
    [5555::aaa:bbb:ccc:ddd]:1357;comp=sigcomp;branch=z9hG4bKnashds7
Record-Route: <sip:pcscf2.visited2.net:5088;lr;comp=sigcomp>
From:
To: <tel:+1-212-555-2222>;tag=2236
Call-ID:
Cseq:
Require: 100rel
Allow: INVITE, ACK, CANCEL, BYE, PRACK, UPDATE, REFER, MESSAGE
RSeq: 9022
Contact: <sip:cat-as.home1>;+g.3gpp.icsi_ref="urn%3Aurn-7%3gpp-service.ims.icsi.mmmtel"
Content-Type: application/sdp
Content-Disposition: early-session
Content-Length: (...)

v=0
o=- 2987933616 2987933616 IN IP6 5555::eee:fff:aaa:bbb
s=-
c=IN IP6 5555::eee:fff:aaa:bbb
t=0 0
m=video 10001 RTP/AVP 98 99
b=AS:75
a=crr:qos local sendrecv
a=crr:qos remote none
a=des:qos mandatory local sendrecv
a=des:qos mandatory remote sendrecv
a=conf:qos remote sendrecv
a=rtpmap:98 H263
a=rtpmap:99 MP4V-ES
a=fmtp:98 profile-level-id=0
m=audio 6544 RTP/AVP 97 96
b=AS:25.4
a=crr:qos local none
a=crr:qos remote none
a=des:qos mandatory local sendrecv
a=des:qos mandatory remote sendrecv
a=conf:qos remote sendrecv
a=rtpmap:97 AMR
a=fmtp:97 mode-set=0,2,5,7; mode-change-period=2
a=rtpmap:96 telephone-event
a=maxptime:20

```

Early Session SDP The early session SDP offer (early-session SDP_O) contains a set of codecs supported to be used for CAT. The SDP content is based on information received from the MRF. The local preconditions are indicated as fulfilled.

6 ACM/CPG message (MGCF to CS domain)

The MGCF sends an ACM or CPG message to CS domain.

If the IMS CAT is multimedia, the MGCF shall take an indication in ACM or CPG message which instructs originating MSC to initiate H.245 negotiation between CS user and MGCF.

NOTE: How to take the indication in ACM or CPG message is out of scope of this specification.

7 PRACK request (MGCF to CAT AS) see example in table A.6.4-7

The MGCF sends a SIP PRACK request, which acknowledges the SIP 180 (Ringing) provisional response, to the CAT-AS.

An early dialog using early-session SDP is established between the MGCF and the CAT-AS.

The CAT-AS instructs the MRF to play CAT media.

Table A.6.4-7: SIP PRACK Request (MGCF to CAT AS)

```

PRACK sip:cat-as.home1.net SIP/2.0
Via: SIP/2.0/UDP [5555::aaa:bbb:ccc:ddd]:1357;comp=sigcomp;branch=z9hG4bKnashds7
Max-Forwards: 70
Route: <sip:pcscf2.visited2.net:5088;lr;comp=sigcomp>
From: <sip:user1_public1@home1.net>;tag=171828
To: <tel:+1-212-555-2222>;tag=2236
Call-ID: cb03a0s09a2sdfglkj490333
Cseq: 128 PRACK
Require: precondition
RAck: 9022 127 INVITE
Content-Type: application/sdp
Content-Disposition: early-session
Content-Length: (...)

v=0
o=- 2987933616 2987933616 IN IP6 5555::aaa:bbb:ccc:ddd
s=-
c=IN IP6 5555::aaa:bbb:ccc:ddd
t=0 0
m=video 3402 RTP/AVP 98
b=AS:75
a=curr:goss local sendrecv
a=curr:goss remote sendrecv
a=des:goss mandatory local sendrecv
a=des:goss mandatory remote sendrecv
a=rtpmap:98 H263
a=fmtp:98 profile-level-id=0
m=audio 3458 RTP/AVP 97 96
b=AS:25.4
a=curr:goss local none
a=curr:goss remote none
a=des:goss mandatory local sendrecv
a=des:goss mandatory remote sendrecv
a=rtpmap:97 AMR
a=fmtp:97 mode-set=0,2,5,7; mode-change-period=2
a=rtpmap:96 telephone-event
a=maxptime:20

```

Early Session SDP The early session SDP answer (early-session SDP_A) contains a set of codecs to be used for the CAT. If preconditions are used, they are indicated as fulfilled.

8 200 (OK) response to PRACK (CAT-AS to MGCF)

The CAT-AS sends a SIP 200 (OK) response for the SIP PRACK request to the MGCF.

9 200 (OK) response to INVITE (UE#2 to CAT-AS) see example in table A.6.4-9

The called party answers the call. UE#2 sends a SIP 200 (OK) final response for the SIP INVITE request to the CAT-AS.

The CAT-AS instructs the MRF to stop CAT media.

Table A.6.4-9: SIP 200 (OK) response (UE#2 to CAT-AS)

```

SIP/2.0 200 OK
Via: SIP/2.0/UDP pcscf2.visited2.net:5088;comp=sigcomp;branch=z9hG4bK361k21.1, SIP/2.0/UDP
scscf2.home2.net;branch=z9hG4bK764XC12.1, SIP/2.0/UDP
catas.home2.net;branch=z9hG4bK764Q32.1, SIP/2.0/UDP
scscf2.home2.net;branch=z9hG4bK764z87.1, SIP/2.0/UDP
icscf2_s.home2.net;branch=z9hG4bK871y12.1, SIP/2.0/UDP
[5555::aaa:bbb:ccc:ddd]:1357;comp=sigcomp;branch=z9hG4bKnashds7
From:
To:
Call-ID:
Cseq:
Allow: INVITE, ACK, CANCEL, BYE, PRACK, UPDATE, REFER, MESSAGE
Contact: <sip:user2_public1@home2.net;gr-urn:uuid:2ad8950e-48a5-4a74-8d99-ad76cc7fc74;
>;+g.3gpp.icsi_ref="urn%3Aurn-7%3gpp-service.ims.icsi.mmstel"
Content-Type: application/sdp
Content-Length: (...)

v=0
o=- 2987933615 2987933615 IN IP6 5555::ggg:hhh:iii:jjj
s=-
c=IN IP6 5555::ggg:hhh:iii:jjj
t=0 0
m=video 3400 RTP/AVP 98
b=AS:75
a=crr:qos local sendrecv
a=crr:qos remote sendrecv
a=des:qos mandatory local sendrecv
a=des:qos mandatory remote sendrecv
a=rtpmap:98 H263
a=fmtp:98 profile-level-id=0
m=audio 3456 RTP/AVP 97 96
b=AS:25.4
a=crr:qos local none
a=crr:qos remote none
a=des:qos mandatory local sendrecv
a=des:qos mandatory remote sendrecv
a=rtpmap:97 AMR
a=fmtp:97 mode-set=0,2,5,7; mode-change-period=2
a=rtpmap:96 telephone-event
a=maxptime:20

```

SDP The SDP answer (SDP_A) contains a set of codecs to be used for the session. If preconditions are used, they are indicated as fulfilled.

10-11 200 (OK) responses to INVITE (CAT-AS to MGCF)

The CAT-AS forwards the SIP 200 (OK) response to the MGCF.

The dialog for session is established between the MGCF and UE#2.

The early dialog using early-session SDP between the MGCF and the CAT-AS is terminated.

The MGCF sends an ISUP ANM message to CS domain.

12 ACK request (MGCF to UE#2)

The MGCF sends a SIP ACK request, which acknowledges the SIP 200 (OK) final response, to UE#2.

Annex B (informative): Change history

Change history							
Date	TSG #	TSG Doc.	CR	Rev	Subject/Comment	Old	New
2008-06					TS skeleton from Rapporteur		0.0.0
2008-07	CT1#54				Implemented C1-0082446, C1-082663, C1-082664, C1-082771 from CT1#54		0.1.0
2008-08	CT1#55				Implemented C1-082960, C1-083205, C1-083375 from CT1#55		0.2.0
2008-09					Version 1.0.0 created for presentation to TSG CT#41 for information	0.2.0	1.0.0
2008-10	CT1#55 bis				Implemented the following from CT1#55bis: C1-083641, C1-083649, C1-083650, C1-083651, C1-083652, C1-083653, C1-083895, C1-083913, C1-083914, C1-084250, C1-084251, C1-084252, C1-084254, C1-084255, C1-084257, C1-084258, C1-084259, C1-084426, C1-084427		1.1.0
2008-11	CT1#56				Implemented the following from CT1#56: C1-084681, C1-085103, C1-085104, C1-085279, C1-085281, C1-085282, C1-085283, C1-085284, C1-085285, C1-085286, C1-085287, C1-085458		1.2.0
2008-11					Version 2.0.0 created for presentation to TSG CT#42 for approval	1.2.0	2.0.0
2008-12	CT#42				Version 8.0.0 created after approval in CT#42	2.0.0	8.0.0
2009-03	CT#43	CP-090155	0007		Interaction with ECT	8.0.0	8.1.0
2009-03	CT#43	CP-090155	0008	1	Correction on UE response for UPDATE in Gateway model	8.0.0	8.1.0
2009-03	CT#43	CP-090155	0009	2	No user configuration specified for IMS CAT	8.0.0	8.1.0
2009-03	CT#43	CP-090155	0011	2	Flow Updates	8.0.0	8.1.0
2009-03	CT#43	CP-090155	0012	2	Intercation between CAT and CDIV	8.0.0	8.1.0
2009-06	CT#44	CP-090406	0017	2	Correction of callflow for CAT	8.1.0	8.2.0
2009-09	CT#45	CP-090661	0023	2	Correction: CAT and OIR interaction	8.2.0	8.3.0
2009-09	CT#45	CP-090661	0025	1	Correction: CAT and OIP interaction	8.2.0	8.3.0
2009-12	CT#46	CP-090904	0046		Removal of editor's note in 24.182	8.3.0	8.4.0
2009-12	CT#46	CP-090904	0048		The features of the CAT are described inaccurately	8.3.0	8.4.0

History

Document history		
V8.0.0	January 2009	Publication
V8.1.0	March 2009	Publication
V8.2.0	June 2009	Publication
V8.3.0	September 2009	Publication
V8.4.0	January 2010	Publication