

# ETSI TS 124 183 V16.4.0 (2020-07)



**Universal Mobile Telecommunications System (UMTS);  
LTE;  
IP Multimedia Subsystem (IMS)  
Customized Ringing Signal (CRS);  
Protocol specification  
(3GPP TS 24.183 version 16.4.0 Release 16)**



---

Reference

RTS/TSGC-0124183vg40

---

Keywords

LTE,UMTS

**ETSI**

650 Route des Lucioles  
F-06921 Sophia Antipolis Cedex - FRANCE

Tel.: +33 4 92 94 42 00 Fax: +33 4 93 65 47 16

Siret N° 348 623 562 00017 - NAF 742 C  
Association à but non lucratif enregistrée à la  
Sous-Préfecture de Grasse (06) N° 7803/88

---

**Important notice**

The present document can be downloaded from:

<http://www.etsi.org/standards-search>

The present document may be made available in electronic versions and/or in print. The content of any electronic and/or print versions of the present document shall not be modified without the prior written authorization of ETSI. In case of any existing or perceived difference in contents between such versions and/or in print, the prevailing version of an ETSI deliverable is the one made publicly available in PDF format at [www.etsi.org/deliver](http://www.etsi.org/deliver).

Users of the present document should be aware that the document may be subject to revision or change of status.

Information on the current status of this and other ETSI documents is available at

<https://portal.etsi.org/TB/ETSIDeliverableStatus.aspx>

If you find errors in the present document, please send your comment to one of the following services:

<https://portal.etsi.org/People/CommiteeSupportStaff.aspx>

---

**Copyright Notification**

No part may be reproduced or utilized in any form or by any means, electronic or mechanical, including photocopying and microfilm except as authorized by written permission of ETSI.

The content of the PDF version shall not be modified without the written authorization of ETSI.

The copyright and the foregoing restriction extend to reproduction in all media.

© ETSI 2020.

All rights reserved.

**DECT™**, **PLUGTESTS™**, **UMTS™** and the ETSI logo are trademarks of ETSI registered for the benefit of its Members.

**3GPP™** and **LTE™** are trademarks of ETSI registered for the benefit of its Members and of the 3GPP Organizational Partners.

**oneM2M™** logo is a trademark of ETSI registered for the benefit of its Members and of the oneM2M Partners.

**GSM®** and the GSM logo are trademarks registered and owned by the GSM Association.

---

## Intellectual Property Rights

### Essential patents

IPRs essential or potentially essential to normative deliverables may have been declared to ETSI. The information pertaining to these essential IPRs, if any, is publicly available for **ETSI members and non-members**, and can be found in ETSI SR 000 314: "*Intellectual Property Rights (IPRs); Essential, or potentially Essential, IPRs notified to ETSI in respect of ETSI standards*", which is available from the ETSI Secretariat. Latest updates are available on the ETSI Web server (<https://ipr.etsi.org/>).

Pursuant to the ETSI IPR Policy, no investigation, including IPR searches, has been carried out by ETSI. No guarantee can be given as to the existence of other IPRs not referenced in ETSI SR 000 314 (or the updates on the ETSI Web server) which are, or may be, or may become, essential to the present document.

### Trademarks

The present document may include trademarks and/or tradenames which are asserted and/or registered by their owners. ETSI claims no ownership of these except for any which are indicated as being the property of ETSI, and conveys no right to use or reproduce any trademark and/or tradename. Mention of those trademarks in the present document does not constitute an endorsement by ETSI of products, services or organizations associated with those trademarks.

---

## Legal Notice

This Technical Specification (TS) has been produced by ETSI 3rd Generation Partnership Project (3GPP).

The present document may refer to technical specifications or reports using their 3GPP identities. These shall be interpreted as being references to the corresponding ETSI deliverables.

The cross reference between 3GPP and ETSI identities can be found under <http://webapp.etsi.org/key/queryform.asp>.

---

## Modal verbs terminology

In the present document "**shall**", "**shall not**", "**should**", "**should not**", "**may**", "**need not**", "**will**", "**will not**", "**can**" and "**cannot**" are to be interpreted as described in clause 3.2 of the [ETSI Drafting Rules](#) (Verbal forms for the expression of provisions).

"**must**" and "**must not**" are **NOT** allowed in ETSI deliverables except when used in direct citation.

# Contents

Intellectual Property Rights .....	2
Legal Notice .....	2
Modal verbs terminology.....	2
Foreword.....	5
1 Scope .....	6
2 References .....	6
3 Definitions and abbreviations.....	7
3.1 Definitions .....	7
3.2 Abbreviations .....	7
4 Customized Ringing Signal (CRS).....	7
4.1 Introduction .....	7
4.2 Description .....	7
4.2.1 General description .....	7
4.3 Operational requirements .....	8
4.3.1 Provision/withdrawal .....	8
4.3.1.1 CRS provision/withdrawal .....	8
4.3.1.2 Requirements on the originating network side.....	8
4.3.1.3 Requirements on the terminating network side.....	8
4.4 Syntax requirements .....	8
4.5 Signalling procedures .....	8
4.5.1 General.....	8
4.5.2 Activation/deactivation.....	8
4.5.3 Registration/erasure .....	9
4.5.4 Interrogation .....	9
4.5.5 Invocation and operation .....	9
4.5.5.1 Actions at the originating UE.....	9
4.5.5.2 Actions at the terminating UE.....	9
4.5.5.2.1 General .....	9
4.5.5.2.2 UE Actions for download and play model .....	9
4.5.5.2.2.1 General.....	9
4.5.5.2.2.2 UE Actions for CRS copy.....	10
4.5.5.2.2.3 UE Actions for CRS stop.....	10
4.5.5.2.3 UE Actions for early session model .....	10
4.5.5.2.3.1 General.....	10
4.5.5.2.3.2 UE Actions for CRS copy.....	10
4.5.5.2.4 UE support of DTMF .....	10
4.5.5.2.4.2 UE Actions for CRS stop.....	10
4.5.5.2.5 UE Actions for gateway model .....	11
4.5.5.2.5.1 General.....	11
4.5.5.3 Actions at the AS serving the originating UE .....	11
4.5.5.3.1 General .....	11
4.5.5.3.2 AS Actions for early session model.....	11
4.5.5.3.2.1 General AS actions .....	11
4.5.5.3.2.2 AS Actions for CRS stop .....	12
4.5.5.3.3 AS Actions for download and play model.....	13
4.5.5.3.4 AS Actions for CRS copy.....	13
4.5.5.3.5 AS support of DTMF.....	13
4.5.5.3.6 AS Actions for Gateway model.....	13
4.5.5.4 Actions at the AS serving the terminating UE .....	14
4.5.5.4.1 AS Actions for CRS stop.....	14
4.5.5.4.2 AS Actions for early session model.....	15
4.5.5.4.3 AS support of DTMF.....	16
4.5.5.4.4 AS Actions for download and play model.....	17
4.5.5.4.5 AS Actions for Gateway model.....	17

4.6	Interaction with other services.....	17
4.6.1	Communication session Hold (HOLD).....	17
4.6.2	Termination Identification Presentation (TIP).....	18
4.6.3	Termination Identification Restriction (TIR).....	18
4.6.4	Originating Identification presentation (OIP).....	18
4.6.5	Originating Identification Restriction (OIR).....	18
4.6.6	Conference (CONF).....	18
4.6.7	Communication Diversion (CDIV).....	18
4.6.7.1	General.....	18
4.6.7.2	CFNR.....	18
4.6.8	Message Waiting Indication (MWI).....	19
4.6.9	Communication Barring (CB).....	19
4.6.10	Communication Waiting (CW).....	19
4.6.11	Explicit Communication Transfer (ECT).....	19
4.6.12	Completion of Communications to Busy Subscriber (CCBS).....	19
4.6.13	Multi-Device (MuD).....	19
4.6.14	Multi-Identity (MiD).....	19
4.7	Service configuration.....	20
<b>Annex A (informative):    Signalling flows .....</b>		<b>21</b>
A.1	CRS download and play model signalling flows.....	21
A.1.1	Introduction.....	21
A.1.2	CRS when UE#1 and UE#2 have resources available.....	22
A.2	CRS signalling flows using early session model.....	26
A.2.1	Introduction.....	26
A.2.2	CRS when UE#1 and UE#2 have resources available.....	26
A.2.3	CRS when UE#1 does not have required resources available while UE#2 has resources available.....	31
A.2.4	CRS when UE#1 has required resources available while UE#2 do not have resources available.....	41
A.2.5	Continue to play CRS during the conversation.....	47
<b>Annex B (informative):    Void .....</b>		<b>56</b>
<b>Annex C (normative):    Registration for URN used within the current document.....</b>		<b>57</b>
<b>Annex D (informative):    XML body in SIP message for indicating to UE .....</b>		<b>58</b>
D.1	CRS service indication XML schema.....	58
D.1.1	General.....	58
D.1.2	XML schema.....	58
D.1.3	IANA registration template.....	58
<b>Annex E (normative):    SDP a=content attribute "g.3gpp.crs" value.....</b>		<b>60</b>
E.1	Introduction.....	60
E.2	IANA registration.....	60
<b>Annex F(informative):    Change history .....</b>		<b>61</b>
History.....		64

---

# Foreword

This Technical Specification has been produced by the 3<sup>rd</sup> Generation Partnership Project (3GPP).

The contents of the present document are subject to continuing work within the TSG and may change following formal TSG approval. Should the TSG modify the contents of the present document, it will be re-released by the TSG with an identifying change of release date and an increase in version number as follows:

Version x.y.z

where:

x the first digit:

- 1 presented to TSG for information;
- 2 presented to TSG for approval;
- 3 or greater indicates TSG approved document under change control.

y the second digit is incremented for all changes of substance, i.e. technical enhancements, corrections, updates, etc.

z the third digit is incremented when editorial only changes have been incorporated in the document.

---

# 1 Scope

The present document provides the protocol details for the Customized Ringing Signal (CRS) service in the IP Multimedia (IM) Core Network (CN) subsystem based on the requirements from 3GPP TS 22.183 [2].

The CRS service is an operator specific service by which an operator enables the subscriber to customize the media which is played to the called party as an incoming communication indication during establishment of a communication.

The present document is applicable to User Equipment (UE) and Application Servers (AS) which are intended to support the CRS service.

---

# 2 References

The following documents contain provisions which, through reference in this text, constitute provisions of the present document.

- References are either specific (identified by date of publication, edition number, version number, etc.) or non-specific.
- For a specific reference, subsequent revisions do not apply.
- For a non-specific reference, the latest version applies. In the case of a reference to a 3GPP document (including a GSM document), a non-specific reference implicitly refers to the latest version of that document *in the same Release as the present document*.

- [1] 3GPP TR 21.905: "Vocabulary for 3GPP Specifications".
- [2] 3GPP TS 22.183: "Customized Ringing Signal (CRS) Requirements; Stage 1".
- [3] 3GPP TS 24.229: "IP multimedia call control protocol based on Session Initiation Protocol (SIP) and Session Description Protocol (SDP); Stage 3".
- [4] RFC 3959: "The Early Session Disposition Type for the Session Initiation Protocol (SIP)".
- [5] 3GPP TS 24.623: "Extensible Markup Language (XML) Configuration Access Protocol (XCAP) over the Ut interface for Manipulating Supplementary Services".
- [6] 3GPP TS 24.238: "Session Initiation Protocol (SIP) based user configuration; Stage 3".
- [7] RFC 6086 (January 2011): "Session Initiation Protocol (SIP) INFO Method and Package Framework".
- [8] RFC 7462 (March 2015): "URNs for the Alert-Info Header Field of the Session Initiation Protocol (SIP)".
- [9] RFC 4796: "The Session Description Protocol (SDP) Content Attribute".
- [10] RFC 3960: "Early Media and Ringing Tone Generation in the Session Initiation Protocol (SIP)".
- [11] 3GPP TS 24.628: "Common Basic Communication procedures; Protocol specification".
- [12] RFC 3311: "The Session Initiation Protocol (SIP) UPDATE Method".
- [13] 3GPP TS 24.174: "Support of Multi-Device and Multi-Identity in IMS; Stage 3".
- [14] RFC 3312: "Integration of Resource Management and Session Initiation Protocol (SIP)".

---

## 3 Definitions and abbreviations

### 3.1 Definitions

For the purposes of the present document, the terms and definitions given in 3GPP TR 21.905 [1] and the following apply. A term defined in the present document takes precedence over the definition of the same term, if any, in 3GPP TR 21.905 [1].

**Media component:** A media component, described by the SDP, is a separate data-flow related to a media type which is sent by using an IP –based transport protocol (e.g. RTP). Multiple media components may be used in the same session to send multiple media types.

### 3.2 Abbreviations

For the purposes of the present document, the abbreviations given in 3GPP TR 21.905 [1] and the following apply. An abbreviation defined in the present document takes precedence over the definition of the same abbreviation, if any, in 3GPP TR 21.905 [1].

CRS	Customized Ringing Signal
MiD	Multi-iDentity
MuD	Multi-Device

---

## 4 Customized Ringing Signal (CRS)

### 4.1 Introduction

The CRS service is an operator specific service by which an operator enables the subscriber to customize the media which is played to the called party during alerting of the called party. The media can consist of music, voice, text, video or other customized ringing signals.

### 4.2 Description

#### 4.2.1 General description

The service user is able to subscribe to the CRS service, activate (or de-activate) the service, and update the settings, e.g., to change by configuration the active CRS media. The media can consist of favourable songs, multimedia clips or other customized ring signals. The CRS subscriber is able to refine the CRS media selection behaviour with configured rules, e.g. time, calling party's location, called party's location, the identity of the calling and called party. The CRS service is able to select the appropriate CRS media according to the rules.

CRS is an originating network service, but can also have a terminating network functional component. That is, CRS media can be selected on behalf of the calling subscriber, but the called (IMS) subscriber can also subscribe to and activate the CRS service. Whether or not the called party's CRS media has precedence over the calling party's selected CRS media is a matter of configuration in the called party's (terminating) network.

The presentation of the selected CRS media to the called party starts some time following the initiation of a session, but prior to session answer. When the called party answers, the CRS media either stops or continues during the conversation, depending on operator or user preferences.



## 4.3 Operational requirements

### 4.3.1 Provision/withdrawal

#### 4.3.1.1 CRS provision/withdrawal

The CRS service may be provided after prior arrangement with the service provider.

The CRS service may be withdrawn at the subscriber's request or for administrative reasons.

#### 4.3.1.2 Requirements on the originating network side

The originating network side may support the "early-session" extension as described in RFC 3959 [7]

For the early session model and the gateway model, if the CRS service is provided by the originating network, the CRS AS shall control an MRF as described in 3GPP TS 24.229 [3] that is acting on behalf of a calling subscriber who has activated CRS.

The CRS service implementing the download and play model adds no additional requirements on the originating network side.

#### 4.3.1.3 Requirements on the terminating network side

The terminating network side may support the "early-session" extension as described in RFC 3959 [7].

NOTE: the CRS service implementing the early-session model needs the early-session extension to be supported by intermediate entities and the terminating UE, else CRS media can not be provided to the called party.

The CRS service implementing the download and play model adds no additional requirements on the terminating network side.

For early session model and the gateway model, if the CRS service is provided by the terminating network, the CRS AS shall control an MRF as described in 3GPP TS 24.229 [3] that is acting on behalf of a called subscriber who has activated CRS.

## 4.4 Syntax requirements

There are no new protocol requirements for the CRS service.

## 4.5 Signalling procedures

### 4.5.1 General

Configuration of supplementary services by the user should:

- take place over the Ut interface using XCAP as enabling protocol as described in 3GPP TS 24.623 [5]; or
- use SIP based user configuration as described in 3GPP TS 24.238 [6].

NOTE: Other possibilities for user configuration, such as web-based provisioning or pre-provisioning by the operator are outside the scope of the present document, but are not precluded.

The details of the XCAP document of CRS service are not specified in this version of the document.

### 4.5.2 Activation/deactivation

The CRS service is activated at provisioning and deactivated at withdrawal.

When a CRS service is activated a subscriber can specify which CRS a called user should experience, or use the operator's default setting.

After a subscriber has activated his CRS service a called user experiences the CRS that was chosen by the subscriber, or if the called user has activated his CRS service, he can experience the CRS that was chosen by himself.

When a CRS service is deactivated a subscriber will not send any CRS to a called user.

After a subscriber has deactivated his CRS service a called user will not experience any CRS unless the called user has activated his CRS service and revert to any alerting provided by the UE.

### 4.5.3 Registration/erasure

The CRS service requires no registration. Erasure is not applicable.

### 4.5.4 Interrogation

For CRS, interrogation is not applicable.

### 4.5.5 Invocation and operation

#### 4.5.5.1 Actions at the originating UE

The UE shall follow the procedures specified in 3GPP TS 24.229 [3] for session initiation and termination.

If a specific CRS media that the originating UE wants to play to the terminating UE exists, the originating UE in the initial INVITE shall:

- a) insert an Alert-Info header field with a URL which indicates the specific CRS media defined by the CRS AS serving the originating UE; and
- b) an XML body as specified in annex D.

#### 4.5.5.2 Actions at the terminating UE

##### 4.5.5.2.1 General

The UE shall follow the procedures specified in 3GPP TS 24.229 [3] for session termination.

If the terminating UE supports the early session mechanism then the UE shall make use of the procedures as specified in RFC 3959 [4].

Upon receiving the CRS media, the terminating UE shall play the CRS media. If media type of the local ringing signal is not in conflict with media type of the received CRS media, the local ringing signal shall be played at the same time to the received CRS media otherwise the local ringing signal shall not be played.

NOTE: How to decide that the media type of the local ringing signal is in conflict with the media type of the CRS media type depends on UE implementation.

##### 4.5.5.2.2 UE Actions for download and play model

###### 4.5.5.2.2.1 General

If the terminating UE supports the download and play model, and an initial INVITE request contains an Alert-Info header field including a URI followed by a URN "urn:alert:service:crs", then the UE shall fetch and play the CRS media from the URL contained in the Alert-Info header field in the INVITE request.

#### 4.5.5.2.2.2 UE Actions for CRS copy

In order for the called party to copy the media for the CRS service, the UE shall send a specific DTMF digit for CRS copy.

NOTE: The definition of which DTMFs are used is outside the scope of this specification and is dependant on the implementation of operator.

#### 4.5.5.2.2.3 UE Actions for CRS stop

It is the local action of UE for the called party to stop and restart the media of the CRS service.

### 4.5.5.2.3 UE Actions for early session model

#### 4.5.5.2.3.1 General

The UE shall follow the procedures specified in 3GPP TS 24.229 [3] for session termination with the following additions:

- a) Upon receiving an initial INVITE request, the UE shall:
  - check whether an Alert-Info header field with a URN "urn:alert:service:crs" present; and
- b) If present, then the UE shall:
  - send a reliable SIP 18x response as specified in 3GPP TS 24.229 [3];
  - not play local ringing tone to terminating user when a 180 response is sent;
  - if SIP PRACK request containing an SDP early session offer, containing an SDP a=content attribute with a "a.3gpp.crs" value for each media description is received, send back a SIP 200(OK) response to the request including an SDP early session answer; and
  - receive the CRS media from network and play it as ringing tone.

NOTE: The UE plays a local ringing tone if no CRS media is received within a specific time.

#### 4.5.5.2.3.2 UE Actions for CRS copy

In order for the called party to copy the media for the CRS service, the UE shall send a specific DTMF digit for CRS copy.

NOTE: The definition of which DTMFs are used is outside the scope of this specification and is dependant on the implementation of operator.

#### 4.5.5.2.4 UE support of DTMF

In addition to indicating support of the telephone-event media subtype in the SDP answer, as defined in 3GPP TS 24.229 [3], the UE shall indicate support of the SIP INFO mechanism for DTMF transport, as defined in 3GPP TS 24.229 [3], by including a Recv-Info header field with a "infoDtmf" value, as defined in IETF RFC 6086 [7]. The AS will indicate to the UE which DTMF transport mechanism to use for CRS control.

#### 4.5.5.2.4.2 UE Actions for CRS stop

In order for the called party to stop the media for the CRS service, the UE shall send a specific DTMF digit for CRS stop.

In order for the called party to restart the media for the CRS service, the UE shall send a specific DTMF digit for CRS restart.

NOTE: The definition of which DTMFs are used is outside the scope of this specification and is dependant on the implementation of operator.

#### 4.5.5.2.5 UE Actions for gateway model

##### 4.5.5.2.5.1 General

If the UE supports playing CRS media, the UE shall follow the procedures specified in 3GPP TS 24.229 [3] for session termination, and additionally, if the received initial INVITE request contains an Alert-Info header field with an URN "urn:alert:service:crs" and without a URL of CRS media, the UE shall play any CRS media that is received from the network as ringing signal. CRS media is identified by the a=content media-level attribute with a "g.3gpp.crs" value being in the SDP offer.

NOTE: The UE plays local ringing tone if no UPDATE request with an SDP offer including a=content media-level attribute with a "g.3gpp.crs" value and no CRS media is received within a specific time.

#### 4.5.5.3 Actions at the AS serving the originating UE

##### 4.5.5.3.1 General

The procedures specified in 3GPP TS 24.229 [3] for an AS acting as a routing B2BUA apply with additions described in the subclauses below.

Upon receiving a SIP INVITE request containing an XML body as specified in annex D, the AS shall fetch the URL indication for a specific CRS media in the Alert-Info header field as indicated in annex D, and delete this URL indication in the Alert-Info header field and delete the XML body before forwarding the SIP INVITE request.

If the first reliable SIP 18x response destined to served user includes a Require header field with "early-session" option-tag and the AS supports the "early-session" extension as described in RFC 3959 [4], the AS shall, based on operator policy, follow the procedures in subclause 4.5.5.3.2 to provide CRS service according to the configuration rules, e.g. time, calling party's location, called party's location, the identity of the calling and called party, if privacy is required, any information which should be private cannot be used as the rules to provide the CRS service. The procedures in subclause 4.5.5.3.2 shall not be used if there are intermediates in the network that do not support the early session extension. In addition, intermediates and network policy must allow media towards the terminating UE before the call has been answered.

##### 4.5.5.3.2 AS Actions for early session model

###### 4.5.5.3.2.1 General AS actions

Upon receiving an initial INVITE request from the served user, the AS shall forward the initial INVITE request to the terminating UE after inserting an Alert-Info header field with an URN "urn:alert:service:crs" and inserting a Supported header field containing "early-session" option-tag as specified in RFC 3959 [4].

Upon receiving the first reliable SIP 18x response to the initial INVITE request including a Supported header field with "early-session" tag, the AS:

- may contact the MRF to request CRS resource; and
- shall forward the reliable SIP 18x response to the originating UE.

Upon receiving the PRACK request of the first reliable SIP 18x response from the served user, the AS shall:

- 1) contact the MRF to request CRS resource if it has not been previously requested; and
- 2) forward the SIP PRACK request to the terminating UE. The PRACK request shall:
  - include the SDP content for CRS as early-session SDP offer based on the information from the MRF and if preconditions are used, indicate the local preconditions are fulfilled. The early session SDP offer shall contain an SDP a=content attribute with a "g.3gpp.crs" value for each media description.

Upon receiving a SIP 200 (OK) response to the SIP PRACK request of the first reliable SIP 18x response, the AS shall remove the early-session SDP answer in the SIP 200 (OK) response, and forward the response to the originator of the SIP PRACK request.

Upon receiving additional SIP 18x responses to the initial INVITE request, the AS shall forward them to the originating UE.

Upon receiving a SIP UPDATE request from served user, the AS shall:

- generate an early-session SDP offer based on the information from the MRF and, if preconditions are used, indicate that the local preconditions are fulfilled;
- include the early-session SDP offer in the SIP request, and forward it to the terminating UE; and
- after receiving a SIP 200 (OK) response to the request, remove the early-session SDP answer in the SIP 200 (OK) response, and forwards the response to the originator.

NOTE 1: The early-session SDP offer included in the SIP UPDATE request can in some cases be identical to a previous early-session SDP offer sent towards the terminating UE, if the associated media parameters have not changed.

If preconditions are used, the AS should not instruct the MRF to start applicable media for the CRS service before the both the originating and terminating UE have indicated that local preconditions are fulfilled, and a 180 (Ringing) response has been received from the terminating UE.

If a SIP message from served UE containing an SDP offer related to an early session is received, the AS shall send an SDP answer to the SDP offer related to the early-session sent by the served UE and set all port numbers of the media types to "0".

Upon receiving a SIP 200 (OK) response from the terminating UE to the initial INVITE request, the AS shall instruct the MRF to stop media for the CRS service and forward the SIP 200 (OK) response to the originating UE.

NOTE 2: The interaction between the AS and MRF is not specified for the CRS service but can use the Cr reference point as described in 3GPP TS 24.229 [3].

Upon receiving a SIP 4xx, 5xx or 6xx response from the terminating UE the AS shall:

- instruct the MRF to stop the media for the CRS service; and
- forward the final response to the originating UE.

#### 4.5.5.3.2.2 AS Actions for CRS stop

Upon receipt of the specific DTMF digit for CRS stop, the AS instructs the MRF to stop the media for the CRS service.

Upon receipt of the specific DTMF digit for CRS restart, the AS instructs the MRF to restart the media for the CRS service.

#### 4.5.5.3.2.3 AS Actions for CRS continue

Upon receiving the SIP 200 (OK) response of the SIP INVITE request from terminating UE, the AS shall:

- a) decide whether the CRS media need to be stopped or continuously played based on the operator policy and the calling subscribers' preferences;
- b) if the CRS media is provided by the originating network, and the calling party need the CRS media to be continuously played, then:
  - 1) send a SIP ACK to terminating UE;
  - 2) contact the MRF to request resource of CRS media and original session;
  - 3) send a SIP re-INVITE request to terminating UE. The SIP re-INVITE request shall include a SDP offer composed of both the original session media received in the last SDP offer plus the CRS media components apart from those used in the original session based on the information from MRF, and include an SDP a=content attribute with a "g.3gpp.crs" value for each media description associated with CRS media.
  - 4) if a SIP 200 (OK) response containing a SDP answer of the re-INVITE request from the terminating network is received, the AS shall:

- send a SIP UPDATE request to originating UE. The SIP UPDATE request shall include a SDP offer related to the media of original session and the IP address and port is set based on the information from MRF.
- upon receiving a SIP 200 (OK) response of SIP UPDATE request from originating UE, send a SIP 200 (OK) response of the SIP INVITE request to originating UE.
- upon receiving the SIP ACK from originating UE, instruct MRF to start to mix CRS media and regular media for terminating UE and just forward regular media to originating UE.

otherwise if a SIP 488 (Not Acceptable Here) response of the SIP re-INVITE request from the terminating network is received, the AS shall send a SIP 200 (OK) response of the SIP INVITE request to the originating UE, but don't need to instruct MRF to start to mix CRS media and regular media for terminating UE.

#### 4.5.5.3.3 AS Actions for download and play model

Upon receiving an initial INVITE request from the served user, the AS supporting download and play model shall insert an Alert-Info header field with the URI of the CRS media labeled with the URN "urn:alert:service:crs" as the value into the INVITE request, and forward the INVITE request to the terminating UE.

#### 4.5.5.3.4 AS Actions for CRS copy

Upon receipt of the specific DTMF digit, the AS copies the media for the calling party's CRS service.

NOTE: How the AS copies the calling party's CRS is out of the scope of this document.

#### 4.5.5.3.5 AS support of DTMF

If the UE has indicated support of both the "telephone-event" media subtype and the SIP INFO mechanism for DTMF transport, the AS shall based on operator policy choose which DTMF transport mechanism to use for CRS control between the UE and the AS.

If the AS wants to use the SIP INFO mechanism for DTMF transport, as defined in 3GPP TS 24.229 [3], the AS shall indicate support of the mechanism in the initial SIP INVITE request sent towards the terminating UE by including a Recv-Info header field with a "infoDtmf" value, as defined in IETF RFC 6086 [7].

If the AS wants to use the "telephone-event" media subtype for DTMF transport, the AS shall include the "telephone-event" in the SDP for CRS media, sent to the UE.

NOTE: The usage of the "telephone-event" media subtype for CRS control requires that intermediates allow the telephone-event packages to traverse from the UE to the AS during the early dialog.

For the remainder of this subclause, when the term "receipt of DTMF digit" is used, it means either the detection of a DTMF digit by the MRF, which is then passed to the AS over the Cr interface, or the receipt of an INFO request containing the appropriate INFO package, as negotiated above.

#### 4.5.5.3.6 AS Actions for Gateway model

The AS performing the Gateway model shall follow the procedure as specified in RFC 3960 [10] and annex G in 3GPP TS 24.628 [11] with the additional procedures described in this subclause.

Upon receiving an initial INVITE request from the originating UE, the AS shall forward the initial INVITE request to the terminating UE with the following clarifications:

- a) insert an Alert-Info header field with an URN "urn:alert:service:crs"; and
- b) if no "precondition" option tag was received in the Supported header field of the incoming INVITE request, and if the AS uses precondition mechanism for providing CRS, add a "precondition" option tag to the Supported header field, insert precondition SDP parameters and indicate the status of local resource availability as specified in RFC 3312 [14].

Upon receiving the first reliable SIP 18x response to the initial INVITE request, the AS:

- a) may contact the MRF to request CRS resource; and

- b) shall forward the reliable SIP 18x response to the originating UE. If no "precondition" option tag was included in the Supported header field of the INVITE request and if the precondition mechanism is used in the received 18x, before forwarding the 18x response, the AS shall remove the "precondition" option tag from the Require header field and remove precondition SDP parameters from the SDP answer.

Upon receiving the PRACK request of the first reliable 18x response from originating UE, the AS shall forward the PRACK request to the terminating UE and contact the MRF to request CRS resource if it has not been previously requested.

When the video media feature tag is not included in the Contact header field of the previously received 18x response from the terminating UE and there is no video description in the SDP answer included in the 18x response, the AS shall not request video CRS resource from MRF, and shall not apply video CRS media to the terminating UE.

After receiving 180 (Ringing) response or receiving a SIP 200 (OK) response to the PRACK request of the first reliable SIP 18x response from terminating UE, the AS shall update media of CRS service with terminating UE by UPDATE request as specified in RFC 3311 [12] with:

- a) P-Early-Media header field with a "sendrecv" value or a "sendonly" value;
- b) an SDP offer, which is based on the CRS information received from the MRF and includes an a=content media-level attribute with a "g.3gpp.crs" value., The media types can include additional media types compared to the SDP answer of the previous 18x response from the terminating UE; and
- c) precondition mechanism as specified in RFC 3312 [14] if "precondition" option tag is included in the Require header field of a received 18x response.

If the terminating UE requires the use of precondition mechanism, the AS shall not instruct the MRF to start applicable media for the CRS service before the terminating UE has indicated that preconditions are fulfilled. The point when the AS instruct the MRF to start applicable media for the CRS service is based on local policy.

Upon receiving a SIP 200 (OK) response to the INVITE request from the terminating UE, the AS shall instruct the MRF to stop media for the CRS service and update media for conversation. If the AS is going to update media with both originating side and terminating side, the AS shall:

- a) send an offerless re-INVITE request to the terminating side;
- b) upon receiving a SIP response to the re-INVITE request containing an SDP offer from the terminating side, generate an UPDATE request as specified in RFC 3311 [12] to send an SDP offer to the originating UE. The SDP offer shall only contain the media components which appeared both in the SDP offer contained in the SIP response to the re-INVITE request and the previously stored SDP offer in the initial INVITE request. The port number of the corresponding m-line shall be set to zero if it has been set to zero during previous SDP negotiation; and
- c) upon receiving a 200 (OK) response to the UPDATE request from the originating side, generate an SDP answer to the terminating side, included in the ACK request associated with the re-INVITE request. The SDP answer shall be based on the SDP answer contained in the 200 (OK) response to the UPDATE request, and for the media components which do not appear in the SDP answer in the 200 (OK) response, set the port number of the corresponding m-line to zero.

Upon receiving a SIP 4xx, 5xx or 6xx response to the initial INVITE request from the terminating UE, the AS shall:

- a) instruct the MRF to stop the media for the CRS service; and
- b) forward the final response to the originating UE.

#### 4.5.5.4 Actions at the AS serving the terminating UE

##### 4.5.5.4.1 AS Actions for CRS stop

When using early session model, upon receipt of the specific DTMF digit for CRS stop, the AS instructs the MRF to stop the media for the CRS service.

When using early session model, upon receipt of the specific DTMF digit for CRS restart, the AS instructs the MRF to restart the media for the CRS service.

#### 4.5.5.4.2 AS Actions for early session model

##### 4.5.5.4.2.1 General

The procedures in subclause 4.5.5.3.2 shall apply with following additions:

- Upon receiving the initial INVITE request containing an Alert-Info header field including only an URN "urn:alert:service:crs", the AS shall:
  - decide which CRS service should have priority based on the operator policy and the called CRS service subscriber's preferences;
  - if the CRS service provided by the AS serving the terminating UE has no priority, then forward the initial INVITE request and do not provide CRS service;
  - if the CRS service provided by the AS serving the terminating UE has priority, then upon receiving the PRACK request of the first reliable 18x response to the initial INVITE request:
    - a) send the PRACK request to the terminating UE. The request shall include the SDP content for CRS service provided by the AS serving the terminating UE instead of the CRS service provided by the AS serving the originating UE as early-session SDP offer and if preconditions are used, and CRS resource has been requested, indicate the local preconditions are fulfilled;
    - b) if a 200 (OK) response of PRACK request from terminating UE containing an SDP answer related to an early session is received, the AS shall forward the 200 (OK) response with a new SDP answer related to the early-session and set all port numbers of the media types to "0".
- Upon receiving the initial INVITE request including the Alert-Info header field with both an URL of CRS media and an URN "urn:alert:service:crs", the AS shall:
  - decide which CRS service should have priority based on the operator policy and the called CRS service subscriber's preferences;
  - if the CRS service provided by the AS serving the terminating UE has no priority, then forward the INVITE request and do not provide CRS service;
  - if the CRS service provided by the AS serving the terminating UE has priority, then:
    - a) forward the INVITE request after removing the Alert-Info header field; and
    - b) send a PRACK request to the terminating UE upon receiving the PRACK request from the originating network of the first reliable SIP 18x response. The PRACK request shall include the SDP content for CRS as early-session SDP offer and if preconditions are used, and CRS resource has been requested, indicate the local preconditions are fulfilled.
  - if a 200 (OK) response of PRACK request from terminating UE containing an SDP answer related to an early session is received, the AS shall forward the 200 response after removing the SDP answer related to the early session.

##### 4.5.5.4.2.2 AS Actions for CRS continue

Upon receiving the SIP 200 (OK) response of the SIP INVITE request from terminating UE, the AS shall:

- a) decide whether the CRS media need to be stopped or continuously played based on the operator policy and the called subscribers' preferences;
- b) if the CRS media is provided by the terminating network, and the called party needs the CRS media to be continuously played, then:
  - 1) send a SIP ACK to terminating UE;
  - 2) contact the MRF to request resource of CRS media and original session;
  - 3) send a SIP re-INVITE request to terminating UE. The SIP re-INVITE request shall include a SDP offer composed of both the original session media received in the last SDP offer plus the CRS media components



apart from those used in the original session based on the information from MRF, and include an SDP a=content attribute with a "g.3gpp.crs" value for each media description associated with CRS media..

- 4) upon receiving a SIP 200 (OK) response contain a SDP answer of the SIP re-INVITE request from the terminating UE, send a SIP UPDATE request to originating UE. The UPDATE request shall include a SDP offer related to the media of original session and the IP address and port is set based on the information from MRF.
  - 5) upon receiving a SIP 200 (OK) response of the SIP UPDATE request from originating UE, send a SIP 200 (OK) of the SIP INVITE request to the originating UE.
  - 6) upon receiving the SIP ACK from originating UE, instruct MRF to start to mix CRS media and regular media for terminating UE and just forward regular media to originating UE.
- c) if the CRS media is provided by the originating network, and the calling party need the CRS media to be continuously played while the called party does not need the CRS media to be continuously played, then:
- 1) upon receiving the first SIP re-INVITE request after forwarding the final SIP 200 (OK) response send from the terminating UE, the AS shall:
    - check whether an SDP a=content attribute with a "g.3gpp.crs" value is present for some media components.
    - If present, then:
      - Send a SIP 488 (Not Acceptable Here) response to reject the SIP re-INVITE request.

#### 4.5.5.4.2.3 AS action of CRS Reject

This subclause describes the procedures when the CRS AS has decided to reject CRS offered by the AS serving the originating UE.

Upon receiving the initial INVITE request containing an Alert-Info header field including an URN "urn:alert:service:crs", the AS shall decide whether the CRS service provided by the AS serving the originating UE should be rejected based on the operator policy and the called CRS service subscriber's preferences.

NOTE: Based on the operator policy, the AS can decide whether to reject the originating CRS service when receiving the first SIP INVITE request or receiving the PRACK request.

If the CRS service provided by the AS serving the originating UE needs to be rejected, the AS shall:

- remove the Alert-Info header field;
- when receiving the PRACK request of the first reliable 18x response to the initial INVITE request,
  - remove the early-session SDP content for CRS service provided by the AS serving the originating UE;
  - forward the PRACK request to the terminating UE; and
  - if a 200 (OK) response of the PRACK request from terminating UE is received, the AS shall forward the 200 (OK) response with a new SDP answer related to the early-session and set all port numbers of the media types to "0".

Upon receiving the initial INVITE request including the Alert-Info header field with a URL of CRS media, the AS shall decide whether the CRS service provided by the AS serving the originating UE should be rejected based on the operator policy and the called CRS service subscriber's preferences. If the CRS service provided by the AS serving the originating UE needs to be rejected, the AS shall forward the INVITE request after removing the Alert-Info header field.

#### 4.5.5.4.3 AS support of DTMF

If the UE has indicated support of both the "telephone-event" media subtype and the SIP INFO mechanism for DTMF transport, the AS shall based on operator policy choose which DTMF transport mechanism to use for CRS control between the UE and the AS.

If the AS wants to use the SIP INFO mechanism for DTMF transport, as defined in 3GPP TS 24.229 [3], the AS shall indicate support of the mechanism in the initial SIP INVITE request sent towards the terminating UE by including a Recv-Info header field with a "infoDtmf" value, as defined in IETF RFC 6086 [7].

If the AS wants to use the "telephone-event" media subtype for DTMF transport, the AS shall include the "telephone-event" in the SDP for CRS media, sent to the UE.

NOTE: The usage of the "telephone-event" media subtype for CRS control requires that intermediates allow the telephone-event packages to traverse from the UE to the AS during the early dialog.

For the remainder of this subclause, when the term "receipt of DTMF digit" is used, it means either the detection of a DTMF digit by the MRF, which is then passed to the AS over the Cr interface, or the receipt of an INFO request containing the appropriate INFO package, as negotiated above.

#### 4.5.5.4.4 AS Actions for download and play model

The procedures in subclause 4.5.5.3.3 shall apply with following additions:

- Upon receiving the initial INVITE request including an Alert-Info header field containing both an URL of CRS media and an URN "urn:alert:service:crs", the AS shall:
  - decide which CRS service has priority, based on the operator policy and the called CRS service subscriber's preferences; and
  - if the CRS service provided by the AS serving the terminating UE has no priority, then forward the INVITE request and do not provide CRS service; or
  - if the CRS service provided by the AS serving the terminating UE has priority, then replace the URL in the Alert-Info header with the URL of CRS media specified by terminating user.

#### 4.5.5.4.5 AS Actions for Gateway model

The procedures in subclause 4.5.5.3.6 shall apply with following additions:

Upon receiving UPDATE request from originating side, if P-Early-Media header field with a "sendrecv" value or a "sendonly" value is included in the request, the AS shall:

- a) decide which CRS service should have priority based on the operator policy and the called CRS service subscriber's preferences;
- b) if the CRS service provided by the AS serving the terminating UE has lower priority, then forward the UPDATE request and do not provide CRS service; and
- c) if the CRS service provided by the AS serving the terminating UE has higher priority, then either:
  - 1) generate an SDP answer based on the received SDP offer, and set all port numbers of the media types to "0", then send the SDP answer to originating side in the 200 (OK) response to the UPDATE request; or
  - 2) send a 200 (OK) response to the UPDATE request to the originating side and include a P-Early-Media header field with an "inactive" value.

## 4.6 Interaction with other services

### 4.6.1 Communication session Hold (HOLD)

In the case that CRS service is stopped after the communication is answered, there is no impact between CRS service and HOLD.

In the case that CRS service is continued after the communication is answered, whether the CRS will also be hold or not by the CRS AS when user requests HOLD depends on user's preferences and capability of terminating UE.

## 4.6.2 Termination Identification Presentation (TIP)

No impact, i.e. neither service shall affect the operation of the other service.

## 4.6.3 Termination Identification Restriction (TIR)

No impact, i.e. neither service shall affect the operation of the other service.

## 4.6.4 Originating Identification presentation (OIP)

No impact, i.e. neither service shall affect the operation of the other service.

## 4.6.5 Originating Identification Restriction (OIR)

The OIR service takes precedence over the CRS service. If the OIR service prevents CRS media from being played to the called party, then the AS providing CRS service shall not apply the CRS service to the session.

## 4.6.6 Conference (CONF)

No impact, i.e. neither service shall affect the operation of the other service.

## 4.6.7 Communication Diversion (CDIV)

### 4.6.7.1 General

If the calling party has CRS service and diverting party has both CRS service and CDIV active, when the diverted-to party does not have active CRS service, based on operator policy, either:

- a) the CRS service of the calling party shall be applied to the session by the AS providing the CRS service of calling party; or
- b) the CRS service of the diverting party shall be applied to the session by the AS providing CRS service for the diverting party.

If the calling party has CRS service and diverting party has both CRS service and CDIV active, when the diverted-to party also has active CRS service, based on operator policy, either:

- a) the CRS service of the calling party shall be applied to the session by the AS providing the CRS service of calling party; or
- b) the CRS service of the diverting party shall be applied to the session by the AS providing CRS service for the diverting party; or
- c) the CRS service of the diverted-to party shall be applied to the session by the AS providing CRS service for the diverted-to party.

### 4.6.7.2 CFNR

Based on operator policy, the CRS service of the calling party shall be applied to the session by the AS providing CRS service for the calling party until the CFNR timer expires. Alternatively, the CRS service of the diverting party shall be applied to the session by the AS providing CRS service for the diverting party until the CFNR timer expires.

Upon the CFNR timer expiring, based on operator policy, either:

- a) the CRS service of the calling party shall be applied to the session by the AS providing the CRS service of calling party; or
- b) the CRS service of the diverting party shall be applied to the session by the AS providing CRS service for the diverting party; or

- c) the CRS service of the diverted-to party shall be applied to the session by the AS providing CRS service for the diverted-to party.

#### 4.6.8 Message Waiting Indication (MWI)

No impact, i.e. neither service shall affect the operation of the other service.

#### 4.6.9 Communication Barring (CB)

No impact, i.e. neither service shall affect the operation of the other service.

#### 4.6.10 Communication Waiting (CW)

The Communication Waiting alert, or the CRS service of calling party or called party whose audio information is replaced by the communication waiting indication shall be applied, based on operator policy.

If the calling party has CRS service, and the called party does not have active CRS service, based on operator policy, either:

- a) the Communication Waiting alert shall be applied by the MMTEL AS; or
- b) the CRS service of calling party shall be applied by the AS providing the CRS service of calling party.

If the calling party and the called party both have active CRS service, based on operator policy, either:

- a) the Communication Waiting alert shall be applied by the MMTEL AS;
- b) the CRS service of calling party shall be applied by the AS providing the CRS service of calling party; or
- c) the CRS service of called party whose audio information is replaced by the communication waiting indication shall be applied by the AS providing the CRS service of called party.

#### 4.6.11 Explicit Communication Transfer (ECT)

Before the call is transferring, the CRS service of calling party shall be applied by the AS providing the CRS service of calling party depending on operator setting., otherwise the CRS service of transferor shall be applied by the AS providing the CRS service of transferor.

Upon the ECT service is invoked, depending on operator setting., either:

- a) the CRS service of calling party shall be applied by the AS providing the CRS service of calling party;
- b) the CRS service of transferor shall be applied by the AS providing the CRS service of transferor; or
- c) the CRS service of transfer target shall be applied by the AS providing the CRS service of transfer target.

#### 4.6.12 Completion of Communications to Busy Subscriber (CCBS)

No impact, i.e. neither service shall affect the operation of the other service.

#### 4.6.13 Multi-Device (MuD)

No impact.

#### 4.6.14 Multi-Identity (MiD)

In the originating network, if identity C, as defined in 3GPP TS 24.174 [13], has CRS service active, and user A, as defined in 3GPP TS 24.174 [13], has CRS service active, based on operator policy, either:

- a) the CRS service of user A shall be applied to the session by the AS providing the CRS service of user A; or

- b) the CRS service of identity C shall be applied to the session by the AS providing CRS service for identity C, without the CRS service of user A applied to the session.

If the identity C has CRS service active, and the user A does not have CRS service active, based on operator policy, either:

- a) no CRS service shall be applied to the session; or
- b) the CRS service of identity C shall be applied to the session by the AS providing CRS service for identity C, without the CRS service of user A applied to the session.

In the terminating network, no impact.

## 4.7 Service configuration

User configuration of CRS service may use Ut interface, SIP based user configuration as described in 3GPP TS 24.238 [6] or other possible interfaces.

The details of the Ut interface are not specified in this version of the document.

---

## Annex A (informative): Signalling flows

User configuration of CRS service may use Ut interface, SIP based user configuration as described in 3GPP TS 24.238 [6] or other possible interfaces.

The details of the Ut interface are not specified in this version of the document.

---

### A.1 CRS download and play model signalling flows

#### A.1.1 Introduction

The following flows show establishment of a session between UE#1 and UE#2, using the down and play model described in subclause 4.5.5.3.2 to provide CRS to UE#2. The following flows are included:

- subclause A.1.2 shows CRS, using the down and play model, when UE#1 and UE#2 have resources available.

### A.1.2 CRS when UE#1 and UE#2 have resources available

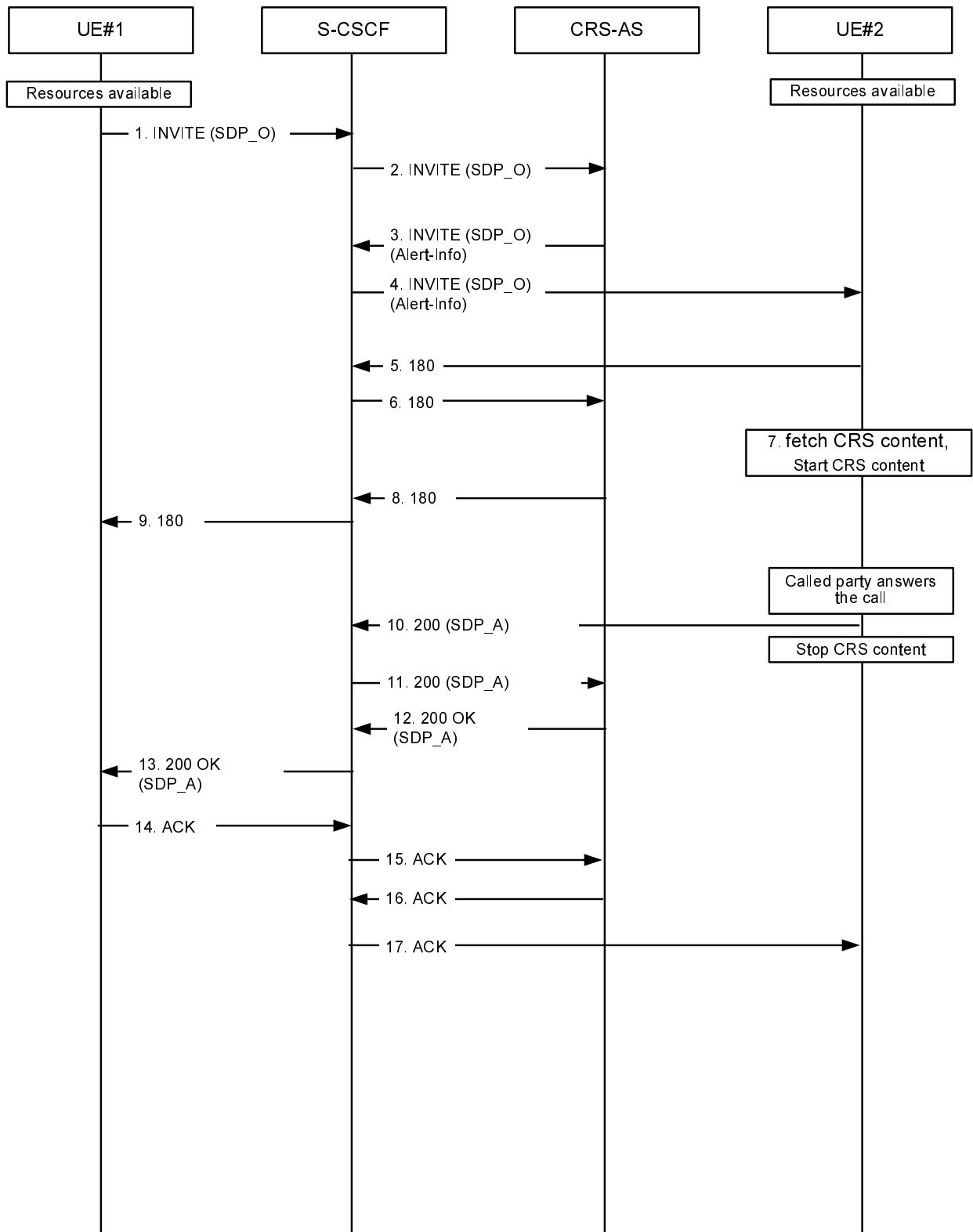

Figure A.1.2-1: CRS, UE#1 and UE#2 have resource available

1 INVITE request (UE#1 to CRS-AS) see example in table A.1.2-1

UE#1 sends a SIP INVITE request to the intermediate IM CN subsystem.

**Table A.1.2-1: INVITE request (UE#1 to S-CSCF)**

```

INVITE tel:+1-212-555-2222 SIP/2.0
Via: SIP/2.0/UDP [5555::aaa:bbb:ccc:ddd]:1357;comp=sigcomp;branch=z9hG4bKnashds7
Max-Forwards: 70
Route: <sip:pcscf1.visited1.net:7531;lr;comp=sigcomp>, <sip:scscf1.home1.net;lr>
P-Preferred-Identity: "John Doe" <sip:user1_public1@home1.net>
P-Access-Network-Info: 3GPP-UTRAN-TDD; utran-cell-id-3gpp=234151D0FCE11
P-Preferred-Service: urn:urn-7:3gpp-service.ims.icsi.mmtel
Accept-Contact: *;+g.3gpp.icsi_ref="urn%3Aurn-7%3gpp-service.ims.icsi.mmtel"
Privacy: none
P-Early-Media: supported
From: <sip:user1_public1@home1.net>;tag=171828
To: <tel:+1-212-555-2222>
Call-ID: cb03a0s09a2sdfglkj490333
Cseq: 127 INVITE
Require: sec-agree
Supported: precondition, 100rel, gruu, 199
Proxy-Require: sec-agree
Security-Verify: ipsec-3gpp; q=0.1; alg=hmac-sha-1-96; spi-c=98765432; spi-s=87654321;
port-c=8642; port-s=7531
Contact: <sip: user1_public1@home1.net;gr=urn:uuid:f81d4fae-7dec-11d0-a765-
00a0c91e6bf6>;+g.3gpp.icsi-ref="urn%3Aurn-7%3gpp-service.ims.icsi.mmtel"
Allow: INVITE, ACK, CANCEL, BYE, PRACK, UPDATE, REFER, MESSAGE
Accept: application/sdp, application/3gpp-ims+xml
Content-Type: application/sdp
Content-Length: (...)

v=0
o=- 2987933615 2987933615 IN IP6 5555::aaa:bbb:ccc:ddd
s=-
c=IN IP6 5555::aaa:bbb:ccc:ddd
t=0 0
m=video 3400 RTP/AVP 98
a=tcap:1 RTP/AVPF
a=pcfg:1 t=1
b=AS:75
a=curr:qos local sendrecv
a=curr:qos remote none
a=des:qos mandatory local sendrecv
a=des:qos none remote sendrecv
a=rtptime:98 H263
a=fmtp:98 profile-level-id=0
m=audio 3456 RTP/AVP 97 96
a=tcap:1 RTP/AVPF
a=pcfg:1 t=1
b=AS:25.4
a=curr:qos local sendrecv
a=curr:qos remote none
a=des:qos mandatory local sendrecv
a=des:qos none remote sendrecv
a=rtptime:97 AMR
a=fmtp:97 mode-set=0,2,5,7; maxframes=2
a=rtptime:96 telephone-event

```

**Supported:** The UE indicates support for GRUU, 199 responses, reliable provisional responses and preconditions.

**SDP** The SDP offer (SDP\_O) contains a set of codecs supported by UE#1 and desired by the calling user for this session. The local preconditions are indicated as fulfilled.

## 2 INVITE request (S-CSCF to CRS-AS)

The S-CSCF forwards the SIP INVITE request to the CRS-AS.

## 3-4 INVITE request (CRS-AS to UE#2) see example in table A.1.2-3

The CRS-AS add an Alert-Info header field with the address of CRS media as the value into the SIP INVITE request, and forwards the SIP INVITE request to UE#2.



**Table A.1.2-3: INVITE request (CRS-AS to S-CSCF)**

```

INVITE tel:+1-212-555-2222 SIP/2.0
Via: SIP/2.0/UDP [5555::aaa:bbb:ccc:ddd]:1357;comp=sigcomp;branch=z9hG4bKnashds7
Max-Forwards: 70
Route: <sip:pcscf1.visited1.net:7531;lr;comp=sigcomp>, <sip:scscf1.home1.net;lr>
P-Preferred-Identity: "John Doe" <sip:user1_public1@home1.net>
P-Access-Network-Info: 3GPP-UTRAN-TDD; utran-cell-id-3gpp=234151D0FCE11
P-Preferred-Service: urn:urn-7:3gpp-service.ims.icsi.mmtel
Accept-Contact: *;+g.3gpp.icsi_ref="urn%3Aurn-7%3gpp-service.ims.icsi.mmtel"
Privacy: none
P-Early-Media: supported
From: <sip:user1_public1@home1.net>;tag=171828
To: <tel:+1-212-555-2222>
Call-ID: cb03a0s09a2sdfglkj490333
Cseq: 127 INVITE
Require: sec-agree
Recv-Info: infoDtmf
Supported: precondition, 100rel, gruu, 199
Proxy-Require: sec-agree
Security-Verify: ipsec-3gpp; q=0.1; alg= hmac-sha-1-96; spi-c=98765432; spi-s=87654321;
    port-c=8642; port-s=7531
Contact: <sip: user1_public1@home1.net;gr=urn:uuid:f81d4fae-7dec-11d0-a765-
    00a0c91e6bf6>;+g.3gpp.icsi_ref="urn%3Aurn-7%3gpp-service.ims.icsi.mmtel"
Allow: INVITE, ACK, CANCEL, BYE, PRACK, UPDATE, REFER, MESSAGE
Accept: application/sdp, application/3gpp-ims+xml
Content-Type: application/sdp
Content-Length: (...)
Alert-Info: <http://aaa.bbb.ccc.ddd/cid/600/300/0/0000/0000/002.mov>;purpose=icon

v=0
o=- 2987933615 2987933615 IN IP6 5555::aaa:bbb:ccc:ddd
s=-
c=IN IP6 5555::aaa:bbb:ccc:ddd
t=0 0
m=video 3400 RTP/AVP 98
a=tcap:1 RTP/AVPF
a=pcfg:1 t=1
b=AS:75
a=curr:qos local sendrecv
a=curr:qos remote none
a=des:qos mandatory local sendrecv
a=des:qos none remote sendrecv
a=rtpmap:98 H263
a=fmtp:98 profile-level-id=0
m=audio 3456 RTP/AVP 97 96
a=tcap:1 RTP/AVPF
a=pcfg:1 t=1
b=AS:25.4
a=curr:qos local sendrecv
a=curr:qos remote none
a=des:qos mandatory local sendrecv
a=des:qos none remote sendrecv
a=rtpmap:97 AMR
a=fmtp:97 mode-set=0,2,5,7; maxframes=2
a=rtpmap:96 telephone-event

```

**Alert-Info:** The Alert-Info header field contains the address of the CRS media.

### 5-6180 (Ringing) provisional response (UE#2 to CRS-AS)

The called party is alerted. UE#2 sends a SIP 180 (Ringing) provisional response for the INVITE request to the CRS-AS.

### 7 fetch and play CRS media

The called party fetches the CRS media from the address carried in the Alert-Info header field, and renders the media.

### 8-9180 (Ringing) provisional response (CRS-AS to UE#1)

The CRS-AS forwards the 180 (Ringing) response to the calling party.

**10-11 200 (OK) response to INVITE request (UE#2 to CRS-AS) see example in table A.1.2-10**

The called party answers the call. UE#2 stops the playback of CRS media and sends a SIP 200 (OK) final response for the SIP INVITE request to the CRS-AS.

**Table A.1.2-10: 200 (OK) response (UE#2 to CRS-AS)**

```
SIP/2.0 200 OK
Via: SIP/2.0/UDP pcscf2.visited2.net:5088;comp=sigcomp;branch=z9hG4bK361k21.1, SIP/2.0/UDP
scscf2.home2.net;branch=z9hG4bK764XC12.1, SIP/2.0/UDP
catas.home2.net;branch=z9hG4bK764Q32.1, SIP/2.0/UDP
scscf2.home2.net;branch=z9hG4bK764z87.1, SIP/2.0/UDP
icscf2_s.home2.net;branch=z9hG4bK871y12.1, SIP/2.0/UDP
scscf1.home1.net;branch=z9hG4bK332b23.1, SIP/2.0/UDP
pcscf1.visited1.net;branch=z9hG4bK240f34.1, SIP/2.0/UDP
[5555::aaa:bbb:ccc:ddd]:1357;comp=sigcomp;branch=z9hG4bKnashds7
Record-Route: <sip:pcscf2.visited2.net:5088;lr;comp=sigcomp>, <sip:scscf2.home2.net;lr>,
<sip:catas.home2.net;lr>, <sip:scscf2.home2.net;lr>, <sip:scscf1.home1.net;lr>,
<sip:pcscf1.visited1.net;lr>
From:
To: <tel:+1-212-555-2222>;tag=2236
Call-ID:
Cseq:
Allow: INVITE, ACK, CANCEL, BYE, PRACK, UPDATE, REFER, MESSAGE
Contact: <sip:user2_public1@home2.net;gr=urn:uuid:2ad8950e-48a5-4a74-8d99-
ad76cc7fc74>;+g.3gpp.icsi-ref="urn%3Aurn-7%3gpp-service.ims.icsi.mmtel"
Content-Type: application/sdp
Content-Length: (...)

v=0
o=- 29879336157 29879336157 IN IP6 6666::eee:fff:aaa:bbb
s=-
c=IN IP6 6666::eee:fff:aaa:bbb
t=0 0
m=video 7398 RTP/AVPF 98
b=AS:75
a=curr:qos local sendrecv
a=curr:qos remote sendrecv
a=des:qos mandatory local sendrecv
a=des:qos mandatory remote sendrecv
a=rtpmap:98 H263
a=fmtp:98 profile-level-id=0
m=audio 8386 RTP/AVPF 97 96
b=AS:25.4
a=curr:qos local sendrecv
a=curr:qos remote sendrecv
a=des:qos mandatory local sendrecv
a=des:qos mandatory remote sendrecv
a=rtpmap:97 AMR
a=fmtp:97 mode-set=0,2,5,7; maxframes
a=rtpmap:96 telephone-event
```

**SDP** The SDP answer (SDP\_A) contains a set of codecs to be used for the session. If preconditions are used, they are indicated as fulfilled.

**12-13 200 (OK) response (CRS-AS to UE#1)**

The CRS-AS forwards the 200 OK final response to the calling party.

**14-15 ACK request (UE#1 to CRS-AS)**

UE#1 sends a SIP ACK request, which acknowledges the SIP 200 (OK) final response, to CRS-AS.

**16-17 ACK request (CRS-AS to UE#2)**

CRS-AS sends a SIP ACK request, which acknowledges the SIP 200 (OK) final response, to UE#2.

## A.2 CRS signalling flows using early session model

### A.2.1 Introduction

The following flows show establishment of a session between UE#1 and UE#2, using the early session model described in subclause 2.2 to provide CRS to UE#2. The following flows are included:

- subclause A.2.2 shows CRS, using the early session model, when UE#1 and UE#2 have resources available;
- subclause A.2.3 shows CRS, using the early session model, when UE#1 does not have resources available; and
- subclause A.2.4 shows CRS, using the early session model, when UE#2 does not have resources available.

### A.2.2 CRS when UE#1 and UE#2 have resources available

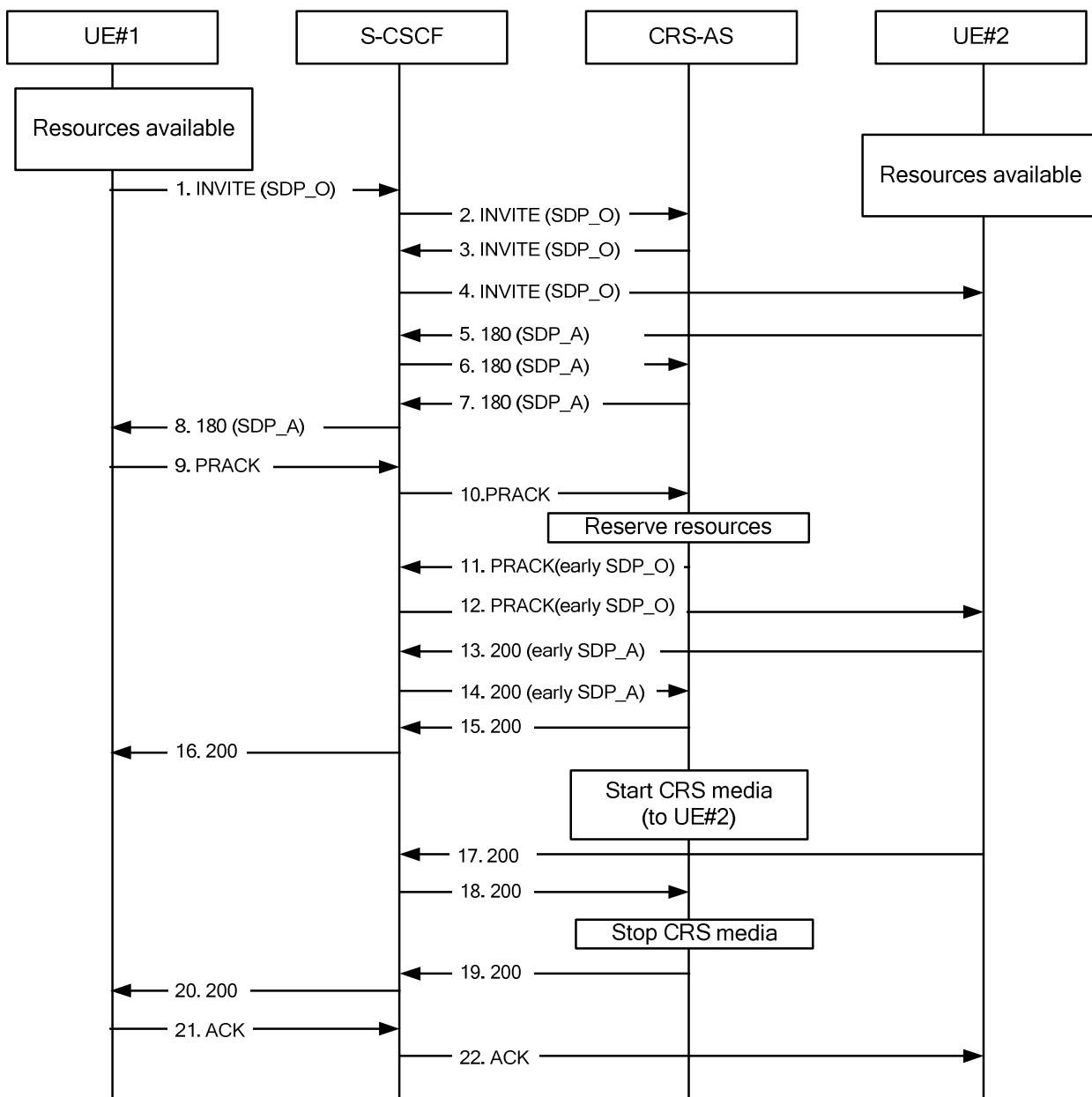

Figure A.2.2-1: CRS, early session model flow when both UE1 and UE2 have resource available

**1-2INVITE request (UE#1 to CRS-AS) see example in table A.2.2-1**

UE#1 sends a SIP INVITE request to the intermediate IM CN subsystem.

The S-CSCF forwards the SIP INVITE request to the CRS-AS.

**Table A.2.2-1: INVITE request (UE#1 to S-CSCF)**

```

INVITE tel:+1-212-555-2222 SIP/2.0
Via: SIP/2.0/UDP [5555::aaa:bbb:ccc:ddd]:1357;comp=sigcomp;branch=z9hG4bKnashds7
Max-Forwards: 70
Route: <sip:pcscf1.visited1.net:7531;lr;comp=sigcomp>, <sip:orig@scscf1.home1.net;lr>
P-Preferred-Identity: "John Doe" <sip:user1_public1@home1.net>
P-Access-Network-Info: 3GPP-UTRAN-TDD; utran-cell-id-3gpp=234151D0FCE11
Privacy: none
From: <sip:user1_public1@home1.net>;tag=171828
To: <tel:+1-212-555-2222>
Call-ID: cb03a0s09a2sdfglkj490333
Cseq: 127 INVITE
Supported: precondition, 100rel
Security-Verify: ipsec-3gpp; q=0.1; alg=hmac-sha-1-96; spi-c=98765432; spi-s=87654321;
port-c=8642; port-s=7531
Contact: <sip:user1_public1@home1.net;gr=urn:uuid:f81d4fae-7dec-11d0-a765-
00a0c91e6bf6>;+g.3gpp.icsi_ref="urn%3Aurn-7%3gpp-service.ims.icsi.mmtel"
Accept:application/sdp, application/3gpp-ims+xml
Content-Type: application/sdp
Content-Disposition: session
Content-Length: (...)

v=0
o=- 2987933615 2987933615 IN IP6 5555::aaa:bbb:ccc:ddd
s=-
c=IN IP6 5555::aaa:bbb:ccc:ddd
t=0 0
m=audio 3456 RTP/AVP 97 96
b=AS:25.4
a=crr:qos local sendrecv
a=crr:qos remote none
a=des:qos mandatory local sendrecv
a=des:qos none remote sendrecv
a=rtpmap:97 AMR
a=fmtp:97 mode-set=0,2,5,7; maxframes=2
a=rtpmap:96 telephone-event

```

**Supported:** The UE indicates support for preconditions, reliable provisional responses, and early-session SDP.

**SDP:** The SDP offer (SDP\_O) contains a set of codecs supported by UE#1 and desired by the calling user for this session. If preconditions are used, the local preconditions are indicated as fulfilled.

**3-4INVITE request (CRS-AS to UE#2) see example in table A.2.2-3**

The CRS-AS forwards the SIP INVITE request to UE#2 after inserting Alert-Info header field with an URN "urn:alert:service:crs".

**Table A.2.2-3: INVITE request (CRS-AS to UE#2)**

```

INVITE tel:+1-212-555-2222 SIP/2.0
Via: SIP/2.0/UDP [5555::aaa:bbb:ccc:ddd]:1357;comp=sigcomp;branch=z9hG4bKnashds7
Max-Forwards: 68
Route: <sip:pcscf1.visited1.net:7531;lr;comp=sigcomp>, <sip:orig@scscf1.home1.net;lr>,
P-Preferred-Identity: "John Doe" <sip:user1_public1@home1.net>
P-Access-Network-Info: 3GPP-UTRAN-TDD; utran-cell-id-3gpp=234151D0FCE11
Privacy: none
From:
To:
Call-ID:
Cseq: 127 INVITE
Recv-Info: infoDtmf
Supported: precondition, 100rel, early-session
Security-Verify: ipsec-3gpp; q=0.1; alg= hmac-sha-1-96; spi-c=98765432; spi-s=87654321;
port-c=8642; port-s=7531
Contact: <sip:user1_public1@home1.net;gr=urn:uuid:f81d4fae-7dec-11d0-a765-
00a0c91e6bf6>;+g.3gpp.icsi_ref="urn%3Aurn-7%3gpp-service.ims.icsi.mmtel"
Accept: application/sdp, application/3gpp-ims+xml
Alert-Info: <urn:alert:service:crs>
Content-Type: application/sdp
Content-Disposition: session
Content-Length: (...)

v=0
o=- 2987933615 2987933615 IN IP6 5555::aaa:bbb:ccc:ddd
s=-
c=IN IP6 5555::aaa:bbb:ccc:ddd
t=0 0
m=audio 3456 RTP/AVP 97 96
b=AS:25.4
a=curr:qos local sendrecv
a=curr:qos remote none
a=des:qos mandatory local sendrecv
a=des:qos none remote sendrecv
a=rtpmap:97 AMR
a=fmtp:97 mode-set=0,2,5,7; maxframes=2
a=rtpmap:96 telephone-event

```

**5-6180 Ringing response (UE#2 to CRS-AS) see example in table A.2.2-5**

Since the SIP INVITE request contains an URN "urn:alert:service:crs" in the Alert-Info header field, UE#2 will not play a local ringing tone when the SIP 180 (Ringing) response is sent. Instead UE#2 will, for a specific time, wait for an SDP offer related to CRS early session and, if not received, play a local ringing tone.

**Table A.2.2-5: 180 (Ringing) response (UE#2 to CRS-AS)**

```

SIP/2.0 180 OK
Via: SIP/2.0/UDP pcscf2.visited2.net;branch=z9hG4bK361k21.1, SIP/2.0/UDP
scscf2.home2.net;branch=z9hG4bK764XC12.1, SIP/2.0/UDP
crsas.home2.net;branch=z9hG4bK764Q32.1, SIP/2.0/UDP
scscf2.home2.net;branch=z9hG4bK764z87.1, SIP/2.0/UDP
scscf1.home1.net;branch=z9hG4bK332b23.1, SIP/2.0/UDP

```

```

pcscfl.visited1.net;branch=z9hG4bK240f34.1, SIP/2.0/UDP
[5555::aaa:bbb:ccc:ddd]:1357;comp=sigcomp;branch=z9hG4bKnashds7
From:
To:
Call-ID:
Cseq:
Require: 100rel, precondition, early-session
Contact: <sip:user2_public1@home2.net;gr=urn:uuid:2ad8950e-48a5-4a74-8d99-ad76cc7fc74
>;+g.3gpp.icsi_ref="urn%3Aurn-7%3gpp-service.ims.icsi.mmtel"
Content-Type: application/sdp
Content-Disposition: session
Content-Length: (...)

v=0
o=- 2987933615 2987933615 IN IP6 5555::eee:fff:aaa:bbb
s=-
c=IN IP6 6666::eee:fff:aaa:bbb
t=0 0
m=audio 3456 RTP/AVP 97 96
b=AS:25.4
a=curr:qos local sendrecv
a=curr:qos remote sendrecv
a=des:qos mandatory local sendrecv
a=des:qos mandatory remote sendrecv
a=rtpmap:97 AMR
a=fmtp:97 mode-set=0,2,5,7; maxframes=2
a=rtpmap:96 telephone-event

```

**SDP** The SDP answer (SDP\_A) contains a set of codecs to be used for the session. The local preconditions are indicated as fulfilled.

#### 7-8180 (Ringing) response (CRS-AS to UE#1)

The CRS-AS forwards the SIP 180 (Ringing) response to UE#1.

#### 9-10 PRACK request (UE#1 to CRS-AS)

UE#1 sends PRACK request.

#### 11-12 PRACK request (CRS-AS to UE#2) see example in table A.2.2-11

CRS-AS reserves CRS resource, and forwards the PRACK request to UE#2 after a CRS SDP is inserted.

**Table A.2.2-11: PRACK request (CRS-AS to UE#2)**

```

PRACK tel:+1-212-555-2222 SIP/2.0
Via: SIP/2.0/UDP crsas.home2.net;branch=z9hG4bK764Q32.1, SIP/2.0/UDP
From:
To:
Call-ID:
Cseq:
Require: precondition, 100rel, early-session
RSeq: 9022
Contact:<sip:cat-as.home1.net>;+g.3gpp.icsi_ref="urn%3Aurn-7%3gpp-service.ims.icsi.mmtel"
Content-Type: application/sdp
Content-Disposition: early-session
Content-Length: (...)

v=0
o=- 2987933615 2987933615 IN IP6 5555::eee:fff:ccc:ddd
s=-
c=IN IP6 6666::eee:fff:aaa:bbb
t=0 0
m=audio 3456 RTP/AVP 97
b=AS:25.4
a=curr:qos local sendonlt
a=curr:qos remote none
a=des:qos mandatory local sendonly
a=des:qos mandatory remote recvonly
a=rtpmap:97 AMR
a=fmtp:97 mode-set=0,2,5,7; maxframes
a=content:g.3gpp.crs

```

**early SDP** The early-session SDP offer (early SDP\_O) contains a set of codecs supported to be used for CRS and includes an SDP a=content attribute with a "g.3gpp.crs" value for each media description. The local preconditions are indicated as fulfilled.

### 13-14 200 (OK) response (UE#2 to CRS-AS) see example in table A.2.2-13

UE#2 sends the 200 (OK) response which contains an SDP answer to the PRACK request containing the SDP offer to CRS-AS.

**Table A.2.2-13:200 (OK) response (UE#2 to CRS-AS)**

```
SIP/2.0 200 OK
Via: SIP/2.0/UDP pcscf2.visited2.net;branch=z9hG4bK361k21.1, SIP/2.0/UDP
    scscf2.home2.net;branch=z9hG4bK764XC12.1, SIP/2.0/UDP
    scscf1.home1.net;branch=z9hG4bK764z87.1, SIP/2.0/UDP
    crsas.home1.net;branch=z9hG4bK764Q32.1, SIP/2.0/UDP
    scscf1.home1.net;branch=z9hG4bK332b23.1, SIP/2.0/UDP
    pcscf1.visited1.net;branch=z9hG4bK240f34.1, SIP/2.0/UDP
    [5555::aaa:bbb:ccc:ddd]:1357;comp=sigcomp;branch=z9hG4bKnashds7
From:
To:
Call-ID:
Cseq: 128 PRACK
Contact:
Content-Type: application/sdp
Content-Disposition: early-session
Content-Length: (...)

v=0
o=- 2987933616 2987933616 IN IP6 5555::eee:fff:aaa:bbb
s=-
c=IN IP6 5555::aaa:bbb:ccc:ddd
t=0 0
m=audio 3466 RTP/AVP 97
b=AS:25.4
a=curr:qos local recvonly
a=curr:qos remote sendonly
a=des:qos mandatory local recvonly
a=des:qos none remote sendonly
a=rtptime:97 AMR
a=fmtp:97 mode-set=0,2,5,7; maxframes
```

**early SDP** The early-session SDP answer (early SDP\_A) contains a set of codecs supported by UE#2 to be used for CRS. The local preconditions are indicated as fulfilled.

### 15-16 200 (OK) response (CRS-AS to UE#1)

The CRS-AS forwards the 200 (OK) response, to the PRACK request, from which the SDP answer is deleted.

The CRS-AS instructs the MRF to send CRS media to UE#2. UE#2 presents the CRS media.

### 17-18 200 (OK) response to INVITE request (UE#2 to CRS-AS)

The called party answers the call. UE#2 sends a SIP 200 (OK) final response to the SIP INVITE request towards UE#1.

The CRS-AS stops CRS media.

### 19-20 200 (OK) response to INVITE request (CRS-AS to UE#1)

The CRS-AS forwards the SIP 200 (OK) response to UE#1.

A regular session is established between UE#1 and UE#2.

The early session between UE#2 and the CRS-AS is terminated.

### 21-22 ACK request (UE#1 to UE#2)

UE#1 sends a SIP ACK request, which acknowledges the SIP 200 (OK) final response, to UE#2.

### A.2.3 CRS when UE#1 does not have required resources available while UE#2 has resources available

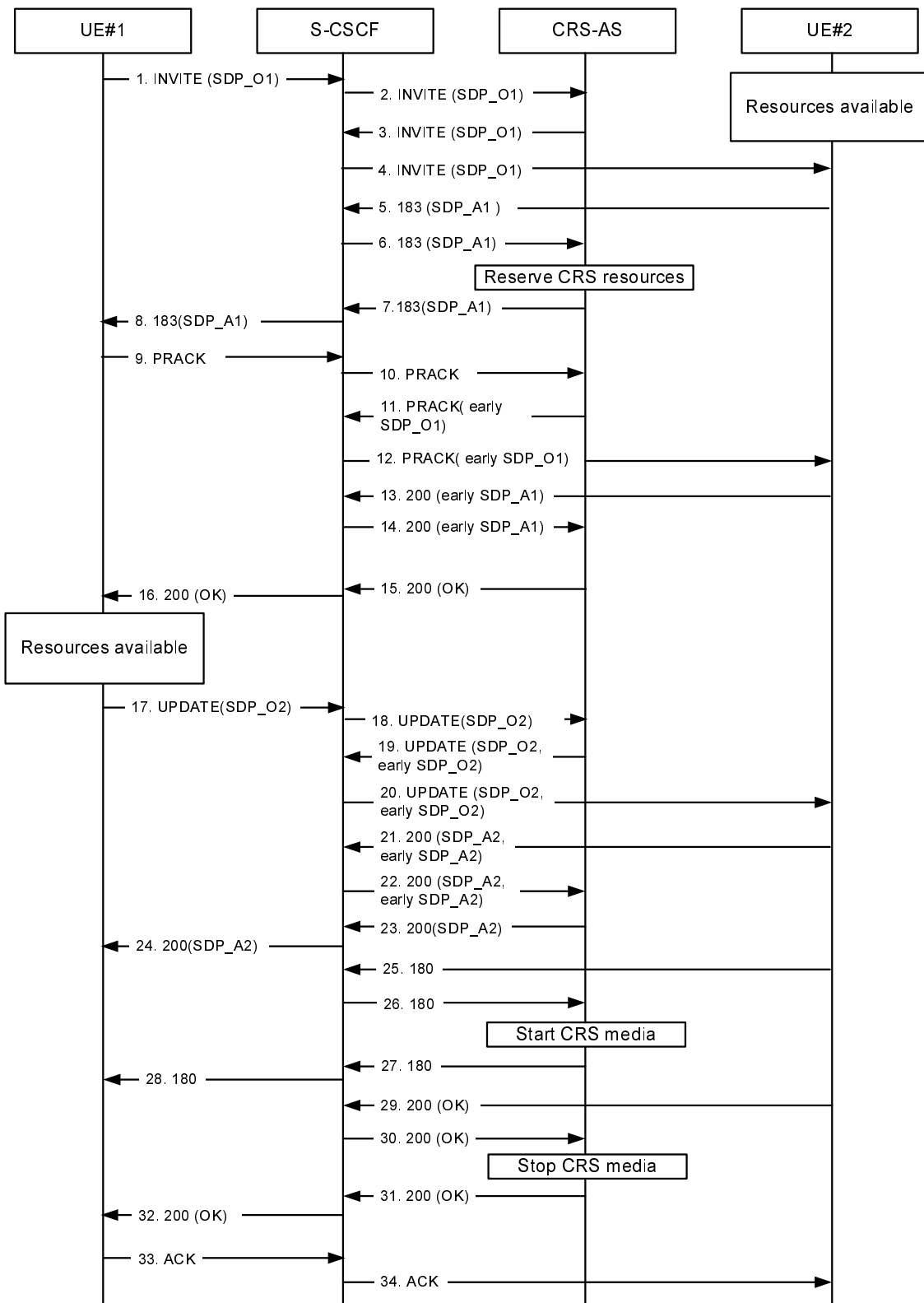

Figure A.2.3-1: CRS, UE#1 does not have resource available

**1 INVITE request (UE#1 to CRS-AS) see example in table A.2.3-1**

UE#1 sends a SIP INVITE request to the intermediate IM CN subsystem.



**Table A.2.3-1: INVITE request (UE#1 to S-CSCF)**

```

INVITE tel:+1-212-555-2222 SIP/2.0
Via: SIP/2.0/UDP [5555::aaa:bbb:ccc:ddd]:1357;comp=sigcomp;branch=z9hG4bKnashds7
Max-Forwards: 70
Route: <sip:pcscf1.visited1.net:7531;lr;comp=sigcomp>, <sip:orig@scscf1.home1.net;lr>
P-Preferred-Identity: "John Doe" <sip:user1_public1@home1.net>
P-Access-Network-Info: 3GPP-UTRAN-TDD; utran-cell-id-3gpp=234151D0FCE11
Privacy: none
From: <sip:user1_public1@home1.net>;tag=171828
To: <tel:+1-212-555-2222>
Call-ID: cb03a0s09a2sdfglkj490333
Cseq: 127 INVITE
Supported: precondition, 100rel, 199
Security-Verify: ipsec-3gpp; q=0.1; alg=hmac-sha-1-96; spi-c=98765432; spi-s=87654321;
port-c=8642; port-s=7531
Contact: <sip:user1_public1@home1.net;gr=urn:uuid:f81d4fae-7dec-11d0-a765-
00a0c91e6bf6>;+g.3gpp.icsi_ref="urn%3Aurn-7%3gpp-service.ims.icsi.mm1tel"
Accept:application/sdp, application/3gpp-ims+xml
Content-Type: application/sdp
Content-Disposition: session
Content-Length: (...)

v=0
o=- 2987933615 2987933615 IN IP6 5555::aaa:bbb:ccc:ddd
s=-
c=IN IP6 5555::aaa:bbb:ccc:ddd
t=0 0
m=video 3400 RTP/AVP 98
b=AS:75
a=curr:qos local none
a=curr:qos remote none
a=des:qos mandatory local sendrecv
a=des:qos mandatory remote sendrecv
a=inactive
a=rtpmap:98 H263
m=audio 3456 RTP/AVP 97 96
b=AS:25.4
a=curr:qos local none
a=curr:qos remote none
a=des:qos mandatory local sendrecv
a=des:qos none remote sendrecv
a=inactive
a=rtpmap:97 AMR
a=fmtp:97 mode-set=0,2,5,7; maxframes=2
a=rtpmap:96 telephone-event

```

**Supported:** The UE indicates support for preconditions and reliable provisional responses.

**SDP:** The SDP offer (SDP\_O1) contains a set of codecs supported by UE#1 and desired by the user at UE#1 for this session. The SDP contains an indication that the local preconditions are not fulfilled.

## 2 INVITE request (S-CSCF to CRS-AS)

The S-CSCF forwards the SIP INVITE request to the CRS-AS.

## 3-4 INVITE request (CRS-AS to UE#2) see example in table A.2.3-3

The CRS-AS forwards the SIP INVITE request to UE#2 after inserting Alert-Info header field with an URN "urn:alert:service:crs".

**Table A.2.3-3: INVITE request (CRS-AS to UE#2)**

```

INVITE tel:+1-212-555-2222 SIP/2.0
Via: SIP/2.0/UDP [5555::aaa:bbb:ccc:ddd]:1357;comp=sigcomp;branch=z9hG4bKnashds7
Max-Forwards: 70
Route: <sip:pcscf1.visited1.net:7531;lr;comp=sigcomp>, <sip:orig@scscf1.home1.net;lr>
P-Preferred-Identity: "John Doe" <sip:user1_public1@home1.net>
P-Access-Network-Info: 3GPP-UTRAN-TDD; utran-cell-id-3gpp=234151D0FCE11
Privacy: none
From: <sip:user1_public1@home1.net>;tag=171828
To: <tel:+1-212-555-2222>
Call-ID: cb03a0s09a2sdfglkj490333
Cseq: 127 INVITE
Recv-Info: infoDtmf
Supported: precondition, 100rel, 199
Security-Verify: ipsec-3gpp; q=0.1; alg=hmac-sha-1-96; spi-c=98765432; spi-s=87654321;
port-c=8642; port-s=7531
Contact: <sip:user1_public1@home1.net;gr=urn:uuid:f81d4fae-7dec-11d0-a765-
00a0c91e6bf6>;+g.3gpp.icsi_ref="urn%3Aurn-7%3gpp-service.ims.icsi.mmtel"
Accept:application/sdp, application/3gpp-ims+xml
Alert-Info: <urn:alert:service:crs>
Content-Type: application/sdp
Content-Disposition: session
Content-Length: (...)

v=0
o=- 2987933615 2987933615 IN IP6 5555::aaa:bbb:ccc:ddd
s=-
c=IN IP6 5555::aaa:bbb:ccc:ddd
t=0 0
m=video 3400 RTP/AVP 98
b=AS:75
a=curr:qos local none
a=curr:qos remote none
a=des:qos mandatory local sendrecv
a=des:qos mandatory remote sendrecv
a=inactive
a=rtpmap:98 H263
m=audio 3456 RTP/AVP 97 96
b=AS:25.4
a=curr:qos local none
a=curr:qos remote none
a=des:qos mandatory local sendrecv
a=des:qos none remote sendrecv
a=inactive
a=rtpmap:97 AMR
a=fmtp:97 mode-set=0,2,5,7; maxframes=2
a=rtpmap:96 telephone-event

```

**5-6183 (Session Progress) provisional response (UE#2 to CRS-AS) see example in table A.2.3-5**

UE#2 sends a SIP 183 (Session Progress) provisional response for the INVITE request to the CRS-AS.

**Table A.2.3-5: 183 (Session Progress) response (UE#2 to CRS-AS)**

```

SIP/2.0 183 Session Progress
Via: SIP/2.0/UDP pcscf2.visited2.net;branch=z9hG4bK361k21.1, SIP/2.0/UDP
scscf2.home2.net;branch=z9hG4bK764XC12.1, SIP/2.0/UDP
scscf1.home1.net;branch=z9hG4bK332b23.1, SIP/2.0/UDP
crsas.home1.net;branch=z9hG4bK764Q32.1, SIP/2.0/UDP
scscf1.home1.net;branch=z9hG4bK332b23.1, SIP/2.0/UDP

```

```

pcscf1.visited1.net;branch=z9hG4bK240f34.1, SIP/2.0/UDP
[5555::aaa:bbb:ccc:ddd]:1357;comp=sigcomp;branch=z9hG4bKnashds7
From:
To: <tel:+1-212-555-2222>;tag=6322
Call-ID:
Cseq:
Require: 100rel, precondition, early-session, 199
RSeq: 9021
Contact: <sip:user2_public1@home2.net;gr=urn:uuid:2ad8950e-48a5-4a74-8d99-
ad76cc7fc74>;+g.3gpp.icsi_ref="urn%3Aurn-7%3gpp-service.ims.icsi.mmtel"
Content-Type: application/sdp
Content-Disposition: session
Content-Length: (...)

v=0
o=- 2987933615 2987933615 IN IP6 5555::eee:fff:aaa:bbb
s=-
c=IN IP6 5555::eee:fff:aaa:bbb
t=0 0
m=video 3400 RTP/AVP 98
b=AS:75
a=crr:qos local sendrecv
a=crr:qos remote none
a=des:qos mandatory local sendrecv
a=des:qos mandatory remote sendrecv
a=rtpmap:98 H263
a=fmtp:98 profile-level-id=0
m=audio 3456 RTP/AVP 97 96
b=AS:25.4
a=crr:qos local sendrecv
a=crr:qos remote none
a=des:qos mandatory local sendrecv
a=des:qos mandatory remote sendrecv
a=rtpmap:97 AMR
a=fmtp:97 mode-set=0,2,5,7; maxframes=2
a=rtpmap:96 telephone-event

```

**SDP:** The SDP answer (SDP\_A1) contains a set of codecs to be used for the session. The local preconditions are indicated as fulfilled.

### 7-8183 (Session Progress) provisional response (CRS-AS to UE#1)

The CRS-AS forwards the SIP 183 (Session Progress) provisional response to UE#1.

### 9-10 PRACK request (UE#1 to CRS-AS) see example in table A.2.3-9

UE#1 sends a SIP PRACK request to acknowledge the 183 (Session Progress) provisional response, towards UE#2.

**Table A.2.3-9: PRACK request (UE#1 to CRS-AS)**

```

PRACK sip:user2_public1@home2.net;gr=urn:uuid:2ad8950e-48a5-4a74-8d99-ad76cc7fc74 SIP/2.0
Via: SIP/2.0/UDP [5555::aaa:bbb:ccc:ddd]:1357;comp=sigcomp;branch=z9hG4bKna234s7
Max-Forwards: 70
Route: <sip:pcscf1.visited1.net:7531;lr;comp=sigcomp>, <sip:orig@scscf1.home1.net;lr>
P-Preferred-Identity: "John Doe" <sip:user1_public1@home1.net>
P-Access-Network-Info: 3GPP-UTRAN-TDD; utran-cell-id-3gpp=234151D0FCE11
Privacy: none
From:
To:
Call-ID:
Cseq: 128 PRACK
Contact:
Content-Length: 0

```

### 11-12 PRACK request (CRS-AS to UE#2) see example in table A.2.3-11

CRS-AS forwards the SIP PRACK request with early-session SDP offer for CRS to UE#2.

**Table A.2.3-11: PRACK request (CRS-AS to UE#2)**

```

PRACK sip:user1_public1@home1.net;gr=urn:uuid:f81d4fae-7dec-11d0-a765-00a0c91e6bf6 SIP/2.0
Via: SIP/2.0/UDP crsas.home2.net;branch=z9hG4bK614Q63.1, SIP/2.0/UDP
    scscf1.home1.net;branch=z9hG4bK351b51.1, SIP/2.0/UDP
    pcscf1.visited1.net;branch=z9hG4bK582f12.1, SIP/2.0/UDP
    [5555::aaa:bbb:ccc:ddd]:1357;comp=sigcomp;branch=z9hG4bKna234s7
Max-Forwards: 66
Privacy:
From:
To:
Call-ID:
Cseq: 128 PRACK
Contact:
Content-Type: application/sdp
Content-Disposition: early-session
Content-Length: (...)

v=0
o=- 2987933616 2987933616 IN IP6 5555::ccc:aaa:bbb:acc
s=-
c=IN IP6 5555::ccc:aaa:bbb:acc
t=0 0
m=video 3400 RTP/AVP 98
b=AS:75
a=curr:qos local sendonly
a=curr:qos remote none
a=des:qos mandatory local sendonly
a=des:qos mandatory remote recvonly
a=rtpmap:98 H263
a=fmtp:98 profile-level-id=0
a=content:g.3gpp.crs
m=audio 3456 RTP/AVP 97
b=AS:25.4
a=curr:qos local sendonly
a=curr:qos remote none
a=des:qos mandatory local sendonly
a=des:qos mandatory remote recvonly
a=rtpmap:97 AMR
a=fmtp:97 mode-set=0,2,5,7; maxframes
a=content:g.3gpp.crs

```

**early SDP:** The early-session SDP offer (early SDP\_O1) contains a set of codecs to be used for CRS and includes an SDP a=content attribute with a "g.3gpp.crs" value for each media description. The preconditions are indicated as fulfilled.

### 13-14 200 (OK) response to PRACK request (UE#2 to CRS-AS) see example in table A.2.3-13

UE#2 sends a SIP 200 (OK) response for the SIP PRACK request with early-session SDP answer for CRS, towards CRS-AS.

**Table A.2.3-13: 200(OK) response (UE#2 to CRS-AS)**

```

SIP/2.0 200 OK
Via: SIP/2.0/UDP pcscf2.visited2.net;branch=z9hG4bK361k21.1, SIP/2.0/UDP
    scscf2.home2.net;branch=z9hG4bK764XC12.1, SIP/2.0/UDP
    scscf1.home1.net;branch=z9hG4bK332b23.1, SIP/2.0/UDP
    crsas.home2.net;branch=z9hG4bK764Q32.1, SIP/2.0/UDP
    scscf1.home1.net;branch=z9hG4bK332b23.1, SIP/2.0/UDP
    pcscf1.visited1.net;branch=z9hG4bK240f34.1, SIP/2.0/UDP
    [5555::aaa:bbb:ccc:ddd]:1357;comp=sigcomp;branch=z9hG4bKnashds7
From:
To: <tel:+1-212-555-2222>;tag=6322
Call-ID:
Cseq:
Require: 100rel, precondition
RSeq: 9021
Contact: <sip:user2_public1@home2.net;gr=urn:uuid:2ad8950e-48a5-4a74-8d99-
    ad76cc7fc74>;+g.3gpp.icsi_ref="urn%3Aurn-7%3gpp-service.ims.icsi.mmtel"
Content-Type: application/sdp
Content-Disposition: early-session
Content-Length: (...)

v=0

```

```

o=- 2987933616 2987933616 IN IP6 5555::aaa:bbb:ccc:ddd
s=-
c=IN IP6 5555::aaa:bbb:ccc:ddd
t=0 0
m=video 3500 RTP/AVP 98
b=AS:75
a=curr:qos local recvonly
a=curr:qos remote sendonly
a=des:qos mandatory local recvonly
a=des:qos mandatory remote sendrecv
a=rtptime:98 H263
m=audio 3556 RTP/AVP 97
b=AS:25.4
a=curr:qos local recvonly
a=curr:qos remote sendonly
a=des:qos mandatory local recvonly
a=des:qos mandatory remote sendonly
a=rtptime:97 AMR
a=fmtp:97 mode-set=0,2,5,7; maxframes

```

**early SDP:** The early-session SDP answer (early SDP\_A1) contains a set of codecs supported by UE#2 to be used for CRS. The preconditions are indicated as fulfilled.

#### 15-16 200 (OK) response to PRACK request (CRS-AS to UE#1) see example in table A.2.3-15

CRS-AS forwards the SIP 200(OK) response without early-session SDP answer to UE#1.

**Table A.2.3-15: 200(OK) response (CRS-AS to UE#1)**

```

SIP/2.0 200 OK
Via: SIP/2.0/UDP crsas.home1.net;branch=z9hG4bK764Q32.1, SIP/2.0/UDP
    scscf1.home1.net;branch=z9hG4bK332b23.1, SIP/2.0/UDP
    pcscf1.visited1.net;branch=z9hG4bK240f34.1, SIP/2.0/UDP
    [5555::aaa:bbb:ccc:ddd]:1357;comp=sigcomp;branch=z9hG4bKnashds7
From:
To: <tel:+1-212-555-2222>;tag=6322
Call-ID:
Cseq:
Require: 100rel, precondition, 199
RSeq: 9021
Contact: <sip:user2_public1@home2.net;gr=urn:uuid:2ad8950e-48a5-4a74-8d99-
    ad76cc7fc74>;+g.3gpp.icsi_ref="urn:3Aurn-7%3gpp-service.ims.icsi.mmtel"
Content-Length: 0

```

#### 17-18 UPDATE request (UE#1 to CRS-AS) see example in table A.2.3-17

After the resources for regular session is reserved, UE#1 sends a SIP UPDATE request with regular session SDP offer towards UE#2.

**Table A.2.3-17: UPDATE request (UE#1 to CRS-AS)**

```

UPDATE sip:user2_public1@home2.net;gr=urn:uuid:2ad8950e-48a5-4a74-8d99-ad76cc7fc74 SIP/2.0
Via: SIP/2.0/UDP [5555::aaa:bbb:ccc:ddd]:1357;comp=sigcomp;branch=z9hG4bKna234s7
Max-Forwards: 70
Route: <sip:pcscf1.visited1.net:7531;lr;comp=sigcomp>, <sip:orig@scscf1.home1.net;lr>
P-Preferred-Identity: "John Doe" <sip:user1_public1@home1.net>
P-Access-Network-Info: 3GPP-UTRAN-TDD; utran-cell-id-3gpp=234151D0FCE11
Privacy: none
From:
To:
Call-ID:
Cseq: 129 UPDATE
Contact:
Content-Type: application/sdp
Content-Disposition: session

v=0
o=- 2987933615 2987933616 IN IP6 5555::aaa:bbb:ccc:ddd
s=-
c=IN IP6 5555::aaa:bbb:ccc:ddd
t=0 0
m=video 3400 RTP/AVP 98
b=AS:75
a=curr:qos local sendrecv
a=curr:qos remote sendrecv
a=des:qos mandatory local sendrecv
a=des:qos mandatory remote sendrecv
a=rtpmap:98 H263
a=fmtp:98 profile-level-id=0
m=audio 3456 RTP/AVP 97 96
b=AS:25.4
a=curr:qos local sendrecv
a=curr:qos remote sendrecv
a=des:qos mandatory local sendrecv
a=des:qos mandatory remote sendrecv
a=rtpmap:97 AMR
a=fmtp:97 mode-set=0,2,5,7; maxframes=2
a=rtpmap:96 telephone-event

```

**SDP:** The SDP offer (SDP\_O2) contains a set of codecs supported by UE#1 and desired by the user at UE#1 for this session. The SDP contains an indication that the preconditions are fulfilled.

#### 19-20 UPDATE request (CRS-AS to UE#2) see example in table A.2.3-19

CRS-AS forwards the SIP UPDATE request towards UE#2 with early-session SDP.

**Table A.2.3-19: UPDATE request (CRS-AS to UE#2)**

```

UPDATE sip:user2_public1@home2.net;gr=urn:uuid:2ad8950e-48a5-4a74-8d99-ad76cc7fc74 SIP/2.0
Via: SIP/2.0/UDP crsas.home1.net;branch=z9hG4bK164Q63.1, SIP/2.0/UDP
scscf1.home1.net;branch=z9hG4bK514b51.1, SIP/2.0/UDP

```

```

pcscfl.visited1.net;branch=z9hG4bK812f12.1, SIP/2.0/UDP
[5555::aaa:bbb:ccc:ddd]:1357;comp=sigcomp;branch=z9hG4bKna234s7
Max-Forwards: 66
Privacy:
From:
To:
Call-ID:
Cseq: 129 UPDATE
Contact:
Content-Type: multipart/mixed; boundary="boundary1"
Content-Length: (...)

--boundary1
Content-Type: application/sdp
Content-Disposition: session

v=0
o=- 2987933615 2987933615 IN IP6 5555::aaa:bbb:ccc:ddd
s=-
c=IN IP6 5555::aaa:bbb:ccc:ddd
t=0 0
m=video 3400 RTP/AVP 98
b=AS:75
a=curr:qos local sendrecv
a=curr:qos remote sendrecv
a=des:qos mandatory local sendrecv
a=des:qos mandatory remote sendrecv
a=rtpmap:98 H263
a=fmtp:98 profile-level-id=0
m=audio 3456 RTP/AVP 97 96
b=AS:25.4
a=curr:qos local sendrecv
a=curr:qos remote sendrecv
a=des:qos mandatory local sendrecv
a=des:qos mandatory remote sendrecv
a=rtpmap:97 AMR
a=fmtp:97 mode-set=0,2,5,7; maxframes=2
a=rtpmap:96 telephone-event

--boundary1
Content-Type: application/sdp
Content-Disposition: early-session

v=0
o=- 2987933616 2987933617 IN IP6 5555::aaa:bbb:ccc:ddd
s=-
c=IN IP6 5555::aaa:bbb:ccc:ddd
t=0 0
m=video 3500 RTP/AVP 98
b=AS:75
a=curr:qos local sendonly
a=curr:qos remote recvonly
a=des:qos mandatory local sendonly
a=des:qos mandatory remote recvonly
a=rtpmap:98 H263
a=fmtp:98 profile-level-id=0
m=audio 3556 RTP/AVP 97
b=AS:25.4
a=curr:qos local sendonly
a=curr:qos remote recvonly
a=des:qos mandatory local sendonly
a=des:qos mandatory remote recvonly
a=rtpmap:97 AMR
a=fmtp:97 mode-set=0,2,5,7; maxframes

--boundary1

```

**early SDP:** The early-session SDP offer (early SDP\_O1) contains a set of codecs to be used for CRS. The local preconditions are indicated as fulfilled.

#### 21-22 200 (OK) response to UPDATE request (UE#2 to CRS-AS) see example in table A.2.3-21

UE#2 sends a SIP 200 (OK) response for the SIP UPDATE request to the CRS-AS.

Table A.2.3-21: 200 (OK) response (UE#2 to CRS-AS)

```

SIP/2.0 200 OK
Via: SIP/2.0/UDP pcscf2.visited2.net;branch=z9hG4bK611k21.1, SIP/2.0/UDP
    scscf2.home2.net;branch=z9hG4bK764KS12.1, SIP/2.0/UDP
    scscf1.home1.net;branch=z9hG4bK514b51.1, SIP/2.0/UDP
    crsas.home1.net;branch=z9hG4bK164Q63.1, SIP/2.0/UDP
    scscf1.home1.net;branch=z9hG4bK514b51.1, SIP/2.0/UDP
    pcscf1.visited1.net;branch=z9hG4bK812f12.1, SIP/2.0/UDP
    [5555::aaa:bbb:ccc:ddd]:1357;comp=sigcomp;branch=z9hG4bKna234s7
From:
To:
Call-ID:
Cseq:
Contact:
Content-Type: multipart/mixed; boundary="boundary1"
Content-Length: (...)

--boundary1
Content-Type: application/sdp
Content-Disposition: session

v=0
o=- 2987933615 2987933615 IN IP6 5555::eee:fff:aaa:bbb
s=-
c=IN IP6 5555::eee:fff:aaa:bbb
t=0 0
m=video 3400 RTP/AVP 98
b=AS:75
a=curr:qos local sendrecv
a=curr:qos remote sendrecv
a=des:qos mandatory local sendrecv
a=des:qos mandatory remote sendrecv
a=rtpmap:98 H263
a=fmtp:98 profile-level-id=0
m=audio 3456 RTP/AVP 97 96
b=AS:25.4
a=curr:qos local sendrecv
a=curr:qos remote sendrecv
a=des:qos mandatory local sendrecv
a=des:qos mandatory remote sendrecv
a=rtpmap:97 AMR
a=fmtp:97 mode-set=0,2,5,7; maxframes=2
a=rtpmap:96 telephone-event

--boundary1
Content-Type: application/sdp
Content-Disposition: early-session

v=0
o=- 2987933616 2987933616 IN IP6 5555::ccc:aaa:bbb:acc
s=-
c=IN IP6 5555::ccc:aaa:bbb:acc
t=0 0
m=video 3400 RTP/AVP 98
b=AS:75
a=curr:qos local recvonly
a=curr:qos remote sendonly
a=des:qos mandatory local recvonly
a=des:qos mandatory remote sendonly
a=rtpmap:98 H263
a=fmtp:98 profile-level-id=0
m=audio 3456 RTP/AVP 97
b=AS:25.4
a=curr:qos local recvonly
a=curr:qos remote sendonly
a=des:qos mandatory local recvonly
a=des:qos mandatory remote sendonly
a=rtpmap:97 AMR
a=fmtp:97 mode-set=0,2,5,7; maxframes

--boundary1

```

**SDP:** The SDP answer (SDP\_A2) contains a set of codecs supported by UE#2 to be used for the session. The preconditions are indicated as fulfilled.



**early SDP:** The early-session SDP answer (early SDP\_A2) contains a set of codecs supported by UE#2 to be used for CRS. The preconditions are indicated as fulfilled.

**23-24 200 (OK) response to UPDATE request (CRS-AS to UE#1) see example in table A.2.3-23**

CRS-AS forwards the SIP 200 (OK) response to the SIP UPDATE request without early session SDP answer, towards UE#1.

**Table A.2.3-23: 200 (OK) response (CRS-AS to UE#1)**

```
SIP/2.0 200 OK
Via: SIP/2.0/UDP crsas.home1.net;branch=z9hG4bK164Q63.1, SIP/2.0/UDP
    scscf1.home1.net;branch=z9hG4bK514b51.1, SIP/2.0/UDP
    pcscf1.visited1.net;branch=z9hG4bK812f12.1, SIP/2.0/UDP
    [5555::aaa:bbb:ccc:ddd]:1357;comp=sigcomp;branch=z9hG4bKna234s7
From:
To:
Call-ID:
Cseq:
Contact:
Content-Type: application/sdp
Content-Disposition: session
Content-Length: (...)

v=0
o=- 2987933615 2987933615 IN IP6 5555::eee:fff:aaa:bbb
s=-
c=IN IP6 5555::eee:fff:aaa:bbb
t=0 0
m=video 3400 RTP/AVP 98
b=AS:75
a=curr:qos local sendrecv
a=curr:qos remote sendrecv
a=des:qos mandatory local sendrecv
a=des:qos mandatory remote sendrecv
a=rtpmap:98 H263
a=fmtp:98 profile-level-id=0
m=audio 3456 RTP/AVP 97 96
b=AS:25.4
a=curr:qos local sendrecv
a=curr:qos remote sendrecv
a=des:qos mandatory local sendrecv
a=des:qos mandatory remote sendrecv
a=rtpmap:97 AMR
a=fmtp:97 mode-set=0,2,5,7; maxframes=2
a=rtpmap:96 telephone-event
```

**25-28 180 (Ringing) response to INVITE request (UE#2 to UE#1)**

UE#2 sends a SIP 180 (Ringing) provisional response to the INVITE request towards UE#1.

The CRS-AS instructs the MRF to play CRS media when it receives the 180 (Ringing) response.

**29-30 200 (OK) response to INVITE request (UE#2 to CRS-AS)**

The called party answers the call. UE#2 sends a SIP 200 (OK) final response to the SIP INVITE request towards UE#1.

The CRS-AS instructs the MRF to stop CRS media.

**31-32 200 (OK) response to INVITE request (CRS-AS to UE#1)**

The CRS-AS forwards the SIP 200 (OK) response to UE#1.

A regular session is established between UE#1 and UE#2.

The early session between the CRS-AS and UE#2 is terminated.

**33-34 ACK request (UE#1 to UE#2)**

UE#1 sends a SIP ACK request, which acknowledges the 200 (OK) final response, to UE#2.

### A.2.4 CRS when UE#1 has required resources available while UE#2 do not have resources available

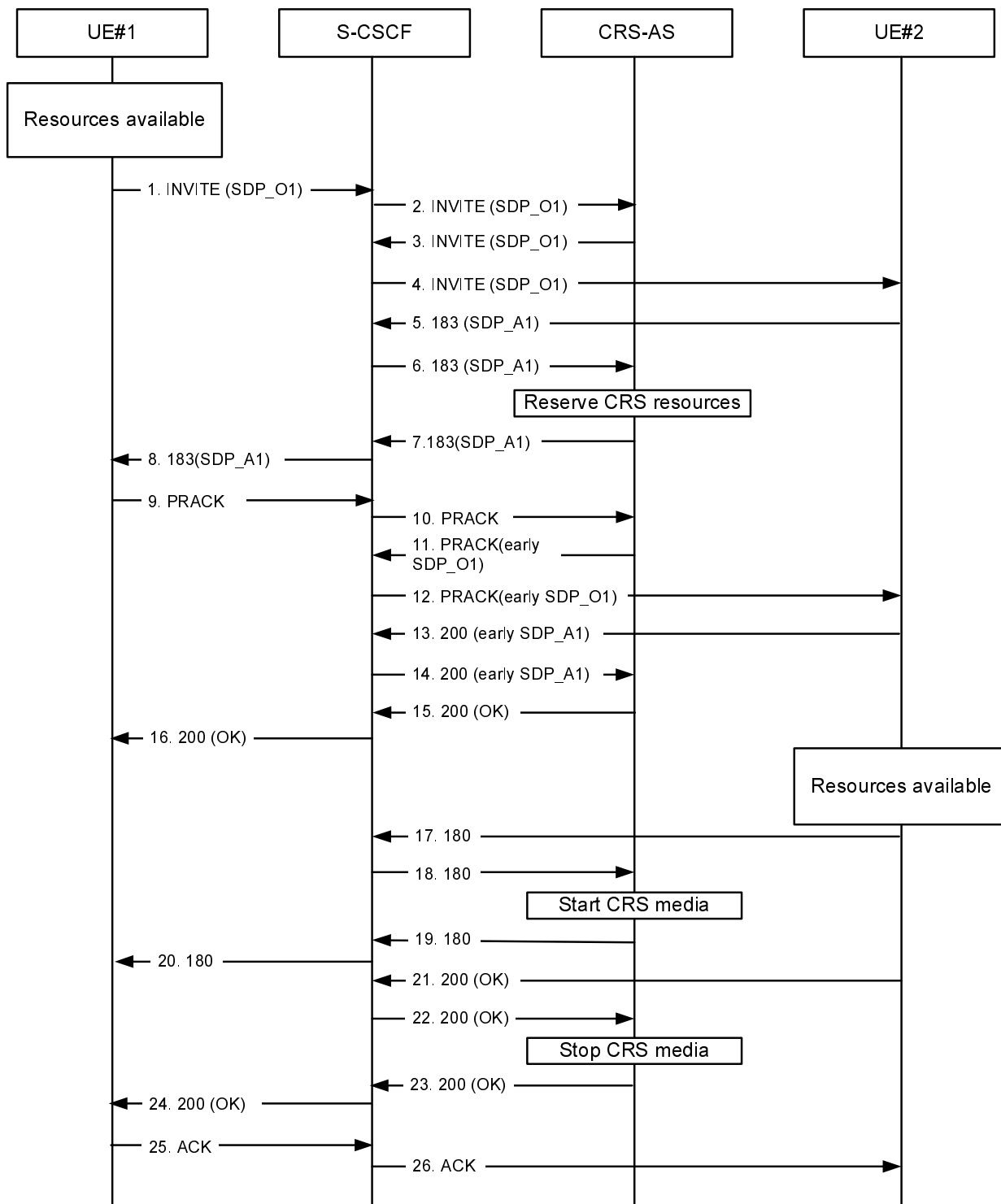

Figure A.2.4-1: CRS, UE#2 does not have resource available

**1 INVITE request (UE#1 to CRS-AS) see example in table A.2.4-1**

UE#1 sends a SIP INVITE request to the intermediate IM CN subsystem.

**Table A.2.4-1: INVITE request (UE#1 to S-CSCF)**

```

INVITE tel:+1-212-555-2222 SIP/2.0
Via: SIP/2.0/UDP [5555::aaa:bbb:ccc:ddd]:1357;comp=sigcomp;branch=z9hG4bKnashds7
Max-Forwards: 70
Route: <sip:pcscf1.visited1.net:7531;lr;comp=sigcomp>, <sip:orig@scscf1.home1.net;lr>
P-Preferred-Identity: "John Doe" <sip:user1_public1@home1.net>
P-Access-Network-Info: 3GPP-UTRAN-TDD; utran-cell-id-3gpp=234151D0FCE11
Privacy: none
From: <sip:user1_public1@home1.net>;tag=171828
To: <tel:+1-212-555-2222>
Call-ID: cb03a0s09a2sdfgkjkj490333
Cseq: 127 INVITE
Supported: precondition, 100rel, 199
Security-Verify: ipsec-3gpp; q=0.1; alg=hmac-sha-1-96; spi-c=98765432; spi-s=87654321;
    port-c=8642; port-s=7531
Contact: <sip:user1_public1@home1.net;gr=urn:uuid:f81d4fae-7dec-11d0-a765-
    00a0c91e6bf6>;+g.3gpp.icsi_ref="urn:3Aurn-7%3gpp-service.ims.icsi.mm1tel"
Accept:application/sdp, application/3gpp-ims+xml
Content-Type: application/sdp
Content-Disposition: session
Content-Length: (...)

v=0
o=- 2987933615 2987933615 IN IP6 5555::aaa:bbb:ccc:ddd
s=-
c=IN IP6 5555::aaa:bbb:ccc:ddd
t=0 0
m=video 3400 RTP/AVP 98
b=AS:75
a=curr:qos local sendrecv
a=curr:qos remote none
a=des:qos mandatory local sendrecv
a=des:qos none remote sendrecv
a=inactive
a=rtpmap:98 H263
m=audio 3456 RTP/AVP 97 96
b=AS:25.4
a=curr:qos local sendrecv
a=curr:qos remote none
a=des:qos mandatory local sendrecv
a=des:qos mandatory remote sendrecv
a=inactive
a=rtpmap:97 AMR
a=fmtp:97 mode-set=0,2,5,7; maxframes=2
a=rtpmap:96 telephone-event

```

**Supported:** The UE indicates support for preconditions and reliable provisional responses.

**SDP:** The SDP offer (SDP\_O1) contains a set of codecs supported by UE#1 and desired by the user at UE#1 for this session. The SDP contains an indication that the local preconditions are fulfilled.

## 2 INVITE request (S-CSCF to CRS-AS)

The S-CSCF forwards the SIP INVITE request to the CRS-AS.

## 3-4 INVITE request (CRS-AS to UE#2) see example in table A.2.4-3

The CRS-AS forwards the SIP INVITE request to UE#2 after inserting Alert-Info header field with an URN "urn:alert:service:crs".

**Table A.2.4-3: INVITE request (CRS-AS to UE#2)**

```

INVITE tel:+1-212-555-2222 SIP/2.0
Via: SIP/2.0/UDP [5555::aaa:bbb:ccc:ddd]:1357;comp=sigcomp;branch=z9hG4bKnashds7
Max-Forwards: 70
Route: <sip:pcscf1.visited1.net:7531;lr;comp=sigcomp>, <sip:orig@scscf1.home1.net;lr>
P-Preferred-Identity: "John Doe" <sip:user1_public1@home1.net>
P-Access-Network-Info: 3GPP-UTRAN-TDD; utran-cell-id-3gpp=234151D0FCE11
Privacy: none
From: <sip:user1_public1@home1.net>;tag=171828
To: <tel:+1-212-555-2222>
Call-ID: cb03a0s09a2sdfglkj490333
Cseq: 127 INVITE
Recv-Info: infoDtmf
Supported: precondition, 100rel, 199
Security-Verify: ipsec-3gpp; q=0.1; alg=hmac-sha-1-96; spi-c=98765432; spi-s=87654321;
port-c=8642; port-s=7531
Contact: <sip:user1_public1@home1.net;gr=urn:uuid:f81d4fae-7dec-11d0-a765-
00a0c91e6bf6>;+g.3gpp.icsi_ref="urn%3Aurn-7%3gpp-service.ims.icsi.mmtel"
Accept:application/sdp, application/3gpp-ims+xml
Alert-Info: <urn:alert:service:crs>
Content-Type: application/sdp
Content-Disposition: session
Content-Length: (...)

v=0
o=- 2987933615 2987933615 IN IP6 5555::aaa:bbb:ccc:ddd
s=-
c=IN IP6 5555::aaa:bbb:ccc:ddd
t=0 0
m=video 3400 RTP/AVP 98
b=AS:75
a=curr:qos local sendrecv
a=curr:qos remote none
a=des:qos mandatory local sendrecv
a=des:qos none remote sendrecv
a=inactive
a=rtpmap:98 H263
m=audio 3456 RTP/AVP 97 96
b=AS:25.4
a=curr:qos local sendrecv
a=curr:qos remote none
a=des:qos mandatory local sendrecv
a=des:qos mandatory remote sendrecv
a=inactive
a=rtpmap:97 AMR
a=fmtp:97 mode-set=0,2,5,7; maxframes=2
a=rtpmap:96 telephone-event

```

**5-6183 (Session Progress) provisional response (UE#2 to CRS-AS) see example in table A.2.4-5**

UE#2 sends a SIP 183 (Session Progress) provisional response for the INVITE request to the CRS-AS.

**Table A.2.4-5: 183 (Session Progress) response (UE#2 to CRS-AS)**

```

SIP/2.0 183 Session Progress
Via: SIP/2.0/UDP pcscf2.visited2.net;branch=z9hG4bK361k21.1, SIP/2.0/UDP
scscf2.home2.net;branch=z9hG4bK764XC12.1, SIP/2.0/UDP
scscf1.home1.net;branch=z9hG4bK332b23.1, SIP/2.0/UDP
crsas.home1.net;branch=z9hG4bK764Q32.1, SIP/2.0/UDP
scscf1.home1.net;branch=z9hG4bK332b23.1, SIP/2.0/UDP

```

```

pcscf1.visited1.net;branch=z9hG4bK240f34.1, SIP/2.0/UDP
[5555::aaa:bbb:ccc:ddd]:1357;comp=sigcomp;branch=z9hG4bKnashds7
From:
To: <tel:+1-212-555-2222>;tag=6322
Call-ID:
Cseq:
Require: 100rel, precondition, early-session, 199
RSeq: 9021
Contact: <sip:user2_public1@home2.net;gr=urn:uuid:2ad8950e-48a5-4a74-8d99-
ad76cc7fc74>;+g.3gpp.icsi_ref="urn%3Aurn-7%3gpp-service.ims.icsi.mmtel"
Content-Type: application/sdp
Content-Disposition: session
Content-Length: (...)

v=0
o=- 2987933615 2987933615 IN IP6 5555::eee:fff:aaa:bbb
s=-
c=IN IP6 5555::eee:fff:aaa:bbb
t=0 0
m=video 3400 RTP/AVP 98
b=AS:75
a=curr:qos local none
a=curr:qos remote sendrecv
a=des:qos mandatory local sendrecv
a=des:qos mandatory remote sendrecv
a=rtpmap:98 H263
a=fmtp:98 profile-level-id=0
m=audio 3456 RTP/AVP 97 96
b=AS:25.4
a=curr:qos local none
a=curr:qos remote sendrecv
a=des:qos mandatory local sendrecv
a=des:qos mandatory remote sendrecv
a=rtpmap:97 AMR
a=fmtp:97 mode-set=0,2,5,7; maxframes=2
a=rtpmap:96 telephone-event

```

**SDP:** The SDP answer (SDP\_A1) contains a set of codecs to be used for the session. The local preconditions are indicated as not fulfilled.

### 7-8183 (Session Progress) provisional response (CRS-AS to UE#1)

The CRS-AS forwards the SIP 183 (Session Progress) provisional response to UE#1.

### 9-10 PRACK request (UE#1 to CRS-AS) see example in table A.2.4-9

UE#1 sends a SIP PRACK request to acknowledge the 183 (Session Progress) provisional response, towards UE#2.

**Table A.2.4-9: PRACK request (UE#1 to CRS-AS)**

```

PRACK sip:user2_public1@home2.net;gr=urn:uuid:2ad8950e-48a5-4a74-8d99-ad76cc7fc74 SIP/2.0
Via: SIP/2.0/UDP [5555::aaa:bbb:ccc:ddd]:1357;comp=sigcomp;branch=z9hG4bKna234s7
Max-Forwards: 70
Route: <sip:pcscf1.visited1.net:7531;lr;comp=sigcomp>, <sip:orig@scscf1.home1.net;lr>
P-Preferred-Identity: "John Doe" <sip:user1_public1@home1.net>
P-Access-Network-Info: 3GPP-UTRAN-TDD; utran-cell-id-3gpp=234151D0FCE11
Privacy: none
From:
To:
Call-ID:
Cseq: 128 PRACK
Contact:
Content-Length: 0

```

### 11-12 PRACK request (CRS-AS to UE#2) see example in table A.2.4-11

CRS-AS forwards the SIP PRACK request with early-session SDP offer for CRS to UE#2.

**Table A.2.4-11: PRACK request (CRS-AS to UE#2)**

```

PRACK sip:user1_public1@home1.net;gr=urn:uuid:f81d4fae-7dec-11d0-a765-00a0c91e6bf6 SIP/2.0
Via: SIP/2.0/UDP crsas.home2.net;branch=z9hG4bK614Q63.1, SIP/2.0/UDP
    scscf1.home1.net;branch=z9hG4bK351b51.1, SIP/2.0/UDP
    pcscf1.visited1.net;branch=z9hG4bK582f12.1, SIP/2.0/UDP
    [5555::aaa:bbb:ccc:ddd]:1357;comp=sigcomp;branch=z9hG4bKna234s7
Max-Forwards: 66
Privacy:
From:
To:
Call-ID:
Cseq: 128 PRACK
Contact:
Content-Type: application/sdp
Content-Disposition: early-session
Content-Length: 0

v=0
o=- 2987933616 2987933616 IN IP6 5555::ccc:aaa:bbb:acc
s=-
c=IN IP6 5555::ccc:aaa:bbb:acc
t=0 0
m=video 3400 RTP/AVP 98
b=AS:75
a=curr:qos local sendonly
a=curr:qos remote none
a=des:qos mandatory local sendonly
a=des:qos mandatory remote recvonly
a=rtpmap:98 H263
a=fmtp:98 profile-level-id=0
a=content:g.3gpp.crs
m=audio 3456 RTP/AVP 97
b=AS:25.4
a=curr:qos local sendonly
a=curr:qos remote none
a=des:qos mandatory local sendonly
a=des:qos mandatory remote recvonly
a=rtpmap:97 AMR
a=fmtp:97 mode-set=0,2,5,7; maxframes
a=content:g.3gpp.crs

```

**early SDP:** The early-session SDP offer (early SDP\_O1) contains a set of codecs to be used for CRS and includes an SDP a=content attribute with a "g.3gpp.crs" value for each media description. The preconditions are indicated as fulfilled.

### 13-14 200 (OK) response to PRACK request (UE#2 to CRS-AS) see example in table A.2.4-13

UE#2 sends a SIP 200 (OK) response for the SIP PRACK request with early-session SDP answer for CRS, towards CRS-AS.

**Table A.2.4-13: 200(OK) response (UE#2 to CRS-AS)**

```

SIP/2.0 200 OK
Via: SIP/2.0/UDP pcscf2.visited2.net;branch=z9hG4bK361k21.1, SIP/2.0/UDP
    scscf2.home2.net;branch=z9hG4bK764XC12.1, SIP/2.0/UDP
    scscf1.home1.net;branch=z9hG4bK332b23.1, SIP/2.0/UDP
    crsas.home2.net;branch=z9hG4bK764Q32.1, SIP/2.0/UDP
    scscf1.home1.net;branch=z9hG4bK332b23.1, SIP/2.0/UDP
    pcscf1.visited1.net;branch=z9hG4bK240f34.1, SIP/2.0/UDP
    [5555::aaa:bbb:ccc:ddd]:1357;comp=sigcomp;branch=z9hG4bKnashds7
From:
To: <tel:+1-212-555-2222>;tag=6322
Call-ID:
Cseq:
Require: 100rel, precondition
RSeq: 9021
Contact: <sip:user2_public1@home2.net;gr=urn:uuid:2ad8950e-48a5-4a74-8d99-
    ad76cc7fc74>;+g.3gpp.icsi_ref="urn%3Aurn-7%3gpp-service.ims.icsi.mmtel"
Content-Type: application/sdp
Content-Disposition: early-session
Content-Length: (...)

v=0

```

```

o=- 2987933616 2987933616 IN IP6 5555::aaa:bbb:ccc:ddd
s=-
c=IN IP6 5555::aaa:bbb:ccc:ddd
t=0 0
m=video 3500 RTP/AVP 98
b=AS:75
a=curr:qos local none
a=curr:qos remote sendonly
a=des:qos mandatory local recvonly
a=des:qos none remote sendonly
a=rtptime:98 H263
m=audio 3556 RTP/AVP 97
b=AS:25.4
a=curr:qos local none
a=curr:qos remote sendonly
a=des:qos mandatory local recvonly
a=des:qos none remote sendonly
a=rtptime:97 AMR
a=fmtp:97 mode-set=0,2,5,7; maxframes

```

**early SDP:** The early-session SDP answer (early SDP\_A1) contains a set of codecs supported by UE#2 to be used for CRS. The preconditions are indicated as not fulfilled.

#### 15-16 200 (OK) response to PRACK request (CRS-AS to UE#1) see example in table A.2.4-15

CRS-AS forwards the SIP 200(OK) response without early-session SDP answer to UE#1.

**Table A.2.4-15: 200(OK) response (CRS-AS to UE#1)**

```

SIP/2.0 200 OK
Via: SIP/2.0/UDP crsas.home1.net;branch=z9hG4bK764Q32.1, SIP/2.0/UDP
    scscf1.home1.net;branch=z9hG4bK332b23.1, SIP/2.0/UDP
    pcscf1.visited1.net;branch=z9hG4bK240f34.1, SIP/2.0/UDP
    [5555::aaa:bbb:ccc:ddd]:1357;comp=sigcomp;branch=z9hG4bKnashds7
From:
To: <tel:+1-212-555-2222>;tag=6322
Call-ID:
Cseq:
Require: 100rel, precondition
RSeq: 9021
Contact: <sip:user2_public1@home2.net;gr=urn:uuid:2ad8950e-48a5-4a74-8d99-
    ad76cc7fc74>;+g.3gpp.icsi_ref="urn:3Aurn-7%3gpp-service.ims.icsi.mmtel"
Content-Length: 0

```

#### 17-20 180 (Ringing) response to INVITE request (UE#2 to UE#1)

UE#2 sends a SIP 180 (Ringing) provisional response to the INVITE request towards UE#1.

The CRS-AS instructs the MRF to play CRS media.

#### 21-22 200 (OK) response to INVITE request (UE#2 to CRS-AS)

The called party answers the call. UE#2 sends a SIP 200 (OK) final response to the SIP INVITE request towards UE#1.

The CRS-AS instructs the MRF to stop CRS media.

#### 23-24 200 (OK) response to INVITE request (CRS-AS to UE#1)

The CRS-AS forwards the SIP 200 (OK) response to UE#1.

A regular session is established between UE#1 and UE#2.

The early session between the CRS-AS and UE#2 is terminated.

#### 25-26 ACK request (UE#1 to UE#2)

UE#1 sends a SIP ACK request, which acknowledges the 200 (OK) final response, to UE#2.

### A.2.5 Continue to play CRS during the conversation

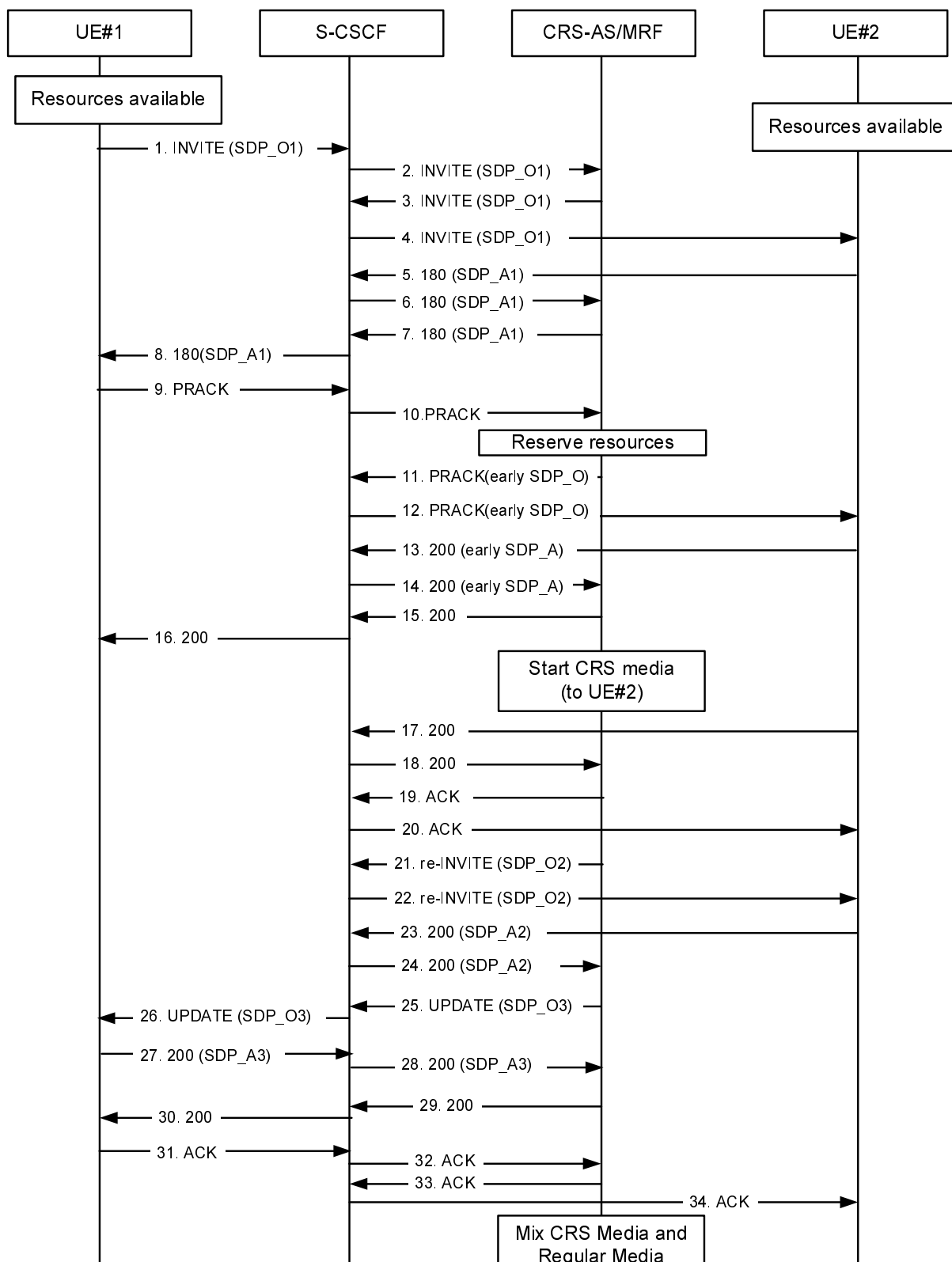

**Figure A.2.5-1: continue to play CRS during the conversation**

**1-2INVITE request (UE#1 to CRS-AS) see example in table A.2.5-1**

UE#1 sends a SIP INVITE request to the intermediate IM CN subsystem.

The S-CSCF forwards the SIP INVITE request to the CRS-AS.



**Table A.2.5-1: INVITE request (UE#1 to S-CSCF)**

```

INVITE tel:+1-212-555-2222 SIP/2.0
Via: SIP/2.0/UDP [5555::aaa:bbb:ccc:ddd]:1357;comp=sigcomp;branch=z9hG4bKnashds7
Max-Forwards: 70
Route: <sip:pcscf1.visited1.net:7531;lr;comp=sigcomp>, <sip:orig@scscf1.home1.net;lr>
P-Preferred-Identity: "John Doe" <sip:user1_public1@home1.net>
P-Access-Network-Info: 3GPP-UTRAN-TDD; utran-cell-id-3gpp=234151D0FCE11
Privacy: none
From: <sip:user1_public1@home1.net>;tag=171828
To: <tel:+1-212-555-2222>
Call-ID: cb03a0s09a2sdfgkjkj490333
Cseq: 127 INVITE
Supported: precondition, 100rel
Security-Verify: ipsec-3gpp; q=0.1; alg=hmac-sha-1-96; spi-c=98765432; spi-s=87654321;
port-c=8642; port-s=7531
Contact: <sip:user1_public1@home1.net;gr=urn:uuid:f81d4fae-7dec-11d0-a765-
00a0c91e6bf6>;+g.3gpp.icsi_ref="urn%3Aurn-7%3gpp-service.ims.icsi.mmtel"
Accept:application/sdp, application/3gpp-ims+xml
Content-Type: application/sdp
Content-Disposition: session
Content-Length: (...)

v=0
o=- 2987933615 2987933615 IN IP6 5555::aaa:bbb:ccc:ddd
s=-
c=IN IP6 5555::aaa:bbb:ccc:ddd
t=0 0
m=audio 3456 RTP/AVP 97 96
b=AS:25.4
a=curr:qos local sendrecv
a=curr:qos remote none
a=des:qos mandatory local sendrecv
a=des:qos none remote sendrecv
a=rtpmap:97 AMR
a=fmtp:97 mode-set=0,2,5,7; maxframes=2
a=rtpmap:96 telephone-event

```

**Supported:** The UE indicates support for preconditions, reliable provisional responses, and early-session SDP.

**SDP:** The SDP offer (SDP\_O) contains a set of codecs supported by UE#1 and desired by the calling user for this session. If preconditions are used, the local preconditions are indicated as fulfilled.

### 3-4INVITE request (CRS-AS to UE#2) see example in table A.2.5-3

The CRS-AS forwards the SIP INVITE request to UE#2 after inserting Alert-Info header field with an URN "urn:alert:service:crs".

**Table A.2.5-3: INVITE request (CRS-AS to UE#2)**

```

INVITE tel:+1-212-555-2222 SIP/2.0
Via: SIP/2.0/UDP [5555::aaa:bbb:ccc:ddd]:1357;comp=sigcomp;branch=z9hG4bKnashds7
Max-Forwards: 68
Route: <sip:pcscf1.visited1.net:7531;lr;comp=sigcomp>, <sip:orig@scscf1.home1.net;lr>,
P-Preferred-Identity: "John Doe" <sip:user1_public1@home1.net>
P-Access-Network-Info: 3GPP-UTRAN-TDD; utran-cell-id-3gpp=234151D0FCE11
Privacy: none
From:
To:
Call-ID:
Cseq: 127 INVITE
Recv-Info: infoDtmf
Supported: precondition, 100rel, early-session
Security-Verify: ipsec-3gpp; q=0.1; alg= hmac-sha-1-96; spi-c=98765432; spi-s=87654321;
port-c=8642; port-s=7531
Contact: <sip:user1_public1@home1.net;gr=urn:uuid:f81d4fae-7dec-11d0-a765-
00a0c91e6bf6>;+g.3gpp.icsi_ref="urn%3Aurn-7%3gpp-service.ims.icsi.mmtel"
Accept: application/sdp, application/3gpp-ims+xml
Alert-Info: <urn:alert:service:crs>
Content-Type: application/sdp
Content-Disposition: session
Content-Length: (...)

v=0
o=- 2987933615 2987933615 IN IP6 5555::aaa:bbb:ccc:ddd
s=-
c=IN IP6 5555::aaa:bbb:ccc:ddd
t=0 0
m=audio 3456 RTP/AVP 97 96
b=AS:25.4
a=curr:qos local sendrecv
a=curr:qos remote none
a=des:qos mandatory local sendrecv
a=des:qos none remote sendrecv
a=rtpmap:97 AMR
a=fmtp:97 mode-set=0,2,5,7; maxframes=2
a=rtpmap:96 telephone-event

```

**5-6180 (Ringing) response (UE#2 to CRS-AS) see example in table A.2.5-5**

Since the SIP INVITE request contains an URN "urn:alert:service:crs" in the Alert-Info header field, UE#2 will not play a local ringing tone when the SIP 180 (Ringing) response is sent. Instead UE#2 will, for a specific time, wait for an SDP offer related to CRS early session and, if not received, play a local ringing tone.

**Table A.2.5-5: 180 (Ringing) response (UE#2 to CRS-AS)**

```

SIP/2.0 180 OK
Via: SIP/2.0/UDP pcscf2.visited2.net;branch=z9hG4bK361k21.1, SIP/2.0/UDP
scscf2.home2.net;branch=z9hG4bK764XC12.1, SIP/2.0/UDP
crsas.home2.net;branch=z9hG4bK764Q32.1, SIP/2.0/UDP
scscf2.home2.net;branch=z9hG4bK764z87.1, SIP/2.0/UDP
scscf1.home1.net;branch=z9hG4bK332b23.1, SIP/2.0/UDP

```

```

pcscfl.visited1.net;branch=z9hG4bK240f34.1, SIP/2.0/UDP
[5555::aaa:bbb:ccc:ddd]:1357;comp=sigcomp;branch=z9hG4bKnashds7
From:
To:
Call-ID:
Cseq:
Require: 100rel, precondition, early-session
Contact: <sip:user2_public1@home2.net;gr=urn:uuid:2ad8950e-48a5-4a74-8d99-ad76cc7fc74
>;+g.3gpp.icsi_ref="urn%3Aurn-7%3gpp-service.ims.icsi.mmtel"
Content-Type: application/sdp
Content-Disposition: session
Content-Length: (...)

v=0
o=- 2987933615 2987933615 IN IP6 5555::eee:fff:aaa:bbb
s=-
c=IN IP6 6666::eee:fff:aaa:bbb
t=0 0
m=audio 3456 RTP/AVP 97 96
b=AS:25.4
a=curr:qos local sendrecv
a=curr:qos remote sendrecv
a=des:qos mandatory local sendrecv
a=des:qos mandatory remote sendrecv
a=rtpmap:97 AMR
a=fmtp:97 mode-set=0,2,5,7; maxframes=2
a=rtpmap:96 telephone-event

```

**SDP** The SDP answer (SDP\_A) contains a set of codecs to be used for the session. The local preconditions are indicated as fulfilled.

#### **7-8180 (Ringing) response (CRS-AS to UE#1)**

The CRS-AS forwards the SIP 180 (Ringing) response to UE#1.

#### **9-10 PRACK request (UE#1 to CRS-AS)**

UE#1 sends PRACK request.

#### **11-12 PRACK request (CRS-AS to UE#2) see example in table A.2.5-11**

CRS-AS reserves CRS resource and forwards the PRACK request to UE#2 after a CRS SDP is inserted.

**Table A.2.5-11: PRACK request (CRS-AS to UE#2)**

```

PRACK tel:+1-212-555-2222 SIP/2.0
Via: SIP/2.0/UDP crsas.home2.net;branch=z9hG4bK764Q32.1, SIP/2.0/UDP
From:
To:
Call-ID:
Cseq:
Require: precondition, 100rel, early-session
RSeq: 9022
Contact:<sip:crs-as.home1.net>;+g.3gpp.icsi_ref="urn%3Aurn-7%3gpp-service.ims.icsi.mmtel"
Content-Type: application/sdp
Content-Disposition: early-session
Content-Length: (...)

v=0
o=- 2987933615 2987933615 IN IP6 5555::eee:fff:ccc:ddd
s=-
c=IN IP6 6666::eee:fff:aaa:bbb
t=0 0
m=video 3400 RTP/AVP 98
b=AS:75
a=curr:gqos local sendrecv
a=curr:gqos remote none
a=des:gqos mandatory local sendrecv
a=des:gqos mandatory remote sendrecv
a=rtpmap:98 H263
a=fmtp:98 profile-level-id=0
a=content:g.3gpp.crs
m=audio 3456 RTP/AVP 97
b=AS:25.4
a=curr:gqos local sendonly
a=curr:gqos remote none
a=des:gqos mandatory local sendonly
a=des:gqos mandatory remote recvonly
a=rtpmap:97 AMR
a=fmtp:97 mode-set=0,2,5,7; maxframes
a=content:g.3gpp.crs

```

**early SDP** The early-session SDP offer (early SDP\_O) contains a set of codecs supported to be used for CRS and includes an SDP a=content attribute with a "g.3gpp.crs" value for each media description. The local preconditions are indicated as fulfilled.

### 13-14 200 (OK) response (UE#2 to CRS-AS) see example in table A.2.5-13

UE#2 sends the 200 (OK) response which contains an answer SDP for the PRACK request to CRS-AS.

**Table A.2.5-13:200 (OK) response (UE#2 to CRS-AS)**

```

SIP/2.0 200 OK
Via: SIP/2.0/UDP pcscf2.visited2.net;branch=z9hG4bK361k21.1, SIP/2.0/UDP
scscf2.home2.net;branch=z9hG4bK764XC12.1, SIP/2.0/UDP
scscf1.home1.net;branch=z9hG4bK764z87.1, SIP/2.0/UDP
crsas.home1.net;branch=z9hG4bK764Q32.1, SIP/2.0/UDP
scscf1.home1.net;branch=z9hG4bK332b23.1, SIP/2.0/UDP

```

```

pcscfl.visited1.net;branch=z9hG4bK240f34.1, SIP/2.0/UDP
[5555::aaa:bbb:ccc:ddd]:1357;comp=sigcomp;branch=z9hG4bKnashds7
From:
To:
Call-ID:
Cseq: 128 PRACK
Contact:
Content-Type: application/sdp
Content-Disposition: early-session
Content-Length: (...)

v=0
o=- 2987933616 2987933616 IN IP6 5555::eee:fff:aaa:bbb
s=-
c=IN IP6 5555::aaa:bbb:ccc:ddd
t=0 0
m=video 3500 RTP/AVP 98
b=AS:75
a=curr:qos local recvonly
a=curr:qos remote sendonly
a=des:qos mandatory local sendrecv
a=des:qos mandatory remote sendrecv
a=rtpmap:98 H263
a=fmtp:98 profile-level-id=0
m=audio 3466 RTP/AVP 97
b=AS:25.4
a=curr:qos local recvonly
a=curr:qos remote sendonly
a=des:qos mandatory local recvonly
a=des:qos none remote sendonly
a=rtpmap:97 AMR
a=fmtp:97 mode-set=0,2,5,7; maxframes

```

**early SDP** The early-session SDP answer (early SDP\_A) contains a set of codecs supported by UE#2 to be used for CRS. The local preconditions are indicated as fulfilled.

#### 15-16 200 (OK) response (CRS-AS to UE#1)

The CRS-AS forwards the 200 (OK) response which the answer SDP is deleted for the PRACK request.

The CRS-AS instructs the MRF to send CRS media to UE#2. UE#2 presents the CRS media.

#### 17-18 200 (OK) response to INVITE request (UE#2 to CRS-AS)

The called party answers the call. UE#2 sends a SIP 200 (OK) final response to the SIP INVITE request towards UE#1.

#### 19-20 ACK request (CRS-AS to UE#2)

CRS-AS sends a SIP ACK request, which acknowledges the SIP 200 (OK) final response, to UE#2.

#### 21-22 re-INVITE request (CRS-AS to UE#2) see example in table A.2.5-21

**Table A.2.5-21: re-INVITE request (CRS-AS to UE#2)**

```

INVITE tel:+1-212-555-2222 SIP/2.0
Via:
From:
To:
Call-ID:
Cseq: 128 INVITE
Contact: <sip:crs-as.homel.net>;+g.3gpp.icsi_ref="urn%3Aurn-7%3gpp-service.ims.icsi.mmtel"
Content-Type: application/sdp
Content-Disposition: session
Content-Length: (...)

v=0
o=- 2987933617 2987933617 IN IP6 7777::eee:fff:ccc:ddd
s=-
c=IN IP6 7777::eee:fff:ccc:ddd
t=0 0
m=video 3400 RTP/AVP 98
b=AS:75
a=curr:qos local sendrecv
a=curr:qos remote none
a=des:qos mandatory local sendrecv
a=des:qos mandatory remote sendrecv
a=rtpmap:98 H263
a=fmtp:98 profile-level-id=0
a=content:g.3gpp.crs
m=audio 3456 RTP/AVP 97 96
b=AS:25.4
a=curr:qos local sendrecv
a=curr:qos remote none
a=des:qos mandatory local sendrecv
a=des:qos mandatory remote sendrecv
a=rtpmap:97 AMR
a=fmtp:97 mode-set=0,2,5,7; maxframes
a=rtpmap:96 telephone-event
a=content:g.3gpp.crs

```

**SDP:** The SDP offer (SDP\_O) contains a set of codecs to be used for original session received in the last SDP offer plus the continuous CRS media, and includes an SDP a=content attribute with a "g.3gpp.crs" value for each media description. If preconditions are used, the local preconditions are indicated as fulfilled.

**23-24 200 (OK) response to re-INVITE request (UE#2 to CRS-AS) see example in table A.2.5-23**

**Table A.2.5-23:200 (OK) response (UE#2 to CRS-AS)**

```

SIP/2.0 200 OK
Via:
From:
To:
Call-ID:
Cseq:
Contact:
Content-Type: application/sdp
Content-Disposition: session
Content-Length: (...)

v=0
o=- 2987933617 2987933617 IN IP6 7777::eee:fff:aaa:bbb
s=-
c=IN IP6 7777::eee:fff:aaa:bbb
t=0 0
m=video 3500 RTP/AVP 98
b=AS:75
a=curr:qos local recvonly
a=curr:qos remote sendonly
a=des:qos mandatory local sendrecv
a=des:qos mandatory remote sendrecv
a=rtpmap:98 H263
a=fmtp:98 profile-level-id=0
m=audio 3456 RTP/AVP 97 96
b=AS:25.4
a=curr:qos local sendrecv
a=curr:qos remote sendrecv
a=des:qos mandatory local sendrecv
a=des:qos mandatory remote sendrecv
a=rtpmap:97 AMR
a=fmtp:97 mode-set=0,2,5,7; maxframes=2
a=rtpmap:96 telephone-event

```

**25-26 UPDATE request (CRS-AS to UE#1) see example in table A.2.5-25****Table A.2.5-25:UPDATE request (CRS-AS to UE#1)**

```

UPDATE sip:user1_public1@home1.net;gr=urn:uuid:f81d4fae-7dec-11d0-a765-00a0c91e6bf6>
SIP/2.0
Via:
From:
To:
Call-ID:
Cseq:
Contact: <sip:crs-as.home1.net>;+g.3gpp.icsi_ref="urn%3Aurn-7%3gpp-service.ims.icsi.mmtel"
Content-Type: application/sdp
Content-Disposition: session
Content-Length: (...)

v=0
o=- 2987933618 2987933618 IN IP6 8888::eee:fff:ccc:ddd
s=-
c=IN IP6 8888::eee:fff:ccc:ddd
t=0 0
m=audio 5678 RTP/AVP 97 96
b=AS:25.4
a=curr:qos local sendrecv
a=curr:qos remote none
a=des:qos mandatory local sendrecv
a=des:qos mandatory remote sendrecv
a=rtpmap:97 AMR
a=fmtp:97 mode-set=0,2,5,7; maxframes
a=rtpmap:96 telephone-event

```

**SDP:** The SDP offer (SDP\_O) contains a set of codecs to be used for regular session. If preconditions are used, the local preconditions are indicated as fulfilled.

**27-28 200 (OK) request to UPDATE request (UE#1 to CRS-AS) see example in table A.2.5-27**

**Table A.2.5-27:200 (OK) response (UE#1 to CRS-AS)**

```
SIP/2.0 200 OK
Via:
From:
To:
Call-ID:
Cseq:
Contact:
Content-Type: application/sdp
Content-Disposition: session
Content-Length: (...)

v=0
o=- 2987933618 2987933618 IN IP6 8888::aaa:bbb:ccc:ddd
s=-
c=IN IP6 8888::aaa:bbb:ccc:ddd
t=0 0
m=audio 5678 RTP/AVP 97 96
b=AS:25.4
a=curr:qos local sendrecv
a=curr:qos remote sendrecv
a=des:qos mandatory local sendrecv
a=des:qos mandatory remote sendrecv
a=rtpmap:97 AMR
a=fmtp:97 mode-set=0,2,5,7; maxframes=2
a=rtpmap:96 telephone-event
```

**29-30 200 (OK) response to INVITE (CRS-AS to UE#1)**

The CRS-AS sends the SIP 200 (OK) response for the (initial) SIP INVITE request to UE#1.

**31-32 ACK request (UE#1 to CRS-AS)**

UE#1 sends a SIP ACK request, which acknowledges the SIP 200 (OK) final response, to CRS-AS.

Upon receiving the SIP ACK request from UE#1, AS shall instruct the MRF to mix CRS media and regular media during the conversation.

**33-34 ACK request (CRS-AS to UE#2)**

CRS-AS sends a SIP ACK request, which acknowledges the SIP 200 (OK) response of re-INVITE request, to UE#2.



Annex B (informative):  
Void

---

## Annex C (normative): Registration for URN used within the current document

Editor's note [CR#0055, WI TEI16]: IANA registration about the CRS service indication "urn:alert:service:crs" needs to be done in IANA.

Namespace ID: alert

Registration Information: Registration version: 1

Registration date: TBD

Declared registrant of the namespace:

Registering organization: 3GPP

Intended Usage: The URN "urn:alert:service:crs" can only be inserted into the initial INVITE request by the AS as specified in 3GPP TS 24.183. It is used to indicate that CRS service is initiated.

On the terminating UE side:

If the received INVITE request contains an Alert-Info header field including the URN "urn:alert:service:crs" and an media URL, the UE shall fetch and play the media from the URL, as specified in subclause 4.5.5.2.2.1 in 3GPP TS 24.183.

If the received INVITE request contains an Alert-Info header field including the URN "urn:alert:service:crs" but not an media URL, the UE shall play the media received from network, as specified in subclause 4.5.5.2.3.1 and subclause 4.5.5.2.5.1 in 3GPP TS 24.183.

Declaration of syntactic structure:

The service-indication under the "service" alert-identifier for CRS service is "crs" and is used according to the ABNF as defined in RFC 7462 [8].

Example:

urn:alert:service:crs

Relevant ancillary documentation: 3GPP TS 24.183

Community considerations: IANA

Namespace considerations: There do not appear to be other URN namespaces that serve the same need of uniquely identifying 'alert' communication and information services.

Identifier uniqueness considerations: This identifier is unique under the namespace of 'alert' URN.

Identifier persistence considerations: This identifier is persistent, as long as it is registered with IANA.

Conformance with URN syntax: The BNF in the 'Declaration of syntactic structure' in RFC 7462 [8] constrains the syntax for this URN scheme.

---

## Annex D (informative): XML body in SIP message for indicating to UE

### D.1 CRS service indication XML schema

#### D.1.1 General

This subclause defines XML schema and MIME type related to the CRS service indication feature.

#### D.1.2 XML schema

```
<?xml version="1.0" encoding="UTF-8"?>
<xs:schema
  xmlns:xs="http://www.w3.org/2001/XMLSchema"
  elementFormDefault="qualified"
  attributeFormDefault="unqualified">

  <xs:element name="fetchAlertInfo" type="crs"/>

  <xs:complexType name="crs"/>

</xs:schema>
```

#### D.1.3 IANA registration template

**Editor's note: The MIME type "application/vnd.3gpp.crs+xml" as defined in this subclause is to be registered in the IANA registry for Application Media Types based upon the following template.**

MIME media type name:

application

MIME subtype name:

vnd.3gpp.crs+xml

Required parameters:

None

Optional parameters:

"charset" the parameter has identical semantics to the charset parameter of the "application/xml" media type as specified in IETF RFC 3023 [21].

Encoding considerations:

Same as encoding considerations of application/xml as specified in IETF RFC 3023 [21]

Security considerations:

Same as general security considerations for application/xml as specified in section 10 of IETF RFC 3023 [21]. In addition, this content type provides a format for exchanging information in SIP, so the security considerations from IETF RFC 3261 [19] apply.

Interoperability considerations:

Same as interoperability considerations as specified in section 3.1 of IETF RFC 3023 [21].

Published specification:

3GPP TS 24.183 " IP Multimedia Subsystem (IMS) Customized Ringing Signal", version 9.1.0, available via <http://www.3gpp.org/specs/numbering.htm>.

Applications which use this media:

Applications support the service continuity as described in the published specification.

Intended usage:

COMMON

Additional information:

1. Magic number(s): none
2. File extension(s): none
3. Macintosh file type code: none
4. Object Identifiers: none

---

## Annex E (normative): SDP a=content attribute "g.3gpp.crs" value

### E.1 Introduction

This annex provides the IANA registration information for a new value, g.3gpp.crs, for the SDP a=content media-level attribute defined in RFC 4796 [9]. The attribute value is used to indicate that an SDP media descriptions are associated with the CRS service.

**Editor's note: [CRS, CR0042] The following parameter should be registered immediately on approval of this specification, and the registration in error removed from "att-field (media level only)" table.**

### E.2 IANA registration

IANA registration table: "content SDP Parameters" table of "Session Description Protocol (SDP) Parameters" registry

SDN name: g.3gpp.crs

Description: Stream associated with the 3GPP Customized Ringing Signal (CRS) service.

Reference: 3GPP TS 24.183

## Annex F(informative): Change history

Change history							
Date	TSG #	TSG Doc.	CR	Rev	Subject/Comment	Old	New
2009-06	CT1#59	C1-092583			Initial skeleton from rapporteur	-	0.0.0
2009-06	CT1#59	C1-092584			Scope of CRS	0.0.0	0.1.0
2009-06	CT1#59	C1-093021			Introduction of CRS	0.0.0	0.1.0
2009-06	CT1#59	C1-093022			Description of CRS	0.0.0	0.1.0
2009-06	CT1#59	C1-092587			Provision of CRS	0.0.0	0.1.0
2009-06	CT1#59	C1-093023			Syntax of CRS	0.0.0	0.1.0
2009-06	CT1#59	C1-093024			Description of signalling procedure of CRS	0.0.0	0.1.0
2009-06	CT1#59	C1-092590			Registration of CRS	0.0.0	0.1.0
2009-06	CT1#59	C1-093082			Activation of CRS	0.0.0	0.1.0
2009-06	CT1#59	C1-092592			Interrogation of CRS	0.0.0	0.1.0
2009-09	CT1#60	C1-093771			action of UE and AS for early session modle	0.1.1	0.2.0
2009-09	CT1#60	C1-093776			Action of UE and AS for download and play modle	0.1.1	0.2.0
2009-09	CT1#60	C1-093777			signalling flow for download and play model	0.1.1	0.2.0
2009-09	CT1#60	C1-093915			signalling flow using early session model when UE#1 resources unavailable	0.1.1	0.2.0
2009-09	CT1#60	C1-093916			Adding the call flow for CRS when UE1# and UE2# have resources available	0.1.1	0.2.0
2009-09	CT1#60	C1-093918			signalling flow using early session model when UE#2 resources unavailable	0.1.1	0.2.0
2009-09					Minor corrections by the rapporteur	0.2.0	0.2.1
2009-10	CT1#61	C1-094513			Adding the description for the requirement on the network	0.2.1	0.3.0
2009-10	CT1#61	C1-094514			Adding text for the interaction with other services	0.2.1	0.3.0
2009-10	CT1#61	C1-094519			CR on CRS control	0.2.1	0.3.0
2009-10	CT1#61	C1-094713			Clarification of the actions at originating UE	0.2.1	0.3.0
2009-10	CT1#61	C1-094714			Adding text for the terminating UE behavior	0.2.1	0.3.0
2009-10	CT1#61	C1-094715			CRS priority	0.2.1	0.3.0
2009-10					Editorial corrections	0.3.0	0.3.1
2009-11	CT1#62	C1-094989			Corrections to Alert-Info header field terminology in A.1.2	0.3.1	0.4.0
2009-11	CT1#62	C1-094990			Miscellaneous editorial corrections	0.3.1	0.4.0
2009-11	CT1#62	C1-095215			DTMF support for Customized ringing signal (CRS) service	0.3.1	0.4.0
2009-11	CT1#62	C1-095430			CRS Reject	0.3.1	0.4.0
2009-11	CT1#62	C1-095647			CRS media continuously playing after call established	0.3.1	0.4.0
2009-11	CT1#62	C1-095673			service Identification of CRS	0.3.1	0.4.0
2009-11	CT1#62	C1-095674			interaction with other service	0.3.1	0.4.0
2009-11					Minor editorial corrections and fixes of incorrect styles	0.3.1	0.4.0
2009-12	CT#46				V1.0.0 created by MCC for presentation to CT#46 for information and approval	0.4.0	1.0.0
2009-12	CT#46				V9.0.0 created by MCC after approval at CT#46	1.0.0	9.0.0
2010-03	CT#47	CP-100146	0001	2	Clarification on how CRS media override the default ringing signal	9.0.0	9.1.0
2010-03	CT#47	CP-100146	0002	1	Deleting the editor note for whether put an early session SDP offer in the initial INVITE request	9.0.0	9.1.0
2010-03	CT#47	CP-100146	0003	1	Deleting the editor note for PCC requirement	9.0.0	9.1.0
2010-03	CT#47	CP-100146	0004	1	Deleting the editor note for the need of CRS indicator	9.0.0	9.1.0
2010-03	CT#47	CP-100146	0005	3	deleting the editor note for privacy requirement	9.0.0	9.1.0
2010-03	CT#47	CP-100146	0006	1	Deleting the editor note about how to trigger the local alerting tone	9.0.0	9.1.0
2010-03	CT#47	CP-100146	0008	1	Apply CRS service indicator in priority procedure	9.0.0	9.1.0
2010-03	CT#47	CP-100146	0010		CRS: Addition of DTMF Info Package	9.0.0	9.1.0
2010-03	CT#47	CP-100146	0011	2	Clarification of the reliable 18x response	9.0.0	9.1.0
2010-03	CT#47	CP-100146	0013	1	Clarification of the priority procedure at the termianting CRS AS	9.0.0	9.1.0
2010-03	CT#47	CP-100146	0014	1	Definition of media components	9.0.0	9.1.0
2010-03	CT#47	CP-100146	0016	3	User configuration of CRS service	9.0.0	9.1.0
2010-03	CT#47	CP-100146	0018	3	Determination of URL insertion for download and play mode	9.0.0	9.1.0
2010-03	CT#47				Editorial cleanup by MCC	9.0.0	9.1.0
2010-06	CT#48	CP-100361	0012	3	Clarification of the CRS continue procedure	9.1.0	9.2.0
2010-06	CT#48	CP-100361	0019	1	Editorial modification	9.1.0	9.2.0
2010-06	CT#48	CP-100361	0020	1	solution of CRS service identifier	9.1.0	9.2.0
2010-06	CT#48	CP-100361	0021	1	CRS priority procedure when termintaing AS using download model	9.1.0	9.2.0
2010-06	CT#48	CP-100361	0022	1	Interaction with CAT	9.1.0	9.2.0
2010-06	CT#48	CP-100361	0023	1	Reference Updating	9.1.0	9.2.0
2010-06	CT#48	CP-100361	0025	3	Procedure about how to insert the indication for CRS media	9.1.0	9.2.0
2010-06	CT#48	CP-100361	0026	1	content attribute usage in CRS	9.1.0	9.2.0
2011-03	CT#51	CP-110180	0027		Reference update: RFC 6086	9.2.0	9.3.0
2011-03	CT#51				Upgrade to Rel-10	9.3.0	10.0.0
2011-06	CT#52	CP-110458	0029		Correction on General AS action	10.0.0	10.1.0
2011-09	CT#53	CP-110663	0031		Clarification of the Supported header field in early session model	10.1.0	10.2.0
2011-12	CT#54	CP-110881	0032		RFC number correction	10.2.0	11.0.0
2011-12	CT#54	CP-110881	0033		g.3gpp.crs correction in early session model	10.2.0	11.0.0

2012-06	CT#56	CP-120298	0036	1	Reference update: draft-liess-dispatch-alert-info-urns	11.0.0	11.1.0
2013-06	CT#60	CP-130229	0039		Incorrect naming of Alert-Info header field	11.1.0	11.2.0
2013-09	CT#61	CP-130486	0042	1	Correction of IANA registration of g.3gpp.cat	11.2.0	11.3.0
2014-03	CT#63	CP-140122	0045	1	Reference update: draft-ietf-salud-alert-info-urns	11.3.0	11.4.0
2014-09	CT#65				Upgrade to Rel-12	11.4.0	12.0.0
2015-12	CT#70				Upgrade to Rel-13	12.0.0	13.0.0

Change history							
Date	Meeting	TDoc	CR	Rev	Cat	Subject/Comment	New version
2017-03	CT-75					Upgrade to Rel-14	14.0.0
2017-06	CT-76	CP-171053	0051	1	A	Reference Update: RFC7462	14.1.0
2018-06	SA-80	-	-	-		Update to Rel-15 version (MCC)	15.0.0
2019-06	CT-84	CP-191147	0052	4	B	Support CRS for Gateway Model in TS 24.183	16.0.0
2019-09	CT-85	CP-192071	0053	2	F	Corrections of two typos in the AS actions for CRS of gateway model	16.1.0
2019-09	CT-85	CP-192071	0054	3	F	Corrections of the CRS media negotiation time	16.1.0
2019-12	CT-86	CP-193116	0055	3	C	Use Alert-Info header as the indication for CRS of gateway model	16.2.0
2020-03	CT-87e	CP-200123	0061	1	B	CRS interactions with MuD and MiD services	16.3.0
2020-06	CT-88e	CP-201133	0062		F	Correction in CSR interactions with CDIV	16.4.0
2020-06	CT-88e	CP-201111	0063	2	B	Use preconditions for CRS when terminating UE supports precondition	16.4.0
2020-06	CT-88e	CP-201133	0064	2	F	Clean-up	16.4.0



---

# History

<b>Document history</b>		
V16.4.0	July 2020	Publication