

ETSI TS 124 237 V8.6.0 (2010-10)

Technical Specification

**Universal Mobile Telecommunications System (UMTS);
LTE;
IP Multimedia (IM) Core Network (CN)
subsystem IP Multimedia Subsystem (IMS)
service continuity;
Stage 3
(3GPP TS 24.237 version 8.6.0 Release 8)**



Reference

RTS/TSGC-0124237v860

Keywords

LTE, UMTS

ETSI

650 Route des Lucioles
F-06921 Sophia Antipolis Cedex - FRANCE

Tel.: +33 4 92 94 42 00 Fax: +33 4 93 65 47 16

Siret N° 348 623 562 00017 - NAF 742 C
Association à but non lucratif enregistrée à la
Sous-Préfecture de Grasse (06) N° 7803/88

Important notice

Individual copies of the present document can be downloaded from:

<http://www.etsi.org>

The present document may be made available in more than one electronic version or in print. In any case of existing or perceived difference in contents between such versions, the reference version is the Portable Document Format (PDF). In case of dispute, the reference shall be the printing on ETSI printers of the PDF version kept on a specific network drive within ETSI Secretariat.

Users of the present document should be aware that the document may be subject to revision or change of status. Information on the current status of this and other ETSI documents is available at

<http://portal.etsi.org/tb/status/status.asp>

If you find errors in the present document, please send your comment to one of the following services:

http://portal.etsi.org/chaicor/ETSI_support.asp

Copyright Notification

No part may be reproduced except as authorized by written permission.
The copyright and the foregoing restriction extend to reproduction in all media.

© European Telecommunications Standards Institute 2010.
All rights reserved.

DECT™, **PLUGTESTS™**, **UMTS™**, **TIPHON™**, the TIPHON logo and the ETSI logo are Trade Marks of ETSI registered for the benefit of its Members.

3GPP™ is a Trade Mark of ETSI registered for the benefit of its Members and of the 3GPP Organizational Partners.

LTE™ is a Trade Mark of ETSI currently being registered

for the benefit of its Members and of the 3GPP Organizational Partners.

GSM® and the GSM logo are Trade Marks registered and owned by the GSM Association.

Intellectual Property Rights

IPRs essential or potentially essential to the present document may have been declared to ETSI. The information pertaining to these essential IPRs, if any, is publicly available for **ETSI members and non-members**, and can be found in ETSI SR 000 314: "*Intellectual Property Rights (IPRs); Essential, or potentially Essential, IPRs notified to ETSI in respect of ETSI standards*", which is available from the ETSI Secretariat. Latest updates are available on the ETSI Web server (<http://webapp.etsi.org/IPR/home.asp>).

Pursuant to the ETSI IPR Policy, no investigation, including IPR searches, has been carried out by ETSI. No guarantee can be given as to the existence of other IPRs not referenced in ETSI SR 000 314 (or the updates on the ETSI Web server) which are, or may be, or may become, essential to the present document.

Foreword

This Technical Specification (TS) has been produced by ETSI 3rd Generation Partnership Project (3GPP).

The present document may refer to technical specifications or reports using their 3GPP identities, UMTS identities or GSM identities. These should be interpreted as being references to the corresponding ETSI deliverables.

The cross reference between GSM, UMTS, 3GPP and ETSI identities can be found under <http://webapp.etsi.org/key/queryform.asp>.

Contents

Intellectual Property Rights	2
Foreword.....	2
Foreword.....	6
1 Scope	7
2 References	7
3 Definitions and abbreviations.....	8
3.1 Definitions	8
3.2 Abbreviations	8
4 Overview of IP Multimedia (IM) Core Network (CN) subsystem Service Continuity.....	9
4.1 General	9
4.2 Underlying network capabilities.....	9
4.3 URI and address assignments.....	9
5 Functional entities	10
5.1 Introduction	10
5.2 User Equipment (UE).....	10
5.3 Application Server (AS).....	10
6 Roles for registration in the IM CN subsystem.....	10
6.1 Introduction	10
6.2 SC UE.....	10
6.3 SCC AS	10
6A Roles for General Capabilities	11
6A.1 Introduction	11
6A.2 UE roles.....	11
7 Roles for call origination.....	12
7.1 Introduction	12
7.2 SC UE.....	12
7.3 SCC AS	12
7.3.1 Distinction of requests sent to the SCC AS	12
7.3.2 Call origination procedures at the SCC AS	12
8 Roles for call termination.....	12
8.1 Introduction	12
8.2 SC UE.....	13
8.3 SCC AS	13
8.3.1 Distinction of requests sent to the SCC AS	13
8.3.2 Call termination procedures in the SCC AS	13
9 Roles for PS-CS session continuity.....	13
9.1 Introduction	13
9.2 SC UE.....	14
9.2.1 SC UE procedures for PS to CS session continuity	14
9.2.2 SC UE procedures for CS to PS session continuity	14
9.3 SCC AS	15
9.3.1 Distinction of requests sent to the SCC AS	15
9.3.2 SCC AS procedures for PS to CS session continuity.....	15
9.3.3 SCC AS procedures for CS to PS session continuity.....	16
10 Roles for PS-PS session continuity	17
10.1 Introduction	17
10.2 SC UE.....	17
10.2.0 General.....	17
10.2.1 Full session transfer	17

10.2.2	Partial session transfer	18
10.3	SCC AS	19
10.3.1	Distinction of requests sent to the SCC AS	19
10.3.2	PS to PS Session Continuity Procedures at the SCC AS	19
11	Roles for PS-PS session continuity in conjunction with PS-CS session continuity	20
11.1	Introduction	20
11.2	SC UE.....	21
11.2.1	SC UE procedures for PS to PS+CS session continuity	21
11.2.1.1	General	21
11.2.1.2	SC UE procedures for PS to PS+CS session continuity using ICS	21
11.2.1.3	SC UE procedures for PS to PS+CS session continuity not using ICS	21
11.2.2	SC UE procedures for PS+CS to PS session continuity	22
11.2.2.1	General	22
11.2.2.2	SC UE procedures for PS+CS to PS session continuity using ICS	22
11.2.2.3	SC UE procedures for PS+CS to PS session continuity not using ICS	22
11.3	SCC AS	23
11.3.1	Distinction of requests sent to the SCC AS	23
11.3.2	SCC AS procedures for PS to PS+CS session continuity	23
11.3.3	SCC AS procedures for PS+CS to PS session continuity	24
12	Roles for PS-CS session continuity, Single Radio	24
12.1	Introduction	24
12.2	SC UE procedures for PS to CS session continuity, SR-VCC	25
12.2.1	General.....	25
12.2.2	ICS-based.....	25
12.2.3	Not based on ICS	25
12.3	SCC AS	26
12.3.1	SCC AS procedures for PS to CS session continuity, SR-VCC	26
13	Roles for media adding/deleting.....	26
13.1	Introduction	26
13.2	SC UE.....	26
13.2.1	Adding or removing media through Gm.....	26
13.2.2	Adding Gm control to existing CS session	27
13.3	SCC AS	27
13.3.1	Adding or removing media through Gm.....	27
13.3.2	Adding Gm control to existing CS session	28
Annex A (informative): Example signalling flows		29
A.1	Scope of signalling flows	29
A.2	Introduction	29
A.2.1	General	29
A.2.2	Key required to interpret signalling flows.....	29
A.3	Signalling flows for registration.....	30
A.3.1	Introduction	30
A.3.2	Signalling flows for multiple registration.....	30
A.4	Signalling flows for call origination.....	35
A.4.1	Session origination for CS calls	35
A.5	Signalling flows for call termination.....	35
A.5.1	Session termination using CS media	35
A.6	Signalling flows for PS-CS session continuity.....	35
A.6.1	PS-CS access transfer: CS-PS	35
A.6.2	PS-CS access transfer: PS-CS	39
A.7	Signalling flows for PS-PS session continuity	42
A.7.1	Introduction	42
A.7.2	PS-PS access transfer with full media transfer	42
A.7.3	PS-PS access transfer with partial media transfer	49

A.8	Signalling flows for PS-PS session continuity in conjunction with PS-CS session continuity.....	57
A.8.1	Introduction	57
A.8.2	PS - PS in conjunction with PS - CS Access Transfer: PS to CS	58
A.8.3	PS - PS in conjunction with PS - CS Access Transfer: CS to PS	65
A.9	Signalling flows for media adding/deleting	69
Annex B (informative):	Change history	73
History		75

Foreword

This Technical Specification has been produced by the 3rd Generation Partnership Project (3GPP).

The contents of the present document are subject to continuing work within the TSG and may change following formal TSG approval. Should the TSG modify the contents of the present document, it will be re-released by the TSG with an identifying change of release date and an increase in version number as follows:

Version x.y.z

where:

- x the first digit:
 - 1 presented to TSG for information;
 - 2 presented to TSG for approval;
 - 3 or greater indicates TSG approved document under change control.
- y the second digit is incremented for all changes of substance, i.e. technical enhancements, corrections, updates, etc.
- z the third digit is incremented when editorial only changes have been incorporated in the document.

1 Scope

IP Multimedia (IM) Core Network (CN) subsystem Service Continuity (SC) provides the capability of continuing ongoing communication sessions with multiple media across different access networks or across different user equipments (UEs) under the control of the same subscriber.

NOTE: Multiple media across different UEs under the control of the same subscriber is not specified in this version of the document.

The present document provides the protocol details for enabling IMS SC based on the Session Initiation protocol (SIP) and the Session Description Protocol (SDP) and the protocols of the 3GPP Circuit-Switched (CS) domain (e.g. CAP, MAP, ISUP, BICC and the NAS call control protocol for the CS access).

The present document is applicable to User Equipment (UEs) and Application Servers (AS) providing IMS Service Continuity capabilities.

2 References

The following documents contain provisions which, through reference in this text, constitute provisions of the present document.

- References are either specific (identified by date of publication, edition number, version number, etc.) or non-specific.
- For a specific reference, subsequent revisions do not apply.
- For a non-specific reference, the latest version applies. In the case of a reference to a 3GPP document (including a GSM document), a non-specific reference implicitly refers to the latest version of that document *in the same Release as the present document*.

- [1] 3GPP TR 21.905: "Vocabulary for 3GPP Specifications".
- [2] 3GPP TS 24.229: "IP multimedia call control protocol based on Session Initiation Protocol (SIP) and Session Description Protocol (SDP); Stage 3".
- [3] 3GPP TS 24.228 Release 5: "Signalling flows for the IP multimedia call control based on Session Initiation Protocol (SIP) and Session Description Protocol (SDP); Stage 3".
- [4] 3GPP TS 24.292: "IP Multimedia (IM) Core Network (CN) subsystem Centralized Services (ICS); Stage 3".
- [5] 3GPP TS 24.216: "Communication continuity managed object".
- [6] 3GPP TS 29.328: "IP Multimedia Subsystem (IMS) Sh interface; Signalling flows and message contents".
- [7] 3GPP TS 29.329: "Sh interface based on the Diameter protocol; Protocol details".
- [8] 3GPP TS 24.008: "Mobile radio interface layer 3 specification; Core Network protocols; Stage 3".
- [9] 3GPP TS 23.237: "IP Multimedia subsystem (IMS) Service Continuity; Stage 2".
- [10] IETF RFC 3891: "The Session Initiation Protocol (SIP) "Replaces" Header".
- [11] IETF RFC 4538: "Request Authorization through Dialog Identification in the Session Initiation Protocol (SIP)".
- [12] 3GPP TS 23.003: "Numbering, addressing and identification".
- [13] 3GPP TS 24.286: "IP Multimedia (IM) Core Network (CN) subsystem Centralised Services (ICS); Management Object (MO)".

[14] 3GPP TS 24.083: "Call Waiting (CW) and Call Hold (HOLD) supplementary services; Stage 3".

3 Definitions and abbreviations

3.1 Definitions

For the purposes of the present document, the terms and definitions given in 3GPP TR 21.905 [1] and the following apply. A term defined in the present document takes precedence over the definition of the same term, if any, in 3GPP TR 21.905 [1].

Dynamic STI: An STI dynamically assigned by the SCC AS, representing the SIP dialog identifier (Call-ID header field and the values of tags in To and From header fields) and used for session transfer request when Gm service control is available.

Static STI: An STI configured in the SC UE either as a SIP URI or as an E.164 number in tel URI or SIP URI representation of tel URI. The static STI is used for CS-PS transfer when dynamic STI is unavailable.

For the purposes of the present document, the following terms and definitions given in 3GPP TS 23.237 [9] apply:

Access Leg
Remote Leg
Target Access Leg
Source Access Leg
Session Transfer Identifier (STI)
Session Transfer Number (STN)
Session Transfer Number for SR-VCC (STN-SR)
Correlation MSISDN

For the purposes of the present document, the following terms and definitions given in 3GPP TS 24.292 [4] apply:

CS call
CS media

For the purposes of the present document, the following terms and definitions given in 3GPP TS 23.003 [12] apply:

IP Multimedia Routing Number (IMRN)

3.2 Abbreviations

For the purposes of the present document, the abbreviations given in 3GPP TR 21.905 [1] and the following apply. An abbreviation defined in the present document takes precedence over the definition of the same abbreviation, if any, in 3GPP TR 21.905 [1].

IMRN	IP Multimedia Routing Number
SC	Service Continuity
SCC	Service Centralization and Continuity
SR-VCC	Single Radio VCC
STI	Session Transfer Identifier
STN	Session Transfer Number
STN-SR	Session Transfer Number - Single Radio

4 Overview of IP Multimedia (IM) Core Network (CN) subsystem Service Continuity

4.1 General

In general, IMS Service Continuity provides the capability of continuing ongoing communication sessions with multiple media across different access networks. The main need for such continuity arises because user equipments (UEs) with multimedia capabilities can move across a multiplicity of different access networks.

The following procedures are provided within this document:

- procedures for registration in IM CN subsystem are specified in clause 6;
- procedures for call origination are specified in clause 7;
- procedures for call termination are specified in clause 8;
- procedures for PS-CS session continuity are specified in clause 9;
- procedures for PS-PS session continuity are specified in clause 10;
- procedures for PS-PS session continuity in conjunction with PS-CS session continuity are specified in clause 11;
- procedures for PS-CS session continuity for Single Radio are specified in clause 12; and
- procedures for media adding/deleting in clause 13.

For a UE or an AS not supporting ICS procedures, PS-CS service continuity is only possible when the UE is active in a single full-duplex speech or speech/video session i.e. support of session transfer with more than one sessions or with non voice media is not provided.

4.2 Underlying network capabilities

SC assumes the use of a number of underlying network capabilities:

- 1) provision by the home network operator of SCC AS on the IM CN subsystem, as specified in 3GPP TS 24.229 [2];
- 2) if ICS is used, the network capabilities as specified in 3GPP TS 24.292 [4];

4.3 URI and address assignments

In order to support SC to a subscriber, the following URI and address assignments are assumed:

- a) in this version of the document, the SC UE will be configured with both a static STI in accordance with subclause 5.11 in 3GPP TS 24.216 [5]; and a static STN in accordance with subclause 5.12 in 3GPP TS 24.216 [5]. The static STI is used by the SC UE to perform CS to PS session transfer when no dynamically assigned STI is provided to the UE over the CS domain (e.g. when the SC UE does not support ICS capabilities). The static STN is used by the SC UE to perform PS to CS session transfer when no service control signalling path as specified in 3GPP TS 24.292 [4] is available.
- b) the SC UE will be configured to be reachable in both the IM CN subsystem and the CS domain by one or more public telecommunication numbers which should be correlated between the CS domain and IM CN subsystem. Either:
 - this public telecommunication number can be the DN (e.g. MSISDN) used in the CS domain and (in international form) comprise part of the implicit registration set associated with that SC UE in the IM CN subsystem; or

- the SCC AS can be configured to provide a functional relationship between separate numbers providing each of these identities in the CS domain and the IM CN subsystem, respectively.

5 Functional entities

5.1 Introduction

This clause associates the functional entities with the SC roles described in the stage 2 architecture document (see 3GPP TS 23.237 [9]).

5.2 User Equipment (UE)

To be compliant with this document, a UE shall implement the role of a SC UE (see subclause 6A.2, subclause 6.2, subclause 7.2, subclause 8.2, subclause 9.2, subclause 10.2, subclause 11.2 and subclause 12.2).

5.3 Application Server (AS)

To be compliant with this document, a AS shall implement the role of a SCC AS (see subclause 6.3, subclause 7.3, subclause 8.3, subclause 9.3, subclause 10.3, subclause 11.3 and subclause 12.3).

6 Roles for registration in the IM CN subsystem

6.1 Introduction

A 3rd-party registration shall be performed via the ISC interface for the SCC AS.

6.2 SC UE

Prior to performing IMS registration the SC UE if it supports ICS capabilities shall check that IMS service continuity using ICS is enabled. An indication that IMS service continuity using ICS is enabled or disabled can be found in the ICS MO ICS_Capabilities_Enabled leaf node (see 3GPP TS 24.286 [13]).

The SC UE shall follow the procedures specified in 3GPP TS 24.229 [2] for registration of the UE in the IM CN subsystem.

If IMS service continuity using ICS is enabled then prior to making use of IMS ICS procedures, the SC UE shall follow the procedures specified in 3GPP TS 24.292 [4] for registration of the ICS UE in the IM CN subsystem.

6.3 SCC AS

The SCC AS can obtain registration state information that it needs to implement SCC specific requirements from:

- a) any received third-party REGISTER request (e.g. including information contained in the body of the third-party REGISTER request) as specified in 3GPP TS 24.229 [2];
- b) any received reg event package as specified in 3GPP TS 24.229 [2]; or
- c) the Sh interface as specified in 3GPP TS 29.328 [6] and 3GPP TS 29.329 [7].

NOTE: Obtaining registration state information from HSS using Sh interface does not allow the SCC AS to know the capabilities supported by the user registered UE(s), including the used IP-CAN(s).

When the SCC AS receives a REGISTER request and obtains the registration state information including an Correlation MSISDN using one of the above procedures, the SCC AS shall determine if the REGISTER request is associated with ongoing CS call by matching the Correlation MSISDN against the:

- a) tel URI in the P-Asserted-Identity header field or associated with the received IMRN when the SIP INVITE request was due to static STN, where the SIP INVITE request was stored according to subclause 7.3.1; or
- b) tel URI in the Request-URI when the SIP INVITE request was due to processing unregistered filter criteria, where the SIP INVITE request was stored according to subclause 7.3.1.

If the REGISTER request is associated with an ongoing call the contents of the Contact header field in the REGISTER request shall be bound to the ongoing CS call session identifier.

6A Roles for General Capabilities

6A.1 Introduction

This section describes the general roles for each functional entity as specified

6A.2 UE roles

The SC UE may receive the operator policy via OMA Device Management, see 3GPP TS 24.216 [5]. When the SC UE receives the operator policy, for each session to be transferred, it shall take the operator policy into account when deciding to perform the following:

- selecting the access for initiating the transfer;
- determining whether to transfer full or partial media during PS-PS transfer; or
- determining whether to add or remove media during the PS-PS transfer.

If the SC UE is configured with the operator policy (e.g. via OMA Device Management as described in 3GPP TS 24.216 [5]) then, for each media or group of media contained in the MediaorGroup node, the SC UE shall:

- 1) restrict originating sessions and session transfer towards the access networks contained in the RestrictedAccessNetworkType node and;
- 2) consider the list of access networks contained in the PreferredAccessNetworks node in the order of priority from the access networks such that, when available, the highest priority access network can be used for originating sessions and session transfer procedures;
- 3) if a new access network gets available- transfer media components to a higher priority target network than the current access network based on the value contained in the SC_media_transfer node value. If the SC_media_transfer node value is:
 - "shall" the UE shall start a session transfer according to the home operator's list of preferred access networks contained in the PreferredAccessNetworks node;
 - "should" the UE is recommended to start session transfer according to the home operator's list of preferred access networks contained in the PreferredAccessNetworks node. The UE can evaluate if session transfer is possible and desirable after having taken into account the Local Operating Environment Information;
 - "may" the UE can decide whether or not to start session transfer in accordance with user preferences if configured in the UE. The UE can evaluate if session transfer is possible and desirable after having taken into account the Local Operating Environment Information. If user preferences are not configured, the UE can evaluate the home operator's list of preferred access networks contained in the PreferredAccessNetworks node.
- 4) decide whether to keep or drop non transferable media components in the case of partial session transfer based on the SC_non_transferrable_media node value.

7 Roles for call origination

7.1 Introduction

This clause specifies the procedures for call origination, both where the SC UE is generating calls in the CS domain and where the SC UE is generating calls using the IM CN subsystem. Procedures are specified for the SC UE and the SCC AS.

7.2 SC UE

The SC UE shall support origination of multimedia sessions in the IM CN subsystem as specified in 3GPP TS 24.229 [2].

The SCC UE shall support origination of calls in the CS domain as specified in 3GPP TS 24.008 [8].

If IMS service continuity using ICS is enabled then the procedures for call origination where the SC UE is initiating calls using CS media are identical to that for ICS UE specified in 3GPP TS 24.292 [4].

7.3 SCC AS

7.3.1 Distinction of requests sent to the SCC AS

The SCC AS needs to distinguish between the following initial SIP INVITE requests to provide specific functionality relating to call origination:

- SIP INVITE requests routed to the SCC AS over the ISC interface as a result of processing filter criteria at the S-CSCF according to the origination procedures as specified in 3GPP TS 24.229 [2], and therefore distinguished by the URI relating to this particular filter criteria appearing in the topmost entry in the Route header. In the procedures below, such requests are known as "SIP INVITE requests due to originating filter criteria". It is assumed that the SCC AS is the first AS that the S-CSCF forwards the request to after receiving the request from the UE.

The SCC AS shall store the SIP INVITE requests due to static STN (as defined in subclause 9.3.1) and the SIP INVITE requests due to originating filter criteria, at least until their sessions are terminated.

Other SIP initial requests for a dialog, and requests for a SIP standalone transaction can be dealt with in any manner conformant with 3GPP TS 24.229 [8].

7.3.2 Call origination procedures at the SCC AS

When the SCC AS receives a SIP INVITE request due to originating filter criteria, the SCC AS shall follow the SCC AS roles for call origination procedures specified in 3GPP TS 24.292 [4].

8 Roles for call termination

8.1 Introduction

This clause specifies the procedures for call termination, both where the SC UE is receiving calls in the CS domain and where the SC UE is receiving calls using the IM CN subsystem. Procedures are specified for the SC UE and the SCC AS.

8.2 SC UE

An SC UE not supporting ICS or an SC UE supporting ICS with ICS capabilities disabled shall support termination of multimedia sessions in the IM CN subsystem as specified in 3GPP TS 24.229 [2] with the following clarification:

NOTE: An indication that an SC UE with ICS capabilities has its ICS capabilities enabled or disabled can be found in the ICS MO ICS_Capabilities_Enabled leaf node (see 3GPP TS 24.286 [23]).

- 1) If the SC UE receives a SIP INVITE request containing a SDP offer which includes audio media with speech codecs transported using an IP bearer, and:
 - a) if the SC UE sends the response to the SIP INVITE request over GERAN;
 - b) if the SC UE sends the response to the SIP INVITE request over E-UTRAN or UTRAN, and the IMSVoPS indicator indicates that voice is not supported; or
 - c) if the SC UE sends the response to the SIP INVITE request over an access network other than E-UTRAN, UTRAN and GERAN and the access network does not support the offered audio media with speech codecs transported using an IP bearer;

then the SC UE shall send back a SIP 488 (Not Acceptable Here) response without a message body.

The SC UE not supporting ICS or an SC UE supporting ICS with ICS capabilities disabled shall support termination of calls in the CS domain as specified in 3GPP TS 24.008 [8].

An SC UE that supports ICS with the ICS capabilities enabled shall follow the call termination procedures as specified in 3GPP TS 24.292 [4].

8.3 SCC AS

8.3.1 Distinction of requests sent to the SCC AS

The SCC AS needs to distinguish between the following initial SIP INVITE requests to provide specific functionality relating to call termination:

- SIP INVITE requests routed to the SCC AS over the ISC interface as a result of processing filter criteria at the S-CSCF according to the termination procedures as specified in 3GPP TS 24.229 [2], and therefore distinguished by the URI relating to this particular filter criteria appearing in the topmost entry in the Route header. In the procedures below, such requests are known as "SIP INVITE requests due to terminating filter criteria". It is assumed that the SCC AS is the last AS that the S-CSCF forwards the request to.

Other SIP initial requests for a dialog, and requests for a SIP standalone transaction can be dealt with in any manner conformant with 3GPP TS 24.229 [2].

8.3.2 Call termination procedures in the SCC AS

When the SCC AS receives a SIP INVITE request due to terminating filter criteria, the SCC AS shall follow the SCC AS roles for call termination procedures specified in 3GPP TS 24.292 [4].

9 Roles for PS-CS session continuity

9.1 Introduction

For a UE or an AS not supporting ICS procedures, PS-CS service continuity is only possible when the UE is active in a single full-duplex speech or speech/video session i.e. support of session transfer with more than one sessions or with non voice media is not provided.

9.2 SC UE

9.2.1 SC UE procedures for PS to CS session continuity

If SC UE uses ICS capabilities, this subclause applies for IMS sessions that contain only a single speech media, otherwise subclause 11.2.1.2 applies.

The SC UE may be engaged in one or more ongoing IMS sessions at the time of initiating session continuity. By an ongoing IMS session, it is meant a session for which the 2xx response for the initial SIP INVITE request to establish this session has been sent or received.

If SC using ICS is enabled then if the SC UE is using Gm, then for each session to be transferred and starting with the active session, the SC UE shall send a SIP INVITE request to the SCC AS according to the ICS UE using Gm procedures for call origination as specified in 3GPP TS 24.292 [4]. The SC UE shall populate the SIP INVITE request as specified for PS-PS session continuity with full media transfer in subclause 10.2.1 (including the STI of the dialog to be transferred) with the following exceptions:

- The SC UE shall indicate in the SIP INVITE request that the speech media is using CS bearer with its corresponding media description.
- Upon receiving the PSI DN from the SCC AS, the SC UE shall follow the procedures for call origination for ICS UE using Gm in 3GPP TS 24.292 [4] to set up the CS bearer.

If the SC UE is not using ICS capabilities, the SC UE shall:

- a) if more than one full-duplex speech session exists, first initiate the release of all the ongoing full-duplex speech sessions except the session with active full-duplex speech component that was most recently made active.
- b) send, to the SCC AS, a CC SETUP message as specified in 3GPP TS 24.008 [8] to set up a call over the CS domain. When sending CC SETUP, the SC UE shall populate the CC SETUP as follows:
 - 1) the called party BCD number information element set to the static STN; and
 - 2) Type Of Number set to "International" and Numbering Plan Indicator set to "E.164".in the Called Party BCD Number information element.

If the SC UE receives a release message to the CC SETUP message sent, then PS-CS session continuity has not completed successfully and the call will continue in the Source Access Leg.

9.2.2 SC UE procedures for CS to PS session continuity

The SC UE may be engaged in one or more ongoing sessions before performing session continuity. By an ongoing session, it is meant a CS call for which the CS call setup procedure is complete, e.g. CC CONNECT message has been sent or received as described in 3GPP TS 24.008 [8] or a call for which the 2xx response for the initial SIP INVITE request to establish this session has been sent or received.

If not already IMS registered, the SC UE shall follow the procedures specified in subclause 6.2 to perform IMS registration over the Target Access Leg before performing CS to PS session continuity.

If IMS service continuity using ICS is enabled then if the original sessions are established using ICS capabilities as defined in 3GPP TS 24.292 [4], then for each session to be transferred and starting with the active session, the SC UE shall send a SIP INVITE request to the SCC AS in accordance with the UE procedures specified in 3GPP TS 24.229 [2]. The SC UE shall populate the SIP INVITE request as specified for PS-PS session continuity with full media transfer in subclause 10.2.1.

If the original sessions are not established using ICS capabilities, subject to the SC_non_transferrable_media node value in the Communication Continuity MO (see subclause 5.27 in 3GPP TS 24.216 [5]) the SC UE shall:

- a) if more than one full-duplex speech session exists, first initiate the release of all the ongoing sessions that are currently not activewith the UE procedures specified in 3GPP TS 24.083 [YY] and then the SC UE shall transfer the remaining ongoing active full-duplex speech session.

When transferring the active session, the SC UE shall send a SIP INVITE request to the SCC AS in accordance with the UE procedures specified in 3GPP TS 24.229 [2]. The SC UE shall populate the SIP INVITE request as follows:

- 1) the Request-URI set to the static STI; and
- 2) include in the Contact header field a public GRUU or temporary GRUU as specified in 3GPP TS 24.229 [2], if a GRUU was received at registration.

If the SC UE receives any SIP 4xx – 6xx response to the SIP INVITE request, then session transfer has not occurred and the call will continue in the CS domain.

When the SC UE receives a CS call release message, e.g. CC DISCONNECT message as specified in 3GPP TS 24.008 [8], from the network, the SC UE shall comply with network initiated call release procedures to release the CS bearer. When CC_DISCONNECT message is received, the SC UE shall comply with the network initiated call release procedures as specified in 3GPP TS 24.008 [8].

9.3 SCC AS

9.3.1 Distinction of requests sent to the SCC AS

The SCC AS needs to distinguish between the following initial SIP INVITE requests to provide specific functionality relating to access transfer:

- SIP INVITE requests routed to the SCC AS containing a STI belonging to the subscribed user in the Replaces header field or Target-Dialog header field. In the procedures below, such requests are known as "SIP INVITE requests due to STI".
- SIP INVITE requests routed to the SCC AS containing a static STI in the Request-URI. In the procedures below, such requests are known as "SIP INVITE requests due to static STI".
- SIP INVITE requests routed to the SCC AS containing either a static STN, a STN-SR or an IMRN (as described in 3GPP TS 24.292 [4]) in the Request-URI. In the procedures below, such requests are known as "SIP INVITE requests due to static STN".

NOTE: The media streams that need to be transferred are identified using information described in the subsequent sections.

Other SIP initial requests for a dialog and requests for a SIP standalone transaction can be dealt with in any manner conformant with 3GPP TS 24.229 [2].

9.3.2 SCC AS procedures for PS to CS session continuity

This subclause does not apply to reception of a SIP INVITE request due to STI with CS media and other kind of media or without CS media.

When the SCC AS receives a SIP INVITE request due to STI with CS media only on the Target Access Leg, the SCC AS shall follow the procedures specified in subclause 10.3.2. with the following exceptions:

- As the SIP INVITE request includes an active speech media component using CS bearer, then the SCC AS shall follow the procedures for SCC AS for service control over Gm in 3GPP TS 24.292 [4] to send the PSI DN to the SC UE and wait for the SC UE to set up CS bearer before sending SIP re-INVITE request to the remote end.
- The SCC AS shall correlate the STI with the allocated PSI DN in order to identify the remote leg to be updated.

When the SCC AS receives SIP INVITE request due to static STN, the SCC AS shall associate the SIP INVITE request with an ongoing SIP dialog based on information associated with the received IMRN (as described in 3GPP TS 24.292 [4]) or based on information from the SIP History-Info header field and P-Asserted header field and send a SIP re-INVITE request towards the remote UE using the existing established dialog. By an ongoing SIP dialog, it is meant a dialog for which a SIP 2xx response to the initial SIP INVITE request has been sent or received. Multiple dialogs associated with the same SCC UE may have been anchored when the SCC AS receives a SIP INVITE request due to static STN. This can occur in the event that the UE does not succeed in releasing all inactive dialogs. The identification of the associated dialog is subject to the following conditions:

- if only one SIP dialog exists for the user identified in the P-Asserted-Identity header field and a SIP 2xx response has been sent and there is active audio media, then continue the session transfer;
- if no SIP dialogs exist for the user identified in the P-Asserted-Identity header field where there is active audio media and a SIP 2xx response has been sent, then send a SIP 480 (Temporarily Unavailable) response to reject the SIP INVITE request relating to the session transfer;
- if more than one SIP dialog exists for the user identified in the P-Asserted-Identity header field for which SIP 2xx responses have been sent and there is active audio media on each of them, then the SCC AS shall perform session transfer procedures for the dialog that originates from the same device that initiated the received SIP INVITE request due to static STN. If more than one such dialogs exists from the same device, the SCC AS shall proceed with the next step in this list; and

NOTE 1: Whether the dialog originates from the same UE as the received SIP INVITE request is determined based on local information and information related to the correlation MSISDN or the Instance-ID of the originating user as determined via registration procedures as defined in subclause 6.3.

- if more than one SIP dialog exists for the user identified in the P-Asserted-Identity header field and exactly one dialog exists where there is active audio media and a SIP 2xx response has been sent for that dialog, then:
 - if the remaining dialogs have inactive audio media, then the SCC AS may release the inactive dialogs and continue the session transfer procedures; or
 - if the SCC AS is not able to identify one dialog for session transfer, then the SCC AS shall send a SIP 480 (Temporarily Unavailable) response to reject the SIP INVITE request relating to the session transfer.
- if more than one SIP dialog with active audio media exist for the user identified in the P-Asserted-Identity header field and a SIP 2xx response has been sent for that dialog, then:
 - the SCC AS may release all SIP dialogs with audio media of the user identified in the P-Asserted-Identity header field for which a SIP 2xx response has been sent except the dialog with the active audio media that was most recently made active and continue the session transfer procedures; or
 - if the SCC AS is not able to identify one dialog for session transfer, then the SCC AS shall send a SIP 480 (Temporarily Unavailable) response to reject the SIP INVITE request relating to the session transfer.

Continuing the session transfer procedures, the SCC AS shall populate the SIP re-INVITE request as follows:

- 1) set the Request-URI to the URI contained in the Contact header field returned at the creation of the dialog with the remote UE; and
- 2) a new SDP offer, including the media characteristics as received in the SIP INVITE request due to static STN, by following the rules of 3GPP TS 24.229 [2].

Upon receiving the SIP ACK request from the IM CN subsystem, then:

- if the source access leg contains only one audio media components the SCC AS shall initiate release of the source access leg by sending a SIP BYE request toward the S-CSCF for sending to the served SCC UE; or
- If the Source Access Leg contains media components other than audio media component, the SCC AS should send a re-INVITE request to update the source access leg.

9.3.3 SCC AS procedures for CS to PS session continuity

When the SCC AS receives a SIP INVITE request due to STI on the Target Access Leg offering PS media only, the SCC AS shall follow the procedures specified in subclause 10.3.2.

When the SCC AS receives a SIP INVITE request due to static STI, the SCC AS shall associate the SIP INVITE request with an ongoing SIP dialog. By an ongoing SIP dialog, it is meant a dialog for which a SIP 2xx response to the initial SIP INVITE request has been sent or received. Multiple dialogs associated with the same SCC UE may have been anchored when the SCC AS receives a SIP INVITE request due to static STI. This can occur in the event that the UE does not succeed in releasing all inactive dialogs, in which case the identification of the associated dialog is subject to the following conditions:

- if only one SIP dialog exists for the user identified in the P-Asserted-Identity header field and a 2xx response has been sent and there is active audio media, then continue the session transfer procedures;
- if no SIP dialogs exist for the user identified in the P-Asserted-Identity header field where there is active audio media and a SIP 2xx response has been sent, then send a SIP 480 (Temporarily Unavailable) response to reject the SIP INVITE request relating to the session transfer;
- if more than one SIP dialog exists for the user identified in the P-Asserted-Identity header field and exactly one dialog exists where there is active audio media and a SIP 2xx response has been sent for that dialog, then:
 - if the remaining dialogs have inactive audio media, then the SCC AS may release the inactive dialogs and continue the session transfer procedures; or
 - if the SCC AS is not able to identify one dialog for session transfer, then the SCC AS shall send a SIP 480 (Temporarily Unavailable) response to reject the SIP INVITE request relating to the session transfer.

Continuing the session transfer procedures, the SCC AS sends a SIP re-INVITE request towards the remote UE using the existing established dialog. The SCC AS shall populate the SIP re-INVITE request as follows:

- 1) set the Request-URI to the URI contained in the Contact header field returned at the creation of the dialog with the remote UE; and
- 2) a new SDP offer, including the media characteristics as received in the SIP INVITE request due to the static STI, by following the rules of 3GPP TS 24.229 [2].

Upon receiving the SIP ACK request originated from the UE, the SCC AS shall initiate release of the source access leg by sending a SIP BYE request over the source access leg.

If, subsequent to initiating the SIP re-INVITE request to the remote UE, and prior to the SIP ACK request originated from the UE being received from the IM CN subsystem for the source access leg, the SCC AS decides (for any reason) to reject the session transfer request back to the UE (e.g. by sending a 4xx response), the SCC AS shall release the target access leg and maintain the source access leg.

10 Roles for PS-PS session continuity

10.1 Introduction

This clause specifies the procedures for PS-PS session continuity for both full media transfer case and partial media transfer case. Procedures are specified for the SC UE and the SCC AS.

10.2 SC UE

10.2.0 General

The SC UE may be engaged in one or more ongoing sessions before performing session continuity. By an ongoing session, it is meant a session for which the SIP 2xx response for the initial SIP INVITE request to establish this session has been sent or received.

The SC UE shall follow the procedures specified in subclause 6.1 to perform IMS registration over the Target Access Leg before performing PS-PS session continuity.

10.2.1 Full session transfer

To initiate PS-PS session continuity for a session, the SC UE shall send a SIP INVITE request over the Target Access Leg in accordance with UE procedures specified in 3GPP TS 24.229 [2]. The SC UE shall populate the SIP INVITE request as follows:

1. the Request-URI set to the URI contained in the Contact header field returned at the creation of the dialog over the Source Access Leg;

2. include in the Contact header field:
 - A a public GRUU or temporary GRUU as specified in 3GPP TS 24.229 [2] if a GRUU was received at registration; and
 - B the media feature tag g.3gpp.ics set to "principal" as specified in annex B of 3GPP TS 24.292 [4];
 3. select one of the following options:
 - A. if usage of SIP Replaces extension is selected:
 - a. the Replaces header field populated as specified in IETF RFC 3891 [10], containing the dialog identifier of the session to be transferred; and
 - b. the Require header field populated with the option tag value "replaces";
 - B. if usage of SIP Target-Dialog extension is selected:
 - a. the Target-Dialog header field populated as specified in IETF RFC 4538 [11], containing the dialog identifier of the session to be transferred; and
 - b. the Require header field populated with the option tag value "tdialog"; and
 4. the SDP payload set for the media component(s) to be transferred, in accordance with the UE SDP origination procedures specified in 3GPP TS 24.229 [2]. The SDP shall contain the same number of media lines, each corresponding to one of the media components in the original session, unless media components need to be added. Each media line shall indicate the same media type as its corresponding media component in the original session and shall contain at least one codec that was negotiated during the original session.
 - A- If the SC UE determines to remove a media component during the transfer, then the media line for this media component shall include a port number with value zero; and
 - B- If the SC UE determines to add new media component(s) during the transfer, then one additional media line with the desired media type and codecs shall be added for each new media component at the end of the SDP.
- NOTE: If an SC UE is an ICS UE with an ongoing session using CS bearer and Gm reference point for service control signalling, the SC UE can perform an access transfer of the service control signalling from the current IP-CAN to a new IP-CAN with the same capabilities (i.e. supporting CS and PS bearers, simultaneously) while retaining the media component in the CS access network, so that service continuity of the session is maintained.

Upon receiving SIP 2xx response for the SIP INVITE request sent over the Target Access Leg and sending SIP ACK request, if the dialog over the Source Access Leg is still active, the SC UE shall send a SIP BYE request to the SCC AS over the Source Access Leg to terminate the original session.

If the SC UE receives any SIP 4xx – 6xx response to the SIP INVITE request sent over the Target Access Leg, then PS-PS session continuity has not completed successfully and the call will continue in the Source Access Leg.

10.2.2 Partial session transfer

To initiate PS-PS session continuity for a session, the SC UE shall send a SIP INVITE request over the Target Access Leg in accordance with UE procedures specified in 3GPP TS 24.229 [2]. The SC UE shall populate the SIP INVITE request as follows:

1. the Request-URI set to the URI contained in the Contact header field returned at the creation of the dialog over the Source Access Leg;
2. include in the Contact header field:
 - A. a public GRUU or temporary GRUU as specified in 3GPP TS 24.229 [2] if a GRUU was received at registration; and
 - B. the media feature tag g.3gpp.ics set to "principal" as specified in annex B of 3GPP TS 24.292 [4];
3. the Require header with the option tag 'tdialog' included;

4. the Target-Dialog header populated as specified in IETF RFC 4538 [11], containing the dialog identifier of the session to be transferred; and
5. the SDP payload set for the media component(s) to be transferred, in accordance with the UE SDP origination procedures specified in 3GPP TS 24.229 [2]. The SDP shall contain the same number of media lines in the same order, each corresponding to one of the media components in the original session, unless media components need to be added during the session transfer. Each media line shall indicate the same media type as its corresponding media component in the original session and shall contain at least one codec that was negotiated during the original session.
 - A. If the SC UE determines to keep the media component on the Source Access Leg, then the media line for this media component shall include a port number with value zero; and
 - B. If the SC UE determines to add new media component(s) during the transfer, then one additional media line with the desired media type and codecs shall be added for each new media component at the end of the SDP.

NOTE: If an SC UE is an ICS UE with an ongoing session using CS bearer and Gm reference point for service control signalling, the SC UE can perform an access transfer of the service control signalling from the current IP-CAN to a new IP-CAN with the same capabilities (i.e. supporting CS and PS bearers, simultaneously) while retaining the media component in the CS access network, so that service continuity of the session is maintained.

Upon receiving SIP 2xx response for the SIP INVITE request sent over the Target Access Leg and sending SIP ACK request, the SC UE shall send a SIP re-INVITE request to the SCC AS over the Source Access Leg to update the original session. The SC UE shall populate the SIP re-INVITE request as follows:

1. the SDP payload set for all the media component(s) within the original session, in accordance with the UE SDP origination procedures specified in 3GPP TS 24.229 [2]. The port number for a media component shall be set to zero if that media component has been transferred to the Target Access Leg or has to be removed.

If the SC UE receives any SIP 4xx – 6xx response to the SIP INVITE request sent over the Target Access Leg, then PS-PS session continuity has not completed successfully and the call will continue in the Source Access Leg.

10.3 SCC AS

10.3.1 Distinction of requests sent to the SCC AS

The SCC AS needs to distinguish between the following initial SIP INVITE requests to provide specific functionality relating to access transfer:

- SIP INVITE requests routed to the SCC AS containing a STI belonging to the subscribed user in the Replaces header or Target-Dialog header. In the procedures below such requests are known as "SIP INVITE requests due to STI".

NOTE: The media streams that need to be transferred are identified using information described in the subsequent sections.

Other SIP initial requests for a dialog and requests for a SIP standalone transaction can be dealt with in any manner conformant with 3GPP TS 24.229 [2].

10.3.2 PS to PS Session Continuity Procedures at the SCC AS

This subclause applies to reception of a SIP INVITE request due to STI with a PS media only.

When the SCC AS receives a SIP INVITE request on the Target Access Leg due to STI, the SCC AS shall:

- associate the SIP INVITE received on the Target Access Leg with an ongoing SIP dialog i.e. identify the Source Access Leg. The Source Access Leg is identified by matching the dialog ID present in the Replaces (see IETF RFC 3891 [10]) or Target Dialog header (see IETF RFC 4538 [11]) of the SIP INVITE with an ongoing dialog. By an ongoing SIP dialog, it is meant a dialog for which a SIP 2xx response to the initial SIP INVITE request has been sent or received;

- if the SCC AS is unable to associate the SIP INVITE with a unique ongoing dialog, send a SIP 480 (Temporarily Unavailable) response to reject the SIP INVITE request relating to the access transfer and not processes the remaining steps;
- if the SIP INVITE request contains a Replaces header:
 - a) follow the procedures defined in IETF RFC 3891 [10] for replacing the Source Access Leg with the SIP request received on the Target Access Leg, including terminating the Source Access Leg by sending a SIP BYE towards the SC UE in accordance with 3GPP TS 24.229 [8]; and
 - b) send a SIP re-INVITE request towards the remote UE using the existing established dialog. The SCC AS shall populate the SIP re-INVITE request as follows:
 - 1) set the Request-URI to the URI contained in the Contact header field returned at the creation of the dialog with the remote UE; and
 - 2) a new SDP offer, including the media characteristics as received in the SIP INVITE request due to STI received on the Target Access Leg, by following the rules of 3GPP TS 24.229 [2].
- otherwise, if the SIP INVITE request contains a Target Dialog header:
 - a) if the number of media lines in the Target Access Leg is less than the number of media lines in the Source Access Leg or the media type for the corresponding media lines is not the same as in the original session, send a SIP 4xx response to reject the SIP INVITE request relating to the access transfer and not process the remaining steps;
 - b) otherwise, send a SIP re-INVITE request towards the remote UE using the existing established dialog. The SCC AS shall populate the SIP re-INVITE request as follows:
 - 1) set the Request-URI to the URI contained in the Contact header field returned at the creation of the dialog with the remote UE; and
 - 2) include a new SDP offer, following the rules specified in 3GPP TS 24.229 [2], containing the following media information:
 - the media characteristics as received in the SIP INVITE request due to STI received on the Target Access Leg for media streams whose port is not set to zero; and
 - for the media streams in the SIP INVITE request due to STI whose port is set to zero, include the corresponding media characteristics of those streams from the Source Access Leg,
 - c) for a full media transfer, send a SIP BYE towards the SC UE in accordance with 3GPP TS 24.229 [2]; otherwise, for a partial media transfer, after receiving the SIP ACK request from the SC UE on the Target Access Leg, upon receiving an update (e.g. SIP re-INVITE) from the SC UE on the Source Access Leg, process the update request in accordance with 3GPP TS 24.229 [2].

If, subsequent to initiating the SIP re-INVITE request to the remote UE, and prior to the SIP ACK request being received on the Target Access Leg, the SCC AS decides (for any reason) to reject the access transfer request (e.g. by sending a 4xx response), the SCC AS shall release the Target Access Leg, retain the Source Access Leg, and update the remote leg to match the Source Access Leg.

11 Roles for PS-PS session continuity in conjunction with PS-CS session continuity

11.1 Introduction

This clause specifies the procedures for PS-PS session continuity in conjunction with PS-CS session continuity. Procedures are specified for the SC UE and the SCC AS. For SC UE or SCC AS not supporting ICS procedures, PS-PS session continuity with a remote end in conjunction with PS-CS session continuity with the same remote end is only possible when the UE is active in a single CS session with full-duplex speech with the remote end i.e. support of session transfer with more than one session containing full-duplex speech component is not provided.

11.2 SC UE

11.2.1 SC UE procedures for PS to PS+CS session continuity

11.2.1.1 General

The SC UE may be engaged in one or more ongoing IMS sessions before performing session continuity. By an ongoing session, it is meant a session for which the SIP 2xx response for the initial SIP INVITE request to establish this session has been sent or received.

11.2.1.2 SC UE procedures for PS to PS+CS session continuity using ICS

This subclause applies for IMS sessions that contain only a single speech media, otherwise subclause 9.2.1 applies.

If IMS service continuity using ICS is enabled then if the SC UE is using Gm, then for each session to be transferred and starting with the session with active full-duplex speech component, the SC UE shall send a SIP INVITE request to the SCC AS as specified for call origination for ICS UE using Gm in 3GPP TS 24.292 [4]. The SC UE shall populate the SIP INVITE request as specified for PS-PS session continuity with full media transfer in subclause 10.2.1 with the following exceptions:

- The SC UE shall indicate in the SIP INVITE request that the speech media is using CS bearer with its corresponding media description.
- When sending the SIP INVITE request for the sessions with inactive full-duplex speech component and if precondition is used, the SC UE shall indicate that the related local preconditions for the speech component are met.

For the session with active full-duplex speech component, upon receiving the PSI DN from the SCC AS, the SC UE shall follow the procedures for call origination for ICS UE using Gm in 3GPP TS 24.292 [4] to set up the CS bearer.

If service control over Gm for the CS bearer is retained on the source access leg, the SC UE shall:

- send an SIP INVITE request as specified for partial session transfer in subclause 10.2.2. indicating transfer of non-speech media to the target access leg; and
- send a SIP re-INVITE request over the source access leg indicating that the speech media is to be transferred to a CS bearer as described in 3GPP TS 24.292 [4] subclause 8.2.2.2. If other media components are retained or added on the source access leg, then these are included in the SDP offer.

For the session with active full-duplex speech component, upon receiving the SCC AS PSI DN from the SCC AS, the SC UE shall follow the procedures for call origination for ICS UE using Gm in 3GPP TS 24.292 [4] to set up the CS bearer.

11.2.1.3 SC UE procedures for PS to PS+CS session continuity not using ICS

If the SC UE is not using ICS capabilities, then session continuity is only possible when the UE is active in a single session with full-duplex speech media component. For the non-speech components to be transferred to the PS Target Access Leg, the SC UE shall send a SIP INVITE request to the SCC AS as specified for PS-PS session continuity with partial media transfer in subclause 10.2.1. For the speech component to be transferred to the CS Target Access leg, the SC UE shall send to the SCC AS a CC SETUP message as specified in 3GPP TS 24.008 [8]. When sending the CC SETUP message, the SC UE shall populate the CC SETUP message as follows:

- 1) the called party BCD number information element set to the STN;
- 2) Type Of Number set to "International" and Numbering Plan Indicator set to "E.164" in the Called Party BCD Number information element.

Upon receiving the SIP 2xx response from the SCC AS for the PS Target Access Leg and sending SIP ACK request and upon receiving CS call setup confirmation message, e.g. CC CONNECT message, for the CS Target Access Leg, the SC UE shall send a SIP BYE request to terminate the Source Access Leg, following the procedures specified in 3GPP TS 24.229 [2].

If the SC UE receives any SIP 4xx – 6xx response to the SIP INVITE request for the PS Target Access leg and receives CS call setup failure message for the CS Target Access Leg, then session transfer has not occurred and the call will continue in the original domains.

If the SC UE receives any SIP 4xx – 6xx response to the SIP INVITE request for the PS Target Access Leg and receives CS call setup confirmation message for the CS Target Access Leg, then the session transfer is only successful for part of the media components. The SC UE shall update the Source Access leg by following the procedures specified for PS-PS session continuity with partial media transfer in subclause 10.2.2 to indicate that all media components other than the speech component are still maintained on the Source Access Leg.

If the SC UE receives CS call setup failure message for the CS Target Access Leg but receives a SIP 2xx response for the PS Target Access Leg, then the session transfer is only successful for part of the media components. Upon sending SIP ACK request, the SC UE shall update the Source Access leg by following the procedures specified for PS-PS session continuity with partial media transfer in subclause 10.2.2 to indicate that the speech component is still maintained on the Source Access Leg.

11.2.2 SC UE procedures for PS+CS to PS session continuity

11.2.2.1 General

The SC UE may be engaged in one or more ongoing sessions before performing session continuity. By an ongoing session, it is meant a CS call for which the CC CONNECT message has been sent or received or a call for which the SIP 2xx response for the initial SIP INVITE request to establish this session has been sent or received.

If not already registered over the PS Target Access Leg, the SC UE shall follow the procedures specified in subclause 6.2 to perform IM CN subsystem registration over the Target Access Leg before performing PS/CS to PS session continuity.

11.2.2.2 SC UE procedures for PS+CS to PS session continuity using ICS

If IMS service continuity using ICS is enabled then if the original sessions are established using ICS capabilities, then for each session to be transferred and starting with the session with active full-duplex speech media component, the SC UE shall send a SIP INVITE request to the SCC AS in accordance with the UE procedures specified in 3GPP TS 24.229 [2]. The SC UE shall populate the SIP INVITE request as specified for PS-PS session continuity with full media transfer in subclause 10.2.1. The SC UE shall indicate in the SIP INVITE request that the speech media component is using PS media.

Upon receiving SIP BYE request for the Source Access Leg, the SC UE shall follow the ICS using Gm procedures specified in 3GPP TS 24.292 [4] to release the session. The SC UE also releases the associated CS bearer if no other sessions depend on the CS bearer.

11.2.2.3 SC UE procedures for PS+CS to PS session continuity not using ICS

If the original sessions are not established using ICS capabilities, then session continuity is only possible when the SC UE has a single session with active full-duplex speech media component. The SC UE shall send a SIP INVITE request to the SCC AS in accordance with the UE procedures specified in 3GPP TS 24.229 [2].

The SC UE shall populate the SIP INVITE request as follows:

- the Request-URI set to static STI;
- the Require header field including "replaces" option tag;
- the Replaces header field populated as specified in IETF RFC 3891 [10], containing the dialog identifier of the session to be transferred on the PS Source Access Leg; and
- the SDP payload set for the media component(s) to be transferred, in accordance the UE SDP origination procedures specified in 3GPP TS 24.229 [2]. The SDP shall contain media components in the following order:
 - 1) The same number of media lines, each corresponding to one of the media components in the session on the PS Source Access Leg; Each media line shall indicate the same media type as its corresponding media component in the original session and shall contain at least one codec that was negotiated during the original

session. If the SC UE determines to remove a media component during the transfer, then the media line for this media component shall include a port number with value zero;

- 2) One speech media component to be transferred, corresponding to the speech media component in the session on the CS Source Access Leg; and
- 3) If the SC UE determines to add new media component(s) during the transfer, then one additional media line with the desired media type and codecs shall be added for each new media component.

If the SC UE receives any SIP 4xx – 6xx response to the SIP INVITE request, then session transfer has not occurred and the call will continue in the original domains.

11.3 SCC AS

11.3.1 Distinction of requests sent to the SCC AS

The SCC AS needs to distinguish between the following initial SIP INVITE requests to provide specific functionality relating to access transfer:

- SIP INVITE requests routed to the SCC AS containing a STI belonging to the subscribed user in the Replaces header field or Target-Dialog header field. In the procedures below, such requests are known as "SIP INVITE requests due to STI".
- SIP INVITE requests routed to the SCC AS containing either a static STN or an IMRN in the Request-URI. In the procedures below, such requests are known as "SIP INVITE requests due to static STN".
- SIP INVITE requests routed to the SCC AS containing a static STI in the Request-URI and a STI in the Replaces or Target-Dialog header field. In the procedures below, such requests are known as "SIP INVITE requests due to two STIs".

NOTE: The media streams that need to be transferred are identified using information described in the subsequent subclauses 11.3.2 and 11.3.3.

Other SIP initial requests for a dialog and requests for a SIP standalone transaction can be dealt with in any manner conformant with 3GPP TS 24.229 [2].

11.3.2 SCC AS procedures for PS to PS+CS session continuity

This subclause does not apply to reception of a SIP INVITE request due to STI with a CS media.

When the SCC AS receives a SIP INVITE request due to STI with PS and CS media on the Target Access Leg, the SCC AS shall follow the PS-PS session continuity procedures specified in subclause 10.3.2 with the following exceptions:

- If the SIP INVITE request includes an active speech media component using CS bearer, then the SCC AS shall follow the procedures for SCC AS for service control over Gm in 3GPP TS 24.292 [4] to send the PSI DN to the SC UE and wait for the SC UE to set up CS bearer before sending re-INVITE to the remote end. The SCC AS shall correlate the STI with the allocated PSI DN in order to identify the remote leg to be updated.
- If service control over Gm is retained on the source access leg, and the SCC AS receives a re-INVITE request indicating CS bearer on an existing session, the SCC AS shall follow procedures as described in 3GPP TS 24.292 [4] subclause 8.4.2 to send the PSI DN to the SC UE and wait for the SC UE to set up CS bearer before sending re-INVITE to the remote end.
- The SCC AS shall include a new SDP offer in the re-INVITE request, following the rules specified in 3GPP TS 24.229 [2], containing the following media information:
 - the media characteristics as received in the SIP INVITE request due to STI with PS+CS media received on the Target Access Leg for media streams whose port is not set to zero; and
 - the media characteristics as received in the SIP re-INVITE request for media streams whose port is not set to zero.

When the SCC AS receives a SIP INVITE request due to static STN on the Target Access Leg, the SCC AS shall follow the PS-CS session continuity procedures specified in subclause 9.3.2. However, as the Source Access Leg contains media components other than speech component, the SCC AS does not initiate release for Source Access Leg.

11.3.3 SCC AS procedures for PS+CS to PS session continuity

This subclause applies to reception of a SIP INVITE request due to STI with a PS media only.

When the SCC AS receives a SIP INVITE request due to STI on the Target Access Leg, the SCC AS shall follow the PS-PS session continuity procedures specified in subclause 10.3.2.

When the SCC AS receives a SIP INVITE request due to two STIs on the Target Access Leg, the SCC AS shall:

- associate the SIP INVITE request received on the Target Access Leg with two ongoing sessions:
 - a) an ongoing SIP dialog on the PS Source Access Leg: This is done by matching the dialog ID present in the Replaces header field (see IETF RFC 3891 [10]) or Target-Dialog header field (see IETF RFC 4538 [11]) of the SIP INVITE request with an ongoing dialog. By an ongoing SIP dialog, it is meant a dialog for which a SIP 2xx response to the initial SIP INVITE request has been sent or received;
 - b) a different ongoing SIP dialog with active full-duplex speech component:
- if the SCC AS is unable to associate the SIP INVITE request with either one of the above two dialogs, send a SIP 480 (Temporarily Unavailable) response to reject the SIP INVITE request relating to the access transfer and not process the remaining steps; and
- if the session transfer is possible:
 - a) follow the procedures defined in IETF RFC 3891 [10] for replacing the two sessions on the Source Access Legs with the SIP request received on the Target Access Leg, including terminating the two Source Access Legs by sending a SIP BYE request on each session towards the SC UE in accordance with 3GPP TS 24.229 [2]; and
 - b) send a SIP re-INVITE request towards the remote UE using the existing established dialog. The SCC AS shall populate the SIP re-INVITE request as follows:
 - 1) set the Request-URI to the URI contained in the Contact header field returned at the creation of the dialog with the remote UE; and
 - 2) a new SDP offer, including the media characteristics as received in the SIP INVITE request due to two STIs received on the Target Access Leg, by following the rules of 3GPP TS 24.229 [2].

12 Roles for PS-CS session continuity, Single Radio

12.1 Introduction

This clause specifies the procedures for PS-CS session continuity in Single Radio VCC. Procedures are specified for the SC UE and the SCC AS. For SC UE or SCC AS not supporting ICS procedures, PS-CS session continuity in SR-VCC is only possible when the UE is active in a single session with full-duplex speech i.e. support of session transfer with more than one session containing full-duplex speech component is not provided.

12.2 SC UE procedures for PS to CS session continuity, SR-VCC

12.2.1 General

The SC UE may be engaged in one or more ongoing IMS sessions before SR-VCC session continuity is performed. By an ongoing session, it is meant a session for which the SIP 2xx response for the initial SIP INVITE request to establish this session has been sent or received.

12.2.2 ICS-based

If:

- IMS service continuity using ICS is enabled;
- the Gm reference point is retained upon PS handover procedure;
- the SC UE is using ICS capabilities; and
- SR-VCC procedures (as described in 3GPP TS 24.008 [8]) have been completed;

the SC UE, in order to add Gm control for the newly established CS session, shall:

- send a SIP re-INVITE request for each speech session to be transferred, starting with the session with active full-duplex speech component that was most recently made active; and
- within the SDP offer indicate the media line for all active and held audio streams as an audio stream over circuit switched bearer in accordance with 3GPP TS 24.292 [4]. If the precondition mechanism is used, the SC UE shall indicate the related local preconditions as met.

NOTE: Within SR-VCC the handover is performed on PS level. Due to this, the SIP dialog established over the source PS access network stays the same after SR-VCC procedures, e.g. the IP address of the UE, the Call-ID, the P-CSCF do not change. Therefore in this case a re-INVITE needs to be sent to add ICS-control for the CS bearer.

12.2.3 Not based on ICS

After successful SR-VCC procedures (as described in 3GPP TS 24.008 [8]), if the SC UE is not using ICS capabilities, the SC UE shall replace the most recent active PS audio session with the newly established CS voice call.

NOTE: In the case when ICS is not supported or used, only the most recent active audio call is transferred from PS to CS audio.

If:

- the Gm reference point is retained upon PS handover;
- the SC UE is not using ICS capabilities; and
- SR-VCC procedures (as described in 3GPP TS 24.008 [8]) have been completed;

the SC UE shall:

- send a SIP re-INVITE request to the SCC AS as specified for media removal in subclause 13.2.1; and
- indicate in the SDP Offer the full-duplex speech media as removed.

12.3 SCC AS

12.3.1 SCC AS procedures for PS to CS session continuity, SR-VCC

The SCC AS needs to distinguish between the following SIP INVITE requests to provide specific functionality for SR-VCC:

- SIP INVITE request routed to the SCC AS due to a STN-SR belonging to the subscribed user in the Request-URI. These SIP INVITE requests originate from the MSC server. In the procedures below, such requests are known as "SIP INVITE requests due to STN-SR".
- SIP re-INVITE request routed to the SCC AS containing one or more already existing media lines for audio indicate a CS bearer. In the procedures below, such requests are known as "SIP re-INVITE requests adding ICS control".
- SIP re-INVITE request routed to the SCC AS containing one or more already existing media lines for audio indicate the port set to "0". In the procedures below, such requests are known as "SIP re-INVITE requests for non-ICS control".

When the SCC AS receives a SIP INVITE request due to STN-SR on the Target Access Leg, the SCC AS shall follow the PS-CS session continuity procedures specified in subclause 9.3.2 for the session with active full-duplex speech component that was most recently made active. However, the SCC AS does not initiate release for Source Access Leg.

If the SCC AS has sent a SIP 480 (Temporarily Unavailable) response to reject a SIP INVITE request due to STN-SR on the Target Access Leg:

- 1) if the speech media flow to be transferred was the only media flow in the SIP dialog, the SCC AS shall release the remote leg as specified in 3GPP TS 24.229 [2]; or
- 2) if the SIP dialog contains other media flows than the active speech flow, the SCC AS shall modify the remote leg and remove the speech media flow, as specified in 3GPP TS 24.229 [2].

When the SCC AS receives a SIP re-INVITE request for adding ICS control, the SCC AS shall follow the procedures as described for ICS using Gm in subclause 13.3.2.

NOTE: When using the ICS controlled CS bearer, only one audio call can be active at a time. Nevertheless, several calls can be held in parallel. If the user decides to switch to another (previously held) call, the ICS controlled CS bearer is re-used for this call. Therefore no specific procedures for handling of held calls in the case of ICS controlled CS bearer are needed.

When the SCC AS receives a SIP re-INVITE for non-ICS control, the SCC AS shall follow the media removal procedures as specified in subclause 13.3.1. As only the most recent active audio call is transferred from PS to CS audio, the SCC AS shall drop all other previously existing audio sessions from this UE and indicate them accordingly in the SDP Offer sent within SIP re-INVITE requests towards the remote UE.

13 Roles for media adding/deleting

13.1 Introduction

This clause specifies the procedures for adding or deleting media to an existing multimedia session. Procedures are specified for the SC UE and the SCC AS.

13.2 SC UE

13.2.1 Adding or removing media through Gm

If the SC UE wants to add or remove media components to a session that was previously established using Gm reference point, the SC UE shall follow the procedures defined in 3GPP TS 24.229 [2] for adding/removing PS media.

If the SC UE wants to transfer media components from the source access leg to an existing target access leg (i.e. the access legs were previously established due to the partial session transfer) using Gm reference point, the SC UE shall:

1. add the media components to the target access leg; and
2. remove those media components from the source access leg,

by using procedures defined in 3GPP TS 24.229 [2] for adding/removing PS media.

If IMS service continuity using ICS is enabled then if the SC UE wants to add or remove CS media components to a session, it shall follow the procedures defined in 3GPP TS 24.292 [4].

If the SC UE receives a SIP re-INVITE request or a SIP UPDATE request from the remote end to add or remove media components to a session that was previously established using Gm, the SC UE shall follow the procedures defined in 3GPP TS 24.229 [2] for adding or removing PS media and shall follow the procedures defined in 3GPP TS 24.292 [4] for adding or removing CS media to the session.

13.2.2 Adding Gm control to existing CS session

The SC UE shall add Gm control to an existing CS session only when there is a single full-duplex speech session over CS. If there is more than one full-duplex speech session, the SC UE shall release all the ongoing sessions that are not currently active before attempting the procedures described in this section.

If the SC UE wants to add Gm control to an existing CS session that was established without Gm, after registering with the IM CN subsystem, the SC UE shall send an initial SIP INVITE request over the PS access in accordance with 3GPP TS 24.229 [2]. The SC UE shall populate the SIP INVITE request as follows:

- set the Request-URI to the static STI; and
- set the SDP payload, in accordance with the procedures defined in 3GPP TS 24.292 [4], proposing an audio stream over a circuit switched bearer. The SC UE can optionally include additional PS media to the SDP in accordance to the procedures defined in 3GPP TS 24.229 [2].

Upon receiving a SIP 200 (OK) response, the SC UE shall treat the ongoing CS call as established using Gm and shall follow the "ICS UE using Gm" procedures defined in 3GPP TS 24.292 [4] for controlling the CS call.

If the SC UE receives a new SIP INVITE request containing an audio stream over a circuit-switched bearer in the SDP and the SCC AS PSI DN matches the B-party number of the ongoing CS call that was established without Gm, the SC UE shall:

- respond to the SIP INVITE request in accordance with the procedures defined in 3GPP TS 24.292 [4]; and
- treat the ongoing CS call as established using Gm and shall follow the "ICS UE using Gm" procedures defined in 3GPP TS 24.292 [4] for controlling the CS call.

13.3 SCC AS

13.3.1 Adding or removing media through Gm

If the SCC AS receives a SIP re-INVITE request or a SIP UPDATE request from the SC UE, in which already existing media components of the session are transferred from a source access leg to an already existing target access leg (i.e. the target access leg was already established due to partial session transfer), the SCC AS shall update the remote end using the session transfer procedures defined in subclause 10.3.2.

NOTE: The SC UE indicates that media is switched from the source access leg to the target access leg by using the procedures defined in 3GPP TS 24.229 [2] for adding / removing PS media, i.e. the related connection and port information of the transferred media component within the SDP is changed from the source access leg to the target access leg.

If the SCC AS receives a SIP re-INVITE request or a SIP UPDATE request from the SC UE or remote end to add/remove new media components, to an existing access leg of the session established using Gm, the SCC AS shall follow the procedures defined in 3GPP TS 24.229 [2] for adding or removing PS media and shall follow the procedures defined in 3GPP TS 24.292 [4] for adding or removing CS media to the session.

13.3.2 Adding Gm control to existing CS session

If the SCC AS receives a SIP INVITE request containing the static STI in the Request-URI the SCC AS shall determine if this SIP INVITE request is for an ongoing call by determining if the received contents of SIP INVITE request's Contact header field is bound to an ongoing CS call session identifier. If the SC UE has an ongoing CS call, the SCC AS shall:

- respond to the SIP INVITE request in accordance with the procedures defined in 3GPP TS 24.292 [4];
- treat the ongoing CS call as established using Gm and shall follow the "SCC AS for service control over Gm" procedures defined in 3GPP TS 24.292 [4] for controlling the CS call; and
- if the SIP INVITE request contains additional PS media, the SCC AS shall send a SIP re-INVITE request towards the remote end, including the newly added PS media, in accordance with the procedures defined in 3GPP TS 24.229 [2].

The SCC AS shall add Gm control to an existing CS session only when there is a single full-duplex speech session over CS. If the SCC AS wants to add Gm control to an existing CS session that was established without Gm, the SCC AS shall send a new SIP INVITE request over the PS access in accordance with 3GPP TS 24.229 [2]. The SCC AS shall populate the SIP INVITE request as follows:

- set the Request-URI to the public user identity of the UE; and
- set the SDP payload, in accordance with the procedures defined in 3GPP TS 24.292 [4], proposing an audio stream over a circuit switched bearer.

Upon receiving a SIP 200 (OK) response, the SCC AS shall treat the ongoing CS call as established using Gm and shall follow the "SCC AS for service control over Gm" procedures defined in 3GPP TS 24.292 [4] for controlling the CS call.

Annex A (informative): Example signalling flows

A.1 Scope of signalling flows

This annex gives examples of signalling flows for Service Continuity based on the Session Initiation Protocol (SIP) and SIP Events.

These signalling flows provide detailed signalling flows, which expand on the overview information flows provided in 3GPP TS 23.237 [9].

A.2 Introduction

A.2.1 General

The signalling flows provided in this annex follow the methodology developed in 3GPP TS 24.228 [3].

A.2.2 Key required to interpret signalling flows

The key to interpret signalling flows specified in 3GPP TS 24.228 [3] subclauses 4.1 and 4.2 applies with the additions specified below:

- tel:+1-237-555-1111 represents the public user identity of SC UE A.
- tel:+1-237-555-2222 represents the public user identity of UE B.
- sip:sccas1.home1.net represents the Internet host of SCC AS.

Each signalling flow table contains descriptions for headers where the content of the header is new to that signalling flow, as is already performed in 3GPP TS 24.228 [3].

However, 3GPP TS 24.228 [3] includes extensive descriptions for the contents of various headers following each of the tables representing the contents of the signalling flows. Where the operation of the header is identical to that shown in 3GPP TS 24.228 [3], then such text is not reproduced in the present document.

Additional text may also be found on the contents of headers within 3GPP TS 24.228 [3] in addition to the material shown in the present document.

In order to differentiate between messages for SIP and media, the notation in figure A.2-1 is used.

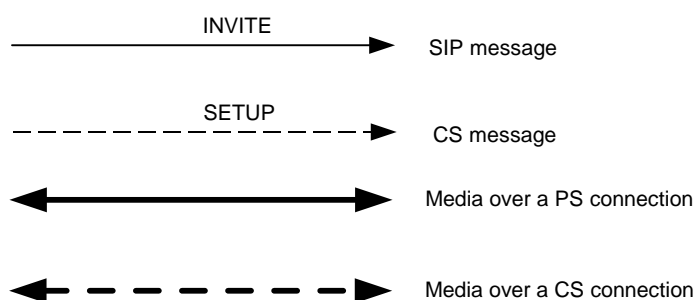

Figure A.2-1: Signalling flow notation

A.3 Signalling flows for registration

A.3.1 Introduction

When using CS access for media and to make use of the IMS ISC procedures, the SC UE is registered in IM CN subsystem and the signalling flows are defined in 3GPP TS 24.292 [4] subclause A.2.

When initiating a CS call, the SC UE can be registered in the CS domain as defined in 3GPP TS 24.008 [8].

Whenever the UE acquires IP connectivity via an IP-CAN, the signalling flows for registration in the IMS are defined in 3GPP TS 24.228 [3].

A.3.2 Signalling flows for multiple registration

The signalling flows shown in figure A.3.2-1 gives an example when a UE connects to different IP-CAN respectively and performs multiple registrations. In this example the SCC AS receives the registration state information that it needs to implement SCC specific requirements from the third-party REGISTER request.

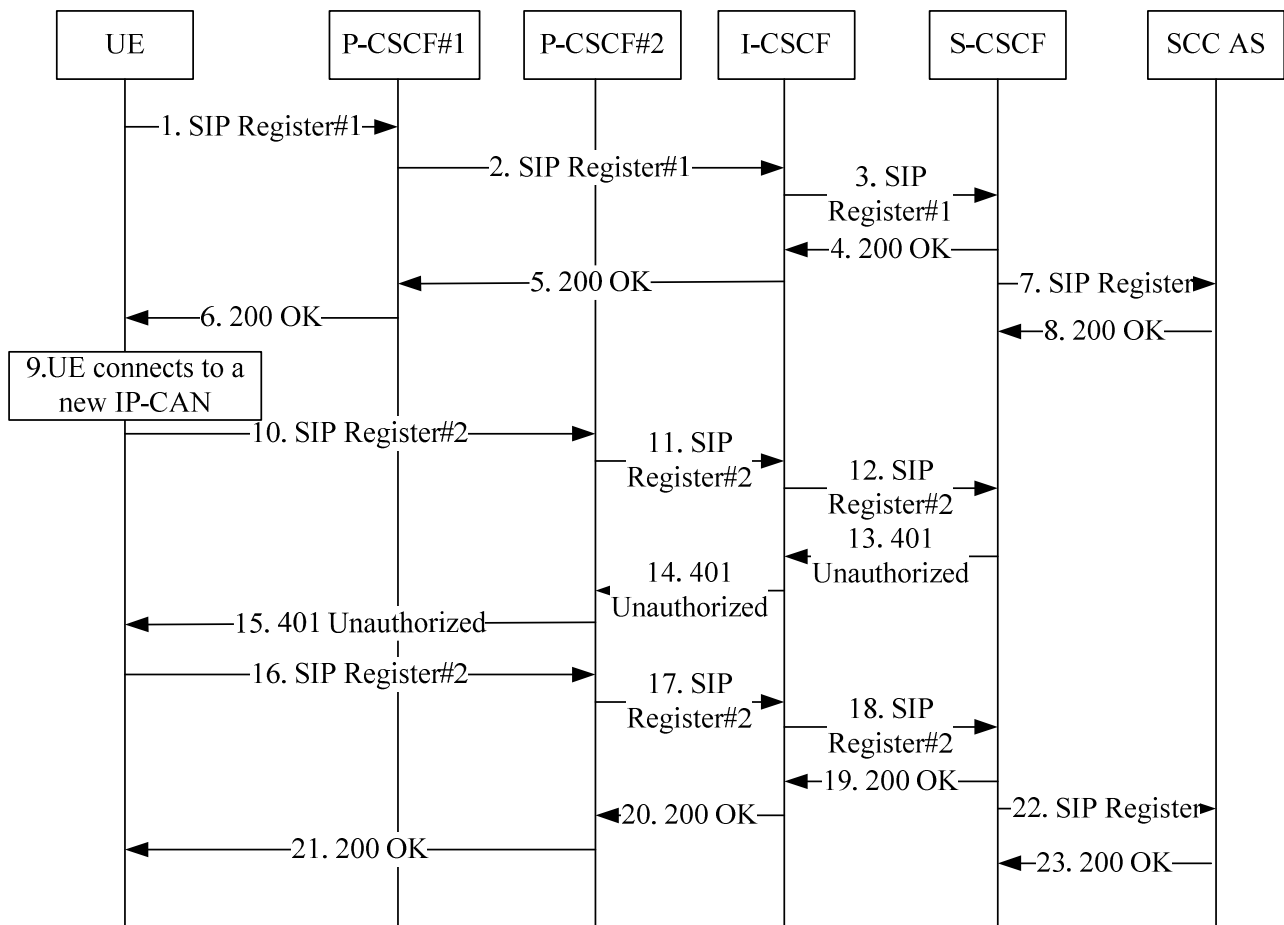

Figure A.3.2-1 Signalling flows for multiple registrations

1. SIP REGISTER request (UE to P-CSCF#1)-See example in table A.3.2-1

UE sends the SIP REGISTER request via the IP-CAN#1.

NOTE 1: For clarity, the unprotected SIP REGISTER request via the IP-CAN#1 is not shown in this example.

Table A.3.2-1 SIP REGISTER request (UE to P-CSCF#1)

```

REGISTER sip:registrar.home1.net SIP/2.0
Via: SIP/2.0/UDP [5555::aaa:bbb:ccc:ddd]:1357;comp=sigcomp;branch=z9hG4bKnashds7
Max-Forwards: 70
P-Access-Network-Info: 3GPP-UTRAN-TDD; utran-cell-id-3gpp=234151D0FCE11
From: <sip:user1_public1@home1.net>;tag=4fa3
To: <sip:user1_public1@home1.net>
Contact: <sip:[5555::aaa:bbb:ccc:ddd]:1357;comp=sigcomp>; reg-id=1; +sip.instance="<
urn:gsma:imei:90420156-025763-0 >";+g.3gpp.icsi-ref="urn%3Aurn-7%3gpp-
service.ims.icsi.mmmtel";+g.3gpp.ics="principal";+g.3gpp.accesstype="cellular1";expires=6000
00
Call-ID: apb03a0s09dkjdfglkj49111
Authorization: Digest username="user1_private@home1.net", realm="registrar.home1.net",
nonce=base64(RAND + AUTN + server specific data), algorithm=AKAv1-MD5,
uri="sip:registrar.home1.net", response="6629fae49393a05397450978507c4ef1"
Security-Client: ipsec-3gpp; alg=hmac-sha-1-96; spi-c=23456789; spi-s=12345678; port-c=2468;
port-s=1357
Security-Verify: ipsec-3gpp; q=0.1; alg=hmac-sha-1-96; spi-c=98765432; spi-s=87654321; port-
c=8642; port-s=7531
Require: sec-agree
Proxy-Require: sec-agree
CSeq: 2 REGISTER
Supported: path, outbound, gruu
Content-Length: 0

```

2. SIP REGISTER request (P-CSCF#1 to I-CSCF)-See example in table A.3.2-2

After performing the DNS query, the P-CSCF#1 forwards the REGISTER request towards I-CSCF. The P-CSCF adds a Path header with a flow token and includes the 'ob' parameter

Table A.3.2-2 SIP REGISTER request (P-CSCF#1 to I-CSCF)

```

REGISTER sip:registrar.home1.net SIP/2.0
Via: SIP/2.0/UDP pcsf1.visited1.net;branch=z9hG4bK240f34.1, SIP/2.0/UDP
[5555::aaa:bbb:ccc:ddd]:1357;comp=sigcomp;branch=z9hG4bKnashds7
Max-Forwards: 69
P-Access-Network-Info:
Path: <sip:VskztcQ/S8p4WPbOnHbuyh5iJvJIW3ib@pcsf1.visited1.net;lr;ob>
Require: path
P-Visited-Network-ID: "Visited Network Number 1"
P-Charging-Vector: icid-value="AyretyU0dm+6O2IrT5tAFrbHLso=023551024"
From:
To:
Contact:
Call-ID:
Authorization: Digest username="user1_private@home1.net", realm="registrar.home1.net",
nonce=base64(RAND + AUTN + server specific data), algorithm=AKAv1-MD5,
uri="sip:registrar.home1.net", response="6629fae49393a05397450978507c4ef1", integrity-
protected="yes"
CSeq:
Supported:
Content-Length:

```

3. SIP REGISTER request (I-CSCF to S-CSCF)

The I-CSCF forwards the SIP REGISTER request to the S-CSCF.

4. SIP 200 (OK) response (S-CSCF to I-CSCF)-See example in table A.3.2-4

The S-CSCF sends a SIP 200 (OK) response to the I-CSCF indicating that Registration was successful. AS the URI in the first path header field has an "ob" URI parameter, it include a Require header with the option-tag "outbound".

Table A.3.2-4: SIP 200 (OK) response (S-CSCF to I-CSCF)

```

SIP/2.0 200 OK
Via: SIP/2.0/UDP icscf1_p.home1.net;branch=z9hG4bK351g45.1, SIP/2.0/UDP
    pcscf1.visited1.net;branch=z9hG4bK240f34.1, SIP/2.0/UDP
    [5555::aaa:bbb:ccc:ddd]:1357;comp=sigcomp;branch=z9hG4bKnashds7
Path: <sip:term@pcscf1.visited1.net;lr;ob>
Service-Route: <sip:orig@scscf1.home1.net;lr>
From:
To:
Call-ID:
Contact: <sip:[5555::aaa:bbb:ccc:ddd]:1357;comp=sigcomp>;
    pub-gruu="sip:user1_public1@home1.net;gr=urn:uuid:f81d4fae-7dec-11d0-a765-00a0c91e6bf6"
    ;temp-gruu="sip:tgruu.7hs==jd7vnzga5w7fajsc7-ajd6fabz0f8g5@example.com;gr"
    ;+sip.instance="<urn:gsm:imei:90420156-025763-0>"+g.3gpp.icsi-ref="urn%3Aurn-7%3gpp-
    service.ims.icsi.mmtel";+g.3gpp.ics="principal";+g.3gpp.accesstype="cellular1"
    ;expires=600000
CSeq:
Supported: path, outbound
Require: outbound
Date: Wed, 11 July 2001 08:49:37 GMT
P-Associated-URI: <sip:user1_public2@home1.net>, <sip:user1_public3@home1.net>, <sip:+1-212-
    555-1111@home1.net;user=phone>
Content-Length:

```

5-6. SIP 200 (OK) response (I-CSCF to UE)

The I-CSCF forwards the SIP 200 (OK) response to the UE via P-CSCF#1.

7. SIP REGISTER request (S-CSCF to SCC AS)-See example in table A.3.2-7

After UE successfully registered in the IM CN subsystem, the S-CSCF sends a third party REGISTER request to the SCC AS based on the initial filter criteria it received.

Table A.3.2-7: SIP REGISTER request (S-CSCF to SCC AS)

```

REGISTER sip:scas.home1.net /2.0
Via: SIP/2.0/UDP scscf1.home1.net;branch=z9hG499ffhy
Max-Forwards: 70
From: <sip:scscf1.home1.net>; tag=538ya
To: <sip:user1_public1@home1.net>
Call-ID: lasdaddlrffjflslj40a222
P-Access-Network-Info: 3GPP-UTRAN-TDD; utran-cell-id-3gpp=234151D0FCE11
Contact: <sip:scscf1.home1.net>; expires=600000
CSeq: 87 REGISTER
Content-Type: multipart/mixed;boundary="boundary1"
Content-Length: (...)

--boundary1
Content-Type: message/sip

REGISTER sip:registrar.home1.net SIP/2.0
Via: SIP/2.0/UDP pcscf1.visited1.net;branch=z9hG4bK240f34.1, SIP/2.0/UDP
    [5555::aaa:bbb:ccc:ddd]:1357;comp=sigcomp;branch=z9hG4bKnashds7
Max-Forwards: 69
P-Access-Network-Info: 3GPP-UTRAN-TDD; utran-cell-id-3gpp=234151D0FCE11
Path: <sip:VskztcQ/S8p4WPbOnHbuyh5iJvJIW3ib@pcscf1.visited1.net;lr;ob>
Require: path
P-Visited-Network-ID: "Visited Network Number 1"
P-Charging-Vector: icid-value="AyretyU0dm+6O2IrT5tAFrbHLso=023551024"
From: <sip:user1_public1@home1.net>; tag=4fa3
To: <sip:user1_public1@home1.net>
Contact: <sip:[5555::aaa:bbb:ccc:ddd]:1357;comp=sigcomp>; reg-id=1; +sip.instance="<
urn:gsm:imei:90420156-025763-0>"+g.3gpp.icsi-ref="urn%3Aurn-7%3gpp-
service.ims.icsi.mmtel";+g.3gpp.ics="principal";+g.3gpp.accesstype="cellular1";expires=600000
Call-ID: apb03a0s09dkjdfglkj49111
Authorization: Digest username="user1_private@home1.net", realm="registrar.home1.net",
    nonce=base64(RAND + AUTN + server specific data), algorithm=AKAV1-MD5,
    uri="sip:registrar.home1.net", response="6629fae49393a05397450978507c4ef1"
CSeq: 2 REGISTER
Supported: path, outbound, gruu
Content-Length: 0

--boundary1

```

```

Content-Type: message/sip

SIP/2.0 200 OK
Via: SIP/2.0/UDP icscf1_p.home1.net;branch=z9hG4bK351g45.1, SIP/2.0/UDP
pcscf1.visited1.net;branch=z9hG4bK240f34.1, SIP/2.0/UDP
[5555::aaa:bbb:ccc:ddd]:1357;comp=sigcomp;branch=z9hG4bKnashds7
Path: <sip:term@pcscf1.visited1.net;lr;ob>
Service-Route: <sip:orig@scscf1.home1.net;lr>
From: <sip:user1_public1@home1.net>;tag=4fa3
To: <sip:user1_public1@home1.net>;tag=3ec1
Call-ID: apb03a0s09dkjdfglkj49111
Contact: <sip:[5555::aaa:bbb:ccc:ddd]:1357;comp=sigcomp>;
pub-gruu="sip:user1_public1@home1.net;gr=urn:uuid:f81d4fae-7dec-11d0-a765-00a0c91e6bf6"
;temp-gruu="sip:tgruu.7hs==jd7vznzga5w7fajsc7-ajd6fabz0f8g5@example.com;gr"
;+sip.instance="urn:gsma:imei:90420156-025763-0";+g.3gpp.icsi-ref="urn%3Aurn-7%3gpp-
service.ims.icsi.mmtel";+g.3gpp.ics="principal"+g.3gpp.accesstype="cellular1"
;expires=600000
Supported: path, outbound
Require: outbound
Date: Wed, 11 July 2001 08:49:37 GMT
P-Associated-URI: <sip:user1_public2@home1.net>, <sip:user1_public3@home1.net>, <sip:+1-212-555-
1111@home1.net;user=phone>
CSeq: 2 REGISTER
Content-Length: 0

--boundary1--

```

8. SIP 200 OK response (SCC AS to S-CSCF)

The SCC AS generates the SIP 200 (OK) response to the third party SIP REGISTER request.

9. UE connects to a new IP-CAN

The UE connects to a new IP-CAN and will perform the registration via the new IP-CAN.

10. SIP REGISTER request (UE to P-CSCF#2)- See example in table A.3.2-10

UE sends the unprotected SIP REGISTER request via the new IP-CAN to P-CSCF#2 which in this example is a different one with previous registration.

Table A.3.2-10: SIP REGISTER request (UE to P-CSCF#2)

```

REGISTER sip:registrar.home1.net SIP/2.0
Via: SIP/2.0/UDP [5555::aaa:bbb:ccc:eee];comp=sigcomp;branch=z9hG4bKnasiuen8
Max-Forwards: 70
P-Access-Network-Info: IEEE-802.11b
From: <sip:user1_public1@home1.net>;tag=2hiue
To: <sip:user1_public1@home1.net>
Contact: <sip:[5555::aaa:bbb:ccc:eee];comp=sigcomp>; reg-id=2; +sip.instance="urn:gsma:imei:90420156-025763-0";+g.3gpp.icsi-ref="urn%3Aurn-7%3gpp-
service.ims.icsi.mmtel";+g.3gpp.ics="principal";+g.3gpp.accesstype="wlan2";expires=600000
Call-ID: E05133BD26DD
Authorization: Digest username="user1_private@home1.net", realm="registrar.home1.net",
nonce="", uri="sip:registrar.home1.net", response=""
Security-Client: ipsec-3gpp; alg=hmac-sha-1-96; spi-c=23456789; spi-s=12345678; port-c=1234;
port-s=5678
Require: sec-agree
Proxy-Require: sec-agree
CSeq: 1 REGISTER
Supported: path, outbound, gruu
Content-Length: 0

```

11-12. SIP REGISTER request (P-CSCF#2 to S-CSCF)

The P-CSCF forwards the SIP REGISTER request towards S-CSCF via I-CSCF. Likewise in message #2, P-CSCF#2 adds a Path header with flow token and 'ob' parameter.

13-15. SIP 401 (Unauthorized) response (S-CSCF to UE)

The authentication challenge is sent in the SIP 401 (Unauthorized) response towards the UE.

16-18. SIP REGISTER request (UE to S-CSCF)

The UE sends the protected SIP REGISTER request towards S-CSCF using contact#2.

19-21. SIP 200 (OK) response (S-CSCF to UE)

The S-CSCF sends a SIP 200 (OK) response towards the UE indicating that registration was successful.

22. SIP REGISTER request (S-CSCF to SCC AS)

The S-CSCF sends a third party REGISTER request to the SCC AS based on the initial filter criteria it received.

Table A.3.2-22: SIP REGISTER request (S-CSCF to SCC AS)

```

REGISTER sip: sccas.home1.net /2.0
Via: SIP/2.0/UDP scscf1.home1.net;branch=z9hG499ffhy
Max-Forwards: 70
From: <sip:scscf1.home1.net>; tag=538ya
To: <sip:user1_public1@home1.net>
P-Access-Network-Info: IEEE-802.11b
Call-ID: lasdaddlrffjflslj40a222
Contact: <sip:scscf1.home1.net>; expires=600000
CSeq: 87 REGISTER
Content-Type: multipart/mixed;boundary="boundary1"
Content-Length: (...)

--boundary1
Content-Type: message/sip

REGISTER sip:registrar.home1.net SIP/2.0
Via: SIP/2.0/UDP pcscf1.visited1.net;branch=z9hG4bK240f34.1, SIP/2.0/UDP
[5555::aaa:bbb:ccc:eee]:1357;comp=sigcomp;branch=z9hG4bKnashds7
Max-Forwards: 69
P-Access-Network-Info: IEEE-802.11b
Path: <sip:VskztcQ/S8p4WPbOnHbuyh5iJvJIW3ib@pcscf1.visited1.net;lr;ob>
Require: path
P-Visited-Network-ID: "Visited Network Number 1"
P-Charging-Vector: icid-value="AyretyU0dm+602IrT5tAFrbHLso=023551024"
From: <sip:user1_public1@home1.net>;tag=2hiue
To: <sip:user1_public1@home1.net>
Contact: <sip:[5555::aaa:bbb:ccc:eee];comp=sigcomp>;reg-id=2;+sip.instance="urn:gsm:imei:90420156-025763-0";+g.3gpp.icsi-ref="urn%3Aurn-7%3gpp-service.ims.icsi.mmtel";+g.3gpp.ics="principal";+g.3gpp.accesstype="wlan2";expires=600000
Call-ID: apb03a0s09dkjdfglkj49111
Authorization: Digest username="user1_private@home1.net", realm="registrar.home1.net",
nonce=base64(RAND + AUTN + server specific data), algorithm=AKAv1-MD5,
uri="sip:registrar.home1.net", response="6629fae49393a05397450978507c4ef1"
CSeq: 3 REGISTER
Supported: path, outbound, gruu
Content-Length: 0

--boundary1
Content-Type: message/sip

SIP/2.0 200 OK
Via: SIP/2.0/UDP icscf1_p.home1.net;branch=z9hG4bK351g45.1, SIP/2.0/UDP
pcscf1.visited1.net;branch=z9hG4bK240f34.1, SIP/2.0/UDP
[5555::aaa:bbb:ccc:eee]:1357;comp=sigcomp;branch=z9hG4bKnashds7
Path: <sip:term@pcscf1.visited1.net;lr;ob>
Service-Route: <sip:orig@scscf1.home1.net;lr>
From: <sip:user1_public1@home1.net>;tag=2hiue
To: <sip:user1_public1@home1.net>;tag=2da87
Call-ID: apb03a0s09dkjdfglkj49111
Contact: <sip:[5555::aaa:bbb:ccc:ddd]:1357;comp=sigcomp>;
pub-gruu="sip:user1_public1@home1.net;gr=urn:uuid:f81d4fae-7dec-11d0-a765-00a0c91e6bf6"
;temp-gruu="sip:tgruu.7hs==jd7vnzga5w7fajsc7-ajd6fabz0f8g5@example.com;gr"
;+sip.instance="urn:gsm:imei:90420156-025763-0";+g.3gpp.icsi-ref="urn%3Aurn-7%3gpp-service.ims.icsi.mmtel";+g.3gpp.ics="principal";+g.3gpp.accesstype="wlan2"
;expires=600000
Supported: path, outbound
Require: outbound
Date: Wed, 11 July 2001 08:49:37 GMT
P-Associated-URI: <sip:user1_public2@home1.net>, <sip:user1_public3@home1.net>, <sip:+1-212-555-1111@home1.net;user=phone>
CSeq: 3 REGISTER

```

```
Content-Length: 0
```

```
--boundary1--
```

23. SIP 200 (OK) response (SCC AS to S-CSCF)

The SCC AS generates the SIP 200 response to the third party REGISTER request.

A.4 Signalling flows for call origination

A.4.1 Session origination for CS calls

An example flow for session origination for CS calls can be found in 3GPP TS 24.292 [4].

A.5 Signalling flows for call termination

A.5.1 Session termination using CS media

An example flow for session termination using CS calls can be found in 3GPP TS 24.292 [4].

A.6 Signalling flows for PS-CS session continuity

A.6.1 PS-CS access transfer: CS-PS

In this example, SC UE A has an ongoing session with remote UE B over CS bearer before access transfer. When SC UE connects to an IP-CAN, it decides to transfer the session over the new IP-CAN.

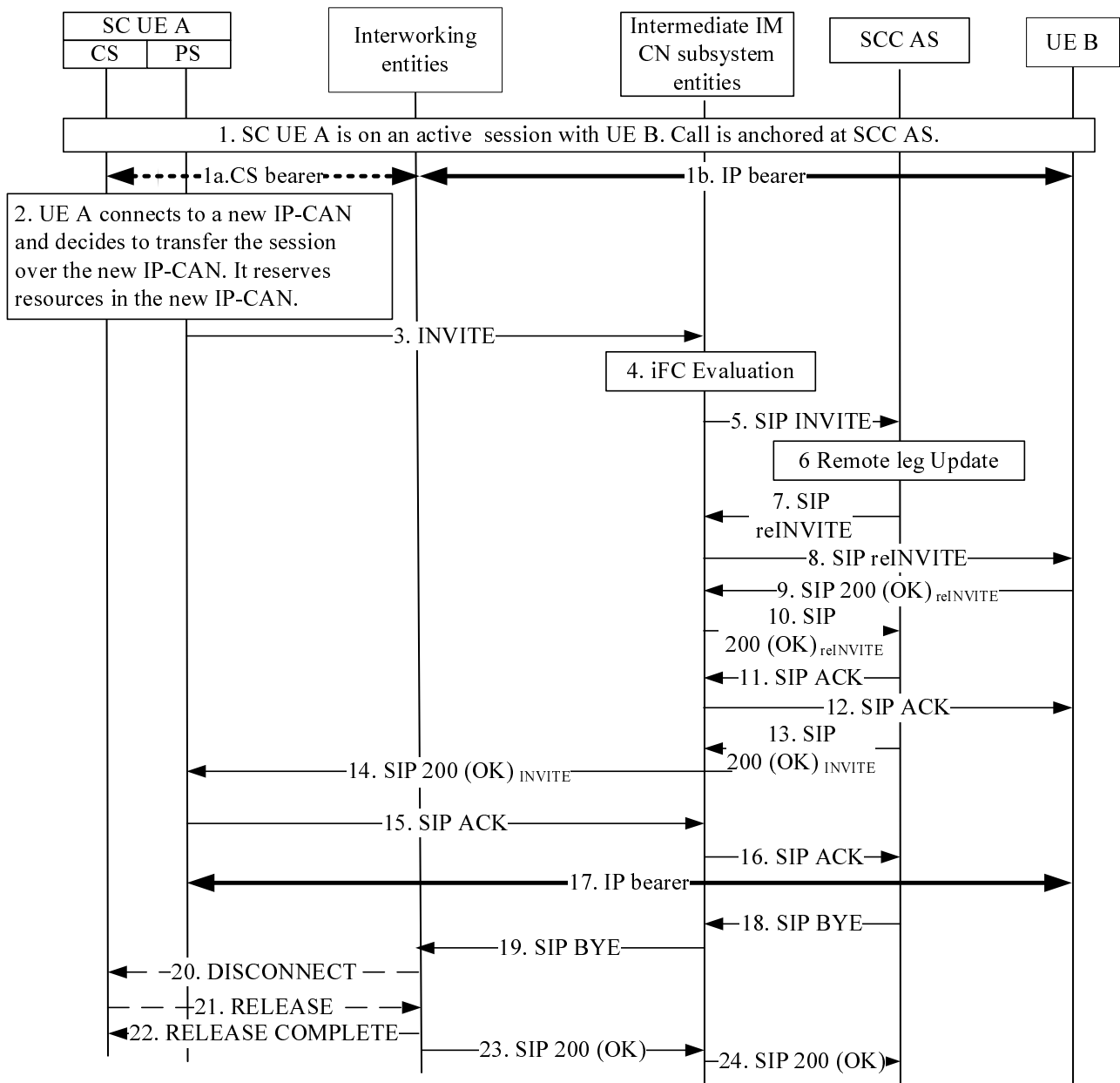

Figure A.6.1-1: Signalling flow for PS-CS Access Transfer: CS to PS

NOTE 1: For clarity, the SIP 100 (Trying) responses are not shown in the signalling flow.

1. SC UE A has an ongoing session with remote UE B

The call has been anchored at the SCC AS which is in the HPLMN of originating SC UE A.

2. SC UE A connects to a new IP-CAN:

The SC UE A decides to transfer the session over the new IP-CAN. The UE A obtains an IP address that it will use for the signalling and media. It registers with the S-CSCF over the new IP-CAN using standard registration procedure and reserves resources in the new IP-CAN.

3. SIP INVITE request (SC UE A to intermediate IM CN subsystem entities) - see example in table A.6.1-3

The SC UE A sends an initial INVITE request to request the new call replaces the existing call.

Table A.6.1-3: SIP INVITE request (UE A to intermediate IM CN subsystem entities)

```

INVITE sip:domain.xfer@scas.home1.net SIP/2.0
Via: SIP/2.0/UDP [5555::aaa:bbb:ccc:ddd]:1357;comp=sigcomp;branch=z9hG4bKnashds7
Max-Forwards: 70
Route: <sip:pcscf1.home1.net:7531;lr >, <sip:orig@scscf1.home1.net;lr>
P-Preferred-Identity: "John Doe" <sip:user1_public1@home1.net>
P-Access-Network-Info: IEEE-802.11b
Privacy: none
From: <sip:user1_public1@home1.net>; tag=171828
To: <tel:+1-237-555-2222>
Call-ID: cb03a0s09a2sdfglkj490237
Cseq: 127 INVITE
Supported: 100rel; precondition
Require: sec-agree
Proxy-Require: sec-agree
Security-Verify: ipsec-3gpp; q=0.1; alg=hmac-sha-1-96; spi=87654321; port1=7531
Contact: <sip:user1_public1@home1.net;gr= urn:uuid:f81d4fae-7dec-11d0-a765-00a0c91e6bf6>;+g.3gpp.icsi-ref="urn%3Aurn-7%3gpp-service.ims.icsi.mmstel";+g.3gpp.ics="principal";
Allow: INVITE, ACK, CANCEL, BYE, PRACK, UPDATE
Accept: application/sdp; application/3gpp-ims+xml
Content-Type: application/sdp
Content-Length: (...)

v=0
o=- 2987933615 2987933615 IN IP6 5555::aaa:bbb:ccc:ddd
s=
c=IN IP6 5555::aaa:bbb:ccc:ddd
t=0 0
m=audio 3456 RTP/AVP 97 96
b=AS:25.4
a=crr:qos local sendrecv
a=crr:qos remote none
a=des:qos mandatory local sendrecv
a=des:qos none remote sendrecv
a=rtmap:97 AMR
a=fmtp:97 mode-set=0,2,5,7; mode-change-period=2
a=rtmap:96 telephone-event
a=maxptime:20

```

4. Evaluation of initial filter criteria

The S-CSCF evaluates initial filter criteria for the served SC user and as a result routes the SIP INVITE request towards the SCC AS.

5. SIP INVITE request (intermediate IM CN subsystem entities to SCC AS)

The SIP INVITE request is forwarded to the SCC AS as the result of the evaluation of iFC.

6. Remote Leg Update

The SCC AS performs the Remote Leg update by sending the SIP re-INVITE request towards the Remote Leg.

7. SIP re-INVITE request (SCC AS to intermediate IM CN subsystem entities)- See example in table A.6.1-7

The SCC AS modifies the message in accordance with routing B2BUA functionality, e.g. mapping of From, To, Cseq and Call-ID headers from one side of the B2BUA to the other. In this example the SCC AS includes the contents of the Contact header from the received SIP INVITE request. The SIP re-INVITE request contains the SDP offer that is identical to the SDP offer that the SCC AS received in the initial SIP INVITE request from the UE A (Step 3).

Table A.6.1-7: SIP re-INVITE request (SCC AS to intermediate IM CN subsystem entities)

```

INVITE < sip:user1_public1@home1.net;gr=urn:uuid:f81d4fae-7dec-11d0-a765-00a0c91e6bf6> SIP/2.0
Via: SIP/2.0/UDP sccas.home1.net; branch=z9hG4bK332b33.3;
Max-Forwards: 67
Route: <scscf1.home1.net;lr >, <sip:scscf2.home2.net;lr>, <sip:pcscf2.visited2.net;lr>
P-Asserted-Identity: "John Doe" <sip:user1_public1@home1.net>, <tel:+1-237-555-1111>
P-Access-Network-Info: IEEE-802.11b
Privacy: none
P-Charging-Vector: icid-value="AyretyU0dm+6O2Irt5tAFrbHLso=023551024"
P-Charging-Function-Addresses:
From: <sip:user1_public1@home1.net>; tag=1717777
To: <tel:+1-237-555-2222>, tag=4321
Call-ID: dc14b1t10b3teghmlk5013237
Cseq: 111 INVITE
Supported: precondition, 100rel
Contact: <sip:user2_public1@home2.net;gr=urn:uuid:2ad8950e-48a5-4a74-8d99-
ad76cc7fc74>;+g.3gpp.icsi-ref="urn%3Aurn-7%3gpp-service.ims.icsi.mmtel"
Allow: INVITE, ACK, CANCEL, BYE, PRACK, UPDATE
Accept: application/sdp
Content-Type: application/sdp
Content-Length: (...)

v=0
o=- 2987933615 2987933615 IN IP6 5555::aaa:bbb:ccc:ddd
s=
c=IN IP6 5555::aaa:bbb:ccc:ddd
t=0 0
m=audio 3456 RTP/AVP 97 96
b=AS:25.4
a=crr:qos local sendrecv
a=crr:qos remote none
a=des:qos mandatory local sendrecv
a=des:qos none remote sendrecv
a=rtpmap:97 AMR
a=fmtp:97 mode-set=0,2,5,7; mode-change-period=2
a=rtpmap:96 telephone-event
a=maxptime:20

```

8. SIP re-INVITE request (Intermediate IM CN subsystem entities to UE B)

The intermediate IM CN subsystem entities forward the SIP re-INVITE request to remote UE B.

9-10: SIP 200 (OK) response (UE B to SCC AS via Intermediate IM CN subsystem entities)

The UE B generates the SIP 200 (OK) response to the SIP re-INVITE request and forwards it to the SCC AS.

11-12: SIP ACK request (SCC AS to UE B via Intermediate IM CN subsystem entities)

The SCC AS generates the SIP ACK request to the SIP 200 (OK) response and forwards it to the remote UE B.

13-14: SIP 200 (OK) response (SCC AS to UE A via Intermediate IM CN subsystem entities)

The SCC AS generates the SIP 200 (OK) response to the SIP INVITE request and forwards it to the SC UE A.

15-16: SIP ACK request (SC UE A to SCC AS via Intermediate IM CN subsystem entities)

The SC UE A generates the SIP ACK request to the SIP 200 (OK) response and forwards it to the SCC AS

17. Media paths between UE A and UE B

The media path is using the new IP-CAN.

18-19. SIP BYE request (SCC AS to interworking entities via intermediate IM CN subsystem entities)

The SCC AS terminates the replaced call leg, which was using the CS bearer, by sending a BYE request.

20-22. ISUP Message

Upon receiving the DISCONNECT request, the SC UE A relinquishes all resources pertaining to the CS bearer.

23-24. SIP 200 (OK) response (Interworking entities to SCC AS via intermediate IM CN subsystem entities)

A.6.2 PS-CS access transfer: PS-CS

In this example, SC UE A has an ongoing session with remote UE B over PS bearer before access transfer which is anchored at SCC AS. When the SC UE attaches to the CS domain, it decides to transfer the session over the CS bearer without ICS capability.

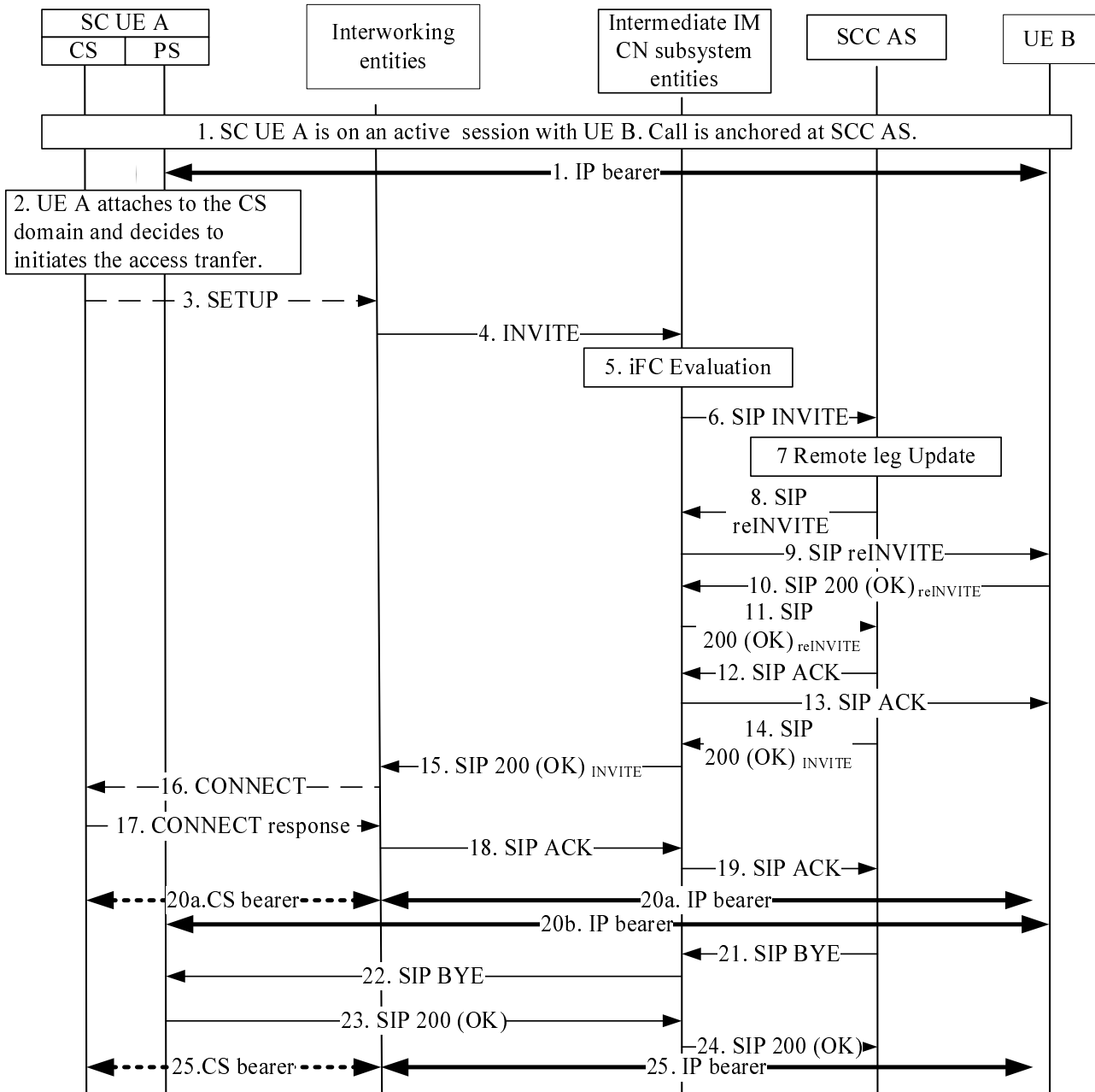

Figure A.6.2-1 Signalling flow for PS-CS access transfer: PS-CS

NOTE 1: For clarity, the SIP 100 (Trying) responses are not shown in the signalling flow.

1. SC UE A is on an active session with UE B:

There is an ongoing IP bearer between the SC UE and the remote end UE B. The call is anchored at SCC AS.

2. SC UE A attaches to the CS domain

The SC UE attaches to the CS domain and decides to transfer the session over the CS bearer.

3. CC SETUP messages

The SC UE sends the CS SETUP message with the static STN as the called party number.

4. SIP INVITE request (Interworking entities to Intermediate IM CN subsystem entities) -see example in table A.6.2-4

Table A.6.2-4: SIP INVITE request (interworking entities to intermediate IM CN subsystem entities)

```
INVITE tel: +1-237-555-3333 SIP/2.0
Via: SIP/2.0/UDP mgcf1.home1.net;branch=z9hG4bk731b87
Max-Forwards: 70
Route: <sip:icscf1.home1.net;lr>
P-Asserted-Identity: <tel: +1-237-555-1111>
P-Charging-Vector: icid-value="AyretyU0dm+6O2IrT5tAFrbHLso=023551024"; orig-ioi=home1.net
Privacy: none
From: <tel: +1-237-555-1111>;tag=171828
To: <tel: +1-237-555-3333>
Call-ID: cb03a0s09a2sdfglkj490333
Cseq: 127 INVITE
Supported: 100rel, precondition
Accept-Contact: *;+g.3gpp.icsi-ref="urn:urn-7:3gpp-service.ims.icsi.mmmtel"
P-Asserted-Service: urn:urn-7:3gpp-service.ims.icsi.mmmtel
Contact: <sip:mgcf1.home1.net;gr>;+g.3gpp.icsi-ref="urn:urn-7:3gpp-service.ims.icsi.mmmtel"
Allow: INVITE, ACK, CANCEL, BYE, PRACK, UPDATE, REFER, MESSAGE
Content-Type: application/sdp
Content-Length: (...)

v=0
o=- 2987933615 2987933615 IN IP6 5555::aaa:bbb:ccc:eee
s=
c=IN IP6 5555::aaa:bbb:ccc:eee
t=0 0
m=audio 3456 RTP/AVP 97 96
a=tcap:1 RTP/AVPF
a=pcfg:1 t=1
b=AS:25.4
a=curr:qos local sendrecv
a=curr:qos remote none
a=des:qos mandatory local sendrecv
a=des:qos none remote sendrecv
a=rtpmap:97 AMR
a=fmtp:97 mode-set=0,2,5,7; mode-change-period=2
a=rtpmap:96 telephone-event
a=maxptime:20
```

Request-URI: contains the IMRN, as obtained from CS networks signalling.

SDP: The SDP contains preconfigured set of codecs supported by the MGW.

5. Evaluation of initial filter criteria

The S-CSCF evaluates initial filter criteria for the served SC user and as a result routes the SIP INVITE request towards the SCC AS.

6. SIP INVITE request (Intermediate IM CN subsystem entities to SCC AS)

7. Remote Leg Update

The SCC AS performs the Remote Leg update by sending the SIP re-INVITE request towards the Remote Leg.

8. SIP re-INVITE request (SCC AS to intermediate IM CN subsystem entities) –see example in table A.6.2-8

The SCC AS acting as a routing B2BUA generates a SIP INVITE request based upon the received SIP INVITE request and the information previously stored against this session and routes it towards UE B via the intermediate IM CN subsystem entities.

Table A.6.2-8: SIP re-INVITE request (SCC AS to intermediate IM CN subsystem entities)

```

INVITE sip:user2_public1@home2.net;gr=urn:uuid:2ad8950e-48a5-4a74-8d99-ad76cc7fc74 SIP/2.0
Via: SIP/2.0/UDP sccas1.home1.net;branch=z9hG4bKnas34r5
Max-Forwards: 67
Route: <sip:scscf1.home1.net:lr>
P-Asserted-Identity: <tel: +1-237-555-1111>
P-Charging-Function-Addresses: ccf=[5555::b99:c88:d77:e66]; ccf=[5555::a55:b44:c33:d22];
    ecf=[5555::1ff:2ee:3dd:4ee]; ecf=[5555::6aa:7bb:8cc:9dd]
P-Charging-Vector: icid-value="BzyretyU0dm+602IrT5tAFrbHLso=023551034"; orig-
    ioi="type3home1.net"
Privacy: none
From: <tel: +1-237-555-1111>;tag=569812
To: <tel:+1-237-555-2222>;tag=26545
Call-ID: dd13a0s09a2sdfglkj490378
Cseq:
Contact: <sip:user1_public1@home1.net;gr=urn:uuid:f81d4fae-7dec-11d0-a765-
    00a0c91e6bf6>;+g.3gpp.icsi-ref="urn%3Aurn-7%3gpp-service.ims.icsi.mmtel"
Allow:
Content-Type: Content-Length:

v=0
o=- 2987933615 2987933615 IN IP6 5555::aaa:bbb:ccc:eee
s=
c=IN IP6 5555::aaa:bbb:ccc:eee
t=0 0
m=audio 3456 RTP/AVPF 97 96
b=AS:25.4
a=curr:qos local sendrecv
a=curr:qos remote none
a=des:qos mandatory local sendrecv
a=des:qos none remote sendrecv
a=rtpmap:97 AMR
a=fmtp:97 mode-set=0,2,5,7; mode-change-period=2
a=rtpmap:96 telephone-event
a=maxptime:20
m=message 0 TCP/MSRP 98
a=accept-types:text/plain

```

9. SIP re-INVITE request (Intermediate IM CN subsystem entities to UE B)

Intermediate IM CN subsystem entities forward the SIP re-INVITE request to remote UE B.

10. SIP 200 (OK) response (UE B to intermediate IM CN subsystem entities)

Upon receiving the SIP re-INVITE request containing the SDP offer, since the UE B has all resources available, it sends immediately the SIP 200 (OK) response to the SIP re-INVITE request that contains the SDP answer. The SDP answer indicates that the resources are available.

11. SIP 200 (OK) response (intermediate IM CN subsystem entities to SCC AS)

The intermediate IM CN subsystem entities forward the SIP 200 (OK) response to the SIP re-INVITE request to the SCC AS in the originating network.

12-13. SIP ACK request (SCC AS to UE B via IM CN subsystem entities)

The SCC AS generates the SIP ACK request to the SIP 200 (OK) response, and forwards the SIP ACK request to the remote UE B.

14-15. SIP 200 (OK) response (SCC AS to interworking entities via IM CN subsystem entities)

The SCC AS generates the SIP 200 (OK) response to the SIP INVITE request, and forwards the SIP 200 (OK) response to the interworking entities.

16. ISUP CONNECT message (interworking entities to SC UE A)**17. ISUP CONNECT Response message (SC UE A to interworking entities)****18-19. SIP ACK request (interworking entities to SCC AS via IM CN subsystem entities)**

The interworking entities generate the SIP ACK request to the SIP 200 (OK) response, and forward it to the SCC AS.

20. Media paths between SC UE A and UE B:

The CS bearer is setup while the PS bearer is still existing.

21-22: SIP BYE request (SCC AS to SC UE A via intermediate IM CN subsystem entities)

The SCC AS terminates the replaced call leg, which was using the old IP-CAN, by sending a BYE request to the UE A.

23-24. SIP 200 (OK) response (SC UE A to SCC AS via intermediate IM CN subsystem entities)

Upon receiving the BYE request over the old IP-CAN, the SC UE A sends a SIP 200 (OK) response over the old IP-CAN to the SCC AS. Subsequently, the SC UE A relinquishes all resources pertaining to the old IP-CAN.

25. Media paths between SC UE A and UE B

Finally, the session is transferred from PS bearer to CS bearer.

A.7 Signalling flows for PS-PS session continuity

A.7.1 Introduction

The signalling flows for PS-PS access transfer demonstrate how a multimedia session is transferred from Source Access Leg to the Target Access Leg. The following signalling flows are included:

- subclause A.7.2 shows an example when all media of an ongoing communication session and the associated signalling are transferred from Source Access Leg to the Target Access Leg; and
- subclause A.7.3 shows an example when not all media of an ongoing communication session are transferred from the Source Access Leg to the Target Access Leg.

A.7.2 PS-PS access transfer with full media transfer

The signalling flows shown in figure A.7.2-1 describes the PS-PS access transfer procedure when all media of an ongoing communication session and the associated signalling are transferred from one contact address of an UE to a different contact address of the same UE. No lower-level mechanism to support the session continuity is assumed or need.

In this example the UE-1 is on an active multimedia session with the UE-2 via one IP-CAN. After changing to a new IP-CAN, obtaining a new IP address, and discovering a P-CSCF, the UE-1 reserves resources in new IP-CAN prior to initiating the PS-PS access transfer procedure. When the PS-PS access transfer procedure is completed, the UE-1 continues the multimedia session with the UE-2 on the new IP-CAN. In this example, when attaching to the new IP-CAN, it is irrelevant whether the UE-1 uses the same P-CSCF or a new P-CSCF.

NOTE 1: This scenario requires that the UE-1 and the IMS network support simultaneous multiple registrations and requires that the UE-1 supports dual mode operation.

NOTE 2: In this example flow, each call leg is uniquely identified with a respective dialog identifier consisting of the Call-ID, From tag, and To tag.

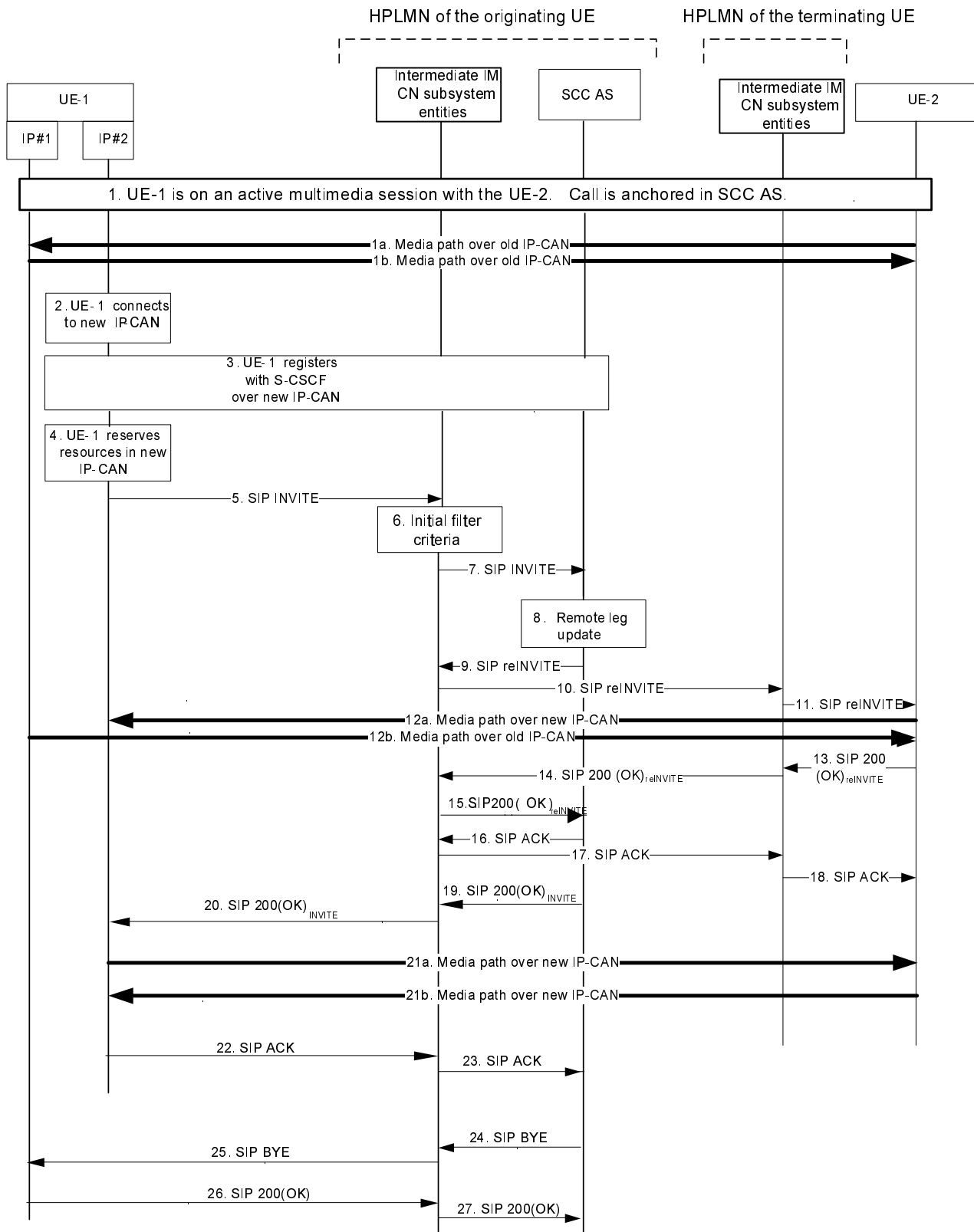

Figure A.7.2-1: Signalling flow for session handover

NOTE 3: For clarity, the SIP 100 (Trying) responses are not shown in the signalling flow.

1. UE-1 is on an active session with UE-2

The UE-1 is in an active session with the UE-2. The call is anchored in the SCC AS. It is irrelevant which endpoint initiated the call. Each call leg is uniquely identified with a respective dialog identifier. The call leg

over old IP-CAN is identified with "Call-ID= me03a0s09a2sdfgjk1491777", "From tag=64727891", and "To tag=774321". The UE-1 and UE-2 exchange media over the old IP-CAN, which is maintained while the UE-1 initiates the handover procedure.

2. UE-1 connects to new IP-CAN

The UE-1 determines that a handover of the session is required. The UE-1 connects to the new IP-CAN. The UE-1 obtains an IP address that it will use for the signalling and media.

3. UE-1 registers with intermediate IM CN subsystem entities over new IP-CAN

The UE-1 registers with the S-CSCF over the new IP-CAN using the standard registration procedure. Depending on the UE-1 configuration, the discovery of the P-CSCF in the new IP-CAN may be needed.

4. UE-1 acquires resources in new IP-CAN

Based on the UE-1 and new IP-CAN capabilities, the UE-1 decides to use the same codec that was used over the old IP-CAN. The UE-1 reserves resources (e.g. QoS) in the new IP-CAN that will be needed for the signalling and transferred media, prior to sending the initial SIP INVITE request.

5. SIP INVITE request (UE-1 to intermediate IM CN subsystem entities) - see example in table A.7.2-5

The UE-1 sends initial SIP INVITE request with a new SDP offer to the UE-2 that indicates that the new call replaces the existing call. The initial SIP INVITE request establishes a dialog for signalling and specifies in the SDP the new contact address that will be used for media over the new IP-CAN. Upon sending the initial SIP INVITE request, the UE-1 is ready to receive the RTP packets either over the new IP-CAN or the old IP-CAN. The RTP packets may arrive over the new IP-CAN prior to the UE-1 receiving the SIP 200 (OK) response for the initial SIP INVITE request.

Table A.7.2-5: SIP INVITE request (UE-1 to intermediate IM CN subsystem entities)

```
INVITE tel:+1-212-555-2222 SIP/2.0
Via: SIP/2.0/UDP [5555::aaa:bbb:ccc:ddd]:1357;comp=sigcomp;branch=z9hG4bKnashds7
Max-Forwards: 70
Route: <sip:pcscf1.home1.net:7531;lr;comp=sigcomp>, <sip:orig@scscf1.home1.net;lr>
P-Preferred-Identity: "John Doe" <sip:user1_public1@home1.net>
P-Access-Network-Info: IEEE-802.11b
Privacy: none
From: <sip:user1_public1@home1.net>; tag=171828
To: <tel:+1-212-555-2222>
Call-ID: cb03a0s09a2sdfgjk1490333
Cseq: 127 INVITE
Supported: 100rel; precondition
Require: sec-agree; replaces
Replaces: me03a0s09a2sdfgjk1491777; to-tag=774321; from-tag=64727891
Proxy-Require: sec-agree
Security-Verify: ipsec-3gpp; q=0.1; alg= hmac-sha-1-96; spi=87654321; port1=7531
Contact: <sip:user1_public1@home1.net;gr=urn:uuid:f81d4fae-7dec-11d0-a765-00a0c91e6bf6>;+g.3gpp.icsi-ref="urn:3Aurn-7%3gpp-service.ims.icsi.mmtel";+g.3gpp.ics="principal"
Allow: INVITE, ACK, CANCEL, BYE, PRACK, UPDATE
Accept: application/sdp; application/3gpp-ims+xml
Content-Type: application/sdp
Content-Length: (...)

v=0
o=- 2987933615 2987933615 IN IP6 5555::aaa:bbb:ccc:ddd
s=-
c=IN IP6 5555::aaa:bbb:ccc:ddd
t=0 0
m=audio 3456 RTP/AVP 97 96
b=AS:25.4
a=curr:qos local sendrecv
a=curr:qos remote none
a=des:qos mandatory local sendrecv
a=des:qos none remote sendrecv
a=rtpmap:97 AMR
a=fmtp:97 mode-set=0,2,5,7; mode-change-period=2
a=rtpmap:96 telephone-event
a=maxptime:20
```

Request-URI: the tel-URI of the destination, i.e. the UE-2.

Require: the "replaces" option tag indicate that the support for Replace header is required.

Replaces: specifies the existing call that will be replaced with the new call.

SDP: specifies the new IP address that the UE-1 has acquired in the new IP-CAN, and indicates that the resources in the new IP-CAN have been acquired.

6. Evaluation of initial filter criteria

Upon the evaluation of the initial filter criteria, as this is an originating initial SIP INVITE request for a registered user, the S-CSCF routes the initial SIP INVITE request to the SCC AS.

7. SIP INVITE request (intermediate IM CN subsystem entities to SCC AS) - see example in table A.7.2-7

The initial INVITE request is forwarded from intermediate IM CN subsystem entities in the home network to the SCC AS. The SCC AS acts as a routing B2BUA as specified in 3GPP TS 24.229 [2]. In this example the SCC AS includes the contents of the Contact header from the received SIP INVITE request.

Table A.7.2-7: SIP INVITE request (intermediate IM CN subsystem entities to SCC AS)

```
INVITE tel:+1-212-555-2222 SIP/2.0
Via: SIP/2.0/UDP scscf1.home1.net;branch=z9hG4bK332b23.1, SIP/2.0/UDP
    pcscf1.home1.net;branch=z9hG4bK240f34.1, SIP/2.0/UDP
    [5555::aaa:bbb:ccc:ddd]:1357;comp=sigcomp;branch=z9hG4bKnashds7
Max-Forwards: 67
Route: <sip:sccas.home1.net;lr>
Record-Route: <sip:scscf1.home1.net;lr>, <sip:pcscf1.home1.net;lr>
P-Asserted-Identity: "John Doe" <sip:user1_public1@home1.net>, <tel:+1-212-555-1111>
P-Access-Network-Info:Privacy:Require: replaces
P-Charging-Vector: icid-value="AyretyU0dm+6O2IrT5tAFrbHLso=023551024";orig-
    ioi=type3ashome1.net>
P-Charging-Function-Addresses: ccf=[5555::b99:c88:d77:e66]; ccf=[5555::a55:b44:c33:d22];
    ecf=[5555::1ff:2ee:3dd:4ee]; ecf=[5555::6aa:7bb:8cc:9dd]
From: <sip:user1_public1@home1.net>; tag=171828
To: <tel:+1-212-555-2222>
Call-ID:
Cseq:
Supported:Replaces:Contact:
Allow:Accept:Content-Type:
Content-Length: (...)

v=
o=
s=
c=
t=0 0
m=
b=
a=
a=
a=
a=
a=
a=
a=
a=
```

8. Remote leg update

The SCC AS based on the content of the Replaces header correlates the initial SIP INVITE request to the existing local and remote call legs of the existing concatenated end to end session between the UE-1 and UE-2. The SCC AS updates the remote call leg by sending a SIP re-INVITE request to the UE-2 containing the new SDP offer that it has received from the UE-1.

9. SIP re-INVITE request (SCC AS to intermediate IM CN subsystem entities) - see example in table A.7.2-9

The UE-2 is informed of the change in access leg by the SCC AS sending a SIP re-INVITE request to the S-CSCF.

The SCC AS modifies the message in accordance with routing B2BUA functionality, e.g. mapping of From, To, Cseq and Call-ID headers from one side of the B2BUA to the other. In this example the SCC AS includes the contents of the Contact header from the received SIP INVITE request. The SIP re-INVITE request contains the SDP offer that is identical to the SDP offer that the SCC AS received in the initial SIP INVITE request from the UE-1 (Step 5).

Table A.7.2-9: SIP re-INVITE request (SCC AS to intermediate IM CN subsystem entities)

```
INVITE < sip:user2_public1@home2.net;gr=urn:uuid:2ad8950e-48a5-4a74-8d99-ad76cc7fc74> SIP/2.0
Via: SIP/2.0/UDP sccas.home1.net; branch=z9hG4bK332b33.3;
Max-Forwards: 67
Route: <scscf1.home1.net;lr>, <sip:scscf2.home2.net;lr>, <sip:pcscf2.visited2.net;lr>
P-Asserted-Identity:P-Access-Network-Info:Privacy:P-Charging-Vector: icid-
  value="BzyretyU0dm+6O2Irt5tAFrbHLso=023551034 "
P-Charging-Function-Addresses:
From: <sip:user1_public1@home1.net>; tag=1717777
To: <tel:+1-212-555-2222>, tag=4321
Call-ID: dc14b1t10b3teghmlk5013333
Cseq: 111 INVITE
Supported:
Contact: < sip:user1_public1@home1.net;gr=urn:uuid:f81d4fae-7dec-11d0-a765-
  00a0c91e6bf6>;+g.3gpp.icsi-ref="urn%3Aurn-7%3gpp-service.ims.icsi.mmtel"
Allow: Accept: application/sdp
Content-Type:
Content-Length: (...)

v=0
o=2987933615 2987933615 IN IP6 5555::aaa:bbb:ccc:ddd
s=-
c= IN IP6 5555::aaa:bbb:ccc:ddd
t=0 0
m=audio 3456 RTP/AVP 97 96
b=AS:25.4
a= curr:qos local sendrecv
a= curr:qos remote none
a= des:qos mandatory local sendrecv
a= des:qos none remote sendrecv
a= rtpmap:97 AMR
a= fmp:97 mode-set=0,2,5,7; mode-change-period=2
a= rtpmap:96 telephone-event
a= maxptime:20
```

Route: The SIP re-INVITE request contains the saved list of Route headers that the SCC AS has saved for the remote leg of the call.

10. SIP re-INVITE request (intermediate IM CN subsystem entities to intermediate IM CN subsystem entities) - see example in table A.7.2-10

In the originating network, the intermediate IM CN subsystem entities forward the SIP re-INVITE request to the intermediate IM CN subsystem entities in the terminating network.

Table A.7.2-10: SIP re-INVITE request (intermediate IM CN subsystem entities to intermediate IM CN subsystem entities)

```

INVITE < sip:user2_public1@home2.net;gr=urn:uuid:2ad8950e-48a5-4a74-8d99-ad76cc7fc74> SIP/2.0
Via: SIP/2.0/UDP scscf1.home1.net;branch=z9hG4bK240f34.1, SIP/2.0/UDP sccas.home1.net;
    branch=z9hG4bK332b33.3;
Max-Forwards: 66
Route: <sip:scscf2.home2.net;lr>, <sip:pcscf2.visited2.net;lr>
P-Asserted-Identity:
Privacy: none
From:
To:
Call-ID:
Cseq:Supported:Contact: <sip:user1_public1@home1.net;gr=urn:uuid:f81d4fae-7dec-11d0-a765-
    00a0c91e6bf6>;+g.3gpp.icsi-ref="urn%3Aurn-7%3gpp-service.ims.icsi.mmtel"
Allow:
Accept:
Content-TypeContent-Length:

v=
o=
s=-
c=
t=
m=
b=
a=
a=
a=
a=
a=
a=
a=

```

11. SIP re-INVITE request (intermediate IM CN subsystem entities to UE-2)

In the terminating network, the SIP re-INVITE request is forwarded towards the UE-2 by the intermediate IM CN subsystem entities.

12. Media paths between UE-1 and UE-2

The UE-2 receives the SIP re-INVITE request containing the SDP offer that indicates that the UE-1 is ready to receive the same media on a different contact address. Since the UE-2 has resources already available, it starts to send the media to the UE-1's contact address specified in the SDP offer immediately.

The UE-1 will be receiving the RTP packets over new IP-CAN. However, the UE-1 can receive some out-of-sequence RTP packets over the old IP-CAN. The RTP packets are delivered to the codec in sequence. Once the UE-1 determine that no media will be received over the old IP-CAN (e.g. by examining the sequence numbers in the RTP headers), it can relinquish the resources that it has been using for incoming media on the old IP-CAN.

The UE-1 sends the media to the UE-2 over the old IP-CAN.

Resources used for signalling on the old IP-CAN are not released.

13. SIP 200 (OK) response (UE-2 to intermediate IM CN subsystem entities)

Upon receiving the SIP re-INVITE request containing the SDP offer, since the UE-2 has all resources available, it sends immediately the SIP 200 (OK) response to the SIP re-INVITE request that contains the SDP answer. The SDP answer indicates that the resources are available.

14. SIP 200 (OK) response (intermediate IM CN subsystem entities to intermediate IM CN subsystem entities)

In the terminating network, the intermediate IM CN subsystem entities forward the SIP 200 (OK) response to the SIP re-INVITE request to the intermediate IM CN subsystem entities in the originating network.

15. SIP 200 (OK) response (intermediate IM CN subsystem entities to SCC AS)

The intermediate IM CN subsystem entities in the originating network forward SIP the 200 (OK) response to the SIP re-INVITE request to the SCC AS.

16. SIP ACK request (SCC AS to intermediate IM CN subsystem entities)

The SCC AS acting as a B2BUA acknowledges the receipt of the SIP 200 (OK) response to the SIP re-INVITE request by forwards a SIP ACK request to the intermediate IM CN subsystem entities.

17. SIP ACK request (intermediate IM CN subsystem entities to intermediate IM CN subsystem entities)

In the originating network, the intermediate IM CN subsystem entities forward the SIP ACK request to the intermediate IM CN subsystem entities in the terminating network.

18. SIP ACK request (intermediate IM CN subsystem entities to UE-2)

In the terminating network, the intermediate IM CN subsystem entities forward the SIP ACK request to the UE-2.

19. SIP 200 (OK) response (SCC AS to intermediate IM CN subsystem entities)

The SCC AS forwards the SIP 200 (OK) response to the initial SIP INVITE request to the intermediate IM CN subsystem entities, using the content of the Via header that was received in the initial INVITE request (step 5).

The SCC AS modifies the message in accordance with routing B2BUA functionality, e.g. mapping of From, To, Cseq and Call-ID headers from one side of the B2BUA to the other. The SIP 200 (OK) response to the initial SIP INVITE request contains the SDP answer that is identical to the SDP answer that the SCC AS has received in the SIP 200 (OK) response to SIP re-INVITE request from the UE-2 (Step 13).

20. SIP 200 (OK) response (intermediate IM CN subsystem entities to UE-1)

The intermediate IM CN subsystem entities forward the SIP 200 (OK) response to the UE-1.

21. Media paths between UE-1 and UE-2

The UE-1 receives the SIP 200 (OK) response containing the SDP answer that indicates that the UE-2 is ready to receive media. Since the UE-1 has already resources available, it starts to send media over new IP-CAN to the UE-2's contact address specified in the SDP answer immediately.

The UE-1 may relinquish the resources that it has been using for outgoing media on the old IP-CAN.

Resources used for signalling on the old IP-CAN are not released.

22. SIP ACK request (UE-1 to intermediate IM CN subsystem entities)

The UE-1 completes the new call leg creation with a SIP ACK request sent to the intermediate IM CN subsystem entities.

23. SIP ACK request (-intermediate IM CN subsystem entities to SCC AS)

The intermediate IM CN subsystem entities forward the SIP ACK request to the SCC AS.

24. SIP BYE request (SCC AS to intermediate IM CN subsystem entities)

The SCC AS terminates the replaced call leg- that was using the old IP-CAN, by sending a SIP BYE request to the UE-1.

25. SIP BYE request (intermediate IM CN subsystem entities to UE-1)

The intermediate IM CN subsystem entities forward the BYE request to the UE-1.

26. SIP 200 (OK) response (UE-1 to intermediate IM CN subsystem entities)

Upon receiving the SIP BYE request over the old IP-CAN, the UE-1 sends a SIP 200 (OK) response over the old IP-CAN. Subsequently, the UE-1 relinquishes all resources pertaining to the old IP-CAN.

27. SIP 200 (OK) response (intermediate IM CN subsystem entities to SCC AS)

The intermediate IM CN subsystem entities forward the SIP 200 (OK) response to the SCC AS.

A.7.3 PS-PS access transfer with partial media transfer

The signalling flows shown in figure A.7.3-1 describes the PS-PS access transfer procedure when not all media of an ongoing communication session are transferred from the Source Access Leg to the Target Access Leg. No lower-level mechanism to support the session continuity is assumed or needed.

In this example, UE-1 is on an active multimedia session with UE-2 via one IP-CAN. After connecting to an additional IP-CAN, obtaining an additional IP address, discovering a P-CSCF, and performing IMS registration, UE-1 reserves resources in the new IP-CAN prior to initiating the PS-PS access transfer procedure. When the PS-PS access transfer procedure is completed, UE-1 continues the multimedia session with UE-2 on both the old and the new IP-CANs. In this example, when attaching to the new IP-CAN, it is irrelevant whether the UE-1 uses the same P-CSCF or a new P-CSCF.

NOTE 1: This scenario requires that UE-1 and the IMS network support simultaneous multiple registrations and requires that UE-1 supports dual mode operation.

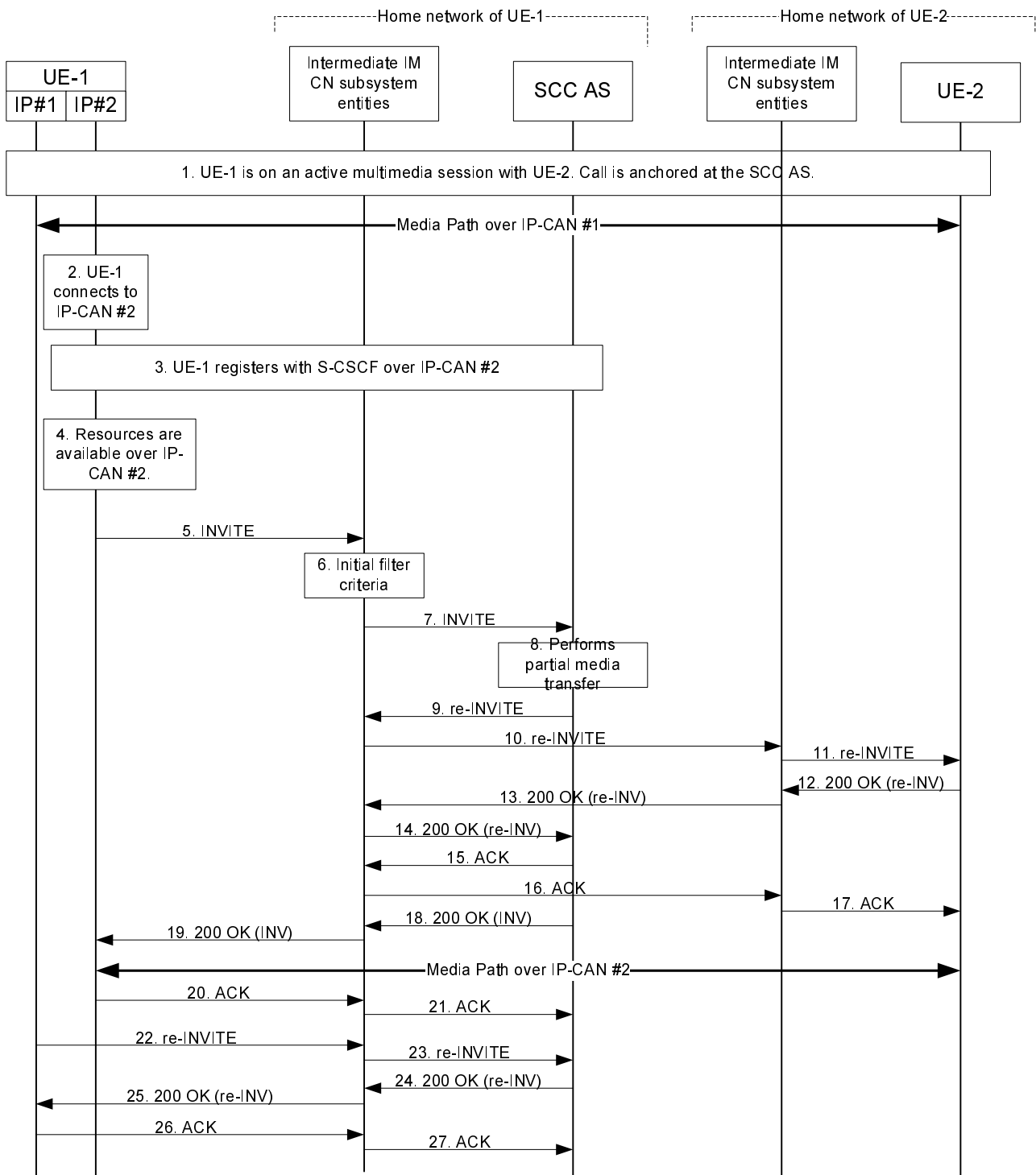

Figure A.7.3-1: Signalling flow for PS-PS session transfer with partial media transfer

NOTE 2: For clarity, the SIP 100 (Trying) responses are not shown in the signalling flow.

1. UE-1 is on an active session with UE-2

UE-1 is in an active session with UE-2. The call is anchored in the SCC AS. It is irrelevant which endpoint initiated the call. Each call leg is uniquely identified with a respective dialog identifier. The call leg over IP-CAN #1 is identified with "Call-ID= me03a0s09a2sdfgjdkl491777", "From tag=64727891", and "To tag=774321". UE-1 and UE-2 exchange media over the IP-CAN #1, which is maintained while the UE-1 initiates the session transfer procedure.

2. UE-1 connects to IP-CAN #2

UE-1 connects to the new IP-CAN and obtains an IP address that it will use for the signalling and media.

3. UE-1 registers with intermediate IM CN subsystem entities over IP-CAN #2

UE-1 registers with the S-CSCF over the IP-CAN #2 using the standard registration procedure. The P-CSCF in the signalling path of this registration may be distinct from the one used in the signalling path over IP-CAN #1.

4. UE-1 acquires resources in IP-CAN #2

UE-1 decides to perform partial media transfer to the IP-CAN #2. Based on UE-1 and IP-CAN #2 capabilities, the UE-1 decides to use the same codec that was used over the IP-CAN #1 for the media components to be transferred. UE-1 ensures that the resources (e.g. QoS) in IP-CAN #2 that will be needed for the signalling and transferred media are available, prior to sending the initial SIP INVITE request.

5. SIP INVITE request (UE-1 to intermediate IM CN subsystem entities) - see example in table A.7.3-5

UE-1 sends initial SIP INVITE request with a new SDP offer to UE-2 and indicates that the video component is to be transferred to IP-CAN #2. The initial SIP INVITE request establishes a dialog for signalling and specifies in the SDP new contact address that will be used for media over IP-CAN #2. Upon sending the initial SIP INVITE request, UE-1 is ready to receive the RTP packets over both IP-CAN #1 and IP-CAN #2.

Table A.7.3-5: SIP INVITE request (UE-1 to intermediate IM CN subsystem entities)

```
INVITE tel:+1-212-555-2222 SIP/2.0
Via: SIP/2.0/UDP [5555::aaa:bbb:ccc:ddd]:1357;comp=sigcomp;branch=z9hG4bKnashds7
Max-Forwards: 70
Route: sip:pcscf1.home1.net:7531;lr;comp=sigcomp>, <sip:orig@scscf1.home1.net;lr>
P-Preferred-Identity: "John Doe" <sip:user1_public1@home1.net>
P-Access-Network-Info: IEET-802.11b
Privacy: none
From: <sip:user1_public1@home1.net>; tag=171828
To: <tel:+1-212-555-2222>
Call-ID: cb03a0s09a2sdfgklj490333
Cseq: 127 INVITE
Supported: 100rel; precondition
Require: sec-agree; tdialog
Target-Dialog: me03a0s09a2sdfgklj491777; remote-tag=774321; local-tag=64727891
Proxy-Require: sec-agree
Security-Verify: ipsec-3gpp; q=0.1; alg=hmac-sha-1-96; spi=87654321; port1=7531
Contact: < sip:user1_public1@home1.net;gr=urn:uuid:f81d4fae-7dec-11d0-a765-
00a0c91e6bf6>;+g.3gpp.icsi-ref="urn:3Aurn-7%3gpp-
service.ims.icsi.mmtel";+g.3gpp.ics="principal";
Allow: INVITE, ACK, CANCEL, BYE, PRACK, UPDATE
Accept: application/sdp; application/3gpp-ims+xml
Content-Type: application/sdp
Content-Length: (...)

v=0
o=- 2987933615 2987933615 IN IP6 5555::aaa:bbb:ccc:ddd
s=-
c=IN IP6 5555::aaa:bbb:ccc:ddd
t=0 0
m=audio 0 RTP/AVP 97 96
a=rtpmap:97 AMR
a=fmtp:97 mode-set=0,2,5,7; mode-change-period=2
a=rtpmap:96 telephone-event
m=video 3400 RTP/AVP 98 99
b=AS:75
a=curr:qos local sendrecv
a=curr:qos remote none
a=des:qos mandatory local sendrecv
a=des:qos none remote sendrecv
a=rtpmap:98 H263
a=fmtp:98 profile-level-id=0
a=rtpmap:99 MP4V-ES
```

Request-URI: the tel-URI of the destination, i.e. the UE-2.

Require: the "tdialog" option tag indicate that the support for Target-Dialog header is required.

Target-Dialog: specifies the existing call that will be transferred.

SDP: specifies the new IP address that the UE-1 has acquired in the new IP-CAN, and indicates that only the video component will be transferred and the resources in the new IP-CAN have been reserved.

6. Evaluation of initial filter criteria

Upon the evaluation of the initial filter criteria, as this is an originating initial SIP INVITE request for a registered user, the S-CSCF routes the initial SIP INVITE request to the SCC AS.

7. SIP INVITE request (intermediate IM CN subsystem entities to SCC AS)

The initial SIP INVITE request is forwarded from intermediate IM CN subsystem entities in the home network to the SCC AS. The SCC AS acts as a routing B2BUA as specified in 3GPP TS 24.229 [2].

8. Remote leg update

Based on the content of the Target-Dialog header, the SCC AS correlates the SIP INVITE request for session transfer to the existing local and remote call legs of the existing concatenated end to end session between UE-1 and UE-2. The SCC AS updates the remote call leg by sending a SIP re-INVITE request to the UE-2 containing the new SDP offer based on the partial media transfer request received from UE-1 and the negotiated SDP for the original session.

9. SIP re-INVITE request (SCC AS to intermediate IM CN subsystem entities) - see example in table A.7.3-9

UE-2 is informed of the change in access leg by the SCC AS sending a re-INVITE request to the S-CSCF.

The SCC AS modifies the message in accordance with routing B2BUA functionality, e.g. mapping of From, To, Cseq and Call-ID headers from one side of the B2BUA to the other. In this example the SCC AS includes the contents of the Contact header from the received SIP INVITE request. The SIP re-INVITE request contains the SDP offer that is based on original SDP offer and the SDP offer that the SCC AS received in the initial SIP INVITE request from the UE-1 (Step 7).

Table A.7.3-9: SIP re-INVITE request (SCC AS to intermediate IM CN subsystem entities)

```

INVITE < sip:user2_public1@home2.net;gr=urn:uuid:2ad8950e-48a5-4a74-8d99-ad76cc7fc74> SIP/2.0>
Via: SIP/2.0/UDP sccas.home1.net; branch=z9hG4bK332b33.3;
Max-Forwards: 70
Route: <scscf1.home1.net;lr>, <sip:scscf2.home2.net;lr>, <sip:pcscf2.visited2.net;lr>
P-Asserted-Identity: "John Doe" <sip:user1_public1@home1.net>, <tel:+1-212-555-1111>
Privacy: none
P-Charging-Vector: icid-value="AyretyU0dm+6O2IrT5tAFrbHLso=023551024"
P-Charging-Function-Addresses:
From: <sip:user1_public1@home1.net>; tag=1717777
To: <tel:+1-212-555-2222>, tag=4321
Call-ID: dc14b1t10b3teghmlk5013333
Cseq: 111 INVITE
Supported: precondition, 100rel
Contact:<sip:user1_public1@home1.net; gr=urn:uuid:f81d4fae-7dec-11d0-a765-
00a0c91e6bf6>;+g.3gpp.icsi-ref="urn:3Aurn-7%3gpp-service.ims.icsi.mmtel"
Allow: INVITE, ACK, CANCEL, BYE, PRACK, UPDATE
Accept: application/sdp
Content-Type: application/sdp
Content-Length: (...)

v=0
o=2987933100 2987933101 IN IP6 5555::aaa:bbb:ccc:eee
s=-
t=0 0
m=audio 3456 RTP/AVP 97 96
c=IN IP6 5555::aaa:bbb:ccc:eee
b=AS:25.4
a= curr:qos local sendrecv
a= curr:qos remote none
a= des:qos mandatory local sendrecv
a= des:qos none remote sendrecv
a= rtpmap:97 AMR
a= fmp:97 mode-set=0,2,5,7; mode-change-period=2
a= rtpmap:96 telephone-event
a= maxptime:20
m=video 3400 RTP/AVP 98 99
c=IN IP6 5555::aaa:bbb:ccc:ddd
b=AS:75
a=curr:qos local sendrecv
a=curr:qos remote none
a=des:qos mandatory local sendrecv
a=des:qos none remote sendrecv
a=rtpmap:98 H263
a=fmp:98 profile-level-id=0
a=rtpmap:99 MP4V-ES

```

Route: The SIP re-INVITE request contains the saved list of Route headers that the SCC AS has saved for the remote leg of the call.

SDP: specifies the new IP address and ports used for the media components. In this case, the audio component is still using the original address and port while the video component is using the new IP address and new port allocated.

10. SIP re-INVITE request (intermediate IM CN subsystem entities to intermediate IM CN subsystem entities)

In the originating network, the intermediate IM CN subsystem entities forward the SIP re-INVITE request to the intermediate IM CN subsystem entities in the terminating network.

11. SIP re-INVITE request (intermediate IM CN subsystem entities to UE-2)

In the terminating network, the SIP re-INVITE request is forwarded towards UE-2 by the intermediate IM CN subsystem entities.

UE-2 receives the SIP re-INVITE request containing the SDP offer that indicates that UE-1 is ready to receive video media on a different contact address. Since UE-2 has resources already available, it starts to send the media to UE-1's contact address specified in the SDP offer immediately.

UE-1 starts receiving the video RTP packets over IP-CAN #2. However, UE-1 may receive some out-of-sequence video RTP packets over IP-CAN #1. The video RTP packets are delivered to the codec in sequence.

Once UE-1 determine that no video will be received over IP-CAN #1 (e.g. by examining the sequence numbers in the RTP headers), it may relinquish the resources that it has been using for incoming video media on IP-CAN #1.

At the same time, UE-1 still sends both the audio and video media to UE-2 over IP-CAN #1.

Resources used for signalling on IP-CAN #1 are not released.

12. SIP 200 (OK) response (UE-2 to intermediate IM CN subsystem entities) – see example in table A.7.3-12

Upon receiving the SIP re-INVITE request containing the SDP offer, since UE-2 has all resources available, it sends immediately the SIP 200 (OK) response to the SIP re-INVITE request that contains the SDP answer. The SDP answer indicates that the resources are available.

Table A.7.3-12: SIP 200 (OK) response (UE-2 to intermediate IM CN subsystem entities)

```
SIP/2.0 200 OK
Via: SIP/2.0/UDP pcscf2.visited2.net:5088;comp=sigcomp;branch=z9hG4bK361k21.1,
    SIP/2.0/UDP scscf2.home2.net;branch=z9hG4bK764z87.1,
    SIP/2.0/UDP scscf1.home1.net;branch=z9hG4bK332b23.1,
    SIP/2.0/UDP scscf1.home1.net;branch=z9hG4bK332b33.3
Record-Route: <sip:pcscf2.visited2.net:5088;lr;comp=sigcomp>, <sip:scscf2.home2.net;lr>,
    <sip:scscf1.home1.net;lr>
P-Access-Network-Info: 3GPP-UTRAN-TDD; utran-cell-id-3gpp=234151D0FCE11
Privacy: none
From: <sip:user1_public1@home1.net>; tag=1717777
To: <tel:+1-212-555-2222>;tag=4321
Call-ID: dc14b1t10b3teghmlk5013333
CSeq: 111 INVITE
Supported: precondition, 100rel
Contact: <sip:user2_public1@home2.net;gr=urn:uuid:2ad8950e-48a5-4a74-8d99-
    ad76cc7fc74>;+g.3gpp.icsi-ref="urn%3Aurn-7%3gpp-service.ims.icsi.mmtel" >
Allow: INVITE, ACK, CANCEL, BYE, PRACK, UPDATE, REFER, MESSAGE
Content-Type: application/sdp
Content-Length: (...)

v=0
o=- 2987933623 2987933624 IN IP6 5555::eee:fff:aaa:bbb
s=-
c=IN IP6 5555::eee:fff:aaa:bbb
t=0 0
m=audio 6544 RTP/AVP 97 96
b=AS:25.4
a=curr:qos local sendrecv
a=curr:qos remote sendrecv
a=des:qos mandatory local sendrecv
a=des:qos mandatory remote sendrecv
a=rtpmap:97 AMR
a=fmtp:97 mode-set=0,2,5,7; mode-change-period=2
a=rtpmap:96 telephone-event
a=maxptime:20
m=video 10001 RTP/AVP 98 99
b=AS:75
a=curr:qos local sendrecv
a=curr:qos remote sendrecv
a=des:qos mandatory local sendrecv
a=des:qos mandatory remote sendrecv
a=rtpmap:98 H263
a=fmtp:98 profile-level-id=0
a=rtpmap:99 MP4V-ES
```

13. SIP 200 (OK) response (intermediate IM CN subsystem entities to intermediate IM CN subsystem entities)

In the terminating network, the intermediate IM CN subsystem entities forward the SIP 200 (OK) response to the SIP re-INVITE request to the intermediate IM CN subsystem entities in the originating network.

14. SIP 200 (OK) response (intermediate IM CN subsystem entities to SCC AS)

The intermediate IM CN subsystem entities in the originating network forward the SIP 200 (OK) response to the SIP re-INVITE request to the SCC AS.

15. SIP ACK request (SCC AS to intermediate IM CN subsystem entities)

The SCC AS acting as a B2BUA acknowledges the receipt of the SIP 200 (OK) response to the SIP re-INVITE request by forwards a SIP ACK request to the intermediate IM CN subsystem entities.

16. SIP ACK request (intermediate IM CN subsystem entities to intermediate IM CN subsystem entities)

In the originating network, the intermediate IM CN subsystem entities forward the SIP ACK request to the intermediate IM CN subsystem entities in the terminating network.

17. SIP ACK request (intermediate IM CN subsystem entities to UE-2)

In the terminating network, the intermediate IM CN subsystem entities forward the SIP ACK request to UE-2.

18. SIP 200 (OK) response (SCC AS to intermediate IM CN subsystem entities) – see example in table A.7.3-18

The SCC AS forwards the SIP 200 (OK) response to the initial SIP INVITE request to the intermediate IM CN subsystem entities, using the content of the Via header that was received in the initial SIP INVITE request (step 5).

The SCC AS modifies the message in accordance with routing B2BUA functionality, e.g. mapping of From, To, Cseq and Call-ID headers from one side of the B2BUA to the other. In this example the SCC AS includes the contents of the Contact header from the received SIP 200 (OK) response. The SIP 200 (OK) response to the initial SIP INVITE request contains the SDP answer derived from the SDP answer that the SCC AS has received in the SIP 200 (OK) response to SIP re-INVITE request from UE-2 (Step 14).

Table A.7.3-18: SIP 200 (OK) response (SCC AS to intermediate IM CN subsystem entities)

```
SIP/2.0 200 OK
Via: SIP/2.0/UDP scscf1.home1.net;branch=z9hG4bK332b23.1,
    SIP/2.0/UDP pcscf1.home1.net;branch=z9hG4bK240f34.1,
    SIP/2.0/UDP [5555::aaa:bbb:ccc:ddd]:1357;comp=sigcomp;branch=z9hG4bKnashds7
Record-Route: <sip:sccas.home1.net;lr>, <sip:scscf1.home1.net;lr>, <sip:pcscf1.home1.net;lr>
Privacy: none
From: <sip:user1_public1@home1.net>; tag=171828
To: <tel:+1-212-555-2222>;tag=8009
Call-ID: cb03a0s09a2sdfg1kj490333
Cseq: 127 INVITE
Supported: 100rel; precondition
Contact: < sip:user2_public1@home2.net;gr=urn:uuid:2ad8950e-48a5-4a74-8d99-
    ad76cc7fc74>;+g.3gpp.icsi-ref="urn%3Aurn-7%3gpp-service.ims.icsi.mmtel"
Allow: INVITE, ACK, CANCEL, BYE, PRACK, UPDATE
Accept: application/sdp;
Content-Type: application/sdp
Content-Length: (...)

v=0
o=- 2987933300 2987933300 IN IP6 5555::eee:fff:aaa:bbb
s=-
c=IN IP6 5555::eee:fff:aaa:bbb
t=0 0
m=audio 0 RTP/AVP 97 96
a=rtpmap:97 AMR
a=fmtp:97 mode-set=0,2,5,7; mode-change-period=2
a=rtpmap:96 telephone-event
m=video 10001 RTP/AVP 98 99
b=AS:75
a=curr:qos local sendrecv
a=curr:qos remote sendrecv
a=des:qos mandatory local sendrecv
a=des:qos mandatory remote sendrecv
a=rtpmap:98 H263
a=fmtp:98 profile-level-id=0
a=rtpmap:99 MP4V-ES
```

19. SIP 200 (OK) response (intermediate IM CN subsystem entities to UE-1)

The intermediate IM CN subsystem entities forward the SIP 200 (OK) response to UE-1.

UE-1 receives the SIP 200 (OK) response containing the SDP answer indicating that UE-2 is ready to receive media. Since UE-1 has already resources available, it starts to send video media over IP-CAN #2 to UE-2's contact address specified in the SDP answer immediately.

The UE-1 may relinquish the resources that it has been using for outgoing video media on IP-CAN #1.

Resources used for signalling and audio media on IP-CAN #1 are not released.

20. SIP ACK request (UE-1 to intermediate IM CN subsystem entities)

UE-1 completes the new call leg creation with a SIP ACK request sent to the intermediate IM CN subsystem entities.

21. SIP ACK request (intermediate IM CN subsystem entities to SCC AS)

The intermediate IM CN subsystem entities forward the SIP ACK request to the SCC AS.

22. SIP re-INVITE request (UE-1 to intermediate IM CN subsystem entities) – see example in table A.7.3-22

UE-1 updates the old call leg on IP-CAN #1 by sending a SIP re-INVITE request to the intermediate IM CN subsystem entities.

Table A.7.3-22: SIP re-INVITE request (UE-1 to intermediate IM CN subsystem entities)

```
INVITE <sip:user2_public1@home2.net;gr=urn:uuid:2ad8950e-48a5-4a74-8d99-ad76cc7fc74> SIP/2.0
Via: SIP/2.0/UDP [5555::aaa:bbb:ccc:eee]:2468;comp=sigcomp;branch=z9hG4bKashdns1
Max-Forwards: 70
Route: sip:pcscf1.home1.net:8765;lr;comp=sigcomp, <sip:orig@scscf1.home1.net;lr>
P-Access-Network-Info: 3GPP-UTRAN-FDD; utran-cell-id-3gpp=123456ABCDE22
Privacy: none
From: <sip:user1_public1@home1.net>; tag=64727891
To: <tel:+1-212-555-2222>; tag=774321
Call-ID: me03a0s09a2sdfgjdkl491777
Cseq: 101 INVITE
Supported: 100rel; precondition; tdialog
Require: sec-agree;
Proxy-Require: sec-agree
Security-Verify: ipsec-3gpp; q=0.1; alg=hmac-sha-1-96; spi=12345678; port1=2468
Contact: <sip:user1_public1@home1.net;gr=urn:uuid:f81d4fae-7dec-11d0-a765-
00a0c91e6bf6>;+g.3gpp.icsi-ref="urn:3Aurn-7%3gpp-
service.ims.icsi.mmtel";+g.3gpp.ics="principal";
Allow: INVITE, ACK, CANCEL, BYE, PRACK, UPDATE
Accept: application/sdp; application/3gpp-ims+xml
Content-Type: application/sdp
Content-Length: (...)

v=0
o=- 2987933000 2987933001 IN IP6 5555::aaa:bbb:ccc:eee
s=-
c=IN IP6 5555::aaa:bbb:ccc:eee
t=0 0
m=audio 3456 RTP/AVP 97 96
b=AS:25.4
a=rtpmap:97 AMR
a=fmtp:97 mode-set=0,2,5,7; mode-change-period=2
a=rtpmap:96 telephone-event
m=video 0 RTP/AVP 98 99
a=rtpmap:98 H263
a=fmtp:98 profile-level-id=0
a=rtpmap:99 MP4V-ES
```

23. SIP re-INVITE request (intermediate IM CN subsystem entities to SCC AS)

The intermediate IM CN subsystem entities forward the SIP re-INVITE request to the SCC AS.

24. SIP 200 (OK) response (SCC AS to intermediate IM CN subsystem entities) – see example in table A.7.3-24

The SCC AS updates the old call leg based on the SIP re-INVITE request and sends the SIP 200 (OK) response to the SIP re-INVITE request to the intermediate IM CN subsystem entities, using the content of the Via header that was received in the SIP re-INVITE request (step 23). In this example the SCC AS includes the contents of

the Contact header from the received SIP 200 (OK) response. The SIP 200 (OK) response to the SIP re-INVITE request contains the SDP answer derived from the SDP answer that the SCC AS previously received from UE-2 (Step 14).

Table A.7.3-24: SIP 200 (OK) response (SCC AS to intermediate IM CN subsystem entities)

```
SIP/2.0 200 OK
Via: SIP/2.0/UDP scscf1.home1.net;branch=z9hG4bK345b32.2,
    SIP/2.0/UDP pcscf1.home1.net;branch=z9hG4bK568f35.1,
    SIP/2.0/UDP [5555::aaa:bbb:ccc:eee]:2468;comp=sigcomp;branch=z9hG4bKashdns1
Record-Route: <sccas.home1.net;lr>, <sip:scscf1.home1.net;lr>, <sip:pcscf1.home1.net;lr>
Privacy: none
From: <sip:user1_public1@home1.net>; tag=64727891
To: <tel:+1-212-555-2222>;tag=774321
Call-ID: me03a0s09a2sdfgjkl491777
Cseq: 101 INVITE
Supported: 100rel; precondition
Contact: < sip:user2_public1@home2.net;gr=urn:uuid:2ad8950e-48a5-4a74-8d99-
    ad76cc7fc74>;+g.3gpp.icsi-ref="urn%3Aurn-7%3gpp-service.ims.icsi.mmtel"
Allow: INVITE, ACK, CANCEL, BYE, PRACK, UPDATE
Accept: application/sdp;
Content-Type: application/sdp
Content-Length: (...)

v=0
o=- 2987933800 2987933801 IN IP6 5555::eee:fff:aaa:bbb
s=-
c=IN IP6 5555::eee:fff:aaa:bbb
t=0 0
m=audio 6544 RTP/AVP 97 96
a=rtpmap:97 AMR
a=fmtp:97 mode-set=0,2,5,7; mode-change-period=2
a=rtpmap:96 telephone-event
m=video 0 RTP/AVP 98 99
a=rtpmap:98 H263
a=fmtp:98 profile-level-id=0
a=rtpmap:99 MP4V-ES
```

25. SIP 200 (OK) response (intermediate IM CN subsystem entities to UE-1)

The intermediate IM CN subsystem entities forward the SIP 200 (OK) response to UE-1.

26. SIP ACK request (UE-1 to intermediate IM CN subsystem entities)

UE-1 completes the old call leg update with a SIP ACK request sent to the intermediate IM CN subsystem entities.

27. SIP ACK request (intermediate IM CN subsystem entities to SCC AS)

The intermediate IM CN subsystem entities forward the SIP ACK request to the SCC AS.

A.8 Signalling flows for PS-PS session continuity in conjunction with PS-CS session continuity

A.8.1 Introduction

The signalling flows for PS-PS access transfer conjunction with PS-CS access transfer demonstrate how a multimedia session is transferred from Source Access Leg to the Target Access Leg. The following signalling flows are included:

- subclause A.8.2 shows an example when a multimedia session is transferred from one IP-CAN to a new IP-CAN and the CS bearer respectively ; and
- subclause A.8.3 shows an example when a multimedia session is transferred from one IP-CAN and CS bearer to a new IP-CAN.

A.8.2 PS - PS in conjunction with PS - CS Access Transfer: PS to CS

In this example, SC UE A has an ongoing multimedia session with remote UE B over IP-CAN#1 before access transfer. When SC UE connects to a new IP-CAN#2, it decides to transfer the multimedia session over the new IP-CAN#2 and the CS bearer respectively.

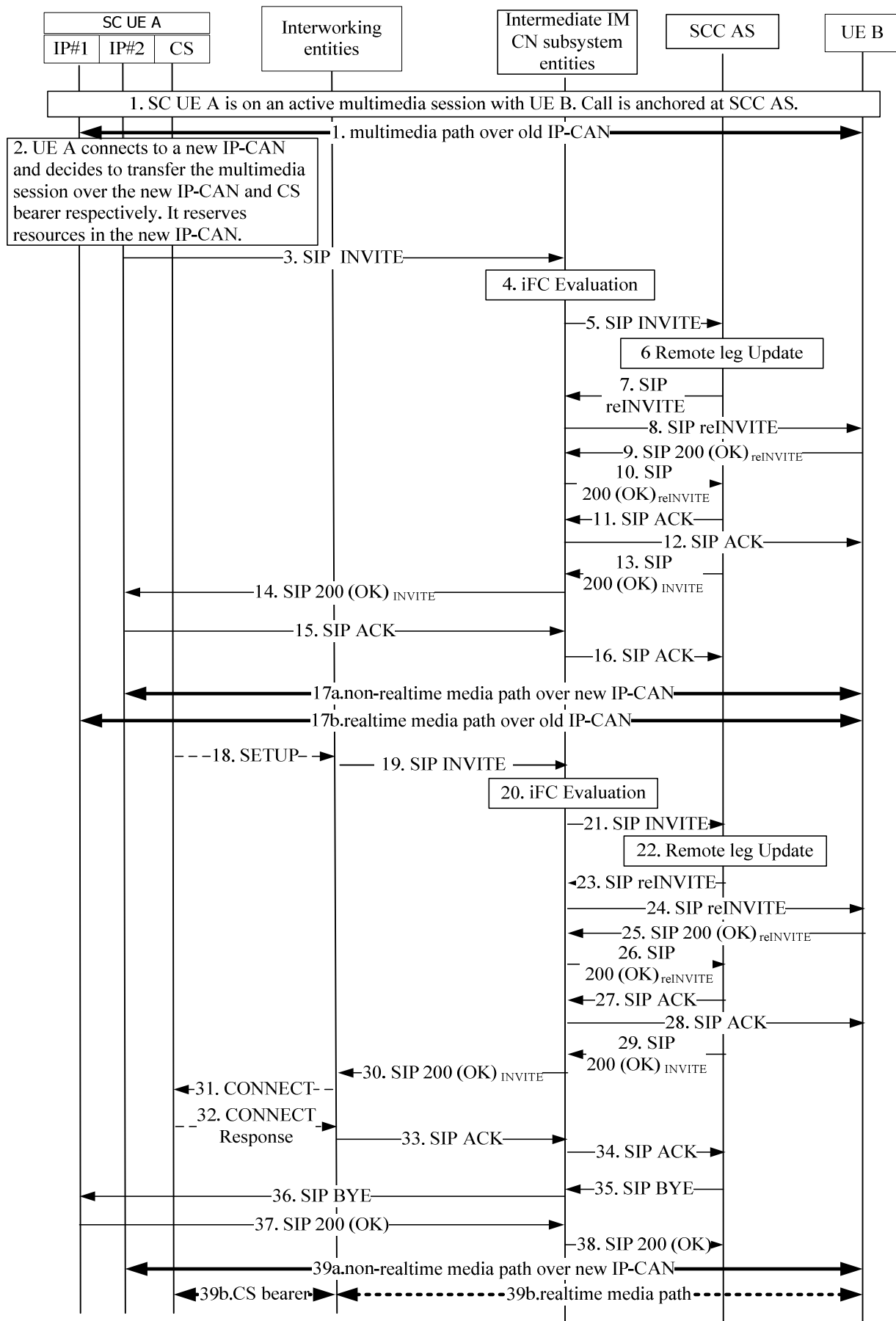

Figure A.8.2-1: Signalling flow for PS - PS in conjunction with PS - CS Access Transfer: PS to CS

NOTE 1: For clarity, the SIP 100 (Trying) responses are not shown in the signalling flow.

2. SC UE A has an ongoing multimedia session with remote UE B

The call has been anchored at the SCC AS which is in the HPLMN of originating SC UE A. The call leg over old IP-CAN is identified with "Call-ID= me03a0s09a2sdfgjdkl491777", "From tag=64727891", and "To tag=774321". The UE A and UE B exchange media over the old IP-CAN, which is maintained while the SC UE A initiates the handover procedure.

Table A.8.2-1 shows an example of the SDP offer from SC UE A to remote UE B.

NOTE 2: To later show how the media is transferred to the new IP-CAN and CS bearer, only the SDP offer is shown in table A.8.2-1.

Table A.8.2-1: SIP INVITE request (SC UE A to intermediate IM CN subsystem entities)

```
INVITE tel:+1-237-555-2222 SIP/2.0
Via:
Max-Forwards:
Route:
P-Asserted-Identity:
P-Charging-Vector:
P-Access-Network-Info:
Privacy:
From:
To:
Call-ID:
Cseq:
Supported:
Require:
Proxy-Require:
Security-Verify:
Contact:
Allow:
Accept:
Content-Type:
Content-Length: (...)

v=0
o=- 2987933615 2987933615 IN IP6 5555::aaa:bbb:ccc:ddd
s=
c=IN IP6 5555::aaa:bbb:ccc:ddd
t=0 0
m=audio 3456 RTP/AVP 97 96
b=AS:25.4
a=crr:qos local sendrecv
a=crr:qos remote none
a=des:qos mandatory local sendrecv
a=des:qos none remote sendrecv
a=rtpmap:97 AMR
a=fmtp:97 mode-set=0,2,5,7; mode-change-period=2
a=rtpmap:96 telephone-event
a=maxptime:20
m=message 7654 TCP/MSRP 98
a=accept-types:text/plain
```

2. SC UE A connects to a new IP-CAN#2:

The SC UE A decides to transfer the multimedia session over the new IP-CAN and CS bearer respectively. The UE A obtains an IP address that it will use for the signalling and media. It registers with the S-CSCF over the new IP-CAN using multiple registrations procedure. Depending on the UE A configuration, the discovery of the P-CSCF in the new IP-CAN may be needed. Based on the UE A and new IP-CAN capabilities, the UE A decides to use the same codec that was used over the old IP-CAN. The UE A reserves resources (e.g. QoS) in the new IP-CAN that will be needed for the signalling and transferred media, prior to sending the initial SIP INVITE request.

3. SIP INVITE request (SC UE A to intermediate IM CN subsystem entities)- see example in table A.8.2-3

The SC UE A sends an initial SIP INVITE request with a STI and a new SDP offer to the UE B that indicates that the new call replaces the existing call. The initial SIP INVITE request establishes a dialog for signalling and specifies in the SDP a new contact address that will be used for non-realtime media over the new IP-CAN. Upon

sending the initial SIP INVITE request, the UE A is ready to receive the RTP packets either over the new IP-CAN or the old IP-CAN. The RTP packets may arrive over the new IP-CAN prior to the SC UE are receiving the SIP 200 (OK) response for the initial SIP INVITE request.

Table A.8.2-3: SIP INVITE request (UE A to intermediate IM CN subsystem entities)

```

INVITE tel:+1-237-555-2222 SIP/2.0
Via: SIP/2.0/UDP [5555::aaa:bbb:ccc:fff]:1357;comp=sigcomp;branch=z9hG4bKnashds7
Max-Forwards: 70
Route: sip:pcscf1.home1.net:7531;lr;comp=sigcomp>, <sip:orig@scscf1.home1.net;lr>
P-Preferred-Identity: "John Doe" <sip:user1_public1@home1.net>
P-Access-Network-Info: IEEE-802.11b
Privacy: none
From: <sip:user1_public1@home1.net>; tag=171828
To: <tel:+1-237-555-2222>
Call-ID: cb03a0s09a2sdfgklkj490237
Cseq: 127 INVITE
Supported: 100rel; precondition
Require: sec-agree
Proxy-Require: sec-agree
Security-Verify: ipsec-3gpp; q=0.1; alg=hmac-sha-1-96; spi=87654321; port1=7531
Contact: <sip:user1_public1@home1.net; gr=urn:uuid:f81d4fae-7dec-11d0-a765-00a0c91e6bf6>;+g.3gpp.icsi-ref="urn%3Aurn-7%3gpp-service.ims.icsi.mmtel";+g.3gpp.ics="principal";
Target-Dialog:me03a0s09a2sdfgklkj491777; to-tag=774321; from-tag=64727891
Allow: INVITE, ACK, CANCEL, BYE, PRACK, UPDATE
Accept: application/sdp; application/3gpp-ims+xml
Content-Type: application/sdp
Content-Length: (...)

v=0
o=- 2987933615 2987933615 IN IP6 5555::aaa:bbb:ccc:fff
s=
t=0 0
m=audio 0 RTP/AVP 97 96
c=IN IP6 5555::aaa:bbb:ccc:ddd
b=AS:25.4
a=crr:qos local sendrecv
a=crr:qos remote none
a=des:qos mandatory local sendrecv
a=des:qos none remote sendrecv
a=rtpmap:97 AMR
a=fmtp:97 mode-set=0,2,5,7; mode-change-period=2
a=rtpmap:96 telephone-event
a=maxptime:20
m=message 7654 TCP/MSRP 98
c=IN IP6 5555::aaa:bbb:ccc:fff
a=accept-types:text/plain

```

4. Evaluation of initial filter criteria

The S-CSCF evaluates initial filter criteria for the served SC user and as a result routes the SIP INVITE request towards the SCC AS.

5. SIP INVITE request (intermediate IM CN subsystem entities to SCC AS)

The SIP INVITE request is forwarded to the SCC AS as the result of the evaluation of iFC.

6. Remote Leg Update

The SCC AS identifies the session to be transferred using the STI. The SCC AS performs the Remote Leg update by sending the SIP re-INVITE request towards the Remote Leg.

7. SIP re-INVITE request (SCC AS to intermediate IM CN subsystem entities)- See example in table A.8.2-7

The SCC AS modifies the message in accordance with routing B2BUA functionality, e.g. mapping of From, To, Cseq and Call-ID headers from one side of the B2BUA to the other. In this example the SCC AS includes the contents of the Contact header from the received SIP INVITE request. The SIP re-INVITE request contains the SDP offer that is identical to the SDP offer that the SCC AS received in the initial SIP INVITE request from the UE A (Step 3).

Table A.8.2-7: SIP re-INVITE request (SCC AS to intermediate IM CN subsystem entities)

```

INVITE < sip:user2_public1@home2.net;gr=urn:uuid:2ad8950e-48a5-4a74-8d99-ad76cc7fc74>; SIP/2.0
Via: SIP/2.0/UDP sccas.home1.net; branch=z9hG4bK332b33.3;
Max-Forwards: 67
Route: <scscf1.home1.net;lr >, <sip:scscf2.home2.net;lr>, <sip:pcscf2.visited2.net;lr>
P-Asserted-Identity: "John Doe" <sip:user1_public1@home1.net>, <tel:+1-237-555-1111>
P-Access-Network-Info: IEEE-802.11b
Privacy: none
P-Charging-Vector: icid-value="AyretyU0dm+6O2IrT5tAFrbHLso=023551024"
P-Charging-Function-Addresses:
From: <sip:user1_public1@home1.net>; tag=1717777
To: <tel:+1-237-555-2222>, tag=4321
Call-ID: dc14b1t10b3teghmlk5013237
Cseq: 111 INVITE
Supported: precondition, 100rel
Contact:< sip:user1_public1@home1.net;gr=urn:uuid:f81d4fae-7dec-11d0-a765-00a0c91e6bf6>;+g.3gpp.icsi-ref="urn:3Aurn-7%3gpp-service.ims.icsi.mmtel"
Allow: INVITE, ACK, CANCEL, BYE, PRACK, UPDATE
Accept: application/sdp
Content-Type: application/sdp
Content-Length: (...)
v=0
o=- 2987933615 2987933615 IN IP6 5555::aaa:bbb:ccc:fff
s=t=0 0
m=audio 0 RTP/AVP 97 96c=IN IP6 5555::aaa:bbb:ccc:ddd
b=AS:25.4
a=curr:qos local sendrecv
a=curr:qos remote none
a=des:qos mandatory local sendrecv
a=des:qos none remote sendrecv
a=rtptime:97 AMR
a=fmtp:97 mode-set=0,2,5,7; mode-change-period=2
a=rtptime:96 telephone-event
a=maxptime:20
m=message 7654 TCP/MSRP 98
c=IN IP6 5555::aaa:bbb:ccc:fff
a=accept-types:text/plain

```

8. SIP re-INVITE request (Intermediate IM CN subsystem entities to UE B)

The intermediate IM CN subsystem entities forwards the SIP re-INVITE request to remote UE B.

9-10: SIP 200 (OK) response (UE B to SCC AS via Intermediate IM CN subsystem entities)

The UE B generates the SIP 200 (OK) response to the SIP re-INVITE request and forwards it to the SCC AS.

11-12: SIP ACK request (SCC AS to UE B via Intermediate IM CN subsystem entities)

The SCC AS generates the SIP ACK request to the SIP 200 (OK) response and forwards it to the remote UE B.

13-14: SIP 200 (OK) response (SCC AS to UE A via Intermediate IM CN subsystem entities)

The SCC AS generates the SIP 200 (OK) response to the SIP INVITE request and forwards it to the SC UE A.

15-16: SIP ACK request (SC UE A to SCC AS via Intermediate IM CN subsystem entities)

The SC UE A generates the SIP ACK request to the SIP 200 (OK) response and forwards it to the SCC AS

17. Media paths between UE A and UE B

The non-realtime media is using the new IP-CAN while the realtime media path is still over the old IP-CAN.

18. SETUP message (SC UE A to Interworking entities)

The SC UE sends the CS SETUP message with the STN as the called party number.

NOTE 3: STN is a PSI DN used by the UE to request a session transfer towards the SCC AS.

19. SIP INVITE request (Interworking entities to Intermediate IM CN subsystem entities) -see example in Table A.8.2-19

Table A.8.2-19: SIP INVITE request (interworking entities to intermediate IM CN subsystem entities)

```

INVITE tel:+1-237-555-3333 SIP/2.0
Via: SIP/2.0/UDP msc1.home1.net; branch=z9hG4bKnashds7
Max-Forwards: 70
Route: <sip:icscf1.home1.net:7531;lr;comp=sigcomp>
P-Asserted-Identity: <tel: +1-237-555-1111>
P-Charging-Vector: icid-value="AyretyU0dm+6O2Irt5tAFrbHLso=023551024"; orig-ioi=home1.net
Privacy: none
From: <tel: +1-237-555-1111>;tag=171828
To: <tel:+1-237-555-2222>
Call-ID: cb03a0s09a2sdfglkj490333
Cseq: 127 INVITE
Supported: 100rel, precondition
Require: sec-agree
Proxy-Require: sec-agree
Security-Verify: ipsec-3gpp; q=0.1; alg=hmac-sha-1-96; spi=87654321; port=7531
Contact: <sip:mgcf2.home2.net;gr>;+g.3gpp.icsi-ref="urn%3Aurn-7%3gpp-service.ims.icsi.mmtel"
Allow: INVITE, ACK, CANCEL, BYE, PRACK, UPDATE, REFER, MESSAGE
Accept: application/sdp, application/3gpp-ims+xml
Content-Type: application/sdp
Content-Length: (...)

v=0
o=- 2987933615 2987933615 IN IP6 5555::aaa:bbb:ccc:eee
s=
c=IN IP6 5555::aaa:bbb:ccc:eee
t=0 0
m=audio 3456 RTP/AVP 97 96
b=AS:25.4
a=curr:qos local sendrecv
a=curr:qos remote none
a=des:qos mandatory local sendrecv
a=des:qos none remote sendrecv
a=rtpmap:97 AMR
a=fmtp:97 mode-set=0,2,5,7; mode-change-period=2
a=rtpmap:96 telephone-event
a=maxptime:20

```

Request-URI: contains the IMRN, as obtained from CS networks signalling.

SDP: The SDP contains preconfigured set of codecs supported by the MGW.

20. Evaluation of initial filter criteria

The S-CSCF evaluates initial filter criteria for the served SC user and as a result routes the SIP INVITE request towards the SCC AS.

21. SIP INVITE request (Intermediate IM CN subsystem entities to SCC AS)

22. Remote Leg Update

The SCC AS performs the Remote Leg update by sending the SIP re-INVITE request towards the Remote Leg.

23. SIP re-INVITE request (SCC AS to intermediate IM CN subsystem entities) –see example in table A.8.2-23

The SCC AS acting as a routing B2BUA generates a SIP INVITE request based upon the received SIP INVITE request and the information previously stored against this session and routes it towards UE B via the intermediate IM CN subsystem entities. In this example the SCC AS includes the contents of the Contact header from the received SIP INVITE request.

Table A.8.2-23: SIP re-INVITE request (SCC AS to intermediate IM CN subsystem entities)

```

INVITE < sip:user2_public1@home2.net;gr=urn:uuid:2ad8950e-48a5-4a74-8d99-ad76cc7fc74> SIP/2.0
Via: SIP/2.0/UDP sccas1.home1.net;branch=z9hG4bKnas34r5
Max-Forwards: 67
Route: <sip:scscf1.home1.net:lr>
P-Asserted-Identity: <tel: +1-237-555-1111>
P-Charging-Function-Addresses: ccf=[5555::b99:c88:d77:e66]; ccf=[5555::a55:b44:c33:d22];
    ecf=[5555::1ff:2ee:3dd:4ee]; ecf=[5555::6aa:7bb:8cc:9dd]
P-Charging-Vector: icid-value="AyretyU0dm+602Irt5tAFrbHLso=023551024"; orig-
    ioi="type3home1.net"
Privacy: none
From: <tel: +1-237-555-1111>;tag=171828
To: <tel:+1-237-555-2222>;tag=26545
Call-ID: cb03a0s09a2sdFglkj490333
Cseq: 127 INVITE
Supported: 100rel, precondition
Require: sec-agree
Proxy-Require: sec-agree
Security-Verify: ipsec-3gpp; q=0.1; alg= hmac-sha-1-96; spi=87654321; port=7531
Contact: < sip:user1_public1@home1.net;gr=urn:uuid:f81d4fae-7dec-11d0-a765-
    00a0c91e6bf6>;+g.3gpp.icsi-ref="urn:3Aurn-7%3gpp-service.ims.icsi.mmtel"
Allow: INVITE, ACK, CANCEL, BYE, PRACK, UPDATE, REFER, MESSAGE
Accept: application/sdp, application/3gpp-ims+xml
Content-Type: application/sdp
Content-Length: (...)

v=0
o=- 2987933615 2987933615 IN IP6 5555::aaa:bbb:ccc:eee
s=
c=IN IP6 5555::aaa:bbb:ccc:eee
t=0 0
m=audio 3456 RTP/AVP 97 96
b=AS:25.4
a=crr:qos local sendrecv
a=crr:qos remote none
a=des:qos mandatory local sendrecv
a=des:qos none remote sendrecv
a=rtpmap:97 AMR
a=fmtp:97 mode-set=0,2,5,7; mode-change-period=2
a=rtpmap:96 telephone-event
a=maxptime:20
m=message 0 TCP/MSRP 98
a=accept-types:text/plain

```

24. SIP re-INVITE request (Intermediate IM CN subsystem entities to UE B)

Intermediate IM CN subsystem entities forward the SIP re-INVITE request to remote UE B.

25. SIP 200 (OK) response (UE B to intermediate IM CN subsystem entities)

Upon receiving the SIP re-INVITE request containing the SDP offer, since the UE B has all resources available, it sends immediately the SIP 200 (OK) response to the SIP re-INVITE request that contains the SDP answer. The SDP answer indicates that the resources are available.

26. SIP 200 (OK) response (intermediate IM CN subsystem entities to SCC AS)

The intermediate IM CN subsystem entities forward the SIP 200 (OK) response to the SIP re-INVITE request to the SCC AS in the originating network.

27-28. SIP ACK request (SCC AS to UE B via IM CN subsystem entities)

The SCC AS generates the SIP ACK request to the SIP 200 (OK) response, and forwards the SIP ACK request to the remote UE B.

29-30. SIP 200 (OK) response (SCC AS to interworking entities via IM CN subsystem entities)

The SCC AS generates the SIP 200 (OK) response to the SIP INVITE request, and forwards the SIP 200 (OK) response to the interworking entities.

31. ISUP CONNECT message (interworking entities to SC UE A)

32. ISUP CONNECT Response message (SC UE A to interworking entities)**33-34. SIP ACK request (interworking entities to SCC AS via IM CN subsystem entities)**

The interworking entities generate the SIP ACK request to the SIP 200 (OK) response, and forward it to the SCC AS.

35-36: SIP BYE request (SCC AS to SC UE A via intermediate IM CN subsystem entities)

The SCC AS terminates the replaced call leg, which was using the old IP-CAN, by sending a BYE request to the UE A.

37-38. SIP 200 (OK) response (SC UE A to SCC AS via intermediate IM CN subsystem entities)

Upon receiving the BYE request over the old IP-CAN, the SC UE A sends a SIP 200 (OK) response over the old IP-CAN to the SCC AS. Subsequently, the SC UE A relinquishes all resources pertaining to the old IP-CAN.

39. Media paths between SC UE A and UE B

Finally, the non-realtime media path is over the new IP-CAN and the realtime media is using the CS bearer.

A.8.3 PS - PS in conjunction with PS - CS Access Transfer: CS to PS

In this example, SC UE A has an ongoing multimedia session with remote UE B over IP-CAN#1 and CS bearer before access transfer. When SC UE connects to a new IP-CAN#2, it decides to transfer all the multimedia session over the new IP-CAN#2.

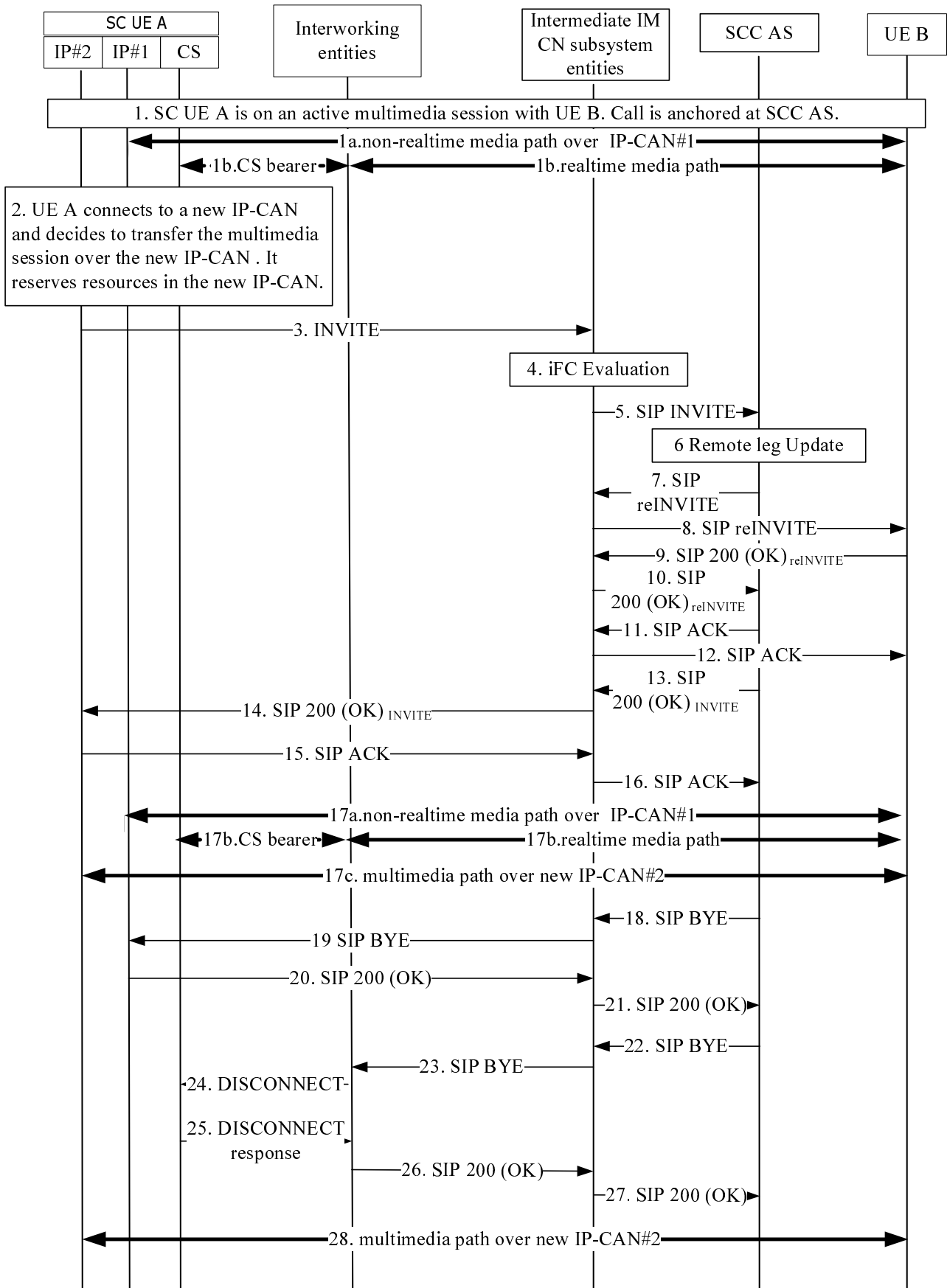

Figure A.8.3-1: Signalling flow for PS - PS in conjunction with PS - CS Access Transfer: CS to PS

NOTE 1: For clarity, the SIP 100 (Trying) responses are not shown in the signalling flow.

1. SC UE A has an ongoing multimedia session with remote UE B

The non realmedia path is over old IP-CAN#1 and the realtime media path is over the CS bearer. The call has been anchored at the SCC AS which is in the HPLMN of originating SC UE A. The call leg over old IP-CAN#1 is identified with "Call-ID= me03a0s09a2sdfgjk1491777", "From tag=64727891", and "To tag=774321". The UE A and UE B exchange media over the old IP-CAN, which is maintained while the SC UE A initiates the handover procedure.

2. SC UE A connects to a new IP-CAN#2

The SC UE A decides to transfer the multimedia session over the new IP-CAN#2. The UE A obtains an IP address that it will use for the signalling and media. It registers with the S-CSCF over the new IP-CAN using multiple registrations procedure. Depending on the UE A configuration, the discovery of the P-CSCF in the new IP-CAN may be needed. Based on the UE A and new IP-CAN capabilities, the UE A decides to use the same codec that was used over the old IP-CAN. The UE A reserves resources (e.g. QoS) in the new IP-CAN that will be needed for the signalling and transferred media, prior to sending the initial SIP INVITE request.

3. SIP INVITE request (SC UE A to intermediate IM CN subsystem entities)- see example in table A.8.3-3

Upon sending the initial SIP INVITE request, the UE A is ready to receive the RTP packets either over the new IP-CAN or the old IP-CAN. The RTP packets may arrive over the new IP-CAN prior to the SC UE are receiving the SIP 200 (OK) response for the initial SIP INVITE request.

Table A.8.3-3: SIP INVITE request (UE A to intermediate IM CN subsystem entities)

```
INVITE tel:+1-237-555-3333 SIP/2.0
Via: SIP/2.0/UDP [5555::aaa:bbb:ccc:fff]:1357;comp=sigcomp;branch=z9hG4bKnashds7
Max-Forwards: 70
Route: sip:pcscf1.home1.net:7531;lr;comp=sigcomp, <sip:orig@scscf1.home1.net;lr>
P-Preferred-Identity: "John Doe" <sip:user1_public1@home1.net>
P-Access-Network-Info: IEEE-802.11b
Privacy: none
From: <sip:user1_public1@home1.net>; tag=171828
To: <tel:+1-237-555-2222>
Call-ID: cb03a0s09a2sdfgjk1490237
Cseq: 127 INVITE
Supported: 100rel; precondition, gruu, 199
Require: sec-agree, replaces
Proxy-Require: sec-agree
Accept-Contact: *;+g.3gpp.icsi-ref="urn:urn-7:3gpp-service.ims.icsi.mmtel"
P-Preferred-Service: urn:urn-7:3gpp-service.ims.icsi.mmtel
Security-Verify: ipsec-3gpp; q=0.1; alg=hmac-sha-1-96; spi=87654321; port1=7531
Contact: <sip:user1_public1@home1.net;gr=urn:uid:f81d4fae-7dec-11d0-a765-00a0c91e6bf6>;+g.3gpp.icsi-ref="urn:urn-7:3gpp-service.ims.icsi.mmtel";+g.3gpp.ics="principal";
Replaces: me03a0s09a2sdfgjk1491777; to-tag=774321; from-tag=64727891
Allow: INVITE, ACK, CANCEL, BYE, PRACK, UPDATE
Accept: application/sdp; application/3gpp-ims+xml
Content-Type: application/sdp
Content-Length: (...)

v=0
o=- 2987933615 2987933615 IN IP6 5555::aaa:bbb:ccc:fff
s=
c=IN IP6 5555::aaa:bbb:ccc:fff
t=0 0
m=audio 3456 RTP/AVP 97 96a=tcap:1 RTP/AVPF
a=pcfg:1 t=1
b=AS:25.4
a=curr:qos local sendrecv
a=curr:qos remote none
a=des:qos mandatory local sendrecv
a=des:qos none remote sendrecv
a=rtptime:97 AMR
a=fmtp:97 mode-set=0,2,5,7; mode-change-period=2
a=rtptime:96 telephone-event
a=maxptime:20
m=message 7654 TCP/MSRP 98
a=accept-types: text/plain
```

Request-URI: Contains the static STI.

4. Evaluation of initial filter criteria

The S-CSCF evaluates initial filter criteria for the served SC user and as a result routes the SIP INVITE request towards the SCC AS.

5. SIP INVITE request (intermediate IM CN subsystem entities to SCC AS)

The SIP INVITE request is forwarded to the SCC AS as the result of the evaluation of iFC.

6. Remote Leg Update

The SCC AS identifies the session to be transferred using the STI. The SCC AS performs the Remote Leg update by sending the SIP re-INVITE request towards the Remote Leg.

7. SIP re-INVITE request (SCC AS to intermediate IM CN subsystem entities)- See example in table A.8.3-7

The SCC AS modifies the message in accordance with routing B2BUA functionality, e.g. mapping of From, To, Cseq and Call-ID headers from one side of the B2BUA to the other. In this example the SCC AS includes the contents of the Contact header from the received SIP INVITE request. The SIP re-INVITE request contains the SDP offer that is identical to the SDP offer that the SCC AS received in the initial SIP INVITE request from the UE A (Step 3).

Table A.8.2-7: SIP re-INVITE request (SCC AS to intermediate IM CN subsystem entities)

```
INVITE sip:user2_public1@home2.net;gr=urn:uuid:2ad8950e-48a5-4a74-8d99-ad76cc7fc74 SIP/2.0
Via: SIP/2.0/UDP sccas.home1.net; branch=z9hG4bK332b33.3;
Max-Forwards: 67
Route: <scscf1.home1.net;lr >, <sip:scscf2.home2.net;lr>, <sip:pcscf2.visited2.net;lr>
P-Asserted-Identity: "John Doe" <sip:user1_public1@home1.net>, <tel:+1-237-555-1111>
P-Access-Network-Info: IEEE-802.11b
Privacy: none
P-Charging-Vector: icid-value="AyretyU0dm+6O2IrT5tAFrbHLso=023551024"
P-Charging-Function-Addresses:
From: <sip:user1_public1@home1.net>; tag=569812
To: <tel:+1-237-555-2222>; tag=4321
Call-ID: dc14b1t10b3teghmlk5013237
Cseq: 111 INVITE
Contact:<sip:user1_public1@home1.net;gr=urn:uuid:f81d4fae-7dec-11d0-a765-00a0c91e6bf6>;+g.3gpp.icsi-ref="urn%3Aurn-7%3gpp-service.ims.icsi.mmtel"
Allow: INVITE, ACK, CANCEL, BYE, PRACK, UPDATE
Content-Type: application/sdp
Content-Length: (...)

v=0
o=- 2987933615 2987933615 IN IP6 5555::aaa:bbb:ccc:fff
s=
c=IN IP6 5555::aaa:bbb:ccc:fff
t=0 0
m=audio 3456 RTP/AVPF 97 96
b=AS:25.4
a=crr:qos local sendrecv
a=crr:qos remote none
a=des:qos mandatory local sendrecv
a=des:qos none remote sendrecv
a=rtpmap:97 AMR
a=fmtp:97 mode-set=0,2,5,7; mode-change-period=2
a=rtpmap:96 telephone-event
a=maxptime:20
m=message 7654 TCP/MSRP 98
a=accept-types: text/plain
```

8. SIP re-INVITE request (Intermediate IM CN subsystem entities to UE B)

The intermediate IM CN subsystem entities forwards the SIP re-INVITE request to remote UE B.

9-10: SIP 200 (OK) response (UE B to SCC AS via Intermediate IM CN subsystem entities)

The UE B generates the SIP 200 (OK) response to the SIP re-INVITE request and forwards it to the SCC AS.

11-12: SIP ACK request (SCC AS to UE B via Intermediate IM CN subsystem entities)

The SCC AS generates the SIP ACK request to the SIP 200 (OK) response and forwards it to the remote UE B.

13-14: SIP 200 (OK) response (SCC AS to UE A via Intermediate IM CN subsystem entities)

The SCC AS generates the SIP 200 (OK) response to the SIP INVITE request and forwards it to the SC UE A.

15-16: SIP ACK request (SC UE A to SCC AS via Intermediate IM CN subsystem entities)

The SC UE A generates the SIP ACK request to the SIP 200 (OK) response and forwards it to the SCC AS

17. Media paths between UE A and UE B

The multimedia is using the new IP-CAN. Resources used for signalling on the old IP-CAN#1 and CS bearer are not released.

18-19. SIP BYE request (SCC AS to SC UE A via intermediate IM CN subsystem entities)

The SCC AS terminates the replaced call leg- that was using the old IP-CAN#1, by sending a SIP BYE request towards the SC UE A.

20-21. SIP 200 (OK) response (SC UE A to SCC AS via intermediate IM CN subsystem entities)

Upon receiving the SIP BYE request over the old IP-CAN#1, the SC UE A sends a SIP 200 (OK) response over the old IP-CAN. Subsequently, the UE-1 relinquishes all resources pertaining to the old IP-CAN.

22-23. SIP BYE request (SCC AS to interworking entities via intermediate IM CN subsystem entities)

The SCC AS terminates the replaced call leg, which was using the CS bearer, by sending a BYE request.

24-25. ISUP Message

Upon receiving the DISCONNECT request, the SC UE A relinquishes all resources pertaining to the CS bearer.

26-27. SIP 200 (OK) response (Interworking entities to SCC AS via intermediate IM CN subsystem entities)

28. Media paths between UE A and UE B

The multimedia session is using the new IP-CAN#2.

A.9 Signalling flows for media adding/deleting

A.9.1 Introduction

The signalling flows for media adding/deleting demonstrate how the media of a multimedia session is added or deleted. The following signalling flow is included:

- subclause A.9.2 shows an example when the non-realtime media of a multimedia session over the IP-CAN is removed.

A.9.2 Remote End Initiation case – Removing media from split CS and PS sessions

As a precondition the SC UE A has a CS call and IMS multimedia session with the remote end after session transfer in a manner that more than one session are presented to UE B as one IMS session by the SCC AS.

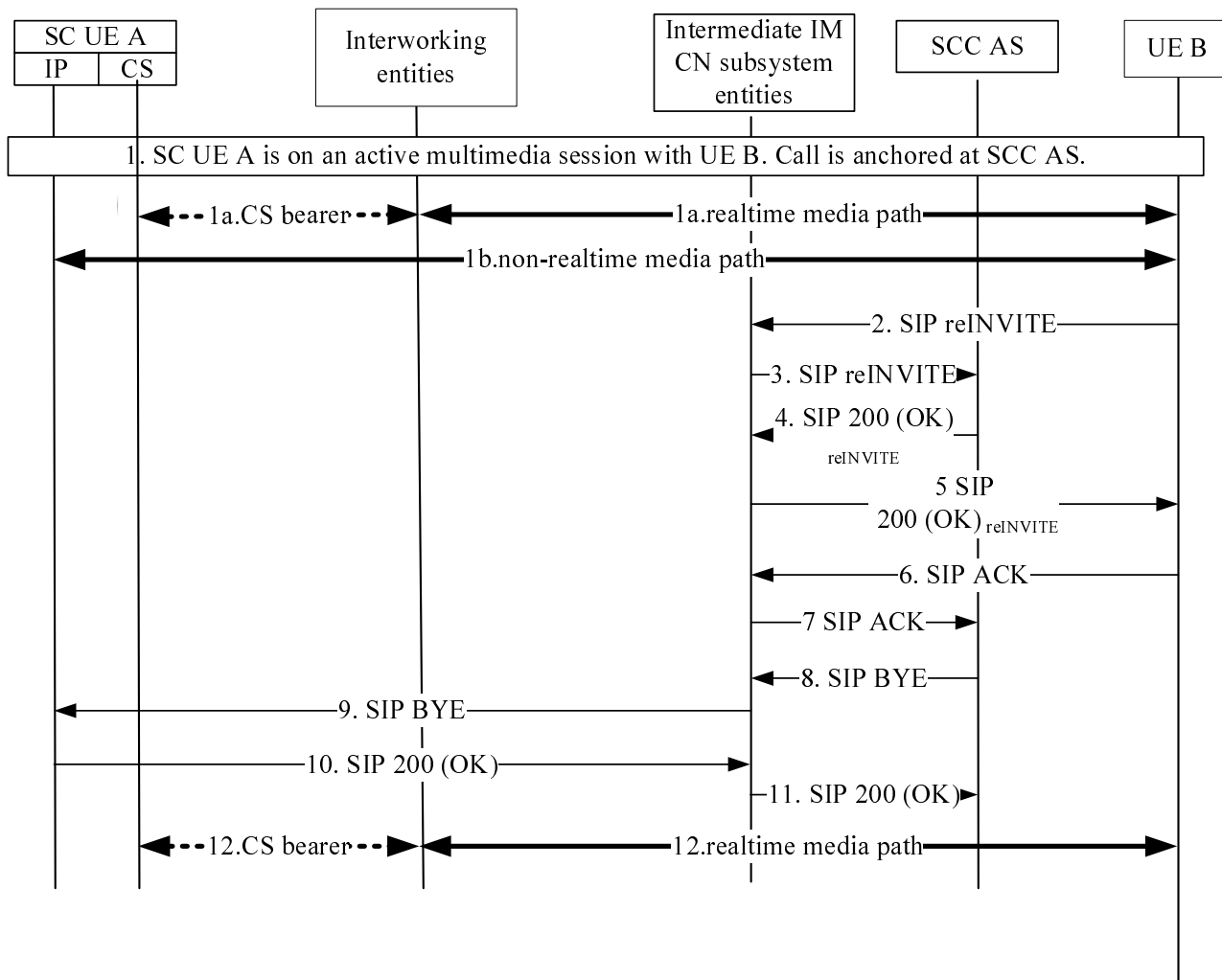

Figure A.9.2-1: Remote End Initiation case – Removing media from split CS and PS sessions

NOTE 1: For clarity, the SIP 100 (Trying) responses are not shown in the signalling flow.

1. SC UE A has an ongoing multimedia session with remote UE B

The call has been anchored at the SCC AS which is in the HPLMN of originating SC UE A.

Table A.9.2-1 shows an example of the SDP offer from SC UE A to remote UE B.

NOTE 2: To show how the media is removed, only the SDP offer is shown in this example.

Table A.9.2-1: SIP INVITE request (SC UE A to intermediate IM CN subsystem entities)

```
INVITE tel:+1-237-555-2222 SIP/2.0
Via:
Max-Forwards:
Route:
P-Asserted-Identity:
P-Charging-Vector:
P-Access-Network-Info:
Privacy:
From:
To:
Call-ID:
Cseq:
Supported:
Require:
Proxy-Require:
Security-Verify:
Contact:
Allow:
Accept:
Content-Type:
Content-Length: (...)

v=0
o=- 2987933615 2987933615 IN IP6 5555::aaa:bbb:ccc:ddd
s=
c=IN IP6 5555::aaa:bbb:ccc:ddd
t=0 0
m=message 7654 TCP/MSRP 98
a=accept-types:text/plain
```

2. SIP re-INVITE request (UE B to intermediate IM CN subsystem entities)- See example in table A.9.2.-2

The remote UE B decides to remove the non-realtime media from the multimedia session. It uses standard IMS procedures to remove one or more PS media from the session.

Table A.9.2-2: SIP re-INVITE request (UE B to intermediate IM CN subsystem entities)

```

INVITE < sip:user1_public1@home1.net;gr=urn:uuid:f81d4fae-7dec-11d0-a765-00a0c91e6bf6> SIP/2.0
Via: SIP/2.0/UDP sccas1.home1.net;branch=z9hG4bKnas34r5
Max-Forwards: 67
Route: < sip:scscf1.home1.net:lr>
P-Asserted-Identity: <tel: +1-237-555-2222>
P-Charging-Function-Addresses: ccf=[5555::b99:c88:d77:e66]; ccf=[5555::a55:b44:c33:d22];
    ecf=[5555::1ff:2ee:3dd:4ee]; ecf=[5555::6aa:7bb:8cc:9dd]
P-Charging-Vector: icid-value="AyretyU0dm+602Irt5tAFrbHLso=023551024"; orig-
    ioi="type3home1.net"
P-Access-Network-Info:
Privacy: none
From: <tel: +1-237-555-2222; gr=hdg7777ad7aflzig8sf7>;tag=171828
To: <tel:+1-237-555-1111>
Call-ID: cb03a0s09a2sdfglkj490333
Cseq: 127 INVITE
Supported: 100rel, precondition
Require: sec-agree
Proxy-Require: sec-agree
Security-Verify: ipsec-3gpp; q=0.1; alg= hmac-sha-1-96; spi=87654321; port=7531
Contact: < sip:user2_public1@home2.net;gr=urn:uuid:2ad8950e-48a5-4a74-8d99-
    ad76cc7fc74>;g.3gpp.icsi-ref="urn%3Aurn-7%3gpp-service.ims.icsi.mmtel"
Allow: INVITE, ACK, CANCEL, BYE, PRACK, UPDATE, REFER, MESSAGE
Accept: application/sdp, application/3gpp-ims+xml
Content-Type: application/sdp
Content-Length: (...)

v=0
o=- 2987933615 2987933615 IN IP6 5555::aaa:bbb:ccc:ddd
s=
c=IN IP6 5555::aaa:bbb:ccc:ddd
t=0 0
m=audio 3456 RTP/AVP 97 96
b=AS:25.4
a=curr:qos local sendrecv
a=curr:qos remote none
a=des:qos mandatory local sendrecv
a=des:qos none remote sendrecv
a=rtpmap:97 AMR
a=fmtp:97 mode-set=0,2,5,7; mode-change-period=2
a=rtpmap:96 telephone-event
a=maxptime:20
m=message 0 TCP/MSRP 98
a=accept-types:text/plain

```

3. SIP re-INVITE request (Intermediate IM CN subsystem entities to SCC AS)**4-5. SIP 200 (OK) response (SCC AS to UE B via Intermediate IM CN subsystem entities)**

The SCC AS generates the SIP 200 (OK) response to the SIP re-INVITE request and forwards it to the remote UE B.

6-7: SIP ACK request (UE B to SCC AS via Intermediate IM CN subsystem entities)

The UE B generates the SIP ACK request to the SIP SIP 200 (OK) response and forwards it to the SCC AS.

8-9: SIP BYE request (SCC AS to SC UE A via intermediate IM CN subsystem entities)

The SCC AS terminates the replaced call leg, which was using the IP-CAN, by sending a SIP BYE request to the UE A.

10-11. SIP 200 (OK) response (SC UE A to SCC AS via intermediate IM CN subsystem entities)

Upon receiving the BYE request over the IP-CAN, the SC UE A sends a SIP 200 (OK) response over the IP-CAN to the SCC AS. Subsequently, the SC UE A relinquishes all resources pertaining to the IP-CAN.

12. Media paths between SC UE A and UE B

Finally, the non-realtime media path over the IP-CAN is removed.

Annex B (informative): Change history

Change history							
Date	TSG #	TSG Doc.	CR	R ev	Subject/Comment	Old	New
2008-05	CT1#53	C1-082007			Skeleton of TS from rapporteur	-	0.0.0
2008-05	CT1#53	C1-082008 C1-082009			Incorporate agreed P-CRs from CT1#53	0.0.0	0.1.0
2008-05	Email Review				Format update	0.1.0	0.1.1
2008-06	CT1#54	C1-082394			Pseudo-CR on Introduction for signalling flows	0.1.1	0.2.0
2008-06	CT1#54	C1-082666			Application level handover	0.1.1	0.2.0
2008-06	CT1#54	C1-082667			Role of UE in registration	0.1.1	0.2.0
2008-06	CT1#54	C1-082668			Role of UE in origination and termination	0.1.1	0.2.0
2008-06	CT1#54	C1-082669			Role of UE in PS-PS session continuity	0.1.1	0.2.0
2008-06	CT1#54	C1-082671			Pseudo-CR on Cleanup of TS 24.237	0.1.1	0.2.0
2008-06	CT1#54	C1-082672			Pseudo-CR on Roles for registration in IMS	0.1.1	0.2.0
2008-06	CT1#54	C1-082766			Pseudo-CR on Signalling flows for CS call origination	0.1.1	0.2.0
2008-06	CT1#54	C1-082767			Pseudo-CR on Signalling flows for CS call termination	0.1.1	0.2.0
2008-08	CT1#55	C1-083376			Clarifications usage of CS and ICS within IMS SC	0.2.0	0.3.0
2008-08	CT1#55	C1-083377			Functional Entities	0.2.0	0.3.0
2008-08	CT1#55	C1-083378			Signalling flows for registration	0.2.0	0.3.0
2008-08	CT1#55	C1-083379			SCC AS procedures for PS-PS session continuity	0.2.0	0.3.0
2008-08	CT1#55	C1-083380			SC UE procedures for PS-PS session continuity	0.2.0	0.3.0
2008-08	CT1#55	C1-083382			Signalling flow for Media adding/deleting	0.2.0	0.3.0
2008-10	CT1#55bis	C1-083783			PS-PS Access transfer with full media transfer	1.0.0	1.1.0
2008-10	CT1#55bis	C1-083903			Editorial Cleanup	1.0.0	1.1.0
2008-10	CT1#55bis	C1-084260			network capabilities and URI assignments for IMS SC	1.0.0	1.1.0
2008-10	CT1#55bis	C1-084261			Procedures for IMS SC call origination	1.0.0	1.1.0
2008-10	CT1#55bis	C1-084262			Procedures for call termination	1.0.0	1.1.0
2008-10	CT1#55bis	C1-084265			Signalling flow for PS-CS session continuity	1.0.0	1.1.0
2008-10	CT1#55bis	C1-084266			Signalling flow for PS-PS session continuity in conjunction with PS- CS session continuity	1.0.0	1.1.0
2008-10	CT1#55bis	C1-084268			Clarification of signalling flow for call termination	1.0.0	1.1.0
2008-10	CT1#55bis	C1-084269			Clarification of signalling flow for call origination	1.0.0	1.1.0
2008-10	CT1#55bis	C1-084433			Signalling Flows for Multiple Registrations	1.0.0	1.1.0
2008-10	CT1#55bis	C1-084447			Procedures for PS-PS session transfer in conjunction with PS- CS session transfer	1.0.0	1.1.0
2008-10	CT1#55bis	C1-084448			Procedures for adding/removing media	1.0.0	1.1.0
2008-10	CT1#55bis	C1-084449			Call flow for PS-PS partial media transfer	1.0.0	1.1.0
2008-10	CT1#55bis	C1-084506			Procedures for PS-CS session transfer	1.0.0	1.1.0
2008-10	CT1#55bis				Change the Keywords to: IMS, Multimedia Session, and Session Continuity.	1.0.0	1.1.0
2008-10	Email Review				Editorial Cleanup	1.1.0	1.1.1
2008-11	CT1#56	C1-084798			Removal of Editor"s Note	1.1.1	1.2.0
2008-11	CT1#56	C1-084866			cleanup for PS-PS session transfer procedures	1.1.1	1.2.0
2008-11	CT1#56	C1-085085			Correction: No usage of CS indication in non-ICS case	1.1.1	1.2.0
2008-11	CT1#56	C1-085242			Scope of signalling flows	1.1.1	1.2.0
2008-11	CT1#56	C1-085243			Cleanup of call origination signalling flows	1.1.1	1.2.0
2008-11	CT1#56	C1-085244			Cleanup of call termination signalling flows	1.1.1	1.2.0
2008-11	CT1#56	C1-085245			Signalling flows for PS to CS session transfer	1.1.1	1.2.0
2008-11	CT1#56	C1-085246			Signalling flows for PS+CS to PS session transfer	1.1.1	1.2.0
2008-11	CT1#56	C1-085247			Clean up of SCC Registration information	1.1.1	1.2.0
2008-11	CT1#56	C1-085251			cleanups to PS-PS in conjunction with PS-CS session transfer procedures	1.1.1	1.2.0
2008-11	CT1#56	C1-085252			cleanups for media adding/removing procedures	1.1.1	1.2.0
2008-11	CT1#56	C1-085449			PS-CS session transfer procedures	1.1.1	1.2.0
2008-11	CT1#56	C1-085464			SR-VCC	1.1.1	1.2.0
2008-11	CT1#56	C1-085481			PS-PS full session transfer using Target-Dialog header	1.1.1	1.2.0
2008-11					Version 2.0.0 created for presentation to CT#42 for approval	1.2.0	2.0.0
2008-12	CT#42				Version 8.0.0 created after approval in CT#42	2.0.0	8.0.0
2009-03	CT#43	CP-090147	0002	3	Cleanup to TS 24.237	8.0.0	8.1.0
2009-03	CT#43	CP-090147	0003	1	Remove void introduction subclauses	8.0.0	8.1.0
2009-03	CT#43	CP-090147	0004	2	UE procedures for operator policy support	8.0.0	8.1.0

2009-03	CT#43	CP-090147	0005	1	Flows for originating and and terminating session in session continuity	8.0.0	8.1.0
2009-03	CT#43	CP-090147	0009	1	Correction SR-VCC procedures	8.0.0	8.1.0
2009-03	CT#43	CP-090147	0010	1	Correction to flows for session continuity	8.0.0	8.1.0
2009-03	CT#43	CP-090147	0011	2	Completion of IMRN functionality	8.0.0	8.1.0
2009-03	CT#43	CP-090147	0012	1	SCC AS Transparently passing Contact To and From headers	8.0.0	8.1.0
2009-03	CT#43	CP-090147	0013	3	Conveying ICS registration information using 3rd party Registration and GRUU/ICSI/IARI corrections	8.0.0	8.1.0
2009-03	CT#43	CP-090147	0014	2	Use of GRUU by SC UE	8.0.0	8.1.0
2009-03	CT#43	CP-090147	0015	2	Modification for the SCC AS procedure for CS to PS session transfer	8.0.0	8.1.0
2009-03	CT#43	CP-090147	0018	2	Definitions of Dynamic and Static STI	8.0.0	8.1.0
2009-03	CT#43	CP-090147	0019	2	Miscellaneous corrections to session continuity procedures	8.0.0	8.1.0
2009-03	CT#43	CP-090147	0020	2	SCC – Correlation	8.0.0	8.1.0
2009-06	CT#44	CP-090417	0006	3	Session transfer when PS session exists in target access – terminating case	8.1.0	8.2.0
2009-06	CT#44	CP-090417	0021	1	PS-PS+CS when service control over Gm is retained on source access leg	8.1.0	8.2.0
2009-06	CT#44	CP-090417	0022	1	Service Control Signalling Path transfer for ICS session continuity during PS-PS transfer	8.1.0	8.2.0
2009-06	CT#44	CP-090417	0026	1	Correlation CS anchored call with IMS Registration	8.1.0	8.2.0
2009-06	CT#44	CP-090417	0029	2	Clarification of the identification of the originating user	8.1.0	8.2.0
2009-06	CT#44	CP-090417	0031	3	Clarification of for the BYE request used in PS-PS partial reansfer	8.1.0	8.2.0
2009-06	CT#44				Editorial cleanup by MCC	8.1.0	8.2.0
2009-09	CT#45	CP-090669	0035	1	CS to PS transfer request by non ICS UE	8.2.0	8.3.0
2009-09	CT#45	CP-090669	0036	1	Multiple active sessions, PS to CS transfer	8.2.0	8.3.0
2009-09	CT#45	CP-090669	0052	1	Use of "Target-Dialog" for (PS+CS) to PS session transfer	8.2.0	8.3.0
2009-09	CT#45	CP-090669	0053	2	Source access leg release at the SCC AS for PS to PS session transfer	8.2.0	8.3.0
2009-09	CT#45	CP-090669	0065	2	Directing requests using the appropriate IP-CAN	8.2.0	8.3.0
2009-09	CT#45	CP-090669	0066	1	Flow updates for directing requests using the appropriate IP-CAN	8.2.0	8.3.0
2009-09	CT#45	CP-090669	0073	2	Session transfer when PS session exists in target access	8.2.0	8.3.0
2009-09	CT#45	CP-090669	0079	2	Clarification of Source Access Leg Release in PS-CS transfer procedure	8.2.0	8.3.0
2009-12	CT#46	CP-090911	0152	2	Enabling session continuity functionality	8.3.0	8.4.0
2009-12	CT#46	CP-090911	0159	1	Address the Editor's Note in A.3.2	8.3.0	8.4.0
2009-12	CT#46	CP-090911	0161	1	Address the Editor's Note in A.8.2	8.3.0	8.4.0
2010-03	CT#47	CP-100123	0143	5	PS to CS or to (PS+CS) session transfer for an SC UE using Gm interface	8.4.0	8.5.0
2010-03	CT#47	CP-100123	0235	1	Clarification of SC OMA MO use	8.4.0	8.5.0
2010-03	CT#47	CP-100123	0239		Correct the definition of Correlation MSISDN	8.4.0	8.5.0
2010-09	CT#49	CP-100493	0306	2	Clarifying SC UE procedures for terminations	8.5.0	8.6.0
2010-09	CT#49	CP-100493	0309	2	Corrections use of 3GPP TS 24.216 MO leaf	8.5.0	8.6.0
2010-09	CT#49	CP-100493	0318	1	UE compliance	8.5.0	8.6.0
2010-09	CT#49	CP-100493	0329		PS-CS access transfer corrections	8.5.0	8.6.0

History

Document history		
V8.0.0	January 2009	Publication
V8.1.0	March 2009	Publication
V8.2.0	June 2009	Publication
V8.3.0	September 2009	Publication
V8.4.0	January 2010	Publication
V8.5.0	April 2010	Publication
V8.6.0	October 2010	Publication