

ETSI TS 124 238 V16.0.0 (2020-07)



**Universal Mobile Telecommunications System (UMTS);
LTE;
Session Initiation Protocol (SIP) based user configuration;
Stage 3
(3GPP TS 24.238 version 16.0.0 Release 16)**



Reference

RTS/TSGC-0124238vg00

Keywords

LTE,UMTS

ETSI

650 Route des Lucioles
F-06921 Sophia Antipolis Cedex - FRANCE

Tel.: +33 4 92 94 42 00 Fax: +33 4 93 65 47 16

Siret N° 348 623 562 00017 - NAF 742 C
Association à but non lucratif enregistrée à la
Sous-Préfecture de Grasse (06) N° 7803/88

Important notice

The present document can be downloaded from:

<http://www.etsi.org/standards-search>

The present document may be made available in electronic versions and/or in print. The content of any electronic and/or print versions of the present document shall not be modified without the prior written authorization of ETSI. In case of any existing or perceived difference in contents between such versions and/or in print, the prevailing version of an ETSI deliverable is the one made publicly available in PDF format at www.etsi.org/deliver.

Users of the present document should be aware that the document may be subject to revision or change of status.

Information on the current status of this and other ETSI documents is available at

<https://portal.etsi.org/TB/ETSIDeliverableStatus.aspx>

If you find errors in the present document, please send your comment to one of the following services:

<https://portal.etsi.org/People/CommitteeSupportStaff.aspx>

Copyright Notification

No part may be reproduced or utilized in any form or by any means, electronic or mechanical, including photocopying and microfilm except as authorized by written permission of ETSI.

The content of the PDF version shall not be modified without the written authorization of ETSI.

The copyright and the foregoing restriction extend to reproduction in all media.

© ETSI 2020.

All rights reserved.

DECT™, **PLUGTESTS™**, **UMTS™** and the ETSI logo are trademarks of ETSI registered for the benefit of its Members.

3GPP™ and **LTE™** are trademarks of ETSI registered for the benefit of its Members and of the 3GPP Organizational Partners.

oneM2M™ logo is a trademark of ETSI registered for the benefit of its Members and of the oneM2M Partners.

GSM® and the GSM logo are trademarks registered and owned by the GSM Association.

Intellectual Property Rights

Essential patents

IPRs essential or potentially essential to normative deliverables may have been declared to ETSI. The information pertaining to these essential IPRs, if any, is publicly available for **ETSI members and non-members**, and can be found in ETSI SR 000 314: "*Intellectual Property Rights (IPRs); Essential, or potentially Essential, IPRs notified to ETSI in respect of ETSI standards*", which is available from the ETSI Secretariat. Latest updates are available on the ETSI Web server (<https://ipr.etsi.org/>).

Pursuant to the ETSI IPR Policy, no investigation, including IPR searches, has been carried out by ETSI. No guarantee can be given as to the existence of other IPRs not referenced in ETSI SR 000 314 (or the updates on the ETSI Web server) which are, or may be, or may become, essential to the present document.

Trademarks

The present document may include trademarks and/or tradenames which are asserted and/or registered by their owners. ETSI claims no ownership of these except for any which are indicated as being the property of ETSI, and conveys no right to use or reproduce any trademark and/or tradename. Mention of those trademarks in the present document does not constitute an endorsement by ETSI of products, services or organizations associated with those trademarks.

Legal Notice

This Technical Specification (TS) has been produced by ETSI 3rd Generation Partnership Project (3GPP).

The present document may refer to technical specifications or reports using their 3GPP identities. These shall be interpreted as being references to the corresponding ETSI deliverables.

The cross reference between 3GPP and ETSI identities can be found under <http://webapp.etsi.org/key/queryform.asp>.

Modal verbs terminology

In the present document "**shall**", "**shall not**", "**should**", "**should not**", "**may**", "**need not**", "**will**", "**will not**", "**can**" and "**cannot**" are to be interpreted as described in clause 3.2 of the [ETSI Drafting Rules](#) (Verbal forms for the expression of provisions).

"**must**" and "**must not**" are **NOT** allowed in ETSI deliverables except when used in direct citation.

Contents

Intellectual Property Rights	2
Legal Notice	2
Modal verbs terminology.....	2
Foreword.....	4
1 Scope	5
2 References	5
3 Definitions, symbols and abbreviations	5
3.1 Definitions	5
3.2 Abbreviations	6
4 SIP based user configuration.....	6
4.1 General description.....	6
4.2 Syntax requirements	6
4.3 Signalling requirements.....	6
4.3.1 General.....	6
4.3.2 Actions at the originating UE (SIP-based user configuration client).....	6
4.3.3 Actions at the AS serving the originating UE.....	7
4.3.4 Password option.....	7
4.3.4.1 General	7
4.3.4.2 Procedures at the UE.....	7
4.3.4.3 Procedures at the AS	7
4.3.4.3.1 General	7
4.3.4.3.2 Password check	8
4.3.4.3.3 Password change	8
Annex A (informative): Signalling flows	9
A.1 User provisioning by SIP-based user configuration, announcement on established dialog	9
A.2 User provisioning by SIP-based user configuration, announcement on early dialog.....	10
Annex B (informative): Change history	13
History	14

Foreword

This Technical Specification has been produced by the 3rd Generation Partnership Project (3GPP).

The contents of the present document are subject to continuing work within the TSG and may change following formal TSG approval. Should the TSG modify the contents of the present document, it will be re-released by the TSG with an identifying change of release date and an increase in version number as follows:

Version x.y.z

where:

- x the first digit:
 - 1 presented to TSG for information;
 - 2 presented to TSG for approval;
 - 3 or greater indicates TSG approved document under change control.
- y the second digit is incremented for all changes of substance, i.e. technical enhancements, corrections, updates, etc.
- z the third digit is incremented when editorial only changes have been incorporated in the document.

1 Scope

The present document provides a Session Initiation Protocol (SIP) based protocol framework that serves as a means of user configuration of supplementary services in the IP Multimedia (IM) Core Network (CN) subsystem. The protocol framework relies upon the contents of the Request-URI in a SIP INVITE request to enable basic configuration of services without requiring use of the Ut interface.

The present document is applicable to User Equipment (UE) and Application Servers (AS) which are intended to support user configuration of supplementary services.

2 References

The following documents contain provisions which, through reference in this text, constitute provisions of the present document.

- References are either specific (identified by date of publication, edition number, version number, etc.) or non-specific.
- For a specific reference, subsequent revisions do not apply.
- For a non-specific reference, the latest version applies. In the case of a reference to a 3GPP document (including a GSM document), a non-specific reference implicitly refers to the latest version of that document *in the same Release as the present document*.

- [1] 3GPP TR 21.905: "Vocabulary for 3GPP Specifications".
- [2] 3GPP TS 24.173: "IMS multimedia telephony communication service and supplementary services; Stage 3".
- [3] 3GPP TS 24.229: "IP Multimedia Call Control Protocol based on Session Initiation Protocol (SIP) and Session Description Protocol (SDP); Stage 3".
- [4] RFC 4967 (July 2007): "Dial String Parameter for the Session Initiation Protocol Uniform Resource Identifier".
- [5] RFC 3966 (December 2004): "The tel URI for Telephone Numbers".
- [6] 3GPP TS 24.315: "IP Multimedia Subsystem (IMS) Operator Determined Barring (ODB); Stage 3".
- [7] 3GPP TS 24.628: "Common Basic Communication procedures using IP Multimedia (IM) Core Network (CN) subsystem; Protocol specification".

3 Definitions, symbols and abbreviations

3.1 Definitions

For the purposes of the present document, the terms and definitions given in 3GPP TR 21.905 [1] and the following apply. A term defined in the present document takes precedence over the definition of the same term, if any, in 3GPP TR 21.905 [1].

3.2 Abbreviations

For the purposes of the present document, the abbreviations given in 3GPP TR 21.905 [1] and the following apply. An abbreviation defined in the present document takes precedence over the definition of the same abbreviation, if any, in 3GPP TR 21.905 [1].

4 SIP based user configuration

4.1 General description

SIP-based protocol framework serves as a means of user configuration of supplementary services in the IM CN subsystem specified in 3GPP TS 24.173 [2]. The contents of the Request-URI in a SIP INVITE request is used to convey the configuration code to the Application Server that hosts the supplementary service. Upon session initiation, the contents of the Request-URI are delivered by means of normal session setup signalling, as described in 3GPP TS 24.229 [3] to an Application Server. The Application Server then acts upon the Request-URI contents to effect the desired configuration data change (e.g., register and activate Communication Forwarding unconditional).

Procedures regarding Operator Determined Barring (ODB) are defined in 3GPP TS 24.315 [6].

4.2 Syntax requirements

The precise digit sequences within the Request-URI that comprise the effective dialstrings for user configuration are defined by the IM CN subsystem service provider and are not subject to standardisation.

NOTE 1: The digit sequence corresponding to the feature code can begin with a special character such as "#" or "*" according to network operator preferences. The length of the digit sequence is also defined by the network operator.

The digit sequences corresponding to the feature code shall be transported to the AS in the Request-URI of a SIP INVITE request as follows:

- 1) as a SIP URI dial string conforming to RFC 4967 [4] where the "phone-context" parameter is set to the home network domain name and the "user" parameter is set to "dialstring";
- 2) as a SIP URI that is not a GRUU, with the user part preceded with a "+", the "user" parameter set to "phone" and the domain part set to the home network domain; or
- 3) as a tel URI with a "phone-context" parameter set to the home network domain as defined in RFC 3966 [5].

NOTE 2: The format for encoding of the digit sequence defined in the first bullet is the preferred format. The other two formats are now deprecated.

4.3 Signalling requirements

4.3.1 General

Two roles are recognized for the implementation of SIP-based user configuration:

- 1) UE (SIP-based user configuration client); and
- 2) Application Server.

4.3.2 Actions at the originating UE (SIP-based user configuration client)

When performing SIP-based user configuration, the UE shall create a SIP URI, as described in RFC 4967 [4], with:

- a) a dialstring, set to either the concatenation of feature code and the number to be provisioned or the feature code alone if no number information needs to be provided for the service; and
- b) a "phone-context" parameter, set to the home network domain name.

The UE shall construct and initiate an appropriate INVITE in accordance with 3GPP TS 24.229 [3] with the Request-URI set to the URI created above.

4.3.3 Actions at the AS serving the originating UE

Upon receiving an INVITE request with a Request-URI containing a URI configured as defined in bullet 1 of subclause 4.2, the AS shall perform service activation, deactivation, or configuration data modification based on the recognized contents of the Request-URI.

An AS can receive an INVITE request with a Request-URI containing a URI configured as defined in bullets 2 and 3 of subclause 4.2. In which case, the AS may treat this Request-URI as a dial-string, as specified above.

Based on the outcome of the service configuration operation, the AS may:

- play an appropriate announcement using the methods specified in 3GPP TS 24.628 [7] to notify the user of the result of the operation; or
- send an appropriate error response in case the AS was unable to perform the requested service configuration operation.

4.3.4 Password option

4.3.4.1 General

By using the subscription option "control of supplementary service", the service configuration may be restricted by a password. The subscription option "control of supplementary service" can be set to "by the service provider" or "by subscriber using a password".

4.3.4.2 Procedures at the UE

When the subscription option "control of supplementary service" is set to "by subscriber using a password", the UE shall create the INVITE request as described in subclause 4.3.2 with a dialstring including a feature code with either the current password or both the current password and the new password to be registered.

4.3.4.3 Procedures at the AS

4.3.4.3.1 General

When the AS receives a Request URI in the INVITE request as defined in subclause 4.2 with a service configuration or a password change request, and the subscription option "control of supplementary service" is set to "by the service provider", the AS shall send a 403 (Forbidden) error response.

As a network option, the AS may play an appropriate announcement using the methods specified in 3GPP TS 24.628 [7] to notify the user that the operation is rejected.

When the subscription option "control of supplementary service" is set to "by subscriber using a password", the AS shall perform the password management procedures that consist of two independent procedures:

- password check; and
- password change;

The password check procedure is used for verifying the current password stored against the user:

- when the user requests a password change; and

- when the user requests modification of a supplementary service configuration document for a service that has password control.

The password change procedure is used by the AS to set a new password for the user.

The AS shall maintain a Wrong Password Attempts (WPA) counter.

When the password is set by the service provider the AS shall reset the WPA counter to zero.

If the AS receives a password that does not match the current password stored for the service, the AS shall increment the WPA counter by 1.

If a password check passes at the AS, the AS shall reset the WPA counter to zero. If the WPA counter exceeds the value three, the AS shall set the subscription option "control of supplementary service" to "by the service provider".

4.3.4.3.2 Password check

If the subscription option "control of supplementary service" is set to "by subscriber using a password" for a supplementary service configuration and a password change request is received, the AS shall verify that the password is present in the Request-URI and matches that stored for the user.

If a password is required, and the AS:

- receives a request where the Request URI is not formatted as defined in subclause 4.2;
- receives a request where the Request URI does not contain a password; or
- receives a request where the Request URI contains a password and the password does not match the current password stored for the user;

then the AS shall send a 403 (Forbidden) error response in case the AS was unable to perform the requested service configuration operation.

As a network option, the AS may play an appropriate announcement using the methods specified in 3GPP TS 24.628 [7] to notify the user of the result of the operation.

4.3.4.3.3 Password change

When the AS receives a Request URI as defined in subclause 4.2 with a password change request and the subscription option "control of supplementary service" is set to a value of "by subscriber using a password", the AS shall determine if the user is authorized to change the password by performing the password check procedure as described in subclause 4.3.4.2, and if so replace the currently used password with the new password. The new password is stored in an implementation specific way such that the password cannot be retrieved by the user.

Annex A (informative): Signalling flows

A.1 User provisioning by SIP-based user configuration, announcement on established dialog

The signalling flow below illustrates the use of the SIP-based user configuration capability. This basic capability is used for activation, deactivation and configuration data modification.

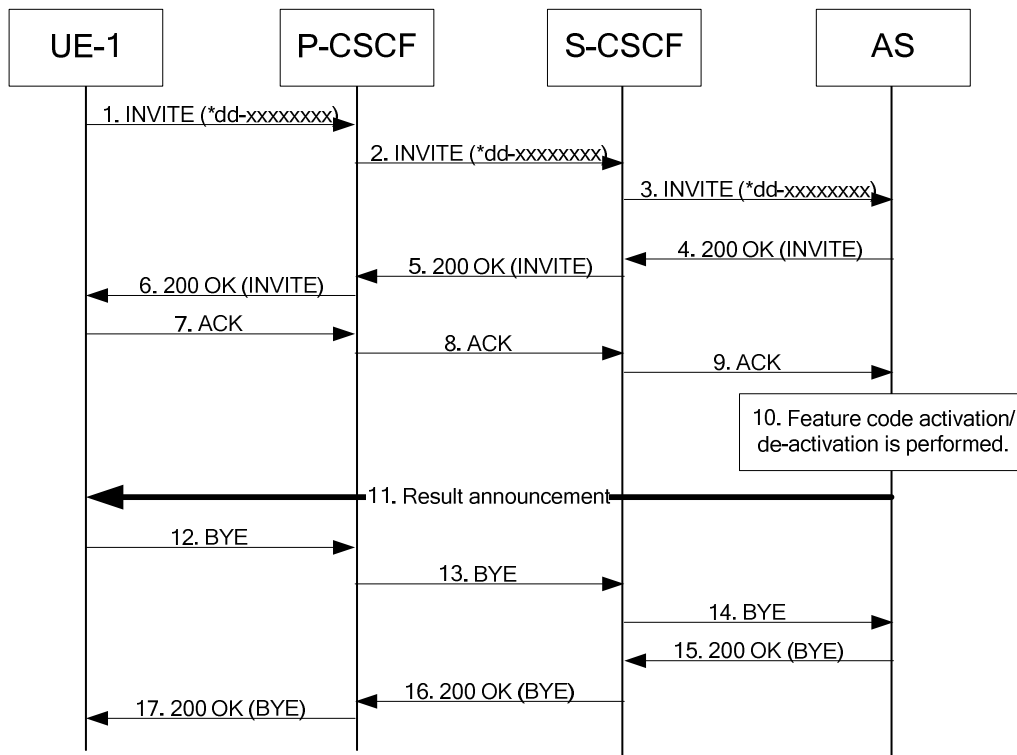

Figure A-1: User provisioning using feature code

1-3. SIP INVITE request including the provisioning information to the provisioning AS as part of the Request URI - see example in table A.1-1.

4-9. Completion of call setup following normal procedures.

Table A.1-1: INVITE request (UE-1 to P-CSCF)

```

INVITE sip:*12345;phone-context=home1.net/home1.net;user=dialstring SIP/2.0
Via: SIP/2.0/UDP [5555::aaa:bbb:ccc:ddd]:1357;comp=sigcomp;branch=z9hG4bKnashds7
Max-Forwards: 70
Route: <sip:pcscf1.visited1.net:7531;lr;comp=sigcomp>, <sip:scscf1.home1.net;lr>
Accept-Contact: *;+g.3gpp.icsi-ref="urn%3Aurn-7%3gpp-service.ims.icsi.mmtel"
P-Preferred-Identity: "John Doe" <sip:user1_public1@home1.net>
P-Access-Network-Info: 3GPP-UTRAN-TDD; utran-cell-id-3gpp=234151D0FCE11
Privacy: none
From: <sip:user1_public1@home1.net>;tag=171828
To: <sip:*12345;phone-context=home1.net;user=dialstring>
Call-ID: cb03a0s09a2sdfg1kj490333
Cseq: 127 INVITE
Require: sec-agree
Supported: precondition, 100rel, gruu
Proxy-Require: sec-agree
Security-Verify: ipsec-3gpp; q=0.1; alg= hmac-sha-1-96; ealg=aes-cbc; spi-c=98765432; spi-
s=87654321; port-c=8642; port-s=7531
  
```

```
Contact: <sip:user1_public1@home1.net;gr=hdg7777ad7aflzig8sf7>;comp=sigcomp;+g.3gpp.icsi-
ref="urn%3Aurn-7%3gpp-service.ims.icsi.mmtel"
Allow: INVITE, ACK, CANCEL, BYE, PRACK, UPDATE, REFER, MESSAGE
Accept: application/sdp; application/3gpp-ims+xml
Content-Type: application/sdp
Content-Length: (...)

v=0
o=- 2987933615 2987933615 IN IP6 5555::aaa:bbb:ccc:ddd
s=-
c=IN IP6 5555::aaa:bbb:ccc:ddd
t=0 0
m=audio 3456 RTP/AVP 97 96
b=AS:25.4
a=curr:qos local none
a=curr:qos remote none
a=des:qos mandatory local sendrecv
a=des:qos none remote sendrecv
a=inactive
a=rtpmap:97 AMR
a=fmtp:97 mode-set=0,2,5,7; maxframes=2
a=rtpmap:96 telephone-event
```

Request-URI: in this example, the configuration feature code is set to *12345 and is represented as a dialstring.

SDP: the SDP is included for audio media, facilitating possible usage of audio announcements, DTMF tones and IVR interaction depending on how the network operator deploys the service configuration.

10. The AS performs feature activation, deactivation or configuration data modification based on the information received from the UE.

11. The AS can also, by interaction with an MRFC, announce the result of the configuration operation to UE-1.

12-17. After the provisioning is completed, UE-1 sends a BYE request to terminate the call with the AS.

A.2 User provisioning by SIP-based user configuration, announcement on early dialog

The signalling flow below illustrates the use of the SIP-based user configuration capability, when an announcement is provided on a dialog in early state. This basic capability is used for activation, deactivation and configuration data modification.

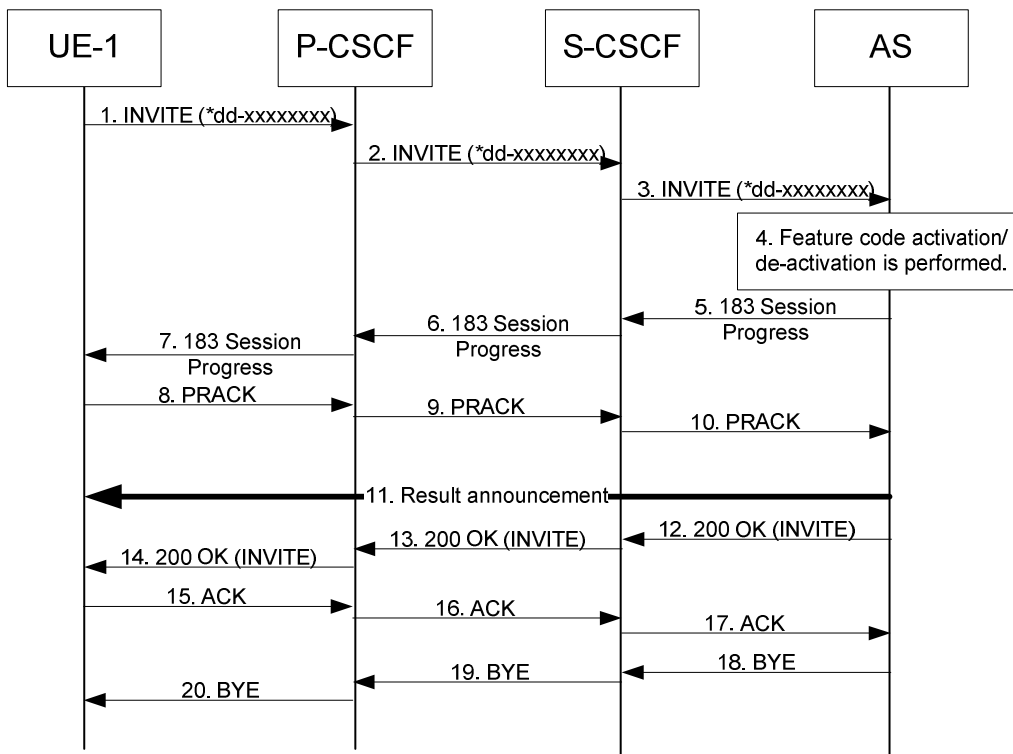

Figure A-2: User provisioning using feature code

1-3. SIP INVITE request including the provisioning information to the provisioning AS as part of the Request URI - see example in table A.2-1.

Table A.2-1: INVITE request (UE-1 to P-CSCF)

```

INVITE sip:*12345;phone-context=homel.net;user=dialstring SIP@homel.net/2.0
Via: SIP/2.0/UDP [5555::aaa:bbb:ccc:ddd]:1357;comp=sigcomp;branch=z9hG4bKnashds7
Max-Forwards: 70
Route: <sip:pcscf1.visited1.net:7531;lr;comp=sigcomp>, <sip:scscf1.homel.net;lr>
Accept-Contact: *;+g.3gpp.icsi-ref="urn%3Aurn-7%3gpp-service.ims.icsi.mmtel"
P-Preferred-Identity: "John Doe" <sip:user1_public1@homel.net>
P-Access-Network-Info: 3GPP-UTRAN-TDD; utran-cell-id-3gpp=234151D0FCE11
Privacy: none
From: <sip:user1_public1@homel.net>;tag=171828
To: < sip:*12345;phone-context=homel.net;user=dialstring>
Call-ID: cb03a0s09a2sdfgk490333
Cseq: 127 INVITE
Require: sec-agree
Supported: precondition, 100rel, gruu
Proxy-Require: sec-agree
Security-Verify: ipsec-3gpp; q=0.1; alg=hmac-sha-1-96; ealg=aes-cbc; spi-c=98765432; spi-
s=87654321; port-c=8642; port-s=7531
Contact: <sip:user1_public1@homel.net;gr=hdg7777ad7aflzig8sf7>;comp=sigcomp;+g.3gpp.icsi-
ref="urn%3Aurn-7%3gpp-service.ims.icsi.mmtel"
Allow: INVITE, ACK, CANCEL, BYE, PRACK, UPDATE, REFER, MESSAGE
Accept: application/sdp; application/3gpp-ims+xml
Content-Type: application/sdp
Content-Length: (...)

v=0
o=- 2987933615 2987933615 IN IP6 5555::aaa:bbb:ccc:ddd
s=-
c=IN IP6 5555::aaa:bbb:ccc:ddd
t=0 0
m=audio 3456 RTP/AVP 97 96
b=AS:25.4
a=curr:qos local none
a=curr:qos remote none
a=des:qos mandatory local sendrecv
a=des:qos none remote sendrecv
a=inactive
a=rtpmap:97 AMR
a=fmtp:97 mode-set=0,2,5,7; maxframes=2
a=rtpmap:96 telephone-event

```

Request-URI: in this example, the configuration feature code is set to *12345 and is represented as a dialstring.

SDP: the SDP is included for audio media, facilitating possible usage of audio announcements, DTMF tones and IVR interaction depending on how the network operator deploys the service configuration.

4. The AS performs feature activation, deactivation or configuration data modification based on the information received from the UE.

5-11. The AS can also, by interaction with an MRFC, announce the result of the configuration operation to UE-1.

12-17. After the announcement is completed, the AS sends a 200 OK response to UE-1.

18-20 After receipt of the ACK the AS terminates the call by sending a BYE request to UE-1.

Annex B (informative): Change history

Change history							
Date	TSG #	TSG Doc.	CR	R e v	Subject/Comment	Old	New
2008-04					Version 0.0.0 TS Skeleton	0.0.0	
2008-04					C1-081430: " Scope and General description for SIP based user configuration"		0.1.0
2008-04					C1-08146: " Text for syntax and signalling requirements for SIP based user configuration"		0.1.0
2008-04					C1-081112: " Example signalling flows for SIP based used configuration"		0.1.0
2008-05					Implemented C1-081948, C1-082046		0.2.0
2008-07					Implemented C1-082447 from CT1#54		0.3.0
2008-08					Implemented C1-082958, C1-083203, C1-083396		0.4.0
2008-09					Version 1.0.0 created for presentation to TSG CT#41 for information	0.4.0	1.0.0
2008-11					Miscellaneous editorial cleanups.	1.0.0	1.0.1
2008-11					Version 2.0.0 created for presentation to TSG CT#42 for approval	1.0.1	2.0.0
2008-12	CT#42				Version 8.0.0 created after approval in CT#42	2.0.0	8.0.0
2009-03	CT#43	CP-090121	0001		Correction of URN-value for Service Identifiers	8.0.0	8.1.0
2009-12	CT#46	CP-090908	0004	1	Removal of editor's note from 24.238	8.1.0	8.2.0
2009-12	CT#46	CP-090923	0005	2	Correction of icsi-ref feature tag	8.2.0	9.0.0
2011-03	CT#51				Upgrade to Rel-10	9.0.0	10.0.0
2012-06	CT#56	CP-120307	0008	2	Correction to URI included in Request URI of SIP INVITE	10.0.0	11.0.0
2012-12	CT#58	CP-120816	0009	2	Reference to ODB specification for SIP-based service configuration	11.0.0	11.1.0
2013-03	CT#59	CP-130122	0010	2	Allow error response for SIP based user configuration	11.1.0	11.2.0
2013-09	CT#61	CP-130511	0011		Correction to SIP user configuration	11.2.0	12.0.0
2015-12	CT#70				Upgrade to Rel-13	12.0.0	13.0.0
2017-03	CT#75	CP-170131	0012	1	Password handling	13.0.0	14.0.0

Change history							
Date	Meeting	TDoc	CR	Rev	Cat	Subject/Comment	New version
2017-06	CT#76	CP-171086	0013	1	F	Changing the Password	14.1.0
2017-09	CT#77	CP-172108	0014		F	Password check alignment	14.2.0
2018-06	SA#80	-	-	-	-	Update to Rel-15 version (MCC)	15.0.0
2020-07	SA-88e	-	-	-	-	Update to Rel-16 version (MCC)	16.0.0

History

Document history		
V16.0.0	July 2020	Publication