

ETSI TS 124 275 V18.1.0 (2024-05)



**LTE;
5G;
Management Object (MO) for Basic Communication Part (BCP)
of IMS Multimedia Telephony (MMTEL) communication service
(3GPP TS 24.275 version 18.1.0 Release 18)**



Reference

RTS/TSGC-0124275vi10

Keywords

5G,LTE

ETSI

650 Route des Lucioles
F-06921 Sophia Antipolis Cedex - FRANCE

Tel.: +33 4 92 94 42 00 Fax: +33 4 93 65 47 16

Siret N° 348 623 562 00017 - APE 7112B
Association à but non lucratif enregistrée à la
Sous-Préfecture de Grasse (06) N° w061004871

Important notice

The present document can be downloaded from:

<https://www.etsi.org/standards-search>

The present document may be made available in electronic versions and/or in print. The content of any electronic and/or print versions of the present document shall not be modified without the prior written authorization of ETSI. In case of any existing or perceived difference in contents between such versions and/or in print, the prevailing version of an ETSI deliverable is the one made publicly available in PDF format at www.etsi.org/deliver.

Users of the present document should be aware that the document may be subject to revision or change of status.

Information on the current status of this and other ETSI documents is available at

<https://portal.etsi.org/TB/ETSIDeliverableStatus.aspx>

If you find errors in the present document, please send your comment to one of the following services:

<https://portal.etsi.org/People/CommitteeSupportStaff.aspx>

If you find a security vulnerability in the present document, please report it through our
Coordinated Vulnerability Disclosure Program:

<https://www.etsi.org/standards/coordinated-vulnerability-disclosure>

Notice of disclaimer & limitation of liability

The information provided in the present deliverable is directed solely to professionals who have the appropriate degree of experience to understand and interpret its content in accordance with generally accepted engineering or other professional standard and applicable regulations.

No recommendation as to products and services or vendors is made or should be implied.

No representation or warranty is made that this deliverable is technically accurate or sufficient or conforms to any law and/or governmental rule and/or regulation and further, no representation or warranty is made of merchantability or fitness for any particular purpose or against infringement of intellectual property rights.

In no event shall ETSI be held liable for loss of profits or any other incidental or consequential damages.

Any software contained in this deliverable is provided "AS IS" with no warranties, express or implied, including but not limited to, the warranties of merchantability, fitness for a particular purpose and non-infringement of intellectual property rights and ETSI shall not be held liable in any event for any damages whatsoever (including, without limitation, damages for loss of profits, business interruption, loss of information, or any other pecuniary loss) arising out of or related to the use of or inability to use the software.

Copyright Notification

No part may be reproduced or utilized in any form or by any means, electronic or mechanical, including photocopying and microfilm except as authorized by written permission of ETSI.

The content of the PDF version shall not be modified without the written authorization of ETSI.

The copyright and the foregoing restriction extend to reproduction in all media.

© ETSI 2024.
All rights reserved.

Intellectual Property Rights

Essential patents

IPRs essential or potentially essential to normative deliverables may have been declared to ETSI. The declarations pertaining to these essential IPRs, if any, are publicly available for **ETSI members and non-members**, and can be found in ETSI SR 000 314: "*Intellectual Property Rights (IPRs); Essential, or potentially Essential, IPRs notified to ETSI in respect of ETSI standards*", which is available from the ETSI Secretariat. Latest updates are available on the ETSI Web server (<https://ipr.etsi.org/>).

Pursuant to the ETSI Directives including the ETSI IPR Policy, no investigation regarding the essentiality of IPRs, including IPR searches, has been carried out by ETSI. No guarantee can be given as to the existence of other IPRs not referenced in ETSI SR 000 314 (or the updates on the ETSI Web server) which are, or may be, or may become, essential to the present document.

Trademarks

The present document may include trademarks and/or tradenames which are asserted and/or registered by their owners. ETSI claims no ownership of these except for any which are indicated as being the property of ETSI, and conveys no right to use or reproduce any trademark and/or tradename. Mention of those trademarks in the present document does not constitute an endorsement by ETSI of products, services or organizations associated with those trademarks.

DECT™, **PLUGTESTS™**, **UMTS™** and the ETSI logo are trademarks of ETSI registered for the benefit of its Members. **3GPP™** and **LTE™** are trademarks of ETSI registered for the benefit of its Members and of the 3GPP Organizational Partners. **oneM2M™** logo is a trademark of ETSI registered for the benefit of its Members and of the oneM2M Partners. **GSM®** and the GSM logo are trademarks registered and owned by the GSM Association.

Legal Notice

This Technical Specification (TS) has been produced by ETSI 3rd Generation Partnership Project (3GPP).

The present document may refer to technical specifications or reports using their 3GPP identities. These shall be interpreted as being references to the corresponding ETSI deliverables.

The cross reference between 3GPP and ETSI identities can be found under <https://webapp.etsi.org/key/queryform.asp>.

Modal verbs terminology

In the present document "**shall**", "**shall not**", "**should**", "**should not**", "**may**", "**need not**", "**will**", "**will not**", "**can**" and "**cannot**" are to be interpreted as described in clause 3.2 of the [ETSI Drafting Rules](#) (Verbal forms for the expression of provisions).

"**must**" and "**must not**" are **NOT** allowed in ETSI deliverables except when used in direct citation.

Contents

Intellectual Property Rights	2
Legal Notice	2
Modal verbs terminology.....	2
Foreword.....	4
1 Scope	5
2 References	5
3 Definitions, symbols and abbreviations	5
3.1 Definitions	5
3.2 Abbreviations	6
4 MO for BCP of MMTEL communication service	7
5 MO configuration parameters	7
5.1 General	7
5.2 Node: /<X>	7
5.3 /<X>/Name	8
5.4 /<X>/Timer_RequestTimeout.....	8
5.5 /<X>/Ext/	8
5.6 /<X>/3GPP_PS_data_off.....	8
5.7 /<X>/3GPP_PS_data_off/MMTEL_voice_exempt	8
5.7a /<X>/3GPP_PS_data_off/MMTEL_voice_roaming_exempt.....	9
5.8 /<X>/3GPP_PS_data_off/MMTEL_video_exempt.....	9
5.8a /<X>/3GPP_PS_data_off/MMTEL_video_roaming_exempt.....	9
5.9 /<X>/SNPN_Configuration	10
5.10 /<X>/SNPN_Configuration/<X>	10
5.11 /<X>/SNPN_Configuration/<X>/SNPN_identifier	10
5.12 /<X>/SNPN_Configuration/<X>/Timer_RequestTimeout.....	10
5.13 /<X>/SNPN_Configuration/<X>/3GPP_PS_data_off.....	11
5.14 /<X>/SNPN_Configuration/<X>/3GPP_PS_data_off/ MMTEL_voice_exempt	11
5.15 /<X>/SNPN_Configuration/<X>/3GPP_PS_data_off/ MMTEL_voice_non-subscribed_exempt.....	11
5.16 /<X>/SNPN_Configuration/<X>/3GPP_PS_data_off/ MMTEL_video_exempt.....	11
5.17 /<X>/SNPN_Configuration/<X>/3GPP_PS_data_off/ MMTEL_video_non-subscribed_exempt.....	12
5.18 /<X>/IMS_DC_configuration.....	12
5.19 /<X>/IMS_DC_configuration/DC_allowed.....	12
5.20 /<X>/IMS_DC_configuration/DC_Setup_Option	12
Annex A (informative): DDF of MO for BCP of MMTEL communication service.....	14
Annex B (informative): Change history	21
History	22

Foreword

This Technical Specification has been produced by the 3rd Generation Partnership Project (3GPP).

The contents of the present document are subject to continuing work within the TSG and may change following formal TSG approval. Should the TSG modify the contents of the present document, it will be re-released by the TSG with an identifying change of release date and an increase in version number as follows:

Version x.y.z

where:

- x the first digit:
 - 1 presented to TSG for information;
 - 2 presented to TSG for approval;
 - 3 or greater indicates TSG approved document under change control.
- y the second digit is incremented for all changes of substance, i.e. technical enhancements, corrections, updates, etc.
- z the third digit is incremented when editorial only changes have been incorporated in the document.

1 Scope

The present document defines the management object (MO) for Basic Communication Part (BCP) of IMS Multimedia Telephony (MMTEL) communication service.

The MO for BCP of MMTEL communication service is compatible with OMA device management protocol specifications, version 1.2 and upwards, and is defined using the OMA DM device description framework as described in the enabler release definition OMA-ERELED_DM-V1_2 [2].

The MO for BCP of MMTEL communication service consists of relevant configuration parameter that can be managed for a UE supporting the timer RequestTimeout specified in 3GPP TS 24.173 [3].

2 References

The following documents contain provisions which, through reference in this text, constitute provisions of the present document.

- References are either specific (identified by date of publication, edition number, version number, etc.) or non-specific.
- For a specific reference, subsequent revisions do not apply.
- For a non-specific reference, the latest version applies. In the case of a reference to a 3GPP document (including a GSM document), a non-specific reference implicitly refers to the latest version of that document in the same Release as the present document.

- [1] 3GPP TR 21.905: "Vocabulary for 3GPP Specifications".
- [2] OMA-ERELED-DM-V1_2-20070209-A: "Enabler Release Definition for OMA Device Management, Version 1.2".
- [3] 3GPP TS 24.173: "IMS multimedia telephony communication service and supplementary services".
- [4] 3GPP TS 22.011: "Service accessibility".
- [5] 3GPP TS 23.122: "Non-Access-Stratum functions related to Mobile Station (MS) in idle mode".
- [6] 3GPP TS 23.003: "Numbering, addressing and identification".

3 Definitions, symbols and abbreviations

3.1 Definitions

For the purposes of the present document, the terms and definitions given in 3GPP TR 21.905 [1] and the following apply. A term defined in the present document takes precedence over the definition of the same term, if any, in 3GPP TR 21.905 [1].

For the purposes of the present document, the following terms and definitions given in 3GPP TS 22.011 [r22011] apply:

3GPP PS data off
3GPP PS data off exempt service

For the purposes of the present document, the following terms and definitions given in 3GPP TS 24.173 [3] apply:

MMTEL voice
MMTEL video

For the purposes of the present document, the following terms and definitions given in 3GPP TS 23.122 [5] apply:

Equivalent Home PLMN (EHPLMN)
Home PLMN (HPLMN)
Visited PLMN (VPLMN)

3.2 Abbreviations

For the purposes of the present document, the abbreviations given in 3GPP TR 21.905 [1] and the following apply. An abbreviation defined in the present document takes precedence over the definition of the same abbreviation, if any, in 3GPP TR 21.905 [1].

BCP	Basic Communication Part
DDF	Device Description Framework
DM	Device Management
MO	Management Object
OMA	Open Mobile Alliance
SNPN	Stand-alone Non-Public Network
UE	User Equipment

4 MO for BCP of MMTEL communication service

The MO for BCP of MMTEL communication service is used to manage settings of the UE, which supports a RequestTimeout timer. The timer RequestTimeout is configurable as specified in 3GPP TS 24.173 [3].

The MO identifier is: urn:oma:mo:ext-3gpp-bcp:1.0.

Protocol compatibility: This MO is compatible with OMA DM 1.2.

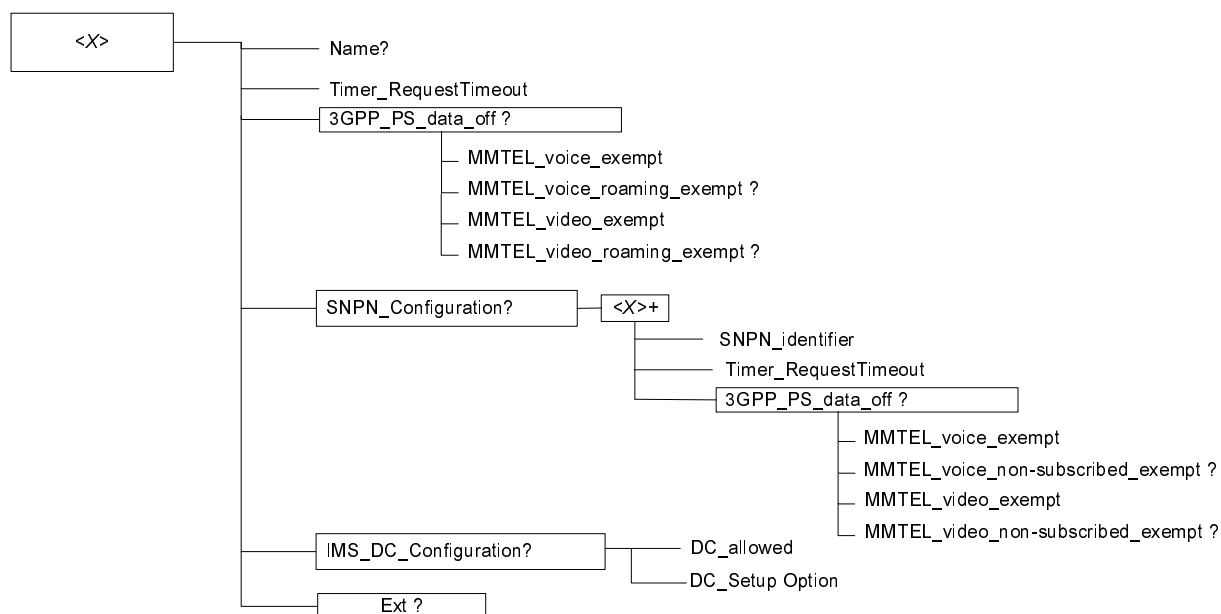

Figure 4-1: MO for BCP of MMTEL communication service

5 MO configuration parameters

5.1 General

This clause describes the configuration parameters for the MO for BCP of MMTEL communication service.

5.2 Node: /<X>

This interior node acts as a placeholder for one or more accounts for a fixed node.

- Occurrence: OneOrMore
- Format: node
- Access Types: Get, Replace
- Values: N/A

The interior node is mandatory for a UE supporting the UE role specified in 3GPP TS 24.173 [3].

NOTE: One node is normally used. More nodes are only used in case the terminal supports multiple UICCs.

Child nodes of this interior node which are not defined in this version of the present document are ignored.

5.3 /<X>/Name

This leaf is a name for the settings for BCP of MMTEL communication service.

- Occurrence: ZeroOrOne
- Format: chr
- Access Types: Get, Replace
- Values: <User displayable name>

5.4 /<X>/Timer_RequestTimeout

The Timer_RequestTimeout leaf defines the time between sending of an initial INVITE request and receipt of any SIP response.

- Occurrence: One
- Format: int
- Access Types: Get, Replace
- Values: <The time for INVITE request timeout>

The Timer_RequestTimeout leaf is the time between sending from the UE the initial INVITE request and the receptions of any SIP response. The timer value shall be given in seconds. The configurable value is between 5 and 15 seconds referring to 3GPP TS 24.173 [3]. The Timer_RequestTimeout is a 16 bits unsigned integer.

5.5 /<X>/Ext/

The Ext is an interior node for where the vendor specific information about the 3GPP-IMS MO is being placed (vendor meaning application vendor, device vendor etc.). Usually the vendor extension is identified by vendor specific name under the ext node. The tree structure under the vendor identified is not defined and can therefore include one or more un-standardized sub-trees.

- Occurrence: ZeroOrOne
- Format: node
- Access Types: Get
- Values: N/A

5.6 /<X>/3GPP_PS_data_off

The interior node contains configuration parameters for 3GPP PS data off.

- Occurrence: ZeroOrOne
- Format: node
- Access Types: Get, Replace
- Values: N/A

5.7 /<X>/3GPP_PS_data_off/MMTEL_voice_exempt

The leaf indicates whether the MMTEL voice is a 3GPP PS data off exempt service.

- Occurrence: One

- Format: bool
- Access Types: Get, Replace
- Values: 0, 1
 - 0 - Indicates that the MMTEL voice is not a 3GPP PS data off exempt service.
 - 1 - Indicates that the MMTEL voice is a 3GPP PS data off exempt service.

NOTE: This MO is used when the UE is in the home PLMN or the EHPLMN, or the UE is in the VPLMN and the MMTEL_voice_roaming_exempt node is not configured.

5.7a /<X>/3GPP_PS_data_off/MMTEL_voice_roaming_exempt

The leaf indicates whether the MMTEL voice is a 3GPP PS data off exempt service when the UE is in the VPLMN.

- Occurrence: ZeroOrOne
- Format: bool
- Access Types: Get, Replace
- Values: 0, 1
 - 0 - Indicates that the MMTEL voice is not a 3GPP PS data off roaming exempt service.
 - 1 - Indicates that the MMTEL voice is a 3GPP PS data off roaming exempt service.

5.8 /<X>/3GPP_PS_data_off/MMTEL_video_exempt

The leaf indicates whether the MMTEL video is a 3GPP PS data off exempt service.

- Occurrence: One
- Format: bool
- Access Types: Get, Replace
- Values: 0, 1
 - 0 - Indicates that the MMTEL video is not a 3GPP PS data off exempt service.
 - 1 - Indicates that the MMTEL video is a 3GPP PS data off exempt service.

NOTE: This MO is used when the UE is in the home PLMN or the EHPLMN, or the MMTEL_video_roaming_exempt node is not configured when the UE is in the VPLMN.

5.8a /<X>/3GPP_PS_data_off/MMTEL_video_roaming_exempt

The leaf indicates whether the MMTEL video is a 3GPP PS data off exempt service when the UE is in the VPLMN.

- Occurrence: ZeroOrOne
- Format: bool
- Access Types: Get, Replace
- Values: 0, 1
 - 0 - Indicates that the MMTEL video is not a 3GPP PS data off roaming exempt service.
 - 1 - Indicates that the MMTEL video is a 3GPP PS data off roaming exempt service.

5.9 /<X>/SNPN_Configuration

This interior node contains configuration parameters regarding a UE operating in SNPN access operation mode.

- Occurrence: ZeroOrOne
- Format: node
- Access Types: Get, Replace
- Values: N/A

5.10 /<X>/SNPN_Configuration/<X>

This interior node acts as a placeholder for a list of:

- a) SNPN identity; and
- b) configuration parameters.

NOTE: For each of the elements in the list, a) must be present and at least one parameter of b) needs to appear.

A configuration parameter in an /<X>/SNPN_Configuration/<X> node other than the SNPN_identifier, is applicable when the UE selects an entry of "list of subscriber data" with the SNPN identity of the subscribed SNPN which is the same as the SNPN identity in the SNPN_identifier leaf.

- Occurrence: OneOrMore
- Format: node
- Access Types: Get, Replace
- Values: N/A

5.11 /<X>/SNPN_Configuration/<X>/SNPN_identifier

This leaf indicates the SNPN identity of the subscribed SNPN for which the list of configuration parameters are applicable.

- Occurrence: One
- Format: chr
- Access Types: Get, Replace
- Values: <PLMN><NID>

The PLMN and NID are in the format defined by 3GPP TS 23.003 [6], with each digit of the MCC and MNC of the PLMN and each digit of the assignment mode and NID value of the NID encoded as an ASCII character.

5.12 /<X>/SNPN_Configuration/<X>/Timer_RequestTimeout

The Timer_RequestTimeout leaf defines the time between sending of an initial INVITE request and receipt of any SIP response.

- Occurrence: One
- Format: int
- Access Types: Get, Replace
- Values: <The time for INVITE request timeout>

The `Timer_RequestTimeout` leaf is the time between sending from the UE the initial INVITE request and the receptions of any SIP response. The timer value shall be given in seconds. The configurable value is between 5 and 15 seconds referring to 3GPP TS 24.173 [3]. The `Timer_RequestTimeout` is a 16 bits unsigned integer.

5.13 /<X>/SNPN_Configuration/<X>/3GPP_PS_data_off

The interior node contains configuration parameters for 3GPP PS data off.

- Occurrence: ZeroOrOne
- Format: node
- Access Types: Get, Replace
- Values: N/A

5.14 /<X>/SNPN_Configuration/<X>/3GPP_PS_data_off/ MMTEL_voice_exempt

The leaf indicates whether the MMTEL voice is a 3GPP PS data off exempt service.

- Occurrence: One
 - Format: bool
 - Access Types: Get, Replace
 - Values: 0, 1
- 0 - Indicates that the MMTEL voice is not a 3GPP PS data off exempt service.
- 1 - Indicates that the MMTEL voice is a 3GPP PS data off exempt service.

NOTE: This MO is used when the UE is in a subscribed SNPN, or the UE is in a non-subscribed SNPN and the `MMTEL_voice_non-subscribed_exempt` node is not configured.

5.15 /<X>/SNPN_Configuration/<X>/3GPP_PS_data_off/ MMTEL_voice_non-subscribed_exempt

The leaf indicates whether the MMTEL voice is a 3GPP PS data off exempt service when the UE is in a non-subscribed SNPN.

- Occurrence: ZeroOrOne
 - Format: bool
 - Access Types: Get, Replace
 - Values: 0, 1
- 0 - Indicates that the MMTEL voice is not a 3GPP PS data off non-subscribed exempt service.
- 1 - Indicates that the MMTEL voice is a 3GPP PS data off non-subscribed exempt service.

5.16 /<X>/SNPN_Configuration/<X>/3GPP_PS_data_off/ MMTEL_video_exempt

The leaf indicates whether the MMTEL video is a 3GPP PS data off exempt service.

- Occurrence: One

- Format: bool
- Access Types: Get, Replace
- Values: 0, 1
 - 0 - Indicates that the MMTEL video is not a 3GPP PS data off exempt service.
 - 1 - Indicates that the MMTEL video is a 3GPP PS data off exempt service.

NOTE: This MO is used when the UE is in a subscribed SNPN, or the MMTEL_video_non-subscribed_exempt node is not configured when the UE is in the non-subscribed SNPN.

5.17 /<X>/SNPN_Configuration/<X>/3GPP_PS_data_off/MMTEL_video_non-subscribed_exempt

The leaf indicates whether the MMTEL video is a 3GPP PS data off exempt service when the UE is in a non-subscribed SNPN.

- Occurrence: ZeroOrOne
- Format: bool
- Access Types: Get, Replace
- Values: 0, 1
 - 0 - Indicates that the MMTEL video is not a 3GPP PS data off non-subscribed exempt service.
 - 1 - Indicates that the MMTEL video is a 3GPP PS data off non-subscribed exempt service.

5.18 /<X>/IMS_DC_configuration

The interior node contains configuration parameters for IMS DC (data channel) service.

- Occurrence: ZeroOrOne
- Format: node
- Access Types: Get, Replace
- Values: N/A

5.19 /<X>/IMS_DC_configuration/DC_allowed

The leaf indicates whether the IMS DC (data channel) is allowed for the UE.

- Occurrence: One
- Format: bool
- Access Types: Get, Replace
- Values: 0, 1
 - 0 - Indicates that the IMS data channel capability is not allowed for the UE.
 - 1 - Indicates that the IMS data channel capability is allowed for the UE.

5.20 /<X>/IMS_DC_configuration/DC_Setup_Option

The leaf indicates to the UE when to setup the IMS DC (data channel).

- Occurrence: One
- Format: bool
- Access Types: Get, Replace
- Values: 0, 1

0 - Indicates that the IMS data channel is to be setup after an IMS session is established.

1 - Indicates that the IMS data channel is to be setup simultaneously while establishing an IMS session.

Annex A (informative): DDF of MO for BCP of MMTEL communication service

This DDF is the standardized minimal set. A vendor can define its own DDF for the complete device. This DDF can include more features than this minimal standardized version.

```
<?xml version="1.0" encoding="UTF-8"?>
<!DOCTYPE MgmtTree PUBLIC "-//OMA//DTD-DM-DDF 1.2//EN"
"http://www.openmobilealliance.org/tech/DTD/DM_DDF-V1_2.dtd">
<MgmtTree>
  <VerDTD>1.2</VerDTD>
  <Man>--The device manufacturer--</Man>
  <Mod>--The device model--</Mod>
  <Node>
    <NodeName/>
    <DFProperties>
      <AccessType>
        <Get/>
        <Replace/>
      </AccessType>
      <Description>Configuration parameters for BCP of MMTEL communication
service</Description>
      <DFFormat>
        <node/>
      </DFFormat>
      <Occurrence>
        <OneOrMore/>
      </Occurrence>
      <Scope>
        <Permanent/>
      </Scope>
      <DFTitle>The Management Object (MO) for Basic Communication Part (BCP) of IMS Multimedia
Telephony(MMTEL) communication service.</DFTitle>
      <DFType>
        <DDFName>urn:oma:mo:ext-3gpp-bcp:1.0</DDFName>
      </DFType>
    </DFProperties>
  </Node>
  <Node>
    <NodeName>Name</NodeName>
    <DFProperties>
      <AccessType>
        <Get/>
        <Replace/>
      </AccessType>
      <DFFormat>
        <chr/>
      </DFFormat>
      <Occurrence>
        <ZeroOrOne/>
      </Occurrence>
      <Scope>
        <Dynamic/>
      </Scope>
      <DFTitle>The name for BCP of MMTEL communication service.</DFTitle>
      <DFType>
        <MIME>text/plain</MIME>
      </DFType>
    </DFProperties>
  </Node>
  <Node>
    <NodeName>Timer_RequestTimeout</NodeName>
    <DFProperties>
      <AccessType>
        <Get/>
        <Replace/>
      </AccessType>
      <DFFormat>
        <int/>
      </DFFormat>
      <Occurrence>
        <One/>
      </Occurrence>
      <Scope>
        <Permanent/>
      </Scope>
    </DFProperties>
  </Node>
</MgmtTree>
```

```

    <DFTitle>Timer RequestTimeout.</DFTitle>
    <DFType>
      <MIME>text/plain</MIME>
    </DFType>
  </DFProperties>
</Node>

<Node>
  <NodeName>3GPP_PS_data_off</NodeName>
  <DFProperties>
    <AccessType>
      <Get/>
      <Replace/>
    </AccessType>
    <DFFormat>
      <node/>
    </DFFormat>
    <Occurrence>
      <ZeroOrOne/>
    </Occurrence>
    <Scope>
      <Dynamic/>
    </Scope>
    <DFTitle>Configuration parameters for 3GPP PS data off.</DFTitle>
    <DFType>
      <DDFName/>
    </DFType>
  </DFProperties>
  <Node>
    <NodeName>MMTEL_voice_exempt</NodeName>
    <DFProperties>
      <AccessType>
        <Get/>
        <Replace/>
      </AccessType>
      <DFFormat>
        <bool/>
      </DFFormat>
      <Occurrence>
        <One/>
      </Occurrence>
      <Scope>
        <Dynamic/>
      </Scope>
      <DFTitle>Whether the MMTEL voice is a 3GPP PS data off exempt service.</DFTitle>
      <DFType>
        <MIME>text/plain</MIME>
      </DFType>
    </DFProperties>
  </Node>
  <Node>
    <NodeName>MMTEL_voice_roaming_exempt</NodeName>
    <DFProperties>
      <AccessType>
        <Get/>
        <Replace/>
      </AccessType>
      <DFFormat>
        <bool/>
      </DFFormat>
      <Occurrence>
        <ZeroOrOne/>
      </Occurrence>
      <Scope>
        <Dynamic/>
      </Scope>
      <DFTitle>Whether the MMTEL voice is a 3GPP PS data off roaming exempt
service.</DFTitle>
      <DFType>
        <MIME>text/plain</MIME>
      </DFType>
    </DFProperties>
  </Node>

  <Node>
    <NodeName>MMTEL_video_exempt</NodeName>
    <DFProperties>
      <AccessType>

```



```

        <Get/>
        <Replace/>
    </AccessType>
    <DFFormat>
        <bool/>
    </DFFormat>
    <Occurrence>
        <One/>
    </Occurrence>
    <Scope>
        <Dynamic/>
    </Scope>
    <DFTitle>Whether the MMTEL video is a 3GPP PS data off exempt service.</DFTitle>
    <DFType>
        <MIME>text/plain</MIME>
    </DFType>
</DFProperties>
</Node>
<Node>
    <NodeName>MMTEL_video_roaming_exempt</NodeName>
    <DFProperties>
        <AccessType>
            <Get/>
            <Replace/>
        </AccessType>
        <DFFormat>
            <bool/>
        </DFFormat>
        <Occurrence>
            <ZeroOrOne/>
        </Occurrence>
        <Scope>
            <Dynamic/>
        </Scope>
        <DFTitle>Whether the MMTEL video is a 3GPP PS data off roaming exempt
service.</DFTitle>
        <DFType>
            <MIME>text/plain</MIME>
        </DFType>
    </DFProperties>
</Node>
</Node>
<Node>
    <NodeName>SNPN_Configuration</NodeName>
    <DFProperties>
        <AccessType>
            <Get/>
            <Replace/>
        </AccessType>
        <DFFormat>
            <node/>
        </DFFormat>
        <Occurrence>
            <ZeroOrOne/>
        </Occurrence>
        <Scope>
            <Permanent/>
        </Scope>
        <DFTitle>SNPN Configuration.</DFTitle>
        <DFType>
            <MIME>text/plain</MIME>
        </DFType>
    </DFProperties>
</Node>
<Node>
    <NodeName/>
    <DFProperties>
        <AccessType>
            <Get/>
        </AccessType>
        <DFFormat>
            <node/>
        </DFFormat>
        <Occurrence>
            <OneOrMore/>
        </Occurrence>
        <Scope>
            <Dynamic/>
        </Scope>
    </DFProperties>

```

```

    <DFTitle>SNPN configuration parameters.</DFTitle>
    <DFType>
      <MIME>text/plain</MIME>
    </DFType>
  </DFProperties>
  <Node>
    <NodeName>Timer_RequestTimeout</NodeName>
    <DFProperties>
      <AccessType>
        <Get/>
        <Replace/>
      </AccessType>
      <DFFormat>
        <int/>
      </DFFormat>
      <Occurrence>
        <One/>
      </Occurrence>
      <Scope>
        <Permanent/>
      </Scope>
      <DFTitle>Timer RequestTimeout.</DFTitle>
      <DFType>
        <MIME>text/plain</MIME>
      </DFType>
    </DFProperties>
  </Node>
  <Node>
    <NodeName>SNPN_identifier</NodeName>
    <DFProperties>
      <AccessType>
        <Get/>
        <Replace/>
      </AccessType>
      <DFFormat>
        <chr/>
      </DFFormat>
      <Occurrence>
        <One/>
      </Occurrence>
      <Scope>
        <Permanent/>
      </Scope>
      <DFTitle>Identifier of the SNPN.</DFTitle>
      <DFType>
        <MIME>text/plain</MIME>
      </DFType>
    </DFProperties>
  </Node>
  <Node>
    <NodeName>3GPP_PS_data_off</NodeName>
    <DFProperties>
      <AccessType>
        <Get/>
        <Replace/>
      </AccessType>
      <DFFormat>
        <node/>
      </DFFormat>
      <Occurrence>
        <ZeroOrOne/>
      </Occurrence>
      <Scope>
        <Dynamic/>
      </Scope>
      <DFTitle>Configuration parameters for 3GPP PS data off.</DFTitle>
      <DFType>
        <DDFName/>
      </DFType>
    </DFProperties>
  <Node>
    <NodeName>MMTEL_voice_exempt</NodeName>
    <DFProperties>
      <AccessType>
        <Get/>
        <Replace/>
      </AccessType>
      <DFFormat>

```

```

        <bool/>
      </DFFormat>
    <Occurrence>
      <One/>
    </Occurrence>
  <Scope>
    <Dynamic/>
  </Scope>
  <DFTitle>Whether the MMTEL voice is a 3GPP PS data off exempt
service.</DFTitle>
  <DFType>
    <MIME>text/plain</MIME>
  </DFType>
</DFProperties>
</Node>
<Node>
  <NodeName>MMTEL_voice_non-subscribed_exempt</NodeName>
  <DFProperties>
    <AccessType>
      <Get/>
      <Replace/>
    </AccessType>
    <DFFormat>
      <bool/>
    </DFFormat>
    <Occurrence>
      <ZeroOrOne/>
    </Occurrence>
    <Scope>
      <Dynamic/>
    </Scope>
    <DFTitle>Whether the MMTEL voice is a 3GPP PS data off non-subscribed
exempt service.</DFTitle>
  <DFType>
    <MIME>text/plain</MIME>
  </DFType>
</DFProperties>
</Node>
<Node>
  <NodeName>MMTEL_video_exempt</NodeName>
  <DFProperties>
    <AccessType>
      <Get/>
      <Replace/>
    </AccessType>
    <DFFormat>
      <bool/>
    </DFFormat>
    <Occurrence>
      <One/>
    </Occurrence>
    <Scope>
      <Dynamic/>
    </Scope>
    <DFTitle>Whether the MMTEL video is a 3GPP PS data off exempt
service.</DFTitle>
  <DFType>
    <MIME>text/plain</MIME>
  </DFType>
</DFProperties>
</Node>
<Node>
  <NodeName>MMTEL_video_non-subscribed_exempt</NodeName>
  <DFProperties>
    <AccessType>
      <Get/>
      <Replace/>
    </AccessType>
    <DFFormat>
      <bool/>
    </DFFormat>
    <Occurrence>
      <ZeroOrOne/>
    </Occurrence>
    <Scope>
      <Dynamic/>
    </Scope>

```

```

    <DFTitle>Whether the MMTEL video is a 3GPP PS data off non-subscribed
exempt s   ervice.</DFTitle>
    <DFType>
      <MIME>text/plain</MIME>
    </DFType>
  </DFProperties>
</Node>
</Node>
</Node>
</Node>
</Node>
<Node>
  <NodeName>IMS_DC_configuration</NodeName>
  <DFProperties>
    <AccessType>
      <Get/>
      <Replace/>
    </AccessType>
    <DFFormat>
      <node/>
    </DFFormat>
    <Occurrence>
      <ZeroOrOne/>
    </Occurrence>
    <Scope>
      <Dynamic/>
    </Scope>
    <DFTitle>Configuration parameters for IMS data channel.</DFTitle>
    <DFType>
      <DDFName/>
    </DFType>
  </DFProperties>
  <Node>
    <NodeName>DC_allowed</NodeName>
    <DFProperties>
      <AccessType>
        <Get/>
        <Replace/>
      </AccessType>
      <DFFormat>
        <bool/>
      </DFFormat>
      <Occurrence>
        <One/>
      </Occurrence>
      <Scope>
        <Dynamic/>
      </Scope>
      <DFTitle>Whether the IMS data channel is allowed.</DFTitle>
      <DFType>
        <MIME>text/plain</MIME>
      </DFType>
    </DFProperties>
  </Node>
  <Node>
    <NodeName>DC_Setup_Option</NodeName>
    <DFProperties>
      <AccessType>
        <Get/>
        <Replace/>
      </AccessType>
      <DFFormat>
        <bool/>
      </DFFormat>
      <Occurrence>
        <One/>
      </Occurrence>
      <Scope>
        <Dynamic/>
      </Scope>
      <DFTitle>When the IMS data channel is to be established.</DFTitle>
      <DFType>
        <MIME>text/plain</MIME>
      </DFType>
    </DFProperties>
  </Node>
</Node>
</Node>

```

```
<Node>
  <NodeName>Ext</NodeName>
  <!-- The Extension node starts here. -->
  <DFProperties>
    <AccessType>
      <Get/>
    </AccessType>
    <DFFormat>
      <node/>
    </DFFormat>
    <Occurrence>
      <ZeroOrOne/>
    </Occurrence>
    <Scope>
      <Dynamic/>
    </Scope>
    <DFTitle>A collection of all Extension objects.</DFTitle>
    <DFType>
      <DDFName/>
    </DFType>
  </DFProperties>
</Node>
</MgmtTree>
```

Annex B (informative): Change history

Change history							
Date	Meeting	TDoc	CR	Rev	Cat	Subject/Comment	New version
2016-11						Description of the new MO.	0.1.0
2016-11	CT-74	CP-160780				Version 1.0.0 created for presentation for information to CT plenary.	1.0.0
2016-12	CT-74	CP-160830				Version 1.0.1 (with TS-number added) created for presentation for information to CT plenary.	1.0.1
2017-01	CT1-101BIS	C1-170328				Version 1.1.0 created for adding MMTEL voice and MMTEL video configuration for PS data off	1.1.0
2017-02	CT1-102	C1-170602				Version 1.2.0 created to remove editor's note for MO identifier (C1-170602) and to remove additional line	1.2.0
2017-02	CT-75	CP-170159				Version 2.0.0 created for presentation for approval to CT plenary.	2.0.0
2017-03	CT-75					Version 14.0.0 created after approval at CT75	14.0.0
2018-06	CT-80	CP-181074	0001	2	B	MMTEL voice and MMTEL video configuration for 3GPP PS Data Off2	15.0.0
2018-12	CT-82	CP-183077	0002		F	Addition of the object identifier in the DDF of the 3GPP Management Object	16.0.0
2022-03	CT-95e	CP-220237	0003	1	B	SNPN configuration of MMTel basic communication	17.0.0
2023-09	CT#101	CP-232211	0004	3	B	Configuration for DC	18.0.0
2023-12	CT#102	CP-233178	0005	1	B	MO configuration for IMS DC setup	18.1.0
2023-12	CT#102	CP-233178	0006	1	F	DDF for IMS data channel	18.1.0

History

Document history		
V18.1.0	May 2024	Publication