

ETSI TS 124 285 V18.0.0 (2024-05)



**Universal Mobile Telecommunications System (UMTS);
LTE;
Allowed Closed Subscriber Group (CSG) list;
Management Object (MO)
(3GPP TS 24.285 version 18.0.0 Release 18)**



Reference

RTS/TSGC-0124285vi00

Keywords

LTE,UMTS

ETSI

650 Route des Lucioles
F-06921 Sophia Antipolis Cedex - FRANCE

Tel.: +33 4 92 94 42 00 Fax: +33 4 93 65 47 16

Siret N° 348 623 562 00017 - APE 7112B
Association à but non lucratif enregistrée à la
Sous-Préfecture de Grasse (06) N° w061004871

Important notice

The present document can be downloaded from:

<https://www.etsi.org/standards-search>

The present document may be made available in electronic versions and/or in print. The content of any electronic and/or print versions of the present document shall not be modified without the prior written authorization of ETSI. In case of any existing or perceived difference in contents between such versions and/or in print, the prevailing version of an ETSI deliverable is the one made publicly available in PDF format at www.etsi.org/deliver.

Users of the present document should be aware that the document may be subject to revision or change of status.

Information on the current status of this and other ETSI documents is available at

<https://portal.etsi.org/TB/ETSIDeliverableStatus.aspx>

If you find errors in the present document, please send your comment to one of the following services:

<https://portal.etsi.org/People/CommitteeSupportStaff.aspx>

If you find a security vulnerability in the present document, please report it through our
Coordinated Vulnerability Disclosure Program:

<https://www.etsi.org/standards/coordinated-vulnerability-disclosure>

Notice of disclaimer & limitation of liability

The information provided in the present deliverable is directed solely to professionals who have the appropriate degree of experience to understand and interpret its content in accordance with generally accepted engineering or other professional standard and applicable regulations.

No recommendation as to products and services or vendors is made or should be implied.

No representation or warranty is made that this deliverable is technically accurate or sufficient or conforms to any law and/or governmental rule and/or regulation and further, no representation or warranty is made of merchantability or fitness for any particular purpose or against infringement of intellectual property rights.

In no event shall ETSI be held liable for loss of profits or any other incidental or consequential damages.

Any software contained in this deliverable is provided "AS IS" with no warranties, express or implied, including but not limited to, the warranties of merchantability, fitness for a particular purpose and non-infringement of intellectual property rights and ETSI shall not be held liable in any event for any damages whatsoever (including, without limitation, damages for loss of profits, business interruption, loss of information, or any other pecuniary loss) arising out of or related to the use of or inability to use the software.

Copyright Notification

No part may be reproduced or utilized in any form or by any means, electronic or mechanical, including photocopying and microfilm except as authorized by written permission of ETSI.

The content of the PDF version shall not be modified without the written authorization of ETSI.

The copyright and the foregoing restriction extend to reproduction in all media.

© ETSI 2024.
All rights reserved.

Intellectual Property Rights

Essential patents

IPRs essential or potentially essential to normative deliverables may have been declared to ETSI. The declarations pertaining to these essential IPRs, if any, are publicly available for **ETSI members and non-members**, and can be found in ETSI SR 000 314: "*Intellectual Property Rights (IPRs); Essential, or potentially Essential, IPRs notified to ETSI in respect of ETSI standards*", which is available from the ETSI Secretariat. Latest updates are available on the ETSI Web server (<https://ipr.etsi.org/>).

Pursuant to the ETSI Directives including the ETSI IPR Policy, no investigation regarding the essentiality of IPRs, including IPR searches, has been carried out by ETSI. No guarantee can be given as to the existence of other IPRs not referenced in ETSI SR 000 314 (or the updates on the ETSI Web server) which are, or may be, or may become, essential to the present document.

Trademarks

The present document may include trademarks and/or tradenames which are asserted and/or registered by their owners. ETSI claims no ownership of these except for any which are indicated as being the property of ETSI, and conveys no right to use or reproduce any trademark and/or tradename. Mention of those trademarks in the present document does not constitute an endorsement by ETSI of products, services or organizations associated with those trademarks.

DECT™, **PLUGTESTS™**, **UMTS™** and the ETSI logo are trademarks of ETSI registered for the benefit of its Members. **3GPP™** and **LTE™** are trademarks of ETSI registered for the benefit of its Members and of the 3GPP Organizational Partners. **oneM2M™** logo is a trademark of ETSI registered for the benefit of its Members and of the oneM2M Partners. **GSM®** and the GSM logo are trademarks registered and owned by the GSM Association.

Legal Notice

This Technical Specification (TS) has been produced by ETSI 3rd Generation Partnership Project (3GPP).

The present document may refer to technical specifications or reports using their 3GPP identities. These shall be interpreted as being references to the corresponding ETSI deliverables.

The cross reference between 3GPP and ETSI identities can be found under <https://webapp.etsi.org/key/queryform.asp>.

Modal verbs terminology

In the present document "**shall**", "**shall not**", "**should**", "**should not**", "**may**", "**need not**", "**will**", "**will not**", "**can**" and "**cannot**" are to be interpreted as described in clause 3.2 of the [ETSI Drafting Rules](#) (Verbal forms for the expression of provisions).

"**must**" and "**must not**" are **NOT** allowed in ETSI deliverables except when used in direct citation.

Contents

Intellectual Property Rights	2
Legal Notice	2
Modal verbs terminology.....	2
Foreword.....	4
1 Scope	5
2 References	5
3 Definitions and abbreviations.....	5
3.1 Definitions	5
3.2 Abbreviations	5
4 Allowed CSG List Management Object.....	6
5 Management Object parameters	6
5.1 General	6
5.2 Node: <X>	6
5.3 /<X>/AllowedCSGEntries	7
5.4 /<X>/AllowedCSGEntries/<X>.....	7
5.5 /<X>/AllowedCSGEntries/<X>/PLMN_ID.....	7
5.6 /<X>/AllowedCSGEntries/<X>/CSG-entries	7
5.7 /<X>/AllowedCSGEntries/<X>/CSG-entries/<X>	7
5.8 /<X>/AllowedCSGEntries/<X>/CSG-entries/<X>/CSG_ID.....	8
5.9 /<X>/AllowedCSGEntries/<X>/CSG-entries/<X>/HNB_Name.....	8
5.10 /<X>/AllowedCSGEntries/<X>/CSG-entries/<X>/CSG_Type.....	8
5.11 /<X>/OperatorCSGEntries.....	8
5.12 /<X>/OperatorCSGEntries/<X>	9
5.13 /<X>/OperatorCSGEntries/<X>/PLMN_ID	9
5.14 /<X>/OperatorCSGEntries/<X>/CSG-entries.....	9
5.15 /<X>/OperatorCSGEntries/<X>/CSG-entries/<X>	9
5.16 /<X>/OperatorCSGEntries/<X>/CSG-entries/<X>/CSG_ID.....	9
5.17 /<X>/OperatorCSGEntries/<X>/CSG-entries/<X>/HNB_Name	10
5.18 /<X>/ OperatorCSGEntries /<X>/CSG-entries/<X>/CSG_Type.....	10
5.19 /<X>/Ext/	10
5.20 /<X>/OperatorCSGEntries/<X>/OperatorCSGEntries_Only_thisPLMN.....	10
5.21 /<X>/OperatorCSGEntries/OperatorCSGEntries_Only	11
Annex A (informative): Management Object DDF	12
Annex B (informative): Change history	16
History	17

Foreword

This Technical Specification has been produced by the 3rd Generation Partnership Project (3GPP).

The contents of the present document are subject to continuing work within the TSG and may change following formal TSG approval. Should the TSG modify the contents of the present document, it will be re-released by the TSG with an identifying change of release date and an increase in version number as follows:

Version x.y.z

where:

- x the first digit:
 - 1 presented to TSG for information;
 - 2 presented to TSG for approval;
 - 3 or greater indicates TSG approved document under change control.
- y the second digit is incremented for all changes of substance, i.e. technical enhancements, corrections, updates, etc.
- z the third digit is incremented when editorial only changes have been incorporated in the document.

1 Scope

The present document specifies an Allowed Closed Subscriber Group (CSG) List Management Object (MO).

The Allowed CSG List MO is compatible with the OMA Device Management (DM) protocol specifications, version 1.2 and upwards, and is defined using the OMA DM Device Description Framework (DDF) as described in the Enabler Release Definition OMA-ERELED-DM-V1_2 [5].

The Allowed CSG List MO consists of relevant parameters for that can be used by the UE to select the appropriate CSG cell based on its subscription.

The Allowed CSG List MO defines the relevant parameters related to the Allowed CSG List and to the Operator CSG List.

The usage of the Allowed CSG List for in the idle mode process and the mobility management procedure is defined in 3GPP TS 23.122 [2], 3GPP TS 24.008 [3] and 3GPP TS 24.301 [4].

2 References

The following documents contain provisions which, through reference in this text, constitute provisions of the present document.

- References are either specific (identified by date of publication, edition number, version number, etc.) or non-specific.
- For a specific reference, subsequent revisions do not apply.
- For a non-specific reference, the latest version applies. In the case of a reference to a 3GPP document (including a GSM document), a non-specific reference implicitly refers to the latest version of that document *in the same Release as the present document*.

- [1] 3GPP TR 21.905: "Vocabulary for 3GPP Specifications".
- [1A] 3GPP TS 23.003: "Numbering, addressing and identification".
- [2] 3GPP TS 23.122: "Non-Access-Stratum functions related to Mobile Station (MS) in idle mode".
- [3] 3GPP TS 24.008: "Mobile Radio Interface Layer 3 specification; Core Network Protocols; Stage 3"
- [4] 3GPP TS 24.301: " Non-Access-Stratum (NAS) protocol for Evolved Packet System (EPS); Stage 3"
- [5] OMA-ERELED-DM-V1_2: "Enabler Release Definition for OMA Device Management".

3 Definitions and abbreviations

3.1 Definitions

For the purposes of the present document, the terms and definitions given in 3GPP TR 21.905 [1] apply.

3.2 Abbreviations

For the purposes of the present document, the following abbreviations apply:

CSG	Closed Subscriber Group
DM	Device Management
HNB	Home NodeB/eNodeB

MO	Management Object
OMA	Open Mobile Alliance
PLMN	Public Land Mobile Network
UE	User Equipment

4 Allowed CSG List Management Object

The Allowed CSG List Management Object (MO) is used to manage the list of allowed CSG IDs, the Operator CSG IDs and the related restricted access information at UE.

The Management Object Identifier is: urn:oma:mo:ext-3gpp-csg:1.0.

The OMA DM Access Control List (ACL) property mechanism (see OMA-ERELED-DM-V1_2 [5]) may be used to grant or deny access rights to OMA DM servers in order to modify nodes and leaf objects of the Allowed CSG list MO.

The following nodes and leaf objects are possible under the Allowed CSG List node as described in figure 4-1:

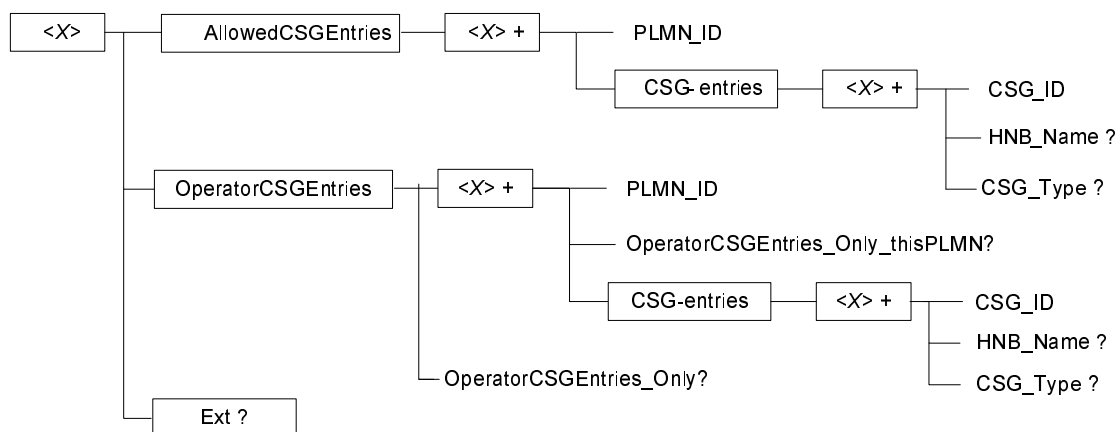

Figure 4-1: The Allowed CSG List Management Object

When a UE receives an Allowed CSG List Management Object (MO) containing the Allowed CSG List, it shall update its Allowed CSG list stored in a USIM or in a non-volatile memory in the ME.

When a UE receives an Allowed CSG List Management Object (MO) containing the Operator CSG List, it shall update the Operator CSG List stored in a non-volatile memory in the ME.

5 Management Object parameters

5.1 General

This clause describes the parameters for the Allowed CSG List Management Object (MO).

5.2 Node: <X>

This interior node acts as a placeholder for zero or one accounts for a fixed node.

- Occurrence: ZeroOrOne
- Format: node
- Access Types: Get

- Values: N/A

5.3 /<X>/AllowedCSGEntries

The AllowedCSGEntries interior node is used to allow a reference to a list of allowed CSG entries.

- Occurrence: One
- Format: node
- Access Types: Get
- Values: N/A

5.4 /<X>/AllowedCSGEntries/<X>

This run-time node acts as a placeholder for one or more allowed CSG entries.

- Occurrence: OneOrMore
- Format: node
- Access Types: Get
- Values: N/A

5.5 /<X>/AllowedCSGEntries/<X>/PLMN_ID

The PLMN_ID leaf represents a PLMN Identifier

- Occurrence: One
- Format: chr
- Access Types: Get, Replace
- Values: <PLMN Identifier>

The value of the PLMN Identifier shall be a PLMN-Id as specified in 3GPP TS 23.003 [1A].

5.6 /<X>/AllowedCSGEntries/<X>/CSG-entries

The CSG-entries interior node is used to allow a reference to a list of allowed CSG entries in a PLMN.

- Occurrence: One
- Format: node
- Access Types: Get
- Values: N/A

5.7 /<X>/AllowedCSGEntries/<X>/CSG-entries/<X>

This run-time node acts as a placeholder for one or more CSG entries (the CSG Identity, its related HNB Name and CSG Type) in a PLMN.

- Occurrence: OneOrMore
- Format: node

- Access Types: Get
- Values: N/A

5.8 /<X>/AllowedCSGEntries/<X>/CSG-entries/<X>/CSG_ID

The CSG_ID leaf represents a CSG Identifier.

- Occurrence: One
- Format: bin
- Access Types: Get, Replace
- Values: <CSG Identifier>

The value of the CSG Identifier shall be coded as a CSG-ID as specified in 3GPP TS 23.003 [1A].

5.9 /<X>/AllowedCSGEntries/<X>/CSG-entries/<X>/HNB_Name

The HNB_name leaf represents a HNB Name.

- Occurrence: ZeroOrOne
- Format: chr
- Access Types: Get, Replace
- Values: <HNB Name>

The value of the HNB Name shall be coded as specified in 3GPP TS 23.003 [1A].

5.10 /<X>/AllowedCSGEntries/<X>/CSG-entries/<X>/CSG_Type

The CSG Type leaf represents a CSG type.

- Occurrence: ZeroOrOne
- Format: chr
- Access Types: Get, Replace
- Values: <CSG Type>

The value of the CSG Type shall be coded as specified in 3GPP TS 23.003 [1A].

5.11 /<X>/OperatorCSGEntries

The OperatorCSGEntries interior node is used to allow a reference to a list of operator CSG entries.

- Occurrence: ZeroOrOne
- Format: node
- Access Types: Get
- Values: N/A

5.12 /<X>/OperatorCSGEntries/<X>

This run-time node acts as a placeholder for one or more operator CSG entries.

- Occurrence: OneOrMore
- Format: node
- Access Types: Get
- Values: N/A

5.13 /<X>/OperatorCSGEntries/<X>/PLMN_ID

The PLMN_ID leaf represents a PLMN Identifier.

- Occurrence: One
- Format: chr
- Access Types: Get, Replace
- Values: <PLMN Identifier>

The value of the PLMN Identifier shall be a PLMN-Id as specified in 3GPP TS 23.003 [1A].

5.14 /<X>/OperatorCSGEntries/<X>/CSG-entries

The CSG-entries interior node is used to allow a reference to a list of operator CSG entries in a PLMN.

- Occurrence: One
- Format: node
- Access Types: Get
- Values: N/A

5.15 /<X>/OperatorCSGEntries/<X>/CSG-entries/<X>

This run-time node acts as a placeholder for one or more CSG entries (the CSG Identity, its related HNB Name and CSG Type) in a PLMN.

- Occurrence: OneOrMore
- Format: node
- Access Types: Get
- Values: N/A

5.16 /<X>/OperatorCSGEntries/<X>/CSG-entries/<X>/CSG_ID

The CSG_ID leaf represents a CSG Identifier.

- Occurrence: One
- Format: bin
- Access Types: Get, Replace
- Values: <CSG Identifier>

The value of the CSG Identifier shall be coded as a CSG-ID as specified in 3GPP TS 23.003 [1A].

5.17 /<X>/OperatorCSGEntries/<X>/CSG-entries/<X>/HNB_Name

The HNB_name leaf represents a HNB Name.

- Occurrence: ZeroOrOne
- Format: chr
- Access Types: Get, Replace
- Values: <HNB Name>

The value of the HNB Name shall be coded as specified in 3GPP TS 23.003 [1A].

5.18 /<X>/ OperatorCSGEntries /<X>/CSG-entries/<X>/CSG_Type

The CSG Type leaf represents a CSG type.

- Occurrence: ZeroOrOne
- Format: chr
- Access Types: Get, Replace
- Values: <CSG Type>

The value of the CSG Type shall be coded as specified in 3GPP TS 23.003 [1A].

5.19 /<X>/Ext/

The Ext is an interior node for where the vendor specific information about the Allowed CSG List MO is being placed (vendor meaning application vendor, device vendor etc.). Usually the vendor extension is identified by vendor specific name under the ext node. The tree structure under the vendor identified is not defined and can therefore include one or more un-standardized sub-trees.

- Occurrence: ZeroOrOne
- Format: node
- Access Types: Get, Replace
- Values: N/A

5.20

/<X>/OperatorCSGEntries/<X>/OperatorCSGEntries_Only_thisPLMN

The OperatorCSGEntries_Only_thisPLMN leaf is used to indicate which CSGs the UE is configured to present to the user for a certain PLMN ID during manual CSG selection.

- Occurrence: ZeroOrOne
- Format: bool
- Access Types: Get, Replace

- Values: "false", "true"

"false" – Indicates that HPLMN has configured the UE to present to the user CSGs for the PLMN indicated in PLMN_ID leaf without any restriction.

"true" – Indicates that HPLMN has configured the UE to present to the user only the CSGs in the Operator CSG List for the PLMN indicated in PLMN_ID leaf.

NOTE: For the value "true", if the HPLMN has not included any CSG entry for the PLMN indicated in PLMN_ID leaf, the UE is implicitly configured to not display any CSG for this PLMN during manual CSG selection.

If the OperatorCSGEntries_Only_thisPLMN leaf is not included, then its value is equal to the value of OperatorCSGEntries_Only leaf.

5.21 /<X>/OperatorCSGEntries/OperatorCSGEntries_Only

The OperatorCSGEntries_Only leaf is used to indicate which CSGs the UE is configured to present to the user during manual CSG selection for every PLMN not included in the OperatorCSGEntries leaf and for every PLMN for which an OperatorCSGEntries_Only_thisPLMN leaf was not included.

- Occurrence: ZeroOrOne
- Format: bool
- Access Types: Get, Replace
- Values: "false", "true"

"false" – Indicates that the HPLMN has configured the UE, for every PLMN not included in any PLMN_ID leaf in the OperatorCSGEntries leaf or for which an OperatorCSGEntries_Only_thisPLMN leaf was not included, to present to the user CSGs without any restriction.

"true" – Indicates that the HPLMN has configured the UE, for every PLMN not included in any PLMN_ID leaf in the OperatorCSGEntries leaf or any PLMN for which an OperatorCSGEntries_Only_thisPLMN leaf was not included, to present to the user only the CSGs in the Operator CSG List.

NOTE: For the value "true", if the HPLMN has not included any CSG entry in the OperatorCSGList for a certain PLMN, the UE is implicitly configured to not display any CSG for that PLMN during manual CSG selection.

If the OperatorCSGEntries_Only leaf is not included, the default OperatorCSGEntries_Only value is "false".

Annex A (informative): Management Object DDF

This DDF is the standardized minimal set. A vendor can define its own DDF for the complete device. This DDF can include more features than this minimal standardized version.

```

<?xml version="1.0" encoding="UTF-8"?>
<!DOCTYPE MgmtTree PUBLIC "-//OMA//DTD-DM-DDF 1.2//EN"
"http://www.openmobilealliance.org/tech/DTD/dm_ddf-v1_2.dtd">

<MgmtTree>
  <VerDTD>1.2</VerDTD>
  <Node>
    <NodeName/>
    <DFProperties>
      <AccessType> <Get/> </AccessType>
      <DFFormat> <node/> </DFFormat>
      <Occurrence> <ZeroOrOne/> </Occurrence>
      <DFTitle>Root Node of the UE Allowed CSG List</DFTitle>
      <DFType>
        <DDFName>urn:oma:ext-3gpp-csg:1.0</DDFName>
      </DFType>
    </DFProperties>
  </Node>
  <Node>
    <NodeName>AllowedCSGEntries</NodeName>
    <DFProperties>
      <AccessType> <Get/> </AccessType>
      <DFFormat> <node/> </DFFormat>
      <Occurrence> <One/> </Occurrence>
      <DFTitle>This node specifies the parent node for allowed CSG entries</DFTitle>
      <DFType> <MIME>text/plain</MIME> </DFType>
    </DFProperties>
  </Node>
  <Node>
    <NodeName/>
    <DFProperties>
      <AccessType> <Get/> </AccessType>
      <DFFormat> <node/> </DFFormat>
      <Occurrence> <OneOrMore/> </Occurrence>
      <DFTitle>This node specifies the parent node for PLMN entries</DFTitle>
      <DFType> <MIME>text/plain</MIME> </DFType>
    </DFProperties>
  </Node>
  <Node>
    <NodeName>PLMN_ID</NodeName>
    <DFProperties>
      <AccessType> <Get/> <Replace/></AccessType>
      <DFFormat> <chr/> </DFFormat>
      <Occurrence> <One/> </Occurrence>
      <DFTitle>This leaf specifies the PLMN ID</DFTitle>
      <DFType> <MIME>text/plain</MIME> </DFType>
    </DFProperties>
  </Node>
  <Node>
    <NodeName>CSG-entries</NodeName>
    <DFProperties>
      <AccessType> <Get/> </AccessType>
      <DFFormat> <node/> </DFFormat>
      <Occurrence> <One/> </Occurrence>
      <DFTitle>This node specifies the parent node for CSG entries</DFTitle>
      <DFType> <MIME>text/plain</MIME> </DFType>
    </DFProperties>
  </Node>
  <Node>
    <NodeName/>
    <DFProperties>
      <AccessType> <Get/> </AccessType>
      <DFFormat> <node/> </DFFormat>
      <Occurrence> <OneOrMore/> </Occurrence>
      <DFTitle>This node specifies CSG entries for specific PLMN</DFTitle>
      <DFType> <MIME>text/plain</MIME> </DFType>
    </DFProperties>
  </Node>
  <Node>
    <NodeName>CSG_ID</NodeName>
    <DFProperties>
      <AccessType> <Get/> <Replace/></AccessType>
      <DFFormat> <bin/> </DFFormat>
      <Occurrence> <One/> </Occurrence>

```

```

        <DFTitle>This leaf specifies the CSG identifier</DFTitle>
        <DFType> <MIME>text/plain</MIME> </DFType>
      </DFProperties>
    </Node>
  <Node>
    <NodeName> HNB_Name </NodeName>
    <DFProperties>
      <AccessType> <Get /> <Replace/></AccessType>
      <DFFormat> <chr/> </DFFormat>
      <Occurrence> <ZeroOrOne/> </Occurrence>
      <DFTitle>This leaf node specifies the HNB Name</DFTitle>
      <DFType> <MIME>text/plain</MIME> </DFType>
    </DFProperties>
  </Node>

  <Node>
    <NodeName> CSG Type </NodeName>
    <DFProperties>
      <AccessType> <Get /> <Replace/></AccessType>
      <DFFormat> <chr/> </DFFormat>
      <Occurrence> <ZeroOrOne/> </Occurrence>
      <DFTitle>This leaf node specifies the CSG Type</DFTitle>
      <DFType> <MIME>text/plain</MIME> </DFType>
    </DFProperties>
  </Node>
</Node>
</Node>
</Node>

<Node>
<NodeName>OperatorCSGEntries</NodeName>
<DFProperties>
  <AccessType> <Get/> </AccessType>
  <DFFormat> <node/> </DFFormat>
  <Occurrence> <ZeroOrOne/> </Occurrence>
  <DFTitle>This node specifies the parent node for operator CSG entries</DFTitle>
  <DFType> <MIME>text/plain</MIME> </DFType>
</DFProperties>
<Node>
  <NodeName>OperatorCSGEntries_Only</NodeName>
  <DFProperties>
    <AccessType> <Get/> <Replace/></AccessType>
    <DFFormat> <bool/> </DFFormat>
    <Occurrence> <ZeroOrOne /> </Occurrence>
    <DFTitle>This leaf specifies which CSGs to display to the user</DFTitle>
    <DFType> <MIME>text/plain</MIME> </DFType>
  </DFProperties>
</Node>
<Node>
  <NodeName/>
  <DFProperties>
    <AccessType> <Get/> </AccessType>
    <DFFormat> <node/> </DFFormat>
    <Occurrence> <OneOrMore/> </Occurrence>
    <DFTitle>This node specifies the parent node for PLMN entries</DFTitle>
    <DFType> <MIME>text/plain</MIME> </DFType>
  </DFProperties>
  <Node>
    <NodeName>PLMN_ID</NodeName>
    <DFProperties>
      <AccessType> <Get/> <Replace/></AccessType>
      <DFFormat> <chr/> </DFFormat>
      <Occurrence> <One/> </Occurrence>
      <DFTitle>This leaf specifies the PLMN ID</DFTitle>
      <DFType> <MIME>text/plain</MIME> </DFType>
    </DFProperties>
  </Node>
  <Node>
    <NodeName>OperatorCSGEntries_Only_thisPLMN</NodeName>
    <DFProperties>
      <AccessType> <Get/> <Replace/></AccessType>
      <DFFormat> <bool/> </DFFormat>
      <Occurrence> <ZeroOrOne /> </Occurrence>
      <DFTitle>This leaf specifies which CSGs to display to the user</DFTitle>
      <DFType> <MIME>text/plain</MIME> </DFType>
    </DFProperties>
  </Node>
</Node>

```

```

<Node>
  <NodeName>CSG-entries</NodeName>
  <DFProperties>
    <AccessType> <Get/> </AccessType>
    <DFFormat> <node/> </DFFormat>
    <Occurrence> <One/> </Occurrence>
    <DFTitle>This node specifies the parent node for CSG entries</DFTitle>
    <DFType> <MIME>text/plain</MIME> </DFType>
  </DFProperties>
  <Node>
    <NodeName/>
    <DFProperties>
      <AccessType> <Get/> </AccessType>
      <DFFormat> <node/> </DFFormat>
      <Occurrence> <OneOrMore/> </Occurrence>
      <DFTitle>This node specifies CSG entries for specific PLMN</DFTitle>
      <DFType> <MIME>text/plain</MIME> </DFType>
    </DFProperties>
    <Node>
      <NodeName>CSG_ID</NodeName>
      <DFProperties>
        <AccessType> <Get/> <Replace/></AccessType>
        <DFFormat> <bin/> </DFFormat>
        <Occurrence> <One/> </Occurrence>
        <DFTitle>This leaf specifies the CSG identifier</DFTitle>
        <DFType> <MIME>text/plain</MIME> </DFType>
      </DFProperties>
    </Node>
    <Node>
      <NodeName> HNB_Name </NodeName>
      <DFProperties>
        <AccessType> <Get /> <Replace/></AccessType>
        <DFFormat> <chr/> </DFFormat>
        <Occurrence> <ZeroOrOne/> </Occurrence>
        <DFTitle>This leaf node specifies the HNB Name</DFTitle>
        <DFType> <MIME>text/plain</MIME> </DFType>
      </DFProperties>
    </Node>
    <Node>
      <NodeName> CSG Type </NodeName>
      <DFProperties>
        <AccessType> <Get /> <Replace/></AccessType>
        <DFFormat> <chr/> </DFFormat>
        <Occurrence> <ZeroOrOne/> </Occurrence>
        <DFTitle>This leaf node specifies the CSG Type</DFTitle>
        <DFType> <MIME>text/plain</MIME> </DFType>
      </DFProperties>
    </Node>
  </Node>
</Node>
</Node>
</Node>
</Node>
<Node>
  <NodeName>Ext</NodeName>
  <DFProperties>
    <AccessType>
      <Get/>
    </AccessType>
    <DFFormat>
      <node/>
    </DFFormat>
    <Occurrence>
      <ZeroOrOne/>
    </Occurrence>
    <Scope>
      <Permanent/>
    </Scope>
    <DFTitle>A collection of all extension objects</DFTitle>
    <DFType>
      <DDFName/>
    </DFType>
  </DFProperties>
</Node>

</Node>
</MgmtTree>

```

Annex B (informative): Change history

Change history							
Date	TSG #	TSG Doc.	CR	Rev	Subject/Comment	Old	New
2008-09					Version 0.0.1: Preliminary proposal		0.0.1
2008-10					Version 0.0.2: TS number is added	0.0.1	0.0.2
2008-11					C1-085374	0.0.2	0.1.0
2008-11					Editorial corrections	0.1.0	0.1.1
2008-11					Version 1.0.0 created for presentation to CT#42 for information	0.1.1	1.0.0
2009-02					C1-090705	1.0.0	1.1.0
2009-02	CT-43				Version 2.0.0 created for presentation to CT#43 for approval	1.1.0	2.0.0
2009-03	CT-43				Version 8.0.0 created after approval at CT#43	2.0.0	8.0.0
2009-06	CT-44	CP-090423	0001		urn for the CSG MO registered by OMNA and minor corrections and cleanups	8.0.0	8.1.0
2009-06	CT-44	CP-090423	0002	1	Updating the allowed CSG list on receiving OMA DM message	8.0.0	8.1.0
2009-06	CT-44				Cover sheet template fixed by MCC	8.0.0	8.1.0
2009-06					Correct version shown on cover	8.1.0	8.1.1
2009-09	CT-45	CP-090677	0003	1	Support of CSG Type in Allowed CSG MO	8.1.1	8.2.0
2009-09	CT-45	CP-090633	0004	2	Introduction of Operator CSG List in the MO	8.2.0	9.0.0
2009-12	CT-46	CP-090918	0006		Correction of the OMA DM object for the Allowed CSG list	9.0.0	9.1.0
2009-12	CT-46	CP-090935	0007		Support of CSG Type for Operator CSG List	9.0.0	9.1.0
2010-06	CT-48	CP-100350	0011		Occurrence of HNB_Name and CSG_Type	9.1.0	9.2.0
2010-06	CT-48	CP-100370	0010	1	Updating Operator CSG List	9.2.0	10.0.0
2010-09	CT-49	CP-100606	0021		Correcting DDF of allowed CSG list MO	10.0.0	10.1.0
2010-12	CT-50	CP-100748	0023	3	Support for displaying only CSGs in the Operator CSG List	10.1.0	10.2.0
2012-09	CT-57				Upgrade to Rel-11	10.2.0	11.0.0
2014-09	CT-65				Upgrade to Rel-12	11.0.0	12.0.0
2015-12	CT-70				Upgrade to Rel-13	12.0.0	13.0.0

Change history							
Date	Meeting	TDoc	CR	Rev	Cat	Subject/Comment	New version
2017-03	CT-75					Upgrade to Rel-14	14.0.0
2018-06	SA-80	-	-	-		Update to Rel-15 version (MCC)	15.0.0
2020-07	SA-88e	-	-	-		Update to Rel-16 version (MCC)	16.0.0
2022-03	CT-95	-	-	-	-	Update to Rel-17 version (MCC)	17.0.0
2024-04	-	-	-	-	-	Update to Rel-18 version (MCC)	18.0.0

History

Document history		
V18.0.0	May 2024	Publication