

# ETSI TS 124 312 V10.2.0 (2011-04)

---

*Technical Specification*

**Universal Mobile Telecommunications System (UMTS);  
LTE;  
Access Network Discovery and Selection Function (ANDSF)  
Management Object (MO)  
(3GPP TS 24.312 version 10.2.0 Release 10)**

---



---

Reference

RTS/TSGC-0124312va20

---

Keywords

LTE, UMTS

**ETSI**

650 Route des Lucioles  
F-06921 Sophia Antipolis Cedex - FRANCE

Tel.: +33 4 92 94 42 00 Fax: +33 4 93 65 47 16

Siret N° 348 623 562 00017 - NAF 742 C  
Association à but non lucratif enregistrée à la  
Sous-Préfecture de Grasse (06) N° 7803/88

---

**Important notice**

Individual copies of the present document can be downloaded from:

<http://www.etsi.org>

The present document may be made available in more than one electronic version or in print. In any case of existing or perceived difference in contents between such versions, the reference version is the Portable Document Format (PDF). In case of dispute, the reference shall be the printing on ETSI printers of the PDF version kept on a specific network drive within ETSI Secretariat.

Users of the present document should be aware that the document may be subject to revision or change of status. Information on the current status of this and other ETSI documents is available at

<http://portal.etsi.org/tb/status/status.asp>

If you find errors in the present document, please send your comment to one of the following services:

[http://portal.etsi.org/chaicor/ETSI\\_support.asp](http://portal.etsi.org/chaicor/ETSI_support.asp)

---

**Copyright Notification**

No part may be reproduced except as authorized by written permission.  
The copyright and the foregoing restriction extend to reproduction in all media.

© European Telecommunications Standards Institute 2011.  
All rights reserved.

**DECT**<sup>™</sup>, **PLUGTESTS**<sup>™</sup>, **UMTS**<sup>™</sup>, **TIPHON**<sup>™</sup>, the TIPHON logo and the ETSI logo are Trade Marks of ETSI registered for the benefit of its Members.

**3GPP**<sup>™</sup> is a Trade Mark of ETSI registered for the benefit of its Members and of the 3GPP Organizational Partners.

**LTE**<sup>™</sup> is a Trade Mark of ETSI currently being registered

for the benefit of its Members and of the 3GPP Organizational Partners.

**GSM**<sup>®</sup> and the GSM logo are Trade Marks registered and owned by the GSM Association.

---

## Intellectual Property Rights

IPRs essential or potentially essential to the present document may have been declared to ETSI. The information pertaining to these essential IPRs, if any, is publicly available for **ETSI members and non-members**, and can be found in ETSI SR 000 314: "*Intellectual Property Rights (IPRs); Essential, or potentially Essential, IPRs notified to ETSI in respect of ETSI standards*", which is available from the ETSI Secretariat. Latest updates are available on the ETSI Web server (<http://webapp.etsi.org/IPR/home.asp>).

Pursuant to the ETSI IPR Policy, no investigation, including IPR searches, has been carried out by ETSI. No guarantee can be given as to the existence of other IPRs not referenced in ETSI SR 000 314 (or the updates on the ETSI Web server) which are, or may be, or may become, essential to the present document.

---

## Foreword

This Technical Specification (TS) has been produced by ETSI 3rd Generation Partnership Project (3GPP).

The present document may refer to technical specifications or reports using their 3GPP identities, UMTS identities or GSM identities. These should be interpreted as being references to the corresponding ETSI deliverables.

The cross reference between GSM, UMTS, 3GPP and ETSI identities can be found under <http://webapp.etsi.org/key/queryform.asp>.

# Contents

Intellectual Property Rights .....	2
Foreword.....	2
Foreword.....	7
1 Scope .....	8
2 References .....	8
3 Definitions and abbreviations.....	9
3.1 Definitions .....	9
3.3 Abbreviations .....	10
4 ANDSF MO .....	10
5 ANDSF MO parameters.....	14
5.1 General .....	14
5.2 Node: <X> .....	14
5.3 <X>/Name .....	15
5.4 <X>/Policy.....	15
5.5 <X>/Policy/<X> .....	15
5.6 <X>/Policy/<X>/RulePriority .....	15
5.7 <X>/Policy/<X>/PrioritizedAccess.....	15
5.8 <X>/Policy/<X>/PrioritizedAccess/<X> .....	16
5.9 <X>/Policy/<X>/PrioritizedAccess/<X>/ AccessTechnology.....	16
5.10 <X>/Policy/<X>/PrioritizedAccess/<X>/ AccessId .....	16
5.10A <X>/Policy/<X>/PrioritizedAccess/<X>/ SecondaryAccessId.....	17
5.11 <X>/Policy/<X>/PrioritizedAccess/<X>/ AccessNetworkPriority .....	17
5.12 <X>/Policy/<X>/ValidityArea .....	18
5.13 <X>/Policy/<X>/ValidityArea/3GPP_Location.....	18
5.14 <X>/Policy/<X>/ValidityArea/3GPP_Location/<X> .....	18
5.15 <X>/Policy/<X>/ValidityArea/3GPP_Location/<X>/PLMN.....	18
5.16 <X>/Policy/<X>/ValidityArea/3GPP_Location/<X>/TAC.....	19
5.17 <X>/Policy/<X>/ValidityArea/3GPP_Location/<X>/LAC.....	19
5.18 <X>/Policy/<X>/ValidityArea/3GPP_Location/<X>/GERAN_CI.....	19
5.18A <X>/Policy/<X>/ValidityArea/3GPP_Location/ <X>/UTRAN_CI.....	19
5.18B <X>/Policy/<X>/ValidityArea/3GPP_Location/ <X>/EUTRA_CI.....	20
5.19 <X>/Policy/<X>/ValidityArea/3GPP2_Location.....	20
5.20 <X>/Policy/<X>/ValidityArea/3GPP2_Location/1x .....	20
5.21 <X>/Policy/<X>/ValidityArea/3GPP2_Location/1x/<X>.....	20
5.22 <X>/Policy/<X>/ValidityArea/3GPP2_Location/1x/<X>/ SID .....	21
5.23 <X>/Policy/<X>/ValidityArea/3GPP2_Location/1x/<X>/ NID .....	21
5.24 <X>/Policy/<X>/ValidityArea/3GPP2_Location/1x/<X>/ Base_ID.....	21
5.25 <X>/Policy/<X>/ValidityArea/3GPP2_Location/HRPD.....	21
5.26 <X>/Policy/<X>/ValidityArea/3GPP2_Location/HRPD/<X> .....	22
5.27 <X>/Policy/<X>/ValidityArea/3GPP2_Location/HRPD/<X>/ Sector_ID.....	22
5.27A <X>/Policy/<X>/ValidityArea/3GPP2_Location/HRPD/<X>/ Netmask.....	22
5.28 <X>/Policy/<X>/ValidityArea/WiMAX_Location.....	22
5.29 <X>/Policy/<X>/ValidityArea/WiMAX_Location/<X> .....	23
5.30 <X>/Policy/<X>/ValidityArea/WiMAX_Location/<X>/NAP-ID .....	23
5.31 <X>/Policy/<X>/ValidityArea/WiMAX_Location/<X>/BS-ID .....	23
5.32 <X>/Policy/<X>/ValidityArea/WLAN_Location.....	23
5.33 <X>/Policy/<X>/ValidityArea/WLAN_Location/<X> .....	24
5.33A <X>/Policy/<X>/ValidityArea/WLAN_Location/<X>/HESSID .....	24
5.34 <X>/Policy/<X>/ValidityArea/WLAN_Location/<X>/SSID .....	24
5.35 <X>/Policy/<X>/ValidityArea/WLAN_Location/<X>/BSSID.....	24
5.36 <X>/Policy/<X>/ValidityArea/Geo_Location .....	24
5.36A <X>/Policy/<X>/ValidityArea/Geo_Location/Circular .....	25
5.36B <X>/Policy/<X>/ValidityArea/Geo_Location/Circular/<X> .....	25

5.36C	<X>/Policy/<X>/ValidityArea/Geo_Location/Circular/<X>/ AnchorLatitude .....	25
5.36D	<X>/Policy/<X>/ValidityArea/Geo_Location/Circular/<X>/ AnchorLongitude .....	25
5.36E	<X>/Policy/<X>/ValidityArea/Geo_Location/Circular/<X>/ Radius .....	26
5.37	<X>/Policy/<X>/Roaming .....	26
5.37A	<X>/Policy/<X>/PLMN.....	26
5.38	<X>/Policy/<X>/TimeOfDay.....	26
5.39	<X>/Policy/<X>/TimeOfDay/<X>.....	27
5.40	<X>/Policy/<X>/TimeOfDay/<X>/TimeStart.....	27
5.41	<X>/Policy/<X>/TimeOfDay/<X>/TimeStop.....	27
5.42	<X>/Policy/<X>/TimeOfDay/<X>/DateStart.....	27
5.43	<X>/Policy/<X>/TimeOfDay/<X>/DateStop.....	28
5.44	Void.....	28
5.45	Void.....	28
5.46	Void.....	28
5.47	Void.....	28
5.48	<X>/Policy/<X>/UpdatePolicy .....	28
5.49	<X>/DiscoveryInformation.....	29
5.50	<X>/DiscoveryInformation/<X> .....	29
5.51	<X>/DiscoveryInformation/<X>/AccessNetworkType .....	29
5.52	<X>/DiscoveryInformation/<X>/AccessNetworkArea.....	29
5.53	<X>/DiscoveryInformation/<X>/AccessNetworkArea/ 3GPP_Location .....	30
5.54	<X>/DiscoveryInformation/<X>/AccessNetworkArea/ 3GPP_Location/<X> .....	30
5.55	<X>/DiscoveryInformation/<X>/AccessNetworkArea/ 3GPP_Location/<X>/PLMN .....	30
5.56	<X>/DiscoveryInformation/<X>/AccessNetworkArea/ 3GPP_Location/<X>/TAC .....	30
5.57	<X>/DiscoveryInformation/<X>/AccessNetworkArea/ 3GPP_Location/<X>/LAC .....	31
5.58	<X>/DiscoveryInformation/<X>/AccessNetworkArea/ 3GPP_Location/<X>/GERAN_CI.....	31
5.58A	<X>/DiscoveryInformation/<X>/ AccessNetworkArea/3GPP_Location/<X>/UTRAN_CI .....	31
5.58B	<X>/DiscoveryInformation/<X>/ AccessNetworkArea/3GPP_Location/<X>/EUTRA_CI .....	31
5.59	<X>/DiscoveryInformation/<X>/AccessNetworkArea/ 3GPP2_Location .....	32
5.60	<X>/DiscoveryInformation/<X>/AccessNetworkArea/ 3GPP2_Location/1x .....	32
5.61	<X>/DiscoveryInformation/<X>/AccessNetworkArea/ 3GPP2_Location/1x/<X> .....	32
5.62	<X>/DiscoveryInformation/<X>/AccessNetworkArea/ 3GPP2_Location/1x/<X>/SID .....	32
5.63	<X>/DiscoveryInformation/<X>/AccessNetworkArea/ 3GPP2_Location/1x/<X>/NID .....	33
5.64	<X>/DiscoveryInformation/<X>/AccessNetworkArea/ 3GPP2_Location/1x/<X>/Base_ID .....	33
5.65	<X>/DiscoveryInformation/<X>/AccessNetworkArea/ 3GPP2_Location/HRPD.....	33
5.66	<X>/DiscoveryInformation/<X>/AccessNetworkArea/ 3GPP2_Location/HRPD/<X> .....	33
5.67	<X>/DiscoveryInformation/<X>/AccessNetworkArea/ 3GPP2_Location/HRPD/<X>/Sector_ID .....	34
5.67A	<X>/DiscoveryInformation/<X>/AccessNetworkArea/ 3GPP2_Location/HRPD/<X>/Netmask.....	34
5.68	<X>/DiscoveryInformation/<X>/AccessNetworkArea/ WiMAX_Location .....	34
5.69	<X>/DiscoveryInformation/<X>/AccessNetworkArea/ WiMAX_Location/<X>.....	34
5.70	<X>/DiscoveryInformation/<X>/AccessNetworkArea/ WiMAX_Location/<X>/NAP-ID .....	35
5.71	<X>/DiscoveryInformation/<X>/AccessNetworkArea/ WiMAX_Location/<X>/BS-ID .....	35
5.72	<X>/DiscoveryInformation/<X>/AccessNetworkArea/ WLAN_Location.....	35
5.73	<X>/DiscoveryInformation/<X>/AccessNetworkArea/ WLAN_Location/<X>.....	35
5.73A	<X>/DiscoveryInformation/<X>/AccessNetworkArea /WLAN_Location/<X>/HESSID.....	36
5.74	<X>/DiscoveryInformation/<X>/AccessNetworkArea /WLAN_Location/<X>/SSID .....	36
5.75	<X>/DiscoveryInformation/<X>/AccessNetworkArea/ WLAN_Location/<X>/BSSID .....	36
5.76	<X>/DiscoveryInformation/<X>/AccessNetworkArea/ Geo_Location .....	36
5.76A	<X>/DiscoveryInformation/<X>/ AccessNetworkArea /Geo_Location/Circular.....	37
5.76B	<X>/DiscoveryInformation/<X>/ AccessNetworkArea /Geo_Location/Circular/<X> .....	37
5.76C	<X>/DiscoveryInformation/<X>/ AccessNetworkArea/Geo_Location/Circular/<X>/AnchorLatitude.....	37
5.76D	<X>/DiscoveryInformation/<X>/ AccessNetworkArea/Geo_Location/Circular/<X>/AnchorLongitude.....	37
5.76E	<X>/DiscoveryInformation/<X>/ AccessNetworkArea/Geo_Location/Circular/<X>/Radius .....	38
5.77	<X>/DiscoveryInformation/<X>/ AccessNetworkInformationRef.....	38
5.78	<X>/UE_Location .....	38
5.79	<X>/UE_Location/3GPP_Location .....	38
5.80	<X>/UE_Location/3GPP_Location/<X> .....	39
5.81	<X>/UE_Location/3GPP_Location/<X>/PLMN .....	39
5.82	<X>/UE_Location/3GPP_Location/<X>/TAC .....	39
5.83	<X>/UE_Location/3GPP_Location/<X>/LAC .....	39
5.84	<X>/UE_Location/3GPP_Location/<X>/GERAN_CI .....	39
5.84A	<X>/UE_Location/3GPP_Location/<X>/ UTRAN_CI .....	40

5.84B	<X>/UE_Location/3GPP_Location/<X>/ EUTRA_CI.....	40
5.85	<X>/UE_Location/3GPP2_Location.....	40
5.86	<X>/UE_Location/3GPP2_Location/1x.....	40
5.87	<X>/UE_Location/3GPP2_Location/1x/<X>.....	41
5.88	<X>/UE_Location/3GPP2_Location/1x/<X>/SID.....	41
5.89	<X>/UE_Location/3GPP2_Location/1x/<X>/NID.....	41
5.90	<X>/UE_Location/3GPP2_Location/1x/<X>/Base_ID.....	41
5.91	<X>/UE_Location/3GPP2_Location/HRPD.....	41
5.92	<X>/UE_Location/3GPP2_Location/HRPD/<X>.....	42
5.93	<X>/UE_Location/3GPP2_Location/HRPD/<X>/Sector_ID.....	42
5.93A	<X>/UE_Location/3GPP2_Location/HRPD/<X>/Netmask.....	42
5.94	<X>/UE_Location/WiMAX_Location.....	42
5.95	<X>/UE_Location/WiMAX_Location/<X>.....	43
5.96	<X>/UE_Location/WiMAX_Location/<X>/NAP-ID.....	43
5.97	<X>/UE_Location/WiMAX_Location/<X>/BS-ID.....	43
5.98	<X>/UE_Location/WLAN_Location.....	43
5.99	<X>/UE_Location/WLAN_Location/<X>.....	43
5.99A	<X>/UE_Location/WLAN_Location/<X>/HESSID.....	44
5.100	<X>/UE_Location/WLAN_Location/<X>/SSID.....	44
5.101	<X>/UE_Location/WLAN_Location/<X>/BSSID.....	44
5.102	<X>/UE_Location/Geo_Location/.....	44
5.102A	Void.....	45
5.102B	<X>/ UE_Location /Geo_Location/Latitude.....	45
5.102C	<X>/ UE_Location /Geo_Location/Longitude.....	45
5.102D	<X>/ UE_Location /RPLMN.....	45
5.102E	<X>/ISRP/.....	45
5.102F	<X>/ISRP/<X>.....	45
5.102G	Void.....	46
5.102H	<X>/ISRP/<X>/ForFlowBased.....	46
5.102I	<X>/ISRP/<X>/ForFlowBased/<X>/.....	46
5.102J	<X>/ISRP/<X>/ForFlowBased/<X>/IPFlow.....	46
5.102K	<X>/ISRP/<X>/ForFlowBased/<X>/IPFlow/<X>/.....	46
5.102L	<X>/ISRP/<X>/ForFlowBased/<X>/IPFlow/<X>/ AddressType.....	47
5.102M	<X>/ISRP/<X>/ForFlowBased/<X>/IPFlow/<X>/ StartSourceIPAddress.....	47
5.102N	<X>/ISRP/<X>/ForFlowBased/<X>/IPFlow/<X>/ EndSourceIPAddress.....	47
5.102O	<X>/ISRP/<X>/ForFlowBased/<X>/IPFlow/<X>/ StartDestIPAddress.....	48
5.102P	<X>/ISRP/<X>/ForFlowBased/<X>/IPFlow/<X>/ EndDestIPAddress.....	48
5.102Q	<X>/ISRP/<X>/ForFlowBased/<X>/IPFlow/<X>/ ProtocolType.....	48
5.102R	<X>/ISRP/<X>/ForFlowBased/<X>/IPFlow/<X>/ StartSourcePortNumber.....	49
5.102S	<X>/ISRP/<X>/ForFlowBased/<X>/IPFlow/<X>/ EndSourcePortNumber.....	49
5.102T	<X>/ISRP/<X>/ForFlowBased/<X>/IPFlow/<X>/ StartDestPortNumber.....	49
5.102U	<X>/ISRP/<X>/ForFlowBased/<X>/IPFlow/<X>/ EndDestPortNumber.....	50
5.102V	<X>/ISRP/<X>/ForFlowBased/<X>/IPFlow/<X>/QoS.....	50
5.102W	<X>/ISRP/<X>/ForFlowBased/<X>/RoutingCriteria.....	50
5.102X	<X>/ISRP/<X>/ForFlowBased/<X>/RoutingCriteria/<X>/.....	51
5.102Y	<X>/ISRP/<X>/ForFlowBased/<X>/RoutingCriteria/<X>/ ValidityArea.....	51
5.102Z	<X>/ISRP/<X>/ForFlowBased/<X>/RoutingCriteria/<X>/ TimeOfDay.....	51
5.102AA	<X>/ISRP/<X>/ForFlowBased/<X>/RoutingCriteria/<X>/ APN.....	51
5.102AB	<X>/ISRP/<X>/ForFlowBased/<X>/RoutingRule.....	51
5.102ABA	<X>/ISRP/<X>/ForFlowBased/<X>/ RulePriority.....	52
5.102AC	<X>/ISRP/<X>/ForServiceBased.....	52
5.102AD	<X>/ISRP/<X>/ForServiceBased/<X>/.....	52
5.102AE	<X>/ISRP/<X>/ForServiceBased/<X>/ APN.....	52
5.102AF	<X>/ISRP/<X>/ForServiceBased/<X>/RoutingCriteria.....	53
5.102AG	<X>/ISRP/<X>/ForServiceBased/<X>/ RoutingCriteria/<X>/.....	53
5.102AH	<X>/ISRP/<X>/ForServiceBased/<X>/RoutingCriteria/ <X>/ ValidityArea.....	53
5.102AI	<X>/ISRP/<X>/ForServiceBased/<X>/RoutingCriteria /<X>/ TimeOfDay.....	53
5.102AJ	<X>/ISRP/<X>/ForServiceBased/<X>/RoutingRule.....	54
5.102AJA	<X>/ISRP/<X>/ForServiceBased/<X>/ RulePriority.....	54
5.102AJB	<X>/ISRP/<X>/ForNonSeamlessOffload/.....	54
5.102AJC	<X>/ISRP/<X>/ForNonSeamlessOffload/<X>/.....	54
5.102AJD	<X>/ISRP/<X>/ForNonSeamlessOffload/<X>/IPFlow.....	55

5.10AJE	<X>/ISRP/<X>/ForNonSeamlessOffload/<X>/IPFlow/<X>	55
5.102AJF	<X>/ISRP/<X>/ForNonSeamlessOffload/<X>/IPFlow/ <X>/AddressType	55
5.102AJG	<X>/ISRP/<X>/ForNonSeamlessOffload/<X>/IPFlow/ <X>/StartSourceIPAddress	55
5.102AJH	<X>/ISRP/<X>/ForNonSeamlessOffload/<X>/IPFlow/ <X>/EndSourceIPAddress	56
5.102AJI	<X>/ISRP/<X>/ForNonSeamlessOffload/<X>/IPFlow/ <X>/StartDestIPAddress	56
5.102AJJ	<X>/ISRP/<X>/ForNonSeamlessOffload/<X>/IPFlow/ <X>/EndDestIPAddress	57
5.102AJK	<X>/ISRP/<X>/ForNonSeamlessOffload/<X>/IPFlow/ <X>/ ProtocolType	57
5.102AJL	<X>/ISRP/<X>/ForNonSeamlessOffload/<X>/IPFlow/ <X>/ StartSourcePortNumber	57
5.102AJM	<X>/ISRP/<X>/ForNonSeamlessOffload/<X>/IPFlow/ <X>/ EndSourcePortNumber	58
5.102AJN	<X>/ISRP/<X>/ForNonSeamlessOffload/<X>/IPFlow/ <X>/ StartDestPortNumber	58
5.102AJO	<X>/ISRP/<X>/ForNonSeamlessOffload/<X>/IPFlow/ <X>/ EndDestPortNumber	58
5.102AJP	<X>/ISRP/<X>/ForNonSeamlessOffload/<X>/IPFlow/ <X>/QoS	59
5.102AJQ	<X>/ISRP/<X>/ForNonSeamlessOffload/<X>/ RoutingCriteria	59
5.102AJR	<X>/ISRP/<X>/ForNonSeamlessOffload/<X>/ RoutingCriteria/ <X>/	59
5.102AJS	<X>/ISRP/<X>/ForNonSeamlessOffload/<X>/ RoutingCriteria/ <X>/ ValidityArea	59
5.102AJT	<X>/ISRP/<X>/ForNonSeamlessOffload/<X>/ RoutingCriteria/ <X>/ TimeOfDay	60
5.102AJU	<X>/ISRP/<X>/ForNonSeamlessOffload/<X>/ RoutingCriteria/<X>/APN	60
5.102AJV	<X>/ISRP/<X>/ForNonSeamlessOffload/<X>/ RoutingRule	60
5.102AJW	<X>/ISRP/<X>/ForNonSeamlessOffload/<X>/ RoutingRule/<X>/	60
5.102AJX	<X>/ISRP/<X>/ForNonSeamlessOffload/<X>/ RoutingRule/AccessID	61
5.102AJY	<X>/ISRP/<X>/ForNonSeamlessOffload/<X>/RoutingRule/SecondaryAccessID	61
5.102AJZ	<X>/ISRP/<X>/ForNonSeamlessOffload/<X>/RoutingRule/AccessNetworkPriority	61
5.102AJAA	<X>/ISRP/<X>/ForFlowBased/<X>/ RulePriority	61
5.102AK	<X>/ISRP/<X>/Roaming	62
5.102AL	<X>/ISRP/<X>/PLMN	62
5.102AM	<X>/ISRP/<X>/UpdatePolicy	62
5.103	<X>/Ext	63
6	MO for WiMAX	63
6.1	Introduction	63
6.2	WNDS MO	63
6.3	WNDS MO parameters	64
6.3.1	General	64
6.3.2	Node: <X>	64
6.3.3	<X>/Name	64
6.3.4	<X>/NetworkList	64
6.3.5	<X>/NetworkList/<X>	65
6.3.6	<X>/NetworkList/<X>/FrequencyInfo	65
6.3.7	<X>/NetworkList/<X>/FrequencyInfo/<X>	65
6.3.8	<X>/NetworkList/<X>/FrequencyInfo/<X>FirstFreq	65
6.3.9	<X>/NetworkList/<X>/FrequencyInfo/<X>LastFreq	65
6.3.10	<X>/NetworkList/<X>/FrequencyInfo/<X>NextFreqStep	66
6.3.11	<X>/NetworkList/<X>/ FrequencyInfo/<X>ChannelBandwidth	66
6.3.12	<X>/NetworkList/<X>/ FrequencyInfo/<X>DuplexMode	66
6.3.13	<X>/NetworkList/<X>/ FrequencyInfo/<X>FFT_Size	67
6.3.14	<X>/NetworkList/<X>/ FrequencyInfo/<X>Preambles	67
6.3.15	<X>/ NetworkList /<X>/NAP-ID	67
6.3.16	<X>/NetworkList/<X>/CellType	67
6.3.17	<X>/NetworkList/<X>/OperatorDifferentiatedTextField	67
6.3.18	<X>/Ext	68
<b>Annex A (informative):</b>	<b>ANDSF MO DDF</b>	<b>69</b>
<b>Annex B (informative):</b>	<b>WNDS MO DDF</b>	<b>148</b>
<b>Annex C (informative):</b>	<b>Change history</b>	<b>153</b>
History		154

---

## Foreword

This Technical Specification has been produced by the 3<sup>rd</sup> Generation Partnership Project (3GPP).

The contents of the present document are subject to continuing work within the TSG and may change following formal TSG approval. Should the TSG modify the contents of the present document, it will be re-released by the TSG with an identifying change of release date and an increase in version number as follows:

Version x.y.z

where:

- x the first digit:
  - 1 presented to TSG for information;
  - 2 presented to TSG for approval;
  - 3 or greater indicates TSG approved document under change control.
- y the second digit is incremented for all changes of substance, i.e. technical enhancements, corrections, updates, etc.
- z the third digit is incremented when editorial only changes have been incorporated in the document.



---

# 1 Scope

The present document defines management objects that can be used by the Access Network Discovery and Selection Function (ANDSF) and the UE.

The Management Object (MO) is compatible with the OMA Device Management (DM) protocol specifications, version 1.2 and upwards, and is defined using the OMA DM Device Description Framework (DDF) as described in the Enabler Release Definition OMA-ERELED-DM-V1\_2 [5].

The MO consists of relevant parameters for intersystem mobility policy- and access network discovery information that can be managed by the ANDSF.

The service requirements and the functional requirements for the access network discovery and selection are described in 3GPP TS 22.278 [2] and in 3GPP TS 23.402 [4] respectively.

---

# 2 References

The following documents contain provisions which, through reference in this text, constitute provisions of the present document.

- References are either specific (identified by date of publication, edition number, version number, etc.) or non-specific.
- For a specific reference, subsequent revisions do not apply.
- For a non-specific reference, the latest version applies. In the case of a reference to a 3GPP document (including a GSM document), a non-specific reference implicitly refers to the latest version of that document *in the same Release as the present document*.

- [1] 3GPP TR 21.905: "Vocabulary for 3GPP Specifications".
- [2] 3GPP TS 22.278: "Service requirements for the Evolved Packet System (EPS)".
- [3] 3GPP TS 23.003: "Numbering, addressing and identification".
- [3A] 3GPP TS 23.032: "Universal Geographical Area Description (GAD)".
- [3AA] 3GPP TS 24.302: "Access to the 3GPP Evolved Packet Core (EPC) via non-3GPP access networks".
- [3AB] 3GPP TS 24.303: "Mobility management based on Dual-Stack Mobile IPv6".
- [3B] 3GPP TS 25.331: "Radio Resource Control (RRC); Protocol Specification".
- [3C] 3GPP TS 36.331: "Evolved Universal Terrestrial Radio Access (E-UTRA) Radio Resource Control (RRC); Protocol specification".
- [4] 3GPP TS 23.402: "Architecture enhancements for non-3GPP accesses".
- [4A] OMA-DDS-DM\_ConnMO-V1\_0- 20081107-A: "Standardized Connectivity Management Objects", Approved Version 1.0 – 07 Nov 2008.
- [4B] OMA-DDS-DM\_ConnMO\_WLAN-V1\_0-20081024-A: "Standardized Connectivity Management Objects WLAN Parameters", Approved Version 1.0 – 24 Oct 2008.
- [5] OMA-ERELED-DM-V1\_2: "Enabler Release Definition for OMA Device Management".
- [6] WiMAX Forum Network Architecture Release 1.0 version 1.2.2 – Stage 2: "Architecture Tenets, Reference Model and Reference Points", May 2008.
- [7] WiMAX Forum Network Architecture Release 1.0 version 1.2.2 – Stage 3: "Detailed Protocols and Procedures", May 2008.

- [8] WiMAX Forum Mobile System Profile Release 1.0 Approved Specification Revision 1.4.0, April 2007.
- [9] IEEE Std 802.11™-2007: "Information Technology- Telecommunications and information exchange between systems-Local and metropolitan area networks-Specific requirements-Part 11: Wireless LAN Medium Access Control (MAC) and Physical Layer (PHY) Specifications".
- [10] IEEE Std 802.16e-2005 and IEEE Std 802.16-2004/Cor1-2005: "IEEE Standard for Local and Metropolitan Area Networks, Part 16: Air Interface for Fixed and Mobile Broadband Wireless Access Systems Amendments 2 and Corrigendum 1", February 2006.
- [10A] IETF RFC 3260 (April 2002): "New Terminology and Clarifications for Diffserv".
- [11] IETF RFC 3629 (November 2003): "UTF-8, a transformation format of ISO 10646".
- [12] "Unicode 5.1.0, Unicode Standard Annex #15; Unicode Normalization Forms", March 2008. <http://www.unicode.org>
- [13] 3GPP2 C.S0005: "Upper Layer (Layer 3) Signaling Standard for cdma2000 Spread Spectrum Systems".
- [14] 3GPP2 C.S0016: "Over-the-Air Service Provisioning of Mobile Stations in Spread Spectrum Standards".
- [15] 3GPP2 C.S0024: "cdma2000 High Rate Packet Data Air Interface Specification".
- [16] ISO 8601:2004: "Data elements and interchange formats -- Information interchange -- Representation of dates and times".
- [17] IEEE 802.11u: "Draft Amendment to Standard for Information Technology - Telecommunications and information exchange between systems-Local and metropolitan area networks-Specific requirements Part 11: Wireless LAN Medium Access Control (MAC) and Physical Layer (PHY) specifications: Amendment 7: Interworking with External Networks".

---

[18] IANA Assigned Internet Protocol Numbers  
 (<http://www.iana.org/assignments/protocol-numbers/protocol-numbers.xml>)<sup>3</sup> Definitions and abbreviations

### 3.1 Definitions

For the purposes of the present document, the terms and definitions given in 3GPP TR 21.905 [1] apply.

For the purpose of the present document, the terms and definitions given in 3GPP TS 24.302 [3AA] apply:

**Home ANDSF**  
**Visited ANDSF**

**Inter-System Routing Policy rule:** In this specification, Inter-System Routing Policy (ISRP) consists of one or more ISRP rules. ISRP rule is a single instance of <X>/ISRP/<X>. The ISRP rule consists of one or more flow distribution container.

**Flow distribution container:** in this specification, Flow distribution container denotes the node <X>/ISRP/<X>/ForFlowBased, <X>/ISRP/<X>/ForServiceBased or <X>/ISRP/<X>/ForNonSeamlessOffload/.

**Flow distribution rule:** In this specification, Flow distribution rule denotes a single instance of <X>/ISRP/<X>/ForFlowBased/<X>, <X>/ISRP/<X>/ForServiceBased/<X> or <X>/ISRP/<X>/ForNonSeamlessOffload/<X>.

For the purposes of the present document, the terms and definitions given in 3GPP TS 24.303 [3AB] apply:

## Home Agent

### 3.3 Abbreviations

For the purposes of the present document, the following abbreviations apply:

ANDSF	Access Network Discovery and Selection Function
DDF	Device Description Framework
DM	Device Management
DS	Differentiated Services
IFOM	IP Flow Mobility
ISRP	Inter-System Routing Policies
MAPCON	Multi Access PDN Connectivity
MO	Management Object
OMA	Open Mobile Alliance
RSSI	Receive Signal Strength Indicator
ToS	Type of Service
UE	User Equipment
WNDS	WiMAX Network Discovery and Selection

---

## 4 ANDSF MO

The ANDSF MO is used to manage intersystem mobility policy- as well as access network discovery information stored in a UE supporting provisioning of such information from an ANDSF.

The ANDSF may initiate the provision of information from the ANDSF to the UE as specified in 3GPP TS 24.302 [3AA].

The UE may initiate the provision of information from the ANDSF, using a client initiated session alert message of code "Generic Alert". The "Type" element of the OMA DM generic alert message shall be set to "urn:oma:at:ext-3gpp-andsf:1.0:provision".

The UE which requires DiscoveryInformation node may initiate the provision of information from the ANDSF using a client initiated session containing a generic alert. The "Type" element of the OMA DM generic alert message shall be set to "urn:oma:at:ext-3gpp-andsf:1.0:provision-disc-info".

The UE configured for IFOM or MAPCON or Non-seamless WLAN or any combination of these capabilities, may initiate the provision of information from the ANDSF, using a client initiated session containing a generic alert. The "Type" element of the OMA DM generic alert message shall be set to "urn:oma:at:ext-3gpp-andsf:1.0:provision-multiple-if".

The UE capable of any combinations of IFOM or MAPCON or non-seamless WLAN offload with all those combination of capabilities disabled, or a UE which is not IFOM capable and is not MAPCON capable and is not non-seamless WLAN capable, may initiate the provision of information from the ANDSF, using a client initiated session containing a generic alert. The "Type" element of the OMA DM generic alert message shall be set to "urn:oma:at:ext-3gpp-andsf:1.0:provision-single-if".

The intersystem mobility policy information consists of a set of one or more intersystem mobility policy rules. At any point in time there shall be at most one rule applied, that rule is referred to as the 'active' rule. There may hence be zero or one 'active' rule.

The rules have a number of conditions (e.g. current access technology and location) where one or more may be present and set to a value. The rules also have a number of results (e.g. preferred access technology and restricted access technology) to be used whenever a rule is 'active'. If there are no results for the 'active' rule, it is implementation dependent how UE performs network selection. Irrespective of whether any rule is 'active' or not, the UE shall periodically re-evaluate ANDSF policies. When ANDSF policy selection rules identify an available network, the highest priority rule becomes 'active' rule and network re-selection is performed.

While the rule remains 'active', UE shall keep considering higher priority networks, than currently selected, in the prioritized network list of the rule. In addition to conditions and results there is a rule-priority that shall be set for each rule in order for the UE to determine which rule, out of potentially several valid rules, it should consider as 'active'. The

trigger for (re-)evaluating rules is that the 'active' rule becomes invalid (conditions no longer fulfilled), or some other manufacturer specific trigger.

The inter-system routing policy information consists of a set of one or more Inter-System Routing Policy rules. Each Inter-System Routing Policy rule contains indication on traffic distribution for UEs that are configured for IFOM, MAPCON or non-seamless WLAN offload.

Each ISRP rule has a PLMN leaf and an optional Roaming leaf. Roaming and PLMN leaves are used by the UE to determine if an ISRP rule is applied. At any point in time there shall be at most one ISRP rule applied, that ISRP rule is referred to as the 'active' ISRP rule. When the UE is roaming, there can be multiple applicable ISRP rules: in this case the ISRP rule received from the Visited ANDSF takes precedence over the ISRP rule received from the Home ANDSF.

An ISRP rule can contain one or more flow distribution containers. A UE evaluates only the flow distribution containers of the 'active' ISRP rule. A flow distribution container can have one or more flow distribution rules.

A flow distribution rule can have a validity condition defined by the RoutingCriteria node. A flow distribution rule is applied only if the validity condition is fulfilled and if the flow distribution rule is contained by the 'active' ISRP rule. A flow distribution rule has a number of results (e.g. preferred access technology and restricted access technology) defined in the RoutingRule node to be used whenever the flow distribution rule is applied. Each flow distribution rule has also a mandatory node identifying the data traffic (e.g. based on APN or IP flow description) to which the results contained in RoutingRule node apply.

If there are no results for an 'active' ISRP rule, it is implementation dependent how UE performs network selection for the class of traffic to which the results apply. The UE shall periodically re-evaluate the flow distribution rules of the 'active' ISRP rule. The value of the periodic re-evaluation timer is implementation dependant.

In addition to conditions, results and traffic class, there is a rule-priority that shall be set for each flow distribution rule. The rule-priority enables the UE to determine which flow distribution rule, out of potentially several flow distribution rules, it should apply to an IP flow matching the data traffic description of the multiple flow distribution rules.

If there are multiple applied flow distribution rules within the 'active' ISRP rule and they prefer the same access technology but different access networks and the UE is not able to have connection to all of them at the same time, the selection of the access network is implementation dependant.

The relation between Policy, ISRP and DiscoveryInformation is that Policies prioritize the access network when the UE is not capable to connect to the EPC through multiple accesses, ISRP indicate how to distribute traffic among available accesses when the UE is capable to connect to the EPC through multiple accesses (i.e. the UE is configured for IFOM, MAPCON, non-seamless WLAN or any combination of these capabilities), while DiscoveryInformation provide further information for the UE to access the access network defined in the policy or in the ISRP.

The validity of the policy takes into account ValidityArea, Roaming, and TimeOfDay, which must all match in order to make the Policy valid. The MO has a node indicating the position of the UE. The trigger for updating the value of this node is that the location information it contains is no longer valid (i.e. the UE has changed its position) or some other manufacturer specific trigger. The update of the information contained in this node doesn't necessarily imply any interaction with the ANDSF server.

The MO defines validity areas, position of the UE and availability of access networks in terms of geographical coordinates. The way such coordinates are retrieved is implementation dependant (e.g. GPS receiver).

The UE is not required to switch on all UE's supported radios for deducing its location for ANDSF purposes or for evaluating the validity area condition of a policy or discovery information.

The Management Object Identifier is: urn:oma:mo:ext-3gpp-andsf:1.0.

The OMA DM Access Control List (ACL) property mechanism as standardized (see Enabler Release Definition OMA-ERELD-DM-V1\_2 [5]) may be used to grant or deny access rights to OMA DM servers in order to modify nodes and leaf objects of the ANDSF MO.

The following nodes and leaf objects are possible under the ANDSF node as described in figure 4.1 through figure 4.3:

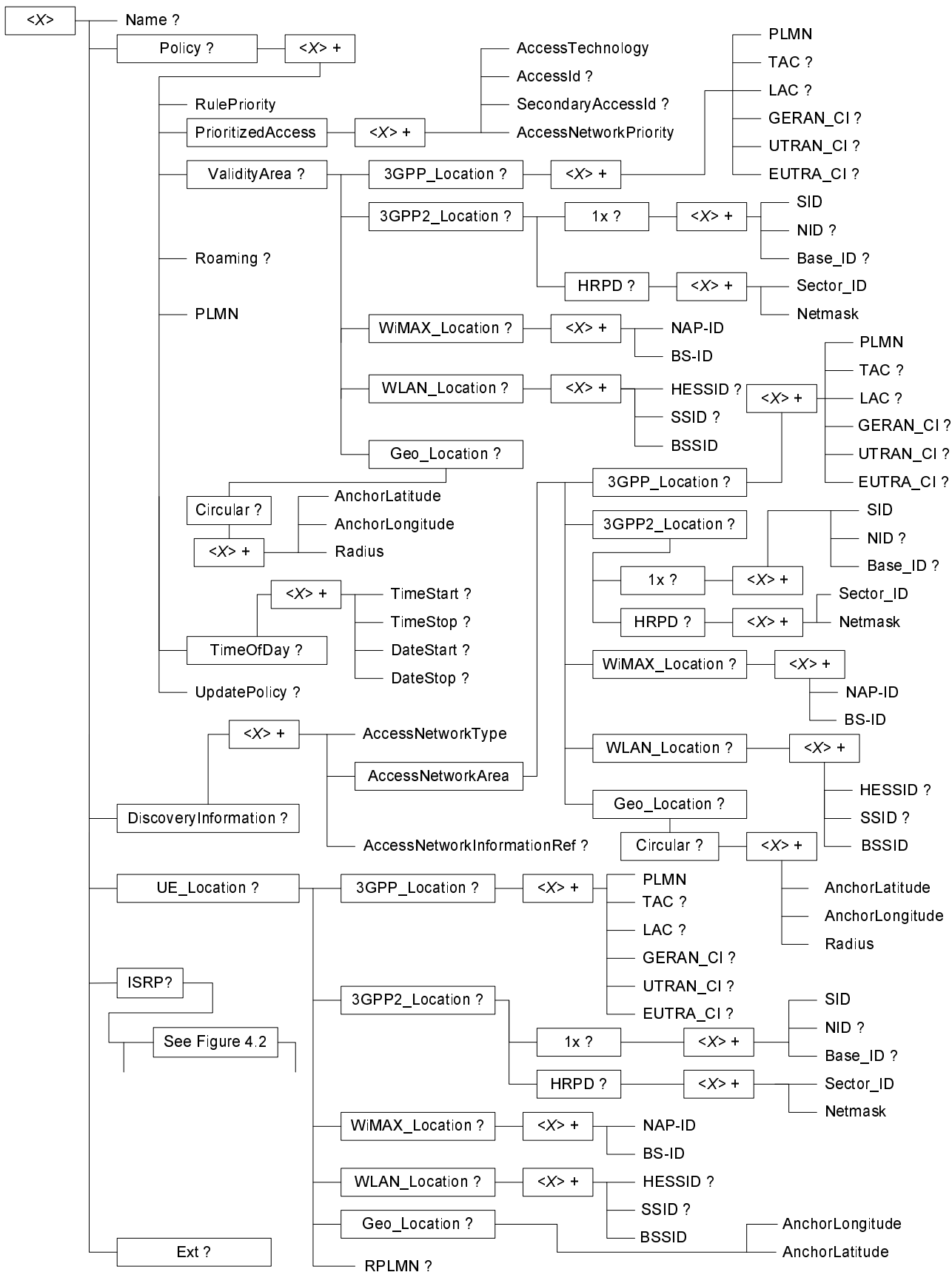

Figure 4.1: The ANDSF MO (part 1 of 3)

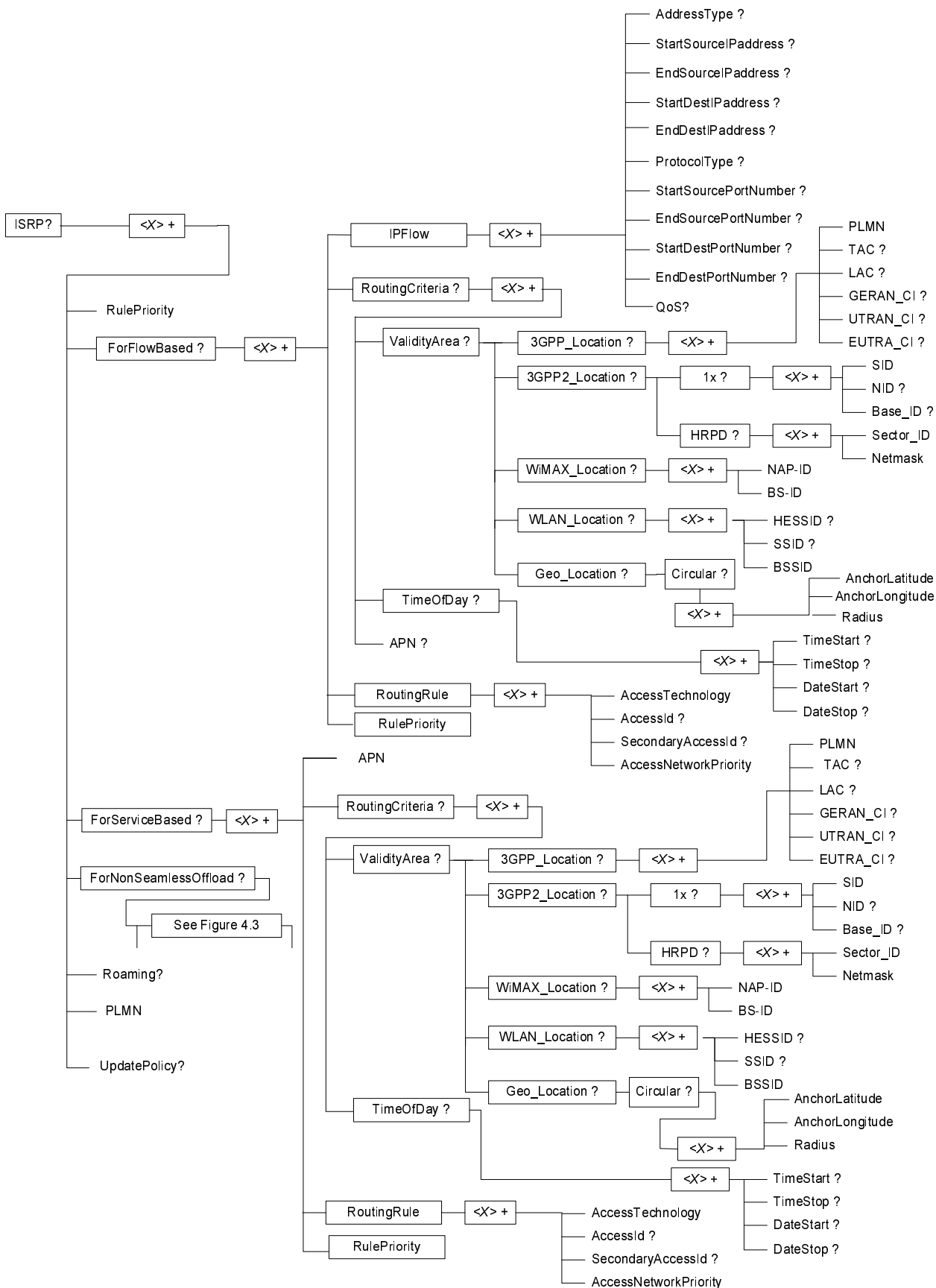

Figure 4.2: The ANDSF MO (part 2 of 3)

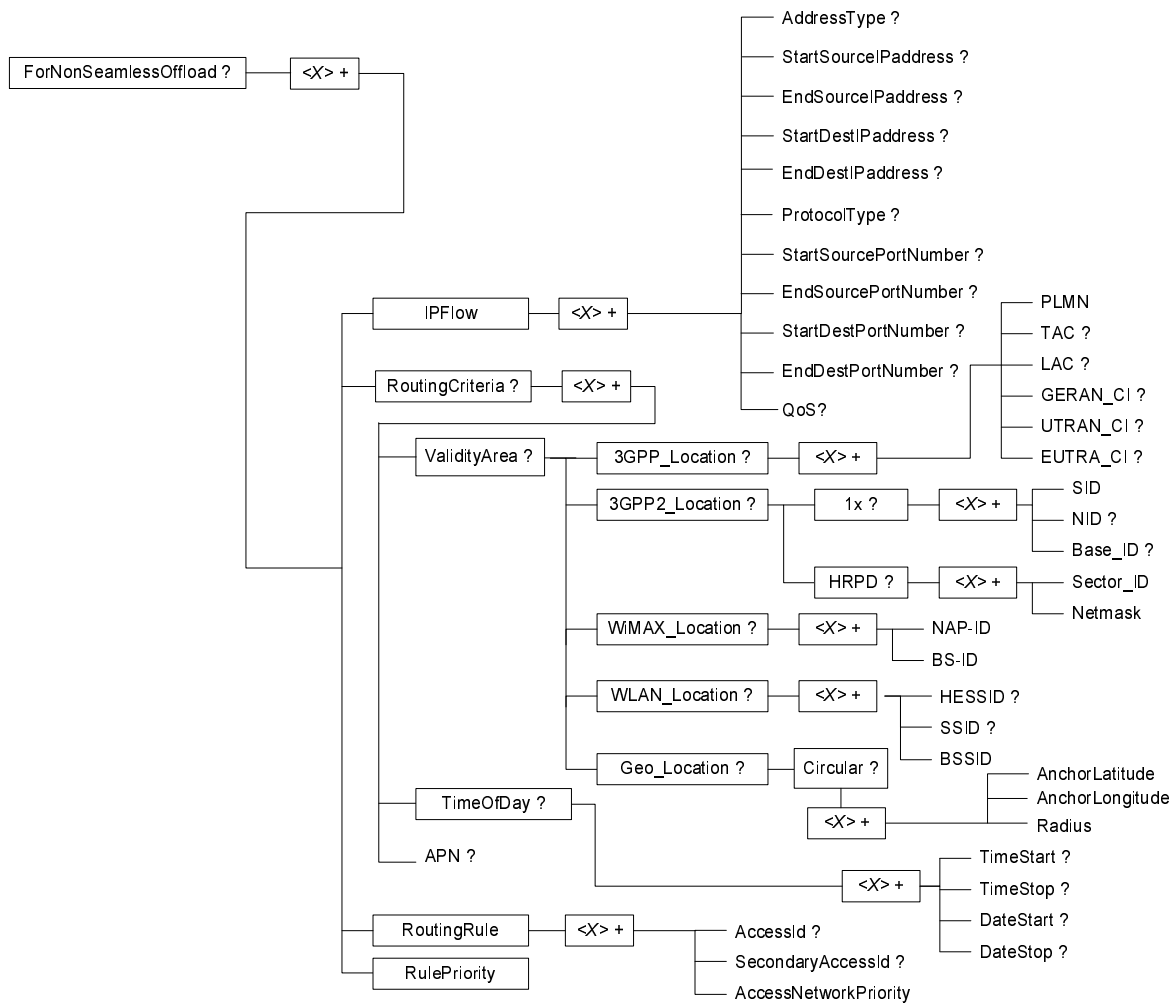

Figure 4.3: The ANDSF MO (part 3 of 3)

## 5 ANDSF MO parameters

### 5.1 General

This clause describes the parameters for the ANDSF MO.

### 5.2 Node: <X>

This interior node acts as a placeholder for zero or one accounts for a fixed node.

- Occurrence: ZeroOrOne
- Format: node
- Access Types: Get
- Values: N/A

### 5.3 <X>/Name

The Name leaf is a name for the ANDSF MO settings.

- Occurrence: ZeroOrOne
- Format: chr
- Access Types: Get
- Values: <User displayable name>

The User displayable name shall be represented by Unicode characters encoded as UTF-8 as specified in IETF RFC 3629 [11] and formatted using Normalization Form KC (NFKC) as specified in Unicode Standard Annex #15; Unicode Normalization Forms [12].

### 5.4 <X>/Policy

The Policy node acts as a placeholder for policies for intersystem mobility.

- Occurrence: ZeroOrOne
- Format: node
- Access Types: Get, Replace
- Values: N/A

### 5.5 <X>/Policy/<X>

This interior node acts as a placeholder for one or more intersystem mobility policy rules.

- Occurrence: OneOrMore
- Format: node
- Access Types: Get, Replace
- Values: N/A

### 5.6 <X>/Policy/<X>/RulePriority

The RulePriority leaf represents the priority given to one particular rule and is represented as a numerical value.

- Occurrence: One
- Format: int
- Access Types: Get, Replace
- Values: <Rule priority>

In case more than one valid intersystem mobility policy rule exists, the UE shall treat the rule with the lowest RulePriority value as the rule having the highest priority among the valid rules. If there are overlapping rules (e.g. by location, for example: rule by CGI, rule by PLMN), they should not have the same priority. If the UE finds multiple rules with the same priority, the choice of the rule is UE implementation specific. If there are no matching access networks according to the rule, other rules with the same priority shall be considered.

### 5.7 <X>/Policy/<X>/PrioritizedAccess

The PrioritizedAccess node indicates the preferred access for one particular rule.



- Occurrence: One
- Format: node
- Access Types: Get, Replace
- Values: N/A

## 5.8 <X>/Policy/<X>/PrioritizedAccess/<X>

This interior node acts as a placeholder for one or more prioritized accesses.

- Occurrence: OneOrMore
- Format: node
- Access Types: Get, Replace
- Values: N/A

## 5.9 <X>/Policy/<X>/PrioritizedAccess/<X>/AccessTechnology

The AccessTechnology leaf indicates a prioritized access technology.

- Occurrence: One
- Format: int
- Access Types: Get, Replace
- Values: <Access technology>

Possible values for the Access technology are specified in table 5.9.1.

**Table 5.9.1: Possible values for the AccessTechnology leaf**

Value	Description
0	Reserved
1	3GPP
3	WLAN
4	WiMAX
5-255	Reserved

## 5.10 <X>/Policy/<X>/PrioritizedAccess/<X>/AccessId

The AccessId leaf represents an access network identifier.

- Occurrence: ZeroOrOne
- Format: chr
- Access Types: Get, Replace
- Values: <Access id>

The AccessId contains an identifier for a specific radio access network. Only SSID for WLAN and NAP-ID for WiMAX radio access network are contained in this leaf. AccessIds in numerical format shall be encoded as character string. The AccessId be represented by Unicode characters encoded as UTF-8 as specified in IETF RFC 3629 [11] and

formatted using Normalization Form KC (NFKC) as specified in Unicode Standard Annex #15; Unicode Normalization Forms [12].

## 5.10A <X>/Policy/<X>/PrioritizedAccess/<X>/SecondaryAccessId

The SecondaryAccessId leaf represents a secondary access network identifier.

- Occurrence: ZeroOrOne
- Format: chr
- Access Types: Get, Replace
- Values: <HESSID>

The SecondaryAccessId contains an identifier for a specific radio access network. Only HESSID for WLAN radio access network is contained in this leaf. The SecondaryAccessId leaf may only be present when the corresponding AccessId leaf for a WLAN radio access network is present. The format of the HESSID is defined by IEEE 802.11u [17].

## 5.11 <X>/Policy/<X>/PrioritizedAccess/<X>/AccessNetworkPriority

The AccessNetworkPriority leaf represents an access technology priority.

- Occurrence: One
- Format: int
- Access Types: Get, Replace
- Values: <Access network priority>

In case more than one valid PrioritizedAccess are available and if the value of the priority belongs to the range 1-250, the UE shall consider the access network (with the corresponding access identifier if present) with the lowest AccessNetworkPriority value as the access network (with the corresponding access identifier if present) having the highest priority, as defined in table 5.11.1. The AccessNetworkPriority value 'Restricted access' (254) indicates an access that should not be used by the UE. The AccessNetworkPriority value 'Forbidden' (255) indicates an access that shall not be used by the UE. The same AccessNetworkPriority value may be used for more than one AccessId and more than one Access Technology. If more than one AccessId or more than one Access Technology with the same value of the AccessNetworkPriority are available, the UE selects one of them in an implementation dependant way. If the UE is not able to find an access network according to ANDSF policies, it is implementation dependent how to proceed with network selection.

**Table 5.11.1: Values of AccessNetworkPriority leaf**

Value	Description
0	Reserved
1-250	Priority value
251-253	Reserved
254	Restricted access. This access should be avoided if the current rule is active.
255	Forbidden. UE is not allowed to use this access if the current rule is active.

NOTE: It is implementation dependent if or when a restricted access is selected if there are no other accesses available.

## 5.12 <X>/Policy/<X>/ValidityArea

The ValidityArea node acts as a placeholder for location conditions for a particular rule.

- Occurrence: ZeroOrOne
- Format: node
- Access Types: Get, Replace
- Values: N/A

This is considered to be fulfilled if at least one of 3GPP\_Location, or 3GPP2\_Location or WiMAX\_Location, or WLAN\_Location, or Geo\_Location is a match. If UE is not able to deduce its location by any means, only rules without Validity Area can be considered for active rule.

## 5.13 <X>/Policy/<X>/ValidityArea/3GPP\_Location

The 3GPP\_Location node acts as a placeholder for 3GPP location descriptions.

- Occurrence: ZeroOrOne
- Format: node
- Access Types: Get, Replace
- Values: N/A

If the UE is currently aware that it is located in the coverage area described by this node, the UE shall consider the corresponding rule as valid. In case of overlapping validity domains of multiple policy rules, RulePriority leaf is used as discriminator.

## 5.14 <X>/Policy/<X>/ValidityArea/3GPP\_Location/<X>

This interior node acts as a placeholder for one or more 3GPP location descriptions.

- Occurrence: OneOrMore
- Format: node
- Access Types: Get, Replace
- Values: N/A

## 5.15 <X>/Policy/<X>/ValidityArea/3GPP\_Location/<X>/PLMN

The PLMN leaf indicates a PLMN code for one particular 3GPP location condition for the intersystem mobility policy rule.

- Occurrence: One
- Format: chr
- Access Types: Get, Replace
- Values: <PLMN>

The format of the PLMN is defined by 3GPP TS 23.003 [3].

## 5.16 <X>/Policy/<X>/ValidityArea/3GPP\_Location/<X>/TAC

The TAC leaf indicates a Tracking Area Code for one particular 3GPP location condition for the intersystem mobility policy rule.

- Occurrence: ZeroOrOne
- Format: chr
- Access Types: Get, Replace
- Values: <Tracking area code>

The format of the TAC is defined by 3GPP TS 23.003 [3].

## 5.17 <X>/Policy/<X>/ValidityArea/3GPP\_Location/<X>/LAC

The LAC leaf indicates a Location Area Code for one particular 3GPP location condition for the intersystem mobility policy rule.

- Occurrence: ZeroOrOne
- Format: chr
- Access Types: Get, Replace
- Values: <Location area code>

The format of the LAC is defined by 3GPP TS 23.003 [3].

## 5.18

### <X>/Policy/<X>/ValidityArea/3GPP\_Location/<X>/GERAN\_CI

The GERAN\_CI leaf indicates a cell identity for one particular GERAN network related location description.

- Occurrence: ZeroOrOne
- Format: bin
- Access Types: Get, Replace
- Values: <GERAN Cell Identity>

The format of the Cell Global Identity, of which the Cell Identity is part, is defined in 3GPP TS 23.003 [3].

The GERAN\_CI value is set to the Cell Identity, CI, obtained from lower layers of the UE. The CI is part of the Cell Global Identity as defined in 3GPP TS 23.003 [3]. The value of GERAN\_CI is coded as a bit string with fixed length of 16 bits.

## 5.18A <X>/Policy/<X>/ValidityArea/3GPP\_Location/ <X>/UTRAN\_CI

The UTRAN\_CI leaf indicates a cell identity for one particular UTRAN network related location description.

- Occurrence: ZeroOrOne
- Format: bin
- Access Types: Get, Replace
- Values: <UTRAN Cell Identity >

The UTRAN\_CI value is set to the UTRAN Cell Identity as defined in 3GPP TS 25.331 [3B] and obtained from lower layers of the UE. The value of UTRAN CI is coded as a bit string with fixed length of 28 bits.

## 5.18B <X>/Policy/<X>/ValidityArea/3GPP\_Location/ <X>/EUTRA\_CI

The EUTRA\_CI leaf indicates a cell identity for one particular E-UTRA network related location description.

- Occurrence: ZeroOrOne
- Format: bin
- Access Types: Get, Replace
- Values: <E-UTRA Cell Identity >

The EUTRA\_CI value is set to the cellidentity part of the Evolved Cell Global Identifier, as described in 3GPP TS 36.331 [3C] and obtained from lower layers of the UE. The value of EUTRA\_CI is coded as a bit string with fixed length of 28 bits.

## 5.19 <X>/Policy/<X>/ValidityArea/3GPP2\_Location

This 3GPP2\_Location node acts as a placeholder for 3GPP2 location descriptions.

- Occurrence: ZeroOrOne
- Format: node
- Access Types: Get, Replace
- Values: N/A

If the UE is currently aware that it is located in the coverage area described by this node, the UE shall consider the corresponding rule as valid. In case of overlapping validity domains of multiple policy rules, RulePriority leaf is used as discriminator.

If ANDSF provides 3GPP2\_Location as a validity area, either the 1x or HRPD interior node, or both, shall be provided.

## 5.20 <X>/Policy/<X>/ValidityArea/3GPP2\_Location/1x

This 1x node acts as a placeholder for 3GPP2 1x RAT location descriptions.

- Occurrence: ZeroOrOne
- Format: node
- Access Types: Get, Replace
- Values: N/A

## 5.21 <X>/Policy/<X>/ValidityArea/3GPP2\_Location/1x/<X>

This interior node acts as a placeholder for one or more 3GPP2 1x RAT location descriptions.

- Occurrence: OneOrMore
- Format: node
- Access Types: Get, Replace
- Values: N/A

## 5.22 <X>/Policy/<X>/ValidityArea/3GPP2\_Location/1x/<X>/SID

This SID leaf indicates a System Identification code for one particular 3GPP2 1x RAT location condition for the intersystem mobility policy rule.

- Occurrence: One
- Format: chr
- Access Types: Get, Replace
- Values: <System Identification>

The format of the SID is defined by 3GPP2 C S0016 [14].

## 5.23 <X>/Policy/<X>/ValidityArea/3GPP2\_Location/1x/<X>/NID

This NID leaf indicates a Network Identification code for one particular 3GPP2 1x RAT location condition for the intersystem mobility policy rule.

- Occurrence: ZeroOrOne
- Format: chr
- Access Types: Get
- Values: <Network Identification>

The format of the NID is defined by 3GPP2 C.S0016 [14].

## 5.24 <X>/Policy/<X>/ValidityArea/3GPP2\_Location/1x/<X>/Base\_ID

This Base\_ID leaf indicates a Base Station Identification code for one particular 3GPP2 1x RAT location condition for the intersystem mobility policy rule.

- Occurrence: ZeroOrOne
- Format: chr
- Access Types: Get, Replace
- Values: <Base Station Identification>

The format of the Base\_ID is defined by 3GPP2 C.S0005 [13].

## 5.25 <X>/Policy/<X>/ValidityArea/3GPP2\_Location/HRPD

This HRPD node acts as a placeholder for 3GPP2 HRPD RAT location descriptions.

- Occurrence: ZeroOrOne
- Format: node
- Access Types: Get, Replace
- Values: N/A

## 5.26 <X>/Policy/<X>/ValidityArea/3GPP2\_Location/HRPD/<X>

This interior node acts as a placeholder for one or more 3GPP2 HRPD RAT location descriptions.

- Occurrence: OneOrMore
- Format: node
- Access Types: Get, Replace
- Values: N/A

## 5.27 <X>/Policy/<X>/ValidityArea/3GPP2\_Location/HRPD/<X>/Sector\_ID

This Sector\_ID leaf indicates a Sector Identification code for one particular 3GPP2 HRPD RAT location condition for the intersystem mobility policy rule.

- Occurrence: One
- Format: bin
- Access Types: Get, Replace
- Values: < Sector\_ID >

The format of the Sector\_ID is defined by 3GPP2 C.S0024-0 [15]. The length of Sector ID contained in this node is 128 bits.

## 5.27A <X>/Policy/<X>/ValidityArea/3GPP2\_Location/HRPD/<X>/Netmask

This Netmask leaf indicates a Netmask code for one particular 3GPP2 HRPD RAT location condition for the intersystem mobility policy rule.

- Occurrence: One
- Format: bin
- Access Types: Get, Replace
- Values: < Netmask >

The format of Netmask is defined by 3GPP2 C.S0024-0 [15]. The length of Netmask contained in this node is 8 bits. The mask contained in this leaf shall be applied to the Sector\_ID bit string contained in the correspondent leaf of interior node <X>/Policy/<X>/ValidityArea/3GPP2\_Location/HRPD/<X>/Sector\_ID.

## 5.28 <X>/Policy/<X>/ValidityArea/WiMAX\_Location

The WiMAX\_Location node acts as a placeholder for WiMAX location descriptions.

- Occurrence: ZeroOrOne
- Format: node
- Access Types: Get, Replace
- Values: N/A

If the UE is currently aware that it is located in the coverage area described by this node, the UE shall consider the corresponding rule as valid. In case of overlapping validity domains of multiple policy rules, RulePriority leaf is used as discriminator.

## 5.29 <X>/Policy/<X>/ValidityArea/WiMAX\_Location/<X>

This interior node acts as a placeholder for one or more WiMAX location descriptions.

- Occurrence: OneOrMore
- Format: node
- Access Types: Get, Replace
- Values: N/A

## 5.30 <X>/Policy/<X>/ValidityArea/WiMAX\_Location/<X>/NAP-ID

The NAP-ID leaf indicates the Network Access Provider for a particular WiMAX location condition for the intersystem mobility policy rule.

- Occurrence: One
- Format: chr
- Access Types: Get, Replace
- Values: <NAP-ID>

The format of the NAP-ID is defined by the WiMAX Forum Network Architecture Release 1.0 version 1.2.2 – Stage 2 [6] and WiMAX Forum Network Architecture Release 1.0 version 1.2.2 – Stage 3 [7].

## 5.31 <X>/Policy/<X>/ValidityArea/WiMAX\_Location/<X>/BS-ID

The BS-ID leaf indicates the BS identifier for a particular WiMAX location condition for the intersystem mobility policy rule.

- Occurrence: One
- Format: chr
- Access Types: Get, Replace
- Values: <BS-ID>

The format of the BS-ID is defined by the IEEE Std 802.16e-2005 and IEEE Std 802.16-2004/Cor1-2005 [10].

## 5.32 <X>/Policy/<X>/ValidityArea/WLAN\_Location

The WLAN\_Location node acts as a placeholder for WLAN location descriptions.

- Occurrence: ZeroOrOne
- Format: node
- Access Types: Get, Replace
- Values: N/A

If the UE is currently aware that it is located in the coverage area described by this node, the UE shall consider the corresponding rule as valid. In case of overlapping validity domains of multiple policy rules, RulePriority leaf is used as discriminator.



### 5.33 <X>/Policy/<X>/ValidityArea/WLAN\_Location/<X>

This interior node acts as a placeholder for one or more WLAN location descriptions.

- Occurrence: OneOrMore
- Format: node
- Access Types: Get, Replace
- Values: N/A

### 5.33A <X>/Policy/<X>/ValidityArea/WLAN\_Location/<X>/HESSID

The HESSID leaf indicates the HESSID for a particular WLAN location condition for the intersystem mobility policy rule.

- Occurrence: ZeroOrOne
- Format: chr
- Access Types: Get, Replace
- Values: <HESSID>

The format of the HESSID is defined by IEEE 802.11u [17].

### 5.34 <X>/Policy/<X>/ValidityArea/WLAN\_Location/<X>/SSID

The SSID leaf indicates the SSID for a particular WLAN location condition for the intersystem mobility policy rule.

- Occurrence: ZeroOrOne
- Format: chr
- Access Types: Get, Replace
- Values: <SSID>

The format of the SSID is defined by IEEE Std 802.11™-2007 [9].

### 5.35 <X>/Policy/<X>/ValidityArea/WLAN\_Location/<X>/BSSID

The BSSID leaf indicates the AP identifier for one particular WLAN location condition for the intersystem mobility policy rule.

- Occurrence: One
- Format: chr
- Access Types: Get, Replace
- Values: <BSSID>

The format of the BSSID is defined by IEEE Std 802.11™-2007 [9].

### 5.36 <X>/Policy/<X>/ValidityArea/Geo\_Location

The Geo\_Location node acts as a placeholder for Geographical location descriptions for one intersystem mobility policy rule.

- Occurrence: ZeroOrOne

- Format: node
- Access Types: Get, Replace
- Values: N/A

If the UE is currently aware that it is located in the area described by this node, the UE shall consider the corresponding rule as valid. In case of overlapping validity domains of multiple policy rules, RulePriority leaf is used as discriminator.

### 5.36A <X>/Policy/<X>/ValidityArea/Geo\_Location/Circular

The Circular node acts as a placeholder for circular areas location descriptions for one intersystem mobility policy rule.

- Occurrence: ZeroOrOne
- Format: node
- Access Types: Get, Replace
- Values: N/A

### 5.36B <X>/Policy/<X>/ValidityArea/Geo\_Location/Circular/<X>

The interior node acts as a placeholder for one or more circular area location descriptions for one intersystem mobility policy rule.

- Occurrence: OneOrMore
- Format: node
- Access Types: Get, Replace
- Values: <N/A >

### 5.36C <X>/Policy/<X>/ValidityArea/Geo\_Location/Circular/<X>/AnchorLatitude

The AnchorLatitude node acts as a placeholder for the latitude value of the center of the circular area.

- Occurrence: One
- Format: bin
- Access Types: Get, Replace
- Values: <Latitude>

The Latitude is defined in subclause 6.1 of 3GPP TS 23.032 [3A].

### 5.36D <X>/Policy/<X>/ValidityArea/Geo\_Location/Circular/<X>/AnchorLongitude

The AnchorLongitude node acts as a placeholder for the longitude value of the centre of the circular area.

- Occurrence: One
- Format: bin
- Access Types: Get, Replace
- Values: <Longitude >

The Longitude is defined in subclause 6.1 of 3GPP TS 23.032 [3A].

## 5.36E <X>/Policy/<X>/ValidityArea/Geo\_Location/Circular/<X>/Radius

The Radius node acts as a placeholder for the radius value of the circular area.

- Occurrence: One
- Format: int
- Access Types: Get, Replace
- Values: <Radius>

The Radius is given in meters and is defined in subclause 6.6 of 3GPP TS 23.032 [3A].

## 5.37 <X>/Policy/<X>/Roaming

The Roaming leaf indicates the roaming condition for the intersystem mobility policy rule.

- Occurrence: ZeroOrOne
- Format: bool
- Access Types: Get, Replace
- Values: 0, 1
  - 0 Indicates that the rule is only valid when the UE is not roaming.
  - 1 Indicates that the rule is only valid when the UE is roaming.

The UE shall consider a rule with the Roaming leaf present as valid only if the current roaming state (roaming/not roaming) of the UE matches the one indicated in the Roaming value.

NOTE: When the UE is roaming, how it discovers and interacts with the ANDSF is not specified in the specification of this release.

## 5.37A <X>/Policy/<X>/PLMN

The PLMN leaf indicates a PLMN code of the operator, which created this policy.

- Occurrence: One
- Format: chr
- Access Types: Get, Replace
- Values: <PLMN>

The format of the PLMN is defined by 3GPP TS 23.003 [3].

## 5.38 <X>/Policy/<X>/TimeOfDay

The TimeOfDay node indicates the time of day condition for the intersystem mobility policy rule.

- Occurrence: ZeroOrOne
- Format: node
- Access Types: Get, Replace

- Values: N/A

The UE shall consider a rule with the TimeOfDay present as valid only if the time of day in the current time zone, as indicated by the UE, matches at least one time interval indicated in the TimeOfDay node.

UE that does not support calendar or clock application does not need to interpret the TimeOfDay leaf.

### 5.39 <X>/Policy/<X>/TimeOfDay/<X>

This interior node acts as a placeholder for one or more time of day condition for the intersystem mobility policy rule.

- Occurrence: OneOrMore
- Format: node
- Access Types: Get, Replace
- Values: N/A

If the time interval is indicated with more than one leaf value pair (e.g. with TimeStart-TimeStop pair and DateStart-DateStop pair), the UE shall consider a rule with the TimeOfDay present as valid only if all the leaf value pairs in the node match with the time indicated by the UE.

### 5.40 <X>/Policy/<X>/TimeOfDay/<X>/TimeStart

The TimeStart leaf acts as a place holder containing the time of the day that indicates when the UE shall start to apply the intersystem policy rule.

- Occurrence: ZeroOrOne
- Format: chr
- Access Types: Get, Replace
- Values: <time of day>

The value this leaf can assume is time of the day represented in string format, as defined in ISO 8601:2004 [16].

### 5.41 <X>/Policy/<X>/TimeOfDay/<X>/TimeStop

The TimeStop leaf node acts as a place holder containing the time of the day that indicates when the UE shall stop to apply the intersystem policy rule.

- Occurrence: ZeroOrOne
- Format: chr
- Access Types: Get, Replace
- Values: <time of day>

The value this leaf can assume is time of the day represented in string format, as defined in ISO 8601:2004 [16].

If within the same occurrence of TimeOfDay the value of TimeStop is smaller than TimeStart, the UE shall consider as validity period of the policy the time starting at TimeStart and ending at TimeStop of the following day.

### 5.42 <X>/Policy/<X>/TimeOfDay/<X>/DateStart

The DateStart leaf acts as a place holder containing the date that indicates when the UE shall start to apply the intersystem policy rule.

- Occurrence: ZeroOrOne

- Format: chr
- Access Types: Get, Replace
- Values: <date>

The value this leaf can assume is a date represented in string format, as defined in ISO 8601:2004 [16]. The UE handling of semantical error where DateStart node indicates a date that does not exist is UE implementation specific.

## 5.43 <X>/Policy/<X>/TimeOfDay/<X>/DateStop

The DateStop leaf acts as a place holder containing the date that indicates when the UE shall stop to apply the intersystem policy rule.

- Occurrence: ZeroOrOne
- Format: chr
- Access Types: Get, Replace
- Values: <date>

The value this leaf can assume is a date represented in string format, as defined in ISO 8601:2004 [16].

The UE handling of semantical error where DateStop node indicates a date that does not exist is UE implementation specific.

The value of this leaf shall be greater (i.e. a later date) than the value of corresponding DateStart leaf.

## 5.44 Void

## 5.45 Void

## 5.46 Void

## 5.47 Void

## 5.48 <X>/Policy/<X>/UpdatePolicy

The UpdatePolicy leaf indicates the update policy for the intersystem mobility policy rule.

- Occurrence: ZeroOrOne
- Format: bool
- Access Types: Get, Replace
- Values: 0, 1

0 Indicates that the UE is not required to request an update of the rules.

1 Indicates that the UE is required to request an update of the rules.

The UpdatePolicy value may be used by the UE to determine whether or not to request an update of its intersystem mobility policy when the rule is no longer considered to be valid by the UE.

## 5.49 <X>/DiscoveryInformation

The DiscoveryInformation node acts as a placeholder for access network discovery information.

- Occurrence: ZeroOrOne
- Format: node
- Access Types: Get, Replace
- Values: N/A

The operator may provide information on available access networks through the ANDSF. The UE may use the information as an aid in discovering other access networks.

## 5.50 <X>/DiscoveryInformation/<X>

This interior node acts as a placeholder for one or more access network information elements.

- Occurrence: OneOrMore
- Format: node
- Access Types: Get, Replace
- Values: N/A

## 5.51 <X>/DiscoveryInformation/<X>/AccessNetworkType

The AccessNetworkType leaf represents the type of an access network.

- Occurrence: One
- Format: int
- Access Types: Get, Replace
- Values: <Access network type>

The value of AccessNetworkType indicates the type of the network for which discovery assistance information is provided. Possible values are specified in table 5.51.1.

**Table 5.51.1: Possible values for the AccessNetworkType leaf**

Value	Description
0	Reserved
1	3GPP
2	Reserved
3	WLAN
4	WiMAX
5-255	Reserved

## 5.52 <X>/DiscoveryInformation/<X>/AccessNetworkArea

The AccessNetworkArea node acts as a placeholder for a description of the location where one particular access network is expected to be available.

- Occurrence: One
- Format: node
- Access Types: Get, Replace

- Values: N/A

If the UE is aware that it is located in at least one of the locations described under this node, the UE may assume the corresponding access network to be available.

### 5.53 <X>/DiscoveryInformation/<X>/AccessNetworkArea/ 3GPP\_Location

The 3GPP\_Location node acts as a placeholder for 3GPP location descriptions.

- Occurrence: ZeroOrOne
- Format: node
- Access Types: Get, Replace
- Values: N/A

If the UE is currently aware that it is located in the coverage area described by this node, the networks described in the correspondent AccessNetworkInformationRef are expected to be available.

### 5.54 <X>/DiscoveryInformation/<X>/AccessNetworkArea/ 3GPP\_Location/<X>

This interior node acts as a placeholder for one or more 3GPP location descriptions.

- Occurrence: OneOrMore
- Format: node
- Access Types: Get, Replace
- Values: N/A

### 5.55 <X>/DiscoveryInformation/<X>/AccessNetworkArea/ 3GPP\_Location/<X>/PLMN

The PLMN leaf indicates a PLMN code for one particular 3GPP location description.

- Occurrence: One
- Format: chr
- Access Types: Get, Replace
- Values: <PLMN>

The format of the PLMN is defined by 3GPP TS 23.003 [3].

### 5.56 <X>/DiscoveryInformation/<X>/AccessNetworkArea/ 3GPP\_Location/<X>/TAC

This TAC leaf indicates a Tracking Area Code for one particular 3GPP location description.

- Occurrence: ZeroOrOne
- Format: chr
- Access Types: Get, Replace

- Values: <Tracking area code>

The format of the TAC is defined by 3GPP TS 23.003 [3].

### 5.57 <X>/DiscoveryInformation/<X>/AccessNetworkArea/ 3GPP\_Location/<X>/LAC

This LAC leaf indicates a Location Area Code for one particular 3GPP location description.

- Occurrence: ZeroOrOne
- Format: chr
- Access Types: Get, Replace
- Values: <Location area code>

The format of the LAC is defined by 3GPP TS 23.003 [3].

### 5.58 <X>/DiscoveryInformation/<X>/AccessNetworkArea/ 3GPP\_Location/<X>/GERAN\_CI

The GERAN\_CI leaf indicates a GERAN Cell Identity for one particular 3GPP network related location description.

- Occurrence: ZeroOrOne
- Format: bin
- Access Types: Get, Replace
- Values: <GERAN Cell Identity>

The leaf format and usage is defined in subclause 5.18.

### 5.58A <X>/DiscoveryInformation/<X>/ AccessNetworkArea/3GPP\_Location/<X>/UTRAN\_CI

The UTRAN\_CI leaf indicates a UTRAN Cell Identity for one particular 3GPP network related location description.

- Occurrence: ZeroOrOne
- Format: bin
- Access Types: Get, Replace
- Values: <UTRAN Cell Identity>

The leaf format and usage is defined in subclause 5.18A.

### 5.58B <X>/DiscoveryInformation/<X>/ AccessNetworkArea/3GPP\_Location/<X>/EUTRA\_CI

The EUTRA\_CI leaf indicates an E-UTRA Cell Identity for one particular 3GPP network related location description.

- Occurrence: ZeroOrOne
- Format: bin
- Access Types: Get, Replace



- Values: <E-UTRA Cell Identity>

The leaf format and usage is defined in subclause 5.18B.

## 5.59 <X>/DiscoveryInformation/<X>/AccessNetworkArea/ 3GPP2\_Location

This 3GPP2\_Location node acts as a placeholder for 3GPP2 location description.

- Occurrence: ZeroOrOne
- Format: node
- Access Types: Get, Replace
- Values: N/A

If the UE is currently aware that it is located in the coverage area described by this 3GPP2\_Location node, the networks described in the correspondent AccessNetworkInformationRef are expected to be available.

If ANDSF provides 3GPP2\_Location in AccessNetworkArea interior node, either the 1x or HRPD interior node, or both, shall be provided.

## 5.60 <X>/DiscoveryInformation/<X>/AccessNetworkArea/ 3GPP2\_Location/1x

This 1x node acts as a placeholder for one or more 3GPP2 1x RAT location descriptions.

- Occurrence: ZeroOrOne
- Format: node
- Access Types: Get, Replace
- Values: N/A

## 5.61 <X>/DiscoveryInformation/<X>/AccessNetworkArea/ 3GPP2\_Location/1x/<X>

This interior node acts as a placeholder for one or more 3GPP2 1x RAT location descriptions.

- Occurrence: OneOrMore
- Format: node
- Access Types: Get, Replace
- Values: N/A

## 5.62 <X>/DiscoveryInformation/<X>/AccessNetworkArea/ 3GPP2\_Location/1x/<X>/SID

This SID leaf indicates a System Identification code for one particular 3GPP2 1x RAT location description.

- Occurrence: One
- Format: chr
- Access Types: Get, Replace

- Values: <System Identification>

The format of the SID is defined by 3GPP2 C.S0016 [14].

### 5.63 <X>/DiscoveryInformation/<X>/AccessNetworkArea/ 3GPP2\_Location/1x/<X>/NID

This NID leaf indicates a Network Identification code for one particular 3GPP2 1x RAT location description.

- Occurrence: ZeroOrOne
- Format: chr
- Access Types: Get, Replace
- Values: <Network Identification>

The format of the NID is defined by 3GPP2 C.S0016 [14].

### 5.64 <X>/DiscoveryInformation/<X>/AccessNetworkArea/ 3GPP2\_Location/1x/<X>/Base\_ID

This Base\_ID leaf indicates a Base Station Identification Code for one particular 3GPP2 1x RAT location description.

- Occurrence: ZeroOrOne
- Format: chr
- Access Types: Get, Replace
- Values: <Base Station Identification>

The format of the Base\_ID is defined by 3GPP2 C.S0005 [13].

### 5.65 <X>/DiscoveryInformation/<X>/AccessNetworkArea/ 3GPP2\_Location/HRPD

This HRPD node acts as a placeholder for one or more 3GPP2 HRPD RAT location descriptions.

- Occurrence: ZeroOrOne
- Format: node
- Access Types: Get, Replace
- Values: N/A

### 5.66 <X>/DiscoveryInformation/<X>/AccessNetworkArea/ 3GPP2\_Location/HRPD/<X>

This interior node acts as a placeholder for one or more 3GPP2 HRPD RAT location descriptions.

- Occurrence: OneOrMore
- Format: node
- Access Types: Get, Replace
- Values: N/A

## 5.67 <X>/DiscoveryInformation/<X>/AccessNetworkArea/ 3GPP2\_Location/HRPD/<X>/Sector\_ID

This Sector\_ID leaf indicates a Sector Identification code for one particular 3GPP2 HRPD RAT location description.

- Occurrence: One
- Format: bin
- Access Types: Get, Replace
- Values: <Sector ID>

The format of the Sector ID is defined by 3GPP2 C.S0024-0 [15]. The length of Sector ID contained in this node is 128 bits.

## 5.67A <X>/DiscoveryInformation/<X>/AccessNetworkArea/ 3GPP2\_Location/HRPD/<X>/Netmask

This Netmask leaf indicates a Netmask code for one particular 3GPP2 HRPD RAT location description.

- Occurrence: One
- Format: bin
- Access Types: Get, Replace
- Values: <Netmask>

The format of Netmask is defined by 3GPP2 C.S0024-0 [15]. The length of Netmask contained in this node is 8 bits. The mask contained in this leaf shall be applied to the Sector\_ID bit string contained in the correspondent leaf of interior node <X>/DiscoveryInformation/<X>/AccessNetworkArea/3GPP2\_Location/HRPD/<X>.

## 5.68 <X>/DiscoveryInformation/<X>/AccessNetworkArea/ WiMAX\_Location

The WiMAX\_Location node acts as a placeholder for WiMAX location descriptions.

- Occurrence: ZeroOrOne
- Format: node
- Access Types: Get, Replace
- Values: N/A

If the UE is currently aware that it is located in the coverage area described by this node, the networks described in the correspondent AccessNetworkInformationRef are expected to be available.

## 5.69 <X>/DiscoveryInformation/<X>/AccessNetworkArea/ WiMAX\_Location/<X>

This interior node acts as a placeholder for one or more WiMAX location descriptions.

- Occurrence: OneOrMore
- Format: node
- Access Types: Get, Replace

- Values: N/A

## 5.70 <X>/DiscoveryInformation/<X>/AccessNetworkArea/ WiMAX\_Location/<X>/NAP-ID

The NASP-ID leaf indicates the Network Access Provider for a particular WiMAX location description.

- Occurrence: One
- Format: chr
- Access Types: Get, Replace
- Values: <NAP-ID>

The format of the NAP-ID is defined by the WiMAX Forum Network Architecture version 1.2.2 – Stage 2 [6] and WiMAX Forum Network Architecture Release 1.0 version 1.2.2 – Stage 3 [7].

## 5.71 <X>/DiscoveryInformation/<X>/AccessNetworkArea/ WiMAX\_Location/<X>/BS-ID

The BS-ID leaf indicates the BS identifier for a particular WiMAX location description.

- Occurrence: One
- Format: chr
- Access Types: Get, Replace
- Values: <BS-ID>

The format of the BS-ID is defined by the IEEE Std 802.16e-2005 and IEEE Std 802.16-2004/Cor1-2005 [10].

## 5.72 <X>/DiscoveryInformation/<X>/AccessNetworkArea/ WLAN\_Location

The WLAN\_Location node acts as a placeholder for WLAN location descriptions.

- Occurrence: ZeroOrOne
- Format: node
- Access Types: Get, Replace
- Values: N/A

If the UE is currently aware that it is located in the coverage area described by this node, the networks described in the correspondent AccessNetworkInformationRef are expected to be available.

## 5.73 <X>/DiscoveryInformation/<X>/AccessNetworkArea/ WLAN\_Location/<X>

This interior node acts as a placeholder for one or more WLAN location descriptions.

- Occurrence: OneOrMore
- Format: node
- Access Types: Get, Replace

- Values: N/A

### 5.73A <X>/DiscoveryInformation/<X>/AccessNetworkArea/WLAN\_Location/<X>/HESSID

The HESSID leaf indicates the HESSID for a particular Home WLAN Specific Identifier location description.

- Occurrence: ZeroOrOne
- Format: chr
- Access Types: Get, Replace
- Values: <HESSID>

The format of the HESSID is defined by IEEE 802.11u [17].

### 5.74 <X>/DiscoveryInformation/<X>/AccessNetworkArea/WLAN\_Location/<X>/SSID

The SSID leaf indicates the SSID for a particular WLAN location description.

- Occurrence: ZeroOrOne
- Format: chr
- Access Types: Get, Replace
- Values: <SSID>

The format of the SSID is defined by IEEE Std 802.11™-2007 [9].

### 5.75 <X>/DiscoveryInformation/<X>/AccessNetworkArea/WLAN\_Location/<X>/BSSID

The BSSID leaf indicates the AP identifier for one particular WLAN location description.

- Occurrence: One
- Format: chr
- Access Types: Get, Replace
- Values: <BSSID>

The format of the BSSID is defined by IEEE Std 802.11™-2007 [9].

### 5.76 <X>/DiscoveryInformation/<X>/AccessNetworkArea/Geo\_Location

This Geo\_Location node acts as a placeholder for geographical location descriptions for location of one or more access networks.

- Occurrence: ZeroOrOne
- Format: node
- Access Types: Get, Replace
- Values: N/A

If the UE is currently aware that it is located in the area described by this Geo\_Location node, the networks described in the correspondent AccessNetworkInformationRef are expected to be available.

### 5.76A <X>/DiscoveryInformation/<X>/ AccessNetworkArea /Geo\_Location/Circular

The Circular node acts as a placeholder for circular areas location descriptions.

- Occurrence: ZeroOrOne
- Format: node
- Access Types: Get, Replace
- Values: N/A

### 5.76B <X>/DiscoveryInformation/<X>/ AccessNetworkArea /Geo\_Location/Circular/<X>

The interior node acts as a placeholder for one or more circular area location descriptions.

- Occurrence: OneOrMore
- Format: node
- Access Types: Get, Replace
- Values: <N/A >

### 5.76C <X>/DiscoveryInformation/<X>/ AccessNetworkArea/Geo\_Location/Circular/<X>/AnchorLatitude

The AnchorLatitude node acts as a placeholder for the latitude value of the center of the circular area.

- Occurrence: One
- Format: bin
- Access Types: Get, Replace
- Values: <Latitude>

The Latitude is defined in subclause 6.1 of 3GPP TS 23.032 [3A].

### 5.76D <X>/DiscoveryInformation/<X>/ AccessNetworkArea/Geo\_Location/Circular/<X>/AnchorLongitude

The AnchorLongitude node acts as a placeholder for the longitude value of the center of the circular area.

- Occurrence: One
- Format: bin
- Access Types: Get, Replace
- Values: <Longitude>

The Longitude is defined in subclause 6.1 of 3GPP TS 23.032 [3A].

## 5.76E <X>/DiscoveryInformation/<X>/ AccessNetworkArea/Geo\_Location/Circular/<X>/Radius

The Radius node acts as a placeholder for the radius value of the circular area.

- Occurrence: One
- Format: int
- Access Types: Get, Replace
- Values: < Radius>

The Radius is given in meters and is defined in subclause 6.6 of 3GPP TS 23.032 [3A].

## 5.77 <X>/DiscoveryInformation/<X>/ AccessNetworkInformationRef

The AccessNetworkInformationRef leaf represents a reference to an access network information object.

- Occurrence: ZeroOrOne
- Format: chr
- Access Types: Get, Replace
- Values: <An access network information object>

The value of AccessNetworkInformationRef is a reference to an object with access network type specific information. For example WLAN related values for the AccessNetworkInformationRef are defined in the OMA Connectivity Management Objects defined e.g. in OMA-DDS-DM\_ConnMO-V1\_0- 20081107-A [4A] and OMA-DDS-DM\_ConnMO\_WLAN-V1\_0-20081024-A [4B], and WiMAX related values for the AccessNetworkInformationRef are defined in the WiMAX MO in clause 6, etc.

## 5.78 <X>/UE\_Location

The UE\_Location node acts as a placeholder for describing the current location of the UE.

- Occurrence: ZeroOrOne
- Format: node
- Access Types: Get
- Values: N/A

## 5.79 <X>/UE\_Location/3GPP\_Location

The 3GPP\_Location node acts as a placeholder for 3GPP location descriptions.

- Occurrence: ZeroOrOne
- Format: node
- Access Types: Get
- Values: N/A

The UE should insert the parameters of all the 3GPP networks it has discovered when updating this node.

## 5.80 <X>/UE\_Location/3GPP\_Location/<X>

This interior node acts as a placeholder for one or more 3GPP location descriptions.

- Occurrence: OneOrMore
- Format: node
- Access Types: Get
- Values: N/A

## 5.81 <X>/UE\_Location/3GPP\_Location/<X>/PLMN

The PLMN leaf indicates a PLMN code for one particular 3GPP network related location of the UE.

- Occurrence: One
- Format: chr
- Access Types: Get
- Values: <PLMN>

The format of the PLMN is defined by 3GPP TS 23.003 [3].

## 5.82 <X>/UE\_Location/3GPP\_Location/<X>/TAC

This TAC leaf indicates a Tracking Area Code for one particular 3GPP network related location of the UE.

- Occurrence: ZeroOrOne
- Format: chr
- Access Types: Get
- Values: <Tracking area code>

The format of the TAC is defined by 3GPP TS 23.003 [3].

## 5.83 <X>/UE\_Location/3GPP\_Location/<X>/LAC

This LAC leaf indicates a Location Area Code for one particular 3GPP network related location of the UE.

- Occurrence: ZeroOrOne
- Format: chr
- Access Types: Get
- Values: <Location area code>

The format of the LAC is defined by 3GPP TS 23.003 [3].

## 5.84 <X>/UE\_Location/3GPP\_Location/<X>/GERAN\_CI

The GERAN\_CI leaf indicates a GERAN Cell Identity for one particular 3GPP network related location description.

- Occurrence: ZeroOrOne
- Format: bin



- Access Types: Get
- Values: <GERAN Cell Identity >

The leaf format and usage is defined in subclause 5.18.

## 5.84A <X>/UE\_Location/3GPP\_Location/<X>/ UTRAN\_CI

The UTRAN\_CI leaf indicates a UTRAN Cell Identity for one particular 3GPP network related location description.

- Occurrence: ZeroOrOne
- Format: bin
- Access Types: Get
- Values: <UTRAN Cell Identity>

The leaf format and usage is defined in subclause 5.18A.

## 5.84B <X>/UE\_Location/3GPP\_Location/<X>/ EUTRA\_CI

The EUTRA\_CI leaf indicates an E-UTRA Cell Identity for one particular 3GPP network related location description.

- Occurrence: ZeroOrOne
- Format: bin
- Access Types: Get
- Values: <E-UTRA Cell Identity>

The leaf format and usage is defined in subclause 5.18B.

## 5.85 <X>/UE\_Location/3GPP2\_Location

This 3GPP2\_Location node acts as a placeholder for 3GPP2 network related location description of UE's position.

- Occurrence: ZeroOrOne
- Format: node
- Access Types: Get
- Values: N/A

The UE should insert the parameters of all the 3GPP2 networks it has discovered when updating this node.

## 5.86 <X>/UE\_Location/3GPP2\_Location/1x

This 1x node acts as a placeholder for one or more 3GPP2 1x RAT network related location descriptions of UE's position.

- Occurrence: ZeroOrOne
- Format: node
- Access Types: Get
- Values: N/A

## 5.87 <X>/UE\_Location/3GPP2\_Location/1x/<X>

This interior node acts as a placeholder for one or more 3GPP2 1x RAT location descriptions of UE position.

- Occurrence: OneOrMore
- Format: node
- Access Types: Get
- Values: N/A

## 5.88 <X>/UE\_Location/3GPP2\_Location/1x/<X>/SID

This SID leaf indicates a System Identification code for one particular 3GPP2 1x RAT location used to indicate UE position.

- Occurrence: One
- Format: chr
- Access Types: Get
- Values: <SID>

The format of the SID is defined by 3GPP2 C.S0016 [14].

## 5.89 <X>/UE\_Location/3GPP2\_Location/1x/<X>/NID

This NID leaf indicates a Network Identification code for one particular 3GPP2 1x RAT location used to indicate UE position.

- Occurrence: ZeroOrOne
- Format: chr
- Access Types: Get
- Values: <NID>

The format of the NID is defined by 3GPP2 C.S0016 [14].

## 5.90 <X>/UE\_Location/3GPP2\_Location/1x/<X>/Base\_ID

This Base\_ID leaf indicates a Base Station Identification code for one particular 3GPP2 1x RAT location used to indicate UE position.

- Occurrence: ZeroOrOne
- Format: chr
- Access Types: Get
- Values: <Base\_ID>

The format of the Base\_ID is defined by 3GPP2 C.S0005 [13].

## 5.91 <X>/UE\_Location/3GPP2\_Location/HRPD

This HRPD node acts as a placeholder for one or more 3GPP2 HRPD RAT location descriptions of UE position.

- Occurrence: ZeroOrOne

- Format: node
- Access Types: Get
- Values: N/A

## 5.92 <X>/UE\_Location/3GPP2\_Location/HRPD/<X>

This interior node acts as a placeholder for one or more 3GPP2 HRPD RAT location descriptions of UE position.

- Occurrence: OneOrMore
- Format: node
- Access Types: Get
- Values: N/A

## 5.93 <X>/UE\_Location/3GPP2\_Location/HRPD/<X>/Sector\_ID

This Sector\_ID leaf indicates a Sector Identification code for one particular 3GPP2 HRPD RAT location used to indicate UE position.

- Occurrence: One
- Format: bin
- Access Types: Get
- Values: <Sector\_ID>

The format of the Sector\_ID is defined by 3GPP2 C.S0024-0 [15]. The length of Sector ID contained in this node is 128 bits.

## 5.93A <X>/UE\_Location/3GPP2\_Location/HRPD/<X>/Netmask

The Netmask leaf indicates a Netmask code for one particular 3GPP2 HRPD RAT location used to indicate UE position.

- Occurrence: One
- Format: bin
- Access Types: Get
- Values: <Netmask>

The format of Netmask is defined by 3GPP2 C.S0024-0 [15]. The length of Netmask contained in this node is 8 bits. The mask contained in this leaf shall be applied to the Sector\_ID bit string contained in the correspondent leaf of interior node.

## 5.94 <X>/UE\_Location/WiMAX\_Location

The WiMAX\_Location node acts as a placeholder for WiMAX location descriptions.

- Occurrence: ZeroOrOne
- Format: node
- Access Types: Get
- Values: N/A

The UE should insert the parameters of all the WiMAX networks it has discovered when updating this node.

## 5.95 <X>/UE\_Location/WiMAX\_Location/<X>

This interior node acts as a placeholder for one or more WiMAX location descriptions.

- Occurrence: OneOrMore
- Format: node
- Access Types: Get
- Values: N/A

## 5.96 <X>/UE\_Location/WiMAX\_Location/<X>/NAP-ID

The NAP-ID leaf indicates the Network Access Provider for a particular WiMAX network related location of the UE.

- Occurrence: One
- Format: chr
- Access Types: Get
- Values: <NAP-ID>

The format of the NAP-ID is defined by the WiMAX Forum Network Architecture version 1.2.2 – Stage 2 [6] and WiMAX Forum Network Architecture Release 1.0 version 1.2.2 – Stage 3 [7].

## 5.97 <X>/UE\_Location/WiMAX\_Location/<X>/BS-ID

The BS-ID leaf indicates the BS identifier for a particular WiMAX network related location of the UE.

- Occurrence: One
- Format: chr
- Access Types: Get
- Values: <BS-ID>

The format of the BS-ID is defined by the IEEE Std 802.16e-2005 and IEEE Std 802.16-2004/Cor1-2005 [10].

## 5.98 <X>/UE\_Location/WLAN\_Location

The WLAN\_Location node acts as a placeholder for WLAN location descriptions.

- Occurrence: ZeroOrOne
- Format: node
- Access Types: Get
- Values: N/A

The UE should insert the parameters of all the WLAN networks it has discovered when updating this node.

## 5.99 <X>/UE\_Location/WLAN\_Location/<X>

This interior node acts as a placeholder for one or more WLAN location descriptions.

- Occurrence: OneOrMore
- Format: node
- Access Types: Get
- Values: N/A

## 5.99A <X>/UE\_Location/WLAN\_Location/<X>/HESSID

The HESSID leaf indicates the HESSID for a particular WLAN network related location of the UE.

- Occurrence: ZeroOrOne
- Format: chr
- Access Types: Get, Replace
- Values: <HESSID>

The format of the HESSID is defined by IEEE 802.11u [17].

## 5.100 <X>/UE\_Location/WLAN\_Location/<X>/SSID

The SSID leaf indicates the SSID for a particular WLAN network related location of the UE.

- Occurrence: ZeroOrOne
- Format: chr
- Access Types: Get
- Values: <SSID>

The format of the SSID is defined by IEEE Std 802.11™-2007 [9].

## 5.101 <X>/UE\_Location/WLAN\_Location/<X>/BSSID

The BSSID leaf indicates the AP identifier for one particular WLAN network related location of the UE.

- Occurrence: One
- Format: chr
- Access Types: Get
- Values: <BSSID>

The format of the BSSID is defined by IEEE Std 802.11™-2007 [9].

## 5.102 <X>/UE\_Location/Geo\_Location/

This node acts as a placeholder for one or more UE Geo\_Location location descriptions.

- Occurrence: ZeroOrOne
- Format: node
- Access Types: Get
- Values: <N/A >

If the UE is aware of its geographical position, it shall insert the coordinates of its position in this Geo\_Location node.

## 5.102A Void

## 5.102B <X>/ UE\_Location /Geo\_Location/Latitude

The Latitude node acts as a placeholder for the latitude value of the position of the UE.

- Occurrence: One
- Format: bin
- Access Types: Get
- Values: <Latitude >

The Latitude is defined in subclause 6.1 of 3GPP TS 23.032 [3A].

## 5.102C <X>/ UE\_Location /Geo\_Location/Longitude

The Longitude node acts as a placeholder for the longitude value of the position of the UE.

- Occurrence: One
- Format: bin
- Access Types: Get
- Values: < Longitude>

The Longitude is defined in subclause 6.1 of 3GPP TS 23.032 [3A].

## 5.102D <X>/ UE\_Location /RPLMN

The RPLMN leaf indicates a PLMN code of the registered PLMN the UE is connected to.

- Occurrence: ZeroOrOne
- Format: chr
- Access Types: Get
- Values: <PLMN>

The format of the PLMN is defined by 3GPP TS 23.003 [3].

## 5.102E <X>/ISRP/

The ISRP node acts as a placeholder for policies for intersystem routing policies.

- Occurrence: ZeroOrOne
- Format: node
- Access Types: Get, Replace
- Values: N/A

## 5.102F <X>/ISRP/<X>

This interior node acts as a placeholder for one or more Inter-System Routing Policy rules.

- Occurrence: OneOrMore

- Format: node
- Access Types: Get, Replace
- Values: N/A

An Inter-System Routing Policy rule can contain one or more of the following nodes: ForFlowBased, ForServiceBased or ForNonSeamlessOffload.

## 5.102G Void

### 5.102H <X>/ISRP/<X>/ForFlowBased

The ForFlowBased node represents flow distribution container indicating data distribution among accesses based on flow description.

- Occurrence: ZeroOrOne
- Format: node
- Access Types: Get, Replace
- Values: N/A

If this node is present, it implies that the Home Agents of the PLMN identified in the leaf <X>/ISRP/<X>/PLMN of the same rule support IFOM.

### 5.102I <X>/ISRP/<X>/ForFlowBased/<X>/

This interior node acts as a placeholder for one or more flow distribution rule.

- Occurrence: OneOrMore
- Format: node
- Access Types: Get, Replace
- Values: N/A

### 5.102J <X>/ISRP/<X>/ForFlowBased/<X>/IPFlow

The IPFlow node indicates the flow description for a particular flow distribution rule.

- Occurrence: One
- Format: node
- Access Types: Get, Replace
- Values: N/A

An empty IPFlow node indicates the match-all flow description.

### 5.102K <X>/ISRP/<X>/ForFlowBased/<X>/IPFlow/<X>/

This interior node acts as a placeholder for one or more flow description.

- Occurrence: OneOrMore
- Format: node

- Access Types: Get, Replace
- Values: N/A

## 5.102L <X>/ISRP/<X>/ForFlowBased/<X>/IPFlow/<X>/AddressType

The AddressType leaf indicates the IP version of the addresses describing the IP flow.

- Occurrence: ZeroOrOne
- Format: chr
- Access Types: Get, Replace
- Values: 'IPv4', 'IPv6'

The absence of this leaf indicates that the IP flow described by the rule can have both IPv4 and IPv6 addresses. This field is mandatory if StartSourceIPAddress leaf, or StartDestIPAddress leaf or both are present.

## 5.102M <X>/ISRP/<X>/ForFlowBased/<X>/IPFlow/<X>/StartSourceIPAddress

The StartSourceIPAddress leaf indicates the first IP source address of the IP address range of the IP flow description. The source address refers to the IP address of the data packets destined for the UE.

- Occurrence: ZeroOrOne
- Format: chr
- Access Types: Get, Replace
- Values: <an IPv4 address>, <an IPv6 address>.

The value of this leaf is an IPv4 address if the AddressType leaf value of the same rule is equal to IPv4. The value of this leaf is an IPv6 address if the AddressType leaf value of the same rule is equal to IPv6.

The absence of this leaf indicates that source address field of the IP header is not examined when matching packets against the IP flow description of the rule.

The UE discards an IPFlow instance with a StartSourceIPAddress leaf without a correspondent AddressType leaf. If the IPFlow instance is the only one contained in the flow distribution rule, the UE discards the flow distribution rule.

## 5.102N <X>/ISRP/<X>/ForFlowBased/<X>/IPFlow/<X>/EndSourceIPAddress

The EndSourceIPAddress leaf indicates the last IP source address of the IP source address range of the IP flow description. The source address refers to the IP address of the data packets destined for the UE.

- Occurrence: ZeroOrOne
- Format: chr
- Access Types: Get, Replace
- Values: <an IPv4 address>, <an IPv6 address>.

This leaf can be present only if the leaf <X>/ISRP/<X>/ForFlowBased/<X>/IPFlow/<X>/StartSourceIPAddress is present. The absence of this leaf indicates that the IP source address range of the IP flow described by the rule is equal to the address contained in <X>/ISRP/<X>/ForFlowBased/<X>/IPFlow/<X>/StartSourceIPAddress.



The value of this leaf is an IPv4 address if the AddressType leaf value of the same rule is equal to IPv4. The value of this leaf is an IPv6 address if the AddressType leaf value of the same rule is equal to IPv6.

The UE discards an IPFlow instance with a EndSourceIPAddress leaf without a correspondent StartSourceIPAddress leaf. If the IPFlow instance is the only one contained in the flow distribution rule, the UE discards the flow distribution rule.

## 5.102O <X>/ISRP/<X>/ForFlowBased/<X>/IPFlow/<X>/ StartDestIPAddress

The StartDestIPAddress leaf indicates the first IP destination address of the IP destination address range of the IP flow description. The IP destination address is any one of the IP addresses allocated to the UE that the UE uses as source address when generating IP traffic.

- Occurrence: ZeroOrOne
- Format: chr
- Access Types: Get, Replace
- Values: <an IPv4 address>, <an IPv6 address>.

The value of this leaf is an IPv4 address if the AddressType leaf value of the same rule is equal to IPv4. The value of this leaf is an IPv6 address if the AddressType leaf value of the same rule is equal to IPv6.

The absence of this leaf indicates that IP destination address field of the IP header is not examined when matching packets against the IP flow description of the rule.

The UE discards an IPFlow instance with a StartDestIPAddress leaf without a correspondent AddressType leaf. If the IPFlow instance is the only one contained in the flow distribution rule, the UE discards the flow distribution rule.

## 5.102P <X>/ISRP/<X>/ForFlowBased/<X>/IPFlow/<X>/ EndDestIPAddress

The StartDestIPAddress leaf indicates the last IP destination address of the IP destination address range of the IP flow description. The IP destination address is any one of the IP addresses allocated to the UE that the UE uses as source address when generating IP traffic.

- Occurrence: ZeroOrOne
- Format: chr
- Access Types: Get, Replace
- Values: <an IPv4 address>, <an IPv6 address>

This leaf can be present only if the leaf <X>/ISRP/<X>/ForFlowBased/<X>/IPFlow/<X>/StartDestIPAddress is present. The absence of this leaf indicates that the the IP destination address range of the IP flow described by the rule is equal to the address contained in <X>/ISRP/<X>/ForFlowBased/<X>/IPFlow/<X>/StartDestIPAddress.

The value of this leaf is an IPv4 address if the AddressType leaf value of the same rule is equal to IPv4. The value of this leaf is an IPv6 address if the AddressType leaf value of the same rule is equal to IPv6.

The UE discards an IPFlow instance with a EndDestIPAddress leaf without a correspondent StartDestIPAddress leaf. If the IPFlow instance is the only one contained in the flow distribution rule, the UE discards the flow distribution rule.

## 5.102Q <X>/ISRP/<X>/ForFlowBased/<X>/IPFlow/<X>/ ProtocolType

The ProtocolType leaf indicates the protocol type in a flow description.

- Occurrence: ZeroOrOne
- Format: int
- Access Types: Get, Replace
- Values: <Protocol type>

The value of ProtocolType leaf is a value among the internet protocol numbers as defined in IANA Assigned Internet Protocol Numbers [18]. In case of IPv4 flow description, the value contained in this leaf is compared with the value of the last protocol type field. In case of IPv6 flow description, the value contained in this leaf is compared with the value of the last next header field. The UE discards an IPFlow instance with a ProtocolType leaf indicating a protocol type not supported by the UE. If the IPFlow instance is the only one contained in the flow distribution rule, the UE discards the flow distribution rule.

## 5.102R <X>/ISRP/<X>/ForFlowBased/<X>/IPFlow/<X>/ StartSourcePortNumber

The StartSourcePortNumber leaf indicates the first source port number of the source port numbers range of the IP flow description. The source port refers to the source port of the data packets destined for the UE.

- Occurrence: ZeroOrOne
- Format: int
- Access Types: Get, Replace
- Values: any value in the range 1-65535.

The absence of this leaf indicates that source port field of the transport protocol header is not examined when matching packets against the IP flow description of the rule.

## 5.102S <X>/ISRP/<X>/ForFlowBased/<X>/IPFlow/<X>/ EndSourcePortNumber

The EndSourcePortNumber leaf indicates the last source port number of the source port numbers range of the IP flow description. The source port refers to the source port of the data packets destined for the UE.

- Occurrence: ZeroOrOne
- Format: int
- Access Types: Get, Replace
- Values: any value in the range 1-65535.

This leaf can be present only if the leaf <X>/ISRP/<X>/ForFlowBased/<X>/IPFlow/<X>/StartSourcePortNumber is present. The absence of this leaf indicates that the source port number range of the IP flow described by the rule is equal to the source port number contained in <X>/ISRP/<X>/ForFlowBased/<X>/IPFlow/<X>/StartSourcePortNumber.

The UE discards an IPFlow instance with a EndSourcePortNumber leaf without a correspondent StartSourcePortNumber leaf. If the IPFlow instance is the only one contained in the flow distribution rule, the UE discards the flow distribution rule.

## 5.102T <X>/ISRP/<X>/ForFlowBased/<X>/IPFlow/<X>/ StartDestPortNumber

The StartDestPortNumber leaf indicates the first destination port number of the destination port numbers range of the IP flow description. The destination port refers to the destination port of the data packets sent by the corresponding node.

- Occurrence: ZeroOrOne
- Format: int
- Access Types: Get, Replace
- Values: any value in the range 1-65535.

The absence of this leaf indicates that destination port field of the transport protocol header is not examined when matching packets against the IP flow description of the rule.

## 5.102U <X>/ISRP/<X>/ForFlowBased/<X>/IPFlow/<X>/EndDestPortNumber

The EndDestPortNumber leaf indicates the last destination port number of the destination port numbers range of the IP flow description. The destination port refers to the destination port of the data packets sent by the corresponding node.

- Occurrence: ZeroOrOne
- Format: int
- Access Types: Get, Replace
- Values: any value in the range 1-65535.

This leaf can be present only if the leaf <X>/ISRP/<X>/ForFlowBased/<X>/IPFlow/<X>/StartDestPortNumber is present. The absence of this leaf indicates that the destination port number range of the IP flow described by the rule is equal to the port number contained in <X>/ISRP/<X>/ForFlowBased/<X>/IPFlow/<X>/StartDestPortNumber.

The UE discards an IPFlow instance with a EndDestPortNumber leaf without a correspondent StartDestPortNumber leaf. If the IPFlow instance is the only one contained in the flow distribution rule, the UE discards the flow distribution rule.

## 5.102V <X>/ISRP/<X>/ForFlowBased/<X>/IPFlow/<X>/QoS

The QoS node indicates the DS or ToS values parameters in a flow description.

- Occurrence: ZeroOrOne
- Format: bin
- Access Types: Get, Replace
- Values: any value in the range 0-63 expressed in a binary form

The DS and ToS values are defined in IETF RFC 3260 [10A].

## 5.102W <X>/ISRP/<X>/ForFlowBased/<X>/RoutingCriteria

The RoutingCriteria node acts as a placeholder for validity conditions for a particular flow distribution rule.

- Occurrence: ZeroOrOne
- Format: node
- Access Types: Get, Replace
- Values: N/A

## 5.102X <X>/ISRP/<X>/ForFlowBased/<X>/RoutingCriteria/<X>/

This internal node acts as a placeholder for one or more validity conditions for a particular flow distribution rule.

- Occurrence: OneOrMore
- Format: node
- Access Types: Get, Replace
- Values: N/A

## 5.102Y <X>/ISRP/<X>/ForFlowBased/<X>/RoutingCriteria/<X>/ ValidityArea

The ValidityArea node acts as a placeholder for location conditions for a particular flow distribution rule.

- Occurrence: ZeroOrOne
- Format: node
- Access Types: Get, Replace
- Values: N/A

This node and its descendants are the same as defined in <X>/Policy/<X>/ValidityArea.

## 5.102Z <X>/ISRP/<X>/ForFlowBased/<X>/RoutingCriteria/<X>/ TimeOfDay

The TimeOfDay node acts as a placeholder for day condition for a particular flow distribution rule.

- Occurrence: ZeroOrOne
- Format: node
- Access Types: Get, Replace
- Values: N/A

This node and its descendants are the same as defined in <X>/Policy/<X>/TimeOfDay.

## 5.102AA <X>/ISRP/<X>/ForFlowBased/<X>/RoutingCriteria/<X>/ APN

The APN leaf indicates the APN for which a particular flow distribution rule is valid.

- Occurrence: ZeroOrOne
- Format: chr
- Access Types: Get, Replace
- Values: <APN>

The APN format is defined in 3GPP TS 23.003 [3].

## 5.102AB <X>/ISRP/<X>/ForFlowBased/<X>/RoutingRule

The RoutingRule node indicates the preferred access for a flow distribution rule.

- Occurrence: OneOrMore
- Format: node
- Access Types: Get, Replace
- Values: N/A

This node and its descendants are the same as defined in <X>/Policy/<X>/PrioritizedAccess

## 5.102ABA <X>/ISRP/<X>/ForFlowBased/<X>/ RulePriority

The RulePriority leaf represents the priority given to one particular flow distribution rule and is represented as a numerical value.

- Occurrence: One
- Format: int
- Access Types: Get, Replace
- Values: <Rule priority>

RulePriority leaf is used to establish to which flow description rule a data traffic matching multiple flow distribution rules apply. The data traffic matching multiple flow distribution rules applies to the flow description rule with the highest priority. The UE shall treat the rule with the lowest RulePriority value as the rule having the highest priority. If the UE finds multiple rules with the same priority, the choice of the rule is UE implementation specific. If there are no matching access networks according to the rule, other rules with the same priority may be considered. If there are no matching access networks according to any rule with a certain priority, rules with lower priority may be considered.

## 5.102AC <X>/ISRP/<X>/ForServiceBased

The ForServiceBased node represents flow distribution container indicating data distribution among accesses based on APN.

- Occurrence: ZeroOrOne
- Format: node
- Access Types: Get, Replace
- Values: N/A

## 5.102AD <X>/ISRP/<X>/ForServiceBased/<X>/

This interior node acts as a placeholder for one or more flow distribution rules indicating data distribution among accesses based on APN.

- Occurrence: OneOrMore
- Format: node
- Access Types: Get, Replace
- Values: N/A

## 5.102AE <X>/ISRP/<X>/ForServiceBased/<X>/ APN

The APN leaf indicates the APN for which a particular flow distribution rule is valid.

- Occurrence: ZeroOrOne
- Format: chr
- Access Types: Get, Replace
- Values: <APN>

The APN format is defined in 3GPP TS 23.003 [3].

## 5.102AF <X>/ISRP/<X>/ForServiceBased/<X>/RoutingCriteria

The RoutingCriteria node acts as a placeholder for validity conditions for a particular flow distribution rule.

- Occurrence: ZeroOrOne
- Format: node
- Access Types: Get, Replace
- Values: N/A

## 5.102AG <X>/ISRP/<X>/ForServiceBased/<X>/ RoutingCriteria/<X>/

This internal node acts as a placeholder for one or more validity conditions for a particular flow distribution rule.

- Occurrence: OneOrMore
- Format: node
- Access Types: Get, Replace
- Values: N/A

## 5.102AH <X>/ISRP/<X>/ForServiceBased/<X>/RoutingCriteria/ <X>/ ValidityArea

The ValidityArea node acts as a placeholder for location conditions for a particular flow distribution rule.

- Occurrence: ZeroOrOne
- Format: node
- Access Types: Get, Replace
- Values: N/A

This node and its descendants are the same as defined in <X>/Policy/<X>/ValidityArea.

## 5.102AI <X>/ISRP/<X>/ForServiceBased/<X>/RoutingCriteria /<X>/ TimeOfDay

The TimeOfDay node acts as a placeholder for day condition for a particular flow distribution rule.

- Occurrence: ZeroOrOne
- Format: node
- Access Types: Get, Replace

- Values: N/A

This node and its descendants are the same as defined in <X>/Policy/<X>/TimeOfDay.

## 5.102AJ <X>/ISRP/<X>/ForServiceBased/<X>/RoutingRule

The RoutingRule node indicates the preferred access for a flow distribution rule.

- Occurrence: OneOrMore
- Format: node
- Access Types: Get, Replace
- Values: N/A

This node and its descendants are the same as defined in <X>/Policy/<X>/PrioritizedAccess.

## 5.102AJA <X>/ISRP/<X>/ForServiceBased/<X>/ RulePriority

The RulePriority leaf represents the priority given to a particular flow distribution rule and is represented as a numerical value.

- Occurrence: One
- Format: int
- Access Types: Get, Replace
- Values: <Rule priority>

RulePriority leaf is used to establish to which flow description rule a data traffic matching multiple flow distribution rules apply. The data traffic matching multiple flow distribution rules applies to the flow description rule with the highest priority. The UE shall treat the rule with the lowest RulePriority value as the rule having the highest priority. If the UE finds multiple rules with the same priority, the choice of the rule is UE implementation specific. If there are no matching access networks according to the rule, other rules with the same priority may be considered. If there are no matching access networks according to any rule with a certain priority, rules with lower priority may be considered.

## 5.102AJB <X>/ISRP/<X>/ForNonSeamlessOffload/

The ForNonSeamlessOffload node represents a flow distribution container indicating data permissible for non-seamless WLAN offload routing based on flow description.

- Occurrence: ZeroOrOne
- Format: node
- Access Types: Get, Replace
- Values: N/A

## 5.102AJC <X>/ISRP/<X>/ForNonSeamlessOffload/<X>/

This interior node acts as a placeholder for one or more flow distribution rules indicating data distribution among accesses based on flow description.

- Occurrence: OneOrMore
- Format: node
- Access Types: Get, Replace

- Values: N/A

## 5.102AJD <X>/ISRP/<X>/ForNonSeamlessOffload/<X>/IPFlow

The IPFlow node indicates the flow description for a particular flow distribution rule.

- Occurrence: One
- Format: node
- Access Types: Get, Replace
- Values: N/A

An empty IPFlow node indicates the match-all flow description.

## 5.10AJE <X>/ISRP/<X>/ForNonSeamlessOffload/<X>/ IPFlow/<X>

This interior node acts as a placeholder for one or more flow description.

- Occurrence: OneOrMore
- Format: node
- Access Types: Get, Replace
- Values: N/A

## 5.102AJF <X>/ISRP/<X>/ForNonSeamlessOffload/<X>/IPFlow/ <X>/AddressType

The AddressType leaf indicates the IP version of the addresses describing the IP flow.

- Occurrence: ZeroOrOne
- Format: chr
- Access Types: Get, Replace
- Values: 'IPv4', 'IPv6'

The absence of this leaf indicates that the IP flow described by the rule can have both IPv4 and IPv6 addresses. This field is mandatory if StartSourceIPAddress leaf, or StartDestIPAddress leaf or both are present.

## 5.102AJG <X>/ISRP/<X>/ForNonSeamlessOffload/<X>/IPFlow/ <X>/StartSourceIPAddress

The StartSourceIPAddress leaf indicates the first IP source address of the IP address range of the IP flow description. The source address refers to the IP address of the data packets destined for the UE.

- Occurrence: ZeroOrOne
- Format: chr
- Access Types: Get, Replace
- Values: <an IPv4 address>, <an IPv6 address>.



The value of this leaf is an IPv4 address if the AddressType leaf value of the same rule is equal to IPv4. The value of this leaf is an IPv6 address if the AddressType leaf value of the same rule is equal to IPv6.

The absence of this leaf indicates that source address field of the IP header is not examined when matching packets against the IP flow description of the rule.

The UE discards an IPFlow instance with a StartSourceIPAddress leaf without a correspondent AddressType leaf. If the IPFlow instance is the only one contained in the flow distribution rule, the UE discards the flow distribution rule.

## 5.102AJH <X>/ISRP/<X>/ForNonSeamlessOffload/<X>/IPFlow/ <X>/EndSourceIPAddress

The EndSourceIPAddress leaf indicates the last IP source address of the IP source address range of the IP flow description. The source address refers to the IP address of the data packets destined for the UE.

- Occurrence: ZeroOrOne
- Format: chr
- Access Types: Get, Replace
- Values: <an IPv4 address>, <an IPv6 address>.

This leaf can be present only if the leaf <X>/ISRP/<X>/ForFlowBased/<X>/IPFlow/<X>/StartSourceIPAddress is present. The absence of this leaf indicates that the IP source address range of the IP flow described by the rule is equal to the address contained in <X>/ISRP/<X>/ForFlowBased/<X>/IPFlow/<X>/StartSourceIPAddress.

The value of this leaf is an IPv4 address if the AddressType leaf value of the same rule is equal to IPv4. The value of this leaf is an IPv6 address if the AddressType leaf value of the same rule is equal to IPv6.

The UE discards an IPFlow instance with an EndSourceIPAddress leaf without a correspondent StartSourceIPAddress leaf. If the IPFlow instance is the only one contained in the flow distribution rule, the UE discards the flow distribution rule.

## 5.102AJI <X>/ISRP/<X>/ForNonSeamlessOffload/<X>/IPFlow/ <X>/StartDestIPAddress

The StartDestIPAddress leaf indicates the first IP destination address of the IP destination address range of the IP flow description. The IP destination address is any one of the IP addresses allocated to the UE that the UE uses as source address when generating IP traffic.

- Occurrence: ZeroOrOne
- Format: chr
- Access Types: Get, Replace
- Values: <an IPv4 address>, <an IPv6 address>.

The value of this leaf is an IPv4 address if the AddressType leaf value of the same rule is equal to IPv4. The value of this leaf is an IPv6 address if the AddressType leaf value of the same rule is equal to IPv6.

The absence of this leaf indicates that IP destination address field of the IP header is not examined when matching packets against the IP flow description of the rule.

The UE discards an IPFlow instance with a StartDestIPAddress leaf without a correspondent AddressType leaf. If the IPFlow instance is the only one contained in the flow distribution rule, the UE discards the flow distribution rule.

## 5.102AJJ <X>/ISRP/<X>/ForNonSeamlessOffload/<X>/IPFlow/ <X>/EndDestIPAddress

The StartDestIPAddress leaf indicates the last IP destination address of the IP destination address range of the IP flow description. The IP destination address is any one of the IP addresses allocated to the UE that the UE uses as source address when generating IP traffic.

- Occurrence: ZeroOrOne
- Format: chr
- Access Types: Get, Replace
- Values: <an IPv4 address>, <an IPv6 address>.

This leaf can be present only if the leaf <X>/ISRP/<X>/ForFlowBased/<X>/IPFlow/<X>/StartDestIPAddress is present. The absence of this leaf indicates that the the IP destination address range of the IP flow described by the rule is equal to the address contained in <X>/ISRP/<X>/ForFlowBased/<X>/IPFlow/<X>/StartDestIPAddress.

The value of this leaf is an IPv4 address if the AddressType leaf value of the same rule is equal to IPv4. The value of this leaf is an IPv6 address if the AddressType leaf value of the same rule is equal to IPv6.

The UE discards an IPFlow instance with a EndDestIPAddress leaf without a correspondent StartDestIPAddress leaf. If the IPFlow instance is the only one contained in the flow distribution rule, the UE discards the flow distribution rule.

## 5.102AJK <X>/ISRP/<X>/ForNonSeamlessOffload/<X>/IPFlow/ <X>/ ProtocolType

The ProtocolType leaf indicates the protocol type in a flow description.

- Occurrence: ZeroOrOne
- Format: int
- Access Types: Get, Replace
- Values: <Protocol type>

The value of ProtocolType leaf is a value among the internet protocol numbers as defined in IANA Assigned Internet Protocol Numbers [18]. In case of IPv4 flow description, the value contained in this leaf is compared with the value of the last protocol type field. In case of IPv6 flow description, the value contained in this leaf is compared with the value of the last next header field. The UE discards an IPFlow instance with a ProtocolType leaf indicating a protocol type not supported by the UE. If the IPFlow instance is the only one contained in the flow distribution rule, the UE discards the flow distribution rule.

## 5.102AJL <X>/ISRP/<X>/ForNonSeamlessOffload/<X>/IPFlow/ <X>/ StartSourcePortNumber

The StartSourcePortNumber leaf indicates the first source port number of the source port numbers range of the IP flow description. The source port refers to the source port of the data packets destined for the UE.

- Occurrence: ZeroOrOne
- Format: int
- Access Types: Get, Replace
- Values: any value in the range 1-65535.

The absence of this leaf indicates that source port field of the transport protocol header is not examined when matching packets against the IP flow description of the rule.

## 5.102AJM <X>/ISRP/<X>/ForNonSeamlessOffload/<X>/IPFlow/ <X>/ EndSourcePortNumber

The EndSourcePortNumber leaf indicates the last source port number of the source port numbers range of the IP flow description. The source port refers to the source port of the data packets destined for the UE.

- Occurrence: ZeroOrOne
- Format: int
- Access Types: Get, Replace
- Values: any value in the range 1-65535.

This leaf can be present only if the leaf <X>/ISRP/<X>/ForFlowBased/<X>/IPFlow/<X>/StartSourcePortNumber is present. The absence of this leaf indicates that the source port number range of the IP flow described by the rule is equal to the source port number contained in <X>/ISRP/<X>/ForFlowBased/<X>/IPFlow/<X>/StartSourcePortNumber.

The UE discards an IPFlow instance with a EndSourcePortNumber leaf without a correspondent StartSourcePortNumber leaf. If the IPFlow instance is the only one contained in the flow distribution rule, the UE discards the flow distribution rule.

## 5.102AJN <X>/ISRP/<X>/ForNonSeamlessOffload/<X>/IPFlow/ <X>/ StartDestPortNumber

The StartDestPortNumber leaf indicates the first destination port number of the destination port numbers range of the IP flow description. The destination port refers to the destination port of the data packets sent by the corresponding node.

- Occurrence: ZeroOrOne
- Format: int
- Access Types: Get, Replace
- Values: any value in the range 1-65535.

The absence of this leaf indicates that destination port field of the transport protocol header is not examined when matching packets against the IP flow description of the rule.

## 5.102AJO <X>/ISRP/<X>/ForNonSeamlessOffload/<X>/IPFlow/ <X>/ EndDestPortNumber

The EndDestPortNumber leaf indicates the last destination port number of the destination port numbers range of the IP flow description. The destination port refers to the destination port of the data packets sent by the corresponding node.

- Occurrence: ZeroOrOne
- Format: int
- Access Types: Get, Replace
- Values: any value in the range 1-65535.

This leaf can be present only if the leaf <X>/ISRP/<X>/ForFlowBased/<X>/IPFlow/<X>/StartDestPortNumber is present. The absence of this leaf indicates that the destination port number range of the IP flow described by the rule is equal to the port number contained in <X>/ISRP/<X>/ForFlowBased/<X>/IPFlow/<X>/StartDestPortNumber.

The UE discards an IPFlow instance with a EndDestPortNumber leaf without a correspondent StartDestPortNumber leaf. If the IPFlow instance is the only one contained in the flow distribution rule, the UE discards the flow distribution rule.

## 5.102AJP <X>/ISRP/<X>/ForNonSeamlessOffload/<X>/IPFlow/ <X>/QoS

The QoS node indicates the DS or ToS values parameters in a flow description.

- Occurrence: ZeroOrOne
- Format: bin
- Access Types: Get, Replace
- Values: Unsigned integer with a range from 0 up to and including 63.

The DS and ToS values are defined in IETF RFC 3260 [10A].

## 5.102AJQ <X>/ISRP/<X>/ForNonSeamlessOffload/<X>/ RoutingCriteria

The RoutingCriteria node acts as a placeholder for validity conditions for a particular flow distribution rule.

- Occurrence: ZeroOrOne
- Format: node
- Access Types: Get, Replace
- Values: N/A

## 5.102AJR <X>/ISRP/<X>/ForNonSeamlessOffload/<X>/ RoutingCriteria/<X>/

This internal node acts as a placeholder for one or more validity conditions for a particular flow distribution rule.

- Occurrence: OneOrMore
- Format: node
- Access Types: Get, Replace
- Values: N/A

## 5.102AJS <X>/ISRP/<X>/ForNonSeamlessOffload/<X>/ RoutingCriteria/ <X>/ ValidityArea

The ValidityArea node acts as a placeholder for location conditions for a particular flow distribution rule.

- Occurrence: ZeroOrOne
- Format: node
- Access Types: Get, Replace
- Values: N/A

This node and its descendants are the same as defined in <X>/Policy/<X>/ValidityArea.

## 5.102AJT <X>/ISRP/<X>/ForNonSeamlessOffload/<X>/ RoutingCriteria/ <X>/ TimeOfDay

The TimeOfDay node acts as a placeholder for day condition for a particular flow distribution rule.

- Occurrence: ZeroOrOne
- Format: node
- Access Types: Get, Replace
- Values: N/A

This node and its descendants are the same as defined in <X>/Policy/<X>/TimeOfDay.

## 5.102AJU <X>/ISRP/<X>/ForNonSeamlessOffload/<X>/ RoutingCriteria/<X>/APN

The APN leaf indicates the APN for which a particular flow distribution rule is valid.

- Occurrence: ZeroOrOne
- Format: chr
- Access Types: Get, Replace
- Values: <APN>

The APN format is defined in 3GPP TS 23.003 [3]. If this node is omitted, the flow description applies to any APN.

## 5.102AJV <X>/ISRP/<X>/ForNonSeamlessOffload/<X>/ RoutingRule

The RoutingRule node indicates the preferred access for a flow distribution rule.

- Occurrence: OneOrMore
- Format: node
- Access Types: Get, Replace
- Values: N/A

This node is the same as defined in <X>/Policy/<X>/PrioritizedAccess.

## 5.102AJW <X>/ISRP/<X>/ForNonSeamlessOffload/<X>/ RoutingRule/<X>/

This interior node acts as a placeholder for one or more prioritized accesses.

- Occurrence: OneOrMore
- Format: node
- Access Types: Get, Replace
- Values: N/A

## 5.102AJX <X>/ISRP/<X>/ForNonSeamlessOffload/<X>/ RoutingRule/AccessID

The AccessID leaf represents an access network identifier.

- Occurrence: ZeroOrOne
- Format: chr
- Access Types: Get, Replace
- Values: <SSID>

The format of the SSID is defined by IEEE Std 802.11™-2007 [9].

## 5.102AJY <X>/ISRP/<X>/ForNonSeamlessOffload/<X>/ RoutingRule/SecondaryAccessID

The SecondaryAccessID leaf represents a secondary access network identifier.

- Occurrence: ZeroOrOne
- Format: chr
- Access Types: Get, Replace
- Values: <HESSID>

This node is the same as defined in <X>/Policy/<X>/PrioritizedAccess/<X>/SecondaryAccessID.

## 5.102AJZ <X>/ISRP/<X>/ForNonSeamlessOffload/<X>/ RoutingRule/AccessNetworkPriority

The AccessNetworkPriority leaf represents an access technology priority.

- Occurrence: One
- Format: int
- Access Types: Get, Replace
- Values: <Access network priority>

This node is the same as defined in <X>/Policy/<X>/PrioritizedAccess/<X>/AccessNetworkPriority.

## 5.102AJAA <X>/ISRP/<X>/ForFlowBased/<X>/ RulePriority

The RulePriority leaf represents the priority given to one particular flow distribution rule and is represented as a numerical value.

- Occurrence: One
- Format: int
- Access Types: Get, Replace
- Values: <Rule priority>

RulePriority leaf is used to establish to which flow description rule a data traffic matching multiple flow distribution rules apply. The data traffic matching multiple flow distribution rules applies to the flow description rule with the highest priority. The UE shall treat the rule with the lowest RulePriority value as the rule having the highest priority. If

the UE finds multiple rules with the same priority, the choice of the rule is UE implementation specific. If there are no matching access networks according to the rule, other rules with the same priority may be considered. If there are no matching access networks according to any rule with a certain priority, rules with lower priority may be considered.

## 5.102AK <X>/ISRP/<X>/Roaming

The Roaming leaf indicates the roaming condition for the Inter-System Routing Policy rule.

- Occurrence: ZeroOrOne
- Format: bool
- Access Types: Get, Replace
- Values: 0, 1
  - 0 Indicates that the rule is only valid when the UE is not roaming.
  - 1 Indicates that the rule is only valid when the UE is roaming.

The UE shall consider a rule with the Roaming leaf present as valid only if the current roaming state (roaming/not roaming) of the UE matches the one indicated in the Roaming value.

The default value 0 applies if this leaf is not provisioned. The node is not used by the UE when the ISRP rule is provided by the V-ANDSF.

## 5.102AL <X>/ISRP/<X>/PLMN

The PLMN leaf indicates a PLMN code of the operator, which created this Inter-System Routing Policy rule.

- Occurrence: One
- Format: chr
- Access Types: Get, Replace
- Values: <PLMN>

The format of the PLMN is defined in 3GPP TS 23.003 [3].

When evaluating the PLMN leaf the following applies:

- if the value contained in this leaf is equal to the HPLMN (or an equivalent HPLMN) of the UE and the UE is not roaming, the ISRP rule is applicable;
- if the value contained in this leaf is equal to the HPLMN (or an equivalent HPLMN) of the UE, the value contained in the Roaming leaf of the ISRP rule is set to 1 and the UE is roaming, the ISRP rule is applicable;
- if the value contained in this leaf is equal to a VPLMN (or an equivalent VPLMN) of the UE, and the UE is roaming in that VPLMN, the ISRP rule is applicable independently from the Roaming leaf;
- if there are multiple ISRP rules with the same value in the PLMN leaf and the PLMN values is not the HPLMN or an equivalent HPLMN, only one ISRP rule is applied. The choice of the ISRP rule to apply is implementation dependant; and
- if there are multiple ISRP rules with the same value in the PLMN leaf, the same value in the Roaming leaf and the PLMN values is the HPLMN or an equivalent HPLMN, only one ISRP rule is applied. The choice of the ISRP rule to apply is implementation dependant.

## 5.102AM <X>/ISRP/<X>/UpdatePolicy

The UpdatePolicy leaf indicates the update policy for the Inter-SystemRouting Policy.

- Occurrence: ZeroOrOne
- Format: bool
- Access Types: Get, Replace
- Values: 0, 1
  - 0 Indicates that the UE is not required to request an update of the rules.
  - 1 Indicates that the UE is required to request an update of the rules.

The UpdatePolicy value may be used by the UE to determine whether or not to request an update of its inter-system routing policy when the rule is no longer considered to be valid by the UE.

The default value 0 applies if this leaf is not provisioned.

## 5.103 <X>/Ext

The Ext is an interior node for where the vendor specific information about the ANDSF MO is being placed (vendor meaning application vendor, device vendor etc.). Usually the vendor extension is identified by vendor specific name under the ext node. The tree structure under the vendor identifier is not defined and can therefore include one or more un-standardized sub-trees.

- Occurrence: ZeroOrOne
- Format: node
- Access Types: Get
- Values: N/A

---

# 6 MO for WiMAX

## 6.1 Introduction

This section defines the WiMAX Network Discovery and Selection (WNDS) MO and the corresponding behaviour of the UE with regard to discovering and selecting WiMAX access networks in the home operator network. The service requirements for the WiMAX network discovery and selection function are described in 3GPP TS 23.402 [4].

The WNDS MO is compatible with the OMA Device Management (DM) protocol specifications, version 1.2 and upwards, and is defined using the OMA DM Device Description Framework (DDF) as described in the Enabler Release Definition OMA-ERELED-DM-V1\_2 [5].

## 6.2 WNDS MO

The WNDS MO is used to manage WiMAX network discovery and selection information stored in the UE and supports provisioning of such information from the ANDSF.

The ANDSF may initiate the provisioning of WiMAX specific information using a server initiated session alert message. The UE may initiate the provision of information from the ANDSF using a client initiated session alert message.

The Management Object Identifier is: urn:oma:mo:ext-3gpp-wnds:1.0.

The OMA DM Access Control List (ACL) property mechanism as standardized (see Enabler Release Definition OMA-ERELED-DM-V1\_2 [5]) may be used to grant or deny access rights to OMA DM servers in order to modify nodes and leaf objects of the WNDS MO.



The following nodes and leaf objects are possible under the WiMAX Network Discovery and Selection node as described in figure 6.2.1:

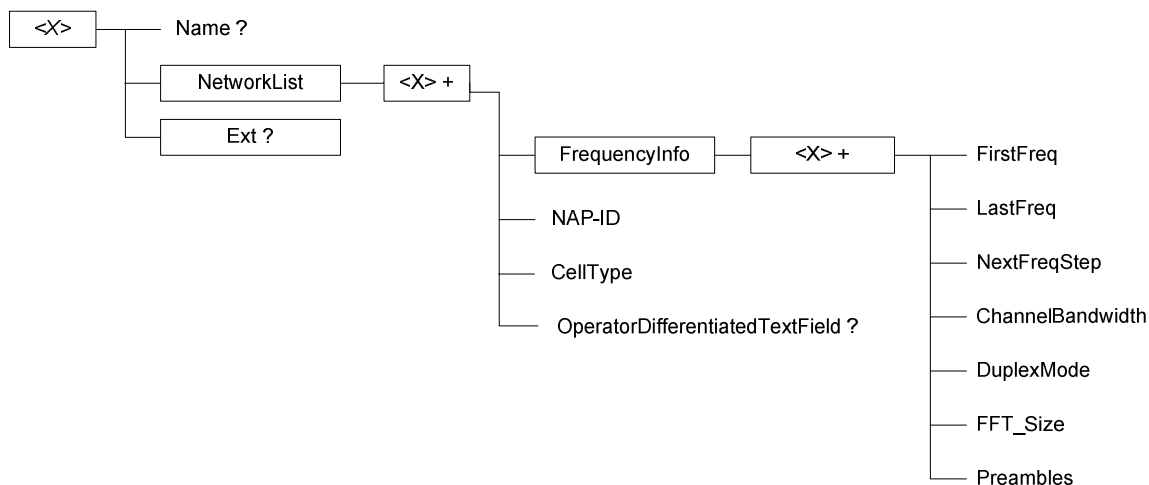

Figure 6.2.1: WND5 MO

## 6.3 WND5 MO parameters

### 6.3.1 General

This clause describes the parameters for the WND5 MO.

### 6.3.2 Node: <X>

This interior node acts as a placeholder for zero or one accounts for a fixed node.

- Occurrence: ZeroOrOne
- Format: node
- Access Types: Get
- Values: N/A

### 6.3.3 <X>/Name

The Name leaf is a name for the WND5 MO settings.

- Occurrence: ZeroOrOne
- Format: chr
- Access Types: Get
- Values: <User displayable name>

### 6.3.4 <X>/NetworkList

This interior node acts as a placeholder for available WiMAX Network.

- Occurrence: ZeroOrOne
- Format: node
- Access Types: Get, Replace
- Values: <N/A>

### 6.3.5 <X>/NetworkList/<X>

This interior node acts as a placeholder for properties of one or more WiMAX Network.

- Occurrence: OneOrMore
- Format: node
- Access Types: Get, Replace
- Values: <N/A>

### 6.3.6 <X>/NetworkList/<X>/FrequencyInfo

The FrequencyInfo node contains WiMAX operating frequency related information.

- Occurrence: One
- Format: node
- Access Types: Get, Replace
- Values: <N/A>

### 6.3.7 <X>/NetworkList/<X>/FrequencyInfo/<X>

This interior node acts as a placeholder for one or more FrequencyInfo node properties..

- Occurrence: OneOrMore
- Format: node
- Access Types: Get, Replace
- Values: <N/A>

### 6.3.8 <X>/NetworkList/<X>/FrequencyInfo/<X>FirstFreq

The FirstFreq leaf specifies the first center frequency in KHz for this channel.

- Occurrence: One
- Format: int
- Access Types: Get, Replace
- Values: <FirstFreq>

### 6.3.9 <X>/NetworkList/<X>/FrequencyInfo/<X>LastFreq

The LastFreq leaf specifies the last center frequency in KHz for this channel. If this value equals to the FirstFreq or the leaf node is omitted, then this entry refers to a single channel rather than a channel range. If this field is present then NextFreqStep shall be present as well.

- Occurrence: One

- Format: int
- Access Types: Get, Replace
- Values: <LastFreq>

### 6.3.10 <X>/NetworkList/<X>/FrequencyInfo/<X>NextFreqStep

The NextFreqStep leaf defines the frequency step in KHz to reach the next central frequency when defining the frequency range using FirstFreq and LastFreq.

- Occurrence: One
- Format: int
- Access Types: Get, Replace
- Values: <NextFreqStep>

When this leaf node is omitted there is only one central frequency (i.e FirstFreq). If this field is present LastFreq shall be present as well. The formula to calculate the next central frequency is:

CurrentFreq = FirstFreq

While (CurrentFreq <= LastFreq) CurrentFreq = CurrentFreq + NextFreqStep

### 6.3.11 <X>/NetworkList/<X>/ FrequencyInfo/<X>ChannelBandwidth

The ChannelBandwidth leaf is the system bandwidth in KHz that is supported by the WiMAX network.

- Occurrence: One
- Format: int
- Access Types: Get, Replace
- Values: <ChannelBandwidth>

### 6.3.12 <X>/NetworkList/<X>/ FrequencyInfo/<X>DuplexMode

The DuplexMode leaf is the duplex mode supported by the network. The DuplexMode can be TDD, FDD or hybrid FDD (HFDD)

- Occurrence: One
- Format: int
- Access Types: Get, Replace
- Values: <Duplex mode>

The value of the DuplexMode shall be used as specified in Table 6.3.15.1.

**Table 6.3.15.1: Values of DuplexMode**

Value	Description
0	Reserved
1	TDD
2	FDD
3	HFDD
4-255	Reserved

### 6.3.13 <X>/NetworkList/<X>/ FrequencyInfo/<X>FFT\_Size

The FFT\_Size leaf specifies the channel's FFT.

- Occurrence: One
- Format: int
- Access Types: Get, Replace
- Values: <FFT size>

### 6.3.14 <X>/NetworkList/<X>/ FrequencyInfo/<X>Preambles

The Preambles leaf specifies the valid preambles for each channel in the channel range.

- Occurrence: One
- Format: chr
- Access Types: Get, Replace
- Values: <Preambles>

The value is a hexadecimal string which is 29 digits long. The two MSB are zeroed and the LSB indicates channel 0.

### 6.3.15 <X>/ NetworkList /<X>/NAP-ID

The NAP-ID leaf is the identifier of the WiMAX radio access infrastructure provider. For further details on Network Access Provider please refer to the WiMAX Forum Network Architecture version 1.2.2 – Stage 2 [6] and WiMAX Forum Network Architecture Release 1.0 version 1.2.2 – Stage 3 [7].

- Occurrence: One
- Format: int
- Access Types: Get, Replace
- Values: <NAP-ID>

### 6.3.16 <X>/NetworkList/<X>/CellType

The CellType leaf represents the type of cell. The cell type can be femto, pico, micro or macro.

- Occurrence: One
- Format: chr
- Access Types: Get, Replace
- Values: <Cell type>

### 6.3.17 <X>/NetworkList/<X>/OperatorDifferentiatedTextField

The OperatorDifferentiatedTextField leaf represents textual information that the operator wants to associate with the access technology.

- Occurrence: ZeroOrOne
- Format: chr
- Access Types: Get, Replace
- Values: <Text field>

The text field contains alphanumeric characters.

### 6.3.18 <X>/Ext

The Ext is an interior node for where the vendor specific information about the WNDIS MO is placed (vendor can be application vendor, device vendor etc.). Usually the vendor extension is identified by vendor specific name under the ext node. The tree structure under the vendor identifier is not defined and can therefore include one or more un-standardized sub-trees.

- Occurrence: ZeroOrOne
- Format: node
- Access Types: Get
- Values: N/A

## Annex A (informative): ANDSF MO DDF

This DDF is the standardized minimal set. A vendor can define its own DDF for the complete device. This DDF can include more features than this minimal standardized version.

```
<?xml version="1.0" encoding="UTF-8"?>
<!DOCTYPE MgmtTree PUBLIC "-//OMA//DTD-DM-DDF 1.2//EN"
"http://www.openmobilealliance.org/tech/DTD/dm_ddf-v1_2.dtd">

<MgmtTree>
  <VerDTD>1.2</VerDTD>
  <Man>--The device manufacturer--</Man>
  <Mod>--The device model--</Mod>

  <Node>
    <NodeName>ANDSF</NodeName>
    <DFProperties>
      <AccessType>
        <Get/>
      </AccessType>
      <Description>ANDSF settings</Description>
      <DFFormat>
        <node/>
      </DFFormat>
      <Occurrence>
        <ZeroOrOne/>
      </Occurrence>
      <DFTitle>The ANDSF Management Object.</DFTitle>
      <DFType>
        <DDFName/>
      </DFType>
    </DFProperties>

    <Node>
      <NodeName>Name</NodeName>
      <DFProperties>
        <AccessType>
          <Get/>
        </AccessType>
        <DFFormat>
          <chr/>
        </DFFormat>
        <Occurrence>
          <ZeroOrOne/>
        </Occurrence>
        <DFTitle>User displayable name for the node.</DFTitle>
        <DFType>
          <MIME>text/plain</MIME>
        </DFType>
      </DFProperties>
    </Node>

    <Node>
      <NodeName>Policy</NodeName>
      <!-- The Policy node starts here. -->
      <DFProperties>
        <AccessType>
          <Get/>
          <Replace/>
        </AccessType>
        <DFFormat>
          <node/>
        </DFFormat>
        <Occurrence>
          <ZeroOrOne/>
        </Occurrence>
        <DFTitle>Policies for access network selection.</DFTitle>
        <DFType>
          <DDFName/>
        </DFType>
      </DFProperties>
    </Node>
  </MgmtTree>

```

```

<Node>
  <NodeName></NodeName>
  <DFProperties>
    <AccessType>
      <Get/>
      <Replace/>
    </AccessType>
    <DFFormat>
      <node/>
    </DFFormat>
    <Occurrence>
      <OneOrMore/>
    </Occurrence>
    <DFTType>
      <DDFName></DDFName>
    </DFTType>
  </DFProperties>

  <Node>
    <NodeName>RulePriority</NodeName>
    <DFProperties>
      <AccessType>
        <Get/>
        <Replace/>
      </AccessType>
      <DFFormat>
        <int/>
      </DFFormat>
      <Occurrence>
        <One/>
      </Occurrence>
      <DFTitle>Rule priority.</DFTitle>
      <DFTType>
        <MIME>text/plain</MIME>
      </DFTType>
    </DFProperties>
  </Node>

  <Node>
    <NodeName>PrioritizedAccess</NodeName>
    <DFProperties>
      <AccessType>
        <Get/>
        <Replace/>
      </AccessType>
      <DFFormat>
        <node/>
      </DFFormat>
      <Occurrence>
        <One/>
      </Occurrence>
      <DFTitle>Prioritized access.</DFTitle>
      <DFTType>
        <DDFName/>
      </DFTType>
    </DFProperties>

  <Node>
    <NodeName></NodeName>
    <DFProperties>
      <AccessType>
        <Get/>
        <Replace/>
      </AccessType>
      <DFFormat>
        <node/>
      </DFFormat>
      <Occurrence>
        <OneOrMore/>
      </Occurrence>
      <DFTType>
        <DDFName></DDFName>
      </DFTType>
    </DFProperties>

  <Node>
    <NodeName>AccessTechnology</NodeName>
    <DFProperties>

```

```

        <AccessType>
          <Get/>
          <Replace/>
        </AccessType>
        <DFFormat>
          <int/>
        </DFFormat>
        <Occurrence>
          <One/>
        </Occurrence>
        <DFTitle>Access technology.</DFTitle>
        <DFType>
          <MIME>text/plain</MIME>
        </DFType>
      </DFProperties>
    </Node>

    <Node>
      <nodeName>AccessId</nodeName>
      <DFProperties>
        <AccessType>
          <Get/>
          <Replace/>
        </AccessType>
        <DFFormat>
          <chr/>
        </DFFormat>
        <Occurrence>
          <ZeroOrOne/>
        </Occurrence>
        <DFTitle>Access identity.</DFTitle>
        <DFType>
          <MIME>text/plain</MIME>
        </DFType>
      </DFProperties>
    </Node>

    <Node>
      <nodeName>SecondaryAccessId</nodeName>
      <DFProperties>
        <AccessType>
          <Get/>
          <Replace/>
        </AccessType>
        <DFFormat>
          <chr/>
        </DFFormat>
        <Occurrence>
          <ZeroOrOne/>
        </Occurrence>
        <DFTitle>Access identity.</DFTitle>
        <DFType>
          <MIME>text/plain</MIME>
        </DFType>
      </DFProperties>
    </Node>

    <Node>
      <nodeName>AccessNetworkPriority</nodeName>
      <DFProperties>
        <AccessType>
          <Get/>
          <Replace/>
        </AccessType>
        <DFFormat>
          <int/>
        </DFFormat>
        <Occurrence>
          <One/>
        </Occurrence>
        <DFTitle>Access network priority.</DFTitle>
        <DFType>
          <MIME>text/plain</MIME>
        </DFType>
      </DFProperties>
    </Node>
  </Node>
</Node>

```



```

<Node>
  <NodeName>ValidityArea</NodeName>
  <DFProperties>
    <AccessType>
      <Get/>
      <Replace/>
    </AccessType>
    <DFFormat>
      <node/>
    </DFFormat>
    <Occurrence>
      <ZeroOrOne/>
    </Occurrence>
    <DFTitle>Validity area.</DFTitle>
    <DFType>
      <DDFName/>
    </DFType>
  </DFProperties>

  <Node>
    <NodeName>_3GPP_Location</NodeName>
    <DFProperties>
      <AccessType>
        <Get/>
        <Replace/>
      </AccessType>
      <DFFormat>
        <node/>
      </DFFormat>
      <Occurrence>
        <ZeroOrOne/>
      </Occurrence>
      <DFTitle>Validity area for 3GPP access.</DFTitle>
      <DFType>
        <DDFName/>
      </DFType>
    </DFProperties>

    <Node>
      <NodeName></NodeName>
      <DFProperties>
        <AccessType>
          <Get/>
          <Replace/>
        </AccessType>
        <DFFormat>
          <node/>
        </DFFormat>
        <Occurrence>
          <OneOrMore/>
        </Occurrence>
        <DFType>
          <DDFName></DDFName>
        </DFType>
      </DFProperties>

    <Node>
      <NodeName>PLMN</NodeName>
      <DFProperties>
        <AccessType>
          <Get/>
          <Replace/>
        </AccessType>
        <DFFormat>
          <chr/>
        </DFFormat>
        <Occurrence>
          <One/>
        </Occurrence>
        <DFTitle>PLMN.</DFTitle>
        <DFType>
          <MIME>text/plain</MIME>
        </DFType>
      </DFProperties>
    </Node>
  </Node>

```

```

<NodeName>TAC</NodeName>
<DFProperties>
  <AccessType>
    <Get/>
    <Replace/>
  </AccessType>
  <DFFormat>
    <chr/>
  </DFFormat>
  <Occurrence>
    <ZeroOrOne/>
  </Occurrence>
  <DFTitle>TAC.</DFTitle>
  <DFType>
    <MIME>text/plain</MIME>
  </DFType>
</DFProperties>
</Node>

<Node>
  <NodeName>LAC</NodeName>
  <DFProperties>
    <AccessType>
      <Get/>
      <Replace/>
    </AccessType>
    <DFFormat>
      <chr/>
    </DFFormat>
    <Occurrence>
      <ZeroOrOne/>
    </Occurrence>
    <DFTitle>LAC.</DFTitle>
    <DFType>
      <MIME>text/plain</MIME>
    </DFType>
  </DFProperties>
</Node>

<Node>
  <NodeName>GERAN_CI</NodeName>
  <DFProperties>
    <AccessType>
      <Get/>
      <Replace/>
    </AccessType>
    <DFFormat>
      <bin/>
    </DFFormat>
    <Occurrence>
      <ZeroOrOne/>
    </Occurrence>
    <DFTitle>GERAN_CI.</DFTitle>
    <DFType>
      <MIME>text/plain</MIME>
    </DFType>
  </DFProperties>
</Node>

<Node>
  <NodeName>UTRAN_CI</NodeName>
  <DFProperties>
    <AccessType>
      <Get/>
      <Replace/>
    </AccessType>
    <DFFormat>
      <bin/>
    </DFFormat>
    <Occurrence>
      <ZeroOrOne/>
    </Occurrence>
    <DFTitle>UTRAN_CI.</DFTitle>
    <DFType>
      <MIME>text/plain</MIME>
    </DFType>
  </DFProperties>
</Node>

```

```

<Node>
  <NodeName>EUTRA_CI</NodeName>
  <DFProperties>
    <AccessType>
      <Get/>
      <Replace/>
    </AccessType>
    <DFFormat>
      <bin/>
    </DFFormat>
    <Occurrence>
      <ZeroOrOne/>
    </Occurrence>
    <DFTitle>EUTRA_CI.</DFTitle>
    <DFType>
      <MIME>text/plain</MIME>
    </DFType>
  </DFProperties>
</Node>
</Node>
</Node>

<Node>
  <NodeName>_3GPP2_Location</NodeName>
  <DFProperties>
    <AccessType>
      <Get/>
      <Replace/>
    </AccessType>
    <DFFormat>
      <node/>
    </DFFormat>
    <Occurrence>
      <ZeroOrOne/>
    </Occurrence>
    <DFTitle> Validity area for 3GPP2 access.</DFTitle>
    <DFType>
      <DDFName/>
    </DFType>
  </DFProperties>

  <Node>
    <NodeName>1x</NodeName>
    <DFProperties>
      <AccessType>
        <Get/>
        <Replace/>
      </AccessType>
      <DFFormat>
        <node/>
      </DFFormat>
      <Occurrence>
        <ZeroOrOne/>
      </Occurrence>
      <DFTitle> Validity area for 3GPP2-1x access.</DFTitle>
      <DFType>
        <DDFName/>
      </DFType>
    </DFProperties>

    <Node>
      <NodeName></NodeName>
      <DFProperties>
        <AccessType>
          <Get/>
          <Replace/>
        </AccessType>
        <DFFormat>
          <node/>
        </DFFormat>
        <Occurrence>
          <OneOrMore/>
        </Occurrence>
        <DFType>
          <DDFName></DDFName>
        </DFType>
      </DFProperties>

```

```

<Node>
  <NodeName>SID</NodeName>
  <DFProperties>
    <AccessType>
      <Get/>
      <Replace/>
    </AccessType>
    <DFFormat>
      <chr/>
    </DFFormat>
    <Occurrence>
      <One/>
    </Occurrence>
    <DFTitle>1x-SID.</DFTitle>
    <DFType>
      <MIME>text/plain</MIME>
    </DFType>
  </DFProperties>
</Node>

<Node>
  <NodeName>NID</NodeName>
  <DFProperties>
    <AccessType>
      <Get/>
      <Replace/>
    </AccessType>
    <DFFormat>
      <chr/>
    </DFFormat>
    <Occurrence>
      <ZeroOrOne/>
    </Occurrence>
    <DFTitle>1x-NID.</DFTitle>
    <DFType>
      <MIME>text/plain</MIME>
    </DFType>
  </DFProperties>
</Node>

<Node>
  <NodeName>Base_ID</NodeName>
  <DFProperties>
    <AccessType>
      <Get/>
      <Replace/>
    </AccessType>
    <DFFormat>
      <chr/>
    </DFFormat>
    <Occurrence>
      <ZeroOrOne/>
    </Occurrence>
    <DFTitle>1x-Base ID.</DFTitle>
    <DFType>
      <MIME>text/plain</MIME>
    </DFType>
  </DFProperties>
</Node>
</Node>
</Node>

<Node>
  <NodeName>HRPD</NodeName>
  <DFProperties>
    <AccessType>
      <Get/>
      <Replace/>
    </AccessType>
    <DFFormat>
      <node/>
    </DFFormat>
    <Occurrence>
      <ZeroOrOne/>
    </Occurrence>
    <DFTitle> Validity area for 3GPP2-HRPD access</DFTitle>
    <DFType>

```

```

        <DDFName/>
    </DFType>
</DFProperties>

<Node>
    <NodeName></NodeName>
    <DFProperties>
        <AccessType>
            <Get/>
            <Replace/>
        </AccessType>
        <DFFormat>
            <node/>
        </DFFormat>
        <Occurrence>
            <OneOrMore/>
        </Occurrence>
        <DFType>
            <DDFName></DDFName>
        </DFType>
    </DFProperties>

    <Node>
        <NodeName>Sector_ID</NodeName>
        <DFProperties>
            <AccessType>
                <Get/>
                <Replace/>
            </AccessType>
            <DFFormat>
                <bin/>
            </DFFormat>
            <Occurrence>
                <One/>
            </Occurrence>
            <DFTitle>HRPD Sector ID</DFTitle>
            <DFType>
                <MIME>text/plain</MIME>
            </DFType>
        </DFProperties>
    </Node>

    <Node>
        <NodeName>Netmask</NodeName>
        <DFProperties>
            <AccessType>
                <Get/>
                <Replace/>
            </AccessType>
            <DFFormat>
                <bin/>
            </DFFormat>
            <Occurrence>
                <One/>
            </Occurrence>
            <DFTitle>HRPD netmask</DFTitle>
            <DFType>
                <MIME>text/plain</MIME>
            </DFType>
        </DFProperties>
    </Node>
</Node>
</Node>
</Node>

<Node>
    <NodeName>WiMAX_Location</NodeName>
    <DFProperties>
        <AccessType>
            <Get/>
            <Replace/>
        </AccessType>
        <DFFormat>
            <node/>
        </DFFormat>
        <Occurrence>
            <ZeroOrOne/>
        </Occurrence>

```

```

    <DFTitle> Validity area for WiMAX access.</DFTitle>
    <DFType>
      <DDFName/>
    </DFType>
  </DFProperties>

  <Node>
    <NodeName></NodeName>
    <DFProperties>
      <AccessType>
        <Get/>
        <Replace/>
      </AccessType>
      <DFFormat>
        <node/>
      </DFFormat>
      <Occurrence>
        <OneOrMore/>
      </Occurrence>
      <DFType>
        <DDFName></DDFName>
      </DFType>
    </DFProperties>

    <Node>
      <NodeName>NAP-ID</NodeName>
      <DFProperties>
        <AccessType>
          <Get/>
          <Replace/>
        </AccessType>
        <DFFormat>
          <chr/>
        </DFFormat>
        <Occurrence>
          <One/>
        </Occurrence>
        <DFTitle>NAP-ID</DFTitle>
        <DFType>
          <MIME>text/plain</MIME>
        </DFType>
      </DFProperties>
    </Node>

    <Node>
      <NodeName>BS-ID</NodeName>
      <DFProperties>
        <AccessType>
          <Get/>
          <Replace/>
        </AccessType>
        <DFFormat>
          <chr/>
        </DFFormat>
        <Occurrence>
          <One/>
        </Occurrence>
        <DFTitle>BS-ID</DFTitle>
        <DFType>
          <MIME>text/plain</MIME>
        </DFType>
      </DFProperties>
    </Node>
  </Node>

  <Node>
    <NodeName>WLAN_Location</NodeName>
    <DFProperties>
      <AccessType>
        <Get/>
        <Replace/>
      </AccessType>
      <DFFormat>
        <node/>
      </DFFormat>
      <Occurrence>
        <ZeroOrOne/>
      </Occurrence>
    </DFProperties>
  </Node>

```

```

    </Occurrence>
    <DFTitle> Validity area for WLAN access.</DFTitle>
    <DFType>
      <DDFName/>
    </DFType>
  </DFProperties>

  <Node>
    <NodeName></NodeName>
    <DFProperties>
      <AccessType>
        <Get/>
        <Replace/>
      </AccessType>
      <DFFormat>
        <node/>
      </DFFormat>
      <Occurrence>
        <OneOrMore/>
      </Occurrence>
      <DFType>
        <DDFName></DDFName>
      </DFType>
    </DFProperties>
  </Node>
  <Node>
    <NodeName>HESSID</NodeName>
    <DFProperties>
      <AccessType>
        <Get/>
        <Replace/>
      </AccessType>
      <DFFormat>
        <chr/>
      </DFFormat>
      <Occurrence>
        <ZeroOrOne/>
      </Occurrence>
      <DFTitle>HESSID</DFTitle>
      <DFType>
        <MIME>text/plain</MIME>
      </DFType>
    </DFProperties>
  </Node>
  <Node>
    <NodeName>SSID</NodeName>
    <DFProperties>
      <AccessType>
        <Get/>
        <Replace/>
      </AccessType>
      <DFFormat>
        <chr/>
      </DFFormat>
      <Occurrence>
        <ZeroOrOne/>
      </Occurrence>
      <DFTitle>SSID</DFTitle>
      <DFType>
        <MIME>text/plain</MIME>
      </DFType>
    </DFProperties>
  </Node>
  <Node>
    <NodeName>BSSID</NodeName>
    <DFProperties>
      <AccessType>
        <Get/>
        <Replace/>
      </AccessType>
      <DFFormat>
        <chr/>
      </DFFormat>
      <Occurrence>
        <One/>
      </Occurrence>
      <DFTitle>BSSID</DFTitle>
      <DFType>

```

```

        <MIME>text/plain</MIME>
      </DFType>
    </DFProperties>
  </Node>
</Node>
</Node>
</Node>
<Node>
  <NodeName>Geo_Location</NodeName>
  <DFProperties>
    <AccessType>
      <Get/>
      <Replace/>
    </AccessType>
    <DFFormat>
      <node/>
    </DFFormat>
    <Occurrence>
      <ZeroOrOne/>
    </Occurrence>
    <DFTitle>Geographical location.</DFTitle>
    <DFType>
      <DDFName/>
    </DFType>
  </DFProperties>

  <Node>
    <NodeName>Circular</NodeName>
    <DFProperties>
      <AccessType>
        <Get/>
        <Replace/>
      </AccessType>
      <DFFormat>
        <node/>
      </DFFormat>
      <Occurrence>
        <ZeroOrOne/>
      </Occurrence>
      <DFTitle>Circular location descripton.</DFTitle>
      <DFType>
        <DDFName/>
      </DFType>
    </DFProperties>

    <Node>
      <NodeName></NodeName>
      <DFProperties>
        <AccessType>
          <Get/>
          <Replace/>
        </AccessType>
        <DFFormat>
          <node/>
        </DFFormat>
        <Occurrence>
          <OneOrMore/>
        </Occurrence>
        <DFType>
          <DDFName></DDFName>
        </DFType>
      </DFProperties>

    <Node>
      <NodeName>AnchorLatitude</NodeName>
      <DFProperties>
        <AccessType>
          <Get/>
          <Replace/>
        </AccessType>
        <DFFormat>
          <chr/>
        </DFFormat>
        <Occurrence>
          <One/>
        </Occurrence>
        <DFTitle>Anchor latitude</DFTitle>
        <DFType>

```



```

        <MIME>text/plain</MIME>
      </DFType>
    </DFProperties>
  </Node>

  <Node>
    <NodeName>AnchorLongitude</NodeName>
    <DFProperties>
      <AccessType>
        <Get/>
        <Replace/>
      </AccessType>
      <DFFormat>
        <chr/>
      </DFFormat>
      <Occurrence>
        <One/>
      </Occurrence>
      <DFTitle>Anchor longitude</DFTitle>
      <DFType>
        <MIME>text/plain</MIME>
      </DFType>
    </DFProperties>
  </Node>

  <Node>
    <NodeName>Radius</NodeName>
    <DFProperties>
      <AccessType>
        <Get/>
        <Replace/>
      </AccessType>
      <DFFormat>
        <chr/>
      </DFFormat>
      <Occurrence>
        <One/>
      </Occurrence>
      <DFTitle>Radius</DFTitle>
      <DFType>
        <MIME>text/plain</MIME>
      </DFType>
    </DFProperties>
  </Node>
</Node>
</Node>
</Node>
</Node>
</Node>
<Node>
  <NodeName>Roaming</NodeName>
  <DFProperties>
    <AccessType>
      <Get/>
      <Replace/>
    </AccessType>
    <DFFormat>
      <bool/>
    </DFFormat>
    <Occurrence>
      <ZeroOrOne/>
    </Occurrence>
    <DFTitle>Rule priority.</DFTitle>
    <DFType>
      <MIME>text/plain</MIME>
    </DFType>
  </DFProperties>
</Node>
<Node>
  <NodeName>PLMN</NodeName>
  <DFProperties>
    <AccessType>
      <Get/>
      <Replace/>
    </AccessType>
    <DFFormat>
      <chr/>

```

```

        </DFFormat>
        <Occurrence>
          <One/>
        </Occurrence>
        <DFTitle>PLMN which created the policy.</DFTitle>
        <DFType>
          <MIME>text/plain</MIME>
        </DFType>
      </DFProperties>
    </Node>

    <Node>
      <NodeName>TimeOfDay</NodeName>
      <DFProperties>
        <AccessType>
          <Get/>
          <Replace/>
        </AccessType>
        <DFFormat>
          <node/>
        </DFFormat>
        <Occurrence>
          <ZeroOrOne/>
        </Occurrence>
        <DFTitle>Time of day.</DFTitle>
        <DFType>
          <DDFName/>
        </DFType>
      </DFProperties>

      <Node>
        <NodeName></NodeName>
        <DFProperties>
          <AccessType>
            <Get/>
            <Replace/>
          </AccessType>
          <DFFormat>
            <node/>
          </DFFormat>
          <Occurrence>
            <OneOrMore/>
          </Occurrence>
          <DFType>
            <DDFName></DDFName>
          </DFType>
        </DFProperties>

        <Node>
          <NodeName>TimeStart</NodeName>
          <DFProperties>
            <AccessType>
              <Get/>
              <Replace/>
            </AccessType>
            <DFFormat>
              <int/>
            </DFFormat>
            <Occurrence>
              <ZeroOrOne/>
            </Occurrence>
            <DFTitle>Start condition for time of rule.</DFTitle>
            <DFType>
              <MIME>text/plain</MIME>
            </DFType>
          </DFProperties>
        </Node>

        <Node>
          <NodeName>TimeStop</NodeName>
          <DFProperties>
            <AccessType>
              <Get/>
              <Replace/>
            </AccessType>
            <DFFormat>
              <int/>
            </DFFormat>
          </DFProperties>
        </Node>

```

```

        </DFFormat>
        <Occurrence>
            <ZeroOrOne/>
        </Occurrence>
        <DFTitle>Stop condition for time of rule.</DFTitle>
        <DFType>
            <MIME>text/plain</MIME>
        </DFType>
    </DFProperties>
</Node>

<Node>
    <NodeName>DateStart</NodeName>
    <DFProperties>
        <AccessType>
            <Get/>
            <Replace/>
        </AccessType>
        <DFFormat>
            <int/>
        </DFFormat>
        <Occurrence>
            <ZeroOrOne/>
        </Occurrence>
        <DFTitle>Starting date for time condition of rule.</DFTitle>
        <DFType>
            <MIME>text/plain</MIME>
        </DFType>
    </DFProperties>
</Node>

<Node>
    <NodeName>DateStop</NodeName>
    <DFProperties>
        <AccessType>
            <Get/>
            <Replace/>
        </AccessType>
        <DFFormat>
            <int/>
        </DFFormat>
        <Occurrence>
            <ZeroOrOne/>
        </Occurrence>
        <DFTitle>Stop date for time condition of rule.</DFTitle>
        <DFType>
            <MIME>text/plain</MIME>
        </DFType>
    </DFProperties>
</Node>
</Node>

<Node>
    <NodeName>UpdatePolicy</NodeName>
    <DFProperties>
        <AccessType>
            <Get/>
            <Replace/>
        </AccessType>
        <DFFormat>
            <bool/>
        </DFFormat>
        <Occurrence>
            <ZeroOrOne/>
        </Occurrence>
        <DFTitle>Update policy.</DFTitle>
        <DFType>
            <MIME>text/plain</MIME>
        </DFType>
    </DFProperties>
</Node>
</Node>
</Node>

<Node>
    <NodeName>DiscoveryInformation</NodeName>
    <!-- The DiscoveryInformation node starts here. -->

```

```

<DFProperties>
  <AccessType>
    <Get/>
    <Replace/>
  </AccessType>
  <DFFormat>
    <node/>
  </DFFormat>
  <Occurrence>
    <ZeroOrOne/>
  </Occurrence>
  <DFTitle>Access network discovery information.</DFTitle>
  <DFType>
    <DDFName/>
  </DFType>
</DFProperties>

<Node>
  <NodeName></NodeName>
  <DFProperties>
    <AccessType>
      <Get/>
      <Replace/>
    </AccessType>
    <DFFormat>
      <node/>
    </DFFormat>
    <Occurrence>
      <OneOrMore/>
    </Occurrence>
    <DFType>
      <DDFName></DDFName>
    </DFType>
  </DFProperties>

<Node>
  <NodeName>AccessNetworkType</NodeName>
  <DFProperties>
    <AccessType>
      <Get/>
      <Replace/>
    </AccessType>
    <DFFormat>
      <int/>
    </DFFormat>
    <Occurrence>
      <One/>
    </Occurrence>
    <DFTitle>Access network type.</DFTitle>
    <DFType>
      <MIME>text/plain</MIME>
    </DFType>
  </DFProperties>
</Node>

<Node>
  <NodeName>AccessNetworkArea</NodeName>
  <DFProperties>
    <AccessType>
      <Get/>
      <Replace/>
    </AccessType>
    <DFFormat>
      <node/>
    </DFFormat>
    <Occurrence>
      <One/>
    </Occurrence>
    <DFTitle>Access network area.</DFTitle>
    <DFType>
      <DDFName/>
    </DFType>
  </DFProperties>

  <Node>
    <NodeName>_3GPP_Location</NodeName>
    <DFProperties>
      <AccessType>

```

```

        <Get/>
        <Replace/>
    </AccessType>
    <DFFormat>
        <node/>
    </DFFormat>
    <Occurrence>
        <ZeroOrOne/>
    </Occurrence>
    <DFTitle>Discovery information for 3GPP access.</DFTitle>
    <DFType>
        <DDFName/>
    </DFType>
</DFProperties>

<Node>
    <NodeName></NodeName>
    <DFProperties>
        <AccessType>
            <Get/>
            <Replace/>
        </AccessType>
        <DFFormat>
            <node/>
        </DFFormat>
        <Occurrence>
            <OneOrMore/>
        </Occurrence>
        <DFType>
            <DDFName></DDFName>
        </DFType>
    </DFProperties>

<Node>
    <NodeName>PLMN</NodeName>
    <DFProperties>
        <AccessType>
            <Get/>
            <Replace/>
        </AccessType>
        <DFFormat>
            <chr/>
        </DFFormat>
        <Occurrence>
            <One/>
        </Occurrence>
        <DFTitle>PLMN.</DFTitle>
        <DFType>
            <MIME>text/plain</MIME>
        </DFType>
    </DFProperties>
</Node>

<Node>
    <NodeName>TAC</NodeName>
    <DFProperties>
        <AccessType>
            <Get/>
            <Replace/>
        </AccessType>
        <DFFormat>
            <chr/>
        </DFFormat>
        <Occurrence>
            <ZeroOrOne/>
        </Occurrence>
        <DFTitle>TAC.</DFTitle>
        <DFType>
            <MIME>text/plain</MIME>
        </DFType>
    </DFProperties>
</Node>

<Node>
    <NodeName>LAC</NodeName>
    <DFProperties>
        <AccessType>
            <Get/>

```

```

        <Replace/>
      </AccessType>
    <DFFormat>
      <chr/>
    </DFFormat>
  <Occurrence>
    <ZeroOrOne/>
  </Occurrence>
  <DFTitle>LAC.</DFTitle>
  <DFType>
    <MIME>text/plain</MIME>
  </DFType>
</DFProperties>
</Node>

<Node>
  <nodeName>GERAN_CI</nodeName>
  <DFProperties>
    <AccessType>
      <Get/>
      <Replace/>
    </AccessType>
    <DFFormat>
      <bin/>
    </DFFormat>
    <Occurrence>
      <ZeroOrOne/>
    </Occurrence>
    <DFTitle>GERAN_CI.</DFTitle>
    <DFType>
      <MIME>text/plain</MIME>
    </DFType>
  </DFProperties>
</Node>

<Node>
  <nodeName>UTRAN_CI</nodeName>
  <DFProperties>
    <AccessType>
      <Get/>
      <Replace/>
    </AccessType>
    <DFFormat>
      <bin/>
    </DFFormat>
    <Occurrence>
      <ZeroOrOne/>
    </Occurrence>
    <DFTitle>UTRAN_CI.</DFTitle>
    <DFType>
      <MIME>text/plain</MIME>
    </DFType>
  </DFProperties>
</Node>

<Node>
  <nodeName>EUTRA_CI</nodeName>
  <DFProperties>
    <AccessType>
      <Get/>
      <Replace/>
    </AccessType>
    <DFFormat>
      <bin/>
    </DFFormat>
    <Occurrence>
      <ZeroOrOne/>
    </Occurrence>
    <DFTitle>EUTRA_CI.</DFTitle>
    <DFType>
      <MIME>text/plain</MIME>
    </DFType>
  </DFProperties>
</Node>
</Node>
</Node>
</Node>

```

```

<NodeName>_3GPP2_Location</NodeName>
<DFProperties>
  <AccessType>
    <Get/>
    <Replace/>
  </AccessType>
  <DFFormat>
    <node/>
  </DFFormat>
  <Occurrence>
    <ZeroOrOne/>
  </Occurrence>
  <DFTitle>Discovery information for 3GPP2 access.</DFTitle>
  <DFType>
    <DDFName/>
  </DFType>
</DFProperties>

<Node>
  <NodeName>1x</NodeName>
  <DFProperties>
    <AccessType>
      <Get/>
      <Replace/>
    </AccessType>
    <DFFormat>
      <node/>
    </DFFormat>
    <Occurrence>
      <ZeroOrOne/>
    </Occurrence>
    <DFTitle>Discovery information for 3GPP2-1x access.</DFTitle>
    <DFType>
      <DDFName/>
    </DFType>
  </DFProperties>

<Node>
  <NodeName></NodeName>
  <DFProperties>
    <AccessType>
      <Get/>
      <Replace/>
    </AccessType>
    <DFFormat>
      <node/>
    </DFFormat>
    <Occurrence>
      <OneOrMore/>
    </Occurrence>
    <DFType>
      <DDFName></DDFName>
    </DFType>
  </DFProperties>

<Node>
  <NodeName>SID</NodeName>
  <DFProperties>
    <AccessType>
      <Get/>
      <Replace/>
    </AccessType>
    <DFFormat>
      <chr/>
    </DFFormat>
    <Occurrence>
      <One/>
    </Occurrence>
    <DFTitle>1x-SID.</DFTitle>
    <DFType>
      <MIME>text/plain</MIME>
    </DFType>
  </DFProperties>
</Node>

<Node>
  <NodeName>NID</NodeName>
  <DFProperties>

```

```

        <AccessType>
          <Get/>
          <Replace/>
        </AccessType>
        <DFFormat>
          <chr/>
        </DFFormat>
        <Occurrence>
          <ZeroOrOne/>
        </Occurrence>
        <DFTitle>1x-NID.</DFTitle>
        <DFType>
          <MIME>text/plain</MIME>
        </DFType>
      </DFProperties>
    </Node>

    <Node>
      <NodeName>Base_ID</NodeName>
      <DFProperties>
        <AccessType>
          <Get/>
          <Replace/>
        </AccessType>
        <DFFormat>
          <chr/>
        </DFFormat>
        <Occurrence>
          <ZeroOrOne/>
        </Occurrence>
        <DFTitle>1x-Base ID.</DFTitle>
        <DFType>
          <MIME>text/plain</MIME>
        </DFType>
      </DFProperties>
    </Node>
  </Node>
</Node>

<Node>
  <NodeName>HRPD</NodeName>
  <DFProperties>
    <AccessType>
      <Get/>
      <Replace/>
    </AccessType>
    <DFFormat>
      <node/>
    </DFFormat>
    <Occurrence>
      <ZeroOrOne/>
    </Occurrence>
    <DFTitle>Discovery information for 3GPP2-HRPD access</DFTitle>
    <DFType>
      <DDFName/>
    </DFType>
  </DFProperties>

  <Node>
    <NodeName></NodeName>
    <DFProperties>
      <AccessType>
        <Get/>
        <Replace/>
      </AccessType>
      <DFFormat>
        <node/>
      </DFFormat>
      <Occurrence>
        <OneOrMore/>
      </Occurrence>
      <DFType>
        <DDFName></DDFName>
      </DFType>
    </DFProperties>

  <Node>
    <NodeName>Sector_ID</NodeName>

```



```

        <DFProperties>
          <AccessType>
            <Get/>
            <Replace/>
          </AccessType>
          <DFFormat>
            <bin/>
          </DFFormat>
          <Occurrence>
            <One/>
          </Occurrence>
          <DFTitle>HRPD Sector ID</DFTitle>
          <DFType>
            <MIME>text/plain</MIME>
          </DFType>
        </DFProperties>
      </Node>

      <Node>
        <NodeName>Netmask</NodeName>
        <DFProperties>
          <AccessType>
            <Get/>
            <Replace/>
          </AccessType>
          <DFFormat>
            <bin/>
          </DFFormat>
          <Occurrence>
            <One/>
          </Occurrence>
          <DFTitle>HRPD netmask</DFTitle>
          <DFType>
            <MIME>text/plain</MIME>
          </DFType>
        </DFProperties>
      </Node>
    </Node>
  </Node>

  <Node>
    <NodeName>WiMAX_Location</NodeName>
    <DFProperties>
      <AccessType>
        <Get/>
        <Replace/>
      </AccessType>
      <DFFormat>
        <node/>
      </DFFormat>
      <Occurrence>
        <ZeroOrOne/>
      </Occurrence>
      <DFTitle>Discovery information for WiMAX access.</DFTitle>
      <DFType>
        <DDFName/>
      </DFType>
    </DFProperties>

    <Node>
      <NodeName></NodeName>
      <DFProperties>
        <AccessType>
          <Get/>
          <Replace/>
        </AccessType>
        <DFFormat>
          <node/>
        </DFFormat>
        <Occurrence>
          <OneOrMore/>
        </Occurrence>
        <DFType>
          <DDFName></DDFName>
        </DFType>
      </DFProperties>
    </Node>
  </Node>

```

```

<Node>
  <NodeName>NAP-ID</NodeName>
  <DFProperties>
    <AccessType>
      <Get/>
      <Replace/>
    </AccessType>
    <DFFormat>
      <chr/>
    </DFFormat>
    <Occurrence>
      <One/>
    </Occurrence>
    <DFTitle>NAP-ID</DFTitle>
    <DFType>
      <MIME>text/plain</MIME>
    </DFType>
  </DFProperties>
</Node>

<Node>
  <NodeName>BS-ID</NodeName>
  <DFProperties>
    <AccessType>
      <Get/>
      <Replace/>
    </AccessType>
    <DFFormat>
      <chr/>
    </DFFormat>
    <Occurrence>
      <One/>
    </Occurrence>
    <DFTitle>BS-ID</DFTitle>
    <DFType>
      <MIME>text/plain</MIME>
    </DFType>
  </DFProperties>
</Node>
</Node>

<Node>
  <NodeName>WLAN_Location</NodeName>
  <DFProperties>
    <AccessType>
      <Get/>
      <Replace/>
    </AccessType>
    <DFFormat>
      <node/>
    </DFFormat>
    <Occurrence>
      <ZeroOrOne/>
    </Occurrence>
    <DFTitle>Discovery information for WLAN access.</DFTitle>
    <DFType>
      <DDFName/>
    </DFType>
  </DFProperties>

  <Node>
    <NodeName></NodeName>
    <DFProperties>
      <AccessType>
        <Get/>
        <Replace/>
      </AccessType>
      <DFFormat>
        <node/>
      </DFFormat>
      <Occurrence>
        <OneOrMore/>
      </Occurrence>
      <DFType>
        <DDFName></DDFName>
      </DFType>
    </DFProperties>
  </Node>

```

```

<Node>
  <NodeName>HESSID</NodeName>
  <DFProperties>
    <AccessType>
      <Get/>
      <Replace/>
    </AccessType>
    <DFFormat>
      <chr/>
    </DFFormat>
    <Occurrence>
      <ZeroOrOne/>
    </Occurrence>
    <DFTitle>HESSID</DFTitle>
    <DFType>
      <MIME>text/plain</MIME>
    </DFType>
  </DFProperties>
</Node>

<Node>
  <NodeName>SSID</NodeName>
  <DFProperties>
    <AccessType>
      <Get/>
      <Replace/>
    </AccessType>
    <DFFormat>
      <chr/>
    </DFFormat>
    <Occurrence>
      <ZeroOrOne/>
    </Occurrence>
    <DFTitle>SSID</DFTitle>
    <DFType>
      <MIME>text/plain</MIME>
    </DFType>
  </DFProperties>
</Node>

<Node>
  <NodeName>BSSID</NodeName>
  <DFProperties>
    <AccessType>
      <Get/>
      <Replace/>
    </AccessType>
    <DFFormat>
      <chr/>
    </DFFormat>
    <Occurrence>
      <One/>
    </Occurrence>
    <DFTitle>BSSID</DFTitle>
    <DFType>
      <MIME>text/plain</MIME>
    </DFType>
  </DFProperties>
</Node>
</Node>

<Node>
  <NodeName>Geo_Location</NodeName>
  <DFProperties>
    <AccessType>
      <Get/>
      <Replace/>
    </AccessType>
    <DFFormat>
      <node/>
    </DFFormat>
    <Occurrence>
      <ZeroOrOne/>
    </Occurrence>
    <DFTitle>Geographical location.</DFTitle>
    <DFType>

```

```

        <DDFName/>
    </DFType>
</DFProperties>
</Node>
<Node>
  <NodeName>Circular</NodeName>
  <DFProperties>
    <AccessType>
      <Get/>
      <Replace/>
    </AccessType>
    <DFFormat>
      <node/>
    </DFFormat>
    <Occurrence>
      <ZeroOrOne/>
    </Occurrence>
    <DFTitle>Circular location descripton.</DFTitle>
    <DFType>
      <DDFName/>
    </DFType>
  </DFProperties>
</Node>
<Node>
  <NodeName></NodeName>
  <DFProperties>
    <AccessType>
      <Get/>
      <Replace/>
    </AccessType>
    <DFFormat>
      <node/>
    </DFFormat>
    <Occurrence>
      <OneOrMore/>
    </Occurrence>
    <DFType>
      <DDFName></DDFName>
    </DFType>
  </DFProperties>
</Node>
<Node>
  <NodeName>AnchorLatitude</NodeName>
  <DFProperties>
    <AccessType>
      <Get/>
      <Replace/>
    </AccessType>
    <DFFormat>
      <chr/>
    </DFFormat>
    <Occurrence>
      <One/>
    </Occurrence>
    <DFTitle>Anchor latitude</DFTitle>
    <DFType>
      <MIME>text/plain</MIME>
    </DFType>
  </DFProperties>
</Node>
<Node>
  <NodeName>AnchorLongitude</NodeName>
  <DFProperties>
    <AccessType>
      <Get/>
      <Replace/>
    </AccessType>
    <DFFormat>
      <chr/>
    </DFFormat>
    <Occurrence>
      <One/>
    </Occurrence>
    <DFTitle>Anchor longitude</DFTitle>
    <DFType>
      <MIME>text/plain</MIME>
    </DFType>
  </DFProperties>
</Node>

```

```

        </DFProperties>
    </Node>

    <Node>
        <NodeName>Radius</NodeName>
        <DFProperties>
            <AccessType>
                <Get/>
                <Replace/>
            </AccessType>
            <DFFormat>
                <chr/>
            </DFFormat>
            <Occurrence>
                <One/>
            </Occurrence>
            <DFTitle>Radius</DFTitle>
            <DFType>
                <MIME>text/plain</MIME>
            </DFType>
        </DFProperties>
    </Node>
</Node>
</Node>
</Node>
</Node>

<Node>
    <NodeName>AccessNetworkInformationRef</NodeName>
    <DFProperties>
        <AccessType>
            <Get/>
            <Replace/>
        </AccessType>
        <DFFormat>
            <chr/>
        </DFFormat>
        <Occurrence>
            <ZeroOrOne/>
        </Occurrence>
        <DFTitle>Access network information reference.</DFTitle>
        <DFType>
            <MIME>text/plain</MIME>
        </DFType>
    </DFProperties>
</Node>
</Node>

<Node>
    <NodeName>UE_Location</NodeName>
    <!-- The UE_Location node starts here. -->
    <DFProperties>
        <AccessType>
            <Get/>
        </AccessType>
        <DFFormat>
            <node/>
        </DFFormat>
        <Occurrence>
            <ZeroOrOne/>
        </Occurrence>
        <DFTitle>Current location of the UE</DFTitle>
        <DFType>
            <DDFName/>
        </DFType>
    </DFProperties>

    <Node>
        <NodeName>_3GPP_Location</NodeName>
        <DFProperties>
            <AccessType>
                <Get/>
            </AccessType>
            <DFFormat>
                <node/>
            </DFFormat>
            <Occurrence>

```

```

        <ZeroOrOne/>
    </Occurrence>
    <DFTitle>Current 3GPP location of the UE</DFTitle>
    <DFType>
        <DDFName/>
    </DFType>
</DFProperties>

<Node>
    <NodeName></NodeName>
    <DFProperties>
        <AccessType>
            <Get/>
        </AccessType>
        <DFFormat>
            <node/>
        </DFFormat>
        <Occurrence>
            <OneOrMore/>
        </Occurrence>
        <DFType>
            <DDFName></DDFName>
        </DFType>
    </DFProperties>

    <Node>
        <NodeName>PLMN</NodeName>
        <DFProperties>
            <AccessType>
                <Get/>
            </AccessType>
            <DFFormat>
                <chr/>
            </DFFormat>
            <Occurrence>
                <One/>
            </Occurrence>
            <DFTitle>Current PLMN</DFTitle>
            <DFType>
                <MIME>text/plain</MIME>
            </DFType>
        </DFProperties>
    </Node>

    <Node>
        <NodeName>TAC</NodeName>
        <DFProperties>
            <AccessType>
                <Get/>
            </AccessType>
            <DFFormat>
                <chr/>
            </DFFormat>
            <Occurrence>
                <ZeroOrOne/>
            </Occurrence>
            <DFTitle>Current TAC</DFTitle>
            <DFType>
                <MIME>text/plain</MIME>
            </DFType>
        </DFProperties>
    </Node>

    <Node>
        <NodeName>LAC</NodeName>
        <DFProperties>
            <AccessType>
                <Get/>
            </AccessType>
            <DFFormat>
                <chr/>
            </DFFormat>
            <Occurrence>
                <ZeroOrOne/>
            </Occurrence>
            <DFTitle>Current LAC</DFTitle>
            <DFType>
                <MIME>text/plain</MIME>
            </DFType>
        </DFProperties>
    </Node>

```

```

        </DFType>
      </DFProperties>
    </Node>

    <Node>
      <NodeName>GERAN_CI</NodeName>
      <DFProperties>
        <AccessType>
          <Get/>
        </AccessType>
        <DFFormat>
          <bin/>
        </DFFormat>
        <Occurrence>
          <ZeroOrOne/>
        </Occurrence>
        <DFTitle>Current GERAN_CI</DFTitle>
        <DFType>
          <MIME>text/plain</MIME>
        </DFType>
      </DFProperties>
    </Node>

    <Node>
      <NodeName>UTRAN_CI</NodeName>
      <DFProperties>
        <AccessType>
          <Get/>
        </AccessType>
        <DFFormat>
          <bin/>
        </DFFormat>
        <Occurrence>
          <ZeroOrOne/>
        </Occurrence>
        <DFTitle>Current UTRAN_CI</DFTitle>
        <DFType>
          <MIME>text/plain</MIME>
        </DFType>
      </DFProperties>
    </Node>

    <Node>
      <NodeName>EUTRA_CI</NodeName>
      <DFProperties>
        <AccessType>
          <Get/>
        </AccessType>
        <DFFormat>
          <bin/>
        </DFFormat>
        <Occurrence>
          <ZeroOrOne/>
        </Occurrence>
        <DFTitle>Current EUTRA_CI</DFTitle>
        <DFType>
          <MIME>text/plain</MIME>
        </DFType>
      </DFProperties>
    </Node>
  </Node>
</Node>

<Node>
  <NodeName>_3GPP2_Location</NodeName>
  <DFProperties>
    <AccessType>
      <Get/>
    </AccessType>
    <DFFormat>
      <node/>
    </DFFormat>
    <Occurrence>
      <ZeroOrOne/>
    </Occurrence>
    <DFTitle>Current 3GPP2 location of the UE</DFTitle>
    <DFType>
      <DDFName/>
    </DFType>
  </DFProperties>
</Node>

```

```

    </DFType>
  </DFProperties>

  <Node>
    <NodeName>lx</NodeName>
    <DFProperties>
      <AccessType>
        <Get/>
      </AccessType>
      <DFFormat>
        <node/>
      </DFFormat>
      <Occurrence>
        <ZeroOrOne/>
      </Occurrence>
      <DFTitle>Current 3GPP2-1x location of the UE</DFTitle>
      <DFType>
        <DDFName/>
      </DFType>
    </DFProperties>

    <Node>
      <NodeName></NodeName>
      <DFProperties>
        <AccessType>
          <Get/>
        </AccessType>
        <DFFormat>
          <node/>
        </DFFormat>
        <Occurrence>
          <OneOrMore/>
        </Occurrence>
        <DFType>
          <DDFName></DDFName>
        </DFType>
      </DFProperties>

      <Node>
        <NodeName>SID</NodeName>
        <DFProperties>
          <AccessType>
            <Get/>
          </AccessType>
          <DFFormat>
            <chr/>
          </DFFormat>
          <Occurrence>
            <One/>
          </Occurrence>
          <DFTitle>Current SID</DFTitle>
          <DFType>
            <MIME>text/plain</MIME>
          </DFType>
        </DFProperties>
      </Node>

      <Node>
        <NodeName>NID</NodeName>
        <DFProperties>
          <AccessType>
            <Get/>
          </AccessType>
          <DFFormat>
            <chr/>
          </DFFormat>
          <Occurrence>
            <ZeroOrOne/>
          </Occurrence>
          <DFTitle>Current NID</DFTitle>
          <DFType>
            <MIME>text/plain</MIME>
          </DFType>
        </DFProperties>
      </Node>

      <Node>
        <NodeName>Base_ID</NodeName>

```



```

        <DFProperties>
            <AccessType>
                <Get/>
            </AccessType>
            <DFFormat>
                <chr/>
            </DFFormat>
            <Occurrence>
                <ZeroOrOne/>
            </Occurrence>
            <DFTitle>Current Base ID</DFTitle>
            <DFType>
                <MIME>text/plain</MIME>
            </DFType>
        </DFProperties>
    </Node>
</Node>
</Node>
<Node>
    <NodeName>HRPD</NodeName>
    <DFProperties>
        <AccessType>
            <Get/>
        </AccessType>
        <DFFormat>
            <node/>
        </DFFormat>
        <Occurrence>
            <ZeroOrOne/>
        </Occurrence>
        <DFTitle>Current 3GPP2-HRPD location of the UE</DFTitle>
        <DFType>
            <DDFName/>
        </DFType>
    </DFProperties>

    <Node>
        <NodeName></NodeName>
        <DFProperties>
            <AccessType>
                <Get/>
            </AccessType>
            <DFFormat>
                <node/>
            </DFFormat>
            <Occurrence>
                <OneOrMore/>
            </Occurrence>
            <DFType>
                <DDFName></DDFName>
            </DFType>
        </DFProperties>

    <Node>
        <NodeName>Sector_ID</NodeName>
        <DFProperties>
            <AccessType>
                <Get/>
            </AccessType>
            <DFFormat>
                <bin/>
            </DFFormat>
            <Occurrence>
                <One/>
            </Occurrence>
            <DFTitle>Current Sector ID</DFTitle>
            <DFType>
                <MIME>text/plain</MIME>
            </DFType>
        </DFProperties>
    </Node>

    <Node>
        <NodeName>Netmask</NodeName>
        <DFProperties>
            <AccessType>
                <Get/>

```

```

        </AccessType>
        <DFFormat>
          <bin/>
        </DFFormat>
        <Occurrence>
          <One/>
        </Occurrence>
        <DFTitle>HRPD netmask</DFTitle>
        <DFType>
          <MIME>text/plain</MIME>
        </DFType>
      </DFProperties>
    </Node>
  </Node>
</Node>
<Node>
  <NodeName>WiMAX_Location</NodeName>
  <DFProperties>
    <AccessType>
      <Get/>
    </AccessType>
    <DFFormat>
      <node/>
    </DFFormat>
    <Occurrence>
      <ZeroOrOne/>
    </Occurrence>
    <DFTitle>Current WiMAX location of the UE</DFTitle>
    <DFType>
      <DDFName/>
    </DFType>
  </DFProperties>
</Node>
<Node>
  <NodeName></NodeName>
  <DFProperties>
    <AccessType>
      <Get/>
    </AccessType>
    <DFFormat>
      <node/>
    </DFFormat>
    <Occurrence>
      <OneOrMore/>
    </Occurrence>
    <DFType>
      <DDFName></DDFName>
    </DFType>
  </DFProperties>
</Node>
<Node>
  <NodeName>NAP- ID</NodeName>
  <DFProperties>
    <AccessType>
      <Get/>
    </AccessType>
    <DFFormat>
      <chr/>
    </DFFormat>
    <Occurrence>
      <One/>
    </Occurrence>
    <DFTitle>Current NAP-ID</DFTitle>
    <DFType>
      <MIME>text/plain</MIME>
    </DFType>
  </DFProperties>
</Node>
<Node>
  <NodeName>BS- ID</NodeName>
  <DFProperties>
    <AccessType>
      <Get/>
    </AccessType>
    <DFFormat>

```

```

        <chr/>
      </DFFormat>
    </Occurrence>
  </One/>
</Occurrence>
<DFTitle>Current BS-ID</DFTitle>
<DFType>
  <MIME>text/plain</MIME>
</DFType>
</DFProperties>
</Node>
</Node>
</Node>
<Node>
  <NodeName>WLAN_Location</NodeName>
  <DFProperties>
    <AccessType>
      <Get/>
    </AccessType>
    <DFFormat>
      <node/>
    </DFFormat>
    <Occurrence>
      <ZeroOrOne/>
    </Occurrence>
    <DFTitle>Current WLAN location of the UE</DFTitle>
    <DFType>
      <DDFName/>
    </DFType>
  </DFProperties>
</Node>
  <Node>
    <NodeName></NodeName>
    <DFProperties>
      <AccessType>
        <Get/>
      </AccessType>
      <DFFormat>
        <node/>
      </DFFormat>
      <Occurrence>
        <OneOrMore/>
      </Occurrence>
      <DFType>
        <DDFName></DDFName>
      </DFType>
    </DFProperties>
  </Node>
  <Node>
    <NodeName>HESSID</NodeName>
    <DFProperties>
      <AccessType>
        <Get/>
      </AccessType>
      <DFFormat>
        <chr/>
      </DFFormat>
      <Occurrence>
        <ZeroOrOne/>
      </Occurrence>
      <DFTitle>Current HESSID</DFTitle>
      <DFType>
        <MIME>text/plain</MIME>
      </DFType>
    </DFProperties>
  </Node>
  <Node>
    <NodeName>SSID</NodeName>
    <DFProperties>
      <AccessType>
        <Get/>
      </AccessType>
      <DFFormat>
        <chr/>
      </DFFormat>
      <Occurrence>

```

```

        <ZeroOrOne/>
      </Occurrence>
      <DFTitle>Current SSID</DFTitle>
      <DFType>
        <MIME>text/plain</MIME>
      </DFType>
    </DFProperties>
  </Node>

  <Node>
    <NodeName>BSSID</NodeName>
    <DFProperties>
      <AccessType>
        <Get/>
      </AccessType>
      <DFFormat>
        <chr/>
      </DFFormat>
      <Occurrence>
        <One/>
      </Occurrence>
      <DFTitle>Current BSSID</DFTitle>
      <DFType>
        <MIME>text/plain</MIME>
      </DFType>
    </DFProperties>
  </Node>
</Node>

<Node>
  <NodeName>Geo_Location</NodeName>
  <DFProperties>
    <AccessType>
      <Get/>
    </AccessType>
    <DFFormat>
      <node/>
    </DFFormat>
    <Occurrence>
      <ZeroOrOne/>
    </Occurrence>
    <DFTitle>Current Geographical location of the UE</DFTitle>
    <DFType>
      <DDFName/>
    </DFType>
  </DFProperties>

  <Node>
    <NodeName>AnchorLatitude</NodeName>
    <DFProperties>
      <AccessType>
        <Get/>
      </AccessType>
      <DFFormat>
        <chr/>
      </DFFormat>
      <Occurrence>
        <One/>
      </Occurrence>
      <DFTitle>Anchor latitude</DFTitle>
      <DFType>
        <MIME>text/plain</MIME>
      </DFType>
    </DFProperties>
  </Node>

  <Node>
    <NodeName>AnchorLongitude</NodeName>
    <DFProperties>
      <AccessType>
        <Get/>
      </AccessType>
      <DFFormat>
        <chr/>
      </DFFormat>
      <Occurrence>
        <One/>
      </Occurrence>

```

```

        </Occurrence>
        <DFTitle>Anchor longitude</DFTitle>
        <DFType>
            <MIME>text/plain</MIME>
        </DFType>
    </DFProperties>
</Node>
</Node>
<Node>
    <NodeName>RPLMN</NodeName>
    <DFProperties>
        <AccessType>
            <Get/>
        </AccessType>
        <DFFormat>
            <chr/>
        </DFFormat>
        <Occurrence>
            <ZeroOrOne/>
        </Occurrence>
        <DFTitle>RPLMN.</DFTitle>
        <DFType>
            <MIME>text/plain</MIME>
        </DFType>
    </DFProperties>
</Node>
</Node>
<Node>
    <NodeName>ISRP</NodeName>
    <!-- The ISRP node starts here. -->
    <DFProperties>
        <AccessType>
            <Get/>
            <Replace/>
        </AccessType>
        <DFFormat>
            <node/>
        </DFFormat>
        <Occurrence>
            <ZeroOrOne/>
        </Occurrence>
        <DFTitle>ISRP rules for routing of specific IP Flows of PDN connections</DFTitle>
        <DFType>
            <DDFName/>
        </DFType>
    </DFProperties>
<Node>
    <NodeName></NodeName>
    <DFProperties>
        <AccessType>
            <Get/>
            <Replace/>
        </AccessType>
        <DFFormat>
            <node/>
        </DFFormat>
        <Occurrence>
            <OneOrMore/>
        </Occurrence>
        <DFType>
            <DDFName></DDFName>
        </DFType>
    </DFProperties>
<Node>
    <NodeName>ForFlowBased</NodeName>
    <DFProperties>
        <AccessType>
            <Get/>
            <Replace/>
        </AccessType>
        <DFFormat>
            <int/>
        </DFFormat>
        <Occurrence>
            <ZeroOrOne/>
        </Occurrence>
    </DFProperties>

```

```

    <DFTitle>List of ISRP for IFOM case.</DFTitle>
    <DFType>
      <MIME>text/plain</MIME>
    </DFType>
  </DFProperties>
  <Node>
    <NodeName></NodeName>
    <DFProperties>
      <AccessType>
        <Get/>
        <Replace/>
      </AccessType>
      <DFFormat>
        <node/>
      </DFFormat>
      <Occurrence>
        <OneOrMore/>
      </Occurrence>
      <DFType>
        <DDFName></DDFName>
      </DFType>
    </DFProperties>
    <Node>
      <NodeName>IPFlow</NodeName>
      <DFProperties>
        <AccessType>
          <Get/>
          <Replace/>
        </AccessType>
        <DFFormat>
          <node/>
        </DFFormat>
        <Occurrence>
          <One/>
        </Occurrence>
        <DFTitle>IPFlow description</DFTitle>
        <DFType>
          <MIME>text/plain</MIME>
        </DFType>
      </DFProperties>

      <Node>
        <NodeName></NodeName>
        <DFProperties>
          <AccessType>
            <Get/>
            <Replace/>
          </AccessType>
          <DFFormat>
            <node/>
          </DFFormat>
          <Occurrence>
            <OneOrMore/>
          </Occurrence>
          <DFType>
            <DDFName></DDFName>
          </DFType>
        </DFProperties>

        <Node>
          <NodeName>AddressType</NodeName>
          <DFProperties>
            <AccessType>
              <Get/>
              <Replace/>
            </AccessType>
            <DFFormat>
              <node/>
            </DFFormat>
            <Occurrence>
              <ZeroOrOne/>
            </Occurrence>
            <DFTitle>IP version of the IP addresses</DFTitle>
            <DFType>
              <MIME>text/plain</MIME>
            </DFType>
          </DFProperties>
        </Node>
      </Node>
    </Node>
  </Node>

```

```

<Node>
  <NodeName>StartSourceIPAddress</NodeName>
<DFProperties>
  <AccessType>
    <Get/>
    <Replace/>
  </AccessType>
  <DFFormat>
    <chr/>
  </DFFormat>
  <Occurrence>
    <ZeroOrOne/>
  </Occurrence>
  <DFTitle>Start IP src address</DFTitle>
  <DFType>
    <MIME>text/plain</MIME>
  </DFType>
</DFProperties>
</Node>

<Node>
  <NodeName>EndSourceIPAddress</NodeName>
<DFProperties>
  <AccessType>
    <Get/>
    <Replace/>
  </AccessType>
  <DFFormat>
    <chr/>
  </DFFormat>
  <Occurrence>
    <ZeroOrOne/>
  </Occurrence>
  <DFTitle>End IP src address</DFTitle>
  <DFType>
    <MIME>text/plain</MIME>
  </DFType>
</DFProperties>
</Node>

<Node>
  <NodeName>StartDestIPAddress</NodeName>
<DFProperties>
  <AccessType>
    <Get/>
    <Replace/>
  </AccessType>
  <DFFormat>
    <chr/>
  </DFFormat>
  <Occurrence>
    <ZeroOrOne/>
  </Occurrence>
  <DFTitle>Start IP dest address</DFTitle>
  <DFType>
    <MIME>text/plain</MIME>
  </DFType>
</DFProperties>
</Node>

<Node>
  <NodeName>EndDestIPAddress</NodeName>
<DFProperties>
  <AccessType>
    <Get/>
    <Replace/>
  </AccessType>
  <DFFormat>
    <chr/>
  </DFFormat>
  <Occurrence>
    <ZeroOrOne/>
  </Occurrence>
  <DFTitle>End IP Dst address</DFTitle>
  <DFType>
    <MIME>text/plain</MIME>
  </DFType>

```

```

</DFProperties>
</Node>

<Node>
  <NodeName>ProtocolType</NodeName>
<DFProperties>
  <AccessType>
    <Get/>
    <Replace/>
  </AccessType>
  <DFFormat>
    <chr/>
  </DFFormat>
  <Occurrence>
    <ZeroOrOne/>
  </Occurrence>
  <DFTitle>protocol type</DFTitle>
  <DFType>
    <MIME>text/plain</MIME>
  </DFType>
</DFProperties>
</Node>

<Node>
  <NodeName>StartSourcePortNumber</NodeName>
<DFProperties>
  <AccessType>
    <Get/>
    <Replace/>
  </AccessType>
  <DFFormat>
    <chr/>
  </DFFormat>
  <Occurrence>
    <ZeroOrOne/>
  </Occurrence>
  <DFTitle>Start src port number</DFTitle>
  <DFType>
    <MIME>text/plain</MIME>
  </DFType>
</DFProperties>
</Node>

<Node>
  <NodeName>EndSourcePortNumber</NodeName>
<DFProperties>
  <AccessType>
    <Get/>
    <Replace/>
  </AccessType>
  <DFFormat>
    <chr/>
  </DFFormat>
  <Occurrence>
    <ZeroOrOne/>
  </Occurrence>
  <DFTitle>End src port number</DFTitle>
  <DFType>
    <MIME>text/plain</MIME>
  </DFType>
</DFProperties>
</Node>

<Node>
  <NodeName>StartDestPortNumber</NodeName>
<DFProperties>
  <AccessType>
    <Get/>
    <Replace/>
  </AccessType>
  <DFFormat>
    <chr/>
  </DFFormat>
  <Occurrence>
    <ZeroOrOne/>
  </Occurrence>
  <DFTitle>Start dest port</DFTitle>

```



```

        <DFType>
          <MIME>text/plain</MIME>
        </DFType>
      </DFProperties>
    </Node>

    <Node>
      <NodeName>EndDestPortNumber</NodeName>
      <DFProperties>
        <AccessType>
          <Get/>
          <Replace/>
        </AccessType>
        <DFFormat>
          <chr/>
        </DFFormat>
        <Occurrence>
          <ZeroOrOne/>
        </Occurrence>
        <DFTitle>End Dst port</DFTitle>
        <DFType>
          <MIME>text/plain</MIME>
        </DFType>
      </DFProperties>
    </Node>

    <Node>
      <NodeName>QoS</NodeName>
      <DFProperties>
        <AccessType>
          <Get/>
          <Replace/>
        </AccessType>
        <DFFormat>
          <bin/>
        </DFFormat>
        <Occurrence>
          <ZeroOrOne/>
        </Occurrence>
        <DFTitle>QoS value</DFTitle>
        <DFType>
          <MIME>text/plain</MIME>
        </DFType>
      </DFProperties>
    </Node>
  </Node>
</Node>

<Node>
  <NodeName>RoutingCriteria</NodeName>
  <DFProperties>
    <AccessType>
      <Get/>
      <Replace/>
    </AccessType>
    <DFFormat>
      <node/>
    </DFFormat>
    <Occurrence>
      <ZeroOrOne/>
    </Occurrence>
    <DFTitle>Routing criteria - area, time and APN validity</DFTitle>
    <DFType>
      <MIME>text/plain</MIME>
    </DFType>
  </DFProperties>

  <Node>
    <NodeName></NodeName>
    <DFProperties>
      <AccessType>
        <Get/>
        <Replace/>
      </AccessType>
      <DFFormat>
        <node/>
      </DFFormat>
      <Occurrence>

```

```

        <OneOrMore/>
    </Occurrence>
    <DFType>
        <DDFName></DDFName>
    </DFType>
</DFProperties>
<Node>
    <NodeName>ValidityArea</NodeName>
    <DFProperties>
        <AccessType>
            <Get/>
            <Replace/>
        </AccessType>
        <DFFormat>
            <node/>
        </DFFormat>
        <Occurrence>
            <ZeroOrOne/>
        </Occurrence>
        <DFTitle>Validity area.</DFTitle>
        <DFType>
            <DDFName/>
        </DFType>
    </DFProperties>

    <Node>
        <NodeName>_3GPP_Location</NodeName>
        <DFProperties>
            <AccessType>
                <Get/>
                <Replace/>
            </AccessType>
            <DFFormat>
                <node/>
            </DFFormat>
            <Occurrence>
                <ZeroOrOne/>
            </Occurrence>
            <DFTitle>Validity area for 3GPP access.</DFTitle>
            <DFType>
                <DDFName/>
            </DFType>
        </DFProperties>

    <Node>
        <NodeName></NodeName>
        <DFProperties>
            <AccessType>
                <Get/>
                <Replace/>
            </AccessType>
            <DFFormat>
                <node/>
            </DFFormat>
            <Occurrence>
                <OneOrMore/>
            </Occurrence>
            <DFType>
                <DDFName></DDFName>
            </DFType>
        </DFProperties>

    <Node>
        <NodeName>PLMN</NodeName>
        <DFProperties>
            <AccessType>
                <Get/>
                <Replace/>
            </AccessType>
            <DFFormat>
                <chr/>
            </DFFormat>
            <Occurrence>
                <One/>
            </Occurrence>
            <DFTitle>PLMN.</DFTitle>
            <DFType>
                <MIME>text/plain</MIME>
            </DFType>
        </DFProperties>
    </Node>

```

```
</DFType>
</DFProperties>
</Node>

<Node>
  <NodeName>TAC</NodeName>
  <DFProperties>
    <AccessType>
      <Get/>
      <Replace/>
    </AccessType>
    <DFFormat>
      <chr/>
    </DFFormat>
    <Occurrence>
      <ZeroOrOne/>
    </Occurrence>
    <DFTitle>TAC.</DFTitle>
    <DFType>
      <MIME>text/plain</MIME>
    </DFType>
  </DFProperties>
</Node>

<Node>
  <NodeName>LAC</NodeName>
  <DFProperties>
    <AccessType>
      <Get/>
      <Replace/>
    </AccessType>
    <DFFormat>
      <chr/>
    </DFFormat>
    <Occurrence>
      <ZeroOrOne/>
    </Occurrence>
    <DFTitle>LAC.</DFTitle>
    <DFType>
      <MIME>text/plain</MIME>
    </DFType>
  </DFProperties>
</Node>

<Node>
  <NodeName>GERAN_CI</NodeName>
  <DFProperties>
    <AccessType>
      <Get/>
      <Replace/>
    </AccessType>
    <DFFormat>
      <bin/>
    </DFFormat>
    <Occurrence>
      <ZeroOrOne/>
    </Occurrence>
    <DFTitle>GERAN_CI.</DFTitle>
    <DFType>
      <MIME>text/plain</MIME>
    </DFType>
  </DFProperties>
</Node>

<Node>
  <NodeName>UTRAN_CI</NodeName>
  <DFProperties>
    <AccessType>
      <Get/>
      <Replace/>
    </AccessType>
    <DFFormat>
      <bin/>
    </DFFormat>
    <Occurrence>
      <ZeroOrOne/>
    </Occurrence>
    <DFTitle>UTRAN_CI.</DFTitle>
```

```

        <DFType>
          <MIME>text/plain</MIME>
        </DFType>
      </DFProperties>
    </Node>

    <Node>
      <NodeName>EUTRA_CI</NodeName>
      <DFProperties>
        <AccessType>
          <Get/>
          <Replace/>
        </AccessType>
        <DFFormat>
          <bin/>
        </DFFormat>
        <Occurrence>
          <ZeroOrOne/>
        </Occurrence>
        <DFTitle>EUTRA_CI.</DFTitle>
        <DFType>
          <MIME>text/plain</MIME>
        </DFType>
      </DFProperties>
    </Node>
  </Node>
</Node>

<Node>
  <NodeName>_3GPP2_Location</NodeName>
  <DFProperties>
    <AccessType>
      <Get/>
      <Replace/>
    </AccessType>
    <DFFormat>
      <node/>
    </DFFormat>
    <Occurrence>
      <ZeroOrOne/>
    </Occurrence>
    <DFTitle> Validity area for 3GPP2 access.</DFTitle>
    <DFType>
      <DDFName/>
    </DFType>
  </DFProperties>

  <Node>
    <NodeName>1x</NodeName>
    <DFProperties>
      <AccessType>
        <Get/>
        <Replace/>
      </AccessType>
      <DFFormat>
        <node/>
      </DFFormat>
      <Occurrence>
        <ZeroOrOne/>
      </Occurrence>
      <DFTitle> Validity area for 3GPP2-1x access.</DFTitle>
      <DFType>
        <DDFName/>
      </DFType>
    </DFProperties>

  <Node>
    <NodeName></NodeName>
    <DFProperties>
      <AccessType>
        <Get/>
        <Replace/>
      </AccessType>
      <DFFormat>
        <node/>
      </DFFormat>
      <Occurrence>
        <OneOrMore/>
      </Occurrence>
    </DFProperties>
  </Node>

```

```

    </Occurrence>
    <DFType>
      <DDFName></DDFName>
    </DFType>
  </DFProperties>

  <Node>
    <NodeName>SID</NodeName>
    <DFProperties>
      <AccessType>
        <Get/>
        <Replace/>
      </AccessType>
      <DFFormat>
        <chr/>
      </DFFormat>
      <Occurrence>
        <One/>
      </Occurrence>
      <DFTitle>lx-SID.</DFTitle>
      <DFType>
        <MIME>text/plain</MIME>
      </DFType>
    </DFProperties>
  </Node>

  <Node>
    <NodeName>NID</NodeName>
    <DFProperties>
      <AccessType>
        <Get/>
        <Replace/>
      </AccessType>
      <DFFormat>
        <chr/>
      </DFFormat>
      <Occurrence>
        <ZeroOrOne/>
      </Occurrence>
      <DFTitle>lx-NID.</DFTitle>
      <DFType>
        <MIME>text/plain</MIME>
      </DFType>
    </DFProperties>
  </Node>

  <Node>
    <NodeName>Base_ID</NodeName>
    <DFProperties>
      <AccessType>
        <Get/>
        <Replace/>
      </AccessType>
      <DFFormat>
        <chr/>
      </DFFormat>
      <Occurrence>
        <ZeroOrOne/>
      </Occurrence>
      <DFTitle>lx-Base ID.</DFTitle>
      <DFType>
        <MIME>text/plain</MIME>
      </DFType>
    </DFProperties>
  </Node>
</Node>
</Node>

  <Node>
    <NodeName>HRPD</NodeName>
    <DFProperties>
      <AccessType>
        <Get/>
        <Replace/>
      </AccessType>
      <DFFormat>
        <node/>
      </DFFormat>

```

```

    <Occurrence>
      <ZeroOrOne/>
    </Occurrence>
    <DFTitle> Validity area for 3GPP2-HRPD access</DFTitle>
    <DFType>
      <DDFName/>
    </DFType>
  </DFProperties>

  <Node>
    <NodeName></NodeName>
    <DFProperties>
      <AccessType>
        <Get/>
        <Replace/>
      </AccessType>
      <DFFormat>
        <node/>
      </DFFormat>
      <Occurrence>
        <OneOrMore/>
      </Occurrence>
      <DFType>
        <DDFName></DDFName>
      </DFType>
    </DFProperties>

    <Node>
      <NodeName>Sector_ID</NodeName>
      <DFProperties>
        <AccessType>
          <Get/>
          <Replace/>
        </AccessType>
        <DFFormat>
          <bin/>
        </DFFormat>
        <Occurrence>
          <One/>
        </Occurrence>
        <DFTitle>HRPD Sector ID</DFTitle>
        <DFType>
          <MIME>text/plain</MIME>
        </DFType>
      </DFProperties>
    </Node>

    <Node>
      <NodeName>Netmask</NodeName>
      <DFProperties>
        <AccessType>
          <Get/>
          <Replace/>
        </AccessType>
        <DFFormat>
          <bin/>
        </DFFormat>
        <Occurrence>
          <One/>
        </Occurrence>
        <DFTitle>HRPD netmask</DFTitle>
        <DFType>
          <MIME>text/plain</MIME>
        </DFType>
      </DFProperties>
    </Node>
  </Node>
</Node>

  <Node>
    <NodeName>WiMAX_Location</NodeName>
    <DFProperties>
      <AccessType>
        <Get/>
        <Replace/>
      </AccessType>
      <DFFormat>

```

```

        <node/>
    </DFFormat>
    <Occurrence>
        <ZeroOrOne/>
    </Occurrence>
    <DFTitle> Validity area for WiMAX access.</DFTitle>
    <DFType>
        <DDFName/>
    </DFType>
</DFProperties>

<Node>
    <NodeName></NodeName>
    <DFProperties>
        <AccessType>
            <Get/>
            <Replace/>
        </AccessType>
        <DFFormat>
            <node/>
        </DFFormat>
        <Occurrence>
            <OneOrMore/>
        </Occurrence>
        <DFType>
            <DDFName></DDFName>
        </DFType>
    </DFProperties>

    <Node>
        <NodeName>NAP-ID</NodeName>
        <DFProperties>
            <AccessType>
                <Get/>
                <Replace/>
            </AccessType>
            <DFFormat>
                <chr/>
            </DFFormat>
            <Occurrence>
                <One/>
            </Occurrence>
            <DFTitle>NAP-ID</DFTitle>
            <DFType>
                <MIME>text/plain</MIME>
            </DFType>
        </DFProperties>
    </Node>

    <Node>
        <NodeName>BS-ID</NodeName>
        <DFProperties>
            <AccessType>
                <Get/>
                <Replace/>
            </AccessType>
            <DFFormat>
                <chr/>
            </DFFormat>
            <Occurrence>
                <One/>
            </Occurrence>
            <DFTitle>BS-ID</DFTitle>
            <DFType>
                <MIME>text/plain</MIME>
            </DFType>
        </DFProperties>
    </Node>
</Node>

<Node>
    <NodeName>WLAN_Location</NodeName>
    <DFProperties>
        <AccessType>
            <Get/>
            <Replace/>
        </AccessType>

```

```

    <DFFormat>
      <node/>
    </DFFormat>
  </DFProperties>
</DFType>
<DFType>
  <DFTitle> Validity area for WLAN access.</DFTitle>
  <DFFormat>
    <node/>
  </DFFormat>
  <Occurrence>
    <ZeroOrOne/>
  </Occurrence>
  <DFType>
    <DDFName/>
  </DFType>
</DFProperties>
</Node>
<Node>
  <NodeName></NodeName>
  <DFProperties>
    <AccessType>
      <Get/>
      <Replace/>
    </AccessType>
    <DFFormat>
      <node/>
    </DFFormat>
    <Occurrence>
      <OneOrMore/>
    </Occurrence>
    <DFType>
      <DDFName></DDFName>
    </DFType>
  </DFProperties>
</Node>
<Node>
  <NodeName>HESSID</NodeName>
  <DFProperties>
    <AccessType>
      <Get/>
      <Replace/>
    </AccessType>
    <DFFormat>
      <chr/>
    </DFFormat>
    <Occurrence>
      <ZeroOrOne/>
    </Occurrence>
    <DFTitle>HESSID</DFTitle>
    <DFType>
      <MIME>text/plain</MIME>
    </DFType>
  </DFProperties>
</Node>
<Node>
  <NodeName>SSID</NodeName>
  <DFProperties>
    <AccessType>
      <Get/>
      <Replace/>
    </AccessType>
    <DFFormat>
      <chr/>
    </DFFormat>
    <Occurrence>
      <ZeroOrOne/>
    </Occurrence>
    <DFTitle>SSID</DFTitle>
    <DFType>
      <MIME>text/plain</MIME>
    </DFType>
  </DFProperties>
</Node>
<Node>
  <NodeName>BSSID</NodeName>
  <DFProperties>
    <AccessType>
      <Get/>
      <Replace/>
    </AccessType>
    <DFFormat>
      <chr/>
    </DFFormat>

```



```

        <Occurrence>
          <One/>
        </Occurrence>
        <DFTitle>BSSID</DFTitle>
        <DFType>
          <MIME>text/plain</MIME>
        </DFType>
      </DFProperties>
    </Node>
  </Node>
</Node>
<Node>
  <NodeName>Geo_Location</NodeName>
  <DFProperties>
    <AccessType>
      <Get/>
      <Replace/>
    </AccessType>
    <DFFormat>
      <node/>
    </DFFormat>
    <Occurrence>
      <ZeroOrOne/>
    </Occurrence>
    <DFTitle>Geographical location.</DFTitle>
    <DFType>
      <DDFName/>
    </DFType>
  </DFProperties>
<Node>
  <NodeName>Circular</NodeName>
  <DFProperties>
    <AccessType>
      <Get/>
      <Replace/>
    </AccessType>
    <DFFormat>
      <node/>
    </DFFormat>
    <Occurrence>
      <ZeroOrOne/>
    </Occurrence>
    <DFTitle>Circular location descripton.</DFTitle>
    <DFType>
      <DDFName/>
    </DFType>
  </DFProperties>
<Node>
  <NodeName></NodeName>
  <DFProperties>
    <AccessType>
      <Get/>
      <Replace/>
    </AccessType>
    <DFFormat>
      <node/>
    </DFFormat>
    <Occurrence>
      <OneOrMore/>
    </Occurrence>
    <DFType>
      <DDFName></DDFName>
    </DFType>
  </DFProperties>
<Node>
  <NodeName>AnchorLatitude</NodeName>
  <DFProperties>
    <AccessType>
      <Get/>
      <Replace/>
    </AccessType>
    <DFFormat>
      <chr/>
    </DFFormat>

```

```

        <Occurrence>
          <One/>
        </Occurrence>
        <DFTitle>Anchor latitude</DFTitle>
        <DFType>
          <MIME>text/plain</MIME>
        </DFType>
      </DFProperties>
    </Node>

    <Node>
      <NodeName>AnchorLongitude</NodeName>
      <DFProperties>
        <AccessType>
          <Get/>
          <Replace/>
        </AccessType>
        <DFFormat>
          <chr/>
        </DFFormat>
        <Occurrence>
          <One/>
        </Occurrence>
        <DFTitle>Anchor longitude</DFTitle>
        <DFType>
          <MIME>text/plain</MIME>
        </DFType>
      </DFProperties>
    </Node>

    <Node>
      <NodeName>Radius</NodeName>
      <DFProperties>
        <AccessType>
          <Get/>
          <Replace/>
        </AccessType>
        <DFFormat>
          <chr/>
        </DFFormat>
        <Occurrence>
          <One/>
        </Occurrence>
        <DFTitle>Radius</DFTitle>
        <DFType>
          <MIME>text/plain</MIME>
        </DFType>
      </DFProperties>
    </Node>
  </Node>
</Node>
<Node>
  <NodeName>TimeOfDay</NodeName>
  <DFProperties>
    <AccessType>
      <Get/>
      <Replace/>
    </AccessType>
    <DFFormat>
      <node/>
    </DFFormat>
    <Occurrence>
      <ZeroOrOne/>
    </Occurrence>
    <DFTitle>Time of day.</DFTitle>
    <DFType>
      <DDFName/>
    </DFType>
  </DFProperties>

  <Node>
    <NodeName></NodeName>
    <DFProperties>
      <AccessType>
        <Get/>
        <Replace/>
      </AccessType>
    </DFProperties>
  </Node>

```

```

    </AccessType>
    <DFFormat>
      <node/>
    </DFFormat>
    <Occurrence>
      <OneOrMore/>
    </Occurrence>
    <DFType>
      <DDFName></DDFName>
    </DFType>
  </DFProperties>

  <Node>
    <NodeName>TimeStart</NodeName>
    <DFProperties>
      <AccessType>
        <Get/>
        <Replace/>
      </AccessType>
      <DFFormat>
        <int/>
      </DFFormat>
      <Occurrence>
        <ZeroOrOne/>
      </Occurrence>
      <DFTitle>Start condition for time of rule.</DFTitle>
      <DFType>
        <MIME>text/plain</MIME>
      </DFType>
    </DFProperties>
  </Node>

  <Node>
    <NodeName>TimeStop</NodeName>
    <DFProperties>
      <AccessType>
        <Get/>
        <Replace/>
      </AccessType>
      <DFFormat>
        <int/>
      </DFFormat>
      <Occurrence>
        <ZeroOrOne/>
      </Occurrence>
      <DFTitle>Stop condition for time of rule.</DFTitle>
      <DFType>
        <MIME>text/plain</MIME>
      </DFType>
    </DFProperties>
  </Node>

  <Node>
    <NodeName>DateStart</NodeName>
    <DFProperties>
      <AccessType>
        <Get/>
        <Replace/>
      </AccessType>
      <DFFormat>
        <int/>
      </DFFormat>
      <Occurrence>
        <ZeroOrOne/>
      </Occurrence>
      <DFTitle>Starting date for time condition of rule.</DFTitle>
      <DFType>
        <MIME>text/plain</MIME>
      </DFType>
    </DFProperties>
  </Node>

  <Node>
    <NodeName>DateStop</NodeName>
    <DFProperties>
      <AccessType>
        <Get/>
        <Replace/>

```

```

        </AccessType>
        <DFFormat>
          <int/>
        </DFFormat>
        <Occurrence>
          <ZeroOrOne/>
        </Occurrence>
        <DFTitle>Stop date for time condition of rule.</DFTitle>
        <DFType>
          <MIME>text/plain</MIME>
        </DFType>
      </DFProperties>
    </Node>
  </Node>
</Node>
<Node>
  <nodeName>APN</nodeName>
  <DFProperties>
    <AccessType>
      <Get/>
      <Replace/>
    </AccessType>
    <DFFormat>
      <chr/>
    </DFFormat>
    <Occurrence>
      <ZeroOrOne/>
    </Occurrence>
    <DFTitle>APN.</DFTitle>
    <DFType>
      <MIME>text/plain</MIME>
    </DFType>
  </DFProperties>
</Node>
</Node>
</Node>
<Node>
  <nodeName>RoutingRule</nodeName>
  <DFProperties>
    <AccessType>
      <Get/>
      <Replace/>
    </AccessType>
    <DFFormat>
      <node/>
    </DFFormat>
    <Occurrence>
      <One/>
    </Occurrence>
    <DFTitle>Prioritized access.</DFTitle>
    <DFType>
      <DDFName/>
    </DFType>
  </DFProperties>
</Node>
  <nodeName></nodeName>
  <DFProperties>
    <AccessType>
      <Get/>
      <Replace/>
    </AccessType>
    <DFFormat>
      <node/>
    </DFFormat>
    <Occurrence>
      <OneOrMore/>
    </Occurrence>
    <DFType>
      <DDFName></DDFName>
    </DFType>
  </DFProperties>
</Node>
  <nodeName>AccessTechnology</nodeName>
  <DFProperties>
    <AccessType>
      <Get/>

```

```

        <Replace/>
    </AccessType>
    <DFFormat>
        <int/>
    </DFFormat>
    <Occurrence>
        <One/>
    </Occurrence>
    <DFTitle>Access technology.</DFTitle>
    <DFType>
        <MIME>text/plain</MIME>
    </DFType>
</DFProperties>
</Node>
<Node>
    <NodeName>AccessId</NodeName>
    <DFProperties>
        <AccessType>
            <Get/>
            <Replace/>
        </AccessType>
        <DFFormat>
            <chr/>
        </DFFormat>
        <Occurrence>
            <ZeroOrOne/>
        </Occurrence>
        <DFTitle>Access identity.</DFTitle>
        <DFType>
            <MIME>text/plain</MIME>
        </DFType>
    </DFProperties>
</Node>
<Node>
    <NodeName>SecondaryAccessId</NodeName>
    <DFProperties>
        <AccessType>
            <Get/>
            <Replace/>
        </AccessType>
        <DFFormat>
            <chr/>
        </DFFormat>
        <Occurrence>
            <ZeroOrOne/>
        </Occurrence>
        <DFTitle>Access identity.</DFTitle>
        <DFType>
            <MIME>text/plain</MIME>
        </DFType>
    </DFProperties>
</Node>
<Node>
    <NodeName>AccessNetworkPriority</NodeName>
    <DFProperties>
        <AccessType>
            <Get/>
            <Replace/>
        </AccessType>
        <DFFormat>
            <int/>
        </DFFormat>
        <Occurrence>
            <One/>
        </Occurrence>
        <DFTitle>Access network priority.</DFTitle>
        <DFType>
            <MIME>text/plain</MIME>
        </DFType>
    </DFProperties>
</Node>
</Node>
<Node>
    <NodeName>RulePriority</NodeName>
    <DFProperties>
        <AccessType>
            <Get/>

```

```

        <Replace/>
      </AccessType>
    <DFFormat>
      <int/>
    </DFFormat>
  </Occurrence>
  <DFTitle>Rule priority.</DFTitle>
  <DFType>
    <MIME>text/plain</MIME>
  </DFType>
</DFProperties>
</Node>
</Node>
</Node>
<Node>
  <NodeName>ForServiceBased</NodeName>
  <DFProperties>
    <AccessType>
      <Get/>
      <Replace/>
    </AccessType>
    <DFFormat>
      <int/>
    </DFFormat>
    <Occurrence>
      <ZeroOrOne/>
    </Occurrence>
    <DFTitle>List of ISRP for MAPCON case.</DFTitle>
    <DFType>
      <MIME>text/plain</MIME>
    </DFType>
  </DFProperties>
  <Node>
    <NodeName></NodeName>
    <DFProperties>
      <AccessType>
        <Get/>
        <Replace/>
      </AccessType>
      <DFFormat>
        <node/>
      </DFFormat>
      <Occurrence>
        <OneOrMore/>
      </Occurrence>
      <DFType>
        <DDFName></DDFName>
      </DFType>
    </DFProperties>
    <Node>
      <NodeName>APN</NodeName>
      <DFProperties>
        <AccessType>
          <Get/>
          <Replace/>
        </AccessType>
        <DFFormat>
          <chr/>
        </DFFormat>
        <Occurrence>
          <One/>
        </Occurrence>
        <DFTitle>IPFlow description</DFTitle>
        <DFType>
          <MIME>text/plain</MIME>
        </DFType>
      </DFProperties>
    </Node>
  </Node>
  <Node>
    <NodeName>RoutingCriteria</NodeName>
    <DFProperties>
      <AccessType>
        <Get/>

```

```

    <Replace/>
  </AccessType>
  <DFFormat>
    <node/>
  </DFFormat>
  <Occurrence>
    <ZeroOrOne/>
  </Occurrence>
  <DFTitle>Routing criteria - area, time and APN validity</DFTitle>
  <DFType>
    <MIME>text/plain</MIME>
  </DFType>
</DFProperties>

<Node>
  <NodeName></NodeName>
  <DFProperties>
    <AccessType>
      <Get/>
      <Replace/>
    </AccessType>
    <DFFormat>
      <node/>
    </DFFormat>
    <Occurrence>
      <OneOrMore/>
    </Occurrence>
    <DFType>
      <DDFName></DDFName>
    </DFType>
  </DFProperties>
  <Node>
    <NodeName>ValidityArea</NodeName>
    <DFProperties>
      <AccessType>
        <Get/>
        <Replace/>
      </AccessType>
      <DFFormat>
        <node/>
      </DFFormat>
      <Occurrence>
        <ZeroOrOne/>
      </Occurrence>
      <DFTitle>Validity area.</DFTitle>
      <DFType>
        <DDFName/>
      </DFType>
    </DFProperties>
  </Node>
  <Node>
    <NodeName>_3GPP_Location</NodeName>
    <DFProperties>
      <AccessType>
        <Get/>
        <Replace/>
      </AccessType>
      <DFFormat>
        <node/>
      </DFFormat>
      <Occurrence>
        <ZeroOrOne/>
      </Occurrence>
      <DFTitle>Validity area for 3GPP access.</DFTitle>
      <DFType>
        <DDFName/>
      </DFType>
    </DFProperties>
  </Node>
  <Node>
    <NodeName></NodeName>
    <DFProperties>
      <AccessType>
        <Get/>
        <Replace/>
      </AccessType>
      <DFFormat>
        <node/>
      </DFFormat>

```

```

</DFFormat>
<Occurrence>
  <OneOrMore/>
</Occurrence>
<DFType>
  <DDFName></DDFName>
</DFType>
</DFProperties>

<Node>
  <NodeName>PLMN</NodeName>
  <DFProperties>
    <AccessType>
      <Get/>
      <Replace/>
    </AccessType>
    <DFFormat>
      <chr/>
    </DFFormat>
    <Occurrence>
      <One/>
    </Occurrence>
    <DFTitle>PLMN.</DFTitle>
    <DFType>
      <MIME>text/plain</MIME>
    </DFType>
  </DFProperties>
</Node>

<Node>
  <NodeName>TAC</NodeName>
  <DFProperties>
    <AccessType>
      <Get/>
      <Replace/>
    </AccessType>
    <DFFormat>
      <chr/>
    </DFFormat>
    <Occurrence>
      <ZeroOrOne/>
    </Occurrence>
    <DFTitle>TAC.</DFTitle>
    <DFType>
      <MIME>text/plain</MIME>
    </DFType>
  </DFProperties>
</Node>

<Node>
  <NodeName>LAC</NodeName>
  <DFProperties>
    <AccessType>
      <Get/>
      <Replace/>
    </AccessType>
    <DFFormat>
      <chr/>
    </DFFormat>
    <Occurrence>
      <ZeroOrOne/>
    </Occurrence>
    <DFTitle>LAC.</DFTitle>
    <DFType>
      <MIME>text/plain</MIME>
    </DFType>
  </DFProperties>
</Node>

<Node>
  <NodeName>GERAN_CI</NodeName>
  <DFProperties>
    <AccessType>
      <Get/>
      <Replace/>
    </AccessType>
    <DFFormat>
      <bin/>

```



```

        </DFFormat>
        <Occurrence>
            <ZeroOrOne/>
        </Occurrence>
        <DFTitle>GERAN_CI.</DFTitle>
        <DFType>
            <MIME>text/plain</MIME>
        </DFType>
    </DFProperties>
</Node>

<Node>
    <NodeName>UTRAN_CI</NodeName>
    <DFProperties>
        <AccessType>
            <Get/>
            <Replace/>
        </AccessType>
        <DFFormat>
            <bin/>
        </DFFormat>
        <Occurrence>
            <ZeroOrOne/>
        </Occurrence>
        <DFTitle>UTRAN_CI.</DFTitle>
        <DFType>
            <MIME>text/plain</MIME>
        </DFType>
    </DFProperties>
</Node>

<Node>
    <NodeName>EUTRA_CI</NodeName>
    <DFProperties>
        <AccessType>
            <Get/>
            <Replace/>
        </AccessType>
        <DFFormat>
            <bin/>
        </DFFormat>
        <Occurrence>
            <ZeroOrOne/>
        </Occurrence>
        <DFTitle>EUTRA_CI.</DFTitle>
        <DFType>
            <MIME>text/plain</MIME>
        </DFType>
    </DFProperties>
</Node>
</Node>

<Node>
    <NodeName>_3GPP2_Location</NodeName>
    <DFProperties>
        <AccessType>
            <Get/>
            <Replace/>
        </AccessType>
        <DFFormat>
            <node/>
        </DFFormat>
        <Occurrence>
            <ZeroOrOne/>
        </Occurrence>
        <DFTitle> Validity area for 3GPP2 access.</DFTitle>
        <DFType>
            <DDFName/>
        </DFType>
    </DFProperties>

    <Node>
        <NodeName>lx</NodeName>
        <DFProperties>
            <AccessType>
                <Get/>
                <Replace/>
            </AccessType>

```

```

</AccessType>
<DFFormat>
  <node/>
</DFFormat>
<Occurrence>
  <ZeroOrOne/>
</Occurrence>
<DFTitle> Validity area for 3GPP2-1x access.</DFTitle>
<DFType>
  <DDFName/>
</DFType>
</DFProperties>

```

```

<Node>
  <NodeName></NodeName>
  <DFProperties>
    <AccessType>
      <Get/>
      <Replace/>
    </AccessType>
    <DFFormat>
      <node/>
    </DFFormat>
    <Occurrence>
      <OneOrMore/>
    </Occurrence>
    <DFType>
      <DDFName></DDFName>
    </DFType>
  </DFProperties>

```

```

<Node>
  <NodeName>SID</NodeName>
  <DFProperties>
    <AccessType>
      <Get/>
      <Replace/>
    </AccessType>
    <DFFormat>
      <chr/>
    </DFFormat>
    <Occurrence>
      <One/>
    </Occurrence>
    <DFTitle>1x-SID.</DFTitle>
    <DFType>
      <MIME>text/plain</MIME>
    </DFType>
  </DFProperties>
</Node>

```

```

<Node>
  <NodeName>NID</NodeName>
  <DFProperties>
    <AccessType>
      <Get/>
      <Replace/>
    </AccessType>
    <DFFormat>
      <chr/>
    </DFFormat>
    <Occurrence>
      <ZeroOrOne/>
    </Occurrence>
    <DFTitle>1x-NID.</DFTitle>
    <DFType>
      <MIME>text/plain</MIME>
    </DFType>
  </DFProperties>
</Node>

```

```

<Node>
  <NodeName>Base_ID</NodeName>
  <DFProperties>
    <AccessType>
      <Get/>
      <Replace/>
    </AccessType>

```

```

        <DFFormat>
          <chr/>
        </DFFormat>
      </Occurrence>
    </Occurrence>
    <DFTitle>lx-Base ID.</DFTitle>
    <DFType>
      <MIME>text/plain</MIME>
    </DFType>
  </DFProperties>
</Node>
</Node>
</Node>
<Node>
  <NodeName>HRPD</NodeName>
  <DFProperties>
    <AccessType>
      <Get/>
      <Replace/>
    </AccessType>
    <DFFormat>
      <node/>
    </DFFormat>
    <Occurrence>
      <ZeroOrOne/>
    </Occurrence>
    <DFTitle> Validity area for 3GPP2-HRPD access</DFTitle>
    <DFType>
      <DDFName/>
    </DFType>
  </DFProperties>
</Node>
<Node>
  <NodeName></NodeName>
  <DFProperties>
    <AccessType>
      <Get/>
      <Replace/>
    </AccessType>
    <DFFormat>
      <node/>
    </DFFormat>
    <Occurrence>
      <OneOrMore/>
    </Occurrence>
    <DFType>
      <DDFName></DDFName>
    </DFType>
  </DFProperties>
</Node>
<Node>
  <NodeName>Sector_ID</NodeName>
  <DFProperties>
    <AccessType>
      <Get/>
      <Replace/>
    </AccessType>
    <DFFormat>
      <bin/>
    </DFFormat>
    <Occurrence>
      <One/>
    </Occurrence>
    <DFTitle>HRPD Sector ID</DFTitle>
    <DFType>
      <MIME>text/plain</MIME>
    </DFType>
  </DFProperties>
</Node>
<Node>
  <NodeName>Netmask</NodeName>
  <DFProperties>
    <AccessType>
      <Get/>
      <Replace/>
    </AccessType>
  </DFProperties>
</Node>

```

```

        </AccessType>
        <DFFormat>
          <bin/>
        </DFFormat>
        <Occurrence>
          <One/>
        </Occurrence>
        <DFTitle>HRPD netmask</DFTitle>
        <DFType>
          <MIME>text/plain</MIME>
        </DFType>
      </DFProperties>
    </Node>
  </Node>
</Node>
</Node>
</Node>
<Node>
  <NodeName>WiMAX_Location</NodeName>
  <DFProperties>
    <AccessType>
      <Get/>
      <Replace/>
    </AccessType>
    <DFFormat>
      <node/>
    </DFFormat>
    <Occurrence>
      <ZeroOrOne/>
    </Occurrence>
    <DFTitle> Validity area for WiMAX access.</DFTitle>
    <DFType>
      <DDFName/>
    </DFType>
  </DFProperties>
</Node>
<Node>
  <NodeName></NodeName>
  <DFProperties>
    <AccessType>
      <Get/>
      <Replace/>
    </AccessType>
    <DFFormat>
      <node/>
    </DFFormat>
    <Occurrence>
      <OneOrMore/>
    </Occurrence>
    <DFType>
      <DDFName></DDFName>
    </DFType>
  </DFProperties>
</Node>
<Node>
  <NodeName>NAP-ID</NodeName>
  <DFProperties>
    <AccessType>
      <Get/>
      <Replace/>
    </AccessType>
    <DFFormat>
      <chr/>
    </DFFormat>
    <Occurrence>
      <One/>
    </Occurrence>
    <DFTitle>NAP-ID</DFTitle>
    <DFType>
      <MIME>text/plain</MIME>
    </DFType>
  </DFProperties>
</Node>
<Node>
  <NodeName>BS-ID</NodeName>
  <DFProperties>
    <AccessType>

```

```

        <Get/>
        <Replace/>
    </AccessType>
    <DFFormat>
        <chr/>
    </DFFormat>
    <Occurrence>
        <One/>
    </Occurrence>
    <DFTitle>BS-ID</DFTitle>
    <DFType>
        <MIME>text/plain</MIME>
    </DFType>
    </DFProperties>
</Node>
</Node>
</Node>
<Node>
    <NodeName>WLAN_Location</NodeName>
    <DFProperties>
        <AccessType>
            <Get/>
            <Replace/>
        </AccessType>
        <DFFormat>
            <node/>
        </DFFormat>
        <Occurrence>
            <ZeroOrOne/>
        </Occurrence>
        <DFTitle> Validity area for WLAN access.</DFTitle>
        <DFType>
            <DDFName/>
        </DFType>
    </DFProperties>
    <Node>
        <NodeName></NodeName>
        <DFProperties>
            <AccessType>
                <Get/>
                <Replace/>
            </AccessType>
            <DFFormat>
                <node/>
            </DFFormat>
            <Occurrence>
                <OneOrMore/>
            </Occurrence>
            <DFType>
                <DDFName></DDFName>
            </DFType>
        </DFProperties>
        <Node>
            <NodeName>HESSID</NodeName>
            <DFProperties>
                <AccessType>
                    <Get/>
                    <Replace/>
                </AccessType>
                <DFFormat>
                    <chr/>
                </DFFormat>
                <Occurrence>
                    <ZeroOrOne/>
                </Occurrence>
                <DFTitle>HESSID</DFTitle>
                <DFType>
                    <MIME>text/plain</MIME>
                </DFType>
            </DFProperties>
        </Node>
    </Node>
    <Node>
        <NodeName>SSID</NodeName>
        <DFProperties>
            <AccessType>
                <Get/>

```

```

        <Replace/>
      </AccessType>
    <DFFormat>
      <chr/>
    </DFFormat>
    <Occurrence>
      <ZeroOrOne/>
    </Occurrence>
    <DFTitle>SSID</DFTitle>
    <DFType>
      <MIME>text/plain</MIME>
    </DFType>
  </DFProperties>
</Node>

<Node>
  <NodeName>BSSID</NodeName>
  <DFProperties>
    <AccessType>
      <Get/>
      <Replace/>
    </AccessType>
    <DFFormat>
      <chr/>
    </DFFormat>
    <Occurrence>
      <One/>
    </Occurrence>
    <DFTitle>BSSID</DFTitle>
    <DFType>
      <MIME>text/plain</MIME>
    </DFType>
  </DFProperties>
</Node>
</Node>

<Node>
  <NodeName>Geo_Location</NodeName>
  <DFProperties>
    <AccessType>
      <Get/>
      <Replace/>
    </AccessType>
    <DFFormat>
      <node/>
    </DFFormat>
    <Occurrence>
      <ZeroOrOne/>
    </Occurrence>
    <DFTitle>Geographical location.</DFTitle>
    <DFType>
      <DDFName/>
    </DFType>
  </DFProperties>

  <Node>
    <NodeName>Circular</NodeName>
    <DFProperties>
      <AccessType>
        <Get/>
        <Replace/>
      </AccessType>
      <DFFormat>
        <node/>
      </DFFormat>
      <Occurrence>
        <ZeroOrOne/>
      </Occurrence>
      <DFTitle>Circular location descripton.</DFTitle>
      <DFType>
        <DDFName/>
      </DFType>
    </DFProperties>

  <Node>
    <NodeName></NodeName>
    <DFProperties>

```

```

    <AccessType>
      <Get/>
      <Replace/>
    </AccessType>
  <DFFormat>
    <node/>
  </DFFormat>
  <Occurrence>
    <OneOrMore/>
  </Occurrence>
  <DFType>
    <DDFName></DDFName>
  </DFType>
</DFProperties>

<Node>
  <NodeName>AnchorLatitude</NodeName>
  <DFProperties>
    <AccessType>
      <Get/>
      <Replace/>
    </AccessType>
    <DFFormat>
      <chr/>
    </DFFormat>
    <Occurrence>
      <One/>
    </Occurrence>
    <DFTitle>Anchor latitude</DFTitle>
    <DFType>
      <MIME>text/plain</MIME>
    </DFType>
  </DFProperties>
</Node>

<Node>
  <NodeName>AnchorLongitude</NodeName>
  <DFProperties>
    <AccessType>
      <Get/>
      <Replace/>
    </AccessType>
    <DFFormat>
      <chr/>
    </DFFormat>
    <Occurrence>
      <One/>
    </Occurrence>
    <DFTitle>Anchor longitude</DFTitle>
    <DFType>
      <MIME>text/plain</MIME>
    </DFType>
  </DFProperties>
</Node>

<Node>
  <NodeName>Radius</NodeName>
  <DFProperties>
    <AccessType>
      <Get/>
      <Replace/>
    </AccessType>
    <DFFormat>
      <chr/>
    </DFFormat>
    <Occurrence>
      <One/>
    </Occurrence>
    <DFTitle>Radius</DFTitle>
    <DFType>
      <MIME>text/plain</MIME>
    </DFType>
  </DFProperties>
</Node>
</Node>
</Node>
</Node>
</Node>

```

```

<Node>
  <NodeName>TimeOfDay</NodeName>
  <DFProperties>
    <AccessType>
      <Get/>
      <Replace/>
    </AccessType>
    <DFFormat>
      <node/>
    </DFFormat>
    <Occurrence>
      <ZeroOrOne/>
    </Occurrence>
    <DFTitle>Time of day.</DFTitle>
    <DFType>
      <DDFName/>
    </DFType>
  </DFProperties>

<Node>
  <NodeName></NodeName>
  <DFProperties>
    <AccessType>
      <Get/>
      <Replace/>
    </AccessType>
    <DFFormat>
      <node/>
    </DFFormat>
    <Occurrence>
      <OneOrMore/>
    </Occurrence>
    <DFType>
      <DDFName></DDFName>
    </DFType>
  </DFProperties>

<Node>
  <NodeName>TimeStart</NodeName>
  <DFProperties>
    <AccessType>
      <Get/>
      <Replace/>
    </AccessType>
    <DFFormat>
      <int/>
    </DFFormat>
    <Occurrence>
      <ZeroOrOne/>
    </Occurrence>
    <DFTitle>Start condition for time of rule.</DFTitle>
    <DFType>
      <MIME>text/plain</MIME>
    </DFType>
  </DFProperties>
</Node>

<Node>
  <NodeName>TimeStop</NodeName>
  <DFProperties>
    <AccessType>
      <Get/>
      <Replace/>
    </AccessType>
    <DFFormat>
      <int/>
    </DFFormat>
    <Occurrence>
      <ZeroOrOne/>
    </Occurrence>
    <DFTitle>Stop condition for time of rule.</DFTitle>
    <DFType>
      <MIME>text/plain</MIME>
    </DFType>
  </DFProperties>
</Node>

<Node>

```



```

        <NodeName>DateStart</NodeName>
        <DFProperties>
            <AccessType>
                <Get/>
                <Replace/>
            </AccessType>
            <DFFormat>
                <int/>
            </DFFormat>
            <Occurrence>
                <ZeroOrOne/>
            </Occurrence>
            <DFTitle>Starting date for time condition of rule.</DFTitle>
            <DFType>
                <MIME>text/plain</MIME>
            </DFType>
        </DFProperties>
    </Node>

    <Node>
        <NodeName>DateStop</NodeName>
        <DFProperties>
            <AccessType>
                <Get/>
                <Replace/>
            </AccessType>
            <DFFormat>
                <int/>
            </DFFormat>
            <Occurrence>
                <ZeroOrOne/>
            </Occurrence>
            <DFTitle>Stop date for time condition of rule.</DFTitle>
            <DFType>
                <MIME>text/plain</MIME>
            </DFType>
        </DFProperties>
    </Node>
</Node>
</Node>
</Node>
</Node>
<Node>
    <NodeName>RoutingRule</NodeName>
    <DFProperties>
        <AccessType>
            <Get/>
            <Replace/>
        </AccessType>
        <DFFormat>
            <node/>
        </DFFormat>
        <Occurrence>
            <One/>
        </Occurrence>
        <DFTitle>Prioritized access.</DFTitle>
        <DFType>
            <DDFName/>
        </DFType>
    </DFProperties>

    <Node>
        <NodeName></NodeName>
        <DFProperties>
            <AccessType>
                <Get/>
                <Replace/>
            </AccessType>
            <DFFormat>
                <node/>
            </DFFormat>
            <Occurrence>
                <OneOrMore/>
            </Occurrence>
            <DFType>
                <DDFName></DDFName>
            </DFType>
        </DFProperties>

```

```

<Node>
  <NodeName>AccessTechnology</NodeName>
  <DFProperties>
    <AccessType>
      <Get/>
      <Replace/>
    </AccessType>
    <DFFormat>
      <int/>
    </DFFormat>
    <Occurrence>
      <One/>
    </Occurrence>
    <DFTitle>Access technology.</DFTitle>
    <DFType>
      <MIME>text/plain</MIME>
    </DFType>
  </DFProperties>
</Node>
<Node>
  <NodeName>AccessId</NodeName>
  <DFProperties>
    <AccessType>
      <Get/>
      <Replace/>
    </AccessType>
    <DFFormat>
      <chr/>
    </DFFormat>
    <Occurrence>
      <ZeroOrOne/>
    </Occurrence>
    <DFTitle>Access identity.</DFTitle>
    <DFType>
      <MIME>text/plain</MIME>
    </DFType>
  </DFProperties>
</Node>
<Node>
  <NodeName>SecondaryAccessId</NodeName>
  <DFProperties>
    <AccessType>
      <Get/>
      <Replace/>
    </AccessType>
    <DFFormat>
      <chr/>
    </DFFormat>
    <Occurrence>
      <ZeroOrOne/>
    </Occurrence>
    <DFTitle>Access identity.</DFTitle>
    <DFType>
      <MIME>text/plain</MIME>
    </DFType>
  </DFProperties>
</Node>
<Node>
  <NodeName>AccessNetworkPriority</NodeName>
  <DFProperties>
    <AccessType>
      <Get/>
      <Replace/>
    </AccessType>
    <DFFormat>
      <int/>
    </DFFormat>
    <Occurrence>
      <One/>
    </Occurrence>
    <DFTitle>Access network priority.</DFTitle>
    <DFType>
      <MIME>text/plain</MIME>
    </DFType>
  </DFProperties>
</Node>

```

```

    </Node>
  <Node>
    <NodeName>RulePriority</NodeName>
    <DFProperties>
      <AccessType>
        <Get/>
        <Replace/>
      </AccessType>
      <DFFormat>
        <int/>
      </DFFormat>
      <Occurrence>
        <One/>
      </Occurrence>
      <DFTitle>Rule priority.</DFTitle>
      <DFType>
        <MIME>text/plain</MIME>
      </DFType>
    </DFProperties>
  </Node>
</Node>
</Node>
<Node>
  <NodeName>ForNonSeamlessOffload</NodeName>
  <DFProperties>
    <AccessType>
      <Get/>
      <Replace/>
    </AccessType>
    <DFFormat>
      <int/>
    </DFFormat>
    <Occurrence>
      <ZeroOrOne/>
    </Occurrence>
    <DFTitle>List of ISRP for non-Seamless WLAN offload case.</DFTitle>
    <DFType>
      <MIME>text/plain</MIME>
    </DFType>
  </DFProperties>
  <Node>
    <NodeName></NodeName>
    <DFProperties>
      <AccessType>
        <Get/>
        <Replace/>
      </AccessType>
      <DFFormat>
        <node/>
      </DFFormat>
      <Occurrence>
        <OneOrMore/>
      </Occurrence>
      <DFType>
        <DDFName></DDFName>
      </DFType>
    </DFProperties>
  <Node>
    <NodeName>IPFlow</NodeName>
    <DFProperties>
      <AccessType>
        <Get/>
        <Replace/>
      </AccessType>
      <DFFormat>
        <node/>
      </DFFormat>
      <Occurrence>
        <One/>
      </Occurrence>
      <DFTitle>IPFlow description</DFTitle>
      <DFType>
        <MIME>text/plain</MIME>
      </DFType>
    </DFProperties>
  </Node>
</Node>

```

```

<NodeName></NodeName>
<DFProperties>
  <AccessType>
    <Get/>
    <Replace/>
  </AccessType>
  <DFFormat>
    <node/>
  </DFFormat>
  <Occurrence>
    <OneOrMore/>
  </Occurrence>
  <DFType>
    <DDFName></DDFName>
  </DFType>
</DFProperties>

  <Node>
    <NodeName>AddressType</NodeName>
    <DFProperties>
      <AccessType>
        <Get/>
        <Replace/>
      </AccessType>
      <DFFormat>
        <node/>
      </DFFormat>
      <Occurrence>
        <ZeroOrOne/>
      </Occurrence>
      <DFTitle>IP version of the IP addresses</DFTitle>
      <DFType>
        <MIME>text/plain</MIME>
      </DFType>
    </DFProperties>
  </Node>

  <Node>
    <NodeName>StartSourceIPAddress</NodeName>
    <DFProperties>
      <AccessType>
        <Get/>
        <Replace/>
      </AccessType>
      <DFFormat>
        <chr/>
      </DFFormat>
      <Occurrence>
        <ZeroOrOne/>
      </Occurrence>
      <DFTitle>Start IP src address</DFTitle>
      <DFType>
        <MIME>text/plain</MIME>
      </DFType>
    </DFProperties>
  </Node>

  <Node>
    <NodeName>EndSourceIPAddress</NodeName>
    <DFProperties>
      <AccessType>
        <Get/>
        <Replace/>
      </AccessType>
      <DFFormat>
        <chr/>
      </DFFormat>
      <Occurrence>
        <ZeroOrOne/>
      </Occurrence>
      <DFTitle>End IP src address</DFTitle>
      <DFType>
        <MIME>text/plain</MIME>
      </DFType>
    </DFProperties>
  </Node>

</Node>

```

```

    <NodeName>StartDestIPAddress</NodeName>
  <DFProperties>
    <AccessType>
      <Get/>
      <Replace/>
    </AccessType>
    <DFFormat>
      <chr/>
    </DFFormat>
    <Occurrence>
      <ZeroOrOne/>
    </Occurrence>
    <DFTitle>Start IP dest address</DFTitle>
    <DFType>
      <MIME>text/plain</MIME>
    </DFType>
  </DFProperties>
</Node>

<Node>
  <NodeName>EndDestIPAddress</NodeName>
  <DFProperties>
    <AccessType>
      <Get/>
      <Replace/>
    </AccessType>
    <DFFormat>
      <chr/>
    </DFFormat>
    <Occurrence>
      <ZeroOrOne/>
    </Occurrence>
    <DFTitle>End IP Dst address</DFTitle>
    <DFType>
      <MIME>text/plain</MIME>
    </DFType>
  </DFProperties>
</Node>

<Node>
  <NodeName>ProtocolType</NodeName>
  <DFProperties>
    <AccessType>
      <Get/>
      <Replace/>
    </AccessType>
    <DFFormat>
      <chr/>
    </DFFormat>
    <Occurrence>
      <ZeroOrOne/>
    </Occurrence>
    <DFTitle>protocol type</DFTitle>
    <DFType>
      <MIME>text/plain</MIME>
    </DFType>
  </DFProperties>
</Node>

<Node>
  <NodeName>StartSourcePortNumber</NodeName>
  <DFProperties>
    <AccessType>
      <Get/>
      <Replace/>
    </AccessType>
    <DFFormat>
      <chr/>
    </DFFormat>
    <Occurrence>
      <ZeroOrOne/>
    </Occurrence>
    <DFTitle>Start src port number</DFTitle>
    <DFType>
      <MIME>text/plain</MIME>
    </DFType>
  </DFProperties>

```

```

</Node>
<Node>
  <NodeName>EndSourcePortNumber</NodeName>
  <DFProperties>
    <AccessType>
      <Get/>
      <Replace/>
    </AccessType>
    <DFFormat>
      <chr/>
    </DFFormat>
    <Occurrence>
      <ZeroOrOne/>
    </Occurrence>
    <DFTitle>End src port number</DFTitle>
    <DFType>
      <MIME>text/plain</MIME>
    </DFType>
  </DFProperties>
</Node>

<Node>
  <NodeName>StartDestPortNumber</NodeName>
  <DFProperties>
    <AccessType>
      <Get/>
      <Replace/>
    </AccessType>
    <DFFormat>
      <chr/>
    </DFFormat>
    <Occurrence>
      <ZeroOrOne/>
    </Occurrence>
    <DFTitle>Start dest port</DFTitle>
    <DFType>
      <MIME>text/plain</MIME>
    </DFType>
  </DFProperties>
</Node>

<Node>
  <NodeName>EndDestPortNumber</NodeName>
  <DFProperties>
    <AccessType>
      <Get/>
      <Replace/>
    </AccessType>
    <DFFormat>
      <chr/>
    </DFFormat>
    <Occurrence>
      <ZeroOrOne/>
    </Occurrence>
    <DFTitle>End Dst port</DFTitle>
    <DFType>
      <MIME>text/plain</MIME>
    </DFType>
  </DFProperties>
</Node>

<Node>
  <NodeName>QoS</NodeName>
  <DFProperties>
    <AccessType>
      <Get/>
      <Replace/>
    </AccessType>
    <DFFormat>
      <bin/>
    </DFFormat>
    <Occurrence>
      <ZeroOrOne/>
    </Occurrence>
    <DFTitle>QoS value</DFTitle>
    <DFType>
      <MIME>text/plain</MIME>

```

```

        </DFType>
      </DFProperties>
    </Node>
  </Node>
</Node>

<Node>
  <NodeName>RoutingCriteria</NodeName>
<DFProperties>
  <AccessType>
    <Get/>
    <Replace/>
  </AccessType>
  <DFFormat>
    <node/>
  </DFFormat>
  <Occurrence>
    <ZeroOrOne/>
  </Occurrence>
  <DFTitle>Routing criteria - area, time and APN validity</DFTitle>
  <DFType>
    <MIME>text/plain</MIME>
  </DFType>
</DFProperties>

  <Node>
    <NodeName></NodeName>
  <DFProperties>
    <AccessType>
      <Get/>
      <Replace/>
    </AccessType>
    <DFFormat>
      <node/>
    </DFFormat>
    <Occurrence>
      <OneOrMore/>
    </Occurrence>
    <DFType>
      <DDFName></DDFName>
    </DFType>
  </DFProperties>
  <Node>
    <NodeName>ValidityArea</NodeName>
  <DFProperties>
    <AccessType>
      <Get/>
      <Replace/>
    </AccessType>
    <DFFormat>
      <node/>
    </DFFormat>
    <Occurrence>
      <ZeroOrOne/>
    </Occurrence>
    <DFTitle>Validity area.</DFTitle>
    <DFType>
      <DDFName/>
    </DFType>
  </DFProperties>

  <Node>
    <NodeName>_3GPP_Location</NodeName>
  <DFProperties>
    <AccessType>
      <Get/>
      <Replace/>
    </AccessType>
    <DFFormat>
      <node/>
    </DFFormat>
    <Occurrence>
      <ZeroOrOne/>
    </Occurrence>
    <DFTitle>Validity area for 3GPP access.</DFTitle>
    <DFType>
      <DDFName/>
    </DFType>
  </DFProperties>

```

```

        </DFProperties>
    <Node>
        <NodeName></NodeName>
        <DFProperties>
            <AccessType>
                <Get/>
                <Replace/>
            </AccessType>
            <DFFormat>
                <node/>
            </DFFormat>
            <Occurrence>
                <OneOrMore/>
            </Occurrence>
            <DFType>
                <DDFName></DDFName>
            </DFType>
        </DFProperties>
    </Node>
    <Node>
        <NodeName>PLMN</NodeName>
        <DFProperties>
            <AccessType>
                <Get/>
                <Replace/>
            </AccessType>
            <DFFormat>
                <chr/>
            </DFFormat>
            <Occurrence>
                <One/>
            </Occurrence>
            <DFTitle>PLMN.</DFTitle>
            <DFType>
                <MIME>text/plain</MIME>
            </DFType>
        </DFProperties>
    </Node>
    <Node>
        <NodeName>TAC</NodeName>
        <DFProperties>
            <AccessType>
                <Get/>
                <Replace/>
            </AccessType>
            <DFFormat>
                <chr/>
            </DFFormat>
            <Occurrence>
                <ZeroOrOne/>
            </Occurrence>
            <DFTitle>TAC.</DFTitle>
            <DFType>
                <MIME>text/plain</MIME>
            </DFType>
        </DFProperties>
    </Node>
    <Node>
        <NodeName>LAC</NodeName>
        <DFProperties>
            <AccessType>
                <Get/>
                <Replace/>
            </AccessType>
            <DFFormat>
                <chr/>
            </DFFormat>
            <Occurrence>
                <ZeroOrOne/>
            </Occurrence>
            <DFTitle>LAC.</DFTitle>
            <DFType>
                <MIME>text/plain</MIME>
            </DFType>
        </DFProperties>
    </Node>

```



```

</Node>
<Node>
  <NodeName>GERAN_CI</NodeName>
  <DFProperties>
    <AccessType>
      <Get/>
      <Replace/>
    </AccessType>
    <DFFormat>
      <bin/>
    </DFFormat>
    <Occurrence>
      <ZeroOrOne/>
    </Occurrence>
    <DFTitle>GERAN_CI.</DFTitle>
    <DFType>
      <MIME>text/plain</MIME>
    </DFType>
  </DFProperties>
</Node>
<Node>
  <NodeName>UTRAN_CI</NodeName>
  <DFProperties>
    <AccessType>
      <Get/>
      <Replace/>
    </AccessType>
    <DFFormat>
      <bin/>
    </DFFormat>
    <Occurrence>
      <ZeroOrOne/>
    </Occurrence>
    <DFTitle>UTRAN_CI.</DFTitle>
    <DFType>
      <MIME>text/plain</MIME>
    </DFType>
  </DFProperties>
</Node>
<Node>
  <NodeName>EUTRA_CI</NodeName>
  <DFProperties>
    <AccessType>
      <Get/>
      <Replace/>
    </AccessType>
    <DFFormat>
      <bin/>
    </DFFormat>
    <Occurrence>
      <ZeroOrOne/>
    </Occurrence>
    <DFTitle>EUTRA_CI.</DFTitle>
    <DFType>
      <MIME>text/plain</MIME>
    </DFType>
  </DFProperties>
</Node>
</Node>
</Node>
<Node>
  <NodeName>_3GPP2_Location</NodeName>
  <DFProperties>
    <AccessType>
      <Get/>
      <Replace/>
    </AccessType>
    <DFFormat>
      <node/>
    </DFFormat>
    <Occurrence>
      <ZeroOrOne/>
    </Occurrence>
    <DFTitle> Validity area for 3GPP2 access.</DFTitle>
  </DFProperties>
</Node>

```

```

    <DFType>
      <DDFName/>
    </DFType>
  </DFProperties>

  <Node>
    <NodeName>1x</NodeName>
    <DFProperties>
      <AccessType>
        <Get/>
        <Replace/>
      </AccessType>
      <DFFormat>
        <node/>
      </DFFormat>
      <Occurrence>
        <ZeroOrOne/>
      </Occurrence>
      <DFTitle> Validity area for 3GPP2-1x access.</DFTitle>
      <DFType>
        <DDFName/>
      </DFType>
    </DFProperties>

  <Node>
    <NodeName></NodeName>
    <DFProperties>
      <AccessType>
        <Get/>
        <Replace/>
      </AccessType>
      <DFFormat>
        <node/>
      </DFFormat>
      <Occurrence>
        <OneOrMore/>
      </Occurrence>
      <DFType>
        <DDFName></DDFName>
      </DFType>
    </DFProperties>

  <Node>
    <NodeName>SID</NodeName>
    <DFProperties>
      <AccessType>
        <Get/>
        <Replace/>
      </AccessType>
      <DFFormat>
        <chr/>
      </DFFormat>
      <Occurrence>
        <One/>
      </Occurrence>
      <DFTitle>1x-SID.</DFTitle>
      <DFType>
        <MIME>text/plain</MIME>
      </DFType>
    </DFProperties>
  </Node>

  <Node>
    <NodeName>NID</NodeName>
    <DFProperties>
      <AccessType>
        <Get/>
        <Replace/>
      </AccessType>
      <DFFormat>
        <chr/>
      </DFFormat>
      <Occurrence>
        <ZeroOrOne/>
      </Occurrence>
      <DFTitle>1x-NID.</DFTitle>
      <DFType>
        <MIME>text/plain</MIME>

```

```

        </DFType>
      </DFProperties>
    </Node>

    <Node>
      <NodeName>Base_ID</NodeName>
      <DFProperties>
        <AccessType>
          <Get/>
          <Replace/>
        </AccessType>
        <DFFormat>
          <chr/>
        </DFFormat>
        <Occurrence>
          <ZeroOrOne/>
        </Occurrence>
        <DFTitle>1x-Base ID.</DFTitle>
        <DFType>
          <MIME>text/plain</MIME>
        </DFType>
      </DFProperties>
    </Node>
  </Node>
</Node>

<Node>
  <NodeName>HRPD</NodeName>
  <DFProperties>
    <AccessType>
      <Get/>
      <Replace/>
    </AccessType>
    <DFFormat>
      <node/>
    </DFFormat>
    <Occurrence>
      <ZeroOrOne/>
    </Occurrence>
    <DFTitle> Validity area for 3GPP2-HRPD access</DFTitle>
    <DFType>
      <DDFName/>
    </DFType>
  </DFProperties>

  <Node>
    <NodeName></NodeName>
    <DFProperties>
      <AccessType>
        <Get/>
        <Replace/>
      </AccessType>
      <DFFormat>
        <node/>
      </DFFormat>
      <Occurrence>
        <OneOrMore/>
      </Occurrence>
      <DFType>
        <DDFName></DDFName>
      </DFType>
    </DFProperties>

  <Node>
    <NodeName>Sector_ID</NodeName>
    <DFProperties>
      <AccessType>
        <Get/>
        <Replace/>
      </AccessType>
      <DFFormat>
        <bin/>
      </DFFormat>
      <Occurrence>
        <One/>
      </Occurrence>
      <DFTitle>HRPD Sector ID</DFTitle>
      <DFType>

```

```

        <MIME>text/plain</MIME>
      </DFType>
    </DFProperties>
  </Node>

  <Node>
    <NodeName>Netmask</NodeName>
    <DFProperties>
      <AccessType>
        <Get/>
        <Replace/>
      </AccessType>
      <DFFormat>
        <bin/>
      </DFFormat>
      <Occurrence>
        <One/>
      </Occurrence>
      <DFTitle>HRPD netmask</DFTitle>
      <DFType>
        <MIME>text/plain</MIME>
      </DFType>
    </DFProperties>
  </Node>
</Node>
</Node>
</Node>

<Node>
  <NodeName>WiMAX_Location</NodeName>
  <DFProperties>
    <AccessType>
      <Get/>
      <Replace/>
    </AccessType>
    <DFFormat>
      <node/>
    </DFFormat>
    <Occurrence>
      <ZeroOrOne/>
    </Occurrence>
    <DFTitle> Validity area for WiMAX access.</DFTitle>
    <DFType>
      <DDFName/>
    </DFType>
  </DFProperties>

  <Node>
    <NodeName></NodeName>
    <DFProperties>
      <AccessType>
        <Get/>
        <Replace/>
      </AccessType>
      <DFFormat>
        <node/>
      </DFFormat>
      <Occurrence>
        <OneOrMore/>
      </Occurrence>
      <DFType>
        <DDFName></DDFName>
      </DFType>
    </DFProperties>

  <Node>
    <NodeName>NAP-ID</NodeName>
    <DFProperties>
      <AccessType>
        <Get/>
        <Replace/>
      </AccessType>
      <DFFormat>
        <chr/>
      </DFFormat>
      <Occurrence>
        <One/>
      </Occurrence>

```

```

        <DFTitle>NAP-ID</DFTitle>
        <DFType>
            <MIME>text/plain</MIME>
        </DFType>
    </DFProperties>
</Node>

<Node>
    <NodeName>BS-ID</NodeName>
    <DFProperties>
        <AccessType>
            <Get/>
            <Replace/>
        </AccessType>
        <DFFormat>
            <chr/>
        </DFFormat>
        <Occurrence>
            <One/>
        </Occurrence>
        <DFTitle>BS-ID</DFTitle>
        <DFType>
            <MIME>text/plain</MIME>
        </DFType>
    </DFProperties>
</Node>
</Node>

<Node>
    <NodeName>WLAN_Location</NodeName>
    <DFProperties>
        <AccessType>
            <Get/>
            <Replace/>
        </AccessType>
        <DFFormat>
            <node/>
        </DFFormat>
        <Occurrence>
            <ZeroOrOne/>
        </Occurrence>
        <DFTitle> Validity area for WLAN access.</DFTitle>
        <DFType>
            <DDFName/>
        </DFType>
    </DFProperties>

<Node>
    <NodeName></NodeName>
    <DFProperties>
        <AccessType>
            <Get/>
            <Replace/>
        </AccessType>
        <DFFormat>
            <node/>
        </DFFormat>
        <Occurrence>
            <OneOrMore/>
        </Occurrence>
        <DFType>
            <DDFName></DDFName>
        </DFType>
    </DFProperties>
<Node>
    <NodeName>HESSID</NodeName>
    <DFProperties>
        <AccessType>
            <Get/>
            <Replace/>
        </AccessType>
        <DFFormat>
            <chr/>
        </DFFormat>
        <Occurrence>
            <ZeroOrOne/>
        </Occurrence>

```

```

        <DFTitle>HESSID</DFTitle>
        <DFType>
            <MIME>text/plain</MIME>
        </DFType>
    </DFProperties>
</Node>
<Node>
    <NodeName>SSID</NodeName>
    <DFProperties>
        <AccessType>
            <Get/>
            <Replace/>
        </AccessType>
        <DFFormat>
            <chr/>
        </DFFormat>
        <Occurrence>
            <ZeroOrOne/>
        </Occurrence>
        <DFTitle>SSID</DFTitle>
        <DFType>
            <MIME>text/plain</MIME>
        </DFType>
    </DFProperties>
</Node>

<Node>
    <NodeName>BSSID</NodeName>
    <DFProperties>
        <AccessType>
            <Get/>
            <Replace/>
        </AccessType>
        <DFFormat>
            <chr/>
        </DFFormat>
        <Occurrence>
            <One/>
        </Occurrence>
        <DFTitle>BSSID</DFTitle>
        <DFType>
            <MIME>text/plain</MIME>
        </DFType>
    </DFProperties>
</Node>
</Node>
</Node>

<Node>
    <NodeName>Geo_Location</NodeName>
    <DFProperties>
        <AccessType>
            <Get/>
            <Replace/>
        </AccessType>
        <DFFormat>
            <node/>
        </DFFormat>
        <Occurrence>
            <ZeroOrOne/>
        </Occurrence>
        <DFTitle>Geographical location.</DFTitle>
        <DFType>
            <DDFName/>
        </DFType>
    </DFProperties>

    <Node>
        <NodeName>Circular</NodeName>
        <DFProperties>
            <AccessType>
                <Get/>
                <Replace/>
            </AccessType>
            <DFFormat>
                <node/>
            </DFFormat>
            <Occurrence>

```

```

        <ZeroOrOne/>
    </Occurrence>
    <DFTitle>Circular location descripton.</DFTitle>
    <DFType>
        <DDFName/>
    </DFType>
</DFProperties>

<Node>
    <NodeName></NodeName>
    <DFProperties>
        <AccessType>
            <Get/>
            <Replace/>
        </AccessType>
        <DFFormat>
            <node/>
        </DFFormat>
        <Occurrence>
            <OneOrMore/>
        </Occurrence>
        <DFType>
            <DDFName></DDFName>
        </DFType>
    </DFProperties>

<Node>
    <NodeName>AnchorLatitude</NodeName>
    <DFProperties>
        <AccessType>
            <Get/>
            <Replace/>
        </AccessType>
        <DFFormat>
            <chr/>
        </DFFormat>
        <Occurrence>
            <One/>
        </Occurrence>
        <DFTitle>Anchor latitude</DFTitle>
        <DFType>
            <MIME>text/plain</MIME>
        </DFType>
    </DFProperties>
</Node>

<Node>
    <NodeName>AnchorLongitude</NodeName>
    <DFProperties>
        <AccessType>
            <Get/>
            <Replace/>
        </AccessType>
        <DFFormat>
            <chr/>
        </DFFormat>
        <Occurrence>
            <One/>
        </Occurrence>
        <DFTitle>Anchor longitude</DFTitle>
        <DFType>
            <MIME>text/plain</MIME>
        </DFType>
    </DFProperties>
</Node>

<Node>
    <NodeName>Radius</NodeName>
    <DFProperties>
        <AccessType>
            <Get/>
            <Replace/>
        </AccessType>
        <DFFormat>
            <chr/>
        </DFFormat>
        <Occurrence>
            <One/>
        </Occurrence>
    </DFProperties>
</Node>

```

```

        </Occurrence>
        <DFTitle>Radius</DFTitle>
        <DFType>
          <MIME>text/plain</MIME>
        </DFType>
      </DFProperties>
    </Node>
  </Node>
</Node>
</Node>
</Node>
<Node>
  <NodeName>TimeOfDay</NodeName>
  <DFProperties>
    <AccessType>
      <Get/>
      <Replace/>
    </AccessType>
    <DFFormat>
      <node/>
    </DFFormat>
    <Occurrence>
      <ZeroOrOne/>
    </Occurrence>
    <DFTitle>Time of day.</DFTitle>
    <DFType>
      <DDFName/>
    </DFType>
  </DFProperties>

  <Node>
    <NodeName></NodeName>
    <DFProperties>
      <AccessType>
        <Get/>
        <Replace/>
      </AccessType>
      <DFFormat>
        <node/>
      </DFFormat>
      <Occurrence>
        <OneOrMore/>
      </Occurrence>
      <DFType>
        <DDFName></DDFName>
      </DFType>
    </DFProperties>

    <Node>
      <NodeName>TimeStart</NodeName>
      <DFProperties>
        <AccessType>
          <Get/>
          <Replace/>
        </AccessType>
        <DFFormat>
          <int/>
        </DFFormat>
        <Occurrence>
          <ZeroOrOne/>
        </Occurrence>
        <DFTitle>Start condition for time of rule.</DFTitle>
        <DFType>
          <MIME>text/plain</MIME>
        </DFType>
      </DFProperties>
    </Node>

    <Node>
      <NodeName>TimeStop</NodeName>
      <DFProperties>
        <AccessType>
          <Get/>
          <Replace/>
        </AccessType>
        <DFFormat>
          <int/>
        </DFFormat>

```



```

        <Occurrence>
          <ZeroOrOne/>
        </Occurrence>
        <DFTitle>Stop condition for time of rule.</DFTitle>
        <DFType>
          <MIME>text/plain</MIME>
        </DFType>
      </DFProperties>
    </Node>

    <Node>
      <NodeName>DateStart</NodeName>
      <DFProperties>
        <AccessType>
          <Get/>
          <Replace/>
        </AccessType>
        <DFFormat>
          <int/>
        </DFFormat>
        <Occurrence>
          <ZeroOrOne/>
        </Occurrence>
        <DFTitle>Starting date for time condition of rule.</DFTitle>
        <DFType>
          <MIME>text/plain</MIME>
        </DFType>
      </DFProperties>
    </Node>

    <Node>
      <NodeName>DateStop</NodeName>
      <DFProperties>
        <AccessType>
          <Get/>
          <Replace/>
        </AccessType>
        <DFFormat>
          <int/>
        </DFFormat>
        <Occurrence>
          <ZeroOrOne/>
        </Occurrence>
        <DFTitle>Stop date for time condition of rule.</DFTitle>
        <DFType>
          <MIME>text/plain</MIME>
        </DFType>
      </DFProperties>
    </Node>
  </Node>
</Node>
<Node>
  <NodeName>APN</NodeName>
  <DFProperties>
    <AccessType>
      <Get/>
      <Replace/>
    </AccessType>
    <DFFormat>
      <chr/>
    </DFFormat>
    <Occurrence>
      <ZeroOrOne/>
    </Occurrence>
    <DFTitle>APN.</DFTitle>
    <DFType>
      <MIME>text/plain</MIME>
    </DFType>
  </DFProperties>
</Node>
</Node>
<Node>
  <NodeName>RoutingRule</NodeName>
  <DFProperties>
    <AccessType>
      <Get/>
      <Replace/>
    </AccessType>
  </DFProperties>
</Node>

```

```

    </AccessType>
    <DFFormat>
      <node/>
    </DFFormat>
    <Occurrence>
      <One/>
    </Occurrence>
    <DFTitle>Prioritized access.</DFTitle>
    <DFType>
      <DDFName/>
    </DFType>
  </DFProperties>
</Node>
<NodeName></NodeName>
<DFProperties>
  <AccessType>
    <Get/>
    <Replace/>
  </AccessType>
  <DFFormat>
    <node/>
  </DFFormat>
  <Occurrence>
    <OneOrMore/>
  </Occurrence>
  <DFType>
    <DDFName></DDFName>
  </DFType>
</DFProperties>
<Node>
  <NodeName>AccessId</NodeName>
  <DFProperties>
    <AccessType>
      <Get/>
      <Replace/>
    </AccessType>
    <DFFormat>
      <chr/>
    </DFFormat>
    <Occurrence>
      <ZeroOrOne/>
    </Occurrence>
    <DFTitle>Access identity.</DFTitle>
    <DFType>
      <MIME>text/plain</MIME>
    </DFType>
  </DFProperties>
</Node>
<Node>
  <NodeName>SecondaryAccessId</NodeName>
  <DFProperties>
    <AccessType>
      <Get/>
      <Replace/>
    </AccessType>
    <DFFormat>
      <chr/>
    </DFFormat>
    <Occurrence>
      <ZeroOrOne/>
    </Occurrence>
    <DFTitle>Access identity.</DFTitle>
    <DFType>
      <MIME>text/plain</MIME>
    </DFType>
  </DFProperties>
</Node>
<Node>
  <NodeName>AccessNetworkPriority</NodeName>
  <DFProperties>
    <AccessType>
      <Get/>
      <Replace/>
    </AccessType>
    <DFFormat>
      <int/>

```

```

        </DFFormat>
        <Occurrence>
            <One/>
        </Occurrence>
        <DFTitle>Access network priority.</DFTitle>
        <DFType>
            <MIME>text/plain</MIME>
        </DFType>
    </DFProperties>
</Node>
</Node>
<Node>
    <NodeName>RulePriority</NodeName>
    <DFProperties>
        <AccessType>
            <Get/>
            <Replace/>
        </AccessType>
        <DFFormat>
            <int/>
        </DFFormat>
        <Occurrence>
            <One/>
        </Occurrence>
        <DFTitle>Rule priority.</DFTitle>
        <DFType>
            <MIME>text/plain</MIME>
        </DFType>
    </DFProperties>
</Node>
</Node>
</Node>
<Node>
    <NodeName>Roaming</NodeName>
    <DFProperties>
        <AccessType>
            <Get/>
            <Replace/>
        </AccessType>
        <DFFormat>
            <bool/>
        </DFFormat>
        <Occurrence>
            <ZeroOrOne/>
        </Occurrence>
        <DFTitle>validity in case of Roaming</DFTitle>
        <DFType>
            <MIME>text/plain</MIME>
        </DFType>
    </DFProperties>
</Node>
<Node>
    <NodeName>PLMN</NodeName>
    <DFProperties>
        <AccessType>
            <Get/>
            <Replace/>
        </AccessType>
        <DFFormat>
            <chr/>
        </DFFormat>
        <Occurrence>
            <One/>
        </Occurrence>
        <DFTitle>PLMN which created the policy.</DFTitle>
        <DFType>
            <MIME>text/plain</MIME>
        </DFType>
    </DFProperties>
</Node>
<Node>
    <NodeName>UpdatePolicy</NodeName>
    <DFProperties>
        <AccessType>
            <Get/>

```

```
        <Replace/>
      </AccessType>
    <DFFormat>
      <bool/>
    </DFFormat>
  </Occurrence>
  <ZeroOrOne/>
</Occurrence>
<DFTitle>Update policy.</DFTitle>
<DFType>
  <MIME>text/plain</MIME>
</DFType>
</DFProperties>
</Node>
</Node>
</Node>

<Node>
  <NodeName>Ext</NodeName>
  <!-- The Extension node starts here. -->
  <DFProperties>
    <AccessType>
      <Get/>
    </AccessType>
    <DFFormat>
      <node/>
    </DFFormat>
    <Occurrence>
      <ZeroOrOne/>
    </Occurrence>
    <DFTitle>A collection of all Extension objects</DFTitle>
    <DFType>
      <DDFName/>
    </DFType>
  </DFProperties>
</Node>

</Node>
</MgmtTree>
```

## Annex B (informative): WNDS MO DDF

This DDF is the standardized minimal set. A vendor can define its own DDF for the complete device. This DDF can include more features than this minimal standardized version.

```
<?xml version="1.0" encoding="UTF-8"?>
<!DOCTYPE MgmtTree PUBLIC "-//OMA//DTD-DM-DDF 1.2//EN"
"http://www.openmobilealliance.org/tech/DTD/dm_ddf-v1_2.dtd">

<MgmtTree>
  <VerDTD>1.2</VerDTD>
  <Man>--The device manufacturer--</Man>
  <Mod>--The device model--</Mod>

  <Node>
    <NodeName>WiMAX_NDS</NodeName>
    <DFProperties>
      <AccessType>
        <Get/>
      </AccessType>
      <Description>WiMAX NDS settings</Description>
      <DFFormat>
        <node/>
      </DFFormat>
      <Occurrence>
        <ZeroOrOne/>
      </Occurrence>
      <DFTitle>The WiMAX NDS Management Object.</DFTitle>
      <DFType>
        <DDFName/>
      </DFType>
    </DFProperties>

    <Node>
      <NodeName>Name</NodeName>
      <DFProperties>
        <AccessType>
          <Get/>
        </AccessType>
        <DFFormat>
          <chr/>
        </DFFormat>
        <Occurrence>
          <ZeroOrOne/>
        </Occurrence>
        <DFTitle>User displayable name for the node.</DFTitle>
        <DFType>
          <MIME>text/plain</MIME>
        </DFType>
      </DFProperties>
    </Node>

    <Node>
      <NodeName>NetworkList</NodeName>
      <!-- The NetworkList node starts here. -->
      <DFProperties>
        <AccessType>
          <Get/>
          <Replace/>
        </AccessType>
        <DFFormat>
          <node/>
        </DFFormat>
        <Occurrence>
          <ZeroOrOne/>
        </Occurrence>
        <DFTitle>Properties for each of the network in NetworkList.</DFTitle>
        <DFType>
          <DDFName/>
        </DFType>
      </DFProperties>
    </Node>
  </MgmtTree>

```

```

<Node>
  <NodeName/>
  <DFProperties>
    <AccessType>
      <Get/>
      <Replace/>
    </AccessType>
    <DFFormat>
      <node/>
    </DFFormat>
    <Occurrence>
      <OneOrMore/>
    </Occurrence>
    <DFTitle>The "name" node for properties of NetworkList.</DFTitle>
    <DFType>
      <DDFName/>
    </DFType>
  </DFProperties>

<Node>
  <NodeName>FrequencyInfo</NodeName>
  <!-- The FrequencyInfo node starts here. -->
  <DFProperties>
    <AccessType>
      <Get/>
    </AccessType>
    <DFFormat>
      <node/>
    </DFFormat>
    <Occurrence>
      <One/>
    </Occurrence>
    <DFTitle>Frequency Information for the network.</DFTitle>
    <DFType>
      <DDFName/>
    </DFType>
  </DFProperties>

<Node>
  <NodeName/>
  <DFProperties>
    <AccessType>
      <Get/>
    </AccessType>
    <DFFormat>
      <node/>
    </DFFormat>
    <Occurrence>
      <OneOrMore/>
    </Occurrence>
    <DFTitle>The "name" node for frequency Information of network.</DFTitle>
    <DFType>
      <DDFName/>
    </DFType>
  </DFProperties>

<Node>
  <NodeName>FirstFreq</NodeName>
  <DFProperties>
    <AccessType>
      <Get/>
      <Replace/>
    </AccessType>
    <DFFormat>
      <int/>
    </DFFormat>
    <Occurrence>
      <One/>
    </Occurrence>
    <DFTitle>The First Center Frequency.</DFTitle>
    <DFType>
      <MIME>text/plain</MIME>
    </DFType>
  </DFProperties>
</Node>

<Node>

```

```

    <NodeName>LastFreq</NodeName>
    <DFProperties>
      <AccessType>
        <Get/>
        <Replace/>
      </AccessType>
      <DFFormat>
        <int/>
      </DFFormat>
      <Occurrence>
        <One/>
      </Occurrence>
      <DFTitle>The Last Center Frequency.</DFTitle>
      <DFType>
        <MIME>text/plain</MIME>
      </DFType>
    </DFProperties>
  </Node>

  <Node>
    <NodeName>NextFreqStep</NodeName>
    <DFProperties>
      <AccessType>
        <Get/>
        <Replace/>
      </AccessType>
      <DFFormat>
        <int/>
      </DFFormat>
      <Occurrence>
        <One/>
      </Occurrence>
      <DFTitle>The frequency step for next central frequency.</DFTitle>
      <DFType>
        <MIME>text/plain</MIME>
      </DFType>
    </DFProperties>
  </Node>

  <Node>
    <NodeName>ChannelBandwidth</NodeName>
    <DFProperties>
      <AccessType>
        <Get/>
        <Replace/>
      </AccessType>
      <DFFormat>
        <int/>
      </DFFormat>
      <Occurrence>
        <One/>
      </Occurrence>
      <DFTitle>The channel bandwidth in KHz.</DFTitle>
      <DFType>
        <MIME>text/plain</MIME>
      </DFType>
    </DFProperties>
  </Node>

  <Node>
    <NodeName>DuplexMode</NodeName>
    <DFProperties>
      <AccessType>
        <Get/>
        <Replace/>
      </AccessType>
      <DFFormat>
        <int/>
      </DFFormat>
      <Occurrence>
        <One/>
      </Occurrence>
      <DFTitle>The duplex mode for this channel.</DFTitle>
      <DFType>
        <MIME>text/plain</MIME>
      </DFType>
    </DFProperties>
  </Node>

```

```

<Node>
  <NodeName>FFTSize</NodeName>
  <DFProperties>
    <AccessType>
      <Get/>
      <Replace/>
    </AccessType>
    <DFFormat>
      <int/>
    </DFFormat>
    <Occurrence>
      <One/>
    </Occurrence>
    <DFTitle>The FFT size for this channel.</DFTitle>
    <DFType>
      <MIME>text/plain</MIME>
    </DFType>
  </DFProperties>
</Node>

<Node>
  <NodeName>Preambles</NodeName>
  <DFProperties>
    <AccessType>
      <Get/>
      <Replace/>
    </AccessType>
    <DFFormat>
      <chr/>
    </DFFormat>
    <Occurrence>
      <One/>
    </Occurrence>
    <DFTitle>The Preambles for this channel.</DFTitle>
    <DFType>
      <MIME>text/plain</MIME>
    </DFType>
  </DFProperties>
</Node>
</Node>

<Node>
  <NodeName>CellType</NodeName>
  <DFProperties>
    <AccessType>
      <Get/>
      <Replace/>
    </AccessType>
    <DFFormat>
      <int/>
    </DFFormat>
    <Occurrence>
      <One/>
    </Occurrence>
    <DFTitle>The Cell Type.</DFTitle>
    <DFType>
      <MIME>text/plain</MIME>
    </DFType>
  </DFProperties>
</Node>

<Node>
  <NodeName>NAP-ID</NodeName>
  <DFProperties>
    <AccessType>
      <Get/>
      <Replace/>
    </AccessType>
    <DFFormat>
      <int/>
    </DFFormat>
    <Occurrence>
      <One/>
    </Occurrence>
    <DFTitle>The Network Access Provider Identifier.</DFTitle>

```



```

        <DFType>
          <MIME>text/plain</MIME>
        </DFType>
      </DFProperties>
    </Node>
  </Node>
</Node>

  <Node>
    <NodeName>OperatorDifferentiatedTextField</NodeName>
    <DFProperties>
      <AccessType>
        <Get/>
        <Replace/>
      </AccessType>
      <DFFormat>
        <chr/>
      </DFFormat>
      <Occurrence>
        <ZeroOrOne/>
      </Occurrence>
      <DFTitle>The differentiated operator text field for this cell.</DFTitle>
      <DFType>
        <MIME>text/plain</MIME>
      </DFType>
    </DFProperties>
  </Node>

<Node>
  <NodeName>Ext</NodeName>
  <!-- The Extension node starts here. -->
  <DFProperties>
    <AccessType>
      <Get/>
    </AccessType>
    <DFFormat>
      <node/>
    </DFFormat>
    <Occurrence>
      <ZeroOrOne/>
    </Occurrence>
    <DFTitle>A collection of all Extension objects.</DFTitle>
    <DFType>
      <DDFName/>
    </DFType>
  </DFProperties>
</Node>
</Node>
</MgmtTree>

```

## Annex C (informative): Change history

Change history							
Date	TSG #	TSG Doc.	CR	Rev	Subject/Comment	Old	New
2008-10	CT1#55 bis				Includes the following contributions agreed by CT1: C1-084148, C1-084151, C1-084557, C1-084451, C1-084452, C1-084558, C1-084559, C1-084560		0.1.0
2008-11	CT1#56				Includes the following contributions agreed by CT1: C1-084830, C1-085155, C1-085346, C1-085535, C1-085554, C1-085343, C1-085536, C1-085347, C1-085339 Alignments and cleanups by the rapporteur	0.1.0	0.2.0
2008-11					Version 1.0.0 created for presentation to CT#42 for information and approval	0.2.0	1.0.0
2008-12	CT#42				Version 8.0.0 created after approval in CT#42	1.0.0	8.0.0
2009-03	CT#43	CP-090125	0001	4	Adding ConnMO reference and Correct the Alert Type	8.0.0	8.1.0
2009-03	CT#43	CP-090131	0005		urn for the ANDSF MO registered by OMNA	8.0.0	8.1.0
2009-03	CT#43	CP-090130	0007	1	TimeOfDay Modification	8.0.0	8.1.0
2009-03	CT#43	CP-090128	0012	2	Geo_location identifiers	8.0.0	8.1.0
2009-03	CT#43	CP-090127	0016	2	Corrections and cleanups of the ANDSF MO	8.0.0	8.1.0
2009-03	CT#43	CP-090127	0017	2	Creating the DDF for the ANDSF MO	8.0.0	8.1.0
2009-03	CT#43	CP-090129	0019	1	Removal of editor's notes	8.0.0	8.1.0
2009-06	CT#44	CP-090413	0008	3	Additional 3GPP cell identities in ANDSF MO	8.1.0	8.2.0
2009-06	CT#44	CP-090413	0020	1	urn for the WNDS MO registered by OMNA and minor corrections	8.1.0	8.2.0
2009-06	CT#44	CP-090413	0021	2	Clarifications and clean-ups	8.1.0	8.2.0
2009-06	CT#44	CP-090413	0024	2	Updates and corrections to the the WNDS MO	8.1.0	8.2.0
2009-09	CT#45	CP-090655	0028	4	Correction of ANDSF initiated provisioning	8.2.0	8.3.0
2009-09	CT#45	CP-090655	0029	1	Format type correction	8.2.0	8.3.0
2009-09	CT#45	CP-090655	0030	1	Corrections to ANDSF MO to align with HESSID of 802.11	8.2.0	8.3.0
2009-12	CT#46	CP-090901	0034	2	Aligning ANDSF MO to request from IEEE 802.11 and to refer to IEEE 802.11u	8.3.0	8.4.0
2009-12	CT#46	CP-090901	0036		Naming of ANDSF MO tree	8.3.0	8.4.0
2009-12	CT#46	CP-090937	0033	3	PLMN information to ANDSF for roaming UE	8.4.0	9.0.0
2010-03	CT#47	CP-100107	0038	1	Usage of AccessNetworkArea in DiscoveryInformation node	9.0.0	9.1.0
2010-03	CT#47	CP-100134	0042		Correcting requirement on UE's detection of networks and reserved values for AccessNetwork	9.0.0	9.1.0
2010-09	CT#49	CP-100513	0045	1	24.312 changes for Inter System Routing Policies (ISRP)	9.1.0	10.0.0
2010-12	CT#50	CP-100754	0046	1	Definition and extension of ISRP	10.0.0	10.1.0
2011-03	CT#51	CP-110197	0049		XML representation of leaf and node names starting with a digit	10.1.0	10.2.0
2011-03	CT#51	CP-110185	0051	2	IFOM capability discovery through ISRP – ANDSF	10.1.0	10.2.0
2011-03	CT#51	CP-110185	0054	2	ISRP trigger	10.1.0	10.2.0
2011-03	CT#51	CP-110185	0055	1	ISRP XML file	10.1.0	10.2.0
2011-03	CT#51	CP-110185	0056	1	Usage of ISRP and conflicts resolution	10.1.0	10.2.0
2011-03	CT#51	CP-110185	0050	3	ANDSF MO support for Non-seamless WLAN Offload	10.1.0	10.2.0
2011-03	CT#51	CP-110185	0057	1	ISRP - definition of coding for IP parameters ISRP	10.1.0	10.2.0
2011-03	CT#51	CP-110185	0058	3	ISRP – definition of coding for protocol type	10.1.0	10.2.0
2011-03	CT#51	CP-110185	0059	1	ISRP – definition of coding for QoS	10.1.0	10.2.0
2011-03	CT#51	CP-110185	0060	1	Clarification of source and destination IP addresses and port usage	10.1.0	10.2.0

---

# History

<b>Document history</b>		
V10.2.0	April 2011	Publication