

# ETSI TS 124 385 V14.0.0 (2017-05)



**LTE;  
V2X services Management Object (MO)  
(3GPP TS 24.385 version 14.0.0 Release 14)**



---

Reference

DTS/TSGC-0124385ve00

---

Keywords

LTE

**ETSI**

650 Route des Lucioles  
F-06921 Sophia Antipolis Cedex - FRANCE

Tel.: +33 4 92 94 42 00 Fax: +33 4 93 65 47 16

Siret N° 348 623 562 00017 - NAF 742 C  
Association à but non lucratif enregistrée à la  
Sous-Préfecture de Grasse (06) N° 7803/88

---

**Important notice**

The present document can be downloaded from:

<http://www.etsi.org/standards-search>

The present document may be made available in electronic versions and/or in print. The content of any electronic and/or print versions of the present document shall not be modified without the prior written authorization of ETSI. In case of any existing or perceived difference in contents between such versions and/or in print, the only prevailing document is the print of the Portable Document Format (PDF) version kept on a specific network drive within ETSI Secretariat.

Users of the present document should be aware that the document may be subject to revision or change of status.

Information on the current status of this and other ETSI documents is available at

<https://portal.etsi.org/TB/ETSI/DeliverableStatus.aspx>

If you find errors in the present document, please send your comment to one of the following services:

<https://portal.etsi.org/People/CommitteeSupportStaff.aspx>

---

**Copyright Notification**

No part may be reproduced or utilized in any form or by any means, electronic or mechanical, including photocopying and microfilm except as authorized by written permission of ETSI.

The content of the PDF version shall not be modified without the written authorization of ETSI.

The copyright and the foregoing restriction extend to reproduction in all media.

© European Telecommunications Standards Institute 2017.

All rights reserved.

DECT™, PLUGTESTS™, UMTS™ and the ETSI logo are Trade Marks of ETSI registered for the benefit of its Members.

3GPP™ and LTE™ are Trade Marks of ETSI registered for the benefit of its Members and of the 3GPP Organizational Partners.

oneM2M logo is protected for the benefit of its Members

GSM® and the GSM logo are Trade Marks registered and owned by the GSM Association.

---

## Intellectual Property Rights

IPRs essential or potentially essential to the present document may have been declared to ETSI. The information pertaining to these essential IPRs, if any, is publicly available for **ETSI members and non-members**, and can be found in ETSI SR 000 314: *"Intellectual Property Rights (IPRs); Essential, or potentially Essential, IPRs notified to ETSI in respect of ETSI standards"*, which is available from the ETSI Secretariat. Latest updates are available on the ETSI Web server (<https://ipr.etsi.org>).

Pursuant to the ETSI IPR Policy, no investigation, including IPR searches, has been carried out by ETSI. No guarantee can be given as to the existence of other IPRs not referenced in ETSI SR 000 314 (or the updates on the ETSI Web server) which are, or may be, or may become, essential to the present document.

---

## Foreword

This Technical Specification (TS) has been produced by ETSI 3rd Generation Partnership Project (3GPP).

The present document may refer to technical specifications or reports using their 3GPP identities, UMTS identities or GSM identities. These should be interpreted as being references to the corresponding ETSI deliverables.

The cross reference between GSM, UMTS, 3GPP and ETSI identities can be found under <http://webapp.etsi.org/key/queryform.asp>.

---

## Modal verbs terminology

In the present document "**shall**", "**shall not**", "**should**", "**should not**", "**may**", "**need not**", "**will**", "**will not**", "**can**" and "**cannot**" are to be interpreted as described in clause 3.2 of the [ETSI Drafting Rules](#) (Verbal forms for the expression of provisions).

"**must**" and "**must not**" are **NOT** allowed in ETSI deliverables except when used in direct citation.

# Contents

|  |    |
|--|----|
| Intellectual Property Rights .....   | 2  |
| Foreword.....  | 2  |
| Modal verbs terminology.....   | 2  |
| Foreword.....  | 6  |
| 1 Scope .....  | 7  |
| 2 References .....   | 7  |
| 3 Definitions and abbreviations.....   | 8  |
| 3.1 Definitions .....  | 8  |
| 3.2 Abbreviations .....  | 8  |
| 4 V2X Communication Provisioning MO.....   | 8  |
| 4.1 Overview .....   | 8  |
| 5 MO configuration parameters .....  | 12 |
| 5.1 General .....  | 12 |
| 5.2 Node: <X> .....  | 13 |
| 5.3 <X>/Name .....   | 13 |
| 5.4 Configuration parameters for V2X provisioning.....   | 13 |
| 5.4.1 <X>/V2XProvisioning.....   | 13 |
| 5.4.2 <X>/V2XProvisioning/V2XControlFunctionAddress.....   | 13 |
| 5.4.3 <X>/V2XProvisioning/ToConRefs .....  | 13 |
| 5.4.4 <X>/V2XProvisioning/ToConRefs/<X> .....  | 14 |
| 5.4.5 <X>/V2XProvisioning/ToConRefs/<X>/ConRef .....   | 14 |
| 5.5 Configuration parameters for V2X communication over PC5 .....  | 14 |
| 5.5.1 <X>/V2XoverPC5 .....   | 14 |
| 5.5.2 <X>/V2XoverPC5/Expiration .....  | 14 |
| 5.5.3 <X>/V2XoverPC5/ServedByEUTRAN .....  | 15 |
| 5.5.4 <X>/V2XoverPC5/ServedByEUTRAN/AuthorizedPLMNs.....   | 15 |
| 5.5.5 <X>/V2XoverPC5/ServedByEUTRAN/AuthorizedPLMNs/<X> .....  | 15 |
| 5.5.6 <X>/V2XoverPC5/ServedByEUTRAN/AuthorizedPLMNs/<X>/PLMN .....   | 15 |
| 5.5.7 <X>/V2XoverPC5/NotServedByEUTRAN .....   | 15 |
| 5.5.8 <X>/V2XoverPC5/NotServedByEUTRAN/Authorized .....  | 16 |
| 5.5.9 <X>/V2XoverPC5/NotServedByEUTRAN/RadioParameters .....   | 16 |
| 5.5.10 <X>/V2XoverPC5/NotServedByEUTRAN/RadioParameters/<X>.....   | 16 |
| 5.5.11 <X>/V2XoverPC5/NotServedByEUTRAN/RadioParameters/<X>/ RadioParametersContents .....                                   | 16 |
| 5.5.12 <X>/V2XoverPC5/NotServedByEUTRAN/RadioParameters/<X>/ GeographicalArea .....  | 17 |
| 5.5.13 <X>/V2XoverPC5/NotServedByEUTRAN/RadioParameters/<X>/ GeographicalArea/Polygon .....                                  | 17 |
| 5.5.14 <X>/V2XoverPC5/NotServedByEUTRAN/RadioParameters/<X>/ GeographicalArea/Polygon/<X>.....                               | 17 |
| 5.5.15 <X>/V2XoverPC5/NotServedByEUTRAN/RadioParameters/<X>/<br>GeographicalArea/Polygon/<X>/Coordinates .....               | 17 |
| 5.5.16 <X>/V2XoverPC5/NotServedByEUTRAN/RadioParameters/<X>/<br>GeographicalArea/Polygon/<X>/Coordinates/<X>.....            | 18 |
| 5.5.17 <X>/V2XoverPC5/NotServedByEUTRAN/RadioParameters/<X>/<br>GeographicalArea/Polygon/<X>/Coordinates/<X>/Latitude .....  | 18 |
| 5.5.18 <X>/V2XoverPC5/NotServedByEUTRAN/RadioParameters/<X>/<br>GeographicalArea/Polygon/<X>/Coordinates/<X>/Longitude ..... | 18 |
| 5.5.19 <X>/V2XoverPC5/NotServedByEUTRAN/RadioParameters/<X>/ OperatorManaged.....  | 18 |
| 5.5.20 <X>/V2XoverPC5/AuthorizedV2XServiceList .....   | 19 |
| 5.5.21 <X>/V2XoverPC5/AuthorizedV2XServiceList/<X> .....   | 19 |
| 5.5.22 <X>/V2XoverPC5/AuthorizedV2XServiceList/<X>/ V2XServiceIdentifier .....   | 19 |
| 5.5.23 <X>/V2XoverPC5/AuthorizedV2XServiceList/<X>/ DestinationLayer2ID .....  | 19 |
| 5.5.24 <X>/V2XoverPC5/PPPPtoPDBMappingRule .....   | 19 |
| 5.5.25 <X>/V2XoverPC5/PPPPtoPDBMappingRule/<X> .....   | 20 |
| 5.5.26 <X>/V2XoverPC5/PPPPtoPDBMappingRule/<X>/ ProSePerPacketPriority.....  | 20 |
| 5.5.27 <X>/V2XoverPC5/PPPPtoPDBMappingRule/<X>/ PacketDelayBudget.....   | 20 |

|        |   |    |
|--------|---|----|
| 5.5.28 | <X>/V2XoverPC5/TimerT5000.....  | 20 |
| 5.6    | Configuration parameters for V2X communication over LTE-Uu.....   | 21 |
| 5.6.1  | <X>/V2XoverLTEUu.....   | 21 |
| 5.6.2  | <X>/V2XoverLTEUu/Expiration.....  | 21 |
| 5.6.3  | <X>/V2XoverLTEUu/ToConRefs.....   | 21 |
| 5.6.4  | <X>/V2XoverLTEUu/ToConRefs/<X>.....   | 21 |
| 5.6.5  | <X>/V2XoverLTEUu/ToConRefs/<X>/ConRef.....  | 21 |
| 5.6.6  | <X>/V2XoverLTEUu/AuthorizedPLMNs.....   | 22 |
| 5.6.7  | <X>/V2XoverLTEUu/AuthorizedPLMNs/<X>.....   | 22 |
| 5.6.8  | <X>/V2XoverLTEUu/AuthorizedPLMNs/<X>/PLMN.....  | 22 |
| 5.6.9  | <X>/V2XoverLTEUu/AuthorizedPLMNs/<X>/V2XASMBMSConfig.....   | 22 |
| 5.6.10 | <X>/V2XoverLTEUu/AuthorizedPLMNs/<X>/V2XASMBMSConfig/ TMGI.....   | 23 |
| 5.6.11 | <X>/V2XoverLTEUu/AuthorizedPLMNs/<X>/V2XASMBMSConfig/ SAIList.....  | 23 |
| 5.6.12 | <X>/V2XoverLTEUu/AuthorizedPLMNs/<X>/V2XASMBMSConfig/ SAIList/<X>.....  | 23 |
| 5.6.13 | <X>/V2XoverLTEUu/AuthorizedPLMNs/<X>/V2XASMBMSConfig/ SAIList/<X>/SAI.....  | 23 |
| 5.6.14 | <X>/V2XoverLTEUu/AuthorizedPLMNs/<X>/V2XASMBMSConfig/ Frequency.....  | 24 |
| 5.6.15 | <X>/V2XoverLTEUu/AuthorizedPLMNs/<X>/V2XASMBMSConfig/<br>SDPInV2XASMBMSConfig.....  | 24 |
| 5.6.16 | <X>/V2XoverLTEUu/AuthorizedPLMNs/<X>/ V2XServiceIdentifierUnrelated.....  | 24 |
| 5.6.17 | <X>/V2XoverLTEUu/AuthorizedPLMNs/<X>/<br>V2XServiceIdentifierUnrelated/V2XMBMSConfigs.....  | 25 |
| 5.6.18 | <X>/V2XoverLTEUu/AuthorizedPLMNs/<X>/<br>V2XServiceIdentifierUnrelated/V2XMBMSConfigs/<X>.....                                      | 25 |
| 5.6.19 | <X>/V2XoverLTEUu/AuthorizedPLMNs/<X>/<br>V2XServiceIdentifierUnrelated/V2XMBMSConfigs/<X>/V2XMBMSConfig.....                        | 25 |
| 5.6.20 | <X>/V2XoverLTEUu/AuthorizedPLMNs/<X>/<br>V2XServiceIdentifierUnrelated/V2XMBMSConfigs/<X>/V2XMBMSConfig/TMGI.....                   | 25 |
| 5.6.21 | <X>/V2XoverLTEUu/AuthorizedPLMNs/<X>/<br>V2XServiceIdentifierUnrelated/V2XMBMSConfigs/<X>/V2XMBMSConfig/SAIList.....                | 26 |
| 5.6.22 | <X>/V2XoverLTEUu/AuthorizedPLMNs/<X>/<br>V2XServiceIdentifierUnrelated/V2XMBMSConfigs/<X>/V2XMBMSConfig/SAIList/<X>.....            | 26 |
| 5.6.23 | <X>/V2XoverLTEUu/AuthorizedPLMNs/<X>/<br>V2XServiceIdentifierUnrelated/V2XMBMSConfigs/<X>/V2XMBMSConfig/SAIList/<X>/SAI.....        | 26 |
| 5.6.24 | <X>/V2XoverLTEUu/AuthorizedPLMNs/<X>/<br>V2XServiceIdentifierUnrelated/V2XMBMSConfigs/<X>/V2XMBMSConfig/Frequency.....              | 26 |
| 5.6.25 | <X>/V2XoverLTEUu/AuthorizedPLMNs/<X>/<br>V2XServiceIdentifierUnrelated/V2XMBMSConfigs/<X>/V2XMBMSConfig/<br>SDPInV2XMBMSConfig..... | 27 |
| 5.6.26 | <X>/V2XoverLTEUu/AuthorizedPLMNs/<X>/ V2XServiceIdentifierUnrelated/V2XASAddresses.....   | 27 |
| 5.6.27 | <X>/V2XoverLTEUu/AuthorizedPLMNs/<X>/<br>V2XServiceIdentifierUnrelated/V2XASAddress/<X>.....  | 27 |
| 5.6.28 | <X>/V2XoverLTEUu/AuthorizedPLMNs/<X>/<br>V2XServiceIdentifierUnrelated/V2XASAddress/<X>/L3Address.....                              | 27 |
| 5.6.29 | <X>/V2XoverLTEUu/AuthorizedPLMNs/<X>/<br>V2XServiceIdentifierUnrelated/V2XASAddress/<X>/UDPPort.....                                | 28 |
| 5.6.30 | <X>/V2XoverLTEUu/AuthorizedPLMNs/<X>/<br>V2XServiceIdentifierUnrelated/V2XASAddress/<X>/ GeographicalArea.....                      | 28 |
| 5.6.31 | <X>/V2XoverLTEUu/AuthorizedPLMNs/<X>/<br>V2XServiceIdentifierUnrelated/V2XASAddress/<X>/GeographicalArea/Polygon.....               | 28 |
| 5.6.32 | <X>/V2XoverLTEUu/AuthorizedPLMNs/<X>/ V2XServiceIdentifierRelated.....  | 28 |
| 5.6.33 | <X>/V2XoverLTEUu/AuthorizedPLMNs/<X>/<br>V2XServiceIdentifierRelated/AuthorizedV2XServiceList.....                                  | 29 |
| 5.6.34 | <X>/V2XoverLTEUu/AuthorizedPLMNs/<X>/<br>V2XServiceIdentifierRelated/AuthorizedV2XServiceList/<X>.....                              | 29 |
| 5.6.35 | <X>/V2XoverLTEUu/AuthorizedPLMNs/<X>/<br>V2XServiceIdentifierRelated/AuthorizedV2XServiceList/<X>/ V2XServiceIdentifier.....        | 29 |
| 5.6.36 | <X>/V2XoverLTEUu/AuthorizedPLMNs/<X>/<br>V2XServiceIdentifierRelated/AuthorizedV2XServiceList/<X>/ V2XMBMSConfigs.....              | 29 |
| 5.6.37 | <X>/V2XoverLTEUu/AuthorizedPLMNs/<X>/<br>V2XServiceIdentifierRelated/AuthorizedV2XServiceList/<X>/ V2XMBMSConfigs/<X>.....          | 30 |

|                               |   |           |
|-------------------------------|---|-----------|
| 5.6.38                        | <X>/V2XoverLTEUu/AuthorizedPLMNs/<X>/<br>V2XServiceIdentifierRelated/AuthorizedV2XServiceList/<X>/V2XMBMSConfigs/<X>/<br>V2XMBMSConfig .....                    | 30        |
| 5.6.39                        | <X>/V2XoverLTEUu/AuthorizedPLMNs/<X>/<br>V2XServiceIdentifierRelated/AuthorizedV2XServiceList/<X>/V2XMBMSConfigs/<X>/<br>V2XMBMSConfig/TMGI .....               | 30        |
| 5.6.40                        | <X>/V2XoverLTEUu/AuthorizedPLMNs/<X>/<br>V2XServiceIdentifierRelated/AuthorizedV2XServiceList/<X>/V2XMBMSConfigs/<X>/<br>V2XMBMSConfig/SAIList.....             | 31        |
| 5.6.41                        | <X>/V2XoverLTEUu/AuthorizedPLMNs/<X>/<br>V2XServiceIdentifierRelated/AuthorizedV2XServiceList/<X>/V2XMBMSConfigs/<X>/<br>V2XMBMSConfig/SAIList/<X> .....        | 31        |
| 5.6.42                        | <X>/V2XoverLTEUu/AuthorizedPLMNs/<X>/<br>V2XServiceIdentifierRelated/AuthorizedV2XServiceList/<X>/V2XMBMSConfigs/<X>/<br>V2XMBMSConfig/SAIList/<X>/SAI.....     | 31        |
| 5.6.43                        | <X>/V2XoverLTEUu/AuthorizedPLMNs/<X>/<br>V2XServiceIdentifierRelated/AuthorizedV2XServiceList/<X>/V2XMBMSConfigs/<X>/<br>V2XMBMSConfig/Frequency.....           | 31        |
| 5.6.44                        | <X>/V2XoverLTEUu/AuthorizedPLMNs/<X>/<br>V2XServiceIdentifierRelated/AuthorizedV2XServiceList/<X>/V2XMBMSConfigs/<X>/<br>V2XMBMSConfig/SDPInV2XMBMSConfig ..... | 32        |
| 5.6.45                        | <X>/V2XoverLTEUu/AuthorizedPLMNs/<X>/<br>V2XServiceIdentifierRelated/AuthorizedV2XServiceList/<X>/ V2XASAddresses .....   | 32        |
| 5.6.46                        | <X>/V2XoverLTEUu/AuthorizedPLMNs/<X>/<br>V2XServiceIdentifierRelated/DefaultV2XMBMSConfigs .....  | 32        |
| 5.6.47                        | <X>/V2XoverLTEUu/AuthorizedPLMNs/<X>/<br>V2XServiceIdentifierRelated/DefaultV2XMBMSConfigs/<X> .....  | 32        |
| 5.6.48                        | <X>/V2XoverLTEUu/AuthorizedPLMNs/<X>/<br>V2XServiceIdentifierRelated/DefaultV2XMBMSConfigs/<X>/ V2XMBMSConfig .....   | 33        |
| 5.6.49                        | <X>/V2XoverLTEUu/AuthorizedPLMNs/<X>/<br>V2XServiceIdentifierRelated/DefaultV2XMBMSConfigs/<X>/ V2XMBMSConfig/TMGI .....  | 33        |
| 5.6.50                        | <X>/V2XoverLTEUu/AuthorizedPLMNs/<X>/<br>V2XServiceIdentifierRelated/DefaultV2XMBMSConfigs/<X>/ V2XMBMSConfig/SAIList.....                                      | 33        |
| 5.6.51                        | <X>/V2XoverLTEUu/AuthorizedPLMNs/<X>/<br>V2XServiceIdentifierRelated/DefaultV2XMBMSConfigs/<X>/ V2XMBMSConfig/SAIList/<X> .....                                 | 33        |
| 5.6.52                        | <X>/V2XoverLTEUu/AuthorizedPLMNs/<X>/<br>V2XServiceIdentifierRelated/DefaultV2XMBMSConfigs/<X>/<br>V2XMBMSConfig/SAIList/<X>/SAI.....                           | 34        |
| 5.6.53                        | <X>/V2XoverLTEUu/AuthorizedPLMNs/<X>/<br>V2XServiceIdentifierRelated/DefaultV2XMBMSConfigs/<X>/ V2XMBMSConfig/Frequency .....                                   | 34        |
| 5.6.54                        | <X>/V2XoverLTEUu/AuthorizedPLMNs/<X>/<br>V2XServiceIdentifierRelated/DefaultV2XMBMSConfigs/<X>/<br>V2XMBMSConfig/SDPInV2XMBMSConfig .....                       | 34        |
| 5.6.55                        | <X>/V2XoverLTEUu/AuthorizedPLMNs/<X>/ V2XServiceIdentifierRelated/<br>DefaultV2XASAddresses .....   | 35        |
| 5.6.56                        | <X>/V2XoverLTEUu/AuthorizedPLMNs/<X>/ V2XServiceIdentifierRelated/<br>DefaultV2XASAddresses/<X>.....  | 35        |
| 5.6.57                        | <X>/V2XoverLTEUu/AuthorizedPLMNs/<X>/ V2XServiceIdentifierRelated/<br>DefaultV2XASAddresses/<X>/TypeOfData.....   | 35        |
| 5.6.58                        | <X>/V2XoverLTEUu/AuthorizedPLMNs/<X>/ V2XServiceIdentifierRelated/<br>DefaultV2XASAddresses/<X>/V2XMessageFamily.....   | 35        |
| 5.6.59                        | <X>/V2XoverLTEUu/AuthorizedPLMNs/<X>/<br>V2XServiceIdentifierRelated/DefaultV2XASAddresses/<X>/ V2XASAddresses .....  | 36        |
| 5.7                           | <X>/Ext .....   | 36        |
| <b>Annex A (informative):</b> | <b>V2X Communication Provisioning MO DDF.....</b>   | <b>37</b> |
| <b>Annex B (informative):</b> | <b>Change history .....</b>   | <b>69</b> |
| History .....                 |   | 70        |

---

# Foreword

This Technical Report has been produced by the 3<sup>rd</sup> Generation Partnership Project (3GPP).

The contents of the present document are subject to continuing work within the TSG and may change following formal TSG approval. Should the TSG modify the contents of the present document, it will be re-released by the TSG with an identifying change of release date and an increase in version number as follows:

Version x.y.z

where:

- x the first digit:
  - 1 presented to TSG for information;
  - 2 presented to TSG for approval;
  - 3 or greater indicates TSG approved document under change control.
- y the second digit is incremented for all changes of substance, i.e. technical enhancements, corrections, updates, etc.
- z the third digit is incremented when editorial only changes have been incorporated in the document.

---

# 1 Scope

The present document defines Management Object (MO) that is used to configure the UE for V2X services.

The MO is compatible with the OMA Device Management (DM) protocol specifications, version 1.2 and upwards, and is defined using the OMA DM Device Description Framework (DDF) as described in the Enabler Release Definition OMA-ERELED-DM-V1\_2 [3].

The MO consists of relevant parameters for provisioning and authorization of V2X communication at the UE.

The protocol aspects for V2X are described in 3GPP TS 24.386 [4].

---

# 2 References

The following documents contain provisions which, through reference in this text, constitute provisions of the present document.

- References are either specific (identified by date of publication, edition number, version number, etc.) or non-specific.
- For a specific reference, subsequent revisions do not apply.
- For a non-specific reference, the latest version applies. In the case of a reference to a 3GPP document (including a GSM document), a non-specific reference implicitly refers to the latest version of that document *in the same Release as the present document*.

- [1] 3GPP TR 21.905: "Vocabulary for 3GPP Specifications".
- [2] 3GPP TS 23.285: "Architecture enhancements for V2X services".
- [3] OMA-ERELED-DM-V1\_2: "Enabler Release Definition for OMA Device Management".
- [4] 3GPP TS 24.386: "User Equipment (UE) to V2X control function; protocol aspects; Stage 3".
- [5] OMA-TS-DM\_Protocol-V1\_2: "OMA Device Management Protocol".
- [6] ISO 8601:2004: "Data elements and interchange formats -- Information interchange -- Representation of dates and times".
- [7] 3GPP TS 23.003: "Numbering, addressing and identification".
- [8] 3GPP TS 36.331: "Evolved Universal Terrestrial Radio Access (E-UTRA); Radio Resource Control (RRC) protocol specification".
- [9] 3GPP TS 23.032: "Universal Geographical Area Description (GAD)".
- [10] ISO TS 17419 ITS-AID AssignedNumbers :  
[http://standards.iso.org/iso/ts/17419/TS17419%20Assigned%20Numbers/TS17419\\_ITS-AID\\_AssignedNumbers.pdf](http://standards.iso.org/iso/ts/17419/TS17419%20Assigned%20Numbers/TS17419_ITS-AID_AssignedNumbers.pdf)
- [11] 3GPP TS 36.101: "Evolved Universal Terrestrial Radio Access (E-UTRA); User Equipment (UE) radio transmission and reception".
- [12] 3GPP TS 23.303: "Proximity-based Services (ProSe); Stage 2".



---

## 3 Definitions and abbreviations

### 3.1 Definitions

For the purposes of the present document, the terms and definitions given in 3GPP TR 21.905 [1] and the following apply.

A term defined in the present document takes precedence over the definition of the same term, if any, in 3GPP TR 21.905 [1].

For the purposes of the present document, the following terms and definitions given in 3GPP TS 23.003 [7] apply:

**TMGI**

### 3.2 Abbreviations

For the purposes of the present document, the abbreviations given in 3GPP TR 21.905 [1] and the following apply.

An abbreviation defined in the present document takes precedence over the definition of the same abbreviation, if any, in 3GPP TR 21.905 [1].

|      |                              |
|------|------------------------------|
| DDF  | Device Description Framework |
| MO   | Management Object            |
| PDB  | Packet Delay Budget          |
| PPPP | ProSe Per-Packet Priority    |
| SAI  | Service Area Identifier      |
| SDP  | Session Description Protocol |
| V2X  | Vehicle-to-Everything        |

---

## 4 V2X Communication Provisioning MO

### 4.1 Overview

The V2X communication provisioning MO is used to manage the V2X configuration parameters in a UE supporting 3GPP TS 24.386 [4].

The MO identifier is: urn:oma:mo:ext-3gpp-V2X-communication-provisioning:1.0.

The OMA DM access control list (ACL) property mechanism (see OMA-ERELED-DM-V1\_2 [3]) can be used to grant or deny access rights to OMA DM servers in order to modify nodes of the V2X communication provisioning MO.

In order to request provisioning of the V2X communication provisioning MO, the UE includes in the Package 1 (see OMA-TS-DM\_Protocol-V1\_2 [5]) a Generic Alert message (along with other commands):

- with the "Type" element set to "urn:oma:mo:ext-3gpp-V2X-communication-provisioning:1.0";
- with the "LocURI" element (inside the "Source" element) set to the address of the V2X communication provisioning MO as specified by OMA-TS-DM\_Protocol-V1\_2 [5]; and
- without the "Data" element.

The V2X communication provisioning MO consists of the nodes described in figure 4.1-1.

**NOTE:** In this release of the document, charging configuration parameters in the V2X communication provisioning MO are not specified.

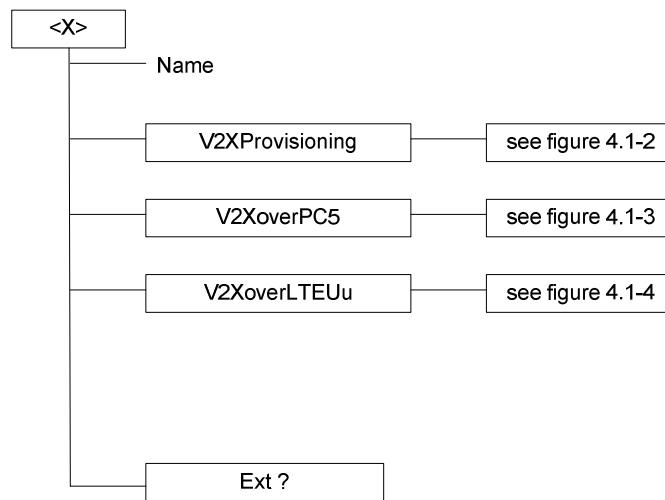

Figure 4.1-1: The V2X communication provisioning MO (part 1)

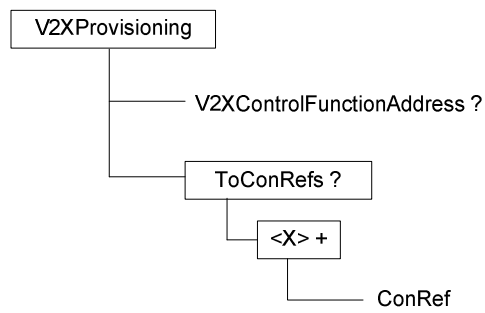

Figure 4.1-2: The V2X communication provisioning MO (part 2)

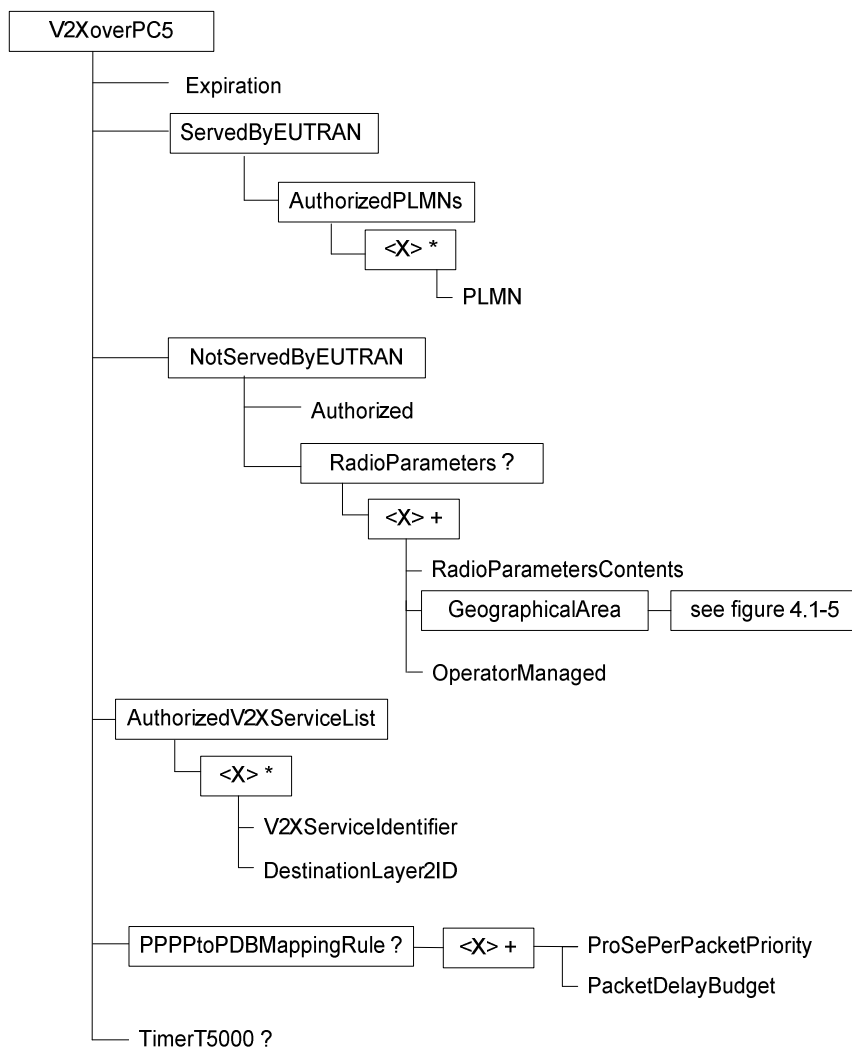

Figure 4.1-3: The V2X communication provisioning MO (part 3)

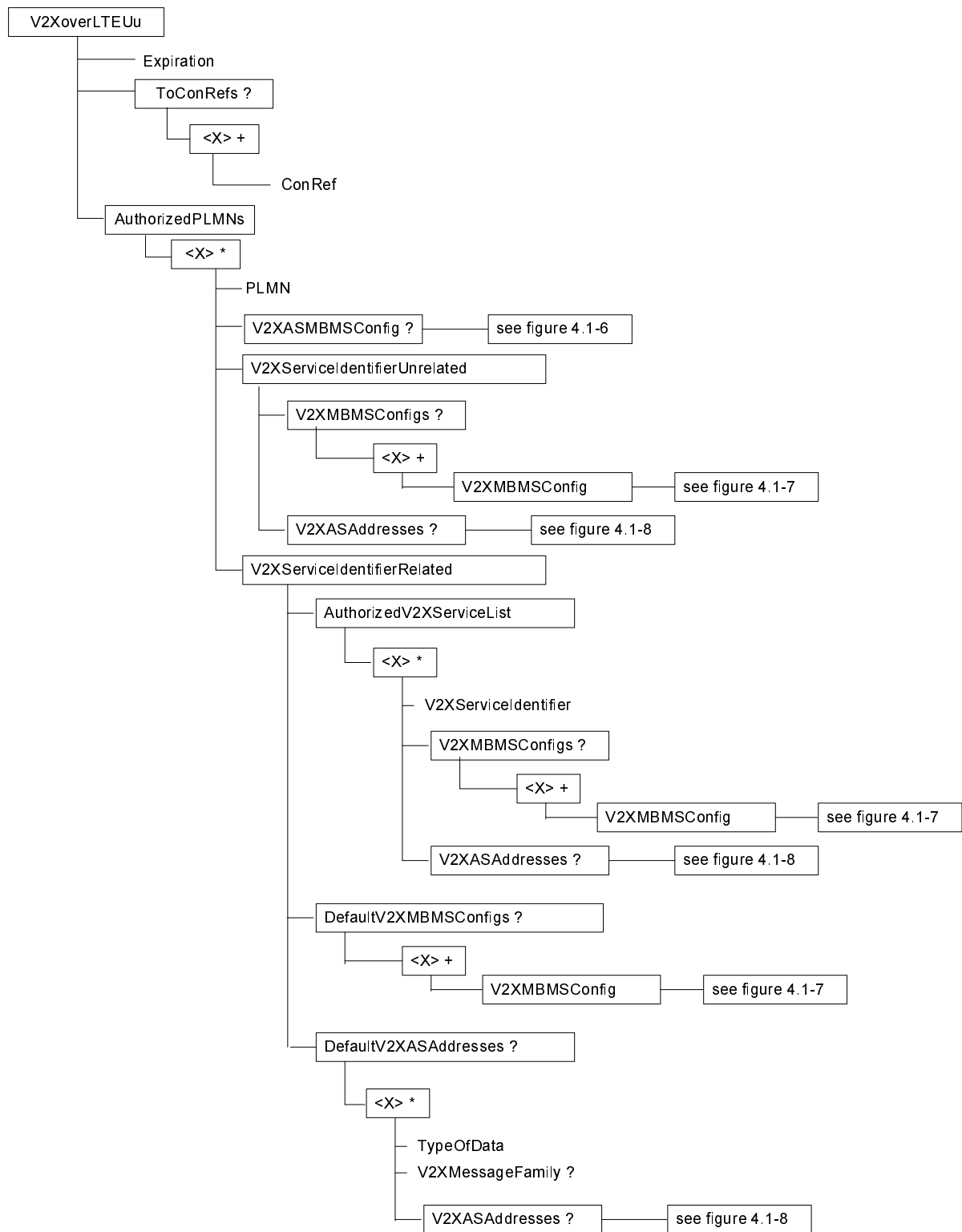

Figure 4.1-4: The V2X communication provisioning MO (part 4)

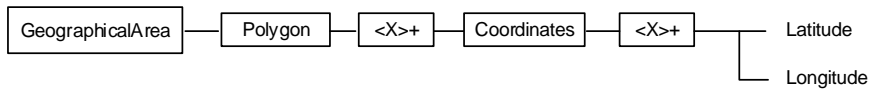

Figure 4.1-5: The V2X communication provisioning MO (part 5)

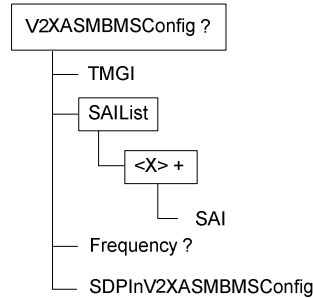

Figure 4.1-6: The V2X communication provisioning MO (part 6)

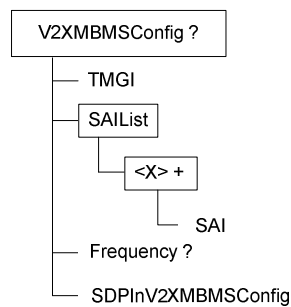

Figure 4.1-7: The V2X communication provisioning MO (part 7)

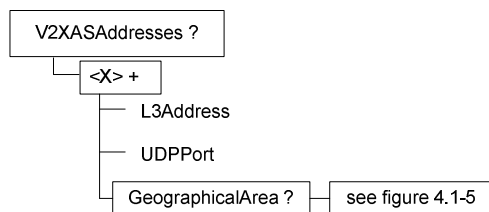

Figure 4.1-8: The V2X communication provisioning MO (part 8)

## 5 MO configuration parameters

### 5.1 General

This clause describes the configuration parameters of the V2X communication provisioning MO.

## 5.2 Node: <X>

This node acts as a placeholder for one or more accounts for a fixed node.

- Occurrence: OneOrMore
- Format: node
- Access Types: Get, Replace
- Values: N/A

This node is mandatory if the UE supports the UE role specified in 3GPP TS 24.386 [4].

NOTE: One node is normally used. More nodes are only used in case the terminal supports multiple UICCs.

## 5.3 <X>/Name

This node contains a name for the V2X configuration parameters.

- Occurrence: One
- Format: chr
- Access Types: Get, Replace
- Values: <User displayable name>

## 5.4 Configuration parameters for V2X provisioning

### 5.4.1 <X>/V2XProvisioning

The V2XProvisioning node contains the configuration parameters for V2X provisioning.

- Occurrence: One
- Format: node
- Access Types: Get, Replace
- Values: N/A

### 5.4.2 <X>/V2XProvisioning/V2XControlFunctionAddress

The V2XControlFunctionAddress leaf indicates the V2X control function address.

- Occurrence: ZeroOrOne
- Format: chr
- Access Types: Get, Replace
- Values: an FQDN or an IP address

### 5.4.3 <X>/V2XProvisioning/ToConRefs

The ToConRefs node is used to allow application to refer to a collection of connectivity definitions. Several connectivity parameters can be listed for a given application under this node.

This node contains configuration parameters for establishment of the PDN connection for reaching the V2X control function.

- Occurrence: ZeroOrOne
- Format: node
- Access Types: Get, Replace
- Values: N/A

#### 5.4.4 <X>/V2XProvisioning/ToConRefs/<X>

This run-time node acts as a placeholder for each reference to connectivity parameters.

- Occurrence: OneOrMore
- Format: node
- Access Types: Get, Replace
- Values: N/A

#### 5.4.5 <X>/V2XProvisioning/ToConRefs/<X>/ConRef

The ConRef leaf indicates a specific linkage to connectivity parameters.

- Occurrence: One
- Format: chr
- Access Types: Get, Replace
- Values: <A network access point object>

### 5.5 Configuration parameters for V2X communication over PC5

#### 5.5.1 <X>/V2XoverPC5

The V2XoverPC5 node contains the configuration parameters for V2X communication over PC5.

- Occurrence: One
- Format: node
- Access Types: Get, Replace
- Values: N/A

#### 5.5.2 <X>/V2XoverPC5/Expiration

The Expiration leaf indicates the expiration time of validity of the configuration parameters for V2X communication over PC5.

- Occurrence: One
- Format: int
- Access Types: Get, Replace
- Values: a 40 bits unsigned integer value indicating a UTC time, in seconds since midnight UTC of January 1, 1970 (not counting leap seconds).

### 5.5.3 <X>/V2XoverPC5/ServedByEUTRAN

The ServedByEUTRAN node contains the configuration parameters for V2X communication over PC5 when the UE is served by E-UTRAN.

- Occurrence: One
- Format: node
- Access Types: Get, Replace
- Values: N/A

### 5.5.4 <X>/V2XoverPC5/ServedByEUTRAN/AuthorizedPLMNs

The AuthorizedPLMNs node contains a list of PLMNs in which the UE is authorized to use V2X communication over PC5 when the UE is served by E-UTRAN.

- Occurrence: One
- Format: node
- Access Types: Get, Replace
- Values: N/A

### 5.5.5 <X>/V2XoverPC5/ServedByEUTRAN/AuthorizedPLMNs/<X>

This node acts as a placeholder for a PLMN in which the UE is authorized to use V2X communication over PC5 when the UE is served by E-UTRAN.

- Occurrence: ZeroOrMore
- Format: node
- Access Types: Get, Replace
- Values: N/A

### 5.5.6 <X>/V2XoverPC5/ServedByEUTRAN/AuthorizedPLMNs/<X>/PLMN

The PLMN leaf indicates a PLMN code of a PLMN in which the UE is authorized to use V2X communication over PC5 when the UE is served by E-UTRAN.

- Occurrence: One
- Format: chr
- Access Types: Get, Replace
- Values: <PLMN code>

The format of the PLMN code is defined by 3GPP TS 23.003 [7].

### 5.5.7 <X>/V2XoverPC5/NotServedByEUTRAN

The NotServedByEUTRAN node contains the configuration parameters for V2X communication over PC5 when the UE is not served by E-UTRAN.

- Occurrence: One
- Format: node
- Access Types: Get, Replace



- Values: N/A

### 5.5.8 <X>/V2XoverPC5/NotServedByEUTRAN/Authorized

The Authorized leaf indicates whether the UE is authorized to use V2X communication over PC5 when the UE is not served by E-UTRAN.

- Occurrence: One
  - Format: bool
  - Access Types: Get, Replace
  - Values: 0, 1
- 0 Indicates that the UE is not authorized to use V2X communication over PC5 when the UE is not served by E-UTRAN.
- 1 Indicates that the UE is authorized to use V2X communication over PC5 when the UE is not served by E-UTRAN.

### 5.5.9 <X>/V2XoverPC5/NotServedByEUTRAN/RadioParameters

The RadioParameters node contains sets of radio parameters for V2X communication over PC5 applicable when the UE is not served by E-UTRAN and is located in a geographical area.

- Occurrence: ZeroOrOne
- Format: node
- Access Types: Get, Replace
- Values: N/A

### 5.5.10 <X>/V2XoverPC5/NotServedByEUTRAN/RadioParameters/<X>

This node acts as a placeholder for one set of radio parameters for V2X communication over PC5 applicable when the UE is not served by E-UTRAN and is located in a given geographical area.

- Occurrence: OneOrMore
- Format: node
- Access Types: Get, Replace
- Values: N/A

The radio parameters indicated in the RadioParametersContents child node apply for V2X communication over PC5 when the UE is not served by E-UTRAN and is located in geographical area indicated by the GeographicalArea child node.

### 5.5.11 <X>/V2XoverPC5/NotServedByEUTRAN/RadioParameters/<X>/RadioParametersContents

The RadioParametersContents leaf indicates the radio parameters for V2x communication over PC5.

- Occurrence: One
- Format: bin
- Access Types: Get, Replace
- Values: <RadioParametersContents>

The RadioParameterContents is defined as *SL-Preconfiguration* in clause 9 of 3GPP TS 36.331 [8].

### 5.5.12 <X>/V2XoverPC5/NotServedByEUTRAN/RadioParameters/<X>/ GeographicalArea

The GeographicalArea node contains a geographical area description.

- Occurrence: One
- Format: node
- Access Types: Get, Replace
- Values: N/A

The UE is located in geographical area indicated by this node, if the UE is located in geographical area indicated by the Polygon child node.

### 5.5.13 <X>/V2XoverPC5/NotServedByEUTRAN/RadioParameters/<X>/ GeographicalArea/Polygon

The Polygon node contains polygon geographical area descriptions.

- Occurrence: One
- Format: node
- Access Types: Get, Replace
- Values: N/A

The UE is located in geographical area indicated by this node, if the UE is located in polygon geographical area indicated by at least one child node.

### 5.5.14 <X>/V2XoverPC5/NotServedByEUTRAN/RadioParameters/<X>/ GeographicalArea/Polygon/<X>

This node acts as a placeholder for a polygon geographical area description.

- Occurrence: OneOrMore
- Format: node
- Access Types: Get, Replace
- Values: N/A

The UE is located in polygon geographical area indicated by this node, if the UE is located inside a polygon described by the Coordinates child node.

### 5.5.15 <X>/V2XoverPC5/NotServedByEUTRAN/RadioParameters/<X>/ GeographicalArea/Polygon/<X>/Coordinates

The Coordinates node contains coordinates of a polygon geographical area description.

- Occurrence: One
- Format: node
- Access Types: Get, Replace
- Values: N/A

The UE is located inside a polygon described by this node, if the UE is located in a polygon outlines of which are formed by coordinates indicated by the child nodes.

### 5.5.16 <X>/V2XoverPC5/NotServedByEUTRAN/RadioParameters/<X>/GeographicalArea/Polygon/<X>/Coordinates/<X>

This node acts as a placeholder for a coordinate.

- Occurrence: OneOrMore
- Format: node
- Access Types: Get, Replace
- Values: N/A

### 5.5.17 <X>/V2XoverPC5/NotServedByEUTRAN/RadioParameters/<X>/GeographicalArea/Polygon/<X>/Coordinates/<X>/Latitude

The Latitude leaf indicates a latitude of a coordinate.

- Occurrence: One
- Format: bin
- Access Types: Get, Replace
- Values: <Latitude>

The latitude is defined in subclause 6.1 of 3GPP TS 23.032 [9].

### 5.5.18 <X>/V2XoverPC5/NotServedByEUTRAN/RadioParameters/<X>/GeographicalArea/Polygon/<X>/Coordinates/<X>/Longitude

The Longitude leaf indicates a longitude of a coordinate.

- Occurrence: One
- Format: bin
- Access Types: Get, Replace
- Values: <Longitude>

The longitude is defined in subclause 6.1 of 3GPP TS 23.032 [9].

### 5.5.19 <X>/V2XoverPC5/NotServedByEUTRAN/RadioParameters/<X>/OperatorManaged

The OperatorManaged leaf indicates whether the radio parameters are "operator managed" or "non-operator managed".

- Occurrence: One
- Format: bool
- Access Types: Get, Replace
- Values: 0, 1
  - 0 Indicates that the radio parameters are "non-operator managed".
  - 1 Indicates that the radio parameters are "operator managed".

### 5.5.20 <X>/V2XoverPC5/AuthorizedV2XServiceList

The AuthorizedV2XServiceList node contains V2X services authorized for V2X communication over PC5.

- Occurrence: One
- Format: node
- Access Types: Get, Replace
- Values: N/A

### 5.5.21 <X>/V2XoverPC5/AuthorizedV2XServiceList/<X>

This node acts as a placeholder for a V2X service authorized for V2X communication over PC5.

- Occurrence: ZeroOrMore
- Format: node
- Access Types: Get, Replace
- Values: N/A

The DestinationLayer2ID child node contains the layer 2 ID for V2X communication over PC5 to be used for V2X messages of V2X service with V2X service identified indicated by the V2XServiceIdentifier child node.

### 5.5.22 <X>/V2XoverPC5/AuthorizedV2XServiceList/<X>/ V2XServiceIdentifier

The V2XServiceIdentifier leaf indicates a V2X service identifier.

- Occurrence: One
- Format: int
- Access Types: Get, Replace
- Values: an integer between 0 and 4294967295.

V2X service identifiers are listed in ISO TS 17419 ITS-AID AssignedNumbers [10].

### 5.5.23 <X>/V2XoverPC5/AuthorizedV2XServiceList/<X>/ DestinationLayer2ID

The DestinationLayer2ID leaf indicates a layer 2 ID for V2X communication over PC5.

- Occurrence: One
- Format: bin
- Access Types: Get, Replace
- Values: layer 2 identifier

**Editor's note: a reference to access stratum spec is needed.**

### 5.5.24 <X>/V2XoverPC5/PPPPtoPDBMappingRule

The PPPPtoPDBMappingRule node contains the mapping rules between the ProSe Per-Packet Priority (PPPP) and Packet Delay Budget (PDB) for V2X communication over the PC5.

- Occurrence: ZeroOrOne

- Format: node
- Access Types: Get, Replace
- Values: N/A

### 5.5.25 <X>/V2XoverPC5/PPPPtoPDBMappingRule/<X>

This interior node acts as a placeholder for one or more mapping rules for V2X communication over the PC5.

- Occurrence: OneOrMore
- Format: node
- Access Types: Get, Replace
- Values: N/A

### 5.5.26 <X>/V2XoverPC5/PPPPtoPDBMappingRule/<X>/ ProSePerPacketPriority

The ProSePerPacketPriority leaf indicates the ProSe Per-Packet Priority value (as specified in 3GPP TS 23.303 [12]) configured by the mapping rule.

- Occurrence: One
- Format: int
- Access Types: Get, Replace
- Values: 1-8

### 5.5.27 <X>/V2XoverPC5/PPPPtoPDBMappingRule/<X>/ PacketDelayBudget

The PacketDelayBudget leaf indicates the Packet Delay Budget value in milliseconds to which the ProSe Per-Packet Priority value associated to the same mapping rule is mapped.

- Occurrence: One
- Format: int
- Access Types: Get, Replace
- Values: 1-65535

### 5.5.28 <X>/V2XoverPC5/TimerT5000

The TimerT5000 leaf indicates the duration, in units of seconds, after which the UE shall change the source Layer-2 ID and source IP address (for IP data) self-assigned by the UE while performing transmission of V2X communication over the PC5.

- Occurrence: ZeroOrOne
- Format: int
- Access Types: Get, Replace
- Values: 1-65535

## 5.6 Configuration parameters for V2X communication over LTE-Uu

### 5.6.1 <X>/V2XoverLTEUu

The V2XoverLTEUu node contains the configuration parameters for V2X communication over LTE-Uu.

- Occurrence: One
- Format: node
- Access Types: Get, Replace
- Values: N/A

### 5.6.2 <X>/V2XoverLTEUu/Expiration

The Expiration leaf indicates the expiration time of validity of the configuration parameters for V2X communication over LTE-Uu.

- Occurrence: One
- Format: int
- Access Types: Get, Replace
- Values: a 40 bits unsigned integer value indicating a UTC time, in seconds since midnight UTC of January 1, 1970 (not counting leap seconds).

### 5.6.3 <X>/V2XoverLTEUu/ToConRefs

The ToConRefs node is used to allow application to refer to a collection of connectivity definitions. Several connectivity parameters can be listed for a given application under this node.

This node contains configuration parameters for establishment of the PDN connection for reaching the V2X application server.

- Occurrence: ZeroOrOne
- Format: node
- Access Types: Get, Replace
- Values: N/A

### 5.6.4 <X>/V2XoverLTEUu/ToConRefs/<X>

This run-time node acts as a placeholder for each reference to connectivity parameters.

- Occurrence: OneOrMore
- Format: node
- Access Types: Get, Replace
- Values: N/A

### 5.6.5 <X>/V2XoverLTEUu/ToConRefs/<X>/ConRef

The ConRef leaf indicates a specific linkage to connectivity parameters.

- Occurrence: One

- Format: chr
- Access Types: Get, Replace
- Values: <A network access point object>

### 5.6.6 <X>/V2XoverLTEUu/AuthorizedPLMNs

The AuthorizedPLMNs node contains a list of PLMNs in which the UE is authorized to use V2X communication over LTE-Uu.

- Occurrence: One
- Format: node
- Access Types: Get, Replace
- Values: N/A

### 5.6.7 <X>/V2XoverLTEUu/AuthorizedPLMNs/<X>

This node acts as a placeholder for a PLMN in which the UE is authorized to use V2X communication over LTE-Uu.

- Occurrence: ZeroOrMore
- Format: node
- Access Types: Get, Replace
- Values: N/A

### 5.6.8 <X>/V2XoverLTEUu/AuthorizedPLMNs/<X>/PLMN

The PLMN leaf indicates a PLMN code of a PLMN in which the UE is authorized to use V2X communication over LTE-Uu.

- Occurrence: One
- Format: chr
- Access Types: Get, Replace
- Values: <PLMN code>

The format of the PLMN code is defined by 3GPP TS 23.003 [7].

### 5.6.9 <X>/V2XoverLTEUu/AuthorizedPLMNs/<X>/V2XASMBMSConfig

The V2XASMBMSConfig node contains an MBMS configuration for receiving V2X application server information using MBMS in the PLMN in which this authorization policy applies.

- Occurrence: ZeroOrOne
- Format: node
- Access Types: Get, Replace
- Values: N/A

### 5.6.10 <X>/V2XoverLTEUu/AuthorizedPLMNs/<X>/V2XASMBMSConfig/ TMGI

The TMGI leaf indicates a TMGI for receiving V2X application server information using MBMS in the PLMN in which this authorization policy applies.

- Occurrence: One
- Format: chr
- Access Types: Get, Replace
- Values: <TMGI>

The format of the TMGI is defined by 3GPP TS 23.003 [7].

### 5.6.11 <X>/V2XoverLTEUu/AuthorizedPLMNs/<X>/V2XASMBMSConfig/ SAIList

The SAIList node contains a list of Service Area Identifiers (SAIs) for receiving V2X application server information using MBMS in the PLMN in which this authorization policy applies.

- Occurrence: One
- Format: node
- Access Types: Get, Replace
- Values: N/A

### 5.6.12 <X>/V2XoverLTEUu/AuthorizedPLMNs/<X>/V2XASMBMSConfig/ SAIList/<X>

This interior node acts as a placeholder for one or more SAI(s) for receiving V2X application server information using MBMS in the PLMN in which this authorization policy applies.

- Occurrence: OneOrMore
- Format: node
- Access Types: Get, Replace
- Values: N/A

### 5.6.13 <X>/V2XoverLTEUu/AuthorizedPLMNs/<X>/V2XASMBMSConfig/ SAIList/<X>/SAI

The SAI leaf indicates an SAI for receiving V2X application server information using MBMS in the PLMN in which this authorization policy applies.

- Occurrence: One
- Format: chr
- Access Types: Get, Replace
- Values: <SAI>

The format of the SAI is defined by 3GPP TS 23.003 [7].



### 5.6.14 <X>/V2XoverLTEUu/AuthorizedPLMNs/<X>/V2XASMBMSConfig/ Frequency

The Frequency leaf indicates a frequency for receiving V2X application server information using MBMS in the PLMN in which this authorization policy applies.

- Occurrence: ZeroOrOne
- Format: chr
- Access Types: Get, Replace
- Values: <EARFCN>

The format of the EARFCN is defined by 3GPP TS 36.101 [11].

### 5.6.15 <X>/V2XoverLTEUu/AuthorizedPLMNs/<X>/V2XASMBMSConfig/ SDPInV2XASMBMSConfig

The SDPInV2XASMBMSConfig leaf indicates an SDP for receiving V2X application server information using MBMS in the PLMN in which this authorization policy applies.

- Occurrence: One
- Format: chr
- Access Types: Get, Replace
- Values: <SDPInV2XASMBMSConfig>

The format of the SDPInV2XASMBMSConfig is defined by 3GPP TS 24.386 [4].

### 5.6.16 <X>/V2XoverLTEUu/AuthorizedPLMNs/<X>/ V2XServiceIdentifierUnrelated

The V2XServiceIdentifierUnrelated node contains parameters related to V2X services not identified by a V2X service identifier.

- Occurrence: One
- Format: node
- Access Types: Get, Replace
- Values: N/A

The V2XMBMSConfigs child node describes one or more MBMS configurations for receiving a V2X message using V2X communication over LTE-Uu applicable when the V2X message is of a V2X service not identified by a V2X service identifier.

Absence of the V2XMBMSConfigs child node indicates that the UE cannot receive the V2X messages of V2X services not identified by a V2X service identifier using V2X communication over LTE-Uu using MBMS.

The V2XASAddresses child node contains the V2X application server addresses for transport of a V2X message using V2X communication over LTE-Uu applicable when the V2X message is of a V2X service not identified by a V2X service identifier.

Absence of the V2XASAddresses child node indicates that the UE cannot receive the V2X messages of V2X services not identified by a V2X service identifier using V2X communication over LTE-Uu using unicast and that the UE cannot send V2X messages of V2X services not identified by a V2X service identifier using V2X communication over LTE-Uu.

### 5.6.17 <X>/V2XoverLTEUu/AuthorizedPLMNs/<X>/ V2XServiceIdentifierUnrelated/V2XMBMSConfigs

The V2XMBMSConfig node contains one or more MBMS configurations for receiving V2X messages using MBMS in the PLMN in which this authorization policy applies.

- Occurrence: ZeroOrOne
- Format: node
- Access Types: Get, Replace
- Values: N/A

### 5.6.18 <X>/V2XoverLTEUu/AuthorizedPLMNs/<X>/ V2XServiceIdentifierUnrelated/V2XMBMSConfigs/<X>

This node acts as a placeholder for one or more MBMS configurations for receiving V2X messages using MBMS in the PLMN in which this authorization policy applies.

- Occurrence: OneOrMore
- Format: node
- Access Types: Get, Replace
- Values: N/A

### 5.6.19 <X>/V2XoverLTEUu/AuthorizedPLMNs/<X>/ V2XServiceIdentifierUnrelated/V2XMBMSConfigs/<X>/V2XMBMSC onfig

The V2XMBMSConfig node contains an MBMS configuration for receiving V2X messages using MBMS in the PLMN in which this authorization policy applies.

- Occurrence: One
- Format: node
- Access Types: Get, Replace
- Values: N/A

### 5.6.20 <X>/V2XoverLTEUu/AuthorizedPLMNs/<X>/ V2XServiceIdentifierUnrelated/V2XMBMSConfigs/<X>/V2XMBMSC onfig/TMGI

The TMGI leaf indicates a TMGI for receiving V2X messages using MBMS in the PLMN in which this authorization policy applies.

- Occurrence: One
- Format: chr
- Access Types: Get, Replace
- Values: <TMGI>

The format of the TMGI is defined by 3GPP TS 23.003 [7].

### 5.6.21 <X>/V2XoverLTEUu/AuthorizedPLMNs/<X>/ V2XServiceIdentifierUnrelated/V2XMBMSConfigs/<X>/V2XMBMSC onfig/SAIList

The SAIList node contains a list of Service Area Identifiers (SAIs) for receiving V2X messages using MBMS in the PLMN in which this authorization policy applies.

- Occurrence: One
- Format: node
- Access Types: Get, Replace
- Values: N/A

### 5.6.22 <X>/V2XoverLTEUu/AuthorizedPLMNs/<X>/ V2XServiceIdentifierUnrelated/V2XMBMSConfigs/<X>/V2XMBMSC onfig/SAIList/<X>

This interior node acts as a placeholder for one or more SAI(s) for receiving V2X messages using MBMS in the PLMN in which this authorization policy applies.

- Occurrence: OneOrMore
- Format: node
- Access Types: Get, Replace
- Values: N/A

### 5.6.23 <X>/V2XoverLTEUu/AuthorizedPLMNs/<X>/ V2XServiceIdentifierUnrelated/V2XMBMSConfigs/<X>/V2XMBMSC onfig/SAIList/<X>/SAI

The SAI leaf indicates an SAI for receiving V2X messages using MBMS in the PLMN in which this authorization policy applies.

- Occurrence: One
- Format: chr
- Access Types: Get, Replace
- Values: <SAI>

The format of the SAI is defined by 3GPP TS 23.003 [7].

### 5.6.24 <X>/V2XoverLTEUu/AuthorizedPLMNs/<X>/ V2XServiceIdentifierUnrelated/V2XMBMSConfigs/<X>/V2XMBMSC onfig/Frequency

The Frequency leaf indicates a frequency for receiving V2X messages using MBMS in the PLMN in which this authorization policy applies.

- Occurrence: ZeroOrOne
- Format: chr
- Access Types: Get, Replace

- Values: <EARFCN>

The format of the EARFCN is defined by 3GPP TS 36.101 [11].

### 5.6.25 <X>/V2XoverLTEUu/AuthorizedPLMNs/<X>/ V2XServiceIdentifierUnrelated/V2XMBMSConfigs/<X>/V2XMBMSC onfig/ SDPInV2XMBMSConfig

The SDPInV2XMBMSConfig leaf indicates an SDP for receiving V2X messages using MBMS in the PLMN in which this authorization policy applies.

- Occurrence: One
- Format: chr
- Access Types: Get, Replace
- Values: <SDPInV2XMBMSConfig>

The format of the SDPInV2XMBMSConfig is defined by 3GPP TS 24.386 [4].

### 5.6.26 <X>/V2XoverLTEUu/AuthorizedPLMNs/<X>/ V2XServiceIdentifierUnrelated/V2XASAddresses

The V2XASAddresses node contains V2X server addresses for transport of V2X messages.

- Occurrence: ZeroOrOne
- Format: node
- Access Types: Get, Replace
- Values: N/A

### 5.6.27 <X>/V2XoverLTEUu/AuthorizedPLMNs/<X>/ V2XServiceIdentifierUnrelated/V2XASAddress/<X>

This node acts as a placeholder for a V2X server address applicable in a geographical area.

- Occurrence: OneOrMore
- Format: node
- Access Types: Get, Replace
- Values: N/A

If the GeographicalArea child node is included, the V2X server address indicated in the L3Address child node and UDPPort child node is applicable when the UE is located in geographical area indicated by the GeographicalArea child node.

If the GeographicalArea child node is not included, the V2X server address indicated in the L3Address child node and UDPPort child node is not restricted to a geographical area.

### 5.6.28 <X>/V2XoverLTEUu/AuthorizedPLMNs/<X>/ V2XServiceIdentifierUnrelated/V2XASAddress/<X>/L3Address

The L3Address leaf indicates a IP address or FQDN of the V2X application server.

- Occurrence: One

- Format: chr
- Access Types: Get, Replace
- Values: an FQDN or an IP address.

### 5.6.29 <X>/V2XoverLTEUu/AuthorizedPLMNs/<X>/ V2XServiceIdentifierUnrelated/V2XASAddress/<X>/UDPPort

The UDPPort leaf indicates a UDP port of the V2X application server.

- Occurrence: One
- Format: int
- Access Types: Get, Replace
- Values: integer between 0 and 65535

### 5.6.30 <X>/V2XoverLTEUu/AuthorizedPLMNs/<X>/ V2XServiceIdentifierUnrelated/V2XASAddress/<X>/ GeographicalArea

The GeographicalArea node contains a geographical area description.

- Occurrence: ZeroOrOne
- Format: node
- Access Types: Get, Replace
- Values: N/A

The UE is located in geographical area indicated by this node, if the UE is located in geographical area indicated by the Polygon child node.

### 5.6.31 <X>/V2XoverLTEUu/AuthorizedPLMNs/<X>/ V2XServiceIdentifierUnrelated/V2XASAddress/<X>/GeographicalAr ea/Polygon

This node and its descendants are the same as the node defined in subclause 5.5.13.

### 5.6.32 <X>/V2XoverLTEUu/AuthorizedPLMNs/<X>/ V2XServiceIdentifierRelated

The V2XServiceIdentifierRelated node contains parameters related to V2X services identified by a V2X service identifier.

The AuthorizedV2XServiceList child node indicates parameters related to V2X services identified by a particular V2X service identifier.

The DefaultV2XMBMConfigs child node and the DefaultV2XASAddresses child node indicate parameters related to a V2X service identified by a V2X service identifier for which the AuthorizedV2XServiceList child node does not contain the parameters.

- Occurrence: One
- Format: node
- Access Types: Get, Replace

- Values: N/A

### 5.6.33 <X>/V2XoverLTEUu/AuthorizedPLMNs/<X>/ V2XServiceIdentifierRelated/AuthorizedV2XServiceList

The AuthorizedV2XServiceList node contains V2X services identified by a V2X service identifier, authorized for V2X communication over LTE-Uu.

- Occurrence: One
- Format: node
- Access Types: Get, Replace
- Values: N/A

### 5.6.34 <X>/V2XoverLTEUu/AuthorizedPLMNs/<X>/ V2XServiceIdentifierRelated/AuthorizedV2XServiceList/<X>

This node acts as a placeholder for a V2X service identified by a V2X service identifier, authorized for V2X communication over LTE-Uu.

- Occurrence: ZeroOrMore
- Format: node
- Access Types: Get, Replace
- Values: N/A

The V2XMBMSConfigs child node describes one or more MBMS configuration(s) for receiving a V2X message using V2X communication over LTE-Uu applicable when the V2X message is of a V2X service with the V2X service identifier indicated by the V2XServiceIdentifier child node.

Absence of the V2XMBMSConfigs child node indicates that the UE cannot receive the V2X messages of the V2X service with the V2X service identifier indicated by the V2XServiceIdentifier child node using V2X communication over LTE-Uu using MBMS.

The V2XASAddresses child node contains the V2X application server addresses for transport of a V2X message using V2X communication over LTE-Uu applicable when the V2X message is of a V2X service with the V2X service identifier indicated by the V2XServiceIdentifier child node.

Absence of the V2XASAddresses child node indicates that the UE cannot receive the V2X messages of the V2X service with the V2X service identifier indicated by the V2XServiceIdentifier child node using V2X communication over LTE-Uu using unicast and that the UE cannot send V2X messages of the V2X service with the V2X service identifier indicated by the V2XServiceIdentifier child node using V2X communication over LTE-Uu.

### 5.6.35 <X>/V2XoverLTEUu/AuthorizedPLMNs/<X>/ V2XServiceIdentifierRelated/AuthorizedV2XServiceList/<X>/ V2XServiceIdentifier

This node is the same as the node defined in subclause 5.5.22.

### 5.6.36 <X>/V2XoverLTEUu/AuthorizedPLMNs/<X>/ V2XServiceIdentifierRelated/AuthorizedV2XServiceList/<X>/ V2XMBMSConfigs

The V2XMBMSConfig node contains one or more MBMS configurations for receiving V2X messages using MBMS in the PLMN in which this authorization policy applies.

- Occurrence: ZeroOrOne
- Format: node
- Access Types: Get, Replace
- Values: N/A

### 5.6.37 <X>/V2XoverLTEUu/AuthorizedPLMNs/<X>/ V2XServiceIdentifierRelated/AuthorizedV2XServiceList/<X>/ V2XMBMSConfigs/<X>

This node acts as a placeholder for one or more MBMS configurations for receiving V2X messages using MBMS in the PLMN in which this authorization policy applies.

- Occurrence: OneOrMore
- Format: node
- Access Types: Get, Replace
- Values: N/A

### 5.6.38 <X>/V2XoverLTEUu/AuthorizedPLMNs/<X>/ V2XServiceIdentifierRelated/AuthorizedV2XServiceList/<X>/V2XMB MSConfigs/<X>/ V2XMBMSConfig

The V2XMBMSConfig node contains an MBMS configuration for receiving V2X messages using MBMS, for the associated V2X service identifier, in the PLMN in which this authorization policy applies.

- Occurrence: One
- Format: node
- Access Types: Get, Replace
- Values: N/A

### 5.6.39 <X>/V2XoverLTEUu/AuthorizedPLMNs/<X>/ V2XServiceIdentifierRelated/AuthorizedV2XServiceList/<X>/V2XMB MSConfigs/<X>/ V2XMBMSConfig/TMGI

The TMGI leaf indicates a TMGI for receiving V2X messages using MBMS, for the associated V2X service identifier, in the PLMN in which this authorization policy applies.

- Occurrence: ZeroOrOne
- Format: chr
- Access Types: Get, Replace
- Values: <TMGI>

The format of the TMGI is defined by 3GPP TS 23.003 [7].

5.6.40 <X>/V2XoverLTEUu/AuthorizedPLMNs/<X>/  
V2XServiceIdentifierRelated/AuthorizedV2XServiceList/<X>/V2XMB  
MSConfigs/<X>/  
V2XMBMSConfig/SAIList

The SAIList node contains a list of Service Area Identifiers (SAIs) for receiving V2X messages using MBMS, for the associated V2X service identifier, in the PLMN in which this authorization policy applies.

- Occurrence: One
- Format: node
- Access Types: Get, Replace
- Values: N/A

5.6.41 <X>/V2XoverLTEUu/AuthorizedPLMNs/<X>/  
V2XServiceIdentifierRelated/AuthorizedV2XServiceList/<X>/V2XMB  
MSConfigs/<X>/  
V2XMBMSConfig/SAIList/<X>

This interior node acts as a placeholder for one or more SAI(s) for receiving V2X messages using MBMS, for the associated V2X service identifier, in the PLMN in which this authorization policy applies.

- Occurrence: OneOrMore
- Format: node
- Access Types: Get, Replace
- Values: N/A

5.6.42 <X>/V2XoverLTEUu/AuthorizedPLMNs/<X>/  
V2XServiceIdentifierRelated/AuthorizedV2XServiceList/<X>/V2XMB  
MSConfigs/<X>/  
V2XMBMSConfig/SAIList/<X>/SAI

The SAI leaf indicates an SAI for receiving V2X messages using MBMS, for the associated V2X service identifier, in the PLMN in which this authorization policy applies.

- Occurrence: One
- Format: chr
- Access Types: Get, Replace
- Values: <SAI>

The format of the SAI is defined by 3GPP TS 23.003 [7].

5.6.43 <X>/V2XoverLTEUu/AuthorizedPLMNs/<X>/  
V2XServiceIdentifierRelated/AuthorizedV2XServiceList/<X>/V2XMB  
MSConfigs/<X>/  
V2XMBMSConfig/Frequency

The Frequency leaf indicates a frequency for receiving V2X messages using MBMS, for the associated V2X service identifier, in the PLMN in which this authorization policy applies.



- Occurrence: ZeroOrOne
- Format: chr
- Access Types: Get, Replace
- Values: <EARFCN>

The format of the EARFCN is defined by 3GPP TS 36.101 [11].

#### 5.6.44 <X>/V2XoverLTEUu/AuthorizedPLMNs/<X>/ V2XServiceIdentifierRelated/AuthorizedV2XServiceList/<X>/V2XMB MSConfigs/<X>/ V2XMBMSConfig/SDPInV2XMBMSConfig

The SDPInV2XMBMSConfig leaf indicates an SDP for receiving V2X messages using MBMS, for the associated V2X service identifier, in the PLMN in which this authorization policy applies.

- Occurrence: One
- Format: chr
- Access Types: Get, Replace
- Values: <SDPInV2XMBMSConfig>

The format of the SDPInV2XMBMSConfig is defined by 3GPP TS 24.386 [4].

- NOTE: The V2X message family information is not included in the SDPInV2XMBMSConfig contained in this leaf since the SDPInV2XMBMSConfig is associated with a V2X service identifier.

#### 5.6.45 <X>/V2XoverLTEUu/AuthorizedPLMNs/<X>/ V2XServiceIdentifierRelated/AuthorizedV2XServiceList/<X>/ V2XASAddresses

This node and its descendants are the same as the node defined in subclause 5.6.26.

#### 5.6.46 <X>/V2XoverLTEUu/AuthorizedPLMNs/<X>/ V2XServiceIdentifierRelated/DefaultV2XMBMSConfigs

The V2XMBMSConfig node contains one or more default MBMS configurations for receiving V2X messages using MBMS in the PLMN in which this authorization policy applies.

- Occurrence: ZeroOrOne
- Format: node
- Access Types: Get, Replace
- Values: N/A

#### 5.6.47 <X>/V2XoverLTEUu/AuthorizedPLMNs/<X>/ V2XServiceIdentifierRelated/DefaultV2XMBMSConfigs/<X>

This node acts as a placeholder for one or more default MBMS configurations for receiving V2X messages of V2X services with a V2X service identifier using MBMS in the PLMN in which this authorization policy applies.

- Occurrence: OneOrMore
- Format: node

- Access Types: Get, Replace
- Values: N/A

#### 5.6.48 <X>/V2XoverLTEUu/AuthorizedPLMNs/<X>/ V2XServiceIdentifierRelated/DefaultV2XMBMSConfigs/<X>/ V2XMBMSConfig

The V2XMBMSConfig node contains a default MBMS configuration for receiving V2X messages of V2X services with a V2X service identifier using MBMS, in the PLMN in which this authorization policy applies.

- Occurrence: One
- Format: node
- Access Types: Get, Replace
- Values: N/A

#### 5.6.49 <X>/V2XoverLTEUu/AuthorizedPLMNs/<X>/ V2XServiceIdentifierRelated/DefaultV2XMBMSConfigs/<X>/ V2XMBMSConfig/TMGI

The TMGI leaf indicates a TMGI for receiving V2X messages of V2X services with a V2X service identifier using MBMS, in the PLMN in which this authorization policy applies.

- Occurrence: ZeroOrOne
- Format: chr
- Access Types: Get, Replace
- Values: <TMGI>

The format of the TMGI is defined by 3GPP TS 23.003 [7].

#### 5.6.50 <X>/V2XoverLTEUu/AuthorizedPLMNs/<X>/ V2XServiceIdentifierRelated/DefaultV2XMBMSConfigs/<X>/ V2XMBMSConfig/SAIList

The SAIList node contains a list of Service Area Identifiers (SAIs) for receiving V2X messages of V2X services with a V2X service identifier using MBMS, in the PLMN in which this authorization policy applies.

- Occurrence: One
- Format: node
- Access Types: Get, Replace
- Values: N/A

#### 5.6.51 <X>/V2XoverLTEUu/AuthorizedPLMNs/<X>/ V2XServiceIdentifierRelated/DefaultV2XMBMSConfigs/<X>/ V2XMBMSConfig/SAIList/<X>

This interior node acts as a placeholder for one or more SAI(s) for receiving V2X messages of V2X services with a V2X service identifier using MBMS, in the PLMN in which this authorization policy applies.

- Occurrence: OneOrMore

- Format: node
- Access Types: Get, Replace
- Values: N/A

#### 5.6.52 <X>/V2XoverLTEUu/AuthorizedPLMNs/<X>/ V2XServiceIdentifierRelated/DefaultV2XMBMSConfigs/<X>/ V2XMBMSConfig/SAIList/<X>/SAI

The SAI leaf indicates an SAI for receiving V2X messages of V2X services with a V2X service identifier using MBMS, in the PLMN in which this authorization policy applies.

- Occurrence: One
- Format: chr
- Access Types: Get, Replace
- Values: <SAI>

The format of the SAI is defined by 3GPP TS 23.003 [7].

#### 5.6.53 <X>/V2XoverLTEUu/AuthorizedPLMNs/<X>/ V2XServiceIdentifierRelated/DefaultV2XMBMSConfigs/<X>/ V2XMBMSConfig/Frequency

The Frequency leaf indicates a frequency for receiving V2X messages of V2X services with a V2X service identifier using MBMS, in the PLMN in which this authorization policy applies.

- Occurrence: ZeroOrOne
- Format: chr
- Access Types: Get, Replace
- Values: <EARFCN>

The format of the EARFCN is defined by 3GPP TS 36.101 [11].

#### 5.6.54 <X>/V2XoverLTEUu/AuthorizedPLMNs/<X>/ V2XServiceIdentifierRelated/DefaultV2XMBMSConfigs/<X>/ V2XMBMSConfig/SDPInV2XMBMSConfig

The SDPInV2XMBMSConfig leaf indicates an SDP for receiving V2X messages of V2X services with a V2X service identifier using MBMS, in the PLMN in which this authorization policy applies.

- Occurrence: One
- Format: chr
- Access Types: Get, Replace
- Values: <SDPInV2XMBMSConfig>

The format of the SDPInV2XMBMSConfig is defined by 3GPP TS 24.386 [4].

### 5.6.55 <X>/V2XoverLTEUu/AuthorizedPLMNs/<X>/ V2XServiceIdentifierRelated/ DefaultV2XASAddresses

The V2XASAddresses node contains default V2X server addresses for transport of V2X messages.

- Occurrence: ZeroOrOne
- Format: node
- Access Types: Get, Replace
- Values: N/A

### 5.6.56 <X>/V2XoverLTEUu/AuthorizedPLMNs/<X>/ V2XServiceIdentifierRelated/ DefaultV2XASAddresses/<X>

This node acts as a placeholder for default V2X server addresses for transport of V2X messages.

- Occurrence: OneOrMore
- Format: node
- Access Types: Get, Replace
- Values: N/A

### 5.6.57 <X>/V2XoverLTEUu/AuthorizedPLMNs/<X>/ V2XServiceIdentifierRelated/ DefaultV2XASAddresses/<X>/TypeOfData

The TypeOfData node indicates type of data of V2X message.

- Occurrence: One
- Format: int
- Access Types: Get, Replace
- Values: 0, 1
  - 0 IP type of data.
  - 1 non-IP type of data.

### 5.6.58 <X>/V2XoverLTEUu/AuthorizedPLMNs/<X>/ V2XServiceIdentifierRelated/ DefaultV2XASAddresses/<X>/V2XMessageFamily

The V2XMessageFamily node indicates V2X message family of V2X message of non-IP type of data.

- Occurrence: ZeroOrOne
- Format: int
- Access Types: Get, Replace
- Values: <a V2X message family as specified in 3GPP TS 24.386 [4] subclause 7.1>

### 5.6.59 <X>/V2XoverLTEUu/AuthorizedPLMNs/<X>/ V2XServiceIdentifierRelated/DefaultV2XASAddresses/<X>/ V2XASAddresses

This node and its descendants are the same as the node defined in subclause 5.6.26.

---

## 5.7 <X>/Ext

The Ext is an interior node for where the vendor specific information about the V2X communication provisioning MO is being placed (vendor meaning application vendor, device vendor etc.). Usually the vendor extension is identified by vendor specific name under the ext node. The tree structure under the vendor identifier is not defined and can therefore include one or more un-standardized sub-trees.

- Occurrence: ZeroOrOne
- Format: node
- Access Types: Get
- Values: N/A

## Annex A (informative): V2X Communication Provisioning MO DDF

This DDF is the standardized minimal set. A vendor can define its own DDF for the complete device. This DDF can include more features than this minimal standardized version.

```
<?xml version="1.0" encoding="UTF-8"?>
<!DOCTYPE MgmtTree PUBLIC "-//OMA//DTD-DM-DDF 1.2//EN"
"http://www.openmobilealliance.org/tech/DTD/dm_ddf-v1_2.dtd">

<MgmtTree>
  <VerDTD>1.2</VerDTD>
  <Man>--The device manufacturer--</Man>
  <Mod>--The device model--</Mod>

  <Node>
    <NodeName/>
    <DFProperties>
      <AccessType>
        <Get/>
      </AccessType>
      <Description>V2X Communication Provisioning</Description>
      <DFFormat>
        <node/>
      </DFFormat>
      <Occurrence>
        <OneOrMore/>
      </Occurrence>
      <DFTitle>The V2X Communication Provisioning Management Object.</DFTitle>
      <DFType>
        <DDFName/>urn:oma:mo:ext-3gpp-V2X-communication-provisioning:1.0<DDFName/>
      </DFType>
    </DFProperties>

    <Node>
      <NodeName>Name</NodeName>
      <DFProperties>
        <AccessType>
          <Get/>
        </AccessType>
        <DFFormat>
          <chr/>
        </DFFormat>
        <Occurrence>
          <One/>
        </Occurrence>
        <DFTitle>User displayable name for the node.</DFTitle>
        <DFType>
          <MIME>text/plain</MIME>
        </DFType>
      </DFProperties>
    </Node>

    <Node>
      <NodeName>V2XProvisioning</NodeName>
      <!-- The V2XProvisioning node starts here. -->
      <DFProperties>
        <AccessType>
          <Get/>
          <Replace/>
        </AccessType>
        <DFFormat>
          <node/>
        </DFFormat>
        <Occurrence>
          <One/>
        </Occurrence>
        <DFTitle>Configuration parameters for V2X provisioning.</DFTitle>
        <DFType>
          <DDFName/>
        </DFType>
      </DFProperties>

    <Node>
      <NodeName>V2XControlFunctionAddress</NodeName>
```

```

    <DFProperties>
      <AccessType>
        <Get/>
        <Replace/>
      </AccessType>
      <DFFormat>
        <chr/>
      </DFFormat>
      <Occurrence>
        <ZeroOrOne/>
      </Occurrence>
      <DFTitle>The V2X control function address.</DFTitle>
      <DFType>
        <DDFName/>
      </DFType>
    </DFProperties>
  </Node>

  <Node>
    <NodeName>ToConRefs</NodeName>
    <DFProperties>
      <AccessType>
        <Get/>
        <Replace/>
      </AccessType>
      <DFFormat>
        <node/>
      </DFFormat>
      <Occurrence>
        <ZeroOrOne/>
      </Occurrence>
      <DFTitle>collection of connectivity definitions.</DFTitle>
      <DFType>
        <DDFName/>
      </DFType>
    </DFProperties>

    <Node>
      <NodeName/>
      <DFProperties>
        <AccessType>
          <Get/>
          <Replace/>
        </AccessType>
        <DFFormat>
          <node/>
        </DFFormat>
        <Occurrence>
          <OneOrMore/>
        </Occurrence>
        <DFTitle>The name node for one or more connectivity parameters.</DFTitle>
        <DFType>
          <DDFName/>
        </DFType>
      </DFProperties>

      <Node>
        <NodeName>ConRef</NodeName>
        <DFProperties>
          <AccessType>
            <Get/>
            <Replace/>
          </AccessType>
          <DFFormat>
            <chr/>
          </DFFormat>
          <Occurrence>
            <One/>
          </Occurrence>
          <DFTitle> Linkage to connectivity parameters.</DFTitle>
          <DFType>
            <MIME>text/plain</MIME>
          </DFType>
        </DFProperties>
      </Node>
    </Node>
  </Node>
</Node>

```

```

<Node>
  <NodeName>V2XoverPC5</NodeName>
  <!-- The V2XoverPC5 node starts here. -->
  <DFProperties>
    <AccessType>
      <Get/>
      <Replace/>
    </AccessType>
    <DFFormat>
      <node/>
    </DFFormat>
    <Occurrence>
      <One/>
    </Occurrence>
    <DFTitle>Configuration parameters for V2X communication over PC5.</DFTitle>
    <DFType>
      <DDFName/>
    </DFType>
  </DFProperties>

  <Node>
    <NodeName>Expiration</NodeName>
    <DFProperties>
      <AccessType>
        <Get/>
        <Replace/>
      </AccessType>
      <DFFormat>
        <int/>
      </DFFormat>
      <Occurrence>
        <One/>
      </Occurrence>
      <DFTitle>Expiration time of validity.</DFTitle>
      <DFType>
        <DDFName/>
      </DFType>
    </DFProperties>
  </Node>

  <Node>
    <NodeName>ServedByEUTRAN</NodeName>
    <DFProperties>
      <AccessType>
        <Get/>
        <Replace/>
      </AccessType>
      <DFFormat>
        <node/>
      </DFFormat>
      <Occurrence>
        <One/>
      </Occurrence>
      <DFTitle>Configuration parameters for V2X communication over PC5 when served by
E-UTRAN.</DFTitle>
      <DFType>
        <DDFName/>
      </DFType>
    </DFProperties>

    <Node>
      <NodeName>AuthorizedPLMNs</NodeName>
      <DFProperties>
        <AccessType>
          <Get/>
          <Replace/>
        </AccessType>
        <DFFormat>
          <node/>
        </DFFormat>
        <Occurrence>
          <One/>
        </Occurrence>
        <DFTitle>Authorization per PLMN policies for V2X communication over PC5 when
served by E-UTRAN.</DFTitle>
        <DFType>
          <DDFName/>
        </DFType>
      </DFProperties>
    </Node>
  </Node>

```



```

    </DFType>
  </DFProperties>

  <Node>
    <NodeName></NodeName>
    <DFProperties>
      <AccessType>
        <Get/>
        <Replace/>
      </AccessType>
      <DFFormat>
        <node/>
      </DFFormat>
      <Occurrence>
        <ZeroOrMore/>
      </Occurrence>
      <DFType>
        <DDFName></DDFName>
      </DFType>
    </DFProperties>

    <Node>
      <NodeName>PLMN</NodeName>
      <DFProperties>
        <AccessType>
          <Get/>
          <Replace/>
        </AccessType>
        <DFFormat>
          <chr/>
        </DFFormat>
        <Occurrence>
          <One/>
        </Occurrence>
        <DFTitle>PLMN code.</DFTitle>
        <DFType>
          <MIME>text/plain</MIME>
        </DFType>
      </DFProperties>
    </Node>
  </Node>
</Node>

<Node>
  <NodeName>NotServedByEUTRAN</NodeName>
  <DFProperties>
    <AccessType>
      <Get/>
      <Replace/>
    </AccessType>
    <DFFormat>
      <node/>
    </DFFormat>
    <Occurrence>
      <One/>
    </Occurrence>
    <DFTitle>Configuration parameters for V2X communicatio over PC5 when not served
  by E-UTRAN.</DFTitle>
    <DFType>
      <DDFName/>
    </DFType>
  </DFProperties>

  <Node>
    <NodeName>Authorized</NodeName>
    <DFProperties>
      <AccessType>
        <Get/>
        <Replace/>
      </AccessType>
      <DFFormat>
        <bool/>
      </DFFormat>
      <Occurrence>
        <One/>
      </Occurrence>
    </DFProperties>
  </Node>

```

```

        <DFTitle>Authorization for V2X communication over PC5 when not served by E-
UTRAN.</DFTitle>
        <DFType>
          <DDFName/>
        </DFType>
      </DFProperties>
    </Node>

    <Node>
      <NodeName>RadioParameters</NodeName>
      <DFProperties>
        <AccessType>
          <Get/>
          <Replace/>
        </AccessType>
        <DFFormat>
          <node/>
        </DFFormat>
        <Occurrence>
          <ZeroOrMore/>
        </Occurrence>
        <DFTitle>Radio parameters for V2X communication over PC5 when not served by
E-UTRAN.</DFTitle>
        <DFType>
          <DDFName/>
        </DFType>
      </DFProperties>

      <Node>
        <NodeName></NodeName>
        <DFProperties>
          <AccessType>
            <Get/>
            <Replace/>
          </AccessType>
          <DFFormat>
            <node/>
          </DFFormat>
          <Occurrence>
            <OneOrMore/>
          </Occurrence>
          <DFType>
            <DDFName></DDFName>
          </DFType>
        </DFProperties>

        <Node>
          <NodeName>RadioParametersContents</NodeName>
          <DFProperties>
            <AccessType>
              <Get/>
              <Replace/>
            </AccessType>
            <DFFormat>
              <bin/>
            </DFFormat>
            <Occurrence>
              <One/>
            </Occurrence>
            <DFTitle>Radio parameters defined by 3GPP RAN WG.</DFTitle>
            <DFType>
              <MIME>text/plain</MIME>
            </DFType>
          </DFProperties>
        </Node>

        <Node>
          <NodeName>GeographicalArea</NodeName>
          <DFProperties>
            <AccessType>
              <Get/>
              <Replace/>
            </AccessType>
            <DFFormat>
              <node/>
            </DFFormat>
            <Occurrence>
              <One/>
            </Occurrence>
          </DFProperties>
        </Node>
      </Node>
    </Node>
  </DFProperties>
</DFType>

```

```

    </Occurrence>
    <DFTitle>Geographical Area description.</DFTitle>
    <DFType>
      <MIME>text/plain</MIME>
    </DFType>
  </DFProperties>

  <Node>
    <NodeName>Polygon</NodeName>
    <DFProperties>
      <AccessType>
        <Get/>
        <Replace/>
      </AccessType>
      <DFFormat>
        <node/>
      </DFFormat>
      <Occurrence>
        <One/>
      </Occurrence>
      <DFTitle>Polygon Area description.</DFTitle>
      <DFType>
        <DDFName/>
      </DFType>
    </DFProperties>

  <Node>
    <NodeName></NodeName>
    <DFProperties>
      <AccessType>
        <Get/>
        <Replace/>
      </AccessType>
      <DFFormat>
        <node/>
      </DFFormat>
      <Occurrence>
        <OneOrMore/>
      </Occurrence>
      <DFType>
        <DDFName></DDFName>
      </DFType>
    </DFProperties>

  <Node>
    <NodeName>Coordinates</NodeName>
    <DFProperties>
      <AccessType>
        <Get/>
        <Replace/>
      </AccessType>
      <DFFormat>
        <node/>
      </DFFormat>
      <Occurrence>
        <One/>
      </Occurrence>
      <DFTitle>Descriptions for geographical
coordinates</DFTitle>
      <DFType>
        <MIME>text/plain</MIME>
      </DFType>
    </DFProperties>

  <Node>
    <NodeName></NodeName>
    <DFProperties>
      <AccessType>
        <Get/>
        <Replace/>
      </AccessType>
      <DFFormat>
        <node/>
      </DFFormat>
      <Occurrence>
        <OneOrMore/>
      </Occurrence>
      <DFType>

```

```

        <DDFName></DDFName>
      </DFType>
    </DFProperties>
  </Node>
  <Node>
    <NodeName>Latitude</NodeName>
    <DFProperties>
      <AccessType>
        <Get/>
        <Replace/>
      </AccessType>
      <DFFormat>
        <bin/>
      </DFFormat>
      <Occurrence>
        <One/>
      </Occurrence>
      <DFTitle>coordinate latitude</DFTitle>
      <DFType>
        <MIME>text/plain</MIME>
      </DFType>
    </DFProperties>
  </Node>
  <Node>
    <NodeName>Longitude</NodeName>
    <DFProperties>
      <AccessType>
        <Get/>
        <Replace/>
      </AccessType>
      <DFFormat>
        <bin/>
      </DFFormat>
      <Occurrence>
        <One/>
      </Occurrence>
      <DFTitle>coordinate longitude</DFTitle>
      <DFType>
        <MIME>text/plain</MIME>
      </DFType>
    </DFProperties>
  </Node>
</Node>
</Node>
</Node>
</Node>
  <Node>
    <NodeName>OperatorManaged</NodeName>
    <DFProperties>
      <AccessType>
        <Get/>
        <Replace/>
      </AccessType>
      <DFFormat>
        <bool/>
      </DFFormat>
      <Occurrence>
        <One/>
      </Occurrence>
      <DFTitle>Whether the radio parameters are operator managed or non-
operator managed.</DFTitle>
      <DFType>
        <MIME>text/plain</MIME>
      </DFType>
    </DFProperties>
  </Node>
</Node>
</Node>
  <Node>
    <NodeName>AuthorizedV2XServiceList</NodeName>
    <DFProperties>
      <AccessType>

```

```

        <Get/>
        <Replace/>
    </AccessType>
    <DFFormat>
        <node/>
    </DFFormat>
    <Occurrence>
        <One/>
    </Occurrence>
    <DFTitle>Authorized V2X services for V2X communication over PC5.</DFTitle>
    <DFType>
        <DDFName/>
    </DFType>
</DFProperties>

<Node>
    <NodeName></NodeName>
    <DFProperties>
        <AccessType>
            <Get/>
            <Replace/>
        </AccessType>
        <DFFormat>
            <node/>
        </DFFormat>
        <Occurrence>
            <ZeroOrMore/>
        </Occurrence>
        <DFType>
            <DDFName></DDFName>
        </DFType>
    </DFProperties>

    <Node>
        <NodeName>V2XServiceIdentifier</NodeName>
        <DFProperties>
            <AccessType>
                <Get/>
                <Replace/>
            </AccessType>
            <DFFormat>
                <int/>
            </DFFormat>
            <Occurrence>
                <One/>
            </Occurrence>
            <DFTitle>V2X service identifier.</DFTitle>
            <DFType>
                <DDFName></DDFName>
            </DFType>
        </DFProperties>
    </Node>

    <Node>
        <NodeName>DestinationLayer2ID</NodeName>
        <DFProperties>
            <AccessType>
                <Get/>
                <Replace/>
            </AccessType>
            <DFFormat>
                <bin/>
            </DFFormat>
            <Occurrence>
                <One/>
            </Occurrence>
            <DFTitle>Layer 2 ID for V2X communication over PC5.</DFTitle>
            <DFType>
                <DDFName></DDFName>
            </DFType>
        </DFProperties>
    </Node>
</Node>

<Node>
    <NodeName>PPPPtoPDBMappingRule</NodeName>
    <DFProperties>

```

```

    <AccessType>
      <Get/>
      <Replace/>
    </AccessType>
    <DFFormat>
      <node/>
    </DFFormat>
    <Occurrence>
      <ZeroOrOne/>
    </Occurrence>
    <DFTitle>Mapping rules between PPPP and PDB.</DFTitle>
    <DFType>
      <DDFName/>
    </DFType>
  </DFProperties>

  <Node>
    <NodeName></NodeName>
    <DFProperties>
      <AccessType>
        <Get/>
        <Replace/>
      </AccessType>
      <DFFormat>
        <node/>
      </DFFormat>
      <Occurrence>
        <OneOrMore/>
      </Occurrence>
      <DFType>
        <DDFName></DDFName>
      </DFType>
    </DFProperties>

    <Node>
      <NodeName>ProSePerPacketPriority</NodeName>
      <DFProperties>
        <AccessType>
          <Get/>
          <Replace/>
        </AccessType>
        <DFFormat>
          <int/>
        </DFFormat>
        <Occurrence>
          <One/>
        </Occurrence>
        <DFTitle>PPPP value used in the mapping rule.</DFTitle>
        <DFType>
          <DDFName/>
        </DFType>
      </DFProperties>
    </Node>

    <Node>
      <NodeName>PacketDelayBudget</NodeName>
      <DFProperties>
        <AccessType>
          <Get/>
          <Replace/>
        </AccessType>
        <DFFormat>
          <int/>
        </DFFormat>
        <Occurrence>
          <One/>
        </Occurrence>
        <DFTitle>PDB used in the mapping rule.</DFTitle>
        <DFType>
          <DDFName/>
        </DFType>
      </DFProperties>
    </Node>
  </Node>

  <Node>
    <NodeName>TimerT5000</NodeName>

```

```

    <DFProperties>
      <AccessType>
        <Get/>
        <Replace/>
      </AccessType>
      <DFFormat>
        <int/>
      </DFFormat>
      <Occurrence>
        <ZeroOrOne/>
      </Occurrence>
      <DFTitle>Timer T5000 to ensure privacy of V2X communication over PC5.</DFTitle>
      <DFType>
        <DDFName/>
      </DFType>
    </DFProperties>
  </Node>
</Node>

<Node>
  <NodeName>V2XoverLTEUu</NodeName>
  <!-- The V2XProvisioning node starts here. -->
  <DFProperties>
    <AccessType>
      <Get/>
      <Replace/>
    </AccessType>
    <DFFormat>
      <node/>
    </DFFormat>
    <Occurrence>
      <One/>
    </Occurrence>
    <DFTitle>Configuration parameters for V2X communication over LTE-Uu.</DFTitle>
    <DFType>
      <DDFName/>
    </DFType>
  </DFProperties>

  <Node>
    <NodeName>Expiration</NodeName>
    <DFProperties>
      <AccessType>
        <Get/>
        <Replace/>
      </AccessType>
      <DFFormat>
        <int/>
      </DFFormat>
      <Occurrence>
        <One/>
      </Occurrence>
      <DFTitle>Expiration time of validity.</DFTitle>
      <DFType>
        <DDFName/>
      </DFType>
    </DFProperties>
  </Node>

  <Node>
    <NodeName>ToConRefs</NodeName>
    <DFProperties>
      <AccessType>
        <Get/>
        <Replace/>
      </AccessType>
      <DFFormat>
        <node/>
      </DFFormat>
      <Occurrence>
        <ZeroOrOne/>
      </Occurrence>
      <DFTitle>collection of connectivity definitions.</DFTitle>
      <DFType>
        <DDFName/>
      </DFType>
    </DFProperties>
  </Node>

```

```

<Node>
  <NodeName/>
  <DFProperties>
    <AccessType>
      <Get/>
      <Replace/>
    </AccessType>
    <DFFormat>
      <node/>
    </DFFormat>
    <Occurrence>
      <OneOrMore/>
    </Occurrence>
    <DFTitle>The name node for one or more connectivity parameters.</DFTitle>
    <DFType>
      <DDFName/>
    </DFType>
  </DFProperties>

  <Node>
    <NodeName>ConRef</NodeName>
    <DFProperties>
      <AccessType>
        <Get/>
        <Replace/>
      </AccessType>
      <DFFormat>
        <chr/>
      </DFFormat>
      <Occurrence>
        <One/>
      </Occurrence>
      <DFTitle> Linkage to connectivity parameters.</DFTitle>
      <DFType>
        <MIME>text/plain</MIME>
      </DFType>
    </DFProperties>
  </Node>
</Node>

<Node>
  <NodeName>AuthorizedPLMNs</NodeName>
  <DFProperties>
    <AccessType>
      <Get/>
      <Replace/>
    </AccessType>
    <DFFormat>
      <node/>
    </DFFormat>
    <Occurrence>
      <One/>
    </Occurrence>
    <DFTitle>Authorization per PLMN policies for V2X communication over LTE-
Uu.</DFTitle>
    <DFType>
      <DDFName/>
    </DFType>
  </DFProperties>

  <Node>
    <NodeName></NodeName>
    <DFProperties>
      <AccessType>
        <Get/>
        <Replace/>
      </AccessType>
      <DFFormat>
        <node/>
      </DFFormat>
      <Occurrence>
        <ZeroOrMore/>
      </Occurrence>
      <DFType>
        <DDFName></DDFName>
      </DFType>
    </DFProperties>
  </Node>

```



```

<Node>
  <NodeName>PLMN</NodeName>
  <DFProperties>
    <AccessType>
      <Get/>
      <Replace/>
    </AccessType>
    <DFFormat>
      <chr/>
    </DFFormat>
    <Occurrence>
      <One/>
    </Occurrence>
    <DFTitle>PLMN code.</DFTitle>
    <DFType>
      <MIME>text/plain</MIME>
    </DFType>
  </DFProperties>
</Node>

<Node>
  <NodeName>V2XASMBMSConfig</NodeName>
  <DFProperties>
    <AccessType>
      <Get/>
      <Replace/>
    </AccessType>
    <DFFormat>
      <node/>
    </DFFormat>
    <Occurrence>
      <ZeroOrOne/>
    </Occurrence>
    <DFTitle>MBMS configuration.</DFTitle>
    <DFType>
      <DDFName/>
    </DFType>
  </DFProperties>

  <Node>
    <NodeName>TMGI</NodeName>
    <DFProperties>
      <AccessType>
        <Get/>
        <Replace/>
      </AccessType>
      <DFFormat>
        <chr/>
      </DFFormat>
      <Occurrence>
        <One/>
      </Occurrence>
      <DFTitle>TMGI value.</DFTitle>
      <DFType>
        <MIME>text/plain</MIME>
      </DFType>
    </DFProperties>
  </Node>

  <Node>
    <NodeName>SAIList</NodeName>
    <DFProperties>
      <AccessType>
        <Get/>
        <Replace/>
      </AccessType>
      <DFFormat>
        <node/>
      </DFFormat>
      <Occurrence>
        <One/>
      </Occurrence>
      <DFTitle>Service Area Identifiers.</DFTitle>
      <DFType>
        <MIME>text/plain</MIME>
      </DFType>
    </DFProperties>
  </Node>

```

```

<Node>
  <NodeName></NodeName>
  <DFProperties>
    <AccessType>
      <Get/>
      <Replace/>
    </AccessType>
    <DFFormat>
      <node/>
    </DFFormat>
    <Occurrence>
      <OneOrMore/>
    </Occurrence>
    <DFType>
      <DDFName></DDFName>
    </DFType>
  </DFProperties>

  <Node>
    <NodeName>SAI</NodeName>
    <DFProperties>
      <AccessType>
        <Get/>
        <Replace/>
      </AccessType>
      <DFFormat>
        <chr/>
      </DFFormat>
      <Occurrence>
        <One/>
      </Occurrence>
      <DFTitle>SAI.</DFTitle>
      <DFType>
        <MIME>text/plain</MIME>
      </DFType>
    </DFProperties>
  </Node>
</Node>

<Node>
  <NodeName>Frequency</NodeName>
  <DFProperties>
    <AccessType>
      <Get/>
      <Replace/>
    </AccessType>
    <DFFormat>
      <chr/>
    </DFFormat>
    <Occurrence>
      <ZeroOrOne/>
    </Occurrence>
    <DFTitle>EARFCN defined by 3GPP RAN WG.</DFTitle>
    <DFType>
      <MIME>text/plain</MIME>
    </DFType>
  </DFProperties>
</Node>

<Node>
  <NodeName>SDPInV2XASMBMSConfig</NodeName>
  <DFProperties>
    <AccessType>
      <Get/>
      <Replace/>
    </AccessType>
    <DFFormat>
      <chr/>
    </DFFormat>
    <Occurrence>
      <One/>
    </Occurrence>
    <DFTitle>V2X MBMS configuration SDP.</DFTitle>
    <DFType>
      <MIME>text/plain</MIME>
    </DFType>
  </DFProperties>
</Node>

```

```

        </DFProperties>
    </Node>
</Node>

<Node>
  <NodeName>V2XServiceIdentifierUnrelated</NodeName>
  <DFProperties>
    <AccessType>
      <Get/>
      <Replace/>
    </AccessType>
    <DFFormat>
      <node/>
    </DFFormat>
    <Occurrence>
      <One/>
    </Occurrence>
    <DFTitle>V2X services not identified by a V2X service
identifier.</DFTitle>
    <DFType>
      <DDFName/>
    </DFType>
  </DFProperties>

  <Node>
    <NodeName>V2XMBMSConfigs</NodeName>
    <DFProperties>
      <AccessType>
        <Get/>
        <Replace/>
      </AccessType>
      <DFFormat>
        <node/>
      </DFFormat>
      <Occurrence>
        <ZeroOrOne/>
      </Occurrence>
      <DFTitle>MBMS configurations.</DFTitle>
      <DFType>
        <DDFName/>
      </DFType>
    </DFProperties>

    <Node>
      <NodeName/>
      <DFProperties>
        <AccessType>
          <Get/>
          <Replace/>
        </AccessType>
        <DFFormat>
          <node/>
        </DFFormat>
        <Occurrence>
          <OneOrMore/>
        </Occurrence>
        <DFTitle>MBMS configurations.</DFTitle>
        <DFType>
          <DDFName/>
        </DFType>
      </DFProperties>

    <Node>
      <NodeName>V2XMBMSConfig</NodeName>
      <DFProperties>
        <AccessType>
          <Get/>
          <Replace/>
        </AccessType>
        <DFFormat>
          <node/>
        </DFFormat>
        <Occurrence>
          <ZeroOrOne/>
        </Occurrence>
        <DFTitle>MBMS configuration.</DFTitle>
        <DFType>
          <DDFName/>
        </DFType>
      </DFProperties>
    </Node>
  </Node>
</Node>

```

```

    </DFType>
  </DFProperties>

  <Node>
    <NodeName>TMGI</NodeName>
    <DFProperties>
      <AccessType>
        <Get/>
        <Replace/>
      </AccessType>
      <DFFormat>
        <chr/>
      </DFFormat>
      <Occurrence>
        <One/>
      </Occurrence>
      <DFTitle>TMGI value.</DFTitle>
      <DFType>
        <MIME>text/plain</MIME>
      </DFType>
    </DFProperties>
  </Node>

  <Node>
    <NodeName>SAIList</NodeName>
    <DFProperties>
      <AccessType>
        <Get/>
        <Replace/>
      </AccessType>
      <DFFormat>
        <node/>
      </DFFormat>
      <Occurrence>
        <One/>
      </Occurrence>
      <DFTitle>Service Area Identifiers.</DFTitle>
      <DFType>
        <MIME>text/plain</MIME>
      </DFType>
    </DFProperties>

  <Node>
    <NodeName></NodeName>
    <DFProperties>
      <AccessType>
        <Get/>
        <Replace/>
      </AccessType>
      <DFFormat>
        <node/>
      </DFFormat>
      <Occurrence>
        <OneOrMore/>
      </Occurrence>
      <DFType>
        <DDFName></DDFName>
      </DFType>
    </DFProperties>

  <Node>
    <NodeName>SAI</NodeName>
    <DFProperties>
      <AccessType>
        <Get/>
        <Replace/>
      </AccessType>
      <DFFormat>
        <chr/>
      </DFFormat>
      <Occurrence>
        <One/>
      </Occurrence>
      <DFTitle>SAI.</DFTitle>
      <DFType>
        <MIME>text/plain</MIME>
      </DFType>
    </DFProperties>

```

```

        </Node>
    </Node>
</Node>

<Node>
  <NodeName>Frequency</NodeName>
  <DFProperties>
    <AccessType>
      <Get/>
      <Replace/>
    </AccessType>
    <DFFormat>
      <chr/>
    </DFFormat>
    <Occurrence>
      <ZeroOrOne/>
    </Occurrence>
    <DFTitle>EARFCN defined by 3GPP RAN WG.</DFTitle>
    <DFType>
      <MIME>text/plain</MIME>
    </DFType>
  </DFProperties>
</Node>

<Node>
  <NodeName>SDPInV2XASMBMSConfig</NodeName>
  <DFProperties>
    <AccessType>
      <Get/>
      <Replace/>
    </AccessType>
    <DFFormat>
      <chr/>
    </DFFormat>
    <Occurrence>
      <One/>
    </Occurrence>
    <DFTitle>V2X MBMS configuration SDP.</DFTitle>
    <DFType>
      <MIME>text/plain</MIME>
    </DFType>
  </DFProperties>
</Node>
</Node>

</Node>
</Node>

<Node>
  <NodeName>V2XASAddresses</NodeName>
  <DFProperties>
    <AccessType>
      <Get/>
      <Replace/>
    </AccessType>
    <DFFormat>
      <node/>
    </DFFormat>
    <Occurrence>
      <ZeroOrOne/>
    </Occurrence>
    <DFTitle>V2X server addresses.</DFTitle>
    <DFType>
      <DDFName/>
    </DFType>
  </DFProperties>

  <Node>
    <NodeName></NodeName>
    <DFProperties>
      <AccessType>
        <Get/>
        <Replace/>
      </AccessType>
      <DFFormat>
        <node/>
      </DFFormat>
      <Occurrence>

```

```

        <OneOrMore/>
    </Occurrence>
    <DFType>
        <DDFName></DDFName>
    </DFType>
</DFProperties>

<Node>
    <NodeName>L3Address</NodeName>
    <DFProperties>
        <AccessType>
            <Get/>
            <Replace/>
        </AccessType>
        <DFFormat>
            <chr/>
        </DFFormat>
        <Occurrence>
            <One/>
        </Occurrence>
        <DFTitle>IP address or FQDN of the V2X application
server.</DFTitle>

        <DFType>
            <DDFName/>
        </DFType>
    </DFProperties>
</Node>

<Node>
    <NodeName>UDPPort</NodeName>
    <DFProperties>
        <AccessType>
            <Get/>
            <Replace/>
        </AccessType>
        <DFFormat>
            <int/>
        </DFFormat>
        <Occurrence>
            <One/>
        </Occurrence>
        <DFTitle>UDP port of the V2X application server.</DFTitle>
        <DFType>
            <DDFName/>
        </DFType>
    </DFProperties>
</Node>

<Node>
    <NodeName>GeographicalArea</NodeName>
    <DFProperties>
        <AccessType>
            <Get/>
            <Replace/>
        </AccessType>
        <DFFormat>
            <node/>
        </DFFormat>
        <Occurrence>
            <ZeroOrOne/>
        </Occurrence>
        <DFTitle>Geographical Area description.</DFTitle>
        <DFType>
            <MIME>text/plain</MIME>
        </DFType>
    </DFProperties>

    <Node>
        <NodeName>Polygon</NodeName>
        <DFProperties>
            <AccessType>
                <Get/>
                <Replace/>
            </AccessType>
            <DFFormat>
                <node/>
            </DFFormat>
            <Occurrence>

```

```

        <One/>
    </Occurrence>
    <DFTitle>Polygon Area description.</DFTitle>
    <DFType>
        <DDFName/>
    </DFType>
</DFProperties>

<Node>
    <NodeName></NodeName>
    <DFProperties>
        <AccessType>
            <Get/>
            <Replace/>
        </AccessType>
        <DFFormat>
            <node/>
        </DFFormat>
        <Occurrence>
            <OneOrMore/>
        </Occurrence>
        <DFType>
            <DDFName></DDFName>
        </DFType>
    </DFProperties>

<Node>
    <NodeName>Coordinates</NodeName>
    <DFProperties>
        <AccessType>
            <Get/>
            <Replace/>
        </AccessType>
        <DFFormat>
            <node/>
        </DFFormat>
        <Occurrence>
            <One/>
        </Occurrence>
        <DFTitle>Descriptions for geographical
coordinates</DFTitle>

        <DFType>
            <MIME>text/plain</MIME>
        </DFType>
    </DFProperties>

<Node>
    <NodeName></NodeName>
    <DFProperties>
        <AccessType>
            <Get/>
            <Replace/>
        </AccessType>
        <DFFormat>
            <node/>
        </DFFormat>
        <Occurrence>
            <OneOrMore/>
        </Occurrence>
        <DFType>
            <DDFName></DDFName>
        </DFType>
    </DFProperties>

<Node>
    <NodeName>Latitude</NodeName>
    <DFProperties>
        <AccessType>
            <Get/>
            <Replace/>
        </AccessType>
        <DFFormat>
            <bin/>
        </DFFormat>
        <Occurrence>
            <One/>
        </Occurrence>
        <DFTitle>coordinate latitude</DFTitle>

```





```

        <Replace/>
    </AccessType>
    <DFFormat>
        <node/>
    </DFFormat>
    <Occurrence>
        <ZeroOrMore/>
    </Occurrence>
    <DFType>
        <DDFName></DDFName>
    </DFType>
</DFProperties>

<Node>
    <NodeName>V2XServiceIdentifier</NodeName>
    <DFProperties>
        <AccessType>
            <Get/>
            <Replace/>
        </AccessType>
        <DFFormat>
            <int/>
        </DFFormat>
        <Occurrence>
            <One/>
        </Occurrence>
        <DFTitle>V2X service identifier.</DFTitle>
        <DFType>
            <DDFName></DDFName>
        </DFType>
    </DFProperties>
</Node>

<Node>
    <NodeName>V2XMBMSConfigs</NodeName>
    <DFProperties>
        <AccessType>
            <Get/>
            <Replace/>
        </AccessType>
        <DFFormat>
            <node/>
        </DFFormat>
        <Occurrence>
            <ZeroOrOne/>
        </Occurrence>
        <DFTitle>MBMS configurations.</DFTitle>
        <DFType>
            <DDFName/>
        </DFType>
    </DFProperties>

<Node>
    <NodeName/>
    <DFProperties>
        <AccessType>
            <Get/>
            <Replace/>
        </AccessType>
        <DFFormat>
            <node/>
        </DFFormat>
        <Occurrence>
            <OneOrMore/>
        </Occurrence>
        <DFTitle>MBMS configurations.</DFTitle>
        <DFType>
            <DDFName/>
        </DFType>
    </DFProperties>

<Node>
    <NodeName>V2XMBMSConfig</NodeName>
    <DFProperties>
        <AccessType>
            <Get/>
            <Replace/>
        </AccessType>

```

```

<DFFormat>
  <node/>
</DFFormat>
<Occurrence>
  <ZeroOrOne/>
</Occurrence>
<DFTitle>MBMS configuration.</DFTitle>
<DFType>
  <DDFName/>
</DFType>
</DFProperties>

<Node>
  <NodeName>TMGI</NodeName>
  <DFProperties>
    <AccessType>
      <Get/>
      <Replace/>
    </AccessType>
    <DFFormat>
      <chr/>
    </DFFormat>
    <Occurrence>
      <One/>
    </Occurrence>
    <DFTitle>TMGI value.</DFTitle>
    <DFType>
      <MIME>text/plain</MIME>
    </DFType>
  </DFProperties>
</Node>

<Node>
  <NodeName>SAIList</NodeName>
  <DFProperties>
    <AccessType>
      <Get/>
      <Replace/>
    </AccessType>
    <DFFormat>
      <node/>
    </DFFormat>
    <Occurrence>
      <One/>
    </Occurrence>
    <DFTitle>Service Area Identifiers.</DFTitle>
    <DFType>
      <MIME>text/plain</MIME>
    </DFType>
  </DFProperties>

<Node>
  <NodeName></NodeName>
  <DFProperties>
    <AccessType>
      <Get/>
      <Replace/>
    </AccessType>
    <DFFormat>
      <node/>
    </DFFormat>
    <Occurrence>
      <OneOrMore/>
    </Occurrence>
    <DFType>
      <DDFName></DDFName>
    </DFType>
  </DFProperties>

  <Node>
    <NodeName>SAI</NodeName>
    <DFProperties>
      <AccessType>
        <Get/>
        <Replace/>
      </AccessType>
      <DFFormat>
        <chr/>
      </DFFormat>
    </DFProperties>
  </Node>

```

```

        </DFFormat>
        <Occurrence>
            <One/>
        </Occurrence>
        <DFTitle>SAI.</DFTitle>
        <DFType>
            <MIME>text/plain</MIME>
        </DFType>
    </DFProperties>
</Node>
</Node>
</Node>
<Node>
    <NodeName>Frequency</NodeName>
    <DFProperties>
        <AccessType>
            <Get/>
            <Replace/>
        </AccessType>
        <DFFormat>
            <chr/>
        </DFFormat>
        <Occurrence>
            <ZeroOrOne/>
        </Occurrence>
        <DFTitle>EARFCN defined by 3GPP RAN
WG.</DFTitle>
        <DFType>
            <MIME>text/plain</MIME>
        </DFType>
    </DFProperties>
</Node>
<Node>
    <NodeName>SDPInV2XASMBMSConfig</NodeName>
    <DFProperties>
        <AccessType>
            <Get/>
            <Replace/>
        </AccessType>
        <DFFormat>
            <chr/>
        </DFFormat>
        <Occurrence>
            <One/>
        </Occurrence>
        <DFTitle>V2X MBMS configuration
SDP.</DFTitle>
        <DFType>
            <MIME>text/plain</MIME>
        </DFType>
    </DFProperties>
</Node>
</Node>
</Node>
<Node>
    <NodeName>V2XASAddresses</NodeName>
    <DFProperties>
        <AccessType>
            <Get/>
            <Replace/>
        </AccessType>
        <DFFormat>
            <node/>
        </DFFormat>
        <Occurrence>
            <ZeroOrOne/>
        </Occurrence>
        <DFTitle>V2X server addresses.</DFTitle>
        <DFType>
            <DDFName/>
        </DFType>
    </DFProperties>

```

```

<Node>
  <NodeName></NodeName>
  <DFProperties>
    <AccessType>
      <Get/>
      <Replace/>
    </AccessType>
    <DFFormat>
      <node/>
    </DFFormat>
    <Occurrence>
      <OneOrMore/>
    </Occurrence>
    <DFType>
      <DDFName></DDFName>
    </DFType>
  </DFProperties>

  <Node>
    <NodeName>L3Address</NodeName>
    <DFProperties>
      <AccessType>
        <Get/>
        <Replace/>
      </AccessType>
      <DFFormat>
        <chr/>
      </DFFormat>
      <Occurrence>
        <One/>
      </Occurrence>
      <DFTitle>IP address or FQDN of the V2X application
server.</DFTitle>

      <DFType>
        <DDFName/>
      </DFType>
    </DFProperties>
  </Node>

  <Node>
    <NodeName>UDPPort</NodeName>
    <DFProperties>
      <AccessType>
        <Get/>
        <Replace/>
      </AccessType>
      <DFFormat>
        <int/>
      </DFFormat>
      <Occurrence>
        <One/>
      </Occurrence>
      <DFTitle>UDP port of the V2X application
server.</DFTitle>

      <DFType>
        <DDFName/>
      </DFType>
    </DFProperties>
  </Node>

  <Node>
    <NodeName>GeographicalArea</NodeName>
    <DFProperties>
      <AccessType>
        <Get/>
        <Replace/>
      </AccessType>
      <DFFormat>
        <node/>
      </DFFormat>
      <Occurrence>
        <ZeroOrOne/>
      </Occurrence>
      <DFTitle>Geographical Area description.</DFTitle>
      <DFType>
        <MIME>text/plain</MIME>
      </DFType>
    </DFProperties>
  </Node>

```

```

<Node>
  <NodeName>Polygon</NodeName>
  <DFProperties>
    <AccessType>
      <Get/>
      <Replace/>
    </AccessType>
    <DFFormat>
      <node/>
    </DFFormat>
    <Occurrence>
      <One/>
    </Occurrence>
    <DFTitle>Polygon Area description.</DFTitle>
    <DFType>
      <DDFName/>
    </DFType>
  </DFProperties>

  <Node>
    <NodeName></NodeName>
    <DFProperties>
      <AccessType>
        <Get/>
        <Replace/>
      </AccessType>
      <DFFormat>
        <node/>
      </DFFormat>
      <Occurrence>
        <OneOrMore/>
      </Occurrence>
      <DFType>
        <DDFName></DDFName>
      </DFType>
    </DFProperties>

    <Node>
      <NodeName>Coordinates</NodeName>
      <DFProperties>
        <AccessType>
          <Get/>
          <Replace/>
        </AccessType>
        <DFFormat>
          <node/>
        </DFFormat>
        <Occurrence>
          <One/>
        </Occurrence>
        <DFTitle>Descriptions for geographical
coordinates</DFTitle>

        <DFType>
          <MIME>text/plain</MIME>
        </DFType>
      </DFProperties>

      <Node>
        <NodeName></NodeName>
        <DFProperties>
          <AccessType>
            <Get/>
            <Replace/>
          </AccessType>
          <DFFormat>
            <node/>
          </DFFormat>
          <Occurrence>
            <OneOrMore/>
          </Occurrence>
          <DFType>
            <DDFName></DDFName>
          </DFType>
        </DFProperties>

        <Node>
          <NodeName>Latitude</NodeName>

```



```

    <Occurrence>
      <OneOrMore/>
    </Occurrence>
    <DFTitle>MBMS configurations.</DFTitle>
    <DFType>
      <DDFName/>
    </DFType>
  </DFProperties>

<Node>
  <NodeName>V2XMBMSConfig</NodeName>
  <DFProperties>
    <AccessType>
      <Get/>
      <Replace/>
    </AccessType>
    <DFFormat>
      <node/>
    </DFFormat>
    <Occurrence>
      <ZeroOrOne/>
    </Occurrence>
    <DFTitle>MBMS configuration.</DFTitle>
    <DFType>
      <DDFName/>
    </DFType>
  </DFProperties>

<Node>
  <NodeName>TMGI</NodeName>
  <DFProperties>
    <AccessType>
      <Get/>
      <Replace/>
    </AccessType>
    <DFFormat>
      <chr/>
    </DFFormat>
    <Occurrence>
      <One/>
    </Occurrence>
    <DFTitle>TMGI value.</DFTitle>
    <DFType>
      <MIME>text/plain</MIME>
    </DFType>
  </DFProperties>
</Node>

<Node>
  <NodeName>SAIList</NodeName>
  <DFProperties>
    <AccessType>
      <Get/>
      <Replace/>
    </AccessType>
    <DFFormat>
      <node/>
    </DFFormat>
    <Occurrence>
      <One/>
    </Occurrence>
    <DFTitle>Service Area Identifiers.</DFTitle>
    <DFType>
      <MIME>text/plain</MIME>
    </DFType>
  </DFProperties>

<Node>
  <NodeName></NodeName>
  <DFProperties>
    <AccessType>
      <Get/>
      <Replace/>
    </AccessType>
    <DFFormat>
      <node/>
    </DFFormat>
    <Occurrence>

```

```

        <OneOrMore/>
    </Occurrence>
    <DFType>
        <DDFName></DDFName>
    </DFType>
</DFProperties>

<Node>
    <NodeName>SAI</NodeName>
    <DFProperties>
        <AccessType>
            <Get/>
            <Replace/>
        </AccessType>
        <DFFormat>
            <chr/>
        </DFFormat>
        <Occurrence>
            <One/>
        </Occurrence>
        <DFTitle>SAI.</DFTitle>
        <DFType>
            <MIME>text/plain</MIME>
        </DFType>
    </DFProperties>
</Node>
</Node>

<Node>
    <NodeName>Frequency</NodeName>
    <DFProperties>
        <AccessType>
            <Get/>
            <Replace/>
        </AccessType>
        <DFFormat>
            <chr/>
        </DFFormat>
        <Occurrence>
            <ZeroOrOne/>
        </Occurrence>
        <DFTitle>EARFCN defined by 3GPP RAN G.</DFTitle>
        <DFType>
            <MIME>text/plain</MIME>
        </DFType>
    </DFProperties>
</Node>

<Node>
    <NodeName>SDPInV2XASMBMSConfig</NodeName>
    <DFProperties>
        <AccessType>
            <Get/>
            <Replace/>
        </AccessType>
        <DFFormat>
            <chr/>
        </DFFormat>
        <Occurrence>
            <One/>
        </Occurrence>
        <DFTitle>V2X MBMS configuration SDP.</DFTitle>
        <DFType>
            <MIME>text/plain</MIME>
        </DFType>
    </DFProperties>
</Node>
</Node>
</Node>
<Node>
    <NodeName>DefaultV2XASAddresses</NodeName>
    <DFProperties>
        <AccessType>
            <Get/>
            <Replace/>
        </AccessType>

```



```

    <DFFormat>
      <node/>
    </DFFormat>
  </Occurrence>
  <DFTitle>V2X server addresses.</DFTitle>
  <DFType>
    <DDFName/>
  </DFType>
</DFProperties>

<Node>
  <NodeName/>
  <DFProperties>
    <AccessType>
      <Get/>
      <Replace/>
    </AccessType>
    <DFFormat>
      <node/>
    </DFFormat>
    <Occurrence>
      <OneOrMore/>
    </Occurrence>
    <DFTitle>MBMS configurations.</DFTitle>
    <DFType>
      <DDFName/>
    </DFType>
  </DFProperties>

  <Node>
    <NodeName>TypeOfData</NodeName>
    <DFProperties>
      <AccessType>
        <Get/>
        <Replace/>
      </AccessType>
      <DFFormat>
        <int/>
      </DFFormat>
      <Occurrence>
        <One/>
      </Occurrence>
      <DFTitle>Type of Data.</DFTitle>
      <DFType>
        <MIME>text/plain</MIME>
      </DFType>
    </DFProperties>
  </Node>

  <Node>
    <NodeName>V2XMessageFamily</NodeName>
    <DFProperties>
      <AccessType>
        <Get/>
        <Replace/>
      </AccessType>
      <DFFormat>
        <int/>
      </DFFormat>
      <Occurrence>
        <ZeroOrOne/>
      </Occurrence>
      <DFTitle>V2X message family.</DFTitle>
      <DFType>
        <MIME>text/plain</MIME>
      </DFType>
    </DFProperties>
  </Node>

  <Node>
    <NodeName>V2XASAddresses</NodeName>
    <DFProperties>
      <AccessType>
        <Get/>
        <Replace/>
      </AccessType>

```

```

    <DFFormat>
      <node/>
    </DFFormat>
  </Occurrence>
  <ZeroOrOne/>
</Occurrence>
<DFTitle>V2X server addresses.</DFTitle>
<DFType>
  <DDFName/>
</DFType>
</DFProperties>

<Node>
  <NodeName></NodeName>
  <DFProperties>
    <AccessType>
      <Get/>
      <Replace/>
    </AccessType>
    <DFFormat>
      <node/>
    </DFFormat>
    <Occurrence>
      <OneOrMore/>
    </Occurrence>
    <DFType>
      <DDFName></DDFName>
    </DFType>
  </DFProperties>

  <Node>
    <NodeName>L3Address</NodeName>
    <DFProperties>
      <AccessType>
        <Get/>
        <Replace/>
      </AccessType>
      <DFFormat>
        <chr/>
      </DFFormat>
      <Occurrence>
        <One/>
      </Occurrence>
      <DFTitle>IP address or FQDN of the V2X application
server.</DFTitle>

      <DFType>
        <DDFName/>
      </DFType>
    </DFProperties>
  </Node>

  <Node>
    <NodeName>UDPPort</NodeName>
    <DFProperties>
      <AccessType>
        <Get/>
        <Replace/>
      </AccessType>
      <DFFormat>
        <int/>
      </DFFormat>
      <Occurrence>
        <One/>
      </Occurrence>
      <DFTitle>UDP port of the V2X application
server.</DFTitle>

      <DFType>
        <DDFName/>
      </DFType>
    </DFProperties>
  </Node>

  <Node>
    <NodeName>GeographicalArea</NodeName>
    <DFProperties>
      <AccessType>
        <Get/>
        <Replace/>

```

```

</AccessType>
<DFFormat>
  <node/>
</DFFormat>
<Occurrence>
  <ZeroOrOne/>
</Occurrence>
<DFTitle>Geographical Area description.</DFTitle>
<DFType>
  <MIME>text/plain</MIME>
</DFType>
</DFProperties>

<Node>
  <NodeName>Polygon</NodeName>
  <DFProperties>
    <AccessType>
      <Get/>
      <Replace/>
    </AccessType>
    <DFFormat>
      <node/>
    </DFFormat>
    <Occurrence>
      <One/>
    </Occurrence>
    <DFTitle>Polygon Area description.</DFTitle>
    <DFType>
      <DDFName/>
    </DFType>
  </DFProperties>

  <Node>
    <NodeName></NodeName>
    <DFProperties>
      <AccessType>
        <Get/>
        <Replace/>
      </AccessType>
      <DFFormat>
        <node/>
      </DFFormat>
      <Occurrence>
        <OneOrMore/>
      </Occurrence>
      <DFType>
        <DDFName></DDFName>
      </DFType>
    </DFProperties>

    <Node>
      <NodeName>Coordinates</NodeName>
      <DFProperties>
        <AccessType>
          <Get/>
          <Replace/>
        </AccessType>
        <DFFormat>
          <node/>
        </DFFormat>
        <Occurrence>
          <One/>
        </Occurrence>
        <DFTitle>Descriptions for geographical
coordinates</DFTitle>
        <DFType>
          <MIME>text/plain</MIME>
        </DFType>
      </DFProperties>

      <Node>
        <NodeName></NodeName>
        <DFProperties>
          <AccessType>
            <Get/>
            <Replace/>
          </AccessType>
          <DFFormat>

```



```
<DFTitle>A collection of all extension objects.</DFTitle>
<DFType>
  <DDFName/>
</DFType>
</DFProperties>
</Node>
</MgmtTree>
```

## Annex B (informative): Change history

| Change history |            |           |    |     |   |        |
|----------------|------------|-----------|----|-----|---|--------|
| Date           | TSG #      | TSG Doc.  | CR | Rev | Subject/Comment   | New    |
| 2016-10        |            | -         | -  | -   | TS skeleton generated for submission at CT1#100   | 0.0.0  |
| 2016-10        | CT1#100    | -         | -  | -   | Implementation of C1-164497. Editorial fixes.   | 0.1.0  |
| 2016-11        | CT1#101    | -         | -  | -   | Implementation of C1-165327, C1-165329 and C1-165390. Editorial fixes.                            | 0.2.0  |
| 2016-11        | CT-74      | CP-160704 |    |     | Version 1.0.0 created for presentation for information to CT plenary                              | 1.0.0  |
| 2017-01        | CT1#101bis | -         | -  | -   | Implementation of C1-170014, C1-170096, C1-170243, C1-170339, C1-170344, C1-170348 and C1-170349. | 1.1.0  |
| 2017-02        | CT1#102    | -         | -  | -   | Implementation of C1-170919, C1-170922 and C1-170993. Editorial fixes.                            | 1.2.0  |
| 2017-02        | CT-75      | CP-170155 |    |     | Version 2.0.0 created for presentation for approval to CT plenary                                 | 2.0.0  |
| 2017-03        | CT-75      |           |    |     | Version 14.0.0 created after approval at CT-75  | 14.0.0 |

---

# History

| <b>Document history</b> |          |             |
|-------------------------|----------|-------------|
| V14.0.0                 | May 2017 | Publication |
|                         |          |             |
|                         |          |             |
|                         |          |             |
|                         |          |             |