

ETSI TS 124 610 V11.1.0 (2012-11)



Technical Specification

**Digital cellular telecommunications system (Phase 2+);
Universal Mobile Telecommunications System (UMTS);
LTE;
Communication HOLD (HOLD) using IP Multimedia (IM)
Core Network (CN) subsystem;
Protocol specification
(3GPP TS 24.610 version 11.1.0 Release 11)**



Reference

RTS/TSGC-0124610vb10

Keywords

GSM,LTE,UMTS

ETSI

650 Route des Lucioles
F-06921 Sophia Antipolis Cedex - FRANCE

Tel.: +33 4 92 94 42 00 Fax: +33 4 93 65 47 16

Siret N° 348 623 562 00017 - NAF 742 C
Association à but non lucratif enregistrée à la
Sous-Préfecture de Grasse (06) N° 7803/88

Important notice

Individual copies of the present document can be downloaded from:

<http://www.etsi.org>

The present document may be made available in more than one electronic version or in print. In any case of existing or perceived difference in contents between such versions, the reference version is the Portable Document Format (PDF). In case of dispute, the reference shall be the printing on ETSI printers of the PDF version kept on a specific network drive within ETSI Secretariat.

Users of the present document should be aware that the document may be subject to revision or change of status. Information on the current status of this and other ETSI documents is available at

<http://portal.etsi.org/tb/status/status.asp>

If you find errors in the present document, please send your comment to one of the following services:

http://portal.etsi.org/chaicor/ETSI_support.asp

Copyright Notification

No part may be reproduced except as authorized by written permission.
The copyright and the foregoing restriction extend to reproduction in all media.

© European Telecommunications Standards Institute 2012.
All rights reserved.

DECT™, **PLUGTESTS™**, **UMTS™** and the ETSI logo are Trade Marks of ETSI registered for the benefit of its Members.
3GPP™ and **LTE™** are Trade Marks of ETSI registered for the benefit of its Members and of the 3GPP Organizational Partners.
GSM® and the GSM logo are Trade Marks registered and owned by the GSM Association.

Intellectual Property Rights

IPRs essential or potentially essential to the present document may have been declared to ETSI. The information pertaining to these essential IPRs, if any, is publicly available for **ETSI members and non-members**, and can be found in ETSI SR 000 314: *"Intellectual Property Rights (IPRs); Essential, or potentially Essential, IPRs notified to ETSI in respect of ETSI standards"*, which is available from the ETSI Secretariat. Latest updates are available on the ETSI Web server (<http://ipr.etsi.org>).

Pursuant to the ETSI IPR Policy, no investigation, including IPR searches, has been carried out by ETSI. No guarantee can be given as to the existence of other IPRs not referenced in ETSI SR 000 314 (or the updates on the ETSI Web server) which are, or may be, or may become, essential to the present document.

Foreword

This Technical Specification (TS) has been produced by ETSI 3rd Generation Partnership Project (3GPP).

The present document may refer to technical specifications or reports using their 3GPP identities, UMTS identities or GSM identities. These should be interpreted as being references to the corresponding ETSI deliverables.

The cross reference between GSM, UMTS, 3GPP and ETSI identities can be found under <http://webapp.etsi.org/key/queryform.asp>.

Contents

Intellectual Property Rights	2
Foreword.....	2
Foreword.....	5
1 Scope	6
2 References	6
3 Definitions and abbreviations.....	6
3.1 Definitions	6
3.2 Abbreviations	6
4 Communication Hold (HOLD)	7
4.1 Void.....	7
4.2 Description	7
4.2.1 General description	7
4.3 Operational requirements	7
4.3.1 Provision/withdrawal	7
4.3.2 Requirements on the originating network side.....	7
4.3.3 Requirements in the network	7
4.3.4 Requirements on the terminating network side.....	7
4.4 Coding requirements	7
4.5 Signalling requirements.....	8
4.5.1 Activation/deactivation	8
4.5.2 Invocation and operation	8
4.5.2.1 Actions at the invoking UE	8
4.5.2.2 Void.....	9
4.5.2.3 Void.....	9
4.5.2.4 Actions at the AS of the invoking UE.....	9
4.5.2.5 Void.....	9
4.5.2.6 Void.....	9
4.5.2.7 Void.....	9
4.5.2.8 Void.....	9
4.5.2.9 Actions at the held UE	9
4.6 Interaction with other services.....	9
4.6.1 Communication Hold (HOLD).....	9
4.6.2 Terminating Identification Presentation (TIP).....	9
4.6.3 Terminating Identification Restriction (TIR).....	9
4.6.4 Originating Identification Presentation (OIP).....	9
4.6.5 Originating identification restriction (OIR)	9
4.6.6 Conference calling (CONF).....	10
4.6.7 Communication DIVersion services (CDIV).....	10
4.6.8 Malicious Communication IDentification (MCID)	10
4.6.9 Anonymous Communication Rejection and Communication Barring (ACR/CB)	10
4.6.10 Explicit Communication Transfer (ECT)	10
4.7 Interactions with other networks	10
4.7.1 Void	10
4.7.2 Void	10
4.7.3 Void	10
4.8 Parameter values (timers).....	10
Annex A (informative): Signalling Flows	11
A.1 HOLD communication	11
A.1.1 HOLD communication without announcement.....	11
A.1.2 HOLD communication with announcement.....	13
A.1.3 HOLD communication with modification of the SDP answer	15

A.2 RESUME Communication17
A.2.1 RESUME communication without announcement.....17
A.2.2 RESUME communication with announcement.....19
Annex B (informative): Change history22
History23

Foreword

This Technical Specification (TS) was been produced by ETSI Technical Committee Telecommunications and Internet converged Services and Protocols for Advanced Networking (TISPAN) and originally published as ETSI TS 183 010 [7]. It was transferred to the 3rd Generation Partnership Project (3GPP) in December 2007.

The contents of the present document are subject to continuing work within the TSG and may change following formal TSG approval. Should the TSG modify the contents of the present document, it will be re-released by the TSG with an identifying change of release date and an increase in version number as follows:

Version x.y.z

where:

- x the first digit:
 - 1 presented to TSG for information;
 - 2 presented to TSG for approval;
 - 3 or greater indicates TSG approved document under change control.
- y the second digit is incremented for all changes of substance, i.e. technical enhancements, corrections, updates, etc.
- z the third digit is incremented when editorial only changes have been incorporated in the document.

1 Scope

The present document specifies the stage three Protocol Description of the Communication Hold (HOLD) services, based on stages one and two of the ISDN Hold (HOLD) supplementary services. It provides the protocol details in the IP Multimedia (IM) Core Network (CN) subsystem based on the Session Initiation Protocol (SIP) and the Session Description Protocol (SDP).

The present document is applicable to User Equipment (UE) and Application Servers (AS) which are intended to support the HOLD supplementary service.

2 References

The following documents contain provisions which, through reference in this text, constitute provisions of the present document.

- References are either specific (identified by date of publication, edition number, version number, etc.) or non-specific.
- For a specific reference, subsequent revisions do not apply.
- For a non-specific reference, the latest version applies. In the case of a reference to a 3GPP document (including a GSM document), a non-specific reference implicitly refers to the latest version of that document *in the same Release as the present document*.

- [1] 3GPP TS 24.229: "Internet Protocol (IP) multimedia call control protocol based on Session Initiation Protocol (SIP) and Session Description Protocol (SDP); Stage 3".
- [2] Void.
- [3] Void
- [4] IETF RFC 3264 (2002): "An Offer/Answer Model with the Session Description Protocol (SDP)".
- [5] 3GPP TS 22.173: "IP Multimedia Core Network Subsystem (IMS) Multimedia Telephony Service and supplementary services; Stage 1".
- [6] 3GPP TS 24.628: "Common Basic Communication procedures; Protocol specification".
- [7] ETSI TS 183 010 V1.2.2: "Telecommunications and Internet converged Services and Protocols for Advanced Networking (TISPAN); NGN Signalling Control Protocol; Communication HOLD (HOLD) PSTN/ISDN simulation services; Protocol specification".

3 Definitions and abbreviations

3.1 Definitions

For the purposes of the present document, the terms and definitions given in 3GPP TS 22.173 [5] apply.

3.2 Abbreviations

For the purposes of the present document, the following abbreviations apply:

ACR/CB	Anonymous Communication Rejection and Communication Barring
AS	SIP Application Server
CDIV	Communication DIVersion
CSCF	Call Session Control Function
ECT	Explicit Communication Transfer

HOLD	communication session HOLD
IMS	IP Multimedia Subsystem
IP	Internet Protocol
ISDN	Integrated Service Digital Network
MCID	Malicious Communication IDentification
OIP	Originating Identification Presentation
OIR	Originating Identification Restriction
P-CSCF	Proxy-CSCF
PSTN	Public Switched Telephone Network
S-CSCF	Serving-CSCF
SDP	Session Description Protocol
SIP	Session Initiation Protocol
TIP	Terminating Identification Presentation
TIR	Terminating Identification Restriction
UE	User Equipment

4 Communication Hold (HOLD)

4.1 Void

4.2 Description

4.2.1 General description

The Communication Hold supplementary service enables a user to suspend the reception of media stream(s) of an established IP multimedia session, and resume the media stream(s) at a later time.

4.3 Operational requirements

4.3.1 Provision/withdrawal

The HOLD service that includes announcements shall be provided after prior arrangement with the service provider.

4.3.2 Requirements on the originating network side

No specific requirements are needed in the network.

4.3.3 Requirements in the network

No specific requirements are needed in the network.

4.3.4 Requirements on the terminating network side

No specific requirements are needed in the network.

4.4 Coding requirements

No specific coding requirements are needed.

4.5 Signalling requirements

4.5.1 Activation/deactivation

The HOLD service is activated at provisioning and deactivated at withdrawal.

4.5.1A Registration/erasure

The HOLD service requires no registration. Erasure is not applicable.

4.5.1B Interrogation

Interrogation of HOLD is not applicable.

4.5.2 Invocation and operation

4.5.2.1 Actions at the invoking UE

In addition to the application of procedures according to 3GPP TS 24.229 [1], the following procedures shall be applied at the invoking UE in accordance with RFC 3264 [4].

If individual media streams are affected, the invoking UE shall generate a new SDP offer where:

- for each media stream that is to be held, the SDP offer that contains:
 - an "inactive" SDP attribute if the stream was previously set to "recvonly" media stream; or
 - a "sendonly" SDP attribute if the stream was previously set to "sendrecv" media stream;
- for each media stream that is to be resumed, the SDP offer contains:
 - a "recvonly" SDP attribute if the stream was previously an inactive media stream; or
 - a "sendrecv" SDP attribute if the stream was previously a sendonly media stream, or the attribute may be omitted, since sendrecv is the default; or
- for each media stream that is unaffected, the media parameters in the SDP offer remain unchanged from the previous SDP offer.

If all the media streams are to be held, the invoking UE shall generate an SDP offer containing a session level direction attribute, or separate media level direction attributes, in the SDP that is set to:

- "inactive" if the streams were previously set to "recvonly" media streams; or
- "sendonly" if the streams were previously set to "sendrecv" media streams; or

If all the media streams that shall be resumed, the invoking UE shall generate a session level direction attribute, or separate media level direction attributes, in the SDP that is set to:

- "recvonly" if the streams were previously inactive media streams; or
- "sendrecv" if the streams were previously sendonly media streams, or the attribute may be omitted, since sendrecv is the default.

Then the UE shall send the generated SDP offer in a re-INVITE request (or UPDATE request) to the remote UE.

4.5.2.2 Void

4.5.2.3 Void

4.5.2.4 Actions at the AS of the invoking UE

As a network option, for each media stream marked "recvonly" in the SDP answer sent to the invoking UE, the AS of the invoking UE shall lower the bandwidth by setting the "b=AS:" parameter to a small value, e.g. "b=AS:0". The "b=RR:" and "b=RS:" parameters shall be set to values large enough to enable continuation of the RTCP flow, e.g. "b=RR:800" and "b=RS:800".

NOTE 1: A media stream in the SDP answer can be marked as "recvonly" at media description level or/and at session description level (i.e. all the media streams are marked "recvonly").

As a network option, the AS of the invoking UE shall initiate the procedures for the provision of an announcement to the held user in accordance with 3GPP TS 24.628 [6].

NOTE 2: Not providing an announcement allows the service provider to provide the possibility to change from bidirectional to unidirectional media streams.

NOTE 3: A service provider can decide to provide announcements only if a pre-defined set of media streams are put on HOLD.

4.5.2.5 Void

4.5.2.6 Void

4.5.2.7 Void

4.5.2.8 Void

4.5.2.9 Actions at the held UE

3GPP TS 24.229 [1] shall apply.

4.6 Interaction with other services

4.6.1 Communication Hold (HOLD)

Not applicable.

4.6.2 Terminating Identification Presentation (TIP)

No impact, i.e. neither service shall affect the operation of the other service.

4.6.3 Terminating Identification Restriction (TIR)

No impact, i.e. neither service shall affect the operation of the other service.

4.6.4 Originating Identification Presentation (OIP)

No impact, i.e. neither service shall affect the operation of the other service.

4.6.5 Originating identification restriction (OIR)

No impact, i.e. neither service shall affect the operation of the other service.

4.6.6 Conference calling (CONF)

If a participant of a conference invokes the HOLD service, it is not desirable to provide an announcement to the conference. If the AS supporting the HOLD supplementary service receives a re-INVITE (or UPDATE) request on a dialog for which the "isfocus" feature parameter was included in the Contact header from the remote end-point, the AS shall not initiate the procedures for the provision of an announcement to the held user(s).

4.6.7 Communication DIVersion services (CDIV)

No impact, i.e. neither service shall affect the operation of the other service.

4.6.8 Malicious Communication IDentification (MCID)

No impact, i.e. neither service shall affect the operation of the other service.

4.6.9 Anonymous Communication Rejection and Communication Barring (ACR/CB)

No impact, i.e. neither service shall affect the operation of the other service.

4.6.10 Explicit Communication Transfer (ECT)

No impact, i.e. neither service shall affect the operation of the other service.

4.7 Interactions with other networks

4.7.1 Void

4.7.2 Void

4.7.3 Void

4.8 Parameter values (timers)

Not applicable.

Annex A (informative): Signalling Flows

A.1 HOLD communication

Assumption is that a session has been established between UE-A and UE-B using basic communication procedures according to 3GPP TS 24.229 [1], therefore the following signalling flows do not apply to the initial INVITE.

A.1.1 HOLD communication without announcement

The following diagram shows a communication session put on hold using a re-INVITE request . The same can be achieved by sending an UPDATE request.

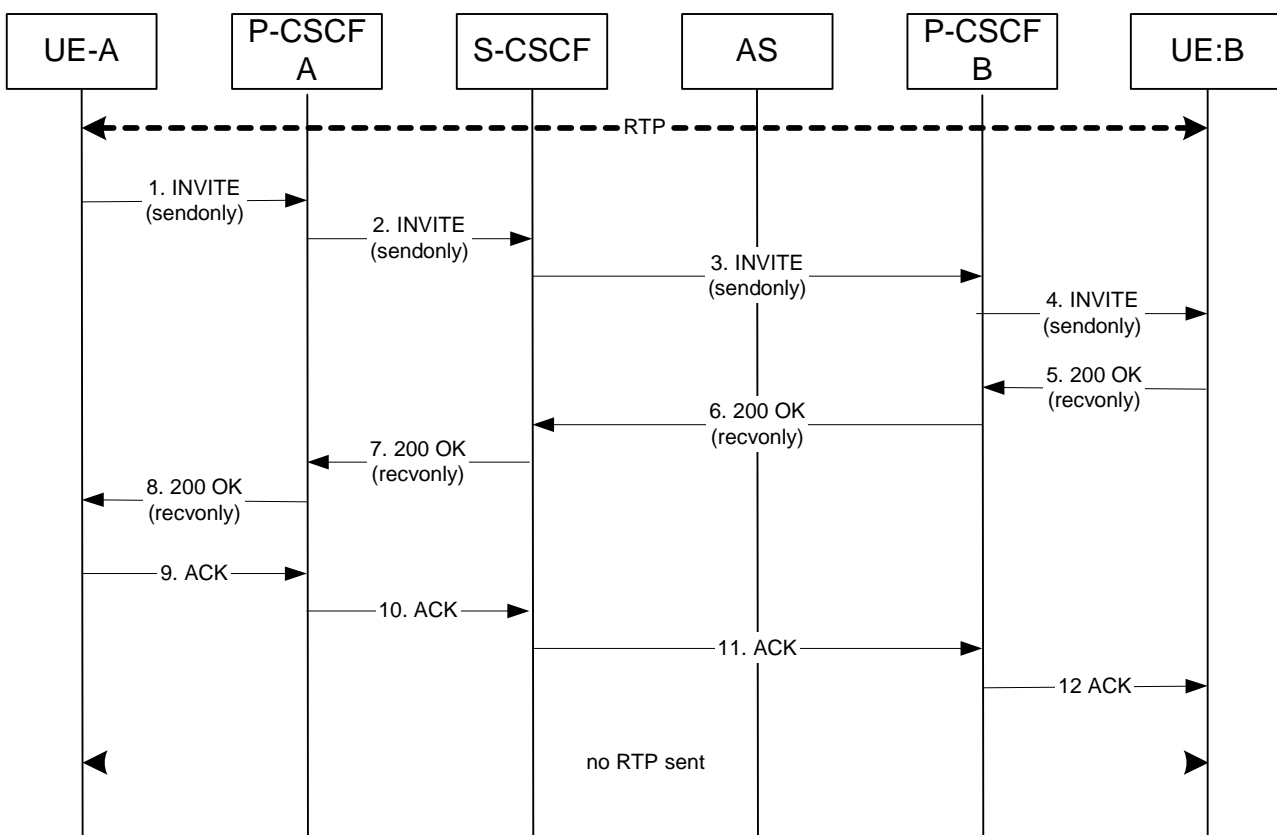

Figure A.1.1.1: HOLD communication without announcement to the held user

1. UE-A sends a re- INVITE to UE-B to hold the session - see example in table A.1.1.1-1. Hold is done by changing the SDP attribute. For each media stream that shall be held:
 - "a=sendonly", if the stream was previously a sendrecv media stream;
 - "a=inactive", if the stream was previously a recvonly media stream.

Table A.1.1.1-1: re-INVITE request (UE to P-CSCF)

```
INVITE user2_public1@home2.net;gr=urn:uuid:2ad8950e-48a5-4a74-8d99-ad76cc7fc74
;comp=sigcomp SIP/2.0
```

```
Via: SIP/2.0/UDP [5555::aaa:bbb:ccc:ddd]:1357;comp=sigcomp;branch=z9hG4bKnashds7
Max-Forwards: 70
Route: <sip:pcscf1.visited1.net:7531;lr;comp=sigcomp>, <sip:orig@scscf1.home1.net;lr>
P-Preferred-Identity: "John Doe" <sip:user1_public1@home1.net>
P-Access-Network-Info: 3GPP-UTRAN-TDD; utran-cell-id-3gpp=234151D0FCE11
Privacy: none
From: <sip:user1_public1@home1.net>; tag=171828
To: <tel:+1-212-555-2222>
Call-ID: cb03a0s09a2sdfglkj490333
Cseq: 127 INVITE
Require: sec-agree
Proxy-Require: sec-agree
Supported: precondition, 100rel, gruu, 199
Security-Verify: ipsec-3gpp; q=0.1; alg= hmac-sha-1-96; spi-c=98765432; spi-s=87654321;
port-c=8642; port-s=7531
Contact: <sip:user1_public1@home1.net; gr=urn:uuid:f81d4fae-7dec-11d0-a765-00a0c91e6bf6
;comp=sigcomp>;+g.3gpp.icsi-ref="urn%3Aurn-7%3gpp-service.ims.icsi.mmtel"
Allow: INVITE, ACK, CANCEL, BYE, PRACK, UPDATE, REFER, MESSAGE, SUBSCRIBE, NOTIFY
Content-Type: application/sdp
Content-Length: (...)
```

```
v=0
o=- 2987933615 2987933615 IN IP6 5555::aaa:bbb:ccc:ddd
s=-
c=IN IP6 5555::aaa:bbb:ccc:ddd
t=0 0
m=video 3400 RTP/AVPF 98 99
b=AS:75
a=crr:qos local none
a=crr:qos remote none
a=des:qos mandatory local sendonly
a=des:qos none remote sendonly
a=inactive
a=rtpmap:98 H263
a=fmtp:98 profile-level-id=0
a=rtpmap:99:MPVMP4V-ES
m=audio 3456 RTP/AVPF 97 96
b=AS:25.4
a=crr:qos local none
a=crr:qos remote none
a=des:qos mandatory local sendonly
a=des:qos none remote sendonly
a=inactive
a=rtpmap:97 AMR
a=fmtp:97 mode-set=0,2,5,7; maxframes=2
a=rtpmap:96 telephone-event
```

A.1.2 HOLD communication with announcement

The following diagram shows a communication session put on hold using a re-INVITE request with an announcement being played by the AS to the held party. The same can be achieved by sending an UPDATE request.

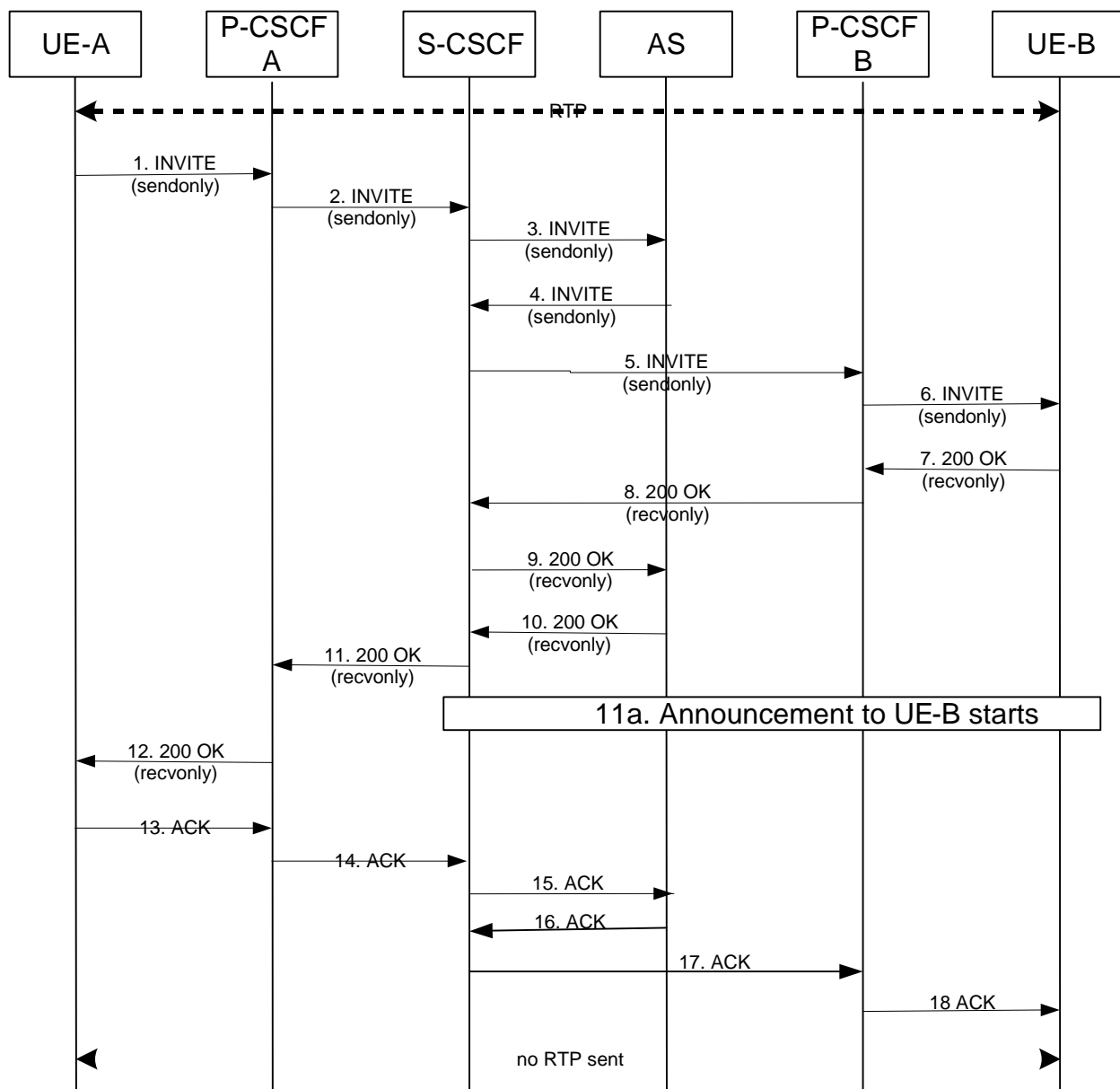

Figure A.1.2.1: HOLD communication with announcement to the held user

1. UE-A sends an INVITE to UE-B to hold the session - see example in table A.1.2.1-1. Hold is done by changing the SDP attribute. For each media stream that shall be held:
 - "a=sendonly", if the stream was previously a sendrecv media stream;
 - "a=inactive", if the stream was previously a recvonly media stream.

Table A.1.2.1-1: re-INVITE request (UE to P-CSCF)

```

INVITE user2_public1@home2.net;gr=urn:uuid:2ad8950e-48a5-4a74-8d99-ad76cc7fc74
;comp=sigcomp SIP/2.0
    
```

```
Via: SIP/2.0/UDP [5555::aaa:bbb:ccc:ddd]:1357;comp=sigcomp;branch=z9hG4bKnashds7
Max-Forwards: 70
Route: <sip:pcscf1.visited1.net:7531;lr;comp=sigcomp>, <sip:orig@scscf1.home1.net;lr>
P-Preferred-Identity: "John Doe" <sip:user1_public1@home1.net>
P-Access-Network-Info: 3GPP-UTRAN-TDD; utran-cell-id-3gpp=234151D0FCE11
Privacy: none
From: <sip:user1_public1@home1.net>; tag=171828
To: <tel:+1-212-555-2222>
Call-ID: cb03a0s09a2sdfglkj490333
Cseq: 127 INVITE
Require: sec-agree
Proxy-Require: sec-agree
Supported: precondition, 100rel, gruu, 199
Security-Verify: ipsec-3gpp; q=0.1; alg=hmac-sha-1-96; spi-c=98765432; spi-s=87654321;
port-c=8642; port-s=7531
Contact: <sip:user1_public1@home1.net; gr=urn:uuid:f81d4fae-7dec-11d0-a765-00a0c91e6bf6
;comp=sigcomp>;+g.3gpp.icsi-ref="urn%3Aurn-7%3gpp-service.ims.icsi.mmtel"
Allow: INVITE, ACK, CANCEL, BYE, PRACK, UPDATE, REFER, MESSAGE, SUBSCRIBE, NOTIFY
Content-Type: application/sdp
Content-Length: (...)

v=0
o=- 2987933615 2987933615 IN IP6 5555::aaa:bbb:ccc:ddd
s=-
c=IN IP6 5555::aaa:bbb:ccc:ddd
t=0 0
m=video 3400 RTP/AVPF 98 99
b=AS:75
a=crr:qos local none
a=crr:qos remote none
a=des:qos mandatory local sendonly
a=des:qos none remote sendonly
a=inactive
a=rtpmap:98 H263
a=fmtp:98 profile-level-id=0
a=rtpmap:99:MPVMP4V-ES
m=audio 3456 RTP/AVPF 97 96
b=AS:25.4
a=crr:qos local none
a=crr:qos remote none
a=des:qos mandatory local sendonly
a=des:qos none remote sendonly
a=inactive
a=rtpmap:97 AMR
a=fmtp:97 mode-set=0,2,5,7; maxframes=2
a=rtpmap:96 telephone-event
```

A.1.3 HOLD communication with modification of the SDP answer

The following diagram shows a communication session put on hold using a re-INVITE request with an announcement being played by the AS to the held party. The same can be achieved by sending an UPDATE request.

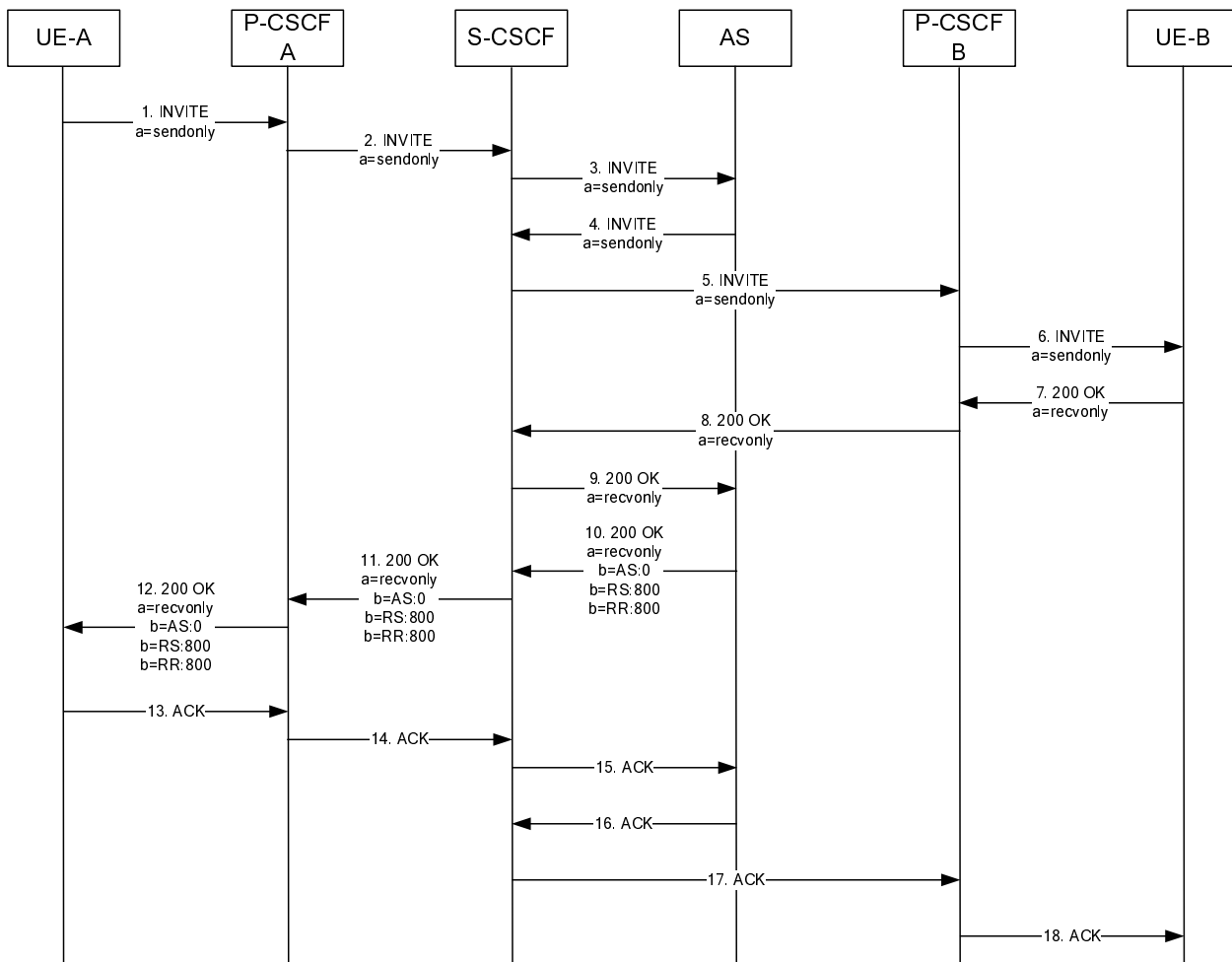

Figure A.1.3.1: HOLD communication with modification of the SDP answer

1. UE-A sends an INVITE request to UE-B to hold the session by changing the direction attribute to "a=sendonly".

Table A.1.3-1: re-INVITE request (UE to P-CSCF)

```
INVITE user2_public1@home2.net;gr=urn:uuid:2ad8950e-48a5-4a74-8d99-ad76cc7fc74
;comp=sigcomp SIP/2.0
```



```
Via: SIP/2.0/UDP [5555::aaa:bbb:ccc:ddd]:1357;comp=sigcomp;branch=z9hG4bKnashds7
Max-Forwards: 70
Route: <sip:pcscf1.visited1.net:7531;lr;comp=sigcomp>, <sip:orig@scscf1.home1.net;lr>
P-Preferred-Identity: "John Doe" <sip:user1_public1@home1.net>
P-Access-Network-Info: 3GPP-UTRAN-TDD; utran-cell-id-3gpp=234151D0FCE11
Privacy: none
From: <sip:user1_public1@home1.net>; tag=171828
To: <tel:+1-212-555-2222>; tag=24615

Call-ID: cb03a0s09a2sdfgklj490333
Cseq: 127 INVITE
Require: sec-agree
Proxy-Require: sec-agree
Supported: precondition, 100rel, gruu, 199
Security-Verify: ipsec-3gpp; q=0.1; alg=hmac-sha-1-96; spi-c=98765432; spi-s=87654321;
port-c=8642; port-s=7531
Contact: <sip:user1_public1@home1.net; gr=urn:uuid:f81d4fae-7dec-11d0-a765-00a0c91e6bf6
;comp=sigcomp>;+g.3gpp.icsi-ref="urn%3Aurn-7%3gpp-service.ims.icsi.mmtel"
Allow: INVITE, ACK, CANCEL, BYE, PRACK, UPDATE, REFER, MESSAGE, SUBSCRIBE, NOTIFY
Content-Type: application/sdp
Content-Length: (...)

v=0
o=- 2987933615 2987933615 IN IP6 5555::aaa:bbb:ccc:ddd
s=-
c=IN IP6 5555::aaa:bbb:ccc:ddd
t=0 0
m=video 3400 RTP/AVPF 98 99
b=AS:75
a=sendonly
a=rtpmap:98 H263
a=fmtp:98 profile-level-id=0
a=rtpmap:99:MPVMP4V-ES
m=audio 3456 RTP/AVPF 97 96
b=AS:25.4
a=sendonly
a=rtpmap:97 AMR
a=fmtp:97 mode-set=0,2,5,7; maxframes=2
a=rtpmap:96 telephone-event
```

10. The AS modifies the bandwidth attribute in the 200 (OK) response.

Table A.1.3-2: 200 (OK) response (AS to S-CSCF)

```

SIP/2.0 200 OK
Via: SIP/2.0/UDP pcscf1.visited1.net;branch=z9hG4bk120f34.1
Via: SIP/2.0/UDP 1.2.3.4:1357;branch=z9hG4bKnashds7
From: <sip:user1_public1@home1.net>;tag=171828
To: <tel:+1-212-555-2222>;tag=24615
Contact: <sip:user2_public1@home2.net;gr=urn:uuid:2ad8950e-48a5-4a74-8d99-
ad76cc7fc74>;+g.3gpp.icsi-ref="urn%3Aurn-7%3gpp-service.ims.icsi.mmtel"
Call-ID: cb03a0s09a2sdfg1kj490333
CSeq: 128 INVITE
Content-Length: (...)

v=0
o=- 2987933615 2987933615 IN IP6 5555::aaa:bbb:ccc:ddd
s=-
c=IN IP6 5555::aaa:bbb:ccc:ddd
t=0 0
m=video 3400 RTP/AVPF 98 99
b=AS:0
b=RS:800
b=RR:2400
a=recvonly
a=rtpmap:98 H263
a=fmtp:98 profile-level-id=0
a=rtpmap:99:MPVMP4V-ES
m=audio 3456 RTP/AVPF 97 96
b=AS:0
b=RS:800
b=RR:800
a=recvonly
a=rtpmap:97 AMR
a=fmtp:97 mode-set=0,2,5,7;maxframes=2
a=rtpmap:96 telephone-event

```

A.2 RESUME Communication

A.2.1 RESUME communication without announcement

The following diagram shows how a communication session is resumed using a re-INVITE request; The same can be achieved by sending an UPDATE request.

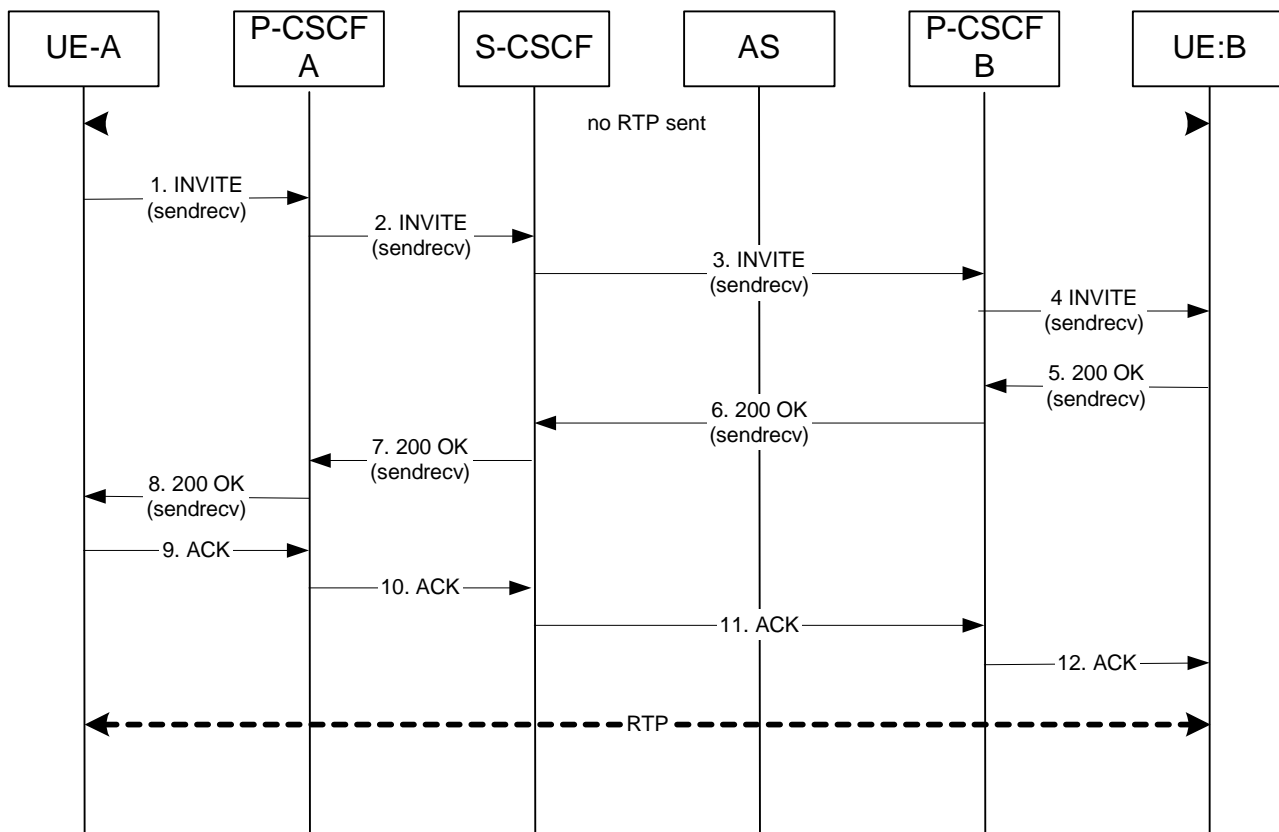

Figure A.2.1.1: RESUME communication without announcement to the held user

1. UE-A sends an INVITE to UE-B to resume the session - see example in table A.2.1.1-1. Resume is done by changing the SDP attribute. For each media stream that shall be resumed:
 - "a=sendrecv", if the stream was previously a recvonly media stream, or the attribute can be omitted, since sendrecv is the default;
 - "a=recvonly", if the stream was previously an inactive media stream.

Table A.2.1.1-1: re-INVITE request (UE to P-CSCF)

```

INVITE user2_public1@home2.net;gr=urn:uuid:2ad8950e-48a5-4a74-8d99-ad76cc7fc74
;comp=sigcomp SIP/2.0
Via: SIP/2.0/UDP [5555::aaa:bbb:ccc:ddd]:1357;comp=sigcomp;branch=z9hG4bKnashds7
Max-Forwards: 70
Route: <sip:pcscf1.visited1.net:7531;lr;comp=sigcomp>, <sip:orig@scscf1.home1.net;lr>
P-Preferred-Identity: "John Doe" <sip:user1_public1@home1.net>
P-Access-Network-Info: 3GPP-UTRAN-TDD; utran-cell-id-3gpp=234151D0FCE11
Privacy: none
From: <sip:user1_public1@home1.net>; tag=171828
To: <tel:+1-212-555-2222>
    
```

```

Call-ID: cb03a0s09a2sdfglkj490333
Cseq: 127 INVITE
Require: sec-agree
Proxy-Require: sec-agree
Supported: precondition, 100rel, gruu, 199
Security-Verify: ipsec-3gpp; q=0.1; alg=hmac-sha-1-96; spi-c=98765432; spi-s=87654321;
port-c=8642; port-s=7531
Contact: <sip:user1_public1@home1.net; gr=urn:uuid:f81d4fae-7dec-11d0-a765-00a0c91e6bf6
;comp=sigcomp>;+g.3gpp.icsi-ref="urn%3Aurn-7%3gpp-service.ims.icsi.mmtel"
Allow: INVITE, ACK, CANCEL, BYE, PRACK, UPDATE, REFER, MESSAGE, SUBSCRIBE, NOTIFY
Content-Type: application/sdp
Content-Length: (...)

v=0
o=- 2987933615 2987933615 IN IP6 5555::aaa:bbb:ccc:ddd
s=-
c=IN IP6 5555::aaa:bbb:ccc:ddd
t=0 0
m=video 3400 RTP/AVPF 98 99
b=AS:75
a=curr:qos local none
a=curr:qos remote none
a=des:qos mandatory local sendrecv
a=des:qos none remote sendrecv
a=inactive
a=rtpmap:98 H263
a=fmtp:98 profile-level-id=0
a=rtpmap:99:MPVMP4V-ES
m=audio 3456 RTP/AVPF 97 96
b=AS:25.4
a=curr:qos local none
a=curr:qos remote none
a=des:qos mandatory local sendrecv
a=des:qos none remote sendrecv
a=inactive
a=rtpmap:97 AMR
a=fmtp:97 mode-set=0,2,5,7; maxframes=2
a=rtpmap:96 telephone-event

```

A.2.2 RESUME communication with announcement

The following diagram shows how a communication session is resumed using a re-INVITE request after it was held with an announcement being played by the AS to the held party. The same can be achieved by sending an UPDATE request.

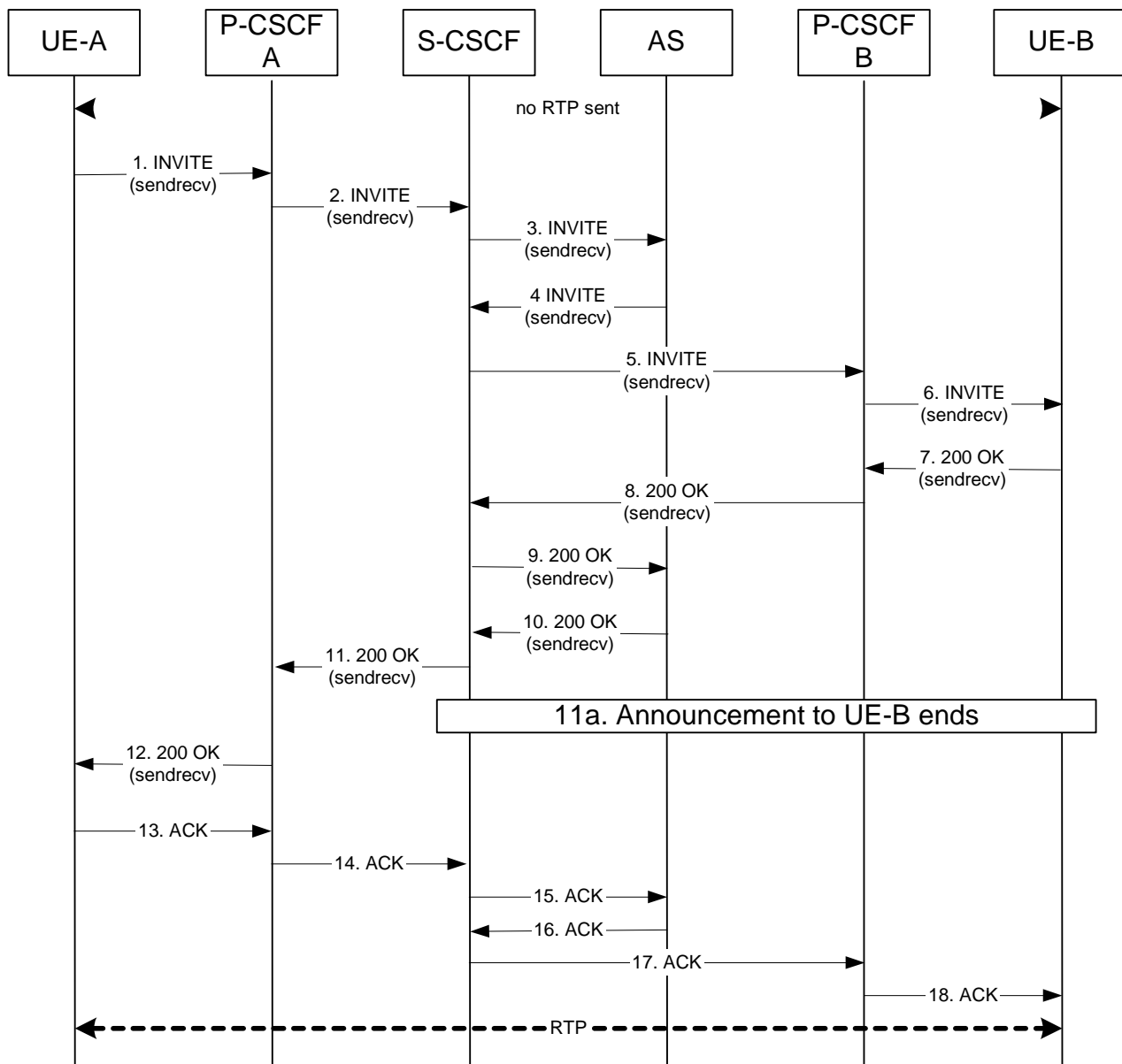

Figure A.2.2.1: RESUME communication with announcement to the held user

1. UE-A sends an INVITE to UE-B to resume the session - see example in table A.2.2.1-1. Resume is done by changing the SDP attribute. For each media stream that shall be resumed:
 - "a=sendrecv", if the stream was previously a recvonly media stream, or the attribute can be omitted, since sendrecv is the default;
 - "a=recvonly", if the stream was previously an inactive media stream.

Table A.2.2.1-1: re-INVITE request (UE to P-CSCF)

```

INVITE user2_public1@home2.net;gr=urn:uuid:2ad8950e-48a5-4a74-8d99-ad76cc7fc74
;comp=sigcomp SIP/2.0
Via: SIP/2.0/UDP [5555::aaa:bbb:ccc:ddd]:1357;comp=sigcomp;branch=z9hG4bKnashds7
Max-Forwards: 70
Route: <sip:pcscf1.visited1.net:7531;lr;comp=sigcomp>, <sip:orig@scscf1.home1.net;lr>
P-Preferred-Identity: "John Doe" <sip:user1_public1@home1.net>
P-Access-Network-Info: 3GPP-UTRAN-TDD; utran-cell-id-3gpp=234151D0FCE11
Privacy: none
From: <sip:user1_public1@home1.net>; tag=171828
To: <tel:+1-212-555-2222>
    
```

```
Call-ID: cb03a0s09a2sdfglkj490333
Cseq: 127 INVITE
Require: sec-agree
Proxy-Require: sec-agree
Supported: precondition, 100rel, gruu, 199
Security-Verify: ipsec-3gpp; q=0.1; alg=hmac-sha-1-96; spi-c=98765432; spi-s=87654321;
port-c=8642; port-s=7531
Contact: <sip:user1_public1@home1.net; gr=urn:uuid:f81d4fae-7dec-11d0-a765-00a0c91e6bf6
;comp=sigcomp>;+g.3gpp.icsi-ref="urn%3Aurn-7%3gpp-service.ims.icsi.mmtel"
Allow: INVITE, ACK, CANCEL, BYE, PRACK, UPDATE, REFER, MESSAGE, SUBSCRIBE, NOTIFY
Content-Type: application/sdp
Content-Length: (...)

v=0
o=- 2987933615 2987933615 IN IP6 5555::aaa:bbb:ccc:ddd
s=-
c=IN IP6 5555::aaa:bbb:ccc:ddd
t=0 0
m=video 3400 RTP/AVPF 98 99
b=AS:75
a=crr:qos local none
a=crr:qos remote none
a=des:qos mandatory local sendrecv
a=des:qos none remote sendrecv
a=inactive
a=rtpmap:98 H263
a=fmtp:98 profile-level-id=0
a=rtpmap:99:MPVMP4V-ES
m=audio 3456 RTP/AVPF 97 96
b=AS:25.4
a=crr:qos local none
a=crr:qos remote none
a=des:qos mandatory local sendrecv
a=des:qos none remote sendrecv
a=inactive
a=rtpmap:97 AMR
a=fmtp:97 mode-set=0,2,5,7; maxframes=2
a=rtpmap:96 telephone-event
```

Annex B (informative): Change history

Change history							
Date	TSG #	TSG Doc.	CR	R e v	Subject/Comment	Old	New
2005-08					Publication as ETSI TS 183 010		1.1.1
2006-04					Publication as ETSI TS 183 010		1.2.1
2007-04					Publication as ETSI TS 183 010		1.2.2
2007-12					Conversion to 3GPP TS 24.410		1.2.3
2008-01					Technically identical copy as 3GPP TS 24.610 as basis for further development.		1.2.4
2008-02					Implemented C1-080101		1.3.0
2008-04					Implemented C1-080886, C1-080887, C1-081090, C1-081091, C1-081113		1.4.0
2008-05					Implemented C1-081831, C1-081913		1.5.0
2008-05					Editorial changes done by MCC	1.5.0	1.5.1
2008-06	CT#40	CP-080330			CP-080330 was approved by CT#40 and version 8.0.0 is created by MCC for publishing	1.5.1	8.0.0
2008-09	CT#41	CP-080533	0001		Correction of Activation/deactivation of HOLD	8.0.0	8.1.0
2008-09	CT#41	CP-080533	0002	1	Miscellaneous clean-up corrections	8.0.0	8.1.0
2008-09	CT#41	CP-080533	0003		Applicability statement in scope	8.0.0	8.1.0
2008-09	CT#41	CP-080533	0004		Interaction of HOLD and CONF	8.0.0	8.1.0
2008-12	CT#42	CP-080865	0005	1	Holding or resuming all media streams	8.1.0	8.2.0
2008-12	CT#42	CP-080865	0006	2	Contents of SDP offer in HOLD	8.1.0	8.2.0
2008-12	CT#42	CP-080865	0007	1	Fixed the flows	8.1.0	8.2.0
2009-03	CT#43	CP-090121	0008		Correction of URN-value for Service Identifiers	8.2.0	8.3.0
2009-12	CT#46	CP-090923	0009	1	Correction of icsi-ref feature tag	8.3.0	9.0.0
2010-09	CT#49	CP-100526	0014		HOLD corrections	9.0.0	9.1.0
2011-03	CT#51				Upgrade to Rel-10	9.1.0	10.0.0
2012-03	CT#55	CP-120124	0015	1	HOLD-CONF interaction	10.0.0	11.0.0
2012-03	CT#55	CP-120197	0016	2	Clarification of HOLD procedures	10.0.0	11.0.0
2012-06	CT#56	CP-120307	0017	1	Usage of SDP direction attributes correction	11.0.0	11.1.0

History

Document history		
V11.1.0	November 2012	Publication