



**Digital cellular telecommunications system (Phase 2+) (GSM);
Universal Mobile Telecommunications System (UMTS);
LTE;
Explicit Communication Transfer (ECT)
using IP Multimedia (IM) Core Network (CN) subsystem;
Protocol specification
(3GPP TS 24.629 version 12.7.0 Release 12)**



Reference

RTS/TSGC-0124629vc70

Keywords

GSM,LTE,UMTS

ETSI

650 Route des Lucioles
F-06921 Sophia Antipolis Cedex - FRANCE

Tel.: +33 4 92 94 42 00 Fax: +33 4 93 65 47 16

Siret N° 348 623 562 00017 - NAF 742 C
Association à but non lucratif enregistrée à la
Sous-Préfecture de Grasse (06) N° 7803/88

Important notice

The present document can be downloaded from:
<http://www.etsi.org/standards-search>

The present document may be made available in electronic versions and/or in print. The content of any electronic and/or print versions of the present document shall not be modified without the prior written authorization of ETSI. In case of any existing or perceived difference in contents between such versions and/or in print, the only prevailing document is the print of the Portable Document Format (PDF) version kept on a specific network drive within ETSI Secretariat.

Users of the present document should be aware that the document may be subject to revision or change of status. Information on the current status of this and other ETSI documents is available at
<http://portal.etsi.org/tb/status/status.asp>

If you find errors in the present document, please send your comment to one of the following services:
<https://portal.etsi.org/People/CommitteeSupportStaff.aspx>

Copyright Notification

No part may be reproduced or utilized in any form or by any means, electronic or mechanical, including photocopying and microfilm except as authorized by written permission of ETSI.

The content of the PDF version shall not be modified without the written authorization of ETSI.
The copyright and the foregoing restriction extend to reproduction in all media.

© European Telecommunications Standards Institute 2016.
All rights reserved.

DECT™, **PLUGTESTS™**, **UMTS™** and the ETSI logo are Trade Marks of ETSI registered for the benefit of its Members.
3GPP™ and **LTE™** are Trade Marks of ETSI registered for the benefit of its Members and of the 3GPP Organizational Partners.
GSM® and the GSM logo are Trade Marks registered and owned by the GSM Association.

Intellectual Property Rights

IPRs essential or potentially essential to the present document may have been declared to ETSI. The information pertaining to these essential IPRs, if any, is publicly available for **ETSI members and non-members**, and can be found in ETSI SR 000 314: *"Intellectual Property Rights (IPRs); Essential, or potentially Essential, IPRs notified to ETSI in respect of ETSI standards"*, which is available from the ETSI Secretariat. Latest updates are available on the ETSI Web server (<https://ipr.etsi.org>).

Pursuant to the ETSI IPR Policy, no investigation, including IPR searches, has been carried out by ETSI. No guarantee can be given as to the existence of other IPRs not referenced in ETSI SR 000 314 (or the updates on the ETSI Web server) which are, or may be, or may become, essential to the present document.

Foreword

This Technical Specification (TS) has been produced by ETSI 3rd Generation Partnership Project (3GPP).

The present document may refer to technical specifications or reports using their 3GPP identities, UMTS identities or GSM identities. These should be interpreted as being references to the corresponding ETSI deliverables.

The cross reference between GSM, UMTS, 3GPP and ETSI identities can be found under <http://webapp.etsi.org/key/queryform.asp>.

Modal verbs terminology

In the present document "**shall**", "**shall not**", "**should**", "**should not**", "**may**", "**need not**", "**will**", "**will not**", "**can**" and "**cannot**" are to be interpreted as described in clause 3.2 of the [ETSI Drafting Rules](#) (Verbal forms for the expression of provisions).

"**must**" and "**must not**" are **NOT** allowed in ETSI deliverables except when used in direct citation.

Contents

| | |
|---|----|
| Intellectual Property Rights | 2 |
| Foreword..... | 2 |
| Modal verbs terminology..... | 2 |
| Foreword..... | 5 |
| 1 Scope | 6 |
| 2 References | 6 |
| 3 Definitions and abbreviations..... | 7 |
| 3.1 Definitions | 7 |
| 3.2 Abbreviations | 7 |
| 4 Explicit Communication Transfer (ECT)..... | 8 |
| 4.1 Introduction | 8 |
| 4.2 Description | 8 |
| 4.2.1 General description | 8 |
| 4.3 Operational requirements | 8 |
| 4.3.1 Provision/withdrawal | 8 |
| 4.3.2 Requirements on the transferor network side | 8 |
| 4.3.3 Requirements on the transferee network side | 8 |
| 4.3.4 Requirements on the transfer target network side | 9 |
| 4.4 Coding requirements | 9 |
| 4.5 Signalling requirements..... | 9 |
| 4.5.1 Activation/deactivation | 9 |
| 4.5.1A Registration/erasure | 9 |
| 4.5.1B Interrogation | 9 |
| 4.5.2 Invocation and operation | 9 |
| 4.5.2.1 Actions at the transferor UE..... | 9 |
| 4.5.2.2 Void..... | 11 |
| 4.5.2.3 Void..... | 11 |
| 4.5.2.4 Actions at the transferor AS | 11 |
| 4.5.2.4.1 Invocation of ECT service..... | 11 |
| 4.5.2.4.1.1 Prerequisite for invocation of the ECT service | 11 |
| 4.5.2.4.1.2 Determine whether the ECT applies | 11 |
| 4.5.2.4.1.2.1 REFER request received on a separate dialog | 11 |
| 4.5.2.4.1.2.2 REFER request received in the to be transferred dialog..... | 11 |
| 4.5.2.4.1.2.2A Procedures for call transfer with 3PCC | 12 |
| 4.5.2.4.1.2.3 Actions of ECT when invoked with a transfer request | 12 |
| 4.5.2.4.2 Subsequent procedures | 13 |
| 4.5.2.4.2.1 Actions of ECT when invoked again by the transferred communication..... | 13 |
| 4.5.2.5 Actions at the transferee UE..... | 13 |
| 4.5.2.5.1 Actions at the transferee UE (without 3PCC)..... | 13 |
| 4.5.2.5.2 Actions at the transferee UE (with 3PCC)..... | 14 |
| 4.5.2.6 Void..... | 14 |
| 4.5.2.7 Actions at the transferee AS..... | 14 |
| 4.5.2.7.0 Prerequisite for invocation of the ECT service..... | 14 |
| 4.5.2.7.1 Determine whether ECT applies..... | 14 |
| 4.5.2.7.2 Actions of the ECT AS when invoked with a transfer request | 14 |
| 4.5.2.7.3 Actions of the ECT AS when invoked again by the transferred communication | 14 |
| 4.5.2.8 Void..... | 15 |
| 4.5.2.9 Void..... | 15 |
| 4.5.2.10 Void..... | 15 |
| 4.5.2.11 Void..... | 15 |
| 4.5.2.12 Void..... | 15 |
| 4.5.2.13 Void..... | 15 |
| 4.5.2.14 Void..... | 15 |

| | | |
|--|---|-----------|
| 4.5.2.15 | Actions at the transfer target's AS | 15 |
| 4.5.2.16 | Void..... | 15 |
| 4.5.2.17 | Actions at the transfer target's UE..... | 15 |
| 4.6 | Interaction with other services..... | 15 |
| 4.6.1 | Communication HOLD (HOLD)..... | 15 |
| 4.6.2 | Terminating Identification Presentation (TIP)..... | 15 |
| 4.6.3 | Terminating Identification Restriction (TIR)..... | 15 |
| 4.6.4 | Originating Identification Presentation (OIP)..... | 15 |
| 4.6.5 | Originating Identification Restriction (OIR)..... | 15 |
| 4.6.6 | CONference Calling (CONF) | 16 |
| 4.6.7 | Communication DIVersion Services (CDIV) | 16 |
| 4.6.8 | Malicious Communication IDentification (MCID) | 16 |
| 4.6.9 | Anonymous Communication Rejection and Communication Barring (ACR/CB) | 16 |
| 4.6.10 | Explicit Communication Transfer (ECT) | 16 |
| 4.6.10.1 | Determine whether a previously transferred communication is transferred again | 16 |
| 4.6.10.2 | Handling of transfer requests | 16 |
| 4.6.10.3 | Actions when this ECT instance is invoked again by the transferred communication..... | 17 |
| 4.7 | Interworking with other networks | 17 |
| 4.7.1 | Void | 17 |
| 4.7.2 | Void | 17 |
| 4.7.3 | Void | 17 |
| 4.8 | Parameter values (timers)..... | 17 |
| 4.9 | Service configuration | 17 |
| Annex A (informative): Signalling flows | | 18 |
| A.1 | Blind transfer..... | 18 |
| A.2 | Consultative transfer..... | 21 |
| A.3 | Blind call transfer with third party call control | 22 |
| A.4 | Consultative call transfer with third party call control..... | 23 |
| Annex B (informative): Example of filter criteria | | 24 |
| B.1 | Example of filter criteria for ECT | 24 |
| Annex C (informative): Example charging model..... | | 25 |
| C.1 | Example of B REFER's A to C | 25 |
| C.2 | Example of A REFER's B to C | 26 |
| Annex D (informative): Void | | 27 |
| Annex E (informative): Change history | | 28 |
| History | | 29 |

Foreword

This Technical Specification (TS) was been produced by ETSI Technical Committee Telecommunications and Internet converged Services and Protocols for Advanced Networking (TISPAN) and originally published as ETSI TS 183 029 [11]. It was transferred to the 3rd Generation Partnership Project (3GPP) in January 2008.

The contents of the present document are subject to continuing work within the TSG and may change following formal TSG approval. Should the TSG modify the contents of the present document, it will be re-released by the TSG with an identifying change of release date and an increase in version number as follows:

Version x.y.z

where:

- x the first digit:
 - 1 presented to TSG for information;
 - 2 presented to TSG for approval;
 - 3 or greater indicates TSG approved document under change control.
- y the second digit is incremented for all changes of substance, i.e. technical enhancements, corrections, updates, etc.
- z the third digit is incremented when editorial only changes have been incorporated in the document.

1 Scope

The present document specifies the stage three (protocol description) of the Explicit Communication transfer (ECT) supplementary service, based on stage one and two of the ISDN ECT supplementary service. It provides the protocol details in the IP Multimedia (IM) Core Network (CN) subsystem based on the Session Initiation Protocol (SIP) and the Session Description Protocol (SDP).

The present document is applicable to User Equipment (UE) and Application Servers (AS) which are intended to support the ECT supplementary service.

2 References

The following documents contain provisions which, through reference in this text, constitute provisions of the present document.

- References are either specific (identified by date of publication, edition number, version number, etc.) or non-specific.
- For a specific reference, subsequent revisions do not apply.
- For a non-specific reference, the latest version applies. In the case of a reference to a 3GPP document (including a GSM document), a non-specific reference implicitly refers to the latest version of that document *in the same Release as the present document*.

- [1] 3GPP TS 24.229: "Internet Protocol (IP) multimedia call control protocol based on Session Initiation Protocol (SIP) and Session Description Protocol (SDP); Stage 3".
- [2] IETF RFC 3515: "The Session Initiation Protocol (SIP) Refer Method".
- [3] IETF RFC 3892: "The Session Initiation Protocol (SIP) Referred-By Mechanism".
- [4] IETF RFC 3891: "The Session Initiation Protocol (SIP) "Replaces" Header".
- [5] Void.
- [6] IETF RFC 3261: "SIP: Session Initiation Protocol".
- [7] 3GPP TS 29.228: "IP Multimedia (IM) Subsystem Cx and Dx Interfaces; Signalling flows and message contents".
- [7A] 3GPP TS 29.229: "Cx and Dx interfaces based on the Diameter protocol; Protocol details".
- [8] 3GPP TS 24.610: "Communication HOLD (HOLD) using IP Multimedia (IM) Core Network (CN) subsystem; Protocol specification".
- [9] 3GPP TS 24.605: "Conference (CONF) using IP Multimedia (IM) Core Network (CN) subsystem; Protocol specification".
- [10] 3GPP TS 24.628: "Common Basic Communication procedures using IP Multimedia (IM) Core Network (CN) subsystem; Protocol specification".
- [11] ETSI TS 183 029 V2.5.0: "Telecommunications and Internet converged Services and Protocols for Advanced Networking (TISPAN); PSTN/ISDN simulation services: Explicit Communication Transfer (ECT); Protocol specification".
- [12] 3GPP TS 24.315: "IP Multimedia Subsystem (IMS) Operator Determined Barring (ODB); Stage 3".
- [13] IETF RFC 7090 (April 2014): "Public Safety Answering Point (PSAP) Callback".
- [14] IETF RFC 6665: "SIP-Specific Event Notification".

- [15] IETF RFC 4538: "Request Authorization through Dialog Identification in the Session Initiation Protocol (SIP)".
- [16] IETF RFC 7647 (September 2015): "Clarifications for the Use of REFER with RFC6665".

3 Definitions and abbreviations

3.1 Definitions

For the purposes of the present document, the following terms and definitions apply:

ECT session identifier URI: PSI created and inserted by an ECT AS that resolves to the AS itself

NOTE 1: If this URI contains correlation information it has to be constructed in such a way that it does not reveal identity information about any party involved in the transfer.

transferee: party being transferred to the transfer target

transferor: party initiating the transfer

transfer target: party that the existing communication is transferred to

NOTE 2: After transfer the transferee and the transfer target are in communication with each other.

3.2 Abbreviations

For the purposes of the present document, the following abbreviations apply:

| | |
|--------|---|
| ACR | Anonymous Communication Rejection |
| AS | SIP Application Server |
| CDIV | Communication DIVersion |
| CONF | CONFerence |
| CSCF | Call Session Control Function |
| ECT | Explicit Communication Transfer |
| GRUU | Globally Routable User agent URI |
| HOLD | communication HOLD |
| IETF | Internet Engineering Task Force |
| IFC | Initial Filter Criteria |
| ISDN | Integrated Services Digital Network |
| MCID | Malicious Call IDentification |
| MGCF | Media Gateway Control Function |
| OCB | Outgoing Communication Barring |
| ODB | Operator Determined Barring |
| OIP | Originating Identification Presentation |
| OIR | Originating Identification presentation Restriction |
| PSAP | Public Safety Answering Point |
| PSTN | Public Switch Telephone Network |
| S-CSCF | Serving-CSCF |
| SIP | Session Initiation Protocol |
| TIP | Terminating Identification Presentation |
| TIR | Terminating Identification presentation Restriction |
| UE | User Equipment |

4 Explicit Communication Transfer (ECT)

4.1 Introduction

The service provides a party involved in a communication to transfer that communication to a third party.

Procedures for the ECT AS regarding operator determined barring (ODB) are defined in 3GPP TS 24.315 [12].

4.2 Description

4.2.1 General description

The explicit communication transfer (ECT) service provides a party involved in a communication to transfer that communication to a third party.

There are three actors active in a transfer, they are acting in the following roles:

transferor: the party that initiates the transfer of the active communication that it has with the transferee;

transferee: the party which stays in the communication which is transferred;

transfer target: the party which the communication is transferred to and which replaces the transferor in the communication.

There are two initial situations in which transfer shall be possible:

- the transferor has no ongoing consultation communication with the transfer target (blind/assured transfer), then either:
 - a) the transferor wants to perform the transfer without any further action on the transfer operation (blind transfer); or
 - b) the transferor wants to have a feedback on the transfer operation progress with the possibility to retrieve the communication with the transferee (assured transfer); or
- the transferor has a consultation communication with the transfer target (consultative transfer).

The transferor AS takes care that it remains in the signalling path even after the communication is transferred, this allows:

- classical charging models;
- anonymization of the transfer target.

4.3 Operational requirements

4.3.1 Provision/withdrawal

The ECT service may be provided after prior arrangement with the service provider or be generally available.

4.3.2 Requirements on the transferor network side

No specific requirements are needed in the network.

4.3.3 Requirements on the transferee network side

No specific requirements are needed in the network.

4.3.4 Requirements on the transfer target network side

No specific requirements are needed in the network.

4.4 Coding requirements

A user agent that wishes to use the ECT service (to act as a transferor):

- Shall support the REFER method as a client as specified in RFC 3515 [2] as updated by IETF RFC 6665 [14] and IETF RFC 7647 [16].
- Shall support the Referred-By header field as specified in RFC 3892 [3].
- Shall support the Target-Dialog header field as specified in RFC 4538 [15].

A user agent that is the transferred party in a communication transfer (acts as the transferee):

- Shall support the REFER method as a server as specified in RFC 3515 [2] and updated by RFC 6665 [14].
- Shall support the Referred-By header field as specified in RFC 3892 [3].
- Shall support Replaces header field as a client as specified in RFC 3891 [4].
- Shall support the Target-Dialog header field as specified in RFC 4538 [15].

A user agent that is the transfer target in a communication transfer:

- May support the Referred-By header field as a server as specified in RFC 3892 [3].
- May support the Replaces header field as a server as specified in RFC 3891 [4].

4.5 Signalling requirements

4.5.1 Activation/deactivation

The ECT service is activated at provisioning and deactivated at withdrawal.

4.5.1A Registration/erasure

The ECT service requires no registration. Erasure is not applicable.

4.5.1B Interrogation

Interrogation of ECT is not applicable.

4.5.2 Invocation and operation

4.5.2.1 Actions at the transferor UE

A UE that has initiated an emergency call, shall not perform any transfer operation involving the dialog associated with the emergency call.

A UE that initiates a transfer operation shall if the Contact address of the transferee is a GRUU:

- issue a REFER outside an existing dialog as specified in RFC 3515 [2] as updated by IETF RFC 6665 [14] and IETF RFC 7647 [16], where:
 - a) the request URI shall contain the SIP URI of the transferee as received in the Contact header field;
 - b) the Refer-To header field shall indicate the public address of the transfer target;

- c) in case of Consultative transfer, the transferor UE has a consultation communication with the transfer target, a Replaces header field parameter shall be added to the Refer-To URI together with a Require=replaces header field parameter;
- d) the Referred-By header field can be used to indicate the identity of the transferor. When privacy was required in the original communications dialog and a Referred-By header field is included, the UE shall include a Privacy header field set to "user"; and
- e) the Target-Dialog header field identifies the dialog to be transferred;

otherwise the UE shall:

- issue a REFER request in the original communications dialog as specified in RFC 3515 [2], where:
 - a) the request URI shall contain the SIP URI of the transferee as received in the Contact header field;
 - b) the Refer-To header field shall indicate the public address of the transfer target;
 - c) in case of consultative transfer, the transferor UE has a consultation communication with the transfer target, a Replaces header field parameter shall be added to the Refer-To URI together with a Require=replaces header field parameter; and
 - d) the Referred-By header field can be used to indicate the identity of the transferor. When privacy was required in the original communications dialog and a Referred-By header field is included, the UE shall include a Privacy header field set to "user".

If assured transfer is requested, the UE may include an Expires header field in the Refer-To URI of the REFER request.

NOTE 1: The value of the Expires header field indicates the maximum duration of the transfer attempt. If the transfer does not succeed within this duration, the UE will receive a NOTIFY request indicating the transfer failure.

After the REFER request is accepted by the other end with a 2xx response, the transferor UE gets notifications of how the transferee's communication setup towards the transfer Target is progressing.

When a NOTIFY request is received on the REFER dialog that indicates that the transferee and the transfer Target have successfully setup a communication, the transferor UE may terminate the original communication with the transferee UE, by sending a BYE request on the original dialog.

If an assured transfer attempt is not completed (i.e. the UE has not received a NOTIFY request with a "message/sipfrag" body's status line containing a final response code indicating the end of the transfer operation), the UE may request to terminate the transfer attempt by:

- sending a REFER request in the same communications dialog as the previous REFER request as specified in RFC 3515 [2] as updated by IETF RFC 6665 [14] and IETF RFC 7647 [16], where:
 - a) the request URI shall contain the SIP URI of the transferee as received in the Contact header field; and
 - b) the Refer-To header field shall indicate the public address of the transfer target and shall contain the method parameter set to "CANCEL"; and
 - c) if applicable include a Target-Dialog header field that identifies the dialog under transfer.

If the UE receives a NOTIFY request indicating that the assured transfer attempt failed, followed by a re-INVITE or an UPDATE request taking the UE off HOLD the UE may decide to retrieve the original communication by sending a re-INVITE request in the original SIP dialog.

NOTE 2: If the user requests the retrieval of the original communication while the transfer attempt has not been completed, the UE needs to first request the termination of the transfer attempt before retrieving the original communication via a re-INVITE request.

4.5.2.2 Void

4.5.2.3 Void

4.5.2.4 Actions at the transferor AS

4.5.2.4.1 Invocation of ECT service

4.5.2.4.1.1 Prerequisite for invocation of the ECT service

For ECT to be provided to end users acting as transferors, the end user's AS providing ECT shall be in the signalling path for all communications.

4.5.2.4.1.2 Determine whether the ECT applies

The transferor AS is the one executing the ECT service logic, which is invoked by the transferor sending a special REFER request.

4.5.2.4.1.2.1 REFER request received on a separate dialog

In order to know whether ECT service applies on a REFER request sent by the served user, the following criteria shall apply before the ECT logic is executed:

- the Target-Dialog header field identifies an existing dialog towards the transferee identified by the Request-URI;
- the REFER request's Request-URI (transferee) is a GRUU targeted at the same UE instance that is involved in the dialog identified by the Target-Dialog header field; and
- the REFER request's Refer-To header field contains a URI so that the method constructed from the URI according to RFC 3261 [6] is equal to INVITE;

4.5.2.4.1.2.2 REFER request received in the to be transferred dialog

In order to know whether ECT service applies on a REFER request sent by the served user, the following criteria shall apply before the ECT logic is executed:

- the REFER request's request-URI (transferee) is targeted at the same UE instance that is involved in the dialog; and
- the REFER request's Refer-To header field contains a URI so that the method constructed from the URI according to RFC 3261 [6] is equal to INVITE.

Any REFER request that does not comply with these criteria shall not invoke the ECT service and is depending on operator policy:

- rejected;
- handled by another service; or
- proxied on.

If any of the following is true:

- the initial INVITE request on the dialog on which the REFER request is received was identified as a PSAP callback request; or
- the Refer-To header field in the REFER request contains a URI with which the referor is involved in a dialog where the initial INVITE request was identified as a PSAP callback request.

the AS shall based on local policy on how to handle PSAP callbacks reject the REFER request.

The mechanism to identify an INVITE request as a PSAP callback depends on local policy and can be based on the PSAP callback indicator specified in IETF RFC 7090 [13].

4.5.2.4.1.2.2A Procedures for call transfer with 3PCC

When a REFER request is received that invokes the call transfer service (see subclause 4.5.2.4.1), the AS shall follow procedures specified in 3GPP TS 24.628 [10] for special REFER request handling using 3PCC procedures. An AS supporting the assured transfer, shall put the INVITE dialog towards the transferor on HOLD, following procedures in 3GPP TS 24.610 [8].

If the received REFER request contained an Expires header field in the Refer-To URI, the AS shall start a timer set to the value received in the Expires header field when the INVITE request is sent towards the transfer target, as requested by the received REFER request. If this timer expires before the transfer attempt is completed, the AS shall send a CANCEL request towards the transfer target according to RFC 3261 [4].

For blind communication transfer, if required by local policy to do so, the AS shall connect a media server to the transferee UE in order to provide in-band announcement about the progress of the communication establishment with the transfer target.

If the assured transfer attempt fails the AS shall resume the INVITE dialog with the transferor, following procedures in 3GPP TS 24.610 [8].

4.5.2.4.1.2.3 Actions of ECT when invoked with a transfer request

When a REFER request is received that invokes the ECT service (see subclause 4.5.2.4.1), the ECT service shall perform the following actions:

- 1) Create a new ECT session identifier URI addressed to this AS. The URI shall be created in such a way that a new dialog set up towards this URI can be easily correlated with the current REFER dialog.
- 2) The AS stores the value of the Refer-To header field (transfer target URI) from the REFER request and links it to the ECT Session Identifier URI.
- 3) The AS replaces the Refer-To header field with the ECT Session Identifier URI (this ensures that the transferor AS remains in the loop when the transferee sets up the communication with the transfer target).

NOTE: If a Replaces header field parameter and/or a Require=replaces header field parameter are available in the URI contained in the Refer-To header field, the above step implies that they are not forwarded to the transferee.

- 4) If a Referred-By header field is available in the request, the AS verifies if the provided Referred-By header field contains a valid public identity of the served user. If not it will replace the Referred-By header field with a valid value matching the REFER request's P-Asserted-Identity and if "id" privacy was requested, include a Privacy header field set to "user". If the Referred-By header field does not contain a valid public identity of the served user and multiple valid public user identities are received in the REFER request's P-Asserted-Identity header field, the AS shall select the first one on the list. The AS then stores the Referred-by header field.
- 5) If no Referred-By header field is available in the request a Referred-By header field is added that matches the REFER request's P-Asserted-Identity and if "id" privacy was requested, include a Privacy header field set to "user". If multiple valid public user identities are received in the REFER request's P-Asserted-Identity header field, the AS shall select the first one on the list.
- 6) The AS sends the REFER request on to the transferee using basic communication procedures 3GPP TS 24.229 [1].

If the AS receives a 403 (Forbidden) or 501 (Not implemented) response to a REFER request, the AS of the initiator of the REFER request may initiate the special REFER handling procedures, according to 3GPP TS 24.628 [10].

If the AS receives a NOTIFY request with a sipfrag message body indicating a 420 (Bad Extension) as defined in RFC 3892 [3], the AS of the initiator of the REFER request may initiate the special REFER handling procedures according to 3GPP TS 24.628 [10].

As a network option, the AS of the initiator of the REFER request that has prior knowledge that the remote party is not allowed to receive or does not support the REFER method, may initiate the special REFER handling procedures directly, according to 3GPP TS 24.628 [10].

4.5.2.4.2 Subsequent procedures

4.5.2.4.2.1 Actions of ECT when invoked again by the transferred communication

When an INVITE is received targeted at the ECT session identifier URI created earlier when the served user requested transfer of an ongoing communication, ECT shall perform the following actions:

- 0) If the stored transfer target URI linked to the ECT session identifier contains a Replaces header field parameter, then the AS inserts the Replaces header field in the INVITE request and:
 - a) If the INVITE request does not contain a Requires header field, then the AS inserts a Requires header field in the INVITE request including a "replaces" token; and
 - b) If the INVITE request does contain a Requires header field without a "replaces" token, then the AS inserts a Requires header field in the INVITE request including a "replaces" token.
- 1) strip all header field parameters and method parameter from the stored transfer target URI and replace the request URI with the stripped version of the stored transfer target URI linked to the specific ECT session identifier URI;
- 2) if a Referred-By header field is available in the request, the AS verifies if the provided Referred-By header field contains a valid identity of the served user. If not it will replace the Referred-By header field with a valid value matching the REFER request's P-Asserted-Identity and if "id" privacy was requested, include a Privacy header field set to "user". If the Referred-By header field does not contain a valid public identity of the served user and multiple valid public user identities are received in the REFER request's P-Asserted-Identity header field, the AS shall select the first one on the list;
- 3) if no Referred-By header field is available in the request a Referred-By header field is added that matches the REFER request's P-Asserted-Identity, and if "id" privacy was requested, include a Privacy header field set to "user". If multiple valid public user identities are received in the REFER request's P-Asserted-Identity header field, the AS shall select the first one on the list; and

NOTE: If needed the AS can generate charging events to charge for the extra leg.

- 4) the INVITE request is forwarded towards the transfer target using basic communication procedures 3GPP TS 24.229 [1].

4.5.2.4.2.2 Actions of ECT on failed REFER request

4.5.2.5 Actions at the transferee UE

4.5.2.5.1 Actions at the transferee UE (without 3PCC)

When a REFER request is received in the context of a call transfer scenario (see subclause 4.5.2.4.1), the transferee UE shall perform the following steps:

- 1) apply the procedure for holding the active communication with the transferor as described in 3GPP TS 24.610 [8] subclause 4.5.2.1;
- 2) form a request as specified by the "method" URI parameter in the Refer-To header field. If no "method" URI parameter is included an INVITE request shall be formed in accordance with RFC 3261 [6];
- 3) send the request to the transfer target;
- 4) if the UE does not support the Assured transfer service, send a BYE request on the INVITE dialog towards the transferor; and
- 5) act as a notifier in accordance with RFC 3515[2] as updated by RFC 6665 [14].

A UE supporting the assured transfer service shall keep the INVITE dialog towards the transferor. If the request towards the transfer target fails, the UE supporting the assured transfer service shall resume the session towards the transferor as described in 3GPP TS 24.610 [8] subclause 4.5.2.1.

4.5.2.5.2 Actions at the transferee UE (with 3PCC)

Apply normal re-INVITE procedures according to 3GPP TS 24.229 [1].

4.5.2.6 Void

4.5.2.7 Actions at the transferee AS

4.5.2.7.0 Prerequisite for invocation of the ECT service

For ECT to be provided to end users acting as transferee, the end user's AS providing ECT shall be in the signalling path for all communications of the served user.

4.5.2.7.1 Determine whether ECT applies

See subclause 4.5.2.4.1 on the criteria that determine that a REFER request is to be treated as a request for transfer of an existing communication.

4.5.2.7.2 Actions of the ECT AS when invoked with a transfer request

When a REFER request is received in the context of a call transfer scenario (see subclause 4.5.2.4.1), the ECT AS shall perform the following steps:

- 1) Store the value of the Refer-To header field (used later to correlate the new communication with this REFER dialog).
- 2) Optionally it may store the value of the Referred-By header field, if it wants to ensure that the Referred-By is correct on the resulting INVITE request.
- 3) Forward the request to the transferee according to basic communication procedures 3GPP TS 24.229 [1].

4.5.2.7.3 Actions of the ECT AS when invoked again by the transferred communication

When an INVITE request is received targeted at the SIP URI stored earlier when a transfer request was received targeted at the served user (transferee), the AS shall perform the following actions:

- 0) Optionally check the following header fields in the received INVITE request:
 - a) if a Referred-By header field is present in the INVITE request, the AS may check if it matches the Referred-By header field of the REFER request stored earlier. If it does not match, depending on the policy of the service provider, the AS shall reject the INVITE request or replace the Referred-By header field in the INVITE request with the value stored earlier; andif a Referred-By header is absent in the INVITE, the AS shall insert a Referred-By header with the value stored earlier.
- 1) optionally generate charging events:
 - a) to charge for the original communication between the transferee and the transferor, in case the transferee was the originating party in the original communication; and
 - b) to switch off charging in case the transferee was the terminating party in the original communication; and
- 2) the INVITE is forwarded towards the transfer Target using basic communication procedures 3GPP TS 24.229 [1].

4.5.2.8 Void

4.5.2.9 Void

4.5.2.10 Void

4.5.2.11 Void

4.5.2.12 Void

4.5.2.13 Void

4.5.2.14 Void

4.5.2.15 Actions at the transfer target's AS

Basic communication procedures according to 3GPP TS 24.229 [1] shall apply.

4.5.2.16 Void

4.5.2.17 Actions at the transfer target's UE

Basic communication procedures according to 3GPP TS 24.229 [1] shall apply.

4.6 Interaction with other services

4.6.1 Communication HOLD (HOLD)

No impact.

4.6.2 Terminating Identification Presentation (TIP)

No impact.

4.6.3 Terminating Identification Restriction (TIR)

No impact.

4.6.4 Originating Identification Presentation (OIP)

No impact.

4.6.5 Originating Identification Restriction (OIR)

Requirements relating to the Referred-By header field are described in subclauses 4.5.2.4.1.2.3 and 4.5.2.4.2.1.

On the reception of an INVITE request from the transferee, the transferor AS shall deduce the "id" related privacy requirement that the transferee has indicated in the initial call between the transferee and the transferor; and shall include a Privacy header field containing the according value in the outgoing INVITE request.

For the transferee AS and the transfer Target AS there is no impact.

4.6.6 CONFerence Calling (CONF)

ECT shall not apply when the following criteria apply:

- a REFER request is received in an INVITE dialog with a conference focus, or a REFER request is received in an INVITE dialog and the Refer-to header field of the REFER request indicates the public address of active dialog to conference focus which is known by the AS providing ECT; and
- the REFER request is originated by the conference controller, the conference controller is the user that created and owns the conference.

An AS can determine that an established INVITE dialog is terminated at a conference focus because according to 3GPP TS 24.605 [9] it either:

- has received a 1xx or 2xx response to the INVITE request with an "isfocus" feature parameter in the Contact header field; or
- has received an INVITE with an "isfocus" feature parameter in the Contact header field.

4.6.7 Communication DIVersion Services (CDIV)

No impact.

4.6.8 Malicious Communication IDentification (MCID)

No impact.

4.6.9 Anonymous Communication Rejection and Communication Barring (ACR/CB)

For the transferor AS the following applies:

- The transferor AS shall not accept transfer requests with a transfer target that is barred by the served users Outgoing Communication Barring (OCB) rules.
- For the transferee AS and the transfer target AS there is no impact.

4.6.10 Explicit Communication Transfer (ECT)

4.6.10.1 Determine whether a previously transferred communication is transferred again

See subclause 4.5.2.4.1 on the criteria that determine that a REFER request is to be treated as a request for transfer of an existing communication.

Additionally the following criteria should apply for this interaction case to apply:

- The INVITE dialog on which the REFER request is received is a previously transferred communication, for which the current ECT instance had the transferor role.

4.6.10.2 Handling of transfer requests

When a REFER request is received and the criteria of subclause 4.6.10.1 apply, then the AS shall perform the following steps:

- 1) Create a new ECT session identifier URI addressed to this AS. The URI shall be created in such a way that a new dialog set up towards this URI can be easily correlated with the current REFER dialog.
- 2) The AS stores the value of the Refer-To header field (transfer target) from the REFER request and links it to the ECT session identifier URI.

- 3) The AS replaces the Refer-To header field with the ECT session identifier URI from step 1). (This ensures that this AS remains in the loop when the transferee sets up the communication with the transfer target.).
- 4) The AS forwards the REFER request to the transferee using basic communication procedures in 3GPP TS 24.229 [1].

4.6.10.3 Actions when this ECT instance is invoked again by the transferred communication

When an INVITE is received targeted at the ECT session identifier URI created earlier in subclause 4.6.10.2, the AS shall perform the following actions:

- 1) The AS replaces the request URI with the stored Refer-To header field value linked to the specific ECT session identifier URI.

NOTE: If needed the AS may generate charging events to charge for the extra leg.

- 2) The AS forwards the INVITE request towards the transfer target using basic communication procedures in 3GPP TS 24.229 [1].

4.7 Interworking with other networks

4.7.1 Void

4.7.2 Void

4.7.3 Void

4.8 Parameter values (timers)

No specific timers are required.

4.9 Service configuration

Not applicable.

Annex A (informative): Signalling flows

A.1 Blind transfer

Figure A.1 signalling flow shows a blind transfer scenario, whereby the REFER request is forwarded the existing INVITE dialog between A and B.

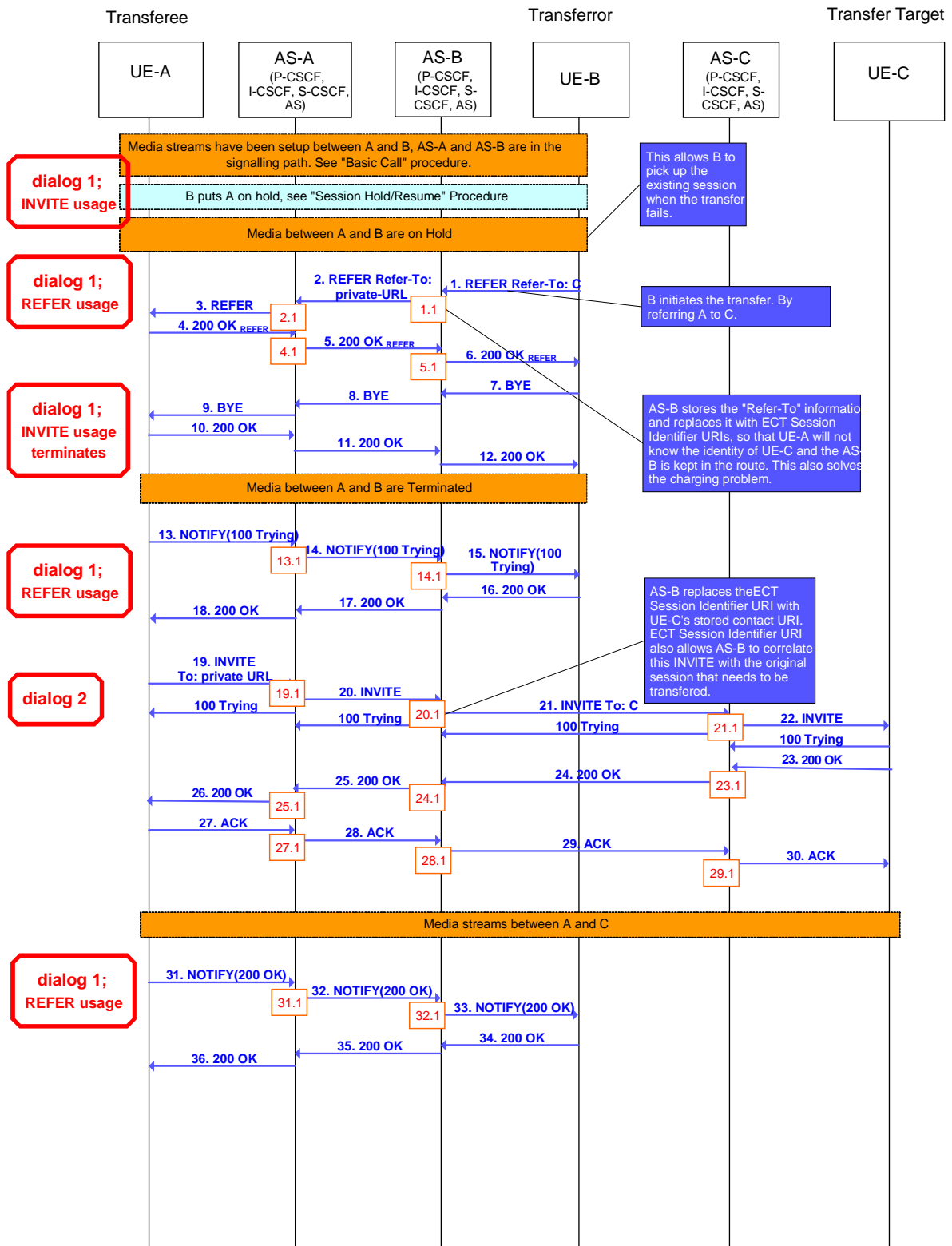

Figure A.1: Blind transfer

1. A multimedia session exists between A-B. B initiates transfer A to C, by sending a REFER request with a Toheader field set to UE-A, a Referred-To header field set to UE-C, a Referred-By header field set to UE-B. The REFER request is sent in the existing dialog between A and B.

1.1 Upon reception of the REFER request, AS-B must check whether there is no outgoing call barring active from B to C. Because B is charged for the call from B-C when A is referred to C, when outgoing call barring is active from B-C the REFER request is rejected.

AS-B checks whether B is allowed to transfer calls, if B is allowed to transfer the call then AS-B generates an ECT session identifier URI, addressed to itself, with the new destination information and billing information that will be needed for the new session. It replaces the Refer-To header field value with the ECT session identifier URI. This ensures that:

AS-B will remain in the loop.

2. The REFER request is forwarded to AS-A.

2.1 AS-A checks whether it is allowed to transfer A.

3. The REFER request is forwarded to A by AS-A.

4. The REFER request is accepted by A's UE.

4.1, 13.1, 31.1 AS-A can use result messages and notifications caused by the REFER request to track success of the REFER request and take appropriate actions. The AS-A can ensure that header fields that were replaced with other content are recreated with the original content on the way back.

5.1, 8.1, 32.1 AS-B can use this to track success of the REFER request and take appropriate actions. The AS-B can ensure that header fields that were replaced with other content are recreated with the original content on the way back.

7. Since the REFER request was accepted in 6. UE-B terminates the existing INVITE dialog by sending a BYE request to UE-A.

19. UE-A initiates a new session by sending an INVITE request to AS-B's ECT session identifier URI (which represents UE-C).

19.1 AS-A routes the INVITE request to AS-B using the AS-B's ECT session identifier URI using normal SIP routing procedures. Normal charging from A to B applies.

20.1 Upon receiving the INVITE request to the ECT session identifier URI that was inserted by the AS-B, the AS-B replaces it with the Request URI of C and creates an INVITE request targeted towards UE-C.

In this scenario it can be assumed that there is no active outgoing call barring towards UE-C, because the REFER was accepted by AS-B. The ECT Session Identifier URI has a limited validity time to ensure that no future barring is violated.

Also the Referred-By: header field is verified or filled in with the original unmodified values. Then the INVITE request is forwarded to UE-C using normal routing procedures.

21.1, 23.1 Normal terminating services apply for UE-C. The call will be treated as a call from A-C regarding call policies.

25.1 AS-A. Normal response handling applies.

27.1 AS-A. Normal ACK handling applies.

28.1 AS-B replaces all modified values and ECT session identifier URI 's with stored values.

A.2 Consultative transfer

Figure A.2 signalling flow shows a consultative transfer scenario.

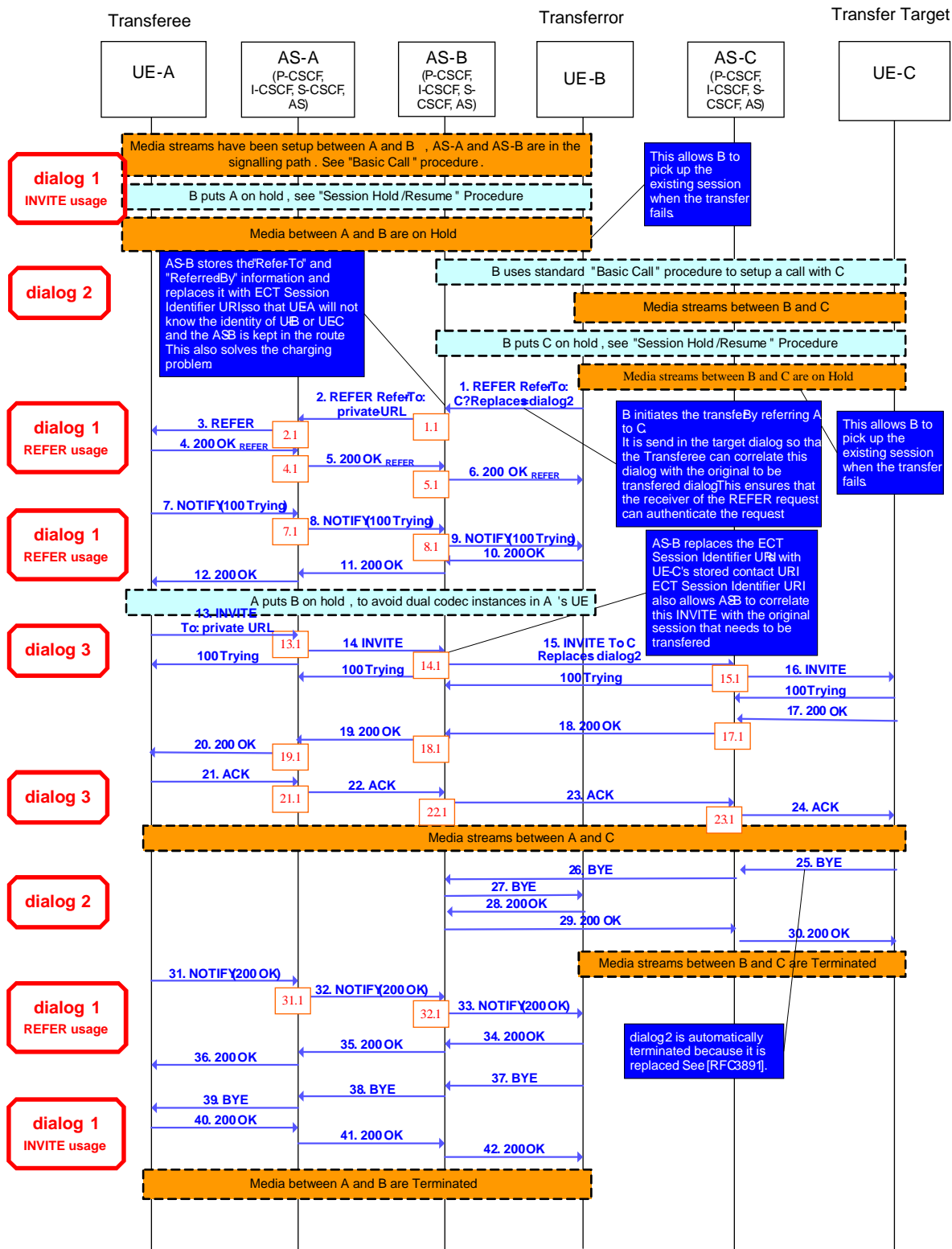

Figure A.2: Consultative transfer

1. Multimedia sessions exist between A-B and between B-C. B initiates transfer of A to C, by sending a REFER request including a To header field set to UE-A GRUU a Refer-To header field set to UE-C?Replaces=dialog2&Require=replaces and a Referred-By header field set to UE-B. The REFER request reuses the dialog that exists from A-B.

1.1 Upon reception of the REFER request AS-B must check whether there is no outgoing call barring active from B to C. Because B is charged for the call from B-C when A is referred to C, when outgoing call barring is active from B-C the REFER is rejected.

AS-B checks whether B is allowed to transfer calls, if it is allowed to transfer the call then AS-B generates an ECT session identifier URI, addressed to itself, with the new destination information and billing information that will be needed for the new session. It replaces the Refer-To header field value with the ECT session identifier URI. This ensures that AS-B will remain in the loop.

2. The REFER request is forwarded to AS-A.

2.1 AS-A checks whether it is allowed to transfer A.

3. The REFER is forwarded to A by AS-A.

4.1, 7.1, 31.1 AS-A can use result messages and notifications caused by the REFER request to track success of the REFER request and take appropriate actions. The AS-A can ensure that header fields that were replaced with other content are recreated with the original content on the way back.

5.1, 8.1, 32.1 AS-B can use this to track success of the REFER request and take appropriate actions. The AS-B can ensure that header fields that were replaced with other content are recreated with the original content on the way back.

13. UE-A initiates a new session by sending an INVITE to AS-B's ECT session identifier URI (which represents UE-C).

13.1 AS-A checks whether A is allowed to use the Replaces extension and routes the INVITE request to AS-B using the AS-B's ECT session identifier URI using normal SIP routing procedures. Normal charging from A to B applies.

14.1 Upon receiving the INVITE request to the ECT session identifier URI that was inserted by AS-B, AS-B replaces the Request URI and creates an INVITE targeted towards UE-C. Further AS-B inserts a Replaces header field with the value of the Replaces parameter of the stored transfer target URI if it is available, which will allow the new session to replace the existing session between B and C.

In this scenario it can be assumed that there is no active outgoing call barring towards UE-C, because UE-B was able to setup a call to UE-C in the first place. However when there was no consultation call to UE-C, there is an issue but this is solved at the initial reception of the REFER from UE-C and not at this stage.

The INVITE request is forwarded to UE-C using normal routing procedures.

15.1, 17.1 Normal terminating services apply for UE-C. The call will be treated as a call from A-C regarding call policies. AS-C checks whether the Replaces mechanism is used.

19.1 AS-A. Normal response handling applies.

21.1 AS-A. Normal ACK handling applies.

22.1 AS-B replaces all codified values and the ECT session identifier URI with stored values.

25. UE-C terminates dialog 2 as consequence of normal Replaces procedures according to RFC 3891 [4].

A.3 Blind call transfer with third party call control

An example of a call flow where a media server is used is given in figure E.1 of 3GPP TS 24.628 [10]. In this call flow, the media server is involved in the media path before transfer is received and remains involved after the call is transferred. For blind communication transfer, the media server may be connected only to the transferee (UE-B) after the REFER request is received and be disconnected when the transfer target accepts the call.

An example of call flow where no media server is used is given in figure E.1 of 3GPP TS 24.628 [10].

A.4 Consultative call transfer with third party call control

An example of a call flow is given in figure E.5 of 3GPP TS 24.628 [10].

Annex B (informative): Example of filter criteria

B.1 Example of filter criteria for ECT

This annex provides an example of a filter criterion that triggers SIP requests that are subject to initial filter criteria evaluation.

When the initial request matches the conditions of the next unexecuted IFC rule for the served user which points to the ECT service, the communication is forwarded to the AS.

An example of an Initial Filter Criteria (IFC) Trigger Point configurations under the assumption that the ECT service is a standalone service that can be invoked by a very specific trigger point active at the destination S-CSCF:

- Method="INVITE".

NOTE 1: The coding of the Initial Filter Criteria is described in 29.228 [7] and 29.229 [7A].

NOTE 2: When the REFER is forwarded on an existing dialog, no IFC processing will be performed, because this is a subsequent request on an existing dialog. It follows that when this scenario is supported, all signalling has to traverse through the AS.

An example of an IFC Trigger Point configuration where the S-CSCF does not invoke the ECT AS for a PSAP callback:

- Method="INVITE" and not Priority header field with a "psap-callback" header field value.

NOTE 3: Not invoking the ECT AS assumes that the ECT invocation request can be handled elsewhere in the network, e.g. in the PSAP itself.

Annex C (informative): Example charging model

C.1 Example of B REFER's A to C

This scenario is added to show that the solution presented in the present document is able to support classical charging models. Assumption in this scenario is that A originated the original call and is thus charged for the initial A-B communication.

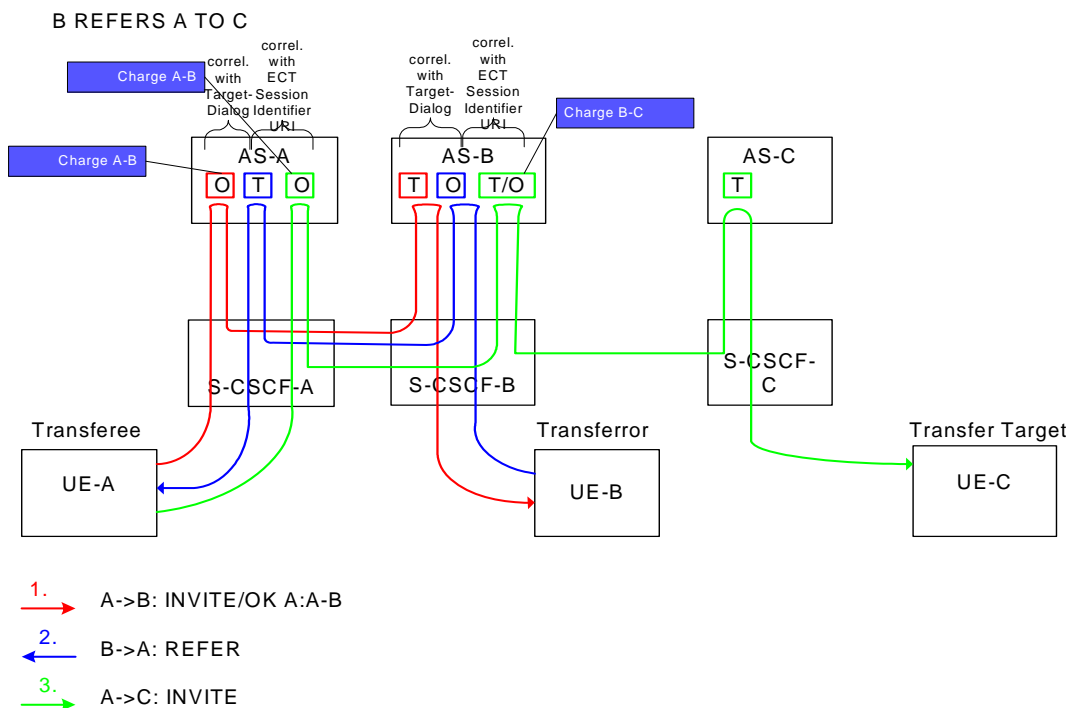

Figure C.1: Example of B REFER's A to C

Table C.1

| Initial Session Initiated By | Initial Session A-B | Transferred Session Transfer Target C |
|------------------------------|---------------------|--|
| A=Transferee | Transferee (A): A-B | Transferee (A): A-B Transferor (B): B-C |
| A=Transferor | Transferor (A): A-B | Transferor (A): A-B Transferor (A): A-C |

C.2 Example of A REFER's B to C

This scenario is added to show that the solution presented in the present document is able to support classical charging models. Assumption in this scenario is that A originated the original call and is thus charged for initial A-B communication.

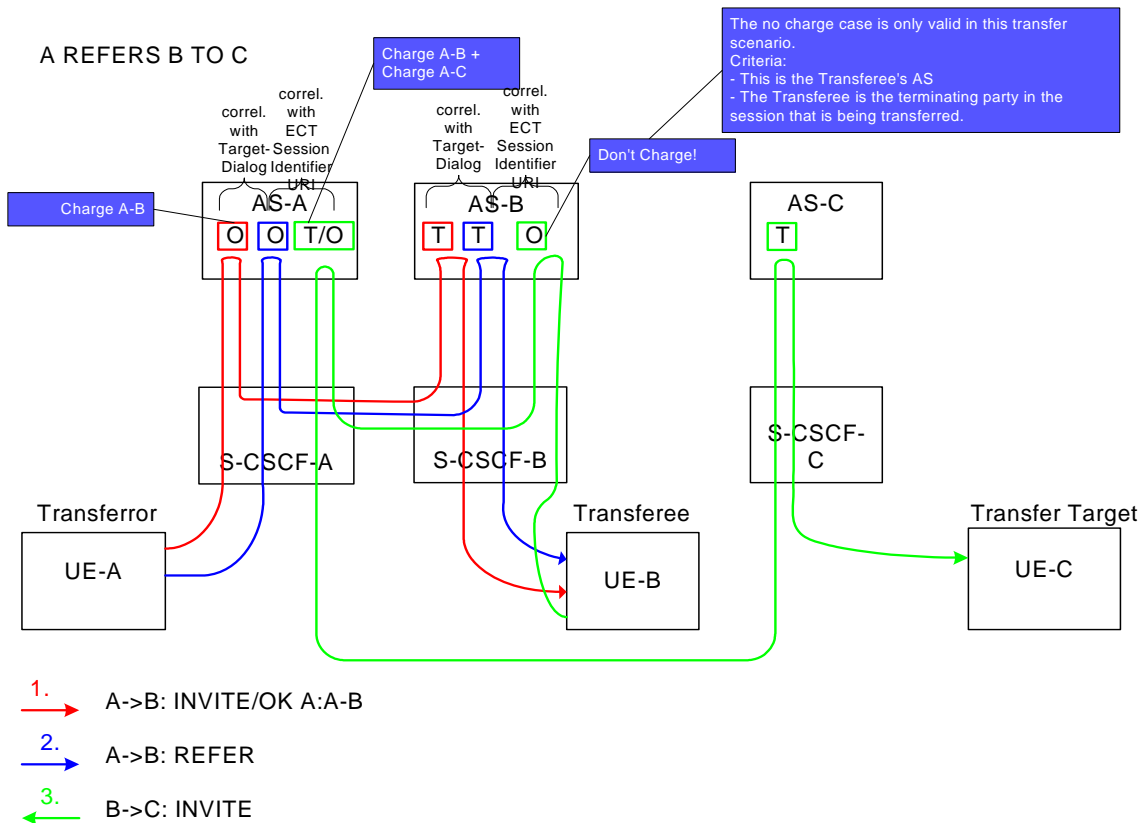

Figure C.2: Example of a REFER's B to C

Table C.2

| Initial Session Initiated By | Initial Session A-B | Transferred Session Transfer Target C |
|------------------------------|---------------------|--|
| A=Transferee | Transferee (A): A-B | Transferee (A): A-B Transferor (B): B-C |
| A=Transferor | Transferor (A): A-B | Transferor (A): A-B Transferor (A): A-C |

Annex D (informative):
Void

Annex E (informative): Change history

| Change history | | | | | | | |
|----------------|-------|-----------|------|-----|---|--------|--------|
| Date | TSG # | TSG Doc. | CR | Rev | Subject/Comment | Old | New |
| 2008-01 | | | | | Publication as ETSI TS 183 029 | | 2.5.0 |
| 2008-01 | | | | | Conversion to 3GPP TS 24.529 | | 2.5.1 |
| 2008-01 | | | | | Technically identical copy as 3GPP TS 24.629 as basis for further development. | | 2.5.2 |
| 2008-02 | | | | | Implemented C1-080104, C1-080665 | | 2.6.0 |
| 2008-04 | | | | | Implemented C1-080894, C1-080895, C1-081098, C1-081099, C1-081114 | | 2.7.0 |
| 2008-05 | | | | | Implemented C1-081918 | | 2.8.0 |
| 2008-05 | | | | | Editorial changes done by MCC | 2.8.0 | 2.8.1 |
| 2008-06 | CT#40 | CP-080335 | | | CP-080629 was approved by CT#40 and version 8.0.0 is created by MCC for publishing | 2.8.1 | 8.0.0 |
| 2008-09 | CT#41 | CP-080533 | 0001 | | Removal of normative statement in a NOTE | 8.0.0 | 8.1.0 |
| 2008-09 | CT#41 | CP-080533 | 0002 | | Applicability statement in scope | 8.0.0 | 8.1.0 |
| 2009-03 | CT#43 | CP-090144 | 0005 | 1 | Invocation of special REFER procedures | 8.1.0 | 8.2.0 |
| 2009-03 | CT#43 | CP-090159 | 0006 | 2 | Clarification of ECT interaction with CONF | 8.1.0 | 8.2.0 |
| 2009-03 | CT#43 | | | | Editorial cleanup by MCC | 8.1.0 | 8.2.0 |
| 2009-06 | CT#44 | CP-090416 | 0007 | 1 | NOTIFY for call transfer with 3PCC | 8.2.0 | 8.3.0 |
| 2009-06 | CT#44 | CP-090416 | 0008 | 1 | Identity handling for ECT | 8.2.0 | 8.3.0 |
| 2009-09 | CT#45 | CP-090682 | 0009 | 1 | Correction to transferee and transfer target UE procedures | 8.3.0 | 9.0.0 |
| 2010-06 | CT#48 | CP-100371 | 0010 | 2 | Blind Call transfer | 9.0.0 | 10.0.0 |
| 2011-09 | CT#53 | CP-110693 | 0012 | 4 | Referred-By header setting by the call transfer AS | 10.0.0 | 11.0.0 |
| 2011-09 | CT#53 | CP-110693 | 0013 | | Removing 3pcc figure | 10.0.0 | 11.0.0 |
| 2012-12 | CT#58 | CP-120778 | 0018 | 3 | Emergency call ECT suppression | 11.0.0 | 11.1.0 |
| 2012-12 | CT#58 | CP-120816 | 0019 | 2 | Reference to ODB specification for ECT | 11.0.0 | 11.1.0 |
| 2013-03 | CT#59 | CP-130100 | 0021 | 1 | Announcement for 3PCC ECT | 11.1.0 | 11.2.0 |
| 2013-06 | CT#60 | CP-130416 | 0014 | 9 | Prevent ECT for PSAP callback | 11.2.0 | 12.0.0 |
| 2013-09 | CT#61 | CP-130511 | 0024 | 2 | Blind and Assured Transfer description | 12.0.0 | 12.1.0 |
| 2013-09 | CT#61 | CP-130507 | 0025 | | draft-ietf-ecrit-psap-callback reference update | 12.0.0 | 12.1.0 |
| 2013-12 | CT#62 | CP-130758 | 0026 | 2 | Reference update: draft-ietf-ecrit-psap-callback | 12.1.0 | 12.2.0 |
| 2013-12 | CT#62 | CP-130744 | 0028 | | Removal of Editor's Note | 12.1.0 | 12.2.0 |
| 2013-12 | CT#62 | CP-130763 | 0029 | 5 | Correction of assured transfer | 12.1.0 | 12.2.0 |
| 2014-03 | CT#63 | CP-140143 | 0032 | | ECT clarification – Transfer attempt signification | 12.2.0 | 12.3.0 |
| 2014-03 | CT#63 | CP-140147 | 0031 | 4 | Update of 3GPP TS 24.629 | 12.2.0 | 12.3.0 |
| 2014-06 | CT#64 | CP-140330 | 0033 | 1 | Editorial corrections to 24.629 | 12.3.0 | 12.4.0 |
| 2014-12 | CT#66 | CP-140833 | 0034 | 1 | Reference update: RFC 7090 (draft-ietf-ecrit-psap-callback) | 12.4.0 | 12.5.0 |
| 2015-03 | CT#67 | CP-150067 | 0035 | 3 | Update REFER to reflect RFC 6665 | 12.5.0 | 12.6.0 |
| 2016-03 | CT#71 | CP-160068 | 0036 | 1 | Update draft-ietf-sipcore-refer-clarifications reference to reflect RFC 7647 | 12.6.0 | 12.7.0 |

History

| Document history | | |
|-------------------------|--------------|-------------|
| V12.4.0 | October 2014 | Publication |
| V12.5.0 | January 2015 | Publication |
| V12.6.0 | April 2015 | Publication |
| V12.7.0 | April 2016 | Publication |
| | | |