

ETSI TS 125 141 V3.2.0 (2000-06)

Technical Specification

**Universal Mobile Telecommunications System (UMTS);
Base station conformance testing (FDD)
(3G TS 25.141 version 3.2.0 Release 1999)**



Reference

RTS/TSGR-0425141UR2

Keywords

UMTS

ETSI

650 Route des Lucioles
F-06921 Sophia Antipolis Cedex - FRANCE

Tel.: +33 4 92 94 42 00 Fax: +33 4 93 65 47 16

Siret N° 348 623 562 00017 - NAF 742 C
Association à but non lucratif enregistrée à la
Sous-Préfecture de Grasse (06) N° 7803/88

Important notice

Individual copies of the present document can be downloaded from:

<http://www.etsi.org>

The present document may be made available in more than one electronic version or in print. In any case of existing or perceived difference in contents between such versions, the reference version is the Portable Document Format (PDF).

In case of dispute, the reference shall be the printing on ETSI printers of the PDF version kept on a specific network drive within ETSI Secretariat.

Users of the present document should be aware that the document may be subject to revision or change of status.

Information on the current status of this and other ETSI documents is available at <http://www.etsi.org/tb/status/>

If you find errors in the present document, send your comment to:

editor@etsi.fr

Copyright Notification

No part may be reproduced except as authorized by written permission.
The copyright and the foregoing restriction extend to reproduction in all media.

© European Telecommunications Standards Institute 2000.

All rights reserved.

Intellectual Property Rights

IPRs essential or potentially essential to the present document may have been declared to ETSI. The information pertaining to these essential IPRs, if any, is publicly available for **ETSI members and non-members**, and can be found in ETSI SR 000 314: *"Intellectual Property Rights (IPRs); Essential, or potentially Essential, IPRs notified to ETSI in respect of ETSI standards"*, which is available from the ETSI Secretariat. Latest updates are available on the ETSI Web server (<http://www.etsi.org/ipr>).

Pursuant to the ETSI IPR Policy, no investigation, including IPR searches, has been carried out by ETSI. No guarantee can be given as to the existence of other IPRs not referenced in ETSI SR 000 314 (or the updates on the ETSI Web server) which are, or may be, or may become, essential to the present document.

Foreword

This Technical Specification (TS) has been produced by the ETSI 3rd Generation Partnership Project (3GPP).

The present document may refer to technical specifications or reports using their 3GPP identities, UMTS identities or GSM identities. These should be interpreted as being references to the corresponding ETSI deliverables.

The cross reference between GSM, UMTS, 3GPP and ETSI identities can be found under www.etsi.org/key .

Contents

| | |
|--|----|
| Foreword | 9 |
| 1 Scope..... | 10 |
| 2 References..... | 10 |
| 3 Definitions and abbreviations | 10 |
| 3.1 Definitions | 10 |
| 3.2 Void | 11 |
| 3.3 Abbreviations..... | 11 |
| 3.4 Radio Frequency bands..... | 12 |
| 3.4.1 Frequency bands..... | 12 |
| 3.4.2 TX–RX frequency separation..... | 12 |
| 3.5 Channel arrangement | 12 |
| 3.5.1 Channel spacing | 12 |
| 3.5.2 Channel raster..... | 12 |
| 3.5.3 Channel number | 12 |
| 4 General test conditions and declarations..... | 13 |
| 4.1 Acceptable uncertainty of measurement equipment | 13 |
| 4.1.1 Test environments | 13 |
| 4.1.2 Transmitter | 13 |
| 4.1.3 Receiver | 15 |
| 4.1.4 Performance requirement | 15 |
| 4.2 Interpretation of measurement results..... | 16 |
| 4.3 Output power and determination of power class..... | 16 |
| 4.4 Test environments..... | 16 |
| 4.4.1 Normal test environment..... | 16 |
| 4.4.2 Extreme test environment..... | 17 |
| 4.4.2.1 Extreme temperature..... | 17 |
| 4.4.3 Vibration | 17 |
| 4.4.4 Power supply..... | 17 |
| 4.5 Selection of configurations for testing..... | 18 |
| 4.6 BS Configurations | 18 |
| 4.6.1 Receiver diversity..... | 18 |
| 4.6.2 Duplexers | 18 |
| 4.6.3 Power supply options | 18 |
| 4.6.4 Ancillary RF amplifiers..... | 19 |
| 4.6.5 BS using antenna arrays | 19 |
| 4.6.5.1 Receiver tests..... | 20 |
| 4.6.5.2 Transmitter tests | 20 |
| 4.7 Regional requirements | 20 |
| 5 Format and interpretation of tests | 21 |
| 6 Transmitter..... | 22 |
| 6.1 General..... | 22 |
| 6.1.1 Test Models..... | 23 |
| 6.1.1.1 Test Model 1..... | 23 |
| 6.1.1.2 Test Model 2..... | 25 |
| 6.1.1.3 Test Model 3..... | 25 |
| 6.2.1.3.1 Test Model 4 | 26 |
| 6.1.1.4 DPCH Structure of the Downlink Test Models | 26 |
| 6.1.1.5 Common channel Structure of the Downlink Test Models | 27 |
| 6.1.1.5.1 P-CCPCH..... | 27 |
| 6.1.1.5.2 PICH | 28 |
| 6.1.1.5.3 Primary scrambling code and SCH | 28 |
| 6.2 Base station output power..... | 28 |
| 6.2.1 Base station maximum output power | 28 |

| | | |
|-------------|---|----|
| 6.2.1.1 | Test Conditions and measurement method | 28 |
| 6.2.1.2 | Minimum requirement | 28 |
| 6.2.2 | CPICH power accuracy | 28 |
| 6.2.2.1 | Definition and applicability | 28 |
| 6.2.2.2 | Conformance Requirement | 28 |
| 6.2.2.3 | Test purpose | 29 |
| 6.2.2.4 | Method of test | 29 |
| 6.2.2.4.1 | Initial conditions | 29 |
| 6.2.2.4.2 | Procedure | 29 |
| 6.2.2.5 | Test requirement | 29 |
| 6.3 | Frequency error | 29 |
| 6.4 | Output power dynamics | 29 |
| 6.4.1 | Inner loop power control | 29 |
| 6.4.2 | Power control steps | 29 |
| 6.4.2.1 | Definition and applicability | 29 |
| 6.4.2.2 | Conformance requirement | 30 |
| 6.4.2.3 | Test purpose | 30 |
| 6.4.2.4 | Method of test | 30 |
| 6.4.2.4.1 | Initial conditions | 30 |
| 6.4.2.4.2 | Procedure | 30 |
| 6.4.2.5 | Test requirement | 31 |
| 6.4.3 | Power control dynamic range | 31 |
| 6.4.3.1 | Definition and applicability | 31 |
| 6.4.3.2 | Conformance requirement | 31 |
| 6.4.3.3 | Test purpose | 31 |
| 6.4.3.4 | Method of test | 31 |
| 6.4.3.4.1 | Initial conditions | 31 |
| 6.4.3.4.2 | Procedure | 31 |
| 6.4.3.5 | Test requirement | 32 |
| 6.4.4 | Total power dynamic range | 32 |
| 6.4.4.1 | Definition and applicability | 32 |
| 6.4.4.2 | Conformance requirement | 32 |
| 6.4.4.3 | Test purpose | 32 |
| 6.4.4.4 | Method of test | 32 |
| 6.4.4.4.1 | Initial requirement | 32 |
| 6.4.4.4.2 | Procedure | 32 |
| 6.4.4.5 | Test requirement | 32 |
| 6.5 | Output RF spectrum emissions | 32 |
| 6.5.1 | Occupied bandwidth | 33 |
| 6.5.1.1 | Definition and applicability | 33 |
| 6.5.1.2 | Conformance requirements | 33 |
| 6.5.1.3 | Test purpose | 33 |
| 6.5.1.4 | Method of test | 33 |
| 6.5.1.4.1 | Initial conditions | 33 |
| 6.5.1.4.2 | Procedure | 33 |
| 6.5.1.5 | Test requirements | 33 |
| 6.5.2 | Out of band emission | 34 |
| 6.5.2.1 | Spectrum emission mask | 34 |
| 6.5.2.1.1 | Test conditions and measurement method | 34 |
| 6.5.2.1.2 | Minimum requirement | 34 |
| 6.5.2.1.3 | Test purpose | 35 |
| 6.5.2.1.4 | Method of test | 35 |
| 6.5.2.1.4.1 | Initial conditions | 35 |
| 6.5.2.1.5 | Procedures | 35 |
| 6.5.2.1.6 | Test requirements | 35 |
| 6.5.2.2 | Adjacent Channel Leakage power Ratio (ACLR) | 36 |
| 6.5.2.2.1 | Definition and applicability | 36 |
| 6.5.2.2.2 | Conformance requirement | 36 |
| 6.5.2.2.3 | Test purpose | 36 |
| 6.5.2.2.4 | Method of test | 36 |
| 6.5.2.2.4.1 | Initial conditions | 36 |
| 6.5.2.2.4.2 | Procedure | 36 |

| | | |
|---------------|--|----|
| 6.5.2.2.5 | Test requirement | 36 |
| 6.5.3 | Spurious emissions | 36 |
| 6.5.3.1 | Definition and applicability | 36 |
| 6.5.3.2 | Test purpose | 37 |
| 6.5.3.3 | Test case | 37 |
| 6.5.3.4 | Conformance Requirements | 37 |
| 6.5.3.4.1 | Spurious emissions (Category A) | 37 |
| 6.5.3.4.1.1 | Minimum Requirement | 37 |
| 6.5.3.4.2 | Spurious emissions (Category B)..... | 37 |
| 6.5.3.4.2.1 | Minimum Requirement | 37 |
| 6.5.3.4.3 | Protection of the BS receiver | 38 |
| 6.5.3.4.3.1 | Minimum Requirement | 38 |
| 6.5.3.4.4 | Co-existence with GSM 900..... | 39 |
| 6.5.3.4.4.1 | Operation in the same geographic area | 39 |
| 6.5.3.4.4.1.1 | Minimum Requirement..... | 39 |
| 6.5.3.4.4.2 | Co-located base stations | 39 |
| 6.5.3.4.4.2.1 | Minimum Requirement..... | 39 |
| 6.5.3.4.5 | Co-existence with DCS 1800..... | 39 |
| 6.5.3.4.5.1 | Operation in the same geographic area | 39 |
| 6.5.3.4.5.1.1 | Minimum Requirement..... | 39 |
| 6.5.3.4.5.2 | Co-located basestations | 39 |
| 6.5.3.4.5.2.1 | Minimum Requirement..... | 40 |
| 6.5.3.4.6 | Co-existence with PHS | 40 |
| 6.5.3.4.6.1 | Minimum Requirement | 40 |
| 6.5.3.4.7 | Co-existence with services in adjacent frequency bands | 40 |
| 6.5.3.4.7.1 | Minimum requirement..... | 40 |
| 6.5.3.4.8 | Co-existence with UTRA-TDD | 40 |
| 6.5.3.4.8.1 | Operation in the same geographic area | 40 |
| 6.5.3.4.8.1.1 | Minimum Requirement..... | 41 |
| 6.5.3.4.8.2 | Co-located base stations | 41 |
| 6.5.3.4.8.2.1 | Minimum Requirement..... | 41 |
| 6.6 | Transmit intermodulation | 41 |
| 6.6.1 | Definition and applicability..... | 41 |
| 6.6.2 | Conformance requirement..... | 41 |
| 6.6.3 | Test purpose | 41 |
| 6.6.4 | Method of test | 42 |
| 6.6.4.1 | Initial conditions | 42 |
| 6.6.4.2 | Procedures | 42 |
| 6.7 | Transmit modulation..... | 42 |
| 6.7.1 | Frequency Error | 42 |
| 6.7.1.1 | Definition and applicability | 42 |
| 6.7.1.2 | Conformance Requirement..... | 42 |
| 6.7.1.3 | Test Purpose | 42 |
| 6.7.1.4 | Method of test..... | 42 |
| 6.7.1.5 | Test Requirement..... | 43 |
| 6.7.2 | Error Vector Magnitude | 43 |
| 6.7.2.1 | Definition and applicability | 43 |
| 6.7.2.2 | Conformance Requirement..... | 43 |
| 6.7.2.3 | Test Purpose | 43 |
| 6.7.2.4 | Method of Test | 43 |
| 6.7.2.5 | Test Requirement..... | 43 |
| 6.7.3 | Peak Code Domain Error | 43 |
| 6.7.3.1 | Definition and applicability | 43 |
| 6.7.3.2 | Conformance requirement | 43 |
| 6.7.3.3 | Test Purpose | 43 |
| 6.7.3.4 | Method of test..... | 44 |
| 6.7.3.4.1 | Initial conditions | 44 |
| 6.7.3.4.2 | Procedure | 44 |
| 6.7.3.5 | Test requirement..... | 44 |
| 7 | Receiver characteristics | 44 |
| 7.1 | General..... | 44 |

| | | |
|-----------|---|----|
| 7.2 | Reference sensitivity level | 45 |
| 7.2.1 | Definition and applicability | 45 |
| 7.2.2 | Conformance requirement | 45 |
| 7.2.3 | Test purpose | 45 |
| 7.2.4 | Method of testing | 45 |
| 7.2.4.1 | Initial conditions | 45 |
| 7.2.4.2 | Procedure | 45 |
| 7.2.5 | Test requirement | 45 |
| 7.3 | Dynamic range | 46 |
| 7.3.1 | Definition and applicability | 46 |
| 7.3.2 | Conformance requirement | 46 |
| 7.3.3 | Test purpose | 46 |
| 7.3.4 | Method of test | 46 |
| 7.3.4.1 | Initial conditions | 46 |
| 7.3.4.2 | Procedure | 46 |
| 7.4 | Adjacent Channel Selectivity (ACS) | 46 |
| 7.4.1 | Test conditions and measurement method | 46 |
| 7.4.2 | Minimum requirement | 47 |
| 7.5 | Blocking characteristics | 47 |
| 7.5.1 | Definition and applicability | 47 |
| 7.5.2 | Conformance requirements | 47 |
| 7.5.3 | Test purpose | 48 |
| 7.5.4 | Method of test | 48 |
| 7.5.4.1 | Initial conditions | 48 |
| 7.5.4.2 | Procedure | 48 |
| 7.5.5 | Test requirements | 48 |
| 7.6 | Intermodulation characteristics | 48 |
| 7.6.1 | Definition and applicability | 48 |
| 7.6.2 | Conformance requirement | 49 |
| 7.6.3 | Test purpose | 49 |
| 7.6.4 | Method of test | 49 |
| 7.6.4.1 | Initial conditions | 49 |
| 7.6.4.2 | Procedures | 49 |
| 7.6.5 | Test requirements | 49 |
| 7.7 | Spurious Emissions | 49 |
| 7.7.1 | Definition and applicability | 49 |
| 7.7.2 | Conformance requirements | 50 |
| 7.7.3 | Test purpose | 50 |
| 7.7.4 | Method of test | 50 |
| 7.7.4.1 | Initial conditions | 50 |
| 7.7.4.2 | Procedure | 50 |
| 7.7.5 | Test requirements | 50 |
| 7.8 | Verification of the internal BER calculation | 50 |
| 7.8.1 | Definition and applicability | 50 |
| 7.8.2 | Conformance requirement | 51 |
| 7.8.3 | Test purpose | 51 |
| 7.8.4 | Method of test | 51 |
| 7.8.4.1 | Initial conditions | 51 |
| 7.8.4.2 | Procedure | 51 |
| 7.8.5 | Test requirement | 51 |
| 8 | Performance requirement | 52 |
| 8.1 | General | 52 |
| 8.2 | Demodulation in static propagation conditions | 52 |
| 8.2.1 | Demodulation of DCH | 52 |
| 8.2.1.1 | Definition and applicability | 52 |
| 8.2.1.2 | Conformance requirement | 52 |
| 8.2.1.3 | Test purpose | 52 |
| 8.2.1.4 | Method of test | 53 |
| 8.2.1.4.1 | Initial conditions | 53 |
| 8.2.1.4.2 | Procedure | 53 |
| 8.2.1.5 | Test requirements | 53 |

| | | |
|-----------|---|----|
| 8.3 | Demodulation of DCH in multipath fading conditions | 53 |
| 8.3.1 | Multipath fading Case 1 | 53 |
| 8.3.1.1 | Definition and applicability | 53 |
| 8.3.1.2 | Conformance requirement | 53 |
| 8.3.1.3 | Test Purpose | 54 |
| 8.3.1.4 | Method of test | 54 |
| 8.3.1.4.1 | Initial conditions | 54 |
| 8.3.1.4.2 | Procedure | 54 |
| 8.3.1.5 | Test requirements | 54 |
| 8.3.2 | Multipath fading Case 2 | 55 |
| 8.3.2.1 | Definition and applicability | 55 |
| 8.3.2.2 | Conformance requirement | 55 |
| 8.3.2.3 | Test Purpose | 55 |
| 8.3.2.4 | Method of test | 55 |
| 8.3.2.4.1 | Initial conditions | 55 |
| 8.3.2.4.2 | Procedure | 55 |
| 8.3.2.5 | Test requirements | 56 |
| 8.3.3 | Multipath fading Case 3 | 56 |
| 8.3.3.1 | Definition and applicability | 56 |
| 8.3.3.2 | Conformance requirement | 56 |
| 8.3.3.3 | Test Purpose | 56 |
| 8.3.3.4 | Method of test | 56 |
| 8.3.3.4.1 | Initial conditions | 56 |
| 8.3.3.4.2 | Procedure | 56 |
| 8.3.3.5 | Test requirements | 57 |
| 8.4 | Demodulation of DCH in moving propagation conditions | 57 |
| 8.4.1 | Definition and applicability | 57 |
| 8.4.2 | Conformance requirement | 57 |
| 8.4.3 | Test Purpose | 57 |
| 8.4.3.1 | Method of test | 58 |
| 8.4.3.1.1 | Initial conditions | 58 |
| 8.4.3.1.2 | Procedure | 58 |
| 8.4.3.4 | Test requirements | 58 |
| 8.5 | Demodulation of DCH in birth/death propagation conditions | 58 |
| 8.5.1 | Definition and applicability | 58 |
| 8.5.2 | Conformance requirement | 58 |
| 8.5.2.1 | Test Purpose | 59 |
| 8.5.2.2 | Method of test | 59 |
| 8.5.2.2.1 | Initial conditions | 59 |
| 8.5.2.2.2 | Procedure | 59 |
| 8.5.2.3 | Test requirements | 59 |
| 8.6 | Verification of the internal BLER calculation | 59 |
| 8.6.1 | Definition and applicability | 59 |
| 8.6.2 | Conformance requirement | 60 |
| 8.6.3 | Test purpose | 60 |
| 8.6.4 | Method of test | 60 |
| 8.6.4.1 | Initial conditions | 60 |
| 8.6.4.2 | Procedure | 60 |
| 8.6.5 | Test requirement | 60 |
| 8.7 | Site Selection Diversity Transmission (SSDT) Mode | 61 |
| 8.7.1 | Definition and applicability | 61 |
| 8.7.1.1 | Conformance requirements | 61 |
| 8.7.1.2 | Test purpose | 61 |
| 8.7.1.3 | Method of test | 61 |
| 8.7.1.3.1 | Initial conditions | 61 |
| 8.7.1.3.2 | Procedure | 62 |
| 8.7.1.3.3 | Test Requirements | 62 |

| | |
|---|-----------|
| Annex A (normative): Measurement channels | 63 |
| A.1 Summary of UL reference measurement channels | 63 |
| A.2 UL reference measurement channel for 12,2 kbps | 63 |
| A.3 UL reference measurement channel for 64 kbps | 64 |
| A.4 UL reference measurement channel for 144 kbps | 65 |
| A.5 UL reference measurement channel for 384 kbps | 66 |
| A.6 UL reference measurement channel for 2048 kbps | 67 |
| Annex B (informative): Measurement system set-up | 69 |
| B.1 Transmitter..... | 69 |
| B.1.1 Maximum output power, total power dynamic range | 69 |
| B.1.2 CPICH power accuracy and Peak code domain error..... | 69 |
| B.1.3 Power control steps and power control dynamic range..... | 69 |
| B.1.4 Out of band emission | 70 |
| B.1.5 Transmit intermodulation | 70 |
| B.1.6 EVM measurement | 70 |
| B.2 Receiver | 71 |
| B.2.1 Reference sensitivity level | 71 |
| B.2.2 Dynamic range..... | 71 |
| B.2.3 Adjacent Channel Selectivity (ACS) | 72 |
| B.2.4 Blocking characteristics..... | 72 |
| B.2.5 Intermodulation characteristics..... | 73 |
| B.2.6 Receiver spurious emission..... | 73 |
| Annex C (normative): Detailed definition of error events | 75 |
| Annex D (normative): Propagation conditions | 76 |
| D.1 Static propagation condition | 76 |
| D.2 Multi-path fading propagation conditions | 76 |
| D.3 Moving propagation conditions | 76 |
| D.4 Birth-Death propagation conditions..... | 77 |
| Annex E (informative): Change Request history | 78 |
| Annex F (informative): Change history | 79 |

Foreword

This Technical Specification (TS) has been produced by the 3rd Generation Partnership Project (3GPP).

The contents of the present document are subject to continuing work within the TSG and may change following formal TSG approval. Should the TSG modify the contents of the present document, it will be re-released by the TSG with an identifying change of release date and an increase in version number as follows:

Version x.y.z

where:

- x the first digit:
 - 1 presented to TSG for information;
 - 2 presented to TSG for approval;
 - 3 or greater indicates TSG approved document under change control.
- y the second digit is incremented for all changes of substance, i.e. technical enhancements, corrections, updates, etc.
- z the third digit is incremented when editorial only changes have been incorporated in the document.

1 Scope

The present document specifies the Radio Frequency (RF) test methods and conformance requirements for UTRA Base Stations (BS) operating in the FDD mode. These have been derived from, and are consistent with the UTRA Base Station (BS) specifications defined in [1].

The present document establishes the minimum RF characteristics of the FDD mode of UTRA for the Base Station (BS).

2 References

The following documents contain provisions which, through reference in this text, constitute provisions of the present document.

- References are either specific (identified by date of publication, edition number, version number, etc.) or non-specific.
- For a specific reference, subsequent revisions do not apply.
- For a non-specific reference, the latest version applies.

- [1] 3GPP TS 25.104: "UTRA(BS) FDD; Radio transmission and Reception".
- [2] 3GPP TS25.942: "RF system scenarios".
- [3] 3GPP TS25.113: "Base station EMC".
- [4] ITU-R recommendation SM.329-7: "Spurious emissions".
- [5] ITU-T recommendation O.153: "Basic parameters for the measurement of error performance at bit rates below the primary rate".
- [6] IEC 60721-3-3 (1994) "Classification of environmental conditions - Part 3: Classification of groups of environmental parameters and their severities - Section 3: Stationary use at weather protected locations".
- [7] IEC 60721-3-4 (1995): "Classification of environmental conditions - Part 3: Classification of groups of environmental parameters and their severities - Section 4: Stationary use at non-weather protected locations".
- [8] IEC 60068-2-1 (1990): "Environmental testing - Part 2: Tests. Tests A: Cold".
- [9] IEC 60068-2-2 (1974): "Environmental testing - Part 2: Tests. Tests B: Dry heat".
- [10] IEC 60068-2-6 (1995): "Environmental testing - Part 2: Tests - Test Fc: Vibration (sinusoidal)".

3 Definitions and abbreviations

3.1 Definitions

For the purposes of the present document, the following terms and definitions apply:

Power Setting: value of the control signal, which determines the desired transmitter, output Power. Typically, the power setting would be altered in response to power control commands.

Maximum Power Setting: highest value of the Power control setting which can be used.

Maximum output Power: this refers to the measure of power when averaged over the transmit timeslot at the maximum power setting.

Peak Power: instantaneous power of the RF envelope which is not expected to be exceeded for [99,9 %] of the time.

Maximum peak power: peak power observed when operating at a given maximum output power.

Average transmit power: average transmitter output power obtained over any specified time interval, including periods with no transmission.

Maximum average power: average transmitter output power obtained over any specified time interval, including periods with no transmission, when the transmit time slots are at the maximum power setting.

3.2 Void

3.3 Abbreviations

For the purposes of the present document, the following abbreviations apply:

| | |
|-----------------------|---|
| ACIR | Adjacent Channel Interference Ratio |
| ACLR | Adjacent Channel Leakage power Ratio |
| ACS | Adjacent Channel Selectivity |
| BER | Bit Error Ratio |
| BLER | Block Error Ratio |
| BS | Base Station |
| Chip Rate | Chip rate of W-CDMA system, equals to 3,84 M chips per second |
| CW | Continuous Wave (unmodulated signal) |
| DCH | Dedicated Channel, which is mapped into Dedicated Physical Channel. DCH contains the data |
| DL | Down Link (forward link) |
| DPCH | Dedicated Physical Channel |
| E_b | Average energy per information bit for the PCCPCH, SCCPCH and DPCH, at the antenna connector |
| E_c | Average energy per PN chip |
| EIRP | Effective Isotropic Radiated Power |
| FDD | Frequency Division Duplexing |
| F_{uw} | Frequency of unwanted signal |
| Information Data Rate | Rate of the user information, which must be transmitted over the Air Interface. For example, output rate of the voice codec |
| MER | Message Error Rate |
| PCCPCH | Primary Common Control Physical Channel |
| PCH | Paging Channel |
| PPM | Parts Per Million |
| RSCP | Given only signal power is received, the average power of the received signal after despreading and combining |
| RSSI | Received Signal Strength Indicator |
| SCCPCH | Secondary Common Control Physical Channel |
| SCCPCH_ E_c | Average energy per PN chip for SCCPCH. |
| SIR | Signal to Interference ratio |
| TDD | Time Division Duplexing |
| TPC | Transmit Power Control |
| UE | User Equipment |
| UL | Up Link (reverse link) |
| UTRA | UMTS Terrestrial Radio Access |

3.4 Radio Frequency bands

3.4.1 Frequency bands

UTRA/FDD is designed to operate in either of the following paired bands:

- (a): 1 920 MHz to 1 980 MHz: up-link (Mobile transmit, base receive);
2 110 MHz to 2 170 MHz: down-link (Base transmit, mobile receive);
- (b)*: 1 850 MHz to 1 910 MHz: up-link (Mobile transmit, base receive);
1 930 MHz to 1 990 MHz: down-link (Base transmit, mobile receive).

NOTE: *: Used in Region 2.

Additional allocations in ITU region 2 are FFS.

Deployment in other frequency bands is not precluded.

3.4.2 TX–RX frequency separation

- (a) The minimum transmit to receive frequency separation is 134,8 MHz and the maximum value is 245,2 MHz and all UE(s) shall support a TX –RX frequency separation of 190 MHz when operating in the paired band defined in subclause 3.4.1(a).
- (b) UTRA/FDD can support both fixed and variable transmit to receive frequency separation.
- (c) When operating in the paired band defined in subclause 3.4.1(b), all UE(s) shall support a TX – RX frequency separation of 80 MHz.
- (d) The use of other transmit to receive frequency separations in existing or other frequency bands shall not be precluded.

3.5 Channel arrangement

3.5.1 Channel spacing

The nominal channel spacing is 5 MHz, but this can be adjusted to optimize performance in a particular deployment scenario.

3.5.2 Channel raster

The channel raster is 200 kHz, which means that the center frequency must be an integer multiple of 200 kHz.

3.5.3 Channel number

The carrier frequency is designated by the UTRA Absolute Radio Frequency Channel Number (UARFCN). The value of the UARFCN in the IMT2000 band is defined as follows.

Table 3.1: UTRA Absolute Radio Frequency Channel Number

| | | |
|----------|---|--|
| Uplink | $N_u = 5 * (F_{\text{uplink}} \text{ MHz})$ | $0.0 \text{ MHz} \leq F_{\text{uplink}} \leq 3276.6 \text{ MHz}$ where F_{uplink} is the uplink frequency in MHz |
| Downlink | $N_d = 5 * (F_{\text{downlink}} \text{ MHz})$ | $0.0 \text{ MHz} \leq F_{\text{downlink}} \leq 3276.6 \text{ MHz}$ where F_{downlink} is the downlink frequency in MHz |

4 General test conditions and declarations

The requirements of this clause apply to all tests in the present document, when applicable.

Many of the tests in the present document measure a parameter relative to a value which is not fully specified in the UTRA specifications. For these tests, the conformance requirement is determined relative to a nominal value specified by the manufacturer.

Certain functions of a BS are optional in the UTRA specifications. Some requirements for the BS may be regional as listed in subclause 4.7.

When specified in a test, the manufacturer shall declare the nominal value of a parameter, or whether an option is supported.

4.1 Acceptable uncertainty of measurement equipment

The maximum acceptable uncertainty of measurement equipment is specified separately for each test, where appropriate. The measurement equipment shall enable the stimulus signals in the test case to be adjusted to within the specified tolerance, and the conformance requirement to be measured with an uncertainty not exceeding the specified values. All tolerances and uncertainties are absolute values, and are valid for a confidence level of 95 %, unless otherwise stated.

It should be noted that the stated uncertainties in subclause 4.1 apply to the test equipment only and do not include system effects due to mismatch between the DUT and the test equipment.

4.1.1 Test environments

Subclause 4.4, Test environments.

- Pressure ± 5 kPa.
- Temperature ± 2 degrees.
- Relative Humidity ± 5 %.
- DC Voltage $\pm 1,0$ %.
- AC Voltage $\pm 1,5$ %.
- Vibration 10 %.
- Vibration frequency 0,1 Hz.

The above values shall apply unless the test environment is controlled and the specification for the control of the test environment specifies the uncertainty for the parameter.

4.1.2 Transmitter

Subclause 6.2, Base station output power:

- base station maximum output power $\pm [0,5]$ dB.

Subclause 6.3, Frequency stability:

- carrier frequency $\pm [10]$ Hz.

Subclause 6.4.1, Inner loop power control in the downlink:

- transmitter power control step (relative 1 dB step) $\pm [0,3]$ dB;
- transmitter average power control step (relative 10×1 dB steps) $\pm [0,5]$ dB.

NOTE 1: Code domain power.

Subclause 6.4.3, Power control dynamic range:

- maximum and minimum power $\pm[0,8]$ dB;
- power control dynamic range (at 25 dB relative power) $\pm[0,5]$ dB.

NOTE 2: Code domain power.

Subclause 6.4.4, Total power dynamic range:

- total power $\pm[0,5]$ dB;
- total power dynamic range (at 18 dB relative power) $\pm[0,3]$ dB.

Subclause 6.2.2, CPICH power accuracy:

- CPICH power $\pm[0,8]$ dB.

NOTE 3: Code domain power.

Subclause 6.5.1, Occupied bandwidth:

- occupied channel bandwidth $\pm[]$ kHz.

Subclause 6.5.2.1, Spectrum emission mask:

- emission power:

Table 4.1: Uncertainty for Spectrum emission mask measurement

| Frequency offset Δf | Uncertainty |
|--|---------------|
| $2,5 \leq \Delta f < 2,7$ MHz | $\pm[1,5]$ dB |
| $2,7 \leq \Delta f < 3,5$ MHz | $\pm[1,5]$ dB |
| $3,5 \leq \Delta f < 7,5$ MHz | $\pm[1,5]$ dB |
| $7,5 \leq \Delta f \leq \Delta f_{\max}$ MHz | $\pm[1,5]$ dB |

Subclause 6.5.2.2, Adjacent Channel Leakage power Ratio (ACLR):

- ACLR ± 5 MHz (Relative carrier power) $\pm[0,8]$ dB;
- ACLR ± 10 MHz (Relative carrier power) $\pm[0,8]$ dB.

Subclause 6.5.3.7, Protection of the BS receiver:

- emission power $\pm[1,5]$ dB.

Subclause 6.5.3, Spurious emissions:

- conformance requirement in BS and coexistence receive bands:
 - emission power $\pm[2,0]$ dB.
- conformance requirements outside BS and coexistence receive bands:
 - emission power:
 - $f \leq 2.2$ GHz $\pm 1,5$ dB;
 - 2.2 GHz $< f \leq 4$ GHz $\pm 2,0$ dB;
 - $f > 4$ GHz $\pm 4,0$ dB.

Subclause 6.6, Transmit intermodulation:

- interference signal power relative the carrier power $\pm[1,0]$ dB;
- intermodulation power $\pm[1,5]$ dB.

Subclause 6.7.1, Modulation Accuracy:

- modulation accuracy (EVM) $\pm[2,5]$ % RMS.

Subclause 6.7.2, Peak code Domain error:

- peak code domain error $\pm[]$ dB.

4.1.3 Receiver

Subclause 7.2, Reference sensitivity level:

- test signal power $\pm[0,8]$ dB.

Subclause 7.3, Dynamic range:

- test signal power $\pm[0,8]$ dB;
- AWGN signal power $\pm[1,0]$ dB.

Subclause 7.4, Adjacent Channel Selectivity (ACS):

- test signal power $\pm[0,8]$ dB;
- interfering signal power (Relative to the test signal) $\pm[0,8]$ dB.

Subclause 7.5, Blocking characteristics:

- test signal power $\pm[0,8]$ dB:
- interfering signal power:
 - $f \leq 2,2$ GHz $\pm 0,7$ dB;
 - $2,2$ GHz $< f \leq 4$ GHz $\pm 1,5$ dB;
 - $f > 4$ GHz $\pm 3,0$ dB.

Subclause 7.6, Intermodulation characteristics:

- test signal power $\pm[0,8]$ dB;
- interfering signals power $\pm[0,7]$ dB.

Subclause 7.7, Spurious emissions:

- emission power:
 - $f \leq 2,2$ GHz $\pm 1,5$ dB;
 - $2,2$ GHz $< f \leq 4$ GHz $\pm 2,0$ dB;
 - $f > 4$ GHz $\pm 4,0$ dB.

4.1.4 Performance requirement

Subclause 8.2, Demodulation in static propagation condtion:

- test signal power $\pm[]$ dB;
- E_b/I_0 (relative) $\pm[]$ dB.

Subclause 8.3, Demodulation of DCH in multipath fading conditions:

- test signal power $\pm[\]$ dB;
- E_b/I_0 (relative) $\pm[\]$ dB.

4.2 Interpretation of measurement results

Compliance with the requirement is determined by comparing the measured value (or derived value from the measured one) with the test limit. The test limit shall be relaxed from the specified limit in the core requirement using the maximum allowed uncertainty for the test equipment as specified in subclause 4.1. The actual measurement uncertainty of the test equipment for the measurement of each parameter shall be included in the test report.

The recorded value for the test equipment uncertainty shall be, for each measurement, equal to or lower than the appropriate figure in subclause 4.1 of the present document.

If the test equipment for a test is known to have a measurement uncertainty greater than that specified in subclause 4.1, it is still permitted to use this apparatus provided that an adjustment is made to the measured value as follows.

The initial test limit is derived as above by relaxing the specified limit using the maximum allowed test equipment uncertainty as specified in subclause 4.1. Any additional uncertainty in the test equipment over and above that specified in subclause 4.1 shall be used to tighten the test limit. This procedure will ensure that test equipment not compliant with subclause 4.1 does not increase the chance of passing a device under test where that device would otherwise have failed the test if test equipment compliant with subclause 4.1 had been used.

4.3 Output power and determination of power class

The requirements in the present document apply to base station intended for general-purpose applications.

In the future further classes of base stations may be defined; the requirements for these may be different than for general-purpose applications.

4.4 Test environments

For each test in the present document, the environmental conditions under which the BS is to be tested are defined.

4.4.1 Normal test environment

When a normal test environment is specified for a test, the test should be performed within the minimum and maximum limits of the conditions stated in table 4.2.

Table 4.2: Limits of conditions for Normal Test Environment

| Condition | Minimum | Maximum |
|---------------------|--|---------|
| Barometric pressure | 86 kPa | 106 kPa |
| Temperature | 15°C | 30°C |
| Relative Humidity | 20 % | 85 % |
| Power supply | Nominal, as declared by the manufacturer | |
| Vibration | Negligible | |

The ranges of barometric pressure, temperature and humidity represent the maximum variation expected in the uncontrolled environment of a test laboratory. If it is not possible to maintain these parameters within the specified limits, the actual values shall be recorded in the test report.

NOTE: This may, for instance, be the case for measurements of radiated emissions performed on an open field test site.

4.4.2 Extreme test environment

The manufacturer shall declare one of the following:

- 1) the equipment class for the equipment under test, as defined in the IEC 60 721-3-3 [6];
- 2) the equipment class for the equipment under test, as defined in the IEC 60 721-3-4 [7];
- 3) the equipment that does not comply to the mentioned classes, the relevant classes from IEC 60 721 documentation for Temperature, Humidity and Vibration shall be declared.

NOTE: Reduced functionality for conditions that fall outside of the standard operational conditions are not tested in the present document. These may be stated and tested separately.

4.4.2.1 Extreme temperature

When an extreme temperature test environment is specified for a test, the test shall be performed at the standard minimum and maximum operating temperatures defined by the manufacturer's declaration for the equipment under test.

Minimum temperature:

The test shall be performed with the environment test equipment and methods including the required environmental phenomena into the equipment, conforming to the test procedure of IEC 60 068-2-1 [8].

Maximum temperature:

The test shall be performed with the environmental test equipment and methods including the required environmental phenomena into the equipment, conforming to the test procedure of IEC 60 068-2-2 [9].

NOTE: It is recommended that the equipment is made fully operational prior to the equipment being taken to its lower operating temperature.

4.4.3 Vibration

When vibration conditions are specified for a test, the test shall be performed while the equipment is subjected to a vibration sequence as defined by the manufacturer's declaration for the equipment under test. This shall use the environmental test equipment and methods of inducing the required environmental phenomena into the equipment, conforming to the test procedure of IEC 60 068-2-6 [10]. Other environmental conditions shall be within the ranges specified in subclause 4.4.1.

NOTE: The higher levels of vibration may induce undue physical stress into equipment after a prolonged series of tests. The testing body should only vibrate the equipment during the RF measurement process.

4.4.4 Power supply

When extreme power supply conditions are specified for a test, the test shall be performed at the standard upper and lower limits of operating voltage defined by manufacturer's declaration for the equipment under test.

Upper voltage limit:

The equipment shall be supplied with a voltage equal to the upper limit declared by the manufacturer (as measured at the input terminals to the equipment). The tests shall be carried out at the steady state minimum and maximum temperature limits declared by the manufacturer for the equipment, to the methods described in IEC 60 068-2-1 [8] Test Ab/Ad and IEC 60 068-2-2 [9] Test Bb/Bd: Dry Heat.

Lower voltage limit:

The equipment shall be supplied with a voltage equal to the lower limit declared by the manufacturer (as measured at the input terminals to the equipment). The tests shall be carried out at the steady state minimum and maximum temperature limits declared by the manufacturer for the equipment, to the methods described in IEC 60 068-2-1 [8] Test Ab/Ad and IEC 60 068-2-2 [9] Test Bb/Bd: Dry Heat.

4.5 Selection of configurations for testing

Most tests in the present document are only performed for a subset of the possible combinations of test conditions. For instance:

- not all transceivers in the configuration may be specified to be tested;
- only one RF channel may be specified to be tested;
- only one timeslot may be specified to be tested.

When a test is performed by a test laboratory, the choice of which combinations are to be tested shall be specified by the laboratory. The laboratory may consult with operators, the manufacturer or other bodies.

When a test is performed by a manufacturer, the choice of which combinations are to be tested may be specified by an operator.

4.6 BS Configurations

4.6.1 Receiver diversity

For the tests in clause 7 of the present document, the specified test signals shall be applied to one receiver antenna connector, with the remaining receivers are disabled or their antenna connectors being terminated with 50 Ω .

4.6.2 Duplexers

The requirements of the present document shall be met with a duplexer fitted, if a duplexer is supplied as part of the BS. If the duplexer is supplied as an option by the manufacturer, sufficient tests should be repeated with and without the duplexer fitted to verify that the BS meets the requirements of the present document in both cases.

The following tests should be performed with the duplexer fitted, and without it fitted if this is an option:

- 1) subclause 6.2.1, base station maximum output power, for the highest static power step only, if this is measured at the antenna connector;
- 2) subclause 6.5, output RF spectrum emissions; outside the BS transmit band;
- 3) subclause 6.5.3.7, protection of the BS receiver;
- 4) subclause 6.6, transmit intermodulation; for the testing of conformance, the carrier frequencies should be selected to minimize intermodulation products from the transmitters falling in receive channels.

The remaining tests may be performed with or without the duplexer fitted.

NOTE 1: When performing receiver tests with a duplexer fitted, it is important to ensure that the output from the transmitters does not affect the test apparatus. This can be achieved using a combination of attenuators, isolators and filters.

NOTE 2: When duplexers are used, intermodulation products will be generated, not only in the duplexer but also in the antenna system. The intermodulation products generated in the antenna system are not controlled by 3GPP specifications, and may degrade during operation (e.g. due to moisture ingress). Therefore, to ensure continued satisfactory operation of a BS, an operator will normally select ARFCNs to minimize intermodulation products falling on receive channels. For testing of complete conformance, an operator may specify the ARFCNs to be used.

4.6.3 Power supply options

If the BS is supplied with a number of different power supply configurations, it may not be necessary to test RF parameters for each of the power supply options, provided that it can be demonstrated that the range of conditions over which the equipment is tested is at least as great as the range of conditions due to any of the power supply configurations.

This applies particularly if a BS contains a DC rail which can be supplied either externally or from an internal mains power supply. In this case, the conditions of extreme power supply for the mains power supply options can be tested by testing only the external DC supply option. The range of DC input voltages for the test should be sufficient to verify the performance with any of the power supplies, over its range of operating conditions within the BS, including variation of mains input voltage, temperature and output current.

4.6.4 Ancillary RF amplifiers

<Table from GSM11.21 will be here. Note on passive elements should be here.>

Ancillary RF amplifier: a piece of equipment, which when connected by RF coaxial cables to the BS, has the primary function to provide amplification between the transmit and/or receive antenna connector of a BS and an antenna without requiring any control signal to fulfil its amplifying function.

The requirements of the present document shall be met with the ancillary RF amplifier fitted. At tests according to clauses 6 and 7 for TX and RX respectively, the ancillary amplifier is connected to the BS by a connecting network (including any cable(s), attenuator(s), etc.) with applicable loss to make sure the appropriate operating conditions of the ancillary amplifier and the BS. The applicable connecting network loss range is declared by the manufacturer. Other characteristics and the temperature dependence of the attenuation of the connecting network are neglected. The actual attenuation value of the connecting network is chosen for each test as one of the applicable extreme values. The lowest value is used unless otherwise stated.

Sufficient tests should be repeated with the ancillary amplifier fitted and, if it is optional, without the ancillary RF amplifier to verify that the BS meets the requirements of the present document in both cases.

When testing, the following tests should be repeated with the optional ancillary amplifier fitted according to the table below, where x denotes that the test is applicable:

Table 4.3

| | Subclause | TX amplifier only | RX amplifier only | TX/RX amplifiers combined (Note) |
|-------------------|-----------|-------------------|-------------------|----------------------------------|
| Receiver Tests | 7.2 | | X | X |
| | 7.5 | | X | X |
| | 7.6 | | x | X |
| | 7.7 | | x | |
| Transmitter Tests | 6.2 | x | | X |
| | 6.5.1 | X | | X |
| | 6.5.2.2 | X | | x |
| | 6.5.3 | x | | X |
| | 6.6 | x | | X |

NOTE: Combining can be by duplex filters or any other network. The amplifiers can either be in RX or TX branch or in both. Either one of these amplifiers could be a passive network.

In test according to subclauses 6.2 and 7.2 highest applicable attenuation value is applied.

4.6.5 BS using antenna arrays

A BS may be configured with a multiple antenna port connection for some or all of its transceivers or with an antenna array related to one cell (not one array per transceiver). This subclause applies to a BS which meets at least one of the following conditions:

- the transmitter output signals from one or more transceiver appear at more than one antenna port; or
- there is more than one receiver antenna port for a transceiver or per cell and an input signal is required at more than one port for the correct operation of the receiver (NOTE: diversity reception does not meet this requirement) thus the outputs from the transmitters as well as the inputs to the receivers are directly connected to several antennas (known as „aircombining"); or
- transmitters and receivers are connected via duplexers to more than one antenna.

If a BS is used, in normal operation, in conjunction with an antenna system which contains filters or active elements which are necessary to meet the UTRA requirements, the conformance tests may be performed on a system comprising the BS together with these elements, supplied separately for the purposes of testing. In this case, it must be demonstrated that the performance of the configuration under test is representative of the system in normal operation, and the conformance assessment is only applicable when the BS is used with the antenna system.

For conformance testing of such a BS, the following procedure may be used.

4.6.5.1 Receiver tests

For each test, the test signals applied to the receiver antenna connectors shall be such that the sum of the powers of the signals applied equals the power of the test signal(s) specified in the test.

An example of a suitable test configuration is shown in figure 4.1.

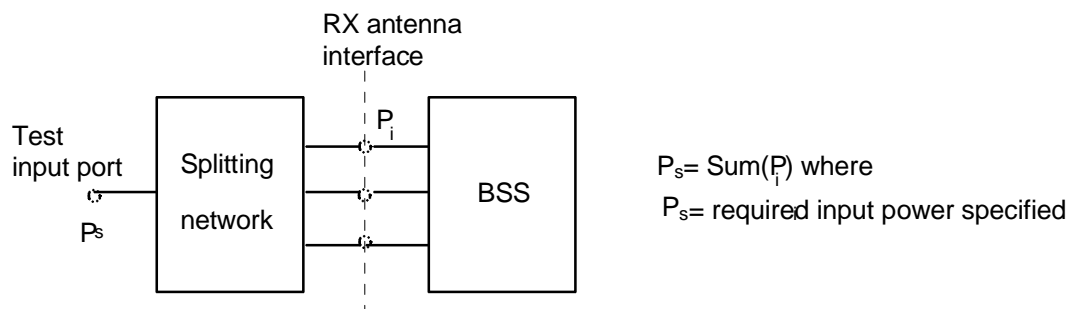

Figure 4.1: Receiver test set-up

For spurious emissions from the receiver antenna connector, the test may be performed separately for each receiver antenna connector.

4.6.5.2 Transmitter tests

For each test, the test signals applied to the transmitter antenna connectors (P_i) shall be such that the sum of the powers of the signals applied equals the power of the test signal(s) (P_s) specified in the test. This may be assessed by separately measuring the signals emitted by each antenna connector and summing the results, or by combining the signals and performing a single measurement. The characteristics (e.g. amplitude and phase) of the combining network should be such that the power of the combined signal is maximised.

An example of a suitable test configuration is shown in figure 4.2.

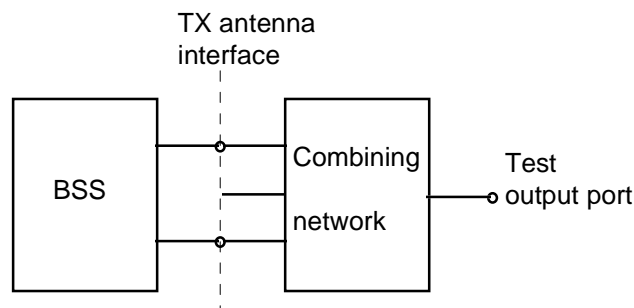

Figure 4.2: Transmitter test set-up

For Intermodulation attenuation, the test may be performed separately for each transmitter antenna connector.

4.7 Regional requirements

Some requirements in TS 25.141 may only apply in certain regions. Table 4.4 lists all requirements that may be applied differently in different regions.

Table 4.4: List of regional requirements

| Subclause number | Requirement | Comments |
|------------------|--|---|
| 3.4.1 | Frequency bands | Some bands may be applied regionally. |
| 3.4.2 | Tx-Rx Frequency Separation | The requirement is applied according to what frequency bands in subclause 5.2 that are supported by the BS. |
| 6.2.1.2 | Base station output power | In certain regions, the minimum requirement for normal conditions may apply also for some conditions outside the ranges defined for the Normal test environment in subclause 4.4.1. |
| 6.5.2.1 | Spectrum emission mask | The mask specified may be mandatory in certain regions. In other regions this mask may not be applied. |
| 6.5.3.5 | Spurious emissions (Category A) | These requirements shall be met in cases where Category A limits for spurious emissions, as defined in ITU-R Recommendation SM.329-7 [1], are applied. |
| 6.5.3.6 | Spurious emissions (Category B) | These requirements shall be met in cases where Category B limits for spurious emissions, as defined in ITU-R Recommendation SM.329-7 [1], are applied. |
| 6.5.3.8.1 | Co-existence with GSM900 – Operation in the same geographic area | This requirement may be applied for the protection of GSM 900 MS in geographic areas in which both GSM 900 and UTRA are deployed. |
| 6.5.3.8.2 | Co-existence with GSM900 – Co-located base stations | This requirement may be applied for the protection of GSM 900 BTS receivers when GSM 900 BTS and UTRA BS are co-located. |
| 6.5.3.9.1 | Co-existence with DCS1800 – Operation in the same geographic area | This requirement may be applied for the protection of DCS 1800 MS in geographic areas in which both DCS 1800 and UTRA are deployed. |
| 6.5.3.9.2 | Co-existence with DCS1800 – Co-located base stations | This requirement may be applied for the protection of DCS 1800 BTS receivers when DCS 1800 BTS and UTRA BS are co-located. |
| 6.5.3.10 | Co-existence with PHS | This requirement may be applied for the protection of PHS in geographic areas in which both PHS and UTRA are deployed. |
| 6.5.3.11 | Co-existence with services in adjacent frequency bands | This requirement may be applied for the protection in bands adjacent to 2110-2170 MHz, as defined in subclause 5.2(a) and 1930-1990 MHz, as defined in subclause 5.2(b) in geographic areas in which both an adjacent band service and UTRA are deployed. |
| 6.5.3.12.1 | Co-existence with UTRA TDD – Operation in the same geographic area | This requirement may be applied to geographic areas in which both UTRA-TDD and UTRA-FDD are deployed. |
| 6.5.3.12.2 | Co-existence with UTRA TDD – Co-located base stations | This requirement may be applied for the protection of UTRA-TDD BS receivers when UTRA-TDD BS and UTRA FDD BS are co-located. |
| 7.5 | Blocking characteristic | The requirement is applied according to what frequency bands in subclause 5.2 that are supported by the BS. |

5 Format and interpretation of tests

Each test in the following clauses has a standard format:

X **Title**

All tests are applicable to all equipment within the scope of the present document, unless otherwise stated.

X.1 Definition and applicability

This subclause gives the general definition of the parameter under consideration and specifies whether the test is applicable to all equipment or only to a certain subset.

X.2 Conformance requirements

This subclause describes the requirement under test has to fulfil to ensure compliance with the relevant specification.

In addition, this subclause contains the reference to the subclause to the 3GPP reference (or core) specification from which the conformance requirements are derived.

X.3 Test purpose

This subclause defines the purpose of the test.

X.4 Method of test

X.4.1 Initial conditions

This subclause defines the initial conditions for each test, including the basic measurement set-up.

X.4.2 Procedure

This subclause describes the steps necessary to perform the test and provides further details of the test definition like point of access (e.g. antenna port), domain (e.g. frequency-span), range, weighting (e.g. bandwidth), and algorithms (e.g. averaging).

X.5 Test requirements

This subclause defines the pass/fail criteria for the equipment under test.

6 Transmitter

6.1 General

Unless otherwise stated, all tests in this clause shall be performed at the BS antenna connector (test port A) with a full complement of transceivers for the configuration in normal operating conditions. If any external apparatus such as a TX amplifier, a diplexer, a filter or the combination of such devices is used, the tests according to subclauses 4.6.2 and/or 4.6.4, depending on the device added, shall be performed to ensure that the requirements are met at test port B.

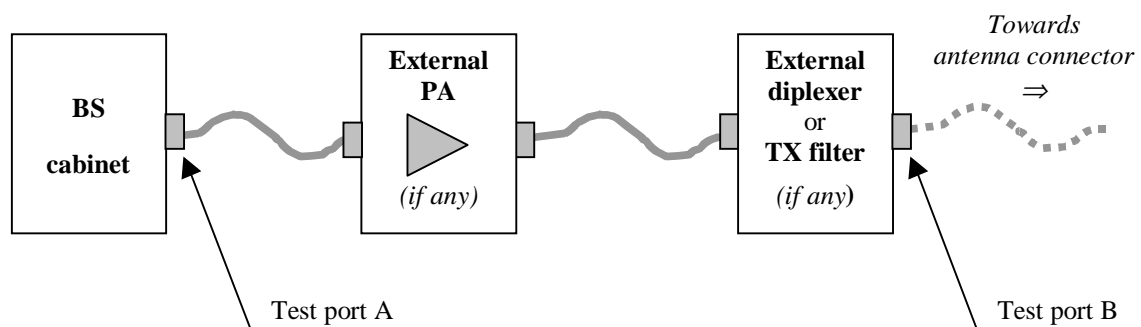

Figure 6.1: Transmitter test ports

Power levels are expressed in dBm.

6.1.1 Test Models

The set-up of physical channels for transmitter tests shall be according to one of the test models below. A reference to the applicable table is made with each test.

A code "level setting" of -X dB is the setting that according to the base station manufacturer will result in a code power of nominally X dB below the maximum output power. The relative accuracy of the level settings shall conform to subclause 6.4.2.

6.1.1.1 Test Model 1

This model shall be used for tests on:

- spectrum emission mask;
- ACLR;
- spurious emissions;
- transmit intermodulation;
- base station maximum output power.

64 DPCHs at 30 kbps (SF=128) distributed randomly across the code space, at random power levels and random timing offsets are defined so as to simulate a realistic traffic scenario which may have high PAR (Peak to Average Ratio).

Considering that not every base station implementation will support 64 DPCH, variants of this test model containing 32 and 16 DPCH are also specified. The conformance test shall be performed using the largest of these three options that can be supported by the equipment under test.

"Fraction of power" is relative to the maximum output power on the TX antenna interface under test.

Table 6.1: Test Model 1 Active Channels

| Type | Number of Channels | Fraction of Power (%) | Level setting (dB) | Channelisation Code | Timing offset (x256T _{chip}) |
|---------------|--------------------|-----------------------|--------------------|---------------------|--|
| PCCPCH+SCH | 1 | 10 | -10 | 1 | 0 |
| Primary CPICH | 1 | 10 | -10 | 0 | 0 |
| PICH | 1 | 3.2 | -15 | 16 | 120 |
| DPCH (SF=128) | 16/32/64 | 76.8 in total | see table 6.2 | see table 6.2 | see table 6.2 |

Table 6.2: DPCH Spreading Code, Timing offsets and level settings for Test Model 1

| Code | Timing offset ($\times 256T_{\text{chip}}$) | Level settings (dB) (16 codes) | Level settings (dB) (32 codes) | Level settings (dB) (64 codes) |
|------|--|-----------------------------------|-----------------------------------|-----------------------------------|
| 2 | 86 | -10 | -13 | -16 |
| 11 | 134 | -12 | -13 | -16 |
| 17 | 52 | -12 | -14 | -16 |
| 23 | 45 | -14 | -15 | -17 |
| 31 | 143 | -11 | -17 | -18 |
| 38 | 112 | -13 | -14 | -20 |
| 47 | 59 | -17 | -16 | -16 |
| 55 | 23 | -16 | -18 | -17 |
| 62 | 1 | -13 | -16 | -16 |
| 69 | 88 | -15 | -19 | -19 |
| 78 | 30 | -14 | -17 | -22 |
| 85 | 18 | -18 | -15 | -20 |
| 94 | 30 | -19 | -17 | -16 |
| 102 | 61 | -17 | -22 | -17 |
| 113 | 128 | -15 | -20 | -19 |
| 119 | 143 | -9 | -24 | -21 |
| 7 | 83 | | -20 | -19 |
| 13 | 25 | | -18 | -21 |
| 20 | 103 | | -14 | -18 |
| 27 | 97 | | -14 | -20 |
| 35 | 56 | | -16 | -24 |
| 41 | 104 | | -19 | -24 |
| 51 | 51 | | -18 | -22 |
| 58 | 26 | | -17 | -21 |
| 64 | 137 | | -22 | -18 |
| 74 | 65 | | -19 | -20 |
| 82 | 37 | | -19 | -17 |
| 88 | 125 | | -16 | -18 |
| 97 | 149 | | -18 | -19 |
| 108 | 123 | | -15 | -23 |
| 117 | 83 | | -17 | -22 |
| 125 | 5 | | -12 | -21 |
| 4 | 91 | | | -17 |
| 9 | 7 | | | -18 |
| 12 | 32 | | | -20 |
| 14 | 21 | | | -17 |
| 19 | 29 | | | -19 |
| 22 | 59 | | | -21 |
| 26 | 22 | | | -19 |
| 28 | 138 | | | -23 |
| 34 | 31 | | | -22 |
| 36 | 17 | | | -19 |
| 40 | 9 | | | -24 |
| 44 | 69 | | | -23 |
| 49 | 49 | | | -22 |
| 53 | 20 | | | -19 |
| 56 | 57 | | | -22 |
| 61 | 121 | | | -21 |
| 63 | 127 | | | -18 |
| 66 | 114 | | | -19 |
| 71 | 100 | | | -22 |
| 76 | 76 | | | -21 |
| 80 | 141 | | | -19 |
| 84 | 82 | | | -21 |
| 87 | 64 | | | -19 |
| 91 | 149 | | | -21 |
| 95 | 87 | | | -20 |
| 99 | 98 | | | -25 |
| 105 | 46 | | | -25 |
| 110 | 37 | | | -25 |
| 116 | 87 | | | -24 |

| Code | Timing offset (x256T _{chip}) | Level settings (dB) (16 codes) | Level settings (dB) (32 codes) | Level settings (dB) (64 codes) |
|------|---|-----------------------------------|-----------------------------------|-----------------------------------|
| 118 | 149 | | | -22 |
| 122 | 85 | | | -20 |
| 126 | 69 | | | -15 |

NOTE: The figures for code power are nominal and have tolerance of ± 1 dB.

6.1.1.2 Test Model 2

This model shall be used for tests on:

- output power dynamics.

Table 6.3: Test Model 2 Active Channels

| Type | Number of Channels | Fraction of Power (%) | Level setting (dB) | Channelisation Code | Timing offset (x256T _{chip}) |
|---------------|--------------------|-----------------------|--------------------|---------------------|--|
| PCCPCH+SCH | 1 | 10 | -10 | 1 | 0 |
| Primary CPICH | 1 | 10 | -10 | 0 | 0 |
| PICH | 1 | 10 | -10 | 16 | 120 |
| DPCH (SF=128) | 3 | 2 x 10, 1 x 50 | 2 x -10, 1 x -3 | 24, 72, 120 | 1, 7, 2 |

6.1.1.3 Test Model 3

This model shall be used for tests on:

- peak code domain error.

Table 6.4: Test Model 3 Active Channels

| Type | Number of Channels | Fraction of Power (%) 16/32 | Level settings (dB) 16/32 | Channelisation Code | Timing offset (x256T _{chip}) |
|---------------|--------------------|--------------------------------|------------------------------|---------------------|--|
| PCCPCH+SCH | 1 | 12,6/7,9 | -9 / -11 | 1 | 0 |
| Primary CPICH | 1 | 12,6/7,9 | -9 / -11 | 0 | 0 |
| PICH | 1 | 10/3,2 | -10 / -15 | 16 | 120 |
| DPCH (SF=256) | 16/32 | 63,7/80,4 in total | see table 6.5 | see table 6.5 | see table 6.5 |

As with Test Model 1, not every base station implementation will support 32 DPCH, a variant of this test model containing 16 DPCH are also specified. The conformance test shall be performed using the larger of these two options that can be supported by the equipment under test.

Table 6.5: DPCH Spreading Code, Toffset and Power for Test Model 3

| Code | T _{offset} | Level settings (dB) (16 codes) | Level settings (dB) (32 codes) |
|------|---------------------|--------------------------------|--------------------------------|
| 64 | 86 | -14 | -16 |
| 69 | 134 | -14 | -16 |
| 74 | 52 | -14 | -16 |
| 78 | 45 | -14 | -16 |
| 83 | 143 | -14 | -16 |
| 89 | 112 | -14 | -16 |
| 93 | 59 | -14 | -16 |
| 96 | 23 | -14 | -16 |
| 100 | 1 | -14 | -16 |
| 105 | 88 | -14 | -16 |
| 109 | 30 | -14 | -16 |
| 111 | 18 | -14 | -16 |
| 115 | 30 | -14 | -16 |
| 118 | 61 | -14 | -16 |
| 122 | 128 | -14 | -16 |
| 125 | 143 | -14 | -16 |
| 67 | 83 | | -16 |
| 71 | 25 | | -16 |
| 76 | 103 | | -16 |
| 81 | 97 | | -16 |
| 86 | 56 | | -16 |
| 90 | 104 | | -16 |
| 95 | 51 | | -16 |
| 98 | 26 | | -16 |
| 103 | 137 | | -16 |
| 108 | 65 | | -16 |
| 110 | 37 | | -16 |
| 112 | 125 | | -16 |
| 117 | 149 | | -16 |
| 119 | 123 | | -16 |
| 123 | 83 | | -16 |
| 126 | 5 | | -16 |

NOTE: The figures for code power are nominal and have tolerance of ± 1 dB.

6.2.1.3.1 Test Model 4

This model shall be used for tests on:

- EVM measurement.

Table 6.6: Test Model 4 Active Channels

| Type | Number of Channels | Fraction of Power (%) | Level setting (dB) | Channelisation Code | Timing offset |
|------------|--------------------|-----------------------|--------------------|---------------------|---------------|
| PCCPCH+SCH | 1 | 50 to 1.6 | -3 to -18 | 1 | |

6.1.1.4 DPCH Structure of the Downlink Test Models

For the above test models the following structure is adopted for the DPCH. The DPDCH and DPCCH have the same power level. The timeslot structure should be as described by TS 25.211-slot format 10 and 6 that are reproduced in table 6.7.

Table 6.7: DPCH structure of the downlink test models

| Slot Format #1 | Channel Bit Rate (kbps) | Channel Symbol Rate (ksps) | SF | Bits/Frame | | | Bits/Slot | DPDCH Bits/Slot | | DPCCH Bits/Slot | | |
|----------------|-------------------------|----------------------------|-----|------------|-------|-----|-----------|-----------------|--------|-----------------|------|--------|
| | | | | DPDCH | DPCCH | TOT | | NData1 | Ndata2 | NTFCI | NTPC | Npilot |
| 10 | 60 | 30 | 128 | 450 | 150 | 600 | 40 | 6 | 24 | 0 | 2 | 8 |
| 6 | 30 | 15 | 256 | 150 | 150 | 300 | 20 | 2 | 8 | 0 | 2 | 8 |

The test DPCH has frame structure so that the pilot bits are defined over 15 timeslots according to the relevant columns of TS 25.211, which are reproduced in table 6.8.

Table 6.8: Frame structure of DPCH

| Symbol # | Npilot = 8 | | | |
|----------|------------|----|----|----|
| | 0 | 1 | 2 | 3 |
| Slot #0 | 11 | 11 | 11 | 10 |
| 1 | 11 | 00 | 11 | 10 |
| 2 | 11 | 01 | 11 | 01 |
| 3 | 11 | 00 | 11 | 00 |
| 4 | 11 | 10 | 11 | 01 |
| 5 | 11 | 11 | 11 | 10 |
| 6 | 11 | 11 | 11 | 00 |
| 7 | 11 | 10 | 11 | 00 |
| 8 | 11 | 01 | 11 | 10 |
| 9 | 11 | 11 | 11 | 11 |
| 10 | 11 | 01 | 11 | 01 |
| 11 | 11 | 10 | 11 | 11 |
| 12 | 11 | 10 | 11 | 00 |
| 13 | 11 | 00 | 11 | 11 |
| 14 | 11 | 00 | 11 | 11 |

The TPC bits alternate 00 / 11 starting with 00 in timeslot 0.

The aggregate 15 x 30 = 450 DPDCH bits per frame are filled with a PN9 sequence generated using the primitive trinomial $x^9 + x^4 + 1$. To ensure non-correlation of the PN9 sequences, each DPDCH shall use its channelisation code as the seed for the PN sequence at the start of each frame, according to its timing offset.

The sequence shall be generated in a nine-stage shift register whose 5th and 9th stage outputs are added in a modulo-two addition stage, and the result is fed back to the input of the first stage. The generator shall be seeded so that the sequence begins with the 7 bit channelisation code starting from the LSB, and followed by 2 consecutive ONES.

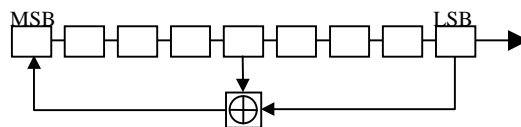

Figure 6.2

6.1.1.5 Common channel Structure of the Downlink Test Models

6.1.1.5.1 P-CCPCH

The aggregate 15 x 18 = 270 P-CCPCH bits per frame are filled with a PN9 sequence generated using the primitive trinomial $x^9 + x^4 + 1$. Channelisation code of the P-CCPCH is used as the seed for the PN sequence at the start of each frame.

The generator shall be seeded so that the sequence begins with the 8 bit channelisation code starting from the LSB, and followed by a ONE.

6.1.1.5.2 PICH

PICH carries 18 Paging Indicators (PI) equals to [1 0 1 1 0 0 0 1 0 1 1 0 0 0 1 0 1 0]. This defines the 288 first symbols ($= \pm 1 \pm j$) of the PICH. No power is transmitted for the 12 remaining unused symbols ($=0$).

6.1.1.5.3 Primary scrambling code and SCH

The scrambling code should be 0.

Where multiple repetitions of the Test Model signals are being used to simulate a multi-carrier signal, the scrambling code for the central carrier should be 0, carriers added at successively lower frequencies should use codes 2, 4, ... and carriers added at successively higher frequencies should use codes 1, 3, ...

The scrambling code defines the SSC sequence of the secondary SCH. In their active part, primary and secondary SCH share equally the power level defined for "PCCPCH+SCH".

6.2 Base station output power

Output power, P_{out} , of the base station is the mean power of one carrier delivered to a load with resistance equal to the nominal load impedance of the transmitter. The physical channels for the following test(s) shall be set-up according to the test model specified in subclause 6.1.1.

6.2.1 Base station maximum output power

Maximum output power, P_{max} , of the base station is the mean power level per carrier that the manufacturer has declared to be available at the antenna connector.

6.2.1.1 Test Conditions and measurement method

1. Connect the power measuring equipment to the base station RF output port.
2. Set the base station to transmit a signal modulated with a combination of PCCPCH, SCCPCH and Dedicated Physical Channels specified as test model1 in subclause 6.1.1.1.
3. Measure the mean power at the RF output port over a certain slots.

6.2.1.2 Minimum requirement

In normal conditions, the Base station maximum output power shall remain within +2 dB and -2 dB of the manufacturer's rated power.

In extreme conditions, the Base station maximum output power shall remain within +2,5 dB and -2,5 dB of the manufacturer's rated power.

In certain regions, the minimum requirement for normal conditions may apply also for some conditions outside the ranges defined for the Normal test environment in subclause 4.4.1.

6.2.2 CPICH power accuracy

6.2.2.1 Definition and applicability

CPICH power accuracy is defined as the maximum deviation between the ordered channel power and the power in that channel measured at the TX antenna interface. The requirement is applicable for all BS types.

6.2.2.2 Conformance Requirement

See subclause 6.2.2.5.

6.2.2.3 Test purpose

The purpose of the test is to verify, that the BS under test delivers CPICH power within margins, thereby allowing reliable cell planning and operation.

6.2.2.4 Method of test

6.2.2.4.1 Initial conditions

Establish applicable temperature and supply voltage, as specified in subclause 4.4.

Connect BS to code domain analyser as shown in annex B.

Disable inner loop power control.

Set-up BS transmission at maximum total power as specified by the supplier. Channel set-up shall be according to subclause 6.1.1.2.

6.2.2.4.2 Procedure

With the Code Domain Analyser measure the power in the PCCPCH and PCPICH.

Repeat the measurement for all other applicable temperatures and supply voltages.

6.2.2.5 Test requirement

The measured CPICH power shall be within ± 2.1 dB of the ordered absolute value.

6.3 Frequency error

Frequency error is the measure of the difference between the actual BTS transmit frequency and the assigned frequency. The same source shall be used for RF frequency and data clock generation.

It is not possible to verify by testing that the data clock is derived from the same frequency source as used for RF generation. This may be confirmed by a manufacturers declaration

Frequency error shall be measured as part of the transmit modulation measurements specified in 6.7.

6.4 Output power dynamics

Power control is used to limit the interference level. The BS transmitter uses a quality-based power control on the downlink. The physical channels for the following test(s) shall be set-up according to subclause 6.1.1.2.

6.4.1 Inner loop power control

Inner loop power control in the downlink is the ability of the BS transmitter to adjust the transmitter output power of a code channel in accordance with the corresponding TPC symbols received in the uplink.

6.4.2 Power control steps

The power control step is the required step change in the DL transmitter output power of a code channel in response to the corresponding power control command. The combined output power change is the required total change in the DL transmitter output power of a code channel in response to multiple consecutive power control commands corresponding to that code channel.

6.4.2.1 Definition and applicability

Inner loop power control in the downlink is the ability of the BS transmitter to adjust the transmitter output power of a code channel in accordance with the corresponding TPC symbols received in the uplink.

The power control step is the required step change in the DL transmitter output power of a code channel in response to the corresponding power control command. The combined output power change is the required total change in the DL transmitter output power of a code channel in response to multiple consecutive power control commands corresponding to that code channel.

6.4.2.2 Conformance requirement

The BS transmitter shall have the capability of setting the inner loop output power with a step sizes of 1 dB mandatory and 0,5 dB optional.

- (a) The tolerance of the power control step due to inner loop power control shall be within the range shown in table 6.9.
- (b) The tolerance of the combined output power change due to inner loop power control shall be within the range shown in table 6.10a.

Table 6.9: Transmitter power control step tolerance

| Power control commands in the down link | Transmitter power control step tolerance | | | |
|---|--|---------|------------------|----------|
| | 1 dB step size | | 0,5 dB step size | |
| | Lower | Upper | Lower | Upper |
| Up(TPC command "1") | +0,5 dB | +1,5 dB | +0,25 dB | +0,75 dB |
| Down(TPC command "0") | -0,5 dB | -1,5 dB | -0,25 dB | -0,75 dB |

Table 6.10a: Transmitter combined output power tolerance

| Power control commands in the down link | Transmitter combined output power change tolerance after 10 consecutive equal commands (up or down) | | | |
|---|---|--------|-----------------|-------|
| | 1 dB step size | | 0.5dB step size | |
| | Lower | Upper | Lower | Upper |
| Up(TPC command "1") | +8 dB | +12 dB | +4 dB | +6 dB |
| Down(TPC command "0") | -8 dB | -12 dB | -4 dB | -6 dB |

The reference for this requirement is TS 25.104 [1] subclause 6.4.1.1.1

6.4.2.3 Test purpose

To verify those requirements for the power control step size and response are met as specified in subclause 6.4.2.2.

6.4.2.4 Method of test

6.4.2.4.1 Initial conditions

- (1) Connect the suitable measurement equipment to the BS antenna connector as shown in annex B.
- (2) Start BS transmission with channel configuration as specified in table 6.3 Test model 2.
- (3) Establish downlink power control with parameters as specified in table 6.10b.

Table 6.10b

| Parameter | Level/status | Unit |
|-----------------|------------------|--------------|
| UL signal level | Ref.sens + 10 dB | DBm/3,84 MHz |
| Data sequence | PN9 | |

6.4.2.4.2 Procedure

- 1) Set and send alternating TPC bits from the UE simulator or UL signal generator.

- 2) Measure mean power level of the code under the test each time TPC command is transmitted. All steps within power control dynamic range declared by manufacturer shall be measured.
- 3) Measure the 10 highest and the 10 lowest power step levels within the power control dynamic range declared by manufacturer by sending 10 consecutive equal commands as described table 6.10a.
- 4) Check that average step size tolerance requirement shall be met.

6.4.2.5 Test requirement

- (a) BS shall fulfil step size requirement for all power control steps declared by manufacture as specified in subclause 6.4.2.2.
- (b) For all measured Up/Down cycles, the difference of transmission power between before and after 10 equal commands (Up and Down), derived in step (3), shall not exceed the prescribed range in subclause 6.4.2.2.

6.4.3 Power control dynamic range

6.4.3.1 Definition and applicability

The power control dynamic range is difference between the maximum and the minimum transmit output power of a code channel for a specified reference condition. Transmit modulation shall be maintained within whole dynamic range as specified in the TS 25.104 subclause 6.8.

6.4.3.2 Conformance requirement

Down link (DL) power control dynamic range:

- maximum power: BS maximum output power -3 dB or greater;
- minimum power: BS maximum output power -28 dB or less.

The reference for this requirement is TS 25.104 [1] subclause 6.4.2.1.

6.4.3.3 Test purpose

To verify that the minimum power control dynamic range is met as specified in subclause 6.4.3.2.

6.4.3.4 Method of test

6.4.3.4.1 Initial conditions

- 1) Connect the measurement equipment to the BS antenna connector as shown in annex B.
- 2) Channel configuration defined in table 6.3 Test model 2 shall be used.
- 3) Set BS frequency.
- 4) Start BS transmission.

6.4.3.4.2 Procedure

P_{max} shall be defined as described in subclause 6.2.1 Base station maximum output power.

- 1) Set power of the DPCH under test to the P_{max}-3 dB level. Power levels for other code channels shall be adjusted as necessary.
- 2) Measure mean power level of the code channel under test.
- 3) Set power of the DPCH under test to the minimum value by means determined by the manufacturer. Power levels for other code channels shall remain unchanged.

- 4) Measure mean power level of the code channel under test.

6.4.3.5 Test requirement

Power control dynamic range requirement shall be met as specified in subclause 6.4.3.2.

6.4.4 Total power dynamic range

6.4.4.1 Definition and applicability

The total power dynamic range is difference between the maximum and the minimum transmit output power for a specified reference condition.

6.4.4.2 Conformance requirement

The down link (DL) total power dynamic range shall be 18 dB or greater. The reference for this requirement is TS 25.104 [1] subclause 6.4.3.1.

6.4.4.3 Test purpose

To verify that the total power dynamic range as specified in TS 25.104 subclause 6.4.3.1. The test is to ensure that the total output power can be reduced while still transmitting a single code. This is to ensure that the interference to neighbouring cells is reduced.

<Editor's note: The rationale of the requirement should be clarified.>

6.4.4.4 Method of test

6.4.4.4.1 Initial requirement

- 1) Connect the measurement equipment to the BS antenna connector as shown in annex B.
- 2) Channel configuration defined in table 6.3 Test model 2 [but without traffic channel] shall be used.

<Editor's note: The conditions should be clarified.>

- 3) Set BS frequency.
- 4) Start BS transmission.

6.4.4.4.2 Procedure

- 1) Pmax shall be defined as described in subclause 6.2.1 Base station maximum output power.
- 2) Set the power level of the code channels such that BS output power level is 18 dB lower than BS maximum output power. All code channels shall use same power level.
- 3) Measure the mean transmission power level

6.4.4.5 Test requirement

BS shall achieve total power dynamic range as specified in subclause 6.4.3.2.

6.5 Output RF spectrum emissions

The physical channels for the following test(s) shall be set-up according to subclause 6.1.1.1.

6.5.1 Occupied bandwidth

6.5.1.1 Definition and applicability

The occupied bandwidth is the width of a frequency band such that, below the lower and above the upper frequency limits, the mean powers emitted are each equal to a specified percentage $\beta/2$ of the total mean transmitted power.

The value of $\beta/2$ should be taken as 0,5%.

6.5.1.2 Conformance requirements

The occupied bandwidth shall be less than 5 MHz based on a chip rate of 3,84 Mcps.

The reference for this requirement is TS 25.104 subclause 6.6.1.

6.5.1.3 Test purpose

The occupied bandwidth, defined in the Radio Regulations of the International Telecommunication Union ITU, is a useful concept for specifying the spectral properties of a given emission in the simplest possible manner; see also Recommendation ITU-R Recommendation SM.328-9 [7]. The test purpose is to verify that the emission of the BS does not occupy an excessive bandwidth for the service to be provided and is, therefore, not likely to create interference to other users of the spectrum beyond undue limits.

6.5.1.4 Method of test

6.5.1.4.1 Initial conditions

- 1) Connect the Measurement device to the BS antenna connector.
- 2) Start transmission on a single carrier according to test model defined in subclause 6.1.1.1.

6.5.1.4.2 Procedure

- 1) Measure the spectrum of the transmitted signal across a span of 10 MHz, based on an occupied bandwidth requirement of 5 MHz. The selected resolution bandwidth (RBW) filter of the analyzer shall be 30 kHz or less. The spectrum shall be measured at 400 or more points across the measurement span.

NOTE: The detection mode of the spectrum analyzer will not have any effect on the result if the statistical properties of the out-of-OBW power are the same as those of the inside-OBW power. Both are expected to have the Rayleigh distribution of the amplitude of Gaussian noise. In any case where the statistics are not the same, though, the detection mode must be power responding. There are at least two ways to be power responding. The spectrum analyzer can be set to "sample" detection, with its video bandwidth setting at least three times its RBW setting. Or the analyzer may be set to respond to the average of the power (root-mean-square of the voltage) across the measurement cell.

- 2) Compute the total of the power, P_0 , (in power units, not decibel units) of all the measurement cells in the measurement span. Compute P_1 , the power outside the occupied bandwidth on each side. P_1 is half of the total power outside the bandwidth. P_1 is half of $(100\% - (\text{occupied percentage}))$ of P_0 . For the occupied percentage of 99 %, P_1 is 0.005 times P_0 .
- 3) Determine the lowest frequency, f_1 , for which the sum of all power in the measurement cells from the beginning of the span to f_1 exceeds P_1 .
- 4) Determine the highest frequency, f_2 , for which the sum of all power in the measurement cells from the end of the span to f_2 exceeds P_1 .
- 5) Compute the occupied bandwidth as $f_2 - f_1$.

6.5.1.5 Test requirements

The bandwidth calculated in step (5) of subclause 6.5.1.4.2 shall be less than 5 MHz.

6.5.2 Out of band emission

Out of band emissions are unwanted emissions immediately outside the channel bandwidth resulting from the modulation process and non-linearity in the transmitter but excluding spurious emissions. This out of band emission limit is specified in terms of a spectrum emission mask and adjacent channel power ratio for the transmitter.

6.5.2.1 Spectrum emission mask

NOTE: This subclause may be mandatory in certain regions. In other regions this mask may not be applied.

6.5.2.1.1 Test conditions and measurement method

F_{offset} is the separation between the carrier frequency and the centre of the measuring filter.

<Editor's note: Test conditions to be specified.>

6.5.2.1.2 Minimum requirement

<Editor's note: The text below is just cut and pasted from 25.104 to keep coincidence. Better description may be applied.>

For regions where this clause applies, the requirement shall be met by a base station transmitting on a single RF carrier configured in accordance with the manufacturer's specification. Emissions shall not exceed the maximum level specified in tables 6.11 to 6.14 for the appropriate BS maximum output power, in the frequency range from $\Delta f = 2.5$ MHz to $f_{\text{offset}_{\text{max}}}$ from the carrier frequency, where:

- Δf is the separation between the carrier frequency and the nominal -3dB point of the measuring filter closest to the carrier frequency.
- f_{offset} is the separation between the carrier frequency and the centre of the measurement filter;
- $f_{\text{offset}_{\text{max}}}$ is either 12,5 MHz or the offset to the UMTS Tx band edge as defined in subclause 3.4.1, whichever is the greater.

Table 6.11: Spectrum emission mask values, BS maximum output power $P \geq 43$ dBm

| Frequency offset of measurement filter – 3dB point, Δf | Frequency offset of measurement filter centre frequency, f_{offset} | Maximum level | Measurement bandwidth |
|--|--|--|-----------------------|
| $2.5 \leq \Delta f < 2.7$ MHz | $2.515\text{MHz} \leq f_{\text{offset}} < 2.715\text{MHz}$ | -14 dBm | 30 kHz |
| $2.7 \leq \Delta f < 3.5$ MHz | $2.715\text{MHz} \leq f_{\text{offset}} < 3.515\text{MHz}$ | $-14 - 15 \cdot (f_{\text{offset}} - 2.715)$ dBm | 30 kHz |
| | $3.515\text{MHz} \leq f_{\text{offset}} < 4.0\text{MHz}$ | -26 dBm | 30 kHz |
| $3.5 \leq \Delta f < 7.5$ MHz | $4.0 \text{ MHz} \leq f_{\text{offset}} < 8.0\text{MHz}$ | -13 dBm | 1 MHz |
| $7.5 \leq \Delta f$ MHz | $8.0 \text{ MHz} \leq f_{\text{offset}} < f_{\text{offset}_{\text{max}}}$ | -13 dBm | 1 MHz |

Table 6.12: Spectrum emission mask values, BS maximum output power $39 \leq P < 43$ dBm

| Frequency offset of measurement filter – 3dB point, Δf | Frequency offset of measurement filter centre frequency, f_{offset} | Maximum level | Measurement bandwidth |
|--|--|--|-----------------------|
| $2.5 \leq \Delta f < 2.7$ MHz | $2.515\text{MHz} \leq f_{\text{offset}} < 2.715\text{MHz}$ | -14 dBm | 30 kHz |
| $2.7 \leq \Delta f < 3.5$ MHz | $2.715\text{MHz} \leq f_{\text{offset}} < 3.515\text{MHz}$ | $-14 - 15 \cdot (f_{\text{offset}} - 2.715)$ dBm | 30 kHz |
| | $3.515\text{MHz} \leq f_{\text{offset}} < 4.0\text{MHz}$ | -26 dBm | 30 kHz |
| $3.5 \leq \Delta f < 7.5$ MHz | $4.0 \text{ MHz} \leq f_{\text{offset}} < 8.0\text{MHz}$ | -13 dBm | 1 MHz |
| $7.5 \leq \Delta f$ MHz | $8.0\text{MHz} \leq f_{\text{offset}} < f_{\text{offset}_{\text{max}}}$ | $P - 56$ dBm | 1 MHz |

Table 6.13: Spectrum emission mask values, BS maximum output power $31 \leq P < 39$ dBm

| Frequency offset of measurement filter – 3dB point, Δf | Frequency offset of measurement filter centre frequency, f_{offset} | Maximum level | Measurement bandwidth |
|--|--|---|-----------------------|
| $2.5 \leq \Delta f < 2.7$ MHz | $2.515\text{MHz} \leq f_{\text{offset}} < 2.715\text{MHz}$ | P - 53 dBm | 30 kHz |
| $2.7 \leq \Delta f < 3.5$ MHz | $2.715\text{MHz} \leq f_{\text{offset}} < 3.515\text{MHz}$ | $P - 53 - 15 \cdot (f_{\text{offset}} - 2.715)$ dBm | 30 kHz |
| | $3.515\text{MHz} \leq f_{\text{offset}} < 4.0\text{MHz}$ | -26 dBm | 30 kHz |
| $3.5 \leq \Delta f < 7.5$ MHz | $4.0 \text{ MHz} \leq f_{\text{offset}} < 8.0\text{MHz}$ | P - 52 dBm | 1 MHz |
| $7.5 \leq \Delta f$ MHz | $8.0\text{MHz} \leq f_{\text{offset}} < f_{\text{offset}_{\text{max}}}$ | P - 56 dBm | 1 MHz |

Table 6.14: Spectrum emission mask values, BS maximum output power $P < 31$ dBm

| Frequency offset of measurement filter – 3dB point, Δf | Frequency offset of measurement filter centre frequency, f_{offset} | Maximum level | Measurement bandwidth |
|--|--|--|-----------------------|
| $2.5 \leq \Delta f < 2.7$ MHz | $2.515\text{MHz} \leq f_{\text{offset}} < 2.715\text{MHz}$ | -22 dBm | 30 kHz |
| $2.7 \leq \Delta f < 3.5$ MHz | $2.715\text{MHz} \leq f_{\text{offset}} < 3.515\text{MHz}$ | $-22 - 15 \cdot (f_{\text{offset}} - 2.715)$ dBm | 30 kHz |
| | $3.515\text{MHz} \leq f_{\text{offset}} < 4.0\text{MHz}$ | -26 dBm | 30 kHz |
| $3.5 \leq \Delta f < 7.5$ MHz | $4.0 \text{ MHz} \leq f_{\text{offset}} < 8.0\text{MHz}$ | -21 dBm | 1 MHz |
| $7.5 \leq \Delta f$ MHz | $8.0\text{MHz} \leq f_{\text{offset}} < f_{\text{offset}_{\text{max}}}$ | -25 dBm | 1 MHz |

6.5.2.1.3 Test purpose

The purpose of this test is to verify that the BS meet the spectrum emission requirements as specified in TS 25.104, subclause 6.6.2.1.

6.5.2.1.4 Method of test

6.5.2.1.4.1 Initial conditions

- 1) Set-up the equipment as shown in annex A.
- 2) The first and last measurement positions with a 30 kHz filter shall be 2,515 MHz and 4.0 MHz.
- 3) The first and last measurement positions with 1 MHz measurement band, when 1MHz band is integrated with 50 kHz measurement filter or narrower, shall be 4.0 MHz and 8.0 MHz.
- 4) The first and last measurement positions with a 1 MHz filter shall be 8.0 MHz and $(\Delta f_{\text{max}} - 500 \text{ kHz})$.
- 5) Detection mode: True RMS.

6.5.2.1.5 Procedures

- 1) Set the BS to transmit a signal in accordance to test model 1, subclause 6.2.1.1.1 at by the manufacturer specified maximum output power.
- 2) Measure the emission at the specified frequencies with specified measurement bandwidth and note that the measured value does not exceed the specified value.

6.5.2.1.6 Test requirements

In all measurements, the requirements according to subclause 6.5.2.1.2 shall be fulfilled.

6.5.2.2 Adjacent Channel Leakage power Ratio (ACLR)

6.5.2.2.1 Definition and applicability

Adjacent Channel Leakage power Ratio (ACLR) is the ratio of the transmitted power to the power measured after a receiver filter in the adjacent channel(s). Both the transmitted power and the received power are measured through a matched filter (Root Raised Cosine and roll-off 0.22) with a noise power bandwidth equal to the chip rate. The requirements shall apply whatever the type of transmitter considered (single carrier or multi-carrier). It applies for all transmission modes foreseen by the manufacturer's specification.

6.5.2.2.2 Conformance requirement

Table 6.15: BS ACLR

| BS channel offset below the first or above the last carrier frequency used | ACLR limit |
|--|------------|
| 5 MHz | 45 dB |
| 10 MHz | 50 dB |

6.5.2.2.3 Test purpose

To verify that the adjacent channel leakage power ratio requirement shall be met as specified in subclause 6.5.2.2.2.

6.5.2.2.4 Method of test

6.5.2.2.4.1 Initial conditions

- 1) Connect measurement device to the base station RF output port as shown in annex B.
- 2) The measurement device characteristics shall be:
 - measurement filter bandwidth: defined in subclause 6.5.2.2;
 - detection mode: true RMS voltage or true average power.
- 3) Set the base station to transmit a signal modulated in accordance with 6.1.1.1 Test model 1. Total power at the RF output port shall be the maximum output power as specified by the manufacturer.
- 4) Set carrier frequency within the frequency band supported by BS. Minimum carrier spacing shall be 5 MHz and maximum carrier spacing shall be specified by manufacturer.

6.5.2.2.4.2 Procedure

- 1) Measure Adjacent channel leakage power ratio for 5 MHz and 10 MHz offsets both side of channel frequency. In multiple carrier case only offset frequencies below the lowest and above the highest carrier frequency used shall be measured.
- 2) All RF channel configurations supported by BS shall be verified.

6.5.2.2.5 Test requirement

Adjacent channel leakage power ratio requirement shall be met as specified in subclause 6.5.2.2.2.

6.5.3 Spurious emissions

6.5.3.1 Definition and applicability

Spurious emissions are emissions which are caused by unwanted transmitter effects such as harmonics emission, parasitic emission, intermodulation products and frequency conversion products, but exclude out of band emissions. This is measured at the base station RF output port.

The requirement applies at frequencies within the specified frequency ranges, which are more than 12,5 MHz under the first carrier frequency used or more than 12,5 MHz above the last carrier frequency used.

The requirements of either subclause 6.5.3.5 or subclause 6.5.3.6 shall apply whatever the type of transmitter considered (single carrier or multi-carrier). It applies for all transmission modes foreseen by the manufacturer's specification.

Unless otherwise stated, all requirements are measured as mean power (RMS).

6.5.3.2 Test purpose

This test measures conducted spurious emission from the BS transmitter antenna connector, while the transmitter is in operation.

6.5.3.3 Test case

The BS shall be configured with transmitters active at their maximum output power for all transmission modes foreseen by the manufacturer's specification.

Set the base station to transmit a signal as stated in subclause 6.1.1.1. Total power at the RF Output port shall be the nominal power as specified by the manufacturer.

The transmitter antenna connector shall be connected to a measurement receiver with the same characteristic impedance, using an attenuator or directional coupler if necessary.

The detecting device shall be configured with a measurement bandwidth as stated in the tables.

6.5.3.4 Conformance Requirements

6.5.3.4.1 Spurious emissions (Category A)

The following requirements shall be met in cases where Category A limits for spurious emissions, as defined in ITU-R Recommendation [4], are applied.

6.5.3.4.1.1 Minimum Requirement

The power of any spurious emission shall be attenuated by at least the minimum requirement.

Table 6.16: BS Mandatory spurious emissions limits, Category A

| Band | Maximum level | Measurement Bandwidth | Note |
|--------------------|---------------|-----------------------|---|
| 9 kHz to 150 kHz | -13 dBm | 1 kHz | Bandwidth as in ITU-R SM.329-7, subclause 4.1 |
| 150 kHz to 30 MHz | | 10 kHz | Bandwidth as in ITU-R SM.329-7, subclause 4.1 |
| 30 MHz to 1 GHz | | 100 kHz | Bandwidth as in ITU-R SM.329-7, subclause 4.1 |
| 1 GHz to 12,75 GHz | | 1 MHz | Upper frequency as in ITU-R SM.329-7, subclause 2.6 |

6.5.3.4.2 Spurious emissions (Category B)

The following requirements shall be met in cases where Category B limits for spurious emissions, as defined in ITU-R Recommendation [4], are applied.

6.5.3.4.2.1 Minimum Requirement

The power of any spurious emission shall not exceed.

Table 6.17: BS Mandatory spurious emissions limits, Category B

| Band | Maximum Level | Measurement Bandwidth | Note |
|---|---------------|-----------------------|--|
| 9 kHz ↔ 150 kHz | -36 dBm | 1 kHz | Bandwidth as in ITU-R SM.329-7, subclause 4.1 |
| 150 kHz ↔ 30 MHz | - 36 dBm | 10 kHz | Bandwidth as in ITU-R SM.329-7, subclause 4.1 |
| 30 MHz ↔ 1 GHz | -36 dBm | 100 kHz | Bandwidth as in ITU-R SM.329-7, subclause 4.1 |
| 1 GHz ↔ Fc1 – 60 MHz or 2 100 MHz <i>Whichever is the higher</i> | -30 dBm | 1 MHz | Bandwidth as in ITU-R SM.329-7, subclause 4.1 |
| Fc1 – 60 MHz or 2 100 MHz whichever is the higher ↔ Fc1 – 50 MHz or 2 100 MHz whichever is the higher | -25 dBm | 1 MHz | Specification more stringent than ITU-R SM.329-7, subclause 4.1 |
| Fc1 – 50 MHz or 2100 MHz whichever is the higher ↔ Fc2 + 50 MHz or 2180 MHz whichever is the lower | -15 dBm | 1 MHz | Specification more stringent than ITU-R SM.329-7, subclause 4.1 |
| Fc2 + 50 MHz or 2180 MHz whichever is the lower ↔ Fc2 + 60 MHz or 2 180 MHz Whichever is the lower | -25 -13 dBm | 1 MHz | Specification more stringent than ITU-R SM.329-7, subclause 4.1 |
| Fc2 + 60 MHz or 2 180 MHz <i>Whichever is the lower</i> ↔ 12,75 GHz | -30 dBm | 1 MHz | Bandwidth as in ITU-R SM.329-7, subclause 4.1. Upper frequency as in ITU-R SM.329-7, subclause 2.6 |
| Fc1: Center frequency of first carrier frequency used. Fc2: Center frequency of last carrier frequency used. | | | |

6.5.3.4.3 Protection of the BS receiver

This requirement may be applied in order to prevent the receiver of the BS being desensitised by emissions from the BS transmitter which are coupled between the antennas of the BS.

This requirement assumes the scenario described in [2]. For different scenarios, the manufacturer may declare a different requirement.

This requirement is not applicable to antenna ports which are used for both transmission and reception (e.g. which have an internal duplexer).

NOTE: In this case, the measurement of Reference Sensitivity will directly show any desensitisation of the receiver.

6.5.3.4.3.1 Minimum Requirement

The power of any spurious emission shall not exceed.

Table 6.18: BS Spurious emissions limits for protection of the BS receiver

| Band | Maximum Level | Measurement Bandwidth | Note |
|--|---------------|-----------------------|------|
| 1 920 MHz to 1 980 MHz For operation in Frequency Bands defined in subclause 3.4.1(a) | -96 dBm | 100 kHz | |
| 1 850 MHz to 1 910 MHz For operation in Frequency Bands defined in subclause 3.4.1(b) | -96 dBm | 100kHz | |

6.5.3.4.4 Co-existence with GSM 900

6.5.3.4.4.1 Operation in the same geographic area

This requirement may be applied for the protection of GSM 900 MS in geographic areas in which both GSM 900 and UTRA are deployed.

This requirement assumes the scenario described in [2]. For different scenarios, the manufacturer may declare a different requirement.

6.5.3.4.4.1.1 Minimum Requirement

The power of any spurious emission shall not exceed.

Table 6.19: BS Spurious emissions limits for BS in geographic coverage area of GSM 900

| Band | Maximum Level | Measurement Bandwidth | Note |
|--------------------|---------------|-----------------------|------|
| 921 MHz to 960 MHz | -47 dBm | 100 kHz | |

6.5.3.4.4.2 Co-located base stations

This requirement may be applied for the protection of GSM 900 BS receivers when GSM 900 BS and UTRA BS are co-located.

6.5.3.4.4.2.1 Minimum Requirement

The power of any spurious emission shall not exceed.

Table 6.20: BS Spurious emissions limits for protection of the BS receiver

| Band | Maximum Level | Measurement Bandwidth | Note |
|--------------------|---------------|-----------------------|------|
| 876 MHz to 915 MHz | -98 dBm | 100 kHz | |

6.5.3.4.5 Co-existence with DCS 1800

6.5.3.4.5.1 Operation in the same geographic area

This requirement may be applied for the protection of DCS 1800 MS in geographic areas in which both DCS 1800 and UTRA are deployed.

This requirement assumes the scenario described in [2]. For different scenarios, the manufacturer may declare a different requirement.

6.5.3.4.5.1.1 Minimum Requirement

The power of any spurious emission shall not exceed:

Table 6.21: BS Spurious emissions limits for BS in geographic coverage area of DCS 1800

| Band | Maximum Level | Measurement Bandwidth | Note |
|------------------------|---------------|-----------------------|------|
| 1 805 MHz to 1 880 MHz | -57 dBm | 100 kHz | |

6.5.3.4.5.2 Co-located basestations

This requirement may be applied for the protection of DCS 1800 BS receivers when DCS 1800 BS and UTRA BS are co-located.

6.5.3.4.5.2.1 Minimum Requirement

The power of any spurious emission shall not exceed.

Table 6.22: BS Spurious emissions limits for BS co-located with DCS 1800 BTS

| Band | Maximum Level | Measurement Bandwidth | Note |
|------------------------|---------------|-----------------------|------|
| 1 710 MHz to 1 785 MHz | -98 dBm | 100 kHz | |

6.5.3.4.6 Co-existence with PHS

This requirement may be applied for the protection of PHS in geographic areas in which both PHS and UTRA are deployed.

6.5.3.4.6.1 Minimum Requirement

The power of any spurious emission shall not exceed.

Table 6.23: BS Spurious emissions limits for BS in geographic coverage area of PHS

| Band | Maximum Level | Measurement Bandwidth | Note |
|-----------------------------|---------------|-----------------------|------|
| 1 893,5 MHz to 1 919,60 MHz | -41 dBm | 300 kHz | |

6.5.3.4.7 Co-existence with services in adjacent frequency bands

This requirement may be applied for the protection in bands adjacent to 2 110 MHz to 2 170 MHz, as defined in subclause 3.4.1(a) and 1 930 MHz to 1 990 MHz, as defined in subclause 3.4.1(b) in geographic areas in which both an adjacent band service and UTRA are deployed.

6.5.3.4.7.1 Minimum requirement

The power of any spurious emission shall not exceed.

Table 6.24: BS spurious emissions limits for protection of adjacent band services

| Band (f) | Maximum Level | Measurement Bandwidth | Note |
|---|--|-----------------------|------|
| 2 100 MHz to 2 105 MHz For operation in frequency bands as defined in subclause 3.4.1(a) | $-30 + 3,4 (f - 2\ 100\ \text{MHz})\ \text{dBm}$ | 1 MHz | |
| 2 175 MHz to 2 180 MHz For operation in frequency bands as defined in subclause 3.4.1(a) | $-30 + 3,4 (2\ 180\ \text{MHz} - f)\ \text{dBm}$ | 1 MHz | |
| 1 920 MHz to 1 925 MHz For operation in frequency bands as defined in subclause 3.4.1(b) | $-30 + 3,4 (f - 1\ 930\ \text{MHz})\ \text{dBm}$ | 1 MHz | |
| 1 995 MHz to 2 000 MHz For operation in frequency bands as defined in subclause 3.4.1(b) | $-30 + 3,4 (2\ 000\ \text{MHz} - f)\ \text{dBm}$ | 1 MHz | |

6.5.3.4.8 Co-existence with UTRA-TDD

6.5.3.4.8.1 Operation in the same geographic area

This requirement may be applied to geographic areas in which both UTRA-TDD and UTRA-FDD are deployed.

6.5.3.4.8.1.1 Minimum Requirement

The power of any spurious emission shall not exceed.

Table 6.25: BS Spurious emissions limits for BS in geographic coverage area of UTRA-TDD

| Band | Maximum Level | Measurement Bandwidth | Note |
|------------------------|---------------|-----------------------|------|
| 1 900 MHz to 1 920 MHz | -52 dBm | 1 MHz | |
| 2 010 MHz to 2 025 MHz | -52 dBm | 1 MHz | |

6.5.3.4.8.2 Co-located base stations

This requirement may be applied for the protection of UTRA-TDD BS receivers when UTRA-TDD BS and UTRA FDD BS are co-located.

6.5.3.4.8.2.1 Minimum Requirement

The power of any spurious emission shall not exceed.

Table 6.26: BS Spurious emissions limits for BS co-located with UTRA-TDD

| Band | Maximum Level | Measurement Bandwidth | Note |
|------------------------|---------------|-----------------------|------|
| 1 900 MHz to 1 920 MHz | -86 dBm | 1 MHz | |
| 2 010 MHz to 2 025 MHz | -86 dBm | 1 MHz | |

6.6 Transmit intermodulation

6.6.1 Definition and applicability

The transmit intermodulation performance is a measure of the capability of the transmitter to inhibit the generation of signals in its non linear elements caused by presence of the wanted signal and an interfering signal reaching the transmitter via the antenna.

The transmit intermodulation level is the power of the intermodulation products when a WCDMA modulated interference signal is injected into an antenna connector at a level of 30 dB lower than that of the wanted signal. The frequency of the interference signal shall be 5 MHz, 10 MHz and 15 MHz offset below the first or above the last carrier frequency used.

The requirements are applicable for single carrier BS.

< Editor's note: Multi Carrier case to be specified. >

6.6.2 Conformance requirement

The transmit intermodulation level shall not exceed the out of band emission or the spurious emission requirements of subclauses 6.5.2 and 6.5.3.

6.6.3 Test purpose

The purpose of this test is to verify that the BS meet the transmit intermodulation requirements as specified in TS 25.104, subclause 6.7.

6.6.4 Method of test

6.6.4.1 Initial conditions

- 1) Test set-up in accordance to annex B.

6.6.4.2 Procedures

- 1) Generate the wanted signal in accordance to test model 1, subclause 6.1.1.1 at specified maximum BS output power.
- 2) Generate the interference signal (WCDMA signal as specified in the table 6.1 and 6.2 (Test model 1)) with frequency offset of 5 MHz relative to the wanted signal in accordance to test model 2, subclause 6.1.1.2.
- 3) Adjust ATT1 so the level of the WCDMA modulated interference signal at BS is 30 dB below the wanted signal.
- 4) Perform the out of band emission test as specified in subclause 6.5.2.
- 5) Perform the spurious emission test as specified in subclause 6.5.3.
- 6) Verify that the emission level does not exceed the required level with the exception of interference signal frequencies.
- 7) Repeat the test for interference frequency off set of -5 MHz.
- 8) Repeat the test for interference frequency off set of ± 10 MHz and ± 15 MHz.

6.7 Transmit modulation

Transmit modulation is measured in three parts, Frequency Error, Error Vector Magnitude and Peak Code Domain Error. These measurements are made with reference to a theoretical modulated waveform.

The physical channels for the following test(s) shall be set-up according to subclause 6.1.1.1.

The theoretical modulated waveform is created by modulating a carrier at the assigned carrier frequency using the same data as was used to generate the measured waveform. The chip modulation rate for the theoretical waveform shall be exactly 3.84 Mcps. The code powers of the theoretical waveform shall be the same as the measured waveform, rather than the nominal code powers defined in the test models.

6.7.1 Frequency Error

6.7.1.1 Definition and applicability

The frequency error is a measure of the difference between the assigned frequency and the frequency selected to modify the measured waveform when measuring EVM in 6.7.2.4 step 4. This relationship is necessary since Frequency Error and EVM are related, and so need to be measured on the same power control group (timeslot).

6.7.1.2 Conformance Requirement

The Frequency Error shall be within ± 0.05 PPM.

6.7.1.3 Test Purpose

To verify that the Frequency Error is within the limit specified in 6.7.1.2

6.7.1.4 Method of test

Frequency Error is measured as part of EVM, see 6.7.2.4

6.7.1.5 Test Requirement

The Frequency Error shall meet the limit specified in 6.7.1.2

6.7.2 Error Vector Magnitude

6.7.2.1 Definition and applicability

The Error Vector Magnitude is a measure of the difference between the theoretical waveform and a modified version of the measured waveform. This difference is called the error vector. The measured waveform is modified by first passing it through a matched Root Raised Cosine filter with bandwidth 3.84 MHz and roll-off $\alpha = 0.22$. The waveform is then further modified by selecting the frequency, absolute phase, absolute amplitude and chip clock timing so as to minimise the error vector. The EVM result is defined as the square root of the ratio of the mean error vector power to the mean reference signal power expressed as a %. The measurement interval is one power control group (timeslot).

6.7.2.2 Conformance Requirement

The Error Vector Magnitude shall be less than 17.5%

6.7.2.3 Test Purpose

To verify that the Error Vector Magnitude is within the limit specified in 6.7.2.2

6.7.2.4 Method of Test

Refer to annex B for a functional block diagram of the test set-up.

- 1) Connect the base station RF output port to the modulation analyzer with root raised cosine filter function.
- 2) Set the base station to transmit a signal modulated with PCCPCH. Total power at the RF output port shall be $P_{\max} - 3\text{dB}$ and $P_{\max} - 18\text{dB}$.
- 3) Trigger the test equipment from the system time reference signal from the base station.
<Editor's note: Precise definition of "Triggering signal" shall be needed.>
4. Measure the Error Vector Magnitude as defined in 6.7.2.1.

6.7.2.5 Test Requirement

The Error Vector Magnitude measured in 6.7.2.4 step 4 shall meet the limit specified in 6.7.2.2

6.7.3 Peak Code Domain Error

6.7.3.1 Definition and applicability

The Peak Code Domain Error is computed by projecting the power of the error vector (as defined in 6.7.2) onto the code domain at a specific spreading factor. The Code Domain Error for every code in the domain is defined as the ratio of the mean power of the projection onto that code, to the mean power of the composite reference waveform. This ratio is expressed in dB. The Peak Code Domain Error is defined as the maximum value for the Code Domain Error for all codes. The measurement interval is one power control group (timeslot).

6.7.3.2 Conformance requirement

The peak code domain error shall not exceed -33 dB at spreading factor 256.

6.7.3.3 Test Purpose

To verify that the Error Vector Magnitude is within the limit specified in 6.7.3.2

6.7.3.4 Method of test

6.7.3.4.1 Initial conditions

- 1) Connect the measurement equipment to the BS antenna connector as shown in annex B.
- 2) Channel configuration defined in subclause 6.1.1.3 Test model 3 shall be used.
- 3) Set BS frequency.
- 4) Start BS transmission

6.7.3.4.2 Procedure

- 1) Set power as defined in subclause 6.1.1.3 Test model 3 for each code channel.
- 2) Measure Peak code domain error.

6.7.3.5 Test requirement

Peak code domain error shall meet the requirement as specified in subclause 6.7.3.2.

7 Receiver characteristics

7.1 General

Unless otherwise stated, all tests in this clause shall be performed at the BS antenna connector (test port A) with a full complement of transceivers for the configuration in normal operating conditions. If any external apparatus such as a RX amplifier, a diplexer, a filter or the combination of such devices is used, the tests according to subclauses 4.6.2 and/or 4.6.4, depending on the device added, shall be performed to ensure that the requirements are met at test port B.

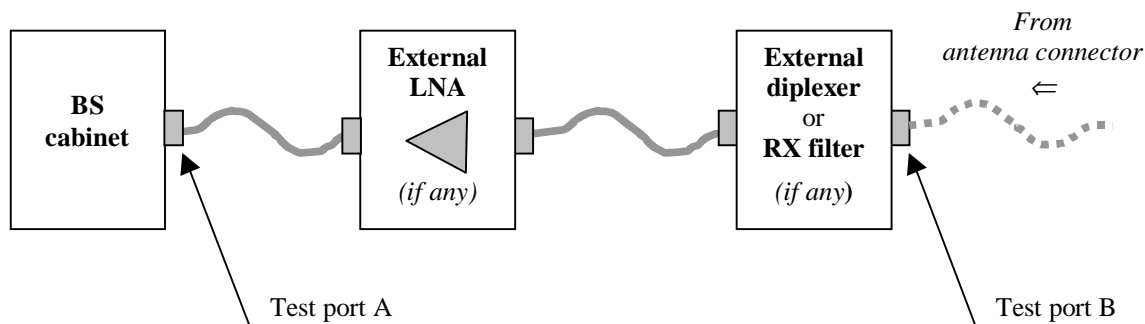

Figure 7.1: Receiver test ports

The tests in clause 7 assume that the receiver is not equipped with diversity. For receivers with diversity, unless otherwise stated, tests shall be performed by applying the specified signals to one of the receiver inputs, and terminating or disabling the other(s). The tests and requirements are otherwise unchanged.

In all the relevant subclauses in this clause all Bit Error Ratio (BER), Residual BER (RBER) and Block Error Ratio (BLER) measurements shall be carried out according to the general rules for statistical testing in annex A.

If external BER measurement is not used then the internal BER calculation shall be used instead. When internal BER calculation is used, the requirements of the verification test according to 7.8 shall be met in advance.

In tests performed with signal generators a synchronisation signal may be provided, from the base station to the signal generator, to enable correct timing of the wanted signal.

7.2 Reference sensitivity level

7.2.1 Definition and applicability

The reference sensitivity is the minimum receiver input power measured at the antenna connector at which the BER does not exceed the specific value indicated in subclause 7.2.2. This test is performed without interfering signal with power applied to the BS antenna connector according to annex B. In the case duplex operation is supported, the measurement configuration principle is indicated for one duplex branch also in Annex B. In case of internal BER calculation is used example of test connection is as shown in figure B.7 The reference point for signal power is at the input of receiver (antenna connector).

7.2.2 Conformance requirement

The BER shall not exceed 0,001 for the parameters specified in table 7.1. The reference for this requirement is in TS 25.104 [1] subclause 7.3.1.

Table 7.1: BS reference sensitivity levels

| Data rate | BS reference sensitivity level (dBm) | FER/BER |
|---|--------------------------------------|----------------------------|
| 12,2 kbps | -121 dBm | BER shall not exceed 0,001 |
| NOTE: Should only be specified for a measurement channel. | | |

7.2.3 Test purpose

To verify that the BS shall meet receiver sensitivity requirement as specified TS 25.104 [1] subclause 7.3.1.

7.2.4 Method of testing

7.2.4.1 Initial conditions

- 1) Connect BS to be tested to RF signal source.
- 2) Set frequency.
- 3) Start transmit 12,2kbps DPCH with reference measurement channel defined in annex A to the BS under test (PN-9 data sequence or longer).
- 4) Disable TPC function.

7.2.4.2 Procedure

- 1) Calculate BER from at least 30000 received data bits.
- 2) Set test signal power level transmitted for corresponding data rate as specified in table 7.1.
- 3) Measure BER.

7.2.5 Test requirement

Requirements for RX reference sensitivity specified in subclause 7.2.2 shall be fulfilled.

7.3 Dynamic range

7.3.1 Definition and applicability

Receiver dynamic range is the receiver ability to handle a rise of interference in the reception frequency channel. The receiver shall fulfil a specified BER requirement for a specified sensitivity degradation of the wanted signal in the presence of an interfering AWGN signal in the same reception frequency channel.

Minimum bandwidth of AWGN interferer shall be 1,5 times chip rate -5,76 MHz for a chip rate of 3,84 MHz.

7.3.2 Conformance requirement

The BER shall not exceed 0,001 for the parameters specified in table 7.2.

Table 7.2: Dynamic range

| Parameter | Level | Unit |
|-------------------------|-------|--------------|
| Data rate | 12,2 | kbps |
| Wanted signal | -91 | dBm |
| Interfering AWGN signal | -73 | dBm/3,84 MHz |

7.3.3 Test purpose

The purpose of this test is to verify that the BS meet the dynamic range requirement as specified in TS 25.104, subclause 7.3.

7.3.4 Method of test

7.3.4.1 Initial conditions

- 1) Connect the test equipment as shown in annex B.

7.3.4.2 Procedure

- 1) Adjust the signal generator for the wanted signal to -91 dBm.
- 2) Adjust the AWGN generator level to -73 dBm/3,84 MHz and set the frequency to the same frequency as the tested channel.
- 3) Measure the BER for the tested service and verify that it is below the specified level.

Repeat the measurement for the other RX port.

7.4 Adjacent Channel Selectivity (ACS)

Adjacent channel selectivity (ACS) is a measure of the receiver ability to receive a wanted signal at its assigned channel frequency in the presence of an adjacent channel signal at a given frequency offset from the center frequency of the assigned channel. ACS is the ratio of the receiver filter attenuation on the assigned channel frequency to the receiver filter attenuation on the adjacent channel(s).

The interference signal be detuned by F_{uw} MHz and modulated by a pseudo random binary sequence uncorrelated to the wanted signal.

7.4.1 Test conditions and measurement method

- 1) Set-up the equipment as shown in annex B.

- 2) Generate the reference channel and adjust the ATT1 to set the input level to the base station under test to the specified -115 dBm.
- 3) Set-up the interference signal at the adjacent channel frequency and adjust the ATT2 to obtain the specified level of interference signal at the base station input. Note that the interference signal shall have an ACLR of at least 63 dB in order to eliminate the impact of interference signal adjacent channel leakage power on the ACS measurement. The interference signal shall be wide band CDMA signal of single code.
- 4) Measure the BER and control that the measured value does not exceed the specified value (BER < 0,001).
- 5) Repeat the test for the port, which was terminated.

7.4.2 Minimum requirement

The BER shall not exceed 0,001 for the parameters specified in the table

Table 7.3: Adjacent channel selectivity

| Parameter | Level | Unit |
|--------------------|-------|------|
| Data rate | 12,2 | kbps |
| Wanted signal | -115 | dBm |
| Interfering signal | -52 | dBm |
| Fuw (Modulated) | ±5 | MHz |

7.5 Blocking characteristics

7.5.1 Definition and applicability

The blocking characteristics is a measure of the receiver ability to receive a wanted signal at its assigned channel frequency in the presence of an unwanted interferer on frequencies other than those of the adjacent channels. The blocking performance shall apply at all frequencies as specified in table 7.4.

The requirements in this subclause shall apply to base stations intended for general-purpose applications.

7.5.2 Conformance requirements

The BER shall not exceed 0.001 for the parameters specified in table 7.4.

Table 7.4(a): Blocking characteristics for operation in frequency bands in subclause 3.4.1(a)

| Center Frequency of Interfering Signal | Interfering Signal Level | Wanted Signal Level | Minimum Offset of Interfering Signal | Type of Interfering Signal |
|--|--------------------------|---------------------|--------------------------------------|----------------------------|
| 1 920 MHz to 1 980 MHz | -40 dBm | -115 dBm | 10 MHz | WCDMA signal with one code |
| 1 900 MHz to 1 920 MHz 1 980 MHz to 2 000 MHz | -40 dBm | -115 dBm | 10 MHz | WCDMA signal with one code |
| 1 MHz to 1 900 MHz and 2 000 MHz to 12 750 MHz | -15 dBm | -115 dBm | - | CW carrier |

Table 7.4(b): Blocking performance requirement for operation in frequency bands in subclause 3.4.1(b)

| Center Frequency of Interfering Signal | Interfering Signal Level | Wanted Signal Level | Minimum Offset of Interfering Signal | Type of Interfering Signal |
|--|--------------------------|---------------------|--------------------------------------|----------------------------|
| 1 850 MHz to 1 910 MHz | -40 dBm | -115 dBm | 10 MHz | WCDMA signal with one code |
| 1 830 MHz to 1 850 MHz 1 910 MHz to 1 930 MHz | -40 dBm | -115 dBm | 10 MHz | WCDMA signal with one code |
| 1 MHz to 1 830 MHz 1 930 MHz to 12 750 MHz | -15 dBm | -115 dBm | - | CW carrier |

7.5.3 Test purpose

The test stresses the ability of the BS receiver to withstand high-level interference from unwanted signals at frequency offsets of 10 MHz or more, without undue degradation of its sensitivity.

7.5.4 Method of test

7.5.4.1 Initial conditions

- 1) Connect WCDMA signal generator at the assigned channel frequency of the wanted signal and a signal generator to the antenna connector of one Rx port.
- 2) Terminate any other Rx port not under test.
- 3) Transmit a signal from the WCDMA signal generator to the BS. The characteristics of the signal shall be set according to the UL reference measurement channel (12,2 kbit/s) specified in annex A subclause A.2.1. The level of the WCDMA signal measured at the BS antenna connector shall be set to the level specified in subclause 7.5.2.

7.5.4.2 Procedure

- 1) Set the signal generator to produce an interfering signal at a frequency offset F_{uw} from the assigned channel frequency of the wanted signal which is given by:

$$F_{uw} = \pm (n \times 1 \text{ MHz}),$$

where n shall be increased in integer steps from $n = 10$ up to such a value that the center frequency of the interfering signal covers the range from 1 MHz to 12,75 GHz. The interfering signal level measured at the antenna connector shall be set in dependency of its center frequency, as specified in table 7.5.2.1. The type of the interfering signal is either equivalent to a continuous WCDMA signal with one code of chip frequency 3,84 Mchip/s, filtered by an RRC transmit pulse-shaping filter with roll-off $\alpha = 0,22$, or a CW signal; see table 7.5.2.1.

- 2) Measure the BER of the wanted signal at the BS receiver.

NOTE: The test procedure as defined in steps (1) and (2) requests to carry out more than 10 000 BER measurements. To reduce the time needed for these measurements, it may be appropriate to conduct the test in two phases: During phase 1, BER measurements are made on all center frequencies of the interfering signal as requested but with a reduced confidence level, with the aim to identify those frequencies which require more detailed investigation. In phase 2, detailed measurements are made only at those critical frequencies identified before, applying the required confidence level.

- 3) Interchange the connections of the BS Rx ports and repeat the measurements according to steps (1) to (2).

<Editor's note: The above NOTE is taken from proposal for TDD specification (R4-99789). Precise parameters for this 2-phase measurement shall be specified. >

7.5.5 Test requirements

In all measurements made according to subclause 7.5.4.2, the BER shall not exceed 0,001.

7.6 Intermodulation characteristics

7.6.1 Definition and applicability

Third and higher order mixing of the two interfering RF signals can produce an interfering signal in the band of the desired channel. Intermodulation response rejection is a measure of the capability of the receiver to receive a wanted signal on its assigned channel frequency in the presence of two or more interfering signals which have a specific frequency relationship to the wanted signal.

7.6.2 Conformance requirement

The intermodulation performance should be met when the following signals are applied to the receiver.

Table 7.5: Interferer signals for intermodulation performance requirement

| Type of Signal | Offset | Signal level |
|----------------------------|--------|--------------|
| Wanted signal | - | -115 dBm |
| CW signal | 10 MHz | -48 dBm |
| WCDMA signal with one code | 20 MHz | -48 dBm |

The BER for wanted signal shall not exceed 0,001 for the parameters specified in table 7.5.

7.6.3 Test purpose

The purpose of this test is to verify that the BS meet the intermodulation characteristics requirements as specified in TS 25.104, subclause 7.6.

7.6.4 Method of test

7.6.4.1 Initial conditions

- 1) Set-up the equipment as shown in annex B.

7.6.4.2 Procedures

- 1) Generate the wanted signal (reference signal) and adjust ATT1 to set the signal level to the BS under test to the specified -115 dBm.
- 2) Adjust the signal generators to the frequency offset of +10 MHz (CW tone) and +20 MHz (WCDMA modulated) from the frequency of the wanted signal if possible.
- 3) Adjust the ATT2 and ATT3 to obtain the specified level of interference signal at the BS input.
- 4) Measure the BER and control that the measured value does not exceed the specified value.
- 5) Repeat the test for interference signal frequency offset of -10 MHz and -20 MHz for CW and WCDMA modulated respectively.
- 6) Repeat the whole test for the port which was terminated.

7.6.5 Test requirements

The BER for wanted signal shall not exceed 0,001.

7.7 Spurious Emissions

7.7.1 Definition and applicability

The spurious emission power is the power of the emissions generated or amplified in a receiver that appears at the BS antenna connector. The requirements apply to all BS with separate RX and TX antenna port. The test shall be performed when both TX and RX are on with the TX port terminated.

For all BS with common RX and TX antenna port the transmitter spurious emission as specified in subclause 6.6.3 is valid.

7.7.2 Conformance requirements

The spurious emission shall be:

- 1) less than -78 dBm/3,84 MHz at the BS antenna connector, for frequencies within the BS receive band;
- 2) less than -57 dBm/100 kHz at the BS antenna connector, for frequencies band from 9 kHz to 1 GHz;
- 3) less than -47 dBm/1 MHz at the BS antenna connector, for frequencies band from 1 GHz to 12,75 GHz with the exception of frequencies which are more than 12,5 MHz under the first carrier frequency used or more than 12,5 MHz above the last carrier frequency used.

The reference for this requirement is TS 25.104 [1] subclause 7.7.1.

7.7.3 Test purpose

To verify that the BS spurious emission meets the specifications described in subclause 7.7.2.

7.7.4 Method of test

7.7.4.1 Initial conditions

- 1) Connect a measurement receiver to the BS antenna connector as shown in annex B.
- 2) Enable the BS receiver.
- 3) Start BS transmission with channel configuration as specified in the table 6.1 and 6.2 (Test model 1).

7.7.4.2 Procedure

- 1) Set measurement equipment parameters as specified in table 7.6.
- 2) Measure the spurious emissions over each frequency range described in subclause 7.7.2.
- 3) Repeat test using diversity antenna connector if available.

Table 7.6

| | |
|--------------------------------------|---|
| Measurement Band width | 3,84 MHz (Root raised cosine,0,22) / 100 kHz (note) |
| Sweep frequency range | 9 kHz to 12,75GHz |
| Detection | True RMS |
| NOTE: As defined in subclause 7.7.2. | |

7.7.5 Test requirements

The all measured spurious emissions, derived in step (2), shall be within requirement limits as specified in subclause 7.7.2.

7.8 Verification of the internal BER calculation

7.8.1 Definition and applicability

Base Station System with internal BER calculation can synchronise it's receiver to known pseudo-random data sequence and calculates bit error ratio from the received data. This test is performed only if Base Station System has this kind of feature. All data rate's which are used in RX conformance testing shall be used in verification test. This test is performed by feeding measurement signal with known BER to the input of the receiver. Locations of the erroneous bits shall be randomly distributed within a frame. Erroneous bits shall be inserted to the data bit stream as shown in figure 7.1.

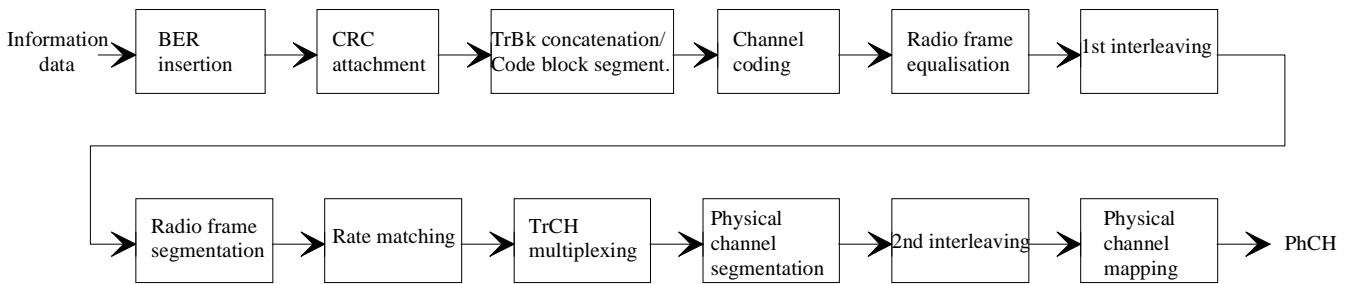

Figure 7.1: BER insertion into the information data

7.8.2 Conformance requirement

BER indicated by the Base Station System shall be within $\pm[10\%]$ of the BER generated by the RF signal source. Measurement shall be repeated for each measurement signal specified in table 7.7.

Table 7.7

| Transport channel combination | Data rate | BER |
|-------------------------------|-----------|----------|
| DPCH | 12,2 kbps | BER 0,01 |
| TBD | TBD | TBD |
| ... | ... | ... |

NOTE: 10 times larger BER generator is used to get a good confidence.

7.8.3 Test purpose

To verify that the internal BER calculation accuracy shall meet requirements for conformance testing.

7.8.4 Method of test

7.8.4.1 Initial conditions

- 1) Connect BS RX antenna connector to the RF signal source or UE simulator as shown in annex B.
- 2) Set correct signal source parameters as specified in table 7.8.

Table 7.8

| Parameter | Level/status | Unit |
|-----------------|-----------------|--------------|
| UL signal level | Ref.sens +10 dB | dBm/3,84 MHz |
| Data sequence | PN9 or longer | |

7.8.4.2 Procedure

- 1) Measure the BER of received signal from RF signal source or UE simulator to BS antenna connector.
- 2) BER calculation shall be done at least over 50 000 bits.
- 3) Repeat test for all required data rates.

7.8.5 Test requirement

BER indicated by the Base Station System shall be within requirement as specified in subclause 7.8.2.

8 Performance requirement

8.1 General

All Bit Error Ratio (BER) and Block Error ratio (BLER) measurements shall be carried out according to the general rules for statistical testing defined in ITU-T Recommendation O.153 [5].

If external BLER measurement is not used then the internal BLER calculation shall be used instead. When internal BLER calculation is used, the requirements of the verification test according to 8.6 shall be met in advance.

Performance requirements are specified for a number of test environments and multi-path channel classes.

The requirements only apply to those measurement channels that are supported by the base station.

The requirements only apply to a base station with dual receiver antenna diversity. The required E_b/N_0 shall be applied separately at each antenna port.

In tests performed with signal generators a synchronisation signal may be provided, from the base station to the signal generator, to enable correct timing of the wanted signal.

8.2 Demodulation in static propagation conditions

8.2.1 Demodulation of DCH

8.2.1.1 Definition and applicability

The performance requirement of DCH in static propagation conditions is determined by the maximum Block Error Ratio (BLER) allowed when the receiver input signal is at a specified E_b/N_0 limit. The BLER is calculated for each of the measurement channels supported by the base station.

The requirement in this subclause shall apply to base stations intended for general-purpose applications.

8.2.1.2 Conformance requirement

The BLER should not exceed the limit for the E_b/N_0 specified in table 8.1.

Table 8.1: Performance requirements in AWGN channel.

| Measurement channel data rate (R_b) | E_b/N_0 for required BLER $< 10^{-1}$ | E_b/N_0 for required BLER $< 10^{-2}$ |
|---|---|---|
| 12.2 kbps | n.a. | 5.1 dB |
| 64 kbps | 1.5 dB | 1.7 dB |
| 144 kbps | 0.8 dB | 0.9 dB |
| 384 kbps | 0.9 dB | 1.0 dB |

The reference for this requirement is TS 25.104 subclause 8.2.1.1.

8.2.1.3 Test purpose

The test shall verify the receiver's ability to receive the test signal under static propagation conditions with a BLER not exceeding a specified limit.

8.2.1.4 Method of test

8.2.1.4.1 Initial conditions

- 1) Connect the BS tester generating the wanted signal and AWGN generators to both BS antenna connectors for diversity reception via a combining network as shown in annex B.

8.2.1.4.2 Procedure

- 1) Adjust the AWGN generator to -84 dBm/3.84 MHz at the BS input.
- 2) The characteristics of the wanted signal shall be configured according to the corresponding UL reference measurement channel defined in annex A.
- 3) Adjust the equipment so that required E_b/N_0 specified in table 8.1 is achieved. To achieve the specified E_b/N_0 , the wanted signal level at the BS input should be adjusted to: $-84+10*\text{Log}_{10}(R_b / 3.84*10^6)+E_b/N_0$ [dBm]. The wanted signal levels at the BS input for the specified E_b/N_0 levels in table 8.1 is found in table 8.2

Table 8.2: Wanted signal levels in AWGN channels.

| Measurement channel data rate (R_b) | Wanted signal level for required BLER < 10^{-1} | Wanted signal level for required BLER < 10^{-2} |
|---|---|---|
| 12.2 kbps | n.a. | -103.9 dBm |
| 64 kbps | -100.3 dBm | -100.1 dBm |
| 144 kbps | -97.5 dBm | -97.4 dBm |
| 384 kbps | -93.1 dBm | -93 dBm |

- 4) For each of the data rates in table 8.1 applicable for the base station, measure the BLER.

8.2.1.5 Test requirements

The BLER measured according to subclause 8.2.1.4.2 shall not exceed the limits specified in table 8.1.

8.3 Demodulation of DCH in multipath fading conditions

8.3.1 Multipath fading Case 1

8.3.1.1 Definition and applicability

The performance requirement of DCH in multipath fading Case 1 is determined by the maximum Block Error Ratio (BLER) allowed when the receiver input signal is at a specified E_b/N_0 limit. The BLER is calculated for each of the measurement channels supported by the base station.

The requirement in this subclause shall apply to base stations intended for general-purpose applications.

8.3.1.2 Conformance requirement

The BLER should not exceed the limit for the E_b/N_0 specified in table 8.3.

Table 8.3: Performance requirements in multipath Case 1 channel

| Measurement channel data rate (R_b) | E_b/N_0 for required BLER $< 10^{-1}$ | E_b/N_0 for required BLER $< 10^{-2}$ |
|---|---|---|
| 12.2 kbps | n.a. | 11.9 dB |
| 64 kbps | 6.2 dB | 9.2 dB |
| 144 kbps | 5.4 dB | 8.4 dB |
| 384 kbps | 5.8 dB | 8.8 dB |

The reference for this requirement is TS 25.104 subclause 8.3.1.1

8.3.1.3 Test Purpose

The test shall verify the receiver's ability to receive the test signal under slow multipath fading propagation conditions with a BLER not exceeding a specified limit.

8.3.1.4 Method of test

8.3.1.4.1 Initial conditions

- 1) Connect the BS tester generating the wanted signal, multipath fading simulators and AWGN generators to both BS antenna connectors for diversity reception via a combining network as shown in annex B.

8.3.1.4.2 Procedure

- 1) Adjust the AWGN generator to -84 dBm/3.84 MHz at the BS input.
- 2) The characteristics of the wanted signal shall be configured according to the corresponding UL reference measurement channel defined in annex A.
- 3) The multipath fading emulators shall be configured according to the corresponding channel model defined in annex D.
- 4) Adjust the equipment so that required E_b/N_0 specified in table 8.3 is achieved. To achieve the specified E_b/N_0 , the wanted signal level at the BS input should be adjusted to: $-84 + 10 \cdot \log_{10}(R_b / 3.84 \cdot 10^6) + E_b/N_0$ [dBm]. The wanted signal levels at the BS input for the specified E_b/N_0 levels in table 8.3 is found in table 8.4

Table 8.4: Wanted signal levels in multipath Case 1 channel

| Measurement channel data rate (R_b) | Wanted signal level for required BLER $< 10^{-1}$ | Wanted signal level for required BLER $< 10^{-2}$ |
|---|---|---|
| 12.2 kbps | n.a. | -97,1 dBm |
| 64 kbps | -95.6 dBm | -92.6 dBm |
| 144 kbps | -92.9 dBm | -89.9 dBm |
| 384 kbps | -88.2 dBm | -85.2 dBm |

- 5) For each of the data rates in table 8.3 applicable for the base station, measure the BLER.

8.3.1.5 Test requirements

The BLER measured according to subclause 8.3.1.4.2 shall not exceed the limits specified in table 8.2.

8.3.2 Multipath fading Case 2

8.3.2.1 Definition and applicability

The performance requirement of DCH in multipath fading Case 2 is determined by the maximum Block Error Rate (BLER) allowed when the receiver input signal is at a specified E_b/N_0 limit. The BLER is calculated for each of the measurement channels supported by the base station.

The requirement in this subclause shall apply to base stations intended for general purpose applications.

8.3.2.2 Conformance requirement

The BLER should not exceed the limit for the E_b/N_0 specified in table 8.5.

Table 8.5: Performance requirements in multipath Case 2 channel

| Measurement channel data rate (R_b) | E_b/N_0 for required BLER $< 10^{-1}$ | E_b/N_0 for required BLER $< 10^{-2}$ |
|---|---|---|
| 12.2 kbps | n.a. | 9.0 dB |
| 64 kbps | 4.3 dB | 6.4 dB |
| 144 kbps | 3.7 dB | 5.6 dB |
| 384 kbps | 4.1 dB | 6.1 dB |

The reference for this requirement is TS 25.104 subclause 8.3.2.1.

8.3.2.3 Test Purpose

The test shall verify the receiver's ability to receive the test signal that has a large time dispersion with a BLER not exceeding a specified limit.

8.2.2.4 Method of test

8.3.2.4.1 Initial conditions

- 1) Connect the BS tester generating the wanted signal, multipath fading simulators and AWGN generators to both BS antenna connectors for diversity reception via a combining network as shown in annex B.

8.3.2.4.2 Procedure

- 1) Adjust the AWGN generator to -84 dBm/3.84 MHz at the BS input.
- 2) The characteristics of the wanted signal shall be configured according to the corresponding UL reference measurement channel defined in annex A.
- 3) The multipath fading emulators shall be configured according to the corresponding channel model defined in annex D.
- 4) Adjust the equipment so that required E_b/N_0 specified in table 8.5 is achieved. To achieve the specified E_b/N_0 , the wanted signal level at the BS input should be adjusted to: $-84 + 10 \cdot \log_{10}(R_b / 3.84 \cdot 10^6) + E_b/N_0$ [dBm]. The wanted signal levels at the BS input for the specified E_b/N_0 levels in table 8.5 is found in table 8.6.

Table 8.6: Wanted signal levels in multipath Case 2 channel

| Measurement channel data rate (R_b) | Wanted signal level for required BLER $< 10^{-1}$ | Wanted signal level for required BLER $< 10^{-2}$ |
|---|---|---|
| 12.2 kbps | n.a. | -100 dBm |
| 64 kbps | -97.5 dBm | -95.4 dBm |
| 144 kbps | -94.6 dBm | -92.7 dBm |
| 384 kbps | -89.9 dBm | -87.9 dBm |

5) For each of the data rates in table 8.5 applicable for the base station, measure the BLER.

8.3.2.5 Test requirements

The BLER measured according to subclause 8.3.1.4.2 shall not exceed the limits specified in table 8.5.

8.3.3 Multipath fading Case 3

8.3.3.1 Definition and applicability

The performance requirement of DCH in multipath fading Case 3 is determined by the maximum Block Error Ratio (BLER) allowed when the receiver input signal is at a specified E_b/N_0 limit. The BLER is calculated for each of the measurement channels supported by the base station.

The requirement in this subclause shall apply to base stations intended for general purpose applications.

8.3.3.2 Conformance requirement

The BLER should not exceed the limit for the E_b/N_0 specified in table 8.7.

Table 8.7: Performance requirements in multipath Case 3 channel

| Measurement channel data rate (R_b) | E_b/N_0 for required BLER $< 10^{-1}$ | E_b/N_0 for required BLER $< 10^{-2}$ | E_b/N_0 for required BLER $< 10^{-3}$ |
|---|---|---|---|
| 12.2 kbps | n.a. | 6.7 dB | 7.5 dB |
| 64 kbps | 2.7 dB | 3.2 dB | 3.4 dB |
| 144 kbps | 2.2 dB | 2.5 dB | 2.8 dB |
| 384 kbps | 2.6 dB | 3.0 dB | 3.5 dB |

The reference for this requirement is TS 25.104 subclause 8.3.3.1.

8.3.3.3 Test Purpose

The test shall verify the receivers ability to receive the test signal under fast fading propagation conditions with a BLER not exceeding a specified limit.

8.3.3.4 Method of test

8.3.3.4.1 Initial conditions

- 1) Connect the BS tester generating the wanted signal, multipath fading simulators and AWGN generators to both BS antenna connectors for diversity reception via a combining network as shown in annex B.

8.3.3.4.2 Procedure

- 1) Adjust the AWGN generator to -84 dBm/3.84 MHz at the BS input.

- 2) The characteristics of the wanted signal shall be configured according to the corresponding UL reference measurement channel defined in annex A.
- 4) The multipath fading emulators shall be configured according to the corresponding channel model defined in annex D.
- 5) Adjust the equipment so that required E_b/N_0 specified in table 8.4 is achieved. To achieve the specified E_b/N_0 , the wanted signal level at the BS input should be adjusted to: $-84+10*\text{Log}_{10}(R_b/3.84*10^6)+E_b/N_0$ [dBm]. The wanted signal levels at the BS input for the specified E_b/N_0 levels in table 8.7 is found in table 8.8.

Table 8.8: Performance requirements in multipath Case 3 channel

| Measurement channel data rate (R_b) | Wanted signal level for required BLER < 10^{-1} | Wanted signal level for required BLER < 10^{-2} | Wanted signal level for required BLER < 10^{-3} |
|---|---|---|---|
| 12.2 kbps | n.a | -102.3 dBm | -101.5 dBm |
| 64 kbps | -99.1 dBm | -98.6 dBm | -98.4 dBm |
| 144 kbps | -96.1 dBm | -95.8 dBm | -95.5 dBm |
| 384 kbps | -91.4 dBm | -91.0 dBm | -90.5 dBm |

- 6) For each of the data rates in table 8.7 applicable for the base station, measure the BLER

8.3.3.5 Test requirements

The BLER measured according to subclause 8.3.3.4.2 shall not exceed the limits specified in table 8.7.

8.4 Demodulation of DCH in moving propagation conditions

8.4.1 Definition and applicability

The performance requirement of DCH in moving propagation conditions is determined by the maximum Block Error Ratio (BLER) allowed when the receiver input signal is at a specified E_b/N_0 limit. The BLER is calculated for each of the measurement channels supported by the base station.

The requirement in this subclause shall apply to base stations intended for general-purpose applications.

8.4.2 Conformance requirement

The BLER should not exceed the limit for the E_b/N_0 specified in table 8.9.

Table 8.9: Performance requirements in moving channel

| Measurement channel data rate (R_b) | E_b/N_0 for required BLER < 10^{-1} | E_b/N_0 for required BLER < 10^{-2} |
|---|---|---|
| 12.2 kbps | n.a. | |
| 64 kbps | | |

The reference for this requirement is TS 25.104 subclause 8.4.1.

8.4.3 Test Purpose

The test shall verify the receiver's ability to receive and track the test signal with a BLER not exceeding the specified limit.

8.4.3.1 Method of test

8.4.3.1.1 Initial conditions

- 1) Connect the BS tester generating the wanted signal, multipath fading simulators and AWGN generators to both BS antenna connectors for diversity reception via a combining network as shown in annex D.

8.4.3.1.2 Procedure

- 1) Adjust the AWGN generator to -84 dBm/3.84 MHz at the BS input.
- 2) The characteristics of the wanted signal shall be configured according to the corresponding UL reference measurement channel defined in annex A.
- 3) The multipath fading emulators shall be configured according to the corresponding channel model defined in annex D.
- 4) Adjust the equipment so that required E_b/N_0 specified in table 8.4 is achieved. To achieve the specified E_b/N_0 , the wanted signal level at the BS input should be adjusted to: $-84 + 10 \cdot \log_{10}(R_b / 3.84 \cdot 10^6) + E_b/N_0$ [dBm]. The wanted signal levels at the BS input for the specified E_b/N_0 levels in table 8.9 is found in table 8.10

Table 8.10: Wanted signal levels in moving channel

| Measurement channel data rate (R_b) | Wanted signal level for required BLER < 10^{-1} | Wanted signal level for required BLER < 10^{-2} |
|---|---|---|
| 12.2 kbps | n.a. | |
| 64 kbps | | |

- 5) For each of the data rates in table 8.9 applicable for the base station, measure the BLER.

8.4.2.4 Test requirements

The BLER measured according to subclause 8.4.2.3.2 shall not exceed the limits specified in table 8.9.

8.5 Demodulation of DCH in birth/death propagation conditions

8.5.1 Definition and applicability

The performance requirement of DCH in birth/death propagation conditions is determined by the maximum Block Error Ratio (BLER) allowed when the receiver input signal is at a specified E_b/N_0 limit. The BLER is calculated for each of the measurement channels supported by the base station.

The requirement in this subclause shall apply to base stations intended for general purpose applications.

8.5.2 Conformance requirement

The BLER should not exceed the limit for the E_b/N_0 specified in table 8.11.

Table 8.11: Performance requirements in birth/death channel

| Measurement channel data rate (R_b) | E_b/N_0 for required BLER < 10^{-1} | E_b/N_0 for required BLER < 10^{-2} |
|---|---|---|
| 12.2 kbps | n.a. | |
| 64 kbps | | |

The reference for this requirement is TS 25.104 subclause 8.5.1.

8.5.2.1 Test Purpose

The test shall verify the receiver's ability to receive the test signal to find new multi path components with a BLER not exceeding the specified limit.

8.5.2.2 Method of test

8.5.2.2.1 Initial conditions

- 1) Connect the BS tester generating the wanted signal, multipath fading simulators and AWGN generators to both BS antenna connectors for diversity reception via a combining network as shown in annex B.

8.5.2.2.2 Procedure

- 1) Adjust the AWGN generator to -84 dBm/3.84 MHz at the BS input.
- 2) The characteristics of the wanted signal shall be configured according to the corresponding UL reference measurement channel defined in annex A.
- 3) The multipath fading emulators shall be configured according to the corresponding channel model defined in annex D.
- 4) Adjust the equipment so that required E_b/N_0 specified in table 8.4 is achieved. To achieve the specified E_b/N_0 , the wanted signal level at the BS input should be adjusted to: $-84+10*\text{Log}_{10}(R_b / 3.84*10^6)+E_b/N_0$ [dBm]. The wanted signal levels at the BS input for the specified E_b/N_0 levels in table 8.11 is found in table 8.12

Table 8.12: Performance requirements in birth/death channel

| Measurement channel data rate (R_b) | Wanted signal level for required BLER < 10^{-1} | Wanted signal level for required BLER < 10^{-2} |
|---|---|---|
| 12.2 kbps | n.a. | |
| 64 kbps | | |

- 5) For each of the data rates in table 8.11 applicable for the base station, measure the BLER.

8.5.2.3 Test requirements

The BLER measured according to subclause 8.5.2.2.2 shall not exceed the limits specified in table 8.11.

8.6 Verification of the internal BLER calculation

8.6.1 Definition and applicability

Base Station System with internal BLER calculates block error rate from the CRC blocks of the received. This test is performed only if Base Station System has this kind of feature. All data rates which are used in clause 8 Performance requirement testing shall be used in verification testing. This test is performed by feeding measurement signal with known BLER to the input of the receiver. Locations of the erroneous blocks shall be randomly distributed within a frame. Erroneous bits shall be inserted into the UL signal as shown in figure 8.1.

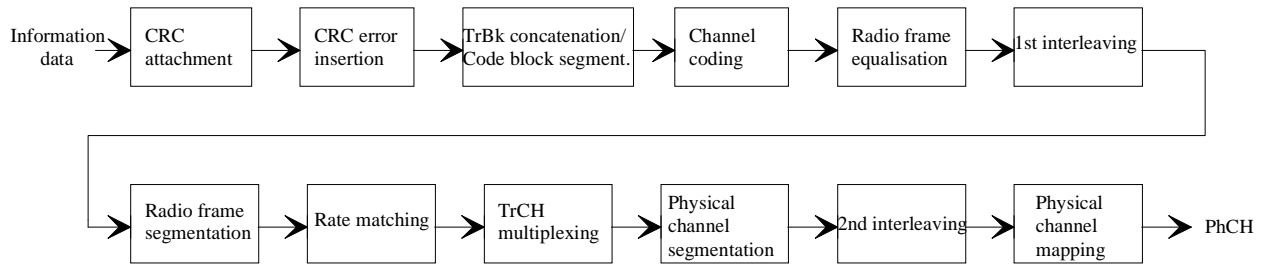

Figure 8.1: BLER insertion to the output data

8.6.2 Conformance requirement

BLER indicated by the Base Station System shall be within $\pm[10\%]$ of the BLER generated by the RF signal source. Measurement shall be repeated for each signal rate as specified in table 8.13.

Table 8.13

| Transport channel combination | Data rate | BLER |
|-------------------------------|-----------|-----------|
| DPCH | 12,2 kbps | BLER 0.01 |
| DPCH | 64 kbps | BLER 0.01 |
| DPCH | 144 kbps | BLER 0.01 |
| DPCH | 384 kbps | BLER 0.01 |

NOTE: 10 times larger BLER generator is used to get a good confidence.

8.6.3 Test purpose

To verify that the internal BLER calculation accuracy shall met requirements for conformance testing.

8.6.4 Method of test

8.6.4.1 Initial conditions

1) Connect the BS tester generating the wanted signal to both BS antenna connectors for diversity reception via a combining network as shown in annex B.

Table 8.14

| Parameter | Level/status | Unit |
|-----------------|-----------------|--------------|
| UL signal level | Ref.sens +10 dB | dBm/3.84 MHz |
| Data sequence | PN9 | |

8.6.4.2 Procedure

- 1) The characteristics of the wanted signal shall be configured according to the corresponding UL reference measurement channel defined in annex A.
- 2) The BLER insertion to the wanted signal shall be configured according to the corresponding data rate in table 8.7.
- 3) Adjust the BS tester so that the required UL signal level specified in table 8.14 is achieved.

For each of the data rates in table 8.13 applicable for the base station, measure the BLER at least over 50 000 blocks.

8.6.5 Test requirement

BLER indicated by the Base Station System shall be within requirement as specified in subclause 8.6.2.

8.7 Site Selection Diversity Transmission (SSDT) Mode

8.7.1 Definition and applicability

Site Selection Diversity Transmission (SSDT) mode is an optional feature of BS and is a macro diversity method in soft handover mode. In SSDT mode, the UE selects one of the cells from its active set to be “primary”, all other active cells are classed as “non-primary”. The non-primary cells switch off the DCH transmission. The primary cell ID code is delivered to active cells using uplink FBI field of DPCCH.

The requirements and this test apply only to Base Station which has a function of SSDT mode.

8.7.1.1 Conformance requirements

According to the conditions specified in Table 8.15, the downlink DPDCH and DPCCH are properly transmitted or stopped.

Table 8.15: Parameters for SSDT mode test

| Parameter | Unit | Test 1 | Test 2 | Test 3 | Test 4 |
|--|------|---------------|---------------|--------------|--------------|
| Cell ID of BS under test | - | A | A | A | A |
| SSDT Quality threshold, Q_{th} , set in BS | dB | -5 | | | |
| Uplink: $\frac{DPCH - E_c}{I_o}$ | dB | $Q_{th} + 10$ | $Q_{th} + 10$ | $Q_{th} - 3$ | $Q_{th} - 3$ |
| Cell ID transmitted by UE | - | A | B | A | B |
| Transmission Of downlink DPCCH | - | Yes | Yes | Yes | yes |
| Transmission Of downlink DPDCH | - | Yes | No | Yes | yes |

The reference for this requirement is in TS 25.104 clause 8.6.

8.7.1.2 Test purpose

To verify that downlink transmission reaction of BS to Layer 1 feedback signalling messages from UE.

8.7.1.3 Method of test

8.7.1.3.1 Initial conditions

1. Connect a UE simulator and an AWGN noise source to the BS antenna connector as shown in Figure B.13.
2. Set up a call according to the Generic call setup procedure using parameters as specified in Table 8.6-1. SSDT Quality threshold Q_{th} should be set to the value specified by the manufacturer.
3. Activate SSDT function.

8.7.1.3.2 Procedure

1. Check downlink DCH, properly transmitted on or off, according to Table 8.6-1 under conditions of Test1 through Test4 with 3 types of Cell ID sets, "long", "medium" and "short", respectively.

8.7.1.3.3 Test Requirements

Downlink DCH of the BS under test shall be transmitted or stopped properly according to the conditions specified in Table 8.9

Annex A (normative): Measurement channels

A.1 Summary of UL reference measurement channels

The parameters for the UL reference measurement channels are specified in Table A.1 and the channel coding is detailed in figure A.1 through A.5 respectively.

NOTE: For all cases, one DPCCH shall be attached to DPDCH(s).

Table A.1: Reference measurement channels for UL DCH

| Parameter | | DCH for DTCH / DCH for DCCH | | | | | Unit |
|--------------------------------|----------------------|-----------------------------|--------|---------|---------|----------|----------|
| DPDCH | Information bit rate | 12,2/2,4 | 64/2,4 | 144/2,4 | 384/2,4 | 2048/2,4 | kbps |
| | Physical channel | 60/15 | 240/15 | 480/15 | 960/15 | 960/15 | kbps |
| | Spreading factor | 64 | 16 | 8 | 4 | 4 | |
| | Repetition rate | 22/22 | 19/19 | 8/9 | -18/-18 | -1/-1 | % |
| | Interleaving | 20 | 40 | 40 | 40 | 80 | ms |
| | Number of DPDCHs | 1 | 1 | 1 | 1 | 6 | |
| DPCCH | Dedicated pilot | 6 | | | | | bit/slot |
| | Power control | 2 | | | | | bit/slot |
| | TFCI | 2 | | | | | bit/slot |
| | Spreading factor | 256 | | | | | |
| Power ratio of DPCCH/DPDCH | | -2,69 | -5,46 | -9,54 | -9,54 | -9,54 | dB |
| Amplitude ratio of DPCCH/DPDCH | | 0,7333 | 0,5333 | 0,3333 | 0,3333 | 03333 | |

A.2 UL reference measurement channel for 12,2 kbps

The parameters for the UL reference measurement channel for 12,2 kbps are specified in table A.2 and the channel coding is detailed in figure A.2.

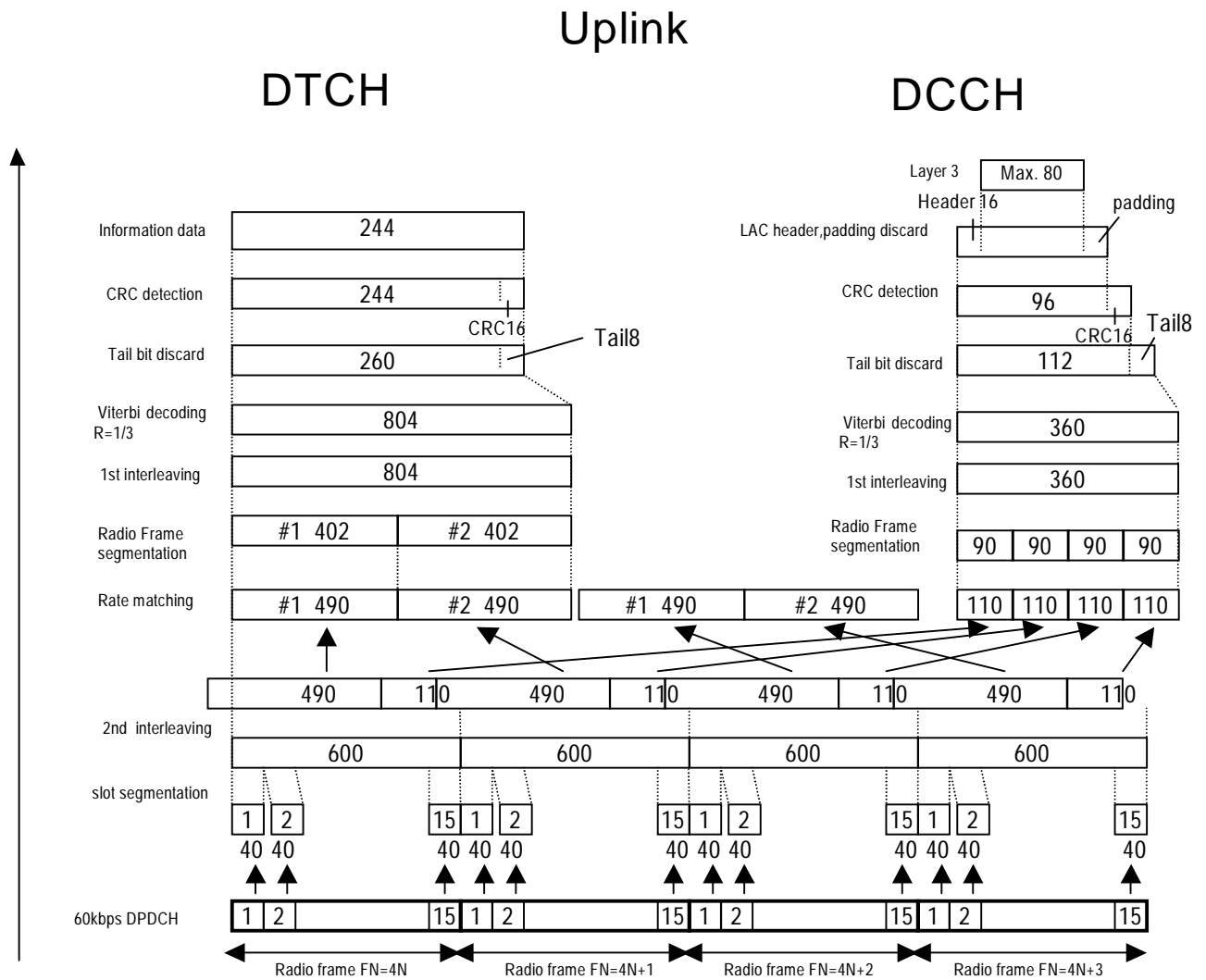

Figure A.2

Table A.2: UL reference measurement channel (12.2 kbps)

| Parameter | Level | Unit |
|----------------------|-------|------|
| Information bit rate | 12,2 | kbps |
| DPCH | 60 | kbps |
| Power control | Off | |
| TFCI | On | |
| Repetition | 22 | % |

A.3 UL reference measurement channel for 64 kbps

The parameters for the UL reference measurement channel for 64 kbps are specified in table A.3 and the channel coding is detailed in figure A.3.

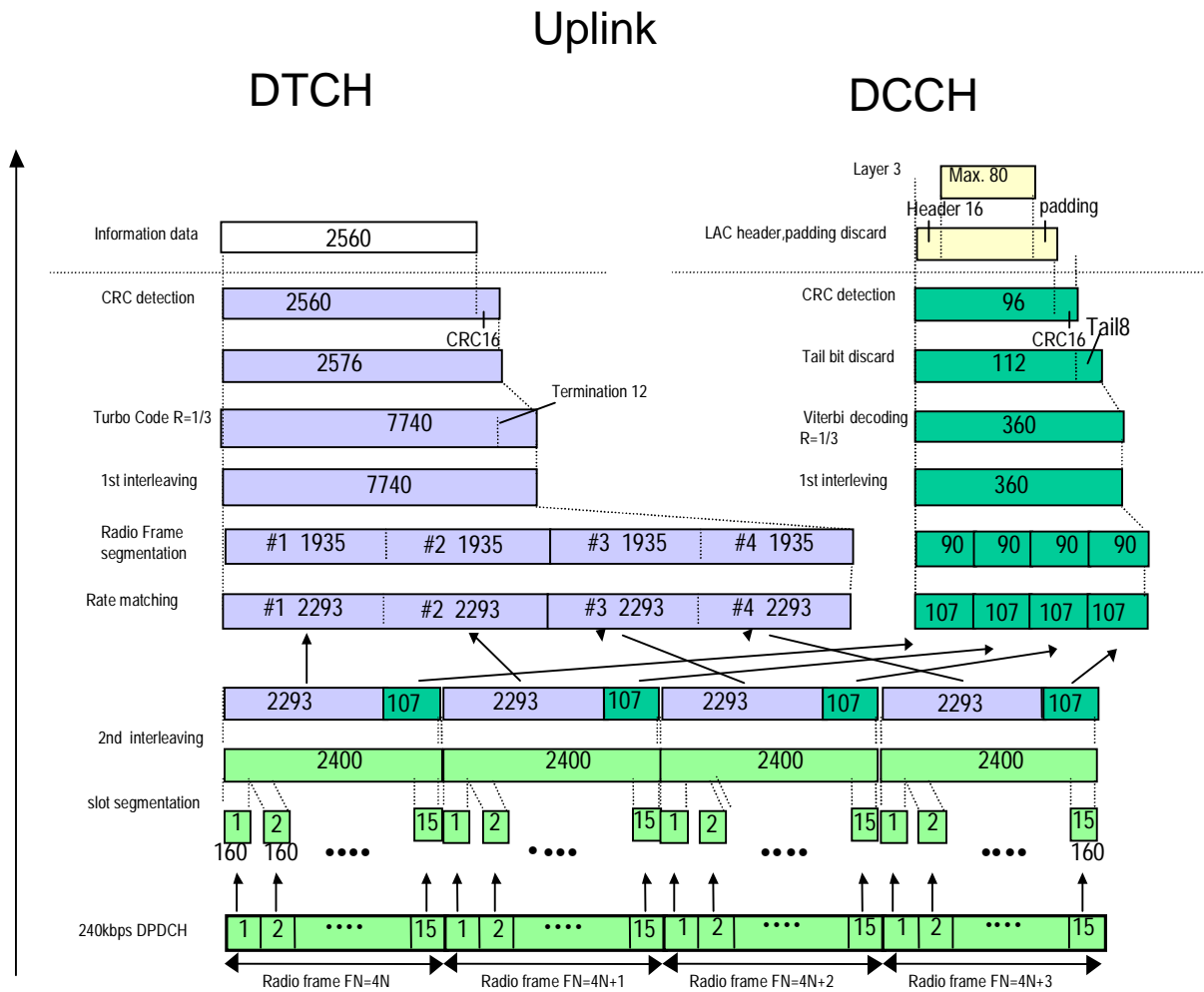

Figure A.3

Table A.3: UL reference measurement channel (64kbps)

| Parameter | Level | Unit |
|----------------------|-------|------|
| Information bit rate | 64 | kbps |
| DPCH | 240 | kbps |
| Power control | Off | |
| TFCI | On | |
| Repetition | 19 | % |

A.4 UL reference measurement channel for 144 kbps

The parameters for the UL reference measurement channel for 144 kbps are specified in table A.4 and the channel coding is detailed in figure A.4.

Uplink

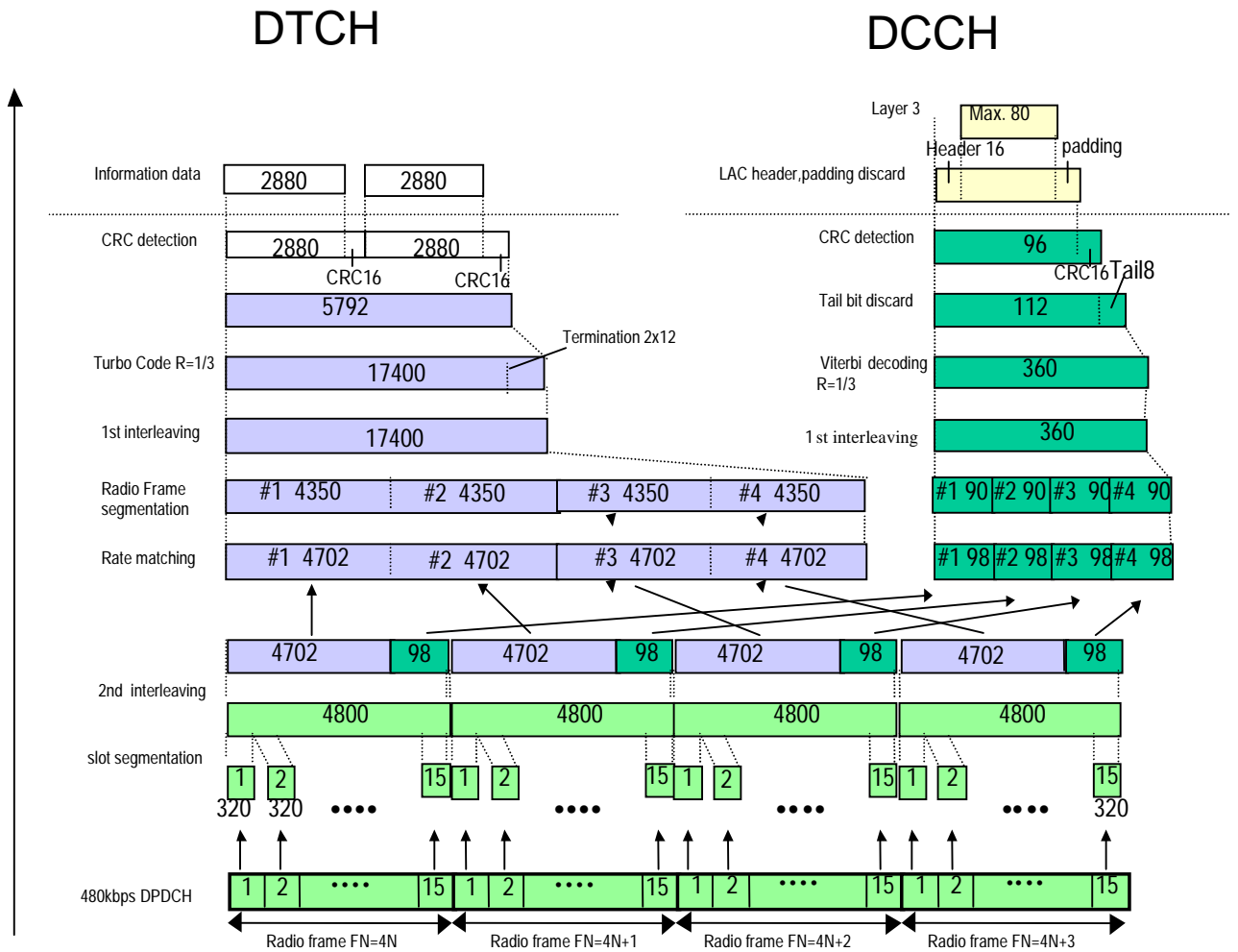

Figure A.4

Table A.4: UL reference measurement channel (144kbps)

| Parameter | Level | Unit |
|----------------------|-------|------|
| Information bit rate | 144 | kbps |
| DPCH | 480 | kbps |
| Power control | Off | |
| TFCI | On | |
| Repetition | 8 | % |

A.5 UL reference measurement channel for 384 kbps

The parameters for the UL reference measurement channel for 384 kbps are specified in table A.5 and the channel coding is detailed in figure A.5.

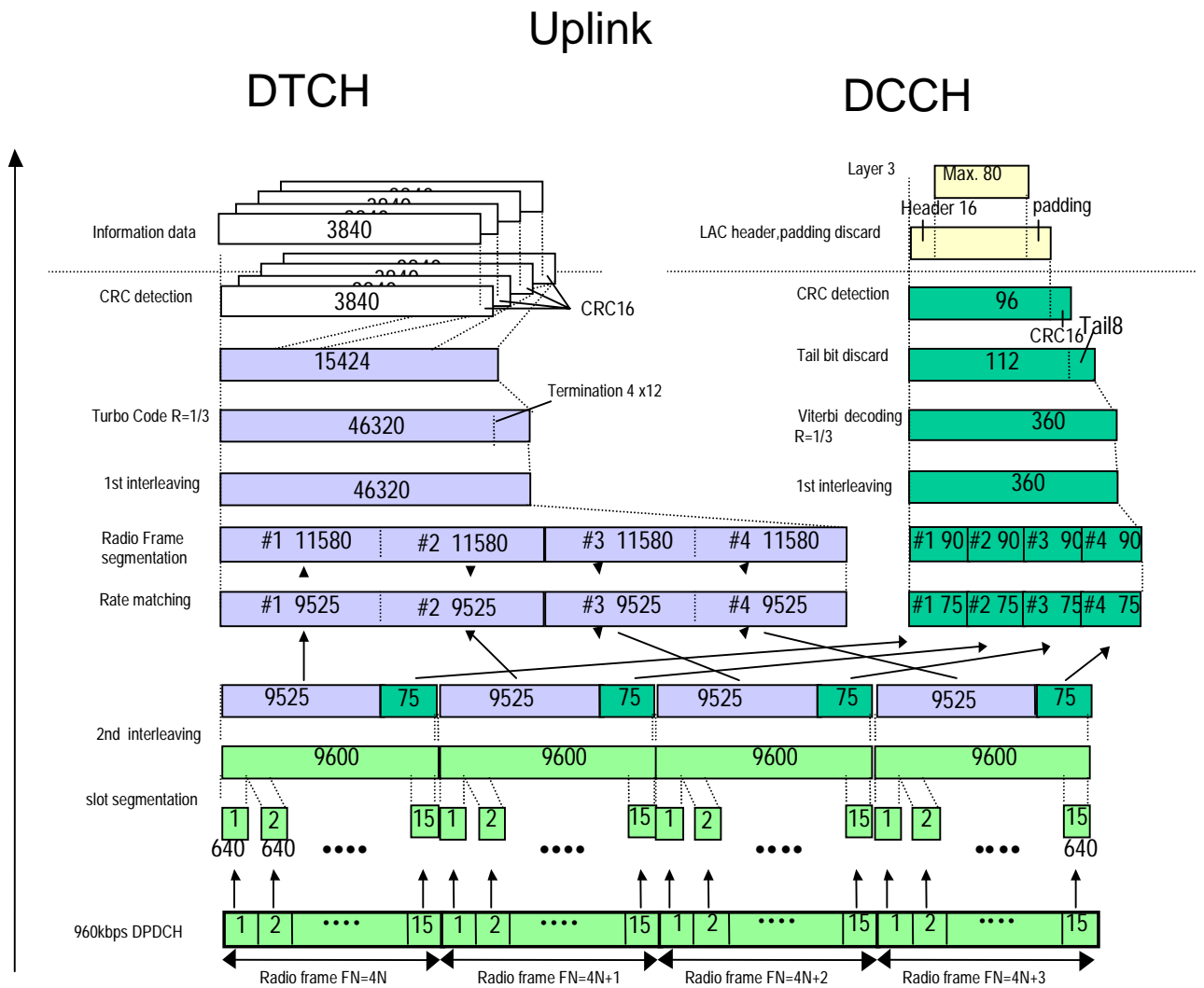

Figure A.5

Table A.5: UL reference measurement channel (384kbps)

| Parameter | Level | Unit |
|----------------------|-------|------|
| Information bit rate | 384 | kbps |
| DPCH | 960 | kbps |
| Power control | Off | |
| TFCI | On | |
| Puncturing | 18 | % |

A.6 UL reference measurement channel for 2048 kbps

The parameters for the UL reference measurement channel for 2 048 kbps are specified in table A.6 and the channel coding is detailed in figure A.6.

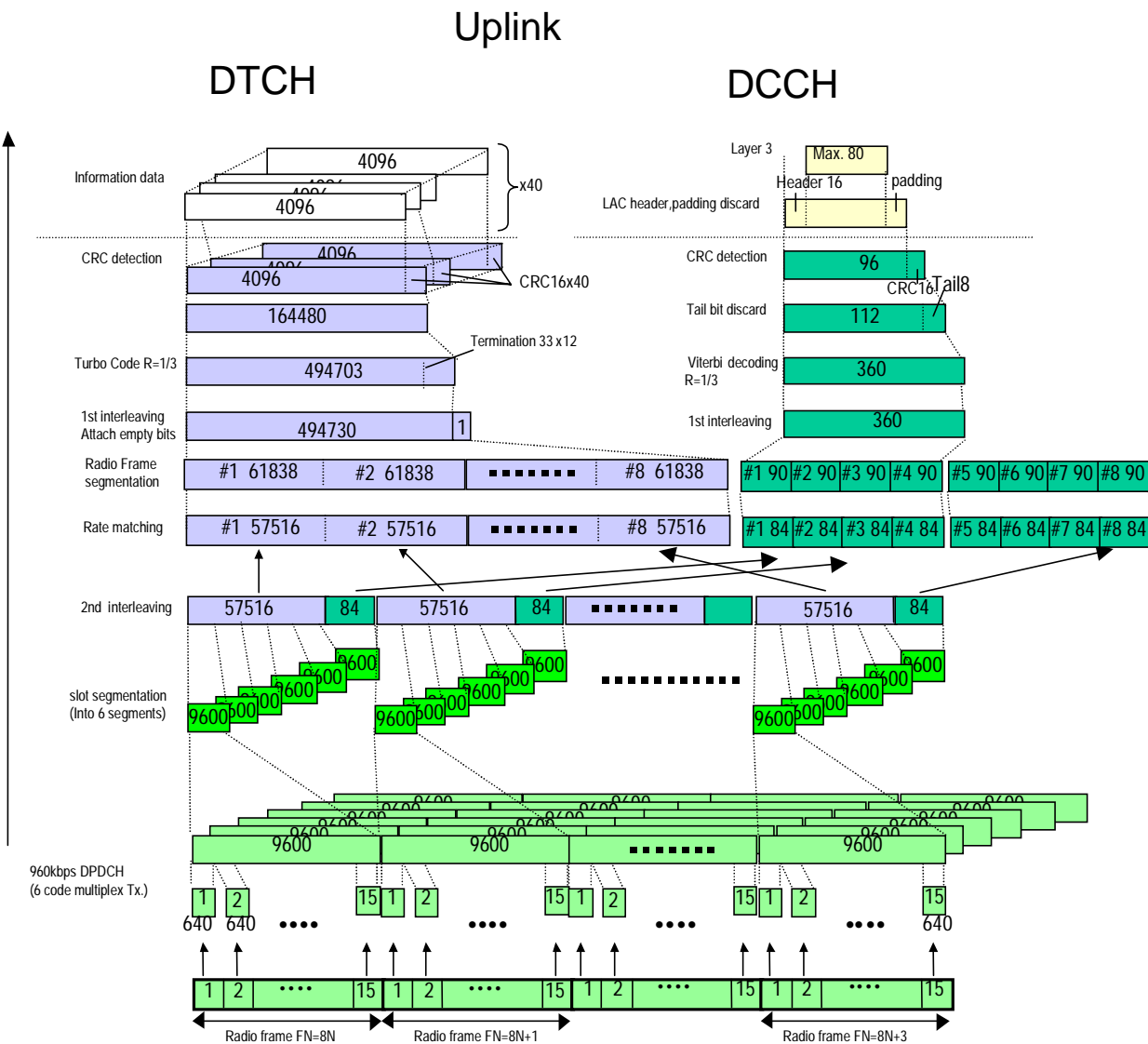

Figure A.6

Table A.6: UL reference measurement channel (2048kbps)

| Parameter | Level | Unit |
|----------------------|-------|------|
| Information bit rate | 2 048 | kbps |
| DPCH | 960 | kbps |
| Power control | Off | |
| TFCI | On | |
| Puncturing | 1 | % |

Annex B (informative): Measurement system set-up

Example of measurement system set-ups are attached below as an informative annex.

B.1 Transmitter

B.1.1 Maximum output power, total power dynamic range

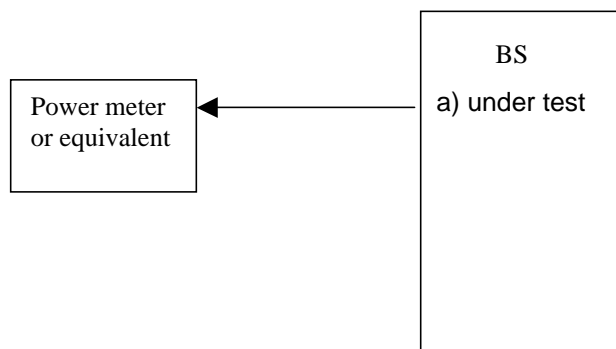

Figure B.1: Measuring system Set-up for maximum output power, total power dynamic range

B.1.2 CPICH power accuracy and Peak code domain error



Figure B.2: Measuring system Set-up for CPICH power accuracy and peak code domain error measurements

B.1.3 Power control steps and power control dynamic range

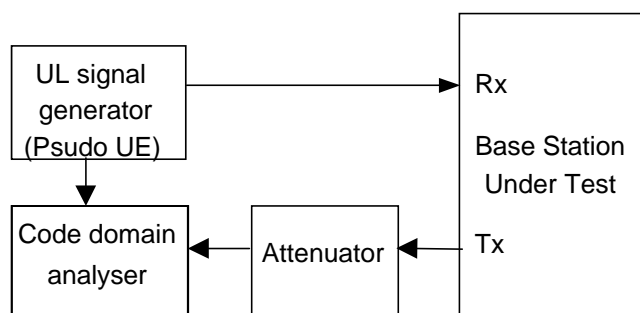

Figure B.3: Measuring system Set-up for power control steps and power control dynamic range measurements

B.1.4 Out of band emission

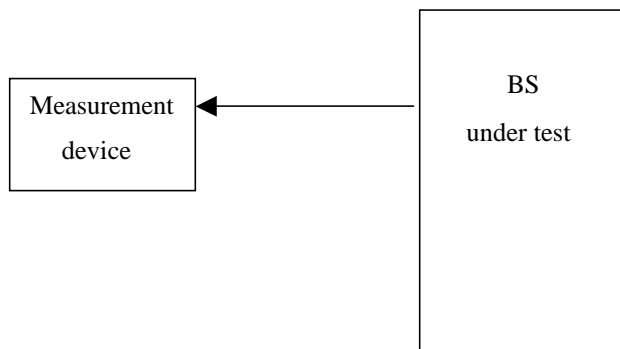

Figure B.4: Measuring system Set-up for Out of band emission measurements

B.1.5 Transmit intermodulation

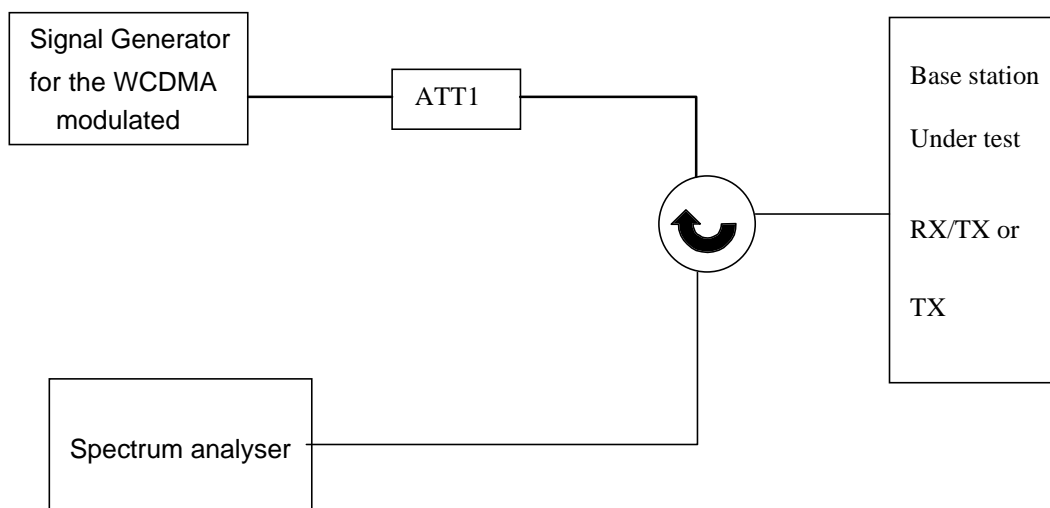

Figure B.5: Measuring system Set-up for Base Station Transmit Intermodulation Tests

B.1.6 EVM measurement

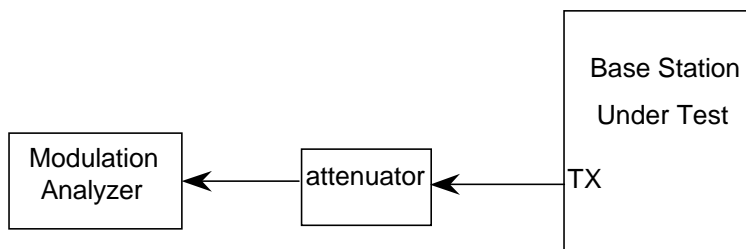

Figure B.6: Measuring system Set-up for EVM test

B.2 Receiver

B.2.1 Reference sensitivity level

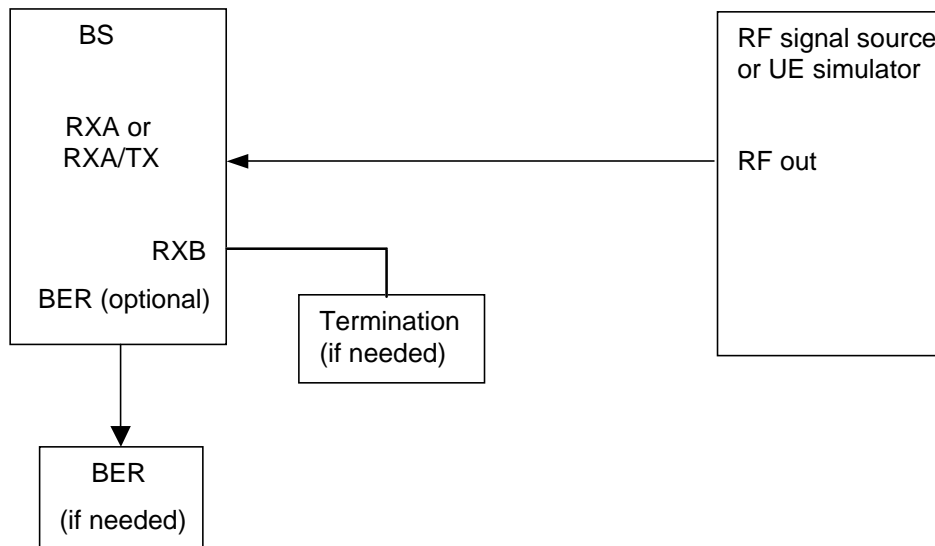

Figure B.7: Measuring system Set-up for Base Station Reference sensitivity level Testes

B.2.2 Dynamic range

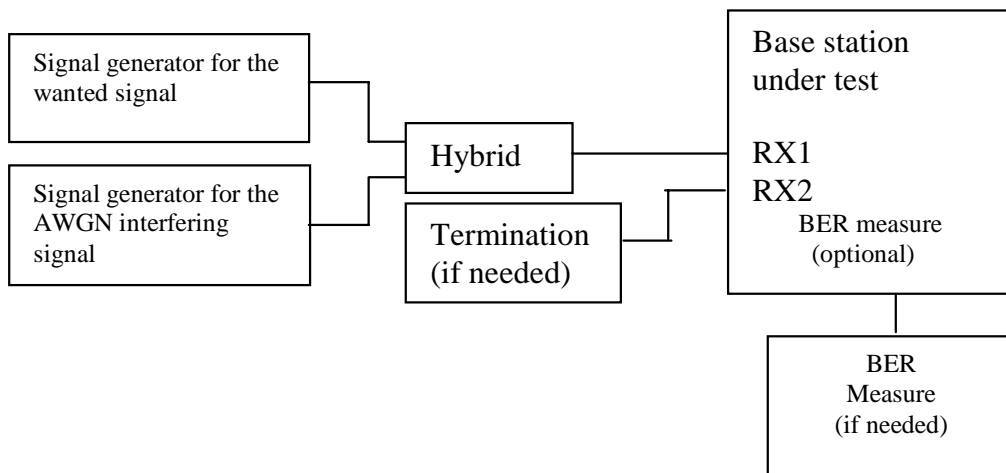

Figure B.8: Measuring system Set-up for Dynamic range

B.2.3 Adjacent Channel Selectivity (ACS)

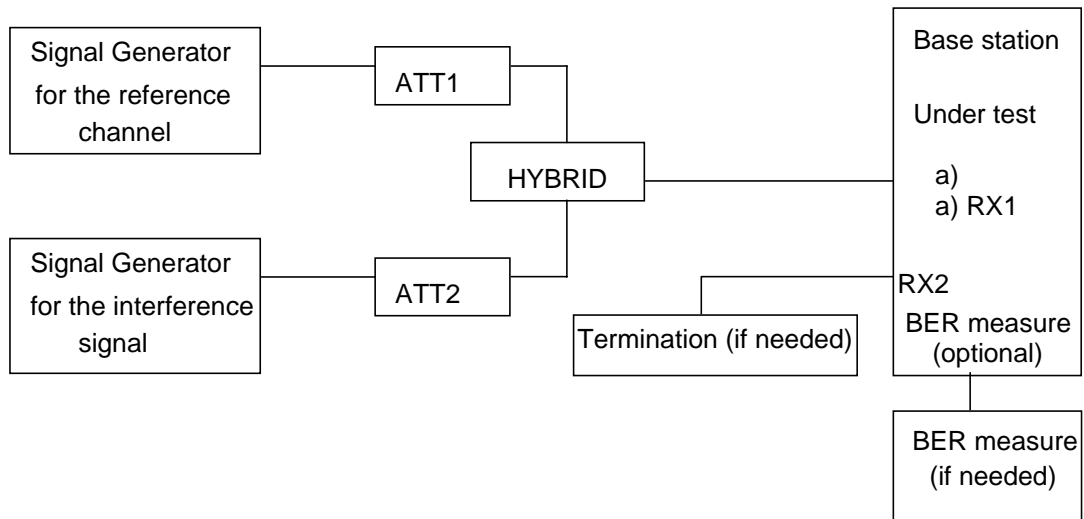

Figure B.9: Measuring system Set-up for Adjacent channel selectivity

B.2.4 Blocking characteristics

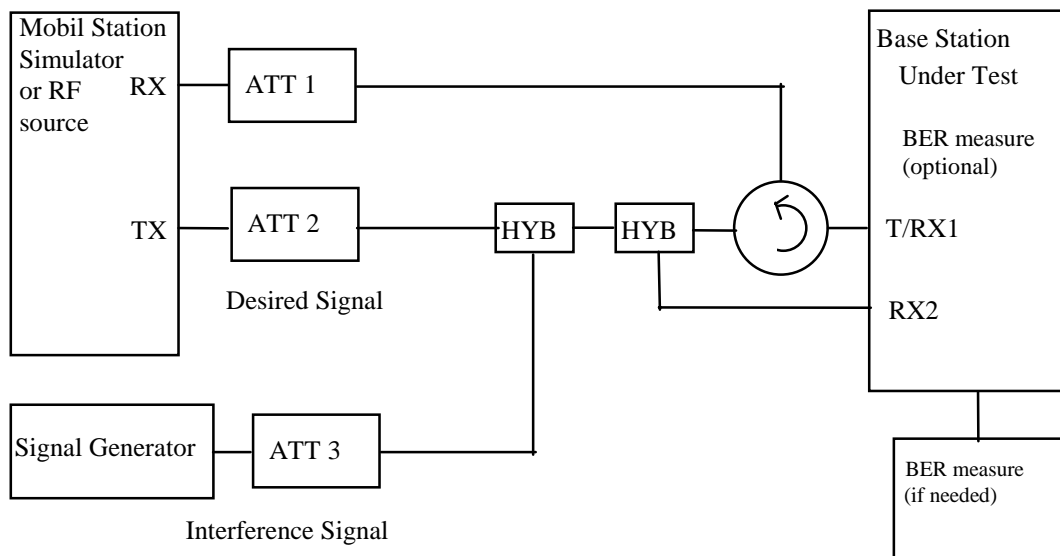

Figure B.10: Measuring system Set-up for Blocking characteristics

B.2.5 Intermodulation characteristics

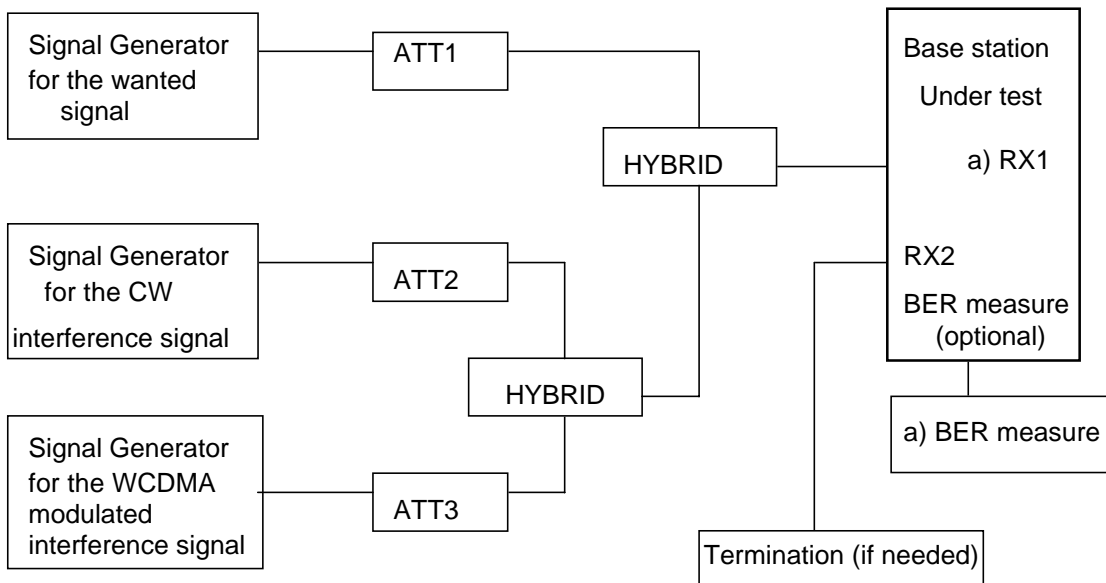

Figure B.11: Measuring system Set-up for intermodulation characteristics

B.2.6 Receiver spurious emission

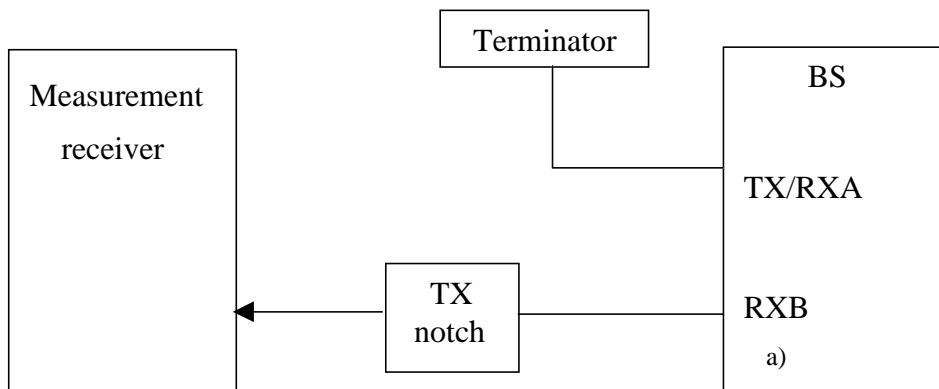

Figure B.12: Measuring system Set-up for Receiver spurious emission

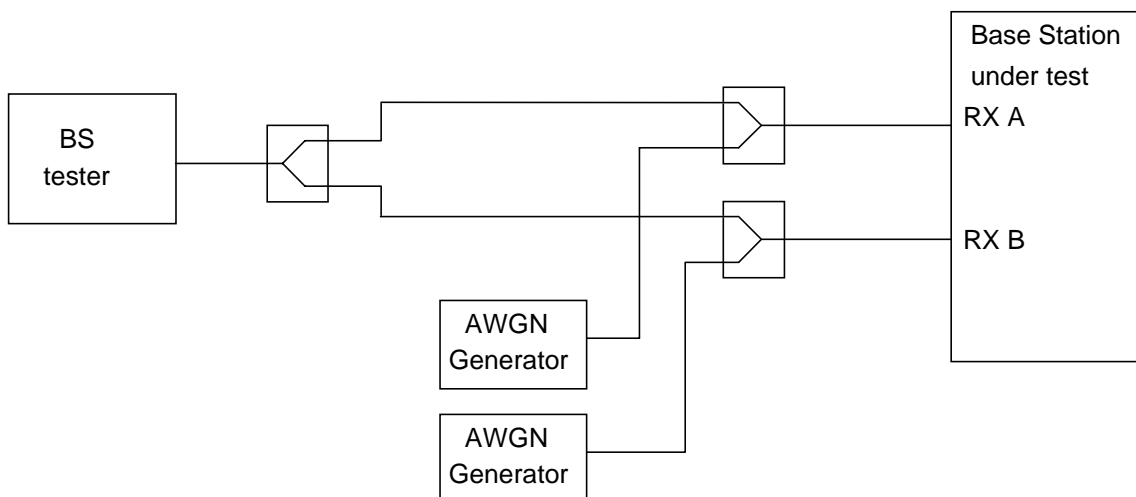

Figure B.13: Functional Set-up for Demodulation in static conditions

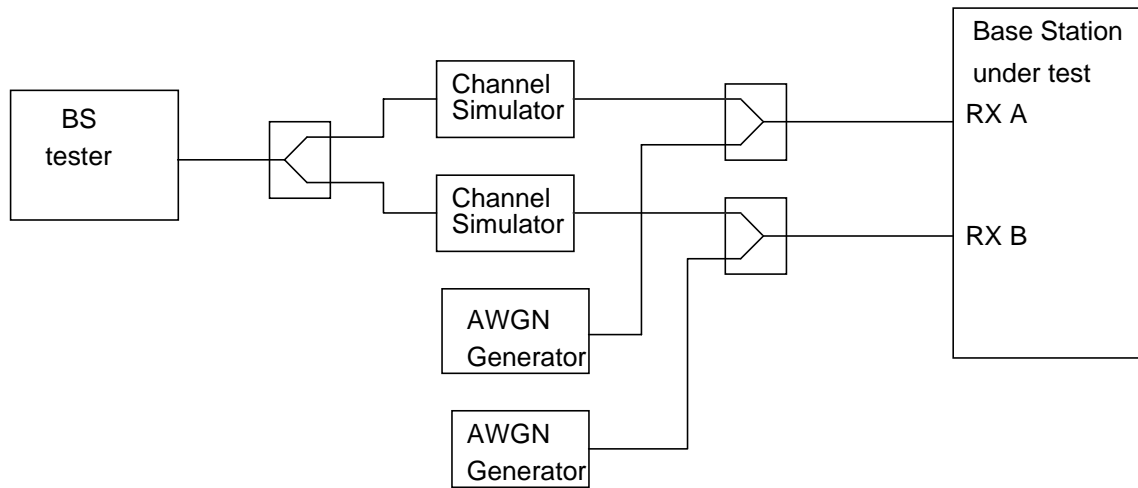

Figure B.14: Functional Set-up for Demodulation of DCH in multipath fading conditions

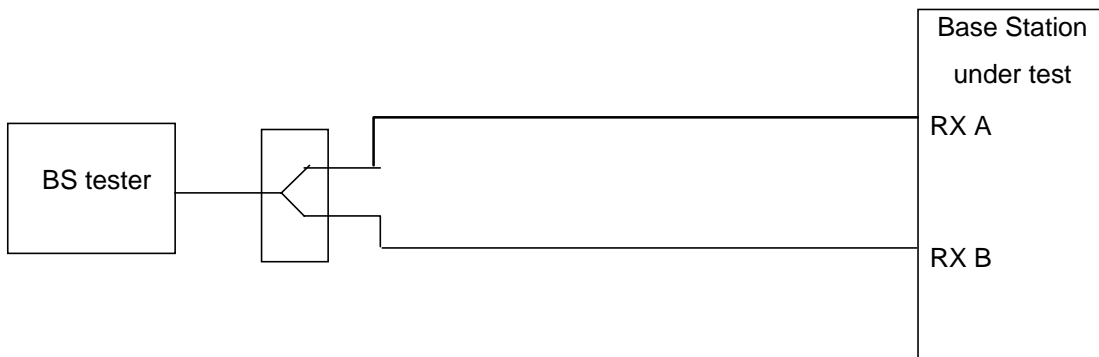

Figure B.15: Functional Set-up for Verification of the internal BLER calculation

Annex C (normative): Detailed definition of error events

1) Block Error Ratio (BLER):

- the block is defined as erased if the error detection functions using Cyclic Redundancy Check (CRC) in layer 1.

<Editor's note: Tentative definition of BLER is given. >

2) Bit Error Ratio (BER):

- the BER is the overall Bit Error Ratio (BER) independent of frame erasures or when erased frames are not defined.

Annex D (normative): Propagation conditions

D.1 Static propagation condition

The propagation for the static performance measurement is an Additive White Gaussian Noise (AWGN) environment. No fading or multi-paths exist for this propagation model.

D.2 Multi-path fading propagation conditions

Table D.1 shows propagation conditions that are used for the performance measurements in multi-path fading environment. All taps have classical Doppler spectrum.

Table D.1: Propagation Conditions for Multi path Fading Environments

| Case 1, speed 3km/h | | Case 2, speed 3 km/h | | Case 3, 120 km/h | |
|---------------------|--------------------|----------------------|--------------------|---------------------|--------------------|
| Relative Delay [ns] | Average Power [dB] | Relative Delay [ns] | Average Power [dB] | Relative Delay [ns] | Average Power [dB] |
| 0 | 0 | 0 | 0 | 0 | 0 |
| 976 | -10 | 976 | 0 | 260 | -3 |
| | | 20000 | 0 | 521 | -6 |
| | | | | 781 | -9 |

D.3 Moving propagation conditions

The dynamic propagation conditions for the test of the baseband performance are non fading channel models with two taps. The moving propagation condition has two tap, one static, Path0, and one moving, Path1. The time difference between the two paths is according Equation (D.1). The taps have equal strengths and equal phases.

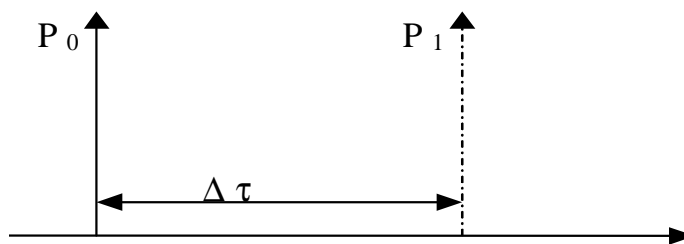

Figure D.1: The moving propagation conditions

$$\Delta\tau = B + \frac{A}{2}(1 + \sin(\Delta\omega \cdot t)) \quad \text{Equation d.1}$$

The parameters in the equation are shown in.

| | |
|-----------|-------------------------------------|
| A | 5 μs |
| B | 1 μs |
| Δω | 40*10 ⁻³ s ⁻¹ |

D.4 Birth-Death propagation conditions

The dynamic propagation conditions for the test of the baseband performance is a non fading propagation channel with two taps. The moving propagation condition has two taps, Path1 and Path2 which alternate between 'birth' and 'death'. The positions the paths appear are randomly selected with an equal probability rate and is shown in figure D.2.

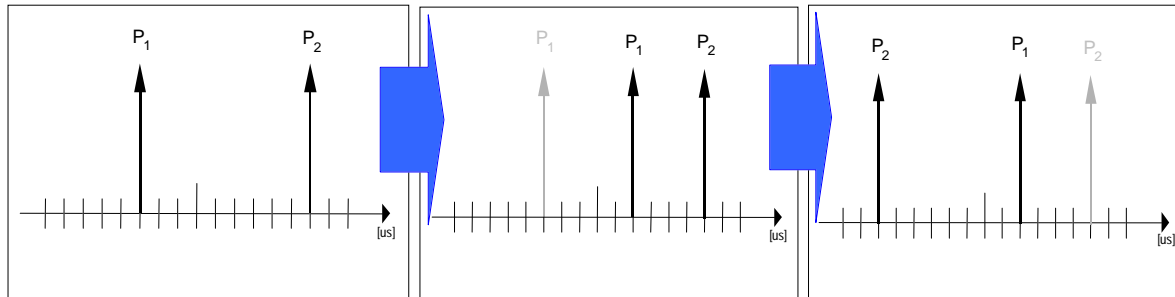

Figure D.2: Birth death propagation sequence

- NOTE 1: Two paths, Path1 and Path2 are randomly selected from the group $[-5, -4, -3, -2, -1, 0, 1, 2, 3, 4, 5]$ μs . The paths have equal strengths and equal phases.
- NOTE 2: After 191 ms, Path1 vanishes and reappears immediately at a new location randomly selected from the group $[-5, -4, -3, -2, -1, 0, 1, 2, 3, 4, 5]$ μs but excludes the point Path2.
- NOTE 3: After an additional 191 ms, Path2 vanishes and reappears immediately at a new location randomly selected from the group $[-5, -4, -3, -2, -1, 0, 1, 2, 3, 4, 5]$ μs but excludes the point Path1.
- NOTE 4: The sequence in 2) and 3) is repeated.

Annex E (informative): Change Request history

CRs approved by TSG-RAN#7.

| RAN doc | Spec | CR | R | Phas | Subject | Cat | Curren | New |
|-----------|--------|-----|---|------|--|-----|--------|-------|
| RP-000022 | 25.141 | 001 | | R99 | Clarification of Receiver Dynamic Range requirement | F | 3.0.0 | 3.1.0 |
| RP-000022 | 25.141 | 002 | | R99 | Editorial changes | D | 3.0.0 | 3.1.0 |
| RP-000022 | 25.141 | 003 | | R99 | Occupied bandwidth measurement | F | 3.0.0 | 3.1.0 |
| RP-000022 | 25.141 | 004 | | R99 | Clarification of "random" in relation to injected bit errors | F | 3.0.0 | 3.1.0 |
| RP-000022 | 25.141 | 005 | | R99 | Test Models for transmitter | B | 3.0.0 | 3.1.0 |
| RP-000022 | 25.141 | 006 | 1 | R99 | Regional requirements in TS 25.104 | D | 3.0.0 | 3.1.0 |
| RP-000022 | 25.141 | 007 | | R99 | Blocking test | F | 3.0.0 | 3.1.0 |
| RP-000022 | 25.141 | 008 | | R99 | ACLR measurement | F | 3.0.0 | 3.1.0 |
| RP-000022 | 25.141 | 009 | | R99 | Peak code domain error measurement | F | 3.0.0 | 3.1.0 |
| RP-000022 | 25.141 | 010 | | R99 | Test point & set of specifications for use of external RF | F | 3.0.0 | 3.1.0 |
| RP-000022 | 25.141 | 011 | | R99 | CR for Performance requirement in TS 25.141 | F | 3.0.0 | 3.1.0 |
| RP-000022 | 25.141 | 012 | | R99 | Spectrum emission mask | F | 3.0.0 | 3.1.0 |
| RP-000022 | 25.141 | 013 | | R99 | BS configurations | B | 3.0.0 | 3.1.0 |
| RP-000022 | 25.141 | 014 | | R99 | Test models | F | 3.0.0 | 3.1.0 |
| RP-000022 | 25.141 | 015 | | R99 | Update to Downlink Test Models | F | 3.0.0 | 3.1.0 |
| RP-000022 | 25.141 | 016 | | R99 | Remove revision marks in annex A | D | 3.0.0 | 3.1.0 |
| RP-000022 | 25.141 | 017 | | R99 | Format and interpretation of tests | D | 3.0.0 | 3.1.0 |
| RP-000022 | 25.141 | 018 | | R99 | Modifications for system set-up's TS25.141v3.0.0 | F | 3.0.0 | 3.1.0 |
| RP-000022 | 25.141 | 019 | | R99 | Intermodulation test | F | 3.0.0 | 3.1.0 |
| RP-000022 | 25.141 | 020 | | R99 | Modifications for test models | C | 3.0.0 | 3.1.0 |
| RP-000022 | 25.141 | 021 | | R99 | Receiver diversity | C | 3.0.0 | 3.1.0 |
| RP-000022 | 25.141 | 023 | | R99 | Spectrum emission mask | F | 3.0.0 | 3.1.0 |
| RP-000022 | 25.141 | 024 | | R99 | Rx spurious emissions measurement bandwidth | F | 3.0.0 | 3.1.0 |
| RP-000022 | 25.141 | 025 | | R99 | Modification to the handling of measurement equipment | F | 3.0.0 | 3.1.0 |
| RP-000022 | 25.141 | 026 | | R99 | Test models | F | 3.0.0 | 3.1.0 |

CRs approved by TSG-RAN#8.

| RAN Doc | Spec | CR | R | Phas | Subject | Cat | Curre | New |
|-----------|--------|-----|---|------|---|-----|-------|-------|
| RP-000211 | 25.141 | 027 | | R99 | Add test specification on SSDT to 8.6. | D | 3.1.0 | 3.2.0 |
| RP-000211 | 25.141 | 028 | | R99 | Synchronisation of signal generators | F | 3.1.0 | 3.2.0 |
| RP-000211 | 25.141 | 029 | | R99 | Correction to Emission mask measurement | F | 3.1.0 | 3.2.0 |
| RP-000211 | 25.141 | 030 | | R99 | Clarification of the specification on Peak Code Domain | F | 3.1.0 | 3.2.0 |
| RP-000211 | 25.141 | 031 | | R99 | Performance requirements | F | 3.1.0 | 3.2.0 |
| RP-000211 | 25.141 | 032 | | R99 | Frequency stability measurement using complex | F | 3.1.0 | 3.2.0 |
| RP-000211 | 25.141 | 033 | | R99 | Editorial corrections on moving propagation conditions | F | 3.1.0 | 3.2.0 |
| RP-000211 | 25.141 | 034 | | R99 | Editorial correction on Spurious emissions | D | 3.1.0 | 3.2.0 |
| RP-000211 | 25.141 | 035 | | R99 | Corrections to the seed of P-CCPCH | F | 3.1.0 | 3.2.0 |
| RP-000211 | 25.141 | 036 | | R99 | Data clock accuracy | F | 3.1.0 | 3.2.0 |
| RP-000211 | 25.141 | 037 | | R99 | Corrections to several missing items and clarifications | F | 3.1.0 | 3.2.0 |

Annex F (informative): Change history

| Version | Date | |
|----------------|---------------|--|
| V3.0.0 | December 1999 | |
| V3.1.0 | March 2000 | |
| V3.2.0 | June 2000 | |

History

| Document history | | |
|-------------------------|--------------|-------------|
| V3.0.0 | January 2000 | Publication |
| V3.1.0 | March 2000 | Publication |
| V3.2.0 | June 2000 | Publication |
| | | |
| | | |