

# ETSI TS 125 141 V4.10.0 (2007-03)

---

*Technical Specification*

## **Universal Mobile Telecommunications System (UMTS); Base Station (BS) conformance testing (FDD) (3GPP TS 25.141 version 4.10.0 Release 4)**

---



---

**Reference**RTS/TSGR-0425141v4a0

---

**Keywords**UMTS

---

**ETSI**

650 Route des Lucioles  
F-06921 Sophia Antipolis Cedex - FRANCE

---

Tel.: +33 4 92 94 42 00 Fax: +33 4 93 65 47 16

Siret N° 348 623 562 00017 - NAF 742 C  
Association à but non lucratif enregistrée à la  
Sous-Préfecture de Grasse (06) N° 7803/88

---

**Important notice**

---

Individual copies of the present document can be downloaded from:

<http://www.etsi.org>

The present document may be made available in more than one electronic version or in print. In any case of existing or perceived difference in contents between such versions, the reference version is the Portable Document Format (PDF). In case of dispute, the reference shall be the printing on ETSI printers of the PDF version kept on a specific network drive within ETSI Secretariat.

Users of the present document should be aware that the document may be subject to revision or change of status. Information on the current status of this and other ETSI documents is available at

<http://portal.etsi.org/tb/status/status.asp>

If you find errors in the present document, please send your comment to one of the following services:

[http://portal.etsi.org/chaicor/ETSI\\_support.asp](http://portal.etsi.org/chaicor/ETSI_support.asp)

---

**Copyright Notification**

---

No part may be reproduced except as authorized by written permission.  
The copyright and the foregoing restriction extend to reproduction in all media.

© European Telecommunications Standards Institute 2007.  
All rights reserved.

**DECT**<sup>TM</sup>, **PLUGTESTS**<sup>TM</sup> and **UMTS**<sup>TM</sup> are Trade Marks of ETSI registered for the benefit of its Members.  
**TIPHON**<sup>TM</sup> and the **TIPHON logo** are Trade Marks currently being registered by ETSI for the benefit of its Members.  
**3GPP**<sup>TM</sup> is a Trade Mark of ETSI registered for the benefit of its Members and of the 3GPP Organizational Partners.

---

## Intellectual Property Rights

IPRs essential or potentially essential to the present document may have been declared to ETSI. The information pertaining to these essential IPRs, if any, is publicly available for **ETSI members and non-members**, and can be found in ETSI SR 000 314: *"Intellectual Property Rights (IPRs); Essential, or potentially Essential, IPRs notified to ETSI in respect of ETSI standards"*, which is available from the ETSI Secretariat. Latest updates are available on the ETSI Web server (<http://webapp.etsi.org/IPR/home.asp>).

Pursuant to the ETSI IPR Policy, no investigation, including IPR searches, has been carried out by ETSI. No guarantee can be given as to the existence of other IPRs not referenced in ETSI SR 000 314 (or the updates on the ETSI Web server) which are, or may be, or may become, essential to the present document.

---

## Foreword

This Technical Specification (TS) has been produced by ETSI 3rd Generation Partnership Project (3GPP).

The present document may refer to technical specifications or reports using their 3GPP identities, UMTS identities or GSM identities. These should be interpreted as being references to the corresponding ETSI deliverables.

The cross reference between GSM, UMTS, 3GPP and ETSI identities can be found under <http://webapp.etsi.org/key/queryform.asp>.

# Contents

Intellectual Property Rights .....	2
Foreword.....	2
Foreword.....	11
1 Scope .....	12
2 References .....	12
3 Definitions and abbreviations.....	12
3.1 Definitions .....	12
3.2 Void.....	13
3.3 Abbreviations .....	13
3.4 Radio Frequency bands .....	14
3.4.1 Frequency bands .....	14
3.4.2 TX–RX frequency separation .....	14
3.5 Channel arrangement.....	14
3.5.1 Channel spacing .....	14
3.5.2 Channel raster .....	14
3.5.3 Channel number.....	14
4 General test conditions and declarations .....	15
4.1 Acceptable uncertainty of Test System .....	15
4.1.1 Measurement of test environments .....	15
4.1.2 Measurement of transmitter .....	16
4.1.3 Measurement of receiver .....	17
4.1.4 Measurement of performance requirement .....	18
4.2 Test Tolerances (informative) .....	18
4.2.1 Transmitter.....	19
4.2.2 Receiver .....	19
4.2.3 Performance requirement.....	19
4.2.4 RRM measurements.....	20
4.3 Interpretation of measurement results .....	20
4.3A Output power and determination of power class .....	20
4.4 Test environments .....	20
4.4.1 Normal test environment .....	20
4.4.2 Extreme test environment .....	21
4.4.2.1 Extreme temperature .....	21
4.4.3 Vibration.....	21
4.4.4 Power supply .....	21
4.4.5 Definition of Additive White Gaussian Noise (AWGN) Interferer .....	22
4.5 Selection of configurations for testing.....	22
4.6 BS Configurations .....	22
4.6.1 Receiver diversity .....	22
4.6.2 Duplexers .....	22
4.6.3 Power supply options.....	23
4.6.4 Ancillary RF amplifiers .....	23
4.6.5 BS using antenna arrays.....	23
4.6.5.1 Receiver tests .....	24
4.6.5.2 Transmitter tests .....	24
4.7 Regional requirements.....	24
4.8 Specified frequency range .....	25
5 Format and interpretation of tests.....	26
6 Transmitter .....	27
6.1 General .....	27
6.1.1 Test Models .....	27
6.1.1.1 Test Model 1 .....	27

6.1.1.2	Test Model 2 .....	30
6.1.1.3	Test Model 3 .....	30
6.1.1.4	Test Model 4 .....	31
6.1.1.5	DPCH Structure of the Downlink Test Models.....	32
6.1.1.6	Common channel Structure of the Downlink Test Models .....	33
6.1.1.6.1	P-CCPCH .....	33
6.1.1.6.2	PICH.....	33
6.1.1.6.3	Primary scrambling code and SCH.....	33
6.1.1.6.4	S-CCPCH containing PCH.....	33
6.2	Base station output power .....	33
6.2.1	Base station maximum output power.....	33
6.2.1.1	Definition and applicability.....	33
6.2.1.2	Minimum Requirement .....	34
6.2.1.3	Test purpose .....	34
6.2.1.4	Method of test .....	34
6.2.1.4.1	Initial conditions.....	34
6.2.1.4.2	Procedure.....	34
6.2.1.5	Test Requirements.....	34
6.2.2	CPICH power accuracy .....	34
6.2.2.1	Definition and applicability.....	34
6.2.2.2	Minimum Requirement .....	34
6.2.2.3	Test purpose .....	35
6.2.2.4	Method of test .....	35
6.2.2.4.1	Initial conditions.....	35
6.2.2.4.2	Procedure.....	35
6.2.2.5	Test Requirement .....	35
6.3	Frequency error .....	35
6.3.1	Definition and applicability .....	35
6.3.2	Minimum Requirement.....	35
6.3.3	Test purpose.....	35
6.3.4	Method of test.....	35
6.3.4.1	Initial Conditions.....	35
6.3.4.2	Procedure .....	36
6.3.5	Test requirement .....	36
6.4	Output power dynamics.....	36
6.4.1	Inner loop power control.....	36
6.4.2	Power control steps.....	36
6.4.2.1	Definition and applicability.....	36
6.4.2.2	Minimum Requirement .....	36
6.4.2.3	Test purpose .....	37
6.4.2.4	Method of test .....	37
6.4.2.4.1	Initial conditions.....	37
6.4.2.4.2	Procedure.....	37
6.4.2.5	Test requirement .....	37
6.4.3	Power control dynamic range .....	38
6.4.3.1	Definition and applicability.....	38
6.4.3.2	Minimum Requirement .....	38
6.4.3.3	Test purpose .....	38
6.4.3.4	Method of test .....	38
6.4.3.4.1	Initial conditions.....	38
6.4.3.4.2	Procedure.....	39
6.4.3.5	Test requirement .....	39
6.4.4	Total power dynamic range .....	39
6.4.4.1	Definition and applicability.....	39
6.4.4.2	Minimum Requirement .....	39
6.4.4.3	Test purpose .....	39
6.4.4.4	Method of test .....	39
6.4.4.5	Test requirement .....	40
6.4.5	IPDL time mask.....	40
6.4.5.1	Definition and applicability.....	40
6.4.5.2	Minimum Requirement .....	40
6.4.5.3	Test purpose .....	40

6.4.5.4	Method of test .....	40
6.4.5.4.1	Initial conditions .....	40
6.4.5.4.2	Procedure.....	41
6.4.5.5	Test Requirements.....	41
6.5	Output RF spectrum emissions.....	41
6.5.1	Occupied bandwidth .....	41
6.5.1.1	Definition and applicability.....	41
6.5.1.2	Minimum Requirements.....	41
6.5.1.3	Test purpose .....	41
6.5.1.4	Method of test .....	42
6.5.1.4.1	Initial conditions .....	42
6.5.1.4.2	Procedure.....	42
6.5.1.5	Test requirements .....	42
6.5.2	Out of band emission .....	42
6.5.2.1	Spectrum emission mask .....	42
6.5.2.1.1	Definitions and applicability .....	42
6.5.2.1.2	Minimum Requirements .....	43
6.5.2.1.3	Test purpose .....	44
6.5.2.1.4	Method of test.....	44
6.5.2.1.4.1	Initial conditions .....	44
6.5.2.1.4.2	Procedures .....	44
6.5.2.1.5	Test requirements .....	44
6.5.2.2	Adjacent Channel Leakage power Ratio (ACLR).....	46
6.5.2.2.1	Definition and applicability .....	46
6.5.2.2.2	Minimum Requirement .....	46
6.5.2.2.3	Test purpose .....	46
6.5.2.2.4	Method of test.....	46
6.5.2.2.4.1	Initial conditions .....	46
6.5.2.2.4.2	Procedure .....	46
6.5.2.2.5	Test Requirement.....	46
6.5.3	Spurious emissions .....	47
6.5.3.1	Definition and applicability.....	47
6.5.3.2	(void).....	47
6.5.3.3	(void).....	47
6.5.3.4	Minimum Requirements.....	47
6.5.3.4.1	Spurious emissions (Category A) .....	47
6.5.3.4.1.1	Minimum Requirement .....	47
6.5.3.4.2	Spurious emissions (Category B) .....	48
6.5.3.4.2.1	Minimum Requirement.....	48
6.5.3.4.3	Protection of the BS receiver of own or different BS.....	48
6.5.3.4.3.1	Minimum Requirement .....	48
6.5.3.4.4	Co-existence with GSM 900.....	48
6.5.3.4.4.1	Operation in the same geographic area .....	48
6.5.3.4.4.1.1	Minimum Requirement .....	48
6.5.3.4.4.2	Co-located base stations.....	49
6.5.3.4.4.2.1	Minimum Requirement .....	49
6.5.3.4.5	Co-existence with DCS 1800 .....	49
6.5.3.4.5.1	Operation in the same geographic area .....	49
6.5.3.4.5.1.1	Minimum Requirement .....	49
6.5.3.4.5.2	Co-located basestations.....	49
6.5.3.4.5.2.1	Minimum Requirement .....	49
6.5.3.4.6	Co-existence with PHS.....	50
6.5.3.4.6.1	Minimum Requirement.....	50
6.5.3.4.7	Co-existence with services in adjacent frequency bands .....	50
6.5.3.4.7.1	Minimum requirement .....	50
6.5.3.4.8	Co-existence with UTRA-TDD.....	50
6.5.3.4.8.1	Operation in the same geographic area .....	50
6.5.3.4.8.1.1	Minimum Requirement .....	50
6.5.3.4.8.2	Co-located base stations.....	51
6.5.3.4.8.2.1	Minimum Requirement .....	51
6.5.3.5	Test purpose .....	51
6.5.3.6	Method of Test.....	51

6.5.3.6.1	Initial conditions .....	51
6.5.3.6.2	Procedure .....	51
6.5.3.7	Test requirements .....	51
6.5.3.7.1	Spurious emissions (Category A) .....	52
6.5.3.7.2	Spurious emissions (Category B) .....	52
6.5.3.7.3	Protection of the BS receiver of own or different BS .....	52
6.5.3.7.4	Co-existence with GSM 900 .....	52
6.5.3.7.4.1	Operation in the same geographic area .....	52
6.5.3.7.4.2	Co-located base stations .....	53
6.5.3.7.5	Co-existence with DCS 1800 .....	53
6.5.3.7.5.1	Operation in the same geographic area .....	53
6.5.3.7.5.2	Co-located base stations .....	53
6.5.3.7.6	Co-existence with PHS .....	53
6.5.3.7.7	Co-existence with services in adjacent frequency bands .....	53
6.5.3.7.8	Co-existence with UTRA-TDD .....	54
6.5.3.7.8.1	Operation in the same geographic area .....	54
6.5.3.7.8.2	Co-located base stations .....	54
6.6	Transmit intermodulation .....	54
6.6.1	Definition and applicability .....	54
6.6.2	Minimum Requirement .....	54
6.6.3	Test purpose .....	54
6.6.4	Method of test .....	54
6.6.4.1	Initial conditions .....	54
6.6.4.2	Procedures .....	55
6.6.5	Test Requirements .....	55
6.7	Transmit modulation .....	55
6.7.1	Error Vector Magnitude .....	55
6.7.1.1	Definition and applicability .....	55
6.7.1.2	Minimum Requirement .....	56
6.7.1.3	Test Purpose .....	56
6.7.1.4	Method of Test .....	56
6.7.1.4.1	Initial Conditions .....	56
6.7.1.4.2	Procedure .....	56
6.7.1.5	Test Requirement .....	56
6.7.2	Peak Code Domain Error .....	56
6.7.2.1	Definition and applicability .....	56
6.7.2.2	Minimum requirement .....	57
6.7.2.3	Test Purpose .....	57
6.7.2.4	Method of test .....	57
6.7.2.4.1	Initial conditions .....	57
6.7.2.4.2	Procedure .....	57
6.7.2.5	Test requirement .....	57
7	Receiver characteristics .....	57
7.1	General .....	57
7.2	Reference sensitivity level .....	58
7.2.1	Definition and applicability .....	58
7.2.2	Minimum Requirement .....	58
7.2.3	Test purpose .....	58
7.2.4	Method of testing .....	59
7.2.4.1	Initial conditions .....	59
7.2.4.2	Procedure .....	59
7.2.5	Test requirement .....	59
7.3	Dynamic range .....	59
7.3.1	Definition and applicability .....	59
7.3.2	Minimum Requirement .....	59
7.3.3	Test purpose .....	60
7.3.4	Method of test .....	60
7.3.4.1	Initial conditions .....	60
7.3.4.2	Procedure .....	60
7.3.5	Test Requirements .....	60
7.4	Adjacent Channel Selectivity (ACS) .....	61

7.4.1	Definition and applicability .....	61
7.4.2	Minimum Requirement .....	61
7.4.3	Test purpose.....	61
7.4.4	Method of test .....	61
7.4.4.1	Initial conditions .....	61
7.4.4.2	Procedure .....	61
7.4.5	Test Requirements .....	62
7.5	Blocking characteristics .....	62
7.5.1	Definition and applicability .....	62
7.5.2	Minimum Requirements .....	62
7.5.3	Test purpose.....	63
7.5.4	Method of test .....	63
7.5.4.1	Initial conditions .....	63
7.5.4.2	Procedure .....	63
7.5.5	Test Requirements .....	64
7.6	Intermodulation characteristics .....	65
7.6.1	Definition and applicability .....	65
7.6.2	Minimum Requirement .....	65
7.6.3	Test purpose.....	65
7.6.4	Method of test .....	65
7.6.4.1	Initial conditions .....	65
7.6.4.2	Procedures .....	65
7.6.5	Test requirements.....	66
7.7	Spurious Emissions .....	66
7.7.1	Definition and applicability .....	66
7.7.2	Minimum Requirements .....	66
7.7.3	Test purpose.....	67
7.7.4	Method of test .....	67
7.7.4.1	Initial conditions .....	67
7.7.4.2	Procedure .....	67
7.7.5	Test requirements.....	67
7.8	Verification of the internal BER calculation .....	68
7.8.1	Definition and applicability .....	68
7.8.2	Minimum Requirement .....	68
7.8.3	Test purpose.....	68
7.8.4	Method of test .....	68
7.8.4.1	Initial conditions .....	68
7.8.4.2	Procedure .....	69
7.8.5	Test Requirement.....	69
8	Performance requirement .....	69
8.1	General .....	69
8.2	Demodulation in static propagation conditions .....	69
8.2.1	Demodulation of DCH.....	69
8.2.1.1	Definition and applicability.....	69
8.2.1.2	Minimum requirement .....	69
8.2.1.3	Test purpose .....	70
8.2.1.4	Method of test .....	70
8.2.1.4.1	Initial conditions .....	70
8.2.1.4.2	Procedure.....	70
8.2.1.5	Test requirements .....	70
8.3	Demodulation of DCH in multipath fading conditions .....	70
8.3.1	Multipath fading Case 1.....	70
8.3.1.1	Definition and applicability.....	70
8.3.1.2	Minimum requirement .....	71
8.3.1.3	Test Purpose .....	71
8.3.1.4	Method of test .....	71
8.3.1.4.1	Initial conditions .....	71
8.3.1.4.2	Procedure.....	71
8.3.1.5	Test requirements .....	71
8.3.2	Multipath fading Case 2.....	72
8.3.2.1	Definition and applicability.....	72



8.3.2.2	Minimum requirement .....	72
8.3.2.3	Test Purpose .....	72
8.3.2.4	Method of test .....	72
8.3.2.4.1	Initial conditions .....	72
8.3.2.4.2	Procedure .....	72
8.3.2.5	Test requirements .....	73
8.3.3	Multipath fading Case 3 .....	73
8.3.3.1	Definition and applicability .....	73
8.3.3.2	Minimum requirement .....	73
8.3.3.3	Test purpose .....	73
8.3.3.4	Method of test .....	74
8.3.3.4.1	Initial conditions .....	74
8.3.3.4.2	Procedure .....	74
8.3.3.5	Test requirements .....	74
8.3.4	Multipath fading Case 4 .....	74
8.3.4.1	Definition and applicability .....	74
8.3.4.2	Minimum requirement .....	74
8.3.4.3	Test purpose .....	75
8.3.4.4	Method of test .....	75
8.3.4.4.1	Initial conditions .....	75
8.3.4.4.2	Procedure .....	75
8.3.4.5	Test requirements .....	75
8.4	Demodulation of DCH in moving propagation conditions .....	76
8.4.1	Definition and applicability .....	76
8.4.2	Minimum requirement .....	76
8.4.3	Test purpose .....	76
8.4.4	Method of test .....	76
8.4.4.1	Initial conditions .....	76
8.4.4.2	Procedure .....	76
8.4.5	Test requirements .....	76
8.5	Demodulation of DCH in birth/death propagation conditions .....	77
8.5.1	Definition and applicability .....	77
8.5.2	Minimum requirement .....	77
8.5.3	Test purpose .....	77
8.5.4	Method of test .....	77
8.5.4.1	Initial conditions .....	77
8.5.4.2	Procedure .....	78
8.5.5	Test requirements .....	78
8.6	Verification of the internal BLER calculation .....	78
8.6.1	Definition and applicability .....	78
8.6.2	Conformance requirement .....	79
8.6.3	Test purpose .....	79
8.6.4	Method of test .....	79
8.6.4.1	Initial conditions .....	79
8.6.4.2	Procedure .....	79
8.6.5	Test requirement .....	79
8.7	void .....	79
8.8	RACH performance .....	80
8.8.1	RACH preamble detection in static propagation conditions .....	80
8.8.1.1	Definition and applicability .....	80
8.8.1.2	Minimum requirement .....	80
8.8.1.3	Test purpose .....	80
8.8.1.4	Method of test .....	80
8.8.1.4.1	Initial conditions .....	80
8.8.1.4.2	Procedure .....	80
8.8.1.5	Test requirements .....	81
8.8.2	RACH preamble detection in multipath fading case 3 .....	81
8.8.2.1	Definition and applicability .....	81
8.8.2.2	Minimum requirement .....	81
8.8.2.3	Test purpose .....	81
8.8.2.4	Method of test .....	81
8.8.2.4.1	Initial conditions .....	81

8.8.2.4.2	Procedure.....	82
8.8.2.5	Test requirements.....	82
8.8.3	Demodulation of RACH message in static propagation conditions.....	82
8.8.3.1	Definition and applicability.....	82
8.8.3.2	Minimum requirement.....	82
8.8.3.3	Test purpose.....	83
8.8.3.4	Method of test.....	83
8.8.3.4.1	Initial conditions.....	83
8.8.3.4.2	Procedure.....	83
8.8.3.5	Test requirements.....	83
8.8.4	Demodulation of RACH message in multipath fading case 3.....	84
8.8.4.1	Definition and applicability.....	84
8.8.4.2	Minimum requirement.....	84
8.8.4.3	Test purpose.....	84
8.8.4.4	Method of test.....	84
8.8.4.4.1	Initial conditions.....	84
8.8.4.4.2	Procedure.....	84
8.8.4.5	Test requirements.....	85
<b>Annex A (normative): Measurement channels.....</b>		<b>86</b>
A.1	Summary of UL reference measurement channels.....	86
A.2	UL reference measurement channel for 12,2 kbps.....	87
A.3	UL reference measurement channel for 64 kbps.....	88
A.4	UL reference measurement channel for 144 kbps.....	89
A.5	UL reference measurement channel for 384 kbps.....	90
A.6	UL reference measurement channel for 2048 kbps.....	91
A.7	Reference measurement channels for UL RACH.....	91
<b>Annex B (informative): Measurement system set-up.....</b>		<b>93</b>
B.1	Transmitter.....	93
B.1.1	Maximum output power, total power dynamic range.....	93
B.1.2	Frequency, Code Power and Transmit Modulation.....	93
B.1.3	Power control steps and power control dynamic range.....	93
B.1.4	Out of band emission.....	94
B.1.5	Transmit intermodulation.....	94
B.2	Receiver.....	94
B.2.1	Reference sensitivity level.....	94
B.2.2	Dynamic range.....	95
B.2.3	Adjacent Channel Selectivity (ACS).....	95
B.2.4	Blocking characteristics.....	96
B.2.5	Intermodulation characteristics.....	96
B.2.6	Receiver spurious emission.....	97
B.3	Performance requirement.....	97
B.3.1	Demodulation of DCH and RACH in static conditions.....	97
B.3.2	Demodulation of DCH and RACH in multipath fading conditions.....	98
B.3.3	Verification of the internal BLER calculation.....	98
<b>Annex C (normative): Detailed definition of error events.....</b>		<b>99</b>
<b>Annex D (normative): Propagation conditions.....</b>		<b>100</b>
D.1	Static propagation condition.....	100
D.2	Multi-path fading propagation conditions.....	100
D.3	Moving propagation conditions.....	100

D.4	Birth-Death propagation conditions .....	101
<b>Annex E (normative): Global In-Channel TX-Test .....</b>		<b>102</b>
E.1	General .....	102
E.2	Definition of the process .....	102
E.2.1	Basic principle.....	102
E.2.2	Output signal of the TX under test .....	102
E.2.3	Reference signal .....	102
E.2.4	Classification of measurement results .....	103
E.2.5	Process definition to achieve results of type 'deviation' .....	103
E.2.5.1	Decision Point Power.....	104
E.2.5.2	Code-Domain Power.....	104
E.2.6	Process definition to achieve results of type 'residual'.....	104
E.2.6.1	Error Vector Magnitude (EVM) .....	105
E.2.6.2	Peak Code Domain Error (PCDE) .....	105
E.3	Notes.....	105
E.3.1	Symbol length .....	105
E.3.2	Deviation .....	106
E.3.3	Residual.....	106
E.3.4	Scrambling Code .....	106
E.3.5	IQ.....	106
E.3.6	Synch Channel.....	106
E.3.7	Formula for the minimum process .....	106
E.3.8	Power Step.....	107
E.3.9	Formula for EVM.....	108
<b>Annex F (informative): Derivation of Test Requirements.....</b>		<b>109</b>
<b>Annex G (informative): Acceptable uncertainty of Test Equipment .....</b>		<b>113</b>
G.1	Transmitter measurements .....	113
G.2	Receiver measurements.....	114
G.3	Performance measurements.....	114
<b>Annex H (Informative): UTRAN Measurement Test Cases.....</b>		<b>115</b>
H.1	Purpose of Annex .....	115
H.2	Received Total Wideband Power .....	115
H.2.1	Absolute RTWP measurement .....	115
H.2.2	Relative RTWP measurement .....	115
<b>Annex I (informative): Change History .....</b>		<b>116</b>
	History .....	118

---

# Foreword

This Technical Specification (TS) has been produced by the 3<sup>rd</sup> Generation Partnership Project (3GPP).

The contents of the present document are subject to continuing work within the TSG and may change following formal TSG approval. Should the TSG modify the contents of the present document, it will be re-released by the TSG with an identifying change of release date and an increase in version number as follows:

Version x.y.z

where:

- x the first digit:
  - 1 presented to TSG for information;
  - 2 presented to TSG for approval;
  - 3 or greater indicates TSG approved document under change control.
- y the second digit is incremented for all changes of substance, i.e. technical enhancements, corrections, updates, etc.
- z the third digit is incremented when editorial only changes have been incorporated in the document.

---

# 1 Scope

The present document specifies the Radio Frequency (RF) test methods and conformance requirements for UTRA Base Stations (BS) operating in the FDD mode. These have been derived from, and are consistent with the UTRA Base Station (BS) specifications defined in [1].

The present document establishes the minimum RF characteristics of the FDD mode of UTRA for the Base Station (BS).

---

# 2 References

The following documents contain provisions which, through reference in this text, constitute provisions of the present document.

- References are either specific (identified by date of publication, edition number, version number, etc.) or non-specific.
- For a specific reference, subsequent revisions do not apply.
- For a non-specific reference, the latest version applies. In the case of a reference to a 3GPP document (including a GSM document), a non-specific reference implicitly refers to the latest version of that document *in the same Release as the present document*.

- [1] 3GPP TS 25.104: "UTRA(BS) FDD; Radio transmission and Reception".
- [2] 3GPP TS 25.942: "RF system scenarios".
- [3] 3GPP TS 25.113: "Base station EMC".
- [4] ITU-R recommendation SM.329-8: "Spurious emissions".
- [5] ITU-T recommendation O.153: "Basic parameters for the measurement of error performance at bit rates below the primary rate".
- [6] IEC 60721-3-3 (1994): "Classification of environmental conditions - Part 3: Classification of groups of environmental parameters and their severities - Section 3: Stationary use at weather protected locations".
- [7] IEC 60721-3-4 (1995): "Classification of environmental conditions - Part 3: Classification of groups of environmental parameters and their severities - Section 4: Stationary use at non-weather protected locations".
- [8] IEC 60068-2-1 (1990): "Environmental testing - Part 2: Tests. Tests A: Cold".
- [9] IEC 60068-2-2 (1974): "Environmental testing - Part 2: Tests. Tests B: Dry heat".
- [10] IEC 60068-2-6 (1995): "Environmental testing - Part 2: Tests - Test Fc: Vibration (sinusoidal)".
- [11] ITU-R recommendation SM.328-9: "Spectra and bandwidth of emissions".
- [12] 3GPP TS 25.214: 'Physical layer procedures (FDD)'

---

# 3 Definitions and abbreviations

## 3.1 Definitions

For the purposes of the present document, the following terms and definitions apply:

**Ancillary RF amplifier:** a piece of equipment, which when connected by RF coaxial cables to the BS, has the primary function to provide amplification between the transmit and/or receive antenna connector of a BS and an antenna without requiring any control signal to fulfil its amplifying function.

**Mean power:** When applied to a W-CDMA modulated signal this is the power (transmitted or received) in a bandwidth of at least  $(1 + \alpha)$  times the chip rate of the radio access mode. The period of measurement shall be at least one timeslot unless otherwise stated.

**RRC filtered mean power:** The mean power as measured through a root raised cosine filter with roll-off factor  $\alpha$  and a bandwidth equal to the chip rate of the radio access mode.

NOTE 1: The RRC filtered mean power of a perfectly modulated W-CDMA signal is 0.246 dB lower than the mean power of the same signal.

NOTE 2: The roll-off factor  $\alpha$  is defined in section 6.8.1 of TS25.104.

**Code domain power:** That part of the mean power which correlates with a particular (OVSF) code channel. The sum of all powers in the code domain equals the mean power in a bandwidth of  $(1 + \alpha)$  times the chip rate of the radio access mode. See Annex E.2.5.2.

**Output power:** The mean power of one carrier of the base station, delivered to a load with resistance equal to the nominal load impedance of the transmitter.

**Rated output power:** Rated output power of the base station is the mean power level per carrier that the manufacturer has declared to be available at the antenna connector.

**Maximum output power:** The mean power level per carrier of the base station measured at the antenna connector in a specified reference condition.

**Power control dynamic range:** The difference between the maximum and the minimum code domain power of a code channel for a specified reference condition.

**Total power dynamic range:** The difference between the maximum and the minimum output power for a specified reference condition.

## 3.2 Void

## 3.3 Abbreviations

For the purposes of the present document, the following abbreviations apply:

ACLR	Adjacent Channel Leakage power Ratio
ACS	Adjacent Channel Selectivity
BER	Bit Error Ratio
BLER	Block Error Ratio
BS	Base Station
CW	Continuous Wave (unmodulated signal)
DCH	Dedicated Channel, which is mapped into Dedicated Physical Channel. DCH contains the data
DL	Down Link (forward link)
DPCH	Dedicated Physical Channel
$E_b$	Average energy per information bit for the PCCPCH, SCCPCH and DPCH, at the antenna connector
$E_c$	Average energy per PN chip
EVM	Error Vector Magnitude
FDD	Frequency Division Duplexing
$F_{uw}$	Frequency of unwanted signal
MS	Mobile Station
PCCPCH	Primary Common Control Physical Channel
PCDE	Peak Code Domain Error
PCH	Paging Channel
PPM	Parts Per Million

SCCPCH	Secondary Common Control Physical Channel
TDD	Time Division Duplexing
TPC	Transmit Power Control
UE	User Equipment
UL	Up Link (reverse link)
UTRA	UMTS Terrestrial Radio Access

## 3.4 Radio Frequency bands

### 3.4.1 Frequency bands

UTRA/FDD is designed to operate in either of the following paired bands:

- (a): 1 920 MHz to 1 980 MHz: up-link (Mobile transmit, base receive);  
2 110 MHz to 2 170 MHz: down-link (Base transmit, mobile receive);
- (b)\*: 1 850 MHz to 1 910 MHz: up-link (Mobile transmit, base receive);  
1 930 MHz to 1 990 MHz: down-link (Base transmit, mobile receive).

NOTE: \*: Used in Region 2.

Additional allocations in ITU region 2 are FFS.

Deployment in other frequency bands is not precluded.

### 3.4.2 TX–RX frequency separation

- (a) The minimum transmit to receive frequency separation is 134,8 MHz and the maximum value is 245,2 MHz and all UE(s) shall support a TX –RX frequency separation of 190 MHz when operating in the paired band defined in subclause 3.4.1(a).
- (b) UTRA/FDD can support both fixed and variable transmit to receive frequency separation.
- (c) When operating in the paired band defined in subclause 3.4.1(b), all UE(s) shall support a TX – RX frequency separation of 80 MHz.
- (d) The use of other transmit to receive frequency separations in existing or other frequency bands shall not be precluded.

## 3.5 Channel arrangement

### 3.5.1 Channel spacing

The nominal channel spacing is 5 MHz, but this can be adjusted to optimise performance in a particular deployment scenario.

### 3.5.2 Channel raster

The channel raster is 200 kHz, which means that the centre frequency must be an integer multiple of 200 kHz.

### 3.5.3 Channel number

The carrier frequency is designated by the UTRA Absolute Radio Frequency Channel Number (UARFCN). The value of the UARFCN in the IMT2000 band is defined as follows.

**Table 3.1: UTRA Absolute Radio Frequency Channel Number**

Uplink	$N_u = 5 * (F_{\text{uplink}} \text{ MHz})$	$0.0 \text{ MHz} \leq F_{\text{uplink}} \leq 3276.6 \text{ MHz}$ where $F_{\text{uplink}}$ is the uplink frequency in MHz
Downlink	$N_d = 5 * (F_{\text{downlink}} \text{ MHz})$	$0.0 \text{ MHz} \leq F_{\text{downlink}} \leq 3276.6 \text{ MHz}$ where $F_{\text{downlink}}$ is the downlink frequency in MHz

**Table 3.2: UARFCN definition (Band b, region 2, Additional Channels)**

Uplink	$N_u = 5 * (F_{\text{uplink}} - 1850.1 \text{ MHz})$	1852.5, 1857.5, 1862.5, 1867.5, 1872.5, 1877.5, 1882.5, 1887.5, 1892.5, 1897.5, 1902.5, 1907.5
Downlink	$N_d = 5 * (F_{\text{downlink}} - 1850.1 \text{ MHz})$	1932.5, 1937.5, 1942.5, 1947.5, 1952.5, 1957.5, 1962.5, 1967.5, 1972.5, 1977.5, 1982.5, 1987.5

## 4 General test conditions and declarations

The requirements of this clause apply to all applicable tests in this specification.

Many of the tests in this specification measure a parameter relative to a value that is not fully specified in the UTRA specifications. For these tests, the Minimum Requirement is determined relative to a nominal value specified by the manufacturer.

Certain functions of a BS are optional in the UTRA specifications. Some requirements for the BS may be regional as listed in subclause 4.7.

When specified in a test, the manufacturer shall declare the nominal value of a parameter, or whether an option is supported.

### 4.1 Acceptable uncertainty of Test System

The maximum acceptable uncertainty of the Test System is specified below for each test, where appropriate. The Test System shall enable the stimulus signals in the test case to be adjusted to within the specified tolerance and the equipment under test to be measured with an uncertainty not exceeding the specified values. All tolerances and uncertainties are absolute values, and are valid for a confidence level of 95 %, unless otherwise stated.

A confidence level of 95% is the measurement uncertainty tolerance interval for a specific measurement that contains 95% of the performance of a population of test equipment.

For RF tests, it should be noted that the uncertainties in subclause 4.1 apply to the Test System operating into a nominal 50 ohm load and do not include system effects due to mismatch between the DUT and the Test System.

#### 4.1.1 Measurement of test environments

The measurement accuracy of the BS test environments defined in Subclause 4.4, Test environments shall be.

- Pressure  $\pm 5 \text{ kPa}$ .
- Temperature  $\pm 2 \text{ degrees}$ .
- Relative Humidity  $\pm 5 \%$ .
- DC Voltage  $\pm 1,0 \%$ .
- AC Voltage  $\pm 1,5 \%$ .
- Vibration  $10 \%$ .



- Vibration frequency 0,1 Hz.

The above values shall apply unless the test environment is otherwise controlled and the specification for the control of the test environment specifies the uncertainty for the parameter.

## 4.1.2 Measurement of transmitter

**Table 4.1: Maximum Test System Uncertainty for transmitter tests**

Subclause	Maximum Test System Uncertainty	Derivation of Test System Uncertainty
6.2.1 Maximum Output Power	$\pm 0.7$ dB	
6.2.2 CPICH Power accuracy	$\pm 0.8$ dB	
6.3 Frequency error	$\pm 12$ Hz	
6.4.2 Power control steps	$\pm 0.1$ dB for one 1 dB step $\pm 0.1$ dB for one 0.5 dB step  $\pm 0.1$ dB for ten 1 dB steps $\pm 0.1$ dB for ten 0.5 dB steps	Result is difference between two absolute CDP measurements on the power controlled DPCH. Assume BTS output power on all other channels is constant. Assume Test equipment relative power accuracy over the range of the test conditions is perfect, or otherwise included in the system measurement error. For this test the absolute power change is $< 3$ dB.
6.4.3 Power control dynamic range	$\pm 1.1$ dB	
6.4.4 Total power dynamic range	$\pm 0.3$ dB	
6.4.5 IPDL time mask	$\pm 0.7$ dB	
6.5.1 Occupied Bandwidth	$\pm 100$ kHz	Accuracy = $\pm 3 \cdot \text{RBW}$ . Assume 30 kHz bandwidth
6.5.2.1 Spectrum emission mask	$\pm 1.5$ dB Due to carrier leakage, for measurements specified in a 1 MHz bandwidth close to the carrier (4 MHz to 8 MHz), integration of the measurement using several narrower measurements may be necessary in order to achieve the above accuracy.	
6.5.2.2 ACLR	5 MHz offset $\pm 0.8$ dB 10 MHz offset $\pm 0.8$ dB Note: Impact of measurement period (averaging) and intermod effects in the measurement receiver not yet fully studied. However, the above limits remain valid.	
6.5.3 Spurious emissions	$\pm 2.0$ dB for BS and coexistence bands for results $> -60$ dBm $\pm 3.0$ dB for results $< -60$ dBm Outside above range: $f \leq 2.2$ GHz : $\pm 1.5$ dB $2.2$ GHz $< f \leq 4$ GHz : $\pm 2.0$ dB $f > 4$ GHz : $\pm 4.0$ dB	
6.6 Transmit intermodulation (interferer requirements)	The value below applies only to the interference signal and is unrelated to the measurement uncertainty of the tests (6.5.2.1, 6.5.2.2 and 6.5.3) which have to be carried out in the presence of the interferer. $\pm 1.0$ dB	The uncertainty of interferer has double the effect on the result due to the frequency offset.
6.7.1 EVM	$\pm 2.5$ % (for single code)	
6.7.2 Peak code Domain error	$\pm 1.0$ dB	

## 4.1.3 Measurement of receiver

Table 4.1A: Maximum Test System Uncertainty for receiver tests

Subclause	Maximum Test System Uncertainty <sup>1</sup>	Derivation of Test System Uncertainty
7.2 Reference sensitivity level	± 0.7 dB	
7.3 Dynamic range	± 1.2 dB	Formula = SQRT(signal level error <sup>2</sup> and AWGN level error <sup>2</sup> )
7.4 Adjacent channel selectivity	± 1.1 dB	Formula = SQRT (wanted_level_error <sup>2</sup> + interferer_level_error <sup>2</sup> ) + ACLR effect. The ACLR effect is calculated by: (Formula to follow)
7.5 Blocking characteristics	System error with blocking signal <15 MHz offset: ± 1.4 dB Blocking signal ≥ 15 MHz offset and f ≤ 2.2 GHz: ± 1.1 dB + broadband noise 2.2 GHz < f ≤ 4 GHz : ±1.8 dB f > 4 GHz: ±3.2 dB	Formula = SQRT (wanted_level_error <sup>2</sup> + interferer_level_error <sup>2</sup> ) + ACLR effect + Broadband noise. (Assuming ACLR 68 dB, and 0.7 dB for signals) Assume -130 dBc broadband noise from blocking signal has 0.1 dB effect. Harmonics and spurs of the interferer need to be carefully considered. Perhaps need to avoid harmonics of the interfere that fall on top of the receive channel. For the -15 dBm CW blocking case, filtering of the blocking signal (at least 25 dB) is necessary to eliminate problems with broadband noise.
7.6 Intermod Characteristics	±1.3 dB	Formula = $\sqrt{(2 \cdot CW\_level\_error)^2 + (mod\_level\_error)}$  (Using CW interferer ±0.5 dB, modulated interferer ±0.5 dB, wanted signal ±0.7 dB)
7.7 Spurious Emissions	The Test System uncertainty figures for Spurious emissions apply to the measurement of the DUT and not any stimulus signals. ± 3.0 dB for BS receive band (-78 dBm) Outside above range: f ≤ 2.2 GHz : ± 2.0 dB (-57 dBm) 2.2 GHz < f ≤ 4 GHz : ± 2.0 dB (-47 dBm) f > 4 GHz : ±4.0 dB (-47 dBm)	
NOTE 1: Unless otherwise noted, only the Test System stimulus error is considered here. The effect of errors in the BER/FER measurements due to finite test duration is not considered.		

## 4.1.4 Measurement of performance requirement

**Table 4.1B: Maximum Test System Uncertainty for Performance Requirements**

Subclause	Maximum Test System Uncertainty <sup>1</sup>	Derivation of Test System Uncertainty
8.2, Demodulation in static propagation condition	$\pm 0.4\text{dB}$	Wanted/AWGN: $\pm 0.4\text{dB}$ (relative uncertainty for $E_b/N_0$ ) (AWGN: $\pm 1\text{dB}$ )
8.3, Demodulation of DCH in multipath fading conditions	$\pm 0.6\text{dB}$	Fader: $\pm 0.5\text{dB}$ Wanted/AWGN: $\pm 0.4\text{dB}$ (relative) Combined relative uncertainty for $E_b/N_0$ : $\pm 0.6\text{dB}$
8.4 Demodulation of DCH in moving propagation conditions	$\pm 0.6\text{dB}$	Fader: $\pm 0.5\text{dB}$ Wanted/AWGN: $\pm 0.4\text{dB}$ (relative) Combined relative uncertainty for $E_b/N_0$ : $\pm 0.6\text{dB}$
8.5 Demodulation of DCH in birth/death propagation conditions	$\pm 0.6\text{dB}$	Fader: $\pm 0.5\text{dB}$ Wanted/AWGN: $\pm 0.4\text{dB}$ (relative) Combined relative uncertainty for $E_b/N_0$ : $\pm 0.6\text{dB}$
8.8.1 RACH preamble detection in static propagation conditions	$\pm 0.4\text{dB}$	Wanted/AWGN: $\pm 0.4\text{dB}$ (relative uncertainty for $E_c/N_0$ ) (AWGN: $\pm 1\text{dB}$ )
8.8.2 RACH preamble detection in multipath fading case 3	$\pm 0.6\text{dB}$	Fader: $\pm 0.5\text{dB}$ Wanted/AWGN: $\pm 0.4\text{dB}$ (relative) Combined relative uncertainty for $E_c/N_0$ : $\pm 0.6\text{dB}$
8.8.3 Demodulation of RACH message in static propagation conditions	$\pm 0.4\text{dB}$	Wanted/AWGN: $\pm 0.4\text{dB}$ (relative uncertainty for $E_b/N_0$ ) (AWGN: $\pm 1\text{dB}$ )
8.8.4 Demodulation of RACH message in multipath fading case 3	$\pm 0.6\text{dB}$	Fader: $\pm 0.5\text{dB}$ Wanted/AWGN: $\pm 0.4\text{dB}$ (relative) Combined relative uncertainty for $E_b/N_0$ : $\pm 0.6\text{dB}$
Note 1: Only the overall stimulus error is considered here. The effect of errors in the BER/FER measurements due to finite test duration is not considered.		

## 4.2 Test Tolerances (informative)

The Test Tolerances defined in this subclause have been used to relax the Minimum Requirements in this specification to derive the Test Requirements.

The Test Tolerances are derived from Test System uncertainties, regulatory requirements and criticality to system performance. As a result, the Test Tolerances may sometimes be set to zero.

The test tolerances should not be modified for any reason e.g. to take account of commonly known test system errors (such as mismatch, cable loss, etc.)

## 4.2.1 Transmitter

**Table 4.1C: Test Tolerances for transmitter tests.**

Subclause	Test Tolerance <sup>1</sup>
6.2.1 Maximum Output Power	0.7 dB
6.2.2 CPICH Power accuracy	0.8 dB
6.3 Frequency error	12 Hz
6.4.2 Power control steps	0.1 dB
6.4.3 Power control dynamic range	1.1 dB
6.4.4 Total power dynamic range	0.3 dB
6.4.5 IPDL time mask	0.7 dB
6.5.1 Occupied Bandwidth	0 kHz
6.5.2.1 Spectrum emission mask	1.5 dB <sup>3</sup>
6.5.2.2 ACLR	0.8 dB
6.5.3 Spurious emissions	0 dB
6.6 Transmit intermodulation (interferer requirements)	0 dB <sup>2</sup>
6.7.1 Frequency error	12 Hz
6.7.12 EVM	0 %
6.7.23 Peak code Domain error	1.0dB
Note 1:	Unless otherwise stated, The Test Tolerances are applied to the DUT Minimum Requirement. See Annex F.
Note 2:	The Test Tolerance is applied to the stimulus signal(s). See Annex F.
Note 3:	0 dB test tolerance for the additional Band b requirements.

## 4.2.2 Receiver

**Table 4.1D: Test Tolerances for receiver tests.**

Subclause	Test Tolerance <sup>1</sup>
7.2 Reference sensitivity level	0.7 dB
7.3 Dynamic range	1.2 dB
7.4 Adjacent channel selectivity	0 dB
7.5 Blocking characteristics	0 dB
7.6 Intermod Characteristics	0 dB
7.7 Spurious Emissions	0 dB <sup>2</sup>
Note 1:	Unless otherwise stated, the Test Tolerances are applied to the stimulus signal(s). See Annex F.
Note 2:	The Test Tolerance is applied to the DUT Minimum Requirement. See Annex F.

## 4.2.3 Performance requirement

**Table 4.1E: Test Tolerances for Performance Requirements.**

Subclause	Test Tolerance <sup>1</sup>
8.2, Demodulation in static propagation condtion	0.4dB
8.3, Demodulation of DCH in multiplath fading conditons	0.6dB
8.4 Demodulation of DCH in moving propagation conditions	0.6dB
8.5 Demodulation of DCH in birth/death propagation conditions	0.6dB
8.8.1 RACH preamble detection in static propagation conditions	0.4dB
8.8.2 RACH preamble detection in multipath fading case 3	0.6dB
8.8.3 Demodulation of RACH message in static propagation conditions	0.4dB
8.8.4 Demodulation of RACH message in multipath fading case 3	0.6dB
Note 1:	Unless otherwise stated, the Test Tolerances are applied to the stimulus signal(s). See Annex F.

## 4.2.4 RRM measurements

The following tolerances refer to the requirements of 25.133.

tbd

## 4.3 Interpretation of measurement results

The measurement results returned by the Test System are compared - without any modification - against the Test Requirements as defined by the shared risk principle.

The Shared Risk principle is defined in ETR 273 Part 1 sub-part 2 section 6.5.

The actual measurement uncertainty of the Test System for the measurement of each parameter shall be included in the test report.

The recorded value for the Test System uncertainty shall be, for each measurement, equal to or lower than the appropriate figure in subclause 4.1 of this specification.

If the Test System for a test is known to have a measurement uncertainty greater than that specified in subclause 4.1, it is still permitted to use this apparatus provided that an adjustment is made as follows.

Any additional uncertainty in the Test System over and above that specified in subclause 4.1 shall be used to tighten the Test Requirement-making the test harder to pass. (For some tests e.g. receiver tests, this may require modification of stimulus signals). This procedure (defined in Annex F) will ensure that a Test System not compliant with subclause 4.1 does not increase the chance of passing a device under test where that device would otherwise have failed the test if a Test System compliant with subclause 4.1 had been used.

### 4.3A Output power and determination of power class

The requirements in the present document apply to base station intended for general-purpose applications.

In the future further classes of base stations may be defined; the requirements for these may be different than for general-purpose applications.

## 4.4 Test environments

For each test in the present document, the environmental conditions under which the BS is to be tested are defined.

### 4.4.1 Normal test environment

When a normal test environment is specified for a test, the test should be performed within the minimum and maximum limits of the conditions stated in table 4.2.

**Table 4.2: Limits of conditions for Normal Test Environment**

Condition	Minimum	Maximum
Barometric pressure	86 kPa	106 kPa
Temperature	15°C	30°C
Relative Humidity	20 %	85 %
Power supply	Nominal, as declared by the manufacturer	
Vibration	Negligible	

The ranges of barometric pressure, temperature and humidity represent the maximum variation expected in the uncontrolled environment of a test laboratory. If it is not possible to maintain these parameters within the specified limits, the actual values shall be recorded in the test report.

NOTE: This may, for instance, be the case for measurements of radiated emissions performed on an open field test site.

## 4.4.2 Extreme test environment

The manufacturer shall declare one of the following:

- 1) the equipment class for the equipment under test, as defined in the IEC 60 721-3-3 [6];
- 2) the equipment class for the equipment under test, as defined in the IEC 60 721-3-4 [7];
- 3) the equipment that does not comply to the mentioned classes, the relevant classes from IEC 60 721 documentation for Temperature, Humidity and Vibration shall be declared.

NOTE: Reduced functionality for conditions that fall outside of the standard operational conditions are not tested in the present document. These may be stated and tested separately.

### 4.4.2.1 Extreme temperature

When an extreme temperature test environment is specified for a test, the test shall be performed at the standard minimum and maximum operating temperatures defined by the manufacturer's declaration for the equipment under test.

#### Minimum temperature:

The test shall be performed with the environment test equipment and methods including the required environmental phenomena into the equipment, conforming to the test procedure of IEC 60 068-2-1 [8].

#### Maximum temperature:

The test shall be performed with the environmental test equipment and methods including the required environmental phenomena into the equipment, conforming to the test procedure of IEC 60 068-2-2 [9].

NOTE: It is recommended that the equipment is made fully operational prior to the equipment being taken to its lower operating temperature.

## 4.4.3 Vibration

When vibration conditions are specified for a test, the test shall be performed while the equipment is subjected to a vibration sequence as defined by the manufacturer's declaration for the equipment under test. This shall use the environmental test equipment and methods of inducing the required environmental phenomena into the equipment, conforming to the test procedure of IEC 60 068-2-6 [10]. Other environmental conditions shall be within the ranges specified in subclause 4.4.1.

NOTE: The higher levels of vibration may induce undue physical stress into equipment after a prolonged series of tests. The testing body should only vibrate the equipment during the RF measurement process.

## 4.4.4 Power supply

When extreme power supply conditions are specified for a test, the test shall be performed at the standard upper and lower limits of operating voltage defined by manufacturer's declaration for the equipment under test.

#### Upper voltage limit:

The equipment shall be supplied with a voltage equal to the upper limit declared by the manufacturer (as measured at the input terminals to the equipment). The tests shall be carried out at the steady state minimum and maximum temperature limits declared by the manufacturer for the equipment, to the methods described in IEC 60 068-2-1 [8] Test Ab/Ad and IEC 60 068-2-2 [9] Test Bb/Bd: Dry Heat.

#### Lower voltage limit:

The equipment shall be supplied with a voltage equal to the lower limit declared by the manufacturer (as measured at the input terminals to the equipment). The tests shall be carried out at the steady state minimum and maximum temperature limits declared by the manufacturer for the equipment, to the methods described in IEC 60 068-2-1 [8] Test Ab/Ad and IEC 60 068-2-2 [9] Test Bb/Bd: Dry Heat.

## 4.4.5 Definition of Additive White Gaussian Noise (AWGN) Interferer

The minimum bandwidth of the AWGN interferer shall be 1.5 times chip rate of the radio access mode. (e.g. 5.76 MHz for a chip rate of 3.84 Mcps). The flatness across this minimum bandwidth shall be less than  $\pm 0.5$  dB and the peak to average ratio at a probability of 0.001% shall exceed 10 dB.

## 4.5 Selection of configurations for testing

Most tests in the present document are only performed for a subset of the possible combinations of test conditions. For instance:

- not all transceivers in the configuration may be specified to be tested;
- only one RF channel may be specified to be tested;
- only one timeslot may be specified to be tested.

When a test is performed by a test laboratory, the choice of which combinations are to be tested shall be specified by the laboratory. The laboratory may consult with operators, the manufacturer or other bodies.

When a test is performed by a manufacturer, the choice of which combinations are to be tested may be specified by an operator.

## 4.6 BS Configurations

### 4.6.1 Receiver diversity

For the tests in clause 7 of the present document, the specified test signals shall be applied to one receiver antenna connector, with the remaining receivers are disabled or their antenna connectors being terminated with 50  $\Omega$ .

### 4.6.2 Duplexers

The requirements of the present document shall be met with a duplexer fitted, if a duplexer is supplied as part of the BS. If the duplexer is supplied as an option by the manufacturer, sufficient tests should be repeated with and without the duplexer fitted to verify that the BS meets the requirements of the present document in both cases.

The following tests should be performed with the duplexer fitted, and without it fitted if this is an option:

- 1) subclause 6.2.1, base station maximum output power, for the highest static power step only, if this is measured at the antenna connector;
- 2) subclause 6.5, output RF spectrum emissions; outside the BS transmit band;
- 3) subclause 6.5.3.4.3, protection of the BS receiver;
- 4) subclause 6.6, transmit intermodulation; for the testing of conformance, the carrier frequencies should be selected to minimize intermodulation products from the transmitters falling in receive channels.

The remaining tests may be performed with or without the duplexer fitted.

NOTE 1: When performing receiver tests with a duplexer fitted, it is important to ensure that the output from the transmitters does not affect the test apparatus. This can be achieved using a combination of attenuators, isolators and filters.

NOTE 2: When duplexers are used, intermodulation products will be generated, not only in the duplexer but also in the antenna system. The intermodulation products generated in the antenna system are not controlled by 3GPP specifications, and may degrade during operation (e.g. due to moisture ingress). Therefore, to ensure continued satisfactory operation of a BS, an operator will normally select ARFCNs to minimize intermodulation products falling on receive channels. For testing of complete conformance, an operator may specify the ARFCNs to be used.

### 4.6.3 Power supply options

If the BS is supplied with a number of different power supply configurations, it may not be necessary to test RF parameters for each of the power supply options, provided that it can be demonstrated that the range of conditions over which the equipment is tested is at least as great as the range of conditions due to any of the power supply configurations.

This applies particularly if a BS contains a DC rail which can be supplied either externally or from an internal mains power supply. In this case, the conditions of extreme power supply for the mains power supply options can be tested by testing only the external DC supply option. The range of DC input voltages for the test should be sufficient to verify the performance with any of the power supplies, over its range of operating conditions within the BS, including variation of mains input voltage, temperature and output current.

### 4.6.4 Ancillary RF amplifiers

The requirements of the present document shall be met with the ancillary RF amplifier fitted. At tests according to clauses 6 and 7 for TX and RX respectively, the ancillary amplifier is connected to the BS by a connecting network (including any cable(s), attenuator(s), etc.) with applicable loss to make sure the appropriate operating conditions of the ancillary amplifier and the BS. The applicable connecting network loss range is declared by the manufacturer. Other characteristics and the temperature dependence of the attenuation of the connecting network are neglected. The actual attenuation value of the connecting network is chosen for each test as one of the applicable extreme values. The lowest value is used unless otherwise stated.

Sufficient tests should be repeated with the ancillary amplifier fitted and, if it is optional, without the ancillary RF amplifier to verify that the BS meets the requirements of the present document in both cases.

When testing, the following tests should be repeated with the optional ancillary amplifier fitted according to the table below, where x denotes that the test is applicable:

**Table 4.3**

Receiver Tests	Subclause	TX amplifier only	RX amplifier only	TX/RX amplifiers combined (Note)
	7.2		X	X
	7.5		X	X
	7.6		X	X
	7.7		X	
Transmitter Tests	6.2	X		X
	6.5.1	X		X
	6.5.2.2	X		X
	6.5.3	X		X
	6.6	X		X

NOTE: Combining can be by duplex filters or any other network. The amplifiers can either be in RX or TX branch or in both. Either one of these amplifiers could be a passive network.

In test according to subclauses 6.2 and 7.2 highest applicable attenuation value is applied.

### 4.6.5 BS using antenna arrays

A BS may be configured with a multiple antenna port connection for some or all of its transceivers or with an antenna array related to one cell (not one array per transceiver). This subclause applies to a BS which meets at least one of the following conditions:

- the transmitter output signals from one or more transceiver appear at more than one antenna port; or
- there is more than one receiver antenna port for a transceiver or per cell and an input signal is required at more than one port for the correct operation of the receiver (NOTE: diversity reception does not meet this requirement) thus the outputs from the transmitters as well as the inputs to the receivers are directly connected to several antennas (known as 'aircombining'); or
- transmitters and receivers are connected via duplexers to more than one antenna.



If a BS is used, in normal operation, in conjunction with an antenna system which contains filters or active elements which are necessary to meet the UTRA requirements, the conformance tests may be performed on a system comprising the BS together with these elements, supplied separately for the purposes of testing. In this case, it must be demonstrated that the performance of the configuration under test is representative of the system in normal operation, and the conformance assessment is only applicable when the BS is used with the antenna system.

For conformance testing of such a BS, the following procedure may be used.

#### 4.6.5.1 Receiver tests

For each test, the test signals applied to the receiver antenna connectors shall be such that the sum of the powers of the signals applied equals the power of the test signal(s) specified in the test.

An example of a suitable test configuration is shown in figure 4.1.

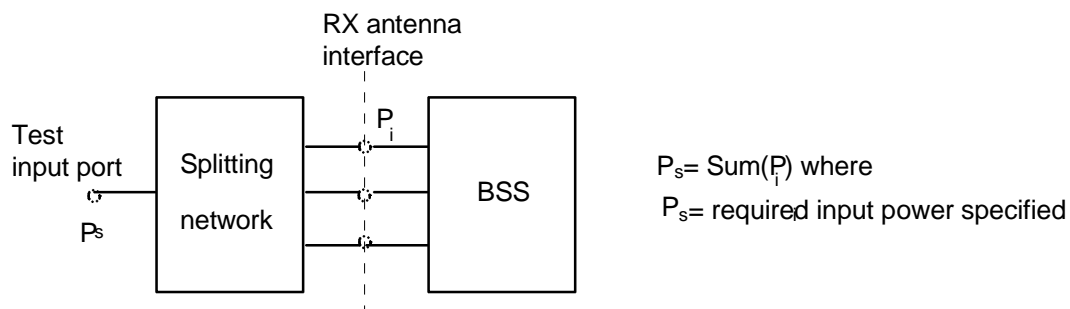

**Figure 4.1: Receiver test set-up**

For spurious emissions from the receiver antenna connector, the test may be performed separately for each receiver antenna connector.

#### 4.6.5.2 Transmitter tests

For each test, the test signals applied to the transmitter antenna connectors ( $P_i$ ) shall be such that the sum of the powers of the signals applied equals the power of the test signal(s) ( $P_s$ ) specified in the test. This may be assessed by separately measuring the signals emitted by each antenna connector and summing the results, or by combining the signals and performing a single measurement. The characteristics (e.g. amplitude and phase) of the combining network should be such that the power of the combined signal is maximised.

An example of a suitable test configuration is shown in figure 4.2.

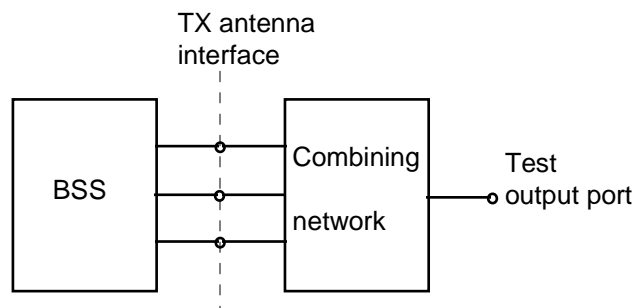

**Figure 4.2: Transmitter test set-up**

For Intermodulation attenuation, the test may be performed separately for each transmitter antenna connector.

## 4.7 Regional requirements

Some requirements in TS 25.141 may only apply in certain regions. Table 4.4 lists all requirements that may be applied differently in different regions.

Table 4.4: List of regional requirements

Subclause number	Requirement	Comments
3.4.1	Frequency bands	Some bands may be applied regionally.
3.4.2	Tx-Rx Frequency Separation	The requirement is applied according to what frequency bands in subclause 3.4.1 that are supported by the BS.
6.2.1.2	Base station output power	In certain regions, the minimum requirement for normal conditions may apply also for some conditions outside the ranges defined for the Normal test environment in subclause 4.4.1.
6.5.2.1	Spectrum emission mask	The mask specified may be mandatory in certain regions. In other regions this mask may not be applied.
6.5.3.4.1	Spurious emissions (Category A)	These requirements shall be met in cases where Category A limits for spurious emissions, as defined in ITU-R Recommendation SM.329-8 [1], are applied.
6.5.3.4.2	Spurious emissions (Category B)	These requirements shall be met in cases where Category B limits for spurious emissions, as defined in ITU-R Recommendation SM.329-8 [1], are applied.
6.5.3.4.4.1	Co-existence with GSM900 – Operation in the same geographic area	This requirement may be applied for the protection of GSM 900 MS and GSM 900 BTS in geographic areas in which both GSM 900 and UTRA are deployed.
6.5.3.4.4.2	Co-existence with GSM900 – Co-located base stations	This requirement may be applied for the protection of GSM 900 BTS receivers when GSM 900 BTS and UTRA BS are co-located.
6.5.3.4.5.1	Co-existence with DCS1800 – Operation in the same geographic area	This requirement may be applied for the protection of DCS 1800 MS and DCS 1800 BTS in geographic areas in which both DCS 1800 and UTRA are deployed.
6.5.3.4.5.2	Co-existence with DCS1800 – Co-located base stations	This requirement may be applied for the protection of DCS 1800 BTS receivers when DCS 1800 BTS and UTRA BS are co-located.
6.5.3.4.6	Co-existence with PHS	This requirement may be applied for the protection of PHS in geographic areas in which both PHS and UTRA are deployed.
6.5.3.4.7	Co-existence with services in adjacent frequency bands	This requirement may be applied for the protection in bands adjacent to 2110-2170 MHz, as defined in subclause 3.4.1(a) and 1930-1990 MHz, as defined in subclause 3.4.1(b) in geographic areas in which both an adjacent band service and UTRA are deployed.
6.5.3.4.8.1	Co-existence with UTRA TDD – Operation in the same geographic area	This requirement may be applied to geographic areas in which both UTRA-TDD and UTRA-FDD are deployed.
6.5.3.4.8.2	Co-existence with UTRA TDD – Co-located base stations	This requirement may be applied for the protection of UTRA-TDD BS receivers when UTRA-TDD BS and UTRA FDD BS are co-located.
7.5	Blocking characteristic	The requirement is applied according to what frequency bands in subclause 3.4.1 that are supported by the BS.
7.5	Blocking characteristics	This requirement may be applied for the protection of UTRA FDD BS receivers when UTRA FDD BS and GSM 900/DCS1800 BS are co-located.

## 4.8 Specified frequency range

The manufacturer shall declare:

- which of the frequency bands defined in sub-clause 3.4 is supported by the BS.

- the frequency range within the above frequency band(s) supported by the BS.

Many tests in this TS are performed with appropriate frequencies in the bottom, middle and top of the operating frequency band of the BS. These are denoted as RF channels B (bottom), M (middle) and T (top).

Unless otherwise stated, the test shall be performed with a single carrier at each of the RF channels B, M and T.

When the requirements are specific to multiple carriers, and the BS is declared to support  $N > 1$  carriers, numbered from 1 to N, the interpretation of B, M and T for test purposes shall be as follows:

For testing at B,

- the carrier of lowest frequency shall be centred on B

For testing at M,

- if the number N of carriers supported is odd, the carrier  $(N+1)/2$  shall be centred on M,
- if the number N of carriers supported is even, the carrier  $N/2$  shall be centred on M.

For testing at T

- the carrier of highest frequency shall be centred on T

When a test is performed by a test laboratory, the UARFCNs to be used for RF channels B, M and T shall be specified by the laboratory. The laboratory may consult with operators, the manufacturer or other bodies.

When a test is performed by a manufacturer, the UARFCNs to be used for RF channels B, M and T may be specified by an operator.

---

## 5 Format and interpretation of tests

Each test in the following clauses has a standard format:

### **X Title**

All tests are applicable to all equipment within the scope of the present document, unless otherwise stated.

#### **X.1 Definition and applicability**

This subclause gives the general definition of the parameter under consideration and specifies whether the test is applicable to all equipment or only to a certain subset.

#### **X.2 Minimum Requirement**

This subclause is an informative copy of the Minimum Requirement defined by the core specification.

In addition, this subclause contains the reference to the subclause to the 3GPP reference (or core) specification which defines the Minimum Requirement.

#### **X.3 Test purpose**

This subclause defines the purpose of the test.

#### **X.4 Method of test**

##### **X.4.1 Initial conditions**

This subclause defines the initial conditions for each test, including the test environment, the RF channels to be tested and the basic measurement set-up.

##### **X.4.2 Procedure**

This subclause describes the steps necessary to perform the test and provides further details of the test definition like point of access (e.g. antenna port), domain (e.g. frequency-span), range, weighting (e.g. bandwidth), and algorithms (e.g. averaging).

### X.5 Test Requirement

This subclause defines the pass/fail criteria for the equipment under test. See subclause 4.3 Interpretation of measurement results.

## 6 Transmitter

### 6.1 General

Unless otherwise stated, all tests in this clause shall be performed at the BS antenna connector (test port A) with a full complement of transceivers for the configuration in normal operating conditions. If any external apparatus such as a TX amplifier, a filter or the combination of such devices is used, the tests according to subclauses 4.6.2 and/or 4.6.4, depending on the device added, shall be performed to ensure that the requirements are met at test port B.

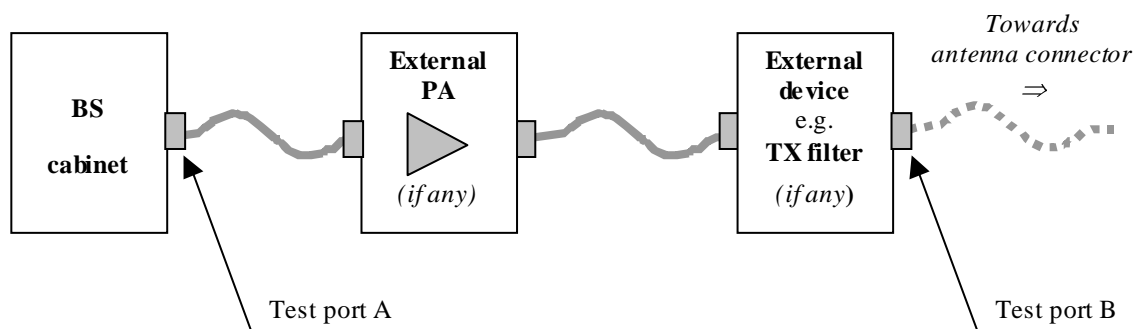

Figure 6.1: Transmitter test ports

Power levels are expressed in dBm.

#### 6.1.1 Test Models

The set-up of physical channels for transmitter tests shall be according to one of the test models below. A reference to the applicable table is made with each test.

A code "level setting" of -X dB is the setting that according to the base station manufacturer will result in a code domain power of nominally X dB below the maximum output power. The relative accuracy of the code domain power to the maximum output power shall have a tolerance of  $\pm 1$  dB

##### 6.1.1.1 Test Model 1

This model shall be used for tests on:

- spectrum emission mask;
- ACLR;
- spurious emissions;
- transmit intermodulation;
- base station maximum output power.
- total power dynamic range (at Pmax)
- IPDL time mask

64 DPCHs at 30 ksps (SF=128) distributed randomly across the code space, at random power levels and random timing offsets are defined so as to simulate a realistic traffic scenario which may have high PAR (Peak to Average Ratio).

Considering that not every base station implementation will support 64 DPCH, variants of this test model containing 32 and 16 DPCH are also specified. The conformance test shall be performed using the largest of these three options that can be supported by the equipment under test.

"Fraction of power" is relative to the maximum output power on the TX antenna interface under test.

**Table 6.1: Test Model 1 Active Channels**

Type	Number of Channels	Fraction of Power (%)	Level setting (dB)	Channelization Code	Timing offset (x256T <sub>chip</sub> )
P-CCPCH+SCH	1	10	-10	1	0
Primary CPICH	1	10	-10	0	0
PICH	1	1.6	-18	16	120
S-CCPCH containing PCH (SF=256)	1	1.6	-18	3	0
DPCH (SF=128)	16/32/64	76.8 in total	see table 6.2	see table 6.2	see table 6.2

Table 6.2: DPCH Spreading Code, Timing offsets and level settings for Test Model 1

Code	Timing offset ( $\times 256T_{\text{chip}}$ )	Level settings (dB) (16 codes)	Level settings (dB) (32 codes)	Level settings (dB) (64 codes)
2	86	-10	-13	-16
11	134	-12	-13	-16
17	52	-12	-14	-16
23	45	-14	-15	-17
31	143	-11	-17	-18
38	112	-13	-14	-20
47	59	-17	-16	-16
55	23	-16	-18	-17
62	1	-13	-16	-16
69	88	-15	-19	-19
78	30	-14	-17	-22
85	18	-18	-15	-20
94	30	-19	-17	-16
102	61	-17	-22	-17
113	128	-15	-20	-19
119	143	-9	-24	-21
7	83		-20	-19
13	25		-18	-21
20	103		-14	-18
27	97		-14	-20
35	56		-16	-24
41	104		-19	-24
51	51		-18	-22
58	26		-17	-21
64	137		-22	-18
74	65		-19	-20
82	37		-19	-17
88	125		-16	-18
97	149		-18	-19
108	123		-15	-23
117	83		-17	-22
125	5		-12	-21
4	91			-17
9	7			-18
12	32			-20
14	21			-17
19	29			-19
22	59			-21
26	22			-19
28	138			-23
34	31			-22
36	17			-19
40	9			-24
44	69			-23
49	49			-22
53	20			-19
56	57			-22
61	121			-21
63	127			-18
66	114			-19
71	100			-22
76	76			-21
80	141			-19
84	82			-21
87	64			-19
91	149			-21
95	87			-20
99	98			-25
105	46			-25
110	37			-25
116	87			-24

Code	Timing offset ( $\times 256T_{\text{chip}}$ )	Level settings (dB) (16 codes)	Level settings (dB) (32 codes)	Level settings (dB) (64 codes)
118	149			-22
122	85			-20
126	69			-15

### 6.1.1.2 Test Model 2

This model shall be used for tests on:

- output power dynamics.
- CPICH power accuracy.

**Table 6.3: Test Model 2 Active Channels**

Type	Number of Channels	Fraction of Power (%)	Level setting (dB)	Channelization Code	Timing offset ( $\times 256T_{\text{chip}}$ )
P-CCPCH+SCH	1	10	-10	1	0
Primary CPICH	1	10	-10	0	0
PICH	1	5	-13	16	120
S-CCPCH containing PCH (SF=256)	1	5	-13	3	0
DPCH (SF=128)	3	2 x 10, 1 x 50	2 x -10, 1 x -3	24, 72, 120	1, 7, 2

### 6.1.1.3 Test Model 3

This model shall be used for tests on:

- peak code domain error.

**Table 6.4: Test Model 3 Active Channels**

Type	Number of Channels	Fraction of Power (%) 16/32	Level settings (dB) 16/32	Channelization Code	Timing offset ( $\times 256T_{\text{chip}}$ )
P-CCPCH+SCH	1	12,6/7,9	-9 / -11	1	0
Primary CPICH	1	12,6/7,9	-9 / -11	0	0
PICH	1	5/1.6	-13/-18	16	120
S-CCPCH containing PCH (SF=256)	1	5/1.6	-13/-18	3	0
DPCH (SF=256)	16/32	63,7/80,4 in total	see table 6.5	see table 6.5	see table 6.5

As with Test Model 1, not every base station implementation will support 32 DPCH, a variant of this test model containing 16 DPCH are also specified. The conformance test shall be performed using the larger of these two options that can be supported by the equipment under test.

**Table 6.5: DPCH Spreading Code, Toffset and Power for Test Model 3**

Code	T <sub>offset</sub>	Level settings (dB) (16 codes)	Level settings (dB) (32 codes)
64	86	-14	-16
69	134	-14	-16
74	52	-14	-16
78	45	-14	-16
83	143	-14	-16
89	112	-14	-16
93	59	-14	-16
96	23	-14	-16
100	1	-14	-16
105	88	-14	-16
109	30	-14	-16
111	18	-14	-16
115	30	-14	-16
118	61	-14	-16
122	128	-14	-16
125	143	-14	-16
67	83		-16
71	25		-16
76	103		-16
81	97		-16
86	56		-16
90	104		-16
95	51		-16
98	26		-16
103	137		-16
108	65		-16
110	37		-16
112	125		-16
117	149		-16
119	123		-16
123	83		-16
126	5		-16

#### 6.1.1.4 Test Model 4

This model shall be used for tests on:

- EVM measurement.
- Total power dynamic range (at P<sub>max</sub> – 18 dB)
- Frequency error

**Table 6.6: Test Model 4 Active Channels**

Type	Number of Channels	Fraction of Power (%)	Level setting (dB)	Channelization Code	Timing offset
PCCPCH+SCH when Primary CPICH is disabled	1	50 to 1.6	-3 to -18	1	0
PCCPCH+SCH when Primary CPICH is enabled	1	25 to 0.8	-6 to -21	1	0
Primary CPICH <sup>1</sup>	1	25 to 0.8	-6 to -21	0	0
Note 1: The CPICH channel is optional.					



6.1.1.5 DPCH Structure of the Downlink Test Models

For the above test models the following structure is adopted for the DPCH. The DPDCH and DPCCH have the same power level. The timeslot structure should be as described by TS 25.211-slot format 10 and 6 that are reproduced in table 6.7.

Table 6.7: DPCH structure of the downlink test models

Slot Format #	Channel Bit Rate (kbps)	Channel Symbol Rate (ksps)	SF	Bits/Frame			Bits/Slot	DPDCH Bits/Slot		DPCCH Bits/Slot		
				DPDCH	DPCCH	TOT		NData1	Ndata2	NTFCI	NTPC	Npilot
10	60	30	128	450	150	600	40	6	24	0	2	8
6	30	15	256	150	150	300	20	2	8	0	2	8

The test DPCH has frame structure so that the pilot bits are defined over 15 timeslots according to the relevant columns of TS 25.211, which are reproduced in table 6.8.

Table 6.8: Frame structure of DPCH

Symbol #	Npilot = 8			
	0	1	2	3
Slot #0	11	11	11	10
1	11	00	11	10
2	11	01	11	01
3	11	00	11	00
4	11	10	11	01
5	11	11	11	10
6	11	11	11	00
7	11	10	11	00
8	11	01	11	10
9	11	11	11	11
10	11	01	11	01
11	11	10	11	11
12	11	10	11	00
13	11	00	11	11
14	11	00	11	11

The TPC bits alternate 00 / 11 starting with 00 in timeslot 0.

The aggregate 15 x 30 = 450 DPDCH bits per frame are filled with a PN9 sequence generated using the primitive trinomial  $x^9 + x^4 + 1$ . In case there are less data bits/frame needed then the first bits of the aggregate shall be selected. To ensure non-correlation of the PN9 sequences, each DPDCH shall use its channelization code as the seed for the PN sequence at the start of each frame, according to its timing offset.

The sequence shall be generated in a nine-stage shift register whose 5<sup>th</sup> and 9<sup>th</sup> stage outputs are added in a modulo-two addition stage, and the result is fed back to the input of the first stage. The generator shall be seeded so that the sequence begins with the channelization code starting from the LSB, and followed by 2 consecutive ONEs for SF=128 and 1 consecutive ONE for SF=256.

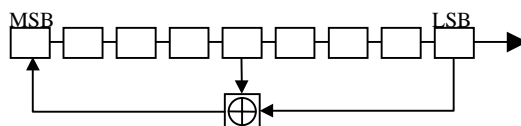

Figure 6.2

### 6.1.1.6 Common channel Structure of the Downlink Test Models

#### 6.1.1.6.1 P-CCPCH

The aggregate  $15 \times 18 = 270$  P-CCPCH bits per frame are filled with a PN9 sequence generated using the primitive trinomial  $x^9 + x^4 + 1$ . Channelization code of the P-CCPCH is used as the seed for the PN sequence at the start of each frame.

The generator shall be seeded so that the sequence begins with the 8 bit channelization code starting from the LSB, and followed by a ONE.

#### 6.1.1.6.2 PICH

PICH carries 18 Paging Indicators (Pq) sent in the following sequence from left to right [1 0 1 1 0 0 0 1 0 1 1 0 0 0 1 0 1 0]. This defines the 288 first bits of the PICH. No power is transmitted for the 12 remaining unused bits.

#### 6.1.1.6.3 Primary scrambling code and SCH

The scrambling code should be 0.

Where multiple repetitions of the Test Model signals are being used to simulate a multi-carrier signal the scrambling code for the lower frequency is 0. Carriers added at successively higher frequencies use codes 1, 2,... and their frame structures are time offset by 1/5, 2/5... of a time slot duration.

The scrambling code defines the SSC sequence of the secondary SCH. In their active part, primary and secondary SCH share equally the power level defined for "PCCPCH+SCH".

#### 6.1.1.6.4 S-CCPCH containing PCH

The aggregate  $15 \times 20 = 300$  S-CCPCH bits per frame are used. Data bits are filled with a PN9 sequence generated using the primitive trinomial  $x^9 + x^4 + 1$ . In case there are less data bits/frame needed then the first bits of the aggregate shall be selected.. Channelization code of the S-CCPCH is used as the seed for the PN sequence at the start of each frame. For test purposes, any one of the four possible slot formats 0,1, 2 and 3 can be supported. The support for all four slot formats is not needed..

The generator shall be seeded so that the sequence begins with the 8 bit channelization code starting from the LSB, and followed by a ONE. The test on S-CCPCH has a frame structure so that the pilot bits are defined over 15 timeslots to the relevant columns of TS 25.211. The TFCI bits are filled with ONES whenever needed.

## 6.2 Base station output power

Output power,  $P_{out}$ , of the base station is the mean power of one carrier delivered to a load with resistance equal to the nominal load impedance of the transmitter.

Rated output power, PRAT, of the base station is the mean power level per carrier that the manufacturer has declared to be available at the antenna connector.

### 6.2.1 Base station maximum output power

#### 6.2.1.1 Definition and applicability

Maximum output power,  $P_{max}$ , of the base station is the mean power level per carrier measured at the antenna connector in specified reference condition.

In certain regions, the minimum requirement for normal conditions may apply also for some conditions outside the ranges defined for the Normal test environment in subclause 4.4.1.

### 6.2.1.2 Minimum Requirement

In normal conditions, the Base station maximum output power shall remain within +2.0 dB and –2.0 dB of the manufacturer's rated output power.

In extreme conditions, the Base station maximum output power shall remain within +2.5 dB and –2.5 dB of the manufacturer's rated output power.

The normative reference for this requirement is in TS 25.104 [1] subclause 6.2.1.

### 6.2.1.3 Test purpose

The test purpose is to verify the accuracy of the maximum output power across the frequency range and under normal and extreme conditions for all transmitters in the BS.

### 6.2.1.4 Method of test

#### 6.2.1.4.1 Initial conditions

Test environment: normal; see subclause 4.4.1.

RF channels to be tested: B, M and T; see subclause 4.8.

In addition, on one UARFCN only, the test shall be performed under extreme power supply as defined in subclause 4.4.2

NOTE: Tests under extreme power supply also test extreme temperature.

- 1) Connect the power measuring equipment to the base station RF output port.

#### 6.2.1.4.2 Procedure

- 1) Set the base station to transmit a signal modulated with a combination of PCCPCH, SCCPCH and Dedicated Physical Channels specified as test model1 in subclause 6.1.1.1.
- 2) Measure the mean power at the RF output port.

### 6.2.1.5 Test Requirements

In normal conditions, the measurement result in step 2 of 6.2.1.4.2 shall remain within +2.7 dB and –2.7 dB of the manufacturer's rated output power.

In extreme conditions, measurement result in step 2 of 6.2.1.4.2 shall remain within +3.2 dB and –3.2 dB of the manufacturer's rated output power.

NOTE: If the above Test Requirement differs from the Minimum Requirement then the Test Tolerance applied for this test is non-zero. The Test Tolerance for this test is defined in subclause 4.2 and the explanation of how the Minimum Requirement has been relaxed by the Test Tolerance is given in Annex F.

## 6.2.2 CPICH power accuracy

### 6.2.2.1 Definition and applicability

CPICH power accuracy is defined as the maximum deviation between the Primary CPICH code domain power indicated on the BCH and the Primary CPICH code domain power measured at the TX antenna interface. The requirement is applicable for all BS types..

### 6.2.2.2 Minimum Requirement

The measured Primary CPICH code domain power shall be within  $\pm 2.1$  dB of the Primary CPICH code domain power indicated on the BCH. The normative reference for this requirement is in TS 25.104 [1] subclause 6.4.4.

### 6.2.2.3 Test purpose

The purpose of the test is to verify, that the BS under test delivers Primary CPICH code domain power within margins, thereby allowing reliable cell planning and operation.

### 6.2.2.4 Method of test

#### 6.2.2.4.1 Initial conditions

Test environment: normal; see subclause 4.4.1.

RF channels to be tested: B, M and T; see subclause 4.8

- 1) Connect BS to code domain analyser as shown in annex B.
- 2) Disable inner loop power control.
- 3) Set-up BS transmission at maximum total power as specified by the supplier. Channel set-up shall be according to subclause 6.1.1.2.

#### 6.2.2.4.2 Procedure

- Measure the code domain power in the PCCPCH and PCPICH according to annex E.

### 6.2.2.5 Test Requirement

The measured CPICH power shall be within  $\pm 2.9$ dB of the ordered absolute value.

NOTE: If the above Test Requirement differs from the Minimum Requirement then the Test Tolerance applied for this test is non-zero. The Test Tolerance for this test is defined in subclause 4.2 and the explanation of how the Minimum Requirement has been relaxed by the Test Tolerance is given in Annex F.

## 6.3 Frequency error

### 6.3.1 Definition and applicability

Frequency error is the measure of the difference between the actual BS transmit frequency and the assigned frequency. The same source shall be used for RF frequency and data clock generation.

It is not possible to verify by testing that the data clock is derived from the same frequency source as used for RF generation. This may be confirmed by a manufacturers declaration

### 6.3.2 Minimum Requirement

The Frequency Error shall be within  $\pm 0.05$  PPM.

The normative reference for this requirement is in TS 25.104 [1] subclause 6.3

### 6.3.3 Test purpose

To verify that the Frequency Error is within the limit specified in 6.3.2

### 6.3.4 Method of test

#### 6.3.4.1 Initial Conditions

Test environment: normal; see subclause 4.4.1

RF channels to be tested: B, M and T; see subclause 4.8.

The following additional tests shall be performed:

- a) On each of B, M and T, the test shall be performed under extreme power supply as defined in subclause 4.4.2

NOTE: Tests under extreme power supply also test extreme temperature.

- 1) Connect the base station RF output port to the test equipment. Refer to annex B.1.2 for a functional block diagram of the test set-up.
- 2) Set the base station to transmit a signal according to 6.1.1.4 (test model 4). Total power at the RF output port shall be  $P_{max}-3dB$  and  $P_{max}-18dB$ .

#### 6.3.4.2 Procedure

- 1) Measure the Frequency Error according to annex E.

#### 6.3.5 Test requirement

The Frequency Error shall be within the range  $(-0.05 \text{ PPM} - 12 \text{ Hz})$  to  $(+0.05 \text{ PPM} + 12 \text{ Hz})$ .

### 6.4 Output power dynamics

Power control is used to limit the interference level. The BS transmitter uses a quality-based power control on the downlink. The physical channels for the following test(s) shall be set-up according to subclause 6.1.1.2.

#### 6.4.1 Inner loop power control

Inner loop power control in the downlink is the ability of the BS transmitter to adjust the code domain power of a code channel in accordance with the corresponding TPC symbols received in the uplink.

#### 6.4.2 Power control steps

The power control step is the required step change in the code domain power of a code channel in response to the corresponding power control command. The combined output power change is the required total change in the DL transmitter output power of a code channel in response to multiple consecutive power control commands corresponding to that code channel.

##### 6.4.2.1 Definition and applicability

Inner loop power control in the downlink is the ability of the BS transmitter to adjust the transmitter output power of a code channel in accordance with the corresponding TPC symbols received in the uplink.

The power control step is the required step change in the DL transmitter output power of a code channel in response to the corresponding power control command. The combined output power change is the required total change in the DL transmitter output power of a code channel in response to multiple consecutive power control commands corresponding to that code channel.

##### 6.4.2.2 Minimum Requirement

The BS transmitter shall have the capability of setting the inner loop output power with a step sizes of 1 dB mandatory and 0,5 dB optional.

- a) The tolerance of the power control step due to inner loop power control shall be within the range shown in table 6.9.
- b) The tolerance of the combined output power change due to inner loop power control shall be within the range shown in table 6.10.

**Table 6.9: Transmitter power control step tolerance**

Power control commands in the down link	Transmitter power control step tolerance			
	1 dB step size		0,5 dB step size	
	Lower	Upper	Lower	Upper
Up(TPC command "1")	+0,5 dB	+1,5 dB	+0,25 dB	+0,75 dB
Down(TPC command "0")	-0,5 dB	-1,5 dB	-0,25 dB	-0,75 dB

**Table 6.10: Transmitter aggregated power control step range**

Power control commands in the down link	Transmitter aggregated power control step range after 10 consecutive equal commands (up or down)			
	1 dB step size		0.5dB step size	
	Lower	Upper	Lower	Upper
Up(TPC command "1")	+8 dB	+12 dB	+4 dB	+6 dB
Down(TPC command "0")	-8 dB	-12 dB	-4 dB	-6 dB

The normative reference for this requirement is TS 25.104 [1] subclause 6.4.1.1.1

### 6.4.2.3 Test purpose

To verify those requirements for the power control step size and response are met as specified in subclause 6.4.2.2.

### 6.4.2.4 Method of test

#### 6.4.2.4.1 Initial conditions

Test environment: normal; see subclause 4.4.1.

RF channels to be tested: B, M and T; see subclause 4.8

- 1) Connect the suitable measurement equipment to the BS antenna connector as shown in annex B.
- 2) Start BS transmission with channel configuration as specified in table 6.3 Test model 2. The DPCH intended for power control is on channel 120 starting at  $-3$  dB.
- 3) Establish downlink power control with parameters as specified in table 6.11.

**Table 6.11**

Parameter	Level/status	Unit
UL signal mean power	Ref.sens + 10 dB	dBm
Data sequence	PN9	

#### 6.4.2.4.2 Procedure

- 1) Set and send alternating TPC bits from the UE simulator or UL signal generator.
- 2) Measure mean power level of the code under the test each time TPC command is transmitted. All steps within power control dynamic range declared by manufacturer shall be measured. Use the code domain power measurement method defined in annex E.
- 3) Measure the 10 highest and the 10 lowest power step levels within the power control dynamic range declared by manufacturer by sending 10 consecutive equal commands as described table 6.10.

### 6.4.2.5 Test requirement

- a) BS shall fulfil step size requirement shown in Table 6.12 for all power control steps declared by manufacture as specified in subclause 6.4.2.2.

- b) For all measured Up/Down cycles, the difference of code domain power between before and after 10 equal commands (Up and Down), derived in step (3), shall not exceed the prescribed tolerance in table 6.13.

**Table 6.12: Transmitter power control step tolerance**

Power control commands in the down link	Transmitter power control step tolerance			
	1 dB step size		0,5 dB step size	
	Lower	Upper	Lower	Upper
Up(TPC command "1")	+0,4 dB	+1,6 dB	+0,15 dB	+0,85 dB
Down(TPC command "0")	-0,4 dB	-1,6 dB	-0,15 dB	-0,85 dB

**Table 6.13: Transmitter aggregated power control step range**

Power control commands in the down link	Transmitter aggregated power control step range after 10 consecutive equal commands (up or down)			
	1 dB step size		0.5dB step size	
	Lower	Upper	Lower	Upper
Up(TPC command "1")	+7.9 dB	+12.1 dB	+3.9 dB	+6.1 dB
Down(TPC command "0")	-7.9 dB	-12.1 dB	-3.9 dB	-6.1 dB

NOTE: If the above Test Requirement differs from the Minimum Requirement then the Test Tolerance applied for this test is non-zero. The Test Tolerance for this test is defined in subclause 4.2 and the explanation of how the Minimum Requirement has been relaxed by the Test Tolerance is given in Annex F.

## 6.4.3 Power control dynamic range

### 6.4.3.1 Definition and applicability

The power control dynamic range is the difference between the maximum and the minimum code domain power of a code channel for a specified reference condition. Transmit modulation quality shall be maintained within the whole dynamic range as specified in TS 25.104 [1] subclause 6.8.

### 6.4.3.2 Minimum Requirement

Down link (DL) power control dynamic range:

- maximum code domain power: BS maximum output power -3 dB or greater;
- minimum code domain power: BS maximum output power -28 dB or less.

The normative reference for this requirement is TS 25.104 [1] subclause 6.4.2.1.

### 6.4.3.3 Test purpose

To verify that the minimum power control dynamic range is met as specified in subclause 6.4.3.2.

### 6.4.3.4 Method of test

#### 6.4.3.4.1 Initial conditions

Test environment: normal; see subclause 4.4.1.

RF channels to be tested: B, M and T; see subclause 4.8

- 1) Connect the measurement equipment to the BS antenna connector as shown in annex B.
- 2) Channel configuration defined in table 6.3 Test model 2 shall be used.

- 3) Set BS frequency.
- 4) Start BS transmission.

#### 6.4.3.4.2 Procedure

P<sub>max</sub> shall be defined as described in subclause 6.2.1 Base station maximum output power.

- 1) Re-measure P<sub>max</sub> according to subclause 6.2.1 (using test model 1).
- 2) Using test model 2, set the code domain power of the DPCH under test to P<sub>max</sub>-3 dB. Power levels for other code channels may be adjusted if necessary.
- 3) Measure the code domain power of the code channel under test. Use the code domain power measurement method defined in annex E.
- 4) Set the code domain power of the DPCH under test to P<sub>max</sub>-28 dB by means determined by the manufacturer. The power levels for the other code channels used in step 2 shall remain unchanged (the overall output power will drop by approximately 3 dB).
- 5) Measure the code domain power of the code channel under test.

#### 6.4.3.5 Test requirement

Down link (DL) power control dynamic range:-

- maximum code domain power: BS maximum output power -4.1 dB or greater;
- minimum code domain power: BS maximum output power -26.9 dB or less.

NOTE: If the above Test Requirement differs from the Minimum Requirement then the Test Tolerance applied for this test is non-zero. The Test Tolerance for this test is defined in subclause 4.2 and the explanation of how the Minimum Requirement has been relaxed by the Test Tolerance is given in Annex F.

### 6.4.4 Total power dynamic range

#### 6.4.4.1 Definition and applicability

The total power dynamic range is the difference between the maximum and the minimum output power for a specified reference condition.

#### 6.4.4.2 Minimum Requirement

The down link (DL) total power dynamic range shall be 18 dB or greater. The normative reference for this requirement is TS 25.104 [1] subclause 6.4.3.1.

#### 6.4.4.3 Test purpose

To verify that the total power dynamic range is met as specified in TS 25.104 subclause 6.4.3.1. The test is to ensure that the total output power can be reduced while still transmitting a single code. This is to ensure that the interference to neighbouring cells is reduced.

#### 6.4.4.4 Method of test

The method of test is carried out as part of 6.2.1 Base station maximum output power and 6.7.1 Error vector magnitude.

The total power dynamic range result is the difference between the power measurement at P<sub>max</sub> made in 6.2.1.4.2 and the power measurement at P<sub>max</sub> - 18 dB made in 6.7.1.4.2.



### 6.4.4.5 Test requirement

The down link (DL) total power dynamic range shall be 17.7 dB or greater.

NOTE: If the above Test Requirement differs from the Minimum Requirement then the Test Tolerance applied for this test is non-zero. The Test Tolerance for this test is defined in subclause 4.2 and the explanation of how the Minimum Requirement has been relaxed by the Test Tolerance is given in Annex F.

## 6.4.5 IPDL time mask

### 6.4.5.1 Definition and applicability

To support IPDL location method, the Node B shall interrupt all transmitted signals in the downlink (i.e. common and dedicated channels).

The IPDL time mask specifies the limits of the BS output power during these idle periods.

The requirement in this section shall apply to BS supporting IPDL.

### 6.4.5.2 Minimum Requirement

The mean power measured over a period starting 27 chips after the beginning of the IPDL period and ending 27 chips before the expiration of the IPDL period shall be equal to or less than

$$\text{BS maximum output power} - 35 \text{ dB};$$

see also Figure 6.4

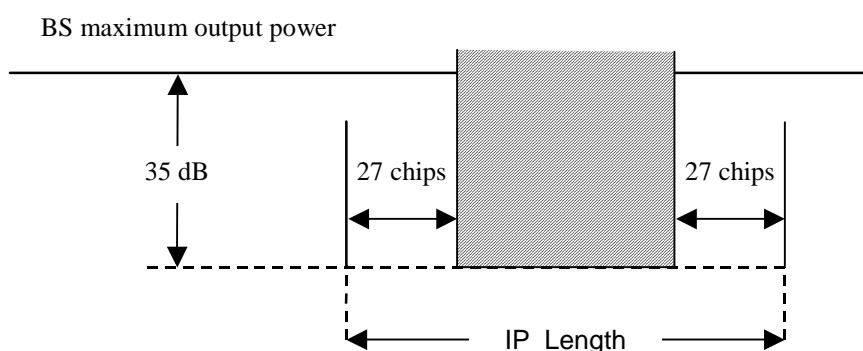

**Figure 6.4: IPDL Time Mask**

The requirement applies to all output powers within the total power dynamic range as specified in TS25.104 [1] subclause 6.4.3.

The normative reference for this requirement is in TS 25.104 [1] subclause 6.4.5.1.

### 6.4.5.3 Test purpose

The test purpose is to verify the ability of the BS to temporarily reduce its output power below a specified value to improve time difference measurements made by UE for location services.

### 6.4.5.4 Method of test

#### 6.4.5.4.1 Initial conditions

Test environment: normal; see subclause 4.4.1.

RF channels to be tested: B, M and T; see subclause 4.8.

- 1) Connect the power measuring equipment to the BS antenna connector.
- 2) Set the BS to transmit a signal according to test model 1 as defined in subclause 6.1.1.1, at the manufacturers specified maximum output power.
- 3) Configure the BS to produce idle periods in continuous mode. The IPDL parameters as defined in TS 25.214 [12] shall have the following values:
  - IP\_Spacing = 5
  - IP\_Length = 10 CPICH symbols
  - Seed = 0

#### 6.4.5.4.2 Procedure

- 1) Measure the mean power at the BS antenna connector over a period starting 27 chips after the beginning of the IPDL period and ending 27 chips before the expiration of the IPDL period.

#### 6.4.5.5 Test Requirements

The mean power measured according to step (1) in subclause 6.4.5.4.2 shall be equal to or less than

BS maximum output power – 34.3 dB.

NOTE: If the above Test Requirement differs from the Minimum Requirement then the Test Tolerance applied for this test is non-zero. The Test Tolerance for this test is defined in subclause 4.2 and the explanation of how the Minimum Requirement has been relaxed by the Test Tolerance is given in Annex F.

## 6.5 Output RF spectrum emissions

The physical channels for the following test(s) shall be set-up according to subclause 6.1.1.1.

### 6.5.1 Occupied bandwidth

#### 6.5.1.1 Definition and applicability

The occupied bandwidth is the width of a frequency band such that, below the lower and above the upper frequency limits, the mean powers emitted are each equal to a specified percentage  $\beta/2$  of the total mean transmitted power.

The value of  $\beta/2$  should be taken as 0,5%.

#### 6.5.1.2 Minimum Requirements

The occupied bandwidth shall be less than 5 MHz based on a chip rate of 3,84 Mcps.

The normative reference for this requirement is TS 25.104 subclause 6.6.1.

#### 6.5.1.3 Test purpose

The occupied bandwidth, defined in the Radio Regulations of the International Telecommunication Union ITU, is a useful concept for specifying the spectral properties of a given emission in the simplest possible manner; see also Recommendation ITU-R Recommendation SM.328-9 [11]. The test purpose is to verify that the emission of the BS does not occupy an excessive bandwidth for the service to be provided and is, therefore, not likely to create interference to other users of the spectrum beyond undue limits.

## 6.5.1.4 Method of test

### 6.5.1.4.1 Initial conditions

Test environment: normal; see subclause 4.4.1.

RF channels to be tested: B, M and T; see subclause 4.8

- 1) Connect the Measurement device to the BS antenna connector.
- 2) Start transmission on a single carrier according to test model defined in subclause 6.1.1.1.

### 6.5.1.4.2 Procedure

- 1) Measure the spectrum of the transmitted signal across a span of 10 MHz, based on an occupied bandwidth requirement of 5 MHz. The selected resolution bandwidth (RBW) filter of the analyser shall be 30 kHz or less. The spectrum shall be measured at 400 or more points across the measurement span.

NOTE: The detection mode of the spectrum analyzer will not have any effect on the result if the statistical properties of the out-of-OBW power are the same as those of the inside-OBW power. Both are expected to have the Rayleigh distribution of the amplitude of Gaussian noise. In any case where the statistics are not the same, though, the detection mode must be power responding. There are at least two ways to be power responding. The spectrum analyser can be set to "sample" detection, with its video bandwidth setting at least three times its RBW setting. Or the analyser may be set to respond to the average of the power (root-mean-square of the voltage) across the measurement cell.

- 2) Compute the total of the power,  $P_0$ , (in power units, not decibel units) of all the measurement cells in the measurement span. Compute  $P_1$ , the power outside the occupied bandwidth on each side.  $P_1$  is half of the total power outside the bandwidth.  $P_1$  is half of  $(100\% - (\text{occupied percentage}))$  of  $P_0$ . For the occupied percentage of 99 %,  $P_1$  is 0.005 times  $P_0$ .
- 3) Determine the lowest frequency,  $f_1$ , for which the sum of all power in the measurement cells from the beginning of the span to  $f_1$  exceeds  $P_1$ .
- 4) Determine the highest frequency,  $f_2$ , for which the sum of all power in the measurement cells from the end of the span to  $f_2$  exceeds  $P_1$ .
- 5) Compute the occupied bandwidth as  $f_2 - f_1$ .

## 6.5.1.5 Test requirements

The occupied bandwidth shall be less than 5 MHz based on a chip rate of 3,84 Mcps

NOTE: If the above Test Requirement differs from the Minimum Requirement then the Test Tolerance applied for this test is non-zero. The Test Tolerance for this test is defined in subclause 4.2 and the explanation of how the Minimum Requirement has been relaxed by the Test Tolerance is given in Annex F.

## 6.5.2 Out of band emission

Out of band emissions are unwanted emissions immediately outside the channel bandwidth resulting from the modulation process and non-linearity in the transmitter but excluding spurious emissions. This out of band emission limit is specified in terms of a spectrum emission mask and adjacent channel leakage power ratio for the transmitter.

### 6.5.2.1 Spectrum emission mask

#### 6.5.2.1.1 Definitions and applicability

The mask defined in Tables 6.14 to 6.17 below may be mandatory in certain regions. In other regions this mask may not be applied.

### 6.5.2.1.2 Minimum Requirements

For regions where this clause applies, the requirement shall be met by a base station transmitting on a single RF carrier configured in accordance with the manufacturer's specification. Emissions shall not exceed the maximum level specified in tables 6.14 to 6.17 for the appropriate BS maximum output power, in the frequency range from  $\Delta f = 2.5$  MHz to  $\Delta f_{\max}$  from the carrier frequency, where:

- $\Delta f$  is the separation between the carrier frequency and the nominal  $-3$ dB point of the measuring filter closest to the carrier frequency.
- $f_{\text{offset}}$  is the separation between the carrier frequency and the centre of the measurement filter;
- $f_{\text{offset}_{\max}}$  is either 12.5 MHz or the offset to the UMTS Tx band edge as defined in subclause 3.4.1, whichever is the greater.
- $\Delta f_{\max}$  is equal to  $f_{\text{offset}_{\max}}$  minus half of the bandwidth of the measuring filter.

**Table 6.14: Spectrum emission mask values, BS maximum output power  $P \geq 43$  dBm**

Frequency offset of measurement filter $-3$ dB point, $\Delta f$	Frequency offset of measurement filter centre frequency, $f_{\text{offset}}$	Minimum requirement	Additional Minimum Requirement for Band b	Measurement bandwidth
$2.5 \leq \Delta f < 2.7$ MHz	$2.515\text{MHz} \leq f_{\text{offset}} < 2.715\text{MHz}$	-14 dBm	-15 dBm	30 kHz
$2.7 \leq \Delta f < 3.5$ MHz	$2.715\text{MHz} \leq f_{\text{offset}} < 3.515\text{MHz}$	$-14 \text{ dBm} - 15 \cdot (f_{\text{offset}} - 2.715) \text{ dB}$	-15 dBm	30 kHz
	$3.515\text{MHz} \leq f_{\text{offset}} < 4.0\text{MHz}$	-26 dBm	NA	30 kHz
$3.5 \leq \Delta f < 7.5$ MHz	$4.0 \text{ MHz} \leq f_{\text{offset}} < 8.0\text{MHz}$	-13 dBm	NA	1 MHz
$7.5 \leq \Delta f$ MHz	$8.0 \text{ MHz} \leq f_{\text{offset}} < f_{\text{offset}_{\max}}$	-13 dBm	NA	1 MHz

**Table 6.15: Spectrum emission mask values, BS maximum output power  $39 \leq P < 43$  dBm**

Frequency offset of measurement filter $-3$ dB point, $\Delta f$	Frequency offset of measurement filter centre frequency, $f_{\text{offset}}$	Minimum requirement	Additional Minimum Requirement for Band b	Measurement bandwidth
$2.5 \leq \Delta f < 2.7$ MHz	$2.515\text{MHz} \leq f_{\text{offset}} < 2.715\text{MHz}$	-14 dBm	-15 dBm	30 kHz
$2.7 \leq \Delta f < 3.5$ MHz	$2.715\text{MHz} \leq f_{\text{offset}} < 3.515\text{MHz}$	$-14\text{dBm} - 15 \cdot (f_{\text{offset}} - 2.715) \text{ dB}$	-15 dBm	30 kHz
	$3.515\text{MHz} \leq f_{\text{offset}} < 4.0\text{MHz}$	-26 dBm	NA	30 kHz
$3.5 \leq \Delta f < 7.5$ MHz	$4.0 \text{ MHz} \leq f_{\text{offset}} < 8.0\text{MHz}$	-13 dBm	NA	1 MHz
$7.5 \leq \Delta f$ MHz	$8.0\text{MHz} \leq f_{\text{offset}} < f_{\text{offset}_{\max}}$	$P - 56 \text{ dB}$	NA	1 MHz

**Table 6.16: Spectrum emission mask values, BS maximum output power  $31 \leq P < 39$  dBm**

Frequency offset of measurement filter $-3$ dB point, $\Delta f$	Frequency offset of measurement filter centre frequency, $f_{\text{offset}}$	Minimum requirement	Additional Minimum Requirement for Band b	Measurement bandwidth
$2.5 \leq \Delta f < 2.7$ MHz	$2.515\text{MHz} \leq f_{\text{offset}} < 2.715\text{MHz}$	$P - 53 \text{ dB}$	-15 dBm	30 kHz
$2.7 \leq \Delta f < 3.5$ MHz	$2.715\text{MHz} \leq f_{\text{offset}} < 3.515\text{MHz}$	$P - 53 \text{ dB} - 15 \cdot (f_{\text{offset}} - 2.715) \text{ dB}$	-15 dBm	30 kHz
	$3.515\text{MHz} \leq f_{\text{offset}} < 4.0\text{MHz}$	$P - 65 \text{ dB}$	NA	30 kHz
$3.5 \leq \Delta f < 7.5$ MHz	$4.0 \text{ MHz} \leq f_{\text{offset}} < 8.0\text{MHz}$	$P - 52 \text{ dB}$	NA	1 MHz
$7.5 \leq \Delta f$ MHz	$8.0\text{MHz} \leq f_{\text{offset}} < f_{\text{offset}_{\max}}$	$P - 56 \text{ dB}$	NA	1 MHz

**Table 6.17: Spectrum emission mask values, BS maximum output power  $P < 31$  dBm**

Frequency offset of measurement filter – 3dB point, $\Delta f$	Frequency offset of measurement filter centre frequency, $f_{\text{offset}}$	Minimum requirement	Measurement bandwidth
$2.5 \leq \Delta f < 2.7$ MHz	$2.515\text{MHz} \leq f_{\text{offset}} < 2.715\text{MHz}$	-22 dBm	30 kHz
$2.7 \leq \Delta f < 3.5$ MHz	$2.715\text{MHz} \leq f_{\text{offset}} < 3.515\text{MHz}$	$-22 \text{ dBm} - 15 \cdot (f_{\text{offset}} - 2.715) \text{ dB}$	30 kHz
	$3.515\text{MHz} \leq f_{\text{offset}} < 4.0\text{MHz}$	-34 dBm	30 kHz
$3.5 \leq \Delta f < 7.5$ MHz	$4.0 \text{ MHz} \leq f_{\text{offset}} < 8.0\text{MHz}$	-21 dBm	1 MHz
$7.5 \leq \Delta f$ MHz	$8.0\text{MHz} \leq f_{\text{offset}} < f_{\text{offset}_{\text{max}}}$	-25 dBm	1 MHz

The normative reference for this requirement is in TS 25.104 [1] subclause 6.6.2.1

### 6.5.2.1.3 Test purpose

This test measures the emissions of the BS, close to the assigned channel bandwidth of the wanted signal, while the transmitter is in operation.

### 6.5.2.1.4 Method of test

#### 6.5.2.1.4.1 Initial conditions

Test environment: normal; see subclause 4.4.1.

RF channels to be tested: B, M and T; see subclause 4.8

- 1) Set-up the equipment as shown in annex B.
- 2) Measurements with an offset from the carrier centre frequency between 2,515 MHz and 4.0 MHz shall use a 30 kHz measurement bandwidth.
- 3) Measurements with an offset from the carrier centre frequency between 4.0 MHz and  $(f_{\text{offset}_{\text{max}}} - 500 \text{ kHz})$ . shall use a 1 MHz measurement bandwidth. The 1MHz measurement bandwidth may be calculated by integrating multiple 50 kHz or narrower filter measurements in order to obtain the equivalent noise bandwidth of the measurement bandwidth.
- 4) Detection mode: True RMS.

#### 6.5.2.1.4.2 Procedures

- 1) Set the BS to transmit a signal in accordance to test model 1, subclause 6.1.1.1 at the manufacturer"s specified maximum output power.
- 2) Measure the emission at the specified frequencies with specified measurement bandwidth and note that the measured value does not exceed the specified value.

### 6.5.2.1.5 Test requirements

The measurement result in step 2 of 6.5.2.1.4.2 shall not exceed the maximum level specified in tables 6.18 to 6.21 for the appropriate BS maximum output power.

Table 6.18: Spectrum emission mask values, BS maximum output power  $P \geq 43$  dBm

Frequency offset of measurement filter – 3dB point, $\Delta f$	Frequency offset of measurement filter centre frequency, $f_{\text{offset}}$	Test Requirement	Additional Test Requirement for Band b	Measurement bandwidth
$2.5 \leq \Delta f < 2.7$ MHz	$2.515\text{MHz} \leq f_{\text{offset}} < 2.715\text{MHz}$	-12.5 dBm	-15 dBm	30 kHz
$2.7 \leq \Delta f < 3.5$ MHz	$2.715\text{MHz} \leq f_{\text{offset}} < 3.515\text{MHz}$	$-12.5 \text{ dBm} - 15 \cdot (f_{\text{offset}} - 2.715) \text{ dB}$	-15 dBm	30 kHz
	$3.515\text{MHz} \leq f_{\text{offset}} < 4.0\text{MHz}$	-24.5 dBm	NA	30 kHz
$3.5 \leq \Delta f < 7.5$ MHz	$4.0 \text{ MHz} \leq f_{\text{offset}} < 8.0\text{MHz}$	-11.5 dBm	NA	1 MHz
$7.5 \leq \Delta f$ MHz	$8.0 \text{ MHz} \leq f_{\text{offset}} < f_{\text{offset}_{\text{max}}}$	-11.5 dBm	NA	1 MHz

Table 6.19: Spectrum emission mask values, BS maximum output power  $39 \leq P < 43$  dBm

Frequency offset of measurement filter – 3dB point, $\Delta f$	Frequency offset of measurement filter centre frequency, $f_{\text{offset}}$	Test Requirement	Additional Test Requirement for Band b	Measurement bandwidth
$2.5 \leq \Delta f < 2.7$ MHz	$2.515\text{MHz} \leq f_{\text{offset}} < 2.715\text{MHz}$	-12.5 dBm	-15 dBm	30 kHz
$2.7 \leq \Delta f < 3.5$ MHz	$2.715\text{MHz} \leq f_{\text{offset}} < 3.515\text{MHz}$	$-12.5 \text{ dBm} - 15 \cdot (f_{\text{offset}} - 2.715) \text{ dB}$	-15 dBm	30 kHz
	$3.515\text{MHz} \leq f_{\text{offset}} < 4.0\text{MHz}$	-24.5 dBm	NA	30 kHz
$3.5 \leq \Delta f < 7.5$ MHz	$4.0 \text{ MHz} \leq f_{\text{offset}} < 8.0\text{MHz}$	-11.5 dBm	NA	1 MHz
$7.5 \leq \Delta f$ MHz	$8.0\text{MHz} \leq f_{\text{offset}} < f_{\text{offset}_{\text{max}}}$	$P - 54.5 \text{ dB}$	NA	1 MHz

Table 6.20: Spectrum emission mask values, BS maximum output power  $31 \leq P < 39$  dBm

Frequency offset of measurement filter – 3dB point, $\Delta f$	Frequency offset of measurement filter centre frequency, $f_{\text{offset}}$	Test Requirement	Additional Test Requirement for Band b	Measurement bandwidth
$2.5 \leq \Delta f < 2.7$ MHz	$2.515\text{MHz} \leq f_{\text{offset}} < 2.715\text{MHz}$	$P - 51.5 \text{ dB}$	-15 dBm	30 kHz
$2.7 \leq \Delta f < 3.5$ MHz	$2.715\text{MHz} \leq f_{\text{offset}} < 3.515\text{MHz}$	$P - 51.5 \text{ dB} - 15 \cdot (f_{\text{offset}} - 2.715) \text{ dB}$	-15 dBm	30 kHz
	$3.515\text{MHz} \leq f_{\text{offset}} < 4.0\text{MHz}$	$P - 63.5 \text{ dB}$	NA	30 kHz
$3.5 \leq \Delta f < 7.5$ MHz	$4.0 \text{ MHz} \leq f_{\text{offset}} < 8.0\text{MHz}$	$P - 50.5 \text{ dB}$	NA	1 MHz
$7.5 \leq \Delta f$ MHz	$8.0\text{MHz} \leq f_{\text{offset}} < f_{\text{offset}_{\text{max}}}$	$P - 54.5 \text{ dB}$	NA	1 MHz

Table 6.21: Spectrum emission mask values, BS maximum output power  $P < 31$  dBm

Frequency offset of measurement filter – 3dB point, $\Delta f$	Frequency offset of measurement filter centre frequency, $f_{\text{offset}}$	Test Requirement	Measurement bandwidth
$2.5 \leq \Delta f < 2.7$ MHz	$2.515\text{MHz} \leq f_{\text{offset}} < 2.715\text{MHz}$	-20.5 dBm	30 kHz
$2.7 \leq \Delta f < 3.5$ MHz	$2.715\text{MHz} \leq f_{\text{offset}} < 3.515\text{MHz}$	$-20.5 \text{ dBm} - 15 \cdot (f_{\text{offset}} - 2.715) \text{ dB}$	30 kHz
	$3.515\text{MHz} \leq f_{\text{offset}} < 4.0\text{MHz}$	-32.5 dBm	30 kHz
$3.5 \leq \Delta f < 7.5$ MHz	$4.0 \text{ MHz} \leq f_{\text{offset}} < 8.0\text{MHz}$	-19.5 dBm	1 MHz
$7.5 \leq \Delta f$ MHz	$8.0\text{MHz} \leq f_{\text{offset}} < f_{\text{offset}_{\text{max}}}$	-23.5 dBm	1 MHz

NOTE: If the above Test Requirement differs from the Minimum Requirement then the Test Tolerance applied for this test is non-zero. The Test Tolerance for this test is defined in subclause 4.2 and the explanation of how the Minimum Requirement has been relaxed by the Test Tolerance is given in Annex F.

## 6.5.2.2 Adjacent Channel Leakage power Ratio (ACLR)

### 6.5.2.2.1 Definition and applicability

Adjacent Channel Leakage power Ratio (ACLR) is the ratio of the RRC filtered mean power centered on the assigned channel frequency to the RRC filtered mean power centered on an adjacent channel frequency.

The requirements shall apply whatever the type of transmitter considered (single carrier or multi-carrier). It applies for all transmission modes foreseen by the manufacturer's specification.

### 6.5.2.2.2 Minimum Requirement

**Table 6.22: BS ACLR**

BS channel offset below the first or above the last carrier frequency used	ACLR limit
5 MHz	45 dB
10 MHz	50 dB

The normative reference for this requirement is in TS 25.104 [1] subclause 6.5.2.2

### 6.5.2.2.3 Test purpose

To verify that the adjacent channel leakage power ratio requirement shall be met as specified in subclause 6.5.2.2.2.

### 6.5.2.2.4 Method of test

#### 6.5.2.2.4.1 Initial conditions

Test environment: normal; see subclause 4.4.1.

RF channels to be tested: B, M and T with multiple carriers if supported; see subclause 4.8

- 1) Connect measurement device to the base station RF output port as shown in annex B.
- 2) The measurement device characteristics shall be:
  - measurement filter bandwidth: defined in subclause 6.5.2.2.1;
  - detection mode: true RMS voltage or true average power.
- 3) Set the base station to transmit a signal modulated in accordance with 6.1.1.1 Test model 1. The mean power at the RF output port shall be the maximum output power as specified by the manufacturer.
- 4) Set carrier frequency within the frequency band supported by BS. Minimum carrier spacing shall be 5 MHz and maximum carrier spacing shall be specified by manufacturer.

#### 6.5.2.2.4.2 Procedure

- 1) Measure Adjacent channel leakage power ratio for 5 MHz and 10 MHz offsets both side of channel frequency. In multiple carrier case only offset frequencies below the lowest and above the highest carrier frequency used shall be measured.

### 6.5.2.2.5 Test Requirement

The measurement result in step 1 of 6.5.2.2.4.2 shall not be less than the ACLR limit specified in tables 6.23

**Table 6.23: BS ACLR**

BS channel offset below the first or above the last carrier frequency used	ACLR limit
5 MHz	44.2 dB
10 MHz	49.2 dB

NOTE: If the above Test Requirement differs from the Minimum Requirement then the Test Tolerance applied for this test is non-zero. The Test Tolerance for this test is defined in subclause 4.2 and the explanation of how the Minimum Requirement has been relaxed by the Test Tolerance is given in Annex F.

## 6.5.3 Spurious emissions

### 6.5.3.1 Definition and applicability

Spurious emissions are emissions which are caused by unwanted transmitter effects such as harmonics emission, parasitic emission, intermodulation products and frequency conversion products, but exclude out of band emissions. This is measured at the base station RF output port.

The requirements (except 6.5.3.4.6 and 6.5.3.7.6) apply at frequencies within the specified frequency ranges, which are more than 12.5 MHz under the first carrier frequency used or more than 12.5 MHz above the last carrier frequency used.

The requirements shall apply whatever the type of transmitter considered (single carrier or multi-carrier). It applies for all transmission modes foreseen by the manufacturer's specification.

Unless otherwise stated, all requirements are measured as mean power (RMS).

### 6.5.3.2 (void)

void

### 6.5.3.3 (void)

void

### 6.5.3.4 Minimum Requirements

#### 6.5.3.4.1 Spurious emissions (Category A)

The following requirements shall be met in cases where Category A limits for spurious emissions, as defined in ITU-R Recommendation [4], are applied.

##### 6.5.3.4.1.1 Minimum Requirement

The power of any spurious emission shall be attenuated by at least the minimum requirement.

**Table 6.24: BS Mandatory spurious emissions limits, Category A**

Band	Maximum level	Measurement Bandwidth	Note
9 kHz to 150 kHz	-13 dBm	1 kHz	Bandwidth as in ITU-R SM.329-8, subclause 4.1
150 kHz to 30 MHz		10 kHz	Bandwidth as in ITU-R SM.329-8, subclause 4.1
30 MHz to 1 GHz		100 kHz	Bandwidth as in ITU-R SM.329-8, subclause 4.1
1 GHz to 12,75 GHz		1 MHz	Upper frequency as in ITU-R SM.329-8, subclause 2.5 Table 1



### 6.5.3.4.2 Spurious emissions (Category B)

The following requirements shall be met in cases where Category B limits for spurious emissions, as defined in ITU-R Recommendation SM.329 [4], are applied.

#### 6.5.3.4.2.1 Minimum Requirement

The power of any spurious emission shall not exceed.

**Table 6.25: BS Mandatory spurious emissions limits, Category B**

Band	Maximum Level	Measurement Bandwidth	Note
9 kHz ↔ 150 kHz	-36 dBm	1 kHz	Note 1
150 kHz ↔ 30 MHz	-36 dBm	10 kHz	Note 1
30 MHz ↔ 1 GHz	-36 dBm	100 kHz	Note 1
1 GHz ↔ 2100 MHz	-30 dBm	1 MHz	Note 1
2100 MHz ↔ 2180 MHz	-15 dBm	1 MHz	Note 2
2180 MHz ↔ 12.75 GHz	-30 dBm	1 MHz	Note 3
NOTE 1: Bandwidth as in ITU-R Recommendation SM.329 [4], s4.1			
NOTE 2: Limit based on ITU-R Recommendation SM.329 [4], s4.3 and Annex 7			
NOTE 3: Bandwidth as in ITU-R Recommendation SM.329 [4], s4.1. Upper frequency as in ITU-R SM.329 [4], s2.5 table 1			

### 6.5.3.4.3 Protection of the BS receiver of own or different BS

This requirement shall be applied in order to prevent the receivers of the BSs being desensitised by emissions from a BS transmitter. This is measured at the transmit antenna port for any type of BS which has common or separate Tx/Rx antenna ports.

#### 6.5.3.4.3.1 Minimum Requirement

The power of any spurious emission shall not exceed.

**Table 6.26: BS Spurious emissions limits for protection of the BS receiver**

Band	Maximum Level	Measurement Bandwidth	Note
1 920 MHz to 1 980 MHz For operation in Frequency Bands defined in subclause 3.4.1(a)	-96 dBm	100 kHz	
1 850 MHz to 1 910 MHz For operation in Frequency Bands defined in subclause 3.4.1(b)	-96 dBm	100 kHz	

### 6.5.3.4.4 Co-existence with GSM 900

#### 6.5.3.4.4.1 Operation in the same geographic area

This requirement may be applied for the protection of GSM 900 MS and GSM 900 BTS receivers in geographic areas in which both GSM 900 and UTRA are deployed.

This requirement assumes the scenario described in [2]. For different scenarios, the manufacturer may declare a different requirement.

#### 6.5.3.4.4.1.1 Minimum Requirement

The power of any spurious emission shall not exceed.

**Table 6.27: BS Spurious emissions limits for BS in geographic coverage area of GSM 900**

Band	Maximum Level	Measurement Bandwidth	Note
876 MHz to 915 MHz	-61 dBm	100 kHz	
921 MHz to 960 MHz	-57 dBm	100 kHz	

#### 6.5.3.4.4.2 Co-located base stations

This requirement may be applied for the protection of GSM 900 BTS receivers when GSM 900 BTS and UTRA BS are co-located.

##### 6.5.3.4.4.2.1 Minimum Requirement

The power of any spurious emission shall not exceed.

**Table 6.28: BS Spurious emissions limits for protection of the BTS receiver**

Band	Maximum Level	Measurement Bandwidth	Note
876 MHz to 915 MHz	-98 dBm	100 kHz	

#### 6.5.3.4.5 Co-existence with DCS 1800

##### 6.5.3.4.5.1 Operation in the same geographic area

This requirement may be applied for the protection of DCS 1800 MS and DCS 1800 BTS receivers in geographic areas in which both DCS 1800 and UTRA are deployed.

This requirement assumes the scenario described in [2]. For different scenarios, the manufacturer may declare a different requirement.

##### 6.5.3.4.5.1.1 Minimum Requirement

The power of any spurious emission shall not exceed:

**Table 6.29: BS Spurious emissions limits for BS in geographic coverage area of DCS 1800**

Band	Maximum Level	Measurement Bandwidth	Note
1710 MHz to 1785 MHz	-61 dBm	100 kHz	
1 805 MHz to 1 880 MHz	-47 dBm	100 kHz	

#### 6.5.3.4.5.2 Co-located basestations

This requirement may be applied for the protection of DCS 1800 BTS receivers when DCS 1800 BTS and UTRA BS are co-located.

##### 6.5.3.4.5.2.1 Minimum Requirement

The power of any spurious emission shall not exceed.

**Table 6.30: BS Spurious emissions limits for BS co-located with DCS 1800 BTS**

Band	Maximum Level	Measurement Bandwidth	Note
1 710 MHz to 1 785 MHz	-98 dBm	100 kHz	

#### 6.5.3.4.6 Co-existence with PHS

This requirement may be applied for the protection of PHS in geographic areas in which both PHS and UTRA are deployed. This requirement is also applicable at specified frequencies falling between 12.5MHz below the first carrier frequency used and 12.5MHz above the last carrier frequency used

##### 6.5.3.4.6.1 Minimum Requirement

The power of any spurious emission shall not exceed.

**Table 6.31: BS Spurious emissions limits for BS in geographic coverage area of PHS**

Band	Maximum Level	Measurement Bandwidth	Note
1 884,5 MHz to 1 919,60 MHz	-41 dBm	300 kHz	

#### 6.5.3.4.7 Co-existence with services in adjacent frequency bands

This requirement may be applied for the protection in bands adjacent to 2 110 MHz to 2 170 MHz, as defined in subclause 3.4.1(a) and 1 930 MHz to 1 990 MHz, as defined in subclause 3.4.1(b) in geographic areas in which both an adjacent band service and UTRA are deployed.

##### 6.5.3.4.7.1 Minimum requirement

The power of any spurious emission shall not exceed.

**Table 6.32: BS spurious emissions limits for protection of adjacent band services**

Band (f)	Maximum Level	Measurement Bandwidth	Note
2 100 MHz to 2 105 MHz For operation in frequency bands as defined in subclause 3.4.1(a)	$-30 + 3,4 (f - 2 100 \text{ MHz}) \text{ dBm}$	1 MHz	
2 175 MHz to 2 180 MHz For operation in frequency bands as defined in subclause 3.4.1(a)	$-30 + 3,4 (2 180 \text{ MHz} - f) \text{ dBm}$	1 MHz	
1 920 MHz to 1 925 MHz For operation in frequency bands as defined in subclause 3.4.1(b)	$-30 + 3,4 (f - 1 920 \text{ MHz}) \text{ dBm}$	1 MHz	
1 995 MHz to 2 000 MHz For operation in frequency bands as defined in subclause 3.4.1(b)	$-30 + 3,4 (2 000 \text{ MHz} - f) \text{ dBm}$	1 MHz	

#### 6.5.3.4.8 Co-existence with UTRA-TDD

##### 6.5.3.4.8.1 Operation in the same geographic area

This requirement may be applied to geographic areas in which both UTRA-TDD and UTRA-FDD are deployed.

##### 6.5.3.4.8.1.1 Minimum Requirement

The power of any spurious emission shall not exceed.

**Table 6.33: BS Spurious emissions limits for BS in geographic coverage area of UTRA-TDD**

Band	Maximum Level	Measurement Bandwidth	Note
1 900 MHz to 1 920 MHz	-52 dBm	1 MHz	
2 010 MHz to 2 025 MHz	-52 dBm	1 MHz	

#### 6.5.3.4.8.2 Co-located base stations

This requirement may be applied for the protection of UTRA-TDD BS receivers when UTRA-TDD BS and UTRA FDD BS are co-located.

##### 6.5.3.4.8.2.1 Minimum Requirement

The power of any spurious emission shall not exceed.

**Table 6.34: BS Spurious emissions limits for BS co-located with UTRA-TDD**

Band	Maximum Level	Measurement Bandwidth	Note
1 900 MHz to 1 920 MHz	-86 dBm	1 MHz	
2 010 MHz to 2 025 MHz	-86 dBm	1 MHz	

#### 6.5.3.5 Test purpose

This test measures conducted spurious emission from the BS transmitter antenna connector, while the transmitter is in operation.

#### 6.5.3.6 Method of Test

##### 6.5.3.6.1 Initial conditions

Test environment: normal; see subclause 4.4.1.

RF channels to be tested: B, M and T with multiple carriers if supported; see subclause 4.8

- 1) Connect the BS antenna connector to a measurement receiver using an attenuator or a directional coupler if necessary
- 2) Measurements shall use a measurement bandwidth in accordance to the tables in section 6.5.3.4.
- 3) Detection mode: True RMS.
- 4) Configure the BS with transmitters active at their maximum output power.

##### 6.5.3.6.2 Procedure

- 1) Set the BS to transmit a signal in accordance to test model 1, subclause 6.1.1.1 at the manufacturer's specified maximum output power.
- 2) Measure the emission at the specified frequencies with specified measurement bandwidth and note that the measured value does not exceed the specified value.

#### 6.5.3.7 Test requirements

The measurement result in step 2 of 6.5.3.6.2 shall not exceed the maximum level specified in tables 6.35 to 6.45 if applicable for the BS under test.

**NOTE:** If a Test Requirement in this section differs from the corresponding Minimum Requirement then the Test Tolerances applied for this test is non-zero. The Test Tolerance for this test is defined in subclause 4.2 and the explanation of how the Minimum Requirement has been relaxed by the Test Tolerance is given in Annex F.

## 6.5.3.7.1 Spurious emissions (Category A)

**Table 6.35: BS Mandatory spurious emissions limits, Category A**

Band	Maximum level	Measurement Bandwidth	Note
9 kHz to 150 kHz	-13 dBm	1 kHz	Bandwidth as in ITU-R SM.329-8, subclause 4.1
150 kHz to 30 MHz		10 kHz	Bandwidth as in ITU-R SM.329-8, subclause 4.1
30 MHz to 1 GHz		100 kHz	Bandwidth as in ITU-R SM.329-8, subclause 4.1
1 GHz to 12,75 GHz		1 MHz	Upper frequency as in ITU-R SM.329-8, subclause 2.5 Table 1

## 6.5.3.7.2 Spurious emissions (Category B)

**Table 6.36: BS Mandatory spurious emissions limits, Category B**

Band	Maximum Level	Measurement Bandwidth	Note
9 kHz ↔ 150 kHz	-36 dBm	1 kHz	Note 1
150 kHz ↔ 30 MHz	-36 dBm	10 kHz	Note 1
30 MHz ↔ 1 GHz	-36 dBm	100 kHz	Note 1
1 GHz ↔ 2100 MHz	-30 dBm	1 MHz	Note 1
2100 MHz ↔ 2180 MHz	-15 dBm	1 MHz	Note 2
2180 MHz ↔ 12.75 GHz	-30 dBm	1 MHz	Note 3
NOTE 1: Bandwidth as in ITU-R Recommendation SM.329 [4], s4.1			
NOTE 2: Limit based on ITU-R Recommendation SM.329 [4], s4.3 and Annex 7			
NOTE 3: Bandwidth as in ITU-R Recommendation SM.329 [4], s4.1. Upper frequency as in ITU-R SM.329 [4], s2.5 table 1			

## 6.5.3.7.3 Protection of the BS receiver of own or different BS

**Table 6.37: BS Spurious emissions limits for protection of the BS receiver**

Band	Maximum Level	Measurement Bandwidth	Note
1 920 MHz to 1 980 MHz For operation in Frequency Bands defined in subclause 3.4.1(a)	-96 dBm	100 kHz	
1 850 MHz to 1 910 MHz For operation in Frequency Bands defined in subclause 3.4.1(b)	-96 dBm	100 kHz	

## 6.5.3.7.4 Co-existence with GSM 900

## 6.5.3.7.4.1 Operation in the same geographic area

**Table 6.38: BS Spurious emissions limits for BS in geographic coverage area of GSM 900**

Band	Maximum Level	Measurement Bandwidth	Note
876 MHz to 915 MHz	-61 dBm	100 kHz	
921 MHz to 960 MHz	-57 dBm	100 kHz	

## 6.5.3.7.4.2 Co-located base stations

**Table 6.39: BS Spurious emissions limits for protection of the BTS receiver**

Band	Maximum Level	Measurement Bandwidth	Note
876 MHz to 915 MHz	-98 dBm	100 kHz	

## 6.5.3.7.5 Co-existence with DCS 1800

## 6.5.3.7.5.1 Operation in the same geographic area

**Table 6.40: BS Spurious emissions limits for BS in geographic coverage area of DCS 1800**

Band	Maximum Level	Measurement Bandwidth	Note
1710 MHz to 1785 MHz	-61 dBm	100 kHz	
1 805 MHz to 1 880 MHz	-47 dBm	100 kHz	

## 6.5.3.7.5.2 Co-located base stations

**Table 6.41: BS Spurious emissions limits for BS co-located with DCS 1800 BTS**

Band	Maximum Level	Measurement Bandwidth	Note
1 710 MHz to 1 785 MHz	-98 dBm	100 kHz	

## 6.5.3.7.6 Co-existence with PHS

**Table 6.42: BS Spurious emissions limits for BS in geographic coverage area of PHS**

Band	Maximum Level	Measurement Bandwidth	Note
1 884,5 MHz to 1 919,60 MHz	-41 dBm	300 kHz	

## 6.5.3.7.7 Co-existence with services in adjacent frequency bands

**Table 6.43: BS spurious emissions limits for protection of adjacent band services**

Band (f)	Maximum Level	Measurement Bandwidth	Note
2 100 MHz to 2 105 MHz For operation in frequency bands as defined in subclause 3.4.1(a)	-30 + 3,4 (f - 2 100 MHz) dBm	1 MHz	
2 175 MHz to 2 180 MHz For operation in frequency bands as defined in subclause 3.4.1(a)	-30 + 3,4 (2 180 MHz - f) dBm	1 MHz	
1 920 MHz to 1 925 MHz For operation in frequency bands as defined in subclause 3.4.1(b)	-30 + 3,4 (f - 1 920 MHz) dBm	1 MHz	
1 995 MHz to 2 000 MHz For operation in frequency bands as defined in subclause 3.4.1(b)	-30 + 3,4 (2 000 MHz - f) dBm	1 MHz	

### 6.5.3.7.8 Co-existence with UTRA-TDD

#### 6.5.3.7.8.1 Operation in the same geographic area

**Table 6.44: BS Spurious emissions limits for BS in geographic coverage area of UTRA-TDD**

Band	Maximum Level	Measurement Bandwidth	Note
1 900 MHz to 1 920 MHz	-52 dBm	1 MHz	
2 010 MHz to 2 025 MHz	-52 dBm	1 MHz	

#### 6.5.3.7.8.2 Co-located base stations

**Table 6.45: BS Spurious emissions limits for BS co-located with UTRA-TDD**

Band	Maximum Level	Measurement Bandwidth	Note
1 900 MHz to 1 920 MHz	-86 dBm	1 MHz	
2 010 MHz to 2 025 MHz	-86 dBm	1 MHz	

## 6.6 Transmit intermodulation

### 6.6.1 Definition and applicability

The transmit intermodulation performance is a measure of the capability of the transmitter to inhibit the generation of signals in its non linear elements caused by presence of the wanted signal and an interfering signal reaching the transmitter via the antenna.

The transmit intermodulation level is the power of the intermodulation products when a WCDMA modulated interference signal is injected into an antenna connector at a mean power level of 30 dB lower than that of the mean power of the wanted signal. The frequency of the interference signal shall be  $\pm 5$  MHz,  $\pm 10$  MHz and  $\pm 15$  MHz offset from the subject signal carrier frequency, but excluding interference frequencies that are outside of the allocated frequency band for UTRA-FDD downlink specified in subclause 3.4.1.

The requirements are applicable for a single carrier.

### 6.6.2 Minimum Requirement

The transmit intermodulation level shall not exceed the out of band emission or the spurious emission requirements of subclauses 6.5.2 and 6.5.3 in the presence of a WCDMA modulated interference signal with a mean power level 30 dB lower than the mean power of the wanted signal.

The normative reference for this requirement is in TS 25.104 [1] subclause 6.7

### 6.6.3 Test purpose

The test purpose is to verify the ability of the BS transmitter to restrict the generation of intermodulation products in its non linear elements caused by presence of the wanted signal and an interfering signal reaching the transmitter via the antenna to below specified levels.

### 6.6.4 Method of test

#### 6.6.4.1 Initial conditions

Test environment: normal; see subclause 4.4.1.

RF channels to be tested: B, M and T; see subclause 4.8

- 1) Test set-up in accordance to annex B.

#### 6.6.4.2 Procedures

- 1) Generate the wanted signal in accordance to test model 1, subclause 6.1.1.1 at specified maximum BS output power.
- 2) Generate the interference signal in accordance to test model 1, subclause 6.1.1.1 with frequency offset of 5 MHz relative to the wanted signal, but excluding interference frequencies that are outside of the allocated frequency band for UTRA-FDD downlink specified in subclause 3.4.1.
- 3) Adjust ATT1 so the level of the WCDMA modulated interference signal is as defined in subclause 6.6.5.
- 4) Perform the out of band emission test as specified in subclause 6.5.2 for all third and fifth order intermodulation products which appear in the frequency ranges defined in subclause 6.5.2. The width of the intermodulation products shall be taken into account.
- 5) Perform the spurious emission test as specified in subclause 6.5.3 for all third and fifth order intermodulation products which appear in the frequency ranges defined in subclause 6.5.3. The width of the intermodulation products shall be taken into account.
- 6) Verify that the emission level does not exceed the required level with the exception of interference signal frequencies.
- 7) Repeat the test for interference frequency off set of -5 MHz but excluding interference frequencies that are outside of the allocated frequency band for UTRA-FDD downlink specified in subclause 3.4.
- 8) Repeat the test for interference frequency off set of  $\pm 10$  MHz and  $\pm 15$  MHz but excluding interference frequencies that are outside of the allocated frequency band for UTRA-FDD downlink specified in subclause 3.4.1.

NOTE: The third order intermodulation products are  $(F1 \pm 2F2)$  and  $(2F1 \pm F2)$ , the fifth order intermodulation products are  $(2F1 \pm 3F2)$ ,  $(3F1 \pm 2F2)$ ,  $(4F1 \pm F2)$ , and  $(F1 \pm 4F2)$ , where F1 represents the subject signal frequencies of 5 MHz channel and F2 represents the interference signal frequencies of 5 MHz channel. The width of intermodulation products is 15 MHz for third order intermodulation products and 25 MHz for fifth order intermodulation products based on a bandwidth of 5 MHz for subject and interference signal.

#### 6.6.5 Test Requirements

In the frequency range relevant for this test, the transmit intermodulation level shall not exceed the out of band emission or the spurious emission requirements of subclauses 6.5.2 and 6.5.3 in the presence of a WCDMA modulated interference signal with a mean power 30 dB below the mean power of the wanted signal.

The measurements for out of band emission or spurious emission requirement due to intermodulation can be limited to the power of all third and fifth order intermodulation products.

NOTE: If the above Test Requirement differs from the Minimum Requirement then the Test Tolerance applied for this test is non-zero. The Test Tolerance for this test is defined in subclause 4.2 and the explanation of how the Minimum Requirement has been relaxed by the Test Tolerance is given in Annex F

### 6.7 Transmit modulation

#### 6.7.1 Error Vector Magnitude

##### 6.7.1.1 Definition and applicability

The Error Vector Magnitude is a measure of the difference between the reference waveform and the measured waveform. This difference is called the error vector. Both waveforms pass through a matched Root Raised Cosine filter with bandwidth 3.84 MHz and roll-off  $\alpha = 0.22$ . Both waveforms are then further modified by selecting the frequency, absolute phase, absolute amplitude and chip clock timing so as to minimise the error vector. The EVM result is defined



as the square root of the ratio of the mean error vector power to the mean reference power expressed as a %. The measurement interval is one timeslot as defined by the C-PICH (when present) otherwise the measurement interval is one timeslot starting with the beginning of the SCH. The requirement is valid over the total power dynamic range as specified in 25.104 subclause 6.4.3. See Annex E of this specification for further details

### 6.7.1.2 Minimum Requirement

The Error Vector Magnitude shall be less than 17.5%

The normative reference for this requirement is in TS 25.104 [1] subclause 6.8.2

### 6.7.1.3 Test Purpose

To verify that the Error Vector Magnitude is within the limit specified in 6.7.1.2

### 6.7.1.4 Method of Test

This test method includes the procedure for 6.4.4.4. Total power dynamic range.

#### 6.7.1.4.1 Initial Conditions

Test environment: normal; see subclause 4.4.1.

RF channels to be tested: B, M and T; see subclause 4.8

Refer to annex B for a functional block diagram of the test set-up.

- 1) Connect the base station RF output port to the measurement equipment.
- 2) Set the base station to transmit a signal according to 6.1.1.4 (test model 4)
- 3) Set BS frequency

#### 6.7.1.4.2 Procedure

- 1) Start BS transmission at  $P_{max}-3dB$
- 2) Measure the Error Vector Magnitude as defined in annex E. If the base station supports STTD or closed loop transmit diversity, EVM shall be measured on both main and diversity RF output ports.
- 3) Set the total output power to  $P_{max}-18dB$ .
- 4) Measure the EVM and mean power.

### 6.7.1.5 Test Requirement

The Error Vector Magnitude shall be less than 17.5%

NOTE: If the above Test Requirement differs from the Minimum Requirement then the Test Tolerance applied for this test is non-zero. The Test Tolerance for this test is defined in subclause 4.2 and the explanation of how the Minimum Requirement has been relaxed by the Test Tolerance is given in Annex F.

## 6.7.2 Peak Code Domain Error

### 6.7.2.1 Definition and applicability

The Peak Code Domain Error is computed by projecting the error vector (as defined in 6.7.1) onto the code domain at a specific spreading factor. The Code Domain Error for every code in the domain is defined as the ratio of the mean power of the projection onto that code, to the mean power of the composite reference waveform. This ratio is expressed in dB. The Peak Code Domain Error is defined as the maximum value for the Code Domain Error for all codes. The

measurement interval is one timeslot as defined by the C-PICH (when present), otherwise the measurement interval is one timeslot starting with the beginning of the SCH. See Annex E of this specification for further details.

### 6.7.2.2 Minimum requirement

The peak code domain error shall not exceed -33 dB at spreading factor 256.

The normative reference for this requirement is in TS 25.104[1] subclause 6.8.3.

### 6.7.2.3 Test Purpose

It is the purpose of this test to discover and limit inter-code cross-talk.

### 6.7.2.4 Method of test

#### 6.7.2.4.1 Initial conditions

Test environment: normal; see subclause 4.4.1.

RF channels to be tested: B, M and T; see subclause 4.8

- 1) Connect the measurement equipment to the BS antenna connector as shown in Figure B.2 annex B.
- 2) Channel configuration defined in subclause 6.1.1.3 Test model 3 shall be used.
- 3) Set BS frequency.
- 4) Start BS transmission at maximum output power.

#### 6.7.2.4.2 Procedure

- 1) Measure Peak code domain error according to annex E.

### 6.7.2.5 Test requirement

The peak code domain error shall not exceed -32 dB at spreading factor 256.

NOTE: If the above Test Requirement differs from the Minimum Requirement then the Test Tolerance applied for this test is non-zero. The Test Tolerance for this test is defined in subclause 4.2 and the explanation of how the Minimum Requirement has been relaxed by the Test Tolerance is given in Annex F.

---

## 7 Receiver characteristics

### 7.1 General

Unless otherwise stated, all tests in this clause shall be performed at the BS antenna connector (test port A) with a full complement of transceivers for the configuration in normal operating conditions. If any external apparatus such as a RX amplifier, a filter or the combination of such devices is used, the tests according to subclauses 4.6.2 and/or 4.6.4, depending on the device added, shall be performed to ensure that the requirements are met at test port B.

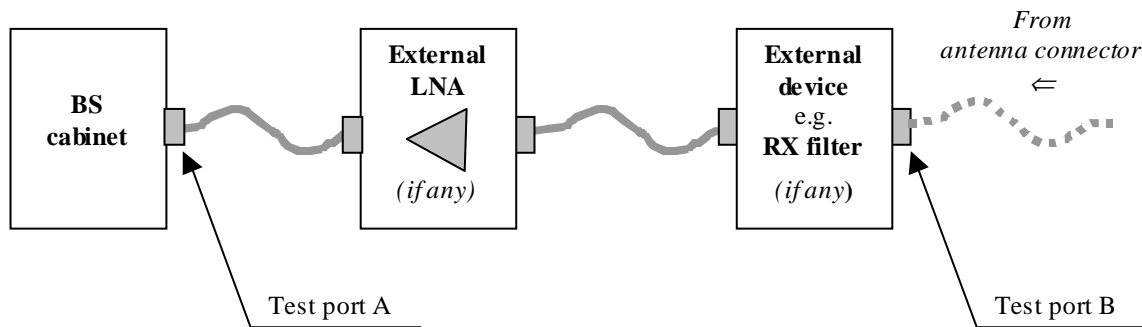

**Figure 7.1: Receiver test ports**

The tests in clause 7 assume that the receiver is not equipped with diversity. For receivers with diversity, unless otherwise stated, tests shall be performed by applying the specified signals to one of the receiver inputs, and terminating or disabling the other(s). The tests and requirements are otherwise unchanged.

In all the relevant subclauses in this clause all Bit Error Ratio (BER), Residual BER (RBER) and Block Error Ratio (BLER) measurements shall be carried out according to the general rules for statistical testing defined in ITU-T Recommendation O.153 [5].

If external BER measurement is not used then the internal BER calculation shall be used instead. When internal BER calculation is used, the requirements of the verification test according to 7.8 shall be met in advance.

In tests performed with signal generators a synchronization signal may be provided, from the base station to the signal generator, to enable correct timing of the wanted signal.

## 7.2 Reference sensitivity level

### 7.2.1 Definition and applicability

The reference sensitivity level is the minimum mean power received at the antenna connector at which the BER shall not exceed the specific value indicated in subclause 7.2.2. The test is set up according to Figure B.7 and performed without interfering signal power applied to the BS antenna connector. For duplex operation, the measurement configuration principle is indicated for one duplex branch in Figure B.7. For internal BER calculation an example of the test connection is as shown in figure B.7. The reference point for signal power is at the input of the receiver (antenna connector).

### 7.2.2 Minimum Requirement

The BER shall not exceed 0,001 for the parameters specified in table 7.1.

**Table 7.1: BS reference sensitivity levels**

Reference measurement channel data rate	BS reference sensitivity level (dBm)	BER
12,2 kbps	-121	BER shall not exceed 0,001

The normative reference for this requirement is in TS 25.104[1] subclause 7.2.

### 7.2.3 Test purpose

To verify that at the BS Reference sensitivity level the BER shall not exceed the specified limit.

## 7.2.4 Method of testing

### 7.2.4.1 Initial conditions

Test environment: normal; see subclause 4.4.1

RF channels to be tested: B, M and T; see subclause 4.8.

The following additional tests shall be performed:

- a) On each of B, M and T, the test shall be performed under extreme power supply as defined in subclause 4.4.2

NOTE: Tests under extreme power supply also test extreme temperature.

- 1) Connect BS to be tested to RF signal source.
- 2) Set frequency.
- 3) Start transmit 12,2kbps DPCH with reference measurement channel defined in annex A to the BS under test (PN-9 data sequence or longer).
- 4) Disable TPC function.

### 7.2.4.2 Procedure

- 1) Calculate BER from at least 30000 received data bits.
- 2) Set the test signal mean power as specified in table 7.1.A.
- 3) Measure BER.

## 7.2.5 Test requirement

The measurement result in step 3 of 7.2.4.2 shall not be greater than the BER with BS reference sensitivity level both specified in tables 7.1A.

**Table 7.1A: BS reference sensitivity levels**

Reference measurement channel data rate	BS reference sensitivity level (dBm)	BER
12,2 kbps	-120.3	BER shall not exceed 0,001
NOTE: Should only be specified for a measurement channel.		

NOTE: If the above Test Requirement differs from the Minimum Requirement then the Test Tolerance applied for this test is non-zero. The Test Tolerance for this test is defined in subclause 4.2 and the explanation of how the Minimum Requirement has been relaxed by the Test Tolerance is given in Annex F.

## 7.3 Dynamic range

### 7.3.1 Definition and applicability

Receiver dynamic range is the receiver ability to handle a rise of interference in the reception frequency channel. The receiver shall fulfil a specified BER requirement for a specified sensitivity degradation of the wanted signal in the presence of an interfering AWGN signal in the same reception frequency channel.

### 7.3.2 Minimum Requirement

The BER shall not exceed 0,001 for the parameters specified in table 7.2.

**Table 7.2: Dynamic range**

Parameter	Level	Unit
Data rate	12,2	kbps
Wanted signal mean power	-91	dBm
Interfering AWGN signal	-73	dBm/3.84 MHz

The normative reference for this requirement is in TS 25.104[1] subclause 7.3

### 7.3.3 Test purpose

The test purpose is to verify the ability of the BS to receive a single-code test signal of maximum with a BER not exceeding a specified limit.

### 7.3.4 Method of test

#### 7.3.4.1 Initial conditions

Test environment: normal; see subclause 4.4.1.

RF channels to be tested: B, M and T; see subclause 4.8

- 1) Connect the test equipment as shown in annex B.

#### 7.3.4.2 Procedure

- 1) Adjust the signal generator for the wanted signal as specified in Table 7.2A.
- 2) Adjust the AWGN generator level as specified in Table 7.2A and set the frequency to the same frequency as the tested channel.
- 3) Measure the BER for the tested service and verify that it is below the specified level.

Repeat the measurement for the other RX port.

### 7.3.5 Test Requirements

The BER measurement result in step 3 of 7.3.4.2 shall not be greater than  $BER < 0,001$  using the parameters specified in tables 7.2A.

**Table 7.2A: Dynamic range**

Parameter	Level	Unit
Reference measurement channel data rate	12,2	Kbps
Wanted signal mean power	-89.8	dBm
Interfering AWGN signal	-73	dBm/3.84 MHz

NOTE: If the above Test Requirement differs from the Minimum Requirement then the Test Tolerance applied for this test is non-zero. The Test Tolerance for this test is defined in subclause 4.2 and the explanation of how the Minimum Requirement has been relaxed by the Test Tolerance is given in Annex F.

## 7.4 Adjacent Channel Selectivity (ACS)

### 7.4.1 Definition and applicability

Adjacent channel selectivity (ACS) is a measure of the receiver ability to receive a wanted signal at its assigned channel frequency in the presence of an adjacent channel signal at a given frequency offset from the center frequency of the assigned channel. ACS is the ratio of the receiver filter attenuation on the assigned channel frequency to the receiver filter attenuation on the adjacent channel(s).

The interference signal is offset from the wanted signal and QPSK modulated by a pseudo random binary sequence uncorrelated to the wanted signal.

### 7.4.2 Minimum Requirement

The BER shall not exceed 0.001 for the parameters specified in table 7.3

**Table 7.3: Adjacent channel selectivity**

Parameter	Level	Unit
Reference measurement channel data rate	12.2	kbps
Wanted signal mean power	-115	dBm
Interfering signal mean power	-52	dBm
Fuw offset (Modulated)	±5	MHz

The normative reference for this requirement is in TS 25.104[1] subclause 7.4.

### 7.4.3 Test purpose

The test purpose is to verify the ability of the BS receiver filter to suppress interfering signals in the channels adjacent to the wanted channel.

### 7.4.4 Method of test

#### 7.4.4.1 Initial conditions

Test environment: normal; see subclause 4.4.1.

RF channels to be tested: B, M and T; see subclause 4.8

- 1) Set-up the equipment as shown in annex B.

#### 7.4.4.2 Procedure

- 1) Generate the wanted signal and adjust the ATT1 to set the input level to the base station under test to the level specified in table 7.3A.
- 2) Set-up the interference signal at the adjacent channel frequency and adjust the ATT2 to obtain the specified level of interference signal at the base station input defined in table 7.3A. Note that the interference signal shall have an ACLR of at least 63 dB in order to eliminate the impact of interference signal adjacent channel leakage power on the ACS measurement.
- 3) Measure the BER.
- 4) Repeat the test for the port, which was terminated.

## 7.4.5 Test Requirements

The BER measurement result in step 3 of 7.4.4.2 shall not be greater than 0,001 using the parameters specified in table 7.3A.

**Table 7.3A: Adjacent channel selectivity**

Parameter	Level	Unit
Reference measurement channel data rate	12.2	kbps
Wanted signal mean power	-115	dBm
Interfering signal mean power	-52	dBm
Fuw offset (Modulated)	±5	MHz

NOTE: If the above Test Requirement differs from the Minimum Requirement then the Test Tolerance applied for this test is non-zero. The Test Tolerance for this test is defined in subclause 4.2 and the explanation of how the Minimum Requirement has been relaxed by the Test Tolerance is given in Annex F.

## 7.5 Blocking characteristics

### 7.5.1 Definition and applicability

The blocking characteristics is a measure of the receiver ability to receive a wanted signal at its assigned channel frequency in the presence of an unwanted interferer on frequencies other than those of the adjacent channels. The blocking performance requirement applies as specified in tables 7.4(a) to 7.4(d).

The requirements in Table 7.4(a) or 7.4(b) shall apply to base stations intended for general-purpose applications, depending on which frequency band is used. The requirements in Tables 7.4 (c) and 7.4 (d) may be applied when the FDD BS for operation in frequency bands in subclause 3.4.1(a) is co-located with GSM900 or DCS1800 BTS respectively.

### 7.5.2 Minimum Requirements

The BER shall not exceed 0.001 for the parameters specified in table 7.4.

**Table 7.4(a): Blocking characteristics for operation in frequency bands in subclause 3.4.1(a)**

Center Frequency of Interfering Signal	Interfering Signal mean power	Wanted Signal mean power	Minimum Offset of Interfering Signal	Type of Interfering Signal
1 920 MHz to 1 980 MHz	-40 dBm	-115 dBm	10 MHz	WCDMA signal with one code
1 900 MHz to 1 920 MHz 1 980 MHz to 2 000 MHz	-40 dBm	-115 dBm	10 MHz	WCDMA signal with one code
1 MHz to 1 900 MHz and 2 000 MHz to 12 750 MHz	-15 dBm	-115 dBm	-	CW carrier

**Table 7.4(b): Blocking performance requirement for operation in frequency bands in subclause 3.4.1(b)**

Center Frequency of Interfering Signal	Interfering Signal mean power	Wanted Signal mean power	Minimum Offset of Interfering Signal	Type of Interfering Signal
1 850 MHz to 1 910 MHz	-40 dBm	-115 dBm	10 MHz	WCDMA signal with one code
1 830 MHz to 1 850 MHz 1 910 MHz to 1 930 MHz	-40 dBm	-115 dBm	10 MHz	WCDMA signal with one code
1 MHz to 1 830 MHz 1 930 MHz to 12 750 MHz	-15 dBm	-115 dBm	-	CW carrier

**Table 7.4(c): Blocking performance requirement for operation in frequency bands in sub-clause 3.4.1.(a) when co-located with GSM900**

Center Frequency of Interfering Signal	Interfering Signal mean power	Wanted Signal mean power	Minimum Offset of Interfering Signal	Type of Interfering Signal
921 -960 MHz	+16 dBm	-115 dBm	—	CW carrier

**Table 7.4(d): Blocking performance requirement for operation in frequency bands in sub-clause 3.4.1(a) when co-located with DCS1800**

Center Frequency of Interfering Signal	Interfering Signal mean power	Wanted Signal mean power	Minimum Offset of Interfering Signal	Type of Interfering Signal
1805 – 1880 MHz	+16 dBm	-115 dBm	—	CW carrier

The normative reference for these requirements is in TS 25.104[1] subclause 7.5

### 7.5.3 Test purpose

The test stresses the ability of the BS receiver to withstand high-level interference from unwanted signals at frequency offsets of 10 MHz or more, without undue degradation of its sensitivity.

### 7.5.4 Method of test

#### 7.5.4.1 Initial conditions

Test environment: normal; see subclause 4.4.1.

RF channels to be tested: M see subclause 4.8. The BS shall be configured to operate as close to the centre of the operating band as possible.

- 1) Connect WCDMA signal generator at the assigned channel frequency of the wanted signal and a signal generator to the antenna connector of one Rx port.
- 2) Terminate any other Rx port not under test.
- 3) Transmit a signal from the WCDMA signal generator to the BS. The characteristics of the signal shall be set according to the UL reference measurement channel (12,2 kbit/s) specified in annex A subclause A.2.1. The level of the WCDMA signal measured at the BS antenna connector shall be set to the level specified in subclause 7.5.5.

#### 7.5.4.2 Procedure

- 1) Set the signal generator to produce an interfering signal at a frequency offset  $F_{uw}$  from the assigned channel frequency of the wanted signal which is given by:

$$F_{uw} = \pm (n \times 1 \text{ MHz}),$$



where  $n$  shall be increased in integer steps from  $n = 10$  up to such a value that the center frequency of the interfering signal covers the range from 1 MHz to 12,75 GHz. The interfering signal level measured at the antenna connector shall be set in dependency of its center frequency, as specified in table 7.4A. The type of the interfering signal is either equivalent to a continuous WCDMA signal with one code of chip frequency 3,84 Mchip/s, filtered by an RRC transmit pulse-shaping filter with roll-off  $\alpha = 0,22$ , or a CW signal; see table 7.4A.

2) Measure the BER of the wanted signal at the BS receiver.

NOTE: The test procedure as defined in steps (1) and (2) requests to carry out more than 10 000 BER measurements. To reduce the time needed for these measurements, it may be appropriate to conduct the test in two phases: During phase 1, BER measurements are made on all center frequencies of the interfering signal as requested but with a reduced confidence level, with the aim to identify those frequencies which require more detailed investigation. In phase 2, detailed measurements are made only at those critical frequencies identified before, applying the required confidence level.

3) Interchange the connections of the BS Rx ports and repeat the measurements according to steps (1) to (2).

<Editor's note: The above NOTE is taken from proposal for TDD specification (R4-99789). Precise parameters for this 2-phase measurement shall be specified. >

## 7.5.5 Test Requirements

The BER shall not exceed 0.001 for the parameters specified in table 7.4A.

**Table 7.4A(a): Blocking characteristics for operation in frequency bands in subclause 3.4.1(a)**

Center Frequency of Interfering Signal	Interfering Signal mean power	Wanted Signal mean power	Minimum Offset of Interfering Signal	Type of Interfering Signal
1 920 MHz to 1 980 MHz	-40 dBm	-115 dBm	10 MHz	WCDMA signal with one code
1 900 MHz to 1 920 MHz 1 980 MHz to 2 000 MHz	-40 dBm	-115 dBm	10 MHz	WCDMA signal with one code
1 MHz to 1 900 MHz and 2 000 MHz to 12 750 MHz	-15 dBm	-115 dBm	-	CW carrier

**Table 7.4A(b): Blocking performance requirement for operation in frequency bands in subclause 3.4.1(b)**

Center Frequency of Interfering Signal	Interfering Signal mean power	Wanted Signal mean power	Minimum Offset of Interfering Signal	Type of Interfering Signal
1 850 MHz to 1 910 MHz	-40 dBm	-115 dBm	10 MHz	WCDMA signal with one code
1 830 MHz to 1 850 MHz 1 910 MHz to 1 930 MHz	-40 dBm	-115 dBm	10 MHz	WCDMA signal with one code
1 MHz to 1 830 MHz 1 930 MHz to 12 750 MHz	-15 dBm	-115 dBm	-	CW carrier

**Table 7.4A(c) : Blocking performance requirement for operation in frequency bands in sub-clause 3.4.1.(a) when co-located with GSM900**

Center Frequency of Interfering Signal	Interfering Signal mean power	Wanted Signal mean power	Minimum Offset of Interfering Signal	Type of Interfering Signal
921 -960 MHz	+16 dBm	-115 dBm	—	CW carrier

**Table 7.4A(d) : Blocking performance requirement for operation in frequency bands in sub-clause 3.4.1(a) when co-located with DCS1800**

Center Frequency of Interfering Signal	Interfering Signal mean power	Wanted Signal mean power	Minimum Offset of Interfering Signal	Type of Interfering Signal
1805 – 1880 MHz	+16 dBm	-115 dBm	—	CW carrier

NOTE: If the above Test Requirement differs from the Minimum Requirement then the Test Tolerance applied for this test is non-zero. The Test Tolerance for this test is defined in subclause 4.2 and the explanation of how the Minimum Requirement has been relaxed by the Test Tolerance is given in Annex F.

## 7.6 Intermodulation characteristics

### 7.6.1 Definition and applicability

Third and higher order mixing of the two interfering RF signals can produce an interfering signal in the band of the desired channel. Intermodulation response rejection is a measure of the capability of the receiver to receive a wanted signal on its assigned channel frequency in the presence of two or more interfering signals which have a specific frequency relationship to the wanted signal.

### 7.6.2 Minimum Requirement

The intermodulation performance should be met when the following signals are applied to the receiver.

**Table 7.5: Interferer signals for intermodulation performance requirement**

Type of Signal	Offset	Signal mean power
Wanted signal	-	-115 dBm
CW signal	10 MHz	-48 dBm
WCDMA signal with one code	20 MHz	-48 dBm

The BER for wanted signal shall not exceed 0,001 for the parameters specified in table 7.5.

The normative reference for this requirement is in TS 25.104 [1] subclause 7.6

### 7.6.3 Test purpose

The test purpose is to verify the ability of the BS receiver to inhibit the generation of intermodulation products in its non-linear elements caused by the presence of two high-level interfering signals at frequencies with a specific relationship to the frequency of the wanted signal.

### 7.6.4 Method of test

#### 7.6.4.1 Initial conditions

Test environment: normal; see subclause 4.4.1.

RF channels to be tested: B, M and T; see subclause 4.8

- 1) Set-up the equipment as shown in annex B.

#### 7.6.4.2 Procedures

- 1) Generate the wanted signal (reference signal) and adjust ATT1 to set the signal level to the BS under test to the level specified in table 7.5A.

- 2) Adjust the signal generators to the frequency offset of +10 MHz (CW tone) and +20 MHz (WCDMA modulated) from the frequency of the wanted signal.
- 3) Adjust the ATT2 and ATT3 to obtain the specified level of interference signal at the BS input.
- 4) Measure the BER.
- 5) Repeat the test for interference signal frequency offset of -10 MHz and -20 MHz for CW and WCDMA modulated respectively.
- 6) Repeat the whole test for the port which was terminated.

## 7.6.5 Test requirements

The intermodulation performance should be met when the following signals are applied to the receiver.

**Table 7.5A: Interferer signals for intermodulation performance requirement**

Type of Signal	Offset	Signal mean power
Wanted signal	-	-115 dBm
CW signal	10 MHz	-48 dBm
WCDMA signal with one code	20 MHz	-48 dBm

The BER for wanted signal shall not exceed 0,001 for the parameters specified in table 7.5A.

NOTE: If the above Test Requirement differs from the Minimum Requirement then the Test Tolerance applied for this test is non-zero. The Test Tolerance for this test is defined in subclause 4.2 and the explanation of how the Minimum Requirement has been relaxed by the Test Tolerance is given in Annex F.

## 7.7 Spurious Emissions

### 7.7.1 Definition and applicability

The spurious emission power is the power of the emissions generated or amplified in a receiver that appears at the BS antenna connector. The requirements apply to all BS with separate RX and TX antenna port. The test shall be performed when both TX and RX are on with the TX port terminated.

For all BS with common RX and TX antenna port the transmitter spurious emission as specified in subclause 6.5.3 is valid.

### 7.7.2 Minimum Requirements

The power of any spurious emission shall not exceed:

**Table 7.6: Spurious emission minimum requirement**

Band	Maximum level	Measurement Bandwidth	Note
1900 – 1980 MHz and 2010 – 2025 MHz	-78 dBm	3.84 MHz	
30 MHz – 1 GHz	-57 dBm	100 kHz	
1 GHz – 12.75 GHz	-47 dBm	1 MHz	With the exception of frequencies between 12.5 MHz below the first carrier frequency and 12.5 MHz above the last carrier frequency used by the BS.

In addition to the requirements in table 7.6, the co-existence requirements for co-located base stations in subclauses 6.5.3.4.4.2, 6.5.3.4.5.2 and 6.5.3.4.8.2 may also be applied.

The normative reference for this requirement is in TS 25.104[1] subclause 7.7

### 7.7.3 Test purpose

The test purpose is to verify the ability of the BS to limit the interference caused by receiver spurious emissions to other systems.

### 7.7.4 Method of test

#### 7.7.4.1 Initial conditions

Test environment: normal; see subclause 4.4.1.

RF channels to be tested: M see subclause 4.8

- 1) Connect a measurement receiver to the BS antenna connector as shown in annex B.
- 2) Enable the BS receiver.
- 3) Start BS transmission with channel configuration as specified in the table 6.1 and 6.2 (Test model 1).

#### 7.7.4.2 Procedure

- 1) Set measurement equipment parameters as specified in table 7.7.
- 2) Measure the spurious emissions over each frequency range described in subclause 7.7.2.
- 3) Repeat test using diversity antenna connector if available.

**Table 7.7**

Measurement Band width	3.84 MHz (Root raised cosine,0.22) / 100 kHz/ 1MHz (note)
Sweep frequency range	30 MHz to 12.75GHz
Detection	True RMS
NOTE:	As defined in subclause 7.7.2.

### 7.7.5 Test requirements

The all measured spurious emissions, derived in step (2), shall be within requirement limits as specified in Table 7.7A.

**Table 7.7A: Spurious emission minimum requirement**

Band	Maximum level	Measurement Bandwidth	Note
1900 – 1980 MHz and 2010 – 2025 MHz	-78 dBm	3.84 MHz	
30 MHz – 1 GHz	-57 dBm	100 kHz	
1 GHz – 12.75 GHz	-47 dBm	1 MHz	With the exception of frequencies between 12.5 MHz below the first carrier frequency and 12.5 MHz above the last carrier frequency used by the BS.

NOTE: If the above Test Requirement differs from the Minimum Requirement then the Test Tolerance applied for this test is non-zero. The Test Tolerance for this test is defined in subclause 4.2 and the explanation of how the Minimum Requirement has been relaxed by the Test Tolerance is given in Annex F.

## 7.8 Verification of the internal BER calculation

### 7.8.1 Definition and applicability

Base Station System with internal BER calculation can synchronise its receiver to known pseudo-random data sequence and calculates bit error ratio from the received data. This test is performed only if Base Station System has this kind of feature. All data rates which are used in RX conformance testing shall be used in verification test. This test is performed by feeding measurement signal with known BER to the input of the receiver. Locations of the erroneous bits shall be randomly distributed within a frame. Erroneous bits shall be inserted to the data bit stream as shown in figure 7.1.

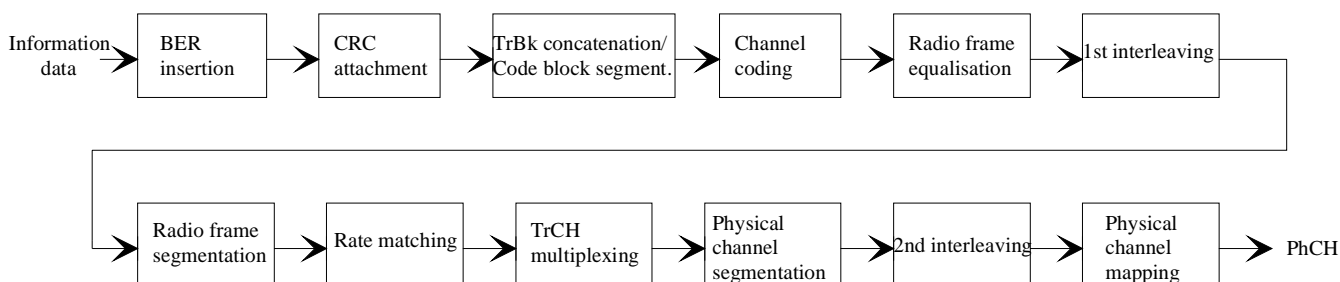

**Figure 7.1: BER insertion into the information data**

### 7.8.2 Minimum Requirement

BER indicated by the Base Station System shall be within  $\pm 10\%$  of the BER generated by the RF signal source. Measurement shall be performed for the measurement signal specified in table 7.8.

**Table 7.8**

Transport channel combination	Data rate	BER
DPCH	12,2 kbps	0,01

### 7.8.3 Test purpose

To verify that the internal BER calculation accuracy shall meet requirements for conformance testing.

### 7.8.4 Method of test

#### 7.8.4.1 Initial conditions

Test environment: normal; see subclause 4.4.1.

RF channels to be tested: B, M and T; see subclause 4.8

- 1) Connect BS RX antenna connector to the RF signal source or UE simulator as shown in annex B.
- 2) Set correct signal source parameters as specified in table 7.9.

**Table 7.9**

Parameter	Level/status	Unit
UL signal level	Ref.sens +10 dB	dBm/3,84 MHz
Data sequence	PN9 or longer	

### 7.8.4.2 Procedure

- 1) Measure the BER of received signal from RF signal source or UE simulator to BS antenna connector.
- 2) BER calculation shall be done at least over 50 000 bits.
- 3) Repeat test for all required data rates.

### 7.8.5 Test Requirement

BER indicated by the Base Station System shall be within requirement as specified in subclause 7.8.2.

---

## 8 Performance requirement

### 8.1 General

All Bit Error Ratio (BER) and Block Error ratio (BLER) measurements shall be carried out according to the general rules for statistical testing defined in ITU-T Recommendation O.153 [5].

If external BLER measurement is not used then the internal BLER calculation shall be used instead. When internal BLER calculation is used, the requirements of the verification test according to 8.6 shall be met in advance.

Performance requirements are specified for a number of test environments and multi-path channel classes.

The requirements only apply to those measurement channels that are supported by the base station.

The requirements only apply to a base station with dual receiver antenna diversity. The required  $E_b/N_0$  shall be applied separately at each antenna port.

In tests performed with signal generators a synchronization signal may be provided, from the base station to the signal generator, to enable correct timing of the wanted signal.

### 8.2 Demodulation in static propagation conditions

#### 8.2.1 Demodulation of DCH

##### 8.2.1.1 Definition and applicability

The performance requirement of DCH in static propagation conditions is determined by the maximum Block Error Ratio (BLER) allowed when the receiver input signal is at a specified  $E_b/N_0$  limit. The BLER is calculated for each of the measurement channels supported by the base station.

The requirement in this subclause shall apply to base stations intended for general-purpose applications.

##### 8.2.1.2 Minimum requirement

The BLER should not exceed the limit for the  $E_b/N_0$  specified in table 8.1.

**Table 8.1: Performance requirements in AWGN channel.**

Measurement channel data rate ( $R_b$ )	$E_b/N_0$ for required BLER < $10^{-1}$	$E_b/N_0$ for required BLER < $10^{-2}$
12.2 kbps	n.a.	5.1 dB
64 kbps	1.5 dB	1.7 dB
144 kbps	0.8 dB	0.9 dB
384 kbps	0.9 dB	1.0 dB

The reference for this requirement is TS 25.104 subclause 8.2.1.1.

### 8.2.1.3 Test purpose

The test shall verify the receiver's ability to receive the test signal under static propagation conditions with a BLER not exceeding a specified limit.

### 8.2.1.4 Method of test

#### 8.2.1.4.1 Initial conditions

Test environment: normal; see subclause 4.4.1.

RF channels to be tested: B, M and T; see subclause 4.8

- 1) Connect the BS tester generating the wanted signal and AWGN generators to both BS antenna connectors for diversity reception via a combining network as shown in annex B.

#### 8.2.1.4.2 Procedure

- 1) Adjust the AWGN generator to -84 dBm/3.84 MHz at the BS input.
- 2) The characteristics of the wanted signal shall be configured according to the corresponding UL reference measurement channel defined in annex A.
- 3) Adjust the equipment so that required  $E_b/N_0$  specified in table 8.2 is achieved. To achieve the specified  $E_b/N_0$ , the ratio of the wanted signal level relative to the AWGN signal at the BS input should be adjusted to:  $10 \cdot \log_{10}(R_b / 3.84 \cdot 10^6) + E_b/N_0$  [dB].
- 4) For each of the data rates in table 8.2 applicable for the base station, measure the BLER.

### 8.2.1.5 Test requirements

The BLER measured according to subclause 8.2.1.4.2 shall not exceed the BLER limits for the  $E_b/N_0$  levels specified in table 8.2.

**Table 8.2: Test requirements in AWGN channel.**

Measurement channel data rate ( $R_b$ )	$E_b/N_0$ for required BLER < $10^{-1}$	$E_b/N_0$ for required BLER < $10^{-2}$
12.2 kbps	n.a.	5.5 dB
64 kbps	1.9 dB	2.1 dB
144 kbps	1.2 dB	1.3 dB
384 kbps	1.3 dB	1.4 dB

NOTE: If the above Test Requirement differs from the Minimum Requirement then the Test Tolerance applied for this test is non-zero. The Test Tolerance for this test is defined in subclause 4.2 and the explanation of how the Minimum Requirement has been relaxed by the Test Tolerance is given in Annex F.

## 8.3 Demodulation of DCH in multipath fading conditions

### 8.3.1 Multipath fading Case 1

#### 8.3.1.1 Definition and applicability

The performance requirement of DCH in multipath fading Case 1 is determined by the maximum Block Error Ratio (BLER) allowed when the receiver input signal is at a specified  $E_b/N_0$  limit. The BLER is calculated for each of the measurement channels supported by the base station.

The requirement in this subclause shall apply to base stations intended for general-purpose applications.

### 8.3.1.2 Minimum requirement

The BLER should not exceed the limit for the  $E_b/N_0$  specified in table 8.3.

**Table 8.3: Performance requirements in multipath Case 1 channel**

Measurement channel data rate ( $R_b$ )	$E_b/N_0$ for required BLER $< 10^{-1}$	$E_b/N_0$ for required BLER $< 10^{-2}$
12.2 kbps	n.a.	11.9 dB
64 kbps	6.2 dB	9.2 dB
144 kbps	5.4 dB	8.4 dB
384 kbps	5.8 dB	8.8 dB

The reference for this requirement is TS 25.104 subclause 8.3.1.1

### 8.3.1.3 Test Purpose

The test shall verify the receiver's ability to receive the test signal under slow multipath fading propagation conditions with a BLER not exceeding a specified limit.

### 8.3.1.4 Method of test

#### 8.3.1.4.1 Initial conditions

Test environment: normal; see subclause 4.4.1.

RF channels to be tested: B, M and T; see subclause 4.8

- 1) Connect the BS tester generating the wanted signal, multipath fading simulators and AWGN generators to both BS antenna connectors for diversity reception via a combining network as shown in annex B.

#### 8.3.1.4.2 Procedure

- 1) Adjust the AWGN generator to -84 dBm/3.84 MHz at the BS input.
- 2) The characteristics of the wanted signal shall be configured according to the corresponding UL reference measurement channel defined in annex A.
- 3) The multipath fading emulators shall be configured according to the corresponding channel model defined in annex D.
- 4) Adjust the equipment so that required  $E_b/N_0$  specified in table 8.4 is achieved. To achieve the specified  $E_b/N_0$ , the ratio of the wanted signal level relative to the AWGN signal at the BS input should be adjusted to:  $10 * \text{Log}_{10}(R_b / 3.84 * 10^6) + E_b/N_0$  [dB].
- 5) For each of the data rates in table 8.43 applicable for the base station, measure the BLER.

### 8.3.1.5 Test requirements

The BLER measured according to subclause 8.3.1.4.2 shall not exceed the BLER limits for the  $E_b/N_0$  levels specified in table 8.4.



**Table 8.4: Test requirements in multipath Case 1 channel**

Measurement channel data rate ( $R_b$ )	$E_b/N_0$ for required BLER $< 10^{-1}$	$E_b/N_0$ for required BLER $< 10^{-2}$
12.2 kbps	n.a.	12.5 dB
64 kbps	6.8 dB	9.8 dB
144 kbps	6.0 dB	9.0 dB
384 kbps	6.4 dB	9.4 dB

NOTE: If the above Test Requirement differs from the Minimum Requirement then the Test Tolerance applied for this test is non-zero. The Test Tolerance for this test is defined in subclause 4.2 and the explanation of how the Minimum Requirement has been relaxed by the Test Tolerance is given in Annex F.

## 8.3.2 Multipath fading Case 2

### 8.3.2.1 Definition and applicability

The performance requirement of DCH in multipath fading Case 2 is determined by the maximum Block Error Rate (BLER) allowed when the receiver input signal is at a specified  $E_b/N_0$  limit. The BLER is calculated for each of the measurement channels supported by the base station.

The requirement in this subclause shall apply to base stations intended for general purpose applications.

### 8.3.2.2 Minimum requirement

The BLER should not exceed the limit for the  $E_b/N_0$  specified in table 8.5.

**Table 8.5: Performance requirements in multipath Case 2 channel**

Measurement channel data rate ( $R_b$ )	$E_b/N_0$ for required BLER $< 10^{-1}$	$E_b/N_0$ for required BLER $< 10^{-2}$
12.2 kbps	n.a.	9.0 dB
64 kbps	4.3 dB	6.4 dB
144 kbps	3.7 dB	5.6 dB
384 kbps	4.1 dB	6.1 dB

The reference for this requirement is TS 25.104 subclause 8.3.2.1.

### 8.3.2.3 Test Purpose

The test shall verify the receiver's ability to receive the test signal that has a large time dispersion with a BLER not exceeding a specified limit.

### 8.3.2.4 Method of test

#### 8.3.2.4.1 Initial conditions

Test environment: normal; see subclause 4.4.1.

RF channels to be tested: B, M and T; see subclause 4.8

- 1) Connect the BS tester generating the wanted signal, multipath fading simulators and AWGN generators to both BS antenna connectors for diversity reception via a combining network as shown in annex B.

#### 8.3.2.4.2 Procedure

- 1) Adjust the AWGN generator to -84 dBm/3.84 MHz at the BS input.
- 2) The characteristics of the wanted signal shall be configured according to the corresponding UL reference measurement channel defined in annex A.

- 3) The multipath fading emulators shall be configured according to the corresponding channel model defined in annex D.
- 4) Adjust the equipment so that required  $E_b/N_0$  specified in table 8.6 is achieved. To achieve the specified  $E_b/N_0$ , the ratio of the wanted signal level relative to the AWGN signal at the BS input should be adjusted to:  
 $10 \cdot \text{Log}_{10}(R_b / 3.84 \cdot 10^6) + E_b/N_0$  [dB].
- 5) For each of the data rates in table 8.6 applicable for the base station, measure the BLER.

### 8.3.2.5 Test requirements

The BLER measured according to subclause 8.3.2.4.2 shall not exceed the BLER limits for the  $E_b/N_0$  levels specified in table 8.6.

**Table 8.6: Test requirements in multipath Case 2 channel**

Measurement channel data rate ( $R_b$ )	$E_b/N_0$ for required BLER < $10^{-1}$	$E_b/N_0$ for required BLER < $10^{-2}$
12.2 kbps	n.a.	9.6 dB
64 kbps	4.9 dB	7.0 dB
144 kbps	4.3 dB	6.2 dB
384 kbps	4.7 dB	6.7 dB

NOTE: If the above Test Requirement differs from the Minimum Requirement then the Test Tolerance applied for this test is non-zero. The Test Tolerance for this test is defined in subclause 4.2 and the explanation of how the Minimum Requirement has been relaxed by the Test Tolerance is given in Annex F.

## 8.3.3 Multipath fading Case 3

### 8.3.3.1 Definition and applicability

The performance requirement of DCH in multipath fading Case 3 is determined by the maximum Block Error Ratio (BLER) allowed when the receiver input signal is at a specified  $E_b/N_0$  limit. The BLER is calculated for each of the measurement channels supported by the base station.

The requirement in this subclause shall apply to base stations intended for general purpose applications.

### 8.3.3.2 Minimum requirement

The BLER should not exceed the limit for the  $E_b/N_0$  specified in table 8.7.

**Table 8.7: Performance requirements in multipath Case 3 channel**

Measurement channel data rate ( $R_b$ )	$E_b/N_0$ for required BLER < $10^{-1}$	$E_b/N_0$ for required BLER < $10^{-2}$	$E_b/N_0$ for required BLER < $10^{-3}$
12.2 kbps	n.a.	7.2 dB	8.0 dB
64 kbps	3.4 dB	3.8 dB	4.1 dB
144 kbps	2.8 dB	3.2 dB	3.6 dB
384 kbps	3.2 dB	3.6 dB	4.2 dB

The reference for this requirement is TS 25.104 subclause 8.3.3.1.

### 8.3.3.3 Test purpose

The test shall verify the receivers ability to receive the test signal under fast fading propagation conditions with a BLER not exceeding a specified limit.

### 8.3.3.4 Method of test

#### 8.3.3.4.1 Initial conditions

Test environment: normal; see subclause 4.4.1.

RF channels to be tested: B, M and T; see subclause 4.8

- 1) Connect the BS tester generating the wanted signal, multipath fading simulators and AWGN generators to both BS antenna connectors for diversity reception via a combining network as shown in annex B.

#### 8.3.3.4.2 Procedure

- 1) Adjust the AWGN generator to -84 dBm/3.84 MHz at the BS input.
- 2) The characteristics of the wanted signal shall be configured according to the corresponding UL reference measurement channel defined in annex A.
- 3) The multipath fading emulators shall be configured according to the corresponding channel model defined in annex D.
- 4) Adjust the equipment so that required  $E_b/N_0$  specified in table 8.8 is achieved. To achieve the specified  $E_b/N_0$ , the ratio of the wanted signal level relative to the AWGN signal at the BS input should be adjusted to:  $10 \cdot \log_{10}(R_b / 3.84 \cdot 10^6) + E_b/N_0$  [dB].
- 5) For each of the data rates in table 8.8 applicable for the base station, measure the BLER

### 8.3.3.5 Test requirements

The BLER measured according to subclause 8.3.3.4.2 shall not exceed the BLER limits for  $E_b/N_0$  levels specified in table 8.8.

**Table 8.8: Test requirements in multipath Case 3 channel**

Measurement channel data rate ( $R_b$ )	$E_b/N_0$ for required BLER < $10^{-1}$	$E_b/N_0$ for required BLER < $10^{-2}$	$E_b/N_0$ for required BLER < $10^{-3}$
12.2 kbps	n.a	7.8 dB	8.6 dB
64 kbps	4.0 dB	4.4 dB	4.7 dB
144 kbps	3.4 dB	3.8 dB	4.2 dB
384 kbps	3.8 dB	4.2 dB	4.8 dB

NOTE: If the above Test Requirement differs from the Minimum Requirement then the Test Tolerance applied for this test is non-zero. The Test Tolerance for this test is defined in subclause 4.2 and the explanation of how the Minimum Requirement has been relaxed by the Test Tolerance is given in Annex F.

## 8.3.4 Multipath fading Case 4

### 8.3.4.1 Definition and applicability

The performance requirement of DCH in multipath fading Case 4 is determined by the maximum Block Error Ratio (BLER) allowed when the receiver input signal is at a specified  $E_b/N_0$  limit. The BLER is calculated for each of the measurement channels supported by the base station.

The requirement in this subclause shall apply to base stations intended for general purpose applications.

### 8.3.4.2 Minimum requirement

The BLER should not exceed the limit for the  $E_b/N_0$  specified in table 8.8A.

**Table 8.8A: Performance requirements in multipath Case 4 channel**

Measurement channel data rate ( $R_b$ )	$E_b/N_0$ for required BLER < $10^{-1}$	$E_b/N_0$ for required BLER < $10^{-2}$	$E_b/N_0$ for required BLER < $10^{-3}$
12.2 kbps	n.a	10.2 dB	11.0 dB
64 kbps	6.4 dB	6.8 dB	7.1 dB
144 kbps	5.8 dB	6.2 dB	6.6 dB
384 kbps	6.2 dB	6.6 dB	7.2 dB

The reference for this requirement is TS 25.104 subclause 8.3.4.1.

### 8.3.4.3 Test purpose

The test shall verify the receivers ability to receive the test signal under fast fading propagation conditions with a BLER not exceeding a specified limit.

### 8.3.4.4 Method of test

#### 8.3.4.4.1 Initial conditions

Test environment: normal; see subclause 4.4.1.

RF channels to be tested: B, M and T; see subclause 4.8

- 1) Connect the BS tester generating the wanted signal, multipath fading simulators and AWGN generators to both BS antenna connectors for diversity reception via a combining network as shown in annex B.

#### 8.3.4.4.2 Procedure

- 1) Adjust the AWGN generator to -84 dBm/3.84 MHz at the BS input.
- 2) The characteristics of the wanted signal shall be configured according to the corresponding UL reference measurement channel defined in annex A.
- 3) The multipath fading emulators shall be configured according to the corresponding channel model defined in annex D.
- 4) Adjust the equipment so that required  $E_b/N_0$  specified in table 8.8B is achieved. To achieve the specified  $E_b/N_0$ , the ratio of the wanted signal level relative to the AWGN signal at the BS input should be adjusted to:  
 $10 \cdot \text{Log}_{10}(R_b / 3.84 \cdot 10^6) + E_b/N_0$  [dB]
- 5) For each of the data rates in table 8.8B applicable for the base station, measure the BLER

### 8.3.4.5 Test requirements

The BLER measured according to subclause 8.3.4.4.2 shall not exceed the BLER limits for the  $E_b/N_0$  levels specified in table 8.8B.

**Table 8.8B: Test requirements in multipath Case 4 channel**

Measurement channel data rate ( $R_b$ )	$E_b/N_0$ for required BLER < $10^{-1}$	$E_b/N_0$ for required BLER < $10^{-2}$	$E_b/N_0$ for required BLER < $10^{-3}$
12.2 kbps	n.a	10.8 dB	11.6 dB
64 kbps	7.0 dB	7.4 dB	7.7 dB
144 kbps	6.4 dB	6.8 dB	7.2 dB
384 kbps	6.8 dB	7.2 dB	7.8 dB

NOTE: If the above Test Requirement differs from the Minimum Requirement then the Test Tolerance applied for this test is non-zero. The Test Tolerance for this test is defined in subclause 4.2 and the explanation of how the Minimum Requirement has been relaxed by the Test Tolerance is given in Annex F.

## 8.4 Demodulation of DCH in moving propagation conditions

### 8.4.1 Definition and applicability

The performance requirement of DCH in moving propagation conditions is determined by the maximum Block Error Ratio (BLER) allowed when the receiver input signal is at a specified  $E_b/N_0$  limit. The BLER is calculated for each of the measurement channels supported by the base station.

The requirement in this subclause shall apply to base stations intended for general-purpose applications.

### 8.4.2 Minimum requirement

The BLER should not exceed the limit for the  $E_b/N_0$  specified in table 8.9.

**Table 8.9: Performance requirements in moving channel**

Measurement channel data rate ( $R_b$ )	$E_b/N_0$ for required BLER $< 10^{-1}$	$E_b/N_0$ for required BLER $< 10^{-2}$
12.2 kbps	n.a.	5.7 dB
64 kbps	2.1 dB	2.2 dB

The reference for this requirement is TS 25.104 subclause 8.4.1.

### 8.4.3 Test purpose

The test shall verify the receiver's ability to receive and track the test signal with a BLER not exceeding the specified limit.

### 8.4.4 Method of test

#### 8.4.4.1 Initial conditions

Test environment: normal; see subclause 4.4.1.

RF channels to be tested: B, M and T; see subclause 4.8

- 1) Connect the BS tester generating the wanted signal, multipath fading simulators and AWGN generators to both BS antenna connectors for diversity reception via a combining network as shown in annex B.

#### 8.4.4.2 Procedure

- 1) Adjust the AWGN generator to -84 dBm/3.84 MHz at the BS input.
- 2) The characteristics of the wanted signal shall be configured according to the corresponding UL reference measurement channel defined in annex A.
- 3) The multipath fading emulators shall be configured according to the corresponding channel model defined in annex D.
- 4) Adjust the equipment so that required  $E_b/N_0$  specified in table 8.10 is achieved. To achieve the specified  $E_b/N_0$ , the ratio of the wanted signal level relative to the AWGN signal at the BS input should be adjusted to:  $10 \cdot \text{Log}_{10}(R_b / 3.84 \cdot 10^6) + E_b/N_0$  [dB].
- 5) For each of the data rates in table 8.10 applicable for the base station, measure the BLER.

### 8.4.5 Test requirements

The BLER measured according to subclause 8.4.4.2 shall not exceed the BLER limits for the  $E_b/N_0$  levels specified in table 8.10.

**Table 8.10: Test requirements in moving channel**

Measurement channel data rate ( $R_b$ )	$E_b/N_0$ for required BLER $< 10^{-1}$	$E_b/N_0$ for required BLER $< 10^{-2}$
12.2 kbps	n.a.	6.3 dB
64 kbps	2.7 dB	2.8 dB

NOTE: If the above Test Requirement differs from the Minimum Requirement then the Test Tolerance applied for this test is non-zero. The Test Tolerance for this test is defined in subclause 4.2 and the explanation of how the Minimum Requirement has been relaxed by the Test Tolerance is given in Annex F.

## 8.5 Demodulation of DCH in birth/death propagation conditions

### 8.5.1 Definition and applicability

The performance requirement of DCH in birth/death propagation conditions is determined by the maximum Block Error Ratio (BLER) allowed when the receiver input signal is at a specified  $E_b/N_0$  limit. The BLER is calculated for each of the measurement channels supported by the base station.

The requirement in this subclause shall apply to base stations intended for general purpose applications.

### 8.5.2 Minimum requirement

The BLER should not exceed the limit for the  $E_b/N_0$  specified in table 8.11.

**Table 8.11: Performance requirements in birth/death channel**

Measurement channel data rate ( $R_b$ )	$E_b/N_0$ for required BLER $< 10^{-1}$	$E_b/N_0$ for required BLER $< 10^{-2}$
12.2 kbps	n.a.	7.7 dB
64 kbps	4.1 dB	4.2 dB

The reference for this requirement is TS 25.104 subclause 8.5.1.

### 8.5.3 Test purpose

The test shall verify the receiver's ability to receive the test signal to find new multi path components with a BLER not exceeding the specified limit.

### 8.5.4 Method of test

#### 8.5.4.1 Initial conditions

Test environment: normal; see subclause 4.4.1.

RF channels to be tested: B, M and T; see subclause 4.8

- 1) Connect the BS tester generating the wanted signal, multipath fading simulators and AWGN generators to both BS antenna connectors for diversity reception via a combining network as shown in annex B.

### 8.5.4.2 Procedure

- 1) Adjust the AWGN generator to -84 dBm/3.84 MHz at the BS input.
- 2) The characteristics of the wanted signal shall be configured according to the corresponding UL reference measurement channel defined in annex A.
- 3) The multipath fading emulators shall be configured according to the corresponding channel model defined in annex D.
- 4) Adjust the equipment so that required  $E_b/N_0$  specified in table 8.12 is achieved. To achieve the specified  $E_b/N_0$ , the ratio of the wanted signal level relative to the AWGN signal at the BS input should be adjusted to:  $10 \cdot \text{Log}_{10}(R_b / 3.84 \cdot 10^6) + E_b/N_0$  [dB].
- 5) For each of the data rates in table 8.12 applicable for the base station, measure the BLER.

### 8.5.5 Test requirements

The BLER measured according to subclause 8.5.4.2 shall not exceed the BLER limits for the  $E_b/N_0$  levels specified in table 8.112.

**Table 8.12: Test requirements in birth/death channel**

Measurement channel data rate ( $R_b$ )	$E_b/N_0$ for required BLER < $10^{-1}$	$E_b/N_0$ for required BLER < $10^{-2}$
12.2 kbps	n.a.	8.3 dB
64 kbps	4.7 dB	4.8 dB

NOTE: If the above Test Requirement differs from the Minimum Requirement then the Test Tolerance applied for this test is non-zero. The Test Tolerance for this test is defined in subclause 4.2 and the explanation of how the Minimum Requirement has been relaxed by the Test Tolerance is given in Annex F.

## 8.6 Verification of the internal BLER calculation

### 8.6.1 Definition and applicability

Base Station System with internal BLER calculates block error rate from the CRC blocks of the received. This test is performed only if Base Station System has this kind of feature. All data rates which are used in clause 8 Performance requirement testing shall be used in verification testing. This test is performed by feeding measurement signal with known BLER to the input of the receiver. Locations of the erroneous blocks shall be randomly distributed within a frame. Erroneous bits shall be inserted into the UL signal as shown in figure 8.1.

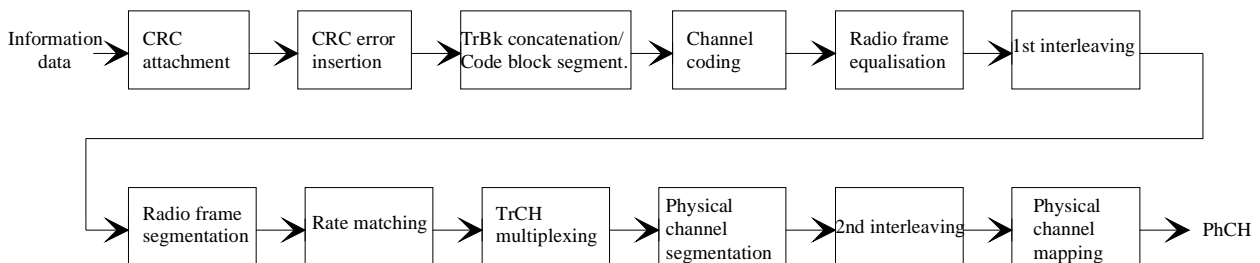

**Figure 8.1: BLER insertion to the output data**

## 8.6.2 Conformance requirement

BLER indicated by the Base Station System shall be within  $\pm 10\%$  of the BLER generated by the RF signal source. Measurement shall be repeated for each signal rate as specified in table 8.13.

**Table 8.13**

Transport channel combination	Data rate	BLER
DPCH	12,2 kbps	0.01
DPCH	64 kbps	0.01
DPCH	144 kbps	0.01
DPCH	384 kbps	0.01

## 8.6.3 Test purpose

To verify that the internal BLER calculation accuracy shall met requirements for conformance testing.

## 8.6.4 Method of test

### 8.6.4.1 Initial conditions

Test environment: normal; see subclause 4.4.1.

RF channels to be tested: B, M and T; see subclause 4.8

- 1) Connect the BS tester generating the wanted signal to both BS antenna connectors for diversity reception via a combining network as shown in annex B.

**Table 8.14**

Parameter	Level/status	Unit
UL signal level	Ref.sens +10 dB	dBm/3.84 MHz
Data sequence	PN9	

### 8.6.4.2 Procedure

- 1) The characteristics of the wanted signal shall be configured according to the corresponding UL reference measurement channel defined in annex A.
- 2) The BLER insertion to the wanted signal shall be configured according to the corresponding data rate in table 8.13.
- 3) Adjust the BS tester so that the required UL signal level specified in table 8.14 is achieved.

For each of the data rates in table 8.13 applicable for the base station, measure the BLER at least over 50 000 blocks.

## 8.6.5 Test requirement

BLER indicated by the Base Station System shall be within requirement as specified in subclause 8.6.2.

## 8.7 void



## 8.8 RACH performance

### 8.8.1 RACH preamble detection in static propagation conditions

#### 8.8.1.1 Definition and applicability

The performance requirement of RACH for preamble detection in static propagation conditions is determined by the two parameters probability of false detection of the preamble (Pfa) and the probability of detection of preamble (Pd). The performance is measured by the required  $E_c/N_0$  at probability of detection, Pd of 0.99 and 0.999. Pfa is defined as a conditional probability of erroneous detection of the preamble when input is only noise (+interference). Pd is defined as conditional probability of detection of the preamble when the signal is present. Pfa shall be  $10^{-3}$  or less. Only one signature is used and it is known by the receiver.

The requirement in this subclause shall apply to base stations intended for general-purpose applications.

#### 8.8.1.2 Minimum requirement

The  $P_d$  shall be above or equal to the limits for the  $E_c/N_0$  specified in table 8.16.

**Table 8.16: Preamble detection requirements in AWGN channel**

$E_c/N_0$ for required Pd $\geq$ 0.99	$E_c/N_0$ for required Pd $\geq$ 0.999
-20.5 dB	-20.1 dB

The reference for this requirement is TS 25.104 subclause 8.7.1.

#### 8.8.1.3 Test purpose

The test shall verify the receiver's ability to detect RACH preambles under static propagation conditions.

#### 8.8.1.4 Method of test

##### 8.8.1.4.1 Initial conditions

Test environment: normal; see subclause 4.4.1.

RF channels to be tested: B, M and T; see subclause 4.8

- 1) Connect the BS tester generating the wanted signal and AWGN generators to both BS antenna connectors for diversity reception via a combining network as shown in annex B.

##### 8.8.1.4.2 Procedure

- 1) Adjust the AWGN generator to -84 dBm/3.84 MHz at the BS input.
- 2) The characteristics of the wanted signal shall be configured according to the corresponding UL reference measurement channel defined in annex A.
- 3) Adjust the equipment so that required  $E_c/N_0$  specified in table 8.17 is achieved. To achieve the specified  $E_c/N_0$ , the ratio of the wanted signal level (of the preamble part) relative to the AWGN signal at the BS input should be adjusted to:  $E_c/N_0$  [dB].
- 4) The test signal generator sends a preamble and the receiver tries to detect the preamble. This pattern is repeated. Preamble detection should be made only on those access slots a preamble has been sent in.



Figure 8.2: RACH test signal pattern

### 8.8.1.5 Test requirements

The  $P_d$  shall be above or equal to the  $P_d$  limits for the  $E_c/N_0$  levels specified in table 8.17.

Table 8.17: Preamble detection test requirements in AWGN channel

$E_c/N_0$ for required $P_d \geq 0.99$	$E_c/N_0$ for required $P_d \geq 0.999$
-20.1 dB	-19.7 dB

NOTE: If the above Test Requirement differs from the Minimum Requirement then the Test Tolerance applied for this test is non-zero. The Test Tolerance for this test is defined in subclause 4.2 and the explanation of how the Minimum Requirement has been relaxed by the Test Tolerance is given in Annex F.

## 8.8.2 RACH preamble detection in multipath fading case 3

### 8.8.2.1 Definition and applicability

The performance requirement of RACH for preamble detection in in multipath fading case 3 is determined by the two parameters probability of false detection of the preamble ( $P_{fa}$ ) and the probability of detection of preamble ( $P_d$ ). The performance is measured by the required  $E_c/N_0$  at probability of detection,  $P_d$  of 0.99 and 0.999.  $P_{fa}$  is defined as a conditional probability of erroneous detection of the preamble when input is only noise (+interference).  $P_d$  is defined as conditional probability of detection of the preamble when the signal is present.  $P_{fa}$  shall be  $10^{-3}$  or less. Only one signature is used and it is known by the receiver.

The requirement in this subclause shall apply to base stations intended for general-purpose applications.

### 8.8.2.2 Minimum requirement

The  $P_d$  shall be above or equal to the limits for the  $E_c/N_0$  specified in table 8.18.

Table 8.18: Preamble detection requirements in fading case 3 channel

$E_c/N_0$ for required $P_d \geq 0.99$	$E_c/N_0$ for required $P_d \geq 0.999$
-15.5 dB	-13.4 dB

The reference for this requirement is TS 25.104 subclause 8.7.1.

### 8.8.2.3 Test purpose

The test shall verify the receiver's ability to detect RACH preambles under multipath fading case 3 propagation conditions.

### 8.8.2.4 Method of test

#### 8.8.2.4.1 Initial conditions

Test environment: normal; see subclause 4.4.1.

RF channels to be tested: B, M and T; see subclause 4.8

- 1) Connect the BS tester generating the wanted signal, multipath fading simulators and AWGN generators to both BS antenna connectors for diversity reception via a combining network as shown in annex B.

**8.8.2.4.2 Procedure**

- 1) Adjust the AWGN generator to -84 dBm/3.84 MHz at the BS input.
- 2) The characteristics of the wanted signal shall be configured according to the corresponding UL reference measurement channel defined in annex A.
- 3) The multipath fading emulators shall be configured according to the corresponding channel model defined in annex D.
- 4) Adjust the equipment so that required  $E_c/N_0$  specified in table 8.19 is achieved. To achieve the specified  $E_c/N_0$ , the ratio of the wanted signal level (of the preamble part) relative to the AWGN signal at the BS input should be adjusted to:  $E_c/N_0$  [dB].
- 5) The test signal generator sends a preamble and the receiver tries to detect the preamble. This pattern is repeated. Preamble detection should be made only on those access slots a preamble has been sent in.



**Figure 8.3: RACH test signal pattern**

**8.8.2.5 Test requirements**

The  $P_d$  shall be above or equal to the  $P_d$  limits for the  $E_c/N_0$  levels specified in table 8.19.

**Table 8.19: Preamble detection test requirements in fading case 3 channel**

$E_c/N_0$ for required $P_d \geq 0.99$	$E_c/N_0$ for required $P_d \geq 0.999$
-14.9 dB	-12.8 dB

NOTE: If the above Test Requirement differs from the Minimum Requirement then the Test Tolerance applied for this test is non-zero. The Test Tolerance for this test is defined in subclause 4.2 and the explanation of how the Minimum Requirement has been relaxed by the Test Tolerance is given in Annex F.

**8.8.3 Demodulation of RACH message in static propagation conditions**

**8.8.3.1 Definition and applicability**

The performance requirement of RACH in static propagation conditions is determined by the maximum Block Error Ratio (BLER) allowed when the receiver input signal is at a specified  $E_b/N_0$  limit. The BLER is calculated for each of the measurement channels supported by the base station.

The preamble threshold factor is chosen to fulfil the requirements on  $P_{fa}$  and  $P_d$  in subclauses 8.8.1 and 8.8.2. Only one signature is used and it is known by the receiver.

The requirement in this subclause shall apply to base stations intended for general-purpose applications.

**8.8.3.2 Minimum requirement**

The BLER shall not exceed the limit for the  $E_b/N_0$  specified in table 8.20.

**Table 8.20: Performance requirements in AWGN channel**

Transport Block size TB and TTI in frames	$E_b/N_0$ for required BLER < $10^{-1}$	$E_b/N_0$ for required BLER < $10^{-2}$
168 bits, TTI = 20 ms	4.1 dB	5.0 dB
360 bits, TTI = 20 ms	3.9 dB	4.8 dB

The reference for this requirement is TS 25.104 subclause 8.7.2.

### 8.8.3.3 Test purpose

The test shall verify the receiver's ability to receive the test signal under static propagation conditions with a BLER not exceeding a specified limit.

### 8.8.3.4 Method of test

#### 8.8.3.4.1 Initial conditions

Test environment: normal; see subclause 4.4.1.

RF channels to be tested: B, M and T; see subclause 4.8

Preamble threshold factor: chosen to fulfil the requirements on Pfa and Pd in subclauses 8.8.1 and 8.8.2

- 1) Connect the BS tester generating the wanted signal and AWGN generators to both BS antenna connectors for diversity reception via a combining network as shown in annex B.

#### 8.8.3.4.2 Procedure

- 1) Adjust the AWGN generator to -84 dBm/3.84 MHz at the BS input.
- 2) The characteristics of the wanted signal shall be configured according to the corresponding UL reference measurement channel defined in annex A.
- 3) Adjust the equipment so that required  $E_b/N_0$  specified in table 8.21 is achieved. To achieve the specified  $E_b/N_0$ , the ratio of the wanted signal level (of the message part) relative to the AWGN signal at the BS input should be adjusted to:  $10 \cdot \log_{10}(\text{TB}/(\text{TTI} \cdot 3.84 \cdot 10^6)) + E_b/N_0$  [dB].
- 4) The test signal generator sends a preamble followed by the actual RACH message. This pattern is repeated (see figure 8.4). The receiver tries to detect the preamble and the message. The block error rate is calculated for the messages that have been decoded. Messages following undetected preambles shall not be taken into account in the BLER measurement.

**Figure 8.4: RACH test signal pattern**

### 8.8.3.5 Test requirements

The BLER measured according the subclause 8.8.3.4.2 shall not exceed the BLER limits for the  $E_b/N_0$  levels specified in table 8.21.

**Table 8.21: Test requirements in AWGN channel**

Transport Block size TB and TTI in frames	$E_b/N_0$ for required BLER < $10^{-1}$	$E_b/N_0$ for required BLER < $10^{-2}$
168 bits, TTI = 20 ms	4.5 dB	5.4 dB
360 bits, TTI = 20 ms	4.3 dB	5.2 dB

NOTE: If the above Test Requirement differs from the Minimum Requirement then the Test Tolerance applied for this test is non-zero. The Test Tolerance for this test is defined in subclause 4.2 and the explanation of how the Minimum Requirement has been relaxed by the Test Tolerance is given in Annex F.

## 8.8.4 Demodulation of RACH message in multipath fading case 3

### 8.8.4.1 Definition and applicability

The performance requirement of RACH in multipath fading case 3 is determined by the maximum Block Error Ratio (BLER) allowed when the receiver input signal is at a specified  $E_b/N_0$  limit. The BLER is calculated for each of the measurement channels supported by the base station.

The preamble threshold factor is chosen to fulfil the requirements on Pfa and Pd in subclauses 8.8.1 and 8.8.2. Only one signature is used and it is known by the receiver.

The requirement in this subclause shall apply to base stations intended for general-purpose applications.

### 8.8.4.2 Minimum requirement

The BLER shall not exceed the limit for the  $E_b/N_0$  specified in table 8.22.

**Table 8.22: Performance requirements in fading case 3 channel**

Transport Block size TB and TTI in frames	$E_b/N_0$ for required BLER < $10^{-1}$	$E_b/N_0$ for required BLER < $10^{-2}$
168 bits, TTI = 20 ms	7.4 dB	8.5 dB
360 bits, TTI = 20 ms	7.3 dB	8.3 dB

The reference for this requirement is TS 25.104 subclause 8.7.2.

### 8.8.4.3 Test purpose

The test shall verify the receiver's ability to receive the test signal under multipath fading case 3 propagation conditions with a BLER not exceeding a specified limit.

### 8.8.4.4 Method of test

#### 8.8.4.4.1 Initial conditions

Test environment: normal; see subclause 4.4.1.

RF channels to be tested: B, M and T; see subclause 4.8

Preamble threshold factor: chosen to fulfil the requirements on Pfa and Pd in subclauses 8.8.1 and 8.8.2

- 1) Connect the BS tester generating the wanted signal, multipath fading simulators and AWGN generators to both BS antenna connectors for diversity reception via a combining network as shown in annex B.

#### 8.8.4.4.2 Procedure

- 1) Adjust the AWGN generator to -84 dBm/3.84 MHz at the BS input.
- 2) The characteristics of the wanted signal shall be configured according to the corresponding UL reference measurement channel defined in annex A.
- 3) The multipath fading emulators shall be configured according to the corresponding channel model defined in annex D.
- 4) Adjust the equipment so that required  $E_b/N_0$  specified in table 8.23 is achieved. To achieve the specified  $E_b/N_0$ , the ratio of the wanted signal level (of the message part) relative to the AWGN signal at the BS input should be adjusted to:  $10 \cdot \log_{10}(TB/(TTI \cdot 3.84 \cdot 10^6)) + E_b/N_0$  [dB].

- 5) The test signal generator sends a preamble followed by the actual RACH message. This pattern is repeated (see figure 8.5). The receiver tries to detect the preamble and the message. The block error rate is calculated for the messages that have been decoded. Messages following undetected preambles shall not be taken into account in the BLER measurement.



**Figure 8.5: RACH test signal pattern**

### 8.8.4.5 Test requirements

The BLER measured according to subclause 8.8.4.2 shall not exceed the BLER limits for the  $E_b/N_0$  levels specified in table 8.23.

**Table 8.23: Test requirements in fading case 3 channel**

Transport Block size TB and TTI in frames	$E_b/N_0$ for required BLER < $10^{-1}$	$E_b/N_0$ for required BLER < $10^{-2}$
168 bits, TTI = 20 ms	8.0 dB	9.1 dB
360 bits, TTI = 20 ms	7.9 dB	8.9 dB

NOTE: If the above Test Requirement differs from the Minimum Requirement then the Test Tolerance applied for this test is non-zero. The Test Tolerance for this test is defined in subclause 4.2 and the explanation of how the Minimum Requirement has been relaxed by the Test Tolerance is given in Annex F.

## Annex A (normative): Measurement channels

### A.1 Summary of UL reference measurement channels

The parameters for the UL reference measurement channels are specified in Table A.1 and the channel coding is detailed in figure A.2 through A.6 respectively.

NOTE: For all cases, one DPCCH shall be attached to DPDCH(s).

**Table A.1: Reference measurement channels for UL DCH**

Parameter		DCH for DTCH / DCH for DCCH					Unit
DPDCH	Information bit rate	12,2/2,4	64/2,4	144/2,4	384/2,4	2048/2,4	kbps
	Physical channel	60/15	240/15	480/15	960/15	960/15	kbps
	Spreading factor	64	16	8	4	4	
	Repetition rate	22/22	19/19	8/9	-18/-18	-1/-1	%
	Interleaving	20	40	40	40	80	ms
	Number of DPDCHs	1	1	1	1	6	
DPCCH	Dedicated pilot	6					bit/slot
	Power control	2					bit/slot
	TFCI	2					bit/slot
	Spreading factor	256					
Power ratio of DPCCH/DPDCH		-2,69	-5,46	-9,54	-9,54	-9,54	dB
Amplitude ratio of DPCCH/DPDCH		0,7333	0,5333	0,3333	0,3333	03333	

## A.2 UL reference measurement channel for 12,2 kbps

The parameters for the UL reference measurement channel for 12,2 kbps are specified in table A.2 and the channel coding is detailed in figure A.2.

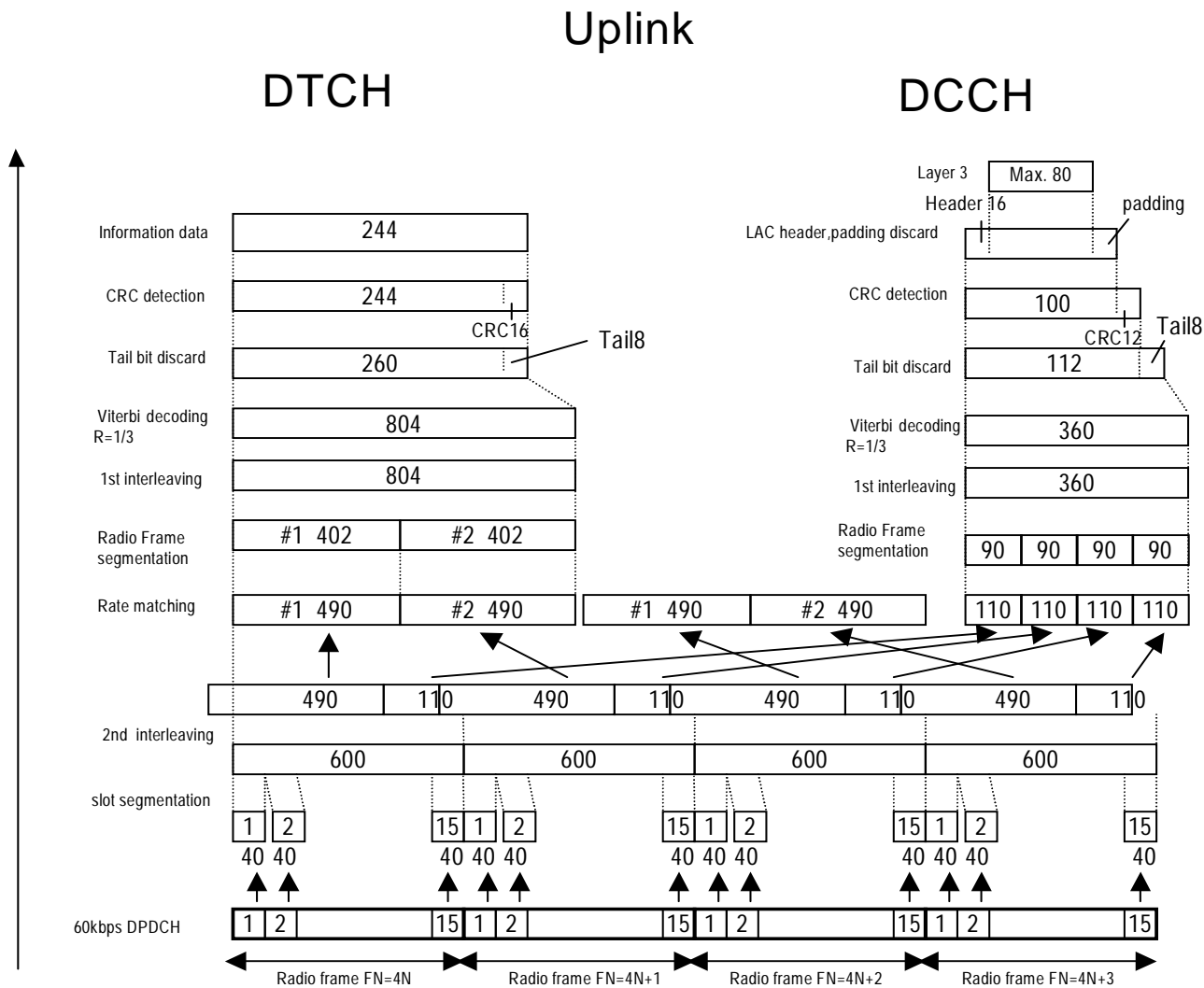

Figure A.2

Table A.2: UL reference measurement channel (12.2 kbps)

Parameter	Level	Unit
Information bit rate	12,2	kbps
DPCH	60	kbps
Power control	Off	
TFCI	On	
Repetition	22	%



# A.3 UL reference measurement channel for 64 kbps

The parameters for the UL reference measurement channel for 64 kbps are specified in table A.3 and the channel coding is detailed in figure A.3.

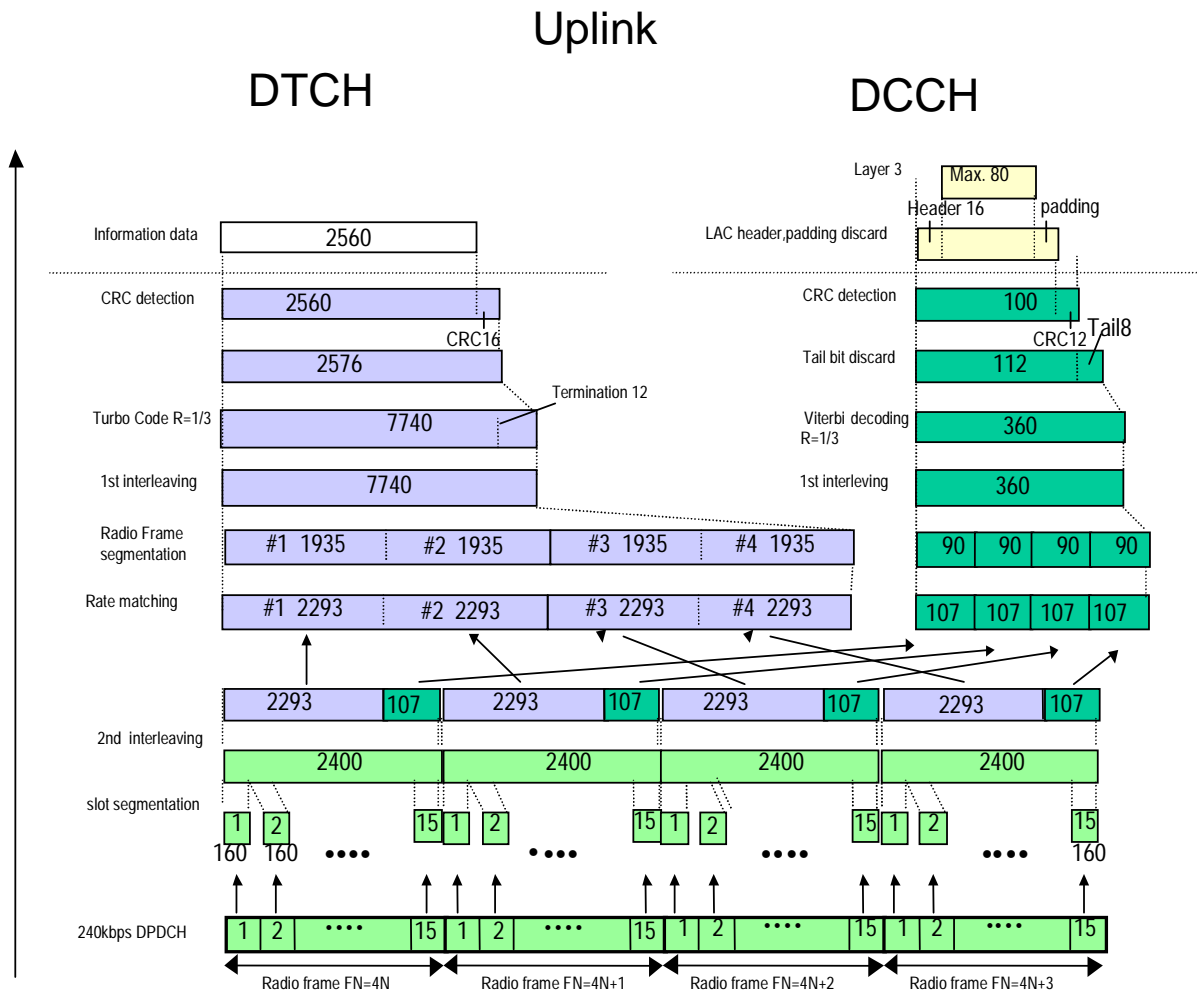

Figure A.3

Table A.3: UL reference measurement channel (64kbps)

Parameter	Level	Unit
Information bit rate	64	kbps
DPCH	240	kbps
Power control	Off	
TFCI	On	
Repetition	19	%

# A.4 UL reference measurement channel for 144 kbps

The parameters for the UL reference measurement channel for 144 kbps are specified in table A.4 and the channel coding is detailed in figure A.4.

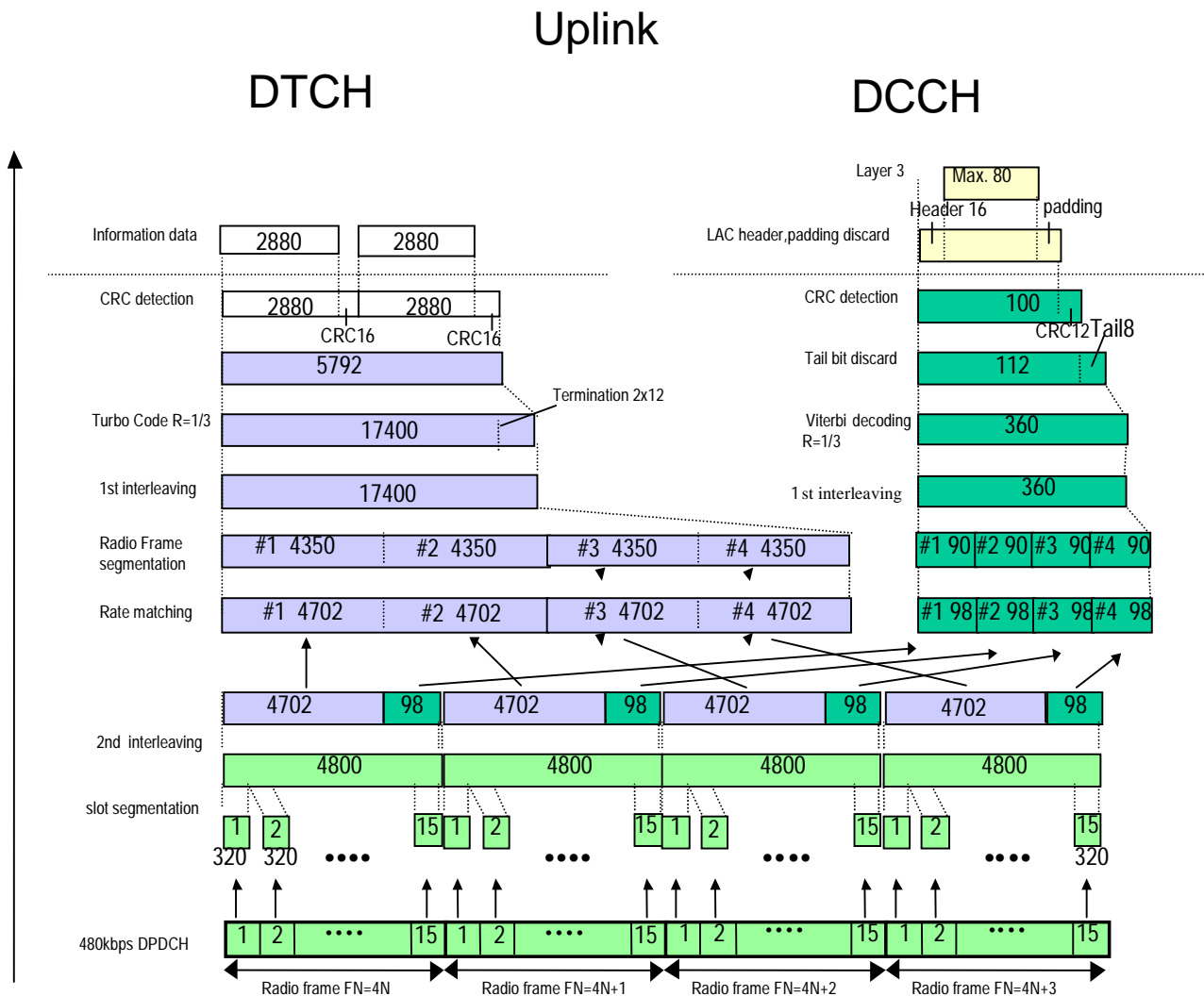

Figure A.4

Table A.4: UL reference measurement channel (144kbps)

Parameter	Level	Unit
Information bit rate	144	kbps
DPCH	480	kbps
Power control	Off	
TFCI	On	
Repetition	8	%

# A.5 UL reference measurement channel for 384 kbps

The parameters for the UL reference measurement channel for 384 kbps are specified in table A.5 and the channel coding is detailed in figure A.5.

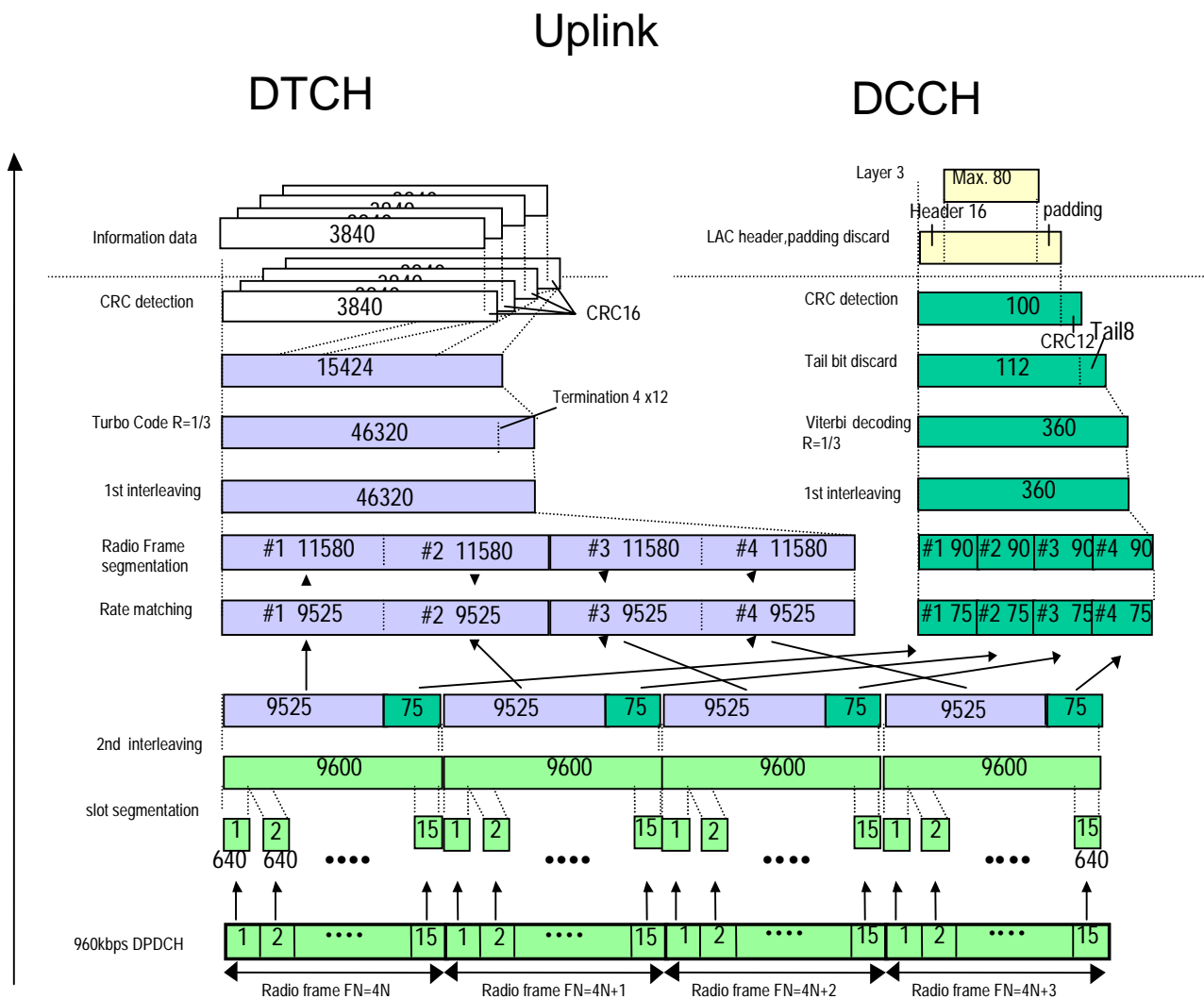

Figure A.5

Table A.5: UL reference measurement channel (384kbps)

Parameter	Level	Unit
Information bit rate	384	kbps
DPCH	960	kbps
Power control	Off	
TFCI	On	
Puncturing	18	%

## A.6 UL reference measurement channel for 2048 kbps

The parameters for the UL reference measurement channel for 2 048 kbps are specified in table A.6 and the channel coding is detailed in figure A.6.

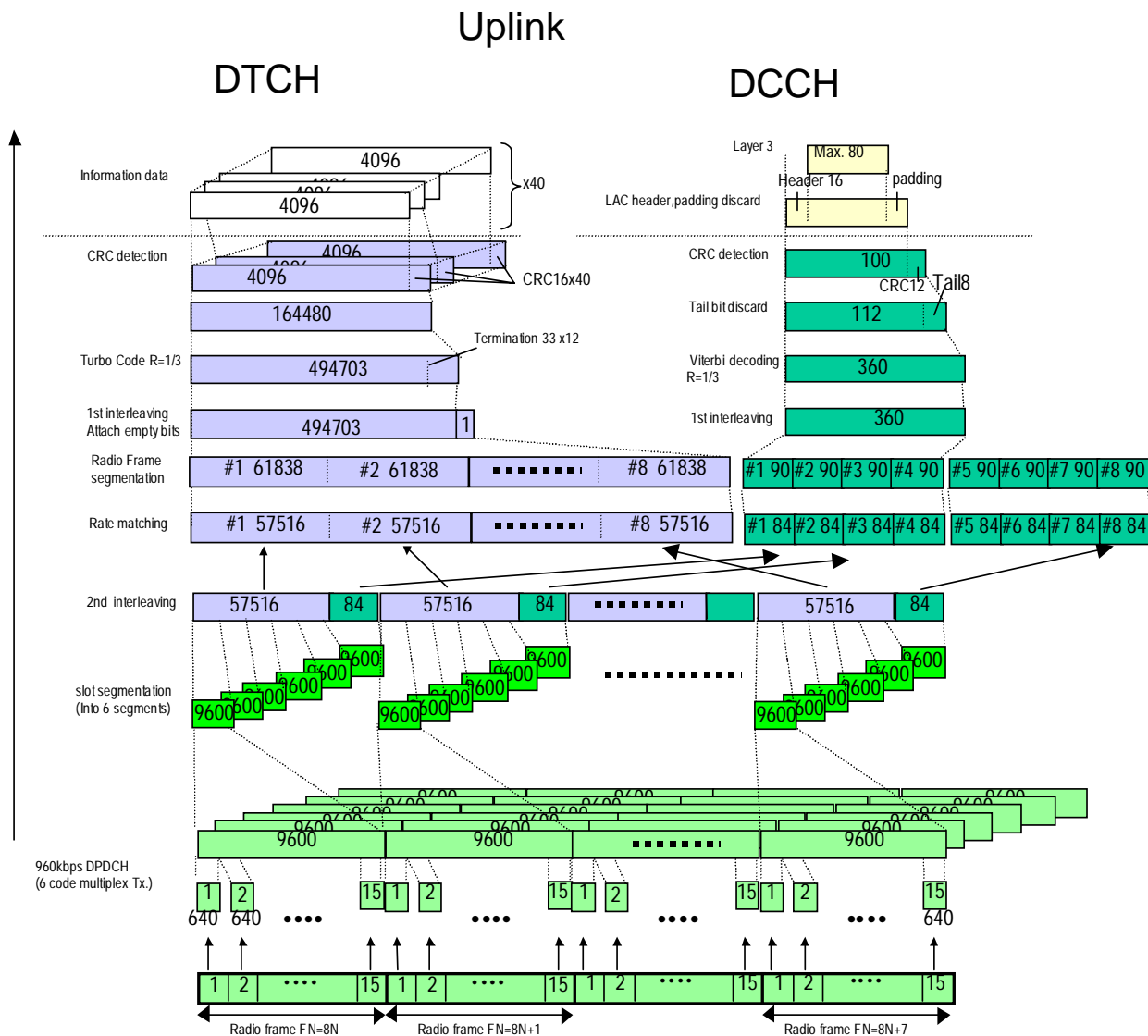

Figure A.6

Table A.6: UL reference measurement channel (2048kbps)

Parameter	Level	Unit
Information bit rate	2 048	kbps
DPCH	960	kbps
Power control	Off	
TFCI	On	
Puncturing	1	%

## A.7 Reference measurement channels for UL RACH

The parameters for the UL RACH reference measurement channels are specified in Table A.7.

**Table A.7: Reference measurement channels for UL RACH**

Parameter		Unit	
RACH	CRC	16	bits
	Channel Coding	Rate ½ conv. coding	
	TTI	20	ms
	TB size	168, 360	bits
	Rate Matching	Repetition	
	Number of diversity antennas	2	
	Preamble detection window size	256	chips
	Ratio of preamble power and total message power (*)	0	dB
Power ratio of RACH Control/Data TB = 168		-2.69	dB
Power ratio of Control/Data TB = 360		-3.52	dB
NOTE *: If Delta Pp-m is used to adjust the power offset, Delta Pp-m shall be equal to -5 dB.			

## Annex B (informative): Measurement system set-up

Example of measurement system set-ups are attached below as an informative annex.

### B.1 Transmitter

#### B.1.1 Maximum output power, total power dynamic range



Figure B.1: Measuring system Set-up for maximum output power, total power dynamic range

#### B.1.2 Frequency, Code Power and Transmit Modulation

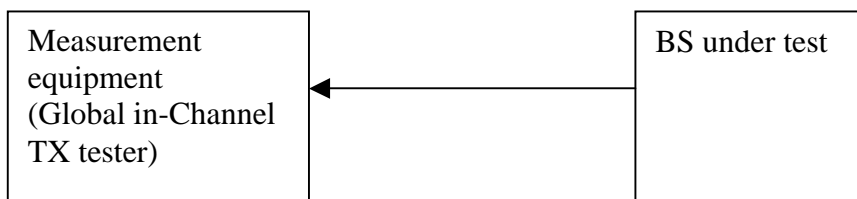

Figure B.2: Measurement system set up for RF frequency, several code power tests and transmit modulation (EVM and PCDE)

#### B.1.3 Power control steps and power control dynamic range

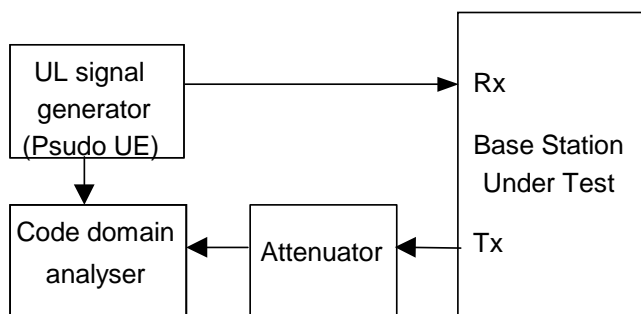

Figure B.3: Measuring system Set-up for power control steps and power control dynamic range measurements

### B.1.4 Out of band emission

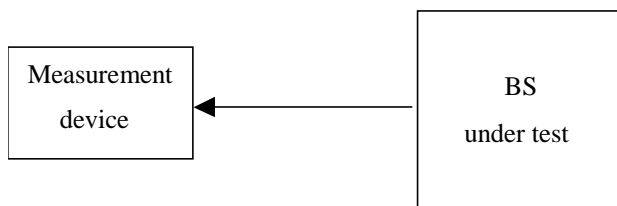

Figure B.4: Measuring system Set-up for Out of band emission measurements

### B.1.5 Transmit intermodulation

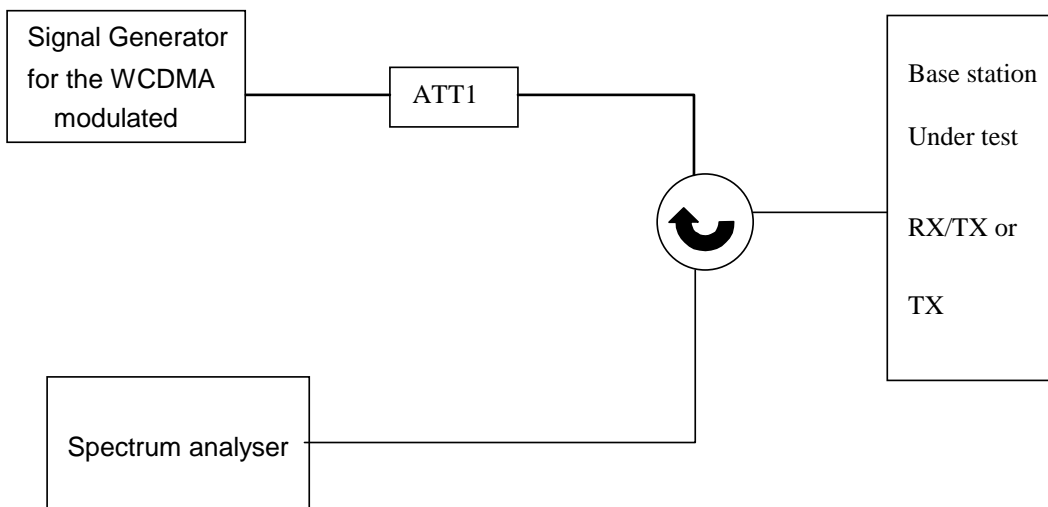

Figure B.5: Measuring system Set-up for Base Station Transmit Intermodulation Tests

## B.2 Receiver

### B.2.1 Reference sensitivity level

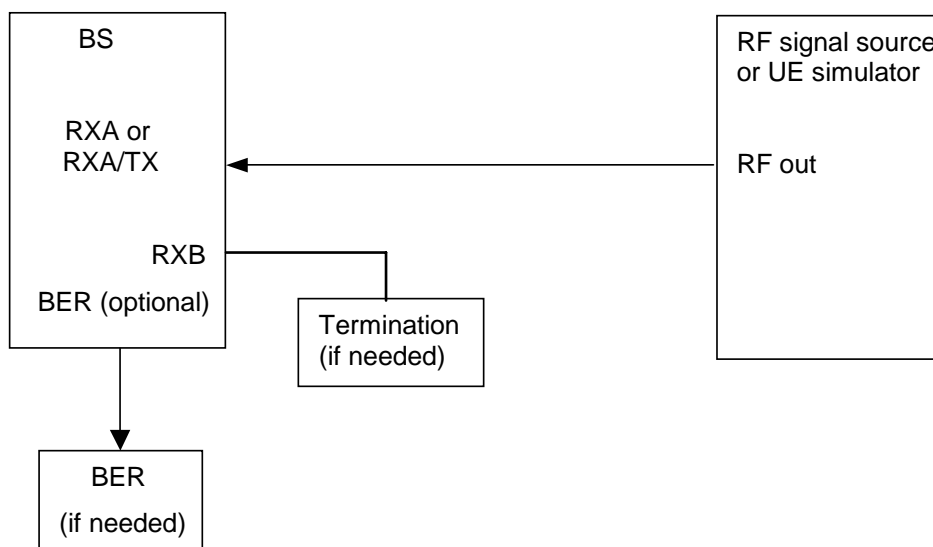

Figure B.7: Measuring system Set-up for Base Station Reference sensitivity level Tests

### B.2.2 Dynamic range

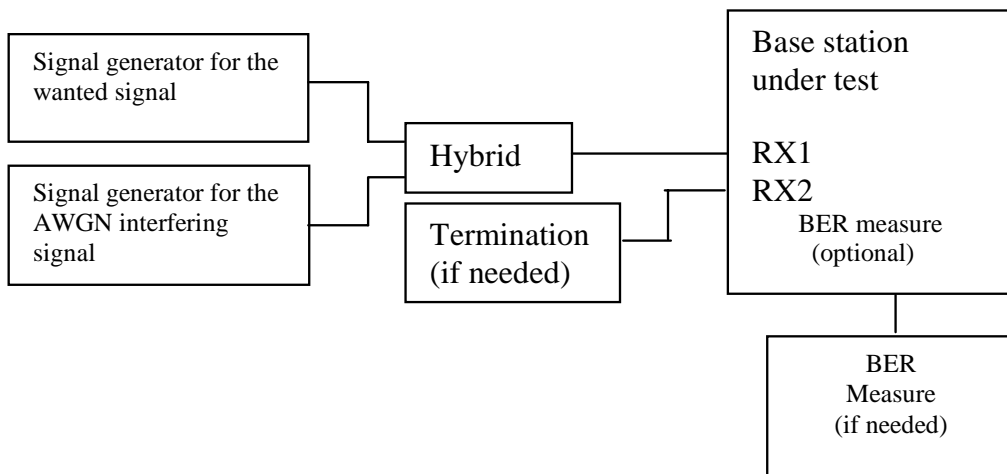

Figure B.8: Measuring system Set-up for Dynamic range

### B.2.3 Adjacent Channel Selectivity (ACS)

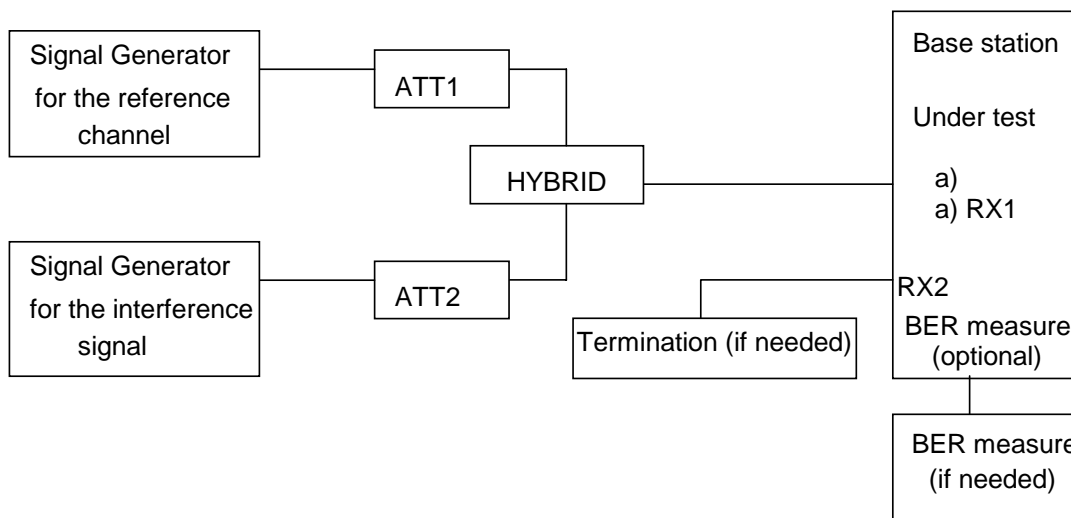

Figure B.9: Measuring system Set-up for Adjacent channel selectivity



### B.2.4 Blocking characteristics

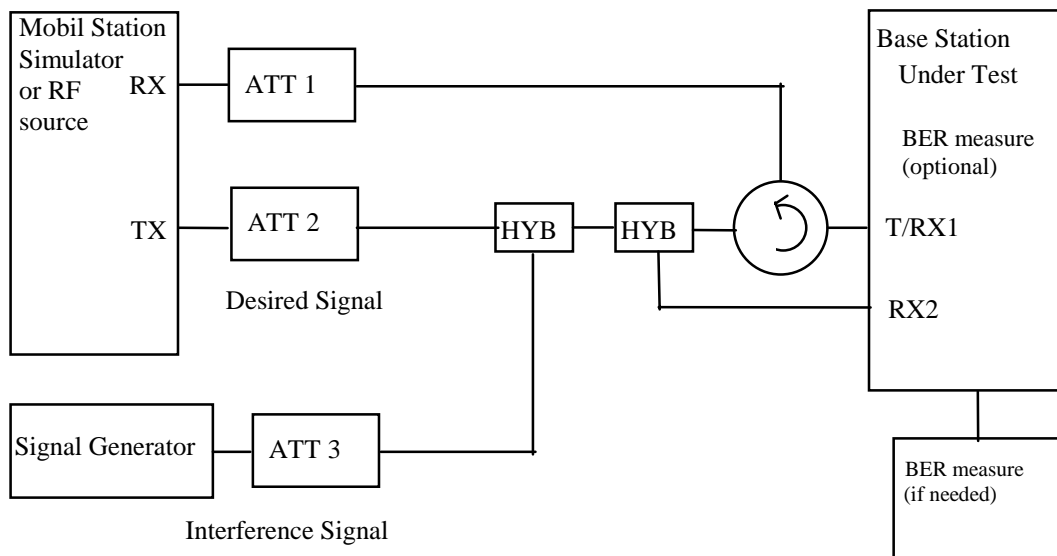

Figure B.10: Measuring system Set-up for Blocking characteristics

### B.2.5 Intermodulation characteristics

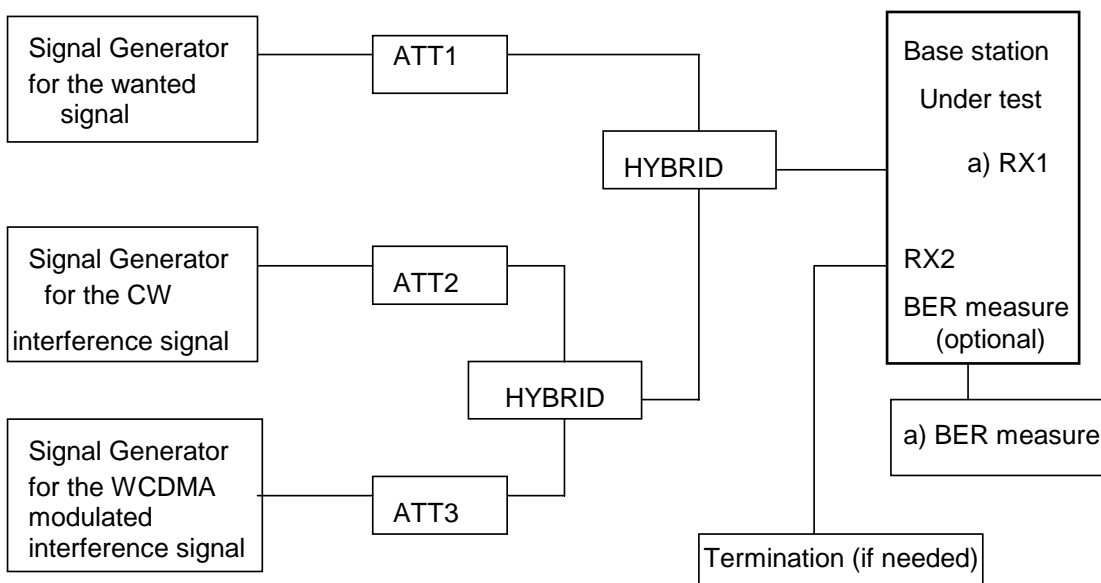

Figure B.11: Measuring system Set-up for intermodulation characteristics

### B.2.6 Receiver spurious emission

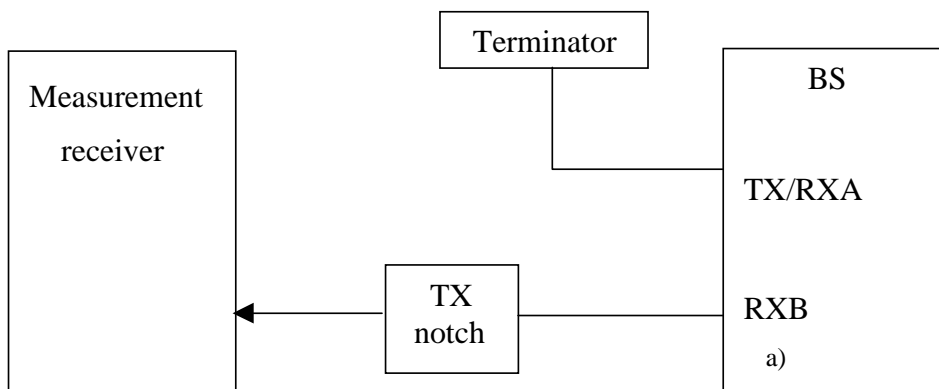

Figure B.12: Measuring system Set-up for Receiver spurious emission

## B.3 Performance requirement

### B.3.1 Demodulation of DCH and RACH in static conditions

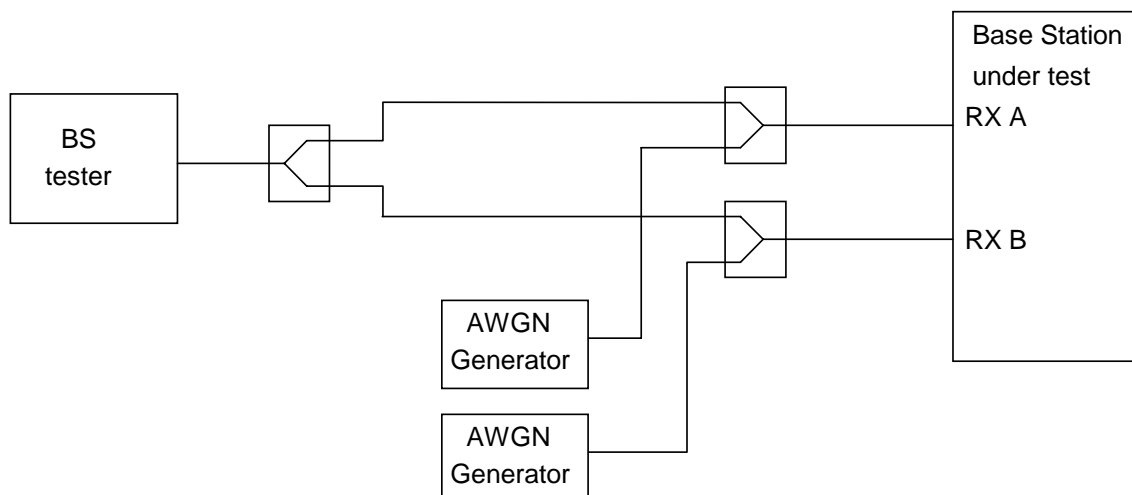

Figure B.13: Functional Set-up for Demodulation of DCH and RACH in static conditions

### B.3.2 Demodulation of DCH and RACH in multipath fading conditions

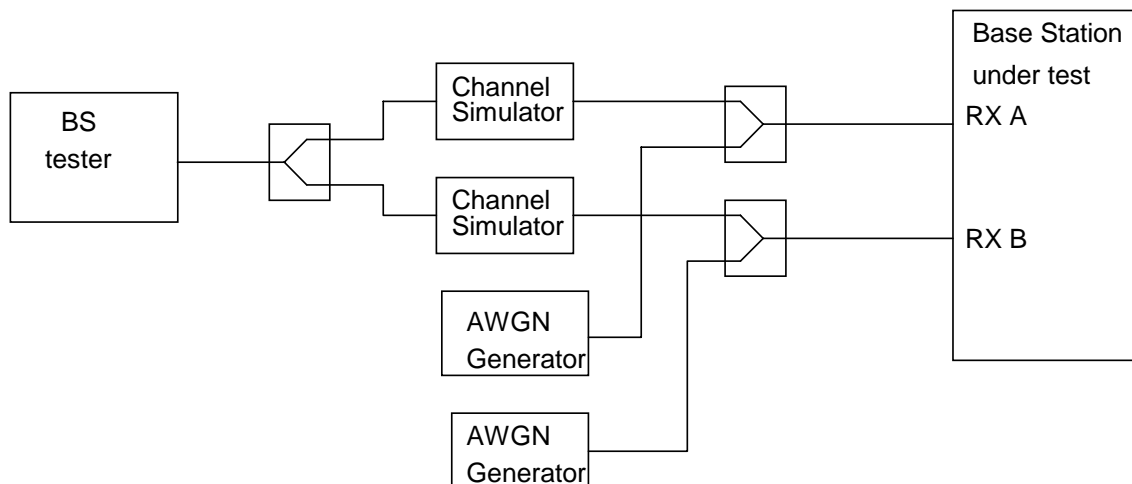

Figure B.14: Functional Set-up for Demodulation of DCH and RACH in multipath fading conditions

### B.3.3 Verification of the internal BLER calculation

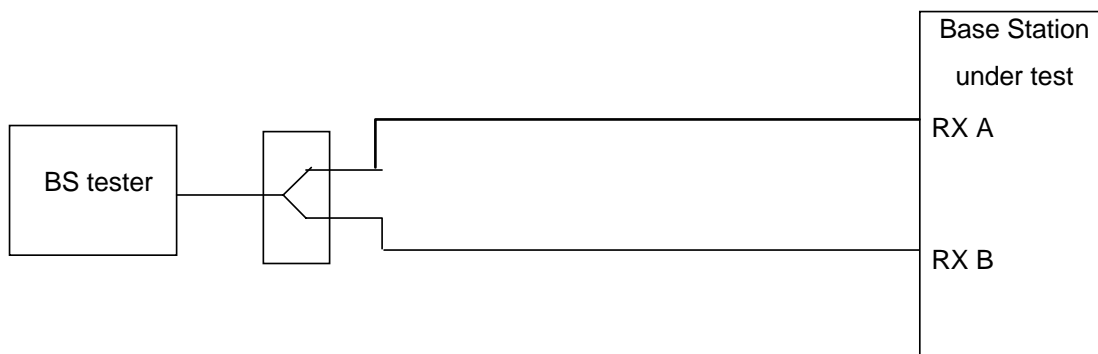

Figure B.15: Functional Set-up for Verification of the internal BLER calculation

---

## Annex C (normative): Detailed definition of error events

### 1) Block Error Ratio (BLER):

- the block is defined as erased if the error detection functions using Cyclic Redundancy Check (CRC) in layer 1.

<Editor's note: Tentative definition of BLER is given. >

### 2) Bit Error Ratio (BER):

- the BER is the overall Bit Error Ratio (BER) independent of frame erasures or when erased frames are not defined.

# Annex D (normative): Propagation conditions

## D.1 Static propagation condition

The propagation for the static performance measurement is an Additive White Gaussian Noise (AWGN) environment. No fading or multi-paths exist for this propagation model.

## D.2 Multi-path fading propagation conditions

Table D.1 shows propagation conditions that are used for the performance measurements in multi-path fading environment. All taps have classical Doppler spectrum, defined as:

$$(CLASS) \quad S(f) \propto 1/(1 - (f / f_D)^2)^{0.5} \quad \text{for } f \in [-f_D, f_D]$$

**Table D.1: Propagation Conditions for Multi path Fading Environments**

Case 1, speed 3km/h		Case 2, speed 3 km/h		Case 3, 120 km/h		Case 4, 250 km/h	
Relative Delay [ns]	Average Power [dB]	Relative Delay [ns]	Average Power [dB]	Relative Delay [ns]	Average Power [dB]	Relative Delay [ns]	Average Power [dB]
0	0	0	0	0	0	0	0
976	-10	976	0	260	-3	260	-3
		20000	0	521	-6	521	-6
				781	-9	781	-9

## D.3 Moving propagation conditions

The dynamic propagation conditions for the test of the baseband performance are non fading channel models with two taps. The moving propagation condition has two tap, one static, Path0, and one moving, Path1. The time difference between the two paths is according Equation (D.1). The taps have equal strengths and equal phases.

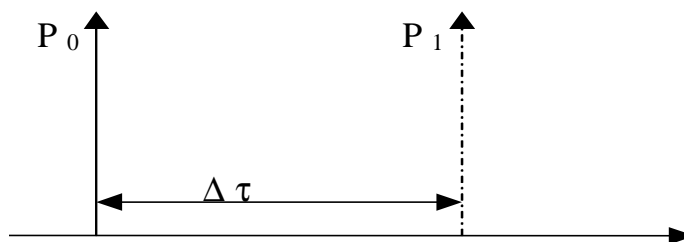

**Figure D.1: The moving propagation conditions**

$$\Delta \tau = B + \frac{A}{2} (1 + \sin(\Delta \omega \cdot t)) \tag{D.1}$$

The parameters in the equation are shown in table D.2

Table D.2

Parameter	Value
A	5 $\mu\text{s}$
B	1 $\mu\text{s}$
$\Delta\omega$	$40 \cdot 10^{-3} \text{ s}^{-1}$

## D.4 Birth-Death propagation conditions

The dynamic propagation conditions for the test of the baseband performance is a non fading propagation channel with two taps. The moving propagation condition has two taps, Path1 and Path2 which alternate between 'birth' and 'death'. The positions the paths appear are randomly selected with an equal probability rate and is shown in figure D.2.

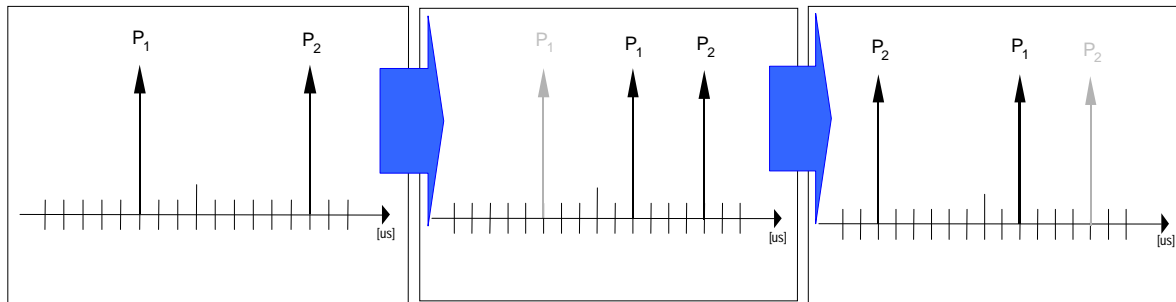

**Figure D.2: Birth death propagation sequence**

1. Two paths, Path1 and Path2 are randomly selected from the group  $[-5, -4, -3, -2, -1, 0, 1, 2, 3, 4, 5] \mu\text{s}$ . The paths have equal magnitudes and equal phases.
2. After 191 ms, Path1 vanishes and reappears immediately at a new location randomly selected from the group  $[-5, -4, -3, -2, -1, 0, 1, 2, 3, 4, 5] \mu\text{s}$  but excludes the point Path2. The magnitudes and the phases of the tap coefficients of Path 1 and Path 2 shall remain unaltered.
3. After an additional 191 ms, Path2 vanishes and reappears immediately at a new location randomly selected from the group  $[-5, -4, -3, -2, -1, 0, 1, 2, 3, 4, 5] \mu\text{s}$  but excludes the point Path1. The magnitudes and the phases of the tap coefficients of Path 1 and Path 2 shall remain unaltered.
4. The sequence in 2) and 3) is repeated.

---

## Annex E (normative): Global In-Channel TX-Test

### E.1 General

The global in-channel Tx test enables the measurement of all relevant parameters that describe the in-channel quality of the output signal of the Tx under test in a single measurement process. The parameters describing the in-channel quality of a transmitter, however, are not necessarily independent. The algorithm chosen for description inside this annex places particular emphasis on the exclusion of all interdependencies among the parameters. Any other algorithm (e.g. having better computational efficiency) may be applied, as long as the results are the same within the acceptable uncertainty of the test system as defined in subclause 4.1

---

### E.2 Definition of the process

#### E.2.1 Basic principle

The process is based on the comparison of the actual **output signal of the TX under test**, received by an ideal receiver, with a **reference signal**, that is generated by the measuring equipment and represents an ideal error free received signal. The reference signal shall be composed of the same number of codes at the correct spreading factors as contained in the test signal. Note, for simplification, the notation below assumes only codes of one spreading factor although the algorithm is valid for signals containing multiple spreading factors. All signals are represented as equivalent (generally complex) baseband signals.

#### E.2.2 Output signal of the TX under test

The output signal of the TX under test is acquired by the measuring equipment, filtered by a matched filter (RRC 0.22, correct in shape and in position on the frequency axis) and stored for further processing

The following form represents the physical signal  $l$  in the entire measurement interval:

one vector  $\mathbf{Z}$ , containing  $N = n_s \times sf$  complex samples;

with

$n_s$ : number of symbols in the measurement interval;

$sf$ : number of chips per symbol. ( $sf$ : spreading factor) (see Note: Symbol length)

#### E.2.3 Reference signal

The reference signal is constructed by the measuring equipment according to the relevant TX specifications.

It is filtered by the same matched filter, mentioned in E.2.2., and stored at the Inter-Symbol-Interference free instants. The following form represents the reference signal in the entire measurement interval:

one vector  $\mathbf{R}$ , containing  $N = n_s \times sf$  complex samples

where

$n_s$ : number of symbols in the measurement interval;

$sf$ : number of chips per symbol. (see Note: Symbol length)

## E.2.4 Classification of measurement results

The measurement results achieved by the global in-channel TX test can be classified into two types:

- Results of type 'deviation', where the error-free parameter has a non-zero magnitude. (These are the parameters that quantify the integral physical characteristic of the signal). These parameters are:

RF Frequency

Power (in case of single code)

Code Domain Power (in case of multi code)

Timing (only for UE) (see Note: Deviation)

(Additional parameters: see Note: Deviation)

- Results of type 'residual', where the error-free parameter has value zero. (These are the parameters that quantify the error values of the measured signal, whose ideal magnitude is zero). These parameters are:

Error Vector Magnitude (EVM);

Peak Code Domain Error (PCDE).

(Additional parameters: see Note: Residual)

## E.2.5 Process definition to achieve results of type 'deviation'

The reference signal (**R**; see subclause E.2.3) and the signal under Test (**Z**; see subclause E.2.2) are varied with respect to the parameters mentioned in subclause E.2.4 under "results of type deviation" in order to achieve best fit. Best fit is achieved when the RMS difference value between the varied signal under test and the varied reference signal is an absolute minimum.

Overview:

$$FCT \left[ Z(\tilde{f}, \tilde{t}, \tilde{\varphi}, g_1, g_2, \dots, g_{synch}) - R(f, t, \varphi, \tilde{g}_1, \tilde{g}_2, \dots, \tilde{g}_{synch}) \right] = Minimum \quad !$$

**Z**: Signal under test.

**R**: Reference signal,

with frequency  $f$ , the timing  $t$ , the phase  $\varphi$ , gain of code1 ( $g_1$ ), gain of code2 ( $g_2$ ) etc, and the gain of the synch channel  $g_{synch}$ . See Note: Power Step

The parameters marked with a tilde in **Z** and **R** are varied in order to achieve a best fit.

Detailed formula: see Note: Formula for the minimum process

The varied reference signal, after the best fit process, will be called **R''**.

The varied signal under test, after the best fit process, will be called **Z''**.

The varying parameters, leading to **R''** and **Z** represent directly the wanted results of type 'deviation'. These measurement parameters are expressed as deviation from the reference value with the same units as the reference value.

In the case of multi code, the type-'deviation'-parameters (frequency, timing and (RF-phase)) are varied commonly for all codes such that the process returns one frequency-deviation, one timing deviation, (one RF-phase –deviation).

(These parameters are not varied on the individual code signals such that the process would return  $kr$  frequency errors... . ( $kr$ : number of codes)).

The only type-'deviation'-parameters varied individually are the code domain gain factors ( $g_1, g_2, \dots$ )

See Note: Power Step.



### E.2.5.1 Decision Point Power

The mean-square value of the signal-under-test, sampled at the best estimate of the of Intersymbol-Interference-free points using the process defined in subclause 2.5, is referred to the *Decision Point Power* (DPP):

$$DPP = \text{mean}(|Z|^2)$$

### E.2.5.2 Code-Domain Power

The samples,  $Z$ , are separated into symbol intervals to create  $n_s$  time-sequential vectors  $\mathbf{z}$  with  $sf$  complex samples comprising one symbol interval. The *Code Domain Power* is calculated according to the following steps:

- 1) Take the vectors  $\mathbf{z}$  defined above.
- 2) To achieve meaningful results it is necessary to descramble  $\mathbf{z}$ , leading to  $\mathbf{z}''$  (see Note: Scrambling code)
- 3) Take the orthogonal vectors of the channelization code set  $\mathbf{C}$  (all codes belonging to one spreading factor) as defined in TS 25.213 and TS 25.223 (range +1, -1), and normalize by the norm of the vectors to produce  $\mathbf{C}_{\text{norm}} = \mathbf{C}/\text{sqrt}(sf)$ . (see Note: Symbol length)
- 4) Calculate the inner product of  $\mathbf{z}''$  with  $\mathbf{C}_{\text{norm}}$ . Do this for all symbols of the measurement interval and for all codes in the code space.  
This gives an array of format  $k \times n_s$ , each value representing a specific symbol and a specific code, which can be exploited in a variety of ways.

$k$ : total number of codes in the code space

$n_s$ : number of symbols in the measurement interval

- 6) Calculate  $k$  mean-square values, each mean-square value unifying  $n_s$  symbols within one code. (These values can be called "*Absolute CodeDomainPower* (CDP)" [Volt<sup>2</sup>].) The sum of the  $k$  values of CDP is equal to DPP.
- 7) Normalize by the decision point power to obtain

$$\text{Relative CodeDomain Power} = \frac{\text{Absolute CodeDomainPower}}{\text{DecisionPointPower}}$$

### E.2.6 Process definition to achieve results of type 'residual'

The difference between the varied reference signal ( $\mathbf{R}''$ ; see subclause E.2.5.) and the varied TX signal under test ( $\mathbf{Z}''$ ; see subclause E.2.5) is the error vector  $\mathbf{E}$  versus time:

$$\mathbf{E} = \mathbf{Z}'' - \mathbf{R}''$$

Depending on the parameter to be evaluated, it is appropriate to represent  $\mathbf{E}$  in one of the following two different forms:

Form EVM (representing the physical error signal in the entire measurement interval)

One vector  $\mathbf{E}$ , containing  $N = n_s \times sf$  complex samples;

with

$n_s$ : number of symbols in the measurement interval

$sf$ : number of chips per symbol (see Note: Symbol length)

Form PCDE (derived from Form EVM by separating the samples into symbol intervals)

$n_s$  time-sequential vectors  $\mathbf{e}$  with  $sf$  complex samples comprising one symbol interval.

$\mathbf{E}$  and  $\mathbf{e}$  give results of type 'residual' applying the two algorithms defined in subclauses E.2.6.1 and E.2.6.2.

### E.2.6.1 Error Vector Magnitude (EVM)

The Error Vector Magnitude (EVM) is calculated according to the following steps:

- 1) Take the error vector **E** defined in subclause E.2.6 (Form EVM) and calculate the RMS value of **E**; the result will be called RMS(**E**).
- 2) Take the varied reference vector **R'** defined in subclause E.2.5 and calculate the RMS value of **R'**; the result will be called RMS(**R'**).
- 3) Calculate EVM according to:

$$EVM = \frac{RMS(\mathbf{E})}{RMS(\mathbf{R}')} \times 100\% \text{ -- (here, EVM is relative and expressed in \%)}$$

(see Note: Formula for EVM)

### E.2.6.2 Peak Code Domain Error (PCDE)

The Peak Code Domain Error is calculated according to the following steps:

- 1) Take the error vectors **e** defined in subclause E.2.6 (Form PCDE)
- 2) To achieve meaningful results it is necessary to descramble **e**, leading to **e''** (see Note: Scrambling code)
- 3) Take the orthogonal vectors of the channelization code set **C** (all codes belonging to one spreading factor) as defined in TS 25.213 and TS 25.223 (range +1, -1). (see Note: Symbol length) and normalize by the norm of the vectors to produce **Cnorm**= **C**/sqrt(sf). (see Note: Symbol length)
- 4) Calculate the inner product of **e''** with **Cnorm**. Do this for all symbols of the measurement interval and for all codes in the code space.  
This gives an array of format  $k \times ns$ , each value representing an error-vector representing a specific symbol and a specific code, which can be exploited in a variety of ways.

k: total number of codes in the code space

ns: number of symbols in the measurement interval

- 5) Calculate k RMS values, each RMS value unifying ns symbols within one code.  
(These values can be called "*Absolute CodeEVMs*" [Volt].)
- 6) Find the peak value among the k "*Absolute CodeEVMs*".  
(This value can be called "*Absolute PeakCodeEVM*" [Volt].)
- 7) Calculate PCDE according to:

$$10 * \lg \frac{("AbsolutePeakCodeEVM")^2}{(RMS(R'))^2} dB \quad \text{(a relative value in dB).}$$

(see Note IQ)

(see Note Synch channel)

## E.3 Notes

### E.3.1 Symbol length

A general code multiplexed signal is multicode and multirate. In order to avoid unnecessary complexity, the measurement applications use a unique symbol-length, corresponding to a spreading factor, regardless of the really

intended spreading factor. Nevertheless the complexity with a multicode / multirate signal can be mastered by introducing appropriate definitions.

## E.3.2 Deviation

It is conceivable to regard more parameters as type „deviation' e.g. Chip frequency and RF-phase.

As chip-frequency and RF-frequency are linked together by a statement in the core specifications [1] it is sufficient to process RF frequency only.

A parameter RF-phase must be varied within the best fit process (E.2.5.). Although necessary, this parameter-variation doesn't describe any error, as the modulation schemes used in the system don't depend on an absolute RF-phase.

The parameter Timing must be varied within the best fit process (E.2.5.) This parameter variation does not describe any error, when applied to the Node B test. However when applied to the UE test, it describes the error of the UE's Timing Advance.

## E.3.3 Residual

It is conceivable to regard more parameters as type „residual' e.g. IQ origin offset. As it is not the intention of the test to separate for different error sources, but to quantify the quality of the signal, all such parameters are not extracted by the best fit process, instead remain part of EVM and PCDE.

## E.3.4 Scrambling Code

In general a signal under test can use more than one scrambling code. Note that PCDE is primarily processed to investigate the unused channelization codes. In order to know which scrambling code shall be applied on unused channelization codes, it is necessary to restrict the test conditions: The signal under test shall use exactly one scrambling code.

## E.3.5 IQ

As in FDD/uplink each channelization code can be used twice, on the I and on the Q channel, the measurement result may indicate separate values of CDP or PCDE for I and Q on which channel (I or Q) they occur.

## E.3.6 Synch Channel

A Node B signal contains a physical synch channel, which is non orthogonal, related to the other channels. In this context note: The code channel bearing the result of PCDE is exactly one of the other physical channels (never the synch channel). The origin of PCDE (erroneous code power) can be any channel (including synch channel) This means that the error due to the synch channel is projected onto the other (orthogonal) codes that make up the code domain.

## E.3.7 Formula for the minimum process

$$L(\Delta \tilde{f}, \Delta \tilde{t}, \Delta \tilde{\varphi}, \Delta \tilde{g}_c, \dots, \Delta \tilde{g}_{prim}, \Delta \tilde{g}_{sec}) = \sum_{v=0}^{N-1} |Z(v) - R(v)|^2$$

where:

L : the function to be minimised

The parameters to be varied in order to minimize are:

$\Delta \tilde{f}$  the RF frequency offset

$\Delta\tilde{t}$	the timing offset
$\Delta\tilde{\varphi}$	the phase offset
$\Delta\tilde{g}_c \dots$	code power offsets (one offset for each code)
$\Delta\tilde{g}_{prim}$	the code power offset of the primary SCH
$\Delta\tilde{g}_{sec}$	the code power offset of the secondary SCH
$Z(v)$	Samples of the signal under Test
$R(v)$	Samples of the reference signal
$\sum_{v=0}^{N-1}$	counting index $v$ starting at the beginning of the measurement interval and ending at its end.
$N$	No of chips during the measurement interval.
$Z(v)$ :	Samples of the signal under Test. It is modelled as a sequence of complex baseband samples $Z(v)$ with a time-shift $\Delta t$ , a frequency offset $\Delta f$ , a phase offset $\Delta\varphi$ , the latter three with respect to the reference signal.

$$Z(v) = Z(v - \Delta\tilde{t}) * e^{-j2\pi\Delta\tilde{f}v} * e^{-j\Delta\tilde{\varphi}}$$

$R(v)$  Samples of the reference signal:

$$R(v) = \sum_{c=1}^{No. of codes} (g_c + \Delta\tilde{g}_c) * Chip_c(v) + (g_{prim} + \Delta\tilde{g}_{prim}) * Chip_{prim}(v) + (g_{sec} + \Delta\tilde{g}_{sec}) * Chip_{sec}(v)$$

where

$g$  nominal gain of the code channel

$\Delta\tilde{g}$  The gain offset to be varied in the minimum process

$Chip(v)$  is the chipsequence of the code channel

Indices at  $g$ ,  $\Delta\tilde{g}$  and  $Chip$ : The index indicates the code channel:  $c = 1, 2, \dots$  No of code channels

prim= primary SCH

sec= secondary SCH

Range for  $Chip_c$ : +1,-1

### E.3.8 Power Step

If the measurement period for any code contains a power step due to power control, it is necessary to model the reference signal for that code using two gain factors.

### E.3.9 Formula for EVM

$$EVM = \sqrt{\frac{\sum_{\nu=0}^{N-1} |Z'(\gamma) - R'(\gamma)|^2}{\sum_{\nu=0}^{N-1} |R'(\gamma)|^2}} * 100 \%$$

$Z'(\gamma)$ ,  $R'(\gamma)$  are the varied measured and reference signals.

---

## Annex F (informative): Derivation of Test Requirements

The Test Requirements in this specification have been calculated by relaxing the Minimum Requirements of the core specification using the Test Tolerances defined in subclause 4.2. When the Test Tolerance is zero, the Test Requirement will be the same as the Minimum Requirement. When the Test Tolerance is non-zero, the Test Requirements will differ from the Minimum Requirements, and the formula used for this relaxation is given in tables F.1, F.2 and F.3

Note that a formula for applying Test Tolerances is provided for all tests, even those with a test tolerance of zero. This is necessary in the case that the Test System uncertainty is greater than that allowed in subclause 4.1. In this event, the excess error shall be subtracted from the defined test tolerance in order to generate the correct tightened Test Requirements as defined in subclause 4.3.

For example, a Test System having 0.9 dB accuracy for test 6.2.1 Base Station maximum output power (which is 0.2 dB above the limit specified in subclause 4.) would subtract 0.2 dB from the Test Tolerance of 0.7 dB defined in subclause 4.2. This new test tolerance of 0.5 dB would then be applied to the Minimum Requirement using the formula defined in Table F.1 to give a new range of  $\pm 2.5$  dB of the manufacturer's rated output power.

Using this same approach for the case where a test had a test tolerance of 0 dB, an excess error of 0.2 dB would result in a modified test tolerance of  $-0.2$  dB.

Table F.1: Derivation of Test Requirements (Transmitter tests)

Test	Minimum Requirement in TS 25.104	Test Tolerance (TT)	Test Requirement in TS 25.141
6.2.1 Base station maximum output power	In normal conditions ... within +2 dB and -2 dB of the manufacturer's rated output power In extreme conditions... within +2.5 dB and -2.5 dB of the manufacturer's rated output power	0.7 dB	Formula: Upper limit + TT Lower limit - TT In normal conditions ... within +2.7 dB and -2.7 dB of the manufacturer's rated output power In extreme conditions... within +3.2 dB and -3.2 dB of the manufacturer's rated output power
6.2.2 CPICH Power accuracy	CPICH power shall be within $\pm 2.1$ dB	0.8 dB	Formula: Upper limit + TT Lower limit - TT CPICH power shall be within $\pm 2.9$ dB
6.3 Frequency error	Frequency error limit = 0.05 ppm	12 Hz	Formula: Frequency Error limit + TT  Frequency Error limit = 0.05 ppm + 12 Hz
6.4.2 Power control steps	Lower and upper limits as specified in tables 6.9 and 6.10a	0.1 dB	Formula: Upper limits + TT Lower limits - TT 0.1 dB applied as above to tables 6.9 and 6.10a
6.4.3 Power control dynamic range	maximum power limit = BS maximum output power -3 dB minimum power limit = BS maximum output power -28 dB	1.1 dB	Formula: maximum power limit - TT minimum power limit + TT maximum power limit = BS maximum output power -4.1 dB minimum power limit = BS maximum output power -26.9 dB
6.4.4 Total power dynamic range	total power dynamic range limit = 18 dB	0.3 dB	Formula: total power dynamic range limit - TT total power dynamic range limit = 17.7 dB
6.4.5. IPDL time mask	maximum power limit = BS maximum output power -35 dB	0.7 dB	Formula: maximum power limit + TT maximum power limit = BS maximum output power - 34.3 dB
6.5.1 Occupied Bandwidth	occupied bandwidth limit = 5 MHz	0 kHz	Formula: Occupied bandwidth limit + TT Occupied bandwidth limit = 5 MHz
6.5.2.1 Spectrum emission mask	Maximum level defined in tables 6.11, 6.12, 6.13 and 6.14:	1.5 dB (0 dB for the additional Band b requirements)	Formula: Maximum level + TT Add 1.5 to Maximum level entries in tables 6.11, 6.12, 6.13 and 6.14.
6.5.2.2 Adjacent Channel Leakage power Ratio (ACLR)	ACLR limit = 45 dB at 5 MHz ACLR limit = 50 dB at 10 MHz	0.8 dB	Formula: ACLR limit - TT  ACLR limit = 44.2 dB at 5 MHz ACLR limit = 49.2 dB at 10 MHz
6.5.3 Spurious emissions	Maximum level defined in tables 6.16 to 6.26	0 dB	Formula: Maximum limit + TT  Add 0 to Maximum level in tables 6.16 to 6.26
6.6 Transmit intermodulation (interferer requirements) This tolerance applies to the stimulus and not the measurements defined in 6.5.2.1, 6.5.2.2 and 6.5.3.	Wanted signal level - interferer level = 30 dB	0 dB	Formula: Ratio + TT  Wanted signal level - interferer level = 30 + 0 dB
6.7.1 EVM	EVM limit = 17.5 %	0 %	Formula: EVM limit + TT  EVM limit = 17.5%

6.7.2 Peak code Domain error	Peak code domain error limit = -33 dB	1.0 dB	Formula: Peak code domain error limit + TT  Peak code domain error limit = -32 dB
------------------------------	---------------------------------------	--------	---

Table F.2: Derivation of Test Requirements (Receiver tests)

Test	Minimum Requirement in TS 25.104	Test Tolerance (TT)	Test Requirement in TS 25.141
7.2 Reference sensitivity	Reference sensitivity level = -121 dBm  FER/BER limit = 0.001	0.7 dB	Formula: Reference sensitivity level + TT  Reference sensitivity level = -120.3 dBm  FER/BER limit is not changed
7.3 Dynamic range	Wanted signal level = -91 dBm AWGN level = -73 dBm/3.84 MHz	1.2 dB	Formula: Wanted signal level + TT AWGN level unchanged  Wanted signal level = -89.8 dBm
7.4 Adjacent channel selectivity	Wanted signal level = -115 dBm W-CDMA interferer level = -52 dBm	0 dB	Formula: Wanted signal level + TT W-CDMA interferer level unchanged  Wanted signal level = -115 dBm
7.5 Blocking characteristics	Wanted signal level = -115 dBm Interferer level See table 7.4a / 7.4b	0 dB	Formula: Wanted signal level + TT Interferer level unchanged  Wanted signal level = -115 dBm
7.6 Intermod Characteristics	Wanted signal level = -115 dBm Interferer1 level (10 MHz offset CW) = -48 dBm Interferer2 level (20 MHz offset W-CDMA Modulated) = -48 dBm	0 dB	Formula: Wanted signal level + TT Interferer1 level unchanged Interferer2 level unchanged  Wanted signal level = -115 dBm
7.7 Spurious Emissions	Maximum level defined in Table 7.7	0 dB	Formula: Maximum level + TT  Add TT to Maximum level in table 7.7



Table F.3: Derivation of Test Requirements (Performance tests)

Test	Minimum Requirement in TS 25.104	Test Tolerance (TT)	Test Requirement in TS 25.141
8.2, Demodulation in static propagation condition	Received $E_b/N_0$ values	0.4 dB	Minimum requirement + TT
8.3, Demodulation of DCH in multipath fading conditions	Received $E_b/N_0$ values	0.6 dB	Minimum requirement + TT
8.4 Demodulation of DCH in moving propagation conditions	Received $E_b/N_0$ values	0.6 dB	Minimum requirement + TT
8.5 Demodulation of DCH in birth/death propagation conditions	Received $E_b/N_0$ values	0.6 dB	Minimum requirement + TT
8.8.1 RACH preamble detection in static propagation conditions	Received $E_b/N_0$ values	0.4dB	Minimum requirement + TT
8.8.2 RACH preamble detection in multipath fading case 3	Received $E_b/N_0$ values	0.6dB	Minimum requirement + TT
8.8.3 Demodulation of RACH message in static propagation conditions	Received $E_b/N_0$ values	0.4dB	Minimum requirement + TT
8.8.4 Demodulation of RACH message in multipath fading case 3	Received $E_b/N_0$ values	0.6dB	Minimum requirement + TT

## Annex G (informative): Acceptable uncertainty of Test Equipment

This informative annex specifies the critical parameters of the components of an overall Test System (e.g. Signal generators, Signal Analysers etc.) which are necessary when assembling a Test System which complies with subclause 4.1 Acceptable Uncertainty of Test System. These Test Equipment parameters are fundamental to the accuracy of the overall Test System and are unlikely to be improved upon through System Calibration.

### G.1 Transmitter measurements

**Table G.1: Equipment accuracy for transmitter measurements**

Test	Equipment accuracy	Range over which equipment accuracy applies
6.2.1 Maximum Output Power	Not critical	Not critical
6.2.2 CPICH Power accuracy	Not critical	Not critical
6.3 Frequency error	$\pm 10$ Hz + timebase = [12] Hz	Measurements in the range $\pm 500$ Hz.
6.4.2 Power control steps	$\pm 0.1$ dB for one 1 dB step $\pm 0.1$ dB for ten 1 dB steps	$P_{\max} - 3$ dB to $P_{\max} - 28$ dB
6.4.3 Power control dynamic range	$\pm 0.2$ dB relative code domain power accuracy	$P_{\max} - 3$ dB to $P_{\max} - 28$ dB
6.4.4 Total power dynamic range	$\pm 0.3$ dB relative error over 18 dB	$P_{\max}$ to $P_{\max} - 18$ dB
6.4.5 IPDL time mask	Not critical	Not critical
6.5.1 Occupied Bandwidth	$\pm 100$ kHz	$\pm 1$ MHz of the minimum requirement
6.5.2.1 Spectrum emission mask	Not critical	Not critical
6.5.2.2 ACLR	$\pm 0.8$ dB	Measurements in the range $\pm 3$ dB of the minimum requirement at signal power = $P_{\max}$
6.5.3 Spurious emissions	Not critical	Not critical
6.6 Transmit intermodulation (interferer requirements)	Not critical	Not critical
6.7.1 EVM	$\pm 2.5$ % (for single code)	Measurements in the range 12.5% to 22.5% at signal power = $P_{\max} - 3$ dB to $P_{\max} - 18$ dB
6.7.2 Peak code Domain error	$\pm 1.0$ dB	Measurements in the range $-30$ to $-36$ dB at signal power = $P_{\max}$

---

## G.2 Receiver measurements

**Table G.2: Equipment accuracy for receiver measurements**

<b>Test</b>	<b>Equipment accuracy</b>	<b>Range over which equipment accuracy applies</b>
7.2 Reference sensitivity level	Not critical	Not critical
7.3 Dynamic range	Not critical	Not critical
7.4 Adjacent channel selectivity	Not critical	Not critical
7.5 Blocking characteristics	Not critical	Not critical
7.6 Intermod Characteristics	Not critical	Not critical
7.7 Spurious Emissions	Not critical	Not critical

---

## G.3 Performance measurements

**Table G.3: Equipment accuracy for performance measurements**

<b>Test</b>	<b>Equipment accuracy</b>	<b>Range over which equipment accuracy applies</b>
8.2, Demodulation in static propagation condition	Not critical	Not critical
8.3, Demodulation of DCH in multipath fading conditions	Not critical	Not critical

---

# Annex H (Informative): UTRAN Measurement Test Cases

## H.1 Purpose of Annex

This Annex specifies test specific parameters for some of the UTRAN requirements in chapter 9.2 TS 25.133. The tests provide additional information to how the requirements should be interpreted. Some requirements may lack a test.

---

## H.2 Received Total Wideband Power

### H.2.1 Absolute RTWP measurement

1. Terminate the BS RX inputs, measure the RTWP and record it.
2. Connect a signal generator and increase the signal generator power until the reported RTWP level ( $I_{rep}$ ) has increased 3dB.
3. Measure the signal level power at the antenna connector port. This signal level is now called the "Internally generated noise" ( $N_i$ ).
4. Sweep the sum of internally generated noise ( $N_i$ ) and signal generator power ( $I$ ) through the defined accuracy range.
5. Check that:  $|(N_i+I)-I_{rep}|$  meets the requirements in chapter 9.2.1.

Note that  $I_o = (N_i+I)$

### H.2.2 Relative RTWP measurement

1. Terminate the BS RX inputs, measure the RTWP and record it.
2. Attach a signal generator to the RX input and increase the power until the by the BS reported RTWP value ( $I_{rep}$ ) has increased 3 dB.
3. Measure the signal level power at the antenna connector port. This signal level is now called the "Internally generated noise" ( $N_i$ ).
4. Calculate the required signal levels  $I$  such that the sum of the internally generated noise ( $N_i$ ) and the signal generator power ( $I$ )
5. The difference between the reported RTWP values shall meet the requirements specified in chapter 9.2.1.

## Annex I (informative): Change History

Table I.1: Change History

Meeting / Date	Doc	CR	R	Title	Cat	Curr	New	WI
RP-12	RP-010355	0085		CR TS25.141 Measurement uncertainty	A	4.0.0	4.1.0	
RP-12	RP-010355	0087		ACLR definition	A	4.0.0	4.1.0	
RP-12	RP-010355	0089		Clarification of AWGN definition	A	4.0.0	4.1.0	
RP-12	RP-010355	0091		Corrections to 25.141 specification	A	4.0.0	4.1.0	
RP-12	RP-010355	0094		Receiver spurious emission for co-located base stations	A	4.0.0	4.1.0	
RP-12	RP-010355	0096		Correction to core requirement spectrum mask	A	4.0.0	4.1.0	
RP-13	RP-010622	0098		Corrections to performance requirements.	A	4.1.0	4.2.0	
RP-13	RP-010622	0100		Correction to PCDE test	A	4.1.0	4.2.0	
RP-13	RP-010622	0102		CR to 25.141 Measurement uncertainty issues	A	4.1.0	4.2.0	
RP-13	RP-010622	0104		Clarification of EVM and PCDE tests	A	4.1.0	4.2.0	
RP-13	RP-010622	0106		Correction of frequency range for receiver spurious emission requirements	A	4.1.0	4.2.0	
RP-13	RP-010622	0108		BS configuration for multi-carrier test cases	A	4.1.0	4.2.0	
RP-13	RP-010622	0110		Definition of "classical Doppler spectrum"	A	4.1.0	4.2.0	
RP-13	RP-010622	0112		S-CCPCH timing offset change to test models	A	4.1.0	4.2.0	
RP-13	RP-010622	0114		Correction of spectrum emission mask requirement	A	4.1.0	4.2.0	
RP-13	RP-010632	0115		RACH message and preamble testcases for static and multipath fading case 3	F	4.1.0	4.2.0	
RP-14	RP-010783	0118		PCDE and TX diversity	A	4.2.0	4.3.0	
RP-14	RP-010783	0121		Corrections to Internal BER verification	A	4.2.0	4.3.0	
RP-14	RP-010783	0124		Corrections to Internal BLER verification	A	4.2.0	4.3.0	
RP-14	RP-010783	0127		Clarification of BMT definition for multicarrier test cases	A	4.2.0	4.3.0	
RP-14	RP-010783	0130		Correction of the definition of the PICH channel (test models)	A	4.2.0	4.3.0	
RP-14	RP-010783	0133		Correction to units and table references in Spectrum emission mask	A	4.2.0	4.3.0	
RP-14	RP-010783	0136		DPCH and S-CCPCH channel structure change to test models.	A	4.2.0	4.3.0	
RP-15	RP-020024	0145	1	Removal of BS conformance tests in SSDT mode	A	4.3.0	4.4.0	
RP-15	RP-020023	0148		Frequency error and Test model 4	A	4.3.0	4.4.0	
RP-15	RP-020023	0151		The definition of AWGN interferer	A	4.3.0	4.4.0	
RP-15	RP-020023	0154		Single and Multi carrier in spurious emission requirements	A	4.3.0	4.4.0	
RP-15	RP-020023	0160	1	Correction for FCC emission mask and frequency raster for band b (UMTS1900)	A	4.3.0	4.4.0	
RP-15	RP-020029	0163		Fading generator for RACH preamble detection and RACH message demodulation	F	4.3.0	4.4.0	
RP-15	RP-020024	0173		Correction of power terms and definitions	A	4.3.0	4.4.0	
RP-15	RP-020023	0178		Maintenance of annex E, Global In-Channel TX-Test	A	4.3.0	4.4.0	
RP-15	RP-020024	0188	1	Correction of transmit inter modulation test method	A	4.3.0	4.4.0	
RP-15	RP-020023	0191		Correction of EVM test procedure	A	4.3.0	4.4.0	
RP-15	RP-020115	0196	2	TBD on test tolerances	A	4.3.0	4.4.0	
RP-16	RP-020294	0207		Reference measurement channels for UL RACH Ratio of preamble power and total message power	F	4.4.0	4.5.0	
RP-16	RP-020294	0219		Test system uncertainties and test tolerances for RACH tests (Rel-4)	F	4.4.0	4.5.0	
RP-16	RP-020286	0227		Correction of power control dynamic range Test Tolerance	A	4.4.0	4.5.0	
RP-16	RP-020286	0230	1	Correction to total power dynamic range test	A	4.4.0	4.5.0	
RP-17	RP-020468	0245		Correction of regional requirements	A	4.5.0	4.6.0	
RP-18	RP-020781	0250	1	FDD GSM co-existence in the Same Geographic Area	A	4.6.0	4.7.0	
RP-18	RP-020791	0255	1	BS IPDL test	F	4.6.0	4.7.0	
RP-18	RP-020788	0257	1	General corrections to TS 25.141	F	4.6.0	4.7.0	
RP-18	RP-020788	0260		Transmit intermodulation test correction	F	4.6.0	4.7.0	
RP-19	RP-030029	0271	1	Protection of the FDD BS receiver	A	4.7.0	4.8.0	
RP-19	RP-030035	0286		Correction to external equipment definition	F	4.7.0	4.8.0	

RP-29	RP-050489	0378	1	Clarification of '12.5MHz rule' and modification of the protection band for PHS	A	4.8.0	4.9.0	
RP-35	RP-070080	0444		Category B spurious emission limits for UTRA BS	A	4.9.0	4.10.0	TEI

---

## History

<b>Document history</b>		
V4.0.0	March 2001	Publication
V4.1.0	July 2001	Publication
V4.2.0	October 2001	Publication
V4.3.0	December 2001	Publication
V4.4.0	March 2002	Publication
V4.5.0	June 2002	Publication
V4.6.0	September 2002	Publication
V4.7.0	December 2002	Publication
V4.8.0	March 2003	Publication
V4.9.0	September 2005	Publication
V4.10.0	March 2007	Publication