

ETSI TS 125 141 V11.10.0 (2015-01)



**Universal Mobile Telecommunications System (UMTS);
Base Station (BS) conformance testing (FDD)
(3GPP TS 25.141 version 11.10.0 Release 11)**



ReferenceRTS/TSGR-0425141vba0

KeywordsUMTS

ETSI

650 Route des Lucioles
F-06921 Sophia Antipolis Cedex - FRANCE

Tel.: +33 4 92 94 42 00 Fax: +33 4 93 65 47 16

Siret N° 348 623 562 00017 - NAF 742 C
Association à but non lucratif enregistrée à la
Sous-Préfecture de Grasse (06) N° 7803/88

Important notice

The present document can be downloaded from:

<http://www.etsi.org>

The present document may be made available in electronic versions and/or in print. The content of any electronic and/or print versions of the present document shall not be modified without the prior written authorization of ETSI. In case of any existing or perceived difference in contents between such versions and/or in print, the only prevailing document is the print of the Portable Document Format (PDF) version kept on a specific network drive within ETSI Secretariat.

Users of the present document should be aware that the document may be subject to revision or change of status. Information on the current status of this and other ETSI documents is available at

<http://portal.etsi.org/tb/status/status.asp>

If you find errors in the present document, please send your comment to one of the following services:

http://portal.etsi.org/chaicor/ETSI_support.asp

Copyright Notification

No part may be reproduced or utilized in any form or by any means, electronic or mechanical, including photocopying and microfilm except as authorized by written permission of ETSI.

The content of the PDF version shall not be modified without the written authorization of ETSI.

The copyright and the foregoing restriction extend to reproduction in all media.

© European Telecommunications Standards Institute 2015.

All rights reserved.

DECT™, **PLUGTESTS™**, **UMTS™** and the ETSI logo are Trade Marks of ETSI registered for the benefit of its Members. **3GPP™** and **LTE™** are Trade Marks of ETSI registered for the benefit of its Members and of the 3GPP Organizational Partners.

GSM® and the GSM logo are Trade Marks registered and owned by the GSM Association.

Intellectual Property Rights

IPRs essential or potentially essential to the present document may have been declared to ETSI. The information pertaining to these essential IPRs, if any, is publicly available for **ETSI members and non-members**, and can be found in ETSI SR 000 314: *"Intellectual Property Rights (IPRs); Essential, or potentially Essential, IPRs notified to ETSI in respect of ETSI standards"*, which is available from the ETSI Secretariat. Latest updates are available on the ETSI Web server (<http://ipr.etsi.org>).

Pursuant to the ETSI IPR Policy, no investigation, including IPR searches, has been carried out by ETSI. No guarantee can be given as to the existence of other IPRs not referenced in ETSI SR 000 314 (or the updates on the ETSI Web server) which are, or may be, or may become, essential to the present document.

Foreword

This Technical Specification (TS) has been produced by ETSI 3rd Generation Partnership Project (3GPP).

The present document may refer to technical specifications or reports using their 3GPP identities, UMTS identities or GSM identities. These should be interpreted as being references to the corresponding ETSI deliverables.

The cross reference between GSM, UMTS, 3GPP and ETSI identities can be found under <http://webapp.etsi.org/key/queryform.asp>.

Modal verbs terminology

In the present document "**shall**", "**shall not**", "**should**", "**should not**", "**may**", "**may not**", "**need**", "**need not**", "**will**", "**will not**", "**can**" and "**cannot**" are to be interpreted as described in clause 3.2 of the [ETSI Drafting Rules](#) (Verbal forms for the expression of provisions).

"**must**" and "**must not**" are **NOT** allowed in ETSI deliverables except when used in direct citation.

Contents

Intellectual Property Rights	2
Foreword.....	2
Modal verbs terminology.....	2
Foreword.....	15
1 Scope	16
2 References	16
3 Definitions and abbreviations.....	17
3.1 Definitions	17
3.2 Symbols.....	18
3.3 Abbreviations	20
3.4 Radio Frequency bands	21
3.4.1 Frequency bands	21
3.4.2 TX-RX frequency separation.....	22
3.5 Channel arrangement.....	23
3.5.1 Channel spacing.....	23
3.5.2 Channel raster	23
3.5.3 Channel number	24
4 General test conditions and declarations	25
4.1 Acceptable uncertainty of Test System	26
4.1.1 Measurement of test environments	26
4.1.2 Measurement of transmitter	27
4.1.3 Measurement of receiver	29
4.1.4 Measurement of performance requirement	30
4.2 Test Tolerances (informative)	31
4.2.1 Transmitter.....	32
4.2.2 Receiver	32
4.2.3 Performance requirement.....	33
4.2.4 RRM measurements.....	33
4.3 Interpretation of measurement results	33
4.3A Base station classes	34
4.4 Test environments	34
4.4.1 Normal test environment	34
4.4.2 Extreme test environment	34
4.4.2.1 Extreme temperature	35
4.4.3 Vibration.....	35
4.4.4 Power supply	35
4.4.5 Definition of Additive White Gaussian Noise (AWGN) Interferer	35
4.5 Selection of configurations for testing.....	35
4.6 BS Configurations	36
4.6.1 Receiver diversity	36
4.6.2 Duplexers.....	36
4.6.3 Power supply options.....	36
4.6.4 Ancillary RF amplifiers	37
4.6.5 BS using antenna arrays.....	37
4.6.5.1 Receiver tests	38
4.6.5.2 Transmitter tests	38
4.6.6 Transmit diversity and MIMO transmission.....	38
4.6.7 BS with integrated Iuant BS modem	39
4.6.8 BS with Virtual Antenna Mapping	39
4.7 Regional requirements.....	40
4.8 Specified frequency range	42
4.8.1 RF bandwidth position for non-single carrier testing	42
4.9 Applicability of requirements.....	43

4.10	Requirements for contiguous and non-contiguous spectrum.....	43
4.11	Manufacturer's declarations of regional and optional requirements	43
4.11.1	Operating band and frequency range	43
4.11.2	Spurious emissions category.....	43
4.11.3	Additional out of band emissions	44
4.11.4	Co-existence with other systems.....	44
4.11.5	Co-location with other base stations	44
4.11.6	Manufacturer's declarations of supported RF configurations	44
4.12	Test configuration for multi-carrier operations	45
4.12.1	UTC1: Contiguous spectrum operation test configuration	45
4.12.1.1	UTC1 power allocation	46
4.12.2	UTC2: Non-contiguous spectrum operation test configuration	46
4.12.2.1	UTC2 power allocation	46
4.12.3	Multi-band operation test configurations	46
4.12.3.1	UTC3: Multi-band test configuration for full carrier allocation.....	46
4.12.3.1.1	UTC3 power allocation	47
4.12.3.2	UTC4: Multi-band test configuration with high PSD per carrier.....	47
4.12.3.2.1	UTC4 power allocation	47
4.12.4	Applicability of test configurations	48
4.13	Requirements for BS capable of multi-band operation	50
5	Format and interpretation of tests.....	51
6	Transmitter	51
6.1	General	51
6.1.1	Test Models	52
6.1.1.1	Test Model 1 – TM1	52
6.1.1.2	Test Model 2 – TM2	55
6.1.1.3	Test Model 3 – TM3	55
6.1.1.4	Test Model 4 – TM4	56
6.1.1.4A	Test Model 5 – TM5	57
6.1.1.4B	Test Model 6 – TM6	58
6.1.1.5	DPCH Structure of the Downlink Test Models.....	60
6.1.1.6	Common channel Structure of the Downlink Test Models	61
6.1.1.6.1	P-CCPCH	61
6.1.1.6.2	PICH.....	61
6.1.1.6.3	Primary scrambling code and SCH.....	61
6.1.1.6.4	S-CCPCH containing PCH.....	61
6.1.1.7	HS-PDSCH Structure of the Downlink TM5.....	62
6.1.1.8	HS-SCCH Structure of the Downlink Test Models 5 and 6.....	62
6.1.1.9	HS-PDSCH Structure of the Downlink TM6.....	62
6.2	Base station output power	62
6.2.1	Base station maximum output power.....	62
6.2.1.1	Definition and applicability.....	62
6.2.1.2	Minimum Requirement	63
6.2.1.3	Test purpose	63
6.2.1.4	Method of test	63
6.2.1.4.1	Initial conditions	63
6.2.1.4.2	Procedure.....	63
6.2.1.5	Test Requirements.....	64
6.2.2	Primary CPICH power accuracy.....	64
6.2.2.1	Definition and applicability.....	64
6.2.2.2	Minimum Requirement	64
6.2.2.3	Test purpose	64
6.2.2.4	Method of test	64
6.2.2.4.1	Initial conditions	64
6.2.2.4.2	Procedure.....	64
6.2.2.5	Test Requirement	65
6.2.3	Secondary CPICH power offset accuracy.....	65
6.2.3.1	Definition and applicability.....	65
6.2.3.2	Minimum Requirement	65
6.2.3.3	Test purpose	65

6.2.3.4	Method of test for MIMO mode.....	65
6.2.3.4.1	Initial conditions.....	65
6.2.3.4.2	Procedure.....	66
6.2.3.4A	Method of test for MIMO mode with four transmit antennas.....	66
6.2.3.4A.1	Initial conditions.....	66
6.2.3.4A.2	Procedure.....	66
6.2.3.5	Test Requirement for MIMO mode.....	66
6.2.3.5A	Test Requirement for MIMO mode with four transmit antennas.....	66
6.3	Frequency error.....	67
6.3.1	Definition and applicability.....	67
6.3.2	Minimum Requirement.....	67
6.3.3	Test purpose.....	67
6.3.4	Method of test.....	67
6.3.5	Test requirement.....	67
6.4	Output power dynamics.....	67
6.4.1	Inner loop power control.....	67
6.4.2	Power control steps.....	68
6.4.2.1	Definition and applicability.....	68
6.4.2.2	Minimum Requirement.....	68
6.4.2.3	Test purpose.....	68
6.4.2.4	Method of test.....	68
6.4.2.4.1	Initial conditions.....	68
6.4.2.4.2	Procedure.....	68
6.4.2.5	Test requirement.....	69
6.4.3	Power control dynamic range.....	69
6.4.3.1	Definition and applicability.....	69
6.4.3.2	Minimum Requirement.....	69
6.4.3.3	Test purpose.....	69
6.4.3.4	Method of test.....	70
6.4.3.4.1	Initial conditions.....	70
6.4.3.4.2	Procedure.....	70
6.4.3.5	Test requirement.....	70
6.4.4	Total power dynamic range.....	70
6.4.4.1	Definition and applicability.....	70
6.4.4.2	Minimum Requirement.....	70
6.4.4.3	Test purpose.....	71
6.4.4.4	Method of test.....	71
6.4.4.4.1	Initial Conditions.....	71
6.4.4.4.2	Procedure.....	71
6.4.4.5	Test requirement.....	71
6.4.5	IPDL time mask.....	71
6.4.5.1	Definition and applicability.....	71
6.4.5.2	Minimum Requirement.....	71
6.4.5.3	Test purpose.....	72
6.4.5.4	Method of test.....	72
6.4.5.4.1	Initial conditions.....	72
6.4.5.4.2	Procedure.....	72
6.4.5.5	Test Requirements.....	72
6.4.6	Home base station output power for adjacent channel protection.....	73
6.4.6.1	Definition and applicability.....	73
6.4.6.2	Minimum Requirement.....	73
6.4.6.3	Test purpose.....	74
6.4.6.4	Method of test.....	74
6.4.6.4.1	Initial conditions.....	74
6.4.6.4.2	Procedure.....	74
6.4.6.5	Test Requirements.....	75
6.5	Output RF spectrum emissions.....	75
6.5.1	Occupied bandwidth.....	75
6.5.1.1	Definition and applicability.....	75
6.5.1.2	Minimum Requirements.....	75
6.5.1.3	Test purpose.....	75
6.5.1.4	Method of test.....	75

6.5.1.4.1	Initial conditions	75
6.5.1.4.2	Procedure	75
6.5.1.5	Test requirements	76
6.5.2	Out of band emission	76
6.5.2.1	Spectrum emission mask	76
6.5.2.1.1	Definitions and applicability	76
6.5.2.1.2	Minimum Requirements	76
6.5.2.1.3	Test purpose	77
6.5.2.1.4	Method of test	77
6.5.2.1.4.1	Initial conditions	77
6.5.2.1.4.2	Procedures	77
6.5.2.1.5	Test requirements	77
6.5.2.2	Adjacent Channel Leakage power Ratio (ACLR)	84
6.5.2.2.1	Definition and applicability	84
6.5.2.2.2	Minimum Requirement	84
6.5.2.2.3	Test purpose	84
6.5.2.2.4	Method of test	84
6.5.2.2.4.1	Initial conditions	84
6.5.2.2.4.2	Procedure	85
6.5.2.2.5	Test Requirement	85
6.5.2.2.6	Cumulative ACLR test requirement in non-contiguous spectrum or multiple-bands	86
6.5.3	Spurious emissions	87
6.5.3.1	Definition and applicability	87
6.5.3.2	(void)	88
6.5.3.3	(void)	88
6.5.3.4	Minimum Requirements	88
6.5.3.5	Test purpose	88
6.5.3.6	Method of Test	88
6.5.3.6.1	Initial conditions	88
6.5.3.6.2	Procedure	89
6.5.3.7	Test requirements	89
6.5.3.7.1	Spurious emissions (Category A)	89
6.5.3.7.2	Spurious emissions (Category B)	90
6.5.3.7.3	Protection of the BS receiver of own or different BS	91
6.5.3.7.4	Co-existence with other systems in the same geographical area	93
6.5.3.7.5	Co-existence with co-located and co-sited base stations	97
6.5.3.7.6	Co-existence with PHS	103
6.5.3.7.7	Co-existence with services in adjacent frequency bands	103
6.5.3.7.8	Void	103
6.5.3.7.8.1	Void	103
6.5.3.7.8.2	Void	103
6.5.3.7.9	Protection of Public Safety Operations	103
6.5.3.7.10	Co-existence with Home BS operating in other bands	104
6.6	Transmitter intermodulation	106
6.6.1	Definition and applicability	106
6.6.2	Minimum Requirement	106
6.6.3	Test purpose	106
6.6.4	Method of test	106
6.6.4.1	Initial conditions	106
6.6.4.2	Procedures	107
6.6.5	Test Requirements	107
6.7	Transmit modulation	108
6.7.1	Error Vector Magnitude	108
6.7.1.1	Definition and applicability	108
6.7.1.2	Minimum Requirement	108
6.7.1.3	Test Purpose	108
6.7.1.4	Method of Test	108
6.7.1.4.1	Initial Conditions	108
6.7.1.4.2	Procedure	108
6.7.1.5	Test Requirement	109
6.7.2	Peak Code Domain Error	109
6.7.2.1	Definition and applicability	109

6.7.2.2	Minimum requirement	109
6.7.2.3	Test Purpose	109
6.7.2.4	Method of test	109
6.7.2.4.1	Initial conditions	109
6.7.2.4.2	Procedure	109
6.7.2.5	Test requirement	110
6.7.3	Time alignment error	110
6.7.3.1	Definition and applicability	110
6.7.3.2	Minimum Requirement	110
6.7.3.3	Test Purpose	110
6.7.3.4	Method of Test	110
6.7.3.4.1	Initial Conditions	110
6.7.3.4.2	Procedure	111
6.7.3.5	Test Requirement	111
6.7.4	Relative Code Domain Error	111
6.7.4.1	Definition and applicability	111
6.7.4.2	Minimum requirement	111
6.7.4.3	Test Purpose	111
6.7.4.4	Method of test	112
6.7.4.4.1	Initial conditions	112
6.7.4.4.2	Procedure	112
6.7.4.5	Test requirement	112
7	Receiver characteristics	112
7.1	General	112
7.2	Reference sensitivity level	113
7.2.1	Definition and applicability	113
7.2.2	Minimum Requirement	113
7.2.3	Test purpose	113
7.2.4	Method of testing	114
7.2.4.1	Initial conditions	114
7.2.4.2	Procedure	114
7.2.5	Test requirement	114
7.3	Dynamic range	115
7.3.1	Definition and applicability	115
7.3.2	Minimum Requirement	115
7.3.3	Test purpose	115
7.3.4	Method of test	115
7.3.4.1	Initial conditions	115
7.3.4.2	Procedure	115
7.3.5	Test Requirements	115
7.4	Adjacent Channel Selectivity (ACS)	116
7.4.1	Definition and applicability	116
7.4.2	Minimum Requirement	116
7.4.3	Test purpose	116
7.4.4	Method of test	116
7.4.4.1	Initial conditions	116
7.4.4.2	Procedure	116
7.4.5	Test Requirements	117
7.5	Blocking characteristics	117
7.5.1	Definition and applicability	117
7.5.2	Minimum Requirements	118
7.5.3	Test purpose	118
7.5.4	Method of test	118
7.5.4.1	Initial conditions	118
7.5.4.2	Procedure	119
7.5.5	Test Requirements	119
7.6	Intermodulation characteristics	133
7.6.1	Definition and applicability	133
7.6.2	Minimum Requirement	133
7.6.3	Test purpose	133
7.6.4	Method of test	134

7.6.4.1	Initial conditions	134
7.6.4.2	Procedures	134
7.6.5	Test requirements	134
7.7	Spurious Emissions	135
7.7.1	Definition and applicability	135
7.7.2	Minimum Requirements	135
7.7.3	Test purpose	135
7.7.4	Method of test	135
7.7.4.1	Initial conditions	135
7.7.4.2	Procedure	136
7.7.5	Test requirements	136
7.8	Verification of the internal BER calculation	137
7.8.1	Definition and applicability	137
7.8.2	Minimum Requirement	137
7.8.3	Test purpose	137
7.8.4	Method of test	137
7.8.4.1	Initial conditions	137
7.8.4.2	Procedure	138
7.8.5	Test Requirement	138
8	Performance requirement	138
8.1	General	138
8.2	Demodulation in static propagation conditions	139
8.2.1	Demodulation of DCH	139
8.2.1.1	Definition and applicability	139
8.2.1.2	Minimum requirement	139
8.2.1.3	Test purpose	139
8.2.1.4	Method of test	139
8.2.1.4.1	Initial conditions	139
8.2.1.4.2	Procedure	139
8.2.1.5	Test requirements	139
8.3	Demodulation of DCH in multipath fading conditions	140
8.3.1	Multipath fading Case 1	140
8.3.1.1	Definition and applicability	140
8.3.1.2	Minimum requirement	140
8.3.1.3	Test Purpose	140
8.3.1.4	Method of test	140
8.3.1.4.1	Initial conditions	140
8.3.1.4.2	Procedure	140
8.3.1.5	Test requirements	141
8.3.2	Multipath fading Case 2	141
8.3.2.1	Definition and applicability	141
8.3.2.2	Minimum requirement	141
8.3.2.3	Test Purpose	141
8.3.2.4	Method of test	142
8.3.2.4.1	Initial conditions	142
8.3.2.4.2	Procedure	142
8.3.2.5	Test requirements	142
8.3.3	Multipath fading Case 3	143
8.3.3.1	Definition and applicability	143
8.3.3.2	Minimum requirement	143
8.3.3.3	Test purpose	143
8.3.3.4	Method of test	143
8.3.3.4.1	Initial conditions	143
8.3.3.4.2	Procedure	143
8.3.3.5	Test requirements	143
8.3.4	Multipath fading Case 4	144
8.3.4.1	Definition and applicability	144
8.3.4.2	Minimum requirement	144
8.3.4.3	Test purpose	144
8.3.4.4	Method of test	144
8.3.4.4.1	Initial conditions	144

8.3.4.4.2	Procedure	144
8.3.4.5	Test requirements	145
8.4	Demodulation of DCH in moving propagation conditions	145
8.4.1	Definition and applicability	145
8.4.2	Minimum requirement	145
8.4.3	Test purpose	145
8.4.4	Method of test	146
8.4.4.1	Initial conditions	146
8.4.4.2	Procedure	146
8.4.5	Test requirements	146
8.5	Demodulation of DCH in birth/death propagation conditions	147
8.5.1	Definition and applicability	147
8.5.2	Minimum requirement	147
8.5.3	Test purpose	147
8.5.4	Method of test	147
8.5.4.1	Initial conditions	147
8.5.4.2	Procedure	147
8.5.5	Test requirements	148
8.5A	Demodulation of DCH in high speed train conditions	148
8.5A.1	Definition and applicability	148
8.5A.2	Minimum requirement	148
8.5A.3	Test purpose	148
8.5A.4	Method of test	148
8.5A.4.1	Initial conditions	148
8.5A.4.2	Procedure	148
8.5A.5	Test requirements	149
8.6	Verification of the internal BLER calculation	149
8.6.1	Definition and applicability	149
8.6.2	Minimum requirement	150
8.6.3	Test purpose	150
8.6.4	Method of test	150
8.6.4.1	Initial conditions	150
8.6.4.2	Procedure	150
8.6.5	Test requirement	150
8.7	(void)	151
8.8	RACH performance	151
8.8.1	RACH preamble detection in static propagation conditions	151
8.8.1.1	Definition and applicability	151
8.8.1.2	Minimum requirement	151
8.8.1.3	Test purpose	151
8.8.1.4	Method of test	151
8.8.1.4.1	Initial conditions	151
8.8.1.4.2	Procedure	151
8.8.1.5	Test requirements	152
8.8.2A	RACH preamble detection in high speed train conditions	152
8.8.2A.1	Definition and applicability	152
8.8.2A.2	Minimum requirement	152
8.8.2A.3	Test purpose	152
8.8.2A.4	Method of test	152
8.8.2A.4.1	Initial conditions	152
8.8.2A.4.2	Procedure	152
8.8.2A.5	Test requirements	153
8.8.2	RACH preamble detection in multipath fading case 3	153
8.8.2.1	Definition and applicability	153
8.8.2.2	Minimum requirement	153
8.8.2.3	Test purpose	154
8.8.2.4	Method of test	154
8.8.2.4.1	Initial conditions	154
8.8.2.4.2	Procedure	154
8.8.2.5	Test requirements	154
8.8.3	Demodulation of RACH message in static propagation conditions	155
8.8.3.1	Definition and applicability	155

8.8.3.2	Minimum requirement	155
8.8.3.3	Test purpose	155
8.8.3.4	Method of test	155
8.8.3.4.1	Initial conditions	155
8.8.3.4.2	Procedure	155
8.8.3.5	Test requirements	156
8.8.4	Demodulation of RACH message in multipath fading case 3	156
8.8.4.1	Definition and applicability	156
8.8.4.2	Minimum requirement	156
8.8.4.3	Test purpose	156
8.8.4.4	Method of test	156
8.8.4.4.1	Initial conditions	156
8.8.4.4.2	Procedure	157
8.8.4.5	Test requirements	157
8.8.5	Demodulation of RACH message in high speed train conditions	158
8.8.5.1	Definition and applicability	158
8.8.5.2	Minimum requirement	158
8.8.5.3	Test purpose	158
8.8.5.4	Method of test	158
8.8.5.4.1	Initial conditions	158
8.8.5.4.2	Procedure	158
8.8.5.5	Test requirements	159
8.9	(void)	159
8.10	(void)	160
8.11	Performance of signalling detection for HS-DPCCH	160
8.11.1	ACK false alarm in static propagation conditions	160
8.11.1.1	Definition and applicability	160
8.11.1.2	Minimum requirement	160
8.11.1.3	Test purpose	160
8.11.1.4	Method of test	160
8.11.1.4.1	Initial conditions	160
8.11.1.4.2	Procedure	160
8.11.1.5	Test requirements	161
8.11.2	ACK false alarm in multipath fading conditions	161
8.11.2.1	Definition and applicability	161
8.11.2.2	Minimum requirement	161
8.11.2.3	Test purpose	161
8.11.2.4	Method of test	161
8.11.2.4.1	Initial conditions	161
8.11.2.4.2	Procedure	161
8.11.2.5	Test requirements	162
8.11.3	ACK mis-detection in static propagation conditions	162
8.11.3.1	Definition and applicability	162
8.11.3.2	Minimum requirement	162
8.11.3.3	Test purpose	162
8.11.3.4	Method of test	162
8.11.3.4.1	Initial conditions	162
8.11.3.4.2	Procedure	163
8.11.3.5	Test requirements	163
8.11.4	ACK mis-detection in multipath fading conditions	163
8.11.4.1	Definition and applicability	163
8.11.4.2	Minimum requirement	163
8.11.4.3	Test purpose	163
8.11.4.4	Method of test	164
8.11.4.4.1	Initial conditions	164
8.11.4.4.2	Procedure	164
8.11.4.5	Test requirements	164
8.11A	Performance of signalling detection for 4C-HSDPA HS-DPCCH	164
8.11A.1	ACK false alarm for 4C-HSDPA in static propagation conditions	165
8.11A.1.1	Definition and applicability	165
8.11A.1.2	Minimum requirement	165
8.11A.1.3	Test purpose	165

8.11A.1.4	Method of test	165
8.11A.1.4.1	Initial conditions	165
8.11A.1.4.2	Procedure.....	165
8.11A.1.5	Test requirements.....	166
8.11A.2	ACK false alarm for 4C-HSDPA in multipath fading conditions.....	166
8.11A.2.1	Definition and applicability.....	166
8.11A.2.2	Minimum requirement	166
8.11A.2.3	Test purpose	166
8.11A.2.4	Method of test	166
8.11A.2.4.1	Initial conditions.....	166
8.11A.2.4.2	Procedure.....	166
8.11A.2.5	Test requirements.....	167
8.11A.3	ACK mis-detection for 4C-HSDPA in static propagation conditions.....	167
8.11A.3.1	Definition and applicability.....	167
8.11A.3.2	Minimum requirement	167
8.11A.3.3	Test purpose	167
8.11A.3.4	Method of test	168
8.11A.3.4.1	Initial conditions.....	168
8.11A.3.4.2	Procedure.....	168
8.11A.3.5	Test requirements.....	168
8.11A.4	ACK mis-detection for 4C-HSDPA in multipath fading conditions.....	168
8.11A.4.1	Definition and applicability.....	168
8.11A.4.2	Minimum requirement	169
8.11A.4.3	Test purpose	169
8.11A.4.4	Method of test	169
8.11A.4.4.1	Initial conditions.....	169
8.11A.4.4.2	Procedure.....	169
8.11A.4.5	Test requirements.....	169
8.11B	Performance of signalling detection for 8C-HSDPA HS-DPCCH.....	170
8.12	Demodulation of E-DPDCH in multipath fading conditions.....	170
8.12.1	Definition and applicability	170
8.12.2	Minimum requirement	171
8.12.3	Test Purpose.....	171
8.12.4	Method of test.....	171
8.12.4.1	Initial conditions	171
8.12.4.2	Procedure	171
8.12.4.3	Test requirements.....	171
8.12A	Demodulation of E-DPDCH and S-E-DPDCH in multipath fading conditions for UL MIMO.....	172
8.12A.1	Definition and applicability	172
8.12A.2	Minimum requirement	172
8.12A.3	Test Purpose.....	173
8.12A.4	Method of test.....	173
8.12A.4.1	Initial conditions	173
8.12A.4.2	Procedure	173
8.12A.4.3	Test requirements.....	173
8.13	Performance of signalling detection for E-DPCCH in multipath fading conditions	174
8.13.1	E-DPCCH false alarm in multipath fading conditions.....	174
8.13.1.1	Definition and applicability.....	174
8.13.1.2	Minimum requirement	174
8.13.1.3	Test purpose	174
8.13.1.4	Method of test	174
8.13.1.4.1	Initial conditions.....	174
8.13.1.4.2	Procedure.....	174
8.13.1.5	Test requirements.....	175
8.13.2	E-DPCCH missed detection in multipath fading conditions.....	175
8.13.2.1	Definition and applicability.....	175
8.13.2.2	Minimum requirement	175
8.13.2.3	Test purpose	176
8.13.2.4	Method of test	176
8.13.2.4.1	Initial conditions.....	176
8.13.2.4.2	Procedure.....	176
8.13.2.5	Test requirements.....	176

Annex A (normative):	Measurement channels	178
A.1	Summary of UL reference measurement channels.....	178
A.2	UL reference measurement channel for 12,2 kbps.....	179
A.3	UL reference measurement channel for 64 kbps.....	180
A.4	UL reference measurement channel for 144 kbps.....	181
A.5	UL reference measurement channel for 384 kbps.....	182
A.6	(void).....	182
A.7	Reference measurement channels for UL RACH	183
A.8	(void).....	183
A.9	Reference measurement channel for HS-DPCCH.....	183
A.9A	Reference measurement channel for 4C-HSDPA HS-DPCCH.....	184
A.10	Summary of E-DPDCH Fixed reference channels.....	185
A.11	E-DPDCH Fixed reference channel 1 (FRC1)	186
A.12	E-DPDCH Fixed reference channel 2 (FRC2)	187
A.13	E-DPDCH Fixed reference channel 3 (FRC3)	188
A.14	E-DPDCH Fixed reference channel 4 (FRC4)	189
A.15	E-DPDCH Fixed reference channel 5 (FRC5)	190
A.16	E-DPDCH Fixed reference channel 6 (FRC6)	191
A.17	E-DPDCH Fixed reference channel 7 (FRC7)	191
A.18	E-DPDCH Fixed reference channel 8 (FRC8)	192
A.19	E-DPDCH Fixed reference channel 9 (FRC9)	193
A.20	E-DPDCH Fixed reference channel 10 (FRC10).....	195
Annex B (informative):	Measurement system set-up	197
B.1	Transmitter	197
B.1.1	Maximum output power, total power dynamic range.....	197
B.1.2	Frequency, Code Power and Transmit Modulation.....	197
B.1.3	Power control steps and power control dynamic range	198
B.1.4	Out of band emission.....	198
B.1.5	Transmit intermodulation	198
B.1.6	Time alignment error in TX diversity, MIMO, DC-HSDPA, DB-DC-HSDPA and 4C-HSDPA	199
B.1.7	Home BS output power for adjacent channel protection.....	199
B.2	Receiver.....	200
B.2.1	Reference sensitivity level.....	200
B.2.2	Dynamic range	200
B.2.3	Adjacent Channel Selectivity (ACS)	201
B.2.4	Blocking characteristics	201
B.2.5	Intermodulation characteristics	202
B.2.6	Receiver spurious emission	202
B.3	Performance requirement	203
B.3.1	Demodulation of DCH, RACH and HS-DPCCH signalling in static conditions	203
B.3.2	Demodulation of DCH, RACH and HS-DPCCH signalling in multipath fading conditions	204
B.3.3	Verification of the internal BER and BLER calculation	204
B.3.4	Demodulation of E-DPDCH, S-E-DPDCH and E-DPCCH signalling in multipath fading conditions.....	205
B.3.5	Demodulation of DCH in moving propagation conditions or birth-death propagation conditions, or Demodulation of DCH, RACH in high speed train conditions	207

Annex C (normative):	General rules for statistical testing.....	208
C.1	Statistical testing of receiver BER/BLER performance	208
C.1.1	Error Definition	208
C.1.2	Test Method.....	208
C.1.3	Test Criteria.....	208
C.1.4	Calculation assumptions.....	208
C.1.4.1	Statistical independence.....	208
C.1.4.2	Applied formulas	208
C.1.4.3	Approximation of the distribution	209
C.1.5	Definition of good pass fail decision.....	209
C.1.6	Good balance between test time and statistical significance	210
C.1.7	Pass fail decision rules	211
C.1.8	Test conditions for BER, BLER, Pd, E-DPCCH tests.....	212
C.1.9	Practical Use (informative).....	217
C.2	Statistical Testing of E-DPDCH Throughput.....	219
C.2.1	Definition	219
C.2.2	Mapping throughput to block error ratio	219
C.2.3	Bad DUT factor.....	220
C.2.3.1	Bad DUT factor, range of applicability	221
C.2.4	Minimum Test time	222
C.2.5	Statistical independence	222
C.2.6	Formula	223
C.2.7	Meaning of a decision	223
C.2.8	The test limit.....	223
Annex D (normative):	Propagation conditions.....	225
D.1	Static propagation condition.....	225
D.2	Multi-path fading propagation conditions.....	225
D.3	Moving propagation conditions.....	225
D.4	Birth-Death propagation conditions	226
D.4A	High speed train conditions	227
D.5	Multi-path fading propagation conditions for E-DPDCH and E-DPCCH	229
Annex E (normative):	Global In-Channel TX-Test	230
E.1	General	230
E.2	Definition of the process	230
E.2.1	Basic principle.....	230
E.2.2	Output signal of the TX under test	230
E.2.3	Reference signal	230
E.2.4	Classification of measurement results	231
E.2.5	Process definition to achieve results of type "deviation".....	231
E.2.5.1	Decision Point Power.....	232
E.2.5.2	Code-Domain Power.....	232
E.2.6	Process definition to achieve results of type "residual".....	232
E.2.6.1	Error Vector Magnitude (EVM)	233
E.2.6.2	Peak Code Domain Error (PCDE)	233
E.2.6.3	Relative Code Domain Error (RCDE)	234
E.3	Notes.....	234
E.3.1	Symbol length	234
E.3.2	Deviation	234
E.3.3	Residual.....	234
E.3.4	Scrambling Code	234
E.3.5	IQ.....	235
E.3.6	Synch Channel.....	235
E.3.7	Formula for the minimum process	235
E.3.8	Power Step.....	236

E.3.9	Formula for EVM.....	236
Annex F (informative):	Derivation of Test Requirements.....	237
Annex G (informative):	Acceptable uncertainty of Test Equipment	243
G.1	Transmitter measurements	243
G.2	Receiver measurements.....	244
G.3	Performance measurements.....	244
Annex H (Informative):	UTRAN Measurement Test Cases.....	245
H.1	Purpose of Annex	245
H.2	Received Total Wideband Power	245
H.2.1	Absolute RTWP measurement	245
H.2.2	Relative RTWP measurement	245
H.3	Transmitted code power	246
H.4	Transmitted carrier power	246
Annex I (normative):	Characteristics of the W-CDMA interference signal.....	247
Annex J (informative):	Change history	248
History		252

Foreword

This Technical Specification (TS) has been produced by the 3rd Generation Partnership Project (3GPP).

The contents of the present document are subject to continuing work within the TSG and may change following formal TSG approval. Should the TSG modify the contents of the present document, it will be re-released by the TSG with an identifying change of release date and an increase in version number as follows:

Version x.y.z

where:

- x the first digit:
 - 1 presented to TSG for information;
 - 2 presented to TSG for approval;
 - 3 or greater indicates TSG approved document under change control.
- y the second digit is incremented for all changes of substance, i.e. technical enhancements, corrections, updates, etc.
- z the third digit is incremented when editorial only changes have been incorporated in the document.

1 Scope

The present document specifies the Radio Frequency (RF) test methods and conformance requirements for UTRA Base Stations (BS) operating in the FDD mode. These have been derived from, and are consistent with the UTRA Base Station (BS) specifications defined in [1].

The present document establishes the minimum RF characteristics of the FDD mode of UTRA for the Base Station (BS).

2 References

The following documents contain provisions which, through reference in this text, constitute provisions of the present document.

- References are either specific (identified by date of publication, edition number, version number, etc.) or non-specific.
- For a specific reference, subsequent revisions do not apply.
- For a non-specific reference, the latest version applies. In the case of a reference to a 3GPP document (including a GSM document), a non-specific reference implicitly refers to the latest version of that document *in the same Release as the present document*.

- [1] 3GPP TS 25.104: "UTRA(BS) FDD; Radio transmission and Reception".
- [2] 3GPP TS 25.942: "RF system scenarios".
- [3] 3GPP TS 25.113: "Base station EMC".
- [4] ITU-R recommendation SM.329: "Unwanted emissions in the spurious domain".
- [5] ITU-T recommendation O.153: "Basic parameters for the measurement of error performance at bit rates below the primary rate".
- [6] IEC 60721-3-3 (1994): "Classification of environmental conditions - Part 3: Classification of groups of environmental parameters and their severities - Section 3: Stationary use at weather protected locations".
- [7] IEC 60721-3-4 (1995): "Classification of environmental conditions - Part 3: Classification of groups of environmental parameters and their severities - Section 4: Stationary use at non-weather protected locations".
- [8] IEC 60068-2-1 (1990): "Environmental testing - Part 2: Tests. Tests A: Cold".
- [9] IEC 60068-2-2 (1974): "Environmental testing - Part 2: Tests. Tests B: Dry heat".
- [10] IEC 60068-2-6 (1995): "Environmental testing - Part 2: Tests - Test Fc: Vibration (sinusoidal)".
- [11] ITU-R recommendation SM.328: "Spectra and bandwidth of emissions".
- [12] 3GPP TS 45.004: "Digital cellular telecommunications system (Phase 2+); Modulation".
- [13] 3GPP TS 25.214: "Physical layer procedures (FDD)".
- [14] 3GPP TS 25.213: "Spreading and modulation (FDD)".
- [15] 3GPP TS 36.104: "Evolved Universal Terrestrial Radio Access (E-UTRA); Base Station (BS) radio transmission and reception".
- [16] 3GPP TS 37.141: "E-UTRA, UTRA and GSM/EDGE; Multi-Standard Radio (MSR) Base Station (BS) conformance testing".

- [17] ITU-R Recommendation M.1545, "Measurement uncertainty as it applies to test limits for the terrestrial component of International Mobile Telecommunications-2000".

3 Definitions and abbreviations

3.1 Definitions

For the purposes of the present document, the following terms and definitions apply:

Ancillary RF amplifier: a piece of equipment, which when connected by RF coaxial cables to the BS, has the primary function to provide amplification between the transmit and/or receive antenna connector of a BS and an antenna without requiring any control signal to fulfil its amplifying function.

Bit Error Ratio: The Bit Error Ratio is defined as the ratio of the bits wrongly received to all data bits sent. The bits are the data bits above the convolutional/turbo decoder. The BER is the overall BER independent of frame erasures or when erased frames are not defined.

Block Error Ratio: A Block Error Ratio is defined as the ratio of the number of erroneous blocks received to the total number of blocks sent. An erroneous block is a Transport Block whose cyclic redundancy check (CRC) is wrong.

Mean power: When applied to a W-CDMA modulated signal this is the power (transmitted or received) in a bandwidth of at least $(1 + \alpha)$ times the chip rate of the radio access mode. The period of measurement shall be at least one timeslot unless otherwise stated.

RRC filtered mean power: The mean power as measured through a root raised cosine filter with roll-off factor α and a bandwidth equal to the chip rate of the radio access mode.

NOTE 1: The RRC filtered mean power of a perfectly modulated W-CDMA signal is 0,246 dB lower than the mean power of the same signal.

NOTE 2: The roll-off factor α factor is defined in [1] section 6.8.1.

Code domain power: That part of the mean power which correlates with a particular (OVSF) code channel. The sum of all powers in the code domain equals the mean power in a bandwidth of $(1 + \alpha)$ times the chip rate of the radio access mode. See Annex E.2.5.1.

Output power: The mean power of one carrier of the base station, delivered to a load with resistance equal to the nominal load impedance of the transmitter.

Rated output power: Rated output power of the base station is the mean power level per carrier that the manufacturer has declared to be available at the antenna connector.

Rated total output power: Rated total output power of the base station is the mean power level that the manufacturer has declared to be available at the antenna connector.

Maximum output power: The mean power level per carrier of the base station measured at the antenna connector in a specified reference condition.

MIMO mode: This term refers to the downlink MIMO configuration with two transmit antennas.

MIMO mode with four transmit antennas: This term refers to the downlink MIMO configuration with four transmit antennas.

Power control dynamic range: The difference between the maximum and the minimum code domain power of a code channel for a specified reference condition.

Total power dynamic range: The difference between the maximum and the minimum total power for a specified reference condition.

Secondary serving HS-DSCH cell(s): In addition to the serving HS-DSCH cell, the set of cells where the UE is configured to simultaneously monitor an HS-SCCH set and receive the HS-DSCH if it is scheduled in that cell. There can be up to 7 secondary serving HS-DSCH cells.

1st secondary serving HS-DSCH cell: If the UE is configured with two uplink frequencies, the 1st secondary serving HS-DSCH cell is the secondary serving HS-DSCH cell that is associated with the secondary uplink frequency. If the UE is configured with a single uplink frequency, the 1st secondary serving HS-DSCH cell is a secondary serving HS-DSCH cell whose index is indicated by higher layers.

BS RF bandwidth: The bandwidth in which a Base Station transmits and receives multiple carriers simultaneously within each supported operating band.

Maximum BS RF bandwidth: The maximum RF bandwidth supported by a BS within each supported operating band.

Maximum radio bandwidth: Maximum frequency difference between the upper edge of the highest used carrier and the lower edge of the lowest used carrier.

BS RF bandwidth edge: The frequency of one of the edges of the Base Station RF bandwidth.

Contiguous spectrum: Spectrum consisting of a contiguous block of spectrum with no sub-block gap(s).

Non-contiguous spectrum: Spectrum consisting of two or more sub-blocks separated by sub-block gap(s).

Sub-block: This is one contiguous allocated block of spectrum for use by the same Base Station. There may be multiple instances of sub-blocks within an RF bandwidth.

Sub-block bandwidth: The bandwidth of one sub-block.

Sub-block gap: A frequency gap between two consecutive sub-blocks within an RF bandwidth, where the RF requirements in the gap are based on co-existence for un-coordinated operation.

Lower Edge: The lowest frequency in the Base station RF bandwidth, or the lowest frequency in the channel bandwidth of a single E-UTRA carrier, used as a frequency reference point for transmitter and receiver requirements.

Lower sub-block edge: The frequency at the lower edge of one sub-block. It is used as a frequency reference point for both transmitter and receiver requirements.

Upper Edge: The highest frequency in the BS RF Bandwidth or the highest frequency in the channel bandwidth of a single UTRA carrier; used as a frequency reference point for transmitter and receiver requirements.

Upper sub-block edge: The frequency at the higher edge of one sub-block. It is used as a frequency reference point for both transmitter and receiver requirements.

Multi-band Base Station: Base Station characterized by the ability of its transmitter and/or receiver to process two or more carriers in common active RF components simultaneously, where at least one carrier is configured at a different non-overlapping operating band than the other carrier(s).

Multi-carrier transmission configuration: A set of one or more contiguous or non-contiguous carriers that a BS is able to transmit simultaneously according to the manufacturer's specification.

Multi-band transmitter: Transmitter characterized by the ability to process two or more carriers in common active RF components simultaneously, where at least one carrier is configured at a different non-overlapping operating band than the other carrier(s).

Multi-band receiver: Receiver characterized by the ability to process two or more carriers in common active RF components simultaneously, where at least one carrier is configured at a different non-overlapping operating band than the other carrier(s).

Inter RF bandwidth gap: The frequency gap between two consecutive RF bandwidths that are placed within two supported operating bands.

Total RF bandwidth: Maximum sum of RF bandwidths in all supported operating bands.

3.2 Symbols

For the purposes of the present document, the following symbols apply:

α Roll-off factor

B_{RFBW}	Maximum BS RF bandwidth located at the bottom of the supported frequency range in each operating band
E_b	Average energy per information bit for the PCCPCH, SCCPCH and DPCH, at the antenna connector
E_c	Average energy per PN chip
f	Frequency
Δf	Separation between the channel edge frequency and the nominal -3dB point of the measuring filter closest to the carrier frequency
Δf_{max}	The largest value of Δf used for defining the requirement
F_{offset}	Frequency offset from the centre frequency of the <i>highest</i> transmitted/received carrier to the <i>upper</i> RF bandwidth edge or sub-block edge, or from the centre frequency of the <i>lowest</i> transmitted/received carrier to the <i>lower</i> RF bandwidth edge or sub-block edge. F_{offset} for UTRA FDD is 2.5 MHz.
F_{DL_low}	The lowest frequency of the downlink operating band
F_{DL_high}	The highest frequency of the downlink operating band
F_{DL_Offset}	The offset parameter used to calculate the UARFCN
F_{UL_low}	The lowest frequency of the uplink operating band
F_{UL_high}	The highest frequency of the uplink operating band
F_{UL_Offset}	The offset parameter used to calculate the UARFCN
M_{RFBW}	Maximum BS RF bandwidth located in the middle of the supported frequency range in each operating band
$P_{EM,N}$	Declared emission level for channel N
$P_{EM,B32,ind}$	Declared emission level in Band 32, ind=a, b, c, d, e
P_{out}	Output power
$PRAT$	Rated output power (per carrier)
$Prated,t$	Rated total output power
P_{max}	Maximum output power (per carrier)
P_{out}	Output power
$P_{REFSENS}$	Reference sensitivity power level
RBW	Resolution bandwidth (of test equipment)
RF	Radio Frequency
T_{RFBW}	Maximum BS RF bandwidth located at the top of the supported frequency range in each operating band
W_{gap}	Sub-block gap or inter RF bandwidth gap size

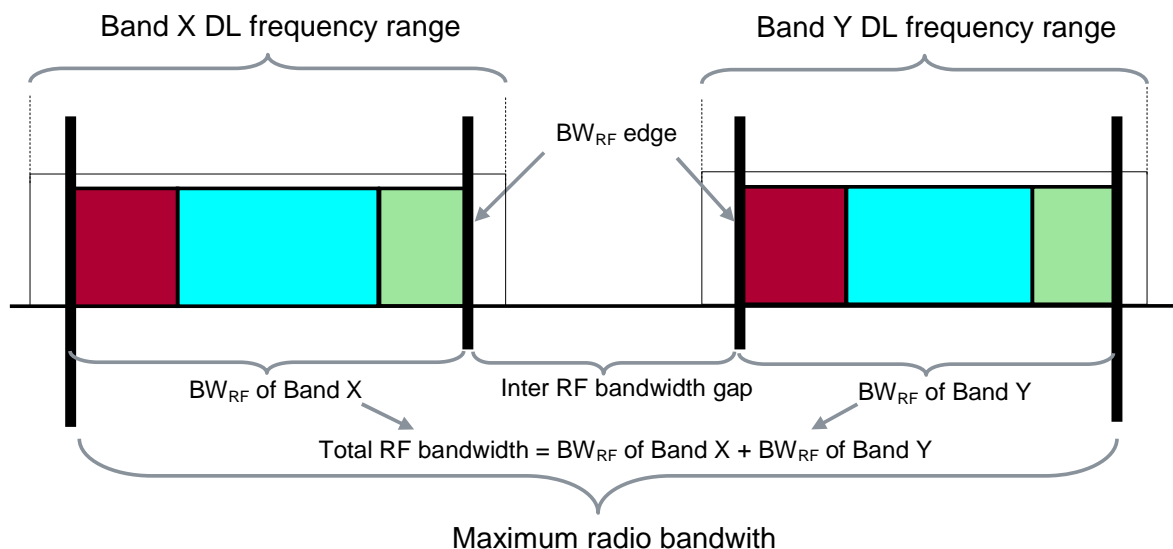

Figure 3.2-1 Illustration of maximum radio bandwidth and Total RF bandwidth for Multi-band Base Station

3.3 Abbreviations

For the purposes of the present document, the following abbreviations apply:

4C-HSDPA	Four-Carrier HSDPA. HSDPA operation configured on 3 or 4 DL carriers
8C-HSDPA	Eight-Carrier HSDPA. HSDPA operation configured for 5 to 8 DL carriers
16QAM	16 Quadrature Amplitude Modulation
ACLR	Adjacent Channel Leakage power Ratio
ACS	Adjacent Channel Selectivity
BER	Bit Error Ratio
BLER	Block Error Ratio
BS	Base Station
CACLR	Cumulative ACLR
CW	Continuous Wave (unmodulated signal)
DB-DC-HSDPA	Dual Band Dual Cell HSDPA
DC-HSDPA	Dual Cell HSDPA
DC-HSUPA	Dual Cell HSUPA
DCH	Dedicated Channel, which is mapped into Dedicated Physical Channel. DCH contains the data
DL	Down Link (forward link)
DPCH	Dedicated Physical Channel
DTT	Digital Terrestrial Television
E_b	Average energy per information bit for the PCCPCH, SCCPCH and DPCH, at the antenna connector
E_c	Average energy per PN chip
EVM	Error Vector Magnitude
FDD	Frequency Division Duplexing
F_{uw}	Frequency of unwanted signal
HSDPA	High Speed Downlink Packet Access
HSUPA	High Speed Uplink Packet Access
HS-DSCH	High Speed Downlink Shared Channel
HS-PDSCH	High Speed Physical Downlink Shared Channel
HS-SCCH	Shared Control Channel for HS-DSCH
MC	Multi-Carrier
MIMO	Multiple Input Multiple Output
MS	Mobile Station
NC	Non-Contiguous
NC-4C-HSDPA	Non-contiguous Four-Carrier HSDPA. HSDPA operation for two non-adjacent blocks within a single band configured on 2, 3 or 4 DL carriers.
PCCPCH	Primary Common Control Physical Channel
PCDE	Peak Code Domain Error
PCH	Paging Channel
PPM	Parts Per Million
PSD	Power Spectral Density
RAT	Radio Access Technology
QPSK	Quadrature Phase Shift Keying
RCDE	Relative Code Domain Error
SC	Single Carrier
SCCPCH	Secondary Common Control Physical Channel
TC	Test Configuration
TAE	Time Alignment Error
TDD	Time Division Duplexing
TPC	Transmit Power Control
UE	User Equipment
UL	Up Link (reverse link)
UTC	UTRA Test Configuration
UTRA	UMTS Terrestrial Radio Access

3.4 Radio Frequency bands

3.4.1 Frequency bands

- a) UTRA/FDD is designed to operate in the following paired bands:

Table 3.0: Frequency bands

Operating Band	UL Frequencies UE transmit, Node B receive	DL frequencies UE receive, Node B transmit
I	1 920 - 1 980 MHz	2 110 - 2 170 MHz
II	1 850 - 1 910 MHz	1 930 - 1 990 MHz
III	1 710 - 1 785 MHz	1 805 - 1 880 MHz
IV	1 710 - 1 755 MHz	2 110 - 2 155 MHz
V	824 - 849MHz	869 - 894MHz
VI	830 - 840 MHz	875 - 885 MHz
VII	2 500 - 2 570 MHz	2 620 - 2 690 MHz
VIII	880 - 915 MHz	925 - 960 MHz
IX	1 749,9 - 1 784,9 MHz	1 844,9 - 1 879,9 MHz
X	1 710 - 1 770 MHz	2 110 - 2 170 MHz
XI	1427.9 - 1447.9 MHz	1475.9 - 1495.9 MHz
XII	699 - 716 MHz	729 - 746 MHz
XIII	777 - 787 MHz	746 - 756 MHz
XIV	788 - 798 MHz	758 - 768 MHz
XV	Reserved	Reserved
XVI	Reserved	Reserved
XVII	Reserved	Reserved
XVIII	Reserved	Reserved
XIX	830 – 845 MHz	875 – 890 MHz
XX	832 – 862 MHz	791 – 821 MHz
XXI	1447.9 - 1462.9 MHz	1495.9 - 1510.9 MHz
XXII	3410 – 3490 MHz	3510 – 3590 MHz
XXV	1850 -1915 MHz	1930 -1995 MHz
XXVI	814-849MHz	859-894MHz

- b) Deployment in other frequency bands is not precluded
c) DB-DC-HSDPA is designed to operate in the following configurations:

Table 3.0aA: DB-DC-HSDPA configurations

DB-DC-HSDPA Configuration	UL Band	DL Bands
1	I or VIII	I and VIII
2	II or IV	II and IV
3	I or V	I and V
4	I or XI	I and XI
5	II or V	II and V

- d) Single band 4C-HSDPA is designed to operate in the following configurations:

Table 3.0aB Single band 4C-HSDPA configurations

Single band 4C-HSDPA Configuration	Operating Band	Number of DL carriers
I-3	I	3
II-3	II	3
II-4	II	4
NOTE:	Single band 4C-HSDPA configuration is numbered as (X-M) where X denotes the operating band and M denotes the number of DL carriers.	

e) Dual band 4C-HSDPA is designed to operate in the following configurations:

Table 3.0aC Dual band 4C-HSDPA configurations

Dual band 4C-HSDPA Configuration	UL Band	DL Band A	Number of DL carriers in Band A	DL Band B	Number of DL carriers in Band B
I-2-VIII-1	I or VIII	I	2	VIII	1
I-3-VIII-1	I or VIII	I	3	VIII	1
II-1-IV-2	II or IV	II	1	IV	2
II-2-IV-1	II or IV	II	2	IV	1
II-2-IV-2	II or IV	II	2	IV	2
I-1-V-2	I or V	I	1	V	2
I-2-V-1	I or V	I	2	V	1
I-2-V-2	I or V	I	2	V	2
I-2-VIII-2	I or VIII	I	2	VIII	2
I-1-VIII-2	I or VIII	I	1	VIII	2
II-1-V-2	II or V	II	1	V	2

NOTE: Dual band 4C-HSDPA configuration is numbered as (X-M-Y-N) where X denotes the DL Band A, M denotes the number DL carriers in the DL Band A, Y denotes the DL Band B, and N denotes the number of DL carriers in the DL Band B

f) Single Band 8C-HSDPA is designed to operate in the following configurations:

Table 3.0aD Single Band 8C-HSDPA configurations

Single Band 8C-HSDPA Configuration	Operating Band	Number of DL carriers
I-8	I	8

NOTE: Single band 8C-HSDPA configuration is numbered as (X-M) where X denotes the operating band and M denotes the number of DL carriers.

g) Single band NC-4C-HSDPA is designed to operate in the following configurations:

Table 3.0aE Single band NC-4C-HSDPA configurations

Single band NC-4C-HSDPA Configuration	Operating Band	Number of DL carriers in one sub-block	Sub-block gap [MHz]	Number of DL carriers in the other sub-block
I-1-5-1	I	1	5	1
I-2-5-1	I	2	5	1
I-3-10-1	I	3	10	1
IV-1-5-1	IV	1	5	1
IV-2-10-1	IV	2	10	1
IV-2-15-2	IV	2	15	2
IV-2-20-1	IV	2	20	1
IV-2-25-2	IV	2	25	2

NOTE: Single band NC-4C-HSDPA configuration is numbered as (X-M-Y-N) where X denotes the operating band, M denotes the number of DL carriers in one sub-block, Y denotes the sub-block gap in MHz and N denotes the number of DL carriers in the other sub-block. M and N can be switched.

3.4.2 TX-RX frequency separation

a) UTRA/FDD is designed to operate with the following TX-RX frequency separation

Table 3.0A: TX-RX frequency separation

Operating Band	TX-RX frequency separation
I	190 MHz
II	80 MHz
III	95 MHz
IV	400 MHz
V	45 MHz
VI	45 MHz
VII	120 MHz
VIII	45 MHz
IX	95 MHz
X	400 MHz
XI	48 MHz
XII	30 MHz
XIII	31 MHz
XIV	30 MHz
XIX	45 MHz
XX	41 MHz
XXI	48 MHz
XXI	100 MHz
XXV	80 MHz
XXVI	45MHz

- b) UTRA/FDD can support both fixed and variable transmit to receive frequency separation.
- c) The use of other transmit to receive frequency separations in existing or other frequency bands shall not be precluded.
- d) When configured to operate in DC-HSDPA with a single UL frequency, the TX-RX frequency separation in Table 3.0A shall be applied for the serving HS-DSCH cell. For bands XII, XIII and XIV, the TX-RX frequency separation in Table 3.0A shall be the minimum spacing between the UL and either of the DL carriers.
- e) When configured to operate on dual cells in both the DL and UL, the TX-RX frequency separation in Table 3.0A shall be applied to the primary UL frequency and DL frequency of the serving HS-DSCH cell, and to the secondary UL frequency and the frequency of the secondary serving HS-DSCH cell respectively.
- f) When configured to operate on single/dual band 4C-HSDPA or single band 8C-HSDPA or single band NC-4C-HSDPA with a single UL frequency, the TX-RX frequency separation in Table 3.0A shall be applied for the DL frequency of the serving HS-DSCH cell. When configured to operate on single/dual band 4C-HSDPA or single band 8C-HSDPA or single band NC-4C-HSDPA with dual UL frequencies, the TX-RX frequency separation in Table 3.0A shall be applied to the primary UL frequency and DL frequency of the serving HS-DSCH cell, and to the secondary UL frequency and the frequency of the 1st secondary serving HS-DSCH cell respectively.
- g) For bands XII, XIII and XIV, the requirements in TS 25.104 are applicable only for a single uplink carrier frequency, however dual cell uplink operation may be considered in future releases.

3.5 Channel arrangement

3.5.1 Channel spacing

The nominal channel spacing is 5 MHz, but this can be adjusted to optimise performance in a particular deployment scenario.

3.5.2 Channel raster

The channel raster is 200 kHz for all bands, which means that the centre frequency must be an integer multiple of 200 kHz. In addition a number of additional centre frequencies are specified according to table 3.2, which means that the centre frequencies for these channels are shifted 100 kHz relative to the general raster.

3.5.3 Channel number

The carrier frequency is designated by the UTRA Absolute Radio Frequency Channel Number (UARFCN). For each operating Band, the UARFCN values are defined as follows.

Uplink: $N_U = 5 * (F_{UL} - F_{UL_Offset})$, for the carrier frequency range $F_{UL_low} \leq F_{UL} \leq F_{UL_high}$

Downlink: $N_D = 5 * (F_{DL} - F_{DL_Offset})$, for the carrier frequency range $F_{DL_low} \leq F_{DL} \leq F_{DL_high}$

For each operating Band, F_{UL_Offset} , F_{UL_low} , F_{UL_high} , F_{DL_Offset} , F_{DL_low} and F_{DL_high} are defined in Table 3.1 for the general UARFCN. For the additional UARFCN, F_{UL_Offset} , F_{DL_Offset} and the specific F_{UL} and F_{DL} are defined in Table 3.2.

Table 3.1: UARFCN definition (general)

Band	UPLINK (UL) UE transmit, Node B receive			DOWNLINK (DL) UE receive, Node B transmit		
	UARFCN formula offset F_{UL_Offset} [MHz]	Carrier frequency (F_{UL}) range [MHz]		UARFCN formula offset F_{DL_Offset} [MHz]	Carrier frequency (F_{DL}) range [MHz]	
		F_{UL_low}	F_{UL_high}		F_{DL_low}	F_{DL_high}
I	0	1 922,4	1 977,6	0	2 112,4	2 167,6
II	0	1 852,4	1 907,6	0	1 932,4	1 987,6
III	1 525	1 712,4	1 782,6	1 575	1 807,4	1 877,6
IV	1 450	1 712,4	1 752,6	1 805	2 112,4	2 152,6
V	0	826,4	846,6	0	871,4	891,6
VI	0	832,4	837,6	0	877,4	882,6
VII	2 100	2 502,4	2 567,6	2 175	2 622,4	2 687,6
VIII	340	882,4	912,6	340	927,4	957,6
IX	0	1 752,4	1 782,4	0	1 847,4	1 877,4
X	1 135	1 712,4	1 767,6	1 490	2 112,4	2 167,6
XI	733	1430,4	1445,4	736	1478,4	1493,4
XII	-22	701,4	713,6	-37	731,4	743,6
XIII	21	779,4	784,6	-55	748,4	753,6
XIV	12	790,4	795,6	-63	760,4	765,6
XIX	770	832,4	842,6	735	877,4	887,6
XX	-23	834,4	859,6	-109	793,4	818,6
XXI	1358	1450,4	1460,4	1326	1498,4	1508,4
XXII	2525	3412,4	3487,6	2580	3512,4	3587,6
XXV	875	1852,4	1912,6	910	1932,4	1992,6
XXVI	-291	816,4	846,6	-291	861,4	891,6

Table 3.2: UARFCN definition (additional channels)

Band	UPLINK (UL) UE transmit, Node B receive		DOWNLINK (DL) UE receive, Node B transmit	
	UARFCN formula offset F_{UL_Offset} [MHz]	Carrier frequency [MHz] (F_{UL})	UARFCN formula offset F_{DL_Offset} [MHz]	Carrier frequency [MHz] (F_{DL})
I	-	-	-	-
II	1 850,1	1 852,5, 1 857,5, 1 862,5, 1 867,5, 1 872,5, 1 877,5, 1 882,5, 1 887,5, 1 892,5, 1 897,5, 1 902,5, 1 907,5	1 850,1	1 932,5, 1 937,5, 1 942,5, 1 947,5, 1 952,5, 1 957,5, 1 962,5, 1 967,5, 1 972,5, 1 977,5, 1 982,5, 1 987,5
III	-	-	-	-
IV	1 380,1	1 712,5, 1 717,5, 1 722,5, 1 727,5, 1 732,5, 1 737,5 1 742,5, 1 747,5, 1 752,5	1 735,1	2 112,5, 2 117,5, 2 122,5, 2 127,5, 2 132,5, 2 137,5, 2 142,5, 2 147,5, 2 152,5
V	670,1	826,5, 827,5, 831,5, 832,5, 837,5, 842,5	670,1	871,5, 872,5, 876,5, 877,5, 882,5, 887,5
VI	670,1	832,5, 837,5	670,1	877,5, 882,5
VII	2 030,1	2 502,5, 2 507,5, 2 512,5, 2 517,5, 2 522,5, 2 527,5, 2 532,5, 2 537,5, 2 542,5, 2 547,5, 2 552,5, 2 557,5, 2 562,5, 2 567,5	2 105,1	2 622,5, 2 627,5, 2 632,5, 2 637,5, 2 642,5, 2 647,5, 2 652,5, 2 657,5, 2 662,5, 2 667,5, 2 672,5, 2 677,5, 2 682,5, 2 687,5
VIII	-	-	-	-
IX	-	-	-	-
X	1 075,1	1 712,5, 1 717,5, 1 722,5, 1 727,5, 1 732,5, 1 737,5, 1 742,5, 1 747,5, 1 752,5, 1 757,5, 1 762,5, 1 767,5	1 430,1	2 112,5, 2 117,5, 2 122,5, 2 127,5, 2 132,5, 2 137,5, 2 142,5, 2 147,5, 2 152,5, 2 157,5, 2 162,5, 2 167,5
XI	-	-	-	-
XII	-39.9	701.5, 706.5, 707.5, 712.5, 713.5	-54.9	731.5, 736.5, 737.5, 742.5, 743.5
XIII	11.1	779.5, 784.5	-64.9	748.5, 753.5
XIV	2.1	790.5, 795.5	-72.9	760.5, 765.5
XIX	755,1	832,5, 837,5, 842,5	720,1	877,5, 882,5, 887,5
XX	-	-	-	-
XXI	-	-	-	-
XXII	-	-	-	-
XXV	810.1	1852.5, 1857.5, 1862.5, 1867.5, 1872.5, 1877.5, 1882.5, 1887.5, 1892.5, 1897.5, 1902.5, 1907.5, 1912.5	845.1	1932.5, 1937.5, 1942.5, 1947.5, 1952.5, 1957.5, 1962.5, 1967.5, 1972.5, 1977.5, 1982.5, 1987.5, 1992.5
XXVI	-325.9	816.5, 821.5, 826.5, 827.5, 831.5, 832.5, 836.5, 837.5, 841.5, 842.5, 846.5	-325.9	861.5, 866.5, 871.5, 872.5, 876.5, 877.5, 881.5, 882.5, 886.5, 887.5, 891.5

4 General test conditions and declarations

Many of the tests in this specification measure a parameter relative to a value that is not fully specified in the UTRA specifications. For these tests, the Minimum Requirement is determined relative to a nominal value specified by the manufacturer.

Certain functions of a BS are optional in the UTRA specifications. Some requirements for the BS may be regional as listed in clause 4.7.

When specified in a test, the manufacturer shall declare the nominal value of a parameter, or whether an option is supported. The manufacturer declarations are listed in clauses 4.8 and 4.11.

4.1 Acceptable uncertainty of Test System

The maximum acceptable uncertainty of the Test System is specified below for each test, where appropriate. The Test System shall enable the stimulus signals in the test case to be adjusted to within the specified tolerance and the equipment under test to be measured with an uncertainty not exceeding the specified values. All tolerances and uncertainties are absolute values, and are valid for a confidence level of 95 %, unless otherwise stated.

A confidence level of 95% is the measurement uncertainty tolerance interval for a specific measurement that contains 95% of the performance of a population of test equipment.

For RF tests, it should be noted that the uncertainties in clause 4.1 apply to the Test System operating into a nominal 50 ohm load and do not include system effects due to mismatch between the DUT and the Test System.

4.1.1 Measurement of test environments

The measurement accuracy of the BS test environments defined in Clause 4.4, Test environments shall be.

Pressure:	± 5 kPa.
Temperature:	± 2 degrees.
Relative Humidity:	± 5 %.
DC Voltage:	$\pm 1,0$ %.
AC Voltage:	$\pm 1,5$ %.
Vibration:	10 %.
Vibration frequency:	0,1 Hz.

The above values shall apply unless the test environment is otherwise controlled and the specification for the control of the test environment specifies the uncertainty for the parameter.

4.1.2 Measurement of transmitter

Table 4.1: Maximum Test System Uncertainty for transmitter tests

Clause	Maximum Test System Uncertainty	Derivation of Test System Uncertainty
6.2.1 Maximum Output Power	± 0.7 dB, $f \leq 3.0$ GHz ± 1.0 dB, 3.0 GHz $< f \leq 4.2$ GHz	
6.2.2 Primary CPICH Power accuracy	± 0.8 dB, $f \leq 3,0$ GHz $\pm 1,1$ dB, $3,0$ GHz $< f \leq 4,2$ GHz	
6.2.3 Secondary CPICH power offset accuracy	± 0.7 dB, $f \leq 3,0$ GHz $\pm 1,0$ dB, $3,0$ GHz $< f \leq 4,2$ GHz	
6.3 Frequency error	± 12 Hz	
6.4.2 Power control steps	$\pm 0,1$ dB for one 2 dB step $\pm 0,1$ dB for one 1,5 dB step $\pm 0,1$ dB for one 1 dB step $\pm 0,1$ dB for one 0,5 dB step $\pm 0,1$ dB for ten 2 dB steps $\pm 0,1$ dB for ten 1,5 dB steps $\pm 0,1$ dB for ten 1 dB steps $\pm 0,1$ dB for ten 0,5 dB steps	Result is difference between two absolute CDP measurements on the power controlled DPCH. Assume BTS output power on all other channels is constant. Assume Test equipment relative power accuracy over the range of the test conditions is perfect, or otherwise included in the system measurement error. For this test the absolute power change is < 3 dB.
6.4.3 Power control dynamic range	$\pm 1,1$ dB	
6.4.4 Total power dynamic range	$\pm 0,3$ dB	
6.4.5 IPDL Time mask	0,7 dB	
6.5.1 Occupied Bandwidth	± 100 kHz	Accuracy = $\pm 3 \cdot \text{RBW}$. Assume 30 kHz bandwidth
6.5.2.1 Spectrum emission mask	$\pm 1,5$ dB, $f \leq 3.0$ GHz ± 1.8 dB, 3.0 GHz $< f \leq 4.2$ GHz Due to carrier leakage, for measurements specified in a 1 MHz bandwidth close to the carrier (4 MHz to 8 MHz), integration of the measurement using several narrower measurements may be necessary in order to achieve the above accuracy.	
6.5.2.2 ACLR	5 MHz offset $\pm 0,8$ dB 10 MHz offset $\pm 0,8$ dB CAACLR: $\pm 0,8$ dB Absolute limit for Home BS $\pm 1,5$ dB, $f \leq 3.0$ GHz Absolute limit for Home BS $\pm 1,8$ dB, 3.0 GHz $< f \leq 4.2$ GHz Note: Impact of measurement period (averaging) and intermod effects in the measurement receiver not yet fully studied. However, the above limits remain valid.	
6.5.3 Spurious emissions	$\pm 2,0$ dB for BS and coexistence bands for results > -60 dBm, $f \leq 3.0$ GHz ± 2.5 dB, 3.0 GHz $< f \leq 4.2$ GHz ± 3.0 dB for results < -60 dBm, $f \leq 3.0$ GHz ± 3.5 dB, 3.0 GHz $< f \leq 4.2$ GHz Outside above range: $f \leq 2,2$ GHz : $\pm 1,5$ dB $2,2$ GHz $< f \leq 4$ GHz : $\pm 2,0$ dB 4 GHz $< f < 19$ GHz : $\pm 4,0$ dB	

6.6 Transmit intermodulation (interferer requirements)	The value below applies only to the interference signal and is unrelated to the measurement uncertainty of the tests (6.5.2.1, 6.5.2.2 and 6.5.3) which have to be carried out in the presence of the interferer. . $\pm 1,0$ dB	The uncertainty of interferer has double the effect on the result due to the frequency offset.
6.7.1 EVM	$\pm 2,5$ % (for single code)	
6.7.2 Peak code Domain error	$\pm 1,0$ dB	
6.7.3 Time alignment error in TX diversity, MIMO, DC-HSDPA and DB-DC-HSDPA	$\pm 0,1 T_c$	
6.7.4 Relative Code Domain Error	$\pm 1,0$ dB	
Annex H.3 Transmitted code power. Absolute	$\pm 0,9$ dB, $f \leq 3.0$ GHz $\pm 1,2$ dB, 3.0 GHz $< f \leq 4.2$ GHz	Absolute power accuracy = ($0,7$ dB, $f \leq 3.0$ GHz or $1,0$ dB, 3.0 GHz $< f \leq 4.2$ GHz) + relative power accuracy $0,2$ dB.
Annex H.3 Transmitted code power. Relative	$\pm 0,2$ dB	
Annex H.4 Transmitted carrier power	$\pm 0,3$ dB	

4.1.3 Measurement of receiver

Table 4.1A: Maximum Test System Uncertainty for receiver tests

Clause	Maximum Test System Uncertainty ¹	Derivation of Test System Uncertainty
7.2 Reference sensitivity level	± 0,7 dB, $f \leq 3.0$ GHz ± 1.0 dB, $3.0 \text{ GHz} < f \leq 4.2$ GHz	
7.3 Dynamic range	± 1,2 dB,	Formula = SQRT(signal level error ² and AWGN level error ²)
7.4 Adjacent channel selectivity	± 1.1 dB, $f \leq 3.0$ GHz ± 1.5 dB, $3.0 \text{ GHz} < f \leq 4.2$ GHz	Formula = SQRT (wanted_level_error ² + interferer_level_error ²) + ACLR effect. The ACLR effect is calculated by: (Formula to follow)
7.5 Blocking characteristics	System error with blocking signal <15 MHz offset: ± 1,4 dB Blocking signal ≥ 15 MHz offset and $f \leq 2,2$ GHz: ± 1,1 dB + broadband noise $2,2 \text{ GHz} < f \leq 4 \text{ GHz}$: ± 1,8 dB $f > 4 \text{ GHz}$: ± 3,2 dB	Formula = SQRT (wanted_level_error ² + interferer_level_error ²) + ACLR effect + Broadband noise. (Assuming ACLR 68 dB, and 0.7 dB for signals) Assume -130 dBc broadband noise from blocking signal has 0.1 dB effect. Harmonics and spurs of the interferer need to be carefully considered. Perhaps need to avoid harmonics of the interfere that fall on top of the receive channel. For the -15 dBm CW blocking case, filtering of the blocking signal (at least 25 dB) is necessary to eliminate problems with broadband noise.
7.6 Intermod Characteristics	± 1,3 dB, $f \leq 3.0$ GHz ± 2,3 dB, $3.0 \text{ GHz} < f \leq 4.2$ GHz	Formula = $\sqrt{(2 \cdot CW_level_error)^2 + (mod_level_error)^2} + (wanted_signal_level_error)^2$ (Using CW interferer ± 0,5 dB, modulated interferer ± 0,5 dB, wanted signal ± 0,7 dB for $f \leq 3.0$ GHz. Using CW interferer ± 0,7 dB, modulated interferer ± 0,7 dB, wanted signal ± 1.0 dB for $3.0 \text{ GHz} < f \leq 4.2$ GHz)
7.7 Spurious Emissions	The Test System uncertainty figures for Spurious emissions apply to the measurement of the DUT and not any stimulus signals. ± 3,0 dB for BS receive band (-78 dBm) , $f \leq 3.0$ GHz ± 3.5 dB, $3.0 \text{ GHz} < f \leq 4.2$ GHz Outside above range: $f \leq 2,2 \text{ GHz}$: ± 2,0 dB (-57 dBm) $2,2 \text{ GHz} < f \leq 4 \text{ GHz}$: ± 2,0 dB (-47 dBm) $4 \text{ GHz} < f < 19 \text{ GHz}$: ± 4,0 dB (-47 dBm)	
Note 1: Unless otherwise noted, only the Test System stimulus error is considered here. The effect of errors in the BER/FER measurements due to finite test duration is not considered.		

4.1.4 Measurement of performance requirement

Table 4.1B: Maximum Test System Uncertainty for Performance Requirements

Clause	Maximum Test System Uncertainty ¹	Derivation of Test System Uncertainty
8.2, Demodulation in static propagation condition	$\pm 0,4$ dB	Wanted/AWGN: $\pm 0,4$ dB (relative uncertainty for E_b/N_0) (AWGN: ± 1 dB)
8.3, Demodulation of DCH in multipath fading conditions	$\pm 0,6$ dB	Fader: $\pm 0,5$ dB Wanted/AWGN: $\pm 0,4$ dB (relative) Combined relative uncertainty for E_b/N_0 : $\pm 0,6$ dB
8.4 Demodulation of DCH in moving propagation conditions	$\pm 0,6$ dB	Fader: $\pm 0,5$ dB Wanted/AWGN: $\pm 0,4$ dB (relative) Combined relative uncertainty for E_b/N_0 : $\pm 0,6$ dB
8.5 Demodulation of DCH in birth/death propagation conditions	$\pm 0,6$ dB	Fader: $\pm 0,5$ dB Wanted/AWGN: $\pm 0,4$ dB (relative) Combined relative uncertainty for E_b/N_0 : $\pm 0,6$ dB
8.5A Demodulation of DCH in high speed train conditions	$\pm 0,6$ dB	Fader: $\pm 0,5$ dB Wanted/AWGN: $\pm 0,4$ dB (relative) Combined relative uncertainty for E_b/N_0 : $\pm 0,6$ dB
8.8.1 RACH preamble detection in static propagation conditions	$\pm 0,4$ dB	Wanted/AWGN: $\pm 0,4$ dB (relative uncertainty for E_c/N_0) (AWGN: ± 1 dB)
8.8.2 RACH preamble detection in multipath fading case 3	$\pm 0,6$ dB	Fader: $\pm 0,5$ dB Wanted/AWGN: $\pm 0,4$ dB (relative) Combined relative uncertainty for E_c/N_0 : $\pm 0,6$ dB
8.8.2A RACH preamble detection in high speed train conditions	$\pm 0,6$ dB	Fader: $\pm 0,5$ dB Wanted/AWGN: $\pm 0,4$ dB (relative) Combined relative uncertainty for E_c/N_0 : $\pm 0,6$ dB
8.8.3 Demodulation of RACH message in static propagation conditions	$\pm 0,4$ dB	Wanted/AWGN: $\pm 0,4$ dB (relative uncertainty for E_b/N_0) (AWGN: ± 1 dB)
8.8.4 Demodulation of RACH message in multipath fading case 3	$\pm 0,6$ dB	Fader: $\pm 0,5$ dB Wanted/AWGN: $\pm 0,4$ dB (relative) Combined relative uncertainty for E_b/N_0 : $\pm 0,6$ dB
8.8.5 Demodulation of RACH message in high speed train conditions	$\pm 0,6$ dB	Fader: $\pm 0,5$ dB Wanted/AWGN: $\pm 0,4$ dB (relative) Combined relative uncertainty for E_b/N_0 : $\pm 0,6$ dB
8.11.1 ACK false alarm in static propagation conditions	$\pm 0,4$ dB	Wanted/AWGN: $\pm 0,4$ dB (relative uncertainty for E_c/N_0) (AWGN: ± 1 dB)
8.11.2 ACK false alarm in multipath fading conditions	$\pm 0,6$ dB	Fader: $\pm 0,5$ dB Wanted/AWGN: $\pm 0,4$ dB (relative) Combined relative uncertainty for E_c/N_0 : $\pm 0,6$ dB
8.11.3 ACK mis-detection in static propagation conditions	$\pm 0,4$ dB	Wanted/AWGN: $\pm 0,4$ dB (relative uncertainty for E_c/N_0) (AWGN: ± 1 dB)
8.11.4 ACK mis-detection in multipath fading conditions	$\pm 0,6$ dB	Fader: $\pm 0,5$ dB Wanted/AWGN: $\pm 0,4$ dB (relative) Combined relative uncertainty for E_c/N_0 : $\pm 0,6$ dB
8.11A.1 4C-HSDPA: ACK false alarm in static propagation conditions	$\pm 0,4$ dB	Wanted/AWGN: $\pm 0,4$ dB (relative uncertainty for E_c/N_0) (AWGN: ± 1 dB)

8.11A.2 4C-HSDPA: ACK false alarm in multipath fading conditions	$\pm 0,6$ dB	Fader: $\pm 0,5$ dB Wanted/AWGN: $\pm 0,4$ dB (relative) Combined relative uncertainty for E_c/N_0 : $\pm 0,6$ dB
8.11A.3 4C-HSDPA: ACK mis-detection in static propagation conditions	$\pm 0,4$ dB	Wanted/AWGN: $\pm 0,4$ dB (relative uncertainty for E_c/N_0) (AWGN: ± 1 dB)
8.11A.4 4C-HSDPA: ACK mis-detection in multipath fading conditions	$\pm 0,6$ dB	Fader: $\pm 0,5$ dB Wanted/AWGN: $\pm 0,4$ dB (relative) Combined relative uncertainty for E_c/N_0 : $\pm 0,6$ dB
8.12 Demodulation of E-DPDCH in multipath fading conditions	$\pm 0,6$ dB	Fader: $\pm 0,5$ dB Wanted/AWGN: $\pm 0,4$ dB (relative) Combined relative uncertainty for E_c/N_0 : $\pm 0,6$ dB
8.13 Performance of signalling detection for E-DPCCH in multipath fading conditions	$\pm 0,6$ dB	Fader: $\pm 0,5$ dB Wanted/AWGN: $\pm 0,4$ dB (relative) Combined relative uncertainty for E_c/N_0 : $\pm 0,6$ dB
Note 1: Only the overall stimulus error is considered here. The effect of errors in the BER/FER measurements due to finite test duration is not considered.		

4.2 Test Tolerances (informative)

The Test Tolerances defined in this clause have been used to relax the Minimum Requirements in this specification to derive the Test Requirements.

The Test Tolerances are derived from Test System uncertainties, regulatory requirements and criticality to system performance. As a result, the Test Tolerances may sometimes be set to zero.

The test tolerances should not be modified for any reason e.g. to take account of commonly known test system errors (such as mismatch, cable loss, etc.)

4.2.1 Transmitter

Table 4.1C: Test Tolerances for transmitter tests

Clause	Test Tolerance ¹	
	f ≤ 3.0 GHz	f > 3.0 GHz
6.2.1 Maximum Output Power	0,7 dB	1.0 dB
6.2.2 Primary CPICH Power accuracy	0,8 dB	1,1 dB
6.2.3 Secondary CPICH power offset accuracy	0,7 dB	1,0 dB
6.3 Frequency error	12 Hz	12 Hz
6.4.2 Power control steps	0,1 dB	0,1 dB
6.4.3 Power control dynamic range	1.1 dB	1.1 dB
6.4.4 Total power dynamic range	0,3 dB	0,3 dB
6.4.5 IPDL time mask	0,7 dB	0,7 dB
6.5.1 Occupied Bandwidth	0 kHz	0 kHz
6.5.2.1 Spectrum emission mask	1.5 dB ³	1.8 dB
6.5.2.2 ACLR, CACLR	0,8 dB ⁴	0,8 dB ⁴
6.5.3 Spurious emissions	0 dB	0 dB
6.6 Transmit intermodulation (interferer requirements)	0 dB ²	0 dB ²
6.7.1 EVM	0 %	0 %
6.7.2 Peak code Domain error	1.0 dB	1.0 dB
6.7.3 Time alignment error in TX diversity, MIMO, DC-HSDPA and DB-DC-HSDPA	0,1 T _c	0,1 T _c
6.7.4 Relative Code Domain Error	1.0 dB	1.0 dB
Annex H.3 Transmitted code power (absolute)	0,9 dB	1,2 dB
Annex H.3 Transmitted code power (relative)	0,2 dB	0,2 dB
Annex H.4 Transmitted carrier power	0,3 dB	0,3 dB
Note 1: Unless otherwise stated, The Test Tolerances are applied to the DUT Minimum Requirement. See Annex F.		
Note 2: The Test Tolerance is applied to the stimulus signal(s). See Annex F.		
Note 3: 0 dB test tolerance for the additional Band II, IV, V, X, XII, XIII and XIV requirements.		
Note 4: 1.5 dB for absolute ACLR limit for Home BS for f ≤ 3.0 GHz and 1.8 dB for 3.0 GHz < f ≤ 4.2 GHz.		

4.2.2 Receiver

Table 4.1D: Test Tolerances for receiver tests

Clause	Test Tolerance ¹	
	f ≤ 3.0 GHz	f > 3.0 GHz
7.2 Reference sensitivity level	0,7 dB	1,0 dB
7.3 Dynamic range	1,2 dB	1,2 dB
7.4 Adjacent channel selectivity	0 dB	0 dB
7.5 Blocking characteristics	0 dB	0 dB
7.6 Intermod Characteristics	0 dB	0 dB
7.7 Spurious Emissions	0 dB ²	0 dB ²
Note 1: Unless otherwise stated, the Test Tolerances are applied to the stimulus signal(s). See Annex F.		
Note 2: The Test Tolerance is applied to the DUT Minimum Requirement. See Annex F.		

4.2.3 Performance requirement

Table 4.1E: Test Tolerances for Performance Requirements

Clause	Test Tolerance ¹
8.2, Demodulation in static propagation condition	0,4 dB
8.3, Demodulation of DCH in multipath fading conditions	0,6 dB
8.4 Demodulation of DCH in moving propagation conditions	0,6 dB
8.5 Demodulation of DCH in birth/death propagation conditions	0,6 dB
8.5A Demodulation of DCH in high speed train conditions	0,6 dB
8.8.1 RACH preamble detection in static propagation conditions	0,4 dB
8.8.2 RACH preamble detection in multipath fading case 3	0,6 dB
8.8.2A RACH preamble detection in high speed train conditions	0,6 dB
8.8.3 Demodulation of RACH message in static propagation conditions	0,4 dB
8.8.4 Demodulation of RACH message in multipath fading case 3	0,6 dB
8.8.5 Demodulation of RACH message in high speed train conditions	0,6 dB
8.11.1 ACK false alarm in static propagation conditions	0,4 dB
8.11.2 ACK false alarm in multipath fading conditions	0,6 dB
8.11.3 ACK mis-detection in static propagation conditions	0,4 dB
8.11.4 ACK mis-detection in multipath fading conditions	0,6 dB
8.11A.1 4C-HSDPA: ACK false alarm in static propagation conditions	0,4 dB
8.11A.2 4C-HSDPA: ACK false alarm in multipath fading conditions	0,6 dB
8.11A.3 4C-HSDPA: ACK mis-detection in static propagation conditions	0,4 dB
8.11A.4 4C-HSDPA: ACK mis-detection in multipath fading conditions	0,6 dB
8.12 Demodulation of E-DPDCH in multipath fading conditions	0,6 dB
8.12A Demodulation of E-DPDCH and S-E-DPDCH in multipath fading conditions for UL MIMO	0,6 dB
8.13 Performance of signalling detection for E-DPCCH in multipath fading conditions	0,6 dB
NOTE 1: Unless otherwise stated, the Test Tolerances are applied to the stimulus signal(s). See Annex F.	

4.2.4 RRM measurements

The following tolerances refer to the requirements of 25.133.

tbd

4.3 Interpretation of measurement results

The measurement results returned by the Test System are compared - without any modification - against the Test Requirements as defined by the shared risk principle.

The Shared Risk principle is defined in ITU-R M.1545 [17].

The actual measurement uncertainty of the Test System for the measurement of each parameter shall be included in the test report.

The recorded value for the Test System uncertainty shall be, for each measurement, equal to or lower than the appropriate figure in clause 4.1 of this specification.

If the Test System for a test is known to have a measurement uncertainty greater than that specified in clause 4.1, it is still permitted to use this apparatus provided that an adjustment is made as follows.

Any additional uncertainty in the Test System over and above that specified in clause 4.1 shall be used to tighten the Test Requirement-making the test harder to pass. (For some tests e.g. receiver tests, this may require modification of stimulus signals). This procedure (defined in Annex F) will ensure that a Test System not compliant with clause 4.1 does

not increase the chance of passing a device under test where that device would otherwise have failed the test if a Test System compliant with clause 4.1 had been used.

4.3A Base station classes

The requirements in the present document apply to Wide Area Base Stations, Medium Range Base Stations, Local Area Base Stations and Home Base Stations unless otherwise stated.

Wide Area Base Stations are characterised by requirements derived from Macro Cell scenarios with a BS to UE minimum coupling loss equals to 70 dB. The Wide Area Base Station class has the same requirements as the base station for General Purpose application in Release 99, 4 and 5.

Medium Range Base Stations are characterised by requirements derived from Micro Cell scenarios with a BS to UE minimum coupling loss equals to 53 dB.

Local Area Base Stations are characterised by requirements derived from Pico Cell scenarios with a BS to UE minimum coupling loss equals to 45 dB.

Home Base Stations are characterised by requirements derived from Femto Cell scenarios.

The manufacturer shall declare the intended class of the BS under test.

4.4 Test environments

For each test in the present document, the environmental conditions under which the BS is to be tested are defined.

4.4.1 Normal test environment

When a normal test environment is specified for a test, the test should be performed within the minimum and maximum limits of the conditions stated in table 4.2.

Table 4.2: Limits of conditions for Normal Test Environment

Condition	Minimum	Maximum
Barometric pressure	86 kPa	106 kPa
Temperature	15°C	30°C
Relative Humidity	20 %	85 %
Power supply	Nominal, as declared by the manufacturer	
Vibration	Negligible	

The ranges of barometric pressure, temperature and humidity represent the maximum variation expected in the uncontrolled environment of a test laboratory. If it is not possible to maintain these parameters within the specified limits, the actual values shall be recorded in the test report.

NOTE: This may, for instance, be the case for measurements of radiated emissions performed on an open field test site.

4.4.2 Extreme test environment

The manufacturer shall declare one of the following:

- 1) the equipment class for the equipment under test, as defined in the IEC 60 721-3-3 [6];
- 2) the equipment class for the equipment under test, as defined in the IEC 60 721-3-4 [7];
- 3) the equipment that does not comply to the mentioned classes, the relevant classes from IEC 60 721 documentation for Temperature, Humidity and Vibration shall be declared.

NOTE: Reduced functionality for conditions that fall outside of the standard operational conditions are not tested in the present document. These may be stated and tested separately.

4.4.2.1 Extreme temperature

When an extreme temperature test environment is specified for a test, the test shall be performed at the standard minimum and maximum operating temperatures defined by the manufacturer's declaration for the equipment under test.

Minimum temperature:

The test shall be performed with the environment test equipment and methods including the required environmental phenomena into the equipment, conforming to the test procedure of IEC 60 068-2-1 [8].

Maximum temperature:

The test shall be performed with the environmental test equipment and methods including the required environmental phenomena into the equipment, conforming to the test procedure of IEC 60 068-2-2 [9].

NOTE: It is recommended that the equipment is made fully operational prior to the equipment being taken to its lower operating temperature.

4.4.3 Vibration

When vibration conditions are specified for a test, the test shall be performed while the equipment is subjected to a vibration sequence as defined by the manufacturer's declaration for the equipment under test. This shall use the environmental test equipment and methods of inducing the required environmental phenomena in to the equipment, conforming to the test procedure of IEC 60 068-2-6 [10]. Other environmental conditions shall be within the ranges specified in clause 4.4.1.

NOTE: The higher levels of vibration may induce undue physical stress in to equipment after a prolonged series of tests. The testing body should only vibrate the equipment during the RF measurement process.

4.4.4 Power supply

When extreme power supply conditions are specified for a test, the test shall be performed at the standard upper and lower limits of operating voltage defined by manufacturer's declaration for the equipment under test.

Upper voltage limit:

The equipment shall be supplied with a voltage equal to the upper limit declared by the manufacturer (as measured at the input terminals to the equipment). The tests shall be carried out at the steady state minimum and maximum temperature limits declared by the manufacturer for the equipment, to the methods described in IEC 60 068-2-1 [8] Test Ab/Ad and IEC 60 068-2-2 [9] Test Bb/Bd: Dry Heat.

Lower voltage limit:

The equipment shall be supplied with a voltage equal to the lower limit declared by the manufacturer (as measured at the input terminals to the equipment). The tests shall be carried out at the steady state minimum and maximum temperature limits declared by the manufacturer for the equipment, to the methods described in IEC 60 068-2-1 [8] Test Ab/Ad and IEC 60 068-2-2 [9] Test Bb/Bd: Dry Heat.

4.4.5 Definition of Additive White Gaussian Noise (AWGN) Interferer

The minimum bandwidth of the AWGN interferer shall be 1.5 times chip rate of the radio access mode. (e.g. 5.76 MHz for a chip rate of 3.84 Mcps). The flatness across this minimum bandwidth shall be less than ± 0.5 dB and the peak to average ratio at a probability of 0.001% shall exceed 10 dB.

4.5 Selection of configurations for testing

Most tests in the present document are only performed for a subset of the possible combinations of test conditions. For instance:

- not all transceivers in the configuration may be specified to be tested;
- only one RF channel may be specified to be tested;

- only one timeslot may be specified to be tested.

When a test is performed by a test laboratory, the choice of which combinations are to be tested shall be specified by the laboratory. The laboratory may consult with operators, the manufacturer or other bodies.

When a test is performed by a manufacturer, the choice of which combinations are to be tested may be specified by an operator.

4.6 BS Configurations

4.6.1 Receiver diversity

For the tests in clause 7 of the present document, the requirement applies at each receiver antenna connector for receivers with antenna diversity.

Receiver requirements are tested at the antenna connector, with the remaining receiver(s) disabled or their antenna connector(s) being terminated. If the manufacturer has declared the receiver paths to be equivalent, it is sufficient to apply the specified test signal at any one of the receiver antenna connectors.

For a multi-band BS, multi-band tests for ACS, blocking and intermodulation are performed with the interferer(s) applied to each antenna connector mapped to the receiver for the wanted signal(s), however only to one antenna at a time. Antenna connectors to which no signals are applied are terminated.

4.6.2 Duplexers

The requirements of the present document shall be met with a duplexer fitted, if a duplexer is supplied as part of the BS. If the duplexer is supplied as an option by the manufacturer, sufficient tests should be repeated with and without the duplexer fitted to verify that the BS meets the requirements of the present document in both cases.

The following tests should be performed with the duplexer fitted, and without it fitted if this is an option:

- 1) clause 6.2.1, base station maximum output power, for the highest static power step only, if this is measured at the antenna connector;
- 2) clause 6.5, output RF spectrum emissions; outside the BS transmit band;
- 3) clause 6.5.3.4.3, protection of the BS receiver;
- 4) clause 6.6, transmit intermodulation; for the testing of conformance, the carrier frequencies should be selected to minimize intermodulation products from the transmitters falling in receive channels.

The remaining tests may be performed with or without the duplexer fitted.

NOTE 1: When performing receiver tests with a duplexer fitted, it is important to ensure that the output from the transmitters does not affect the test apparatus. This can be achieved using a combination of attenuators, isolators and filters.

NOTE 2: When duplexers are used, intermodulation products will be generated, not only in the duplexer but also in the antenna system. The intermodulation products generated in the antenna system are not controlled by 3GPP specifications, and may degrade during operation (e.g. due to moisture ingress). Therefore, to ensure continued satisfactory operation of a BS, an operator will normally select ARFCNs to minimize intermodulation products falling on receive channels. For testing of complete conformance, an operator may specify the ARFCNs to be used.

4.6.3 Power supply options

If the BS is supplied with a number of different power supply configurations, it may not be necessary to test RF parameters for each of the power supply options, provided that it can be demonstrated that the range of conditions over which the equipment is tested is at least as great as the range of conditions due to any of the power supply configurations.

This applies particularly if a BS contains a DC rail which can be supplied either externally or from an internal mains power supply. In this case, the conditions of extreme power supply for the mains power supply options can be tested by testing only the external DC supply option. The range of DC input voltages for the test should be sufficient to verify the performance with any of the power supplies, over its range of operating conditions within the BS, including variation of mains input voltage, temperature and output current.

4.6.4 Ancillary RF amplifiers

The requirements of the present document shall be met with the ancillary RF amplifier fitted. At tests according to clauses 6 and 7 for TX and RX respectively, the ancillary amplifier is connected to the BS by a connecting network (including any cable(s), attenuator(s), etc.) with applicable loss to make sure the appropriate operating conditions of the ancillary amplifier and the BS. The applicable connecting network loss range is declared by the manufacturer. Other characteristics and the temperature dependence of the attenuation of the connecting network are neglected. The actual attenuation value of the connecting network is chosen for each test as one of the applicable extreme values. The lowest value is used unless otherwise stated.

Sufficient tests should be repeated with the ancillary amplifier fitted and, if it is optional, without the ancillary RF amplifier to verify that the BS meets the requirements of the present document in both cases.

When testing, the following tests should be repeated with the optional ancillary amplifier fitted according to the table below, where x denotes that the test is applicable:

Table 4.3

Receiver Tests	Clause	TX amplifier only	RX amplifier only	TX/RX amplifiers combined (Note)
	7.2		X	X
	7.5		X	X
	7.6		X	X
	7.7		X	
Transmitter Tests	6.2	X		X
	6.5.1	X		X
	6.5.2.2	X		X
	6.5.3	X		X
	6.6	X		X

NOTE: Combining can be by duplex filters or any other network. The amplifiers can either be in RX or TX branch or in both. Either one of these amplifiers could be a passive network.

In test according to clauses 6.2 and 7.2 highest applicable attenuation value is applied.

4.6.5 BS using antenna arrays

A BS may be configured with a multiple antenna port connection for some or all of its transceivers or with an antenna array related to one cell (not one array per transceiver). This clause applies to a BS which meets at least one of the following conditions:

- the transmitter output signals from one or more transceiver appear at more than one antenna port; or
- there is more than one receiver antenna port for a transceiver or per cell and an input signal is required at more than one port for the correct operation of the receiver thus the outputs from the transmitters as well as the inputs to the receivers are directly connected to several antennas (known as "aircombining"); or
- transmitters and receivers are connected via duplexers to more than one antenna.

In case of diversity or MIMO, multiple antennas are not considered as an antenna array. If a BS is used, in normal operation, in conjunction with an antenna system which contains filters or active elements which are necessary to meet the UTRA requirements, the conformance tests may be performed on a system comprising the BS together with these elements, supplied separately for the purposes of testing. In this case, it must be demonstrated that the performance of the configuration under test is representative of the system in normal operation, and the conformance assessment is only applicable when the BS is used with the antenna system.

For conformance testing of such a BS, the following procedure may be used.

4.6.5.1 Receiver tests

For each test, the test signals applied to the receiver antenna connectors shall be such that the sum of the powers of the signals applied equals the power of the test signal(s) specified in the test.

An example of a suitable test set-up is shown in figure 4.1.

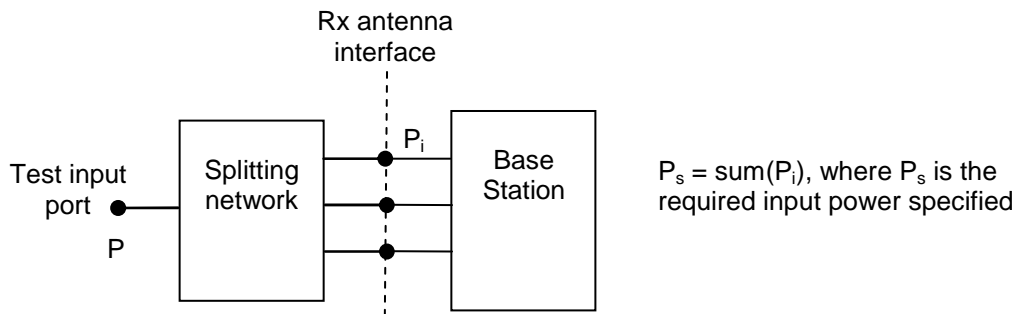

Figure 4.1: Receiver test set-up

For spurious emissions from the receiver antenna connector, the test may be performed separately for each receiver antenna connector.

4.6.5.2 Transmitter tests

For each test, the test signals applied to the transmitter antenna connectors (P_i) shall be such that the sum of the powers of the signals applied equals the power of the test signal(s) (P_s) specified in the test. This may be assessed by separately measuring the signals emitted by each antenna connector and summing the results, or by combining the signals and performing a single measurement. The characteristics (e.g. amplitude and phase) of the combining network should be such that the power of the combined signal is maximised.

An example of a suitable test set-up is shown in figure 4.2.

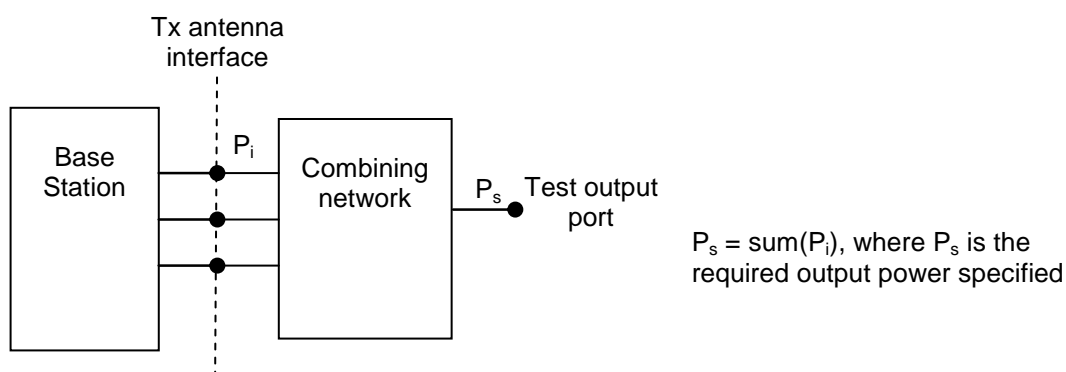

Figure 4.2: Transmitter test set-up

For Intermodulation attenuation, the test may be performed separately for each transmitter antenna connector.

4.6.6 Transmit diversity and MIMO transmission

Unless otherwise stated, for the tests in clause 6 of the present document, the requirement applies for each transmitter antenna connector in case of transmit diversity, DB-DC-HSDPA or MIMO transmission.

Transmitter requirements are tested at the antenna connector, with the remaining antenna connector(s) being terminated. If the manufacturer has declared the transmitter paths to be equivalent, it is sufficient to measure the signal at any one of the transmitter antenna connectors.

4.6.7 BS with integrated Iuant BS modem

Unless otherwise stated, for the tests in the present document, the integrated Iuant BS modem shall be switched off. Spurious emissions according to clauses 6.5.3 and 7.7 shall be measured only for frequencies above 20MHz with the integrated Iuant BS modem switched on.

4.6.8 BS with Virtual Antenna Mapping

A BS may be configured with virtual antenna mapping (VAM) as shown as example in Figure 4.3 for MIMO mode with two transmit antennas. The purpose of VAM is to achieve the goal of power balancing of physical channels across the multiple physical antennas when MIMO mode with two or four transmit antennas is deployed in the downlink. Since the non-MIMO channels are transmitted only via virtual antenna 1, the transmission powers are not balanced at point a. The VAM function transforms the input signals at point a to output signals at point b such that the transmission powers are balanced.

In the following some characteristics of VAM are described in the context of MIMO mode with two transmit antennas. Similar characteristics apply also when VAM is implemented in the context of MIMO mode with four transmit antennas.

Some characteristics of VAM are as follows:

- The VAM can be represented by a unitary matrix $\begin{bmatrix} s_1 & s_3 \\ s_2 & s_4 \end{bmatrix}$
- The same pair of weights (s_1, s_2) are applied to each physical channel that appears at virtual antenna port 1
- The same pair of weights (s_3, s_4) are applied to each physical channel that appears at virtual antenna port 2
- The VAM weights (s_1, s_2, s_3, s_4) should satisfy the following condition for MIMO and non-MIMO channels : $|s_1|^2 + |s_3|^2 = |s_2|^2 + |s_4|^2 = 1$
- Power balancing at the output of VAM is achieved by setting $|s_1|^2 = |s_2|^2$ and $|s_3|^2 = |s_4|^2$
- The VAM function is implemented in the digital domain prior to digital to analog conversion.

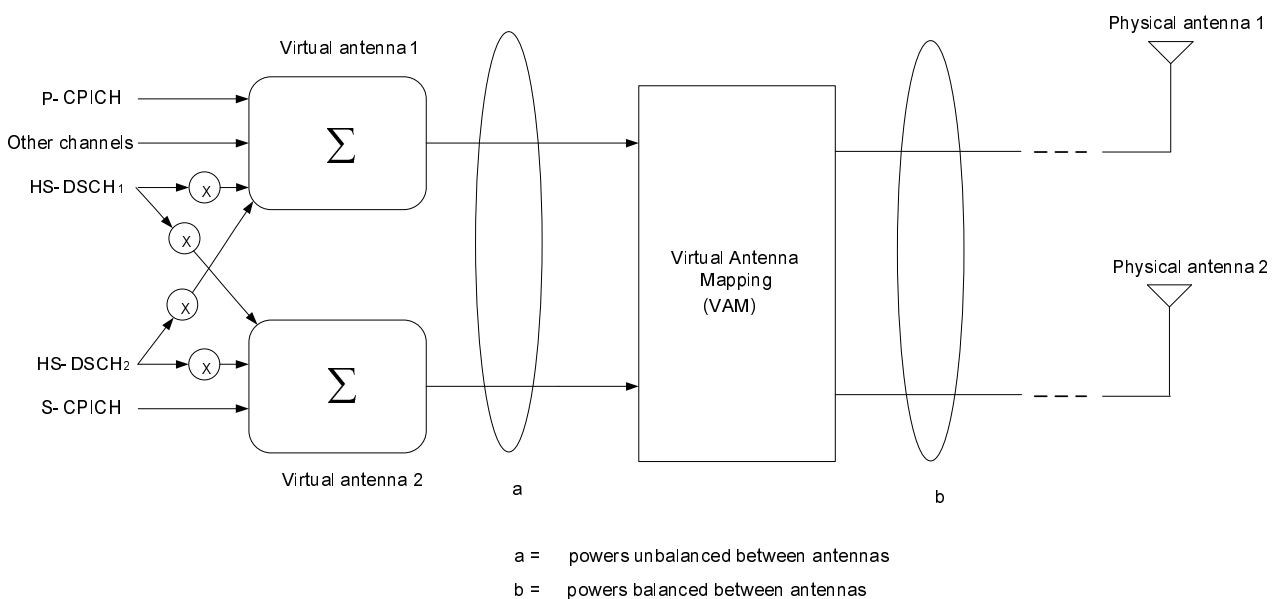

Figure 4.3: Example of VAM for MIMO mode with two transmit antennas.

If NodeB manufacturer declares the implementation of a Virtual Antenna Mapping (VAM), then the S-CPICH power accuracy test in section 6.2.3 will not be performed.

4.7 Regional requirements

Some requirements in TS 25.141 may only apply in certain regions. Table 4.4 lists all requirements that may be applied differently in different regions.

Table 4.4: List of regional requirements

Clause number	Requirement	Comments
3.4.1	Frequency bands	Some bands may be applied regionally.
3.4.2	Tx-Rx Frequency Separation	The requirement is applied according to what frequency bands in clause 3.4.1 that are supported by the BS.
3.5	Channel arrangement	The requirement is applied according to what frequency bands in clause 3.4.1 that are supported by the BS.
6.2.1.2	Base station output power	In certain regions, the minimum requirement for normal conditions may apply also for some conditions outside the ranges defined for the Normal test environment in clause 4.4.1.
6.5.2.1	Spectrum emission mask	The mask specified may be mandatory in certain regions. In other regions this mask may not be applied.
6.5.2.2	Adjacent Channel Leakage power Ratio	In Japan, the requirement depicted in the note of Table 6.23 shall be applied.
6.5.3.7.1	Spurious emissions (Category A)	These requirements shall be met in cases where Category A limits for spurious emissions, as defined in ITU-R Recommendation SM.329 [4], are applied.
6.5.3.7.2	Spurious emissions (Category B)	These requirements shall be met in cases where Category B limits for spurious emissions, as defined in ITU-R Recommendation SM.329 [4], are applied.
6.5.3.7.4	Co-existence with other systems in the same geographical area	These requirements may apply in geographic areas in which both UTRA FDD and GSM900, DCS1800, PCS1900, GSM850 and/or UTRA FDD operating in another frequency band are deployed.
6.5.3.7.5	Co-existence with co-located and co-sited base stations	These requirements may be applied for the protection of other BS receivers when GSM900, DCS1800, PCS1900, GSM850 and/or FDD BS operating in another frequency band are co-located with a UTRA FDD BS.
6.5.3.7.6	Co-existence with PHS	This requirement may be applied for the protection of PHS in geographic areas in which both PHS and UTRA FDD are deployed.
6.5.3.7.7	Co-existence with services in adjacent frequency bands	This requirement may be applied for the protection in bands adjacent to the downlink band as defined in clause 3.4.1 in geographic areas in which both an adjacent band service and UTRA FDD are deployed.
6.5.3.7.8.1	Co-existence with UTRA TDD - Operation in the same geographic area	This requirement may be applied to geographic areas in which both UTRA-TDD and UTRA-FDD are deployed.
6.5.3.7.8.2	Co-existence with UTRA TDD - Co-located base stations	This requirement may be applied for the protection of UTRA-TDD BS receivers when UTRA-TDD BS and UTRA FDD BS are co-located.
6.5.3.7.9	Protection of public safety operations	This requirement shall be applied to BS operating in Bands XIII and XIV to ensure that appropriate interference protection is provided to 700 MHz public safety operations.
7.5	Blocking characteristic	The requirement is applied according to what frequency bands in clause 3.4.1 that are supported by the BS.
7.5	Blocking characteristics	This requirement may be applied for the protection of UTRA FDD BS receivers when UTRA FDD BS and GSM 900, GSM850, PCS 1900 and BS operating in the /DCS1800 band (GSM or UTRA) are co-located.
7.6	Intermodulation characteristics	The requirement is applied according to what frequency bands in clause 3.4.1 that are supported by the BS.
7.7	Spurious emissions	The requirement is applied according to what frequency bands in clause 3.4.1 that are supported by the BS.

	Base station classes*	Only requirements for Wide Area (General Purpose), Medium Range and Local Area Base Stations are applicable in Japan.
--	-----------------------	---

Note *: Base station classes,; This regional requirement should be reviewed to check its necessity every TSG RAN meeting.

4.8 Specified frequency range

The manufacturer shall declare:

- which of the frequency bands defined in sub-clause 3.4 are supported by the BS.
- the frequency range within the above frequency band(s) supported by the BS.

Many tests in this TS are performed with appropriate frequencies in the bottom, middle and top of the frequency range supported by the BS. These are denoted as RF channels B (bottom), M (middle) and T (top).

Unless otherwise stated, the test shall be performed with a single carrier at each of the RF channels B, M and T.

When a test is performed by a test laboratory, the UARFCNs to be used for RF channels B, M and T shall be specified by the laboratory. The laboratory may consult with operators, the manufacturer or other bodies.

When a test is performed by a manufacturer, the UARFCNs to be used for RF channels B, M and T may be specified by an operator.

4.8.1 RF bandwidth position for non-single carrier testing

Many tests in this TS are performed with the maximum BS RF bandwidth located at the bottom, middle and top of the supported frequency range in each operating band. These are denoted as B_{RFBW} (bottom), M_{RFBW} (middle) and T_{RFBW} (top).

Unless otherwise stated, the test shall be performed at B_{RFBW} , M_{RFBW} and T_{RFBW} defined as following:

- B_{RFBW} : Maximum BS RF bandwidth located at the bottom of the supported frequency range in each operating band;
- M_{RFBW} : Maximum BS RF bandwidth located in the middle of the supported frequency range in each operating band;
- T_{RFBW} : maximum BS RF bandwidth located at the top of the supported frequency range in each operating band.

For BS capable of dual-band operation, unless otherwise stated, the test shall be performed at $B_{\text{RFBW_T''RFBW}}$ and $B''_{\text{RFBW_T_{RFBW}}}$ defined as following:

$B_{\text{RFBW_T''RFBW}}$: the RF bandwidths located at the bottom of the supported frequency range in the lower operating band and at the highest possible simultaneous frequency position, within the maximum radio bandwidth, in the upper operating band.

$B''_{\text{RFBW_T_{RFBW}}}$: the RF bandwidths located at the top of the supported frequency range in the upper operating band and at the lowest possible simultaneous frequency position, within the maximum radio bandwidth, in the lower operating band.

NOTE: $B_{\text{RFBW_T''RFBW}} = B''_{\text{RFBW_T_{RFBW}}} = B_{\text{RFBW_T_{RFBW}}$ when the declared maximum radio bandwidth spans both operating bands. $B_{\text{RFBW_T_{RFBW}}}$ means the RF bandwidths are located at the bottom of the supported frequency range in the lower operating band and at the top of the supported frequency range in the upper operating band.

When a test is performed by a test laboratory, the position of B_{RFBW} , M_{RFBW} and T_{RFBW} in each supported operating band, as well as the position of $B_{\text{RFBW_T''RFBW}}$ and $B''_{\text{RFBW_T_{RFBW}}}$ in the supported operating band combinations, shall be specified by the laboratory. The laboratory may consult with operators, the manufacturer or other bodies.

4.9 Applicability of requirements

For BS that is UTRA (single-RAT) capable only, the requirements in the present document are applicable and additional conformance to TS 37.141 [16] is optional. For a BS additionally conforming to TS 37.141 [16], conformance to some of the RF requirements in the present document can be demonstrated through the corresponding requirements in TS 37.141 [16] as listed in Table 4.5

Table 4.5: Alternative RF test requirements for a BS additionally conforming to TS 37.141 [16]

RF requirement	Clause in the present document	Alternative clause in TS 37.141 [16]
Base station output power	6.2.1.5	6.2.1 6.2.2
Unwanted emissions		
Spectrum emission mask	6.5.2.1.5	6.6.2.5 (except for 6.6.2.5.3 and 6.6.2.5.4)
Transmitter spurious emissions	6.5.3.7 (except for 6.5.3.7.9)	6.6.1.5 (except for 6.6.1.5.3)
Transmitter intermodulation	6.6.5	6.7.5.1
Narrowband blocking	7.5.5	7.4.5.2
Blocking	7.5.5	7.4.5.1
Out-of-band blocking	7.5.5	7.5.5.1
Co-location with other base stations	7.5.5	7.5.5.2
Receiver spurious emissions	7.7.5	7.6.5.1
Intermodulation	7.6.5	7.7.5.1
Narrowband intermodulation	7.6.5	7.7.5.2

4.10 Requirements for contiguous and non-contiguous spectrum

A spectrum allocation where the BS operates can either be contiguous or non-contiguous. Unless otherwise stated, the requirements in the present specification apply for BS configured for both contiguous spectrum operation and non-contiguous spectrum operation.

For BS operation in non-contiguous spectrum, some requirements apply also inside the sub-block gaps. For each such requirement, it is stated how the limits apply relative to the sub-block edges.

4.11 Manufacturer's declarations of regional and optional requirements

4.11.1 Operating band and frequency range

Manufacturer declarations related to supported frequency band(s) and frequency ranges are contained in section 4.8. Requirements for other operating bands and frequency ranges need not be tested.

Some tests are performed with the maximum BS RF bandwidth. The manufacturer shall declare that the requirements are also fulfilled for all other supported BS RF bandwidths which are not tested.

4.11.2 Spurious emissions category

The manufacturer shall declare one of the following:

- a) The BS is tested against Category A limits for spurious emissions, as defined in ITU-R Recommendation SM.329 [4]. In this case:
 - conformance with the spurious emissions requirements in clause 6.5.3.7.1 is mandatory, and the requirements specified in clause 6.5.3.7.2 need not be tested.
- b) The BS is tested against Category B limits for spurious emissions, as defined in ITU-R Recommendation SM.329 [4]. In this case:

- conformance with the spurious emissions requirements in clause 6.5.3.7.2 is mandatory, and the requirements specified in clause 6.5.3.7.1 need not be tested.

4.11.3 Additional out of band emissions

For a BS declared to support Band XX and to operate in geographic areas within the CEPT in which frequencies are allocated to broadcasting (DTT) service, the manufacturer shall additionally declare the following quantities associated with the applicable test conditions of Table 6.21F and information in annex D of [1] :

$P_{EM,N}$ Declared emission level for channel N

P_{10MHz} Maximum output Power in 10 MHz

4.11.4 Co-existence with other systems

The manufacturer shall declare whether the BS under test is intended to operate in geographic areas where one or more of the systems GSM850, GSM900, DCS1800, PCS1900, UTRA FDD, UTRA TDD, E-UTRA and/or PHS operating in another band are deployed. If this is the case, compliance with the applicable test requirement for spurious emissions specified in clauses 6.5.3.7.4, 6.5.3.7.6, 6.5.3.7.7 and 6.5.3.7.9 shall be tested.

4.11.5 Co-location with other base stations

The manufacturer shall declare whether the BS under test is intended to operate co-located with base stations of one or more of the systems GSM850, GSM900, DCS1800, PCS1900, UTRA FDD, UTRA TDD and/or E-UTRA operating in another band. If this is the case,

- compliance with the applicable test requirement for spurious emissions specified in clause 6.5.3.7.5 shall be tested.
- compliance with the applicable test requirement for receiver blocking specified in clause 7.5 shall be tested.

4.11.6 Manufacturer's declarations of supported RF configurations

The manufacturer shall declare the intended class of the BS under test, as specified in subclause 4.3A.

The manufacturer shall declare which operational configurations the BS supports by declaring the following parameters:

- Support of the BS in non-contiguous spectrum operation. If the BS does not support non-contiguous spectrum operation the parameters for non-contiguous spectrum operation below shall not be declared.
- The supported operating bands defined in subclause 3.4;
- The frequency range within the above operating band(s) supported by the BS;
- The Maximum Base Station RF bandwidth supported by a BS within each operating band;
 - for contiguous spectrum operation
 - for non-contiguous spectrum operation
- The supported operating configurations (multi-carrier and/or single carrier) within each operating band.
- The rated output power per carrier (PRAT);
 - for contiguous spectrum operation
 - for non-contiguous spectrum operation

NOTE: Different rated output powers may be declared for different operating configurations.

- The rated total output power (Prated,t) as a sum of all carriers;
 - for contiguous spectrum operation

- for non-contiguous spectrum operation
- Maximum number of supported carriers within each band;
 - for contiguous spectrum operation
 - for non-contiguous spectrum operation
- Total number of supported carriers

If the rated total output power and total number of supported carriers are not simultaneously supported, the manufacturer shall declare the following additional parameters:

- The reduced number of supported carriers at the rated total output power.
- The reduced total output power at the maximum number of supported carriers.
- Whether virtual antenna mapping (VAM) as described in 4.6.8 is implemented in the BS under test.
- Primary CPICH code domain power, in the case of MIMO or transmit diversity.

For BS capable of multi-band operation, the parameters above shall be declared for each supported operating band, in which declarations of the maximum Base Station RF bandwidth, the rated output power per carrier, the rated total output power and maximum number of supported carriers are applied for single-band operation only. In addition the manufacturer shall declare the following additional parameters for BS capable of multi-band operation:

- Supported operating band combinations of the BS
- Supported operating band(s) of each antenna connector
- Support of multi-band transmitter and/or multi-band receiver, including mapping to antenna connector(s)
- Total number of supported carriers for the declared band combinations of the BS
- Maximum number of supported carriers per band in multi-band operation
- Total RF bandwidth of transmitter and receiver for the declared band combinations of the BS
- Maximum RF bandwidth of each supported operating band in multi-band operation
- Maximum radio bandwidth in transmit and receive direction for the declared band combinations of the BS
- Any other limitations under simultaneous operation in the declared band combinations of the BS which have any impact on the test configuration generation
- Total output power as a sum over all supported operating bands in the declared band combinations of the BS
- Maximum supported power difference between any two carriers in any two different supported operating bands
- The rated output power per carrier in multi-band operation
- Rated total output power of each supported operating band in multi-band operation

4.12 Test configuration for multi-carrier operations

The test configurations shall be constructed using the methods defined below, subject to the parameters declared by the manufacturer for the supported RF configurations as listed in subclause 4.11.6. The test configurations to use for conformance testing are defined for each supported RF configuration in subclause 4.12.4

The applicable Test Models for generation of the carrier transmit test signal are defined in subclause 6.1.1.

4.12.1 UTC1: Contiguous spectrum operation test configuration

The purpose of the UTC1 is to test both BS transmitter and receiver requirements. UTC1 should be constructed using the following method:

- The RF bandwidth shall be the declared maximum BS RF bandwidth for contiguous operation.
- Place one UTRA FDD carrier adjacent to the upper RF bandwidth edge and one UTRA FDD carrier adjacent to the lower RF bandwidth edge. The specified F_{Offset} shall apply.
- For transmitter tests, alternately place a UTRA FDD carrier adjacent to the already placed carriers at the low and high edge of the RF bandwidth until there is no more space to fit a carrier or the BS does not support more carriers. The nominal carrier spacing defined in subclause 3.5.1 shall apply.
- The carrier(s) may be shifted maximum 100 kHz towards lower frequencies for B_{RFBW} and M_{RFBW} and towards higher frequencies for T_{RFBW} to align with the channel raster.

4.12.1.1 UTC1 power allocation

Set the power of each carrier to the same level so that the sum of the carrier powers equals the rated total output power ($P_{\text{rated,t}}$) according to the manufacturer's declaration in sub clause 4.11.6.

4.12.2 UTC2: Non-contiguous spectrum operation test configuration

The purpose of the UTC2 is to test both the BS transmitter and receiver requirements. UTC2 should be constructed using the following method:

- The RF bandwidth shall be the maximum BS RF bandwidth for non-contiguous operation. The RF bandwidth consists of one sub-block gap and two sub-blocks located at the edges of the declared maximum supported RF bandwidth.
- For transmitter tests, place one UTRA FDD carrier adjacent to the upper RF bandwidth edge and one UTRA FDD carrier adjacent to the lower RF bandwidth edge. The specified F_{Offset} shall apply.
- For receiver tests, place one UTRA carrier adjacent to the upper RF bandwidth edge and one UTRA carrier adjacent to the lower RF bandwidth edge. If the maximum supported RF bandwidth is at least 35 MHz and the BS supports at least 4 UTRA FDD carriers, place a UTRA FDD carrier adjacent to each already placed carrier for each sub-block. The nominal carrier spacing defined in subclause 3.5.1 shall apply.
- The sub-block edges adjacent to the sub-block gap shall be determined using the specified F_{Offset} for the carrier adjacent to the sub-block gap.
- The UTRA FDD carrier in the lower sub-block may be shifted maximum 100 kHz towards lower frequencies and the UTRA FDD carrier in the upper sub-block may be shifted maximum 100 kHz towards higher frequencies to align with the channel raster.

4.12.2.1 UTC2 power allocation

Set the power of each carrier to the same power so that the sum of the carrier powers equals the rated total output power ($P_{\text{rated,t}}$) according to the manufacturer's declaration in subclause 4.11.6.

4.12.3 Multi-band operation test configurations

4.12.3.1 UTC3: Multi-band test configuration for full carrier allocation

The purpose of UTC3 is to test multi-band operation aspects considering maximum supported number of carriers.

UTC3 is based on re-using the existing test configuration applicable per band involved in multi-band operation. It is constructed using the following method:

- The BS RF bandwidth of each supported operating band shall be the declared maximum BS RF bandwidth of each supported operating band in multi-band operation.
- The number of carriers of each supported operating band shall be the declared maximum number of supported carriers in multi-band operation. Carriers shall first be placed at the outermost edges of the declared maximum radio bandwidth. Additional carriers shall next be placed at the edges of the RF bandwidths, if possible.

- The allocated BS RF bandwidth of the outermost bands shall be located at the outermost edges of the declared maximum radio bandwidth.
- Each concerned band shall be considered as an independent band and the corresponding UTC1 shall be generated in each band.
- If a multi-band BS supports three carriers only, two carriers shall be placed in one band according to UTC1 while the remaining carrier shall be placed at the edge of the maximum radio bandwidth in the other band.
- If the sum of the maximum BS RF bandwidth of each supported operating bands is larger than the declared total RF bandwidth of transmitter and receiver for the declared band combinations of the BS, repeat the steps above for test configurations where the RF bandwidth of one of the operating band shall be reduced so that the total RF bandwidth of transmitter and receiver is not exceeded and vice versa.
- If the sum of the maximum number of supported carrier of each supported operating bands in multi-band operation is larger than the declared total number of supported carriers for the declared band combinations of the BS, repeat the steps above for test configurations where in each test configuration the number of carriers of one of the operating band shall be reduced so that the total number of supported carriers is not exceeded and vice versa.

4.12.3.1.1 UTC3 power allocation

Unless otherwise stated, set the power of each carrier in all supported operating bands to the same power so that the sum of the carrier powers equals the total output power, according to the manufacturer's declaration.

If the allocated power of a supported operating band(s) exceeds the declared PRated,t of the operating band(s) in multi-band operation, the exceeded part shall, if possible, be reallocated into the other band(s). If the power allocated for a carrier exceeds the declared PRAT for that carrier, the exceeded power shall, if possible, be reallocated into the other carriers.

4.12.3.2 UTC4: Multi-band test configuration with high PSD per carrier

The purpose of UTC4 is to test multi-band operation aspects considering higher PSD cases with reduced number of carriers.

UTC4 is based on re-using the existing test configuration applicable per band involved in multi-band operation. It is constructed using the following method:

- The BS RF bandwidth of each supported operating band shall be the declared maximum BS RF bandwidth in multi-band operation.
- The allocated RF bandwidth of the outermost bands shall be located at the outermost edges of the declared maximum radio bandwidth.
- The maximum number of carriers is limited to two per band. Carriers shall first be placed at the outermost edges of the declared maximum radio bandwidth. Additional carriers shall next be placed at the edges of the RF bandwidths, if possible.
- Each concerned band shall be considered as an independent band and the corresponding UTC2 shall be generated in each band.
- If a multi-band BS supports three carriers only, two carriers shall be placed in one band according to UTC2 while the remaining carrier shall be placed at the edge of the maximum radio bandwidth in the other band.
- If the sum of the maximum BS RF bandwidth of each supported operating bands is larger than the declared total RF bandwidth of transmitter and receiver for the declared band combinations of the BS, repeat the steps above for test configurations where the RF bandwidth of one of the operating band shall be reduced so that the total RF bandwidth of transmitter and receiver is not exceeded and vice versa.

4.12.3.2.1 UTC4 power allocation

Unless otherwise stated, set the power of each carrier in all supported operating bands to the same power so that the sum of the carrier powers equals the total output power, according to manufacturer's declaration.

If the allocated power of a supported operating band(s) exceeds the declared PRated,t of the operating band(s) in multi-band operation, the exceeded part shall, if possible, be reallocated into the other band(s). If the power allocated for a carrier exceeds the declared PRAT for that carrier, the exceeded power shall, if possible, be reallocated into the other carriers.

4.12.4 Applicability of test configurations

The present subclause defines for each RF test requirement the set of mandatory test configurations which shall be used for demonstrating conformance. The applicable test configurations are specified in the tables below for each the supported RF configuration, which shall be declared according to subclause 4.11.6. The generation and power allocation for each test configuration is defined in subclauses 4.12.1 to 4.12.3.

For a BS declared to be capable of single carrier operation only, a single carrier (SC) shall be used for testing.

For a BS declared to be capable of multi-carrier operation in contiguous spectrum operation in single band only, the test configurations in Table 4.6 shall be used for testing.

Table 4.6: Test configurations for a BS capable of multi-carrier operation in contiguous spectrum in single band only

BS test case	Test configuration
6.2 Base station output power	
6.2.1 Base station maximum output power	UTC1
6.2.2 Primary CPICH accuracy	SC
6.2.3 Secondary CPICH accuracy	SC
6.3 Frequency error	Tested with EVM
6.4 Output power dynamics	-
6.4.1 Inner loop power control	SC
6.4.2 Power control steps	SC
6.4.3 Power Control Dynamic Range	SC
6.4.4 Total Power Dynamic Range	SC or UTC1
6.4.5 IPDL time mask	SC
6.4.6 Home base station output power for adjacent channel protection	SC
6.5. Output RF spectrum emissions	-
6.5.1 Occupied bandwidth	SC
6.5.2 Out of band emission	-
6.5.2.1 Spectrum emission mask	UTC1
6.5.2.2 Adjacent Channel Leakage Ratio	UTC1
6.5.3 Spurious emissions	UTC1
6.6 Transmit intermodulation	UTC1
6.7 Transmit modulation	-
6.7.1 Error Vector Magnitude	UTC1
6.7.2 Peak Code Domain Error	UTC1
6.7.3 Time alignment error	UTC1
6.7.4 Relative Code Domain Error	UTC1
7.2 Reference sensitivity level	SC
7.3 Dynamic range	SC
7.4 Adjacent Channel Selectivity (ACS)	UTC1
7.5 Blocking Characteristics	UTC1
7.6 Receiver intermodulation	UTC1
7.7 Spurious emissions	UTC1
7.8 Verification of the internal BER calculation	SC

For a BS declared to be capable of multi-carrier in contiguous and non-contiguous spectrum in single band and where the parameters in the manufacture"s declaration according to subclause 4.12.6 are identical for contiguous (C) and non-contiguous (NC) spectrum operation, the test configurations in the second column of Table 4.7 shall be used for testing.

For a BS declared to be capable of multi-carrier in contiguous and non-contiguous spectrum in single band and where the parameters in the manufacture"s declaration according to subclause 4.12.6 are not identical for contiguous and non-contiguous spectrum operation, the test configurations in the third column of Table 4.7 shall be used for testing.

Table 4.7: Test configuration for a BS capable of multi-carrier operation in both contiguous and non-contiguous spectrum in single band

BS test case	C and NC capable BS with identical parameters	C and NC capable BS with different parameters
6.2 Base station output power		
6.2.1 Base station maximum output power	UTC1	UTC1, UTC2
6.2.2 Primary CPICH accuracy	SC	SC
6.2.3 Secondary CPICH accuracy	SC	SC
6.3 Frequency error	Tested with EVM	Tested with EVM
6.4 Output power dynamics	-	-
6.4.1 Inner loop power control	SC	SC
6.4.2 Power control steps	SC	SC
6.4.3 Power Control Dynamic Range	SC	SC
6.4.4 Total Power Dynamic Range	SC or UTC1	SC or UTC1
6.4.5 IPDL time mask	SC	SC
6.4.6 Home base station output power for adjacent channel protection	SC	SC
6.5. Output RF spectrum emissions	-	-
6.5.1 Occupied bandwidth	SC	SC
6.5.2 Out of band emissions	-	-
6.5.2.1 Spectrum emission mask	UTC1, UTC2	UTC1, UTC2
6.5.2.2 Adjacent Channel Leakage Ratio	UTC2	UTC1, UTC2
6.5.2.2.6 Cumulative Adjacent Channel Leakage Ratio	UTC2	UTC2
6.5.3 Spurious emissions	UTC2	UTC1, UTC2
6.6 Transmit intermodulation	Same TC as used in 6.5	Same TC as used in 6.5
6.7 Transmit modulation	-	-
6.7.1 Error Vector Magnitude	UTC1	UTC1, UTC2
6.7.2 Peak Code Domain Error	UTC1	UTC1, UTC2
6.7.3 Time alignment error	UTC1	UTC1, UTC2
6.7.4 Relative Code Domain Error	UTC1	UTC1
7.2 Reference sensitivity level	SC	SC
7.3 Dynamic range	SC	SC
7.4 Adjacent Channel Selectivity (ACS)	UTC2	UTC1, UTC2
7.5 Blocking Characteristics	UTC2	UTC1, UTC2
7.6 Receiver intermodulation	UTC2	UTC1, UTC2
7.7 Spurious emissions	UTC2	UTC1, UTC2
7.8 Verification of the internal BER calculation	SC	SC

For a BS declared to be capable of multi-band operation, the test configuration in Table 4.8 shall be used for testing. In the case where multiple bands are mapped on common antenna connector, the test configuration in the second column of Table 4.8 shall be used. In the case where multiple bands are mapped on separate antenna connectors, the test configuration in the third column of Table 4.8 shall be used.

Table 4.8: Test configuration for a BS capable of multi-band operation

BS test case	Test Configuration	
	Common antenna connector	Separate antenna connector
6.2 Base station output power	-	-
6.2.1 Base station maximum output power	UTC1/2 (Note1) UTC3	UTC1/2 (Note1) UTC3
6.2.2 Primary CPICH accuracy	SC	SC
6.2.3 Secondary CPICH accuracy	SC	SC
6.3 Frequency error	Tested with EVM	Tested with EVM
6.4 Output power dynamics	-	-
6.4.1 Inner loop power control	SC	SC
6.4.2 Power control steps	SC	SC
6.4.3 Power Control Dynamic Range	SC	SC
6.4.4 Total Power Dynamic Range	SC or UTC1	SC or UTC1
6.4.5 IPDL time mask	SC	SC
6.4.6 Home base station output power for adjacent channel protection	SC	SC
6.5. Output RF spectrum emissions	-	-
6.5.1 Occupied bandwidth	SC	SC
6.5.2 Out of band emissions	-	-
6.5.2.1 Spectrum emission mask	UTC1/2 (Note1) UTC4	UTC1/2 (Note1,3) UTC4 (Note 3)
6.5.2.2 Adjacent Channel Leakage Ratio	UTC1/2 (Note1) UTC4 (Note2)	UTC1/2 (Note1,3), UTC4 (Note 2,3)
6.5.2.2.6 Cumulative Adjacent Channel Leakage Ratio	UTC2 (Note1) UTC4 (Note2)	UTC2 (Note 1,3)
6.5.3 Spurious emissions	UTC1/2 (Note1) UTC4	UTC1/2 (Note1,3) UTC4 (Note 3)
6.6 Transmit intermodulation	UTC1/2 (Note 1)	UTC1/2 (Note 1,3)
6.7 Transmit modulation	-	-
6.7.1 Error Vector Magnitude	UTC1/UTC2 (Note1), UTC3	UTC1/UTC2 (Note1), UTC3
6.7.2 Peak Code Domain Error	UTC1/2 (Note1)	UTC1/2 (Note1)
6.7.3 Time alignment error	UTC1/2 (Note1) UTC4	UTC1/2 (Note1) UTC4
6.7.4 Relative Code Domain Error	UTC1	UTC1
7.2 Reference sensitivity level	SC	SC
7.3 Dynamic range	SC	SC
7.4 Adjacent Channel Selectivity (ACS)	UTC4	UTC1/2 (Note1) UTC4 (Note 4)
7.5 Blocking Characteristics	UTC4	UTC1/2 (Note1) UTC4 (Note 4)
7.6 Receiver intermodulation	UTC4	UTC1/2 (Note1) UTC4 (Note 4)
7.7 Spurious emissions	UTC1/2 (Note1) UTC4	UTC1/2 (Note1,3) UTC4 (Note 3)
7.8 Verification of the internal BER calculation	SC	SC
Note 1:	UTC1 and/or UTC2 shall be applied in each supported operating band according to Tables 4.6 and 4.7.	
Note 2:	UTC4 may be applied for Inter RF bandwidth gap only.	
Note 3:	Single-band requirement apply to each antenna connector for both multi-band operation test and single-band operation test. For single-band operation test, other antenna connector(s) is (are) terminated.	
Note 4:	UTC4 is only applicable for multi-band receiver.	

4.13 Requirements for BS capable of multi-band operation

For BS capable of multi-band operation, the RF requirements in clause 6 and 7 apply for each supported operating band unless otherwise stated. For some requirements it is explicitly stated that specific additions or exclusions to the requirement apply for BS capable of multi-band operation.

For BS capable of multi-band operation, various structures in terms of combinations of different transmitter and receiver implementations (multi-band or single band) with mapping of transceivers to one or more antenna port(s) in different ways are possible. In the case where multiple bands are mapped on separate antenna connectors, the following applies:

- Single-band transmitter spurious emissions, spectrum emission mask, ACLR, transmitter intermodulation and receiver spurious emissions requirements apply to each antenna connector.
- If the BS is configured for single-band operation, single-band requirements shall apply to the antenna connector configured for single-band operation and no exclusions or provisions for multi-band capable BS are applicable. Single-band requirements are tested separately at the antenna connector configured for single-band operation, with all other antenna connectors terminated.

5 Format and interpretation of tests

Each test in the following clauses has a standard format:

X Title

All tests are applicable to all equipment within the scope of the present document, unless otherwise stated.

X.1 Definition and applicability

This clause gives the general definition of the parameter under consideration and specifies whether the test is applicable to all equipment or only to a certain subset.

X.2 Minimum Requirement

This clause contains the reference to the clause to the 3GPP reference (or core) specification which defines the Minimum Requirement.

X.3 Test purpose

This clause defines the purpose of the test.

X.4 Method of test

X.4.1 Initial conditions

This clause defines the initial conditions for each test, including the test environment, the RF channels to be tested and the basic measurement set-up.

X.4.2 Procedure

This clause describes the steps necessary to perform the test and provides further details of the test definition like point of access (e.g. antenna port), domain (e.g. frequency-span), range, weighting (e.g. bandwidth), and algorithms (e.g. averaging).

X.5 Test Requirement

This clause defines the pass/fail criteria for the equipment under test. See clause 4.3 Interpretation of measurement results.

6 Transmitter

6.1 General

Unless otherwise stated, the requirements in clause 6 are expressed for a single transmitter antenna connector. In case of transmit diversity, DB-DC-HSDPA or MIMO transmission, the requirements apply for each transmitter antenna connector.

A BS supporting DC-HSDPA and DB-DC-HSDPA transmits two cells simultaneously. A BS supporting DC-HSDPA transmits two cells simultaneously on adjacent carrier frequencies.

Unless otherwise stated, all tests in this clause shall be performed at the BS antenna connector (test port A) with a full complement of transceivers for the configuration in normal operating conditions. If any external apparatus such as a TX amplifier, a filter or the combination of such devices is used, the tests according to clauses 4.6.2 and/or 4.6.4, depending on the device added, shall be performed to ensure that the requirements are met at test port B.

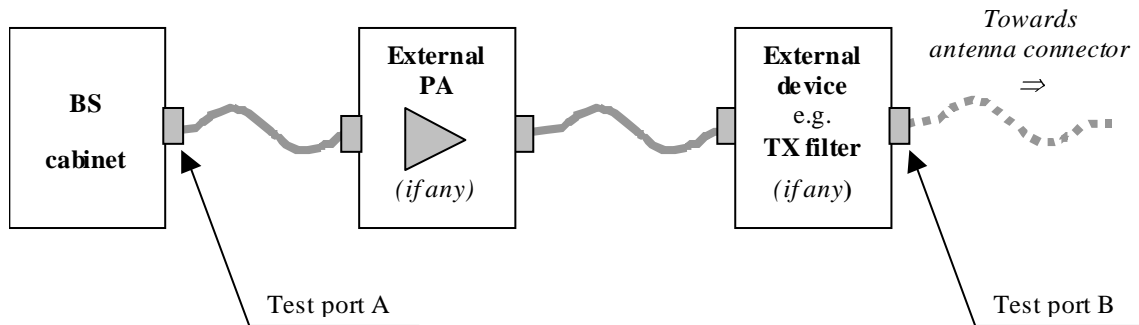

Figure 6.1: Transmitter test ports

Power levels are expressed in dBm.

6.1.1 Test Models

The set-up of physical channels for transmitter tests shall be according to one of the Test Models below. A reference to the applicable table is made with each test.

For Tx diversity transmission, the same Test Model shall be used for both antennas. No diversity coding of the Test Models is required.

A code "level setting" of -X dB is the setting that according to the base station manufacturer will result in a code domain power of nominally X dB below the maximum output power. The relative accuracy of the code domain power to the maximum output power shall have tolerance of ± 1 dB.

6.1.1.1 Test Model 1 – TM1

This model shall be used for tests on:

- occupied bandwidth;
- spectrum emission mask;
- ACLR;
- spurious emissions;
- transmit intermodulation;
- base station maximum output power.
- Total power dynamic range (at Pmax)
- Home base station output power for adjacent channel protection
- Frequency error (at Pmax)
- IPDL time mask

Due to the amplitude statistics of TM1 [2], it is sufficient to test all requirements above with TM1 regardless of the modulation schemes supported by the Node-B.

In addition, the test model is used for Error Vector Magnitude using QPSK modulation (at Pmax).

64 DPCHs at 30 kbps (SF=128) are distributed randomly across the code space, at random power levels and random timing offsets are defined so as to simulate a realistic traffic scenario which may have high PAR (Peak to Average Ratio).

Considering that not every base station implementation will support 64 DPCH, variants of this test model containing 32 and 16 DPCH are also specified. For Home base station, additional options of this test model containing 8 and 4 DPCH are also specified. The conformance test shall be performed using the largest of these options that can be supported by the equipment under test.

"Fraction of power" is relative to the maximum output power on the TX antenna interface under test.

Table 6.1: TM1 Active Channels

Type	Number of Channels	Fraction of Power (%)	Level setting (dB)	Channelization Code	Timing offset ($\times 256T_{\text{chip}}$)
P-CCPCH+SCH	1	10	-10	1	0
Primary CPICH	1	10	-10	0	0
PICH	1	1.6	-18	16	120
S-CCPCH containing PCH (SF=256)	1	1.6	-18	3	0
DPCH (SF=128)	4*/8*/16/32/6 4	76.8 in total	see table 6.2	see table 6.2	see table 6.2
Note *: Only applicable to Home BS					

Table 6.2: DPCH Spreading Code, Timing offsets and level settings for TM1

Code	Timing offset (x256T _{chip})	Level settings (dB) (4 codes)*	Level settings (dB) (8 codes)*	Level settings (dB) (16 codes)	Level settings (dB) (32 codes)	Level settings (dB) (64 codes)
2	86	-5	-7	-10	-13	-16
11	134		-16	-12	-13	-16
17	52			-12	-14	-16
23	45			-14	-15	-17
31	143			-11	-17	-18
38	112	-7	-11	-13	-14	-20
47	59			-17	-16	-16
55	23		-11	-16	-18	-17
62	1			-13	-16	-16
69	88			-15	-19	-19
78	30	-9	-10	-14	-17	-22
85	18		-12	-18	-15	-20
94	30			-19	-17	-16
102	61			-17	-22	-17
113	128		-8	-15	-20	-19
119	143	-9	-12	-9	-24	-21
7	83				-20	-19
13	25				-18	-21
20	103				-14	-18
27	97				-14	-20
35	56				-16	-24
41	104				-19	-24
51	51				-18	-22
58	26				-17	-21
64	137				-22	-18
74	65				-19	-20
82	37				-19	-17
88	125				-16	-18
97	149				-18	-19
108	123				-15	-23
117	83				-17	-22
125	5				-12	-21
4	91					-17
9	7					-18
12	32					-20
14	21					-17
19	29					-19
22	59					-21
26	22					-19
28	138					-23
34	31					-22
36	17					-19
40	9					-24
44	69					-23
49	49					-22
53	20					-19
56	57					-22
61	121					-21
63	127					-18
66	114					-19
71	100					-22
76	76					-21
80	141					-19
84	82					-21
87	64					-19
91	149					-21
95	87					-20
99	98					-25
105	46					-25
110	37					-25
116	87					-24

Code	Timing offset (x256T _{chip})	Level settings (dB) (4 codes)*	Level settings (dB) (8 codes)*	Level settings (dB) (16 codes)	Level settings (dB) (32 codes)	Level settings (dB) (64 codes)
118	149					-22
122	85					-20
126	69					-15
Note *: Only applicable to Home BS						

6.1.1.2 Test Model 2 – TM2

This model shall be used for tests on:

- output power dynamics.
- CPICH power accuracy.

Table 6.3: TM2 Active Channels

Type	Number of Channels	Fraction of Power (%)	Level setting (dB)	Channelization Code	Timing offset (x256T _{chip})
P-CCPCH+SCH	1	10	-10	1	0
Primary CPICH	1	10	-10	0	0
PICH	1	5	-13	16	120
S-CCPCH containing PCH (SF=256)	1	5	-13	3	0
DPCH (SF=128)	3	2 x 10, 1 x 50	2 x -10, 1 x -3	24, 72, 120	1, 7, 2

6.1.1.3 Test Model 3 – TM3

This model shall be used for tests on:

- peak code domain error.

Table 6.4: TM3 Active Channels

Type	Number of Channels	Fraction of Power (%) 4*/8*/16/32	Level settings (dB) 4*/8*/16/32	Channelization Code	Timing offset (x256T _{chip})
P-CCPCH+SCH	1	15,8/15,8/12,6 /7,9	-8/ -8 / -9 / -11	1	0
Primary CPICH	1	15,8/15,8/12,6 /7,9	-8 / -8 / -9 / -11	0	0
PICH	1	2,5/2,5/5/1,6	-16/-16/-13/-18	16	120
S-CCPCH containing PCH (SF=256)	1	2,5/2,5/5/1,6	-16/-16/-13/-18	3	0
DPCH (SF=256)	4*/8*/16/32	63,4/63,4/63,7 /80,4 in total	see table 6.5	see table 6.5	see table 6.5
Note *: Only applicable to Home BS					

As with TM1, not every base station implementation will support 32 DPCH, a variant of this test model containing 16 DPCH are also specified. For Home base station, additional options of this test model containing 8 and 4 DPCH are also specified. The conformance test shall be performed using the larger of these options that can be supported by the equipment under test.

Table 6.5: DPCH Spreading Code, Toffset and Power for TM3

Code	T _{offset}	Level settings (dB) (4 codes)*	Level settings (dB) (8 codes)*	Level settings (dB) (16 codes)	Level settings (dB) (32 codes)
64	86	-8	-11	-14	-16
69	134			-14	-16
74	52		-11	-14	-16
78	45			-14	-16
83	143			-14	-16
89	112	-8	-11	-14	-16
93	59			-14	-16
96	23		-11	-14	-16
100	1			-14	-16
105	88			-14	-16
109	30	-8	-11	-14	-16
111	18		-11	-14	-16
115	30			-14	-16
118	61			-14	-16
122	128		-11	-14	-16
125	143	-8	-11	-14	-16
67	83				-16
71	25				-16
76	103				-16
81	97				-16
86	56				-16
90	104				-16
95	51				-16
98	26				-16
103	137				-16
108	65				-16
110	37				-16
112	125				-16
117	149				-16
119	123				-16
123	83				-16
126	5				-16
Note *: Only applicable to Home BS					

6.1.1.4 Test Model 4 – TM4

This model shall be used for tests on:

- EVM measurement
- Total power dynamic range
- Frequency error

Table 6.6: TM4 Active Channels

Type	Number of Channels	Fraction of Power (%)	Level setting (dB)	Channelization Code	Timing offset
PCCPCH+SCH when Primary CPICH is disabled	1	$100 \cdot 10^{\frac{-X}{10}}$	-X	1	0
PCCPCH+SCH when Primary CPICH is enabled	1	$100 \cdot 10^{\frac{-X-3}{10}}$	-X-3	1	0
Primary CPICH1	1	$100 \cdot 10^{\frac{-X-3}{10}}$	-X-3	0	0
Note 1: The CPICH channel is optional.					

6.1.1.4A Test Model 5 – TM5

This model shall be used for tests on:

- EVM for base stations supporting HS-PDSCH transmission using 16QAM modulation (at Pmax)

Considering that not every base station implementation will support 8 HS-PDSCH + 30 DPCH, variants of this test model containing 4 HS-PDSCH + 14 DPCH and 2 HS-PDSCH + 6 DPCH are also specified. For Home base station, an additional option of this test model containing 4 HS-PDSCH + 4 DPCH is also specified. The conformance test shall be performed using the largest of these options that can be supported by the equipment under test, where the largest is firstly determined by the number of HS-PDSCH and then by the number of DPCH.

Each HS-PDSCH is modulated by 16QAM.

Table 6.6A: TM5 Active Channels

Type	Number of Channels	Fraction of Power (%)	Level setting (dB)	Channelization Code	Timing offset ($\times 256T_{\text{chip}}$)
P-CCPCH+SCH	1	7.9	-11	1	0
Primary CPICH	1	7.9	-11	0	0
PICH	1	1.3	-19	16	120
S-CCPCH containing PCH (SF=256)	1	1.3	-19	3	0
DPCH (SF=128)	30/14/6/4(*)	14/14.2/14.4/14.2 in total	see table 6.6.B	see table 6.6B	see table 6.6.B
HS-SCCH	2	4 in total	see table 6.6C	see table 6.6C	see table 6.6C
HS-PDSCH (16QAM)	8/4/2(*)	63.6/63.4/63.2 in total	see table 6.6D	see table 6.6D	see table 6.6D
Note *: 2 HS-PDSCH shall be taken together with 6 DPCH, 4 HS-PDSCH shall be taken with 14 DPCH or (for Home BS only) 4 DPCH, and 8 HS-PDSCH shall be taken together with 30 DPCH.					

Table 6.6B: DPCH Spreading Code, Timing offsets and level settings for TM5

Code (SF=128)	Timing offset (x256T _{chip})	Level settings (dB) (30 codes)	Level settings (dB) (14 codes)	Level settings (dB) (6 codes)	Level settings (dB) (4 codes)*
15	86	-20	-17	-17	-15
23	134	-20	-19	-15	-15
68	52	-21	-19	-15	-18
76	45	-22	-20	-18	-12
82	143	-24	-18	-16	
90	112	-21	-20	-17	
5	59	-23	-25		
11	23	-25	-23		
17	1	-23	-20		
27	88	-26	-22		
64	30	-24	-21		
72	18	-22	-22		
86	30	-24	-19		
94	61	-28	-20		
3	128	-27			
7	143	-26			
13	83	-27			
19	25	-25			
21	103	-21			
25	97	-21			
31	56	-23			
66	104	-26			
70	51	-25			
74	26	-24			
78	137	-27			
80	65	-26			
84	37	-23			
88	125	-25			
89	149	-22			
92	123	-24			
Note *: Only applicable to Home BS					

Table 6.6C: HS-SCCH Spreading Code, Timing offsets and level settings for TM5

Code (SF=128)	Timing offset (x256T _{chip})	Level settings (dB)
9	0	-15
29	0	-21

Table 6.6D: HS-PDSCH Spreading Code, Timing offsets, level settings for TM5

Code (SF=16)	Timing offset (x256T _{chip})	Level settings (dB) (8 codes)	Level settings (dB) (4 codes)	Level settings (dB) (2 codes)
4	0	-11	-8	-5
5	0	-11	-8	
6	0	-11		
7	0	-11		
12	0	-11	-8	-5
13	0	-11	-8	
14	0	-11		
15	0	-11		

6.1.1.4B Test Model 6 – TM6

This model shall be used for tests on:

- Relative CDE for base stations supporting HS-PDSCH transmission using 64QAM modulation

For Home base station, an additional option of this test model containing 4 HS-PDSCH + 4 DPCH is also specified. The conformance test shall be performed using the larger option that can be supported by the Home base station under test.

Each HS-PDSCH is modulated by 64QAM.

Table 6.6E: TM6 Active Channels

Type	Number of Channels	Fraction of Power (%)	Level setting (dB)	Channelization Code	Timing offset ($\times 256T_{\text{chip}}$)
P-CCPCH+SCH	1	7.9	-11	1	0
Primary CPICH	1	7.9	-11	0	0
PICH	1	1.3	-19	16	120
S-CCPCH containing PCH (SF=256)	1	1.3	-19	3	0
DPCH (SF=128)	30/4*	27.1 in total	see table 6.6F	see table 6.6F	see table 6.6F
HS-SCCH	2	4 in total	see table 6.6G	see table 6.6G	see table 6.6G
HS-PDSCH (64QAM)	8/4*	50.5 in total	see table 6.6H	see table 6.6H	see table 6.6H
Note *: 8 HS-PDSCH shall be taken together with 30 DPCH, and (for Home BS only) 4 HS-PDSCH shall be taken with 4 DPCH.					

Table 6.6F: DPCH Spreading Code, Timing offsets and level settings for TM6

Code (SF=128)	Timing offset ($\times 256T_{\text{chip}}$)	Level settings (dB) (30 codes)	Level settings (dB) (4 codes)*
15	86	-17	-13
23	134	-17	-15
68	52	-18	-9
76	45	-19	-12
82	143	-21	
90	112	-18	
5	59	-20	
11	23	-22	
17	1	-20	
27	88	-23	
64	30	-21	
72	18	-19	
86	30	-21	
94	61	-25	
3	128	-24	
7	143	-23	
13	83	-24	
19	25	-22	
21	103	-18	
25	97	-18	
31	56	-20	
66	104	-23	
70	51	-22	
74	26	-21	
78	137	-24	
80	65	-23	
84	37	-22	
88	125	-22	
89	149	-22	
92	123	-21	
Note *: Only applicable to Home BS			

Table 6.6G: HS-SCCH Spreading Code, Timing offsets and level settings for TM6

Code (SF=128)	Timing offset (x256T _{chip})	Level settings (dB)
9	0	-15
29	0	-21

Table 6.6H: HS-PDSCH Spreading Code, Timing offsets, level settings for TM6

Code (SF=16)	Timing offset (x256T _{chip})	Level settings (dB) (8 codes)	Level settings (dB) (4 codes)*
4	0	-12	-9
5	0	-12	-9
6	0	-12	
7	0	-12	
12	0	-12	-9
13	0	-12	-9
14	0	-12	
15	0	-12	

Note *: Only applicable to Home BS

6.1.1.5 DPCH Structure of the Downlink Test Models

For the above test models the following structure is adopted for the DPCH. The DPDCH and DPCCH have the same power level. The timeslot structure should be as described by TS 25.211-slot format 10 and 6 that are reproduced in table 6.7.

Table 6.7: DPCH structure of the downlink Test Models

Slot Format #1	Channel Bit Rate (kbps)	Channel Symbol Rate (ksps)	SF	Bits/Frame			Bits/Slot	DPDCH Bits/Slot		DPCCH Bits/Slot		
				DPDCH	DPCCH	TOT		NData1	Ndata2	NTFCI	NTPC	Npilot
10	60	30	128	450	150	600	40	6	24	0	2	8
6	30	15	256	150	150	300	20	2	8	0	2	8

The test DPCH has frame structure so that the pilot bits are defined over 15 timeslots according to the relevant columns of TS 25.211, which are reproduced in table 6.8.

Table 6.8: Frame structure of DPCH

Symbol #	N _{pilot} = 8			
	0	1	2	3
Slot #0	11	11	11	10
1	11	00	11	10
2	11	01	11	01
3	11	00	11	00
4	11	10	11	01
5	11	11	11	10
6	11	11	11	00
7	11	10	11	00
8	11	01	11	10
9	11	11	11	11
10	11	01	11	01
11	11	10	11	11
12	11	10	11	00
13	11	00	11	11
14	11	00	11	11

The TPC bits alternate 00 / 11 starting with 00 in timeslot 0.

The aggregate $15 \times 30 = 450$ DPDCH bits per frame are filled with a PN9 sequence generated using the primitive trinomial $x^9 + x^4 + 1$. In case there are less data bits/frame needed then the first bits of the aggregate shall be selected. To ensure non-correlation of the PN9 sequences, each DPDCH shall use its channelization code as the seed for the PN sequence at the start of each frame, according to its timing offset.

The sequence shall be generated in a nine-stage shift register whose 5th and 9th stage outputs are added in a modulo-two addition stage, and the result is fed back to the input of the first stage. The generator shall be seeded so that the sequence begins with the channelization code starting from the LSB, and followed by 2 consecutive ONES for SF=128 and 1 consecutive ONE for SF=256.

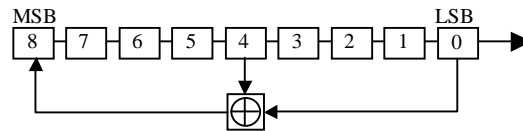

Figure 6.2

6.1.1.6 Common channel Structure of the Downlink Test Models

6.1.1.6.1 P-CCPCH

The aggregate $15 \times 18 = 270$ P-CCPCH bits per frame are filled with a PN9 sequence generated using the primitive trinomial $x^9 + x^4 + 1$. Channelization code of the P-CCPCH is used as the seed for the PN sequence at the start of each frame.

The generator shall be seeded so that the sequence begins with the 8 bit channelization code starting from the LSB, and followed by a ONE.

6.1.1.6.2 PICH

PICH carries 18 Paging Indicators (Pq) sent in the following sequence from left to right [1 0 1 1 0 0 0 1 0 1 1 0 0 0 1 0 1 0]. This defines the 288 first bits of the PICH. No power is transmitted for the 12 remaining unused bits.

6.1.1.6.3 Primary scrambling code and SCH

The scrambling code should be 0.

Where multiple repetitions of the Test Model signals are being used to simulate a multi-carrier signal the scrambling code for the lower frequency is 0. Carriers added at successively higher frequencies use codes 1, 2,... and their frame structures are time offset by $1/5, 2/5...$ of a time slot duration.

The scrambling code defines the SSC sequence of the secondary SCH. In their active part, primary and secondary SCH share equally the power level defined for "PCCPCH+SCH".

6.1.1.6.4 S-CCPCH containing PCH

The aggregate $15 \times 20 = 300$ S-CCPCH bits per frame are used. Data bits are filled with a PN9 sequence generated using the primitive trinomial $x^9 + x^4 + 1$. In case there are less data bits/frame needed then the first bits of the aggregate shall be selected.. Channelization code of the S-CCPCH is used as the seed for the PN sequence at the start of each frame. For test purposes, any one of the four possible slot formats 0,1, 2 and 3 can be supported. The support for all four slot formats is not needed..

The generator shall be seeded so that the sequence begins with the 8 bit channelization code starting from the LSB, and followed by a ONE. The test on S-CCPCH has a frame structure so that the pilot bits are defined over 15 timeslots to the relevant columns of TS 25.211. The TFCI bits are filled with ONES whenever needed.

6.1.1.7 HS-PDSCH Structure of the Downlink TM5

There are 640 bits per slot in a 16QAM-modulated HS-PDSCH. The aggregate $15 \times 640 = 9600$ bits per frame are filled with repetitions of a PN9 sequence generated using the primitive trinomial $x^9 + x^4 + 1$. To ensure non-correlation of the PN9 sequences, each HS-PDSCH shall use its channelization code multiplied by 23 as the seed for the PN sequence at the start of each frame.

The generator shall be seeded so that the sequence begins with the channelization code multiplied by 23 starting from the LSB.

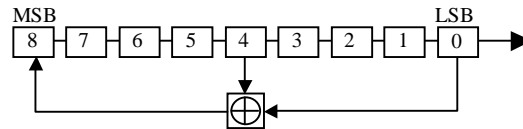

Figure 6.2

6.1.1.8 HS-SCCH Structure of the Downlink Test Models 5 and 6

There are 40 bits per time slot in a HS-SCCH. The aggregate $15 \times 40 = 600$ bits per frame are filled with repetitions of a PN9 sequence generated using the primitive trinomial $x^9 + x^4 + 1$. Channelization code of the HS-SCCH is used as the seed for the PN sequence at the start of each frame. The generator shall be seeded so that the sequence begins with the channelization code starting from the LSB, and followed by 2 consecutive ONES.

6.1.1.9 HS-PDSCH Structure of the Downlink TM6

There are 960 bits per slot in a 64QAM-modulated HS-PDSCH. The aggregate $15 \times 960 = 14400$ bits per frame are filled with repetitions of a PN9 sequence generated using the primitive trinomial $x^9 + x^4 + 1$. To ensure non-correlation of the PN9 sequences, each HS-PDSCH shall use its channelization code multiplied by 23 as the seed for the PN sequence at the start of each frame.

The generator shall be seeded so that the sequence begins with the channelization code multiplied by 23 starting from the LSB.

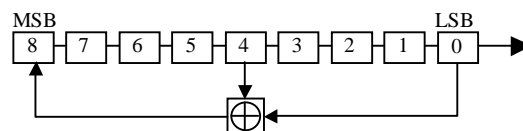

Figure 6.3

6.2 Base station output power

6.2.1 Base station maximum output power

6.2.1.1 Definition and applicability

In certain regions, the minimum requirement for normal conditions may apply also for some conditions outside the ranges defined for the Normal test environment in clause 4.4.1.

The rated output power, PRAT, of the BS shall be as specified in Table 6.8AA.

Table 6.8AA: Base Station rated output power

BS class	PRAT
Wide Area BS	- (note)
Medium Range BS	$\leq +38$ dBm
Local Area BS	$\leq +24$ dBm
Home BS	$\leq +20$ dBm (without transmit diversity or any MIMO mode) $\leq +17$ dBm (with transmit diversity or MIMO mode) $< +14$ dBm (with MIMO mode with four transmit antennas)
NOTE: There is no upper limit required for the rated output power of the Wide Area Base Station like for the base station for General Purpose application in Release 99, 4, and 5.	

6.2.1.2 Minimum Requirement

The minimum requirement is in TS 25.104 [1] clause 6.2.1.

6.2.1.3 Test purpose

The test purpose is to verify the accuracy of the maximum output power across the frequency range and under normal and extreme conditions for all transmitters in the BS.

6.2.1.4 Method of test

6.2.1.4.1 Initial conditions

Test environment: normal; see clause 4.4.1.

RF channels to be tested for single carrier: B, M and T; see clause 4.8.

RF bandwidth positions to be tested for multi-carrier: B_{RFBW} , M_{RFBW} and T_{RFBW} in single band operation; $B''_{\text{RFBW_T}}_{\text{RFBW}}$ and $B''_{\text{RFBW_T}}_{\text{RFBW}}$ in multi-band operation; see subclause 4.8.1.

In addition, for only one UARFCN or BS RF bandwidth position, the test shall be performed under extreme power supply as defined in clause 4.4.4

NOTE: Tests under extreme power supply also test extreme temperature.

- 1) Connect the power measuring equipment to the base station antenna connector.

6.2.1.4.2 Procedure

- 1) For a BS declared to be capable of single carrier operation only, set the BS to transmit a signal in accordance to TM1, clause 6.1.1.1, at manufacturer's declared rated output power, PRAT.

For a BS declared to be capable of multi-carrier operation, set the base station to transmit according to TM1 on all carriers configured using the applicable test configuration and corresponding power setting specified in sub-clause 4.12.

- 2) Measure the mean power for each carrier, P_{out} , at the BS antenna connector.

In addition, for a multi-band capable BS, the following steps shall apply:

- 3) For multi-band capable BS and single band tests, repeat the steps above per involved band where single band test configurations and test models shall apply with no carrier activated in the other band.
- 4) For multi-band capable BS with separate antenna connector, the antenna connector not being under test in case of single-band or multi-band test shall be terminated.

6.2.1.5 Test Requirements

In normal conditions, the measurement result in step 2 of 6.2.1.4.2 shall remain:

within +2.7 dB and -2.7 dB of the manufacturer's rated output power, PRAT, for carrier frequency $f \leq 3.0$ GHz,

within +3.0 dB and -3.0 dB of the manufacturer's rated output power, PRAT, for carrier frequency $3.0 \text{ GHz} < f \leq 4.2$ GHz.

In extreme conditions, measurement result in step 2 of 6.2.1.4.2 shall remain:

within +3.2 dB and -3.2 dB of the manufacturer's rated output power, PRAT, for carrier frequency $f \leq 3.0$ GHz,

within +3.5 dB and -3.5 dB of the manufacturer's rated output power, PRAT, for carrier frequency $3.0 \text{ GHz} < f \leq 4.2$ GHz.

NOTE: If the above Test Requirement differs from the Minimum Requirement then the Test Tolerance applied for this test is non-zero. The Test Tolerance for this test is defined in clause 4.2 and the explanation of how the Minimum Requirement has been relaxed by the Test Tolerance is given in Annex F.

6.2.2 Primary CPICH power accuracy

6.2.2.1 Definition and applicability

Primary CPICH (P-CPICH) power is the code domain power of the Primary Common Pilot Channel. P-CPICH power is indicated on the BCH. The requirement is applicable for all BS types.

6.2.2.2 Minimum Requirement

The minimum requirement is in TS 25.104 [1] clause 6.4.4.

6.2.2.3 Test purpose

The purpose of the test is to verify, that the BS under test delivers Primary CPICH code domain power within margins, thereby allowing reliable cell planning and operation.

6.2.2.4 Method of test

6.2.2.4.1 Initial conditions

Test environment: normal; see clause 4.4.1.

RF channels to be tested: B, M and T; see clause 4.8

- 1) Connect BS to code domain analyser as shown in annex B.1.2.
- 2) Disable inner loop power control.
- 3) Set the BS to transmit a signal in accordance to TM2, clause 6.1.1.2, at manufacturer's declared rated output power, PRAT. In case of transmit diversity or MIMO transmission the configured Primary CPICH code domain power per antenna connector shall be declared by the manufacturer.

6.2.2.4.2 Procedure

- Measure the P-CPICH power in one timeslot according to annex E.

In addition, for a multi-band capable BS, the following steps shall apply:

- 1) For multi-band capable BS and single band tests, repeat the steps above per involved band where single carrier test models shall apply with no carrier activated in the other band.

- 2) For multi-band capable BS with separate antenna connector, the antenna connector not being under test shall be terminated.

6.2.2.5 Test Requirement

The measured P-CPICH code domain power shall be:

within ± 2.9 dB of the configured absolute value for carrier frequency $f \leq 3.0$ GHz

within +3.2 dB and -3.2 dB of the configured absolute value for carrier frequency $3.0 \text{ GHz} < f \leq 4.2 \text{ GHz}$.

NOTE: If the above Test Requirement differs from the Minimum Requirement then the Test Tolerance applied for this test is non-zero. The Test Tolerance for this test is defined in clause 4.2 and the explanation of how the Minimum Requirement has been relaxed by the Test Tolerance is given in Annex F.

6.2.3 Secondary CPICH power offset accuracy

6.2.3.1 Definition and applicability

Secondary CPICH (S-CPICH) power is the code domain power of the Secondary Common Pilot Channel. S-CPICH power is equal to the sum of the P-CPICH power and the power offset, which are signalled to the UE. The power offset for MIMO mode is signalled in the IE 'Power Offset for S-CPICH for MIMO', defined in section 10.3.6.41b in TS 25.331. The requirement is applicable for BS supporting MIMO operation. If the manufacturer declares the implementation of a Virtual Antenna Mapping (VAM), then this test will not be performed.

For MIMO mode with four transmit antennas, the power offset of S-CPICH on antenna 2 is signalled in the IE 'Power Offset for S-CPICH for MIMO mode with four transmit antennas on Antenna2' as defined in section 10.3.6.143 in TS 25.331 [11]. The power offset of S-CPICH on antenna 3 and 4 is signalled in the IE 'Common Power Offset for S-CPICH for MIMO mode with four transmit antennas on Antenna 3 and 4', as defined in section 10.3.6.143 in TS 25.331.

6.2.3.2 Minimum Requirement

The minimum requirement is in TS 25.104 [1] clause 6.4.4A.1 for MIMO mode and in subclause 6.4.4A.2 for MIMO mode with four transmit antennas.

6.2.3.3 Test purpose

The purpose of the test is to verify, that the BS under test delivers the advertised power offset for S-CPICH power within margins, thereby allowing reliable MIMO HS-DSCH demodulation and CQI reporting.

6.2.3.4 Method of test for MIMO mode

6.2.3.4.1 Initial conditions

Test environment: normal; see clause 4.4.1.

RF channels to be tested: B, M and T; see clause 4.8

- 1) Connect BS to code domain analyser as shown in annex B.1.2. Figure B.2A.
- 2) Disable inner loop power control.
- 3) Set the BS to transmit a signal in accordance to TM2, clause 6.1.1.2, at manufacturer's declared rated output power, PRAT. The configured Primary CPICH code domain power intended per antenna connector shall be declared by the manufacturer.
- 4) The same BS set up is applied on both the antenna connectors.

6.2.3.4.2 Procedure

- During the same timeslot:
 - 1) Measure the P-CPICH power, according to annex E on first antenna connector.
 - 2) Measure the P-CPICH power, according to annex E on second antenna connector.

In addition, for a multi-band capable BS, the following steps shall apply:

- 3) For multi-band capable BS and single band tests, repeat the steps above per involved band where single carrier test models shall apply with no carrier activated in the other band.
- 4) For multi-band capable BS with separate antenna connector, the antenna connector not being under test shall be terminated.

6.2.3.4A Method of test for MIMO mode with four transmit antennas

6.2.3.4A.1 Initial conditions

Test environment: normal; see subclause 4.4.1.

RF channels to be tested: B, M and T; see subclause 4.8

- 1) Connect BS to code domain analyser as shown in annex B.1.2. Figure B.2A.
- 2) Disable inner loop power control.
- 3) Set-up BS transmission at manufacturer's declared rated output power per carrier, PRAT. Channel set-up shall be according to TM2 subclause 6.1.1.2. Primary CPICH code domain power intended per antenna connector shall be declared by the manufacturer.
- 4) The same BS set up is applied on antenna connectors 1, 2, 3, 4.

6.2.3.4A.2 Procedure

- a) Measure the P-CPICH power, on first antenna connector.
- b) Measure the P-CPICH power, on second antenna connector.
- c) Measure the P-CPICH power, on third antenna connector.
- d) Measure the P-CPICH power, on fourth antenna connector.

6.2.3.5 Test Requirement for MIMO mode

The difference between measured P-CPICH power on two different antenna connectors shall be:

within ± 2.7 dB for carrier frequency $f \leq 3.0$ GHz,

within ± 3.0 dB for carrier frequency $3.0 \text{ GHz} < f \leq 4.2 \text{ GHz}$.

NOTE: If the above Test Requirement differs from the Minimum Requirement then the Test Tolerance applied for this test is non-zero. The Test Tolerance for this test is defined in clause 4.2 and the explanation of how the Minimum Requirement has been relaxed by the Test Tolerance is given in Annex F.

6.2.3.5A Test Requirement for MIMO mode with four transmit antennas

The difference between measured P-CPICH powers on any two different antenna connectors shall be:

within ± 2.7 dB for carrier frequency $f \leq 3.0$ GHz,

within ± 3.0 dB for carrier frequency $3.0 \text{ GHz} < f \leq 4.2 \text{ GHz}$.

NOTE: If the above Test Requirement differs from the Minimum Requirement then the Test Tolerance applied for this test is non-zero. The Test Tolerance for this test is defined in subclause 4.2 and the explanation of how the Minimum Requirement has been relaxed by the Test Tolerance is given in Annex F.

6.3 Frequency error

6.3.1 Definition and applicability

Frequency error is the measure of the difference between the actual BS transmit frequency and the assigned frequency. The same source shall be used for RF frequency and data clock generation.

It is not possible to verify by testing that the data clock is derived from the same frequency source as used for RF generation. This may be confirmed by a manufacturers declaration

6.3.2 Minimum Requirement

The minimum requirement is in TS 25.104 [1] clause 6.3.

Table 6.8A: (void)

6.3.3 Test purpose

To verify that the Frequency Error is within the limit of the minimum requirement.

6.3.4 Method of test

Requirement is tested together with Error Vector Magnitude test, as described in clause 6.7.1.4.

6.3.5 Test requirement

The Frequency Error for every measured slot shall be between the minimum and maximum value specified in Table 6.8B.

Table 6.8B: Frequency error test requirement

BS class	Minimum frequency error	Maximum frequency error
Wide Area BS	-0.05 ppm - 12 Hz	+0.05 ppm + 12 Hz
Medium Range BS	-0.1 ppm - 12 Hz	+0.1 ppm + 12 Hz
Local Area BS	-0.1 ppm - 12 Hz	+0.1 ppm + 12 Hz
Home BS	-0.25 ppm - 12 Hz	+0.25 ppm + 12 Hz

NOTE: If the above Test Requirement differs from the Minimum Requirement then the Test Tolerance applied for this test is non-zero. The Test Tolerance for this test is defined in clause 4.2 and the explanation of how the Minimum Requirement has been relaxed by the Test Tolerance is given in Annex F.

6.4 Output power dynamics

Power control is used to limit the interference level. The BS transmitter uses a quality-based power control on the downlink. The physical channels for the following test(s) shall be set-up according to clause 6.1.1.2.

6.4.1 Inner loop power control

Inner loop power control in the downlink is the ability of the BS transmitter to adjust the code domain power of a code channel in accordance with the corresponding TPC symbols received in the uplink.

6.4.2 Power control steps

The power control step is the required step change in the code domain power of a code channel in response to the corresponding power control command. The combined output power change is the required total change in the DL transmitter output power of a code channel in response to multiple consecutive power control commands corresponding to that code channel.

6.4.2.1 Definition and applicability

Inner loop power control in the downlink is the ability of the BS transmitter to adjust the transmitter output power of a code channel in accordance with the corresponding TPC symbols received in the uplink.

The power control step is the required step change in the DL transmitter output power of a code channel in response to the corresponding power control command. The combined output power change is the required total change in the DL transmitter output power of a code channel in response to multiple consecutive power control commands corresponding to that code channel.

6.4.2.2 Minimum Requirement

The minimum requirement is in TS 25.104 [1] clause 6.4.1.1.1.

Table 6.9: (void)

Table 6.10: (void)

6.4.2.3 Test purpose

To verify those requirements for the power control step size and response are met as specified in clause 6.4.2.2.

6.4.2.4 Method of test

6.4.2.4.1 Initial conditions

Test environment: normal; see clause 4.4.1.

RF channels to be tested: B, M and T; see clause 4.8

- 1) Connect the suitable measurement equipment to the BS antenna connector as shown in annex B.
- 2) Set the BS to transmit a signal in accordance to TM2, clause 6.1.1.2, at manufacturer's declared rated output power, PRAT.

The DPCH intended for power control is on channel 120 starting at -3 dB.

- 3) Establish downlink power control with parameters as specified in table 6.11.

Table 6.11

Parameter	Level/status	Unit
UL signal mean power	Ref.sens + 10 dB	dBm
Data sequence	PN9	

6.4.2.4.2 Procedure

- 1) Set and send alternating TPC bits from the UE simulator or UL signal generator.
- 2) Measure mean power level of the code under the test each time TPC command is transmitted. All steps within power control dynamic range declared by manufacturer shall be measured. Use the code domain power measurement method defined in annex E.

- 3) Measure the 10 highest and the 10 lowest power step levels within the power control dynamic range declared by manufacturer by sending 10 consecutive equal commands as described table 6.10.

In addition, for a multi-band capable BS, the following steps shall apply:

- 4) For multi-band capable BS and single band tests, repeat the steps above per involved band where single carrier test models shall apply with no carrier activated in the other band.
- 5) For multi-band capable BS with separate antenna connector, the antenna connector not being under test shall be terminated.

6.4.2.5 Test requirement

- a) BS shall fulfil step size requirement shown in Table 6.12 for all power control steps declared by manufacture as specified in clause 6.4.2.2.
- b) For all measured Up/Down cycles, the difference of code domain power between before and after 10 equal commands (Up and Down), derived in step (3), shall not exceed the prescribed tolerance in table 6.13.

Table 6.12: Transmitter power control step tolerance

Power control commands in the downlink	Transmitter power control step tolerance							
	2 dB step size		1.5 dB step size		1 dB step size		0.5 dB step size	
	Lower	Upper	Lower	Upper	Lower	Upper	Lower	Upper
Up(TPC command "1")	+0.9 dB	+3.1 dB	+0.65 dB	+2.35 dB	+0.4 dB	+1.6 dB	+0.15 dB	+0.85 dB
Down(TPC command "0")	-0.9 dB	-3.1 dB	-0.65 dB	-2.35 dB	-0.4 dB	-1.6 dB	-0.15 dB	-0.85 dB

Table 6.13: Transmitter aggregated power control step range

Power control commands in the downlink	Transmitter aggregated power control step range after 10 consecutive equal commands (up or down)							
	2 dB step size		1.5 dB step size		1 dB step size		0.5 dB step size	
	Lower	Upper	Lower	Upper	Lower	Upper	Lower	Upper
Up(TPC command "1")	+15.9 dB	+24.1 dB	+11.9 dB	+18.1 dB	+7.9 dB	+12.1 dB	+3.9 dB	+6.1 dB
Down(TPC command "0")	-15.9 dB	-24.1 dB	-11.9 dB	-18.1 dB	-7.9 dB	-12.1 dB	-3.9 dB	-6.1 dB

NOTE: If the above Test Requirement differs from the Minimum Requirement then the Test Tolerance applied for this test is non-zero. The Test Tolerance for this test is defined in clause 4.2 and the explanation of how the Minimum Requirement has been relaxed by the Test Tolerance is given in Annex F.

6.4.3 Power control dynamic range

6.4.3.1 Definition and applicability

The power control dynamic range is the difference between the maximum and the minimum code domain power of a code channel for a specified reference condition. Transmit modulation quality shall be maintained within the whole dynamic range as specified in TS 25.104 [1] clause 6.8.

6.4.3.2 Minimum Requirement

The minimum requirement is in TS 25.104 [1] clause 6.4.2.1.

6.4.3.3 Test purpose

To verify that the minimum power control dynamic range is met as specified by the minimum requirement.

6.4.3.4 Method of test

6.4.3.4.1 Initial conditions

Test environment: normal; see clause 4.4.1.

RF channels to be tested: B, M and T; see clause 4.8

- 1) Connect the measurement equipment to the BS antenna connector as shown in annex B.

6.4.3.4.2 Procedure

- 1) Set the BS to transmit a signal in accordance to TM2, clause 6.1.1.2, at manufacturers declared rated output power, PRAT.
- 2) Using TM2, set the code domain power of the DPCH under test to PRAT - 3 dB. Power levels for other code channels may be adjusted if necessary.
- 3) Measure the code domain power of the code channel under test. Use the code domain power measurement method defined in annex E.
- 4) Set the code domain power of the DPCH under test to PRAT - 28 dB by means determined by the manufacturer. The power levels for the other code channels used in step 2 shall remain unchanged (the overall output power will drop by approximately 3 dB).
- 5) Measure the code domain power of the code channel under test.

In addition, for a multi-band capable BS, the following steps shall apply:

- 6) For multi-band capable BS and single band tests, repeat the steps above per involved band where single carrier test models shall apply with no carrier activated in the other band.
- 7) For multi-band capable BS with separate antenna connector, the antenna connector not being under test shall be terminated.

6.4.3.5 Test requirement

Downlink (DL) power control dynamic range:

- maximum code domain power: BS maximum output power -4.1 dB or greater;
- minimum code domain power: BS maximum output power -26.9 dB or less.

NOTE: If the above Test Requirement differs from the Minimum Requirement then the Test Tolerance applied for this test is non-zero. The Test Tolerance for this test is defined in clause 4.2 and the explanation of how the Minimum Requirement has been relaxed by the Test Tolerance is given in Annex F.

6.4.4 Total power dynamic range

6.4.4.1 Definition and applicability

The downlink total power dynamic range is the difference between the maximum and the minimum output power per carrier for a specified reference condition.

6.4.4.2 Minimum Requirement

The minimum requirement is in TS 25.104 [1] clause 6.4.3.1.

6.4.4.3 Test purpose

To verify that the total power dynamic range is met as specified by the minimum requirement. The test is to ensure that the total output power can be reduced while still transmitting a single code. This is to ensure that the interference to neighbouring cells is reduced.

6.4.4.4 Method of test

6.4.4.4.1 Initial Conditions

Test environment: normal; see clause 4.4.1.

RF channels to be tested: B, M and T; see clause 4.8

RF bandwidth positions to be tested for multi-carrier: B_{RFBW} , M_{RFBW} and T_{RFBW} in single band operation; see subclause 4.8.1.

Refer to annex B for a functional block diagram of the test set-up.

Connect the base station antenna connector to the measurement equipment.

6.4.4.4.2 Procedure

The downlink total dynamic range is computed as the difference of the maximum carrier output power, measured as defined in step 2 in clause 6.2.1.4.2 and the carrier power measured at step 3 of the Error Vector Magnitude test, as described in clause 6.7.1.4.2.

In addition, for a multi-band capable BS, the following steps shall apply:

- 1) For multi-band capable BS and single band tests, repeat the steps above per involved band where single carrier test models shall apply with no carrier activated in the other band.
- 2) For multi-band capable BS with separate antenna connector, the antenna connector not being under test shall be terminated.

6.4.4.5 Test requirement

The downlink total power dynamic range shall be 17.7 dB or greater.

NOTE: If the above Test Requirement differs from the Minimum Requirement then the Test Tolerance applied for this test is non-zero. The Test Tolerance for this test is defined in clause 4.2 and the explanation of how the Minimum Requirement has been relaxed by the Test Tolerance is given in Annex F.

6.4.5 IPDL time mask

6.4.5.1 Definition and applicability

To support IPDL location method, the Node B shall interrupt all transmitted signals in the downlink (i.e. common and dedicated channels).

The IPDL time mask specifies the limits of the BS output power during these idle periods.

The requirement in this section shall apply to BS supporting IPDL. The requirement applies to all output powers within the total power dynamic range as specified in TS 25.104 [1] clause 6.4.3.

6.4.5.2 Minimum Requirement

The minimum requirement is in TS 25.104 [1] clause 6.4.5.1.

6.4.5.3 Test purpose

The test purpose is to verify the ability of the BS to temporarily reduce its output power below a specified value to improve time difference measurements made by UE for location services.

6.4.5.4 Method of test

6.4.5.4.1 Initial conditions

Test environment: normal; see clause 4.4.1.

RF channels to be tested: B, M and T; see clause 4.8.

- 1) Connect the power measuring equipment to the BS antenna connector.
- 2) Set the BS to transmit a signal in accordance to TM1, clause 6.1.1.1, at manufacturer's declared rated output power, PRAT.
- 3) Configure the BS to produce idle periods in continuous mode. The IPDL parameters as defined in TS 25.214 [12] shall have the following values:

IP_Spacing = 5

IP_Length = 10 CPICH symbols

Seed = 0

6.4.5.4.2 Procedure

- 1) Measure the mean power at the BS antenna connector over a period starting 27 chips after the beginning of the IPDL period and ending 27 chips before the expiration of the IPDL period.

In addition, for a multi-band capable BS, the following steps shall apply:

- 2) For multi-band capable BS and single band tests, repeat the step above per involved band where single carrier test models shall apply with no carrier activated in the other band.
- 3) For multi-band capable BS with separate antenna connector, the antenna connector not being under test shall be terminated.

6.4.5.5 Test Requirements

The mean power measured according to step (1) in clause 6.4.5.4.2 shall be equal to or less than

BS maximum output power - 34.3 dB.

See also Figure 6.4

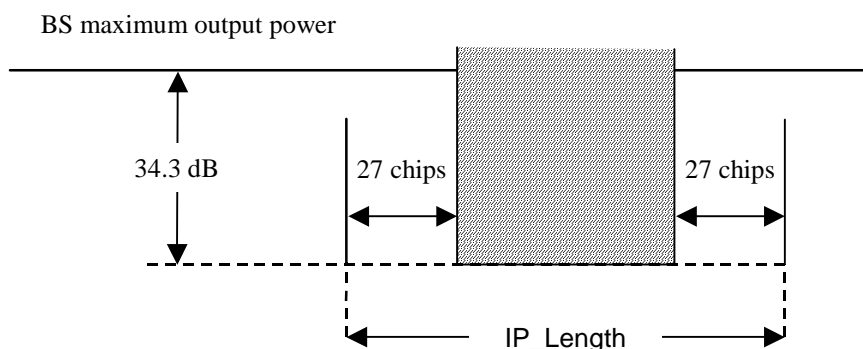

Figure 6.4: IPDL Time Mask

NOTE: If the above Test Requirement differs from the Minimum Requirement then the Test Tolerance applied for this test is non-zero. The Test Tolerance for this test is defined in clause 4.2 and the explanation of how the Minimum Requirement has been relaxed by the Test Tolerance is given in Annex F.

6.4.6 Home base station output power for adjacent channel protection

6.4.6.1 Definition and applicability

The Home BS shall be capable of adjusting the transmitter output power to minimize the interference level on the adjacent channels licensed to other operators in the same geographical area while optimize the Home BS coverage. These requirements are only applicable to Home BS. The requirements in this clause are applicable for AWGN radio propagation conditions.

The output power, P_{out} , of the Home BS shall be as specified in Table 6.13A under the following input conditions:

- $CPICH \hat{E}_c$, measured in dBm, is the code power of the Primary CPICH on one of the adjacent channels presented at the Home BS antenna connector for the CPICH received on the adjacent channels. If Tx diversity is applied on the Primary CPICH, $CPICH \hat{E}_c$ shall be the sum in [W] of the code powers of the Primary CPICH transmitted from each antenna.
- I_{oh} , measured in dBm, is the total received power density, including signals and interference but excluding the own Home BS signal, presented at the Home BS antenna connector on the Home BS operating channel.

In case that both adjacent channels are licensed to other operators, the most stringent requirement shall apply for P_{out} . In case the Home BS's operating channel and both adjacent channels are licensed to the same operator, the requirements of this clause do not apply.

The input conditions defined for the requirements in this section are specified at the antenna connector of the Home BS. For Home BS receivers with diversity, the requirements apply to each antenna connector separately, with the other one(s) terminated or disabled. The requirements are otherwise unchanged. For Home BS(s) without measurement capability, a reference antenna with a gain of 0 dBi is assumed for converting these power levels into field strength requirements.

Table 6.13A: Home BS output power for adjacent operator channel protection

Input Conditions	Output power, P_{out} (without transmit diversity or any MIMO mode)	Output power, P_{out} (with transmit diversity or MIMO mode)	Output power, P_{out} (with MIMO mode with four transmit antennas)
$I_{oh} > CPICH \hat{E}_c + 43 \text{ dB}$ and $CPICH \hat{E}_c \geq -105 \text{ dBm}$	$\leq 10 \text{ dBm}$	$\leq 7 \text{ dBm}$	$\leq 4 \text{ dBm}$
$I_{oh} \leq CPICH \hat{E}_c + 43 \text{ dB}$ and $CPICH \hat{E}_c \geq -105 \text{ dBm}$	$\leq \max(8 \text{ dBm}, \min(20 \text{ dBm}, CPICH \hat{E}_c + 100 \text{ dB}))$	$\leq \max(5 \text{ dBm}, \min(17 \text{ dBm}, CPICH \hat{E}_c + 97 \text{ dB}))$	$\leq \max(2 \text{ dBm}, \min(14 \text{ dBm}, CPICH \hat{E}_c + 94 \text{ dB}))$

NOTE 1: The Home BS transmitter output power specified in Table 6.13A assumes a Home BS reference antenna gain of 0 dBi, an target outage zone of 47dB around the Home BS for an UE on the adjacent channel, with an allowance of 2 dB for measurement errors, an ACIR of 33 dB, an adjacent channel UE $CPICH \hat{E}_c/I_o$ target of -18 dB and the same $CPICH \hat{E}_c$ value at the adjacent channel UE as for the Home BS.

NOTE 2: For $CPICH \hat{E}_c < -105 \text{ dBm}$, the requirement in section 6.2.1 applies.

6.4.6.2 Minimum Requirement

The minimum requirement is in TS 25.104 [1] clause 6.4.6.

6.4.6.3 Test purpose

The test purpose is to verify the capability of the Home BS to adjust the transmitter output power according to the input conditions, as specified in Table 6.13A, across the frequency range and under normal and extreme conditions for all transmitters in the BS.

6.4.6.4 Method of test

6.4.6.4.1 Initial conditions

Test environment: normal; see clause 4.4.1.

RF channels to be tested: M; see clause 4.8

In addition, on one UARFCN only, the test shall be performed under extreme power supply as defined in clause 4.4.4

NOTE: Tests under extreme power supply also test extreme temperature.

Signal generators delivering co-channel and adjacent channel interferers are switched off.

- 1) Set-up the equipment as shown as shown in Annex B.1.7.
- 2) The Home BS is configured such that the adjacent channel is known to belong to another operator.

6.4.6.4.2 Procedure

- 1) Connect the combined downlink interfering signals (referred to as point D in Figure B.7) to the dedicated measurement port (referred to as point 1 in Figure B.7) if available, otherwise connect to point 2.
- 2) Configure the signal generator for co-channel interference to transmit AWGN over a 3.84MHz bandwidth centred on RF channel M.
- 3) Configure the signal generator for adjacent channel DL signal to transmit TM1 at the centre frequency equal to RF channel M +5 MHz.
- 4) Switch on signal generators delivering co-channel and adjacent channel interferers, and adjust the ATT1 and ATT2 such that $CPICH \hat{E}_c = -80$ dBm and $I_{oh} = -50$ dBm.
- 5) Trigger the Home BS power adjustment mechanism.
- 6) Set the Home BS to transmit a signal in accordance to TM1, clause 6.1.1.1

NOTE: The signal shall be transmitted with the maximum allowed output power.

- 7) Measure Home BS output power, P_{out} , and check it is below the required value according to the $CPICH \hat{E}_c$ and I_{oh} values determined in step 4.
- 8) Repeat steps 3) to 7) with the frequency in step 3 set to RF channel M -5 MHz.
- 9) Repeat steps 3) to 8) with different settings for ATT1 and ATT2 to arrive the $CPICH \hat{E}_c$ and I_{oh} pairs as specified in Table 6.13B.

Table 6.13B: $CPICH \hat{E}_c$ and I_{oh} pairs

Test Case	$CPICH \hat{E}_c$ (dBm)	I_{oh} (dBm)
2	-90	-60
3	-100	-70
4	-100	-50

6.4.6.5 Test Requirements

In normal operating conditions, the output power, P_{out} , of the Home BS shall be equal to or less than the value specified in Table 6.13A plus 2.7 dB.

In extreme operating conditions, the output power, P_{out} , of the Home BS shall be equal to or less than the value specified in Table 6.13A plus 3.2 dB.

NOTE: If the above Test Requirement differs from the Minimum Requirement then the Test Tolerance applied for this test is non-zero. The Test Tolerance for this test is defined in clause 4.2 and the explanation of how the Minimum Requirement has been relaxed by the Test Tolerance is given in Annex F.

6.5 Output RF spectrum emissions

The physical channels for the following test(s) shall be set-up according to clause 6.1.1.1.

6.5.1 Occupied bandwidth

6.5.1.1 Definition and applicability

The occupied bandwidth is the width of a frequency band such that, below the lower and above the upper frequency limits, the mean powers emitted are each equal to a specified percentage $\beta/2$ of the total mean transmitted power.

The value of $\beta/2$ shall be taken as 0,5%.

6.5.1.2 Minimum Requirements

The minimum requirement is in TS 25.104 [1] clause 6.6.1.1.

6.5.1.3 Test purpose

The occupied bandwidth, defined in the Radio Regulations of the International Telecommunication Union ITU, is a useful concept for specifying the spectral properties of a given emission in the simplest possible manner; see also ITU-R Recommendation SM.328 [11]. The test purpose is to verify that the emission of the BS does not occupy an excessive bandwidth for the service to be provided and is, therefore, not likely to create interference to other users of the spectrum beyond undue limits.

6.5.1.4 Method of test

6.5.1.4.1 Initial conditions

Test environment: normal; see clause 4.4.1.

RF channels to be tested: B, M and T; see clause 4.8

- 1) Connect the Measurement device to the BS antenna connector.
- 2) Set the BS to transmit a signal in accordance to TM1, clause 6.1.1.1, at manufacturer's declared rated output power, PRAT.

6.5.1.4.2 Procedure

- 1) Measure the spectrum of the transmitted signal across a span of 10 MHz, based on an occupied bandwidth requirement of 5 MHz. The selected resolution bandwidth (RBW) filter of the analyser shall be 30 kHz or less. The spectrum shall be measured at 400 or more points across the measurement span.

NOTE: The detection mode of the spectrum analyzer will not have any effect on the result if the statistical properties of the out-of-OBW power are the same as those of the inside-OBW power. Both are expected to have the Rayleigh distribution of the amplitude of Gaussian noise. In any case where the statistics are not the same, though, the detection mode must be power responding. There are at least two ways to be power responding. The spectrum analyser can be set to "sample" detection, with its video bandwidth setting at least three times its RBW setting. Or the analyser may be set to respond to the average of the power (root-mean-square of the voltage) across the measurement cell.

- 2) Compute the total of the power, P0, (in power units, not decibel units) of all the measurement cells in the measurement span. Compute P1, the power outside the occupied bandwidth on each side. P1 is half of the total power outside the bandwidth. P1 is half of (100 % - (occupied percentage)) of P0. For the occupied percentage of 99 %, P1 is 0.005 times P0.
- 3) Determine the lowest frequency, f1, for which the sum of all power in the measurement cells from the beginning of the span to f1 exceeds P1.
- 4) Determine the highest frequency, f2, for which the sum of all power in the measurement cells from the end of the span to f2 exceeds P1.
- 5) Compute the occupied bandwidth as f2 - f1.

In addition, for a multi-band capable BS, the following steps shall apply:

- 6) For multi-band capable BS and single band tests, repeat the steps above per involved band where single carrier test models shall apply with no carrier activated in the other band.
- 7) For multi-band capable BS with separate antenna connector, the antenna connector not being under test shall be terminated.

6.5.1.5 Test requirements

The occupied bandwidth shall be less than 5 MHz based on a chip rate of 3,84 Mcps

NOTE: If the above Test Requirement differs from the Minimum Requirement then the Test Tolerance applied for this test is non-zero. The Test Tolerance for this test is defined in clause 4.2 and the explanation of how the Minimum Requirement has been relaxed by the Test Tolerance is given in Annex F.

6.5.2 Out of band emission

Out of band emissions are unwanted emissions immediately outside the channel bandwidth resulting from the modulation process and non-linearity in the transmitter but excluding spurious emissions. This out of band emission limit is specified in terms of a spectrum emission mask and adjacent channel leakage power ratio for the transmitter.

6.5.2.1 Spectrum emission mask

6.5.2.1.1 Definitions and applicability

The mask defined in Tables 6.18 to 6.21 below may be mandatory in certain regions. In other regions this mask may not be applied.

For regions where this clause applies, the requirement shall be met by a base station transmitting on a single RF carrier configured in accordance with the manufacturer's specification. In addition, for a BS operating in non-contiguous spectrum, the requirements apply inside any sub-block gap. In addition, for a BS capable of multi-band operation, the requirements apply inside any inter-RF bandwidth gap.

For BS capable of multi-band operation where multiple bands are mapped on separate antenna connectors, the single-band requirements apply and the cumulative evaluation of the emission limit in the inter-RF bandwidth gap are not applicable.

6.5.2.1.2 Minimum Requirements

The minimum requirement is in TS 25.104 [1] clause 6.6.2.1.

Table 6.14: (void)

Table 6.15: (void)

Table 6.16: (void)

Table 6.17: (void)

6.5.2.1.3 Test purpose

This test measures the emissions of the BS, close to the assigned channel bandwidth of the wanted signal, while the transmitter is in operation.

6.5.2.1.4 Method of test

6.5.2.1.4.1 Initial conditions

Test environment: normal; see clause 4.4.1.

RF channels to be tested for single carrier: B, M and T; see clause 4.8

RF bandwidth positions to be tested for multi-carrier: B_{RFBW} , M_{RFBW} and T_{RFBW} in single band operation; $B_{\text{RFBW_T}}^{\text{RFBW}}$ and $B_{\text{RFBW_T}}^{\text{RFBW}}$ in multi-band operation; see subclause 4.8.1.

- 1) Set-up the equipment as shown in annex B.
As a general rule, the resolution bandwidth of the measuring equipment should be equal to the measurement bandwidth. However, to improve measurement accuracy, sensitivity, efficiency and avoiding e.g. carrier leakage, the resolution bandwidth may be smaller than the measurement bandwidth. When the resolution bandwidth is smaller than the measurement bandwidth, the result should be integrated over the measurement bandwidth in order to obtain the equivalent noise bandwidth of the measurement bandwidth.
- 2) Measurements with an offset from the carrier centre frequency between 2,515 MHz and 4.0 MHz shall use a 30 kHz measurement bandwidth.
- 3) Measurements with an offset from the carrier centre frequency between 4.0 MHz and $(f_{\text{offset,max}} - 500 \text{ kHz})$. shall use a 1 MHz measurement bandwidth.
- 4) Detection mode: True RMS.

6.5.2.1.4.2 Procedures

- 1) For a BS declared to be capable of single carrier operation only, set the base station to transmit a signal according to TM1, clause 6.1.1.1, at manufacturer"s declared rated output power, PRAT.

For a BS declared to be capable of multi-carrier operation, set the base station to transmit according to TM1 on all carriers configured using the applicable test configuration and corresponding power setting specified in sub-clause 4.12.

- 2) Step the centre frequency of the measurement filter in contiguous steps and measure the emission within the specified frequency ranges with the specified measurement bandwidth.

In addition, for a multi-band capable BS, the following steps shall apply:

- 3) For multi-band capable BS and single band tests, repeat the steps above per involved band where single band test configurations and test models shall apply with no carrier activated in the other band.
- 4) For multi-band capable BS with separate antenna connector, the antenna connector not being under test in case of single-band or multi-band test shall be terminated.

6.5.2.1.5 Test requirements

The measurement results in step 2 of 6.5.2.1.4.2 shall not exceed the test requirements specified in tables 6.18 to 6.21 for the appropriate BS maximum output power, where:

- Δf is the separation between the carrier frequency and the nominal -3 dB point of the measuring filter closest to the carrier frequency.
- f_{offset} is the separation between the carrier frequency and the centre of the measurement filter;
- $f_{\text{offset}_{\text{max}}}$ is either 12.5 MHz or the offset to the UMTS Tx band edge as defined in clause 3.4.1, whichever is the greater.
- Δf_{max} is equal to $f_{\text{offset}_{\text{max}}}$ minus half of the bandwidth of the measuring filter.

Inside any inter-RF bandwidth gaps with $W_{\text{gap}} < 20$ MHz for BS operating in multiple bands, emissions shall not exceed the cumulative sum of the test requirements specified at the RF bandwidth edges on each side of the inter-RF bandwidth gap. The test requirement for RF bandwidth edge is specified in Tables 6.3 to 6.6E below, where in this case:

- Δf is equal to 2.5MHz plus the separation between the RF bandwidth edge frequency and the nominal -3dB point of the measuring filter closest to the RF bandwidth edge.
- f_{offset} is equal to 2.5MHz plus the separation between the RF bandwidth edge frequency and the centre of the measuring filter.
- $f_{\text{offset}_{\text{max}}}$ is either 12.5 MHz or the offset to the UMTS Tx band edge as defined in section 5.2, whichever is the greater.
- Δf_{max} is equal to $f_{\text{offset}_{\text{max}}}$ minus half of the bandwidth of the measuring filter.

Inside any sub-block gap for a BS operating in non-contiguous spectrum, the measurement results shall not exceed the cumulative sum of the test requirements specified for the adjacent sub blocks on each side of the sub block gap. The test requirement for each sub block is specified in Tables 6.18 to 6.21E below, where in this case:

- Δf is equal to 2.5MHz plus the separation between the sub block edge frequency and the nominal -3 dB point of the measuring filter closest to the sub block edge.
- f_{offset} is equal to 2.5MHz plus the separation between the sub block edge frequency and the centre of the measuring filter.
- $f_{\text{offset}_{\text{max}}}$ is equal to the sub block gap bandwidth divided by two plus 2.5MHz.
- Δf_{max} is equal to $f_{\text{offset}_{\text{max}}}$ minus half of the bandwidth of the measuring filter.

Table 6.18: Spectrum emission mask values, BS maximum output power $P \geq 43$ dBm for UTRA FDD bands ≤ 3 GHz

Frequency offset of measurement filter - 3 dB point, Δf	Frequency offset of measurement filter centre frequency, f_{offset}	Test Requirement (Note 1, 2)	Measurement bandwidth (Note 4)
$2.5 \text{ MHz} \leq \Delta f < 2.7 \text{ MHz}$	$2.515\text{MHz} \leq f_{\text{offset}} < 2.715\text{MHz}$	-12.5 dBm	30 kHz
$2.7 \text{ MHz} \leq \Delta f < 3.5 \text{ MHz}$	$2.715\text{MHz} \leq f_{\text{offset}} < 3.515\text{MHz}$	$-12.5\text{dBm} - 15 \cdot \left(\frac{f_{\text{offset}} - 2.715}{\text{MHz}} \right) \text{dB}$	30 kHz
	$3.515\text{MHz} \leq f_{\text{offset}} < 4.0\text{MHz}$	-24.5 dBm	30 kHz
$3.5 \text{ MHz} \leq \Delta f < 7.5 \text{ MHz}$	$4.0 \text{ MHz} \leq f_{\text{offset}} < 8.0\text{MHz}$	-11.5 dBm	1 MHz
$7.5 \text{ MHz} \leq \Delta f \leq \Delta f_{\text{max}}$	$8.0 \text{ MHz} \leq f_{\text{offset}} < f_{\text{offset}_{\text{max}}}$	-11.5 dBm	1 MHz
<p>NOTE 1: For BS supporting non-contiguous spectrum operation the test requirement within sub-block gaps within any operating band is calculated as a cumulative sum of contributions from adjacent sub blocks on each side of the sub block gap. Exception is $\Delta f \geq 12.5\text{MHz}$ from both adjacent sub blocks on each side of the sub-block gap, where the spurious emission test requirements in clause 6.5.2.1.5 shall be met.</p> <p>NOTE 2: For BS supporting multi-band operation with inter RF bandwidth gap $< 20\text{MHz}$ the minimum requirement within the inter RF bandwidth gaps is calculated as a cumulative sum of contributions from adjacent sub-blocks on each side of the inter RF bandwidth gap.</p>			

Table 6.18A: Spectrum emission mask values, BS maximum output power $P \geq 43$ dBm for UTRA FDD bands > 3 GHz

Frequency offset of measurement filter - 3 dB point, Δf	Frequency offset of measurement filter centre frequency, f_{offset}	Test Requirement (Note 1, 2)	Measurement bandwidth (Note 4)
$2.5 \text{ MHz} \leq \Delta f < 2.7 \text{ MHz}$	$2.515 \text{ MHz} \leq f_{\text{offset}} < 2.715 \text{ MHz}$	-12.2 dBm	30 kHz
$2.7 \text{ MHz} \leq \Delta f < 3.5 \text{ MHz}$	$2.715 \text{ MHz} \leq f_{\text{offset}} < 3.515 \text{ MHz}$	$-12.2 \text{ dBm} - 15 \cdot \left(\frac{f_{\text{offset}}}{\text{MHz}} - 2.715 \right) \text{ dB}$	30 kHz
	$3.515 \text{ MHz} \leq f_{\text{offset}} < 4.0 \text{ MHz}$	-24.2 dBm	30 kHz
$3.5 \text{ MHz} \leq \Delta f < 7.5 \text{ MHz}$	$4.0 \text{ MHz} \leq f_{\text{offset}} < 8.0 \text{ MHz}$	-11.2 dBm	1 MHz
$7.5 \text{ MHz} \leq \Delta f \leq \Delta f_{\text{max}}$	$8.0 \text{ MHz} \leq f_{\text{offset}} < f_{\text{offset}_{\text{max}}}$	-11.2 dBm	1 MHz
<p>NOTE 1: For BS supporting non-contiguous spectrum operation the test requirement within sub-block gaps within any operating band is calculated as a cumulative sum of contributions from adjacent sub blocks on each side of the sub block gap. Exception is $\Delta f \geq 12.5 \text{ MHz}$ from both adjacent sub blocks on each side of the sub-block gap, where the spurious emission test requirements in clause 6.5.2.1.5 shall be met.</p> <p>NOTE 2: For BS supporting multi-band operation with inter RF bandwidth gap $< 20 \text{ MHz}$ the minimum requirement within the inter RF bandwidth gaps is calculated as a cumulative sum of contributions from adjacent sub-blocks on each side of the inter RF bandwidth gap.</p>			

Table 6.19: Spectrum emission mask values, BS maximum output power $39 \leq P < 43$ dBm for UTRA FDD bands ≤ 3 GHz

Frequency offset of measurement filter -3 dB point, Δf	Frequency offset of measurement filter centre frequency, f_{offset}	Test Requirement (Note 1, 2)	Measurement bandwidth (Note 4)
$2.5 \text{ MHz} \leq \Delta f < 2.7 \text{ MHz}$	$2.515 \text{ MHz} \leq f_{\text{offset}} < 2.715 \text{ MHz}$	-12.5 dBm	30 kHz
$2.7 \text{ MHz} \leq \Delta f < 3.5 \text{ MHz}$	$2.715 \text{ MHz} \leq f_{\text{offset}} < 3.515 \text{ MHz}$	$-12.5 \text{ dBm} - 15 \cdot \left(\frac{f_{\text{offset}}}{\text{MHz}} - 2.715 \right) \text{ dB}$	30 kHz
	$3.515 \text{ MHz} \leq f_{\text{offset}} < 4.0 \text{ MHz}$	-24.5 dBm	30 kHz
$3.5 \text{ MHz} \leq \Delta f < 7.5 \text{ MHz}$	$4.0 \text{ MHz} \leq f_{\text{offset}} < 8.0 \text{ MHz}$	-11.5 dBm	1 MHz
$7.5 \text{ MHz} \leq \Delta f \leq \Delta f_{\text{max}}$	$8.0 \text{ MHz} \leq f_{\text{offset}} < f_{\text{offset}_{\text{max}}}$	$P - 54.5 \text{ dB}$	1 MHz
<p>NOTE 1: For BS supporting non-contiguous spectrum operation the test requirement within sub-block gaps within any operating band is calculated as a cumulative sum of contributions from adjacent sub blocks on each side of the sub block gap. Exception is $\Delta f \geq 12.5 \text{ MHz}$ from both adjacent sub blocks on each side of the sub-block gap, where the spurious emission test requirements in clause 6.5.2.1.5 shall be met.</p> <p>NOTE 2: For BS supporting multi-band operation with inter RF bandwidth gap $< 20 \text{ MHz}$ the minimum requirement within the inter RF bandwidth gaps is calculated as a cumulative sum of contributions from adjacent sub-blocks on each side of the inter RF bandwidth gap.</p>			

Table 6.19A: Spectrum emission mask values, BS maximum output power $39 \leq P < 43$ dBm for UTRA FDD bands > 3 GHz

Frequency offset of measurement filter -3 dB point, Δf	Frequency offset of measurement filter centre frequency, f_{offset}	Test Requirement (Note 1, 2)	Measurement bandwidth (Note 4)
$2.5 \text{ MHz} \leq \Delta f < 2.7 \text{ MHz}$	$2.515 \text{ MHz} \leq f_{\text{offset}} < 2.715 \text{ MHz}$	-12.2 dBm	30 kHz
$2.7 \text{ MHz} \leq \Delta f < 3.5 \text{ MHz}$	$2.715 \text{ MHz} \leq f_{\text{offset}} < 3.515 \text{ MHz}$	$-12.2 \text{ dBm} - 15 \cdot \left(\frac{f_{\text{offset}}}{\text{MHz}} - 2.715 \right) \text{ dB}$	30 kHz
	$3.515 \text{ MHz} \leq f_{\text{offset}} < 4.0 \text{ MHz}$	-24.2 dBm	30 kHz
$3.5 \text{ MHz} \leq \Delta f < 7.5 \text{ MHz}$	$4.0 \text{ MHz} \leq f_{\text{offset}} < 8.0 \text{ MHz}$	-11.2 dBm	1 MHz
$7.5 \text{ MHz} \leq \Delta f \leq \Delta f_{\text{max}}$	$8.0 \text{ MHz} \leq f_{\text{offset}} < f_{\text{offset}_{\text{max}}}$	$P - 54.2 \text{ dB}$	1 MHz
<p>NOTE 1: For BS supporting non-contiguous spectrum operation the test requirement within sub-block gaps within any operating band is calculated as a cumulative sum of contributions from adjacent sub blocks on each side of the sub block gap. Exception is $\Delta f \geq 12.5 \text{ MHz}$ from both adjacent sub blocks on each side of the sub-block gap, where the spurious emission test requirements in clause 6.5.2.1.5 shall be met.</p> <p>NOTE 2: For BS supporting multi-band operation with inter RF bandwidth gap $< 20 \text{ MHz}$ the minimum requirement within the inter RF bandwidth gaps is calculated as a cumulative sum of contributions from adjacent sub-blocks on each side of the inter RF bandwidth gap.</p>			

Table 6.20: Spectrum emission mask values, BS maximum output power $31 \leq P < 39$ dBm for UTRA FDD bands ≤ 3 GHz

Frequency offset of measurement filter - 3 dB point, Δf	Frequency offset of measurement filter centre frequency, f_{offset}	Test Requirement (Note 1, 2)	Measurement bandwidth (Note 4)
$2.5 \text{ MHz} \leq \Delta f < 2.7 \text{ MHz}$	$2.515 \text{ MHz} \leq f_{\text{offset}} < 2.715 \text{ MHz}$	$P - 51.5 \text{ dB}$	30 kHz
$2.7 \text{ MHz} \leq \Delta f < 3.5 \text{ MHz}$	$2.715 \text{ MHz} \leq f_{\text{offset}} < 3.515 \text{ MHz}$	$P - 51.5 \text{ dB} - 15 \cdot \left(\frac{f_{\text{offset}}}{\text{MHz}} - 2.715 \right) \text{ dB}$	30 kHz
(Note 3)	$3.515 \text{ MHz} \leq f_{\text{offset}} < 4.0 \text{ MHz}$	$P - 63.5 \text{ dB}$	30 kHz
$3.5 \text{ MHz} \leq \Delta f < 7.5 \text{ MHz}$	$4.0 \text{ MHz} \leq f_{\text{offset}} < 8.0 \text{ MHz}$	$P - 50.5 \text{ dB}$	1 MHz
$7.5 \text{ MHz} \leq \Delta f \leq \Delta f_{\text{max}}$	$8.0 \text{ MHz} \leq f_{\text{offset}} < f_{\text{offset}_{\text{max}}}$	$P - 54.5 \text{ dB}$	1 MHz
<p>NOTE 1: For BS supporting non-contiguous spectrum operation the test requirement within sub-block gaps within any operating band is calculated as a cumulative sum of contributions from adjacent sub blocks on each side of the sub block gap. Exception is $\Delta f \geq 12.5 \text{ MHz}$ from both adjacent sub blocks on each side of the sub-block gap, where the spurious emission test requirements in clause 6.5.2.1.5 shall be met.</p> <p>NOTE 2: For BS supporting multi-band operation with inter RF bandwidth gap $< 20 \text{ MHz}$ the minimum requirement within the inter RF bandwidth gaps is calculated as a cumulative sum of contributions from adjacent sub-blocks on each side of the inter RF bandwidth gap.</p>			

Table 6.20A: Spectrum emission mask values, BS maximum output power $31 \leq P < 39$ dBm for UTRA FDD bands > 3 GHz

Frequency offset of measurement filter - 3 dB point, Δf	Frequency offset of measurement filter centre frequency, f_{offset}	Test Requirement (Note 1, 2)	Measurement bandwidth (Note 4)
$2.5 \text{ MHz} \leq \Delta f < 2.7 \text{ MHz}$	$2.515 \text{ MHz} \leq f_{\text{offset}} < 2.715 \text{ MHz}$	$P - 51.2 \text{ dB}$	30 kHz
$2.7 \text{ MHz} \leq \Delta f < 3.5 \text{ MHz}$	$2.715 \text{ MHz} \leq f_{\text{offset}} < 3.515 \text{ MHz}$	$P - 51.2 \text{ dB} - 15 \cdot \left(\frac{f_{\text{offset}} - 2.715}{\text{MHz}} \right) \text{ dB}$	30 kHz
(Note 3)	$3.515 \text{ MHz} \leq f_{\text{offset}} < 4.0 \text{ MHz}$	$P - 63.2 \text{ dB}$	30 kHz
$3.5 \text{ MHz} \leq \Delta f < 7.5 \text{ MHz}$	$4.0 \text{ MHz} \leq f_{\text{offset}} < 8.0 \text{ MHz}$	$P - 50.2 \text{ dB}$	1 MHz
$7.5 \text{ MHz} \leq \Delta f \leq \Delta f_{\text{max}}$	$8.0 \text{ MHz} \leq f_{\text{offset}} < f_{\text{offset}_{\text{max}}}$	$P - 54.2 \text{ dB}$	1 MHz
<p>NOTE 1: For BS supporting non-contiguous spectrum operation the test requirement within sub-block gaps within any operating band is calculated as a cumulative sum of contributions from adjacent sub blocks on each side of the sub block gap. Exception is $\Delta f \geq 12.5 \text{ MHz}$ from both adjacent sub blocks on each side of the sub-block gap, where the spurious emission test requirements in clause 6.5.2.1.5 shall be met.</p> <p>NOTE 2: For BS supporting multi-band operation with inter RF bandwidth gap $< 20 \text{ MHz}$ the minimum requirement within the inter RF bandwidth gaps is calculated as a cumulative sum of contributions from adjacent sub-blocks on each side of the inter RF bandwidth gap.</p>			

Table 6.21: Spectrum emission mask values, BS maximum output power $P < 31$ dBm for UTRA FDD bands ≤ 3 GHz

Frequency offset of measurement filter - 3 dB point, Δf	Frequency offset of measurement filter centre frequency, f_{offset}	Test Requirement (Note 1, 2)	Measurement bandwidth (Note 4)
$2.5 \text{ MHz} \leq \Delta f < 2.7 \text{ MHz}$	$2.515 \text{ MHz} \leq f_{\text{offset}} < 2.715 \text{ MHz}$	-20.5 dBm	30 kHz
$2.7 \leq \Delta f < 3.5 \text{ MHz}$	$2.715 \text{ MHz} \leq f_{\text{offset}} < 3.515 \text{ MHz}$	$-20.5 \text{ dBm} - 15 \cdot \left(\frac{f_{\text{offset}} - 2.715}{\text{MHz}} \right) \text{ dB}$	30 kHz
(Note 3)	$3.515 \text{ MHz} \leq f_{\text{offset}} < 4.0 \text{ MHz}$	-32.5 dBm	30 kHz
$3.5 \text{ MHz} \leq \Delta f < 7.5 \text{ MHz}$	$4.0 \text{ MHz} \leq f_{\text{offset}} < 8.0 \text{ MHz}$	-19.5 dBm	1 MHz
$7.5 \text{ MHz} \leq \Delta f \leq \Delta f_{\text{max}}$	$8.0 \text{ MHz} \leq f_{\text{offset}} < f_{\text{offset}_{\text{max}}}$	-23.5 dBm	1 MHz
<p>NOTE 1: For BS supporting non-contiguous spectrum operation the test requirement within sub-block gaps within any operating band is calculated as a cumulative sum of contributions from adjacent sub blocks on each side of the sub block gap. Exception is $\Delta f \geq 12.5 \text{ MHz}$ from both adjacent sub blocks on each side of the sub-block gap, where the spurious emission test requirements in clause 6.5.2.1.5 shall be met.</p> <p>NOTE 2: For BS supporting multi-band operation with inter RF bandwidth gap $< 20 \text{ MHz}$ the minimum requirement within the inter RF bandwidth gaps is calculated as a cumulative sum of contributions from adjacent sub-blocks on each side of the inter RF bandwidth gap.</p>			

Table 6.21a: Spectrum emission mask values, BS maximum output power P < 31 dBm for UTRA FDD bands > 3 GHz

Frequency offset of measurement filter - 3 dB point, Δf	Frequency offset of measurement filter centre frequency, f_{offset}	Test Requirement (Note 1, 2)	Measurement bandwidth (Note 4)
$2.5 \text{ MHz} \leq \Delta f < 2.7 \text{ MHz}$	$2.515 \text{ MHz} \leq f_{\text{offset}} < 2.715 \text{ MHz}$	-20.2 dBm	30 kHz
$2.7 \leq \Delta f < 3.5 \text{ MHz}$	$2.715 \text{ MHz} \leq f_{\text{offset}} < 3.515 \text{ MHz}$	$-20.2 \text{ dBm} - 15 \cdot \left(\frac{f_{\text{offset}}}{\text{MHz}} - 2.715 \right) \text{ dB}$	30 kHz
(Note 3)	$3.515 \text{ MHz} \leq f_{\text{offset}} < 4.0 \text{ MHz}$	-32.2 dBm	30 kHz
$3.5 \text{ MHz} \leq \Delta f < 7.5 \text{ MHz}$	$4.0 \text{ MHz} \leq f_{\text{offset}} < 8.0 \text{ MHz}$	-19.2 dBm	1 MHz
$7.5 \text{ MHz} \leq \Delta f \leq \Delta f_{\text{max}}$	$8.0 \text{ MHz} \leq f_{\text{offset}} < f_{\text{offset}_{\text{max}}}$	-23.2 dBm	1 MHz
<p>NOTE 1: For BS supporting non-contiguous spectrum operation the test requirement within sub-block gaps within any operating band is calculated as a cumulative sum of contributions from adjacent sub blocks on each side of the sub block gap. Exception is $\Delta f \geq 12.5 \text{ MHz}$ from both adjacent sub blocks on each side of the sub-block gap, where the spurious emission test requirements in clause 6.5.2.1.5 shall be met.</p> <p>NOTE 2: For BS supporting multi-band operation with inter RF bandwidth gap < 20MHz the minimum requirement within the inter RF bandwidth gaps is calculated as a cumulative sum of contributions from adjacent sub-blocks on each side of the inter RF bandwidth gap.</p>			

For operation in band II, IV, V, X, XII, XIII, XIV, XXV and XXVI, the applicable additional requirement in Tables 6.21A, 6.21B or 6.21C apply in addition to the minimum requirements in Tables 6.18 to 6.21.

Table 6.21A: Additional spectrum emission limits for Bands II, IV, X, XXV

Frequency offset of measurement filter -3dB point, Δf	Frequency offset of measurement filter centre frequency, f_{offset}	Additional requirement	Measurement bandwidth (Note 4)
$2.5 \text{ MHz} \leq \Delta f < 3.5 \text{ MHz}$	$2.515 \text{ MHz} \leq f_{\text{offset}} < 3.515 \text{ MHz}$	-15 dBm	30 kHz
$3.5 \text{ MHz} \leq \Delta f \leq \Delta f_{\text{max}}$	$4.0 \text{ MHz} \leq f_{\text{offset}} < f_{\text{offset}_{\text{max}}}$	-13 dBm	1 MHz

Table 6.21B: Additional spectrum emission limits for Bands V, XXVI

Frequency offset of measurement filter -3dB point, Δf	Frequency offset of measurement filter centre frequency, f_{offset}	Additional requirement	Measurement bandwidth (Note 4)
$2.5 \text{ MHz} \leq \Delta f < 3.5 \text{ MHz}$	$2.515 \text{ MHz} \leq f_{\text{offset}} < 3.515 \text{ MHz}$	-15 dBm	30 kHz
$3.5 \text{ MHz} \leq \Delta f \leq \Delta f_{\text{max}}$	$3.55 \text{ MHz} \leq f_{\text{offset}} < f_{\text{offset}_{\text{max}}}$	-13 dBm	100 kHz

Table 6.21C: Additional spectrum emission limits for Bands XII, XIII, XIV

Frequency offset of measurement filter -3dB point, Δf	Frequency offset of measurement filter centre frequency, f_{offset}	Additional requirement	Measurement bandwidth (Note 4)
$2.5 \text{ MHz} \leq \Delta f < 2.6 \text{ MHz}$	$2.515 \text{ MHz} \leq f_{\text{offset}} < 2.615 \text{ MHz}$	-13 dBm	30 kHz
$2.6 \text{ MHz} \leq \Delta f \leq \Delta f_{\text{max}}$	$2.65 \text{ MHz} \leq f_{\text{offset}} < f_{\text{offset}_{\text{max}}}$	-13 dBm	100 kHz

For Home BS, the applicable additional requirements in Tables 6.21D or 6.21E apply in addition to the minimum requirements in Tables 6.18 to 6.21.

Table 6.21D: Additional spectrum emission limit for Home BS, BS maximum output power $6 \leq P \leq 20$ dBm for UTRA FDD bands ≤ 3 GHz

Frequency offset of measurement filter -3dB point, Δf	Frequency offset of measurement filter centre frequency, f_{offset}	Additional requirement	Measurement bandwidth (Note 4)
$12.5 \text{ MHz} \leq \Delta f \leq \Delta f_{\text{max}}$	$13 \text{ MHz} \leq f_{\text{offset}} < f_{\text{offset}_{\text{max}}}$	$P - 54.5 \text{ dBm}$	1 MHz

Table 6.21Da: Additional spectrum emission limit for Home BS, BS maximum output power $6 \leq P \leq 20$ dBm for UTRA FDD bands > 3 GHz

Frequency offset of measurement filter -3dB point, Δf	Frequency offset of measurement filter centre frequency, f_{offset}	Additional requirement	Measurement bandwidth (Note 4)
$12.5 \text{ MHz} \leq \Delta f \leq \Delta f_{\text{max}}$	$13 \text{ MHz} \leq f_{\text{offset}} < f_{\text{offset}_{\text{max}}}$	$P - 54.2 \text{ dBm}$	1 MHz

Table 6.21E: Additional spectrum emission limit for Home BS, BS maximum output power $P < 6$ dBm for UTRA FDD bands ≤ 3 GHz

Frequency offset of measurement filter -3dB point, Δf	Frequency offset of measurement filter centre frequency, f_{offset}	Additional requirement	Measurement bandwidth (Note 4)
$12.5 \text{ MHz} \leq \Delta f \leq \Delta f_{\text{max}}$	$13 \text{ MHz} \leq f_{\text{offset}} < f_{\text{offset}_{\text{max}}}$	-48.5 dBm	1 MHz

Table 6.21Ea: Additional spectrum emission limit for Home BS, BS maximum output power $P < 6$ dBm for UTRA FDD bands > 3 GHz

Frequency offset of measurement filter -3dB point, Δf	Frequency offset of measurement filter centre frequency, f_{offset}	Additional requirement	Measurement bandwidth (Note 4)
$12.5 \text{ MHz} \leq \Delta f \leq \Delta f_{\text{max}}$	$13 \text{ MHz} \leq f_{\text{offset}} < f_{\text{offset}_{\text{max}}}$	-48.2 dBm	1 MHz

NOTE: If the above Test Requirement differs from the Minimum Requirement then the Test Tolerance applied for this test is non-zero. The Test Tolerance for this test is defined in clause 4.2 and the explanation of how the Minimum Requirement has been relaxed by the Test Tolerance is given in Annex F.

In certain regions the following requirement may apply for protection of DTT. For UTRA BS operating in Band XX, the level of emissions in the band 470-790 MHz, measured in an 8MHz filter bandwidth on centre frequencies F_{filter} according to Table 6.21F, shall not exceed the maximum emission level $P_{\text{EM,N}}$ declared by the manufacturer.

Table 6.21F: Declared emissions levels for protection of DTT

Filter centre frequency, F_{filter}	Measurement bandwidth	Declared emission level [dBm]
$F_{\text{filter}} = 8 \cdot N + 306 \text{ (MHz)}$; $21 \leq N \leq 60$	8 MHz	$P_{\text{EM,N}}$

NOTE: The regional requirement is defined in terms of EIRP (effective isotropic radiated power), which is dependent on both the BS emissions at the antenna connector and the deployment (including antenna gain and feeder loss). The requirement defined above provides the characteristics of the basestation needed to verify compliance with the regional requirement. Compliance with the regional requirement can be determined using the method outlined in Annex D of [1].

Notes for the Tables in this subclause:

NOTE 3: This frequency range ensures that the range of values of f_{offset} is continuous.

NOTE 4: As a general rule, the resolution bandwidth of the measuring equipment should be equal to the measurement bandwidth. However, to improve measurement accuracy, sensitivity and efficiency, the resolution bandwidth can be smaller than the measurement bandwidth. When the resolution bandwidth is smaller than the measurement bandwidth, the result should be integrated over the measurement bandwidth in order to obtain the equivalent noise bandwidth of the measurement bandwidth.

6.5.2.2 Adjacent Channel Leakage power Ratio (ACLR)

6.5.2.2.1 Definition and applicability

Adjacent Channel Leakage power Ratio (ACLR) is the ratio of the RRC filtered mean power centered on the assigned channel frequency to the RRC filtered mean power centered on an adjacent channel frequency.

The requirements shall apply outside the BS RF bandwidth edges or maximum radio bandwidth edges whatever the type of transmitter considered (single carrier or multi-carrier). It applies for all transmission modes foreseen by the manufacturer's specification.

For a BS operating in non-contiguous spectrum, ACLR requirement also applies for the first adjacent channel, inside any sub-block gap with a gap size $W_{\text{gap}} \geq 15$ MHz. The ACLR requirement for the second adjacent channel applies inside any sub-block gap with a gap size $W_{\text{gap}} \geq 20$ MHz. The CAACLR requirement in subclause 6.5.2.2.2 applies in sub block gaps for the frequency ranges defined in Table 6.23B.

For a BS operating in multiple bands, where multiple bands are mapped onto the same antenna connector, ACLR requirement also applies for the first adjacent channel, inside any inter RF bandwidth gap with a gap size $W_{\text{gap}} \geq 15$ MHz. The ACLR requirement for the second adjacent channel applies inside any inter RF bandwidth gap with a gap size $W_{\text{gap}} \geq 20$ MHz. The CAACLR requirement in subclause 6.5.2.2.2 applies in inter RF bandwidth gaps for the frequency ranges defined in Table 6.23B.

6.5.2.2.2 Minimum Requirement

The minimum requirement is in TS 25.104 [1] clause 6.6.2.2

Table 6.22: (void)

6.5.2.2.3 Test purpose

To verify that the adjacent channel leakage power ratio requirement shall be met as specified by the minimum requirement.

6.5.2.2.4 Method of test

6.5.2.2.4.1 Initial conditions

Test environment: normal; see clause 4.4.1.

RF channels to be tested for single carrier: B, M and T; see clause 4.8

RF bandwidth positions to be tested for multi-carrier: B_{RFBW} , M_{RFBW} and T_{RFBW} in single band operation; $B_{\text{RFBW_T}}$, T_{RFBW} and $B_{\text{RFBW_T}}$ in multi-band operation; see subclause 4.8.1.

- 1) Connect measurement device to the base station antenna connector as shown in annex B.

- 2) The measurement device characteristics shall be:
 - measurement filter bandwidth: defined in clause 6.5.2.2.1;
 - detection mode: true RMS voltage or true average power.
- 3) Set the base station to transmit a signal modulated in accordance to TM1, clause 6.1.1.1, at manufacturer's declared rated output power, PRAT.

For a BS declared to be capable of multi-carrier operation, set the base station to transmit according to TM1 on all carriers configured using the applicable test configuration and corresponding power setting specified in sub-clause 4.12.

- 4) Set carrier frequency within the frequency band supported by BS. Minimum carrier spacing shall be 5 MHz and maximum carrier spacing shall be specified by manufacturer.

6.5.2.2.4.2 Procedure

- 1) Measure Adjacent channel leakage power ratio for 5 MHz and 10 MHz offsets both side of channel frequency. In multiple carrier case only offset frequencies below the lowest and above the highest carrier frequency used shall be measured.
- 2) For the ACLR requirement applied inside sub-block gap for non-contiguous spectrum operation or inside inter RF bandwidth gap for multi-band operation:
 - a) Measure ACLR inside sub-block gap or inter RF bandwidth gap as specified in clause 6.5.2.2.5, if applicable.
 - b) Measure Cumulative Adjacent Channel Leakage power Ratio (CACLR) inside sub-block gap or inter RF bandwidth gap as specified in clause 6.5.2.2.6, if applicable.

In addition, for a multi-band capable BS, the following steps shall apply:

- 3) For multi-band capable BS and single band tests, repeat the steps above per involved band where single band test configurations and test models shall apply with no carrier activated in the other band.
- 4) For multi-band capable BS with separate antenna connector, the antenna connector not being under test in case of single-band or multi-band test shall be terminated.

6.5.2.2.5 Test Requirement

For Category A Wide Area BS, either the ACLR limits in the tables below or the absolute limit of -13dBm/MHz apply, whichever is less stringent.

For Category B Wide Area BS, either the ACLR limits in the tables below or the absolute limit of -15dBm/MHz apply, whichever is less stringent.

For Medium Range BS, either the ACLR limits in the tables below or the absolute limit of -25 dBm/MHz shall apply, whichever is less stringent.

For Local Area BS, either the ACLR limits in the tables below or the absolute limit of -32dBm/MHz shall apply, whichever is less stringent.

The measurement result in step 1 of 6.5.2.2.4.2 shall not be less than the ACLR limit specified in tables 6.23

Table 6.23: BS ACLR

BS channel offset below the first or above the last carrier frequency used	ACLR limit
5 MHz	44.2 dB
10 MHz	49.2 dB
Note 1: In certain regions, the adjacent channel power (the RRC filtered mean power centered on an adjacent channel frequency) shall be less than or equal to -7.2 dBm/3.84 MHz (for Band I, III, IX, XI and XXI) or +2.8 dBm/3.84MHz (for Band VI, VIII and XIX) or as specified by the ACLR limit, whichever is the higher. This note is not applicable for Home BS. Note 2: For Home BS, the adjacent channel power (the RRC filtered mean power centered on an adjacent channel frequency) shall be less than or equal to -42.7 dBm/3.84MHz $f \leq 3.0$ GHz and -42.4 dBm/3.84MHz for 3.0 GHz $< f \leq 4.2$ GHz or as specified by the ACLR limit, whichever is the higher.	

NOTE: If the above Test Requirement differs from the Minimum Requirement then the Test Tolerance applied for this test is non-zero. The Test Tolerance for this test is defined in clause 4.2 and the explanation of how the Minimum Requirement has been relaxed by the Test Tolerance is given in Annex F.

The measurement result in step 2a of 6.5.2.2.4.2 shall not be less than the ACLR limit specified in table 6.23A

Table 6.23A: BS ACLR in non-contiguous spectrum or multiple bands

Sub-block or inter RF bandwidth gap size (W_{gap}) where the limit applies	BS adjacent channel centre frequency offset below or above the sub-block edge or the RF bandwidth edge (inside the gap)	Assumed adjacent channel carrier (informative)	Filter on the adjacent channel frequency and corresponding filter bandwidth	ACLR limit
$W_{\text{gap}} \geq 15$ MHz	2.5 MHz	3.84 Mcps UTRA	RRC (3.84 Mcps)	44.2 dB
$W_{\text{gap}} \geq 20$ MHz	7.5 MHz	3.84 Mcps UTRA	RRC (3.84 Mcps)	44.2 dB
NOTE: The RRC filter shall be equivalent to the transmit pulse shape filter defined in TS 25.104, with a chip rate as defined in this table.				

6.5.2.2.6 Cumulative ACLR test requirement in non-contiguous spectrum or multiple-bands

The following test requirement applies for a BS operating in non-contiguous spectrum or multiple bands.

The following requirement applies for the gap sizes listed in Table 6.23B,

- inside a sub-block gap within an operating band for a BS operating in non-contiguous spectrum;
- inside an inter-RF bandwidth gap for a BS capable of multi-band operation, where multiple bands are mapped on the same antenna connector.

The Cumulative Adjacent Channel Leakage power Ratio (CACLR) in a sub-block gap or inter-RF bandwidth gap is the ratio of

- a) the sum of the filtered mean power centred on the assigned channel frequencies for the two carriers adjacent to each side of the sub-block gap or inter-RF bandwidth gap, and
- b) the filtered mean power centred on a frequency channel adjacent to one of the respective sub-block edges or RF bandwidth edges.

The assumed filter for the adjacent channel frequency is defined in Table 6.23B and the filters on the assigned channels are defined in Table 6.23C.

For Wide Area Category A BS, either the CACLR limits in Table 6.23B or the absolute limit of -13dBm/MHz apply, whichever is less stringent.

For Wide Area Category B BS, either the CACLR limits in Table 6.23B or the absolute limit of -15dBm/MHz apply, whichever is less stringent.

For Medium Range BS, either the CA CLR limits in Table 6.23B or the absolute limit of -25 dBm/MHz shall apply, whichever is less stringent.

For Local Area BS, either the CA CLR limits in Table 6.23B or the absolute limit of -32 dBm/MHz shall apply, whichever is less stringent.

The CA CLR for UTRA carriers located on either side of the sub-block gap or inter-RF bandwidth gap shall be higher than the value specified in Table 6.23B.

Table 6.23B: Base Station CA CLR in non-contiguous spectrum or multiple bands

Sub-block or inter-RF bandwidth gap size (W_{gap}) where the limit applies	BS adjacent channel centre frequency offset below or above the sub-block edge or the RF bandwidth edge (inside the gap)	Assumed adjacent channel carrier (informative)	Filter on the adjacent channel frequency and corresponding filter bandwidth	CA CLR limit
$5 \text{ MHz} \leq W_{\text{gap}} < 15 \text{ MHz}$	2.5 MHz	3.84 Mcps UTRA	RRC (3.84 Mcps)	44.2 dB
$10 \text{ MHz} < W_{\text{gap}} < 20 \text{ MHz}$	7.5 MHz	3.84 Mcps UTRA	RRC (3.84 Mcps)	44.2 dB
NOTE: The RRC filter shall be equivalent to the transmit pulse shape filter defined in TS 25.104, with a chip rate as defined in this table.				

Table 6.23C: Filter parameters for the assigned channel

RAT of the carrier adjacent to the sub-block or inter-RF bandwidth gap	Filter on the assigned channel frequency and corresponding filter bandwidth
UTRA FDD	RRC (3.84 Mcps)
NOTE: The RRC filter shall be equivalent to the transmit pulse shape filter defined in TS 25.104, with a chip rate as defined in this table.	

6.5.3 Spurious emissions

6.5.3.1 Definition and applicability

Spurious emissions are emissions which are caused by unwanted transmitter effects such as harmonics emission, parasitic emission, intermodulation products and frequency conversion products, but exclude out of band emissions. This is measured at the base station antenna connector.

The requirements (except 6.5.3.7.6 and 6.5.3.7.9 and specifically stated exceptions in Table 6.38) apply at frequencies within the specified frequency ranges, which are more than 12.5 MHz under the first carrier frequency used or more than 12.5 MHz above the last carrier frequency used.

The requirements shall apply whatever the type of transmitter considered (single carrier or multi-carrier). It applies for all transmission modes foreseen by the manufacturer's specification.

For BS capable of multi-band operation where multiple bands are mapped on the same antenna connector, the requirements (except 6.5.3.7.6 and 6.5.3.7.9 and specifically stated exceptions in Table 6.38) apply at frequencies within the specified frequency ranges, excluding the frequency ranges which are less than or equal to 12.5MHz below the first carrier frequency used and less than or equal to 12.5MHz above the last carrier frequency used for each supported operating band. For BS capable of multi-band operation where multiple bands are mapped on separate antenna connectors, the single-band requirements apply and the multi-band exclusions and provisions are not applicable.

Unless otherwise stated, all requirements are measured as mean power (RMS).

6.5.3.2 (void)

6.5.3.3 (void)

6.5.3.4 Minimum Requirements

The minimum requirements are in TS 25.104 [1] clause 6.6.3.

Table 6.24: (void)

Table 6.25: (void)

Table 6.25A: (void)

Table 6.25B: (void)

Table 6.25C: (void)

Table 6.25D: (void)

Table 6.25E: (void)

Table 6.26: (void)

Table 6.26A: (void)

Table 6.26B: (void)

Table 6.27: (void)

Table 6.28: (void)

Table 6.29: (void)

Table 6.30: (void)

Table 6.31: (void)

Table 6.32: (void)

Table 6.33: (void)

Table 6.34: (void)

6.5.3.5 Test purpose

This test measures conducted spurious emission from the BS transmitter antenna connector, while the transmitter is in operation.

6.5.3.6 Method of Test

6.5.3.6.1 Initial conditions

Test environment: normal; see clause 4.4.1.

RF channels to be tested for single carrier: B, M and T; see clause 4.8

RF bandwidth positions to be tested for multi-carrier: B_{RFBW} , M_{RFBW} and T_{RFBW} in single band operation; $B''_{\text{RFBW-T}}_{\text{RFBW}}$ and $B''_{\text{RFBW-T}}_{\text{RFBW}}$ in multi-band operation; see subclause 4.8.1.

- 1) Connect the BS antenna connector to a measurement receiver using an attenuator or a directional coupler if necessary
- 2) Measurements shall use a measurement bandwidth in accordance to the tables in section 6.5.3.4.
- 3) Detection mode: True RMS.

6.5.3.6.2 Procedure

- 1) For a BS declared to be capable of single carrier operation only, set the base station to transmit a signal according to TM1, clause 6.1.1.1 at the manufacturer's declared rated output power, PRAT.

For a BS declared to be capable of multi-carrier operation, set the base station to transmit according to TM1 on all carriers configured using the applicable test configuration and corresponding power setting specified in sub-clause 4.12.

- 2) Measure the emission at the specified frequencies with specified measurement bandwidth and note that the measured value does not exceed the specified value.

In addition, for a multi-band capable BS, the following steps shall apply:

- 3) For multi-band capable BS and single band tests, repeat the steps above per involved band where single band test configurations and test models shall apply with no carrier activated in the other band.
- 4) For multi-band capable BS with separate antenna connector, the antenna connector not being under test in case of single-band or multi-band test shall be terminated.

6.5.3.7 Test requirements

The measurement result in step 2 of 6.5.3.6.2 shall not exceed the maximum level specified in tables 6.35 to 6.47 if applicable for the BS under test.

NOTE: If a Test Requirement in this section differs from the corresponding Minimum Requirement then the Test Tolerance applied for this test is non-zero. The Test Tolerance for this test is defined in clause 4.2 and the explanation of how the Minimum Requirement has been relaxed by the Test Tolerance is given in Annex F.

6.5.3.7.1 Spurious emissions (Category A)

The following requirements shall be met in cases where Category A limits for spurious emissions, as defined in ITU-R Recommendation SM.329 [4], are applied.

Table 6.35: BS Mandatory spurious emissions limits, Category A

Band	Maximum level	Measurement Bandwidth	Notes
9 kHz to 150 kHz	-13 dBm	1 kHz	Note 1
150 kHz to 30 MHz		10 kHz	Note 1
30 MHz to 1 GHz		100 kHz	Note 1
1 GHz to 12,75 GHz		1 MHz	Note 2
12,75 GHz - 5 th harmonic of the upper frequency edge of the DL operating band in GHz		1 MHz	Note 2, Note 3
NOTE 1: Bandwidth as in ITU-R SM.329 [4], clause 4.1			
NOTE 2: Upper frequency as in ITU-R SM.329 [4], clause 2.5 Table 1			
NOTE 3: Applies only for Band XXII			

6.5.3.7.2 Spurious emissions (Category B)

The following requirements shall be met in cases where Category B limits for spurious emissions, as defined in ITU-R Recommendation SM.329[4], are applied.

Table 6.36: BS Mandatory spurious emissions limits, operating band I, II, III, IV, VII, X, XXV (Category B)

Band	Maximum Level	Measurement Bandwidth	Note
9 kHz ↔ 150 kHz	-36 dBm	1 kHz	Note 1
150 kHz ↔ 30 MHz	-36 dBm	10 kHz	Note 1
30 MHz ↔ 1 GHz	-36 dBm	100 kHz	Note 1
1 GHz ↔ $F_{low} - 10$ MHz	-30 dBm	1 MHz	Note 1
$F_{low} - 10$ MHz ↔ $F_{high} + 10$ MHz	-15 dBm	1 MHz	Note 2
$F_{high} + 10$ MHz ↔ 12.75 GHz	-30 dBm	1 MHz	Note 3
12.75 GHz - 5 th harmonic of the upper frequency edge of the DL operating band in GHz	-30 dBm	1 MHz	Note 3, Note 4
NOTE 1: Bandwidth as in ITU-R Recommendation SM.329 [4], s4.1			
NOTE 2: Limit based on ITU-R Recommendation SM.329 [4], s4.3 and Annex 7			
NOTE 3: Bandwidth as in ITU-R Recommendation SM.329 [4], s4.1. Upper frequency as in ITU-R SM.329 [4], s2.5 table 1			
NOTE 4: Applies only for Band XXII			
Key:			
F_{low} : The lowest downlink frequency of the operating band as defined in Table 3.0.			
F_{high} : The highest downlink frequency of the operating band as defined in Table 3.0.			

Table 6.36A: BS Mandatory spurious emissions limits, operating band V, VIII, XII, XIII, XIV, XX, XXVI (Category B)

Band	Maximum Level	Measurement Bandwidth	Note
9 kHz ↔ 150 kHz	-36 dBm	1 kHz	Note 1
150 kHz ↔ 30 MHz	-36 dBm	10 kHz	Note 1
30 MHz ↔ $F_{low} - 10$ MHz	-36 dBm	100 kHz	Note 1
$F_{low} - 10$ MHz ↔ $F_{high} + 10$ MHz	-16 dBm	100 kHz	Note 2
$F_{high} + 10$ MHz ↔ 1 GHz	-36 dBm	100 kHz	Note 1
1GHz ↔ 12.75GHz	-30 dBm	1 MHz	Note 3
NOTE 1: Bandwidth as in ITU-R Recommendation SM.329 [4], s4.1			
NOTE 2: Limit based on ITU-R Recommendation SM.329 [4], s4.3 and Annex 7			
NOTE 3: Bandwidth as in ITU-R Recommendation SM.329 [4], s4.1. Upper frequency as in ITU-R SM.329 [4], s2.5 table 1			
Key:			
F_{low} : The lowest downlink frequency of the operating band as defined in Table 3.0.			
F_{high} : The highest downlink frequency of the operating band as defined in Table 3.0.			

Table 6.36B: (void)

Table 6.36C: (void)

Table 6.36D: (void)

Table 6.36E: (void)

Table 6.36F: (void)

Table 6.36G: (void)

6.5.3.7.3 Protection of the BS receiver of own or different BS

This requirement shall be applied in order to prevent the receivers of the BS being desensitised by emissions from a BS transmitter. This is measured at the transmit antenna port for any type of BS which has common or separate Tx/Rx antenna ports.

Table 6.37: Wide Area BS Spurious emissions limits for protection of the BS receiver

Operating Band	Band	Maximum Level	Measurement Bandwidth	Note
I	1920 - 1980MHz	-96 dBm	100 kHz	
II	1850 - 1910 MHz	-96 dBm	100 kHz	
III	1710 - 1785 MHz	-96 dBm	100 kHz	
IV	1710 - 1755 MHz	-96 dBm	100 kHz	
V	824 - 849 MHz	-96 dBm	100 kHz	
VI, XIX	815 - 845 MHz	-96 dBm	100 kHz	
VII	2500 - 2570 MHz	-96 dBm	100 kHz	
VIII	880-915 MHz	-96 dBm	100 kHz	
IX	1749.9 - 1784.9 MHz	-96 dBm	100 kHz	
X	1710 - 1770 MHz	-96 dBm	100 kHz	
XI	1427.9 - 1447.9 MHz	-96 dBm	100 kHz	
XII	699 - 716 MHz	-96 dBm	100 kHz	
XIII	777 - 787 MHz	-96 dBm	100 kHz	
XIV	788 - 798 MHz	-96 dBm	100 kHz	
XX	832 - 862 MHz	-96 dBm	100 kHz	
XXI	1447.9 - 1462.9 MHz	-96 dBm	100 kHz	
XXII	3410 – 3490 MHz	-96 dBm	100 kHz	
XXV	1850-1915 MHz	-96 dBm	100 kHz	
XXVI	814-849 MHz	-96 dBm	100 kHz	

Table 6.37A: Medium Range BS Spurious emissions limits for protection of the BS receiver

Operating Band	Band	Maximum Level	Measurement Bandwidth	Note
I	1920 - 1980MHz	-86 dBm	100 kHz	
II	1850 - 1910 MHz	-86 dBm	100 kHz	
III	1710 - 1785 MHz	-86 dBm	100 kHz	
IV	1710 - 1755 MHz	-86 dBm	100 kHz	
V	824 - 849 MHz	-86 dBm	100 kHz	
VI, XIX	815 - 845 MHz	-86 dBm	100 kHz	
VII	2500 - 2570 MHz	-86 dBm	100 kHz	
VIII	880-915 MHz	-86 dBm	100 kHz	
IX	1749.9 - 1784.9 MHz	-86 dBm	100 kHz	
X	1710 - 1770 MHz	-86 dBm	100 kHz	
XI	1427.9 - 1447.9 MHz	-86 dBm	100 kHz	
XII	699 - 716 MHz	-86 dBm	100 kHz	
XIII	777 - 787 MHz	-86 dBm	100 kHz	
XIV	788 - 798 MHz	-86 dBm	100 kHz	
XX	832 - 862 MHz	-86 dBm	100 kHz	
XXI	1447.9 - 1462.9 MHz	-86 dBm	100 kHz	
XXII	3410 – 3490 MHz	-86 dBm	100 kHz	
XXV	1850-1915 MHz	-86 dBm	100 kHz	
XXVI	814-849 MHz	-86 dBm	100 kHz	

Table 6.37B: Local Area BS Spurious emissions limits for protection of the BS receiver

Operating Band	Band	Maximum Level	Measurement Bandwidth	Note
I	1920 - 1980MHz	-82 dBm	100 kHz	
II	1850 - 1910 MHz	-82 dBm	100 kHz	
III	1710 - 1785 MHz	-82 dBm	100 kHz	
IV	1710 - 1755 MHz	-82 dBm	100 kHz	
V	824 - 849 MHz	-82 dBm	100 kHz	
VI, XIX	815 - 845 MHz	-82 dBm	100 kHz	
VII	2500 - 2570 MHz	-82 dBm	100 kHz	
VIII	880-915 MHz	-82 dBm	100 kHz	
IX	1749.9 - 1784.9 MHz	-82 dBm	100 kHz	
X	1710 - 1770 MHz	-82 dBm	100 kHz	
XI	1427.9 - 1447.9 MHz	-82 dBm	100 kHz	
XII	699 - 716 MHz	-82 dBm	100 kHz	
XIII	777 - 787 MHz	-82 dBm	100 kHz	
XIV	788 - 798 MHz	-82 dBm	100 kHz	
XX	832 - 862 MHz	-82 dBm	100 kHz	
XXI	1447.9 - 1462.9 MHz	-82 dBm	100 kHz	
XXII	3410 – 3490 MHz	-82 dBm	100 kHz	
XXV	1850-1915 MHz	-82 dBm	100 kHz	
XXVI	814-849 MHz	-82 dBm	100 kHz	

Table 6.37C: Home BS Spurious emissions limits for protection of the BS receiver

Operating Band	Band	Maximum Level	Measurement Bandwidth	Note
I	1920 - 1980MHz	-82 dBm	100 kHz	
II	1850-1910 MHz	-82 dBm	100 kHz	
III	1710-1785 MHz	-82 dBm	100 kHz	
IV	1710-1755 MHz	-82 dBm	100 kHz	
V	824-849 MHz	-82 dBm	100 kHz	
VI, XIX	815-845 MHz	-82 dBm	100 kHz	
VII	2500-2570 MHz	-82 dBm	100 kHz	
VIII	880-915 MHz	-82 dBm	100 kHz	
IX	1749.9-1784.9 MHz	-82 dBm	100 kHz	
X	1710-1770 MHz	-82 dBm	100 kHz	
XI	1427.9 - 1447.9 MHz	-82 dBm	100 kHz	
XII	699 - 716 MHz	-82 dBm	100 kHz	
XIII	777 - 787 MHz	-82 dBm	100 kHz	
XIV	788 - 798 MHz	-82 dBm	100 kHz	
XX	832 - 862 MHz	-82 dBm	100 kHz	
XXI	1447.9 - 1462.9 MHz	-82 dBm	100 kHz	
XXII	3410 – 3490 MHz	-82 dBm	100 kHz	
XXV	1850-1915 MHz	-82 dBm	100 kHz	
XXVI	814-849 MHz	-82 dBm	100 kHz	

6.5.3.7.4 Co-existence with other systems in the same geographical area

These requirements may be applied for the protection of UE, MS and/or BS operating in other frequency bands in the same geographical area. The requirements may apply in geographic areas in which both a UTRA FDD BS and a system operating in another frequency band than the FDD operating band are deployed. The system operating in the other frequency band may be GSM, DCS, PCS, CDMA, E-UTRA and/or UTRA.

The power of any spurious emission shall not exceed the limits of Table 6.38 for a BS where requirements for co-existence with the system listed in the first column apply. For BS capable of multi-band operation, the exclusions and conditions in the Note column of Table 6.38 apply for each supported operating band. For BS capable of multi-band operation where multiple bands are mapped on separate antenna connectors, the exclusions and conditions in the Note column of Table 6.38 apply for the operating band supported at that antenna connector.

Table 6.38: BS Spurious emissions limits for UTRA FDD BS in geographic coverage area of systems operating in other frequency bands

System type operating in the same geographical area	Band for co-existence requirement	Maximum Level	Measurement Bandwidth	Note
GSM900	921 - 960 MHz	-57 dBm	100 kHz	This requirement does not apply to UTRA FDD operating in band VIII
	876 - 915 MHz	-61 dBm	100 kHz	For the frequency range 880-915 MHz, this requirement does not apply to UTRA FDD operating in band VIII, since it is already covered by the requirement in sub-clause 6.5.3.7.3.
DCS1800	1805 - 1880 MHz	-47 dBm	100 kHz	This requirement does not apply to UTRA FDD operating in band III
	1710 - 1785 MHz	-61 dBm	100 kHz	This requirement does not apply to UTRA FDD operating in band III, since it is already covered by the requirement in sub-clause 6.5.3.7.3 .
PCS1900	1930 - 1990 MHz	-47 dBm	100 kHz	This requirement does not apply to UTRA FDD BS operating in frequency band II or band XXV
	1850 - 1910 MHz	-61 dBm	100 kHz	This requirement does not apply to UTRA FDD BS operating in frequency band II or band XXV, since it is already covered by the requirement in sub-clause 6.5.3.7.3.
GSM850 or CDMA850	869 - 894 MHz	-57 dBm	100 kHz	This requirement does not apply to UTRA FDD BS operating in frequency band V or XXVI
	824 - 849 MHz	-61 dBm	100 kHz	This requirement does not apply to UTRA FDD BS operating in frequency band V or XXVI, since it is already covered by the requirement in sub-clause 6.5.3.7.3.
UTRA FDD Band I or E-UTRA Band 1	2110 - 2170 MHz	-52 dBm	1 MHz	This requirement does not apply to UTRA FDD BS operating in band I,
	1920 - 1980 MHz	-49 dBm	1 MHz	This requirement does not apply to UTRA FDD BS operating in band I, since it is already covered by the requirement in sub-clause 6.5.3.7.3 .
UTRA FDD Band II or E-UTRA Band 2	1930 - 1990 MHz	-52 dBm	1 MHz	This requirement does not apply to UTRA FDD BS operating in band II or band XXV
	1850 - 1910 MHz	-49 dBm	1 MHz	This requirement does not apply to UTRA FDD BS operating in band II or band XXV, since it is already covered by the requirement in sub-clause 6.5.3.7.3.
UTRA FDD Band III or E-UTRA Band 3	1805 - 1880 MHz	-52 dBm	1 MHz	This requirement does not apply to UTRA FDD BS operating in band III or band IX
	1710 - 1785 MHz	-49 dBm	1 MHz	This requirement does not apply to UTRA FDD BS operating in band III, since it is already covered by the requirement in sub-clause 6.5.3.7.3 . For UTRA BS operating in band IX, it applies for 1710 MHz to 1749.9 MHz and 1784.9 MHz to 1785 MHz, while the rest is covered in sub-clause 6.5.3.7.3.
UTRA FDD Band IV or E-UTRA Band 4	2110 - 2155 MHz	-52 dBm	1 MHz	This requirement does not apply to UTRA FDD BS operating in band IV or band X
	1710 - 1755 MHz	-49 dBm	1 MHz	This requirement does not apply to UTRA FDD BS operating in band IV or band X, since it is already covered by the requirement in sub-clause 6.5.3.7.3 .
UTRA FDD Band V or E-UTRA Band 5	869 - 894 MHz	-52 dBm	1 MHz	This requirement does not apply to UTRA FDD BS operating in band V or XXVI
	824 - 849 MHz	-49 dBm	1 MHz	This requirement does not apply to UTRA FDD BS operating in band V or XXVI, since it is already covered by the requirement in sub-clause 6.5.3.7.3 .

UTRA FDD Band VI or XIX, or E-UTRA Band 6, 18 or 19	860 - 890 MHz	-52 dBm	1 MHz	This requirement does not apply to UTRA FDD BS operating in band VI or XIX
	815 - 845 MHz	-49 dBm	1 MHz	This requirement does not apply to UTRA FDD BS operating in band VI or XIX, since it is already covered by the requirement in sub-clause 6.5.3.7.3 .
UTRA FDD Band VII or E-UTRA Band 7	2620 - 2690 MHz	-52 dBm	1 MHz	This requirement does not apply to UTRA FDD BS operating in band VII,
	2500 - 2570 MHz	-49 dBm	1 MHz	This requirement does not apply to UTRA FDD BS operating in band VII, since it is already covered by the requirement in sub-clause 6.5.3.7.3 .
UTRA FDD Band VIII or E-UTRA Band 8	925 - 960 MHz	-52 dBm	1 MHz	This requirement does not apply to UTRA FDD BS operating in band VIII.
	880 - 915 MHz	-49 dBm	1 MHz	This requirement does not apply to UTRA FDD BS operating in band VIII, since it is already covered by the requirement in sub-clause 6.5.3.7.3.
UTRA FDD Band IX or E-UTRA Band 9	1844.9 - 1879.9 MHz	-52 dBm	1 MHz	This requirement does not apply to UTRA FDD BS operating in band III or band IX
	1749.9 - 1784.9 MHz	-49 dBm	1 MHz	This requirement does not apply to UTRA FDD BS operating in band III or band IX, since it is already covered by the requirement in sub-clause 6.5.3.7.3 .
UTRA FDD Band X or E-UTRA Band 10	2110 - 2170 MHz	-52 dBm	1 MHz	This requirement does not apply to UTRA FDD BS operating in band IV or band X
	1710 - 1770 MHz	-49 dBm	1 MHz	This requirement does not apply to UTRA FDD BS operating in band X, since it is already covered by the requirement in sub-clause 6.5.3.7.3. For UTRA FDD BS operating in Band IV, it applies for 1755 MHz to 1770 MHz, while the rest is covered in sub-clause 6.5.3.7.3.
UTRA FDD Band XI or XXI or E-UTRA Band 11 or 21	1475.9 - 1510.9 MHz	-52 dBm	1 MHz	This requirement does not apply to UTRA FDD BS operating in band XI or XXI.
	1427.9 - 1447.9 MHz	-49 dBm	1 MHz	This requirement does not apply to UTRA FDD BS operating in band XI, since it is already covered by the requirement in sub-clause 6.5.3.7.3.
	1447.9 - 1462.9 MHz	-49 dBm	1 MHz	This requirement does not apply to UTRA FDD BS operating in band XXI, since it is already covered by the requirement in sub-clause 6.5.3.7.3.
UTRA FDD Band XII or E-UTRA Band 12	729 - 746 MHz	-52 dBm	1 MHz	This requirement does not apply to UTRA FDD BS operating in band XII
	699 - 716 MHz	-49 dBm	1 MHz	This requirement does not apply to UTRA FDD BS operating in band XII, since it is already covered by the requirement in sub-clause 6.5.3.7.3.
UTRA FDD Band XIII or E-UTRA Band 13	746 - 756 MHz	-52 dBm	1 MHz	This requirement does not apply to UTRA FDD BS operating in band XIII
	777 - 787 MHz	-49 dBm	1 MHz	This requirement does not apply to UTRA FDD BS operating in band XIII, since it is already covered by the requirement in sub-clause 6.5.3.7.3.
UTRA FDD Band XIV or E-UTRA Band 14	758 - 768 MHz	-52 dBm	1 MHz	This requirement does not apply to UTRA FDD BS operating in band XIV
	788 - 798 MHz	-49 dBm	1 MHz	This requirement does not apply to UTRA FDD BS operating in band XIV, since it is already covered by the requirement in sub-clause 6.5.3.7.3.
E-UTRA Band 17	734 - 746 MHz	-52 dBm	1 MHz	This requirement does not apply to UTRA FDD BS operating in band XII
	704 - 716 MHz	-49 dBm	1 MHz	This requirement does not apply to UTRA FDD BS operating in band XII, since it is already covered by the requirement in sub-clause 6.6.3.2.

UTRA FDD Band XX or E-UTRA Band 20	791 - 821 MHz	-52 dBm	1 MHz	This requirement does not apply to UTRA FDD BS operating in band XX
	832 - 862 MHz	-49 dBm	1 MHz	This requirement does not apply to UTRA FDD BS operating in band XX, since it is already covered by the requirement in sub-clause 6.6.3.2.
UTRA FDD Band XXII or E-UTRA Band 22	3510 - 3590 MHz	-52 dBm	1 MHz	This requirement does not apply to UTRA FDD BS operating in band XXII
	3410 - 3490 MHz	-49 dBm	1 MHz	This requirement does not apply to UTRA FDD BS operating in band XXII, since it is already covered by the requirement in sub-clause 6.5.3.7.3.
E-UTRA Band 23	2180 - 2200 MHz	-52 dBm	1 MHz	
	2000 - 2020 MHz	-49 dBm	1 MHz	This requirement does not apply to UTRA FDD BS operating in Band II or XXV, where the limits are defined separately.
	2000 – 2010 MHz	-30 dBm	1 MHz	This requirement only applies to UTRA FDD BS operating in Band II or Band XXV. This requirement applies starting 5 MHz above the Band XXV downlink operating band. (Note 3)
	2010 – 2020 MHz	-49 dBm	1 MHz	
E-UTRA Band 24	1525 – 1559 MHz	-52 dBm	1 MHz	
	1626.5 – 1660.5 MHz	-49 dBm	1 MHz	
UTRA FDD Band XXV or E-UTRA Band 25	1930 - 1995 MHz	-52 dBm	1 MHz	This requirement does not apply to UTRA FDD BS operating in band II or band XXV
	1850 - 1915 MHz	-49 dBm	1 MHz	This requirement does not apply to UTRA FDD BS operating in band XXV, since it is already covered by the requirement in sub-clause 6.5.3.7.3. For UTRA FDD BS operating in Band II, it applies for 1910 MHz to 1915 MHz, while the rest is covered in sub-clause 6.5.3.7.3.
UTRA FDD Band XXVI or E-UTRA Band 26	859-894 MHz	-52 dBm	1 MHz	This requirement does not apply to UTRA FDD BS operating in band V or band XXVI
	814-849 MHz	-49 MHz	1 MHz	This requirement does not apply to UTRA FDD BS operating in band XXVI, since it is already covered by the requirements in sub-clause 6.6.3.2 For UTRA FDD BS operating in band V, it applies for 814MHz to 824MHz, while the rest is covered in sub-clause 6.6.3.2
E-UTRA Band 27	852 – 869 MHz	-52 dBm	1 MHz	This requirement does not apply to UTRA BS operating in Band V or XXVI.
	807 – 824 MHz	-49 dBm	1 MHz	For UTRA BS operating in Band XXVI, it applies for 807 MHz to 814 MHz, while the rest is covered in sub-clause 6.5.3.7.3.
E-UTRA Band 28	758 – 803 MHz	-52 dBm	1 MHz	
	703 – 748 MHz	-49 MHz	1 MHz	
E-UTRA Band 29	717 - 728 MHz	-52 dBm	1 MHz	
UTRA TDD in Band a) or E-UTRA Band 33	1900 - 1920 MHz	-52 dBm	1 MHz	
UTRA TDD in Band a) or E-UTRA Band 34	2010 - 2025 MHz	-52 dBm	1 MHz	
UTRA TDD in Band d) or E-UTRA Band 38	2570 - 2620 MHz	-52 dBm	1 MHz	
UTRA TDD in Band f) or E-UTRA Band 39	1880 - 1920MHz	-52 dBm	1 MHz	Applicable in China

UTRA TDD in Band e) or E-UTRA Band 40	2300 - 2400MHz	-52 dBm	1 MHz	
E-UTRA Band 41	2496 - 2690 MHz	-52 dBm	1 MHz	
E-UTRA Band 42	3400 – 3600 MHz	-52 dBm	1 MHz	
E-UTRA Band 43	3600 – 3800 MHz	-52 dBm	1 MHz	
E-UTRA Band 44	703 – 803 MHz	-52 dBm	1 MHz	
<p>NOTE 1: The co-existence requirements do not apply for the 10 MHz frequency range immediately outside the downlink operating band (see Table 3.0). Emission limits for this excluded frequency range may be covered by local or regional requirements.</p> <p>NOTE 2: The table above assumes that two operating bands, where the frequency ranges would be overlapping, are not deployed in the same geographical area. For such a case of operation with overlapping frequency arrangements in the same geographical area, special co-existence requirements may apply that are not covered by the 3GPP specifications.</p> <p>NOTE 3: This requirement does not apply to a Band II UTRA BS of an earlier release. In addition, it does not apply to an UTRA Band II BS from an earlier release manufactured before 31 December, 2012, which is upgraded to support Rel-10 features, where the upgrade does not affect existing RF parts of the radio unit related to this requirement.</p>				

6.5.3.7.5 Co-existence with co-located and co-sited base stations

These requirements may be applied for the protection of other BS receivers when GSM900, DCS1800, PCS1900, GSM850, E-UTRA FDD and/or UTRA FDD BS, CDMA, E-UTRA TDD and or UTRA TDD are co-located with a UTRA FDD BS.

The power of any spurious emission shall not exceed the limits of Table 6.39 for a Wide Area (WA) BS where requirements for co-location with a BS type listed in the first column apply. For BS capable of multi-band operation, the exclusions and conditions in the Note column of Table 6.39 apply for each supported operating band. For BS capable of multi-band operation where multiple bands are mapped on separate antenna connectors, the exclusions and conditions in the Note column of Table 6.39 apply for the operating band supported at that antenna connector.

Table 6.39: BS Spurious emissions limits for Wide Area BS co-located with another BS

Type of co-located BS	Band for co-location requirement	Maximum Level	Measurement Bandwidth	Note
Macro GSM900	876-915 MHz	-98 dBm	100 kHz	
Macro DCS1800	1710 - 1785 MHz	-98 dBm	100 kHz	
Macro PCS1900	1850 - 1910 MHz	-98 dBm	100 kHz	
Macro GSM850 or CDMA850	824 - 849 MHz	-98 dBm	100 kHz	
WA UTRA FDD Band I or E-UTRA Band 1	1920 - 1980 MHz	-96 dBm	100 kHz	
WA UTRA FDD Band II or E-UTRA Band 2	1850 - 1910 MHz	-96 dBm	100 kHz	
WA UTRA FDD Band III or E-UTRA Band 3	1710 - 1785 MHz	-96 dBm	100 kHz	
WA UTRA FDD Band IV or E-UTRA Band 4	1710 - 1755 MHz	-96 dBm	100 kHz	
WA UTRA FDD Band V or E-UTRA Band 5	824 - 849 MHz	-96 dBm	100 kHz	
WA UTRA FDD Band VI or XIX or E-UTRA Band 6, 18 or 19	815 - 845 MHz	-96 dBm	100 kHz	
WA UTRA FDD Band VII or E-UTRA Band 7	2500 - 2570 MHz	-96 dBm	100 kHz	
WA UTRA FDD Band VIII or E-UTRA Band 8	880 - 915 MHz	-96 dBm	100 kHz	
WA UTRA FDD Band IX or E-UTRA Band 9	1749.9 - 1784.9 MHz	-96 dBm	100 kHz	
WA UTRA FDD Band X or E-UTRA Band 10	1710 - 1770 MHz	-96 dBm	100 kHz	
WA UTRA FDD Band XI or E-UTRA Band 11	1427.9 - 1447.9 MHz	-96 dBm	100 kHz	
WA UTRA FDD Band XII or E-UTRA Band 12	699 - 716 MHz	-96 dBm	100 kHz	
WA UTRA FDD Band XIII or E-UTRA Band 13	777 - 787 MHz	-96 dBm	100 kHz	
WA UTRA FDD Band XIV or E-UTRA Band 14	788 - 798 MHz	-96 dBm	100 kHz	
WA E-UTRA Band 17	704 - 716 MHz	-96 dBm	100 kHz	
WA UTRA FDD Band XX or E-UTRA Band 20	832 - 862 MHz	-96 dBm	100 kHz	
WA UTRA FDD Band XXI or E-UTRA Band 21	1447.9 - 1462.9 MHz	-96 dBm	100 kHz	
WA UTRA FDD Band XXII or E-UTRA Band 22	3410 – 3490 MHz	-96 dBm	100 kHz	
WA E-UTRA Band 23	2000 - 2020 MHz	-96 dBm	100 kHz	
WA E-UTRA Band 24	1626.5 – 1660.5 MHz	-96 dBm	100 kHz	
WA UTRA FDD Band XXV or E-UTRA Band 25	1850 - 1915 MHz	-96 dBm	100 kHz	
WA UTRA FDD Band XXVI or E-UTRA Band 26	814-849 MHz	-96 dBm	100 kHz	
WA E-UTRA Band 27	807 - 824 MHz	-96 dBm	100 kHz	
WA E-UTRA Band 28	703 – 748 MHz	-96 dBm	100 kHz	
WA UTRA TDD Band a) or E-UTRA Band 33	1900 - 1920 MHz	-86 dBm	1 MHz	
WA UTRA TDD Band a) or E-UTRA Band 34	2010 - 2025 MHz	-86 dBm	1 MHz	
WA UTRA TDD Band d) or E-UTRA Band 38	2570 - 2620 MHz	-86 dBm	1 MHz	
WA UTRA TDD Band f) or E-UTRA Band 39	1880 - 1920MHz	-86 dBm	1 MHz	Applicable in China
WA UTRA TDD Band e) or E-UTRA Band 40	2300 - 2400MHz	-86 dBm	1 MHz	
WA E-UTRA Band 41	2496 – 2690 MHz	-86 dBm	1 MHz	
WA E-UTRA Band 42	3400 – 3600 MHz	-86 dBm	1 MHz	
WA E-UTRA Band 43	3600 – 3800 MHz	-86 dBm	1 MHz	
WA E-UTRA Band 44	703 – 803 MHz	-86 dBm	1 MHz	

<p>NOTE 1: The co-location requirements do not apply for the 10 MHz frequency range immediately outside the BS transmit frequency range of a downlink operating band (see Table 3.0). The current state-of-the-art technology does not allow a single generic solution for co-location with other system on adjacent frequencies for 30dB BS-BS minimum coupling loss. However, there are certain site-engineering solutions that can be used. These techniques are addressed in TR 25.942 [2].</p> <p>NOTE 2: The table above assumes that two operating bands, where the frequency ranges would be overlapping, are not deployed in the same geographical area. For such a case of operation with overlapping frequency arrangements in the same geographical area, special co-existence requirements may apply that are not covered by the 3GPP specifications.</p>
--

The power of any spurious emission shall not exceed the limits of Table 6.40 for a Medium Range (MR) BS where requirements for co-location with a BS type listed in the first column apply. For BS capable of multi-band operation, the exclusions and conditions in the Note column of Table 6.40 apply for each supported operating band. For BS capable of multi-band operation where multiple bands are mapped on separate antenna connectors, the exclusions and conditions in the Note column of Table 6.40 apply for the operating band supported at that antenna connector.

Table 6.40: BS Spurious emissions limits for Medium Range BS co-located with another BS

Type of co-located BS	Band for co-location requirement	Maximum Level	Measurement Bandwidth	Note
Micro GSM900	876-915 MHz	-91 dBm	100 kHz	
Micro DCS1800	1710 - 1785 MHz	-96 dBm	100 kHz	
Micro PCS1900	1850 - 1910 MHz	-96 dBm	100 kHz	
Micro GSM850	824 - 849 MHz	-91 dBm	100 kHz	
MR UTRA FDD Band I or E-UTRA Band 1	1920 - 1980 MHz	-91 dBm	100 kHz	
MR UTRA FDD Band II or E-UTRA Band 2	1850 - 1910 MHz	-91 dBm	100 kHz	
MR UTRA FDD Band III or E-UTRA Band 3	1710 - 1785 MHz	-91 dBm	100 kHz	
MR UTRA FDD Band IV or E-UTRA Band 4	1710 - 1755 MHz	-91 dBm	100 kHz	
MR UTRA FDD Band V or E-UTRA Band 1	824 - 849 MHz	-91 dBm	100 kHz	
MR UTRA FDD Band VI or XIX or E-UTRA Band 6, 18 or 19	815 - 845 MHz	-91 dBm	100 kHz	
MR UTRA FDD Band VII or E-UTRA Band 7	2500 - 2570 MHz	-91 dBm	100 kHz	
MR UTRA FDD Band VIII or E-UTRA Band 8	880 - 915 MHz	-91 dBm	100 kHz	
MR UTRA FDD Band IX or E-UTRA Band 9	1749.9 - 1784.9 MHz	-91 dBm	100 kHz	
MR UTRA FDD Band X or E-UTRA Band 10	1710 - 1770 MHz	-91 dBm	100 kHz	
MR UTRA FDD Band XI or E-UTRA Band 11	1427.9 - 1447.9 MHz	-91 dBm	100 kHz	
MR UTRA FDD Band XII or E-UTRA Band 12	699 - 716 MHz	-91 dBm	100 kHz	
MR UTRA FDD Band XIII or E-UTRA Band 13	777 - 787 MHz	-91 dBm	100 kHz	
MR UTRA FDD Band XIV or E-UTRA Band 14	788 - 798 MHz	-91 dBm	100 kHz	
MR E-UTRA Band 17	704 - 716 MHz	-91 dBm	100 kHz	
MR UTRA FDD Band XX or E-UTRA Band 20	832 - 862 MHz	-91 dBm	100 kHz	
MR UTRA FDD Band XXI or E-UTRA Band 21	1447.9 - 1462.9 MHz	-91 dBm	100 kHz	
MR UTRA FDD Band XXII or E-UTRA Band 22	3410 – 3490 MHz	-91 dBm	100 kHz	
MR E-UTRA Band 23	2000 - 2020 MHz	-91 dBm	100 kHz	
MR E-UTRA Band 24	1626.5 – 1660.5 MHz	-91 dBm	100 kHz	
MR UTRA FDD Band XXV or E-UTRA Band 25	1850 - 1915 MHz	-91 dBm	100 kHz	
MR UTRA FDD Band XXVI or E-UTRA Band 26	814.849 MHz	-91 dBm	100 kHz	
MR E-UTRA Band 27	807 - 824 MHz	-91 dBm	100 kHz	
MR E-UTRA Band 28	703 – 748 MHz	-91 dBm	100 kHz	
MR E-UTRA Band 33	1900 - 1920 MHz	-91 dBm	100 kHz	
MR E-UTRA Band 34	2010 - 2025 MHz	-91 dBm	100 kHz	
MR E-UTRA Band 38	2570 - 2620 MHz	-91 dBm	100 kHz	
MR E-UTRA Band 39	1880 - 1920MHz	-91 dBm	100 kHz	
MR E-UTRA Band 40	2300 - 2400MHz	-91 dBm	100 kHz	
MR E-UTRA Band 41	2496 – 2690 MHz	-91 dBm	100 kHz	
MR E-UTRA Band 42	3400 – 3600 MHz	-91 dBm	100 kHz	
MR E-UTRA Band 43	3600 – 3800 MHz	-91 dBm	100 kHz	
MR E-UTRA Band 44	703 – 803 MHz	-91 dBm	100 kHz	

- | |
|---|
| <p>NOTE 1: The co-location requirements do not apply for the 10 MHz frequency range immediately outside the BS transmit frequency range of a downlink operating band (see Table 3.0). The current state-of-the-art technology does not allow a single generic solution for co-location with other system on adjacent frequencies for 30dB BS-BS minimum coupling loss. However, there are certain site-engineering solutions that can be used. These techniques are addressed in TR 25.942 [2].</p> <p>NOTE 2: The table above assumes that two operating bands, where the frequency ranges would be overlapping, are not deployed in the same geographical area. For such a case of operation with overlapping frequency arrangements in the same geographical area, special co-existence requirements may apply that are not covered by the 3GPP specifications.</p> <p>NOTE 3: The requirements in this table do not apply to a Rel-10 or an earlier release UTRA MR BS, which is manufactured before 31 December 2015 and upgraded to support features in the present release, where the upgrade does not affect existing RF parts of the radio unit related to this requirement. For such a UTRA MR BS, the corresponding requirements in Rel-10 or the earlier release, which the BS was manufactured for, shall apply.</p> |
|---|

The power of any spurious emission shall not exceed the limits of Table 6.41 for a Local Area (LA) BS where requirements for co-location with a BS type listed in the first column apply. For BS capable of multi-band operation, the exclusions and conditions in the Note column of Table 6.41 apply for each supported operating band. For BS capable of multi-band operation where multiple bands are mapped on separate antenna connectors, the exclusions and conditions in the Note column of Table 6.41 apply for the operating band supported at that antenna connector.

Table 6.41: BS Spurious emissions limits for Local Area BS co-located with another BS

Type of co-located BS	Band for co-location requirement	Maximum Level	Measurement Bandwidth	Note
Pico GSM900	876-915 MHz	-70 dBm	100 kHz	
Pico DCS1800	1710 - 1785 MHz	-80 dBm	100 kHz	
Pico PCS1900	1850 - 1910 MHz	-80 dBm	100 kHz	
Pico GSM850	824 - 849 MHz	-70 dBm	100 kHz	
LA UTRA FDD Band I or E-UTRA Band 1	1920 - 1980 MHz	-88 dBm	100 kHz	
LA UTRA FDD Band II or E-UTRA Band 2	1850 - 1910 MHz	-88 dBm	100 kHz	
LA UTRA FDD Band III or E-UTRA Band 3	1710 - 1785 MHz	-88 dBm	100 kHz	
LA UTRA FDD Band IV or E-UTRA Band 4	1710 - 1755 MHz	-88 dBm	100 kHz	
LA UTRA FDD Band V or E-UTRA Band 5	824 - 849 MHz	-88 dBm	100 kHz	
LA UTRA FDD Band VI or XIX or E-UTRA Band 6, 18 or 19	815 - 845 MHz	-88 dBm	100 kHz	
LA UTRA FDD Band VII or E-UTRA Band 7	2500 - 2570 MHz	-88 dBm	100 kHz	
LA UTRA FDD Band VIII or E-UTRA Band 8	880 - 915 MHz	-88 dBm	100 kHz	
LA UTRA FDD Band IX or E-UTRA Band 9	1749.9 - 1784.9 MHz	-88 dBm	100 kHz	
LA UTRA FDD Band X or E-UTRA Band 10	1710 - 1770 MHz	-88 dBm	100 kHz	
LA UTRA FDD Band XI or E-UTRA Band 11	1427.9 - 1447.9 MHz	-88 dBm	100 kHz	
LA UTRA FDD Band XII or E-UTRA Band 12	699 - 716 MHz	-88 dBm	100 kHz	
LA UTRA FDD Band XIII or E-UTRA Band 13	777 - 787 MHz	-88 dBm	100 kHz	
LA UTRA FDD Band XIV or E-UTRA Band 14	788 - 798 MHz	-88 dBm	100 kHz	
LA E-UTRA Band 17	704 - 716 MHz	-88 dBm	100 kHz	
LA UTRA FDD Band XX or E-UTRA Band 20	832 - 862 MHz	-88 dBm	100 kHz	
LA UTRA FDD Band XXI or E-UTRA Band 21	1447.9 - 1462.9 MHz	-88 dBm	100 kHz	
LA UTRA FDD Band XXII or E-UTRA Band 22	3410 – 3490 MHz	-88 dBm	100 kHz	
LA E-UTRA Band 23	2000 - 2020 MHz	-88 dBm	100 kHz	
LA E-UTRA Band 24	1626.5 – 1660.5 MHz	-88 dBm	100 kHz	
LA UTRA FDD Band XXV or E-UTRA Band 25	1850 - 1915 MHz	-88 dBm	100 kHz	
LA UTRA FDD Band XXVI or E-UTRA Band 26	814-849 MHz	-88 dBm	100 kHz	
LA E-UTRA Band 27	807 - 824 MHz	-88 dBm	100 kHz	
LA E-UTRA Band 28	703 – 748 MHz	-88 dBm	100 kHz	
LA UTRA TDD Band a) or E-UTRA Band 33	1900 - 1920 MHz	-78 dBm	1 MHz	
LA UTRA TDD Band a) or E-UTRA Band 34	2010 - 2025 MHz	-78 dBm	1 MHz	
LA UTRA TDD Band d) or E-UTRA Band 38	2570 - 2620 MHz	-78 dBm	1 MHz	
LA UTRA TDD Band f) or E-UTRA Band 39	1880 - 1920MHz	-78 dBm	1 MHz	Applicable in China
LA UTRA TDD Band e) or E-UTRA Band 40	2300 - 2400MHz	-78 dBm	1 MHz	
LA E-UTRA Band 41	2496 - 2690 MHz	-78 dBm	1 MHz	
LA E-UTRA Band 42	3400 - 3600MHz	-78 dBm	1 MHz	
LA E-UTRA Band 43	3600 - 3800MHz	-78 dBm	1 MHz	

LA E-UTRA Band 44	703 - 803 MHz	-78 dBm	1 MHz	
NOTE 1: The co-location requirements do not apply for the 10 MHz frequency range immediately outside the BS transmit frequency range of a downlink operating band (see Table 3.0). The current state-of-the-art technology does not allow a single generic solution for co-location with other system on adjacent frequencies for 30dB BS-BS minimum coupling loss. However, there are certain site-engineering solutions that can be used. These techniques are addressed in TR 25.942 [2].				
NOTE 2: The table above assumes that two operating bands, where the frequency ranges would be overlapping, are not deployed in the same geographical area. For such a case of operation with overlapping frequency arrangements in the same geographical area, special co-existence requirements may apply that are not covered by the 3GPP specifications.				
NOTE 3: The requirements in this table do not apply to a Rel-10 or an earlier release UTRA LA BS, which is manufactured before 31 December 2013 and upgraded to support features in the present release, where the upgrade does not affect existing RF parts of the radio unit related to this requirement. For such a UTRA LA BS, the corresponding requirements in Rel-10 or the earlier release, which the BS was manufactured for, shall apply.				

6.5.3.7.6 Co-existence with PHS

This requirement may be applied for the protection of PHS in geographic areas in which both PHS and UTRA FDD are deployed. This requirement is also applicable at specified frequencies falling between 12.5MHz below the first carrier frequency used and 12.5MHz above the last carrier frequency used.

Table 6.42: BS Spurious emissions limits for BS in geographic coverage area of PHS

Band	Maximum Level	Measurement Bandwidth	Note
1884.5 MHz to 1915.7 MHz	-41 dBm	300 kHz	

6.5.3.7.7 Co-existence with services in adjacent frequency bands

This requirement may be applied for the protection in bands adjacent to bands I or VII, as defined in clause 3.4.1, in geographic areas in which both an adjacent band service and UTRA FDD are deployed.

Table 6.43: BS spurious emissions limits for protection of adjacent band services

Operating Band	Band	Maximum Level	Measurement Bandwidth	Note
I	2100-2105 MHz	$-30 + 3.4 \cdot (f - 2100 \text{ MHz})$ dBm	1 MHz	
	2175-2180 MHz	$-30 + 3.4 \cdot (2180 \text{ MHz} - f)$ dBm	1 MHz	
VII	2610-2615 MHz	$-30 + 3.4 \cdot (f - 2610 \text{ MHz})$ dBm	1 MHz	
	2695-2700 MHz	$-30 + 3.4 \cdot (2700 \text{ MHz} - f)$ dBm	1 MHz	

6.5.3.7.8 Void

6.5.3.7.8.1 Void

Table 6.44: Void

6.5.3.7.8.2 Void

Table 6.45: Void

6.5.3.7.9 Protection of Public Safety Operations

This requirement shall be applied to BS operating in Bands XIII and XIV to ensure that appropriate interference protection is provided to 700 MHz public safety operations. This requirement is also applicable at specified frequencies falling between 12.5 MHz below the first carrier frequency used and 12.5 MHz above the last carrier frequency used.

Table 6.46: BS spurious emissions limits

Operating Band	Band	Maximum Level	Measurement Bandwidth	Note
XIII	763 - 775 MHz	-46 dBm	6.25 kHz	
XIII	793 - 805 MHz	-46 dBm	6.25 kHz	
XIV	769 - 775 MHz	-46 dBm	6.25 kHz	
XIV	799 - 805 MHz	-46 dBm	6.25 kHz	

This requirement shall be applied to BS operating in Bands XXVI to ensure that appropriate interference protection is provided to 800 MHz public safety operations. This requirement is also applicable at specified frequencies falling between 12.5 MHz below the first carrier frequency used and 12.5 MHz above the last carrier frequency used.

Table 6.46A: BS spurious emissions limits

Operating Band	Band	Maximum Level	Measurement Bandwidth	Note
XXVI	851 - 859 MHz	-13 dBm	100 kHz	Applicable for offsets > 37.5kHz from the channel edge

6.5.3.7.10 Co-existence with Home BS operating in other bands

These requirements may be applied for the protection of Home BS receivers operating in other bands. These requirements are only applicable to Home BS.

The power of any spurious emission shall not exceed the limits of Table 6.47 for a Home BS where requirements for co-existence with a Home BS type listed in the first column apply.

Table 6.47: Home BS Spurious emissions limits for co-existence with Home BS operating in other bands

Type of Home BS	Band for co-existence requirement	Maximum Level	Measurement Bandwidth	Note
UTRA FDD Band I or E-UTRA Band 1	1920 - 1980 MHz	-71 dBm	100 kHz	
UTRA FDD Band II or E-UTRA Band 2	1850 - 1910 MHz	-71 dBm	100 kHz	
UTRA FDD Band III or E-UTRA Band 3	1710 - 1785 MHz	-71 dBm	100 kHz	
UTRA FDD Band IV or E-UTRA Band 4	1710 - 1755 MHz	-71 dBm	100 kHz	
UTRA FDD Band V or E-UTRA Band 5	824 - 849 MHz	-71 dBm	100 kHz	
UTRA FDD Band VI or XIX or E-UTRA Band 6, 19	815 - 845 MHz	-71 dBm	100 kHz	
UTRA FDD Band VII or E-UTRA Band 7	2500 - 2570 MHz	-71 dBm	100 kHz	
UTRA FDD Band VIII or E-UTRA Band 8	880 - 915 MHz	-71 dBm	100 kHz	
UTRA FDD Band IX or E-UTRA Band 9	1749.9 - 1784.9 MHz	-71 dBm	100 kHz	
UTRA FDD Band X or E-UTRA Band 10	1710 - 1770 MHz	-71 dBm	100 kHz	
UTRA FDD Band XI or E-UTRA Band 11	1427.9 - 1447.9 MHz	-71 dBm	100 kHz	
UTRA FDD Band XII or E-UTRA Band 12	699 - 716 MHz	-71 dBm	100 kHz	
UTRA FDD Band XIII or E-UTRA Band 13	777 - 787 MHz	-71 dBm	100 kHz	
UTRA FDD Band XIV or E-UTRA Band 14	788 - 798 MHz	-71 dBm	100 kHz	
E-UTRA Band 17	704 - 716 MHz	-71 dBm	100 kHz	
UTRA FDD Band XX or E-UTRA Band 20	832 - 862 MHz	-71 dBm	100 kHz	
UTRA FDD Band XXI or E-UTRA Band 21	1447.9 - 1462.9 MHz	-71 dBm	100 kHz	
UTRA FDD Band XXII or E-UTRA Band 22	3410 - 3490 MHz	-71 dBm	100 kHz	
E-UTRA FDD Band 23	2000 – 2020 MHz	TBD	TBD	
E-UTRA FDD Band 24	1626.5 – 1660.5 MHz	-71 dBm	100 kHz	
UTRA FDD Band XXV or E-UTRA Band 25	1850-1915 MHz	-71 dBm	100 kHz	
UTRA FDD Band XXVI or E-UTRA Band 26	814-849 MHz	-71dBm	100 kHz	
E-UTRA FDD Band 27	807 – 824 MHz	-71 dBm	100 kHz	
E-UTRA Band 28	703 – 748 MHz	-71dBm	100 kHz	
UTRA TDD Band a) or E-UTRA Band 33	1900 - 1920 MHz	-71 dBm	100 kHz	
UTRA TDD Band a) or E-UTRA Band 34	2010 - 2025 MHz	-71 dBm	100 kHz	
UTRA TDD Band d) or E-UTRA Band 38	2570 - 2620 MHz	-71 dBm	100 kHz	
UTRA TDD Band f) or E-UTRA Band 39	1880 - 1920 MHz	-71 dBm	100 kHz	
UTRA TDD Band e) E-UTRA Band 40	2300 - 2400 MHz	-71 dBm	100 kHz	
E-UTRA Band 41	2496 - 2690 MHz	-71 dBm	100 kHz	
E-UTRA Band 42	3400 -3600 MHz	-71 dBm	100 kHz	
E-UTRA Band 43	3600 -3800 MHz	-71 dBm	100 kHz	
E-UTRA Band 44	703 -803 MHz	-71 dBm	100 kHz	

6.6 Transmitter intermodulation

6.6.1 Definition and applicability

The transmitter intermodulation requirement is a measure of the capability of the transmitter to inhibit the generation of signals in its non-linear elements caused by presence of the wanted signal and an interfering signal reaching the transmitter via the antenna.

The transmitter intermodulation level is the power of the intermodulation products when a WCDMA interfering signal is injected into an antenna connector at a mean power level of 30 dB lower than that of the mean power of the wanted signal.

For BS capable of multi-band operation where multiple bands are mapped on separate antenna connectors, the single-band requirements apply regardless of the interfering signals position relative to the inter-RF bandwidth gap.

For multi-carrier operation, the interfering signal offset is defined relative to the lower (upper) edge of the wanted signal or edge of sub-block inside a gap.

The interfering signal frequency offset shall be as in Table 6.48.

Table 6.48: Interfering signal frequency offset

Parameter	Value
Interfering signal centre frequency offset from the wanted signal centre frequency	-5 MHz -10 MHz -15 MHz +5 MHz +10 MHz +15 MHz
Interfering signal centre frequency offset from the lower (upper) edge of the wanted signal or edge of sub-block inside a gap	-2.5 MHz -7.5 MHz -12.5 MHz +2.5 MHz +7.5 MHz +12.5 MHz
NOTE 1: Interference frequencies that are outside of any allocated frequency band for UTRA-FDD downlink specified in clause 3.4.1 are excluded from the requirement, unless the interfering signal positions fall within the frequency range of adjacent downlink operating bands in the same geographical area.	
NOTE 2: In certain regions, NOTE 1 is not applied in Band I, III, VI, VIII, IX, XI, XIX, XXI.	

6.6.2 Minimum Requirement

The minimum requirement is in TS 25.104 [1] clause 6.7.

6.6.3 Test purpose

The test purpose is to verify the ability of the BS transmitter to restrict the generation of intermodulation products in its non linear elements caused by presence of the wanted signal and an interfering signal reaching the transmitter via the antenna to below specified levels.

6.6.4 Method of test

6.6.4.1 Initial conditions

Test environment: normal; see clause 4.4.1.

RF channels to be tested for single carrier: B, M and T; see clause 4.8

RF bandwidth positions to be tested for multi-carrier: B_{RFBW} , M_{RFBW} and T_{RFBW} in single band operation; see subclause 4.8.1.

- 1) Test set-up in accordance to annex B.

6.6.4.2 Procedures

- 1) For a BS declared to be capable of single carrier operation only, set the base station to transmit a signal according to TM1, clause 6.1.1.1 at manufacturer's declared rated output power, PRAT.

For a BS declared to be capable of multi-carrier operation, set the base station to transmit according to TM1 on all carriers configured using the applicable test configuration and corresponding power setting specified in sub-clause 4.12.

- 2) Generate the interference signal in accordance to TM1, clause 6.1.1.1 with a frequency offset of according to the conditions of Table 6.48 but exclude interfering frequencies that are outside of the allocated downlink operating band or interfering frequencies that are not completely within the sub-block gap or within the inter-RF bandwidth gap.
- 3) Adjust ATT1 so the level of the WCDMA interference signal is as defined in clause 6.6.5.
- 4) Perform the out of band emission test as specified in clause 6.5.2, for all third and fifth order intermodulation products which appear in the frequency ranges defined in clause 6.5.2. The width of the intermodulation products shall be taken into account.
- 5) Perform the spurious emission test as specified in clause 6.5.3, for all third and fifth order intermodulation products which appear in the frequency ranges defined in clause 6.5.3. The width of the intermodulation products shall be taken into account.
- 6) Verify that the emission level does not exceed the required level with the exception of interference signal frequencies.
- 7) Repeat the test for the remaining interference frequency offsets according to the conditions of Table 6.48.

In addition, for a multi-band capable BS, the following steps shall apply:

- 8) For multi-band capable BS and single band tests, repeat the steps above per involved band where single band test configurations and test models shall apply with no carrier activated in the other band.
- 9) For multi-band capable BS with separate antenna connector, the antenna connector not being under test shall be terminated.

NOTE: The third order intermodulation products are $(F1 \pm 2F2)$ and $(2F1 \pm F2)$, the fifth order intermodulation products are $(2F1 \pm 3F2)$, $(3F1 \pm 2F2)$, $(4F1 \pm F2)$, and $(F1 \pm 4F2)$, where F1 represents the wanted signal frequencies of 5 MHz channel and F2 represents the interference signal frequencies of 5 MHz channel. The width of intermodulation products is 15 MHz for third order intermodulation products and 25 MHz for fifth order intermodulation products based on a bandwidth of 5 MHz for subject and interference signal.

6.6.5 Test Requirements

In the frequency range relevant for this test, the transmit intermodulation level shall not exceed the out of band emission or the spurious emission requirements of clauses 6.5.2 and 6.5.3 in the presence of a WCDMA interfering signal with a mean power 30 dB below the mean power of the wanted signal.

For a BS operating in non-contiguous spectrum, the requirement is also applicable inside a sub-block gap for interfering signal offsets where the interfering signal falls completely within the sub-block gap. The interfering signal offset is defined relative to the sub-block edges.

For a BS capable of multi-band operation, the requirement is also applicable inside a inter RF bandwidth gap for interfering signal offsets where the interfering signal falls completely within the inter RF bandwidth gap. The interfering signal offset is defined relative to the RF bandwidth edges.

The measurements for out of band emission or spurious emission requirement due to intermodulation can be limited to the frequency ranges of all third and fifth order intermodulation products, considering the width of these products and excluding the bandwidths of the wanted and interfering signals.

NOTE: If the above Test Requirement differs from the Minimum Requirement then the Test Tolerance applied for this test is non-zero. The Test Tolerance for this test is defined in clause 4.2 and the explanation of how the Minimum Requirement has been relaxed by the Test Tolerance is given in Annex F

6.7 Transmit modulation

6.7.1 Error Vector Magnitude

6.7.1.1 Definition and applicability

The Error Vector Magnitude is a measure of the difference between the reference waveform and the measured waveform. This difference is called the error vector. Both waveforms pass through a matched Root Raised Cosine filter with bandwidth 3.84 MHz and roll-off $\alpha = 0.22$. Both waveforms are then further modified by selecting the frequency, absolute phase, absolute amplitude and chip clock timing so as to minimise the error vector. The EVM result is defined as the square root of the ratio of the mean error vector power to the mean reference power expressed as a %. The measurement interval is one timeslot as defined by the C-PICH (when present) otherwise the measurement interval is one timeslot starting with the beginning of the SCH. The requirement is valid over the total power dynamic range as specified in 25.104 [1] clause 6.4.3. See Annex E of this specification for further details

6.7.1.2 Minimum Requirement

The minimum requirement is in TS 25.104 [1] clause 6.8.2.

6.7.1.3 Test Purpose

To verify that the Error Vector Magnitude is within the limit specified by the minimum requirement.

6.7.1.4 Method of Test

This test method includes the procedure for clause 6.3.4 Frequency error.

6.7.1.4.1 Initial Conditions

Test environment: normal; see clause 4.4.1.

RF channels to be tested for single carrier: B, M and T; see clause 4.8

RF bandwidth positions to be tested for multi-carrier: B_{RFBW} , M_{RFBW} and T_{RFBW} ; B_{RFBW_T} and B_{RFBW_T} in multi-band operation; see subclause 4.8.1;

Refer to annex B for a functional block diagram of the test set-up.

- 1) Connect the base station antenna connector to the measurement equipment.

6.7.1.4.2 Procedure

- 1) For a BS declared to be capable of single carrier operation only, set the base station to transmit a signal according to TM1, clause 6.1.1.1, at manufacturer's declared rated output power, PRAT.

For a BS declared to be capable of multi-carrier operation, set the BS to transmit according to TM1 on all carriers configured using the applicable test configuration and corresponding power setting specified in sub-clause 4.12.

- 2) For each carrier, measure the Error Vector Magnitude and frequency error as defined in annex E and the mean power of the signal. The measurement shall be performed on all 15 slots of the frame defined by the Test Model.
- 3) Using the same setting as in step 1), set the base station to transmit a signal according to TM4, clause 6.1.1.4, with X value equal to 18, and repeat step 2). If the requirement in clause 6.4.4.5 is not fulfilled, decrease the total output power by setting the base station to transmit a signal according to TM4 with X greater than 18, and repeat step 2)

The following test shall be additionally performed if the base station supports HS-PDSCH transmission using 16QAM.

- 4) Using the same setting as in step 1), set the base station to transmit according to TM5, clause 6.1.1.4A
- 5) Repeat step 2)

In addition, for a multi-band capable BS, the following steps shall apply:

- 6) For multi-band capable BS and single band tests, repeat the steps above per involved band where single band test configuration and test models shall apply with no carrier activated in the other band.
- 7) For multi-band capable BS with separate antenna connector, the antenna connector not being under test, in case of single-band or multi-band tests, shall be terminated.

6.7.1.5 Test Requirement

The Error Vector Magnitude for each UTRA carrier and every measured slot shall be less than 17.5% when the base station is transmitting a composite signal using only QPSK modulation and shall be less than 12.5 % when the base station is transmitting a composite signal that includes 16QAM modulation.

NOTE: If the above Test Requirement differs from the Minimum Requirement then the Test Tolerance applied for this test is non-zero. The Test Tolerance for this test is defined in clause 4.2 and the explanation of how the Minimum Requirement has been relaxed by the Test Tolerance is given in Annex F.

6.7.2 Peak Code Domain Error

6.7.2.1 Definition and applicability

The Peak Code Domain Error is computed by projecting the error vector (as defined in 6.7.1) onto the code domain at a specific spreading factor. The Code Domain Error for every code in the domain is defined as the ratio of the mean power of the projection onto that code, to the mean power of the composite reference waveform. This ratio is expressed in dB. The Peak Code Domain Error is defined as the maximum value for the Code Domain Error for all codes. The measurement interval is one timeslot as defined by the C-PICH (when present), otherwise the measurement interval is one timeslot starting with the beginning of the SCH. See Annex E of this specification for further details.

6.7.2.2 Minimum requirement

The minimum requirement is in TS 25.104[1] clause 6.8.3.

6.7.2.3 Test Purpose

It is the purpose of this test to discover and limit inter-code cross-talk.

6.7.2.4 Method of test

6.7.2.4.1 Initial conditions

Test environment: normal; see clause 4.4.1.

RF channels to be tested for single carrier: B, M and T; see clause 4.8

RF bandwidth positions to be tested for multi-carrier: B_{RFBW} , M_{RFBW} and T_{RFBW} , see subclause 4.8.1;1) Connect the measurement equipment to the BS antenna connector as shown in Figure B.2 annex B.

6.7.2.4.2 Procedure

- 1) For a BS declared to be capable of single carrier operation only, set the base station to transmit a signal according to TM3, clause 6.1.1.3, at manufacturer"s declared rated output power, PRAT.

For a BS declared to be capable of multi-carrier operation, set the BS to transmit according to TM3 on all carriers configured using the applicable test configuration and corresponding power setting specified in sub-clause 4.12.

- 2) Measure Peak code domain error according to annex E. The measurement shall be performed on all 15 slots of the frame defined by TM3. For a BS declared to be capable of multi-carrier operation the measurement is performed on one of the carriers under test.

In addition, for a multi-band capable BS, the following steps shall apply:

- 3) For multi-band capable BS and single band tests, repeat the steps above per involved band where single band test configurations and test models shall apply with no carrier activated in the other band.
- 4) For multi-band capable BS with separate antenna connector, the antenna connector not being under test shall be terminated.

6.7.2.5 Test requirement

The peak code domain error for every measured slot shall not exceed -32 dB at spreading factor 256.

NOTE: If the above Test Requirement differs from the Minimum Requirement then the Test Tolerance applied for this test is non-zero. The Test Tolerance for this test is defined in clause 4.2 and the explanation of how the Minimum Requirement has been relaxed by the Test Tolerance is given in Annex F.

6.7.3 Time alignment error

6.7.3.1 Definition and applicability

This test is only applicable for Node B supporting TX diversity transmission, MIMO, DC-HSDPA, DB-DC-HSDPA, 4C-HSDPA, NC-4C-HSDPA, or 8C-HSDPA, and their combinations.

Frames of the WCDMA signals present at the BS transmitter antenna port(s) are not perfectly aligned in time. In relation to each other, the RF signals present at the BS transmitter antenna port(s) experience certain timing differences.

For a specific set of signals/transmitter configuration/transmission mode, Time Alignment Error (TAE) is defined as the largest timing difference between any two signals.

6.7.3.2 Minimum Requirement

The minimum requirement is in TS 25.104 [1] clause 6.8.4.

6.7.3.3 Test Purpose

To verify that the frame timing alignment is within the limits specified in 6.7.3.2.

6.7.3.4 Method of Test

6.7.3.4.1 Initial Conditions

Test environment: normal; see clause 4.4.1.

RF channels to be tested for single carrier: M. See clause 4.8.

RF bandwidth positions to be tested for multi-carrier: B_{RFBW} , M_{RFBW} and T_{RFBW} ; B_{RFBW_T} and B_{RFBW_T} in multi-band operation; see subclause 4.8.1;

Refer to annex B 1.6 for a functional block diagram of the test set-up.

- 1) Connect base station RF antenna ports to the measurement equipment according to figure B.6.

6.7.3.4.2 Procedure

- 1) If the BS supports TX diversity or MIMO, set the base station to transmit TM1, clause 6.1.1.1, at manufacturer's declared rated output power, PRAT, on one cell using TX diversity or MIMO.
- 2) Measure the time alignment error between the signals using the P-CPICH on the main antenna port and the CPICH on the diversity antenna port.3) If the BS supports DC-HSDPA, 4C-HSDPA, NC-4C-HSDPA or 8C-HSDPA set the base station to transmit according to TM1, without using TX diversity or MIMO, on all carriers configured using the applicable test configuration and corresponding power setting specified in sub-clause 4.12..
- 4) Measure the time alignment error between the signals using the P-CPICH and CPICH signals on the antenna port(s).
- 5) If the BS supports DB-DC-HSDPA or any of the multi-band 4C-HSDPA or 8C-HSDPA configurations set the base station to transmit TM1 on two carriers belonging to different frequency bands, without using TX diversity or MIMO on any of the carriers.
- 6) Measure the time alignment error between the signals using the P-CPICH and CPICH signals on the antenna ports.

In addition, for a multi-band capable BS, the following steps shall apply:

- 7) For multi-band capable BS and single band tests, repeat the steps above per involved band where single band test configurations and test models shall apply with no carrier activated in the other band.
- 8) For multi-band capable BS with separate antenna connector, the antenna connector not being under test shall be terminated.

6.7.3.5 Test Requirement

For Tx diversity and MIMO transmission, in the tested cell, TAE shall not exceed $0.35 T_c$.

For transmission of multiple cells within a frequency band TAE shall not exceed $0.6 T_c$.

For transmission of multiple cells in different frequency bands TAE shall not exceed $5.1 T_c$.

NOTE: If the above Test Requirement differs from the Minimum Requirement then the Test Tolerance applied for this test is non-zero. The Test Tolerance for this test is defined in clause 4.2 and the explanation of how the Minimum Requirement has been relaxed by the Test Tolerance is given in Annex F.

6.7.4 Relative Code Domain Error

6.7.4.1 Definition and applicability

The Relative Code Domain Error is computed by projecting the error vector (as defined in 6.7.1) onto the code domain at a specified spreading factor. Only the active code channels in the composite reference waveform are considered for this requirement. The Relative Code Domain Error for every active code is defined as the ratio of the mean power of the error projection onto that code, to the mean power of the active code in the composite reference waveform. This ratio is expressed in dB. The measurement interval is one frame.

The requirement for Relative Code Domain Error is only applicable for 64QAM modulated codes.

See Annex E of this specification for further details.

6.7.4.2 Minimum requirement

The minimum requirement is in TS 25.104[1] clause 6.8.5.1.

6.7.4.3 Test Purpose

It is the purpose of this test to verify that the Relative Code Domain Error is within the limit specified by 6.7.4.2.

6.7.4.4 Method of test

6.7.4.4.1 Initial conditions

Test environment: normal; see clause 4.4.1.

RF channels to be tested for single carrier: B, M and T; see clause 4.8

RF bandwidth positions to be tested for multi-carrier: B_{RFBW} , M_{RFBW} and T_{RFBW} , see subclause 4.8.1;

- 1) For a BS declared to be capable of single carrier operation only, set the base station to transmit a signal according to TM6, clause 6.1.1.4B, at manufacturer's declared rated output power, PRAT.

For a BS declared to be capable of multi-carrier operation, set the BS to transmit according to TM6, clause 6.1.1.4B, on all carriers configured using the applicable test configuration and corresponding power setting specified in sub-clause 4.12.

- 2) Connect the measurement equipment to the BS antenna connector as shown in Figure B.2 annex B.
- 2) Channel configuration defin TM6ed in clause 6.1.1.4B Test model 6 shall be used.
- 3) Set BS frequency.
- 4) Start BS transmission at maximum output power.

6.7.4.4.2 Procedure

- 1) Measure average Relative code domain error according to annex E. The measurement shall be performed over one frame defined by and averaged as specified in clause E.2.6.3. For a BS declared to be capable of multi-carrier operation the measurement is performed on one of the carriers under test.

In addition, for a multi-band capable BS, the following steps shall apply:

- 3) For multi-band capable BS and single band tests, repeat the steps above per involved band where single band test configuration and test models shall apply with no carrier activated in the other band.
- 4) For multi-band capable BS with separate antenna connector, the antenna connector not being under test shall be terminated.

6.7.4.5 Test requirement

The average Relative Code Domain Error for 64QAM modulated codes shall not exceed -20 dB at spreading factor 16.

NOTE: If the above Test Requirement differs from the Minimum Requirement then the Test Tolerance applied for this test is non-zero. The Test Tolerance for this test is defined in clause 4.2 and the explanation of how the Minimum Requirement has been relaxed by the Test Tolerance is given in Annex F.

7 Receiver characteristics

7.1 General

The requirements in clause 7 are expressed for a single receiver antenna connector. For receivers with antenna diversity, the requirements apply for each receiver antenna connector.

Unless otherwise stated, all tests in this clause shall be performed at the BS antenna connector (test port A) with a full complement of transceivers for the configuration in normal operating conditions. If any external apparatus such as a RX amplifier, a filter or the combination of such devices is used, the tests according to clauses 4.6.2 and/or 4.6.4, depending on the device added, shall be performed to ensure that the requirements are met at test port B.

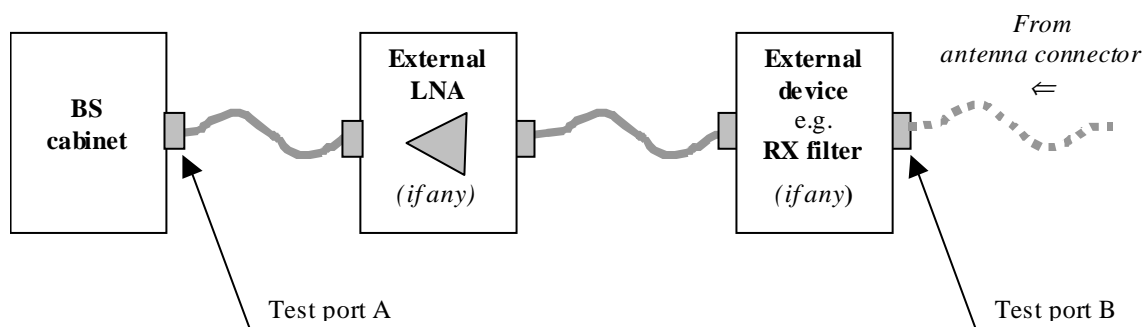

Figure 7.1: Receiver test ports

For ACS, blocking and intermodulation characteristics, the negative offsets of the interfering signal apply relative to the assigned channel frequency of the lowest carrier frequency used and positive offsets of the interfering signal apply relative to the assigned channel frequency of the highest carrier frequency used.

The BER requirements defined for the receiver characteristics in this clause do not assume HARQ transmissions.

When the BS is configured to receive multiple carriers, all the BER requirements are applicable for each received carrier.

A BS supporting DC-HSUPA receives two cells simultaneously on adjacent carrier frequencies.

In all the relevant clauses in this clause all Bit Error Ratio (BER), Residual BER (RBER) and Block Error Ratio (BLER) measurements shall be carried out according to the general rules for statistical testing defined in ITU-T Recommendation O.153 [5] and Annex C.

If external BER measurement is not used then the internal BER calculation shall be used instead. When internal BER calculation is used, the requirements of the verification test according to 7.8 shall be met in advance.

In tests performed with signal generators a synchronization signal may be provided, from the base station to the signal generator, to enable correct timing of the wanted signal.

7.2 Reference sensitivity level

7.2.1 Definition and applicability

The reference sensitivity level is the minimum mean power received at the antenna connector at which the BER shall not exceed the specific value indicated by the minimum requirement.

The test is set up according to Figure B.7 and performed without interfering signal power applied to the BS antenna connector. For duplex operation, the measurement configuration principle is indicated for one duplex branch in Figure B.7. For internal BER calculation an example of the test connection is as shown in figure B.7. The reference point for signal power is at the input of the receiver (antenna connector).

7.2.2 Minimum Requirement

The minimum requirement is in TS 25.104 [1] clause 7.2.

Table 7.1: (void)

7.2.3 Test purpose

To verify that at the BS Reference sensitivity level the BER shall not exceed the specified limit.

7.2.4 Method of testing

7.2.4.1 Initial conditions

Test environment: normal; see clause 4.4.1

RF channels to be tested: B, M and T; see clause 4.8.

The following additional tests shall be performed:

- a) On each of B, M and T, the test shall be performed under extreme power supply as defined in clause 4.4.4

NOTE: Tests under extreme power supply also test extreme temperature.

- 1) Connect BS to be tested to RF signal source.
- 2) Start transmit 12,2kbps DPCH with reference measurement channel defined in annex A to the BS under test (PN-9 data sequence or longer).
- 3) Disable TPC function.

7.2.4.2 Procedure

- 1) Set the base station to transmit a signal according to TM1, clause 6.1.1.1, at manufacturer's declared rated output power, PRAT.
- 2) Calculate BER according to Annex C.
- 3) Set the test signal mean power as specified in table 7.1A.
- 4) Measure BER.

In addition, for a multi-band capable BS, the following steps shall apply:

- 5) For multi-band capable BS and single band tests, repeat the steps above per involved band where single carrier test models shall apply with no carrier activated in the other band.
- 6) For multi-band capable BS with separate antenna connector, the antenna connector not being under test shall be terminated.

7.2.5 Test requirement

The BER measurement result in step 3 of 7.2.4.2 shall not be greater than the limit specified in table 7.1A.

Table 7.1A: BS reference sensitivity levels

BS class	Reference measurement channel data rate	BS reference sensitivity level (dBm)		BER
		$f \leq 3.0$ GHz	3.0 GHz $< f \leq 4.2$ GHz	
Wide Area BS	12.2 kbps	-120.3	-120.0	BER shall not exceed 0.001
Medium Range BS	12.2 kbps	-110.3	-110.0	BER shall not exceed 0.001
Local Area BS / Home BS	12.2 kbps	-106.3	-106.0	BER shall not exceed 0.001

NOTE: If the above Test Requirement differs from the Minimum Requirement then the Test Tolerance applied for this test is non-zero. The Test Tolerance for this test is defined in clause 4.2 and the explanation of how the Minimum Requirement has been relaxed by the Test Tolerance is given in Annex F.

7.3 Dynamic range

7.3.1 Definition and applicability

Receiver dynamic range is the receiver ability to handle a rise of interference in the reception frequency channel. The receiver shall fulfil a specified BER requirement for a specified sensitivity degradation of the wanted signal in the presence of an interfering AWGN signal in the same reception frequency channel.

7.3.2 Minimum Requirement

The minimum requirement is in TS 25.104 [1] clause 7.3

Table 7.2: (void)

7.3.3 Test purpose

The test purpose is to verify the ability of the BS to receive a single-code test signal of maximum with a BER not exceeding a specified limit.

7.3.4 Method of test

7.3.4.1 Initial conditions

Test environment: normal; see clause 4.4.1.

RF channels to be tested: B, M and T; see clause 4.8

- 1) Connect the test equipment as shown in annex B.

7.3.4.2 Procedure

- 1) Adjust the signal generator for the wanted signal as specified in Table 7.2A.
- 2) Adjust the AWGN generator level as specified in Table 7.2A and set the frequency to the same frequency as the tested channel.
- 3) Measure the BER for the tested service and verify that it is below the specified level.

In addition, for a multi-band capable BS, the following steps shall apply:

- 4) For multi-band capable BS and single band tests, repeat the steps above per involved band, with no carrier activated in the other band.
- 5) For multi-band capable BS with separate antenna connector, the antenna connector not being under test shall be terminated.

7.3.5 Test Requirements

The BER measurement result in step 3 of 7.3.4.2 shall not be greater than 0,001 using the parameters specified in tables 7.2A.

Table 7.2A: Dynamic range

Parameter	Level Wide Area BS	Level Medium Range BS	Level Local Area / Home BS	Level Home BS ¹	Unit
Reference measurement channel data rate	12,2	12.2	12.2	12.2	Kbps
Wanted signal mean power	-89.8	-79.8	-75.8	-55.8	dBm
Interfering AWGN signal	-73	-63	-59	-39	dBm/3.84 MHz

Note 1: For Home BS, this additional requirement ensures the performance is met over a large dynamic range.

NOTE: If the above Test Requirement differs from the Minimum Requirement then the Test Tolerance applied for this test is non-zero. The Test Tolerance for this test is defined in clause 4.2 and the explanation of how the Minimum Requirement has been relaxed by the Test Tolerance is given in Annex F.

7.4 Adjacent Channel Selectivity (ACS)

7.4.1 Definition and applicability

Adjacent channel selectivity (ACS) is a measure of the receiver ability to receive a wanted signal at its assigned channel frequency in the presence of an adjacent channel signal at a given frequency offset from the centre frequency of the assigned channel. ACS is the ratio of the receiver filter attenuation on the assigned channel frequency to the receive filter attenuation on the adjacent channel(s).

The interference signal is offset from the wanted signal by the frequency offset F_{uw} . The interference signal shall be a W-CDMA signal as specified in Annex I.

7.4.2 Minimum Requirement

The minimum requirement is in TS 25.104 [1] clause 7.4.

Table 7.3: (void)

7.4.3 Test purpose

The test purpose is to verify the ability of the BS receiver filter to suppress interfering signals in the channels adjacent to the wanted channel.

7.4.4 Method of test

7.4.4.1 Initial conditions

Test environment: normal; see clause 4.4.1.

RF channels to be tested for single carrier: B, M and T; see clause 4.8

RF bandwidth positions to be tested for multi-carrier: M_{RFBW} ; $B_{RFBW_T_{RFBW}}$ and $B''_{RFBW_T_{RFBW}}$ in multi-band operation; see subclause 4.8.1;

- 1) Set-up the equipment as shown in annex B.

7.4.4.2 Procedure

- 1) Generate the wanted signal and adjust the ATT1 to set the input level to the base station under test to the level specified in table 7.3A. For a BS supporting multi-carrier operation, generate the wanted signal according to the applicable test configuration (see clause 4.12) using applicable reference measurement channel to the BS under test. Power settings are specified in Table 7.3A.

- 2) Set-up the interference signal at the adjacent channel frequency and adjust the ATT2 to obtain the specified level of interference signal at the base station input defined in table 7.3A. Note that the interference signal shall have an ACLR of at least 63 dB in order to eliminate the impact of interference signal adjacent channel leakage power on the ACS measurement.
- 3) Measure the BER of the wanted signal. For a BS supporting multi-carrier operation the BER shall be measured for all relevant carriers specified by the test configuration.

In addition, for a multi-band capable BS with separate antenna connectors, the following steps shall apply:

- 4) For single band tests, repeat the steps above per involved band where single band test configurations shall apply with no carrier activated in the other band.
- 5) The interfering signal shall first be applied on the same port as the wanted signal. The test shall be repeated with the interfering signal applied on the other port (if any) mapped to the same receiver as the wanted signal. Any antenna connector with no signal applied in case of single-band or multi-band test shall be terminated.
- 6) Repeat step 5) with the wanted signal for the other band(s) applied on the respective port(s).

7.4.5 Test Requirements

For each measured carrier, the BER shall not exceed 0,001 for the parameters specified in table 7.3A.

For multi-carrier BS the ACS requirement is applicable outside the Base Station RF bandwidth or maximum radio bandwidth edges. The interfering signal offset is defined relative to the lower (upper) or maximum radio bandwidth edges.

For a BS operating in non-contiguous spectrum within any operating band, the requirement applies in addition inside any sub-block gap, in case the sub-block gap size is at least 5MHz. The interfering signal offset is defined relative to the lower/upper sub-block edge inside the sub-block gap and is equal to -2.5MHz/+2.5MHz, respectively.

For a BS capable of multi-band operation, the requirement applies in addition inside any inter RF bandwidth gap, in case the inter RF bandwidth gap size is at least 5MHz. The interfering signal offset is defined relative to lower/upper RF bandwidth edges inside the inter RF bandwidth gap and is equal to -2.5MHz/+2.5MHz, respectively.

Table 7.3A: Adjacent channel selectivity

Parameter	Level Wide Area BS	Level Medium Range BS	Level Local Area / Home BS	Level Home BS ¹	Unit
Reference measurement channel data rate	12.2	12.2	12.2	12.2	kbps
Wanted signal mean power	-115	-105	-101	-91	dBm
Interfering signal mean power	-52	-42	-38	-28	dBm
Fuw (Modulated)	±5	±5	±5	±5	MHz
Note 1: For Home BS, this additional requirement ensures the performance is met over a large dynamic range.					

NOTE: If the above Test Requirement differs from the Minimum Requirement then the Test Tolerance applied for this test is non-zero. The Test Tolerance for this test is defined in clause 4.2 and the explanation of how the Minimum Requirement has been relaxed by the Test Tolerance is given in Annex F.

7.5 Blocking characteristics

7.5.1 Definition and applicability

The blocking characteristics are measure of the receiver ability to receive a wanted signal at its assigned channel frequency in the presence of an unwanted interferer on frequencies other than those of the adjacent channels. The interferences are either a WDCMA signal for in-band blocking or a CW signal for out-of-band blocking.

The requirements shall apply to the indicated base station class, depending on which frequency band is used. The test requirements in Tables 7.4N to 7.4Q may be applied for the protection of FDD BS receivers when GSM, DCS, PCS, CDMA, E-UTRA and/or UTRA BS operating in Bands I to XXI are co-located with a UTRA FDD BS.

The additional test requirements in Tables 7.4U and 7.4V may be applied for the protection of FDD BS receivers when a UTRA TDD BS is co-located with a UTRA FDD BS.

7.5.2 Minimum Requirements

The minimum requirement is in TS 25.104 [1] clause 7.5.

Table 7.4A: (void)

Table 7.4B: (void)

Table 7.4C: (void)

Table 7.4D: (void)

Table 7.4E: (void)

Table 7.4F: (void)

Table 7.4G: (void)

Table 7.4H: (void)

Table 7.4J: (void)

Table 7.4J(a): (void)

Table 7.4J(b): (void)

7.5.3 Test purpose

The test stresses the ability of the BS receiver to withstand high-level interference from unwanted signals at frequency offsets of 10 MHz or more, without undue degradation of its sensitivity.

7.5.4 Method of test

7.5.4.1 Initial conditions

Test environment: normal; see clause 4.4.1.

RF channels to be tested for single carrier: M see clause 4.8. The BS shall be configured to operate as close to the centre of the operating band as possible.

RF bandwidth positions to be tested for multi-carrier: M_{RFBW} ; $B_{\text{RFBW_T}}^{\text{RFBW}}$ and $B_{\text{RFBW_T}}^{\text{RFBW}}$ in multi-band operation; see subclause 4.8.1;

In addition, in multi-band operation:

- For $B_{\text{RFBW_T}}^{\text{RFBW}}$, out-of-band blocking testing above the highest operating band may be omitted
- For $B_{\text{RFBW_T}}^{\text{RFBW}}$, out-of-band blocking testing below the lowest operating band may be omitted

- 1) Connect WCDMA signal generator at the assigned channel frequency of the wanted signal and a signal generator to the antenna connector of one Rx port.
- 2) Transmit a signal from the WCDMA signal generator to the BS. The characteristics of the signal shall be set according to the UL reference measurement channel (12,2 kbit/s) specified in annex A clause A.2.1. The level of the WCDMA signal measured at the BS antenna connector shall be set to the level specified in clause 7.5.5. For a BS supporting multi-carrier operation, generate the wanted signal according to the applicable test configuration (see clause 4.12) using applicable reference measurement channel to the BS under test. Power settings are specified in clause 7.5.5.
- 3) For BS capable of single carrier operation only, start BS transmission according to TM1, clause 6.1.1.1, at manufacturer"s declared rated output power, PRAT.

For a BS declared to be capable of multi-carrier operation, set the BS to transmit according to TM1 on all carriers configured, using the applicable test configuration and corresponding power setting for receiver tests, as specified in sub-clause 4.12.

In addition, for a multi-band capable BS with separate antenna connectors, the following steps shall apply:

- 4) For single band tests, repeat the steps above per involved band where single band test configurations and test models shall apply with no carrier activated in the other band.
- 5) The interfering signal shall first be applied on the same port as the wanted signal. The test shall be repeated with the interfering signal applied on the other port (if any) mapped to the same receiver as the wanted signal. Any antenna connector with no signal applied in case of single-band or multi-band test shall be terminated.
- 6) Repeat step 6) with the wanted signal for the other band(s) applied on the respective port(s)

The transmitter may be turned off for the out-of-band blocker tests when the frequency of the blocker is such that no IM2 or IM3 products fall inside the bandwidth of the wanted signal.

7.5.4.2 Procedure

- 1) Adjust the signal generators to the type of interfering signals and the frequency offsets as specified in Tables 7.4K to 7.4T . Note that the GMSK modulated interfering signal shall have an ACLR of at least 72 dB in order to eliminate the impact of interference signal adjacent channel leakage power on the blocking characteristics measurement. For the tests defined in Tables 7.4K to 7.4M, the interfering signal shall be at a frequency offset F_{uw} from the assigned channel frequency of the wanted signal which is given by:

$$F_{uw} = \pm (n \times 1 \text{ MHz}),$$

where n shall be increased in integer steps from n = 10 up to such a value that the center frequency of the interfering signal covers the range from 1 MHz to 12,75 GHz.

- 2) Measure the BER of the wanted signal at the BS receiver. For a BS supporting multi-carrier operation the BER shall be measured for all relevant carriers specified by the test configuration.

7.5.5 Test Requirements

For each measured carrier, the BER shall not exceed 0.001 for the parameters specified in tables 7.4K to 7.4V if applicable for the BS under test.

The requirement is applicable outside the Base Station RF bandwidth or maximum radio bandwidth edges. The interfering signal offset is defined relative to the lower (upper) or maximum radio bandwidth edges.

For a BS operating in non-contiguous spectrum within any operating band, the blocking requirement applies in addition inside any sub-block gap, in case the sub-block gap size is at least 15MHz. The interfering signal offset is defined relative to the lower/upper sub-block edge inside the sub-block gap and is equal to -7.5MHz/+7.5MHz, respectively.

For a BS operating in non-contiguous spectrum within any operating band, the narrowband blocking requirements in Tables 7.4R-7.4T apply in addition inside any sub-block gap, in case the sub-block gap size is at least 400kHz or 600kHz, depending on the operating band. The interfering signal offset is defined relative to the lower/upper sub-block edge inside the sub-block gap and is equal to -200kHz/+200kHz or -300kHz/+300kHz, respectively.

For a BS capable of multi-band operation, the requirement in the in-band blocking frequency range applies for each supported operating band. The requirement applies in addition inside any inter RF bandwidth gap, in case the inter RF bandwidth gap size is at least 15MHz. The interfering signal offset is defined relative to lower/upper RF bandwidth edges inside the inter RF bandwidth gap and is equal to $-7.5\text{MHz}/+7.5\text{MHz}$, respectively.

For a BS capable of multi-band operation, the requirement in the out-of-band blocking frequency ranges apply for each operating band, with the exception that the in-band blocking frequency ranges of all supported operating bands according to Tables 7.4K - 7.4M shall be excluded from the out-of-band blocking requirement.

For a BS capable of multi-band operation, the narrowband blocking requirement applies in addition inside any inter RF bandwidth gap, in case the inter RF bandwidth gap size is at least 400kHz or 600kHz, depending on the operating band. The interfering signal offset is defined relative to lower/upper RF bandwidth edges inside the inter RF bandwidth gap and is equal to $-200\text{kHz}/+200\text{kHz}$ or $-300\text{kHz}/+300\text{kHz}$, respectively.

Table 7.4K: Blocking characteristics for Wide Area BS

Operating Band	Center Frequency of Interfering Signal	Interfering Signal mean power	Wanted Signal mean power	Minimum Offset of Interfering Signal	Type of Interfering Signal
I	1920 - 1980 MHz	-40 dBm	-115 dBm	± 10 MHz	WCDMA signal *
	1900 - 1920 MHz	-40 dBm	-115 dBm	± 10 MHz	WCDMA signal *
	1980 - 2000 MHz	-40 dBm	-115 dBm	± 10 MHz	WCDMA signal *
II	1 MHz -1900 MHz	-15 dBm	-115 dBm	—	CW carrier
	2000 MHz - 12750 MHz	-15 dBm	-115 dBm	—	CW carrier
	1850 - 1910 MHz	-40 dBm	-115 dBm	± 10 MHz	WCDMA signal *
III	1830 - 1850 MHz	-40 dBm	-115 dBm	± 10 MHz	WCDMA signal *
	1910 - 1930 MHz	-40 dBm	-115 dBm	± 10 MHz	WCDMA signal *
	1 MHz - 1830 MHz	-15 dBm	-115 dBm	—	CW carrier
IV	1930 MHz - 12750 MHz	-15 dBm	-115 dBm	—	CW carrier
	1710 - 1785 MHz	-40 dBm	-115 dBm	± 10 MHz	WCDMA signal *
	1690 - 1710 MHz	-40 dBm	-115 dBm	± 10 MHz	WCDMA signal *
V	1785 - 1805 MHz	-40 dBm	-115 dBm	± 10 MHz	WCDMA signal *
	1 MHz - 1690 MHz	-15 dBm	-115 dBm	—	CW carrier
	1805 MHz - 12750 MHz	-15 dBm	-115 dBm	—	CW carrier
VI	1710 - 1755 MHz	-40 dBm	-115 dBm	± 10 MHz	WCDMA signal *
	1690 - 1710 MHz	-40 dBm	-115 dBm	± 10 MHz	WCDMA signal *
	1755 - 1775 MHz	-40 dBm	-115 dBm	± 10 MHz	WCDMA signal *
VII	1 MHz - 1690 MHz	-15 dBm	-115 dBm	—	CW carrier
	1775 MHz - 12750 MHz	-15 dBm	-115 dBm	—	CW carrier
	824-849 MHz	-40 dBm	-115 dBm	± 10 MHz	WCDMA signal *
VIII	804-824 MHz	-40 dBm	-115 dBm	± 10 MHz	WCDMA signal *
	849-869 MHz	-40 dBm	-115 dBm	± 10 MHz	WCDMA signal *
	1 MHz - 804 MHz	-15 dBm	-115 dBm	—	CW carrier
IX	869 MHz - 12750 MHz	-15 dBm	-115 dBm	—	CW carrier
	810 - 830 MHz	-40 dBm	-115 dBm	± 10 MHz	WCDMA signal *
	840 - 860 MHz	-40 dBm	-115 dBm	± 10 MHz	WCDMA signal *
X	1 MHz - 810 MHz	-15 dBm	-115 dBm	—	CW carrier
	860 MHz - 12750 MHz	-15 dBm	-115 dBm	—	CW carrier
	2500 - 2570 MHz	-40 dBm	-115 dBm	± 10 MHz	WCDMA signal *
XI	2480 - 2500 MHz	-40 dBm	-115 dBm	± 10 MHz	WCDMA signal *
	2570 - 2590 MHz	-40 dBm	-115 dBm	± 10 MHz	WCDMA signal *
	1 MHz -2480 MHz	-15 dBm	-115 dBm	—	CW carrier
XII	2590 MHz - 12750 MHz	-15 dBm	-115 dBm	—	CW carrier
	880 - 915 MHz	-40 dBm	-115 dBm	± 10 MHz	WCDMA signal *
	860 - 880 MHz	-40 dBm	-115 dBm	± 10 MHz	WCDMA signal *
XIII	915 - 925 MHz	-40 dBm	-115 dBm	± 10 MHz	WCDMA signal *
	1 MHz -860 MHz	-15 dBm	-115 dBm	—	CW carrier
	925 MHz - 12750 MHz	-15 dBm	-115 dBm	—	CW carrier
XIV	1749.9 - 1784.9 MHz	-40 dBm	-115 dBm	± 10 MHz	WCDMA signal *
	1729.9 - 1749.9 MHz	-40 dBm	-115 dBm	± 10 MHz	WCDMA signal *
	1784.9 - 1804.9 MHz	-40 dBm	-115 dBm	± 10 MHz	WCDMA signal *
XV	1 MHz - 1729.9 MHz	-15 dBm	-115 dBm	—	CW carrier
	1804.9 MHz - 12750 MHz	-15 dBm	-115 dBm	—	CW carrier
	1710 - 1770 MHz	-40 dBm	-115 dBm	± 10 MHz	WCDMA signal *
XVI	1690 - 1710 MHz	-40 dBm	-115 dBm	± 10 MHz	WCDMA signal *
	1770 - 1790 MHz	-40 dBm	-115 dBm	± 10 MHz	WCDMA signal *
	1 MHz - 1690 MHz	-15 dBm	-115 dBm	—	CW carrier
XVII	1790 MHz - 12750 MHz	-15 dBm	-115 dBm	—	CW carrier
	1427.9 - 1447.9 MHz	-40 dBm	-115 dBm	± 10 MHz	WCDMA signal *
	1407.9 - 1427.9 MHz	-40 dBm	-115 dBm	± 10 MHz	WCDMA signal *
XVIII	1447.9 - 1467.9 MHz	-40 dBm	-115 dBm	± 10 MHz	WCDMA signal *
	1 MHz - 1407.9 MHz	-15 dBm	-115 dBm	—	CW carrier
	1467.9 MHz - 12750 MHz	-15 dBm	-115 dBm	—	CW carrier
XIX	699 - 716 MHz	-40 dBm	-115 dBm	± 10 MHz	WCDMA signal *
	679 - 699 MHz	-40 dBm	-115 dBm	± 10 MHz	WCDMA signal *
	716 - 729 MHz	-40 dBm	-115 dBm	± 10 MHz	WCDMA signal *

	1 MHz - 679 MHz 729 MHz – 12750 MHz	-15 dBm	-115 dBm	—	CW carrier
XIII	777 - 787 MHz	-40 dBm	-115 dBm	±10 MHz	WCDMA signal *
	757 - 777 MHz 787 - 807 MHz	-40 dBm	-115 dBm	±10 MHz	WCDMA signal *
	1 - 757 MHz 807 MHz - 12750 MHz	-15 dBm	-115 dBm	—	CW carrier
XIV	788 - 798 MHz	-40 dBm	-115 dBm	±10 MHz	WCDMA signal *
	768 - 788 MHz 798 - 818 MHz	-40 dBm	-115 dBm	±10 MHz	WCDMA signal *
	1 - 768 MHz 818 MHz - 12750 MHz	-15 dBm	-115 dBm	—	CW carrier
XIX	830 - 845 MHz	-40 dBm	-115 dBm	±10 MHz	WCDMA signal *
	810 - 830 MHz 845 - 865 MHz	-40 dBm	-115 dBm	±10 MHz	WCDMA signal *
	1 MHz - 810 MHz 865 MHz - 12750 MHz	-15 dBm	-115 dBm	—	CW carrier
XX	832 - 862 MHz	-40 dBm	-115 dBm	±10 MHz	WCDMA signal *
	821 - 832 MHz 862 - 882 MHz	-40 dBm	-115 dBm	±10 MHz	WCDMA signal *
	1 MHz - 821 MHz 882 MHz - 12750 MHz	-15 dBm	-115 dBm	—	CW carrier
XXI	1447.9 - 1462.9 MHz	-40 dBm	-115 dBm	±10 MHz	WCDMA signal *
	1427.9 - 1447.9 MHz 1462.9 - 1482.9 MHz	-40 dBm	-115 dBm	±10 MHz	WCDMA signal *
	1 MHz - 1427.9 MHz 1482.9 MHz - 12750 MHz	-15 dBm	-115 dBm	—	CW carrier
XXII	3410 - 3490 MHz	-40 dBm	-115 dBm	±10 MHz	WCDMA signal *
	3390 - 3410 MHz 3490 - 3510 MHz	-40 dBm	-115 dBm	±10 MHz	WCDMA signal *
	1 MHz - 3390 MHz 3510 MHz - 12750 MHz	-15 dBm	-115 dBm	—	CW carrier
XXV	1850 - 1915 MHz	-40 dBm	-115 dBm	±10 MHz	WCDMA signal *
	1830 - 1850 MHz 1915 - 1930 MHz	-40 dBm	-115 dBm	±10 MHz	WCDMA signal *
	1 MHz - 1830 MHz 1930 MHz - 12750 MHz	-15 dBm	-115 dBm	—	CW carrier
XXVI	814-849 MHz	-40 dBm	-115 dBm	±10 MHz	WCDMA signal *
	794-814 MHz 849-859 MHz	-40 dBm	-115 dBm	±10 MHz	WCDMA signal *
	1 MHz - 794 MHz 859 MHz - 12750 MHz	-15 dBm	-115 dBm	—	CW carrier
Note *: The characteristics of the W-CDMA interference signal are specified in Annex I.					
NOTE **: For a BS capable of multiband operation, in case of interfering signal that is not in the in-band blocking frequency range of the operating band where the wanted signal is present, the wanted Signal mean power is equal to -119.6 dBm.					

NOTE: Table 7.4K assumes that two operating bands, where the downlink frequencies (see Table 3.0) of one band would be within the in-band blocking region of the other band, are not deployed in the same geographical area.

Table 7.4L: Blocking characteristics for Medium Range BS

Operating Band	Center Frequency of Interfering Signal	Interfering Signal Level	Wanted Signal mean power	Minimum Offset of Interfering Signal	Type of Interfering Signal
I	1920 - 1980 MHz	-35 dBm	-105 dBm	± 10 MHz	WCDMA signal *
	1900 - 1920 MHz 1980 - 2000 MHz	-35 dBm	-105 dBm	± 10 MHz	WCDMA signal *
	1 MHz -1900 MHz 2000 MHz - 12750 MHz	-15 dBm	-105 dBm	—	CW carrier
II	1850 - 1910 MHz	-35 dBm	-105 dBm	± 10 MHz	WCDMA signal *
	1830 - 1850 MHz 1910 - 1930 MHz	-35 dBm	-105 dBm	± 10 MHz	WCDMA signal *
	1 MHz - 1830 MHz 1930 MHz - 12750 MHz	-15 dBm	-105 dBm	—	CW carrier
III	1710 - 1785 MHz	-35 dBm	-105 dBm	± 10 MHz	WCDMA signal *
	1690 - 1710 MHz 1785 - 1805 MHz	-35 dBm	-105 dBm	± 10 MHz	WCDMA signal *
	1 MHz - 1690 MHz 1805 MHz - 12750 MHz	-15 dBm	-105 dBm	—	CW carrier
IV	1710 - 1755 MHz	-35 dBm	-105 dBm	± 10 MHz	WCDMA signal *
	1690 - 1710 MHz 1755 - 1775 MHz	-35 dBm	-105 dBm	± 10 MHz	WCDMA signal *
	1 MHz - 1690 MHz 1775 MHz - 12750 MHz	-15 dBm	-105 dBm	—	CW carrier
V	824-849 MHz	-35 dBm	-105 dBm	± 10 MHz	WCDMA signal *
	804-824 MHz 849-869 MHz	-35 dBm	-105 dBm	± 10 MHz	WCDMA signal *
	1 MHz - 804 MHz 869 MHz - 12750 MHz	-15 dBm	-105 dBm	—	CW carrier
VI	810 - 830 MHz 840 - 860 MHz	-35 dBm	-105 dBm	± 10 MHz	WCDMA signal *
	1 MHz - 810 MHz 860 MHz - 12750 MHz	-15 dBm	-105 dBm	—	CW carrier
VII	2500 - 2570 MHz	-35 dBm	-105 dBm	± 10 MHz	WCDMA signal *
	2480 - 2500 MHz 2570 - 2590 MHz	-35 dBm	-105 dBm	± 10 MHz	WCDMA signal *
	1 MHz -2480 MHz 2590 MHz - 12750 MHz	-15 dBm	-105 dBm	—	CW carrier
VIII	880 - 915 MHz	-35 dBm	-105 dBm	± 10 MHz	WCDMA signal *
	860 - 880 MHz 915 - 925 MHz	-35 dBm	-105 dBm	± 10 MHz	WCDMA signal *
	1 MHz -860 MHz 925 MHz - 12750 MHz	-15 dBm	-105 dBm	—	CW carrier
IX	1749.9 - 1784.9 MHz	-35 dBm	-105 dBm	± 10 MHz	WCDMA signal *
	1729.9 - 1749.9 MHz 1784.9 - 1804.9 MHz	-35 dBm	-105 dBm	± 10 MHz	WCDMA signal *
	1 MHz - 1729.9 MHz 1804.9 MHz - 12750 MHz	-15 dBm	-105 dBm	—	CW carrier
X	1710 - 1770 MHz	-35 dBm	-105 dBm	± 10 MHz	WCDMA signal *
	1690 - 1710 MHz 1770 - 1790 MHz	-35 dBm	-105 dBm	± 10 MHz	WCDMA signal *
	1 MHz - 1690 MHz 1790 MHz - 12750 MHz	-15 dBm	-105 dBm	—	CW carrier
XI	1427.9 - 1447.9 MHz	-35 dBm	-105 dBm	± 10 MHz	WCDMA signal *
	1407.9 - 1427.9 MHz 1447.9 - 1467.9 MHz	-35 dBm	-105 dBm	± 10 MHz	WCDMA signal *
	1 MHz - 1407.9 MHz 1467.9 MHz - 12750 MHz	-15 dBm	-105 dBm	—	CW carrier
XII	699 - 716 MHz	-35 dBm	-105 dBm	± 10 MHz	WCDMA signal *
	679 - 699 MHz 716 - 729 MHz	-35 dBm	-105 dBm	± 10 MHz	WCDMA signal *
	1 MHz - 679 MHz 729 MHz - 12750 MHz	-15 dBm	-105 dBm	—	CW carrier

XIII	777 - 787 MHz	-35 dBm	-105 dBm	± 10 MHz	WCDMA signal *
	757 - 777 MHz 787 - 807 MHz	-35 dBm	-105 dBm	± 10 MHz	WCDMA signal *
	1 - 757 MHz 807 MHz - 12750 MHz	-15 dBm	-105 dBm	—	CW carrier
XIV	788 - 798 MHz	-35 dBm	-105 dBm	± 10 MHz	WCDMA signal *
	768 - 788 MHz 798 - 818 MHz	-35 dBm	-105 dBm	± 10 MHz	WCDMA signal *
	1 - 768 MHz 818 MHz - 12750 MHz	-15 dBm	-105 dBm	—	CW carrier
XIX	830 - 845 MHz	-35 dBm	-105 dBm	± 10 MHz	WCDMA signal *
	810 - 830 MHz 845 - 865 MHz	-35 dBm	-105 dBm	± 10 MHz	WCDMA signal *
	1 MHz - 810 MHz 865 MHz - 12750 MHz	-15 dBm	-105 dBm	—	CW carrier
XX	832 - 862 MHz	-35 dBm	-105 dBm	± 10 MHz	WCDMA signal *
	821 - 832 MHz 862 - 882 MHz	-35 dBm	-105 dBm	± 10 MHz	WCDMA signal *
	1 MHz - 821 MHz 882 MHz - 12750 MHz	-15 dBm	-105 dBm	—	CW carrier
XXI	1447.9 - 1462.9 MHz	-35 dBm	-105 dBm	± 10 MHz	WCDMA signal *
	1427.9 - 1447.9 MHz 1462.9 - 1482.9 MHz	-35 dBm	-105 dBm	± 10 MHz	WCDMA signal *
	1 MHz - 1427.9 MHz 1482.9 MHz - 12750 MHz	-15 dBm	-105 dBm	—	CW carrier
XXII	3410 - 3490 MHz	-35 dBm	-105 dBm	± 10 MHz	WCDMA signal *
	3390 - 3410 MHz 3490 - 3510 MHz	-35 dBm	-105 dBm	± 10 MHz	WCDMA signal *
	1 MHz - 3390 MHz 3510 MHz - 12750 MHz	-15 dBm	-105 dBm	—	CW carrier
XXV	1850 - 1915 MHz	-35 dBm	-105 dBm	± 10 MHz	WCDMA signal *
	1830 - 1850 MHz 1915 - 1930 MHz	-35 dBm	-105 dBm	± 10 MHz	WCDMA signal *
	1 MHz - 1830 MHz 1930 MHz - 12750 MHz	-15 dBm	-105 dBm	—	CW carrier
XXVI	814-849 MHz	-35 dBm	-105 dBm	± 10 MHz	WCDMA signal *
	794-814 MHz 849-859 MHz	-35 dBm	-105 dBm	± 10 MHz	WCDMA signal *
	1 MHz - 794 MHz 859 MHz - 12750 MHz	-15 dBm	-105 dBm	—	CW carrier
Note *: The characteristics of the W-CDMA interference signal are specified in Annex I.					
NOTE **: For a BS capable of multiband operation, in case of interfering signal that is not in the in-band blocking frequency range of the operating band where the wanted signal is present, the wanted Signal mean power is equal to -109.6 dBm.					

NOTE: Table 7.4L assumes that two operating bands, where the downlink frequencies (see Table 3.0) of one band would be within the in-band blocking region of the other band, are not deployed in the same geographical area.

Table 7.4M: Blocking characteristics for Local Area / Home BS

Operating Band	Center Frequency of Interfering Signal	Interfering Signal Level	Wanted Signal mean power	Minimum Offset of Interfering Signal	Type of Interfering Signal
I	1920 - 1980 MHz	-30 dBm	-101 dBm	± 10 MHz	WCDMA signal *
	1900 - 1920 MHz 1980 - 2000 MHz	-30 dBm	-101 dBm	± 10 MHz	WCDMA signal *
	1 MHz -1900 MHz 2000 MHz - 12750 MHz	-15 dBm	-101 dBm	—	CW carrier

II	1850 - 1910 MHz	-30 dBm	-101 dBm	± 10 MHz	WCDMA signal *
	1830 - 1850 MHz 1910 - 1930 MHz	-30 dBm	-101 dBm	± 10 MHz	WCDMA signal *
	1 MHz - 1830 MHz 1930 MHz - 12750 MHz	-15 dBm	-101 dBm	—	CW carrier
III	1710 - 1785 MHz	-30 dBm	-101 dBm	± 10 MHz	WCDMA signal *
	1690 - 1710 MHz 1785 - 1805 MHz	-30 dBm	-101 dBm	± 10 MHz	WCDMA signal *
	1 MHz - 1690 MHz 1805 MHz - 12750 MHz	-15 dBm	-101 dBm	—	CW carrier
IV	1710 - 1755 MHz	-30 dBm	-101 dBm	± 10 MHz	WCDMA signal *
	1690 - 1710 MHz 1755 - 1775 MHz	-30 dBm	-101 dBm	± 10 MHz	WCDMA signal *
	1 MHz - 1690 MHz 1775 MHz - 12750 MHz	-15 dBm	-101 dBm	—	CW carrier
V	824-849 MHz	-30 dBm	-101 dBm	± 10 MHz	WCDMA signal *
	804-824 MHz 849-869 MHz	-30 dBm	-101 dBm	± 10 MHz	WCDMA signal *
	1 MHz - 804 MHz 869 MHz - 12750 MHz	-15 dBm	-101 dBm	—	CW carrier
VI	810 - 830 MHz 840 - 860 MHz	-30 dBm	-101 dBm	± 10 MHz	WCDMA signal *
	1 MHz - 810 MHz 860 MHz - 12750 MHz	-15 dBm	-101 dBm	—	CW carrier
	2500 - 2570 MHz	-30 dBm	-101 dBm	± 10 MHz	WCDMA signal *
VII	2480 - 2500 MHz 2570 - 2590 MHz	-30 dBm	-101 dBm	± 10 MHz	WCDMA signal *
	1 MHz -2480 MHz 2590 MHz - 12750 MHz	-15 dBm	-101 dBm	—	CW carrier
	880 - 915 MHz	-30 dBm	-101 dBm	± 10 MHz	WCDMA signal *
VIII	860 - 880 MHz 915 - 925 MHz	-30 dBm	-101 dBm	± 10 MHz	WCDMA signal *
	1 MHz -860 MHz 925 MHz - 12750 MHz	-15 dBm	-101 dBm	—	CW carrier
	1749.9 - 1784.9 MHz	-30 dBm	-101 dBm	± 10 MHz	WCDMA signal *
IX	1729.9 - 1749.9 MHz 1784.9 - 1804.9 MHz	-30 dBm	-101 dBm	± 10 MHz	WCDMA signal *
	1 MHz - 1729.9 MHz 1804.9 MHz - 12750 MHz	-15 dBm	-101 dBm	—	CW carrier
	1710 - 1770 MHz	-30 dBm	-101 dBm	± 10 MHz	WCDMA signal *
X	1690 - 1710 MHz 1770 - 1790 MHz	-30 dBm	-101 dBm	± 10 MHz	WCDMA signal *
	1 MHz - 1690 MHz 1790 MHz - 12750 MHz	-15 dBm	-101 dBm	—	CW carrier
	1427.9 - 1447.9 MHz	-30 dBm	-101 dBm	± 10 MHz	WCDMA signal *
XI	1407.9 - 1427.9 MHz 1447.9 - 1467.9 MHz	-30 dBm	-101 dBm	± 10 MHz	WCDMA signal *
	1 MHz - 1407.9 MHz 1467.9 MHz - 12750 MHz	-15 dBm	-101 dBm	—	CW carrier
	699 - 716 MHz	-30 dBm	-101 dBm	± 10 MHz	WCDMA signal *
XII	679 - 699 MHz 716 - 729 MHz	-30 dBm	-101 dBm	± 10 MHz	WCDMA signal *
	1 MHz - 679 MHz 729 MHz – 12750 MHz	-15 dBm	-101 dBm	—	CW carrier
	777 - 787 MHz	-30 dBm	-101 dBm	± 10 MHz	WCDMA signal *
XIII	757 - 777 MHz 787 - 807 MHz	-30 dBm	-101 dBm	± 10 MHz	WCDMA signal *
	1 - 757 MHz 807 MHz - 12750 MHz	-15 dBm	-101 dBm	—	CW carrier
	788 - 798 MHz	-30 dBm	-101 dBm	± 10 MHz	WCDMA signal *
XIV	768 - 788 MHz 798 - 818 MHz	-30 dBm	-101 dBm	± 10 MHz	WCDMA signal *
	1 - 768 MHz 818 MHz - 12750 MHz	-15 dBm	-101 dBm	—	CW carrier

XIX	830 - 845 MHz	-30 dBm	-101 dBm	± 10 MHz	WCDMA signal *
	810 - 830 MHz 845 - 865 MHz	-30 dBm	-101 dBm	± 10 MHz	WCDMA signal *
	1 MHz - 810 MHz 865 MHz - 12750 MHz	-15 dBm	-101 dBm	—	CW carrier
XX	832 - 862 MHz	-30 dBm	-101 dBm	± 10 MHz	WCDMA signal *
	821 - 832 MHz 862 - 882 MHz	-30 dBm	-101 dBm	± 10 MHz	WCDMA signal *
	1 MHz - 821 MHz 882 MHz - 12750 MHz	-15 dBm	-101 dBm	—	CW carrier
XXI	1447.9 - 1462.9 MHz	-30 dBm	-101 dBm	± 10 MHz	WCDMA signal *
	1427.9 - 1447.9 MHz 1462.9 - 1482.9 MHz	-30 dBm	-101 dBm	± 10 MHz	WCDMA signal *
	1 MHz - 1427.9 MHz 1482.9 MHz - 12750 MHz	-15 dBm	-101 dBm	—	CW carrier
XXII	3410 - 3490 MHz	-30 dBm	-101 dBm	± 10 MHz	WCDMA signal *
	3390 - 3410 MHz 3490 - 3510 MHz	-30 dBm	-101 dBm	± 10 MHz	WCDMA signal *
	1 MHz - 3390 MHz 3510 MHz - 12750 MHz	-15 dBm	-101 dBm	—	CW carrier
XXV	1850 - 1915 MHz	-30 dBm	-101 dBm	± 10 MHz	WCDMA signal *
	1830 - 1850 MHz 1915 - 1930 MHz	-30 dBm	-101 dBm	± 10 MHz	WCDMA signal *
	1 MHz - 1830 MHz 1930 MHz - 12750 MHz	-15 dBm	-101 dBm	—	CW carrier
XXVI	814-849 MHz	-30 dBm	-101 dBm	± 10 MHz	WCDMA signal *
	794-814 MHz 849-859 MHz	-30 dBm	-101 dBm	± 10 MHz	WCDMA signal *
	1 MHz - 794 MHz 859 MHz - 12750 MHz	-15 dBm	-101 dBm	—	CW carrier
Note *: The characteristics of the W-CDMA interference signal are specified in Annex I.					
NOTE **: For a BS capable of multiband operation, in case of interfering signal that is not in the in-band blocking frequency range of the operating band where the wanted signal is present, the wanted Signal mean power is equal to -105.6 dBm.					

NOTE: Table 7.4M assumes that two operating bands, where the downlink frequencies (see Table 3.0) of one band would be within the in-band blocking region of the other band, are not deployed in the same geographical area.

Table 7.4N: Blocking performance requirement for Wide Area BS when co-located with BS in other bands.

Co-located BS type	Center Frequency of Interfering Signal	Interfering Signal mean power	Wanted Signal mean power	Type of Interfering Signal
Macro GSM900	921 - 960 MHz	+16 dBm	-115 dBm	CW carrier
Macro DCS1800	1805 - 1880 MHz	+16 dBm	-115 dBm	CW carrier
Macro PCS1900	1930 - 1990 MHz	+16 dBm	-115 dBm	CW carrier
Macro GSM850 or CDMA850	869 - 894 MHz	+16 dBm	-115 dBm	CW carrier
WA UTRA-FDD Band I or E-UTRA Band 1	2110 - 2170 MHz	+16 dBm	-115 dBm	CW carrier
WA UTRA-FDD Band II or E-UTRA Band 2	1930 - 1990 MHz	+16 dBm	-115 dBm	CW carrier
WA UTRA-FDD Band III or E-UTRA Band 3	1805 - 1880 MHz	+16 dBm	-115 dBm	CW carrier
WA UTRA-FDD Band IV or E-UTRA Band 4	2110 - 2155 MHz	+16 dBm	-115 dBm	CW carrier
WA UTRA-FDD Band V or E-UTRA Band 5	869 - 894 MHz	+16 dBm	-115 dBm	CW carrier
WA UTRA-FDD Band VI or E-UTRA Band 6	875 - 885 MHz	+16 dBm	-115 dBm	CW carrier
WA UTRA-FDD Band VII or E-UTRA Band 7	2620 - 2690 MHz	+16 dBm	-115 dBm	CW carrier
WA UTRA-FDD Band VIII or E-UTRA Band 8	925 - 960 MHz	+16 dBm	-115 dBm	CW carrier
WA UTRA-FDD Band IX or E-UTRA Band 9	1844.9 - 1879.9 MHz	+16 dBm	-115 dBm	CW carrier
WA UTRA-FDD Band X or E-UTRA Band 10	2110 - 2170 MHz	+16 dBm	-115 dBm	CW carrier
WA UTRA-FDD Band XI or E-UTRA Band 11	1475.9 - 1495.9 MHz	+16 dBm	-115 dBm	CW carrier
WA UTRA-FDD Band XII or E-UTRA Band 12	729 - 746 MHz	+16 dBm	-115 dBm	CW carrier
WA UTRA-FDD Band XIII or E-UTRA Band 13	746 - 756 MHz	+16 dBm	-115 dBm	CW carrier
WA UTRA-FDD Band XIV or E-UTRA Band 14	758 - 768 MHz	+16 dBm	-115 dBm	CW carrier
WA E-UTRA Band 17	734 - 746 MHz	+16 dBm	-115 dBm	CW carrier
WA E-UTRA Band 18	860 - 875 MHz	+16 dBm	-115 dBm	CW carrier
WA UTRA-FDD Band XIX or E-UTRA Band 19	875 - 890 MHz	+16 dBm	-115 dBm	CW carrier
WA UTRA-FDD Band XX or E-UTRA Band 20	791 - 821 MHz	+16 dBm	-115 dBm	CW carrier
WA UTRA-FDD Band XXI or E-UTRA Band 21	1495.9 - 1510.9 MHz	+16 dBm	-115 dBm	CW carrier
WA UTRA-FDD Band XXII or E-UTRA Band 22	3510 - 3590 MHz	+16 dBm	-115 dBm	CW carrier
WA E-UTRA Band 23	2180 - 2200 MHz	+16 dBm	-115 dBm	CW carrier
WA E-UTRA Band 24	1525 - 1559 MHz	+16 dBm	-115 dBm	CW carrier
WA UTRA-FDD Band XXV or E-UTRA Band 25	1930 - 1995 MHz	+16 dBm	-115 dBm	CW carrier
WA UTRA-FDD Band XXVI or E-UTRA Band 26	859 - 894 MHz	+16 dBm	-115 dBm	CW carrier
WA E-UTRA Band 27	852 - 859 MHz	+16 dBm	-115 dBm	CW carrier
WA E-UTRA Band 28	758 - 803 MHz	+16 dBm	-115 dBm	CW carrier
WA E-UTRA Band 29	717 - 728 MHz	+16 dBm	-115 dBm	CW carrier
WA UTRA TDD Band a) or E-UTRA Band 33	1900 - 1920 MHz	+16 dBm	-115 dBm	CW carrier
WA UTRA TDD Band a) or E-UTRA Band 34	2010 - 2025 MHz	+16 dBm	-115 dBm	CW carrier
WA UTRA TDD Band d) or E-UTRA Band 38	2570 - 2620 MHz	+16 dBm	-115 dBm	CW carrier
WA UTRA TDD Band f) or E-UTRA Band 39	1880 - 1920 MHz	+16 dBm	-115 dBm	CW carrier
WA UTRA TDD Band e) E-	2300 - 2400 MHz	+16 dBm	-115 dBm	CW carrier

UTRA Band 40				
WA E-UTRA Band 41	2496 - 2690 MHz	+16 dBm	-115 dBm	CW carrier
WA E-UTRA Band 42	3400 - 3600 MHz	+16 dBm	-115 dBm	CW carrier
WA E-UTRA Band 43	3600 - 3800 MHz	+16 dBm	-115 dBm	CW carrier
WA E-UTRA Band 44	703 - 803 MHz	+16 dBm	-115 dBm	CW carrier
<p>NOTE 1: Except for a BS operating in Band XIII, these requirements do not apply when the interfering signal falls within any of the supported uplink operating band or in the 10 MHz immediately outside any of the supported uplink operating band. For a BS operating in band XIII the requirements do not apply when the interfering signal falls within the frequency range 768-797 MHz.</p> <p>NOTE 2: Some combinations of bands may not be possible to co-site based on the requirements above. The current state-of-the-art technology does not allow a single generic solution for co-location of UTRA FDD with UTRA TDD or E-UTRA TDD on adjacent frequencies for 30dB BS-BS minimum coupling loss. However, there are certain site-engineering solutions that can be used. These techniques are addressed in TR 25.942 [4].</p>				

Table 7.4P: Blocking performance requirement for Medium Range BS when co-located with BS in other bands.

Co-located BS type	Center Frequency of Interfering Signal	Interfering Signal mean power	Wanted Signal mean power	Type of Interfering Signal
Micro GSM900	921 - 960 MHz	-3 dBm	-105 dBm	CW carrier
Micro DCS1800	1805 - 1880 MHz	+5 dBm	-105 dBm	CW carrier
Micro PCS1900	1930 - 1990 MHz	+5 dBm	-105 dBm	CW carrier
Micro GSM850	869 - 894 MHz	-3 dBm	-105 dBm	CW carrier
MR UTRA-FDD Band I or E-UTRA Band 1	2110 - 2170 MHz	+8 dBm	-105 dBm	CW carrier
MR UTRA-FDD Band II or E-UTRA Band 2	1930 - 1990 MHz	+8 dBm	-105 dBm	CW carrier
MR UTRA-FDD Band III or E-UTRA Band 3	1805 - 1880 MHz	+8 dBm	-105 dBm	CW carrier
MR UTRA-FDD Band IV or E-UTRA Band 4	2110 - 2155 MHz	+8 dBm	-105 dBm	CW carrier
MR UTRA-FDD Band V or E-UTRA Band 5	869 - 894 MHz	+8 dBm	-105 dBm	CW carrier
MR UTRA-FDD Band VI or E-UTRA Band 6	875 - 885 MHz	+8 dBm	-105 dBm	CW carrier
MR UTRA-FDD Band VII or E-UTRA Band 7	2620 - 2690 MHz	+8 dBm	-105 dBm	CW carrier
MR UTRA-FDD Band VIII or E-UTRA Band 8	925 - 960 MHz	+8 dBm	-105 dBm	CW carrier
MR UTRA-FDD Band IX or E-UTRA Band 9	1844.9 - 1879.9 MHz	+8 dBm	-105 dBm	CW carrier
MR UTRA-FDD Band X or E-UTRA Band 10	2110 - 2170 MHz	+8 dBm	-105 dBm	CW carrier
MR UTRA-FDD Band XI or E-UTRA Band 11	1475.9 - 1495.9 MHz	+8 dBm	-105 dBm	CW carrier
MR UTRA-FDD Band XII or E-UTRA Band 12	729 - 746 MHz	+8 dBm	-105 dBm	CW carrier
MR UTRA-FDD Band XIII or E-UTRA Band 13	746 - 756 MHz	+8 dBm	-105 dBm	CW carrier
MR UTRA-FDD Band XIV or E-UTRA Band 14	758 - 768 MHz	+8 dBm	-105 dBm	CW carrier
MR E-UTRA Band 17	734 - 746 MHz	+8 dBm	-105 dBm	CW carrier
MR E-UTRA Band 18	860 - 875 MHz	+8 dBm	-105 dBm	CW carrier
MR UTRA-FDD Band XIX or E-UTRA Band 19	875 - 890 MHz	+8 dBm	-105 dBm	CW carrier
MR UTRA-FDD Band XX or E-UTRA Band 20	791 - 821 MHz	+8 dBm	-105 dBm	CW carrier
MR UTRA-FDD Band XXI or E-UTRA Band 21	1495.9 - 1510.9 MHz	+8 dBm	-105 dBm	CW carrier
MR UTRA-FDD Band XXII or E-UTRA Band 22	3510 - 3590 MHz	+8 dBm	-105 dBm	CW carrier
MR E-UTRA Band 23	2180 - 2200 MHz	+8 dBm	-105 dBm	CW carrier
MR E-UTRA Band 24	1525 - 1559 MHz	+8 dBm	-105 dBm	CW carrier
MR UTRA-FDD Band XXV or E-UTRA Band 25	1930 - 1995 MHz	+8 dBm	-105 dBm	CW carrier
MR UTRA-FDD Band XXVI or E-UTRA Band 26	859 - 894 MHz	+8 dBm	-105 dBm	CW carrier
MR E-UTRA Band 27	852 - 859 MHz	+8 dBm	-105 dBm	CW carrier
MR E-UTRA Band 28	758 - 803 MHz	+8 dBm	-105 dBm	CW carrier
MR E-UTRA Band 29	717 - 728 MHz	+8 dBm	-105 dBm	CW carrier
MR E-UTRA Band 33	1900 - 1920 MHz	+8 dBm	-105 dBm	CW carrier
MR E-UTRA Band 34	2010 - 2025 MHz	+8 dBm	-105 dBm	CW carrier
MR E-UTRA Band 38	2570 - 2620 MHz	+8 dBm	-105 dBm	CW carrier
MR E-UTRA Band 39	1880 - 1920 MHz	+8 dBm	-105 dBm	CW carrier
MR E-UTRA Band 40	2300 - 2400 MHz	+8 dBm	-105 dBm	CW carrier
MR E-UTRA Band 41	2496 - 2690 MHz	+8 dBm	-105 dBm	CW carrier
MR E-UTRA Band 42	3400 - 3600 MHz	+8 dBm	-105 dBm	CW carrier
MR E-UTRA Band 43	3600 - 3800 MHz	+8 dBm	-105 dBm	CW carrier
MR E-UTRA Band 44	703 - 803 MHz	+8 dBm	-105 dBm	CW carrier

NOTE 1: Except for a BS operating in Band XIII, these requirements do not apply when the interfering signal falls within any of the supported uplink operating band or in the 10 MHz immediately outside any of the supported uplink operating band.
For a BS operating in band XIII the requirements do not apply when the interfering signal falls within the frequency range 768-797 MHz.

NOTE 2: Some combinations of bands may not be possible to co-site based on the requirements above. The current state-of-the-art technology does not allow a single generic solution for co-location of UTRA FDD with UTRA TDD or E-UTRA TDD on adjacent frequencies for 30dB BS-BS minimum coupling loss. However, there are certain site-engineering solutions that can be used. These techniques are addressed in TR 25.942 [4].

Table 7.4Q: Blocking performance requirement for Local Area BS when co-located with BS in other bands.

Co-located BS type	Center Frequency of Interfering Signal	Interfering Signal mean power	Wanted Signal mean power	Type of Interfering Signal
Pico GSM900	921 - 960 MHz	-7 dBm	-101 dBm	CW carrier
Pico DCS1800	1805 - 1880 MHz	-4 dBm	-101 dBm	CW carrier
Pico PCS1900	1930 - 1990 MHz	-4 dBm	-101 dBm	CW carrier
Pico GSM850	869 - 894 MHz	-7 dBm	-101 dBm	CW carrier
LA UTRA-FDD Band I or E-UTRA Band 1	2110 - 2170 MHz	-6 dBm	-101 dBm	CW carrier
LA UTRA-FDD Band II or E-UTRA Band 2	1930 - 1990 MHz	-6 dBm	-101 dBm	CW carrier
LA UTRA-FDD Band III or E-UTRA Band 3	1805 - 1880 MHz	-6 dBm	-101 dBm	CW carrier
LA UTRA-FDD Band IV or E-UTRA Band 4	2110 - 2155 MHz	-6 dBm	-101 dBm	CW carrier
LA UTRA-FDD Band V or E-UTRA Band 5	869 - 894 MHz	-6 dBm	-101 dBm	CW carrier
LA UTRA-FDD Band VI or E-UTRA Band 6	875 - 885 MHz	-6 dBm	-101 dBm	CW carrier
LA UTRA-FDD Band VII or E-UTRA Band 7	2620 - 2690 MHz	-6 dBm	-101 dBm	CW carrier
LA UTRA-FDD Band VIII or E-UTRA Band 8	925 - 960 MHz	-6 dBm	-101 dBm	CW carrier
LA UTRA-FDD Band IX or E-UTRA Band 9	1844.9 - 1879.9 MHz	-6 dBm	-101 dBm	CW carrier
LA UTRA-FDD Band X or E-UTRA Band 10	2110 - 2170 MHz	-6 dBm	-101 dBm	CW carrier
LA UTRA-FDD Band XI or E-UTRA Band 11	1475.9 - 1495.9 MHz	-6 dBm	-101 dBm	CW carrier
LA UTRA-FDD Band XII or E-UTRA Band 12	729 - 746 MHz	-6 dBm	-101 dBm	CW carrier
LA UTRA-FDD Band XIII or E-UTRA Band 13	746 - 756 MHz	-6 dBm	-101 dBm	CW carrier
LA UTRA-FDD Band XIV or E-UTRA Band 14	758 - 768 MHz	-6 dBm	-101 dBm	CW carrier
LA E-UTRA Band 17	734 - 746 MHz	-6 dBm	-101 dBm	CW carrier
LA UTRA-FDD Band XIX or E-UTRA Band 19	875 - 890 MHz	-6 dBm	-101 dBm	CW carrier
LA UTRA-FDD Band XX or E-UTRA Band 20	791 - 821 MHz	-6 dBm	-101 dBm	CW carrier
LA UTRA-FDD Band XXI or E-UTRA Band 21	1495.9 - 1510.9 MHz	-6 dBm	-101 dBm	CW carrier
LA UTRA-FDD Band XXII or E-UTRA Band 22	3510 - 3590 MHz	-6 dBm	-101 dBm	CW carrier
LA E-UTRA Band 23	2180 - 2200 MHz	-6 dBm	-101 dBm	CW carrier
LA E-UTRA Band 24	1525 - 1559 MHz	-6 dBm	-101 dBm	CW carrier
LA UTRA-FDD Band XXV or E-UTRA Band 25	1930 - 1995 MHz	-6 dBm	-101 dBm	CW carrier
LA UTRA-FDD Band XXVI or E-UTRA Band 26	859 - 894 MHz	-6 dBm	-101 dBm	CW carrier
LA E-UTRA Band 27	852 - 869 MHz	-6 dBm	-101 dBm	CW carrier
LA E-UTRA Band 28	758 - 803 MHz	-6 dBm	-101 dBm	CW carrier
LA E-UTRA Band 29	717 - 728 MHz	-6 dBm	-101 dBm	CW carrier
LA UTRA TDD Band a) or E-UTRA Band 33	1900 - 1920 MHz	-6 dBm	-101 dBm	CW carrier
LA UTRA TDD Band a) or E-UTRA Band 34	2010 - 2025 MHz	-6 dBm	-101 dBm	CW carrier
LA UTRA TDD Band d) or E-UTRA Band 38	2570 - 2620 MHz	-4 dBm	-101 dBm	CW carrier
LA UTRA TDD Band f) or E-UTRA Band 39	1880 - 1920 MHz	-6 dBm	-101 dBm	CW carrier
LA UTRA TDD Band e) E-UTRA Band 40	2300 - 2400 MHz	-6 dBm	-101 dBm	CW carrier
LA E-UTRA Band 41	2496 - 2690 MHz	-6 dBm	-101 dBm	CW carrier

LA E-UTRA Band 42	3400 - 3600 MHz	-6 dBm	-101 dBm	CW carrier
LA E-UTRA Band 43	3600 – 3800 MHz	-6 dBm	-101 dBm	CW carrier
LA E-UTRA Band 44	703 – 803 MHz	-6 dBm	-101 dBm	CW carrier
<p>NOTE 1: Except for a BS operating in Band XIII, these requirements do not apply when the interfering signal falls within any of the supported uplink operating band or in the 10 MHz immediately outside any of the supported the uplink operating band. For a BS operating in band XIII the requirements do not apply when the interfering signal falls within the frequency range 768-797 MHz.</p> <p>NOTE 2: Some combinations of bands may not be possible to co-site based on the requirements above. The current state-of-the-art technology does not allow a single generic solution for co-location of UTRA FDD with UTRA TDD or E-UTRA TDD on adjacent frequencies for 30dB BS-BS minimum coupling loss. However, there are certain site-engineering solutions that can be used. These techniques are addressed in TR 25.942 [4].</p>				

Table 7.4R: Blocking performance requirement (narrowband) for Wide Area BS

Operating Band	Center Frequency of Interfering Signal	Interfering Signal mean power	Wanted Signal mean power	Minimum Offset of Interfering Signal	Type of Interfering Signal
II	1850 - 1910 MHz	- 47 dBm	-115 dBm	±2.7 MHz	GMSK modulated*
III	1710 - 1785 MHz	- 47 dBm	-115 dBm	±2.8 MHz	GMSK modulated*
IV	1710 - 1755 MHz	- 47 dBm	-115 dBm	±2.7 MHz	GMSK modulated*
V	824 - 849 MHz	- 47 dBm	-115 dBm	±2.7 MHz	GMSK modulated*
VIII	880 - 915 MHz	- 47 dBm	-115 dBm	±2.8 MHz	GMSK modulated*
X	1710 - 1770 MHz	- 47 dBm	-115 dBm	±2.7 MHz	GMSK modulated*
XII	699 - 716 MHz	- 47 dBm	-115 dBm	±2.7 MHz	GMSK modulated*
XIII	777 - 787 MHz	- 47 dBm	-115 dBm	±2.7 MHz	GMSK modulated*
XIV	788 - 798 MHz	- 47 dBm	-115 dBm	±2.7 MHz	GMSK modulated*
XXV	1850 - 1915 MHz	- 47 dBm	-115 dBm	±2.7 MHz	GMSK modulated*
XXVI	814-849 MHz	-47 dBm	-115 dBm	±2.7 MHz	GMSK modulated*

Note *: GMSK modulation as defined in TS 45.004 [12].

Table 7.4S: Blocking performance requirement (narrowband) for Medium range BS

Operating Band	Center Frequency of Interfering Signal	Interfering Signal mean power	Wanted Signal mean power	Minimum Offset of Interfering Signal	Type of Interfering Signal
II	1850 - 1910 MHz	- 42 dBm	-105 dBm	±2.7 MHz	GMSK modulated*
III	1710 - 1785 MHz	- 42 dBm	-105 dBm	±2.8 MHz	GMSK modulated*
IV	1710 - 1755 MHz	- 42 dBm	-105 dBm	±2.7 MHz	GMSK modulated*
V	824 - 849 MHz	- 42 dBm	-105 dBm	±2.7 MHz	GMSK modulated*
VIII	880 - 915 MHz	- 42 dBm	-105 dBm	±2.8 MHz	GMSK modulated*
X	1710 - 1770 MHz	- 42 dBm	-105 dBm	±2.7 MHz	GMSK modulated*
XII	699 - 716 MHz	- 42 dBm	-105 dBm	±2.7 MHz	GMSK modulated*
XIII	777 - 787 MHz	- 42 dBm	-105 dBm	±2.7 MHz	GMSK modulated*
XIV	788 - 798 MHz	- 42 dBm	-105 dBm	±2.7 MHz	GMSK modulated*
XXV	1850 - 1915 MHz	- 42 dBm	-105 dBm	±2.7 MHz	GMSK modulated*
XXVI	814-849 MHz	- 42 dBm	-105 dBm	±2.7 MHz	GMSK modulated*

Note *: GMSK modulation as defined in TS 45.004 [12].

Table 7.4T: Blocking performance requirement (narrowband) for Local Area / Home BS

Operating Band	Center Frequency of Interfering Signal	Interfering Signal mean power	Wanted Signal mean power	Minimum Offset of Interfering Signal	Type of Interfering Signal
II	1850 - 1910 MHz	- 37 dBm	-101 dBm	±2.7 MHz	GMSK modulated*
III	1710 - 1785 MHz	- 37 dBm	-101 dBm	±2.8 MHz	GMSK modulated*
IV	1710 - 1755 MHz	- 37 dBm	-101 dBm	±2.7 MHz	GMSK modulated*
V	824 - 849 MHz	- 37 dBm	-101 dBm	±2.7 MHz	GMSK modulated*
VIII	880 - 915 MHz	- 37 dBm	-101 dBm	±2.8 MHz	GMSK modulated*
X	1710 - 1770 MHz	- 37 dBm	-101 dBm	±2.7 MHz	GMSK modulated*
XII	699 - 716 MHz	- 37 dBm	-101 dBm	±2.7 MHz	GMSK modulated*
XIII	777 - 787 MHz	- 37 dBm	-101 dBm	±2.7 MHz	GMSK modulated*
XIV	788 - 798 MHz	- 37 dBm	-101 dBm	±2.7 MHz	GMSK modulated*
XXV	1850 – 1915 MHz	- 37 dBm	-101 dBm	±2.7 MHz	GMSK modulated*
XXVI	814-849 MHz	- 37 dBm	-101 dBm	±2.7 MHz	GMSK modulated*

Note *: GMSK modulation as defined in TS 45.004 [12].

Table 7.4U: Void**Table 7.4V: Void**

NOTE 1: If the above Test Requirement differs from the Minimum Requirement then the Test Tolerance applied for this test is non-zero. The Test Tolerance for this test is defined in clause 4.2 and the explanation of how the Minimum Requirement has been relaxed by the Test Tolerance is given in Annex F.

NOTE 2: Annex C describes the procedure for BER tests taking into account the statistical consequence of frequent repetition of BER measurements within the blocking test . The consequence is: a DUT exactly on the limit may fail due to the statistical nature 2.55 times(mean value) in 12750 BER measurements using the predefined wrong decision probability of 0.02%. If the fail cases are ≤ 12 , it is allowed to repeat the fail cases 1 time before the final verdict.

7.6 Intermodulation characteristics

7.6.1 Definition and applicability

Third and higher order mixing of the two interfering RF signals can produce an interfering signal in the band of the desired channel. Intermodulation response rejection is a measure of the capability of the receiver to receive a wanted signal on its assigned channel frequency in the presence of two or more interfering signals which have a specific frequency relationship to the wanted signal.

7.6.2 Minimum Requirement

The minimum requirement is in TS 25.104 [1] clause 7.6.

7.5(a): (void)**Table 7.5(b): (void)**

7.6.3 Test purpose

The test purpose is to verify the ability of the BS receiver to inhibit the generation of intermodulation products in its non-linear elements caused by the presence of two high-level interfering signals at frequencies with a specific relationship to the frequency of the wanted signal.

7.6.4 Method of test

7.6.4.1 Initial conditions

Test environment: normal; see clause 4.4.1.

RF channels to be tested for single carrier: B, M and T; see clause 4.8

RF bandwidth positions to be tested for multi-carrier: B_{RFBW} , M_{RFBW} and T_{RFBW} ; B_{RFBW_T} and B_{RFBW_T} in multi-band operation; see subclause 4.8.1;

- 1) Set-up the equipment as shown in annex B.

7.6.4.2 Procedures

- 1) Generate the wanted signal (reference signal) and adjust ATT1 to set the signal level to the BS under test to the level specified in table 7.5A. For a BS supporting multi-carrier operation, generate the wanted signal according to the applicable test configuration (see clause 4.12) using applicable reference measurement channel to the BS under test. Power settings are specified in Table 7.5A.
- 2) Adjust the signal generators to the type of interfering signals and the frequency offsets as specified in Tables 7.5A(a) and 7.5A(b). Note that the GMSK modulated interfering signal shall have an ACLR of at least 72 dB in order to eliminate the impact of interference signal adjacent channel leakage power on the intermodulation characteristics measurement.
- 3) Adjust the ATT2 and ATT3 to obtain the specified level of interference signal at the BS input.
- 4) Measure the BER of the wanted signal. For a BS supporting multi-carrier operation the BER shall be measured for all relevant carriers specified by the test configuration.

In addition, for a multi-band capable BS with separate antenna connectors, the following steps shall apply:

- 5) For single band tests, repeat the steps above per involved band where single band test configurations shall apply with no carrier activated in the other band.
- 6) The interfering signal shall first be applied on the same port as the wanted signal. The test shall be repeated with the interfering signal applied on the other port (if any) mapped to the same receiver as the wanted signal. Any antenna connector with no signal applied in case of single-band or multi-band test shall be terminated.
- 7) Repeat step 6) with the wanted signal for the other band(s) applied on the respective port(s).

7.6.5 Test requirements

For each measured carrier, the BER shall not exceed 0,001 for the parameters specified in tables 7.5A(a) and 7.5(b).

The intermodulation performance shall be met when the following signals are applied to the receiver.

For a BS operating in non-contiguous spectrum within any operating band, the narrowband intermodulation requirement applies in addition inside any sub-block gap, in case the sub-block gap size is at least 6.8MHz. The CW interfering signal offset is defined relative to the lower/upper sub-block edge inside the sub-block gap and is equal to -1MHz/+1MHz, respectively. The GMSK modulated interfering signal offset is defined relative to the lower/upper sub-block edge inside the sub-block gap and is equal to -3.4MHz/+3.4MHz, respectively. The requirement applies separately for both sub-blocks.

For a BS capable of multi-band operation, the narrowband intermodulation requirement applies in addition inside any inter RF bandwidth gap, in case the inter RF bandwidth gap size is at least 6.8MHz. The CW interfering signal offset is defined relative to lower/upper RF bandwidth edges inside the inter RF bandwidth gap and is equal to -1MHz/+1MHz, respectively. The GMSK modulated interfering signal offset is defined relative to lower/upper RF bandwidth edges inside the inter RF bandwidth gap and is equal to -3.4MHz/+3.4MHz, respectively.

Table 7.5A(a): Intermodulation performance requirement

Operating Band	Type of Signal	Offset	Signal mean power		
			Wide Area BS	Medium Range BS	Local Area / Home BS
All bands	Wanted signal	-	-115 dBm	-105 dBm	-101 dBm
	CW signal	± 10 MHz	-48 dBm	-44 dBm	-38 dBm
	WCDMA signal *	± 20 MHz	-48 dBm	-44 dBm	-38 dBm
Note*: The characteristics of the W-CDMA interference signal are specified in Annex I.					

Table 7.5A(b): Narrowband intermodulation performance requirement

Operating band	Type of Signal	Offset	Signal mean power		
			Wide Area BS	Medium Range BS	Local Area / Home BS
II, III, IV, V, VIII, X, XII, XIII, XIV, XXV, XXVI	Wanted signal	-	-115 dBm	-105 dBm	-101 dBm
	CW signal	± 3.5 MHz	- 47 dBm	- 43 dBm	-37 dBm
	GMSK modulated*	± 5.9 MHz	- 47 dBm	- 43 dBm	-37 dBm
Note *: GMSK as defined in TS 45.004 [12].					

NOTE: If the above Test Requirement differs from the Minimum Requirement then the Test Tolerance applied for this test is non-zero. The Test Tolerance for this test is defined in clause 4.2 and the explanation of how the Minimum Requirement has been relaxed by the Test Tolerance is given in Annex F.

7.7 Spurious Emissions

7.7.1 Definition and applicability

The spurious emission power is the power of the emissions generated or amplified in a receiver that appears at the BS antenna connector. The requirements apply to all BS with separate RX and TX antenna port. The test shall be performed when both TX and RX are on with the TX port terminated.

For all BS with common RX and TX antenna port the transmitter spurious emission as specified in clause 6.5.3 is valid.

7.7.2 Minimum Requirements

The minimum requirement is in TS 25.104 [1] clause 7.7.

Table 7.6(a): (void)

Table 7.6(b): (void)

7.7.3 Test purpose

The test purpose is to verify the ability of the BS to limit the interference caused by receiver spurious emissions to other systems.

7.7.4 Method of test

7.7.4.1 Initial conditions

Test environment: normal; see clause 4.4.1.

RF channels to be tested for single carrier: M. See clause 4.8

RF bandwidth positions to be tested for multi-carrier: M_{RFBW} ; B_{RFBW} ; T_{RFBW} and B''_{RFBW} ; T_{RFBW} in multi-band operation; see sub-clause 4.8.1;

- 1) Connect a measurement receiver to the BS antenna connector as shown in annex B.

7.7.4.2 Procedure

- 1) For BS capable of single carrier operation only, start BS transmission according to TM1, clause 6.1.1.1, at manufacturer's declared rated output power, PRAT.

For a BS declared to be capable of multi-carrier operation, set the BS to transmit according to TM1 on all carriers configured, using the applicable test configuration and corresponding power setting for receiver tests, as specified in sub-clause 4.12.

- 2) Set measurement equipment parameters as specified in table 7.7.
- 3) Measure the spurious emissions over each frequency range described in clause 7.7.2.

Table 7.7

Measurement Band width	3.84 MHz (Root raised cosine,0.22) / 100 kHz/ 1MHz (note)
Sweep frequency range	30 MHz to 12.75GHz
Detection	True RMS
NOTE: As defined in clause 7.7.2.	

In addition, for a multi-band capable BS, the following steps shall apply:

- 4) For multi-band capable BS and single band tests, repeat the steps above per involved band where single band test configurations and test models shall apply with no carrier activated in the other band.
- 5) For multi-band capable BS with separate antenna connector, the antenna connector not being under test in case of single-band or multi-band test shall be terminated.

7.7.5 Test requirements

All measured spurious emissions, derived in step (3) and (4), shall be within requirement limits as specified in Tables 7.7A. For BS capable of multi-band operation, the exclusions and conditions in the Note column of Table 7.7A apply for each supported operating band. For BS capable of multi-band operation where multiple bands are mapped on separate antenna connectors, the single-band requirements apply and the excluded frequency range is only applicable for the operating band supported on each antenna connector.

Table 7.7A(a): Spurious emission minimum requirement

Band	Maximum level	Measurement Bandwidth	Note
30 MHz - 1 GHz	-57 dBm	100 kHz	With the exception of frequencies between 12.5 MHz below the first carrier frequency and 12.5 MHz above the last carrier frequency transmitted used by the BS.
1 GHz - 12.75 GHz	-47 dBm	1 MHz	With the exception of frequencies between 12.5 MHz below the first carrier frequency and 12.5 MHz above the last carrier frequency transmitted used by the BS.
12.75 GHz - 5 th harmonic of the upper frequency edge of the UL operating band in GHz	-47 dBm	1 MHz	NOTE 1: Applies only for Band XXII

In addition to the requirements in Table 7.7A(a), the power of any spurious emission shall not exceed the levels specified for Protection of the BS receiver of own or different BS in clause 6.5.3.7.3 and for Co-existence with other systems in the same geographical area in clause 6.5.3.7.4 and 6.5.3.7.8.1. In addition, the co-existence requirements for co-located base stations specified in clause 6.5.3.7.5 and 6.5.3.7.8.2 may also be applied.

Table 7.7A(b): Void

Table 7.7A(c): Void

NOTE: If the above Test Requirement differs from the Minimum Requirement then the Test Tolerance applied for this test is non-zero. The Test Tolerance for this test is defined in clause 4.2 and the explanation of how the Minimum Requirement has been relaxed by the Test Tolerance is given in Annex F.

7.8 Verification of the internal BER calculation

7.8.1 Definition and applicability

Base Station System with internal BER calculation can synchronise its receiver to known pseudo-random data sequence and calculates bit error ratio from the received data. This test is performed only if Base Station System has this kind of feature. This test is performed by feeding measurement signal with known BER to the input of the receiver. Locations of the erroneous bits shall be randomly distributed within a frame. Erroneous bits shall be inserted to the data bit stream as shown in figure 7.1.

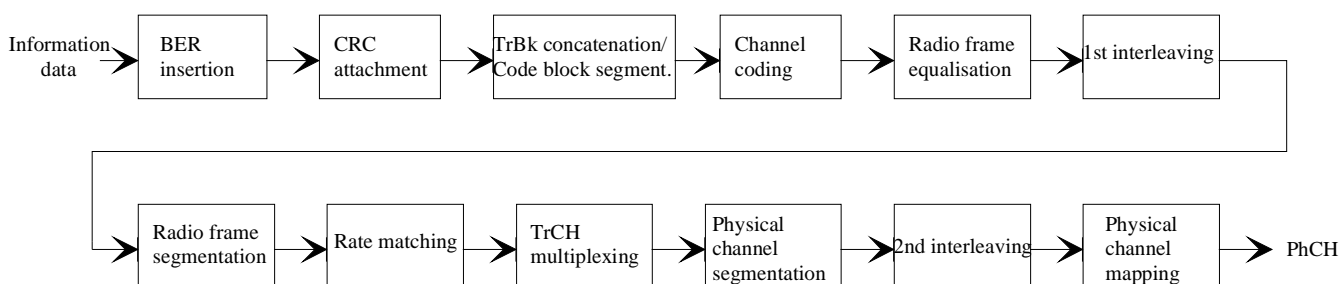

Figure 7.1: BER insertion into the information data

7.8.2 Minimum Requirement

BER indicated by the Base Station System shall be within $\pm 10\%$ of the BER generated by the RF signal source. Measurement shall be performed for the measurement signal specified in table 7.8.

Table 7.8

Transport channel combination	Data rate	BER
DPCH	12,2 kbps	0,01

7.8.3 Test purpose

To verify that the internal BER calculation accuracy shall meet requirements for conformance testing.

7.8.4 Method of test

7.8.4.1 Initial conditions

Test environment: normal; see clause 4.4.1.

RF channels to be tested: B, M and T; see clause 4.8

- 1) Connect BS RX antenna connector to the RF signal source or UE simulator as shown in annex B.
- 2) Set correct signal source parameters as specified in table 7.9.

Table 7.9

Parameter	Level/status	Unit
UL signal level	Ref.sens +10 dB	dBm/3,84 MHz
Data sequence	PN9 or longer	

7.8.4.2 Procedure

- 1) Measure the BER of received signal from RF signal source or UE simulator to BS antenna connector.
- 2) BER calculation shall be done at least over 50 000 bits.

In addition, for a multi-band capable BS, the following steps shall apply:

- 3) For multi-band capable BS and single band tests, repeat the steps above per involved band, with no carrier activated in the other band.
- 4) For multi-band capable BS with separate antenna connector, the antenna connector not being under test shall be terminated.

7.8.5 Test Requirement

BER indicated by the Base Station System shall be within requirement as specified in clause 7.8.2.

8 Performance requirement

8.1 General

All Bit Error Ratio (BER) and Block Error ratio (BLER) measurements shall be carried out according to the general rules for statistical testing defined in ITU-T Recommendation O.153 [5] and Annex C.

If external BLER measurement is not used then the internal BLER calculation shall be used instead. When internal BLER calculation is used, the requirements of the verification test according to 8.6 shall be met in advance.

Performance requirements are specified for a number of test environments and multi-path channel classes.

The requirements only apply to those measurement channels that are supported by the base station. The performance requirements for the high speed train conditions which scenarios defined in Annex D.4A are optional. For FRC8 in Annex 9 and Annex 17 the Non E-DPCCH boosting and E-DPCCH boosting requirement only apply for the option supported by the base station.

Unless stated otherwise, performance requirements apply for a single cell only. Performance requirements for a BS supporting DC-HSUPA are defined in terms of single carrier requirements.

For BS with dual receiver antenna diversity, only the BS performance requirements with Rx diversity are to be tested, the required E_b/N_0 shall be applied separately at each antenna port.

For BS without receiver antenna diversity, only the BS performance requirements without Rx diversity are to be tested, the required E_b/N_0 shall be applied at the BS Rx antenna port.

In tests performed with signal generators a synchronization signal may be provided, from the base station to the signal generator, to enable correct timing of the wanted signal.

For tests in clause 8 the transmitter may be off.

8.2 Demodulation in static propagation conditions

8.2.1 Demodulation of DCH

8.2.1.1 Definition and applicability

The performance requirement of DCH in static propagation conditions is determined by the maximum Block Error Ratio (BLER) allowed when the receiver input signal is at a specified E_b/N_0 limit. The BLER is calculated for each of the measurement channels supported by the base station.

8.2.1.2 Minimum requirement

The minimum requirement is in TS 25.104 [1] clause 8.2.1.1.

Table 8.1: (void)

8.2.1.3 Test purpose

The test shall verify the receiver's ability to receive the test signal under static propagation conditions with a BLER not exceeding a specified limit.

8.2.1.4 Method of test

8.2.1.4.1 Initial conditions

Test environment: normal; see clause 4.4.1.

RF channels to be tested: B, M and T; see clause 4.8

- 1) For BS with Rx diversity, connect the BS tester generating the wanted signal and AWGN generators to both BS antenna connectors for diversity reception via a combining network as shown in annex B.
- 2) For BS without Rx diversity, connect the BS tester generating the wanted signal and AWGN generator to the BS antenna connector via a combining network as shown in annex B.

8.2.1.4.2 Procedure

- 1) Adjust the AWGN generator depending on the BS class under test at the BS input as follows:

Wide Area: -84 dBm/3.84 MHz

Medium Range: -74 dBm/3.84 MHz

Local Area / Home BS: -70 dBm/3.84 MHz) The characteristics of the wanted signal shall be configured according to the corresponding UL reference measurement channel defined in annex A.

- 3) Adjust the equipment so that required E_b/N_0 specified in table 8.2 is achieved. To achieve the specified E_b/N_0 , the ratio of the wanted signal level relative to the AWGN signal at the BS input should be adjusted to: $10 \cdot \log_{10}(R_b / (3.84 \cdot 10^6) + E_b/N_0)$ [dB].

- 4) For each of the data rates in table 8.2 applicable for the base station, measure the BLER.

8.2.1.5 Test requirements

The BLER measured according to clause 8.2.1.4.2 shall not exceed the BLER limits for the E_b/N_0 levels specified in table 8.2.

Table 8.2: Test requirements in AWGN channel

Measurement channel	Received E_b/N_0 For BS with Rx diversity	Received E_b/N_0 For BS without Rx diversity	Required BLER
12.2 kbps	n.a.	n.a.	$< 10^{-1}$
	5.5 dB	8.7 dB	$< 10^{-2}$
64 kbps	1.9 dB	5.1 dB	$< 10^{-1}$
	2.1 dB	5.2 dB	$< 10^{-2}$
144 kbps	1.2 dB	4.2 dB	$< 10^{-1}$
	1.3 dB	4.4 dB	$< 10^{-2}$
384 kbps	1.3 dB	4.4 dB	$< 10^{-1}$
	1.4 dB	4.5 dB	$< 10^{-2}$

NOTE: If the above Test Requirement differs from the Minimum Requirement then the Test Tolerance applied for this test is non-zero. The Test Tolerance for this test is defined in clause 4.2 and the explanation of how the Minimum Requirement has been relaxed by the Test Tolerance is given in Annex F.

8.3 Demodulation of DCH in multipath fading conditions

8.3.1 Multipath fading Case 1

8.3.1.1 Definition and applicability

The performance requirement of DCH in multipath fading Case 1 is determined by the maximum Block Error Ratio (BLER) allowed when the receiver input signal is at a specified E_b/N_0 limit. The BLER is calculated for each of the measurement channels supported by the base station.

8.3.1.2 Minimum requirement

The minimum requirement is in TS 25.104 [1] clause 8.3.1.1

Table 8.3: (void)

8.3.1.3 Test Purpose

The test shall verify the receiver's ability to receive the test signal under slow multipath fading propagation conditions with a BLER not exceeding a specified limit.

8.3.1.4 Method of test

8.3.1.4.1 Initial conditions

Test environment: normal; see clause 4.4.1.

RF channels to be tested: B, M and T; see clause 4.8

- 1) For BS with Rx diversity, connect the BS tester generating the wanted signal, multipath fading simulators and AWGN generators to both BS antenna connectors for diversity reception via a combining network as shown in annex B.
- 2) For BS without Rx diversity, connect the BS tester generating the wanted signal, multipath fading simulator and AWGN generator to the BS antenna connector via a combining network as shown in annex B.

8.3.1.4.2 Procedure

- 1) Adjust the AWGN generator depending on the BS class under test at the BS input as follows:.

Wide Area: -84 dBm/3.84 MHz

Medium Range: -74 dBm/3.84 MHz

Local Area / Home BS: -70 dBm/3.84 MHz

- 2) The characteristics of the wanted signal shall be configured according to the corresponding UL reference measurement channel defined in annex A.
- 3) The multipath fading emulators shall be configured according to the corresponding channel model defined in annex D.
- 4) Adjust the equipment so that required E_b/N_0 specified in table 8.4 is achieved. To achieve the specified E_b/N_0 , the ratio of the wanted signal level relative to the AWGN signal at the BS input should be adjusted to: $10 \cdot \text{Log}_{10}(R_b / 3.84 \cdot 10^6) + E_b/N_0$ [dB].
- 5) For each of the data rates in table 8.4 applicable for the base station, measure the BLER.

8.3.1.5 Test requirements

The BLER measured according to clause 8.3.1.4.2 shall not exceed the BLER limits for the E_b/N_0 levels specified in table 8.4.

Table 8.4: Test requirements in multipath Case 1 channel

Measurement channel	Received E_b/N_0 For BS with Rx diversity	Received E_b/N_0 For BS without Rx diversity	Required BLER
12.2 kbps	n.a.	n.a.	$< 10^{-1}$
	12.5 dB	19.7 dB	$< 10^{-2}$
64 kbps	6.8 dB	12.2 dB	$< 10^{-1}$
	9.8 dB	16.5 dB	$< 10^{-2}$
144 kbps	6.0 dB	11.4 dB	$< 10^{-1}$
	9.0 dB	15.6 dB	$< 10^{-2}$
384 kbps	6.4 dB	11.8 dB	$< 10^{-1}$
	9.4 dB	16.1 dB	$< 10^{-2}$

NOTE: If the above Test Requirement differs from the Minimum Requirement then the Test Tolerance applied for this test is non-zero. The Test Tolerance for this test is defined in clause 4.2 and the explanation of how the Minimum Requirement has been relaxed by the Test Tolerance is given in Annex F.

8.3.2 Multipath fading Case 2

8.3.2.1 Definition and applicability

The performance requirement of DCH in multipath fading Case 2 is determined by the maximum Block Error Rate (BLER) allowed when the receiver input signal is at a specified E_b/N_0 limit. The BLER is calculated for each of the measurement channels supported by the base station.

The requirement shall not be applied to Home BS.

8.3.2.2 Minimum requirement

The minimum requirement is in TS 25.104 [1] clause 8.3.2.1.

Table 8.5: (void)

8.3.2.3 Test Purpose

The test shall verify the receiver's ability to receive the test signal that has a large time dispersion with a BLER not exceeding a specified limit.

8.3.2.4 Method of test

8.3.2.4.1 Initial conditions

Test environment: normal; see clause 4.4.1.

RF channels to be tested: B, M and T; see clause 4.8

- 1) For BS with Rx diversity, connect the BS tester generating the wanted signal, multipath fading simulators and AWGN generators to both BS antenna connectors for diversity reception via a combining network as shown in annex B.
- 2) For BS without Rx diversity, connect the BS tester generating the wanted signal, multipath fading simulator and AWGN generator to the BS antenna connector via a combining network as shown in annex B.

8.3.2.4.2 Procedure

- 1) Adjust the AWGN generator depending on the BS class under test at the BS input as follows:.

Wide Area: -84 dBm/3.84 MHz

Medium Range: -74 dBm/3.84 MHz

Local Area: -70 dBm/3.84 MHz

- 2) The characteristics of the wanted signal shall be configured according to the corresponding UL reference measurement channel defined in annex A.
- 3) The multipath fading emulators shall be configured according to the corresponding channel model defined in annex D.
- 4) Adjust the equipment so that required E_b/N_0 specified in table 8.6 is achieved. To achieve the specified E_b/N_0 , the ratio of the wanted signal level relative to the AWGN signal at the BS input should be adjusted to:
 $10 \cdot \text{Log}_{10}(R_b / 3.84 \cdot 10^6) + E_b/N_0$ [dB].
- 5) For each of the data rates in table 8.6 applicable for the base station, measure the BLER.

8.3.2.5 Test requirements

The BLER measured according to clause 8.3.2.4.2 shall not exceed the BLER limits for the E_b/N_0 levels specified in table 8.5.

Table 8.6: Test requirements in multipath Case 2 channel

Measurement channel	Received E_b/N_0 For BS with Rx Diversity	Received E_b/N_0 For BS without Rx Diversity	Required BLER
12.2 kbps	n.a.	n.a.	$< 10^{-1}$
	9.6 dB	15.6 dB	$< 10^{-2}$
64 kbps	4.9 dB	9.8 dB	$< 10^{-1}$
	7.0 dB	12.9 dB	$< 10^{-2}$
144 kbps	4.3 dB	8.8 dB	$< 10^{-1}$
	6.2 dB	12.1 dB	$< 10^{-2}$
384 kbps	4.7 dB	9.3 dB	$< 10^{-1}$
	6.7 dB	12.7 dB	$< 10^{-2}$

NOTE: If the above Test Requirement differs from the Minimum Requirement then the Test Tolerance applied for this test is non-zero. The Test Tolerance for this test is defined in clause 4.2 and the explanation of how the Minimum Requirement has been relaxed by the Test Tolerance is given in Annex F.

8.3.3 Multipath fading Case 3

8.3.3.1 Definition and applicability

The performance requirement of DCH in multipath fading Case 3 is determined by the maximum Block Error Ratio (BLER) allowed when the receiver input signal is at a specified E_b/N_0 limit. The BLER is calculated for each of the measurement channels supported by the base station.

The requirement shall not be applied to Home BS.

8.3.3.2 Minimum requirement

The minimum requirement is in TS 25.104 [1] clause 8.3.3.1.

Table 8.7: (void)

8.3.3.3 Test purpose

The test shall verify the receivers ability to receive the test signal under fast fading propagation conditions with a BLER not exceeding a specified limit.

8.3.3.4 Method of test

8.3.3.4.1 Initial conditions

Test environment: normal; see clause 4.4.1.

RF channels to be tested: B, M and T; see clause 4.8

- 1) For BS with Rx diversity, connect the BS tester generating the wanted signal, multipath fading simulators and AWGN generators to both BS antenna connectors for diversity reception via a combining network as shown in annex B.
- 2) For BS without Rx diversity, connect the BS tester generating the wanted signal, multipath fading simulator and AWGN generator to the BS antenna connector via a combining network as shown in annex B.

8.3.3.4.2 Procedure

- 1) Adjust the AWGN generator depending on the BS class under test at the BS input as follows:
 - Wide Area: -84 dBm/3.84 MHz
 - Medium Range: -74 dBm/3.84 MHz
 - Local Area: -70 dBm/3.84 MHz
- 2) The characteristics of the wanted signal shall be configured according to the corresponding UL reference measurement channel defined in annex A.
- 3) The multipath fading emulators shall be configured according to the corresponding channel model defined in annex D.
- 4) Adjust the equipment so that required E_b/N_0 specified in table 8.8 is achieved. To achieve the specified E_b/N_0 , the ratio of the wanted signal level relative to the AWGN signal at the BS input should be adjusted to:

$$10 \cdot \text{Log}_{10}(\text{R}_b / 3.84 \cdot 10^6) + E_b/N_0 \text{ [dB]}.$$
- 5) For each of the data rates in table 8.8 applicable for the base station, measure the BLER

8.3.3.5 Test requirements

The BLER measured according to clause 8.3.3.4.2 shall not exceed the BLER limits for E_b/N_0 levels specified in table 8.7.

Table 8.8: Test requirements in multipath Case 3 channel

Measurement channel	Received E_b/N_0 For BS with Rx Diversity	Received E_b/N_0 For BS without Rx Diversity	Required BLER
12.2 kbps	n.a.	n.a.	$< 10^{-1}$
	7.8 dB	11.4 dB	$< 10^{-2}$
	8.6 dB	12.3 dB	$< 10^{-3}$
64 kbps	4.0 dB	7.7 dB	$< 10^{-1}$
	4.4 dB	8.3 dB	$< 10^{-2}$
	4.7 dB	9.1 dB	$< 10^{-3}$
144 kbps	3.4 dB	6.6 dB	$< 10^{-1}$
	3.8 dB	7.3 dB	$< 10^{-2}$
	4.2 dB	7.8 dB	$< 10^{-3}$
384 kbps	3.8 dB	7.1 dB	$< 10^{-1}$
	4.2 dB	7.8 dB	$< 10^{-2}$
	4.8 dB	8.5 dB	$< 10^{-3}$

NOTE: If the above Test Requirement differs from the Minimum Requirement then the Test Tolerance applied for this test is non-zero. The Test Tolerance for this test is defined in clause 4.2 and the explanation of how the Minimum Requirement has been relaxed by the Test Tolerance is given in Annex F.

8.3.4 Multipath fading Case 4

8.3.4.1 Definition and applicability

The performance requirement of DCH in multipath fading Case 4 for Wide Area BS is determined by the maximum Block Error Ratio (BLER) allowed when the receiver input signal is at a specified E_b/N_0 limit. The BLER is calculated for each of the measurement channels supported by the base station.

The requirement in this clause shall apply Wide Area BS only.

8.3.4.2 Minimum requirement

The minimum requirement is in TS 25.104 [1] clause 8.3.4.1.

Table 8.8A: (void)

8.3.4.3 Test purpose

The test shall verify the receivers ability to receive the test signal under fast fading propagation conditions with a BLER not exceeding a specified limit.

8.3.4.4 Method of test

8.3.4.4.1 Initial conditions

Test environment: normal; see clause 4.4.1.

RF channels to be tested: B, M and T; see clause 4.8

- 1) For BS with Rx diversity, connect the BS tester generating the wanted signal, multipath fading simulators and AWGN generators to both BS antenna connectors for diversity reception via a combining network as shown in annex B.
- 2) For BS without Rx diversity, connect the BS tester generating the wanted signal, multipath fading simulator and AWGN generator to the BS antenna connector via a combining network as shown in annex B.

8.3.4.4.2 Procedure

- 1) Adjust the AWGN generator to -84 dBm/3.84 MHz at the BS input.

- 2) The characteristics of the wanted signal shall be configured according to the corresponding UL reference measurement channel defined in annex A.
- 3) The multipath fading emulators shall be configured according to the corresponding channel model defined in annex D.
- 4) Adjust the equipment so that required E_b/N_0 specified in table 8.8B is achieved. To achieve the specified E_b/N_0 , the ratio of the wanted signal level relative to the AWGN signal at the BS input should be adjusted to: $10 \cdot \text{Log}_{10}(R_b / 3.84 \cdot 10^6) + E_b/N_0$ [dB].
- 5) For each of the data rates in table 8.8B applicable for the base station, measure the BLER.

8.3.4.5 Test requirements

The BLER measured according to clause 8.3.4.4.2 shall not exceed the BLER limits for the E_b/N_0 levels specified in table 8.8B.

Table 8.8B: Test requirements in multipath Case 4 channel

Measurement channel	Received E_b/N_0 For BS with Rx Diversity	Received E_b/N_0 For BS without Rx Diversity	Required BLER
12.2 kbps	n.a.	n.a.	$< 10^{-1}$
	10.8 dB	14.4 dB	$< 10^{-2}$
	11.6 dB	15.3 dB	$< 10^{-3}$
64 kbps	7.0 dB	10.7 dB	$< 10^{-1}$
	7.4 dB	11.3 dB	$< 10^{-2}$
	7.7 dB	12.1 dB	$< 10^{-3}$
144 kbps	6.4 dB	9.6 dB	$< 10^{-1}$
	6.8 dB	10.3 dB	$< 10^{-2}$
	7.2 dB	10.8 dB	$< 10^{-3}$
384 kbps	6.8 dB	10.1 dB	$< 10^{-1}$
	7.2 dB	10.8 dB	$< 10^{-2}$
	7.8 dB	11.5 dB	$< 10^{-3}$

NOTE: If the above Test Requirement differs from the Minimum Requirement then the Test Tolerance applied for this test is non-zero. The Test Tolerance for this test is defined in clause 4.2 and the explanation of how the Minimum Requirement has been relaxed by the Test Tolerance is given in Annex F.

8.4 Demodulation of DCH in moving propagation conditions

8.4.1 Definition and applicability

The performance requirement of DCH in moving propagation conditions is determined by the maximum Block Error Ratio (BLER) allowed when the receiver input signal is at a specified E_b/N_0 limit. The BLER is calculated for each of the measurement channels supported by the base station.

The requirement shall not be applied to Home BS.

8.4.2 Minimum requirement

The minimum requirement is in TS 25.104 [1] clause 8.4.1.

Table 8.9: (void)

8.4.3 Test purpose

The test shall verify the receiver's ability to receive and track the test signal with a BLER not exceeding the specified limit.

8.4.4 Method of test

8.4.4.1 Initial conditions

Test environment: normal; see clause 4.4.1.

RF channels to be tested: B, M and T; see clause 4.8

- 1) For BS with Rx diversity, connect the BS tester generating the wanted signal, multipath fading simulators and AWGN generators to both BS antenna connectors for diversity reception via a combining network as shown in annex B.
- 2) For BS without Rx diversity, connect the BS tester generating the wanted signal, multipath fading simulator and AWGN generator to the BS antenna connector via a combining network as shown in annex B.

8.4.4.2 Procedure

- 1) Adjust the AWGN generator depending on the BS class under test at the BS input as follows:
 - Wide Area: -84 dBm/3.84 MHz
 - Medium Range: -74 dBm/3.84 MHz
 - Local Area: -70 dBm/3.84 MHz
- 2) The characteristics of the wanted signal shall be configured according to the corresponding UL reference measurement channel defined in annex A.
- 3) The multipath fading emulators shall be configured according to the corresponding channel model defined in annex D.
- 4) Adjust the equipment so that required E_b/N_0 specified in table 8.10 is achieved. To achieve the specified E_b/N_0 , the ratio of the wanted signal level relative to the AWGN signal at the BS input should be adjusted to: $10 \cdot \log_{10}(R_b / 3.84 \cdot 10^6) + E_b/N_0$ [dB].
- 5) For each of the data rates in table 8.10 applicable for the base station, measure the BLER.

8.4.5 Test requirements

The BLER measured according to clause 8.4.4.2 shall not exceed the BLER limits for the E_b/N_0 levels specified in table 8.10.

Table 8.10: Test requirements in moving channel

Measurement channel	Received E_b/N_0 For BS with Rx Diversity	Received E_b/N_0 For BS without Rx Diversity	Required BLER
12.2 kbps	n.a.	n.a.	$< 10^{-1}$
	6.3 dB	9.3 dB	$< 10^{-2}$
64 kbps	2.7 dB	5.9 dB	$< 10^{-1}$
	2.8 dB	6.1 dB	$< 10^{-2}$

NOTE: If the above Test Requirement differs from the Minimum Requirement then the Test Tolerance applied for this test is non-zero. The Test Tolerance for this test is defined in clause 4.2 and the explanation of how the Minimum Requirement has been relaxed by the Test Tolerance is given in Annex F.

8.5 Demodulation of DCH in birth/death propagation conditions

8.5.1 Definition and applicability

The performance requirement of DCH in birth/death propagation conditions is determined by the maximum Block Error Ratio (BLER) allowed when the receiver input signal is at a specified E_b/N_0 limit. The BLER is calculated for each of the measurement channels supported by the base station.

The requirement shall not be applied to Home BS.

8.5.2 Minimum requirement

The minimum requirement is in TS 25.104 [1] clause 8.5.1.

Table 8.11: (void)

8.5.3 Test purpose

The test shall verify the receiver's ability to receive the test signal to find new multi path components with a BLER not exceeding the specified limit.

8.5.4 Method of test

8.5.4.1 Initial conditions

Test environment: normal; see clause 4.4.1.

RF channels to be tested: B, M and T; see clause 4.8

- 1) For BS with Rx diversity, connect the BS tester generating the wanted signal, multipath fading simulators and AWGN generators to both BS antenna connectors for diversity reception via a combining network as shown in annex B.
- 2) For BS without Rx diversity, connect the BS tester generating the wanted signal, multipath fading simulator and AWGN generator to the BS antenna connector via a combining network as shown in annex B.

8.5.4.2 Procedure

- 1) Adjust the AWGN generator depending on the BS class under test at the BS input as follows:
 - Wide Area: -84 dBm/3.84 MHz
 - Medium Range: -74 dBm/3.84 MHz
 - Local Area: -70 dBm/3.84 MHz
- 2) The characteristics of the wanted signal shall be configured according to the corresponding UL reference measurement channel defined in annex A.
- 3) The multipath fading emulators shall be configured according to the corresponding channel model defined in annex D.
- 4) Adjust the equipment so that required E_b/N_0 specified in table 8.12 is achieved. To achieve the specified E_b/N_0 , the ratio of the wanted signal level relative to the AWGN signal at the BS input should be adjusted to:

$$10 \cdot \text{Log}_{10}(R_b / 3.84 \cdot 10^6) + E_b/N_0 \text{ [dB]}.$$
- 5) For each of the data rates in table 8.12 applicable for the base station, measure the BLER.

8.5.5 Test requirements

The BLER measured according to clause 8.5.4.2 shall not exceed the BLER limits for the E_b/N_0 levels specified in table 8.12.

Table 8.12: Test requirements in birth/death channel

Measurement channel	Received E_b/N_0 For BS with Rx Diversity	Received E_b/N_0 For BS without Rx Diversity	Required BLER
12.2 kbps	n.a.	n.a.	$< 10^{-1}$
	8.3 dB	11.4 dB	$< 10^{-2}$
64 kbps	4.7 dB	8.0 dB	$< 10^{-1}$
	4.8 dB	8.1 dB	$< 10^{-2}$

NOTE: If the above Test Requirement differs from the Minimum Requirement then the Test Tolerance applied for this test is non-zero. The Test Tolerance for this test is defined in clause 4.2 and the explanation of how the Minimum Requirement has been relaxed by the Test Tolerance is given in Annex F.

8.5A Demodulation of DCH in high speed train conditions

8.5A.1 Definition and applicability

The performance requirement of DCH in high speed train conditions is determined by the maximum Block Error Ratio (BLER) allowed when the receiver input signal is at a specified E_b/N_0 limit. The BLER is calculated for 12.2 kbps.

The requirement shall not be applied to Home BS.

8.5A.2 Minimum requirement

The minimum requirement is in TS 25.104 [1] clause 8.5A.2.

8.5A.3 Test purpose

The test shall verify the receiver's ability to receive the test signal in high speed train conditions with a BLER not exceeding the specified limit.

8.5A.4 Method of test

8.5A.4.1 Initial conditions

Test environment: normal; see clause 4.4.1.

RF channels to be tested: B, M and T; see clause 4.8

- 1) For BS with Rx diversity, connect the BS tester generating the wanted signal, multipath fading simulators and AWGN generators to both BS antenna connectors for diversity reception via a combining network as shown in annex B.
- 2) For BS without Rx diversity, connect the BS tester generating the wanted signal, multipath fading simulator and AWGN generator to the BS antenna connector via a combining network as shown in annex B.

8.5A.4.2 Procedure

- 1) Adjust the AWGN generator depending on the BS class under test at the BS input as follows:.

Wide Area: -84 dBm/3.84 MHz

Medium Range: -74 dBm/3.84 MHz

Local Area: -70 dBm/3.84 MHz

- 2) The characteristics of the wanted signal shall be configured according to the corresponding UL reference measurement channel defined in annex A.
- 3) The multipath fading emulators shall be configured according to the corresponding channel model defined in annex D.
- 4) Adjust the equipment so that required E_b/N_0 specified in table 8.12A is achieved. To achieve the specified E_b/N_0 , the ratio of the wanted signal level relative to the AWGN signal at the BS input should be adjusted to: $10 \cdot \text{Log}_{10}(R_b / 3.84 \cdot 10^6) + E_b/N_0$ [dB].
- 5) For each of the data rates in table 8.12A applicable for the base station, measure the BLER.

8.5A.5 Test requirements

The BLER measured according to clause 8.5A.4.2 shall not exceed the BLER limits for the E_b/N_0 levels specified in table 8.12A.

Table 8.12A: Test requirements in high speed train conditions

Scenario	Measurement channel	Received E_b/N_0 For BS with Rx Diversity	Received E_b/N_0 For BS without Rx Diversity	Required BLER
1	12.2 kbps	7.1 dB	10.2 dB	$< 10^{-2}$
2	12.2 kbps	n.a.	9.4 dB	$< 10^{-2}$
3	12.2 kbps	n.a.	10.7 dB	$< 10^{-2}$

NOTE: If the above Test Requirement differs from the Minimum Requirement then the Test Tolerance applied for this test is non-zero. The Test Tolerance for this test is defined in clause 4.2 and the explanation of how the Minimum Requirement has been relaxed by the Test Tolerance is given in Annex F.

8.6 Verification of the internal BLER calculation

8.6.1 Definition and applicability

Base Station System with internal BLER calculates block error rate from the CRC blocks of the received. This test is performed only if Base Station System has this kind of feature. All data rates which are used in clause 8 Performance requirement testing shall be used in verification testing. This test is performed by feeding measurement signal with known BLER to the input of the receiver. Locations of the erroneous blocks shall be randomly distributed within a frame. Erroneous blocks shall be inserted into the UL signal as shown in figure 8.1.

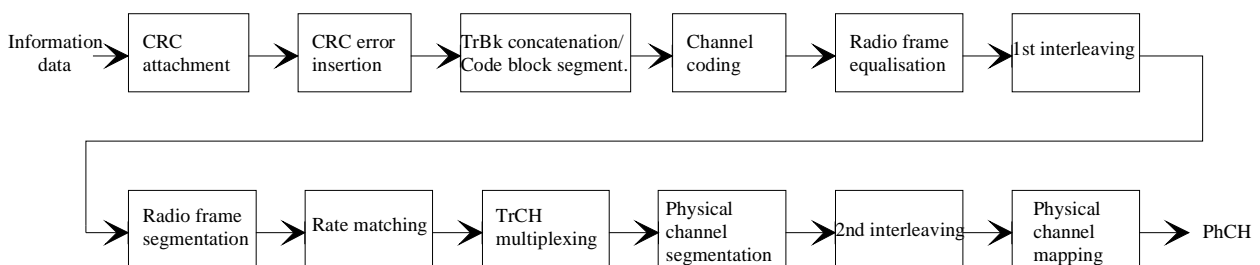

Figure 8.1: BLER insertion to the output data

8.6.2 Minimum requirement

BLER indicated by the Base Station System shall be within $\pm 10\%$ of the BLER generated by the RF signal source. Measurement shall be repeated for each data rate as specified in table 8.13.

Table 8.13

Transport channel combination	Data rate	BLER
DPCH	12,2 kbps	0.01
DPCH	64 kbps	0.01
DPCH	144 kbps	0.01
DPCH	384 kbps	0.01

8.6.3 Test purpose

To verify that the internal BLER calculation accuracy shall met requirements for conformance testing.

8.6.4 Method of test

8.6.4.1 Initial conditions

Test environment: normal; see clause 4.4.1.

RF channels to be tested: B, M and T; see clause 4.8

- 1) For BS with Rx diversity, connect the BS tester generating the wanted signal to both BS antenna connectors for diversity reception via a combining network as shown in annex B.
- 2) For BS without Rx diversity, connect the BS tester generating the wanted signal to the BS antenna connector as shown in annex B.
- 3) Set correct signal source parameters depending on the BS class under test as specified in table 8.14.

Table 8.14: UL Signal levels for different data rates

Data rate	Signal level for WA BS	Signal level for MR BS	Signal level for LA BS	Unit
12,2 kbps	-111	-101	-97	dBm/3.84 MHz
64 kbps	-107	-97	-93	dBm/3.84 MHz
144 kbps	-104	-94	-90	dBm/3.84 MHz
384 kbps	-100	-90	-86	dBm/3.84 MHz

NOTE: PN9 can be used as data sequence for the test

8.6.4.2 Procedure

- 1) The characteristics of the wanted signal shall be configured according to the corresponding UL reference measurement channel defined in annex A.
- 2) The BLER insertion to the wanted signal shall be configured according to the corresponding data rate in table 8.13.
- 3) Adjust the BS tester so that the required UL signal level specified in table 8.14 is achieved.

For each of the data rates in table 8.13 applicable for the base station, measure the BLER at least over 50 000 blocks.

8.6.5 Test requirement

BLER indicated by the Base Station System shall be within requirement as specified in clause 8.6.2.

8.7 (void)

8.8 RACH performance

8.8.1 RACH preamble detection in static propagation conditions

8.8.1.1 Definition and applicability

The performance requirement of RACH for preamble detection in static propagation conditions is determined by the two parameters probability of false detection of the preamble (Pfa) and the probability of detection of preamble (Pd). The performance is measured by the required E_c/N_0 at probability of detection, Pd of 0.99 and 0.999. Pfa is defined as a conditional probability of erroneous detection of the preamble when input is only noise (+interference). Pd is defined as conditional probability of detection of the preamble when the signal is present. Pfa shall be 10^{-3} or less. Only one signature is used and it is known by the receiver.

8.8.1.2 Minimum requirement

The minimum requirement is in TS 25.104 [1] clause 8.7.1.

Table 8.16: (void)

8.8.1.3 Test purpose

The test shall verify the receiver's ability to detect RACH preambles under static propagation conditions.

8.8.1.4 Method of test

8.8.1.4.1 Initial conditions

Test environment: normal; see clause 4.4.1.

RF channels to be tested: B, M and T; see clause 4.8

- 1) For BS with Rx diversity, connect the BS tester generating the wanted signal and AWGN generators to both BS antenna connectors for diversity reception via a combining network as shown in annex B.
- 2) For BS without Rx diversity, connect the BS tester generating the wanted signal and AWGN generator to the BS antenna connector via a combining network as shown in annex B.

8.8.1.4.2 Procedure

- 1) Adjust the AWGN generator depending on the BS class under test at the BS input as follows:
 - Wide Area: -84 dBm/3.84 MHz
 - Medium Range: -74 dBm/3.84 MHz
 - Local Area / Home BS: -70 dBm/3.84 MHz
- 2) The characteristics of the wanted signal shall be configured according to the corresponding UL reference measurement channel defined in annex A.
- 3) Adjust the equipment so that required E_c/N_0 specified in table 8.17 is achieved. To achieve the specified E_c/N_0 , the ratio of the wanted signal level (of the preamble part) relative to the AWGN signal at the BS input should be adjusted to: E_c/N_0 [dB].
- 4) The test signal generator sends a preamble and the receiver tries to detect the preamble. This pattern is repeated. Preamble detection should be made only on those access slots a preamble has been sent in.



Figure 8.2: RACH test signal pattern

8.8.1.5 Test requirements

The P_d shall be above or equal to the P_d limits for the E_c/N_0 levels specified in table 8.17.

Table 8.17: Preamble detection test requirements in AWGN channel

	E_c/N_0 for required $P_d \geq 0.99$	E_c/N_0 for required $P_d \geq 0.999$
BS with Rx Diversity	-20.1 dB	-19.7 dB
BS without Rx Diversity	-17.2 dB	-16.4 dB

NOTE: If the above Test Requirement differs from the Minimum Requirement then the Test Tolerance applied for this test is non-zero. The Test Tolerance for this test is defined in clause 4.2 and the explanation of how the Minimum Requirement has been relaxed by the Test Tolerance is given in Annex F.

8.8.2A RACH preamble detection in high speed train conditions

8.8.2A.1 Definition and applicability

The performance requirement of RACH for preamble detection in high speed train conditions is determined by the two parameters probability of false detection of the preamble (P_{fa}) and the probability of detection of preamble (P_d). The performance is measured by the required E_c/N_0 at probability of detection, P_d of 0.99 and 0.999. P_{fa} is defined as a conditional probability of erroneous detection of the preamble when input is only noise (+interference). P_d is defined as conditional probability of detection of the preamble when the signal is present. P_{fa} shall be 10^{-3} or less. Only one signature is used and it is known by the receiver.

The requirement shall not be applied to Home BS.

8.8.2A.2 Minimum requirement

The minimum requirement is in TS 25.104 [1] clause 8.7.1.

8.8.2A.3 Test purpose

The test shall verify the receiver's ability to detect RACH preambles under high speed train conditions.

8.8.2A.4 Method of test

8.8.2A.4.1 Initial conditions

Test environment: normal; see clause 4.4.1.

RF channels to be tested: B, M and T; see clause 4.8

- 1) For BS with Rx diversity, connect the BS tester generating the wanted signal, multipath fading simulators and AWGN generators to both BS antenna connectors for diversity reception via a combining network as shown in annex B.
- 2) For BS without Rx diversity, connect the BS tester generating the wanted signal, multipath fading simulator and AWGN generator to the BS antenna connector via a combining network as shown in annex B.

8.8.2A.4.2 Procedure

- 1) Adjust the AWGN generator depending on the BS class under test at the BS input as follows:.

Wide Area: -84 dBm/3.84 MHz

Medium Range: -74 dBm/3.84 MHz

Local Area: -70 dBm/3.84 MHz

- 2) The characteristics of the wanted signal shall be configured according to the corresponding UL reference measurement channel defined in annex A.
- 3) The multipath fading emulators shall be configured according to the corresponding channel model defined in annex D.
- 4) Adjust the equipment so that required E_c/N_0 specified in table 8.19A is achieved. To achieve the specified E_c/N_0 , the ratio of the wanted signal level (of the preamble part) relative to the AWGN signal at the BS input should be adjusted to: E_c/N_0 [dB].
- 5) The test signal generator sends a preamble and the receiver tries to detect the preamble. This pattern is repeated. Preamble detection should be made only on those access slots a preamble has been sent in.



Figure 8.3A: RACH test signal pattern

8.8.2A.5 Test requirements

The P_d shall be above or equal to the P_d limits for the E_c/N_0 levels specified in table 8.19A.

Table 8.19A: Preamble detection test requirements in high speed train conditions

Scenario		E_c/N_0 for required $P_d \geq 0.99$	E_c/N_0 for required $P_d \geq 0.999$
1	BS with Rx Diversity	-17.5 dB	-17.3 dB
	BS without Rx Diversity	-14.6 dB	-14.2 dB
2	BS with Rx Diversity	n.a.	n.a.
	BS without Rx Diversity	-15.0 dB	-14.2 dB
3	BS with Rx Diversity	n.a.	n.a.
	BS without Rx Diversity	-14.7 dB	-14.5 dB

NOTE: If the above Test Requirement differs from the Minimum Requirement then the Test Tolerance applied for this test is non-zero. The Test Tolerance for this test is defined in clause 4.2 and the explanation of how the Minimum Requirement has been relaxed by the Test Tolerance is given in Annex F.

8.8.2 RACH preamble detection in multipath fading case 3

8.8.2.1 Definition and applicability

The performance requirement of RACH for preamble detection in in multipath fading case 3 is determined by the two parameters probability of false detection of the preamble (P_{fa}) and the probability of detection of preamble (P_d). The performance is measured by the required E_c/N_0 at probability of detection, P_d of 0.99 and 0.999. P_{fa} is defined as a conditional probability of erroneous detection of the preamble when input is only noise (+interference). P_d is defined as conditional probability of detection of the preamble when the signal is present. P_{fa} shall be 10^{-3} or less. Only one signature is used and it is known by the receiver.

The requirement shall not be applied to Home BS.

8.8.2.2 Minimum requirement

The minimum requirement is in TS 25.104 [1] clause 8.7.1.

Table 8.18: (void)

8.8.2.3 Test purpose

The test shall verify the receiver's ability to detect RACH preambles under multipath fading case 3 propagation conditions.

8.8.2.4 Method of test

8.8.2.4.1 Initial conditions

Test environment: normal; see clause 4.4.1.

RF channels to be tested: B, M and T; see clause 4.8

- 1) For BS with Rx diversity, connect the BS tester generating the wanted signal, multipath fading simulators and AWGN generators to both BS antenna connectors for diversity reception via a combining network as shown in annex B.
- 2) For BS without Rx diversity, connect the BS tester generating the wanted signal, multipath fading simulator and AWGN generator to the BS antenna connector via a combining network as shown in annex B.

8.8.2.4.2 Procedure

- 1) Adjust the AWGN generator depending on the BS class under test at the BS input as follows:
 - Wide Area: -84 dBm/3.84 MHz
 - Medium Range: -74 dBm/3.84 MHz
 - Local Area: -70 dBm/3.84 MHz
- 2) The characteristics of the wanted signal shall be configured according to the corresponding UL reference measurement channel defined in annex A.
- 3) The multipath fading emulators shall be configured according to the corresponding channel model defined in annex D.
- 4) Adjust the equipment so that required E_c/N_0 specified in table 8.19 is achieved. To achieve the specified E_c/N_0 , the ratio of the wanted signal level (of the preamble part) relative to the AWGN signal at the BS input should be adjusted to: E_c/N_0 [dB].
- 5) The test signal generator sends a preamble and the receiver tries to detect the preamble. This pattern is repeated. Preamble detection should be made only on those access slots a preamble has been sent in.



Figure 8.3: RACH test signal pattern

8.8.2.5 Test requirements

The P_d shall be above or equal to the P_d limits for the E_c/N_0 levels specified in table 8.19.

Table 8.19: Preamble detection test requirements in fading case 3 channel

	E_c/N_0 for required $P_d \geq 0.99$	E_c/N_0 for required $P_d \geq 0.999$
BS with Rx Diversity	-14.9 dB	-12.8 dB
BS without Rx Diversity	-8.8 dB	-5.8 dB

NOTE: If the above Test Requirement differs from the Minimum Requirement then the Test Tolerance applied for this test is non-zero. The Test Tolerance for this test is defined in clause 4.2 and the explanation of how the Minimum Requirement has been relaxed by the Test Tolerance is given in Annex F.

8.8.3 Demodulation of RACH message in static propagation conditions

8.8.3.1 Definition and applicability

The performance requirement of RACH in static propagation conditions is determined by the maximum Block Error Ratio (BLER) allowed when the receiver input signal is at a specified E_b/N_0 limit. The BLER is calculated for each of the measurement channels supported by the base station.

The same preamble threshold factor as required to pass the tests in clauses 8.8.1 and 8.8.2 shall be used for the same BS Rx diversity configuration. Only one signature is used and it is known by the receiver.

8.8.3.2 Minimum requirement

The minimum requirement is in TS 25.104 [1] clause 8.7.2.

Table 8.20: (void)

8.8.3.3 Test purpose

The test shall verify the receiver's ability to receive the test signal under static propagation conditions with a BLER not exceeding a specified limit.

8.8.3.4 Method of test

8.8.3.4.1 Initial conditions

Test environment: normal; see clause 4.4.1.

RF channels to be tested: B, M and T; see clause 4.8

Preamble threshold factor: same as required to pass the tests in clauses 8.8.1 and 8.8.2 for the same BS Rx diversity configuration.

- 1) For BS with Rx diversity, connect the BS tester generating the wanted signal and AWGN generators to both BS antenna connectors for diversity reception via a combining network as shown in annex B.
- 2) For BS without Rx diversity, connect the BS tester generating the wanted signal and AWGN generator to the BS antenna connector via a combining network as shown in annex B.

8.8.3.4.2 Procedure

- 1) Adjust the AWGN generator depending on the BS class under test at the BS input as follows:.

Wide Area: -84 dBm/3.84 MHz

Medium Range: -74 dBm/3.84 MHz

Local Area / Home BS: -70 dBm/3.84 MHz

- 2) The characteristics of the wanted signal shall be configured according to the corresponding UL reference measurement channel defined in annex A.
- 3) Adjust the equipment so that required E_b/N_0 specified in table 8.21 is achieved. To achieve the specified E_b/N_0 , the ratio of the wanted signal level (of the message part) relative to the AWGN signal at the BS input should be adjusted to:

$$10 \cdot \log_{10} \left(\frac{TB}{TTI \cdot 3.84 \cdot 10^6} \right) + E_b/N_0 \text{ [dB]}.$$

- 4) The test signal generator sends a preamble followed by the actual RACH message. This pattern is repeated (see figure 8.4). The receiver tries to detect the preamble and the message. The block error rate is calculated for the messages that have been decoded. Messages following undetected preambles shall not be taken into account in the BLER measurement.



Figure 8.4: RACH test signal pattern

8.8.3.5 Test requirements

The BLER measured according the clause 8.8.3.4.2 shall not exceed the BLER limits for the E_b/N_0 levels specified in table 8.21.

Table 8.21: Test requirements in AWGN channel

Transport Block size TB and TTI in frames	168 bits, TTI = 20 ms		360 bits, TTI = 20 ms	
	E_b/N_0 for required BLER < 10^{-1}	E_b/N_0 for required BLER < 10^{-2}	E_b/N_0 for required BLER < 10^{-1}	E_b/N_0 for required BLER < 10^{-2}
BS with Rx Diversity	4.5 dB	5.4 dB	4.3 dB	5.2 dB
BS without Rx Diversity	7.6 dB	8.5 dB	7.3 dB	8.2 dB

NOTE: If the above Test Requirement differs from the Minimum Requirement then the Test Tolerance applied for this test is non-zero. The Test Tolerance for this test is defined in clause 4.2 and the explanation of how the Minimum Requirement has been relaxed by the Test Tolerance is given in Annex F.

8.8.4 Demodulation of RACH message in multipath fading case 3

8.8.4.1 Definition and applicability

The performance requirement of RACH in multipath fading case 3 is determined by the maximum Block Error Ratio (BLER) allowed when the receiver input signal is at a specified E_b/N_0 limit. The BLER is calculated for each of the measurement channels supported by the base station.

The same preamble threshold factor as required to pass the tests in clauses 8.8.1 and 8.8.2 shall be used for the same BS Rx diversity configuration. Only one signature is used and it is known by the receiver.

The requirement shall not be applied to Home BS.

8.8.4.2 Minimum requirement

The minimum requirement is in TS 25.104 [1] clause 8.7.2.

Table 8.22: (void)

8.8.4.3 Test purpose

The test shall verify the receiver's ability to receive the test signal under multipath fading case 3 propagation conditions with a BLER not exceeding a specified limit.

8.8.4.4 Method of test

8.8.4.4.1 Initial conditions

Test environment: normal; see clause 4.4.1.

RF channels to be tested: B, M and T; see clause 4.8

Preamble threshold factor: same as required to pass the tests in clauses 8.8.1 and 8.8.2 for the same BS Rx diversity configuration.

- 1) For BS with Rx diversity, connect the BS tester generating the wanted signal, multipath fading simulators and AWGN generators to both BS antenna connectors for diversity reception via a combining network as shown in annex B.
- 2) For BS without Rx diversity, connect the BS tester generating the wanted signal, multipath fading simulator and AWGN generator to the BS antenna connector via a combining network as shown in annex B.

8.8.4.4.2 Procedure

- 1) Adjust the AWGN generator depending on the BS class under test at the BS input as follows:.

Wide Area: -84 dBm/3.84 MHz

Medium Range: -74 dBm/3.84 MHz

Local Area: -70 dBm/3.84 MHz

- 2) The characteristics of the wanted signal shall be configured according to the corresponding UL reference measurement channel defined in annex A.
- 3) The multipath fading emulators shall be configured according to the corresponding channel model defined in annex D.
- 4) Adjust the equipment so that required E_b/N_0 specified in table 8.23 is achieved. To achieve the specified E_b/N_0 , the ratio of the wanted signal level (of the message part) relative to the AWGN signal at the BS input should be adjusted to:

$$10 * \text{Log}_{10}(\text{TB}/(\text{TTI} * 3.84 * 10^6)) + E_b/N_0 \text{ [dB]}$$

- 5) The test signal generator sends a preamble followed by the actual RACH message. This pattern is repeated (see figure 8.5). The receiver tries to detect the preamble and the message. The block error rate is calculated for the messages that have been decoded. Messages following undetected preambles shall not be taken into account in the BLER measurement.



Figure 8.5: RACH test signal pattern

8.8.4.5 Test requirements

The BLER measured according to clause 8.8.4.2 shall not exceed the BLER limits for the E_b/N_0 levels specified in table 8.23.

Table 8.23: Test requirements in fading case 3 channel

Transport Block size TB and TTI in frames	168 bits, TTI = 20 ms		360 bits, TTI = 20 ms	
	E_b/N_0 for required BLER < 10^{-1}	E_b/N_0 for required BLER < 10^{-2}	E_b/N_0 for required BLER < 10^{-1}	E_b/N_0 for required BLER < 10^{-2}
BS with Rx Diversity	8.0 dB	9.1 dB	7.9 dB	8.9 dB
BS without Rx Diversity	11.7 dB	13.0 dB	11.6 dB	12.7 dB

NOTE: If the above Test Requirement differs from the Minimum Requirement then the Test Tolerance applied for this test is non-zero. The Test Tolerance for this test is defined in clause 4.2 and the explanation of how the Minimum Requirement has been relaxed by the Test Tolerance is given in Annex F.

8.8.5 Demodulation of RACH message in high speed train conditions

8.8.5.1 Definition and applicability

The performance requirement of RACH in high speed train conditions is determined by the maximum Block Error Ratio (BLER) allowed when the receiver input signal is at a specified E_b/N_0 limit. The BLER is calculated for each of the measurement channels supported by the base station.

The requirement shall not be applied to Home BS.

The same preamble threshold factor as required to pass the tests in clauses 8.8.1, 8.8.2, and 8.8.2A shall be used for the same BS Rx diversity configuration. Only one signature is used and it is known by the receiver.

8.8.5.2 Minimum requirement

The minimum requirement is in TS 25.104 [1] clause 8.7.2.

8.8.5.3 Test purpose

The test shall verify the receiver's ability to receive the test signal under multipath fading case 3 propagation conditions with a BLER not exceeding a specified limit.

8.8.5.4 Method of test

8.8.5.4.1 Initial conditions

Test environment: normal; see clause 4.4.1.

RF channels to be tested: B, M and T; see clause 4.8

Preamble threshold factor: same as required to pass the tests in clauses 8.8.1, 8.8.2, and 8.8.2A for the same BS Rx diversity configuration.

- 1) For BS with Rx diversity, connect the BS tester generating the wanted signal, multipath fading simulators and AWGN generators to both BS antenna connectors for diversity reception via a combining network as shown in annex B.
- 2) For BS without Rx diversity, connect the BS tester generating the wanted signal, multipath fading simulator and AWGN generator to the BS antenna connector via a combining network as shown in annex B.

8.8.5.4.2 Procedure

- 1) Adjust the AWGN generator depending on the BS class under test at the BS input as follows:.

Wide Area: -84 dBm/3.84 MHz

Medium Range: -74 dBm/3.84 MHz

Local Area: -70 dBm/3.84 MHz

- 2) The characteristics of the wanted signal shall be configured according to the corresponding UL reference measurement channel defined in annex A.
- 3) The multipath fading emulators shall be configured according to the corresponding channel model defined in annex D.
- 4) Adjust the equipment so that required E_b/N_0 specified in table 8.23A is achieved. To achieve the specified E_b/N_0 , the ratio of the wanted signal level (of the message part) relative to the AWGN signal at the BS input should be adjusted to:

$$10 * \text{Log}_{10}(\text{TB}/(\text{TTI} * 3.84 * 10^6)) + E_b/N_0 \text{ [dB]}$$

5) The test signal generator sends a preamble followed by the actual RACH message. This pattern is repeated (see figure 8.5A). The receiver tries to detect the preamble and the message. The block error rate is calculated for the messages that have been decoded. Messages following undetected preambles shall not be taken into account in the BLER measurement.



Figure 8.5A: RACH test signal pattern

8.8.5.5 Test requirements

The BLER measured according to clause 8.8.5.4.2 shall not exceed the BLER limits for the E_b/N_0 levels specified in table 8.23A.

Table 8.23A: Test requirements in high speed train conditions

Transport Block size TB and TTI in frames		168 bits, TTI = 20 ms		360 bits, TTI = 20 ms	
Scenario		E_b/N_0 for required BLER < 10^{-1}	E_b/N_0 for required BLER < 10^{-2}	E_b/N_0 for required BLER < 10^{-1}	E_b/N_0 for required BLER < 10^{-2}
1	BS with Rx Diversity	5.7 dB	7.0 dB	5.9 dB	6.8 dB
	BS without Rx Diversity	8.7 dB	10.0 dB	8.9 dB	9.8 dB
2	BS with Rx Diversity	n.a.	n.a.	n.a.	n.a.
	BS without Rx Diversity	8.3 dB	9.2 dB	8.0 dB	8.9 dB
3	BS with Rx Diversity	n.a.	n.a.	n.a.	n.a.
	BS without Rx Diversity	8.8 dB	10.2 dB	9.0 dB	9.9 dB

NOTE: If the above Test Requirement differs from the Minimum Requirement then the Test Tolerance applied for this test is non-zero. The Test Tolerance for this test is defined in clause 4.2 and the explanation of how the Minimum Requirement has been relaxed by the Test Tolerance is given in Annex F.

8.9 (void)

Table 8.24: (void)

Figure 8.6: (void)

Table 8.25: (void)

Table 8.26: (void)

Figure 8.7: (void)

Table 8.27: (void)

8.10 (void)

Table 8.28: (void)

Table 8.29: (void)

8.11 Performance of signalling detection for HS-DPCCH

The performance requirement of HS-DPCCH signalling detection is determined by the two parameters: the probability of false detection of ACK; $P(\text{DTX} \rightarrow \text{ACK})$ and the probability of mis-detection of ACK; $P(\text{ACK} \rightarrow \text{DTX or NACK})$.

8.11.1 ACK false alarm in static propagation conditions

8.11.1.1 Definition and applicability

ACK false alarm is defined as a conditional probability of erroneous detection of ACK when input is only DPCCH and DPDCH (+interference). The performance requirement of ACK false alarm in static propagation conditions is determined by the maximum error ratio allowed when the receiver input signal is at a specified E_c/N_0 limit. ACK false alarm: $P(\text{DTX} \rightarrow \text{ACK})$ shall be 10^{-2} or less.

8.11.1.2 Minimum requirement

The minimum requirement is in TS 25.104 [1] clause 8.10.1.

Table 8.30: (void)

8.11.1.3 Test purpose

The test shall verify the receiver's ability to detect HS-DPCCH signalling (ACK/NACK) under static propagation conditions.

8.11.1.4 Method of test

8.11.1.4.1 Initial conditions

Test environment: normal; see clause 4.4.1.

RF channels to be tested: B, M and T; see clause 4.8

- 1) Connect the BS tester generating the wanted signal and AWGN generators to both BS antenna connectors for diversity reception via a combining network as shown in annex B.

8.11.1.4.2 Procedure

- 1) Adjust the AWGN generator depending on the BS class under test at the BS input as follows:.

Wide Area: -84 dBm/3.84 MHz

Medium Range: -74 dBm/3.84 MHz

Local Area / Home BS: -70 dBm/3.84 MHz

- 2) The characteristics of the wanted signal shall be configured according to the corresponding UL reference measurement channel defined in annex A.

- 3) Adjust the equipment so that required E_c/N_0 specified in table 8.31 is achieved. To achieve the specified E_c/N_0 , the ratio of the wanted signal level relative to the AWGN signal at the BS input should be adjusted to: E_c/N_0 [dB].
- 4) The test signal generator sends only DPCCH and DPDCH. The receiver tries to detect HS-DPCCH signalling. The ACK false detection rate should be measured only on those slots corresponding to the ACK/NACK field of HS-DPCCH.

8.11.1.5 Test requirements

ACK false alarm, $P(\text{DTX} \rightarrow \text{ACK})$ shall not exceed the limits for the E_c/N_0 specified in Table 8.31.

Table 8.31: Performance requirements for ACK false alarm in AWGN channel

Received E_c/N_0	Required error ratio
-19.5 dB	$< 10^{-2}$

NOTE: If the above Test Requirement differs from the Minimum Requirement then the Test Tolerance applied for this test is non-zero. The Test Tolerance for this test is defined in clause 4.2 and the explanation of how the Minimum Requirement has been relaxed by the Test Tolerance is given in Annex F.

8.11.2 ACK false alarm in multipath fading conditions

8.11.2.1 Definition and applicability

ACK false alarm is defined as a conditional probability of erroneous detection of ACK when input is only DPCCH and DPDCH (+interference). The performance requirement of ACK false alarm in multipath fading conditions is determined by the maximum error ratio allowed when the receiver input signal is at a specified E_c/N_0 limit. ACK false alarm: $P(\text{DTX} \rightarrow \text{ACK})$ shall be 10^{-2} or less.

Only test in Case 1 shall be applied to Home BS.

8.11.2.2 Minimum requirement

The minimum requirement is in TS 25.104 [1] clause 8.10.1.

Table 8.32: (void)

8.11.2.3 Test purpose

The test shall verify the receiver's ability to detect HS-DPCCH signalling (ACK/NACK) under multipath fading case 3 propagation conditions.

8.11.2.4 Method of test

8.11.2.4.1 Initial conditions

Test environment: normal; see clause 4.4.1.

RF channels to be tested: B, M and T; see clause 4.8

- 1) Connect the BS tester generating the wanted signal, multipath fading simulators and AWGN generators to both BS antenna connectors for diversity reception via a combining network as shown in annex B.

8.11.2.4.2 Procedure

- 1) Adjust the AWGN generator depending on the BS class under test at the BS input as follows:

Wide Area: -84 dBm/3.84 MHz

Medium Range: -74 dBm/3.84 MHz

Local Area / Home BS: -70 dBm/3.84 MHz

- 2) The characteristics of the wanted signal shall be configured according to the corresponding UL reference measurement channel defined in annex A.
- 3) The multipath fading emulators shall be configured according to the corresponding channel model defined in annex D.
- 4) Adjust the equipment so that required E_c/N_0 specified in table 8.33 is achieved. To achieve the specified E_c/N_0 , the ratio of the wanted signal level relative to the AWGN signal at the BS input should be adjusted to: E_c/N_0 [dB].
- 5) The test signal generator sends only DPCCH and DPDCH. The receiver tries to detect HS-DPCCH signalling. The ACK false detection rate should be measured only on those slots corresponding to the ACK/NACK field of HS-DPCCH..

8.11.2.5 Test requirements

ACK false alarm, $P(\text{DTX} \rightarrow \text{ACK})$ shall not exceed the limits for the E_c/N_0 specified in Table 8.33.

Table 8.33: Performance requirements for ACK false alarm in fading channels

Propagation conditions	Received E_c/N_0	Required error ratio
Case 1	-12.5 dB	$< 10^{-2}$
Case 2*	-15.4 dB	$< 10^{-2}$
Case 3*	-17.2 dB	$< 10^{-2}$
* Not applicable for Home BS		

NOTE: If the above Test Requirement differs from the Minimum Requirement then the Test Tolerance applied for this test is non-zero. The Test Tolerance for this test is defined in clause 4.2 and the explanation of how the Minimum Requirement has been relaxed by the Test Tolerance is given in Annex F.

8.11.3 ACK mis-detection in static propagation conditions

8.11.3.1 Definition and applicability

The probability of ACK mis-detection is defined a probability of ACK mis-detected when ACK is transmitted. The performance requirement of ACK mis-detection in static propagation conditions is determined by the maximum error ratio allowed when the receiver input signal is at a specified E_c/N_0 limit.

8.11.3.2 Minimum requirement

The minimum requirement is in TS 25.104 [1] clause 8.10.2.

Table 8.34: (void)

8.11.3.3 Test purpose

The test shall verify the receiver's ability to receive the test signal under static propagation conditions with an error ratio not exceeding a specified limit.

8.11.3.4 Method of test

8.11.3.4.1 Initial conditions

Test environment: normal; see clause 4.4.1.

RF channels to be tested: B, M and T; see clause 4.8

- 1) Connect the BS tester generating the wanted signal and AWGN generators to both BS antenna connectors for diversity reception via a combining network as shown in annex B.

8.11.3.4.2 Procedure

- 1) Adjust the AWGN generator depending on the BS class under test at the BS input as follows:
 - Wide Area: -84 dBm/3.84 MHz
 - Medium Range: -74 dBm/3.84 MHz
 - Local Area / Home BS: -70 dBm/3.84 MHz
- 2) The characteristics of the wanted signal shall be configured according to the corresponding UL reference measurement channel defined in annex A.
- 3) Adjust the equipment so that required E_c/N_0 specified in table 8.35 is achieved. To achieve the specified E_c/N_0 , the ratio of the wanted signal level relative to the AWGN signal at the BS input should be adjusted to: E_c/N_0 [dB].
- 4) The test signal generator sends the ACKs and CQIs with DPCCH/DPDCH. The receiver tries to detect HS-DPCCH signalling. The ACK mis-detection rate should be measured only on those slots corresponding to the ACK/NACK field of HS-DPCCH..

8.11.3.5 Test requirements

The probability of ACK mis-detection, $P(\text{ACK} \rightarrow \text{NACK or DTX})$ (= mis-detected when ACK is transmitted) shall not exceed the required error ratio for the E_c/N_0 specified in Table 8.35.

Table 8.35: Performance requirements for ACK mis-detection in AWGN channel

Received E_c/N_0	Required error ratio
-16.9 dB	$< 10^{-2}$

NOTE: If the above Test Requirement differs from the Minimum Requirement then the Test Tolerance applied for this test is non-zero. The Test Tolerance for this test is defined in clause 4.2 and the explanation of how the Minimum Requirement has been relaxed by the Test Tolerance is given in Annex F.

8.11.4 ACK mis-detection in multipath fading conditions

8.11.4.1 Definition and applicability

The probability of ACK mis-detection is defined a probability of ACK mis-detected when ACK is transmitted. The performance requirement of ACK mis-detection in multipath fading conditions is determined by the maximum error ratio allowed when the receiver input signal is at a specified E_c/N_0 limit.

Only test in Case 1 shall be applied to Home BS.

8.11.4.2 Minimum requirement

The minimum requirement is in TS 25.104 [1] clause 8.10.2.

Table 8.36: (void)

8.11.4.3 Test purpose

The test shall verify the receiver's ability to receive the test signal under multipath fading propagation conditions with an error ratio not exceeding a specified limit.

8.11.4.4 Method of test

8.11.4.4.1 Initial conditions

Test environment: normal; see clause 4.4.1.

RF channels to be tested: B, M and T; see clause 4.8

- 1) BS antenna connectors for diversity reception via a combining network as shown in annex B.

8.11.4.4.2 Procedure

- 1) Adjust the AWGN generator depending on the BS class under test at the BS input as follows:.

Wide Area: -84 dBm/3.84 MHz

Medium Range: -74 dBm/3.84 MHz

Local Area / Home BS: -70 dBm/3.84 MHz

- 2) The characteristics of the wanted signal shall be configured according to the corresponding UL reference measurement channel defined in annex A.
- 3) The multipath fading emulators shall be configured according to the corresponding channel model defined in annex D.
- 4) Adjust the equipment so that required E_c/N_0 specified in table 8.37 is achieved. To achieve the specified E_c/N_0 , the ratio of the wanted signal level relative to the AWGN signal at the BS input should be adjusted to: E_c/N_0 [dB]
- 5) The test signal generator sends the ACKs and CQIs with DPCCH/DPDCH. The receiver tries to detect HS-DPCCH signalling. The ACK mis-detection rate should be measured only on those slots corresponding to the ACK/NACK field of HS-DPCCH.

8.11.4.5 Test requirements

The probability of ACK mis-detection, $P(\text{ACK} \rightarrow \text{NACK or DTX})$ (= mis-detected when ACK is transmitted) shall not exceed the required error ratio for the E_c/N_0 specified in Table 8.37.

Table 8.37: Performance requirements for ACK mis-detection in fading channels

Propagation conditions	Received E_c/N_0	Required error ratio
Case 1	-10.1 dB	$< 10^{-2}$
Case 2*	-13.0 dB	$< 10^{-2}$
Case 3*	-11.5 dB	$< 10^{-2}$
* Not applicable for Home BS		

NOTE: If the above Test Requirement differs from the Minimum Requirement then the Test Tolerance applied for this test is non-zero. The Test Tolerance for this test is defined in clause 4.2 and the explanation of how the Minimum Requirement has been relaxed by the Test Tolerance is given in Annex F.

8.11A Performance of signalling detection for 4C-HSDPA HS-DPCCH

This test shall be performed only for the BS supporting 4C-HSDPA. The performance requirement of 4C-HSDPA HS-DPCCH signalling detection is determined by the two parameters:

- (i) The probability of ACK false alarm for each stream, $P(\text{DTX} \rightarrow \text{ACK})$ (=false ACK detection for a given stream in the detected HARQ message given that no HARQ message is transmitted)

- (ii) The probability of ACK mis-detection for each stream, $P(\text{ACK} \rightarrow \text{NACK}, \text{DTX (no transmission)})$ or DTX codeword) (=an ACK for a given stream in a transmitted HARQ message is mis-detected as a NACK or DTX (no transmission) or DTX codeword in the received HARQ message)

Performance requirements of HS-DPCCH signaling detection for 4C-HSDPA apply also for HSDPA Multiflow operation on three/four cells on two frequencies without MIMO. If tested NodeB supports both 4C-HSDPA and HSDPA Multiflow operation on three/four cells on two frequencies without MIMO, this test shall be performed only once.

The appropriate codebook subset is chosen for testing.

8.11A.1 ACK false alarm for 4C-HSDPA in static propagation conditions

8.11A.1.1 Definition and applicability

ACK false alarm for 4C-HSDPA HS-DPCCH is defined as in Section 8.11A when input is only DPCCH and DPDCH (+interference). The performance requirement of ACK false alarm in static propagation conditions is determined by the maximum error ratio allowed when the receiver input signal is at a specified E_c/N_0 limit. ACK false alarm shall be 10^{-2} or less.

8.11A.1.2 Minimum requirement

The minimum requirement is in TS 25.104 [1] clause 8.10A.1.1

8.11A.1.3 Test purpose

The test shall verify the receiver's ability to detect 4C-HSDPA UL HS-DPCCH signalling (ACK/NACK) under static propagation conditions.

8.11A.1.4 Method of test

8.11A.1.4.1 Initial conditions

Test environment: normal; see clause 4.4.1.

RF channels to be tested: B, M and T; see clause 4.8

- 1) Connect the BS tester generating the wanted signal and AWGN generators to both BS antenna connectors for diversity reception via a combining network as shown in Annex B.3.1.

8.11A.1.4.2 Procedure

- 1) Adjust the AWGN generator depending on the BS class under test at the BS input as follows:.

Wide Area: -84 dBm/3.84 MHz

Medium Range: -74 dBm/3.84 MHz

Local Area / Home BS: -70 dBm/3.84 MHz

- 2) The characteristics of the wanted signal shall be configured according to the corresponding UL reference measurement channel defined in Annex A.9A.
- 3) Adjust the equipment so that required E_c/N_0 specified in Table 8.11A.1 is achieved. To achieve the specified E_c/N_0 , the ratio of the wanted signal level relative to the AWGN signal at the BS input should be adjusted to: E_c/N_0 [dB].
- 4) The test signal generator sends only DPCCH and DPDCH. The receiver tries to detect HS-DPCCH signalling. The ACK false detection rate should be measured only on those slots corresponding to the ACK/NACK field of HS-DPCCH.

8.11A.1.5 Test requirements

The probability of ACK false alarm for each stream shall not exceed the required error ratio for the E_c/N_0 specified in Table 8.11A.1.

Table 8.11A.1: Performance requirements for ACK false alarm per stream in static conditions

Carrier Configuration ¹	Propagation condition	Received E_c/N_0 [dB] (Test condition) For BS with Rx Diversity	Required error ratio
4/4/4	Static	-16.3	$< 10^{-2}$
4/2/2	Static	-16.3	$< 10^{-2}$
3/3/3	Static	-16.6	$< 10^{-2}$
3/2/1	Static	-16.6	$< 10^{-2}$
3/3/0	Static	-17.0	$< 10^{-2}$
Note:	Carrier configuration X/Y/Z denotes X number of carriers configured, Y number of active carriers, and Z number of carriers configured as MIMO out of Y carriers.		

NOTE: If the above Test Requirement differs from the Minimum Requirement then the Test Tolerance applied for this test is non-zero. The Test Tolerance for this test is defined in clause 4.2 and the explanation of how the Minimum Requirement has been relaxed by the Test Tolerance is given in Annex F.

8.11A.2 ACK false alarm for 4C-HSDPA in multipath fading conditions

8.11A.2.1 Definition and applicability

ACK false alarm for 4C-HSDPA HS-DPCCH is defined as in Section 8.11A when input is only DPCCH and DPDCH (+interference). The performance requirement of ACK false alarm in multipath fading conditions is determined by the maximum error ratio allowed when the receiver input signal is at a specified E_c/N_0 limit. ACK false alarm: $P(\text{DTX} > \text{ACK})$ shall be 10^{-2} or less.

8.11A.2.2 Minimum requirement

The minimum requirement is in TS 25.104 [1] clause 8.10A.1.1.

8.11A.2.3 Test purpose

The test shall verify the receiver's ability to detect 4C-HSDPA HS-DPCCH signalling (ACK/NACK) under multipath fading case 1 propagation conditions.

8.11A.2.4 Method of test

8.11A.2.4.1 Initial conditions

Test environment: normal; see clause 4.4.1.

RF channels to be tested: B, M and T; see clause 4.8

- 1) Connect the BS tester generating the wanted signal, multipath fading simulators and AWGN generators to both BS antenna connectors for diversity reception via a combining network as shown in Annex B.3.2.

8.11A.2.4.2 Procedure

- 1) Adjust the AWGN generator depending on the BS class under test at the BS input as follows:

Wide Area: -84 dBm/3.84 MHz

Medium Range: -74 dBm/3.84 MHz

Local Area / Home BS: -70 dBm/3.84 MHz

- 2) The characteristics of the wanted signal shall be configured according to the corresponding UL reference measurement channel defined in Annex A.9A.
- 3) The multipath fading emulators shall be configured according to the corresponding channel model defined in Annex D.
- 4) Adjust the equipment so that required E_c/N_0 specified in Table 8.11A.2 is achieved. To achieve the specified E_c/N_0 , the ratio of the wanted signal level relative to the AWGN signal at the BS input should be adjusted to: E_c/N_0 [dB].
- 5) The test signal generator sends only DPCCH and DPDCH. The receiver tries to detect HS-DPCCH signalling. The ACK false detection rate should be measured only on those slots corresponding to the ACK/NACK field of HS-DPCCH..

8.11A.2.5 Test requirements

The probability of ACK false alarm for each stream shall not exceed the required error ratio for the E_c/N_0 specified in Table 8.11A.2

Table 8.11A.2: Performance requirements for ACK false alarm per stream in multipath conditions

Carrier Configuration ¹	Propagation condition	Received E_c/N_0 [dB] (Test condition) For BS with Rx Diversity	Required error ratio
4/4/4	Case 1	-10.8	$< 10^{-2}$
4/2/2	Case 1	-10.8	$< 10^{-2}$
3/3/3	Case 1	-10.8	$< 10^{-2}$
3/2/1	Case 1	-10.8	$< 10^{-2}$
3/3/0	Case 1	-11.9	$< 10^{-2}$
Note: Carrier configuration X/Y/Z denotes X number of carriers configured, Y number of active carriers, and Z number of carriers configured as MIMO out of Y carriers.			

NOTE: If the above Test Requirement differs from the Minimum Requirement then the Test Tolerance applied for this test is non-zero. The Test Tolerance for this test is defined in clause 4.2 and the explanation of how the Minimum Requirement has been relaxed by the Test Tolerance is given in Annex F.

8.11A.3 ACK mis-detection for 4C-HSDPA in static propagation conditions

8.11A.3.1 Definition and applicability

The probability of ACK mis-detection for each stream, P(ACK->NACK, DTX (no transmission) or DTX codeword) (=an ACK for a given stream in a transmitted HARQ message is mis-detected as a NACK or DTX (no transmission) or DTX codeword in the received HARQ message) shall not exceed the required error ratio for the E_c/N_0 specified in Table 8.11A.3. This requirement shall be conditioned on that the ACK false alarm requirement in Table 8.11A.1. above shall also be concurrently satisfied.

The performance requirement of ACK mis-detection in static propagation conditions is determined by the maximum error ratio allowed when the receiver input signal is at a specified E_c/N_0 limit.

8.11A.3.2 Minimum requirement

The minimum requirement is in TS 25.104 [1] clause 8.10A.1.2.

8.11A.3.3 Test purpose

The test shall verify the receiver's ability to receive the test signal under static propagation conditions with an error ratio not exceeding a specified limit.

8.11A.3.4 Method of test

8.11A.3.4.1 Initial conditions

Test environment: normal; see clause 4.4.1.

RF channels to be tested: B, M and T; see clause 4.8

- 1) Connect the BS tester generating the wanted signal and AWGN generators to both BS antenna connectors for diversity reception via a combining network as shown in Annex B.3.1.

8.11A.3.4.2 Procedure

- 1) Adjust the AWGN generator depending on the BS class under test at the BS input as follows:
 - Wide Area: -84 dBm/3.84 MHz
 - Medium Range: -74 dBm/3.84 MHz
 - Local Area / Home BS: -70 dBm/3.84 MHz
- 2) The characteristics of the wanted signal shall be configured according to the corresponding UL reference measurement channel defined in Annex A.9A.
- 3) Adjust the equipment so that required E_c/N_0 specified in Table 8.11A.3 is achieved. To achieve the specified E_c/N_0 , the ratio of the wanted signal level relative to the AWGN signal at the BS input should be adjusted to: E_c/N_0 [dB].
- 4) The test signal generator sends the ACKs with DPCCH/DPDCH. The receiver tries to detect HS-DPCCH signalling. The ACK mis-detection rate should be measured only on those slots corresponding to the ACK/NACK field of HS-DPCCH.

8.11A.3.5 Test requirements

The probability of ACK mis-detection shall not exceed the required error ratio for the E_c/N_0 specified in Table 8.11A.3.

Table 8.11A.3: Performance requirements for ACK mis-detection per stream conditioned on ACK false alarm per stream is less than 1%.

Carrier Configuration ¹	Propagation condition	Received E_c/N_0 [dB] (Test condition) For BS with Rx Diversity	Required error ratio
4/4/4	Static	-13.5	$< 10^{-2}$
4/2/2	Static	-14.0	$< 10^{-2}$
3/3/3	Static	-13.8	$< 10^{-2}$
3/2/1	Static	-14.6	$< 10^{-2}$
3/3/0	Static	-15.0	$< 10^{-2}$
Note: Carrier configuration X/Y/Z denotes X number of carriers configured, Y number of active carriers, and Z number of carriers configured as MIMO out of Y carriers.			

NOTE: If the above Test Requirement differs from the Minimum Requirement then the Test Tolerance applied for this test is non-zero. The Test Tolerance for this test is defined in clause 4.2 and the explanation of how the Minimum Requirement has been relaxed by the Test Tolerance is given in Annex F.

8.11A.4 ACK mis-detection for 4C-HSDPA in multipath fading conditions

8.11A.4.1 Definition and applicability

The probability of ACK mis-detection for each stream, P(ACK->NACK, DTX (no transmission) or DTX codeword) (=an ACK for a given stream in a transmitted HARQ message is mis-detected as a NACK or DTX (no transmission) or

DTX codeword in the received HARQ message) shall not exceed the required error ratio for the E_c/N_0 specified in Table 8.11A.4. This requirement shall be conditioned on that the ACK false alarm requirement in Table 8.11A.2. above shall also be concurrently satisfied.

The performance requirement of ACK mis-detection in multipath fading conditions is determined by the maximum error ratio allowed when the receiver input signal is at a specified E_c/N_0 limit.

8.11A.4.2 Minimum requirement

The minimum requirement is in TS 25.104 [1] clause 8.10A.1.2.

8.11A.4.3 Test purpose

The test shall verify the receiver's ability to receive the test signal under multipath fading propagation conditions with an error ratio not exceeding a specified limit.

8.11A.4.4 Method of test

8.11A.4.4.1 Initial conditions

Test environment: normal; see clause 4.4.1.

RF channels to be tested: B, M and T; see clause 4.8

- 1) BS antenna connectors for diversity reception via a combining network as shown in Annex B.3.2

8.11A.4.4.2 Procedure

- 1) Adjust the AWGN generator depending on the BS class under test at the BS input as follows:
 - Wide Area: -84 dBm/3.84 MHz
 - Medium Range: -74 dBm/3.84 MHz
 - Local Area / Home BS: -70 dBm/3.84 MHz
- 2) The characteristics of the wanted signal shall be configured according to the corresponding UL reference measurement channel defined in Annex A.9A.
- 3) The multipath fading emulators shall be configured according to the corresponding channel model defined in Annex D.
- 4) Adjust the equipment so that required E_c/N_0 specified in Table 8.11A.4 is achieved. To achieve the specified E_c/N_0 , the ratio of the wanted signal level relative to the AWGN signal at the BS input should be adjusted to: E_c/N_0 [dB]
- 5) The test signal generator sends the ACKs with DPCCH/DPDCH. The receiver tries to detect HS-DPCCH signalling. The ACK mis-detection rate should be measured only on those slots corresponding to the ACK/NACK field of HS-DPCCH.

8.11A.4.5 Test requirements

The probability of ACK mis-detection shall not exceed the required error ratio for the E_c/N_0 specified in Table 8.11A.4.

Table 8.11A.4: Performance requirements for ACK mis-detection per stream conditioned on ACK false alarm per stream is less than 1%.

Carrier Configuration ¹	Propagation condition	Received E_c/N_0 [dB] (Test condition) For BS with Rx Diversity	Required error ratio
4/4/4	Case 1	-8.1	$< 10^{-2}$
4/2/2	Case 1	-8.4	$< 10^{-2}$
3/3/3	Case 1	-8.0	$< 10^{-2}$
3/2/1	Case 1	-8.2	$< 10^{-2}$
3/3/0	Case 1	-9.9	$< 10^{-2}$
Note: Carrier configuration X/Y/Z denotes X number of carriers configured, Y number of active carriers, and Z number of carriers configured as MIMO out of Y carriers.			

NOTE: If the above Test Requirement differs from the Minimum Requirement then the Test Tolerance applied for this test is non-zero. The Test Tolerance for this test is defined in clause 4.2 and the explanation of how the Minimum Requirement has been relaxed by the Test Tolerance is given in Annex F.

8.11B Performance of signalling detection for 8C-HSDPA HS-DPCCH

This test shall be performed only for the BS supporting 8C-HSDPA.

In 8C-HSDPA two identical HS-DPCCH channels similar to the 4C-HSDPA HS-DPCCH are used and they are transmitted by means of I/Q multiplexing. One HS-DPCCH is dedicated to carriers 1 to 4, while the other to carriers 5 to 8. The same test requirements as for 4C-HSDPA HS-DPCCH, as defined in section 8.11A, shall be fulfilled for both I and Q HS-DPCCH channels.

The appropriate codebook subset is chosen for testing.

8.12 Demodulation of E-DPDCH in multipath fading conditions

8.12.1 Definition and applicability

The performance requirement of the E-DPDCH in multi path fading condition is determined by the minimum throughput, R. Test parameters are specified in Table 8.38.

For a BS supporting DC-HSUPA the requirements for FRC1, FRC2, FRC3 and FRC8 shall apply on each cell.

Table 8.38: Test parameters for testing E-DPDCH

Parameter	Unit	Test	
RSN		{0, 1, 2, 3}	
HARQ combining		IR	
Maximum number of HARQ transmission		4	
Power control		OFF	
DPCCH slot format		FRC8 or BS supporting DC-HSUPA	1
		Otherwise	0
E-DPCCH # code words		1024, no optimization based on prior knowledge of valid code words.	
Physical channels to be turned on		DPCCH, E-DPDCH and E-DPCCH	

Only tests in Pedestrian A shall be applied to Home BS.

8.12.2 Minimum requirement

The minimum requirement is in TS 25.104 [1] clause 8.11.

Table 8.39: (void)

8.12.3 Test Purpose

The test shall verify the receiver's ability to receive the test signal under slow multipath fading propagation conditions with a throughput not below a specified limit.

8.12.4 Method of test

8.12.4.1 Initial conditions

Test environment: normal; see clause 4.4.1.

RF channels to be tested: B, M and T; see clause 4.8

- 1) For BS with Rx diversity, connect the BS tester generating the wanted signal, multipath fading simulators and AWGN generators to both BS antenna connectors for diversity reception via a combining network as shown in annex B.
- 2) For BS without Rx diversity, connect the BS tester generating the wanted signal, multipath fading simulator and AWGN generator to the BS antenna connector via a combining network as shown in annex B.

8.12.4.2 Procedure

- 1) Adjust the AWGN generator depending on the BS class under test at the BS input as follows:
 - Wide Area: -84 dBm/3.84 MHz
 - Medium Range: -74 dBm/3.84 MHz
 - Local Area / Home BS: -70 dBm/3.84 MHz
- 2) The characteristics of the wanted signal shall be configured according to the corresponding UL reference measurement channel defined in annex A.
- 3) The multipath fading emulators shall be configured according to the corresponding channel model defined in annex D.
- 4) Adjust the equipment so that required E_C/N_0 specified in table 8.40 is achieved.
- 5) For each of the reference channels in table 8.40 applicable for the base station, measure the throughput.

8.12.4.3 Test requirements

The throughput measured according to clause 8.12.4.2 shall not be below the limits for the E_C/N_0 levels specified in table 8.40.

Table 8.40: Test Requirement for E-DPDCH

Fixed Reference Channel		Reference value, E_c/N_0 (dB), for $R \geq 30\%$ and $R \geq 70\%$ of maximum information bit rate								
		FRC1	FRC2	FRC3	FRC4	FRC5	FRC6	FRC7	FRC8	
Propagations conditions	Non E-DPCCH boosting								E-DPCCH Boosting	
Pedestrian A without RX diversity	30%	-1.8	1.4	3.0	-6.5	-3.8	-0.8	-14.4	NA	NA
	70%	4.3	7.7	9.7	0.0	2.7	5.8	-7.8	16.8	17.5
Pedestrian A with RX diversity	30%	-5.6	-2.5	-0.8	-10.0	-7.4	-4.4	-17.7	NA	NA
	70%	-0.4	2.8	4.7	-4.6	-2.0	0.8	-12.7	10.7	11.0
Pedestrian B without RX diversity*	30%	-1.9	1.7	4.1	-6.9	-4.1	-0.7	-13.0	NA	NA
	70%	4.5	NA	NA	-1.5	1.5	5.9	-9.5	NA	NA
Pedestrian B with RX diversity*	30%	-5.5	-2.5	-0.4	-10.1	-7.5	-4.3	-17.4	NA	NA
	70%	0.3	4.5	8.8	-5.1	-2.3	1.3	-13.2	13.0	13.7
Vehicular 30 without RX diversity*	30%	-1.9	1.6	3.8	-6.9	-4.0	-0.8	-13.7	NA	NA
	70%	5.5	NA	NA	-1.1	2.0	6.4	-9.5	NA	NA
Vehicular 30 with RX diversity*	30%	-5.5	-2.3	-0.3	-10.1	-7.4	-4.3	-17.0	NA	NA
	70%	1.2	5.3	9.4	-4.8	-2.0	1.6	-13.1	13.9	14.2
Vehicular 120 without RX diversity*	30%	-1.5	1.9	4.2	-6.7	-3.6	-0.6	-13.4	NA	NA
	70%	5.7	NA	NA	-0.7	2.1	6.7	-9.5	NA	NA
Vehicular 120 with RX diversity*	30%	-5.1	-2.0	0.1	-9.8	-7.0	-3.7	-16.4	NA	NA
	70%	1.3	5.6	10.1	-4.5	-1.7	1.8	-12.6	NA	NA

* Not applicable for Home BS

NOTE: If the above Test Requirement differs from the Minimum Requirement then the Test Tolerance applied for this test is non-zero. The Test Tolerance for this test is defined in clause 4.2 and the explanation of how the Minimum Requirement has been relaxed by the Test Tolerance is given in Annex F.

8.12A Demodulation of E-DPDCH and S-E-DPDCH in multipath fading conditions for UL MIMO

8.12A.1 Definition and applicability

The performance requirements of the E-DPDCH and S-E-DPDCH in multi path fading condition for UL MIMO are determined by the minimum throughput, R . Test parameters are specified in Table 8.38A.

Table 8.38A: Test parameters for testing E-DPDCH and S-E-DPDCH for UL MIMO

Parameter	Test
RSN	{0, 1, 2, 3}
HARQ combining	IR
Maximum number of HARQ transmission	4
Power control	OFF
TX weight vector selection	A fixed precoding weight vector
Physical channels to be turned on	DPCCH, S-DPCCH, E-DPCCH, S-E-DPCCH, E-DPDCH and S-E-DPDCH

8.12A.2 Minimum requirement

The minimum requirement is in TS 25.104 [1] clause 8.11A.

8.12A.3 Test Purpose

The test shall verify the receiver's ability to receive the test signal under slow multipath fading propagation conditions with a throughput not below a specified limit.

8.12A.4 Method of test

8.12A.4.1 Initial conditions

Test environment: normal; see clause 4.4.1.

RF channels to be tested: B, M and T; see clause 4.8

For BS with Rx diversity, connect the BS tester generating the wanted signal, multipath fading simulators and AWGN generators to both BS antenna connectors for diversity reception via a combining network as shown in annex B.

8.12A.4.2 Procedure

1) Adjust the AWGN generator depending on the BS class under test at the BS input as follows:

Wide Area: -84 dBm/3.84 MHz

Medium Range: -74 dBm/3.84 MHz

Local Area / Home BS: -70 dBm/3.84 MHz

2) The characteristics of the wanted signal shall be configured according to the corresponding UL reference measurement channel defined in annex A.

3) The multipath fading emulators shall be configured according to the corresponding channel model defined in annex D.

4) Adjust the equipment so that required E_C/N_0 specified in table 8.40A is achieved.

5) For each of the reference channels in table 8.40A applicable for the base station, measure the throughput.

8.12A.4.3 Test requirements

The throughput measured according to clause 8.12A.4.2 shall not be below the limits for the E_C/N_0 levels specified in table 8.40A.

Table 8.40A: Test Requirement for E-DPDCH and S-E-DPDCH for UL MIMO

Fixed Reference Channel	Reference value, E_C/N_0 (dB), for $R \geq 70\%$ of maximum information bit rate			
	FRC9		FRC10	
	E-DPDCH	S-E-DPDCH	E-DPDCH	S-E-DPDCH
Ped A, 3 km/h	9.7	9.7	18.4	18.4
Veh A, 3 km/h	11.0	11.0	N/A	N/A

NOTE: If the above Test Requirement differs from the Minimum Requirement then the Test Tolerance applied for this test is non-zero. The Test Tolerance for this test is defined in clause 4.2 and the explanation of how the Minimum Requirement has been relaxed by the Test Tolerance is given in Annex F.

8.13 Performance of signalling detection for E-DPCCH in multipath fading conditions

The performance requirement of E-DPCCH signalling detection is determined by the two parameters: the probability of false detection of codeword; $P(\text{DTX} \rightarrow \text{codeword})$ and the probability of missed detection of codeword; $P(\text{codeword} \rightarrow \text{DTX})$.

Table 8.41: Test parameters for testing E-DPCCH

Parameter	Unit	Test
Power control		Off
E-DPCCH # code words		1024, no optimization based on prior knowledge of valid code words.
Physical channels to be turned on for missed detection test		DPCCH, E-DPDCH and E-DPCCH
Physical channels to be turned on for false alarm test		DPCCH

8.13.1 E-DPCCH false alarm in multipath fading conditions

8.13.1.1 Definition and applicability

E-DPCCH false alarm is defined as a conditional probability of detection of codeword when input is only DPCCH (+interference). The E-DPDCH and E-DPCCH is turned off. The performance requirement of E-DPCCH false alarm in multipath fading conditions is determined by the maximum detection probability allowed when the receiver input signal is at a specified E_c/N_0 limit. E-DPCCH false alarm: $P(\text{DTX} \rightarrow \text{codeword})$ shall be 10^{-2} or less.

Only tests in Pedestrian A shall be applied to Home BS.

8.13.1.2 Minimum requirement

The minimum requirement is in TS 25.104 [1] clause 8.12.

Table 8.42: (void)

8.13.1.3 Test purpose

The test shall verify the receiver's ability to detect E-DPCCH signalling under multipath fading propagation conditions.

8.13.1.4 Method of test

8.13.1.4.1 Initial conditions

Test environment: normal; see clause 4.4.1.

RF channels to be tested: B, M and T; see clause 4.8

- 1) For BS with Rx diversity, connect the BS tester generating the wanted signal, multipath fading simulators and AWGN generators to both BS antenna connectors for diversity reception via a combining network as shown in annex B.
- 2) For BS without Rx diversity, connect the BS tester generating the wanted signal, multipath fading simulator and AWGN generator to the BS antenna connector via a combining network as shown in annex B.

8.13.1.4.2 Procedure

- 1) Adjust the AWGN generator depending on the BS class under test at the BS input as follows:

Wide Area: -84 dBm/3.84 MHz

Medium Range: -74 dBm/3.84 MHz

Local Area / Home BS: -70 dBm/3.84 MHz

- 2) The characteristics of the wanted signal shall be configured according to the corresponding UL reference measurement channel defined in annex A.
- 3) The multipath fading emulators shall be configured according to the corresponding channel model defined in annex D.
- 4) Adjust the equipment so that required E_c/N_0 specified in table 8.42 is achieved. To achieve the specified E_c/N_0 , the ratio of the wanted signal level relative to the AWGN signal at the BS input should be adjusted to: E_c/N_0 [dB].
- 5) The test signal generator sends only DPCCH. The receiver shall be set to detect E-DPCCH signalling. The E-DPCCH detection probability, false alarm, is measured.

8.13.1.5 Test requirements

E-DPCCH false alarm, $P(\text{DTX} \rightarrow \text{codeword})$ shall not exceed the limits for the E_c/N_0 specified in Table 8.43.

Table 8.43: Test requirements for E-DPCCH false alarm in fading channels

Propagation conditions	Received E_c/N_0		Required detection probability
	FRC1	FRC4	
Pedestrian A without RX diversity	-1.0 dB	-4.4 dB	$< 10^{-2}$
Pedestrian A with RX diversity	-10.6 dB	-11.7 dB	$< 10^{-2}$
Pedestrian B without RX diversity*	-13.2 dB	-14.6 dB	$< 10^{-2}$
Pedestrian B with RX diversity*	-15.8 dB	-17.0 dB	$< 10^{-2}$
Vehicular 30 without RX diversity*	-11.5 dB	-16.1 dB	$< 10^{-2}$
Vehicular 30 with RX diversity*	-15.1 dB	-18.0 dB	$< 10^{-2}$
Vehicular 120 without RX diversity*	-13.2 dB	-17.7 dB	$< 10^{-2}$
Vehicular 120 with RX diversity*	-16.5 dB	-19.0 dB	$< 10^{-2}$
* Not applicable for Home BS			

NOTE: If the above Test Requirement differs from the Minimum Requirement then the Test Tolerance applied for this test is non-zero. The Test Tolerance for this test is defined in clause 4.2 and the explanation of how the Minimum Requirement has been relaxed by the Test Tolerance is given in Annex F.

8.13.2 E-DPCCH missed detection in multipath fading conditions

8.13.2.1 Definition and applicability

The probability of E-DPCCH missed detection is defined a probability of E-DPCCH missed detected when E-DPCCH is transmitted. The performance requirement of E-DPCCH missed detection in multipath fading conditions is determined by the maximum missed detection probability allowed when the receiver input signal is at a specified E_c/N_0 limit.

Only tests in Pedestrian A shall be applied to Home BS.

8.13.2.2 Minimum requirement

The minimum requirement is in TS 25.104 [1] clause 8.12.

Table 8.44: (void)

8.13.2.3 Test purpose

The test shall verify the receiver's ability to receive the test signal under multipath fading propagation conditions with a missed detection probability not exceeding a specified limit.

8.13.2.4 Method of test

8.13.2.4.1 Initial conditions

Test environment: normal; see clause 4.4.1.

RF channels to be tested: B, M and T; see clause 4.8

- 1) For BS with Rx diversity, connect the BS tester generating the wanted signal, multipath fading simulators and AWGN generators to both BS antenna connectors for diversity reception via a combining network as shown in annex B.
- 2) For BS without Rx diversity, connect the BS tester generating the wanted signal, multipath fading simulator and AWGN generator to the BS antenna connector via a combining network as shown in annex B.

8.13.2.4.2 Procedure

- 1) Adjust the AWGN generator depending on the BS class under test at the BS input as follows:.

Wide Area: -84 dBm/3.84 MHz (see NOTE).

Medium Range: -74 dBm/3.84 MHz (see NOTE).

Local Area / Home BS: -70 dBm/3.84 MHz (see NOTE).

NOTE: For FRC1 and Pedestrian A without RX diversity, the level of the AWGN generator shall be reduced by 6 dB from the levels stated above.

- 2) The characteristics of the wanted signal shall be configured according to the corresponding UL reference measurement channel defined in annex A.
- 3) The multipath fading emulators shall be configured according to the corresponding channel model defined in annex D.
- 4) Adjust the equipment so that required E_c/N_0 specified in table 8.44 is achieved. To achieve the specified E_c/N_0 , the ratio of the wanted signal level relative to the AWGN signal at the BS input should be adjusted to: E_c/N_0 [dB]
- 5) The test signal generator sends the DPCCH, E-DPCCH and E-DPDCH. The receiver shall be set to detect E-DPCCH signalling. The E-DPCCH missed detection probability is measured.

8.13.2.5 Test requirements

The probability of E-DPCCH missed detection, $P(\text{codeword} \rightarrow \text{DTX})$ (= missed detection when codeword is transmitted) shall not exceed the required missed detection probability for the E_c/N_0 specified in Table 8.45.

Table 8.45: Test requirements for E-DPCCH missed detection in fading channels

Propagation conditions	Received E_c/N_0		Required missed detection probability
	FRC1	FRC4	
Pedestrian A without RX diversity	14.5 dB	8.0 dB	$< 2 \cdot 10^{-3}$
Pedestrian A with RX diversity	1.8 dB	-2.2 dB	$< 2 \cdot 10^{-3}$
Pedestrian B without RX diversity*	2.1 dB	-2.2 dB	$< 2 \cdot 10^{-3}$
Pedestrian B with RX diversity*	-3.4 dB	-7.5 dB	$< 2 \cdot 10^{-3}$
Vehicular 30 without RX diversity*	3.8 dB	-3.7 dB	$< 2 \cdot 10^{-3}$
Vehicular 30 with RX diversity*	-2.7 dB	-8.5 dB	$< 2 \cdot 10^{-3}$
Vehicular 120 without RX diversity*	2.1 dB	-5.3 dB	$< 2 \cdot 10^{-3}$
Vehicular 120 with RX diversity*	-4.1 dB	-9.5 dB	$< 2 \cdot 10^{-3}$
* Not applicable for Home BS			

NOTE: If the above Test Requirement differs from the Minimum Requirement then the Test Tolerance applied for this test is non-zero. The Test Tolerance for this test is defined in clause 4.2 and the explanation of how the Minimum Requirement has been relaxed by the Test Tolerance is given in Annex F. For FRC1 and Pedestrian A without RX diversity an additional 0.2 dB is added to the test requirement to compensate for the increased influence of the thermal noise, when the level of the AWGN generator is reduced by 6 dB.

Annex A (normative): Measurement channels

A.1 Summary of UL reference measurement channels

The parameters for the UL reference measurement channels are specified in Table A.1 and the channel coding is detailed in figure A.2 through A.6 respectively.

NOTE: For all cases, one DPCCH shall be attached to DPDCH(s).

Table A.1: Reference measurement channels for UL DCH

Parameter		DCH for DTCH / DCH for DCCH				Unit
DPDCH	Information bit rate	12,2/2,4	64/2,4	144/2,4	384/2,4	kbps
	Physical channel	60/15	240/15	480/15	960/15	kbps
	Spreading factor	64	16	8	4	
	Repetition rate	22/22	19/19	8/9	-18/-17	%
	Interleaving	20	40	40	40	ms
	Number of DPDCHs	1	1	1	1	
DPCCH	Dedicated pilot	6				bit/slot
	Power control	2				bit/slot
	TFCI	2				bit/slot
	FBI	0 / 2				bit/slot
	Spreading factor	256				
Power ratio of DPCCH/DPDCH		-2,69	-5,46	-9,54	-9,54	dB
Amplitude ratio of DPCCH/DPDCH		0,7333	0,5333	0,3333	0,3333	
Note: Combination of TFCI bit of 0 bit/slot and FBI bit of 2 bit /slot is applied in test of Site Selection Diversity Transmission specified in 8.10.						

A.2 UL reference measurement channel for 12,2 kbps

The parameters for the UL reference measurement channel for 12,2 kbps are specified in table A.2 and the channel coding is detailed in figure A.2.

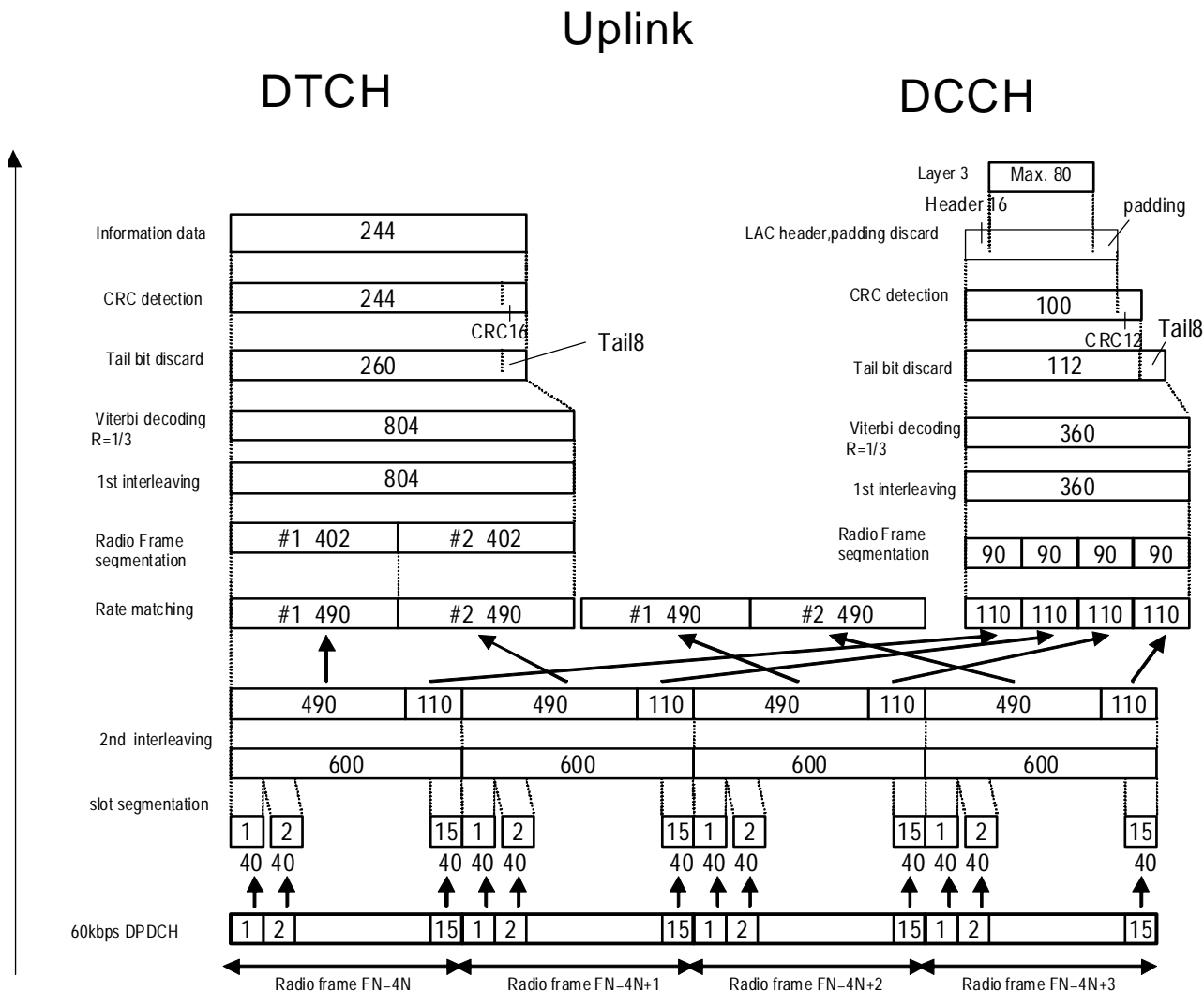

Figure A.2

Table A.2: UL reference measurement channel (12.2 kbps)

Parameter	Level	Unit
Information bit rate	12,2	kbps
DPCH	60	kbps
Power control	Off	
TFCI	On	
Repetition	22	%

A.3 UL reference measurement channel for 64 kbps

The parameters for the UL reference measurement channel for 64 kbps are specified in table A.3 and the channel coding is detailed in figure A.3.

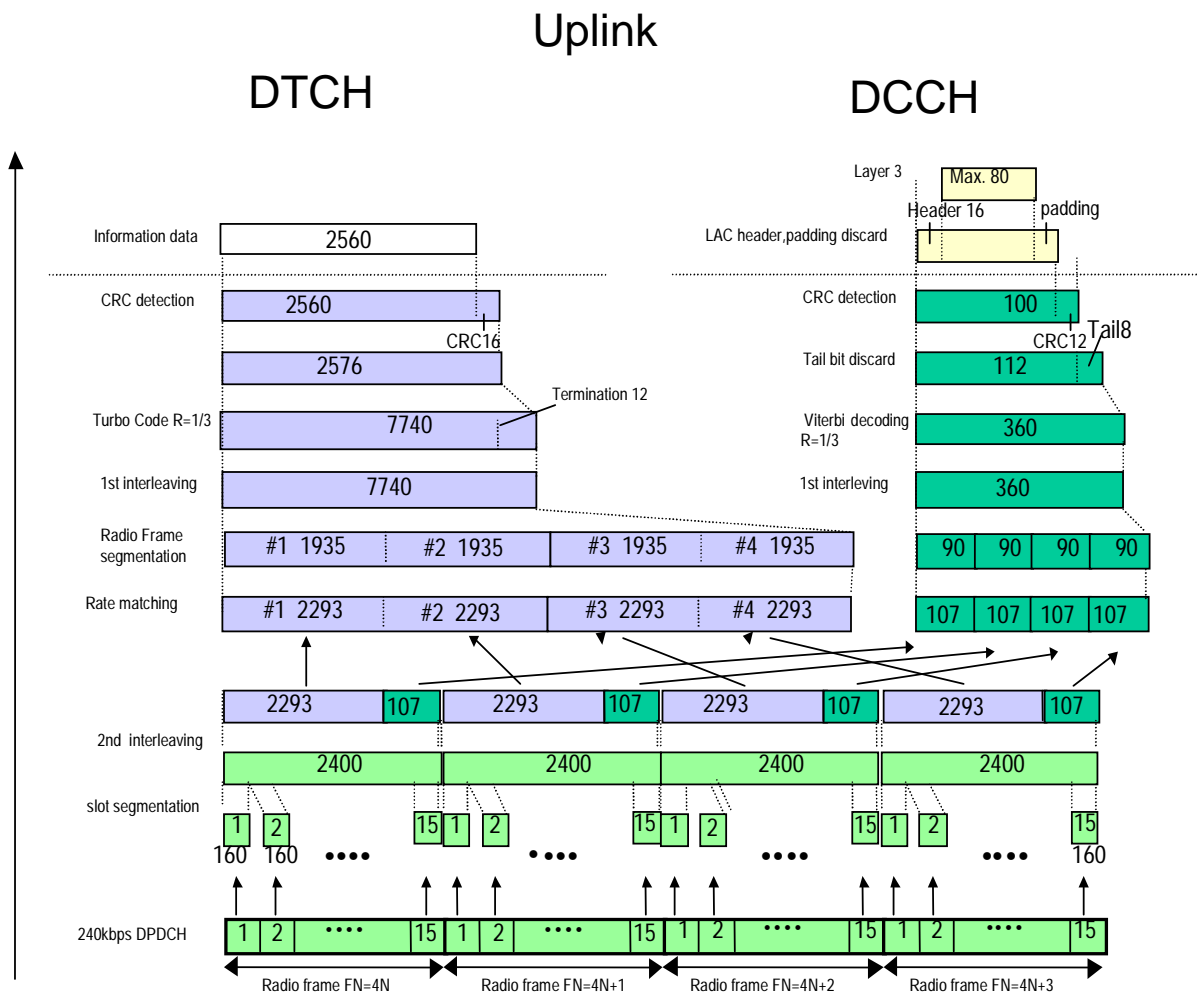

Figure A.3

Table A.3: UL reference measurement channel (64kbps)

Parameter	Level	Unit
Information bit rate	64	kbps
DPCH	240	kbps
Power control	Off	
TFCI	On	
Repetition	19	%

A.4 UL reference measurement channel for 144 kbps

The parameters for the UL reference measurement channel for 144 kbps are specified in table A.4 and the channel coding is detailed in figure A.4.

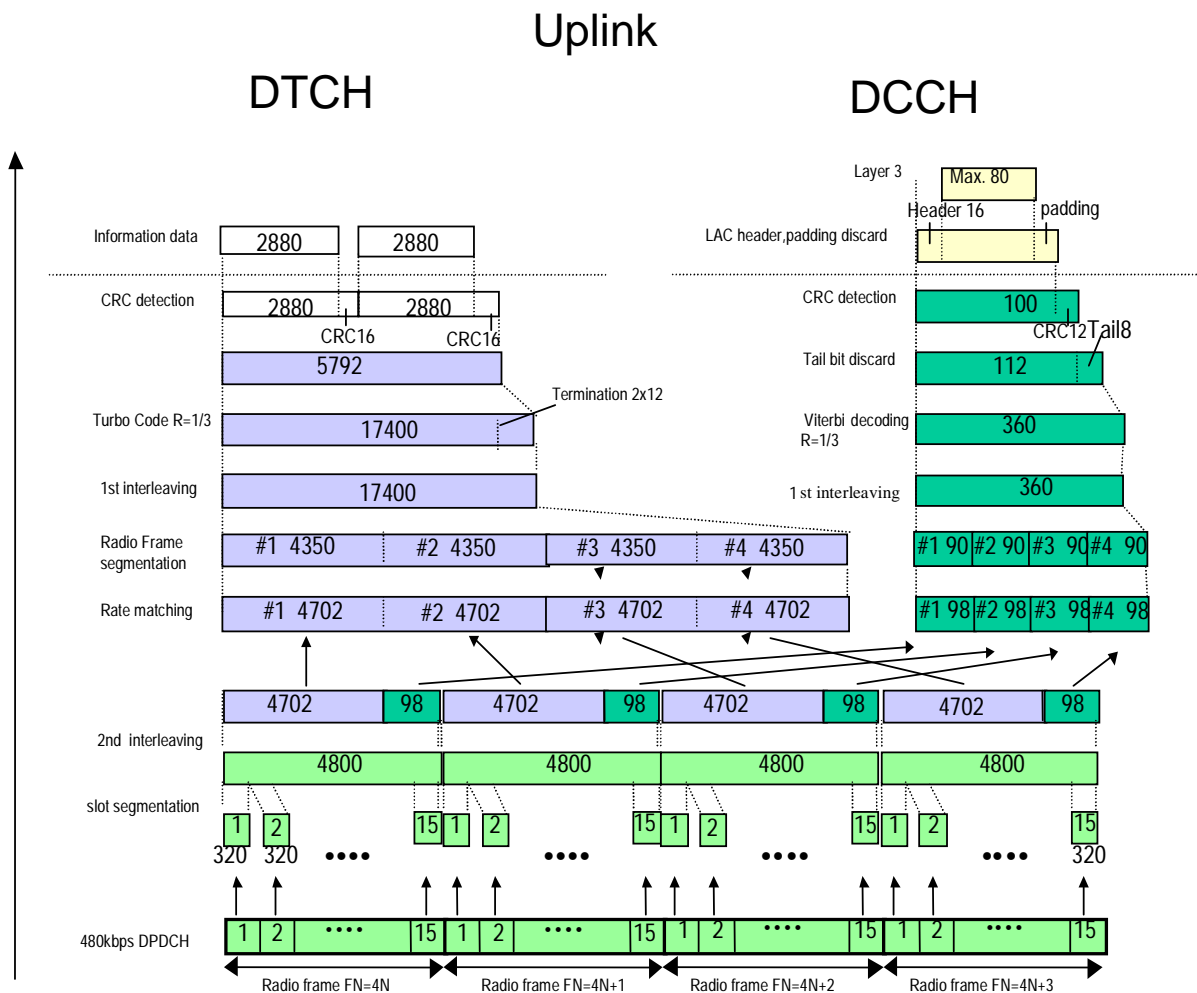

Figure A.4

Table A.4: UL reference measurement channel (144kbps)

Parameter	Level	Unit
Information bit rate	144	kbps
DPCH	480	kbps
Power control	Off	
TFCI	On	
Repetition	8	%

A.5 UL reference measurement channel for 384 kbps

The parameters for the UL reference measurement channel for 384 kbps are specified in table A.5 and the channel coding is detailed in figure A.5.

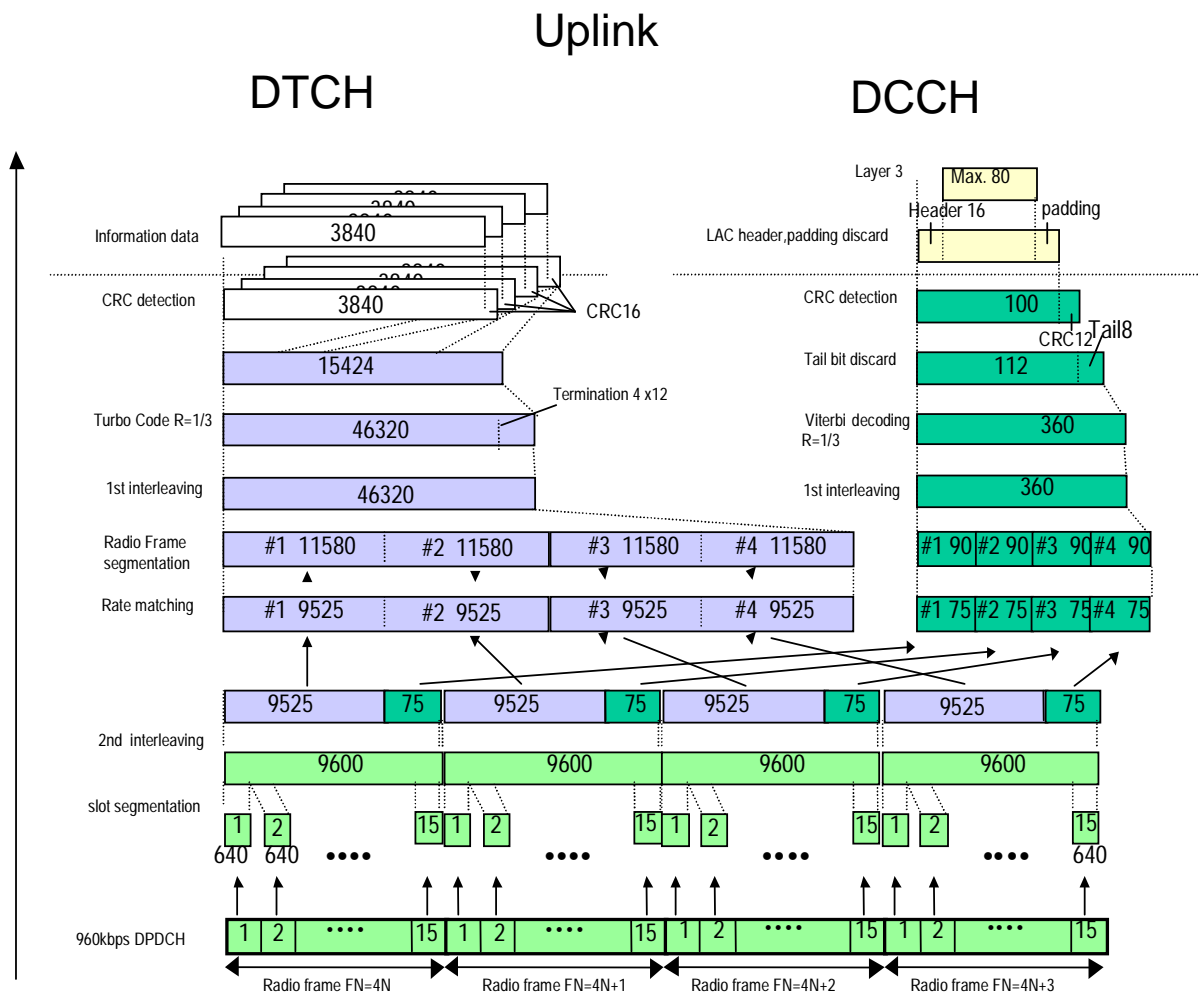

Figure A.5

Table A.5: UL reference measurement channel (384kbps)

Parameter	Level	Unit
Information bit rate	384	kbps
DPCH	960	kbps
Power control	Off	
TFCI	On	
Puncturing	18	%

A.6 (void)

Figure A.6: (void)

Table A.6: (void)

A.7 Reference measurement channels for UL RACH

The parameters for the UL RACH reference measurement channels are specified in Table A.7.

Table A.7: Reference measurement channels for UL RACH

Parameter		Unit
RACH	CRC	16 bits
	Channel Coding	Rate ½ conv. coding
	TTI	20 ms
	TB size	168, 360 bits
	Rate Matching	Repetition
	Number of diversity antennas	2
	Preamble detection window size	256 chips
	Ratio of preamble power and total message power (*)	0 dB
	Power ratio of RACH Control/Data TB = 168	-2.69 dB
Power ratio of Control/Data TB = 360	-3.52 dB	
NOTE *: If Power Offset Pp-m is used to adjust the power offset, Power Offset Pp-m shall be equal to -5 dB.		

A.8 (void)

Table A.8: (void)

A.9 Reference measurement channel for HS-DPCCH

The parameters for the UL HS-DPCCH reference measurement channel are specified in Table A.9.

Table A.9: Reference measurement channel for HS-DPCCH

		Parameter	Value	Unit
DPDCH	DTCH	Information bit rate	12.2	kbps
		Physical channel	60	kbps
		Repetition rate	22	%
	DCCH	Information bit rate	2.4	kbps
		Physical channel	15	kbps
		Repetition rate	22	%
	Spreading factor		64	
	Interleaving		20	ms
	Number of DPDCHs		1	
DPCCH	Dedicated pilot		6	Bits/slot
	Power control		2	Bits/slot
	TFCI		2	Bits/slot
	Spreading factor		256	
Power ratio of DPCCH/DPDCH		-2.69	dB	
Amplitude ratio of DPCCH/DPDCH		0.7333		
Closed loop power control		OFF		
Repetition factor of ACK/NACK		1		
HS-DPCCH power offset to DPCCH		0	dB	
HS-DPCCH timing offset to DPCCH		0	symbol	

DPDCH/DPCCH are same as 12.2kbps reference measurement channel specified in Annex A.2.

A.9A Reference measurement channel for 4C-HSDPA HS-DPCCH

The parameters for the 4C-HSDPA UL HS-DPCCH reference measurement channel are specified in Table A.9A.

For RRC configuration, 0 dB shall be used for HS-DPCCH power offset to DPCCH in the test. In the reference measurement channels, HS-DPCCH power offset to DPCCH in Table A.9A shall be used for the waveform during the test as per the rule in Table 2b in Section 5.1.2.5A in TS 25.214 [13].

Table A.9A: Reference measurement channels for 4C-HSDPA HS-DPCCH

Carrier Configuration		Parameter					Unit	
		4/4/4	4/4/2	3/3/3	3/2/1	3/3/0		
DPDCH	DTCH	Information bit rate	12.2					kbps
		Physical channel	60					kbps
		Repetition rate	22					%
	DCCH	Information bit rate	2.4					kbps
		Physical channel	15					kbps
		Repetition rate	22					%
	Spreading factor		64					
	Interleaving		20					Ms
Number of DPDCHs		1						
DPCCH	Dedicated pilot		6					bits/slot
	Power control		2					bits/slot
	TFCI		2					bits/slot
	Spreading factor		256					
Power ratio of DPCCH/DPDCH		-2.69					dB	
Amplitude ratio of DPCCH/DPDCH		0.7333						
Closed loop power control		OFF						
HS-DPCCH repetition		1						
HS-DPCCH power offset to DPCCH		4.08	2.05	4.08	2.05	2.05	dB	
HS-DPCCH timing offset to DPCCH		0					Symbol	
HS-DPCCH spreading factor		128	128	128	128	256		
Secondary_Cell_Enabled		3	3	2	2	2		
Secondary_Cell_Active		3	1	2	1	2		
Number of MIMO carriers		4	2	3	1	0		
Codebook		Rel10 DC-MIMO codebook	Rel10 DC-MIMO codebook repeated	Rel10 DC-MIMO codebook	Rel10 DC-MIMO codebook repeated	Rel10 TC-MIMO codebook		
		Notes 2		Notes 3	Note 3			
<p>Note 1: Carrier configuration X/Y/Z denotes X number of carriers configured, Y number of active carriers, and Z number of carriers configured as MIMO out of Y carriers. However, the configuration during the test follows Table 8.17C in TS 25.104.</p> <p>Note 2: If the NodeB is not capable of MIMO on all 4 active carriers, the maximum supportable number of MIMO carriers is configured.</p> <p>Note 3: Optional: Applies only if the NodeB is not capable of simultaneous 4 carrier operation.</p>								

A.10 Summary of E-DPDCH Fixed reference channels

Table A.10.

Fixed Ref Channel	TTI [ms]	N _{INF}	SF ₁	SF ₂	SF ₃	SF ₄	N _{BIN}	Coding rate	Max inf bit rate [kbps]
FRC1	2	2706	4	4	0	0	3840	0.705	1353.0
FRC2	2	5412	2	2	0	0	7680	0.705	2706.0
FRC3	2	8100	2	2	4	4	11520	0.703	4050.0
FRC4	10	5076	4	0	0	0	9600	0.529	507.6
FRC5	10	9780	4	4	0	0	19200	0.509	978.0
FRC6	10	19278	2	2	0	0	38400	0.502	1927.8
FRC7	10	690	16	0	0	0	2400	0.288	69.0
FRC8	2	16218	2	2	4	4	23040	0.704	8109.0
FRC9	2	16200	2	2	4	4	23040	0.703	8100.0
FRC10	2	32436	2	2	4	4	46080	0.704	16218.0

A.11 E-DPDCH Fixed reference channel 1 (FRC1)

Table A.11

Parameter	Unit	Value
Maximum. Inf. Bit Rate	kbps	1353.0
TTI	ms	2
Number of HARQ Processes	Processes	8
Information Bit Payload (N_{INF})	Bits	2706
Binary Channel Bits per TTI (N_{BIN}) ($3840 / SF \times TTI$ sum for all channels)	Bits	3840
Coding Rate (N_{INF} / N_{BIN})		0.705
Physical Channel Codes	SF for each physical channel	{4,4}
E-DPDCH testing: E-DPDCH/DPCCH power ratio E-DPCCH/DPCCH power ratio	dB dB dB dB	Diversity: 8.94 Non-diversity: 12.04 Diversity: 2.05 Non-diversity: 6.02 E-DPDCH /DPCCH power ratio is calculated for a single E-DPDCH.
E-DPCCH missed detection testing: E-DPDCH/DPCCH power ratio E-DPCCH/DPCCH power ratio	dB dB dB dB	Diversity: 8.94 Non-diversity: 12.04 Diversity: -1.94 Non-diversity: 0.00

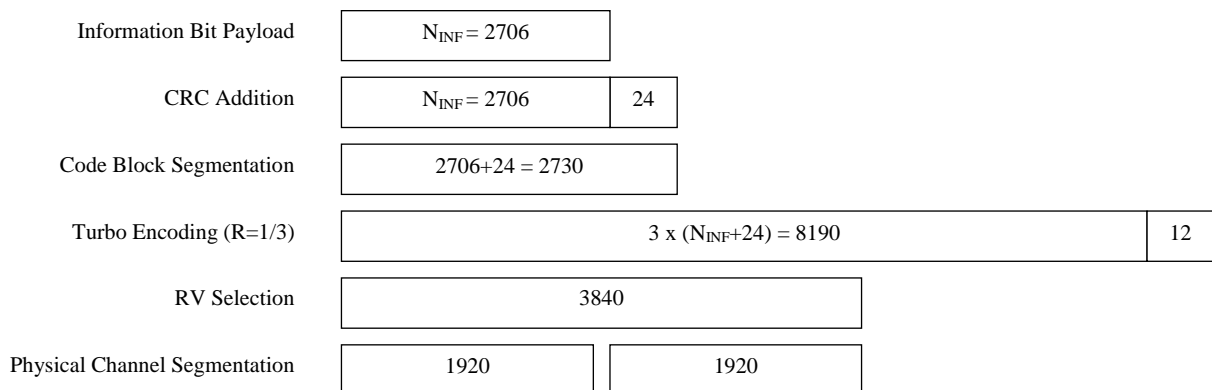

Figure A.11

A.12 E-DPDCH Fixed reference channel 2 (FRC2)

Table A.12

Parameter	Unit	Value
Maximum. Inf. Bit Rate	kbps	2706.0
TTI	ms	2
Number of HARQ Processes	Processes	8
Information Bit Payload (N_{INF})	Bits	5412
Binary Channel Bits per TTI (N_{BIN}) (3840 / SF x TTI sum for all channels)	Bits	7680
Coding Rate (N_{INF}/ N_{BIN})		0.705
Physical Channel Codes	SF for each physical channel	{2,2}
E-DPDCH testing: E-DPDCH/DPCCH power ratio E-DPCCH/DPCCH power ratio	dB dB dB dB	Diversity: 9.92 Non-diversity: 13.00 Diversity: 4.08 Non-diversity: 6.02 E-DPDCH /DPCCH power ratio is calculated for a single E-DPDCH.

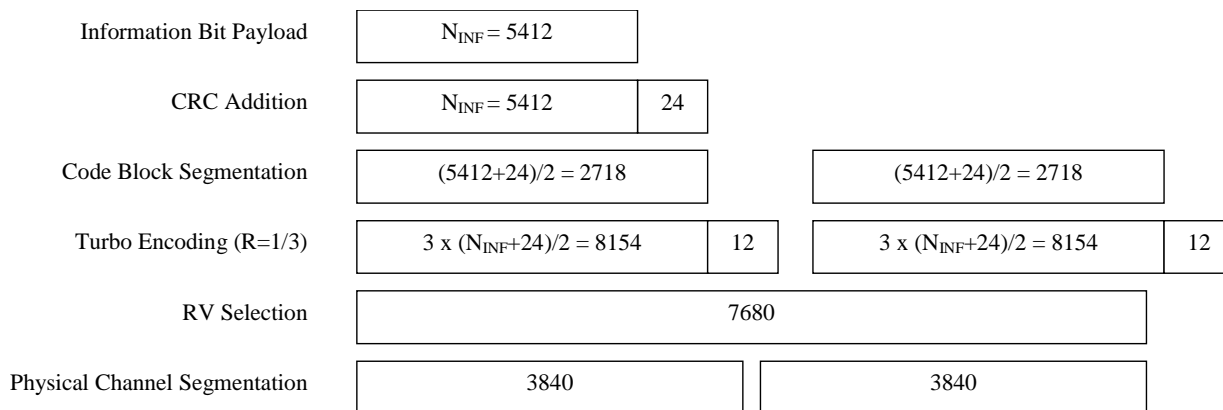

Figure A.12

A.13 E-DPDCH Fixed reference channel 3 (FRC3)

Table A.13

Parameter	Unit	Value
Maximum. Inf. Bit Rate	kbps	4050.0
TTI	ms	2
Number of HARQ Processes	Processes	8
Information Bit Payload (N_{INF})	Bits	8100
Binary Channel Bits per TTI (N_{BIN}) (3840 / SF x TTI sum for all channels)	Bits	11520
Coding Rate (N_{INF} / N_{BIN})		0.703
Physical Channel Codes	SF for each physical channel	{2,2,4,4}
E-DPDCH testing: E-DPDCH/DPCCH power ratio E-DPCCH/DPCCH power ratio	dB dB dB dB	Diversity: 6.02 Non-diversity: 8.94 Diversity: 0.0 Non-diversity: 2.05 E-DPDCH/DPCCH power ratio is calculated for a single E-DPDCH with SF 4. The power of an E-DPDCH with SF2 is twice that of an E-DPDCH with SF4.

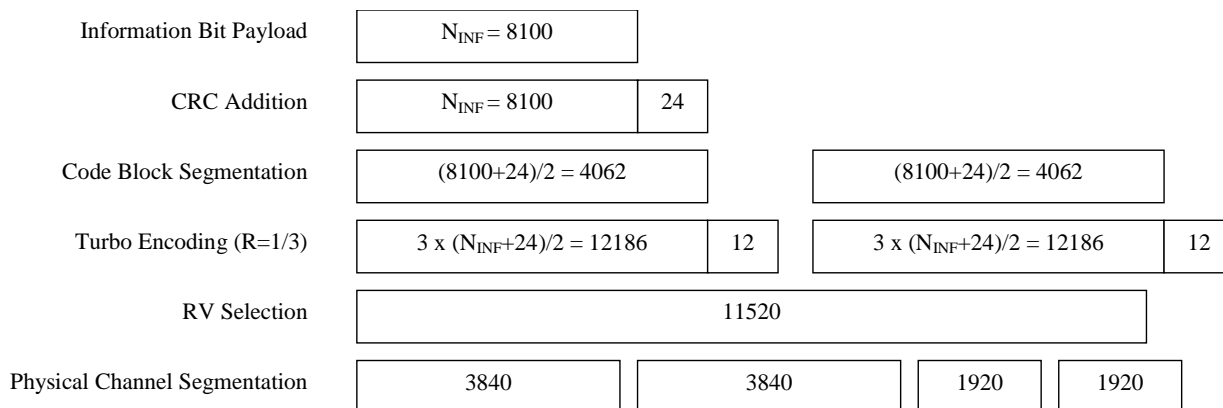

Figure A.13

A.14 E-DPDCH Fixed reference channel 4 (FRC4)

Table A.14

Parameter	Unit	Value
Maximum. Inf. Bit Rate	kbps	507.6
TTI	ms	10
Number of HARQ Processes	Processes	4
Information Bit Payload (N_{INF})	Bits	5076
Binary Channel Bits per TTI (N_{BIN}) ($3840 / SF \times TTI$ sum for all channels)	Bits	9600
Coding Rate (N_{INF} / N_{BIN})		0.529
Physical Channel Codes	SF for each physical channel	{4}
E-DPDCH testing: E-DPDCH/DPCCH power ratio	dB	Diversity: 8.94
E-DPCCH/DPCCH power ratio	dB	Non-diversity: 12.04
	dB	Diversity: -1.94
	dB	Non-diversity: 0.0
E-DPCCH missed detection testing: E-DPDCH/DPCCH power ratio	dB	Diversity: 8.94
	dB	Non-diversity: 12.04
E-DPCCH/DPCCH power ratio	dB	Diversity: -7.96
	dB	Non-diversity: -5.46

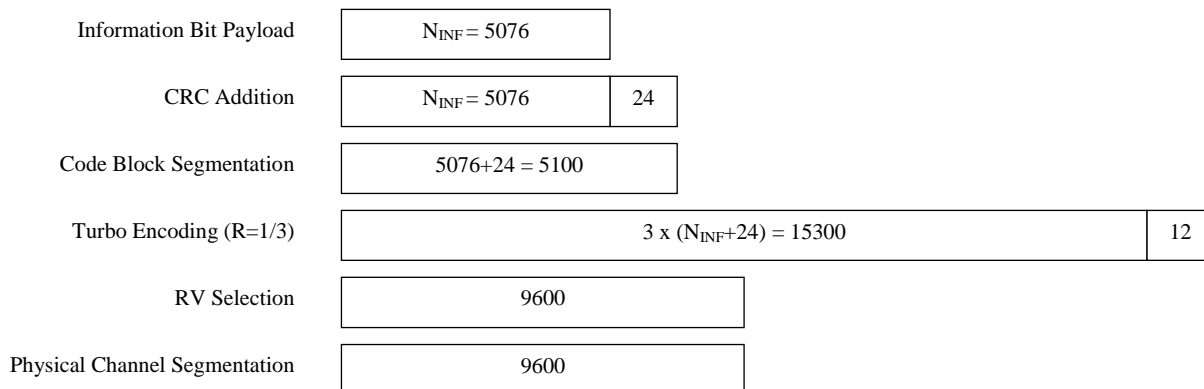

Figure A.14

A.15 E-DPDCH Fixed reference channel 5 (FRC5)

Table A.15

Parameter	Unit	Value
Maximum. Inf. Bit Rate	kbps	978.0
TTI	ms	10
Number of HARQ Processes	Processes	4
Information Bit Payload (N_{INF})	Bits	9780
Binary Channel Bits per TTI (N_{BIN}) (3840 / SF x TTI sum for all channels)	Bits	19200
Coding Rate (N_{INF} / N_{BIN})		0.509
Physical Channel Codes	SF for each physical channel	{4,4}
E-DPDCH testing: E-DPDCH/DPCCH power ratio E-DPCCH/DPCCH power ratio	dB dB dB dB	Diversity: 8.94 Non-diversity: 12.04 Diversity: -1.94 Non-diversity: 0.0 E-DPDCH /DPCCH power ratio is calculated for a single E-DPDCH.

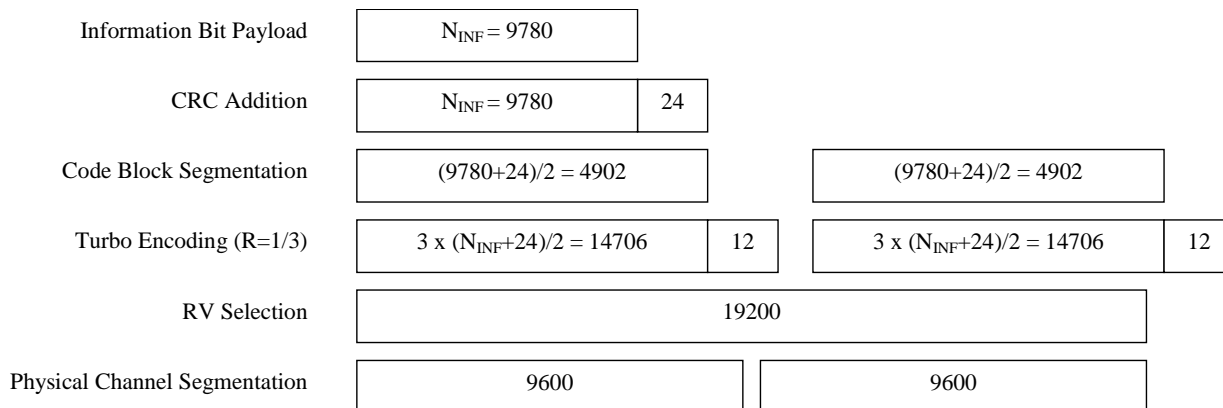

Figure A.15

A.16 E-DPDCH Fixed reference channel 6 (FRC6)

Table A.16

Parameter	Unit	Value
Maximum. Inf. Bit Rate	kbps	1927.8
TTI	ms	10
Number of HARQ Processes	Processes	4
Information Bit Payload (N_{INF})	Bits	19278
Binary Channel Bits per TTI (N_{BIN}) (3840 / SF x TTI sum for all channels)	Bits	38400
Coding Rate (N_{INF}/ N_{BIN})		0.502
Physical Channel Codes	SF for each physical channel	{2,2}
E-DPDCH testing: E-DPDCH/DPCCH power ratio E-DPCCH/DPCCH power ratio	dB dB dB dB	Diversity: 9.92 Non-diversity: 13.00 Diversity: -5.46 Non-diversity: -1.94 E-DPDCH /DPCCH power ratio is calculated for a single E-DPDCH.

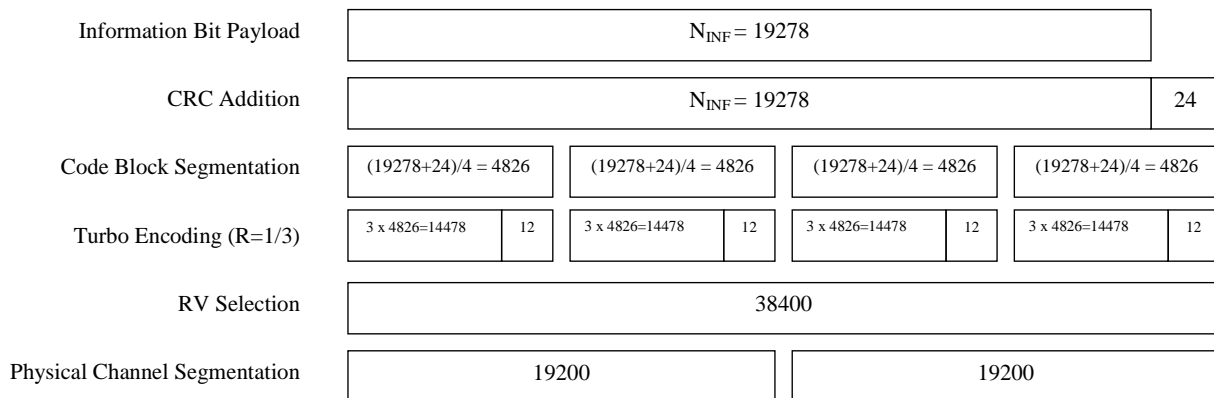

Figure A.16

A.17 E-DPDCH Fixed reference channel 7 (FRC7)

Table A.17

Parameter	Unit	Value
Maximum. Inf. Bit Rate	kbps	69.0
TTI	ms	10
Number of HARQ Processes	Processes	4
Information Bit Payload (N_{INF})	Bits	690
Binary Channel Bits per TTI (N_{BIN}) (3840 / SF x TTI sum for all channels)	Bits	2400
Coding Rate (N_{INF}/ N_{BIN})		0.288
Physical Channel Codes	SF for each physical channel	{16}
E-DPDCH testing: E-DPDCH/DPCCH power ratio E-DPCCH/DPCCH power ratio	dB dB dB dB	Diversity: 6.02 Non-diversity: 8.94 Diversity: 0.0 Non-diversity: 4.08

Information Bit Payload	N _{INF} = 690	
CRC Addition	N _{INF} = 690	24
Code Block Segmentation	690+24 = 714	
Turbo Encoding (R=1/3)	3 x (N _{INF} +24) = 2142	
RV Selection	2400	
Physical Channel Segmentation	2400	

Figure A.17

A.18 E-DPDCH Fixed reference channel 8 (FRC8)

Table A.18

Parameter	Unit	Value
Modulation		16QAM
Maximum. Inf. Bit Rate	kbps	8109.0
TTI	ms	2
Number of HARQ Processes	Processes	8
Information Bit Payload (N _{INF})	Bits	16218
Binary Channel Bits per TTI (NBIN) (3840 / SF x TTI sum for all channels)	Bits	23040
Coding Rate (N _{INF} / NBIN)		0.704
Physical Channel Codes	SF for each physical channel	{2,2,4,4}
E-DPDCH testing:		Non E-DPCCH boosting
E-DPDCH/DPCCH power ratio	dB	Diversity: 4.09
E-DPCCH/DPCCH power ratio	dB	Non-diversity: 6.98
	dB	Diversity: -9.54
	dB	Non-diversity: -5.46
ΔT2TP	dB	E-DPCCH Boosting
E-DPDCH/DPCCH power ratio	dB	Diversity: 12
E-DPCCH/DPCCH power ratio	dB	Non-diversity: 15
	dB	Diversity: 19.99
	dB	Non-diversity: 22.00
	dB	Diversity: 16.03
	dB	Non-diversity: 14.09
E-DPDCH/DPCCH power ratio is calculated for a single E-DPDCH with SF 4. The power of an E-DPDCH with SF2 is twice that of an E-DPDCH with SF4.		

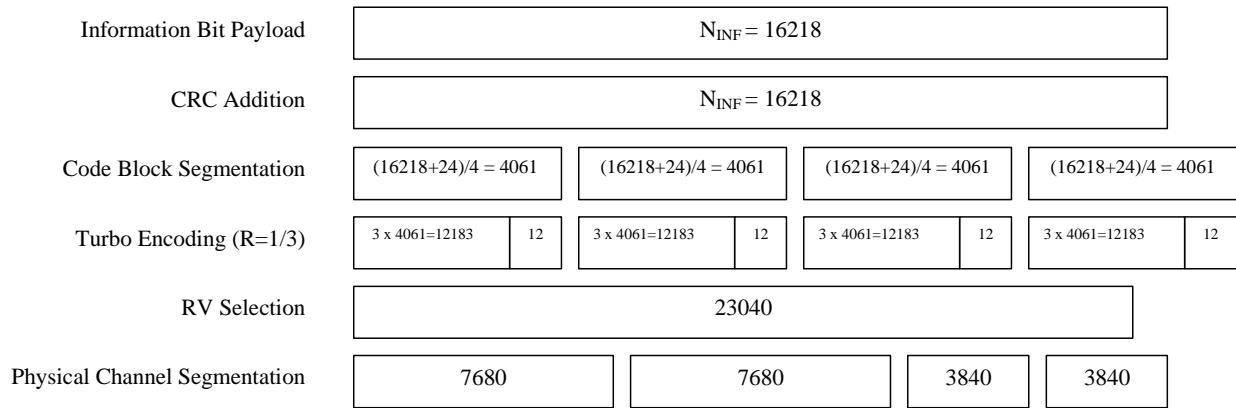

Figure A.18

A.19 E-DPDCH Fixed reference channel 9 (FRC9)

Table A.19

Parameter	Unit	Value
Modulation		QPSK
Maximum. Inf. Bit Rate	kbps	8100
TTI	ms	2
Number of HARQ Processes	Processes	8
Information Bit Payload (N_{INF})	Bits	16200
Binary Channel Bits per TTI (N_{BIN}) (3840 / SF x TTI sum for all channels)	Bits	23040
Coding Rate (N_{INF}/ N_{BIN})		0.703
Physical Channel Codes	SF for each physical channel	{2,2,4,4}
E-DPDCH/DPCCH power ratio	dB	6.02
E-DPCCH/DPCCH power ratio	dB	-1.94
S-DPCCH/DPCCH power ratio	dB	-1.94
S-E-DPCCH/DPCCH power ratio	dB	0.00
S-E-DPDCH/DPCCH power ratio	dB	6.02
		E-DPDCH/DPCCH power ratio is calculated for a single E-DPDCH with SF 4. The power of an E-DPDCH with SF2 is twice that of an E-DPDCH with SF4.

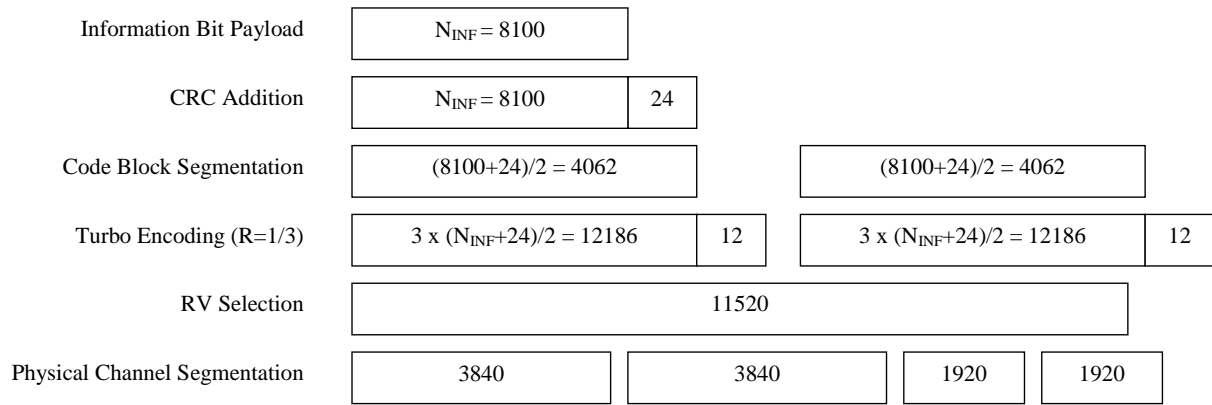

Figure A.19 E-DPDCH

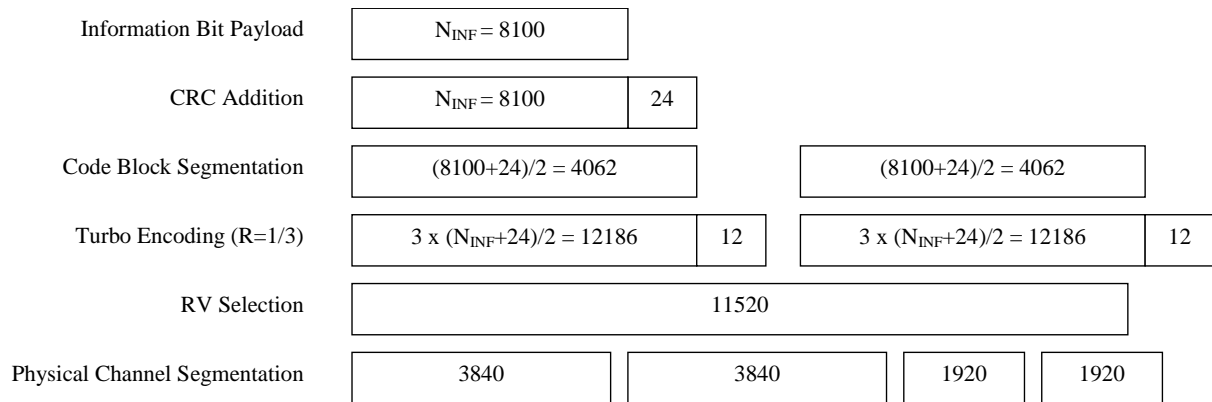

Figure A.19A S-E-DPDCH

A.20 E-DPDCH Fixed reference channel 10 (FRC10)

Table A.20

Parameter	Unit	Value
Modulation		16QAM
Maximum. Inf. Bit Rate	kbps	16218
TTI	ms	2
Number of HARQ Processes	Processes	8
Information Bit Payload (N_{INF})	Bits	32436
Binary Channel Bits per TTI (N_{BIN}) (3840 / SF x TTI sum for all channels)	Bits	46080
Coding Rate (N_{INF}/ N_{BIN})		0.704
Physical Channel Codes	SF for each physical channel	{2,2,4,4}
E-DPDCH/DPCCH power ratio E-DPCCH/DPCCH power ratio S-DPCCH/DPCCH power ratio S-E-DPCCH/DPCCH power ratio S-E-DPDCH/DPCCH power ratio	dB dB dB dB dB	19.99 16.03 16.03 6.02 19.99 E-DPDCH/DPCCH power ratio is calculated for a single E-DPDCH with SF 4. The power of an E-DPDCH with SF2 is twice that of an E-DPDCH with SF4.

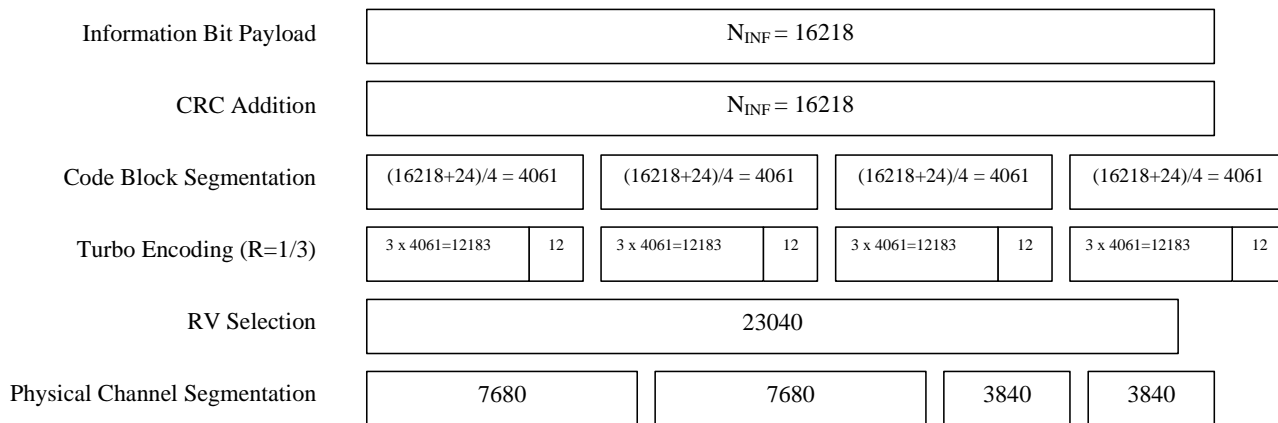

Figure A.20 E-DPDCH

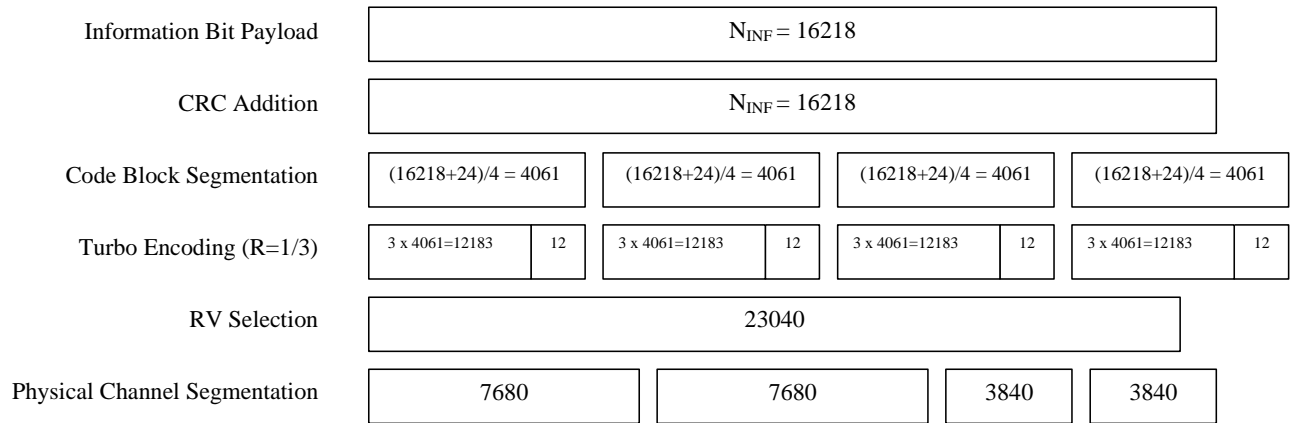

Figure A.20A S-E-DPDCH

Annex B (informative): Measurement system set-up

Example of measurement system set-ups are attached below as an informative annex.

B.1 Transmitter

B.1.1 Maximum output power, total power dynamic range

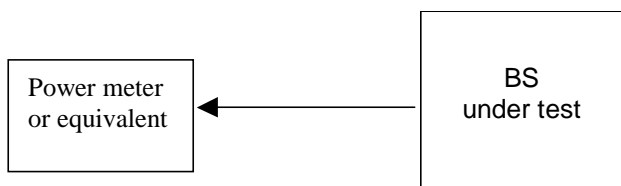

Figure B.1: Measuring system Set-up for maximum output power, total power dynamic range

B.1.2 Frequency, Code Power and Transmit Modulation

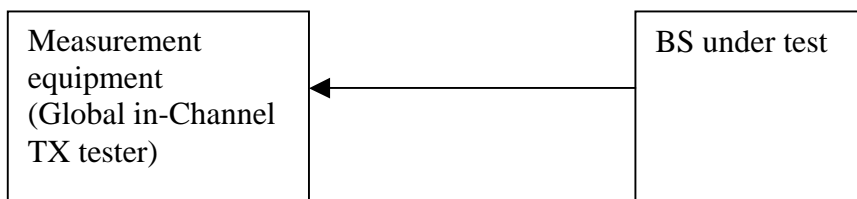

Figure B.2: Measurement system set up for RF frequency, several code power tests and transmit modulation (EVM, RCDE and PCDE)

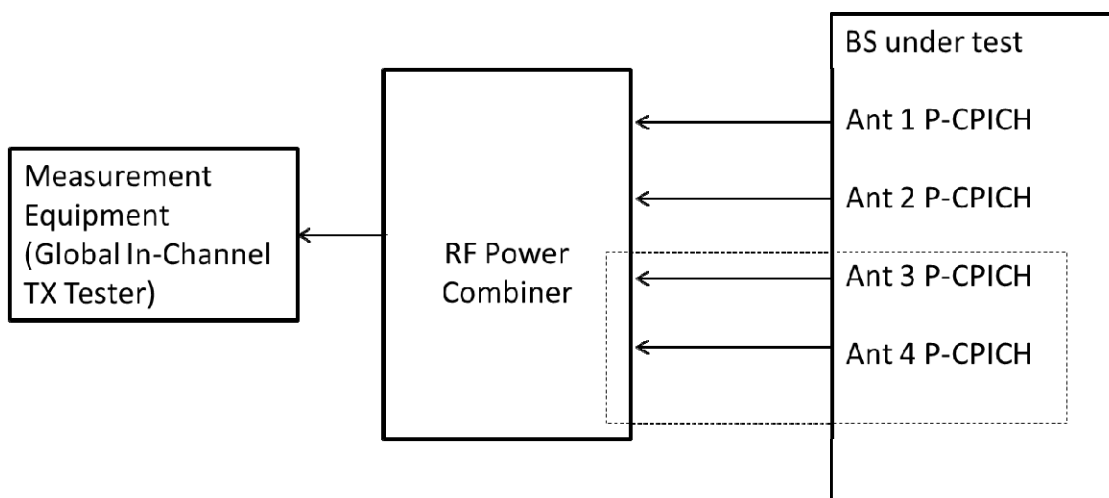

Figure B.2A: Measurement system set-up for S-CPICH power offset accuracy. For MIMO mode with two antennas the components surrounded by the dashed line do not exist.

B.1.3 Power control steps and power control dynamic range

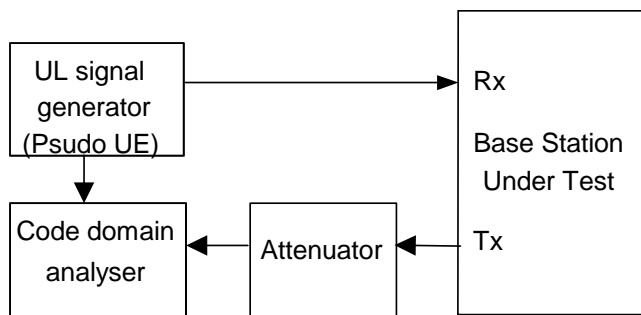

Figure B.3: Measuring system Set-up for power control steps and power control dynamic range measurements

B.1.4 Out of band emission

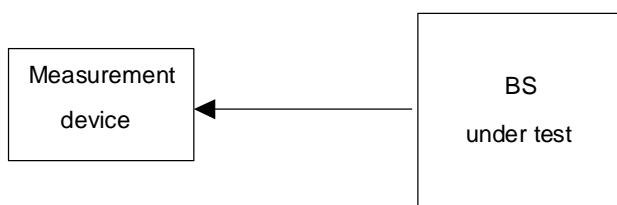

Figure B.4: Measuring system Set-up for Out of band emission measurements

B.1.5 Transmit intermodulation

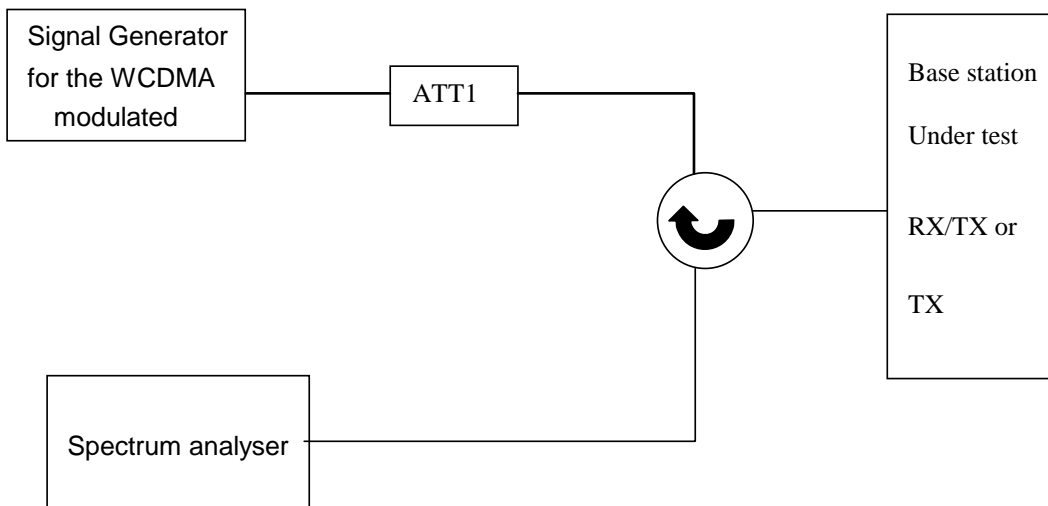

Figure B.5: Measuring system Set-up for Base Station Transmit Intermodulation Tests

B.1.6 Time alignment error in TX diversity, MIMO, DC-HSDPA, DB-DC-HSDPA and 4C-HSDPA

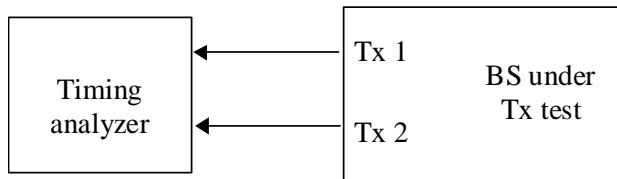

Figure B.6: Measuring system set-up for time alignment error in TX diversity, MIMO, DC-HSDPA and DB-DC-HSDPA transmission (one of Tx1 or Tx2 may not be used for DC-HSDPA or 4C-HSDPA)

B.1.7 Home BS output power for adjacent channel protection

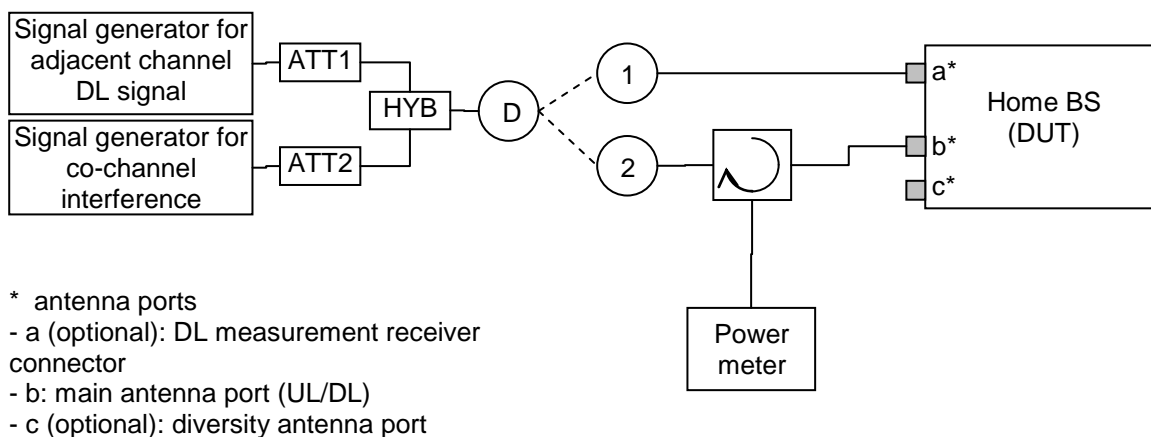

Figure B.7: Measuring system set-up for Home BS output power for adjacent channel protection

B.2 Receiver

B.2.1 Reference sensitivity level

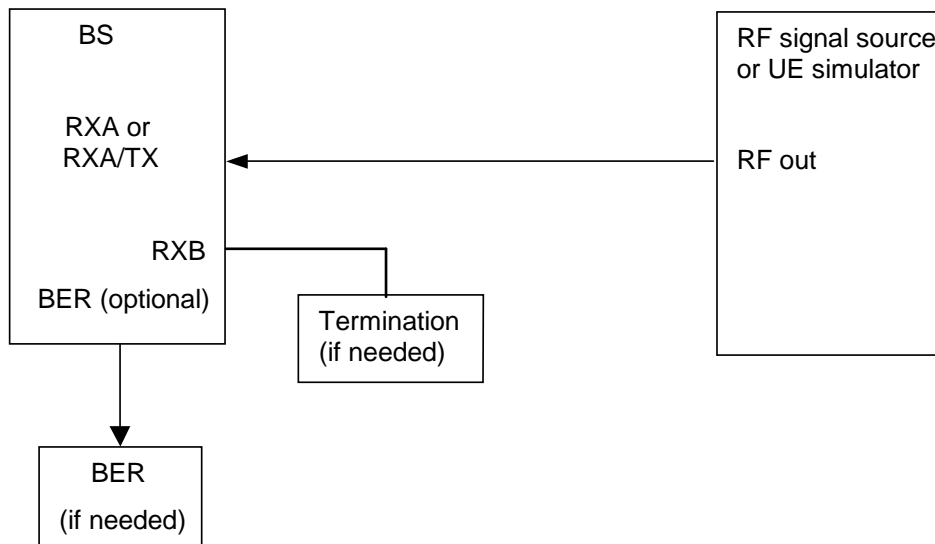

Figure B.7: Measuring system Set-up for Base Station Reference sensitivity level Testes

B.2.2 Dynamic range

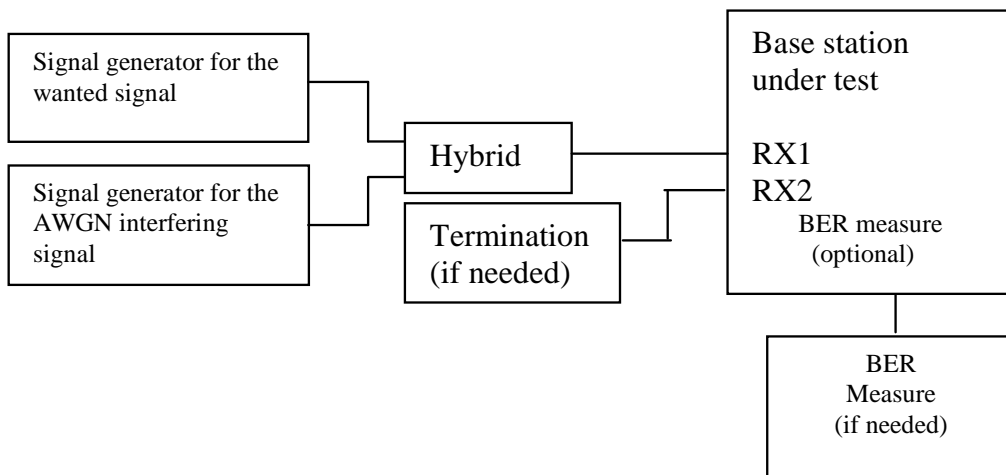

Figure B.8: Measuring system Set-up for Dynamic range

B.2.3 Adjacent Channel Selectivity (ACS)

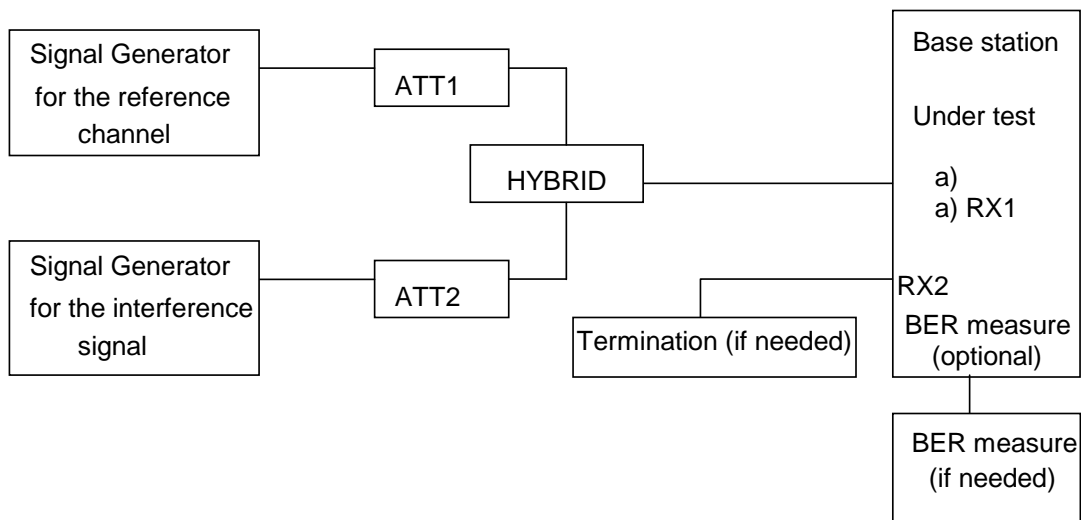

Figure B.9: Measuring system Set-up for Adjacent channel selectivity

B.2.4 Blocking characteristics

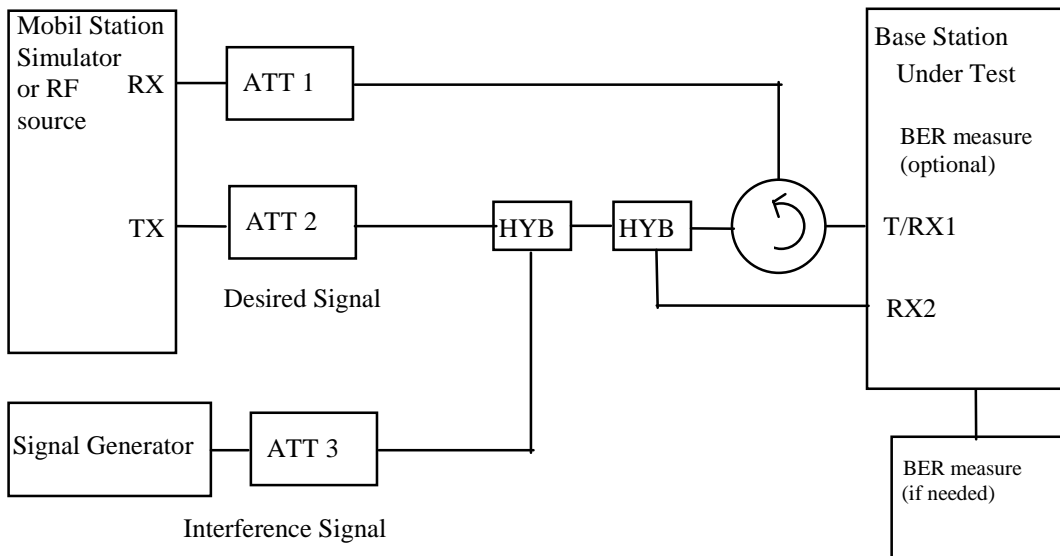

Figure B.10: Measuring system Set-up for Blocking characteristics

B.2.5 Intermodulation characteristics

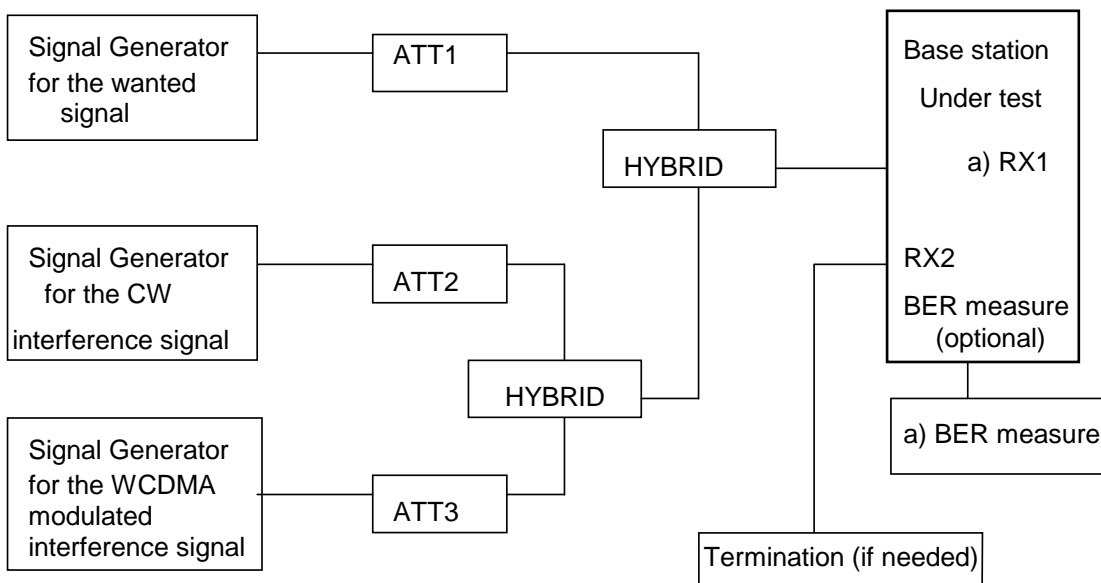

Figure B.11: Measuring system Set-up for intermodulation characteristics

B.2.6 Receiver spurious emission

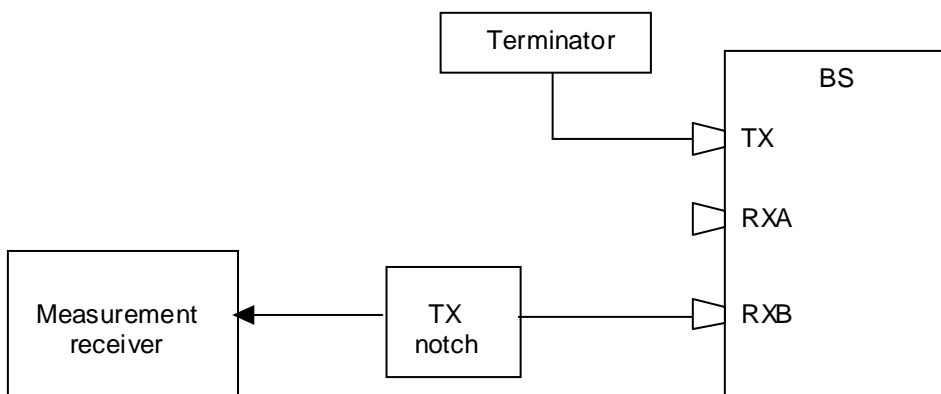

Figure B.12: Measuring system Set-up for Receiver spurious emission

B.3 Performance requirement

B.3.1 Demodulation of DCH, RACH and HS-DPCCH signalling in static conditions

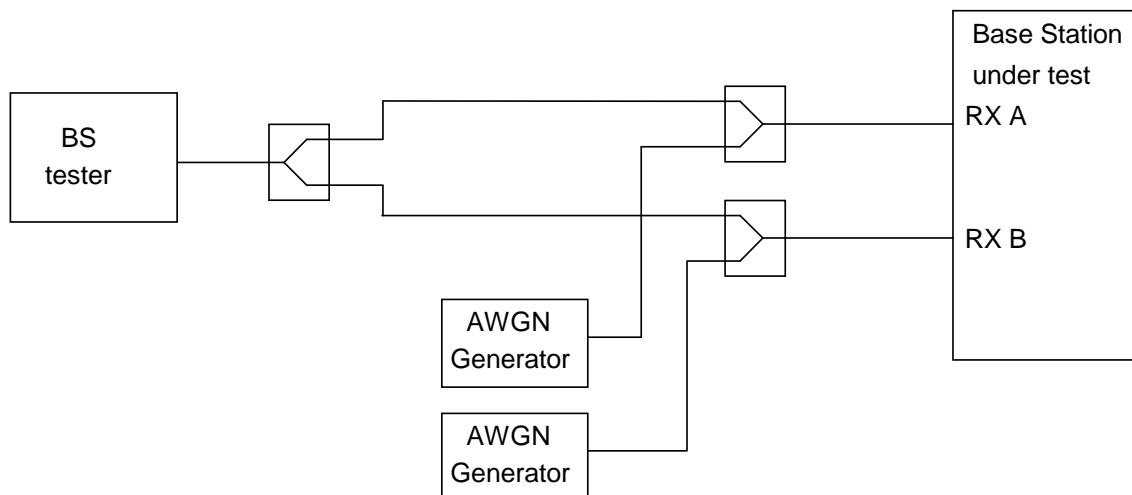

Figure B.13: Functional Set-up for Demodulation of DCH, RACH and HS-DPCCH in static conditions for BS with Rx diversity

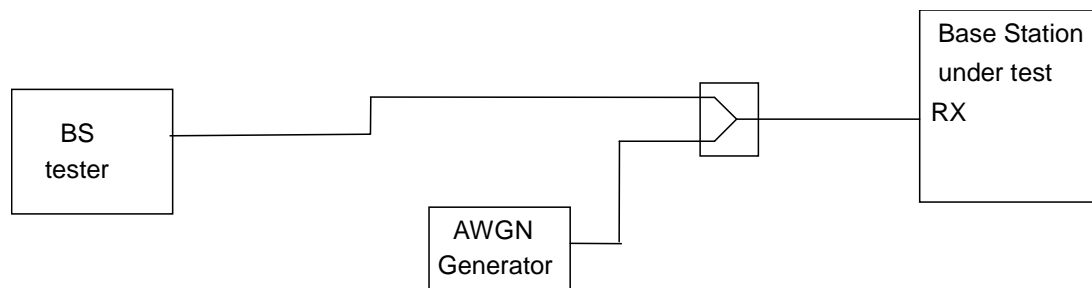

Figure B.13A: Functional Set-up for Demodulation of DCH, RACH and HS-DPCCH in static conditions for BS without Rx diversity

B.3.2 Demodulation of DCH, RACH and HS-DPCCH signalling in multipath fading conditions

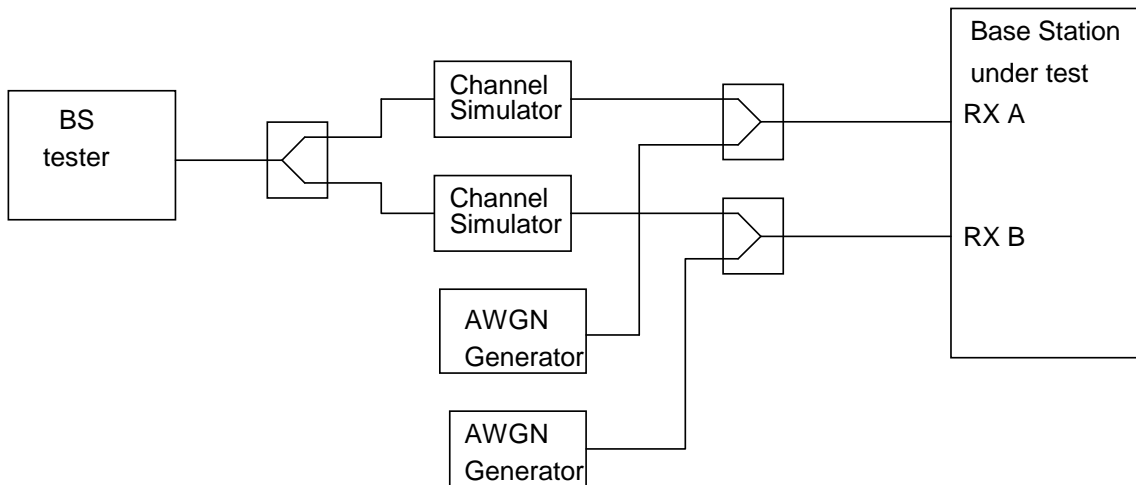

Figure B.14: Functional Set-up for Demodulation of DCH, RACH and HS-DPCCH in multipath fading conditions for BS with Rx diversity

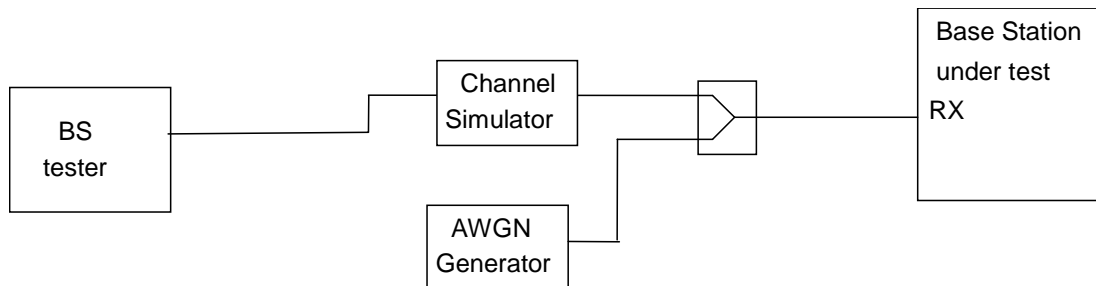

Figure B.14A: Functional Set-up for Demodulation of DCH, RACH and HS-DPCCH in multi-path fading conditions for BS without Rx diversity

B.3.3 Verification of the internal BER and BLER calculation

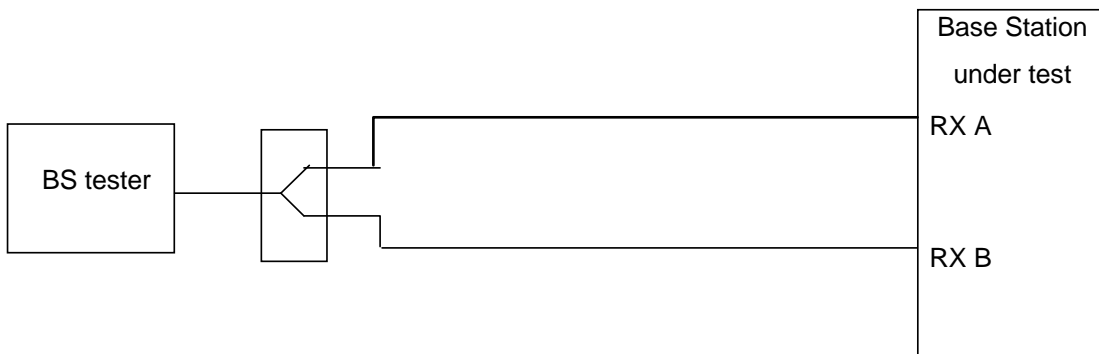

Figure B.15: Functional Set-up for Verification of the internal BLER calculation for BS with Rx diversity



Figure B.15A: Functional Set-up for Verification of the internal BLER calculation for BS without Rx diversity

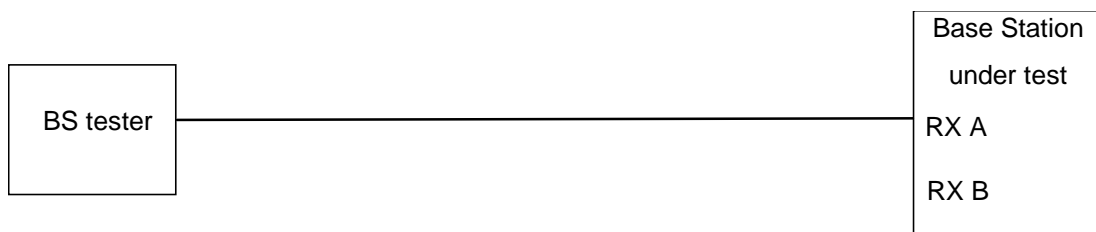
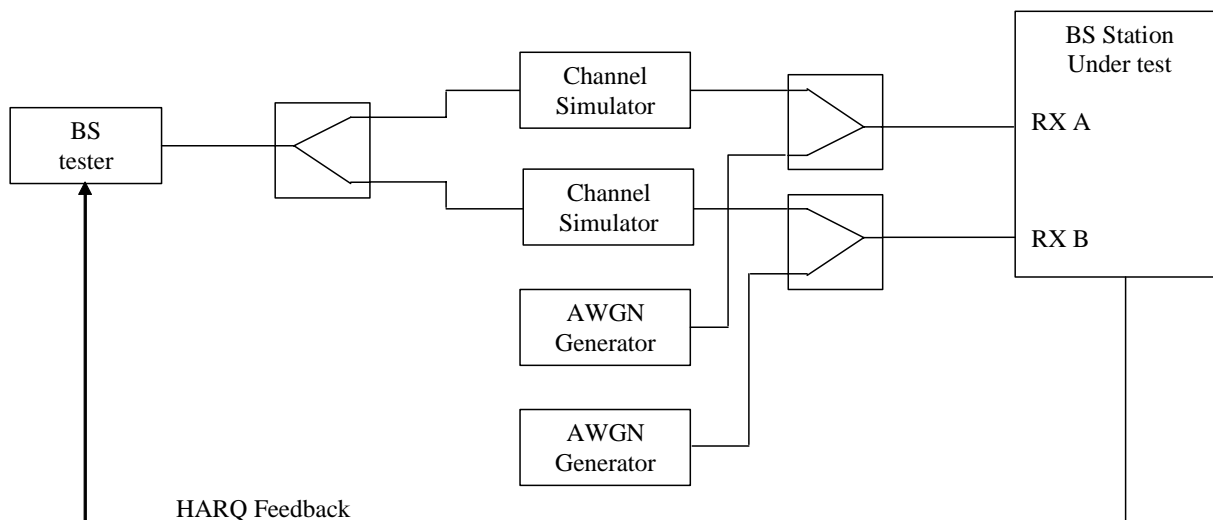

Figure B.16: Functional Set-up for Verification of the internal BER calculation

B.3.4 Demodulation of E-DPDCH, S-E-DPDCH and E-DPCCH signalling in multipath fading conditions



NOTE: The HARQ feedback could be done as an RF feedback or as a digital feedback. The HARQ feedback should be error free.

Figure B.17: Functional Set-up for Demodulation of E-DPDCH and E-DPCCH in multipath fading conditions for BS with Rx diversity

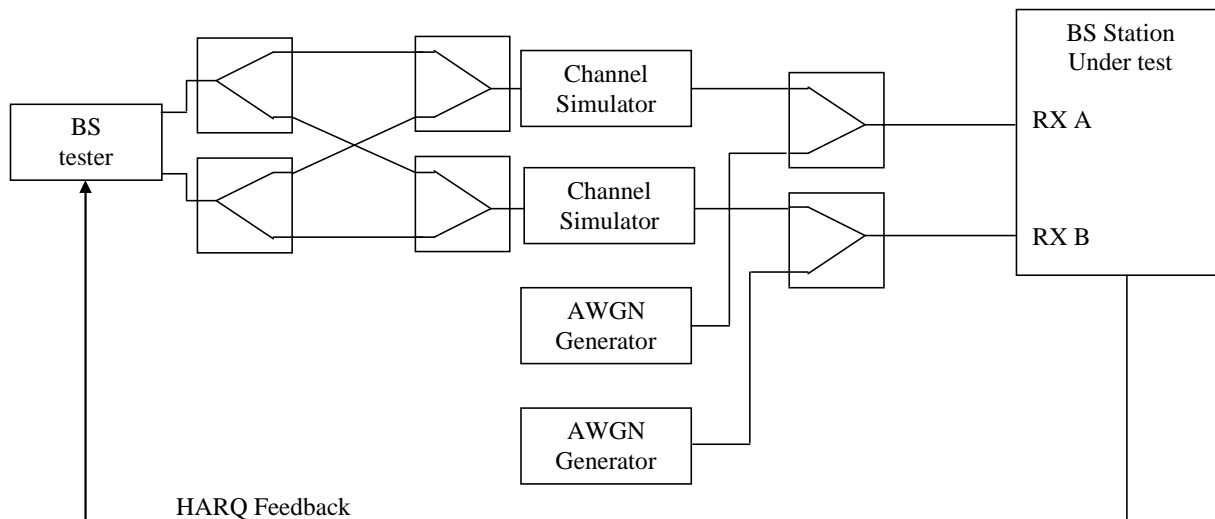

NOTE: The HARQ feedback could be done as an RF feedback or as a digital feedback. The HARQ feedback should be error free.

Figure B.17A: Functional Set-up for Demodulation of E-DPDCH and S-E-DPDCH in multipath fading conditions for UL MIMO

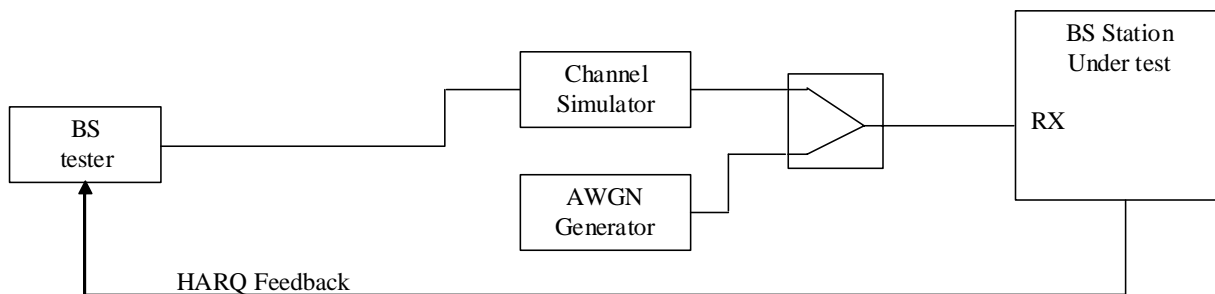

NOTE: The HARQ feedback could be done as an RF feedback or as a digital feedback. The HARQ feedback should be error free.

Figure B.18: Functional Set-up for Demodulation of E-DPDCH and E-DPCCH in multipath fading conditions for BS without Rx diversity

B.3.5 Demodulation of DCH in moving propagation conditions or birth-death propagation conditions, or Demodulation of DCH, RACH in high speed train conditions

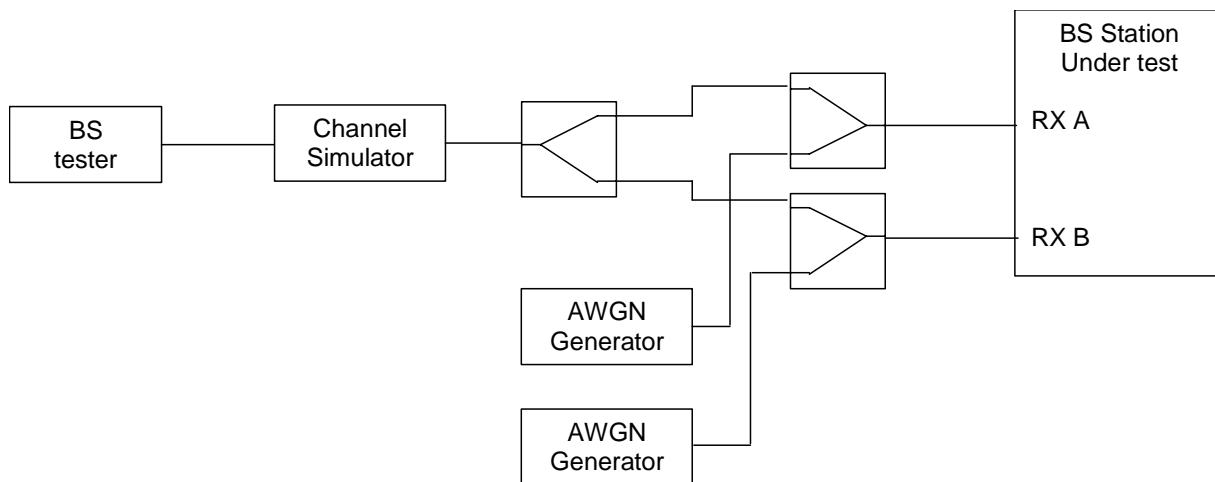

Figure B.19: Functional Set-up for Demodulation of DCH in moving propagation conditions or birth-death propagation conditions, or Demodulation of DCH, RACH in high speed train conditions for BS with Rx diversity

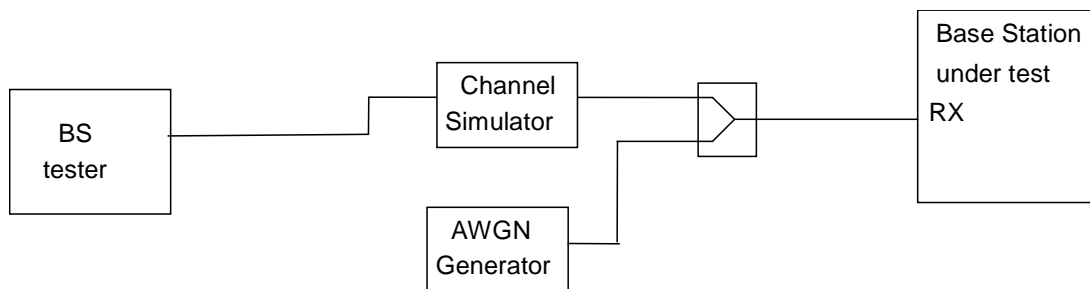

Figure B.20: Functional Set-up for Demodulation of DCH in moving propagation conditions or birth-death propagation conditions, or Demodulation of DCH, RACH in high speed train conditions for BS without Rx diversity

Annex C (normative): General rules for statistical testing

C.1 Statistical testing of receiver BER/BLER performance

C.1.1 Error Definition

Bit Error Ratio (BER) and Block Error Ratio (BLER) are defined in section 3.1.

C.1.2 Test Method

Each test is performed in the following manner:

- a) Setup the required test conditions.
- b) Record the number of samples tested and the number of occurred events (bit error or block error)
- c) Stop the test at a stop criterion which is minimum test time or an early pass or an early fail event.
- d) Once the test is stopped decide according to the pass fail decision rules (clause C.1.7)

C.1.3 Test Criteria

The test shall fulfil the following requirements:

- a) good pass fail decision
 - 1) to keep reasonably low the probability (risk) of passing a bad unit for each individual test;
 - 2) to have high probability of passing a good unit for each individual test;
- b) good balance between test time and statistical significance
 - 3) to perform measurements with a high degree of statistical significance;
 - 4) to keep the test time as low as possible.

C.1.4 Calculation assumptions

C.1.4.1 Statistical independence

- a) It is assumed, that error events are rare ($\lim BER, BLER \rightarrow 0$) independent statistical events. However the memory of the convolutional /turbo coder is terminated after one TTI. Samples and errors are summed up every TTI. So the assumption of independent error events is justified.
- b) In the BLER test with fading there is the memory of the multipath fading channel which interferes the statistical independence. A minimum test time is introduced to average fluctuations of the multipath fading channel. So the assumption of independent error events is justified approximately.

C.1.4.2 Applied formulas

The formulas, applied to describe the BER BLER test, are based on the following experiments:

- 1) After having observed a certain number of errors (**ne**) the number of samples are counted to calculate BER BLER. Provisions are made (note 1) such that the complementary experiment is valid as well:

2) After a certain number of samples (**ns**) the number of errors, occurred, are counted to calculate BER BLER.

Experiment 1) stipulates to use the following Chi Square Distribution with degree of freedom ne :

$$2 * dchisq(2 * NE, 2 * ne).$$

Experiment 2) stipulates to use the Poisson Distribution:

$$dpois(ne, NE)$$

(NE: mean of the distribution)

To determine the early stop conditions, the following inverse cumulative operation is applied:

$$0.5 * qchisq(D, 2 * ne). \quad \text{This is applicable for experiment (1) and (2).}$$

D: wrong decision risk per test step

NOTE: Other inverse cumulative operations are available, however only this is suited for experiment (1) and (2).

C.1.4.3 Approximation of the distribution

The test procedure is as follows:

During a running measurement for a UE ns (number of samples) and ne (number of errors) are accumulated and from this the preliminary BER BLER is calculated. Then new samples up to the next error are taken. The entire past and the new samples are basis for the next preliminary BER BLER. Depending on the result at every step, the UE can pass, can fail or must continue the test.

As early pass- and early fail-UEs leave the statistical totality under consideration, the experimental conditions are changed every step resulting in a distribution that is truncated more and more towards the end of the entire test. Such a distribution can not any more be handled analytically. The unchanged distribution is used as an approximation to calculate the early fail and early pass bounds.

C.1.5 Definition of good pass fail decision.

This is defined by the probability of wrong decision F at the end of the test. The probability of a correct decision is $1-F$.

The probability (risk) to fail a good DUT shall be $\leq F$ according to the following definition: The failed DUT is still better than the specified error ratio (Test requirement) with a probability of $\leq F$.

The probability to pass a bad DUT shall be $\leq F$ according to the following definition: The passed DUT is still worse than M times the specified error ratio ($M > 1$ is the bad DUT factor) with a probability of $\leq F$.

This definitions lead to an early pass and an early fail limit:

Early fail: $ber \geq berlim_{fail}$

$$berlim_{fail}(D, ne) = \frac{2 * ne}{qchisq(D, 2 * ne)} \quad (1)$$

For $ne \geq 7$

Early pass: $ber \leq berlim_{pass}$

$$berlim_{pass}(D, ne) = \frac{2 * ne * M}{qchisq(1 - D, 2 * ne)} \quad (2)$$

For $ne \geq 1$

With

ber (normalized BER,BLER):	BER,BLER according to C.1.1 divided by Test requirement
D:	wrong decision probability for a test step . This is a numerically evaluated fraction of F, the wrong decision probability at the end of the test. See table C.1.
ne:	Number of error events
M:	bad DUT factor see table C.1.
qchisq:	inverse-cumulative-function of the chi-squared-distribution

C.1.6 Good balance between test time and statistical significance

Three independent test parameters are introduced into the test and shown in Table C.1. These are the obvious basis of test time and statistical significance. From the first two of them four dependent test parameters are derived. The third independent test parameter is justified separately.

Table C.1: independent and dependent test parameters

Independent test parameters			Dependent test parameters		
Test Parameter	Value	Reference	Test parameter	Value	Reference
Bad DUT factor M	1.5	Tables C.3 to C.9	Early pass/fail condition	Curves	Clause C.1.5 Figure C.1.9
Final probability of wrong pass/fail decision F	0.2%, (0.02%, note 2)	Clause C.1.5	Target number of error events	345	Tables C.3 to C.9
			Probability of wrong pass/fail decision per test step D	0.0085%, (0.0008% and 0.008%, note 2)	
			Test limit factor TL	1.234	Tables C.3 to C.9
Minimum test time		Table C.2			

The minimum test time is derived from the following justification:

- 1) For no propagation conditions and static propagation condition

No early fail calculated from fractional number of errors <1 (see note 1)

- 2) For multipath fading condition

No stop of the test until 990 wavelengths are crossed with the speed given in the fading profile.

- 3) For birth death propagation conditions

No stop of the test until 200 birth death transitions occur

- 4) For moving propagation conditions: 628 sec

This is necessary in order to pass all potential critical points in the moving propagation profile 4 times:
Maximum rake window, Maximum adjustment speed, Intersection of moving taps

- 5) For high speed train conditions

Scenario 1: 82.3s. This corresponds to 4 complete cycles of approach towards and departure leave to and from a BS antenna

Scenario 2: The test shall continue until 990 wavelengths are crossed with the speed given in the fading profile (1.8s corresponding 300 km/h)

Scenario 3: 28.8s. This corresponds to 4 complete cycles of approach towards and departure from a BS antenna

Table C.2: minimum Test time

Fading profile	Minimum test time
Multipath propagation Case 1, Case 2	164 sec
Multipath propagation Case 3	4.1 sec
Multipath propagation Case 4	2 sec
Birth Death propagation	38.2 sec
Moving propagation	628 sec
High speed train conditions Scenario 1	82.3 sec
High speed train conditions Scenario 2	1.8 sec
High speed train conditions Scenario 3	28.8 sec

In table C.3 to C.9 the minimum test time is converted in minimum number of samples.

C.1.7 Pass fail decision rules

No decision is allowed before the minimum test time is elapsed.

- 1) If minimum Test time < time for target number of error events then the following applies: The required confidence level $1-F$ (= correct decision probability) shall be achieved. This is fulfilled at an early pass or early fail event.

For BER:

For every TTI (Transmit Time Interval) sum up the number of bits (n_s) and the number of errors (n_e) from the beginning of the test and calculate

BER_1 (including the artificial error at the beginning of the test (Note 1)) and

BER_0 (excluding the artificial error at the beginning of the test (Note 1)).

If BER_0 is above the early fail limit, fail the DUT.

If BER_1 is below the early pass limit, pass the DUT.

Otherwise continue the test

For BLER:

For every TTI sum up the number of blocks (n_s) and the number of erroneous blocks (n_e) from the beginning of the test and calculate

$BLER_1$ (including the artificial error at the beginning of the test (Note 1)) and

$BLER_0$ (excluding the artificial error at the beginning of the test (Note 1)).

If $BLER_1$ is below the early pass limit, pass the DUT.

If $BLER_0$ is above the early fail limit, fail the DUT.

Otherwise continue the test

- 2) If the minimum test time \geq time for target error events, then the test runs for the minimum test time and the decision is done by comparing the result with the test limit.

For BER:

For every TTI (Transmit Time Interval) sum up the number of bits (n_s) and the number of errors (n_e) from the beginning of the test and calculate BER_0

For BLER:

For every TTI sum up the number of blocks (n_s) and the number of erroneous blocks (n_e) from the beginning of the test and calculate $BLER_0$

If $BER_0/BLER_0$ is above the test limit, fail the DUT.

If $BER_0/BLER_0$ is on or below the test limit, pass the DUT.

C.1.8 Test conditions for BER, BLER, Pd, E-DPCCH tests

Table C.3: Test conditions for BER tests

Type of test (BER)	Propagation conditions	Test requirement (BER)	Test limit (BER)= Test requirement (BER)x TL TL	Target number of error events (time)	Minimum number of samples	Prob that good unit will fail = Prob that bad unit will pass (%)	Bad unit BER factor M
Reference Sensitivity Level	-	0.001	1.234	345 (22.9s)	Note 1	0.2	1.5
Dynamic Range	-	0.001	1.234	345 (22.9s)	Note 1	0.2	1.5
Adjacent Channel Selectivity	-	0.001	1.234	345 (22.9s)	Note 1	0.2	1.5
Blocking Characteristics Pass condition Note 2	-	0.001	1.251	402 (26.3s)	Note 1	0.2	1.5
Blocking Characteristics Fail condition Note 2	-	0.001	1.251	402 (26.3s)	Note 1	0.02	1.5
Intermodulation Characteristics	-	0.001	1.234	345 (22.9s)	Note 1	0.2	1.5
Verification of internal BER calculation	Not applicable, TS 34.121 Annex F.6.1.10 Dual limit BLER Tests may be applied in principle						

Table C.4: Test conditions for BLER tests

Type of test (BLER)	Information Bit rate	Test requirement (BLER)	Test limit (BLER)= Test requirement (BLER)x TL TL	Target number of error events (time)	Minimum number of samples (time)	Prob that bad unit will pass = Prob that good unit will fail (%)	Bad unit BLER factor M
Demodulation in Static Propagation conditions	12.2	0.01	1.234	345 (559s)	Note 1	0.2	1.5
	64	0.1		(112s)			
	144	0.01		(1118s)			
	384	0.1		(55.9s)			
		0.01		(559s)			
		0.1		(28s)			
		0.01		(280s)			
Demodulation of DCH in Multi-path Fading Propagation conditions (Case 1, Case 2)	12.2	0.01	1.234	345 (559s)	(164s)	0.2	1.5
	64	0.1		(112s)	8200		
	144	0.01		(1118s)	4100		
	384	0.1		(55.9s)	4100		
		0.01		(559s)	8200		
		0.1		(28s)	16400		
		0.01		(280s)	16400		
Demodulation of DCH in Multi-path Fading Propagation conditions (Case3)	12.2	0.01	1.234	345 (559s)	(4.1s)	0.2	1.5
	64	0.001		(5592s)	205		
	144	0.1		(112s)	205		
	384	0.01		(1118s)	103		
		0.01		(11183s)	103		
		0.001		(11183s)	103		
		0.1		(55.9s)	205		
		0.01		(559s)	205		
		0.001		(5592s)	205		
		0.1		(28s)	410		
		0.01		(280s)	410		
		0.001		(2796s)	410		
Demodulation of DCH in Multi-path Fading Propagation conditions (Case 4)	12.2	0.01	1.234	345 (559s)	(2s)	0.2	1.5
	64	0.001		(5592s)	100		
	144	0.1		(112s)	100		
	384	0.01		(1118s)	50		
		0.01		(11183s)	50		
		0.001		(11183s)	50		
		0.1		(55.9s)	100		
		0.01		(559s)	100		
		0.001		(5592s)	100		
		0.1		(28s)	200		
		0.01		(280s)	200		
		0.001		(2796s)	200		
Demodulation of DCH in moving propagation conditions	12.2	0.01	1.234	345 (559s)	(628s)	0.2	1.5
	64	0.1		(112s)	31400		
	384	0.01		(1118s)	15700		
Demodulation of DCH in birth/death propagation conditions	12.2	0.01	1.234	345 (559s)	(38.2s)	0.2	1.5
	64	0.1		(112s)	1910		
	384	0.01		(1118s)	955		
Demodulation of DCH in high speed train conditions	12.2	0.01	1.234	345 (559s)	Scenario 1 (82.3s)	0.2	1.5
					4115		
					Scenario 2 (1.8s)		
				90			
				Scenario 3 (28.8s)			
				1440			
Verification of internal BLER calculation	Not applicable, TS 34.121 Annex F.6.1.10 Dual limit BLER Tests may be applied in principle						

Table C.5: Test conditions for Pd tests (Probability of detection)

Type of test	Information Bit rate Not applicable	Test requirement (1-Pd)	Test limit (1-Pd)= Test requirement (1-Pd)x TL TL	Target number of error events (time)	Minimum number of samples (time)	Prob that bad unit will pass = Prob that good unit will fail (%)	Bad unit BLER factor M
RACH preamble detection in static propagation conditions		0.01 0.001	1.234	345 (29.8s) (298s) (net preamble TX time)	Note 1	0.2	1.5
RACH preamble detection in multipath fading conditions (case3)		0.01 0.001	1.234	345 (29.8s) (298s) (net preamble TX time)	3844 preambles (4.1s)	0.2	1.5
RACH preamble detection in high speed train conditions		0.01 0.001	1.234	345 (29.8s) (298s) (net preamble TX time)	Scenario 1 77157 preambles (82.3s) Scenario 2 1688 preambles (1.8s) Scenario 3 27000 preambles (28.8s)	0.2	1.5

Table C.6: Test conditions for BLER tests

Type of test (BLER)	Information Bits	Test requirement (BLER)	Test limit (BLER)= Test requirement (BLER)x TL TL	Target number of error events (time)	Minimum number of samples (time)	Prob that bad unit will pass = Prob that good unit will fail (%)	Bad unit BLER factor M
Demodulation of RACH message in static propagation conditions	168 bits 360 bits	0.1 0.01 0.1 0.01	1.234	345 (55.9s) (559s) (55.9s) (559s) (net message TX time)	Note 1	0.2	1.5
Demodulation of RACH message in multipath fading case 3	168 bits 360 bits	0.1 0.01 0.1 0.01	1.234	345 55.9s) (559s) (55.9s) (559s) (net message TX time)	205 messages (4.1s)	0.2	1.5
Demodulation of RACH message in high speed train conditions	168 bits 360 bits	0.1 0.01 0.1 0.01	1.234	345 (55.9s) (559s) (55.9s) (559s) (net message TX time)	Scenario 1 4115 messages (82.3s) Scenario 2 90 messages (1.8s) Scenario 3 1440 messages (28.8s)	0.2	1.5

Table C.7: (void)

Table C.8: (void)

Table C.9: Test conditions for Error ratio tests

Type of test	Information Bit rate (Not applicable)	Test requirement error ratio	Test limit (error ratio) = Test requirement (error rate) x TL TL	Target number of error events (time)	Minimum number of samples (time)	Prob that bad unit will pass = Prob that good unit will fail (%)	Bad unit Error ratio factor M
ACK false alarm in static propagation conditions		0.01	1.234	345 (18.6s) (net ACK/NACK TX time)	Note 1	0.2	1.5
ACK false alarm in multipath fading conditions (Case 1, Case 2)		0.01	1.234	345 (18.6s) (net ACK/NACK TX time)	(164s) 246000 ACK/NAK slots	0.2	1.5
ACK false alarm in multipath fading conditions (Case 3)		0.01	1.234	345 (18.6s) (net ACK/NACK TX time)	(4.1s) 6150 ACK/NAK slots	0.2	1.5
ACK mis-detection in static propagation conditions		0.01	1.234	345 (18.6s) (net ACK/NACK TX time)	Note 1	0.2	1.5
ACK mis-detection in multipath fading conditions (Case 1, Case 2)		0.01	1.234	345 (18.6s) (net ACK/NACK TX time)	(164s) 246000 ACK/NAK slots	0.2	1.5
ACK mis-detection in multipath fading conditions (Case 3)		0.01	1.234	345 (18.6s) (net ACK/NACK TX time)	(4.1s) 6150 ACK/NAK slots	0.2	1.5

Table C.10: Test conditions E-DPCCH tests

Type of test	Information Bit rate (Not applicable)	Test requirement error ratio	Test limit (error ratio) = Test requirement (error rate) x $\frac{TL}{TL}$	Target number of error events (time)	Minimum number of samples (time)	Prob that bad unit will pass = Prob that good unit will fail (%)	Bad unit Error ratio factor M
E-DPCCH false alarm in multipath fading conditions (PA3, PB3)		0.01	1.234	345 (279.6s for 10ms TTI) (55.9s for 2ms TTI)	(164s) 16400 TTIs for 10ms TTI, 82000 TTIs for 2ms TTI	0.2	1.5
E-DPCCH false alarm in multipath fading conditions (VA30)		0.01	1.234	345 (279.6s for 10ms TTI) (55.9s for 2ms TTI)	(16.4s) 1640 TTIs for 10ms TTI, 8200 TTIs for 2ms TTI	0.2	1.5
E-DPCCH false alarm in multipath fading conditions (VA120)		0.01	1.234	345 (279.6s for 10ms TTI) (55.9s for 2ms TTI)	(4.1s) 410 TTIs for 10ms TTI, 2050 TTIs for 2ms TTI	0.2	1.5
E-DPCCH missed detection in multipath fading conditions (PA3, PB3)		0.002	1.234	345 (1397.9s for 10ms TTI, 279.6s for 2ms TTI)	(164s) 16400 TTIs for 10ms TTI, 82000 TTIs for 2ms TTI	0.2	1.5
E-DPCCH missed detection in multipath fading conditions (VA30)		0.002	1.234	345 (1397.9s for 10ms TTI, 279.6s for 2ms TTI)	(16.4s) 1640 TTIs for 10ms TTI, 8200 TTIs for 2ms TTI	0.2	1.5
E-DPCCH missed detection in multipath fading conditions (VA120)		0.002	1.234	345 (1397.9s for 10ms TTI, 279.6s for 2ms TTI)	(4.1s) 410 TTIs for 10ms TTI, 2050 TTIs for 2ms TTI	0.2	1.5

C.1.9 Practical Use (informative)

See figure C.1.9:

The early fail limit represents formula (1) in C.1.5. The range of validity is $n_e \geq 7$ (≥ 8 in case of blocking test) to $n_e = 345$

The early pass limit represents formula (2) in C.1.5. The range of validity is $n_e = 1$ to $n_e = 345$. See note 1

The intersection co-ordinates of both curves are : target number of errors $n_e = 345$ and test limit $TL = 1.234$.

The range of validity for TL is $n_e > 345$.

A typical BER BLER test, calculated from the number of samples and errors (C.1.2.(b)) using experimental method (1) or (2) (see C.1.4.2 calculation assumptions) runs along the yellow trajectory. With an errorless sample the trajectory goes down vertically. With an erroneous sample it jumps up right. The tester checks if the BER BLER test intersects the early fail or early pass limits. The real time processing can be reduced by the following actions:

BLER₀ (excluding the artificial error at the beginning of the test (Note 1)). is calculated only in case of an error event.

BER₀ (excluding the artificial error at the beginning of the test (Note 1)). is calculated only in case of an error event within a TTI.

So the early fail limit cannot be missed by errorless samples.

The check against the early pass limit may be done by transforming formula (2) in C.1.5 such that the tester checks against a Limit-Number-of-samples (NL(ne)) depending on the current number of errors (including the artificial error at the beginning of the test (Note 1)).

Early pass if

$$NL(ne) \geq \frac{qchisq(1 - D, 2 * ne)}{2 * TR * M}$$

TR: test requirement (0.001)

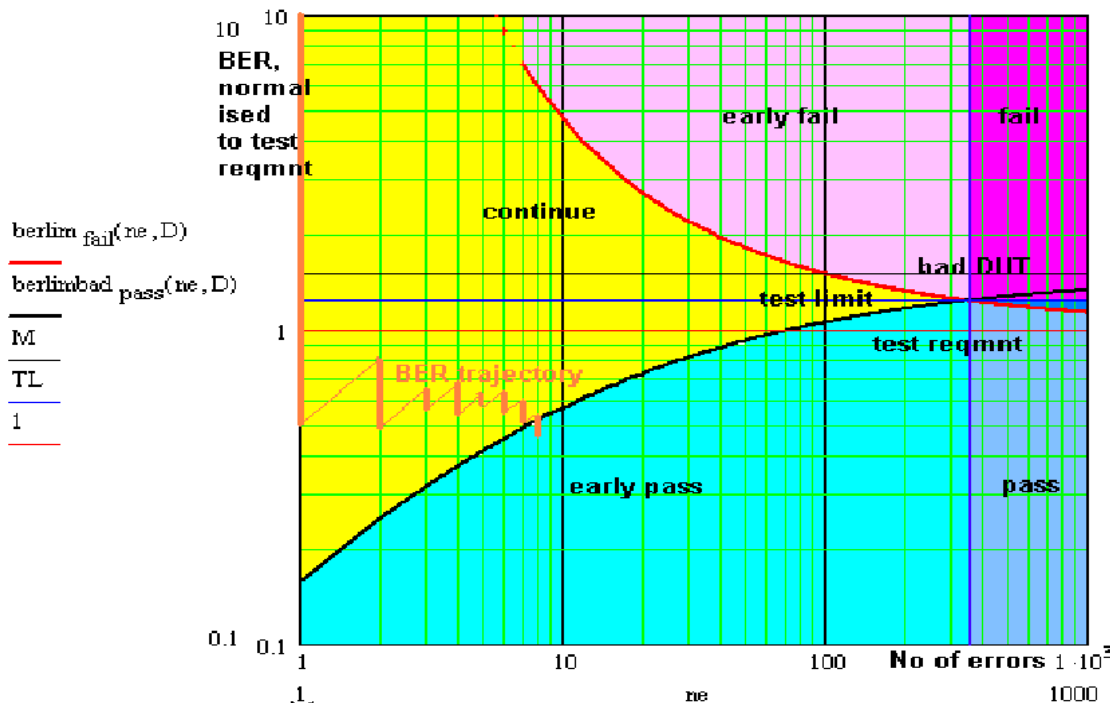

Figure C.1.9

NOTE 1: At the beginning of the test, an artificial error is introduced. This ensures that an ideal DUT meets the valid range of the early pass limit. In addition this ensures that the complementary experiment (C.1.4.2 bullet point (2)) is applicable as well.

For the check against the early fail limit the artificial erroneous sample, introduced at the beginning of the test, is disregarded.

Due to the nature of the test, namely discrete error events, the early fail condition shall not be valid, when fractional errors <1 are used to calculate the early fail limit: Any early fail decision is postponed until number of errors ne ≥ 7. In the blocking test any early fail decision is postponed until number of errors ne ≥ 8.

NOTE 2: $F=0.2\%$ is intended to be used for a test containing a few BER/BLER tests (e.g. receiver sensitivity is repeated 12 times (3 RF Channels * 2 Power-supplies * 2 Temperatures)). For a test containing many BER/BLER tests (e.g. blocking test) this value is not appropriate for a single BER/BLER test. The blocking test contains approx. 12750 single BER tests. A DUT on the limit will fail approx. 25 to 26 times due to statistical reasons using wrong decision probability at the end of the test $F=0.2\%$. This shall be solved by the following rule:

All passes (based on $F=0.2\%$) are accepted, including the wrong decisions due to statistical reasons.

An early fail limit based on $F=0.02\%$ instead of 0.2% is established. That ensures that wrong decisions due to statistical reasons are reduced to 2 to 3 in 12750 BER measurements. If the fail cases are ≤ 12 , it is allowed to repeat each fail cases 1 time before the final verdict.

These asymmetric test conditions ensure that a DUT on the limit consumes hardly more test time for a blocking test than in the symmetric case and reduces the wrong decision probability considerably and on the other hand the repetition allowance sufficiently suppresses the residual statistically caused wrong verdict for the aggregate test.

C.2 Statistical Testing of E-DPDCH Throughput

C.2.1 Definition

Information Bit Throughput R:

The measured information bit throughput R is defined as the sum (in kilobits) of the information bit payloads (excluding the 24-bit CRC) successfully received during the test interval, divided by the duration of the test interval (in seconds).

C.2.2 Mapping throughput to block error ratio

- a) In measurement practice the BS indicates successfully received information bit payload by signalling an ACK to the tester.
If payload is received, but damaged and cannot be decoded, the BS signals a NACK.
- b) Only the ACK and NACK signals, not the data bits received, are accessible to the tester.
The number of bits is known in the tester from knowledge of what payload was sent.
- c) For fixed reference channel the number of bits in a TTI is fixed during one test.
- d) The time in the measurement interval is composed of successful TTIs (ACK), unsuccessful TTIs (NACK) and DTX-TTIs.
- e) DTX-TTIs occur statistically when the BS is not responding ACK or NACK where it should. (statDTX)
This may happen when the BS misses data, that are intended for it.

The pass / fail decision is done by observing the:

- number of NACKs
- number of ACKs and
- number of statDTXs

The ratio $(\text{NACK} + \text{statDTX}) / (\text{NACK} + \text{statDTX} + \text{ACK})$ is the Block Error Ratio BLER. Taking into account the time consumed by the ACK-, NACK-, and statDTX-TTIs, BLER can be mapped unambiguously to throughput for any single FRC test.

C.2.3 Bad DUT factor

NOTE: A statistical test of limited test duration and confidence level $>1/2$ exhibits limited selectivity. The Bad DUT factor $\neq 1$ is a measure of limited selectivity.

Data throughput in a communication system is of statistical nature and must be measured and decided pass or fail. The specified limit of throughput related to the ideal throughput in different throughput tests is in the range of a few % to near 100%. To make it comparable with BER, we define the complement of the relative throughput: BLER as defined above. Complementary this is in the range of near 100% down to a few % For e.g. BLER = 1%, the currently in BER BLER used Bad DUT factor $M=1.5$ is highly meaningful. For e.g. BLER = 99%, the currently used $M=1.5$ is obviously meaningless.

An appropriate definition of the bad DUT factor is illustrated in figure C.2.3: constant and variable Bad DUT factor.

It illustrates how to find the Bad BLER when the nominal BLER is given.

- 1) In the range $0% < \text{nominal BLER} > 10%$ the Bad DUT factor is constant 1.5
- 2) In the range $90% < \text{bad BLER} > 100%$ it decreases to 1. (symmetrical to (1))
- 3) The range in between is interpolated by an arc section.

The example shows: nominal BLER=35,6% \rightarrow bad BLER=47.67.5% \rightarrow $M=1.34$

(blue mapping)

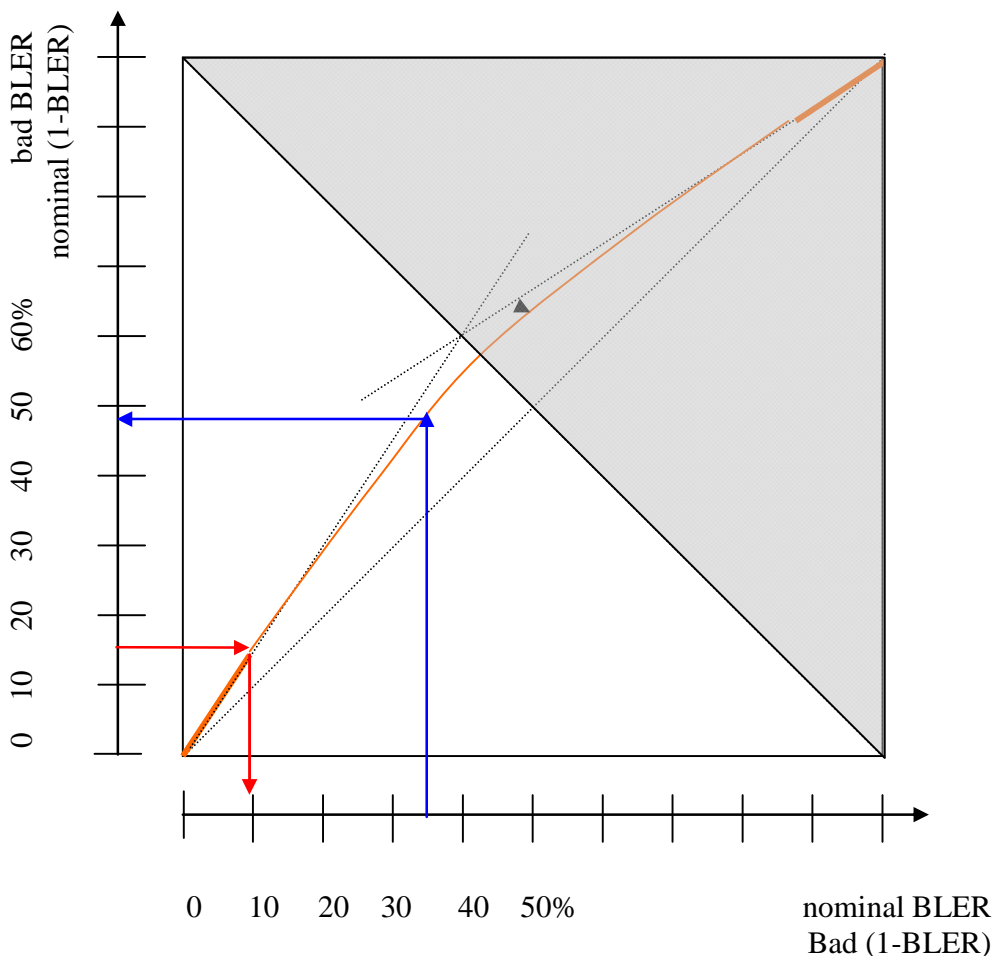

Figure C.2.3: constant and variable Bad DUT factor

Formula:

For $0 < BLER \leq 0.1$

$$M = 1.5$$

For $0.1 < BLER < 0.85$

$$M(BLER) := \frac{\sqrt{r^2 - (BLER - 2.35)^2}}{BLER} - \frac{1.35}{BLER}$$

For $0.85 \leq BLER < 1$ $M(BLER) = 2/3BLER + 1/3$

With BLER: nominal Block Error Ratio ($0 < BLER < 1$)

With $r = 2.70415$ (Radius of the arc)

C.2.3.1 Bad DUT factor, range of applicability

Inaccuracy is one practical reason to avoid the grey shaded area of figure C.2.3: constant and variable Bad DUT factor. For BLER near 1 the Bad DUT factor M is near 1. For M=1, exactly, the pass and fail criteria do not intersect. The test never is finalised.

For M near 1 the pass and fail criteria exhibit a very smooth intersection. In addition the binomial distribution and its inverse are of discrete nature. Therefore the test limit and the number of samples is calculable only very ambiguous.

It is proposed to apply the bad DUT factor only in the not shaded area of figure C.2.3.

This is done by the following:

BLER mode:

Use BLER as defined above in the range of 0 to 50%, use $M > 1$ as defined above.

The Test Limit will be $>$ the Minimum Requirement in the table C.10 below.

Relative Throughput mode:

If BLER is in the range 50 to 100%, use 1-BLER instead. Use $m < 1$ instead of M .

1-BLER is the relative throughput with respect to the ideal throughput.

As a consequence, the Test Limit $<$ the Minimum Requirement

Formula for m :

For $0 < (1-BLER) \leq 0.15$, $m = 1/1.5$

For $0.15 < (1-BLER) < 0.85$,
$$m := \frac{2.35 - \sqrt{r^2 - [(1-BLER) + 1.35]^2}}{1 - BLER}$$

In the figure C.2.3 this is represented by the red mapping.

The table C.10 below distinguishes between m and M .

C.2.4 Minimum Test time

Same as with BER BLER there is a minimum test time necessary for multipath fading profiles with the same justification: Table C.2 in Annex C.1 applies for throughput tests as well.

The minimum Test Time is

- 1) the minimum test time due to statistical reasons

(To ensure the confidence level, the test must be continued until a certain number of samples (NACK+statDTX+ACK) is reached.)

- 2) the minimum test time due to multipath fading.

The longer test time applies.

C.2.5 Statistical independence

If a process works within an incremental redundancy sequence, the samples and errors are not independent. The incremental redundancy sequence for every process must be finalised, successfully or unsuccessfully, on or beyond the minimum test time.

Then the BLER (or 1-BLER) is compared with the Test Limit to decide pass or fail.

The distribution of errors in an HARQ process with dependent errors is narrower, than the equivalent binomial distribution.

The distribution of errors, where the current BLER fluctuates due to the multipath propagation channel, is narrower than the equivalent binomial distribution.

Hence the application of the binomial distribution and its inverse function yields a conservative decision in the sense that the true confidence level is slightly higher than the given one.

(The binomial distribution describes a time-independent statistical process, where the errors occur memoryless)

C.2.6 Formula

True BLER in the range of near 0% to near 100% does not allow to use any approximated distributions. The binomial distribution and its inverse cumulative function: qbinom is appropriate for this test.

a) For the BLER test mode:

$$ne_{low}=qbinom(D,ns,M*BLER_{limit}) \quad (1)$$

$$ne_{high}=qbinom(1-D,ns,BLER_{limit}) \quad (2)$$

given: 1-D: confidence level= 99.8%

BLER_{limit}=Block error ratio at the limit

M: Bad DUT factor >1

Input: ns: number of samples (NACK+ statDTX + ACK)

Output ne: number of events (NACK+ statDTX)

The intersection of (1) and (2) is the Test Limit with the coordinates: ns and ne

b) For the Relative Throughput test mode:

$$ne_{low}=qbinom(D,ns,1-BLER_{limit}) \quad (3)$$

$$ne_{high}=qbinom(1-D,ns,m*(1-BLER_{limit})) \quad (4)$$

given: 1-D: confidence level= 99.8%

1-BLER_{limit}= Relative Throughput at the limit

m: Bad DUT factor <1

Input: ns: number of samples (NACK+ statDTX + ACK)

Output ne: number of events (ACK)

The intersection of (3) and (4) is the Test Limit with the coordinates: ns and ne

NOTE: In contrast to BER BLER test, this approach does not contain any test time optimisation.
(early pass, early fail)

C.2.7 Meaning of a decision

After the minimum test time in terms of ns, ne is compared against the test limit and an individual throughput test is decided accordingly.

A pass means: The true throughput is not worse than a Bad Throughput with 99.8% confidence level.

A fail means: The true throughput is not better than a Limit Throughput with 99.8% confidence level.

NOTE: A single throughput test measured on a marginal receiver will be correctly decided with 99.8% probability, but incorrectly with 0.2% probability. A single throughput test is repeated in 112 variations. (7 FRCs * 4 fading profiles * 2 diversity modes * 2 limits). A marginal DUT, marginal on each variation, will experience one fail due to statistical reasons with approx. 22% probability. This situation is accepted but may be revised in future.

C.2.8 The test limit

- NACK+ statDTX + ACK is summarised as No of samples (ns)
- NACK+ statDTX is summarised as No of errors

- ACK is summarised as No of successes
- In the BLER test mode the ratio: No of errors/ No of samples is recorded. In this mode the test limit is above the minimum requirement and a pass is below the test limit.
- In the Relative Throughput test mode (1-BLER) the ratio: No of successes/ No of samples is recorded. In this mode the test limit is below the minimum requirement and a pass is above the test limit.
- The test mode, used, is indicated by bold versus gray-shading
- The generic term for No of errors (BLER mode) or No of successes (Relative Throughput mode) is No of events (ne). This is used in the table columns Test Limit and pass condition.

Table C.11: Test limit

Relative throughput Minimum requirement	BLER Minimum requirement	Bad DUT factor	Test limit expressed as No of events / statistical min No of samples	Pass condition	Test time
30%	(70%)	m=0.692	183/725	ne/ns≥183/725	The test time is determined by the propagation condition or by the minimum No of samples, which ever is greater. See table C.2 and C.12
(70%)	30%	M=1.378	209/587	ne/ns≤209/587	

Table C.12 Test time

Fading condition	Relative Throughput =30%		BLER=30%	
	TTI=2ms	TTI=10ms	TTI=2ms	TTI=10ms
3 Km/h	164 s	164s	164s	164s
30Km/h	16.4s	16.4s	16.4s	16.4s
120Km/h	4.1s	725 TTI (7.25s)	4.1s	587 TTI (5.78s)

Annex D (normative): Propagation conditions

D.1 Static propagation condition

The propagation for the static performance measurement is an Additive White Gaussian Noise (AWGN) environment. No fading or multi-paths exist for this propagation model.

D.2 Multi-path fading propagation conditions

Table D.1 shows propagation conditions that are used for the performance measurements in multi-path fading environment. All taps have classical Doppler spectrum, defined as:

$$(CLASS) \quad S(f) \propto 1/(1 - (f/f_D)^2)^{0.5} \quad \text{for } f \in [-f_d, f_d]$$

Table D.1: Propagation Conditions for Multi path Fading Environments

Case 1		Case 2		Case 3		Case 4	
Speed for Band I, II, III, IV, IX, X, XXV 3 km/h		Speed for Band I, II, III, IV, IX, X, XXV 3 km/h		Speed for Band I, II, III, IV, IX, X, XXV 120 km/h		Speed for Band I, II, III, IV, IX, X, XXV 250 km/h	
Speed for Band V, VI, VIII, XIX, XX, XXVI 7 km/h		Speed for Band V, VI, VIII, XIX, XX, XXVI 7 km/h		Speed for Band V, VI, VIII, XIX, XX, XXVI 280 km/h		Speed for Band V, VI, VIII, XIX, XX, XXVI 583 km/h (Note 1)	
Speed for Band VII 2.3 km/h		Speed for Band VII 2.3 km/h		Speed for Band VII 92 km/h		Speed for Band VII 192 km/h	
Speed for Band XI, XXI 4.1 km/h		Speed for Band XI, XXI 4.1 km/h		Speed for Band XI, XXI 166 km/h		Speed for Band XI, XXI 345 km/h (Note 1)	
Speed for Band XII, XIII, XIV 8 km/h		Speed for Band XII, XIII, XIV 8 km/h		Speed for Band XII, XIII, XIV 320 km/h		Speed for Band XII, XIII, XIV 668 km/h	
Speed for Band XXII: 1.7 km/h		Speed for Band XXII: 1.7 km/h		Speed for Band XXII: 69 km/h		Speed for Band XXII: 143 km/h	
Relative Delay [ns]	Average Power [dB]	Relative Delay [ns]	Average Power [dB]	Relative Delay [ns]	Average Power [dB]	Relative Delay [ns]	Average Power [dB]
0	0	0	0	0	0	0	0
976	-10	976	0	260	-3	260	-3
		20000	0	521	-6	521	-6
				781	-9	781	-9

NOTE 1: Speed above 250km/h is applicable to demodulation performance requirements only.

D.3 Moving propagation conditions

The dynamic propagation conditions for the test of the baseband performance are non fading channel models with two taps. The moving propagation condition has two tap, one static, Path0, and one moving, Path1. The time difference between the two paths is according Equation (D.1). The taps have equal strengths and equal phases.

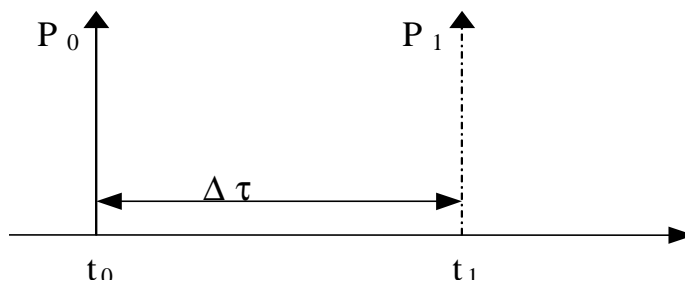

Figure D.1: The moving propagation conditions

$$\Delta\tau = B + \frac{A}{2}(1 + \sin(\Delta\omega \cdot t)) \tag{D.1}$$

The parameters in the equation are shown in table D.2

Table D.2

Parameter	Value
A	5 μs
B	1 μs
Δω	40*10 ⁻³ s ⁻¹

D.4 Birth-Death propagation conditions

The dynamic propagation conditions for the test of the baseband performance is a non fading propagation channel with two taps. The birth-death propagation condition has two taps, Path1 and Path2 which alternate between 'birth' and 'death'. The positions the paths appear are randomly selected with an equal probability rate and is shown in figure D.2. For BS with receiver diversity, the same path positions shall be applied to both receiver antenna connectors, and the path switching times shall be synchronized on the two receiver antenna connectors, but the AWGN signals applied to the two receiver antenna connectors shall be uncorrelated.

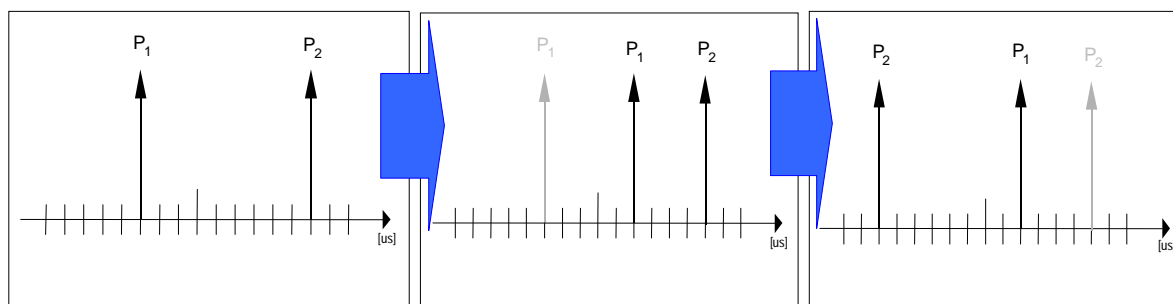

Figure D.2: Birth death propagation sequence

1. Two paths, Path1 and Path2 are randomly selected from the group [-5, -4, -3, -2, -1, 0, 1, 2, 3, 4, 5] μs. The paths have equal magnitudes and equal phases.
2. After 191 ms, Path1 vanishes and reappears immediately at a new location randomly selected from the group [-5, -4, -3, -2, -1, 0, 1, 2, 3, 4, 5] μs but excludes the point Path2. The magnitudes and the phases of the tap coefficients of Path 1 and Path 2 shall remain unaltered.
3. After an additional 191 ms, Path2 vanishes and reappears immediately at a new location randomly selected from the group [-5, -4, -3, -2, -1, 0, 1, 2, 3, 4, 5] μs but excludes the point Path1. The magnitudes and the phases of the tap coefficients of Path 1 and Path 2 shall remain unaltered.
4. The sequence in 2) and 3) is repeated.

D.4A High speed train conditions

High speed train conditions are as follows:

Scenario 1: Open space

Scenario 2: Tunnel with leaky cable

Scenario 3: Tunnel for multi-antennas

The high speed train conditions for the test of the baseband performance are 2 non fading propagation channels (scenario 1 and 3) and 1 fading propagation channel (scenario 2) with one tap. For BS with Rx diversity defined in scenario 1, the Doppler shift variation is the same between antennas.

For scenario 1 and 3, Doppler shift is given by

$$f_s(t) = f_d \cos \theta(t) \quad (\text{D.2})$$

where $f_s(t)$ is the Doppler shift and f_d is the maximum Doppler frequency. The cosine of angle $\theta(t)$ is given by

$$\cos \theta(t) = \frac{D_s/2 - vt}{\sqrt{D_{\min}^2 + (D_s/2 - vt)^2}}, \quad 0 \leq t \leq D_s/v \quad (\text{D.3})$$

$$\cos \theta(t) = \frac{-1.5D_s + vt}{\sqrt{D_{\min}^2 + (-1.5D_s + vt)^2}}, \quad D_s/v < t \leq 2D_s/v \quad (\text{D.4})$$

$$\cos \theta(t) = \cos \theta(t \bmod (2D_s/v)), \quad t > 2D_s/v \quad (\text{D.5})$$

where $D_s/2$ is the initial distance of the train from BS, and D_{\min} is BS-Railway track distance, both in meters; v is the velocity of the train in m/s, t is time in seconds.

For scenario 2, Rician fading is considered where Rician factor, K is defined as the ratio between the dominant signal power and the variant of the other weaker signals.

Doppler shift and cosine angle is given by equation D.2 and D.3-D.5 respectively, where the required input parameters listed in table D.2A and the resulting Doppler shift shown in Figure D.3 and D.4 are applied for all frequency bands.

Table D.2A: Parameters for high speed train conditions

Parameter	Value		
	Scenario 1	Scenario 2	Scenario 3
D_s	1000 m	Infinity	300 m
D_{min}	50 m	-	2 m
K	-	10 dB	-
v	350 km/h	300 km/h	300 km/h
f_d	1340 Hz	1150 Hz	1150 Hz

NOTE1: Parameters for HST conditions in table D.2A including f_d and Doppler shift trajectories presented on figures D.3 and D.4 were derived for Band1.

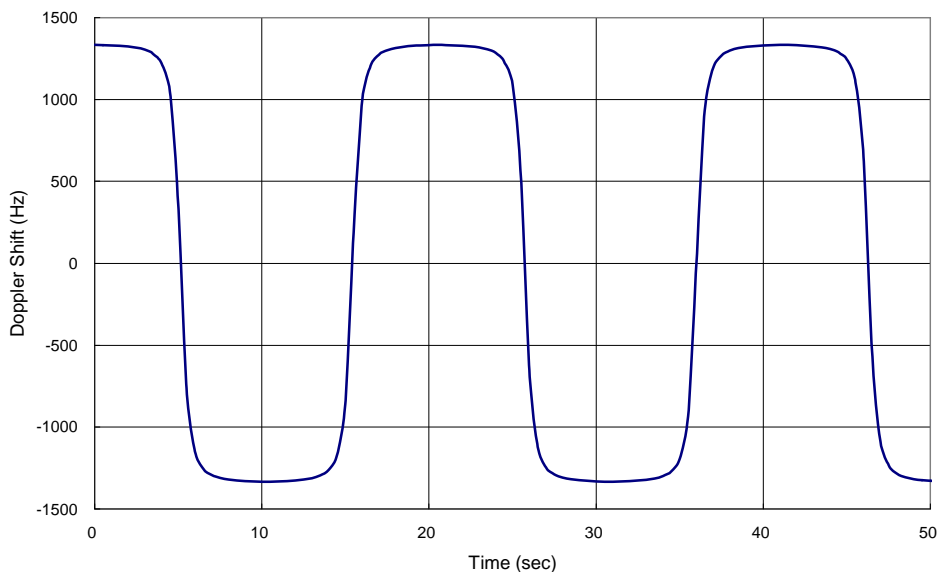

Figure D.3: Doppler shift trajectory for scenario 1

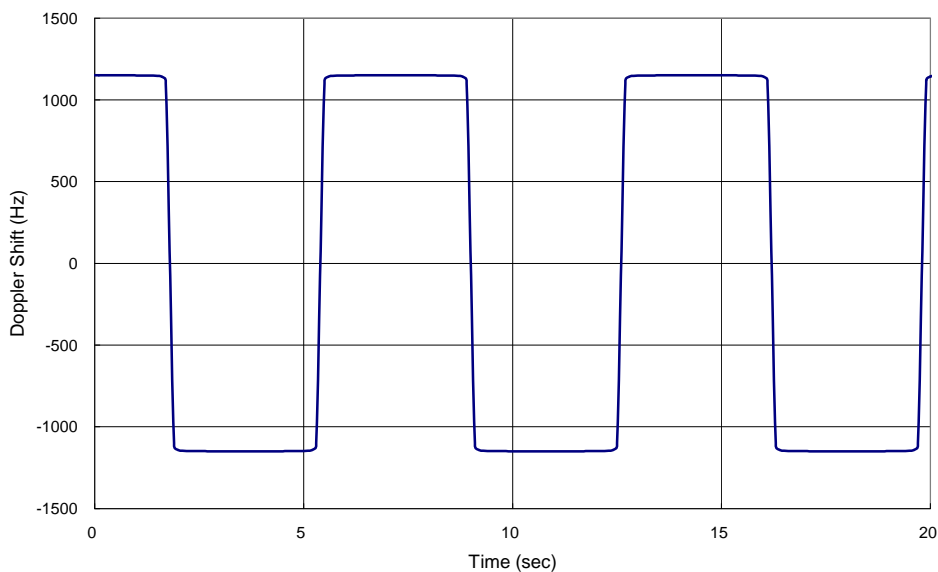

Figure D.4: Doppler shift trajectory for scenario 3

D.5 Multi-path fading propagation conditions for E-DPDCH and E-DPCCH

Table D.3 shows propagation conditions that are used for E-DPDCH and E-DPCCH performance measurements in multi-path fading environment. For DC-HSUPA requirements, the fading of the signals for each cell shall be independent.

Table D.3: Propagation Conditions for Multipath Fading Environments for E-DPDCH and E-DPCCH Performance Requirements

ITU Pedestrian A Speed 3km/h (PA3)		ITU Pedestrian B Speed 3km/h (PB3)		ITU vehicular A Speed 30km/h (VA30)		ITU vehicular A Speed 120km/h (VA120)	
Speed for Band I, II, III, IV, IX, X, XXV 3 km/h		Speed for Band I, II, III, IV, IX, X, XXV 3 km/h		Speed for Band I, II, III, IV, IX, X, XXV 30 km/h		Speed for Band I, II, III, IV, IX, X, XXV 120 km/h	
Speed for Band V, VI, VIII, XIX, XX, XXVI 7 km/h		Speed for Band V, VI, VIII, XIX, XX, XXVI 7 km/h		Speed for Band V, VI, VIII, XIX, XX, XXVI 71 km/h		Speed for Band V, VI, VIII, XIX, XX, XXVI 282 km/h (Note 1)	
Speed for Band VII 2.3 km/h		Speed for Band VII 2.3 km/h		Speed for Band VII 23 km/h		Speed for Band VII 92 km/h	
Speed for Band XI, XXI 4.1 km/h		Speed for Band XI, XXI 4.1 km/h		Speed for Band XI, XXI 41 km/h		Speed for Band XI, XXI 166 km/h (Note 1)	
Speed for Band XII, XIII, XIV 8 km/h		Speed for Band XII, XIII, XIV 8 km/h		Speed for Band XII, XIII, XIV 80 km/h		Speed for Band XII, XIII, XIV 320 km/h	
Speed for Band XXII: 1.7 km/h		Speed for Band XXII: 1.7 km/h		Speed for Band XXII: 17.1 km/h		Speed for Band XXII: 69 km/h	
Relative Delay [ns]	Relative Mean Power [dB]	Relative Delay [ns]	Relative Mean Power [dB]	Relative Delay [ns]	Relative Mean Power [dB]	Relative Delay [ns]	Relative Mean Power [dB]
0	0	0	0	0	0	0	0
110	-9.7	200	-0.9	310	-1.0	310	-1.0
190	-19.2	800	-4.9	710	-9.0	710	-9.0
410	-22.8	1200	-8.0	1090	-10.0	1090	-10.0
		2300	-7.8	1730	-15.0	1730	-15.0
		3700	-23.9	2510	-20.0	2510	-20.0

NOTE 1: Speed above 120km/h is applicable to demodulation performance requirements only.

Annex E (normative): Global In-Channel TX-Test

E.1 General

The global in-channel Tx test enables the measurement of all relevant parameters that describe the in-channel quality of the output signal of the Tx under test in a single measurement process. The parameters describing the in-channel quality of a transmitter, however, are not necessarily independent. The algorithm chosen for description inside this annex places particular emphasis on the exclusion of all interdependencies among the parameters. Any other algorithm (e.g. having better computational efficiency) may be applied, as long as the results are the same within the acceptable uncertainty of the test system as defined in clause 4.1

E.2 Definition of the process

E.2.1 Basic principle

The process is based on the comparison of the actual **output signal of the TX under test**, received by an ideal receiver, with a **reference signal**, that is generated by the measuring equipment and represents an ideal error free received signal. The reference signal shall be composed of the same number of codes at the correct spreading factors as contained in the test signal. Note, for simplification, the notation below assumes only codes of one spreading factor although the algorithm is valid for signals containing multiple spreading factors. All signals are represented as equivalent (generally complex) baseband signals.

E.2.2 Output signal of the TX under test

The output signal of the TX under test is acquired by the measuring equipment, filtered by a matched filter (RRC 0.22, correct in shape and in position on the frequency axis) and stored for further processing

The following form represents the physical signal l in the entire measurement interval:

one vector \mathbf{Z} , containing $N = n_s \times sf$ complex samples;

with

n_s : number of symbols in the measurement interval;

sf : number of chips per symbol. (sf : spreading factor) (see Note: Symbol length)

E.2.3 Reference signal

The reference signal is constructed by the measuring equipment according to the relevant TX specifications.

It is filtered by the same matched filter, mentioned in E.2.2., and stored at the Inter-Symbol-Interference free instants. The following form represents the reference signal in the entire measurement interval:

one vector \mathbf{R} , containing $N = n_s \times sf$ complex samples

where

n_s : number of symbols in the measurement interval;

sf : number of chips per symbol. (see Note: Symbol length)

E.2.4 Classification of measurement results

The measurement results achieved by the global in-channel TX test can be classified into two types:

- Results of type "deviation", where the error-free parameter has a non-zero magnitude. (These are the parameters that quantify the integral physical characteristic of the signal). These parameters are:

RF Frequency

Power (in case of single code)

Code Domain Power (in case of multi code)

Timing (only for UE) (see Note: Deviation)

(Additional parameters: see Note: Deviation)

- Results of type "residual", where the error-free parameter has value zero. (These are the parameters that quantify the error values of the measured signal, whose ideal magnitude is zero). These parameters are:

Error Vector Magnitude (EVM);

Peak Code Domain Error (PCDE).

(Additional parameters: see Note: Residual)

E.2.5 Process definition to achieve results of type "deviation"

The reference signal (**R**; see clause E.2.3) and the signal under Test (**Z**; see clause E.2.2) are varied with respect to the parameters mentioned in clause E.2.4 under "results of type deviation" in order to achieve best fit. Best fit is achieved when the RMS difference value between the varied signal under test and the varied reference signal is an absolute minimum.

Overview:

$$FCT \left[Z(\tilde{f}, \tilde{t}, \tilde{\varphi}, g_1, g_2, \dots, g_{synch}) - R(f, t, \varphi, \tilde{g}_1, \tilde{g}_2, \dots, \tilde{g}_{synch}) \right] = Minimum \quad !$$

Z: Signal under test.

R: Reference signal,

with frequency f , the timing t , the phase φ , gain of code1 (g_1), gain of code2 (g_2) etc, and the gain of the synch channel g_{synch} . See Note: Power Step

The parameters marked with a tilde in **Z** and **R** are varied in order to achieve a best fit.

For most measurement results the best fit process is to be carried out over the whole measurement interval corresponding to the duration of one slot, i.e. $ns * sf = 2560$ chips in E.2.2 and E.2.3. Some measurements are, however, defined for a measurement interval corresponding to the duration of one frame, i.e. $ns * sf = 38400$ chips. In this latter case, the best fit with respect to **Z** and **R** is to be carried out successively over multiple best fit intervals (segments) corresponding to the duration of one slot each, i.e. 15 times for a measurement interval corresponding to the duration of one frame.

Detailed formula: see Note: Formula for the minimum process

The varied reference signal, after the best fit process, will be called **R''**.

The varied signal under test, after the best fit process, will be called **Z''**.

R'' and **Z''** are each of length $ns * sf$ and depending on the length of the measurement interval result of possibly multiple successive applications of the minimum process.

The varying parameters, leading to **R''** and **Z** represent directly the wanted results of type "deviation". These measurement parameters are expressed as deviation from the reference value with the same units as the reference value.

In the case of multi code, the type-"deviation"-parameters (frequency, timing and (RF-phase)) are varied commonly for all codes such that the process returns one frequency-deviation, one timing deviation, (one RF-phase -deviation).

(These parameters are not varied on the individual code signals such that the process would return kr frequency errors... (kr: number of codes)).

The only type-"deviation"-parameters varied individually are the code domain gain factors (g1, g2, ...)

See Note: Power Step.

E.2.5.1 Decision Point Power

The mean-square value of the signal-under-test, sampled at the best estimate of the of Intersymbol-Interference-free points using the process defined in clause 2.5, is referred to the *Decision Point Power* (DPP):

$$DPP = \text{mean}(|Z|^2)$$

E.2.5.2 Code-Domain Power

The samples, Z , are separated into symbol intervals to create n_s time-sequential vectors \mathbf{z} with sf complex samples comprising one symbol interval. The *Code Domain Power* is calculated according to the following steps:

- 1) Take the vectors \mathbf{z} defined above.
- 2) To achieve meaningful results it is necessary to descramble \mathbf{z} , leading to \mathbf{z}'' (see Note: Scrambling code)
- 3) Take the orthogonal vectors of the channelization code set \mathbf{C} (all codes belonging to one spreading factor) as defined in TS 25.213 and TS 25.223 (range +1, -1), and normalize by the norm of the vectors to produce $\mathbf{C}_{\text{norm}} = \mathbf{C} / \text{sqrt}(sf)$. (see Note: Symbol length)
- 4) Calculate the inner product of \mathbf{z}'' with \mathbf{C}_{norm} . Do this for all symbols of the measurement interval and for all codes in the code space.
This gives an array of format $k \times n_s$, each value representing a specific symbol and a specific code, which can be exploited in a variety of ways.

k: total number of codes in the code space

n_s: number of symbols in the measurement interval
- 5) Calculate k mean-square values, each mean-square value unifying n_s symbols within one code. (These values can be called "*Absolute CodeDomainPower* (CDP)" [Volt²].) The sum of the k values of CDP is equal to DPP.
- 6) Normalize by the decision point power to obtain

$$\text{Relative CodeDomain Power} = \frac{\text{Absolute CodeDomainPower}}{\text{DecisionPointPower}}$$

E.2.6 Process definition to achieve results of type "residual"

The difference between the varied reference signal (\mathbf{R}'' ; see clause E.2.5.) and the varied TX signal under test (\mathbf{Z}'' ; see clause E.2.5) is the error vector \mathbf{E} versus time:

$$\mathbf{E} = \mathbf{Z}'' - \mathbf{R}''$$

Depending on the parameter to be evaluated, it is appropriate to represent \mathbf{E} in one of the following two different forms:

Form EVM (representing the physical error signal in the entire measurement interval)

One vector \mathbf{E} , containing $N = n_s \times sf$ complex samples;

with

ns: number of symbols in the measurement interval

sf: number of chips per symbol (see Note: Symbol length)

Form PCDE (derived from Form EVM by separating the samples into symbol intervals)

ns time-sequential vectors \mathbf{e} with sf complex samples comprising one symbol interval.

\mathbf{E} and \mathbf{e} give results of type "residual" applying the two algorithms defined in clauses E.2.6.1 and E.2.6.2.

E.2.6.1 Error Vector Magnitude (EVM)

The Error Vector Magnitude (EVM) is calculated according to the following steps:

- 1) Take the error vector \mathbf{E} defined in clause E.2.6 (Form EVM) and calculate the RMS value of \mathbf{E} ; the result will be called RMS(\mathbf{E}).
- 2) Take the varied reference vector \mathbf{R}' defined in clause E.2.5 and calculate the RMS value of \mathbf{R}' ; the result will be called RMS(\mathbf{R}').
- 3) Calculate EVM according to:

$$\text{EVM} = \frac{\text{RMS}(\mathbf{E})}{\text{RMS}(\mathbf{R}')} \times 100\% \text{ – (here, EVM is relative and expressed in \%)}$$

(see Note: Formula for EVM)

E.2.6.2 Peak Code Domain Error (PCDE)

The Peak Code Domain Error is calculated according to the following steps:

- 1) Take the error vectors \mathbf{e} defined in clause E.2.6 (Form PCDE)
- 2) To achieve meaningful results it is necessary to descramble \mathbf{e} , leading to \mathbf{e}'' (see Note: Scrambling code)
- 3) Take the orthogonal vectors of the channelization code set \mathbf{C} (all codes belonging to one spreading factor) as defined in TS 25.213 and TS 25.223 (range +1, -1). (see Note: Symbol length) and normalize by the norm of the vectors to produce $\mathbf{C}_{\text{norm}} = \mathbf{C}/\text{sqrt}(\text{sf})$. (see Note: Symbol length)
- 4) Calculate the inner product of \mathbf{e}'' with \mathbf{C}_{norm} . Do this for all symbols of the measurement interval and for all codes in the code space.
This gives an array of format $k \times ns$, each value representing an error-vector representing a specific symbol and a specific code, which can be exploited in a variety of ways.

k: total number of codes in the code space

ns: number of symbols in the measurement interval

- 5) Calculate k RMS values, each RMS value unifying ns symbols within one code.
(These values can be called "Absolute CodeEVMs" [Volt].)
- 6) Find the peak value among the k "Absolute CodeEVMs".
(This value can be called "Absolute PeakCodeEVM" [Volt].)
- 7) Calculate PCDE according to:

$$10 * \lg \frac{("AbsolutePeakCodeEVM")^2}{(\text{RMS}(\mathbf{R}'))^2} \text{ dB} \quad (\text{a relative value in dB}).$$

(see Note IQ)

(see Note Synch channel)

E.2.6.3 Relative Code Domain Error (RCDE)

The Relative Code Domain Error is calculated for a wanted code according to the following steps:

- 1) Calculate the value "*Absolute CodeEVM*" [Volt] for the wanted code according to E.2.6.2, as an RMS value unifying $n_s = 2400$ symbols corresponding to the measurement interval of 1 frame.
- 2) Calculate the value "*Absolute CodeDomainPower (CDP)*" [Volt²] for the wanted code according to E.2.5.2, with $n_s = 2400$ symbols corresponding to the measurement interval of 1 frame.
- 3) Calculate RCDE according to:

$$10 * \lg \frac{("Absolute CodeEVM")^2}{"Absolute CodeDomainPower (CDP)} \text{ dB}$$

- 4) The average RCDE across a set of wanted codes is defined as the mean of the linear RCDE values and subsequently expressed in dB.

E.3 Notes

E.3.1 Symbol length

A general code multiplexed signal is multicode and multirate. In order to avoid unnecessary complexity, the measurement applications use a unique symbol-length, corresponding to a spreading factor, regardless of the really intended spreading factor. Nevertheless the complexity with a multicode / multirate signal can be mastered by introducing appropriate definitions.

E.3.2 Deviation

It is conceivable to regard more parameters as type "deviation" e.g. Chip frequency and RF-phase.

As chip-frequency and RF-frequency are linked together by a statement in the core specifications [1] it is sufficient to process RF frequency only.

A parameter RF-phase must be varied within the best fit process (E.2.5.). Although necessary, this parameter-variation doesn't describe any error, as the modulation schemes used in the system don't depend on an absolute RF-phase.

The parameter Timing must be varied within the best fit process (E.2.5.) This parameter variation does not describe any error, when applied to the Node B test. However when applied to the UE test, it describes the error of the UE's Timing Advance.

E.3.3 Residual

It is conceivable to regard more parameters as type „residual" e.g. IQ origin offset. As it is not the intention of the test to separate for different error sources, but to quantify the quality of the signal, all such parameters are not extracted by the best fit process, instead remain part of EVM and PCDE.

E.3.4 Scrambling Code

In general a signal under test can use more than one scrambling code. Note that PCDE is primarily processed to investigate the unused channelization codes. In order to know which scrambling code shall be applied on unused channelization codes, it is necessary to restrict the test conditions: The signal under test shall use exactly one scrambling code.

E.3.5 IQ

As in FDD/uplink each channelization code can be used twice, on the I and on the Q channel, the measurement result may indicate separate values of CDP or PCDE for I and Q on which channel (I or Q) they occur.

E.3.6 Synch Channel

A Node B signal contains a physical synch channel, which is non orthogonal, related to the other channels. In this context note: The code channel bearing the result of PCDE is exactly one of the other physical channels (never the synch channel). The origin of PCDE (erroneous code power) can be any channel (including synch channel) This means that the error due to the synch channel is projected onto the other (orthogonal) codes that make up the code domain.

E.3.7 Formula for the minimum process

$$L(\Delta \tilde{f}, \Delta \tilde{t}, \Delta \tilde{\varphi}, \Delta \tilde{g}_c, \dots, \Delta \tilde{g}_{prim}, \Delta \tilde{g}_{sec}) = \sum_{v=0}^{N-1} |Z(v) - R(v)|^2$$

where:

L : the function to be minimised

The parameters to be varied in order to minimize are:

$\Delta \tilde{f}$	the RF frequency offset
$\Delta \tilde{t}$	the timing offset
$\Delta \tilde{\varphi}$	the phase offset
$\Delta \tilde{g}_c \dots$	code power offsets (one offset for each code)
$\Delta \tilde{g}_{prim}$	the code power offset of the primary SCH
$\Delta \tilde{g}_{sec}$	the code power offset of the secondary SCH
Z(v)	Samples of the signal under Test
R(v)	Samples of the reference signal
$\sum_{v=0}^{N-1}$	counting index v starting at the beginning of the best fit interval and ending at its end.
N	No of chips during the best fit interval.
Z(v):	Samples of the signal under Test. It is modelled as a sequence of complex baseband samples Z(γ) with a time-shift Δt , a frequency offset Δf , a phase offset $\Delta \varphi$, the latter three with respect to the reference signal.

$$Z(v) = Z(v - \Delta \tilde{t}) * e^{-j2\pi\Delta \tilde{f}v} * e^{-j\Delta \tilde{\varphi}}$$

R(v) Samples of the reference signal:

$$R(v) = \sum_{c=1}^{No. of codes} (g_c + \Delta \tilde{g}_c) * Chip_c(v) + (g_{prim} + \Delta \tilde{g}_{prim}) * Chip_{prim}(v) + (g_{sec} + \Delta \tilde{g}_{sec}) * Chip_{sec}(v)$$

where

g nominal gain of the code channel
 $\Delta\tilde{g}$ The gain offset to be varied in the minimum process

Chip(v) is the chipsequence of the code channel

Indices at g , Δg and Chip: The index indicates the code channel: $c = 1, 2, \dots$ No of code channels

prim= primary SCH

sec= secondary SCH

Range for Chip _{c} : +1,-1

E.3.8 Power Step

If the measurement period for any code contains a power step due to power control, it is necessary to model the reference signal for that code using two gain factors.

E.3.9 Formula for EVM

$$EVM = \sqrt{\frac{\sum_{\nu=0}^{N-1} |Z'(\gamma) - R'(\gamma)|^2}{\sum_{\nu=0}^{N-1} |R'(\gamma)|^2}} * 100 \%$$

$Z''(\gamma)$, $R''(\gamma)$ are the varied measured and reference signals.

Annex F (informative): Derivation of Test Requirements

The Test Requirements in this specification have been calculated by relaxing the Minimum Requirements of the core specification using the Test Tolerances defined in clause 4.2. When the Test Tolerance is zero, the Test Requirement will be the same as the Minimum Requirement. When the Test Tolerance is non-zero, the Test Requirements will differ from the Minimum Requirements, and the formula used for this relaxation is given in tables F.1, F.2 and F.3

Note that a formula for applying Test Tolerances is provided for all tests, even those with a test tolerance of zero. This is necessary in the case that the Test System uncertainty is greater than that allowed in clause 4.1. In this event, the excess error shall be subtracted from the defined test tolerance in order to generate the correct tightened Test Requirements as defined in clause 4.3.

For example, a Test System having 0.9 dB accuracy for test 6.2.1 Base Station maximum output power (which is 0.2 dB above the limit specified in clause 4.) would subtract 0.2 dB from the Test Tolerance of 0.7 dB defined in clause 4.2. This new test tolerance of 0.5 dB would then be applied to the Minimum Requirement using the formula defined in Table F.1 to give a new range of ± 2.5 dB of the manufacturer's rated output power.

Using this same approach for the case where a test had a test tolerance of 0 dB, an excess error of 0.2 dB would result in a modified test tolerance of -0.2 dB.

Table F.1: Derivation of Test Requirements (Transmitter tests)

Test	Minimum Requirement in TS 25.104	Test Tolerance (TT)	Test Requirement in TS 25.141
6.2.1 Base station maximum output power	In normal conditions ... within +2 dB and -2 dB of the manufacturer's rated output power In extreme conditions... within +2.5 dB and -2.5 dB of the manufacturer's rated output power	Normal and extreme conditions : 0.7 dB, $f \leq 3.0$ GHz 1.0 dB, 3.0 GHz < $f \leq 4.2$ GHz	Formula: Upper limit + TT Lower limit - TT In normal conditions ... within +2.7 dB and -2.7 dB of the manufacturer's rated output power, $f \leq 3.0$ GHz; within +3.0 dB and -3.0 dB of the manufacturer's rated output power, 3.0 GHz < $f \leq 4.2$ GHz In extreme conditions... within +3.2 dB and -3.2 dB of the manufacturer's rated output power, $f \leq 3.0$ GHz; within +3.5 dB and -3.5 dB of the manufacturer's rated output power, 3.0 GHz < $f \leq 4.2$ GHz
6.2.2 Primary CPICH Power accuracy	P-CPICH power shall be within ± 2.1 dB	0.8 dB, $f \leq 3,0$ GHz 1,1 dB, 3,0 GHz < $f \leq 4,2$ GHz	Formula: Upper limit + TT Lower limit - TT CPICH power shall be within ± 2.9 dB, $f \leq 3,0$ GHz; ± 3.2 dB, 3,0 GHz < $f \leq 4,2$ GHz
6.2.3 Secondary CPICH power offset accuracy	S-CPICH power offset shall be within ± 2 dB of the value....	0.7 dB, $f \leq 3,0$ GHz 1,0 dB, 3,0 GHz < $f \leq 4,2$ GHz	Formula: Upper limit + TT Lower limit - TT S-CPICH power offset shall be within ± 2.7 dB of the value ... $f \leq 3,0$ GHz; ± 3.0 dB of the value..., 3,0 GHz < $f \leq 4,2$ GHz
6.3 Frequency error	Frequency error limit = 0.05 ppm	12 Hz	Formula: Frequency Error limit + TT Frequency Error limit = 0.05 ppm + 12 Hz
6.4.2 Power control steps	Lower and upper limits as specified in tables 6.1 and 6.2 of TS 25.104 [1]	0.1 dB	Formula: Upper limits + TT Lower limits - TT 0.1 dB applied as above to tables 6.1 and 6.2 of TS 25.104 [1]
6.4.3 Power control dynamic range	maximum power limit = BS maximum output power -3 dB minimum power limit = BS maximum output power -28 dB	1.1 dB	Formula: maximum power limit - TT minimum power limit + TT maximum power limit = BS maximum output power -4.1 dB minimum power limit = BS maximum output power -26.9 dB
6.4.4 Total power dynamic range	total power dynamic range limit = 18 dB	0.3 dB	Formula: total power dynamic range limit - TT total power dynamic range limit = 17.7 dB
6.4.5. IPDL time mask	maximum power limit = BS maximum output power -35 dB	0.7 dB	Formula: maximum power limit + TT maximum power limit = BS maximum output power - 34.3 dB
6.5.1 Occupied Bandwidth	occupied bandwidth limit = 5 MHz	0 kHz	Formula: Occupied bandwidth limit + TT Occupied bandwidth limit = 5 MHz
6.5.2.1 Spectrum emission mask	Maximum level defined in tables 6.3, 6.4, 6.5 and 6.6 of TS 25.104 [1]	1.5 dB, $f \leq 3.0$ GHz (0 dB for the additional Band II, IV, V, X, XII, XIII and XIV requirements) 1.8 dB, 3.0 GHz < $f \leq 4.2$ GHz	Formula: Maximum level + TT Add 1.5 dB, $f \leq 3.0$ GHz or 1.8 dB, 3.0 GHz < $f \leq 4.2$ GHz to Maximum level entries in tables 6.3, 6.4, 6.5 and 6.6 of TS 25.104 [1].

6.5.2.2 Adjacent Channel Leakage power Ratio (ACLR)	ACLR limit = 45 dB at 5 MHz ACLR limit = 50 dB at 10 MHz Absolute ACLR limit for Home BS	0.8 dB 1.5 dB, $f \leq 3.0\text{GHz}$ 1.8 dB, $3.0\text{ GHz} < f \leq 4.2\text{ GHz}$	Formula: ACLR/CACLR limit - TT ACLR limit = 44.2 dB at 5 MHz ACLR limit = 49.2 dB at 10 MHz Absolute ACLR limit for Home BS = -42.7 dBm/3.84 MHz, $f \leq 3.0\text{ GHz}$; -42.4 dBm/3.84MHz, $3.0\text{ GHz} < f \leq 4.2\text{ GHz}$
	CACLR limit = 45 dB	0.8 dB	CACLR limit = 44.2 dB
6.5.3 Spurious emissions	Maximum level defined in tables 6.8 to 6.18 of TS 25.104 [1]	0 dB	Formula: Maximum limit + TT Add 0 to Maximum level in tables 6.8 to 6.18 of TS 25.104 [1].
6.6 Transmit intermodulation (interferer requirements) This tolerance applies to the stimulus and not the measurements defined in 6.5.2.1, 6.5.2.2 and 6.5.3.	Wanted signal level - interferer level = 30 dB	0 dB	Formula: Ratio + TT Wanted signal level - interferer level = 30 + 0 dB
6.7.1 EVM	EVM limit = 17.5 % for a composite signal modulated only by QPSK EVM limit = 12.5 % for a composite signal modulated by QPSK and 16QAM	0 %	Formula: EVM limit + TT EVM limit = 17.5% for a composite signal modulated only by QPSK EVM limit = 12.5 % for a composite signal modulated by QPSK and 16QAM
6.7.2 Peak code Domain error	Peak code domain error limit = -33 dB	1.0 dB	Formula: Peak code domain error limit + TT Peak code domain error limit = -32 dB
6.7.3 Time alignment error in TX diversity, MIMO, DC-HSDPA and DB-DC-HSDPA transmission	For TX diversity, MIMO and DC-HSDPA: Max time alignment error = $0.25 T_c$ Min time alignment error = $-0.25 T_c$	0.1 T_c	Formula: Max time alignment error + TT Min time alignment error - TT For TX diversity, MIMO and DC-HSDPA: Max time alignment error = $0.35 T_c$ Min time alignment error = $-0.35 T_c$ For DB-DC-HSDPA: Max time alignment error = $5.1 T_c$ Min time alignment error = $-5.1 T_c$
	For DB-DC-HSDPA: Max time alignment error = $5 T_c$ Min time alignment error = $-5 T_c$		
6.7.4 Relative Code Domain Error	Relative code domain error limit = -21 dB	1.0 dB	Formula: Relative code domain error limit + TT Relative code domain error limit = -20 dB
Annex H.3 Transmitted code power (absolute)	Absolute accuracy limit = $P_{\text{out,code}} - 3\text{ dB}$ $P_{\text{out,code}} + 3\text{ dB}$	0.9 dB, $f \leq 3.0\text{ GHz}$ 1,2 dB, $3.0\text{ GHz} < f \leq 4.2\text{ GHz}$	Formula: Absolute accuracy limit -TT Absolute accuracy limit +TT Absolute accuracy limit: minimum power limit = -3.9 dB, $f \leq 3.0\text{ GHz}$; -4.2 dB, $3.0\text{ GHz} < f \leq 4.2\text{ GHz}$ maximum power limit = +3.9 dB, $f \leq 3.0\text{ GHz}$; +4.2 dB, $3.0\text{ GHz} < f \leq 4.2\text{ GHz}$
Annex H.3 Transmitted code power (relative)	Relative accuracy limit = $ P_{\text{out,code1}} - P_{\text{out,code2}} \leq 2\text{ dB}$	0.2 dB	Formula: Relative accuracy limit + TT Relative accuracy limit = 2.2 dB

Annex H.4 Transmitted carrier power	total power dynamic range limit = 18 dB	0.3 dB	Formula: total power dynamic range limit - TT total power dynamic range limit = 17.7 dB
-------------------------------------	---	--------	--

Table F.2: Derivation of Test Requirements (Receiver tests)

Test	Minimum Requirement in TS 25.104	Test Tolerance (TT)	Test Requirement in TS 25.141
7.2 Reference sensitivity	Reference sensitivity level = -121 dBm FER/BER limit = 0.001	0.7 dB, $f \leq 3.0$ GHz 1.0 dB, 3.0 GHz < $f \leq 4.2$ GHz	Formula: Reference sensitivity level + TT Reference sensitivity level = -120.3 dBm, $f \leq 3.0$ GHz; -120.0 dBm, 3.0 GHz < $f \leq 4.2$ GHz FER/BER limit is not changed
7.3 Dynamic range	Wanted signal level = -91 dBm AWGN level = -73 dBm/3.84 MHz	1.2 dB	Formula: Wanted signal level + TT AWGN level unchanged Wanted signal level = -89.8 dBm
7.4 Adjacent channel selectivity	Wanted signal level = -115 dBm W-CDMA interferer level = -52 dBm	0 dB	Formula: Wanted signal level + TT W-CDMA interferer level unchanged Wanted signal level = -115 dBm
7.5 Blocking characteristics	Wanted signal level = -115 dBm Interferer level See table 7.4a / 7.4b	0 dB	Formula: Wanted signal level + TT Interferer level unchanged Wanted signal level = -115 dBm
7.6 Intermod Characteristics	Wanted signal level = -115 dBm Interferer1 level (10 MHz offset CW) = -48 dBm Interferer2 level (20 MHz offset W-CDMA Modulated) = -48 dBm	0 dB	Formula: Wanted signal level + TT Interferer1 level unchanged Interferer2 level unchanged Wanted signal level = -115 dBm
7.7 Spurious Emissions	Maximum level defined in Table 7.7	0 dB	Formula: Maximum level + TT Add TT to Maximum level in table 7.7

Table F.3: Derivation of Test Requirements (Performance tests)

Test	Minimum Requirement in TS 25.104	Test Tolerance (TT)	Test Requirement in TS 25.141
8.2, Demodulation in static propagation condition	Received E_b/N_0 values	0.4 dB	Minimum requirement + TT
8.3, Demodulation of DCH in multipath fading conditions	Received E_b/N_0 values	0.6 dB	Minimum requirement + TT
8.4 Demodulation of DCH in moving propagation conditions	Received E_b/N_0 values	0.6 dB	Minimum requirement + TT
8.5 Demodulation of DCH in birth/death propagation conditions	Received E_b/N_0 values	0.6 dB	Minimum requirement + TT
8.5A Demodulation of DCH in high speed train conditions	Received E_b/N_0 values	0.6 dB	Minimum requirement + TT
8.8.1 RACH preamble detection in static propagation conditions	Received E_b/N_0 values	0.4 dB	Minimum requirement + TT
8.8.2 RACH preamble detection in multipath fading case 3	Received E_b/N_0 values	0.6 dB	Minimum requirement + TT
8.8.2A RACH preamble detection in high speed train conditions	Received E_b/N_0 values	0.6 dB	Minimum requirement + TT
8.8.3 Demodulation of RACH message in static propagation conditions	Received E_b/N_0 values	0.4 dB	Minimum requirement + TT
8.8.4 Demodulation of RACH message in multipath fading case 3	Received E_b/N_0 values	0.6 dB	Minimum requirement + TT
8.8.5 Demodulation of RACH message in high speed train conditions	Received E_b/N_0 values	0.6 dB	Minimum requirement + TT
8.11.1 ACK false alarm in static propagation conditions	Received E_b/N_0 values	0.4 dB	Minimum requirement + TT
8.11.2 ACK false alarm in multipath fading conditions	Received E_b/N_0 values	0.6 dB	Minimum requirement + TT
8.11.3 ACK mis-detection in static propagation conditions	Received E_b/N_0 values	0.4 dB	Minimum requirement + TT
8.11.4 ACK mis-detection in multipath fading conditions	Received E_b/N_0 values	0.6 dB	Minimum requirement + TT
8.11A.1 4C-HSDPA ACK false alarm in static propagation conditions	Received E_b/N_0 values	0.4 dB	Minimum requirement + TT
8.11A.2 4C-HSDPA ACK false alarm in multipath fading conditions	Received E_b/N_0 values	0.6 dB	Minimum requirement + TT
8.11A.3 4C-HSDPA ACK mis-detection in static propagation conditions	Received E_b/N_0 values	0.4 dB	Minimum requirement + TT
8.11A.4 4C-HSDPA ACK mis-detection in multipath fading conditions	Received E_b/N_0 values	0.6 dB	Minimum requirement + TT
8.12 Demodulation of E-DPDCH in multipath fading conditions	Received E_b/N_0 values	0.6 dB	Minimum requirement + TT
8.12A Demodulation of E-DPDCH and S-E-DPDCH in multipath fading conditions for UL MIMO	Received E_b/N_0 values	0.6 dB	Minimum requirement + TT

8.13 Performance of signalling detection for E-DPCCH in multipath fading conditions	Received E_r/N_0 values	0.6 dB	Minimum requirement + TT
---	---------------------------	--------	--------------------------

Annex G (informative): Acceptable uncertainty of Test Equipment

This informative annex specifies the critical parameters of the components of an overall Test System (e.g. Signal generators, Signal Analysers etc.) which are necessary when assembling a Test System which complies with clause 4.1 Acceptable Uncertainty of Test System. These Test Equipment parameters are fundamental to the accuracy of the overall Test System and are unlikely to be improved upon through System Calibration.

G.1 Transmitter measurements

Table G.1: Equipment accuracy for transmitter measurements

Test	Equipment accuracy	Range over which equipment accuracy applies
6.2.1 Maximum Output Power	Not critical	Not critical
6.2.2 CPICH Power accuracy	Not critical	Not critical
6.3 Frequency error	± 10 Hz + timebase = [12] Hz	Measurements in the range ± 500 Hz.
6.4.2 Power control steps	± 0.1 dB for one 1 dB step ± 0.1 dB for ten 1 dB steps	$P_{max} - 3$ dB to $P_{max} - 28$ dB
6.4.3 Power control dynamic range	± 0.2 dB relative code domain power accuracy	$P_{max} - 3$ dB to $P_{max} - 28$ dB
6.4.4 Total power dynamic range	± 0.3 dB relative error over 18 dB	P_{max} to $P_{max} - 18$ dB
6.4.5 IPDL time mask	Not critical	Not critical
6.5.1 Occupied Bandwidth	± 100 kHz	± 1 MHz of the minimum requirement
6.5.2.1 Spectrum emission mask	Not critical	Not critical
6.5.2.2 ACLR/CACLR	± 0.8 dB	Measurements in the range ± 3 dB of the minimum requirement at signal power = P_{max}
6.5.3 Spurious emissions	Not critical	Not critical
6.6 Transmit intermodulation (interferer requirements)	Not critical	Not critical
6.7.1 EVM	± 2.5 % (for single code)	Measurements in the range 12.5% to 22.5% at signal power = $P_{max} - 3$ dB to $P_{max} - 18$ dB
6.7.2 Peak code Domain error	± 1.0 dB	Measurements in the range -30 to -36 dB at signal power = P_{max}
6.7.3 Time alignment error in TX diversity, MIMO, DC-HSDPA and DB-DC-HSDPA transmission	$0.1 T_c$	
6.7.4 Relative Code Domain Error	± 1.0 dB	Measurements in the range -18 to -24 dB at signal power = P_{max}
Annex H.3 Transmitted code power (absolute)	± 0.9 dB	$P_{max} - 3$ dB to $P_{max} - 28$ dB
Annex H.3 Transmitted code power (relative)	± 0.2 dB	$P_{max} - 3$ dB to $P_{max} - 28$ dB
Annex H.4 Transmitted carrier power	± 0.3 dB relative error over 18 dB	P_{max} to $P_{max} - 18$ dB

G.2 Receiver measurements

Table G.2: Equipment accuracy for receiver measurements

Test	Equipment accuracy	Range over which equipment accuracy applies
7.2 Reference sensitivity level	Not critical	Not critical
7.3 Dynamic range	Not critical	Not critical
7.4 Adjacent channel selectivity	Not critical	Not critical
7.5 Blocking characteristics	Not critical	Not critical
7.6 Intermod Characteristics	Not critical	Not critical
7.7 Spurious Emissions	Not critical	Not critical

G.3 Performance measurements

Table G.3: Equipment accuracy for performance measurements

Test	Equipment accuracy	Range over which equipment accuracy applies
8.2, Demodulation in static propagation condition	Not critical	Not critical
8.3, Demodulation of DCH in multiplath fading conditons	Not critical	Not critical

Annex H (Informative): UTRAN Measurement Test Cases

H.1 Purpose of Annex

This Annex specifies test specific parameters for some of the UTRAN requirements in chapter 9.2 TS 25.133. The tests provide additional information to how the requirements should be tested. Some requirements may lack a test.

Unless explicitly stated:

- Measurement channel is 12.2 kbps as defined in TS 25.104 annex A, sub-clause A.2 for UL measurements
- Test models defined in TS 25.141 sub-clause 6.1 are used for DL measurements

H.2 Received Total Wideband Power

H.2.1 Absolute RTWP measurement

1. Terminate the BS RX inputs, measure the RTWP and record it.
2. Attach a signal generator to the RX input connector and increase the power until the BS reported RTWP value (I_{rep}) has increased 3 dB.
3. Measure the signal power level delivered from the signal generator. This signal level is now called the "Internally generated noise" (N_i).
4. Sweep the signal generator power such that the sum of internally generated noise (N_i) and signal generator power (I) is swept through the defined conditions range.
5. Check that: $|(N_i+I)-I_{rep}|$ meets the accuracy requirements specified in chapter 9.2.1.1.

Note that $I_{ob} = (N_i+I)$

H.2.2 Relative RTWP measurement

1. Terminate the BS RX inputs, measure the RTWP and record it.
2. Attach a signal generator to the RX input connector and increase the power until the BS reported RTWP value (I_{rep}) has increased 3 dB.
3. Measure the signal power level delivered from the signal generator. This signal level is now called the "Internally generated noise" (N_i).
4. Sweep the signal generator power such that the sum of internally generated noise (N_i) and signal generator power (I) is swept through the defined conditions range.
5. The difference between the reported RTWP values shall meet the accuracy requirements specified in chapter 9.2.1.2.

Note that $I_{ob} = (N_i+I)$

H.3 Transmitted code power

1. Generate the wanted signal in accordance to test model 2, clause 6.1.1.2. Set power of the DPCH under test to the $P_{max}-3$ dB level. Power levels for other code channels shall be adjusted as necessary.
2. Measure the output power on code channel under test, $P_{out,code}$, at the antenna connector. Record the transmitted code power reported in the BS, P_{code} .
3. Check that $P_{out,code}$ meets the absolute accuracy requirement in TS 25.133 chapter 9.2.5.1. If STTD or closed loop transmit diversity is supported by the BS, the transmitted code power for each branch are measured, summed together and reported to higher layers. In case of TX diversity or MIMO transmission both branches need to be measured and summed together in order to find out the wanted value. The absolute accuracy of P_{code} can be accepted if $P_{out,code}$ will fullfill the following conditions:

$$P_{code}-3.9 \text{ dB} \leq P_{out,code} \leq P_{code} + 3.9 \text{ dB}, f \leq 3.0 \text{ GHz};$$

$$P_{code}-4.2 \text{ dB} \leq P_{out,code} \leq P_{code} + 4.2 \text{ dB}, 3.0 \text{ GHz} < f \leq 4.2 \text{ GHz}$$

4. Check that the relative accuracy requirement for P_{code} in TS 25.133 chapter 9.2.5.2 is met. Set P_{code1} and P_{code2} to transmit with the same power level. The relative accuracy between P_{code1} and P_{code2} can be accepted if the difference between the measured power of one code channel, $P_{out,code1}$ and another code channel $P_{out,code2}$ will fullfill the following conditions:

$$| P_{out,code1} - P_{out,code2} | \leq 2.2 \text{ dB.}$$

5. Set the power of the DPCH under test to the minimum power of the power control dynamic range and repeat steps 2, 3 and 4.

H.4 Transmitted carrier power

- 1) Set the BS to transmit with the maximum transmission power and measure the output power at the antenna connector, $PMTP$. Maximum transmission power is the mean power on one carrier measured at the antenna connector with the code level settings that according to the base station manufacturer will result in an output power of nominally the maximum output power in a specified reference condition. Test model 2, clause 6.1.1.2, when the code powers are set according to table 6.3. shall be used.
- 2) Operate the BS in closed loop power control until the output power has reached a stable state. Measure the output power, P_{out} , at the antenna connector and record the transmitted carrier power measured and reported in the BS, $Prep$. Note that $Prep$ is normalised to the output power measured in Test Model 2 with all codes at their default levels. If STTD or closed loop transmit diversity is supported by the BS, only the highest of the transmit powers is reported to higher layers. In case of TX diversity or MIMO transmission both branches need to be measured in order to find out which one is the highest.
- 3) Check that the P_{out} meets the requirement in TS 25.133 chapter 9.2.4.1, with the same test equipment accuracy as in chapter 6.4.4. in TS 25.141. $Prep$ can be accepted if P_{out} will fullfill the following conditions:

$$PMTP + 10 \log \left(\frac{Prep - 5}{100} \right) - 0.3 \leq P_{out} \leq PMTP + 10 \log \left(\frac{Prep + 5}{100} \right) + 0.3 \text{ [dBm]}$$

- 4) Repeat step 2 and 3 over the 5%-95% range of the $Prep$. Use first the standard code powers of test model 2 to verify the $Prep$ range from 50% to 95%. After that put the other dedicated channels off and reduce the powers of the control codes in order to be able to verify the $Prep$ range from 5% to 50%.

NOTE: P_{out} shall be tested immediately after $PMTP$ in order to avoid the influence of long term stability variation to measurement results.

Annex I (normative): Characteristics of the W-CDMA interference signal

The W-CDMA interference signal shall be a DPCH containing the DPCCH and one DPDCH. The data content for each channelization code shall be uncorrelated with each other and to the wanted signal and spread and modulated according to clause 4 of TS25.213 [14]. Further characteristics of DPDCH and DPCCH are specified in table I.1.

Table I.1.: Characteristics of the W-CDMA interference signal

Channel	Bit Rate	Spreading Factor	Channelization Code	Relative Power
DPDCH	240 kbps	16	4	0 dB
DPCCH	15 kbps	256	0	-5.46 dB

NOTE: The DPDCH and DPCCH settings are chosen to simulate a signal with realistic Peak to Average Ratio.

Annex J (informative): Change history

TSG	Doc	CR	R	Title	Cat	Curr	New	Work Item
RP-37				Rel-8 version created based on v7.9.0			8.0.0	
RP-37	RP-070658	0461		Introduction of UMTS1500 requirements	B	7.9.0	8.0.0	RInImp8-UMTS1500
RP-38	RP-070936	0466	1	Base Station MIMO corrections	A	8.0.0	8.1.0	MIMO-RF
RP-38	RP-070937	0468		Spurious emissions limits for coexistence with CDMA850	A	8.0.0	8.1.0	TEI7
RP-39	RP-080120	0478		Correction to RX spurious emissions	A	8.1.0	8.2.0	TEI6
RP-39	RP-080122	0473	1	Editorial modifications of the test requirement table for the demodulation of E-DPDCH in multipath fading conditions and table and figure title in A.18 in 25.141	A	8.1.0	8.2.0	TEI7
RP-39	RP-080124	0471	1	Introduction of UMTS700 requirements (Band XII, XIII and XIV) in TS 25.141	B	8.1.0	8.2.0	RInImp8-UMTS700
RP-39	RP-080126	0469	1	Correction of the node for Band XI BS ACLR	F	8.1.0	8.2.0	RInImp8-UMTS1500
RP-39	RP-080126	0470		Correction of spurious emissions limits for coexistence with CDMA850	F	8.1.0	8.2.0	TEI8
RP-40	RP-080326	0479	2	Correction on emission requirements for protection of public safety operations	F	8.2.0	8.3.0	RInImp8-UMTS700
RP-41	RP-080632	0480		Corrections on the section on BS using antenna array	F	8.3.0	8.4.0	MIMO-RF
RP-42	RP-080904	0485		Clarification on HS-SCCH structure for Test Model 6	F	8.4.0	8.5.0	TEI7
RP-42	RP-080904	0491	3	Clarification for test model 1	F	8.4.0	8.5.0	TEI7
RP-42	RP-080927	0487	1	Clarification of eNB HST propagation conditions (25.141, rel-7)	F	8.4.0	8.5.0	TEI7
RP-42	RP-080948	0489	1	TS 25.141 modification due to DC HSDPA	B	8.4.0	8.5.0	RANimp-DCHSDPA
RP-42	RP-080945	481		Transmitter characteristics Tests for 3G Home NodeB	F	8.4.0	8.5.0	HNB-RF
RP-42	RP-080945	492	1	Regional requirement on Home Node B applicability	F	8.4.0	8.5.0	HNB-RF
RP-42	RP-080945	482		Receiver characteristics Tests for 3G Home NodeB	F	8.4.0	8.5.0	HNB-RF
RP-42	RP-080945	483		Demodulation Requirements Tests for 3G Home NodeB	F	8.4.0	8.5.0	HNB-RF
RP-42	RP-080945	493		Modified Test Models for 3G Home NodeB	F	8.4.0	8.5.0	HNB-RF
RP-43	RP-090197	496		Co-existence requirement for the band 1880MHz	F	8.5.0	8.6.0	RInImp9-UMTS1880TDD
RP-43	RP-090192	494		Change reference bandwidth for ACLR limit for Home BS	F	8.5.0	8.6.0	HNB-RF
RP-43	RP-090192	495		3G Home NodeB Transmit Power Conformance Testing for Adjacent Channel Protection	F	8.5.0	8.6.0	HNB-RF
RP-44	RP-090553	499		Correction of local area base station coexistence spurious emission requirements	F	8.6.0	8.7.0	RInImp9-UMTS1880TDD
RP-44	RP-090605	497		Correction on Home BS Output Power Requirements for Adjacent Channel Protection	F	8.6.0	8.7.0	HNB-RF
RP-44	RP-090605	502		Correction on test system uncertainty for Home BS absolute ACLR limit	F	8.6.0	8.7.0	HNB-RF
RP-44	RP-090559	498		Introduction of Extended UMTS800 requirements	B	8.7.0	9.0.0	RInImp9-UMTSLTE800
RP-45	RP-090827	516	1	Correction of DPCCH slot format for FRC8	A	9.0.0	9.1.0	TEI7
RP-45	RP-090825	505		Spectrum emission mask test tolerance correction	A	9.0.0	9.1.0	TEI8
RP-45	RP-090825	509		Correction of Receiver additional spurious emission requirement	A	9.0.0	9.1.0	TEI8
RP-45	RP-090824	511		Editorial correction on 6.5.3.7	F	9.0.0	9.1.0	TEI9
RP-46	RP-091286	517		Introduction of Extended UMTS1500 requirements for TS25.141 (Technically endorsed at RAN 4 52bis in R4-093628)	B	9.1.0	9.2.0	UMTSLTE1500

RP-46	RP-091276	519		Testing in case of Rx diversity, Tx diversity and MIMO (Technically endorsed at RAN 4 52bis in R4-093983)	A	9.1.0	9.2.0	TEI8
RP-46	RP-091288	520		Introduction of the BS requirements for DC-HSUPA (Technically Endorsed in R4-52, R4-093331)	B	9.1.0	9.2.0	RANimp-DC_HSUPA
RP-46	RP-091289	521		Introduction of BS requirements for DB-DC-HSDPA (Technically Endorsed in R4-52, R4-093416)	B	9.1.0	9.2.0	RANimp-MultiBand_DC_HSDPA
RP-46	RP-091277	523		Corrections on additional spectrum emission limits for Bands XII, XIII, XIV	A	9.1.0	9.2.0	TEI8
RP-46	RP-091296	524	1	Correction to the transmitter intermodulation	F	9.1.0	9.2.0	TEI9
RP-46	RP-091296	527	1	Time alignment error definition correction for DC-HSDPA	A	9.1.0	9.2.0	TEI9
RP-46	RP-091268	529	1	Protection of E-UTRA for UTRA BS	A	9.1.0	9.2.0	LTE-RF
RP-47	RP-100261	537		Corrections on Home BS Output Power Conformance Testing	A	9.2.0	9.3.0	TEI8
RP-47	RP-100261	539	1	TS 25.141 Removal of testing for receiver diversity port	A	9.2.0	9.3.0	TEI8
RP-47	RP-100272	535	1	Clarification of time alignment error requirements	F	9.2.0	9.3.0	TEI9
RP-47	RP-100263	540	1	Introduction of Band XX in 25.141	B	9.2.0	9.3.0	RInImp9-UMTSLTE80 0EU
RP-47	RP-100264	534		Corrections for Extended UMTS1500 requirements	F	9.2.0	9.3.0	UMTSLTE15 00
RP-47	RP-100267	542		Tx-Rx frequency separation for DC-HSUPA	B	9.2.0	9.3.0	RANimp-DC_HSUPA
RP-48	RP-100625	548		Clarification of applicability of requirements for multi-carrier BS	F	9.3.0	9.4.0	RInImp9-RFmulti
RP-48	RP-100626	543		Correction of blocking performance requirement when co-located with BS in other bands (Band 20)	F	9.3.0	9.4.0	RInImp9-UMTSLTE80 0EU
RP-48	RP-100631	549		Correction of RACH message demodulation requirement definitions	F	9.3.0	9.4.0	TEI9
RP-48	RP-100631	547	1	Co-existence with services in adjacent frequency bands	F	9.3.0	9.4.0	TEI9
RP-49	RP-100918	551		Corrections on Home BS spurious emission limits for co-existence with Home BS operating in other bands	A	9.4.0	9.5.0	HNB-RF
RP-49	RP-100918	553		Clarifications on Base Station transmit and receive configurations	A	9.4.0	9.5.0	TEI8
RP-50	RP-101334	566	1	Band XII channel arrangement correction on 25.141	A	9.5.0	9.6.0	TEI8
RP-50	RP-101340	561	1	Revision of Time Alignment Error requirement testing	F	9.5.0	9.6.0	TEI9
RP-50	RP-101353	563		Introduction of frequency bands for 4C-HSDPA	B	9.6.0	10.0.0	4c_HSDPA-Core
RP-50	RP-101353	562	1	Revision of Time Alignment Error requirement testing	B	9.6.0	10.0.0	4C_HSDPA-Core
RP-50	RP-101361	558		Protection of E-UTRA Band 24	B	9.6.0	10.0.0	L_Band_LTE_ATC_MSS-Core
RP-51	RP-110355	0564	2	DB-DC-HSDPA: New band combinations	B	10.0.0	10.1.0	DB_DC_HSD PA-Core
RP-51	RP-110341	0573	-	Clarification of ambiguity in Test Model 5	A	10.0.0	10.1.0	TEI8
RP-51	RP-110352	0576	1	Correction of the test port description for TS 25.141 Rel-10	F	10.0.0	10.1.0	TEI10
RP-51	RP-110352	0577	1	UTRA BS Receiver spurious requirements for protection of other bands	F	10.0.0	10.1.0	TEI10
RP-51	RP-110352	0578	1	Harmonization of co-existence/co-location requirements between 25.141 and 36.141	F	10.0.0	10.1.0	TEI10
RP-52	RP-110788	583		Modifications to Band 3 to allow LTE Band 3 operation in Japan (Rel-10 TS25.141 CR)	A	10.1.0	10.2.0	TEI8
RP-52	RP-110804	584		Add coexistence requirements for expanded 1900MHz band in 25.141	B	10.1.0	10.2.0	E1900_UB-Core
RP-52	RP-110813	585		Add 2GHz S-Band (Band 23) in 25.141	B	10.1.0	10.2.0	S_Band_LTE_ATC_MSS-Perf
RP-52	RP-110800	586		Definition of Virtual Antenna Mapping (VAM) and applicability of S-CPICH power accuracy requirement	B	10.1.0	10.2.0	MIMO_HSDPA-Core

RP-53	RP-111255	592		Add Band 42 and 43 for LTE 3500 (TDD) to TS 25.141	B	10.2.0	10.3.0	RInImp8-UMTSLTE3500
RP-53	RP-111255	593	1	Add Band 22/XXII for LTE/UMTS 3500 (FDD) to TS 25.141	B	10.2.0	10.3.0	RInImp8-UMTSLTE3500
RP-53	RP-111262	588		Co-existence requirements on TS 25.141	F	10.2.0	10.3.0	TEI10
RP-53	RP-111268	587	1	Updating BS Coexistence table for Band 23 in TS 25.141	B	10.2.0	10.3.0	S_Band_LTE_ATC_MSS-Perf
RP-53	RP-111270	594	1	Introduction of S-CPICH power offset accuracy test	B	10.2.0	10.3.0	4C_HSDPA-Perf
RP-54	RP-111686	595		Removal of TBD in the S-CPICH power offset test	F	10.3.0	10.4.0	MIMO_HSDPA-Core, TEI10
RP-54	RP-111734	596		Band 42 and 43 for LTE 3500 (TDD) correction to TS 25.141	F	10.3.0	10.4.0	TEI10
RP-54	RP-111686	597		Introduction of HS-DPCCH demodulation performance testing for 4C-HSDPA	F	10.3.0	10.4.0	4C_HSDPA-Perf, TEI10
RP-54	RP-111734	598		Clarification of general blocking requirements for co-existence in TS 25.141	F	10.3.0	10.4.0	TEI10
RP-54	RP-111687	600	3	TX ON or OFF CR 25.141	F	10.3.0	10.4.0	TEI10
RP-54	RP-111696	599	1	Introduction of new configuration for 4C-HSDPA	B	10.4.0	11.0.0	4C_HSDPA_Core
RP-55	RP-120305	605		Introduction of Band 26/XXVI to TS 25. 141	B	11.0.0	11.1.0	e850_UB-Core
RP-55	RP-120301	606		MC DB HSDPA: Introduction of configurations I-2-VIII-2 and II-1-V-2 in TS 25.141	B	11.0.0	11.1.0	HSDPA_DB_MC-Core
RP-55	RP-120297	607		Correction of frequency range for spurious emission requirements	A	11.0.0	11.1.0	RInImp8-UMTSLTE3500
RP-55	RP-120339	0608		Addition of Band 23 HeNB specifications in TS 25.141	A	11.0.0	11.1.0	S_Band_LTE_ATC_MSS-Core
RP-56	RP-120787	0609		Introduction of non-contiguous operation for 4C-HSDPA	B	11.1.0	11.2.0	NC_4C_HSDPA
RP-56	RP-120786	0610	1	8C-HSDPA: Introduction of BS conformance testing for 8C-HSDPA operation	B	11.1.0	11.2.0	8C_HSDPA-Core
RP-56	RP-120783	0612	1	Update to Regional Requirements table 25.141 – CR Not implemented as the content is not from this spec but from 25.104	A	11.1.0		TEI10
RP-56	RP-120771	0616		Introduction of Japanese Regulatory Requirements to W-CDMA Band VIII (R11)	A	11.1.0	11.2.0	TEI9
RP-56	RP-120793	0619		Introduction of Band 28	B	11.1.0	11.2.0	LTE_APAC700-Core
RP-56	RP-120793	0620		Introduction of Band 44	B	11.1.0	11.2.0	LTE_APAC700-Core
RP-56	RP-120792	0621	2	Introduction of E850_LB (Band 27) to TS 25.141	B	11.1.0	11.2.0	LTE_e850_LB-Perf
RP-56	RP-120766	0625		Correction of PHS protection requirements for TS 25.141	A	11.1.0	11.2.0	TEI8
RP-57	RP-121314	626		Alignment of NC-4C-HSDPA configurations table	F	11.2.0	11.3.0	NC_4C_HSDPA-Core
RP-57	RP-121316	627	1	Update of co-location spurious emission in TS 25.141	F	11.2.0	11.3.0	LTE_APAC700-Core
RP-57	RP-121300	631		Modifications of frequency ranges on spurious emission requirements for Band 6, 18, 19	A	11.2.0	11.3.0	RInImp9-UMTSLTE800
RP-57	RP-121301	634		Band VIII ACLR	A	11.2.0	11.3.0	TEI9
RP-57	RP-121312	636		BS test uncertainties above 3 GHz	A	11.2.0	11.3.0	RInImp8-UMTSLTE3500
RP-58	RP-121848	0640	-	Introducing the additional frequency bands of 5 MHz x 2 in 1.7 GHz in Japan to Band III	A	11.3.0	11.4.0	RInImp-UMTS1700
RP-58	RP-121909	0641	-	Correct f_offsetmax definition for a BS operating in non-contiguous spectrum in TS 25.141	F	11.3.0	11.4.0	NC_4C_HSDPA-Perf
RP-58	RP-121902	0642	-	Introduction of Band 29	B	11.3.0	11.4.0	LTE_DL_FDD700-Perf

RP-60	RP-130768	643		Introduction of dual-band 4C-HSDPA configuration for Band I and VIII	B	11.4.0	11.5.0	HSDPA_DB_MC-Perf
RP-60	RP-130764	645		2X2MIMO: BS conformance testing for S-CPICH	A	11.4.0	11.5.0	TEI10
RP-60	RP-130768	646		Correction to Definitions list	F	11.4.0	11.5.0	8C_HSDPA-Core
RP-60	RP-130800	647	1	Indication of HSDPA Multiflow BS performance requirements	B	11.4.0	11.5.0	HSDPA_MFT X-Perf
RP-61	RP-131293	0652		Correction on TX-RX separation for TS25.141	F	11.5.0	11.6.0	TEI11
RP-61	RP-131283	0654	1	Co-location requirements for E-UTRA Medium Range BS	F	11.5.0	11.6.0	medBS_class_LTE_MSR
RP-61	RP-131293	0657	1	Correction on Base station maximum output power for TS25.141	F	11.5.0	11.6.0	TEI11
RP-61	RP-131287	0659	1	Introduction of MIMO mode with 4 transmit antennas	B	11.5.0	11.6.0	4Tx_HSDPA-Perf
RP-61	RP-131288	0660	1	Introduction of BS demodulation performance requirements for HSUPA MIMO	B	11.5.0	11.6.0	MIMO_64QA M_HSUPA-Perf
RP-62	RP-131939	666	1	Alignment of Note related to BS Spurious emissions limits for co-location with another BS	F	11.6.0	11.7.0	TEI11
RP-62	RP-131929	669	1	Correction of the terminology used for MIMO mode with 4 transmit antennas	F	11.6.0	11.7.0	4Tx_HSDPA-Core
RP-62	RP-131930	671		Clarification for CA CLR in TS25.141	F	11.6.0	11.7.0	medBS_class_LTE_MSR-Perf
RP-63	RP-140368	674		Correction on tested frequency range	A	11.7.0	11.8.0	TEI10
RP-65	RP-141532	694		CR for RTWP tests (Rel-11)	A	11.8.0	11.9.0	TEI10
RP-66	RP-142145	703		Absolute ACLR limit for UTRA	F	11.9.0	11.10.0	NC_4C_HSDPA-Perf
RP-66	RP-142149	705	1	Introduction of multi-carrier multi-band BS testing in TS 25.141 - clauses 1-5	F	11.9.0	11.10.0	TEI11
RP-66	RP-142149	706	1	Introduction of multi-carrier and multi-band BS testing in TS 25.141 - clauses 6-7	F	11.9.0	11.10.0	TEI11

History

Document history		
V11.3.0	October 2012	Publication
V11.4.0	February 2013	Publication
V11.5.0	July 2013	Publication
V11.6.0	October 2013	Publication
V11.7.0	January 2014	Publication
V11.8.0	April 2014	Publication
V11.9.0	October 2014	Publication
V11.10.0	January 2015	Publication