

ETSI TS 125 142 V3.2.0 (2000-06)

Technical Specification

**Universal Mobile Telecommunications System (UMTS);
Base station conformance testing (TDD)
(3G TS 25.142 version 3.2.0 Release 1999)**



Reference

RTS/TSGR-0425142UR2

Keywords

UMTS

ETSI

650 Route des Lucioles
F-06921 Sophia Antipolis Cedex - FRANCE

Tel.: +33 4 92 94 42 00 Fax: +33 4 93 65 47 16

Siret N° 348 623 562 00017 - NAF 742 C
Association à but non lucratif enregistrée à la
Sous-Préfecture de Grasse (06) N° 7803/88

Important notice

Individual copies of the present document can be downloaded from:

<http://www.etsi.org>

The present document may be made available in more than one electronic version or in print. In any case of existing or perceived difference in contents between such versions, the reference version is the Portable Document Format (PDF).

In case of dispute, the reference shall be the printing on ETSI printers of the PDF version kept on a specific network drive within ETSI Secretariat.

Users of the present document should be aware that the document may be subject to revision or change of status.

Information on the current status of this and other ETSI documents is available at <http://www.etsi.org/tb/status/>

If you find errors in the present document, send your comment to:

editor@etsi.fr

Copyright Notification

No part may be reproduced except as authorized by written permission.
The copyright and the foregoing restriction extend to reproduction in all media.

© European Telecommunications Standards Institute 2000.

All rights reserved.

Intellectual Property Rights

IPRs essential or potentially essential to the present document may have been declared to ETSI. The information pertaining to these essential IPRs, if any, is publicly available for **ETSI members and non-members**, and can be found in ETSI SR 000 314: *"Intellectual Property Rights (IPRs); Essential, or potentially Essential, IPRs notified to ETSI in respect of ETSI standards"*, which is available from the ETSI Secretariat. Latest updates are available on the ETSI Web server (<http://www.etsi.org/ipr>).

Pursuant to the ETSI IPR Policy, no investigation, including IPR searches, has been carried out by ETSI. No guarantee can be given as to the existence of other IPRs not referenced in ETSI SR 000 314 (or the updates on the ETSI Web server) which are, or may be, or may become, essential to the present document.

Foreword

This Technical Specification (TS) has been produced by the ETSI 3rd Generation Partnership Project (3GPP).

The present document may refer to technical specifications or reports using their 3GPP identities, UMTS identities or GSM identities. These should be interpreted as being references to the corresponding ETSI deliverables.

The cross reference between GSM, UMTS, 3GPP and ETSI identities can be found under www.etsi.org/key .

Contents

Foreword.....	9
1 Scope.....	10
2 References.....	10
3 Definitions, symbols, and abbreviations.....	10
4 Frequency bands and channel arrangement.....	11
4.1 General.....	11
4.2 Frequency bands.....	11
4.3 TX–RX frequency separation.....	11
4.4 Channel arrangement.....	12
4.4.1 Channel spacing.....	12
4.4.2 Channel raster.....	12
4.4.3 Channel number.....	12
5 General test conditions and declarations.....	13
5.1 Base station classes.....	13
5.2 Output power.....	13
5.3 Specified frequency range.....	13
5.4 Relationship between RF generation and chip clock.....	13
5.5 Spectrum emission mask.....	14
5.6 Adjacent Channel Leakage power Ratio (ACLR).....	14
5.7 Tx spurious emissions.....	14
5.7.1 Category of spurious emissions limit.....	14
5.7.2 Co-existence with GSM.....	14
5.7.3 Co-existence with DCS 1800.....	14
5.7.4 Co-existence with UTRA FDD.....	15
5.8 Blocking characteristics.....	15
5.9 Test environments.....	15
5.9.1 Normal test environment.....	15
5.9.2 Extreme test environment.....	16
5.9.2.1 Extreme temperature.....	16
5.9.3 Vibration.....	16
5.9.4 Power supply.....	16
5.9.5 Acceptable uncertainty of measurement equipment.....	17
5.10 Interpretation of measurement results.....	20
5.11 Selection of configurations for testing.....	20
5.12 BS Configurations.....	20
5.12.1 Receiver diversity.....	21
5.12.2 Duplexers.....	21
5.12.3 Power supply options.....	21
5.12.4 Ancillary RF amplifiers.....	21
5.12.5 BS using antenna arrays.....	22
5.13 Overview of the conformance test requirements.....	23
5.14 Format and interpretation of tests.....	24
5.15 Regional requirements.....	25
6 Transmitter characteristics.....	26
6.1 General.....	26
6.2 Maximum output power.....	26
6.2.1 Definition and applicability.....	26
6.2.2 Conformance requirements.....	26
6.2.3 Test purpose.....	26
6.2.4 Method of test.....	26
6.2.4.1 Initial conditions.....	26
6.2.4.2 Procedure.....	27
6.2.5 Test requirements.....	27

6.3	Frequency stability	27
6.3.1	Definition and applicability	27
6.3.2	Conformance requirements	27
6.3.3	Test purpose	27
6.3.4	Method of test.....	27
6.3.4.1	Initial conditions.....	27
6.3.4.2	Procedure.....	29
6.3.5	Test requirements	29
6.4	Output power dynamics	29
6.4.1	Inner loop power control	29
6.4.2	Power control steps	29
6.4.2.1	Definition and applicability	29
6.4.2.2	Conformance requirements	29
6.4.2.3	Test purpose	29
6.4.2.4	Method of test.....	30
6.4.2.4.1	Initial conditions	30
6.4.2.4.2	Procedure.....	30
6.4.2.5	Test requirements	31
6.4.3	Power control dynamic range.....	31
6.4.3.1	Definition and applicability	31
6.4.3.2	Conformance requirements	31
6.4.3.3	Test purpose	31
6.4.3.4	Method of test.....	31
6.4.3.4.1	Initial conditions	31
6.4.3.4.2	Procedure.....	32
6.4.3.5	Test requirements	32
6.4.4	Minimum transmit power.....	32
6.4.4.1	Definition and applicability	32
6.4.4.2	Conformance requirements	32
6.4.4.3	Test purpose	33
6.4.4.4	Method of test.....	33
6.4.4.4.1	Initial conditions	33
6.4.4.4.2	Procedure.....	33
6.4.4.5	Test requirements	33
6.4.5	Primary CCPCH power	34
6.4.5.1	Definition and applicability	34
6.4.5.2	Conformance requirements	34
6.4.5.3	Test purpose	34
6.4.5.4	Method of test.....	34
6.4.5.4.1	Initial conditions	34
6.4.5.4.2	Procedure.....	35
6.4.5.5	Test requirements	35
6.5	Transmit OFF power.....	35
6.5.1	Definition and applicability	35
6.5.2	Conformance requirements	35
6.5.3	Test purpose	35
6.5.4	Method of test.....	35
6.5.4.1	Initial conditions.....	35
6.5.4.2	Procedure.....	35
6.5.5	Test requirements	36
6.6	Output RF spectrum emissions	36
6.6.1	Occupied bandwidth.....	36
6.6.1.1	Definition and applicability	36
6.6.1.2	Conformance requirements	36
6.6.1.3	Test purpose	36
6.6.1.4	Method of test.....	36
6.6.1.4.1	Initial conditions	36
6.6.1.4.2	Procedure.....	37
6.6.1.5	Test requirements	37
6.6.2	Out of band emission.....	37
6.6.2.1	Spectrum emission mask.....	37
6.6.2.1.1	Definition and applicability	37

6.6.2.1.2	Conformance requirements	37
6.6.2.1.3	Test purpose	38
6.6.2.1.4	Method of test	38
6.6.2.1.4.1	Initial conditions	38
6.6.2.1.4.2	Procedure 39	
6.6.2.1.5	Test requirements	39
6.6.2.2	Adjacent Channel Leakage power Ratio (ACLR)	39
6.6.2.2.1	Definition and applicability	39
6.6.2.2.2	Conformance requirements	39
6.6.2.2.1	Definition and applicability	39
6.6.2.2.2	Conformance requirements	39
6.6.2.2.2.1	Minimum requirement	39
6.6.2.2.2.2	Requirement in case of operation in proximity to TDD BS or FDD BS operating on an adjacent frequency	40
6.6.2.2.2.3	Requirement in case of co-siting with TDD BS or FDD BS operating on an adjacent frequency	40
6.6.2.2.3	Test purpose	40
6.6.2.2.4	Method of test	40
6.6.2.2.4.1	Initial conditions	40
6.6.2.2.4.2	Procedure 41	
6.6.2.2.5	Test requirements	41
6.6.3	Spurious emissions	41
6.6.3.1	Definition and applicability	41
6.6.3.2	Conformance requirements	41
6.6.3.2.1	Mandatory requirements	41
6.6.3.2.1.1	Spurious emissions (Category A)	42
6.6.3.2.1.2	Spurious emissions (Category B)	42
6.6.3.2.2	Co-existence with GSM	43
6.6.3.2.2.1	Operation in the same geographic area	43
6.6.3.2.2.2	Co-located base stations	43
6.6.3.2.3	Co-existence with DCS 1800	43
6.6.3.2.3.1	Operation in the same geographic area	43
6.6.3.2.3.2	Co-located base stations	44
6.6.3.2.4	Co-existence with UTRA FDD	44
6.6.3.2.4.1	Operation in the same geographic area	44
6.6.3.2.4.2	Co-located base stations	44
6.6.3.3	Test purpose	44
6.6.3.4	Method of test	44
6.6.3.4.1	Initial conditions	44
6.6.3.4.2	Procedure	45
6.6.3.5	Test requirements	45
6.7	Transmit intermodulation	45
6.7.1	Definition and applicability	45
6.7.2	Conformance requirements	45
6.7.3	Test purpose	45
6.7.4	Method of test	46
6.7.4.1	Initial conditions	46
6.7.4.2	Procedure	46
6.7.5	Test requirements	46
6.8	Transmit Modulation	47
6.8.1	Modulation accuracy	47
6.8.1.1	Definition and applicability	47
6.8.1.2	Conformance requirements	47
6.8.1.3	Test purpose	47
6.8.1.4	Method of test	47
6.8.1.4.1	Initial conditions	47
6.8.1.4.2	Procedure	48
6.8.1.5	Test requirements	48
6.8.2	Peak code domain error	48
6.8.2.1	Definition and applicability	48
6.8.2.2	Conformance requirements	48
6.8.2.3	Test purpose	48
6.8.2.4	Method of test	48

6.8.2.4.1	Initial conditions	48
6.8.2.4.2	Procedure	48
6.8.2.5	Test requirements	48
7	Receiver characteristics	49
7.1	General	49
7.2	Reference sensitivity level	49
7.2.1	Definition and applicability	49
7.2.2	Conformance requirements	49
7.2.3	Test purpose	49
7.2.4	Method of test	49
7.2.4.1	Initial conditions	49
7.2.4.2	Procedure	50
7.2.5	Test requirements	50
7.3	Dynamic range	50
7.3.1	Definition and applicability	50
7.3.2	Conformance requirements	50
7.3.3	Test purpose	50
7.3.4	Method of test	50
7.3.4.1	Initial conditions	50
7.3.4.2	Procedure	51
7.3.5	Test requirements	51
7.4	Adjacent Channel Selectivity (ACS)	51
7.4.1	Definition and applicability	51
7.4.2	Conformance requirements	51
7.4.3	Test purpose	51
7.4.4	Method of test	51
7.4.4.1	Initial conditions	51
7.4.4.2	Procedure	52
7.4.5	Test requirements	52
7.5	Blocking characteristics	52
7.5.1	Definition and applicability	52
7.5.2	Conformance requirements	52
7.5.3	Test purpose	53
7.5.4	Method of test	53
7.5.4.1	Initial conditions	53
7.5.4.2	Procedure	53
7.5.5	Test requirements	54
7.6	Intermodulation characteristics	54
7.6.1	Definition and applicability	54
7.6.2	Conformance requirements	54
7.6.3	Test purpose	54
7.6.4	Method of test	54
7.6.4.1	Initial conditions	54
7.6.4.2	Procedure	55
7.6.5	Test requirements	55
7.7	Spurious emissions	55
7.7.1	Definition and applicability	55
7.7.2	Conformance requirements	55
7.7.3	Test purpose	56
7.7.4	Method of test	56
7.7.4.1	Initial conditions	56
7.7.4.2	Procedure	57
7.7.5	Test requirements	57
8	Performance requirements	58
8.1	General	58
8.2	Demodulation in static propagation conditions	58
8.2.1	Demodulation of DCH	58
8.2.1.1	Definition and applicability	58
8.2.1.2	Conformance requirements	58
8.2.1.3	Test purpose	59

8.2.1.4	Method of test.....	59
8.2.1.4.1	Initial conditions	59
8.2.1.4.2	Procedure	59
8.2.1.5	Test requirements	60
8.3	Demodulation of DCH in multipath fading conditions	60
8.3.1	Multipath fading Case 1	60
8.3.1.1	Definition and applicability	60
8.3.1.2	Conformance requirements	60
8.3.1.3	Test purpose	61
8.3.1.4	Method of test.....	61
8.3.1.4.1	Initial conditions	61
8.3.1.4.2	Procedure	61
8.3.1.5	Test requirements	62
8.3.2	Multipath fading Case 2	62
8.3.2.1	Definition and applicability	62
8.3.2.2	Conformance requirements	62
8.3.2.3	Test purpose	63
8.3.2.4	Method of test.....	63
8.3.2.4.1	Initial conditions	63
8.3.2.4.2	Procedure	63
8.3.2.5	Test requirements	64
8.3.3	Multipath fading Case 3	64
8.3.3.1	Definition and applicability	64
8.3.3.2	Conformance requirements	64
8.3.3.3	Test purpose	65
8.3.3.4	Method of test.....	65
8.3.3.4.1	Initial conditions	65
8.3.3.4.2	Procedure	65
8.3.3.5	Test requirements	66
Annex A (normative): Measurement Channels		67
A.1	General	67
A.2	Reference measurement channel.....	67
A.2.1	UL reference measurement channel (12.2 kbps).....	67
A.2.2	UL reference measurement channel (64 kbps).....	68
A.2.3	UL reference measurement channel (144 kbps).....	69
A.2.4	UL reference measurement channel (384 kbps).....	70
A.2.5	RACH reference measurement channel	71
A.2.5.1	RACH mapped to 1 code SF16	71
A.2.5.2	RACH mapped to 1 code SF8	72
Annex B (normative): Propagation conditions		73
B.1	Static propagation condition.....	73
B.2	Multi-path fading propagation conditions.....	73
Annex C (normative): Global in-channel Tx test.....		74
C.1	General	74
C.2	Definition of the process	74
C.2.1	Basic principle.....	74
C.2.2	Output signal of the Tx under test	74
C.2.3	Reference signal	74
C.2.4	Classification of measurement results	75
C.2.5	Process definition to achieve results of type "deviation"	75
C.2.6	Process definition to achieve results of type "residual"	75
C.2.6.1	Error Vector Magnitude (EVM)	76
C.2.6.2	Peak Code Domain Error (PCDE).....	76

C.3 Applications77

C.4 Notes.....77

Annex D (informative): Change history78

Foreword

This Technical Specification has been produced by the 3GPP.

The contents of the present document are subject to continuing work within the TSG and may change following formal TSG approval. Should the TSG modify the contents of this TS, it will be re-released by the TSG with an identifying change of release date and an increase in version number as follows:

Version x.y.z

where:

- x the first digit:
 - 1 presented to TSG for information;
 - 2 presented to TSG for approval;
 - 3 Indicates TSG approved document under change control.
- y the second digit is incremented for all changes of substance, i.e. technical enhancements, corrections, updates, etc.
- z the third digit is incremented when editorial only changes have been incorporated in the specification.

1 Scope

The present document specifies the Radio Frequency (RF) test methods and conformance requirements for UTRA Base Stations (BS) operating in the TDD mode. These have been derived from, and are consistent with, the UTRA base station (BS) specifications defined in 3G TS 25.105 [1].

In this TS, the reference point for RF connections (except for the measurement of mean transmitted RF carrier power) is the antenna connector, as defined by the manufacturer. This TS does not apply to repeaters or RF devices which may be connected to an antenna connector of a BS.

2 References

The following documents contain provisions which, through reference in this text, constitute provisions of the present document.

- References are either specific (identified by date of publication, edition number, version number, etc.) or non-specific.
- For a specific reference, subsequent revisions do not apply.
- For a non-specific reference, the latest version applies.
- A non-specific reference to an ETS shall also be taken to refer to later versions published as an EN with the same number.

- [1] 3G TS 25.105: " UTRA (BS) TDD; Radio transmission and Reception ".
- [2] ETR 027: "Methods of measurement for mobile radio equipment".
- [3] IEC 721: "Classification of environmental conditions".
- [4] IEC 68-2: "Basic environmental testing procedures; Part 2: Tests".
- [5] ETR 028: "Uncertainties in the measurement of mobile radio equipment characteristics".
- [6] Recommendation ITU-R SM.329-7: "Spurious emissions".
- [7] Recommendation ITU-R SM.328-9: "Spectra and bandwidth of emissions".
- [8] ETS 300 019-1: "Equipment Engineering (EE); Environmental conditions and environmental tests for telecommunications equipment Part 1-0: Classification of environmental conditions Introduction".

3 Definitions, symbols, and abbreviations

For the purposes of the present document, the following definitions, symbols and abbreviations apply:

3GPP	3rd Generation Partnership Project
α	Roll-off factor
dB	decibel
dBm	decibel relative to 1 milliWatt
DPCH _o	Mechanism used to simulate an individual intracell interferer in the cell with one code and a spreading factor of 16
$\frac{DPCH_o - E_c}{I_{or}}$	Ratio of the average transmit energy per PN chip for the DPCH _o to the total transmit power
EVM	spectral density of all users in the cell in one timeslot as measured at the BS antenna connector Error Vector Magnitude
F	Frequency (of the assigned channel frequency of the wanted signal)

F _w	Frequency offset of the unwanted interfering signal from the assigned channel frequency of the wanted signal
IMT-2000	International Mobile Telecommunications 2000
I _{oc}	Power spectral density of a band limited white noise source (simulating interference from other cells) as measured at the BS antenna connector.
\hat{I}_{or}	Received power spectral density of all users in the cell in one timeslot as measured at the BS antenna connector
IPR	Intellectual Property Rights
P	Transmit power
P _{out}	Output power of the base station; defined as the mean power of one carrier delivered to a load with resistance equal to the nominal load impedance of the transmitter during one slot
P _{max}	Maximum output power of the base station; defined as the mean power level per carrier over an active timeslot measured at the antenna connector for a specified reference condition
RBER	Residual BER
REFSENS	Reference Sensitivity Level
RMS	Root-Mean Square
PRAT	Rated output power of the base station; defined as the mean power level per carrier over an active timeslot that the manufacturer has declared to be available at the antenna connector
RRC	Root-Raised Cosine
T _c	Chip duration
TS	Time Slot

4 Frequency bands and channel arrangement

4.1 General

The information presented in this section is based on a chip rate of 3,84 Mcps.

NOTE: Other chip rates may be considered in future releases.

4.2 Frequency bands

UTRA/TDD is designed to operate in the following bands:

- a) 1900 – 1920 MHz: Uplink and downlink transmission
2010 – 2025 MHz Uplink and downlink transmission
- b)* 1850 – 1910 MHz: Uplink and downlink transmission
1930 – 1990 MHz: Uplink and downlink transmission
- c)* 1910 – 1930 MHz: Uplink and downlink transmission

* Used in ITU Region 2

Additional allocations in ITU region 2 are FFS.

Deployment in existing and other frequency bands is not precluded.

The co-existence of TDD and FDD in the same bands is still under study in WG4.

4.3 TX–RX frequency separation

No TX-RX frequency separation is required as Time Division Duplex (TDD) is employed. Each TDMA frame consists of 15 timeslots where each timeslot can be allocated to either transmit or receive.

4.4 Channel arrangement

4.4.1 Channel spacing

The nominal channel spacing is 5 MHz, but this can be adjusted to optimize performance in a particular deployment scenario.

4.4.2 Channel raster

The channel raster is 200 kHz, which means that the carrier frequency must be a multiple of 200 kHz.

4.4.3 Channel number

The carrier frequency is designated by the UTRA absolute radio frequency channel number (UARFCN). The value of the UARFCN in the IMT2000 band is defined as follows:

$$N_t = 5 * F \text{ MHz} \quad 0,0 \leq F \leq 3276,6 \text{ MHz} \quad \text{where } F \text{ is the carrier frequency in MHz}$$

5 General test conditions and declarations

The requirements of this clause apply to all tests in this TS, when applicable.

The general conditions during the tests should be according to the relevant parts of ETR 027 [2] (methods of measurement for mobile radio equipment) with the exceptions and additions defined in the individual tests.

Many of the tests in this TS measure a parameter relative to a value which is not fully specified in the UTRA specifications. For these tests, the conformance requirement is determined relative to a nominal value specified by the manufacturer.

Certain functions of a BS are optional in the UTRA specifications. Some requirements for the BS may be regional as listed in subclause 5.15.

When specified in a test, the manufacturer shall declare the nominal value of a parameter, or whether an option is supported.

5.1 Base station classes

The requirements in this specification apply to base stations intended for general-purpose applications in co-ordinated network operation.

In future, further classes of base stations may be defined; the requirements for these may be different than for general-purpose applications.

5.2 Output power

The manufacturer shall declare the rated output power, PRAT, of the base station which is defined as the mean power level per carrier over an active timeslot available at the antenna connector; see subclause 6.2.

5.3 Specified frequency range

The manufacturer shall declare:

- which of the frequency bands defined in sub-clause 4.2 is supported by the BS.
- the frequency range within the above frequency band(s) supported by the BS. As TDD is employed, the same frequency range is used for transmit and receive operation.

Many tests in this TS are performed with appropriate frequencies in the bottom, middle and top of the operating frequency band of the BS. These are denoted as RF channels B (bottom), M (middle) and T (top).

When a test is performed by a test laboratory, the UARFCNs to be used for RF channels B, M and T shall be specified by the laboratory. The laboratory may consult with operators, the manufacturer or other bodies.

When a test is performed by a manufacturer, the UARFCNs to be used for RF channels B, M and T may be specified by an operator.

5.4 Relationship between RF generation and chip clock

The manufacturer shall declare compliance with the requirement that the BS shall use the same frequency source for both RF generation and the chip clock.

5.5 Spectrum emission mask

The manufacturer shall declare whether the BS under test is intended to operate in regions where conformance to the spectrum emission mask defined in subclause 6.6.2.1.2 is mandatory. If so, the conformance test for spectrum emission mask specified in subclause 6.6.2.1 shall be performed; otherwise, this test is not required.

5.6 Adjacent Channel Leakage power Ratio (ACLR)

The manufacturer shall declare:

- whether the BS under test is intended to operate in proximity to another TDD BS or FDD BS operating on the first or second adjacent frequency. If so, conformance with the ACLR requirement specified in subclause 6.6.2.2.2 is mandatory; otherwise, this requirement needs not to be tested.
- whether the BS under test is intended to operate co-sited to another TDD BS or FDD BS operating on the first or second adjacent frequency. If so, conformance with the ACLR requirement specified in subclause 6.6.2.2.3 is mandatory; otherwise, this requirement needs not to be tested.

5.7 Tx spurious emissions

5.7.1 Category of spurious emissions limit

The manufacturer shall declare one of the following:

- a) the BS shall be tested against Category A limits for spurious emissions, as defined in ITU-R Recommendation SM.329-7 [6].

or

- b) the BS shall be tested against Category B limits for spurious emissions, as defined in ITU-R Recommendation SM.329-7 [6].

If the manufacturer declares Category A limits to be applicable, conformance with the spurious emissions requirements specified in subclause 6.6.3.2.1.1 is mandatory, and the requirements specified in subclause 6.6.3.2.1.2 need not to be tested. If the manufacturer declares Category B limits to be applicable, conformance with the spurious emissions requirements specified in subclause 6.6.3.2.1.2 is mandatory, and the requirements specified in subclause 6.6.3.2.1.1 need not to be tested.

5.7.2 Co-existence with GSM

The manufacturer shall declare:

- whether the BS under test is intended to operate in geographic areas in which also GSM 900 is deployed. If so, compliance with the conformance requirement specified in subclause 6.6.3.2.2.1 is mandatory; otherwise, this requirement needs not to be tested.
- whether the BS under test is intended to operate co-located with a GSM 900 BTS. If so, compliance with the conformance requirement specified in subclause 6.6.3.2.2.2 is mandatory; otherwise, this requirement needs not to be tested.

5.7.3 Co-existence with DCS 1800

The manufacturer shall declare:

- whether the BS under test is intended to operate in geographic areas in which also DCS 1800 is deployed. If so, compliance with the conformance requirement specified in subclause 6.6.3.2.3.1 is mandatory; otherwise, this requirement needs not to be tested.

- whether the BS under test is intended to operate co-located with a DCS 1800 BTS. If so, compliance with the conformance requirement specified in subclause 6.6.3.2.3.2 is mandatory; otherwise, this requirement needs not to be tested.

5.7.4 Co-existence with UTRA FDD

The manufacturer shall declare:

- whether the BS under test is intended to operate in geographic areas in which also UTRA FDD is deployed. If so, compliance with the conformance requirement specified in subclause 6.6.3.2.4.1 is mandatory; otherwise, this requirement needs not to be tested.
- whether the BS under test is intended to operate co-located with a UTRA FDD BS. If so, compliance with the conformance requirement specified in subclause 6.6.3.2.4.2 is mandatory; otherwise, this requirement needs not to be tested.

5.8 Blocking characteristics

The conformance requirements with respect to the parameter blocking characteristics are dependent on the operating frequency bands of the BS under test; see subclause 7.5.2. However, no additional declaration is required; the need for a manufacturer's declaration of the frequency bands supported by the BS is already covered by subclause 5.3. The relationship between the frequency bands supported by the BS and the mandatory blocking requirements is given in table 5.8.1.

Table 5.8.1: Relationship between the frequency bands supported by the BS and the mandatory blocking requirements

Supported frequency band according to manufacturer's declaration	Mandatory blocking requirement
subclause 4.2a)	table 7.5.2.1
subclause 4.2b)	table 7.5.2.2
subclause 4.2c)	table 7.5.2.3

5.9 Test environments

For each test in this TS, the environmental conditions under which the BS is to be tested are defined.

5.9.1 Normal test environment

When a normal test environment is specified for a test, the test should be performed under any combination of conditions between the minimum and maximum limits stated in table 5.9.1.1.

Table 5.9.1.1: Limits of conditions for Normal Test Environment

Condition	Minimum	Maximum
Barometric pressure	86 kPa	106 kPa
Temperature	15°C	30°C
Relative Humidity	20 %	85 %
Power supply	Nominal, as declared by the manufacturer	
Vibration	Negligible	

The ranges of barometric pressure, temperature and humidity represent the maximum variation expected in the uncontrolled environment of a test laboratory. If it is not possible to maintain these parameters within the specified limits, the actual values shall be recorded in the test report.

NOTE: This may, for instance, be the case for measurements of radiated emissions performed on an open field test site.

5.9.2 Extreme test environment

The manufacturer shall declare one of the following:

- a) The equipment class for the equipment under test, as defined in ETS 300 019-1-3, (Equipment Engineering (EE); Environmental conditions and environmental test for telecommunications equipment, Part 1-3: Classification of environmental conditions, Stationary use at weather protected locations).
- b) The equipment class for the equipment under test, as defined in ETS 300 019-1-4, (Equipment Engineering (EE); Environmental conditions and environmental test for telecommunications equipment, Part 1-4: Classification of environmental conditions, Stationary use at non-weather protected locations).
- c) For equipment that does not comply to an ETS 300 019-1 [8] class, the relevant classes from IEC 721 [3] documentation for Temperature, Humidity and Vibration shall be declared.

NOTE: Reduced functionality for conditions that fall out side of the standard operational conditions are not tested in this TS. These may be stated and tested separately.

5.9.2.1 Extreme temperature

When an extreme temperature test environment is specified for a test, the test shall be performed at the standard minimum and maximum operating temperatures defined by the manufacturer's declaration for the equipment under test.

Minimum temperature:

The test shall be performed with the environmental test equipment and methods of inducing the required environmental phenomena into the equipment, conforming to the test procedure of IEC 68-2-1 [4], Environmental Testing, Part 2: Tests - Tests A: Cold. The equipment shall be maintained at the stabilized condition for the duration of the test sequence.

Maximum temperature:

The test shall be performed with the environmental test equipment and methods of inducing the required environmental phenomena in to the equipment, conforming to the test procedure of IEC 68-2-2 [4] (Environmental Testing, Part 2: Tests - Tests Bd Dry heat). The equipment shall be maintained at the stabilized condition for the duration of the test sequence.

NOTE: It is recommended that the equipment is made fully operational prior to the equipment being taken to its lower operating temperature.

5.9.3 Vibration

When vibration conditions are specified for a test, the test shall be performed while the equipment is subjected to a vibration sequence as defined by the manufacturers declaration for the equipment under test. This shall use the environmental test equipment and methods of inducing the required environmental phenomena in to the equipment, conforming to the test procedure of IEC 68-2-6 [4], Environmental Testing, Part 2: Tests - Test Fc and guidance: Vibration (Sinusoidal). Other environmental conditions shall be within the ranges specified in subclause 5.9.1, Normal test environment.

NOTE: The higher levels of vibration may induce undue physical stress in to equipment after a prolonged series of tests. The testing body should only vibrate the equipment during the RF measurement process.

5.9.4 Power supply

When extreme power supply conditions are specified for a test, the test shall be performed at the standard upper and lower limits of operating voltage defined by the manufacturer's declaration for the equipment under test.

Upper voltage limit

The equipment shall be supplied with a voltage equal to the upper limit declared by the manufacturer (as measured at the input terminals to the equipment). The tests shall be carried out at a steady state minimum and maximum limit declared by the manufacturer for the equipment, to the methods described in IEC 68-2-1 [4] Test Ab/Ad: Cold and IEC 68-2-2 Test Bb/Bd: Dry Heat.

Lower voltage limit

The equipment shall be supplied with a voltage equal to the lower limit declared by the manufacturer (as measured at the input terminals to the equipment). The tests shall be carried out at a steady state minimum and maximum limit declared by the manufacturer for the equipment, to the methods described in IEC 68-2-1 [4] Test Ab/Ad: Cold and IEC 68-2-2 [4] Test Bb/Bd: Dry Heat.

5.9.5 Acceptable uncertainty of measurement equipment

The maximum acceptable uncertainty of measurement equipment is specified separately for each test, where appropriate. The measurement equipment shall enable the stimulus signals in the test case to be adjusted to within the specified tolerance, and the conformance requirement to be measured with an uncertainty not exceeding the specified values. All tolerances and uncertainties are absolute values and are valid for a confidence level of 95 %, unless otherwise stated.

It should be noted that the stated uncertainties in subclause 4.1 apply to the test equipment only and do not include system effects due to mismatch between the DUT and the test equipment.

Subclause 5.9, Test environments:

Pressure	± 5 kPa
Temperature	± 2 degrees
Relative Humidity	± 5 %
DC Voltage	$\pm 1,0$ %
AC Voltage	$\pm 1,5$ %
Vibration	10 %
Vibration frequency	0,1 Hz

The above values shall apply unless the test environment is controlled and the specification for the control of the test environment specifies the uncertainty for the parameter.

Transmitter

Subclause 6.2, Base station maximum output power:

Conformance requirement:

RF power, for static power step 0	$\pm 1,0$ dB
-----------------------------------	--------------

Subclause 6.3, Frequency stability:

Conformance requirement:

Frequency	± 10 Hz
-----------	-------------

Subclause 6.4, Output power dynamics

Conformance requirement:

RF power, for static power steps (minimum and maximum Tx power)	$\pm 1,0$ dB
Relative RF Power	$\pm 0,7$ dB

Subclause 6.5, Transmit OFF power:

Conformance requirement:

RF power difference

Power difference < 50 dB	$\pm 0,7$ dB
Power difference ≥ 50 dB	$\pm 1,5$ dB

Subclause 6.6, Output RF spectrum emissions

Conformance requirement:

RF power difference

Power difference < 50 dB	$\pm 0,7$ dB
Power difference ≥ 50 dB	$\pm 1,5$ dB

Relative RF power:

Table 5.9.5.1: Acceptable uncertainty of relative RF power measurements

Offset from carrier, MHz	Power difference, dB	Uncertainty of relative power, dB

Spurious emissions

RF power

- inside the BS transmit band ± 1.5 dB

- outside the BS transmit band:

$f \leq 2$ GHz	± 1.5 dB
2 GHz < $f \leq 4$ GHz	± 2.0 dB
$f > 4$ GHz	± 4.0 dB

Subclause 6.7, Transmit intermodulation:

Test case:

Relative RF power (of injected signal) ± 1.5 dB

Conformance requirement (outside RX band):

RF power; absolute limit values	± 1.5 dB
RF power, relative measurements	± 2.0 dB

Conformance requirement (inside RX band):

RF power; absolute limit values	+4 dB -3 dB
---------------------------------	-------------

NOTE: The positive limit for uncertainty is greater than the negative limit because the measurement result can be increased (but not decreased) due to intermodulation products within the measurement apparatus.

Receiver

Where a measurement uncertainty of +5 dB -0 dB is specified for an input signal, the measured value of the input signal should be increased by an amount equal to the uncertainty with which it can be measured. This will ensure that the true value of the input signal is not below the specified nominal.

Subclause 7.2, Reference sensitivity level

Test case:

RF power	± 1.0 dB
----------	--------------

Subclause 7.3, Dynamic range:

Test case:

RF power	± 1.5 dB
Relative RF power	± 3.0 dB

Subclause 7.4, Adjacent Channel Selectivity (ACS):

Test case:

RF power	± 1.5 dB
Relative RF power	± 3.0 dB

Subclause 7.5, Blocking characteristics:

Test case:

RF power, wanted signal	± 1.0 dB
RF power, interfering signal;	
$f \leq 2$ GHz	± 0.7 dB
2 GHz $< f \leq 4$ GHz	± 1.5 dB
$f > 4$ GHz	± 3.0 dB

Subclause 7.6, Intermodulation characteristics:

Test case:

RF power, wanted signal	± 1.0 dB
RF power, interfering signals	± 0.7 dB

Subclause 7.7, Spurious emissions:

Conformance requirement:

RF power;

$f \leq 2$ GHz	± 1.5 dB
2 GHz $< f \leq 4$ GHz	± 2.0 dB
$f > 4$ GHz	± 4.0 dB

5.10 Interpretation of measurement results

Compliance with the requirement is determined by comparing the measured value (or derived value from the measured one) with the test limit. The test limit shall be relaxed from the specified limit in the core requirement using the maximum allowed uncertainty for the test equipment as specified in subclause 5.9.5.

The actual measurement uncertainty of the test equipment for the measurement of each parameter shall be included in the test report.

The recorded value for the test equipment uncertainty shall be, for each measurement, equal to or lower than the appropriate figure in subclause 5.9.5 of this TS.

If the test equipment for a test is known to have a measurement uncertainty greater than that specified in subclause 5.9.5, it is still permitted to use this equipment provided that an adjustment is made to the measured value as follows:

The initial test limit is derived as above by relaxing the specified limit using the maximum allowed test equipment uncertainty as specified in subclause 5.9.5. Any additional uncertainty in the test equipment over and above that specified in subclause 5.9.5 shall be used to tighten the test limit. This procedure will ensure that test equipment not compliant with subclause 5.9.5 does not increase the chance of passing a device under test where that device would otherwise have failed the test if test equipment compliant with subclause 5.9.5 had been used.

5.11 Selection of configurations for testing

Most tests in this TS are only performed for a subset of the possible combinations of test conditions. For instance:

- Not all TRXs in the configuration may be specified to be tested.
- Only one RF channel may be specified to be tested.
- Only one timeslot may be specified to be tested.

When a test is performed by a test laboratory, the choice of which combinations are to be tested shall be specified by the laboratory. The laboratory may consult with operators, the manufacturer or other bodies.

When a test is performed by a manufacturer, the choice of which combinations are to be tested may be specified by an operator.

5.12 BS Configurations

This TS has been written to specify tests for the standard configurations of BS which have been assumed in UTRA requirements specifications, in particular TS 25.105 "UTRA (BS) TDD; Radio transmission and Reception "

[1]. However, there are other configurations of BS which comply with these specifications, but for which the application of these specifications is not fully defined. For some such configurations there may be alternate ways to apply the requirements of this specification to testing of the configuration, or some variation in the test method may be necessary. It may therefore be necessary for the parties to the testing to reach agreement over the method of testing in advance.

If the BS is supplied in a number of different environmental enclosures or configurations, it may not be necessary to test RF parameters for each environmental configuration, provided that it can be demonstrated that the equipment has been tested at the worst internal environmental conditions.

Where alternative interpretations of this specification are possible for a BS configuration under test, the interpretation which has been adopted in performing the test shall be recorded with the test results.

Where variation in the test method within this TS has been necessary to enable a BS configuration to be tested, the variation in the test method which has been made in performing the test shall be recorded with the test results. Where possible, agreement should be reached in advance about the nature of such a variation with any party who will later receive the test results.

Possible interpretations of this TS for some common configurations are given in the following subclauses.

5.12.1 Receiver diversity

For the tests in clause 7 of this TS, the specified test signals shall be applied to one receiver antenna connector, with the remaining receiver antenna connectors being terminated with 50 ohms.

5.12.2 Duplexers

Due to TDD operation, there is no need to use a duplexer in the BS.

5.12.3 Power supply options

If the BS is supplied with a number of different power supply configurations, it may not be necessary to test RF parameters for each of the power supply options, provided that it can be demonstrated that the range of conditions over which the equipment is tested is at least as great as the range of conditions due to any of the power supply configurations.

This applies particularly if a BS contains a DC rail which can be supplied either externally or from an internal mains power supply. In this case, the conditions of extreme power supply for the mains power supply options can be tested by testing only the external DC supply option. The range of DC input voltages for the test should be sufficient to verify the performance with any of the power supplies, over its range of operating conditions within the BS, including variation of mains input voltage, temperature and output current.

5.12.4 Ancillary RF amplifiers

Ancillary RF amplifier: a piece of equipment, which when connected by RF coaxial cables to the BS, has the primary function to provide amplification between the transmit and/or receive antenna connector of a BS and an antenna without requiring any control signal to fulfil its amplifying function.

The requirements of this TS shall be met with the ancillary RF amplifier fitted. At tests according to clause 6 and 7 for TX and RX respectively, the ancillary amplifier is connected to the BS by a connecting network (including any cable(s), attenuator(s), etc.) with applicable loss to make sure the appropriate operating conditions of the ancillary amplifier and the BS. The applicable connecting network loss range is declared by the manufacturer. Other characteristics and the temperature dependence of the attenuation of the connecting network are neglected. The actual attenuation value of the connecting network is chosen for each test as one of the applicable extreme values. The lowest value is used unless otherwise stated.

Sufficient tests should be repeated with the ancillary amplifier fitted and, if it is optional, without the ancillary RF amplifier to verify that the BS meets the requirements of this TS in both cases.

5.12.5 BS using antenna arrays

A BS may be configured with a multiple antenna port connection for some or all of its TRXs or with an antenna array related to one cell (not one array per TRX). This subclause applies to a BS which meets at least one of the following conditions:

- The transmitter output signals from one or more TRX appear at more than one antenna port, or
- there is more than one receiver antenna port for a TRX or per cell and an input signal is required at more than one port for the correct operation of the receiver (NOTE: diversity reception does not meet this requirement) thus the outputs from the transmitters as well as the inputs to the receivers are directly connected to several antennas (known as "aircombining"), or
- transmitters and receivers are connected via duplexers to more than one antenna

If a BS is used, in normal operation, in conjunction with an antenna system which contains filters or active elements which are necessary to meet the UTRA requirements, the tests of conformance may be performed on a system comprising the BS together with these elements, supplied separately for the purposes of testing. In this case, it must be demonstrated that the performance of the configuration under test is representative of the system in normal operation, and the conformance assessment is only applicable when the BS is used with the antenna system.

For testing of conformance of such a BS, the following procedure may be used:

Receiver tests

For each test, the test signals applied to the receiver antenna connectors shall be such that the sum of the powers of the signals applied equals the power of the test signal(s) specified in the test.

An example of a suitable test configuration is shown in figure 5.12.5.1.

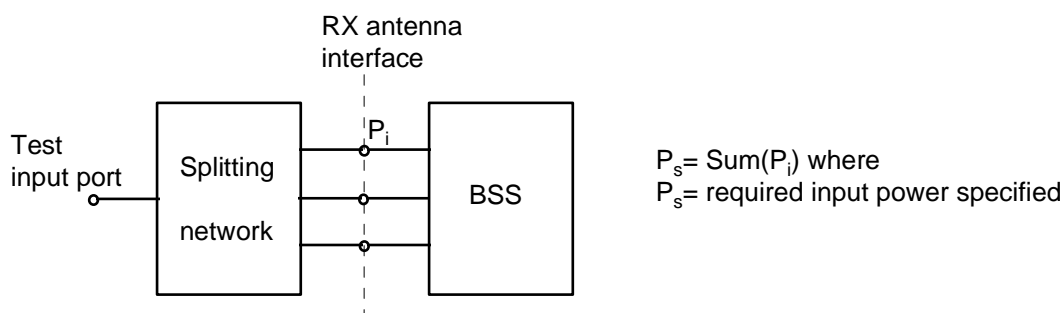

Figure 5.12.5.1: Receiver test setup

For spurious emissions from the receiver antenna connector, the test may be performed separately for each receiver antenna connector.

Transmitter tests

For each test, the conformance requirement shall be met by the sum of the signals emitted by each transmitter antenna connector. This may be assessed by separately measuring the signals emitted by each antenna connector and summing the results, or by combining the signals and performing a single measurement. The characteristics (e.g. amplitude and phase) of the combining network should be such that the power of the combined signal is maximised.

An example of a suitable test configuration is shown in figure 5.12.5.2.

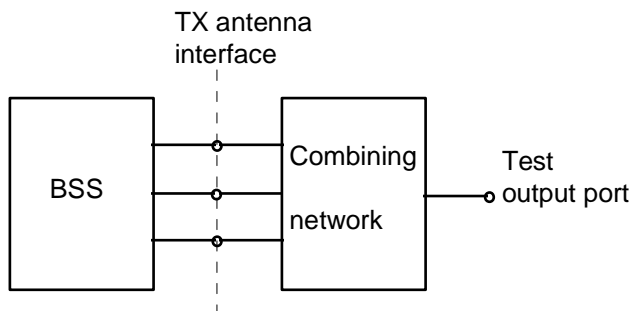

Figure 5.12.5.2: Transmitter test setup

For Intermodulation attenuation, the test may be performed separately for each transmitter antenna connector.

5.13 Overview of the conformance test requirements

Tables 5.13.1, 5.13.2 and 5.13.3 give an overview of the conformance test requirements for the transmitter, the receiver and system performance, respectively.

Table 5.13.1: Overview of the conformance tests requirements for the transmitter

Parameter	Subclause	Note
Maximum output power	6.2	manufacturer's declaration required
Frequency stability	6.3	manufacturer's declaration required
Output power dynamics	6.4	
Inner loop power control	6.4.1	
Power control steps	6.4.2	
Power control dynamic range	6.4.3	
Minimum transmit power	6.4.4	
Primary CCPCH power	6.4.5.	
Transmit OFF power	6.5	
Output RF spectrum emissions	6.6	
Occupied bandwidth	6.6.1	
Out-of-band emission	6.6.2	
Spectrum emission mask	6.6.2.1	manufacturer's declaration required
Adjacent Channel Leakage power Ratio (ACLR)	6.6.2.2	manufacturer's declaration required
Spurious emissions	6.6.3	
Mandatory requirements	6.6.3.2.1	manufacturer's declaration required
Co-existence with GSM 900	6.6.3.2.2	manufacturer's declaration required
Co-existence with DCS 1800	6.6.3.2.3	manufacturer's declaration required
Co-existence with UTRA FDD	6.6.3.2.4	manufacturer's declaration required
Transmit intermodulation	6.7	
Transmit modulation	6.8	
Modulation accuracy	6.8.1	
Peak code domain error	6.8.2	

Table 5.13.2: Overview of the conformance tests requirements for the receiver

Parameter	Subclause	Note
Reference sensitivity level	7.2	
Dynamic range	7.3	
Adjacent Channel Selectivity (ACS)	7.4	
Blocking characteristics	7.5	manufacturer's declaration required
Intermodulation characteristics	7.6	
Spurious emissions	7.7	

Table 5.13.3: Overview of the conformance test requirements for system performance

Parameter	Subclause	Note
Demodulation in static propagation conditions	8.2	
Demodulation of DCH	8.2.1	
Demodulation of DCH in multipath fading conditions	8.3	
Multipath fading Case 1	8.3.1	
Multipath fading Case 2	8.3.2	
Multipath fading Case 3	8.3.3	

5.14 Format and interpretation of tests

Each test in the following clauses has a standard format:

X Title

The title gives the name of the parameter to be tested.

X.1 Definition and applicability

This subclause gives the general definition of the parameter under consideration and specifies whether the test is applicable to all equipment or to a certain subset only.

X.2 Conformance requirements

This subclause describes the requirements the equipment under test has to fulfil to ensure compliance with the relevant specification.

In addition, this subclause contains the reference to the subclause to the 3GPP reference (or core) specification from which the conformance requirements are derived.

X.3 Test purpose

This subclause defines the purpose of the test.

X.4 Method of test

X.4.1 Initial conditions

This subclause defines the initial conditions for each test, including the basic measurement setup.

X.4.2 Procedure

This subclause describes the steps necessary to perform the test and provides further details of the test definition like point of access (e.g. antenna port), domain (e.g. frequency-span), range, weighting (e.g. bandwidth), and algorithms (e.g. averaging).

X.5 Test requirements

This subclause defines the pass/fail criteria for the equipment under test.

5.15 Regional requirements

Some requirements in TS 25.142 may only apply in certain regions. Table 5.15.1 lists all requirements that may be applied differently in different regions.

Table 5.15.1: List of regional requirements

Subclause number	Requirement	Comments
4.2	Frequency bands	Some bands may be applied regionally.
6.2.2	Maximum output power	In certain regions, the minimum requirement for normal conditions may apply also for some conditions outside the ranges defined for the Normal test environment in subclause 5.8.1
6.6.2.1.	Spectrum emission mask	The mask specified may be mandatory in certain regions. In other regions this mask may not be applied.
6.6.3.2.1.1	Spurious emissions (Category A)	These requirements shall be met in cases where Category A limits for spurious emissions, as defined in ITU-R Recommendation SM.329-7 [1], are applied.
6.6.3.2.1.2	Spurious emissions (Category B)	These requirements shall be met in cases where Category B limits for spurious emissions, as defined in ITU-R Recommendation SM.329-7 [1], are applied.
6.6.3.2.2.1	Co-existence with GSM900 – Operation in the same geographic area	This requirement may be applied for the protection of GSM 900 MS in geographic areas in which both GSM 900 and UTRA are deployed.
6.6.3.2.2.2	Co-existence with GSM900 – Co-located base stations	This requirement may be applied for the protection of GSM 900 BTS receivers when GSM 900 BTS and UTRA BS are co-located.
6.6.3.2.3.1	Co-existence with DCS1800 – Operation in the same geographic area	This requirement may be applied for the protection of DCS 1800 MS in geographic areas in which both DCS 1800 and UTRA are deployed.
6.6.3.2.3.2	Co-existence with DCS1800 – Co-located base stations	This requirement may be applied for the protection of DCS 1800 BTS receivers when DCS 1800 BTS and UTRA BS are co-located.
6.6.3.2.4.1	Co-existence with UTRA FDD – Operation in the same geographic area	This requirement may be applied to geographic areas in which both UTRA-TDD and UTRA-FDD are deployed.
6.6.3.2.4.2	Co-existence with UTRA FDD – Co-located base stations	This requirement may be applied for the protection of UTRA-FDD BS receivers when UTRA-TDD BS and UTRA FDD BS are co-located.
7.5	Blocking characteristic	The requirement is applied according to what frequency bands in subclause 4.2 that are supported by the BS.

6 Transmitter characteristics

6.1 General

Unless otherwise stated, all measurements shall be made at the BS antenna connector.

6.2 Maximum output power

6.2.1 Definition and applicability

Output power, P_{out} , of the base station is the power of one carrier delivered to a load with resistance equal to the nominal load impedance, when averaged (in the sense of thermal power) over the useful part of the burst (time slot).

Rated output power, PRAT, of the base station is the mean power level per carrier over an active timeslot that the manufacturer has declared to be available at the antenna connector.

Maximum output power, P_{max} , of the base station is the mean power level per carrier over an active timeslot measured at the antenna connector for a specified reference condition.

The requirements in this subclause shall apply to base stations intended for general-purpose applications.

6.2.2 Conformance requirements

In normal conditions, the base station maximum output power shall remain within +2 dB and –2 dB of the manufacturer's rated output power.

In extreme conditions, the base station maximum output power shall remain within +2,5 dB and –2,5 dB of the manufacturer's rated output power.

In certain regions, the minimum requirement for normal conditions may apply also for some conditions outside the ranges defined for the Normal test environment in subclause 5.8.1.

The reference for this requirement is TS 25.105 subclause 6.2.1.1.

6.2.3 Test purpose

The test purpose is to verify the accuracy of the maximum output power across the frequency range and under normal and extreme conditions for all transmitters in the BS.

6.2.4 Method of test

6.2.4.1 Initial conditions

- (1) The transmitter under test and all other transmitters of the base station (if any) are switched on.
- (2) The power of the transmitters not under test (if any) are controlled down.
- (3) Connect the power measuring equipment to the BS antenna connector.
- (4) Set the parameters of the transmitted signal according to table 6.2.4.1.1.

Table 6.2.4.1.1: Parameters of the transmitted signal for maximum output power test

Parameter	Value/description
TDD Duty Cycle	TS i ; $i = 0, 1, 2, \dots, 14$: transmit, if i is even; receive, if i is odd.
BS output power setting	PRAT
Number of DPCH in each active TS	9
Power of each DPCH	1/9 of Base Station output power
Data content of DPCH	real life (sufficient irregular)

6.2.4.2 Procedure

- (1) Measure thermal power over the 2464 active chips of an even time slot (this excludes the guard periods), and with a measurement bandwidth of at least 5 MHz.
- (2) Average over TBD time slots.
- (3) Run steps (1) and (2) for RF channels Low / Mid / High.

6.2.5 Test requirements

The value of the measured output power, derived according to subclause 6.2.4.2, shall be within the tolerance defined in subclause 6.2.2.

6.3 Frequency stability

6.3.1 Definition and applicability

Frequency stability is the ability of the BS to transmit at the assigned carrier frequency.

The requirements in this subclause shall apply to base stations intended for general-purpose applications.

6.3.2 Conformance requirements

The BS frequency stability shall be within $\pm 0,05$ ppm.

The reference for this requirement is TS 25.105 subclause 6.3.1.

TS 25.105 subclause 6.3 specifies the additional requirement that the BS shall use the same frequency source for both RF generation and the chip clock. Compliance with this requirement is demonstrated by manufacturer's declaration; see subclause 5.4; a dedicated conformance test for this requirement is not defined.

6.3.3 Test purpose

The test purpose is to verify the accuracy of the carrier frequency across the frequency range and under normal and extreme conditions.

6.3.4 Method of test

6.3.4.1 Initial conditions

- (1) The transmitter under test and all other transmitters of the base station (if any) are switched on.
- (2) The power of the transmitters not under test (if any) are controlled down.
- (3) Connect the tester to the BS antenna connector.

(4) Set the parameters of the transmitted signal according to table 6.3.4.1.1.

Table 6.3.4.1.1: Parameters of the transmitted signal for frequency stability test

Parameter	Value/description
TDD Duty Cycle	TS i ; $i = 0, 1, 2, \dots, 14$: transmit, if i is even; receive, if i is odd.
Number of DPCH in each active TS	1
BS output power setting	PRAT
Data content of DPCH	real life (sufficient irregular)

6.3.4.2 Procedure

- (1) Measure the frequency error Δf across one burst (time slot), by applying the global in-channel Tx test method described in Annex C.
- (2) Repeat step (1) for 200 bursts (time slots).
- (3) Run steps (1) and (2) for RF channels Low / Mid / High.

6.3.5 Test requirements

For all measured bursts (time slots), the frequency error, derived according to subclause 6.3.4.2, shall not exceed $0,5 \times 10E-7$.

6.4 Output power dynamics

6.4.1 Inner loop power control

Inner loop power control is the ability of the BS transmitter to adjust its output power in response to the UL received signal.

For inner loop correction on the Downlink Channel, the base station adjusts its mean output power level in response to each valid power control bit received from the UE on the Uplink Channel. Inner loop control is based on SIR measurements at the UE receiver, and the corresponding TPC commands are generated by the UE.

6.4.2 Power control steps

6.4.2.1 Definition and applicability

The power control step is the step change in the DL transmitter output power in response to a TPC message from the UE.

The requirements in this subclause shall apply to base stations intended for general-purpose applications.

6.4.2.2 Conformance requirements

The power control step sizes in the DL shall be 1 dB, 2 dB and 3 dB.

The tolerance of the transmitter output power and the greatest average rate of change in mean power due to the power control step shall be within the range shown in Table 6.4.2.2.1.

Table 6.4.2.2.1: Power control step size tolerance

Step size	tolerance	Range of average rate of change in mean power per 10 steps	
		Minimum	maximum
1dB	$\pm 0,5$ dB	± 8 dB	± 12 dB
2dB	$\pm 0,75$ dB	± 16 dB	± 24 dB
3dB	± 1 dB	± 24 dB	± 36 dB

The reference for this requirement is TS 25.105 subclause 6.4.2.1.

6.4.2.3 Test purpose

The DL power control is applied to adjust the BS output power to a value that is sufficiently high to generate a SIR at the UE receiver equal to the target SIR, while limiting the intercell interference.

The test purpose is to verify the ability of the BS to interpret received TPC commands in a correct way and to adjust its output power according to these commands with the specified accuracy.

6.4.2.4 Method of test

6.4.2.4.1 Initial conditions

- (1) Connect the BS tester to the antenna connector of the BS under test.
- (2) Disable closed loop power control in the BS under test.
- (3) Set the initial parameters of the BS transmitted signal according to table 6.4.2.4.1.1.
- (4) Operate the BS in such a mode that it is able to interpret received TPC commands.
- (5) Start BS transmission.

NOTE: The BS tester used for this test must have the ability

- to analyze the output signal of the BS under test with respect to code domain power, by applying the global in-channel Tx test method described in Annex C;

- to simulate an UE with respect to the generation of TPC commands embedded in a valid UE signal.

Table 6.4.2.4.1.1: Initial parameters of the BS transmitted signal for power control steps test

Parameter	Value/description
TDD Duty Cycle	TS i ; $i = 0, 1, 2, \dots, 14$: transmit, if i is even; receive, if i is odd.
Number of DPCH in each active TS	1
DPCH power	Minimum
Data content of DPCH	real life (sufficient irregular)

6.4.2.4.2 Procedure

- (1) Configure the BS transmitter to enable power control steps of size 1 dB.
- (2) Set the BS tester to produce a sequence of TPC commands related to the active DPCH. This sequence shall be transmitted to the BS within the odd time slots TS i (receive time slots of the BS) and shall consist of a series of TPC commands with content "Increase Tx power", followed by a series of TPC commands with content "Decrease Tx power". Each of these series should be sufficiently long so that the transmit output power of the active DPCH is controlled to reach its maximum and its minimum, respectively.
- (3) Measure the power of the active DPCH over the 2464 active chips of each even time slot TS i (-this excludes the guard period), and with a measurement filter that has a RRC filter response with a roll off $\alpha = 0,22$ and a bandwidth equal to the chip rate. The power is determined by calculating the RMS value of the signal samples at the measurement filter output taken at the decision points.
- (4) Based on the measurement made in step (3), calculate the power control step sizes and the average rate of change per 10 steps.
- (5) Configure the BS transmitter to enable power control steps of 2 dB and of 3 dB, respectively, and repeat steps (2) to (4).

NOTE: In case of power control step size 3 dB, the number of power control steps feasible within the power control dynamic range of the BS under test may be lower than 10. In this case, the evaluation of the average rate of change in mean power may be based on less than 10 power control steps.

6.4.2.5 Test requirements

For all measurements, the tolerance of the power control step sizes and the average rate of change per 10 steps shall be within the limits given in Table 6.4.2.2.1.

6.4.3 Power control dynamic range

6.4.3.1 Definition and applicability

The power control dynamic range is the difference between the maximum and the minimum transmit output power for a specified reference condition.

The requirements in this subclause shall apply to base stations intended for general-purpose applications.

6.4.3.2 Conformance requirements

The DL power control dynamic range shall be greater than or equal to 30 dB.

The reference for this requirement is TS 25.105 subclause 6.4.3.1.

6.4.3.3 Test purpose

The test purpose is to verify the ability of the BS to control the power of a single code signal over the specified dynamic range.

6.4.3.4 Method of test

6.4.3.4.1 Initial conditions

- (1) Connect the BS tester to the antenna connector of the BS under test.
- (2) Set the parameters of the BS transmitted signal according to table 6.4.3.4.1.1.
- (3) Operate the BS in such a mode that it is able to interpret received TPC commands
- (4) Start BS transmission.

NOTE: The BS tester used for this test must have the ability

- to analyze the output signal of the BS under test with respect to code domain power, by applying the global in-channel Tx test method described in Annex C;
- to simulate an UE with respect to the generation of TPC commands embedded in a valid UE signal.

Table 6.4.3.4.1.1: Parameters of the BS transmitted signal for power control dynamic range test

Parameter	Value/description
TDD Duty Cycle	TS i ; $i = 0, 1, 2, \dots, 14$: transmit, if i is even; receive, if i is odd.
Number of DPCH in each active TS	1
Data content of DPCH	real life (sufficient irregular)

6.4.3.4.2 Procedure

- (1) Configure the BS transmitter to enable power control steps of size 1 dB.
- (2) Set the BS tester to produce a sequence of TPC commands related to the active DPCH, with content "Increase Tx power". This sequence shall be sufficiently long so that the transmit output power of the active DPCH is controlled to reach its maximum, and shall be transmitted to the BS within the odd time slots TS i (receive time slots of the BS).
- (3) Measure the power of the active DPCH over the 2464 active chips of each even time slot TS i (this excludes the guard period), and with a measurement filter that has a RRC filter response with a roll off $\alpha = 0,22$ and a bandwidth equal to the chip rate. The power is determined by calculating the RMS value of the signal samples at the measurement filter output taken at the decision points.
- (4) Average over TBD time slots.
- (5) Set the BS tester to produce a sequence of TPC commands related to the active DPCH, with content "Decrease Tx power". This sequence shall be sufficiently long so that the transmit output power of the active DPCH is controlled to reach its minimum, and shall be transmitted to the BS within the odd time slots TS i (receive time slots of the BS).
- (6) Measure the power of the active DPCH over the 2464 active chips of each even time slot TS i (this excludes the guard period), and with a measurement filter that has a RRC filter response with a roll off $\alpha = 0,22$ and a bandwidth equal to the chip rate. The power is determined by calculating the RMS value of the signal samples at the measurement filter output taken at the decision points.
- (7) Average over TBD time slots.
- (8) Calculated the power control dynamic range difference between the maximum transmit output power measured in steps (3) and (4) and the minimum transmit output power measured in steps (6) and (7).
- (9) Configure the BS transmitter to enable power control steps of 2 dB and of 3 dB, respectively, and repeat steps (2) to (8).

6.4.3.5 Test requirements

The power control dynamic range derived according to 6.4.3.4.2 shall be in compliance with the requirements in 6.4.3.2.

6.4.4 Minimum transmit power

6.4.4.1 Definition and applicability

The minimum controlled output power of the BS is when the power control setting is set to a minimum value. This is when the power control indicates a minimum transmit output power is required.

The requirements in this subclause shall apply to base stations intended for general-purpose applications.

6.4.4.2 Conformance requirements

The DL minimum transmit power shall be lower than or equal to

Maximum output power – 30 dB.

The reference for this requirement is TS 25.105 subclause 6.4.4.1.

6.4.4.3 Test purpose

The test purpose is to verify the ability of the BS to reduce its output power to a specified value.

6.4.4.4 Method of test

6.4.4.4.1 Initial conditions

- (1) Connect the BS tester to the antenna connector of the BS under test.
- (2) Set the parameters of the BS transmitted signal according to table 6.4.4.4.1.1.
- (3) Operate the BS in such a mode that it is able to interpret received TPC commands
- (4) Start BS transmission.

NOTE: The BS tester used for this test must have the ability

- to analyze the output signal of the BS under test with respect to thermal power;
- to simulate an UE with respect to the generation of TPC commands embedded in a valid UE signal.

Table 6.4.4.4.1.1: Parameters of the BS transmitted signal for minimum transmit power test

Parameter	Value/description
TDD Duty Cycle	TS i ; $i = 0, 1, 2, \dots, 14$: transmit, if i is even; receive, if i is odd.
Number of DPCH in each active TS	9
Power of each DPCH	1/9 of Base Station output power
Data content of DPCH	real life (sufficient irregular)

6.4.4.4.2 Procedure

- (1) Configure the BS transmitter to enable power control steps of size 1 dB.
- (2) Set the BS tester to produce a sequence of TPC commands related to all active DPCH, with content "Decrease Tx power". This sequence shall be sufficiently long so that the transmit output power of all active DPCH is controlled to reach its minimum, and shall be transmitted to the BS within the odd time slots TS i (receive time slots of the BS).
- (3) Measure the power of the BS output signal over the 2464 active chips of each even time slot TS i (this excludes the guard period), and with a measurement filter that has a RRC filter response with a roll off $\alpha = 0,22$ and a bandwidth equal to the chip rate. The power is determined by calculating the RMS value of the signal samples at the measurement filter output taken at the decision points.
- (4) Average over TBD time slots.
- (5) Configure the BS transmitter to enable power control steps of 2 dB and of 3 dB, respectively, and repeat steps (2) to (4).

6.4.4.5 Test requirements

For all measurements, the minimum transmit power derived in step (4) of 6.4.4.4.2 shall be at least 30 dB below the maximum output power as declared by the manufacturer; see 6.2.

6.4.5 Primary CCPCH power

6.4.5.1 Definition and applicability

Primary CCPCH power is the transmission power of the Primary Common Control Physical Channel averaged over the transmit timeslot. Primary CCPCH power is signaled on the BCH.

The requirements in this subclause shall apply to base stations intended for general-purpose applications.

6.4.5.2 Conformance requirements

The error between the BCH-broadcast value of the Primary CCPCH power and the Primary CCPCH power averaged over the timeslot shall not exceed the values in table 6.4.5.2.1. The error is a function of the total power averaged over the timeslot, P_{out} , and the manufacturer's rated output power, PRAT.

Table 6.4.5.2.1: Errors between Primary CCPCH power and the broadcast value

Total power in slot, dB	PCCPCH power tolerance
$PRAT - 3 < P_{out} \leq PRAT + 2$	+/- 2,5 dB
$PRAT - 6 < P \leq PRAT - 3$	+/- 3,5 dB
$PRAT - 13 < P \leq PRAT - 6$	+/- 5 dB

The reference for this requirement is TS 25.105 subclause 6.4.5.

6.4.5.3 Test purpose

The power of the Primary CCPCH received by the UE, together with the information on the Primary CCPCH nominal transmit power signaled on the BCH, are used by the UE for path loss estimation and adjustment of its own transmit power. Therefore, deviations of the Primary CCPCH power from its nominal value are transposed by the UE into deviations from the wanted transmit power of the UE.

The test purpose is to verify that the Primary CCPCH power remains within its specified tolerances under normal and extreme conditions.

6.4.5.4 Method of test

6.4.5.4.1 Initial conditions

- (1) Connect the BS tester to the antenna connector of the BS under test. The BS tester must have the ability to analyze the output signal of the BS under test with respect to code domain power, by applying the global in-channel Tx test method described in Annex C.
- (2) Set the parameters of the BS transmitted signal according to table 6.4.5.4.1.1.

Table 6.4.5.4.1.1: Parameters of the BS transmitted signal for Primary CCPCH power testing

Parameter	Value/description
TDD Duty Cycle	TS i ; $i = 0, 1, 2, \dots, 14$: transmit, if i is even; receive, if i is odd.
Time slots carrying PCCPCH	TS 0 and TS 8
Number of additional DPCH in TS 0 and TS 8	3
BS output power setting	PRAT
Relative power of PCCPCH	$\frac{1}{4}$ of BS output power
Relative power of each DPCH in TS 0 and TS 8	$\frac{1}{4}$ of BS output power
Data content of DPCH	real life (sufficient irregular)

6.4.5.4.2 Procedure

- (1) Measure the PCCPCH power in TS 0 and TS 8 by applying the global in-channel Tx test method described in Annex C.
- (2) Reduce the base station output power by 2 dB, 5 dB and 13 dB, without changing the relative powers of the PCCPCH and the DPCHs, and repeat step (1) for each output power setting.

6.4.5.5 Test requirements

The Primary CCPCH power, measured according to subclause 6.4.5.4.2, shall be within the limits defined in subclause 6.4.5.2.

6.5 Transmit OFF power

6.5.1 Definition and applicability

The transmit OFF power is the maximum residual output power within the channel bandwidth when the BS does not transmit.

6.5.2 Conformance requirements

The transmit OFF power shall be less than -79 dBm measured with a filter that has a Root-Raised Cosine (RRC) filter response with a roll-off $\alpha = 0,22$ and a bandwidth equal to the chip rate.

The reference for this requirement is TS 25.105 subclause 6.5.1.

6.5.3 Test purpose

This test verifies the ability of the BS to reduce its transmit OFF power to a value below the specified limit. This ability is needed to minimize the interference for other users receiving on the same frequency.

6.5.4 Method of test

6.5.4.1 Initial conditions

- (1) Connect the power measuring equipment to the BS antenna connector.
- (2) Set the parameters of the transmitted signal according to table 6.5.4.1.1.

Table 6.5.4.1.1 Parameters of the transmitted signal for transmit OFF power test

Parameter	Value/description
TDD Duty Cycle	TS i ; $i = 0, 1, 2, \dots, 14$: transmit, if i is even; receive, if i is odd.
BS output power setting	PRAT
Number of DPCH in each active TS	9
Power of each DPCH	1/9 of Base Station output power
Data content of DPCH	Real life (sufficient irregular)

6.5.4.2 Procedure

- (1) Measure the power of the BS output signal chipwise (i.e. averaged over time intervals of one chip duration) over the transmit off power period starting 20 chips before the start of the odd time slots TS i (receive time slots of the BS), and ending 16 chips before the next even time slot (transmit time slot of the BS) starts, and with a measurement

filter that has a RRC filter response with a roll off $\alpha = 0,22$ and a bandwidth equal to the chip rate. If the power measuring equipment is based on signal sampling, the sampling theorem shall be met. In this case, the power is determined by calculating the RMS value of the signal samples taken at the measurement filter output over one chip duration.

(2) Run steps (1) and (2) for RF channels Low / Mid / High.

6.5.5 Test requirements

The value of the transmit OFF power derived according to subclause 6.5.4.2, shall be below the limit defined in subclause 6.5.2.

6.6 Output RF spectrum emissions

6.6.1 Occupied bandwidth

6.6.1.1 Definition and applicability

Occupied bandwidth is a measure of the bandwidth containing 99% of the total integrated power for transmitted spectrum and is centered on the assigned channel frequency.

The requirements in this subclause shall apply to base stations intended for general-purpose applications.

6.6.1.2 Conformance requirements

The occupied bandwidth shall be less than 5 MHz based on a chip rate of 3,84 Mcps.

The reference for this requirement is TS 25.105 subclause 6.6.1.

6.6.1.3 Test purpose

The occupied bandwidth, defined in the Radio Regulations of the International Telecommunication Union ITU, is a useful concept for specifying the spectral properties of a given emission in the simplest possible manner; see also Recommendation ITU-R SM.328-9 [7]. The test purpose is to verify that the emission of the BS does not occupy an excessive bandwidth for the service to be provided and is, therefore, not likely to create interference to other users of the spectrum beyond undue limits.

6.6.1.4 Method of test

6.6.1.4.1 Initial conditions

(1) Connect the measuring equipment to the antenna connector of the BS under test.

(2) Set the parameters of the BS transmitted signal according to table 6.6.1.4.1.1.

Table 6.6.1.4.1.1: Parameters of the BS transmitted signal for occupied bandwidth testing

Parameter	Value/description
TDD Duty Cycle	TS i ; $i = 0, 1, 2, \dots, 14$: transmit, if i is even; receive, if i is odd.
BS output power setting	PRAT
Number of DPCH in each active TS	9
Power of each DPCH	1/9 of Base Station output power
Data content of DPCH	Real life (sufficient irregular)

6.6.1.4.2 Procedure

- (1) Measure the power of the transmitted signal with a measurement filter of bandwidth 30 kHz. The characteristic of the filter shall be approximately Gaussian (typical spectrum analyzer filter). The center frequency of the filter shall be stepped in contiguous 30 kHz steps from a minimum frequency, which shall be $(7,5 - 0,015)$ MHz below the assigned channel frequency of the transmitted signal, up to a maximum frequency, which shall be $(7,5 - 0,015)$ MHz above the assigned channel frequency of the transmitted signal. The time duration of each step shall be sufficiently long to capture one active time slot. The measured power shall be recorded for each step.
- (2) Determine the transmitted power within the assigned channel bandwidth by accumulating the recorded power measurements results of all steps with center frequencies from $(2,5 - 0,015)$ MHz below the assigned channel frequency up to $(2,5 - 0,015)$ MHz above the assigned channel frequency.
- (3) Determine the total transmitted power by accumulating the recorded power measurements results of all steps.
- (4) Calculate the ratio

transmitted power within the assigned channel bandwidth acc. to (2) / total transmitted power acc. to (3).

6.6.1.5 Test requirements

The ratio calculated in step (4) of subclause 6.6.1.4.2 shall be 0,99 or greater.

6.6.2 Out of band emission

Out of band emissions are unwanted emissions immediately outside the channel bandwidth resulting from the modulation process and non-linearity in the transmitter but excluding spurious emissions. This out of band emission requirement is specified both in terms of a spectrum emission mask and adjacent channel power ratio for the transmitter.

6.6.2.1 Spectrum emission mask

6.6.2.1.1 Definition and applicability

The spectrum emission mask specifies the limit of the transmitter out of band emissions at frequency offsets from the assigned channel frequency of the wanted signal between 2,5 MHz and 12,5 MHz.

The mask defined in subclause 6.6.2.1.2 below may be mandatory in certain regions. In other regions this mask may not be applied.

6.6.2.1.2 Conformance requirements

For regions where this subclause applies, the requirement shall be met by a base station transmitting on a single RF carrier configured in accordance with the manufacturer's specification. Emissions shall not exceed the maximum level specified in tables 6.6.2.1.2.1 to 6.6.2.1.2.4 in the frequency range of f_{offset} from 2,515 MHz to $f_{\text{offset}_{\text{max}}}$ from the carrier frequency, where:

- f_{offset} is the separation between the carrier frequency and the centre of the measurement filter
- $f_{\text{offset}_{\text{max}}}$ is either 12,5 MHz or the offset to the UMTS Tx band edge as defined in subclause 4.2, whichever is the greater.

Table 6.6.2.1.2.1: Spectrum emission mask values, BS rated output power PRAT \geq 43 dBm

	Frequency offset of measurement filter centre frequency, f_{offset}	Maximum level	Measurement bandwidth
	$2,515 \text{ MHz} \leq f_{\text{offset}} < 2,715 \text{ MHz}$	-14 dBm	30 kHz
	$2,715 \text{ MHz} \leq f_{\text{offset}} < 3,515 \text{ MHz}$	$-14 - 15 \cdot (f_{\text{offset}} - 2,715) \text{ dBm}$	30 kHz
	$3,515 \text{ MHz} \leq f_{\text{offset}} < 4,0 \text{ MHz}$	-26 dBm	30 kHz
	$4,0 \text{ MHz} \leq f_{\text{offset}} < 8,0 \text{ MHz}$	-13 dBm	1 MHz
	$4,0 \text{ MHz} \leq f_{\text{offset}} < f_{\text{offset}_{\text{max}}}$	-13 dBm	1 MHz

Table 6.6.2.1.2.2: Spectrum emission mask values, BS rated output power $39 \leq \text{PRAT} < 43$ dBm

	Frequency offset of measurement filter centre frequency, f_{offset}	Maximum level	Measurement bandwidth
	$2,515 \text{ MHz} \leq f_{\text{offset}} < 2,715 \text{ MHz}$	-14 dBm	30 kHz
	$2,715 \text{ MHz} \leq f_{\text{offset}} < 3,515 \text{ MHz}$	$-14 - 15 \cdot (f_{\text{offset}} - 2,715) \text{ dBm}$	30 kHz
	$3,515 \text{ MHz} \leq f_{\text{offset}} < 4,0 \text{ MHz}$	-26 dBm	30 kHz
	$4,0 \text{ MHz} \leq f_{\text{offset}} < 8,0 \text{ MHz}$	-13 dBm	1 MHz
	$8,0 \text{ MHz} \leq f_{\text{offset}} < f_{\text{offset}_{\text{max}}}$	$P - 56 \text{ dBm}$	1 MHz

Table 6.6.2.1.2.3: Spectrum emission mask values, BS rated output power $31 \leq \text{PRAT} < 39$ dBm

	Frequency offset of measurement filter centre frequency, f_{offset}	Maximum level	Measurement bandwidth
	$2,515 \text{ MHz} \leq f_{\text{offset}} < 2,715 \text{ MHz}$	$P - 53 \text{ dBm}$	30 kHz
	$2,715 \text{ MHz} \leq f_{\text{offset}} < 3,515 \text{ MHz}$	$P - 53 - 15 \cdot (f_{\text{offset}} - 2,715) \text{ dBm}$	30 kHz
	$3,515 \text{ MHz} \leq f_{\text{offset}} < 4,0 \text{ MHz}$	-26 dBm	30 kHz
	$4,0 \text{ MHz} \leq f_{\text{offset}} < 8,0 \text{ MHz}$	$P - 52 \text{ dBm}$	1 MHz
	$8,0 \text{ MHz} \leq f_{\text{offset}} < f_{\text{offset}_{\text{max}}}$	$P - 56 \text{ dBm}$	1 MHz

Table 6.6.2.1.2.4: Spectrum emission mask values, BS rated output power $\text{PRAT} < 31$ dBm

	Frequency offset of measurement filter centre frequency, f_{offset}	Maximum level	Measurement bandwidth
	$2,515 \text{ MHz} \leq f_{\text{offset}} < 2,715 \text{ MHz}$	-22 dBm	30 kHz
	$2,715 \text{ MHz} \leq f_{\text{offset}} < 3,515 \text{ MHz}$	$-22 - 15 \cdot (f_{\text{offset}} - 2,715) \text{ dBm}$	30 kHz
	$3,515 \text{ MHz} \leq f_{\text{offset}} < 4,0 \text{ MHz}$	-26 dBm	30 kHz
	$4,0 \text{ MHz} \leq f_{\text{offset}} < 8,0 \text{ MHz}$	-21 dBm	1 MHz
	$8,0 \text{ MHz} \leq f_{\text{offset}} < f_{\text{offset}_{\text{max}}}$	-25 dBm	1 MHz

6.6.2.1.3 Test purpose

The test purpose is to verify that the BS out of band emissions do not result in undue interference to any other system (wideband, narrowband) operating at frequencies close to the assigned channel bandwidth of the wanted signal.

This test is independent of the characteristics of possible victim systems and, therefore, complements the tests on occupied bandwidth in 6.6.1 (verifying the spectral concentration of the BS Tx emissions) and on ACLR in 6.6.2.2 (simulating the perception of other UTRA receivers).

6.6.2.1.4 Method of test

6.6.2.1.4.1 Initial conditions

- (1) Connect the measuring equipment to the antenna connector of the BS under test.
- (2) Set the parameters of the BS transmitted signal according to table 6.6.2.1.4.1.1.

Table 6.6.2.1.4.1.1: Parameters of the BS transmitted signal for spectrum emission mask testing

Parameter	Value/description
TDD Duty Cycle	TS i ; $i = 0, 1, 2, \dots, 14$: transmit, if i is even; receive, if i is odd.
BS output power setting	PRAT
Number of DPCH in each active TS	9
Power of each DPCH	1/9 of Base Station output power
Data content of DPCH	real life (sufficient irregular)

6.6.2.1.4.2 Procedure

Measure the power of the BS spectrum emissions by applying measurement filters with bandwidths as specified in the relevant table in subclause 6.6.2.1.2. The characteristic of the filters shall be approximately Gaussian (typical spectrum analyzer filters). The center frequency of the filter shall be stepped in contiguous steps over the frequency bands as given in the tables. The step width shall be equal to the respective measurement bandwidth. The time duration of each step shall be sufficiently long to capture one active time slot.

For frequency offsets of the measurement filter centre frequency in the range $4,0 \text{ MHz} \leq f_{\text{offset}} < 8,0 \text{ MHz}$, the measurement shall be performed by applying filters with measurement bandwidth of 50 kHz or less and integrating the measured results over the nominal measurement bandwidth 1 MHz specified in the tables in subclause 6.6.2.1.2.1.

6.6.2.1.5 Test requirements

The spectrum emissions measured according to subclause 6.6.2.1.4.2 shall be within the mask defined in the relevant table of subclause 6.6.2.1.2.

6.6.2.2 Adjacent Channel Leakage power Ratio (ACLR)

6.6.2.2.1 Definition and applicability

Adjacent Channel Leakage power Ratio (ACLR) is the ratio of the transmitted power to the power measured in an adjacent channel. Both the transmitted and the adjacent channel power are measured through a matched filter (root raised cosine and roll-off 0,22) with a noise power bandwidth equal to the chip rate. The requirements shall apply for all configurations of BS (single carrier or multi-carrier), and for all operating modes foreseen by the manufacturer's specification.

The requirements in this subclause shall apply to base stations intended for general-purpose applications.

6.6.2.2.2 Conformance requirements

6.6.2.2.1 Definition and applicability

Adjacent Channel Leakage power Ratio (ACLR) is the ratio of the transmitted power to the power measured after a receive filter in the adjacent channel(s). Both the transmitted and the received power are measured through a matched filter (root raised cosine and roll-off 0,22) with a noise power bandwidth equal to the chip rate.

The requirements in this subclause shall apply to base stations intended for general-purpose applications.

6.6.2.2.2 Conformance requirements

6.6.2.2.1 Minimum requirement

The ACLR shall be equal to or greater than the limits given in Table 6.6.2.2.1.1.

Table 6.6.2.2.1.1: BS ACLR limits

BS adjacent channel offset	ACLR limit
± 5 MHz	45 dB
± 10 MHz	55 dB

The reference for this requirement is TS 25.105 subclause 6.6.2.2.1.

6.6.2.2.2 Requirement in case of operation in proximity to TDD BS or FDD BS operating on an adjacent frequency

In case the equipment is operated in proximity to another TDD BS or FDD BS on an adjacent frequency, the ACLR shall be equal to or greater than the value specified in Table 6.6.2.2.2.1.

Table 6.6.2.2.2.1: BS ACLR limits in case of operation in proximity

BS adjacent channel offset	ACLR limit
± 5 MHz	70 dB
± 10 MHz	70 dB

The requirement is based on the assumption that the coupling loss between the base stations is at least 84dB.

The reference for this requirement is TS 25.105 subclause 6.6.2.2.2.

NOTE: The necessary dynamic range to verify the conformance requirements specified in table 6.6.2.2.2.1 is at the limits of the capability of state-of-art measuring equipment.

6.6.2.2.3 Requirement in case of co-siting with TDD BS or FDD BS operating on an adjacent frequency

In case the equipment is co-sited to another TDD BS or FDD BS operating on an adjacent frequency, the ACLR is specified in terms of the absolute transmit power level of the BS measured in the adjacent channel. The maximum power level shall not exceed the limit in Table 6.6.2.2.3.1.

Table 6.6.2.2.3.1: BS ACLR limits in case of co-siting

BS adjacent channel offset	Maximum Level	Measurement Bandwidth
± 5 MHz	-80 dBm	3.84 MHz
± 10 MHz	-80 dBm	3.84 MHz

The reference for this requirement is TS 25.105 subclause 6.6.2.2.3.

NOTE: The necessary dynamic range of the measuring equipment to verify the conformance requirements specified in table 6.6.2.2.3.1 is dependent on the BS output power. If the BS output power is larger than -10 dBm, the necessary dynamic range is beyond the capability of state-of-the-art measuring equipment; direct verification of the conformance requirements is not feasible. Alternatively, indirect measurement methods need to be defined.

6.6.2.2.3 Test purpose

The test purpose is to verify the ability of the BS to limit the interference produced by the transmitted signal to other UTRA receivers operating at the first or second adjacent RF channel.

6.6.2.2.4 Method of test

6.6.2.2.4.1 Initial conditions

- (1) Connect the measuring equipment to the antenna connector of the BS under test.
- (2) Set the parameters of the BS transmitted signal according to table 6.6.2.2.4.1.1.

Table 6.6.2.4.1.1: Parameters of the BS transmitted signal for ACLR testing

Parameter	Value/description
TDD Duty Cycle	TS i ; $i = 0, 1, 2, \dots, 14$: transmit, if i is even; receive, if i is odd.
BS output power setting	PRAT
Number of DPCH in each active TS	9
Power of each DPCH	1/9 of Base Station output power
Data content of DPCH	Real life (sufficient irregular)

6.6.2.4.2 Procedure

- (1) Measure transmitted power over the 2464 active chips of the even time slots TS i (this excludes the guard period), and with a measurement filter that has a RRC filter response with a roll off $\alpha = 0,22$ and a bandwidth equal to the chip rate. The power is determined by calculating the RMS value of the signal samples at the measurement filter output taken at the decision points. (The global in-channel Tx test described in Annex C may be applied.)
- (2) Average over TBD time slots.
- (3) Measure interference power at the first lower adjacent RF channel (center frequency 5 MHz below the assigned channel frequency of the transmitted signal) over the useful part of the burst within the even time slots TS i (this excludes the guard period), and with a measurement filter that has a RRC filter response with a roll off $\alpha = 0,22$ and a bandwidth equal to the chip rate. The power is determined by calculating the RMS value of the signal samples at the measurement filter output taken with adherence to the sampling theorem.
- (4) Average over TBD time slots.
- (5) Calculate the ACLR by the ratio

$$\text{ACLR} = \text{transmitted power acc. to (2)} / \text{interference power acc. to (4)}.$$

- (6) Repeat steps (3), (4) and (5) for the second lower adjacent RF channel (center frequency 10 MHz below the assigned channel frequency of the transmitted signal) and also for the first and second upper adjacent RF channel (center frequency 5 MHz and 10 MHz above the assigned channel frequency of the transmitted signal, respectively).

6.6.2.5 Test requirements

The ACLR calculated in step (5) of subclause 6.6.2.4.2 shall be equal or greater than the limits given in table 6.6.2.2.1.1 or table 6.6.2.2.2.1, respectively. In case the equipment is co-sited to another TDD BS or FDD BS operating on an adjacent frequency, the interference power at the first and second adjacent channel measured according to steps (3) and (4) of subclause 6.6.2.4.2 shall not exceed the maximum level specified in table 6.6.2.2.3.1.

6.6.3 Spurious emissions

6.6.3.1 Definition and applicability

Spurious emissions are emissions which are caused by unwanted transmitter effects such as harmonics emission, parasitic emission, intermodulation products and frequency conversion products, but exclude out of band emissions. This is measured at the base station RF output port.

The requirements in this subclause shall apply to base stations intended for general-purpose applications.

6.6.3.2 Conformance requirements

6.6.3.2.1 Mandatory requirements

The requirements of either subclause 6.6.3.2.1.1 or subclause 6.6.3.2.1.2 shall apply whatever the type of transmitter considered (single carrier or multi-carrier). It applies for all transmission modes foreseen by the manufacturer.

Either requirement applies at frequencies within the specified frequency ranges which are more than 12.5 MHz under the first carrier frequency used or more than 12.5 MHz above the last carrier frequency used.

6.6.3.2.1.1 Spurious emissions (Category A)

The following requirements shall be met in cases where Category A limits for spurious emissions, as defined in ITU-R Recommendation SM.329-7 [6], are applied.

The power of any spurious emission shall not exceed the maximum level given in Table 6.6.3.2.1.1.1.

Table 6.6.3.2.1.1.1: BS Mandatory spurious emissions limits, Category A

Band	Maximum level	Measurement bandwidth	Note
9 kHz – 150 kHz	-13 dBm	1 kHz	Bandwidth as in ITU SM.329-7, s4.1
150 kHz – 30 MHz		10 kHz	Bandwidth as in ITU SM.329-7, s4.1
30 MHz – 1 GHz		100 kHz	Bandwidth as in ITU SM.329-7, s4.1
1 GHz – 12,75 GHz		1 MHz	Upper frequency as in ITU SM.329-7, s2.6

The reference for this requirement is TS 25.105 subclause 6.6.3.1.1.1.

6.6.3.2.1.2 Spurious emissions (Category B)

The following requirements shall be met in cases where Category B limits for spurious emissions, as defined in ITU-R Recommendation SM.329-7 [6], are applied.

The power of any spurious emission shall not exceed the maximum levels given in Table 6.6.3.2.1.2.1.

Table 6.6.3.2.1.2.1: BS Mandatory spurious emissions limits, Category B

Band	Maximum level	Measurement bandwidth	Note
9 kHz – 150 kHz	-36 dBm	1 kHz	Bandwidth as in ITU SM.329-7, s4.1
150 kHz – 30 MHz	-36 dBm	10 kHz	Bandwidth as in ITU SM.329-7, s4.1
30 MHz – 1 GHz	-36 dBm	100 kHz	Bandwidth as in ITU SM.329-7, s4.1
1 GHz – Fc1 - 60 MHz or FI - 10 MHz <i>whichever is the higher</i>	-30 dBm	1 MHz	Bandwidth as in ITU SM.329-7, s4.1
Fc1 - 60 MHz or FI - 10 MHz <i>whichever is the higher</i> – Fc1 - 50 MHz or FI -10 MHz <i>whichever is the higher</i>	-25 dBm	1 MHz	Specification in accordance with ITU-R SM.329-7, s4.1
Fc1 - 50 MHz or FI -10 MHz <i>whichever is the higher</i> – Fc2 + 50 MHz or Fu +10 MHz <i>whichever is the lower</i>	-15 dBm	1 MHz	Specification in accordance with ITU-R SM.329-7, s4.1
Fc2 + 50 MHz or Fu + 10 MHz <i>whichever is the lower</i> – Fc2 + 60 MHz or Fu + 10 MHz <i>whichever is the lower</i>	-25 dBm	1 MHz	Specification in accordance with ITU-R SM.329-7, s4.1
Fc2 + 60 MHz or Fu + 10 MHz <i>whichever is the lower</i> – 12,5 GHz	-30 dBm	1 MHz	Bandwidth as in ITU-R SM.329-7, s4.1. Upper frequency as in ITU-R SM.329-7, s2.6

Fc1: Center frequency of emission of the first carrier transmitted by the BS

Fc2: Center frequency of emission of the last carrier transmitted by the BS

F_l : Lower frequency of the band in which TDD operates

F_u : Upper frequency of the band in which TDD operates

The reference for this requirement is TS 25.105 subclause 6.6.3.1.2.1.

6.6.3.2.2 Co-existence with GSM

6.6.3.2.2.1 Operation in the same geographic area

This requirement may be applied for the protection of GSM 900 MS in geographic areas in which both GSM 900 and UTRA are deployed.

The power of any spurious emission shall not exceed the maximum level given in Table 6.6.3.2.2.1.1.

Table 6.6.3.2.2.1.1: BS Spurious emissions limits for BS in geographic coverage area of GSM 900 MS receiver

Band	Maximum level	Measurement bandwidth	Note
921 MHz – 960 MHz	-57 dBm	100 kHz	

The reference for this requirement is TS 25.105 subclause 6.6.3.2.1.1.

6.6.3.2.2.2 Co-located base stations

This requirement may be applied for the protection of GSM 900 BTS receivers when GSM 900 BTS and UTRA BS are co-located.

The power of any spurious emission shall not exceed the maximum level given in Table 6.6.3.2.2.2.1.

Table 6.6.3.2.2.2.1: BS Spurious emissions limits for protection of the GSM 900 BTS receiver

Band	Maximum level	Measurement bandwidth	Note
876 MHz – 915 MHz	-98 dBm	100 kHz	

The reference for this requirement is TS 25.105 subclause 6.6.3.2.2.1.

6.6.3.2.3 Co-existence with DCS 1800

6.6.3.2.3.1 Operation in the same geographic area

This requirement may be applied for the protection of DCS 1800 MS in geographic areas in which both DCS 1800 and UTRA are deployed.

The power of any spurious emission shall not exceed the maximum level given in Table 6.6.3.2.3.1.1.

Table 6.6.3.2.3.1.1: BS Spurious emissions limits for BS in geographic coverage area of DCS 1800 MS receiver

Band	Maximum level	Measurement bandwidth	Note
1805 MHz – 1880 MHz	-47 dBm	100 kHz	

The reference for this requirement is TS 25.105 subclause 6.6.3.3.1.1.

6.6.3.2.3.2 Co-located base stations

This requirement may be applied for the protection of DCS 1800 BTS receivers when DCS 1800 BTS and UTRA BS are co-located.

The power of any spurious emission shall not exceed the maximum level given in Table 6.6.3.2.3.2.1.

Table 6.6.3.2.3.2.1: BS Spurious emissions limits for BS co-located with DCS 1800 BTS

Band	Maximum level	Measurement bandwidth	Note
1710 MHz – 1785 MHz	-98 dBm	100 kHz	

The reference for this requirement is TS 25.105 subclause 6.6.3.3.3.1.

6.6.3.2.4 Co-existence with UTRA FDD

6.6.3.2.4.1 Operation in the same geographic area

This requirement may be applied to geographic areas in which both UTRA TDD and UTRA FDD are deployed.

The power of any spurious emission shall not exceed the maximum level given in Table 6.6.3.2.4.1.1.

Table 6.6.3.2.4.1.1: BS Spurious emissions limits for BS in geographic coverage area of UTRA FDD

Band	Maximum Level	Measurement Bandwidth	Note
1920 – 1980 MHz	-32 dBm	1 MHz	
2110 – 2170 MHz	-52 dBm	1 MHz	

The reference for this requirement is TS 25.105 subclause 6.6.3.4.1.1.

6.6.3.2.4.2 Co-located base stations

This requirement may be applied for the protection of UTRA FDD BS receivers when UTRA TDD BS and UTRA FDD BS are co-located.

The power of any spurious emission shall not exceed the maximum level given in Table 6.6.3.2.4.2.1.

Table 6.6.3.2.4.2.1: BS Spurious emissions limits for BS co-located with UTRA FDD

Band	Maximum Level	Measurement Bandwidth	Note
1920 – 1980 MHz	-86 dBm	1 MHz	
2110 – 2170 MHz	-52 dBm	1 MHz	

The reference for this requirement is TS 25.105 subclause 6.6.3.4.2.1.

6.6.3.3 Test purpose

The test purpose is to verify the ability of the BS to limit the interference caused by unwanted transmitter effects to other systems operating at frequencies which are more than 12,5 MHz away from of the UTRA band used.

6.6.3.4 Method of test

6.6.3.4.1 Initial conditions

(1) Connect the measuring equipment to the antenna connector of the BS under test.

(2) Set the parameters of the BS transmitted signal according to table 6.6.3.4.1.1.

Table 6.6.3.4.1.1: Parameters of the BS transmitted signal for spurious emissions testing

Parameter	Value/description
TDD Duty Cycle	TS i ; $i = 0, 1, 2, \dots, 14$: transmit, if i is even; receive, if i is odd.
BS output power setting	PRAT
Number of DPCH in each active TS	9
Power of each DPCH	1/9 of Base Station output power
Data content of DPCH	real life (sufficient irregular)

6.6.3.4.2 Procedure

Measure the power of the spurious emissions by applying measurement filters with bandwidths as specified in the relevant tables of 6.6.3.2. The characteristic of the filters shall be approximately Gaussian (typical spectrum analyzer filters). The center frequency of the filter shall be stepped in contiguous steps over the frequency bands as given in the tables. The step width shall be equal to the respective measurement bandwidth. The time duration of each step shall be sufficiently long to capture one active time slot.

6.6.3.5 Test requirements

The spurious emissions measured according to subclause 6.6.3.4.2 shall not exceed the limits specified in the relevant tables of 6.6.3.2.

6.7 Transmit intermodulation

6.7.1 Definition and applicability

The transmit intermodulation performance is a measure of the capability of the transmitter to inhibit the generation of signals in its non linear elements caused by presence of the wanted signal and an interfering signal reaching the transmitter via the antenna.

The transmit intermodulation level is the power of the intermodulation products when a CDMA modulated interference signal is injected into the antenna connector at a level of 30 dB lower than that of the subject signal. The frequency of the interference signal shall be ± 5 MHz, ± 10 MHz and ± 15 MHz offset from the subject signal.

The requirements in this subclause shall apply to base stations intended for general-purpose applications.

6.7.2 Conformance requirements

The transmit intermodulation level shall not exceed the out of band or the spurious emission requirements of subclause 6.6.2 and 6.6.3, respectively.

The reference for this requirement is TS 25.105 subclause 6.7.1.

6.7.3 Test purpose

The test purpose is to verify the ability of the BS transmitter to restrict the generation of intermodulation products in its non linear elements caused by presence of the wanted signal and an interfering signal reaching the transmitter via the antenna to below specified levels.

6.7.4 Method of test

6.7.4.1 Initial conditions

(1) Connect the measuring equipment, the BS under test and the CDMA signal generator as shown in figure 6.7.4.1.1.

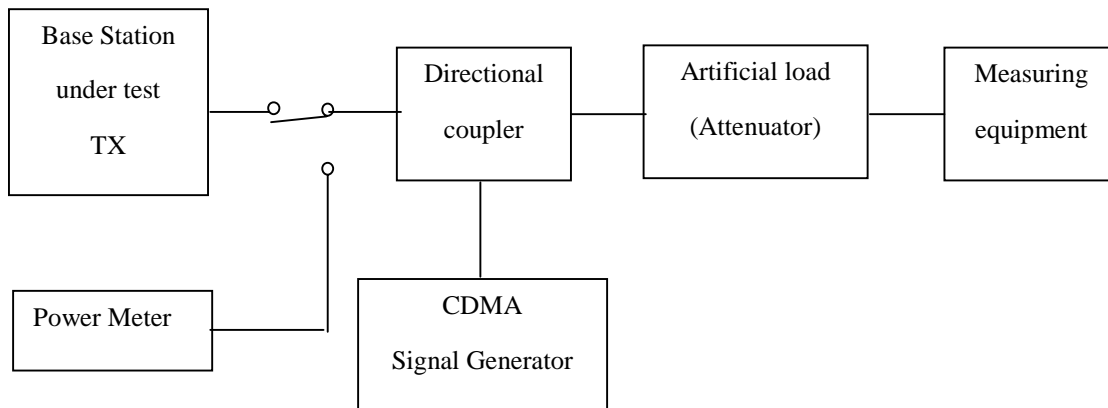

Figure 6.7.4.1.1: Measuring setup for Base Station transmit intermodulation testing

(2) Set the parameters of the BS transmitted signal according to table 6.7.4.1.1.

Table 6.7.4.1.1: Parameters of the BS transmitted signal for transmit intermodulation testing

Parameter	Value/description
TDD Duty Cycle	TS i ; $i = 0, 1, 2, \dots, 14$: transmit, if i is odd; receive, if i is even.
BS output power setting	PRAT
Number of DPCH in each active TS	9
Power of each DPCH	1/9 of Base Station output power
Data content of DPCH	real life (sufficient irregular)

(3) Configure the CDMA signal generator to produce an interference signal with a level of 30 dB lower than that of the BS transmitted signal. The interference signal shall be like-modulated as the BS transmitted signal, and the active time slots of both signals shall be synchronized. The frequency of the interference signal shall be ± 5 MHz, ± 10 MHz and ± 15 MHz offset from the BS transmitted signal.

6.7.4.2 Procedure

Apply the test procedures for out of band and spurious emissions as described in 6.6.2 and 6.6.3, respectively. The frequency band occupied by the interference signal are excluded from the measurements.

6.7.5 Test requirements

The conformance requirements for out of band and spurious emissions as specified in 6.6.2 and 6.6.3 shall be met.

6.8 Transmit Modulation

6.8.1 Modulation accuracy

6.8.1.1 Definition and applicability

The modulation accuracy is a measure of the difference between the measured waveform and the theoretical modulated waveform (the error vector). A quantitative measure of the modulation accuracy is the error vector magnitude (EVM) which is defined as the square root of the ratio of the mean error vector power to the mean reference signal power expressed as %. The measurement interval is one timeslot.

The requirements in this subclause shall apply to base stations intended for general-purpose applications.

NOTE: The theoretical modulated waveform shall be calculated on the basis that the transmit pulse shaping filter is a root-raised cosine (RRC) with roll-off $\alpha = 0,22$ in the frequency domain. The impulse response of the chip impulse filter $RC_0(t)$ is

$$RC_0(t) = \frac{\sin\left(\pi \frac{t}{T_c}(1-\alpha)\right) + 4\alpha \frac{t}{T_c} \cos\left(\pi \frac{t}{T_c}(1+\alpha)\right)}{\pi \frac{t}{T_c} \left(1 - \left(4\alpha \frac{t}{T_c}\right)^2\right)}$$

Where the roll-off factor $\alpha = 0,22$ and the chip duration $T_c = \frac{1}{\text{chiprate}} \approx 0.26042 \mu\text{s}$.

6.8.1.2 Conformance requirements

The error vector magnitude (EVM) shall not exceed 12,5 %.

The reference for this requirement is TS 25.105 subclause 6.8.2.1.

6.8.1.3 Test purpose

The test purpose is to verify the ability of the BS transmitter to generate a sufficient precise waveform and thus to enable the UE receiver to achieve the specified error performance.

6.8.1.4 Method of test

6.8.1.4.1 Initial conditions

- (1) Connect the measuring equipment to the antenna connector of the BS under test.
- (2) Set the parameters of the BS transmitted signal according to table 6.8.1.4.1.1.

Table 6.8.1.4.1.1: Parameters of the BS transmitted signal for modulation accuracy testing

Parameter	Value/description
TDD Duty Cycle	TS i ; $i = 0, 1, 2, \dots, 14$: transmit, if i is even; receive, if i is odd.
Number of DPCH in each active TS	1
Base station power	maximum, according to manufacturer's declaration
Data content of DPCH	real life (sufficient irregular)

6.8.1.4.2 Procedure

Measure the error vector magnitude (EVM) by applying the global in-channel Tx test method described in Annex C.

6.8.1.5 Test requirements

The error vector magnitude (EVM) measured according to subclause 6.8.1.4.2 shall not exceed 12,5 %.

6.8.2 Peak code domain error

6.8.2.1 Definition and applicability

The code domain error is computed by projecting the error vector power onto the code domain at a specific spreading factor. The error power for each code is defined as the ratio to the mean power of the reference waveform expressed in dB. And the Peak Code Domain Error is defined as the maximum value for Code Domain Error. The measurement interval is one timeslot.

The requirements in this subclause shall apply to base stations intended for general-purpose applications.

6.8.2.2 Conformance requirements

The peak code domain error shall not exceed -28 dB at spreading factor 16.

The reference for this requirement is TS 25.105 subclause 6.8.3.1.

6.8.2.3 Test purpose

The test purpose is to verify the ability of the BS transmitter to limit crosstalk among codes and thus to enable the UE receiver to achieve the specified error performance.

6.8.2.4 Method of test

6.8.2.4.1 Initial conditions

- (1) Connect the measuring equipment to the antenna connector of the BS under test.
- (2) Set the parameters of the BS transmitted signal according to table 6.8.2.4.1.1.

Table 6.8.2.4.1.1: Parameters of the BS transmitted signal

Parameter	Value/description
TDD Duty Cycle	TS i ; $i = 0, 1, 2, \dots, 14$: transmit, if i is even; receive, if i is odd.
BS output power setting	PRAT
Number of DPCH in each active TS	9
Power of each DPCH	1/9 of Base Station output power
Data content of DPCH	real life (sufficient irregular)
Spreading factor	16

6.8.2.4.2 Procedure

Measure the peak code domain error by applying the global in-channel Tx test method described in Annex C.

6.8.2.5 Test requirements

The peak code domain error measured according to subclause 6.8.2.4.2 shall not exceed -28 dB.

7 Receiver characteristics

7.1 General

All tests unless otherwise stated in this subclause shall be conducted on Base Station Systems fitted with a full complement of Transceivers for the configuration. The manufacturer shall provide appropriate logical or physical test access to perform all tests in this subclause. Measurements shall include any RX multicoupler.

The tests in clause 7 assume that the receiver is not equipped with diversity. For receivers with diversity, the tests may be performed by applying the specified signals to one of the receiver inputs, and terminating or disabling the other(s). The tests and requirements are otherwise unchanged.

For receivers with diversity, testing of conformance shall be performed by applying the specified signals to one of the receiver inputs, and terminating or disabling the other(s).

In all the relevant subclauses in this clause all Bit Error Ratio (BER), Residual BER (RBER) and Frame Erasure Ratio (FER) measurements shall be carried out according to the general rules for statistical testing.

Unless detailed the receiver characteristic are specified at each antenna connector of the BS.

7.2 Reference sensitivity level

7.2.1 Definition and applicability

The reference sensitivity is the minimum receiver input power measured at the antenna connector at which the BER does not exceed the specific value.

The requirements in this subclause shall apply to base stations intended for general-purpose applications.

7.2.2 Conformance requirements

For the measurement channel specified in Annex A.2.1, the reference sensitivity level and performance of the BS shall be as specified in table 7.2.2.1 below.

Table 7.2.2.1: BS reference sensitivity levels

Data rate	BS reference sensitivity level (dBm)	BER
12,2 kbps	-109 dBm	BER shall not exceed 0,001

The reference for this requirement is TS 25.105 subclause 7.2.1.

7.2.3 Test purpose

The test purpose is to verify the ability of the BS to receive a prescribed single-code test signal of minimum input power under defined conditions (no interference, no multipath propagation) with a BER not exceeding a specified limit. This test is also used as a reference case for other tests to allow the assessment of degradations due to various sources of interference.

7.2.4 Method of test

7.2.4.1 Initial conditions

- (1) Connect the BS tester (UE simulator) to the antenna connector of one BS Rx port.
- (2) Terminate or disable any other BS Rx port not under test.

- (3) Start transmission from the BS tester to the BS using the UL reference measurement channel (12.2 kbps) defined in Annex A.2.1.
- (4) The level of BS tester output signal measured at the BS antenna connector shall be adjusted to -109 dBm.

7.2.4.2 Procedure

- (1) Measure the BER by comparing the bit sequence of the information data transmitted by the BS tester with the bit sequence obtained from the BS receiver.
- (2) Interchange the connections of the BS Rx ports and repeat the measurement according to (1).

7.2.5 Test requirements

For any BS Rx port tested, the measured BER shall not exceed 0,001.

7.3 Dynamic range

7.3.1 Definition and applicability

Receiver dynamic range is the receiver ability to handle a rise of interference in the reception frequency channel. The receiver shall fulfil a specified BER requirement for a specified sensitivity degradation of the wanted signal in the presence of an interfering AWGN signal in the same reception frequency channel.

The requirements in this subclause shall apply to base stations intended for general-purpose applications.

7.3.2 Conformance requirements

The BER shall not exceed 0,001 for the parameters specified in table 7.3.2.1.

Table 7.3.2.1: Dynamic Range

Parameter	Level	Unit
Data rate	12,2	kbit/s
Wanted signal	<REFSENS> + 30 dB	dBm
Interfering AWGN signal	-73	dBm/3,84 MHz

The reference for this requirement is TS 25.105 subclause 7.3.

7.3.3 Test purpose

The test purpose is to verify the ability of the BS to receive a prescribed single-code test signal of maximum input power under defined conditions (specified interference, no multipath) with a BER not exceeding a specified limit.

7.3.4 Method of test

7.3.4.1 Initial conditions

- (1) Connect the BS tester (UE simulator), generating the wanted signal, and a band-limited white noise source, generating the interfering AWGN signal, to the antenna connector of one BS Rx port.
- (2) Terminate or disable any other BS Rx port not under test.
- (3) Start transmission from the BS tester to the BS using the UL reference measurement channel (12.2 kbps) defined in Annex A.2.1.
- (4) The level of the BS tester output signal measured at the BS antenna connector shall be adjusted as specified in table 7.3.2.1.

- (5) The power spectral density of the band-limited white noise source measured at the BS antenna connector shall be adjusted as specified in table 7.3.2.1. The minimum bandwidth of the white noise source shall be 1,5 times the chip rate (5,76 MHz for a chip rate of 3,84 MHz).

7.3.4.2 Procedure

- (1) Measure the BER by comparing the bit sequence of the information data transmitted by the BS tester with the bit sequence obtained from the BS receiver.
- (2) Interchange the connections of the BS Rx ports and repeat the measurement according to (1)

7.3.5 Test requirements

For any BS Rx port tested, the measured BER shall not exceed 0,001.

7.4 Adjacent Channel Selectivity (ACS)

7.4.1 Definition and applicability

Adjacent channel selectivity (ACS) is a measure of the receiver ability to receive a wanted signal at its assigned channel frequency in the presence of an adjacent channel signal at a given frequency offset from the center frequency of the assigned channel.

The requirements in this subclause shall apply to base stations intended for general-purpose applications.

7.4.2 Conformance requirements

The BER, measured on the wanted signal in the presence of an interfering signal, shall not exceed 0,001 for the parameters specified in table 7.4.2.2.1.

Table 7.4.2.2.1: Parameters of the wanted signal and the interfering signal for ACS testing

Parameter	Level	Unit
Data rate	12,2	kbit/s
Wanted signal	Reference sensitivity level + 6 dB	dBm
Interfering signal	-52	dBm
F _w (modulated)	5	MHz
NOTE: F _w is the frequency offset of the unwanted interfering signal from the assigned channel frequency of the wanted signal.		

The reference for this requirement is TS 25.105 subclause 7.4.1.

7.4.3 Test purpose

The test purpose is to verify the ability of the BS receiver filter to sufficiently suppress interfering signals in the channels adjacent to the wanted channel.

7.4.4 Method of test

7.4.4.1 Initial conditions

- (1) Connect an UE simulator operating at the assigned channel frequency of the wanted signal and a signal generator used to produce the interfering signal in the adjacent channel to the antenna connector of one Rx port.
- (2) Terminate or disable any other Rx port not under test.

- (3) Start transmission from the BS tester to the BS using the UL reference measurement channel (12.2 kbps) defined in Annex A.2.1. The level of the UE simulator signal measured at the BS antenna connector shall be adjusted to the value specified in table 7.4.2.2.1.
- (4) Set the signal generator to produce an interfering signal that is equivalent to a continuous wideband CDMA signal with one code of chip frequency 3,84 Mchip/s, filtered by an RRC transmit pulse-shaping filter with roll-off $\alpha = 0,22$. The level of the interfering signal measured at the BS antenna connector shall be adjusted to the value specified in table 7.4.2.2.1.

7.4.4.2 Procedure

- (1) Set the center frequency of the interfering signal to 5 MHz above the assigned channel frequency of the wanted signal.
- (2) Measure the BER of the wanted signal at the BS receiver.
- (3) Set the center frequency of the interfering signal to 5 MHz below the assigned channel frequency of the wanted signal.
- (4) Measure the BER of the wanted signal at the BS receiver.
- (5) Interchange the connections of the BS Rx ports and repeat the measurements according to steps (1) to (4).

7.4.5 Test requirements

The BER measured according subclause 7.4.4.2 to shall not exceed 0,001.

7.5 Blocking characteristics

7.5.1 Definition and applicability

The blocking characteristics is a measure of the receiver ability to receive a wanted signal at its assigned channel frequency in the presence of an unwanted interferer on frequencies other than those of the adjacent channels. The blocking performance shall apply at all frequencies as specified in tables 7.5.2.1, 7.5.2.2 or 7.5.2.3 respectively, using a 1 MHz step size.

The requirements in this subclause shall apply to base stations intended for general-purpose applications.

7.5.2 Conformance requirements

The static reference performance as specified in clause 7.2 should be met with a wanted and an interfering signal coupled to the BS antenna input using the parameters specified in tables 7.5.2.1 or 7.5.2.2, respectively.

Table 7.5.2.1: Blocking requirements for operating bands defined in subclause 4.2 a)

Center frequency of interfering signal	Interfering signal level	Wanted signal level	Minimum offset of interfering signal	Type of interfering signal
1900 – 1920 MHz, 2010 – 2025 MHz	-40 dBm	<REFSENS> + 6 dB	10 MHz	WCDMA signal with one code
1880 – 1900 MHz, 1990 – 2010 MHz, 2025 – 2045 MHz	-40 dBm	<REFSENS> + 6 dB	10 MHz	WCDMA signal with one code
1920 – 1980 MHz	-40 dBm	<REFSENS> + 6 dB	10 MHz	WCDMA signal with one code
1 - 1880 MHz, 1980 – 1990 MHz, 2045 – 12750 MHz	-15 dBm	<REFSENS> + 6 dB	—	CW carrier

Table 7.5.2.2: Blocking requirements for operating bands defined in subclause 4.2 b)

Center frequency of interfering signal	Interfering signal level	Wanted signal level	Minimum offset of interfering signal	Type of interfering signal
1850 – 1990 MHz	-40 dBm	<REFSENS> + 6 dB	10 MHz	WCDMA signal with one code
1830 – 1850 MHz, 1990 – 2010 MHz	-40 dBm	<REFSENS> + 6 dB	10 MHz	WCDMA signal with one code
1 – 1830 MHz, 2045 – 12750 MHz	-15 dBm	<REFSENS> + 6 dB	—	CW carrier

Table 7.5.2.3: Blocking requirements for operating bands defined in subclause 4.2 c)

Center frequency of interfering signal	Interfering signal level	Wanted signal level	Minimum offset of interfering signal	Type of interfering signal
1910 – 1930 MHz	-40 dBm	<REFSENS> + 6 dB	10 MHz	WCDMA signal with one code
1890 – 1910 MHz, 1930 – 1950 MHz	-40 dBm	<REFSENS> + 6 dB	10 MHz	WCDMA signal with one code
1 – 1890 MHz, 1950 – 12750 MHz	-15 dBm	<REFSENS> + 6 dB	—	CW carrier

The reference for this requirement is TS 25.105 subclause 7.5.

7.5.3 Test purpose

The test stresses the ability of the BS receiver to withstand high-level interference from unwanted signals at frequency offsets of 10 MHz or more, without undue degradation of its sensitivity.

7.5.4 Method of test

7.5.4.1 Initial conditions

- (1) Connect an UE simulator operating at the assigned channel frequency of the wanted signal and a signal generator to the antenna connector of one Rx port.
- (2) Terminate or disable any other Rx port not under test.
- (3) Start transmission from the BS tester to the BS using the UL reference measurement channel (12.2 kbps) defined in Annex A.2.1. The level of the UE simulator signal measured at the BS antenna connector shall be set to 6 dB above the reference sensitivity level specified in subclause 7.2.2.

7.5.4.2 Procedure

- (1) Set the signal generator to produce an interfering signal at a frequency offset F_{uw} from the assigned channel frequency of the wanted signal which is given by

$$F_{uw} = \pm (n \times 1 \text{ MHz}),$$

where n shall be increased in integer steps from $n = 10$ up to such a value that the center frequency of the interfering signal covers the range from 1 MHz to 12,75 GHz. The interfering signal level measured at the antenna connector shall be set in dependency of its center frequency, as specified in tables 7.5.2.1, 7.5.2.2, or 7.5.2.3 respectively. The type of the interfering signal is either equivalent to a continuous wideband CDMA signal with one code of chip frequency 3,84 Mchip/s, filtered by an RRC transmit pulse-shaping filter with roll-off $\alpha = 0,22$, or a CW signal; see tables 7.5.2.1, 7.5.2.2 or 7.5.2.3 respectively.

- (2) Measure the BER of the wanted signal at the BS receiver.
- (3) Interchange the connections of the BS Rx ports and repeat the measurements according to steps (1) and (2).

NOTE: The test procedure as defined in steps (1) and (2) requests to carry out more than 10000 BER measurements. To reduce the time needed for these measurements, it may be appropriate to conduct the test in two phases: During phase 1, BER measurements are made on all center frequencies of the interfering signal as requested but with a reduced confidence level, with the aim to identify those frequencies which require more detailed investigation. In phase 2, detailed measurements are made only at those critical frequencies identified before, applying the required confidence level.

7.5.5 Test requirements

In all measurements made according to subclause 7.5.4.2, the BER shall not exceed 0,001.

7.6 Intermodulation characteristics

7.6.1 Definition and applicability

Third and higher order mixing of two interfering RF signals can produce an interfering signal in the band of the desired channel. Intermodulation response rejection is a measure of the capability of the receiver to receive a wanted signal on its assigned channel frequency in the presence of two or more interfering signals which have a specific frequency relationship to the wanted signal.

The requirements in this subclause shall apply to base stations intended for general-purpose applications.

7.6.2 Conformance requirements

The static reference performance as specified in clause 7.2 should be met when the following signals are coupled to the BS antenna input.

- A wanted signal at the assigned channel frequency, 6 dB above the static reference level.
- Two interfering signals with the parameters specified in table 7.6.2.1.

Table 7.6.2.1: Parameters of the interfering signals for intermodulation characteristics testing

Interfering Signal Level	Offset	Type of Interfering Signal
- 48 dBm	10 MHz	CW signal
- 48 dBm	20 MHz	WCDMA signal with one code

The reference for this requirement is TS 25.105 subclause 7.6.

7.6.3 Test purpose

The test purpose is to verify the ability of the BS receiver to inhibit the generation of intermodulation products in its non-linear elements caused by the presence of two high-level interfering signals at frequencies with a specific relationship to the frequency of the wanted signal.

7.6.4 Method of test

7.6.4.1 Initial conditions

- (1) Connect an UE simulator operating at the assigned channel frequency of the wanted signal and two signal generators to the antenna connector of one Rx port.
- (2) Terminate or disable any other Rx port not under test.

- (3) Start transmission from the BS tester to the BS using the UL reference measurement channel (12.2 kbps) defined in Annex A.2.1. The level of the UE simulator signal measured at the BS antenna connector shall be set to 6 dB above the reference sensitivity level specified in subclause 7.2.2.
- (4) Set the first signal generator to produce a CW signal with a level measured at the BS antenna connector of - 48 dBm.
- (5) Set the second signal generator to produce an interfering signal equivalent to a wideband CDMA signal with one code of chip frequency 3,84 Mchip/s, filtered by an RRC transmit pulse-shaping filter with roll-off $\alpha = 0,22$. The level of the signal measured at the BS antenna connector shall be set to - 48 dBm.

7.6.4.2 Procedure

- (1) The frequency of the first and the second signal generator shall be set to 10 MHz and 20 MHz, respectively, above the assigned channel frequency of the wanted signal.
- (2) Measure the BER of the wanted signal at the BS receiver.
- (3) The frequency of the first and the second signal generator shall be set to 10 MHz and 20 MHz, respectively, below the assigned channel frequency of the wanted signal.
- (4) Measure the BER of the wanted signal at the BS receiver.
- (5) Interchange the connections of the BS Rx ports and repeat the measurements according to steps (1) to (4).

7.6.5 Test requirements

The BER measured according subclause 7.6.4.2 to shall not exceed 0,001.

7.7 Spurious emissions

7.7.1 Definition and applicability

The spurious emissions power is the power of emissions generated or amplified in a receiver that appear at the BS antenna connector. The requirements apply to all BS with separate Rx and Tx antenna connectors. For BS equipped with only a single antenna connector for both transmitter and receiver, the requirements of subclause 6.6.3 shall apply to this port, and this test need not be performed.

The requirements in this subclause shall apply to base stations intended for general-purpose applications.

7.7.2 Conformance requirements

The power of any spurious emission shall not exceed the values given in table 7.7.2.1.

Table 7.7.2.1: Receiver spurious emission requirements

Band	Maximum level	Measurement Bandwidth	Note
9 kHz – 1 GHz	-57 dBm	100 kHz	
1 GHz – 1,9 GHz	-47 dBm	1 MHz	With the exception of frequencies between 12,5 MHz below the first carrier frequency and 12,5 MHz above the last carrier frequency used by the BS
1,900 – 1,980 GHz	-78 dBm	3,84 MHz	With the exception of frequencies between 12,5 MHz below the first carrier frequency and 12,5 MHz above the last carrier frequency used by the BS
1,980 – 2,010 GHz	-47 dBm	1 MHz	With the exception of frequencies between 12,5 MHz below the first carrier frequency and 12,5 MHz above the last carrier frequency used by the BS
2,010 – 2,025 GHz	-78 dBm	3,84 MHz	With the exception of frequencies between 12,5 MHz below the first carrier frequency and 12,5 MHz above the last carrier frequency used by the BS
2,025 GHz – 12,75 GHz	-47 dBm	1 MHz	With the exception of frequencies between 12,5 MHz below the first carrier frequency and 12,5 MHz above the last carrier frequency used by the BS

The reference for this requirement is TS 25.105 subclause 7.7.1.

7.7.3 Test purpose

The test purpose is to verify the ability of the BS to limit the interference caused by receiver spurious emissions to other systems.

7.7.4 Method of test

7.7.4.1 Initial conditions

- (1) Connect the measuring equipment to the antenna connector of one BS Rx port.
- (2) Terminate or disable any other BS Rx port not under test.
- (3) Set the BS receiver to operational mode.
- (4) Set the BS to transmit a signal with parameters according to table 7.7.4.1.1.
- (5) Terminate the Tx port(s).

Table 7.7.4.1.1: Parameters of the transmitted signal for Rx spurious emissions test

Parameter	Value/description
TDD Duty Cycle	TS i ; $i = 0, 1, 2, \dots, 14$: transmit, if i is even; receive, if i is odd.
BS output power setting	PRAT
Number of DPCH in each active TS	9
Power of each DPCH	1/9 of Base Station output power
Data content of DPCH	real life (sufficient irregular)

7.7.4.2 Procedure

- (1) Measure the power of the spurious emissions by applying the measuring equipment with the settings as specified in table 7.7.4.2.1. The characteristics of the measurement filter with the bandwidth 3,84 MHz shall be RRC with roll-off $\alpha = 0,22$. The characteristics of the measurement filters with bandwidths 100 kHz and 1 MHz shall be approximately Gaussian (typical spectrum analyzer filter). The center frequency of the filters shall be stepped in contiguous steps over the frequency bands as specified in table 7.7.4.2.1. The time duration of each step shall be sufficiently long to capture one even (transmit) time slot.
- (2) If the BS is equipped with more than one Rx port, interchange the connections of the BS Rx ports and repeat the measurement according to (1).

Table 7.7.4.2.1: Measurement equipment settings

Stepped frequency range	Measurement bandwidth	Step width	Note	Detection mode
9 kHz – 1 GHz	100 kHz	100 kHz	With the exception of frequencies between 12,5 MHz below the first carrier frequency and 12,5 MHz above the last carrier frequency used by the BS	true RMS
1 GHz – 1,900 GHz	1 MHz	1 MHz		
1,900 GHz – 1,980 GHz	3,84 MHz	200 kHz		
1,980 GHz – 2,010 GHz	1 MHz	1 MHz		
2,010 GHz – 2,025 GHz	3,84 MHz	200 kHz		
2,025 GHz – 12,75 GHz	1 MHz	1 MHz		

7.7.5 Test requirements

The spurious emissions measured according to subclause 7.7.4.2 shall not exceed the limits specified in subclause 7.7.2.

8 Performance requirements

8.1 General

Performance requirements for the BS are specified for the measurement channels defined in Annex A and the propagation conditions in Annex B. The requirements only apply to those measurement channels that are supported by the base station.

The minimum bandwidth of the white noise source, simulating interference from other cells (I_{oc}) shall be 1,5 times the chip rate (5,76 MHz for a chip rate of 3,84 MHz).

The requirements only apply to a base station with dual receiver antenna diversity. The required \hat{I}_{or}/I_{oc} shall be applied separately at each antenna port.

Table 8.1.1: Summary of Base Station performance targets

Physical channel	Measurement channel	Static	Multi-path Case 1	Multi-path Case 2	Multi-path Case 3
		Performance metric			
DCH	12,2 kbps	BLER < 10^{-2}	BLER < 10^{-2}	BLER < 10^{-2}	BLER < 10^{-2}
	64 kbps	BLER < $10^{-1}, 10^{-2}$	BLER < $10^{-1}, 10^{-2}$	BLER < $10^{-1}, 10^{-2}$	BLER < $10^{-1}, 10^{-2}, 10^{-3}$
	144 kbps	BLER < $10^{-1}, 10^{-2}$	BLER < $10^{-1}, 10^{-2}$	BLER < $10^{-1}, 10^{-2}$	BLER < $10^{-1}, 10^{-2}, 10^{-3}$
	384 kbps	BLER < $10^{-1}, 10^{-2}$	BLER < $10^{-1}, 10^{-2}$	BLER < $10^{-1}, 10^{-2}$	BLER < $10^{-1}, 10^{-2}, 10^{-3}$

8.2 Demodulation in static propagation conditions

8.2.1 Demodulation of DCH

8.2.1.1 Definition and applicability

The performance requirement of DCH in static propagation conditions is determined by the maximum Block Error Ratio (BLER) allowed when the receiver input signal is at a specified \hat{I}_{or}/I_{oc} limit. The BLER is calculated for each of the measurement channels supported by the base station.

The requirements in this subclause shall apply to base stations intended for general-purpose applications.

8.2.1.2 Conformance requirements

For the parameters specified in table 8.2.1.2.1, the BLER should not exceed the piece-wise linear BLER curve specified in table 8.2.1.2.2.

Table 8.2.1.2.1: Parameters in static propagation conditions

Parameters	Unit	Test 1	Test 2	Test 3	Test 4
Number of DPCH _o		6	4	0	0
$\frac{DPCH_{o} - E_c}{I_{or}}$	dB	-9	-9,5	-	-
I_{oc}	dBm/3,84 MHz	-89			
Information Data Rate	kbps	12,2	64	144	384

Table 8.2.1.2.2: Performance requirements in AWGN channel.

Test Number	$\frac{\hat{I}_{or}}{I_{oc}}$ [dB]	BLER
1	-1,9	10^{-2}
2	-0,3	10^{-1}
	0,0	10^{-2}
3	0,0	10^{-1}
	0,2	10^{-2}
4	-0,5	10^{-1}
	-0,3	10^{-2}

The reference for this requirement is TS 25.105 subclause 8.2.1.

8.2.1.3 Test purpose

The test purpose is to verify the ability of the BS to receive a prescribed test signal under static propagation conditions with a BLER not exceeding a specified limit. Within the wanted channel, intracell interference sources as well as an additional intercell interference source are taken into account. Therefore, this test – as all other tests in clause 8 - mainly checks the ability of the signal processing part of the receiver to extract the wanted signal from the interfered-with input signal, whereas the tests in clause 7 concentrate on the receiver RF part.

8.2.1.4 Method of test

8.2.1.4.1 Initial conditions

Connect the BS tester (UE simulator) generating the wanted signal and a set of interference generators to both BS antenna connectors for diversity reception via a combining network. The set of interference generators comprises a number of CDMA generators, each representing an individual intracell interferer (subsequently called DPCH₀ generators), and an additional band-limited white noise source, simulating interference from other cells. Each DPCH₀ generator shall produce an interfering signal that is equivalent to a valid UTRA TDD signal with spreading factor 16, using the same time slot(s) than the wanted signal and applying the same cell-specific scrambling code. The number of the DPCH₀ generators used in each test is given in table 8.2.1.2.1.

8.2.1.4.2 Procedure

- (1) Adjust the power of the band-limited white noise source in such a way that its power spectral density measured at the BS antenna connector takes on the value I_{oc} as specified in table 8.2.1.2.1.
- (2) For a given test defined by the information data rate and the BLER objective, set the power of each DPCH₀ measured at the BS antenna connector during the active time slots to the value specified in table 8.2.1.4.2.1.
- (3) Set up a call between the BS tester generating the wanted signal and the BS. The characteristics of the call shall be configured according to the information data rate to be provided and the corresponding UL reference measurement channel defined in Annex A. Depending on the information data rate, the UL reference measurement channel makes use of one or two Dedicated Physical Channels (DPCH₁ and DPCH₂) with different spreading factors SF. The power(s) of DPCH₁ and DPCH₂ (if applicable) measured at the BS antenna connector during the active time slots shall be set to the value(s) given in table 8.2.1.4.2.1.
- (4) Measure the BLER of the wanted signal at the BS receiver.

Table 8.2.1.4.2.1: Parameters of DPCH₀ and the wanted signal

Test Number	BLER objective	Number of DPCH ₀	Power of each DPCH ₀ measured at the BS antenna connector [dBm]	Parameters of the wanted signal		
				DPCH	SF	Power measured at the BS antenna connector [dBm]
1	10 ⁻²	6	-70,9	DPCH ₁	8	-67,9
2	10 ⁻¹	4	-69,8	DPCH ₁	16	-69,8
				DPCH ₂	4	-63,8
	10 ⁻²	4	-69,5	DPCH ₁	16	-69,5
				DPCH ₂	4	-63,5
3	10 ⁻¹	0	-	DPCH ₁	16	-69,5
				DPCH ₂	2	-60,5
	10 ⁻²	0	-	DPCH ₁	16	-69,3
				DPCH ₂	2	-60,3
4	10 ⁻¹	0	-	DPCH ₁	2	-60,5
	10 ⁻²	0	-	DPCH ₁	2	-60,3

8.2.1.5 Test requirements

The BLER measured according to subclause 8.2.1.4.2 shall not exceed the limits specified in table 8.2.1.2.2.

8.3 Demodulation of DCH in multipath fading conditions

8.3.1 Multipath fading Case 1

8.3.1.1 Definition and applicability

The performance requirement of DCH in multipath fading Case 1 is determined by the maximum Block Error Ratio (BLER) allowed when the receiver input signal is at a specified \hat{I}_{or}/I_{oc} limit. The BLER is calculated for each of the measurement channels supported by the base station.

The requirements in this subclause shall apply to base stations intended for general-purpose applications.

8.3.1.2 Conformance requirements

For the parameters specified in table 8.3.1.2.1, the BLER should not exceed the piece-wise linear BLER curve specified in table 8.3.1.2.2.

Table 8.3.1.2.1: Parameters in multipath Case 1 channel

Parameters	Unit	Test 1	Test 2	Test 3	Test 4
Number of DPCH ₀		6	4	0	0
$\frac{DPCH_o - E_c}{I_{or}}$	dB	-9	-9,5	-	-
I_{oc}	dBm/3,84 MHz	-89			
Information Data Rate	kbps	12,2	64	144	384

Table 8.3.1.2.2: Performance requirements in multipath Case 1 channel.

Test Number	$\frac{\hat{I}_{or}}{I_{oc}}$ [dB]	BLER
1	6,3	10^{-2}
2	5,5	10^{-1}
	9,4	10^{-2}
3	5,6	10^{-1}
	9,4	10^{-2}
4	5,5	10^{-1}
	8,7	10^{-2}

The reference for this requirement is TS 25.105 subclause 8.3.1.

8.3.1.3 Test purpose

The test purpose is to verify the ability of the BS to receive a prescribed test signal under defined propagation conditions (multipath fading Case 1) with a BLER not exceeding a specified limit. Within the wanted channel, independent intracell interference sources as well as an additional intercell interference source are taken into account. Therefore, this test – as all other tests in clause 8 - mainly checks the ability of the signal processing part of the receiver to extract the wanted signal from the distorted and interfered-with input signal, whereas the tests in clause 7 concentrate on the receiver RF part.

8.3.1.4 Method of test

8.3.1.4.1 Initial conditions

- (1) Connect the BS tester (UE simulator) generating the wanted signal and a set of interference generators to both BS antenna connectors for diversity reception via a combining network. The set of interference generators comprises a number of CDMA generators, each representing an individual intracell interferer (subsequently called DPCH₀ generators), and an additional band-limited white noise source, simulating interference from other cells. Each DPCH₀ generator shall produce an interfering signal that is equivalent to a valid UTRA TDD signal with spreading factor 16, using the same time slot(s) than the wanted signal and applying the same cell-specific scrambling code. The number of the DPCH₀ generators used in each test is given in table 8.3.1.2.1.
- (2) The wanted signal produced by the BS tester and the interfering signals produced by the DPCH₀ generators are individually passed through independent Multipath Fading Simulators (MFS) before entering the combining network. Each MFS shall be configured to simulate multipath fading Case 1.

8.3.1.4.2 Procedure

- (1) Adjust the power of the band-limited white noise source in such a way that its power spectral density measured at the BS antenna connector takes on the value I_{oc} as specified in table 8.3.1.2.1.
- (2) For a given test defined by the information data rate and the BLER objective, set the power of each DPCH₀ measured at the BS antenna connector during the active time slots to the value specified in table 8.3.1.4.2.1.
- (3) Set up a call between the BS tester generating the wanted signal and the BS. The characteristics of the call shall be configured according to the information data rate to be provided and the corresponding UL reference measurement channel defined in Annex A. Depending on the information data rate, the UL reference measurement channel makes use of one or two Dedicated Physical Channels (DPCH₁ and DPCH₂) with different spreading factors SF.

The power(s) of DPCH₁ and DPCH₂ (if applicable) measured at the BS antenna connector during the active time slots shall be set to the value(s) given in table 8.3.1.4.2.1.

(4) Measure the BLER of the wanted signal at the BS receiver.

Table 8.3.1.4.2.1: Parameters of DPCH₀ and the wanted signal

Test Number	BLER objective	Number of DPCH ₀	Power of each DPCH ₀ measured at the BS antenna connector [dBm]	Parameters of the wanted signal		
				DPCH	SF	Power measured at the BS antenna connector [dBm]
1	10 ⁻²	6	-62,7	DPCH ₁	8	-59,7
2	10 ⁻¹	4	-64	DPCH ₁	16	-64
				DPCH ₂	4	58
3	10 ⁻²	4	-60,1	DPCH ₁	16	-60,1
				DPCH ₂	4	-54,1
	10 ⁻¹	0	-	DPCH ₁	16	-63,9
				DPCH ₂	2	-54,9
10 ⁻²	0	-	DPCH ₁	16	-60,1	
			DPCH ₂	2	-51,1	
4	10 ⁻¹	0	-	DPCH ₁	2	-54,5
	10 ⁻²	0	-	DPCH ₁	2	-51,3

8.3.1.5 Test requirements

The BLER measured according to subclause 8.3.1.4.2 shall not exceed the limits specified in table 8.3.1.2.2.

8.3.2 Multipath fading Case 2

8.3.2.1 Definition and applicability

The performance requirement of DCH in multipath fading Case 2 is determined by the maximum Block Error Ratio (BLER) allowed when the receiver input signal is at a specified \hat{I}_{or}/I_{oc} limit. The BLER is calculated for each of the measurement channels supported by the base station.

The requirements in this subclause shall apply to base stations intended for general-purpose applications.

8.3.2.2 Conformance requirements

For the parameters specified in table 8.3.2.2.1, the BLER should not exceed the piece-wise linear BLER curve specified in table 8.3.2.2.2.

Table 8.3.2.2.1: Parameters in multipath Case 2 channel

Parameters	Unit	Test 1	Test 2	Test 3	Test 4
Number of DPCH ₀		2	0	0	0
$\frac{DPCH_o - E_c}{I_{or}}$	dB	-6	-	-	-
I_{oc}	dBm/3,84 MHz	-89			
Information Data Rate	kbps	12,2	64	144	384

Table 8.3.2.2.2: Performance requirements in multipath Case 2 channel.

Test Number	$\frac{\hat{I}_{or}}{I_{oc}}$ [dB]	BLER
1	0,1	10^{-2}
2	0,4	10^{-1}
	2,8	10^{-2}
3	3,6	10^{-1}
	6,0	10^{-2}
4	3,0	10^{-1}
	5,4	10^{-2}

The reference for this requirement is TS 25.105 subclause 8.3.2.

8.3.2.3 Test purpose

The test purpose is to verify the ability of the BS to receive a prescribed test signal under defined propagation conditions (multipath fading Case 2) with a BLER not exceeding a specified limit. Within the wanted channel, independent intracell interference sources as well as an additional intercell interference source are taken into account. Therefore, this test – as all other tests in clause 8 - mainly checks the ability of the signal processing part of the receiver to extract the wanted signal from the distorted and interfered-with input signal, whereas the tests in clause 7 concentrate on the receiver RF part.

8.3.2.4 Method of test

8.3.2.4.1 Initial conditions

- (1) Connect the BS tester (UE simulator) generating the wanted signal and a set of interference generators to both BS antenna connectors for diversity reception via a combining network. The set of interference generators comprises a number of CDMA generators, each representing an individual intracell interferer (subsequently called DPCH₀ generators), and an additional band-limited white noise source, simulating interference from other cells. Each DPCH₀ generator shall produce an interfering signal that is equivalent to a valid UTRA TDD signal with spreading factor 16, using the same time slot(s) than the wanted signal and applying the same cell-specific scrambling code. The number of the DPCH₀ generators used in each test is given in table 8.3.2.2.1.
- (2) The wanted signal produced by the BS tester and the interfering signals produced by the DPCH₀ generators are individually passed through independent Multipath Fading Simulators (MFS) before entering the combining network. Each MFS shall be configured to simulate multipath fading Case 2.

8.3.2.4.2 Procedure

- (1) Adjust the power of the band-limited white noise source in such a way that its power spectral density measured at the BS antenna connector takes on the value I_{oc} as specified in table 8.3.2.2.1.
- (2) For a given test defined by the information data rate and the BLER objective, set the power of each DPCH₀ measured at the BS antenna connector during the active time slots to the value specified in table 8.3.2.4.2.1.
- (3) Set up a call between the BS tester generating the wanted signal and the BS. The characteristics of the call shall be configured according to the information data rate to be provided and the corresponding UL reference measurement channel defined in Annex A. Depending on the information data rate, the UL reference measurement channel makes use of one or two Dedicated Physical Channels (DPCH₁ and DPCH₂) with different spreading factors SF. The power(s) of DPCH₁ and DPCH₂ (if applicable) measured at the BS antenna connector during the active time slots shall be set to the value(s) given in table 8.3.2.4.2.1.
- (4) Measure the BLER of the wanted signal at the BS receiver.

Table 8.3.2.4.2.1: Parameters of DPCH₀ and the wanted signal

Test Number	BLER objective	Number of DPCH ₀	Power of each DPCH ₀ measured at the BS antenna connector [dBm]	Parameters of the wanted signal		
				DPCH	SF	Power measured at the BS antenna connector [dBm]
1	10 ⁻²	2	-65,9	DPCH ₁	8	-62,9
2	10 ⁻¹	0	-	DPCH ₁	16	-66,6
				DPCH ₂	4	-60,6
	10 ⁻²	0	-	DPCH ₁	16	-64,2
				DPCH ₂	4	-58,2
3	10 ⁻¹	0	-	DPCH ₁	16	-65,9
				DPCH ₂	2	-56,9
	10 ⁻²	0	-	DPCH ₁	16	-63,5
				DPCH ₂	2	-54,5
4	10 ⁻¹	0	-	DPCH ₁	2	-57
	10 ⁻²	0	-	DPCH ₁	2	-54,6

8.3.2.5 Test requirements

The BLER measured according to subclause 8.3.2.4.2 shall not exceed the limits specified in table 8.3.2.2.2.

8.3.3 Multipath fading Case 3

8.3.3.1 Definition and applicability

The performance requirement of DCH in multipath fading Case 3 is determined by the maximum Block Error Ratio (BLER) allowed when the receiver input signal is at a specified \hat{I}_{or}/I_{oc} limit. The BLER is calculated for each of the measurement channels supported by the base station.

The requirements in this subclause shall apply to base stations intended for general-purpose applications.

8.3.3.2 Conformance requirements

For the parameters specified in table 8.3.3.2.1, the BLER should not exceed the piece-wise linear BLER curve specified in Table 8.3.3.2.2.

Table 8.3.3.2.1: Parameters in multipath Case 3 channel

Parameters	Unit	Test 1	Test 2	Test 3	Test 4
Number of DPCH ₀		2	0	0	0
$\frac{DPCH_o - E_c}{I_{or}}$	dB	-6	-	-	-
I_{oc}	dBm/3,84 MHz	-89			
Information Data Rate	kbps	12,2	64	144	384

Table 8.8: Performance requirements in multipath Case 3 channel.

Test Number	$\frac{\hat{I}_{or}}{I_{oc}}$ [dB]	BLER
1	-0,6	10^{-2}
2	0,7	10^{-1}
	2,4	10^{-2}
	3,8	10^{-3}
3	3,9	10^{-1}
	5,9	10^{-2}
	7,3	10^{-3}
4	2,8	10^{-1}
	4,2	10^{-2}
	4,8	10^{-3}

The reference for this requirement is TS 25.105 subclause 8.3.3.

8.3.3.3 Test purpose

The test purpose is to verify the ability of the BS to receive a prescribed test signal under defined propagation conditions (multipath fading Case 3) with a BLER not exceeding a specified limit. Within the wanted channel, independent intracell interference sources as well as an additional intercell interference source are taken into account. Therefore, this test – as all other tests in clause 8 - mainly checks the ability of the signal processing part of the receiver to extract the wanted signal from the distorted and interfered-with input signal, whereas the tests in clause 7 concentrate on the receiver RF part.

8.3.3.4 Method of test

8.3.3.4.1 Initial conditions

- (1) Connect the BS tester (UE simulator) generating the wanted signal and a set of interference generators to both BS antenna connectors for diversity reception via a combining network. The set of interference generators comprises a number of CDMA generators, each representing an individual intracell interferer (subsequently called DPCH₀ generators), and an additional band-limited white noise source, simulating interference from other cells. Each DPCH₀ generator shall produce an interfering signal that is equivalent to a valid UTRA TDD signal with spreading factor 16, using the same time slot(s) than the wanted signal and applying the same cell-specific scrambling code. The number of the DPCH₀ generators used in each test is given in table 8.3.3.2.1.
- (2) The wanted signal produced by the BS tester and the interfering signals produced by the DPCH₀ generators are individually passed through independent Multipath Fading Simulators (MFS) before entering the combining network. Each MFS shall be configured to simulate multipath fading Case 3.

8.3.3.4.2 Procedure

- (1) Adjust the power of the band-limited white noise source in such a way that its power spectral density measured at the BS antenna connector takes on the value I_{oc} as specified in table 8.3.3.2.1.
- (2) For a given test defined by the information data rate and the BLER objective, set the power of each DPCH₀ measured at the BS antenna connector during the active time slots to the value specified in table 8.3.3.4.2.1.
- (3) Set up a call between the BS tester generating the wanted signal and the BS. The characteristics of the call shall be configured according to the information data rate to be provided and the corresponding UL reference measurement channel defined in Annex A. Depending on the information data rate, the UL reference measurement channel makes use of one or two Dedicated Physical Channels (DPCH₁ and DPCH₂) with different spreading factors SF. The power(s) of DPCH₁ and DPCH₂ (if applicable) measured at the BS antenna connector during the active time slots shall be set to the value(s) given in table 8.3.3.4.2.1.
- (4) Measure the BLER of the wanted signal at the BS receiver.

Table 8.3.3.4.2.1: Parameters of DPCH₀ and the wanted signal

Test Number	BLER objective	Number of DPCH ₀	Power of each DPCH ₀ measured at the BS antenna connector [dBm]	Parameters of the wanted signal		
				DPCH	SF	Power measured at the BS antenna connector [dBm]
1	10 ⁻²	2	-66,6	DPCH ₁	8	-63,6
2	10 ⁻¹	0	-	DPCH ₁	16	-66,3
				DPCH ₂	4	-60,3
	10 ⁻²	0	-	DPCH ₁	16	-64,6
				DPCH ₂	4	-58,6
				DPCH ₁	16	-63,2
10 ⁻³	0	-	DPCH ₁	16	-63,2	
			DPCH ₂	4	-57,2	
3	10 ⁻¹	0	-	DPCH ₁	16	-65,6
				DPCH ₂	2	-56,6
	10 ⁻²	0	-	DPCH ₁	16	-63,6
				DPCH ₂	2	-54,6
10 ⁻³	0	-	DPCH ₁	16	-62,2	
			DPCH ₂	2	-53,2	
4	10 ⁻¹	0	-	DPCH ₁	2	-57,2
	10 ⁻²	0	-	DPCH ₁	2	-55,8
	10 ⁻³	0	-	DPCH ₁	2	-55,2

8.3.3.5 Test requirements

The BLER measured according to subclause 8.3.3.4.2 shall not exceed the limits specified in table 8.3.3.2.2.

Annex A (normative): Measurement Channels

A.1 General

A.2 Reference measurement channel

A.2.1 UL reference measurement channel (12.2 kbps)

Parameter	
Information data rate	12.2 kbps
RU's allocated	2 RU
Midamble	512 chips
Interleaving	20 ms
Power control	2 Bit/user
TFCI	16 Bit/user
Inband signalling DCCH	2 kbps
Puncturing level at Code rate 1/3 : DCH / DCCH	5% / 0%

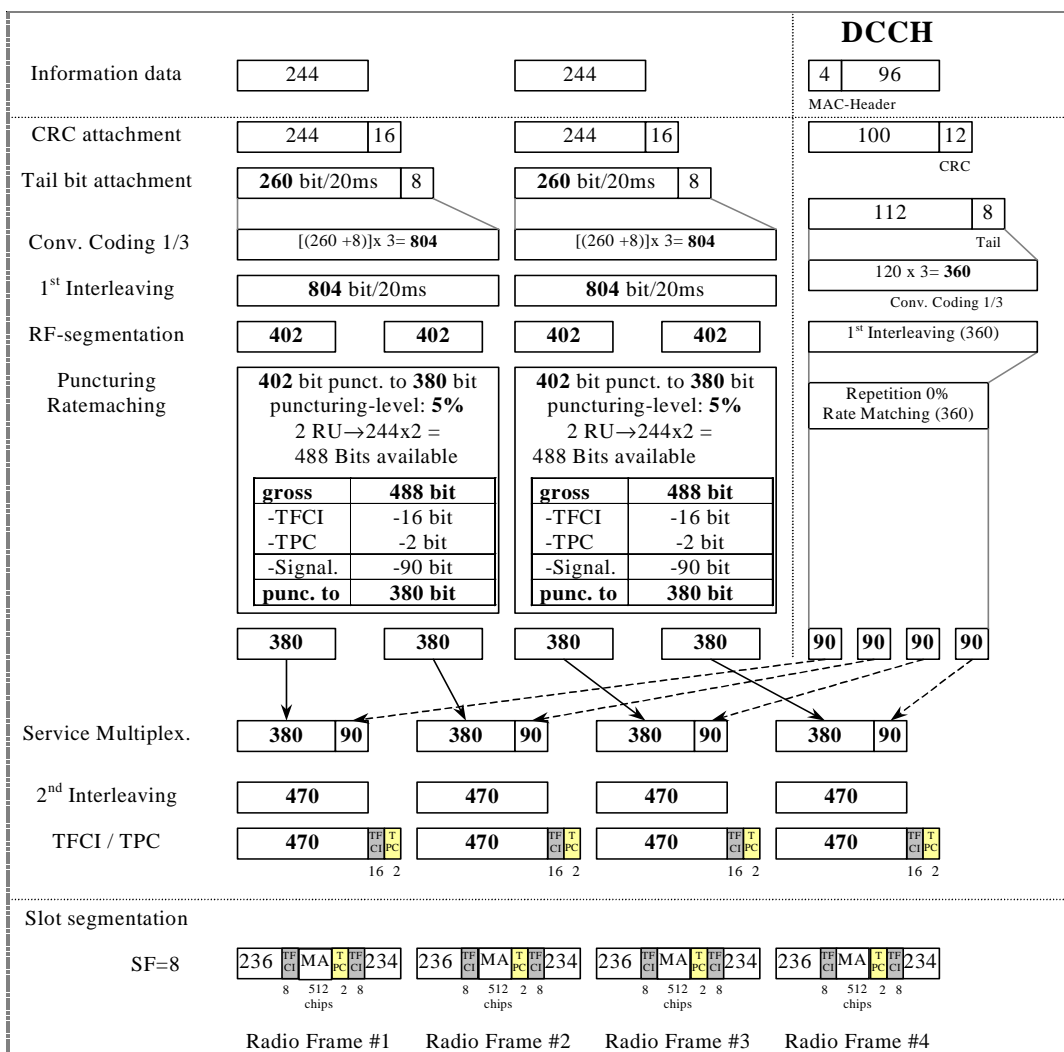

A.2.2 UL reference measurement channel (64 kbps)

Parameter	
Information data rate	64 kbps
RU's allocated	1 SF4 + 1 SF16 = 5RU
Midamble	512 chips
Interleaving	20 ms
Power control	2 Bit/user
TFCI	16 Bit/user
Inband signalling DCCH	2 kbps
Puncturing level at Code rate : 1/3 DCH / 1/2 DCCH	41.2% / 10%

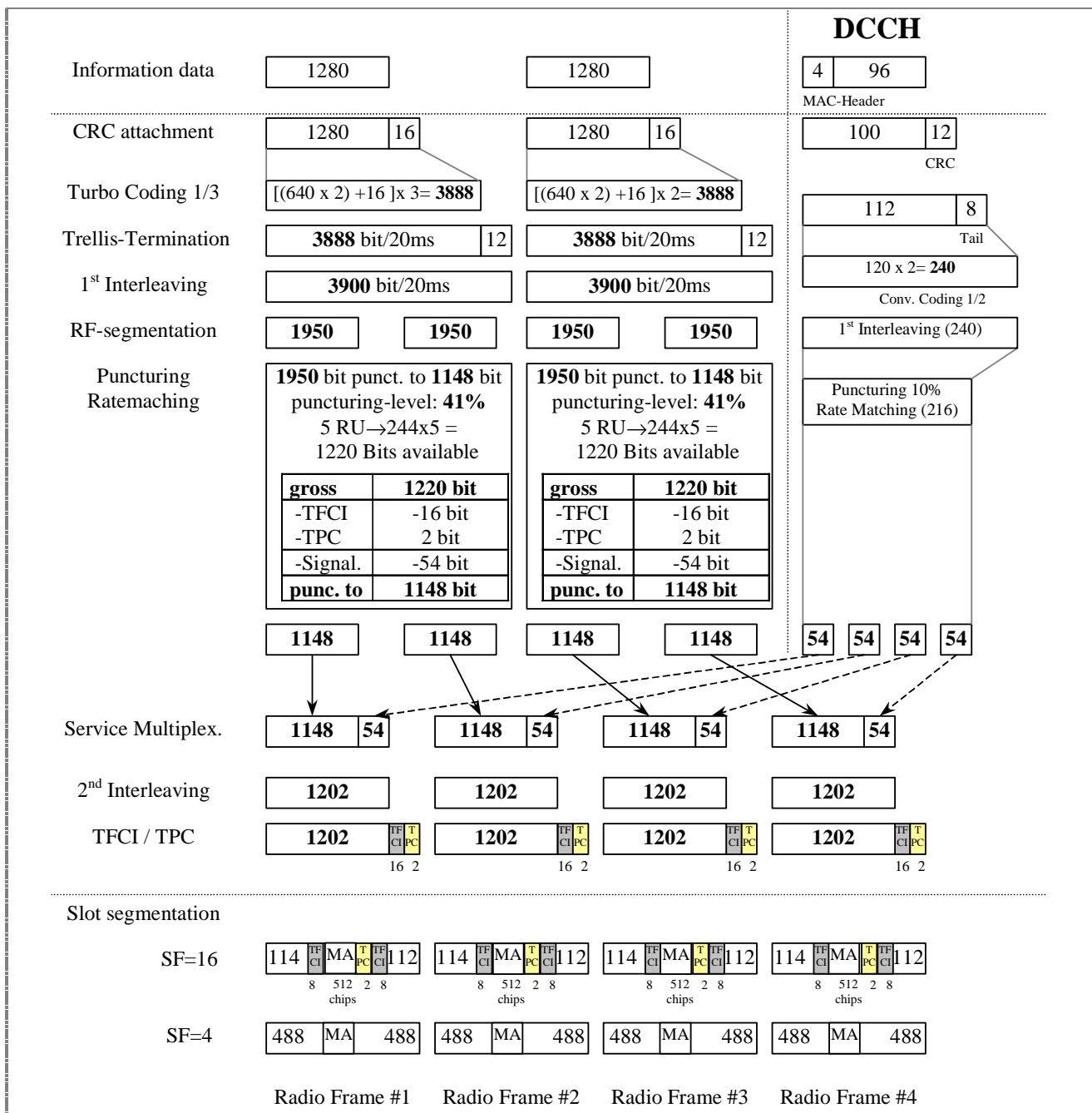

A.2.3 UL reference measurement channel (144 kbps)

Parameter	
Information data rate	144 kbps
RU's allocated	1 SF2 + 1 SF16 = 9RU
Midamble	256 chips
Interleaving	20 ms
Power control	2 Bit/user
TFCI	16 Bit/user
Inband signalling DCCH	2 kbps
Puncturing level at Code rate : 1/3 DCH / 1/2 DCCH	44.4% / 16.6%

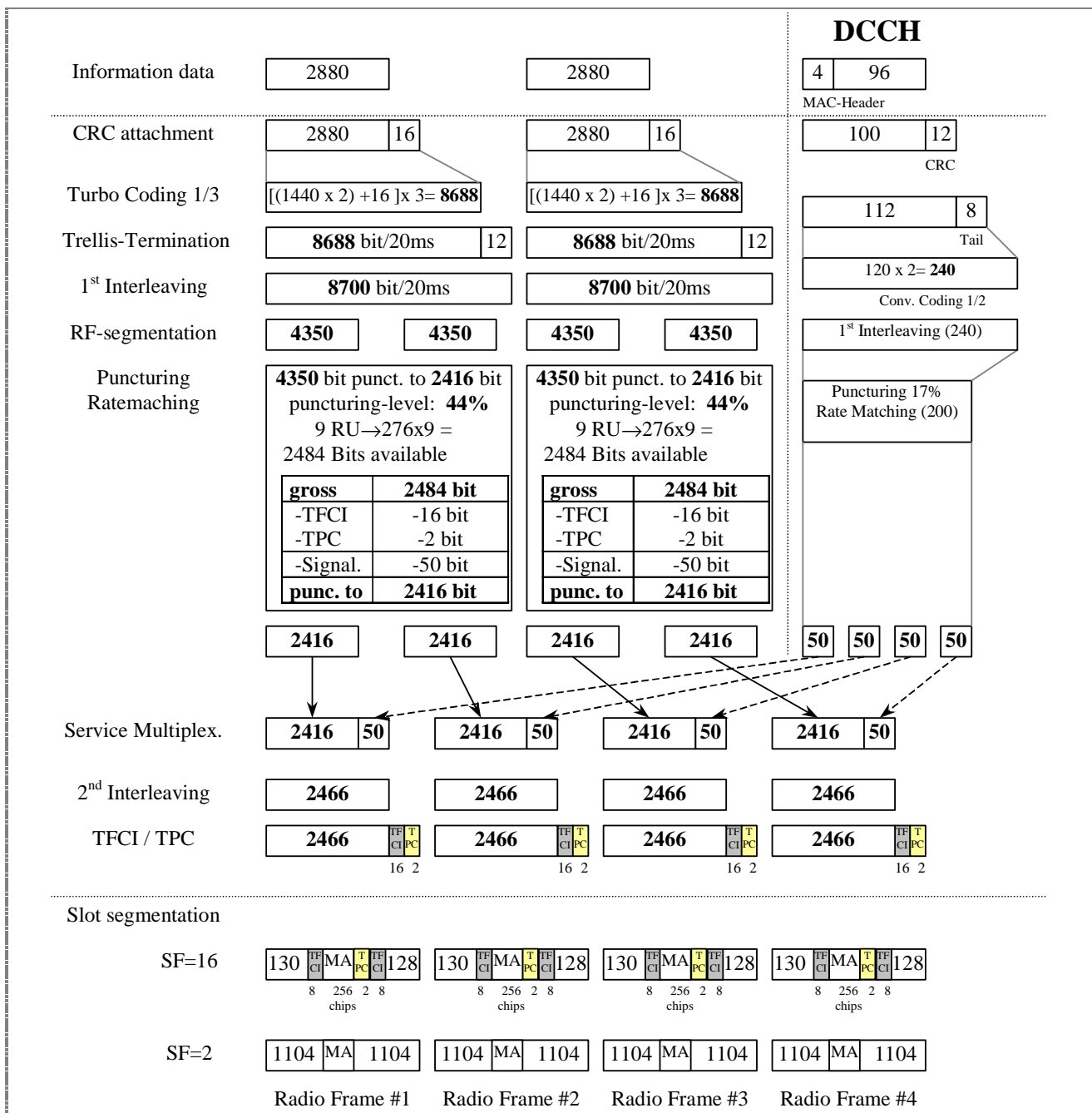

A.2.4 UL reference measurement channel (384 kbps)

Parameter	
Information data rate	384 kbps
RU's allocated	8*3TS = 24RU
Midamble	256 chips
Interleaving	20 ms
Power control	2 Bit/user
TFCI	16 Bit/user
Inband signalling DCCH	2 kbps
Puncturing level at Code rate : 1/3 DCH / 1/2 DCCH	43.4% / 15.3%

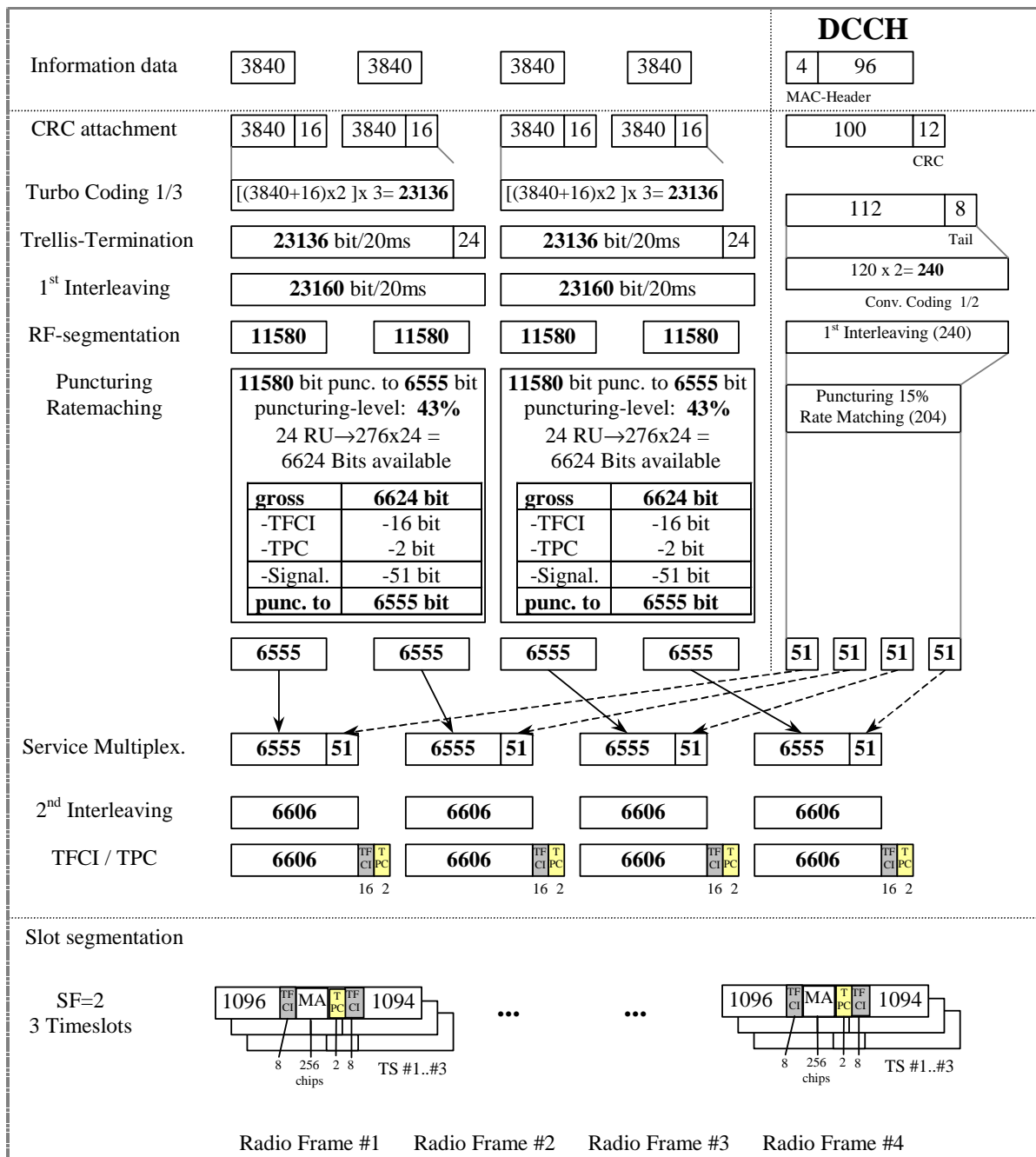

A.2.5 RACH reference measurement channel

Parameter	
Information data rate e.g. 2 TBs ($B_{RACH}=2$):	
SF16: 0% puncturing rate at CR=1/2 10% puncturing rate at CR=1/2 $N_{RACH} = \frac{232 + N_{RM} - 8}{B_{RACH}} - 8$	46 bits per frame and TB 53 bits per frame and TB
SF8: 0% puncturing rate at CR=1/2 10% puncturing rate at CR=1/2 $N_{RACH} = \frac{464 + N_{RM} - 8}{B_{RACH}} - 16$	96 bits per frame and TB 109 bits per frame and TB
RU's allocated	1 RU
Midamble	512 chips
Power control	0 bit
TFCI	0 bit

N_{RACH} = number of bits per TB

B_{RACH} = number of TBs

A.2.5.1 RACH mapped to 1 code SF16

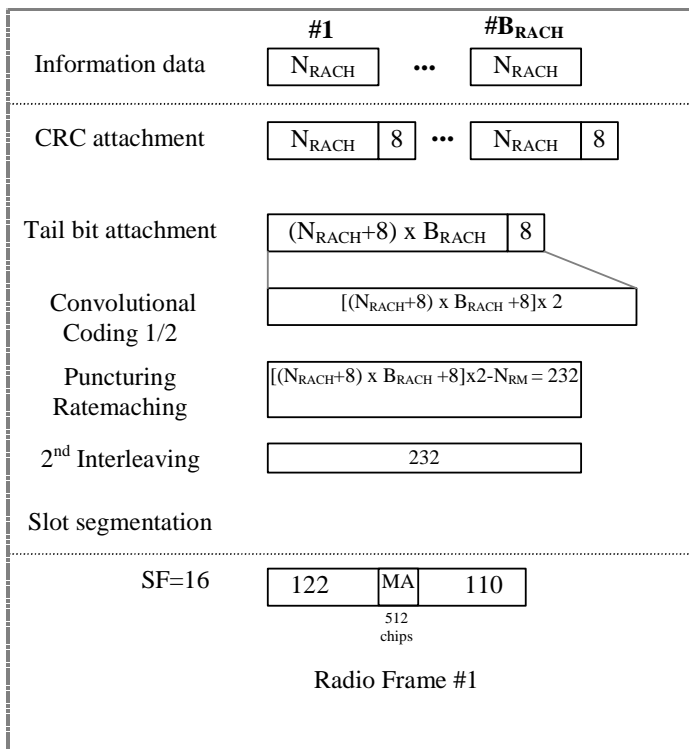

A.2.5.2 RACH mapped to 1 code SF8

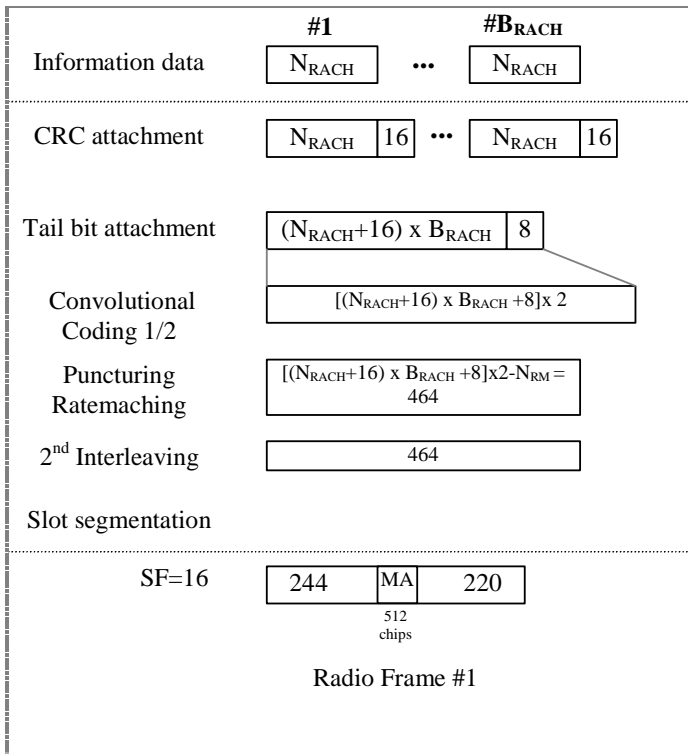

Annex B (normative): Propagation conditions

B.1 Static propagation condition

The propagation for the static performance measurement is an Additive White Gaussian Noise (AWGN) environment. No fading and multi-paths exist for this propagation model.

B.2 Multi-path fading propagation conditions

Table B1 shows propagation conditions that are used for the performance measurements in multi-path fading environment. All taps have classical Doppler spectrum.

Table B2.1: Propagation Conditions for Multi path Fading Environments

Case 1, speed 3km/h		Case 2, speed 3 km/h		Case 3, 120 km/h	
Relative Delay [ns]	Average Power [dB]	Relative Delay [ns]	Average Power [dB]	Relative Delay [ns]	Average Power [dB]
0	0	0	0	0	0
976	-10	976	0	260	-3
		12000	0	521	-6
				781	-9

Annex C (normative): Global in-channel Tx test

C.1 General

The global in-channel Tx test enables the measurement of all relevant parameters that describe the in-channel quality of the output signal of the Tx under test in a single measurement process.

The objective of this Annex is to list the results that shall be available from the global in-Channel TX-Test. To aid understanding, an example algorithmic description of the measurement process is provided. It is not intended that this particular method is required. It is however required that any algorithm that is used for in-channel Tx tests should deliver the required results with the required accuracy.

All notes referred to in the various subclauses of C.2 are put together in clause C.4

C.2 Definition of the process

C.2.1 Basic principle

The process is based on the comparison of the actual **output signal of the Tx under test**, received by an ideal receiver, with a **reference signal**, that is generated by the measuring equipment and represents an ideal error free received signal. All signals are represented as equivalent (generally complex) baseband signals.

C.2.2 Output signal of the Tx under test

The output signal of the Tx under test is acquired by the measuring equipment, filtered by a matched filter (RRC characteristic with roll-off $\alpha = 0,22$, correct in shape and in position on the frequency axis) and stored at one sample per chip at the intersymbol interference free instants.

The following form represents the physical signal in the entire measurement interval:

one vector **Z**, containing $N = ns \times sf + ma$ complex samples;

with

ns: number of symbols in the measurement interval;

sf: number of chips per symbol. (sf: spreading factor) (see Note: Symbol length)

ma: number of midamble chips (TDD only)

C.2.3 Reference signal

The reference signal is constructed by the measuring equipment according to the relevant Tx specifications.

It is filtered by the same matched filter, mentioned in C.2.2, and stored at the intersymbol interference free instants. The following form represents the reference signal in the entire measurement interval:

one vector **R**, containing $N = ns \times sf + ma$ complex samples;

where ns, sf and ma have the same meaning as defined above in C.2.2.

C.2.4 Classification of measurement results

The measurement results achieved by the global in-channel Tx test can be classified into two types:

- **Results of type “deviation”**, where the error-free parameter has a non-zero magnitude. (These are the parameters that represent the signal). These parameters are:

RF Frequency

Power (in case of single code)

Code Domain Power (in case of multi-code)

Timing (only for UE)

(Additional parameters: see Note: Deviation)

- **Results of type “residual”**, where the error-free parameter has value zero. (These are the parameters that represent the error values of the measured signal; ideally, their magnitude is zero). These parameters are:

Error Vector Magnitude (EVM)

Peak Code Domain Error (PCDE)

(Additional parameters: see Note: Residual)

C.2.5 Process definition to achieve results of type “deviation”

The reference signal (**R**; see subclause C.2.3) is varied with respect to the parameters mentioned in subclause C.2.4 under "results of type deviation" in order to achieve best fit with the recorded signal under test (**Z**; see subclause C.2.2). Best fit is achieved when the RMS difference value between the signal under test and the varied reference signal is an absolute minimum. The varied reference signal, after the best-fit process, will be called **R'**.

Those parameter values, which - after the best-fit process - are leading to **R'**, represent directly the wanted results of type “deviation”. These parameter values are expressed as deviations from the reference value, using the same units as the corresponding reference value.

In case of multi-code transmission, the best-fit process of the type “deviation” parameters frequency, timing (and any additional parameter as e.g. RF phase) is not done with respect to the individual codes, but commonly for the complete code set used; therefore, the process returns one measurement value only for each parameter.

The only exception is the type “deviation” parameter Code Domain Power: The Code Domain Power is varied individually for each used code; therefore, the process returns k individual code power deviations (k: number of codes).

C.2.6 Process definition to achieve results of type “residual”

The difference between the varied reference signal (**R'**; see subclause C.2.5.) and the Tx signal under test (**Z**; see subclause C.2.2) is the error vector **E** versus time:

$$\mathbf{E} = \mathbf{Z} - \mathbf{R}'.$$

Depending on the parameter to be evaluated, it is appropriate to represent **E** in one of the following two different forms:

- **Form EVM** (representing the physical error signal in the entire measurement interval)

One vector **E**, containing $N = n_s \times s_f + m_a$ complex samples;

where n_s , s_f and m_a have the same meaning as defined above in C.2.2.

- **Form PCDE** (derived from Form EVM by separating the samples into symbol intervals)

ns time-sequential vectors \mathbf{e} with sf complex samples comprising one symbol interval.

\mathbf{E} gives results of type "residual" applying the two algorithms defined in subclauses C.2.6.1 and C.2.6.2.

C.2.6.1 Error Vector Magnitude (EVM)

The Error Vector Magnitude EVM is calculated according to the following steps:

- (1) Take the error vector \mathbf{E} defined in subclause C.2.6 (Form EVM) and calculate the RMS value of \mathbf{E} ; the result will be called RMS(\mathbf{E}).
- (2) Take the reference vector \mathbf{R} defined in subclause C.2.3 and calculate the RMS value of \mathbf{R} ; the result will be called RMS(\mathbf{R}).
- (3) Calculate EVM according to:

$$\text{EVM} = \frac{\text{RMS}(\mathbf{E})}{\text{RMS}(\mathbf{R})} \times 100\% \quad (\text{here, EVM is relative and expressed in \%})$$

(see Note: TDD)

C.2.6.2 Peak Code Domain Error (PCDE)

The Peak Code Domain Error is calculated according to the following steps:

- (1) Take the error vectors \mathbf{e} defined in subclause C.2.6 (Form PCDE)
- (2) Take the orthogonal vectors of the spreading code set C (all codes belonging to one spreading factor) as defined in TS 25.213 and TS 25.223 (range +1, -1). (see Note: Symbol length)
- (3) To achieve meaningful results, it is necessary to descramble \mathbf{e} , leading to \mathbf{e}' (see Note: Scrambling code)
- (4) Calculate the inner product of \mathbf{e}' with C. Do this for all symbols of the measurement interval and for all codes in the code space.
This gives an array of format $k \times ns$, each value representing an error-vector representing a specific symbol and a specific code, which can be exploited in a variety of ways.

k: number of codes

ns: number of symbols in the measurement interval

- (5) Calculate k RMS values, each RMS value unifying n symbols within one code. (These values can be called "Absolute CodeEVMs" [Volt].)
- (6) Find the peak value among the k "absolute Code-EVMs". (This value can be called "Absolute PeakCodeEVM" [Volt].)
- (7) Calculate PCDE according to:

$$\text{PCDE} = 10 \lg \frac{(\text{absolute PeakCodeEVM})^2}{(\text{RMS}(\mathbf{R}))^2} \text{ dB}. \quad (\text{a relative value in dB}).$$

see Note: TDD

see Note: Synch channel

C.3 Applications

This process may be applied in the measurements defined in the following subclauses:

- 6.3 Frequency Stability
- 6.4 Output Power Dynamics
 - 6.4.2 Power control steps
 - 6.4.3 Power control dynamic range
 - 6.4.4 Minimum transmit power
 - 6.4.5 Primary CCPCH power
- 6.6.2.2 Adjacent Channel Leakage power Ratio (ACLR)
- 6.8 Transmit Modulation
 - 6.8.1 Modulation accuracy
 - 6.8.2 Peak Code Domain Error

C.4 Notes

NOTE: Symbol length

A general code-multiplexed signal is multi-code and multi-rate. In order to avoid unnecessary complexity, the measurement applications use a unique symbol-length, corresponding to a specific spreading factor, regardless of the really intended spreading factor. Nevertheless, the complexity with a multi-code / multi-rate signal can be mastered by introducing appropriate definitions.

NOTE: Deviation

It is conceivable to regard more parameters as type „deviation“, e.g. chip clock and RF phase. However, because chip clock and RF frequency are linked together by a statement in the core specifications [1], it is sufficient to process RF frequency only.

The parameter RF phase must be varied within the best-fit process (C.2.5). Although necessary, this parameter-variation does not describe any error, as the modulation schemes used in the system do not depend on an absolute RF-phase.

NOTE: Residual

It is conceivable to regard more parameters as type „residual“, e.g. IQ origin offset. As it is not the intention of the test to separate for different error sources, but to quantify the quality of the signal, all such parameters are not extracted by the best-fit process, instead remain part of EVM and PCDE.

NOTE: Scrambling code

To interpret the measurement results in practice, it should be kept in mind that erroneous code power on unused codes is generally de-scrambled differently under test conditions and under real life conditions, whereas erroneous code power on used codes is generally de-scrambled equally under test conditions and under real life conditions. It might be indicated if a used or unused code hits PCDE.

NOTE: TDD

EVM covers the midamble part as well as the data part; however PCDE disregards the midamble part.

NOTE: Synch channel

A BS signal contains a physical synch channel, which is non-orthogonal, related to the other DPCHs. In this context note: The code channel bearing the result of PCDE is exactly one of the DPCHs (never the synch channel). The origin of PCDE (erroneous code power) can be any DPCH and/or the synch channel.

Annex D (informative): Change history

CRs approved at TSG-RAN#7.

RAN doc	Spec	CR	Rev	Phase	Subject	Cat	Current	New
RP-000023	25.142	001		R99	Conformance test descriptions for spectrum emission mask and ACLR	C	3.0.0	3.1.0
RP-000023	25.142	002		R99	Conformance test description for Adjacent Channel Selectivity (ACS)	F	3.0.0	3.1.0
RP-000023	25.142	003		R99	Conformance test description for blocking characteristics	F	3.0.0	3.1.0
RP-000023	25.142	004	1	R99	Conformance test description for performance requirements	F	3.0.0	3.1.0
RP-000023	25.142	005		R99	Protection outside a licensee's frequency block	F	3.0.0	3.1.0
RP-000023	25.142	006		R99	ACLR	F	3.0.0	3.1.0
RP-000023	25.142	007		R99	Corrected reference sensitivity value	F	3.0.0	3.1.0
RP-000023	25.142	008		R99	Conformance test description for Tx spurious emissions	F	3.0.0	3.1.0
RP-000023	25.142	009		R99	Clause 5: General test conditions and declarations	F	3.0.0	3.1.0
RP-000023	25.142	010		R99	Conformance test description for Primary CCPCH power	F	3.0.0	3.1.0
RP-000023	25.142	011		R99	Conformance test description for transmit OFF power	F	3.0.0	3.1.0
RP-000023	25.142	012		R99	Conformance test description for Rx spurious emissions	F	3.0.0	3.1.0

CRs approved at TSG-RAN#8.

Doc-1st-Level	Spec	CR	Rev	Phase	Subject	Cat	Version-Current	Version-New
RP-000212	25.142	013		R99	UL Reference Measurement Channels	F	3.1.0	3.2.0
RP-000212	25.142	014		R99	Regional requirements in TS 25.142	F	3.1.0	3.2.0

RP-000212	25.142	015	R99	Conformance test description for receiver dynamic range.	F	3.1.0	3.2.0
RP-000212	25.142	016	R99	Correction of the interfering power level for performance requirements	F	3.1.0	3.2.0
RP-000212	25.142	017	R99	Definitions of maximum output power and rated output power	F	3.1.0	3.2.0
RP-000212	25.142	018	R99	Correction of blocking requirements	F	3.1.0	3.2.0
RP-000212	25.142	020	R99	Conformance test description for modulation accuracy	F	3.1.0	3.2.0
RP-000212	25.142	021	R99	Modification to the handling of BS TDD Measurement Uncertainty	F	3.1.0	3.2.0
RP-000212	25.142	022	R99	Clarification of the specification on Peak Code Domain Error (PCDE)	F	3.1.0	3.2.0
RP-000212	25.142	023	R99	Relationship between RF generation and chip clock	F	3.1.0	3.2.0
RP-000212	25.142	024	R99	Correction on Receiver tests, terminating RX port	F	3.1.0	3.2.0
RP-000212	25.142	025	R99	Revision of Annex C: Global in-channel Tx test	F	3.1.0	3.2.0
RP-000212	25.142	026	R99	Conformance test description for spectrum emission mask	F	3.1.0	3.2.0
RP-000212	25.142	027	R99	Test connection definition	F	3.1.0	3.2.0
July 2000	25.142			Replace header and correct subclause references in clause 5.		3.2.0	3.2.1

History

Document history		
V3.0.0	January 2000	Publication
V3.1.0	March 2000	Publication
V3.2.0	June 2000	Publication