

# ETSI TS 125 142 V9.5.0 (2012-07)



## **Universal Mobile Telecommunications System (UMTS); Base Station (BS) conformance testing (TDD) (3GPP TS 25.142 version 9.5.0 Release 9)**



---

**Reference**

RTS/TSGR-0425142v950

---

**Keywords**

UMTS

**ETSI**

---

650 Route des Lucioles  
F-06921 Sophia Antipolis Cedex - FRANCE

Tel.: +33 4 92 94 42 00 Fax: +33 4 93 65 47 16

Siret N° 348 623 562 00017 - NAF 742 C  
Association à but non lucratif enregistrée à la  
Sous-Préfecture de Grasse (06) N° 7803/88

---

**Important notice**

Individual copies of the present document can be downloaded from:

<http://www.etsi.org>

The present document may be made available in more than one electronic version or in print. In any case of existing or perceived difference in contents between such versions, the reference version is the Portable Document Format (PDF). In case of dispute, the reference shall be the printing on ETSI printers of the PDF version kept on a specific network drive within ETSI Secretariat.

Users of the present document should be aware that the document may be subject to revision or change of status. Information on the current status of this and other ETSI documents is available at

<http://portal.etsi.org/tb/status/status.asp>

If you find errors in the present document, please send your comment to one of the following services:

[http://portal.etsi.org/chaicor/ETSI\\_support.asp](http://portal.etsi.org/chaicor/ETSI_support.asp)

---

**Copyright Notification**

No part may be reproduced except as authorized by written permission.  
The copyright and the foregoing restriction extend to reproduction in all media.

© European Telecommunications Standards Institute 2012.  
All rights reserved.

**DECT™**, **PLUGTESTS™**, **UMTS™** and the ETSI logo are Trade Marks of ETSI registered for the benefit of its Members.  
**3GPP™** and **LTE™** are Trade Marks of ETSI registered for the benefit of its Members and  
of the 3GPP Organizational Partners.  
**GSM®** and the GSM logo are Trade Marks registered and owned by the GSM Association.

---

## Intellectual Property Rights

IPRs essential or potentially essential to the present document may have been declared to ETSI. The information pertaining to these essential IPRs, if any, is publicly available for **ETSI members and non-members**, and can be found in ETSI SR 000 314: *"Intellectual Property Rights (IPRs); Essential, or potentially Essential, IPRs notified to ETSI in respect of ETSI standards"*, which is available from the ETSI Secretariat. Latest updates are available on the ETSI Web server (<http://ipr.etsi.org>).

Pursuant to the ETSI IPR Policy, no investigation, including IPR searches, has been carried out by ETSI. No guarantee can be given as to the existence of other IPRs not referenced in ETSI SR 000 314 (or the updates on the ETSI Web server) which are, or may be, or may become, essential to the present document.

---

## Foreword

This Technical Specification (TS) has been produced by ETSI 3rd Generation Partnership Project (3GPP).

The present document may refer to technical specifications or reports using their 3GPP identities, UMTS identities or GSM identities. These should be interpreted as being references to the corresponding ETSI deliverables.

The cross reference between GSM, UMTS, 3GPP and ETSI identities can be found under <http://webapp.etsi.org/key/queryform.asp>.

# Contents

|  |    |
|--|----|
| Intellectual Property Rights .....                                     | 2  |
| Foreword.....  | 2  |
| Foreword.....  | 17 |
| 1 Scope .....  | 18 |
| 2 References .....   | 18 |
| 3 Definitions, symbols, and abbreviations .....                        | 19 |
| 3.1 Definitions .....  | 19 |
| 3.2 Symbols.....   | 20 |
| 3.3 Abbreviations .....  | 20 |
| 4 Frequency bands and channel arrangement.....                         | 21 |
| 4.1 General .....  | 21 |
| 4.2 Frequency bands.....   | 21 |
| 4.3 TX-RX frequency separation .....                                   | 21 |
| 4.3.1 3,84 Mcps TDD option .....                                       | 21 |
| 4.3.2 1,28 Mcps TDD option .....                                       | 21 |
| 4.3.3 7,68 Mcps TDD option .....                                       | 21 |
| 4.4 Channel arrangement.....   | 21 |
| 4.4.1 Channel spacing.....   | 21 |
| 4.4.1.1 3,84 Mcps TDD option .....                                     | 21 |
| 4.4.1.2 1,28 Mcps TDD option .....                                     | 22 |
| 4.4.1.3 7,68 Mcps TDD option .....                                     | 22 |
| 4.4.2 Channel raster .....   | 22 |
| 4.4.2.1 3,84 Mcps TDD Option.....                                      | 22 |
| 4.4.3 Channel number .....   | 22 |
| 5 General test conditions and declarations .....                       | 22 |
| 5.1 Base station classes .....   | 22 |
| 5.1.1 Applicability of requirements and BS class definition .....      | 22 |
| 5.1.2 Manufacturer"s declaration.....                                  | 23 |
| 5.2 Output power.....  | 23 |
| 5.3 Specified frequency range .....                                    | 23 |
| 5.4 Relationship between RF generation and chip clock.....             | 23 |
| 5.5 Spectrum emission mask .....                                       | 24 |
| 5.6 Adjacent Channel Leakage power Ratio (ACLR).....                   | 24 |
| 5.7 Tx spurious emissions .....  | 24 |
| 5.7.1 Category of spurious emissions limit.....                        | 24 |
| 5.7.2 Co-existence with GSM.....                                       | 24 |
| 5.7.3 Co-existence with DCS 1800.....                                  | 24 |
| 5.7.4 Co-existence with UTRA FDD.....                                  | 25 |
| 5.7.5 Co-existence with unsynchronised UTRA TDD and/or E-UTRA TDD..... | 25 |
| 5.8 Blocking characteristics .....                                     | 25 |
| 5.9 Test environments .....  | 25 |
| 5.9.1 Normal test environment .....                                    | 26 |
| 5.9.2 Extreme test environment .....                                   | 26 |
| 5.9.2.1 Extreme temperature .....                                      | 26 |
| 5.9.3 Vibration.....   | 26 |
| 5.9.4 Power supply .....   | 27 |
| 5.10 Acceptable uncertainty of Test System.....                        | 27 |
| 5.10.1 Measurement of test environments .....                          | 27 |
| 5.10.2 Measurement of transmitter .....                                | 28 |
| 5.10.3 Measurement of receiver .....                                   | 32 |
| 5.10.4 Measurement of performance requirements .....                   | 33 |
| 5.11 Test Tolerances (informative).....                                | 33 |
| 5.11.1 Transmitter.....  | 34 |

|                 |  |    |
|-----------------|--|----|
| 5.11.2          | Receiver .....   | 36 |
| 5.11.3          | Performance requirements .....                                     | 36 |
| 5.12            | Interpretation of measurement results .....                        | 36 |
| 5.13            | Selection of configurations for testing.....                       | 36 |
| 5.14            | BS Configurations .....  | 37 |
| 5.14.1          | Receiver diversity .....   | 37 |
| 5.14.2          | Duplexers .....  | 37 |
| 5.14.3          | Power supply options.....  | 37 |
| 5.14.4          | Ancillary RF amplifiers .....                                      | 37 |
| 5.14.5          | BS using antenna arrays.....                                       | 38 |
| 5.14.5.1        | Receiver tests .....   | 38 |
| 5.14.5.2        | Transmitter tests.....   | 38 |
| 5.14.6          | MIMO transmission.....   | 39 |
| 5.15            | Overview of the conformance test requirements .....                | 39 |
| 5.16            | Format and interpretation of tests.....                            | 41 |
| 5.17            | Regional requirements.....   | 41 |
| 5.18            | Definition of Additive White Gaussian Noise (AWGN) Interferer..... | 42 |
| 5.19            | Applicability of requirements.....                                 | 43 |
| 6               | Transmitter characteristics .....                                  | 43 |
| 6.1             | General .....  | 43 |
| IMB Test Models | .....  | 43 |
| 6.1.1.1         | IMB Test Model 1.....  | 44 |
| 6.1.1.2         | IMB Test Model 2.....  | 44 |
| 6.2             | Maximum output power .....   | 44 |
| 6.2.1           | Definition and applicability .....                                 | 44 |
| 6.2.2           | Minimum Requirements .....   | 44 |
| 6.2.3           | Test purpose.....  | 45 |
| 6.2.4           | Method of test.....  | 45 |
| 6.2.4.1         | Initial conditions .....   | 45 |
| 6.2.4.1.0       | General test conditions .....                                      | 45 |
| 6.2.4.1.1       | 3,84 Mcps TDD option.....  | 45 |
| 6.2.4.1.2       | 1,28 Mcps TDD option.....  | 45 |
| 6.2.4.1.3       | 7,68 Mcps TDD option.....  | 46 |
| 6.2.4.2         | Procedure .....  | 46 |
| 6.2.4.2.1       | 3,84 Mcps TDD option.....  | 46 |
| 6.2.4.2.2       | 1,28 Mcps TDD option.....  | 46 |
| 6.2.4.2.3       | 7,68 Mcps TDD option.....  | 46 |
| 6.2.5           | Test Requirements .....  | 47 |
| 6.3             | Frequency stability .....  | 47 |
| 6.3.1           | Definition and applicability .....                                 | 47 |
| 6.3.2           | Minimum Requirements .....   | 47 |
| 6.3.3           | Test purpose.....  | 47 |
| 6.3.4           | Method of test.....  | 47 |
| 6.3.4.1         | Initial conditions .....   | 47 |
| 6.3.4.1.0       | General test conditions .....                                      | 47 |
| 6.3.4.1.1       | 3,84 Mcps TDD option.....  | 48 |
| 6.3.4.1.2       | 1,28 Mcps TDD option.....  | 48 |
| 6.3.4.1.3       | 7,68 Mcps TDD option.....  | 48 |
| 6.3.4.2         | Procedure .....  | 49 |
| 6.3.5           | Test Requirements .....  | 49 |
| 6.4             | Output power dynamics.....   | 49 |
| 6.4.1           | Inner loop power control.....                                      | 49 |
| 6.4.2           | Power control steps.....   | 49 |
| 6.4.2.1         | Definition and applicability.....                                  | 49 |
| 6.4.2.2         | Minimum Requirements.....  | 50 |
| 6.4.2.3         | Test purpose .....   | 50 |
| 6.4.2.4         | Method of test .....   | 50 |
| 6.4.2.4.1       | Initial conditions .....   | 50 |
| 6.4.2.4.1.0     | General test conditions.....                                       | 50 |
| 6.4.2.4.1.1     | 3,84 Mcps TDD option .....   | 50 |
| 6.4.2.4.1.2     | 1,28 Mcps TDD option .....   | 51 |

|             |  |    |
|-------------|--|----|
| 6.4.2.4.1.3 | 7,68 Mcps TDD option .....                         | 51 |
| 6.4.2.4.2   | Procedure .....                                    | 52 |
| 6.4.2.4.2.1 | 3,84 Mcps TDD option .....                         | 52 |
| 6.4.2.4.2.2 | 1,28 Mcps TDD option .....                         | 52 |
| 6.4.2.4.2.3 | 7,68 Mcps TDD option .....                         | 52 |
| 6.4.2.5     | Test Requirements .....                            | 53 |
| 6.4.2.5.1   | 3,84 Mcps TDD option .....                         | 53 |
| 6.4.2.5.2   | 1,28 Mcps TDD option .....                         | 53 |
| 6.4.2.5.3   | 7,68 Mcps TDD option .....                         | 53 |
| 6.4.3       | Power control dynamic range .....                  | 54 |
| 6.4.3.1     | Definition and applicability .....                 | 54 |
| 6.4.3.2     | Minimum Requirements .....                         | 54 |
| 6.4.3.3     | Test purpose .....                                 | 54 |
| 6.4.3.4     | Method of test .....                               | 54 |
| 6.4.3.4.1   | Initial conditions .....                           | 54 |
| 6.4.3.4.1.0 | General test conditions .....                      | 54 |
| 6.4.3.4.1.1 | 3,84 Mcps TDD option .....                         | 54 |
| 6.4.3.4.1.2 | 1,28 Mcps TDD option .....                         | 55 |
| 6.4.3.4.1.3 | 7,68 Mcps TDD option .....                         | 55 |
| 6.4.3.4.2   | Procedure .....                                    | 56 |
| 6.4.3.4.2.1 | 3,84 Mcps TDD option .....                         | 56 |
| 6.4.3.4.2.2 | 1,28 Mcps TDD option .....                         | 56 |
| 6.4.3.4.2.3 | 7,68 Mcps TDD option .....                         | 57 |
| 6.4.3.5     | Test Requirements .....                            | 57 |
| 6.4.4       | Minimum output power .....                         | 57 |
| 6.4.4.1     | Definition and applicability .....                 | 57 |
| 6.4.4.2     | Minimum Requirements .....                         | 57 |
| 6.4.4.3     | Test purpose .....                                 | 57 |
| 6.4.4.4     | Method of test .....                               | 57 |
| 6.4.4.4.1   | Initial conditions .....                           | 57 |
| 6.4.4.4.1.0 | General test conditions .....                      | 57 |
| 6.4.4.4.1.1 | 3,84 Mcps TDD option .....                         | 58 |
| 6.4.4.4.1.2 | 1,28 Mcps TDD option .....                         | 58 |
| 6.4.4.4.1.3 | 7,68 Mcps TDD option .....                         | 58 |
| 6.4.4.4.2   | Procedure .....                                    | 59 |
| 6.4.4.4.2.1 | 3,84 Mcps TDD option .....                         | 59 |
| 6.4.4.4.2.2 | 1,28 Mcps TDD option .....                         | 59 |
| 6.4.4.4.2.3 | 7,68 Mcps TDD option .....                         | 59 |
| 6.4.4.5     | Test Requirements .....                            | 60 |
| 6.4.5       | Primary CCPCH power .....                          | 60 |
| 6.4.5.1     | Definition and applicability .....                 | 60 |
| 6.4.5.2     | Minimum Requirements .....                         | 60 |
| 6.4.5.3     | Test purpose .....                                 | 60 |
| 6.4.5.4     | Method of test .....                               | 61 |
| 6.4.5.4.1   | Initial conditions .....                           | 61 |
| 6.4.5.4.1.0 | General test conditions .....                      | 61 |
| 6.4.5.4.1.1 | 3,84 Mcps TDD option .....                         | 61 |
| 6.4.5.4.1.2 | 1,28 Mcps TDD option .....                         | 61 |
| 6.4.5.4.1.3 | 7,68 Mcps TDD option .....                         | 61 |
| 6.4.5.4.2   | Procedure .....                                    | 62 |
| 6.4.5.4.2.1 | 3,84 Mcps TDD option .....                         | 62 |
| 6.4.5.4.2.2 | 1,28 Mcps TDD option .....                         | 62 |
| 6.4.5.4.2.3 | 7,68 Mcps TDD option .....                         | 62 |
| 6.4.5.5     | Test Requirements .....                            | 62 |
| 6.4.6       | Differential accuracy of Primary CCPCH power ..... | 63 |
| 6.4.6.1     | Definition and applicability .....                 | 63 |
| 6.4.6.2     | Minimum Requirements .....                         | 63 |
| 6.4.6.3     | Test purpose .....                                 | 63 |
| 6.4.6.4     | Method of test .....                               | 63 |
| 6.4.6.4.1   | Initial conditions .....                           | 63 |
| 6.4.6.4.1.0 | General test conditions .....                      | 63 |
| 6.4.6.4.1.1 | 3,84 Mcps TDD option .....                         | 63 |

|             |                                   |    |
|-------------|-----------------------------------|----|
| 6.4.6.4.1.2 | 1,28 Mcps TDD option .....        | 64 |
| 6.4.6.4.1.3 | 7,68 Mcps TDD option .....        | 64 |
| 6.4.6.4.2   | Procedure.....                    | 64 |
| 6.4.6.4.2.1 | 3,84 Mcps TDD option .....        | 64 |
| 6.4.6.4.2.2 | 1,28 Mcps TDD option .....        | 64 |
| 6.4.6.4.2.3 | 7,68 Mcps TDD option .....        | 65 |
| 6.4.6.5     | Test Requirements.....            | 65 |
| 6.5         | Transmit ON/OFF power .....       | 65 |
| 6.5.1       | Transmit OFF power.....           | 65 |
| 6.5.1.1     | Definition and applicability..... | 65 |
| 6.5.1.2     | Minimum Requirements.....         | 65 |
| 6.5.1.2.1   | 3,84 Mcps TDD option.....         | 65 |
| 6.5.1.2.2   | 1,28 Mcps TDD option.....         | 65 |
| 6.5.1.2.3   | 7,68 Mcps TDD option.....         | 65 |
| 6.5.1.3     | Test purpose .....                | 65 |
| 6.5.1.4     | Method of test .....              | 65 |
| 6.5.1.4.1   | Initial conditions.....           | 65 |
| 6.5.1.4.2   | Procedure.....                    | 66 |
| 6.5.1.5     | Test Requirements.....            | 66 |
| 6.5.2       | Transmit ON/OFF time mask .....   | 66 |
| 6.5.2.1     | Definition and applicability..... | 66 |
| 6.5.2.2     | Minimum Requirements.....         | 66 |
| 6.5.2.2.1   | 3,84 Mcps TDD option.....         | 66 |
| 6.5.2.2.2   | 1,28 Mcps TDD option.....         | 66 |
| 6.5.2.2.3   | 7,68 Mcps TDD option.....         | 67 |
| 6.5.2.3     | Test purpose .....                | 67 |
| 6.5.2.4     | Method of test .....              | 67 |
| 6.5.2.4.1   | Initial conditions.....           | 67 |
| 6.5.2.4.1.0 | General test conditions.....      | 67 |
| 6.5.2.4.1.1 | 3,84 Mcps TDD option .....        | 68 |
| 6.5.2.4.1.2 | 1,28 Mcps TDD option .....        | 68 |
| 6.5.2.4.1.3 | 7,68 Mcps TDD option .....        | 68 |
| 6.5.2.4.2   | Procedure.....                    | 69 |
| 6.5.2.4.2.1 | 3,84 Mcps TDD option .....        | 69 |
| 6.5.2.4.2.2 | 1,28 Mcps TDD option .....        | 69 |
| 6.5.2.4.2.3 | 7,68 Mcps TDD option .....        | 69 |
| 6.5.2.5     | Test Requirements.....            | 69 |
| 6.5.2.5.1   | 3,84 Mcps TDD option.....         | 69 |
| 6.5.2.5.2   | 1,28 Mcps TDD option.....         | 69 |
| 6.5.2.5.3   | 7,68 Mcps TDD option.....         | 69 |
| 6.6         | Output RF spectrum emissions..... | 69 |
| 6.6.1       | Occupied bandwidth .....          | 69 |
| 6.6.1.1     | Definition and applicability..... | 69 |
| 6.6.1.2     | Minimum Requirements.....         | 69 |
| 6.6.1.2.1   | 3,84 Mcps TDD option.....         | 69 |
| 6.6.1.2.2   | 1,28 Mcps TDD option.....         | 70 |
| 6.6.1.2.3   | 7,68 Mcps TDD option.....         | 70 |
| 6.6.1.3     | Test purpose .....                | 70 |
| 6.6.1.4     | Method of test .....              | 70 |
| 6.6.1.4.1   | Initial conditions.....           | 70 |
| 6.6.1.4.1.0 | General test conditions.....      | 70 |
| 6.6.1.4.1.1 | 3,84 Mcps TDD option .....        | 70 |
| 6.6.1.4.1.2 | 1,28 Mcps TDD option .....        | 70 |
| 6.6.1.4.1.3 | 7,68 Mcps TDD option .....        | 71 |
| 6.6.1.4.2   | Procedure.....                    | 71 |
| 6.6.1.4.2.1 | 3,84 Mcps TDD option.....         | 71 |
| 6.6.1.4.2.2 | 1,28 Mcps TDD option .....        | 71 |
| 6.6.1.4.2.3 | 7,68 Mcps TDD option.....         | 72 |
| 6.6.1.5     | Test Requirements.....            | 72 |
| 6.6.1.5.1   | 3,84 Mcps TDD option.....         | 72 |
| 6.6.1.5.2   | 1,28 Mcps TDD option.....         | 72 |
| 6.6.1.5.3   | 7,68 Mcps TDD option.....         | 72 |

|                 |  |    |
|-----------------|--|----|
| 6.6.2           | Out of band emission .....   | 73 |
| 6.6.2.1         | Spectrum emission mask .....   | 73 |
| 6.6.2.1.1       | Definition and applicability .....   | 73 |
| 6.6.2.1.1.1     | 3,84 Mcps TDD option .....   | 73 |
| 6.6.2.1.1.2     | 1,28 Mcps TDD option .....   | 73 |
| 6.6.2.1.1.3     | 7,68 Mcps TDD option .....   | 73 |
| 6.6.2.1.2       | Minimum Requirements .....   | 73 |
| 6.6.2.1.2.1     | 3,84 Mcps TDD option .....   | 73 |
| 6.6.2.1.2.2     | 1,28 Mcps TDD option .....   | 74 |
| 6.6.2.1.2.3     | 7,68 Mcps TDD option .....   | 75 |
| 6.6.2.1.3       | Test purpose .....   | 76 |
| 6.6.2.1.4       | Method of test .....   | 77 |
| 6.6.2.1.4.1     | Initial conditions .....   | 77 |
| 6.6.2.1.4.1.0   | General test conditions .....  | 77 |
| 6.6.2.1.4.1.1   | 3,84 Mcps TDD option - General test set up .....   | 77 |
| 6.6.2.1.4.1.2   | 1,28 Mcps TDD option - General test set up .....   | 77 |
| 6.6.2.1.4.1.3   | 1,28 Mcps TDD option - Special test set up for 16QAM capable BS .....  | 77 |
| 6.6.2.1.4.1.4   | 3,84 Mcps TDD option - Special test set up for 16QAM capable BS .....  | 78 |
| 6.6.2.1.4.1.5   | 7,68 Mcps TDD option - General test set up .....   | 78 |
| 6.6.2.1.4.1.6   | 7,68 Mcps TDD option - Special test set up for 16QAM capable BS .....  | 79 |
| 6.6.2.1.4.2     | Procedure .....  | 79 |
| 6.6.2.1.4.2.1   | 3,84 Mcps TDD option .....   | 79 |
| 6.6.2.1.4.2.2   | 1,28 Mcps TDD option .....   | 79 |
| 6.6.2.1.4.2.3   | 1,28 Mcps TDD option - 16QAM capable BS .....  | 80 |
| 6.6.2.1.4.2.4   | 3,84 Mcps TDD option - 16QAM capable BS .....  | 80 |
| 6.6.2.1.4.2.5   | 7,68 Mcps TDD option .....   | 80 |
| 6.6.2.1.4.2.6   | 7,68 Mcps TDD option - 16QAM capable BS .....  | 80 |
| 6.6.2.1.5       | Test Requirements .....  | 80 |
| 6.6.2.1.5.1     | 3,84 Mcps TDD option .....   | 80 |
| 6.6.2.1.5.2     | 1,28 Mcps TDD option .....   | 81 |
| 6.6.2.1.5.3     | 1,28 Mcps TDD option - 16QAM capable BS .....  | 82 |
| 6.6.2.1.5.4     | 3,84 Mcps TDD option - 16QAM capable BS .....  | 82 |
| 6.6.2.1.5.5     | 7,68 Mcps TDD option .....   | 82 |
| 6.6.2.1.5.6     | 7,68 Mcps TDD option - 16QAM capable BS .....  | 83 |
| 6.6.2.2         | Adjacent Channel Leakage power Ratio (ACLR) .....  | 83 |
| 6.6.2.2.1       | Definition and applicability .....   | 83 |
| 6.6.2.2.2       | Minimum Requirements .....   | 84 |
| 6.6.2.2.2.1     | Minimum requirement .....  | 84 |
| 6.6.2.2.2.1.1   | 3,84 Mcps TDD option .....   | 84 |
| 6.6.2.2.2.1.2   | 1,28 Mcps TDD option .....   | 84 |
| 6.6.2.2.2.1.3   | 7,68 Mcps TDD option .....   | 84 |
| 6.6.2.2.2.2     | Additional requirement for operation in the same geographic area with FDD or unsynchronised TDD on adjacent channels ..... | 85 |
| 6.6.2.2.2.2.1   | 3,84 Mcps TDD option .....   | 85 |
| 6.6.2.2.2.2.1.1 | Additional requirement for operation in the same geographic area with unsynchronised TDD on adjacent channels .....        | 85 |
| 6.6.2.2.2.2.1.2 | Additional requirement for operation in the same geographic area with FDD on adjacent channels .....                       | 85 |
| 6.6.2.2.2.2.2   | 1,28 Mcps TDD option .....   | 86 |
| 6.6.2.2.2.2.2.1 | Additional requirement for operation in the same geographic area with unsynchronised TDD on adjacent channels .....        | 86 |
| 6.6.2.2.2.2.2.2 | Additional requirement for operation in the same geographic area with FDD on adjacent channels .....                       | 86 |
| 6.6.2.2.2.2.3   | 7,68 Mcps TDD option .....   | 87 |
| 6.6.2.2.2.2.3.1 | Additional requirement for operation in the same geographic area with unsynchronised TDD on adjacent channels .....        | 87 |
| 6.6.2.2.2.2.3.2 | Additional requirement for operation in the same geographic area with FDD on adjacent channels .....                       | 87 |
| 6.6.2.2.2.3     | Additional requirement in case of co-siting with unsynchronised TDD BS or FDD BS operating on an adjacent channel .....    | 88 |
| 6.6.2.2.2.3.1   | 3,84 Mcps TDD option .....   | 88 |



|               |   |     |
|---------------|---|-----|
| 6.6.2.2.3.1.1 | Additional requirement in case of co-siting with unsynchronised TDD BS operating on an adjacent channel ..... | 88  |
| 6.6.2.2.3.1.2 | Additional requirement in case of co-siting with FDD BS operating on adjacent channels.....                   | 89  |
| 6.6.2.2.3.2   | 1,28 Mcps TDD option.....   | 89  |
| 6.6.2.2.3.2.1 | Additional requirement in case of co-siting with unsynchronised TDD BS operating on an adjacent channel ..... | 89  |
| 6.6.2.2.3.2.2 | Additional requirement in case of co-siting with FDD BS operating on an adjacent channel .....                | 90  |
| 6.6.2.2.3.3   | 7,68 Mcps TDD option.....   | 90  |
| 6.6.2.2.3.3.1 | Additional requirement in case of co-siting with unsynchronised TDD BS operating on an adjacent channel ..... | 90  |
| 6.6.2.2.3.3.2 | Additional requirement in case of co-siting with FDD BS operating on an adjacent channel .....                | 91  |
| 6.6.2.2.3     | Test purpose .....  | 91  |
| 6.6.2.2.4     | Method of test.....   | 91  |
| 6.6.2.2.4.1   | Initial conditions .....  | 91  |
| 6.6.2.2.4.1.0 | General test conditions .....   | 91  |
| 6.6.2.2.4.1.1 | 3,84 Mcps TDD option - General test set up .....  | 91  |
| 6.6.2.2.4.1.2 | 1,28 Mcps TDD option - General test set up .....  | 92  |
| 6.6.2.2.4.1.3 | 1,28 Mcps TDD option - Special test set up for 16QAM capable BS .....   | 92  |
| 6.6.2.2.4.1.4 | 3,84 Mcps TDD option - Special test set up for 16QAM capable BS .....   | 92  |
| 6.6.2.2.4.1.5 | 7,68 Mcps TDD option - General test set up .....  | 93  |
| 6.6.2.2.4.1.6 | 7,68 Mcps TDD option - Special test set up for 16QAM capable BS .....   | 93  |
| 6.6.2.2.4.2   | Procedure .....   | 94  |
| 6.6.2.2.4.2.1 | 3,84 Mcps TDD option.....   | 94  |
| 6.6.2.2.4.2.2 | 1,28 Mcps TDD option.....   | 94  |
| 6.6.2.2.4.2.3 | 1,28 Mcps TDD option - 16QAM capable BS .....   | 95  |
| 6.6.2.2.4.2.4 | 3,84 Mcps TDD option - 16QAM capable BS .....   | 95  |
| 6.6.2.2.4.2.5 | 7,68 Mcps TDD option.....   | 95  |
| 6.6.2.2.4.2.6 | 7,68 Mcps TDD option - 16QAM capable BS .....   | 95  |
| 6.6.2.2.5     | Test Requirements .....   | 95  |
| 6.6.2.2.5.1   | 3,84 Mcps TDD option .....  | 96  |
| 6.6.2.2.5.2   | 1,28 Mcps TDD option .....  | 96  |
| 6.6.2.2.5.3   | 1,28 Mcps TDD option - 16QAM capable BS .....   | 98  |
| 6.6.2.2.5.4   | 3,84 Mcps TDD option - 16QAM capable BS .....   | 98  |
| 6.6.2.2.5.5   | 7,68 Mcps TDD option .....  | 98  |
| 6.6.2.2.5.6   | 7,68 Mcps TDD option - 16QAM capable BS .....   | 99  |
| 6.6.3         | Spurious emissions .....  | 99  |
| 6.6.3.1       | Definition and applicability.....   | 99  |
| 6.6.3.2       | Minimum Requirements.....   | 100 |
| 6.6.3.2.1     | Mandatory requirements.....   | 100 |
| 6.6.3.2.1.1   | Spurious emissions (Category A) .....   | 100 |
| 6.6.3.2.1.1.1 | 3,84 Mcps TDD option.....   | 100 |
| 6.6.3.2.1.1.2 | 1,28 Mcps TDD option.....   | 100 |
| 6.6.3.2.1.1.3 | 7,68 Mcps TDD option.....   | 101 |
| 6.6.3.2.1.2   | Spurious emissions (Category B).....  | 101 |
| 6.6.3.2.1.2.1 | 3,84 Mcps TDD option.....   | 101 |
| 6.6.3.2.1.2.2 | 1,28 Mcps TDD option.....   | 102 |
| 6.6.3.2.1.2.3 | 7,68 Mcps TDD option.....   | 102 |
| 6.6.3.2.2     | Co-existence with GSM 900.....  | 103 |
| 6.6.3.2.2.1   | Operation in the same geographic area .....   | 103 |
| 6.6.3.2.2.2   | Co-located base stations.....   | 103 |
| 6.6.3.2.3     | Co-existence with DCS 1800 .....  | 103 |
| 6.6.3.2.3.1   | Operation in the same geographic area .....   | 103 |
| 6.6.3.2.3.2   | Co-located base stations.....   | 104 |
| 6.6.3.2.4     | Co-existence with UTRA FDD .....  | 104 |
| 6.6.3.2.4.1   | Operation in the same geographic area .....   | 104 |
| 6.6.3.2.4.2   | Co-located base stations.....   | 105 |
| 6.6.3.2.5     | Co-existence with unsynchronised UTRA TDD and/or E-UTRA TDD .....   | 106 |
| 6.6.3.2.5.1   | Operation in the same geographic area .....   | 106 |
| 6.6.3.2.5.1.1 | 3,84 Mcps TDD option.....   | 106 |

|               |  |     |
|---------------|--|-----|
| 6.6.3.2.5.1.2 | 1,28 Mcps TDD option.....  | 107 |
| 6.6.3.2.5.1.3 | 7,68 Mcps TDD option.....  | 108 |
| 6.6.3.2.5.2   | Co-located base stations.....  | 109 |
| 6.6.3.2.5.2.1 | 3,84 Mcps TDD option.....  | 109 |
| 6.6.3.2.5.2.2 | 1,28 Mcps TDD option.....  | 110 |
| 6.6.3.2.5.2.3 | 7,68 Mcps TDD option.....  | 111 |
| 6.6.3.2.6     | Co-existence with PHS .....  | 111 |
| 6.6.3.2.6.1   | 3,84 Mcps TDD option .....   | 111 |
| 6.6.3.2.6.2   | (void).....  | 112 |
| 6.6.3.2.6.3   | 7,68 Mcps TDD option .....   | 112 |
| 6.6.3.3       | Test purpose .....   | 112 |
| 6.6.3.3.1     | 3,84 Mcps TDD option.....  | 112 |
| 6.6.3.3.2     | 1,28 Mcps TDD option.....  | 112 |
| 6.6.3.3.3     | 7,68 Mcps TDD option.....  | 112 |
| 6.6.3.4       | Method of test .....   | 112 |
| 6.6.3.4.1     | Initial conditions.....  | 112 |
| 6.6.3.4.1.0   | General test conditions.....   | 113 |
| 6.6.3.4.1.1   | 3,84 Mcps TDD option - General test set up .....                     | 113 |
| 6.6.3.4.1.2   | 1,28 Mcps TDD option - General test set up .....                     | 113 |
| 6.6.3.4.1.3   | 1,28 Mcps TDD option - Special test set up for 16QAM capable BS..... | 113 |
| 6.6.3.4.1.4   | 3,84 Mcps TDD option - Special test set up for 16QAM capable BS..... | 114 |
| 6.6.3.4.1.5   | 7,68 Mcps TDD option - General test set up .....                     | 114 |
| 6.6.3.4.1.6   | 7,68 Mcps TDD option - Special test set up for 16QAM capable BS..... | 115 |
| 6.6.3.4.2     | Procedure.....   | 115 |
| 6.6.3.5       | Test Requirements.....   | 115 |
| 6.7           | Transmit intermodulation .....                                       | 115 |
| 6.7.1         | Definition and applicability .....                                   | 115 |
| 6.7.1.1       | 3,84 Mcps TDD option .....   | 116 |
| 6.7.1.2       | 1,28 Mcps TDD option .....   | 116 |
| 6.7.1.3       | 7,68 Mcps TDD option .....   | 116 |
| 6.7.2         | Minimum Requirements .....   | 116 |
| 6.7.3         | Test purpose.....  | 116 |
| 6.7.4         | Method of test.....  | 116 |
| 6.7.4.1       | Initial conditions .....   | 116 |
| 6.7.4.1.0     | General test conditions .....  | 116 |
| 6.7.4.1.1     | 3,84 Mcps TDD option - General test set up .....                     | 117 |
| 6.7.4.1.2     | 1,28 Mcps TDD option - General test set up .....                     | 117 |
| 6.7.4.1.3     | 1,28 Mcps TDD option - Special test set up for 16QAM capable BS..... | 118 |
| 6.7.4.1.4     | 3,84 Mcps TDD option - Special test set up for 16QAM capable BS..... | 119 |
| 6.7.4.1.5     | 7,68 Mcps TDD option - General test set up .....                     | 120 |
| 6.7.4.1.6     | 7,68 Mcps TDD option - Special test set up for 16QAM capable BS..... | 121 |
| 6.7.4.2       | Procedure .....  | 122 |
| 6.7.5         | Test Requirements .....  | 122 |
| 6.8           | Transmit Modulation.....   | 122 |
| 6.8.1         | Modulation accuracy.....   | 122 |
| 6.8.1.1       | Definition and applicability.....                                    | 122 |
| 6.8.1.2       | Minimum Requirements.....  | 122 |
| 6.8.1.3       | Test purpose .....   | 123 |
| 6.8.1.4       | Method of test .....   | 123 |
| 6.8.1.4.1     | Initial conditions.....  | 123 |
| 6.8.1.4.1.0   | General test conditions.....   | 123 |
| 6.8.1.4.1.1   | 3,84 Mcps TDD option - General test setup .....                      | 123 |
| 6.8.1.4.1.2   | 1,28 Mcps TDD option - General test set up .....                     | 123 |
| 6.8.1.4.1.3   | 1,28 Mcps TDD option - Special test set up for 16QAM capable BS..... | 124 |
| 6.8.1.4.1.4   | 3,84 Mcps TDD option - Special test set up for 16QAM capable BS..... | 124 |
| 6.8.1.4.1.5   | 7,68 Mcps TDD option - General test setup .....                      | 124 |
| 6.8.1.4.1.6   | 7,68 Mcps TDD option - Special test set up for 16QAM capable BS..... | 125 |
| 6.8.1.4.2     | Procedure.....   | 125 |
| 6.8.1.4.2.1   | 3,84 Mcps TDD option - General procedure .....                       | 125 |
| 6.8.1.4.2.2   | 1,28 Mcps TDD option - General procedure .....                       | 126 |
| 6.8.1.4.2.3   | 1,28 Mcps TDD option - Special procedure for 16QAM capable BS.....   | 126 |
| 6.8.1.4.2.4   | 3,84 Mcps TDD option - Special test set up for 16QAM capable BS..... | 127 |

|             |  |     |
|-------------|--|-----|
| 6.8.1.4.2.5 | 7,68 Mcps TDD option - General procedure .....                       | 127 |
| 6.8.1.4.2.6 | 7,68 Mcps TDD option - Special test set up for 16QAM capable BS..... | 127 |
| 6.8.1.5     | Test Requirements.....   | 128 |
| 6.8.2       | Peak code domain error .....   | 128 |
| 6.8.2.1     | Definition and applicability.....                                    | 128 |
| 6.8.2.2     | Minimum Requirements.....  | 128 |
| 6.8.2.3     | Test purpose .....   | 128 |
| 6.8.2.4     | Method of test .....   | 128 |
| 6.8.2.4.1   | Initial conditions .....   | 128 |
| 6.8.2.4.1.0 | General test conditions.....   | 129 |
| 6.8.2.4.1.1 | 3,84 Mcps TDD option - General test set up .....                     | 129 |
| 6.8.2.4.1.2 | 1,28 Mcps TDD option- General test set up .....                      | 129 |
| 6.8.2.4.1.3 | 1,28 Mcps TDD option - Special test set up for 16QAM capable BS..... | 129 |
| 6.8.2.4.1.4 | 3,84 Mcps TDD option - Special test set up for 16QAM capable BS..... | 130 |
| 6.8.2.4.1.5 | 7,68 Mcps TDD option - General test set up .....                     | 130 |
| 6.8.2.4.1.6 | 7,68 Mcps TDD option - Special test set up for 16QAM capable BS..... | 131 |
| 6.8.2.4.2   | Procedure.....   | 131 |
| 6.8.2.5     | Test Requirements.....   | 131 |
| 6.8.3       | Relative Code Domain Error .....                                     | 131 |
| 6.8.3.1     | Definition and applicability.....                                    | 131 |
| 6.8.3.2     | Minimum requirement .....  | 131 |
| 6.8.3.3     | Test Purpose.....  | 131 |
| 6.8.3.4     | Method of test .....   | 132 |
| 6.8.3.4.1   | Initial conditions .....   | 132 |
| 6.8.3.4.1.0 | General test conditions.....   | 132 |
| 6.8.3.4.1.1 | 1,28 Mcps TDD option- General test set up .....                      | 132 |
| 6.8.3.4.1.2 | 1,28 Mcps TDD option - Special test set up for 64QAM capable BS..... | 132 |
| 6.8.3.4.2   | Procedure.....   | 132 |
| 6.8.3.5     | Test Requirements.....   | 133 |
| 6.8.4       | Time alignment error in MIMO transmission.....                       | 133 |
| 6.8.4.1     | Definition and applicability.....                                    | 133 |
| 6.8.4.2     | Minimum requirement .....  | 133 |
| 6.8.4.3     | Test Purpose.....  | 133 |
| 6.8.4.4     | Method of test .....   | 133 |
| 6.8.4.4.1   | Initial conditions.....  | 133 |
| 6.8.4.4.1.0 | General test conditions.....   | 133 |
| 6.8.4.4.1.1 | 1,28 Mcps TDD option- General test set up .....                      | 133 |
| 6.8.4.4.2   | Procedure.....   | 134 |
| 6.8.4.4.2.1 | 1,28 Mcps TDD option .....   | 134 |
| 6.8.4.5     | Test Requirements.....   | 134 |
| 6.8.4.5.1   | 1,28 Mcps TDD option.....  | 134 |
| 7           | Receiver characteristics.....  | 134 |
| 7.1         | General .....  | 134 |
| 7.2         | Reference sensitivity level.....                                     | 135 |
| 7.2.1       | Definition and applicability .....                                   | 135 |
| 7.2.2       | Minimum Requirements .....   | 135 |
| 7.2.2.1     | 3,84 Mcps TDD option .....   | 135 |
| 7.2.2.2     | 1,28 Mcps option.....  | 135 |
| 7.2.2.3     | 7,68 Mcps TDD option .....   | 136 |
| 7.2.3       | Test purpose.....  | 136 |
| 7.2.4       | Method of test .....   | 136 |
| 7.2.4.1     | Initial conditions .....   | 136 |
| 7.2.4.1.0   | General test requirements .....                                      | 136 |
| 7.2.4.1.1   | 3,84 Mcps TDD option.....  | 136 |
| 7.2.4.1.2   | 1,28 Mcps TDD option.....  | 136 |
| 7.2.4.1.3   | 7,68 Mcps TDD option.....  | 137 |
| 7.2.4.2     | Procedure .....  | 137 |
| 7.2.5       | Test Requirements .....  | 137 |
| 7.2.5.1     | 3,84 Mcps TDD option .....   | 137 |
| 7.2.5.2     | 1,28 Mcps TDD option .....   | 137 |
| 7.2.5.3     | 7,68 Mcps TDD option .....   | 137 |

|           |   |     |
|-----------|---|-----|
| 7.3       | Dynamic range .....                               | 138 |
| 7.3.1     | Definition and applicability .....                | 138 |
| 7.3.2     | Minimum Requirements .....                        | 138 |
| 7.3.2.1   | 3,84 Mcps TDD option .....                        | 138 |
| 7.3.2.2   | 1,28 Mcps TDD option .....                        | 138 |
| 7.3.2.3   | 7,68 Mcps TDD option .....                        | 138 |
| 7.3.3     | Test purpose.....                                 | 139 |
| 7.3.4     | Method of test .....                              | 139 |
| 7.3.4.1   | Initial conditions .....                          | 139 |
| 7.3.4.1.0 | General test conditions .....                     | 139 |
| 7.3.4.1.1 | 3,84 Mcps TDD option.....                         | 139 |
| 7.3.4.1.2 | 1,28 Mcps TDD option.....                         | 139 |
| 7.3.4.1.3 | 7,68 Mcps TDD option.....                         | 140 |
| 7.3.4.2   | Procedure .....                                   | 140 |
| 7.3.5     | Test Requirements .....                           | 140 |
| 7.3.5.1   | 3,84 Mcps TDD option .....                        | 140 |
| 7.3.5.2   | 1,28 Mcps TDD option .....                        | 140 |
| 7.3.5.3   | 7,68 Mcps TDD option .....                        | 141 |
| 7.4       | Adjacent Channel Selectivity (ACS).....           | 141 |
| 7.4.1     | Definition and applicability .....                | 141 |
| 7.4.2     | Minimum Requirements .....                        | 141 |
| 7.4.2.1   | 3,84 Mcps TDD option .....                        | 141 |
| 7.4.2.2   | 1,28 Mcps TDD option .....                        | 141 |
| 7.4.2.3   | 7,68 Mcps TDD option .....                        | 142 |
| 7.4.3     | Test purpose.....                                 | 142 |
| 7.4.4     | Method of test .....                              | 142 |
| 7.4.4.1   | Initial conditions .....                          | 142 |
| 7.4.4.1.0 | General test conditions .....                     | 142 |
| 7.4.4.1.1 | 3,84 Mcps TDD option.....                         | 142 |
| 7.4.4.1.2 | 1,28 Mcps TDD option.....                         | 143 |
| 7.4.4.1.3 | 7,68 Mcps TDD option.....                         | 143 |
| 7.4.4.2   | Procedure .....                                   | 143 |
| 7.4.4.2.1 | 3,84 Mcps TDD option.....                         | 143 |
| 7.4.4.2.2 | 1,28 Mcps TDD option.....                         | 143 |
| 7.4.4.2.3 | 7,68 Mcps TDD option.....                         | 144 |
| 7.4.5     | Test Requirements .....                           | 144 |
| 7.5       | Blocking characteristics .....                    | 144 |
| 7.5.1     | Definition and applicability .....                | 144 |
| 7.5.1.1   | 3,84 Mcps TDD option .....                        | 144 |
| 7.5.1.2   | 1,28 Mcps TDD option .....                        | 144 |
| 7.5.1.3   | 7,68 Mcps TDD option .....                        | 145 |
| 7.5.2     | Minimum Requirements .....                        | 145 |
| 7.5.2.1   | 3,84 Mcps TDD option .....                        | 145 |
| 7.5.2.1.1 | General requirements.....                         | 145 |
| 7.5.2.1.2 | Co-location with GSM900 and/or DCS 1800.....      | 147 |
| 7.5.2.1.3 | Co-location with UTRA-FDD and/or E-UTRA FDD ..... | 147 |
| 7.5.2.2   | 1,28 Mcps TDD option .....                        | 148 |
| 7.5.2.2.1 | General requirements.....                         | 148 |
| 7.5.2.2.2 | Co-location with GSM900 and/or DCS 1800.....      | 151 |
| 7.5.2.2.3 | Co-location with UTRA-FDD and/or E-UTRA FDD ..... | 151 |
| 7.5.2.3   | 7,68 Mcps TDD option .....                        | 152 |
| 7.5.2.3.1 | General requirements.....                         | 152 |
| 7.5.2.3.2 | Co-location with GSM900 and/or DCS 1800.....      | 154 |
| 7.5.2.3.3 | Co-location with UTRA-FDD and/or E-UTRA FDD ..... | 154 |
| 7.5.3     | Test purpose.....                                 | 155 |
| 7.5.3.1   | 3,84 Mcps TDD option .....                        | 155 |
| 7.5.3.2   | 1,28 Mcps TDD option .....                        | 155 |
| 7.5.3.3   | 7,68 Mcps TDD option .....                        | 155 |
| 7.5.4     | Method of test .....                              | 155 |
| 7.5.4.1   | Initial conditions .....                          | 155 |
| 7.5.4.2   | Procedure .....                                   | 155 |
| 7.5.4.2.1 | 3,84 Mcps TDD option.....                         | 155 |

|             |   |     |
|-------------|---|-----|
| 7.5.4.2.2   | 1,28 Mcps TDD option.....                           | 156 |
| 7.5.4.2.3   | 7,68 Mcps TDD option.....                           | 156 |
| 7.5.5       | Test Requirements .....                             | 156 |
| 7.6         | Intermodulation characteristics .....               | 157 |
| 7.6.1       | Definition and applicability .....                  | 157 |
| 7.6.2       | Minimum Requirements .....                          | 157 |
| 7.6.2.1     | 3,84 Mcps TDD option .....                          | 157 |
| 7.6.2.2     | 1,28 Mcps TDD option .....                          | 157 |
| 7.6.2.3     | 7,68 Mcps TDD option .....                          | 157 |
| 7.6.3       | Test purpose.....                                   | 158 |
| 7.6.4       | Method of test .....                                | 158 |
| 7.6.4.1     | Initial conditions .....                            | 158 |
| 7.6.4.1.1   | 3,84 Mcps TDD option.....                           | 158 |
| 7.6.4.1.2   | 1,28 Mcps TDD option.....                           | 158 |
| 7.6.4.1.3   | 7,68 Mcps TDD option.....                           | 159 |
| 7.6.4.2     | Procedure .....                                     | 159 |
| 7.6.4.2.1   | 3,84 Mcps TDD option.....                           | 159 |
| 7.6.4.2.2   | 1,28 Mcps TDD option.....                           | 159 |
| 7.6.4.2.3   | 7,68 Mcps TDD option.....                           | 159 |
| 7.6.5       | Test Requirements .....                             | 160 |
| 7.7         | Spurious emissions .....                            | 160 |
| 7.7.1       | Definition and applicability .....                  | 160 |
| 7.7.2       | Minimum Requirements .....                          | 160 |
| 7.7.2.1     | 3,84 Mcps TDD option .....                          | 160 |
| 7.7.2.2     | 1,28 Mcps TDD option .....                          | 161 |
| 7.7.2.3     | 7,68 Mcps TDD option .....                          | 161 |
| 7.7.3       | Test purpose.....                                   | 162 |
| 7.7.4       | Method of test .....                                | 162 |
| 7.7.4.1     | Initial conditions .....                            | 162 |
| 7.7.4.1.0   | General test conditions .....                       | 162 |
| 7.7.4.1.1   | 3,84 Mcps TDD option.....                           | 162 |
| 7.7.4.1.2   | 1,28 Mcps TDD option.....                           | 163 |
| 7.7.4.1.3   | 7,68 Mcps TDD option.....                           | 163 |
| 7.7.4.2     | Procedure .....                                     | 164 |
| 7.7.4.2.1   | 3,84 Mcps TDD option.....                           | 164 |
| 7.7.4.2.2   | 1,28 Mcps TDD option.....                           | 164 |
| 7.7.4.2.3   | 7,68 Mcps TDD option.....                           | 165 |
| 7.7.5       | Test Requirements .....                             | 165 |
| 8           | Performance requirements.....                       | 166 |
| 8.1         | General .....                                       | 166 |
| 8.2         | Demodulation in static propagation conditions ..... | 166 |
| 8.2.1       | Demodulation of DCH.....                            | 166 |
| 8.2.1.1     | Definition and applicability.....                   | 166 |
| 8.2.1.2     | Minimum Requirements.....                           | 166 |
| 8.2.1.2.1   | 3,84 Mcps TDD option.....                           | 166 |
| 8.2.1.2.2   | 1,28 Mcps TDD option.....                           | 167 |
| 8.2.1.2.3   | 7,68 Mcps TDD option.....                           | 168 |
| 8.2.1.3     | Test purpose .....                                  | 168 |
| 8.2.1.4     | Method of test .....                                | 168 |
| 8.2.1.4.1   | Initial conditions .....                            | 168 |
| 8.2.1.4.1.0 | General test conditions.....                        | 168 |
| 8.2.1.4.1.1 | 3,84 Mcps TDD option .....                          | 168 |
| 8.2.1.4.1.2 | 1,28 Mcps TDD option .....                          | 169 |
| 8.2.1.4.1.3 | 7,68 Mcps TDD option .....                          | 169 |
| 8.2.1.4.2   | Procedure.....                                      | 169 |
| 8.2.1.4.2.1 | 3,84 Mcps TDD option .....                          | 169 |
| 8.2.1.4.2.2 | 1,28 Mcps TDD option .....                          | 170 |
| 8.2.1.4.2.3 | 7,68 Mcps TDD option .....                          | 170 |
| 8.2.1.5     | Test Requirements.....                              | 171 |
| 8.2.1.5.1   | 3,84 Mcps TDD option.....                           | 171 |
| 8.2.1.5.2   | 1,28 Mcps TDD option.....                           | 171 |

|             |  |     |
|-------------|--|-----|
| 8.2.1.5.3   | 7,68 Mcps TDD option.....                                | 171 |
| 8.3         | Demodulation of DCH in multipath fading conditions ..... | 171 |
| 8.3.1       | Multipath fading Case 1 .....                            | 171 |
| 8.3.1.1     | Definition and applicability.....                        | 171 |
| 8.3.1.2     | Minimum Requirements.....                                | 171 |
| 8.3.1.2.1   | 3,84 Mcps TDD option.....                                | 171 |
| 8.3.1.2.2   | 1,28 Mcps TDD option.....                                | 172 |
| 8.3.1.2.3   | 7,68 Mcps TDD option.....                                | 172 |
| 8.3.1.3     | Test purpose .....                                       | 173 |
| 8.3.1.4     | Method of test .....                                     | 173 |
| 8.3.1.4.1   | Initial conditions.....                                  | 173 |
| 8.3.1.4.1.0 | General test conditions.....                             | 173 |
| 8.3.1.4.1.1 | 3,84 Mcps TDD option .....                               | 173 |
| 8.3.1.4.1.2 | 1,28 Mcps TDD option .....                               | 174 |
| 8.3.1.4.1.3 | 7,68 Mcps TDD option .....                               | 174 |
| 8.3.1.4.2   | Procedure.....   | 174 |
| 8.3.1.4.2.1 | 3,84 Mcps TDD option .....                               | 174 |
| 8.3.1.4.2.2 | 1,28 Mcps TDD option .....                               | 175 |
| 8.3.1.4.2.3 | 7,68 Mcps TDD option .....                               | 175 |
| 8.3.1.5     | Test Requirements.....                                   | 176 |
| 8.3.1.5.1   | 3,84 Mcps TDD option.....                                | 176 |
| 8.3.1.5.2   | 1,28 Mcps TDD option.....                                | 176 |
| 8.3.1.5.3   | 7,68 Mcps TDD option.....                                | 176 |
| 8.3.2       | Multipath fading Case 2.....                             | 176 |
| 8.3.2.1     | Definition and applicability.....                        | 176 |
| 8.3.2.2     | Minimum Requirements.....                                | 176 |
| 8.3.2.2.1   | 3,84 Mcps TDD option.....                                | 176 |
| 8.3.2.2.2   | 1,28 Mcps option.....                                    | 177 |
| 8.3.2.2.3   | 7,68 Mcps TDD option.....                                | 178 |
| 8.3.2.3     | Test purpose .....                                       | 178 |
| 8.3.2.4     | Method of test .....                                     | 178 |
| 8.3.2.4.1   | Initial conditions.....                                  | 178 |
| 8.3.2.4.1.0 | General test conditions.....                             | 178 |
| 8.3.2.4.1.1 | 3,84 Mcps TDD option .....                               | 178 |
| 8.3.2.4.1.2 | 1,28 Mcps TDD option .....                               | 179 |
| 8.3.2.4.1.3 | 7,68 Mcps TDD option .....                               | 179 |
| 8.3.2.4.2   | Procedure.....   | 179 |
| 8.3.2.4.2.1 | 3,84 Mcps TDD option .....                               | 179 |
| 8.3.2.4.2.2 | 1,28 Mcps TDD option .....                               | 180 |
| 8.3.2.4.2.3 | 7,68 Mcps TDD option .....                               | 180 |
| 8.3.2.5     | Test Requirements.....                                   | 181 |
| 8.3.2.5.1   | 3,84 Mcps TDD option .....                               | 181 |
| 8.3.2.5.2   | 1,28 Mcps TDD option.....                                | 181 |
| 8.3.2.5.3   | 7,68 Mcps TDD option .....                               | 181 |
| 8.3.3       | Multipath fading Case 3.....                             | 181 |
| 8.3.3.1     | Definition and applicability.....                        | 181 |
| 8.3.3.2     | Minimum Requirements.....                                | 181 |
| 8.3.3.2.1   | 3,84 Mcps TDD option.....                                | 181 |
| 8.3.3.2.2   | 1,28 Mcps TDD option.....                                | 182 |
| 8.3.3.2.3   | 7,68 Mcps TDD option.....                                | 183 |
| 8.3.3.3     | Test purpose .....                                       | 183 |
| 8.3.3.4     | Method of test .....                                     | 184 |
| 8.3.3.4.1   | Initial conditions.....                                  | 184 |
| 8.3.3.4.1.0 | General test conditions.....                             | 184 |
| 8.3.3.4.1.1 | 3,84 Mcps TDD option .....                               | 184 |
| 8.3.3.4.1.2 | 1,28 Mcps TDD option .....                               | 184 |
| 8.3.3.4.1.3 | 7,68 Mcps TDD option .....                               | 184 |
| 8.3.3.4.2   | Procedure.....   | 184 |
| 8.3.3.4.2.1 | 3,84 Mcps TDD option .....                               | 184 |
| 8.3.3.4.2.2 | 1,28 Mcps TDD option .....                               | 185 |
| 8.3.3.4.2.3 | 7,68 Mcps TDD option .....                               | 186 |
| 8.3.3.5     | Test Requirements.....                                   | 186 |

|             |  |     |
|-------------|--|-----|
| 8.3.3.5.1   | 3,84 Mcps TDD option.....                                      | 186 |
| 8.3.3.5.2   | 1,28 Mcps TDD option.....                                      | 186 |
| 8.3.3.5.3   | 7,68 Mcps TDD option.....                                      | 187 |
| 8.3A        | Demodulation of DCH in high speed train conditions .....       | 187 |
| 8.3A.1      | Definition and applicability .....                             | 187 |
| 8.3A.2      | Minimum requirement .....                                      | 187 |
| 8.3A.2.1    | 3.84 Mcps TDD option .....                                     | 187 |
| 8.3A.2.2    | 1.28 Mcps TDD option .....                                     | 187 |
| 8.3A.2.3    | 7.68 Mcps TDD option .....                                     | 188 |
| 8.3A.3      | Test purpose.....  | 188 |
| 8.3A.4      | Method of test.....  | 189 |
| 8.3A.4.1    | Initial conditions .....                                       | 189 |
| 8.3A.4.1.1  | General test conditions .....                                  | 189 |
| 8.3A.4.1.1  | 3.84 Mcps TDD option.....                                      | 189 |
| 8.3A.4.1.1  | 1.28 Mcps TDD option.....                                      | 189 |
| 8.3A.4.1.1  | 7.68 Mcps TDD option.....                                      | 189 |
| 8.3A.4.2    | Procedure .....  | 189 |
| 8.3A.4.2.1  | 3.84 Mcps TDD option.....                                      | 189 |
| 8.3A.4.2.2  | 1.28 Mcps TDD option.....                                      | 189 |
| 8.3A.4.2.3  | 7.68 Mcps TDD option.....                                      | 190 |
| 8.3A.5      | Test requirements.....   | 190 |
| 8.3A.5.1    | 3,84 Mcps TDD option .....                                     | 190 |
| 8.3A.5.2    | 1,28 Mcps TDD option .....                                     | 190 |
| 8.3A.5.3    | 7,68 Mcps TDD option .....                                     | 191 |
| 8.4         | Demodulation of E-DCH FRC in multipath fading conditions ..... | 191 |
| 8.4.1       | Definition and applicability .....                             | 191 |
| 8.4.2       | Minimum Requirements .....                                     | 191 |
| 8.4.2.1     | 3,84 Mcps TDD Option.....                                      | 191 |
| 8.4.2.2     | 1.28Mcps TDD option .....                                      | 192 |
| 8.4.2.3     | 7.68 Mcps TDD Option.....                                      | 192 |
| 8.4.3       | Test purpose.....  | 193 |
| 8.4.4       | Method of test.....  | 193 |
| 8.4.4.1     | Initial conditions .....                                       | 193 |
| 8.4.4.1.0   | General test conditions .....                                  | 193 |
| 8.4.4.1.1   | 3,84 Mcps TDD option.....                                      | 193 |
| 8.4.4.1.2   | 1.28Mcps TDD option.....                                       | 194 |
| 8.4.4.1.3   | 7.68 Mcps TDD option.....                                      | 194 |
| 8.4.4.2     | Procedure .....  | 194 |
| 8.4.4.2.1   | 3,84 Mcps TDD option.....                                      | 194 |
| 8.4.4.2.2   | 1.28Mcps TDD option.....                                       | 194 |
| 8.4.4.2.3   | 7.68 Mcps TDD option.....                                      | 195 |
| 8.4.5       | Test Requirements .....  | 195 |
| 8.4.5.1     | 3,84 Mcps TDD option .....                                     | 196 |
| 8.4.5.2     | 1.28Mcps TDD option .....                                      | 196 |
| 8.4.5.3     | 7.68 Mcps TDD option .....                                     | 196 |
| 8.5         | Performance of ACK error detection for HS-SICH .....           | 196 |
| 8.5.1       | ACK error detection in static propagation conditions .....     | 196 |
| 8.5.1.1     | 3.84 Mcps TDD option .....                                     | 196 |
| 8.5.1.2     | 1.28 Mcps TDD option .....                                     | 196 |
| 8.5.1.2.1   | Definition and applicability .....                             | 196 |
| 8.5.1.2.2   | Minimum requirement.....                                       | 196 |
| 8.5.1.2.3   | Test purpose .....   | 197 |
| 8.5.1.2.4   | Method of test.....  | 197 |
| 8.5.1.2.4.1 | Initial conditions .....                                       | 197 |
| 8.5.1.2.4.2 | Procedure .....  | 198 |
| 8.5.1.2.5   | Test requirements .....  | 198 |
| 8.5.2       | ACK error detection in multipath fading conditions.....        | 198 |
| 8.5.2.1     | 3,84Mcps TDD option .....                                      | 198 |
| 8.5.2.2     | 1,28Mcps TDD option .....                                      | 198 |
| 8.5.2.2.1   | Definition and applicability .....                             | 198 |
| 8.5.2.2.2   | Minimum requirement.....                                       | 199 |
| 8.5.2.2.3   | Test purpose .....   | 200 |

|   |  |            |
|---|--|------------|
| 8.5.2.2.4   | Method of test.....                                | 200        |
| 8.5.2.2.4.1   | Initial conditions .....                           | 200        |
| 8.5.2.2.4.2   | Procedure .....                                    | 200        |
| 8.5.2.2.5   | Test requirements .....                            | 201        |
| <b>Annex A (normative): Measurement Channels.....</b>   |  | <b>202</b> |
| A.1   | (void).....  | 202        |
| A.2   | Reference measurement channel .....                | 202        |
| A.2.1   | UL reference measurement channel (12,2 kbps) ..... | 202        |
| A.2.1.1   | 3,84 Mcps TDD option .....                         | 202        |
| A.2.1.2   | 1,28 Mcps option .....                             | 203        |
| A.2.1.3   | 7,68 Mcps TDD Option .....                         | 204        |
| A.2.2   | UL reference measurement channel (64 kbps) .....   | 205        |
| A.2.2.1   | 3,84 Mcps TDD option .....                         | 205        |
| A.2.2.2   | 1,28 Mcps TDD option .....                         | 207        |
| A.2.2.3   | 7,68 Mcps TDD Option .....                         | 208        |
| A.2.3   | UL reference measurement channel (144 kbps) .....  | 209        |
| A.2.3.1   | 3,84 Mcps TDD option .....                         | 209        |
| A.2.3.2   | 1,28 Mcps TDD option .....                         | 211        |
| A.2.3.3   | 7,68 Mcps TDD Option .....                         | 212        |
| A.2.4   | UL reference measurement channel (384 kbps) .....  | 213        |
| A.2.4.1   | 3,84 Mcps TDD option .....                         | 213        |
| A.2.4.2   | 1,28 Mcps TDD option .....                         | 215        |
| A.2.4.3   | 7,68 Mcps TDD Option .....                         | 216        |
| A.2.5   | RACH reference measurement channel .....           | 217        |
| A.2.5.1   | 3,84 Mcps TDD option .....                         | 217        |
| A.2.5.1.1   | RACH mapped to 1 code SF16.....                    | 217        |
| A.2.5.1.2   | RACH mapped to 1 code SF8.....                     | 218        |
| A.2.5.2   | 1,28 Mcps TDD option .....                         | 218        |
| A.2.5.2.1   | RACH mapped to 1 code SF16.....                    | 219        |
| A.2.5.2.2   | RACH mapped to 1 code SF8.....                     | 219        |
| A.2.5.2.3   | RACH mapped to 1 code SF4.....                     | 220        |
| A.2.5.3   | 7,68 Mcps TDD option .....                         | 220        |
| A.2.5.3.1   | RACH mapped to 1 code SF16.....                    | 221        |
| A.2.5.3.2   | RACH mapped to 1 code SF32.....                    | 221        |
| A.3   | E-DCH Reference measurement channels .....         | 222        |
| A.3.1   | E-DCH Fixed Reference Channels.....                | 222        |
| A.3.1.1   | 3,84 Mcps TDD Option .....                         | 222        |
| A.3.1.1.1   | Fixed Reference Channel 1 (FRC1) .....             | 222        |
| A.3.1.1.2   | Fixed Reference Channel 2 (FRC2) .....             | 223        |
| A.3.1.1.3   | Fixed Reference Channel 3 (FRC3) .....             | 223        |
| A.3.1.2   | 1.28Mcps TDD Option .....                          | 224        |
| A.3.1.2.1   | Fixed reference channel 1(FRC1).....               | 224        |
| A.3.1.2.2   | Fixed reference channel 2(FRC2) .....              | 225        |
| A.3.1.2.3   | Fixed reference channel 3(FRC3) .....              | 226        |
| A.3.1.2.4   | Fixed reference channel 4(FRC4).....               | 227        |
| A.3.1.3   | 7,68 Mcps TDD Option .....                         | 228        |
| A.3.1.3.1   | Fixed Reference Channel 1 (FRC1) .....             | 228        |
| A.3.1.3.2   | Fixed Reference Channel 2 (FRC2) .....             | 229        |
| A.3.1.3.3   | Fixed Reference Channel 3 (FRC3) .....             | 230        |
| A.4   | HS-SICH Reference measurement channels .....       | 231        |
| A.4.1   | 3,84 Mcps TDD Option.....                          | 231        |
| A.4.2   | 1,28 Mcps TDD Option.....                          | 231        |
| <b>Annex B (normative): Propagation conditions.....</b> |  | <b>233</b> |
| B.1   | Static propagation condition.....                  | 233        |
| B.2   | Multi-path fading propagation conditions.....      | 233        |
| B.2.1   | 3,84 Mcps TDD option.....                          | 233        |



|                               |   |            |
|-------------------------------|---|------------|
| B.2.2                         | 1,28 Mcps TDD option.....   | 233        |
| B.2.3                         | 7,68 Mcps TDD option.....   | 234        |
| B.3                           | High speed train conditions .....                                 | 235        |
| <b>Annex C (normative):</b>   | <b>Global in-channel Tx test .....</b>                            | <b>237</b> |
| C.1                           | General .....   | 237        |
| C.2                           | Definition of the process .....                                   | 237        |
| C.2.1                         | Basic principle.....  | 237        |
| C.2.2                         | Output signal of the Tx under test .....                          | 237        |
| C.2.3                         | Reference signal .....  | 237        |
| C.2.4                         | Classification of measurement results .....                       | 238        |
| C.2.5                         | Process definition to achieve results of type "deviation".....    | 238        |
| C.2.5.1                       | Decision Point Power.....   | 239        |
| C.2.5.2                       | Code-Domain Power.....  | 239        |
| C.2.6                         | Process definition to achieve results of type "residual".....     | 239        |
| C.2.6.1                       | Error Vector Magnitude (EVM) .....                                | 240        |
| C.2.6.2                       | Peak Code Domain Error (PCDE) .....                               | 240        |
| C.2.6.3                       | Relative Code Domain Error (RCDE) .....                           | 240        |
| C.3                           | Notes.....  | 241        |
| C.3.1                         | Symbol length .....   | 241        |
| C.3.2                         | Deviation .....   | 241        |
| C.3.3                         | Residual.....   | 241        |
| C.3.4                         | TDD.....  | 241        |
| C.3.5                         | Synch channel .....   | 241        |
| C.3.6                         | Formula for the minimum process .....                             | 242        |
| C.3.7                         | Formula for EVM.....  | 243        |
| <b>Annex D (informative):</b> | <b>Derivation of Test Requirements.....</b>                       | <b>244</b> |
| <b>Annex E (informative):</b> | <b>Acceptable uncertainty of Test Equipment .....</b>             | <b>251</b> |
| <b>Annex F (normative):</b>   | <b>General rules for statistical testing.....</b>                 | <b>253</b> |
| F.1                           | Statistical testing of receiver BER/BLER performance .....        | 253        |
| F.1.1                         | Error Definition .....  | 253        |
| F.1.2                         | Test Method.....  | 253        |
| F.1.3                         | Test Criteria.....  | 253        |
| F.1.4                         | Calculation assumptions.....                                      | 253        |
| F.1.4.1                       | Statistical independence.....                                     | 253        |
| F.1.4.2                       | Applied formulas .....  | 253        |
| F.1.4.3                       | Approximation of the distribution .....                           | 254        |
| F.1.5                         | Definition of good pass fail decision .....                       | 254        |
| F.1.6                         | Good balance between test time and statistical significance ..... | 255        |
| F.1.7                         | Pass fail decision rules .....                                    | 256        |
| F.1.8                         | Test conditions for BER,BLER Tests.....                           | 257        |
| F.1.9                         | Practical Use (informative).....                                  | 258        |
| <b>Annex G (informative):</b> | <b>Change History .....</b>                                       | <b>261</b> |
| History .....                 |   | 263        |

---

# Foreword

This Technical Specification has been produced by the 3GPP.

The contents of the present document are subject to continuing work within the TSG and may change following formal TSG approval. Should the TSG modify the contents of this TS, it will be re-released by the TSG with an identifying change of release date and an increase in version number as follows:

Version x.y.z

where:

- x the first digit:
  - 1 presented to TSG for information;
  - 2 presented to TSG for approval;
  - 3 Indicates TSG approved document under change control.
- y the second digit is incremented for all changes of substance, i.e. technical enhancements, corrections, updates, etc.
- z the third digit is incremented when editorial only changes have been incorporated in the specification.

---

# 1 Scope

The present document specifies the Radio Frequency (RF) test methods and conformance requirements for UTRA Base Stations (BS) operating in the TDD mode. These have been derived from, and are consistent with, the UTRA base station (BS) specifications defined in 3GPP TS 25.105 [1]. The document covers all three options of the TDD mode, which are the 3,84 Mcps (incorporating MBSFN IMB), the 1,28 Mcps and the 7.68 Mcps options respectively. The requirements are listed in different subsections only if the parameters deviate.

In this TS, the reference point for RF connections (except for the measurement of mean transmitted RF carrier power) is the antenna connector, as defined by the manufacturer. This TS does not apply to repeaters or RF devices which may be connected to an antenna connector of a BS.

---

# 2 References

The following documents contain provisions which, through reference in this text, constitute provisions of the present document.

- References are either specific (identified by date of publication, edition number, version number, etc.) or non-specific.
- For a specific reference, subsequent revisions do not apply.
- For a non-specific reference, the latest version applies. In the case of a reference to a 3GPP document (including a GSM document), a non-specific reference implicitly refers to the latest version of that document in the same Release as the present document.

- [1] 3GPP TS 25.105: "UTRA (BS) TDD: Radio transmission and reception".
- [2] IEC 60721-3-3 (1994): "Classification of environmental conditions - Part 3: Classification of groups of environmental parameters and their severities - Section 3: Stationary use at weather protected locations".
- [3] IEC 60721-3-4 (1995): "Classification of environmental conditions - Part 3: Classification of groups of environmental parameters and their severities - Section 4: Stationary use at non-weather protected locations".
- [4] IEC 60068-2-1 (1990): "Environmental testing - Part 2: Tests. Tests A: Cold".
- [5] ETR 028: "Uncertainties in the measurement of mobile radio equipment characteristics".
- [6] Recommendation ITU-R SM.329: "Unwanted emissions in the spurious domain".
- [7] Recommendation ITU-R SM.328: "Spectra and bandwidth of emissions".
- [8] IEC 60068-2-6 (1995): "Environmental testing - Part 2: Tests - Test Fc: Vibration (sinusoidal)".
- [9] 3GPP TR 25.942: "RF System Scenarios".
- [10] ITU-T recommendation O.153: "Basic parameters for the measurement of error performance at bit rates below the primary rate".
- [11] 3GPP TS 36.104: "Evolved Universal Terrestrial Radio Access (E-UTRA); Base Station (BS) radio transmission and reception".
- [12] 3GPP TS 37.141: "E-UTRA, UTRA and GSM/EDGE; Multi-Standard Radio (MSR) Base Station (BS) conformance testing".

## 3 Definitions, symbols, and abbreviations

### 3.1 Definitions

**Ancillary RF amplifier:** a piece of equipment, which when connected by RF coaxial cables to the BS, has the primary function to provide amplification between the transmit and/or receive antenna connector of a BS and an antenna without requiring any control signal to fulfil its amplifying function.

**Bit Error Ratio:** The Bit Error Ratio is defined as the ratio of the bits wrongly received to all data bits sent. The bits are the data bits above the convolutional/turbo decoder. The BER is the overall BER independent of frame erasures or when erased frames are not defined.

**Block Error Ratio:** A Block Error Ratio is defined as the ratio of the number of erroneous blocks received to the total number of blocks sent. An erroneous block is a Transport Block whose cyclic redundancy check (CRC) is wrong.

**Power Spectral Density:** The units of Power Spectral Density (PSD) are extensively used in this document. PSD is a function of power versus frequency and when integrated across a given bandwidth, the function represents the mean power in such a bandwidth. When the mean power is normalised to (divided by) the chip-rate it represents the mean energy per chip. Some signals are directly defined in terms of energy per chip, (DPCH\_Ec, Ec, and P-CCPCH\_Ec) and others defined in terms of PSD (Io, Ioc, Ior and  $\dot{I}$ or). There also exist quantities that are a ratio of energy per chip to PSD (DPCH\_Ec/Ior, Ec/Ior etc.). This is the common practice of relating energy magnitudes in communication systems.

It can be seen that if both energy magnitudes in the ratio are divided by time, the ratio is converted from an energy ratio to a power ratio, which is more useful from a measurement point of view. It follows that an energy per chip of X dBm/3,84 MHz can be expressed as a mean power per chip of X dBm. Similarly, a signal PSD of Y dBm/3,84 MHz can be expressed as a signal power of Y dBm.

**Mean power:** When applied to a CDMA modulated signal this is the power (transmitted or received) in a bandwidth of at least  $(1 + \alpha)$  times the chip rate of the radio access mode. The period of measurement shall be a transmit timeslot excluding the guard period unless otherwise stated.

NOTE: The roll-off factor  $\alpha$  is defined in section 6.8.1.

**RRC filtered mean power:** The mean power as measured through a root raised cosine filter with roll-off factor  $\alpha$  and a bandwidth equal to the chip rate of the radio access mode.

NOTE: The RRC filtered mean power of a perfectly modulated CDMA signal is 0.246 dB lower than the mean power of the same signal.

**Code domain power:** That part of the mean power which correlates with a particular (OVSF) code channel. The sum of all powers in the code domain equals the mean power in a bandwidth of  $(1 + \alpha)$  times the chip rate of the radio access mode.

**Output power:** The mean power of one carrier of the base station, delivered to a load with resistance equal to the nominal load impedance of the transmitter.

**Maximum output power:** The mean power level per carrier of the base station measured at the antenna connector in a specified reference condition. The period of measurement shall be a transmit timeslot excluding the guard period.

**MBSFN-only operation:** Operation of a dedicated carrier solely for the purposes of MBSFN transmission. No receive functionality is implemented on the specified carrier frequency.

**Rated output power:** Rated output power of the base station is the mean power level per carrier that the manufacturer has declared to be available at the antenna connector.

**Total power dynamic range:** The difference between the maximum and the minimum output power of the base station for a specified reference condition.

## 3.2 Symbols

For the purposes of the present document, the following symbols apply:

$\alpha$  Roll-off factor

## 3.3 Abbreviations

For the purposes of the present document, the following and abbreviations apply:

|                               |  |
|-------------------------------|--|
| 3GPP                          | 3rd Generation Partnership Project   |
| 16QAM                         | 16 - Quadrature Amplitude Modulation   |
| AWGN                          | Additive White Gaussian Noise  |
| BER                           | Bit Error Ratio  |
| BLER                          | Block Error Ratio  |
| dB                            | decibel  |
| dBm                           | decibel relative to 1 milliWatt  |
| DPCHo                         | Mechanism used to simulate an individual intracell interferer in the cell with one code and a spreading factor of 16   |
| $\frac{DPCH_o - E_c}{I_{or}}$ | Ratio of the average transmit energy per PN chip for the DPCH <sub>o</sub> to the total transmit power spectral density of all users in the cell in one timeslot as measured at the BS antenna connector                                 |
| EVM                           | Error Vector Magnitude   |
| F                             | Frequency (of the assigned channel frequency of the wanted signal)   |
| F <sub>w</sub>                | Frequency offset of the unwanted interfering signal from the assigned channel frequency of the wanted signal   |
| HSDPA                         | High Speed Downlink Packet Access  |
| HS-DSCH                       | High Speed Downlink Shared Channel   |
| HS-PDSCH                      | High Speed Physical Downlink Shared Channel  |
| IMB                           | Integrated Mobile Broadcast  |
| IMT-2000                      | International Mobile Telecommunications 2000   |
| I <sub>oc</sub>               | Power spectral density (integrated in a noise bandwidth equal to the chip rate and normalized to the chip rate) of a band limited white noise source (simulating interference from other cells) as measured at the BS antenna connector. |
| $\hat{I}_{or}$                | Received power spectral density (integrated in a bandwidth (1+a) times the chip rate and normalized to the chip rate) of all users in the cell in one timeslot as measured at the BS antenna connector                                   |
| IPR                           | Intellectual Property Rights   |
| MBMS                          | Multimedia Broadcast Multicast Service   |
| MBSFN                         | MBMS over a Single Frequency Network   |
| P                             | Output power   |
| P <sub>out</sub>              | Output power of the base station   |
| P <sub>max</sub>              | Maximum output power of the base station   |
| QPSK                          | Quadrature Phase Shift Keying  |
| RAT                           | Radio Access Technology  |
| RBER                          | Residual BER   |
| RCDE                          | Relative Code Domain Error   |
| REFSENS                       | Reference Sensitivity Level  |
| RMS                           | Root-Mean Square   |
| PRAT                          | Rated output power of the base station   |
| RRC                           | Root-Raised Cosine   |
| T <sub>c</sub>                | Chip duration  |
| TDM                           | Time Division Multiplexing   |
| TS                            | Time Slot  |

---

## 4 Frequency bands and channel arrangement

### 4.1 General

The information presented in this section is based on a chip rate of 3,84 Mcps, 1,28 Mcps respectively and 7.68 Mcps .

NOTE: Other chip rates may be considered in future releases.

### 4.2 Frequency bands

UTRA/TDD is designed to operate in the following bands:

- a) 1900 - 1920 MHz: Uplink and downlink transmission  
2010 - 2025 MHz Uplink and downlink transmission
- b) 1850 - 1910 MHz: Uplink and downlink transmission  
1930 - 1990 MHz: Uplink and downlink transmission
- c) 1910 - 1930 MHz: Uplink and downlink transmission
- d) 2570 - 2620 MHz Uplink and downlink transmission
- e) 2300 - 2400 MHz Uplink and downlink transmission
- f) 1880 - 1920 MHz: Uplink and downlink transmission

Note: Deployment in existing and other frequency bands is not precluded.

### 4.3 TX-RX frequency separation

#### 4.3.1 3,84 Mcps TDD option

No TX-RX frequency separation is required as Time Division Duplex (TDD) is employed. Each TDMA frame consists of 15 timeslots where each timeslot can be allocated to either transmit or receive.

#### 4.3.2 1,28 Mcps TDD option

No TX-RX frequency separation is required as Time Division Duplex (TDD) is employed. Each subframe consists of 7 main timeslots where all main timeslots (at least the first one) before the single switching point are allocated UL and all main timeslots (at least the last one) after the single switching point are allocated DL.

#### 4.3.3 7,68 Mcps TDD option

No TX-RX frequency separation is required as Time Division Duplex (TDD) is employed. Each TDMA frame consists of 15 timeslots where each timeslot can be allocated to either transmit or receive.

## 4.4 Channel arrangement

### 4.4.1 Channel spacing

#### 4.4.1.1 3,84 Mcps TDD option

The nominal channel spacing is 5 MHz, but this can be adjusted to optimise performance in a particular deployment scenario.

#### 4.4.1.2 1,28 Mcps TDD option

The nominal channel spacing is 1,6 MHz, but this can be adjusted to optimise performance in a particular deployment scenario.

#### 4.4.1.3 7,68 Mcps TDD option

The nominal channel spacing is 10 MHz, but this can be adjusted to optimise performance in a particular deployment scenario.

### 4.4.2 Channel raster

The channel raster is 200 kHz for all bands, which means that the carrier frequency must be a multiple of 200 kHz.

#### 4.4.2.1 3,84 Mcps TDD Option

In addition a number of additional centre frequencies are specified according to table 5.1, which means that the centre frequencies for these channels are shifted 100 kHz relative to the general raster.

### 4.4.3 Channel number

The carrier frequency is designated by the UTRA absolute radio frequency channel number (UARFCN). The value of the UARFCN in the IMT2000 band is defined in the general case as follows:

$$N_t = 5 * F \text{ MHz} \qquad 0,0 \leq F \leq 3276,6 \text{ MHz}$$

where F is the carrier frequency in MHz.

Additional channels applicable to operation in the frequency band defined in sub-clause 5.2(d) for 3,84 Mcps are defined via the following UARFCN definition:

$$N_t = 5 * (F - 2150.1 \text{ MHz}) \qquad 2572.5 \text{ MHz} \leq F \leq 2617.5 \text{ MHz}$$

The 10 additional UARFCN for operations in frequency band defined in sub-clause 5.2(d) for 3,84 Mcps are hence: 2112, 2137, 2162, 2187, 2212, 2237, 2262, 2287, 2312, 2337.

---

## 5 General test conditions and declarations

The requirements of this clause apply to all applicable tests in this TS.

Many of the tests in this TS measure a parameter relative to a value that is not fully specified in the UTRA specifications. For these tests, the Minimum Requirement is determined relative to a nominal value specified by the manufacturer.

Certain functions of a BS are optional in the UTRA specifications. Some requirements for the BS may be regional as listed in subclause 5.17.

When specified in a test, the manufacturer shall declare the nominal value of a parameter, or whether an option is supported.

### 5.1 Base station classes

#### 5.1.1 Applicability of requirements and BS class definition

The requirements in this specification apply to both Wide Area base stations and Local Area base stations in co-ordinated network operation, unless otherwise stated.

Wide Area BS are characterised by requirements derived from Macro Cell and Micro Cell scenarios with BS to UE coupling losses equal to 70 dB and 53 dB. The Wide Area Base Station has the same requirements as the base station

for General Purpose application in Release 99 for 3,84 Mcps option, and in release 4 for both 3,84 Mcps and 1,28 Mcps option.

Local Area BS are characterised by requirements derived from Pico Cell scenarios with a BS to UE coupling loss equals to 45 dB.

### 5.1.2 Manufacturer's declaration

The manufacturer shall declare the intended class of the BS under test.

## 5.2 Output power

The manufacturer shall declare the rated output power, PRAT, of the base station. PRAT is defined in subclause 3.1.

## 5.3 Specified frequency range

The manufacturer shall declare:

- which of the frequency bands defined in sub-clause 4.2 is supported by the BS.
- the frequency range within the above frequency band(s) supported by the BS. As TDD is employed, the same frequency range is used for transmit and receive operation. For the case of MBSFN-only operation, the frequency range is used for transmit only, since no receive requirement exists.

Many tests in this TS are performed with appropriate frequencies in the bottom, middle and top of the operating frequency band of the BS. These are denoted as RF channels B (bottom), M (middle) and T (top).

Unless otherwise stated, the test shall be performed with a single carrier at each of the RF channels B, M and T.

When the requirements are specific to multiple carriers, and the BS is declared to support  $N > 1$  carriers, numbered from 1 to N, the interpretation of B, M and T for test purposes shall be as follows:

For testing at B,

- the carrier of lowest frequency shall be centered on B.

For testing at M,

- if the number N of carriers supported is odd, the carrier  $(N+1)/2$  shall be centered on M,
- if the number N of carriers supported is even, the carrier  $N/2$  shall be centered on M.

For testing at T,

- the carrier of highest frequency shall be centered on T.

When a test is performed by a test laboratory, the UARFCNs to be used for RF channels B, M and T shall be specified by the laboratory. The laboratory may consult with operators, the manufacturer or other bodies.

When a test is performed by a manufacturer, the UARFCNs to be used for RF channels B, M and T may be specified by an operator.

## 5.4 Relationship between RF generation and chip clock

The manufacturer shall declare compliance with the requirement that the BS shall use the same frequency source for both RF generation and the chip clock.



## 5.5 Spectrum emission mask

The manufacturer shall declare whether the BS under test is intended to operate in regions where conformance to the spectrum emission mask defined in subclause 6.6.2.1.2 is mandatory. If so, the conformance test for spectrum emission mask specified in subclause 6.6.2.1 shall be performed; otherwise, this test is not required.

## 5.6 Adjacent Channel Leakage power Ratio (ACLR)

The manufacturer shall declare:

- whether the BS under test is intended to operate in proximity to either another TDD BS or FDD BS that comprises uplink receive functionality operating on the first or second adjacent frequency. If so, conformance with the ACLR requirement specified in subclause 6.6.2.2.2 is mandatory; otherwise, this requirement need not to be tested.
- whether the BS under test is intended to operate co-sited to either another TDD BS or FDD BS that comprises uplink receive functionality operating on the first or second adjacent frequency. If so, conformance with the ACLR requirement specified in subclause 6.6.2.2.3 is mandatory; otherwise, this requirement need not to be tested.

## 5.7 Tx spurious emissions

### 5.7.1 Category of spurious emissions limit

The manufacturer shall declare one of the following:

- a) the BS shall be tested against Category A limits for spurious emissions, as defined in ITU-R Recommendation SM.329-9 [6].

or

- b) the BS shall be tested against Category B limits for spurious emissions, as defined in ITU-R Recommendation SM.329-9 [6].

If the manufacturer declares Category A limits to be applicable, conformance with the spurious emissions requirements specified in subclause 6.6.3.2.1.1 is mandatory, and the requirements specified in subclause 6.6.3.2.1.2 need not to be tested.

If the manufacturer declares Category B limits to be applicable, conformance with the spurious emissions requirements specified in subclause 6.6.3.2.1.2 is mandatory, and the requirements specified in subclause 6.6.3.2.1.1 need not to be tested.

### 5.7.2 Co-existence with GSM

The manufacturer shall declare:

- whether the BS under test is intended to operate in geographic areas in which also GSM 900 is deployed. If so, compliance with the conformance requirement specified in subclause 6.6.3.2.2.1 is mandatory; otherwise, this requirement needs not to be tested.
- whether the BS under test is intended to operate co-located with a GSM 900 BTS. If so, compliance with the conformance requirement specified in subclause 6.6.3.2.2.2 is mandatory; otherwise, this requirement needs not to be tested.

### 5.7.3 Co-existence with DCS 1800

The manufacturer shall declare:

- whether the BS under test is intended to operate in geographic areas in which also DCS 1800 is deployed. If so, compliance with the conformance requirement specified in subclause 6.6.3.2.3.1 is mandatory; otherwise, this requirement needs not to be tested.
- whether the BS under test is intended to operate co-located with a DCS 1800 BTS. If so, compliance with the conformance requirement specified in subclause 6.6.3.2.3.2 is mandatory; otherwise, this requirement needs not to be tested.

#### 5.7.4 Co-existence with UTRA FDD

The manufacturer shall declare:

- whether the BS under test is intended to operate in geographic areas in which also UTRA FDD is deployed. If so, compliance with the conformance requirement specified in subclause 6.6.3.2.4.1 is mandatory; otherwise, this requirement needs not to be tested.
- whether the BS under test is intended to operate co-located with a UTRA FDD BS. If so, compliance with the conformance requirement specified in subclause 6.6.3.2.4.2 is mandatory; otherwise, this requirement needs not to be tested.

#### 5.7.5 Co-existence with unsynchronised UTRA TDD and/or E-UTRA TDD

The manufacturer shall declare:

- whether the BS under test is intended to operate in geographic areas in which also unsynchronised UTRA TDD and/or E-UTRA TDD that comprises uplink receive functionality is deployed. If so, compliance with the conformance requirement specified in subclause 6.6.3.2.5.1 is mandatory; otherwise, this requirement need not to be tested.
- whether the BS under test is intended to operate co-located with a unsynchronised UTRA TDD and/or E-UTRA TDD BS that comprises uplink receive functionality. If so, compliance with the conformance requirement specified in subclause 6.6.3.2.5.2 is mandatory; otherwise, this requirement needs not to be tested.

### 5.8 Blocking characteristics

The conformance requirements with respect to the parameter blocking characteristics are dependent on the operating frequency bands of the BS under test; see subclause 7.5.2. However, the need for a manufacturer's declaration of the frequency bands supported by the BS is already covered by subclause 5.3. The relationship between the frequency bands supported by the BS and the mandatory blocking requirements is given in table 5.1.

**Table 5.1: Relationship between the frequency bands supported by the BS and the mandatory blocking requirements**

| Supported frequency band according to manufacturer's declaration | Mandatory blocking requirement |
|--|--------------------------------|
| subclause 4.2a)  | table 7.6                      |
| subclause 4.2b)  | table 7.7                      |
| subclause 4.2c)  | table 7.8                      |

In addition, the manufacturer shall declare:

- whether the BS under test is intended to operate co-located with a GSM 900 BTS or a DCS 1800 BTS. If so, compliance with the conformance requirement specified in table 7.9 or 7.10, respectively, is mandatory; otherwise, this requirement needs not to be tested.

### 5.9 Test environments

For each test in this TS, the environmental conditions under which the BS is to be tested are defined.

## 5.9.1 Normal test environment

When a normal test environment is specified for a test, the test should be performed under any combination of conditions between the minimum and maximum limits stated in table 5.2.

**Table 5.2: Limits of conditions for Normal Test Environment**

| Condition           | Minimum                                  | Maximum |
|---------------------|--|---------|
| Barometric pressure | 86 kPa                                   | 106 kPa |
| Temperature         | 15°C                                     | 30°C    |
| Relative Humidity   | 20 %                                     | 85 %    |
| Power supply        | Nominal, as declared by the manufacturer |         |
| Vibration           | Negligible                               |         |

The ranges of barometric pressure, temperature and humidity represent the maximum variation expected in the uncontrolled environment of a test laboratory. If it is not possible to maintain these parameters within the specified limits, the actual values shall be recorded in the test report.

NOTE: This may, for instance, be the case for measurements of radiated emissions performed on an open field test site.

## 5.9.2 Extreme test environment

The manufacturer shall declare one of the following:

- a) The equipment class for the equipment under test, as defined in IEC 60721-3-3 [2].
- b) The equipment class for the equipment under test, as defined in IEC 60721-3-4 [3].
- c) For equipment that does not comply to the mentioned classes, the relevant classes from IEC 60 721 documentation for Temperature, Humidity and Vibration shall be declared.

NOTE: Reduced functionality for conditions that fall out side of the standard operational conditions are not tested in this TS. These may be stated and tested separately.

### 5.9.2.1 Extreme temperature

When an extreme temperature test environment is specified for a test, the test shall be performed at the standard minimum and maximum operating temperatures defined by the manufacturer's declaration for the equipment under test.

#### Minimum temperature:

- The test shall be performed with the environmental test equipment and methods of inducing the required environmental phenomena into the equipment, conforming to the test procedure of IEC 60 068-2-1 [4], Environmental Testing, Part 2: Tests - Tests A: Cold. The equipment shall be maintained at the stabilized condition for the duration of the test sequence.

#### Maximum temperature:

- The test shall be performed with the environmental test equipment and methods of inducing the required environmental phenomena in to the equipment, conforming to the test procedure of IEC 60 068-2-2 [5] (Environmental Testing, Part 2: Tests - Tests Bd Dry heat). The equipment shall be maintained at the stabilized condition for the duration of the test sequence.

NOTE: It is recommended that the equipment is made fully operational prior to the equipment being taken to its lower operating temperature.

## 5.9.3 Vibration

When vibration conditions are specified for a test, the test shall be performed while the equipment is subjected to a vibration sequence as defined by the manufacturers declaration for the equipment under test. This shall use the environmental test equipment and methods of inducing the required environmental phenomena in to the equipment,

conforming to the test procedure of IEC 60 068-2-6 [8], Environmental Testing, Part 2: Tests - Test Fc and guidance: Vibration (Sinusoidal). Other environmental conditions shall be within the ranges specified in subclause 5.9.1, Normal test environment.

NOTE: The higher levels of vibration may induce undue physical stress in to equipment after a prolonged series of tests. The testing body should only vibrate the equipment during the RF measurement process.

## 5.9.4 Power supply

When extreme power supply conditions are specified for a test, the test shall be performed at the standard upper and lower limits of operating voltage defined by the manufacturer's declaration for the equipment under test.

### Upper voltage limit

- The equipment shall be supplied with a voltage equal to the upper limit declared by the manufacturer (as measured at the input terminals to the equipment). The tests shall be carried out at a steady state minimum and maximum limit declared by the manufacturer for the equipment, to the methods described in IEC 60 068-2-1 [4] Test Ab/Ad: Cold and IEC 60 068-2-2 [5] Test Bb/Bd: Dry Heat.

### Lower voltage limit

- The equipment shall be supplied with a voltage equal to the lower limit declared by the manufacturer (as measured at the input terminals to the equipment). The tests shall be carried out at a steady state minimum and maximum limit declared by the manufacturer for the equipment, to the methods described in IEC 60 068-2-1 [4] Test Ab/Ad: Cold and IEC 60 068-2-2 [5] Test Bb/Bd: Dry Heat.

## 5.10 Acceptable uncertainty of Test System

The maximum acceptable uncertainty of the Test System is specified below for each test, where appropriate. The Test System shall enable the stimulus signals in the test case to be adjusted to within the specified tolerance and the equipment under test to be measured with an uncertainty not exceeding the specified values. All tolerances and uncertainties are absolute values and are valid for a confidence level of 95 %, unless otherwise stated.

A confidence level of 95 % is the measurement uncertainty tolerance interval for a specific measurement that contains 95 % of the performance of a population of test equipment.

For RF tests it should be noted that the uncertainties in subclause 5.10 apply to the Test System operating into a nominal 50 ohm load and do not include system effects due to mismatch between the DUT and the Test System.

### 5.10.1 Measurement of test environments

The measurement accuracy of the BS test environments defined in subclause 5.9 shall be:

|                      |                 |
|----------------------|-----------------|
| Pressure:            | $\pm 5$ kPa     |
| Temperature:         | $\pm 2$ degrees |
| Relative Humidity:   | $\pm 5$ %       |
| DC Voltage:          | $\pm 1,0$ %     |
| AC Voltage:          | $\pm 1,5$ %     |
| Vibration:           | 10 %            |
| Vibration frequency: | 0,1 Hz          |

The above values shall apply unless the test environment is otherwise controlled and the specification for the control of the test environment specifies the uncertainty for the parameter.

## 5.10.2 Measurement of transmitter

Table 5.3: Maximum Test System Uncertainty for transmitter tests

| Subclause  | Maximum Test System Uncertainty  | Derivation of Test System Uncertainty  |
|--|--|--|
| 6.2 Maximum output power                           | $\pm 0,7$ dB   |  |
| 6.3 Frequency stability                            | $\pm 12$ Hz  |  |
| 6.4.2 Power control steps                          | single step: $\pm 0,1$ dB<br>ten steps: $\pm 0,3$ dB   | Result is difference between two absolute Code Domain Power measurements on the power controlled DPCH. |
| 6.4.3 Power control dynamic range                  | $\pm 0,3$ dB   |  |
| 6.4.4 Minimum output power                         | $\pm 0,7$ dB   |  |
| 6.4.5 Primary CCPCH power                          | $\pm 0,8$ dB   |  |
| 6.4.6 Differential accuracy of Primary CCPCH power | $\pm 0,1$ dB   |  |
| 6.5.1 Transmit OFF power                           | $\pm 2,0$ dB   |  |
| 6.5.2 Transmit ON/OFF time mask                    | 3,84 Mcps TDD option:<br>Tx power limit = -79 dBm: $\pm 2,0$ dB<br>Tx power limit = -33 dBm: $\pm 0,7$ dB<br><br>1,28 Mcps TDD option:<br>Tx power limit = -82 dBm: $\pm 2,0$ dB<br>Tx power limit = -42 dBm: $\pm 0,7$ dB |  |
| 6.6.1 Occupied Bandwidth                           | $\pm 100$ kHz  | Accuracy = $\pm 3 \cdot \text{RBW}$ .<br>Assume 30 kHz bandwidth                                       |
| 6.6.2.1 Spectrum emission mask                     | $\pm 1,5$ dB   |  |

|   |   |  |
|---|---|--|
| 6.6.2.2 Adjacent Channel Leakage power Ratio (ACLR) | <p><u>3,84 Mcps TDD option:</u></p> <p>minimum requirement:<br/> 5 MHz offset: <math>\pm 0,8</math> dB<br/> 10 MHz offset: <math>\pm 0,8</math> dB</p> <p>requirement for operation in the same geographic area with unsynchronised TDD BS on adjacent channels:<br/> Wide Area BS:<br/> 5 MHz offset: <math>\pm 4</math> dB<br/> 10 MHz offset: <math>\pm 4</math> dB<br/> Local Area BS:<br/> 5 MHz offset: <math>\pm 0,8</math> dB<br/> 10 MHz offset: <math>\pm 0,8</math> dB</p> <p>requirement for operation in the same geographic area with FDD BS on adjacent channels:<br/> Wide Area BS:<br/> 5 MHz offset: TBD<br/> 10 MHz offset: <math>\pm 4</math> dB<br/> Local Area BS:<br/> 5 MHz offset: <math>\pm 0,8</math> dB<br/> 10 MHz offset: <math>\pm 0,8</math> dB</p> <p>requirement in case of co-siting with unsynchronised TDD BS or FDD BS operating on adjacent channels:<br/> Wide Area BS:<br/> 5 MHz offset: TBD<br/> 10 MHz offset: TBD<br/> Local Area BS (co-siting with TDD BS):<br/> 5 MHz offset: <math>\pm 1</math> dB<br/> 10 MHz offset: <math>\pm 1</math> dB</p> <p><u>1,28 Mcps TDD option:</u></p> <p>minimum requirement:<br/> 1,6 MHz offset: <math>\pm 0,8</math> dB<br/> 3,2 MHz offset: <math>\pm 0,8</math> dB</p> <p>requirement for operation in the same geographic area with unsynchronised 1,28 Mcps TDD BS on adjacent channels:<br/> Wide Area BS:<br/> 1,6 MHz offset: <math>\pm 1</math> dB<br/> 3,2 MHz offset: <math>\pm 1</math> dB<br/> Local Area BS:<br/> 1,6 MHz offset: <math>\pm 0,8</math> dB<br/> 3,2 MHz offset: <math>\pm 0,8</math> dB</p> <p>requirement for operation in the same geographic area with unsynchronised TDD BS on adjacent channels:<br/> Wide Area BS:<br/> 3,4 MHz offset: <math>\pm 1</math> dB<br/> Local Area BS:<br/> 3,4 MHz offset: <math>\pm 0,8</math> dB</p> <p>requirement for operation in the same geographic area with FDD BS on adjacent channels:<br/> Wide Area BS: <math>\pm 4</math> dB<br/> Local Area BS: <math>\pm 0,8</math> dB</p> |  |
|---|---|--|

|  |  |  |
|--|--|--|
|  | <p>requirement in case of co-siting with unsynchronised 1,28 Mcps TDD BS on an adjacent channel:<br/>Wide Area BS:<br/>    1,6 MHz offset: TBD<br/>    3,2 MHz offset: TBD<br/>Local Area BS:<br/>    Wide Area BS: <math>\pm 1</math> dB<br/>    Local Area BS: <math>\pm 1</math> dB</p> <p>requirement in case of co-siting with unsynchronised TDD BS on an adjacent channel:<br/>Wide Area BS:<br/>    3,4 MHz offset: TBD<br/>Local Area BS:<br/>    3,4 MHz offset: <math>\pm 1</math> dB</p> <p>requirement in case of co-siting with FDD BS on an adjacent channel:<br/>Wide Area BS: TBD</p> <p>Note: Impact of measurement period (averaging) and intermod effects in the measurement receiver not yet fully studied.</p> |  |
|--|--|--|

|   |   |  |
|---|---|--|
| 6.6.3 Spurious emissions                        | $\pm 2,0$ dB for BS and coexistence bands for results<br>$> -60$ dBm<br>$\pm 3,0$ dB for results $< -60$ dBm<br><br>Outside above range:<br>$f \leq 2,2$ GHz: $\pm 1,5$ dB<br>$2,2$ GHz $< f \leq 4$ GHz: $\pm 2,0$ dB<br>$f > 4$ GHz: $\pm 4,0$ dB               |  |
| 6.7 Transmit intermodulation                    | The value below applies to the setting of the interference signal level only and is unrelated to the measurement uncertainty of the tests (6.6.2.1, 6.6.2.2 and 6.6.3) which have to be carried out in the presence of the interference signal.<br><br>$\pm 1$ dB | The uncertainty of the interferer has double the effect on the result due to the frequency offset. |
| 6.8.1 Modulation accuracy                       | $\pm 2,5$ % (for single code)   |  |
| 6.8.2 Peak code domain error                    | $\pm 1$ dB  |  |
| 6.8.3 Relative Code Domain Error                | $\pm 1,0$ dB  |  |
| 6.8.4 Time alignment error in MIMO transmission | 1,28 Mcps TDD option:<br>$\pm [78]$ ns  |  |



### 5.10.3 Measurement of receiver

**Table 5.4: Maximum Test System Uncertainty for receiver tests**

| Subclause                                 | Maximum Test System Uncertainty<br>(see NOTE 1)   | Derivation of Test System<br>Uncertainty   |
|---|---|--|
| 7.2 Reference sensitivity level           | ± 0,7 dB  |  |
| 7.3 Dynamic range                         | ± 1,2 dB  | Formula =<br>SQRT(signal level error <sup>2</sup><br>and AWGN level error <sup>2</sup> )   |
| 7.4 Adjacent Channel Selectivity<br>(ACS) | ± 1,1 dB  | Formula = SQRT<br>(wanted_level_error <sup>2</sup> +<br>interferer_level_error <sup>2</sup> ) +<br>ACLR effect<br><br>The ACLR effect is<br>calculated by:<br>(Formula to follow)  |
| 7.5 Blocking characteristics              | Maximum Test System Accuracy with Frequency<br>offset of interfering signal < 15MHz:<br>± 1,4dB<br><br>Frequency offset of interfering signal ≥ 15MHz:<br>f < 2,2 GHz: ± 1,1 dB<br>2,2 GHz < f ≤ 4 GHz: ± 1,8 dB<br>f > 4 GHz: ± 3,2 dB | Formula =<br>SQRT (wanted_level_error <sup>2</sup><br>+ interferer_level_error <sup>2</sup> ) +<br>ACLR effect + Broadband<br>noise<br><br>(Frequency offset < 15<br>MHz: assuming ACLR of<br>interfering signal = 68 dB,<br>measurement uncertainty<br>of wanted signal = 0,7 dB)<br><br>(Frequency offset ≥ 15<br>MHz:<br>assuming -130 dBc<br>broadband noise from<br>interfering signal)<br><br>Harmonics and spurs of the<br>interfering signal need to<br>be carefully considered.<br>Perhaps need to avoid<br>harmonics of the interferer<br>that fall on top of the<br>receive channel.<br><br>For the -15 dBm CW<br>interfering signal, filtering of<br>the interfering signal (at<br>least 25 dB) is necessary to<br>eliminate problems with<br>broadband noise falling into<br>the bandwidth of the<br>wanted signal. |
| 7.6 Intermodulation<br>characteristics    | ± 1,3 dB  | Formula = SQRT<br>((2*CW_level_error) <sup>2</sup> +<br>(mod_level_error) <sup>2</sup> +<br>(wanted_signal_level_error<br>) <sup>2</sup> )<br><br>(assuming:<br>CW_level_error: 0,5 dB<br>mod_level_error: 0,5 dB<br>wanted_signal_level_error:<br>0,7 dB)   |

|  |  |  |
|--|--|--|
| 7.7 Spurious emissions   | $\pm 3,0$ dB for BS receive band (-78 dBm)<br><br>Outside above range:<br>$f \leq 2,2$ GHz: $\pm 2,0$ dB (-57 dBm)<br>$2,2$ GHz < $f \leq 4$ GHz: $\pm 2,0$ dB (-47 dBm)<br>$f > 4$ GHz : $\pm 4,0$ dB (-47 dBm)<br>(see note 2) |  |
| NOTE 1: Unless otherwise noted, only the Test System stimulus error is considered here. The effect of errors in the BER/FER measurements due to finite test duration is not considered.<br>NOTE 2: The Test System uncertainty figures for Spurious emissions apply to the measurement of the DUT and not to any stimulus signals. |  |  |

## 5.10.4 Measurement of performance requirements

**Table 5.5: Maximum Test System Uncertainty for Performance Requirements**

| Subclause   | Maximum Test System Uncertainty<br>(see NOTE 1) |
|---|---|
| 8.2 Demodulation in static propagation conditions   | TBD   |
| 8.3 Demodulation of DCH in multipath fading conditions  | TBD   |
| 8.3A Demodulation of DCH in high speed train conditions   | $\pm 0.4$ dB                                    |
| NOTE 1: Only the overall stimulus error is considered here. The effect of errors in the BER/FER measurements due to finite test duration is not considered. |   |

## 5.11 Test Tolerances (informative)

The Test Tolerances defined in this subclause have been used to relax the Minimum Requirements in this specification to derive the Test Requirements.

The Test Tolerances are derived from Test System uncertainties, regulatory requirements and criticality to system performance. As a result, the Test Tolerance may sometimes be set to zero.

The test tolerances should not be modified for any reason, e. g. to take account of commonly known test system errors (such as mismatch, cable loss, etc.)

## 5.11.1 Transmitter

Table 5.6: Test Tolerance for transmitter tests

| Subclause  | Test Tolerance (see NOTE)   |
|--|---|
| 6.2 Maximum output power                           | 0,7 dB  |
| 6.3 Frequency stability                            | 12 Hz   |
| 6.4.2 Power control steps                          | single step: 0,1 dB<br>ten steps: 0,3 dB  |
| 6.4.3 Power control dynamic range                  | 0,3 dB  |
| 6.4.4 Minimum output power                         | 0,7 dB  |
| 6.4.5 Primary CCPCH power                          | 0,8 dB  |
| 6.4.6 Differential accuracy of Primary CCPCH power | $\pm 0,1$ dB  |
| 6.5.1 Transmit OFF power                           | 2,0 dB  |
| 6.5.2 Transmit ON/OFF time mask                    | 3,84 Mcps TDD option:<br>Tx power limit = -79 dBm: 2,0 dB<br>Tx power limit = -33 dBm: 0,7 dB<br><br>1,28 Mcps TDD option:<br>Tx power limit = -82 dBm: 2,0 dB<br>Tx power limit = -42 dBm: 0,7 dB<br><br>7,68 Mcps TDD option:<br>Tx power limit = -76 dBm: 2,0 dB<br>Tx power limit = -33 dBm: 0,7 dB |
| 6.6.1 Occupied Bandwidth                           | 0 kHz   |
| 6.6.2.1 Spectrum emission mask                     | 1,5 dB  |

|   |   |
|---|---|
| 6.6.2.2 Adjacent Channel Leakage power Ratio (ACLR)   | <p><u>3,84 Mcps TDD option:</u><br/>minimum requirement: 0,8 dB</p> <p>operation in the same geographic area:<br/>Wide Area BS:<br/>4 dB for TDD BS on adjacent channels<br/>TBD/4 dB for FDD BS on adjacent channels<br/>Local Area BS: 0,8 dB</p> <p>co-siting:<br/>Wide Area BS: TBD<br/>Local Area BS: 1 dB</p> <p><u>1,28 Mcps TDD option:</u><br/>minimum requirement: 0,8 dB</p> <p>operation in the same geographic area:<br/>Wide Area BS: 1 dB for TDD BS on adjacent channels<br/>4 dB for FDD BS on adjacent channels<br/>Local Area BS: 0,8 dB</p> <p>co-siting:<br/>Wide Area BS: TBD<br/>Local Area BS: 1 dB for TDD BS on adjacent channels</p> <p><u>7,68 Mcps TDD option:</u><br/>minimum requirement: 0,8 dB</p> <p>operation in the same geographic area:<br/>Wide Area BS:<br/>4 dB for TDD BS on adjacent channels<br/>TBD/4 dB for FDD BS on adjacent channels<br/>Local Area BS: 0,8 dB</p> <p>co-siting:<br/>Wide Area BS: TBD<br/>Local Area BS: 1 dB</p> |
| 6.6.3 Spurious emissions  | 0 dB  |
| 6.7 Transmit intermodulation  | <p>Testing of transmit intermodulation consists of 3 parts:</p> <ul style="list-style-type: none"> <li>- testing of spectrum emission mask, see 6.6.2.1</li> <li>- testing of ACLR, see 6.6.2.2</li> <li>- testing of spurious emissions, see 6.6.3</li> </ul> <p>For each of these parts, the respective Test Tolerances as specified in this table shall apply.</p> <p>Test Tolerance for setting of the interferer power level: 0 dB</p>   |
| 6.8.1 Modulation accuracy   | 0 %   |
| 6.8.2 Peak code domain error  | 1 dB  |
| 6.8.3 Relative Code Domain Error  | 1.0 dB  |
| 6.8.4 Time alignment error in MIMO transmission   | 1,28 Mcps TDD option:<br>[78] ns  |
| NOTE: Unless otherwise stated, the Test Tolerances are applied to the DUT Minimum Requirement. See Annex D. |   |

## 5.11.2 Receiver

**Table 5.7: Test Tolerances for receiver tests**

| Subclause  | Test Tolerances (see NOTE 1) |
|--|------------------------------|
| 7.2 Reference sensitivity level  | 0,7 dB                       |
| 7.3 Dynamic range  | 1,2 dB                       |
| 7.4 Adjacent Channel Selectivity (ACS)   | 0 dB                         |
| 7.5 Blocking characteristics   | 0 dB                         |
| 7.6 Intermodulation characteristics  | 0 dB                         |
| 7.7 Spurious emissions   | 0 dB (see NOTE 2)            |
| NOTE 1: Unless otherwise stated, the Test Tolerances are applied to the stimulus signal(s). See Annex D. |                              |
| NOTE 2: The Test Tolerance is applied to the DUT Minimum Requirement. See Annex D.                       |                              |

## 5.11.3 Performance requirements

**Table 5.8: Test Tolerances for performance requirements**

| Subclause  | Test Tolerance (see NOTE) |
|--|---------------------------|
| 8.2 Demodulation in static propagation conditions  | TBD                       |
| 8.3 Demodulation of DCH in multipath fading conditions   | TBD                       |
| 8.3A Demodulation of DCH in high speed train conditions  | 0.4dB                     |
| NOTE: Unless otherwise stated, the Test Tolerances are applied to the stimulus signal(s). See Annex D. |                           |

## 5.12 Interpretation of measurement results

The measurement results returned by the Test System are compared - without any modification - against the Test Requirements as defined by the shared risk principle.

The Shared Risk principle is defined in ETR 273 Part 1 sub-part 2 section 6.5.

The actual measurement uncertainty of the Test System for the measurement of each parameter shall be included in the test report.

The recorded value for the Test System uncertainty shall be, for each measurement, equal to or lower than the appropriate figure in subclause 5.10 of this TS.

If the Test System for a test is known to have a measurement uncertainty greater than that specified in subclause 5.10, it is still permitted to use this equipment provided that an adjustment is made as follows:

Any additional uncertainty in the Test System over and above that specified in subclause 5.10 shall be used to tighten the Test Requirement - making the test harder to pass. (For some tests, e. g. receiver tests, this may require modification of stimulus signals).

This procedure (defined in Annex D) will ensure that a Test System not compliant with subclause 5.10 does not increase the chance of passing a device under test where that device would otherwise have failed the test if a Test System compliant with subclause 5.10 had been used.

## 5.13 Selection of configurations for testing

Measurements shall be performed within the time slots under test as specified individually for each test within the subclause "Initial conditions".

Most tests in this TS are only performed for a subset of the possible combinations of test conditions. For instance:

- Not all TRXs in the configuration may be specified to be tested.
- Only one RF channel may be specified to be tested.
- Only one timeslot may be specified to be tested.

When a test is performed by a test laboratory, the choice of which combinations are to be tested shall be specified by the laboratory. The laboratory may consult with operators, the manufacturer or other bodies.

When a test is performed by a manufacturer, the choice of which combinations are to be tested may be specified by an operator.

## 5.14 BS Configurations

This TS has been written to specify tests for the standard configurations of BS which have been assumed in UTRA requirements specifications, in particular TS 25.105 [1]. However, there are other configurations of BS which comply with these specifications, but for which the application of these specifications is not fully defined. For some such configurations there may be alternate ways to apply the requirements of this specification to testing of the configuration, or some variation in the test method may be necessary. It may therefore be necessary for the parties to the testing to reach agreement over the method of testing in advance.

If the BS is supplied in a number of different environmental enclosures or configurations, it may not be necessary to test RF parameters for each environmental configuration, provided that it can be demonstrated that the equipment has been tested at the worst internal environmental conditions.

Where alternative interpretations of this specification are possible for a BS configuration under test, the interpretation which has been adopted in performing the test shall be recorded with the test results.

Where variation in the test method within this TS has been necessary to enable a BS configuration to be tested, the variation in the test method which has been made in performing the test shall be recorded with the test results. Where possible, agreement should be reached in advance about the nature of such a variation with any party who will later receive the test results.

Possible interpretations of this TS for some common configurations are given in the following subclauses.

### 5.14.1 Receiver diversity

For the tests in clause 7 of the present document, the requirement applies at each receiver antenna connector for receivers with antenna diversity.

Receiver requirements are tested at the antenna connector, with the remaining receiver(s) disabled or their antenna connector(s) being terminated. If the manufacturer has declared the receiver paths to be equivalent, it is sufficient to apply the specified test signal at any one of the receiver antenna connectors.

### 5.14.2 Duplexers

Due to TDD operation, there is no need to use a duplexer in the BS.

### 5.14.3 Power supply options

If the BS is supplied with a number of different power supply configurations, it may not be necessary to test RF parameters for each of the power supply options, provided that it can be demonstrated that the range of conditions over which the equipment is tested is at least as great as the range of conditions due to any of the power supply configurations.

This applies particularly if a BS contains a DC rail which can be supplied either externally or from an internal mains power supply. In this case, the conditions of extreme power supply for the mains power supply options can be tested by testing only the external DC supply option. The range of DC input voltages for the test should be sufficient to verify the performance with any of the power supplies, over its range of operating conditions within the BS, including variation of mains input voltage, temperature and output current.

### 5.14.4 Ancillary RF amplifiers

The requirements of this TS shall be met with the ancillary RF amplifier fitted. At tests according to clause 6 and 7 for TX and RX respectively, the ancillary amplifier is connected to the BS by a connecting network (including any cable(s), attenuator(s), etc.) with applicable loss to make sure the appropriate operating conditions of the ancillary amplifier and

the BS. The applicable connecting network loss range is declared by the manufacturer. Other characteristics and the temperature dependence of the attenuation of the connecting network are neglected. The actual attenuation value of the connecting network is chosen for each test as one of the applicable extreme values. The lowest value is used unless otherwise stated.

Sufficient tests should be repeated with the ancillary amplifier fitted and, if it is optional, without the ancillary RF amplifier to verify that the BS meets the requirements of this TS in both cases.

### 5.14.5 BS using antenna arrays

A BS may be configured with a multiple antenna port connection for some or all of its TRXs or with an antenna array related to one cell (not one array per TRX). This subclause applies to a BS which meets at least one of the following conditions:

- The transmitter output signals from one or more TRX appear at more than one antenna port, or
- there is more than one receiver antenna port for a TRX or per cell and an input signal is required at more than one port for the correct operation of the receiver (NOTE: diversity reception does not meet this requirement) thus the outputs from the transmitters as well as the inputs to the receivers are directly connected to several antennas (known as "aircombining"), or

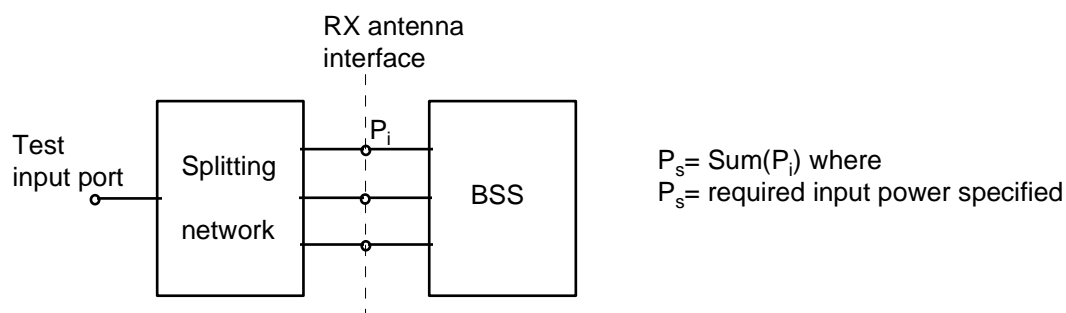
If a BS is used, in normal operation, in conjunction with an antenna system which contains filters or active elements which are necessary to meet the UTRA requirements, the tests of conformance may be performed on a system comprising the BS together with these elements, supplied separately for the purposes of testing. In this case, it must be demonstrated that the performance of the configuration under test is representative of the system in normal operation, and the conformance assessment is only applicable when the BS is used with the antenna system.

For testing of conformance of such a BS, the following procedure may be used:

#### 5.14.5.1 Receiver tests

For each test, the test signals applied to the receiver antenna connectors shall be such that the sum of the powers of the signals applied equals the power of the test signal(s) specified in the test.

An example of a suitable test configuration is shown in figure 5.1.



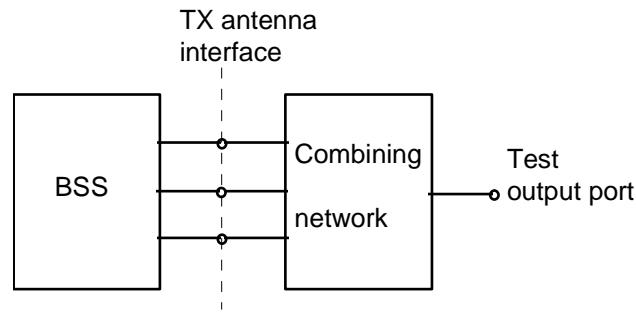
**Figure 5.1: Receiver test set up**

For spurious emissions from the receiver antenna connector, the test may be performed separately for each receiver antenna connector.

#### 5.14.5.2 Transmitter tests

For each test, the conformance requirement shall be met by the sum of the signals emitted by each transmitter antenna connector. This may be assessed by separately measuring the signals emitted by each antenna connector and summing the results, or by combining the signals and performing a single measurement. The characteristics (e.g. amplitude and phase) of the combining network should be such that the power of the combined signal is maximised.

An example of a suitable test configuration is shown in figure 5.2.



**Figure 5.2: Transmitter test setup**

For Intermodulation attenuation, the test may be performed separately for each transmitter antenna connector.

### 5.14.6 MIMO transmission

Unless otherwise stated, for the tests in clause 6 of the present document, the requirement applies for each transmitter antenna connector in the case of MIMO transmission.

Transmitter requirements are tested at the antenna connector, with the remaining antenna connector(s) being terminated. If the manufacturer has declared the transmitter paths to be equivalent, it is sufficient to measure the signal at any one of the transmitter antenna connectors.

## 5.15 Overview of the conformance test requirements

Tables 5.9, 5.10 and 5.11 give an overview of the conformance test requirements for the transmitter, the receiver and system performance, respectively. Requirements related to receive functionality for the BS under test do not apply for the case of MBSFN-only operation.



**Table 5.9: Overview of the conformance tests requirements for the transmitter**

| Parameter                                    | Subclause | Note                                |
|--|-----------|-------------------------------------|
| Maximum output power                         | 6.2       | manufacturer's declaration required |
| Frequency stability                          | 6.3       | manufacturer's declaration required |
| Output power dynamics                        | 6.4       |                                     |
| Inner loop power control                     | 6.4.1     |                                     |
| Power control steps                          | 6.4.2     |                                     |
| Power control dynamic range                  | 6.4.3     |                                     |
| Minimum output power                         | 6.4.4     |                                     |
| Primary CCPCH power                          | 6.4.5     |                                     |
| Differential accuracy of Primary CCPCH power | 6.4.6     |                                     |
| Transmit OFF power                           | 6.5.1     |                                     |
| Transmit ON/OFF time mask                    | 6.5.2     |                                     |
| Output RF spectrum emissions                 | 6.6       |                                     |
| Occupied bandwidth                           | 6.6.1     |                                     |
| Out-of-band emission                         | 6.6.2     |                                     |
| Spectrum emission mask                       | 6.6.2.1   | manufacturer's declaration required |
| Adjacent Channel Leakage power Ratio (ACLR)  | 6.6.2.2   | manufacturer's declaration required |
| Spurious emissions                           | 6.6.3     |                                     |
| Mandatory requirements                       | 6.6.3.2.1 | manufacturer's declaration required |
| Co-existence with GSM 900                    | 6.6.3.2.2 | manufacturer's declaration required |
| Co-existence with DCS 1800                   | 6.6.3.2.3 | manufacturer's declaration required |
| Co-existence with UTRA FDD                   | 6.6.3.2.4 | manufacturer's declaration required |
| Co-existence with unsynchronised TDD         | 6.6.3.2.5 | manufacturer's declaration required |
| Transmit intermodulation                     | 6.7       |                                     |
| Transmit modulation                          | 6.8       |                                     |
| Modulation accuracy                          | 6.8.1     |                                     |
| Peak code domain error                       | 6.8.2     |                                     |

**Table 5.10: Overview of the conformance tests requirements for the receiver**

| Parameter                          | Subclause | Note                                |
|------------------------------------|-----------|-------------------------------------|
| Reference sensitivity level        | 7.2       |                                     |
| Dynamic range                      | 7.3       |                                     |
| Adjacent Channel Selectivity (ACS) | 7.4       |                                     |
| Blocking characteristics           | 7.5       | manufacturer's declaration required |
| Intermodulation characteristics    | 7.6       |                                     |
| Spurious emissions                 | 7.7       |                                     |

**Table 5.11: Overview of the conformance test requirements for system performance**

| Parameter  | Subclause | Note |
|--|-----------|------|
| Demodulation in static propagation conditions      | 8.2       |      |
| Demodulation of DCH                                | 8.2.1     |      |
| Demodulation of DCH in multipath fading conditions | 8.3       |      |
| Multipath fading Case 1                            | 8.3.1     |      |
| Multipath fading Case 2                            | 8.3.2     |      |
| Multipath fading Case 3                            | 8.3.3     |      |
| Demodulation of DCH in high speed train conditions | 8.3A      |      |

## 5.16 Format and interpretation of tests

Each test in the following clauses has a standard format:

### **X Title**

The title gives the name of the parameter to be tested.

### **X.1 Definition and applicability**

This subclause gives the general definition of the parameter under consideration and specifies whether the test is applicable to all equipment or to a certain subset only.

### **X.2 Minimum Requirements**

This subclause is an informative copy of the Minimum Requirements defined by the core specification.

In addition, this subclause contains the reference to the subclause of the 3GPP reference (or core) specification which defines the Minimum Requirements.

### **X.3 Test purpose**

This subclause defines the purpose of the test.

### **X.4 Method of test**

#### **X.4.1 Initial conditions**

This subclause defines the initial conditions for each test, including the test environment, the RF channels to be tested and the basic measurement setup.

#### **X.4.2 Procedure**

This subclause describes the steps necessary to perform the test and provides further details of the test definition like point of access (e.g. antenna port), domain (e.g. frequency-span), range, weighting (e.g. bandwidth), and algorithms (e.g. averaging).

### **X.5 Test Requirements**

This subclause defines the pass/fail criteria for the equipment under test. See subclause 5.12 Interpretation of measurement results.

## 5.17 Regional requirements

Some requirements in this specification may only apply in certain regions. Table 5.12 lists all requirements that may be applied differently in different regions.

Table 5.12: List of regional requirements

| Subclause number | Requirement  | Comments   |
|------------------|--|--|
| 4.1              | General  | Only 3,84 Mcps and 7,68 Mcps TDD options are currently applicable in Japan.  |
| 4.2              | Frequency bands  | Some bands may be applied regionally.  |
| 5.1              | Base station classes   | Only requirements for Wide Area Base Stations shall be applied as regional requirements in Japan.  |
| 6.2.2            | Maximum output power   | In certain regions, the minimum requirement for normal conditions may apply also for some conditions outside the ranges defined for the Normal test environment in subclause 5.8.1 |
| 6.6.2.1.         | Spectrum emission mask   | The mask specified may be mandatory in certain regions. In other regions this mask may not be applied.   |
| 6.6.3.2.1.1      | Spurious emissions (Category A)  | These requirements shall be met in cases where Category A limits for spurious emissions, as defined in ITU-R Recommendation SM.329 [6], are applied.                               |
| 6.6.3.2.1.2      | Spurious emissions (Category B)  | These requirements shall be met in cases where Category B limits for spurious emissions, as defined in ITU-R Recommendation SM.329 [6], are applied.                               |
| 6.6.3.2.2.1      | Co-existence with GSM900 - Operation in the same geographic area             | This requirement may be applied for the protection of GSM 900 MS and GSM 900 BTS in geographic areas in which both GSM 900 and UTRA are deployed.                                  |
| 6.6.3.2.2.2      | Co-existence with GSM900 - Co-located base stations                          | This requirement may be applied for the protection of GSM 900 BTS receivers when GSM 900 BTS and UTRA BS are co-located.   |
| 6.6.3.2.3.1      | Co-existence with DCS1800 - Operation in the same geographic area            | This requirement may be applied for the protection of DCS 1800 MS and DCS 1800 BTS in geographic areas in which both DCS 1800 and UTRA are deployed.                               |
| 6.6.3.2.3.2      | Co-existence with DCS1800 - Co-located base stations                         | This requirement may be applied for the protection of DCS 1800 BTS receivers when DCS 1800 BTS and UTRA BS are co-located.   |
| 6.6.3.2.4.1      | Co-existence with UTRA FDD - Operation in the same geographic area           | This requirement may be applied to geographic areas in which both UTRA-TDD and UTRA-FDD are deployed.  |
| 6.6.3.2.4.2      | Co-existence with UTRA FDD - Co-located base stations                        | This requirement may be applied for the protection of UTRA-FDD BS receivers when UTRA-TDD BS and UTRA FDD BS are co-located.   |
| 6.6.3.2.5.1      | Co-existence with unsynchronised TDD - Operation in the same geographic area | This requirement may be applied for the protection of TDD BS receivers in geographic areas in which unsynchronised TDD is deployed.  |
| 6.6.3.2.5.2      | Co-existence with unsynchronised TDD - Co-located base stations              | This requirement may be applied for the protection of TDD BS receivers when unsynchronised TDD BS are co-located.  |
| 6.6.3.2.6        | Co-existence with PHS  | This requirement may be applied for the protection of PHS in geographic areas in which both PHS and UTRA TDD are deployed.   |
| 7.5              | Blocking characteristic  | The requirement is applied according to what frequency bands in subclause 4.2 that are supported by the BS.  |
| 7.5              | Blocking characteristics   | This requirement may be applied for the protection of UTRA TDD BS receivers when UTRA TDD BS and GSM 900/DCS1800 BS are co-located.  |

## 5.18 Definition of Additive White Gaussian Noise (AWGN) Interferer

The minimum bandwidth of the AWGN interferer shall be 1,5 times chip rate of the radio access mode (e.g. 5,76 MHz for a chip rate of 3,84 Mcps and 1,92 MHz for a chip rate of 1,28 Mcps). The flatness across this minimum bandwidth shall be within  $\pm 0,5$  dB, and the peak to average ratio at a probability of 0,001% shall exceed 10 dB.

## 5.19 Applicability of requirements

For BS that is UTRA TDD (single-RAT) capable only, the requirements in the present document are applicable and additional conformance to TS 37.141 [12] is optional. For a BS additionally conforming to TS 37.141 [12], conformance to some of the RF requirements in the present document can be demonstrated through the corresponding requirements in TS 37.141 [12] as listed in Table 5.13

**Table 5.13: Alternative RF test requirements for a BS additionally conforming to TS 37.141 [12]**

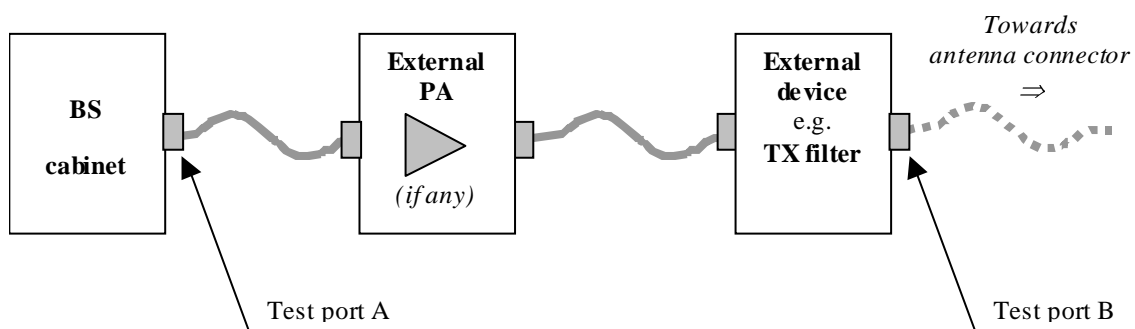
| RF requirement                       | Clause in the present document | Alternative clause in TS 37.141 [16]         |
|--------------------------------------|--------------------------------|--|
| Base station output power            | 6.2.5                          | 6.2.1<br>6.2.2                               |
| Transmit OFF power                   | 6.5.1.5                        | 6.4  |
| Transmit ON/OFF time mask            | 6.5.2.5                        | 6.4  |
| Unwanted emissions                   |                                |  |
| Spectrum emission mask               | 6.6.2.1.5                      | 6.6.2.5.1                                    |
| Transmitter spurious emissions       | 6.6.3.5                        | 6.6.1.5 (except for 6.6.1.5.3 and 6.6.1.5.4) |
| Transmitter intermodulation          | 6.7.5                          | 6.7.5.1&6.7.5.3                              |
| Blocking                             | 7.5.5                          | 7.4.5.1 and 7.4.5.5                          |
| Out-of-band blocking                 | 7.5.5                          | 7.5.5.1                                      |
| Co-location with other base stations | 7.5.5                          | 7.5.5.2                                      |
| Receiver spurious emissions          | 7.7.5                          | 7.6.5.1                                      |
| Intermodulation                      | 7.6.5                          | 7.7.5.1                                      |

## 6 Transmitter characteristics

### 6.1 General

Unless otherwise stated, the requirements in clause 6 are expressed for a single transmitter antenna connector. In case of MIMO transmission, the requirements apply for each transmitter antenna connector.

Unless otherwise stated, all measurements shall be made at the BS antenna connector (test port A) with a full complement of transceivers for the configuration in normal operating conditions. If any external apparatus such as a TX amplifier, a filter or the combination of such devices is used, the tests according to subclauses 5.14.4 shall be performed to ensure that the requirements are met at test port B.



**Figure 6.1: Transmitter test ports**

### IMB Test Models

The set-up of physical channels for IMB transmitter tests shall be according with the test models below.

### 6.1.1.1 IMB Test Model 1

This model shall apply to QPSK tests.

**Table 6.0A: IMB Test Model 1 Active Channels**

| Type                                | Number of Channels | Time Activity          | Fraction of Power (when channel is active) (%) | Level setting (per code) ( dB) | Channelisati on Code Index |
|-------------------------------------|--------------------|------------------------|--|--------------------------------|----------------------------|
| P-CCPCH+SCH                         | 1                  | All slots              | 10   | -10                            | 1                          |
| P-CPICH                             | 1                  | All slots              | 10   | -10                            | 0                          |
| T-CPICH                             | 1                  | All slots              | 90   | -12.22                         | 1-15                       |
| S-CCPCH Frame Type 1 (SF=256, QPSK) | 1                  | All slots              | 0.5  | -23                            | 3                          |
| S-CCPCH Frame Type 2 (SF=16, QPSK)  | 15                 | Sub-frames {0,1,2,3,4} | 79.5   | -12.75                         | 1-15                       |

The Base Station output power is set according to PRAT.

### 6.1.1.2 IMB Test Model 2

This model shall apply to 16QAM tests.

**Table 6.0B: IMB Test Model 2 Active Channels**

| Type                                | Number of Channels | Time Activity          | Fraction of Power (when channel is active) (%) | Level setting (per code) ( dB) | Channelisati on Code Index |
|-------------------------------------|--------------------|------------------------|--|--------------------------------|----------------------------|
| P-CCPCH+SCH                         | 1                  | All slots              | 10   | -10                            | 1                          |
| P-CPICH                             | 1                  | All slots              | 10   | -10                            | 0                          |
| T-CPICH                             | 1                  | All slots              | 90   | -12.22                         | 1-15                       |
| S-CCPCH Frame Type 1 (SF=256, QPSK) | 1                  | All slots              | 0.5  | -23                            | 3                          |
| S-CCPCH Frame Type 2 (SF=16, 16QAM) | 15                 | Sub-frames {0,1,2,3,4} | 79.5   | -12.75                         | 1-15                       |

The Base Station output power is set according to PRAT.

## 6.2 Maximum output power

### 6.2.1 Definition and applicability

Maximum output power (Pmax) and rated output power (PRAT) are defined in subclause 3.1.

The requirements in this subclause shall apply to both Wide Area BS and Local Area BS.

### 6.2.2 Minimum Requirements

In normal conditions, the base station maximum output power shall remain within +2 dB and -2 dB of the manufacturer's rated output power.

In extreme conditions, the base station maximum output power shall remain within +2,5 dB and -2,5 dB of the manufacturer's rated output power.

In certain regions, the minimum requirement for normal conditions may apply also for some conditions outside the ranges defined for the Normal test environment in subclause 5.9.1.

The normative reference for this requirement is TS 25.105 [1] subclause 6.2.1.1.

## 6.2.3 Test purpose

The test purpose is to verify the accuracy of the maximum output power across the frequency range and under normal and extreme conditions for all transmitters in the BS.

## 6.2.4 Method of test

### 6.2.4.1 Initial conditions

#### 6.2.4.1.0 General test conditions

Test environment: normal; see subclause 5.9.1.

RF channels to be tested: B, M and T; see subclause 5.3.

In addition, on one UARFCN only, the test shall be performed under extreme power supply as defined in subclause 5.9.4.

NOTE: Tests under extreme power supply also test extreme temperature.

#### 6.2.4.1.1 3,84 Mcps TDD option

- (1) The transmitter under test and all other transmitters of the base station (if any) are switched on.
- (2) The power of the transmitters not under test (if any) are controlled down.
- (3) Connect the power measuring equipment to the BS antenna connector.
- (4) Set the parameters of the transmitted signal according to table 6.1. For MBSFN IMB operation the set of parameters for the transmitted signals is according to IMB test model 1 in subclause 6.1.1.1.

**Table 6.1: Parameters of the transmitted signal for maximum output power test**

| Parameter                                  | Value/description   |
|--|---|
| TDD Duty Cycle                             | TS $i$ ; $i = 0, 1, 2, \dots, 14$ :<br>transmit, if $i$ is even;<br>receive, if $i$ is odd. |
| Time slot carrying SCH                     | TS0   |
| Time slots under test                      | TS $i$ , $i$ even and non zero  |
| BS output power setting                    | PRAT  |
| Number of DPCH in eachtime slot under test | 9   |
| Power of each DPCH                         | 1/9 of Base Station output power  |
| Data content of DPCH                       | real life (sufficient irregular)  |

#### 6.2.4.1.2 1,28 Mcps TDD option

- (1) The transmitter under test and all other transmitters of the base station (if any) are switched on.
- (2) The power of the transmitters not under test (if any) are controlled down.
- (3) Connect the power measuring equipment to the BS antenna connector.
- (4) Set the parameters of the transmitted signal according to table 6.1A.

**Table 6.1A: Parameters of the transmitted signal for maximum output power test for 1,28 Mcps TDD**

| Parameter                                   | Value/description   |
|---|---|
| TDD Duty Cycle                              | TS $i$ ; $i = 0, 1, 2, 3, 4, 5, 6$ :<br>transmit, if $i$ is 0,4,5,6;<br>receive, if $i$ is 1,2,3. |
| Time slots under test                       | TS4, TS5 and TS6  |
| BS output power setting                     | PRAT  |
| Number of DPCH in each time slot under test | 8   |
| Power of each DPCH                          | 1/8 of Base Station output power  |
| Data content of DPCH                        | real life (sufficient irregular)  |

#### 6.2.4.1.3 7,68 Mcps TDD option

- (1) The transmitter under test and all other transmitters of the base station (if any) are switched on.
- (2) The power of the transmitters not under test (if any) are controlled down.
- (3) Connect the power measuring equipment to the BS antenna connector.
- (4) Set the parameters of the transmitted signal according to table 6.1AA.

**Table 6.1AA: Parameters of the transmitted signal for maximum output power test**

| Parameter                                   | Value/description   |
|---|---|
| TDD Duty Cycle                              | TS $i$ ; $i = 0, 1, 2, \dots, 14$ :<br>transmit, if $i$ is even;<br>receive, if $i$ is odd. |
| Time slot carrying SCH                      | TS0   |
| Time slots under test                       | TS $i$ , $i$ even and non zero  |
| BS output power setting                     | PRAT  |
| Number of DPCH in each time slot under test | 9   |
| Power of each DPCH                          | 1/9 of Base Station output power  |
| Data content of DPCH                        | real life (sufficient irregular)  |

#### 6.2.4.2 Procedure

##### 6.2.4.2.1 3,84 Mcps TDD option

- (1) Measure the output power of the BS signal.
- (2) Run step (1) for RF channels Low / Mid / High.

##### 6.2.4.2.2 1,28 Mcps TDD option

- (1) Measure the output power of the BS signal.
- (2) Run step (1) for RF channels Low / Mid / High.

##### 6.2.4.2.3 7,68 Mcps TDD option

- (1) Measure the output power of the BS signal.
- (2) Run step (1) for RF channels Low / Mid / High.

## 6.2.5 Test Requirements

NOTE: If the Test Requirement below differs from the Minimum Requirement, then the Test Tolerance applied for this test is non-zero. The Test Tolerance for this test is defined in subclause 5.11 and the explanation of how the Minimum Requirement has been relaxed by the Test Tolerance is given in Annex D.

In normal conditions, the measured output power, derived according to subclause 6.2.4.2, shall remain within +2,7 dB and -2,7 dB of the manufacturer's rated output power.

In extreme conditions, the measured output power, derived according to subclause 6.2.4.2, shall remain within +3,2 dB and -3,2 dB of the manufacturer's rated output power.

## 6.3 Frequency stability

### 6.3.1 Definition and applicability

Frequency stability is the ability of the BS to transmit at the assigned carrier frequency.

In this subclause, different requirements shall apply to Wide Area BS and Local Area BS.

### 6.3.2 Minimum Requirements

The modulated carrier frequency of the BS is observed over a period of one timeslot. The frequency error shall be within the accuracy range given in Table 6.1B.

**Table 6.1B: Frequency error Minimum Requirements**

| BS class      | Accuracy       |
|---------------|----------------|
| Wide Area BS  | $\pm 0,05$ ppm |
| Local Area BS | $\pm 0,1$ ppm  |

The normative reference for this requirement is TS 25.105 [1] subclause 6.3.1.1 for the 3,84 Mcps TDD option, subclause 6.3.1.2 for the 1,28 Mcps TDD option and subclause 6.3.1.3 for the 7,68 Mcps TDD option.

TS 25.105 subclause 6.3 specifies the additional requirement that the BS shall use the same frequency source for both RF generation and the chip clock. Compliance with this requirement is demonstrated by manufacturer's declaration; see subclause 5.4; a dedicated conformance test for this requirement is not defined.

### 6.3.3 Test purpose

The test purpose is to verify the accuracy of the carrier frequency across the frequency range and under normal and extreme conditions.

### 6.3.4 Method of test

#### 6.3.4.1 Initial conditions

##### 6.3.4.1.0 General test conditions

Test environment: normal; see subclause 5.9.1.

RF channels to be tested: B, M and T; see subclause 5.3.

The following additional test shall be performed:

On each of B, M and T, the test shall be performed under extreme power supply as defined in subclause 5.9.4.

NOTE: Tests under extreme power supply also test extreme temperature.



#### 6.3.4.1.1 3,84 Mcps TDD option

- (1) The transmitter under test and all other transmitters of the base station (if any) are switched on.
- (2) The power of the transmitters not under test (if any) are controlled down.
- (3) Connect the tester to the BS antenna connector.
- (4) Set the parameters of the transmitted signal according to table 6.2. For MBSFN IMB operation the set of parameters for the transmitted signals is according to IMB test model 1 in subclause 6.1.1.1.

**Table 6.2: Parameters of the transmitted signal for frequency stability test**

| Parameter                                   | Value/description   |
|---|---|
| TDD Duty Cycle                              | TS $i$ ; $i = 0, 1, 2, \dots, 14$ :<br>transmit, if $i$ is even;<br>receive, if $i$ is odd. |
| Time slot carrying SCH                      | TS0   |
| Time slots under test                       | TS $i$ , $i$ even and non zero  |
| Number of DPCH in each time slot under test | 1   |
| BS output power setting                     | PRAT  |
| Data content of DPCH                        | real life (sufficient irregular)  |

#### 6.3.4.1.2 1,28 Mcps TDD option

- (1) The transmitter under test and all other transmitters of the base station (if any) are switched on.
- (2) The power of the transmitters not under test (if any) are controlled down.
- (3) Connect the tester to the BS antenna connector.
- (4) Set the parameters of the transmitted signal according to table 6.2A.

**Table 6.2A: Parameters of the transmitted signal for Frequency stability test for 1,28 Mcps TDD**

| Parameter                                   | Value/description  |
|---|--|
| TDD Duty Cycle                              | TS $i$ ; $i = 0, 1, 2, \dots, 6$ :<br>transmit, if $i$ is 0, 4,5,6;<br>receive, if $i$ is 1,2,3. |
| Time slots under test                       | TS4, TS5 and TS6   |
| Number of DPCH in each time slot under test | 1  |
| BS output power setting                     | PRAT   |
| Data content of DPCH                        | real life (sufficient irregular)   |

#### 6.3.4.1.3 7,68 Mcps TDD option

- (1) The transmitter under test and all other transmitters of the base station (if any) are switched on.
- (2) The power of the transmitters not under test (if any) are controlled down.
- (3) Connect the tester to the BS antenna connector.
- (4) Set the parameters of the transmitted signal according to table 6.2AA.

**Table 6.2AA: Parameters of the transmitted signal for frequency stability test**

| Parameter                                   | Value/description   |
|---|---|
| TDD Duty Cycle                              | TS $i$ ; $i = 0, 1, 2, \dots, 14$ :<br>transmit, if $i$ is even;<br>receive, if $i$ is odd. |
| Time slot carrying SCH                      | TS0   |
| Time slots under test                       | TS $i$ , $i$ even and non zero  |
| Number of DPCH in each time slot under test | 1   |
| BS output power setting                     | PRAT  |
| Data content of DPCH                        | real life (sufficient irregular)  |

### 6.3.4.2 Procedure

- (1) Measure the frequency error  $\Delta f$  across one burst (time slot), by applying the global in-channel Tx test method described in Annex C.
- (2) Repeat step (1) for 200 bursts (time slots).
- (3) Run steps (1) and (2) for RF channels Low / Mid / High.

### 6.3.5 Test Requirements

NOTE: If the Test Requirement below differs from the Minimum Requirement, then the Test Tolerance applied for this test is non-zero. The Test Tolerance for this test is defined in subclause 5.11 and the explanation of how the Minimum Requirement has been relaxed by the Test Tolerance is given in Annex D.

For all measured bursts (time slots), the frequency error, derived according to subclause 6.3.4.2, shall be within the accuracy range given in table 6.2B.

**Table 6.2B: Frequency error Test Requirements**

| BS class      | Accuracy                                 |
|---------------|--|
| Wide Area BS  | $\pm (0,05 \text{ ppm} + 12 \text{ Hz})$ |
| Local Area BS | $\pm (0,1 \text{ ppm} + 12 \text{ Hz})$  |

## 6.4 Output power dynamics

### 6.4.1 Inner loop power control

Inner loop power control is the ability of the BS transmitter to adjust its code domain power in response to the UL received signal.

For inner loop correction on the Downlink Channel, the base station adjusts the code domain power of a power controlled CCTrCH in response to each valid power control bit received from the UE on the Uplink Traffic Channel based on the mapping of the TPC bits in uplink CCTrCH to downlink CCTrCH. Inner loop control is based on SIR measurements at the UE receiver, and the corresponding TPC commands are generated by the UE.

### 6.4.2 Power control steps

#### 6.4.2.1 Definition and applicability

The power control step is the step change in the DL code domain power in response to a TPC message from the UE.

The requirements in this subclause shall apply to both Wide Area BS and Local Area BS.

### 6.4.2.2 Minimum Requirements

The power control step sizes in the DL shall be 1 dB, 2 dB and 3 dB.

The tolerance of the code domain power and the greatest average rate of change in code domain power due to the power control step shall be within the range shown in Table 6.3.

**Table 6.3: Power control step size tolerance**

| Step size | Tolerance     | Range of average rate of change in code domain power per 10 steps |             |
|-----------|---------------|---|-------------|
|           |               | Minimum   | maximum     |
| 1 dB      | $\pm 0,5$ dB  | $\pm 8$ dB  | $\pm 12$ dB |
| 2 dB      | $\pm 0,75$ dB | $\pm 16$ dB   | $\pm 24$ dB |
| 3 dB      | $\pm 1$ dB    | $\pm 24$ dB   | $\pm 36$ dB |

The normative reference for this requirement is TS 25.105 [1] subclause 6.4.2.1.

### 6.4.2.3 Test purpose

The DL power control is applied to adjust the BS code domain power to a value that is sufficiently high to generate a SIR at the UE receiver equal to the target SIR, while limiting the intercell interference.

The test purpose is to verify the ability of the BS to interpret received TPC commands in a correct way and to adjust its code domain power according to these commands with the specified accuracy.

### 6.4.2.4 Method of test

#### 6.4.2.4.1 Initial conditions

##### 6.4.2.4.1.0 General test conditions

Test environment: normal; see subclause 5.9.1.

RF channels to be tested: B, M and T; see subclause 5.3.

##### 6.4.2.4.1.1 3,84 Mcps TDD option

- (1) Connect the BS tester to the antenna connector of the BS under test.
- (2) Disable closed loop power control in the BS under test.
- (3) Set the initial parameters of the BS transmitted signal according to table 6.4.
- (4) Operate the BS in such a mode that it is able to interpret received TPC commands.
- (5) Start BS transmission.

NOTE: The BS tester used for this test must have the ability:

- to analyze the output signal of the BS under test with respect to code domain power, by applying the global in-channel Tx test method described in Annex C;
- to simulate an UE with respect to the generation of TPC commands embedded in a valid UE signal.

**Table 6.4: Initial parameters of the BS transmitted signal for power control steps test**

| Parameter                                   | Value/description   |
|---|---|
| TDD Duty Cycle                              | TS $i$ ; $i = 0, 1, 2, \dots, 14$ :<br>transmit, if $i$ is even;<br>receive, if $i$ is odd. |
| Time slot carrying SCH                      | TS0   |
| Time slots under test                       | TS $i$ , $i$ even and non zero  |
| Number of DPCH in each time slot under test | 1   |
| DPCH power                                  | Minimum   |
| Data content of DPCH                        | real life (sufficient irregular)  |

#### 6.4.2.4.1.2 1,28 Mcps TDD option

- (1) Connect the BS tester to the antenna connector of the BS under test.
- (2) Disable closed loop power control in the BS under test.
- (3) Set the initial parameters of the BS transmitted signal according to table 6.4A.
- (4) Operate the BS in such a mode that it is able to interpret received TPC commands.
- (5) Start BS transmission.

NOTE: The BS tester used for this test must have the ability

- to analyze the output signal of the BS under test with respect to code domain power, by applying the global in-channel Tx test method described in Annex C;
- to simulate an UE with respect to the generation of TPC commands embedded in a valid UE signal.

**Table 6.4A: Initial parameters of the BS transmitted signal for power control steps test for 1,28 Mcps TDD**

| Parameter                                   | Value/description  |
|---|--|
| TDD Duty Cycle                              | TS $i$ ; $i = 0, 1, 2, \dots, 6$ :<br>transmit, if $i$ is 0, 4,5,6;<br>receive, if $i$ is 1,2,3. |
| Time slots under test                       | TS4, TS5 and TS6   |
| Number of DPCH in each time slot under test | 1  |
| DPCH power                                  | Minimum  |
| Data content of DPCH                        | real life (sufficient irregular)   |

#### 6.4.2.4.1.3 7,68 Mcps TDD option

- (1) Connect the BS tester to the antenna connector of the BS under test.
- (2) Disable closed loop power control in the BS under test.
- (3) Set the initial parameters of the BS transmitted signal according to table 6.4B.
- (4) Operate the BS in such a mode that it is able to interpret received TPC commands.
- (5) Start BS transmission.

NOTE: The BS tester used for this test must have the ability:

- to analyze the output signal of the BS under test with respect to code domain power, by applying the global in-channel Tx test method described in Annex C;
- to simulate an UE with respect to the generation of TPC commands embedded in a valid UE signal.

**Table 6.4B: Initial parameters of the BS transmitted signal for power control steps test**

| Parameter                                   | Value/description   |
|---|---|
| TDD Duty Cycle                              | TS $i$ ; $i = 0, 1, 2, \dots, 14$ :<br>transmit, if $i$ is even;<br>receive, if $i$ is odd. |
| Time slot carrying SCH                      | TS0   |
| Time slots under test                       | TS $i$ , $i$ even and non zero  |
| Number of DPCH in each time slot under test | 1   |
| DPCH power                                  | Minimum   |
| Data content of DPCH                        | real life (sufficient irregular)  |

#### 6.4.2.4.2 Procedure

##### 6.4.2.4.2.1 3,84 Mcps TDD option

- (1) Configure the BS transmitter to enable power control steps of size 1 dB.
- (2) Set the BS tester to produce a sequence of TPC commands related to the active DPCH. This sequence shall be transmitted to the BS within the odd time slots TS  $i$  (receive time slots of the BS) and shall consist of a series of TPC commands with content "Increase Tx power", followed by a series of TPC commands with content "Decrease Tx power". Each of these series should be sufficiently long so that the code domain power of the active DPCH is controlled to reach its maximum and its minimum, respectively.
- (3) Measure the code domain power of the active DPCH over the 2464 active chips of each even time slot TS  $i$  (this excludes the guard period) by applying the global in-channel Tx test method described in Annex C.
- (4) Based on the measurement made in step (3), calculate the power control step sizes and the average rate of change per 10 steps.
- (5) Configure the BS transmitter to enable power control steps of 2 dB and of 3 dB, respectively, and repeat steps (2) to (4).

##### 6.4.2.4.2.2 1,28 Mcps TDD option

- (1) Configure the BS transmitter to enable power control steps of size 1 dB.
- (2) Set the BS tester to produce a sequence of TPC commands related to the active DPCH. This sequence shall be transmitted to the BS within receive time TS  $i$  slots of the BS and shall consist of a series of TPC commands with content "Increase Tx power", followed by a series of TPC commands with content "Decrease Tx power". Each of these series should be sufficiently long so that the code domain power of the active DPCH is controlled to reach its maximum and its minimum, respectively.
- (3) Measure the code domain power of the active DPCH over the 848 active chips of each transmit time slot TS  $i$  of the BS (this excludes the guard period) by applying the global in-channel Tx test method described in Annex C.
- (4) Based on the measurement made in step (3), calculate the power control step sizes and the average rate of change per 10 steps.
- (5) Configure the BS transmitter to enable power control steps of 2 dB and of 3 dB, respectively, and repeat steps (2) to (4).

##### 6.4.2.4.2.3 7,68 Mcps TDD option

- (1) Configure the BS transmitter to enable power control steps of size 1 dB.
- (2) Set the BS tester to produce a sequence of TPC commands related to the active DPCH. This sequence shall be transmitted to the BS within the odd time slots TS  $i$  (receive time slots of the BS) and shall consist of a series of TPC commands with content "Increase Tx power", followed by a series of TPC commands with content "Decrease Tx power". Each of these series should be sufficiently long so that the code domain power of the active DPCH is controlled to reach its maximum and its minimum, respectively.

- (3) Measure the code domain power of the active DPCH over the 4928 active chips of each even time slot TS  $i$  (this excludes the guard period) by applying the global in-channel Tx test method described in Annex C.
- (4) Based on the measurement made in step (3), calculate the power control step sizes and the average rate of change per 10 steps.
- (5) Configure the BS transmitter to enable power control steps of 2 dB and of 3 dB, respectively, and repeat steps (2) to (4).

### 6.4.2.5 Test Requirements

NOTE: If the Test Requirements below differ from the Minimum Requirement, then the Test Tolerance applied for this test is non-zero. The Test Tolerance for this test is defined in subclause 5.1.1 and the explanation of how the Minimum Requirement has been relaxed by the Test Tolerance is given in Annex D.

#### 6.4.2.5.1 3,84 Mcps TDD option

For all measurements, the tolerance of the power control step sizes and the average rate of change per 10 steps shall be within the limits given in Table 6.5.

**Table 6.5: Test Requirements for power control step size tolerance**

| Step size | Single step tolerance | Range of average rate of change in code domain power per 10 steps |               |
|-----------|-----------------------|---|---------------|
|           |                       | Minimum   | maximum       |
| 1dB       | $\pm 0,6$ dB          | $\pm 7,7$ dB  | $\pm 12,3$ dB |
| 2dB       | $\pm 0,85$ dB         | $\pm 15,7$ dB   | $\pm 24,3$ dB |
| 3dB       | $\pm 1,1$ dB          | $\pm 23,7$ dB   | $\pm 36,3$ dB |

In case, the power control step size is set to 3 dB, the number of power control steps feasible within the power control dynamic range of the BS under test may be less than 10. In this case, the evaluation of the average rate of change in code domain power shall be based on the number of power control steps actually feasible, and the permitted range of average rate of change shall be reduced compared to the values given in table 6.5 in proportion to the ratio (number of power control steps actually feasible /10).

EXAMPLE: If the number of power control steps actually feasible is 9, the minimum and maximum value of the range of average rate of change in code domain power are given by  $\pm 21,3$  dB and  $\pm 32,7$  dB, respectively.

#### 6.4.2.5.2 1,28 Mcps TDD option

For all measurements, the tolerance of the power control step sizes and the average rate of change per 10 steps shall be within the limits given in Table 6.5.

In case, the power control step size is set to 3 dB, the number of power control steps feasible within the power control dynamic range of the BS under test may be less than 10. In this case, the evaluation of the average rate of change in code domain power shall be based on the number of power control steps actually feasible, and the permitted range of average rate of change shall be reduced compared to the values given in table 6.5 in proportion to the ratio (number of power control steps actually feasible /10).

EXAMPLE: If the number of power control steps actually feasible is 9, the minimum and maximum value of the range of average rate of change in code domain power are given by 21,6 dB and 32,4 dB, respectively.

#### 6.4.2.5.3 7,68 Mcps TDD option

For all measurements, the tolerance of the power control step sizes and the average rate of change per 10 steps shall be within the limits given in Table 6.5.

In case, the power control step size is set to 3 dB, the number of power control steps feasible within the power control dynamic range of the BS under test may be less than 10. In this case, the evaluation of the average rate of change in

code domain power shall be based on the number of power control steps actually feasible, and the permitted range of average rate of change shall be reduced compared to the values given in table 6.5 in proportion to the ratio (number of power control steps actually feasible /10).

EXAMPLE: If the number of power control steps actually feasible is 9, the minimum and maximum value of the range of average rate of change in code domain power are given by  $\pm 21,3$  dB and  $\pm 32,7$  dB, respectively.

### 6.4.3 Power control dynamic range

#### 6.4.3.1 Definition and applicability

The power control dynamic range is the difference between the maximum and the minimum code domain power of one power controlled code channel for a specified reference condition.

The requirements in this subclause shall apply to both Wide Area BS and Local Area BS.

#### 6.4.3.2 Minimum Requirements

The DL power control dynamic range shall be greater than or equal to 30 dB.

The normative reference for this requirement is TS 25.105 [1] subclause 6.4.3.1.

#### 6.4.3.3 Test purpose

The test purpose is to verify the ability of the BS to control the code domain power of a single code signal over the specified dynamic range.

#### 6.4.3.4 Method of test

##### 6.4.3.4.1 Initial conditions

###### 6.4.3.4.1.0 General test conditions

Test environment: normal; see subclause 5.9.1.

RF channels to be tested: B, M and T; see subclause 5.3.

###### 6.4.3.4.1.1 3,84 Mcps TDD option

- (1) Connect the BS tester to the antenna connector of the BS under test.
- (2) Set the parameters of the BS transmitted signal according to table 6.6.
- (3) Operate the BS in such a mode that it is able to interpret received TPC commands
- (4) Start BS transmission.

NOTE: The BS tester used for this test must have the ability:

- to analyze the output signal of the BS under test with respect to code domain power, by applying the global in-channel Tx test method described in Annex C;
- to simulate an UE with respect to the generation of TPC commands embedded in a valid UE signal.

**Table 6.6: Parameters of the BS transmitted signal for power control dynamic range test**

| Parameter                                   | Value/description   |
|---|---|
| TDD Duty Cycle                              | TS $i$ ; $i = 0, 1, 2, \dots, 14$ :<br>transmit, if $i$ is even;<br>receive, if $i$ is odd. |
| Time slot carrying SCH                      | TS0   |
| Time slots under test                       | TS $i$ , $i$ even and non zero  |
| Number of DPCH in each time slot under test | 1   |
| Data content of DPCH                        | real life (sufficient irregular)  |

#### 6.4.3.4.1.2 1,28 Mcps TDD option

- (1) Connect the BS tester to the antenna connector of the BS under test.
- (2) Set the parameters of the BS transmitted signal according to table 6.6A.
- (3) Operate the BS in such a mode that it is able to interpret received TPC commands
- (4) Start BS transmission.

NOTE: The BS tester used for this test must have the ability

- to analyze the output signal of the BS under test with respect to code domain power, by applying the global in-channel Tx test method described in Annex C;
- to simulate an UE with respect to the generation of TPC commands embedded in a valid UE signal.

**Table 6.6A: Parameters of the BS transmitted signal for power control dynamic range test for 1,28 Mcps TDD**

| Parameter                                   | Value/description  |
|---|--|
| TDD Duty Cycle                              | TS $i$ ; $i = 0, 1, 2, \dots, 6$ :<br>transmit, if $i$ is 0, 4,5,6;<br>receive, if $i$ is 1,2,3. |
| Time slots under test                       | TS4, TS5 and TS6   |
| Number of DPCH in each time slot under test | 1  |
| Data content of DPCH                        | real life (sufficient irregular)   |

#### 6.4.3.4.1.3 7,68 Mcps TDD option

- (1) Connect the BS tester to the antenna connector of the BS under test.
- (2) Set the parameters of the BS transmitted signal according to table 6.6B.
- (3) Operate the BS in such a mode that it is able to interpret received TPC commands
- (4) Start BS transmission.

NOTE: The BS tester used for this test must have the ability:

- to analyze the output signal of the BS under test with respect to code domain power, by applying the global in-channel Tx test method described in Annex C;
- to simulate an UE with respect to the generation of TPC commands embedded in a valid UE signal.



**Table 6.6B: Parameters of the BS transmitted signal for power control dynamic range test**

| Parameter                                   | Value/description   |
|---|---|
| TDD Duty Cycle                              | TS $i$ ; $i = 0, 1, 2, \dots, 14$ :<br>transmit, if $i$ is even;<br>receive, if $i$ is odd. |
| Time slot carrying SCH                      | TS0   |
| Time slots under test                       | TS $i$ , $i$ even and non zero  |
| Number of DPCH in each time slot under test | 1   |
| Data content of DPCH                        | real life (sufficient irregular)  |

#### 6.4.3.4.2 Procedure

##### 6.4.3.4.2.1 3,84 Mcps TDD option

- (1) Configure the BS transmitter to enable power control steps of size 1 dB.
- (2) Set the BS tester to produce a sequence of TPC commands related to the active DPCH, with content "Increase Tx power". This sequence shall be sufficiently long so that the code domain power of the active DPCH is controlled to reach its maximum, and shall be transmitted to the BS within the odd time slots TS  $i$  (receive time slots of the BS).
- (3) Measure the code domain power of the active DPCH over the 2464 active chips of an even time slot TS  $i$  (this excludes the guard period) by applying the global in-channel Tx test method described in Annex C.
- (4) Set the BS tester to produce a sequence of TPC commands related to the active DPCH, with content "Decrease Tx power". This sequence shall be sufficiently long so that the code domain power of the active DPCH is controlled to reach its minimum, and shall be transmitted to the BS within the odd time slots TS  $i$  (receive time slots of the BS).
- (5) Measure the code domain power of the active DPCH over the 2464 active chips of an even time slot TS  $i$  (this excludes the guard period) by applying the global in-channel Tx test method described in Annex C.
- (6) Determine the power control dynamic range by calculating the difference between the maximum code domain power measured in step (3) and the minimum code domain power measured in step (5).
- (7) Configure the BS transmitter to enable power control steps of 2 dB and of 3 dB, respectively, and repeat steps (2) to (6).

##### 6.4.3.4.2.2 1,28 Mcps TDD option

- (1) Configure the BS transmitter to enable power control steps of size 1 dB.
- (2) Set the BS tester to produce a sequence of TPC commands related to the active DPCH, with content "Increase Tx power". This sequence shall be sufficiently long so that the code domain power of the active DPCH is controlled to reach its maximum, and shall be transmitted to the BS within the receive time slots TS  $i$  of the BS.
- (3) Measure the code domain power of the active DPCH over the 848 active chips of a transmit time slot TS  $i$  of the BS (this excludes the guard period) by applying the global in-channel Tx test method described in Annex C.
- (4) Set the BS tester to produce a sequence of TPC commands related to the active DPCH, with content "Decrease Tx power". This sequence shall be sufficiently long so that the code domain power of the active DPCH is controlled to reach its minimum, and shall be transmitted to the BS within the receive time slots TS  $i$  of the BS.
- (5) Measure the code domain power of the active DPCH over the 848 active chips of a transmit time slot TS  $i$  of the BS (this excludes the guard period) by applying the global in-channel Tx test method described in Annex C.
- (6) Determine the power control dynamic range by calculating the difference between the maximum code domain power measured in step (3) and the minimum code domain power measured in step (5).
- (7) Configure the BS transmitter to enable power control steps of 2 dB and of 3 dB, respectively, and repeat steps (2) to (6).

#### 6.4.3.4.2.3 7,68 Mcps TDD option

- (1) Configure the BS transmitter to enable power control steps of size 1 dB.
- (2) Set the BS tester to produce a sequence of TPC commands related to the active DPCH, with content "Increase Tx power". This sequence shall be sufficiently long so that the code domain power of the active DPCH is controlled to reach its maximum, and shall be transmitted to the BS within the odd time slots TS *i* (receive time slots of the BS).
- (3) Measure the code domain power of the active DPCH over the 4928 active chips of an even time slot TS *i* (this excludes the guard period) by applying the global in-channel Tx test method described in Annex C.
- (4) Set the BS tester to produce a sequence of TPC commands related to the active DPCH, with content "Decrease Tx power". This sequence shall be sufficiently long so that the code domain power of the active DPCH is controlled to reach its minimum, and shall be transmitted to the BS within the odd time slots TS *i* (receive time slots of the BS).
- (5) Measure the code domain power of the active DPCH over the 4928 active chips of an even time slot TS *i* (this excludes the guard period) by applying the global in-channel Tx test method described in Annex C.
- (6) Determine the power control dynamic range by calculating the difference between the maximum code domain power measured in step (3) and the minimum code domain power measured in step (5).
- (7) Configure the BS transmitter to enable power control steps of 2 dB and of 3 dB, respectively, and repeat steps (2) to (6).

#### 6.4.3.5 Test Requirements

NOTE: If the Test Requirement below differs from the Minimum Requirement, then the Test Tolerance applied for this test is non-zero. The Test Tolerance for this test is defined in subclause 5.11 and the explanation of how the Minimum Requirement has been relaxed by the Test Tolerance is given in Annex D.

The power control dynamic range derived according to subclause 6.4.3.4.2 shall be greater than or equal to 29,7 dB

### 6.4.4 Minimum output power

#### 6.4.4.1 Definition and applicability

The minimum controlled output power of the BS is when the power is set to a minimum value.

The requirements in this subclause shall apply to both Wide Area BS and Local Area BS.

#### 6.4.4.2 Minimum Requirements

The DL minimum output power shall be less than or equal to:

Maximum output power - 30 dB.

The normative reference for this requirement is TS 25.105 [1] subclause 6.4.4.1.

#### 6.4.4.3 Test purpose

The test purpose is to verify the ability of the BS to reduce its output power to a specified value.

#### 6.4.4.4 Method of test

##### 6.4.4.4.1 Initial conditions

##### 6.4.4.4.1.0 General test conditions

Test environment: normal; see subclause 5.9.1.

RF channels to be tested: B, M and T; see subclause 5.3.

#### 6.4.4.4.1.1 3,84 Mcps TDD option

- (1) Connect the BS tester to the antenna connector of the BS under test.
- (2) Set the parameters of the BS transmitted signal according to table 6.7.
- (3) Operate the BS in such a mode that it is able to interpret received TPC commands
- (4) Start BS transmission.

NOTE: The BS tester used for this test must have the ability:

- to analyse the output signal of the BS under test with respect to mean power;
- to simulate an UE with respect to the generation of TPC commands embedded in a valid UE signal.

**Table 6.7: Parameters of the BS transmitted signal for minimum power test**

| Parameter                                   | Value/description   |
|---|---|
| TDD Duty Cycle                              | TS $i$ ; $i = 0, 1, 2, \dots, 14$ :<br>transmit, if $i$ is even;<br>receive, if $i$ is odd. |
| Time slot carrying SCH                      | TS0   |
| Time slots under test                       | TS $i$ , $i$ even and non zero  |
| Number of DPCH in each time slot under test | 1   |
| Data content of DPCH                        | real life (sufficient irregular)  |

#### 6.4.4.4.1.2 1,28 Mcps TDD option

- (1) Connect the BS tester to the antenna connector of the BS under test.
- (2) Set the parameters of the BS transmitted signal according to table 6.7A.
- (3) Operate the BS in such a mode that it is able to interpret received TPC commands
- (4) Start BS transmission.

NOTE: The BS tester used for this test must have the ability

- to analyse the output signal of the BS under test with respect to mean power;
- to simulate an UE with respect to the generation of TPC commands embedded in a valid UE signal.

**Table 6.7A: Parameters of the BS transmitted signal for minimum power test for 1,28 Mcps TDD**

| Parameter                                   | Value/description   |
|---|---|
| TDD Duty Cycle                              | TS $i$ ; $i = 0, 1, 2, 3, 4, 5, 6$ :<br>transmit, if $i$ is 0,4,5,6;<br>receive, if $i$ is 1,2,3. |
| Time slots under test                       | TS4, TS5 and TS6  |
| BS output power setting                     | PRAT  |
| Number of DPCH in each time slot under test | 1   |
| Power of each DPCH                          | PRAT  |
| Data content of DPCH                        | real life (sufficient irregular)  |

#### 6.4.4.4.1.3 7,68 Mcps TDD option

- (1) Connect the BS tester to the antenna connector of the BS under test.
- (2) Set the parameters of the BS transmitted signal according to table 6.7B.

- (3) Operate the BS in such a mode that it is able to interpret received TPC commands
- (4) Start BS transmission.

NOTE: The BS tester used for this test must have the ability:

- to analyse the output signal of the BS under test with respect to mean power;
- to simulate an UE with respect to the generation of TPC commands embedded in a valid UE signal.

**Table 6.7B: Parameters of the BS transmitted signal for minimum power test**

| Parameter                                   | Value/description   |
|---|---|
| TDD Duty Cycle                              | TS $i$ ; $i = 0, 1, 2, \dots, 14$ :<br>transmit, if $i$ is even;<br>receive, if $i$ is odd. |
| Time slot carrying SCH                      | TS0   |
| Time slots under test                       | TS $i$ , $i$ even and non zero  |
| Number of DPCH in each time slot under test | 1   |
| Data content of DPCH                        | real life (sufficient irregular)  |

#### 6.4.4.4.2 Procedure

##### 6.4.4.4.2.1 3,84 Mcps TDD option

- (1) Configure the BS transmitter to enable power control steps of size 1 dB.
- (2) Set the BS tester to produce a sequence of TPC commands related to all active DPCH, with content "Decrease Tx power". This sequence shall be sufficiently long so that the output power of all active DPCH is controlled to reach its minimum, and shall be transmitted to the BS within the odd time slots TS  $i$  (receive time slots of the BS).
- (3) Measure the power of the BS output signal over the 2464 active chips of an even and non zero time slot TS  $i$  (this excludes the guard period), and with a measurement filter that has a RRC filter response with a roll off  $\alpha = 0,22$  and a bandwidth equal to the chip rate. The power is determined by calculating the RMS value of the signal samples at the measurement filter output taken at the decision points.
- (4) Configure the BS transmitter to enable power control steps of 2 dB and of 3 dB, respectively, and repeat steps (2) and (3).

##### 6.4.4.4.2.2 1,28 Mcps TDD option

- (1) Configure the BS transmitter to enable power control steps of size 1 dB.
- (2) Set the BS tester to produce a sequence of TPC commands related to all active DPCH, with content "Decrease Tx power". This sequence shall be sufficiently long so that the output power of all active DPCH is controlled to reach its minimum, and shall be transmitted to the BS within the receive time slots TS  $i$  of the BS.
- (3) Measure the power of the BS output signal over the 848 active chips of a time slot TS  $i$  (this excludes the guard period), and with a measurement filter that has a RRC filter response with a roll off  $\alpha = 0,22$  and a bandwidth equal to the chip rate. The power is determined by calculating the RMS value of the signal samples at the measurement filter output taken at the decision points.
- (4) Configure the BS transmitter to enable power control steps of 2 dB and of 3 dB, respectively, and repeat steps (2) and (3).

##### 6.4.4.4.2.3 7,68 Mcps TDD option

- (1) Configure the BS transmitter to enable power control steps of size 1 dB.
- (2) Set the BS tester to produce a sequence of TPC commands related to all active DPCH, with content "Decrease Tx power". This sequence shall be sufficiently long so that the output power of all active DPCH is controlled to

reach its minimum, and shall be transmitted to the BS within the odd time slots TS  $i$  (receive time slots of the BS).

- (3) Measure the power of the BS output signal over the 4928 active chips of an even and non zero time slot TS  $i$  (this excludes the guard period), and with a measurement filter that has a RRC filter response with a roll off  $\alpha = 0,22$  and a bandwidth equal to the chip rate. The power is determined by calculating the RMS value of the signal samples at the measurement filter output taken at the decision points.
- (4) Configure the BS transmitter to enable power control steps of 2 dB and of 3 dB, respectively, and repeat steps (2) and (3).

#### 6.4.4.5 Test Requirements

NOTE: If the Test Requirement below differs from the Minimum Requirement, then the Test Tolerance applied for this test is non-zero. The Test Tolerance for this test is defined in subclause 5.11 and the explanation of how the Minimum Requirement has been relaxed by the Test Tolerance is given in Annex D.

For all measurements, the minimum output power derived in step (4) of subclause 6.4.4.2 shall be at least 29,3 dB below the maximum output power; see 6.2.

### 6.4.5 Primary CCPCH power

#### 6.4.5.1 Definition and applicability

Primary CCPCH power is the code domain power of the Primary Common Control Physical Channel averaged over the transmit timeslot. Primary CCPCH power is signalled on the BCH.

The requirements in this subclause shall apply to both Wide Area BS and Local Area BS.

#### 6.4.5.2 Minimum Requirements

The error between the BCH-broadcast value of the Primary CCPCH power and the Primary CCPCH code domain power averaged over the timeslot shall not exceed the values in table 6.8. The error is a function of the output power averaged over the timeslot,  $P_{out}$ , and the manufacturer's rated output power, PRAT.

**Table 6.8: Errors between Primary CCPCH power and the broadcast value**

| Output power in slot, dB            | PCCPCH power tolerance |
|-------------------------------------|------------------------|
| $PRAT - 3 < P_{out} \leq PRAT + 2$  | +/- 2,5 dB             |
| $PRAT - 6 < P_{out} \leq PRAT - 3$  | +/- 3,5 dB             |
| $PRAT - 13 < P_{out} \leq PRAT - 6$ | +/- 5 dB               |

The normative reference for this requirement is TS 25.105 [1] subclause 6.4.5.

#### 6.4.5.3 Test purpose

The code domain power of the Primary CCPCH received by the UE, together with the information on the Primary CCPCH nominal output power signaled on the BCH, are used by the UE for path loss estimation and adjustment of its own transmit power. Therefore, deviations of the Primary CCPCH code domain power from its nominal value are transposed by the UE into deviations from the wanted output power of the UE.

The test purpose is to verify that the Primary CCPCH code domain power remains within its specified tolerances.

## 6.4.5.4 Method of test

### 6.4.5.4.1 Initial conditions

#### 6.4.5.4.1.0 General test conditions

Test environment: normal; see subclause 5.9.1.

RF channels to be tested: B, M and T; see subclause 5.3.

#### 6.4.5.4.1.1 3,84 Mcps TDD option

- (1) Connect the BS tester to the antenna connector of the BS under test. The BS tester must have the ability to analyze the output signal of the BS under test with respect to code domain power, by applying the global in-channel Tx test method described in Annex C.
- (2) Set the parameters of the BS transmitted signal according to table 6.9.

**Table 6.9: Parameters of the BS transmitted signal for Primary CCPCH power testing**

| Parameter                                    | Value/description   |
|--|---|
| TDD Duty Cycle                               | TS $i$ ; $i = 0, 1, 2, \dots, 14$ :<br>transmit, if $i$ is even;<br>receive, if $i$ is odd. |
| Time slots carrying PCCPCH                   | TS 0 and TS 8   |
| Number of additional DPCH in TS 0 and TS 8   | 3   |
| BS output power setting                      | PRAT  |
| Relative power of PCCPCH                     | $\frac{1}{4}$ of BS output power  |
| Relative power of each DPCH in TS 0 and TS 8 | $\frac{1}{4}$ of BS output power  |
| Data content of DPCH                         | real life (sufficient irregular)  |

#### 6.4.5.4.1.2 1,28 Mcps TDD option

- (1) Connect the BS tester to the antenna connector of the BS under test. The BS tester must have the ability to analyze the output signal of the BS under test with respect to code domain power, by applying the global in-channel Tx test method described in Annex C.
- (2) Set the parameters of the BS transmitted signal according to table 6.9A.

**Table 6.9A: Parameters of the BS transmitted signal for Primary CCPCH power testing for 1,28 Mcps TDD**

| Parameter                  | Value/description   |
|----------------------------|---|
| TDD Duty Cycle             | TS $i$ ; $i = 0, 1, 2, \dots, 6$ :<br>transmit, if $i$ is 0,4,5,6;<br>receive, if $i$ is 1,2,3. |
| Time slots carrying PCCPCH | TS 0  |
| BS output power setting    | PRAT  |
| Relative power of PCCPCH   | $\frac{1}{2}$ of BS output power  |
| Data content of DPCH       | real life (sufficient irregular)  |

#### 6.4.5.4.1.3 7,68 Mcps TDD option

- (1) Connect the BS tester to the antenna connector of the BS under test. The BS tester must have the ability to analyze the output signal of the BS under test with respect to code domain power, by applying the global in-channel Tx test method described in Annex C.
- (2) Set the parameters of the BS transmitted signal according to table 6.9B.

**Table 6.9B: Parameters of the BS transmitted signal for Primary CCPCH power testing**

| Parameter                                    | Value/description   |
|--|---|
| TDD Duty Cycle                               | TS $i$ ; $i = 0, 1, 2, \dots, 14$ :<br>transmit, if $i$ is even;<br>receive, if $i$ is odd. |
| Time slots carrying PCCPCH                   | TS 0 and TS 8   |
| Number of additional DPCH in TS 0 and TS 8   | 3   |
| BS output power setting                      | PRAT  |
| Relative power of PCCPCH                     | $\frac{1}{4}$ of BS output power  |
| Relative power of each DPCH in TS 0 and TS 8 | $\frac{1}{4}$ of BS output power  |
| Data content of DPCH                         | real life (sufficient irregular)  |

#### 6.4.5.4.2 Procedure

##### 6.4.5.4.2.1 3,84 Mcps TDD option

- (1) Measure the PCCPCH code domain power in TS 0 and TS 8 by applying the global in-channel Tx test method described in Annex C.
- (2) Reduce the base station output power by 2 dB, 5 dB and 13 dB, without changing the relative powers of the PCCPCH and the DPCHs, and repeat step (1) for each output power setting.

##### 6.4.5.4.2.2 1,28 Mcps TDD option

- (1) Measure the PCCPCH code domain power in TS 0 by applying the global in-channel Tx test method described in Annex C.
- (2) Reduce the base station output power by 2 dB, 5 dB and 13 dB, without changing the relative powers of the PCCPCH and the DPCHs, and repeat step (1) for each output power setting.

##### 6.4.5.4.2.3 7,68 Mcps TDD option

- (1) Measure the PCCPCH code domain power in TS 0 and TS 8 by applying the global in-channel Tx test method described in Annex C.
- (2) Reduce the base station output power by 2 dB, 5 dB and 13 dB, without changing the relative powers of the PCCPCH and the DPCHs, and repeat step (1) for each output power setting.

#### 6.4.5.5 Test Requirements

NOTE: If the Test Requirement below differs from the Minimum Requirement, then the Test Tolerance applied for this test is non-zero. The Test Tolerance for this test is defined in subclause 5.11 and the explanation of how the Minimum Requirement has been relaxed by the Test Tolerance is given in Annex D.

The Primary CCPCH power, measured according to subclause 6.4.5.4.2, shall be within the limits defined in table 6.10

**Table 6.10: Test Requirements for errors between Primary CCPCH power and the broadcast value**

| Output power in slot, dB            | PCCPCH power tolerance |
|-------------------------------------|------------------------|
| $PRAT - 3 < P_{out} \leq PRAT + 2$  | +/- 3,3 dB             |
| $PRAT - 6 < P_{out} \leq PRAT - 3$  | +/- 4,3 dB             |
| $PRAT - 13 < P_{out} \leq PRAT - 6$ | +/- 5,8 dB             |

## 6.4.6 Differential accuracy of Primary CCPCH power

### 6.4.6.1 Definition and applicability

The differential accuracy of the Primary CCPCH power is the relative transmitted power accuracy of PCCPCH in consecutive frames when the nominal PCCPCH power is not changed.

The requirements in this subclause shall apply to both Wide Area BS and Local Area BS.

### 6.4.6.2 Minimum Requirements

The differential accuracy of PCCPCH power shall be within  $\pm 0,5$  dB.

The normative reference for this requirement is TS 25.105 [1] subclause 6.4.6.

### 6.4.6.3 Test purpose

The power of the Primary CCPCH received by the UE, together with the information on the Primary CCPCH nominal transmit power signaled on the BCH, are used by the UE for path loss estimation and adjustment of its own transmit power. Therefore, a lack of accuracy of the Primary CCPCH power over time will result in unwanted fluctuations of the transmit power of the UE which may degrade system performance.

The test purpose is to verify that the differential accuracy of the Primary CCPCH power remains within its specified tolerances.

### 6.4.6.4 Method of test

#### 6.4.6.4.1 Initial conditions

##### 6.4.6.4.1.0 General test conditions

Test environment: normal; see subclause 5.9.1.

RF channels to be tested: B, M and T; see subclause 5.3.

##### 6.4.6.4.1.1 3,84 Mcps TDD option

- 1) Connect the BS tester to the antenna connector of the BS under test. The BS tester must have the ability to analyze the output signal of the BS under test with respect to code domain power, by applying the global in-channel Tx test method described in Annex C.
- 2) Set the parameters of the BS transmitted signal according to table 6.10A.

**Table 6.10A: Parameters of the BS transmitted signal for testing of differential accuracy of the Primary CCPCH power**

| Parameter                                    | Value/description   |
|--|---|
| TDD Duty Cycle                               | TS $i$ ; $i = 0, 1, 2, \dots, 14$ :<br>transmit, if $i$ is even;<br>receive, if $i$ is odd. |
| Time slots carrying PCCPCH                   | TS 0 and TS 8   |
| Number of additional DPCH in TS 0 and TS 8   | 3   |
| BS output power setting                      | PRAT  |
| Relative power of PCCPCH                     | $\frac{1}{4}$ of BS output power  |
| Relative power of each DPCH in TS 0 and TS 8 | $\frac{1}{4}$ of BS output power  |
| Data content of DPCH                         | real life (sufficient irregular)  |



## 6.4.6.4.1.2 1,28 Mcps TDD option

- 1) Connect the BS tester to the antenna connector of the BS under test. The BS tester must have the ability to analyze the output signal of the BS under test with respect to code domain power, by applying the global in-channel Tx test method described in Annex C.
- 2) Set the parameters of the BS transmitted signal according to table 6.9A.

**Table 6.10B: Parameters of the BS transmitted signal for testing of differential accuracy of the Primary CCPCH power for 1,28 Mcps TDD**

| Parameter                  | Value/description   |
|----------------------------|---|
| TDD Duty Cycle             | TS $i$ ; $i = 0, 1, 2, \dots, 6$ :<br>transmit, if $i$ is 0,4,5,6;<br>receive, if $i$ is 1,2,3. |
| Time slots carrying PCCPCH | TS 0  |
| BS output power setting    | PRAT  |
| Relative power of PCCPCH   | $\frac{1}{2}$ of BS output power  |
| Data content of DPCH       | real life (sufficient irregular)  |

## 6.4.6.4.1.3 7,68 Mcps TDD option

- 1) Connect the BS tester to the antenna connector of the BS under test. The BS tester must have the ability to analyze the output signal of the BS under test with respect to code domain power, by applying the global in-channel Tx test method described in Annex C.
- 2) Set the parameters of the BS transmitted signal according to table 6.10C.

**Table 6.10C: Parameters of the BS transmitted signal for testing of differential accuracy of the Primary CCPCH power**

| Parameter                                    | Value/description   |
|--|---|
| TDD Duty Cycle                               | TS $i$ ; $i = 0, 1, 2, \dots, 14$ :<br>transmit, if $i$ is even;<br>receive, if $i$ is odd. |
| Time slots carrying PCCPCH                   | TS 0 and TS 8   |
| Number of additional DPCH in TS 0 and TS 8   | 3   |
| BS output power setting                      | PRAT  |
| Relative power of PCCPCH                     | $\frac{1}{4}$ of BS output power  |
| Relative power of each DPCH in TS 0 and TS 8 | $\frac{1}{4}$ of BS output power  |
| Data content of DPCH                         | real life (sufficient irregular)  |

## 6.4.6.4.2 Procedure

## 6.4.6.4.2.1 3,84 Mcps TDD option

- 1) Measure the PCCPCH code domain power in TS 0 and TS 8 of consecutive frames by applying the global in-channel Tx test method described in Annex C.
- 2) Calculate the differential accuracy of the Primary CCPCH power by taking the the difference between the PCCPCH power measurement results of consecutive frames.

## 6.4.6.4.2.2 1,28 Mcps TDD option

- 1) Measure the PCCPCH code domain power in TS 0 of consecutive frames by applying the global in-channel Tx test method described in Annex C.
- 2) Calculate the differential accuracy of the Primary CCPCH power by taking the the difference between the PCCPCH power measurement results of consecutive frames.

#### 6.4.6.4.2.3 7,68 Mcps TDD option

- 1) Measure the PCCPCH code domain power in TS 0 and TS 8 of consecutive frames by applying the global in-channel Tx test method described in Annex C.
- 2) Calculate the differential accuracy of the Primary CCPCH power by taking the the difference between the PCCPCH power measurement results of consecutive frames.

#### 6.4.6.5 Test Requirements

NOTE: If the Test Requirement below differs from the Minimum Requirement, then the Test Tolerance applied for this test is non-zero. The Test Tolerance for this test is defined in subclause 5.1.1 and the explanation of how the Minimum Requirement has been relaxed by the Test Tolerance is given in Annex D.

The differential accuracy of the Primary CCPCH power, measured according to subclause 6.4.6.4.2, shall be within  $\pm 0,6$  dB.

### 6.5 Transmit ON/OFF power

#### 6.5.1 Transmit OFF power

##### 6.5.1.1 Definition and applicability

The transmit OFF power is defined as the RRC filtered mean power measured over one chip when the transmitter is off. The transmit OFF power state is when the BS does not transmit.

The requirements in this subclause shall apply to both Wide Area BS and Local Area BS.

##### 6.5.1.2 Minimum Requirements

###### 6.5.1.2.1 3,84 Mcps TDD option

The transmit OFF power shall be less than -79 dBm.

###### 6.5.1.2.2 1,28 Mcps TDD option

The transmit OFF power shall be less than -82 dBm.

The normative reference for this requirement is TS 25.105 [1] subclause 6.5.1.

###### 6.5.1.2.3 7,68 Mcps TDD option

The transmit OFF power shall be less than -76 dBm.

##### 6.5.1.3 Test purpose

This test verifies the ability of the BS to reduce its transmit OFF power to a value below the specified limit. This ability is needed to minimize the interference for other users receiving on the same frequency.

##### 6.5.1.4 Method of test

###### 6.5.1.4.1 Initial conditions

The conformance testing of transmit OFF power is included in the conformance testing of transmit ON/OFF time mask; therefore, see subclause 6.5.2.4.1 for initial conditions.

#### 6.5.1.4.2 Procedure

The conformance testing of transmit OFF power is included in the conformance testing of transmit ON/OFF time mask; therefore, see subclause 6.5.2.4.2 for procedure.

#### 6.5.1.5 Test Requirements

The conformance testing of transmit OFF power is included in the conformance testing of transmit ON/OFF time mask; therefore, see subclause 6.5.2.5 for test requirements.

### 6.5.2 Transmit ON/OFF time mask

#### 6.5.2.1 Definition and applicability

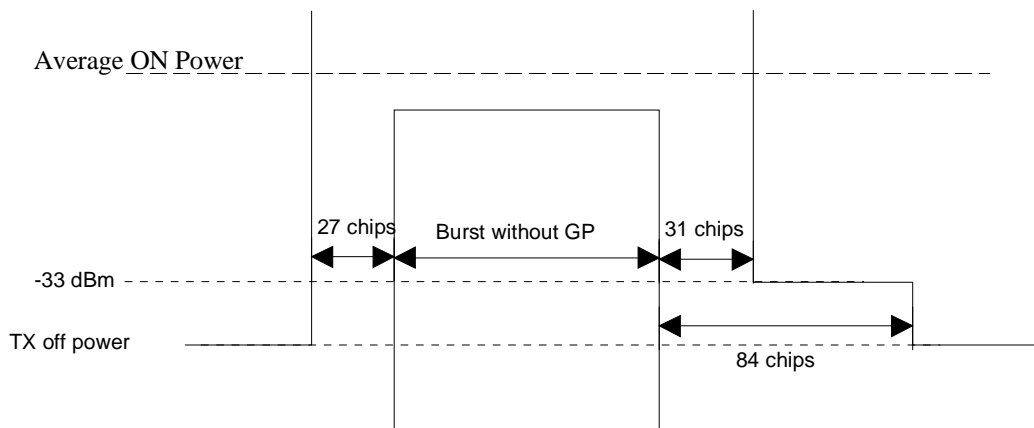
The transmit ON/OFF time mask defines the ramping time allowed for the BS between transmit OFF power and transmit ON power.

The requirements in this subclause shall apply to both Wide Area BS and Local Area BS.

#### 6.5.2.2 Minimum Requirements

##### 6.5.2.2.1 3,84 Mcps TDD option

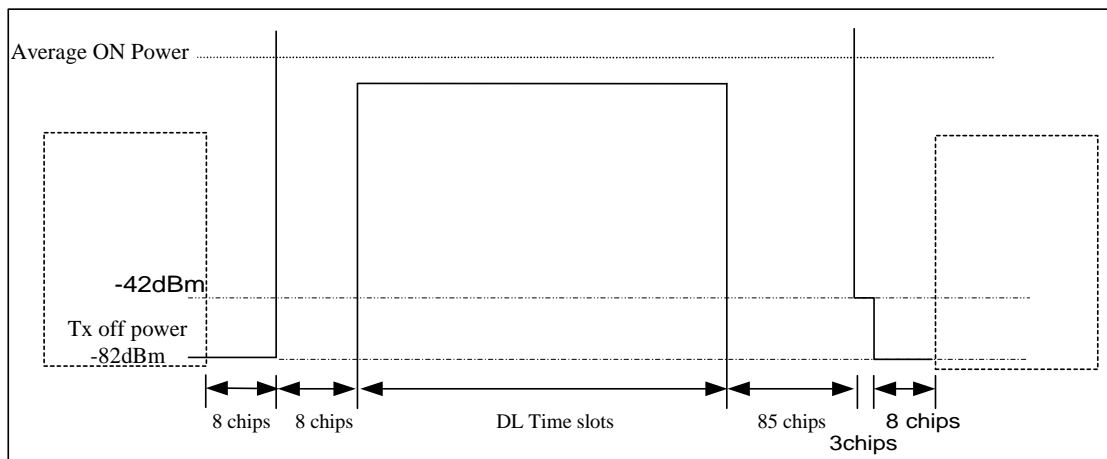
The transmit power level versus time should meet the mask specified in figure 6.1.



**Figure 6.1: Transmit ON/OFF template**

##### 6.5.2.2.2 1,28 Mcps TDD option

The transmit power level versus time should meet the mask specified in figure 6.1A.

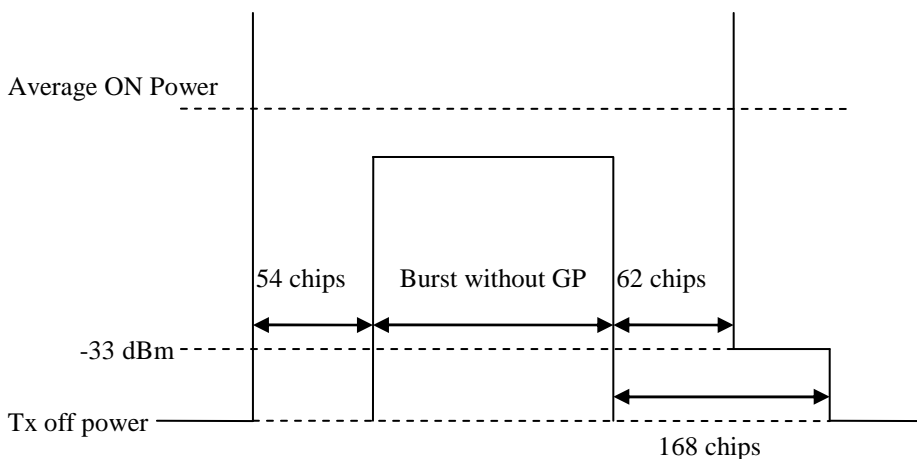


**Figure 6.1A: Transmit ON/OFF template for 1,28 Mcps TDD option**

The normative reference for this requirement is TS 25.105 [1] subclause 6.5.2.

**6.5.2.2.3 7,68 Mcps TDD option**

The transmit power level versus time should meet the mask specified in Figure 6.1B.



**Figure 6.1B: Transmit ON/OFF template**

**6.5.2.3 Test purpose**

This test verifies the ability of the BS to reduce its transmit power outside of the active part of the Tx time slot (burst without guard period) to values below specified limits. This ability is needed to minimize the interference for other users receiving on the same frequency.

**6.5.2.4 Method of test**

**6.5.2.4.1 Initial conditions**

**6.5.2.4.1.0 General test conditions**

Test environment: normal; see subclause 5.9.1.

RF channels to be tested: B, M and T; see subclause 5.3.

## 6.5.2.4.1.1 3,84 Mcps TDD option

- (1) Connect the power measuring equipment to the BS antenna connector.
- (2) Set the parameters of the transmitted signal according to table 6.11.

**Table 6.11: Parameters of the transmitted signal for transmit ON/OFF time mask test**

| Parameter                                   | Value/description   |
|---|---|
| TDD Duty Cycle                              | TS $i$ ; $i = 0, 1, 2, \dots, 14$ :<br>transmit, if $i$ is even;<br>receive, if $i$ is odd. |
| Time slot carrying SCH                      | TS0   |
| Time slots under test                       | TS $i$ , $i$ even and non zero  |
| BS output power setting                     | PRAT  |
| Number of DPCH in each time slot under test | 9   |
| Power of each DPCH                          | 1/9 of Base Station output power  |
| Data content of DPCH                        | Real life (sufficient irregular)  |

## 6.5.2.4.1.2 1,28 Mcps TDD option

- (1) Connect the power measuring equipment to the BS antenna connector.
- (2) Set the parameters of the transmitted signal according to table 6.11A.

**Table 6.11A: Parameters of the transmitted signal for transmit ON/OFF time mask test for 1,28 Mcps TDD**

| Parameter                                   | Value/description   |
|---|---|
| TDD Duty Cycle                              | TS $i$ ; $i = 0, 1, 2, 3, 4, 5, 6$ :<br>transmit, if $i$ is 0,4,5,6;<br>receive, if $i$ is UpPCH,1,2,3. |
| Time slots under test                       | TS4, TS5 and TS6  |
| BS output power setting                     | PRAT  |
| Number of DPCH in each time slot under test | 8   |
| Power of each DPCH                          | 1/8 of Base Station output power  |
| Data content of DPCH                        | real life (sufficient irregular)  |

## 6.5.2.4.1.3 7,68 Mcps TDD option

- (1) Connect the power measuring equipment to the BS antenna connector.
- (2) Set the parameters of the transmitted signal according to table 6.11B.

**Table 6.11B: Parameters of the transmitted signal for transmit ON/OFF time mask test**

| Parameter                                   | Value/description   |
|---|---|
| TDD Duty Cycle                              | TS $i$ ; $i = 0, 1, 2, \dots, 14$ :<br>transmit, if $i$ is even;<br>receive, if $i$ is odd. |
| Time slot carrying SCH                      | TS0   |
| Time slots under test                       | TS $i$ , $i$ even and non zero  |
| BS output power setting                     | PRAT  |
| Number of DPCH in each time slot under test | 9   |
| Power of each DPCH                          | 1/9 of Base Station output power  |
| Data content of DPCH                        | Real life (sufficient irregular)  |

#### 6.5.2.4.2 Procedure

##### 6.5.2.4.2.1 3,84 Mcps TDD option

- (1) Measure the RRC filtered mean power of the BS output signal chipwise (i.e. averaged over time intervals of one chip duration) over the period starting 65 chips before the start of the odd time slots TS  $i$  (receive time slots of the BS), and ending 27 chips before the next even time slot (transmit time slot of the BS) starts.

##### 6.5.2.4.2.2 1,28 Mcps TDD option

- (1) Measure the RRC filtered mean power of the BS output signal chipwise (i.e. averaged over time intervals of one chip duration) over the transmit off power period starting 11 chips before the start of the receive time slot TS  $i = \text{UpPCH}$ , and ending 8 chips before the next transmit time slot TS  $i=4$  starts.

##### 6.5.2.4.2.3 7,68 Mcps TDD option

- (1) Measure the RRC filtered mean power of the BS output signal chipwise (i.e. averaged over time intervals of one chip duration) over the period starting 130 chips before the start of the odd time slots TS  $i$  (receive time slots of the BS), and ending 54 chips before the next even time slot (transmit time slot of the BS) starts.

#### 6.5.2.5 Test Requirements

NOTE: If the Test Requirements below differ from the Minimum Requirements, then the Test Tolerance applied for this test is non-zero. The Test Tolerance for this test is defined in subclause 5.11 and the explanation of how the Minimum Requirement has been relaxed by the Test Tolerance is given in Annex D.

##### 6.5.2.5.1 3,84 Mcps TDD option

Each value of the power measured according to subclause 6.5.2.4.2.1 shall be below - 32,3 dBm in the period from 32 chips to 84 chips after the burst and below - 77 dBm in the period where the Tx OFF power specification is applicable.

##### 6.5.2.5.2 1,28 Mcps TDD option

Each value of the power measured according to subclause 6.5.2.4.2.2 shall be below - 41,3 dBm in the period from 85 chips to 88 chips after the burst and below - 80 dBm in the period where the Tx OFF power specification is applicable.

##### 6.5.2.5.3 7,68 Mcps TDD option

Each value of the power measured according to subclause 6.5.2.4.2.3 shall be below - 32,3 dBm in the period from 64 chips to 168 chips after the burst and below - 74 dBm in the period where the Tx OFF power specification is applicable.

## 6.6 Output RF spectrum emissions

### 6.6.1 Occupied bandwidth

#### 6.6.1.1 Definition and applicability

Occupied bandwidth is a measure of the bandwidth containing 99% of the total integrated power for transmitted spectrum and is centered on the assigned channel frequency.

The requirements in this subclause shall apply to both Wide Area BS and Local Area BS.

#### 6.6.1.2 Minimum Requirements

##### 6.6.1.2.1 3,84 Mcps TDD option

The occupied bandwidth shall be less than 5 MHz based on a chip rate of 3,84 Mcps.

The normative reference for this requirement is TS 25.105 [1] subclause 6.6.1.1.

#### 6.6.1.2.2 1,28 Mcps TDD option

The occupied bandwidth shall be less than 1,6 MHz based on a chip rate of 1,28 Mcps.

The reference for this requirement is TS 25.105 [1] subclause 6.6.1.2.

#### 6.6.1.2.3 7,68 Mcps TDD option

The occupied bandwidth shall be less than 10 MHz based on a chip rate of 7,68 Mcps.

The reference for this requirement is TS 25.105 [1] subclause 6.6.1.3.

### 6.6.1.3 Test purpose

The occupied bandwidth, defined in the Radio Regulations of the International Telecommunication Union ITU, is a useful concept for specifying the spectral properties of a given emission in the simplest possible manner; see also Recommendation ITU-R SM.328 [7]. The test purpose is to verify that the emission of the BS does not occupy an excessive bandwidth for the service to be provided and is, therefore, not likely to create interference to other users of the spectrum beyond undue limits.

### 6.6.1.4 Method of test

#### 6.6.1.4.1 Initial conditions

##### 6.6.1.4.1.0 General test conditions

Test environment: normal; see subclause 5.9.1.

RF channels to be tested: B, M and T; see subclause 5.3.

##### 6.6.1.4.1.1 3,84 Mcps TDD option

- (1) Connect the measuring equipment to the antenna connector of the BS under test.
- (2) Set the parameters of the BS transmitted signal according to table 6.12. For MBSFN IMB operation the set of parameters for the transmitted signals is according to IMB test model 1 in subclause 6.1.1.1.

**Table 6.12: Parameters of the BS transmitted signal for occupied bandwidth testing**

| Parameter                                   | Value/description   |
|---|---|
| TDD Duty Cycle                              | TS $i$ ; $i = 0, 1, 2, \dots, 14$ :<br>transmit, if $i$ is even;<br>receive, if $i$ is odd. |
| Time slot carrying SCH                      | TS0   |
| Time slots under test                       | TS $i$ , $i$ even and non zero  |
| BS output power setting                     | PRAT  |
| Number of DPCH in each time slot under test | 9   |
| Power of each DPCH                          | 1/9 of Base Station output power  |
| Data content of DPCH                        | Real life (sufficient irregular)  |

##### 6.6.1.4.1.2 1,28 Mcps TDD option

- (1) Connect the measuring equipment to the antenna connector of the BS under test.
- (2) Set the parameters of the BS transmitted signal according to table 6.12A.

**Table 6.12A: Parameters of the BS transmitted signal for occupied bandwidth testing for 1,28 Mcps TDD**

| Parameter                                   | Value/description   |
|---|---|
| TDD Duty Cycle                              | TS $i$ ; $i = 0, 1, 2, 3, 4, 5, 6$ :<br>transmit, if $i$ is 0,4,5,6;<br>receive, if $i$ is 1,2,3. |
| Time slots under test                       | TS4, TS5 and TS6  |
| BS output power setting                     | PRAT  |
| Number of DPCH in each time slot under test | 8   |
| Power of each DPCH                          | 1/8 of Base Station output power  |
| Data content of DPCH                        | real life (sufficient irregular)  |

#### 6.6.1.4.1.3 7,68 Mcps TDD option

- (1) Connect the measuring equipment to the antenna connector of the BS under test.
- (2) Set the parameters of the BS transmitted signal according to table 6.12B.

**Table 6.12B: Parameters of the BS transmitted signal for occupied bandwidth testing**

| Parameter                                   | Value/description   |
|---|---|
| TDD Duty Cycle                              | TS $i$ ; $i = 0, 1, 2, \dots, 14$ :<br>transmit, if $i$ is even;<br>receive, if $i$ is odd. |
| Time slot carrying SCH                      | TS0   |
| Time slots under test                       | TS $i$ , $i$ even and non zero  |
| BS output power setting                     | PRAT  |
| Number of DPCH in each time slot under test | 9   |
| Power of each DPCH                          | 1/9 of Base Station output power  |
| Data content of DPCH                        | Real life (sufficient irregular)  |

#### 6.6.1.4.2 Procedure

##### 6.6.1.4.2.1 3,84 Mcps TDD option

- (1) Measure the power of the transmitted signal with a measurement filter of bandwidth 30 kHz. The characteristic of the filter shall be approximately Gaussian (typical spectrum analyzer filter). The centre frequency of the filter shall be stepped in contiguous 30 kHz steps from a minimum frequency, which shall be (7,5 - 0,015) MHz below the assigned channel frequency of the transmitted signal, up to a maximum frequency, which shall be (7,5 + 0,015) MHz above the assigned channel frequency of the transmitted signal. The time duration of each step shall be sufficiently long to capture one active time slot. The measured power shall be recorded for each step.
- (2) Determine the total output power by accumulating the recorded power measurement results of all steps.
- (3) Sum up the recorded power measurement results, starting from the step at the minimum frequency defined in (1) up to the step at a lower limit frequency by which this sum is equal to or greater than 0.5 % of the total output power determined in (2). This limit frequency is recorded as "Lower Frequency".
- (4) Sum up the recorded power measurement results, starting from the step at the maximum frequency defined in (1) down to the step at an upper limit frequency by which this sum is equal to or greater than 0.5 % of the total output power determined in (2). This limit frequency is recorded as "Upper Frequency".
- (5) Calculate the occupied bandwidth as the difference between the "Upper Frequency" obtained in (3) and the "Lower Frequency" obtained in (4).

##### 6.6.1.4.2.2 1,28 Mcps TDD option

- (1) Measure the power of the transmitted signal with a measurement filter of bandwidth 30 kHz. The characteristic of the filter shall be approximately Gaussian (typical spectrum analyser filter). The centre frequency of the filter



shall be stepped in contiguous 30 kHz steps from a minimum frequency, which shall be (2,4 - 0,015) MHz below the assigned channel frequency of the transmitted signal, up to a maximum frequency, which shall be (2,4 - 0,015) MHz above the assigned channel frequency of the transmitted signal. The time duration of each step shall be sufficiently long to capture one active time slot. The measured power shall be recorded for each step.

- (2) Determine the total output power by accumulating the recorded power measurement results of all steps.
- (3) Sum up the recorded power measurement results, starting from the step at the minimum frequency defined in (1) up to the step at a lower limit frequency by which this sum is equal to or greater than 0,5 % of the total output power determined in (2). This limit frequency is recorded as "Lower Frequency".
- (4) Sum up the recorded power measurement results, starting from the step at the maximum frequency defined in (1) down to the step at an upper limit frequency by which this sum is equal to or greater than 0,5 % of the total output power determined in (2). This limit frequency is recorded as "Upper Frequency".
- (5) Calculate the occupied bandwidth as the difference between the "Upper Frequency" obtained in (3) and the "Lower Frequency" obtained in (4).

#### 6.6.1.4.2.3 7,68 Mcps TDD option

- (1) Measure the power of the transmitted signal with a measurement filter of bandwidth 30 kHz. The characteristic of the filter shall be approximately Gaussian (typical spectrum analyzer filter). The centre frequency of the filter shall be stepped in contiguous 30 kHz steps from a minimum frequency, which shall be (15 - 0,015) MHz below the assigned channel frequency of the transmitted signal, up to a maximum frequency, which shall be (15 - 0,015) MHz above the assigned channel frequency of the transmitted signal. The time duration of each step shall be sufficiently long to capture one active time slot. The measured power shall be recorded for each step.
- (2) Determine the total output power by accumulating the recorded power measurement results of all steps.
- (3) Sum up the recorded power measurement results, starting from the step at the minimum frequency defined in (1) up to the step at a lower limit frequency by which this sum is equal to or greater than 0.5 % of the total output power determined in (2). This limit frequency is recorded as "Lower Frequency".
- (4) Sum up the recorded power measurement results, starting from the step at the maximum frequency defined in (1) down to the step at an upper limit frequency by which this sum is equal to or greater than 0.5 % of the total output power determined in (2). This limit frequency is recorded as "Upper Frequency".
- (5) Calculate the occupied bandwidth as the difference between the "Upper Frequency" obtained in (3) and the "Lower Frequency" obtained in (4).

#### 6.6.1.5 Test Requirements

NOTE: If the Test Requirement below differ from the Minimum Requirements, then the Test Tolerance applied for this test is non-zero. The Test Tolerance for this test is defined in subclause 5.11 and the explanation of how the Minimum Requirement has been relaxed by the Test Tolerance is given in Annex D.

##### 6.6.1.5.1 3,84 Mcps TDD option

The occupied bandwidth calculated in step (5) of subclause 6.6.1.4.2.1 shall be less than 5 MHz.

##### 6.6.1.5.2 1,28 Mcps TDD option

The occupied bandwidth calculated in step (5) of subclause 6.6.1.4.2.2 shall be less than 1,6 MHz.

##### 6.6.1.5.3 7,68 Mcps TDD option

The occupied bandwidth calculated in step (5) of subclause 6.6.1.4.2.3 shall be less than 10 MHz.

## 6.6.2 Out of band emission

Out of band emissions are unwanted emissions immediately outside the channel bandwidth resulting from the modulation process and non-linearity in the transmitter but excluding spurious emissions. This out of band emission requirement is specified both in terms of a spectrum emission mask and adjacent channel power ratio for the transmitter.

### 6.6.2.1 Spectrum emission mask

#### 6.6.2.1.1 Definition and applicability

##### 6.6.2.1.1.1 3,84 Mcps TDD option

The spectrum emission mask specifies the limit of the transmitter out of band emissions at frequency offsets from the assigned channel frequency of the wanted signal between 2,5 MHz and 12,5 MHz.

The mask defined in subclause 6.6.2.1.2.1 below may be mandatory in certain regions. In other regions this mask may not be applied.

For regions in which the mask is mandatory, the requirements shall apply to both Wide Area BS and Local Area BS.

##### 6.6.2.1.1.2 1,28 Mcps TDD option

The spectrum emission mask specifies the limit of the transmitter out of band emissions at frequency offsets from the assigned channel frequency of the wanted signal between 0,8 MHz and 4 MHz.

The mask defined in subclause 6.6.2.1.2.2 below may be mandatory in certain regions. In other regions this mask may not be applied.

For regions in which the mask is mandatory, the requirements shall apply to both Wide Area BS and Local Area BS.

##### 6.6.2.1.1.3 7,68 Mcps TDD option

The spectrum emission mask specifies the limit of the transmitter out of band emissions at frequency offsets from the assigned channel frequency of the wanted signal between 5 MHz and 25 MHz.

The mask defined in subclause 6.6.2.1.2.3 below may be mandatory in certain regions. In other regions this mask may not be applied.

For regions in which the mask is mandatory, the requirements shall apply to both Wide Area BS and Local Area BS.

#### 6.6.2.1.2 Minimum Requirements

##### 6.6.2.1.2.1 3,84 Mcps TDD option

For regions where this subclause applies, the requirement shall be met by a base station transmitting on a single RF carrier configured in accordance with the manufacturer's specification. Emissions shall not exceed the maximum level specified in tables 6.13 to 6.16 in the frequency range of  $f_{\text{offset}}$  from 2,515 MHz to  $f_{\text{offset}_{\text{max}}}$  from the carrier frequency, where:

- $f_{\text{offset}}$  is the separation between the carrier frequency and the centre of the measurement filter
- $f_{\text{offset}_{\text{max}}}$  is either 12,5 MHz or the offset to the UMTS Tx band edge as defined in subclause 4.2, whichever is the greater.

**Table 6.13: Spectrum emission mask values, BS maximum output power  $P \geq 43$  dBm**

| Frequency offset of measurement filter centre frequency, $f_{\text{offset}}$ | Maximum level  | Measurement bandwidth |
|--|--|-----------------------|
| $2,515 \text{ MHz} \leq f_{\text{offset}} < 2,715 \text{ MHz}$               | -14 dBm  | 30 kHz                |
| $2,715 \text{ MHz} \leq f_{\text{offset}} < 3,515 \text{ MHz}$               | $-14\text{dBm} - 15 \cdot \left( \frac{f_{\text{offset}}}{\text{MHz}} - 2,715 \right) \text{dB}$ | 30 kHz                |
| $3,515 \text{ MHz} \leq f_{\text{offset}} < 4,0 \text{ MHz}$                 | -26 dBm  | 30 kHz                |
| $4,0 \text{ MHz} \leq f_{\text{offset}} < 8,0 \text{ MHz}$                   | -13 dBm  | 1 MHz                 |
| $8,0 \text{ MHz} \leq f_{\text{offset}} < f_{\text{offset}_{\text{max}}}$    | -13 dBm  | 1 MHz                 |

**Table 6.14: Spectrum emission mask values, BS maximum output power  $39 \leq P < 43$  dBm**

| Frequency offset of measurement filter centre frequency, $f_{\text{offset}}$ | Maximum level  | Measurement bandwidth |
|--|--|-----------------------|
| $2,515 \text{ MHz} \leq f_{\text{offset}} < 2,715 \text{ MHz}$               | -14 dBm  | 30 kHz                |
| $2,715 \text{ MHz} \leq f_{\text{offset}} < 3,515 \text{ MHz}$               | $-14\text{dBm} - 15 \cdot \left( \frac{f_{\text{offset}}}{\text{MHz}} - 2,715 \right) \text{dB}$ | 30 kHz                |
| $3,515 \text{ MHz} \leq f_{\text{offset}} < 4,0 \text{ MHz}$                 | -26 dBm  | 30 kHz                |
| $4,0 \text{ MHz} \leq f_{\text{offset}} < 8,0 \text{ MHz}$                   | -13 dBm  | 1 MHz                 |
| $8,0 \text{ MHz} \leq f_{\text{offset}} < f_{\text{offset}_{\text{max}}}$    | $P - 56 \text{ dB}$  | 1 MHz                 |

**Table 6.15: Spectrum emission mask values, BS maximum output power  $31 \leq P < 39$  dBm**

| Frequency offset of measurement filter centre frequency, $f_{\text{offset}}$ | Maximum level  | Measurement bandwidth |
|--|--|-----------------------|
| $2,515 \text{ MHz} \leq f_{\text{offset}} < 2,715 \text{ MHz}$               | $P - 53 \text{ dB}$  | 30 kHz                |
| $2,715 \text{ MHz} \leq f_{\text{offset}} < 3,515 \text{ MHz}$               | $P - 53\text{dB} - 15 \cdot \left( \frac{f_{\text{offset}}}{\text{MHz}} - 2,715 \right) \text{dB}$ | 30 kHz                |
| $3,515 \text{ MHz} \leq f_{\text{offset}} < 4,0 \text{ MHz}$                 | $P - 65 \text{ dB}$  | 30 kHz                |
| $4,0 \text{ MHz} \leq f_{\text{offset}} < 8,0 \text{ MHz}$                   | $P - 52 \text{ dB}$  | 1 MHz                 |
| $8,0 \text{ MHz} \leq f_{\text{offset}} < f_{\text{offset}_{\text{max}}}$    | $P - 56 \text{ dB}$  | 1 MHz                 |

**Table 6.16: Spectrum emission mask values, BS maximum output power  $P < 31$  dBm**

| Frequency offset of measurement filter centre frequency, $f_{\text{offset}}$ | Maximum level  | Measurement bandwidth |
|--|--|-----------------------|
| $2,515 \text{ MHz} \leq f_{\text{offset}} < 2,715 \text{ MHz}$               | -22 dBm  | 30 kHz                |
| $2,715 \text{ MHz} \leq f_{\text{offset}} < 3,515 \text{ MHz}$               | $-22\text{dBm} - 15 \cdot \left( \frac{f_{\text{offset}}}{\text{MHz}} - 2,715 \right) \text{dB}$ | 30 kHz                |
| $3,515 \text{ MHz} \leq f_{\text{offset}} < 4,0 \text{ MHz}$                 | -34 dBm  | 30 kHz                |
| $4,0 \text{ MHz} \leq f_{\text{offset}} < 8,0 \text{ MHz}$                   | -21 dBm  | 1 MHz                 |
| $8,0 \text{ MHz} \leq f_{\text{offset}} < f_{\text{offset}_{\text{max}}}$    | -25 dBm  | 1 MHz                 |

The normative reference for this requirement is TS 25.105 [1] subclause 6.6.2.1.1

#### 6.6.2.1.2.2 1,28 Mcps TDD option

For regions where this subclause applies, the requirement shall be met by a base station transmitting on a single RF carrier configured in accordance with the manufacturer's specification. Emissions shall not exceed the maximum level specified in tables 6.13A to 16A in the frequency range of  $f_{\text{offset}}$  from 0.815 MHz to  $f_{\text{offset}_{\text{max}}}$  from the carrier frequency, where:

- $f_{\text{offset}}$  is the separation between the carrier frequency and the centre of the measurement filter
- $f_{\text{offset}_{\text{max}}}$  is either 4 MHz or the offset to the UMTS Tx band edge as defined in subclause 4.2, whichever is the greater.

**Table 6.13A: Spectrum emission mask values, BS maximum output power  $P \geq 34$  dBm for 1,28 Mcps TDD**

| Frequency offset of measurement filter centre frequency, $f_{\text{offset}}$ | Maximum level  | Measurement bandwidth |
|--|--|-----------------------|
| $0.815\text{MHz} \leq f_{\text{offset}} < 1.015\text{MHz}$                   | -20 dBm  | 30 kHz                |
| $1.015\text{MHz} \leq f_{\text{offset}} < 1.815\text{MHz}$                   | $-20\text{dBm} - 10 \cdot \left( \frac{f_{\text{offset}}}{\text{MHz}} - 1,015 \right) \text{dB}$ | 30 kHz                |
| $1.815\text{MHz} \leq f_{\text{offset}} < 2.3\text{MHz}$                     | -28 dBm  | 30 kHz                |
| $2.3\text{MHz} \leq f_{\text{offset}} < f_{\text{offset}_{\text{max}}}$      | -13 dBm  | 1 MHz                 |

**Table 6.14A: Spectrum emission mask values, BS maximum output power  $26 \leq P < 34$  dBm for 1,28 Mcps TDD**

| Frequency offset of measurement filter centre frequency, $f_{\text{offset}}$ | Maximum level  | Measurement bandwidth |
|--|--|-----------------------|
| $0.815\text{MHz} \leq f_{\text{offset}} < 1.015\text{MHz}$                   | $P - 54$ dB  | 30 kHz                |
| $1.015\text{MHz} \leq f_{\text{offset}} < 1.815\text{MHz}$                   | $P - 54\text{dB} - 10 \cdot \left( \frac{f_{\text{offset}}}{\text{MHz}} - 1,015 \right) \text{dB}$ | 30 kHz                |
| $1.815\text{MHz} \leq f_{\text{offset}} < 2.3\text{MHz}$                     | $P - 62$ dB  | 30 kHz                |
| $2.3\text{MHz} \leq f_{\text{offset}} < f_{\text{offset}_{\text{max}}}$      | $P - 47$ dB  | 1 MHz                 |

**Table 6.16A: Spectrum emission mask values, BS maximum output power  $P < 26$  dBm for 1,28 Mcps TDD**

| Frequency offset of measurement filter centre frequency, $f_{\text{offset}}$ | Maximum level  | Measurement bandwidth |
|--|--|-----------------------|
| $0.815\text{MHz} \leq f_{\text{offset}} < 1.015\text{MHz}$                   | -28 dBm  | 30 kHz                |
| $1.015\text{MHz} \leq f_{\text{offset}} < 1.815\text{MHz}$                   | $-28\text{dBm} - 10 \cdot \left( \frac{f_{\text{offset}}}{\text{MHz}} - 1,015 \right) \text{dB}$ | 30 kHz                |
| $1.815\text{MHz} \leq f_{\text{offset}} < 2.3\text{MHz}$                     | -36 dBm  | 30 kHz                |
| $2.3\text{MHz} \leq f_{\text{offset}} < f_{\text{offset}_{\text{max}}}$      | -21 dBm  | 1 MHz                 |

The normative reference for this requirement is TS 25.105 [1] subclause 6.6.2.1.2.

#### 6.6.2.1.2.3 7,68 Mcps TDD option

For regions where this subclause applies, the requirement shall be met by a base station transmitting on a single RF carrier configured in accordance with the manufacturer's specification. Emissions shall not exceed the maximum level specified in tables 6.13B to 6.16B in the frequency range of  $f_{\text{offset}}$  from 5,015 MHz to  $f_{\text{offset}_{\text{max}}}$  from the carrier frequency, where:

- $f_{\text{offset}}$  is the separation between the carrier frequency and the centre of the measurement filter
- $f_{\text{offset}_{\text{max}}}$  is either 25 MHz or the offset to the UMTS Tx band edge as defined in subclause 4.2, whichever is the greater.

**Table 6.13B: Spectrum emission mask values, BS maximum output power  $P \geq 43$  dBm**

| Frequency offset of measurement filter centre frequency, $f_{\text{offset}}$ | Maximum level  | Measurement bandwidth |
|--|--|-----------------------|
| $5.015\text{MHz} \leq f_{\text{offset}} < 5.215\text{MHz}$                   | -17 dBm  | 30 kHz                |
| $5.215\text{MHz} \leq f_{\text{offset}} < 6.015\text{MHz}$                   | $-17\text{dBm} - 15 \cdot \left( \frac{f_{\text{offset}}}{\text{MHz}} - 5.215 \right) \text{dB}$ | 30 kHz                |
| $6.015\text{MHz} \leq f_{\text{offset}} < 6.5\text{MHz}$                     | -29 dBm  | 30 kHz                |
| $6.5\text{MHz} \leq f_{\text{offset}} < f_{\text{offset}_{\text{max}}}$      | -16 dBm  | 1 MHz                 |
| $5.015\text{MHz} \leq f_{\text{offset}} < 5.215\text{MHz}$                   | -17 dBm  | 30 kHz                |

**Table 6.14B: Spectrum emission mask values, BS maximum output power  $39 \leq P < 43$  dBm**

| Frequency offset of measurement filter centre frequency, $f_{\text{offset}}$ | Maximum level  | Measurement bandwidth |
|--|--|-----------------------|
| $5.015\text{MHz} \leq f_{\text{offset}} < 5.215\text{MHz}$                   | -17 dBm  | 30 kHz                |
| $5.215\text{MHz} \leq f_{\text{offset}} < 6.015\text{MHz}$                   | $-17\text{dBm} - 15 \cdot \left( \frac{f_{\text{offset}}}{\text{MHz}} - 5.215 \right) \text{dB}$ | 30 kHz                |
| $6.015\text{MHz} \leq f_{\text{offset}} < 6.5\text{MHz}$                     | -29 dBm  | 30 kHz                |
| $6.5\text{MHz} \leq f_{\text{offset}} < 15.5\text{MHz}$                      | -16 dBm  | 1 MHz                 |
| $15.5\text{MHz} \leq f_{\text{offset}} < f_{\text{offset}_{\text{max}}}$     | $P - 59$ dB  | 1 MHz                 |

**Table 6.15B: Spectrum emission mask values, BS maximum output power  $31 \leq P < 39$  dBm**

| Frequency offset of measurement filter centre frequency, $f_{\text{offset}}$ | Maximum level  | Measurement bandwidth |
|--|--|-----------------------|
| $5.015\text{MHz} \leq f_{\text{offset}} < 5.215\text{MHz}$                   | $P - 56$ dB  | 30 kHz                |
| $5.215\text{MHz} \leq f_{\text{offset}} < 6.015\text{MHz}$                   | $P - 56\text{dB} - 15 \cdot \left( \frac{f_{\text{offset}}}{\text{MHz}} - 5.215 \right) \text{dB}$ | 30 kHz                |
| $6.015\text{MHz} \leq f_{\text{offset}} < 6.5\text{MHz}$                     | $P - 68$ dB  | 30 kHz                |
| $6.5\text{MHz} \leq f_{\text{offset}} < 15.5\text{MHz}$                      | $P - 55$ dB  | 1 MHz                 |
| $15.5\text{MHz} \leq f_{\text{offset}} < f_{\text{offset}_{\text{max}}}$     | $P - 59$ dB  | 1 MHz                 |

**Table 6.16B: Spectrum emission mask values, BS maximum output power  $P < 31$  dBm**

| Frequency offset of measurement filter centre frequency, $f_{\text{offset}}$ | Maximum level  | Measurement bandwidth |
|--|--|-----------------------|
| $5.015\text{MHz} \leq f_{\text{offset}} < 5.215\text{MHz}$                   | -25 dBm  | 30 kHz                |
| $5.215\text{MHz} \leq f_{\text{offset}} < 6.015\text{MHz}$                   | $-25\text{dBm} - 15 \cdot \left( \frac{f_{\text{offset}}}{\text{MHz}} - 5.215 \right) \text{dB}$ | 30 kHz                |
| $6.015\text{MHz} \leq f_{\text{offset}} < 6.5\text{MHz}$                     | -37 dBm  | 30 kHz                |
| $6.5\text{MHz} \leq f_{\text{offset}} < 15.5\text{MHz}$                      | -24 dBm  | 1 MHz                 |
| $15.5\text{MHz} \leq f_{\text{offset}} < f_{\text{offset}_{\text{max}}}$     | -28 dBm  | 1 MHz                 |

The normative reference for this requirement is TS 25.105 [1] subclause 6.6.2.1.3.

### 6.6.2.1.3 Test purpose

The test purpose is to verify that the BS out of band emissions do not result in undue interference to any other system (wideband, narrowband) operating at frequencies close to the assigned channel bandwidth of the wanted signal.

This test is independent of the characteristics of possible victim systems and, therefore, complements the tests on occupied bandwidth in 6.6.1 (verifying the spectral concentration of the BS Tx emissions) and on ACLR in 6.6.2.2 (simulating the perception of other UTRA receivers).

#### 6.6.2.1.4 Method of test

##### 6.6.2.1.4.1 Initial conditions

For 3,84 Mcps BS supporting 16QAM, the spectrum emission mask requirements shall be tested with the general test set up specified in section 6.6.2.1.4.1.1 and also with the special test set up for 16QAM capable BS specified in section 6.6.2.1.4.1.4.

For 1,28 Mcps BS supporting 16QAM, the spectrum emission mask requirements shall be tested with the general test set up specified in section 6.6.2.1.4.1.2 and also with the special test set up for 16QAM capable BS specified in section 6.6.2.1.4.1.3.

##### 6.6.2.1.4.1.0 General test conditions

Test environment: normal; see subclause 5.9.1.

RF channels to be tested: B, M and T; see subclause 5.3.

##### 6.6.2.1.4.1.1 3,84 Mcps TDD option - General test set up

- (1) Connect the measuring equipment to the antenna connector of the BS under test.
- (2) Set the parameters of the BS transmitted signal according to table 6.17. For MBSFN IMB operation the set of parameters for the transmitted signals is according to IMB test model 1 in subclause 6.1.1.1.

**Table 6.17: Parameters of the BS transmitted signal for spectrum emission mask testing**

| Parameter                                   | Value/description   |
|---|---|
| TDD Duty Cycle                              | TS $i$ ; $i = 0, 1, 2, \dots, 14$ :<br>transmit, if $i$ is even;<br>receive, if $i$ is odd. |
| Time slot carrying SCH                      | TS0   |
| Time slots under test                       | TS $i$ , $i$ even and non zero  |
| BS output power setting                     | PRAT  |
| Number of DPCH in each time slot under test | 9   |
| Power of each DPCH                          | 1/9 of Base Station output power  |
| Data content of DPCH                        | real life (sufficient irregular)  |

##### 6.6.2.1.4.1.2 1,28 Mcps TDD option - General test set up

- (1) Connect the measuring equipment to the antenna connector of the BS under test.
- (2) Set the parameters of the BS transmitted signal according to table 6.17A.

**Table 6.17A: Parameters of the BS transmitted signal for spectrum emission mask testing for 1,28 Mcps TDD**

| Parameter                                   | Value/description   |
|---|---|
| TDD Duty Cycle                              | TS $i$ ; $i = 0, 1, 2, 3, 4, 5, 6$ :<br>transmit, if $i$ is 0,4,5,6;<br>receive, if $i$ is 1,2,3. |
| Time slots under test                       | TS4, TS5 and TS6  |
| BS output power setting                     | PRAT  |
| Number of DPCH in each time slot under test | 8   |
| Power of each DPCH                          | 1/8 of Base Station output power  |
| Data content of DPCH                        | real life (sufficient irregular)  |

##### 6.6.2.1.4.1.3 1,28 Mcps TDD option - Special test set up for 16QAM capable BS

This test set up only applies for 16QAM capable BS.

- (1) Connect the measuring equipment to the antenna connector of the BS under test.
- (2) Set the parameters of the BS transmitted signal according to table 6.17B.

**Table 6.17B: Parameters of the BS transmitted signal for spectrum emission mask testing for 1,28 Mcps TDD - 16QAM capable BS**

| Parameter                                       | Value/description   |
|---|---|
| TDD Duty Cycle                                  | TS $i$ ; $i = 0, 1, 2, 3, 4, 5, 6$ :<br>transmit, if $i$ is 0,4,5,6;<br>receive, if $i$ is 1,2,3. |
| Time slots under test                           | TS4, TS5 and TS6  |
| BS output power setting                         | PRAT  |
| HS-PDSCH modulation                             | 16QAM   |
| Number of HS-PDSCH in each time slot under test | 8   |
| Power of each HS-PDSCH                          | 1/8 of Base Station output power  |
| Data content of HS-PDSCH                        | real life (sufficient irregular)  |
| Spreading factor                                | 16  |

#### 6.6.2.1.4.1.4 3,84 Mcps TDD option - Special test set up for 16QAM capable BS

This test set up only applies for 16QAM capable BS.

- (1) Connect the measuring equipment to the antenna connector of the BS under test.
- (2) Set the parameters of the BS transmitted signal according to table 6.17C. For MBSFN IMB operation the set of parameters for the transmitted signals is according to IMB test model 2 in subclause 6.1.1.2.

**Table 6.17C: Parameters of the BS transmitted signal for spectrum emission mask testing - 16QAM capable BS**

| Parameter                                       | Value/description   |
|---|---|
| TDD Duty Cycle                                  | TS $i$ ; $i = 0, 1, 2, \dots, 14$ :<br>transmit, if $i$ is even;<br>receive, if $i$ is odd. |
| Time slot carrying SCH                          | TS0   |
| Time slots under test                           | TS $i$ , $i$ even and non zero  |
| BS output power setting                         | PRAT  |
| HS-PDSCH modulation                             | 16QAM   |
| Number of HS-PDSCH in each time slot under test | 9   |
| Power of each HS-PDSCH                          | 1/9 of Base Station output power  |
| Data content of HS-PDSCH                        | real life (sufficient irregular)  |
| Spreading factor                                | 16  |

#### 6.6.2.1.4.1.5 7,68 Mcps TDD option - General test set up

- (1) Connect the measuring equipment to the antenna connector of the BS under test.
- (2) Set the parameters of the BS transmitted signal according to table 6.17D.

**Table 6.17D: Parameters of the BS transmitted signal for spectrum emission mask testing**

| Parameter                                   | Value/description   |
|---|---|
| TDD Duty Cycle                              | TS $i$ ; $i = 0, 1, 2, \dots, 14$ :<br>transmit, if $i$ is even;<br>receive, if $i$ is odd. |
| Time slot carrying SCH                      | TS0   |
| Time slots under test                       | TS $i$ , $i$ even and non zero  |
| BS output power setting                     | PRAT  |
| Number of DPCH in each time slot under test | 9   |
| Power of each DPCH                          | 1/9 of Base Station output power  |
| Data content of DPCH                        | real life (sufficient irregular)  |

#### 6.6.2.1.4.1.6 7,68 Mcps TDD option - Special test set up for 16QAM capable BS

This test set up only applies for 16QAM capable BS.

- (1) Connect the measuring equipment to the antenna connector of the BS under test.
- (2) Set the parameters of the BS transmitted signal according to table 6.17E.

**Table 6.17E: Parameters of the BS transmitted signal for spectrum emission mask testing - 16QAM capable BS**

| Parameter                                       | Value/description   |
|---|---|
| TDD Duty Cycle                                  | TS $i$ ; $i = 0, 1, 2, \dots, 14$ :<br>transmit, if $i$ is even;<br>receive, if $i$ is odd. |
| Time slot carrying SCH                          | TS0   |
| Time slots under test                           | TS $i$ , $i$ even and non zero  |
| BS output power setting                         | PRAT  |
| HS-PDSCH modulation                             | 16QAM   |
| Number of HS-PDSCH in each time slot under test | 9   |
| Power of each HS-PDSCH                          | 1/9 of Base Station output power  |
| Data content of HS-PDSCH                        | real life (sufficient irregular)  |
| Spreading factor                                | 32  |

#### 6.6.2.1.4.2 Procedure

##### 6.6.2.1.4.2.1 3,84 Mcps TDD option

Measure the power of the BS spectrum emissions by applying measurement filters with bandwidths as specified in the relevant table in subclause 6.6.2.1.2.1. The characteristic of the filters shall be approximately Gaussian (typical spectrum analyzer filters). The centre frequency of the filter shall be stepped in contiguous steps over the ranges of frequency offsets  $f_{\text{offset}}$  as given in the tables. The step width shall be equal to the respective measurement bandwidth. The time duration of each step shall be sufficiently long to capture one active time slot.

For frequency offsets of the measurement filter centre frequency in the range  $4,0 \text{ MHz} \leq f_{\text{offset}} < f_{\text{offset}_{\text{max}}}$ , the measurement shall be performed by applying filters with measurement bandwidth of 50 kHz or less and integrating the measured results over the nominal measurement bandwidth 1 MHz specified in the tables in subclause 6.6.2.1.2.1.

##### 6.6.2.1.4.2.2 1,28 Mcps TDD option

Measure the power of the BS spectrum emissions by applying measurement filters with bandwidths as specified in the relevant table in subclause 6.6.2.1.2.2. The characteristic of the filters shall be approximately Gaussian (typical spectrum analyzer filters). The centre frequency of the filter shall be stepped in contiguous steps over the ranges of frequency offsets  $f_{\text{offset}}$  as given in the tables. The step width shall be equal to the respective measurement bandwidth. The time duration of each step shall be sufficiently long to capture one active time slot.



The measurement shall be performed by applying filters with measurement bandwidth of 50 kHz or less and integrating the measured results over the nominal measurement bandwidth 1 MHz specified in the tables in subclause 6.6.2.1.2.2 when the measurement bandwidth is 1MHz.

#### 6.6.2.1.4.2.3 1,28 Mcps TDD option - 16QAM capable BS

The same procedure specified in 6.6.2.1.4.2.2 applies to 1,28 Mcps TDD option BS supporting 16QAM.

#### 6.6.2.1.4.2.4 3,84 Mcps TDD option - 16QAM capable BS

The same procedure specified in 6.6.2.1.4.2.1 applies to 3,84 Mcps TDD option BS supporting 16QAM.

#### 6.6.2.1.4.2.5 7,68 Mcps TDD option

Measure the power of the BS spectrum emissions by applying measurement filters with bandwidths as specified in the relevant table in subclause 6.6.2.1.2.3. The characteristic of the filters shall be approximately Gaussian (typical spectrum analyzer filters). The centre frequency of the filter shall be stepped in contiguous steps over the ranges of frequency offsets  $f_{\text{offset}}$  as given in the tables. The step width shall be equal to the respective measurement bandwidth. The time duration of each step shall be sufficiently long to capture one active time slot.

For frequency offsets of the measurement filter centre frequency in the range  $6,5 \text{ MHz} \leq f_{\text{offset}} < f_{\text{offset}_{\text{max}}}$ , the measurement shall be performed by applying filters with measurement bandwidth of 50 kHz or less and integrating the measured results over the nominal measurement bandwidth 1 MHz specified in the tables in subclause 6.6.2.1.2.3.

#### 6.6.2.1.4.2.6 7,68 Mcps TDD option - 16QAM capable BS

The same procedure specified in 6.6.2.1.4.2.5 applies to 7,68 Mcps TDD option BS supporting 16QAM.

### 6.6.2.1.5 Test Requirements

NOTE: If the Test Requirements below differ from the Minimum Requirements, then the Test Tolerance applied for this test is non-zero. The Test Tolerance for this test is defined in subclause 5.11 and the explanation of how the Minimum Requirement has been relaxed by the Test Tolerance is given in Annex D.

#### 6.6.2.1.5.1 3,84 Mcps TDD option

The spectrum emissions measured according to subclause 6.6.2.1.4.2.1 shall not exceed the maximum level specified in tables 6.18 to 6.21 for the appropriate BS maximum output power

**Table 6.18: Test Requirements for spectrum emission mask values,  
BS maximum output power  $P \geq 43 \text{ dBm}$**

| Frequency offset of measurement filter centre frequency, $f_{\text{offset}}$ | Maximum level   | Measurement bandwidth |
|--|---|-----------------------|
| $2,515 \text{ MHz} \leq f_{\text{offset}} < 2,715 \text{ MHz}$               | -12,5 dBm   | 30 kHz                |
| $2,715 \text{ MHz} \leq f_{\text{offset}} < 3,515 \text{ MHz}$               | $-12,5 \text{ dBm} - 15 \cdot \left( \frac{f_{\text{offset}}}{\text{MHz}} - 2,715 \right) \text{ dB}$ | 30 kHz                |
| $3,515 \text{ MHz} \leq f_{\text{offset}} < 4,0 \text{ MHz}$                 | -24,5 dBm   | 30 kHz                |
| $4,0 \text{ MHz} \leq f_{\text{offset}} < 8,0 \text{ MHz}$                   | -11,5 dBm   | 1 MHz                 |
| $8,0 \text{ MHz} \leq f_{\text{offset}} < f_{\text{offset}_{\text{max}}}$    | -11,5 dBm   | 1 MHz                 |

**Table 6.19: Test Requirements for spectrum emission mask values,  
BS maximum output power  $39 \leq P < 43$  dBm**

| Frequency offset of measurement filter centre frequency, $f_{\text{offset}}$ | Maximum level  | Measurement bandwidth |
|--|--|-----------------------|
| $2,515 \text{ MHz} \leq f_{\text{offset}} < 2,715 \text{ MHz}$               | -12,5 dBm  | 30 kHz                |
| $2,715 \text{ MHz} \leq f_{\text{offset}} < 3,515 \text{ MHz}$               | $-12,5\text{dBm} - 15 \cdot \left( \frac{f_{\text{offset}}}{\text{MHz}} - 2,715 \right) \text{dB}$ | 30 kHz                |
| $3,515 \text{ MHz} \leq f_{\text{offset}} < 4,0 \text{ MHz}$                 | -24,5 dBm  | 30 kHz                |
| $4,0 \text{ MHz} \leq f_{\text{offset}} < 8,0 \text{ MHz}$                   | -11,5 dBm  | 1 MHz                 |
| $8,0 \text{ MHz} \leq f_{\text{offset}} < f_{\text{offset}_{\text{max}}}$    | $P - 54,5 \text{ dB}$  | 1 MHz                 |

**Table 6.20: Test Requirements for spectrum emission mask values,  
BS maximum output power  $31 \leq P < 39$  dBm**

| Frequency offset of measurement filter centre frequency, $f_{\text{offset}}$ | Maximum level  | Measurement bandwidth |
|--|--|-----------------------|
| $2,515 \text{ MHz} \leq f_{\text{offset}} < 2,715 \text{ MHz}$               | $P - 51,5 \text{ dB}$  | 30 kHz                |
| $2,715 \text{ MHz} \leq f_{\text{offset}} < 3,515 \text{ MHz}$               | $P - 51,5\text{dB} - 15 \cdot \left( \frac{f_{\text{offset}}}{\text{MHz}} - 2,715 \right) \text{dB}$ | 30 kHz                |
| $3,515 \text{ MHz} \leq f_{\text{offset}} < 4,0 \text{ MHz}$                 | $P - 63,5 \text{ dB}$  | 30 kHz                |
| $4,0 \text{ MHz} \leq f_{\text{offset}} < 8,0 \text{ MHz}$                   | $P - 50,5 \text{ dB}$  | 1 MHz                 |
| $8,0 \text{ MHz} \leq f_{\text{offset}} < f_{\text{offset}_{\text{max}}}$    | $P - 54,5 \text{ dB}$  | 1 MHz                 |

**Table 6.21: Test Requirements for spectrum emission mask values,  
BS maximum output power  $P < 31$  dBm**

| Frequency offset of measurement filter centre frequency, $f_{\text{offset}}$ | Maximum level  | Measurement bandwidth |
|--|--|-----------------------|
| $2,515 \text{ MHz} \leq f_{\text{offset}} < 2,715 \text{ MHz}$               | -20,5 dBm  | 30 kHz                |
| $2,715 \text{ MHz} \leq f_{\text{offset}} < 3,515 \text{ MHz}$               | $-20,5\text{dBm} - 15 \cdot \left( \frac{f_{\text{offset}}}{\text{MHz}} - 2,715 \right) \text{dB}$ | 30 kHz                |
| $3,515 \text{ MHz} \leq f_{\text{offset}} < 4,0 \text{ MHz}$                 | -32,5 dBm  | 30 kHz                |
| $4,0 \text{ MHz} \leq f_{\text{offset}} < 8,0 \text{ MHz}$                   | -19,5 dBm  | 1 MHz                 |
| $8,0 \text{ MHz} \leq f_{\text{offset}} < f_{\text{offset}_{\text{max}}}$    | -23,5 dBm  | 1 MHz                 |

#### 6.6.2.1.5.2 1,28 Mcps TDD option

The spectrum emissions measured according to subclause 6.6.2.1.4.2.2 shall be within the mask defined in the table 6.18A to 6.21A.

**Table 6.18A: Test requirements for spectrum emission mask values, BS maximum output power  $P \geq 34$  dBm for 1,28 Mcps TDD**

| Frequency offset of measurement filter centre frequency, $f_{\text{offset}}$ | Maximum level  | Measurement bandwidth |
|--|--|-----------------------|
| $0,815\text{MHz} \leq f_{\text{offset}} < 1,015\text{MHz}$                   | -18.5 dBm  | 30 kHz                |
| $1,015\text{MHz} \leq f_{\text{offset}} < 1,815\text{MHz}$                   | $-18,5\text{dBm} - 10 \cdot \left( \frac{f_{\text{offset}}}{\text{MHz}} - 1,015 \right) \text{dB}$ | 30 kHz                |
| $1,815\text{MHz} \leq f_{\text{offset}} < 2,3\text{MHz}$                     | -26.5 dBm  | 30 kHz                |
| $2,3\text{MHz} \leq f_{\text{offset}} < f_{\text{offset}_{\text{max}}}$      | -11.5 dBm  | 1 MHz                 |

**Table 6.19A: Test requirements for spectrum emission mask values, BS maximum output power  $26 \leq P < 34$  dBm for 1,28 Mcps TDD**

| Frequency offset of measurement filter centre frequency, $f_{\text{offset}}$ | Maximum level  | Measurement bandwidth |
|--|--|-----------------------|
| $0.815\text{MHz} \leq f_{\text{offset}} < 1.015\text{MHz}$                   | P-52.5 dB  | 30 kHz                |
| $1.015\text{MHz} \leq f_{\text{offset}} < 1.815\text{MHz}$                   | $P - 52.5\text{dB} - 10 \cdot \left( \frac{f_{\text{offset}}}{\text{MHz}} - 1,015 \right) \text{dB}$ | 30 kHz                |
| $1.815\text{MHz} \leq f_{\text{offset}} < 2.3\text{MHz}$                     | P-60.5 dB  | 30 kHz                |
| $2.3\text{MHz} \leq f_{\text{offset}} < f_{\text{offset}_{\text{max}}}$      | P - 45.5 dB  | 1 MHz                 |

**Table 6.21A: Test requirements for spectrum emission mask values, BS maximum output power  $P < 26$  dBm for 1,28 Mcps TDD**

| Frequency offset of measurement filter centre frequency, $f_{\text{offset}}$ | Maximum level  | Measurement bandwidth |
|--|--|-----------------------|
| $0.815\text{MHz} \leq f_{\text{offset}} < 1.015\text{MHz}$                   | -26.5 dBm  | 30 kHz                |
| $1.015\text{MHz} \leq f_{\text{offset}} < 1.815\text{MHz}$                   | $-26.5\text{dBm} - 10 \cdot \left( \frac{f_{\text{offset}}}{\text{MHz}} - 1,015 \right) \text{dB}$ | 30 kHz                |
| $1.815\text{MHz} \leq f_{\text{offset}} < 2.3\text{MHz}$                     | -34.5 dBm  | 30 kHz                |
| $2.3\text{MHz} \leq f_{\text{offset}} < f_{\text{offset}_{\text{max}}}$      | -19.5 dBm  | 1 MHz                 |

#### 6.6.2.1.5.3 1,28 Mcps TDD option - 16QAM capable BS

The spectrum emissions measured according to subclause 6.6.2.1.4.2.3 shall be within the mask defined in the table 6.18A to 6.21A in section 6.6.2.1.5.2.

#### 6.6.2.1.5.4 3,84 Mcps TDD option - 16QAM capable BS

The spectrum emissions measured according to subclause 6.6.2.1.4.2.4 shall be within the mask defined in the table 6.18 to 6.21 in section 6.6.2.1.5.1.

#### 6.6.2.1.5.5 7,68 Mcps TDD option

The spectrum emissions measured according to subclause 6.6.2.1.4.2.5 shall not exceed the maximum level specified in tables 6.18B to 6.21B for the appropriate BS maximum output power

**Table 6.18B: Test Requirements for spectrum emission mask values, BS maximum output power  $P \geq 43$  dBm**

| Frequency offset of measurement filter centre frequency, $f_{\text{offset}}$ | Maximum level  | Measurement bandwidth |
|--|--|-----------------------|
| $5.015\text{MHz} \leq f_{\text{offset}} < 5.215\text{MHz}$                   | -15.5 dBm  | 30 kHz                |
| $5.215\text{MHz} \leq f_{\text{offset}} < 6.015\text{MHz}$                   | $-15.5\text{dBm} - 15 \cdot \left( \frac{f_{\text{offset}}}{\text{MHz}} - 5.215 \right) \text{dB}$ | 30 kHz                |
| $6.015\text{MHz} \leq f_{\text{offset}} < 6.5\text{MHz}$                     | -27.5 dBm  | 30 kHz                |
| $6.5\text{MHz} \leq f_{\text{offset}} < f_{\text{offset}_{\text{max}}}$      | -14.5 dBm  | 1 MHz                 |
| $15.5\text{MHz} \leq f_{\text{offset}} < f_{\text{offset}_{\text{max}}}$     | -14.5 dBm  | 1 MHz                 |

**Table 6.19B: Test Requirements for spectrum emission mask values,  
BS maximum output power  $39 \leq P < 43$  dBm**

| Frequency offset of measurement filter centre frequency, $f_{\text{offset}}$ | Maximum level  | Measurement bandwidth |
|--|--|-----------------------|
| $5.015\text{MHz} \leq f_{\text{offset}} < 5.215\text{MHz}$                   | -15.5 dBm  | 30 kHz                |
| $5.215\text{MHz} \leq f_{\text{offset}} < 6.015\text{MHz}$                   | $-15.5\text{dBm} - 15 \cdot \left( \frac{f_{\text{offset}}}{\text{MHz}} - 5.215 \right) \text{dB}$ | 30 kHz                |
| $6.015\text{MHz} \leq f_{\text{offset}} < 6.5\text{MHz}$                     | -27.5 dBm  | 30 kHz                |
| $6.5\text{MHz} \leq f_{\text{offset}} < 15.5\text{MHz}$                      | -14.5 dBm  | 1 MHz                 |
| $15.5\text{MHz} \leq f_{\text{offset}} < f_{\text{offset}_{\text{max}}}$     | $P - 57.5$ dB  | 1 MHz                 |

**Table 6.20B: Test Requirements for spectrum emission mask values,  
BS maximum output power  $31 \leq P < 39$  dBm**

| Frequency offset of measurement filter centre frequency, $f_{\text{offset}}$ | Maximum level  | Measurement bandwidth |
|--|--|-----------------------|
| $5.015\text{MHz} \leq f_{\text{offset}} < 5.215\text{MHz}$                   | $P - 54.5$ dB  | 30 kHz                |
| $5.215\text{MHz} \leq f_{\text{offset}} < 6.015\text{MHz}$                   | $P - 54.5\text{dB} - 15 \cdot \left( \frac{f_{\text{offset}}}{\text{MHz}} - 5.215 \right) \text{dB}$ | 30 kHz                |
| $6.015\text{MHz} \leq f_{\text{offset}} < 6.5\text{MHz}$                     | $P - 66.5$ dB  | 30 kHz                |
| $6.5\text{MHz} \leq f_{\text{offset}} < 15.5\text{MHz}$                      | $P - 53.5$ dB  | 1 MHz                 |
| $15.5\text{MHz} \leq f_{\text{offset}} < f_{\text{offset}_{\text{max}}}$     | $P - 57.5$ dB  | 1 MHz                 |

**Table 6.21B: Test Requirements for spectrum emission mask values,  
BS maximum output power  $P < 31$  dBm**

| Frequency offset of measurement filter centre frequency, $f_{\text{offset}}$ | Maximum level  | Measurement bandwidth |
|--|--|-----------------------|
| $5.015\text{MHz} \leq f_{\text{offset}} < 5.215\text{MHz}$                   | -23.5 dBm  | 30 kHz                |
| $5.215\text{MHz} \leq f_{\text{offset}} < 6.015\text{MHz}$                   | $-23.5\text{dBm} - 15 \cdot \left( \frac{f_{\text{offset}}}{\text{MHz}} - 5.215 \right) \text{dB}$ | 30 kHz                |
| $6.015\text{MHz} \leq f_{\text{offset}} < 6.5\text{MHz}$                     | -35.5 dBm  | 30 kHz                |
| $6.5\text{MHz} \leq f_{\text{offset}} < 15.5\text{MHz}$                      | -22.5 dBm  | 1 MHz                 |
| $15.5\text{MHz} \leq f_{\text{offset}} < f_{\text{offset}_{\text{max}}}$     | -26.5 dBm  | 1 MHz                 |

#### 6.6.2.1.5.6 7,68 Mcps TDD option - 16QAM capable BS

The spectrum emissions measured according to subclause 6.6.2.1.4.2.6 shall be within the mask defined in the table 6.18B to 6.21B in section 6.6.2.1.5.5.

### 6.6.2.2 Adjacent Channel Leakage power Ratio (ACLR)

#### 6.6.2.2.1 Definition and applicability

Adjacent Channel Leakage power Ratio (ACLR) is the ratio of the RRC filtered mean power centered on the assigned channel frequency to the RRC filtered mean power centered on an adjacent channel frequency. The requirements shall apply for all configurations of BS (single carrier or multi-carrier), and for all operating modes foreseen by the manufacturer's specification.

In some cases the requirement is expressed as adjacent channel leakage power, which is the RRC filtered mean power for the given bandwidth of the victim system at the defined adjacent channel offset.

In this subclause, different requirements shall apply to Wide Area BS and Local Area BS.

## 6.6.2.2.2 Minimum Requirements

## 6.6.2.2.2.1 Minimum requirement

## 6.6.2.2.2.1.1 3,84 Mcps TDD option

The ACLR of a single carrier BS or a multi-carrier BS with contiguous carrier frequencies shall be equal to or greater than the limits given in table 6.22.

**Table 6.22: BS ACLR limits**

| BS adjacent channel offset below the first or above the last carrier frequency used | ACLR limit |
|---|------------|
| 5 MHz   | 45 dB      |
| 10 MHz  | 55 dB      |

If a BS provides multiple non-contiguous single carriers or multiple non-contiguous groups of contiguous single carriers, the above requirements shall be applied individually to the single carriers or group of single carriers.

The normative reference for this requirement is TS 25.105 [1] subclause 6.6.2.2.1.1.

## 6.6.2.2.2.1.2 1,28 Mcps TDD option

The ACLR of a single carrier BS or a multi-carrier BS with contiguous carrier frequencies shall be equal to or greater than the limits given in Table 6.22A.

**Table 6.22A: BS ACLR limits for 1,28 Mcps TDD**

| BS adjacent channel offset below the first or above the last carrier frequency used | ACLR limit |
|---|------------|
| 1,6 MHz   | 40 dB      |
| 3,2 MHz   | 45 dB      |

If a BS provides multiple non-contiguous single carriers or multiple non-contiguous groups of contiguous single carriers, the above requirements shall be applied individually to the single carriers or group of single carriers.

The normative reference for this requirement is TS 25.105 [1] subclause 6.6.2.2.1.2

## 6.6.2.2.2.1.3 7,68 Mcps TDD option

The ACLR of a single carrier BS or a multi-carrier BS with contiguous carrier frequencies shall be equal to or greater than the limits given in table 6.22B.

**Table 6.22B: BS ACLR limits**

| BS adjacent channel offset below the first or above the last carrier frequency used | ACLR limit |
|---|------------|
| 10 MHz  | 45 dB      |
| 20 MHz  | 55 dB      |

If a BS provides multiple non-contiguous single carriers or multiple non-contiguous groups of contiguous single carriers, the above requirements shall be applied individually to the single carriers or group of single carriers.

The normative reference for this requirement is TS 25.105 [1] subclause 6.6.2.2.1.3.

6.6.2.2.2.2 Additional requirement for operation in the same geographic area with FDD or unsynchronised TDD on adjacent channels

6.6.2.2.2.2.1 3,84 Mcps TDD option

6.6.2.2.2.2.1.1 Additional requirement for operation in the same geographic area with unsynchronised TDD on adjacent channels

In case the equipment is operated in the same geographic area with an unsynchronised TDD BS operating on the first or second adjacent frequency, the adjacent channel leakage power of a single carrier BS or a multi-carrier BS with contiguous carrier frequencies shall not exceed the limits specified in table 6.23.

**Table 6.23: Adjacent channel leakage power limits for operation in the same geographic area with unsynchronised TDD on adjacent channels**

| BS Class      | BS adjacent channel offset below the first or above the last carrier frequency used | Maximum Level | Measurement Bandwidth |
|---------------|---|---------------|-----------------------|
| Wide Area BS  | 5 MHz   | -29 dBm       | 3,84 MHz              |
| Wide Area BS  | 10 MHz  | -29 dBm       | 3,84 MHz              |
| Local Area BS | 5 MHz   | -16 dBm       | 3,84 MHz              |
| Local Area BS | 10 MHz  | -26 dBm       | 3,84 MHz              |

NOTE: The requirements in table 6.23 for the Wide Area BS are based on a coupling loss of 74 dB between the unsynchronised TDD base stations. The requirement in table 6.23 for the Local Area BS ACLR1 ( $\pm 5$  MHz channel offset) is based on a coupling loss of 87 dB between unsynchronised Wide Area and Local Area TDD base stations. The requirement in table 6.23 for the Local Area BS ACLR2 ( $\pm 10$  MHz channel offset) is based on a coupling loss of 77 dB between unsynchronised Wide Area and Local Area TDD base stations. The scenarios leading to these requirements are addressed in TR25.942 [9].

If a BS provides multiple non-contiguous single carriers or multiple non-contiguous groups of contiguous single carriers, the above requirements shall be applied to those adjacent channels of the single carriers or group of single channels which are used by the TDD BS in the same geographic area.

The normative reference for this requirement is TS 25.105 [1] subclause 6.6.2.2.2.1.1.

NOTE: The necessary dynamic range to verify the conformance requirements specified in table 6.23 is at the limits of the capability of state-of-art measuring equipment.

6.6.2.2.2.2.1.2 Additional requirement for operation in the same geographic area with FDD on adjacent channels

In case the equipment is operated in the same geographic area with a FDD BS operating on the first or second adjacent channel, the adjacent channel leakage power shall not exceed the limits specified in table 6.23AA.

**Table 6.23AA: Adjacent channel leakage power limits for operation in the same geographic area with FDD on adjacent channels**

| BS Class      | BS Adjacent Channel Offset | Maximum Level | Measurement Bandwidth |
|---------------|----------------------------|---------------|-----------------------|
| Wide Area BS  | $\pm 5$ MHz                | -36 dBm       | 3,84 MHz              |
| Wide Area BS  | $\pm 10$ MHz               | -36 dBm       | 3,84 MHz              |
| Local Area BS | $\pm 5$ MHz                | -23 dBm       | 3,84 MHz              |
| Local Area BS | $\pm 10$ MHz               | -33 dBm       | 3,84 MHz              |

NOTE: The requirements in table 6.23AA for the Wide Area BS are based on a coupling loss of 74 dB between the FDD and TDD base stations. The requirements in table 6.23AA for the Local Area BS ACLR1 ( $\pm 5$  MHz channel offset) are based on a relaxed coupling loss of 87 dB between TDD and FDD base stations. The requirement for the Local Area BS ACLR2 ( $\pm 10$  MHz channel offset) are based on a relaxed coupling loss of 77 dB between TDD and FDD base stations. The scenarios leading to these requirements are addressed in TR 25.942 [9].

If a BS provides multiple non-contiguous single carriers or multiple non-contiguous groups of contiguous single carriers, the above requirements shall be applied to those adjacent channels of the single carriers or group of single channels which are used by the FDD BS in the same geographic area.

The normative reference for this requirement is TS 25.105 [1] subclause 6.6.2.2.2.1.2.

#### 6.6.2.2.2.2 1,28 Mcps TDD option

##### 6.6.2.2.2.2.1 Additional requirement for operation in the same geographic area with unsynchronised TDD on adjacent channels

In case the equipment is operated in the same geographic area with an unsynchronised TDD BS operating on an adjacent channel, the requirement is specified in terms of adjacent channel leakage power. In geographic areas where only UTRA 1,28 Mcps TDD option is deployed, the adjacent channel leakage power limits shall not exceed the limits specified in table 6.23A, otherwise the limits in table 6.23B shall apply.

**Table 6.23A: Adjacent channel leakage power limits for operation in the same geographic area with unsynchronised 1,28 Mcps TDD on adjacent channels**

| BS Class      | BS Adjacent Channel Offset | Maximum Level | Measurement Bandwidth |
|---------------|----------------------------|---------------|-----------------------|
| Wide Area BS  | $\pm 1,6$ MHz              | -29 dBm       | 1,28 MHz              |
| Wide Area BS  | $\pm 3,2$ MHz              | -29 dBm       | 1,28 MHz              |
| Local Area BS | $\pm 1,6$ MHz              | -16 dBm       | 1,28 MHz              |
| Local Area BS | $\pm 3,2$ MHz              | -16 dBm       | 1,28 MHz              |

**Table 6.23B: Adjacent channel leakage power limits for operation in the same geographic area with unsynchronised TDD on adjacent channels**

| BS Class      | BS Adjacent Channel Offset | Maximum Level | Measurement Bandwidth |
|---------------|----------------------------|---------------|-----------------------|
| Wide Area BS  | $\pm 3,4$ MHz              | -29 dBm       | 3,84 MHz              |
| Local Area BS | $\pm 3,4$ MHz              | -16 dBm       | 3,84 MHz              |

NOTE: The requirements in table 6.23A and 6.23B for the Wide Area BS are based on a coupling loss of 74 dB between the unsynchronised TDD base stations. The requirements in table 6.23A and 6.23B for the Local Area BS are based on a coupling loss of 87 dB between unsynchronised Wide Area and Local Area TDD base stations. The scenarios leading to these requirements are addressed in TR25.942 [9].

The normative reference for this requirement is TS 25.105 [1] subclause 6.6.2.2.2.2.1.

##### 6.6.2.2.2.2.2 Additional requirement for operation in the same geographic area with FDD on adjacent channels

In case the equipment is operated in the same geographic area with a FDD BS operating on an adjacent channel, the adjacent channel leakage power shall not exceed the limits specified in table 6.23C. This requirement is only applicable if the equipment is intended to operate in frequency bands specified in 4.2 a) and the highest carrier frequency used is in the range 1916,2 - 1920 MHz.

**Table 6.23C: Adjacent channel leakage power limits for BS in the band a) when operating in the same geographic area with FDD on adjacent channels**

| BS Class      | Center Frequency for Measurement | Maximum Level | Measurement Bandwidth |
|---------------|----------------------------------|---------------|-----------------------|
| Wide Area BS  | 1922,6 MHz                       | -36 dBm       | 3,84 MHz              |
| Local Area BS | 1922,6 MHz                       | -23 dBm       | 3,84 MHz              |

NOTE: The requirement in table 6.23C for Wide Area BS is based on a relaxed coupling loss of 74 dB between the TDD and FDD base stations. The requirement in table 6.23C for Local Area BS is based on a relaxed coupling loss of 87 dB between TDD and FDD base stations. The scenarios leading to these requirements are addressed in TR 25.942 [9].

The normative reference for this requirement is TS 25.105 [1] subclause 6.6.2.2.2.2.

6.6.2.2.2.3 7,68 Mcps TDD option

6.6.2.2.2.3.1 Additional requirement for operation in the same geographic area with unsynchronised TDD on adjacent channels

In case the equipment is operated in the same geographic area with an unsynchronised TDD BS operating on the first or second adjacent frequency, the adjacent channel leakage power of a single carrier BS or a multi-carrier BS with contiguous carrier frequencies shall not exceed the limits specified in table 6.23D and 6.23E.

**Table 6.23D: Adjacent channel leakage power limits for operation in the same geographic area with unsynchronised TDD (7.68 Mcps TDD and 3,84 Mcps TDD) on adjacent channels**

| BS Class      | BS adjacent channel offset below the first or above the last carrier frequency used | Maximum Level | Measurement Bandwidth |
|---------------|---|---------------|-----------------------|
| Wide Area BS  | 7.5 MHz   | - 29 dBm      | 3,84 MHz              |
| Wide Area BS  | 12.5 MHz  | - 29 dBm      | 3,84 MHz              |
| Wide Area BS  | 17.5 MHz  | - 29 dBm      | 3,84 MHz              |
| Wide Area BS  | 22.5 MHz  | - 29 dBm      | 3,84 MHz              |
| Local Area BS | 7.5 MHz   | -16 dBm       | 3,84 MHz              |
| Local Area BS | 12.5 MHz  | -26 dBm       | 3,84 MHz              |
| Local Area BS | 17.5 MHz  | -26 dBm       | 3,84 MHz              |
| Local Area BS | 22.5 MHz  | -26 dBm       | 3,84 MHz              |

**Table 6.23E: Adjacent channel leakage power limits for operation in the same geographic area with unsynchronised 1,28 Mcps TDD on adjacent channels**

| BS Class      | BS adjacent channel offset below the first or above the last carrier frequency used | Maximum Level | Measurement Bandwidth |
|---------------|---|---------------|-----------------------|
| Wide Area BS  | 5.8 MHz   | - 29 dBm      | 1,28 MHz              |
| Wide Area BS  | 7.4 MHz   | - 29 dBm      | 1,28 MHz              |
| Local Area BS | 5.8 MHz   | - 16 dBm      | 1,28 MHz              |
| Local Area BS | 7.4 MHz   | - 16 dBm      | 1,28 MHz              |

NOTE: The requirements in Table 6.23D and 6.23E for the Wide Area BS are based on a coupling loss of 74 dB between the unsynchronised TDD base stations. The requirement in Table 6.23D and 6.23E for the Local Area BS ACLR1 are based on a coupling loss of 87 dB between unsynchronised Wide Area and Local Area TDD base stations. The requirement in Table 6.23D and 6.23E for the Local Area BS ACLR2 are based on a coupling loss of 77 dB and 87 dB between unsynchronised Wide Area and Local Area 3,84 Mcps TDD and 1,28 Mcps TDD base stations respectively.

If a BS provides multiple non-contiguous single carriers or multiple non-contiguous groups of contiguous single carriers, the above requirements shall be applied to those adjacent channels of the single carriers or group of single channels which are used by the TDD BS in the same geographic area.

The normative reference for this requirement is TS 25.105 [1] subclause 6.6.2.2.2.3.1.

NOTE: The necessary dynamic range to verify the conformance requirements specified in table 6.23D and 6.23E is at the limits of the capability of state-of-art measuring equipment.

6.6.2.2.2.3.2 Additional requirement for operation in the same geographic area with FDD on adjacent channels

In case the equipment is operated in the same geographic area with a FDD BS operating on the first or second adjacent channel, the adjacent channel leakage power shall not exceed the limits specified in table 6.23F.



**Table 6.23F: Adjacent channel leakage power limits for operation in the same geographic area with FDD on adjacent channels**

| BS Class      | BS Adjacent Channel Offset | Maximum Level | Measurement Bandwidth |
|---------------|----------------------------|---------------|-----------------------|
| Wide Area BS  | $\pm 7.5$ MHz              | -36 dBm       | 3,84 MHz              |
| Wide Area BS  | $\pm 12.5$ MHz             | -36 dBm       | 3,84 MHz              |
| Wide Area BS  | $\pm 17.5$ MHz             | -39 dBm       | 3,84 MHz              |
| Wide Area BS  | $\pm 22.5$ MHz             | -43 dBm       | 3,84 MHz              |
| Local Area BS | $\pm 7.5$ MHz              | -23 dBm       | 3,84 MHz              |
| Local Area BS | $\pm 12.5$ MHz             | -33 dBm       | 3,84 MHz              |
| Local Area BS | $\pm 17.5$ MHz             | -36 dBm       | 3,84 MHz              |
| Local Area BS | $\pm 22.5$ MHz             | -40 dBm       | 3,84 MHz              |

NOTE: The requirements in Table 6.23F for the Wide Area BS are based on a coupling loss of 74 dB between the FDD and TDD base stations. The requirements in Table 6.23F for the Local Area BS ACLR1 ( $\pm 10$  MHz channel offset) are based on a relaxed coupling loss of 87 dB between TDD and FDD base stations. The requirements for the Local Area BS ACLR2 ( $\pm 20$  MHz channel offset) are based on a relaxed coupling loss of 77 dB between TDD and FDD base stations.

If a BS provides multiple non-contiguous single carriers or multiple non-contiguous groups of contiguous single carriers, the above requirements shall be applied to those adjacent channels of the single carriers or group of single channels which are used by the FDD BS in the same geographic area.

The normative reference for this requirement is TS 25.105 [1] subclause 6.6.2.2.2.3.2.

6.6.2.2.2.3 Additional requirement in case of co-siting with unsynchronised TDD BS or FDD BS operating on an adjacent channel

6.6.2.2.2.3.1 3,84 Mcps TDD option

6.6.2.2.2.3.1.1 Additional requirement in case of co-siting with unsynchronised TDD BS operating on an adjacent channel

In case the equipment is co-sited to an unsynchronised TDD BS operating on the first or second adjacent frequency, the adjacent channel leakage power of a single carrier BS or a multi-carrier BS with contiguous carrier frequencies shall not exceed the limits specified in table 6.24.

**Table 6.24: Adjacent channel leakage power limits in case of co-siting with unsynchronised TDD on adjacent channels**

| BS Class      | BS adjacent channel offset below the first or above the last carrier frequency used | Maximum Level | Measurement Bandwidth |
|---------------|---|---------------|-----------------------|
| Wide Area BS  | 5 MHz   | -73 dBm       | 3,84 MHz              |
| Wide Area BS  | 10 MHz  | -73 dBm       | 3,84 MHz              |
| Local Area BS | 5 MHz   | -46 dBm       | 3,84 MHz              |
| Local Area BS | 10 MHz  | -46 dBm       | 3,84 MHz              |

NOTE: The requirements in table 6.24 for the Wide Area BS are based on a minimum coupling loss of 30 dB between unsynchronised TDD base stations. The requirements in table 6.24 for the Local Area BS are based on a minimum coupling loss of 30 dB between unsynchronised Local Area base stations. The co-location of different base station classes is not considered.

If a BS provides multiple non-contiguous single carriers or multiple non-contiguous groups of contiguous single carriers, the above requirements shall be applied to those adjacent channels of the single carriers or group of single channels which are used by the co-sited TDD BS.

The normative reference for this requirement is TS 25.105 [1] subclause 6.6.2.2.3.1.1.

NOTE: The necessary dynamic range of the measuring equipment to verify the conformance requirements specified in table 6.24 for the Wide Area BS is dependent on the BS output power. If the BS output power is larger than -10 dBm, the necessary dynamic range is beyond the capability of state-of-the-art measuring equipment; direct verification of the conformance requirements is not feasible. Alternatively, indirect measurement methods need to be defined.

#### 6.6.2.2.3.1.2 Additional requirement in case of co-siting with FDD BS operating on adjacent channels

In case the equipment is co-sited to a FDD BS operating on the first or second adjacent channel, the adjacent channel leakage power shall not exceed the limits specified in table 6.24A.

**Table 6.24A: Adjacent channel leakage power limits in case of co-siting with FDD on adjacent channels**

| BS Class     | BS Adjacent Channel Offset | Maximum Level | Measurement Bandwidth |
|--------------|----------------------------|---------------|-----------------------|
| Wide Area BS | $\pm 5$ MHz                | -80 dBm       | 3,84 MHz              |
| Wide Area BS | $\pm 10$ MHz               | -80 dBm       | 3,84 MHz              |

NOTE: The requirements in table 6.24A are based on a minimum coupling loss of 30 dB between base stations. The co-location of different base station classes is not considered. A co-location requirement for the Local Area TDD BS is intended to be part of a later release.

If a BS provides multiple non-contiguous single carriers or multiple non-contiguous groups of contiguous single carriers, the above requirements shall be applied to those adjacent channels of the single carriers or group of single channels which are used by the co-sited FDD BS.

The normative reference for this requirement is TS 25.105 [1] subclause 6.6.2.2.3.1.2.

#### 6.6.2.2.3.2 1,28 Mcps TDD option

##### 6.6.2.2.3.2.1 Additional requirement in case of co-siting with unsynchronised TDD BS operating on an adjacent channel

In case the equipment is co-sited to an unsynchronised TDD BS operating on an adjacent channel, the requirement is specified in terms of adjacent channel leakage power. In geographic areas where only UTRA 1,28 Mcps TDD option is deployed, the adjacent channel leakage power shall not exceed the limits specified in table 6.24B, otherwise the limits in table 6.24C shall apply.

**Table 6.24B: Adjacent channel leakage power limits in case of co-siting with unsynchronised 1,28 Mcps TDD on adjacent channels**

| BS Class      | BS Adjacent Channel Offset | Maximum Level | Measurement Bandwidth |
|---------------|----------------------------|---------------|-----------------------|
| Wide Area BS  | $\pm 1,6$ MHz              | -73 dBm       | 1,28 MHz              |
| Wide Area BS  | $\pm 3,2$ MHz              | -73 dBm       | 1,28 MHz              |
| Local Area BS | $\pm 1,6$ MHz              | -49 dBm       | 1,28 MHz              |
| Local Area BS | $\pm 3,2$ MHz              | -49 dBm       | 1,28 MHz              |

**Table 6.24C: Adjacent channel leakage power limits in case of co-siting with unsynchronised TDD on an adjacent channel**

| BS Class      | BS Adjacent Channel Offset | Maximum Level | Measurement Bandwidth |
|---------------|----------------------------|---------------|-----------------------|
| Wide Area BS  | $\pm 3,4$ MHz              | -73 dBm       | 3,84 MHz              |
| Local Area BS | $\pm 3,4$ MHz              | -46 dBm       | 3,84 MHz              |

NOTE: The requirements in table 6.24B and 6.24C for the Wide Area BS are based on a minimum coupling loss of 30 dB between unsynchronised TDD base stations. The requirements in table 6.24B and 6.24C for the Local Area BS are based on a minimum coupling loss of 30 dB between unsynchronised Local Area base stations. The co-location of different base station classes is not considered.

The normative reference for this requirement is TS 25.105 [1] subclause 6.6.2.2.3.2.1.

#### 6.6.2.2.3.2.2 Additional requirement in case of co-siting with FDD BS operating on an adjacent channel

In case the equipment is co-sited to a FDD BS operating on an adjacent channel, the adjacent channel leakage power shall not exceed the limits specified in table 6.24D. This requirement is only applicable if the equipment is intended to operate in frequency bands specified in 4.2 a) and the highest carrier frequency used is in the range 1916,2 - 1920 MHz.

**Table 6.24D: Adjacent channel leakage power for BS in the band a) when co-siting with UTRA FDD on an adjacent channel**

| BS Class     | Center Frequency for Measurement | Maximum Level | Measurement Bandwidth |
|--------------|----------------------------------|---------------|-----------------------|
| Wide Area BS | 1922,6 MHz                       | -80 dBm       | 3,84 MHz              |

NOTE: The requirements in table 6.24D are based on a minimum coupling loss of 30 dB between base stations. The co-location of different base station classes is not considered. A co-location requirement for the Local Area TDD BS is intended to be part of a later release.

The normative reference for this requirement is TS 25.105 [1] subclause 6.6.2.2.3.2.2.

#### 6.6.2.2.3.3 7,68 Mcps TDD option

##### 6.6.2.2.3.3.1 Additional requirement in case of co-siting with unsynchronised TDD BS operating on an adjacent channel

In case the equipment is co-sited to an unsynchronised TDD BS operating on the first or second adjacent frequency, the adjacent channel leakage power of a single carrier BS or a multi-carrier BS with contiguous carrier frequencies shall not exceed the limits specified in table 6.24E and 6.24F.

**Table 6.24E: Adjacent channel leakage power limits in case of co-siting with unsynchronised TDD (7.68 Mcps TDD and 3,84 Mcps TDD) on adjacent channels**

| BS Class      | BS adjacent channel offset below the first or above the last carrier frequency used | Maximum Level | Measurement Bandwidth |
|---------------|---|---------------|-----------------------|
| Wide Area BS  | 7.5 MHz   | -73 dBm       | 3,84 MHz              |
| Wide Area BS  | 12.5 MHz  | -73 dBm       | 3,84 MHz              |
| Wide Area BS  | 17.5 MHz  | -73 dBm       | 3,84 MHz              |
| Wide Area BS  | 22.5 MHz  | -73 dBm       | 3,84 MHz              |
| Local Area BS | 7.5 MHz   | -46 dBm       | 3,84 MHz              |
| Local Area BS | 12.5 MHz  | -46 dBm       | 3,84 MHz              |
| Local Area BS | 17.5 MHz  | -46 dBm       | 3,84 MHz              |
| Local Area BS | 22.5 MHz  | -46 dBm       | 3,84 MHz              |

**Table 6.24F: Adjacent channel leakage power limits in case of co-siting with unsynchronised 1,28 Mcps TDD on adjacent channel**

| BS Class      | BS adjacent channel offset below the first or above the last carrier frequency used | Maximum Level | Measurement Bandwidth |
|---------------|---|---------------|-----------------------|
| Wide Area BS  | 5.8 MHz   | -73 dBm       | 1,28 MHz              |
| Wide Area BS  | 7.4 MHz   | -73 dBm       | 1,28 MHz              |
| Local Area BS | 5.8 MHz   | -49 dBm       | 1,28 MHz              |
| Local Area BS | 7.4 MHz   | -49 dBm       | 1,28 MHz              |

NOTE: The requirements in Table 6.24E and 6.24F for the Wide Area BS are based on a minimum coupling loss of 30 dB between unsynchronised TDD base stations. The requirements in Table 6.24E and 6.24F for the Local Area BS are based on a minimum coupling loss of 30 dB between unsynchronised Local Area base stations. The co-location of different base station classes is not considered.

If a BS provides multiple non-contiguous single carriers or multiple non-contiguous groups of contiguous single carriers, the above requirements shall be applied to those adjacent channels of the single carriers or group of single channels which are used by the co-sited TDD BS.

The normative reference for this requirement is TS 25.105 [1] subclause 6.6.2.2.3.3.1.

#### 6.6.2.2.3.3.2 Additional requirement in case of co-siting with FDD BS operating on an adjacent channel

In case the equipment is co-sited to a FDD BS operating on the first or second adjacent channel, the adjacent channel leakage power shall not exceed the limits specified in table 6.24G.

**Table 6.24G: Adjacent channel leakage power limits in case of co-siting with FDD on adjacent channels**

| BS Class     | BS Adjacent Channel Offset | Maximum Level | Measurement Bandwidth |
|--------------|----------------------------|---------------|-----------------------|
| Wide Area BS | $\pm 7.5$ MHz              | -80 dBm       | 3,84 MHz              |
| Wide Area BS | $\pm 12.5$ MHz             | -80 dBm       | 3,84 MHz              |
| Wide Area BS | $\pm 17.5$ MHz             | -80 dBm       | 3,84 MHz              |
| Wide Area BS | $\pm 22.5$ MHz             | -80 dBm       | 3,84 MHz              |

NOTE: The requirements in Table 6.24G are based on a minimum coupling loss of 30 dB between base stations. The co-location of different base station classes is not considered. A co-location requirement for the Local Area TDD BS is intended to be part of a later release.

If a BS provides multiple non-contiguous single carriers or multiple non-contiguous groups of contiguous single carriers, the above requirements shall be applied to those adjacent channels of the single carriers or group of single channels which are used by the co-sited FDD BS.

The normative reference for this requirement is TS 25.105 [1] subclause 6.6.2.2.3.3.2.

#### 6.6.2.2.3 Test purpose

The test purpose is to verify the ability of the BS to limit the interference produced by the transmitted signal to other UTRA receivers operating at the first or second adjacent RF channel.

#### 6.6.2.2.4 Method of test

##### 6.6.2.2.4.1 Initial conditions

For 3,84 Mcps BS supporting 16QAM, the ALCR requirements shall be tested with the general test set up specified in section 6.6.2.2.4.1.1 and also with the special test set up for 16QAM capable BS specified in section 6.6.2.2.4.1.4.

For 1,28 Mcps BS supporting 16QAM, the ALCR requirements shall be tested with the general test set up specified in section 6.6.2.2.4.1.2 and also with the special test set up for 16QAM capable BS specified in section 6.6.2.2.4.1.3.

For 7,68 Mcps BS supporting 16QAM, the ALCR requirements shall be tested with the general test set up specified in section 6.6.2.2.4.1.5 and also with the special test set up for 16QAM capable BS specified in section 6.6.2.2.4.1.6.

##### 6.6.2.2.4.1.0 General test conditions

Test environment: normal; see subclause 5.9.1.

RF channels to be tested: B, M and T with multiple carriers if supported; see subclause 5.3.

##### 6.6.2.2.4.1.1 3,84 Mcps TDD option - General test set up

- (1) Connect the measuring equipment to the antenna connector of the BS under test.
- (2) Set the parameters of the BS transmitted signal according to table 6.25. For MBSFN IMB operation the set of parameters for the transmitted signals is according to IMB test model 1 in subclause 6.1.1.1.

**Table 6.25: Parameters of the BS transmitted signal for ACLR testing**

| Parameter                                   | Value/description   |
|---|---|
| TDD Duty Cycle                              | TS $i$ ; $i = 0, 1, 2, \dots, 14$ :<br>transmit, if $i$ is even;<br>receive, if $i$ is odd. |
| Time slot carrying SCH                      | TS0   |
| Time slots under test                       | TS $i$ , $i$ even and non zero  |
| BS output power setting                     | PRAT  |
| Number of DPCH in each time slot under test | 9   |
| Power of each DPCH                          | 1/9 of Base Station output power  |
| Data content of DPCH                        | Real life (sufficient irregular)  |

## 6.6.2.2.4.1.2 1,28 Mcps TDD option - General test set up

- (1) Connect the measuring equipment to the antenna connector of the BS under test.
- (2) Set the parameters of the BS transmitted signal according to table 6.25A.

**Table 6.25A: Parameters of the BS transmitted signal for ACLR testing for 1,28 Mcps TDD**

| Parameter                                   | Value/description   |
|---|---|
| TDD Duty Cycle                              | TS $i$ ; $i = 0, 1, 2, 3, 4, 5, 6$ :<br>transmit, if $i$ is 0,4,5,6;<br>receive, if $i$ is 1,2,3. |
| Time slots under test                       | TS4, TS5 and TS6  |
| BS output power setting                     | PRAT  |
| Number of DPCH in each time slot under test | 8   |
| Power of each DPCH                          | 1/8 of Base Station output power  |
| Data content of DPCH                        | real life (sufficient irregular)  |

## 6.6.2.2.4.1.3 1,28 Mcps TDD option - Special test set up for 16QAM capable BS

This test set up only applies for 16QAM capable BS.

- (1) Connect the measuring equipment to the antenna connector of the BS under test.
- (2) Set the parameters of the BS transmitted signal according to table 6.25B.

**Table 6.25B: Parameters of the BS transmitted signal for ACLR testing for 1,28 Mcps TDD- 16QAM capable BS**

| Parameter                                       | Value/description   |
|---|---|
| TDD Duty Cycle                                  | TS $i$ ; $i = 0, 1, 2, 3, 4, 5, 6$ :<br>transmit, if $i$ is 0,4,5,6;<br>receive, if $i$ is 1,2,3. |
| Time slots under test                           | TS4, TS5 and TS6  |
| BS output power setting                         | PRAT  |
| HS-PDSCH modulation                             | 16QAM   |
| Number of HS-PDSCH in each time slot under test | 8   |
| Power of each HS-PDSCH                          | 1/8 of Base Station output power  |
| Data content of HS-PDSCH                        | real life (sufficient irregular)  |
| Spreading factor                                | 16  |

## 6.6.2.2.4.1.4 3,84 Mcps TDD option - Special test set up for 16QAM capable BS

This test set up only applies for 16QAM capable BS.

- (1) Connect the measuring equipment to the antenna connector of the BS under test.

- (2) Set the parameters of the BS transmitted signal according to table 6.25C. For MBSFN IMB operation the set of parameters for the transmitted signals is according to IMB test model 2 in subclause 6.1.1.2.

**Table 6.25C: Parameters of the BS transmitted signal for ACLR testing - 16QAM capable BS**

| Parameter                                       | Value/description   |
|---|---|
| TDD Duty Cycle                                  | TS $i$ ; $i = 0, 1, 2, \dots, 14$ :<br>transmit, if $i$ is even;<br>receive, if $i$ is odd. |
| Time slot carrying SCH                          | TS0   |
| Time slots under test                           | TS $i$ , $i$ even and non zero  |
| BS output power setting                         | PRAT  |
| HS-PDSCH modulation                             | 16QAM   |
| Number of HS-PDSCH in each time slot under test | 9   |
| Power of each HS-PDSCH                          | 1/9 of Base Station output power  |
| Data content of HS-PDSCH                        | real life (sufficient irregular)  |
| Spreading factor                                | 16  |

#### 6.6.2.2.4.1.5 7,68 Mcps TDD option - General test set up

- (1) Connect the measuring equipment to the antenna connector of the BS under test.
- (2) Set the parameters of the BS transmitted signal according to table 6.25D.

**Table 6.25D: Parameters of the BS transmitted signal for ACLR testing**

| Parameter                                   | Value/description   |
|---|---|
| TDD Duty Cycle                              | TS $i$ ; $i = 0, 1, 2, \dots, 14$ :<br>transmit, if $i$ is even;<br>receive, if $i$ is odd. |
| Time slot carrying SCH                      | TS0   |
| Time slots under test                       | TS $i$ , $i$ even and non zero  |
| BS output power setting                     | PRAT  |
| Number of DPCH in each time slot under test | 9   |
| Power of each DPCH                          | 1/9 of Base Station output power  |
| Data content of DPCH                        | Real life (sufficient irregular)  |

#### 6.6.2.2.4.1.6 7,68 Mcps TDD option - Special test set up for 16QAM capable BS

This test set up only applies for 16QAM capable BS.

- (1) Connect the measuring equipment to the antenna connector of the BS under test.
- (2) Set the parameters of the BS transmitted signal according to table 6.25E.

**Table 6.25E: Parameters of the BS transmitted signal for ACLR testing - 16QAM capable BS**

| Parameter                                       | Value/description   |
|---|---|
| TDD Duty Cycle                                  | TS $i$ ; $i = 0, 1, 2, \dots, 14$ :<br>transmit, if $i$ is even;<br>receive, if $i$ is odd. |
| Time slot carrying SCH                          | TS0   |
| Time slots under test                           | TS $i$ , $i$ even and non zero  |
| BS output power setting                         | PRAT  |
| HS-PDSCH modulation                             | 16QAM   |
| Number of HS-PDSCH in each time slot under test | 9   |
| Power of each HS-PDSCH                          | 1/9 of Base Station output power  |
| Data content of HS-PDSCH                        | real life (sufficient irregular)  |
| Spreading factor                                | 32  |

## 6.6.2.2.4.2 Procedure

## 6.6.2.2.4.2.1 3,84 Mcps TDD option

- 1) Measure the RRC filtered mean power centered on the lowest assigned channel frequency over the 2464 active chips of the even time slots TS *i* (this excludes the guard period).
- 2) Average over TBD time slots.
- 3) Measure the RRC filtered mean power at the first lower adjacent RF channel (center frequency 5 MHz below the lowest assigned channel frequency of the transmitted signal) over the useful part of the burst within the even time slots TS *i* (this excludes the guard period).
- 4) Average over TBD time slots.
- 5) Calculate the ACLR by the ratio

$$\text{ACLR} = \text{average acc. to (2)} / \text{average interference power acc. to (4)}.$$

- 6) Repeat steps (3), (4) and (5) for the second lower adjacent RF channel (center frequency 10 MHz below the lowest assigned channel frequency of the transmitted signal).
- 7) In case of a multi-carrier Bs, repeat steps (1) and (2) for the highest assigned channel frequency. Otherwise, use the result obtained in step (2) above for further calculation in step (10).
- 8) Measure the RRC filtered mean power at the first higher adjacent RF channel (center frequency 5 MHz above the highest assigned channel frequency of the transmitted signal) over the useful part of the burst within the even time slots TS *i* (this excludes the guard period).
- 9) Average over TBD time slots.
- 10) Calculate the ACLR by the ratio

$$\text{ACLR} = \text{average power acc. to (7)} / \text{average interference power acc. to (9)}.$$

- 11) Repeat steps (8) to (10) for the second upper adjacent RF channel (center frequency 10 MHz above the highest assigned channel frequency of the transmitted signal).

## 6.6.2.2.4.2.2 1,28 Mcps TDD option

- 1) Measure the RRC filtered mean power centered on the lowest assigned channel frequency over the 848 active chips of the transmit time slots TS *i* (this excludes the guard period).
- 2) Average over at least one time slot.
- 3) Measure the RRC filtered mean power at the first lower adjacent RF channel (center frequency 1,6 MHz below the assigned channel frequency of the transmitted signal) over the useful part of the burst within the transmit time slots TS *i* (this excludes the guard period).
- 4) Average over at least one time slot.
- 5) Calculate the ACLR by the ratio:

$$\text{ACLR} = \text{average power acc. to (2)} / \text{average interference power acc. to (4)}.$$

- 6) Repeat steps (3), (4) and (5) for the second lower adjacent RF channel (center frequency 3,2 MHz below the lowest assigned channel frequency of the transmitted signal) and also for the first and second upper adjacent RF channel (center frequency 1,6 MHz and 3,2 MHz above the assigned channel frequency of the transmitted signal, respectively).
- 7) In case of a multi-carrier BS, repeat steps (1) and 2 for the highest assigned channel frequency. Otherwise, use the result obtained in step (2) above for further calculation in step (10).
- 8) Measure the RRC filtered mean power at the first higher adjacent RF channel (center frequency 1,6 MHz above the highest assigned channel frequency of the transmitted signal) over the useful part of the burst within the transmit time slots TS *i* (this excludes the guard period).

9) Average over at least one time slot.

10) Calculate the ACLR by the ratio

$$\text{ACLR} = \text{average power acc. to (7)} / \text{average interference power acc. to (9)}.$$

11) Repeat steps (8) to (10) for the second upper adjacent RF channel (center frequency 3,2 MHz above the highest assigned channel frequency of the transmitted signal).

#### 6.6.2.2.4.2.3 1,28 Mcps TDD option - 16QAM capable BS

The same procedure specified in 6.6.2.2.4.2.2 applies to 1,28 Mcps TDD option BS supporting 16QAM.

#### 6.6.2.2.4.2.4 3,84 Mcps TDD option - 16QAM capable BS

The same procedure specified in 6.6.2.2.4.2.1 applies to 3,84 Mcps TDD option BS supporting 16QAM.

#### 6.6.2.2.4.2.5 7,68 Mcps TDD option

- 1) Measure the RRC filtered mean power centered on the lowest assigned channel frequency over the 4928 active chips of the even time slots TS  $i$  (this excludes the guard period).
- 2) Average over TBD time slots.
- 3) Measure the RRC filtered mean power at the first lower adjacent RF channel (center frequency 10 MHz below the lowest assigned channel frequency of the transmitted signal) over the useful part of the burst within the even time slots TS  $i$  (this excludes the guard period).
- 4) Average over TBD time slots.
- 5) Calculate the ACLR by the ratio

$$\text{ACLR} = \text{average acc. to (2)} / \text{average interference power acc. to (4)}.$$

- 6) Repeat steps (3), (4) and (5) for the second lower adjacent RF channel (center frequency 20 MHz below the lowest assigned channel frequency of the transmitted signal).
- 7) In case of a multi-carrier Bs, repeat steps (1) and (2) for the highest assigned channel frequency. Otherwise, use the result obtained in step (2) above for further calculation in step (10).
- 8) Measure the RRC filtered mean power at the first higher adjacent RF channel (center frequency 10 MHz above the highest assigned channel frequency of the transmitted signal) over the useful part of the burst within the even time slots TS  $i$  (this excludes the guard period).
- 9) Average over TBD time slots.
- 10) Calculate the ACLR by the ratio

$$\text{ACLR} = \text{average power acc. to (7)} / \text{average interference power acc. to (9)}.$$

11) Repeat steps (8) to (10) for the second upper adjacent RF channel (center frequency 20 MHz above the highest assigned channel frequency of the transmitted signal).

#### 6.6.2.2.4.2.6 7,68 Mcps TDD option - 16QAM capable BS

The same procedure specified in 6.6.2.2.4.2.5 applies to 7,68 Mcps TDD option BS supporting 16QAM.

### 6.6.2.2.5 Test Requirements

NOTE: If the Test Requirements below differ from the Minimum Requirements, then the Test Tolerance applied for this test is non-zero. The Test Tolerance for this test is defined in subclause 5.11 and the explanation of how the Minimum Requirement has been relaxed by the Test Tolerance is given in Annex D.



## 6.6.2.2.5.1 3,84 Mcps TDD option

The ACLR calculated in steps (5) and (10) of subclause 6.6.2.2.4.2.1 shall be equal or greater than the limits given in table 6.26. In case the equipment is tested against the requirements defined for operation in the same geographic area or co-sited with unsynchronised TDD or FDD on adjacent channels, the adjacent channel leakage power measured according to steps (4) and (9) of subclause 6.6.2.2.4.2.1 shall not exceed the maximum levels specified in table 6.27, 6.27A, 6.28 or 6.28A, respectively.

**Table 6.26: BS ACLR Test Requirements**

| BS adjacent channel offset below the first or above the last carrier frequency used | ACLR limit |
|---|------------|
| 5 MHz   | 44,2 dB    |
| 10 MHz  | 54,2 dB    |

**Table 6.27: Adjacent channel leakage power Test Requirements for operation in the same geographic area with unsynchronised TDD on adjacent channels**

| BS Class      | BS adjacent channel offset below the first or above the last carrier frequency used | Maximum Level | Measurement Bandwidth |
|---------------|---|---------------|-----------------------|
| Wide Area BS  | 5 MHz   | -25 dBm       | 3,84 MHz              |
| Wide Area BS  | 10 MHz  | -25 dBm       | 3,84 MHz              |
| Local Area BS | 5 MHz   | -15,2 dBm     | 3,84 MHz              |
| Local Area BS | 10 MHz  | -25,2 dBm     | 3,84 MHz              |

**Table 6.27A: Adjacent channel leakage power Test Requirements for operation in the same geographic area with FDD on adjacent channels**

| BS Class      | BS Adjacent Channel Offset | Maximum Level  | Measurement Bandwidth |
|---------------|----------------------------|----------------|-----------------------|
| Wide Area BS  | ± 5 MHz                    | -[36 dBm - TT] | 3,84 MHz              |
| Wide Area BS  | ± 10 MHz                   | -32 dBm        | 3,84 MHz              |
| Local Area BS | ± 5 MHz                    | -22,2 dBm      | 3,84 MHz              |
| Local Area BS | ± 10 MHz                   | -32,2 dBm      | 3,84 MHz              |

**Table 6.28: Adjacent channel leakage power Test Requirements in case of co-siting with unsynchronised TDD on adjacent channels**

| BS Class      | BS adjacent channel offset below the first or above the last carrier frequency used | Maximum Level  | Measurement Bandwidth |
|---------------|---|----------------|-----------------------|
| Wide Area BS  | 5 MHz   | -[73 dBm - TT] | 3,84 MHz              |
| Wide Area BS  | 10 MHz  | -[73 dBm - TT] | 3,84 MHz              |
| Local Area BS | 5 MHz   | -30 dBm        | 3,84 MHz              |
| Local Area BS | 10 MHz  | -30 dBm        | 3,84 MHz              |

**Table 6.28A: Adjacent channel leakage power Test Requirements in case of co-siting with FDD on adjacent channels**

| BS Class     | BS Adjacent Channel Offset | Maximum Level | Measurement Bandwidth |
|--------------|----------------------------|---------------|-----------------------|
| Wide Area BS | ± 5 MHz                    | -80 dBm       | 3,84 MHz              |
| Wide Area BS | ± 10 MHz                   | -80 dBm       | 3,84 MHz              |

## 6.6.2.2.5.2 1,28 Mcps TDD option

The ACLR calculated in steps (5) and (10) of subclause 6.6.2.2.4.2.2 shall be equal or greater than the limits given in table 6.26A. In case the equipment is tested against the requirements defined for operation in the same geographic area or co-sited with unsynchronised TDD or FDD on adjacent channels, the adjacent channel leakage power measured

according to steps (3) and (4) of subclause 6.6.2.2.4.2.2 shall not exceed the maximum levels specified in tables 6.27B, 6.27C, 6.27D, 6.28B, 6.28C or 6.28D, respectively.

**Table 6.26A: BS ACLR Test Requirements (1,28 Mcps option)**

| BS adjacent channel offset below the first or above the last carrier frequency used | ACLR limit |
|---|------------|
| 1,6 MHz   | 39.2 dB    |
| 3,2 MHz   | 44.2 dB    |

**Table 6.27B: Adjacent channel leakage power Test Requirements for operation in the same geographic area with unsynchronised 1,28 Mcps TDD on adjacent channels**

| BS Class      | BS Adjacent Channel Offset | Maximum Level | Measurement Bandwidth |
|---------------|----------------------------|---------------|-----------------------|
| Wide Area BS  | ± 1,6 MHz                  | -28 dBm       | 1,28 MHz              |
| Wide Area BS  | ± 3,2 MHz                  | -28 dBm       | 1,28 MHz              |
| Local Area BS | ± 1,6 MHz                  | -15,2 dBm     | 1,28 MHz              |
| Local Area BS | ± 3,2 MHz                  | -15,2 dBm     | 1,28 MHz              |

**Table 6.27C: Adjacent channel leakage power Test Requirements for operation in the same geographic area with unsynchronised TDD on an adjacent channel**

| BS Class      | BS Adjacent Channel Offset | Maximum Level | Measurement Bandwidth |
|---------------|----------------------------|---------------|-----------------------|
| Wide Area BS  | ± 3,4 MHz                  | -28 dBm       | 3,84 MHz              |
| Local Area BS | ± 3,4 MHz                  | -15,2 dBm     | 3,84 MHz              |

**Table 6.27D: Adjacent channel leakage power Test Requirements for BS in band a) when operating in the same geographic area with FDD on an adjacent channel**

| BS Class      | Center Frequency for Measurement | Maximum Level | Measurement Bandwidth |
|---------------|----------------------------------|---------------|-----------------------|
| Wide Area BS  | 1922,6 MHz                       | -32 dBm       | 3,84 MHz              |
| Local Area BS | 1922,6 MHz                       | -22,2 dBm     | 3,84 MHz              |

**Table 6.28B: Adjacent channel leakage power Test Requirements in case of co-siting with unsynchronised 1,28 Mcps TDD on adjacent channels**

| BS Class      | BS Adjacent Channel Offset | Maximum Level  | Measurement Bandwidth |
|---------------|----------------------------|----------------|-----------------------|
| Wide Area BS  | ± 1,6 MHz                  | -[73 dBm - TT] | 1,28 MHz              |
| Wide Area BS  | ± 3,2 MHz                  | -[73 dBm - TT] | 1,28 MHz              |
| Local Area BS | ± 1,6 MHz                  | -33 dBm        | 1,28 MHz              |
| Local Area BS | ± 3,2 MHz                  | -33 dBm        | 1,28 MHz              |

**Table 6.28C: Adjacent channel leakage power Test Requirements for operation in the same geographic area with unsynchronised TDD on an adjacent channel**

| BS Class      | BS Adjacent Channel Offset | Maximum Level  | Measurement Bandwidth |
|---------------|----------------------------|----------------|-----------------------|
| Wide Area BS  | ± 3,4 MHz                  | -[73 dBm - TT] | 3,84 MHz              |
| Local Area BS | ± 3,4 MHz                  | -30 dBm        | 3,84 MHz              |

**Table 6.28D: Adjacent channel leakage power Test Requirements for BS in the band a) when co-siting with UTRA FDD on an adjacent channel**

| BS Class     | Center Frequency for Measurement | Maximum Level  | Measurement Bandwidth |
|--------------|----------------------------------|----------------|-----------------------|
| Wide Area BS | 1922,6 MHz                       | -[80 dBm - TT] | 3,84 MHz              |

## 6.6.2.2.5.3 1,28 Mcps TDD option - 16QAM capable BS

The same test requirements specified in section 6.6.2.2.5.2 apply to 1,28 Mcps TDD option BS supporting 16QAM.

## 6.6.2.2.5.4 3,84 Mcps TDD option - 16QAM capable BS

The same test requirements specified in section 6.6.2.2.5.1 apply to 3,84 Mcps TDD option BS supporting 16QAM.

## 6.6.2.2.5.5 7,68 Mcps TDD option

The ACLR calculated in steps (5) and (10) of subclause 6.6.2.2.4.2.5 shall be equal or greater than the limits given in table 6.26B. In case the equipment is tested against the requirements defined for operation in the same geographic area or co-sited with unsynchronised TDD or FDD on adjacent channels, the adjacent channel leakage power measured according to steps (4) and (9) of subclause 6.6.2.2.4.2.5 shall not exceed the maximum levels specified in table 6.27E, 6.27F, 6.27G, 6.28E, 6.28F or 6.28G, respectively.

**Table 6.26B: BS ACLR Test Requirements**

| BS adjacent channel offset below the first or above the last carrier frequency used | ACLR limit |
|---|------------|
| 10 MHz  | 44,2 dB    |
| 20 MHz  | 54,2 dB    |

**Table 6.27E: Adjacent channel leakage power Test Requirements for operation in the same geographic area with unsynchronised TDD (7.68 Mcps TDD and 3,84 Mcps TDD) on adjacent channels**

| BS Class      | BS adjacent channel offset below the first or above the last carrier frequency used | Maximum Level | Measurement Bandwidth |
|---------------|---|---------------|-----------------------|
| Wide Area BS  | 7.5 MHz   | - 25 dBm      | 3,84 MHz              |
| Wide Area BS  | 12.5 MHz  | - 25 dBm      | 3,84 MHz              |
| Wide Area BS  | 17.5 MHz  | - 25 dBm      | 3,84 MHz              |
| Wide Area BS  | 22.5 MHz  | - 25 dBm      | 3,84 MHz              |
| Local Area BS | 7.5 MHz   | -15,2 dBm     | 3,84 MHz              |
| Local Area BS | 12.5 MHz  | -25,2 dBm     | 3,84 MHz              |
| Local Area BS | 17.5 MHz  | -25,2 dBm     | 3,84 MHz              |
| Local Area BS | 22.5 MHz  | -25,2 dBm     | 3,84 MHz              |

**Table 6.27F: Adjacent channel leakage power limits for operation in the same geographic area with unsynchronised 1,28 Mcps TDD on adjacent channels**

| BS Class      | BS adjacent channel offset below the first or above the last carrier frequency used | Maximum Level | Measurement Bandwidth |
|---------------|---|---------------|-----------------------|
| Wide Area BS  | 5.8 MHz   | - 28 dBm      | 1,28 MHz              |
| Wide Area BS  | 7.4 MHz   | - 28 dBm      | 1,28 MHz              |
| Local Area BS | 5.8 MHz   | - 15,2 dBm    | 1,28 MHz              |
| Local Area BS | 7.4 MHz   | - 15,2 dBm    | 1,28 MHz              |

**Table 6.27G: Adjacent channel leakage power Test Requirements for operation in the same geographic area with FDD on adjacent channels**

| BS Class      | BS Adjacent Channel Offset | Maximum Level  | Measurement Bandwidth |
|---------------|----------------------------|----------------|-----------------------|
| Wide Area BS  | $\pm 7.5$ MHz              | -[36 dBm - TT] | 3,84 MHz              |
| Wide Area BS  | $\pm 12.5$ MHz             | -32 dBm        | 3,84 MHz              |
| Wide Area BS  | $\pm 17.5$ MHz             | -35 dBm        | 3,84 MHz              |
| Wide Area BS  | $\pm 22.5$ MHz             | -39 dBm        | 3,84 MHz              |
| Local Area BS | $\pm 7.5$ MHz              | -22,2 dBm      | 3,84 MHz              |
| Local Area BS | $\pm 12.5$ MHz             | -32,2 dBm      | 3,84 MHz              |
| Local Area BS | $\pm 17.5$ MHz             | -35,2 dBm      | 3,84 MHz              |
| Local Area BS | $\pm 22.5$ MHz             | -39,2 dBm      | 3,84 MHz              |

**Table 6.28E: Adjacent channel leakage power Test Requirements in case of co-siting with unsynchronised TDD (7.68 Mcps TDD and 3,84 Mcps TDD) on adjacent channels**

| BS Class      | BS adjacent channel offset below the first or above the last carrier frequency used | Maximum Level  | Measurement Bandwidth |
|---------------|---|----------------|-----------------------|
| Wide Area BS  | 7.5 MHz   | -[73 dBm - TT] | 3,84 MHz              |
| Wide Area BS  | 12.5 MHz  | -[73 dBm - TT] | 3,84 MHz              |
| Wide Area BS  | 17.5 MHz  | -[73 dBm - TT] | 3,84 MHz              |
| Wide Area BS  | 22.5 MHz  | -[73 dBm - TT] | 3,84 MHz              |
| Local Area BS | 7.5 MHz   | -30 dBm        | 3,84 MHz              |
| Local Area BS | 12.5 MHz  | -30 dBm        | 3,84 MHz              |
| Local Area BS | 17.5 MHz  | -30 dBm        | 3,84 MHz              |
| Local Area BS | 22.5 MHz  | -30 dBm        | 3,84 MHz              |

**Table 6.28F: Adjacent channel leakage power limits in case of co-siting with unsynchronised 1,28 Mcps TDD on adjacent channel**

| BS Class      | BS adjacent channel offset below the first or above the last carrier frequency used | Maximum Level  | Measurement Bandwidth |
|---------------|---|----------------|-----------------------|
| Wide Area BS  | 5.8 MHz   | -[73 dBm - TT] | 1,28 MHz              |
| Wide Area BS  | 7.4 MHz   | -[73 dBm - TT] | 1,28 MHz              |
| Local Area BS | 5.8 MHz   | -33 dBm        | 1,28 MHz              |
| Local Area BS | 7.4 MHz   | -33 dBm        | 1,28 MHz              |

**Table 6.28G: Adjacent channel leakage power Test Requirements in case of co-siting with FDD on adjacent channels**

| BS Class     | BS Adjacent Channel Offset | Maximum Level | Measurement Bandwidth |
|--------------|----------------------------|---------------|-----------------------|
| Wide Area BS | $\pm 5$ MHz                | -80 dBm       | 3,84 MHz              |
| Wide Area BS | $\pm 10$ MHz               | -80 dBm       | 3,84 MHz              |

#### 6.6.2.2.5.6 7,68 Mcps TDD option - 16QAM capable BS

The same test requirements specified in section 6.6.2.2.5.5 apply to 7,68 Mcps TDD option BS supporting 16QAM.

### 6.6.3 Spurious emissions

#### 6.6.3.1 Definition and applicability

Spurious emissions are emissions which are caused by unwanted transmitter effects such as harmonics emission, parasitic emission, intermodulation products and frequency conversion products, but exclude out of band emissions. This is measured at the base station RF output port.

The requirements shall apply whatever the type of transmitter considered (single carrier or multiple carrier). It applies for all transmission modes foreseen by the manufacturer's specification.

For 3,84 Mcps TDD option, either requirement (except 6.6.3.2.6) applies at frequencies within the specified frequency ranges which are more than 12,5 MHz under the first carrier frequency used or more than 12,5 MHz above the last carrier frequency used.

For 1,28 Mcps TDD option, either requirement applies at frequencies within the specified frequency ranges which are more than 4 MHz under the first carrier frequency used or more than 4 MHz above the last carrier frequency used.

For 7.68 Mcps TDD option, either requirement (except 6.6.3.2.6) applies at frequencies within the specified frequency ranges which are more than 25 MHz under the first carrier frequency used or more than 25 MHz above the last carrier frequency used.

Unless otherwise stated, all requirements are measured as mean power.

The requirements in this subclause shall apply to both Wide Area BS and Local Area BS, with the exception of the requirements which may be applied for co-existence with UTRA FDD; in this case, different requirements shall apply to Wide Area BS and Local Area BS.

## 6.6.3.2 Minimum Requirements

### 6.6.3.2.1 Mandatory requirements

The requirements of either subclause 6.6.3.2.1.1 or subclause 6.6.3.2.1.2 shall apply.

#### 6.6.3.2.1.1 Spurious emissions (Category A)

The following requirements shall be met in cases where Category A limits for spurious emissions, as defined in ITU-R Recommendation SM.329 [6], are applied.

##### 6.6.3.2.1.1.1 3,84 Mcps TDD option

The power of any spurious emission shall not exceed the maximum level given in Table 6.29.

**Table 6.29: BS Mandatory spurious emissions limits, Category A**

| Band   | Maximum level | Measurement bandwidth | Notes  |
|--|---------------|-----------------------|--------|
| 9 kHz - 150 kHz  | -13 dBm       | 1 kHz                 | Note 1 |
| 150 kHz - 30 MHz   |               | 10 kHz                | Note 1 |
| 30 MHz - 1 GHz   |               | 100 kHz               | Note 1 |
| 1 GHz - 12,75 GHz  |               | 1 MHz                 | Note 2 |
| NOTE 1: Bandwidth as in ITU-R SM.329 [6], s4.1               |               |                       |        |
| NOTE 2: Upper frequency as in ITU-R SM.329 [6], s2.5 table 1 |               |                       |        |

The normative reference for this requirement is TS 25.105 [1] subclause 6.6.3.1.1.1.1.

##### 6.6.3.2.1.1.2 1,28 Mcps TDD option

The power of any spurious emission shall not exceed the maximum level given in Table 6.29A.

**Table 6.29A: BS Mandatory spurious emissions limits, Category A**

| Band   | Maximum level | Measurement bandwidth | Notes  |
|--|---------------|-----------------------|--------|
| 9 kHz - 150 kHz  | -13 dBm       | 1 kHz                 | Note 1 |
| 150 kHz - 30 MHz   |               | 10 kHz                | Note 1 |
| 30 MHz - 1 GHz   |               | 100 kHz               | Note 1 |
| 1 GHz - 12,75 GHz  |               | 1 MHz                 | Note 2 |
| NOTE 1: Bandwidth as in ITU-R SM.329 [6], s4.1               |               |                       |        |
| NOTE 2: Upper frequency as in ITU-R SM.329 [6], s2.5 table 1 |               |                       |        |

The normative reference for this requirement is TS 25.105 [1] subclause 6.6.3.1.1.1.2.

#### 6.6.3.2.1.1.3 7,68 Mcps TDD option

The power of any spurious emission shall not exceed the maximum level given in Table 6.29B.

**Table 6.29B: BS Mandatory spurious emissions limits, Category A**

| Band   | Maximum level | Measurement bandwidth | Notes  |
|--|---------------|-----------------------|--------|
| 9 kHz - 150 kHz  | -13 dBm       | 1 kHz                 | Note 1 |
| 150 kHz - 30 MHz   |               | 10 kHz                | Note 1 |
| 30 MHz - 1 GHz   |               | 100 kHz               | Note 1 |
| 1 GHz - 12,75 GHz  |               | 1 MHz                 | Note 2 |
| NOTE 1: Bandwidth as in ITU-R SM.329 [6], s4.1               |               |                       |        |
| NOTE 2: Upper frequency as in ITU-R SM.329 [6], s2.5 table 1 |               |                       |        |

The normative reference for this requirement is TS 25.105 [1] subclause 6.6.3.1.1.1.3.

#### 6.6.3.2.1.2 Spurious emissions (Category B)

The following requirements shall be met in cases where Category B limits for spurious emissions, as defined in ITU-R Recommendation SM.329-9 [6], are applied.

##### 6.6.3.2.1.2.1 3,84 Mcps TDD option

The power of any spurious emission shall not exceed the maximum levels given in Table 6.30.

**Table 6.30: BS Mandatory spurious emissions limits, Category B**

| Band   | Maximum level | Measurement bandwidth | Notes  |
|--|---------------|-----------------------|--------|
| 9 kHz - 150 kHz  | -36 dBm       | 1 kHz                 | Note 1 |
| 150 kHz - 30 MHz   | -36 dBm       | 10 kHz                | Note 1 |
| 30 MHz - 1 GHz   | -36 dBm       | 100 kHz               | Note 1 |
| 1 GHz<br>-<br>Fl - 10 MHz  | -30 dBm       | 1 MHz                 | Note 1 |
| Fl - 10 MHz-<br>Fu + 10 MHz  | -15 dBm       | 1 MHz                 | Note 2 |
| Fu + 10 MHz<br>-<br>12,75 GHz  | -30 dBm       | 1 MHz                 | Note 3 |
| NOTE 1: Bandwidth as in ITU-R SM.329 [6], s4.1   |               |                       |        |
| NOTE 2: Specification in accordance with ITU-R SM.329 [6], s4.3 and Annex 7                          |               |                       |        |
| NOTE 3: Bandwidth as in ITU-R SM.329 [6], s4.1. Upper frequency as in ITU-R SM.329 [6], s2.5 table 1 |               |                       |        |

Fl: Lower frequency of the band in which TDD operates  
Fu: Upper frequency of the band in which TDD operates

The normative reference for this requirement is TS 25.105 [1] subclause 6.6.3.1.2.1.1.

#### 6.6.3.2.1.2.2 1,28 Mcps TDD option

The power of any spurious emission shall not exceed the maximum levels given in Table 6.30A.

**Table 6.30A: BS Mandatory spurious emissions limits, Category B for 1,28 Mcps TDD**

| Band  | Maximum Level | Measurement Bandwidth | Notes  |
|---|---------------|-----------------------|--------|
| 9kHz - 150kHz   | -36 dBm       | 1 kHz                 | Note 1 |
| 150kHz - 30MHz  | - 36 dBm      | 10 kHz                | Note 1 |
| 30MHz - 1GHz  | -36 dBm       | 100 kHz               | Note 1 |
| 1GHz<br>↔<br>FI -10 MHz   | -30 dBm       | 1 MHz                 | Note 1 |
| FI -10 MHz↔Fu +10 MHz   | -15 dBm       | 1 MHz                 | Note 2 |
| Fu +10 MHz<br>↔<br>12,75 GHz  | -30 dBm       | 1 MHz                 | Note 3 |
| NOTE 1: Bandwidth as in ITU-R SM.329 [6], s4.1<br>NOTE 2: Specification in accordance with ITU-R SM.329 [6], s4.1<br>NOTE 3: Bandwidth as in ITU-R SM.329-9, s4.1. Upper frequency as in ITU-R SM.329-9, s2.5 table 1 |               |                       |        |

Fl: Lower frequency of the band in which TDD operates

Fu: Upper frequency of the band in which TDD operates

The reference for this requirement is TS 25.105 subclause 6.6.3.1.2.1.2.

#### 6.6.3.2.1.2.3 7,68 Mcps TDD option

The power of any spurious emission shall not exceed the maximum levels given in Table 6.30B.

**Table 6.30B: BS Mandatory spurious emissions limits, Category B**

| Band  | Maximum Level | Measurement Bandwidth | Notes  |
|---|---------------|-----------------------|--------|
| 9kHz - 150kHz   | -36 dBm       | 1 kHz                 | Note 1 |
| 150kHz - 30MHz  | - 36 dBm      | 10 kHz                | Note 1 |
| 30MHz - 1GHz  | -36 dBm       | 100 kHz               | Note 1 |
| 1GHz<br>↔<br>FI -10 MHz   | -30 dBm       | 1 MHz                 | Note 1 |
| FI -10 MHz↔Fu +10 MHz   | -15 dBm       | 1 MHz                 | Note 2 |
| Fu + 10 MHz<br>↔<br>12,75 GHz   | -30 dBm       | 1 MHz                 | Note 3 |
| NOTE 1: Bandwidth as in ITU SM.329 [6], s4.1<br>NOTE 2: Specification in accordance with ITU-R SM.329 [6], s4.3 and Annex 7<br>NOTE 3: Bandwidth as in ITU-R SM.329 [6], s4.3 and Annex 7. Upper frequency as in ITU-R SM.329 [6], s2.5 table 1 |               |                       |        |

Fl: Lower frequency of the band in which TDD operates

Fu: Upper frequency of the band in which TDD operates

The normative reference for this requirement is TS 25.105 [1] subclause 6.6.3.1.2.1.3.

## 6.6.3.2.2 Co-existence with GSM 900

## 6.6.3.2.2.1 Operation in the same geographic area

This requirement may be applied for the protection of GSM 900 MS and GSM 900 BTS receivers in geographic areas in which both GSM 900 and UTRA are deployed.

The power of any spurious emission shall not exceed the maximum level given in Table 6.31.

**Table 6.31: BS Spurious emissions limits for BS in geographic coverage area of GSM 900 MS and GSM 900 BTS receiver**

| Band              | Maximum level | Measurement bandwidth | Note |
|-------------------|---------------|-----------------------|------|
| 876 MHz - 915 MHz | -61 dBm       | 100 kHz               |      |
| 921 MHz - 960 MHz | -57 dBm       | 100 kHz               |      |

The normative reference for this requirement is TS 25.105 [1] subclause 6.6.3.2.1.1.

## 6.6.3.2.2.2 Co-located base stations

This requirement may be applied for the protection of GSM 900 BTS receivers when GSM 900 BTS and UTRA BS are co-located.

The power of any spurious emission shall not exceed the maximum level given in table 6.32.

**Table 6.32: BS Spurious emissions limits for protection of the GSM 900 BTS receiver**

| Band              | Maximum level | Measurement bandwidth | Note |
|-------------------|---------------|-----------------------|------|
| 876 MHz - 915 MHz | -98 dBm       | 100 kHz               |      |

The normative reference for this requirement is TS 25.105 [1] subclause 6.6.3.2.2.1.

## 6.6.3.2.3 Co-existence with DCS 1800

## 6.6.3.2.3.1 Operation in the same geographic area

This requirement may be applied for the protection of DCS 1800 MS and DCS 1800 BTS receivers in geographic areas in which both DCS 1800 and UTRA are deployed.

The power of any spurious emission shall not exceed the maximum level given in table 6.33.

**Table 6.33: Spurious emissions limits for BS in the band a), d), e) when operating in geographic coverage area of DCS 1800 MS and DCS 1800 BTS receiver**

| Band                | Maximum level | Measurement bandwidth | Note |
|---------------------|---------------|-----------------------|------|
| 1710 MHz - 1785 MHz | -61 dBm       | 100 kHz               |      |
| 1805 MHz - 1880 MHz | -47 dBm       | 100 kHz               |      |



**Table 6.33a: BS Spurious emissions limits for BS in the band f) when operating in geographic coverage area of DCS 1800 MS and DCS 1800 BTS receiver operating in 1710-1755 MHz/1805-1850 MHz**

| Band            | Maximum Level | Measurement Bandwidth | Note |
|-----------------|---------------|-----------------------|------|
| 1710 - 1755 MHz | -61 dBm       | 100 kHz               |      |
| 1805 - 1850MHz  | -47 dBm       | 100 kHz               |      |

The normative reference for this requirement is TS 25.105 [1] subclause 6.6.3.3.1.1.

#### 6.6.3.2.3.2 Co-located base stations

This requirement may be applied for the protection of DCS 1800 BTS receivers when DCS 1800 BTS and UTRA BS are co-located.

The power of any spurious emission shall not exceed the maximum level given in table 6.34.

**Table 6.34: BS Spurious emissions limits for BS in the band a), d) and e) when co-located with DCS 1800 BTS**

| Band                | Maximum level | Measurement bandwidth | Note |
|---------------------|---------------|-----------------------|------|
| 1710 MHz - 1785 MHz | -98 dBm       | 100 kHz               |      |

**Table 6.34a: BS Spurious emissions limits for BS in the band f) when co-located with DCS1800 BTS**

| Band            | Maximum Level | Measurement Bandwidth | Note |
|-----------------|---------------|-----------------------|------|
| 1710 - 1755 MHz | -98 dBm       | 100 kHz               |      |

The normative reference for this requirement is TS 25.105 [1] subclause 6.6.3.3.2.1.

#### 6.6.3.2.4 Co-existence with UTRA FDD

##### 6.6.3.2.4.1 Operation in the same geographic area

This requirement may be applied to geographic areas in which both UTRA TDD and UTRA FDD operating in bands specified in Table 6.35 are deployed.

For TDD base stations which use carrier frequencies within the band 2010 - 2025 MHz the requirements applies at all frequencies within the specified frequency bands in table 6.35. For 3,84 Mcps TDD option base stations which use a carrier frequency within the band 1900-1920 MHz, the requirement applies at frequencies within the specified frequency range which are more than 12,5 MHz above the last carrier used in the frequency band 1900-1920 MHz. For 1,28 Mcps TDD option base stations which use carrier frequencies within the band 1900-1920 MHz, the requirement applies at frequencies within the specified frequency range which are more than 4 MHz above the last carrier used in the frequency band 1900-1920 MHz. For 7.68 Mcps TDD option base stations which use a carrier frequency within the band 1900-1920 MHz, the requirement applies at frequencies within the specified frequency range which are more than 25 MHz above the last carrier used in the frequency band 1900-1920 MHz.

The power of any spurious emission shall not exceed the maximum level given in table 6.35.

**Table 6.35: BS Spurious emissions limits for BS in geographic coverage area of UTRA FDD**

| BS Class           | Band  | Maximum Level         | Measurement Bandwidth | Note                |
|--------------------|---|-----------------------|-----------------------|---------------------|
| Wide Area BS       | 1920 - 1980 MHz   | -43 dBm (*)           | 3,84 MHz              |                     |
| Wide Area BS       | 2110 - 2170 MHz   | -52 dBm               | 1 MHz                 |                     |
| Wide Area BS       | 2500 - 2570 MHz   | -43 dBm(**)           | 3,84 MHz              |                     |
| Wide Area BS       | 2620 - 2690 MHz   | -52 dBm               | 1 MHz                 |                     |
| Wide Area BS       | 815 - 850 MHz   | -43 dBm <sup>†</sup>  | 3,84 MHz              | Applicable in Japan |
| Wide Area BS       | 860 - 895 MHz   | -52 dBm <sup>†</sup>  | 1 MHz                 | Applicable in Japan |
| Wide Area BS       | 1427,9MHz - 1452,9MHz   | -43 dBm <sup>††</sup> | 3,84 MHz              | Applicable in Japan |
| Wide Area BS       | 1475,9MHz - 1500,9MHz   | -52 dBm <sup>††</sup> | 1 MHz                 | Applicable in Japan |
| Wide Area BS       | 1749,9 - 1784,9 MHz   | -43 dBm <sup>†</sup>  | 3,84 MHz              | Applicable in Japan |
| Wide Area BS       | 1844,9 - 1879,9 MHz   | -52 dBm <sup>†</sup>  | 1 MHz                 | Applicable in Japan |
| Local Area BS      | 1920 - 1980 MHz   | -40 dBm (*)           | 3,84 MHz              |                     |
| Local Area BS      | 2110 - 2170 MHz   | -52 dBm               | 1 MHz                 |                     |
| Local Area BS      | 2500 - 2570 MHz   | -40 dBm(**)           | 3,84 MHz              |                     |
| Local Area BS      | 2620 - 2690 MHz   | -52 dBm               | 1 MHz                 |                     |
| Note *:            | For 3,84 Mcps TDD option base stations which use a carrier frequency within the band 1900-1920 MHz, or 1880-1920MHz, the requirement shall be measured RRC filtered mean power with the lowest center frequency of measurement at 1922,6 MHz or 15 MHz above the highest TDD carrier used, whichever is higher. For 1,28 Mcps TDD option base stations which use a carrier frequency within the band 1900-1920 MHz, the requirement shall be measured RRC filtered mean power with the lowest center frequency of measurement at 1922,6 MHz or 6,6 MHz above the highest TDD carrier used, whichever is higher. For 7,68 Mcps TDD option base stations which use carrier frequencies within the band 1900 - 1920 MHz, the requirement shall be measured RRC filtered mean power with the lowest centre frequency of measurement at 1922,6 MHz or 30 MHz above the highest TDD carrier used, whichever is higher.    |                       |                       |                     |
| NOTE **            | For 3,84 Mcps TDD option base stations which use carrier frequencies within the band 2570 - 2620 MHz, the requirement shall be measured RRC filtered mean power with the highest center frequency of measurement at 2567,5 MHz or 15 MHz below the lowest TDD carrier used, whichever is lower. For 1,28 Mcps TDD option base stations which use carrier frequencies within the band 2570 - 2620 MHz, the requirement shall be measured RRC filtered mean power with the highest center frequency of measurement at 2567,5 MHz or 6,6 MHz below the lowest TDD carrier used, whichever is lower. . For 7,68 Mcps TDD option base stations which use carrier frequencies within the band 2570 - 2620 MHz, the requirement shall be measured RRC filtered mean power with the highest centre frequency of measurement at 2567,5 MHz or 30 MHz below the lowest TDD carrier used, whichever is lower.NOTE <sup>†</sup> |                       |                       |                     |
| NOTE <sup>††</sup> | This is applicable only in Japan for 3,84 Mcps and 7,68 Mcps TDD options operating in 2010-2025 MHz of band referenced in subclause 4.2(a).   |                       |                       |                     |

NOTE: The requirements for Wide Area BS in Table 6.35 are based on a coupling loss of 67 dB between the TDD and FDD base stations. The requirements for Local Area BS in Table 6.35 are based on a coupling loss of 70 dB between TDD and FDD Wide Area base stations. The scenarios leading to these requirements are addressed in TR 25.942 [9].

The normative reference for this requirement is TS 25.105 [1] subclause 6.6.3.4.1.1.

#### 6.6.3.2.4.2 Co-located base stations

This requirement may be applied for the protection of UTRA FDD BS receivers when UTRA TDD BS and UTRA FDD BS are co-located.

For TDD base stations which use carrier frequencies within the band 2010 - 2025 MHz the requirements applies at all frequencies within the specified frequency bands in table 6.36. For 3,84 Mcps TDD option base stations which use a carrier frequency within the band 1900-1920 MHz, the requirement applies at frequencies within the specified frequency range which are more than 12,5 MHz above the last carrier used in the frequency band 1900-1920 MHz. For 1,28 Mcps TDD option base stations which use carrier frequencies within the band 1900-1920 MHz, the requirement applies at frequencies within the specified frequency range which are more than 4 MHz above the last carrier used in the frequency band 1900-1920 MHz. For 7,68 Mcps TDD option base stations which use a carrier frequency within the

band 1900-1920 MHz, the requirement applies at frequencies within the specified frequency range which are more than 25 MHz above the last carrier used in the frequency band 1900-1920 MHz.

The power of any spurious emission shall not exceed the maximum level given in table 6.36.

**Table 6.36: BS Spurious emissions limits for BS co-located with UTRA FDD**

| BS Class     | Band  | Maximum Level | Measurement Bandwidth | Note |
|--------------|---|---------------|-----------------------|------|
| Wide Area BS | 1920 - 1980 MHz   | -80 dBm (*)   | 3,84 MHz              |      |
| Wide Area BS | 2110 - 2170 MHz   | -52 dBm       | 1 MHz                 |      |
| Wide Area BS | 2500 - 2570 MHz   | - 80 dBm(**)  | 3,84 MHz              |      |
| Wide Area BS | 2620 - 2690 MHz   | -52 dBm       | 1 MHz                 |      |
| Note *:      | For 3,84 Mcps TDD option base stations which use a carrier frequency within the band 1900-1920 MHz or 1880-1920MHz, the requirement shall be measured RRC filtered mean power with the lowest center frequency of measurement at 1922,6 MHz or 15 MHz above the highest TDD carrier used, whichever is higher. For 1,28 Mcps TDD option base stations which use a carrier frequency within the band 1900-1920 MHz, the requirement shall be measured RRC filtered mean power with the lowest center frequency of measurement at 1922,6 MHz or 6,6 MHz above the highest TDD carrier used, whichever is higher. For 7.68 Mcps TDD option base stations which use carrier frequencies within the band 1900 - 1920 MHz, the requirement shall be measured RRC filtered mean power with the lowest centre frequency of measurement at 1922.6 MHz or 30 MHz above the highest TDD carrier used, whichever is higher. |               |                       |      |
| NOTE **      | For 3,84 Mcps TDD option base stations which use carrier frequencies within the band 2570 - 2620 MHz, the requirement shall be measured RRC filtered mean power with the highest center frequency of measurement at 2567.5 MHz or 15 MHz below the lowest TDD carrier used, whichever is lower. For 1,28 Mcps TDD option base stations which use carrier frequencies within the band 2570 - 2620 MHz, the requirement shall be measured RRC filtered mean power with the highest center frequency of measurement at 2567.5 MHz or 6.6 MHz below the lowest TDD carrier used, whichever is lower. . For 7.68 Mcps TDD option base stations which use carrier frequencies within the band 2570 - 2620 MHz, the requirement shall be measured RRC filtered mean power with the highest center frequency of measurement at 2567.5 MHz or 30 MHz below the lowest TDD carrier used, whichever is lower.              |               |                       |      |

NOTE: The requirements in table 6.36 are based on a minimum coupling loss of 30 dB between base stations. The co-location of different base station classes is not considered. A co-location requirement for the Local Area TDD BS is intended to be part of a later release.

The normative reference for this requirement is TS 25.105 [1] subclause 6.6.3.4.2.1.

### 6.6.3.2.5 Co-existence with unsynchronised UTRA TDD and/or E-UTRA TDD

#### 6.6.3.2.5.1 Operation in the same geographic area

This requirement may be applied for the protection of TDD BS receivers in geographic areas in which unsynchronised UTRA TDD and/or E-UTRA TDD is deployed.

##### 6.6.3.2.5.1.1 3,84 Mcps TDD option

The RRC filtered mean power of any spurious emission shall not exceed the maximum level given in table 6.36A.

**Table 6.36A: BS Spurious emissions limits for operation in same geographic area with unsynchronised UTRA TDD and/or E-UTRA TDD**

| System type operating in the same geographic area | Frequency range | Maximum Level | Measurement Bandwidth |
|---|-----------------|---------------|-----------------------|
| WA UTRA TDD Band a) or E-UTRA Band 33             | 1900 - 1920 MHz | -39 dBm       | 3,84 MHz              |
| WA UTRA TDD Band a) or E-UTRA Band 34             | 2010 - 2025 MHz | -39 dBm       | 3,84 MHz              |
| WA UTRA TDD Band d) or E-UTRA Band 38             | 2570 - 2620 MHz | -39 dBm       | 3,84 MHz              |
| LA UTRA TDD Band a) or E-UTRA Band 33             | 1900 - 1920 MHz | -36 dBm       | 3,84 MHz              |
| LA UTRA TDD Band a) or E-UTRA Band 34             | 2010 - 2025 MHz | -36 dBm       | 3,84 MHz              |
| LA UTRA TDD Band d) or E-UTRA Band 38             | 2570 - 2620 MHz | -36 dBm       | 3,84 MHz              |

NOTE: The requirements in Table 6.36A for the Wide Area BS are based on a minimum coupling loss of 67 dB between unsynchronised TDD base stations. The requirements in Table 6.36A for the Local Area BS are based on a coupling loss of 70 dB between unsynchronised Wide Area and Local Area TDD base stations. The scenarios leading to these requirements are addressed in TR 25.942 [9].

The normative reference for this requirement is TS 25.105 [1] subclause 6.6.3.5.1.1.1.

#### 6.6.3.2.5.1.2 1,28 Mcps TDD option

In geographic areas where only 1,28 Mcps TDD is deployed, the RRC filtered mean power of any spurious emission shall not exceed the maximum level given in table 6.36B, otherwise the limits in table 6.36C shall apply.

**Table 6.36B: BS Spurious emissions limits for operation in same geographic area with unsynchronised 1,28 Mcps UTRA TDD and/or E-UTRA TDD**

| System type operating in the same geographic area | Frequency range | Maximum Level | Measurement Bandwidth |
|---|-----------------|---------------|-----------------------|
| WA UTRA TDD Band a) or E-UTRA Band 33             | 1900 - 1920 MHz | -39 dBm       | 1,28 MHz              |
| WA UTRA TDD Band a) or E-UTRA Band 34             | 2010 - 2025 MHz | -39 dBm       | 1,28 MHz              |
| WA UTRA TDD Band d) or E-UTRA Band 38             | 2570 - 2620 MHz | -39 dBm       | 1,28 MHz              |
| WA UTRA TDD Band e) or E-UTRA Band 40             | 2300 - 2400 MHz | -39 dBm       | 1,28 MHz              |
| WA UTRA TDD Band f) or E-UTRA Band 39             | 1880 – 1920 MHz | -39 dBm       | 1,28 MHz              |
| LA UTRA TDD Band a) or E-UTRA Band 33             | 1900 - 1920 MHz | -36 dBm       | 1,28 MHz              |
| LA UTRA TDD Band a) or E-UTRA Band 34             | 2010 - 2025 MHz | -36 dBm       | 1,28 MHz              |
| LA UTRA TDD Band d) or E-UTRA Band 38             | 2570 - 2620 MHz | -36 dBm       | 1,28 MHz              |
| LA UTRA TDD Band e) or E-UTRA Band 40             | 2300 - 2400 MHz | -36 dBm       | 1,28 MHz              |
| LA UTRA TDD Band f) or E-UTRA Band 39             | 1880 – 1920 MHz | -36 dBm       | 1,28 MHz              |

**Table 6.36C: BS Spurious emissions limits for operation in same geographic area with unsynchronised UTRA TDD and E-UTRA TDD**

| System type operating in the same geographic area | Frequency range | Maximum Level | Measurement Bandwidth |
|---|-----------------|---------------|-----------------------|
| WA UTRA TDD Band a) or E-UTRA Band 33             | 1900 - 1920 MHz | -39 dBm       | 3,84 MHz              |
| WA UTRA TDD Band a) or E-UTRA Band 34             | 2010 - 2025 MHz | -39 dBm       | 3,84 MHz              |
| WA UTRA TDD Band d) or E-UTRA Band 38             | 2570 - 2620 MHz | -39 dBm       | 3,84 MHz              |
| LA UTRA TDD Band a) or E-UTRA Band 33             | 1900 - 1920 MHz | -36 dBm       | 3,84 MHz              |
| LA UTRA TDD Band a) or E-UTRA Band 34             | 2010 - 2025 MHz | -36 dBm       | 3,84 MHz              |
| LA UTRA TDD Band d) or E-UTRA Band 38             | 2570 - 2620 MHz | -36 dBm       | 3,84 MHz              |

NOTE: The requirements in Table 6.36B and 6.36C for the Wide Area BS are based on a minimum coupling loss of 67 dB between unsynchronised TDD base stations. The requirements in Table 6.36B and 6.36C for the Local Area BS are based on a coupling loss of 70 dB between unsynchronised Wide Area and Local Area TDD base stations. The scenarios leading to these requirements are addressed in TR 25.942 [9].

The normative reference for this requirement is TS 25.105 [1] subclause 6.6.3.5.1.1.2.

#### 6.6.3.2.5.1.3 7,68 Mcps TDD option

The RRC filtered mean power of any spurious emission shall not exceed the maximum level given in table 6.36CA and 6.36CB.

**Table 6.36CA: BS Spurious emissions limits for operation in same geographic area with unsynchronised UTRA TDD (7.68 Mcps TDD and 3,84 Mcps TDD) and/or E-UTRA TDD**

| System type operating in the same geographic area | Frequency range | Maximum Level | Measurement Bandwidth |
|---|-----------------|---------------|-----------------------|
| WA UTRA TDD Band a) or E-UTRA Band 33             | 1900 - 1920 MHz | -39 dBm       | 3,84 MHz              |
| WA UTRA TDD Band a) or E-UTRA Band 34             | 2010 - 2025 MHz | -39 dBm       | 3,84 MHz              |
| WA UTRA TDD Band d) or E-UTRA Band 38             | 2570 - 2620 MHz | -39 dBm       | 3,84 MHz              |
| LA UTRA TDD Band a) or E-UTRA Band 33             | 1900 - 1920 MHz | -36 dBm       | 3,84 MHz              |
| LA UTRA TDD Band a) or E-UTRA Band 34             | 2010 - 2025 MHz | -36 dBm       | 3,84 MHz              |
| LA UTRA TDD Band d) or E-UTRA Band 38             | 2570 - 2620 MHz | -36 dBm       | 3,84 MHz              |

**Table 6.36CB: BS Spurious emissions limits for operation in same geographic area with unsynchronised 1,28 Mcps UTRA TDD and/or E-UTRA TDD**

| System type operating in the same geographic area | Frequency range | Maximum Level | Measurement Bandwidth |
|---|-----------------|---------------|-----------------------|
| WA UTRA TDD Band a) or E-UTRA Band 33             | 1900 - 1920 MHz | -39 dBm       | 1,28 MHz              |
| WA UTRA TDD Band a) or E-UTRA Band 34             | 2010 - 2025 MHz | -39 dBm       | 1,28 MHz              |
| WA UTRA TDD Band d) or E-UTRA Band 38             | 2570 - 2620 MHz | -39 dBm       | 1,28 MHz              |
| WA UTRA TDD Band e) or E-UTRA Band 40             | 2300 - 2400 MHz | -39 dBm       | 1,28 MHz              |
| LA UTRA TDD Band a) or E-UTRA Band 33             | 1900 - 1920 MHz | -36 dBm       | 1,28 MHz              |
| LA UTRA TDD Band a) or E-UTRA Band 34             | 2010 - 2025 MHz | -36 dBm       | 1,28 MHz              |
| LA UTRA TDD Band d) or E-UTRA Band 38             | 2570 - 2620 MHz | -36 dBm       | 1,28 MHz              |
| LA UTRA TDD Band e) or E-UTRA Band 40             | 2300 - 2400 MHz | -36 dBm       | 1,28 MHz              |

NOTE: The requirements in Table 6.36CA and 6.36CB for the Wide Area BS are based on a minimum coupling loss of 67 dB between unsynchronised TDD base stations. The requirements in Table 6.36CA and 6.36CB for the Local Area BS are based on a coupling loss of 70 dB between unsynchronised Wide Area and Local Area TDD base stations.

The normative reference for this requirement is TS 25.105 [1] subclause 6.6.3.5.1.1.3.

#### 6.6.3.2.5.2 Co-located base stations

This requirement may be applied for the protection of TDD BS receivers when unsynchronised UTRA TDD and/or E-UTRA TDD BS are co-located.

##### 6.6.3.2.5.2.1 3,84 Mcps TDD option

The RRC filtered mean power of any spurious emission shall not exceed the maximum level given in table 6.36D.

**Table 6.36D: BS Spurious emissions limits for co-location with unsynchronised UTRA TDD and/or E-UTRA TDD**

| System type operating in the same geographic area | Frequency range | Maximum Level | Measurement Bandwidth |
|---|-----------------|---------------|-----------------------|
| WA UTRA TDD Band a) or E-UTRA Band 33             | 1900 - 1920 MHz | -76 dBm       | 3,84 MHz              |
| WA UTRA TDD Band a) or E-UTRA Band 34             | 2010 - 2025 MHz | -76 dBm       | 3,84 MHz              |
| WA UTRA TDD Band d) or E-UTRA Band 38             | 2570 - 2620 MHz | -76 dBm       | 3,84 MHz              |
| LA UTRA TDD Band a) or E-UTRA Band 33             | 1900 - 1920 MHz | -66 dBm       | 3,84 MHz              |
| LA UTRA TDD Band a) or E-UTRA Band 3              | 2010 - 2025 MHz | -66 dBm       | 3,84 MHz              |
| LA UTRA TDD Band d) or E-UTRA Band 38             | 2570 - 2620 MHz | -66 dBm       | 3,84 MHz              |

NOTE: The requirements in Table 6.36D for the Wide Area BS are based on a minimum coupling loss of 30 dB between unsynchronised TDD base stations. The requirements in Table 6.36D for the Local Area BS are based on a minimum coupling loss of 30 dB between unsynchronised Local Area base stations. The co-location of different base station classes is not considered.

The normative reference for this requirement is TS 25.105 [1] subclause 6.6.3.5.2.1.1.

#### 6.6.3.2.5.2.2 1,28 Mcps TDD option

In geographic areas where only 1,28 Mcps TDD is deployed, the RRC filtered mean power of any spurious emission in case of co-location shall not exceed the maximum level given in table 6.36E, otherwise the limits in table 6.36F shall apply.

**Table 6.36E: BS Spurious emissions limits for co-location with unsynchronised 1,28 Mcps UTRA TDD and/or E-UTRA TDD**

| System type operating in the same geographic area   | Frequency range | Maximum Level | Measurement Bandwidth |
|---|-----------------|---------------|-----------------------|
| WA UTRA TDD Band a) or E-UTRA Band 33   | 1900 - 1920 MHz | -76 dBm       | 1,28 MHz              |
| WA UTRA TDD Band a) or E-UTRA Band 34   | 2010 - 2025 MHz | -76 dBm       | 1,28 MHz              |
| WA UTRA TDD Band d) or E-UTRA Band 38   | 2570 - 2620 MHz | -76 dBm       | 1,28 MHz              |
| WA UTRA TDD Band e) or E-UTRA Band 40   | 2300 - 2400 MHz | -76 dBm       | 1,28 MHz              |
| WA UTRA TDD Band f) or E-UTRA Band 39   | 1880 - 1920 MHz | -76 dBm       | 1,28 MHz              |
| LA UTRA TDD Band a) or E-UTRA Band 33   | 1900 - 1920 MHz | -71 dBm       | 1,28 MHz              |
| LA UTRA TDD Band a) or E-UTRA Band 34   | 2010 - 2025 MHz | -71 dBm       | 1,28 MHz              |
| LA UTRA TDD Band d) or E-UTRA Band 38   | 2570 - 2620 MHz | -71 dBm       | 1,28 MHz              |
| LA UTRA TDD Band e) or E-UTRA Band 40   | 2300 - 2400 MHz | -71 dBm       | 1,28 MHz              |
| LA UTRA TDD Band f) or E-UTRA Band 39   | 1880 - 1920 MHz | -71 dBm       | 1,28 MHz              |
| NOTE: The requirement applies for frequencies more than 10 MHz below or above the supported frequency range declared by the vendor. |                 |               |                       |

**Table 6.36F: BS Spurious emissions limits for co-location with unsynchronised UTRA TDD and/or E-UTRA TDD**

| System type operating in the same geographic area | Frequency range | Maximum Level | Measurement Bandwidth |
|---|-----------------|---------------|-----------------------|
| WA UTRA TDD Band a) or E-UTRA Band 33             | 1900 - 1920 MHz | -76 dBm       | 3,84 MHz              |
| WA UTRA TDD Band a) or E-UTRA Band 34             | 2010 - 2025 MHz | -76 dBm       | 3,84 MHz              |
| WA UTRA TDD Band d) or E-UTRA Band 38             | 2570 - 2620 MHz | -76 dBm       | 3,84 MHz              |
| LA UTRA TDD Band a) or E-UTRA Band 33             | 1900 - 1920 MHz | -66 dBm       | 3,84 MHz              |
| LA UTRA TDD Band a) or E-UTRA Band 34             | 2010 - 2025 MHz | -66 dBm       | 3,84 MHz              |
| LA UTRA TDD Band d) or E-UTRA Band 38             | 2570 - 2620 MHz | -66 dBm       | 3,84 MHz              |

NOTE: The requirements in Table 6.36E and 6.36F for the Wide Area BS are based on a minimum coupling loss of 30 dB between unsynchronised TDD base stations. The requirements in Table 6.36E and 6.36F for the Local Area BS are based on a minimum coupling loss of 30 dB between unsynchronised Local Area base stations. The co-location of different base station classes is not considered.

The normative reference for this requirement is TS 25.105 [1] subclause 6.6.3.5.2.1.2.

## 6.6.3.2.5.2.3 7,68 Mcps TDD option

The RRC filtered mean power of any spurious emission shall not exceed the maximum level given in table 6.36G and 6.36H.

**Table 6.36G: BS Spurious emissions limits for co-location with unsynchronised UTRA TDD (7,68 Mcps TDD and 3,84 Mcps TDD) and/or E-UTRA TDD**

| System type operating in the same geographic area | Frequency range | Maximum Level | Measurement Bandwidth |
|---|-----------------|---------------|-----------------------|
| WA UTRA TDD Band a) or E-UTRA Band 33             | 1900 - 1920 MHz | -76 dBm       | 3,84 MHz              |
| WA UTRA TDD Band a) or E-UTRA Band 34             | 2010 - 2025 MHz | -76 dBm       | 3,84 MHz              |
| WA UTRA TDD Band d) or E-UTRA Band 38             | 2570 - 2620 MHz | -76 dBm       | 3,84 MHz              |
| LA UTRA TDD Band a) or E-UTRA Band 33             | 1900 - 1920 MHz | -66 dBm       | 3,84 MHz              |
| LA UTRA TDD Band a) or E-UTRA Band 34             | 2010 - 2025 MHz | -66 dBm       | 3,84 MHz              |
| LA UTRA TDD Band d) or E-UTRA Band 38             | 2570 - 2620 MHz | -66 dBm       | 3,84 MHz              |

**Table 6.36H: BS Spurious emissions limits for co-location with unsynchronised 1,28 Mcps UTRA TDD and/or E-UTRA TDD**

| System type operating in the same geographic area | Frequency range | Maximum Level | Measurement Bandwidth |
|---|-----------------|---------------|-----------------------|
| WA UTRA TDD Band a) or E-UTRA Band 33             | 1900 - 1920 MHz | -76 dBm       | 1,28 MHz              |
| WA UTRA TDD Band a) or E-UTRA Band 34             | 2010 - 2025 MHz | -76 dBm       | 1,28 MHz              |
| WA UTRA TDD Band d) or E-UTRA Band 38             | 2570 - 2620 MHz | -76 dBm       | 1,28 MHz              |
| WA UTRA TDD Band e) or E-UTRA Band 40             | 2300 - 2400 MHz | -76 dBm       | 1,28 MHz              |
| LA UTRA TDD Band a) or E-UTRA Band 33             | 1900 - 1920 MHz | -71 dBm       | 1,28 MHz              |
| LA UTRA TDD Band a) or E-UTRA Band 34             | 2010 - 2025 MHz | -71 dBm       | 1,28 MHz              |
| LA UTRA TDD Band d) or E-UTRA Band 38             | 2570 - 2620 MHz | -71 dBm       | 1,28 MHz              |
| LA UTRA TDD Band e) or E-UTRA Band 40             | 2300 - 2400 MHz | -71 dBm       | 1,28 MHz              |

NOTE: The requirements in Table 6.36G and 6.36H for the Wide Area BS are based on a minimum coupling loss of 30 dB between unsynchronised TDD base stations. The requirements in Table 6.36G and 6.36H for the Local Area BS are based on a minimum coupling loss of 30 dB between unsynchronised Local Area base stations. The co-location of different base station classes is not considered.

The normative reference for this requirement is TS 25.105 [1] subclause 6.6.3.5.2.1.3.

## 6.6.3.2.6 Co-existence with PHS

## 6.6.3.2.6.1 3,84 Mcps TDD option

This requirement may be applied for the protection of PHS in geographic areas in which both PHS and 3,84 Mcps UTRA TDD are deployed. For 3,84 Mcps TDD option, this requirement is also applicable at specified frequencies falling between 12.5MHz below the first carrier frequency used and 12.5MHz above the last carrier frequency used.



The power of any spurious emission shall not exceed the maximum level given in table 6.36I.

**Table 6.36I: BS Spurious emissions limits for BS in geographic coverage area of PHS (3,84 Mcps TDD option)**

| Band                | Maximum Level | Measurement Bandwidth | Note  |
|---------------------|---------------|-----------------------|---|
| 1884.5 - 1915.7 MHz | -41 dBm       | 300 kHz               | Applicable for transmission in 2010-2025 MHz as defined in subclause 4.2 (a). |

6.6.3.2.6.2 (void)

6.6.3.2.6.3 7,68 Mcps TDD option

This requirement may be applied for the protection of PHS in geographic areas in which both PHS and 7,68 Mcps UTRA TDD are deployed. For 7,68 Mcps TDD option, this requirement is also applicable at specified frequencies falling between 25 MHz below the first carrier frequency used and 25MHz above the last carrier frequency used.

The power of any spurious emission shall not exceed the maximum level given in table 6.36J.

**Table 6.36J: BS Spurious emissions limits for BS in geographic coverage area of PHS (7,68 Mcps TDD option)**

| Band                | Maximum Level | Measurement Bandwidth | Note  |
|---------------------|---------------|-----------------------|---|
| 1884.5 - 1915.7 MHz | -41 dBm       | 300 kHz               | Applicable for transmission in 2010-2025 MHz as defined in subclause 4.2 (a). |

6.6.3.3 Test purpose

6.6.3.3.1 3,84 Mcps TDD option

The test purpose is to verify the ability of the BS to limit the interference caused by unwanted transmitter effects to other systems operating at frequencies which are more than 12,5 MHz away from of the UTRA band used.

6.6.3.3.2 1,28 Mcps TDD option

The test purpose is to verify the ability of the BS to limit the interference caused by unwanted transmitter effects to other systems operating at frequencies which are more than 4 MHz away from of the UTRA band used.

6.6.3.3.3 7,68 Mcps TDD option

The test purpose is to verify the ability of the BS to limit the interference caused by unwanted transmitter effects to other systems operating at frequencies which are more than 25 MHz away from of the UTRA band used.

6.6.3.4 Method of test

6.6.3.4.1 Initial conditions

For 3,84 Mcps BS supporting 16QAM, the spurious requirements shall be tested with the general test set up specified in section 6.6.3.4.1.1 and also with the special test set up for 16QAM capable BS specified in section 6.6.3.4.1.4.

For 1,28 Mcps BS supporting 16QAM, the spurious requirements shall be tested with the general test set up specified in section 6.6.3.4.1.2 and also with the special test set up for 16QAM capable BS specified in section 6.6.3.4.1.3.

For 7,68 Mcps BS supporting 16QAM, the spurious requirements shall be tested with the general test set up specified in section 6.6.3.4.1.5 and also with the special test set up for 16QAM capable BS specified in section 6.6.3.4.1.6.

#### 6.6.3.4.1.0 General test conditions

Test environment: normal; see subclause 5.9.1.

RF channels to be tested: B, M and T with multiple carriers if supported; see subclause 5.3.

#### 6.6.3.4.1.1 3,84 Mcps TDD option - General test set up

- (1) Connect the measuring equipment to the antenna connector of the BS under test.
- (2) Set the parameters of the BS transmitted signal according to table 6.37. For MBSFN IMB operation the set of parameters for the transmitted signals is according to IMB test model 1 in subclause 6.1.1.1.

**Table 6.37: Parameters of the BS transmitted signal for spurious emissions testing**

| Parameter                                   | Value/description   |
|---|---|
| TDD Duty Cycle                              | TS $i$ ; $i = 0, 1, 2, \dots, 14$ :<br>transmit, if $i$ is even;<br>receive, if $i$ is odd. |
| Time slot carrying SCH                      | TS0   |
| Time slots under test                       | TS $i$ , $i$ even and non zero  |
| BS output power setting                     | PRAT  |
| Number of DPCH in each time slot under test | 9   |
| Power of each DPCH                          | 1/9 of Base Station output power  |
| Data content of DPCH                        | real life (sufficient irregular)  |

#### 6.6.3.4.1.2 1,28 Mcps TDD option - General test set up

- (1) Connect the measuring equipment to the antenna connector of the BS under test.
- (2) Set the parameters of the BS transmitted signal according to table 6.37A.

**Table 6.37A: Parameters of the BS transmitted signal for spurious emissions testing for 1,28 Mcps TDD**

| Parameter  | Value/description   |
|--|---|
| TDD Duty Cycle                                   | TS $i$ ; $i = 0, 1, 2, 3, 4, 5, 6$ :<br>transmit, if $i$ is 0,4,5,6;<br>receive, if $i$ is 1,2,3. |
| Time slots under test                            | TS4, TS5 and TS6  |
| BS output power setting                          | PRAT  |
| Number of DPCH in each each time slot under test | 8   |
| Power of each DPCH                               | 1/8 of Base Station output power  |
| Data content of DPCH                             | real life (sufficient irregular)  |

#### 6.6.3.4.1.3 1,28 Mcps TDD option - Special test set up for 16QAM capable BS

This test set up only applies for 16QAM capable BS.

- (1) Connect the measuring equipment to the antenna connector of the BS under test.
- (2) Set the parameters of the BS transmitted signal according to table 6.37B.

**Table 6.37B: Parameters of the BS transmitted signal for spurious emissions testing for 1,28 Mcps TDD - 16QAM capable BS**

| Parameter                                       | Value/description   |
|---|---|
| TDD Duty Cycle                                  | TS $i$ ; $i = 0, 1, 2, 3, 4, 5, 6$ :<br>transmit, if $i$ is 0,4,5,6;<br>receive, if $i$ is 1,2,3. |
| Time slots under test                           | TS4, TS5 and TS6  |
| BS output power setting                         | PRAT  |
| HS-PDSCH modulation                             | 16QAM   |
| Number of HS-PDSCH in each time slot under test | 8   |
| Power of each HS-PDSCH                          | 1/8 of Base Station output power  |
| Data content of HS-PDSCH                        | real life (sufficient irregular)  |
| Spreading factor                                | 16  |

#### 6.6.3.4.1.4 3,84 Mcps TDD option - Special test set up for 16QAM capable BS

This test set up only applies for 16QAM capable BS.

- (1) Connect the measuring equipment to the antenna connector of the BS under test.
- (2) Set the parameters of the BS transmitted signal according to table 6.37C. For MBSFN IMB operation the set of parameters for the transmitted signals is according to IMB test model 2 in subclause 6.1.1.2.

**Table 6.37C: Parameters of the BS transmitted signal for spurious emissions testing - 16QAM capable BS**

| Parameter                                       | Value/description   |
|---|---|
| TDD Duty Cycle                                  | TS $i$ ; $i = 0, 1, 2, \dots, 14$ :<br>transmit, if $i$ is even;<br>receive, if $i$ is odd. |
| Time slot carrying SCH                          | TS0   |
| Time slots under test                           | TS $i$ , $i$ even and non zero  |
| BS output power setting                         | PRAT  |
| HS-PDSCH modulation                             | 16QAM   |
| Number of HS-PDSCH in each time slot under test | 9   |
| Power of each HS-PDSCH                          | 1/9 of Base Station output power  |
| Data content of HS-PDSCH                        | real life (sufficient irregular)  |
| Spreading factor                                | 16  |

#### 6.6.3.4.1.5 7,68 Mcps TDD option - General test set up

- (1) Connect the measuring equipment to the antenna connector of the BS under test.
- (2) Set the parameters of the BS transmitted signal according to table 6.37D.

**Table 6.37D: Parameters of the BS transmitted signal for spurious emissions testing**

| Parameter                                   | Value/description   |
|---|---|
| TDD Duty Cycle                              | TS $i$ ; $i = 0, 1, 2, \dots, 14$ :<br>transmit, if $i$ is even;<br>receive, if $i$ is odd. |
| Time slot carrying SCH                      | TS0   |
| Time slots under test                       | TS $i$ , $i$ even and non zero  |
| BS output power setting                     | PRAT  |
| Number of DPCH in each time slot under test | 9   |
| Power of each DPCH                          | 1/9 of Base Station output power  |
| Data content of DPCH                        | real life (sufficient irregular)  |

#### 6.6.3.4.1.6 7,68 Mcps TDD option - Special test set up for 16QAM capable BS

This test set up only applies for 16QAM capable BS.

- (1) Connect the measuring equipment to the antenna connector of the BS under test.
- (2) Set the parameters of the BS transmitted signal according to table 6.37E.

**Table 6.37E: Parameters of the BS transmitted signal for spurious emissions testing - 16QAM capable BS**

| Parameter                                       | Value/description   |
|---|---|
| TDD Duty Cycle                                  | TS $i$ ; $i = 0, 1, 2, \dots, 14$ :<br>transmit, if $i$ is even;<br>receive, if $i$ is odd. |
| Time slot carrying SCH                          | TS0   |
| Time slots under test                           | TS $i$ , $i$ even and non zero  |
| BS output power setting                         | PRAT  |
| HS-PDSCH modulation                             | 16QAM   |
| Number of HS-PDSCH in each time slot under test | 9   |
| Power of each HS-PDSCH                          | 1/9 of Base Station output power  |
| Data content of HS-PDSCH                        | real life (sufficient irregular)  |
| Spreading factor                                | 32  |

#### 6.6.3.4.2 Procedure

Measure the power of the spurious emissions by applying measurement filters with bandwidths as specified in the relevant tables of subclause 6.6.3.2. The characteristics of the measurement filter with the bandwidth 1,28 MHz or 3,84MHz shall be RRC with roll-off  $\alpha = 0,22$ . The characteristics of the measurement filters with bandwidths 100 kHz and 1 MHz shall be approximately Gaussian (typical spectrum analyzer filter). The center frequency of the filter shall be stepped in contiguous steps over the frequency bands as given in the tables. The step width shall be equal to the respective measurement bandwidth. The time duration of each step shall be sufficiently long to capture one active time slot.

#### 6.6.3.5 Test Requirements

**NOTE:** If the Test Requirement below differs from the Minimum Requirement, then the Test Tolerance applied for this test is non-zero. The Test Tolerance for this test is defined in subclause 5.11 and the explanation of how the Minimum Requirement has been relaxed by the Test Tolerance is given in Annex D.

The spurious emissions measured according to subclause 6.6.3.4.2 shall not exceed the limits specified in the relevant tables of 6.6.3.2.

For 3,84 Mcps TDD BS supporting 16QAM, the measured spurious emissions shall not exceed the limits specified for 3,84 Mcps TDD option in section 6.6.3.2.

For 1,28 Mcps TDD BS supporting 16QAM, the measured spurious emissions shall not exceed the limits specified for 1,28 Mcps TDD option in section 6.6.3.2.

For 7,68 Mcps TDD BS supporting 16QAM, the measured spurious emissions shall not exceed the limits specified for 7,68 Mcps TDD option in section 6.6.3.2.

## 6.7 Transmit intermodulation

### 6.7.1 Definition and applicability

The transmit intermodulation performance is a measure of the capability of the transmitter to inhibit the generation of signals in its non linear elements caused by presence of the wanted signal and an interfering signal reaching the transmitter via the antenna.

The transmit intermodulation level is the power of the intermodulation products when a CDMA modulated interference signal is injected into the antenna connector at a mean power level of 30 dB lower than that of the mean power of the subject signal.

The requirements are applicable for a single carrier.

The requirements in this subclause shall apply to both Wide Area BS and Local Area BS.

#### 6.7.1.1 3,84 Mcps TDD option

The carrier frequency of the interference signal shall be  $\pm 5$  MHz,  $\pm 10$  MHz and  $\pm 15$  MHz offset from the subject signal carrier frequency, but excluding interference carrier frequencies outside of the UTRA frequency bands specified in 4.2a, 4.2b or 4.2c, respectively.

#### 6.7.1.2 1,28 Mcps TDD option

The carrier frequency of the interference signal shall be  $\pm 1,6$  MHz,  $\pm 3,2$  MHz and  $\pm 4,8$  MHz offset from the subject signal carrier frequency, but excluding interference carrier frequencies outside of the UTRA frequency bands specified in 4.2a, 4.2b or 4.2c, respectively.

#### 6.7.1.3 7,68 Mcps TDD option

The carrier frequency of the interference signal shall be  $\pm 10$  MHz,  $\pm 20$  MHz and  $\pm 30$  MHz offset from the subject signal carrier frequency, but excluding interference carrier frequencies outside of the UTRA frequency bands specified in 4.2a, 4.2b or 4.2c, respectively.

### 6.7.2 Minimum Requirements

The transmit intermodulation level shall not exceed the out of band or the spurious emission requirements of subclause 6.6.2 and 6.6.3, respectively.

The normative reference for this requirement is TS 25.105 [1] subclause 6.7.1.

### 6.7.3 Test purpose

The test purpose is to verify the ability of the BS transmitter to restrict the generation of intermodulation products in its non linear elements caused by presence of the wanted signal and an interfering signal reaching the transmitter via the antenna to below specified levels.

### 6.7.4 Method of test

#### 6.7.4.1 Initial conditions

For 3,84 Mcps BS supporting 16QAM, the transmit intermodulation requirements shall be tested with the general test set up specified in section 6.7.4.1.1 and also with the special test set up for 16QAM capable BS specified in section 6.7.4.1.4.

For 1,28 Mcps BS supporting 16QAM, the transmit intermodulation requirements shall be tested with the general test set up specified in section 6.7.4.1.2 and also with the special test set up for 16QAM capable BS specified in section 6.7.4.1.3.

For 7,68 Mcps BS supporting 16QAM, the transmit intermodulation requirements shall be tested with the general test set up specified in section 6.7.4.5.1 and also with the special test set up for 16QAM capable BS specified in section 6.7.4.1.6.

#### 6.7.4.1.0 General test conditions

Test environment: normal; see subclause 5.9.1.

RF channels to be tested: B, M and T; see subclause 5.3.

### 6.7.4.1.1 3,84 Mcps TDD option - General test set up

- (1) Connect the measuring equipment, the BS under test and the WCDMA signal generator as shown in figure 6.2.
- (2) Set the parameters of the BS transmitted signal according to table 6.38. For MBSFN IMB operation the set of parameters for the transmitted signals is according to IMB test model 1 in subclause 6.1.1.1.
- (3) Configure the WCDMA signal generator to produce an interference signal with a mean power level according to subclause 6.7.5. The interference signal shall be like-modulated as the BS transmitted signal, and the active time slots of both signals shall be synchronized. The carrier frequency of the interference signal shall be  $\pm 5$  MHz,  $\pm 10$  MHz and  $\pm 15$  MHz offset from the carrier frequency of the wanted signal, but excluding interference frequencies outside of the UTRA frequency bands specified in 4.2a, 4.2b or 4.2c, respectively.

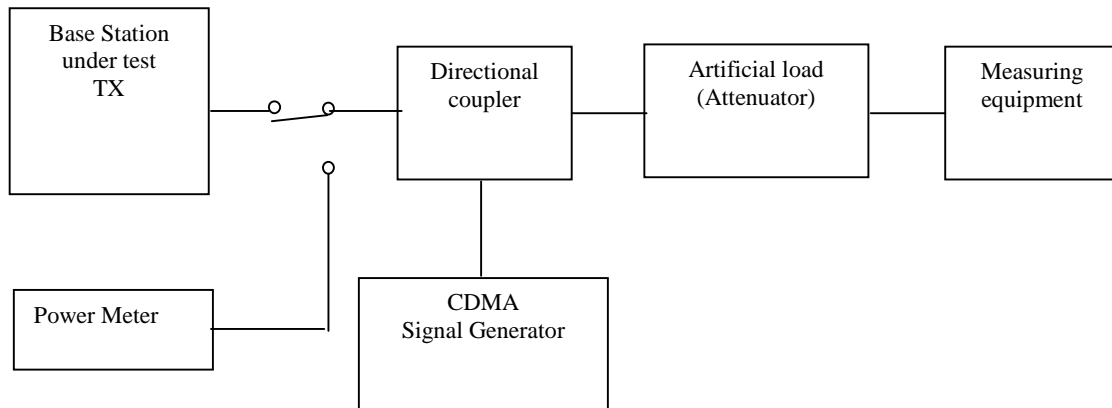


Figure 6.2: Measuring setup for Base Station transmit intermodulation testing

Table 6.38: Parameters of the BS transmitted signal for transmit intermodulation testing

| Parameter                                   | Value/description   |
|---|---|
| TDD Duty Cycle                              | TS $i$ ; $i = 0, 1, 2, \dots, 14$ :<br>transmit, if $i$ is odd;<br>receive, if $i$ is even. |
| Time slot carrying SCH                      | TS0   |
| Time slots under test                       | TS $i$ , $i$ even and non zero  |
| BS output power setting                     | PRAT  |
| Number of DPCH in each time slot under test | 9   |
| Power of each DPCH                          | 1/9 of Base Station output power  |
| Data content of DPCH                        | real life (sufficient irregular)  |

### 6.7.4.1.2 1,28 Mcps TDD option - General test set up

- (1) Connect the measuring equipment, the BS under test and the 1,28 Mcps TDD signal generator as shown in figure 6.2A.
- (2) Set the parameters of the BS transmitted signal according to table 6.38A.
- (3) Configure the 1,28 Mcps TDD signal generator to produce an interference signal with a mean power level according to subclause 6.7.5. The interference signal shall be like-modulated as the BS transmitted signal, and the active time slots of both signals shall be synchronized. The carrier frequency of the interference signal shall be  $\pm 1,6$  MHz,  $\pm 3,2$  MHz and  $\pm 4,8$  MHz offset from the carrier frequency of the wanted signal, but excluding interference frequencies outside of the UTRA frequency bands specified in 4.2a, 4.2b or 4.2c, respectively.

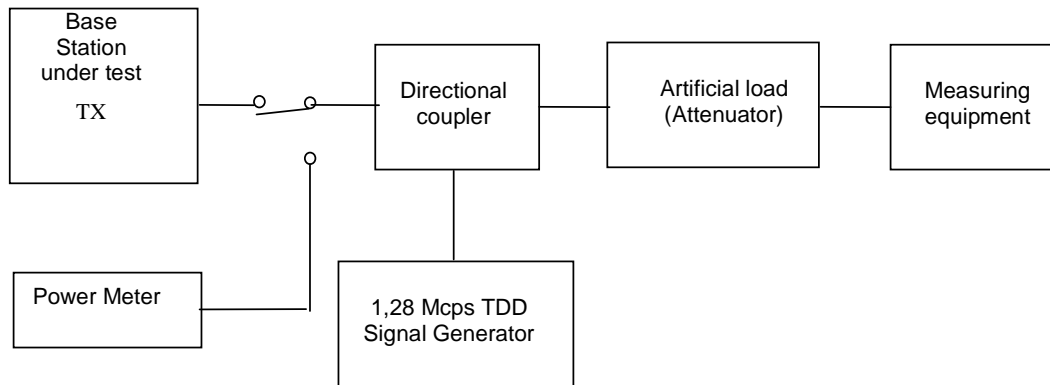


Figure 6.2A: Measuring set up for Base Station transmit intermodulation testing

Table 6.38A: Parameters of the BS transmitted signal for transmit intermodulation testing for 1,28 Mcps TDD

| Parameter                                   | Value/description   |
|---|---|
| TDD Duty Cycle                              | TS $i$ ; $i = 0, 1, 2, 3, 4, 5, 6$ :<br>transmit, if $i$ is 0,4,5,6;<br>receive, if $i$ is 1,2,3. |
| Time slots under test                       | TS4, TS5 and TS6  |
| BS output power setting                     | PRAT  |
| Number of DPCH in each time slot under test | 8   |
| Power of each DPCH                          | 1/8 of Base Station output power  |
| Data content of DPCH                        | real life (sufficient irregular)  |

6.7.4.1.3 1,28 Mcps TDD option - Special test set up for 16QAM capable BS

This test set up only applies for 16QAM capable BS.

- (1) Connect the measuring equipment, the BS under test and the 1,28 Mcps TDD signal generator as shown in figure 6.2B.
- (2) Set the parameters of the BS transmitted signal according to table 6.38B.
- (3) Configure the 1,28 Mcps TDD signal generator to produce an interference signal with a mean power level according to subclause 6.7.5. The interference signal shall be like-modulated as the BS transmitted signal, and the active time slots of both signals shall be synchronized. The carrier frequency of the interference signal shall be  $\pm 1,6$  MHz,  $\pm 3,2$  MHz and  $\pm 4,8$  MHz offset from the carrier frequency of the wanted signal, but excluding interference frequencies outside of the UTRA frequency bands specified in 4.2a, 4.2b or 4.2c, respectively.

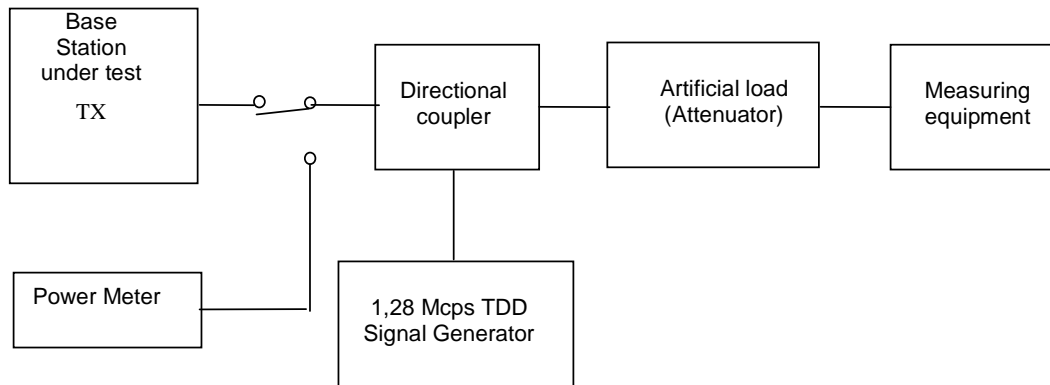


Figure 6.2B: Measuring setup for Base Station transmit intermodulation testing

Table 6.38B: Parameters of the BS transmitted signal for transmit intermodulation testing for 1,28 Mcps TDD- 16QAM capable BS

| Parameter                                       | Value/description   |
|---|---|
| TDD Duty Cycle                                  | TS $i$ ; $i = 0, 1, 2, 3, 4, 5, 6$ :<br>transmit, if $i$ is 0,4,5,6;<br>receive, if $i$ is 1,2,3. |
| Time slots under test                           | TS4, TS5 and TS6  |
| BS output power setting                         | PRAT  |
| HS-PDSCH modulation                             | 16QAM   |
| Number of HS-PDSCH in each time slot under test | 8   |
| Power of each HS-PDSCH                          | 1/8 of Base Station output power  |
| Data content of HS-PDSCH                        | real life (sufficient irregular)  |
| Spreading factor                                | 16  |

6.7.4.1.4 3,84 Mcps TDD option - Special test set up for 16QAM capable BS

- (1) Connect the measuring equipment, the BS under test and the WCDMA signal generator as shown in figure 6.3.
- (2) Set the parameters of the BS transmitted signal according to table 6.38C. For MBSFN IMB operation the set of parameters for the transmitted signals is according to IMB test model 2 in subclause 6.1.1.2.
- (3) Configure the WCDMA signal generator to produce an interference signal with a mean power level according to subclause 6.7.5. The interference signal shall be like-modulated as the BS transmitted signal, and the active time slots of both signals shall be synchronized. The carrier frequency of the interference signal shall be  $\pm 5$  MHz,  $\pm 10$  MHz and  $\pm 15$  MHz offset from the carrier frequency of the wanted signal, but excluding interference frequencies outside of the UTRA frequency bands specified in 4.2a, 4.2b or 4.2c, respectively.



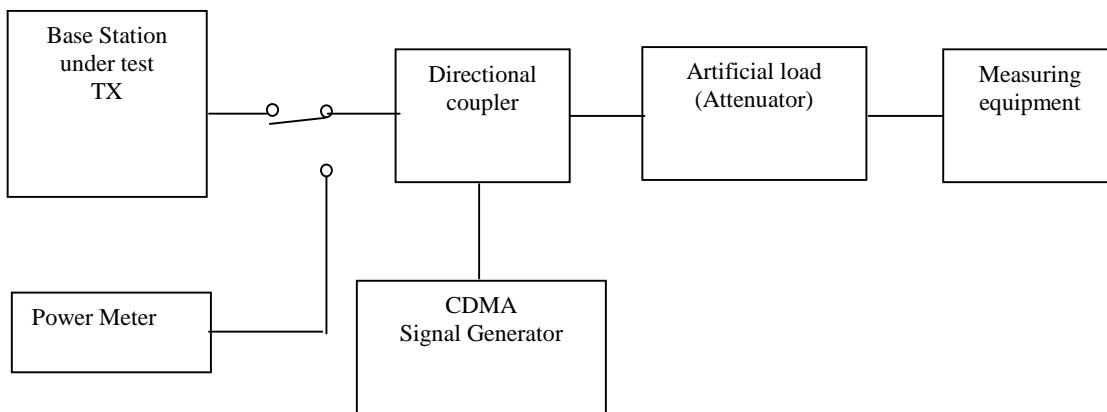


Figure 6.3: Measuring setup for Base Station transmit intermodulation testing

Table 6.38C: Parameters of the BS transmitted signal for transmit intermodulation testing - 16QAM capable BS

| Parameter                                       | Value/description   |
|---|---|
| TDD Duty Cycle                                  | TS $i$ ; $i = 0, 1, 2, \dots, 14$ :<br>transmit, if $i$ is even;<br>receive, if $i$ is odd. |
| Time slot carrying SCH                          | TS0   |
| Time slots under test                           | TS $i$ , $i$ even and non zero  |
| BS output power setting                         | PRAT  |
| HS-PDSCH modulation                             | 16QAM   |
| Number of HS-PDSCH in each time slot under test | 9   |
| Power of each HS-PDSCH                          | 1/9 of Base Station output power  |
| Data content of HS-PDSCH                        | real life (sufficient irregular)  |
| Spreading factor                                | 16  |

6.7.4.1.5 7,68 Mcps TDD option - General test set up

- (1) Connect the measuring equipment, the BS under test and the WCDMA signal generator as shown in figure 6.4.
- (2) Set the parameters of the BS transmitted signal according to table 6.38D.
- (3) Configure the WCDMA signal generator to produce an interference signal with a mean power level according to subclause 6.7.5. The interference signal shall be like-modulated as the BS transmitted signal, and the active time slots of both signals shall be synchronized. The carrier frequency of the interference signal shall be  $\pm 10$  MHz,  $\pm 20$  MHz and  $\pm 30$  MHz offset from the carrier frequency of the wanted signal, but excluding interference frequencies outside of the UTRA frequency bands specified in 4.2a, 4.2b or 4.2c, respectively.

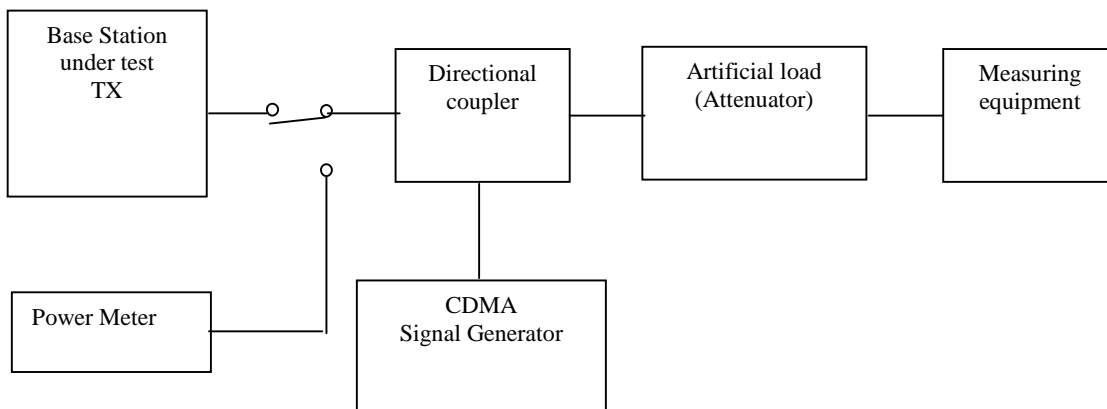


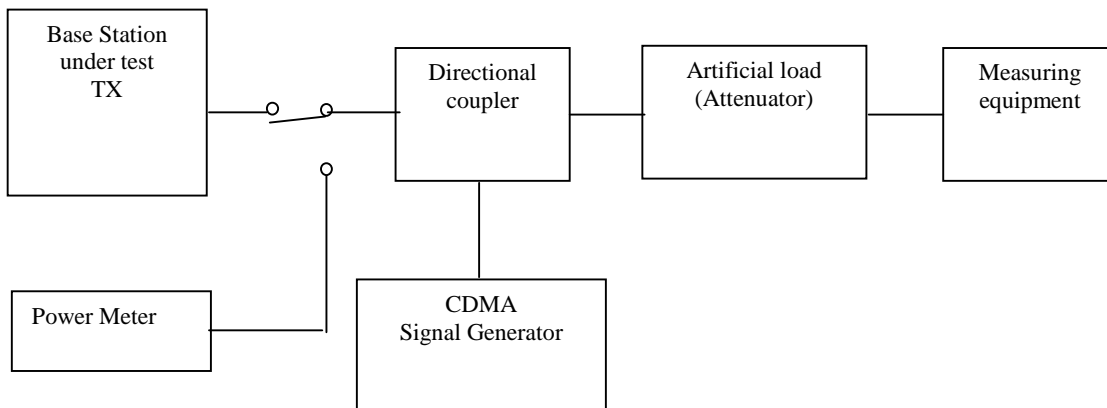
Figure 6.4: Measuring setup for Base Station transmit intermodulation testing

**Table 6.38D: Parameters of the BS transmitted signal for transmit intermodulation testing**

| Parameter                                   | Value/description  |
|---|--|
| TDD Duty Cycle                              | TS <i>i</i> ; <i>i</i> = 0, 1, 2, ..., 14:<br>transmit, if <i>i</i> is odd;<br>receive, if <i>i</i> is even. |
| Time slot carrying SCH                      | TS0  |
| Time slots under test                       | TS <i>i</i> , <i>i</i> even and non zero   |
| BS output power setting                     | PRAT   |
| Number of DPCH in each time slot under test | 9  |
| Power of each DPCH                          | 1/9 of Base Station output power   |
| Data content of DPCH                        | real life (sufficient irregular)   |

6.7.4.1.6 7,68 Mcps TDD option - Special test set up for 16QAM capable BS

- (1) Connect the measuring equipment, the BS under test and the WCDMA signal generator as shown in figure 6.5.
- (2) Set the parameters of the BS transmitted signal according to table 6.38D.
- (3) Configure the WCDMA signal generator to produce an interference signal with a mean power level according to subclause 6.7.5. The interference signal shall be like-modulated as the BS transmitted signal, and the active time slots of both signals shall be synchronized. The carrier frequency of the interference signal shall be ±10 MHz, ±20 MHz and ±30 MHz offset from the carrier frequency of the wanted signal, but excluding interference frequencies outside of the UTRA frequency bands specified in 4.2a, 4.2b or 4.2c, respectively.



**Figure 6.5: Measuring setup for Base Station transmit intermodulation testing**

**Table 6.38D: Parameters of the BS transmitted signal for transmit intermodulation testing - 16QAM capable BS**

| Parameter                                       | Value/description  |
|---|--|
| TDD Duty Cycle                                  | TS <i>i</i> ; <i>i</i> = 0, 1, 2, ..., 14:<br>transmit, if <i>i</i> is even;<br>receive, if <i>i</i> is odd. |
| Time slot carrying SCH                          | TS0  |
| Time slots under test                           | TS <i>i</i> , <i>i</i> even and non zero   |
| BS output power setting                         | PRAT   |
| HS-PDSCH modulation                             | 16QAM  |
| Number of HS-PDSCH in each time slot under test | 9  |
| Power of each HS-PDSCH                          | 1/9 of Base Station output power   |
| Data content of HS-PDSCH                        | real life (sufficient irregular)   |
| Spreading factor                                | 32   |

### 6.7.4.2 Procedure

Apply the test procedures for out of band and spurious emissions as described in 6.6.2 and 6.6.3, respectively, at the frequencies of all third and fifth order intermodulation products. The frequency band occupied by the interference signal are excluded from the measurements.

NOTE: The third order intermodulation products are at frequencies  $(F1 \pm 2F2)$  and  $(2F1 \pm F2)$ , the fifth order intermodulation products are at frequencies  $(2F1 \pm 3F2)$ ,  $(3F1 \pm 2F2)$ ,  $(4F1 \pm F2)$  and  $(F1 \pm 4F2)$ , where  $F1$  represents the frequencies within the bandwidth of the wanted signal and  $F2$  represents the frequencies within the bandwidth of the CDMA modulated interference signal.

### 6.7.5 Test Requirements

NOTE: If the Test Requirement below differs from the Minimum Requirement, then the Test Tolerance applied for this test is non-zero. The Test Tolerance for this test is defined in subclause 5.11 and the explanation of how the Minimum Requirement has been relaxed by the Test Tolerance is given in Annex D.

The mean power level of the CDMA modulated interference signal shall be 30 dB below the mean power level of the wanted signal.

At the frequencies of all third and fifth order intermodulation products, the Test Requirements for out of band and spurious emissions as specified in subclauses 6.6.2.1.5 (Spectrum emission mask), 6.6.2.2.5 (ACLR) and 6.6.3.5 (Spurious emissions) shall be met.

## 6.8 Transmit Modulation

### 6.8.1 Modulation accuracy

#### 6.8.1.1 Definition and applicability

The Error Vector Magnitude is a measure of the difference between the reference waveform and the measured waveform. This difference is called the error vector. Both waveforms pass through a matched Root Raised Cosine filter with bandwidth corresponding to the considered chip rate and roll-off  $\alpha = 0,22$ . Both waveforms are then further modified by selecting the frequency, absolute phase, absolute amplitude and chip clock timing so as to minimise the error vector. The EVM result is defined as the square root of the ratio of the mean error vector power to the mean reference power expressed as a %. The measurement interval is one timeslot. The requirement is valid over the total power dynamic range as specified in section 3.1. See Annex C of this specification for further details.

The requirements in this subclause shall apply to both Wide Area BS and Local Area BS.

NOTE: The theoretical modulated waveform shall be calculated on the basis that the transmit pulse shaping filter is a root-raised cosine (RRC) with roll-off  $\alpha = 0,22$  in the frequency domain. The impulse response of the chip impulse filter  $RC_0(t)$  is

$$RC_0(t) = \frac{\sin\left(\pi \frac{t}{T_C}(1-\alpha)\right) + 4\alpha \frac{t}{T_C} \cos\left(\pi \frac{t}{T_C}(1+\alpha)\right)}{\pi \frac{t}{T_C} \left(1 - \left(4\alpha \frac{t}{T_C}\right)^2\right)}$$

Where the roll-off factor  $\alpha = 0,22$  and  $T_C$  is the chip duration

#### 6.8.1.2 Minimum Requirements

The error vector magnitude (EVM) shall not exceed 12,5 %. The requirement is valid over the total power dynamic range as specified in section 3.1.

The normative reference for this requirement is TS 25.105 [1] subclause 6.8.2.1.

### 6.8.1.3 Test purpose

The test purpose is to verify the ability of the BS transmitter to generate a sufficient precise waveform and thus to enable the UE receiver to achieve the specified error performance.

### 6.8.1.4 Method of test

#### 6.8.1.4.1 Initial conditions

For 1,28 Mcps BS supporting 16QAM, the EVM requirements shall be tested with the general test set up specified in section 6.8.1.4.1.2 and also with the special test set up for 16QAM capable base station specified in section 6.8.1.4.1.2.

#### 6.8.1.4.1.0 General test conditions

Test environment: normal; see subclause 5.9.1.

RF channels to be tested: B, M and T; see subclause 5.3.

#### 6.8.1.4.1.1 3,84 Mcps TDD option - General test setup

- (1) Connect the measuring equipment to the antenna connector of the BS under test.
- (2) Set the parameters of the BS transmitted signal according to table 6.39. For MBSFN IMB operation the set of parameters for the transmitted signals is according to IMB test model 1 in subclause 6.1.1.1.

**Table 6.39: Parameters of the BS transmitted signal for modulation accuracy testing**

| Parameter                                   | Value/description   |
|---|---|
| TDD Duty Cycle                              | TS $i$ ; $i = 0, 1, 2, \dots, 14$ :<br>transmit, if $i$ is even;<br>receive, if $i$ is odd. |
| Time slot carrying SCH                      | TS0   |
| Time slots under test                       | TS $i$ , $i$ even and non zero  |
| Number of DPCH in each time slot under test | 1   |
| Power of each DPCH                          | 1/9 of Base Station output power  |
| BS power setting                            | PRAT  |
| Data content of DPCH                        | real life (sufficient irregular)  |

#### 6.8.1.4.1.2 1,28 Mcps TDD option - General test set up

- (1) Connect the measuring equipment to the antenna connector of the BS under test.
- (2) Set the parameters of the BS transmitted signal according to table 6.39A.

**Table 6.39A: Parameters of the BS transmitted signal for modulation accuracy testing at maximum BS output power for 1,28 Mcps TDD**

| Parameter                                   | Value/description   |
|---|---|
| TDD Duty Cycle                              | TS $i$ ; $i = 0, 1, 2, \dots, 6$ :<br>Transmit, if $i$ is 0,4,5,6;<br>receive, if $i$ is 1,2,3. |
| Time slots under test                       | TS4, TS5 and TS6  |
| Number of DPCH in each time slot under test | 10  |
| Power of each DPCH                          | 1/10 of Base Station output power   |
| Base station power                          | PRAT  |
| Data content of DPCH                        | real life (sufficient irregular)  |

## 6.8.1.4.1.3 1,28 Mcps TDD option - Special test set up for 16QAM capable BS

This test set up only applies for 16QAM capable BS.

- (1) Connect the measuring equipment to the antenna connector of the BS under test.
- (2) Set the parameters of the BS transmitted signal according to table 6.39B.

**Table 6.39B: Parameters of the BS transmitted signal for modulation accuracy testing at maximum BS output power setting for 1,28 Mcps TDD - 16QAM capable BS**

| Parameter                                       | Value/description   |
|---|---|
| TDD Duty Cycle                                  | TS $i$ ; $i = 0, 1, 2, 3, 4, 5, 6$ :<br>transmit, if $i$ is 0,4,5,6;<br>receive, if $i$ is 1,2,3. |
| Time slots under test                           | TS4, TS5 and TS6  |
| HS-PDSCH modulation                             | 16QAM   |
| Number of HS-PDSCH in each time slot under test | 10  |
| Power of each HS-PDSCH                          | 1/10 of Base Station output power   |
| BS station power                                | PRAT  |
| Data content of HS-PDSCH                        | Real life (sufficient irregular)  |
| Spreading factor                                | 16  |

## 6.8.1.4.1.4 3,84 Mcps TDD option - Special test set up for 16QAM capable BS

This test set up only applies for 16QAM capable BS.

- (1) Connect the measuring equipment to the antenna connector of the BS under test.
- (2) Set the parameters of the BS transmitted signal according to table 6.39BA. For MBSFN IMB operation the set of parameters for the transmitted signals is according to IMB test model 2 in subclause 6.1.1.2.

**Table 6.39BA: Parameters of the BS transmitted signal for modulation accuracy testing at maximum BS output power setting for 3,84 Mcps TDD - 16QAM capable BS**

| Parameter                                   | Value/description   |
|---|---|
| TDD Duty Cycle                              | TS $i$ ; $i = 0, 1, 2, \dots, 14$ :<br>transmit, if $i$ is even;<br>receive, if $i$ is odd. |
| Time slots under test                       | TS $i$ , $i$ even and non zero  |
| HS-PDSCH modulation                         | 16QAM   |
| Number of DPCH in each time slot under test | 9   |
| Power of each DPCH                          | 1/9 of Base Station output power  |
| BS power setting                            | PRAT  |
| Data content of DPCH                        | real life (sufficient irregular)  |
| Spreading factor                            | 16  |

## 6.8.1.4.1.5 7,68 Mcps TDD option - General test setup

- (1) Connect the measuring equipment to the antenna connector of the BS under test.
- (2) Set the parameters of the BS transmitted signal according to table 6.39BC.

**Table 6.39BC: Parameters of the BS transmitted signal for modulation accuracy testing**

| Parameter                                   | Value/description   |
|---|---|
| TDD Duty Cycle                              | TS $i$ ; $i = 0, 1, 2, \dots, 14$ :<br>transmit, if $i$ is even;<br>receive, if $i$ is odd. |
| Time slot carrying SCH                      | TS0   |
| Time slots under test                       | TS $i$ , $i$ even and non zero  |
| Number of DPCH in each time slot under test | 1   |
| Power of each DPCH                          | 1/9 of Base Station output power  |
| BS power setting                            | PRAT  |
| Data content of DPCH                        | real life (sufficient irregular)  |

#### 6.8.1.4.1.6 7,68 Mcps TDD option - Special test set up for 16QAM capable BS

This test set up only applies for 16QAM capable BS.

- (1) Connect the measuring equipment to the antenna connector of the BS under test.
- (2) Set the parameters of the BS transmitted signal according to table 6.39BD.

**Table 6.39BD: Parameters of the BS transmitted signal for modulation accuracy testing at maximum BS output power setting for 7.68 Mcps TDD - 16QAM capable BS**

| Parameter                                   | Value/description   |
|---|---|
| TDD Duty Cycle                              | TS $i$ ; $i = 0, 1, 2, \dots, 14$ :<br>transmit, if $i$ is even;<br>receive, if $i$ is odd. |
| Time slots under test                       | TS $i$ , $i$ even and non zero  |
| HS-PDSCH modulation                         | 16QAM   |
| Number of DPCH in each time slot under test | 9   |
| Power of each DPCH                          | 1/9 of Base Station output power  |
| BS power setting                            | PRAT  |
| Data content of DPCH                        | real life (sufficient irregular)  |
| Spreading factor                            | 32  |

#### 6.8.1.4.2 Procedure

##### 6.8.1.4.2.1 3,84 Mcps TDD option - General procedure

- (1) Measure the error vector magnitude (EVM) by applying the global in-channel Tx test method described in Annex C with the BS transmitted signal set as described in Table 6.39.
- (2) Set the BS transmitted signal according to Table 6.39BB and measure the error vector magnitude (EVM) by applying the global in-channel Tx test method described in Annex C. For MBSFN IMB operation the set of parameters for the transmitted signals is according to IMB test model 1 in subclause 6.1.1.1. A prerequisite for the test is that the BS output power setting is set to the maximum – 30 dB.

**Table 6.39BB: Parameters of the BS transmitted signal for modulation accuracy testing at minimum BS output power setting for 3,84 Mcps TDD**

| Parameter                                   | Value/description   |
|---|---|
| TDD Duty Cycle                              | TS $i$ ; $i = 0, 1, 2, \dots, 14$ :<br>transmit, if $i$ is even;<br>receive, if $i$ is odd. |
| Time slot carrying SCH                      | TS0   |
| Time slots under test                       | TS $i$ , $i$ even and non zero  |
| BS output power setting                     | Maximum output power - 30 dB  |
| Number of DPCH in each time slot under test | 1   |
| Data content of DPCH                        | real life (sufficient irregular)  |

#### 6.8.1.4.2.2 1,28 Mcps TDD option - General procedure

- (1) Measure the error vector magnitude (EVM) by applying the global in-channel Tx test method described in Annex C with the BS transmitted signal set as described in Table 6.39A.
- (2) Set the BS transmitted signal according Table 6.39C and measure the error vector magnitude (EVM) by applying the global in-channel Tx test method described in Annex C.

**Table 6.39C: Parameters of the BS transmitted signal for modulation accuracy testing at minimum BS output power for 1,28 Mcps TDD**

| Parameter                                   | Value/description   |
|---|---|
| TDD Duty Cycle                              | TS $i$ ; $i = 0, 1, 2, \dots, 6$ :<br>Transmit, if $i$ is 0,4,5,6;<br>receive, if $i$ is 1,2,3. |
| Time slot under test                        | TS4, TS5 and TS6  |
| Number of DPCH in each time slot under test | 1   |
| BS output power setting                     | Maximum output power - 30 dB  |
| Data content of DPCH                        | Real life<br>(sufficient irregular)   |

#### 6.8.1.4.2.3 1,28 Mcps TDD option - Special procedure for 16QAM capable BS

- (1) Measure the error vector magnitude (EVM) by applying the global in-channel Tx test method described in Annex C with the BS transmitted signal set as described in Table 6.39B.
- (2) Set the BS transmitted signal according Table 6.39D and measure the error vector magnitude (EVM) by applying the global in-channel Tx test method described in Annex C.

**Table 6.39D: Parameters of the BS transmitted signal for modulation accuracy testing at minimum BS output power setting for 1,28 Mcps TDD - 16QAM capable BS**

| Parameter                                       | Value/description   |
|---|---|
| TDD Duty Cycle                                  | TS $i$ ; $i = 0, 1, 2, 3, 4, 5, 6$ :<br>transmit, if $i$ is 0,4,5,6;<br>receive, if $i$ is 1,2,3. |
| HS-PDSCH modulation                             | 16QAM   |
| Time slots under test                           | TS4, TS5 and TS6  |
| Number of HS-PDSCH in each time slot under test | 1   |
| BS output power setting                         | Maximum output power - 30 dB  |
| Data content of HS-PDSCH                        | Real life<br>(sufficient irregular)   |
| Spreading factor                                | 16  |

## 6.8.1.4.2.4 3,84 Mcps TDD option - Special test set up for 16QAM capable BS

This test set up only applies for 16QAM capable BS.

- (1) Measure the error vector magnitude (EVM) by applying the global in-channel Tx test method described in Annex C.
- (2) Set the BS transmitted signal according Table 6.39E and measure the error vector magnitude (EVM) by applying the global in-channel Tx test method described in Annex C. For MBSFN IMB operation the set of parameters for the transmitted signals is according to IMB test model 2 in subclause 6.1.1.2. A prerequisite for the test is that the BS output power setting is set to the maximum – 30 dB.

**Table 6.39E: Parameters of the BS transmitted signal for modulation accuracy testing at minimum BS output power setting for 3,84 Mcps TDD - 16QAM capable BS**

| Parameter                                       | Value/description   |
|---|---|
| TDD Duty Cycle                                  | TS i; i = 0, 1, 2, ..., 14:<br>transmit, if i is even;<br>receive, if i is odd. |
| Time slot carrying SCH                          | TS0   |
| Time slots under test                           | TS i, i even and non zero   |
| BS output power setting                         | Maximum output power- 30 dB   |
| HS-PDSCH modulation                             | 16QAM   |
| Number of HS-PDSCH in each time slot under test | 1   |
| Data content of HS-PDSCH                        | real life (sufficient irregular)  |
| Spreading factor                                | 16  |

## 6.8.1.4.2.5 7,68 Mcps TDD option - General procedure

- (1) Measure the error vector magnitude (EVM) by applying the global in-channel Tx test method described in Annex C with the BS transmitted signal set as described in Table 6.39F.
- (2) Set the BS transmitted signal according to Table 6.39F and measure the error vector magnitude (EVM) by applying the global in-channel Tx test method described in Annex C

**Table 6.39F: Parameters of the BS transmitted signal for modulation accuracy testing at minimum BS output power setting for 7,68 Mcps TDD**

| Parameter                                   | Value/description   |
|---|---|
| TDD Duty Cycle                              | TS i; i = 0, 1, 2, ..., 14:<br>transmit, if i is even;<br>receive, if i is odd. |
| Time slot carrying SCH                      | TS0   |
| Time slots under test                       | TS i, i even and non zero   |
| BS output power setting                     | Maximum output power - 30 dB  |
| Number of DPCH in each time slot under test | 1   |
| Data content of DPCH                        | real life (sufficient irregular)  |

## 6.8.1.4.2.6 7,68 Mcps TDD option - Special test set up for 16QAM capable BS

This test set up only applies for 16QAM capable BS.

- (1) Measure the error vector magnitude (EVM) by applying the global in-channel Tx test method described in Annex C.
- (2) Set the BS transmitted signal according Table 6.39G and measure the error vector magnitude (EVM) by applying the global in-channel Tx test method described in Annex C.



**Table 6.39G: Parameters of the BS transmitted signal for modulation accuracy testing at minimum BS output power setting for 7,68 Mcps TDD - 16QAM capable BS**

| Parameter                                       | Value/description   |
|---|---|
| TDD Duty Cycle                                  | TS $i$ ; $i = 0, 1, 2, \dots, 14$ :<br>transmit, if $i$ is even;<br>receive, if $i$ is odd. |
| Time slot carrying SCH                          | TS0   |
| Time slots under test                           | TS $i$ , $i$ even and non zero  |
| BS output power setting                         | Maximum output power- 30 dB   |
| HS-PDSCH modulation                             | 16QAM   |
| Number of HS-PDSCH in each time slot under test | 1   |
| Data content of HS-PDSCH                        | real life (sufficient irregular)  |
| Spreading factor                                | 32  |

### 6.8.1.5 Test Requirements

NOTE: If the Test Requirement below differs from the Minimum Requirement, then the Test Tolerance applied for this test is non-zero. The Test Tolerance for this test is defined in subclause 5.11 and the explanation of how the Minimum Requirement has been relaxed by the Test Tolerance is given in Annex D.

The error vector magnitude (EVM) measured according to subclause 6.8.1.4.2 shall not exceed 12,5 %.

## 6.8.2 Peak code domain error

### 6.8.2.1 Definition and applicability

The code domain error is computed by projecting the error vector power onto the code domain at a specific spreading factor. The error power for each code is defined as the ratio to the mean power of the reference waveform expressed in dB. And the Peak Code Domain Error is defined as the maximum value for Code Domain Error. The measurement interval is one timeslot.

The requirements in this subclause shall apply to both Wide Area BS and Local Area BS.

### 6.8.2.2 Minimum Requirements

The peak code domain error shall not exceed -28 dB at spreading factor 16. For 7.68 Mcps, the peak code domain error shall not exceed -31 dB at spreading factor 32.

The normative reference for this requirement is TS 25.105 [1] subclause 6.8.3.1.

### 6.8.2.3 Test purpose

The test purpose is to verify the ability of the BS transmitter to limit crosstalk among codes and thus to enable the UE receiver to achieve the specified error performance.

### 6.8.2.4 Method of test

#### 6.8.2.4.1 Initial conditions

For 3,84 Mcps BS supporting 16QAM, the PCDE requirement shall be tested with the general test set up specified in section 6.8.2.4.1 and also with the special test set up for 16QAM capable BS specified in section 6.8.2.4.4.

For 1,28 Mcps BS supporting 16QAM, the PCDE requirement shall be tested with the general test set up specified in section 6.8.2.4.2 and also with the special test set up for 16QAM capable BS specified in section 6.8.2.4.3.

For 7,68 Mcps BS supporting 16QAM, the PCDE requirement shall be tested with the general test set up specified in section 6.8.2.4.1.5 and also with the special test set up for 16QAM capable BS specified in section 6.8.2.4.1.6.

## 6.8.2.4.1.0 General test conditions

Test environment: normal; see subclause 5.9.1.

RF channels to be tested: B, M and T; see subclause 5.3.

## 6.8.2.4.1.1 3,84 Mcps TDD option - General test set up

- (1) Connect the measuring equipment to the antenna connector of the BS under test.
- (2) Set the parameters of the BS transmitted signal according to table 6.40. For MBSFN IMB operation the set of parameters for the transmitted signals is according to IMB test model 1 in subclause 6.1.1.1.

**Table 6.40: Parameters of the BS transmitted signal**

| Parameter                                   | Value/description   |
|---|---|
| TDD Duty Cycle                              | TS $i$ ; $i = 0, 1, 2, \dots, 14$ :<br>transmit, if $i$ is even;<br>receive, if $i$ is odd. |
| Time slot carrying SCH                      | TS0   |
| Time slots under test                       | TS $i$ , $i$ even and non zero  |
| BS output power setting                     | PRAT  |
| Number of DPCH in each time slot under test | 9   |
| Power of each DPCH                          | 1/9 of Base Station output power  |
| Data content of DPCH                        | real life (sufficient irregular)  |
| Spreading factor                            | 16  |

## 6.8.2.4.1.2 1,28 Mcps TDD option- General test set up

- (1) Connect the measuring equipment to the antenna connector of the BS under test.
- (2) Set the parameters of the BS transmitted signal according to table 6.40A.

**Table 6.40A: Parameters of the BS transmitted signal for 1,28 Mcps TDD**

| Parameter                                   | Value/description   |
|---|---|
| TDD Duty Cycle                              | TS $i$ ; $i = 0, 1, 2, \dots, 6$ :<br>transmit, if $i$ is 0,4,5,6;<br>receive, if $i$ is 1,2,3. |
| Time slots under test                       | TS4, TS5 and TS6  |
| BS output power setting                     | PRAT  |
| Number of DPCH in each time slot under test | 10  |
| Power of each DPCH                          | 1/10 of Base Station output power   |
| Data content of DPCH                        | real life (sufficient irregular)  |
| Spreading factor                            | 16  |

## 6.8.2.4.1.3 1,28 Mcps TDD option - Special test set up for 16QAM capable BS

This test set up only applies for 16QAM capable BS.

- (1) Connect the measuring equipment to the antenna connector of the BS under test.
- (2) Set the parameters of the BS transmitted signal according to table 6.40B.

**Table 6.40B: Parameters of the BS transmitted signal for 1,28 Mcps TDD - 16QAM capable BS**

| Parameter                                       | Value/description   |
|---|---|
| TDD Duty Cycle                                  | TS $i$ ; $i = 0, 1, 2, \dots, 6$ :<br>transmit, if $i$ is 0,4,5,6;<br>receive, if $i$ is 1,2,3. |
| Time slots under test                           | TS4, TS5 and TS6  |
| HS-PDSCH modulation                             | 16QAM   |
| BS output power setting                         | PRAT  |
| Number of HS-PDSCH in each time slot under test | 10  |
| Power of each HS-PDSCH                          | 1/10 of Base Station output power   |
| Data content of HS-DSCH                         | real life (sufficient irregular)  |
| Spreading factor                                | 16  |

#### 6.8.2.4.1.4 3,84 Mcps TDD option - Special test set up for 16QAM capable BS

This test set up only applies for 16QAM capable BS.

- (1) Connect the measuring equipment to the antenna connector of the BS under test.
- (2) Set the parameters of the BS transmitted signal according to table 6.40C. For MBSFN IMB operation the set of parameters for the transmitted signals is according to IMB test model 2 in subclause 6.1.1.2.

**Table 6.40C: Parameters of the BS transmitted signal - 16QAM capable BS**

| Parameter                                       | Value/description   |
|---|---|
| TDD Duty Cycle                                  | TS $i$ ; $i = 0, 1, 2, \dots, 14$ :<br>transmit, if $i$ is even;<br>receive, if $i$ is odd. |
| Time slot carrying SCH                          | TS0   |
| Time slots under test                           | TS $i$ , $i$ even and non zero  |
| BS output power setting                         | PRAT  |
| HS-PDSCH modulation                             | 16QAM   |
| Number of HS-PDSCH in each time slot under test | 9   |
| Power of each HS-PDSCH                          | 1/9 of Base Station output power  |
| Data content of HS-PDSCH                        | real life (sufficient irregular)  |
| Spreading factor                                | 16  |

#### 6.8.2.4.1.5 7,68 Mcps TDD option - General test set up

- (1) Connect the measuring equipment to the antenna connector of the BS under test.
- (2) Set the parameters of the BS transmitted signal according to table 6.40D.

**Table 6.40D: Parameters of the BS transmitted signal**

| Parameter                                   | Value/description   |
|---|---|
| TDD Duty Cycle                              | TS $i$ ; $i = 0, 1, 2, \dots, 14$ :<br>transmit, if $i$ is even;<br>receive, if $i$ is odd. |
| Time slot carrying SCH                      | TS0   |
| Time slots under test                       | TS $i$ , $i$ even and non zero  |
| BS output power setting                     | PRAT  |
| Number of DPCH in each time slot under test | 9   |
| Power of each DPCH                          | 1/9 of Base Station output power  |
| Data content of DPCH                        | real life (sufficient irregular)  |
| Spreading factor                            | 32  |

#### 6.8.2.4.1.6 7,68 Mcps TDD option - Special test set up for 16QAM capable BS

This test set up only applies for 16QAM capable BS.

- (1) Connect the measuring equipment to the antenna connector of the BS under test.
- (2) Set the parameters of the BS transmitted signal according to table 6.40E.

**Table 6.40E: Parameters of the BS transmitted signal - 16QAM capable BS**

| Parameter                                       | Value/description   |
|---|---|
| TDD Duty Cycle                                  | TS $i$ ; $i = 0, 1, 2, \dots, 14$ :<br>transmit, if $i$ is even;<br>receive, if $i$ is odd. |
| Time slot carrying SCH                          | TS0   |
| Time slots under test                           | TS $i$ , $i$ even and non zero  |
| BS output power setting                         | PRAT  |
| HS-PDSCH modulation                             | 16QAM   |
| Number of HS-PDSCH in each time slot under test | 9   |
| Power of each HS-PDSCH                          | 1/9 of Base Station output power  |
| Data content of HS-PDSCH                        | real life (sufficient irregular)  |
| Spreading factor                                | 32  |

#### 6.8.2.4.2 Procedure

Measure the peak code domain error by applying the global in-channel Tx test method described in Annex C.

#### 6.8.2.5 Test Requirements

NOTE: If the Test Requirement below differs from the Minimum Requirement, then the Test Tolerance applied for this test is non-zero. The Test Tolerance for this test is defined in subclause 5.11 and the explanation of how the Minimum Requirement has been relaxed by the Test Tolerance is given in Annex D.

The peak code domain error measured according to subclause 6.8.2.4.2 shall not exceed -27 dB.

### 6.8.3 Relative Code Domain Error

#### 6.8.3.1 Definition and applicability

The Relative Code Domain Error is computed by projecting the error vector onto the code domain at a specified spreading factor. Only the active code channels in the composite reference waveform are considered for this requirement. The Relative Code Domain Error for every active code is defined as the ratio of the mean power of the error projection onto that code, to the mean power of the active code in the composite reference waveform. This ratio is expressed in dB. The measurement interval is one timeslot.

The requirement for Relative Code Domain Error is only applicable for 64QAM modulated codes.

#### 6.8.3.2 Minimum requirement

The average Relative Code Domain Error for 64QAM modulated codes shall not exceed -21.9dB at spreading factor 16. The normative reference for this requirement is TS 25.105 [1] subclause 6.8.4.1

#### 6.8.3.3 Test Purpose

It is the purpose of this test to verify that the Relative Code Domain Error is within the limit specified by 6.8.3.2.

## 6.8.3.4 Method of test

### 6.8.3.4.1 Initial conditions

For 1,28 Mcps BS supporting 64QAM, the RCDE requirement shall be tested with the general test set up specified in section 6.8.3.4.1.1 and also with the special test set up for 64QAM capable BS specified in section 6.8.3.4.1.2.

#### 6.8.3.4.1.0 General test conditions

Test environment: normal; see subclause 5.9.1.

RF channels to be tested: B, M and T; see subclause 5.3.

#### 6.8.3.4.1.1 1.28 Mcps TDD option- General test set up

- (1) Connect the measuring equipment to the antenna connector of the BS under test.
- (2) Set the parameters of the BS transmitted signal according to table 6.41..

**Table 6.41: Parameters of the BS transmitted signal for 1,28 Mcps TDD**

| Parameter                                       | Value/description   |
|---|---|
| TDD Duty Cycle                                  | TS $i$ ; $i = 0, 1, 2, \dots, 6$ :<br>transmit, if $i$ is 0,4,5,6;<br>receive, if $i$ is 1,2,3. |
| Time slots under test                           | TS4, TS5 and TS6  |
| BS output power setting                         | PRAT  |
| Number of HS-PDSCH in each time slot under test | 10  |
| Power of each HS-PDSCH                          | 1/10 of Base Station output power   |
| Data content of HS-PDSCH                        | real life (sufficient irregular)  |
| Spreading factor                                | 16  |

#### 6.8.3.4.1.2 1.28 Mcps TDD option - Special test set up for 64QAM capable BS

This test set up only applies for 64QAM capable BS.

- (1) Connect the measuring equipment to the antenna connector of the BS under test.
- (2) Set the parameters of the BS transmitted signal according to table 6.41A.

**Table 6.41A: Parameters of the BS transmitted signal for 1,28 Mcps TDD - 64QAM capable BS**

| Parameter                                       | Value/description   |
|---|---|
| TDD Duty Cycle                                  | TS $i$ ; $i = 0, 1, 2, \dots, 6$ :<br>transmit, if $i$ is 0,4,5,6;<br>receive, if $i$ is 1,2,3. |
| Time slots under test                           | TS4, TS5 and TS6  |
| HS-PDSCH modulation                             | 64QAM   |
| BS output power setting                         | PRAT  |
| Number of HS-PDSCH in each time slot under test | 10  |
| Power of each HS-PDSCH                          | 1/10 of Base Station output power   |
| Data content of HS-PDSCH                        | real life (sufficient irregular)  |
| Spreading factor                                | 16  |

#### 6.8.3.4.2 Procedure

Measure the Relative code domain error by applying the global in-channel Tx test method described in Annex C.

### 6.8.3.5 Test Requirements

NOTE: If the Test Requirement below differs from the Minimum Requirement, then the Test Tolerance applied for this test is non-zero. The Test Tolerance for this test is defined in subclause 5.1.1 and the explanation of how the Minimum Requirement has been relaxed by the Test Tolerance is given in Annex D.

The Relative code domain error measured according to subclause 6.8.3.4.2 shall not exceed -20.9 dB.

## 6.8.4 Time alignment error in MIMO transmission

### 6.8.4.1 Definition and applicability

In MIMO transmission, signals are transmitted from two or more antennas. These signals shall be aligned. The time alignment error in MIMO transmission is specified as the delay between the signals from two antennas at the antenna ports.

This test is only applicable for Node B supporting MIMO transmission.

### 6.8.4.2 Minimum requirement

The time alignment error in MIMO for any possible configuration of two transmit antennas shall not exceed 65 ns.

The normative reference for this requirement is TS 25.105 [1] subclause 6.8.5.1.

### 6.8.4.3 Test Purpose

It is the purpose of this test to verify that the timing alignment error in MIMO is within the limit specified in 6.8.4.2.

### 6.8.4.4 Method of test

#### 6.8.4.4.1 Initial conditions

For 1,28 Mcps BS supporting MIMO transmission, the time alignment error shall be tested with the general test set up specified in section 6.8.4.4.1.1.

##### 6.8.4.4.1.0 General test conditions

Test environment: normal; see subclause 5.9.1.

RF channels to be tested: Middle; see subclause 5.3.

##### 6.8.4.4.1.1 1.28 Mcps TDD option- General test set up

- 1) Connect two base station RF antenna ports to the measurement equipment as shown in Figure 6.6. If available terminate the other unused antenna ports.

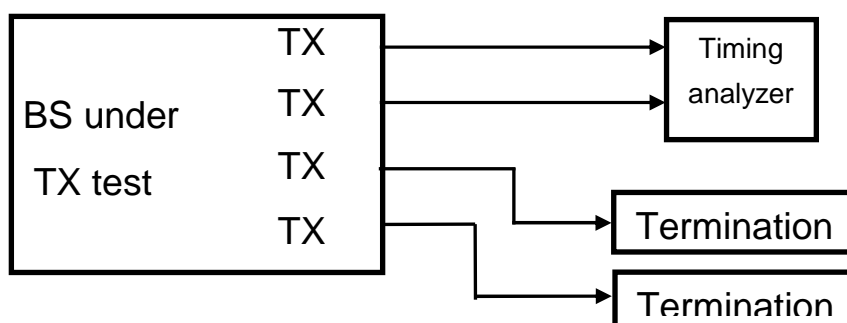


Figure 6.6: Measuring system Set-up for Test of Time alignment error

- 2) Set the base station to transmit P-CCPCH and DwPTS using all the antennas. Set the parameters of the BS transmitted signal according to table 6.42.

**Table 6.42: Parameters of the BS transmitted signal for 1,28 Mcps TDD**

| Parameter               | Value/description   |
|-------------------------|---|
| TDD Duty Cycle          | TS $i$ ; $i = 0, 1, 2, \dots, 6$ :<br>transmit, if $i$ is 0,4,5,6;<br>receive, if $i$ is 1,2,3. |
| Time slots under test   | TS0 and DwPTS   |
| BS output power setting | PRAT  |
| Spreading factor        | 16  |

- 3) Set BS frequency.

#### 6.8.4.4.2 Procedure

##### 6.8.4.4.2.1 1.28 Mcps TDD option

- 1) Start BS transmission at the manufacturer"s specified maximum output power.
- 2) Measure the time alignment error between the P-CCPCH and DwPTS on the antenna ports under test.
- 3) Repeat the measurement for any other possible configuration of 2 transmit antennas.

#### 6.8.4.5 Test Requirements

NOTE: If the Test Requirement below differs from the Minimum Requirement, then the Test Tolerance applied for this test is non-zero. The Test Tolerance for this test is defined in subclause 5.11 and the explanation of how the Minimum Requirement has been relaxed by the Test Tolerance is given in Annex D.

##### 6.8.4.5.1 1.28 Mcps TDD option

The time alignment error shall be less than  $65+[78]ns$ .

## 7 Receiver characteristics

### 7.1 General

The requirements in clause 7 are expressed for a single receiver antenna connector. For receivers with antenna diversity, the requirements apply for each receiver antenna connector.

All tests unless otherwise stated in this subclause shall be conducted on Base Station Systems fitted with a full complement of Transceivers for the configuration. The manufacturer shall provide appropriate logical or physical test access to perform all tests in this subclause. Measurements shall include any RX multicoupler.

In all the relevant subclauses in this clause all Bit Error Ratio (BER), Residual BER (RBER) and Frame Erasure Ratio (FER) measurements shall be carried out according to the general rules for statistical testing defined in ITU-T Recommendation O.153 [10] and Annex F.

Unless otherwise stated, all tests in this clause shall be performed at the BS antenna connector (test port A). If any external apparatus such as a RX amplifier, a filter or the combination of such devices is used, the tests according to subclauses 5.14.4 shall be performed to ensure that the requirements are met at test port B.

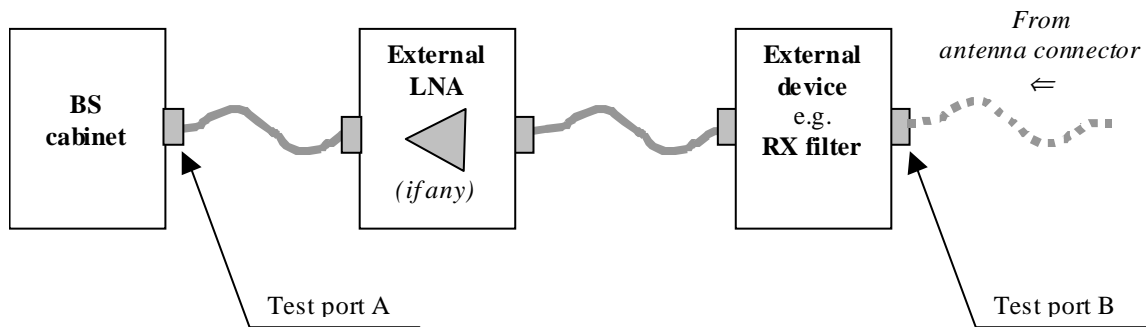


Figure 7.1: Receiver test ports

## 7.2 Reference sensitivity level

### 7.2.1 Definition and applicability

The reference sensitivity level is the minimum mean power received at the antenna connector at which the BER shall not exceed the specific value.

In this subclause, different requirements shall apply to Wide Area BS and Local Area BS.

### 7.2.2 Minimum Requirements

#### 7.2.2.1 3,84 Mcps TDD option

Using the reference measurement channel specified in Annex A.2.1, the reference sensitivity level and performance of the BS shall be as specified in table 7.1.

Table 7.1: Minimum Requirements for BS reference sensitivity level

| BS class      | Reference measurement channel data rate | BS reference sensitivity level | BER                        |
|---------------|---|--------------------------------|----------------------------|
| Wide Area BS  | 12,2 kbps                               | -109 dBm                       | BER shall not exceed 0,001 |
| Local Area BS | 12,2 kbps                               | -95 dBm                        | BER shall not exceed 0,001 |

The normative reference for this requirement is TS 25.105 [1] subclause 7.2.1.1.

#### 7.2.2.2 1,28 Mcps option

Using the reference measurement channel specified in Annex A.2.1.2, the reference sensitivity level and performance of the BS shall be as specified in table 7.1A.

Table 7.1A: Minimum Requirements for BS reference sensitivity level (1,28 Mcps option)

| BS class      | Reference measurement channel data rate | BS reference sensitivity level | BER                        |
|---------------|---|--------------------------------|----------------------------|
| Wide Area BS  | 12,2 kbps                               | -110 dBm                       | BER shall not exceed 0,001 |
| Local Area BS | 12,2 kbps                               | -96 dBm                        | BER shall not exceed 0,001 |

The normative reference for this requirement is TS 25.105 [1] subclause 7.2.1.2.



### 7.2.2.3 7,68 Mcps TDD option

Using the reference measurement channel specified in Annex A.2.1, the reference sensitivity level and performance of the BS shall be as specified in table 7.1B.

**Table 7.1B: Minimum Requirements for BS reference sensitivity level**

| BS class      | Reference measurement channel data rate | BS reference sensitivity level | BER                        |
|---------------|---|--------------------------------|----------------------------|
| Wide Area BS  | 12,2 kbps                               | -109 dBm                       | BER shall not exceed 0,001 |
| Local Area BS | 12,2 kbps                               | -95 dBm                        | BER shall not exceed 0,001 |

The normative reference for this requirement is TS 25.105 [1] subclause 7.2.1.3.

## 7.2.3 Test purpose

The test purpose is to verify the ability of the BS to receive a prescribed single-code test signal of minimum input power under defined conditions (no interference, no multipath propagation) with a BER not exceeding a specified limit. This test is also used as a reference case for other tests to allow the assessment of degradations due to various sources of interference.

## 7.2.4 Method of test

### 7.2.4.1 Initial conditions

#### 7.2.4.1.0 General test requirements

Test environment: normal; see subclause 5.9.1.

RF channels to be tested: B, M and T; see subclause 5.3.

The following additional test shall be performed:

On each of B, M and T, the test shall be performed under extreme power supply as defined in subclause 5.9.4.

NOTE: Tests under extreme power supply also test extreme temperature.

#### 7.2.4.1.1 3,84 Mcps TDD option

- (1) Connect the BS tester (UE simulator) to the antenna connector of one BS Rx port.
- (2) Terminate or disable any other BS Rx port not under test.
- (3) Start transmission from the BS tester to the BS using the UL reference measurement channel (12.2 kbps) defined in Annex A.2.1.
- (4) The level of the BS tester output signal measured at the BS antenna connector shall be adjusted to the Test Requirement for the BS reference sensitivity level specified in table 7.2.

#### 7.2.4.1.2 1,28 Mcps TDD option

- (1) Connect the BS tester (UE simulator) to the antenna connector of one BS Rx port.
- (2) Terminate or disable any other BS Rx port not under test.
- (3) Start transmission from the BS tester to the BS using the UL reference measurement channel (12.2 kbps) defined in Annex A.2.1.
- (4) The level of BS tester output signal measured at the BS antenna connector shall be adjusted to -110 dBm.

### 7.2.4.1.3 7,68 Mcps TDD option

- (1) Connect the BS tester (UE simulator) to the antenna connector of one BS Rx port.
- (2) Terminate or disable any other BS Rx port not under test.
- (3) Start transmission from the BS tester to the BS using the UL reference measurement channel (12.2 kbps) defined in Annex A.2.1.
- (4) The level of the BS tester output signal measured at the BS antenna connector shall be adjusted to the Test Requirement for the BS reference sensitivity level specified in table 7.2B.

### 7.2.4.2 Procedure

- (1) Calculate BER according to annex F.
- (2) Set the test signal mean power as specified in table 7.1A.
- (3) Measure BER.
- (4) Interchange the connections of the BS Rx ports and repeat the measurement according to (1).

## 7.2.5 Test Requirements

NOTE: If the Test Requirements below differ from the Minimum Requirements, then the Test Tolerance applied for this test is non-zero. The Test Tolerance for this test is defined in subclause 5.11 and the explanation of how the Minimum Requirement has been relaxed by the Test Tolerance is given in Annex D.

### 7.2.5.1 3,84 Mcps TDD option

For any BS Rx port tested, the measured BER at the Test Requirement of the BS reference sensitivity level specified in table 7.2 shall not exceed 0,001.

**Table 7.2: Test Requirement for BS reference sensitivity level**

| BS class      | Reference measurement channel data rate | BS reference sensitivity level | BER                        |
|---------------|---|--------------------------------|----------------------------|
| Wide Area BS  | 12,2 kbps                               | -108,3 dBm                     | BER shall not exceed 0,001 |
| Local Area BS | 12,2 kbps                               | -94,3 dBm                      | BER shall not exceed 0,001 |

### 7.2.5.2 1,28 Mcps TDD option

For any BS Rx port tested, the measured BER at the Test Requirement of the BS reference sensitivity level specified in table 7.2A shall not exceed 0,001.

**Table 7.2A: Test Requirement for BS reference sensitivity level for 1,28 Mcps option**

| BS class      | Reference measurement channel data rate | BS reference sensitivity level | BER                        |
|---------------|---|--------------------------------|----------------------------|
| Wide Area BS  | 12,2 kbps                               | -109,3 dBm                     | BER shall not exceed 0,001 |
| Local Area BS | 12,2 kbps                               | -95,3 dBm                      | BER shall not exceed 0,001 |

### 7.2.5.3 7,68 Mcps TDD option

For any BS Rx port tested, the measured BER at the Test Requirement of the BS reference sensitivity level specified in table 7.2B shall not exceed 0,001.

**Table 7.2B: Test Requirement for BS reference sensitivity level**

| BS class      | Reference measurement channel data rate | BS reference sensitivity level | BER                        |
|---------------|---|--------------------------------|----------------------------|
| Wide Area BS  | 12,2 kbps                               | -108,3 dBm                     | BER shall not exceed 0,001 |
| Local Area BS | 12,2 kbps                               | -94,3 dBm                      | BER shall not exceed 0,001 |

## 7.3 Dynamic range

### 7.3.1 Definition and applicability

Receiver dynamic range is the receiver ability to handle a rise of interference in the reception frequency channel. The receiver shall fulfil a specified BER requirement for a specified sensitivity degradation of the wanted signal in the presence of an interfering AWGN signal in the same reception frequency channel.

In this subclause, different requirements shall apply to Wide Area BS and Local Area BS.

### 7.3.2 Minimum Requirements

#### 7.3.2.1 3,84 Mcps TDD option

The BER shall not exceed 0,001 for the parameters specified in table 7.3.

**Table 7.3: Minimum Requirements for Dynamic Range**

| Parameter                               |               | Level | Unit         |
|---|---------------|-------|--------------|
| Reference measurement channel data rate |               | 12,2  | kbit/s       |
| Wanted signal mean power                | Wide Area BS  | -79   | dBm          |
|   | Local Area BS | -65   | dBm          |
| Interfering AWGN signal                 | Wide Area BS  | -73   | dBm/3,84 MHz |
|   | Local Area BS | -59   | dBm/3,84 MHz |

The normative reference for this requirement is TS 25.105 [1] subclause 7.3.1.1.

#### 7.3.2.2 1,28 Mcps TDD option

The BER shall not exceed 0,001 for the parameters specified in table 7.3A.

**Table 7.3A: Minimum Requirements for Dynamic Range for 1,28 Mcps TDD**

| Parameter                               |               | Level | Unit         |
|---|---------------|-------|--------------|
| Reference measurement channel data rate |               | 12,2  | kbit/s       |
| Wanted signal mean power                | Wide Area BS  | -80   | dBm          |
|   | Local Area BS | -66   | dBm          |
| Interfering AWGN signal                 | Wide Area BS  | -76   | dBm/1,28 MHz |
|   | Local Area BS | -62   | dBm/1,28 MHz |

The normative reference for this requirement is TS 25.105 [1] subclause 7.3.1.2.

#### 7.3.2.3 7,68 Mcps TDD option

The BER shall not exceed 0,001 for the parameters specified in table 7.3B.

**Table 7.3B: Minimum Requirements for Dynamic Range**

| Parameter                               |               | Level | Unit         |
|---|---------------|-------|--------------|
| Reference measurement channel data rate |               | 12,2  | kbit/s       |
| Wanted signal mean power                | Wide Area BS  | -79   | dBm          |
|   | Local Area BS | -65   | dBm          |
| Interfering AWGN signal                 | Wide Area BS  | -70   | dBm/7,68 MHz |
|   | Local Area BS | -56   | dBm/7,68 MHz |

The normative reference for this requirement is TS 25.105 [1] subclause 7.3.1.3.

### 7.3.3 Test purpose

The test purpose is to verify the ability of the BS to receive a prescribed single-code test signal of maximum input power under defined conditions (specified interference, no multipath) with a BER not exceeding a specified limit.

### 7.3.4 Method of test

#### 7.3.4.1 Initial conditions

##### 7.3.4.1.0 General test conditions

Test environment: normal; see subclause 5.9.1.

RF channels to be tested: B, M and T; see subclause 5.3.

##### 7.3.4.1.1 3,84 Mcps TDD option

- (1) Connect the BS tester (UE simulator), generating the wanted signal, and a band-limited white noise source, generating the interfering AWGN signal, to the antenna connector of one BS Rx port.
- (2) Terminate or disable any other BS Rx port not under test.
- (3) Start transmission from the BS tester to the BS using the UL reference measurement channel (12,2 kbps) defined in Annex A.2.1.
- (4) The level of the BS tester output signal measured at the BS antenna connector shall be adjusted as specified in table 7.4.
- (5) The power spectral density of the band-limited white noise source measured at the BS antenna connector shall be adjusted as specified in table 7.4. The characteristics of the white noise source shall comply with the AWGN interferer definition in subclause 5.18

##### 7.3.4.1.2 1,28 Mcps TDD option

- (1) Connect the BS tester (UE simulator), generating the wanted signal, and a band-limited white noise source, generating the interfering AWGN signal, to the antenna connector of one BS Rx port.
- (2) Terminate or disable any other BS Rx port not under test.
- (3) Start transmission from the BS tester to the BS using the UL reference measurement channel (12,2 kbps) defined in Annex A.2.1.
- (4) The level of the BS tester output signal measured at the BS antenna connector shall be adjusted as specified in table 7.3A.
- (5) The power spectral density of the band-limited white noise source measured at the BS antenna connector shall be adjusted as specified in table 7.3A. The characteristics of the white noise source shall comply with the AWGN interferer definition in subclause 5.18.

### 7.3.4.1.3 7,68 Mcps TDD option

- (1) Connect the BS tester (UE simulator), generating the wanted signal, and a band-limited white noise source, generating the interfering AWGN signal, to the antenna connector of one BS Rx port.
- (2) Terminate or disable any other BS Rx port not under test.
- (3) Start transmission from the BS tester to the BS using the UL reference measurement channel (12,2 kbps) defined in Annex A.2.1.
- (4) The level of the BS tester output signal measured at the BS antenna connector shall be adjusted as specified in table 7.4B.
- (5) The power spectral density of the band-limited white noise source measured at the BS antenna connector shall be adjusted as specified in table 7.4B. The characteristics of the white noise source shall comply with the AWGN interferer definition in subclause 5.18

### 7.3.4.2 Procedure

- (1) Measure the BER by comparing the bit sequence of the information data transmitted by the BS tester with the bit sequence obtained from the BS receiver.
- (2) Interchange the connections of the BS Rx ports and repeat the measurement according to (1)

## 7.3.5 Test Requirements

NOTE: If the Test Requirement below differs from the Minimum Requirement, then the Test Tolerance applied for this test is non-zero. The Test Tolerance for this test is defined in subclause 5.11 and the explanation of how the Minimum Requirement has been relaxed by the Test Tolerance is given in Annex D.

### 7.3.5.1 3,84 Mcps TDD option

For any BS Rx port tested, the measured BER shall not exceed 0,001 for the parameters specified in table 7.4.

**Table 7.4: Test Requirements for Dynamic Range**

| Parameter                               |               | Level | Unit         |
|---|---------------|-------|--------------|
| Reference measurement channel data rate |               | 12,2  | kbit/s       |
| Wanted signal mean power                | Wide Area BS  | -77,8 | dBm          |
|   | Local Area BS | -63,8 | dBm          |
| Interfering AWGN signal                 | Wide Area BS  | -73   | dBm/3,84 MHz |
|   | Local Area BS | -59   | dBm/3,84 MHz |

### 7.3.5.2 1,28 Mcps TDD option

For any BS Rx port tested, the measured BER shall not exceed 0,001 for the parameters specified in table 7.4A.

**Table 7.4A: Test Requirements for Dynamic Range for 1,28 Mcps TDD option**

| Parameter                               |               | Level | Unit         |
|---|---------------|-------|--------------|
| Reference measurement channel data rate |               | 12,2  | kbit/s       |
| Wanted signal mean power                | Wide Area BS  | -79,8 | dBm          |
|   | Local Area BS | -65,8 | dBm          |
| Interfering AWGN signal                 | Wide Area BS  | -76   | dBm/1,28 MHz |
|   | Local Area BS | -62   | dBm/1,28 MHz |

### 7.3.5.3 7,68 Mcps TDD option

For any BS Rx port tested, the measured BER shall not exceed 0,001 for the parameters specified in table 7.4B.

**Table 7.4B: Test Requirements for Dynamic Range**

| Parameter                               |               | Level | Unit         |
|---|---------------|-------|--------------|
| Reference measurement channel data rate |               | 12,2  | kbit/s       |
| Wanted signal mean power                | Wide Area BS  | -77,8 | dBm          |
|   | Local Area BS | -63,8 | dBm          |
| Interfering AWGN signal                 | Wide Area BS  | -70   | dBm/7,68 MHz |
|   | Local Area BS | -56   | dBm/7,68 MHz |

## 7.4 Adjacent Channel Selectivity (ACS)

### 7.4.1 Definition and applicability

Adjacent channel selectivity (ACS) is a measure of the receiver ability to receive a wanted signal at its assigned channel frequency in the presence of a single code CDMA modulated adjacent channel signal at a given frequency offset from the center frequency of the assigned channel.

In this subclause, different requirements shall apply to Wide Area BS and Local Area BS.

### 7.4.2 Minimum Requirements

#### 7.4.2.1 3,84 Mcps TDD option

The BER, measured on the wanted signal in the presence of an interfering signal, shall not exceed 0,001 for the parameters specified in table 7.5.

**Table 7.5: Parameters of the wanted signal and the interfering signal for ACS testing**

| Parameter   |               | Level | Unit   |
|---|---------------|-------|--------|
| Reference measurement channel data rate   |               | 12,2  | kbit/s |
| Wanted signal mean power  | Wide Area BS  | -103  | dBm    |
|   | Local Area BS | -89   | dBm    |
| Interfering signal mean power   | Wide Area BS  | -52   | dBm    |
|   | Local Area BS | -38   | dBm    |
| F <sub>w</sub> (modulated)  |               | 5     | MHz    |
| NOTE: F <sub>w</sub> is the frequency offset of the unwanted interfering signal from the assigned channel frequency of the wanted signal. |               |       |        |

The normative reference for this requirement is TS 25.105 [1] subclause 7.4.1.1.

#### 7.4.2.2 1,28 Mcps TDD option

The BER, measured on the wanted signal in the presence of an interfering signal, shall not exceed 0,001 for the parameters specified in table 7.5A.

**Table 7.5A: Parameters of the wanted signal and the interfering signal for ACS testing for 1,28 Mcps TDD**

| Parameter  |               | Level | Unit   |
|--|---------------|-------|--------|
| Reference measurement channel data rate  |               | 12,2  | kbit/s |
| Wanted signal mean power   | Wide Area BS  | -104  | dBm    |
|  | Local Area BS | -90   | dBm    |
| Interfering signal mean power  | Wide Area BS  | -55   | dBm    |
|  | Local Area BS | -41   | dBm    |
| Fuw (modulated)  |               | 1,6   | MHz    |
| NOTE: Fuw is the frequency offset of the unwanted interfering signal from the assigned channel frequency of the wanted signal. |               |       |        |

The normative reference for this requirement is TS 25.105 [1] subclause 7.4.1.2.

### 7.4.2.3 7,68 Mcps TDD option

The BER, measured on the wanted signal in the presence of an interfering signal, shall not exceed 0,001 for the parameters specified in table 7.5B.

**Table 7.5B: Parameters of the wanted signal and the interfering signal for ACS testing**

| Parameter  |               | Level | Unit   |
|--|---------------|-------|--------|
| Reference measurement channel data rate  |               | 12,2  | kbit/s |
| Wanted signal mean power   | Wide Area BS  | -103  | dBm    |
|  | Local Area BS | -89   | dBm    |
| Interfering signal mean power  | Wide Area BS  | -49   | dBm    |
|  | Local Area BS | -35   | dBm    |
| Fuw (modulated)  |               | 10    | MHz    |
| NOTE: Fuw is the frequency offset of the unwanted interfering signal from the assigned channel frequency of the wanted signal. |               |       |        |

The normative reference for this requirement is TS 25.105 [1] subclause 7.4.1.3.

## 7.4.3 Test purpose

The test purpose is to verify the ability of the BS receiver filter to sufficiently suppress interfering signals in the channels adjacent to the wanted channel.

## 7.4.4 Method of test

### 7.4.4.1 Initial conditions

#### 7.4.4.1.0 General test conditions

Test environment: normal; see subclause 5.9.1.

RF channels to be tested: B, M and T; see subclause 5.3.

#### 7.4.4.1.1 3,84 Mcps TDD option

- (1) Connect an UE simulator operating at the assigned channel frequency of the wanted signal and a signal generator used to produce the interfering signal in the adjacent channel to the antenna connector of one Rx port.
- (2) Terminate or disable any other Rx port not under test.

- (3) Start transmission from the BS tester to the BS using the UL reference measurement channel (12,2 kbps) defined in Annex A.2.1. The level of the UE simulator signal measured at the BS antenna connector shall be adjusted to the value specified in table 7.5.
- (4) Set the signal generator to produce an interfering signal that is equivalent to a continuous wideband CDMA signal with one code of chip frequency 3,84 Mchip/s, filtered by an RRC transmit pulse-shaping filter with roll-off  $\alpha = 0,22$ . The mean power level of the interfering signal measured at the BS antenna connector shall be adjusted to the value specified in table 7.5.

#### 7.4.4.1.2 1,28 Mcps TDD option

- (1) Connect an UE simulator operating at the assigned channel frequency of the wanted signal and a signal generator used to produce the interfering signal in the adjacent channel to the antenna connector of one Rx port.
- (2) Terminate or disable any other Rx port not under test.
- (3) Start transmission from the BS tester to the BS using the UL reference measurement channel (12,2 kbps) defined in Annex A.2.1. The level of the UE simulator signal measured at the BS antenna connector shall be adjusted to the value specified in table 7.5A.
- (4) Set the signal generator to produce an interfering signal that is equivalent to a continuous wideband CDMA signal with one code of chip frequency 1,28 Mchip/s, filtered by an RRC transmit pulse-shaping filter with roll-off  $\alpha = 0,22$ . The mean power level of the interfering signal measured at the BS antenna connector shall be adjusted to the value specified in table 7.5A.

#### 7.4.4.1.3 7,68 Mcps TDD option

- (1) Connect an UE simulator operating at the assigned channel frequency of the wanted signal and a signal generator used to produce the interfering signal in the adjacent channel to the antenna connector of one Rx port.
- (2) Terminate or disable any other Rx port not under test.
- (3) Start transmission from the BS tester to the BS using the UL reference measurement channel (12,2 kbps) defined in Annex A.2.1. The level of the UE simulator signal measured at the BS antenna connector shall be adjusted to the value specified in table 7.5B.
- (4) Set the signal generator to produce an interfering signal that is equivalent to a continuous wideband CDMA signal with one code of chip frequency 7,68 Mchip/s, filtered by an RRC transmit pulse-shaping filter with roll-off  $\alpha = 0,22$ . The mean power level of the interfering signal measured at the BS antenna connector shall be adjusted to the value specified in table 7.5B.

### 7.4.4.2 Procedure

#### 7.4.4.2.1 3,84 Mcps TDD option

- (1) Set the center frequency of the interfering signal to 5 MHz above the assigned channel frequency of the wanted signal.
- (2) Measure the BER of the wanted signal at the BS receiver.
- (3) Set the center frequency of the interfering signal to 5 MHz below the assigned channel frequency of the wanted signal.
- (4) Measure the BER of the wanted signal at the BS receiver.
- (5) Interchange the connections of the BS Rx ports and repeat the measurements according to steps (1) to (4).

#### 7.4.4.2.2 1,28 Mcps TDD option

- (1) Set the center frequency of the interfering signal to 1,6 MHz above the assigned channel frequency of the wanted signal.
- (2) Measure the BER of the wanted signal at the BS receiver.



- (3) Set the center frequency of the interfering signal to 1,6 MHz below the assigned channel frequency of the wanted signal.
- (4) Measure the BER of the wanted signal at the BS receiver.
- (5) Interchange the connections of the BS Rx ports and repeat the measurements according to steps (1) to (4).

#### 7.4.4.2.3 7,68 Mcps TDD option

- (1) Set the center frequency of the interfering signal to 10 MHz above the assigned channel frequency of the wanted signal.
- (2) Measure the BER of the wanted signal at the BS receiver.
- (3) Set the center frequency of the interfering signal to 10 MHz below the assigned channel frequency of the wanted signal.
- (4) Measure the BER of the wanted signal at the BS receiver.
- (5) Interchange the connections of the BS Rx ports and repeat the measurements according to steps (1) to (4).

### 7.4.5 Test Requirements

NOTE: If the Test Requirement below differs from the Minimum Requirement, then the Test Tolerance applied for this test is non-zero. The Test Tolerance for this test is defined in subclause 5.11 and the explanation of how the Minimum Requirement has been relaxed by the Test Tolerance is given in Annex D.

The BER measured according to subclause 7.4.4.2 shall not exceed 0,001.

## 7.5 Blocking characteristics

### 7.5.1 Definition and applicability

#### 7.5.1.1 3,84 Mcps TDD option

The blocking characteristics is a measure of the receiver ability to receive a wanted signal at its assigned channel frequency in the presence of an unwanted interferer on frequencies other than those of the adjacent channels. The blocking performance requirements apply to interfering signals with center frequency within the ranges specified in tables 7.6-1, 7.7-1, 7.8-1, 7.9-1, 7.6-2, 7.7-2, 7.8-2, 7.9-2, 7.9 and 7.10 respectively, using a 1 MHz step size.

In this subclause, different requirements shall apply to Wide Area BS and Local Area BS. The requirements in tables 7.6-1, 7.7-1, 7.8-1, 7.9-1 apply to Wide Area BS, and the requirements in tables 7.6-2, 7.7-2, 7.8-2 or 7.9-2 apply to Local Area BS, depending on which frequency band is used. The additional requirements in Tables 7.9 and 7.10 may be applied for the protection of TDD BS receivers when GSM900 and/or DCS1800 BTS are co-located with UTRA TDD Wide Area BS.

#### 7.5.1.2 1,28 Mcps TDD option

The blocking characteristics is a measure of the receiver ability to receive a wanted signal at its assigned channel frequency in the presence of an unwanted interferer on frequencies other than those of the adjacent channels. The blocking performance requirements apply to interfering signals with center frequency within the ranges specified in tables 7.6A-1, 7.7A-1, 7.8A-1, 7.8B-1, 7.8C-1, 7.6A-2, 7.7A-2, 7.8A-2, 7.8B-2, 7.8C-2, 7.9A and 7.10A respectively, using a 1 MHz step size.

In this subclause, different requirements apply to Wide Area BS and Local Area BS. The requirements in tables 7.6A-1, 7.7A-1, 7.8A-1, 7.8B-1 or 7.8C-1 apply to Wide Area BS, and the requirements in tables 7.6A-2, 7.7A-2, 7.8A-2, 7.8B-2 or 7.8C-2 apply to Local Area BS, depending on which frequency band is used. The additional requirements in Tables 7.9A and 7.10A may be applied for the protection of TDD BS receivers when GSM900 and/or DCS1800 BTS are co-located with UTRA TDD Wide Area BS.

### 7.5.1.3 7,68 Mcps TDD option

The blocking characteristics is a measure of the receiver ability to receive a wanted signal at its assigned channel frequency in the presence of an unwanted interferer on frequencies other than those of the adjacent channels. The blocking performance requirements apply to interfering signals with center frequency within the ranges specified in tables 7.6-1B, 7.7-1B, 7.8-1B, 7.6-2B, 7.7-2B, 7.8-2B, 7.9B and 7.10F respectively, using a 1 MHz step size.

In this subclause, different requirements shall apply to Wide Area BS and Local Area BS. The requirements in tables 7.6-1B, 7.7-1B or 7.8-1B apply to Wide Area BS, and the requirements in tables 7.6-2B, 7.7-2B or 7.8-2B apply to Local Area BS, depending on which frequency band is used. The additional requirements in Tables 7.9B and 7.10F may be applied for the protection of TDD BS receivers when GSM900 and/or DCS1800 BTS are co-located with UTRA TDD Wide Area BS.

## 7.5.2 Minimum Requirements

### 7.5.2.1 3,84 Mcps TDD option

#### 7.5.2.1.1 General requirements

The static reference performance as specified in clause 7.2 shall be met with a wanted and an interfering signal coupled to the BS antenna input using the parameters specified in tables 7.6-1, 7.7-1, 7.8-1, 7.9-1, 7.6-2, 7.7-2, 7.8-2 or 7.9-2, respectively.

**Table 7.6-1: Blocking requirements for Wide Area BS in operating bands defined in subclause 4.2 a)**

| Center frequency of interfering signal                  | Interfering signal mean power | Wanted signal mean power | Minimum offset of interfering signal | Type of interfering signal |
|---|-------------------------------|--------------------------|--------------------------------------|----------------------------|
| 1900 - 1920 MHz,<br>2010 - 2025 MHz                     | -40 dBm                       | -103 dBm                 | 10 MHz                               | WCDMA signal with one code |
| 1880 - 1900 MHz,<br>1990 - 2010 MHz,<br>2025 - 2045 MHz | -40 dBm                       | -103 dBm                 | 10 MHz                               | WCDMA signal with one code |
| 1920 - 1980 MHz   | -40 dBm                       | -103 dBm                 | 10 MHz                               | WCDMA signal with one code |
| 1 - 1880 MHz,<br>1980 - 1990 MHz,<br>2045 - 12750 MHz   | -15 dBm                       | -103 dBm                 | —                                    | CW carrier                 |

**Table 7.7-1: Blocking requirements for Wide Area BS in operating bands defined in subclause 4.2 b)**

| Center frequency of interfering signal | Interfering signal mean power | Wanted signal mean power | Minimum offset of interfering signal | Type of interfering signal |
|--|-------------------------------|--------------------------|--------------------------------------|----------------------------|
| 1850 - 1990 MHz                        | -40 dBm                       | -103 dBm                 | 10 MHz                               | WCDMA signal with one code |
| 1830 - 1850 MHz,<br>1990 - 2010 MHz    | -40 dBm                       | -103 dBm                 | 10 MHz                               | WCDMA signal with one code |
| 1 - 1830 MHz,<br>2010 - 12750 MHz      | -15 dBm                       | -103 dBm                 | —                                    | CW carrier                 |

**Table 7.8-1: Blocking requirements for Wide Area BS in operating bands defined in subclause 4.2 c)**

| Center frequency of interfering signal | Interfering signal mean power | Wanted signal mean power | Minimum offset of interfering signal | Type of interfering signal |
|--|-------------------------------|--------------------------|--------------------------------------|----------------------------|
| 1910 - 1930 MHz                        | -40 dBm                       | -103 dBm                 | 10 MHz                               | WCDMA signal with one code |
| 1890 - 1910 MHz,<br>1930 - 1950 MHz    | -40 dBm                       | -103 dBm                 | 10 MHz                               | WCDMA signal with one code |
| 1 - 1890 MHz,<br>1950 - 12750 MHz      | -15 dBm                       | -103 dBm                 | —                                    | CW carrier                 |

**Table 7.9-1: Blocking requirements for Wide Area BS in operating bands defined in subclause 4.2 d)**

| Center frequency of interfering signal | Interfering signal mean power | Wanted signal mean power | Minimum offset of interfering signal | Type of interfering signal |
|--|-------------------------------|--------------------------|--------------------------------------|----------------------------|
| 2570 - 2620 MHz                        | -40 dBm                       | -103 dBm                 | 10 MHz                               | WCDMA signal with one code |
| 2550 - 2570 MHz<br>2620 - 2640 MHz     | -40 dBm                       | -103 dBm                 | 10 MHz                               | WCDMA signal with one code |
| 2500 - 2570 MHz<br>2620 - 2690 MHz     | -40 dBm                       | -103 dBm                 | 10 MHz                               | WCDMA signal with one code |
| 1 - 2550 MHz,<br>2690 - 12750 MHz      | -15 dBm                       | -103 dBm                 | —                                    | CW carrier                 |

**Table 7.6-2: Blocking requirements for Local Area BS in operating bands defined in subclause 4.2 a)**

| Center frequency of interfering signal                  | Interfering signal level | Wanted signal level | Minimum offset of interfering signal | Type of interfering signal |
|---|--------------------------|---------------------|--------------------------------------|----------------------------|
| 1900 - 1920 MHz,<br>2010 - 2025 MHz                     | -30 dBm                  | <REFSENS> + 6 dB    | 10 MHz                               | WCDMA signal with one code |
| 1880 - 1900 MHz,<br>1990 - 2010 MHz,<br>2025 - 2045 MHz | -30 dBm                  | <REFSENS> + 6 dB    | 10 MHz                               | WCDMA signal with one code |
| 1920 - 1980 MHz   | -30 dBm                  | <REFSENS> + 6 dB    | 10 MHz                               | WCDMA signal with one code |
| 1 - 1880 MHz,<br>1980 - 1990 MHz,<br>2045 - 12750 MHz   | -15 dBm                  | <REFSENS> + 6 dB    | —                                    | CW carrier                 |

**Table 7.7-2: Blocking requirements for Local Area BS in operating bands defined in subclause 4.2 b)**

| Center frequency of interfering signal | Interfering signal level | Wanted signal level | Minimum offset of interfering signal | Type of interfering signal |
|--|--------------------------|---------------------|--------------------------------------|----------------------------|
| 1850 - 1990 MHz                        | -30 dBm                  | <REFSENS> + 6 dB    | 10 MHz                               | WCDMA signal with one code |
| 1830 - 1850 MHz,<br>1990 - 2010 MHz    | -30 dBm                  | <REFSENS> + 6 dB    | 10 MHz                               | WCDMA signal with one code |
| 1 - 1830 MHz,<br>2010 - 12750 MHz      | -15 dBm                  | <REFSENS> + 6 dB    | —                                    | CW carrier                 |

**Table 7.8-2: Blocking requirements for Local Area BS in operating bands defined in subclause 4.2 c)**

| Center frequency of interfering signal | Interfering signal level | Wanted signal level | Minimum offset of interfering signal | Type of interfering signal |
|--|--------------------------|---------------------|--------------------------------------|----------------------------|
| 1910 - 1930 MHz                        | -30 dBm                  | <REFSENS> + 6 dB    | 10 MHz                               | WCDMA signal with one code |
| 1890 - 1910 MHz,<br>1930 - 1950 MHz    | -30 dBm                  | <REFSENS> + 6 dB    | 10 MHz                               | WCDMA signal with one code |
| 1 - 1890 MHz,<br>1950 - 12750 MHz      | -15 dBm                  | <REFSENS> + 6 dB    | —                                    | CW carrier                 |

**Table 7.9-2: Blocking requirements for Local Area BS in operating bands defined in subclause 4.2 d)**

| Center frequency of interfering signal | Interfering signal level | Wanted signal level | Minimum offset of interfering signal | Type of interfering signal |
|--|--------------------------|---------------------|--------------------------------------|----------------------------|
| 2570 - 2620 MHz                        | -30 dBm                  | <REFSENS> + 6 dB    | 10 MHz                               | WCDMA signal with one code |
| 2550 - 2570 MHz<br>2620 - 2640 MHz     | -30 dBm                  | <REFSENS> + 6 dB    | 10 MHz                               | WCDMA signal with one code |
| 2500 - 2570 MHz<br>2620 - 2690 MHz     | -30 dBm                  | <REFSENS> + 6 dB    | 10 MHz                               | WCDMA signal with one code |
| 1 - 2550 MHz,<br>2690 - 12750 MHz      | -15 dBm                  | <REFSENS> + 6 dB    | —                                    | CW carrier                 |

The normative reference for this requirement is TS 25.105 [1] subclause 7.5.0.1.

### 7.5.2.1.2 Co-location with GSM900 and/or DCS 1800

This additional blocking requirement may be applied for the protection of TDD BS receivers when GSM900 and/or DCS1800 BTS are co-located with UTRA TDD Wide Area BS.

The blocking performance requirement applies to interfering signals with center frequency within the ranges specified in the tables below, using a 1MHz step size.

In case this additional blocking requirement is applied, the static reference performance as specified in clause 7.2.1 shall be met with a wanted and an interfering signal coupled to BS antenna input using the following parameters.

**Table 7.9: Additional blocking requirements for Wide Area BS in operating bands defined in subclause 4.2 a) and 4.2 d) when co-located with GSM900**

| Center Frequency of Interfering Signal | Interfering Signal mean power | Wanted Signal mean power | Minimum Offset of Interfering Signal | Type of Interfering Signal |
|--|-------------------------------|--------------------------|--------------------------------------|----------------------------|
| 921 - 960 MHz                          | +16 dBm                       | -103 dBm                 | —                                    | CW carrier                 |

**Table 7.10: Additional blocking requirements for Wide Area BS in operating bands defined in subclause 4.2 a) and 4.2 d) when co-located with DCS1800**

| Center Frequency of Interfering Signal | Interfering Signal mean power | Wanted Signal mean power | Minimum Offset of Interfering Signal | Type of Interfering Signal |
|--|-------------------------------|--------------------------|--------------------------------------|----------------------------|
| 1805 - 1880                            | +16 dBm                       | -103 dBm                 | —                                    | CW carrier                 |

The normative reference for this requirement is TS 25.105 [1] subclause 7.5.1.1.

### 7.5.2.1.3 Co-location with UTRA-FDD and/or E-UTRA FDD

This additional blocking requirement may be applied for the protection of TDD BS receivers when UTRA-FDD and/or E-UTRA FDD are co-located with UTRA TDD Wide Area BS.

The blocking performance requirement applies to interfering signals with center frequency within the ranges specified in the tables below, using a 1MHz step size.

In case this additional blocking requirement is applied, the static reference performance as specified in clause 7.2.1 of TS25.105 shall be met with a wanted and an interfering signal coupled to BS antenna input using the following parameters.

**Table 7.10A: Additional blocking requirements for operating bands defined in 4.2(d) when co-located with UTRA-FDD and/or E-UTRA FDD WA BS**

| Centre Frequency of Interfering Signal | Interfering Signal Mean Power | Wanted Signal Mean Power | Minimum Offset of Interfering Signal | Type of Interfering Signal |
|--|-------------------------------|--------------------------|--------------------------------------|----------------------------|
| 2620 - 2690 MHz                        | +13 dBm                       | -103 dBm                 | —                                    | CW carrier                 |

**Table 7.10B: Additional blocking requirements for operating bands defined in 4.2(d) when co-located with UTRA-FDD and/or E-UTRA FDD LA BS**

| Center Frequency of Interfering Signal | Interfering Signal Mean Power | Wanted Signal Mean Power | Minimum Offset of Interfering Signal | Type of Interfering Signal |
|--|-------------------------------|--------------------------|--------------------------------------|----------------------------|
| 2620 - 2690 MHz                        | -6 dBm                        | -103 dBm                 | —                                    | CW carrier                 |

## 7.5.2.2 1,28 Mcps TDD option

## 7.5.2.2.1 General requirements

The static reference performance as specified in clause 7.2 shall be met with a wanted and an interfering signal coupled to the BS antenna input using the parameters specified in tables 7.6A-1, 7.7A-1, 7.8A-1, 7.9A-1, 7.6A-2, 7.7A-2, 7.8A-2 or 7.9A-2, respectively.

**Table 7.6A-1: Blocking requirements for Wide Area BS in operating bands defined in subclause 4.2 a) for 1,28 Mcps TDD**

| Center frequency of interfering signal                  | Interfering signal mean power | Wanted signal mean power | Minimum offset of interfering signal | Type of interfering signal         |
|---|-------------------------------|--------------------------|--------------------------------------|------------------------------------|
| 1900 - 1920 MHz,<br>2010 - 2025 MHz                     | -40 dBm                       | -104 dBm                 | 3.2 MHz                              | 1,28 Mcps TDD signal with one code |
| 1880 - 1900 MHz,<br>1990 - 2010 MHz,<br>2025 - 2045 MHz | -40 dBm                       | -104 dBm                 | 3.2 MHz                              | 1,28 Mcps TDD signal with one code |
| 1920 - 1980 MHz   | -40 dBm                       | -104 dBm                 | 3.2 MHz                              | 1,28 Mcps TDD signal with one code |
| 1 - 1880 MHz,<br>1980 - 1990 MHz,<br>2045 - 12750 MHz   | -15 dBm                       | -104 dBm                 | —                                    | CW carrier                         |

**Table 7.7A-1: Blocking requirements for Wide Area BS in operating bands defined in subclause 4.2 b) for 1,28 Mcps TDD**

| Center frequency of interfering signal | Interfering signal mean power | Wanted signal mean power | Minimum offset of interfering signal | Type of interfering signal         |
|--|-------------------------------|--------------------------|--------------------------------------|------------------------------------|
| 1850 - 1990 MHz                        | -40 dBm                       | -104 dBm                 | 3.2 MHz                              | 1,28 Mcps TDD signal with one code |
| 1830 - 1850 MHz,<br>1990 - 2010 MHz    | -40 dBm                       | -104 dBm                 | 3.2 MHz                              | 1,28 Mcps TDD signal with one code |
| 1 - 1830 MHz,<br>2010 - 12750 MHz      | -15 dBm                       | -104 dBm                 | —                                    | CW carrier                         |

**Table 7.8A-1: Blocking requirements for Wide Area BS in operating bands defined in subclause 4.2 c) for 1,28 Mcps TDD**

| Center frequency of interfering signal | Interfering signal mean power | Wanted signal mean power | Minimum offset of interfering signal | Type of interfering signal         |
|--|-------------------------------|--------------------------|--------------------------------------|------------------------------------|
| 1910 - 1930 MHz                        | -40 dBm                       | -104 dBm                 | 3.2 MHz                              | 1,28 Mcps TDD signal with one code |
| 1890 - 1910 MHz,<br>1930 - 1950 MHz    | -40 dBm                       | -104 dBm                 | 3.2 MHz                              | 1,28 Mcps TDD signal with one code |
| 1 - 1890 MHz,<br>1950 - 12750 MHz      | -15 dBm                       | -104 dBm                 | —                                    | CW carrier                         |

**Table 7.8B-1: Blocking requirements for Wide Area BS in operating bands defined in 4.2(d) for 1,28 Mcps TDD**

| Center Frequency of Interfering Signal | Interfering Signal Mean Power | Wanted Signal Mean Power | Minimum Offset of Interfering Signal | Type of Interfering Signal         |
|--|-------------------------------|--------------------------|--------------------------------------|------------------------------------|
| 2570 - 2620 MHz                        | -40dBm                        | -104 dBm                 | 3.2MHz                               | 1,28 Mcps TDD signal with one code |
| 2500 - 2570 MHz,<br>2620 - 2690 MHz    | -40dBm                        | -104 dBm                 | 3.2 MHz                              | 1,28 Mcps TDD signal with one code |
| 1 - 2500 MHz,<br>2690 - 12750 MHz      | -15 dBm                       | -104 dBm                 | —                                    | CW carrier                         |

**Table 7.8C-1: Blocking requirements for Wide Area BS in operating bands defined in 4.2(e) for 1,28 Mcps TDD**

| Center Frequency of Interfering Signal | Interfering Signal Mean Power | Wanted Signal Mean Power | Minimum Offset of Interfering Signal | Type of Interfering Signal         |
|--|-------------------------------|--------------------------|--------------------------------------|------------------------------------|
| 2300 - 2400 MHz                        | -40dBm                        | -104 dBm                 | 3.2MHz                               | 1,28 Mcps TDD signal with one code |
| 2280 - 2300 MHz,<br>2400 - 2420MHz     | -40dBm                        | -104 dBm                 | 3.2 MHz                              | 1,28 Mcps TDD signal with one code |
| 1 - 2280 MHz,<br>2420 - 12750 MHz      | -15 dBm                       | -104 dBm                 | —                                    | CW carrier                         |

**Table 7.8D-1: Blocking requirements for Wide Area BS in operating bands defined in 5.2(f) for 1.28Mcps TDD**

| Center Frequency of Interfering Signal | Interfering Signal Mean Power | Wanted Signal Mean Power | Minimum Offset of Interfering Signal | Type of Interfering Signal            |
|--|-------------------------------|--------------------------|--------------------------------------|---------------------------------------|
| 1880 - 1920 MHz                        | -40dBm                        | -104 dBm                 | 3.2 MHz                              | Narrow band CDMA signal with one code |
| 1860 - 1880 MHz,<br>1920 - 1940 MHz    | -40dBm                        | -104 dBm                 | 3.2 MHz                              | Narrow band CDMA signal with one code |
| 1 - 1860 MHz,<br>1940 - 12750 MHz      | -15 dBm                       | -104 dBm                 | —                                    | CW carrier                            |

**Table 7.6A-2: Blocking requirements for Local Area BS in operating bands defined in subclause 4.2 a) for 1,28 Mcps TDD**

| Center frequency of interfering signal                  | Interfering signal level | Wanted signal level | Minimum offset of interfering signal | Type of interfering signal         |
|---|--------------------------|---------------------|--------------------------------------|------------------------------------|
| 1900 - 1920 MHz,<br>2010 - 2025 MHz                     | -30 dBm                  | <REFSENS> + 6 dB    | 3,2 MHz                              | 1,28 Mcps TDD signal with one code |
| 1880 - 1900 MHz,<br>1990 - 2010 MHz,<br>2025 - 2045 MHz | -30 dBm                  | <REFSENS> + 6 dB    | 3,2 MHz                              | 1,28 Mcps TDD signal with one code |
| 1920 - 1980 MHz   | -30 dBm                  | <REFSENS> + 6 dB    | 3,2 MHz                              | 1,28 Mcps TDD signal with one code |
| 1 - 1880 MHz,<br>1980 - 1990 MHz,<br>2045 - 12750 MHz   | -15 dBm                  | <REFSENS> + 6 dB    | —                                    | CW carrier                         |

**Table 7.7A-2: Blocking requirements for Local Area BS in operating bands defined in subclause 4.2 b) for 1,28 Mcps TDD**

| Center frequency of interfering signal | Interfering signal level | Wanted signal level | Minimum offset of interfering signal | Type of interfering signal         |
|--|--------------------------|---------------------|--------------------------------------|------------------------------------|
| 1850 - 1990 MHz                        | -30 dBm                  | <REFSENS> + 6 dB    | 3,2 MHz                              | 1,28 Mcps TDD signal with one code |
| 1830 - 1850 MHz,<br>1990 - 2010 MHz    | -30 dBm                  | <REFSENS> + 6 dB    | 3,2 MHz                              | 1,28 Mcps TDD signal with one code |
| 1 - 1830 MHz,<br>2010 - 12750 MHz      | -15 dBm                  | <REFSENS> + 6 dB    | —                                    | CW carrier                         |

**Table 7.8A-2: Blocking requirements for Local Area BS in operating bands defined in subclause 4.2 c) for 1,28 Mcps TDD**

| Center frequency of interfering signal | Interfering signal level | Wanted signal level | Minimum offset of interfering signal | Type of interfering signal         |
|--|--------------------------|---------------------|--------------------------------------|------------------------------------|
| 1910 - 1930 MHz                        | -30 dBm                  | <REFSENS> + 6 dB    | 3,2 MHz                              | 1,28 Mcps TDD signal with one code |
| 1890 - 1910 MHz,<br>1930 - 1950 MHz    | -30 dBm                  | <REFSENS> + 6 dB    | 3,2 MHz                              | 1,28 Mcps TDD signal with one code |
| 1 - 1890 MHz,<br>1950 - 12750 MHz      | -15 dBm                  | <REFSENS> + 6 dB    | —                                    | CW carrier                         |

**Table 7.8B-2: Blocking requirements for Local Area BS in operating bands defined in 4.2(d) for 1,28 Mcps TDD**

| Center Frequency of Interfering Signal | Interfering Signal mean power | Wanted Signal mean power | Minimum Offset of Interfering Signal | Type of Interfering Signal         |
|--|-------------------------------|--------------------------|--------------------------------------|------------------------------------|
| 2570 - 2620 MHz                        | -30 dBm                       | <REFSENS> + 6 dB         | 3.2MHz                               | 1,28 Mcps TDD signal with one code |
| 2500 - 2570 MHz,<br>2620 - 2690 MHz    | -30 dBm                       | <REFSENS> + 6 dB         | 3.2 MHz                              | 1,28 Mcps TDD signal with one code |
| 1 - 2500 MHz,<br>2690 - 12750 MHz      | -15 dBm                       | <REFSENS> + 6 dB         | —                                    | CW carrier                         |

**Table 7.8C-2: Blocking requirements for Local Area BS in operating bands defined in 4.2(e) for 1,28 Mcps TDD**

| Center Frequency of Interfering Signal | Interfering Signal mean power | Wanted Signal mean power | Minimum Offset of Interfering Signal | Type of Interfering Signal         |
|--|-------------------------------|--------------------------|--------------------------------------|------------------------------------|
| 2300 - 2400 MHz                        | -30 dBm                       | <REFSENS> + 6 dB         | 3.2MHz                               | 1,28 Mcps TDD signal with one code |
| 2280 - 2300 MHz,<br>2400 - 2420MHz     | -30 dBm                       | <REFSENS> + 6 dB         | 3.2 MHz                              | 1,28 Mcps TDD signal with one code |
| 1 - 2280 MHz,<br>2420 - 12750 MHz      | -15 dBm                       | <REFSENS> + 6 dB         | —                                    | CW carrier                         |

**Table 7.8D-2: Blocking requirements for Local Area BS in operating bands defined in 5.2(f)**

| Center Frequency of Interfering Signal | Interfering Signal mean power | Wanted Signal mean power | Minimum Offset of Interfering Signal | Type of Interfering Signal            |
|--|-------------------------------|--------------------------|--------------------------------------|---------------------------------------|
| 1880-1920 MHz                          | -30 dBm                       | -90 dBm                  | 3.2 MHz                              | Narrow band CDMA signal with one code |
| 1860 - 1880 MHz,<br>1920 - 1940MHz     | -30 dBm                       | -90 dBm                  | 3.2 MHz                              | Narrow band CDMA signal with one code |
| 1 - 1860 MHz,<br>1940 – 12750 MHz      | -15 dBm                       | -90 dBm                  | —                                    | CW carrier                            |

The normative reference for this requirement is TS 25.105 [1] subclause 7.5.0.2.

#### 7.5.2.2.2 Co-location with GSM900 and/or DCS 1800

This additional blocking requirement may be applied for the protection of TDD BS receivers when GSM900 and/or DCS1800 BTS are co-located with UTRA TDD Wide Area BS.

The blocking performance requirement applies to interfering signals with center frequency within the ranges specified in the tables below, using a 1MHz step size.

In case this additional blocking requirement is applied, the static reference performance as specified in clause 7.2.1 shall be met with a wanted and an interfering signal coupled to BS antenna input using the following parameters.

**Table 7.9A: Additional blocking requirements for Wide Area BS in operating bands defined in 4.2(a), 4.2(d), 4.2(e) and 5.2(f) when co-located with GSM900**

| Centre Frequency of Interfering Signal | Interfering Signal mean power | Wanted Signal mean power | Minimum Offset of Interfering Signal | Type of Interfering Signal |
|--|-------------------------------|--------------------------|--------------------------------------|----------------------------|
| 921 - 960 MHz                          | +16 dBm                       | -104 dBm                 | —                                    | CW carrier                 |

**Table 7.10A: Additional blocking requirements for Wide Area BS in operating bands defined in 4.2(a), 4.2(d) and 4.2(e) when co-located with DCS1800**

| Center Frequency of Interfering Signal | Interfering Signal mean power | Wanted Signal mean power | Minimum Offset of Interfering Signal | Type of Interfering Signal |
|--|-------------------------------|--------------------------|--------------------------------------|----------------------------|
| 1805 - 1880 MHz                        | +16 dBm                       | -104 dBm                 | —                                    | CW carrier                 |

**Table 7.10A-1: Additional blocking requirements for Wide Area BS in operating bands defined in 5.2(f) when co-located with DCS1800**

| Center Frequency of Interfering Signal | Interfering Signal Mean Power | Wanted Signal Mean Power | Minimum Offset of Interfering Signal | Type of Interfering Signal |
|--|-------------------------------|--------------------------|--------------------------------------|----------------------------|
| 1805 -- 1850 MHz                       | +16 dBm                       | -104 dBm                 | —                                    | CW carrier                 |

The normative reference for this requirement is TS 25.105 [1] subclause 7.5.1.2.

#### 7.5.2.2.3 Co-location with UTRA-FDD and/or E-UTRA FDD

This additional blocking requirement may be applied for the protection of 1,28Mcps TDD BS receivers when UTRA-FDD and/or E-UTRA FDD are co-located with UTRA 1,28Mcps TDD Wide Area BS.



The blocking performance requirement applies to interfering signals with center frequency within the ranges specified in the tables below, using a 1MHz step size.

In case this additional blocking requirement is applied, the static reference performance as specified in clause 7.2.1 of TS25.105 shall be met with a wanted and an interfering signal coupled to BS antenna input using the following parameters.

**Table 7.10B: Additional blocking requirements for operating bands defined in 4.2(d) when co-located with UTRA-FDD and/or E-UTRA FDD WA BS**

| Centre Frequency of Interfering Signal | Interfering Signal Mean Power | Wanted Signal Mean Power | Minimum Offset of Interfering Signal | Type of Interfering Signal |
|--|-------------------------------|--------------------------|--------------------------------------|----------------------------|
| 2620 - 2690 MHz                        | +13 dBm                       | -104 dBm                 | —                                    | CW carrier                 |

**Table 7.10C: Additional blocking requirements for operating bands defined in 4.2(d) when co-located with UTRA-FDD and/or E-UTRA FDD LA BS**

| Center Frequency of Interfering Signal | Interfering Signal Mean Power | Wanted Signal Mean Power | Minimum Offset of Interfering Signal | Type of Interfering Signal |
|--|-------------------------------|--------------------------|--------------------------------------|----------------------------|
| 2620 - 2690 MHz                        | -6 dBm                        | -104 dBm                 | —                                    | CW carrier                 |

### 7.5.2.3 7,68 Mcps TDD option

#### 7.5.2.3.1 General requirements

The static reference performance as specified in clause 7.2 shall be met with a wanted and an interfering signal coupled to the BS antenna input using the parameters specified in tables 7.6-1B, 7.7-1B, 7.8-1B, 7.6-2B, 7.7-2B or 7.8-2B, respectively.

**Table 7.6-1B: Blocking requirements for Wide Area BS in operating bands defined in subclause 4.2 a)**

| Center frequency of interfering signal                  | Interfering signal mean power | Wanted signal mean power | Minimum offset of interfering signal | Type of interfering signal |
|---|-------------------------------|--------------------------|--------------------------------------|----------------------------|
| 1900 - 1920 MHz,<br>2010 - 2025 MHz                     | -40 dBm                       | -103 dBm                 | 20 MHz                               | WCDMA signal with one code |
| 1880 - 1900 MHz,<br>1990 - 2010 MHz,<br>2025 - 2045 MHz | -40 dBm                       | -103 dBm                 | 20 MHz                               | WCDMA signal with one code |
| 1920 - 1980 MHz   | -40 dBm                       | -103 dBm                 | 20 MHz                               | WCDMA signal with one code |
| 1 - 1880 MHz,<br>1980 - 1990 MHz,<br>2045 - 12750 MHz   | -15 dBm                       | -103 dBm                 | —                                    | CW carrier                 |

**Table 7.7-1B: Blocking requirements for Wide Area BS in operating bands defined in subclause 4.2 b)**

| Center frequency of interfering signal | Interfering signal mean power | Wanted signal mean power | Minimum offset of interfering signal | Type of interfering signal |
|--|-------------------------------|--------------------------|--------------------------------------|----------------------------|
| 1850 - 1990 MHz                        | -40 dBm                       | -103 dBm                 | 20 MHz                               | WCDMA signal with one code |
| 1830 - 1850 MHz,<br>1990 - 2010 MHz    | -40 dBm                       | -103 dBm                 | 20 MHz                               | WCDMA signal with one code |
| 1 - 1830 MHz,<br>2010 - 12750 MHz      | -15 dBm                       | -103 dBm                 | —                                    | CW carrier                 |

**Table 7.8-1B: Blocking requirements for Wide Area BS in operating bands defined in subclause 4.2 c)**

| Center frequency of interfering signal | Interfering signal mean power | Wanted signal mean power | Minimum offset of interfering signal | Type of interfering signal |
|--|-------------------------------|--------------------------|--------------------------------------|----------------------------|
| 1910 - 1930 MHz                        | -40 dBm                       | -103 dBm                 | 20 MHz                               | WCDMA signal with one code |
| 1890 - 1910 MHz,<br>1930 - 1950 MHz    | -40 dBm                       | -103 dBm                 | 20 MHz                               | WCDMA signal with one code |
| 1 - 1890 MHz,<br>1950 - 12750 MHz      | -15 dBm                       | -103 dBm                 | —                                    | CW carrier                 |

**Table 7.9-1B: Blocking requirements for Wide Area BS in operating bands defined in subclause 4.2 d)**

| Centre Frequency of Interfering Signal | Interfering Signal Mean Power | Wanted Signal Mean Power | Minimum Offset of Interfering Signal | Type of Interfering Signal |
|--|-------------------------------|--------------------------|--------------------------------------|----------------------------|
| 2570 - 2620 MHz                        | -40 dBm                       | -103 dBm                 | 20 MHz                               | WCDMA signal with one code |
| 2550 - 2570 MHz<br>2620 - 2640 MHz     | -40 dBm                       | -103 dBm                 | 20 MHz                               | WCDMA signal with one code |
| 2500 - 2570 MHz<br>2620 - 2690 MHz     | -40 dBm                       | -103 dBm                 | 20 MHz                               | WCDMA signal with one code |
| 1 - 2550 MHz,<br>2690 - 12750 MHz      | -15 dBm                       | -103 dBm                 | —                                    | CW carrier                 |

**Table 7.6-2B: Blocking requirements for Local Area BS in operating bands defined in subclause 4.2 a)**

| Center frequency of interfering signal                  | Interfering signal level | Wanted signal level | Minimum offset of interfering signal | Type of interfering signal |
|---|--------------------------|---------------------|--------------------------------------|----------------------------|
| 1900 - 1920 MHz,<br>2010 - 2025 MHz                     | -30 dBm                  | -89 dBm             | 20 MHz                               | WCDMA signal with one code |
| 1880 - 1900 MHz,<br>1990 - 2010 MHz,<br>2025 - 2045 MHz | -30 dBm                  | -89 dBm             | 20 MHz                               | WCDMA signal with one code |
| 1920 - 1980 MHz   | -30 dBm                  | -89 dBm             | 20 MHz                               | WCDMA signal with one code |
| 1 - 1880 MHz,<br>1980 - 1990 MHz,<br>2045 - 12750 MHz   | -15 dBm                  | -89 dBm             | —                                    | CW carrier                 |

**Table 7.7-2B: Blocking requirements for Local Area BS in operating bands defined in subclause 4.2 b)**

| Center frequency of interfering signal | Interfering signal level | Wanted signal level | Minimum offset of interfering signal | Type of interfering signal |
|--|--------------------------|---------------------|--------------------------------------|----------------------------|
| 1850 - 1990 MHz                        | -30 dBm                  | -89 dBm             | 20 MHz                               | WCDMA signal with one code |
| 1830 - 1850 MHz,<br>1990 - 2010 MHz    | -30 dBm                  | -89 dBm             | 20 MHz                               | WCDMA signal with one code |
| 1 - 1830 MHz,<br>2010 - 12750 MHz      | -15 dBm                  | -89 dBm             | —                                    | CW carrier                 |

**Table 7.8-2B: Blocking requirements for Local Area BS in operating bands defined in subclause 4.2 c)**

| Center frequency of interfering signal | Interfering signal level | Wanted signal level | Minimum offset of interfering signal | Type of interfering signal |
|--|--------------------------|---------------------|--------------------------------------|----------------------------|
| 1910 - 1930 MHz                        | -30 dBm                  | -89 dBm             | 20 MHz                               | WCDMA signal with one code |
| 1890 - 1910 MHz,<br>1930 - 1950 MHz    | -30 dBm                  | -89 dBm             | 20 MHz                               | WCDMA signal with one code |
| 1 - 1890 MHz,<br>1950 - 12750 MHz      | -15 dBm                  | -89 dBm             | —                                    | CW carrier                 |

**Table 7.9-2B: Blocking requirements for Local Area BS in operating bands defined in subclause 4.2 d)**

| Centre Frequency of Interfering Signal | Interfering Signal mean power | Wanted Signal mean power | Minimum Offset of Interfering Signal | Type of Interfering Signal |
|--|-------------------------------|--------------------------|--------------------------------------|----------------------------|
| 2570 - 2620 MHz                        | -30 dBm                       | -89 dBm                  | 20 MHz                               | WCDMA signal with one code |
| 2550 - 2570 MHz<br>2620 - 2640 MHz     | -30 dBm                       | -89 dBm                  | 20 MHz                               | WCDMA signal with one code |
| 2500 - 2570 MHz<br>2620 - 2690 MHz     | -30 dBm                       | -89 dBm                  | 20 MHz                               | WCDMA signal with one code |
| 1 - 2550 MHz,<br>2690 - 12750 MHz      | -15 dBm                       | -89 dBm                  | —                                    | CW carrier                 |

The normative reference for this requirement is TS 25.105 [1] subclause 7.5.0.3.

#### 7.5.2.3.2 Co-location with GSM900 and/or DCS 1800

This additional blocking requirement may be applied for the protection of TDD BS receivers when GSM900 and/or DCS1800 BTS are co-located with UTRA TDD Wide Area BS.

The blocking performance requirement applies to interfering signals with center frequency within the ranges specified in the tables below, using a 1MHz step size.

In case this additional blocking requirement is applied, the static reference performance as specified in clause 7.2.1 shall be met with a wanted and an interfering signal coupled to BS antenna input using the following parameters.

**Table 7.9B: Additional blocking requirements for Wide Area BS in operating bands defined in subclause 4.2 a) and 4.2 d) when co-located with GSM900**

| Center Frequency of Interfering Signal | Interfering Signal mean power | Wanted Signal mean power | Minimum Offset of Interfering Signal | Type of Interfering Signal |
|--|-------------------------------|--------------------------|--------------------------------------|----------------------------|
| 921 - 960 MHz                          | +16 dBm                       | -103 dBm                 | —                                    | CW carrier                 |

**Table 7.10F: Additional blocking requirements for Wide Area BS in operating bands defined in subclause 4.2 a) and 4.2 d) when co-located with DCS1800**

| Center Frequency of Interfering Signal | Interfering Signal mean power | Wanted Signal mean power | Minimum Offset of Interfering Signal | Type of Interfering Signal |
|--|-------------------------------|--------------------------|--------------------------------------|----------------------------|
| 1805 - 1880                            | +16 dBm                       | -103 dBm                 | —                                    | CW carrier                 |

The normative reference for this requirement is TS 25.105 [1] subclause 7.5.1.3.

#### 7.5.2.3.3 Co-location with UTRA-FDD and/or E-UTRA FDD

This additional blocking requirement may be applied for the protection of TDD BS receivers when UTRA-FDD and/or E-UTRA FDD are co-located with UTRA TDD Wide Area BS.

The blocking performance requirement applies to interfering signals with center frequency within the ranges specified in the tables below, using a 1MHz step size.

In case this additional blocking requirement is applied, the static reference performance as specified in clause 7.2.1 of TS25.105 shall be met with a wanted and an interfering signal coupled to BS antenna input using the following parameters.

**Table 7.10G: Additional blocking requirements for operating bands defined in 4.2(d) when co-located with UTRA-FDD and/or E-UTRA FDD WA BS**

| Centre Frequency of Interfering Signal | Interfering Signal Mean Power | Wanted Signal Mean Power | Minimum Offset of Interfering Signal | Type of Interfering Signal |
|--|-------------------------------|--------------------------|--------------------------------------|----------------------------|
| 2620 - 2690 MHz                        | +13 dBm                       | -103 dBm                 | —                                    | CW carrier                 |

**Table 7.10H: Additional blocking requirements for operating bands defined in 4.2(d) when co-located with UTRA-FDD and/or E-UTRA FDD LA BS**

| Center Frequency of Interfering Signal | Interfering Signal Mean Power | Wanted Signal Mean Power | Minimum Offset of Interfering Signal | Type of Interfering Signal |
|--|-------------------------------|--------------------------|--------------------------------------|----------------------------|
| 2620 - 2690 MHz                        | -6 dBm                        | -103 dBm                 | —                                    | CW carrier                 |

### 7.5.3 Test purpose

#### 7.5.3.1 3,84 Mcps TDD option

The test stresses the ability of the BS receiver to withstand high-level interference from unwanted signals at frequency offsets of 10 MHz or more, without undue degradation of its sensitivity.

#### 7.5.3.2 1,28 Mcps TDD option

The test stresses the ability of the BS receiver to withstand high-level interference from unwanted signals at frequency offsets of 3,2 MHz or more, without undue degradation of its sensitivity.

#### 7.5.3.3 7,68 Mcps TDD option

The test stresses the ability of the BS receiver to withstand high-level interference from unwanted signals at frequency offsets of 20 MHz or more, without undue degradation of its sensitivity.

### 7.5.4 Method of test

#### 7.5.4.1 Initial conditions

Test environment: normal; see subclause 5.9.1.

RF channels to be tested: M; see subclause 5.3. The BS shall be configured to operate as close to the centre of the operating band as possible.

- (1) Connect an UE simulator operating at the assigned channel frequency of the wanted signal and a signal generator to the antenna connector of one Rx port.
- (2) Terminate or disable any other Rx port not under test.
- (3) Start transmission from the BS tester to the BS using the UL reference measurement channel (12,2 kbps) defined in Annex A.2.1. The level of the UE simulator signal measured at the BS antenna connector shall be set to 6 dB above the reference sensitivity level specified in subclause 7.2.2.

#### 7.5.4.2 Procedure

##### 7.5.4.2.1 3,84 Mcps TDD option

- (1) Set the signal generator to produce an interfering signal at a frequency offset  $F_{uw}$  from the assigned channel frequency of the wanted signal which is given by

$$F_{uw} = \pm (n \times 1 \text{ MHz}),$$

where  $n$  shall be increased in integer steps from  $n = 10$  up to such a value that the center frequency of the interfering signal covers the range from 1 MHz to 12,75 GHz. The interfering signal level measured at the antenna connector shall be set in dependency of its center frequency, as specified in tables 7.6 to 7.10. The type of the interfering signal is either equivalent to a continuous wideband CDMA signal with one code of chip frequency 3,84 Mchip/s, filtered by an RRC transmit pulse-shaping filter with roll-off  $\alpha = 0,22$ , or a CW signal; see tables 7.6 to 7.10.

- (2) Measure the BER of the wanted signal at the BS receiver.
- (3) Interchange the connections of the BS Rx ports and repeat the measurements according to steps (1) and (2).

#### 7.5.4.2.2 1,28 Mcps TDD option

- (1) Set the signal generator to produce an interfering signal at a frequency offset  $F_{uw}$  from the assigned channel frequency of the wanted signal which is given by

$$F_{uw} = \pm (3,2 + n) \times 1 \text{ MHz}$$

where  $n$  shall be increased in integer steps from  $n = 0$  up to such a value that the center frequency of the interfering signal covers the range from 1 MHz to 12,75 GHz. The interfering signal level measured at the antenna connector shall be set in dependency of its center frequency, as specified in tables 7.6A to 7.10A. The type of the interfering signal is either equivalent to a continuous wideband CDMA signal with one code of chip frequency 1,28 Mchip/s, filtered by an RRC transmit pulse-shaping filter with roll-off  $\alpha = 0,22$ , or a CW signal; see tables 7.6A to 7.10A.

- (2) Measure the BER of the wanted signal at the BS receiver.
- (3) Interchange the connections of the BS Rx ports and repeat the measurements according to steps (1) and (2).

#### 7.5.4.2.3 7,68 Mcps TDD option

- (1) Set the signal generator to produce an interfering signal at a frequency offset  $F_{uw}$  from the assigned channel frequency of the wanted signal which is given by

$$F_{uw} = \pm (n \times 1 \text{ MHz}),$$

where  $n$  shall be increased in integer steps from  $n = 20$  up to such a value that the center frequency of the interfering signal covers the range from 1 MHz to 12,75 GHz. The interfering signal level measured at the antenna connector shall be set in dependency of its center frequency, as specified in tables 7.6B to 7.10F. The type of the interfering signal is either equivalent to a continuous wideband CDMA signal with one code of chip frequency 7,68 Mchip/s, filtered by an RRC transmit pulse-shaping filter with roll-off  $\alpha = 0,22$ , or a CW signal; see subclause tables 7.6B to 7.10F.

- (2) Measure the BER of the wanted signal at the BS receiver.
- (3) Interchange the connections of the BS Rx ports and repeat the measurements according to steps (1) and (2).

### 7.5.5 Test Requirements

NOTE 1: If the Test Requirement below differs from the Minimum Requirement, then the Test Tolerance applied for this test is non-zero. The Test Tolerance for this test is defined in subclause 5.11 and the explanation of how the Minimum Requirement has been relaxed by the Test Tolerance is given in Annex D.

In all measurements made according to subclause 7.5.4.2, the BER shall not exceed 0,001.

NOTE 2: Annex F describes the procedure for BER tests taking into account the statistical consequence of frequent repetition of BER measurements within the blocking test. The consequence is: a DUT exactly on the limit may fail due to the statistical nature 2.55 times(mean value) in 12750 BER measurements using the predefined wrong decision probability of 0.02%. If the fail cases are  $\leq 12$ , it is allowed to repeat the fail cases 1 time before the final verdict.

## 7.6 Intermodulation characteristics

### 7.6.1 Definition and applicability

Third and higher order mixing of two interfering RF signals can produce an interfering signal in the band of the desired channel. Intermodulation response rejection is a measure of the capability of the receiver to receive a wanted signal on its assigned channel frequency in the presence of two or more interfering signals which have a specific frequency relationship to the wanted signal.

In this subclause, different requirements shall apply to Wide Area BS and Local Area BS.

### 7.6.2 Minimum Requirements

#### 7.6.2.1 3,84 Mcps TDD option

The static reference performance as specified in clause 7.2 should be met when the following signals are coupled to the BS antenna input.

- A wanted signal at the assigned channel frequency, with mean power 6 dB above the static reference level.
- Two interfering signals with the parameters specified in table 7.11.

**Table 7.11: Parameters of the interfering signals for intermodulation characteristics testing**

| Interfering Signal mean power |               | Offset | Type of Interfering Signal |
|-------------------------------|---------------|--------|----------------------------|
| Wide Area BS                  | Local Area BS |        |                            |
| - 48 dBm                      | - 38 dBm      | 10 MHz | CW signal                  |
| - 48 dBm                      | - 38 dBm      | 20 MHz | WCDMA signal with one code |

The normative reference for this requirement is TS 25.105 [1] subclause 7.6.1.1.

#### 7.6.2.2 1,28 Mcps TDD option

The static reference performance as specified in clause 7.2 should be met when the following signals are coupled to the BS antenna input.

- A wanted signal at the assigned channel frequency, with mean power 6 dB above the static reference level.
- Two interfering signals with the parameters specified in table 7.11A.

**Table 7.11A: Parameters of the interfering signals for intermodulation characteristics testing for 1,28 Mcps TDD**

| Interfering Signal mean power |               | Offset  | Type of Interfering Signal         |
|-------------------------------|---------------|---------|------------------------------------|
| Wide Area BS                  | Local Area BS |         |                                    |
| - 48 dBm                      | - 38 dBm      | 3,2 MHz | CW signal                          |
| - 48 dBm                      | - 38 dBm      | 6,4 MHz | 1,28 Mcps TDD signal with one code |

The normative reference for this requirement is TS 25.105 [1] subclause 7.6.1.2.

#### 7.6.2.3 7,68 Mcps TDD option

The static reference performance as specified in clause 7.2 should be met when the following signals are coupled to the BS antenna input.

- A wanted signal at the assigned channel frequency, with mean power 6 dB above the static reference level.
- Two interfering signals with the parameters specified in table 7.11B.

**Table 7.11B: Parameters of the interfering signals for intermodulation characteristics testing**

| Interfering Signal mean power |               | Offset | Type of Interfering Signal |
|-------------------------------|---------------|--------|----------------------------|
| Wide Area BS                  | Local Area BS |        |                            |
| - 48 dBm                      | - 38 dBm      | 20 MHz | CW signal                  |
| - 48 dBm                      | - 38 dBm      | 40 MHz | WCDMA signal with one code |

The normative reference for this requirement is subclause 7.6.1.3.

### 7.6.3 Test purpose

The test purpose is to verify the ability of the BS receiver to inhibit the generation of intermodulation products in its non-linear elements caused by the presence of two high-level interfering signals at frequencies with a specific relationship to the frequency of the wanted signal.

### 7.6.4 Method of test

#### 7.6.4.1 Initial conditions

##### 7.6.4.1.1 3,84 Mcps TDD option

Test environment: normal; see subclause 5.9.1.

RF channels to be tested: B, M and T; see subclause 5.3.

- (1) Connect an UE simulator operating at the assigned channel frequency of the wanted signal and two signal generators to the antenna connector of one Rx port.
- (2) Terminate or disable any other Rx port not under test.
- (3) Start transmission from the BS tester to the BS using the UL reference measurement channel (12,2 kbps) defined in Annex A.2.1. The level of the UE simulator signal measured at the BS antenna connector shall be set to 6 dB above the reference sensitivity level specified in subclause 7.2.2.
- (4) Set the first signal generator to produce a CW signal with a level measured at the BS antenna connector as specified in table 7.11..
- (5) Set the second signal generator to produce an interfering signal equivalent to a wideband CDMA signal with one code of chip frequency 3,84 MHz, filtered by an RRC transmit pulse-shaping filter with roll-off  $\alpha = 0,22$ . The level of the signal measured at the BS antenna connector shall be set as specified in table 7.11.

##### 7.6.4.1.2 1,28 Mcps TDD option

Test environment: normal; see subclause 5.9.1.

RF channels to be tested: B, M and T; see subclause 5.3.

- (1) Connect an UE simulator operating at the assigned channel frequency of the wanted signal and two signal generators to the antenna connector of one Rx port.
- (2) Terminate or disable any other Rx port not under test.
- (3) Start transmission from the BS tester to the BS using the UL reference measurement channel (12,2 kbps) defined in Annex A.2.1. The level of the UE simulator signal measured at the BS antenna connector shall be set to 6 dB above the reference sensitivity level specified in subclause 7.2.2.
- (4) Set the first signal generator to produce a CW signal with a level measured at the BS antenna connector as specified in table 7.11A.
- (5) Set the second signal generator to produce an interfering signal equivalent to a wideband CDMA signal with one code of chip frequency 1,28 MHz, filtered by an RRC transmit pulse-shaping filter with roll-off  $\alpha = 0,22$ . The level of the signal measured at the BS antenna connector shall be set as specified in table 7.11A.

#### 7.6.4.1.3 7,68 Mcps TDD option

Test environment: normal; see subclause 5.9.1.

RF channels to be tested: B, M and T; see subclause 5.3.

- (1) Connect an UE simulator operating at the assigned channel frequency of the wanted signal and two signal generators to the antenna connector of one Rx port.
- (2) Terminate or disable any other Rx port not under test.
- (3) Start transmission from the BS tester to the BS using the UL reference measurement channel (12,2 kbps) defined in Annex A.2.1. The level of the UE simulator signal measured at the BS antenna connector shall be set to 6 dB above the reference sensitivity level specified in subclause 7.2.2.
- (4) Set the first signal generator to produce a CW signal with a level measured at the BS antenna connector as specified in table 7.11B.
- (5) Set the second signal generator to produce an interfering signal equivalent to a wideband CDMA signal with one code of chip frequency 7,68 MHz, filtered by an RRC transmit pulse-shaping filter with roll-off  $\alpha = 0,22$ . The level of the signal measured at the BS antenna connector shall be set as specified in table 7.11B.

#### 7.6.4.2 Procedure

##### 7.6.4.2.1 3,84 Mcps TDD option

- (1) The frequency of the first and the second signal generator shall be set to 10 MHz and 20 MHz, respectively, above the assigned channel frequency of the wanted signal.
- (2) Measure the BER of the wanted signal at the BS receiver.
- (3) The frequency of the first and the second signal generator shall be set to 10 MHz and 20 MHz, respectively, below the assigned channel frequency of the wanted signal.
- (4) Measure the BER of the wanted signal at the BS receiver.
- (5) Interchange the connections of the BS Rx ports and repeat the measurements according to steps (1) to (4).

##### 7.6.4.2.2 1,28 Mcps TDD option

- (1) The frequency of the first and the second signal generator shall be set to 3,2 MHz and 6,4 MHz, respectively, above the assigned channel frequency of the wanted signal.
- (2) Measure the BER of the wanted signal at the BS receiver.
- (3) The frequency of the first and the second signal generator shall be set to 3,2 MHz and 6,4 MHz, respectively, below the assigned channel frequency of the wanted signal.
- (4) Measure the BER of the wanted signal at the BS receiver.
- (5) Interchange the connections of the BS Rx ports and repeat the measurements according to steps (1) to (4).

##### 7.6.4.2.3 7,68 Mcps TDD option

- (1) The frequency of the first and the second signal generator shall be set to 20 MHz and 40 MHz, respectively, above the assigned channel frequency of the wanted signal.
- (2) Measure the BER of the wanted signal at the BS receiver.
- (3) The frequency of the first and the second signal generator shall be set to 20 MHz and 40 MHz, respectively, below the assigned channel frequency of the wanted signal.
- (4) Measure the BER of the wanted signal at the BS receiver.
- (5) Interchange the connections of the BS Rx ports and repeat the measurements according to steps (1) to (4).



## 7.6.5 Test Requirements

NOTE: If the Test Requirement below differs from the Minimum Requirement, then the Test Tolerance applied for this test is non-zero. The Test Tolerance for this test is defined in subclause 5.11 and the explanation of how the Minimum Requirement has been relaxed by the Test Tolerance is given in Annex D.

The BER measured according subclause 7.6.4.2 to shall not exceed 0,001.

## 7.7 Spurious emissions

### 7.7.1 Definition and applicability

The spurious emissions power is the power of emissions generated or amplified in a receiver that appear at the BS antenna connector. The requirements apply to all BS with separate Rx and Tx antenna connectors. For BS equipped with only a single antenna connector for both transmitter and receiver, the requirements of subclause 6.6.3 shall apply to this port, and this test need not be performed.

The requirements in this subclause shall apply to both Wide Area BS and Local Area BS.

### 7.7.2 Minimum Requirements

#### 7.7.2.1 3,84 Mcps TDD option

The power of any spurious emission shall not exceed the values given in table 7.12.

**Table 7.12: Receiver spurious emission requirements**

| Band                  | Maximum level | Measurement Bandwidth | Note  |
|-----------------------|---------------|-----------------------|---|
| 30 MHz - 1 GHz        | -57 dBm       | 100 kHz               |   |
| 1 GHz - 1,9 GHz       | -47 dBm       | 1 MHz                 | With the exception of frequencies between 12,5 MHz below the first carrier frequency and 12,5 MHz above the last carrier frequency used by the BS |
| 1,900 - 1,980 GHz     | -78 dBm       | 3,84 MHz              | With the exception of frequencies between 12,5 MHz below the first carrier frequency and 12,5 MHz above the last carrier frequency used by the BS |
| 1,980 - 2,010 GHz     | -47 dBm       | 1 MHz                 | With the exception of frequencies between 12,5 MHz below the first carrier frequency and 12,5 MHz above the last carrier frequency used by the BS |
| 2,010 - 2,025 GHz     | -78 dBm       | 3,84 MHz              | With the exception of frequencies between 12,5 MHz below the first carrier frequency and 12,5 MHz above the last carrier frequency used by the BS |
| 2,025 - 2,500 GHz     | -47 dBm       | 1 MHz                 | With the exception of frequencies between 12,5 MHz below the first carrier frequency and 12,5 MHz above the last carrier frequency used by the BS |
| 2,500 - 2,620         | -78 dBm       | 3,84 MHz              | With the exception of frequencies between 12,5 MHz below the first carrier frequency and 12,5 MHz above the last carrier frequency used by the BS |
| 2,620 GHz - 12,75 GHz | -47 dBm       | 1 MHz                 | With the exception of frequencies between 12,5 MHz below the first carrier frequency and 12,5 MHz above the last carrier frequency used by the BS |

**Table 7.12AA: Additional receiver spurious emission requirements**

| Band   | Maximum level | Measurement Bandwidth | Note   |
|--|---------------|-----------------------|--|
| 815 MHz - 850 MHz<br>1749.9 MHz - 1784.9 MHz | -78 dBm       | 3,84 MHz              | Applicable in Japan<br>With the exception of frequencies between 12,5 MHz below the first carrier frequency and 12,5 MHz above the last carrier frequency used by the BS |

In addition to the requirements in table 7.12 and 7.12AA, the co-existence requirements for co-located base stations in subclauses 6.6.3.2.2.2, 6.6.3.2.3.2 and 6.6.3.2.4.2 may also be applied.

The normative reference for this requirement is TS 25.105 [1] subclause 7.7.1.1.

### 7.7.2.2 1,28 Mcps TDD option

The power of any spurious emission shall not exceed the values given in table 7.12A.

**Table 7.12A: General receiver spurious emission minimum requirements**

| Band              | Maximum level | Measurement Bandwidth | Note   |
|-------------------|---------------|-----------------------|--|
| 30MHz - 1 GHz     | -57 dBm       | 100 kHz               |  |
| 1 GHz - 12.75 GHz | -47 dBm       | 1 MHz                 | With the exception of frequencies between 4 MHz below the first carrier frequency and 4 MHz above the last carrier frequency used by the BS. |

**Table 7.12A-1: Additional spurious emission requirements**

| Operating Band | Band            | Maximum level | Measurement Bandwidth | Note   |
|----------------|-----------------|---------------|-----------------------|--|
| a              | 1900 - 1920 MHz | -83 dBm       | 1.28 MHz              | With the exception of frequencies between 4 MHz below the first carrier frequency and 4 MHz above the last carrier frequency used by the BS. |
|                | 2010 – 2025 MHz | -83 dBm       | 1.28 MHz              |  |
| b              | 1850 - 1910 MHz | -83 dBm       | 1.28 MHz              |  |
|                | 1930 – 1990 MHz | -83 dBm       | 1.28 MHz              |  |
| c              | 1910 – 1930 MHz | -83 dBm       | 1.28 MHz              |  |
| d              | 2570 - 2620 MHz | -83 dBm       | 1.28 MHz              |  |
| e              | 2300 - 2400 MHz | -83 dBm       | 1.28 MHz              |  |
| f              | 1880 - 1920 MHz | -83 dBm       | 1.28 MHz              |  |

In addition, the requirement in Table 7.12A-2 may be applied to geographic areas in which both UTRA-TDD and UTRA-FDD are deployed.

**Table 7.12A-2: Additional spurious emission requirements for the FDD bands**

| Operating Band | Protected Band  | Maximum level | Measurement Bandwidth | Note   |
|----------------|-----------------|---------------|-----------------------|--|
| a, e, f        | 1920 - 1980     | -78 dBm       | 3.84 MHz              | With the exception of frequencies between 4 MHz below the first carrier frequency and 4 MHz above the last carrier frequency used by the BS. |
| d, e           | 2500 – 2570 MHz | -78 dBm       | 3.84 MHz              |  |

The normative reference for this requirement is TS 25.105 [1] subclause 7.7.1.2.

### 7.7.2.3 7,68 Mcps TDD option

The power of any spurious emission shall not exceed the values given in table 7.12B and table7.12BB.

**Table 7.12B: Receiver spurious emission requirements**

| Band   | Maximum level | Measurement Bandwidth | Note   |
|--|---------------|-----------------------|--|
| 30 MHz - 1 GHz   | -57 dBm       | 100 kHz               |  |
| 1 GHz - 1.9 GHz and<br>1.98 GHz - 2.01 GHz<br>2.025 GHz - 2.5 GHz    | -47 dBm       | 1 MHz                 | With the exception of frequencies between 25MHz below the first carrier frequency and 25MHz above the last carrier frequency used by the BS. |
| 1.9 GHz - 1.98 GHz and<br>2.01 GHz - 2.025 GHz<br>2.5 GHz - 2.62 GHz | -75 dBm       | 7.68 MHz              | With the exception of frequencies between 25MHz below the first carrier frequency and 25MHz above the last carrier frequency used by the BS. |
| 2.62 GHz - 12.75 GHz   | -47 dBm       | 1 MHz                 | With the exception of frequencies between 25MHz below the first carrier frequency and 25MHz above the last carrier frequency used by the BS. |

**Table 7.12BB: Additional receiver spurious emission requirements**

| Band  | Maximum level | Measurement Bandwidth | Note  |
|---|---------------|-----------------------|---|
| 815 MHz - 850 MHz<br>1427.9MHz - 1452.9MHz<br>1749.9 MHz - 1784.9 MHz | -78 dBm       | 3,84 MHz              | Applicable in Japan<br>With the exception of frequencies between 25MHz below the first carrier frequency and 25MHz above the last carrier frequency used by the BS. |

In addition to the requirements in table 7.12B and 7.12BB, the co-existence requirements for co-located base stations specified in subclause 6.6.3.2.2.2, 6.6.3.2.3.2 and 6.6.3.2.4.2 may also be applied.

The normative reference for this requirement is subclause 6.3.7.1.

### 7.7.3 Test purpose

The test purpose is to verify the ability of the BS to limit the interference caused by receiver spurious emissions to other systems.

### 7.7.4 Method of test

#### 7.7.4.1 Initial conditions

##### 7.7.4.1.0 General test conditions

Test environment: normal; see subclause 5.9.1.

RF channels to be tested: M; see subclause 5.3.

##### 7.7.4.1.1 3,84 Mcps TDD option

- (1) Connect the measuring equipment to the antenna connector of one BS Rx port.
- (2) Terminate or disable any other BS Rx port not under test.
- (3) Set the BS receiver to operational mode.
- (4) Set the BS to transmit a signal with parameters according to table 7.13.
- (5) Terminate the Tx port(s).

**Table 7.13: Parameters of the transmitted signal for Rx spurious emissions test**

| Parameter                                   | Value/description   |
|---|---|
| TDD Duty Cycle                              | TS $i$ ; $i = 0, 1, 2, \dots, 14$ :<br>transmit, if $i$ is even;<br>receive, if $i$ is odd. |
| Time slot carrying SCH                      | TS0   |
| Time slots under test                       | TS $i$ , $i$ even and non zero  |
| BS output power setting                     | PRAT  |
| Number of DPCH in each time slot under test | 9   |
| Power of each DPCH                          | 1/9 of Base Station output power  |
| Data content of DPCH                        | real life (sufficient irregular)  |

#### 7.7.4.1.2 1,28 Mcps TDD option

- (1) Connect the measuring equipment to the antenna connector of one BS Rx port.
- (2) Terminate or disable any other BS Rx port not under test.
- (3) Set the BS receiver to operational mode.
- (4) Set the BS to transmit a signal with parameters according to table 7.13A.
- (5) Terminate the Tx port(s).

**Table 7.13A: Parameters of the transmitted signal for Rx spurious emissions test for 1,28 Mcps TDD**

| Parameter                                   | Value/description   |
|---|---|
| TDD Duty Cycle                              | TS $i$ ; $i = 0, 1, 2, \dots, 6$ :<br>transmit, if $i$ is 0,4,5,6;<br>receive, if $i$ is 1,2,3. |
| Time slots under test                       | TS4, TS5 and TS6  |
| BS output power setting                     | PRAT  |
| Number of DPCH in each time slot under test | 8   |
| Power of each DPCH                          | 1/8 of Base Station output power  |
| Data content of DPCH                        | real life (sufficient irregular)  |

#### 7.7.4.1.3 7,68 Mcps TDD option

- (1) Connect the measuring equipment to the antenna connector of one BS Rx port.
- (2) Terminate or disable any other BS Rx port not under test.
- (3) Set the BS receiver to operational mode.
- (4) Set the BS to transmit a signal with parameters according to table 7.13B.
- (5) Terminate the Tx port(s).

**Table 7.13B: Parameters of the transmitted signal for Rx spurious emissions test**

| Parameter                                   | Value/description   |
|---|---|
| TDD Duty Cycle                              | TS $i$ ; $i = 0, 1, 2, \dots, 14$ :<br>transmit, if $i$ is even;<br>receive, if $i$ is odd. |
| Time slot carrying SCH                      | TS0   |
| Time slots under test                       | TS $i$ , $i$ even and non zero  |
| BS output power setting                     | PRAT  |
| Number of DPCH in each time slot under test | 9   |
| Power of each DPCH                          | 1/9 of Base Station output power  |
| Data content of DPCH                        | real life (sufficient irregular)  |

## 7.7.4.2 Procedure

### 7.7.4.2.1 3,84 Mcps TDD option

- (1) Measure the power of the spurious emissions by applying the measuring equipment with the settings as specified in table 7.14. The characteristics of the measurement filter with the bandwidth 3,84 MHz shall be RRC with roll-off  $\alpha = 0,22$ . The characteristics of the measurement filters with bandwidths 100 kHz and 1 MHz shall be approximately Gaussian (typical spectrum analyzer filter). The center frequency of the filters shall be stepped in contiguous steps over the frequency bands as specified in table 7.14 and table 7.14AA. The time duration of each step shall be sufficiently long to capture one even (transmit) time slot.
- (2) If the BS is equipped with more than one Rx port, interchange the connections of the BS Rx ports and repeat the measurement according to (1).

**Table 7.14: Measurement equipment settings**

| Stepped frequency range | Measurement bandwidth | Step width | Note  | Detection mode |
|-------------------------|-----------------------|------------|---|----------------|
| 30 MHz - 1 GHz          | 100 kHz               | 100 kHz    | With the exception of frequencies between 12,5 MHz below the first carrier frequency and 12,5 MHz above the last carrier frequency used by the BS | true RMS       |
| 1 GHz - 1,900 GHz       | 1 MHz                 | 1 MHz      |   |                |
| 1,900 GHz - 1,980 GHz   | 3,84 MHz              | 200 kHz    |   |                |
| 1,980 GHz - 2,010 GHz   | 1 MHz                 | 1 MHz      |   |                |
| 2,010 GHz - 2,025 GHz   | 3,84 MHz              | 200 kHz    |   |                |
| 2,025 GHz - 2,500 GHz   | 1 MHz                 | 1 MHz      |   |                |
| 2,500 GHz - 2,620GHz    | 3,84 MHz              | 200 kHz    |   |                |
| 2,620 GHz - 12,75 GHz   | 1 MHz                 | 1 MHz      |   |                |

**Table 7.14 AA: Additional measurement equipment settings**

| Band   | Measurement Bandwidth | Step Width | Note   | Detection mode |
|--|-----------------------|------------|--|----------------|
| 815 MHz - 850 MHz<br>1749,9 MHz - 1784,9 MHz | 3,84 MHz              | 200 kHz    | Applicable in Japan<br>With the exception of frequencies between 12,5 MHz below the first carrier frequency and 12,5 MHz above the last carrier frequency used by the BS | True RMS       |

### 7.7.4.2.2 1,28 Mcps TDD option

- (1) Measure the power of the spurious emissions by applying the measuring equipment with the settings as specified in table 7.14A. The characteristics of the measurement filter with the bandwidth 1,28 MHz shall be RRC with roll-off  $\alpha = 0,22$ . The characteristics of the measurement filters with bandwidths 100 kHz and 1 MHz shall be approximately Gaussian (typical spectrum analyzer filter). The center frequency of the filters shall be stepped in contiguous steps over the frequency bands as specified in table 7.14A. The time duration of each step shall be sufficiently long to capture one even (transmit) time slot.

- (2) If the BS is equipped with more than one Rx port, interchange the connections of the BS Rx ports and repeat the measurement according to (1).

**Table 7.14A: Measurement equipment settings**

| Stepped frequency range | Measurement bandwidth | Step width | Note  | Detection mode |
|-------------------------|-----------------------|------------|---|----------------|
| 30 MHz - 1 GHz          | 100 kHz               | 100 kHz    | With the exception of frequencies between 4 MHz below the first carrier frequency and 4 MHz above the last carrier frequency used by the BS | true RMS       |
| 1 GHz - 1,880 GHz       | 1 MHz                 | 1 MHz      |   |                |
| 1,880 GHz - 1,980 GHz   | 1,28 MHz              | 200 kHz    |   |                |
| 1,980 GHz - 2,010 GHz   | 1 MHz                 | 1 MHz      |   |                |
| 2,010 GHz - 2,025 GHz   | 1,28 MHz              | 200 kHz    |   |                |
| 2,025 – 2,300 GHz       | 1 MHz                 | 1 MHz      |   |                |
| 2,300 GHz -2,400 GHz    | 1,28 MHz              | 200 kHz    |   |                |
| 2,400 GHz -2,500 GHz    | 1 MHz                 | 1 MHz      |   |                |
| 2,500 GHz - 2,620GHz    | 1,28 MHz              | 200 kHz    |   |                |
| 2,620 GHz - 12,75 GHz   | 1 MHz                 | 1 MHz      |   |                |

#### 7.7.4.2.3 7,68 Mcps TDD option

- (1) Measure the power of the spurious emissions by applying the measuring equipment with the settings as specified in table 7.14B. The characteristics of the measurement filter with the bandwidth 7,68 MHz shall be RRC with roll-off  $\alpha = 0,22$ . The characteristics of the measurement filters with bandwidths 100 kHz and 1 MHz shall be approximately Gaussian (typical spectrum analyzer filter). The center frequency of the filters shall be stepped in contiguous steps over the frequency bands as specified in table 7.14B and 7.14BB. The time duration of each step shall be sufficiently long to capture one even (transmit) time slot.
- (2) If the BS is equipped with more than one Rx port, interchange the connections of the BS Rx ports and repeat the measurement according to (1).

**Table 7.14B: Measurement equipment settings**

| Stepped frequency range | Measurement bandwidth | Step width | Note  | Detection mode |
|-------------------------|-----------------------|------------|---|----------------|
| 30 MHz - 1 GHz          | 100 kHz               | 100 kHz    | With the exception of frequencies between 25 MHz below the first carrier frequency and 25 MHz above the last carrier frequency used by the BS | true RMS       |
| 1 GHz - 1,900 GHz       | 1 MHz                 | 1 MHz      |   |                |
| 1,900 GHz - 1,980 GHz   | 7,68 MHz              | 200 kHz    |   |                |
| 1,980 GHz - 2,010 GHz   | 1 MHz                 | 1 MHz      |   |                |
| 2,010 GHz - 2,025 GHz   | 7,68 MHz              | 200 kHz    |   |                |
| 2,025 GHz - 12,75 GHz   | 1 MHz                 | 1 MHz      |   |                |

**Table 7.14 BB: Additional measurement equipment settings**

| Band  | Measurement bandwidth | Step width | Note  | Detection mode |
|---|-----------------------|------------|---|----------------|
| 815 MHz - 850 MHz<br>1427.9MHz - 1452.9MHz<br>1749.9 MHz - 1784.9 MHz | 3,84 MHz              | 200 kHz    | Applicable in Japan<br>With the exception of frequencies between 25MHz below the first carrier frequency and 25MHz above the last carrier frequency used by the BS. | true RMS       |

## 7.7.5 Test Requirements

NOTE: If the Test Requirement below differs from the Minimum Requirement, then the Test Tolerance applied for this test is non-zero. The Test Tolerance for this test is defined in subclause 5.11 and the explanation of how the Minimum Requirement has been relaxed by the Test Tolerance is given in Annex D.

The spurious emissions measured according to subclause 7.7.4.2 shall not exceed the limits specified in subclause 7.7.2.

## 8 Performance requirements

### 8.1 General

Performance requirements for the BS are specified for the measurement channels defined in Annex A and the propagation conditions in Annex B. The requirements only apply to those measurement channels that are supported by the base station. The performance requirements for the high speed train conditions defined in Annex B.3 are optional. All Bit Error Ratio (BER) and Block Error ratio (BLER) measurements shall be carried out according to the general rules for statistical testing defined in ITU-T Recommendation O.153 [10] and Annex F.

The characteristics of the white noise source, simulating interference from other cells ( $I_{oc}$ ), shall comply with the AWGN interferer definition in subclause 5.18.

The requirements only apply to a base station with dual receiver antenna diversity unless otherwise stated. The required  $\hat{I}_{or}/I_{oc}$  shall be applied separately at each antenna port.

**Table 8.1: Summary of Base Station performance targets**

| Physical channel | Measurement channel | Static                    | Multi-path Case 1         | Multi-path Case 2         | Multi-path Case 3                  | High speed train*         |
|------------------|---------------------|---------------------------|---------------------------|---------------------------|------------------------------------|---------------------------|
|                  |                     | Performance metric        |                           |                           |                                    |                           |
| DCH              | 12,2 kbps           | $BLER < 10^{-2}$          | $BLER < 10^{-2}$          | $BLER < 10^{-2}$          | $BLER < 10^{-2}$                   | $BLER < 10^{-2}$          |
|                  | 64 kbps             | $BLER < 10^{-1}, 10^{-2}$ | $BLER < 10^{-1}, 10^{-2}$ | $BLER < 10^{-1}, 10^{-2}$ | $BLER < 10^{-1}, 10^{-2}, 10^{-3}$ | $BLER < 10^{-1}, 10^{-2}$ |
|                  | 144 kbps            | $BLER < 10^{-1}, 10^{-2}$ | $BLER < 10^{-1}, 10^{-2}$ | $BLER < 10^{-1}, 10^{-2}$ | $BLER < 10^{-1}, 10^{-2}, 10^{-3}$ | -                         |
|                  | 384 kbps            | $BLER < 10^{-1}, 10^{-2}$ | $BLER < 10^{-1}, 10^{-2}$ | $BLER < 10^{-1}, 10^{-2}$ | $BLER < 10^{-1}, 10^{-2}, 10^{-3}$ | -                         |

\*Note: Optional condition, not applicable for all BSs.

### 8.2 Demodulation in static propagation conditions

#### 8.2.1 Demodulation of DCH

##### 8.2.1.1 Definition and applicability

The performance requirement of DCH in static propagation conditions is determined by the maximum Block Error Ratio (BLER) allowed when the receiver input signal is at a specified  $\hat{I}_{or}/I_{oc}$  limit. The BLER is calculated for each of the measurement channels supported by the base station.

In this subclause, different requirements shall apply to Wide Area BS and Local Area BS.

##### 8.2.1.2 Minimum Requirements

###### 8.2.1.2.1 3,84 Mcps TDD option

For the parameters specified in table 8.2, the BLER should not exceed the piece-wise linear BLER curve specified in table 8.3. These requirements are applicable for TFCS size 16.

**Table 8.2: Parameters in static propagation conditions**

| Parameters   |               | Unit         | Test 1            | Test 2            | Test 3            | Test 4 |
|--|---------------|--------------|-------------------|-------------------|-------------------|--------|
| Number of DPCH <sub>o</sub>  |               |              | 6                 | 4                 | 0                 | 0      |
| $\frac{DPCH_{o} - E_c}{I_{or}}$  |               | DB           | -9                | -9,5              | -                 | -      |
| I <sub>oc</sub>  | Wide Area BS  | dBm/3,84 MHz | -89               |                   |                   |        |
|  | Local Area BS | dBm/3,84 MHz | -74               |                   |                   |        |
| Cell Parameter*  |               |              | 0,1               |                   |                   |        |
| DPCH Channelization Codes*   |               | C(k,Q)       | C(1,8)            | C(1,4)<br>C(5,16) | C(1,2)<br>C(9,16) | C(1,2) |
| DPCH <sub>o</sub> Channelization Codes*  |               | C(k,Q)       | C(i,16) 3 ≤ i ≤ 8 | C(i,16) 6 ≤ i ≤ 9 | -                 | -      |
| Information Data Rate  |               | Kbps         | 12,2              | 64                | 144               | 384    |
| *Note: Refer to TS 25.223 for definition of channelization codes and cell parameter. |               |              |                   |                   |                   |        |

**Table 8.3: Performance requirements in AWGN channel.**

| Test Number | $\frac{\hat{I}_{or}}{I_{oc}}$ [dB] | BLER             |
|-------------|------------------------------------|------------------|
| 1           | -2,0                               | 10 <sup>-2</sup> |
| 2           | -0,4                               | 10 <sup>-1</sup> |
|             | -0,1                               | 10 <sup>-2</sup> |
| 3           | -0,2                               | 10 <sup>-1</sup> |
|             | 0,1                                | 10 <sup>-2</sup> |
| 4           | -0,8                               | 10 <sup>-1</sup> |
|             | -0,6                               | 10 <sup>-2</sup> |

The normative reference for this requirement is TS 25.105 [1] subclause 8.2.1.1.1.

### 8.2.1.2.2 1,28 Mcps TDD option

For the parameters specified in table 8.2A, the BLER should not exceed the piece-wise linear BLER curve specified in table 8.3A. These requirements are applicable for TFCS size 16.

**Table 8.2A: Parameters in static propagation conditions for 1,28 Mcps TDD**

| Parameters                         |               | Unit         | Test 1 | Test 2 | Test 3 | Test 4 |
|------------------------------------|---------------|--------------|--------|--------|--------|--------|
| Number of DPCH <sub>o</sub>        |               |              | 4      | 1      | 1      | 0      |
| Spread factor of DPCH <sub>o</sub> |               |              | 8      | 8      | 8      |        |
| $\frac{DPCH_{o} - E_c}{I_{or}}$    |               | dB           | -7     | -7     | -7     | -      |
| I <sub>oc</sub>                    | Wide Area BS  | dBm/1,28 MHz | -91    |        |        |        |
|                                    | Local Area BS | dBm/1,28 MHz | -77    |        |        |        |
| Information Data Rate              |               | kbps         | 12,2   | 64     | 144    | 384    |

**Table 8.3A: Performance requirements in AWGN channel for 1,28 Mcps TDD**

| Test Number | $\frac{\hat{I}_{or}}{I_{oc}}$ [dB] | BLER             |
|-------------|------------------------------------|------------------|
| 1           | 0.6                                | 10 <sup>-2</sup> |
| 2           | -0.9                               | 10 <sup>-1</sup> |
|             | -0.4                               | 10 <sup>-2</sup> |
| 3           | -0.3                               | 10 <sup>-1</sup> |
|             | -0.1                               | 10 <sup>-2</sup> |
| 4           | 0.6                                | 10 <sup>-1</sup> |
|             | 0.8                                | 10 <sup>-2</sup> |



The normative reference for this requirement is TS 25.105 [1] subclause 8.2.1.1.2.

### 8.2.1.2.3 7,68 Mcps TDD option

For the parameters specified in table 8.2B, the BLER should not exceed the piece-wise linear BLER curve specified in table 8.3B. These requirements are applicable for TFCS size 16.

**Table 8.2B: Parameters in static propagation conditions**

| Parameters   | Unit          | Test 1                 |
|--|---------------|------------------------|
| Number of DPCH <sub>o</sub>  |               | 14                     |
| $\frac{DPCH_o - E_c}{I_{or}}$  | dB            | -12                    |
| I <sub>oc</sub>  | Wide Area BS  | dBm/7.68 MHz           |
|  | Local Area BS | dBm/7.68 MHz           |
| Cell Parameter*  |               | 0,1                    |
| DPCH Channelization Codes*   | C(k,Q)        | C(1, 16)               |
| DPCH <sub>o</sub> Channelization Codes*  | C(k,Q)        | C(i, 32)<br>3 ≤ i ≤ 16 |
| Information Data Rate  | kbps          | 12.2                   |
| *Note: Refer to TS 25.223 for definition of channelization codes and cell parameter. |               |                        |

**Table 8.3B: Performance requirements in AWGN channel.**

| Test Number | $\frac{\hat{I}_{or}}{I_{oc}}$ [dB] | BLER             |
|-------------|------------------------------------|------------------|
| 1           | -2.0                               | 10 <sup>-2</sup> |

The normative reference for this requirement is TS 25.105 [1] subclause 8.2.1.1.3.

### 8.2.1.3 Test purpose

The test purpose is to verify the ability of the BS to receive a prescribed test signal under static propagation conditions with a BLER not exceeding a specified limit. Within the wanted channel, intracell interference sources as well as an additional intercell interference source are taken into account. Therefore, this test - as all other tests in clause 8 - mainly checks the ability of the signal processing part of the receiver to extract the wanted signal from the interfered-with input signal, whereas the tests in clause 7 concentrate on the receiver RF part.

### 8.2.1.4 Method of test

#### 8.2.1.4.1 Initial conditions

##### 8.2.1.4.1.0 General test conditions

Test environment: normal; see subclause 5.9.1.

RF channels to be tested: B, M and T; see subclause 5.3.

##### 8.2.1.4.1.1 3,84 Mcps TDD option

Connect the BS tester (UE simulator) generating the wanted signal and a set of interference generators to both BS antenna connectors for diversity reception via a combining network. The set of interference generators comprises a number of CDMA generators, each representing an individual intracell interferer (subsequently called DPCH<sub>o</sub> generators), and an additional band-limited white noise source, simulating interference from other cells. Each DPCH<sub>o</sub> generator shall produce an interfering signal that is equivalent to a valid UTRA TDD signal with spreading factor 16,

using the same time slot(s) than the wanted signal and applying the same cell-specific scrambling code. The number of the DPCH<sub>0</sub> generators used in each test is given in table 8.2.

#### 8.2.1.4.1.2 1,28 Mcps TDD option

Connect the BS tester (UE simulator) generating the wanted signal and a set of interference generators to both BS antenna connectors for diversity reception via a combining network. The set of interference generators comprises a number of CDMA generators, each representing an individual intracell interferer (subsequently called DPCH<sub>0</sub> generators), and an additional band-limited white noise source, simulating interference from other cells. Each DPCH<sub>0</sub> generator shall produce an interfering signal that is equivalent to a valid UTRA TDD signal with spreading factor 8, using the same time slot(s) than the wanted signal and applying the same cell-specific scrambling code. The number of the DPCH<sub>0</sub> generators used in each test is given in table 8.2A.

#### 8.2.1.4.1.3 7,68 Mcps TDD option

Connect the BS tester (UE simulator) generating the wanted signal and a set of interference generators to both BS antenna connectors for diversity reception via a combining network. The set of interference generators comprises a number of CDMA generators, each representing an individual intracell interferer (subsequently called DPCH<sub>0</sub> generators), and an additional band-limited white noise source, simulating interference from other cells. Each DPCH<sub>0</sub> generator shall produce an interfering signal that is equivalent to a valid UTRA TDD signal with spreading factor 32, using the same time slot(s) than the wanted signal and applying the same cell-specific scrambling code. The number of the DPCH<sub>0</sub> generators used in each test is given in table 8.2B.

#### 8.2.1.4.2 Procedure

##### 8.2.1.4.2.1 3,84 Mcps TDD option

- (1) Adjust the power of the band-limited white noise source in such a way that its power spectral density measured at the BS antenna connector takes on the value  $I_{oc}$  as specified in table 8.2.
- (2) For a given test defined by the information data rate and the BLER objective, set the power of each DPCH<sub>0</sub> measured at the BS antenna connector during the active time slots to the value specified in table 8.4.
- (3) Set up a call between the BS tester generating the wanted signal and the BS. The characteristics of the call shall be configured according to the information data rate to be provided and the corresponding UL reference measurement channel defined in Annex A. Depending on the information data rate, the UL reference measurement channel makes use of one or two Dedicated Physical Channels (DPCH<sub>1</sub> and DPCH<sub>2</sub>) with different spreading factors SF. The power(s) of DPCH<sub>1</sub> and DPCH<sub>2</sub> (if applicable) measured at the BS antenna connector during the active time slots shall be set to the value(s) given in table 8.4.
- (4) Measure the BLER of the wanted signal at the BS receiver.

**Table 8.4: Parameters of DPCH<sub>0</sub> and the wanted signal**

| Test Number | BLER objective | Number of DPCH <sub>0</sub> | Power of each DPCH <sub>0</sub> measured at the BS antenna connector [dBm] |               | Parameters of the wanted signal |    |  |               |
|-------------|----------------|-----------------------------|--|---------------|---------------------------------|----|--|---------------|
|             |                |                             |  |               | DPCH                            | SF | Power measured at the BS antenna connector [dBm] |               |
|             |                |                             | Wide Area BS   | Local Area BS |                                 |    | Wide Area BS                                     | Local Area BS |
| 1           | $10^{-2}$      | 6                           | -100,0   | -85           | DPCH <sub>1</sub>               | 8  | -97,0  | -82,0         |
| 2           | $10^{-1}$      | 4                           | -98,9  | -83,9         | DPCH <sub>1</sub>               | 16 | -98,9  | -83,9         |
|             |                |                             |  |               | DPCH <sub>2</sub>               | 4  | -92,9  | -77,9         |
|             | $10^{-2}$      | 4                           | -98,6  | -83,6         | DPCH <sub>1</sub>               | 16 | -98,6  | -83,6         |
|             |                |                             |  |               | DPCH <sub>2</sub>               | 4  | -92,6  | -77,6         |
| 3           | $10^{-1}$      | 0                           | -  | -             | DPCH <sub>1</sub>               | 16 | -98,7  | -83,7         |
|             |                |                             |  |               | DPCH <sub>2</sub>               | 2  | -89,7  | -74,7         |
|             | $10^{-2}$      | 0                           | -  | -             | DPCH <sub>1</sub>               | 16 | -98,4  | -83,4         |
|             |                |                             |  |               | DPCH <sub>2</sub>               | 2  | -89,4  | -74,4         |
| 4           | $10^{-1}$      | 0                           | -  | -             | DPCH <sub>1</sub>               | 2  | -89,8  | -74,8         |
|             |                |                             |  |               | DPCH <sub>1</sub>               | 2  | -89,6  | -74,6         |
|             | $10^{-2}$      | 0                           | -  | -             | DPCH <sub>1</sub>               | 2  | -89,6  | -74,6         |

## 8.2.1.4.2.2 1,28 Mcps TDD option

- (1) Adjust the power of the band-limited white noise source in such a way that its power spectral density measured at the BS antenna connector takes on the value  $I_{oc}$  as specified in table 8.2A.
- (2) For a given test defined by the information data rate and the BLER objective, set the power of each DPCH<sub>0</sub> measured at the BS antenna connector during the active time slots to the value specified in table 8.4A.
- (3) Set up a call between the BS tester generating the wanted signal and the BS. The characteristics of the call shall be configured according to the information data rate to be provided and the corresponding UL reference measurement channel defined in Annex A. Depending on the information data rate, the UL reference measurement channel makes use of one or two Dedicated Physical Channels (DPCH<sub>1</sub> and DPCH<sub>2</sub>) with different spreading factors SF. The power(s) of DPCH<sub>1</sub> and DPCH<sub>2</sub> (if applicable) measured at the BS antenna connector during the active time slots shall be set to the value(s) given in table 8.4A.
- (4) Measure the BLER of the wanted signal at the BS receiver.

**Table 8.4A: Parameters of DPCH<sub>0</sub> and the wanted signal for 1,28 Mcps TDD**

| Test Number | BLER objective   | Number of DPCH <sub>0</sub> | Power of each DPCH <sub>0</sub> measured at the BS antenna connector [dBm] |               | Parameters of the wanted signal |    |  |               |
|-------------|------------------|-----------------------------|--|---------------|---------------------------------|----|--|---------------|
|             |                  |                             |  |               | DPCH                            | SF | Power measured at the BS antenna connector [dBm] |               |
|             |                  |                             | Wide Area BS   | Local Area BS |                                 |    | Wide Area BS                                     | Local Area BS |
| 1           | 10 <sup>-2</sup> | 4                           | -97,4  | -83,4         | DPCH <sub>1</sub>               | 8  | -97,4  | -83,4         |
| 2           | 10 <sup>-1</sup> | 1                           | -98,9  | -84,9         | DPCH <sub>1</sub>               | 2  | -92,9  | -78,9         |
|             | 10 <sup>-2</sup> | 1                           | -98,4  | -84,4         | DPCH <sub>1</sub>               | 2  | -92,5  | -78,5         |
| 3           | 10 <sup>-1</sup> | 1                           | -98,3  | -84,3         | DPCH <sub>1</sub>               | 2  | -92,3  | -78,3         |
|             | 10 <sup>-2</sup> | 1                           | -98,1  | -84,1         | DPCH <sub>1</sub>               | 2  | -92,1  | -78,1         |
| 4           | 10 <sup>-1</sup> | 0                           | -  | -             | DPCH <sub>1</sub>               | 16 | -99,9  | -85,9         |
|             |                  |                             |  |               | DPCH <sub>2</sub>               | 2  | -90,9  | -76,9         |
|             | 10 <sup>-2</sup> | 0                           | -  | -             | DPCH <sub>1</sub>               | 16 | -99,7  | -85,7         |
|             |                  |                             |  |               | DPCH <sub>2</sub>               | 2  | -90,7  | -76,7         |

## 8.2.1.4.2.3 7,68 Mcps TDD option

- (1) Adjust the power of the band-limited white noise source in such a way that its power spectral density measured at the BS antenna connector takes on the value  $I_{oc}$  as specified in table 8.2B.
- (2) For a given test defined by the information data rate and the BLER objective, set the power of each DPCH<sub>0</sub> measured at the BS antenna connector during the active time slots to the value specified in table 8.4B.
- (3) Set up a call between the BS tester generating the wanted signal and the BS. The characteristics of the call shall be configured according to the information data rate to be provided and the corresponding UL reference measurement channel defined in Annex A. Depending on the information data rate, the UL reference measurement channel makes use of one or two Dedicated Physical Channels (DPCH<sub>1</sub> and DPCH<sub>2</sub>) with different spreading factors SF. The power(s) of DPCH<sub>1</sub> and DPCH<sub>2</sub> (if applicable) measured at the BS antenna connector during the active time slots shall be set to the value(s) given in table 8.4B.
- (4) Measure the BLER of the wanted signal at the BS receiver.

**Table 8.4B: Parameters of DPCH<sub>0</sub> and the wanted signal**

| Test Number | BLER objective   | Number of DPCH <sub>0</sub> | Power of each DPCH <sub>0</sub> measured at the BS antenna connector [dBm] |               | Parameters of the wanted signal |    |  |               |
|-------------|------------------|-----------------------------|--|---------------|---------------------------------|----|--|---------------|
|             |                  |                             |  |               | DPCH                            | SF | Power measured at the BS antenna connector [dBm] |               |
|             |                  |                             | Wide Area BS   | Local Area BS |                                 |    | Wide Area BS                                     | Local Area BS |
| 1           | 10 <sup>-2</sup> | 14                          | -103,0   | -88           | DPCH <sub>1</sub>               | 16 | -100,0   | -85,0         |

### 8.2.1.5 Test Requirements

NOTE: If the Test Requirement below differs from the Minimum Requirement, then the Test Tolerance applied for this test is non-zero. The Test Tolerance for this test is defined in subclause 5.1.1 and the explanation of how the Minimum Requirement has been relaxed by the Test Tolerance is given in Annex D.

#### 8.2.1.5.1 3,84 Mcps TDD option

The BLER measured according to subclause 8.2.1.4.2 shall not exceed the limits specified in table 8.3.

#### 8.2.1.5.2 1,28 Mcps TDD option

The BLER measured according to subclause 8.2.1.4.2. shall not exceed the limits specified in table 8.3A.

#### 8.2.1.5.3 7,68 Mcps TDD option

The BLER measured according to subclause 8.2.1.4.2 shall not exceed the limits specified in table 8.3B.

## 8.3 Demodulation of DCH in multipath fading conditions

### 8.3.1 Multipath fading Case 1

#### 8.3.1.1 Definition and applicability

The performance requirement of DCH in multipath fading Case 1 is determined by the maximum Block Error Ratio (BLER) allowed when the receiver input signal is at a specified  $I_{or}/I_{oc}$  limit. The BLER is calculated for each of the measurement channels supported by the base station.

In this subclause, different requirements shall apply to Wide Area BS and Local Area BS.

#### 8.3.1.2 Minimum Requirements

##### 8.3.1.2.1 3,84 Mcps TDD option

For the parameters specified in table 8.5, the BLER should not exceed the piece-wise linear BLER curve specified in table 8.6. These requirements are applicable for TFCS size 16.

**Table 8.5: Parameters in multipath Case 1 channel**

| Parameters   |               | Unit         | Test 1            | Test 2            | Test 3            | Test 4 |
|--|---------------|--------------|-------------------|-------------------|-------------------|--------|
| Number of DPCH <sub>o</sub>  |               |              | 6                 | 4                 | 0                 | 0      |
| $\frac{DPCH_o - E_c}{I_{or}}$  |               | dB           | -9                | -9,5              | -                 | -      |
| I <sub>oc</sub>  | Wide Area BS  | dBm/3,84 MHz | -89               |                   |                   |        |
|  | Local Area BS | dBm/3,84 MHz | -74               |                   |                   |        |
| Cell Parameter*  |               |              | 0,1               |                   |                   |        |
| DPCH Channelization Codes*   |               | C(k,Q)       | C(1,8)            | C(1,4)<br>C(5,16) | C(1,2)<br>C(9,16) | C(1,2) |
| DPCH <sub>o</sub> Channelization Codes*  |               | C(k,Q)       | C(i,16) 3 ≤ i ≤ 8 | C(i,16) 6 ≤ i ≤ 9 | -                 | -      |
| Information Data Rate  |               | Kbps         | 12,2              | 64                | 144               | 384    |
| *Note: Refer to TS 25.223 for definition of channelization codes and cell parameter. |               |              |                   |                   |                   |        |

**Table 8.6: Performance requirements in multipath Case 1 channel.**

| Test Number | $\frac{\hat{I}_{or}}{I_{oc}}$ [dB] | BLER      |
|-------------|------------------------------------|-----------|
| 1           | 6,5                                | $10^{-2}$ |
| 2           | 5,5                                | $10^{-1}$ |
|             | 9,8                                | $10^{-2}$ |
| 3           | 5,5                                | $10^{-1}$ |
|             | 9,8                                | $10^{-2}$ |
| 4           | 5,1                                | $10^{-1}$ |
|             | 9,5                                | $10^{-2}$ |

The normative reference for this requirement is TS 25.105 [1] subclause 8.3.1.1.1.

### 8.3.1.2.2 1,28 Mcps TDD option

For the parameters specified in table 8.5A, the BLER should not exceed the piece-wise linear BLER curve specified in table 8.6A. These requirements are applicable for TFCS size 16.

**Table 8.5A: Parameters in multipath Case 1 channel for 1,28 Mcps TDD**

| Parameters                         |               | Unit         | Test 1 | Test 2 | Test 3 | Test 4 |
|------------------------------------|---------------|--------------|--------|--------|--------|--------|
| Number of DPCH <sub>o</sub>        |               |              | 4      | 1      | 1      | 0      |
| Spread factor of DPCH <sub>o</sub> |               |              | 8      | 8      | 8      |        |
| $\frac{DPCH_o - E_c}{I_{or}}$      |               | dB           | -7     | -7     | -7     | -      |
| I <sub>oc</sub>                    | Wide Area BS  | dBm/1,28 MHz | -91    |        |        |        |
|                                    | Local Area BS | dBm/1,28 MHz | -77    |        |        |        |
| Information Data Rate              |               | kbps         | 12,2   | 64     | 144    | 384    |

**Table 8.6A: Performance requirements multipath Case 1 channel for 1,28 Mcps TDD**

| Test Number | $\frac{\hat{I}_{or}}{I_{oc}}$ [dB] | BLER      |
|-------------|------------------------------------|-----------|
| 1           | 10.4                               | $10^{-2}$ |
| 2           | 5.3                                | $10^{-1}$ |
|             | 9.4                                | $10^{-2}$ |
| 3           | 5.7                                | $10^{-1}$ |
|             | 10.1                               | $10^{-2}$ |
| 4           | 6.8                                | $10^{-1}$ |
|             | 10.9                               | $10^{-2}$ |

The normative reference for this requirement is TS 25.105 [1] subclause 8.3.1.1.2.

### 8.3.1.2.3 7,68 Mcps TDD option

For the parameters specified in table 8.5B, the BLER should not exceed the piece-wise linear BLER curve specified in table 8.6B. These requirements are applicable for TFCS size 16.

**Table 8.5B: Parameters in multipath Case 1 channel**

| Parameters   |               | Unit         | Test 1                 |
|--|---------------|--------------|------------------------|
| Number of DPCH <sub>0</sub>  |               |              | 14                     |
| $\frac{DPCH_o - E_c}{I_{or}}$  |               | dB           | -12                    |
| I <sub>oc</sub>  | Wide Area BS  | dBm/7.68 MHz | -89                    |
|  | Local Area BS | dBm/7.68 MHz | -74                    |
| Cell Parameter*  |               |              | 0,1                    |
| DPCH Channelization Codes*   |               | C(k,Q)       | C(1, 16)               |
| DPCH <sub>0</sub> Channelization Codes*  |               | C(k,Q)       | C(i, 32)<br>3 ≤ i ≤ 16 |
| Information Data Rate  |               | Kbps         | 12.2                   |
| *Note: Refer to TS 25.223 for definition of channelization codes and cell parameter. |               |              |                        |

**Table 8.6B: Performance requirements in multipath Case 1 channel.**

| Test Number | $\frac{\hat{I}_{or}}{I_{oc}}$ [dB] | BLER             |
|-------------|------------------------------------|------------------|
| 1           | 6.5                                | 10 <sup>-2</sup> |

The normative reference for this requirement is TS 25.105 [1] subclause 8.3.1.1.3.

### 8.3.1.3 Test purpose

The test purpose is to verify the ability of the BS to receive a prescribed test signal under defined propagation conditions (multipath fading Case 1) with a BLER not exceeding a specified limit. Within the wanted channel, independent intracell interference sources as well as an additional intercell interference source are taken into account. Therefore, this test - as all other tests in clause 8 - mainly checks the ability of the signal processing part of the receiver to extract the wanted signal from the distorted and interfered-with input signal, whereas the tests in clause 7 concentrate on the receiver RF part.

### 8.3.1.4 Method of test

#### 8.3.1.4.1 Initial conditions

##### 8.3.1.4.1.0 General test conditions

Test environment: normal; see subclause 5.9.1.

RF channels to be tested: B, M and T; see subclause 5.3.

##### 8.3.1.4.1.1 3,84 Mcps TDD option

- (1) Connect the BS tester (UE simulator) generating the wanted signal and a set of interference generators to both BS antenna connectors for diversity reception via a combining network. The set of interference generators comprises a number of CDMA generators, each representing an individual intracell interferer (subsequently called DPCH<sub>0</sub> generators), and an additional band-limited white noise source, simulating interference from other cells. Each DPCH<sub>0</sub> generator shall produce an interfering signal that is equivalent to a valid UTRA TDD signal with spreading factor 16, using the same time slot(s) than the wanted signal and applying the same cell-specific scrambling code. The number of the DPCH<sub>0</sub> generators used in each test is given in table 8.5.
- (2) The wanted signal produced by the BS tester and the interfering signals produced by the DPCH<sub>0</sub> generators are individually passed through independent Multipath Fading Simulators (MFS) before entering the combining network. Each MFS shall be configured to simulate multipath fading Case 1.

#### 8.3.1.4.1.2 1,28 Mcps TDD option

- (1) Connect the BS tester (UE simulator) generating the wanted signal and a set of interference generators to both BS antenna connectors for diversity reception via a combining network. The set of interference generators comprises a number of CDMA generators, each representing an individual intracell interferer (subsequently called DPCH<sub>0</sub> generators), and an additional band-limited white noise source, simulating interference from other cells. Each DPCH<sub>0</sub> generator shall produce an interfering signal that is equivalent to a valid UTRA TDD signal with spreading factor 8, using the same time slot(s) than the wanted signal and applying the same cell-specific scrambling code. The number of the DPCH<sub>0</sub> generators used in each test is given in table 8.5A.
- (2) The wanted signal produced by the BS tester and the interfering signals produced by the DPCH<sub>0</sub> generators are individually passed through independent Multipath Fading Simulators (MFS) before entering the combining network. Each MFS shall be configured to simulate multipath fading Case 1.

#### 8.3.1.4.1.3 7,68 Mcps TDD option

- (1) Connect the BS tester (UE simulator) generating the wanted signal and a set of interference generators to both BS antenna connectors for diversity reception via a combining network. The set of interference generators comprises a number of CDMA generators, each representing an individual intracell interferer (subsequently called DPCH<sub>0</sub> generators), and an additional band-limited white noise source, simulating interference from other cells. Each DPCH<sub>0</sub> generator shall produce an interfering signal that is equivalent to a valid UTRA TDD signal with spreading factor 32, using the same time slot(s) than the wanted signal and applying the same cell-specific scrambling code. The number of the DPCH<sub>0</sub> generators used in each test is given in table 8.5B.
- (2) The wanted signal produced by the BS tester and the interfering signals produced by the DPCH<sub>0</sub> generators are individually passed through independent Multipath Fading Simulators (MFS) before entering the combining network. Each MFS shall be configured to simulate multipath fading Case 1.

#### 8.3.1.4.2 Procedure

##### 8.3.1.4.2.1 3,84 Mcps TDD option

- (1) Adjust the power of the band-limited white noise source in such a way that its power spectral density measured at the BS antenna connector takes on the value  $I_{oc}$  as specified in table 8.5.
- (2) For a given test defined by the information data rate and the BLER objective, set the power of each DPCH<sub>0</sub> measured at the BS antenna connector during the active time slots to the value specified in table 8.7.
- (3) Set up a call between the BS tester generating the wanted signal and the BS. The characteristics of the call shall be configured according to the information data rate to be provided and the corresponding UL reference measurement channel defined in Annex A. Depending on the information data rate, the UL reference measurement channel makes use of one or two Dedicated Physical Channels (DPCH<sub>1</sub> and DPCH<sub>2</sub>) with different spreading factors SF. The power(s) of DPCH<sub>1</sub> and DPCH<sub>2</sub> (if applicable) measured at the BS antenna connector during the active time slots shall be set to the value(s) given in table 8.7.
- (4) Measure the BLER of the wanted signal at the BS receiver.

Table 8.7: Parameters of DPCH<sub>0</sub> and the wanted signal

| Test Number       | BLER objective   | Number of DPCH <sub>0</sub> | Power of each DPCH <sub>0</sub> measured at the BS antenna connector [dBm] |               | Parameters of the wanted signal |       |  |               |
|-------------------|------------------|-----------------------------|--|---------------|---------------------------------|-------|--|---------------|
|                   |                  |                             |  |               | DPCH                            | SF    | Power measured at the BS antenna connector [dBm] |               |
|                   |                  |                             | Wide Area BS   | Local Area BS |                                 |       | Wide Area BS                                     | Local Area BS |
| 1                 | 10 <sup>-2</sup> | 6                           | -91,5  | -76,5         | DPCH <sub>1</sub>               | 8     | -88,5  | -73,5         |
| 2                 | 10 <sup>-1</sup> | 4                           | -93,0  | -78,0         | DPCH <sub>1</sub>               | 16    | -93,0  | -78,0         |
|                   | 10 <sup>-2</sup> | 4                           | -88,7  | -73,7         | DPCH <sub>2</sub>               | 4     | -87,0  | -72,0         |
| DPCH <sub>1</sub> |                  |                             |  |               | 16                              | -88,7 | -73,7  |               |
| 3                 | 10 <sup>-1</sup> | 0                           | -  | -             | DPCH <sub>1</sub>               | 16    | -93,0  | -78,0         |
|                   |                  |                             |  |               | DPCH <sub>2</sub>               | 2     | -84,0  | -69,0         |
|                   | 10 <sup>-2</sup> | 0                           | -  | -             | DPCH <sub>1</sub>               | 16    | -88,7  | -73,7         |
|                   |                  |                             |  |               | DPCH <sub>2</sub>               | 2     | -79,7  | -64,7         |
| 4                 | 10 <sup>-1</sup> | 0                           | -  | -             | DPCH <sub>1</sub>               | 2     | -83,9  | -68,9         |
|                   | 10 <sup>-2</sup> | 0                           | -  | -             | DPCH <sub>1</sub>               | 2     | -79,5  | -64,5         |

## 8.3.1.4.2.2 1,28 Mcps TDD option

- (1) Adjust the power of the band-limited white noise source in such a way that its power spectral density measured at the BS antenna connector takes on the value  $I_{oc}$  as specified in table 8.5A.
- (2) For a given test defined by the information data rate and the BLER objective, set the power of each DPCH<sub>0</sub> measured at the BS antenna connector during the active time slots to the value specified in table 8.7A.
- (3) Set up a call between the BS tester generating the wanted signal and the BS. The characteristics of the call shall be configured according to the information data rate to be provided and the corresponding UL reference measurement channel defined in Annex A. Depending on the information data rate, the UL reference measurement channel makes use of one or two Dedicated Physical Channels (DPCH<sub>1</sub> and DPCH<sub>2</sub>) with different spreading factors SF. The power(s) of DPCH<sub>1</sub> and DPCH<sub>2</sub> (if applicable) measured at the BS antenna connector during the active time slots shall be set to the value(s) given in table 8.7A.
- (4) Measure the BLER of the wanted signal at the BS receiver.

Table 8.7A: Parameters of DPCH<sub>0</sub> and the wanted signal for 1,28 Mcps TDD

| Test Number | BLER objective   | Number of DPCH <sub>0</sub> | Power of each DPCH <sub>0</sub> measured at the BS antenna connector [dBm] |               | Parameters of the wanted signal |    |  |               |
|-------------|------------------|-----------------------------|--|---------------|---------------------------------|----|--|---------------|
|             |                  |                             |  |               | DPCH                            | SF | Power measured at the BS antenna connector [dBm] |               |
|             |                  |                             | Wide Area BS   | Local Area BS |                                 |    | Wide Area BS                                     | Local Area BS |
| 1           | 10 <sup>-2</sup> | 4                           | -87,6  | -73,6         | DPCH <sub>1</sub>               | 8  | -87,6  | -73,6         |
| 2           | 10 <sup>-1</sup> | 1                           | -92,7  | -78,7         | DPCH <sub>1</sub>               | 2  | -86,7  | -72,7         |
|             | 10 <sup>-2</sup> | 1                           | -88,6  | -74,6         | DPCH <sub>1</sub>               | 2  | -82,6  | -68,6         |
| 3           | 10 <sup>-1</sup> | 1                           | -92,3  | -78,3         | DPCH <sub>1</sub>               | 2  | -86,3  | -72,3         |
|             | 10 <sup>-2</sup> | 1                           | -87,9  | -73,9         | DPCH <sub>1</sub>               | 2  | -81,9  | -67,9         |
| 4           | 10 <sup>-1</sup> | 0                           | -  | -             | DPCH <sub>1</sub>               | 16 | -93,7  | -79,7         |
|             |                  |                             |  |               | DPCH <sub>2</sub>               | 2  | -84,7  | -70,7         |
|             | 10 <sup>-2</sup> | 0                           | -  | -             | DPCH <sub>1</sub>               | 16 | -89,6  | -75,6         |
|             |                  |                             |  |               | DPCH <sub>2</sub>               | 2  | -80,6  | -66,6         |

## 8.3.1.4.2.3 7,68 Mcps TDD option

- (1) Adjust the power of the band-limited white noise source in such a way that its power spectral density measured at the BS antenna connector takes on the value  $I_{oc}$  as specified in table 8.5B.



- (2) For a given test defined by the information data rate and the BLER objective, set the power of each DPCH<sub>0</sub> measured at the BS antenna connector during the active time slots to the value specified in table 8.7B.
- (3) Set up a call between the BS tester generating the wanted signal and the BS. The characteristics of the call shall be configured according to the information data rate to be provided and the corresponding UL reference measurement channel defined in Annex A. Depending on the information data rate, the UL reference measurement channel makes use of one or two Dedicated Physical Channels (DPCH<sub>1</sub> and DPCH<sub>2</sub>) with different spreading factors SF. The power(s) of DPCH<sub>1</sub> and DPCH<sub>2</sub> (if applicable) measured at the BS antenna connector during the active time slots shall be set to the value(s) given in table 8.7B.
- (4) Measure the BLER of the wanted signal at the BS receiver.

**Table 8.7B: Parameters of DPCH<sub>0</sub> and the wanted signal**

| Test Number | BLER objective   | Number of DPCH <sub>0</sub> | Power of each DPCH <sub>0</sub> measured at the BS antenna connector [dBm] |               | Parameters of the wanted signal |    |  |               |
|-------------|------------------|-----------------------------|--|---------------|---------------------------------|----|--|---------------|
|             |                  |                             |  |               | DPCH                            | SF | Power measured at the BS antenna connector [dBm] |               |
|             |                  |                             | Wide Area BS   | Local Area BS |                                 |    | Wide Area BS                                     | Local Area BS |
| 1           | 10 <sup>-2</sup> | 14                          | -94,5  | -79,5         | DPCH <sub>1</sub>               | 16 | -91,5  | -76,5         |

### 8.3.1.5 Test Requirements

NOTE: If the Test Requirements below differ from the Minimum Requirements, then the Test Tolerance applied for this test is non-zero. The Test Tolerance for this test is defined in subclause 5.11 and the explanation of how the Minimum Requirement has been relaxed by the Test Tolerance is given in Annex D.

#### 8.3.1.5.1 3,84 Mcps TDD option

The BLER measured according to subclause 8.3.1.4.2 shall not exceed the limits specified in table 8.6.

#### 8.3.1.5.2 1,28 Mcps TDD option

The BLER measured according to subclause 8.3.1.4.2 shall not exceed the limits specified in table 8.6A.

#### 8.3.1.5.3 7,68 Mcps TDD option

The BLER measured according to subclause 8.3.1.4.2 shall not exceed the limits specified in table 8.6B.

## 8.3.2 Multipath fading Case 2

### 8.3.2.1 Definition and applicability

The performance requirement of DCH in multipath fading Case 2 is determined by the maximum Block Error Ratio (BLER) allowed when the receiver input signal is at a specified  $\hat{I}_{or}/I_{oc}$  limit. The BLER is calculated for each of the measurement channels supported by the base station.

The requirements in this subclause shall apply to Wide Area BS only. There is no requirement to test Local Area BS in multipath fading Case 2 conditions.

### 8.3.2.2 Minimum Requirements

#### 8.3.2.2.1 3,84 Mcps TDD option

For the parameters specified in table 8.8, the BLER should not exceed the piece-wise linear BLER curve specified in table 8.8. These requirements are applicable for TFCS size 16.

**Table 8.8: Parameters in multipath Case 2 channel**

| Parameters                              | Unit         | Test 1            | Test 2            | Test 3            | Test 4 |
|---|--------------|-------------------|-------------------|-------------------|--------|
| Number of DPCH <sub>o</sub>             |              | 2                 | 0                 | 0                 | 0      |
| $\frac{DPCH_o - E_c}{I_{or}}$           | DB           | -6                | -                 | -                 | -      |
| $I_{oc}$                                | dBm/3,84 MHz | -89               |                   |                   |        |
| Cell Parameter*                         |              | 0,1               |                   |                   |        |
| DPCH Channelization Codes*              | C(k,Q)       | C(1,8)            | C(1,4)<br>C(5,16) | C(1,2)<br>C(9,16) | C(1,2) |
| DPCH <sub>o</sub> Channelization Codes* | C(k,Q)       | C(i,16) 3 ≤ i ≤ 4 | -                 | -                 | -      |
| Information Data Rate                   | Kbps         | 12,2              | 64                | 144               | 384    |

\*Note: Refer to TS 25.223 for definition of channelization codes and cell parameter.

**Table 8.9: Performance requirements in multipath Case 2 channel.**

| Test Number | $\frac{\hat{I}_{or}}{I_{oc}}$ [dB] | BLER             |
|-------------|------------------------------------|------------------|
| 1           | -0,4                               | 10 <sup>-2</sup> |
| 2           | 0,2                                | 10 <sup>-1</sup> |
|             | 2,5                                | 10 <sup>-2</sup> |
| 3           | 3,6                                | 10 <sup>-1</sup> |
|             | 6,0                                | 10 <sup>-2</sup> |
| 4           | 2,8                                | 10 <sup>-1</sup> |
|             | 5,2                                | 10 <sup>-2</sup> |

The normative reference for this requirement is TS 25.105 [1] subclause 8.3.2.1.1.

### 8.3.2.2.2 1,28 Mcps option

For the parameters specified in table 8.8A, the BLER should not exceed the piece-wise linear BLER curve specified in table 8.9A. These requirements are applicable for TFCS size 16.

**Table 8.8A: Parameters in multipath Case 2 channel for 1,28 Mcps TDD**

| Parameters                         | Unit         | Test 1 | Test 2 | Test 3 | Test 4 |
|------------------------------------|--------------|--------|--------|--------|--------|
| Number of DPCH <sub>o</sub>        |              | 4      | 1      | 1      | 0      |
| Spread factor of DPCH <sub>o</sub> |              | 8      | 8      | 8      |        |
| $\frac{DPCH_o - E_c}{I_{or}}$      | dB           | -7     | -7     | -7     | -      |
| $I_{oc}$                           | dBm/1,28 MHz | -91    |        |        |        |
| Information Data Rate              | kbps         | 12,2   | 64     | 144    | 384    |

**Table 8.9A: Performance requirements multipath Case 2 channel for 1,28 Mcps TDD.**

| Test Number | $\frac{\hat{I}_{or}}{I_{oc}}$ [dB] | BLER             |
|-------------|------------------------------------|------------------|
| 1           | 6.7                                | 10 <sup>-2</sup> |
| 2           | 3.6                                | 10 <sup>-1</sup> |
|             | 5.9                                | 10 <sup>-2</sup> |
| 3           | 4.2                                | 10 <sup>-1</sup> |
|             | 6.3                                | 10 <sup>-2</sup> |
| 4           | 4.8                                | 10 <sup>-1</sup> |
|             | 7.1                                | 10 <sup>-2</sup> |

The normative reference for this requirement is TS 25.105 [1] subclause 8.3.2.1.2.

### 8.3.2.2.3 7,68 Mcps TDD option

For the parameters specified in table 8.8B, the BLER should not exceed the piece-wise linear BLER curve specified in table 8.9B. These requirements are applicable for TFCS size 16.

**Table 8.8B: Parameters in multipath Case 2 channel**

| Parameters   | Unit         | Test 1                |
|--|--------------|-----------------------|
| Number of DPCH <sub>0</sub>  |              | 6                     |
| $\frac{DPCH_o - E_c}{I_{or}}$  | dB           | -9                    |
| $I_{oc}$   | dBm/7.68 MHz | -89                   |
| Cell Parameter*  |              | 0,1                   |
| DPCH Channelization Codes*   | C(k,Q)       | C(1, 16)              |
| DPCH <sub>0</sub> Channelization Codes*  | C(k,Q)       | C(i, 32)<br>3 ≤ i ≤ 8 |
| Information Data Rate  | kbps         | 12.2                  |
| *Note: Refer to TS 25.223 for definition of channelization codes and cell parameter. |              |                       |

**Table 8.9B: Performance requirements in multipath Case 2 channel.**

| Test Number | $\frac{\hat{I}_{or}}{I_{oc}}$ [dB] | BLER      |
|-------------|------------------------------------|-----------|
| 1           | 1                                  | $10^{-2}$ |

The normative reference for this requirement is TS 25.105 [1] subclause 8.3.2.1.3.

### 8.3.2.3 Test purpose

The test purpose is to verify the ability of the BS to receive a prescribed test signal under defined propagation conditions (multipath fading Case 2) with a BLER not exceeding a specified limit. Within the wanted channel, independent intracell interference sources as well as an additional intercell interference source are taken into account. Therefore, this test - as all other tests in clause 8 - mainly checks the ability of the signal processing part of the receiver to extract the wanted signal from the distorted and interfered-with input signal, whereas the tests in clause 7 concentrate on the receiver RF part.

### 8.3.2.4 Method of test

#### 8.3.2.4.1 Initial conditions

##### 8.3.2.4.1.0 General test conditions

Test environment: normal; see subclause 5.9.1.

RF channels to be tested: B, M and T; see subclause 5.3.

##### 8.3.2.4.1.1 3,84 Mcps TDD option

- (1) Connect the BS tester (UE simulator) generating the wanted signal and a set of interference generators to both BS antenna connectors for diversity reception via a combining network. The set of interference generators comprises a number of CDMA generators, each representing an individual intracell interferer (subsequently called DPCH<sub>0</sub> generators), and an additional band-limited white noise source, simulating interference from other cells. Each DPCH<sub>0</sub> generator shall produce an interfering signal that is equivalent to a valid UTRA TDD signal with spreading factor 16, using the same time slot(s) than the wanted signal and applying the same cell-specific scrambling code. The number of the DPCH<sub>0</sub> generators used in each test is given in table 8.8.

- (2) The wanted signal produced by the BS tester and the interfering signals produced by the DPCH<sub>0</sub> generators are individually passed through independent Multipath Fading Simulators (MFS) before entering the combining network. Each MFS shall be configured to simulate multipath fading Case 2.

#### 8.3.2.4.1.2 1,28 Mcps TDD option

- (1) Connect the BS tester (UE simulator) generating the wanted signal and a set of interference generators to both BS antenna connectors for diversity reception via a combining network. The set of interference generators comprises a number of CDMA generators, each representing an individual intracell interferer (subsequently called DPCH<sub>0</sub> generators), and an additional band-limited white noise source, simulating interference from other cells. Each DPCH<sub>0</sub> generator shall produce an interfering signal that is equivalent to a valid UTRA TDD signal with spreading factor 8, using the same time slot(s) than the wanted signal and applying the same cell-specific scrambling code. The number of the DPCH<sub>0</sub> generators used in each test is given in table 8.8A.
- (2) The wanted signal produced by the BS tester and the interfering signals produced by the DPCH<sub>0</sub> generators are individually passed through independent Multipath Fading Simulators (MFS) before entering the combining network. Each MFS shall be configured to simulate multipath fading Case 2.

#### 8.3.2.4.1.3 7,68 Mcps TDD option

- (1) Connect the BS tester (UE simulator) generating the wanted signal and a set of interference generators to both BS antenna connectors for diversity reception via a combining network. The set of interference generators comprises a number of CDMA generators, each representing an individual intracell interferer (subsequently called DPCH<sub>0</sub> generators), and an additional band-limited white noise source, simulating interference from other cells. Each DPCH<sub>0</sub> generator shall produce an interfering signal that is equivalent to a valid UTRA TDD signal with spreading factor 32, using the same time slot(s) than the wanted signal and applying the same cell-specific scrambling code. The number of the DPCH<sub>0</sub> generators used in each test is given in table 8.8B.
- (2) The wanted signal produced by the BS tester and the interfering signals produced by the DPCH<sub>0</sub> generators are individually passed through independent Multipath Fading Simulators (MFS) before entering the combining network. Each MFS shall be configured to simulate multipath fading Case 2.

#### 8.3.2.4.2 Procedure

##### 8.3.2.4.2.1 3,84 Mcps TDD option

- (1) Adjust the power of the band-limited white noise source in such a way that its power spectral density measured at the BS antenna connector takes on the value  $I_{oc}$  as specified in table 8.8.
- (2) For a given test defined by the information data rate and the BLER objective, set the power of each DPCH<sub>0</sub> measured at the BS antenna connector during the active time slots to the value specified in table 8.101.
- (3) Set up a call between the BS tester generating the wanted signal and the BS. The characteristics of the call shall be configured according to the information data rate to be provided and the corresponding UL reference measurement channel defined in Annex A. Depending on the information data rate, the UL reference measurement channel makes use of one or two Dedicated Physical Channels (DPCH<sub>1</sub> and DPCH<sub>2</sub>) with different spreading factors SF. The power(s) of DPCH<sub>1</sub> and DPCH<sub>2</sub> (if applicable) measured at the BS antenna connector during the active time slots shall be set to the value(s) given in table 8.10.
- (4) Measure the BLER of the wanted signal at the BS receiver.

**Table 8.10: Parameters of DPCH<sub>0</sub> and the wanted signal**

| Test Number | BLER objective   | Number of DPCH <sub>0</sub> | Power of each DPCH <sub>0</sub> measured at the BS antenna connector [dBm] | Parameters of the wanted signal |    |  |
|-------------|------------------|-----------------------------|--|---------------------------------|----|--|
|             |                  |                             |  | DPCH                            | SF | Power measured at the BS antenna connector [dBm] |
| 1           | 10 <sup>-2</sup> | 2                           | -95,4  | DPCH <sub>1</sub>               | 8  | -92,4  |
| 2           | 10 <sup>-1</sup> | 0                           | -  | DPCH <sub>1</sub>               | 16 | -95,8  |
|             |                  |                             |  | DPCH <sub>2</sub>               | 4  | -89,8  |
|             | 10 <sup>-2</sup> | 0                           | -  | DPCH <sub>1</sub>               | 16 | -93,5  |
|             |                  |                             |  | DPCH <sub>2</sub>               | 4  | -87,5  |
| 3           | 10 <sup>-1</sup> | 0                           | -  | DPCH <sub>1</sub>               | 16 | -94,9  |
|             |                  |                             |  | DPCH <sub>2</sub>               | 2  | -85,9  |
|             | 10 <sup>-2</sup> | 0                           | -  | DPCH <sub>1</sub>               | 16 | -92,5  |
|             |                  |                             |  | DPCH <sub>2</sub>               | 2  | -83,5  |
| 4           | 10 <sup>-1</sup> | 0                           | -  | DPCH <sub>1</sub>               | 2  | -86,2  |
|             | 10 <sup>-2</sup> | 0                           | -  | DPCH <sub>1</sub>               | 2  | -83,8  |

## 8.3.2.4.2.2 1,28 Mcps TDD option

- (1) Adjust the power of the band-limited white noise source in such a way that its power spectral density measured at the BS antenna connector takes on the value  $I_{oc}$  as specified in table 8.8A.
- (2) For a given test defined by the information data rate and the BLER objective, set the power of each DPCH<sub>0</sub> measured at the BS antenna connector during the active time slots to the value specified in table 8.10A.
- (3) Set up a call between the BS tester generating the wanted signal and the BS. The characteristics of the call shall be configured according to the information data rate to be provided and the corresponding UL reference measurement channel defined in Annex A. Depending on the information data rate, the UL reference measurement channel makes use of one or two Dedicated Physical Channels (DPCH<sub>1</sub> and DPCH<sub>2</sub>) with different spreading factors SF. The power(s) of DPCH<sub>1</sub> and DPCH<sub>2</sub> (if applicable) measured at the BS antenna connector during the active time slots shall be set to the value(s) given in table 8.10A.
- (4) Measure the BLER of the wanted signal at the BS receiver.

**Table 8.10A: Parameters of DPCH<sub>0</sub> and the wanted signal for 1,28 Mcps TDD**

| Test Number | BLER objective   | Number of DPCH <sub>0</sub> | Power of each DPCH <sub>0</sub> measured at the BS antenna connector [dBm] | Parameters of the wanted signal |    |  |
|-------------|------------------|-----------------------------|--|---------------------------------|----|--|
|             |                  |                             |  | DPCH                            | SF | Power measured at the BS antenna connector [dBm] |
| 1           | 10 <sup>-2</sup> | 4                           | -91.3  | DPCH <sub>1</sub>               | 8  | -91.3  |
| 2           | 10 <sup>-1</sup> | 1                           | -94.4  | DPCH <sub>1</sub>               | 2  | -88.4  |
|             | 10 <sup>-2</sup> | 1                           | -92.1  | DPCH <sub>1</sub>               | 2  | -86.1  |
| 3           | 10 <sup>-1</sup> | 1                           | -93.8  | DPCH <sub>1</sub>               | 2  | -87.8  |
|             | 10 <sup>-2</sup> | 1                           | -91.7  | DPCH <sub>1</sub>               | 2  | -85.7  |
| 4           | 10 <sup>-1</sup> | 0                           | -  | DPCH <sub>1</sub>               | 16 | -95.7  |
|             |                  |                             |  | DPCH <sub>2</sub>               | 2  | -86.7  |
|             | 10 <sup>-2</sup> | 0                           | -  | DPCH <sub>1</sub>               | 16 | -93.4  |
|             |                  |                             |  | DPCH <sub>2</sub>               | 2  | -84.4  |

## 8.3.2.4.2.3 7,68 Mcps TDD option

- (1) Adjust the power of the band-limited white noise source in such a way that its power spectral density measured at the BS antenna connector takes on the value  $I_{oc}$  as specified in table 8.8B.
- (2) For a given test defined by the information data rate and the BLER objective, set the power of each DPCH<sub>0</sub> measured at the BS antenna connector during the active time slots to the value specified in table 8.10B.
- (3) Set up a call between the BS tester generating the wanted signal and the BS. The characteristics of the call shall be configured according to the information data rate to be provided and the corresponding UL reference measurement channel defined in Annex A. Depending on the information data rate, the UL reference

measurement channel makes use of one or two Dedicated Physical Channels (DPCH<sub>1</sub> and DPCH<sub>2</sub>) with different spreading factors SF. The power(s) of DPCH<sub>1</sub> and DPCH<sub>2</sub> (if applicable) measured at the BS antenna connector during the active time slots shall be set to the value(s) given in table 8.10B.

(4) Measure the BLER of the wanted signal at the BS receiver.

**Table 8.10B: Parameters of DPCH<sub>0</sub> and the wanted signal**

| Test Number | BLER objective   | Number of DPCH <sub>0</sub> | Power of each DPCH <sub>0</sub> measured at the BS antenna connector [dBm] | Parameters of the wanted signal |    |  |
|-------------|------------------|-----------------------------|--|---------------------------------|----|--|
|             |                  |                             |  | DPCH                            | SF | Power measured at the BS antenna connector [dBm] |
| 1           | 10 <sup>-2</sup> | 6                           | -97  | DPCH <sub>1</sub>               | 16 | -94  |

### 8.3.2.5 Test Requirements

NOTE: If the Test Requirements below differ from the Minimum Requirements, then the Test Tolerance applied for this test is non-zero. The Test Tolerance for this test is defined in subclause 5.11 and the explanation of how the Minimum Requirement has been relaxed by the Test Tolerance is given in Annex D.

#### 8.3.2.5.1 3,84 Mcps TDD option

The BLER measured according to subclause 8.3.2.4.2 shall not exceed the limits specified in table 8.9.

#### 8.3.2.5.2 1,28 Mcps TDD option

The BLER measured according to subclause 8.3.2.4.2 shall not exceed the limits specified in table 8.9A

#### 8.3.2.5.3 7,68 Mcps TDD option

The BLER measured according to subclause 8.3.2.4.2 shall not exceed the limits specified in table 8.9B.

## 8.3.3 Multipath fading Case 3

### 8.3.3.1 Definition and applicability

The performance requirement of DCH in multipath fading Case 3 is determined by the maximum Block Error Ratio (BLER) allowed when the receiver input signal is at a specified  $\hat{I}_{or}/I_{oc}$  limit. The BLER is calculated for each of the measurement channels supported by the base station.

The requirements in this subclause shall apply to Wide Area BS only. There is no requirement to test Local Area BS in multipath fading Case 3 conditions.

### 8.3.3.2 Minimum Requirements

#### 8.3.3.2.1 3,84 Mcps TDD option

For the parameters specified in table 8.11, the BLER should not exceed the piece-wise linear BLER curve specified in Table 8.12. These requirements are applicable for TFCS size 16.

**Table 8.11: Parameters in multipath Case 3 channel**

| Parameters                              | Unit         | Test 1            | Test 2            | Test 3            | Test 4 |
|---|--------------|-------------------|-------------------|-------------------|--------|
| Number of DPCH <sub>o</sub>             |              | 2                 | 0                 | 0                 | 0      |
| $\frac{DPCH_o - E_c}{I_{or}}$           | dB           | -6                | -                 | -                 | -      |
| $I_{oc}$                                | dBm/3,84 MHz | -89               |                   |                   |        |
| Cell Parameter*                         |              | 0,1               |                   |                   |        |
| DPCH Channelization Codes*              | C(k,Q)       | C(1,8)            | C(1,4)<br>C(5,16) | C(1,2)<br>C(9,16) | C(1,2) |
| DPCH <sub>o</sub> Channelization Codes* | C(k,Q)       | C(i,16) 3 ≤ i ≤ 4 | -                 | -                 | -      |
| Information Data Rate                   | Kbps         | 12,2              | 64                | 144               | 384    |

\*Note: Refer to TS 25.223 for definition of channelization codes and cell parameter.

**Table 8.12: Performance requirements in multipath Case 3 channel.**

| Test Number | $\frac{\hat{I}_{or}}{I_{oc}}$ [dB] | BLER             |
|-------------|------------------------------------|------------------|
| 1           | -0,1                               | 10 <sup>-2</sup> |
| 2           | 0,8                                | 10 <sup>-1</sup> |
|             | 2,7                                | 10 <sup>-2</sup> |
|             | 4,2                                | 10 <sup>-3</sup> |
| 3           | 4,5                                | 10 <sup>-1</sup> |
|             | 6,3                                | 10 <sup>-2</sup> |
|             | 8,0                                | 10 <sup>-3</sup> |
| 4           | 3,6                                | 10 <sup>-1</sup> |
|             | 5,0                                | 10 <sup>-2</sup> |
|             | 6,3                                | 10 <sup>-3</sup> |

The normative reference for this requirement is TS 25.105 [1] subclause 8.3.3.1.1.

### 8.3.3.2.2 1,28 Mcps TDD option

For the parameters specified in table 8.11A, the BLER should not exceed the piece-wise linear BLER curve specified in Table 8.12A. These requirements are applicable for TFCS size 16.

**Table 8.11A: Parameters in multipath Case 3 channel (1,28 Mcps option)**

| Parameters                         | Unit         | Test 1 | Test 2 | Test 3 | Test 4 |
|------------------------------------|--------------|--------|--------|--------|--------|
| Number of DPCH <sub>o</sub>        |              | 4      | 1      | 1      | 0      |
| Spread factor of DPCH <sub>o</sub> |              | 8      | 8      | 8      |        |
| $\frac{DPCH_o - E_c}{I_{or}}$      | dB           | -7     | -7     | -7     | -      |
| $I_{oc}$                           | dBm/1,28 MHz | -91    |        |        |        |
| Information Data Rate              | kbps         | 12,2   | 64     | 144    | 384    |

**Table 8.12A: Performance requirements multipath Case 3 channel (1,28 Mcps option).**

| Test Number | $\frac{\hat{I}_{or}}{I_{oc}}$ [dB] | BLER      |
|-------------|------------------------------------|-----------|
| 1           | 5.6                                | $10^{-2}$ |
| 2           | 3.2                                | $10^{-1}$ |
|             | 4.6                                | $10^{-2}$ |
|             | 5.9                                | $10^{-3}$ |
| 3           | 3.7                                | $10^{-1}$ |
|             | 4.8                                | $10^{-2}$ |
|             | 5.9                                | $10^{-3}$ |
| 4           | 3.9                                | $10^{-1}$ |
|             | 4.8                                | $10^{-2}$ |
|             | 5.7                                | $10^{-3}$ |

The normative reference for this requirement is TS 25.105 [1] subclause 8.3.3.1.2

### 8.3.3.2.3 7,68 Mcps TDD option

For the parameters specified in table 8.11B, the BLER should not exceed the piece-wise linear BLER curve specified in Table 8.12B. These requirements are applicable for TFCS size 16.

**Table 8.11B: Parameters in multipath Case 3 channel**

| Parameters   | Unit         | Test 1                |
|--|--------------|-----------------------|
| Number of DPCH <sub>o</sub>  |              | 6                     |
| $\frac{DPCH_o - E_c}{I_{or}}$  | dB           | -9                    |
| $I_{oc}$   | dBm/7.68 MHz | -89                   |
| Cell Parameter*  |              | 0,1                   |
| DPCH Channelization Codes*   | C(k,Q)       | C(1, 16)              |
| DPCH <sub>o</sub> Channelization Codes*  | C(k,Q)       | C(i, 32)<br>3 ≤ i ≤ 8 |
| Information Data Rate  | kbps         | 12.2                  |
| *Note: Refer to TS 25.223 for definition of channelization codes and cell parameter. |              |                       |

**Table 8.12B: Performance requirements in multipath Case 3 channel.**

| Test Number | $\frac{\hat{I}_{or}}{I_{oc}}$ [dB] | BLER      |
|-------------|------------------------------------|-----------|
| 1           | -0.1                               | $10^{-2}$ |

The normative reference for this requirement is TS 25.105 [1] subclause 8.3.3.1.3.

### 8.3.3.3 Test purpose

The test purpose is to verify the ability of the BS to receive a prescribed test signal under defined propagation conditions (multipath fading Case 3) with a BLER not exceeding a specified limit. Within the wanted channel, independent intracell interference sources as well as an additional intercell interference source are taken into account. Therefore, this test - as all other tests in clause 8 - mainly checks the ability of the signal processing part of the receiver to extract the wanted signal from the distorted and interfered-with input signal, whereas the tests in clause 7 concentrate on the receiver RF part.



### 8.3.3.4 Method of test

#### 8.3.3.4.1 Initial conditions

##### 8.3.3.4.1.0 General test conditions

Test environment: normal; see subclause 5.9.1.

RF channels to be tested: B, M and T; see subclause 5.3.

##### 8.3.3.4.1.1 3,84 Mcps TDD option

- (1) Connect the BS tester (UE simulator) generating the wanted signal and a set of interference generators to both BS antenna connectors for diversity reception via a combining network. The set of interference generators comprises a number of CDMA generators, each representing an individual intracell interferer (subsequently called DPCH<sub>0</sub> generators), and an additional band-limited white noise source, simulating interference from other cells. Each DPCH<sub>0</sub> generator shall produce an interfering signal that is equivalent to a valid UTRA TDD signal with spreading factor 16, using the same time slot(s) than the wanted signal and applying the same cell-specific scrambling code. The number of the DPCH<sub>0</sub> generators used in each test is given in table 8.11.
- (2) The wanted signal produced by the BS tester and the interfering signals produced by the DPCH<sub>0</sub> generators are individually passed through independent Multipath Fading Simulators (MFS) before entering the combining network. Each MFS shall be configured to simulate multipath fading Case 3.

##### 8.3.3.4.1.2 1,28 Mcps TDD option

- (1) Connect the BS tester (UE simulator) generating the wanted signal and a set of interference generators to both BS antenna connectors for diversity reception via a combining network. The set of interference generators comprises a number of CDMA generators, each representing an individual intracell interferer (subsequently called DPCH<sub>0</sub> generators), and an additional band-limited white noise source, simulating interference from other cells. Each DPCH<sub>0</sub> generator shall produce an interfering signal that is equivalent to a valid UTRA TDD signal with spreading factor 8, using the same time slot(s) than the wanted signal and applying the same cell-specific scrambling code. The number of the DPCH<sub>0</sub> generators used in each test is given in table 8.11A.
- (2) The wanted signal produced by the BS tester and the interfering signals produced by the DPCH<sub>0</sub> generators are individually passed through independent Multipath Fading Simulators (MFS) before entering the combining network. Each MFS shall be configured to simulate multipath fading Case 3.

##### 8.3.3.4.1.3 7,68 Mcps TDD option

- (1) Connect the BS tester (UE simulator) generating the wanted signal and a set of interference generators to both BS antenna connectors for diversity reception via a combining network. The set of interference generators comprises a number of CDMA generators, each representing an individual intracell interferer (subsequently called DPCH<sub>0</sub> generators), and an additional band-limited white noise source, simulating interference from other cells. Each DPCH<sub>0</sub> generator shall produce an interfering signal that is equivalent to a valid UTRA TDD signal with spreading factor 32, using the same time slot(s) than the wanted signal and applying the same cell-specific scrambling code. The number of the DPCH<sub>0</sub> generators used in each test is given in table 8.11B.
- (2) The wanted signal produced by the BS tester and the interfering signals produced by the DPCH<sub>0</sub> generators are individually passed through independent Multipath Fading Simulators (MFS) before entering the combining network. Each MFS shall be configured to simulate multipath fading Case 3.

#### 8.3.3.4.2 Procedure

##### 8.3.3.4.2.1 3,84 Mcps TDD option

- (1) Adjust the power of the band-limited white noise source in such a way that its power spectral density measured at the BS antenna connector takes on the value  $I_{oc}$  as specified in table 8.11.
- (2) For a given test defined by the information data rate and the BLER objective, set the power of each DPCH<sub>0</sub> measured at the BS antenna connector during the active time slots to the value specified in table 8.13.

- (3) Set up a call between the BS tester generating the wanted signal and the BS. The characteristics of the call shall be configured according to the information data rate to be provided and the corresponding UL reference measurement channel defined in Annex A. Depending on the information data rate, the UL reference measurement channel makes use of one or two Dedicated Physical Channels (DPCH<sub>1</sub> and DPCH<sub>2</sub>) with different spreading factors SF. The power(s) of DPCH<sub>1</sub> and DPCH<sub>2</sub> (if applicable) measured at the BS antenna connector during the active time slots shall be set to the value(s) given in table 8.131.
- (4) Measure the BLER of the wanted signal at the BS receiver.

**Table 8.13: Parameters of DPCH<sub>0</sub> and the wanted signal**

| Test Number      | BLER objective   | Number of DPCH <sub>0</sub> | Power of each DPCH <sub>0</sub> measured at the BS antenna connector [dBm] | Parameters of the wanted signal |       |  |
|------------------|------------------|-----------------------------|--|---------------------------------|-------|--|
|                  |                  |                             |  | DPCH                            | SF    | Power measured at the BS antenna connector [dBm] |
| 1                | 10 <sup>-2</sup> | 2                           | -95,1  | DPCH <sub>1</sub>               | 8     | -92,1  |
| 2                | 10 <sup>-1</sup> | 0                           | -  | DPCH <sub>1</sub>               | 16    | -95,2  |
|                  |                  |                             |  | DPCH <sub>2</sub>               | 4     | -89,2  |
|                  | 10 <sup>-2</sup> | 0                           | -  | DPCH <sub>1</sub>               | 16    | -93,3  |
|                  |                  |                             |  | DPCH <sub>2</sub>               | 4     | -87,3  |
|                  | 10 <sup>-3</sup> | 0                           | -  | DPCH <sub>1</sub>               | 16    | -91,8  |
|                  |                  |                             |  | DPCH <sub>2</sub>               | 4     | -85,8  |
| 3                | 10 <sup>-1</sup> | 0                           | -  | DPCH <sub>1</sub>               | 16    | -94,0  |
|                  |                  |                             |  | DPCH <sub>2</sub>               | 2     | -85,0  |
|                  | 10 <sup>-2</sup> | 0                           | -  | DPCH <sub>1</sub>               | 16    | -92,2  |
|                  |                  |                             |  | DPCH <sub>2</sub>               | 2     | -83,2  |
| 10 <sup>-3</sup> | 0                | -                           | DPCH <sub>1</sub>  | 16                              | -90,5 |  |
|                  |                  |                             | DPCH <sub>2</sub>  | 2                               | -81,5 |  |
| 4                | 10 <sup>-1</sup> | 0                           | -  | DPCH <sub>1</sub>               | 2     | -85,4  |
|                  | 10 <sup>-2</sup> | 0                           | -  | DPCH <sub>1</sub>               | 2     | -84,0  |
|                  | 10 <sup>-3</sup> | 0                           | -  | DPCH <sub>1</sub>               | 2     | -82,7  |

#### 8.3.3.4.2.2 1,28 Mcps TDD option

- (1) Adjust the power of the band-limited white noise source in such a way that its power spectral density measured at the BS antenna connector takes on the value  $I_{oc}$  as specified in table 8.11A.
- (2) For a given test defined by the information data rate and the BLER objective, set the power of each DPCH<sub>0</sub> measured at the BS antenna connector during the active time slots to the value specified in table 8.13A.
- (3) Set up a call between the BS tester generating the wanted signal and the BS. The characteristics of the call shall be configured according to the information data rate to be provided and the corresponding UL reference measurement channel defined in Annex A. Depending on the information data rate, the UL reference measurement channel makes use of one or two Dedicated Physical Channels (DPCH<sub>1</sub> and DPCH<sub>2</sub>) with different spreading factors SF. The power(s) of DPCH<sub>1</sub> and DPCH<sub>2</sub> (if applicable) measured at the BS antenna connector during the active time slots shall be set to the value(s) given in table 8.13A.
- (4) Measure the BLER of the wanted signal at the BS receiver.

**Table 8.13A: Parameters of DPCH<sub>0</sub> and the wanted signal for 1,28 Mcps TDD**

| Test Number       | BLER objective   | Number of DPCH <sub>0</sub> | Power of each DPCH <sub>0</sub> measured at the BS antenna connector [dBm] | Parameters of the wanted signal |       |  |
|-------------------|------------------|-----------------------------|--|---------------------------------|-------|--|
|                   |                  |                             |  | DPCH                            | SF    | Power measured at the BS antenna connector [dBm] |
| 1                 | 10 <sup>-2</sup> | 4                           | -92.4  | DPCH <sub>1</sub>               | 8     | -92.4  |
| 2                 | 10 <sup>-1</sup> | 1                           | -94.8  | DPCH <sub>1</sub>               | 2     | -88.8  |
|                   | 10 <sup>-2</sup> | 1                           | -93.4  | DPCH <sub>1</sub>               | 2     | -87.4  |
|                   | 10 <sup>-3</sup> | 1                           | -92.1  | DPCH <sub>1</sub>               | 2     | -86.1  |
| 3                 | 10 <sup>-1</sup> | 1                           | -94.3  | DPCH <sub>1</sub>               | 2     | -88.3  |
|                   | 10 <sup>-2</sup> | 1                           | -93.2  | DPCH <sub>1</sub>               | 2     | -87.2  |
|                   | 10 <sup>-3</sup> | 1                           | -92.1  | DPCH <sub>1</sub>               | 2     | -86.1  |
| 4                 | 10 <sup>-1</sup> | 0                           | -  | DPCH <sub>1</sub>               | 16    | -96.6  |
|                   |                  |                             |  | DPCH <sub>2</sub>               | 2     | -87.6  |
|                   | 10 <sup>-2</sup> | 0                           | -  | DPCH <sub>1</sub>               | 16    | -95.7  |
|                   |                  |                             |  | DPCH <sub>2</sub>               | 2     | -86.7  |
|                   | 10 <sup>-3</sup> | 0                           | -  | DPCH <sub>1</sub>               | 16    | -94.8  |
| DPCH <sub>2</sub> |                  |                             |  | 2                               | -85.8 |  |

#### 8.3.3.4.2.3 7,68 Mcps TDD option

- (1) Adjust the power of the band-limited white noise source in such a way that its power spectral density measured at the BS antenna connector takes on the value  $I_{oc}$  as specified in table 8.11B.
- (2) For a given test defined by the information data rate and the BLER objective, set the power of each DPCH<sub>0</sub> measured at the BS antenna connector during the active time slots to the value specified in table 8.13B.
- (3) Set up a call between the BS tester generating the wanted signal and the BS. The characteristics of the call shall be configured according to the information data rate to be provided and the corresponding UL reference measurement channel defined in Annex A. Depending on the information data rate, the UL reference measurement channel makes use of one or two Dedicated Physical Channels (DPCH<sub>1</sub> and DPCH<sub>2</sub>) with different spreading factors SF. The power(s) of DPCH<sub>1</sub> and DPCH<sub>2</sub> (if applicable) measured at the BS antenna connector during the active time slots shall be set to the value(s) given in table 8.13B.
- (4) Measure the BLER of the wanted signal at the BS receiver.

**Table 8.13B: Parameters of DPCH<sub>0</sub> and the wanted signal**

| Test Number | BLER objective   | Number of DPCH <sub>0</sub> | Power of each DPCH <sub>0</sub> measured at the BS antenna connector [dBm] | Parameters of the wanted signal |    |  |
|-------------|------------------|-----------------------------|--|---------------------------------|----|--|
|             |                  |                             |  | DPCH                            | SF | Power measured at the BS antenna connector [dBm] |
| 1           | 10 <sup>-2</sup> | 6                           | -98,1  | DPCH <sub>1</sub>               | 16 | -95,1  |

#### 8.3.3.5 Test Requirements

NOTE: If the Test Requirements below differ from the Minimum Requirements, then the Test Tolerance applied for this test is non-zero. The Test Tolerance for this test is defined in subclause 5.11 and the explanation of how the Minimum Requirement has been relaxed by the Test Tolerance is given in Annex D.

##### 8.3.3.5.1 3,84 Mcps TDD option

The BLER measured according to subclause 8.3.3.4.2 shall not exceed the limits specified in table 8.12.

##### 8.3.3.5.2 1,28 Mcps TDD option

The BLER measured according to subclause 8.3.3.4.2 shall not exceed the limits specified in table 8.12A.

### 8.3.3.5.3 7,68 Mcps TDD option

The BLER measured according to subclause 8.3.3.4.2 shall not exceed the limits specified in table 8.12B.

## 8.3A Demodulation of DCH in high speed train conditions

### 8.3A.1 Definition and applicability

The performance requirement of DCH in high speed train conditions is determined by the maximum BLER allowed when the receiver input signal is at a specified  $\hat{I}_{or}/I_{oc}$  limit. The BLER is calculated for the measurement channel supported by the base station.

This requirement shall only be applied to BS supporting high speed mode.

### 8.3A.2 Minimum requirement

#### 8.3A.2.1 3.84 Mcps TDD option

(void)

#### 8.3A.2.2 1.28 Mcps TDD option

For the parameters specified in Table 8.13C the BLER should not exceed the BLER requirement specified in Table 8.13D. These requirements are applicable for TFCS size 16.

**Table 8.13C: DCH parameters in high speed train condition**

| Parameters                                      | Unit        | Test 1              | Test 2 |
|---|-------------|---------------------|--------|
| Number of DPCHo                                 |             | 4                   | 1      |
| Spread factor of DPCHo                          |             | 8                   | 8      |
| Scrambling code and basic midamble code number* |             | 0                   | 0      |
| DPCH Channelization Codes*                      | C(k,Q)      | C(1,8)              | C(1,2) |
| DPCHo Channelization Codes*                     | C(k,Q)      | C(i,8)<br>2 ≤ i ≤ 5 | C(5,8) |
| $\frac{DPCH_o - E_c}{I_{or}}$                   | dB          | -7                  | -7     |
| loc   | dBm/1.28MHz | -91                 |        |
| Information Data Rate                           | Kbps        | 12.2                | 64     |

\*Note: Refer to TS 25.223 for definition of channelization codes and cell parameter.

**Table 8.13D: DCH requirements in high speed train condition**

| Test number | Scenario | dual receiver antenna diversity | $\frac{\hat{I}_{or}}{I_{oc}}$ [dB] | BLER      |
|-------------|----------|---------------------------------|------------------------------------|-----------|
| 1           | 1        | On                              | 4.0                                | $10^{-2}$ |
|             |          | Off *                           | 7.5                                | $10^{-2}$ |
|             | 3        | Off *                           | 7.7                                | $10^{-2}$ |
| 2           | 1        | On                              | 1.2                                | $10^{-1}$ |
|             |          | On                              | 2.0                                | $10^{-2}$ |
|             |          | Off *                           | 4.6                                | $10^{-1}$ |
|             | 3        | Off *                           | 5.4                                | $10^{-2}$ |
|             |          | Off *                           | 4.8                                | $10^{-1}$ |
|             |          | Off *                           | 6.0                                | $10^{-2}$ |

\*Note: The requirement is only applicable for BS without receiver antenna diversity, the required  $\frac{\hat{I}_{or}}{I_{oc}}$  shall be applied at the BS Rx antenna port.

The normative reference for this requirement is TS 25.105 [1] subclause 8.3A.2.2.

### 8.3A.2.3 7.68 Mcps TDD option

(void)

### 8.3A.3 Test purpose

The test shall verify the receiver's ability to receive the test signal in high speed train conditions with a BLER not exceeding the specified limit.

## 8.3A.4 Method of test

### 8.3A.4.1 Initial conditions

#### 8.3A.4.1.1 General test conditions

Test environment: normal; see subclause 5.9.1

RF channels to be tested: B, M and T; see subclause 5.3

#### 8.3A.4.1.1 3.84 Mcps TDD option

(void)

#### 8.3A.4.1.1 1.28 Mcps TDD option

Connect the BS tester (UE simulator) generating the wanted signal, Channel Simulator generating Doppler shift and a set of interference generators to both BS antenna connectors for diversity reception via a combining network. The set of interference generators comprises a number of CDMA generators, each representing an individual intracell interferer (subsequently called DPCH<sub>0</sub> generators), and an additional band-limited white noise source, simulating interference from other cells. Each DPCH<sub>0</sub> generator shall produce an interfering signal that is equivalent to a valid UTRA TDD signal with spreading factor 8, using the same time slot(s) than the wanted signal and applying the same cell-specific scrambling code. The number of the DPCH<sub>0</sub> generators used in each test is given in table 8.13C.

#### 8.3A.4.1.1 7.68 Mcps TDD option

(void)

### 8.3A.4.2 Procedure

#### 8.3A.4.2.1 3.84 Mcps TDD option

(void)

#### 8.3A.4.2.2 1.28 Mcps TDD option

- (1) Adjust the power of the band-limited white noise source in such a way that its power spectral density measured at the BS antenna connector takes on the value  $I_{oc}$  as specified in table 8.13C.
- (2) For a given test defined by the information data rate and the BLER objective, set the power of each DPCH<sub>0</sub> measured at the BS antenna connector during the active time slots to the value specified in table 8.13E.
- (4) The Channel Simulator shall be configured according to the corresponding Doppler shift trajectories defined in annex B.
- (5) Set up a call between the BS tester generating the wanted signal and the BS. The characteristics of the call shall be configured according to the information data rate to be provided and the corresponding UL reference measurement channel defined in Annex A. Depending on the information data rate, the UL reference measurement channel makes use of one or two Dedicated Physical Channels (DPCH<sub>1</sub> and DPCH<sub>2</sub>) with different spreading factors SF. The power(s) of DPCH<sub>1</sub> and DPCH<sub>2</sub> (if applicable) measured at the BS antenna connector during the active time slots shall be set to the value(s) given in table 8.13E.
- (6) Measure the BLER of the wanted signal at the BS receiver.

Table 8.13E: Parameters of DPCH<sub>0</sub> and the wanted signal for 1,28 Mcps TDD

| Test Number   | Scenario | Dual receiver antenna diversity | BLER objective   | Number of DPCH <sub>0</sub> | Power of each DPCH <sub>0</sub> measured at the BS antenna connector [dBm] | Parameters of the wanted signal |    |  |
|---|----------|---------------------------------|------------------|-----------------------------|--|---------------------------------|----|--|
|   |          |                                 |                  |                             |  | DPCH                            | SF | Power measured at the BS antenna connector [dBm] |
| 1   | 1        | On                              | 10 <sup>-2</sup> | 4                           | -94.0  | DPCH <sub>1</sub>               | 8  | -94.0  |
|   |          | Off *                           | 10 <sup>-2</sup> | 4                           | -90.5  | DPCH <sub>1</sub>               | 8  | -90.5  |
|   | 3        | Off *                           | 10 <sup>-2</sup> | 4                           | -90.3  | DPCH <sub>1</sub>               | 8  | -90.3  |
| 2   | 1        | On                              | 10 <sup>-1</sup> | 1                           | -96.8  | DPCH <sub>1</sub>               | 2  | -90.8  |
|   |          | On                              | 10 <sup>-2</sup> | 1                           | -96.0  | DPCH <sub>1</sub>               | 2  | -90.0  |
|   |          | Off *                           | 10 <sup>-1</sup> | 1                           | -93.4  | DPCH <sub>1</sub>               | 2  | -87.4  |
|   |          | Off *                           | 10 <sup>-2</sup> | 1                           | -92.6  | DPCH <sub>1</sub>               | 2  | -86.6  |
|   | 3        | Off *                           | 10 <sup>-1</sup> | 1                           | -93.2  | DPCH <sub>1</sub>               | 2  | -87.2  |
|   |          | Off *                           | 10 <sup>-2</sup> | 1                           | -92.0  | DPCH <sub>1</sub>               | 2  | -86.0  |
| *Note: The requirement is only applicable for BS without receiver antenna diversity, the required $\frac{\hat{I}_{or}}{I_{oc}}$ shall be applied at the BS Rx antenna port. |          |                                 |                  |                             |  |                                 |    |  |

## 8.3A.4.2.3 7.68 Mcps TDD option

(void)

## 8.3A.5 Test requirements

NOTE: If the Test Requirement below differs from the Minimum Requirement, then the Test Tolerance applied for this test is non-zero. The Test Tolerance for this test is defined in subclause 5.11 and the explanation of how the Minimum Requirement has been relaxed by the Test Tolerance is given in Annex D.

## 8.3A.5.1 3,84 Mcps TDD option

(void)

## 8.3A.5.2 1,28 Mcps TDD option

The BLER measured according to subclause 8.3A.4.2.2. shall not exceed the limits specified in table 8.13F.

Table 8.13F: DCH requirements in high speed train condition

| Test number  | Scenario | dual receiver antenna diversity | $\frac{\hat{I}_{or}}{I_{oc}}$ [dB] | BLER      |
|--|----------|---------------------------------|------------------------------------|-----------|
| 1  | 1        | On                              | 4.4                                | $10^{-2}$ |
|  |          | Off *                           | 7.9                                | $10^{-2}$ |
|  | 3        | Off *                           | 8.1                                | $10^{-2}$ |
| 2  | 1        | On                              | 1.6                                | $10^{-1}$ |
|  |          | On                              | 2.4                                | $10^{-2}$ |
|  |          | Off *                           | 5.0                                | $10^{-1}$ |
|  |          | Off *                           | 5.8                                | $10^{-2}$ |
|  | 3        | Off *                           | 5.2                                | $10^{-1}$ |
|  |          | Off *                           | 6.4                                | $10^{-2}$ |
| <p><b>*Note:</b> The requirement is only applicable for BS without receiver antenna diversity, the required <math>\frac{\hat{I}_{or}}{I_{oc}}</math> shall be applied at the BS Rx antenna port.</p> |          |                                 |                                    |           |

## 8.3A.5.3 7,68 Mcps TDD option

(void)

## 8.4 Demodulation of E-DCH FRC in multipath fading conditions

## 8.4.1 Definition and applicability

The performance requirement of the E-DCH in multi-path fading condition is determined by the minimum throughput R.

## 8.4.2 Minimum Requirements

## 8.4.2.1 3,84 Mcps TDD Option

For the test parameters specified in Table 8.14, the minimum requirements are specified in Table 8.15.

Table 8.14: Test parameters for testing E-DCH (3,84 Mcps TDD Option)

| Parameter  |               | Unit         | Value                 |         |         |
|--|---------------|--------------|-----------------------|---------|---------|
|  |               |              | FRC1                  | FRC2    | FRC3    |
| Max information rate   |               | kbps         | 34.7                  | 1083.1  | 2073.7  |
| $I_{oc}$   | Wide Area BS  | dBm/3,84 MHz | -89                   |         |         |
|  | Local Area BS | dBm/3,84 MHz | -74                   |         |         |
| E-DCH $E_c/I_{or}$   |               | dB           | 0                     | 0       | 0       |
| Cell Parameter*  |               |              | 0, 1                  |         |         |
| E-DCH channelization code*   |               | C(k, Q)      | C(1, 16)              | C(1, 2) | C(1, 1) |
| RSN  |               |              | {0, 1, 2, 3}          |         |         |
| HARQ combining   |               |              | IR                    |         |         |
| Maximum number of HARQ transmission  |               |              | 4                     |         |         |
| Power control  |               |              | OFF                   |         |         |
| Receiver antenna diversity   |               |              | ON                    |         |         |
| Midamble   |               |              | Default midamble      |         |         |
| Physical channels to be turned on  |               |              | E-PUCH                |         |         |
| Propagation condition  |               |              | PA3, PB3, VA30, VA120 |         |         |
| *Note: Refer to TS 25.223 for definition of channelization codes and cell parameter. |               |              |                       |         |         |



**Table 8.15 Minimum Requirement for E-DCH (3,84 Mcps TDD Option)**

| Fixed Reference Channel   |     | Reference value, $\hat{I}_{or}/I_{oc}$ (dB),<br>for $R \geq 30\%$ and $R \geq 70\%$ of maximum information bit rate |       |       |
|---------------------------|-----|---|-------|-------|
| Propagation conditions    |     | FRC1  | FRC2  | FRC3  |
| Pedestrian A<br>(3 kmph)  | 30% | -13.76  | -0.55 | 4.94  |
|                           | 70% | -9.89   | 5.2   | 12.76 |
| Pedestrian B<br>(3 kmph)  | 30% | -12.12  | 0.48  | 5.13  |
|                           | 70% | -9.46   | 5.22  | 13.1  |
| Vehicular A<br>(30 kmph)  | 30% | -12.58  | -0.62 | 5.14  |
|                           | 70% | -9.51   | 5.3   | 13.46 |
| Vehicular A<br>(120 kmph) | 30% | -12.55  | -0.69 | 5.1   |
|                           | 70% | -9.78   | 5.22  | 13.14 |

### 8.4.2.2 1.28Mcps TDD option

For the test parameters specified in Table 8.14A, the minimum requirements are specified in Table 8.15A.

**Table 8.14A: Test parameters for testing E-DCH (1.28 Mcps TDD Option)**

| Parameter   |               | Unit         | Value            |         |        |        |
|---|---------------|--------------|------------------|---------|--------|--------|
|   |               |              | FRC1             | FRC2    | FRC3   | FRC4   |
| Max information rate  |               | kbps         | 56.4             | 227.8   | 515.6  | 1281.2 |
| $I_{oc}$  | Wide Area BS  | dBm/1.28 MHz | -91              |         |        |        |
|   | Local Area BS | dBm/1.28MHz  | -77              |         |        |        |
| Scrambling code and basic midamble code number*   |               |              | 0                | 0       | 0      | 0      |
| E-PUCH channelization code*   |               | C(k, Q)      | C(1, 4)          | C(1, 2) | C(1,2) | C(1,1) |
| RSN   |               |              | {0, 1, 2, 3}     |         |        |        |
| HARQ combining  |               |              | IR               |         |        |        |
| Maximum number of HARQ transmission   |               |              | 4                |         |        |        |
| Power control   |               |              | OFF              |         |        |        |
| Receiver antenna diversity  |               |              | ON               |         |        |        |
| Midamble  |               |              | Default midamble |         |        |        |
| Propagation condition   |               |              | PA3, PB3, VA30   |         |        |        |
| *Note: Refer to TS 25.223 for definition of channelization codes, scrambling code and basic midamble code |               |              |                  |         |        |        |

**Table 8.15A Minimum Requirement for E-DCH (1.28 Mcps TDD Option)**

| Fixed Reference Channel |     | Reference value, $\hat{I}_{or}/I_{oc}$ (dB),<br>for $R \geq 30\%$ and $R \geq 70\%$ of maximum information bit rate |       |       |       |
|-------------------------|-----|---|-------|-------|-------|
| Propagation conditions  |     | FRC1  | FRC2  | FRC3  | FRC4  |
| Pedestrian A (3 kmph)   | 30% | -6.78   | -1.58 | 2.84  | 6.34  |
|                         | 70% | -1.83   | 4.6   | 10.19 | 13.45 |
| Pedestrian B (3 kmph)   | 30% | -5.62   | -1.1  | 2.88  | 6.55  |
|                         | 70% | -1.65   | 5.09  | 8.99  | 12.26 |
| Vehicular A (30 kmph)   | 30% | -4.96   | -0.88 | 3.09  | 7.14  |
|                         | 70% | -1.2  | 6.0   | 10.89 | 14.01 |

### 8.4.2.3 7.68 Mcps TDD Option

For the test parameters specified in Table 8.14B, the minimum requirements are specified in Table 8.15B.

**Table 8.14B: Test parameters for testing E-DCH (7.68 Mcps TDD Option)**

| Parameter  |               | Unit         | Value                 |         |         |
|--|---------------|--------------|-----------------------|---------|---------|
|  |               |              | FRC1                  | FRC2    | FRC3    |
| Max information rate   |               | kbps         | 35.9                  | 1083.1  | 2085.1  |
| $I_{oc}$   | Wide Area BS  | dBm/7.68 MHz | -89                   |         |         |
|  | Local Area BS | dBm/7.68 MHz | -74                   |         |         |
| E-DCH $E_c/I_{or}$   |               | dB           | 0                     | 0       | 0       |
| Cell Parameter*  |               |              | 0, 1                  |         |         |
| E-DCH channelization code*   |               | C(k, Q)      | C(1, 32)              | C(1, 4) | C(1, 2) |
| RSN  |               |              | {0, 1, 2, 3}          |         |         |
| HARQ combining   |               |              | IR                    |         |         |
| Maximum number of HARQ transmission  |               |              | 4                     |         |         |
| Power control  |               |              | OFF                   |         |         |
| Receiver antenna diversity   |               |              | ON                    |         |         |
| Midamble   |               |              | Default midamble      |         |         |
| Physical channels to be turned on  |               |              | E-PUCH                |         |         |
| Propagation condition  |               |              | PA3, PB3, VA30, VA120 |         |         |
| *Note: Refer to TS 25.223 for definition of channelization codes and cell parameter. |               |              |                       |         |         |

**Table 8.15B Minimum Requirement for E-DCH (7.68 Mcps TDD Option)**

| Fixed Reference Channel   |     | Reference value, $\hat{I}_{or}/I_{oc}$ (dB),<br>for $R \geq 30\%$ and $R \geq 70\%$ of maximum information bit rate |       |      |
|---------------------------|-----|---|-------|------|
| Propagation conditions    |     | FRC1  | FRC2  | FRC3 |
| Pedestrian A<br>(3 kmph)  | 30% | -16.22  | -3.71 | 1.72 |
|                           | 70% | -12.56  | 1.79  | 9.39 |
| Pedestrian B<br>(3 kmph)  | 30% | -14.44  | -3.71 | 1.45 |
|                           | 70% | -11.54  | 1.48  | 8.87 |
| Vehicular A<br>(30 kmph)  | 30% | -14.81  | -3.68 | 1.48 |
|                           | 70% | -11.84  | 1.89  | 9.28 |
| Vehicular A<br>(120 kmph) | 30% | -14.81  | -3.83 | 1.38 |
|                           | 70% | -12.27  | 1.67  | 9.17 |

### 8.4.3 Test purpose

The test shall verify the receiver's ability to receive the test signal under multipath fading propagation conditions with a throughput not below a specified limit.<sup>1</sup>

### 8.4.4 Method of test

#### 8.4.4.1 Initial conditions

##### 8.4.4.1.0 General test conditions

Test environment: normal; see subclause 5.9.1.

RF channels to be tested: B, M and T; see subclause 5.3.

##### 8.4.4.1.1 3,84 Mcps TDD option

- (1) Connect the BS tester (UE simulator) generating the wanted signal and a band-limited white noise source, simulating interference from other cells, to both BS antenna connectors for diversity reception via a combining network.
- (2) The wanted signal produced by the BS tester to both BS antenna connectors are individually passed through independent Multipath Fading Simulators (MFS) before entering the combining network. Each MFS shall be configured to simulate multipath fading conditions specified in Table 8.14 and 8.15.

#### 8.4.4.1.2 1.28Mcps TDD option

- (1) Connect the BS tester (UE simulator) generating the wanted signal and a band-limited white noise source, simulating interference from other cells, to both BS antenna connectors for diversity reception via a combining network.
- (2) The wanted signal produced by the BS tester to both BS antenna connectors are individually passed through independent Multipath Fading Simulators (MFS) before entering the combining network. Each MFS shall be configured to simulate multipath fading conditions specified in Table 8.14A and 8.15A.

#### 8.4.4.1.3 7.68 Mcps TDD option

- (1) Connect the BS tester (UE simulator) generating the wanted signal and a band-limited white noise source, simulating interference from other cells, to both BS antenna connectors for diversity reception via a combining network.
- (2) The wanted signal produced by the BS tester to both BS antenna connectors are individually passed through independent Multipath Fading Simulators (MFS) before entering the combining network. Each MFS shall be configured to simulate multipath fading conditions specified in Table 8.14B and 8.15B.

### 8.4.4.2 Procedure

#### 8.4.4.2.1 3,84 Mcps TDD option

- (1) Adjust the power of the band-limited white noise source in such a way that its power spectral density measured at the BS antenna connector takes on the value  $I_{oc}$  as specified in table 8.14.
- (2) The characteristics of the wanted signal shall be configured according to the corresponding E-DCH Fixed Reference Channel (FRC) measurement channel defined in annex A.3. Depending upon the E-DCH FRC measurement channel makes use of one physical channel (E-PUCH) with different spreading factors SF. The power of the E-PUCH measured at the BS antenna connector during the active time slots shall be set to the values given in Table 8.16.
- (3) The Multipath Fading Simulators shall be configured according to the corresponding channel model defined in annex D.
- (4) For each of the fixed reference channels in table 8.16 applicable for the base station, measure the throughput for each E-PUCH power and propagation condition settings.

**Table 8.16: Parameters of the wanted signal (E-PUCH) (3,84 Mcps TDD Option)**

| Propagation Conditions | Throughput R<br>(% of max<br>information bit<br>rate) | Wanted signal (E-PUCH) power measured at the BS<br>antenna connector (dBm) |        |        |               |        |        |
|------------------------|---|--|--------|--------|---------------|--------|--------|
|                        |   | Wide Area BS   |        |        | Local Area BS |        |        |
|                        |   | FRC1   | FRC2   | FRC3   | FRC1          | FRC2   | FRC3   |
| Pedestrian A (3 kmph)  | 30%   | -102.76  | -89.55 | -84.06 | -87.76        | -74.55 | -69.06 |
|                        | 70%   | -98.89   | -83.80 | -76.24 | -83.89        | -68.80 | -61.24 |
| Pedestrian B (3 kmph)  | 30%   | -101.12  | -88.52 | -83.87 | -86.12        | -73.52 | -68.87 |
|                        | 70%   | -98.46   | -83.78 | -75.90 | -83.46        | -68.78 | -60.90 |
| Vehicular A (30 kmph)  | 30%   | -101.58  | -89.62 | -83.86 | -86.58        | -74.62 | -68.86 |
|                        | 70%   | -98.51   | -83.70 | -75.54 | -83.51        | -68.70 | -60.54 |
| Vehicular A (120 kmph) | 30%   | -101.55  | -89.69 | -83.90 | -86.55        | -74.69 | -68.90 |
|                        | 70%   | -98.78   | -83.78 | -75.86 | -83.78        | -68.78 | -60.86 |

#### 8.4.4.2.2 1.28Mcps TDD option

- (1) Adjust the power of the band-limited white noise source in such a way that its power spectral density measured at the BS antenna connector takes on the value  $I_{oc}$  as specified in table 8.14A.
- (2) The characteristics of the wanted signal shall be configured according to the corresponding E-DCH Fixed Reference Channel (FRC) measurement channel defined in annex A.3. Depending upon the E-DCH FRC measurement channel makes use of one physical channel (E-PUCH) with different spreading factors SF. The

power of the E-PUCH measured at the BS antenna connector during the active time slots shall be set to the values given in Table 8.16A.

- (3) The Multipath Fading Simulators shall be configured according to the corresponding channel model defined in annex B.
- (4) For each of the fixed reference channels in table 8.16A applicable for the base station, measure the throughput for each E-PUCH power and propagation condition settings.

**Table 8.16A: Parameters of the wanted signal (E-PUCH) (1.28 Mcps TDD Option)**

| Propagation Conditions | Throughput R (% of max information bit rate) | Wanted signal (E-PUCH) power measured at the BS antenna connector (dBm) |        |        |        |               |        |        |        |
|------------------------|--|---|--------|--------|--------|---------------|--------|--------|--------|
|                        |  | Wide Area BS  |        |        |        | Local Area BS |        |        |        |
|                        |  | FRC1  | FRC2   | FRC3   | FRC4   | FRC1          | FRC2   | FRC3   | FRC4   |
| Pedestrian A (3 kmph)  | 30%  | -97.78  | -92.58 | -88.16 | -84.66 | -83.78        | -78.58 | -74.16 | -70.66 |
|                        | 70%  | -92.83  | -86.4  | -80.81 | -77.55 | -78.83        | -72.4  | -66.81 | -63.55 |
| Pedestrian B (3 kmph)  | 30%  | -96.62  | -92.1  | -88.12 | -84.45 | -82.62        | -78.1  | -74.12 | -70.45 |
|                        | 70%  | -92.65  | -85.91 | -82.01 | -78.74 | -78.65        | -71.91 | -68.01 | -64.74 |
| Vehicular A (30 kmph)  | 30%  | -95.96  | -91.88 | -87.91 | -83.86 | -81.96        | -77.88 | -73.91 | -69.86 |
|                        | 70%  | -92.2   | -85    | -80.11 | -76.99 | -78.2         | -71    | -66.11 | -62.99 |

#### 8.4.4.2.3 7.68 Mcps TDD option

- (1) Adjust the power of the band-limited white noise source in such a way that its power spectral density measured at the BS antenna connector takes on the value  $I_{oc}$  as specified in table 8.14B.
- (2) The characteristics of the wanted signal shall be configured according to the corresponding E-DCH Fixed Reference Channel (FRC) measurement channel defined in annex A.3. Depending upon the E-DCH FRC measurement channel makes use of one physical channel (E-PUCH) with different spreading factors SF. The power of the E-PUCH measured at the BS antenna connector during the active time slots shall be set to the values given in Table 8.16B.
- (3) The Multipath Fading Simulators shall be configured according to the corresponding channel model defined in annex D.
- (4) For each of the fixed reference channels in table 8.16B applicable for the base station, measure the throughput for each E-PUCH power and propagation condition settings.

**Table 8.16B: Parameters of the wanted signal (E-PUCH) (7.68 Mcps TDD Option)**

| Propagation Conditions | Throughput R (% of max information bit rate) | Wanted signal (E-PUCH) power measured at the BS antenna connector (dBm) |        |        |               |        |        |
|------------------------|--|---|--------|--------|---------------|--------|--------|
|                        |  | Wide Area BS  |        |        | Local Area BS |        |        |
|                        |  | FRC1  | FRC2   | FRC3   | FRC1          | FRC2   | FRC3   |
| Pedestrian A (3 kmph)  | 30%  | -105.22   | -92.71 | -87.28 | -90.22        | -77.71 | -72.28 |
|                        | 70%  | -101.56   | -87.21 | -79.61 | -86.56        | -72.21 | -64.61 |
| Pedestrian B (3 kmph)  | 30%  | -103.44   | -92.71 | -87.55 | -88.44        | -77.71 | -72.55 |
|                        | 70%  | -100.54   | -87.52 | -80.13 | -85.54        | -72.52 | -65.13 |
| Vehicular A (30 kmph)  | 30%  | -103.81   | -92.68 | -87.52 | -88.81        | -77.68 | -72.52 |
|                        | 70%  | -100.84   | -87.11 | -79.72 | -85.84        | -72.11 | -64.72 |
| Vehicular A (120 kmph) | 30%  | -103.81   | -92.83 | -87.62 | -88.81        | -77.83 | -72.62 |
|                        | 70%  | -101.27   | -87.33 | -79.83 | -86.27        | -72.33 | -64.83 |

## 8.4.5 Test Requirements

NOTE: If the Test Requirements below differ from the Minimum Requirements, then the Test Tolerance applied for this test is non-zero. The Test Tolerance for this test is defined in subclause 5.11 and the explanation of how the Minimum Requirement has been relaxed by the Test Tolerance is given in Annex D.

### 8.4.5.1 3,84 Mcps TDD option

The throughput measured according to subclause 8.4.4.2 shall be at least the limits specified in table 8.15.

### 8.4.5.2 1.28Mcps TDD option

The throughput measured according to subclause 8.4.4.2 shall be at least the limits specified in table 8.15A.

### 8.4.5.3 7.68 Mcps TDD option

The throughput measured according to subclause 8.4.4.2 shall be at least the limits specified in table 8.15B.

## 8.5 Performance of ACK error detection for HS-SICH

### 8.5.1 ACK error detection in static propagation conditions

#### 8.5.1.1 3.84 Mcps TDD option

(void)

#### 8.5.1.2 1.28 Mcps TDD option

##### 8.5.1.2.1 Definition and applicability

The performance requirement of the HS-SICH is ACK error detection, P(ACK->NACK) when ACK is transmitted.

##### 8.5.1.2.2 Minimum requirement

The performance requirement of ACK error detection, P(ACK->NACK) should not exceed the required error ratio for the  $\frac{\hat{I}_{or}}{I_{oc}}$  specified in Table 8.18A.

**Table 8.17A: Test parameters for testing ACK error detection using HS-SICH type1 (1.28Mcps TDD Option)**

| Parameters                                      | Unit   | Test                |
|---|--|---------------------|
| Number of DPCHo                                 |  | 2                   |
| Spread factor of DPCHo                          |  | 8                   |
| Scrambling code and basic midamble code number* |  | 0                   |
| DPCHo Channelization Codes*                     | C(k,Q)   | C(i,8)<br>2 ≤ i ≤ 3 |
| $\frac{DPCH_o - E_c}{I_{or}}$                   | dB   | -4                  |
| $\frac{HS - SICH_o - E_c}{I_{or}}$              | dB   | -7                  |
| loc   | dBm/1,28 MHz   | -91                 |
| Closed loop power control                       |  | Off                 |
| Midamble  |  | Default midamble    |
| *Note:  | Refer to TS 25.223 for definition of channelizationcodes and cell parameter. |                     |

**Table 8.17B: Test parameters for testing ACK error detection using HS-SICH type2 (1.28Mcps TDD Option)**

| Parameters   | Unit         | Test                |
|--|--------------|---------------------|
| Number of DPCH <sub>o</sub>  |              | 2                   |
| Spread factor of DPCH <sub>o</sub>   |              | 8                   |
| Scrambling code and basic midamble code number (note)                              |              | 0                   |
| DPCH <sub>o</sub> Channelization Codes*  | C(k,Q)       | C(i,8)<br>2 ≤ i ≤ 3 |
| $\frac{DPCH_o - E_c}{I_{or}}$  | dB           | -4.8                |
| $\frac{HS - SICH - E_c}{I_{or}}$   | dB           | -4.8                |
| I <sub>oc</sub>  | dBm/1.28 MHz | -91                 |
| Closed loop power control  |              | Off                 |
| Midamble   |              | Default midamble    |
| NOTE: Refer to TS 25.223 for definition of channelizationcodes and cell parameter. |              |                     |

**Table 8.18A: Performance requirements for ACK error detection in AWGN channel using HS-SICH type1**

| Received $\frac{\hat{I}_{or}}{I_{oc}}$ | Required error ratio |
|--|----------------------|
| -3,1 dB                                | < 10 <sup>-2</sup>   |

**Table 8.18B: Performance requirements for ACK error detection in AWGN channel using HS-SICH type2**

| Received $\frac{\hat{I}_{or}}{I_{oc}}$ | Required error ratio |
|--|----------------------|
| -5.3 dB                                | < 10 <sup>-2</sup>   |

The reference for this requirement is TS 25.105 subclause 8.5.

#### 8.5.1.2.3 Test purpose

The test shall verify the receiver's ability to receive the test signal under static propagation conditions with an error ratio not exceeding a specified limit.

#### 8.5.1.2.4 Method of test

##### 8.5.1.2.4.1 Initial conditions

Test environment: normal; see subclause 5.9.1.

RF channels to be tested: B, M and T; see subclause 5.3

- (1) Connect the BS tester generating the wanted signal and AWGN generators to both BS antenna connectors for diversity reception via a combining network as shown in annex B. Connect the BS tester (UE simulator) generating the wanted signal and a set of interference generators to both BS antenna connectors for diversity reception via a combining network. The set of interference generators comprises a number of CDMA generators, each representing an individual intracell interferer (subsequently called DPCH0 generators), and an additional band-limited white noise source, simulating interference from other cells. Each DPCH0 generator shall produce an interfering signal that is equivalent to a valid UTRA TDD signal with spreading factor 8, using the same time

slot(s) than the wanted signal and applying the same cell-specific scrambling code. The number of the DPCH0 generators used in each test is given in table 8.17A.

#### 8.5.1.2.4.2 Procedure

- (1) Adjust the power of the band-limited white noise source in such a way that its power spectral density measured at the BS antenna connector takes on the value  $I_{oc}$  as specified in table 8.17A.
- (2) The characteristics of the wanted signal (HS-SICH) shall be configured according to the corresponding UL reference measurement channel defined in annex A. Set the power of HS-SICH and each DPCH0 measured at the BS antenna connector during the active time slots to the value specified in table 8.17A.
- (3) The test signal generator sends the ACKs with HS-SICH and DPCH0s. Adjust the equipment so that required  $\frac{\hat{I}_{or}}{I_{oc}}$  specified in table 8.18A is achieved. The receiver tries to detect ACK. The error ratio is calculated for the ACKs that have been detected.

#### 8.5.1.2.5 Test requirements

The performance of ACK error detection,  $P(\text{ACK} \rightarrow \text{NACK})$  should not exceed the required error ratio for the  $\frac{\hat{I}_{or}}{I_{oc}}$  specified in Table 8.19A.

**Table 8.19A: Performance requirements for ACK error detection in AWGN channel using HS-SICH type1**

| Received $\frac{\hat{I}_{or}}{I_{oc}}$ | Required error ratio |
|--|----------------------|
| -2,7dB                                 | $< 10^{-2}$          |

**Table 8.19B: Performance requirements for ACK error detection in AWGN channel using HS-SICH type2**

| Received $\frac{\hat{I}_{or}}{I_{oc}}$ | Required error ratio |
|--|----------------------|
| -4.9dB                                 | $< 10^{-2}$          |

NOTE: If the Test Requirements below differ from the Minimum Requirements, then the Test Tolerance applied for this test is non-zero. The Test Tolerance for this test is defined in subclause 5.11 and the explanation of how the Minimum Requirement has been relaxed by the Test Tolerance is given in Annex D.

## 8.5.2 ACK error detection in multipath fading conditions

### 8.5.2.1 3,84Mcps TDD option

(void)

### 8.5.2.2 1,28Mcps TDD option

#### 8.5.2.2.1 Definition and applicability

The performance requirement of the HS-SICH is ACK error detection,  $P(\text{ACK} \rightarrow \text{NACK})$  when ACK is transmitted..

## 8.5.2.2.2 Minimum requirement

The performance of ACK error detection,  $P(\text{ACK} \rightarrow \text{NACK})$  should not exceed the required error ratio for the  $\frac{\hat{I}_{or}}{I_{oc}}$  specified in Table 8.20A.

**Table 8.20A: Test parameters for testing ACK error detection using HS-SICH type1 (1,28Mcps TDD Option)**

| Parameters  | Unit         | Test                |
|---|--------------|---------------------|
| Number of DPCH <sub>o</sub>   |              | 2                   |
| Spread factor of DPCH <sub>o</sub>  |              | 8                   |
| Scrambling code and basic midamble code number*                                     |              | 0                   |
| DPCH <sub>o</sub> Channelization Codes*   | C(k,Q)       | C(i,8)<br>2 ≤ i ≤ 3 |
| $\frac{DPCH_o - E_c}{I_{or}}$   | dB           | -4                  |
| $\frac{HS - SICH_o - E_c}{I_{or}}$  | dB           | -7                  |
| I <sub>oc</sub>   | dBm/1,28 MHz | -91                 |
| Closed loop power control   |              | Off                 |
| Midamble  |              | Default midamble    |
| *Note: Refer to TS 25.223 for definition of channelizationcodes and cell parameter. |              |                     |

**Table 8.20B: Test parameters for testing ACK error detection using HS-SICH type2 (1.28Mcps TDD Option)**

| Parameters   | Unit         | Test                |
|--|--------------|---------------------|
| Number of DPCH <sub>o</sub>  |              | 2                   |
| Spread factor of DPCH <sub>o</sub>   |              | 8                   |
| Scrambling code and basic midamble code number (note)                              |              | 0                   |
| DPCH <sub>o</sub> Channelization Codes*  | C(k,Q)       | C(i,8)<br>2 ≤ i ≤ 3 |
| $\frac{DPCH_o - E_c}{I_{or}}$  | dB           | -4.8                |
| $\frac{HS - SICH_o - E_c}{I_{or}}$   | dB           | -4.8                |
| I <sub>oc</sub>  | dBm/1.28 MHz | -91                 |
| Closed loop power control  |              | Off                 |
| Midamble   |              | Default midamble    |
| NOTE: Refer to TS 25.223 for definition of channelizationcodes and cell parameter. |              |                     |



**Table 8.21A: Performance requirements for ACK error detection in fading channels using HS-SICH type1**

| Propagation conditions | Received $\frac{\hat{I}_{or}}{I_{oc}}$ (dB) | Required error ratio |
|------------------------|---|----------------------|
| Case 1                 | 1,2   | $< 10^{-2}$          |
| Case 2                 | 0,9   | $< 10^{-2}$          |
| Case 3                 | 0,2   | $< 10^{-2}$          |

**Table 8.21B: Performance requirements for ACK error detection in fading channels using HS-SICH type2**

| Propagation conditions | Received $\frac{\hat{I}_{or}}{I_{oc}}$ (dB) | Required error ratio |
|------------------------|---|----------------------|
| Case 1                 | -1,2  | $< 10^{-2}$          |
| Case 2                 | -0,7  | $< 10^{-2}$          |

The reference for this requirement is TS 25.105 subclause 8.5.

#### 8.5.2.2.3 Test purpose

The test shall verify the receiver's ability to receive the test signal under multipath fading propagation conditions with an error ratio not exceeding a specified limit.

#### 8.5.2.2.4 Method of test

##### 8.5.2.2.4.1 Initial conditions

Test environment: normal; see subclause 5.9.1.

RF channels to be tested: B, M and T; see subclause 5.3

- (1) Connect the BS tester generating the wanted signal and AWGN generators to both BS antenna connectors for diversity reception via a combining network as shown in annex B. Connect the BS tester (UE simulator) generating the wanted signal and a set of interference generators to both BS antenna connectors for diversity reception via a combining network. The set of interference generators comprises a number of CDMA generators, each representing an individual intracell interferer (subsequently called DPCH0 generators), and an additional band-limited white noise source, simulating interference from other cells. Each DPCH0 generator shall produce an interfering signal that is equivalent to a valid UTRA TDD signal with spreading factor 8, using the same time slot(s) than the wanted signal and applying the same cell-specific scrambling code. The number of the DPCH0 generators used in each test is given in table 8.20A.
- (2) The wanted signal produced by the BS tester and the interfering signals produced by the DPCH0 generators are individually passed through independent Multipath Fading Simulators (MFS) before entering the combining network. Each MFS shall be configured to simulate multipath fading Case 3.

##### 8.5.2.2.4.2 Procedure

- (1) Adjust the power of the band-limited white noise source in such a way that its power spectral density measured at the BS antenna connector takes on the value  $I_{oc}$  as specified in table 8.20A.
- (2) The characteristics of the wanted signal (HS-SICH) shall be configured according to the corresponding UL reference measurement channel defined in annex A. Set the power of HS-SICH and each DPCH0 measured at the BS antenna connector during the active time slots to the value specified in table 8.20A.

- (3) The test signal generator sends the ACKs with HS-SICH and DPCH0s. Adjust the equipment so that required  $\frac{\hat{I}_{or}}{I_{oc}}$  specified in table 8.21A is achieved. The receiver tries to detect ACK. The error ratio is calculated for the ACKs that have been detected.

#### 8.5.2.2.5 Test requirements

The performance of ACK error detection,  $P(\text{ACK} \rightarrow \text{NACK})$  should not exceed the required error ratio for the  $\frac{\hat{I}_{or}}{I_{oc}}$  specified in Table 8.22A.

**Table 8.22A: Performance requirements for ACK error detection in fading channels using HS-SICH type1**

| Propagation conditions | Received $\frac{\hat{I}_{or}}{I_{oc}}$ (dB) | Required error ratio |
|------------------------|---|----------------------|
| Case 1                 | 1,8   | $< 10^{-2}$          |
| Case 2                 | 1,5   | $< 10^{-2}$          |
| Case 3                 | 0,8   | $< 10^{-2}$          |

**Table 8.22B: Performance requirements for ACK error detection in fading channels using HS-SICH type2**

| Propagation conditions | Received $\frac{\hat{I}_{or}}{I_{oc}}$ (dB) | Required error ratio |
|------------------------|---|----------------------|
| Case 1                 | -0.6  | $< 10^{-2}$          |
| Case 2                 | -0.1  | $< 10^{-2}$          |

NOTE: If the Test Requirements below differ from the Minimum Requirements, then the Test Tolerance applied for this test is non-zero. The Test Tolerance for this test is defined in subclause 5.11 and the explanation of how the Minimum Requirement has been relaxed by the Test Tolerance is given in Annex D.

---

## Annex A (normative): Measurement Channels

### A.1 (void)

### A.2 Reference measurement channel

#### A.2.1 UL reference measurement channel (12,2 kbps)

##### A.2.1.1 3,84 Mcps TDD option

**Table A.1**

| <b>Parameter</b>  | <b>Value</b>     |
|---|------------------|
| Information data rate   | 12.2 kbps        |
| RU's allocated  | 2 RU             |
| Midamble  | <b>512</b> chips |
| Interleaving  | 20 ms            |
| Power control   | 2 Bit/user       |
| TFCI  | 16 Bit/user      |
| Inband signalling DCCH  | 2 kbps           |
| Puncturing level at Code rate 1/3 : DCH of the DTCH / DCH of the DCCH | 10% / 0%         |

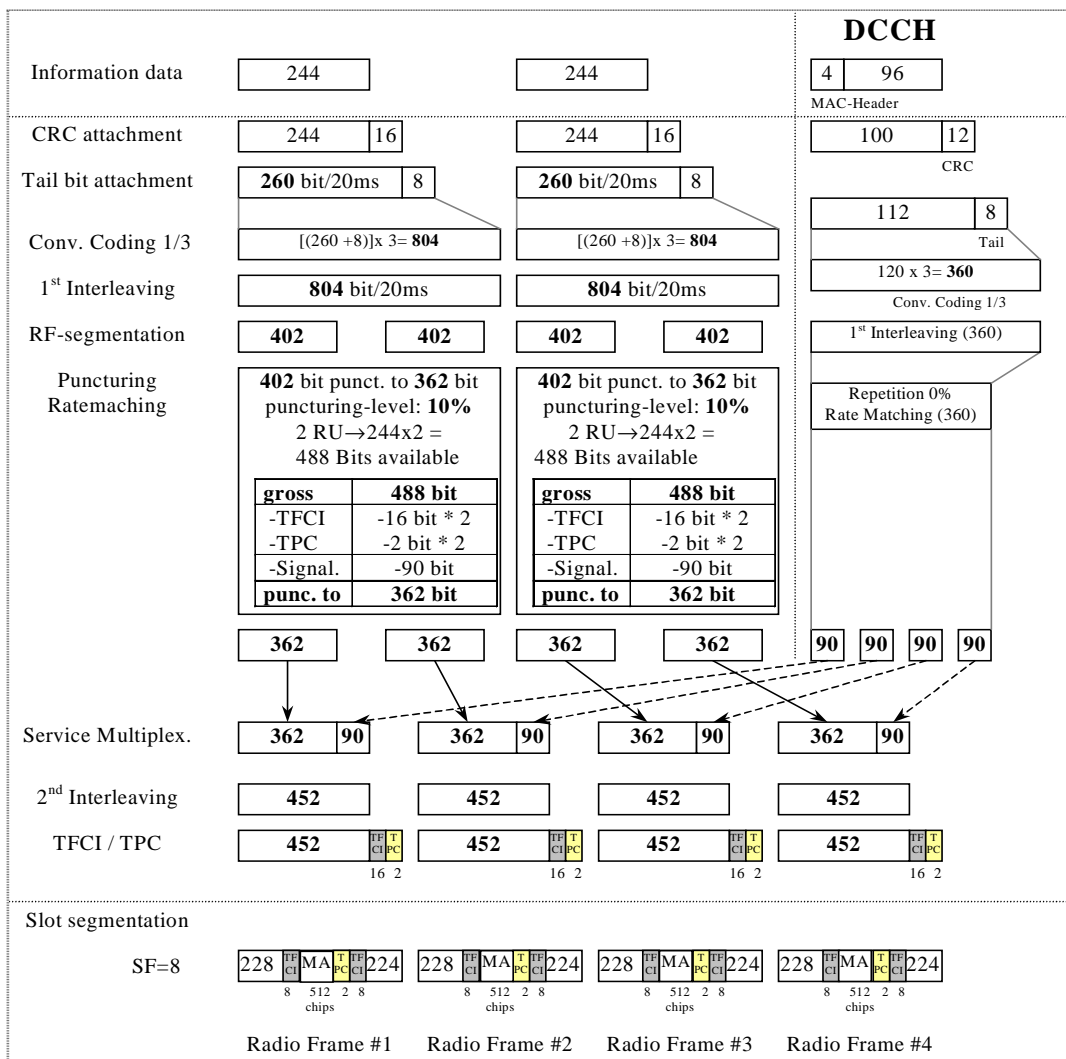


Figure A.1

A.2.1.2 1,28 Mcps option

Table A.1A

| Parameter  | Value                 |
|--|-----------------------|
| Information data rate  | 12.2 kbps             |
| RU's allocated   | 1TS (1*SF8) = 2RU/5ms |
| Midamble   | 144                   |
| Interleaving   | 20 ms                 |
| Power control  | 4 Bit/user/10ms       |
| TFCI   | 16 Bit/user/10ms      |
| Synchronisation Shift (SS)   | 4 Bit/user/10ms       |
| Inband signalling DCCH   | 2.4 kbps              |
| Puncturing level at Code rate 1/3 : DCH of the DTCH/ DCH of the DCCH | 33% / 33%             |

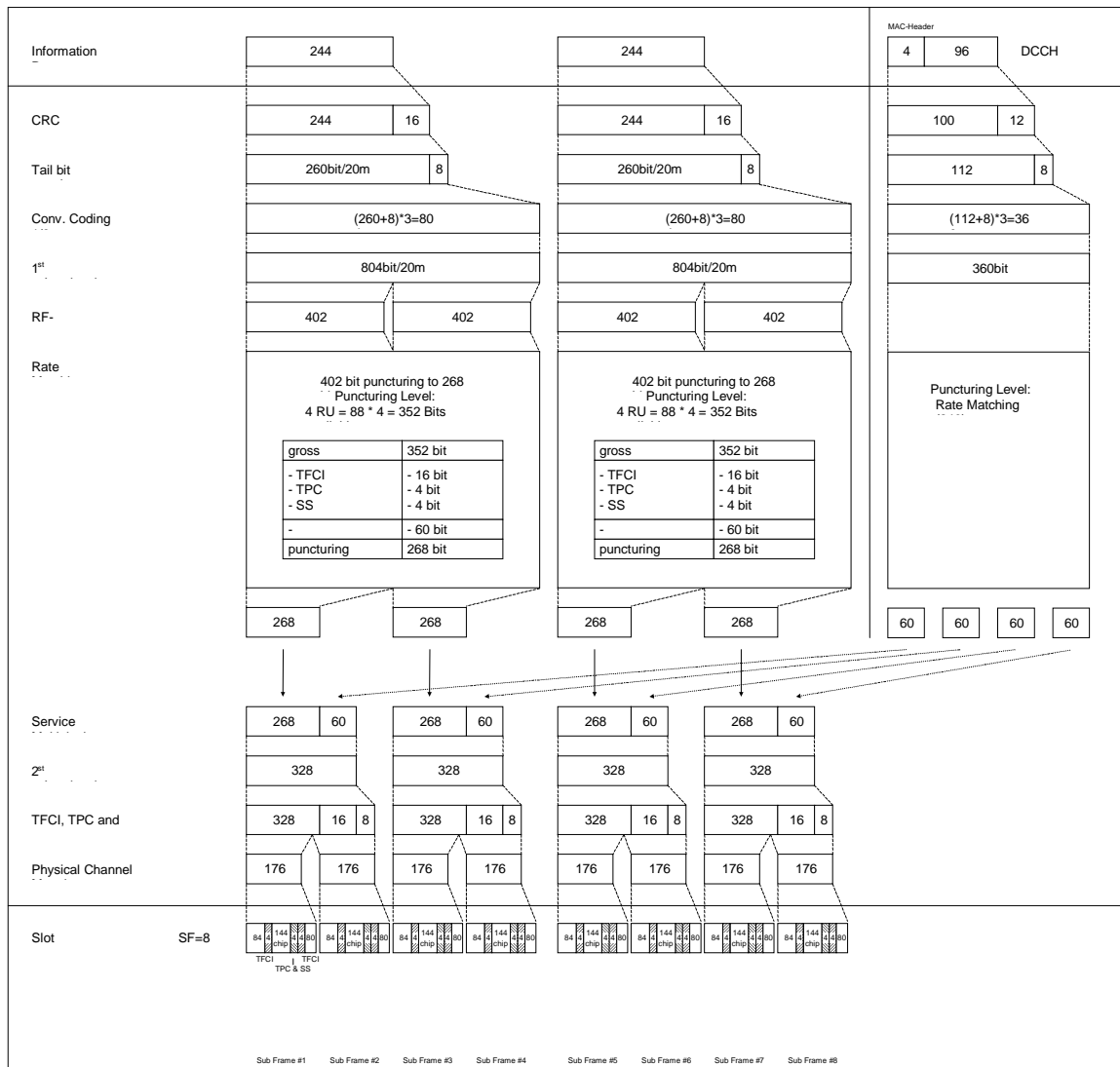


Figure A.1A

A.2.1.3 7,68 Mcps TDD Option

Table A.1B

| Parameter   | Value       |
|---|-------------|
| Information data rate   | 12.2 kbps   |
| RU's allocated  | 2 RU        |
| Midamble  | 1024 chips  |
| Interleaving  | 20 ms       |
| Power control   | 2 Bit/user  |
| TFCI  | 16 Bit/user |
| Inband signalling DCCH  | 2 kbps      |
| Puncturing level at Code rate 1/3 : DCH of the DTCH / DCH of the DCCH | 10% / 0%    |

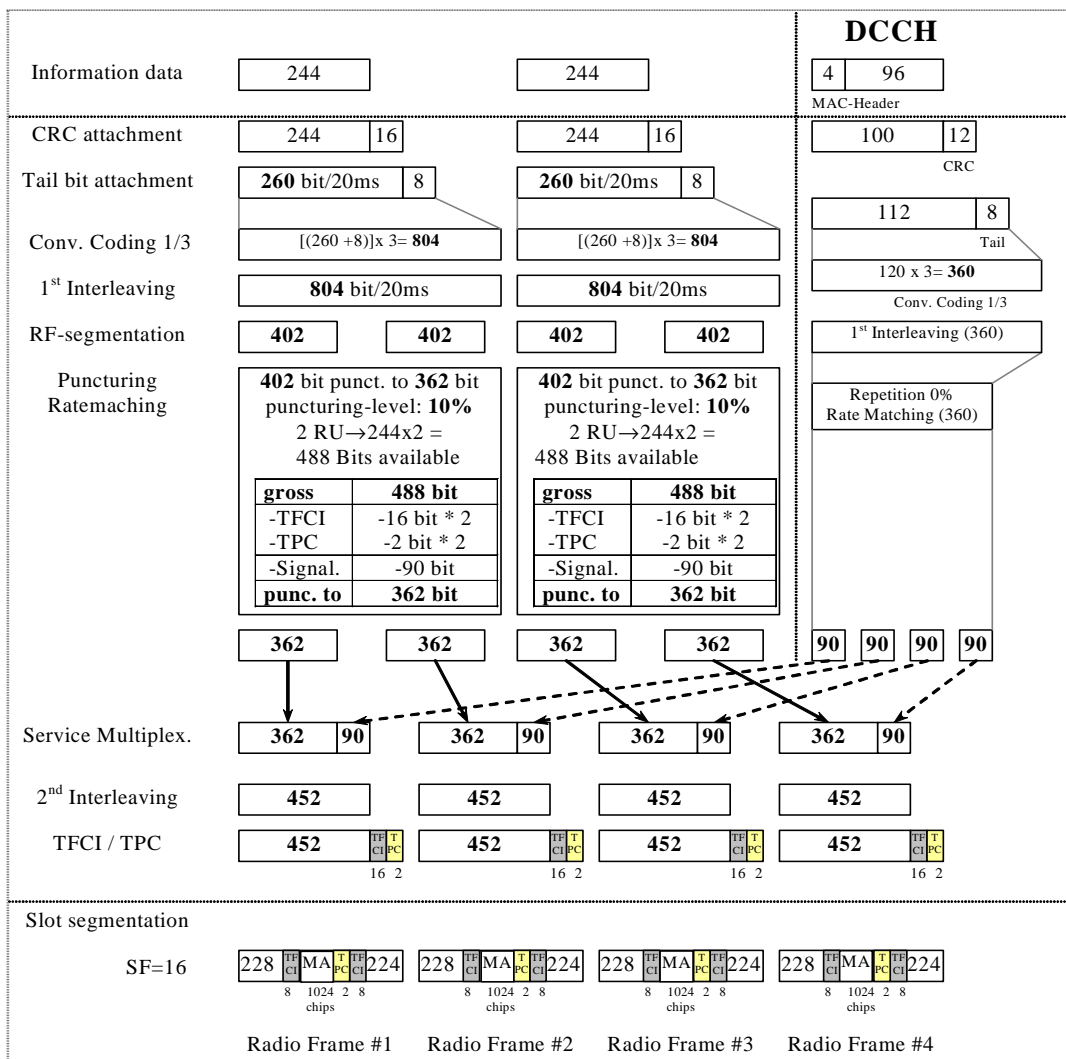


Figure A.1B

## A.2.2 UL reference measurement channel (64 kbps)

### A.2.2.1 3,84 Mcps TDD option

Table A.2

| Parameter   | Value                |
|---|----------------------|
| Information data rate   | 64 kbps              |
| RU's allocated  | 1 SF4 + 1 SF16 = 5RU |
| Midamble  | 512 chips            |
| Interleaving  | 20 ms                |
| Power control   | 2 Bit/user           |
| TFCI  | 16 Bit/user          |
| Inband signalling DCCH  | 2 kbps               |
| Puncturing level at Code rate : 1/3 DCH of the DTCH / 1/2 DCH of the DCCH | 43.8% / 13.3%        |

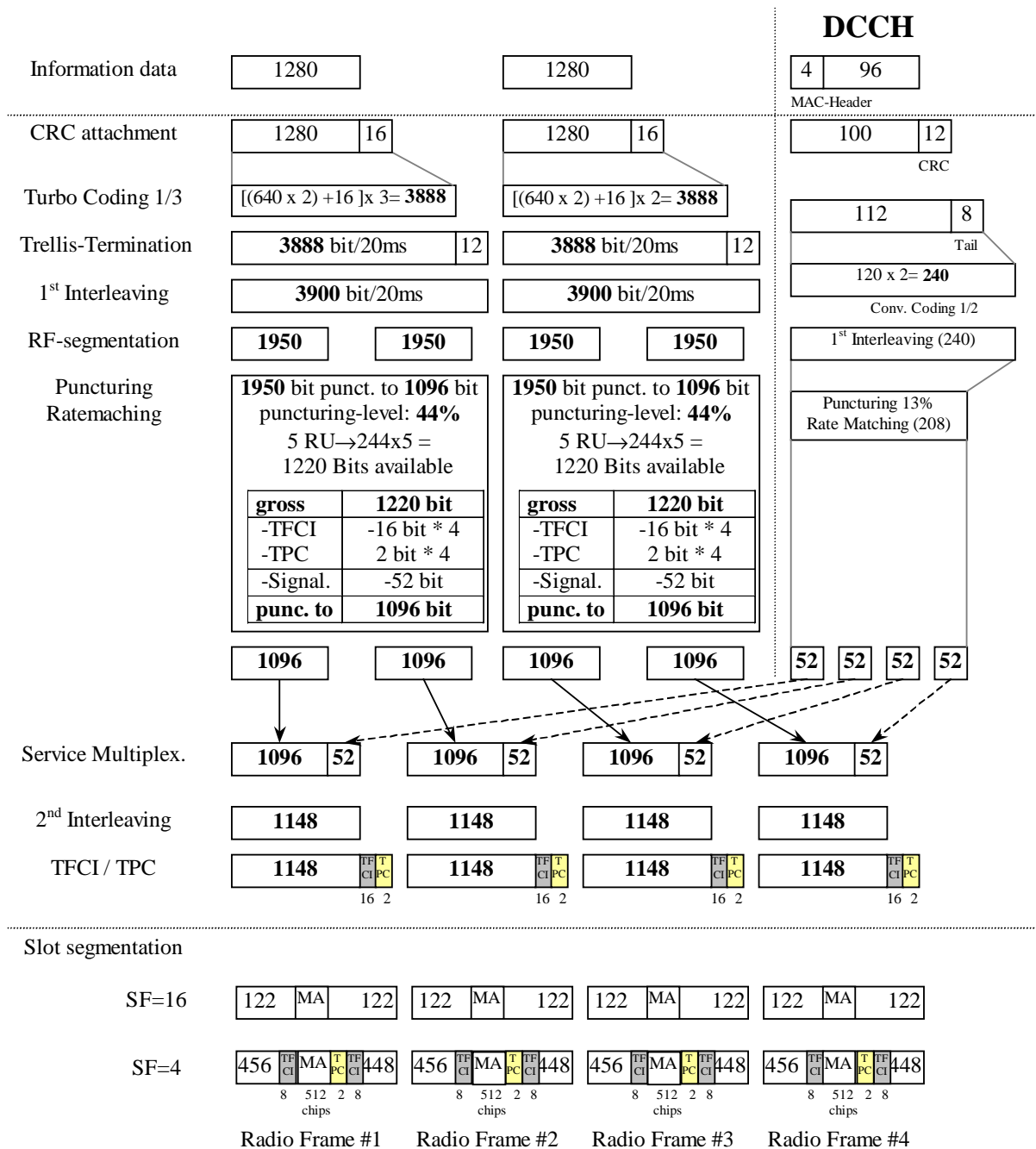


Figure A.2

A.2.2.2 1,28 Mcps TDD option

Table A.2A

| Parameter  | Value                 |
|--|-----------------------|
| Information data rate  | 64 kbps               |
| RU's allocated   | 1TS (1*SF2) = 8RU/5ms |
| Midamble   | 144                   |
| Interleaving   | 20 ms                 |
| Power control (TPC)  | 4 Bit/user/10ms       |
| TFCI   | 16 Bit/user/10ms      |
| Synchronisation Shift (SS)   | 4 Bit/user/10ms       |
| Inband signalling DCCH   | 2.4 kbps              |
| Puncturing level at Code rate: 1/3 DCH of the DTCH / 1/2 DCH of the DCCH | 32% / 0               |

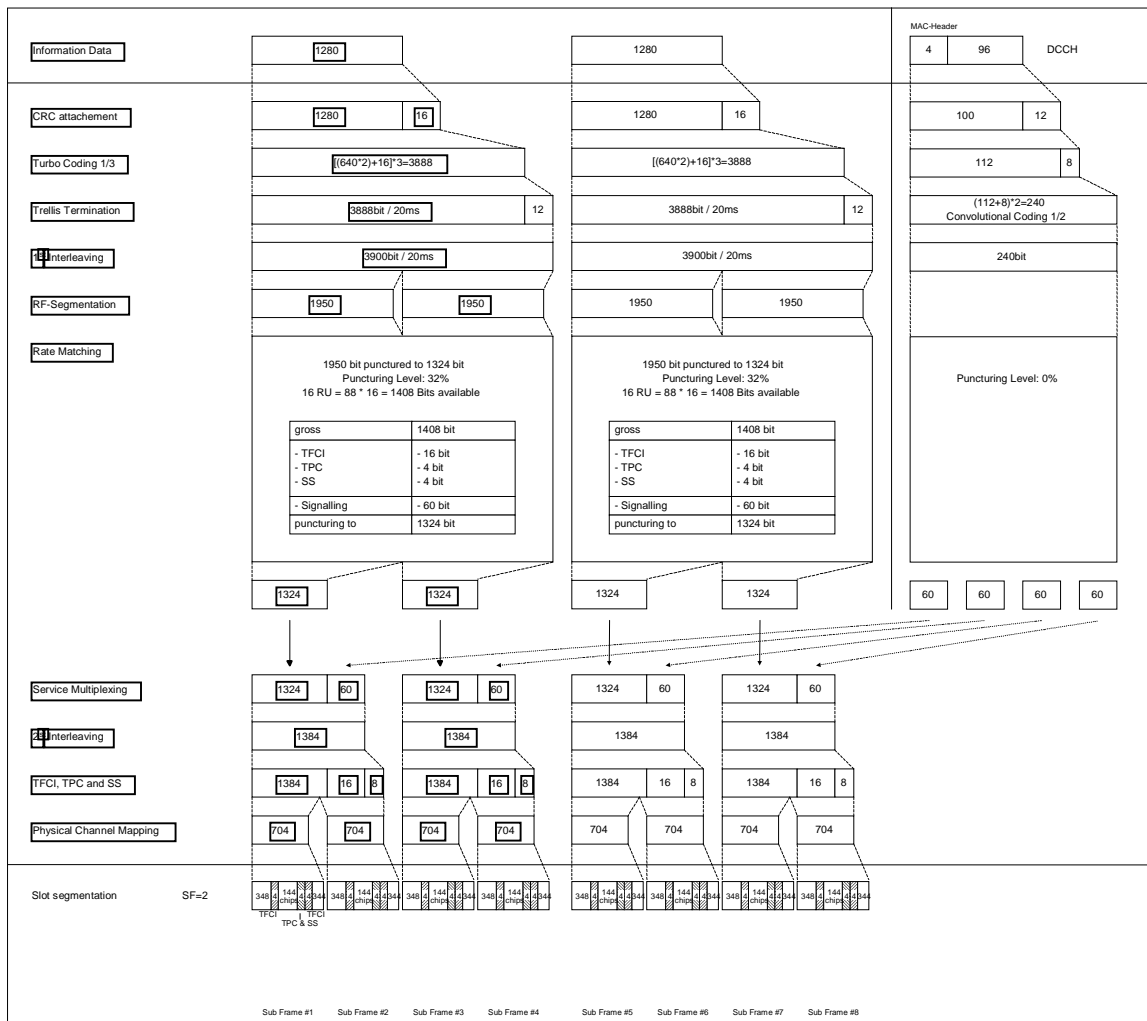


Figure A.2A



### A.2.2.3 7,68 Mcps TDD Option

Table A.2B

| Parameter   | Value                |
|---|----------------------|
| Information data rate   | 64 kbps              |
| RU's allocated  | 1 SF8 + 1 SF32 = 5RU |
| Midamble  | 1024 chips           |
| Interleaving  | 20 ms                |
| Power control   | 2 Bit/user           |
| TFCI  | 16 Bit/user          |
| Inband signalling DCCH  | 2 kbps               |
| Puncturing level at Code rate : 1/3 DCH of the DTCH / 1/2 DCH of the DCCH | 43.8% / 13.3%        |

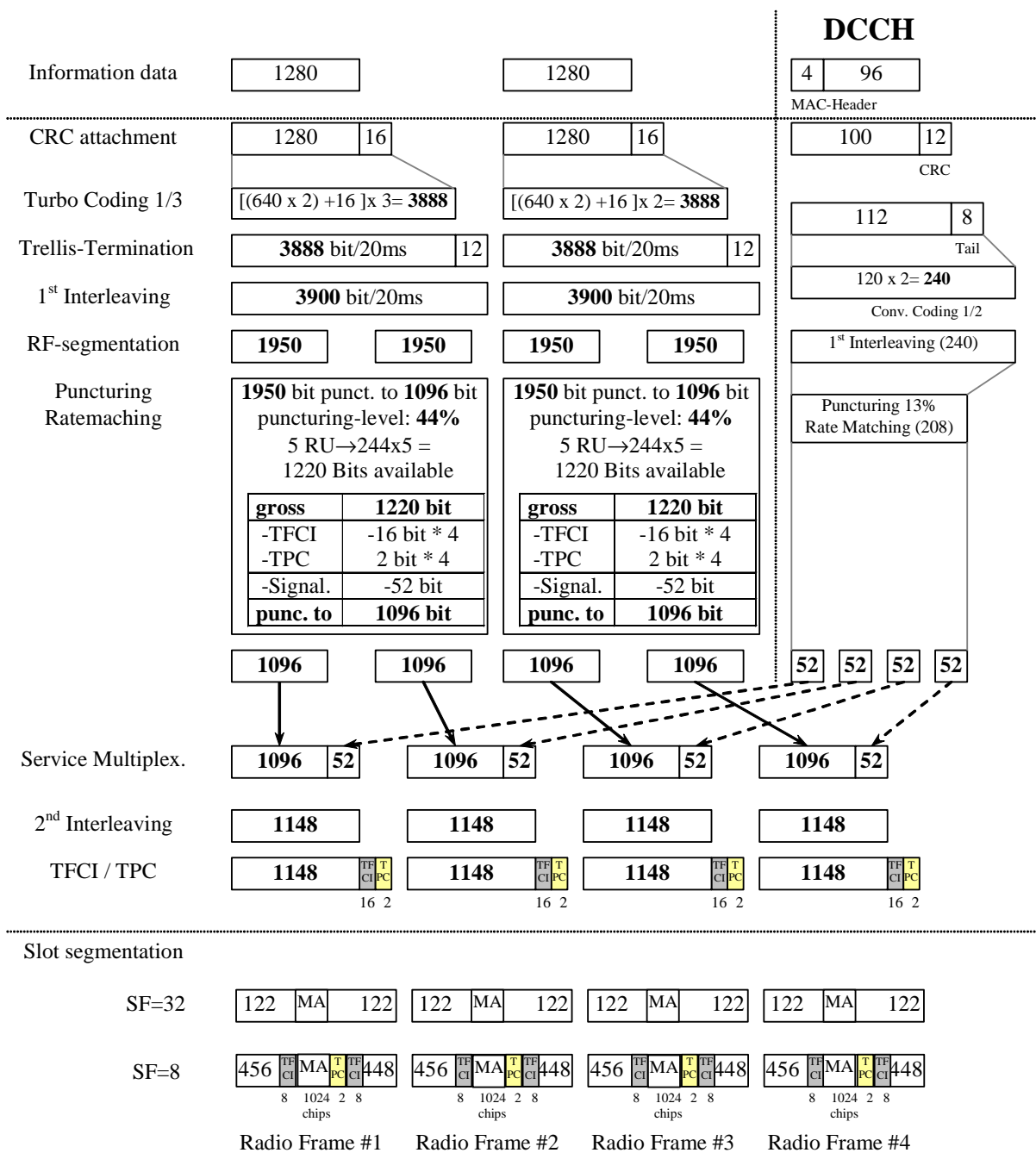


Figure A.2B

## A.2.3 UL reference measurement channel (144 kbps)

### A.2.3.1 3,84 Mcps TDD option

Table A.3

| Parameter   | Value                |
|---|----------------------|
| Information data rate   | 144 kbps             |
| RU's allocated  | 1 SF2 + 1 SF16 = 9RU |
| Midamble  | 256 chips            |
| Interleaving  | 20 ms                |
| Power control   | 2 Bit/user           |
| TFCI  | 16 Bit/user          |
| Inband signalling DCCH  | 2 kbps               |
| Puncturing level at Code rate : 1/3 DCH of the DTCH / 1/2 DCH of the DCCH | 47.3% / 20%          |

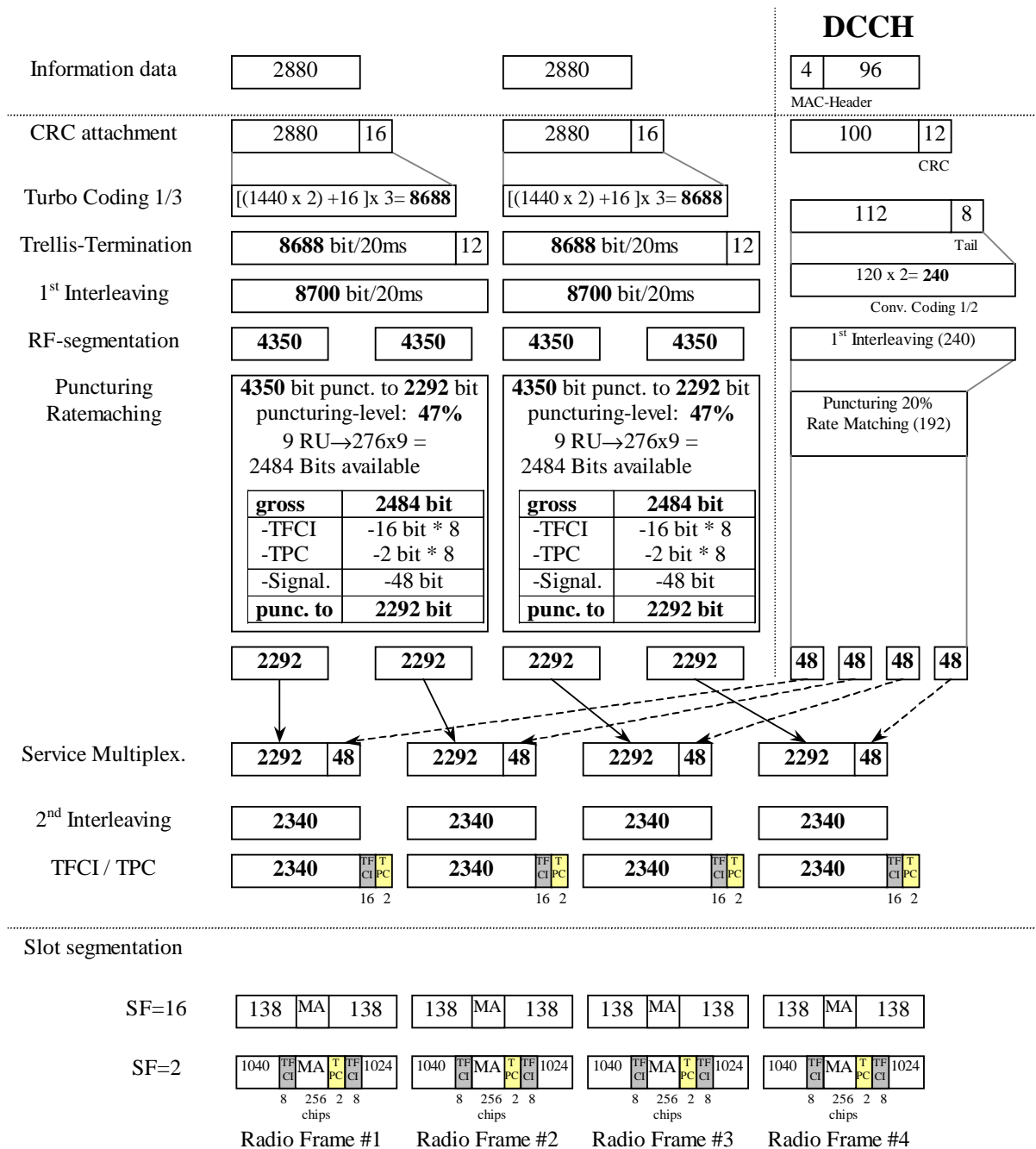


Figure A.3

### A.2.3.2 1,28 Mcps TDD option

Table A.3A

| Parameter  | Value                  |
|--|------------------------|
| Information data rate  | 144 kbps               |
| RU's allocated   | 2TS (1*SF2) = 16RU/5ms |
| Midamble   | 144                    |
| Interleaving   | 20 ms                  |
| Power control (TPC)  | 8 Bit/user/10ms        |
| TFCI   | 32 Bit/user/10ms       |
| Synchronisation Shift (SS)   | 8 Bit/user/10ms        |
| Inband signalling DCCH   | 2.4 kbps               |
| Puncturing level at Code rate: 1/3 DCH of the DTCH / 1/2 DCH of the DCCH | 38% / 7%               |

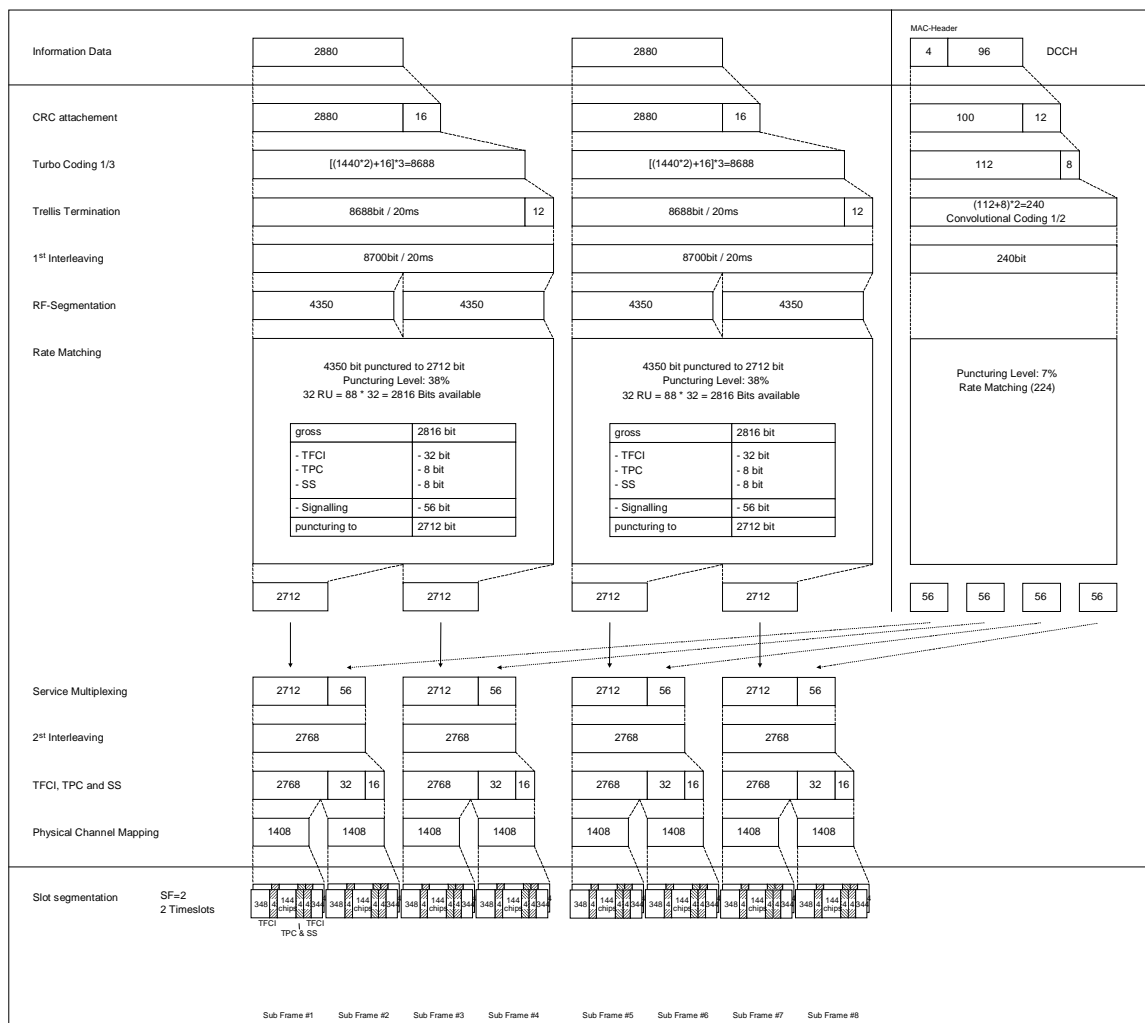


Figure A.3A

### A.2.3.3 7,68 Mcps TDD Option

Table A.3B

| Parameter   | Value                |
|---|----------------------|
| Information data rate   | 144 kbps             |
| RU's allocated  | 1 SF4 + 1 SF32 = 9RU |
| Midamble  | 512 chips            |
| Interleaving  | 20 ms                |
| Power control   | 2 Bit/user           |
| TFCI  | 16 Bit/user          |
| Inband signalling DCCH  | 2 kbps               |
| Puncturing level at Code rate : 1/3 DCH of the DTCH / 1/2 DCH of the DCCH | 47.3% / 20%          |

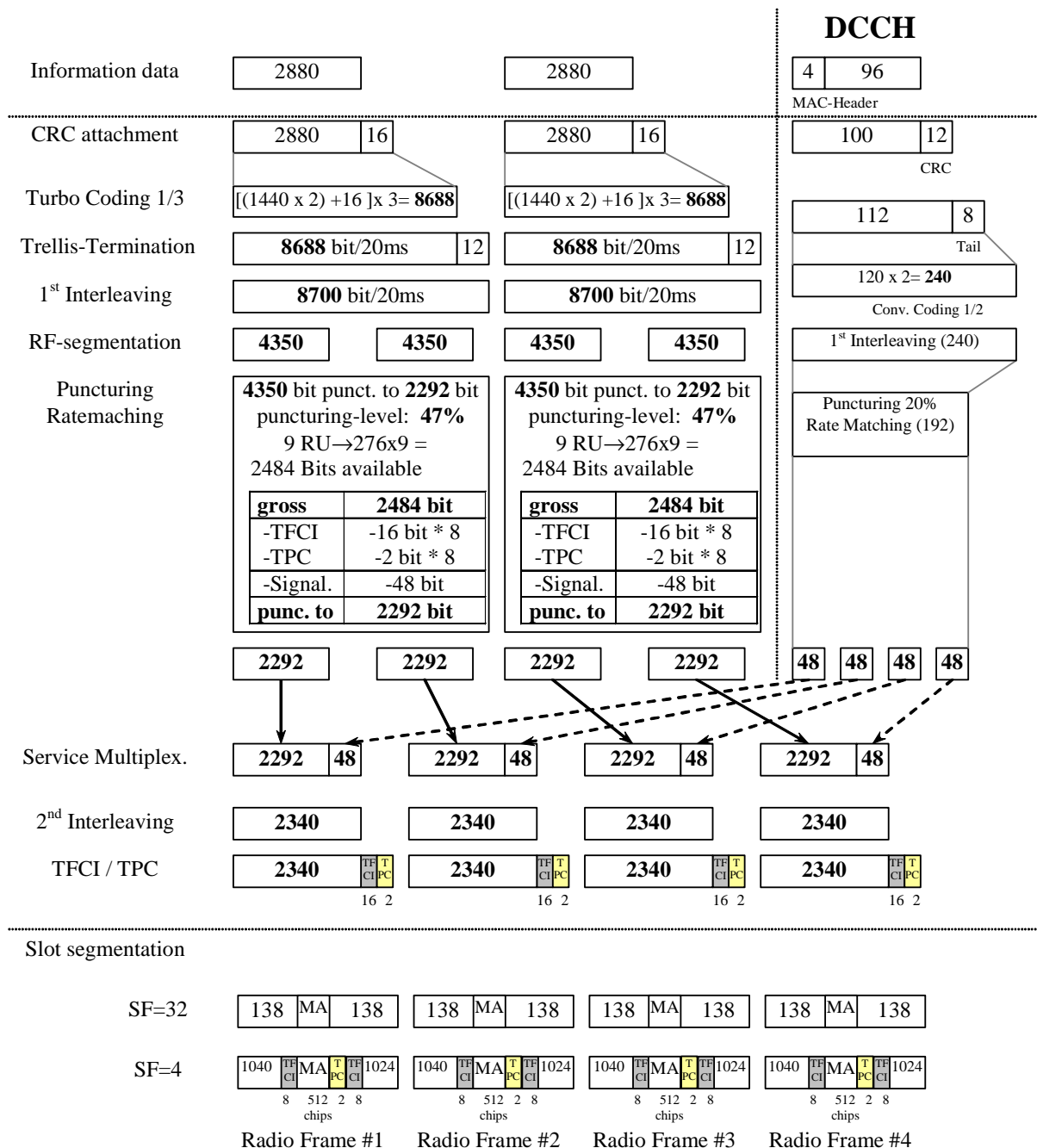


Figure A.3B

## A.2.4 UL reference measurement channel (384 kbps)

### A.2.4.1 3,84 Mcps TDD option

Table A.4

| Parameter   | Value        |
|---|--------------|
| Information data rate   | 384 kbps     |
| RU's allocated  | 8*3TS = 24RU |
| Midamble  | 256 chips    |
| Interleaving  | 20 ms        |
| Power control   | 2 Bit/user   |
| TFCI  | 16 Bit/user  |
| Inband signalling DCCH  | 2 kbps       |
| Puncturing level at Code rate : 1/3 DCH of the DTCH / 1/2 DCH of the DCCH | 44% / 15.3%  |

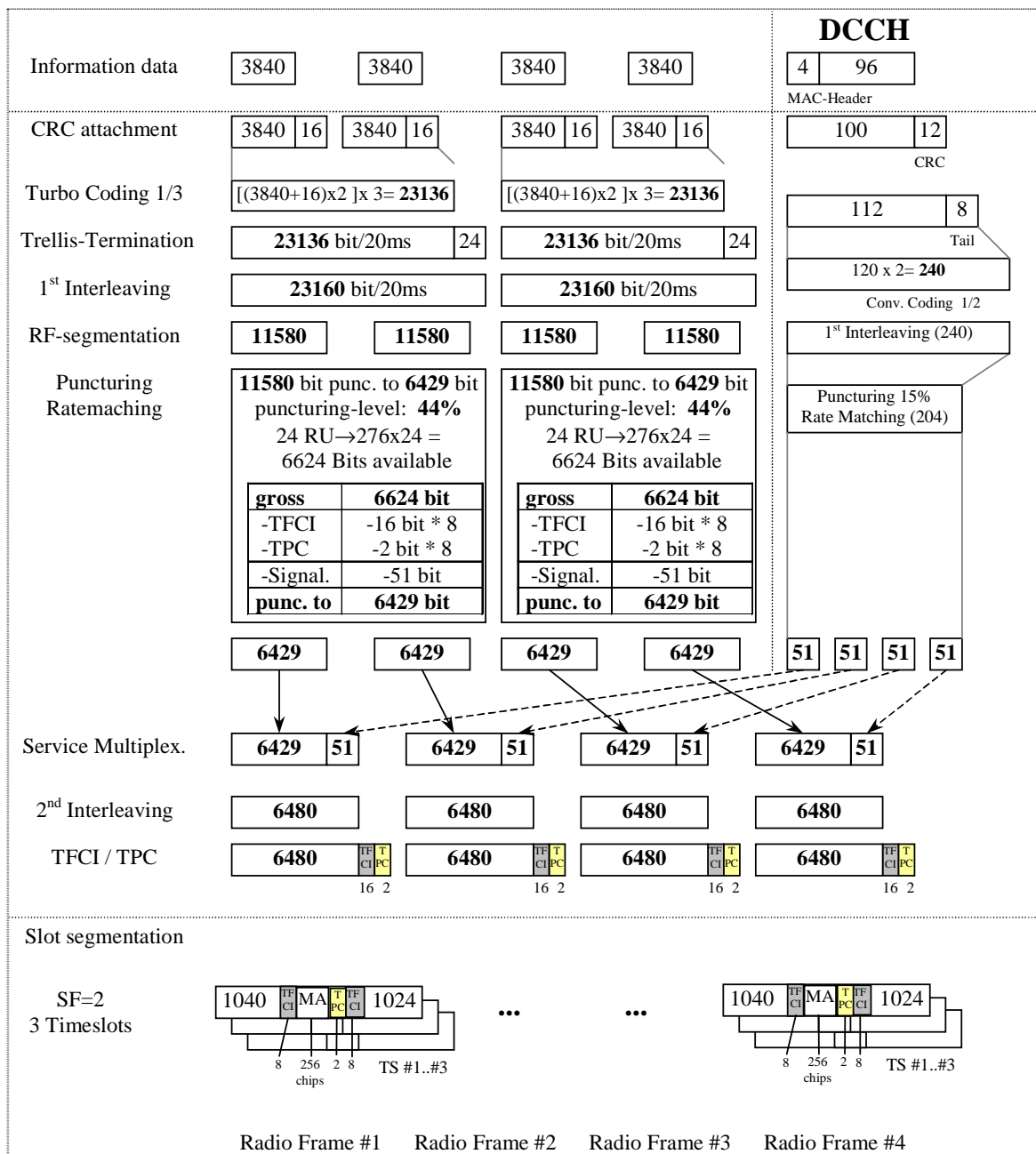


Figure A.4

A.2.4.2 1,28 Mcps TDD option

Table A.4A

| Parameter  | Value                           |
|--|---------------------------------|
| Information data rate  | 384 kbps                        |
| RU's allocated   | 4TS (1*SF2 + 1*SF16) = 36RU/5ms |
| Midamble   | 144                             |
| Interleaving   | 20 ms                           |
| Power control (TPC)  | 16 Bit/user/10ms                |
| TFCI   | 64 Bit/user/10ms                |
| Synchronisation Shift (SS)   | 16 Bit/user/10ms                |
| Inband signalling DCCH   | 2.4 kbps                        |
| Puncturing level at Code rate: 1/3 DCH of the DTCH / 1/2 DCH of the DCCH | 47% / 12%                       |

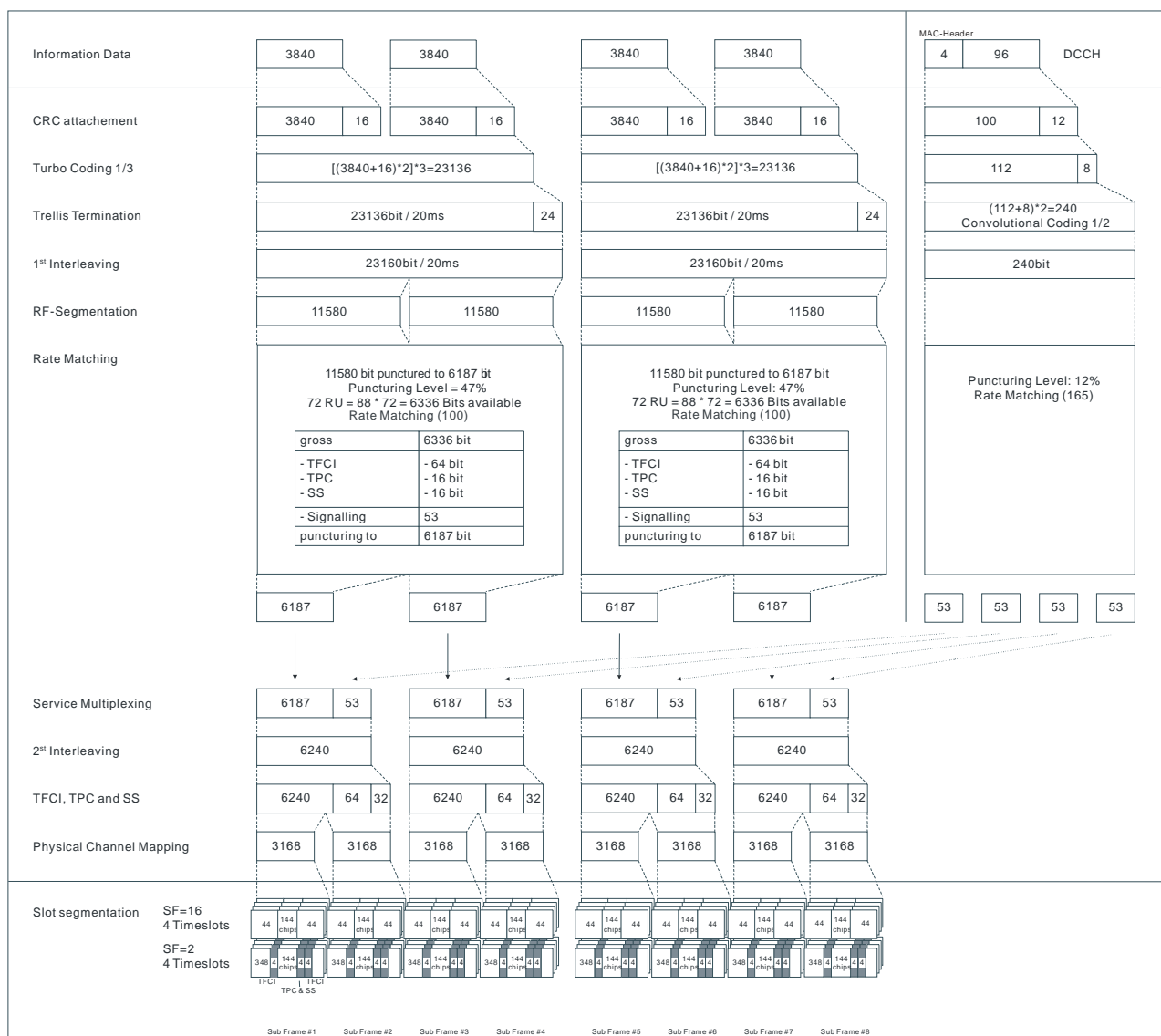


Figure A.4A



### A.2.4.3 7,68 Mcps TDD Option

Table A.4B

| Parameter   | Value         |
|---|---------------|
| Information data rate   | 384 kbps      |
| RU's allocated  | 8*3TS = 24RU  |
| Midamble  | 512 chips     |
| Interleaving  | 20 ms         |
| Power control   | 2 Bit/user    |
| TFCI  | 16 Bit/user   |
| Inband signalling DCCH  | 2 kbps        |
| Puncturing level at Code rate : 1/3 DCH of the DTCH / 1/2 DCH of the DCCH | 43.4% / 15.3% |

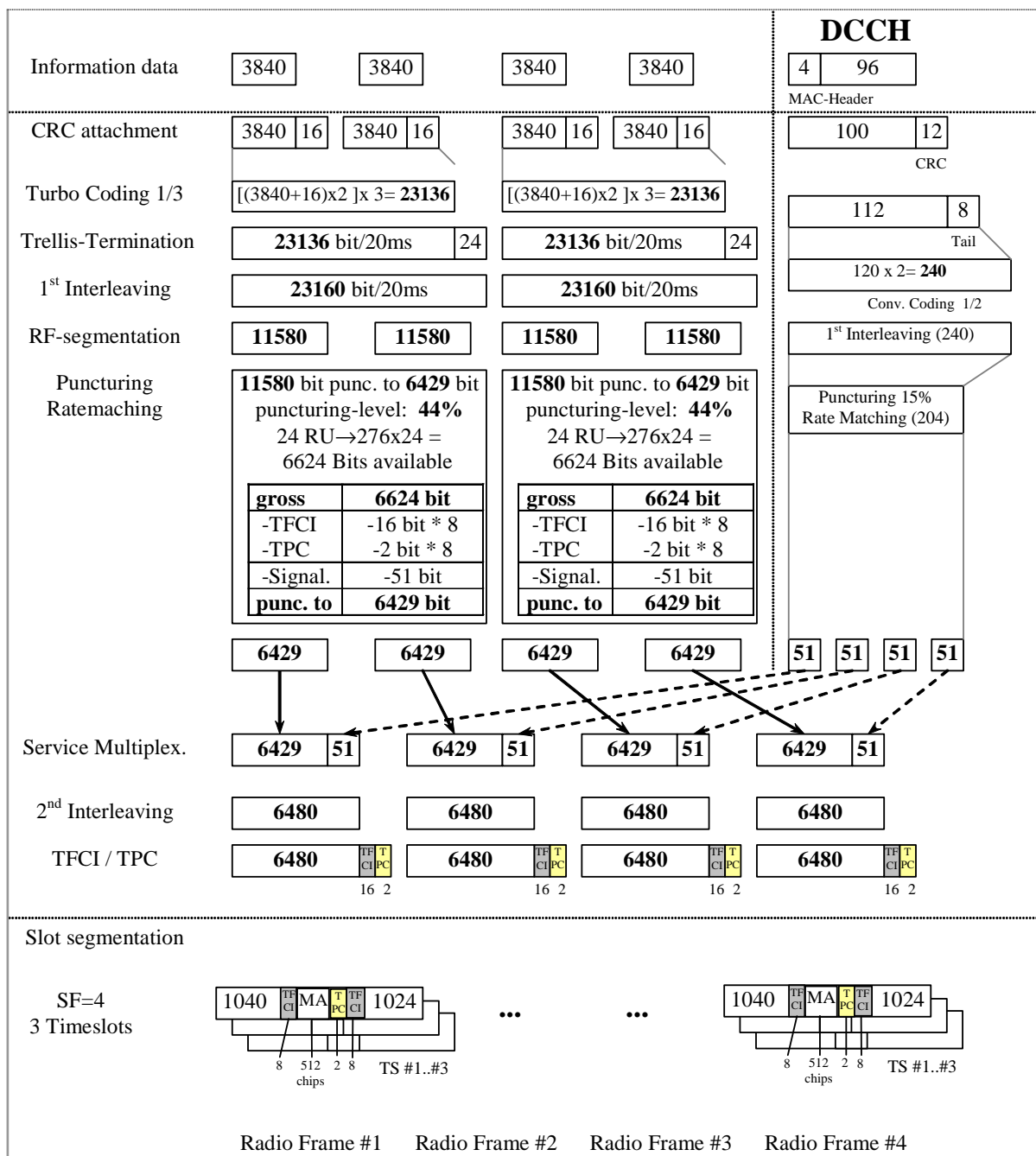


Figure A.4B

## A.2.5 RACH reference measurement channel

### A.2.5.1 3,84 Mcps TDD option

Table A.5

| Parameter   | Value   |
|---|---|
| Information data rate e.g. 2 TBs<br>( $B_{RACH}=2$ ):<br><b>SF16:</b><br>0% puncturing rate at CR=1/2<br>10% puncturing rate at CR=1/2<br>$N_{RACH} = \frac{232 + N_{RM} - 8}{B_{RACH}} - 8$<br><b>SF8:</b><br>0% puncturing rate at CR=1/2<br>10% puncturing rate at CR=1/2<br>$N_{RACH} = \frac{464 + N_{RM} - 8}{B_{RACH}} - 16$ | 46 bits per frame and TB<br>53 bits per frame and TB<br><br>96 bits per frame and TB<br>109 bits per frame and TB |
| RU's allocated  | 1 RU  |
| Midamble  | 512 chips   |
| Power control   | 0 bit   |
| TFCI  | 0 bit   |

$N_{RACH}$  = number of bits per TB

$B_{RACH}$  = number of TBs

#### A.2.5.1.1 RACH mapped to 1 code SF16

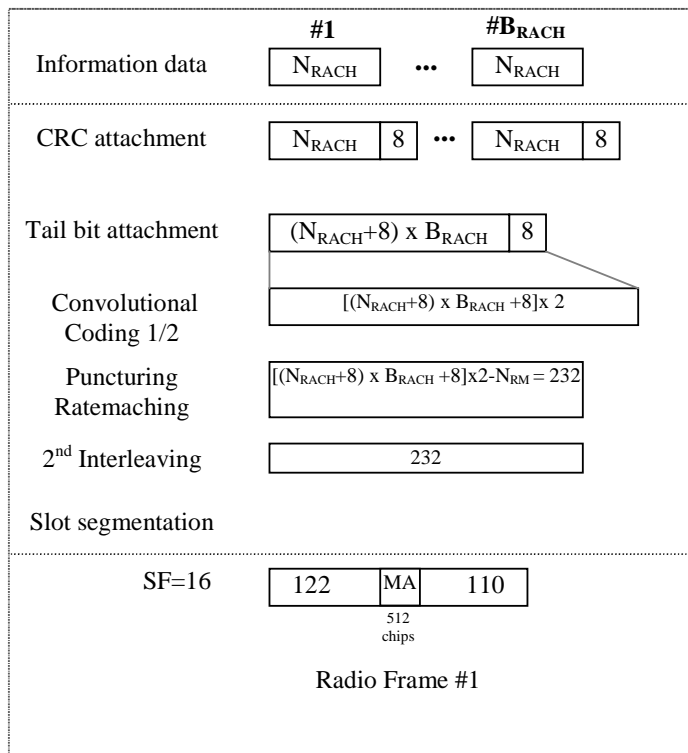


Figure A.5

A.2.5.1.2 RACH mapped to 1 code SF8

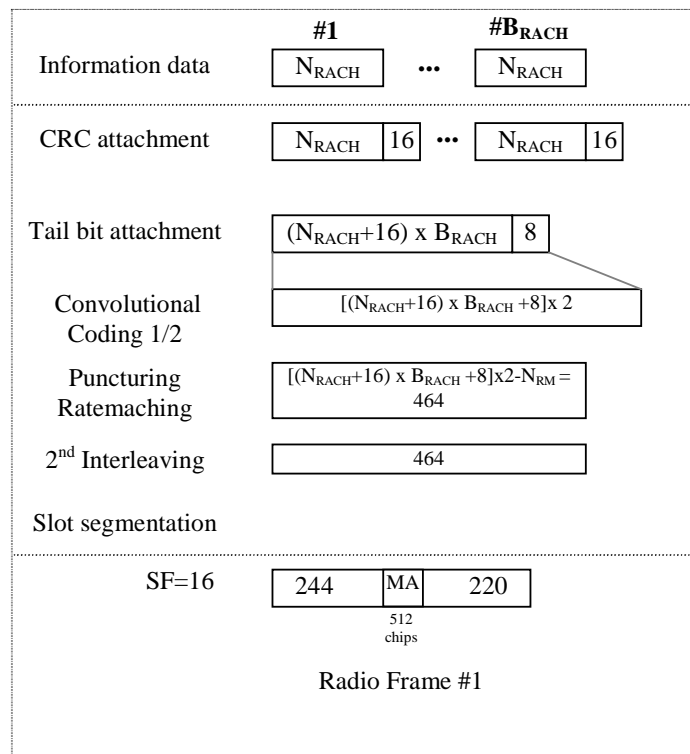


Figure A.6

A.2.5.2 1,28 Mcps TDD option

Table A5.A

| Parameter   | Value  |
|---|--|
| Information data rate:<br>$N_{RACH} = \frac{88 * \frac{16}{SF} \left( \frac{N_{RM}}{100} + 1 \right) - 8}{B_{RACH}} - 16$ | Transport Block Set Size=1<br>CRC length = 16<br>Tail Bits = 8 |
| <b>SF16</b> (RU"s allocated:1):<br>0% puncturing rate at CR=1/2<br>~10% puncturing rate at CR=1/2                         | 20 bits per frame and TB<br>24 bits per frame and TB           |
| <b>SF8</b> (RU"s allocated:2):<br>0% puncturing rate at CR=1/2<br>~10% puncturing rate at CR=1/2                          | 64 bits per frame and TB<br>73 bits per frame and TB           |
| <b>SF4</b> (RU"s allocated:4):<br>0% puncturing rate at CR=1/2<br>~10% puncturing rate at CR=1/2                          | 152 bits per frame and TB<br>170 bits per frame and TB         |
| TTI   | 5msec  |
| Midamble  | 144 chips  |
| Power control   | 0 bit  |
| TFCI  | 0 bit  |

$N_{RACH}$  = number of bits per TB

$B_{RACH}$  = number of TBs

$N_{RM}$  = puncturing rate

A.2.5.2.1 RACH mapped to 1 code SF16

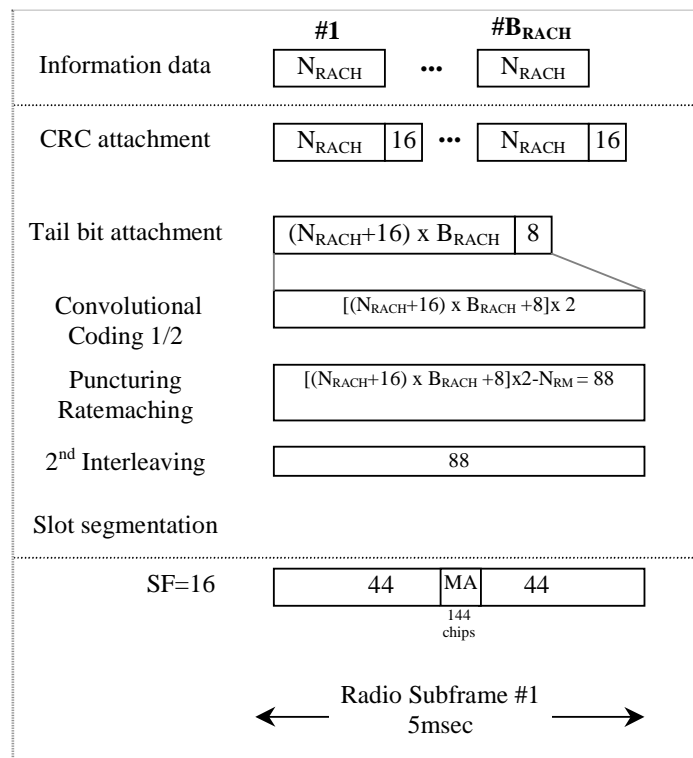


Figure A.5A

A.2.5.2.2 RACH mapped to 1 code SF8

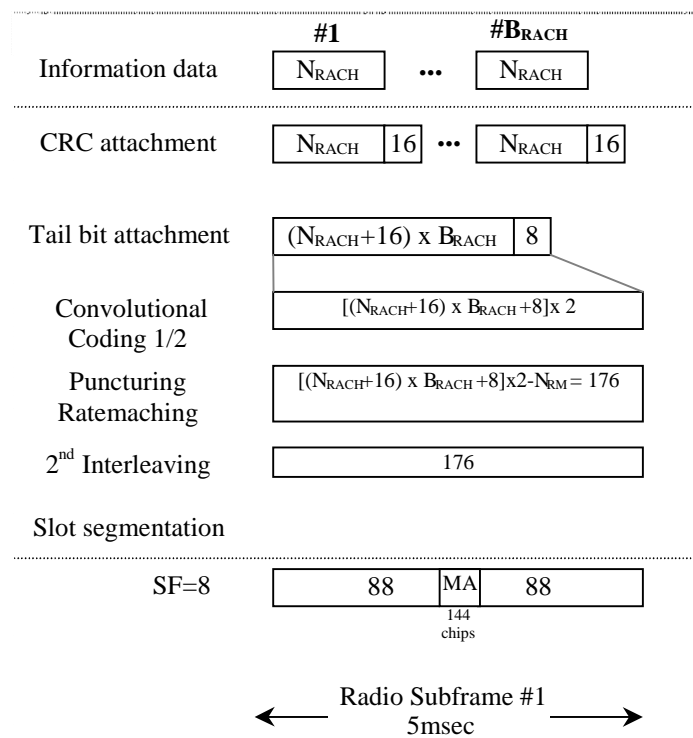


Figure A.6A

A.2.5.2.3 RACH mapped to 1 code SF4

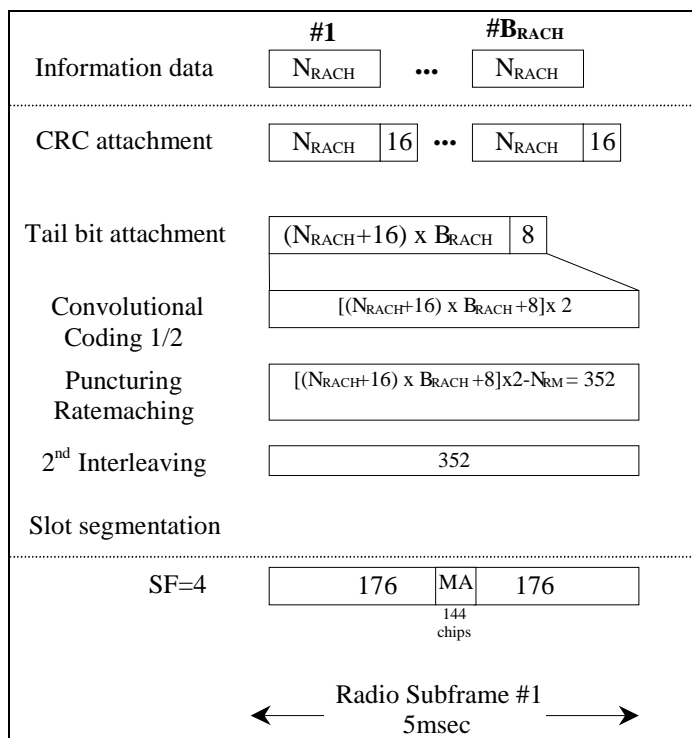


Figure A.7

A.2.5.3 7,68 Mcps TDD option

Table A5.B

| Parameter   | Value  |
|---|--|
| Information data rate e.g. 2 TBs<br>( $B_{RACH}=2$ ):<br><b>SF32:</b><br>0% puncturing rate at CR=1/2<br>10% puncturing rate at CR=1/2<br>$N_{RACH} = \frac{232 + N_{RM} - 8}{2 \times B_{RACH}} - 8$ | 46 bits per frame and TB<br>53 bits per frame and TB |
| <b>SF16:</b><br>0% puncturing rate at CR=1/2<br>10% puncturing rate at CR=1/2<br>$N_{RACH} = \frac{464 + N_{RM} - 8}{2 \times B_{RACH}} - 16$   |  |
| RU's allocated  | 1 RU for SF32, 2 RUs for SF16                        |
| Midamble  | 1024 chips   |
| Power control   | 0 bit  |
| TFCI  | 0 bit  |

$N_{RACH}$  = number of bits per TB

$B_{RACH}$  = number of TBs

A.2.5.3.1 RACH mapped to 1 code SF16

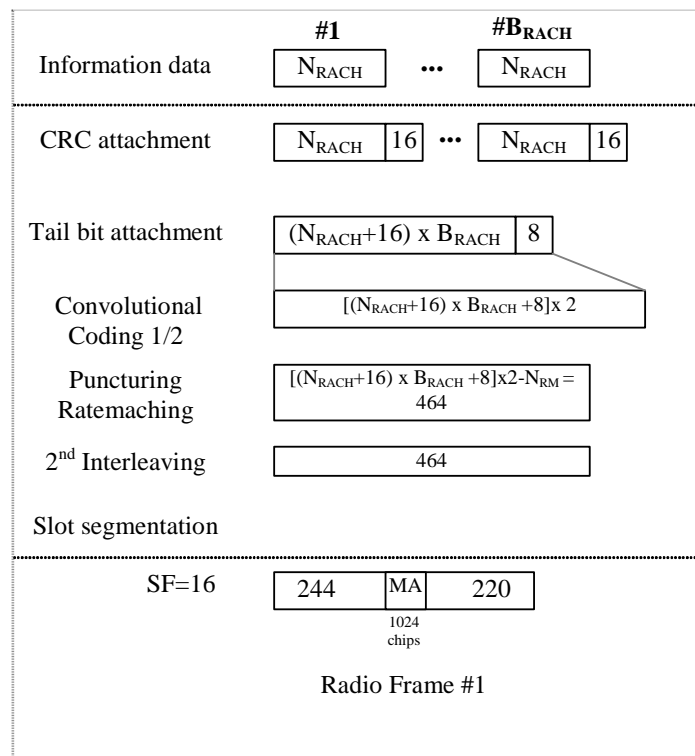


Figure A.8

A.2.5.3.2 RACH mapped to 1 code SF32

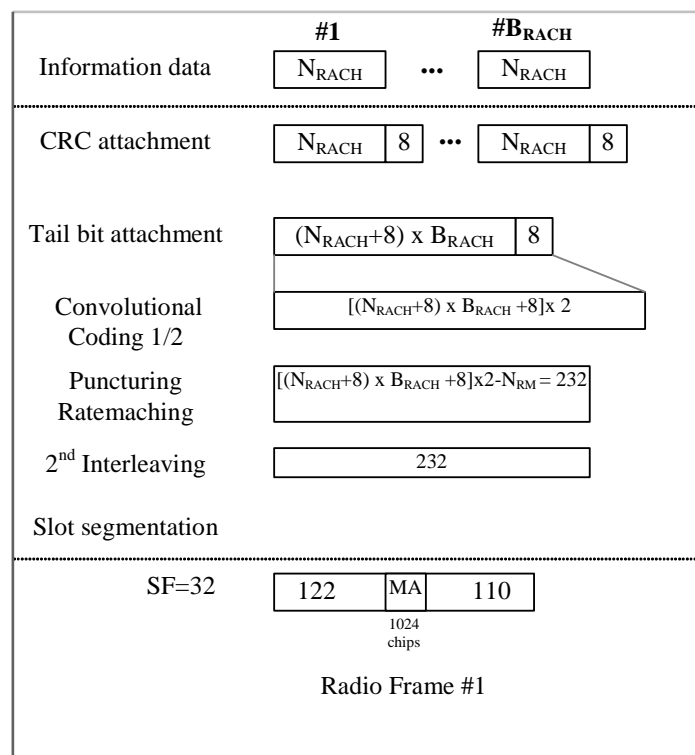


Figure A.9

## A.3 E-DCH Reference measurement channels

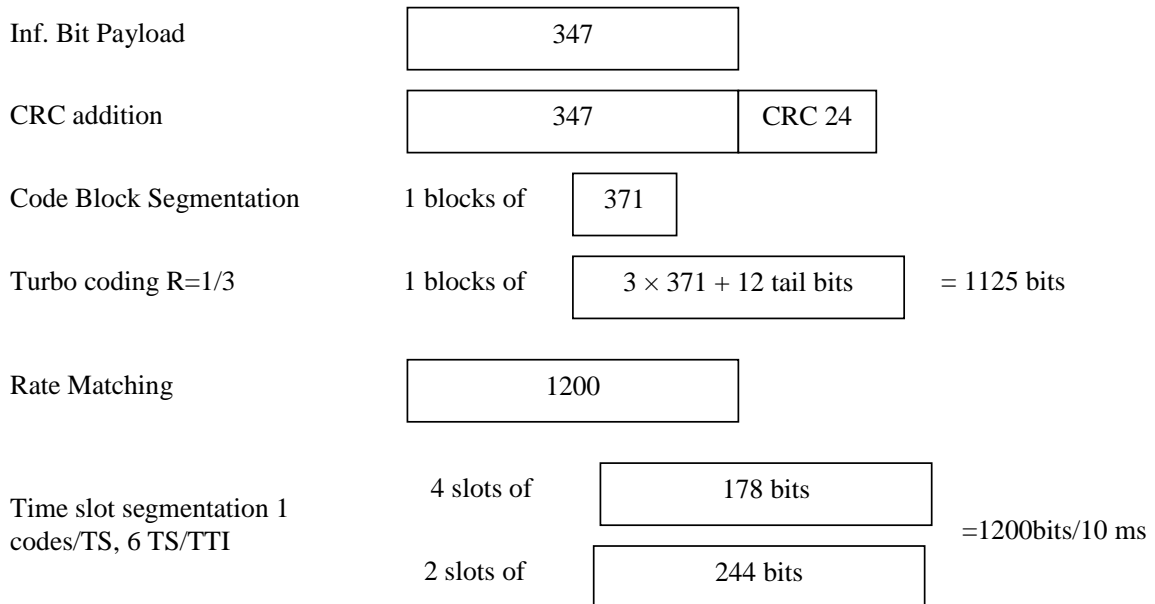
### A.3.1 E-DCH Fixed Reference Channels

#### A.3.1.1 3,84 Mcps TDD Option

##### A.3.1.1.1 Fixed Reference Channel 1 (FRC1)

**Table A.6: E-DCH Fixed Reference Channel 1 (3,84 Mcps TDD Option)**

| Parameter                             | Unit   | Value |
|---------------------------------------|--------|-------|
| Maximum information bit throughput    | kbps   | 34.7  |
| Information Bit Payload ( $N_{INF}$ ) | Bits   | 347   |
| Number Code Blocks                    | Blocks | 1     |
| Number of coded bits per TTI          | Bits   | 1200  |
| Coding Rate                           |        | 0.312 |
| Modulation                            |        | QPSK  |
| Number of E-DCH Timeslots             | Slots  | 6     |
| Number of E-DCH codes per TS          | Codes  | 1     |
| Spreading factor                      | SF     | 16    |
| Number of E-UCCH per TTI              |        | 4     |

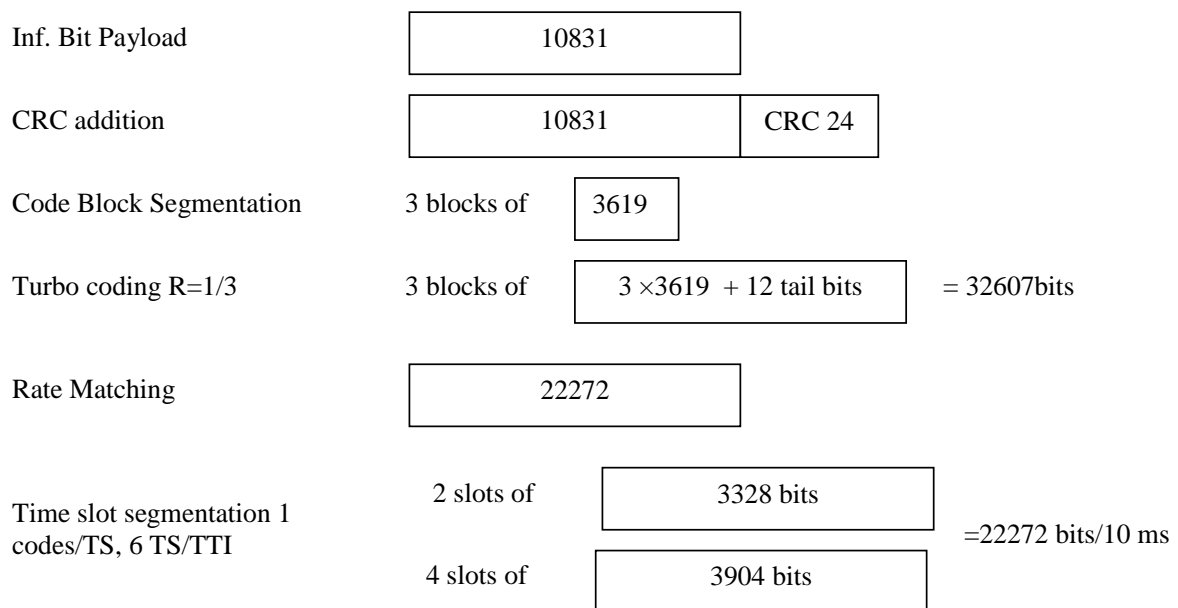


**Figure A.10: Coding for E-DCH FRC1 (3,84 Mcps TDD Option)**

## A.3.1.1.2 Fixed Reference Channel 2 (FRC2)

**Table A.7: E-DCH Fixed Reference Channel 2 (3,84 Mcps TDD Option)**

| Parameter                             | Unit   | Value  |
|---------------------------------------|--------|--------|
| Maximum information bit throughput    | kbps   | 1083.1 |
| Information Bit Payload ( $N_{INF}$ ) | Bits   | 10831  |
| Number Code Blocks                    | Blocks | 3      |
| Number of coded bits per TTI          | Bits   | 22272  |
| Coding Rate                           |        | 0.488  |
| Modulation                            |        | 16QAM  |
| Number of E-DCH Timeslots             | Slots  | 6      |
| Number of E-DCH codes per TS          | Codes  | 1      |
| Spreading factor                      | SF     | 2      |
| Number of E-UCCH per TTI              |        | 2      |

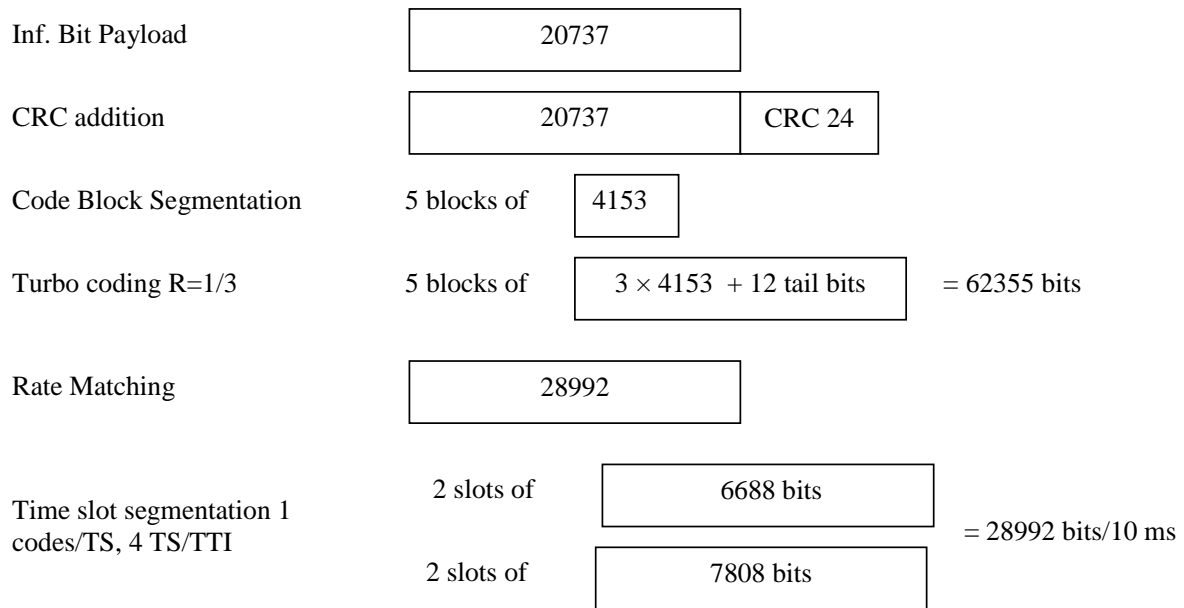
**Figure A.11: Coding for E-DCH FRC2 (3,84 Mcps TDD Option)**

## A.3.1.1.3 Fixed Reference Channel 3 (FRC3)

**Table A.8: E-DCH Fixed Reference Channel 3 (3,84 Mcps TDD Option)**

| Parameter                             | Unit   | Value  |
|---------------------------------------|--------|--------|
| Maximum information bit throughput    | kbps   | 2073.7 |
| Information Bit Payload ( $N_{INF}$ ) | Bits   | 20737  |
| Number Code Blocks                    | Blocks | 5      |
| Number of coded bits per TTI          | Bits   | 28992  |
| Coding Rate                           |        | 0.716  |
| Modulation                            |        | 16QAM  |
| Number of E-DCH Timeslots             | Slots  | 4      |
| Number of E-DCH codes per TS          | Codes  | 1      |
| Spreading factor                      | SF     | 1      |
| Number of E-UCCH per TTI              |        | 2      |





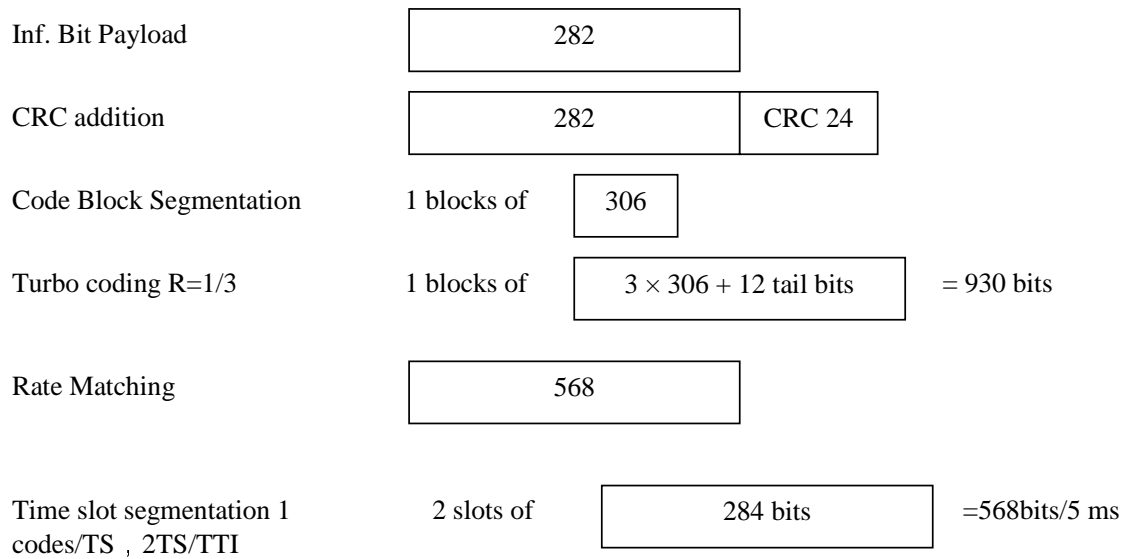
**Figure A.12: Coding for E-DCH FRC3 (3,84 Mcps TDD Option)**

### A.3.1.2 1.28Mcps TDD Option

#### A.3.1.2.1 Fixed reference channel 1(FRC1)

**Table A.9: E-DCH Fixed reference channel 1 (1.28Mcps TDD option)**

| Parameter                             | Unit   | Value  |
|---------------------------------------|--------|--------|
| Maximum information bit throughput    | kbps   | 56.4   |
| Information Bit Payload ( $N_{INF}$ ) | Bits   | 282    |
| Number Code Blocks                    | Blocks | 1      |
| Number of coded bits per TTI          | Bits   | 306    |
| Coding Rate                           |        | 0.4965 |
| Modulation                            |        | QPSK   |
| Number of E-DCH Timeslots             | Slots  | 2      |
| Number of E-DCH codes per TS          | Codes  | 1      |
| Spreading factor                      | SF     | 4      |
| Number of E-UCCH per TTI              |        | 4      |

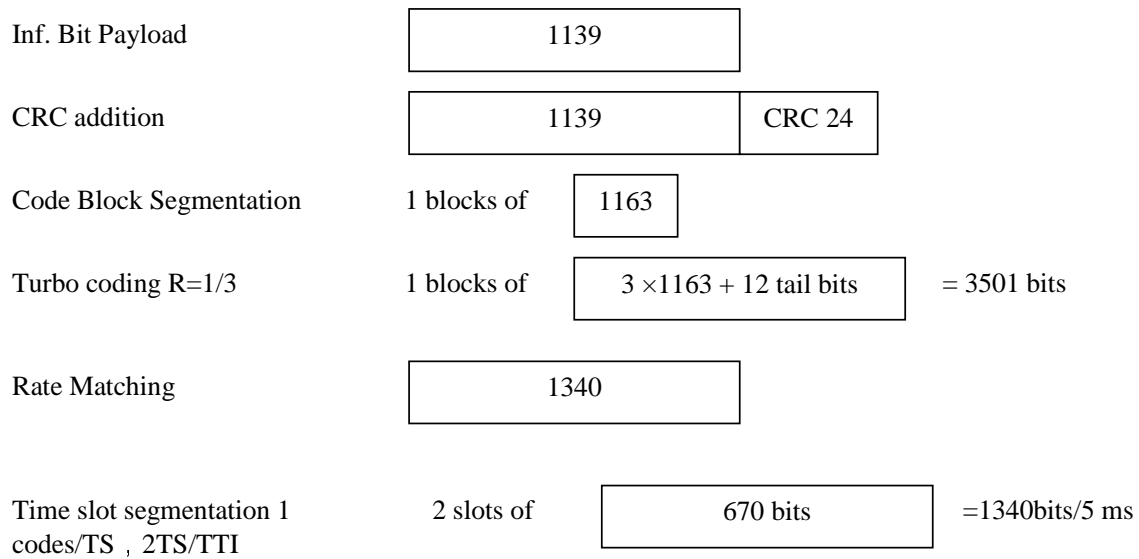


**Figure A.12A: Coding for E-DCH FRC1 (1.28 Mcps TDD Option)**

#### A.3.1.2.2 Fixed reference channel 2(FRC2)

**Table A.10: E-DCH Fixed reference channel 2(1.28Mcps TDD option)**

| Parameter                             | Unit   | Value |
|---------------------------------------|--------|-------|
| Maximum information bit throughput    | kbps   | 227.8 |
| Information Bit Payload ( $N_{INF}$ ) | Bits   | 1139  |
| Number Code Blocks                    | Blocks | 1     |
| Number of coded bits per TTI          | Bits   | 1163  |
| Coding Rate                           |        | 0.85  |
| Modulation                            |        | QPSK  |
| Number of E-DCH Timeslots             | Slots  | 2     |
| Number of E-DCH codes per TS          | Codes  | 1     |
| Spreading factor                      | SF     | 2     |
| Number of E-UCCH per TTI              |        | 2     |

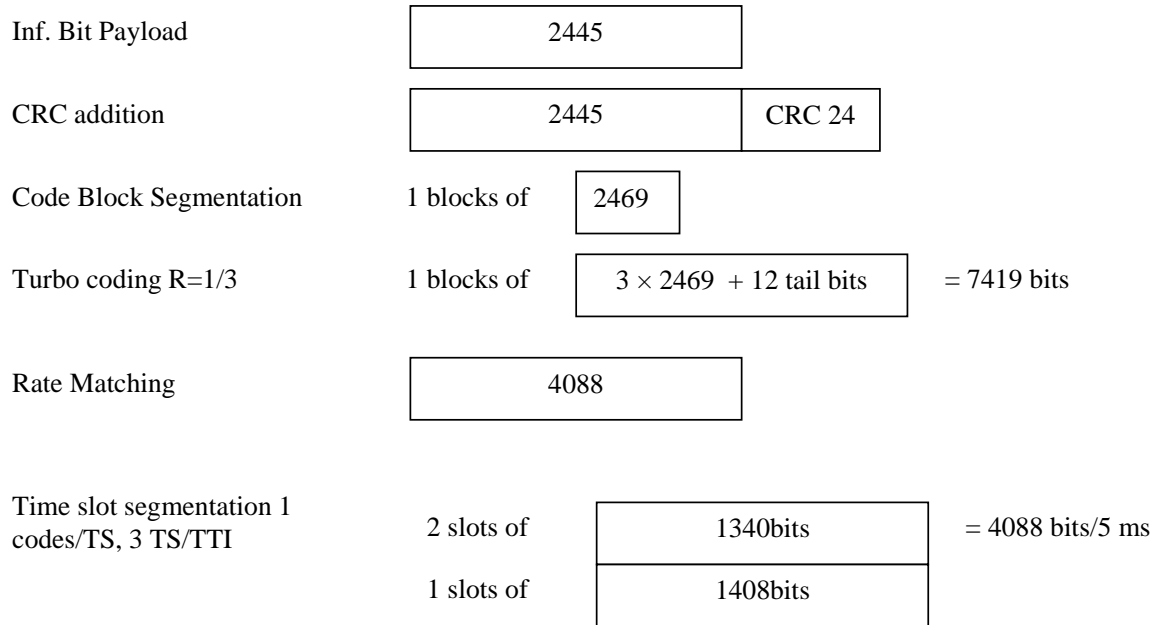


**Figure A.13: Coding for E-DCH FRC2 (1.28 Mcps TDD Option)**

#### A.3.1.2.3 Fixed reference channel 3(FRC3)

**Table A.11: E-DCH Fixed reference channel 3 (1.28Mcps TDD option)**

| Parameter                             | Unit   | Value |
|---------------------------------------|--------|-------|
| Maximum information bit throughput    | kbps   | 489   |
| Information Bit Payload ( $N_{INF}$ ) | Bits   | 2445  |
| Number Code Blocks                    | Blocks | 1     |
| Number of coded bits per TTI          | Bits   | 2469  |
| Coding Rate                           |        | 0.598 |
| Modulation                            |        | 16QAM |
| Number of E-DCH Timeslots             | Slots  | 3     |
| Number of E-DCH codes per TS          | Codes  | 1     |
| Spreading factor                      | SF     | 2     |
| Number of E-UCCH per TTI              |        | 2     |



**Figure A.14: Coding for E-DCH FRC3 (1.28 Mcps TDD Option)**

A.3.1.2.4 Fixed reference channel 4(FRC4)

**Table A.12: E-DCH Fixed reference channel 4 (1.28Mcps TDD option)**

| Parameter                             | Unit   | Value  |
|---------------------------------------|--------|--------|
| Maximum information bit throughput    | kbps   | 1281.2 |
| Information Bit Payload ( $N_{INF}$ ) | Bits   | 6406   |
| Number Code Blocks                    | Blocks | 2      |
| Number of coded bits per TTI          | Bits   | 6430   |
| Coding Rate                           |        | 0.5757 |
| Modulation                            |        | 16QAM  |
| Number of E-DCH Timeslots             | Slots  | 4      |
| Number of E-DCH codes per TS          | Codes  | 1      |
| Spreading factor                      | SF     | 1      |
| Number of E-UCCH per TTI              |        | 2      |

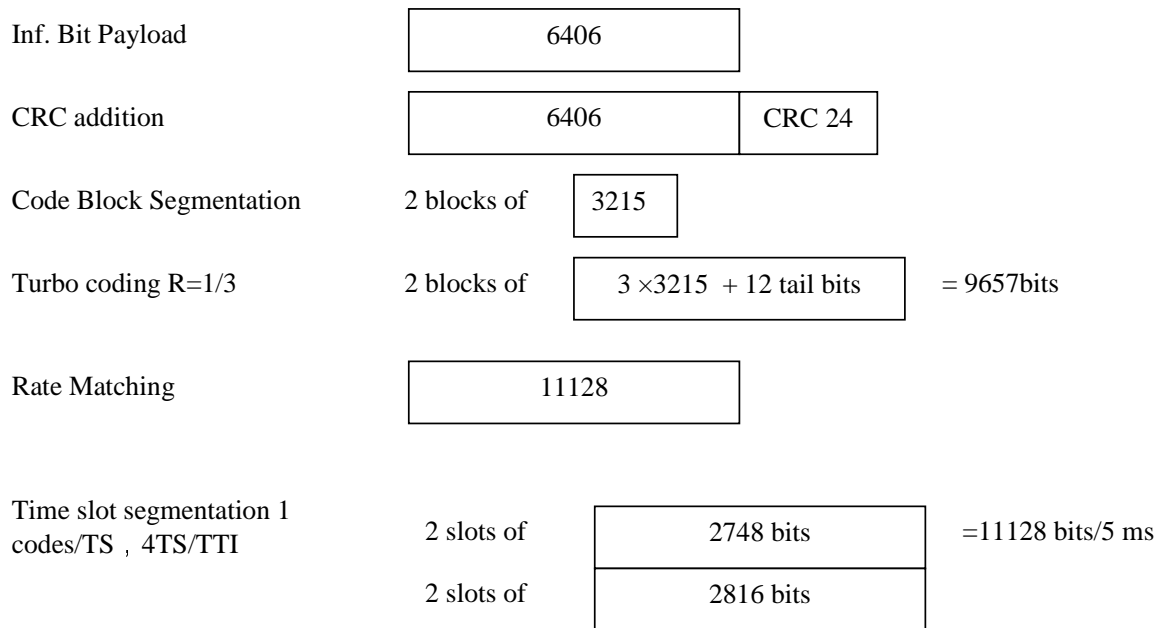


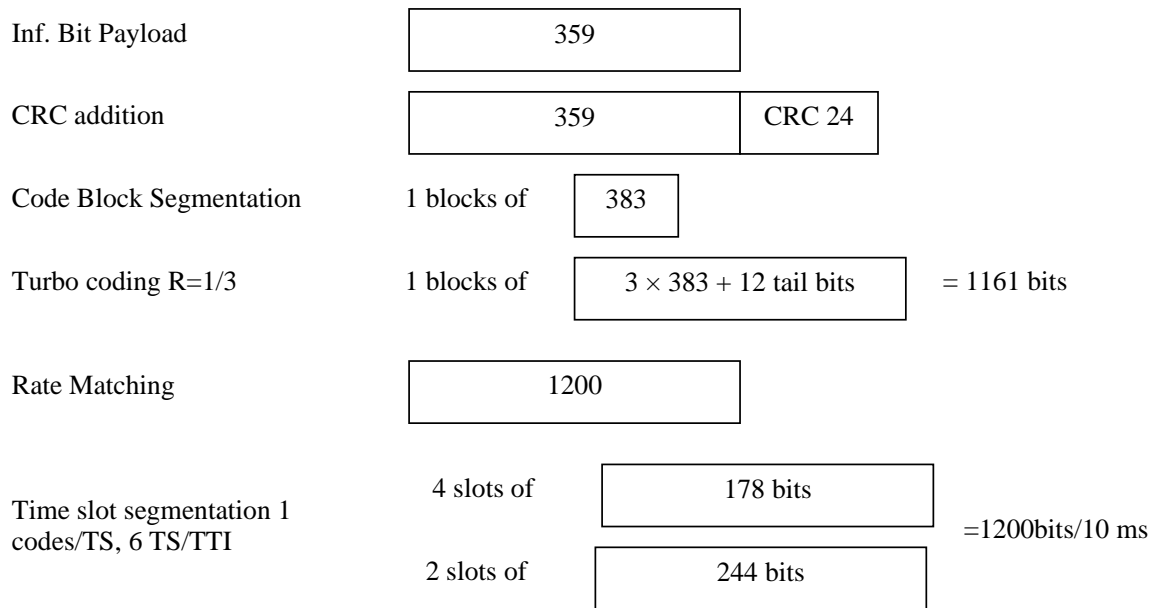
Figure A.15: Coding for E-DCH FRC4 (1.28 Mcps TDD Option)

### A.3.1.3 7,68 Mcps TDD Option

#### A.3.1.3.1 Fixed Reference Channel 1 (FRC1)

Table A.13: E-DCH Fixed Reference Channel 1 (7.68 Mcps TDD Option)

| Parameter                             | Unit   | Value |
|---------------------------------------|--------|-------|
| Maximum information bit throughput    | kbps   | 35.9  |
| Information Bit Payload ( $N_{INF}$ ) | Bits   | 359   |
| Number Code Blocks                    | Blocks | 1     |
| Number of coded bits per TTI          | Bits   | 1200  |
| Coding Rate                           |        | 0.323 |
| Modulation                            |        | QPSK  |
| Number of E-DCH Timeslots             | Slots  | 6     |
| Number of E-DCH codes per TS          | Codes  | 1     |
| Spreading factor                      | SF     | 32    |
| Number of E-UCCH per TTI              |        | 4     |

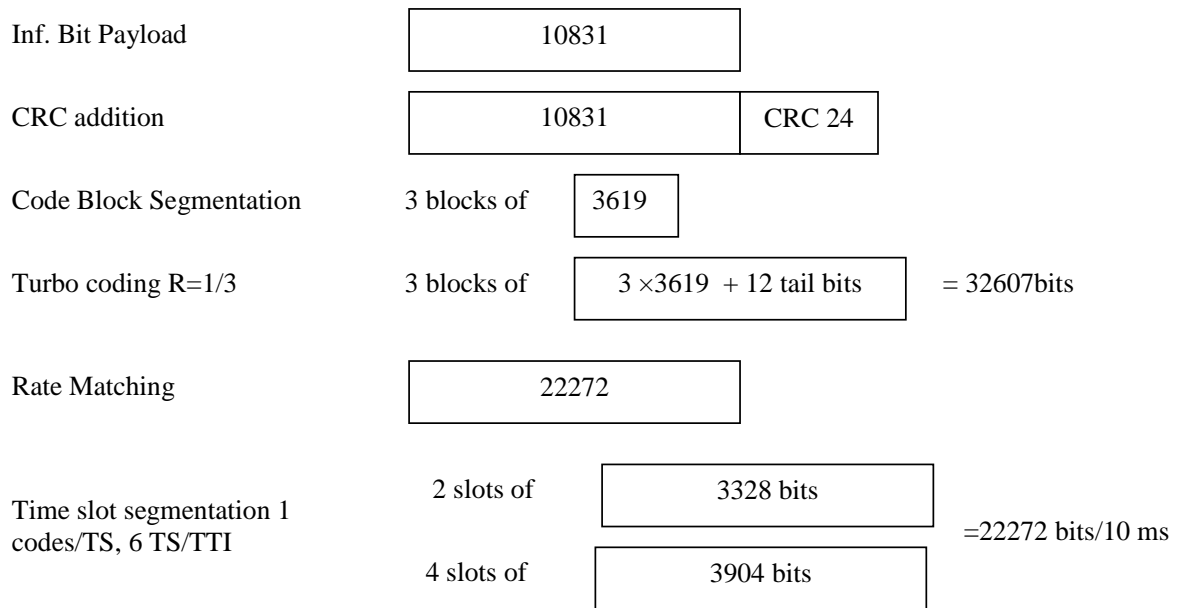


**Figure A.16: Coding for E-DCH FRC1 (7.68 Mcps TDD Option)**

#### A.3.1.3.2 Fixed Reference Channel 2 (FRC2)

**Table A.14: E-DCH Fixed Reference Channel 2 (7.68 Mcps TDD Option)**

| Parameter                             | Unit   | Value  |
|---------------------------------------|--------|--------|
| Maximum information bit throughput    | kbps   | 1083.1 |
| Information Bit Payload ( $N_{INF}$ ) | Bits   | 10831  |
| Number Code Blocks                    | Blocks | 3      |
| Number of coded bits per TTI          | Bits   | 22272  |
| Coding Rate                           |        | 0.488  |
| Modulation                            |        | 16QAM  |
| Number of E-DCH Timeslots             | Slots  | 6      |
| Number of E-DCH codes per TS          | Codes  | 1      |
| Spreading factor                      | SF     | 4      |
| Number of E-UCCH per TTI              |        | 2      |



**Figure A.17: Coding for E-DCH FRC2 (7.68 Mcps TDD Option)**

#### A.3.1.3.3 Fixed Reference Channel 3 (FRC3)

**Table A.15: E-DCH Fixed Reference Channel 3 (7.68 Mcps TDD Option)**

| Parameter                             | Unit   | Value  |
|---------------------------------------|--------|--------|
| Maximum information bit throughput    | kbps   | 2085.1 |
| Information Bit Payload ( $N_{INF}$ ) | Bits   | 20851  |
| Number Code Blocks                    | Blocks | 5      |
| Number of coded bits per TTI          | Bits   | 28992  |
| Coding Rate                           |        | 0.720  |
| Modulation                            |        | 16QAM  |
| Number of E-DCH Timeslots             | Slots  | 6      |
| Number of E-DCH codes per TS          | Codes  | 1      |
| Spreading factor                      | SF     | 2      |
| Number of E-UCCH per TTI              |        | 2      |

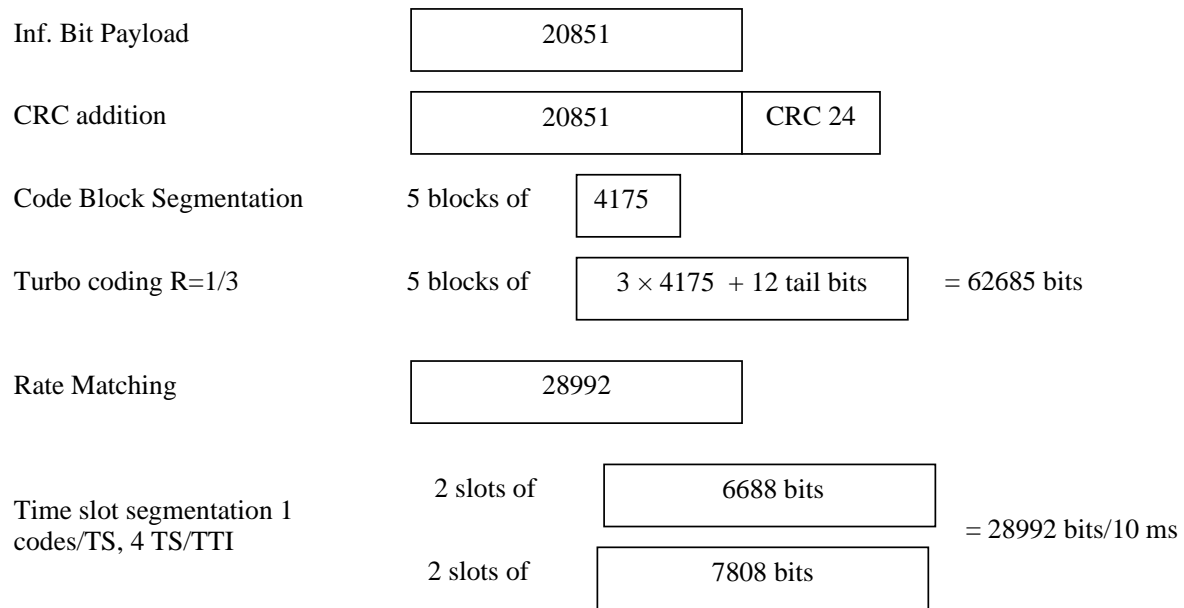


Figure A.18: Coding for E-DCH FRC3 (7.68 Mcps TDD Option)

## A.4 HS-SICH Reference measurement channels

### A.4.1 3,84 Mcps TDD Option

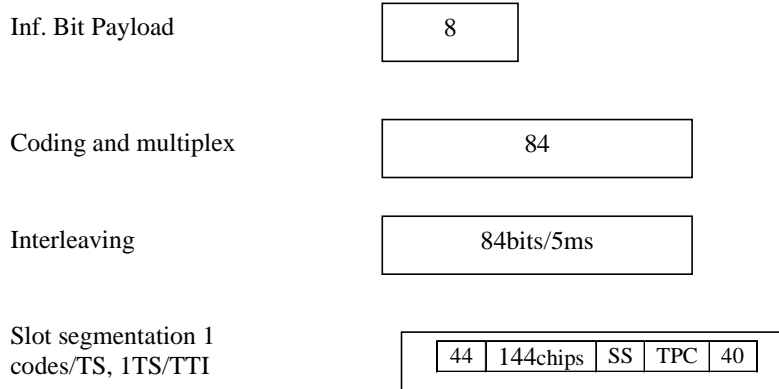
(void)

### A.4.2 1,28 Mcps TDD Option

Table A.16: HS-SICH type1 Reference Channel 1 (1,28 Mcps TDD Option)

| Parameter           | Unit | Value |
|---------------------|------|-------|
| Information bits    | bits | 8     |
| Encoded bits        | bits | 84    |
| Number of codes     | -    | 1     |
| Number of timeslots | -    | 1     |
| TTI                 | ms   | 5     |
| Spreading Factor    | SF   | 16    |

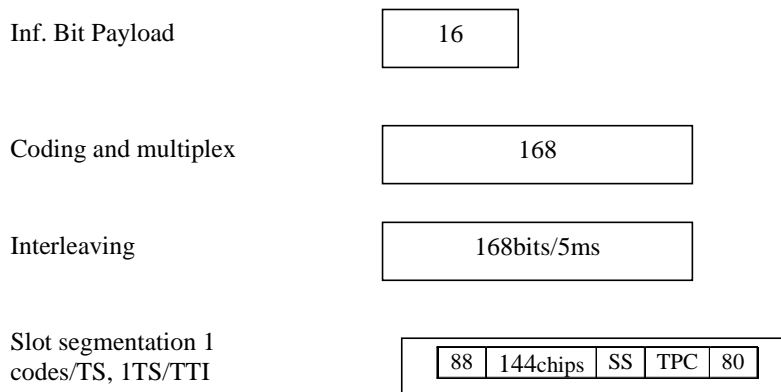




**Figure A.19: Coding for HS-SICH type1 channel (1,28 Mcps TDD Option)**

**Table A.17: HS-SICH type2 Reference Channel 1 (1.28 Mcps TDD Option)**

| Parameter           | Unit | Value |
|---------------------|------|-------|
| Information bits    | bits | 16    |
| Encoded bits        | bits | 168   |
| Number of codes     | -    | 1     |
| Number of timeslots | -    | 1     |
| TTI                 | ms   | 5     |
| Spreading Factor    | SF   | 8     |



**Figure A.20: Coding for HS-SICH type2 channel (1.28 Mcps TDD Option)**

## Annex B (normative): Propagation conditions

### B.1 Static propagation condition

The propagation for the static performance measurement is an Additive White Gaussian Noise (AWGN) environment. No fading and multi-paths exist for this propagation model.

### B.2 Multi-path fading propagation conditions

#### B.2.1 3,84 Mcps TDD option

Table B.1 and B.1A shows propagation conditions that are used for the performance measurements in multi-path fading environment. All taps have classical Doppler spectrum, defined as:

$$(CLASS) \quad S(f) \propto 1/(1 - (f / f_D)^2)^{0.5} \quad \text{for } f \in [-f_D, f_D]$$

**Table B.1: Propagation Conditions for Multi path Fading Environments for 3,84 Mcps TDD option for operations referenced in 4.2 a), 4.2 b) and 4.2 c)**

| Case 1, speed 3km/h |                          | Case 2, speed 3 km/h |                          | Case 3, speed 120 km/h |                          |
|---------------------|--------------------------|----------------------|--------------------------|------------------------|--------------------------|
| Relative Delay [ns] | Relative Mean Power [dB] | Relative Delay [ns]  | Relative Mean Power [dB] | Relative Delay [ns]    | Relative Mean Power [dB] |
| 0                   | 0                        | 0                    | 0                        | 0                      | 0                        |
| 976                 | -10                      | 976                  | 0                        | 260                    | -3                       |
|                     |                          | 12000                | 0                        | 521                    | -6                       |
|                     |                          |                      |                          | 781                    | -9                       |

**Table B.1A: Propagation Conditions for Multi path Fading Environments for operations referenced in 4.2 d)**

| Case 1, speed 2.3km/h |                          | Case 2, speed 2.3 km/h |                          | Case 3, speed 92 km/h |                          |
|-----------------------|--------------------------|------------------------|--------------------------|-----------------------|--------------------------|
| Relative Delay [ns]   | Relative Mean Power [dB] | Relative Delay [ns]    | Relative Mean Power [dB] | Relative Delay [ns]   | Relative Mean Power [dB] |
| 0                     | 0                        | 0                      | 0                        | 0                     | 0                        |
| 976                   | -10                      | 976                    | 0                        | 260                   | -3                       |
|                       |                          | 12000                  | 0                        | 521                   | -6                       |
|                       |                          |                        |                          | 781                   | -9                       |

#### B.2.2 1,28 Mcps TDD option

Table B.2 shows propagation conditions that are used for the performance measurements in multi-path fading environment. All taps have classical Doppler spectrum, defined as:

$$(CLASS) \quad S(f) \propto 1/(1 - (f / f_D)^2)^{0.5} \quad \text{for } f \in [-f_D, f_D]$$

**Table B2: Propagation Conditions for Multi path Fading Environments**

| Case 1                                       |                          | Case 2  |                          | Case 3  |                          |
|--|--------------------------|---|--------------------------|---|--------------------------|
| Speed for operating in band a, b, c, f 3km/h |                          | Speed for operating in band a, b, c, f: 3km/h |                          | Speed for operating in band a, b, c, f: 120km/h |                          |
| Speed for operating in band d: 2.3km/h       |                          | Speed for operating in band d: 2.3km/h        |                          | Speed for operating in band d: 92km/h           |                          |
| Speed for operating in band e: 2.6km/h       |                          | Speed for operating in band e: 2.6km/h        |                          | Speed for operating in band e: 102km/h          |                          |
| Relative Delay [ns]                          | Relative Mean Power [dB] | Relative Delay [ns]                           | Relative Mean Power [dB] | Relative Delay [ns]                             | Relative Mean Power [dB] |
| 0  | 0                        | 0   | 0                        | 0   | 0                        |
| 2928   | -10                      | 2928  | 0                        | 781   | -3                       |
|  |                          | 12000   | 0                        | 1563  | -6                       |
|  |                          |   |                          | 2344  | -9                       |

**Table B.2A: Propagation Conditions for Multipath Fading Environments for E-DCH Performance Requirements for 1,28 Mcps TDD**

| ITU Pedestrian A Speed 3km/h (PA3)            |                          | ITU Pedestrian B Speed 3km/h (PB3)           |                          | ITU vehicular A Speed 30km/h (VA30)            |                          |
|---|--------------------------|--|--------------------------|--|--------------------------|
| Speed for operating in band a, b, c, f: 3km/h |                          | Speed for operating in band a, b, c, f 3km/h |                          | Speed for operating in band a, b, c, f: 30km/h |                          |
| Speed for operating in band d: 2.3km/h        |                          | Speed for operating in band d: 2.3km/h       |                          | Speed for operating in band d: 23km/h          |                          |
| Speed for operating in band e: 2.6km/h        |                          | Speed for operating in band e: 2.6km/h       |                          | Speed for operating in band e: 26km/h          |                          |
| Relative Delay [ns]                           | Relative Mean Power [dB] | Relative Delay [ns]                          | Relative Mean Power [dB] | Relative Delay [ns]                            | Relative Mean Power [dB] |
| 0   | 0                        | 0  | 0                        | 0  | 0                        |
| 110   | -9.7                     | 200  | -0.9                     | 310  | -1.0                     |
| 190   | -19.2                    | 800  | -4.9                     | 710  | -9.0                     |
| 410   | -22.8                    | 1200   | -8.0                     | 1090   | -10.0                    |
|   |                          | 2300   | -7.8                     | 1730   | -15.0                    |
|   |                          | 3700   | -23.9                    | 2510   | -20.0                    |

## B.2.3 7,68 Mcps TDD option

Table B.4 and B.5 shows propagation conditions that are used for the performance measurements in multi-path fading environment. All taps have classical Doppler spectrum, defined as:

$$(CLASS) \quad S(f) \propto 1/(1 - (f/f_D)^2)^{0.5} \quad \text{for } f \in [-f_d, f_d]$$

**Table B.3: Propagation Conditions for Multi path Fading Environments for 3,84 Mcps TDD option for operations referenced in 4.2 a), 4.2 b) and 4.2 c)**

| Case 1, speed 3km/h |                          | Case 2, speed 3 km/h |                          | Case 3, speed 120 km/h |                          |
|---------------------|--------------------------|----------------------|--------------------------|------------------------|--------------------------|
| Relative Delay [ns] | Relative Mean Power [dB] | Relative Delay [ns]  | Relative Mean Power [dB] | Relative Delay [ns]    | Relative Mean Power [dB] |
| 0                   | 0                        | 0                    | 0                        | 0                      | 0                        |
| 976                 | -10                      | 976                  | 0                        | 260                    | -3                       |
|                     |                          | 12000                | 0                        | 521                    | -6                       |
|                     |                          |                      |                          | 781                    | -9                       |

**Table B.5: Propagation Conditions for Multi path Fading Environments for operations referenced in 4.2 d)**

| Case 1, speed 2.3km/h |                          | Case 2, speed 2.3 km/h |                          | Case 3, speed 92 km/h |                          |
|-----------------------|--------------------------|------------------------|--------------------------|-----------------------|--------------------------|
| Relative Delay [ns]   | Relative Mean Power [dB] | Relative Delay [ns]    | Relative Mean Power [dB] | Relative Delay [ns]   | Relative Mean Power [dB] |
| 0                     | 0                        | 0                      | 0                        | 0                     | 0                        |
| 976                   | -10                      | 976                    | 0                        | 260                   | -3                       |
|                       |                          | 12000                  | 0                        | 521                   | -6                       |
|                       |                          |                        |                          | 781                   | -9                       |

## B.3 High speed train conditions

High speed train conditions are as follows:

Scenario 1: Open space

Scenario 3: Tunnel for multi-antennas

The high speed train conditions for the test of the baseband performance are two non-fading propagation channels in both scenarios.

Doppler shift for both scenarios is given by:

$$f_s(t) = f_d \cos \theta(t) \quad (\text{B.1})$$

where  $f_s(t)$  is the Doppler shift and  $f_d$  is the maximum Doppler frequency. The cosine of angle  $\theta(t)$  is given by:

$$\cos \theta(t) = \frac{D_s/2 - vt}{\sqrt{D_{\min}^2 + (D_s/2 - vt)^2}}, \quad 0 \leq t \leq D_s/v \quad (\text{B.2})$$

$$\cos \theta(t) = \frac{-1.5D_s + vt}{\sqrt{D_{\min}^2 + (-1.5D_s + vt)^2}}, \quad D_s/v < t \leq 2D_s/v \quad (\text{B.3})$$

$$\cos \theta(t) = \cos \theta(t \bmod (2D_s/v)), \quad t > 2D_s/v \quad (\text{B.4})$$

where  $D_s/2$  is the initial distance of the train from BS, and  $D_{\min}$  is BS-Railway track distance, both in meters;  $v$  is the velocity of the train in m/s,  $t$  is time in seconds.

Doppler shift and cosine angle is given by equation B.1 and B.2-B.4 respectively, where the required input parameters listed in table B.6 and the resulting Doppler shift shown in Figure B.1 and B.2 are applied for all frequency bands.

**Table B.6: Parameters for high speed train conditions**

| Parameter | Value      |            |
|-----------|------------|------------|
|           | Scenario 1 | Scenario 3 |
| $D_s$     | 1000 m     | 300 m      |
| $D_{min}$ | 50 m       | 2 m        |
| $v$       | 350 km/h   | 300 km/h   |
| $f_d$     | 1310 Hz    | 1125 Hz    |

NOTE1: Parameters for HST conditions in table B. including  $f_d$  and Doppler shift trajectories presented on figures B.1 and B.2 were derived for Band a).

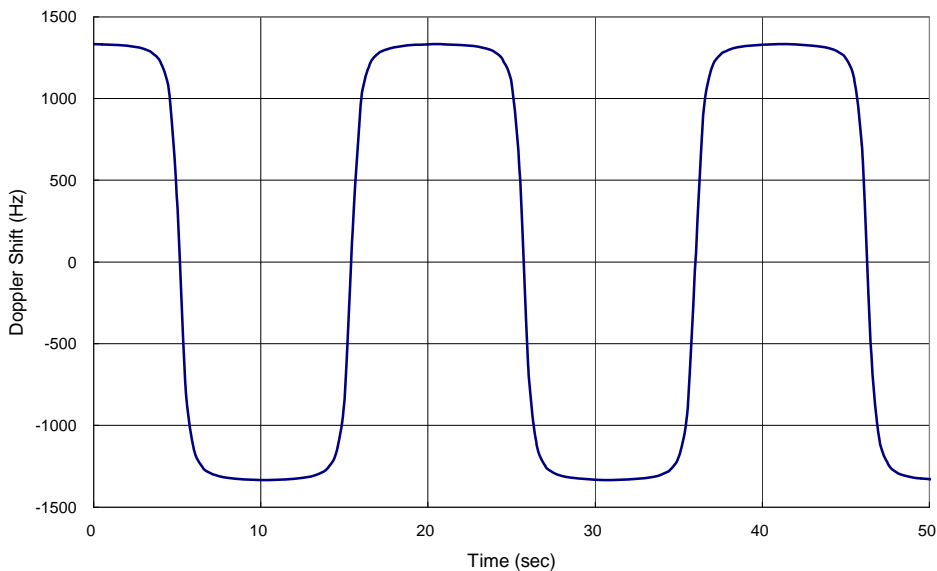


Figure B.1: Doppler shift trajectory for scenario 1

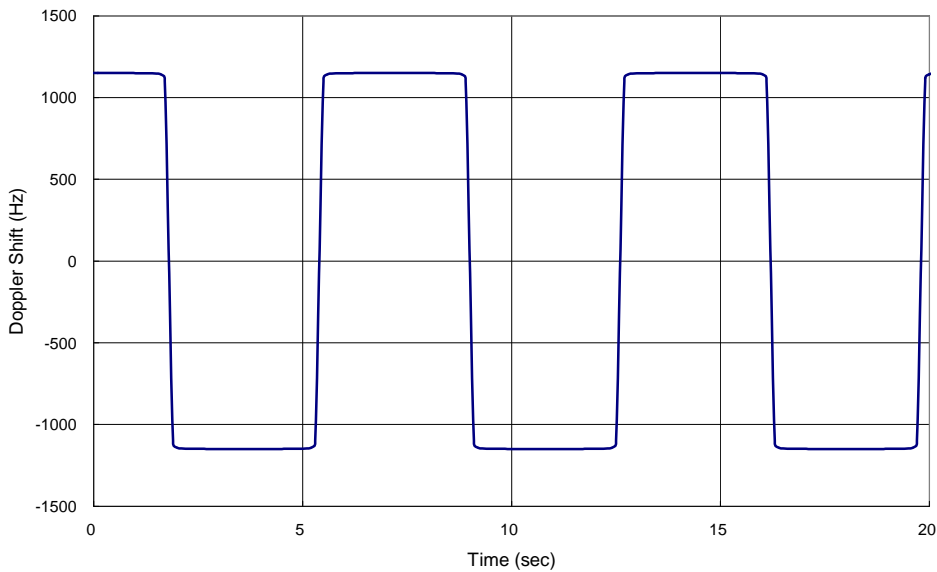


Figure B.2: Doppler shift trajectory for scenario 3

---

## Annex C (normative): Global in-channel Tx test

### C.1 General

The global in-channel Tx test enables the measurement of all relevant parameters that describe the in-channel quality of the output signal of the Tx under test in a single measurement process.

The parameters describing the in-channel quality of a transmitter, however, are not necessarily independent. The algorithm chosen for description inside this annex places particular emphasis on the exclusion of all interdependencies among the parameters. Any other algorithm (e.g. having better computational efficiency) may be applied, as long as the results are the same within the accuracy limits.

All notes referred to in the various subclauses of C.2 are put together in clause C.3

---

### C.2 Definition of the process

#### C.2.1 Basic principle

The process is based on the comparison of the actual **output signal of the Tx under test**, received by an ideal receiver, with a **reference signal**, that is generated by the measuring equipment and represents an ideal error free received signal. The reference signal shall be composed of the same number of codes at the correct spreading factors as contained in the test signal. Note, for simplification, the notation below assumes only codes of one spreading factor although the algorithm is valid for signals containing multiple spreading factors. All signals are represented as equivalent (generally complex) base band signals.

#### C.2.2 Output signal of the Tx under test

The output signal of the Tx under test is acquired by the measuring equipment, filtered by a matched filter (RRC characteristic with roll-off  $\alpha = 0,22$ , correct in shape and in position on the frequency axis) and stored for further processing.

The following form represents the physical signal in the entire measurement interval:

one vector **Z**, containing  $N = ns \times sf + ma$  complex samples;

with

- ns:                    number of symbols in the measurement interval;
- sf:                    number of chips per symbol. (sf: spreading factor) (see Note: Symbol length)
- ma:                    number of midambles chips, or for IMB the number of chips in the TDM pilot region

#### C.2.3 Reference signal

The reference signal is constructed by the measuring equipment according to the relevant Tx specifications.

It is filtered by the same matched filter, mentioned in C.2.2, and stored at the intersymbol interference free instants. The following form represents the reference signal in the entire measurement interval:

one vector **R**, containing  $N = ns \times sf + ma$  complex samples;

where ns, sf and ma have the same meaning as defined above in C.2.2.

## C.2.4 Classification of measurement results

The measurement results achieved by the global in-channel Tx test can be classified into two types:

- **Results of type "deviation"**, where the error-free parameter has a non-zero magnitude. (These are the parameters that represent the signal). These parameters are:

RF Frequency

Power (in case of single code)

Code Domain Power (in case of multi-code)

Timing (only for UE) (see Note: Deviation)

(Additional parameters: see Note: Deviation)

- **Results of type "residual"**, where the error-free parameter has value zero. (These are the parameters that represent the error values of the measured signal; ideally, their magnitude is zero). These parameters are:

Error Vector Magnitude (EVM)

Peak Code Domain Error (PCDE)

(Additional parameters: see Note: Residual)

## C.2.5 Process definition to achieve results of type "deviation"

The reference signal (**R**; see subclause C.2.3) and the signal under Test (**Z**; see subclause C.2.2) are varied with respect to the parameters mentioned in subclause C.2.4 under "results of type deviation" in order to achieve best fit. Best fit is achieved when the RMS difference value between the varied signal under test and the varied reference signal is an absolute minimum.

Overview:

$$FCT [ Z(\tilde{f}, \tilde{t}, \tilde{\varphi}, g_1, g_2, \dots, g_{synch}) - R(f, t, \varphi, \tilde{g}_1, \tilde{g}_2, \dots, \tilde{g}_{synch}) ] = Minimum \quad !$$

**Z**: Signal under test.

**R**: Reference signal,

with frequency  $f$ , the timing  $t$ , the phase  $\varphi$ , gain of code1 ( $g_1$ ), gain of code2 ( $g_2$ ) etc, and the gain of the synch channel  $g_{synch}$

The parameters marked with a tilde in **Z** and **R** are varied in order to achieve a best fit.

**R''** and **Z''** are each of length  $n_s * sf$  and depending on the length of the measurement interval result of possibly multiple successive applications of the minimum process.

Detailed formula: see Note: Formula for the minimum process

The varied reference signal, after the best-fit process, will be called **R''**.

The varied signal under test, after the best fit process, will be called **Z''**.

**R''** and **Z''** are each of length  $n_s * sf$  and depending on the length of the measurement interval result of possibly multiple successive applications of the minimum process.

Those parameter values, which - after the best-fit process -lead to **R''** and **Z''**, represent directly the wanted results of type "deviation". These parameter values are expressed as deviations from the reference value, using the same units as the corresponding reference value.

In the case of multi-code transmission, the best-fit process of the type "deviation" parameters frequency, timing (and any additional parameter as e.g. RF phase) is not done with respect to the individual codes, but commonly for the complete code set used; therefore, the process returns one measurement value only for each parameter.

(These parameters are not varied on the individual codes signals such that the process would return  $k_r$  frequency errors... . ( $k_r$ : number of codes in the reference signal)).

The only type-"deviation"-parameters varied individually are the code domain gain factors ( $g_1, g_2, \dots$ )

### C.2.5.1 Decision Point Power

The mean-square value of the signal-under-test, sampled at the best estimate of the of Intersymbol-Interference-free points using the process defined in subclause 2.5, is referred to the *Decision Point Power* (DPP):

### C.2.5.2 Code-Domain Power

The samples,  $Z''$ , are separated into symbol intervals to create  $n_s$  time-sequential vectors  $\mathbf{z}$  with  $sf$  complex samples comprising one symbol interval. The *Code Domain Power* is calculated according to the following steps:

- 1) Take the vectors  $\mathbf{z}$  defined above.
- 2) To achieve meaningful results it is necessary to descramble  $\mathbf{z}$ , leading to  $\mathbf{z}''$
- 3) Take the orthogonal vectors of the channelization code set  $\mathbf{C}$  (all codes belonging to one spreading factor) as defined in TS 25.213 and TS 25.223 (range +1, -1), and normalize by the norm of the vectors to produce  $\mathbf{C}_{norm} = \mathbf{C} / \text{sqrt}(sf)$ . (see Note: Symbol length)
- 4) Calculate the inner product of  $\mathbf{z}''$  with  $\mathbf{C}_{norm}$ . Do this for all symbols of the measurement interval and for all codes in the code space.  
This gives an array of format  $k \times n_s$ , each value representing a specific symbol and a specific code, which can be exploited in a variety of ways.  
  
  - k: total number of codes in the code space
  - $n_s$ : number of symbols in the measurement interval
- 5) Calculate  $k$  mean-square values, each mean-square value unifying  $n_s$  symbols within one code. (These values can be called "*Absolute CodeDomainPower* (CDP)" [ $\text{Volt}^2$ ].) The sum of the  $k$  values of CDP is equal to DPP.
- 6) Normalize by the decision point power to obtain

$$\text{Relative CodeDomain Power} = \frac{\text{Absolute CodeDomainPower}}{\text{DecisionPointPower}}$$

## C.2.6 Process definition to achieve results of type "residual"

The difference between the varied reference signal ( $\mathbf{R}''$ ; see subclause C.2.5.) and the varied Tx signal under test ( $\mathbf{Z}$ ; see subclause C.2.2) is the error vector  $\mathbf{E}$  versus time:

$$\mathbf{E} = \mathbf{Z}'' - \mathbf{R}''.$$

Depending on the parameter to be evaluated, it is appropriate to represent  $\mathbf{E}$  in one of the following two different forms:

**Form EVM** (representing the physical error signal in the entire measurement interval)

One vector  $\mathbf{E}$ , containing  $N = n_s \times sf + m_a$  complex samples;

where  $n_s$ ,  $sf$  and  $m_a$  have the same meaning as defined above in C.2.2.

**Form PCDE** (derived from Form EVM by separating the samples into symbol intervals)

$n_s$  time-sequential vectors  $\mathbf{e}$  with  $sf$  complex samples comprising one symbol interval.



**E** gives results of type "residual" applying the two algorithms defined in subclauses C.2.6.1 and C.2.6.2.

### C.2.6.1 Error Vector Magnitude (EVM)

The Error Vector Magnitude EVM is calculated according to the following steps:

- 1) Take the error vector **E** defined in subclause C.2.6 (Form EVM) and calculate the RMS value of **E**; the result will be called RMS(**E**).
- 2) Take the varied reference vector **R** defined in subclause C.2.3 and calculate the RMS value of **R**; the result will be called RMS(**R**).
- 3) Calculate EVM according to:

$$\text{EVM} = \frac{\text{RMS}(\mathbf{E})}{\text{RMS}(\mathbf{R})} \times 100\% \text{ (here, EVM is relative and expressed in \%)}$$

(see Note: TDD)

(see Note: Formula for EVM)

### C.2.6.2 Peak Code Domain Error (PCDE)

The Peak Code Domain Error is calculated according to the following steps:

- 1) Take the error vectors **e** defined in subclause C.2.6 (Form PCDE)
- 2) Take the orthogonal vectors of the spreading code set **C** (all codes belonging to one spreading factor) as defined in TS 25.213 and TS 25.223 (range +1, -1). (see Note: Symbol length) and normalize by the norm of the vectors to produce  $\mathbf{C}_{\text{norm}} = \mathbf{C}/\text{sqrt}(\text{sf})$ . (see Note: Symbol length)
- 3) To achieve meaningful results, it is necessary to descramble **e**, leading to **e''**
- 4) Calculate the inner product of **e''** with  $\mathbf{C}_{\text{norm}}$ . Do this for all symbols of the measurement interval and for all codes in the code space.  
This gives an array of format  $k \times n_s$ , each value representing an error-vector representing a specific symbol and a specific code, which can be exploited in a variety of ways.  
  - k: total number of codes in the code space
  - $n_s$ : number of symbols in the measurement interval
- 5) Calculate  $k$  RMS values, each RMS value unifying  $n$  symbols within one code.  
(These values can be called "Absolute CodeEVMs" [Volt].)
- 6) Find the peak value among the  $k$  "absolute Code-EVMs".  
(This value can be called "Absolute PeakCodeEVM" [Volt].)
- 7) Calculate PCDE according to:

$$\text{PCDE} = 10 \lg \frac{(\text{absolute PeakCodeEVM})^2}{(\text{RMS}(\mathbf{R}))^2} \text{ dB} . \quad (\text{a relative value in dB}).$$

see Note: TDD

see Note: Synch channel

### C.2.6.3 Relative Code Domain Error (RCDE)

The Relative Code Domain Error is calculated for a wanted code according to the following steps:

- 1) Calculate the value "*Absolute CodeEVM*" [Volt] for the wanted code according to C.2.6.2, as an RMS value unifying  $n_s = 2400$  symbols corresponding to the measurement interval of one timeslot.
- 2) Calculate the value "*Absolute CodeDomainPower (CDP)*" [Volt<sup>2</sup>] for the wanted code according to C.2.5.2, with  $n_s = 2400$  symbols corresponding to the measurement interval of one timeslot.
- 3) Calculate RCDE according to:

$$10 * \lg \frac{(\text{"Absolute CodeEVM"})^2}{\text{"Absolute CodeDomainPower (CDP)"}} \text{dB}$$

- 4) The average RCDE across a set of wanted codes is defined as the mean of the linear RCDE values and subsequently expressed in dB.

## C.3 Notes

### C.3.1 Symbol length

A general code-multiplexed signal is multi-code and multi-rate. In order to avoid unnecessary complexity, the measurement applications use a unique symbol-length, corresponding to a specific spreading factor, regardless of the really intended spreading factor. Nevertheless, the complexity with a multi-code / multi-rate signal can be mastered by introducing appropriate definitions.

### C.3.2 Deviation

It is conceivable to regard more parameters as type „deviation“, e.g. chip clock and RF phase. However, because chip clock and RF frequency are linked together by a statement in the core specifications [1], it is sufficient to process RF frequency only.

The parameter RF phase must be varied within the best-fit process (C.2.5). Although necessary, this parameter-variation does not describe any error, as the modulation schemes used in the system do not depend on an absolute RF-phase.

The parameter Timing must be varied within the best fit process (C.2.5.) This parameter variation does not describe any error, when applied to the Node B test. However when applied to the UE test, it describes the error of the UE's Timing Advance.

### C.3.3 Residual

It is conceivable to regard more parameters as type „residual“, e.g. IQ origin offset. As it is not the intention of the test to separate for different error sources, but to quantify the quality of the signal, all such parameters are not extracted by the best-fit process, instead remain part of EVM and PCDE.

### C.3.4 TDD

EVM covers the midamble (or for IMB the TDM pilot region) part as well as the data part; however PCDE disregards the midamble (or IMB TDM pilot) part.

### C.3.5 Synch channel

A node B signal contains a physical synch channel, which is non-orthogonal, related to the other DPCHs. In this context note: The code channel bearing the result of PCDE is exactly one of the DPCHs (never the synch channel). The origin of PCDE (erroneous code power) can be any DPCH and/or the synch channel. This means that the error due to the synch channel is projected onto the other (orthogonal) codes that make up the code domain.

### C.3.6 Formula for the minimum process

$$L(\Delta\tilde{f}, \Delta\tilde{t}, \Delta\tilde{\varphi}, \Delta\tilde{g}_c, \dots, \Delta\tilde{g}_{prim}, \Delta\tilde{g}_{sec\ i}, \Delta\tilde{g}_{mid}) = \sum_{v=0}^{N-1} |Z(v) - R(v)|^2$$

where

L is the function to be minimised

The parameters to be varied in order to minimize are:

$\Delta\tilde{f}$  the RF frequency offset

$\Delta\tilde{t}$  the timing offset

$\Delta\tilde{\varphi}$  the phase offset

$\Delta\tilde{g}_c \dots$  code power offsets (one offset for each code)

$\Delta\tilde{g}_{mid}$  the power offset of the midamble (or for IMB the TDM pilot region)

$\Delta\tilde{g}_{prim}$  the code power offset of the primary SCH

$\Delta\tilde{g}_{sec\ i}$  the code power offsets of secondary SCHs, (i: 1,2,3)

( $\Delta\tilde{g}_{prim}$  and  $\Delta\tilde{g}_{sec\ i}$  are only applied, if the timeslot under test contains the synchronisation channel.)

Z(v) Samples of the signal under Test

R(v) Samples of the reference signal

$\sum_{v=0}^{N-1}$  counting index  $v$  starting at the beginning of the measurement interval and ending at its end.

N No of chips during the measurement interval.

Z(v): Samples of the signal under Test. It is modelled as a sequence of complex baseband samples Z( $\gamma$ ) with a time-shift  $\Delta t$ , a frequency offset  $\Delta f$ , a phase offset  $\Delta\varphi$ , the latter three with respect to the reference signal.

$$Z(v) = Z(v - \Delta\tilde{t}) * e^{-j2\pi\Delta\tilde{f}v} * e^{-j\Delta\tilde{\varphi}}$$

R(v): Samples of the reference signal:

$$R(v) = \sum_{c=1}^{No.\ of\ codes} (g_c + \Delta\tilde{g}_c) * Chip_c(v) + (g_{prim} + \Delta\tilde{g}_{prim}) * Chip_{prim}(v) + (g_{sec\ i} + \Delta\tilde{g}_{sec\ i}) * Chip_{sec\ i}(v) + (g_{mid} + \Delta\tilde{g}_{mid}) * Chip_{mid}(v)$$

where

g nominal gain of the code channel or midamble (or for IMB the TDM pilot region)

$\Delta\tilde{g}$  The gain offset to be varied in the minimum process

Chip(v) is the chip sequence of the code channel or midamble (or for IMB the TDM pilot region)

Indices at g, Δg and Chip: The index indicates the code channel:

c = 1,2,... No of code channels

prim = primary SCH

seci = three secondary SCHs, i:1,2,3

Range for Chip<sub>c</sub>: +1,-1

### C.3.7 Formula for EVM

$$EVM = \sqrt{\frac{\sum_{\nu=0}^{N-1} |Z'(\gamma) - R'(\gamma)|^2}{\sum_{\nu=0}^{N-1} |R'(\gamma)|^2}} * 100 \%$$

Z''(γ), R''(γ) are the varied measured and reference signals.

---

## Annex D (informative): Derivation of Test Requirements

The Test Requirements in this specification have been calculated by relaxing the Minimum Requirements of the core specification using the Test Tolerances defined in subclause 5.11. When the Test Tolerance is zero, the Test Requirement will be the same as the Minimum Requirement. When the Test Tolerance is non-zero, the Test Requirements will differ from the Minimum Requirements, and the formula used for this relaxation is given in tables D.1 to D.3

Note that a formula for applying Test Tolerances is provided for all tests, even those with a test tolerance of zero. This is necessary in the case that the Test System uncertainty is greater than that allowed in subclause 5.10. In this event, the excess error shall be subtracted from the defined test tolerance in order to generate the correct tightened Test Requirements as defined in subclause 5.12.

For example, a Test System having 0,9 dB accuracy for test 6.2 Maximum output power (which is 0,2 dB above the limit specified in subclause 5.10.2) would subtract 0,2 dB from the Test Tolerance of 0,7 dB defined in subclause 5.11.1. This new test tolerance of 0,5 dB would then be applied to the Minimum Requirement using the formula defined in Table D.1 to give a new range of  $\pm 2,5$  dB of the manufacturer's rated output power.

For the case where an excess error of 0.2 dB exists, when applied to a test with a test tolerance of zero, the test tolerance used in the formula would be -0.2 dB.

Table D.1: Derivation of Test Requirements (Transmitter tests)

| Test   | Minimum Requirement in TS 25.105<br>(numbering of tables in the column below refers to TS 25.142)  | Test Tolerance (TT)                                | Test Requirement in TS 25.142   |
|--|--|--|---|
| 6.2 Maximum output power                           | In normal conditions ...<br>within +2 dB and -2 dB of the manufacturer's rated output power<br><br>In extreme conditions...<br>within +2,5 dB and -2,5 dB of the manufacturer's rated output power | 0,7 dB   | Formula: Upper limit + TT<br>Lower limit - TT<br><br>In normal conditions ...<br>within +2,7 dB and -2,7 dB of the manufacturer's rated output power<br><br>In extreme conditions...<br>within +3,2 dB and -3,2 dB of the manufacturer's rated output power |
| 6.3 Frequency stability                            | Frequency stability<br>Wide Area BS: = $\pm 0,05$ ppm<br>Local Area BS: $\pm 0,1$ ppm  | 12 Hz  | Formula:<br>$\pm$ (frequency stability + TT)<br>Wide Area BS:<br>$\pm (0,05 \text{ ppm} + 12 \text{ Hz})$<br><br>Local Area BS:<br>$\pm (0,1 \text{ ppm} + 12 \text{ Hz})$  |
| 6.4.2 Power control steps                          | single step: step size tolerance specified in table 6.3<br><br>ten steps: minimum and maximum average rate of change in mean power specified in table 6.3  | single step:<br>0,1 dB<br><br>ten steps:<br>0,3 dB | Formula:<br>single step:<br>$\pm$ (step size tolerance + TT)<br><br>ten steps:<br>maximum average rate + TT<br>minimum average rate - TT<br><br>0,1 dB and 0,3 dB, respectively, applied as above to table 6.3  |
| 6.4.3 Power control dynamic range                  | range $\geq 30$ dB   | 0,3 dB   | Formula: Range - TT<br><br>range $\geq 29,7$ dB   |
| 6.4.4 Minimum output power                         | PRAT - 30 dB   | 0,7 dB   | Formula :<br>PRAT - 30 dB + TT<br><br>PRAT - 29,3 dB  |
| 6.4.5 Primary CCPCH power                          | PCCPCH power tolerance defined in table 6.8  | 0,8 dB   | Formula:<br>$\pm$ (power tolerance + TT)<br><br>0,8 dB applied as above to table 6.8  |
| 6.4.6 Differential accuracy of Primary CCPCH power | Differential accuracy of PCCPCH power: $\leq \pm 0,5$ dB   | 0,1 dB   | Formula:<br>$\pm$ (PCCPCH tolerance + TT)<br><br>$\pm 0,6$ dB   |
| 6.5.1 Transmit OFF power                           | Tx OFF power limit < -79 dBm   | 2,0 dB   | Formula:<br>< Tx OFF power limit + TT<br><br>< - 77 dBm   |

|                                 |  |        |   |
|---------------------------------|--|--------|---|
| 6.5.2 Transmit ON/OFF time mask | <p>Tx power limit:</p> <p>3,84 Mcps TDD option:<br/>&lt; -33 dBm or -79 dBm, resp.</p> <p>1,28 Mcps TDD option:<br/>&lt; -42 dBm or -82 dBm, resp.</p> |        | <p>Formula:<br/>&lt; Tx power limit + TT</p> <p>&lt; -33 dBm: for 3,84 Mcps TDD option:<br/>0,7 dB &lt; -32,3 dBm<br/>&lt; -79 dBm: or<br/>2,0 dB &lt; - 77 dBm</p> <p>&lt; -42 dBm: for 1,28 Mcps TDD option:<br/>0,7 dB &lt; -41,3 dBm<br/>&lt; -82 dBm: or<br/>2,0 dB &lt; -80 dBm</p> |
| 6.6.1 Occupied bandwidth        | <p>occupied bandwidth limit</p> <p>3,84 Mcps TDD option: = 5 MHz<br/>1,28 Mcps TDD option: 1,6 MHz</p>   | 0 kHz  | <p>Formula:<br/>Occupied bandwidth limit + TT</p> <p>3,84 Mcps TDD option: = 5 MHz<br/>1,28 Mcps TDD option: 1,6 MHz</p>  |
| 6.6.2.1 Spectrum emission mask  | <p>Maximum level defined in tables 6.13 to 6.16</p>  | 1,5 dB | <p>Formula: Maximum level + TT</p> <p>Add 1,5 dB to Maximum level entries in tables 6.13 to 6.16</p>  |

|  |   |  |   |
|--|---|--|---|
| <p>6.6.2.2 Adjacent Channel Leakage power Ratio (ACLR)</p> | <p><u>3,84 Mcps TDD option:</u><br/>                     minimum requirement:<br/>                     ACLR limit = 45 dB at 5 MHz<br/>                     ACLR limit = 55 dB at 10 MHz<br/>                     requirement for operation in the same geographic area with unsynchronised TDD BS or FDD BS on adjacent channels:<br/>                     Maximum Level defined in tables 6.23 and 6.23AA<br/>                     requirement in case of co-siting with unsynchronised TDD BS or FDD BS operating on adjacent channels:<br/>                     Maximum Level defined in tables 6.24 and 6.24A<br/> <u>1,28 Mcps TDD option:</u><br/>                     minimum requirement:<br/>                     ACLR limit = 40 dB at 1,6 MHz<br/>                     ACLR limit = 45 dB at 3,2 MHz<br/>                     requirement for operation in the same geographic area with unsynchronised TDD or FDD on adjacent channels:<br/>                     Maximum Level defined in tables 6.23A, 6.23B and 6.23C<br/>                     requirement in case of co-siting with unsynchronised TDD or FDD on an adjacent channel:<br/>                     Maximum Level defined in tables 6.24B, 6.24C and 6.24D</p> | <p><u>3,84 Mcps TDD option:</u><br/>                     min. req. : 0,8 dB<br/>                     operation in the same geographic area:<br/>                     4 dB (TBD in table 6.23A, 5 MHz offset, resp.) for Wide Area BS ; 0,8 dB for Local Area BS<br/>                     co-siting: TBD for Wide Area BS; 1 dB for Local Area BS<br/> <u>1,28 Mcps TDD option:</u><br/>                     min. req. : 0,8 dB<br/>                     operation in the same geographic area:<br/>                     1 dB or 4 dB for the Wide Area BS; 0,8 dB for the Local Area BS<br/>                     co-siting: TBD for the Wide Area BS; 1 dB for the Local Area BS</p> | <p>Formula: ACLR limit - TT<br/> <u>3,84 Mcps TDD option:</u><br/>                     min. requirement:<br/>                     ACLR limit = 44,2 dB at 5 MHz<br/>                     ACLR limit = 54,2 dB at 10 MHz<br/>                     operation in the same geographic area:<br/>                     Wide Area BS:<br/>                     Add 4 dB (TBD in table 6.23A, 5 MHz offset, resp.) to the Maximum Level entries in tables 6.23 and 6.23AA.<br/>                     Local Area BS:<br/>                     Add 0,8 dB to the Maximum Level entries in tables 6.23 and 6.23AA.<br/>                     co-siting:<br/>                     Wide Area BS:<br/>                     Add TBD to the Maximum Level entries in tables 6.24 and 6.24A.<br/>                     Local Area BS:<br/>                     Add 1 dB to the Maximum Level entries in tables 6.24 and 6.24A.<br/> <u>1,28 Mcps TDD option:</u><br/>                     min. requirement:<br/>                     ACLR limit = 39,2 dB at 1,6 MHz<br/>                     ACLR limit = 44,2 dB at 3,2 MHz<br/>                     operation in the same geographic area:<br/>                     Wide Area BS:<br/>                     Add 1 dB to the Maximum Level entries in tables 6.23A and 6.23B, and 4 dB to the Maximum Level entry in table 6.23C.<br/>                     Local Area BS:<br/>                     Add 0,8 dB to the Maximum Level entries in tables 6.23A, 6.23B and 6.23C.<br/>                     co-siting:<br/>                     Wide Area BS:<br/>                     Add TBD to the Maximum Level entries in tables 6.24B, 6.24C and 6.24D.<br/>                     Local Area BS:<br/>                     Add 1 dB to the Maximum Level entries in tables 6.24B, 6.24C and 6.24D.</p> |
| <p>6.6.3 Spurious emissions</p>                            | <p>maximum level defined in tables 6.29 to 6.37</p>   | <p>0 dB</p>  | <p>Formula: Maximum limit + TT<br/>                     add 0 dB to maximum levels in tables 6.29 to 6.37</p>   |



|  |   |                                      |  |
|--|---|--------------------------------------|--|
| 6.7 Transmit intermodulation (interferer requirements)<br><br>This tolerance applies to the stimulus and not the measurements defined in 6.6.2.1, 6.6.2.2 and 6.6.3. | Wanted signal level - interferer level = 30 dB  | 0 dB                                 | Formula: Ratio + TT<br><br>Wanted signal level - interferer level = 30 + 0 dB  |
| 6.8.1 Modulation accuracy  | EVM limit = 12,5 %  | 0 %                                  | Formula: EVM limit + TT<br><br>EVM limit = 12,5 %  |
| 6.8.2 Peak code domain error   | PCDE limit = - 28 dB  | 1 dB                                 | Formula: PCDE limit + TT<br><br>PCDE limit = - 27 dB   |
| 6.8.3 Relative Code Domain Error   | RCDE limit = -21.9 dB   | 1.0 dB                               | Formula: RCDE limit + TT<br><br>RCDE limit = -20.9 dB  |
| 6.8.4 Time alignment error in MIMO transmission  | 1,28 Mcps TDD option:<br><br>Max time alignment error = 65 ns<br>Min time alignment error = - 65 ns | 1,28 Mcps TDD option:<br><br>[78] ns | Formula:<br>Max time alignment error + TT<br>Min time alignment error - TT<br><br>1,28 Mcps TDD option:<br>Max time alignment error = [143]ns<br>Min time alignment error = [-143]ns |

Table D.2: Derivation of Test Requirements (Receiver tests)

| Test                                   | Minimum Requirement in TS 25.105<br>(numbering of tables in the column below refers to TS 25.142)   | Test Tolerance (TT) | Test Requirement in TS 25.142  |
|--|---|---------------------|--|
| 7.2 Reference sensitivity              | Reference sensitivity level<br>3,84 Mcps TDD option: =<br>Wide Area BS: -109 dBm<br>Local Area BS: -95 dBm<br><br>1,28 Mcps TDD option:<br>Wide Area BS: -110 dBm<br>Local Area BS: -96 dBm<br><br>BER limit = 0,001  | 0,7 dB              | Formula:<br>Reference sensitivity level + TT<br><br>Reference sensitivity level<br>3,84 Mcps TDD option:<br>Wide Area BS: -108,3 dBm<br>Local Area BS: -94,3 dBm<br><br>1,28 Mcps TDD option:<br>Wide Area BS: -110dBm<br>Local Area BS: -95,3 dBm<br><br>BER limit is not changed |
| 7.3 Dynamic range                      | Wanted signal level =<br><REFSENS> + 30 dB<br><br>Interfering AWGN level<br>3,84 Mcps TDD option:<br>Wide Area BS: -73 dBm/3,84 MHz<br>Local Area BS: -59 dBm/3,84 MHz<br><br>1,28 Mcps TDD option:<br>Wide Area BS: -76 dBm/1,28 MHz<br>Local Area BS: -62 dBm/1,28 MHz  | 1,2 dB              | Formula:<br>Wanted signal level + TT<br>AWGN level unchanged<br><br>Wanted signal level =<br><REFSENS> + 31,2 dB   |
| 7.4 Adjacent Channel Selectivity (ACS) | Wanted signal level =<br>Ref. sensitivity level + 6 dB<br><br>Interfering signal level<br>3,84 Mcps TDD option:<br>Wide Area BS: -52 dBm/3,84 MHz<br>Local Area BS: -38 dBm/3,84 MHz<br><br>1,28 Mcps TDD option:<br>Wide Area BS: -55 dBm/1,28 MHz<br>Local Area BS: -41 dBm/1,28 MHz  | 0 dB                | Formula:<br>Wanted signal level + TT<br>Interfering signal level unchanged<br><br>Wanted signal level =<br>Ref. sensitivity level + 6 dB   |
| 7.5 Blocking characteristics           | Wanted signal level =<br><REFSENS> + 6 dB<br><br>3,84 Mcps TDD option:<br>Interfering signal level see tables<br>7.6 to 7.10<br><br>1,28 Mcps TDD option:<br>Interfering signal level see tables<br>7.6A to 7.10A   | 0 dB                | Formula:<br>Wanted signal level + TT<br>Interfering signal level unchanged<br><br>Wanted signal level =<br><REFSENS> + 6 dB  |
| 7.6 Intermodulation characteristics    | Wanted signal level =<br><REFSENS> + 6 dB<br><br>Interferer1 level (10 MHz offset CW<br>for 3,84 Mcps TDD option; 3,2 MHz<br>offset CW for 1,28 Mcps TDD<br>option)) = -48 dBm<br><br>Interferer2 level (20 MHz offset W-<br>CDMA Modulated for 3,84 Mcps<br>TDD option; 6,4 Mcps offset W-<br>CDMA Modulated for 1,28 Mcps<br>TDD option)) = -48 dBm | 0 dB                | Formula:<br>Wanted signal level + TT<br><br>Interferer 1 level: unchanged<br>Interferer 2 level: unchanged<br><br>Wanted signal level =<br><REFSENS> + 6 dB  |

|     |                    |                                     |      |  |
|-----|--------------------|-------------------------------------|------|--|
| 7.7 | Spurious emissions | Maximum level defined in table 7.12 | 0 dB | Formula: Maximum level + TT<br><br>Add TT to maximum level in table 7.12 |
|-----|--------------------|-------------------------------------|------|--|

**Table D.3: Derivation of Test Requirements (Performance requirements)**

| Test  | Minimum Requirement in TS 25.105             | Test Tolerance (TT) | Test Requirement in TS 25.142 |
|---|--|---------------------|-------------------------------|
| 8.2 Demodulation in static propagation conditions       |  | TBD                 |                               |
| 8.3 Demodulation of DCH in multipath fading conditions  |  | TBD                 |                               |
| 8.3A Demodulation of DCH in high speed train conditions | Received $\frac{\hat{I}_{or}}{I_{oc}}$ value | 0.4dB               | Minimum requirement + TT      |

## Annex E (informative): Acceptable uncertainty of Test Equipment

This informative annex specifies the critical parameters of the components of an overall Test System (e.g. Signal generators, Signal Analysers etc.) which are necessary when assembling a Test System which complies with subclause 5.10 Acceptable Uncertainty of Test System. These Test Equipment parameters are fundamental to the accuracy of the overall Test System and are unlikely to be improved upon through System Calibration.

**Table E.1: Equipment accuracy for transmitter measurements**

| Test   | Equipment accuracy  | Range over which equipment accuracy applies   |
|--|---|---|
| 6.2 Maximum output power                               | Not critical  | Not critical  |
| 6.3 Frequency stability                                | $\pm 10$ Hz + timebase = 12 Hz  | Measurements in the range $\pm 500$ Hz.   |
| 6.4.2 Power control steps                              | single step: $\pm 0,1$ dB<br>ten steps: $\pm 0,3$ dB  | $P_{max}$ to $P_{max} - 30$ dB  |
| 6.4.3 Power control dynamic range                      | $\pm 0,3$ dB  | $P_{max}$ to $P_{max} - 30$ dB  |
| 6.4.4 Minimum output power                             | Not critical  | $P_{max}$ to $P_{max} - 30$ dB  |
| 6.4.5 Primary CCPCH power                              | Not critical  | Not critical  |
| 6.4.6 Differential accuracy of Primary CCPCH power     | $\pm 0,1$ dB  |   |
| 6.5.1 Transmit OFF power                               | Not critical  | Not critical  |
| 6.5.2 Transmit ON/OFF time mask                        | Not critical  | Not critical  |
| 6.6.1 Occupied bandwidth                               | $\pm 100$ kHz   | $\pm 1$ MHz of the minimum requirement  |
| 6.6.2.1 Spectrum emission mask                         | Not critical  | Not critical  |
| 6.6.2.2 ACLR   | minimum requirement: $\pm 0,8$ dB<br>requirement in case of operation in proximity: $\pm 4,0$ dB<br>requirement in case of co-siting: TBD | Measurements in the range $\pm 3$ dB of the minimum requirement at signal power = $P_{max}$   |
| 6.6.3 Spurious emissions                               | Not critical  | Not critical  |
| 6.7 Transmit intermodulation (interferer requirements) | Not critical  | Not critical  |
| 6.8.1 Modulation accuracy                              | $\pm 2,5$ %<br>(for single code)  | Specified accuracy applies to measurement results between $\pm 7,5$ % and $17,5$ % at signal power = $P_{max}$ to $P_{max} - 30$ dB |
| 6.8.2 Peak code domain error                           | $\pm 1$ dB  | Measurements in the range $-25$ dB to $-30$ dB at signal power = $P_{max}$  |
| 6.8.3 Relative Code Domain Error                       | $\pm 1,0$ dB  | Measurements in the range $-18,9$ to $-24,9$ dB at signal power = $P_{max}$   |
| 6.8.4 Time alignment error in MIMO transmission        | 1,28 Mcps TDD option:<br>$\pm [78]$ ns  |   |

**Table E.2: Equipment accuracy for receiver measurements**

| Subclause                           | Equipment accuracy | Range over which equipment accuracy applies |
|-------------------------------------|--------------------|---|
| 7.2 Reference sensitivity level     | Not critical       | Not critical                                |
| 7.3 Dynamic range                   | Not critical       | Not critical                                |
| 7.4 Adjacent channel selectivity    | Not critical       | Not critical                                |
| 7.5 Blocking characteristics        | Not critical       | Not critical                                |
| 7.6 Intermodulation characteristics | Not critical       | Not critical                                |
| 7.7 Spurious Emissions              | Not critical       | Not critical                                |

**Table E.3: Equipment accuracy for performance measurements**

| <b>Subclause</b>  | <b>Equipment accuracy</b> | <b>Range over which equipment accuracy applies</b> |
|---|---------------------------|--|
| 8.2 Demodulation in static propagation conditions       | Not critical              | Not critical                                       |
| 8.3 Demodulation of DCH in multipath fading conditions  | Not critical              | Not critical                                       |
| 8.3A Demodulation of DCH in high speed train conditions | Not critical              | Not critical                                       |

---

## Annex F (normative): General rules for statistical testing

### F.1 Statistical testing of receiver BER/BLER performance

#### F.1.1 Error Definition

Bit Error Ratio (BER) and Block Error Ratio (BLER) are defined in section 3.1.

#### F.1.2 Test Method

Each test is performed in the following manner:

- a) Setup the required test conditions.
- b) Record the number of samples tested and the number of occurred events (bit error or block error)
- c) Stop the test at a stop criterion which is minimum test time or an early pass or an early fail event.
- d) Once the test is stopped decide according to the pass fail decision rules ( subclause F.1.7)

#### F.1.3 Test Criteria

The test shall fulfil the following requirements:

- a) good pass fail decision
  - 1) to keep reasonably low the probability (risk) of passing a bad unit for each individual test;
  - 2) to have high probability of passing a good unit for each individual test;
- b) good balance between test time and statistical significance
  - 3) to perform measurements with a high degree of statistical significance;
  - 4) to keep the test time as low as possible.

#### F.1.4 Calculation assumptions

##### F.1.4.1 Statistical independence

- a) It is assumed, that error events are rare ( $\lim \text{BER BLER} \rightarrow 0$ ) independent statistical events. However the memory of the convolutional /turbo coder is terminated after oneTTI. Samples and errors are summed up everyTTI. So the assumption of independent error events is justified.
- b) In the BLER test with fading there is the memory of the multipath fading channel which interferes the statistical independence. A minimum test time is introduced to average fluctuations of the multipath fading channel. So the assumption of independent error events is justified approximately.

##### F.1.4.2 Applied formulas

The formulas, applied to describe the BER BLER test, are based on the following experiments:

- 1) After having observed a certain number of errors (**ne**) the number of samples are counted to calculate BER BLER. Provisions are made (note 1) such that the complementary experiment is valid as well:

2) After a certain number of samples (**ns**) the number of errors, occurred, are counted to calculate BER BLER.

Experiment 1) stipulates to use the following Chi Square Distribution with degree of freedom  $ne$ :

$$2 * dchisq(2 * NE, 2 * ne).$$

Experiment 2) stipulates to use the Poisson Distribution:

$$dpois(ne, NE)$$

(NE: mean of the distribution)

To determine the early stop conditions, the following inverse cumulative operation is applied:

$0.5 * qchisq(D, 2 * ne)$ . This is applicable for experiment (1) and (2).

D: wrong decision risk per test step

Note: other inverse cumulative operations are available, however only this is suited for experiment (1) and (2).

### F.1.4.3 Approximation of the distribution

The test procedure is as follows:

During a running measurement for a BS  $ns$  (number of samples) and  $ne$  (number of errors) are accumulated and from this the preliminary BER BLER is calculated. Then new samples up to the next error are taken. The entire past and the new samples are basis for the next preliminary BER BLER. Depending on the result at every step, the BS can pass, can fail or must continue the test.

As early pass- and early fail-BSs leave the statistical totality under consideration, the experimental conditions are changed every step resulting in a distribution that is truncated more and more towards the end of the entire test. Such a distribution can not any more be handled analytically. The unchanged distribution is used as an approximation to calculate the early fail and early pass bounds.

### F.1.5 Definition of good pass fail decision

This is defined by the probability of wrong decision  $F$  at the end of the test. The probability of a correct decision is  $1-F$ .

The probability (risk) to fail a good DUT shall be  $\leq F$  according to the following definition: The failed DUT is still better than the specified error ratio (Test requirement) with a probability of  $\leq F$ .

The probability to pass a bad DUT shall be  $\leq F$  according to the following definition: The passed DUT is still worse than  $M$  times the specified error ratio ( $M > 1$  is the bad DUT factor) with a probability of  $\leq F$ .

This definitions lead to an early pass and an early fail limit:

Early fail:  $ber \geq berlim_{fail}$

$$berlim_{fail}(D, ne) = \frac{2 * ne}{qchisq(D, 2 * ne)} \quad (1)$$

For  $ne \geq 7$

Early pass:  $ber \leq berlim_{pass}$

$$berlim_{pass}(D, ne) = \frac{2 * ne * M}{qchisq(1 - D, 2 * ne)} \quad (2)$$

For  $ne \geq 1$

With

ber (normalized BER,BLER): BER,BLER according to F.1.1 divided by Test requirement

D: wrong decision probability for a test step . This is a numerically evaluated fraction of F, the wrong decision probability at the end of the test. See table F.1.

ne: Number of error events

M: bad DUT factor see table F.1.

qchisq: inverse-cumulative-function of the chi-squared-distribution

## F.1.6 Good balance between test time and statistical significance

Three independent test parameters are introduced into the test and shown in Table F.1. These are the obvious basis of test time and statistical significance. From the first two of them four dependent test parameters are derived. The third independent test parameter is justified separately.

**Table F.1: independent and dependant test parameters**

| Independent parameters                          |                             |                  | Dependant parameters                                    |   |                               |
|---|-----------------------------|------------------|---|---|-------------------------------|
| Test Parameter                                  | Value                       | Reference        | Test parameter  | Value                                       | Reference                     |
| Bad DUT factor M                                | 1.5                         | Tables F.4 & F.5 | Early pass/fail condition                               | Curves                                      | Subclause F.1.5<br>Figure F.1 |
| Final probability of wrong pass/fail decision F | 0.2%,<br>(0.02%,<br>note 2) | Subclause F.1.5  | Target number of error events                           | 345   | Table F.4 & F.5               |
|   |                             |                  | Probability of wrong pass/fail decision per test step D | 0.0085%,<br>(0.0008% and<br>0.008%, note 2) |                               |
|   |                             |                  | Test limit factor TL                                    | 1.234                                       | Table F.4 & F.5               |
| Minimum test time                               |                             | Tables F.2 & F.3 |   |   |                               |

The minimum test time is derived from the following justification:

- 1) For no propagation conditions and static propagation condition

No early fail calculated from fractional number of errors <1 (see note 1)

- 2) For multipath fading condition

No stop of the test until [990] wavelengths are crossed during relevant BS reception timeslots, relevant for BER BLER testing, with the speed given in the fading profile.

- 3) For high speed train condition

Scenario 1: 82.3s. This corresponds to 4 complete cycles of approach towards and departure leave to and from a BS antenna

Scenario 3: 28.8s. This corresponds to 4 complete cycles of approach towards and departure from a BS antenna

**Table F.2: minimum Test time**

| Fading profile                            | Minimum test time  |
|---|--------------------|
| Multipath propagation 3 km/h              | [164 s* TSPF/TSRX] |
| Multipath propagation 120 km/h            | [4.1 s* TSPF/TSRX] |
| High speed train conditions<br>Scenario 1 | 82.3 sec           |
| High speed train conditions<br>Scenario 3 | 28.8 sec           |



TSPF = Time slots per frame  
 TSRX = relevant reception timeslots per frame, relevant for the BER BLER test

TSPF and TSRX form the prolongation factor and depend on the user data rate and the TDD Option (3,84 Mchip/s or 1,28 Mchip/s )

**Table F.3: Prolongation factor for minimum Test time**

| User Data rate | TSPF/TSRX for TDD 3,84 Mchip/s | TSPF/TSRX for TDD 1,28 Mchip/s |
|----------------|--------------------------------|--------------------------------|
| 12.2 kbit/s    | 15/1                           | 7/1                            |
| 64 kbit/s      | 15/1                           | 7/1                            |
| 144 kbit/s     | 15/1                           | 7/2                            |
| 384 kbit/s     | 15/3                           | 7/4                            |

In tables F.4 and F.5 the minimum test time is converted in minimum number of samples.

## F.1.7 Pass fail decision rules

No decision is allowed before the minimum test time is elapsed.

- 1) If minimum Test time < time for target number of error events then the following applies: The required confidence level 1-F (= correct decision probability) shall be achieved. This is fulfilled at an early pass or early fail event.

### For BER:

For every TTI (Transmit Time Interval) sum up the number of bits (ns) and the number if errors (ne) from the beginning of the test and calculate

$BER_1$  (including the artificial error at the beginning of the test (Note 1))and

$BER_0$  (excluding the artificial error at the beginning of the test (Note 1)).

If  $BER_0$  is above the early fail limit, fail the DUT.

If  $BER_1$  is below the early pass limit, pass the DUT.

Otherwise continue the test

### For BLER:

For every TTI sum up the number of blocks (ns) and the number of erroneous blocks (ne) from the beginning of the test and calculate

$BLER_1$  (including the artificial error at the beginning of the test (Note 1))and

$BLER_0$  (excluding the artificial error at the beginning of the test (Note 1)).

If  $BLER_1$  is below the early pass limit, pass the DUT.

If  $BLER_0$  is above the early fail limit, fail the DUT.

Otherwise continue the test

- 2) If the minimum test time  $\geq$  time for target error events, then the test runs for the minimum test time and the decision is done by comparing the result with the test limit.

### For BER:

For every TTI (Transmit Time Interval) sum up the number of bits (ns) and the number if errors (ne) from the beginning of the test and calculate  $BER_0$

**For BLER:**

For every TTI sum up the number of blocks (ns) and the number of erroneous blocks (ne) from the beginning of the test and calculate  $BLER_0$

If  $BER_0/BLER_0$  is above the test limit, fail the DUT.

If  $BER_0/BLER_0$  is on or below the test limit, pass the DUT.

**F.1.8 Test conditions for BER, BLER Tests****Table F.4: Test conditions for BER tests**

| Type of test (BER)                             | Propagation conditions | Test requirement (BER) | Test limit (BER)= Test requirement (BER)x TL TL | Target number of error events (time) Note * | Minimum number of samples | Prob that good unit will fail = Prob that bad unit will pass (%) | Bad unit BER factor M |
|--|------------------------|------------------------|---|---|---------------------------|--|-----------------------|
| Reference Sensitivity Level                    | -                      | 0.001                  | 1.234   | 345 (22.9s)                                 | Note 1                    | 0.2  | 1.5                   |
| Dynamic Range                                  | -                      | 0.001                  | 1.234   | 345 (22.9s)                                 | Note 1                    | 0.2  | 1.5                   |
| Adjacent Channel Selectivity                   | -                      | 0.001                  | 1.234   | 345 (22.9s)                                 | Note 1                    | 0.2  | 1.5                   |
| Blocking Characteristics Pass condition Note 2 | -                      | 0.001                  | 1.251   | 402 (26.3s)                                 | Note 1                    | 0.2  | 1.5                   |
| Blocking Characteristics Fail condition Note 2 | -                      | 0.001                  | 1.251   | 402 (26.3s)                                 | Note 1                    | 0.02   | 1.5                   |
| Intermodulation Characteristics                | -                      | 0.001                  | 1.234   | 345 (22.9s)                                 | Note 1                    | 0.2  | 1.5                   |

Note \*: the time in the bracket means the reception time

Table F.5: Test conditions for BLER tests

| Type of test (BLER)  | Information Bit rate (kbit/s) | Test requirement (BLER)            | Test limit (BLER)= Test requirement (BLER)x TL TL | Target number of error events (time)                                       | Minimum number of samples (time) TDD 3,84 Mchip/s | Minimum number of samples (time) TDD 1,28 Mchip/s   | Prob that bad unit will pass = Prob that good unit will fail (%) | Bad unit BLER factor M |
|--|-------------------------------|------------------------------------|---|--|---|---|--|------------------------|
| Demodulation in Static Propagation conditions  | 12.2<br>64<br>144<br>384      | 0.01<br>0.1<br>0.01<br>0.1<br>0.01 | 1.234   | 345<br>(559s)<br>(55.9s)<br>(559s)<br>(55.9s)<br>(28s)<br>(280s)           | Note1   | Note1   | 0.2  | 1.5                    |
| Demodulation of DCH in Multi-path Fading Propagation conditions 3km/h (Case 1, Case 2) | 12.2<br>64<br>144<br>384      | 0.01<br>0.1<br>0.01<br>0.1<br>0.01 | 1.234   | 345<br>(559s)<br>(55.9s)<br>(559s)<br>(55.9s)<br>(559s)<br>(28s)<br>(280s) | [(2460s)]<br>[123000]<br>[123000]<br>[123000]     | [ (1148s)]<br>[5740]<br>[5740]<br>[5740]<br>[(574s)]<br>[2870]<br>[2870]<br>[(278s)]<br>[27800]<br>[27800]<br>[27800] | 0.2  | 1.5                    |
| Demodulation of DCH in Multi-path Fading Propagation conditions 120 km/h (Case3)       | 12.2<br>64<br>144<br>384      | 0.01<br>0.1<br>0.01<br>0.1<br>0.01 | 1.234   | 345<br>(559s)<br>(55.9s)<br>(559s)<br>(55.9s)<br>(559s)<br>(28s)<br>(280s) | [(61.5s)]<br>[3075]<br>[3075]<br>[3075]           | [(28.7s)]<br>[1435]<br>[1435]<br>[1435]<br>[(14.35s)]<br>[718]<br>[718]<br>[(7.175s)]<br>[718]<br>[718]               | 0.2  | 1.5                    |
| Demodulation of DCH in high speed train condition                                      | 12.2<br>64                    | 0.01<br>0.1<br>0.01                | 1.234   | 345<br>(559s)<br>(55.9s)<br>(559s)   |   | Scenario 1 (82.3s)<br>4115<br>Scenario 3 (28.8s)<br>1440  | 0.2  | 1.5                    |

## F.1.9 Practical Use (informative)

See figure F.1:

- The early fail limit represents formula (1) in F.1.5. The range of validity is  $n_e \geq 7$  ( $\geq 8$  in case of blocking test) to  $n_e = 345$
- The early pass limit represents formula (2) in F.1.5. The range of validity is  $n_e = 1$  to  $n_e = 345$ . See note 1
- The intersection co-ordinates of both curves are : target number of errors  $n_e = 345$  and test limit  $TL = 1.234$ .
- The range of validity for TL is  $n_e > 345$ .

A typical BER BLER test, calculated from the number of samples and errors (F.1.2.(b)) using experimental method (1) or (2) (see F.1.4.2 calculation assumptions) runs along the yellow trajectory. With an errorless sample the trajectory goes down vertically. With an erroneous sample it jumps up right. The tester checks if the BER BLER test intersects the early fail or early pass limits. The real time processing can be reduced by the following actions:

$BLER_0$  (excluding the artificial error at the beginning of the test (Note 1)). is calculated only in case of an error event.

BER<sub>0</sub> (excluding the artificial error at the beginning of the test (Note 1)). is calculated only in case of an error event within a TTI.

So the early fail limit cannot be missed by errorless samples.

The check against the early pass limit may be done by transforming formula (2) in F.1.5 such that the tester checks against a Limit-Number-of-samples (NL(ne)) depending on the current number of errors (including the artificial error at the beginning of the test (Note 1)).

Early pass if

$$NL(ne) \geq \frac{qchisq(1 - D, 2 * ne)}{2 * TR * M}$$

TR: test requirement (0.001)

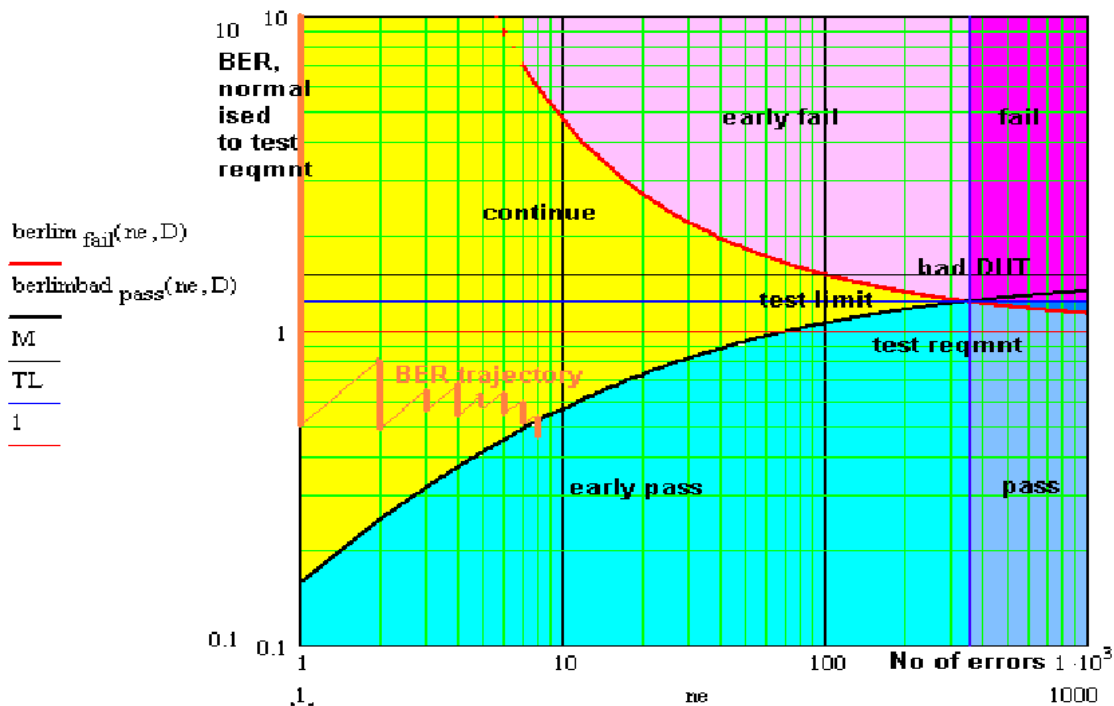


Figure F.1

NOTE 1: At the beginning of the test, an artificial error is introduced. This ensures that an ideal DUT meets the valid range of the early pass limit. In addition this ensures that the complementary experiment (F.1.4.2 bullet point (2)) is applicable as well.

For the check against the early fail limit the artificial erroneous sample, introduced at the beginning of the test, is disregarded.

Due to the nature of the test, namely discrete error events, the early fail condition shall not be valid, when fractional errors <1 are used to calculate the early fail limit: Any early fail decision is postponed until number of errors ne ≥ 7. In the blocking test any early fail decision is postponed until number of errors ne ≥ 8.

NOTE 2: F=0.2% is intended to be used for a test containing a few BER/BLER tests (e.g. receiver sensitivity is repeated 12 times(3 RF Channels \* 2 Power-supplies \* 2 Temperatures). For a test containing many BER/BLER tests (e.g. blocking test) this value is not appropriate for a single BER/BLER test.

The blocking test contains approx. 12750 single BER tests. A DUT on the limit will fail approx. 25 to 26 times due to statistical reasons using wrong decision probability at the end of the test  $F=0.2\%$ . This shall be solved by the following rule:

All passes (based on  $F=0.2\%$ ) are accepted, including the wrong decisions due to statistical reasons.

An early fail limit based on  $F=0.02\%$  instead of  $0.2\%$  is established. That ensures that wrong decisions due to statistical reasons are reduced to 2 to 3 in 12750 BER measurements. If the fail cases are  $\leq 12$ , it is allowed to repeat each fail cases 1 time before the final verdict.

These asymmetric test conditions ensure that a DUT on the limit consumes hardly more test time for a blocking test than in the symmetric case and reduces the wrong decision probability considerably and on the other hand the repetition allowance sufficiently suppresses the residual statistically caused wrong verdict for the aggregate test.

## Annex G (informative): Change History

**Table G.1: Change History**

| TSG   | Doc       | CR   | R | Title   | Cat | Curr  | New   | Work Item             |
|-------|-----------|------|---|---|-----|-------|-------|-----------------------|
| RP-29 |           |      |   | Rel-7 version created based on v6.3.0   |     |       | 7.0.0 |                       |
| RP-29 | RP-050579 | 0176 |   | Introduction of UMTS 2.6 GHz operating band for TDD   | B   | 6.2.0 | 7.0.0 | RInImp-UMTS2600 TDD   |
| RP-29 | RP-050579 | 0177 |   | UMTS 2.6 GHz TDD Propagation Conditions   | B   | 6.2.0 | 7.0.0 | RInImp-UMTS2600 TDD   |
| RP-29 | RP-050579 | 0178 | 2 | Channel Raster for 3,84 Mcps TDD in UMTS 2.6 GHz  | B   | 6.2.0 | 7.0.0 | RInImp-UMTS2600 TDD   |
| RP-29 | RP-050579 | 0179 |   | UMTS 2.6 GHz TDD BS Transmitter Specifications  | B   | 6.2.0 | 7.0.0 | RInImp-UMTS2600 TDD   |
| RP-29 | RP-050579 | 0180 |   | UMTS 2.6 GHz TDD BS Receiver Specifications   | B   | 6.2.0 | 7.0.0 | RInImp-UMTS2600 TDD   |
| RP-29 | RP-050579 | 0181 |   | Introduction of Propagation Conditions for UMTS 2.6 GHz for 1,28Mcps TDD                      | B   | 6.2.0 | 7.0.0 | RInImp-UMTS2600 TDD   |
| RP-29 | RP-050579 | 0182 |   | UMTS 2.6 GHz TDD BS receiver spurious emission  | B   | 6.2.0 | 7.0.0 | RInImp-UMTS2600 TDD   |
| RP-30 | RP-050740 | 0183 |   | Introduction of UMTS 2.6 BS transmitter specification for 1,28Mcps TDD                        | B   | 7.0.0 | 7.1.0 | RInImp-UMTS2600 TDD   |
| RP-30 | RP-050740 | 0184 |   | Introduction of UMTS 2.6 BS receiver specification for 1,28Mcps TDD                           | B   | 7.0.0 | 7.1.0 | RInImp-UMTS2600 TDD   |
| RP-30 | RP-050841 | 0186 |   | Name correction of logical and transport channels in Annex 2                                  | A   | 7.0.0 | 7.1.0 | TEI6                  |
| RP-32 | RP-060307 | 0187 |   | UMTS 2.6 GHz blocking and spurious emission test condition                                    | F   | 7.1.0 | 7.2.0 | RInImp-UMTS2600 TDD   |
| RP-32 | RP-060312 | 0188 | 1 | 7.68 Mcps Frequency Band & Channel Arrangement  | B   | 7.1.0 | 7.2.0 | VHCRTDD-RF            |
| RP-32 | RP-060312 | 0189 |   | 7.68 Mcps Transmitter Characteristics   | B   | 7.1.0 | 7.2.0 | VHCRTDD-RF            |
| RP-32 | RP-060312 | 0190 | 1 | 7.68 Mcps Receiver Characteristics  | B   | 7.1.0 | 7.2.0 | VHCRTDD-RF            |
| RP-32 | RP-060312 | 0191 |   | 7.68 Mcps - Channel Performance   | B   | 7.1.0 | 7.2.0 | VHCRTDD-RF            |
| RP-32 | RP-060312 | 0192 |   | 7.68 Mcps Measurement Channels & Propagation Conditions                                       | B   | 7.1.0 | 7.2.0 | VHCRTDD-RF            |
| RP-33 | RP-060517 | 0205 |   | Clarification of Tx spurious emission level from 3,84 Mcps and 7.68 Mcps TDD BS into PHS band | F   | 7.2.0 | 7.3.0 | TEI7                  |
| RP-33 | RP-060518 | 0212 | 1 | Clarification on the deployment of UTRA TDD in Japan  | A   | 7.2.0 | 7.3.0 | TEI                   |
| RP-33 | RP-060519 | 0214 | 1 | Tx and Rx Spurious Emission from 3,84 Mcps and 7.68 Mcps TDD BS into FDD bands in Japan       | A   | 7.2.0 | 7.3.0 | TEI6                  |
| RP-33 | RP-060528 | 0206 |   | Performance requirements for 3,84 Mcps E-DCH channel.   | B   | 7.2.0 | 7.3.0 | EDCHTDD-RF            |
| RP-33 | RP-060526 | 0207 | 2 | 7.68 Mcps Operations in 2.6 GHz band  | B   | 7.2.0 | 7.3.0 | RInImp-UMTS26V HCRTDD |
| RP-34 | RP-060818 | 0215 |   | Performance requirements for 7.68 Mcps E-DCH channel.   | B   | 7.3.0 | 7.4.0 | TEI7                  |
| RP-35 | RP-070081 | 0219 |   | HS-SICH detection performance test specification for 1.28Mcps TDD                             | A   | 7.4.0 | 7.5.0 | TEI6                  |

|       |           |      |   |  |   |       |       |                      |
|-------|-----------|------|---|--|---|-------|-------|----------------------|
| RP-35 | RP-070082 | 0216 |   | Tx and Rx Spurious Emission from 7.68 Mcps TDD BS into FDD band in Japan                               | F | 7.4.0 | 7.5.0 | TEI7                 |
| RP-35 | RP-070082 | 0217 |   | Clarification on the deployment of UTRA TDD in Japan   | F | 7.4.0 | 7.5.0 | TEI7                 |
| RP-36 | RP-070369 | 0225 |   | Modifying category B spurious emission limits for UTRA TDD BS  | A | 7.5.0 | 7.6.0 | TEI                  |
| RP-36 | RP-070377 | 0221 |   | Adding test case of E-DCH performance requirement for 1.28Mcps TDD option                              | F | 7.5.0 | 7.6.0 | LCRTDD-EDCH-RF       |
| RP-37 | RP-070651 | 0227 |   | 7.68 Mcps TDD Option test tolerances and transmit ON/OFF time mask level.                              | F | 7.6.0 | 7.7.0 | TEI7                 |
| RP-37 | RP-070651 | 0226 |   | Inclusion of 7.68 Mcps in the scope of document  | F | 7.6.0 | 7.7.0 | TEI7                 |
| RP-39 | RP-080119 | 0229 | 1 | Correcting the power allocation for HS-SICH performance detection                                      | A | 7.7.0 | 7.8.0 | TEI6                 |
| RP-40 | RP-080329 | 0234 |   | RCDE for 1.28Mcps TDD 64QAM modulated codes  | B | 7.8.0 | 7.9.0 | RANimp-64Qam1.28 TDD |
| RP-40 | RP-080384 | 0233 | 1 | UMTS2300MHz propagation channel model addition for 1.28Mcps TDD in 25.142                              | B | 7.9.0 | 8.0.0 | RInImp8-UMTS2300 TDD |
| RP-40 | RP-080384 | 0232 | 1 | UMTS2300MHz Receiver performance addition for 1.28Mcps TDD in 25.142                                   | B | 7.9.0 | 8.0.0 | RInImp8-UMTS2300 TDD |
| RP-40 | RP-080384 | 0231 | 1 | UMTS2300MHz Transmitter performance addition for 1.28Mcps TDD in 25.142                                | B | 7.9.0 | 8.0.0 | RInImp8-UMTS2300 TDD |
| RP-40 | RP-080384 | 0230 | 1 | UMTS2300MHz New band introduction for 1.28Mcps TDD in 25.142   | B | 7.9.0 | 8.0.0 | RInImp8-UMTS2300 TDD |
| RP-41 | RP-080636 | 0236 | 1 | Modify the Fixed Reference Channels of E-DCH for LCR TDD   | A | 8.0.0 | 8.1.0 | TEI7                 |
| RP-43 | RP-090166 | 0241 |   | Correction of BS reference measurement channel and performance requirement for LCR TDD 384kbps service | A | 8.1.0 | 8.2.0 | TEI4                 |
| RP-43 | RP-090197 | 0242 |   | Introduction of band 1880MHz for 25.142  | F | 8.1.0 | 8.2.0 | RInImp9-UMTS1880 TDD |
| RP-43 | RP-090197 | 0243 |   | UMTS1880MHz: transmitter characteristic  | F | 8.1.0 | 8.2.0 | RInImp9-UMTS1880 TDD |
| RP-43 | RP-090197 | 0244 |   | UMTS1880MHz: receiver characteristic and propagation conditions  | F | 8.1.0 | 8.2.0 | RInImp9-UMTS1880 TDD |
| RP-44 | RP-090553 | 0247 |   | Correction of local area base station coexistence requirements   | F | 8.2.0 | 8.3.0 | RInImp9-UMTS1880 TDD |
| RP-44 | RP-090554 | 0245 | 1 | Addition of Time alignment error test for BS supporting 1.28Mcps TDD MIMO                              | F | 8.2.0 | 8.3.0 | RANimp-LCRMIMO       |
| RP-44 | RP-090556 | 0246 |   | Correction on the test parameter table of E-DCH for 1.28Mcps TDD                                       | F | 8.2.0 | 8.3.0 | TEI8                 |
| RP-45 | RP-090818 | 251  |   | Changes to 25.142 accommodating IMB  | F | 8.3.0 | 8.4.0 | MBSFN-DOB            |
| RP-46 | RP-091285 | 255  |   | BS test requirements in high speed train condition for LCR TDD   | B | 8.5.0 | 9.0.0 | RInImp9-LCRTDD350    |
| RP-47 | RP-100257 | 260  |   | Correction of E-DCH FRC3 for LCR TDD   | A | 9.0.0 | 9.1.0 | TEI7                 |
| RP-47 | RP-100253 | 262  |   | Protection of E-UTRA for UTRA TDD BS   | A | 9.0.0 | 9.1.0 | LTE-RF               |
| RP-47 | RP-100273 | 257  |   | Additional BS test requirements in high speed train conditions for LCR TDD                             | F | 9.0.0 | 9.1.0 | RInImp9-LCRTDD350    |
| RP-48 | RP-100631 | 263  | 1 | Corrections for performance requirements in HST condition  | F | 9.1.0 | 9.2.0 | TEI9                 |
| RP-49 | RP-100922 | 264  | 1 | Clarification on applicability of requirements for multi-carrier BS                                    | F | 9.2.0 | 9.3.0 | RInImp9-RFmulti      |
| RP-50 | RP-101340 | 275  |   | Addition of test case for HS-SICH type2 performance  | A | 9.3.0 | 9.4.0 | TEI8                 |
| RP-50 | RP-101340 | 277  |   | Clarifications of Base Station transmit and receive configurations                                     | A | 9.3.0 | 9.4.0 | TEI8                 |
| RP-56 | RP-120765 | 291  |   | Additional spurious emissions requirements for PHS   | A | 9.4.0 | 9.5.0 | TEI8                 |

---

## History

| <b>Document history</b> |               |             |
|-------------------------|---------------|-------------|
| V9.0.0                  | February 2010 | Publication |
| V9.1.0                  | April 2010    | Publication |
| V9.2.0                  | July 2010     | Publication |
| V9.3.0                  | October 2010  | Publication |
| V9.4.0                  | January 2011  | Publication |
| V9.5.0                  | July 2012     | Publication |