

# ETSI TS 125 211 V3.1.1 (2000-01)

---

*Technical Specification*

## **Universal Mobile Telecommunications System (UMTS); Physical channels and mapping of transport channels onto physical channels (FDD) (3G TS 25.211 version 3.1.1 Release 1999)**



Reference

---

DTS/TSGR-0125211U

Keywords

---

UMTS

**ETSI**

Postal address

---

F-06921 Sophia Antipolis Cedex - FRANCE

Office address

---

650 Route des Lucioles - Sophia Antipolis  
Valbonne - FRANCE  
Tel.: +33 4 92 94 42 00 Fax: +33 4 93 65 47 16  
Siret N° 348 623 562 00017 - NAF 742 C  
Association à but non lucratif enregistrée à la  
Sous-Préfecture de Grasse (06) N° 7803/88

Internet

---

secretariat@etsi.fr  
Individual copies of this ETSI deliverable  
can be downloaded from  
<http://www.etsi.org>  
If you find errors in the present document, send your  
comment to: editor@etsi.fr

---

**Important notice**

This ETSI deliverable may be made available in more than one electronic version or in print. In any case of existing or perceived difference in contents between such versions, the reference version is the Portable Document Format (PDF). In case of dispute, the reference shall be the printing on ETSI printers of the PDF version kept on a specific network drive within ETSI Secretariat.

---

**Copyright Notification**

No part may be reproduced except as authorized by written permission.  
The copyright and the foregoing restriction extend to reproduction in all media.

© European Telecommunications Standards Institute 2000.  
All rights reserved.

---

## Intellectual Property Rights

IPRs essential or potentially essential to the present document may have been declared to ETSI. The information pertaining to these essential IPRs, if any, is publicly available for **ETSI members and non-members**, and can be found in SR 000 314: "*Intellectual Property Rights (IPRs); Essential, or potentially Essential, IPRs notified to ETSI in respect of ETSI standards*", which is available from the ETSI Secretariat. Latest updates are available on the ETSI Web server (<http://www.etsi.org/ipr>).

Pursuant to the ETSI IPR Policy, no investigation, including IPR searches, has been carried out by ETSI. No guarantee can be given as to the existence of other IPRs not referenced in SR 000 314 (or the updates on the ETSI Web server) which are, or may be, or may become, essential to the present document.

---

## Foreword

This Technical Specification (TS) has been produced by the ETSI 3<sup>rd</sup> Generation Partnership Project (3GPP).

The present document may refer to technical specifications or reports using their 3GPP identities or GSM identities. These should be interpreted as being references to the corresponding ETSI deliverables. The mapping of document identities is as follows:

For 3GPP documents:

3G TS | TR nn.nnn "<title>" (with or without the prefix 3G)

is equivalent to

ETSI TS | TR 1nn nnn "[Digital cellular telecommunications system (Phase 2+) (GSM);] Universal Mobile Telecommunications System; <title>

For GSM document identities of type "GSM xx.yy", e.g. GSM 01.04, the corresponding ETSI document identity may be found in the Cross Reference List on [www.etsi.org/key](http://www.etsi.org/key)

# Contents

Foreword.....	5
1 Scope.....	6
2 References.....	6
3 Abbreviations.....	6
4 Transport channels.....	7
4.1 Dedicated transport channels.....	7
4.1.1 DCH – Dedicated Channel.....	7
4.2 Common transport channels.....	7
4.2.1 BCH – Broadcast Channel.....	8
4.2.2 FACH – Forward Access Channel.....	8
4.2.3 PCH – Paging Channel.....	8
4.2.4 RACH – Random Access Channel.....	8
4.2.5 CPCH – Common Packet Channel.....	8
4.2.6 DSCH – Downlink Shared Channel.....	8
5 Physical channels.....	8
5.1 The physical resource.....	8
5.2 Uplink physical channels.....	8
5.2.1 Dedicated uplink physical channels.....	8
5.2.2 Common uplink physical channels.....	11
5.2.2.1 Physical Random Access Channel (PRACH).....	11
5.2.2.1.1 RACH transmission.....	11
5.2.2.1.2 RACH preamble part.....	12
5.2.2.1.3 RACH message part.....	12
5.2.2.2 Physical Common Packet Channel (PCPCH).....	13
5.2.2.2.1 CPCH transmission.....	14
5.2.2.2.2 CPCH access preamble part.....	14
5.2.2.2.3 CPCH collision detection preamble part.....	14
5.2.2.2.4 CPCH power control preamble part.....	14
5.2.2.2.5 CPCH message part.....	14
5.3 Downlink physical channels.....	15
5.3.1 Downlink Transmit Diversity.....	15
5.3.1.1 Open loop transmit diversity.....	15
5.3.1.1.1 Space time block coding based transmit antenna diversity (STTD).....	15
5.3.1.1.2 Time Switched Transmit Diversity for SCH (TSTD).....	15
5.3.2 Dedicated downlink physical channels.....	16
5.3.2.1 STTD for DPCH.....	19
5.3.2.2 Dedicated channel pilots with closed loop mode transmit diversity.....	20
5.3.2.3 DL-DPCCH for CPCH.....	20
5.3.3 Common downlink physical channels.....	21
5.3.3.1 Common Pilot Channel (CPICH).....	21
5.3.3.1.1 Primary Common Pilot Channel.....	21
5.3.3.1.2 Secondary Common Pilot Channel.....	22
5.3.3.2 Primary Common Control Physical Channel (P-CCPCH).....	22
5.3.3.2.1 Primary CCPCH structure with STTD encoding.....	22
5.3.3.3 Secondary Common Control Physical Channel (S-CCPCH).....	23
5.3.3.3.1 Secondary CCPCH structure with STTD encoding.....	24
5.3.3.4 Synchronisation Channel (SCH).....	25
5.3.3.4.1 SCH transmitted by TSTD.....	26
5.3.3.5 Physical Downlink Shared Channel (PDSCH).....	26
5.3.3.6 Acquisition Indicator Channel (AICH).....	27
5.3.3.7 Page Indicator Channel (PICH).....	28

6	Mapping of transport channels onto physical channels .....	29
7	Timing relationship between physical channels .....	30
7.1	General.....	30
7.2	PICH/S-CCPCH timing relation.....	31
7.3	PRACH/AICH timing relation.....	31
7.4	PCPCH/AICH timing relation .....	32
7.5	DPCH/PDSCH timing .....	33
7.6	DPCCH/DPDCH timing relations .....	33
7.6.1	Uplink.....	33
7.6.2	Downlink.....	33
7.6.3	Uplink/downlink timing at UE.....	33
7.7	Timing relations for initialisation of channels.....	34
	<b>Annex A (informative): Change history.....</b>	<b>36</b>
	History.....	37

---

# Foreword

This Technical Specification has been produced by the 3GPP.

The contents of the present document are subject to continuing work within the TSG and may change following formal TSG approval. Should the TSG modify the contents of this TS, it will be re-released by the TSG with an identifying change of release date and an increase in version number as follows:

Version 3.y.z

where:

- x the first digit:
  - 1 presented to TSG for information;
  - 2 presented to TSG for approval;
  - 3 Indicates TSG approved document under change control.
- y the second digit is incremented for all changes of substance, i.e. technical enhancements, corrections, updates, etc.
- z the third digit is incremented when editorial only changes have been incorporated in the specification;

---

# 1 Scope

The present document describes the characteristics of the Layer 1 transport channels and physical channels in the FDD mode of UTRA. The main objectives of the document are to be a part of the full description of the UTRA Layer 1, and to serve as a basis for the drafting of the actual technical specification (TS).

---

# 2 References

The following documents contain provisions which, through reference in this text, constitute provisions of the present document.

- References are either specific (identified by date of publication, edition number, version number, etc.) or non-specific.
- For a specific reference, subsequent revisions do not apply.
- For a non-specific reference, the latest version applies.

- [1] 3G TS 25.201: "Physical layer - general description"
- [2] 3G TS 25.211: "Physical channels and mapping of transport channels onto physical channels (FDD)"
- [3] 3G TS 25.212: "Multiplexing and channel coding (FDD)"
- [4] 3G TS 25.213: "Spreading and modulation (FDD)"
- [5] 3G TS 25.214: "Physical layer procedures (FDD)"
- [6] 3G TS 25.221: "Transport channels and physical channels (TDD)"
- [7] 3G TS 25.222: "Multiplexing and channel coding (TDD)"
- [8] 3G TS 25.223: "Spreading and modulation (TDD)"
- [9] 3G TS 25.224: "Physical layer procedures (TDD)"
- [10] 3G TS 25.231: "Measurements"
- [11] 3G TS 25.301: "Radio Interface Protocol Architecture"
- [12] 3G TS 25.302: "Services Provided by the Physical Layer"
- [13] 3G TS 25.401: "UTRAN Overall Description"

---

# 3 Abbreviations

For the purposes of the present document, the following abbreviations apply:

AI	Acquisition Indicator
AICH	Acquisition Indicator Channel
AP	Access Preamble
BCH	Broadcast Channel
CCPCH	Common Control Physical Channel
CCTrCH	Coded Composite Transport Channel
CD	Collision Detection
CPCH	Common Packet Channel
CPICH	Common Pilot Channel
DCH	Dedicated Channel
DPCCH	Dedicated Physical Control Channel

DPCH	Dedicated Physical Channel
DPDCH	Dedicated Physical Data Channel
DSCH	Downlink Shared Channel
DTX	Discontinuous Transmission
FACH	Forward Access Channel
FBI	Feedback Information
MUI	Mobile User Identifier
PCH	Paging Channel
P-CCPCH	Primary Common Control Physical Channel
PCPCH	Physical Common Packet Channel
PDSCH	Physical Downlink Shared Channel
PI	Page Indicator
PICH	Page Indicator Channel
PRACH	Physical Random Access Channel
PSC	Primary Synchronisation Code
RACH	Random Access Channel
RNC	Radio Network Controller
S-CCPCH	Secondary Common Control Physical Channel
SCH	Synchronisation Channel
SF	Spreading Factor
SFN	System Frame Number
SSC	Secondary Synchronisation Code
STTD	Space Time Transmit Diversity
TFCI	Transport Format Combination Indicator
TSTD	Time Switched Transmit Diversity
TPC	Transmit Power Control
UE	User Equipment
UTRAN	UMTS Terrestrial Radio Access Network

---

## 4 Transport channels

Transport channels are the services offered by Layer 1 to the higher layers. General concepts about transport channels are described in [12].

A transport channel is defined by how and with what characteristics data is transferred over the air interface. A general classification of transport channels is into two groups:

- Dedicated Channels
- Common Channels

### 4.1 Dedicated transport channels

There exists only one type of dedicated transport channel, the Dedicated Channel (DCH).

#### 4.1.1 DCH – Dedicated Channel

The Dedicated Channel (DCH) is a downlink or uplink transport channel. The DCH is transmitted over the entire cell or over only a part of the cell using beam-forming antennas. The Dedicated Channel (DCH) is characterized by the possibility of fast rate change (every 10ms), fast power control and inherent addressing of UEs.

### 4.2 Common transport channels

There are six types of common transport channels: BCH, FACH, PCH, RACH, CPCH and DSCH.



### 4.2.1 BCH – Broadcast Channel

The Broadcast Channel (BCH) is a downlink transport channel that is used to broadcast system- and cell-specific information. The BCH is always transmitted over the entire cell with a low fixed bit rate.

### 4.2.2 FACH – Forward Access Channel

The Forward Access Channel (FACH) is a downlink transport channel. The FACH is transmitted over the entire cell or over only a part of the cell using beam-forming antennas. The FACH uses slow power control.

### 4.2.3 PCH – Paging Channel

The Paging Channel (PCH) is a downlink transport channel. The PCH is always transmitted over the entire cell. The transmission of the PCH is associated with the transmission of a physical layer signal, the Paging Indicator, to support efficient sleep-mode procedures.

### 4.2.4 RACH – Random Access Channel

The Random Access Channel (RACH) is an uplink transport channel. The RACH is always received from the entire cell. The RACH is characterized by a limited size data field, a collision risk and by the use of open loop power control.

### 4.2.5 CPCH – Common Packet Channel

The Common Packet Channel (CPCH) is an uplink transport channel. The CPCH is a contention based random access channel used for transmission of bursty data traffic. CPCH is associated with a dedicated channel on the downlink which provides power control for the uplink CPCH.

### 4.2.6 DSCH – Downlink Shared Channel

The downlink shared channel (DSCH) is a downlink transport channel shared by several UEs. The DSCH is associated with a DCH.

---

## 5 Physical channels

Physical channels typically consist of a layered structure of radio frames and time slots, although this is not true for all physical channels. Depending on the symbol rate of the physical channel, the configuration of radio frames or time slots varies.

Radio frame: A Radio frame is a processing unit which consists of 15 time slots.

Time slot: A Time slot is a unit which consists of fields containing bits. The number of bits per time slot depends on the physical channel.

### 5.1 The physical resource

The basic physical resource is the code/frequency plane. In addition, on the uplink, different information streams may be transmitted on the I and Q branch. Consequently, a physical channel corresponds to a specific carrier frequency, code, and, on the uplink, relative phase (0 or  $\pi/2$ ).

### 5.2 Uplink physical channels

#### 5.2.1 Dedicated uplink physical channels

There are two types of uplink dedicated physical channels, the uplink Dedicated Physical Data Channel (uplink DPDCH) and the uplink Dedicated Physical Control Channel (uplink DPCCCH).

The DPDCH and the DPCCH are I/Q code multiplexed within each radio frame (see [4]).

The uplink DPDCH is used to carry dedicated data generated at Layer 2 and above, i.e. the dedicated transport channel (DCH). There may be zero, one, or several uplink DPDCHs on each Layer 1 connection.

The uplink DPCCH is used to carry control information generated at Layer 1. The Layer 1 control information consists of known pilot bits to support channel estimation for coherent detection, transmit power-control (TPC) commands, feedback information (FBI), and an optional transport-format combination indicator (TFCI). The transport-format combination indicator informs the receiver about the instantaneous parameters of the different transport channels multiplexed on the uplink DPDCH, and corresponds to the data transmitted in the same frame. It is the UTRAN that determines if a TFCI should be transmitted, hence making it mandatory for all UEs to support the use of TFCI in the uplink. There is one and only one uplink DPCCH on each Layer 1 connection.

Figure 1 shows the frame structure of the uplink dedicated physical channels. Each frame of length 10 ms is split into 15 slots, each of length  $T_{slot} = 2560$  chips, corresponding to one power-control period

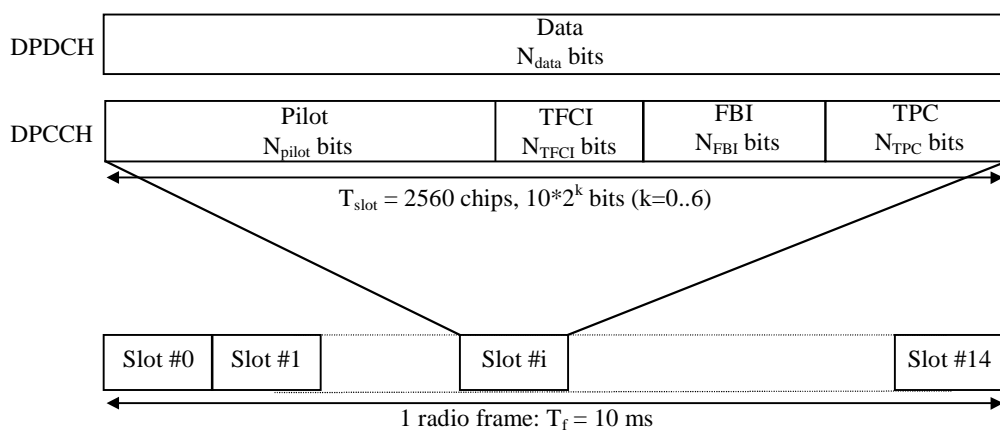

**Figure 1: Frame structure for uplink DPDCH/DPCCH**

The parameter  $k$  in figure 1 determines the number of bits per uplink DPDCH/DPCCH slot. It is related to the spreading factor  $SF$  of the physical channel as  $SF = 256/2^k$ . The DPDCH spreading factor may thus range from 256 down to 4. Note that an uplink DPDCH and uplink DPCCH on the same Layer 1 connection generally are of different rates, i.e. have different spreading factors and different values of  $k$ .

The exact number of bits of the different uplink DPCCH fields ( $N_{pilot}$ ,  $N_{TFCI}$ ,  $N_{FBI}$ , and  $N_{TPC}$ ) is determined in table 2. The field order and total number of bits/slot are fixed, though the number of bits per field may vary during a connection.

The values for the number of bits per field are given in table 1 and table 2. The channel bit and symbol rates given in table 1 are the rates immediately before spreading. The pilot patterns are given in table 3 and table 4, the TPC bit pattern is given in table 5.

The  $N_{FBI}$  bits are used to support techniques requiring feedback between the UE and the UTRAN Access Point (=cell transceiver), including closed loop mode transmit diversity and site selection diversity (SSDT). The exact details of the FBI field are shown in figure 2 and described below.

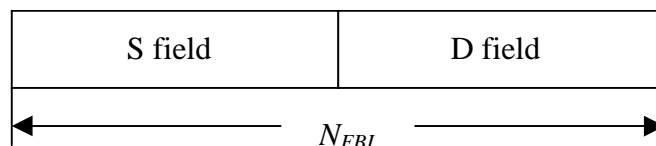

**Figure 2: Details of FBI field**

The S field is used for SSDT signalling, while the D field is used for Closed Loop Mode Transmit Diversity Signalling. The S field can be of length 0, 1 or 2. The D field can be of length 0 or 1. The total FBI field size  $N_{FBI}$  is according to table 2 (DPCCH fields). Simultaneous use of SSDT power control and Closed Loop Mode Transmit Diversity requires that the S field is of length 1. The use of these FBI fields is described in [5].

**Table 1: DPDCH fields**

Slot Format #i	Channel Bit Rate (kbps)	Channel Symbol Rate (ksps)	SF	Bits/Frame	Bits/Slot	N <sub>data</sub>
0	15	15	256	150	10	10
1	30	30	128	300	20	20
2	60	60	64	600	40	40
3	120	120	32	1200	80	80
4	240	240	16	2400	160	160
5	480	480	8	4800	320	320
6	960	960	4	9600	640	640

There are two types of Uplink Dedicated Physical Channels; those that include TFCI(e.g. for several simultaneous services) and those that do not include TFCI(e.g. for fixed-rate services). These types are reflected by the duplicated rows of table 2. In compressed mode, DPCCH slot formats with TFCI fields are changed. There are two possible compressed slot formats for each normal slot format. They are labelled A and B and the selection between them is dependent on the number of slots that are transmitted in each frame in compressed mode. The channel bit and symbol rates given in table 2 are the rates immediately before spreading.

**Table 2: DPCCH fields**

Slot Format #i	Channel Bit Rate (kbps)	Channel Symbol Rate (ksps)	SF	Bits/Frame	Bits/Slot	N <sub>pilot</sub>	N <sub>TPC</sub>	N <sub>TFCI</sub>	N <sub>FBI</sub>	Transmitted slots per radio frame
0	15	15	256	150	10	6	2	2	0	15
0A	15	15	256	150	10	5	2	3	0	10-14
0B	15	15	256	150	10	4	2	4	0	8-9
1	15	15	256	150	10	8	2	0	0	8-15
2	15	15	256	150	10	5	2	2	1	15
2A	15	15	256	150	10	4	2	3	1	10-14
2B	15	15	256	150	10	3	2	4	1	8-9
3	15	15	256	150	10	7	2	0	1	8-15
4	15	15	256	150	10	6	2	0	2	8-15
5	15	15	256	150	10	5	1	2	2	15
5A	15	15	256	150	10	4	1	3	2	10-14
5B	15	15	256	150	10	3	1	4	2	8-9

The pilot bit pattern is described in table 3 and table 4. The shadowed part can be used as frame synchronization words. (The value of the pilot bit other than the frame synchronization word shall be "1".)

**Table 3: Pilot bit patterns for uplink DPCCH with N<sub>pilot</sub> = 3, 4, 5 and 6**

Bit #	N <sub>pilot</sub> = 3			N <sub>pilot</sub> = 4				N <sub>pilot</sub> = 5					N <sub>pilot</sub> = 6					
	0	1	2	0	1	2	3	0	1	2	3	4	0	1	2	3	4	5
Slot #0	1	1	1	1	1	1	1	1	1	1	1	0	1	1	1	1	1	0
1	0	0	1	1	0	0	1	0	0	1	1	0	1	0	0	1	1	0
2	0	1	1	1	0	1	1	0	1	1	0	1	1	0	1	1	0	1
3	0	0	1	1	0	0	1	0	0	1	0	0	1	0	0	1	0	0
4	1	0	1	1	1	0	1	1	0	1	0	1	1	1	0	1	0	1
5	1	1	1	1	1	1	1	1	1	1	1	0	1	1	1	1	1	0
6	1	1	1	1	1	1	1	1	1	1	0	0	1	1	1	1	0	0
7	1	0	1	1	1	0	1	1	0	1	0	0	1	1	0	1	0	0
8	0	1	1	1	0	1	1	0	1	1	1	0	1	0	1	1	1	0
9	1	1	1	1	1	1	1	1	1	1	1	1	1	1	1	1	1	1
10	0	1	1	1	0	1	1	0	1	1	0	1	1	0	1	1	0	1
11	1	0	1	1	1	0	1	1	0	1	1	1	1	1	0	1	1	1
12	1	0	1	1	1	0	1	1	0	1	0	0	1	1	0	1	0	0
13	0	0	1	1	0	0	1	0	0	1	1	1	1	0	0	1	1	1
14	0	0	1	1	0	0	1	0	0	1	1	1	1	0	0	1	1	1

**Table 4: Pilot bit patterns for uplink DPCCH with  $N_{\text{pilot}} = 7$  and 8**

Bit #	$N_{\text{pilot}} = 7$							$N_{\text{pilot}} = 8$							
	0	1	2	3	4	5	6	0	1	2	3	4	5	6	7
Slot #0	1	1	1	1	1	0	1	1	1	1	1	1	1	1	0
1	1	0	0	1	1	0	1	1	0	1	0	1	1	1	0
2	1	0	1	1	0	1	1	1	0	1	1	1	0	1	1
3	1	0	0	1	0	0	1	1	0	1	0	1	0	1	0
4	1	1	0	1	0	1	1	1	1	1	0	1	0	1	1
5	1	1	1	1	1	0	1	1	1	1	1	1	1	1	0
6	1	1	1	1	0	0	1	1	1	1	1	1	0	1	0
7	1	1	0	1	0	0	1	1	1	1	0	1	0	1	0
8	1	0	1	1	1	0	1	1	0	1	1	1	1	1	0
9	1	1	1	1	1	1	1	1	1	1	1	1	1	1	1
10	1	0	1	1	0	1	1	1	0	1	1	1	0	1	1
11	1	1	0	1	1	1	1	1	1	1	0	1	1	1	1
12	1	1	0	1	0	0	1	1	1	1	0	1	0	1	0
13	1	0	0	1	1	1	1	1	0	1	0	1	1	1	1
14	1	0	0	1	1	1	1	1	0	1	0	1	1	1	1

The relationship between the TPC bit pattern and transmitter power control command is presented in table 5.

**Table 5: TPC Bit Pattern**

TPC Bit Pattern		Transmitter power control command
$N_{\text{TPC}} = 1$	$N_{\text{TPC}} = 2$	
1	11	1
0	00	0

For slot formats using TFCI, the TFCI value in each radio frame corresponds to a certain combination of bit rates of the DCHs currently in use. This correspondence is (re-)negotiated at each DCH addition/removal. The mapping of the TFCI bits onto slots is described in [3].

Multi-code operation is possible for the uplink dedicated physical channels. When multi-code transmission is used, several parallel DPDCH are transmitted using different channelization codes, see [4]. However, there is only one DPCCH per connection.

## 5.2.2 Common uplink physical channels

### 5.2.2.1 Physical Random Access Channel (PRACH)

The Physical Random Access Channel (PRACH) is used to carry the RACH.

#### 5.2.2.1.1 RACH transmission

The random-access transmission is based on a Slotted ALOHA approach with fast acquisition indication. The UE can start the transmission at a number of well-defined time-offsets, denoted *access slots*. There are 15 access slots per two frames and they are spaced 5120 chips apart. Timing information on the access slots and the acquisition indication is given in section 7.3. Figure 3 shows the access slot numbers and their spacing to each other. Information on what access slots are available in the current cell is given by higher layers.

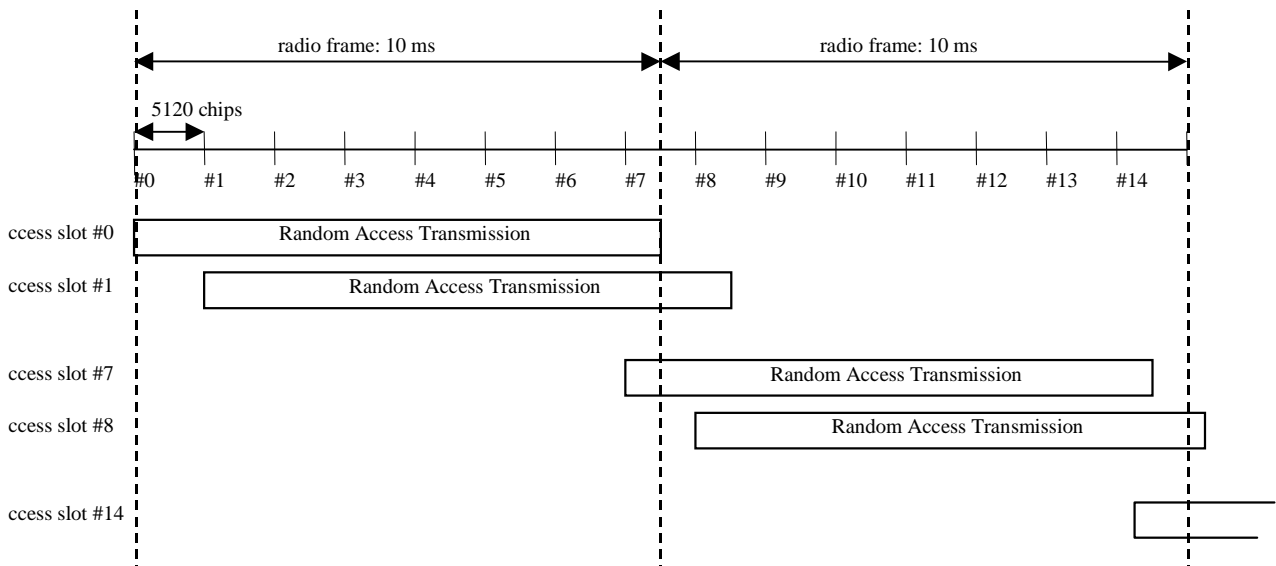

**Figure 3: RACH access slot numbers and their spacing**

The structure of the random-access transmission is shown in figure 4. The random-access transmission consists of one or several *preambles* of length 4096 chips and a *message* of length 10 or 20 ms. The UE indicates the length of the message part to the network by using specific signatures and/or access slots. The assignment, which signatures and/or access slots are used for which message length, is performed by higher layers.

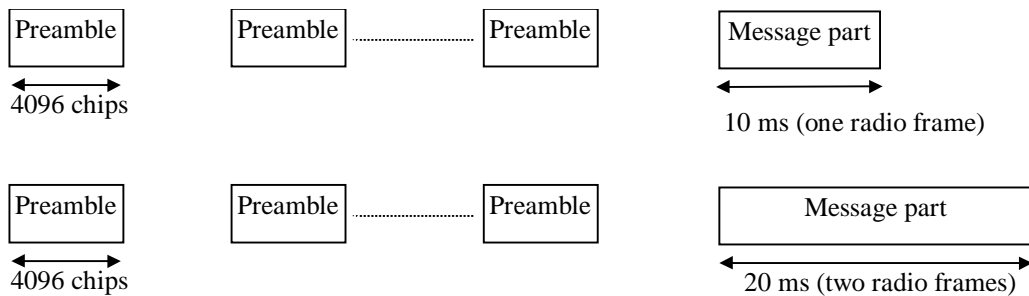

**Figure 4: Structure of the random-access transmission**

**5.2.2.1.2 RACH preamble part**

The preamble part of the random-access burst consists of 256 repetitions of a signature. There are a total of 16 different signatures, based on the Hadamard code set of length 16 (see [4] for more details).

**5.2.2.1.3 RACH message part**

Figure 5 shows the structure of the Random-access message part radio frame. The 10 ms message part radio frame is split into 15 slots, each of length  $T_{slot} = 2560$  chips. Each slot consists of two parts, a data part that carries Layer 2 information and a control part that carries Layer 1 control information. The data and control parts are transmitted in parallel. A 20 ms long message part consists of two consecutive message part radio frames.

The data part consists of  $10 \cdot 2^k$  bits, where  $k=0,1,2,3$ . This corresponds to a spreading factor of 256, 128, 64, and 32 respectively for the message data part.

The control part consists of 8 known pilot bits to support channel estimation for coherent detection and 2 TFCI bits. This corresponds to a spreading factor of 256 for the message control part. The pilot bit pattern is described in table 8. The total number of TFCI bits in the random-access message is  $15 \cdot 2 = 30$ . The TFCI value corresponds to a certain transport format of the current Random-access message.

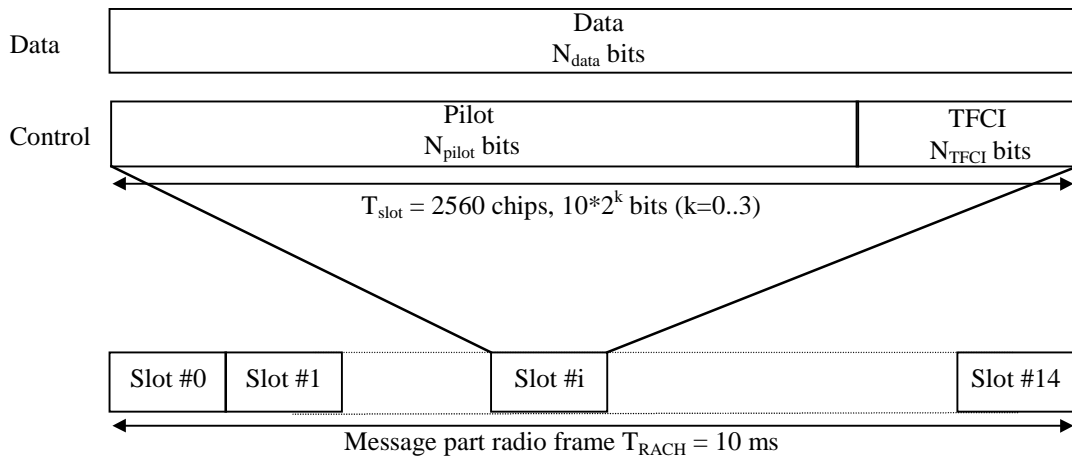

Figure 5: Structure of the random-access message part radio frame

Table 6: Random-access message data fields

Slot Format #i	Channel Bit Rate (kbps)	Channel Symbol Rate (ksps)	SF	Bits/ Frame	Bits/ Slot	$N_{data}$
0	15	15	256	150	10	10
1	30	30	128	300	20	20
2	60	60	64	600	40	40
3	120	120	32	1200	80	80

Table 7: Random-access message control fields

Slot Format #i	Channel Bit Rate (kbps)	Channel Symbol Rate (ksps)	SF	Bits/ Frame	Bits/ Slot	$N_{pilot}$	$N_{TFCI}$
0	15	15	256	150	10	8	2

Table 8: Pilot bit patterns for RACH message part with  $N_{pilot} = 8$

Bit #	$N_{pilot} = 8$							
	0	1	2	3	4	5	6	7
Slot #0	1	1	1	1	1	1	1	0
1	1	0	1	0	1	1	1	0
2	1	0	1	1	1	0	1	1
3	1	0	1	0	1	0	1	0
4	1	1	1	0	1	0	1	1
5	1	1	1	1	1	1	1	0
6	1	1	1	1	1	0	1	0
7	1	1	1	0	1	0	1	0
8	1	0	1	1	1	1	1	0
9	1	1	1	1	1	1	1	1
10	1	0	1	1	1	0	1	1
11	1	1	1	0	1	1	1	1
12	1	1	1	0	1	0	1	0
13	1	0	1	0	1	1	1	1
14	1	0	1	0	1	1	1	1

### 5.2.2.2 Physical Common Packet Channel (PCPCH)

The Physical Common Packet Channel (PCPCH) is used to carry the CPCH.

5.2.2.2.1 CPCH transmission

The CPCH transmission is based on DSMA-CD approach with fast acquisition indication. The UE can start transmission at a number of well-defined time-offsets, relative to the frame boundary of the received BCH of the current cell. The access slot timing and structure is identical to RACH in section 5.2.2.1.1. The structure of the CPCH random access transmission is shown in figure 6. The CPCH random access transmission consists of one or several Access Preambles [A-P] of length 4096 chips, one Collision Detection Preamble (CD-P) of length 4096 chips, a DPCCCH Power Control Preamble (PC-P) which is either 0 slots or 8 slots in length, and a message of variable length  $N \times 10$  ms.

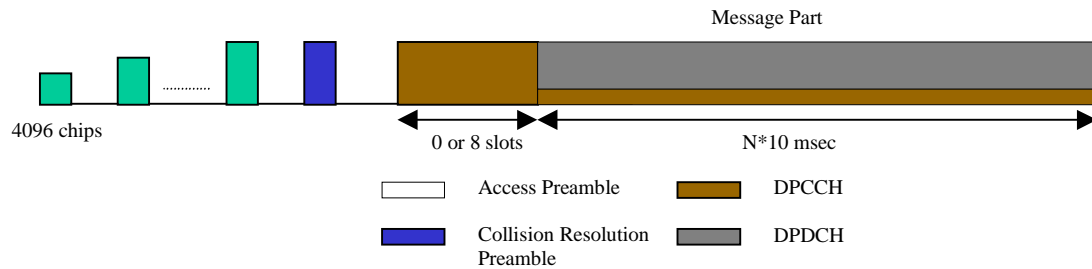

Figure 6: Structure of the CPCH random access transmission

5.2.2.2.2 CPCH access preamble part

Similar to 5.2.2.1.2 (RACH preamble part). The RACH preamble signature sequences are used. The number of sequences used could be less than the ones used in the RACH preamble. The scrambling code could either be chosen to be a different code segment of the Gold code used to form the scrambling code of the RACH preambles (see [4] for more details) or could be the same scrambling code in case the signature set is shared.

5.2.2.2.3 CPCH collision detection preamble part

Similar to 5.2.2.1.2 (RACH preamble part). The RACH preamble signature sequences are used. The scrambling code is chosen to be a different code segment of the Gold code used to form the scrambling code for the RACH and CPCH preambles (see [4] for more details).

5.2.2.2.4 CPCH power control preamble part

The power control preamble segment is a DPCCCH Power Control Preamble (PC-P). The following table 9 is identical to Rows 2 and 4 of table 2 in section 5.2.1. Table 9 defines the DPCCCH fields which only include Pilot, FBI and TPC bits. The Power Control Preamble length is a parameter which shall take the values 0 or 8 slots, as set by the higher layers.

Table 9: DPCCCH fields for CPCH power control preamble segment

Slot Format #i	Channel Bit Rate (kbps)	Channel Symbol Rate (ksps)	SF	Bits/ Frame	Bits/ Slot	$N_{pilot}$	$N_{TFCI}$	$N_{FBI}$	$N_{TPC}$
0	15	15	256	150	10	8	0	0	2
1	15	15	256	150	10	7	0	1	2

5.2.2.2.5 CPCH message part

Figure 1 in section 5.2.1 shows the structure of the CPCH message part. Each message consists of up to  $N_{Max\_frames}$  10 ms frames.  $N_{Max\_frames}$  is a higher layer parameter. Each 10 ms frame is split into 15 slots, each of length  $T_{slot} = 2560$  chips. Each slot consists of two parts, a data part that carries higher layer information and a control part that carries Layer 1 control information. The data and control parts are transmitted in parallel.

The data part consists of  $10 \times 2^k$  bits, where  $k = 0, 1, 2, 3, 4, 5, 6$ , corresponding to spreading factors of 256, 128, 64, 32, 16, 8, 4 respectively. Note that various rates might be mapped to different signature sequences.

The spreading factor for the UL-DPCCH (message control part) is 256. The entries in table 1 corresponding to spreading factors of 256 and below and table 2 [both in section 5.2.1] apply to the DPDCH and DPCCH fields respectively for the CPCH message part.

### 5.3 Downlink physical channels

#### 5.3.1 Downlink Transmit Diversity

Table 10 summarizes the possible application of open and closed loop Transmit diversity modes on different downlink physical channels. Simultaneous use of STTD and closed loop modes on DPCH and PDSCH is not allowed.

**Table 10: Application of Tx diversity modes on downlink physical channels**  
 "X" – can be applied, "-" – not applied

Channel	Open loop mode		Closed loop Mode
	TSTD	STTD	
P-CCPCH	-	X	-
SCH	X	-	-
S-CCPCH	-	X	-
DPCH	-	X	X
PICH	-	X	-
PDSCH (associated with DPCH)	-	X	X
AICH	-	X	-

#### 5.3.1.1 Open loop transmit diversity

##### 5.3.1.1.1 Space time block coding based transmit antenna diversity (STTD)

The open loop downlink transmit diversity employs a space time block coding based transmit diversity (STTD). The STTD encoding is optional in UTRAN. STTD support is mandatory at the UE. A block diagram of a generic STTD encoder for channel bits  $b_0, b_1, b_2, b_3$  is shown in the figure 7 below. Channel coding, rate matching and interleaving is done as in the non-diversity mode. The bit  $b_i$  is real valued  $\{0\}$  for DTX bits and  $\{1, -1\}$  for all other channel bits.

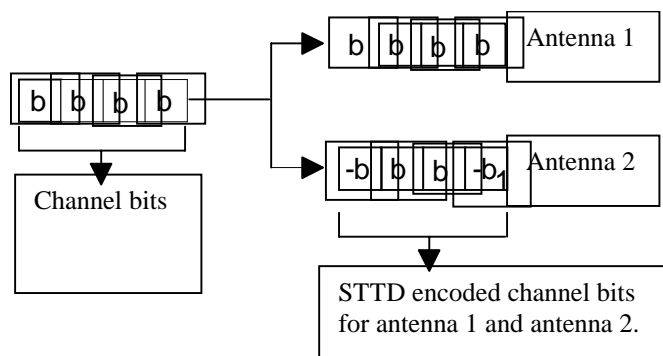

**Figure 7: Generic block diagram of the STTD encoder**

##### 5.3.1.1.2 Time Switched Transmit Diversity for SCH (TSTD)

Transmit diversity, in the form of Time Switched Transmit Diversity (TSTD), can be applied to the SCH. TSTD for the SCH is optional in UTRAN, while TSTD support is mandatory in the UE. TSTD for the SCH is described in sub-clause 5.3.3.4.1.



### 5.3.2 Dedicated downlink physical channels

There is only one type of downlink dedicated physical channel, the Downlink Dedicated Physical Channel (downlink DPCH).

Within one downlink DPCH, dedicated data generated at Layer 2 and above, i.e. the dedicated transport channel (DCH), is transmitted in time-multiplex with control information generated at Layer 1 (known pilot bits, TPC commands, and an optional TFCI). The downlink DPCH can thus be seen as a time multiplex of a downlink DPDCH and a downlink DPCCH, compare section 5.2.1. It is the UTRAN that determines if a TFCI should be transmitted, hence making it mandatory for all UEs to support the use of TFCI in the downlink. In case of USTS, the TPC bits in slot #14 in frames with  $CFN \bmod 2 = 0$  are replaced by Time Alignment Bits (TABs) as described in section 9.3 of [5]

Figure 8 shows the frame structure of the downlink DPCH. Each frame of length 10 ms is split into 15 slots, each of length  $T_{\text{slot}} = 2560$  chips, corresponding to one power-control period.

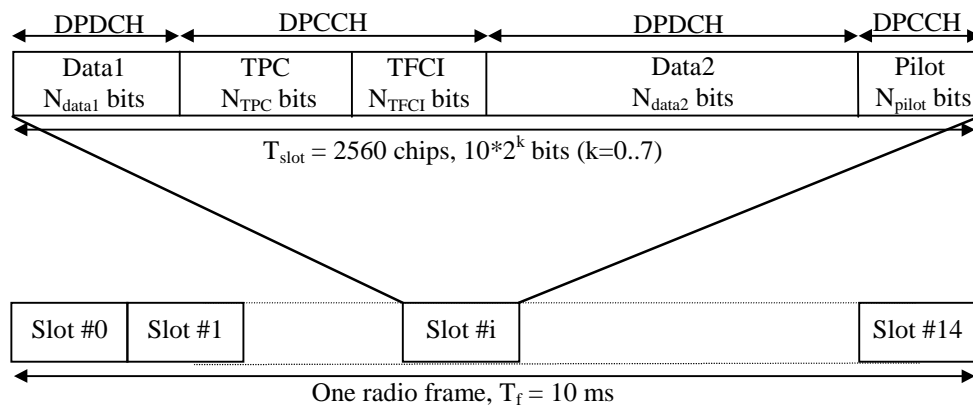

**Figure 8: Frame structure for downlink DPCH**

The parameter  $k$  in figure 8 determines the total number of bits per downlink DPCH slot. It is related to the spreading factor  $SF$  of the physical channel as  $SF = 512/2^k$ . The spreading factor may thus range from 512 down to 4.

The exact number of bits of the different downlink DPCH fields ( $N_{\text{pilot}}$ ,  $N_{\text{TPC}}$ ,  $N_{\text{TFCI}}$ ,  $N_{\text{data1}}$  and  $N_{\text{data2}}$ ) is determined in table 11. The overhead due to the DPCCH transmission has to be negotiated at the connection set-up and can be re-negotiated during the communication, in order to match particular propagation conditions.

There are basically two types of downlink Dedicated Physical Channels; those that include TFCI (e.g. for several simultaneous services) and those that do not include TFCI (e.g. for fixed-rate services). These types are reflected by the duplicated rows of table 11. In compressed mode, a different slot format is used compared to normal mode. There are two possible compressed slot formats that are labelled A and B. Format B is used for compressed mode by spreading factor reduction and format A is used for all other transmission time reduction methods. The channel bit and symbol rates given in table 11 are the rates immediately before spreading.

Table 11: DPDCH and DPCCH fields

Slot Format #i	Channel Bit Rate (kbps)	Channel Symbol Rate (ksps)	SF	Bits/Slot	DPDCH Bits/Slot		DPCCH Bits/Slot			Transmitted slots per radio frame $N_{Tr}$
					$N_{Data1}$	$N_{Data2}$	$N_{TPC}$	$N_{TFCI}$	$N_{Pilot}$	
0	15	7.5	512	10	0	4	2	0	4	15
0A	15	7.5	512	10	0	4	2	0	4	8-14
0B	30	15	256	20	0	8	4	0	8	8-14
1	15	7.5	512	10	0	2	2	2	4	15
1B	30	15	256	20	0	4	4	4	8	8-14
2	30	15	256	20	2	14	2	0	2	15
2A	30	15	256	20	2	14	2	0	2	8-14
2B	60	30	128	40	4	28	4	0	4	8-14
3	30	15	256	20	2	12	2	2	2	15
3A	30	15	256	20	2	10	2	4	2	8-14
3B	60	30	128	40	4	24	4	4	4	8-14
4	30	15	256	20	2	12	2	0	4	15
4A	30	15	256	20	2	12	2	0	4	8-14
4B	60	30	128	40	4	24	4	0	8	8-14
5	30	15	256	20	2	10	2	2	4	15
5A	30	15	256	20	2	8	2	4	4	8-14
5B	60	30	128	40	4	20	4	4	8	8-14
6	30	15	256	20	2	8	2	0	8	15
6A	30	15	256	20	2	8	2	0	8	8-14
6B	60	30	128	40	4	16	4	0	16	8-14
7	30	15	256	20	2	6	2	2	8	15
7A	30	15	256	20	2	4	2	4	8	8-14
7B	60	30	128	40	4	12	4	4	16	8-14
8	60	30	128	40	6	28	2	0	4	15
8A	60	30	128	40	6	28	2	0	4	8-14
8B	120	60	64	80	12	56	4	0	8	8-14
9	60	30	128	40	6	26	2	2	4	15
9A	60	30	128	40	6	24	2	4	4	8-14
9B	120	60	64	40	12	52	4	4	8	8-14
10	60	30	128	40	6	24	2	0	8	15
10A	60	30	128	40	6	24	2	0	8	8-14
10B	120	60	64	80	12	48	4	0	16	8-14
11	60	30	128	40	6	22	2	2	8	15
11A	60	30	128	40	6	20	2	4	8	8-14
11B	120	60	64	80	12	44	4	4	16	8-14
12	120	60	64	80	12	48	4	8*	8	15
12A	120	60	64	80	12	40	4	16*	8	8-14
12B	240	120	32	160	24	96	8	16*	16	8-14
13	240	120	32	160	28	112	4	8*	8	15
13A	240	120	32	160	28	104	4	16*	8	8-14
13B	480	240	16	320	56	224	8	16*	16	8-14
14	480	240	16	320	56	232	8	8*	16	15
14A	480	240	16	320	56	224	8	16*	16	8-14
14B	960	480	8	640	112	464	16	16*	32	8-14
15	960	480	8	640	120	488	8	8*	16	15
15A	960	480	8	640	120	480	8	16*	16	8-14
15B	1920	960	4	1280	240	976	16	16*	32	8-14
16	1920	960	4	1280	248	1000	8	8*	16	15
16A	1920	960	4	1280	248	992	8	16*	16	8-14

\* If TFCI bits are not used, then DTX shall be used in TFCI field.

NOTE1: Compressed mode is only supported through spreading factor reduction for SF=512 with TFCI.

NOTE2: Compressed mode by spreading factor reduction is not supported for SF=4.

The pilot symbol pattern is described in table 12. The shadowed part can be used as frame synchronization words. (The symbol pattern of the pilot symbols other than the frame synchronization word shall be "11".) In table 12, the transmission order is from left to right. (Each two-bit pair represents an I/Q pair of QPSK modulation.)

In downlink compressed mode through spreading factor reduction, the number of bits in the TPC and Pilot fields are doubled. Symbol repetition is used to fill up the fields. Denote the bits in one of these fields in normal mode by  $x_1, x_2, x_3, \dots, x_X$ . In compressed mode the following bit sequence is sent in corresponding field:  $x_1, x_2, x_1, x_2, x_3, x_4, x_3, x_4, \dots, x_X$ .

**Table 12: Pilot Symbol Pattern**

Symbol #	Npilot = 2	Npilot = 4		Npilot = 8				Npilot = 16							
	0	0	1	0	1	2	3	0	1	2	3	4	5	6	7
Slot #0	11	11	11	11	11	11	10	11	11	11	10	11	11	11	10
1	00	11	00	11	00	11	10	11	00	11	10	11	11	11	00
2	01	11	01	11	01	11	01	11	01	11	01	11	10	11	00
3	00	11	00	11	00	11	00	11	00	11	00	11	01	11	10
4	10	11	10	11	10	11	01	11	10	11	01	11	11	11	11
5	11	11	11	11	11	11	10	11	11	11	10	11	01	11	01
6	11	11	11	11	11	11	00	11	11	11	00	11	10	11	11
7	10	11	10	11	10	11	00	11	10	11	00	11	10	11	00
8	01	11	01	11	01	11	10	11	01	11	10	11	00	11	11
9	11	11	11	11	11	11	11	11	11	11	11	11	00	11	11
10	01	11	01	11	01	11	01	11	01	11	01	11	11	11	10
11	10	11	10	11	10	11	11	11	10	11	11	11	00	11	10
12	10	11	10	11	10	11	00	11	10	11	00	11	01	11	01
13	00	11	00	11	00	11	11	11	00	11	11	11	00	11	00
14	00	11	00	11	00	11	11	11	00	11	11	11	10	11	01

The relationship between the TPC symbol and the transmitter power control command is presented in table 13.

**Table 13: TPC Bit Pattern**

TPC Bit Pattern			Transmitter power control command
N <sub>TPC</sub> = 2	N <sub>TPC</sub> = 4	N <sub>TPC</sub> = 8	
11	1111	11111111	1
00	0000	00000000	0

For slot formats using TFCI, the TFCI value in each radio frame corresponds to a certain combination of bit rates of the DCHs currently in use. This correspondence is (re-)negotiated at each DCH addition/removal. The mapping of the TFCI bits onto slots is described in [3].

When the total bit rate to be transmitted on one downlink CCTrCH exceeds the maximum bit rate for a downlink physical channel, multicode transmission is employed, i.e. several parallel downlink DPCHs are transmitted for one CCTrCH using the same spreading factor. In this case, the Layer 1 control information is put on only the first downlink DPCH. The additional downlink DPCHs belonging to the CCTrCH do not transmit any data during the corresponding time period, see figure 9.

In the case of several CCTrCHs of dedicated type for one UE different spreading factors can be used for each CCTrCH and only one DPCH would be transmitted for them in the downlink.

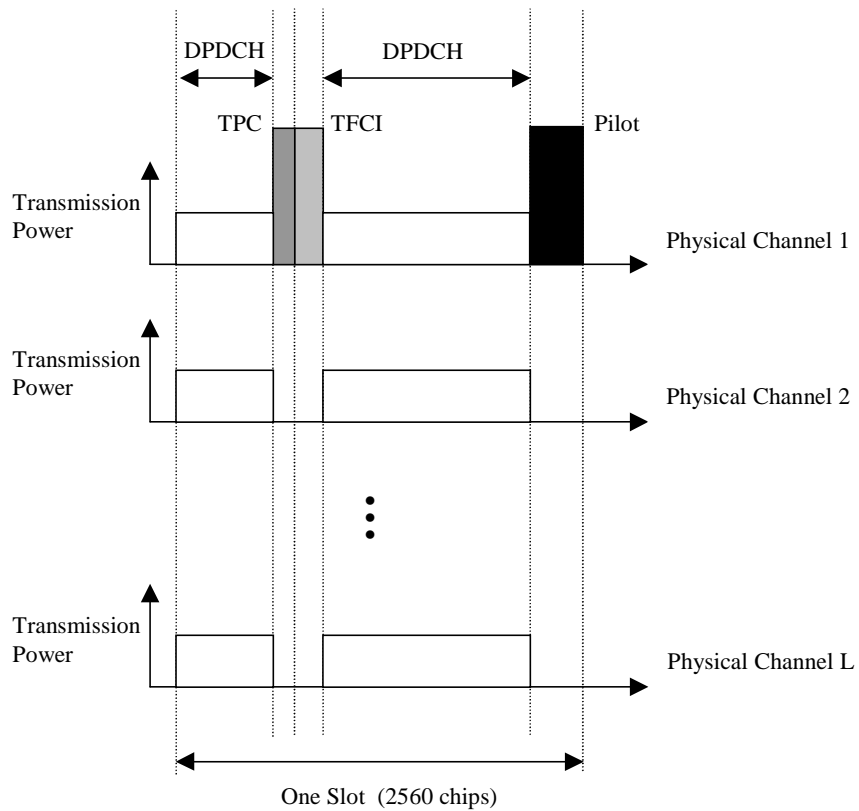

**Figure 9: Downlink slot format in case of multi-code transmission**

**5.3.2.1 STTD for DPCH**

The pilot bit pattern for the DPCH channel transmitted on the diversity antenna is given in table 14. The shadowed part indicates pilot bits that are STTD encoded from the corresponding (shadowed) bits in Table 12. For the SF=256 DPCH, if there are only two dedicated pilot bits ( $N_{pilot} = 2$  in Tables 12 and 14), they are STTD encoded together with the last two bits (data or DTX) of the second data field (data2) of the slot. STTD encoding for the DPDCH, TPC, and TFCI fields is done as described in section 5.3.1.1.1. For the SF=512 DPCH, the first two bits in each slot, i.e. TPC bits, are not STTD encoded and the same bits are transmitted with equal power from the two antennas. The following four bits are STTD encoded.

**Table 14: Pilot pattern of the DPCH channel for the diversity antenna using STTD**

Symbol #	N <sub>pilot</sub> = 2	N <sub>pilot</sub> = 4		N <sub>pilot</sub> = 8				N <sub>pilot</sub> = 16							
	0	0	1	0	1	2	3	0	1	2	3	4	5	6	7
Slot #0	01	01	10	11	00	00	10	11	00	00	10	11	00	00	10
1	10	10	10	11	00	00	01	11	00	00	01	11	10	00	10
2	11	11	10	11	11	00	00	11	11	00	00	11	10	00	11
3	10	10	10	11	10	00	01	11	10	00	01	11	00	00	00
4	00	00	10	11	11	00	11	11	11	00	11	11	01	00	10
5	01	01	10	11	00	00	10	11	00	00	10	11	11	00	00
6	01	01	10	11	10	00	10	11	10	00	10	11	01	00	11
7	00	00	10	11	10	00	11	11	10	00	11	11	10	00	11
8	11	11	10	11	00	00	00	11	00	00	00	11	01	00	01
9	01	01	10	11	01	00	10	11	01	00	10	11	01	00	01
10	11	11	10	11	11	00	00	11	11	00	00	11	00	00	10
11	00	00	10	11	01	00	11	11	01	00	11	11	00	00	01
12	00	00	10	11	10	00	11	11	10	00	11	11	11	00	00
13	10	10	10	11	01	00	01	11	01	00	01	11	10	00	01
14	10	10	10	11	01	00	01	11	01	00	01	11	11	00	11

**5.3.2.2 Dedicated channel pilots with closed loop mode transmit diversity**

In closed loop mode 1 orthogonal pilot patterns are used between the transmit antennas. Pilot patterns defined in the table 12 will be used on the non-diversity antenna and pilot patterns defined in the table 14 on the diversity antenna. This is illustrated in the figure 10 a which indicates the difference in the pilot patterns with different shading.

In closed loop mode 2 same pilot pattern is used on both of the antennas (see figure 10 b). The pattern to be used is according to the table 12.

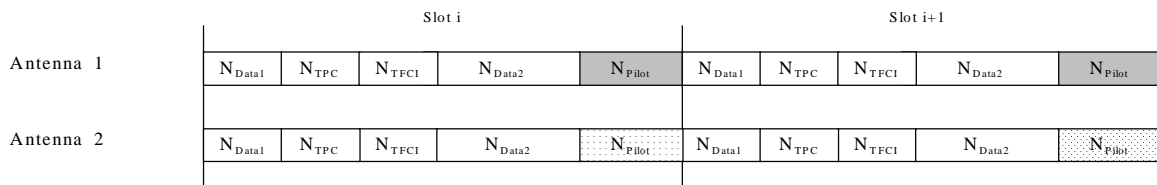

(a)

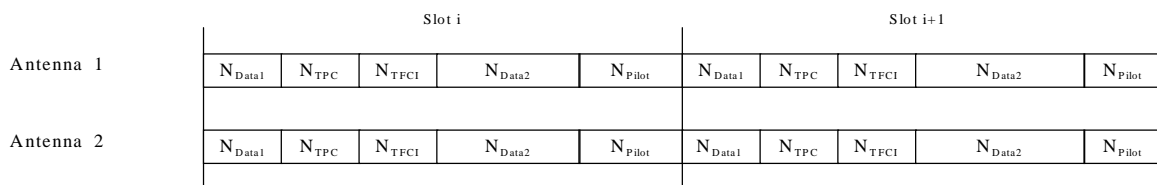

(b)

**Figure 10: Slot structures for downlink dedicated physical channel diversity transmission. Structure (a) is used in closed loop mode 1. Structure (b) is used in closed loop mode 2. Different shading of the pilots indicate orthogonality of the patterns**

**5.3.2.3 DL-DPCCH for CPCH**

The spreading factor for the UL-DPCCH (message control part) is 256. The spreading factor for the DL-DPCCH (message control part) is 512. The following table 15 shows the DL-DPCCH fields (message control part) which are identical to the first row of table 11 in section 5.3.2.

**Table 15: DPDCH and DPCCH fields for CPCH message transmission**

Slot Format #i	Channel Bit Rate (kbps)	Channel Symbol Rate (ksps)	SF	Bits/Frame			Bits/Slot	DPDCH Bits/Slot		DPCCH Bits/Slot		
				DPDCH	DPCCH	TOT		NData1	NData2	NTFCI	NTPC	NPilot
0	15	7.5	512	60	90	150	10	2	2	0	2	4

### 5.3.3 Common downlink physical channels

#### 5.3.3.1 Common Pilot Channel (CPICH)

The CPICH is a fixed rate (30 kbps, SF=256) downlink physical channel that carries a pre-defined bit/symbol sequence. Figure 11 shows the frame structure of the CPICH.

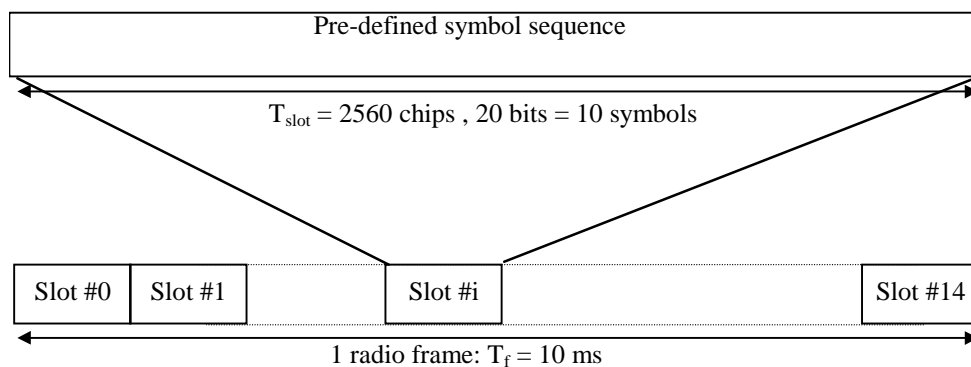

**Figure 11: Frame structure for Common Pilot Channel**

In case of Transmit Diversity (open or closed loop), the CPICH shall be transmitted from both antennas using the same channelization and scrambling code. In this case, the pre-defined symbol sequence of the CPICH is different for Antenna 1 and Antenna 2, see figure 12. In case of no Transmit Diversity, the symbol sequence of Antenna 1 in figure 12 is used.

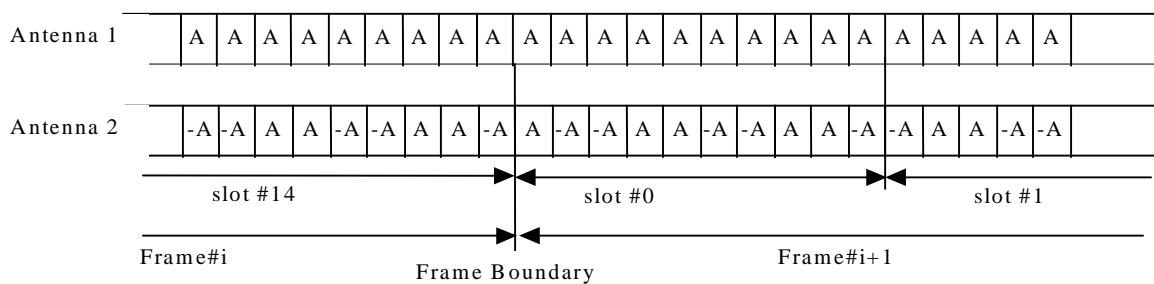

**Figure 12: Modulation pattern for Common Pilot Channel (with A = 1+j)**

There are two types of Common pilot channels, the Primary and Secondary CPICH. They differ in their use and the limitations placed on their physical features.

##### 5.3.3.1.1 Primary Common Pilot Channel

The Primary Common Pilot Channel has the following characteristics:

- The same channelization code is always used for this channel, see [4]
- Scrambled by the primary scrambling code, see [4]

- One per cell
- Broadcast over the entire cell

The Primary CPICH is the phase reference for the following downlink channels: SCH, Primary CCPCH, AICH, PICH. The Primary CPICH is also the *default* phase reference for all other downlink physical channels.

### 5.3.3.1.2 Secondary Common Pilot Channel

A Secondary Common Pilot Channel the following characteristics:

- Can use an arbitrary channelization code of  $SF=256$ , see [4]
- Scrambled by either the primary or a secondary scrambling code, see [4]
- Zero, one, or several per cell
- May be transmitted over only a part of the cell
- A Secondary CPICH may be the reference for the Secondary CCPCH and the downlink DPCH. If this is the case, the UE is informed about this by higher-layer signalling.

### 5.3.3.2 Primary Common Control Physical Channel (P-CCPCH)

The Primary CCPCH is a fixed rate (30 kbps,  $SF=256$ ) downlink physical channels used to carry the BCH.

Figure 13 shows the frame structure of the Primary CCPCH. The frame structure differs from the downlink DPCH in that no TPC commands, no TFCI and no pilot bits are transmitted. The Primary CCPCH is not transmitted during the first 256 chips of each slot. Instead, Primary SCH and Secondary SCH are transmitted during this period (see section 5.3.3.4).

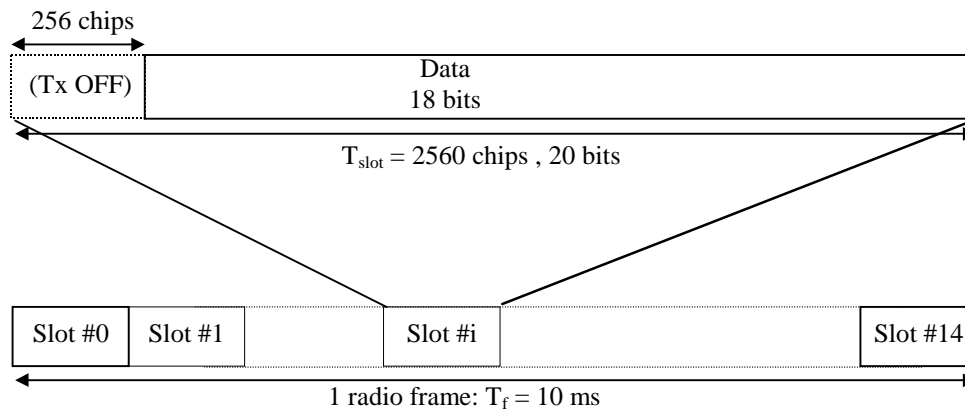

**Figure 13: Frame structure for Primary Common Control Physical Channel**

#### 5.3.3.2.1 Primary CCPCH structure with STTD encoding

In case the diversity antenna is present in UTRAN and the P-CCPCH is to be transmitted using open loop transmit diversity, the data bits of the P-CCPCH are STTD encoded as given in section 5.3.1.1.1. The last two data bits in even numbered slots are STTD encoded together with the first two data bits in the following slot, except for slot #14 where the two last data bits are not STTD encoded and instead transmitted with equal power from both the antennas, see figure 14. Higher layers signal whether STTD encoding is used for the P-CCPCH or not. In addition, higher layer signalling indicates the presence/absence of STTD encoding on P-CCPCH, by modulating the SCH. During power on and hand over between cells the UE determines the presence of STTD encoding on the P-CCPCH, by either receiving the higher layer message, by demodulating the SCH channel or by a combination of the above two schemes.

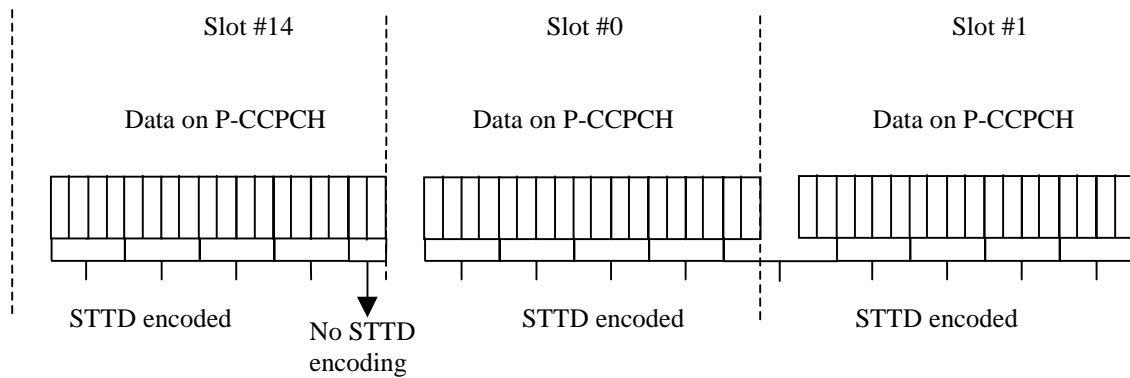

Figure 14: STTD encoding for the data bits of the P-CCPCH

### 5.3.3.3 Secondary Common Control Physical Channel (S-CCPCH)

The Secondary CCPCH is used to carry the FACH and PCH. There are two types of Secondary CCPCH: those that include TFCI and those that do not include TFCI. It is the UTRAN that determines if a TFCI should be transmitted, hence making it mandatory for all UEs to support the use of TFCI. The set of possible rates is the same as for the downlink DPCH, see section 5.3.2. The frame structure of the Secondary CCPCH is shown in figure 15.

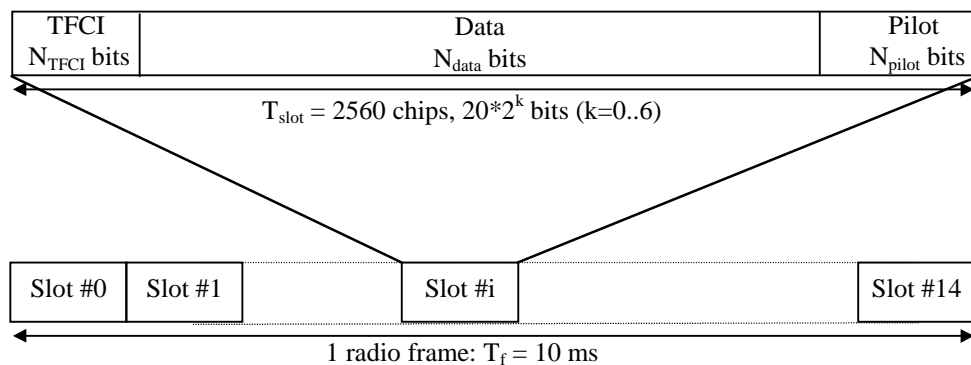

Figure 15: Frame structure for Secondary Common Control Physical Channel

The parameter  $k$  in figure 15 determines the total number of bits per downlink Secondary CCPCH slot. It is related to the spreading factor  $SF$  of the physical channel as  $SF = 256/2^k$ . The spreading factor range is from 256 down to 4.

The values for the number of bits per field are given in table 16. The channel bit and symbol rates given in table 16 are the rates immediately before spreading. The pilot patterns are given in table 17.

The FACH and PCH can be mapped to the same or to separate Secondary CCPCHs. If FACH and PCH are mapped to the same Secondary CCPCH, they can be mapped to the same frame. The main difference between a CCPCH and a downlink dedicated physical channel is that a CCPCH is not inner-loop power controlled. The main difference between the Primary and Secondary CCPCH is that the Primary CCPCH has a fixed predefined rate while the Secondary CCPCH can support variable rate with the help of the TFCI field included. Furthermore, a Primary CCPCH is continuously transmitted over the entire cell while a Secondary CCPCH is only transmitted when there is data available and may be transmitted in a narrow lobe in the same way as a dedicated physical channel (only valid for a Secondary CCPCH carrying the FACH).



Table 16: Secondary CCPCH fields

Slot Format #i	Channel Bit Rate (kbps)	Channel Symbol Rate (ksps)	SF	Bits/ Frame	Bits/ Slot	N <sub>data</sub>	N <sub>pilot</sub>	N <sub>TFCI</sub>
0	30	15	256	300	20	20	0	0
1	30	15	256	300	20	12	8	0
2	30	15	256	300	20	18	0	2
3	30	15	256	300	20	10	8	2
4	60	30	128	600	40	40	0	0
5	60	30	128	600	40	32	8	0
6	60	30	128	600	40	38	0	2
7	60	30	128	600	40	30	8	2
8	120	60	64	1200	80	72	0	8*
9	120	60	64	1200	80	64	8	8*
10	240	120	32	2400	160	152	0	8*
11	240	120	32	2400	160	144	8	8*
12	480	240	16	4800	320	312	0	8*
13	480	240	16	4800	320	296	16	8*
14	960	480	8	9600	640	632	0	8*
15	960	480	8	9600	640	616	16	8*
16	1920	960	4	19200	1280	1272	0	8*
17	1920	960	4	19200	1280	1256	16	8*

\* If TFCI bits are not used, then DTX shall be used in TFCI field.

The pilot symbol pattern is described in table 17. The shadowed part can be used as frame synchronization words. (The symbol pattern of pilot symbols other than the frame synchronization word shall be "11"). In table 17, the transmission order is from left to right. (Each two-bit pair represents an I/Q pair of QPSK modulation.)

Table 17: Pilot Symbol Pattern

Symbol #	N <sub>pilot</sub> = 8				N <sub>pilot</sub> = 16							
	0	1	2	3	0	1	2	3	4	5	6	7
Slot #0	11	11	11	10	11	11	11	10	11	11	11	10
1	11	00	11	10	11	00	11	10	11	11	11	00
2	11	01	11	01	11	01	11	01	11	10	11	00
3	11	00	11	00	11	00	11	00	11	01	11	10
4	11	10	11	01	11	10	11	01	11	11	11	11
5	11	11	11	10	11	11	11	10	11	01	11	01
6	11	11	11	00	11	11	11	00	11	10	11	11
7	11	10	11	00	11	10	11	00	11	10	11	00
8	11	01	11	10	11	01	11	10	11	00	11	11
9	11	11	11	11	11	11	11	11	11	00	11	11
10	11	01	11	01	11	01	11	01	11	11	11	10
11	11	10	11	11	11	10	11	11	11	00	11	10
12	11	10	11	00	11	10	11	00	11	01	11	01
13	11	00	11	11	11	00	11	11	11	00	11	00
14	11	00	11	11	11	00	11	11	11	10	11	01

For slot formats using TFCI, the TFCI value in each radio frame corresponds to a certain transport format combination of the FACHs and/or PCHs currently in use. This correspondence is (re-)negotiated at each FACH/PCH addition/removal. The mapping of the TFCI bits onto slots is described in [3].

#### 5.3.3.3.1 Secondary CCPCH structure with STTD encoding

In case the diversity antenna is present in UTRAN and the S-CCPCH is to be transmitted using open loop transmit diversity, the data symbols of the S-CCPCH are STTD encoded as given in Section 5.3.1.1.1. The diversity antenna pilot symbol pattern for the S-CCPCH is given in table 18 below.

**Table 18: Pilot symbol pattern for the diversity antenna when STTD encoding is used on the S-CCPCH**

Symbol #	N <sub>pilot</sub> = 8				N <sub>pilot</sub> = 16							
	0	1	2	3	0	1	2	3	4	5	6	7
Slot #0	11	00	00	10	11	00	00	10	11	00	00	10
1	11	00	00	01	11	00	00	01	11	10	00	10
2	11	11	00	00	11	11	00	00	11	10	00	11
3	11	10	00	01	11	10	00	01	11	00	00	00
4	11	11	00	11	11	11	00	11	11	01	00	10
5	11	00	00	10	11	00	00	10	11	11	00	00
6	11	10	00	10	11	10	00	10	11	01	00	11
7	11	10	00	11	11	10	00	11	11	10	00	11
8	11	00	00	00	11	00	00	00	11	01	00	01
9	11	01	00	10	11	01	00	10	11	01	00	01
10	11	11	00	00	11	11	00	00	11	00	00	10
11	11	01	00	11	11	01	00	11	11	00	00	01
12	11	10	00	11	11	10	00	11	11	11	00	00
13	11	01	00	01	11	01	00	01	11	10	00	01
14	11	01	00	01	11	01	00	01	11	11	00	11

**5.3.3.4 Synchronisation Channel (SCH)**

The Synchronisation Channel (SCH) is a downlink signal used for cell search. The SCH consists of two sub channels, the Primary and Secondary SCH. The 10 ms radio frames of the Primary and Secondary SCH are divided into 15 slots, each of length 2560 chips. Figure 16 illustrates the structure of the SCH radio frame.

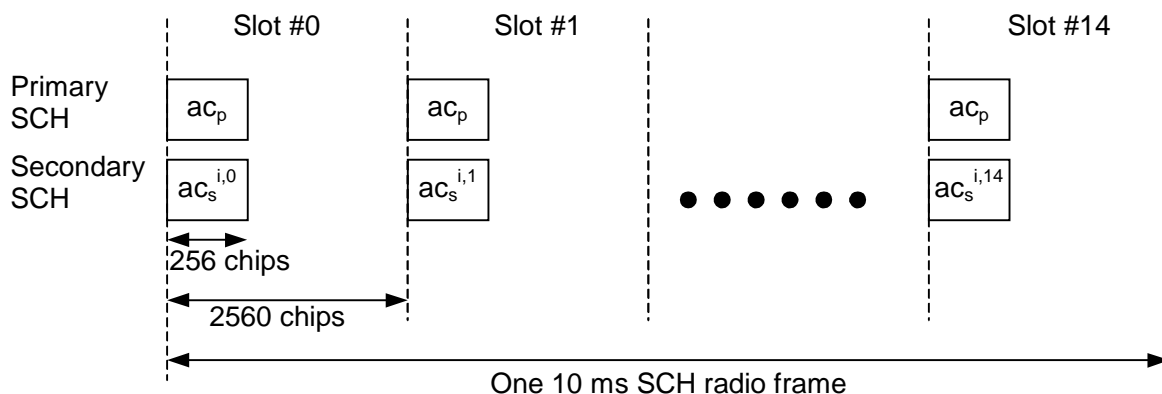

**Figure 16: Structure of Synchronisation Channel (SCH)**

The Primary SCH consists of a modulated code of length 256 chips, the Primary Synchronisation Code (PSC) denoted  $c_p$  in figure 16, transmitted once every slot. The PSC is the same for every cell in the system.

The Secondary SCH consists of repeatedly transmitting a length 15 sequence of modulated codes of length 256 chips, the Secondary Synchronisation Codes (SSC), transmitted in parallel with the Primary SCH. The SSC is denoted  $c_s^{i,k}$  in figure 17, where  $i = 1, 2, \dots, 64$  is the number of the scrambling code group, and  $k = 0, 1, \dots, 14$  is the slot number. Each SSC is chosen from a set of 16 different codes of length 256. This sequence on the Secondary SCH indicates which of the code groups the cell's downlink scrambling code belongs to.

The primary and secondary synchronization codes are modulated by the symbol  $a$  shown in figure 17, which indicates the presence/ absence of STTD encoding on the P-CCPCH and is given by the following table:

P-CCPCH STTD encoded	$a = +1$
P-CCPCH not STTD encoded	$a = -1$

5.3.3.4.1 SCH transmitted by TSTD

Figure 17 illustrates the structure of the SCH transmitted by the TSTD scheme. In even numbered slots both PSC and SSC are transmitted on antenna 1, and in odd numbered slots both PSC and SSC are transmitted on antenna 2.

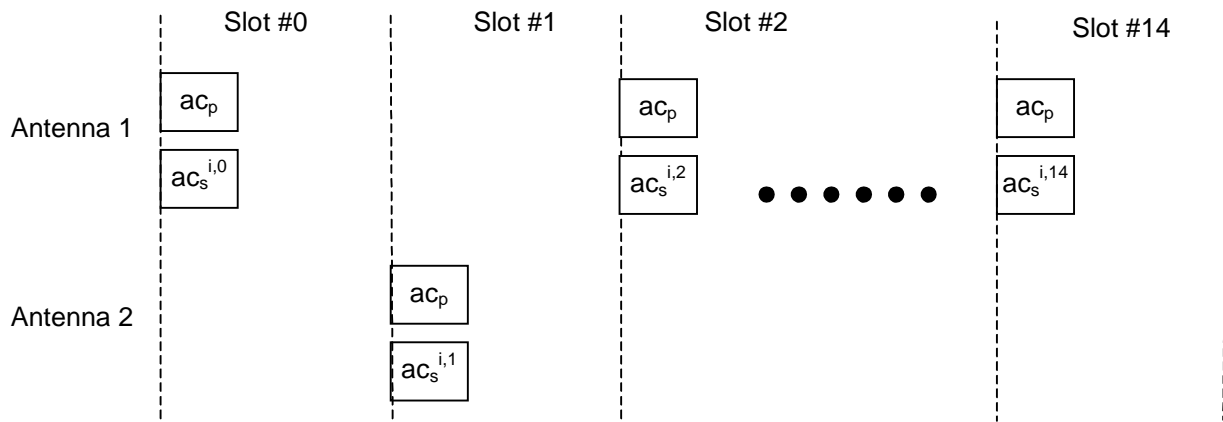

Figure 17: Structure of SCH transmitted by TSTD scheme

5.3.3.5 Physical Downlink Shared Channel (PDSCH)

The Physical Downlink Shared Channel (PDSCH), used to carry the Downlink Shared Channel (DSCH), is shared by users based on code multiplexing. As the DSCH is always associated with a DCH, the PDSCH is always associated with a downlink DPCH.

The frame and slot structure of the PDSCH are shown on figure 18.

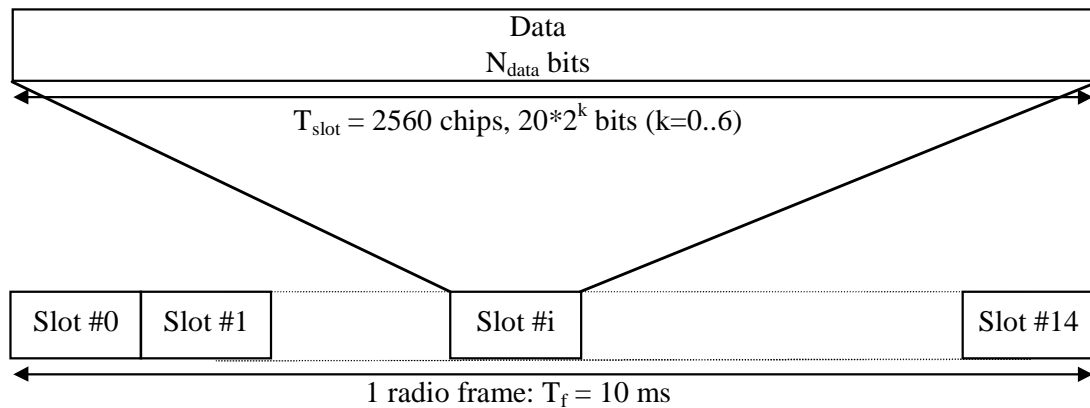

Figure 18: Frame structure for the PDSCH

To indicate for UE that there is data to decode on the DSCH, two signalling methods are possible, either using the TFCI field, or higher layer signalling.

The PDSCH transmission with associated DPCH is a special case of multicode transmission. The PDSCH and DPCH do not have necessary the same spreading factors and for PDSCH the spreading factor may vary from frame to frame. The relevant Layer 1 control information is transmitted on the DPCCCH part of the associated DPCH, the PDSCH does not contain physical layer information. The channel bit and symbol rates for PDSCH are given in table 19.

For PDSCH the allowed spreading factors may vary from 256 to 4.

If the spreading factor and other physical layer parameters can vary on a frame-by-frame basis, the TFCI shall be used to inform the UE what are the instantaneous parameters of PDSCH including the channelisation code from the PDSCH OVSF code tree.

A DSCH may be mapped to multiple parallel PDSCHs as well, as negotiated at higher layer prior to starting data transmission. In such a case the parallel PDSCHs shall be operated with frame synchronization between each other.

**Table 19: PDSCH fields**

Slot format #i	Channel Bit Rate (kbps)	Channel Symbol Rate (ksps)	SF	Bits/ Frame	Bits/ Slot	Ndata
0	30	15	256	300	20	20
1	60	30	128	600	40	40
2	120	60	64	1200	80	80
3	240	120	32	2400	160	160
4	480	240	16	4800	320	320
5	960	480	8	9600	640	640
6	1920	960	4	19200	1280	1280

When transmit diversity is employed for the PDSCH, STTD encoding is used on the data bits as described in section 5.3.1.1.1.

### 5.3.3.6 Acquisition Indicator Channel (AICH)

The Acquisition Indicator channel (AICH) is a physical channel used to carry Acquisition Indicators (AI). Acquisition Indicator  $AI_s$  corresponds to signature  $s$  on the PRACH or PCPCH. Note that for PCPCH, the AICH either corresponds to an access preamble or a CD preamble. The AICH corresponding to the access preamble is an AP-AICH and the AICH corresponding to the CD preamble is a CD-AICH. The AP-AICH and CD-AICH use different channelization codes, see further[4], Section 4.3.3.2.

Figure 19 illustrates the structure of the AICH. The AICH consists of a repeated sequence of 15 consecutive *access slots* (AS), each of length 40 bit intervals. Each access slot consists of two parts, an *Acquisition-Indicator* (AI) part consisting of 32 real-valued symbols  $a_0, \dots, a_{31}$  and an unused part consisting of 8 real-valued symbols  $a_{32}, \dots, a_{39}$ .

The phase reference for the AICH is the Primary CPICH.

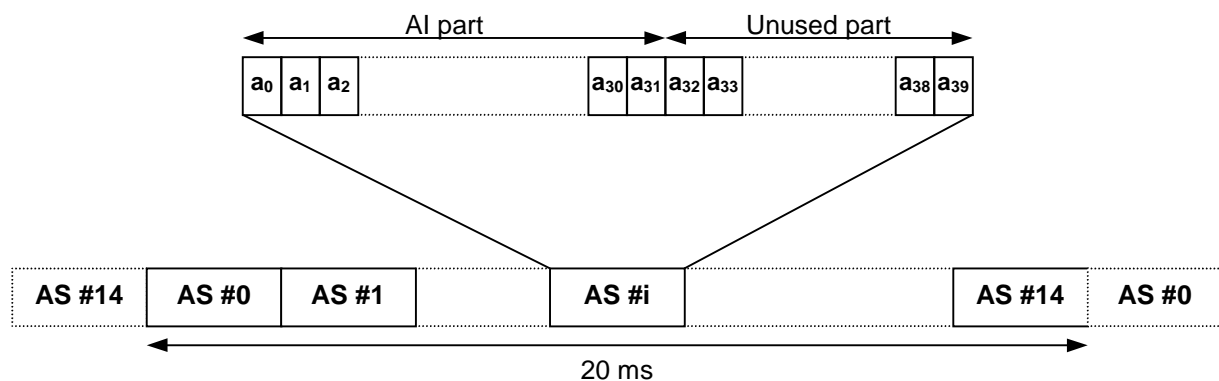

**Figure 19: Structure of Acquisition Indicator Channel (AICH)**

The real-valued symbols  $a_0, a_1, \dots, a_{31}$  in Figure 19 are given by

$$a_j = \sum_{s=0}^{15} AI_s b_{s,j}$$

where  $AI_s$ , taking the values +1, -1, and 0, is the acquisition indicator corresponding to signature  $s$  and the sequence  $b_{s,0}, \dots, b_{s,31}$  is given by Table 20.

The real-valued symbols  $a_{32}, a_{33}, \dots, a_{39}$  in Figure 19 are undefined.



**Table 21: Mapping of Page Indicators (PI) to PICH bits**

Number of PI per frame (N)	$PI_p = 1$	$PI_p = 0$
N=18	$\{b_{16p}, \dots, b_{16p+15}\} = \{1, 1, \dots, 1\}$	$\{b_{16p}, \dots, b_{16p+15}\} = \{0, 0, \dots, 0\}$
N=36	$\{b_{8p}, \dots, b_{8p+7}\} = \{1, 1, \dots, 1\}$	$\{b_{8p}, \dots, b_{8p+7}\} = \{0, 0, \dots, 0\}$
N=72	$\{b_{4p}, \dots, b_{4p+3}\} = \{1, 1, \dots, 1\}$	$\{b_{4p}, \dots, b_{4p+3}\} = \{0, 0, \dots, 0\}$
N=144	$\{b_{2p}, b_{2p+1}\} = \{1, 1\}$	$\{b_{2p}, b_{2p+1}\} = \{0, 0\}$

If a Paging Indicator in a certain frame is set to "1" it is an indication that UEs associated with this Page Indicator should read the corresponding frame of the associated S-CCPCH.

When transmit diversity is employed for the PICH, STTD encoding is used on the PICH bits as described in section 5.3.1.1.1.

## 6 Mapping of transport channels onto physical channels

Figure 21 summarises the mapping of transport channels onto physical channels.

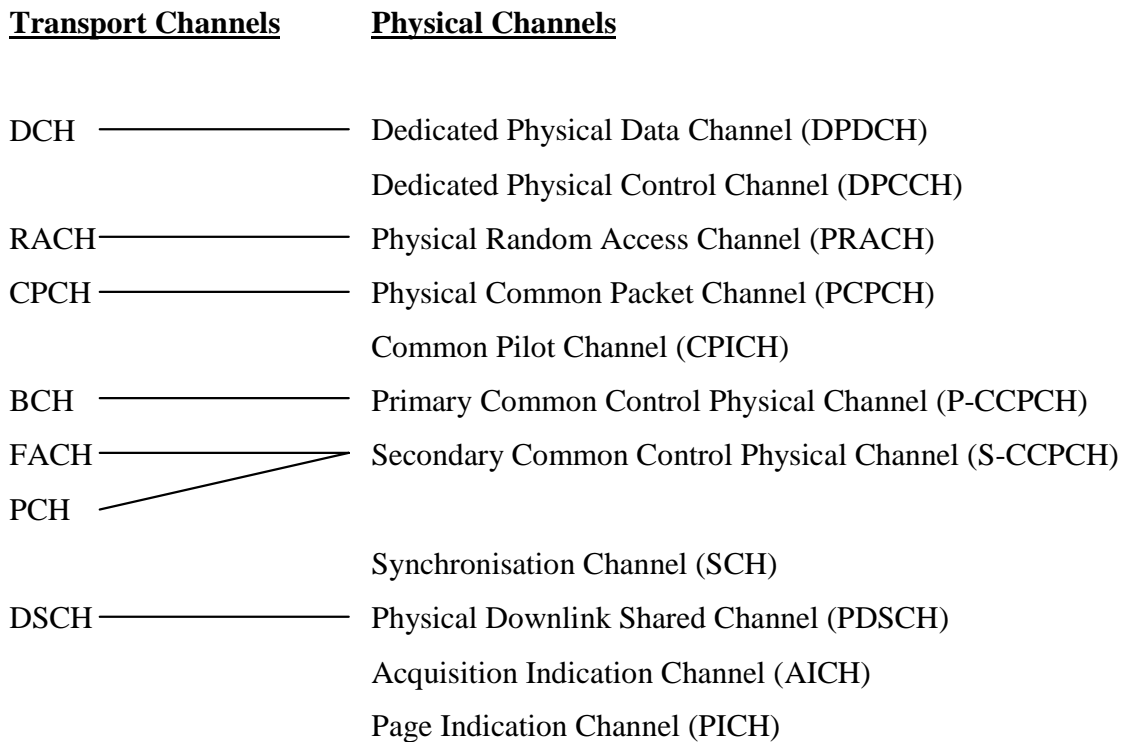
**Figure 21: Transport-channel to physical-channel mapping**

The DCHs are coded and multiplexed as described in [3], and the resulting data stream is mapped sequentially (first-in-first-mapped) directly to the physical channel(s). The mapping of BCH and FACH/PCH is equally straightforward, where the data stream after coding and interleaving is mapped sequentially to the Primary and Secondary CCPCH respectively. Also for the RACH, the coded and interleaved bits are sequentially mapped to the physical channel, in this case the message part of the random access burst on the PRACH.

# 7 Timing relationship between physical channels

## 7.1 General

The P-CCPCH, on which the cell SFN is transmitted, is used as timing reference for all the physical channels, directly for downlink and indirectly for uplink.

Figure 22 below describes the frame timing of the downlink physical channels. For the AICH the access slot timing is included. Timing for uplink physical channels is given by the downlink timing, as described in the following sections.

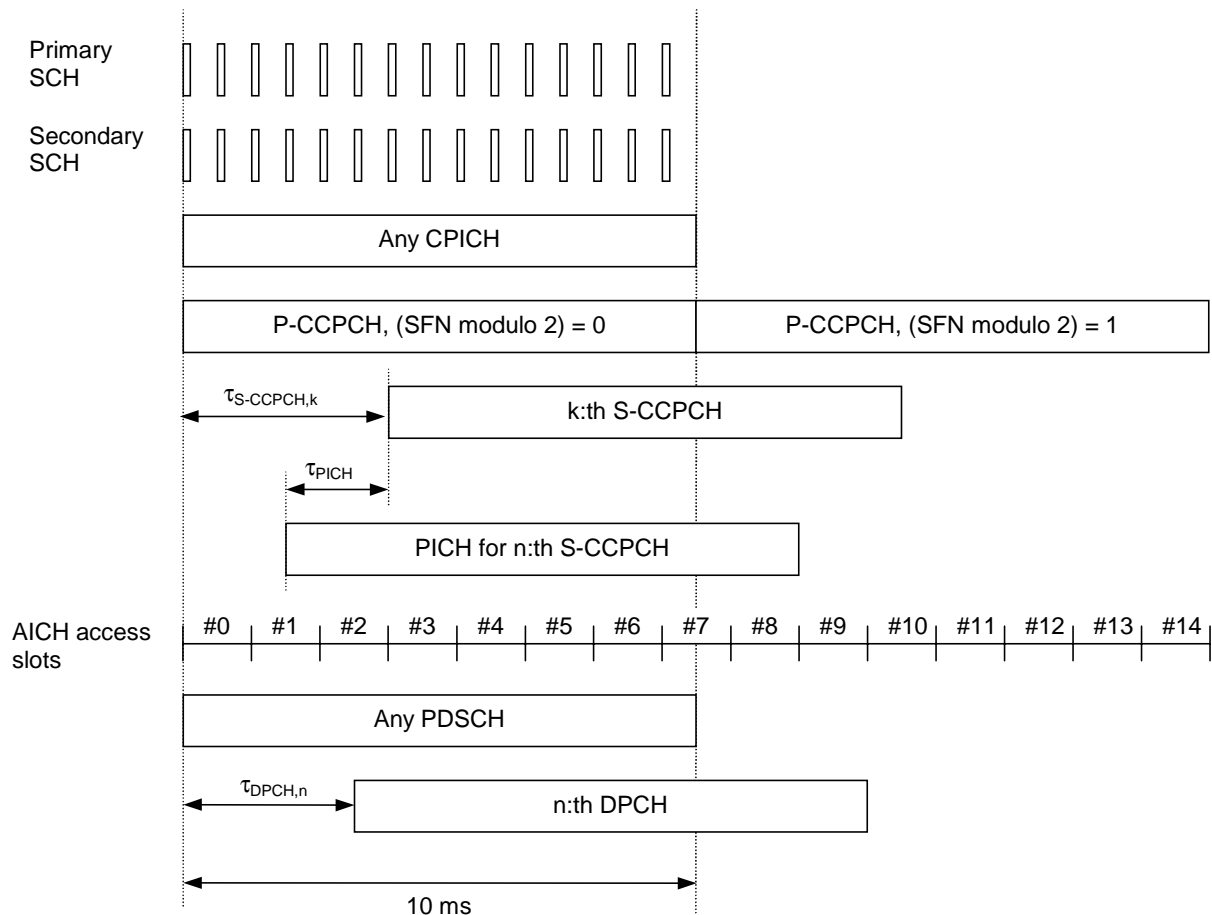

**Figure 22: Frame timing and access slot timing of downlink physical channels**

In figure 22 the following applies:

- SCH (primary and secondary), CPICH (primary and secondary), P-CCPCH, and PDSCH have identical frame timings.
- The S-CCPCH timing may be different for different S-CCPCHs, but the offset from the P-CCPCH frame timing is a multiple of 256 chips, i.e.  $\tau_{S-CCPCH,k} = T_k \times 256$  chip,  $T_k \in \{0, 1, \dots, 149\}$ .
- The PICH timing is  $\tau_{PICH} = 7680$  chips prior to its corresponding S-CCPCH frame timing. The PICH timing relation to the S-CCPCH is described more in section 7.2.
- The AICH access slot #0 starts the same time as a P-CCPCH frame with (SFN modulo 2) = 0. The AICH/PRACH and AICH/PCPCH timing is described in sections 7.3 and 7.4 respectively.
- The PDSCH timing relative the DPCH timing is described in section 7.5.

- The DPCH timing may be different for different DPCHs, but the offset from the P-CCPCH frame timing is a multiple of 256 chips, i.e.  $\tau_{DPCH,n} = T_n \times 256 \text{ chip}$ ,  $T_n \in \{0, 1, \dots, 149\}$ . The DPCH (DPCCH/DPDCH) timing relation with uplink DPCCH/DPDCHs is described in section 7.6.

## 7.2 PICH/S-CCPCH timing relation

Figure 23 illustrates the timing between a PICH frame and its associated S-CCPCH frame. A paging indicator set in a PICH frame means that the paging message is transmitted on the PCH in the S-CCPCH frame starting  $\tau_{PICH}$  chips after the transmitted PICH frame.  $\tau_{PICH}$  is defined in section 7.1.

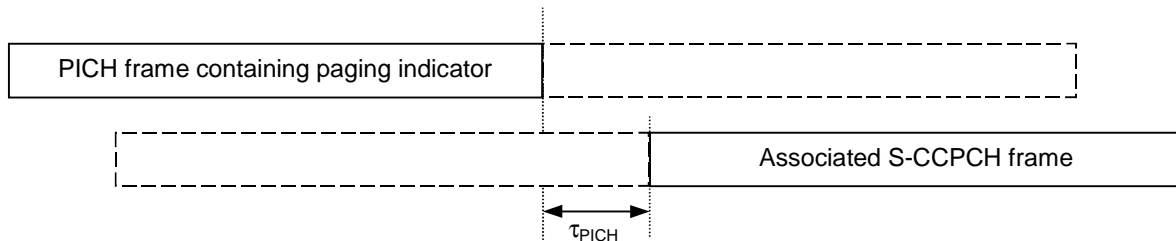

Figure 23: Timing relation between PICH frame and associated S-CCPCH frame

## 7.3 PRACH/AICH timing relation

The downlink AICH is divided into downlink access slots, each access slot is of length 5120 chips. The downlink access slots are time aligned with the P-CCPCH as described in section 7.1.

The uplink PRACH is divided into uplink access slots, each access slot is of length 5120 chips. Uplink access slot number  $n$  is transmitted from the UE  $\tau_{p-a}$  chips prior to the reception of downlink access slot number  $n$ ,  $n = 0, 1, \dots, 14$ .

Transmission of downlink acquisition indicators may only start at the beginning of a downlink access slot. Similarly, transmission of uplink RACH preambles and RACH message parts may only start at the beginning of an uplink access slot.

The PRACH/AICH timing relation is shown in figure 24.

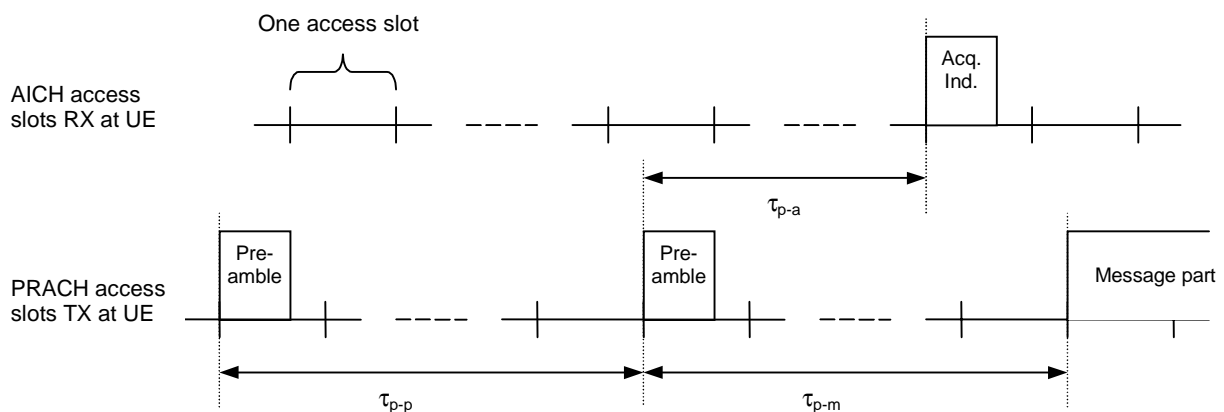

Figure 24: Timing relation between PRACH and AICH as seen at the UE

The preamble-to-preamble distance  $\tau_{p-p}$  shall be larger than or equal to the minimum preamble-to-preamble distance  $\tau_{p-p,min}$ , i.e.  $\tau_{p-p} \geq \tau_{p-p,min}$ .

In addition to  $\tau_{p-p,min}$ , the preamble-to-AI distance  $\tau_{p-a}$  and preamble-to-message distance  $\tau_{p-m}$  are defined as follows:



- when AICH\_Transmission\_Timing is set to 0, then

$$\tau_{p-p,\min} = 15360 \text{ chips (3 access slots)}$$

$$\tau_{p-a} = 7680 \text{ chips}$$

$$\tau_{p-m} = 15360 \text{ chips (3 access slots)}$$

- when AICH\_Transmission\_Timing is set to 1, then

$$\tau_{p-p,\min} = 20480 \text{ chips (4 access slots)}$$

$$\tau_{p-a} = 12800 \text{ chips}$$

$$\tau_{p-m} = 20480 \text{ chips (4 access slots)}$$

## 7.4 PCPCH/AICH timing relation

Transmission of random access bursts on the PCPCH is aligned with access slot times. The timing of the access slots is derived from the received Primary CCPCH timing. The transmit timing of access slot  $n$  starts  $n \times 20/15$  ms after the frame boundary of the received Primary CCPCH, where  $n = 0, 1, \dots, 14$ . In addition, transmission of access preambles in PCPCH is limited to the allocated access slot subchannel group which is assigned by higher layer signalling to each CPCH set. Twelve access slot subchannels are defined and PCPCH may be allocated all subchannel slots or any subset of the twelve subchannel slots. The access slot subchannel identification is identical to that for the RACH and is described in table 6 of section 6.1 of [5].

Everything in the previous section [PRACH/AICH] applies to this section as well. The timing relationship between preambles, AICH, and the message is the same as PRACH/AICH. Note that the collision resolution preambles follow the access preambles in PCPCH/AICH. However, the timing relationships between CD-Preamble and CD-AICH is identical to RACH Preamble and AICH. The timing relationship between CD-AICH and the Power Control Preamble in CPCH is identical to AICH to message in RACH. The  $T_{cpch}$  timing parameter is identical to the PRACH/AICH transmission timing parameter. When  $T_{cpch}$  is set to zero or one, the following PCPCH/AICH timing values apply:

Note that a1 corresponds to AP-AICH and a2 corresponds to CD-AICH.

$\tau_{p-p}$  = Time to next available access slot, between Access Preambles.

$$\text{Minimum time} = 15360 \text{ chips} + 5120 \text{ chips} \times T_{cpch}$$

$$\text{Maximum time} = 5120 \text{ chips} \times 12 = 61440 \text{ chips}$$

Actual time is time to next slot (which meets minimum time criterion) in allocated access slot subchannel group.

$\tau_{p-a1}$  = Time between Access Preamble and AP-AICH has two alternative values: 7680 chips or 12800 chips, depending on  $T_{cpch}$

$\tau_{a1-cdp}$  = Time between receipt of AP-AICH and transmission of the CD Preamble has one value: 7680 chips.

$\tau_{p-cdp}$  = Time between the last AP and CD Preamble. is either 3 or 4 access slots, depending on  $T_{cpch}$

$\tau_{cdp-a2}$  = Time between the CD Preamble and the CD-AICH has two alternative values: 7680 chips or 12800 chips, depending on  $T_{cpch}$

$\tau_{cdp-pcp}$  = Time between CD Preamble and the start of the Power Control Preamble is either 3 or 4 access slots, depending on  $T_{cpch}$ .

Figure 25 illustrates the PCPCH/AICH timing relationship when  $T_{cpch}$  is set to 0 and all access slot subchannels are available for PCPCH.

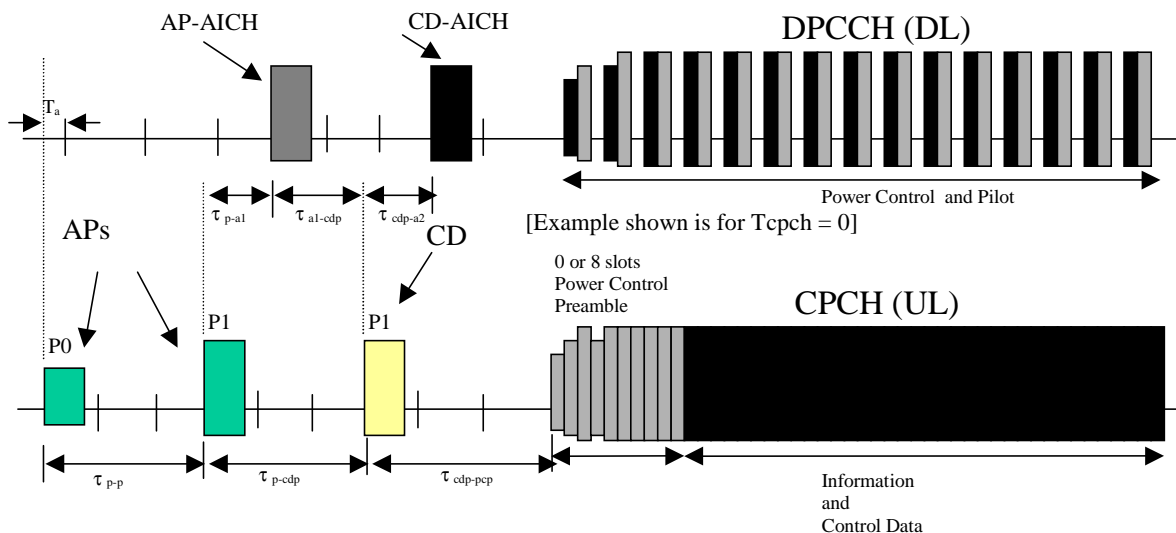

Figure 25: Timing of PCPCH and AICH transmission as seen by the UE, with  $T_{cpch} = 0$

## 7.5 DPCH/PDSCH timing

The relative timing between a DPCH frame and the associated PDSCH frame is shown in figure 26.

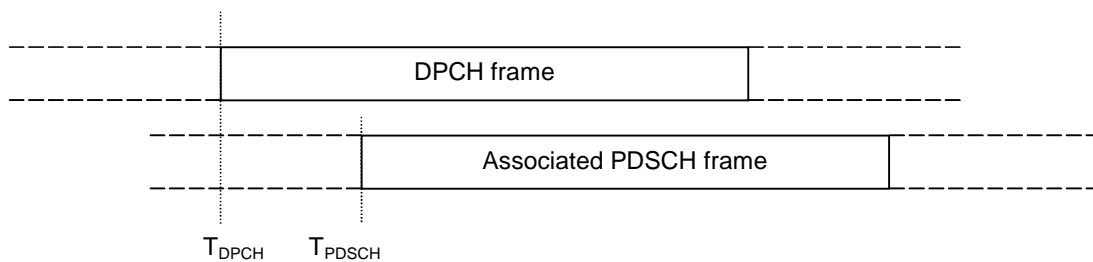

Figure 26: Timing relation between DPCH frame and associated PDSCH frame

The start of a DPCH frame is denoted  $T_{DPCH}$  and the start of the associated PDSCH frame is denoted  $T_{PDSCH}$ . Any DPCH frame is associated to one PDSCH frame through the relation  $-35840 \text{ chips} < T_{DPCH} - T_{PDSCH} \leq 2560 \text{ chips}$ , i.e. the associated PDSCH frame starts anywhere between 1 slot before or up to 14 slots behind the DPCH.

## 7.6 DPCCH/DPDCH timing relations

### 7.6.1 Uplink

In uplink the DPCCH and all the DPDCHs transmitted from one UE have the same frame timing.

### 7.6.2 Downlink

In downlink, the DPCCH and all the DPDCHs carrying CCTrCHs of dedicated type to one UE have the same frame timing.

### 7.6.3 Uplink/downlink timing at UE

At the UE, the uplink DPCCH/DPDCH frame transmission takes place approximately  $T_0$  chips after the reception of the first significant path of the corresponding downlink DPCCH/DPDCH frame.  $T_0$  is a constant defined to be 1024 chips. More information about the uplink/downlink timing relation and meaning of  $T_0$  can be found in [5].

In case of USTS, the uplink DPCCH/DPDCH frame transmission for Initial synchronization takes place  $T_0 + T_{\text{INIT\_SYNC}}$  after the reception of the first significant path of the corresponding downlink DPCCH/DPDCH frame where  $T_{\text{INIT\_SYNC}}$  is Initial synchronization time delivered by UTRAN. However the uplink DPCCH/DPDCH frame transmission for Tracking of USTS takes place approximately  $T_0 + T_{\text{INIT\_SYNC}} \pm \delta T$  after the reception of the first significant path of the corresponding downlink DPCCH/DPDCH frame where  $\delta T$  is the resultant timing adjustment due to the timing control by TAB command bits. More information on  $T_{\text{INIT\_SYNC}}$  and  $\delta T$  can be found in section 9.2 and 9.3 of [5]

## 7.7 Timing relations for initialisation of channels

Figure 27 shows the timing relationships between the physical channels involved in the initialisation of a DCH.

The maximum time permitted for the UE to decode the relevant FACH frame before the first frame of the DPCCH is received shall be  $T_{B-\text{min}} = 38400$  chips (i.e.15 slots).

The downlink DPCCH shall commence at a time  $T_B$  after the end of the relevant FACH frame, where  $T_B \geq T_{B-\text{min}}$  according to the following equation:

$$T_B = (T_n - T_k) \times 256 - N_{pcp} \times 2560 + N_{\text{offset}_1} \times 38400 \text{ chips, where:}$$

$N_{pcp}$  is a higher layer parameter set by the network, and represents the length (in slots) of the power control preamble (see [5], section 5.1.2.4).

$N_{\text{offset}_1}$  is a parameter derived from the activation time set by higher layers. In order that  $T_B \geq T_{B-\text{min}}$ ,  $N_{\text{offset}_1}$  shall be an integer number of frames such that:

$$N_{\text{offset}_1} \geq \begin{cases} 1 & \text{when } T_n - T_k \geq \frac{T_{B-\text{min}}}{256} + 10N_{pcp} - 150 \\ 2 & \text{when } \frac{T_{B-\text{min}}}{256} + 10N_{pcp} - 300 \leq T_n - T_k < \frac{T_{B-\text{min}}}{256} + 10N_{pcp} - 150 \\ 3 & \text{when } T_n - T_k < \frac{T_{B-\text{min}}}{256} + 10N_{pcp} - 300 \end{cases}$$

$T_n$  and  $T_k$  are parameters defining the timing of the frame boundaries on the DL DPCCH and S-CCPCH respectively (see section 7.1). These parameters are provided by higher layers.

The uplink DPCCH shall commence at a time  $T_C$  after the end of the relevant FACH frame, where

$T_C = T_B + T_0 + N_{\text{offset}_2} \times 38400$  chips, where  $T_0$  is as in section 7.6.3 and  $N_{\text{offset}_2}$  is a UE-specific higher-layer parameter which shall be an integer number of frames greater than or equal to zero.

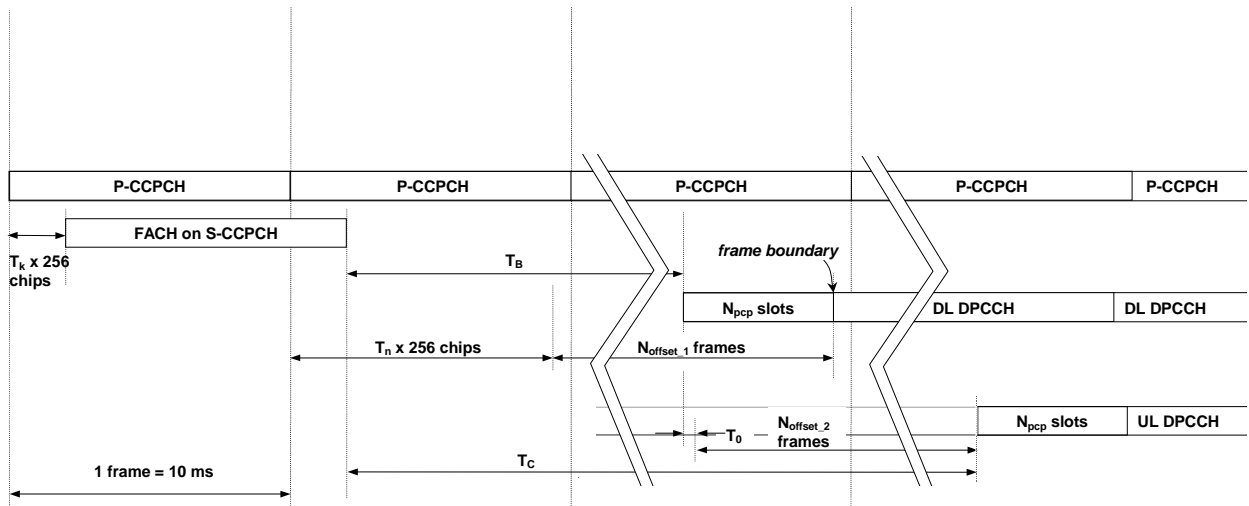

**Figure 27: Timing for initialisation of DCH.**

The data channels shall not commence before the end of the power control preamble.

## Annex A (informative): Change history

Change history					
TSG RAN#	Version	CR	Tdoc RAN	New Version	Subject/Comment
RAN_05	-	-	RP-99587	3.0.0	Approved at TSG RAN #5 and placed under Change Control
RAN_06	3.0.0	001	RP-99676	3.1.0	Removal of superframe notation
RAN_06	3.0.0	002	RP-99677	3.1.0	Use of CPICH in case of open loop Tx
RAN_06	3.0.0	003	RP-99677	3.1.0	CPCH power control preamble length
RAN_06	3.0.0	005	RP-99684	3.1.0	Editorial corrections
RAN_06	3.0.0	006	RP-99676	3.1.0	Change to the description of TSTD for SCH
RAN_06	3.0.0	007	RP-99678	3.1.0	Introduction of compressed mode by higher layer scheduling
RAN_06	3.0.0	008	RP-99676	3.1.0	Modifications to STTD text
RAN_06	3.0.0	009	RP-99684	3.1.0	20 ms RACH message length
RAN_06	3.0.0	010	RP-99676	3.1.0	Update to AICH description
RAN_06	3.0.0	011	RP-99678	3.1.0	Sliding paging indicators
RAN_06	3.0.0	016	RP-99677	3.1.0	TAB structure and timing relation for USTS
RAN_06	3.0.0	017	RP-99677	3.1.0	Timing for initialisation procedures
RAN_06	3.0.0	022	RP-99677	3.1.0	Modification of the STTD encoding scheme on DL DPCH with SF 512
-	3.1.0	-	-	3.1.1	Change history was added by the editor

---

# History

<b>Document history</b>		
V3.1.1	January 2000	Publication