

ETSI TS 125 214 V11.5.0 (2013-04)



**Universal Mobile Telecommunications System (UMTS);
Physical layer procedures (FDD)
(3GPP TS 25.214 version 11.5.0 Release 11)**



Reference

RTS/TSGR-0125214vb50

Keywords

UMTS

ETSI

650 Route des Lucioles
F-06921 Sophia Antipolis Cedex - FRANCE

Tel.: +33 4 92 94 42 00 Fax: +33 4 93 65 47 16

Siret N° 348 623 562 00017 - NAF 742 C
Association à but non lucratif enregistrée à la
Sous-Préfecture de Grasse (06) N° 7803/88

Important notice

Individual copies of the present document can be downloaded from:

<http://www.etsi.org>

The present document may be made available in more than one electronic version or in print. In any case of existing or perceived difference in contents between such versions, the reference version is the Portable Document Format (PDF). In case of dispute, the reference shall be the printing on ETSI printers of the PDF version kept on a specific network drive within ETSI Secretariat.

Users of the present document should be aware that the document may be subject to revision or change of status. Information on the current status of this and other ETSI documents is available at

<http://portal.etsi.org/tb/status/status.asp>

If you find errors in the present document, please send your comment to one of the following services:

http://portal.etsi.org/chaicor/ETSI_support.asp

Copyright Notification

No part may be reproduced except as authorized by written permission.
The copyright and the foregoing restriction extend to reproduction in all media.

© European Telecommunications Standards Institute 2013.
All rights reserved.

DECT™, **PLUGTESTS™**, **UMTS™** and the ETSI logo are Trade Marks of ETSI registered for the benefit of its Members.
3GPP™ and **LTE™** are Trade Marks of ETSI registered for the benefit of its Members and of the 3GPP Organizational Partners.
GSM® and the GSM logo are Trade Marks registered and owned by the GSM Association.

Intellectual Property Rights

IPRs essential or potentially essential to the present document may have been declared to ETSI. The information pertaining to these essential IPRs, if any, is publicly available for **ETSI members and non-members**, and can be found in ETSI SR 000 314: *"Intellectual Property Rights (IPRs); Essential, or potentially Essential, IPRs notified to ETSI in respect of ETSI standards"*, which is available from the ETSI Secretariat. Latest updates are available on the ETSI Web server (<http://ipr.etsi.org>).

Pursuant to the ETSI IPR Policy, no investigation, including IPR searches, has been carried out by ETSI. No guarantee can be given as to the existence of other IPRs not referenced in ETSI SR 000 314 (or the updates on the ETSI Web server) which are, or may be, or may become, essential to the present document.

Foreword

This Technical Specification (TS) has been produced by ETSI 3rd Generation Partnership Project (3GPP).

The present document may refer to technical specifications or reports using their 3GPP identities, UMTS identities or GSM identities. These should be interpreted as being references to the corresponding ETSI deliverables.

The cross reference between GSM, UMTS, 3GPP and ETSI identities can be found under <http://webapp.etsi.org/key/queryform.asp>.

Contents

Intellectual Property Rights	2
Foreword.....	2
Foreword.....	7
1 Scope	8
2 References	8
3 Definitions and Abbreviations.....	8
3.1 Definitions	8
3.2 Abbreviations	9
4 Synchronisation procedures	11
4.1 Cell search	11
4.2 Common physical channel synchronisation	11
4.2.1 P-CCPCH radio frame timing	11
4.2.2 S-CCPCH soft combining timing	11
4.2.3 Radio frame timing on the MBSFN layer	11
4.2.4 Secondary serving HS-DSCH cell timing	11
4.2.5 HS-DSCH cell timing when Multiflow is configured.....	11
4.3 DPCCH/DPDCH/F-DPCH synchronisation.....	12
4.3.1 Synchronisation primitives	12
4.3.1.1 General	12
4.3.1.2 Downlink synchronisation primitives	12
4.3.1.3 Uplink synchronisation primitives	13
4.3.2 Radio link establishment and physical layer reconfiguration for dedicated channels.....	13
4.3.2.1 General	13
4.3.2.2 Node B radio link set state machine.....	14
4.3.2.3 Synchronisation procedure A	14
4.3.2.3A Synchronisation procedure AA	16
4.3.2.4 Synchronisation procedure B	16
4.3.3 Radio link monitoring	17
4.3.3.1 Downlink radio link failure	17
4.3.3.2 Uplink radio link failure/restore in CELL_DCH state	17
4.3.3.2A Uplink radio link failure/restore in CELL_FACH state and IDLE mode	17
4.3.4 Transmission timing adjustments	17
5 Power control	18
5.1 Uplink power control.....	18
5.1.1 PRACH.....	18
5.1.1.1 General	18
5.1.1.2 Setting of PRACH control and data part power difference	18
5.1.2 DPCCH/DPDCH	18
5.1.2.1 General	18
5.1.2.2 Ordinary transmit power control	18
5.1.2.2.1 General	18
5.1.2.2.2 Algorithm 1 for processing TPC commands	20
5.1.2.2.3 Algorithm 2 for processing TPC commands	21
5.1.2.3 Transmit power control in compressed mode	22
5.1.2.4 Transmit power control in the uplink DPCCH power control preamble.....	25
5.1.2.5 Setting of the uplink DPCCH/DPDCH relative powers	25
5.1.2.5.1 General	25
5.1.2.5.2 Signalled gain factors	25
5.1.2.5.3 Computed gain factors.....	25
5.1.2.5.4 Setting of the uplink DPCCH/DPDCH relative powers in compressed mode.....	26
5.1.2.5A Setting of the uplink HS-DPCCH power relative to DPCCH power	27
5.1.2.5B Setting of the uplink E-DPCCH and E-DPDCH powers relative to DPCCH power.....	30
5.1.2.5B.1 E-DPCCH/DPCCH when one transport block is transmitted on E-DCH.....	30

5.1.2.5B.1A	E-DPCCH/DPCCH when two transport blocks are transmitted on E-DCH (rank-2).....	31
5.1.2.5B.2	E-DPDCH/DPCCH	31
5.1.2.5C	Setting of the uplink DPCCH gain factor when no DPDCH is configured	36
5.1.2.5D	Setting of the uplink S-DPCCH power relative to DPCCH power	36
5.1.2.5D.1	Setting of the uplink S-DPCCH/DPCCH power ratio when less than two transport blocks are transmitted on E-DCH	36
5.1.2.5D.2	Setting of the uplink S-DPCCH/DPCCH power ratio when two transport blocks are transmitted on E-DCH (rank-2).....	37
5.1.2.5E	Setting of the uplink S-E-DPCCH power relative to DPCCH power	37
5.1.2.5F	Setting of the uplink S-E-DPDCH power relative to E-DPDCH power	37
5.1.2.6	Maximum and minimum power limits	37
5.1.3	Void	40
5.2	Downlink power control.....	40
5.2.1	DPCCH/DPDCH/F-DPCH	40
5.2.1.1	General	40
5.2.1.2	Ordinary transmit power control	40
5.2.1.2.1	UE behaviour	40
5.2.1.2.2	UTRAN behaviour	41
5.2.1.3	Power control in compressed mode	42
5.2.1.4	Void.....	43
5.2.2	Void	43
5.2.3	Void	43
5.2.4	AICH	43
5.2.5	PICH	43
5.2.6	S-CCPCH.....	43
5.2.7	Void	44
5.2.8	Void	44
5.2.9	Void	44
5.2.10	HS-SCCH	44
5.2.11	HS-PDSCH	44
5.2.12	E-AGCH	44
5.2.13	E-HICH	44
5.2.14	E-RGCH	44
5.2.15	MICH.....	44
5.2.16	S-CPICH	44
5.2.17	F-TPICH	45
5.2.18	D-CPICH	45
5.2.19	E-ROCH	45
6	Random access procedure	45
6.1	Physical random access procedure	45
6.1.1	RACH sub-channels	46
6.1.2	RACH access slot sets	47
6.1A	Physical random access procedure for Enhanced Uplink in CELL_FACH state and IDLE mode.....	47
6.2	Void.....	49
6A	HS-DSCH-related procedures	49
6A.1	General procedure	49
6A.1.1	UE procedure for receiving HS-DSCH and HS-SCCH in the CELL_DCH state.....	52
6A.1.1A	UE procedure for receiving HS-DSCH and HS-SCCH in CELL_FACH state	55
6A.1.1B	UE procedure for receiving HS-DSCH and HS-SCCH in the URA_PCH and CELL_PCH states	56
6A.1.2	UE procedure for reporting channel quality indication (CQI) and precoding control indication (PCI).....	57
6A.1.2.1	CQI reporting procedure in case the UE is not configured in MIMO mode and not configured in MIMO mode with four transmit antennas in any cell	57
6A.1.2.2	Composite PCI/CQI reporting procedure in case the UE is configured in MIMO mode.....	59
6A.1.2.3	Composite NTBP/PCI/CQI reporting procedure in case the UE is configured in MIMO mode with four transmit antennas	61
6A.1.3	Node B procedure for transmitting the HS-DSCH and HS-SCCH.....	62
6A.1.3.1	Node B procedure for transmitting the HS-DSCH and HS-SCCH in the CELL_DCH state.....	62
6A.1.3.2	Node B procedure for transmitting the HS-DSCH and HS-SCCH in the CELL_FACH state.....	63
6A.1.3.3	Node B procedure for transmitting the HS-DSCH and HS-SCCH in the URA_PCH or CELL_PCH state.....	63

6A.2	Channel quality indicator (CQI) definition.....	64
6A.2.1	CQI definition when the UE is not configured in MIMO mode and not configured in MIMO mode with four transmit antennas.....	64
6A.2.2	CQI definition when the UE is configured in MIMO mode	65
6A.2.2A	CQI definition when the UE is configured in MIMO mode with four transmit antennas.....	66
6A.2.3	CQI tables	67
6A.3	Operation during compressed mode on the associated DPCH or F-DPCH.....	78
6A.4	Precoding control indication (PCI) definition	78
6A.4.1	PCI definition when the UE is configured in MIMO mode.....	78
6A.4.2	PCI definition when the UE is configured in MIMO mode with four transmit antennas	79
6B	E-DCH related procedures	80
6B.1	ACK/NACK detection	80
6B.2	Relative grants detection	81
6B.3	E-DCH control timing.....	81
6B.3.1	10 ms E-DCH TTI	81
6B.3.2	2 ms E-DCH TTI	82
6B.4	Operation during compressed mode.....	82
6B.4.1	Uplink compressed mode.....	82
6B.4.2	Downlink compressed mode.....	83
6C	Discontinuous transmission and reception procedures.....	83
6C.1	Uplink CQI transmission.....	84
6C.2	Discontinuous uplink DPCCCH transmission operation	84
6C.2.1	Uplink DPCCCH burst pattern	85
6C.2.2	Uplink DPCCCH preamble and postamble	86
6C.2.2.1	Uplink DPCCCH preamble and postamble for the DPCCCH only transmission.....	86
6C.2.2.2	Uplink DPCCCH preamble and postamble for the E-DCH transmission.....	86
6C.2.2.3	Uplink DPCCCH preamble and postamble for the HS-DPCCCH transmission	87
6C.3	Discontinuous downlink reception	87
6C.3.1	Discontinuous downlink reception when the UE is in Multiflow mode	89
6C.4	HS-SCCH orders	90
6C.5	Operation during compressed mode	90
7	Closed loop mode 1 transmit diversity.....	91
7.1	General procedure	92
7.2	Determination of feedback information	93
7.2.1	End of frame adjustment.....	93
7.2.2	Normal initialisation	94
7.2.3	Operation during compressed mode	94
7.2.3.1	Downlink in compressed mode and uplink in normal mode	94
7.2.3.2	Both downlink and uplink in compressed mode	94
7.2.3.3	Uplink in compressed mode and downlink in normal mode	95
7.2.4	Initialisation during compressed mode	95
7.2.4.1	Downlink in compressed mode.....	95
7.2.4.2	Uplink in compressed mode.....	96
7.3	Void.....	96
8	Idle periods for IPDL location method.....	96
8.1	General	96
8.2	Parameters of IPDL.....	96
8.3	Calculation of idle period position	97
9	MIMO operation of HS-DSCH	99
9.1	General procedure	101
10	Uplink Closed Loop Transmit Diversity operation.....	101
10.1	General procedure	101
10.2	Downlink TPI transmission and control timing.....	103
10.3	Combining TPI bits from multiple radio links	104
10.4	Operation during discontinuous uplink DPCCCH operation	104
10.5	Operation during compressed mode	104
10.5.1	Uplink compressed mode.....	104
10.5.2	Downlink compressed mode.....	104

10.6	HS-SCCH orders	104
11	Uplink MIMO	105
11.1	General procedure	107
11.2	Downlink TPI transmission and control timing.....	107
11.3	Combining TPI bits from radio links of the serving radio link set	108
11.4	Operation during discontinuous uplink DPCCH operation	108
11.5	Operation during compressed mode	108
11.6	HS-SCCH orders	108
11.7	Uplink power control.....	108
12	MIMO operation of HS-DSCH with four transmit antennas	108
12.1	General procedure	110
12.2	Symbol level interleaving.....	110
12.3	Retransmission Procedures.....	111
12.4	Precoding weight restriction.....	111
12.5	HS-SCCH Orders	112
Annex A (informative): (no title).....		113
A.1	Antenna verification.....	113
A.2	Computation of feedback information for closed loop mode 1 transmit diversity	114
Annex B (Informative): Power control		115
B.1	Downlink power control timing	115
B.2	Example of implementation in the UE.....	118
B.3	UL power control when losing UL synchronisation	118
Annex C (Informative): Cell search procedure.....		120
Annex D (Informative): F-TPICH Transmission.....		121
Annex E (informative): Change history		122
History		128

Foreword

This Technical Specification (TS) has been produced by the 3rd Generation Partnership Project (3GPP).

The contents of the present document are subject to continuing work within the TSG and may change following formal TSG approval. Should the TSG modify the contents of this present document, it will be re-released by the TSG with an identifying change of release date and an increase in version number as follows:

Version x.y.z

where:

- x the first digit:
 - 1 presented to TSG for information;
 - 2 presented to TSG for approval;
 - 3 or greater indicates TSG approved document under change control.
- y the second digit is incremented for all changes of substance, i.e. technical enhancements, corrections, updates, etc.
- z the third digit is incremented when editorial only changes have been incorporated in the document.

1 Scope

The present document specifies and establishes the characteristics of the physical layer procedures in the FDD mode of UTRA.

2 References

The following documents contain provisions which, through reference in this text, constitute provisions of the present document.

- References are either specific (identified by date of publication, edition number, version number, etc.) or non-specific.
- For a specific reference, subsequent revisions do not apply.
- For a non-specific reference, the latest version applies. In the case of a reference to a 3GPP document (including a GSM document), a non-specific reference implicitly refers to the latest version of that document *in the same Release as the present document*.

- [1] 3GPP TS 25.211: "Physical channels and mapping of transport channels onto physical channels (FDD)".
- [2] 3GPP TS 25.212: "Multiplexing and channel coding (FDD)".
- [3] 3GPP TS 25.213: "Spreading and modulation (FDD)".
- [4] 3GPP TS 25.215: "Physical layer – Measurements (FDD)".
- [5] 3GPP TS 25.331: "RRC Protocol Specification".
- [6] 3GPP TS 25.433: "UTRAN Iub Interface NBAP Signalling".
- [7] 3GPP TS 25.101: "UE Radio transmission and Reception (FDD)".
- [8] 3GPP TS 25.133: "Requirements for Support of Radio Resource Management (FDD)".
- [9] 3GPP TS 25.321: "MAC protocol specification".
- [10] 3GPP TS 25.306: "UE Radio Access Capabilities".

3 Definitions and Abbreviations

3.1 Definitions

For the purposes of the present document, the following terms and definitions apply:

Activated uplink frequency: For a specific UE, an uplink frequency is said to be activated if the UE is allowed to transmit on that frequency. The primary uplink frequency is always activated when configured while a secondary uplink frequency has to be activated by means of an HS-SCCH order in order to become activated. Similarly, for a specific UE, an uplink frequency is said to be deactivated if it is configured but disallowed by the NodeB to transmit on that frequency.

Assisting secondary serving HS-DSCH Cell: In addition to the serving HS-DSCH cell, a cell in the secondary downlink frequency, where the UE is configured to simultaneously monitor a HS-SCCH set and receive HS-DSCH if it is scheduled in that cell.

Assisting serving HS-DSCH Cell: In addition to the serving HS-DSCH cell, a cell in the same frequency, where the UE is configured to simultaneously monitor a HS-SCCH set and receive HS-DSCH if it is scheduled in that cell.

Cell group: A group of (one or two) Multiflow mode cells that have the same CPICH timing. The CQI reports for all the cells in a cell group are reported together in the same sub frame. The cells that belong to a cell group are indicated by higher layers.

Configured uplink frequency: For a specific UE, an uplink frequency is said to be configured if the UE has received all relevant information from higher layers in order to perform transmission on that frequency.

L1 combining period: An interval of contiguous TTIs when S-CCPCHs, each on different RLs, may be soft combined.

MIMO mode: This term refers to the downlink MIMO configuration with two transmit antennas.

MIMO mode with four transmit antennas: This term refers to the downlink MIMO configuration with four transmit antennas.

Multiflow mode: The UE is configured in Multiflow mode when it is configured with an assisting serving HS-DSCH cell.

Non-time reference cell: An HS-DSCH cell configured for a UE in Multiflow mode that has a different timing than the time reference cell. If the time reference cell is the Assisting Serving HS-DSCH cell then the non-time reference cell is the Serving HS-DSCH cell. If the time reference cell is the Serving HS-DSCH Cell, then the non-time reference cell is the Assisting Serving HS-DSCH cell.

Primary uplink frequency: If a single uplink frequency is configured for the UE, then it is the primary uplink frequency. In case more than one uplink frequency is configured for the UE, then the primary uplink frequency is the frequency on which the E-DCH corresponding to the serving E-DCH cell associated with the serving HS-DSCH cell is transmitted. The association between a pair of uplink and downlink frequencies is indicated by higher layers.

Secondary uplink frequency: A secondary uplink frequency is a frequency on which an E-DCH corresponding to a serving E-DCH cell associated with a secondary serving HS-DSCH cell is transmitted. The association between a pair of uplink and downlink frequencies is indicated by higher layers.

Time reference cell: The (Serving or Assisting Serving, but not Secondary Serving or Assisting Secondary Serving) HS-DSCH cell that carries the HS-PDSCH acting as the time reference for the uplink HS-DPCCH when in Multiflow mode. There is one and only one Time reference cell.

1st secondary serving HS-DSCH cell: If the UE is configured with two uplink frequencies, the 1st secondary serving HS-DSCH cell is the secondary serving HS-DSCH cell that is associated with the secondary uplink frequency. If the UE is configured with a single uplink frequency, the 1st secondary serving HS-DSCH cell is a secondary serving HS-DSCH cell whose index is indicated by higher layers.

2nd secondary serving HS-DSCH cell: If the UE is configured with more than two serving HS-DSCH cells, the 2nd secondary serving HS-DSCH cell is a secondary serving HS-DSCH cell whose index is indicated by higher layers.

3rd secondary serving HS-DSCH cell: If the UE is configured with more than three serving HS-DSCH cells, the 3rd secondary serving HS-DSCH cell is a secondary serving HS-DSCH cell whose index is indicated by higher layers.

4th secondary serving HS-DSCH cell: If the UE is configured with more than four serving HS-DSCH cells, the 4th secondary serving HS-DSCH cell is a secondary serving HS-DSCH cell whose index is indicated by higher layers.

5th secondary serving HS-DSCH cell: If the UE is configured with more than five serving HS-DSCH cells, the 5th secondary serving HS-DSCH cell is a secondary serving HS-DSCH cell whose index is indicated by higher layers.

6th secondary serving HS-DSCH cell: If the UE is configured with more than six serving HS-DSCH cells, the 6th secondary serving HS-DSCH cell is a secondary serving HS-DSCH cell whose index is indicated by higher layers.

7th secondary serving HS-DSCH cell: If the UE is configured with eight serving HS-DSCH cells, the 7th secondary serving HS-DSCH cell is a secondary serving HS-DSCH cell whose index is indicated by higher layers.

3.2 Abbreviations

For the purposes of the present document, the following abbreviations apply:

ACK	Acknowledgement
AICH	Acquisition Indicator Channel

ASC	Access Service Class
BCH	Broadcast Channel
CCPCH	Common Control Physical Channel
CCTrCH	Coded Composite Transport Channel
CLTD	Closed Loop Transmit Diversity
CPICH	Common Pilot Channel
CQI	Channel Quality Indicator
CRC	Cyclic Redundancy Check
DCH	Dedicated Channel
DL	Downlink
DPCCH	Dedicated Physical Control Channel
DPCH	Dedicated Physical Channel
DPDCH	Dedicated Physical Data Channel
DTX	Discontinuous Transmission
E-AGCH	E-DCH Absolute Grant Channel
E-DCH	Enhanced Dedicated Channel
E-DPCCH	E-DCH Dedicated Physical Control Channel
E-DPDCH	E-DCH Dedicated Physical Data Channel
E-HICH	E-DCH HARQ Acknowledgement Indicator Channel
E-RGCH	E-DCH Relative Grant Channel
E-ROCH	E-DCH Rank and Offset Channel
F-DPCH	Fractional Dedicated Physical Channel
F-TPICH	Fractional Transmitted Precoding Indicator Channel
HSDPA	High Speed Downlink Packet Access
HS-DPCCH	Dedicated Physical Control Channel (uplink) for HS-DSCH
HS-DPCCH ₂	Secondary Dedicated Physical Control Channel (uplink) for HS-DSCH, when Secondary_Cell_Enabled is greater than 3 when the UE is not configured in MIMO mode with four transmit antennas and is greater than 1 when the UE is configured in MIMO mode with four transmit antennas
HS-DSCH	High Speed Downlink Shared Channel
HS-PDSCH	High Speed Physical Downlink Shared Channel
HS-SCCH	High Speed Physical Downlink Shared Control Channel
MBSFN	MBMS over a Single Frequency Network
MICH	MBMS Indicator Channel
MIMO	Multiple Input Multiple Output
NACK	Negative Acknowledgement
NT-HS-DPCCH	NodeB Triggered HS-DPCCH
P-CCPCH	Primary Common Control Physical Channel
PCA	Power Control Algorithm
PICH	Paging Indicator Channel
PRACH	Physical Random Access Channel
RACH	Random Access Channel
RL	Radio Link
RPL	Recovery Period Length
RSCP	Received Signal Code Power
S-CCPCH	Secondary Common Control Physical Channel
SCH	Synchronisation Channel
S-DPCCH	Secondary Dedicated Physical Control Channel
S-E-DPCCH	Secondary Dedicated Physical Control Channel for E-DCH
S-E-DPDCH	Secondary Dedicated Physical Data Channel for E-DCH
SFN	System Frame Number
SIR	Signal-to-Interference Ratio
SNIR	Signal to Noise Interference Ratio
TFC	Transport Format Combination
TFRI	Transport Format and Resource Indicator
TPC	Transmit Power Control
TPI	Transmitted Precoding Indicator
TrCH	Transport Channel
TTI	Transmission Time Interval
UE	User Equipment
UL	Uplink
UTRAN	UMTS Terrestrial Radio Access Network

4 Synchronisation procedures

4.1 Cell search

During the cell search, the UE searches for a cell and determines the downlink scrambling code and common channel frame synchronisation of that cell. How cell search is typically done is described in Annex C.

4.2 Common physical channel synchronisation

The radio frame timing of all common physical channels can be determined after cell search.

4.2.1 P-CCPCH radio frame timing

The P-CCPCH radio frame timing is found during cell search and the radio frame timing of all common physical channels are related to that timing as described in [1].

4.2.2 S-CCPCH soft combining timing

Higher layers will provide timing information when S-CCPCHs, each on different RLCs, can be soft combined. The timing information allows the UE to determine the L1 combining period that applies to each S-CCPCH. The information also identifies the S-CCPCHs and the RLCs that can be soft combined. The set of S-CCPCHs that can be combined does not change during an L1 combining period. When S-CCPCHs can be soft combined, all S-CCPCHs shall contain identical bits in their data fields, although the TFCI fields of the S-CCPCHs may be different. (TFCI detection when S-CCPCHs may be soft combined is discussed in [2].) The maximum delay between S-CCPCHs that the UE may combine is set by UE performance requirements. The maximum number of S-CCPCHs that UE may simultaneously combine is defined by the UE capability in [10].

4.2.3 Radio frame timing on the MBSFN layer

MBSFN cluster search and radio frame synchronisation on the MBSFN layer can be performed via SCH and follow the same principles as described in Annex C. After the primary scrambling code has been identified, the P-CCPCH can be detected and MBSFN system information can be read.

4.2.4 Secondary serving HS-DSCH cell timing

When the UE is configured with one or more secondary serving HS-DSCH cells, it shall not assume the presence of any common physical channel from these cells other than CPICH. The radio frame timing and timing reference for each of the secondary serving HS-DSCH cells are defined in [1].

4.2.5 HS-DSCH cell timing when Multiflow is configured

When the UE is configured in Multiflow mode, the UE shall not assume any timing relation between the serving HS-DSCH cell and the assisting serving HS-DSCH cell. The UE can only be configured with an assisting serving HS-DSCH cell if that cell is contained in the UE's active set.

The UE may assume that the serving HS-DSCH cell and the secondary serving HS-DSCH cell, if present, have the same radio frame timing.

The UE may assume that the assisting serving HS-DSCH cell and the assisting secondary serving HS-DSCH cell, if present, have the same radio frame timing.

4.3 DPCCH/DPDCH/F-DPCH synchronisation

4.3.1 Synchronisation primitives

4.3.1.1 General

For the dedicated channels, synchronisation primitives are used to indicate the synchronisation status of radio links, both in uplink and downlink. The definition of the primitives is given in the following subclauses.

4.3.1.2 Downlink synchronisation primitives

If `UL_DTX_Active` is FALSE (see section 6C), layer 1 in the UE shall every radio frame check synchronisation status of either the DPCH or the F-DPCH depending on which is configured. If `UL_DTX_Active` is TRUE (see section 6C), the layer 1 in the UE shall check synchronisation status of the F-DPCH for each radio frame in which the F-DPCH transmission is known to be present in at least one slot, and for the other radio frames, the layer 1 will not indicate any synchronisation status to the higher layers. Synchronisation status is indicated to higher layers using the CPHY-Sync-IND and CPHY-Out-of-Sync-IND primitives.

The criteria for reporting synchronisation status are defined in two different phases. Each phase is performed by the UE for each individual downlink frequency associated with the activated uplink frequencies. The downlink synchronization primitives are also reported to higher layers for each individual downlink frequency associated with the activated uplink frequencies.

The first phase starts when higher layers initiate physical dedicated channel establishment (as described in [5]) or whenever the UE initiates synchronisation procedure A or synchronisation procedure AA (as described in section 4.3.2.1 and 4.3.2.3A) and lasts until 160 ms after the downlink dedicated channel is considered established by higher layers (physical channel establishment is defined in [5]). During this time out-of-sync shall not be reported and in-sync shall be reported using the CPHY-Sync-IND primitive if the following criterion is fulfilled:

- The UE estimates the DPCCH quality or the quality of the TPC fields of the F-DPCH frame received from the associated serving HS-DSCH cell (or secondary serving HS-DSCH cell) over the previous 40 ms period to be better than a threshold Q_{in} . This criterion shall be assumed not to be fulfilled before 40 ms of DPCCH quality measurements have been collected. Q_{in} is defined implicitly by the relevant tests in [7].

The second phase starts 160 ms after the downlink dedicated channel is considered established by higher layers. During this phase both out-of-sync and in-sync are reported as follows.

Out-of-sync shall be reported using the CPHY-Out-of-Sync-IND primitive if any of the following criteria is fulfilled:

- `UL_DTX_Active` is FALSE (see section 6C) and the UE estimates the DPCCH quality or the quality of the TPC fields of the F-DPCH frame received from the associated serving HS-DSCH cell (or secondary serving HS-DSCH cell) over the previous 160 ms period to be worse than a threshold Q_{out} . Q_{out} is defined implicitly by the relevant tests in [7].
- `UL_DTX_Active` is TRUE (see section 6C) and the UE estimates the quality of the TPC fields of the F-DPCH from the associated serving HS-DSCH cell (or secondary serving HS-DSCH cell) over the previous 240 slots in which the TPC symbols are known to be present to be worse than a threshold Q_{out} . Q_{out} is defined implicitly by the relevant tests in [7].
- The 20 most recently received transport blocks with a non-zero length CRC attached, as observed on all TrCHs using non-zero length CRC mapped to the DPDCH, have been received with incorrect CRC. In addition, over the previous 160 ms, all transport blocks with a non-zero length CRC attached have been received with incorrect CRC. In case no TFCI is used this criterion shall not be considered for the TrCH(s) not using guided detection if they do not use a non-zero length CRC in all transport formats. If no transport blocks with a non-zero length CRC attached are received over the previous 160 ms this criterion shall not be assumed to be fulfilled.

For a DPCH, in-sync shall be reported using the CPHY-Sync-IND primitive if both of the following criteria are fulfilled:

- The UE estimates the DPCCH quality over the previous 160 ms period to be better than a threshold Q_{in} . Q_{in} is defined implicitly by the relevant tests in [7].

- At least one transport block with a non-zero length CRC attached, as observed on all TrCHs using non-zero length CRC mapped to the DPDCH, is received in a TTI ending in the current frame with correct CRC. If no transport blocks are received, or no transport block has a non-zero length CRC attached in a TTI ending in the current frame and in addition over the previous 160 ms at least one transport block with a non-zero length CRC attached has been received with a correct CRC, this criterion shall be assumed to be fulfilled. If no transport blocks with a non-zero length CRC attached are received over the previous 160 ms this criterion shall also be assumed to be fulfilled. In case no TFCI is used this criterion shall not be considered for the TrCH(s) not using guided detection if they do not use a non-zero length CRC in all transport formats.

For a F-DPCH, in-sync shall be reported using the CPHY-Sync-IND primitive if any of the following criteria is fulfilled:

- UL_DTX_Active is FALSE (see section 6C) and the UE estimates the quality of the TPC fields of the F-DPCH frame received from the associated serving HS-DSCH cell (or secondary serving HS-DSCH cell) over the previous 160 ms period to be better than a threshold Q_{in} . Q_{in} is defined implicitly by the relevant tests in [7].
- UL_DTX_Active is TRUE (see section 6C) and the UE estimates the quality of the TPC fields of the F-DPCH from the associated serving HS-DSCH cell (or secondary serving HS-DSCH cell) over the previous 240 slots in which the TPC symbols are known to be present to be better than a threshold Q_{in} . Q_{in} is defined implicitly by the relevant tests in [7].

How the primitives are used by higher layers is described in [5]. The above definitions may lead to radio frames where neither the in-sync nor the out-of-sync primitives are reported.

4.3.1.3 Uplink synchronisation primitives

Layer 1 in the Node B shall every radio frame check synchronisation status of all radio link sets. Synchronisation status is indicated to the RL Failure/Restored triggering function using either the CPHY-Sync-IND or CPHY-Out-of-Sync-IND primitive. Hence, only one synchronisation status indication shall be given per radio link set.

The exact criteria for indicating in-sync/out-of-sync is not subject to specification, but could e.g. be based on received DPCCCH quality or CRC checks. One example would be to have the same criteria as for the downlink synchronisation status primitives.

4.3.2 Radio link establishment and physical layer reconfiguration for dedicated channels

4.3.2.1 General

Three synchronisation procedures are defined in order to obtain physical layer synchronisation of dedicated channels between UE and UTRAN:

- Synchronisation procedure A: This procedure shall be used when at least one downlink dedicated physical channel (i.e. a DPCH or F-DPCH) and one uplink dedicated physical channel are to be set up on a frequency and none of the radio links after the establishment/reconfiguration existed on that frequency prior to the establishment/reconfiguration which also includes the following cases :
 - the UE was previously on another RAT i.e. inter-RAT handover
 - the UE was previously on another frequency i.e. inter-frequency hard handover
 - the UE has all its previous radio links removed and replaced by other radio links i.e. intra-frequency hard-handover
 - after it fails to complete an inter-RAT, intra- or inter-frequency hard-handover [8], the UE attempts to re-establish [5] all the dedicated physical channels which were already established immediately before the hard-handover attempt. In this case only steps c) and d) of synchronisation procedure A are applicable.
 - the UE receives an HS-SCCH order to activate the secondary uplink frequency as specified in [2] and the UE is configured with multiple frequencies on the uplink.

For transitions from the CELL_FACH state of a cell to the CELL_DCH state of the same cell,, when synchronisation has already been achieved by a synchronisation procedure AA and the UE has not already

released its uplink common E-DCH resource before the time of transition to CELL_DCH, the synchronisation procedure A shall not be executed. Else, the synchronisation procedure A shall be executed.

- Synchronisation procedure AA: This procedure shall be used when one downlink F-DPCH and uplink dedicated physical channels are to be set up on a frequency as a consequence of an Enhanced Uplink in CELL_FACH procedure.
- Synchronisation procedure B: This procedure shall be used when one or several radio links are added to the active set on a frequency and at least one of the radio links prior to the establishment/reconfiguration still exists on that frequency after the establishment/reconfiguration.
- If higher layers indicate that the UE shall not perform any synchronisation procedure for timing maintained intra- and inter-frequency hard handover, the UE shall not perform any of the synchronisation procedures A or B. If higher layers indicate to the Node B timing maintained intra- or inter-frequency hard handover where the UE does not perform any of the synchronisation procedures A, AA or B, the Node B shall perform steps a) and b) of synchronisation procedure B.

For all physical layer reconfigurations not listed above, the UE and UTRAN shall not perform any of the synchronisation procedures listed above.

The three synchronisation procedures are described in subclauses 4.3.2.3, 4.3.2.3A and 4.3.2.4 respectively.

4.3.2.2 Node B radio link set state machine

In Node B, each radio link set can be in three different states: initial state, out-of-sync state and in-sync state. Transitions between the different states are shown in figure 1 below. The state of the Node B at the start of radio link establishment is described in the following subclauses. Transitions between initial state and in-sync state are described in subclauses 4.3.2.3, 4.3.2.3A and 4.3.2.4 and transitions between the in-sync and out-of-sync states are described in subclause 4.3.3.2.

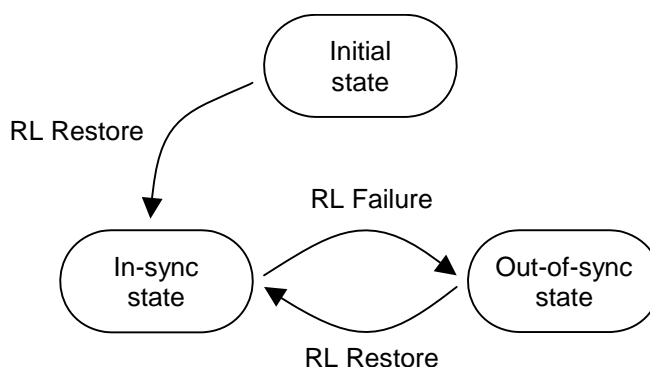

Figure 1: Node B radio link set states and transitions

4.3.2.3 Synchronisation procedure A

For each configured uplink frequency, the synchronisation establishment procedure, which begins at the time indicated by higher layers (either immediately at receipt of upper layer signalling, or at an indicated activation time), or by an HS-SCCH order to activate the secondary uplink frequency (in the case multiple frequencies are configured on the uplink) is as follows:

- a) Each Node B involved in the procedure sets all the radio link sets which are to be set-up for this UE in the initial state.
- b) UTRAN shall start the transmission of the downlink DPCCCH or F-DPCH corresponding to the activated uplink frequency and may start the transmission of DPDCH if any data is to be transmitted. The initial downlink DPCCCH or F-DPCH transmit power is set by higher layers [6]. Downlink TPC commands are generated as described in 5.1.2.2.1.2.
- c) The UE establishes downlink chip and frame synchronisation of DPCCCH or F-DPCH corresponding to the activated uplink frequency, using the P-CCPCH timing and timing offset information notified from UTRAN. For

DPCH, frame synchronisation can be confirmed using the frame synchronisation word. Downlink synchronisation status is reported to higher layers every radio frame according to subclause 4.3.1.2.

- d) If higher layers indicate the usage of a post-verification period for the primary uplink frequency the UE shall start transmission on the primary uplink frequency immediately when the physical dedicated channel establishment is initiated by the UE. Post-verification period is always used for the secondary uplink frequency.

If higher layers do not indicate the usage of a post-verification period for the primary uplink frequency, or if higher layers do indicate the usage of a post-verification period (as specified in 5.1.2.2.1.1) and the post-verification has failed, the UE shall not transmit on the activated uplink frequency until higher layers consider the downlink physical channel established;

- If no activation time for uplink DPCCH has been signalled to the UE or if the UE attempts to re-establish the DPCH after an inter-RAT, intra- or inter-frequency hard-handover failure [5], uplink DPCCH transmission shall start on the activated uplink frequency when higher layers consider the downlink physical channel established;
- If an activation time has been given, uplink DPCCH transmission shall not start on the activated uplink frequency before the downlink physical channel has been established and the activation time has been reached. Physical channel establishment and activation time are defined in [5].

The initial uplink DPCCH transmit power is set by higher layers [5]. In case the synchronisation procedure A is executed because the UE receives an HS-SCCH order to activate the secondary uplink frequency, then the initial DPCCH transmit power on the secondary uplink frequency is computed (in dB) as

$$\text{Uplink DPCCH transmit power} = P_{\text{DPCCH},1} - \text{UE_Sec_Tx_Power_Backoff}$$

where $P_{\text{DPCCH},1}$ is the DPCCH transmit power on the primary uplink frequency at the start of the transmission on the secondary uplink frequency and UE_Sec_Tx_Power_Backoff is set by higher layers.

In case the UE attempts to re-establish the DPCH after an inter-RAT, intra- or inter-frequency hard-handover failure [5] the initial uplink DPCCH power shall be the same as the one used immediately preceding the inter-RAT, intra- or inter-frequency hard-handover attempt. In case of physical layer reconfiguration the uplink DPCCH power is kept unchanged between before and after the reconfiguration except for inner loop power control adjustments.

A power control preamble shall be applied on the activated uplink frequency as indicated by higher layers. The transmission of the uplink DPCCH power control preamble shall start N_{pcp} radio frames prior to the radio frame where the uplink DPDCH/E-DPCCH/E-DPDCH transmission starts, where N_{pcp} is a higher layer parameter set by UTRAN [5]; in case the UE attempts to re-establish the DPCH after an inter-RAT, intra- or inter-frequency hard-handover failure [5] the UE shall use the value of N_{pcp} as specified in [5] for this case. Note that the transmission start delay between DPCCH and DPDCH/E-DPCCH/E-DPDCH may be cancelled using a power control preamble of 0 length. If higher layers indicate the usage of a post-verification period, and the start of the uplink DPCCH power control preamble with a length of N_{pcp} radio frames would be in a radio frame later than the first uplink radio frame after physical dedicated channel establishment is initiated by the UE, then the duration of the uplink DPCCH power control preamble shall be equal to or longer than N_{pcp} radio frames such that the uplink DPCCH power control preamble is transmitted from the first uplink radio frame after physical dedicated channel establishment is initiated by the UE.

The starting time for transmission of DPDCHs/E-DPCCH/E-DPDCHs shall also satisfy the constraints on adding transport channels to a CCTrCH, as defined in [2] sub-clause 4.2.14, independently of whether there are any bits mapped to the DPDCHs/E-DPCCH/E-DPDCHs. During the uplink DPCCH power control preamble, independently of the selected TFC, no transmission is done on the DPDCH/E-DPCCH/E-DPDCH.

- e) UTRAN establishes uplink chip and frame synchronisation on the activated uplink frequency. Frame synchronisation can be confirmed using the frame synchronisation word. Radio link sets remain in the initial state until $N_{\text{INSYNC_IND}}$ successive in-sync indications are received from layer 1, when Node B shall trigger the RL Restore procedure indicating which radio link set has obtained synchronisation. When RL Restore has been triggered the radio link set shall be considered to be in the in-sync state. The parameter value of $N_{\text{INSYNC_IND}}$ is configurable, see [6]. The RL Restore procedure may be triggered several times, indicating when synchronisation is obtained for different radio link sets.

Note: The total signalling response delay for the establishment of a new DPCH shall not exceed the requirements given in [5] sub-clause 13.5.

4.3.2.3A Synchronisation procedure AA

The synchronisation establishment procedure, which begins at the time defined in [1] for the Enhanced Uplink in CELL_FACH state and IDLE mode, is as follows:

- a) The Node B involved in the procedure sets the radio link which is to be set-up for this UE in the initial state.
- b) UTRAN shall start the transmission of the downlink F-DPCH at the time defined for the Enhanced Uplink in CELL_FACH state and IDLE mode in [1].
- c) The UE establishes downlink chip and frame synchronisation of F-DPCH, using the P-CCPCH timing and timing offset information notified from UTRAN and based on the timing definition for the Enhanced Uplink in CELL_FACH state and IDLE mode as defined in [1]. Downlink synchronisation status is reported to higher layers every radio frame according to subclause 4.3.1.2.
- d) The UE shall start transmission on uplink at the time defined for the Enhanced Uplink in CELL_FACH state and IDLE mode in [1] and shall use a post-verification period for confirming the establishment of the downlink physical channel as follows: During the first 40 ms period of the first phase of the downlink synchronisation procedure the UE shall control its transmitter according to a downlink F-DPCH quality criterion as follows:
 - When the UE estimates the F-DPCH quality over the first 40 ms period of the first phase of the downlink synchronisation status evaluation to be worse than a threshold Q_{in} , the UE shall shut its transmitter off and consider post-verification failed. Q_{in} is defined implicitly by the relevant tests in [7].

If the post-verification has failed, the UE shall not transmit on uplink and await higher layer orders.

- e) UTRAN establishes uplink chip and frame synchronisation. Frame synchronisation can be confirmed using the frame synchronisation word.

4.3.2.4 Synchronisation procedure B

For each configured uplink frequency, the synchronisation procedure B, which begins at the time indicated by higher layers (either immediately at receipt of upper layer signalling, or at an indicated activation time) is as follows:

- a) The following applies to each Node B involved in the procedure:
 - New radio link sets are set up to be in initial state.
 - If one or several radio links are added to an existing radio link set, this radio link set shall be considered to be in the state the radio link set was prior to the addition of the radio link, i.e. if the radio link set was in the in-sync state before the addition of the radio link it shall remain in that state.
- b) UTRAN starts the transmission of the downlink DPCCH/DPDCH or F-DPCH for each new radio link corresponding to the activated uplink frequency at a frame timing such that the frame timing received at the UE will be within $T_0 \pm 148$ chips prior to the frame timing of the uplink DPCCH/DPDCH at the UE. Simultaneously, UTRAN establishes uplink chip and frame synchronisation of each new radio link. Frame synchronisation can be confirmed using the frame synchronisation word. Radio link sets considered to be in the initial state shall remain in the initial state until N_{INSYNC_IND} successive in-sync indications are received from layer 1, when Node B shall trigger the RL Restore procedure indicating which radio link set has obtained synchronisation. When RL Restore is triggered the radio link set shall be considered to be in the in-sync state. The parameter value of N_{INSYNC_IND} is configurable, see [6]. The RL Restore procedure may be triggered several times, indicating when synchronisation is obtained for different radio link sets.
- c) The UE establishes chip and frame synchronisation of each new radio link. Layer 1 in the UE keeps reporting downlink synchronisation status to higher layers every radio frame according to the second phase of sub-clause 4.3.1.2. For DPCH, frame synchronisation can be confirmed using the frame synchronisation word.

4.3.3 Radio link monitoring

4.3.3.1 Downlink radio link failure

The downlink radio links shall be monitored by the UE, to trigger radio link failure procedures. The downlink radio link failure criteria is specified in [5], and is based on the synchronisation status primitives CPHY-Sync-IND and CPHY-Out-of-Sync-IND, indicating in-sync and out-of-sync respectively.

4.3.3.2 Uplink radio link failure/restore in CELL_DCH state

The uplink radio link sets are monitored by the Node B, to trigger radio link failure/restore procedures. Once the radio link sets have been established, they will be in the in-sync or out-of-sync states as shown in figure 1 in subclause 4.3.2.1. Transitions between those two states are described below.

The uplink radio link failure/restore criteria is based on the synchronisation status primitives CPHY-Sync-IND and CPHY-Out-of-Sync-IND, indicating in-sync and out-of-sync respectively. Note that only one synchronisation status indication shall be given per radio link set.

When the radio link set is in the in-sync state, Node B shall start timer T_RLFAILURE after receiving N_OUTSYNC_IND consecutive out-of-sync indications. Node B shall stop and reset timer T_RLFAILURE upon receiving successive N_INSYNC_IND in-sync indications. If T_RLFAILURE expires, Node B shall trigger the RL Failure procedure and indicate which radio link set is out-of-sync. When the RL Failure procedure is triggered, the state of the radio link set change to the out-of-sync state.

When the radio link set is in the out-of-sync state, after receiving N_INSYNC_IND successive in-sync indications Node B shall trigger the RL Restore procedure and indicate which radio link set has re-established synchronisation. When the RL Restore procedure is triggered, the state of the radio link set change to the in-sync state.

The specific parameter settings (values of T_RLFAILURE, N_OUTSYNC_IND, and N_INSYNC_IND) are configurable, see [6].

4.3.3.2A Uplink radio link failure/restore in CELL_FACH state and IDLE mode

The uplink radio link failure/restore is under the control of the Node B.

4.3.4 Transmission timing adjustments

During a connection the UE may adjust its DPDCH/DPCCH transmission time instant.

When the UE autonomously adjusts its DPDCH/DPCCH transmission time instant, it shall simultaneously adjust the HS-DPCCH, E-DPCCH, E-DPDCH, S-DPCCH, S-E-DPCCH and S-E-DPDCH transmission time instant by the same amount so that the relative timing between DPCCH/DPDCH and HS-DPCCH is kept constant and that DPCCH/DPDCH and E-DPCCH/E-DPDCH and S-DPCCH and S-E-DPCCH/S-E-DPDCH remain time aligned.

If the receive timing for any downlink DPCCH/DPDCH or F-DPCH in the current active set has drifted, so the time between reception of the downlink DPCCH/DPDCH in question and transmission of uplink DPCCH/DPDCH lies outside the valid range, L1 shall inform higher layers of this, so that the network can be informed of this and downlink timing can be adjusted by the network.

The maximum rate of uplink TX time adjustment, and the valid range for the time between downlink DPCCH/DPDCH or F-DPCH reception and uplink DPCCH/DPDCH transmission in the UE are defined by the requirements specified in [8].

When the UE's time reference cell for HSDPA Multiflow is changed, the UE shall adjust its HS-DPCCH transmission timing to comply with the definitions in [1].

5 Power control

5.1 Uplink power control

5.1.1 PRACH

5.1.1.1 General

The power control during the physical random access procedure is described in clause 6. The setting of power of the message control and data parts is described in the next subclause.

5.1.1.2 Setting of PRACH control and data part power difference

The message part of the uplink PRACH channel shall employ gain factors to control the control/data part relative power similar to the uplink dedicated physical channels. Hence, subclause 5.1.2.5 applies also for the RACH message part, with the differences that:

- β_c is the gain factor for the control part (similar to DPCCH);
- β_d is the gain factor for the data part (similar to DPDCH);
- no inner loop power control is performed.

5.1.2 DPCCH/DPDCH

5.1.2.1 General

The initial uplink DPCCH transmit power is set by higher layers. Subsequently the uplink transmit power control procedure simultaneously and independently controls the power of a DPCCH on each activated uplink frequency and its corresponding DPDCHs (if present). The relative transmit power offset between DPCCH and DPDCHs is determined by the network and is computed according to subclause 5.1.2.5 using the gain factors signalled to the UE using higher layer signalling.

The operation of the inner power control loop, described in sub clause 5.1.2.2, adjusts the power of the DPCCH and DPDCHs by the same amount, provided there are no changes in gain factors. Additional adjustments to the power of the DPCCH associated with the use of compressed mode are described in sub clause 5.1.2.3.

Any change in the uplink DPCCH transmit power shall take place immediately before the start of the pilot field on the DPCCH. The change in DPCCH power with respect to its previous value is derived by the UE and is denoted by Δ_{DPCCH} (in dB). The previous value of DPCCH power shall be that used in the previous slot, except in the event of an interruption in transmission due to the use of compressed mode or discontinuous uplink DPCCH transmission operation, when the previous value shall be that used in the last slot before the transmission gap.

During the operation of the uplink power control procedure the UE transmit power shall not exceed a maximum allowed value which is the lower out of the maximum output power of the terminal power class and a value which may be set by higher layer signalling.

Uplink power control shall be performed while the UE transmit power is below the maximum allowed output power.

The provisions for power control at the maximum allowed value and below the required minimum output power (as defined in [7]) are described in sub-clause 5.1.2.6.

5.1.2.2 Ordinary transmit power control

5.1.2.2.1 General

For each activated uplink frequency, the uplink inner-loop power control adjusts the UE transmit power in order to keep the received uplink signal-to-interference ratio (SIR) on that frequency at a given SIR target, $\text{SIR}_{\text{target}}$.

The cells in the active set should estimate signal-to-interference ratio SIR_{est} of the received uplink DPCH. The cells in the active set should then generate TPC commands and transmit the commands once per slot according to the following rule: if $SIR_{est} > SIR_{target}$ then the TPC command to transmit is "0", while if $SIR_{est} < SIR_{target}$ then the TPC command to transmit is "1". When UL_DTX_Active is TRUE (see section 6C), a TPC command is not required to be transmitted in any downlink slot starting during an uplink DPCCCH slot which is in an uplink DPCCCH transmission gap as defined in subclause 6C.2, in which case it is not known to be present.

Upon reception of one or more TPC commands in a TPC command combining period, the UE shall derive a single TPC command, TPC_cmd, for each TPC command combining period in which a TPC command is known to be present, combining multiple TPC commands if more than one is received in a TPC command combining period. The TPC command combining period has a length of one slot, beginning at the downlink slot boundary for DPCH, and 512 chips after the downlink slot boundary for F-DPCH. The UE shall ignore any TPC commands received in an F-DPCH slot starting during an uplink DPCCCH slot which is in an uplink DPCCCH transmission gap as defined in subclause 6C.2.

Further, in case of an uplink DPCCCH transmission gap as defined in subclause 6C.2, the UE shall add together the values of TPC_cmd derived from each TPC command combining period in which a TPC command is known to be present and is not ignored as described above and which cannot be applied before the uplink DPCCCH transmission gap, and apply the resulting sum of TPC_cmd values when the uplink DPCCCH transmission resumes.

Two algorithms shall be supported by the UE for deriving a TPC_cmd. Which of these two algorithms is used is determined by a UE-specific higher-layer parameter, "PowerControlAlgorithm", and is under the control of the UTRAN. If "PowerControlAlgorithm" indicates "algorithm1", then the layer 1 parameter PCA shall take the value 1 and if "PowerControlAlgorithm" indicates "algorithm2" then PCA shall take the value 2.

If PCA has the value 1, Algorithm 1, described in subclause 5.1.2.2.2, shall be used for processing TPC commands.

If PCA has the value 2, Algorithm 2, described in subclause 5.1.2.2.3, shall be used for processing TPC commands unless UE_DTX_DRX_Enabled is TRUE, in which case Algorithm 1 shall be used for processing TPC commands.

The step size Δ_{TPC} is a layer 1 parameter which is derived from the UE-specific higher-layer parameter "TPC-StepSize" which is under the control of the UTRAN. If "TPC-StepSize" has the value "dB1", then the layer 1 parameter Δ_{TPC} shall take the value 1 dB and if "TPC-StepSize" has the value "dB2", then Δ_{TPC} shall take the value 2 dB. The parameter "TPC-StepSize" only applies to Algorithm 1 as stated in [5]. For Algorithm 2 Δ_{TPC} shall always take the value 1 dB.

After deriving of the combined TPC command TPC_cmd using one of the two supported algorithms, the UE shall adjust the transmit power of the uplink DPCCCH with a step of Δ_{DPCCCH} (in dB) which is given by:

$$\Delta_{DPCCCH} = \Delta_{TPC} \times TPC_cmd.$$

5.1.2.2.1.1 Out of synchronisation handling

After 160 ms after physical channel establishment (defined in [5]), the UE shall independently control its transmitter on each activated uplink frequency according to a downlink DPCCCH or F-DPCH quality criterion on the associated downlink frequency as follows:

- If UL_DTX_Active is FALSE (see section 6C), the UE shall stop transmitting on the associated uplink frequency when the UE estimates the DPCCCH or F-DPCH quality over the last 160 ms period to be worse than a threshold Q_{out} . If UL_DTX_Active is TRUE (see section 6C), the UE shall stop transmitting on the associated uplink frequency when the UE estimates the quality of the TPC fields of the F-DPCH from the serving HS-DSCH cell (or secondary serving HS-DSCH cell) over the last 240 slots in which the TPC symbols are known to be present to be worse than a threshold Q_{out} . Q_{out} is defined implicitly by the relevant tests in [7].
- If UL_DTX_Active is FALSE (see section 6C), the UE can start transmitting on the associated uplink frequency again when the UE estimates the DPCCCH or F-DPCH quality over the last 160 ms period to be better than a threshold Q_{in} . If UL_DTX_Active is TRUE (see section 6C), the UE can start transmitting on the associated uplink frequency again when the UE estimates the quality of the TPC fields of the F-DPCH from the serving HS-DSCH cell (or secondary serving HS-DSCH cell) over the last 240 slots in which the TPC symbols are known to be present to be better than a threshold Q_{in} . Q_{in} is defined implicitly by the relevant tests in [7]. When transmission is resumed, the power of the DPCCCH shall be the same as when the UE transmitter was shut off.

If higher layers indicate the usage of a post-verification period, the UE shall independently control its transmitter on each activated uplink frequency according to a downlink DPCCCH or F-DPCH quality criterion on the associated downlink frequency as follows:

- When the UE estimates the DPCCH or F-DPCH quality over the first 40 ms period of the first phase of the downlink synchronisation status evaluation to be worse than a threshold Q_{in} , the UE shall stop transmitting on the associated uplink frequency and consider post-verification failed. Q_{in} is defined implicitly by the relevant tests in [7]. When the UE transmission is resumed, the transmission of the uplink DPCCH power control preamble shall start N_{pcp} radio frames prior to the start of uplink DPDCH transmission, where N_{pcp} is a higher layer parameter set by UTRAN [5].

In case F-DPCH is configured in the downlink, the F-DPCH quality criterion shall be estimated as explained in subclause 4.3.1.2.

5.1.2.2.1.2 TPC command generation on downlink during RL initialisation

When commanded by higher layers the TPC commands sent on a downlink radio link from Node Bs that have not yet achieved uplink synchronisation shall follow a pattern as follows:

If higher layers indicate by "First RLS indicator" that the radio link is part of the first radio link set sent to the UE or if the radio link initialisation is caused by an HS-SCCH order to activate the secondary uplink frequency and the value 'n' obtained from the parameter "DL TPC pattern 01 count" passed by higher layers is different from 0 then :

- the TPC pattern shall consist of n instances of the pair of TPC commands ("0", "1"), followed by one instance of TPC command "1", where ("0", "1") indicates the TPC commands to be transmitted in 2 consecutive slots,
- the TPC pattern continuously repeat but shall be forcibly re-started at the beginning of each frame where $CFN \bmod 4 = 0$.

else

- The TPC pattern shall consist only of TPC commands "1".

The TPC pattern shall terminate once uplink synchronisation is achieved.

5.1.2.2.2 Algorithm 1 for processing TPC commands

5.1.2.2.2.1 Derivation of TPC_cmd when only one TPC command is received in each slot

When a UE is not in soft handover, only one TPC command will be received in each slot in which a TPC command is known to be present. In this case, the value of TPC_cmd shall be derived as follows:

- If the received TPC command is equal to 0 then TPC_cmd for that slot is -1.
- If the received TPC command is equal to 1, then TPC_cmd for that slot is 1.

5.1.2.2.2.2 Combining of TPC commands from radio links of the same radio link set

When a UE is in soft handover, multiple TPC commands may be received in each slot in which a TPC command is known to be present from different cells in the active set. In some cases, the UE has the knowledge that some of the transmitted TPC commands in a TPC command combining period are the same. This is the case when the radio links are in the same radio link set. For these cases, the TPC commands from the same radio link set in the same TPC command combining period shall be combined into one TPC command, to be further combined with other TPC commands as described in subclause 5.1.2.2.2.3.

5.1.2.2.2.3 Combining of TPC commands from radio links of different radio link sets

This subclause describes the general scheme for combination of the TPC commands from radio links of different radio link sets.

First, the UE shall for each TPC command combining period conduct a soft symbol decision W_i on each of the power control commands TPC_i , where $i = 1, 2, \dots, N$, where N is greater than 1 and is the number of TPC commands from radio links of different radio link sets, that may be the result of a first phase of combination according to subclause 5.1.2.2.2.2.

Finally, the UE derives a combined TPC command, TPC_cmd, as a function γ of all the N soft symbol decisions W_i :

- $TPC_cmd = \gamma (W_1, W_2, \dots, W_N)$, where TPC_cmd can take the values 1 or -1.

The function γ shall fulfil the following criteria:

If the N TPC_i commands are random and uncorrelated, with equal probability of being transmitted as "0" or "1", the probability that the output of γ is equal to 1 shall be greater than or equal to $1/(2^N)$, and the probability that the output of γ is equal to -1 shall be greater than or equal to 0.5. Further, the output of γ shall equal 1 if the TPC commands from all the radio link sets, that are not ignored according to section 5.1.2.2.1 or 5.1.2.3 are reliably "1", and the output of γ shall equal -1 if a TPC command from any of the radio link sets, that are not ignored according to section 5.1.2.2.1 or 5.1.2.3 is reliably "0".

5.1.2.2.3 Algorithm 2 for processing TPC commands

NOTE: Algorithm 2 makes it possible to emulate smaller step sizes than the minimum power control step specified in subclause 5.1.2.2.1, or to turn off uplink power control by transmitting an alternating series of TPC commands.

5.1.2.2.3.1 Derivation of TPC_cmd when only one TPC command is received in each slot

When a UE is not in soft handover, only one TPC command will be received in each slot. In this case, the UE shall process received TPC commands on a 5-slot cycle, where the sets of 5 slots shall be aligned to the frame boundaries and there shall be no overlap between each set of 5 slots.

The value of TPC_cmd shall be derived as follows:

- For the first 4 slots of a set, $TPC_cmd = 0$.
- For the fifth slot of a set, the UE uses hard decisions on each of the 5 received TPC commands as follows:
 - If all 5 hard decisions within a set are 1 then $TPC_cmd = 1$ in the 5th slot.
 - If all 5 hard decisions within a set are 0 then $TPC_cmd = -1$ in the 5th slot.
 - Otherwise, $TPC_cmd = 0$ in the 5th slot.

5.1.2.2.3.2 Combining of TPC commands from radio links of the same radio link set

When a UE is in soft handover, multiple TPC commands may be received in each slot from different cells in the active set. In some cases, the UE has the knowledge that some of the transmitted TPC commands in a TPC command combining period are the same. This is the case when the radio links are in the same radio link set. For these cases, the TPC commands from radio links of the same radio link set in the same TPC command combining period shall be combined into one TPC command, to be processed and further combined with any other TPC commands as described in subclause 5.1.2.2.3.3.

5.1.2.2.3.3 Combining of TPC commands from radio links of different radio link sets

This subclause describes the general scheme for combination of the TPC commands from radio links of different radio link sets.

The UE shall make a hard decision on the value of each TPC_i , where $i = 1, 2, \dots, N$ and N is the number of TPC commands from radio links of different radio link sets, that may be the result of a first phase of combination according to subclause 5.1.2.2.3.2.

The UE shall follow this procedure for 5 consecutive TPC command combining periods, resulting in N hard decisions for each of the 5 TPC command combining periods.

The sets of 5 TPC command combining periods shall for DPCH be aligned to the frame boundaries and for F-DPCH be aligned to 512 chips offset from the frame boundaries, and there shall be no overlap between each set of 5 TPC command combining periods.

The value of TPC_cmd is zero for the first 4 TPC command combining periods. After 5 TPC command combining periods have elapsed, the UE shall determine the value of TPC_cmd for the fifth TPC command combining period in the following way:

The UE first determines one temporary TPC command, TPC_temp_i, for each of the N sets of 5 TPC commands as follows:

- If all 5 hard decisions within a set are "1", TPC_temp_i = 1.
- If all 5 hard decisions within a set are "0", TPC_temp_i = -1.
- Otherwise, TPC_temp_i = 0.

Finally, the UE derives a combined TPC command for the fifth TPC command combining period, TPC_cmd, as a function γ of all the N temporary power control commands TPC_temp_i:

TPC_cmd(5th TPC command combining period) = γ (TPC_temp₁, TPC_temp₂, ..., TPC_temp_N), where TPC_cmd(5th TPC command combining period) can take the values 1, 0 or -1, and γ is given by the following definition:

- TPC_cmd is set to -1 if any of TPC_temp₁ to TPC_temp_N are equal to -1.
- Otherwise, TPC_cmd is set to 1 if $\frac{1}{N} \sum_{i=1}^N TPC_temp_i > 0.5$.
- Otherwise, TPC_cmd is set to 0.

5.1.2.3 Transmit power control in compressed mode

NOTE: 'Transmission gaps' correspond to transmission gaps created as a result of compressed mode. Another type of transmission gap may exist if DPCCH discontinuous transmission is applied (as described in section 6C), however these gaps are named 'uplink DPCCH transmission gaps'.

In compressed mode, one or more transmission gap pattern sequences are active. Therefore some frames are compressed and contain transmission gaps. The uplink power control procedure is as specified in clause 5.1.2.2, using the same UTRAN supplied parameters for Power Control Algorithm and step size (Δ_{TPC}), but with additional features which aim to recover as rapidly as possible a signal-to-interference ratio (SIR) close to the target SIR after each transmission gap.

The cells in the active set should estimate signal-to-interference ratio SIR_{est} of the received uplink DPCH. The cells in the active set should then generate TPC commands and transmit the commands once per slot, except during downlink transmission gaps, according to the following rule: if SIR_{est} > SIR_{cm_target} then the TPC command to transmit is "0", while if SIR_{est} < SIR_{cm_target} then the TPC command to transmit is "1".

SIR_{cm_target} is the target SIR during compressed mode and fulfils

$$SIR_{cm_target} = SIR_{target} + \Delta SIR_{PILOT} + \Delta SIR1_coding + \Delta SIR2_coding,$$

where $\Delta SIR1_coding$ and $\Delta SIR2_coding$ are computed from uplink parameters DeltaSIR1, DeltaSIR2, DeltaSIRafter1, DeltaSIRafter2 signalled by higher layers as:

- $\Delta SIR1_coding = \Delta SIR1$ if the start of the first transmission gap in the transmission gap pattern is within the current uplink frame and UE_DTX_DRX_Enabled is FALSE for the UE.
- $\Delta SIR1_coding = \Delta SIRafter1$ if the current uplink frame just follows a frame containing the start of the first transmission gap in the transmission gap pattern and UE_DTX_DRX_Enabled is FALSE for the UE.
- $\Delta SIR2_coding = \Delta SIR2$ if the start of the second transmission gap in the transmission gap pattern is within the current uplink frame and UE_DTX_DRX_Enabled is FALSE for the UE.
- $\Delta SIR2_coding = \Delta SIRafter2$ if the current uplink frame just follows a frame containing the start of the second transmission gap in the transmission gap pattern and UE_DTX_DRX_Enabled is FALSE for the UE.

- $\Delta\text{SIR1_coding} = 0$ dB and $\Delta\text{SIR2_coding} = 0$ dB in all other cases.

$\Delta\text{SIR}_{\text{PILOT}}$ is defined as: $\Delta\text{SIR}_{\text{PILOT}} = 10\text{Log}_{10}(N_{\text{pilot},N}/N_{\text{pilot,curr_frame}})$,

where $N_{\text{pilot,curr_frame}}$ is the number of pilot bits per slot in the current uplink frame, and $N_{\text{pilot},N}$ is the number of pilot bits per slot in a normal uplink frame without a transmission gap.

In the case of several compressed mode pattern sequences being used simultaneously, $\Delta\text{SIR1_coding}$ and $\Delta\text{SIR2_coding}$ offsets are computed for each compressed mode pattern and all $\Delta\text{SIR1_coding}$ and $\Delta\text{SIR2_coding}$ offsets are summed together.

In compressed mode, compressed frames may occur in either the uplink or the downlink or both. In uplink compressed frames, the transmission of uplink DPDCH(s) and DPCCH shall both be stopped during transmission gaps.

Due to the transmission gaps in compressed frames, there may be missing TPC commands in the downlink. If no downlink TPC command is transmitted, the corresponding TPC_cmd derived by the UE shall be set to zero.

Compressed and non-compressed frames in the uplink DPCCH may have a different number of pilot bits per slot. A change in the transmit power of the uplink DPCCH would be needed in order to compensate for the change in the total pilot energy. Therefore at the start of each slot the UE shall derive the value of a power offset Δ_{PILOT} . If the number of pilot bits per slot in the uplink DPCCH is different from its value in the most recently transmitted slot, Δ_{PILOT} (in dB) shall be given by:

$$\Delta_{\text{PILOT}} = 10\text{Log}_{10}(N_{\text{pilot,prev}}/N_{\text{pilot,curr}});$$

where $N_{\text{pilot,prev}}$ is the number of pilot bits in the most recently transmitted slot, and $N_{\text{pilot,curr}}$ is the number of pilot bits in the current slot. Otherwise, including during transmission gaps in the downlink, Δ_{PILOT} shall be zero.

Unless otherwise specified, in every slot during compressed mode the UE shall adjust the transmit power of the uplink DPCCH with a step of Δ_{DPCCH} (in dB) which is given by:

$$\Delta_{\text{DPCCH}} = \Delta_{\text{TPC}} \times \text{TPC_cmd} + \Delta_{\text{PILOT}}.$$

At the start of the first slot after an uplink or downlink transmission gap the UE shall apply a change in the transmit power of the uplink DPCCH by an amount Δ_{DPCCH} (in dB), with respect to the uplink DPCCH power in the most recently transmitted uplink slot, where:

$$\Delta_{\text{DPCCH}} = \Delta_{\text{RESUME}} + \Delta_{\text{PILOT}}.$$

The value of Δ_{RESUME} (in dB) shall be determined by the UE according to the Initial Transmit Power mode (ITP). The ITP is a UE specific parameter, which is signalled by the network with the other compressed mode parameters (see [4]). The different modes are summarised in table 1.

Table 1: Initial Transmit Power modes during compressed mode

Initial Transmit Power mode	Description
0	$\Delta_{\text{RESUME}} = \Delta_{\text{TPC}} \times \text{TPC_cmd}_{\text{gap}}$
1	$\Delta_{\text{RESUME}} = \delta_{\text{last}}$

If UE_DTX_DRX_Enabled is TRUE, the UE shall behave as if the ITP mode is 0.

In the case of a transmission gap in the uplink, $\text{TPC_cmd}_{\text{gap}}$ shall be derived as follows:

If DPCH is configured in the downlink then $\text{TPC_cmd}_{\text{gap}}$ shall be the value of TPC_cmd derived in the first slot of the uplink transmission gap, if a downlink TPC_command is transmitted in that slot. Otherwise $\text{TPC_cmd}_{\text{gap}}$ shall be zero if no downlink TPC_command is transmitted in that slot.

If F-DPCH is configured in the downlink then $\text{TPC_cmd}_{\text{gap}}$ shall be equal to the sum of the values of TPC_cmd derived from each TPC command combining period in which a TPC command is known to be present and is not ignored as described below and which cannot be applied before the uplink transmission gap. The UE shall ignore any TPC commands received in an F-DPCH slot starting during an uplink DPCCH slot which is in an uplink transmission gap. In case there are no TPC commands to be summed $\text{TPC_cmd}_{\text{gap}}$ shall be zero.

δ_{last} shall be equal to the most recently computed value of δ_i . δ_i shall be updated according to the following recursive relations, which shall be executed in all slots in which both the uplink DPCCH and a downlink TPC command are transmitted, and in the first slot of an uplink transmission gap if a downlink TPC command is transmitted in that slot:

$$\begin{aligned}\delta_i &= 0.9375\delta_{i-1} - 0.96875\text{TPC_cmd}_i\Delta_{\text{TPC}}k_{sc} \\ \delta_{i-1} &= \delta_i\end{aligned}$$

where: TPC_cmd_i is the power control command derived by the UE in that slot;

$k_{sc} = 0$ if additional scaling is applied in the current slot and the previous slot as described in sub-clause 5.1.2.6, and $k_{sc} = 1$ otherwise.

δ_{i-1} is the value of δ_i computed for the previous slot. The value of δ_{i-1} shall be initialised to zero when the uplink DPCCH is activated, and also at the end of the first slot after each uplink transmission gap, and also at the end of the first slot after each downlink transmission gap. The value of δ_i shall be set to zero at the end of the first slot after each uplink transmission gap.

After a transmission gap in either the uplink or the downlink, the period following resumption of simultaneous uplink and downlink DPCCH or F-DPCH transmission is called a recovery period. RPL is the recovery period length and is expressed as a number of slots. RPL is equal to the minimum value out of the transmission gap length and 7 slots. If a transmission gap or an Uplink DPCCH burst pattern gap as defined in subclause 6C.2 is scheduled to start before RPL slots have elapsed, then the recovery period shall end at the start of the gap, and the value of RPL shall be reduced accordingly.

During the recovery period, 2 modes are possible for the power control algorithm. The Recovery Period Power control mode (RPP) is signalled with the other compressed mode parameters (see [4]). The different modes are summarised in the table 2:

Table 2: Recovery Period Power control modes during compressed mode

Recovery Period power control mode	Description
0	Transmit power control is applied using the algorithm determined by the value of PCA, as in subclause 5.1.2.2 with step size Δ_{TPC} .
1	Transmit power control is applied using algorithm 1 (see subclause 5.1.2.2.2) with step size $\Delta_{\text{RP-TPC}}$ during RPL slots after each transmission gap.

If $\text{UE_DTX_DRX_Enabled}$ is TRUE, the UE shall behave as if the RPP mode is 0.

For RPP mode 0, the step size is not changed during the recovery period and ordinary transmit power control is applied (see subclause 5.1.2.2), using the algorithm for processing TPC commands determined by the value of PCA (see subclauses 5.1.2.2.2 and 5.1.2.2.3).

For RPP mode 1, during RPL slots after each transmission gap, power control algorithm 1 is applied with a step size $\Delta_{\text{RP-TPC}}$ instead of Δ_{TPC} , regardless of the value of PCA. Therefore, the change in uplink DPCCH transmit power at the start of each of the RPL+1 slots immediately following the transmission gap (except for the first slot after the transmission gap) is given by:

$$\Delta_{\text{DPCCH}} = \Delta_{\text{RP-TPC}} \times \text{TPC_cmd} + \Delta_{\text{PILOT}}$$

$\Delta_{\text{RP-TPC}}$ is called the recovery power control step size and is expressed in dB. If PCA has the value 1, $\Delta_{\text{RP-TPC}}$ is equal to the minimum value of 3 dB and $2\Delta_{\text{TPC}}$. If PCA has the value 2, $\Delta_{\text{RP-TPC}}$ is equal to 1 dB.

After the recovery period, ordinary transmit power control resumes using the algorithm specified by the value of PCA and with step size Δ_{TPC} .

If PCA has the value 2, the sets of slots over which the TPC commands are processed shall remain aligned to the frame boundaries in the compressed frame. For both RPP mode 0 and RPP mode 1, if the transmission gap or the recovery period results in any incomplete sets of TPC commands, TPC_cmd shall be zero for those sets of slots which are incomplete.

5.1.2.4 Transmit power control in the uplink DPCCH power control preamble

An uplink DPCCH power control preamble is a period of uplink DPCCH transmission prior to the start of the uplink DPDCH transmission. The downlink DPCCH or F-DPCH shall also be transmitted during an uplink DPCCH power control preamble.

The length of the uplink DPCCH power control preamble is a higher layer parameter signalled by the network as defined in [5]. The uplink DPDCH transmission shall commence after the end of the uplink DPCCH power control preamble.

During the uplink DPCCH power control preamble the change in uplink DPCCH transmit power shall be given by:

$$\Delta_{\text{DPCCH}} = \Delta_{\text{TPC}} \times \text{TPC_cmd.}$$

During the uplink DPCCH power control preamble TPC_cmd is derived according to algorithm 1 as described in sub clause 5.1.2.2.1, regardless of the value of PCA.

Ordinary power control (see subclause 5.1.2.2), with the power control algorithm determined by the value of PCA and step size Δ_{TPC} , shall be used after the end of the uplink DPCCH power control preamble.

5.1.2.5 Setting of the uplink DPCCH/DPDCH relative powers

5.1.2.5.1 General

The uplink DPCCH and DPDCH(s) are transmitted on different codes as defined in subclause 4.2.1 of [3]. In the case that at least one DPDCH is configured, the gain factors β_c and β_d may vary for each TFC. There are two ways of controlling the gain factors of the DPCCH code and the DPDCH codes for different TFCs in normal (non-compressed) frames:

- β_c and β_d are signalled for the TFC, or
- β_c and β_d is computed for the TFC, based on the signalled settings for a reference TFC.

Combinations of the two above methods may be used to associate β_c and β_d values to all TFCs in the TFCS. The two methods are described in subclauses 5.1.2.5.2 and 5.1.2.5.3 respectively. Several reference TFCs may be signalled from higher layers.

The gain factors may vary on radio frame basis depending on the current TFC used. Further, the setting of gain factors is independent of the inner loop power control.

After applying the gain factors, the UE shall scale the total transmit power of the DPCCH and DPDCH(s), such that the DPCCH output power follows the changes required by the power control procedure with power adjustments of Δ_{DPCCH} dB, subject to the provisions of sub-clause 5.1.2.6.

The gain factors during compressed frames are based on the nominal power relation defined in normal frames, as specified in subclause 5.1.2.5.4.

5.1.2.5.2 Signalled gain factors

When the gain factors β_c and β_d are signalled by higher layers for a certain TFC, the signalled values are used directly for weighting of DPCCH and DPDCH(s). The variable A_j , called the nominal power relation is then computed as:

$$A_j = \frac{\beta_d}{\beta_c}.$$

5.1.2.5.3 Computed gain factors

The gain factors β_c and β_d may also be computed for certain TFCs, based on the signalled settings for a reference TFC.

Let $\beta_{c,ref}$ and $\beta_{d,ref}$ denote the signalled gain factors for the reference TFC. Further, let $\beta_{c,j}$ and $\beta_{d,j}$ denote the gain factors used for the j :th TFC. Also let L_{ref} denote the number of DPDCHs used for the reference TFC and L_j denote the number of DPDCHs used for the j :th TFC.

Define the variable

$$K_{ref} = \sum_i RM_i \cdot N_i ;$$

where RM_i is the semi-static rate matching attribute for transport channel i (defined in [2] subclause 4.2.7), N_i is the number of bits output from the radio frame segmentation block for transport channel i (defined in [2] subclause 4.2.6.1), and the sum is taken over all the transport channels i in the reference TFC.

Similarly, define the variable

$$K_j = \sum_i RM_i \cdot N_i ;$$

where the sum is taken over all the transport channels i in the j :th TFC.

The variable A_j , called the nominal power relation is then computed as:

$$A_j = \frac{\beta_{d,ref}}{\beta_{c,ref}} \cdot \sqrt{\frac{L_{ref}}{L_j}} \sqrt{\frac{K_j}{K_{ref}}} .$$

The gain factors for the j :th TFC are then computed as follows:

- If $A_j > 1$, then $\beta_{d,j} = 1.0$ and $\beta_{c,j}$ is the largest quantized β -value, for which the condition $\beta_{c,j} \leq 1 / A_j$ holds. Since $\beta_{c,j}$ may not be set to zero, if the above rounding results in a zero value, $\beta_{c,j}$ shall be set to the lowest quantized amplitude ratio of 1/15 as specified in [3].
- If $A_j \leq 1$, then $\beta_{d,j}$ is the smallest quantized β -value, for which the condition $\beta_{d,j} \geq A_j$ holds and $\beta_{c,j} = 1.0$.

The quantized β -values are defined in [3] subclause 4.2.1, table 1.

5.1.2.5.4 Setting of the uplink DPCCH/DPDCH relative powers in compressed mode

The gain factors used during a compressed frame for a certain TFC are calculated from the nominal power relation used in normal (non-compressed) frames for that TFC. Let A_j denote the nominal power relation for the j :th TFC in a normal frame. Further, let $\beta_{c,C,j}$ and $\beta_{d,C,j}$ denote the gain factors used for the j :th TFC when the frame is compressed. The variable $A_{C,j}$ is computed as:

$$A_{C,j} = A_j \cdot \sqrt{\frac{15 \cdot N_{pilot,C}}{N_{slots,C} \cdot N_{pilot,N}}} ;$$

where $N_{pilot,C}$ is the number of pilot bits per slot when in compressed mode, and $N_{pilot,N}$ is the number of pilot bits per slot in normal mode. $N_{slots,C}$ is the number of slots in the compressed frame used for transmitting the data.

The gain factors for the j :th TFC in a compressed frame are computed as follows:

- If $A_{C,j} > 1$, then $\beta_{d,C,j} = 1.0$ and $\beta_{c,C,j}$ is the largest quantized β -value, for which the condition $\beta_{c,C,j} \leq 1 / A_{C,j}$ holds. Since $\beta_{c,C,j}$ may not be set to zero, if the above rounding results in a zero value, $\beta_{c,C,j}$ shall be set to the lowest quantized amplitude ratio of 1/15 as specified in [3].
- If $A_{C,j} \leq 1$, then $\beta_{d,C,j}$ is the smallest quantized β -value, for which the condition $\beta_{d,C,j} \geq A_{C,j}$ holds and $\beta_{c,C,j} = 1.0$.

The quantized β -values are defined in [3] subclause 4.2.1, table 1.

5.1.2.5A Setting of the uplink HS-DPCCH power relative to DPCCH power

When one or two HS-DPCCH are active, the values for Δ_{ACK} , Δ_{NACK} and Δ_{CQI} set by higher layers are translated to the quantized amplitude ratios A_{hs} as specified in [3] subclause 4.2.1.2, and shall be set for each HS-DPCCH slot as follows.

When only one activated cell's HARQ-ACK information is mapped to a HS-DPCCH, for each HS-DPCCH and each slot carrying HARQ Acknowledgement, the HS-DPCCH power settings are described in Table 2a. When more than one activated cell whose HARQ-ACK information are mapped to a specific HS-DPCCH, the HS-DPCCH power settings are described in Table 2b. When the UE is configured in Multiflow mode, the HARQ-ACK slot power settings of the HS-DPCCH are described in table 2b.1.

Table 2a: HARQ-ACK power offset setting when Secondary_Cell_Active is 0 or when Secondary_Cell_Enabled is more than 3 in case UE is not configured in MIMO mode with four transmit antennas in any cell, is more than 1 in case the UE is configured in MIMO mode with four transmit antennas in at least one cell and only HARQ-ACK information of one active downlink cell is mapped to either HS-DPCCH or HS-DPCCH₂

HARQ-ACK message sent in one time slot	A_{hs} equals the quantized amplitude ratio translated from
ACK	Δ_{ACK}
NACK	Δ_{NACK}
PRE before single transport block or POST after a single transport block	$\text{MAX}(\Delta_{ACK}, \Delta_{NACK})$
ACK/ACK	$\Delta_{ACK} + 1$
NACK/NACK	$\Delta_{NACK} + 1$
ACK/NACK or NACK/ACK or PRE before a dual transport block or POST after a dual transport block	$\text{MAX}(\Delta_{ACK} + 1, \Delta_{NACK} + 1)$

Table 2b: HARQ-ACK power offset setting when the HARQ-ACK information of more than one active downlink cell is mapped to either HS-DPCCH or HS-DPCCH₂

Number of active cells mapped to the HS-DPCCH or HS-DPCCH ₂	Condition	A_{hs} equals the quantized amplitude ratio translated from		
		Composite HARQ-ACK message(s) sent in one time slot		
		contains at least one ACK but no NACK	contains at least one NACK but no ACK	contains both ACK and NACK or is a PRE or is a POST
2	MIMO mode with four transmit antennas is not configured in any cell	$\Delta_{ACK} + 1$	$\Delta_{NACK} + 1$	$\text{MAX}(\Delta_{ACK} + 1, \Delta_{NACK} + 1)$
2	MIMO mode with four transmit antennas is configured in at least one cell	$\Delta_{ACK} + 2$	$\Delta_{NACK} + 2$	$\text{MAX}(\Delta_{ACK} + 2, \Delta_{NACK} + 2)$
3	Secondary_Cell_Enabled is 2 and MIMO or MIMO mode with four transmit antennas is not configured in any cell	$\Delta_{ACK} + 1$	$\Delta_{NACK} + 1$	$\text{MAX}(\Delta_{ACK} + 1, \Delta_{NACK} + 1)$
3	Otherwise	$\Delta_{ACK} + 2$	$\Delta_{NACK} + 2$	$\text{MAX}(\Delta_{ACK} + 2, \Delta_{NACK} + 2)$
4		$\Delta_{ACK} + 2$	$\Delta_{NACK} + 2$	$\text{MAX}(\Delta_{ACK} + 2, \Delta_{NACK} + 2)$

Table 2b.1: HARQ-ACK power offset setting when the UE is configured in Multiflow mode

Number of cells configured to the UE (Note 1)	Condition	A_{hs} equals the quantized amplitude ratio translated from		
		Composite HARQ-ACK message(s) sent in one time slot		
		contains at least one ACK but no NACK	contains at least one NACK but no ACK	contains both ACK and NACK or is a PRE or is a POST
2		$\Delta_{ACK} + 1$	$\Delta_{NACK} + 1$	$\text{MAX}(\Delta_{ACK} + 1, \Delta_{NACK} + 1)$
3	MIMO not configured in any cell	$\Delta_{ACK} + 1$	$\Delta_{NACK} + 1$	$\text{MAX}(\Delta_{ACK} + 1, \Delta_{NACK} + 1)$
3	MIMO configured in at least one cell	$\Delta_{ACK} + 2$	$\Delta_{NACK} + 2$	$\text{MAX}(\Delta_{ACK} + 2, \Delta_{NACK} + 2)$
4		$\Delta_{ACK} + 2$	$\Delta_{NACK} + 2$	$\text{MAX}(\Delta_{ACK} + 2, \Delta_{NACK} + 2)$

Note 1: When the UE is configured in the Multiflow mode, the cell deactivation with HS-SCCH orders do not impact the HARQ-ACK power offset used.

For each HS-DPCCH and each slot carrying CQI, the HS-DPCCH power setting is described in Tables 2c and 2d:

Table 2c: CQI power offset setting when the UE is not in Multiflow mode

Number of active cells mapped to HS-DPCCH or HS-DPCCH ₂	Condition	A_{hs} equals the quantized amplitude ratio translated from		
		MIMO or MIMO with four transmit antennas is not configured in a cell	MIMO or MIMO with four transmit antennas is configured in a cell	
			CQI of Type A	CQI of Type B
1	-	Δ_{CQI}	$\Delta_{CQI} + 1$	Δ_{CQI}
2	Secondary_Cell_Enabled is 1, and MIMO or MIMO with four transmit antennas is not configured in any cell	$\Delta_{CQI} + 1$	N/A	N/A
2	Otherwise	Δ_{CQI}	$\Delta_{CQI} + 1$	Δ_{CQI}
3 (Note 1)	Secondary_Cell_Enabled is 2 and MIMO is not configured in any cell	Δ_{CQI}	N/A	N/A
3 (Note 2)		$\Delta_{CQI} + 1$	N/A	N/A
3	Otherwise	$\Delta_{CQI} + 1$	$\Delta_{CQI} + 2$	$\Delta_{CQI} + 1$
4		$\Delta_{CQI} + 1$	$\Delta_{CQI} + 2$	$\Delta_{CQI} + 1$

Note 1: When the UE transmits a CQI report for the serving HS-DSCH cell in a subframe

Note 2: When the UE transmits a composite CQI report for 1st and 2nd secondary serving HS-DSCH cells in a subframe.

Table 2d: CQI power offset setting when the UE is in Multiflow mode

Number of cells configured to the UE (Note 1)	MIMO configured in at least one cell	A_{hs} equals the quantized amplitude ratio translated from		
		MIMO is not configured in a cell	MIMO is configured in a cell	
			CQI of Type A	CQI of Type B
2	No	$\Delta_{CQI} + 1$	N/A	
2	Yes	Δ_{CQI}	$\Delta_{CQI} + 1$	Δ_{CQI}
3 (Note 2)	No	Δ_{CQI}	N/A	
3 (Note 3)		$\Delta_{CQI} + 1$		
3	Yes	$\Delta_{CQI} + 1$	$\Delta_{CQI} + 2$	$\Delta_{CQI} + 1$
4	No	$\Delta_{CQI} + 1$	N/A	
4	Yes	$\Delta_{CQI} + 1$	$\Delta_{CQI} + 2$	$\Delta_{CQI} + 1$

Note 1: When the UE is configured in the Multiflow mode, the cell activations and deactivations with HS-SCCH orders do not impact the CQI power offsets used.

Note 2: When the UE transmits a CQI report for the cell group consisting of one cell only

Note 3: When the UE transmits a composite CQI report of the cell group consisting of two cells, or a CQI report of the remaining active cell if the secondary cell of this cell group was deactivated by a HS-SCCH order.

Then, in non-compressed frames β_{hs} , which is the gain factor defined in [3] subclause 4.2.1.2, is calculated according to

$$\beta_{hs} = \beta_c \cdot A_{hs},$$

where β_c value is signalled by higher-layer or calculated as described in subclause 5.1.2.5.2 or 5.1.2.5.3 if at least one DPDCH is configured. In case no DPDCH is configured, β_c value is set as described in subclause 5.1.2.5C.

With the exception of the start and end of compressed frames, any DPCCH power change shall not modify the power ratio between the DPCCH and the HS-DPCCH. The power ratio between the DPCCH and the HS-DPCCH during compressed DPCCH frames is described below.

During the period between the start and end of a compressed DPCCH frame, when HS-DPCCH is transmitted, β_{hs} is calculated according to

$$\beta_{hs} = \beta_{c,C,j} \cdot A_{hs} \cdot \sqrt{\frac{N_{pilot,C}}{N_{pilot,N}}},$$

where $\beta_{c,C,j}$ is calculated as described in subclause 5.1.2.5.4 if at least one DPDCH is configured. In case no DPDCH is configured, $\beta_{c,C,j}$ value is set as described in subclause 5.1.2.5C. $N_{pilot,C}$ is the number of pilot bits per slot on the DPCCH in compressed frames, and $N_{pilot,N}$ is the number of pilot bits per slot in non-compressed frames.

Thus the gain factor β_{hs} varies depending on the current quantized amplitude ratio A_{hs} and on whether the UL DPCCH is currently in a compressed frame.

5.1.2.5B Setting of the uplink E-DPCCH and E-DPDCH powers relative to DPCCH power

5.1.2.5B.1 E-DPCCH/DPCCH when one transport block is transmitted on E-DCH

The E-DPCCH gain factor computation depends on the transmitted E-TFC at a given TTI.

In non compressed frames, if $E-TFCI_i$ is smaller than or equal to $E-TFCI_{ec,boost}$, where $E-TFCI_i$ denotes the E-TFCI of the i :th E-TFC, the E-DPCCH gain factor, β_{ec} , which is defined in [3] subclause 4.2.1.3, is calculated according to

$$\beta_{ec} = \beta_c \cdot A_{ec}$$

where β_c value is signalled by higher-layers or calculated as described in subclause 5.1.2.5.2 or 5.1.2.5.3 if at least one DPDCH is configured. In case no DPDCH is configured, β_c value is set as described in subclause 5.1.2.5C. A_{ec} is defined in [3] subclause 4.2.1.3. The $E-TFCI_{ec,boost}$ value is signalled by higher layers.

In non compressed frames if $E-TFCI_i$ is greater than $E-TFCI_{ec,boost}$, the unquantized E-DPCCH gain factor for the i :th E-TFC, $\beta_{ec,i,uq}$, is calculated according to

$$\beta_{ec,i,uq} = \beta_c \cdot \sqrt{\max \left(A_{ec}^2, \frac{\sum_{k=1}^{k_{max,i}} \left(\frac{\beta_{ed,i,k}}{\beta_c} \right)^2}{10^{\frac{\Delta T_{2TP}}{10}}} - 1 \right)}$$

where ΔT_{2TP} is signalled by higher layers and is defined in [3] subclause 4.2.1.3, $\beta_{ed,i,k}$ is the E-DPDCH gain factor for the i :th E-TFC on the k :th physical channel and $k_{max,i}$ is the number of physical channels used for the i :th E-TFC.

If $\beta_{ec,i,uq}$ is less than the smallest quantized value of Table 1B.0A in [3] subclause 4.2.1.3, then the E-DPCCH gain factor of $E-TFCI_i$, $\beta_{ec,i}$ is set such that $\beta_{ec,i}/\beta_c$ is the smallest quantized value of Table 1B.0A in [3] subclause 4.2.1.3. Otherwise, $\beta_{ec,i}$ is selected from Table 1B.0A in [3] subclause 4.2.1.3, such that $20 \cdot \log_{10}(\beta_{ec,i}/\beta_c)$ is the nearest quantized value to $20 \cdot \log_{10}(\beta_{ec,i,uq}/\beta_c)$.

During compressed frames where the E-DCH TTI is 2msec, the E-DPCCH gain factor, β_{ec} , which is defined in [3] subclause 4.2.1.3, is calculated according to:

$$\beta_{ec} = \beta_{c,C,j} \cdot A_{ec} \cdot \sqrt{\frac{N_{pilot,C}}{N_{pilot,N}}} \text{ if } E-TFCI_i \text{ is smaller than or equal to } E-TFCI_{ec,boost}.$$

and according to

$$\beta_{ec,i,uq} = \beta_{c,C,j} \cdot \sqrt{\max \left(A_{ec}^2, \frac{\sum_{k=1}^{k_{max,i}} \left(\frac{\beta_{ed,i,k}}{\beta_c} \right)^2}{10^{\frac{\Delta T_{2TP}}{10}}} - 1 \right)} \cdot \sqrt{\frac{N_{pilot,C}}{N_{pilot,N}}} \text{ if } E-TFCI_i \text{ is greater than } E-TFCI_{ec,boost}.$$

where $\beta_{c,C,j}$ is calculated as described in subclause 5.1.2.5.4 if at least one DPDCH is configured. In case no DPDCH is configured, the $\beta_{c,C,j}$ value is set as described in subclause 5.1.2.5C. $\beta_{ed,i,k}$ is the E-DPDCH gain factor for the i :th E-TFC on the k :th physical channel in non-compressed frames. $N_{pilot,C}$ is the number of pilot bits per slot on the

DPCCH in compressed frames, and $N_{pilot,N}$ is the number of pilot bits per slot in non-compressed frames. $N_{slots,C}$ is the number of non DTX slots in the compressed frame.

During compressed frames and where the E-DCH TTI is 10msec, the E-DPCCH gain factor, β_{ec} , which is defined in [3] subclause 4.2.1.3, is calculated according to:

$$\beta_{ec} = \beta_{c,C,j} \cdot A_{ec} \cdot \sqrt{\frac{15 \cdot N_{pilot,C}}{N_{slots,C} \cdot N_{pilot,N}}} \text{ if } E\text{-}TFCI_i \text{ is smaller than or equal to } E\text{-}TFCI_{ec,boost}$$

and according to

$$\beta_{ec,i,uq} = \beta_{c,C,j} \cdot \sqrt{\max \left(A_{ec}^2, \frac{\sum_{k=1}^{k_{\max,j}} \left(\frac{\beta_{ed,i,k}}{\beta_c} \right)^2}{10^{\frac{\Delta_{T27P}}{10}}} - 1 \right)} \cdot \sqrt{\frac{15 \cdot N_{pilot,C}}{N_{slots,C} \cdot N_{pilot,N}}} \text{ if } E\text{-}TFCI_i \text{ is greater than } E\text{-}TFCI_{ec,boost}$$

where, $N_{slots,C}$ is the number of non DTX slots in the compressed frame.

5.1.2.5B.1A E-DPCCH/DPCCH when two transport blocks are transmitted on E-DCH (rank-2)

When UL_MIMO_Enabled is TRUE, and the UE is transmitting two transport blocks, the E-DPCCH/DPCCH power ratio is calculated according to the definitions in subclause 5.1.2.5B.1 assuming $E\text{-}TFCI_{ec,boost} = -1$.

5.1.2.5B.2 E-DPDCH/DPCCH

5.1.2.5B.2.1 General

The E-DPDCH gain factor, β_{ed} , which is defined in [3] subclause 4.2.1.3, may take a different value for each E-TFC and HARQ offset. The gain factors for different E-TFCs and HARQ offsets are computed as described in subclause 5.1.2.5B.2.3 based on reference gain factor(s) $\beta_{ed,ref}$ of E-TFC(s) signalled as reference E-TFC(s). The $\beta_{ed,ref}$ are computed as described in subclause 5.1.2.5B.2.2. At least one E-TFC of the set of E-TFCs configured by the network shall be signalled as a reference E-TFC.

The gain factors may vary on radio frame basis or sub-frame basis depending on the E-DCH TTI used. Further, the setting of gain factors is independent of the inner loop power control.

5.1.2.5B.2.2 Computation of reference gain factors

Let $E\text{-}TFCI_{ref,m}$ denote the E-TFCI of the m :th reference E-TFC, where $m=1,2,\dots,M$ and M is the number of signalled reference E-TFCs and $E\text{-}TFCI_{ref,1} < E\text{-}TFCI_{ref,2} < \dots < E\text{-}TFCI_{ref,M}$.

For each reference E-TFC, a reference gain factor $\beta_{ed,ref}$ is calculated according to

$$\beta_{ed,ref} = \beta_c \cdot A_{ed}$$

where β_c value is signalled by higher-layer or calculated as described in subclause 5.1.2.5.2 or 5.1.2.5.3 if at least one DPDCH is configured. In case no DPDCH is configured, β_c value is set as described in subclause 5.1.2.5C. A_{ed} is defined in [3] subclause 4.2.1.3 table 1B.1 when the reference $E\text{-}TFCI_{ref,m}$ is smaller than or equal to $E\text{-}TFCI_{ec,boost}$; otherwise, A_{ed} is defined in [3] subclause 4.2.1.3 table 1B.2A when reference $E\text{-}TFCI_{ref,m}$ is greater than $E\text{-}TFCI_{ec,boost}$.

5.1.2.5B.2.3 Computation of gain factors

The gain factor β_{ed} of an E-TFC is computed based on the signalled settings for its corresponding reference E-TFC.

Whether E-DPDCH power extrapolation formula or E-DPDCH power interpolation formula is used to compute the gain factor β_{ed} is signalled by higher layers.

Let $E-TFCI_i$ denote the E-TFCI of the i :th E-TFC.

For the i :th E-TFC:

If E-DPDCH power extrapolation formula is configured

if $E-TFCI_i \geq E-TFCI_{ref,M}$, the reference E-TFC is the M :th reference E-TFC.

if $E-TFCI_i < E-TFCI_{ref,1}$, the reference E-TFC is the 1st reference E-TFC.

if $E-TFCI_{ref,1} \leq E-TFCI_i < E-TFCI_{ref,M}$, the reference E-TFC is the m :th reference E-TFC such that $E-TFCI_{ref,m} \leq E-TFCI_i < E-TFCI_{ref,m+1}$.

Else If E-DPDCH power interpolation formula is configured

if $E-TFCI_i \geq E-TFCI_{ref,M}$, the primary and secondary reference E-TFCs are the $(M-1)$:th and M :th reference E-TFCs respectively.

if $E-TFCI_i < E-TFCI_{ref,1}$, the primary and secondary reference E-TFCs are the 1st and 2nd reference E-TFCs respectively.

if $E-TFCI_{ref,1} \leq E-TFCI_i < E-TFCI_{ref,M}$, the primary and secondary reference E-TFCs are the m :th and $(m+1)$:th reference E-TFCs respectively, such that $E-TFCI_{ref,m} \leq E-TFCI_i < E-TFCI_{ref,m+1}$.

When E-DPDCH power extrapolation formula is configured, let $\beta_{ed,ref}$ denote the reference gain factor of the reference E-TFC. Let $L_{e,ref}$ denote the number of E-DPDCHs used for the reference E-TFC and $L_{e,i}$ denote the number of E-DPDCHs used for the i :th E-TFC. If SF2 is used, $L_{e,ref}$ and $L_{e,i}$ are the equivalent number of physical channels assuming SF4. Let $K_{e,ref}$ denote the transport block size of the reference E-TFC and $K_{e,i}$ denote the transport block size of the i :th E-TFC, where the mapping between the E-TFCI and the E-DCH transport block size is defined in [9]. For the i :th E-TFC, the temporary variable $\beta_{ed,i,harq}$ is then computed as:

$$\beta_{ed,i,harq} = \beta_{ed,ref} \sqrt{\frac{L_{e,ref}}{L_{e,i}}} \sqrt{\frac{K_{e,i}}{K_{e,ref}}} \cdot 10^{\left(\frac{\Delta_{harq}}{20}\right)}$$

where the HARQ offset Δ_{harq} is defined in [3] subclause 4.2.1.3.

When E-DPDCH power interpolation formula is configured, let $\beta_{ed,ref,1}$ and $\beta_{ed,ref,2}$ denote the reference gain factors of the primary and secondary reference E-TFCs respectively. Let $L_{e,ref,1}$ and $L_{e,ref,2}$ denote the number of E-DPDCHs used for the primary and secondary reference E-TFCs respectively. Let $L_{e,i}$ denotes the number of E-DPDCHs used for the i :th E-TFC. If SF2 is used, $L_{e,ref,1}$, $L_{e,ref,2}$ and $L_{e,i}$ are the equivalent number of physical channels assuming SF4. Let $K_{e,ref,1}$ and $K_{e,ref,2}$ denote the transport block sizes of the primary and secondary reference E-TFCs respectively. Let $K_{e,i}$ denotes the transport block size of the i :th E-TFC, where the mapping between the E-TFCI and the E-DCH transport block size is defined in [9]. For the i :th E-TFC, the temporary variable $\beta_{ed,i,harq}$ is computed as:

$$\beta_{ed,i,harq} = \sqrt{\frac{L_{e,ref,1}}{L_{e,i}}} \cdot \sqrt{\left(\frac{\frac{L_{e,ref,2}}{L_{e,ref,1}} \beta_{ed,ref,2}^2 - \beta_{ed,ref,1}^2}{K_{e,ref,2} - K_{e,ref,1}} \right) (K_{e,i} - K_{e,ref,1}) + \beta_{ed,ref,1}^2} \cdot 10^{\left(\frac{\Delta_{harq}}{20}\right)} \text{ with the exception}$$

that $\beta_{ed,i,harq}$ is set to 0 if

$$\left(\frac{\frac{L_{e,ref,2}}{L_{e,ref,1}} \beta_{ed,ref,2}^2 - \beta_{ed,ref,1}^2}{K_{e,ref,2} - K_{e,ref,1}} \right) (K_{e,i} - K_{e,ref,1}) + \beta_{ed,ref,1}^2 \leq 0.$$

For the i :th E-TFC, the unquantized gain factor $\beta_{ed,k,i,uq}$ for the k :th E-DPDCH (denoted E-DPDCH _{k} in [3] subclause 4.2.1.3) shall be set to $\sqrt{2} \times \beta_{ed,i,harq}$ if the spreading factor for E-DPDCH _{k} is 2 and to $\beta_{ed,i,harq}$ otherwise.

The following applies:

- For E-TFCI smaller than or equal to $E-TFCI_{ec,boost}$,
 - If $\beta_{ed,k,i,uq}/\beta_c$ is less than the smallest quantized value of Table 1B.2 in [3] subclause 4.2.1.3, then the gain factor of E-DPDCH _{k} , $\beta_{ed,k}$ is set such that $\beta_{ed,k}/\beta_c$ is the smallest quantized value of Table 1B.2 in [3] subclause 4.2.1.3.
 - Otherwise, $\beta_{ed,k}$ is set such that $\beta_{ed,k}/\beta_c$ is the largest quantized value of Table 1B.2 in [3] subclause 4.2.1.3, for which the condition $\beta_{ed,k} \leq \beta_{ed,k,i,uq}$ holds.
- For E-TFCI greater than $E-TFCI_{ec,boost}$,
 - If $\beta_{ed,k,i,uq}/\beta_c$ is less than the smallest quantized value of Table 1B.2B in [3] subclause 4.2.1.3, then the gain factor of E-DPDCH _{k} , $\beta_{ed,k}$ is set such that $\beta_{ed,k}/\beta_c$ is the smallest quantized value of Table 1B.2B in [3] subclause 4.2.1.3.
 - Otherwise, $\beta_{ed,k}$ is set such that $\beta_{ed,k}/\beta_c$ is the largest quantized value of Table 1B.2B in [3] subclause 4.2.1.3, for which the condition $\beta_{ed,k} \leq \beta_{ed,k,i,uq}$ holds.

5.1.2.5B.2.4 E-DPDCH/DPCCH adjustments relating to compressed mode

The gain factor applied to E-DPDCH is adjusted as a result of compressed mode operation in the following cases:

- E-DCH transmissions that overlap a compressed frame
- For 10msec E-DCH TTI case, retransmissions that do not themselves overlap a compressed frame, but for which the corresponding initial transmission overlapped a compressed frame.

The gain factors used during a compressed frame for a certain E-TFC are calculated from the nominal power relation used in normal (non-compressed) frames for that E-TFC. When the frame is compressed, the gain factor used for the i :th E-TFC is derived from $\beta_{ed,C,i}$ as described below.

When the E-DCH TTI is 2msec, $\beta_{ed,C,i}$ shall be calculated as follows:

If E-DPDCH power extrapolation formula is configured,

$$\beta_{ed,C,i} = \beta_{c,C,j} \cdot A_{ed} \cdot \sqrt{\frac{L_{e,ref}}{L_{e,i}}} \cdot \sqrt{\frac{K_{e,i}}{K_{e,ref}}} \cdot 10^{\left(\frac{\Delta_{harq}}{20}\right)} \cdot \sqrt{\frac{N_{pilot,C}}{N_{pilot,N}}}$$

Else if E-DPDCH power interpolation formula is configured,

$$\beta_{ed,C,i} = \beta_{c,C,j} \cdot \sqrt{\frac{L_{e,ref,1}}{L_{e,i}}} \cdot \sqrt{\left(\frac{\left(\frac{L_{e,ref,2}}{L_{e,ref,1}} A_{ed,2}^2 - A_{ed,1}^2 \right)}{K_{e,ref,2} - K_{e,ref,1}} \right) \left(K_{e,i} - K_{e,ref,1} \right) + A_{ed,1}^2} \cdot 10^{\left(\frac{\Delta_{harq}}{20}\right)} \cdot \sqrt{\frac{N_{pilot,C}}{N_{pilot,N}}}$$

with the exception that $\beta_{ed,C,i}$ is set to 0 if $\left(\frac{L_{e,ref,2}}{L_{e,ref,1}} A_{ed,2}^2 - A_{ed,1}^2 \right) \left(K_{e,i} - K_{e,ref,1} \right) + A_{ed,1}^2 \leq 0$

where $\beta_{c,C,j}$ is calculated for the j :th TFC as described in subclause 5.1.2.5.4 if at least one DPDCH is configured. In case no DPDCH is configured, the $\beta_{c,C,j}$ value is set as described in subclause 5.1.2.5C. A_{ed} , $A_{ed,1}$ and $A_{ed,2}$ are as defined in [3] subclause 4.2.1.3. $A_{ed,1}$ and $A_{ed,2}$ denote the quantized amplitude ratios assigned to the primary and secondary reference E-TFCs respectively.

$L_{e,ref}$, $L_{e,i}$, $K_{e,ref}$, $K_{e,i}$, $L_{e,ref,1}$, $L_{e,ref,2}$, $K_{e,ref,1}$ and $K_{e,ref,2}$ are as defined in subclause 5.1.2.5B.2.3, Δ_{harq} is as defined in [3] subclause 4.2.1.3, $N_{pilot,C}$ is the number of pilot bits per slot on the DPCCCH in compressed frames, and $N_{pilot,N}$ is the number of pilot bits per slot in non-compressed frames.

When the E-DCH TTI is 10msec and the current frame is compressed, $\beta_{ed,C,i}$ shall be calculated as follows:

If E-DPDCH power extrapolation formula is configured

$$\beta_{ed,C,i} = \beta_{c,C,j} \cdot A_{ed} \cdot \sqrt{\frac{L_{e,ref}}{L_{e,I,i}}} \cdot \sqrt{\frac{K_{e,i}}{K_{e,ref}}} \cdot 10^{\left(\frac{\Delta_{harq}}{20}\right)} \cdot \sqrt{\frac{15 \cdot N_{pilot,C}}{N_{slots,I} \cdot N_{pilot,N}}},$$

Else if E-DPDCH power interpolation formula is configured

$$\beta_{ed,C,i} = \beta_{c,C,j} \cdot \sqrt{\frac{L_{e,ref,1}}{L_{e,I,i}}} \cdot \sqrt{\left(\frac{\frac{L_{e,ref,2} A_{ed,2}^2 - A_{ed,1}^2}{L_{e,ref,1}}}{\frac{K_{e,ref,2} - K_{e,ref,1}}{K_{e,i} - K_{e,ref,1}} + A_{ed,1}^2} \right)} \cdot 10^{\left(\frac{\Delta_{harq}}{20}\right)} \cdot \sqrt{\frac{15 \cdot N_{pilot,C}}{N_{slots,I} \cdot N_{pilot,N}}}$$

with the exception that $\beta_{ed,C,i}$ is set to 0 if $\left(\frac{L_{e,ref,2} A_{ed,2}^2 - A_{ed,1}^2}{L_{e,ref,1}} \right) (K_{e,i} - K_{e,ref,1}) + A_{ed,1}^2 \leq 0$

where $L_{e,I,i}$ denotes the number of E-DPDCHs used for the i :th E-TFC in the first frame used for transmitting the data and $N_{slots,I}$ is the number of non DTX slots in the first frame used for transmitting the data.

For the i :th E-TFC, the unquantized gain factor $\beta_{ed,k,i,uq}$ for the k :th E-DPDCH (denoted E-DPDCH_k in [3] subclause 4.2.1.3) shall be set to $\sqrt{2} \times \beta_{ed,C,i}$ if the spreading factor for E-DPDCH_k is 2 and to $\beta_{ed,C,i}$ otherwise.

Quantization may be applied as follows:

- For E-TFCI smaller than or equal to $E-TFCI_{ec,boost}$,
 - If $\beta_{ed,k,i,uq}/\beta_{c,C,j}$ is less than the smallest quantized value of Table 1B.2 in [3] subclause 4.2.1.3, then the gain factor of E-DPDCH_k, $\beta_{ed,k}$ is set such that $\beta_{ed,k}/\beta_{c,C,j}$ is the smallest quantized value of Table 1B.2 in [3] subclause 4.2.1.3.
 - Otherwise, $\beta_{ed,k}$ is set such that $\beta_{ed,k}/\beta_{c,C,j}$ is the largest quantized value of Table 1B.2 in [3] subclause 4.2.1.3, for which the condition $\beta_{ed,k} \leq \beta_{ed,k,i,uq}$ holds.
- For E-TFCI greater than $E-TFCI_{ec,boost}$,
 - If $\beta_{ed,k,i,uq}/\beta_{c,C,j}$ is less than the smallest quantized value of Table 1B.2B in [3] subclause 4.2.1.3, then the gain factor of E-DPDCH_k, $\beta_{ed,k}$ is set such that $\beta_{ed,k}/\beta_{c,C,j}$ is the smallest quantized value of Table 1B.2B in [3] subclause 4.2.1.3.

- Otherwise, $\beta_{ed,k}$ is set such that $\beta_{ed,k}/\beta_{c,C,j}$ is the largest quantized value of Table 1B.2B in [3] subclause 4.2.1.3, for which the condition $\beta_{ed,k} \leq \beta_{ed,k,i,uq}$ holds.

If quantization is not applied, $\beta_{ed,k}$ shall be set to $\beta_{ed,k,i,uq}$.

When the E-DCH TTI is 10msec and the current frame is not compressed, but is a retransmission for which the corresponding first transmission was compressed, the gain factor used for the k :th E-DPDCH for the i :th E-TFC is derived from $\beta_{ed,R,i}$ as follows:

If E-DPDCH power extrapolation formula is configured

$$\beta_{ed,R,i} = \beta_{ed,ref} \sqrt{\frac{L_{e,ref}}{L_{e,I,i}}} \sqrt{\frac{K_{e,i}}{K_{e,ref}}} \sqrt{\frac{15}{N_{slots,I}}} \cdot 10^{\left(\frac{\Delta_{harq}}{20}\right)}$$

Else if E-DPDCH power interpolation formula is configured

$$\beta_{ed,R,i} = \sqrt{\frac{L_{e,ref,1}}{L_{e,I,i}}} \cdot \sqrt{\left(\frac{\frac{L_{e,ref,2}}{L_{e,ref,1}} \beta_{ed,ref,2}^2 - \beta_{ed,ref,1}^2}{K_{e,ref,2} - K_{e,ref,1}} \right) (K_{e,i} - K_{e,ref,1}) + \beta_{ed,ref,1}^2} \sqrt{\frac{15}{N_{slots,I}}} \cdot 10^{\left(\frac{\Delta_{harq}}{20}\right)}$$

with the exception that $\beta_{ed,R,i}$ is set to 0 if $\left(\frac{\frac{L_{e,ref,2}}{L_{e,ref,1}} \beta_{ed,ref,2}^2 - \beta_{ed,ref,1}^2}{K_{e,ref,2} - K_{e,ref,1}} \right) (K_{e,i} - K_{e,ref,1}) + \beta_{ed,ref,1}^2 \leq 0$

where $\beta_{ed,ref}$, $\beta_{ed,ref,1}$, $\beta_{ed,ref,2}$, $L_{e,ref}$, $K_{e,ref}$, $K_{e,i}$, $L_{e,ref,1}$, $L_{e,ref,2}$, $K_{e,ref,1}$ and $K_{e,ref,2}$ are as defined in subclause 5.1.2.5B.2.3, Δ_{harq} is as defined in [3] subclause 4.2.1.3, and $L_{e,I,i}$ and $N_{slots,I}$ are as defined above.

For the i :th E-TFC, the unquantized gain factor $\beta_{ed,k,i,uq}$ for the k :th E-DPDCH (denoted E-DPDCH_k in [3] subclause 4.2.1.3) shall be set to $\sqrt{2} \times \beta_{ed,R,i}$ if the spreading factor for E-DPDCH_k is 2 and to $\beta_{ed,R,i}$ otherwise.

Quantization may be applied as follows:

- For E-TFCI smaller than or equal to $E-TFCI_{ec,boost}$,
 - If $\beta_{ed,k,i,uq}/\beta_c$ is less than the smallest quantized value of Table 1B.2 in [3] subclause 4.2.1.3, then the gain factor of E-DPDCH_k, $\beta_{ed,k}$ is set such that $\beta_{ed,k}/\beta_c$ is the smallest quantized value of Table 1B.2 in [3] subclause 4.2.1.3.
 - Otherwise, $\beta_{ed,k}$ is set such that $\beta_{ed,k}/\beta_c$ is the largest quantized value of Table 1B.2 in [3] subclause 4.2.1.3, for which the condition $\beta_{ed,k} \leq \beta_{ed,k,i,uq}$ holds.
- For E-TFCI greater than $E-TFCI_{ec,boost}$,
 - If $\beta_{ed,k,i,uq}/\beta_c$ is less than the smallest quantized value of Table 1B.2B in [3] subclause 4.2.1.3, then the gain factor of E-DPDCH_k, $\beta_{ed,k}$ is set such that $\beta_{ed,k}/\beta_c$ is the smallest quantized value of Table 1B.2B in [3] subclause 4.2.1.3.
 - Otherwise, $\beta_{ed,k}$ is set such that $\beta_{ed,k}/\beta_c$ is the largest quantized value of Table 1B.2B in [3] subclause 4.2.1.3, for which the condition $\beta_{ed,k} \leq \beta_{ed,k,i,uq}$ holds.

If quantization is not applied, $\beta_{ed,k}$ shall be set to $\beta_{ed,k,i,uq}$.

5.1.2.5C Setting of the uplink DPCCH gain factor when no DPDCH is configured

In the case that no DPDCH is configured, the gain factor β_c is equal to 1. During a compressed frame, the gain factor $\beta_{c,C,j}$ is also equal to 1.

5.1.2.5D Setting of the uplink S-DPCCH power relative to DPCCH power

5.1.2.5D.1 Setting of the uplink S-DPCCH/DPCCH power ratio when less than two transport blocks are transmitted on E-DCH

If UL_CLTD_Enabled is set to TRUE and UL_CLTD_Active is 1, or if UL_MIMO_Enabled is set to TRUE and UL_CLTD_Active is 1 and the UE is transmitting either one or zero transport blocks on E-DCH, the S-DPCCH gain factor, β_{sc} , which is defined in [3] subclause 4.2.1.4, is calculated depending on the transmitted E-TFC at a given TTI.

In non compressed frames, if no transmission on E-DCH is taking place, or if E-DCH transmission is taking place and $E-TFCI_i$ is smaller than or equal to $E-TFCI_{ec,boost}$, where $E-TFCI_i$ denotes the E-TFCI of the i :th E-TFC, β_{sc} is calculated according to

$$\beta_{sc} = \beta_c \cdot A_{sc}$$

Where the β_c value is signalled by higher layers or calculated as described in subclause 5.1.2.5.2 or 5.1.2.5.3 if at least one DPDCH is configured. In the case that no DPDCH is configured, the β_c value is set as described in subclause 5.1.2.5C. A_{sc} is defined in [3] subclause 4.2.1.4 Table 1C.1. The $E-TFCI_{ec,boost}$ value is signalled by higher layers.

In non compressed frames if $E-TFCI_i$ is greater than $E-TFCI_{ec,boost}$, the unquantized S-DPCCH gain factor for the i :th E-TFC, β_{sc} is calculated according to

$$\beta_{sc,i,uq} = \beta_c \cdot \sqrt{\max \left(A_{sc}^2, \frac{\sum_{k=1}^{K_{max,i}} \left(\frac{\beta_{ed,i,k}}{\beta_c} \right)^2}{10^{\frac{\Delta_{T2SP}}{10}}} \right)},$$

where Δ_{T2SP} is signalled by higher layers and is defined in [3] subclause 4.2.1.4, $\beta_{ed,i,k}$ is the E-DPDCH gain factor for the i :th E-TFC on the k :th physical channel and $k_{max,i}$ is the number of physical channels used for the i :th E-TFC, and the quantization of $\beta_{sc,i,uq}$ follows the quantization according to the definition of β_{ec} quantization in table 1B.0A of [3].

If $\beta_{sc,i,uq}$ is less than the smallest quantized value of Table 1B.0A in [3], then the S-DPCCH gain factor of $E-TFCI_i$, $\beta_{sc,i}$ is set such that $\beta_{sc,i}/\beta_c$ is the smallest quantized value of Table 1B.0A in [3]. Otherwise, $\beta_{sc,i}$ is selected from that table such that $20 \cdot \log_{10}(\beta_{sc,i}/\beta_c)$ is the nearest quantized value to $20 \cdot \log_{10}(\beta_{sc,i,uq}/\beta_c)$.

During the period between the start and end of a compressed DPCCH frame, when S-DPCCH is transmitted, β_{sc} is calculated according to

$$\beta_{sc} = \beta_{c,C,j} \cdot A_{sc} \cdot \sqrt{\frac{N_{pilot,C}}{N_{pilot,N}}},$$

if no transmission on E-DCH is taking place, or $E-TFCI_i$ is smaller than or equal to $E-TFCI_{ec,boost}$,

and according to

$$\beta_{sc,i,uq} = \beta_{c,C,j} \cdot \sqrt{\max \left(A_{sc}^2, \frac{\sum_{k=1}^{K_{\max,j}} \left(\frac{\beta_{ed,i,k}}{\beta_c} \right)^2}{10^{\frac{\Delta_T \cdot SP}{10}}} \right)} \cdot \sqrt{\frac{N_{pilot,C}}{N_{pilot,N}}}, \text{ if } E\text{-}TFCI_i \text{ is greater than } E\text{-}TFCI_{ec,boost},$$

where $\beta_{c,C,j}$ is calculated as described in subclause 5.1.2.5.4 if at least one DPDCH is configured. In case no DPDCH is configured, $\beta_{c,C,j}$ value is set as described in subclause 5.1.2.5C. $N_{pilot,C}$ is the number of pilot bits per slot on the DPCCH in compressed frames, and $N_{pilot,N}$ is the number of pilot bits per slot in non-compressed frames.

5.1.2.5D.2 Setting of the uplink S-DPCCH/DPCCH power ratio when two transport blocks are transmitted on E-DCH (rank-2)

When two transport blocks are transmitted on uplink E-DCH, the S-DPCCH gain factor setting, β_{sc} , is defined in [3] subclause 4.2.1.4.2.

5.1.2.5E Setting of the uplink S-E-DPCCH power relative to DPCCH power

When two transport blocks are transmitted on uplink E-DCH, the S-E-DPCCH gain factor setting, β_{sec} , is defined in [3] subclause 4.2.1.5. When one or zero transport blocks are transmitted on uplink E-DCH, the S-E-DPCCH is not transmitted.

5.1.2.5F Setting of the uplink S-E-DPDCH power relative to E-DPDCH power

When two transport blocks are transmitted on uplink E-DCH, the S-E-DPDCH gain factor setting, β_{sed} , is defined in [3] subclause 4.2.1.6.

When only one or zero transport blocks are transmitted on uplink E-DCH, the S-E-DPDCH is not transmitted.

5.1.2.6 Maximum and minimum power limits

When E-DCH is not configured, in the case that the total UE transmit power (after applying DPCCH power adjustments and gain factors) would exceed the maximum allowed value, the UE shall apply additional scaling to the total transmit power so that it is equal to the maximum allowed power. This additional scaling shall be such that the power ratio between DPCCH and DPDCH, between DPCCH and HS-DPCCH, and between DPCCH and S-DPCCH remains as required by sub-clause 5.1.2.5, 5.1.2.5A, and 5.1.2.5D.

Single uplink frequency configured for E-DCH

When E-DCH is configured on a single frequency or E-DCH is configured on multiple frequencies but Secondary_EDCH_Cell_Active is 0,

Single transport block transmission (no MIMO)

- If the total UE transmit power (after applying DPCCH power adjustments and gain factors) would exceed the maximum allowed value, the UE shall firstly reduce all the E-DPDCH gain factors $\beta_{ed,k}$ by an equal scaling factor to respective values $\beta_{ed,k,reduced}$ so that the total transmit power would be equal to the maximum allowed power.
- Also if $E\text{-}TFCI_i$ is greater than $E\text{-}TFCI_{ec,boost}$, UE shall reduce only E-DPDCH gain factors to respective values $\beta_{ed,k,reduced}$ and E-DPCCH is transmitted using original β_{ec} which is not recalculated according to the reduced E-DPDCH gain factors.
- After calculating the reduced E-DPDCH gain factors, if $E\text{-}TFCI_i$ is smaller than or equal to $E\text{-}TFCI_{ec,boost}$, quantization according to table 1B.2 in [3] subclause 4.2.1.3 may be applied, or if $E\text{-}TFCI_i$ is greater than $E\text{-}$

$TFCI_{ec,boost}$, quantization according to table 1B.2B in [3] subclause 4.2.1.3 may be applied, where each $\beta_{ed,k, reduced}$ is quantized such that $\beta_{ed,k}/\beta_c$ is the largest quantized value for which the condition $\beta_{ed,k} \leq \beta_{ed,k, reduced}$ holds.

- In case a DPDCH is transmitted, if any $\beta_{ed,k, reduced}/\beta_c$ is less than the smallest quantized value of Table 1B.2 in [3] subclause 4.2.1.3, DTX may be used on that E-DPDCH (E-DPCCH is, however still transmitted using β_{ec}).
- In case no DPDCH is transmitted and regardless of the applied uplink modulation, if any $\beta_{ed,k, reduced}/\beta_c$ is less than $\beta_{ed,k, reduced, min}/\beta_c$, that $\beta_{ed,k}$ shall be set to $\beta_{ed,k, min}$ such that $\beta_{ed,k, min}/\beta_c = \min(\beta_{ed,k, reduced, min}/\beta_c, \beta_{ed,k, original}/\beta_c)$, where $\beta_{ed,k, original}$ denotes the E-DPDCH gain factor before reduction.

Dual transport block transmission (MIMO)

- Also if the UE is transmitting both a set of E-DPDCHs and a set of S-E-DPDCHs, the UE shall reduce all the E-DPDCH and S-E-DPDCH gain factors $\beta_{ed,k}$ and $\beta_{sed,k}$ by an equal scaling factor to respective values $\beta_{ed,k, reduced}$ and $\beta_{sed,k, reduced}$ so that the total transmit power would be equal to the maximum allowed power,
 - if any $\beta_{ed,k, reduced}/\beta_c$ is less than $\beta_{ed,k, reduced, min}/\beta_c$, that $\beta_{ed,k}$ shall be set to $\beta_{ed,k, min}$ such that $\beta_{ed,k, min}/\beta_c = \min(\beta_{ed,k, reduced, min}/\beta_c, \beta_{ed,k, original}/\beta_c)$, where $\beta_{ed,k, original}$ denotes the E-DPDCH gain factor before reduction,
 - if any $\beta_{sed,k, reduced}/\beta_c$ is less than $\beta_{sed,k, reduced, min}/\beta_c$, that $\beta_{sed,k}$ shall be set to $\beta_{sed,k, min}$ such that $\beta_{sed,k, min}/\beta_c = \min(\beta_{sed,k, reduced, min}/\beta_c, \beta_{sed,k, original}/\beta_c)$, where $\beta_{sed,k, original}$ denotes the S-E-DPDCH gain factor before reduction,
- $\beta_{ed,k, reduced, min}$ is configurable by higher layers.

Additional scaling rules applicable to both non-MIMO and MIMO transmissions

- In the following cases, the UE shall then apply additional scaling to the total transmit power so that it is equal to the maximum allowed power:
 - if a DPDCH is transmitted and the total UE transmit power would still exceed the maximum allowed value even though DTX is used on all E-DPDCHs;
 - if no DPDCH is transmitted and the total UE transmit power would still exceed the maximum allowed value even though $\beta_{ed,k}$ is equal to $\beta_{ed,k, min}$ for all k .
- Any additional scaling of the total transmit power as described above shall be such that the power ratio between DPCCH and DPDCH, between DPCCH and HS-DPCCH, between DPCCH and E-DPCCH, and between DPCCH and S-DPCCH, remains as required by sub-clauses 5.1.2.5, 5.1.2.5A, 5.1.2.5B.1, and 5.1.2.5D, and such that the power ratio between each E-DPDCH and DPCCH remains as required by $\beta_{ed,k, min}/\beta_c$ if DTX is not used on E-DPDCH. Any slot-level scaling of β_{ed} or DTX of E-DPDCH as described above is applied at layer 1 only and is transparent to higher layers.
- If the UE is transmitting both a set of E-DPDCHs and a set of S-E-DPDCHs, the UE shall reduce all the E-DPDCH and S-E-DPDCH gain factors $\beta_{ed,k}$ and $\beta_{sed,k}$ by an equal scaling factor to respective values $\beta_{ed,k, reduced}$ and $\beta_{sed,k, reduced}$ so that the total transmit power would be equal to the maximum allowed power and the rule that $\beta_{sed,k, reduced}$ is equal to $\beta_{ed,k, reduced}$ is always kept.

Two uplink frequencies configured for E-DCH

When Secondary_EDCH_Cell_Active is 1,

- If the total UE transmit power (after applying DPCCH power adjustments and gain factors) would exceed the maximum allowed value, the UE shall start by reducing all the E-DPDCH gain factors $\beta_{ed,k}$ on the frequency with highest DPCCH power by an equal scaling factor to respective values $\beta_{ed,k, reduced}$ so that the total transmit power would be equal to the maximum allowed power.
- Also if $E-TFCI_i$ is greater than $E-TFCI_{ec, boost}$, UE shall reduce only E-DPDCH gain factors to respective values $\beta_{ed,k, reduced}$ and E-DPCCH is transmitted using original β_{ec} which is not recalculated according to the

reduced E-DPDCH gain factors. After calculating the reduced E-DPDCH gain factors, if $E-TFCI_i$ is smaller than or equal to $E-TFCI_{ec,boost}$, quantization according to table 1B.2 in [3] subclause 4.2.1.3 may be applied, or if $E-TFCI_i$ is greater than $E-TFCI_{ec,boost}$, quantization according to table 1B.2B in [3] subclause 4.2.1.3 may be applied, where each $\beta_{ed,k, reduced}$ is quantized such that $\beta_{ed,k}/\beta_c$ is the largest quantized value for which the condition $\beta_{ed,k} \leq \beta_{ed,k, reduced}$ holds.

- If $\beta_{ed,k, reduced}/\beta_c$ is less than $\beta_{ed,k, reduced, min}/\beta_c$ then $\beta_{ed,k}$ shall be set to $\beta_{ed,k, min}$ such that $\beta_{ed,k, min}/\beta_c = \min(\beta_{ed,k, reduced, min}/\beta_c, \beta_{ed,k, original}/\beta_c)$, where $\beta_{ed,k, original}$ denotes the E-DPDCH gain factor before reduction and $\beta_{ed,k, reduced, min}$ is individually configured by higher layers for each frequency.
- The UE shall then apply the same procedure on the uplink frequency with second highest DPCCH power.
- If $\beta_{ed,k, min}/\beta_c = \min(\beta_{ed,k, reduced, min}/\beta_c, \beta_{ed,k, original}/\beta_c)$ for all activated uplink frequencies, any additional scaling of the total transmit power shall be such that
 - the power ratio between DPCCH and HS-DPCCH, and between DPCCH and E-DPCCH, for each activated uplink frequency remains as required by sub-clauses 5.1.2.5, 5.1.2.5A and 5.1.2.5B.1, and such that the power ratio between each E-DPDCH and DPCCH remains as required by $\beta_{ed,k, min}/\beta_c$ and
 - the power ratio between DPCCH on the activated frequencies remains unchanged.

Additional generic power scaling rules

Any scaling, and any reduction in the E-DPDCH gain factor as described above, shall only be applied or changed at a DPCCH slot boundary. In order that the total UE transmit power does not exceed the maximum allowed value the scaling or E-DPDCH gain factor reduction shall be computed using the maximum HS-DPCCH power transmitted in the next DPCCH slot. In the case that either an ACK or a NACK transmission will start during the next DPCCH slot, the maximum HS-DPCCH power shall be computed using one of the following:

- (a) whichever of Δ_{ACK} and Δ_{NACK} will be used according to whether the transmission will be ACK or NACK, or
- (b) whichever of Δ_{ACK} and Δ_{NACK} is the largest.

When transmitting on a DPCCH the UE is not required to be capable of reducing its total transmit power below the minimum level required in [7]. However, it may do so, provided that the power ratio between DPCCH and DPDCH, between DPCCH and HS-DPCCH, and between DPCCH and S-DPCCH remains as specified in sub clause 5.1.2.5, 5.1.2.5A, and 5.1.2.5D. Some further regulations also apply as follows: In the case that the total UE transmit power (after applying DPCCH power adjustments and gain factors) would be at or below the total transmit power in the previously transmitted slot and also at or below the required minimum power specified in [7], the UE may apply additional scaling to the total transmit power, subject to the following restrictions:

- The total transmit power after applying any additional scaling shall not exceed the required minimum power, nor the total transmit power in the previously transmitted slot;
- The magnitude of any reduction in total transmit power between slots after applying any additional scaling shall not exceed the magnitude of the calculated power reduction before the additional scaling.

In the case that the total UE transmit power in the previously transmitted slot is at or below the required minimum power specified in [7] and the DPCCH power adjustment and gain factors for the current slot would result in an increase in total power, then no additional scaling shall be used (i.e. power control shall operate as normal).

If the UE applies any additional scaling to the total transmit power as described above, this scaling shall be included in the computation of any DPCCH power adjustments to be applied in the next transmitted slot.

5.1.3 Void

5.2 Downlink power control

The transmit power of the downlink channels is determined by the network. In general the ratio of the transmit power between different downlink channels is not specified and may change with time. However, regulations exist as described in the following subclauses.

Higher layer power settings shall be interpreted as setting of the total power, i.e. the sum of the power from the two antennas in case of transmit diversity.

5.2.1 DPCCH/DPDCH/F-DPCH

5.2.1.1 General

The downlink transmit power control procedure controls simultaneously the power of a DPCCH and its corresponding DPDCHs. The power control loop adjusts the power of the DPCCH and DPDCHs with the same amount, i.e. the relative power difference between the DPCCH and DPDCHs is not changed. In case of F-DPCH, the power control loop adjusts the F-DPCH power. If multiple frequencies are activated in the uplink, then the downlink transmit power control procedure shall be followed independently for each associated downlink frequency.

For DPCH, the relative transmit power offset between DPCCH fields and DPDCHs is determined by the network. The TFCI, TPC and pilot fields of the DPCCH are offset relative to the DPDCHs power by PO1, PO2 and PO3 dB respectively. The power offsets may vary in time. The method for controlling the power offsets within UTRAN is specified in [6]. The power offsets PO1, PO2 and PO3 do not apply to F-DPCH.

5.2.1.2 Ordinary transmit power control

5.2.1.2.1 UE behaviour

The UE shall generate TPC commands to control the network transmit power and send them in the TPC field of the uplink DPCCH. An example on how to derive the TPC commands is given in Annex B.2.

The UE shall check the downlink power control mode (DPC_MODE) before generating the TPC command:

- if DPC_MODE = 0 : the UE sends a unique TPC command in each slot and the TPC command generated is transmitted in the first available TPC field in the uplink DPCCH. In case uplink DPCCH slot format #4 is used then UE may delay transmitting generated TPC command to the next available TPC field
- if DPC_MODE = 1 : the UE repeats the same TPC command over 3 slots and the new TPC command is transmitted such that there is a new command at the beginning of the frame, unless UE_DTX_DRX_Enabled is TRUE, in which case the UE shall behave as for DPC_MODE=0. If DPC_MODE=1 when uplink DPCCH slot format #4 is configured, the UE behaviour is undefined.

The DPC_MODE parameter is a UE specific parameter controlled by the UTRAN.

The UE shall not make any assumptions on how the downlink power is set by UTRAN, in order to not prohibit usage of other UTRAN power control algorithms than what is defined in subclause 5.2.1.2.2.

5.2.1.2.1.1 F-DPCH quality target control

The UTRAN sets a quality target for the F-DPCH. The UE autonomously sets a SIR target value and adjusts it in order to achieve the same quality as the quality target set by UTRAN. The quality target is set as a downlink TPC command error rate target value for the F-DPCH belonging to the radio link from the HS-DSCH serving cell as signalled by the UTRAN. The UE shall set the SIR target when the F-DPCH has been setup or reconfigured. It shall not increase the SIR target value before the power control has converged on the current value. The UE may estimate whether the power control has converged on the current value, by comparing the averaged measured SIR to the SIR target value. When UL_DTX_Active is TRUE, the UE shall ignore in the SIR target value adjustment any TPC commands received in F-DPCH slot starting during an uplink DPCCH slot which is in an uplink DPCCH transmission gap.

5.2.1.2.2 UTRAN behaviour

Upon receiving the TPC commands UTRAN shall adjust its downlink DPCCH/DPDCH or F-DPCH power accordingly. For $DPC_MODE = 0$, and for $DPC_MODE=1$ if $UE_DTX_DRX_Enabled$ is TRUE, UTRAN shall estimate the transmitted TPC command TPC_{est} to be 0 or 1, and shall update the power every transmitted slot. If $DPC_MODE = 1$ and $UE_DTX_DRX_Enabled$ is FALSE, UTRAN shall estimate the transmitted TPC command TPC_{est} over three slots to be 0 or 1, and shall update the power every three slots.

After estimating the k :th TPC command, UTRAN shall adjust the current downlink power $P(k-1)$ [dB] to a new power $P(k)$ [dB] according to the following formula:

$$P(k) = P(k-1) + P_{TPC}(k) + P_{bal}(k),$$

where $P_{TPC}(k)$ is the k :th power adjustment due to the inner loop power control, and $P_{bal}(k)$ [dB] is a correction according to the downlink power control procedure for balancing radio link powers towards a common reference power. The power balancing procedure and control of the procedure is described in [6].

$P_{TPC}(k)$ is calculated according to the following.

If the value of *Limited Power Increase Used* parameter is 'Not used', then

$$P_{TPC}(k) = \begin{cases} +\Delta_{TPC} & \text{if } TPC_{est}(k) = 1 \\ -\Delta_{TPC} & \text{if } TPC_{est}(k) = 0 \end{cases}, \text{ [dB].} \quad (1)$$

If the value of *Limited Power Increase Used* parameter is 'Used', then the k :th inner loop power adjustment shall be calculated as:

$$P_{TPC}(k) = \begin{cases} +\Delta_{TPC} & \text{if } TPC_{est}(k) = 1 \text{ and } \Delta_{sum}(k) + \Delta_{TPC} < \text{Power_Raise_Limit} \\ 0 & \text{if } TPC_{est}(k) = 1 \text{ and } \Delta_{sum}(k) + \Delta_{TPC} \geq \text{Power_Raise_Limit} \\ -\Delta_{TPC} & \text{if } TPC_{est}(k) = 0 \end{cases}, \text{ [dB]} \quad (2)$$

where

$$\Delta_{sum}(k) = \sum_{i=k-DL_Power_Averaging_Window_Size}^{k-1} P_{TPC}(i)$$

is the temporary sum of the last *DL_Power_Averaging_Window_Size* inner loop power adjustments (in dB).

For the first (*DL_Power_Averaging_Window_Size* – 1) adjustments after the activation of the limited power increase method, formula (1) shall be used instead of formula (2). *Power_Raise_Limit* and *DL_Power_Averaging_Window_Size* are parameters configured in the UTRAN.

The power control step size Δ_{TPC} can take four values: 0.5, 1, 1.5 or 2 dB. It is mandatory for UTRAN to support Δ_{TPC} of 1 dB, while support of other step sizes is optional.

In addition to the above described formulas on how the downlink power is updated, the restrictions below apply.

In case of congestion (commanded power not available), UTRAN may disregard the TPC commands from the UE.

The average power of transmitted DPDCH symbols over one timeslot shall not exceed *Maximum_DL_Power* (dB), nor shall it be below *Minimum_DL_Power* (dB). Transmitted DPDCH symbol means here a complex QPSK symbol before spreading which does not contain DTX. *Maximum_DL_Power* (dB) and *Minimum_DL_Power* (dB) are power limits for one channelisation code, relative to the primary CPICH power [6].

In case of F-DPCH, the power of the transmitted symbol over one timeslot for a given UE shall not exceed *Maximum_DL_Power* (dB), nor shall it be below *Minimum_DL_Power* (dB). Transmitted symbol means here a complex QPSK symbol before spreading which does not contain DTX.

In the case that *UL_DTX_Active* is TRUE (see section 6C), if no uplink TPC command is received due to Uplink DPCCH burst pattern gap as defined in subclause 6C.2.1, $P_{TPC}(k)$ derived by the Node B shall be set to zero.

5.2.1.3 Power control in compressed mode

The aim of downlink power control in uplink or/and downlink compressed mode is to recover as fast as possible a signal-to-interference ratio (SIR) close to the target SIR after each transmission gap.

The UE behaviour is the same in compressed mode as in normal mode, described in subclause 5.2.1.2, except that the target SIR for a DPCH is offset by higher layer signalling. However due to transmission gaps in uplink compressed frames there may be incomplete sets of TPC commands when DPC_MODE=1.

UTRAN behaviour is as stated in section 5.2.1.2.2 except for DPC_MODE = 1 where missing TPC commands in the UL may lead the UTRAN to changing its power more frequently than every 3 slots.

In compressed mode, compressed frames may occur in either the uplink or the downlink or both. In downlink compressed frames, the transmission of downlink DPDCH(s), DPCCH and F-DPCH shall be stopped during transmission gaps.

The power of the DPCCH and DPDCH in the first slot after the transmission gap, or the power of the F-DPCH in the first slot after the transmission gap, should be set to the same value as in the slot just before the transmission gap.

During compressed mode except during downlink transmission gaps, UTRAN shall estimate the k :th TPC command and adjust the current downlink power $P(k-1)$ [dB] to a new power $P(k)$ [dB] according to the following formula:

$$P(k) = P(k-1) + P_{TPC}(k) + P_{SIR}(k) + P_{bal}(k),$$

where $P_{TPC}(k)$ is the k :th power adjustment due to the inner loop power control, $P_{SIR}(k)$ is the k -th power adjustment due to the downlink target SIR variation, and $P_{bal}(k)$ [dB] is a correction according to the downlink power control procedure for balancing radio link powers towards a common reference power. The power balancing procedure and control of the procedure is described in [6].

Due to transmission gaps in uplink compressed frames, there may be missing TPC commands in the uplink.

For DPC_MODE = 0, and for DPC_MODE=1 if UE_DTX_DRX_Enabled is TRUE, if no uplink TPC command is received, $P_{TPC}(k)$ derived by the Node B shall be set to zero. Otherwise, $P_{TPC}(k)$ is calculated the same way as in normal mode (see sub-clause 5.2.1.2.2) but with a step size Δ_{STEP} instead of Δ_{TPC} .

For DPC_MODE = 1 if UE_DTX_DRX_Enabled is FALSE, the sets of slots over which the TPC commands are processed shall remain aligned to the frame boundaries in the compressed frame. If this results in an incomplete set of TPC commands, the UE shall transmit the same TPC commands in all slots of the incomplete set.

The power control step size $\Delta_{STEP} = \Delta_{RP-TPC}$ during RPL slots after each transmission gap and $\Delta_{STEP} = \Delta_{TPC}$ otherwise, where:

- RPL is the recovery period length and is expressed as a number of slots. RPL is equal to the minimum value out of the transmission gap length and 7 slots. If a transmission gap or an Uplink DPCCH burst pattern gap as defined in subclause 6C.2 is scheduled to start before RPL slots have elapsed, then the recovery period shall end at the start of the gap, and the value of RPL shall be reduced accordingly.
- Δ_{RP-TPC} is called the recovery power control step size and is expressed in dB. Δ_{RP-TPC} is equal to the minimum value of 3 dB and $2\Delta_{TPC}$.

For F-DPCH, $P_{SIR}(k) = 0$.

For DPCH, the power offset $P_{SIR}(k) = \delta P_{curr} - \delta P_{prev}$, where δP_{curr} and δP_{prev} are respectively the value of δP in the current slot and the most recently transmitted slot and δP is computed as follows:

$$\delta P = \max(\Delta P1_compression, \dots, \Delta Pn_compression) + \Delta P1_coding + \Delta P2_coding$$

where n is the number of different TTI lengths amongst TTIs of all TrChs of the CCTrCh, where $\Delta P1_coding$ and $\Delta P2_coding$ are computed from uplink parameters DeltaSIR1, DeltaSIR2, DeltaSIRafter1, DeltaSIRafter2 signaled by higher layers as:

- $\Delta P1_coding = \text{DeltaSIR1}$ if the start of the first transmission gap in the transmission gap pattern is within the current frame and UE_DTX_DRX_Enabled is FALSE.

- $\Delta P1_{\text{coding}} = \text{DeltaSIRafter1}$ if the current frame just follows a frame containing the start of the first transmission gap in the transmission gap pattern and $\text{UE_DTX_DRX_Enabled}$ is FALSE.
- $\Delta P2_{\text{coding}} = \text{DeltaSIR2}$ if the start of the second transmission gap in the transmission gap pattern is within the current frame and $\text{UE_DTX_DRX_Enabled}$ is FALSE.
- $\Delta P2_{\text{coding}} = \text{DeltaSIRafter2}$ if the current frame just follows a frame containing the start of the second transmission gap in the transmission gap pattern and $\text{UE_DTX_DRX_Enabled}$ is FALSE.
- $\Delta P1_{\text{coding}} = 0$ dB and $\Delta P2_{\text{coding}} = 0$ dB in all other cases.

and $\Delta P_i_{\text{compression}}$ is defined by :

- $\Delta P_i_{\text{compression}} = 3$ dB for downlink frames compressed by reducing the spreading factor by 2.
- $\Delta P_i_{\text{compression}} = 0$ dB in all other cases.

In case several compressed mode patterns are used simultaneously, a δP offset is computed for each compressed mode pattern and the sum of all δP offsets is applied to the frame.

For all time slots except those in transmissions gaps, the average power of transmitted DPDCH symbols over one timeslot shall not exceed Maximum_DL_Power (dB) by more than δP_{curr} , nor shall it be below Minimum_DL_Power (dB). Transmitted DPDCH symbol means here a complex QPSK symbol before spreading which does not contain DTX. Maximum_DL_Power (dB) and Minimum_DL_Power (dB) are power limits for one channelisation code, relative to the primary CPICH power [6].

For F-DPCH, for all time slots except those in transmissions gaps the power of the transmitted symbol over one timeslot for a given UE shall not exceed Maximum_DL_Power (dB), nor shall it be below Minimum_DL_Power (dB). Transmitted symbol means here a complex QPSK symbol before spreading which does not contain DTX.

5.2.1.4 Void

5.2.2 Void

5.2.3 Void

5.2.4 AICH

The UE is informed about the relative transmit power of the AIs (measured as the power per transmitted acquisition indicator) and the relative transmit power of the EAIs (measured as the power per transmitted extended acquisition indicator), both compared to the primary CPICH transmit power by the higher layers.

5.2.5 PICH

The UE is informed about the relative transmit power of the PICH (measured as the power over the paging indicators) compared to the primary CPICH transmit power by the higher layers.

5.2.6 S-CCPCH

The TFCI and pilot fields may be offset relative to the power of the data field. The power offsets may vary in time.

For MBSFN FACH transmission with 16QAM, the UE is informed about the relative transmit power of the S-CCPCH (measured as the power of the transmitted data of S-CCPCH) compared to the primary CPICH transmit power by the higher layers.

5.2.7 Void

5.2.8 Void

5.2.9 Void

5.2.10 HS-SCCH

The HS-SCCH power control is under the control of the node B. It may e.g. follow the power control commands sent by the UE to the node B or any other power control procedure applied by the node B.

5.2.11 HS-PDSCH

The HS-PDSCH power control is under the control of the node B. When the HS-PDSCH is transmitted using 16QAM or 64QAM, the UE may assume that the power is kept constant during the corresponding HS-DSCH subframe.

In case of multiple HS-PDSCH transmission to one UE, all the HS-PDSCHs intended for that UE shall be transmitted with equal power.

The sum of the powers used by all HS-PDSCHs, HS-SCCHs, E-AGCHs, E-RGCHs and E-HICHs in a cell shall not exceed the value of *HS-PDSCH*, *HS-SCCH*, *E-AGCH*, *E-RGCH* and *E-HICH Total Power* if signaled by higher layers [6].

5.2.12 E-AGCH

The E-AGCH power control is under the control of the node B. It may e.g. follow the power control commands sent by the UE to the node B or any other power control procedure applied by the node B.

5.2.13 E-HICH

The E-HICH power control is under the control of the node B. It may e.g. follow the power control commands sent by the UE to the node B or any other power control procedure applied by the node B.

5.2.14 E-RGCH

The E-RGCH power control is under the control of the node B. It may e.g. follow the power control commands sent by the UE to the node B or any other power control procedure applied by the node B.

5.2.15 MICH

The UE is informed about the relative transmit power of the MICH (measured as the power over the notification indicators) compared to the primary CPICH transmit power by the higher layers.

5.2.16 S-CPICH

In case the UE is configured in MIMO mode, and S-CPICH is used as a phase reference for a second transmit antenna, the UE is informed about the relative transmit power of the S-CPICH compared to the primary CPICH transmit power by the higher layers.

In case the UE is configured in MIMO mode with four transmit antennas, the S-CPICHs are used as a phase reference for the second, third and fourth transmit antennas and, the UE is informed about the relative transmit power of each S-CPICH compared to the primary CPICH transmit power by the higher layers. The S-CPICHs transmitted on the third and fourth transmit antennas are transmitted with equal power.

5.2.17 F-TPICH

F-TPICH power control is under the control of the node B. It may e.g. follow the power control commands sent by the UE to the node B or any other power control procedure applied by the node B.

5.2.18 D-CPICH

In case the UE is configured in MIMO mode with four transmit antennas, D-CPICHs are configured for the third and fourth transmit antenna, the UE is informed about the relative transmit power of each D-CPICH compared to the primary CPICH transmit power by the higher layers. The two D-CPICHs are transmitted with equal power.

5.2.19 E-ROCH

The E-ROCH power control is under the control of the node B. It may e.g. follow the power control commands sent by the UE to the node B or any other power control procedure applied by the node B.

6 Random access procedure

6.1 Physical random access procedure

The physical random access procedure described in this subclause is initiated upon request from the MAC sublayer (cf. [9]). This procedure can also be initiated if indicated by higher layers and `Fallback_R99_Enabled` is TRUE.

Before the physical random-access procedure can be initiated, Layer 1 shall receive the following information from the higher layers (RRC):

- The preamble scrambling code.
- The message length in time, either 10 or 20 ms.
- The `AICH_Transmission_Timing` parameter [0 or 1].
- The set of available signatures and the set of available RACH sub-channels for each Access Service Class (ASC). Sub-channels are defined in subclause 6.1.1.
- The power-ramping factor Power Ramp Step [integer > 0].
- The parameter Preamble Retrans Max [integer > 0].
- The initial preamble power `Preamble_Initial_Power`.
- The Power offset $P_{p-m} = P_{\text{message-control}} - P_{\text{preamble}}$, measured in dB, between the power of the last transmitted preamble and the control part of the random-access message.
- The set of Transport Format parameters. This includes the power offset between the data part and the control part of the random-access message for each Transport Format.

Note that the above parameters may be updated from higher layers before each physical random access procedure is initiated.

At each initiation of the physical random access procedure, Layer 1 shall receive the following information from the higher layers (MAC):

- The Transport Format to be used for the PRACH message part.
- The ASC of the PRACH transmission.
- The data to be transmitted (Transport Block Set).

The physical random-access procedure shall be performed as follows:

- 1 Derive the available uplink access slots, in the next full access slot set or in the next 8 access slots, for the set of available RACH sub-channels within the given ASC with the help of subclauses 6.1.1. and 6.1.2. Randomly select one access slot among the ones previously determined. If there is no access slot available in the selected set, randomly select one uplink access slot corresponding to the set of available RACH sub-channels within the given ASC from the next access slot set or in the next 7 access slots. The random function shall be such that each of the allowed selections is chosen with equal probability.
- 2 Randomly select a signature from the set of available signatures within the given ASC. The random function shall be such that each of the allowed selections is chosen with equal probability.
- 3 Set the Preamble Retransmission Counter to Preamble Retrans Max.
- 4 If the Preamble_Initial_Power is below the minimum level required in [7], set the Commanded Preamble Power to a value, which shall be at or above the Preamble_Initial_Power and at or below the required minimum power specified in [7]. Otherwise set the parameter Commanded Preamble Power to Preamble_Initial_Power.
- 5 In the case that the Commanded Preamble Power exceeds the maximum allowed value, set the preamble transmission power to the maximum allowed power. In the case that the Commanded Preamble Power is below the minimum level required in [7], set the preamble transmission power to a value, which shall be at or above the Commanded Preamble Power and at or below the required minimum power specified in [7]. Otherwise set the preamble transmission power to the Commanded Preamble Power. Transmit a preamble using the selected uplink access slot, signature, and preamble transmission power.
- 6 If no positive or negative acquisition indicator ($AI \neq +1$ nor -1) corresponding to the selected signature is detected in the downlink access slot corresponding to the selected uplink access slot:
 - 6.1 Select the next available access slot in the set of available RACH sub-channels within the given ASC.
 - 6.2 Randomly select a new signature from the set of available signatures within the given ASC. The random function shall be such that each of the allowed selections is chosen with equal probability.
 - 6.3 Increase the Commanded Preamble Power by $\Delta P_0 = \text{Power Ramp Step [dB]}$. If the Commanded Preamble Power exceeds the maximum allowed power by 6dB, the UE may pass L1 status ("No ack on AICH") to the higher layers (MAC) and exit the physical random access procedure.
 - 6.4 Decrease the Preamble Retransmission Counter by one.
 - 6.5 If the Preamble Retransmission Counter > 0 then repeat from step 5. Otherwise pass L1 status ("No ack on AICH") to the higher layers (MAC) and exit the physical random access procedure.
- 7 If a negative acquisition indicator corresponding to the selected signature is detected in the downlink access slot corresponding to the selected uplink access slot, pass L1 status ("Nack on AICH received") to the higher layers (MAC) and exit the physical random access procedure.
- 8 Transmit the random access message three or four uplink access slots after the uplink access slot of the last transmitted preamble depending on the AICH transmission timing parameter. Transmission power of the control part of the random access message should be P_{p-m} [dB] higher than the power of the last transmitted preamble. Transmission power of the data part of the random access message is set according to subclause 5.1.1.2.
- 9 Pass L1 status "RACH message transmitted" to the higher layers and exit the physical random access procedure.

6.1.1 RACH sub-channels

A RACH sub-channel defines a sub-set of the total set of uplink access slots. There are a total of 12 RACH sub-channels. RACH sub-channel # i ($i = 0, \dots, 11$) consists of the following uplink access slots:

- Uplink access slot # i leading by τ_{p-a} chips the downlink access slot # i contained within the 10 ms interval that is time aligned with P-CCPCH frames for which $SFN \bmod 8 = 0$ or $SFN \bmod 8 = 1$.
- Every 12th access slot relative to this access slot.

The access slots of different RACH sub-channels are also illustrated in Table 7.

Table 7: The available uplink access slots for different RACH sub-channels

SFN modulo 8 of corresponding P-CCPCH frame	Sub-channel number											
	0	1	2	3	4	5	6	7	8	9	10	11
0	0	1	2	3	4	5	6	7				
1	12	13	14						8	9	10	11
2				0	1	2	3	4	5	6	7	
3	9	10	11	12	13	14						8
4	6	7					0	1	2	3	4	5
5			8	9	10	11	12	13	14			
6	3	4	5	6	7					0	1	2
7						8	9	10	11	12	13	14

6.1.2 RACH access slot sets

The PRACH contains two sets of access slots as shown in Figure 2. Access slot set 1 contains PRACH slots 0 – 7 and starts τ_{p-a} chips before the downlink P-CCPCH frame for which SFN mod 2 = 0. Access slot set 2 contains PRACH slots 8 - 14 and starts $(\tau_{p-a}-2560)$ chips before the downlink P-CCPCH frame for which SFN mod 2 = 1.

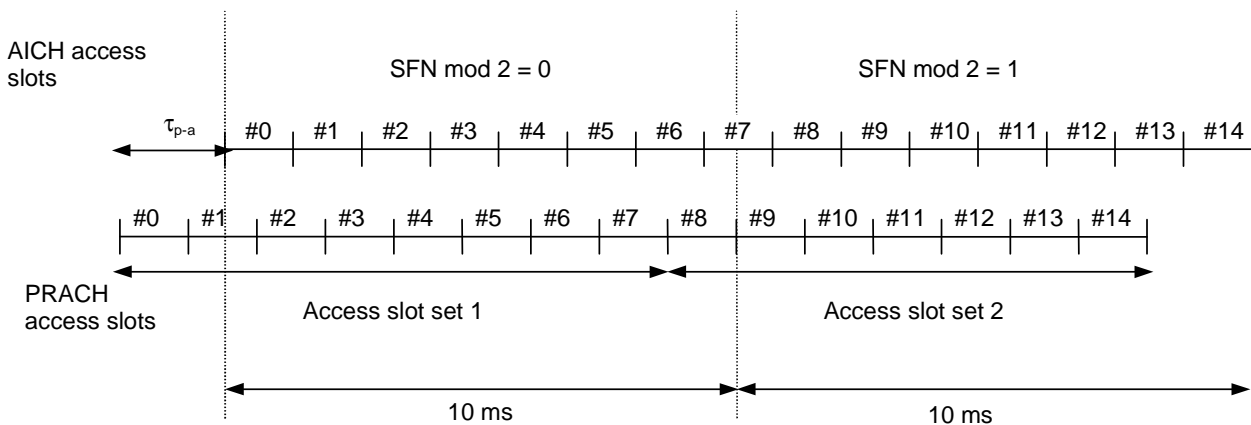

Figure 2: PRACH access slot and downlink AICH relation ($\tau_{p-a} = 7680$ chips)

6.1A Physical random access procedure for Enhanced Uplink in CELL_FACH state and IDLE mode

The physical random access procedure described in this subclause is initiated upon request from the MAC sublayer (cf. [9]).

Before the physical random-access procedure can be initiated, Layer 1 shall receive the following information from the higher layers (RRC):

- Preamble scrambling code(s) for 2 and 10ms TTI.
- The AICH_Transmission_Timing parameter [0 or 1].
- The set of available signatures and the set of available RACH sub-channels corresponding to E-DCH resources for each Access Service Class (ASC). Sub-channels are defined in subclause 6.1.1.
- The total number of E-DCH resources configured in the cell.
- The power-ramping factor Power Ramp Step [integer > 0].
- The parameter Preamble Retrans Max [integer > 0].
- The initial preamble power Preamble_Initial_Power.

- The Power offset $P_{p-e} = P_{\text{dpcch}} - P_{\text{preamble}}$, measured in dB, between the power of the last transmitted preamble and the initial DPCCH transmission power.
- The number of TTIs in which only the uplink DPCCH is sent before the E-DCH transmission may start for 2 and 10ms TTI.

Note that the above parameters may be updated from higher layers before each physical random access procedure is initiated.

At each initiation of the physical random access procedure, Layer 1 shall receive the following information from the higher layers (MAC):

- The ASC of the PRACH transmission.

If `Concurrent_TTI_Deployment_Enabled` is TRUE, Layer 1 shall also receive the following additional parameters from the higher layers (MAC):

- TTI length, either 2 or 10ms.

The procedure for the selection of the TTI length is defined in subclause 8.5.b1 in [5]. The TTI length may be updated by higher layers before each preamble retransmission.

The physical random-access procedure shall be performed as follows:

- 1 If `NT-HS-DPCCH_Enabled` is FALSE, or if `NT-HS-DPCCH_Enabled` is TRUE and the physical random-access procedure is not triggered by an HS-SCCH order, then derive the available uplink access slots, in the next full access slot set or in the next 8 access slots, for the set of available RACH sub-channels within the given ASC with the help of subclauses 6.1.1. and 6.1.2. Randomly select one access slot among the ones previously determined. If there is no access slot available in the selected set, randomly select one uplink access slot corresponding to the set of available RACH sub-channels within the given ASC from the next access slot set or in the next 7 access slots. The random function shall be such that each of the allowed selections is chosen with equal probability. If `NT-HS-DPCCH_Enabled` is TRUE and the physical random-access procedure is triggered by an HS-SCCH order, then the next available access slot is chosen.
- 2 Randomly select a signature from the set of available signatures within the given ASC. The random function shall be such that each of the allowed selections is chosen with equal probability. If `Concurrent_TTI_Deployment_Enabled` is TRUE, the set of available signatures corresponds to the indicated TTI length.
- 2a If `Concurrent_TTI_Deployment_Enabled` is TRUE, the scrambling code corresponding to the indicated TTI length is chosen.
- 3 Set the Preamble Retransmission Counter to Preamble Retrans Max.
- 4 If the `Preamble_Initial_Power` is below the minimum level required in [7], set the Commanded Preamble Power to a value, which shall be at or above the `Preamble_Initial_Power` and at or below the required minimum power specified in [7]. Otherwise set the parameter Commanded Preamble Power to `Preamble_Initial_Power`.
- 5 In the case that the Commanded Preamble Power exceeds the maximum allowed value, set the preamble transmission power to the maximum allowed power. In the case that the Commanded Preamble Power is below the minimum level required in [7], set the preamble transmission power to a value, which shall be at or above the Commanded Preamble Power and at or below the required minimum power specified in [7]. Otherwise set the preamble transmission power to the Commanded Preamble Power. Transmit a preamble using the selected uplink access slot, signature, and preamble transmission power.
- 6 If no positive or negative acquisition indicator ($AI \neq +1$ nor -1) corresponding to the selected signature is detected in the downlink access slot corresponding to the selected uplink access slot:
 - 6.1 Select the next available access slot in the set of available RACH sub-channels within the given ASC.
 - 6.2 Randomly select a new signature from the set of available signatures within the given ASC. The random function shall be such that each of the allowed selections is chosen with equal probability. If an update to the TTI length is indicated by higher layers, then the set of available signatures and the preamble scrambling code are also updated correspondingly.

- 6.3 Increase the Commanded Preamble Power by $\Delta P_0 = \text{Power Ramp Step [dB]}$. If the **Commanded Preamble Power** exceeds the maximum allowed power by 6dB, the UE may pass L1 status ("No ack on AICH") to the higher layers (MAC) and exit the physical random access procedure.
- 6.4 Decrease the Preamble Retransmission Counter by one.
- 6.5 If the Preamble Retransmission Counter > 0 then repeat from step 5. Otherwise pass L1 status ("No ack on AICH") to the higher layers (MAC) and exit the physical random access procedure.
- 7 If a negative acquisition indicator on AICH corresponding to the selected signature is detected in the downlink access slot corresponding to the selected uplink access slot.
- 7.1 If no Extended Acquisition Indicator signature set is configured in the cell, pass L1 status ('Nack on AICH received') to the higher layers (MAC) and exit the physical random access procedure.
- 7.2 If an Extended Acquisition Indicator signature set is configured in the cell, detect which one of the defined Extended Acquisition Indicator signatures is present.
- 7.2.1 If the detected Extended Acquisition Indicator signature and modulation symbol corresponds to "NACK" as defined in [1], pass L1 status ('Nack on AICH received') to the higher layers (MAC) and exit the physical random access procedure.
- 7.2.2 If the detected Extended Acquisition Indicator signature and modulation symbol do not correspond to "NACK", pass L1 status ('Ack on AICH received') with the corresponding E-DCH resource index as defined in [1] to higher layers (MAC) and skip step 8.
- 8 If a positive acquisition indicator on AICH corresponding to the selected signature is detected in the downlink access slot corresponding to the selected uplink access slot, pass L1 status ('Ack on AICH received') with the default E-DCH resource index corresponding to the selected signature as defined in [1] to higher layers (MAC),
- 9 Start transmitting DPCCH (timing as specified in [1] and synchronisation according to synchronisation procedure AA). The initial transmission power of DPCCH prior to starting the E-DCH transmission should be P_{p-e} [dB] higher than the power of the last transmitted preamble.
- 10 Proceed to transmitting E-DPCCH and E-DPDCH, and transmit HS-DPCCH if so instructed by MAC layer after the defined number of TTIs of DPCCH only transmission has passed.

6.2 Void

6A HS-DSCH-related procedures

6A.1 General procedure

Scheduling and transport format selection is controlled by the MAC-hs or MAC-ehs sublayer in the Node B [9].

The following parameters are signalled to the physical layer in the UE and the Node B from higher layers:

- 1) HS-SCCH set to be monitored in the serving HS-DSCH cell
- 2) Repetition factor of ACK/NACK: $N_{\text{acknack_transmit}}$
- 3) Channel Quality Indicator (CQI) feedback cycle k
- 4) Repetition factor of CQI: $N_{\text{cqi_transmit}}$
- 5) Measurement power offset Γ and Γ_1
- 6) Status of preamble/postamble transmission: $\text{HARQ_preamble_mode}$
- 7) Status of 64QAM configuration

- 8) Set of P-CPICH and/or S-CPICH (which shall be transmitted on the same scrambling code) that shall be used for HS-PDSCH demodulation in case the UE is configured in MIMO mode and in MIMO mode with four transmit antennas. Set of D-CPICH (which shall be transmitted on the same scrambling code as that of P-CPICH) in case the UE is configured in MIMO mode with four transmit antennas.
- 9) The number N of dynamic single/dual CQI reports out of a sequence of M CQI reports in case the UE is configured in MIMO mode (not applicable when single-stream restriction is configured) and in MIMO mode with four transmit antennas: $N_{\text{cqi_typeA}}$, M_{cqi} , respectively
- 10) Set of transport block sizes configured for HS-SCCH-less operation
- 11) Set of HS-PDSCHs configured for HS-SCCH-less operation
- 12) Status variables HS_SCCH_LESS_STATUS and DTX_DRX_STATUS
- 13) Enabling_Delay
- 14) RRC protocol state (CELL_DCH, CELL_FACH, CELL_PCH or URA_PCH)
- 15) H-RNTI values (dedicated H-RNTI, common H-RNTI, BCCH specific H-RNTI) to be monitored when the UE is configured to receive HS-DSCH in CELL_FACH or CELL_PCH state
- 16) HS-DSCH paging system information, which includes the following information when the UE is configured to receive HS-DSCH in URA_PCH state or in CELL_PCH state:
 - a. Number of PCCH transmissions: The number of subframes used to transmit PAGING TYPE 1 as defined in [5].
 - b. HS-PDSCH Channelisation Code configured for HS-SCCH less paging operation
 - c. Transport Block Size: List of Transport Block Sizes
- 17) Status of MIMO configuration and MIMO configuration with four transmit antennas
- 18) HS-SCCH set to be monitored in each secondary serving HS-DSCH cell
- 19) HS-SCCH set to be monitored in one non-serving cell
- 20) Status of "Support for different HS-SCCHs in contiguous TTIs"
- 21) HS-SCCH set to be monitored in the assisting serving HS-DSCH cell
- 22) HS-SCCH set to be monitored in the assisting secondary serving HS-DSCH cell

If HS_SCCH_LESS_STATUS is TRUE then HS-SCCH_less_mode=1. Otherwise HS-SCCH_less_mode=0.

HS-SCCH-less_Active shall be set to TRUE while HS-SCCH_less_mode=1 and HS-SCCH-less operation is activated. Otherwise HS-SCCH_less_Active shall be set to FALSE. HS-SCCH-less operation shall be activated at the time when HS-SCCH_less_mode is set to 1, and may be further deactivated or activated by HS-SCCH orders as specified in [2]. This ordered deactivation or activation of the HS-SCCH-less operation is applied by the UE 12 slots after the end of the HS-SCCH subframe delivering the order.

If the higher layers set DTX_DRX_STATUS to TRUE (as described in [5]) then UE_DTX_DRX_Enabled is FALSE until Enabling_Delay radio frames have passed. After the higher layers have set DTX_DRX_STATUS to TRUE (as described in [5]) and Enabling_Delay radio frames have passed then UE_DTX_DRX_Enabled is TRUE. Otherwise UE_DTX_DRX_Enabled is FALSE.

If the UE is not configured in Multiflow mode;

- If the UE is configured with at least one secondary serving HS-DSCH cell, then Secondary_Cell_Enabled is equal to the number of the configured secondary serving HS-DSCH cells, otherwise Secondary_Cell_Enabled is 0 and Secondary_Cell_Active is 0.
- Configured secondary serving HS-DSCH cells shall be activated at the time when Secondary_Cell_Enabled is changed from 0 to a value not equal to 0, or Secondary_Cell_Enabled is not equal to 0 and the higher layers indicate a change of the serving HS-DSCH cell, and may further be deactivated or activated by HS-SCCH orders as specified in [2].

- Secondary_Cell_Active shall be set to 1, 2, 3, 4, 5, 6, or 7 while Secondary_Cell_Enabled is set to a value not equal to 0, and 1, 2, 3, 4, 5, 6, or 7 secondary serving HS-DSCH cells are activated respectively; otherwise Secondary_Cell_Active shall be set to 0.
- If the UE receives an HS-SCCH order for activation of a secondary serving HS-DSCH cell that is already activated as specified in [2], then the UE shall not change the activation status of that secondary serving HS-DSCH cell, but shall transmit the HARQ-ACK acknowledging the HS-SCCH order.

If the UE is configured in Multiflow mode and with a secondary serving cell or an assisting secondary serving cell, the cell(s) are initially activated, and may further be deactivated or activated using HS-SCCH orders.

- The Secondary Serving HS-DSCH cell can be deactivated with an order transmitted only by the Serving or the Secondary Serving HS-DSCH cell and reactivated with an order transmitted only by the serving HS-DSCH cell.
- The Assisting Secondary Serving HS-DSCH cell can be deactivated with an order transmitted only by the Assisting Serving or Assisting Secondary Serving HS-DSCH cell and reactivated with an order transmitted only by the Assisting Serving HS-DSCH cell.
- If the UE receives an HS-SCCH order for activation of a Secondary Serving HS-DSCH or Assisting Secondary Serving cell that is already activated as specified in [2], then the UE shall not change the activation status of that secondary serving HS-DSCH cell, but shall transmit the HARQ-ACK acknowledging the HS-SCCH order.
- If the higher layers indicate a change in the HS-DSCH cells,
 - if the new configuration contains a Secondary Serving HS-DSCH cell that was either the Secondary Serving or Assisting Secondary Serving HS-DSCH cell in the earlier configuration and the cell was deactivated with HS-SCCH orders, it shall remain deactivated. Otherwise after the change the Secondary Serving HS-DSCH cell shall be active.
 - if the new configuration contains an Assisting Secondary Serving HS-DSCH cell that was either the Secondary Serving or Assisting Secondary Serving HS-DSCH cell in the earlier configuration and the cell was deactivated with HS-SCCH orders, it shall remain deactivated. Otherwise after the change the Assisting Secondary Serving HS-DSCH cell shall be active.

If the UE is not configured with multiple uplink frequencies, HS-SCCH ordered deactivation or activation of the secondary serving HS-DSCH cell(s) is applied by the UE 12 slots after the end of the HS-SCCH subframe delivering the order, and any transient behaviour related to this change should take place before this point in time. If the activation statuses of all secondary serving HS-DSCH cells in a frequency band (as defined in [7]) remain unaffected by an HS-SCCH ordered deactivation or activation the maximum allowed interruption time for the cells in this band is 1 slot and the interrupt shall take place during the next downlink HS-SCCH slot after the end of the HS-DPCCH slot that contains the HARQ-ACK information acknowledging the HS-SCCH order. The corresponding change of the HS-DPCCH channel coding scheme as specified in [2] is applied by the UE at the first HS-DPCCH subframe boundary after the activation or deactivation has been applied.

If the UE is configured with multiple uplink frequencies, HS-SCCH ordered deactivation or activation of the secondary serving HS-DSCH cell(s) is applied by the UE 18 slots after the end of the HS-SCCH subframe delivering the order, and any transient behaviour related to this change should take place before this point in time. If:

- the activation statuses of all secondary serving HS-DSCH cells in a frequency band (as defined in [7]) remain unaffected by the HS-SCCH ordered deactivation or activation and the serving HS-DSCH cell is not configured in this band or
- the activation statuses of all secondary serving HS-DSCH cells and the secondary uplink frequency in a frequency band remain unaffected by the HS-SCCH ordered deactivation or activation and the serving HS-DSCH cell is configured in this band

The maximum allowed interruption time for the downlink cells and uplink frequencies configured in this frequency band is 1 slot. The interrupt shall take place during the next downlink HS-SCCH slot after the end of the HS-DPCCH slot that contains the HARQ-ACK information acknowledging the HS-SCCH order. The corresponding change of the HS-DPCCH channel coding scheme as specified in [2] is applied by the UE at the first HS-DPCCH subframe boundary after the activation or deactivation has been applied.

6A.1.1 UE procedure for receiving HS-DSCH and HS-SCCH in the CELL_DCH state

NOTE: The Node B procedure for transmitting the HS-DSCH and the HS-SCCH is specified in subclause 6A.1.3.

In this sub-clause, sub-frame n on the HS-SCCHs refers to the sub-frame which is associated with sub-frame n on the HS-PDSCH as defined in [1], and sub-frame n on the HS-DPCCH refers to the sub-frame which is related to sub-frame n on the HS-PDSCH as defined in [1].

If the UE did not detect consistent control information intended for this UE on any of the HS-SCCHs in the HS-SCCH set in the immediately preceding subframe $n - 1$, the UE shall in sub-frame n monitor all HS-SCCHs in the HS-SCCH set. The maximum size of the HS-SCCH set in the serving HS-DSCH cell is 4.

If 64QAM is not configured for the UE and "Support for different HS-SCCHs in contiguous TTIs" is false, then if the UE did detect consistent control information intended for this UE in the immediately preceding subframe $n - 1$, it is sufficient in sub-frame n to only monitor the same HS-SCCH used in the immediately preceding subframe $n - 1$. If 64QAM is configured for the UE or "Support for different HS-SCCHs in contiguous TTIs" is true, then if the UE did detect consistent control information intended for this UE in the immediately preceding subframe $n - 1$, the UE shall in sub-frame n monitor all HS-SCCHs in the HS-SCCH set. These rules apply regardless of the value of HS-SCCH_less_mode.

If Secondary_Cell_Active is not 0 and the UE is not configured in Multiflow mode,

- The UE shall simultaneously monitor an HS-SCCH set in each of the activated secondary serving HS-DSCH cells, and receive HS-DSCH if it is scheduled in that cell. The maximum size of the HS-SCCH set in a secondary serving HS-DSCH cell is 4 and the maximum number of HS-SCCHs monitored by the UE across
 - both the serving HS-DSCH cell and the secondary serving HS-DSCH cell is 6 if the UE is capable of HS-DSCH reception in a maximum of 2 cells.
 - the serving HS-DSCH cell, the 1st and 2nd secondary serving HS-DSCH cells is 9 if the UE is capable of HS-DSCH reception in a maximum of 3 cells.
 - the serving HS-DSCH cell, the 1st, 2nd and 3rd secondary serving HS-DSCH cells is 12 if the UE is capable of HS-DSCH reception in 4 cells.
 - the serving HS-DSCH cell, the 1st, 2nd, 3rd and 4th secondary serving HS-DSCH cells is 15 if the UE is capable of HS-DSCH reception in 5 cells.
 - the serving HS-DSCH cell, the 1st, 2nd, 3rd, 4th and 5th secondary serving HS-DSCH cells is 18 if the UE is capable of HS-DSCH reception in 6 cells.
 - the serving HS-DSCH cell, the 1st, 2nd, 3rd, 4th, 5th and 6th secondary serving HS-DSCH cells is 21 if the UE is capable of HS-DSCH reception in 7 cells.
 - the serving HS-DSCH cell, the 1st, 2nd, 3rd, 4th, 5th, 6th and 7th secondary serving HS-DSCH cells is 24 if the UE is capable of HS-DSCH reception in 8 cells.
- From the serving HS-DSCH cell, the UE shall be able to receive up to one HS-DSCH if MIMO mode and MIMO mode with four transmit antennas is not configured or two HS-DSCHs if MIMO mode is configured or four HS-DSCHs if MIMO mode with four transmit antennas is configured or one HS-SCCH order.
- In addition, from each of the activated secondary serving HS-DSCH cells, the UE shall be able to simultaneously receive up to one HS-DSCH if MIMO mode and MIMO mode with four transmit antennas is not configured or two HS-DSCHs if MIMO mode is configured or four HS-DSCHs if MIMO mode with four transmit antennas is configured or one HS-SCCH order.
- The maximum number of HS-SCCH orders simultaneously received by the UE across the serving HS-DSCH cell and all the activated secondary serving HS-DSCH cells is 2.
- HS-SCCH-less HS-DSCH transmission shall not be used in a secondary serving HS-DSCH cell.
- The UE behaviour is unspecified in case more than two HS-SCCH orders are received simultaneously or contradictory HS-SCCH orders (i.e. orders for activation and deactivation of the same functionality) are received from the serving HS-DSCH cell and/or any of the secondary serving HS-DSCH cells during the same subframe.

If the UE is configured in Multiflow mode

- The UE shall simultaneously monitor an HS-SCCH set in each of the activated serving, assisting serving, secondary serving and assisting secondary serving HS-DSCH cells, and receive HS-DSCH if it is scheduled in that cell. The maximum size of the HS-SCCH set in any cell is 4 and the maximum number of HS-SCCHs monitored by the UE across
 - both the serving HS-DSCH cell and the assisting serving HS-DSCH cell is 6 if the UE is capable of HS-DSCH reception in a maximum of 2 cells in Multiflow mode.
 - the (secondary) serving HS-DSCH cell(s) and the assisting (secondary) serving HS-DSCH cell(s) is 9 if the UE is capable of HS-DSCH reception in a maximum of 3 cells in Multiflow mode.
 - the (secondary) serving HS-DSCH cell(s) and the assisting (secondary) serving HS-DSCH cell(s) is 12 if the UE is capable of HS-DSCH reception in a maximum of 4 cells in Multiflow mode.
- From the serving HS-DSCH cell, the UE shall be able to receive up to one HS-DSCH if MIMO mode is not configured or two HS-DSCHs if MIMO mode is configured or one HS-SCCH order.
- In addition, from each of the assisting serving and the activated assisting secondary serving HS-DSCH cells, the UE shall be able to simultaneously receive up to one HS-DSCH if MIMO mode is not configured or two HS-DSCHs if MIMO mode is configured or one HS-SCCH order.
- HS-SCCH-less HS-DSCH transmission shall not be used in any cell other than the serving HS-DSCH cell.
- The UE behaviour is unspecified in case more than two HS-SCCH orders are received simultaneously or contradictory HS-SCCH orders (i.e. orders for activation and deactivation of the same functionality) are received simultaneously.

The UE can be configured to simultaneously monitor a maximum of 1 HS-SCCH in one non-serving cell. This HS-SCCH is only used for HS-SCCH orders that indicate HS-DSCH serving cell change as defined in section 4.6C.2.2.1 in [2]. Upon successfully receiving an HS-SCCH order that indicates HS-DSCH serving cell change from this non-serving cell, the UE shall be able to start listening to the full configured HS-SCCH set from this new serving cell and from the new secondary serving HS-DSCH cells if configured by higher layers, at the activation time configured by higher layers if the activation time is not equal to 'now', or otherwise within 40 ms from the end of the subframe in which the HS-SCCH order is received.

When the UE monitors HS-SCCHs, the UE shall only consider the control information to be consistent if either:

- the decoded 'channelization-code-set information' is lower than or equal to 'maximum number of HS-DSCH codes received' in its UE capability and the decoded 'modulation scheme information' is valid in terms of its UE capability,

or

- the decoded 'channelization-code-set information' and decoded "modulation scheme information" correspond to an indication of an HS-SCCH order as defined in [2] subclause 4.6C.2.

Control information for one UE shall not be transmitted from the serving cell on more than one HS-SCCH in a single sub-frame.

If a UE detects that one of the monitored HS-SCCHs in sub-frame n carries consistent control information intended for this UE, the UE shall perform the following:

- If the decoded 'channelization-code-set information' and decoded "modulation scheme information" do not correspond to an indication of an HS-SCCH order, start receiving the HS-PDSCHs indicated by this consistent control information
- If the CRC of the HS-SCCH is OK:
 - If HS-SCCH_less_mode=1 and the TFRI value corresponds to the retransmissions of HS-SCCH-less operation, the transport block size information shall be derived from the signalled transport block size indicator as defined in [5] and [9].

- Else if UE_DTX_DRX_Enabled is TRUE or HS-SCCH_less_mode=1 or Secondary_Cell_Enabled is not 0 or UL_CLTD_Enabled is TRUE, and the "channelization-code-set information" and "modulation scheme information" correspond to an HS-SCCH order, the UE shall:
 - o if the TFRI value corresponds to an HS-SCCH order as defined in [2] subclause 4.6C.2,
 - If the HS-SCCH order was sent by the serving HS-DSCH cell or by one of the secondary serving HS-DSCH cells, transmit ACK information in the slot allocated to the HARQ-ACK in the corresponding HS-DPCCH sub-frame as defined in [1] and [2];
 - Process the HS-SCCH orders as described in subclauses 6A.1, 6B, 6C.4 and 10.6.
 - o else, discard the information received on this HS-SCCH.
- Else, the transport block size information shall be derived from the signalled TFRI value as defined in [9].
 - o If the 'Hybrid-ARQ process information' is not included in the set configured by upper layers, the UE shall discard the information received on this HS-SCCH and on the HS-PDSCHs.
- Else, if HS-SCCH_less_Active is TRUE, the UE may start receiving the HS-PDSCHs configured for HS-SCCH-less operation and attempt to decode the HS-DSCH bits based on the set of possible HS-DSCH transport block sizes configured for HS-SCCH-less operation. Otherwise, the UE shall discard the information received on this HS-SCCH and HS-PDSCH.

Otherwise, if the UE does not detect consistent control information intended for this UE on any of the HS-SCCHs in its HS-SCCH sets, the UE shall perform the following:

- the UE shall discard the information received on this HS-SCCH.
- if HS-SCCH_less_Active is TRUE, the UE shall start receiving the HS-PDSCHs configured for HS-SCCH-less operation and attempt to decode the HS-DSCH bits based on the set of possible HS-DSCH transport block sizes configured for HS-SCCH-less operation.
- otherwise, the UE shall discard the information received on the HS-PDSCHs.

If UL_DTX_Active is TRUE (see section 6C) and either of the following is true:

- the UE detects consistent control information intended for this UE and the TFRI value does not correspond to an HS-SCCH order, or
- the UE has successfully decoded HS-PDSCHs intended for this UE;

then, at the HS-DPCCH sub frame that contains or would contain the HARQ-ACK corresponding to the HS-SCCH or to the HS-PDSCHs that generated the priority change, the UE shall perform the following:

- set CQI_DTX_Priority to 1 and,
- reset the CQI nominal reporting timer to CQI_DTX_TIMER.

If HARQ_preamble_mode = 1 and the information received on HS-SCCH is not discarded, the UE shall:

- transmit a HARQ Preamble (PRE for HS-DPCCH slot format 0 or PRE/PRE for HS-DPCCH slot format 1) in the slot allocated to HARQ-ACK in HS-DPCCH sub-frame $n - 1$ (if two HS-DPCCHs are active then a HARQ preamble is sent on each of HS-DPCCH and HS-DPCCH₂), unless an ACK or NACK or any combination of ACK and NACK is to be transmitted in sub-frame $n - 1$ as a result of an HS-DSCH transmission earlier than sub-frame n on the HS-PDSCH, and
- if $N_{\text{acknack_transmit}} > 1$, the UE shall transmit a HARQ Preamble in the slot allocated to HARQ-ACK in HS-DPCCH sub-frame $n - 2$ (if two HS-DPCCHs are active then a HARQ preamble is sent on each of HS-DPCCH and HS-DPCCH₂), unless an ACK or NACK or any combination of ACK and NACK is to be transmitted in sub-frame $n - 2$ as a result of an HS-DSCH transmission earlier than sub-frame n on the HS-PDSCH.

The UE shall transmit the ACK/NACK information received from MAC-hs or MAC-ehs in the slot allocated to the HARQ-ACK in the corresponding HS-DPCCH sub-frame as defined in [1] and [2]. When $N_{\text{acknack_transmit}}$ is greater than one, the UE shall:

- repeat the transmission of the ACK/NACK information over the next ($N_{acknack_transmit}-1$) consecutive HS-DPCCH sub-frames, in the slots allocated to the HARQ-ACK as defined in [1] and
- not attempt to receive any HS-SCCH in HS-SCCH subframes corresponding to HS-DPCCH sub-frames in which the ACK/NACK information transmission is repeated, nor to receive or decode transport blocks from the HS-PDSCH in HS-DSCH sub-frames corresponding to HS-DPCCH sub-frames in which the ACK/NACK information transmission is repeated.

If ACK or NACK or any combination of ACK and NACK is transmitted in HS-DPCCH sub-frame n , and $HARQ_preamble_mode = 1$ and $UE\ InterTTI \leq N_{acknack_transmit}$, then the UE shall:

- transmit a HARQ Postamble (POST for HS-DPCCH slot format 0 or POST/POST for HS-DPCCH slot format 1) in the slot allocated to HARQ-ACK in HS-DPCCH subframe $n + 2 * N_{acknack_transmit} - 1$ (if two HS-DPCCHs are active then a HARQ preamble is sent on each of HS-DPCCH and HS-DPCCH₂), unless ACK or NACK or PRE or PRE/PRE or any combination of ACK and NACK is to be transmitted in this subframe, and
- if $N_{acknack_transmit} > 1$, transmit a HARQ Postamble (POST) in the slot allocated to HARQ-ACK in HS-DPCCH subframe $n + 2 * N_{acknack_transmit} - 2$ (if two HS-DPCCHs are active then a HARQ preamble is sent on each of HS-DPCCH and HS-DPCCH₂), unless an ACK or NACK or PRE or PRE/PRE or any combination of ACK and NACK is to be transmitted in this subframe.

For the case where $Secondary_Cell_Active$ is less than 4 when the UE is not configured in MIMO mode with four transmit antennas in any cell or is less than 2 when the UE is configured in MIMO mode with four transmit antennas in at least one cell DTX shall be used on the HS-DPCCH in the slot allocated to HARQ-ACK in the corresponding HS-DPCCH subframe unless a HARQ-ACK message is to be transmitted as described above.

For the case where $Secondary_Cell_Active$ is greater than 3 when the UE is not configured in MIMO mode with four transmit antennas in any cell or is greater than 1 when the UE is configured in MIMO mode with four transmit antennas in at least one cell DTX shall be used on HS-DPCCH and HS-DPCCH₂ in the slot allocated to HARQ-ACK in each of the corresponding HS-DPCCH subframes unless a HARQ-ACK message is to be transmitted as described above on either of the HS-DPCCHs. If a HARQ-ACK message is to be transmitted on only one of the active HS-DPCCHs, the DTX codeword should be repeated in the HARQ-ACK field on the other HS-DPCCH in the corresponding HS-DPCCH subframe.

6A.1.1A UE procedure for receiving HS-DSCH and HS-SCCH in CELL_FACH state

The HS-SCCH reception procedure is as defined in subclause 6A.1.1.

The UE shall perform these actions in the following order:

- The UE shall monitor the first indexed HS-SCCH of the configured HS-SCCH set with the BCCH specific H-RNTI.
- If the UE is configured with a dedicated H-RNTI, the UE shall monitor the HS-SCCHs of the configured HS-SCCH set with the dedicated H-RNTI. If the UE is not configured with a dedicated H-RNTI, the UE shall monitor the HS-SCCHs of the configured HS-SCCH set with the common H-RNTI as defined in [5].

If the higher layers configure NodeB triggered HS-DPCCH transmission (as described in [5]) then $NT-HS-DPCCH_Enabled$ is set to TRUE. Otherwise, $NT-HS-DPCCH_Enabled$ is set to FALSE.

If the UE detects that one HS-SCCH carries consistent control information intended for this UE, the UE shall perform the following:

- If the decoded 'channelization-code-set information' and decoded "modulation scheme information" do not correspond to an indication of an HS-SCCH order, start receiving the HS-PDSCHs indicated by this consistent control information.
- If the CRC of the HS-SCCH is OK:
 - o If the "channelization-code-set information" and "modulation scheme information" correspond to an HS-SCCH order as defined in [2] subclause 4.6C.3,

- if the TFRI value corresponds to an HS-SCCH order, the UE shall process the HS-SCCH orders as described in subclause 6B. If NT-HS-DPCCH_Enabled is TRUE, the UE shall not transmit the associated HARQ-ACK information acknowledging the HS-SCCH order.
 - else, discard the information received on this HS-SCCH
- Else, the transport block size information shall be derived from the signalled TFRI value as defined in [9]. If the 'Hybrid-ARQ process information' is not included in the set configured by upper layers, the UE shall discard the information received on this HS-SCCH and on the HS-PDSCHs.

Otherwise, if the UE does not detect consistent control information intended for this UE on any of the HS-SCCHs, the UE shall discard the information received on this HS-SCCH and on the HS-PDSCHs.

If HS-DPCCH transmission is indicated by higher layers, the HS-DPCCH transmission procedure as defined in subclauses 6A.1.1 and 6A.1.2 are followed. Otherwise, the UE shall not transmit any HARQ-ACK or CQI information and DTX shall be used on all the HS-DPCCH subframes.

6A.1.1B UE procedure for receiving HS-DSCH and HS-SCCH in the URA_PCH and CELL_PCH states

The HS-SCCH reception procedure is as defined in subclause 6A.1.1.

If the UE has detected a paging indication intended for this UE, the UE shall perform the actions below:

In CELL_PCH state, if the UE is configured with a dedicated H-RNTI, the UE shall perform these actions in the following order:

- The UE shall monitor the first indexed HS-SCCH of the configured HS-SCCH set with the BCCH specific H-RNTI.
- The UE shall monitor the HS-SCCHs of the configured HS-SCCH set with the dedicated H-RNTI.

In CELL_PCH state, if the higher layers configure NodeB triggered HS-DPCCH transmission (as described in [5]) then NT-HS-DPCCH_Enabled is set to TRUE. Otherwise, NT-HS-DPCCH_Enabled is set to FALSE.

If the UE is configured with a dedicated H-RNTI, and if the UE detects that one HS-SCCH in a set of 5 associated HS-SCCH subframes (as defined in [1]) carries consistent control information intended for this UE, the UE shall perform the following:

- If the decoded 'channelization-code-set information' and decoded "modulation scheme information" do not correspond to an indication of an HS-SCCH order, start receiving the HS-PDSCHs indicated by this consistent control information.
- If the CRC of the HS-SCCH is OK,
 - If the "channelization-code-set information" and "modulation scheme information" correspond to an HS-SCCH order as defined in [2] subclause 4.6C.3,
 - if the TFRI value corresponds to an HS-SCCH order, the UE shall process the HS-SCCH orders as described in subclause 6B. If NT-HS-DPCCH_Enabled is TRUE, the UE shall not transmit the associated HARQ-ACK information acknowledging the HS-SCCH order.
 - else, discard the information received on this HS-SCCH
- Else, the transport block size information shall be derived from the signalled TFRI value as defined in [9]. If the 'Hybrid-ARQ process information' is not included in the set configured by upper layers, the UE shall discard the information received on this HS-SCCH and on the HS-PDSCHs.

If the UE is configured with a dedicated H-RNTI and the UE does not detect consistent control information intended for this UE on any of the HS-SCCHs, the UE shall discard the information received on this HS-SCCH and on the HS-PDSCHs.

In CELL_PCH state, when the UE is configured to receive HS-DSCH without a dedicated H-RNTI, or in URA_PCH state, the UE shall perform the following:

- the UE shall start receiving the HS-PDSCH configured for HS-SCCH-less operation and attempt to decode the HS-DSCH bits of the first associated HS-DSCH sub-frame (as defined in [1]) and the subsequent repetitions in the (Number of PCCH transmissions-1) next contiguous HS-DSCH subframes based on the set of possible HS-DSCH Transport Block Sizes configured by higher layers.

The UE shall not transmit any HARQ-ACK or CQI information and DTX shall be used on all the HS-DPCCH subframes.

6A.1.2 UE procedure for reporting channel quality indication (CQI) and precoding control indication (PCI)

The UE procedure for reporting PCI/CQI is given in sub-clause 6A.1.2.1 for the case when the UE is not configured in MIMO mode and not configured in MIMO mode with four transmit antennas in any cell, in sub-clause 6A.1.2.2 for the case when the UE is configured in MIMO mode in all cells, and in sub-clause 6A.1.2.3 for the case when the UE is configured in MIMO mode with four transmit antennas in all cells.

If the UE is configured in MIMO mode in at least one cell, but not in all cells and is not configured in MIMO mode with four transmit antennas in any cell, then the overall PCI/CQI reporting procedure shall be the same as if the UE was configured in MIMO mode in all cells as specified in subclause 6A.1.2.2 except that a CQI value as defined in subclause 6A.2.1 is derived and reported for the non-MIMO cells.

6A.1.2.1 CQI reporting procedure in case the UE is not configured in MIMO mode and not configured in MIMO mode with four transmit antennas in any cell

With the exception of the provisions of subclause 6A.3, the following shall apply when the UE is not configured in MIMO mode and not configured in MIMO mode with four transmit antennas in any cell:

- 1) The UE derives the CQI value for the serving HS-DSCH cell as defined in subclause 6A.2.1.

If the UE is not configured in Multiflow mode and Secondary_Cell_Active is not 0, the UE also derives a CQI value for the activated secondary serving HS-DSCH cells as defined in subclause 6A.2.1.

If the UE is configured in the Multiflow mode, the UE also derives the CQI values for the assisting serving and any activated secondary serving and assisting secondary serving HS-DSCH cells as defined in subclause 6A.2.1.

The CQI report(s) are constructed from the CQI value(s) as specified in [2].

- 2) For $k = 0$, the UE shall not transmit the CQI report(s).
For $k > 0$ when DTX_DRX_STATUS is not TRUE, the UE shall transmit the CQI report containing the CQI value for the serving HS-DSCH cell in each subframe that starts $m \times 256$ chips after the start of the associated uplink DPCCH frame with m fulfilling:

$$(5 \times CFN + \lceil m \times 256 \text{ chip} / 7680 \text{ chip} \rceil) \bmod k' = 0 \quad \text{with } k' = k / (2ms),$$

where CFN denotes the connection frame number for the associated DPCH and the set of five possible values of m is calculated as described in subclause 7.7 in [1].

For $k > 0$ when DTX_DRX_STATUS is TRUE, the UE shall transmit the CQI report containing the CQI value for the serving HS-DSCH cell as specified in 6C.2 based on the CQI transmission pattern. The CQI transmission pattern is the set of HS-DPCCH subframes whose HS-DPCCH discontinuous transmission radio frame number CFN_DRX and subframe number S_DRX, both defined in 6C.3, verify:

$$((5 * CFN_DRX - UE_DTX_DRX_Offset + S_DRX) \bmod k') = 0, \quad \text{with } k' = k / (2ms).$$

- 3) The UE shall repeat the transmission of the CQI report containing the CQI value for the serving HS-DSCH cell derived in 1) over the next $(N_cqi_transmit - 1)$ consecutive HS-DPCCH sub frames in the slots respectively allocated to the CQI as defined in [1]. UE does not support the case of $k' < N_cqi_transmit$.
- 4a) If Secondary_Cell_Enabled is less than 4, the UE is not in Multiflow mode, and if an additional CQI report is derived in 1), the UE shall transmit this CQI report over the next $N_cqi_transmit$ consecutive HS-DPCCH sub frames immediately following the transmission of the CQI report in 2) and 3). UE does not support the case of $k' < 2 \cdot N_cqi_transmit$.

4b) If Secondary_Cell_Enabled is 7 and Secondary_Cell_Active is 7 the UE shall for the activated cells

- Transmit the CQI report containing the CQI value of the 4th secondary serving HS-DSCH cell simultaneously as the CQI report containing the CQI value of the serving HS-DSCH cell.
- Transmit the CQI report containing the CQI value of the 6th secondary serving HS-DSCH cell simultaneously as the CQI report containing the CQI value of the 2nd secondary serving HS-DSCH cell
- Transmit the CQI report containing the CQI value of the 5th secondary serving HS-DSCH cell simultaneously as the CQI report containing the CQI value of the 1st secondary serving HS-DSCH cell
- Transmit the CQI report containing the CQI value of the 7th secondary serving HS-DSCH cell simultaneously as the CQI report containing the CQI value of the 3rd secondary serving HS-DSCH cell

The CQI report is transmitted over $(N_cqi_transmit - 1)$ consecutive HS-DPCCH sub frames. The UE does not support the case of $k' < 2 \cdot N_cqi_transmit$.

4c) If Secondary_Cell_Enabled is greater than 3 and Secondary_Cell_Active is less than 7 the UE shall

- For HS-DPCCH
 - Transmit the CQI reports in the same slots as it would transmit the CQI reports if Secondary_Cell_Enabled is equal to 4 and the 1st, 2nd and 3rd secondary serving HS-DSCH cell were active.
- For HS-DPCCH₂
 - Transmit the CQI report of the 4th secondary serving HS-DSCH cell (if present) so that it starts in the same slot as the transmissions of CQI report of the serving HS-DSCH starts.
 - If at most one of the 4th, 5th, 6th or 7th secondary serving HS-DSCH cell is deactivated the transmissions of the CQI reports for the active secondary serving HS-DSCH cells occurs in the same slots as if Secondary_Cell_Active is equal to 7.
 - If at most two of 4th, 5th, 6th and 7th secondary serving HS-DSCH cell are active the transmissions of the CQI reports associated with the active secondary serving HS-DSCH cell with lowest index as indicated by higher layers is transmitted in the CQI field of the subframe where the 4th and 6th secondary serving HS-DSCH cell would be transmitted if Secondary_Cell_Active is 7. The CQI report associated with the other secondary serving HS-DSCH cell (if present) is always transmitted in the subframe(s) immediately following the transmissions of the first CQI report.

The CQI reports transmitted on HS-DPCCH₂ are always over $(N_cqi_transmit-1)$ consecutive HS-DPCCH sub frames.

4d) If the UE is configured in the Multiflow mode

- 4d.1) If the UE is configured with the Serving HS-DSCH and Assisting Serving HS-DSCH only, and neither of the cells is in MIMO mode, the combined CQI report is transmitted and repeated as defined in steps 2) and 3) and no other CQI reports are sent. The CQI reports are constructed from the CQI value(s) as specified in subclause 4.7.4.3.1, MF case 1 in table 15C.8 of [2]
- 4d.2) For all other non-MIMO Multiflow configurations, the UE shall transmit the CQI report(s) associated with the assisting serving cells over the next $N_cqi_transmit_2-1$ consecutive HS-DPCCH sub frames immediately following the transmission of the CQI report(s) defined in steps 2) and 3). UE does not support the case of $k' < (N_cqi_transmit + N_cqi_transmit_2)$. The CQI reports are constructed from the CQI value(s) as specified in subclause 4.7.4.3, MF cases 3 to 6 and 11 to 14 in tables 15C.10, 15C.11 and 15C.15 of [2].

5) The UE shall not transmit CQI reports in other subframes than those described in 2), 3), 4a), 4b), 4c) and 4d).

6A.1.2.2 Composite PCI/CQI reporting procedure in case the UE is configured in MIMO mode

The following types of CQI reports have to be supported by the UE when the UE is configured in MIMO mode and single-stream restriction is not configured:

- Type A: CQI reports that indicate the supported transport format(s) for the number of simultaneously transmitted transport blocks that the UE prefers according to the current channel conditions assuming that the preferred primary precoding vector as indicated by the PCI value signalled in the same HS-DPCCH sub-frame would be applied at the Node-B for the primary transport block and in case two transport blocks are preferred the precoding vector orthogonal to the preferred primary precoding vector would be applied for the secondary transport block. This type of CQI report contains information on either one transport format or a combination of two transport formats depending on what is currently the preferred number of transport blocks (either 1 or 2).
- Type B: CQI reports that indicate the supported transport format for a single transmitted transport block according to the current channel conditions assuming that the preferred primary precoding vector as indicated by the PCI value signalled in the same HS-DPCCH sub-frame would be applied at the Node-B for the primary transport block and that no secondary transport block is transmitted.

When UE is configured in MIMO mode and single-stream restriction is configured only type B CQI report have to be supported by the UE.

With the exception of the provisions of subclause 6A.3, the following shall apply when the UE is configured in MIMO mode:

- 1) The UE derives the PCI value for the serving HS-DSCH cell as defined in subclause 6A.4.1 and when single-stream restriction is not configured either a type A or a type B CQI value and when single-stream restriction is configured type B CQI value for the serving HS-DSCH cell as defined in subclause 6A.2.2 depending on which type of CQI shall be reported as defined below.

If UE is not configured in Multiflow mode and Secondary_Cell_Active is not 0, the UE also derives a PCI value for the activated secondary serving HS-DSCH cell(s) as defined in subclause 6A.4 and when single-stream restriction is not configured either a type A or a type B CQI value and when single-stream restriction is configured type B CQI value for the secondary serving HS-DSCH cell as defined in subclause 6A.2.2 depending on which type of CQI shall be reported as defined below.

If the UE is configured in the Multiflow mode,

- the UE also derives a PCI value for the assisting serving and any activated secondary serving and assisting secondary serving HS-DSCH cells as defined in subclause 6A.4 if the UE is configured in MIMO mode in that cell,
- and when single-stream restriction is not configured, either type A or type B CQI value, and when single-stream restriction is configured, type B CQI value for the assisting serving and any activated secondary serving and assisting secondary serving HS-DSCH cells as defined in subclause 6A.2.2 depending on which type of CQI shall be reported.

The PCI/CQI report(s) in each subframe are constructed from the composite PCI/CQI value(s) as specified in [2].

2)

- a. For $k = 0$, the UE shall not transmit a composite PCI/CQI value.
- b. For $k > 0$ when DTX_DRX_STATUS is not TRUE (see section 6A.1), the UE shall transmit the composite PCI/CQI value(s) for the cells in the PCI/CQI report containing the composite PCI/CQI value for the serving HS-DSCH cell in each subframe that starts $m \times 256$ chips after the start of the associated uplink DPCCH frame with m fulfilling

$$(5 \times CFN + \lceil m \times 256 \text{chip} / 7680 \text{chip} \rceil) \bmod k' = 0 \quad \text{with } k' = k / (2ms), \quad (x1)$$

where CFN denotes the connection frame number for the associated DPCH and the set of five possible values of m is calculated as described in subclause 7.7 in [1].

When single-stream restriction is not configured and the relation

$$\left\lfloor \frac{5 \times CFN + \lceil m \times 256 \text{chip} / 7680 \text{chip} \rceil}{k'} \right\rfloor \bmod M_{\text{cqi}} < N_{\text{cqi_typeA}}$$

holds, the UE shall report a type A CQI value. Otherwise the UE shall report a type B CQI value.

- c. For $k > 0$ when DTX_DRX_STATUS is TRUE (see section 6A.1), the UE shall transmit the CQI value for the cells in the PCI/CQI report containing the composite PCI/CQI value for the serving HS-DSCH cell as specified in 6C.2 based on the CQI transmission pattern. The CQI transmission pattern is the set of HS-DPCCH subframes whose HS-DPCCH discontinuous transmission radio frame number CFN_DRX and subframe number S_DRX, both defined in 6C.3, verify:

$$((5 \times \text{CFN_DRX} - \text{UE_DTX_DRX_Offset} + \text{S_DRX}) \bmod k') = 0, \text{ with } k' = k / (2ms).$$

When single-stream restriction is not configured and the relation

$$\left\lfloor \frac{5 \times \text{CFN_DRX} - \text{UE_DTX_DRX_Offset} + \text{S_DRX}}{k'} \right\rfloor \bmod M_{\text{cqi}} < N_{\text{cqi_typeA}}$$

holds, the UE shall report a type A CQI value. Otherwise the UE shall report a type B CQI value.

- d. For $k > 0$, each PCI value derived in 1) shall be transmitted together with the corresponding CQI value as a composite PCI/CQI value. It should be noted that in case that 2560 is not an integer multiple of M_{cqi} , the sequence of type A and type B CQI reports might not always be periodic due to CFN roll-over.
- 3) The UE shall repeat the transmission of the CQI report containing the composite PCI/CQI value for the serving HS-DSCH cell derived above over the next $(N_{\text{cqi_transmit}} - 1)$ consecutive HS-DPCCH sub frames in the slots respectively allocated to CQI as defined in [1]. The UE does not support the case of $k' < N_{\text{cqi_transmit}}$.
- 4a) If Secondary_Cell_Enabled is less than 4, the UE is not in Multiflow mode, and if an additional PCI/CQI report is derived in 1), the UE shall transmit this PCI/CQI report over the next $N_{\text{cqi_transmit}}$ consecutive HS-DPCCH sub frames immediately following the transmission of the CQI report in 2) and 3). UE does not support the case of $k' < 2 \cdot N_{\text{cqi_transmit}}$.
- 4b) If Secondary_Cell_Enabled is 7 and Secondary_Cell_Active is 7 the UE shall:
- Transmit the PCI/CQI report containing the PCI/CQI value of the 4th secondary serving HS-DSCH cell simultaneously as the PCI/CQI report containing the PCI/CQI value of the serving HS-DSCH cell.
 - Transmit the PCI/CQI report containing the PCI/CQI value of the 6th secondary serving HS-DSCH cell simultaneously as the PCI/CQI report containing the PCI/CQI value of the 2nd secondary serving HS-DSCH cell
 - Transmit the PCI/CQI report containing the PCI/CQI value of the 5th secondary serving HS-DSCH cell simultaneously as the PCI/CQI report containing the PCI/CQI value of the 1st secondary serving HS-DSCH cell
 - Transmit the PCI/CQI report containing the PCI/CQI value of the 7th secondary serving HS-DSCH cell simultaneously as the PCI/CQI report containing the PCI/CQI value of the 3rd secondary serving HS-DSCH cell

The PCI/CQI report is transmitted over $(N_{\text{cqi_transmit}} - 1)$ consecutive HS-DPCCH sub frames. The UE does not support the case of $k' < 2 \cdot N_{\text{cqi_transmit}}$.

- 4c) If Secondary_Cell_Enabled is greater than 3 and Secondary_Cell_Active is less than 7 the UE shall:

- For HS-DPCCH

- Transmit the PCQ/CQI reports in the same slots as it would transmit the PCI/CQI reports if Secondary_Cell_Enabled is equal to 4 and the same of the 1st, 2nd and 3rd secondary serving HS-DSCH cell were active.
- For HS-DPCCH₂
 - Transmit the PCI/CQI report of the 4th secondary serving HS-DSCH cell (if present) so that it starts in the same slot as the transmissions of PCI/CQI report of the serving HS-DSCH cell starts.
 - If at most one of the 4th, 5th, 6th or 7th secondary serving HS-DSCH cell is deactivated the transmissions of the PCI/CQI reports for the active secondary serving HS-DSCH cells occurs in the same slots as if Secondary_Cell_Active is equal to 7.
 - If at most two of 4th, 5th, 6th and 7th secondary serving HS-DSCH cell are active the transmissions of the PCI/CQI reports associated with the active secondary serving HS-DSCH cell with lowest index as indicated by higher layers is transmitted in the PCI/CQI field of the subframe where the 4th and 6th secondary serving HS-DSCH cell would be transmitted if Secondary_Cell_Active is 7. The PCI/CQI report associated with the other secondary serving HS-DSCH cell (if present) is always transmitted in the subframe(s) immediately following the transmissions of the first PCI/CQI report.

The PCI/CQI reports transmitted on HS-DPCCH₂ are always over ($N_{cqi_transmit}-1$) consecutive HS-DPCCH sub frames.

4d) If the UE is configured in the Multiflow mode, the UE shall transmit the PCI/CQI report(s) associated with the assisting serving cells over the next $N_{cqi_transmit_2}-1$ consecutive HS-DPCCH sub frames immediately following the transmission of the PCI/CQI report(s) defined in steps 2) and 3). UE does not support the case of $k < (N_{cqi_transmit} + N_{cqi_transmit_2})$. The PCI/CQI reports are constructed from the PCI/CQI value(s) as specified in subclause 4.7.4.3, MF cases 2, 7...10 and 15...18 in tables 15C.9, 15C.12, 15C.13 and 15C.15 of [2].

5) The UE shall not transmit PCI/CQI reports in other subframes than those described in 2), 3), 4a), 4b), 4c) and 4d).

6A.1.2.3 Composite NTBP/PCI/CQI reporting procedure in case the UE is configured in MIMO mode with four transmit antennas

The following types of CQI reports have to be supported by the UE when the UE is configured in MIMO mode with four transmit antennas:

Type A:

CQI reports that indicate the supported transport format(s) for the number of simultaneously transmitted transport blocks that the UE prefers according to the current channel conditions assuming that the preferred precoding matrix as indicated by the PCI value signalled in the same HS-DPCCH sub-frame would be applied at the Node-B.

Type B:

CQI reports that indicate the supported transport format for a single transmitted transport block according to the current channel conditions assuming that the preferred precoding vector as indicated by the PCI value signalled in the same HS-DPCCH sub-frame would be applied at the Node-B for the primary transport block and that no second, third, and fourth transport blocks are transmitted.

With the exception of the provisions of subclause 6A.3, the following shall apply when the UE is configured in MIMO mode with four transmit antennas:

- 1) The UE derives the NTBP, PCI value for the serving HS-DSCH cell as defined in subclause 6A.4. 2 and either a type A or a type B CQI value for the serving HS-DSCH cell depending on which type of CQI shall be reported as defined below.

If Secondary_Cell_Active is not 0, the UE also derives NTBP, PCI value for the activated secondary serving HS-DSCH cell(s) as defined in subclause 6A.4.1 and 6A.4.2 and either a type A or a type B CQI value for the secondary serving HS-DSCH cell depending on which type of CQI shall be reported as defined below.

The NTBP/PCI/CQI report(s) in each subframe are constructed from the composite NTBP/PCI/CQI value(s) as specified in [2].

2)

- a. For $k = 0$, the UE shall not transmit a composite NTBP/PCI/CQI value.
- b. For $k > 0$ when DTX_DRX_STATUS is not TRUE (see section 6A.1), the UE shall transmit the composite NTBP/PCI/CQI value(s) for the cells in the NTBP/PCI/CQI report containing the composite NTBP/PCI/CQI value for the serving HS-DSCH cell in each subframe that starts $m \times 256$ chips after the start of the associated uplink DPCCH frame with m fulfilling

$$(5 \times CFN + \lceil m \times 256 \text{chip} / 7680 \text{chip} \rceil) \bmod k' = 0 \quad \text{with } k' = k / (2ms), \quad (\text{x1})$$

where CFN denotes the connection frame number for the associated DPCH and the set of five possible values of m is calculated as described in subclause 7.7 in [1].

- c. For $k > 0$ when DTX_DRX_STATUS is TRUE (see section 6A.1), the UE shall transmit the CQI value for the cells in the NTBP/PCI/CQI report containing the composite NTBP/PCI/CQI value for the serving HS-DSCH cell as specified in 6C.2 based on the CQI transmission pattern. The CQI transmission pattern is the set of HS-DPCCH subframes whose HS-DPCCH discontinuous transmission radio frame number CFN_DRX and subframe number S_DRX, both defined in 6C.3, verify:

$$((5 * CFN_DRX - UE_DTX_DRX_Offset + S_DRX) \bmod k') = 0, \quad \text{with } k' = k / (2ms).$$

- d. For $k > 0$, each NTBP/PCI value derived in 1) shall be transmitted together with the corresponding CQI value as a composite PCI/CQI value. It should be noted that in case that 2560 is not an integer multiple of M_{cqi} , the sequence of type A and type B CQI reports might not always be periodic due to CFN roll-over.

3) The UE shall repeat the transmission of the CQI report containing the composite NTBP/PCI/CQI value for the serving HS-DSCH cell derived above over the next $(N_{cqi_transmit} - 1)$ consecutive HS-DPCCH sub frames in the slots respectively allocated to CQI as defined in [1]. The UE does not support the case of $k' < N_{cqi_transmit}$.

4a) If Secondary_Cell_Enabled is less than 2, and if an additional NTBP/PCI/CQI report is derived in 1), the UE shall transmit this NTBP/PCI/CQI report over the next $N_{cqi_transmit}$ consecutive HS-DPCCH sub frames immediately following the transmission of the CQI report in 2) and 3). UE does not support the case of $k' < 2 \cdot N_{cqi_transmit}$.

4b) If Secondary_Cell_Enabled is 3 and Secondary_Cell_Active is 3 the UE shall:

- Transmit the NTBP/PCI/CQI report containing the NTBP/PCI/CQI value of the 2nd secondary serving HS-DSCH cell simultaneously as the NTBP/PCI/CQI report containing the NTBP/PCI/CQI value of the serving HS-DSCH cell.
- Transmit the NTBP/PCI/CQI report containing the NTBP/PCI/CQI value of the 3rd secondary serving HS-DSCH cell simultaneously as the NTBP/PCI/CQI report containing the NTBP/PCI/CQI value of the 1st secondary serving HS-DSCH cell.

The NTBP/PCI/CQI report is transmitted over $(N_{cqi_transmit})$ consecutive HS-DPCCH sub frames. The UE does not support the case of $k' < 2 \cdot N_{cqi_transmit}$.

5) The UE shall not transmit NTBP/PCI/CQI reports in other subframes than those described in 2), 3), 4a) and 4b).

6A.1.3 Node B procedure for transmitting the HS-DSCH and HS-SCCH

6A.1.3.1 Node B procedure for transmitting the HS-DSCH and HS-SCCH in the CELL_DCH state

When transmitting to a UE for which the HS-SCCH_less_mode=1, the Node B shall use the following procedures:

- The Node B can always transmit an HS-DSCH transport block using CRC attachment method 1 and HS-SCCH type 1.
- If HS-SCCH_less_Active is TRUE, the Node B may transmit an HS-DSCH transport block using CRC attachment method 2 and HS-SCCH type 2 according to [2] provided that the size of the transport block belongs to the set of transport block sizes configured for HS-SCCH less operation by higher layers. In this case, a maximum of two retransmissions may be used for each HS-DSCH transport block.

Otherwise,

- The Node B should always transmit an HS-DSCH transport block using CRC attachment method 1 and
 - o HS-SCCH type 1 in a cell where the UE is not configured in MIMO mode and not configured in MIMO mode with four transmit antennas, or
 - o HS-SCCH type 3 in a cell where the UE is configured in MIMO mode, or
 - o HS-SCCH type 4 in a cell where the UE is configured in MIMO mode with four transmit antennas.

If Node B uses CRC attachment method 1 or CRC attachment method 2 for the first transmission of a transport block, Node B shall use CRC attachment method 1 or CRC attachment method 2 respectively for any retransmission of the transport block.

When transmitting/retransmitting, in a cell where the UE is not configured in MIMO mode and not configured in MIMO mode with four transmit antennas, a transport block using CRC attachment method 1 or retransmitting a transport block to a UE using CRC attachment method 2, the Node B shall transmit the corresponding control information using HS-SCCH type 1 or HS-SCCH type 2 respectively on one of the HS-SCCHs in the UE's HS-SCCH set.

When transmitting/retransmitting, in a cell where the UE is configured in MIMO mode, a transport block the Node B shall use CRC attachment method 1 and transmit the corresponding control information using HS-SCCH type 3 on one of the HS-SCCHs in the UE's HS-SCCH set.

When transmitting/retransmitting, in a cell where the UE is configured in MIMO mode with four transmit antennas, the Node B shall use CRC attachment method 1 and transmit the corresponding control information using HS-SCCH type 4 on one of the HS-SCCHs in the UE's HS-SCCH set.

6A.1.3.2 Node B procedure for transmitting the HS-DSCH and HS-SCCH in the CELL_FACH state

When transmitting to a UE the Node B shall use the following procedures:

- The Node B shall always transmit an HS-DSCH transport block using CRC attachment method 1 and HS-SCCH type 1.
- When transmitting/retransmitting a transport block the Node B shall transmit the corresponding control information using HS-SCCH type 1 on one of the HS-SCCHs in the configured HS-SCCH set. When transmitting/retransmitting a transport block with the BCCH specific H-RNTI, the Node B shall use the first indexed HS-SCCH of the configured HS-SCCH set.

6A.1.3.3 Node B procedure for transmitting the HS-DSCH and HS-SCCH in the URA_PCH or CELL_PCH state

The timing relation of the PICH frame to the first associated HS-SCCH subframe and its associated HS-DSCH subframe is described in 7.2A of [1].

In CELL_PCH state, when transmitting with a dedicated H-RNTI or BCCH specific H-RNTI, the Node B shall use the following procedures:

- The Node B may transmit HS-SCCH type 1 in any of the 5 HS-SCCH subframes associated with the PICH frame (as defined in [1]), and the corresponding HS-DSCH transport block using CRC attachment method 1 in

the associated HS-DSCH subframe. When transmitting with the BCCH specific H-RNTI, the Node B shall use the first indexed HS-SCCH of the configured HS-SCCH set.

- The Node B may retransmit the HS-DSCH in any of the subsequent sub-frames associated with the PICH (as defined in [1]). All retransmissions shall be sent with HS-SCCH type 1.
- The Node B may also transmit an HS-SCCH order, as defined in [2] subclause 4.6C.3, in any of the 5 HS-SCCH subframes associated with the PICH frame (as defined in [1]).

In CELL_PCH state, when transmitting to a UE not configured with a dedicated H-RNTI, or in URA_PCH state, the Node B shall use the following procedures:

- The Node B shall not transmit an HS-SCCH.
- The Node B shall transmit an HS-DSCH transport block in the HS-DSCH subframe associated with the first associated HS-SCCH subframe, with the following parameters:
 - o QPSK modulation
 - o HS-PDSCH channelisation code configured for HS-SCCH less paging operation by higher layers
 - o CRC attachment method 1 for the HS-DSCH
 - o the size of the transport block belongs to the set of transport block sizes configured for HS-SCCH less paging operation by higher layers.
- The Node B shall retransmit the HS-DSCH transport block (Number of PCCH transmissions-1) times in the next contiguous subframes without transmitting HS-SCCH.
- For the first, second, third, fourth and fifth transmissions, the redundancy and constellation version of the HS-DSCH transport block are 0, 2, 5, 6, and 1, respectively.

6A.2 Channel quality indicator (CQI) definition

Any overlap between the 3-slot reference period (as defined in either 6A.2.1 or 6A.2.2 or 6A.2.2A) and a DRX period (as defined in section 6C.3) shall not prevent the UE transmitting a CQI report.

6A.2.1 CQI definition when the UE is not configured in MIMO mode and not configured in MIMO mode with four transmit antennas

This definition of CQI applies only when the UE is not configured in MIMO mode and not configured in MIMO mode with four transmit antennas.

Based on an unrestricted observation interval, the UE shall report the highest tabulated CQI value for which a single HS-DSCH sub-frame formatted with the transport block size, number of HS-PDSCH codes and modulation corresponding to the reported or lower CQI value could be received with a transport block error probability not exceeding 0.1 in a 3-slot reference period ending 1 slot before the start of the first slot in which the reported CQI value is transmitted. Depending on the UE category as derived by higher layers in [5], either Table 7A, 7B, 7C, 7D, 7E, 7F or 7G should be used.

For the purpose of CQI reporting, the UE shall assume a total received HS-PDSCH power of

$$P_{HSPDSCH} = P_{CPICH} + \Gamma + \Delta \text{ in dB,}$$

where the total received power is evenly distributed among the HS-PDSCH codes of the reported CQI value, the measurement power offset Γ is signalled by higher layers and the reference power adjustment Δ is given by Table 7A, 7B, 7C, 7D, 7E, 7F or 7G depending on the UE category.

Further, for the purpose of CQI reporting, the UE shall assume the number of soft channel bits available in the virtual IR buffer (N_{IR}), and redundancy and constellation version parameter (X_{RV}) as given by Table 7A, 7B, 7C, 7D, 7E, 7F or 7G depending on the UE category irrespective of the actual number of HARQ processes that are configured. The indicated HSDPA category applies independent of whether the UE is configured in Multiflow mode or not.

If higher layer signalling informs the UE that for the relevant radio link (i.e. the radio link from the serving HS-DSCH cell in the case of a CQI value for the serving HS-DSCH cell, or the radio link from a secondary serving HS-DSCH cell in the case of a CQI value for a secondary serving HS-DSCH cell) it may use a S-CPICH as a phase reference and the P-CPICH is not a valid phase reference, P_{CPICH} is the received power of the S-CPICH used by the UE, otherwise

P_{CPICH} is the received power of the P-CPICH. In the case of a CQI value for the serving HS-DSCH cell, if closed loop transmit diversity is used for the radio link from the serving HS-DSCH cell, P_{CPICH} denotes the power of the combined received CPICH from both transmit antennas, determined as if error-free transmitter weights had been applied to the CPICH, where those weights are determined as described in sub-clause 7.2. If STTD is used, P_{CPICH} denotes the combined CPICH power received from each transmit antenna and if no transmit diversity is used P_{CPICH} denotes the power received from the non diversity antenna.

For the purpose of CQI reporting the UE shall assume that all HS-PDSCH channelisation codes it may receive from the relevant radio link are under the same scrambling code as the Common Pilot Channel used to determine P_{CPICH} .

6A.2.2 CQI definition when the UE is configured in MIMO mode

This definition of CQI applies only when the UE is configured in MIMO mode.

Based on an unrestricted observation interval, the UE shall report the highest tabulated CQI value(s) for which a single HS-DSCH sub-frame formatted with the set of transport block size(s), number of HS-PDSCH codes and set of modulation(s) corresponding to the reported CQI value(s) could be received with individual transport block error probabilities not exceeding 0.1 in a 3-slot reference period ending 1 slot before the start of the first slot in which the reported CQI value(s) is/are transmitted if the preferred primary precoding vector as indicated by the PCI value reported in the same HS-DPCCH sub-frame would be applied at the Node B for the primary transport block and in case two transport blocks are preferred the precoding vector orthogonal to the preferred primary precoding vector would be applied for the secondary transport block. When single-stream restriction is not configured and depending on the UE category as derived by higher layers [5], either Table 7H, 7I, 7Ia or 7Ib shall be used for dual transport block type A CQI reports, and either Table 7C, 7D, 7F or 7G shall be used for single transport block type A or type B CQI reports.

Type A CQI reports are constructed using a CQI value that is computed according to

$$CQI = \begin{cases} 15 \times CQI_1 + CQI_2 + 31 & \text{when 2 transport blocks are preferred by the UE} \\ CQI_s & \text{when 1 transport block is preferred by the UE} \end{cases}$$

where CQI_1 indicates the supported transport format according to Table 7H, 7I, 7Ia or 7Ib for the transport block that could be received with the specified block error probability if it was transmitted with the preferred primary precoding vector and CQI_2 indicates the supported transport format according to Table 7H, 7I, 7Ia or 7Ib for the transport block that could be received with the specified block error probability if it was transmitted with the precoding vector orthogonal to the preferred primary precoding vector. CQI_s indicates the supported transport format according to Table 7C, 7D, 7F or 7G for the transport block that could be received with the specified block error probability if it was transmitted with the preferred primary precoding vector.

When single-stream restriction is not configured type B CQI reports are constructed using the CQI value of the supported transport format according to Table 7C, 7D, 7F or 7G for the transport block that could be received with the specified block error probability if it was transmitted with the preferred primary precoding vector.

When single-stream restriction is configured type B CQI reports are constructed using the CQI value of the supported transport format according to Table 7A, 7B, 7C, 7D, 7F or 7G for the transport block that could be received with the specified block error probability if it was transmitted with the preferred primary precoding vector.

For the purpose of CQI reporting, the UE shall assume a total transmit power of HS-PDSCH

$$P_{HSPDSCH} = P_{CPICH} + \Gamma \text{ in dB,}$$

where the total transmit power is assumed to be evenly distributed among the HS-PDSCH codes corresponding to the reported CQI value, and the measurement power offset Γ is signaled by higher layers. P_{CPICH} denotes the combined transmit power of the set of CPICH(s) used for MIMO operation of HS-DSCH.

When single-stream restriction is not configured and if a CQI for a single transport block is reported, the parameter Δ that is given by Table 7C, 7D, 7F or 7G depending on the UE category and configuration indicates a reference power adjustment for the Node B transmit power on the indicated HS-PDSCH(s). If a CQI for two transport blocks is reported, the parameter Δ that is given by Table 7H, 7I, 7Ia or 7Ib depending on the UE category and configuration indicates by how much the equivalent AWGN symbol SINR for a specific transport block would be different from the one required to meet the predicted BLER performance.

When single-stream restriction is configured, the parameter Δ that is given by Table 7A, 7B, 7C, 7D, 7F or 7G depending on the UE category and configuration indicates a reference power adjustment for the Node B transmit power on the indicated HS-PDSCH(s).

When deriving the CQI value, the UE assumes that the Node B would be using a uniform power allocation across the number of HS-PDSCH codes corresponding to the CQI value to be reported. In case the UE reports a CQI for two transport blocks, it is assumed by the UE that the Node B uses an equal power per HS-PDSCH code for both of the two transport blocks.

When the Node B schedules the UE with two transport blocks, if the Node B does not transmit with equal power per used HS-PDSCH code or use different power per code than indicated by the measurement power offset Γ , it should not assume that the reported transport block sizes can be received with the specified block error probabilities or that transmission of two transport blocks is preferred by the UE.

Further, for the purpose of CQI reporting, the UE shall assume the number of soft channel bits available in the virtual IR buffer (N_{IR}), and redundancy and constellation version parameter (X_{rv} , X_{rvpb} , or X_{rvsb}) as given by Table 7A, 7B, 7C, 7D, 7F, 7G, 7H, 7I, 7Ia or 7Ib depending on the UE category and on the CQI report type irrespective of the actual number of HARQ processes that are configured.

For the purpose of CQI reporting the UE shall assume that all HS-PDSCH channelisation codes it may receive are under the same scrambling code as the set of CPICH(s) used to determine P_{CPICH} .

6A.2.2A CQI definition when the UE is configured in MIMO mode with four transmit antennas

This definition of CQI applies only when the UE is configured in MIMO mode with four transmit antennas.

Based on an unrestricted observation interval, the UE shall report the highest tabulated CQI value(s) for which a single HS-DSCH sub-frame formatted with the set of transport block size(s), number of HS-PDSCH codes and set of modulation(s) corresponding to the reported CQI value(s) could be received with individual transport block error probabilities not exceeding 0.1 in a 3-slot reference period ending 1 slot before the start of the first slot in which the reported CQI value(s) is/are transmitted if the preferred precoding matrix as indicated by the PCI value reported in the same HS-DPCCH sub-frame that would be applied at the Node B on transport blocks as indicated by the UE. Either Table 7H, 7I, 7Ia or 7Ib shall be used for two, three or four transport block type A CQI reports, and either Table 7C, 7D, 7F or 7G shall be used for single transport block type A or type B CQI reports.

Type A CQI reports are constructed using a CQI value that is computed according to

$$CQI = \begin{cases} 15 \times CQI_1 + CQI_2 & \text{when 2,3,4 transport blocks are preferred by the UE} \\ CQI_s & \text{when 1 transport block is preferred by the UE} \end{cases}$$

When the number of transport blocks preferred by the UE is equal to four, CQI_1 indicates the supported transport format according to Table 7H, 7I, 7Ia or 7Ib for the primary and fourth transport blocks that could be received with the specified block error probability if it was transmitted with the preferred precoding matrix and CQI_2 indicates the supported transport format according to Table 7H, 7I, 7Ia or 7Ib for the second and third transport blocks that could be received with the specified block error probability if it was transmitted with the preferred precoding matrix.

When the number of transport blocks preferred by the UE is equal to three, CQI_1 indicates the supported transport format according to Table 7H, 7I, 7Ia or 7Ib for the primary transport block that could be received with the specified block error probability if it was transmitted with the preferred precoding matrix and CQI_2 indicates the supported transport format according to Table 7H, 7I, 7Ia or 7Ib for the second and third transport blocks that could be received with the specified block error probability if it was transmitted with the preferred precoding matrix.

When the number of transport blocks preferred by the UE is equal to two, CQI_1 indicates the supported transport format according to Table 7H, 7I, 7Ia or 7Ib for the primary transport block that could be received with the specified block error probability if it was transmitted with the preferred precoding matrix and CQI_2 indicates the supported transport format according to Table 7H, 7I, 7Ia or 7Ib for the second transport block that could be received with the specified block error probability if it was transmitted with the preferred precoding matrix.

When the number of transport blocks preferred by the UE is equal to one, CQI_S indicates the supported transport format according to Table 7C, 7D, 7F or 7G for the transport block that could be received with the specified block error probability if it was transmitted with the preferred precoding vector.

Type B CQI reports are constructed using the CQI value of the supported transport format according to Table 7C, 7D, 7F or 7G for the transport block that could be received with the specified block error probability if it was transmitted with the preferred precoding vector.

When D-CPICH(s) are not activated for data demodulation by Node B, for the purpose of CQI reporting, the UE shall assume a total transmit power of HS-PDSCH

$$P_{HSPDSCH} = P_{CPICH} + \Gamma \text{ in dB,}$$

where the total transmit power is assumed to be evenly distributed among the HS-PDSCH codes corresponding to the reported CQI value, and the measurement power offset Γ is signaled by higher layers. P_{CPICH} denotes the combined transmit power of the set of primary and three secondary CPICHs used for MIMO operation of HS-DSCH.

When D-CPICH(s) are activated for data demodulation by Node B, for the purpose of CQI reporting, the UE shall assume a total transmit power of HS-PDSCH

$$P_{HSPDSCH} = P_{CPICH} + \Gamma_1 \text{ in dB,}$$

where the total transmit power is assumed to be evenly distributed among the HS-PDSCH codes corresponding to the reported CQI value, and the measurement power offset Γ_1 are signaled by higher layers. P_{CPICH} denotes the combined transmit power of the set of primary and three secondary CPICHs used for MIMO operation of HS-DSCH.

If a CQI for a single transport block is reported, the parameter Δ that is given by Table 7C, 7D, 7F or 7G depending on the UE category and configuration indicates a reference power adjustment for the Node B transmit power on the indicated HS-PDSCH(s). If a CQI for two or three or four transport blocks are reported, the parameter Δ that is given by Table 7H, 7I, 7Ia or 7Ib depending on the UE category and configuration indicates by how much the equivalent AWGN symbol SINR for a specific transport block would be different from the one required to meet the predicted BLER performance.

When deriving the CQI value, the UE assumes that the Node B would be using a uniform power allocation across the number of HS-PDSCH codes corresponding to the CQI value to be reported. In case the UE reports a CQI for more than one transport block, it is assumed by the UE that the Node B uses an equal power per HS-PDSCH code for all the transport blocks.

When the Node B schedules the UE with more than one transport block, if the Node B does not transmit each transport block with equal power per used HS-PDSCH code or use different power per code than indicated by the measurement power offset Γ , it should not assume that the reported transport block sizes can be received with the specified block error probabilities or that transmission of more than one transport block is preferred by the UE.

Further, for the purpose of CQI reporting, the UE shall assume the number of soft channel bits available in the virtual IR buffer (N_{IR}), and redundancy and constellation version parameter (X_{rv} , X_{rvpb} , or X_{rvsb}) as given by Table 7A, 7B, 7C, 7D, 7F, 7G, 7H, 7I, 7Ia or 7Ib depending on the UE category and on the CQI report type irrespective of the actual number of HARQ processes that are configured.

For the purpose of CQI reporting the UE shall assume that all HS-PDSCH channelisation codes it may receive are under the same scrambling code as the set of CPICH(s) used to determine P_{CPICH} .

6A.2.3 CQI tables

The CQI mapping table for each UE category and configured mode of operation is described in Table 7a.

Table 7a: Applicability of CQI mapping tables.

Category	Used CQI mapping table							
	MIMO not configured		MIMO configured and single-stream restriction not configured				MIMO and single-stream restriction configured	
	64QAM not configured	64QAM configured	64QAM not configured		64QAM configured		64QAM not configured	64QAM configured
			In case of type B or single transport block type A CQI reports	In case of dual transport block type A CQI reports	In case of type B or single transport block type A CQI reports	In case of dual transport block type A CQI reports		
1-6	A	N/A				A	N/A	
7 and 8	B	N/A				B	N/A	
9	C	N/A				C	N/A	
10	D	N/A				D	N/A	
11 and 12	E	N/A						
13	C	F	N/A			C	F	
14	D	G	N/A			D	G	
15	C	N/A	C	H	N/A			
16	D	N/A	D	I	N/A			
17	C	F	C	H	N/A		N/A F	
18	D	G	D	I	N/A		N/A G	
19	C	F	C	H	F	J	N/A	
20	D	G	D	I	G	K	N/A	
21	C	N/A				C	N/A	
22	D	N/A				D	N/A	
23	C	F	N/A			C	F	
24	D	G	N/A			D	G	
25	C	N/A	C	H	N/A		N/A	
26	D	N/A	D	I	N/A		N/A	
27	C	F	C	H	F	J	N/A	
28	D	G	D	I	G	K	N/A	
29 and 31	D	G	N/A			D	G	
30 and 32	D	G	D	I	G	K	N/A	
33 and 35	D	G	N/A			D	G	
34 and 36	D	G	D	I	G	K	N/A	
37 and 38	D	G	D	I	G	K	N/A	

Table 7A: CQI mapping table A.

CQI value	Transport Block Size	Number of HS-PDSCH	Modulation	Reference power adjustment Δ	N_{IR}	X_{rv}
0	N/A	Out of range				
1	137	1	QPSK	0	9600	0
2	173	1	QPSK	0		
3	233	1	QPSK	0		
4	317	1	QPSK	0		
5	377	1	QPSK	0		
6	461	1	QPSK	0		
7	650	2	QPSK	0		
8	792	2	QPSK	0		
9	931	2	QPSK	0		
10	1262	3	QPSK	0		
11	1483	3	QPSK	0		
12	1742	3	QPSK	0		
13	2279	4	QPSK	0		
14	2583	4	QPSK	0		
15	3319	5	QPSK	0		
16	3565	5	16-QAM	0		
17	4189	5	16-QAM	0		
18	4664	5	16-QAM	0		
19	5287	5	16-QAM	0		
20	5887	5	16-QAM	0		
21	6554	5	16-QAM	0		
22	7168	5	16-QAM	0		
23	7168	5	16-QAM	-1		
24	7168	5	16-QAM	-2		
25	7168	5	16-QAM	-3		
26	7168	5	16-QAM	-4		
27	7168	5	16-QAM	-5		
28	7168	5	16-QAM	-6		
29	7168	5	16-QAM	-7		
30	7168	5	16-QAM	-8		

Table 7B: CQI mapping table B.

CQI value	Transport Block Size	Number of HS-PDSCH	Modulation	Reference power adjustment Δ	N_{IR}	X_{rv}
0	N/A	Out of range				
1	137	1	QPSK	0	19200	0
2	173	1	QPSK	0		
3	233	1	QPSK	0		
4	317	1	QPSK	0		
5	377	1	QPSK	0		
6	461	1	QPSK	0		
7	650	2	QPSK	0		
8	792	2	QPSK	0		
9	931	2	QPSK	0		
10	1262	3	QPSK	0		
11	1483	3	QPSK	0		
12	1742	3	QPSK	0		
13	2279	4	QPSK	0		
14	2583	4	QPSK	0		
15	3319	5	QPSK	0		
16	3565	5	16-QAM	0		
17	4189	5	16-QAM	0		
18	4664	5	16-QAM	0		
19	5287	5	16-QAM	0		
20	5887	5	16-QAM	0		
21	6554	5	16-QAM	0		
22	7168	5	16-QAM	0		
23	9719	7	16-QAM	0		
24	11418	8	16-QAM	0		
25	14411	10	16-QAM	0		
26	14411	10	16-QAM	-1		
27	14411	10	16-QAM	-2		
28	14411	10	16-QAM	-3		
29	14411	10	16-QAM	-4		
30	14411	10	16-QAM	-5		

Table 7C: CQI mapping table C.

CQI or CQI _S value	Transport Block Size	Number of HS-PDSCH	Modulation	Reference power adjustment Δ	N _{IR}	X _{rv} or X _{rvpb}
0	N/A	Out of range				
1	137	1	QPSK	0	28800	0
2	173	1	QPSK	0		
3	233	1	QPSK	0		
4	317	1	QPSK	0		
5	377	1	QPSK	0		
6	461	1	QPSK	0		
7	650	2	QPSK	0		
8	792	2	QPSK	0		
9	931	2	QPSK	0		
10	1262	3	QPSK	0		
11	1483	3	QPSK	0		
12	1742	3	QPSK	0		
13	2279	4	QPSK	0		
14	2583	4	QPSK	0		
15	3319	5	QPSK	0		
16	3565	5	16-QAM	0		
17	4189	5	16-QAM	0		
18	4664	5	16-QAM	0		
19	5287	5	16-QAM	0		
20	5887	5	16-QAM	0		
21	6554	5	16-QAM	0		
22	7168	5	16-QAM	0		
23	9719	7	16-QAM	0		
24	11418	8	16-QAM	0		
25	14411	10	16-QAM	0		
26	17237	12	16-QAM	0		
27	17237	12	16-QAM	-1		
28	17237	12	16-QAM	-2		
29	17237	12	16-QAM	-3		
30	17237	12	16-QAM	-4		

Table 7D: CQI mapping table D.

CQI or CQI _S value	Transport Block Size	Number of HS-PDSCH	Modulation	Reference power adjustment Δ	N _{IR}	X _{rv} or X _{rvpb}
0	N/A	Out of range				
1	137	1	QPSK	0	28800	0
2	173	1	QPSK	0		
3	233	1	QPSK	0		
4	317	1	QPSK	0		
5	377	1	QPSK	0		
6	461	1	QPSK	0		
7	650	2	QPSK	0		
8	792	2	QPSK	0		
9	931	2	QPSK	0		
10	1262	3	QPSK	0		
11	1483	3	QPSK	0		
12	1742	3	QPSK	0		
13	2279	4	QPSK	0		
14	2583	4	QPSK	0		
15	3319	5	QPSK	0		
16	3565	5	16-QAM	0		
17	4189	5	16-QAM	0		
18	4664	5	16-QAM	0		
19	5287	5	16-QAM	0		
20	5887	5	16-QAM	0		
21	6554	5	16-QAM	0		
22	7168	5	16-QAM	0		
23	9719	7	16-QAM	0		
24	11418	8	16-QAM	0		
25	14411	10	16-QAM	0		
26	17237	12	16-QAM	0		
27	21754	15	16-QAM	0		
28	23370	15	16-QAM	0		
29	24222	15	16-QAM	0		
30	25558	15	16-QAM	0		

Table 7E: CQI mapping table E.

CQI value	Transport Block Size	Number of HS-PDSCH	Modulation	Reference power adjustment Δ	N_{IR}	X_{rv}
0	N/A	Out of range				
1	137	1	QPSK	0	4800	0
2	173	1	QPSK	0		
3	233	1	QPSK	0		
4	317	1	QPSK	0		
5	377	1	QPSK	0		
6	461	1	QPSK	0		
7	650	2	QPSK	0		
8	792	2	QPSK	0		
9	931	2	QPSK	0		
10	1262	3	QPSK	0		
11	1483	3	QPSK	0		
12	1742	3	QPSK	0		
13	2279	4	QPSK	0		
14	2583	4	QPSK	0		
15	3319	5	QPSK	0		
16	3319	5	QPSK	-1		
17	3319	5	QPSK	-2		
18	3319	5	QPSK	-3		
19	3319	5	QPSK	-4		
20	3319	5	QPSK	-5		
21	3319	5	QPSK	-6		
22	3319	5	QPSK	-7		
23	3319	5	QPSK	-8		
24	3319	5	QPSK	-9		
25	3319	5	QPSK	-10		
26	3319	5	QPSK	-11		
27	3319	5	QPSK	-12		
28	3319	5	QPSK	-13		
29	3319	5	QPSK	-14		
30	3319	5	QPSK	-15		

Table 7F: CQI mapping table F.

CQI value	Transport Block Size	Number of HS-PDSCH	Modulation	Reference power adjustment Δ	N _{IR}	X _{RV}	
0	N/A	Out of range					
1	136	1	QPSK	0	43200	0	
2	176	1	QPSK	0			
3	232	1	QPSK	0			
4	320	1	QPSK	0			
5	376	1	QPSK	0			
6	464	1	QPSK	0			
7	648	2	QPSK	0			
8	792	2	QPSK	0			
9	928	2	QPSK	0			
10	1264	3	QPSK	0			
11	1488	3	QPSK	0			
12	1744	3	QPSK	0			
13	2288	4	QPSK	0			
14	2592	4	QPSK	0			
15	3328	5	QPSK	0			
16	3576	5	16-QAM	0			
17	4200	5	16-QAM	0			
18	4672	5	16-QAM	0			
19	5296	5	16-QAM	0			
20	5896	5	16-QAM	0			
21	6568	5	16-QAM	0			
22	7184	5	16-QAM	0			
23	9736	7	16-QAM	0			
24	11432	8	16-QAM	0			
25	14424	10	16-QAM	0			
26	15776	10	64-QAM	0			
27	21768	12	64-QAM	0			
28	26504	13	64-QAM	0			
29	32264	14	64-QAM	0			
30	32264	14	64-QAM	-2			

Table 7G: CQI mapping table G.

CQI value	Transport Block Size	Number of HS-PDSCH	Modulation	Reference power adjustment Δ	N _{IR}	X _{RV}
0	N/A	Out of range				
1	136	1	QPSK	0	43200	0
2	176	1	QPSK	0		
3	232	1	QPSK	0		
4	320	1	QPSK	0		
5	376	1	QPSK	0		
6	464	1	QPSK	0		
7	648	2	QPSK	0		
8	792	2	QPSK	0		
9	928	2	QPSK	0		
10	1264	3	QPSK	0		
11	1488	3	QPSK	0		
12	1744	3	QPSK	0		
13	2288	4	QPSK	0		
14	2592	4	QPSK	0		
15	3328	5	QPSK	0		
16	3576	5	16-QAM	0		
17	4200	5	16-QAM	0		
18	4672	5	16-QAM	0		
19	5296	5	16-QAM	0		
20	5896	5	16-QAM	0		
21	6568	5	16-QAM	0		
22	7184	5	16-QAM	0		
23	9736	7	16-QAM	0		
24	11432	8	16-QAM	0		
25	14424	10	16-QAM	0		
26	15776	10	64-QAM	0		
27	21768	12	64-QAM	0		
28	26504	13	64-QAM	0		
29	32264	14	64-QAM	0		
30	38576	15	64-QAM	0		

Table 7H: CQI mapping table H.

CQI ₁ or CQI ₂	Transport Block Size	Number of HS-PDSCH	Modulation	Equivalent AWGN SINR difference Δ	N _{IR}	X _{rvpb} or X _{rvsb}
0	4581	15	QPSK	-3.00	28800	0
1	4581	15	QPSK	-1.00		
2	5101	15	QPSK	0		
3	6673	15	QPSK	0		
4	8574	15	QPSK	0		
5	10255	15	QPSK	0		
6	11835	15	QPSK	0		
7	14936	15	16QAM	0		
8	17548	15	16QAM	0		
9	20617	15	16QAM	0		
10	23370	15	16QAM	0		
11	23370	15	16QAM	1.50		
12	23370	15	16QAM	2.50		
13	23370	15	16QAM	4.00		
14	23370	15	16QAM	5.00		

Table 7I: CQI mapping table I.

CQI ₁ or CQI ₂	Transport Block Size	Number of HS-PDSCH	Modulation	Equivalent AWGN SINR difference Δ	N _{IR}	X _{rvpb} or X _{rvsb}
0	4581	15	QPSK	-3.00	28800	0
1	4581	15	QPSK	-1.00		
2	5101	15	QPSK	0		
3	6673	15	QPSK	0		
4	8574	15	QPSK	0		
5	10255	15	QPSK	0		
6	11835	15	QPSK	0		
7	14936	15	16QAM	0		
8	17548	15	16QAM	0		
9	20617	15	16QAM	0		
10	23370	15	16QAM	0		
11	25558	15	16QAM	0		
12	26969	15	16QAM	0		
13	27456	15	16QAM	0		
14	27952	15	16QAM	0		

Table 71a: CQI mapping table J.

CQI ₁ or CQI ₂	Transport Block Size	Number of HS-PDSCH	Modulation	Equivalent AWGN SINR difference Δ	N _{IR}	X _{rvpb} or X _{rvsb}
0	4592	15	QPSK	-3.00	43200	0
1	4592	15	QPSK	-1.00		
2	5296	15	QPSK	0		
3	7312	15	QPSK	0		
4	9392	15	QPSK	0		
5	11032	15	QPSK	0		
6	14952	15	16QAM	0		
7	17880	15	16QAM	0		
8	21384	15	16QAM	0		
9	24232	15	16QAM	0		
10	27960	15	64QAM	0		
11	32264	15	64QAM	0		
12	32264	15	64QAM	2		
13	32264	15	64QAM	4		
14	32264	15	64QAM	6		

Table 71b: CQI mapping table K.

CQI ₁ or CQI ₂	Transport Block Size	Number of HS-PDSCH	Modulation	Equivalent AWGN SINR difference Δ	N _{IR}	X _{rvpb} or X _{rvsb}
0	4592	15	QPSK	-3.00	43200	0
1	4592	15	QPSK	-1.00		
2	5296	15	QPSK	0		
3	7312	15	QPSK	0		
4	9392	15	QPSK	0		
5	11032	15	QPSK	0		
6	14952	15	16QAM	0		
7	17880	15	16QAM	0		
8	21384	15	16QAM	0		
9	24232	15	16QAM	0		
10	27960	15	64QAM	0		
11	32264	15	64QAM	0		
12	36568	15	64QAM	0		
13	39984	15	64QAM	0		
14	42192	15	64QAM	0		

6A.3 Operation during compressed mode on the associated DPCH or F-DPCH

During compressed mode on the associated DPCH or F-DPCH, and the Secondary Cell Active is 0, or the Secondary Cell Active is not 0 and the compressed mode is applied to the serving HS-DSCH cell and all the secondary serving HS-DSCH cells, the following applies for the UE for transmission of HS-DPCCH and reception of HS-SCCH and HS-PDSCH:

- The UE shall neglect a HS-SCCH or HS-PDSCH transmission, if a part of the HS-SCCH or a part of the corresponding HS-PDSCH overlaps with a downlink transmission gap on the associated DPCH or F-DPCH. In this case, neither ACK, nor NACK shall be transmitted by the UE to respond to the corresponding downlink transmission.
- If a part of a HS-DPCCH slot allocated to HARQ-ACK overlaps with an uplink transmission gap on the associated DPCH, the UE shall use DTX on the HS-DPCCH in that HS-DPCCH slot.
- If in a HS-DPCCH sub-frame a part of a slot allocated for CQI information overlaps with an uplink transmission gap on the associated DPCH, the UE shall not transmit that CQI or composite PCI/CQI information in that sub-frame (if HS-DPCCH slot format 0 is used) or in that slot (if HS-DPCCH slot format 1 is used).
- If a CQI report or a composite PCI/CQI report is scheduled in the current CQI field according to subclause 6A.1.2.1 paragraph (2) or subclause 6A.1.2.2 paragraph (2), and the corresponding 3-slot reference period (as defined in subclause 6A.2.1 or subclause 6A.2.2) wholly or partly overlaps a downlink transmission gap, then the UE shall use DTX in the current CQI field and in the CQI fields in the next ($N_{cqi_transmit}-1$) subframes.

During compressed mode, when Secondary_Cell_Active is not 0 and the compressed mode is not applied to all the active cells, the following applies for the UE for transmission of HS-DPCCH and reception of HS-SCCH and HS-PDSCH on the cell(s) in which the compressed mode is applied:

- The UE shall neglect a HS-SCCH or HS-PDSCH transmission on a cell, if a part of the HS-SCCH or a part of the corresponding HS-PDSCH overlaps with a downlink transmission gap on that cell. In this case, neither ACK, nor NACK shall be transmitted by the UE to respond to the corresponding downlink transmission.
- If a CQI report or a composite PCI/CQI report for a cell is scheduled in the current CQI field according to subclause 6A.1.2.1 paragraph (2) or subclause 6A.1.2.2 paragraph (2), and the corresponding 3-slot reference period (as defined in subclause 6A.2.1 or subclause 6A.2.2) wholly or partly overlaps a downlink transmission gap on that cell, then the UE shall use DTX in the current CQI field and in the CQI fields in the next ($N_{cqi_transmit}-1$) subframes if using DTX in the CQI field is possible. In the case that using DTX in the CQI field is not possible due to the need to transmit a CQI or a composite PCI/CQI report of another cell not experiencing a compressed mode gap, the UE shall transmit a CQI or a composite PCI/CQI report based on measurements prior to the start of the compressed mode gap for the cell experiencing the compressed mode gap.

6A.4 Precoding control indication (PCI) definition

6A.4.1 PCI definition when the UE is configured in MIMO mode

The UE uses the CPICH(s) transmitted from antenna 1 and antenna 2 to calculate the preferred precoding vectors to be applied at Node B to maximise the aggregate transport block size that could be supported under current channel conditions. No matter whether one or two transport blocks are preferred, it is sufficient to signal from the UE to the Node B only the preferred primary precoding vector (w_1^{pref}, w_2^{pref}) , since the optional secondary precoding vector will be a unique function of the primary one. When single-stream restriction is not configured the information on whether one or two transport blocks are preferred is part of the CQI reporting as defined in subclause 6A.2.2. Since the first precoding weight w_1^{pref} of the preferred primary precoding vector (w_1^{pref}, w_2^{pref}) is constant, it is sufficient to determine the precoding weight for antenna 2. In each TTI during which the UE derives a composite PCI/CQI report, the UE shall calculate the optimum precoding weight w_2^{pref} for antenna 2.

If the UE is not configured with precoding weight set restriction by the higher layers, the optimum precoding weight w_2^{pref} for antenna 2 is taken from the set:

$$w_2^{\text{pref}} \in \left\{ \frac{1+j}{2}, \frac{1-j}{2}, \frac{-1+j}{2}, \frac{-1-j}{2} \right\}.$$

If the UE is configured with precoding weight set restriction by the higher layers, the optimum precoding vector weight w_2^{pref} for antenna 2 is taken from the set as defined in table 7J0.

Table 7J0 : Selection of the precoding weight set when the precoding weight set restriction is configured by higher layers

Number of Transport Blocks preferred in the composite PCI/CQI report	Precoding weight set from which the optimum precoding weight w_2^{pref} for antenna 2 is taken.
1 (always the case when single-stream restriction is configured to the UE)	$w_2^{\text{pref}} \in \left\{ \frac{1+j}{2}, \frac{-1-j}{2} \right\}$
2	$w_2^{\text{pref}} \in \left\{ \frac{1+j}{2}, \frac{1-j}{2}, \frac{-1+j}{2}, \frac{-1-j}{2} \right\}$

The precoding weight w_2^{pref} is mapped to PCI values as defined in table 7J.

Table 7J : Mapping of preferred precoding weight w_2^{pref} to PCI values.

w_2^{pref}	PCI value
$\frac{1+j}{2}$	0
$\frac{1-j}{2}$	1
$\frac{-1+j}{2}$	2
$\frac{-1-j}{2}$	3

6A.4.2 PCI definition when the UE is configured in MIMO mode with four transmit antennas

This section applies only when the UE is configured in MIMO mode with four transmit antennas.

The UE uses the CPICHs transmitted from antenna 1, antenna 2, antennas 3 and antenna 4 to calculate the preferred precoding matrix to be applied at Node B to maximise the aggregate transport block sizes that could be supported under current channel conditions.

The preferred precoding information PCI ($pci_0, pci_1, pci_2, pci_3$) is defined as the precoding weight information in section 4.6D.2.7 of [2] with the following PCI mapping to table 14B.7:

$$pci_0, pci_1, pci_2, pci_3 = x_{pwibp,1}, x_{pwibp,2}, x_{pwibp,3}, x_{pwibp,4}.$$

The number of transport blocks corresponding corresponding to table 14B.7 used in the PCI derivation corresponds to the number of transport blocks preferred (NTBP) reported in the composite NTBP/PCI/CQI report carrying the corresponding NTBP.

6B E-DCH related procedures

The following physical layer parameters are signalled to the UE from higher layers:

- 1) E-HICH set to be monitored for each uplink frequency for which E-DCH is configured
- 2) E-RGCH set to be monitored for each uplink frequency for which E-DCH is configured

If the UE is configured with multiple uplink frequencies, then the Secondary_EDCH_Cell_Enabled is 1, otherwise Secondary_EDCH_Cell_Enabled is 0 and Secondary_EDCH_Cell_Active is 0.

The Secondary_EDCH_Cell_Active shall be set according to the following rules:

- Secondary_EDCH_Cell_Active is set to 0 when Secondary_EDCH_Cell_Enabled is 0 or Secondary_Cell_Active is 0 (as described in subclause 6A.1).
- Secondary_EDCH_Cell_Active shall remain set to 0, when Secondary_EDCH_Cell_Enabled is changed from 0 to 1.
- Secondary_EDCH_Cell_Active shall be set to 0 or 1, upon the reception of HS-SCCH orders to deactivate or activate the secondary uplink carrier respectively as specified in [2] when Secondary_EDCH_Cell_Enabled is 1 and Secondary_Cell_Active is not 0 (as described in subclause 6A.1) and the 1st secondary serving HS-DSCH cell is activated.
- Secondary_EDCH_Cell_Active shall be set to 0 or 1, upon the reception of HS-SCCH orders to deactivate or activate both the secondary uplink carrier and the 1st secondary serving HS-DSCH cell as specified in [2] when Secondary_EDCH_Cell_Enabled is 1 (as described in subclause 6A.1).
- Secondary_EDCH_Cell_Active can be set to 0 by higher layers (as described in [5]).

Secondary_EDCH_Cell_Active shall be set to 1 while Secondary_EDCH_Cell_Enabled is 1, Secondary_Cell_Active is not 0, 1st secondary serving HS-DSCH cell is activated, and the secondary uplink frequency is activated, otherwise Secondary_EDCH_Cell_Active shall be set to 0. If the Secondary_EDCH_Cell_Active is already equal to 1 when the UE receives an HS-SCCH order for activation of the secondary uplink frequency as specified in [2], then the UE shall not change the status of Secondary_EDCH_Cell_Active regarding the contents of the order, but shall transmit the HARQ-ACK acknowledging the HS-SCCH order.

HS-SCCH ordered deactivation or activation of the secondary uplink frequency is applied by the UE at the same point in time as in the case of HS-SCCH ordered deactivation and activation of the secondary serving HS-DSCH cell for a UE configured with multiple uplink frequencies (see subclause 6A.1).

If higher layers set READY_FOR_COMMON_ERGCH to TRUE (as described in [5]) then Common_RGCH_Enabled is TRUE. Otherwise, Common_RGCH_Enabled is FALSE.

If higher layers configure concurrent deployment of 2ms and 10ms TTI in a cell (as described in [5]) then Concurrent_TTI_Deployment_Enabled is TRUE. Otherwise, Concurrent_TTI_Deployment_Enabled is FALSE.

If higher layers set READY_FOR_FALLBACK_R99_PRACH to TRUE (as described in [5]) then Fallback_R99_Enabled is TRUE. Otherwise, Fallback_R99_Enabled is FALSE.

If NT-HS-DPCCH_Enabled is TRUE, the UE shall inform higher layers about the reception of an HS-SCCH order and the order type.

6B.1 ACK/NACK detection

For each activated uplink frequency, the physical layer in the UE shall detect ACK or NACK within the E-HICH set that is monitored by the UE in the subframes where ACK/NACK is transmitted by the UTRAN and deliver the ACK/NACK to the higher layers as follows:

- When a UE is not in soft handover, an ACK shall be delivered to the higher layers if a reliable ACK is detected by the physical layer in the UE, else a NACK shall be delivered to the higher layers.

- When a UE is in soft handover, multiple ACK/NACKs may be received in an E-DCH TTI from different cells in the active set. In some cases, the UE has the knowledge that some of the transmitted ACK/NACKs are the same. This is the case when the radio links are in the same radio link set. For these cases, ACK/NACKs from the same radio link set shall be soft combined into one ACK/NACK information and delivered to higher layers. If a radio link set contains only one radio link, the detection shall be done as specified above for the case where the UE is not in soft handover. For each radio link set containing multiple radio links, an ACK shall be delivered to the higher layers if a reliable ACK is detected by the physical layer in the UE after soft combining, else a NACK shall be delivered to the higher layers.

6B.2 Relative grants detection

In CELL_DCH state, for each activated uplink frequency, the physical layer in the UE shall detect relative grants within the E-RGCH set that is monitored by the UE and deliver the relative grants to the higher layers as follows:

- When a UE is not in soft handover, an UP shall be delivered to the higher layers if a reliable UP is detected by the physical layer in the UE, else a DOWN shall be delivered to the higher layers if a reliable DOWN is detected by the UE, else a HOLD shall be delivered to the higher layers.
- When a UE is in soft handover, multiple relative grants may be received in an E-DCH TTI from different cells in the E-DCH active set. The UE shall handle the E-RGCH received from these cells as follows:
 - o If the E-DCH serving radio link set contains only one radio link, the detection shall be done as specified above for the case where the UE is not in soft handover. If the E-DCH serving radio link set contains more than one radio link, the relative grants from the E-DCH serving radio link set are the same and shall be soft combined into one single relative grant information; an UP shall be delivered to the higher layers if a reliable UP is detected by the physical layer in the UE after soft combining, else a DOWN shall be delivered to the higher layers if a reliable DOWN is detected by the UE after soft combining, else a HOLD shall be delivered to the higher layers.
 - o Furthermore, for each relative grant received from a radio link which does not belong to the E-DCH serving radio link set, a DOWN shall be delivered to the higher layers if a reliable DOWN is detected by the UE, else a HOLD shall be delivered to the higher layers. The UE shall not soft combine relative grants received from radio links which do not belong to the E-DCH serving radio link set.

In CELL_FACH state, if Common_RGCH_Enabled is TRUE, the physical layer in the UE shall detect relative grants within the E-RGCH set that is monitored by the UE and deliver the relative grants to the higher layers as follows:

- Multiple relative grants may be received in an E-DCH TTI from different cells that do not belong to the E-DCH serving radio link set. For each relative grant received from a cell, a DOWN shall be delivered to the higher layers if a reliable DOWN is detected by the physical layer in the UE, else a HOLD shall be delivered to the higher layers. The UE shall not soft combine relative grants received from any of the cells.

6B.3 E-DCH control timing

In sub-clauses 6B.3.1 and 6B.3.2 the word "first" refers to the earliest point in time.

6B.3.1 10 ms E-DCH TTI

For each cell in the E-DCH active set, the UE shall associate the control data received in the E-HICH frame associated with SFN i to the data transmitted in the E-DPDCH frame associated with SFN $i-3$.

For each cell which belongs to the serving E-DCH radio link set, the UE shall first take into account E-DCH control data received in the E-RGCH frame associated with SFN i in the higher layer procedures which correspond to E-DCH transmission in the E-DPDCH frame associated with SFN $i+1$.

For each cell which does not belong to the serving E-DCH radio link set the UE shall first take into account E-DCH control data received in the E-RGCH frame associated with SFN i in the higher layer procedures which correspond to E-DCH transmission in the E-DPDCH frame associated with SFN $i+1+s$ where:

$$s = \left\lceil \frac{160 - (\tau_{DPCH,n}/256)}{150} \right\rceil$$

The UE shall first take into account E-DCH control data received in the E-AGCH frame associated with SFN i in the higher layer procedures which correspond to E-DCH transmission in the E-DPDCH frame associated with SFN $i+1+s$ where:

$$s = \left\lceil \frac{100 - (\tau_{DPCH,n}/256)}{150} \right\rceil$$

When a downlink F-DPCH is configured, $\tau_{DPCH,n} = \tau_{F-DPCH,n}$.

6B.3.2 2 ms E-DCH TTI

For each cell in the E-DCH active set, the UE shall associate the E-DCH control data received in sub-frame j of the E-HICH frame associated with SFN i to sub-frame t of the E-DPDCH frame associated with SFN $i-s$ where:

$$s = 1 - \lfloor j/3 \rfloor, \text{ and } t = (j+2) \bmod 5$$

For each cell which belongs to the serving E-DCH radio link set, the UE shall first take into account E-DCH control data received in sub-frame j of the E-RGCH frame associated with SFN i in the higher layer procedures which correspond to E-DCH transmission in sub-frame j of the E-DPDCH frame associated with SFN $i+1$.

For each cell which does not belong to the serving E-DCH radio link set the UE shall first take into account E-DCH control data received in the E-RGCH frame associated with SFN i in the higher layer procedures which correspond to E-DCH transmission in sub-frame t of the E-DPDCH frame associated with SFN $i+1+s$ where:

$$s = \left\lceil \frac{\left\lceil \frac{160 - (\tau_{DPCH,n}/256)}{30} \right\rceil}{5} \right\rceil, \text{ and } t = \left\lceil \frac{160 - (\tau_{DPCH,n}/256) - 150s}{30} \right\rceil$$

The UE shall first take into account E-DCH control data received in sub-frame j of the E-AGCH frame associated with SFN i in the higher layer procedures which correspond to E-DCH transmission in sub-frame t of the E-DPDCH frame associated with SFN $i+s$ where:

$$s = \left\lceil \frac{\left\lceil \frac{30j + 100 - (\tau_{DPCH,n}/256)}{30} \right\rceil}{5} \right\rceil, \text{ and } t = \left\lceil \frac{30j + 100 - (\tau_{DPCH,n}/256) - 150s}{30} \right\rceil$$

The same relationship applies for E-ROCH to S-E-DPDCH timing relationship as is defined above for the E-AGCH to E-DPDCH timing relationship.

When a downlink F-DPCH is configured, $\tau_{DPCH,n} = \tau_{F-DPCH,n}$.

6B.4 Operation during compressed mode

6B.4.1 Uplink compressed mode

When E-DCH TTI length is 2 ms, the UE shall not transmit E-DCH data in a TTI which fully or partly overlaps with an uplink transmission gap.

Handling of uplink compressed mode when the E-DCH TTI is 10msec is described in [2].

6B.4.2 Downlink compressed mode

The following applies for the UE for reception of E-HICH, E-RGCH and E-AGCH, during compressed mode on the DPCH or F-DPCH:

- A UE shall decode E-HICH, E-RGCH, E-ROCH or E-AGCH transmissions to the UE using all the slots which do not overlap a downlink transmission gap.
- The UE may discard E-HICH, E-RGCH, E-ROCH or E-AGCH slots which overlap a downlink transmission gap.

6C Discontinuous transmission and reception procedures

Whether discontinuous uplink DPCCCH transmission operation or discontinuous downlink reception operation are applied is determined by the settings of UL_DTX_Active and DL_DRX_Active as follows:

UL_DTX_Active shall be set to TRUE while UE_DTX_DRX_Enabled is TRUE and discontinuous uplink DPCCCH transmission is activated. Otherwise, UL_DTX_Active shall be set to FALSE.

Discontinuous uplink DPCCCH transmission shall be activated at the time when UE_DTX_DRX_Enabled is set to TRUE, and may be further deactivated or activated by layer 1 HS-SCCH orders (see section 6C.4).

DL_DRX_Active shall be set to TRUE while UE_DTX_DRX_Enabled is TRUE and UL_DTX_Active is TRUE and discontinuous downlink reception is activated. Otherwise, DL_DRX_Active shall be set to FALSE.

Discontinuous downlink reception shall be activated at the time when UE_DTX_DRX_Enabled is set to TRUE, and may be further deactivated or activated by layer 1 HS-SCCH orders (see section 6C.4).

The higher layers define the discontinuous transmission and reception procedures using the following parameters:

For discontinuous UL DPCCCH transmission:

CQI_DTX_TIMER: Specifies the number of subframes during which the CQI reports have higher priority than the DTX pattern. This is the initial value of CQI nominal reporting timer.

UE_DTX_cycle_1: Uplink DPCCCH burst pattern length in subframes.

UE_DTX_cycle_2: Uplink DPCCCH burst pattern length in subframes.

Inactivity_Threshold_for_UE_DTX_cycle_2: Defines a number of consecutive E-DCH TTIs without an E-DCH transmission, after which the UE shall immediately move from UE_DTX_cycle_1 to using UE_DTX_cycle_2.

UE_DPCCCH_burst_1: Determines the Uplink DPCCCH burst length in subframes, when UE_DTX_cycle_1 is applied.

UE_DPCCCH_burst_2: Determines the Uplink DPCCCH burst length in subframes, when UE_DTX_cycle_2 is applied.

UE_DTX_long_preamble_length: Determines in slots the length of the preamble associated with the UE_DTX_cycle_2.

For both discontinuous UL DPCCCH transmission and discontinuous downlink reception:

UE_DTX_DRX_Offset: Uplink DPCCCH burst pattern and HS-SCCH reception pattern offset in subframes.

Enabling_Delay: defined in [5], ensures that the uplink DPCCCH, the downlink F-DPCH and, if configured, the downlink F-TPICH are transmitted continuously for Enabling_Delay radio frames after DTX_DRX_STATUS is set to TRUE or ensures that, with DTX_DRX_STATUS set to TRUE, the uplink DPCCCH on the secondary uplink frequency is transmitted continuously for Enabling_Delay radio frames after application of secondary uplink frequency activation.

For discontinuous downlink reception:

UE_DRX cycle: HS-SCCH reception pattern length in subframes.

Inactivity_Threshold_for_UE_DRX_cycle: Defines the number of subframes after an HS-SCCH reception or after the first slot of an HS-PDSCH reception (as defined in 6C.3) during which the UE is required to monitor the HS-SCCHs in the UE's HS-SCCH set continuously with the exceptions of $N_{\text{acknack_transmit}} > 1$ or $\text{InterTTI} > 1$.

UE_DRX_Grant_Monitoring: A Boolean which determines whether the UE is required to monitor the E-AGCH and E-ROCH transmissions from the serving E-DCH cell and the E-RGCH from cells in the serving E-DCH radio link set when the conditions in subclause 6C.3 are met.

6C.1 Uplink CQI transmission

When UL_DTX_Active is FALSE (see section 6C), the UE shall always transmit the Channel-Quality Indication (CQI) in the CQI transmission pattern defined in 6A.1.2.

When UL_DTX_Active is TRUE (see section 6C), the UE shall perform the following procedures:

- The UE shall set the initial value of the variable $CQI_DTX_Priority$ to 1.
- Reset the "CQI nominal reporting timer" to CQI_DTX_TIMER at the first HS-DPCCH subframe boundary.

Afterwards, when UL_DTX_Active is TRUE, the UE sets the $CQI_DTX_Priority$ based on the status of a "CQI nominal reporting timer" which is counting down to zero in HS-DPCCH subframes from the value CQI_DTX_TIMER which is configured by higher layers.

The setting of $CQI_DTX_Priority$ to 1 is described in subclause 6A.1.1.

Upon the expiration of the CQI nominal reporting timer, the UE shall set $CQI_DTX_Priority$ to 0.

$CQI_DTX_Priority=0$ indicates that CQI reports have lower priority than the Uplink DPCCH burst pattern. If $CQI_DTX_Priority$ is set to 0, the UE shall transmit the Channel-Quality Indication (CQI), and all repeated CQI transmissions (corresponding to the serving HS-DSCH cell and the secondary serving HS-DSCH cell) according to the value of $N_{\text{cqi_transmit}}$, only if the start of the CQI field corresponding to the serving HS-DSCH cell in the CQI transmission pattern as defined in 6A.1.2 overlaps with a DPCCH transmission burst of the Uplink DPCCH burst pattern as indicated in 6C.2.1.

$CQI_DTX_Priority=1$ indicates that CQI reports have higher priority than the Uplink DPCCH burst pattern. If $CQI_DTX_Priority$ is set to 1,

- the UE shall always transmit the Channel-Quality Indication (CQI), in the CQI transmission pattern defined in 6A.1.2.
- The repeated CQI transmissions according to the value of $N_{\text{cqi_transmit}}$ are transmitted only if the start of the CQI field in the CQI transmission pattern, as defined in 6A.1.2, is transmitted.

6C.2 Discontinuous uplink DPCCH transmission operation

When UL_DTX_Active is FALSE (see section 6C) the UE shall transmit the uplink DPCCH in each slot except in the slots overlapping a compressed mode transmission gap.

When UL_DTX_Active is TRUE (see section 6C), in addition to the conditions defined in 6C.5 the UE shall not transmit the uplink DPCCH in a slot on an activated uplink frequency when all of the following conditions are met for that uplink frequency:

1. There is no HARQ-ACK transmission on HS-DPCCH as indicated in 6A.1 overlapping with the UL DPCCH slot,
2. There is no CQI transmission on HS-DPCCH as indicated in 6C.1 overlapping with the UL DPCCH slot,
3. There is no E-DCH transmission during the UL DPCCH slot,
4. The slot is in a gap in the Uplink DPCCH burst pattern defined in 6C.2.1,
5. The UL DPCCH preamble or postamble defined in 6C.2.2 is not transmitted in the slot.

6. Either the uplink frequency is a secondary uplink frequency where at least Enabling_Delay radio frames have passed since the activation of the secondary uplink frequency was applied, or it is a primary uplink frequency.

The procedures for the F-DPCH transmission and reception in case of discontinuous uplink DPCCCH operation are defined in sub-clause 5.1.

The procedures for the F-TPICH transmission and reception in case of discontinuous uplink DPCCCH operation are defined in sub-clause 10.4.

6C.2.1 Uplink DPCCCH burst pattern

The Uplink DPCCCH burst pattern and the uplink DPCCCH preamble and postamble (6C.2.2) together define the discontinuous uplink DPCCCH operation.

The Uplink DPCCCH burst pattern is illustrated in Figure 2A for 2ms E-DCH TTI and Figure 2B for 10ms E-DCH TTI. The Uplink DPCCCH burst pattern defines the minimum set of slots where the UE shall transmit the UL-DPCCCH.

The Uplink DPCCCH burst pattern shall be derived as follows.

If there has not been any E-DCH transmission for the last Inactivity_Threshold_for_UE_DTX_cycle_2 E-DCH TTIs, and at least this many TTIs have passed since the end of the Enabling_Delay, then:

- The transmission length in the Uplink DPCCCH burst pattern shall be UE_DPCCCH_burst_2 subframes.
- The gap length following the DPCCCH transmission burst in the Uplink DPCCCH burst pattern shall be
 - (UE_DTX_cycle_2 – UE_DPCCCH_burst_2) subframes,
- The first subframe in each Uplink DPCCCH burst pattern shall be such that
 - the CFN and DPCCCH subframe number S verify $((5 * \text{CFN} - \text{UE_DTX_DRX_Offset} + S) \bmod \text{UE_DTX_cycle_2}) = 0$

Otherwise:

- The transmission length in the Uplink DPCCCH burst pattern shall be UE_DPCCCH_burst_1 subframes.
- The gap length following the DPCCCH transmission burst in the Uplink DPCCCH burst pattern shall be
 - (UE_DTX_cycle_1 – UE_DPCCCH_burst_1) subframes.
- The first subframe in each Uplink DPCCCH burst pattern shall be such that
 - the CFN and DPCCCH subframe number S verify $((5 * \text{CFN} - \text{UE_DTX_DRX_Offset} + S) \bmod \text{UE_DTX_cycle_1}) = 0$

In case the DTX cycle pattern changes during a transmission of an Uplink DPCCCH burst, the following shall apply:

- the previously derived length of the Uplink DPCCCH burst which has already been started shall not be affected by the change of the DTX cycle pattern.
- if the UL DPCCCH burst, which is derived according to the new DTX cycle pattern, overlaps with the ongoing UL DPCCCH burst, the non-overlapping portion of the burst, if any, shall be transmitted.
- the change in the DTX cycle pattern from UE_DTX_cycle_2 to UE_DTX_cycle_1 shall occur only at the end of an E-DCH transmission.

NOTE: The E-DCH transmission start time after data transmission inactivity may be restricted as described in [9] to allow discontinuous reception at Node B.

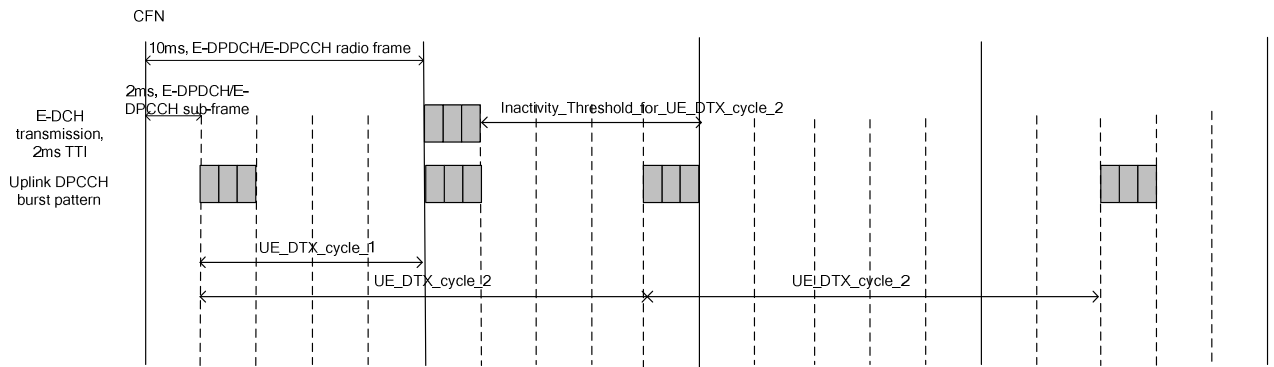

Figure 2A: Example for Uplink DPCCH burst pattern for 2ms E-DCH TTI beginning at CFN=1 (with UE_DTX_DRX_Offset = 6)

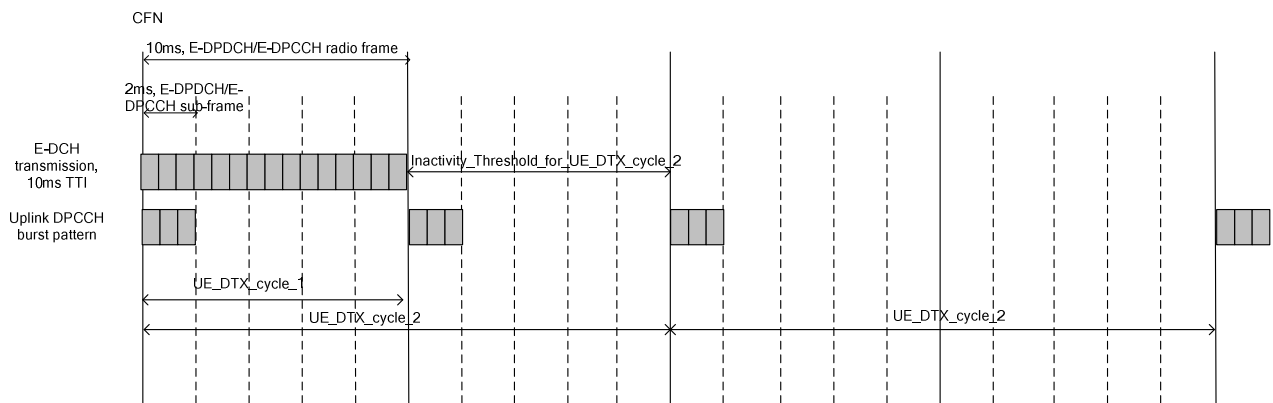

Figure 2B: Example for Uplink DPCCH burst pattern for 10ms E-DCH TTI beginning at CFN=1 (with UE_DTX_DRX_Offset = 5)

Note: Figures 2A and 2B do not show the application of preambles and postambles as described in section 6C.2.2.

6C.2.2 Uplink DPCCH preamble and postamble

NOTE: The 'uplink DPCCH preamble' specified in this subclause is not the same as the 'uplink DPCCH power control preamble' specified in clauses 4 and 5.

6C.2.2.1 Uplink DPCCH preamble and postamble for the DPCCH only transmission

If a UE will start a transmission of DPCCH based on the Uplink DPCCH burst pattern at the start of slot s and finish its DPCCH transmission at the end of slot t , the UE shall start the DPCCH transmission at the start of slot $s-2$ and continue the DPCCH transmission till the end of slot $t+1$.

6C.2.2.2 Uplink DPCCH preamble and postamble for the E-DCH transmission

If a UE will start a transmission of E-DPCCH and E-DPDCH on a E-DCH TTI, the UE shall start the DPCCH transmission 2 slots prior to the E-DCH TTI and continue the DPCCH transmission during the E-DCH TTI and consecutive E-DCH TTIs and 1 slot after the last consecutive E-DCH TTI.

In addition, if there has not been any E-DCH transmission for the last $Inactivity_Threshold_for_UE_DTX_cycle_2$ E-DCH TTIs, and if a UE will start a transmission of E-DPCCH and E-DPDCH on a E-DCH TTI, the UE shall start the DPCCH transmission $UE_DTX_long_preamble_length$ slots prior to the E-DCH TTI and continue the DPCCH transmission during the E-DCH TTI and consecutive E-DCH TTIs and 1 slot after the last consecutive E-DCH TTI.

6C.2.2.3 Uplink DPCCH preamble and postamble for the HS-DPCCH transmission

If a UE will start a transmission of HARQ-ACK, the UE shall start the DPCCH transmission 2 slots prior to the DPCCH slot that coincides with or overlaps the start of the HARQ-ACK field, unless the HARQ-ACK transmission is an HARQ Preamble (PRE) in an HS-DPCCH sub-frame $n - 2$ as defined in subclause 6A.1.1. The UE shall continue the DPCCH transmission during the HARQ-ACK field and until the end of the first full DPCCH slot after the end of the HARQ-ACK field.

If a UE will start a transmission of CQI, the UE shall start the DPCCH transmission 3 slots prior to the DPCCH slot that coincides with or overlaps the start of the CQI field, and continue the DPCCH transmission during the CQI field and until the end of the first full DPCCH slot after the end of the CQI field.

In addition, if there has not been any E-DCH transmission for the last `Inactivity_Threshold_for_UE_DTX_cycle_2` E-DCH TTIs, and if a UE will start a transmission of CQI, the UE shall start the DPCCH transmission $(\text{UE_DTX_long_preamble_length} + 1)$ slots prior to the DPCCH slot that coincides with or overlaps the start of the CQI field, and continue the DPCCH transmission during the CQI field and until the end of the first full DPCCH slot after the end of the CQI field. If the transmission of the CQI is not known to the UE in advance due to the change of `CQI_DTX_Priority` from 0 to 1, or due to the change from `UE_DTX_cycle_1` to `UE_DTX_cycle_2`, the preamble for the first CQI after the change may start late resulting in a shorter preamble.

6C.3 Discontinuous downlink reception

The HS-SCCH reception pattern is derived from a discontinuous reception subframe numbering as follows.

The discontinuous HS-SCCH reception subframe numbering is such that:

- A HS-SCCH discontinuous reception radio frame is 10 ms long and is indexed using `CFN_DRX`.
- The start of the HS-SCCH discontinuous reception radio frame of `CFN_DRX n` is aligned with the start of the HS-SCCH subframe that starts τ_{DRX} chips after the start of the associated downlink F-DPCH of `CFN n` where $-3840\text{chips} \leq \tau_{\text{DRX}} - T_0 < 3840\text{chips}$.
- The HS-SCCH subframe `S_DRX=0` is aligned with the start of the HS-SCCH discontinuous reception radio frame. The HS-SCCH subframes are numbered `S_DRX=0` to `S_DRX=4`.
- The HS-PDSCH discontinuous reception radio frame of `CFN_DRX n` starts $\tau_{\text{HS-PDSCH}}$ chips after the start of the HS-SCCH discontinuous reception radio frame of `CFN_DRX n`. The HS-PDSCH subframe `S_DRX=0` is aligned with the start of the HS-PDSCH discontinuous reception radio frame. The HS-PDSCH subframes are numbered `S_DRX=0` to `S_DRX=4`.
- The HS-DPCCH discontinuous transmission radio frame of `CFN_DRX n` starts at the HS-DPCCH subframe boundary closest in time to 1280 chips after the start of the HS-SCCH discontinuous reception radio frame of `CFN_DRX n` as received at the UE. The HS-DPCCH subframe `S_DRX=0` is aligned with the start of the HS-DPCCH discontinuous transmission radio frame. The HS-DPCCH subframes are numbered `S_DRX=0` to `S_DRX=4`.

The HS-SCCH reception pattern is the set of subframes whose HS-SCCH discontinuous reception radio frame number `CFN_DRX` and subframe number `S_DRX` verify:

$$((5 * \text{CFN_DRX} - \text{UE_DTX_DRX_Offset} + \text{S_DRX}) \bmod \text{UE_DRX cycle}) = 0$$

When `DL_DRX_Active` is FALSE (see section 6C), the UE shall monitor and receive all downlink physical channels continuously.

When `DL_DRX_Active` is TRUE (see section 6C), the UE shall continue to receive F-DPCH as described in sub-clause 5.1 and the UE need not receive physical downlink channels other than the F-DPCH except for the following cases:

1. The UE shall receive E-HICH (sub-)frame corresponding to an E-DCH transmission as specified in subclause 6B.
2. The UE shall monitor the HS-SCCH subframes in the HS-SCCH reception pattern.
3. The UE shall receive an HS-PDSCH subframe as specified in sub-clause 6A.

4. The UE has received an HS-SCCH or an HS-PDSCH subframe during the last Inactivity_Threshold_for_UE_DRX_cycle subframes which was not an HS-SCCH order.
5. The UE shall monitor E-AGCH and E-ROCH transmission from the serving E-DCH cell in the following cases:
 - o If UE_DRX_Grant_Monitoring is TRUE and the E-AGCH/E-ROCH subframe (in case of a 2ms TTI) or E-AGCH frame (in case of a 10ms TTI) overlaps with the start of an HS-SCCH reception subframe as defined in the HS-SCCH reception pattern,
 - o When conditions defined in subclause 11.8.1.8 of [9] are fulfilled.
6. The UE shall monitor E-RGCH transmission from a cell in the serving E-DCH radio link set in the following cases:
 - o If UE_DRX_Grant_Monitoring is TRUE and the corresponding subframe (in case of a 2ms TTI) or frame (in case of a 10ms TTI) of the serving cell E-RGCH overlaps with the start of an HS-SCCH reception subframe as defined in the HS-SCCH reception pattern.
 - o When conditions defined in subclause 11.8.1.8 of [9] are fulfilled.
7. The UE shall monitor the E-RGCH(s) from all the other cells in the E-DCH active set, except from the cells in the serving E-DCH radio link set, in the following case:
 - o When conditions defined as determined in subclause 11.8.1.8 of [9] are fulfilled.

The HS-SCCH reception pattern is illustrated by Figure 2C for a 2ms E-DCH TTI. The grey subframes correspond to the HS-SCCH reception pattern UE_DRX_cycle=4.

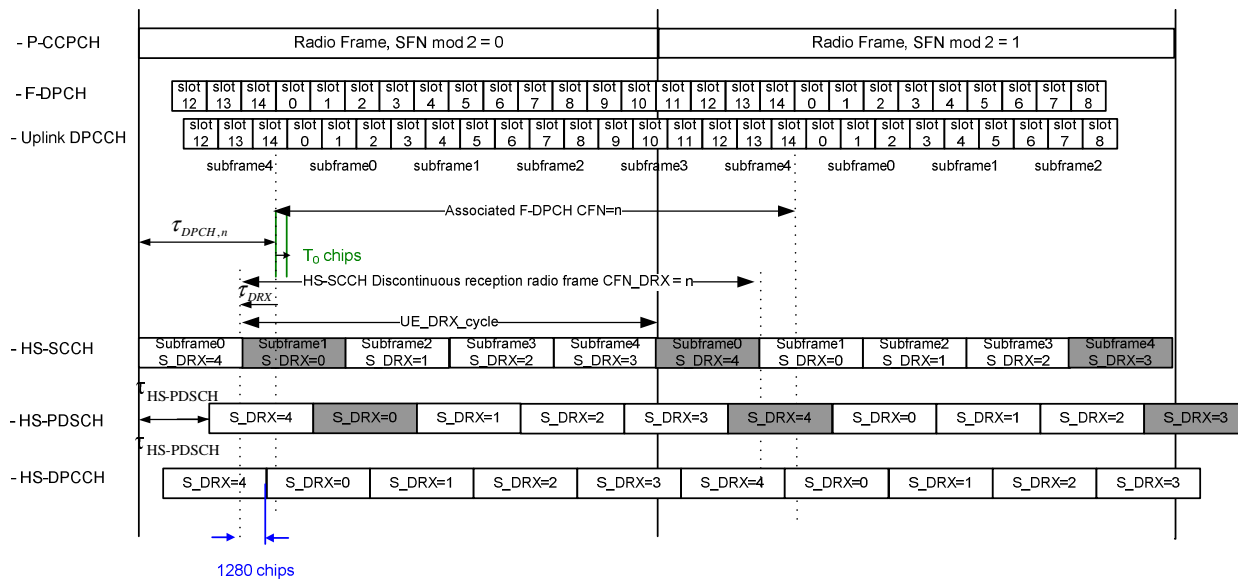

Figure 2C: Example for HS-SCCH reception pattern, 2ms E-DCH TTI

The HS-SCCH reception pattern is illustrated by Figure 2D for a 10 ms TTI E-DCH. The grey subframes correspond to the HS-SCCH reception pattern UE_DRX_cycle=5.

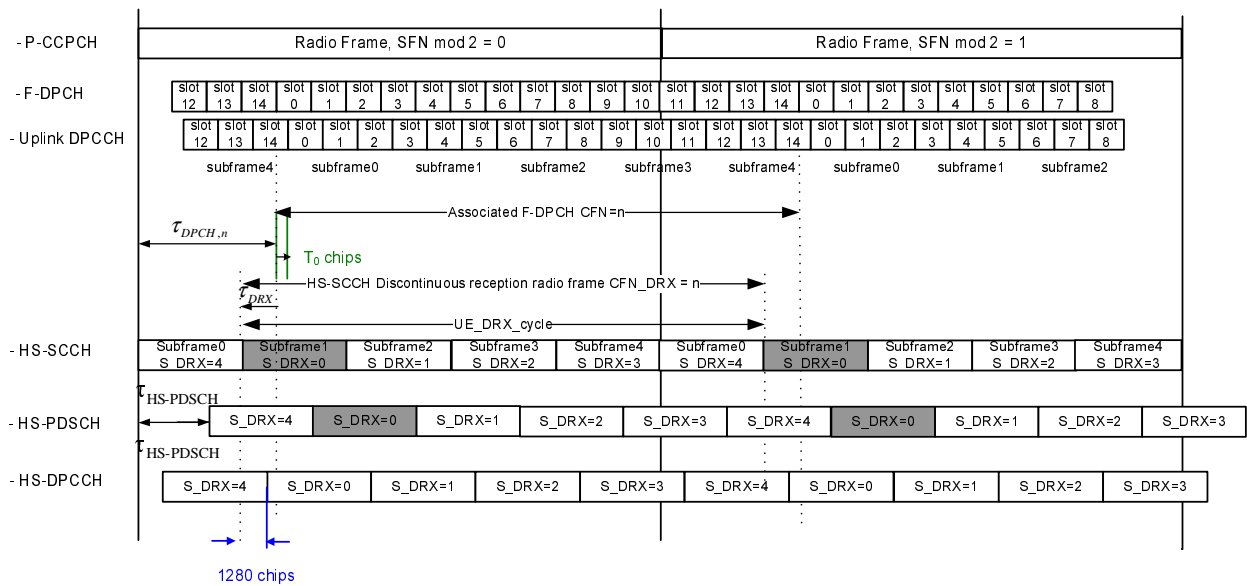

Figure 2D: Example for HS-SCCH reception pattern, 10ms E-DCH TTI

6C.3.1 Discontinuous downlink reception when the UE is in Multiflow mode

When the UE is in Multiflow mode the discontinuous downlink reception for the time reference cell operates as defined in sub-clause 6C.3 for the case when the UE is not in Multiflow mode.

The discontinuous HS-SCCH reception subframe numbering in the non-time reference cell is such that:

- A HS-SCCH discontinuous reception radio frame is 10 ms long and is indexed using CFN_DRX.
- The start of the HS-SCCH discontinuous reception radio frame of CFN_DRX n is aligned with the start of the HS-SCCH subframe that starts τ_{DRX} chips after the start of the associated downlink F-DPCH of CFN n where $-3840chips \leq \tau_{DRX} - T_0 - 7680 * DRX_OFFSET < 3840chips$, and DRX_OFFSET is defined in table 7K.

Table 7K: Definition of DRX_Offset for the non-time reference cell

Condition:	DRX_OFFSET defined as:
When the UE is not configured in MIMO mode, or when the UE is configured in MIMO mode in any cell and the UE indicated not requiring a <i>Longer HARQ processing Time</i> in higher layers.	$DRX_OFFSET = \left\lfloor \frac{T_{TX_diff} - 0.9}{3} \right\rfloor - \left\lfloor \frac{T_{TX_diff} - \tau_{DIFF} - 0.9}{3} \right\rfloor$
When the UE is configured in MIMO mode in any cell, and the UE indicated requiring a <i>Longer HARQ processing Time</i> in higher layers.	$DRX_OFFSET = \left\lfloor \frac{T_{TX_diff} - 0.9}{3} \right\rfloor - \left\lfloor \frac{T_{TX_diff} + \tau_{DIFF} - 0.9}{3} \right\rfloor$

T_{TX_diff} is of the non-time reference cell and defined in subclause 7.7, and τ_{DIFF} is defined in sub-clause 7.7.2 of [1].

- The HS-SCCH subframe S_DRX=0 is aligned with the start of the HS-SCCH discontinuous reception radio frame. The HS-SCCH subframes are numbered S_DRX=0 to S_DRX=4.
- The HS-PDSCH discontinuous reception radio frame of CFN_DRX n starts $\tau_{HS-PDSCH}$ chips after the start of the HS-SCCH discontinuous reception radio frame of CFN_DRX n. The HS-PDSCH subframe S_DRX=0 is aligned

with the start of the HS-PDSCH discontinuous reception radio frame. The HS-PDSCH subframes are numbered $S_DRX=0$ to $S_DRX=4$.

- The HS-DPCCH discontinuous transmission radio frame of $CFN_DRX\ n$ starts at the HS-DPCCH subframe boundary closest in time to $1280/+/-\tau_{DIFF}$ chips after the start of the HS-SCCH discontinuous reception radio frame of $CFN_DRX\ n$ as received at the UE. The HS-DPCCH subframe $S_DRX=0$ is aligned with the start of the HS-DPCCH discontinuous transmission radio frame. The HS-DPCCH subframes are numbered $S_DRX=0$ to $S_DRX=4$.

6C.4 HS-SCCH orders

When the UE is not configured in Multiflow mode, the Node B may activate and deactivate the discontinuous downlink reception operation and discontinuous uplink DPCCH transmission operation through physical layer commands transmitted on one of the HS-SCCH in the HS-SCCH set as specified in [2] and in subclause 6A.1.1.

- The activation and deactivation of the discontinuous uplink DPCCH transmission operation is applied by the UE at the earliest E-DCH TTI boundary coinciding with or following the beginning of the HS-DPCCH subframe containing the HARQ-ACK corresponding to the order.
- The activation and deactivation of the discontinuous downlink reception operation is applied by the UE 12 slots after the ending of the HS-SCCH subframe delivering the order.
- The activation and deactivation shall affect all frequencies configured to the UE.

6C.5 Operation during compressed mode

When in compressed mode, the UE shall behave according to subclauses 6A.3 and 6B.4 including the following rules.

The uplink discontinuous transmission operation is not impacted by the compressed mode in the radio frames that do not overlap an uplink compressed mode transmission gap as defined in subclause 6.1.1 of [4].

In radio frames that overlap an uplink compressed mode transmission gap as defined in subclause 6.1.1 of [4], the uplink DPCCH shall be transmitted in all slots in the radio frame that do not overlap the uplink compressed mode transmission gap if either of the following is true:

- an uplink DPCCH transmission defined by the Uplink DPCCH burst pattern according to subclause 6C.2.1 overlaps an uplink compressed mode transmission gap, or
- an uplink DPCCH preamble or postamble according to subclause 6C.2.2 corresponding to an uplink DPCCH transmission defined by the Uplink DPCCH burst pattern overlaps an uplink compressed mode transmission gap.

If the 2 bullets above are not true, the following are not affected by compressed mode:

- uplink DPCCH transmission according to Uplink DPCCH burst patterns defined in subclause 6C.2.1,
- uplink DPCCH preamble transmission corresponding to an uplink DPCCH transmission defined by the Uplink DPCCH burst pattern,
- uplink DPCCH postamble transmission corresponding to an uplink DPCCH transmission defined by the Uplink DPCCH burst pattern.

If part of an uplink DPCCH preamble or postamble corresponding to an E-DCH or HS-DPCCH transmission overlaps an uplink compressed mode transmission gap, then that part of the preamble or postamble shall not be transmitted.

If an HS-SCCH subframe in the HS-SCCH reception pattern for downlink discontinuous reception according to subclause 6C.3 overlaps with a downlink compressed mode transmission gap, the following is true:

- the reception of an HS-SCCH subframe is postponed to the first full HS-SCCH subframe after the downlink compressed mode transmission gap.

- if UE_DRX_Grant_Monitoring is TRUE and the conditions defined in subclause 11.8.1.8 of [9] are not fulfilled, the UE may discard the E-AGCH/E-ROCH and E-RGCH subframe (in case of 2ms TTI) or frame (in case of 10ms TTI) that overlaps with the start of the postponed HS-SCCH subframe.

Note that the compressed mode parameters (see [5]) 'UL compressed mode method', 'DL compressed mode method' and 'scrambling code change' have no effect on the UE behaviour while DTX_DRX_STATUS is TRUE.

7 Closed loop mode 1 transmit diversity

The general transmitter structure to support closed loop mode transmit diversity for DPCH transmission is shown in figure 3. Channel coding, interleaving and spreading are done as in non-diversity mode. The spread complex valued signal is fed to both TX antenna branches, and weighted with antenna specific weight factors w_1 and w_2 . The weight factor w_1 is a constant scalar and the weight factor w_2 is complex valued signal.

The weight factor w_2 (actually the corresponding phase adjustment) is determined by the UE, and signalled to the UTRAN access point (i.e. cell transceiver) using the FBI field of uplink DPCCH.

For the closed loop mode 1 different orthogonal dedicated pilot symbols in the DPCCH are sent on the 2 different antennas.

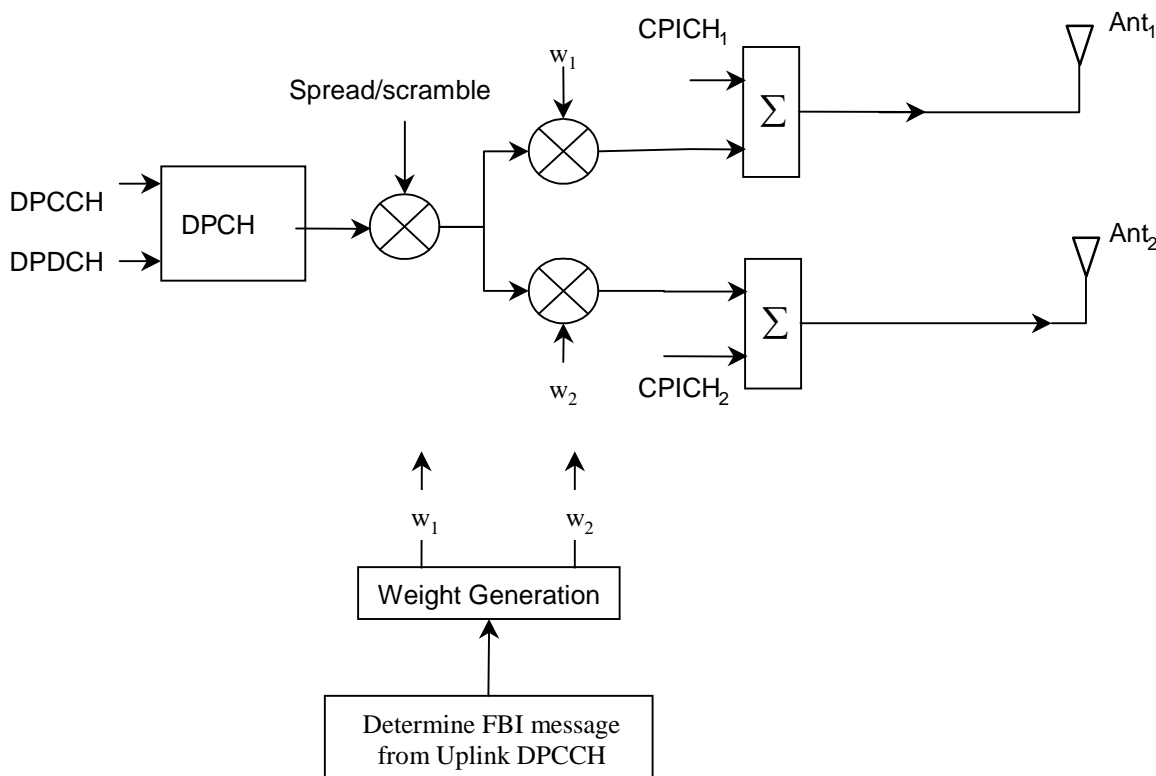

Figure 3: The generic downlink transmitter structure to support closed loop mode transmit diversity for DPCH transmission.

Closed loop mode 1 characteristics are summarised in the Table 8. The use of the closed loop mode 1 is controlled via higher layer signalling.

Table 8: Summary of number of feedback information bits per slot, N_{FBD} , feedback command length in slots, N_{W} , feedback command rate, feedback bit rate, number of phase bits, N_{ph} , per signalling word, number of amplitude bits, N_{po} , per signalling word and amount of constellation rotation at UE for the closed loop mode 1.

N_{FBD}	N_{W}	Update rate	Feedback bit rate	N_{po}	N_{ph}	Constellation rotation
1	1	1500 Hz	1500 bps	0	1	$\pi/2$

7.1 General procedure

The UE uses the CPICH to separately estimate the channels seen from each antenna.

Once every slot, the UE computes the phase adjustment, ϕ , that should be applied at the UTRAN access point to maximise the UE received power. During soft handover, the UE computes the phase adjustment to maximise the total UE received power from the cells in the active set. In the case that a HS-PDSCH is associated with a DPCH for which closed loop mode 1 is applied, the antenna weights applied to the HS-PDSCH, are the same as the antenna weights applied to the associated DPCH. In case a HS-PDSCH is associated with a DPCH during soft handover, the UE may emphasize the radio link transmitted from HS-DSCH serving cell, respectively, when calculating the antenna weights. An example of how the computations can be accomplished is given in Annex A.2.

The UE feeds back to the UTRAN access point the information on which phase/power settings to use. Feedback Signalling Message (FSM) bits are transmitted in the FBI field of uplink DPCCCH slot(s) (see [1]). Each message is of length $N_{\text{W}} = N_{\text{po}} + N_{\text{ph}}$ bits and its format is shown in the figure 4. The transmission order of bits is from MSB to LSB, i.e. MSB is transmitted first. FSM_{po} and FSM_{ph} subfields are used to transmit the power and phase settings, respectively.

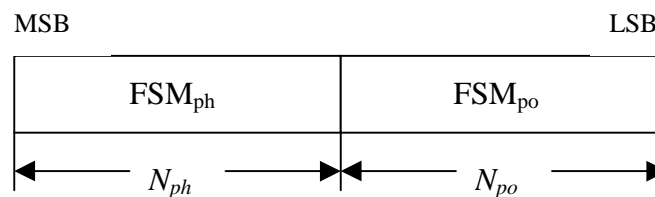

Figure 4: Format of feedback signalling message. FSM_{po} transmits the power setting and FSM_{ph} the phase setting.

The adjustments are made by the UTRAN Access Point at the beginning of the downlink DPCCCH pilot field. The downlink slot in which the adjustment is done is signalled to L1 of UE by higher layers. Two possibilities exist:

- 1) When feedback command is transmitted in uplink slot i , which is transmitted approximately 1024 chips in offset from the received downlink slot j , the adjustment is done at the beginning of the pilot field of the downlink slot $(j+1) \bmod 15$.
- 2) When feedback command is transmitted in uplink slot i , which is transmitted approximately 1024 chips in offset from the received downlink slot j , the adjustment is done at the beginning of the pilot field of the downlink slot $(j+2) \bmod 15$.

Thus, adjustment timing at UTRAN Access Point is either according to 1) or 2) as controlled by the higher layers.

In case of soft handover, Layer 1 shall support different adjustment timing values for different radio links in the same active set.

The timing of the weight adjustment of the HS-PDSCH is such that the HS-PDSCH weight adjustment is done at the HS-PDSCH slot border, respectively, M chips after the adjustment of the associated DPCH, where $0 \leq M < 2560$.

7.2 Determination of feedback information

The UE uses the CPICH transmitted both from antenna 1 and antenna 2 to calculate the phase adjustment to be applied at UTRAN access point to maximise the UE received power. In each slot, UE calculates the optimum phase adjustment, ϕ , for antenna 2, which is then quantized into ϕ_Q having two possible values as follows:

$$\phi_Q = \begin{cases} \pi, & \text{if } \pi/2 < \phi - \phi_r(i) \leq 3\pi/2 \\ 0, & \text{otherwise} \end{cases} \quad (1)$$

where:

$$\phi_r(i) = \begin{cases} 0, & i = 0,2,4,6,8,10,12,14 \\ \pi/2, & i = 1,3,5,7,9,11,13 \end{cases} \quad (2)$$

If $\phi_Q = 0$, a command '0' is send to UTRAN using the FSM_{ph} field. Correspondingly, if $\phi_Q = \pi$, command '1' is send to UTRAN using the FSM_{ph} field.

Due to rotation of the constellation at UE the UTRAN interprets the received commands according to table 9 which shows the mapping between phase adjustment, ϕ_i , and received feedback command for each uplink slot.

Table 9: Phase adjustments, ϕ_i , corresponding to feedback commands for the slots i of the UL radio frame

Slot #	0	1	2	3	4	5	6	7	8	9	10	11	12	13	14
FSM	0	$\pi/2$	0	$\pi/2$	0	$\pi/2$	0	$\pi/2$	0	$\pi/2$	0	$\pi/2$	0	$\pi/2$	0
	1	π	$-\pi/2$	π	$-\pi/2$	π	$-\pi/2$	π	$-\pi/2$	π	$-\pi/2$	π	$-\pi/2$	π	$-\pi/2$

The weight w_2 is then calculated by averaging the received phases over 2 consecutive slots. Algorithmically, w_2 is calculated as follows:

$$w_2 = \frac{\sum_{i=n-1}^n \cos(\phi_i)}{2} + j \frac{\sum_{i=n-1}^n \sin(\phi_i)}{2} \quad (3)$$

where:

$$\phi_i \in \{0, \pi, \pi/2, -\pi/2\} \quad (4)$$

For antenna 1, w_1 is constant:

$$w_1 = 1/\sqrt{2} \quad (5)$$

7.2.1 End of frame adjustment

In closed loop mode 1 at frame borders the averaging operation is slightly modified. Upon reception of the FB command for slot 0 of a frame, the average is calculated based on the command for slot 13 of the previous frame and the command for slot 0 of the current frame, i.e. ϕ_i from slot 14 is not used:

$$w_2 = \frac{\cos(\phi_{13}^{j-1}) + \cos(\phi_0^j)}{2} + j \frac{\sin(\phi_{13}^{j-1}) + \sin(\phi_0^j)}{2} \quad (6)$$

where:

- ϕ_{13}^{j-1} = phase adjustment from frame j-1, slot 13.

- ϕ_0^j = phase adjustment from frame j, slot 0.

7.2.2 Normal initialisation

For the first frame of transmission UE determines the feedback commands in a normal way and sends them to UTRAN.

Before the first FB command is received, the UTRAN shall use the initial weight $w_2 = \frac{1}{2}(1 + j)$.

Having received the first FB command the UTRAN calculates w_2 as follows:

$$w_2 = \frac{\cos(\pi / 2) + \cos(\phi_0)}{2} + j \frac{\sin(\pi / 2) + \sin(\phi_0)}{2} \quad (7)$$

where:

ϕ_0 = phase adjustment from slot 0 of the first frame.

7.2.3 Operation during compressed mode

7.2.3.1 Downlink in compressed mode and uplink in normal mode

When downlink is in compressed mode but uplink is operating normally (i.e. not compressed) the UTRAN continues its Tx diversity related functions in the same way as in non-compressed downlink mode.

In downlink transmission gaps there are uplink slots for which no new estimate of the phase adjustment is calculated. During these slots the following rules are applied in UE when determining the feedback command:

- 1) If no new estimate of phase adjustment ϕ_i exists corresponding to the feedback command to be sent in uplink slot i :
 - If $1 < i < 15$:
 - the feedback command sent in uplink slot $i-2$ is used;
 - else if $i = 0$:
 - the feedback command sent in uplink slot 14 of previous frame is used;
 - else if $i = 1$:
 - the feedback command sent in uplink slot 13 of previous frame is used;
 - end if.
- 2) When transmission in downlink is started again in downlink slot $N_{\text{last}+1}$ (if $N_{\text{last}+1} = 15$, then slot 0 in the next frame) the UE must resume calculating new estimates of the phase adjustment. The feedback command corresponding to the first new estimate of ϕ_i must be sent in the uplink slot which is transmitted approximately 1024 chips in offset from the downlink slot $N_{\text{last}+1}$.

7.2.3.2 Both downlink and uplink in compressed mode

During the uplink transmission gaps no FB commands are sent from UE to UTRAN. When transmission in downlink is started again in downlink slot $N_{\text{last}+1}$ (if $N_{\text{last}+1} = 15$, then slot 0 in the next frame) the UE must resume calculating new estimates of the phase adjustment. The feedback command corresponding to the first new estimate of ϕ_i must be sent in the uplink slot which is transmitted approximately 1024 chips in offset from the downlink slot $N_{\text{last}+1}$.

The UTRAN continues to update the weight w_2 until the uplink transmission gap starts and no more FB commands are received. When the transmission in downlink resumes in slot $N_{\text{last}+1}$, the value of w_2 , calculated after receiving the last FB command before the start of the uplink transmission gap, is applied to antenna 2 signal.

After the UE resumes transmission in uplink and sends the first FB command, the new value of w_2 is calculated as follows:

- $S_1 = \{0, 2, 4, 6, 8, 10, 12, 14\}$.
- $S_2 = \{1, 3, 5, 7, 9, 11, 13\}$.
- i = number of uplink slot at which the transmission resumes.
- j = number of uplink slot at which the last FB command was sent before the start of the uplink transmission gap.
- Do while ($i \in S_1$ and $j \in S_1$) or ($i \in S_2$ and $j \in S_2$):
 - $j = j-1$;
 - if $j < 0$;
 - $j = 14$;
 - end if;
 - end do;
- calculate w_2 based on FB commands received in uplink slots i and j .

Note that for $N_{\text{last}} = 13$ the end of frame adjustment procedure shall be based on the FB commands for the last odd slot prior to the uplink transmission gap and slot 0.

7.2.3.3 Uplink in compressed mode and downlink in normal mode

The UTRAN continues to update the value of w_2 until the uplink transmission gap starts and no more FB commands are received. Then, the value of w_2 calculated after receiving the last FB command before the uplink transmission gap is applied to the antenna 2 signal. When the UE resumes transmission in uplink, it shall send FB commands according to section 7.2 equations 2 and 3 (normal operation) and the UTRAN Access Point shall interpret the FB commands according to Table 9.

The calculation of w_2 by the UTRAN following the uplink transmission gap, and before the first two FB commands following the gap are received is not specified.

7.2.4 Initialisation during compressed mode

7.2.4.1 Downlink in compressed mode

When closed loop mode 1 is initialised during the downlink transmission gap of compressed mode there are slots for which no estimate of the phase adjustment is calculated and no previous feedback command is available.

In this case, if the UE is required to send feedback in the uplink, the FB command to the UTRAN shall be "0".

When transmission in downlink is started again in slot $N_{\text{last}}+1$ (if $N_{\text{last}}+1 = 15$, then slot 0 in the next frame), the

UTRAN shall use the initial weight $w_2 = \frac{1}{2}(1 + j)$. The UE must start calculating estimates of the phase adjustment.

The feedback command corresponding to the first estimate of ϕ_i must be sent in the uplink slot which is transmitted approximately 1024 chips in offset from the downlink slot $N_{\text{last}}+1$. Having received this feedback command the UTRAN calculates w_2 as follows:

$$w_2 = \frac{\cos(\phi_i) + \cos(\phi_j)}{2} + j \frac{\sin(\phi_i) + \sin(\phi_j)}{2} \quad (8)$$

where:

ϕ_i = phase adjustment in uplink slot i , which is transmitted approximately 1024 chips in offset from the downlink slot $N_{\text{last}}+1$.

$$\phi_j = \frac{\pi}{2}, \text{ if slot } i \text{ is even (} i \in \{0, 2, 4, 6, 8, 10, 12, 14\} \text{) and}$$

$$\phi_j = 0, \text{ if slot } i \text{ is odd (} i \in \{1, 3, 5, 7, 9, 11, 13\} \text{)}$$

7.2.4.2 Uplink in compressed mode

Initialisation of closed loop mode 1 operation during uplink compressed mode only is not specified.

7.3 Void

8 Idle periods for IPDL location method

8.1 General

To support time difference measurements for location services, idle periods can be created in the downlink (hence the name IPDL) during which time transmission of all channels from a Node B is temporarily seized. During these idle periods the visibility of neighbour cells from the UE is improved.

The idle periods are arranged in a predetermined pseudo random fashion according to higher layer parameters. Idle periods differ from compressed mode in that they are shorter in duration, all channels are silent simultaneously, and no attempt is made to prevent data loss.

In general there are two modes for these idle periods:

- Continuous mode, and
- Burst mode.

In continuous mode the idle periods are active all the time. In burst mode the idle periods are arranged in bursts where each burst contains enough idle periods to allow a UE to make sufficient measurements for its location to be calculated. The bursts are separated by a period where no idle periods occur.

8.2 Parameters of IPDL

The following parameters are signalled to the UE via higher layers:

IP_Status: This is a logic value that indicates if the idle periods are arranged in continuous or burst mode.

IP_Spacing: The number of 10 ms radio frames between the start of a radio frame that contains an idle period and the next radio frame that contains an idle period. Note that there is at most one idle period in a radio frame.

IP_Length: The length of the idle periods, expressed in symbols of the CPICH.

IP_Offset: A cell specific offset that can be used to synchronise idle periods from different sectors within a Node B.

Seed: Seed for the pseudo random number generator.

Additionally in the case of burst mode operation the following parameters are also communicated to the UE.

Burst_Start: Specifies the start of the first burst of idle periods. $256 \times \text{Burst_Start}$ is the SFN where the first burst of idle periods starts.

Burst_Length: The number of idle periods in a burst of idle periods.

Burst_Freq: Specifies the time between the start of a burst and the start of the next burst. $256 \times \text{Burst_Freq}$ is the number of radio frames of the primary CPICH between the start of a burst and the start of the next burst.

8.3 Calculation of idle period position

In burst mode, burst #0 starts in the radio frame with $\text{SFN} = 256 \times \text{Burst_Start}$. Burst # k starts in the radio frame with $\text{SFN} = 256 \times \text{Burst_Start} + k \times 256 \times \text{Burst_Freq}$ ($k = 0, 1, 2, \dots$). The sequence of bursts according to this formula continues up to and including the radio frame with $\text{SFN} = 4095$. At the start of the radio frame with $\text{SFN} = 0$, the burst sequence is terminated (no idle periods are generated) and at $\text{SFN} = 256 \times \text{Burst_Start}$ the burst sequence is restarted with burst #0 followed by burst #1 etc., as described above.

Continuous mode is equivalent to burst mode, with only one burst spanning the whole SFN cycle of 4096 radio frames, this burst starting in the radio frame with $\text{SFN} = 0$.

Assume that $\text{IP_Position}(x)$ is the position of idle period number x within a burst, where $x = 1, 2, \dots$, and $\text{IP_Position}(x)$ is measured in number of CPICH symbols from the start of the first radio frame of the burst.

The positions of the idle periods within each burst are then given by the following equation:

$$\text{IP_Position}(x) = (x \times \text{IP_Spacing} \times 150) + (\text{rand}(x \text{ modulo } 64) \text{ modulo } (150 - \text{IP_Length})) + \text{IP_Offset};$$

where $\text{rand}(m)$ is a pseudo random generator defined as follows:

$$\text{rand}(0) = \text{Seed};$$

$$\text{rand}(m) = (106 \times \text{rand}(m - 1) + 1283) \text{ modulo } 6075, m = 1, 2, 3, \dots$$

Note that x is reset to $x = 1$ for the first idle period in every burst.

Figure 6 below illustrates the idle periods for the burst mode case.

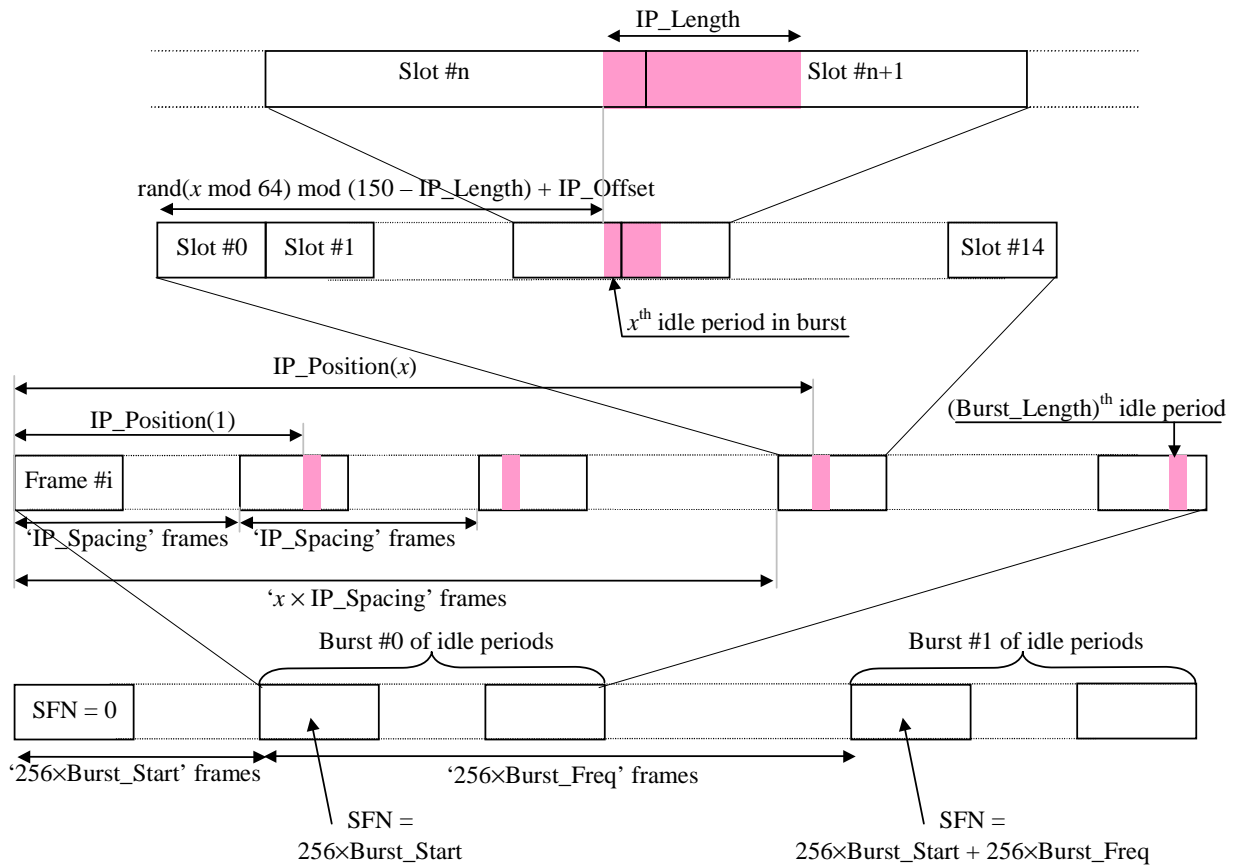

Figure 6: Idle Period placement in the case of burst mode operation

9 MIMO operation of HS-DSCH

There are two possibilities for operating MIMO: MIMO mode when single-stream restriction is not configured, in which both single and dual stream transmission can be applied, and MIMO mode when single-stream restriction is configured, which is restricted only to single stream transmission. This section applies only when a UE is configured in MIMO mode.

The general transmitter structure to support MIMO operation of HS-PDSCH transmission is shown in figure 7. Channel coding, interleaving and spreading are done as in non-MIMO mode. When single-stream restriction is not configured the Node B scheduler can decide to transmit one or two transport blocks to a UE in one TTI in the serving HS-DSCH cell, and one or two transport blocks in a secondary serving HS-DSCH cell if the UE is configured with a secondary serving HS-DSCH cell in which MIMO is configured, whereas when single-stream restriction is configured only transmission of single transport block is allowed in any of the cells. The spread complex valued signals are fed to both TX antenna branches, and weighted with precoding weights w_1 , w_2 , w_3 and w_4 . The precoding weights w_1 and w_3 are constant real valued scalars and the precoding weights w_2 and w_4 are variable complex valued scalars. The precoding weights w_1 , w_2 , w_3 and w_4 are defined as follows:

$$w_3 = w_1 = 1/\sqrt{2},$$

$$w_4 = -w_2,$$

$$w_2 \in \left\{ \frac{1+j}{2}, \frac{1-j}{2}, \frac{-1+j}{2}, \frac{-1-j}{2} \right\}.$$

If single-stream restriction is configured, or single-stream restriction is not configured and the Node B schedules a single transport block in a cell to a UE in one TTI, it uses the precoding vector (w_1, w_2) for transmission of that transport block on the HS-PDSCH sub-frame. If single-stream restriction is not configured and the UTRAN schedules two transport blocks in a cell to a UE in one TTI, it uses two orthogonal precoding vectors to transmit the two transport blocks. The precoding vector (w_1, w_2) is called the primary precoding vector which is used for transmitting the primary transport block and the precoding vector (w_3, w_4) is called secondary precoding vector which is used for transmitting the secondary transport block, respectively.

If single-stream restriction is configured (Figure 7a) the secondary transport block is never present. If single-stream restriction is not configured (figure 7) the Node B can dynamically schedule the UE with one or two transport blocks.

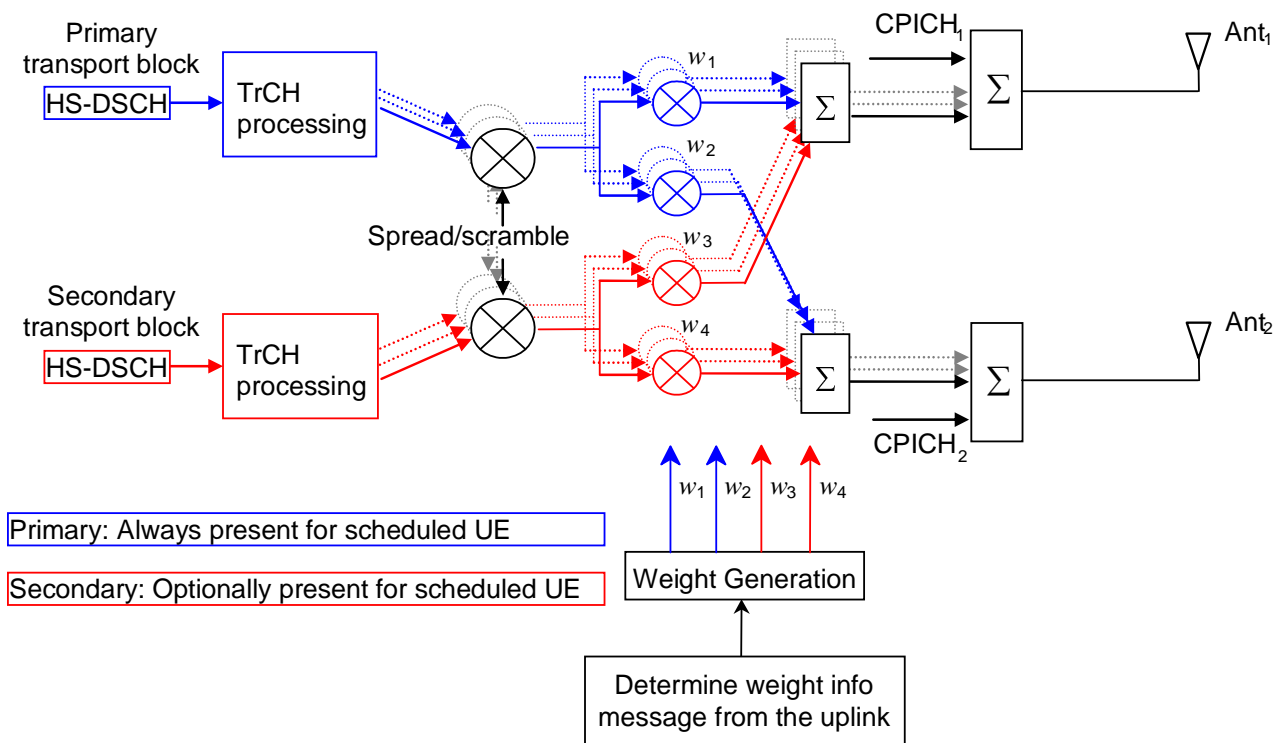

Figure 7: The generic downlink transmitter structure to support MIMO operation for HS-PDSCH transmission when single-stream restriction is not configured.

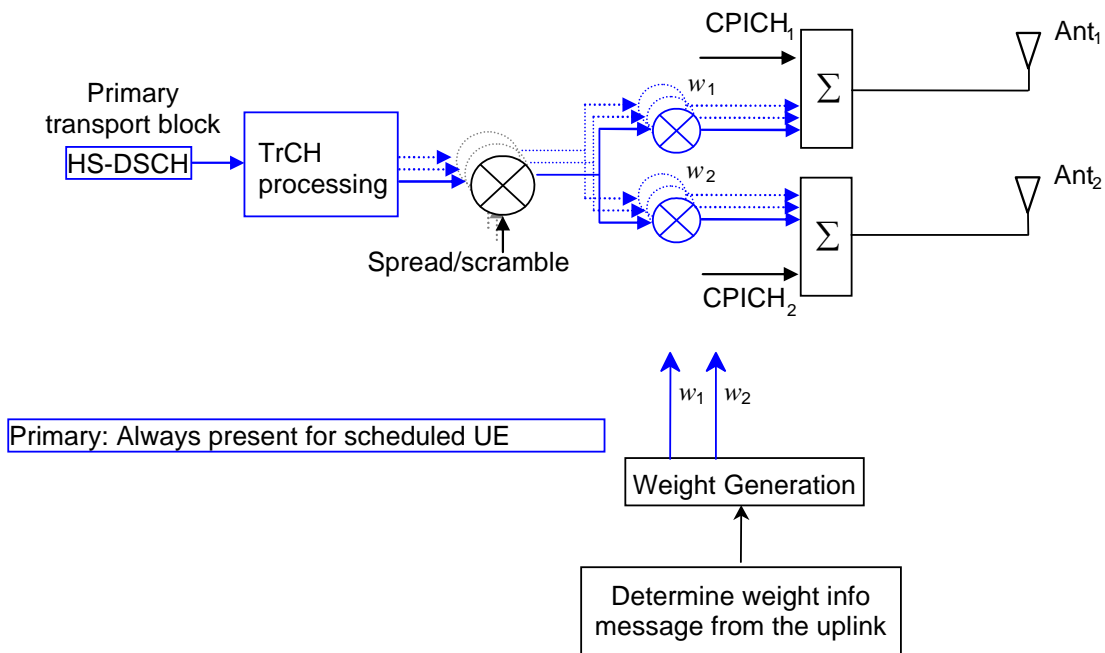

Figure 7a: The generic downlink transmitter structure to support MIMO operation for HS-PDSCH transmission when single-stream restriction is configured.

9.1 General procedure

The UE uses the CPICH to separately estimate the channels seen from each antenna. One of the antennas will transmit the Antenna 1 modulation pattern of the P-CPICH as defined in subclause 5.3.3.1 of [1]. The other antenna will transmit either the Antenna 2 modulation pattern of the P-CPICH or the Antenna 1 modulation pattern of a S-CPICH. The Pilot configuration in support of MIMO operation of HS-DSCH in the cell is signalled by higher layers.

The UE determines a preferred primary precoding vector $(w_1^{\text{pref}}, w_2^{\text{pref}})$ and signals it to the Node B. The signalled information about the preferred primary precoding vector is termed precoding control indication (PCI) and is defined in subclause 6A.4. The PCI is signalled to the Node B together with channel quality indication (CQI) as a composite PCI/CQI report according to the procedure defined in subclause 6A.1.2.2. The UE transmits the composite PCI/CQI report to the Node B using the CQI field on the HS-DPCCH as defined in [1]. Based on the composite PCI/CQI reports, the Node B scheduler decides when single-stream restriction is not configured whether to schedule one or two transport blocks in a cell to a UE in one TTI and what transport block size(s) and modulation scheme(s) to use for each of them.

The Node B signals to the UE the precoding weight w_2 applied on the HS-PDSCH sub-frame using the precoding weight indication bits of part 1 of the corresponding HS-SCCH sub-frame. The precoding weight adjustment of each HS-PDSCH is done at the HS-PDSCH sub-frame border.

10 Uplink Closed Loop Transmit Diversity operation

The use of uplink CLTD is controlled by higher layer signalling. If the UE is configured with UL CLTD, then UL_CLTD_Enabled is set to TRUE, otherwise UL_CLTD_Enabled is set to FALSE and UL_CLTD_Active is 0. UL_CLTD_Active shall be set to 1, 2 or 3 while UL_CLTD_Enabled is TRUE and CLTD activation state 1, 2 or 3 is activated through HS-SCCH orders respectively.

At the time when UL_CLTD_Enabled is set to TRUE, UL_CLTD_Active shall be set to 1 or 2 as indicated by higher layer signaling. If activation state 1 is configured, or a transition from a different activation state to activation state 1 occurs through an HS-SCCH order, the TPI is initially set to the fixed precoder weight corresponding to the bit pattern "1100" in Table 10. The parameter UL_CLTD_Active may be further switched to other CLTD activation states through HS-SCCH orders, as described in [2].

Upon higher layer signaling that does not result in a serving cell change, the UE shall remember its current UL CLTD activation state and use the last received pre-coding vector after the RRC reconfiguration. Upon higher layer signaling that results in serving cell change, CLTD activation state is either reset or maintained in the RRC reconfiguration message. If activation state 1 is configured, the TPI is initially set to the fixed precoder weight corresponding to the bit pattern "1100" in Table 10.

The secondary dedicated pilot channel, S-DPCCH, is transmitted as long as UL DPCCH is transmitted when UL_CLTD_Enabled is TRUE and UL_CLTD_Active is set to 1.

10.1 General procedure

The general transmitter structure to support uplink CLTD activation state 1 is shown in Figure 8. Channel coding, interleaving and spreading are done as in the case where uplink CLTD is not configured. If UL_CLTD_Active is 1, the complex-valued signal after spreading is fed to both TX antenna branches and weighted with precoding weights w_1 , w_2 , w_3 and w_4 . The same precoding weights, w_1 and w_2 , are always applied to DPCCH, DPDCH if present, E-DPCCH, E-DPDCH and the HS-DPCCH. The S-DPCCH is pre-coded with precoding weights w_3 and w_4 .

The beamforming weight matrix is given by

$$\begin{bmatrix} w_1 & w_3 \\ w_2 & w_4 \end{bmatrix} = \begin{bmatrix} ae^{-j\frac{\theta}{2}} & ae^{-j\frac{\theta}{2}} \\ ae^{j\frac{\theta}{2}} & -ae^{j\frac{\theta}{2}} \end{bmatrix}$$

where normalized amplitude $a = \frac{1}{\sqrt{2}}$ and $\theta = \theta^{(n+1)}$ is the phase to be applied in the current TPI update period, which is determined as follows.

Let $\tilde{\theta}^{(n+1)}$ be the currently received TPI phase calculated by the NodeB and signalled to the UE via the F-TPICH bit pattern, and $\theta^{(n)}$ the phase applied in the previous TPI update period.

Then the final beamforming phase applied $\theta^{(n+1)}$ for the current TPI update period is calculated as:

if $|\phi_1 - \theta^{(n)}| \leq \pi$

$$\theta^{(n+1)} = \phi_1$$

else

$$\theta^{(n+1)} = \phi_2$$

where

$$\phi_1 = \begin{cases} \tilde{\theta}^{(n+1)} - 2\pi, & \text{if } \theta^{(n)} < 0 \\ \tilde{\theta}^{(n+1)}, & \text{else} \end{cases}$$

and

$$\phi_2 = \begin{cases} \tilde{\theta}^{(n+1)} - 2\pi, & \text{if } \theta^{(n)} \geq 0 \\ \tilde{\theta}^{(n+1)}, & \text{else} \end{cases}$$

The mapping between the F-TPICH bit pattern and the TPI phase $\tilde{\theta}^{(n+1)}$ is given by Table 10.

Table 10: Mapping of precoding weight information

$\tilde{\theta}^{(n+1)}$	Bit pattern	
	i	$i+1$
0	00	00
$\pi/2$	00	11
π	11	11
$3\pi/2$	11	00

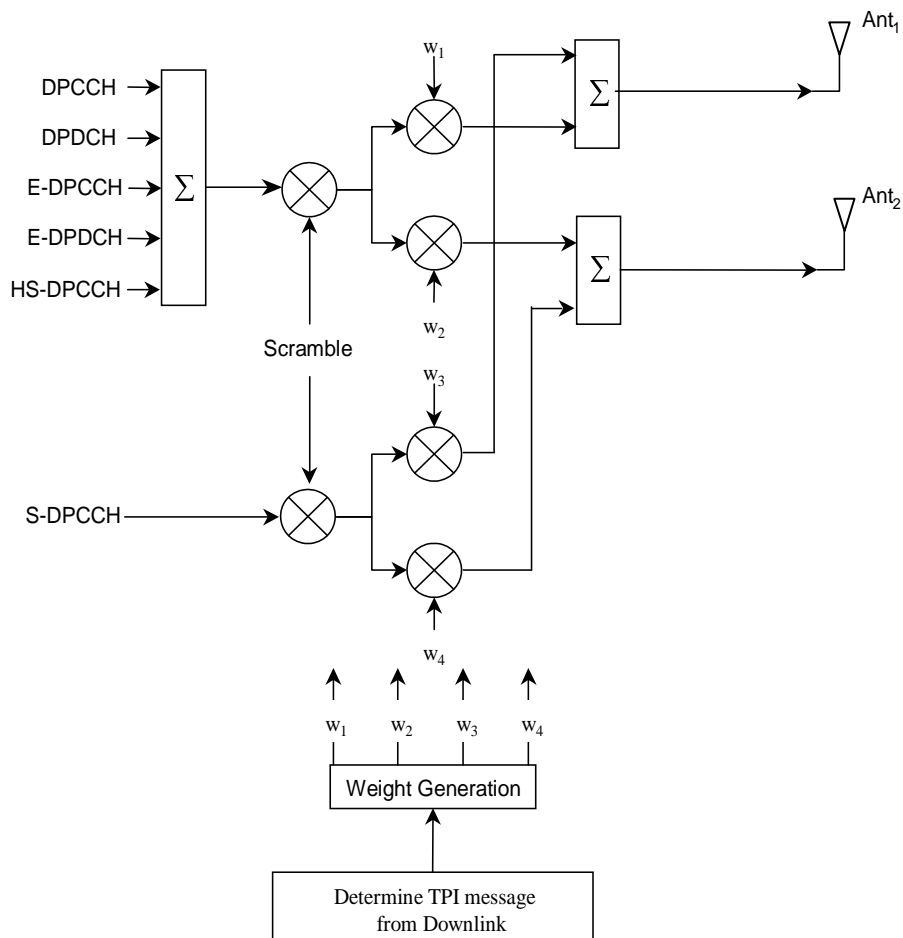

Figure 8: The generic uplink transmitter structure to support UL CLTD activation state 1

The channel combining for UL CLTD when UL_CLTD_Enabled is set to TRUE is described in [3] subclause 4.2.4. When UL_CLTD_Active is not equal to 1, no UL closed loop beamforming is performed for uplink transmission.

In the case that UL_CLTD_Active is 2, the DPCCH/DPDCH/E-DPCCH/E-DPDCH/HS-DPCCH are transmitted on antenna 1, and S-DPCCH is switched off.

In the case that UL_CLTD_Active is 3, the DPCCH/DPDCH/E-DPCCH/E-DPDCH/HS-DPCCH are transmitted on antenna 2, and S-DPCCH is switched off.

10.2 Downlink TPI transmission and control timing

If UL_CLTD_Enabled is TRUE and UL_CLTD_Active is 1, the Node B determines a precoding phase which is signalled to the UE using the allocated TPI field on the F-TPICH as defined in [1]; see also Table 10. The following applies:

- if the UE is configured with an HS-DPCCH, higher layers indicate to the UE which cells in the active set transmit the F-TPICH, with the restriction that either only the HS-DSCH serving cell transmits the F-TPICH or all cells from the serving radio link set transmit the F-TPICH.
- if the UE is not configured with an HS-DPCCH, higher layers indicate to the UE which cells in the active set transmit the F-TPICH, with the restriction that either only one cell transmits the F-TPICH or all cells from one radio link set transmit the F-TPICH.

The TPI information update rate is 3 slots. However, the uplink channel measurement periods are not specified for Node B. The UE shall apply the precoding weight indicated by the TPI on the first DPCCH slot boundary, after 512 chips after

- the end of the TPI field carrying the second of the two bits in the TPI bit pattern, if the F-TPICH is configured to be transmitted from one radio link only.
- the end of the last TPI field carrying the second of the two bits in a TPI bit pattern received during a TPI combining period, if the F-TPICH is configured to be transmitted from multiple radio links.

The UE shall measure the reliability of the received TPI bits over the 3 slot period in which the TPI bit pattern corresponding to a precoding weight is received. The received TPI bits are mapped to precoding weights and applied by the UE only if the estimated quality of the TPI bits is determined to be better than a threshold Q_{tpi} . Otherwise, the UE shall apply the precoding weights corresponding to the last reliably received TPI bit pattern. Q_{tpi} is defined implicitly by the relevant tests in [7].

10.3 Combining TPI bits from multiple radio links

When a UE is in softer handover and if F-TPICH is configured to be transmitted from multiple radio links as defined in subclause 10.2, the UE may assume that the transmitted TPI bits from those radio links in a TPI combining period are the same. The TPI combining period has the length of one slot, beginning at the downlink slot boundary of the F-TPICH. Upon reception of one or more TPI bits in a TPI combining period, the UE combines all the TPI bits received in that TPI combining period into a single TPI bit.

10.4 Operation during discontinuous uplink DPCCH operation

When `UL_DTX_Active` is TRUE (see section 6C), the UE shall not transmit the uplink S-DPCCH in a slot where UE does not transmit uplink DPCCH according to section 6C.2.

The UE shall ignore any TPI commands received in an F-TPICH subframe starting during an uplink DPCCH slot which is in an uplink DPCCH transmission gap as defined in subclause 6C.2. When uplink transmission resumes after a transmission gap, the UE shall apply the precoding weights corresponding to the last applied TPI before the uplink DPCCH transmission gap until a new reliable TPI is received.

10.5 Operation during compressed mode

10.5.1 Uplink compressed mode

In the case that `UL_CLTD_Active` is 1, the UE shall keep the last applied TPI before an uplink transmission gap until a new reliable TPI is received.

10.5.2 Downlink compressed mode

The following applies for the UE for reception of F-TPICH, during compressed mode on the DPCH or F-DPCH:

The UE shall decode F-TPICH transmissions in all slots that do not overlap with a downlink transmission gap. The UE shall ignore the other TPI bit if one of the two slots carrying the TPI bits overlaps a downlink transmission gap.

10.6 HS-SCCH orders

The Node B may switch uplink CLTD activation state to one of three CLTD activation states through HS-SCCH orders as described in [2]. HS-SCCH ordered transitions between any CLTD activation states are applied at the first E-DCH slot boundary after the end of the HS-DPCCH subframe in which the ACK is sent. The maximum allowed interruption time is 2 slots, ending at the end of the HS-DPCCH subframe in which the ACK is sent. If the UE receives an HS-SCCH order for transitioning to an activation state that is already being applied, then the UE shall not change its activation state, but shall transmit the HARQ-ACK acknowledging the HS-SCCH order.

11 Uplink MIMO

If the UE is configured with UL MIMO, then `UL_MIMO_Enabled` is set to `TRUE`, otherwise `UL_MIMO_Enabled` is set to `FALSE`. When `UL_MIMO_Enabled` is set to `TRUE`, `UL_CLTD_Enabled` is also set to `TRUE`. `UL_CLTD_Active` can be set to 1, 2 or 3 while `UL_MIMO_Enabled` is `TRUE` and CLTD activation state can be changed through HS-SCCH orders. The initial state of the `UL_CLTD_Active` follows the definition in section 10.

Two separate transport blocks are transmitted via two independent spatial streams when rank-2 transmission is used. The data rates on each stream can be independently adapted. The number of HARQ processes in dual stream operation is double of that in single stream operation, and two E-HICH signature sequences are allocated, providing HARQ-ACK feedback for each stream independently.

Rank-2 transmissions are only possible when the `UL_CLTD_Active` = 1.

The pre-coded physical channels structure for UL MIMO rank-2 transmission is depicted in Figure 9. When `UL_MIMO_Enabled` is `TRUE` either single or dual-stream transmissions can take place. In case of single stream (rank-1) transmission, the transport block is carried over E-DPDCH(s) as in UL CLTD. In case of dual stream (rank-2) transmission, the primary transport block is carried over 4 E-DPDCHs and the secondary transport block is carried over 4 S-E-DPDCHs. S-E-DPCCH is used to indicate the transport block size and retransmission sequence number of the secondary transport block on S-E-DPDCH. S-E-DPCCH is I/Q multiplexed with E-DPCCH and transmitted on primary pre-coding vector. S-E-DPCCH is only sent with rank-2 transmissions. Both the E-DPDCHs and the S-E-DPDCHs are always sent with $2xSF2 + 2xSF4$ code combination for rank-2 transmission. The UE can be configured with uplink MIMO only with 2 ms TTI on E-DCH.

For dual stream transmissions the following applies on setting the relative transmit powers of the uplink physical channels:

- For the calculation of the E-DPCCH gain factors, E-DPCCH boosting is always applied regardless of the selected E-TFC to be transmitted,
- The S-DPCCH gain factor equals the E-DPCCH gain factor,
- The S-E-DPCCH gain factor is configured by higher layers.

UL MIMO rank-1 transmission and the setting of the channel transmit powers function as defined for UL CLTD. The pre-coded physical channels structure for UL MIMO rank-1 transmission is depicted in Figure 10.

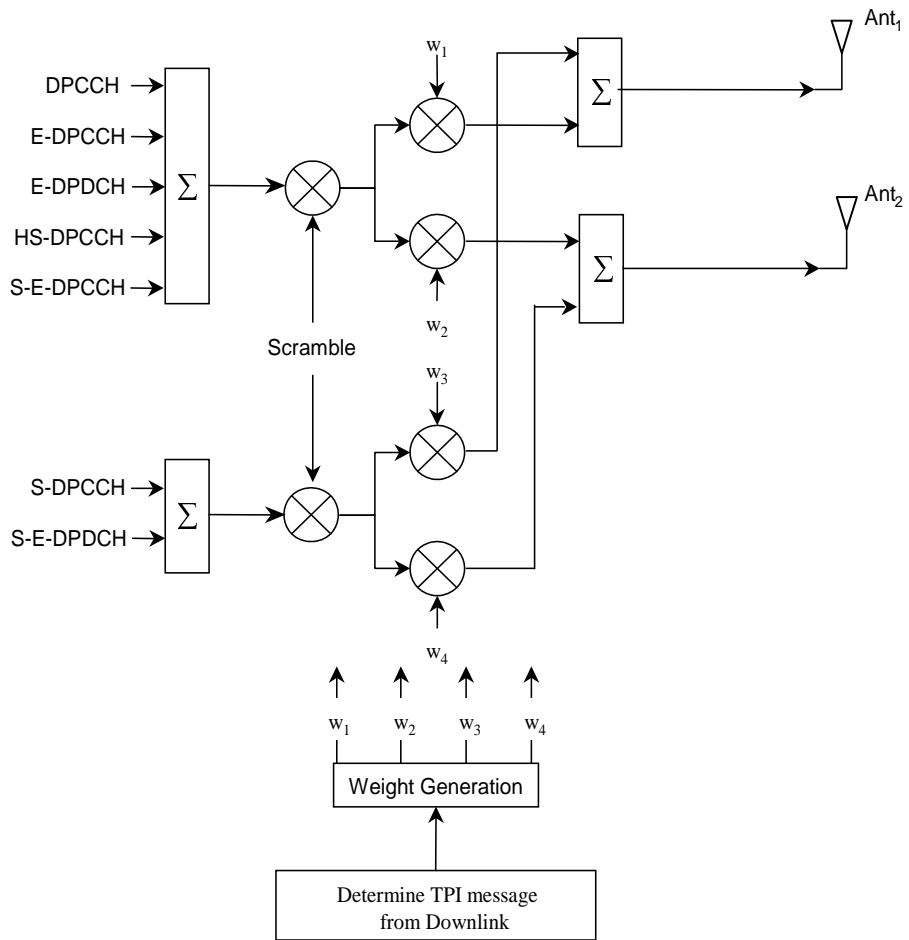

Figure 9: Pre-coded physical channel structure of UL MIMO with rank-2 transmission

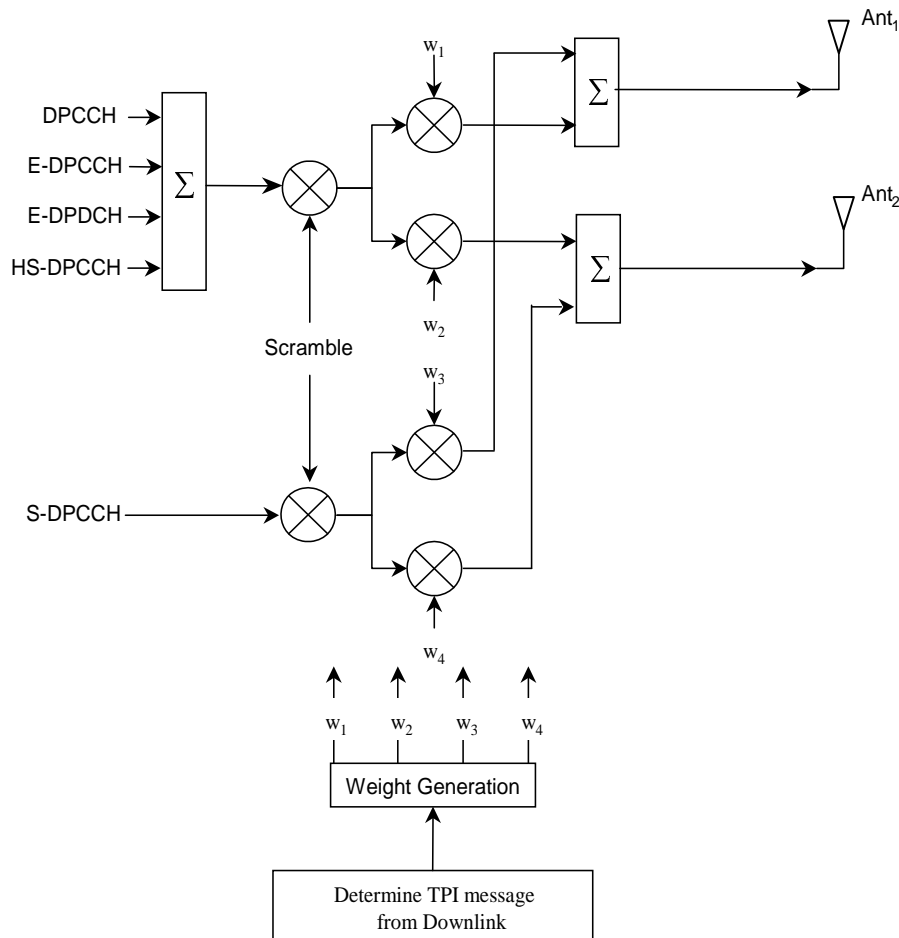

Figure 10: Pre-coded physical channel structure of UL MIMO with rank-1 transmission

11.1 General procedure

The UE transmits two orthogonal pilot signals on DPCCH and S-DPCCH. Node B estimates the preferred rank, precoding vector and S-ETFC Offset of the two streams from the received pilot signals. The Node B transmits the preferred precoding vector to the UE in the form of TPI bits using the F-TPICH as in UL CLTD. The UE applies TPI as with UL CLTD. The preferred rank and S-ETFC Offset to be applied by the UE E-TFC selection are signalled to the UE using the E-ROCH channel.

Rank-1 transmissions occur if the maximum rank signalled over the E-ROCH is 1, or if the UE does not have sufficient data or power headroom to transmit at least the *Minimum E-TFCI for Rank 2 transmission* sized transport blocks on both streams. *Minimum E-TFCI for Rank 2 transmission* is configured by higher layers.

The signal after spreading is fed to both TX antenna branches and weighted with pre-coding weights w_1 , w_2 , w_3 and w_4 . The same pre-coding weights, w_1 and w_2 are always applied to DPCCH, E-DPCCH, E-DPDCH, HS-DPCCH and S-E-DPCCH. The S-DPCCH and S-E-DPDCH are pre-coded with pre-coding weights w_3 and w_4 .

11.2 Downlink TPI transmission and control timing

When uplink MIMO is configured, downlink TPI transmission and control timing follows that defined for UL CLTD as defined in section 10.2.

11.3 Combining TPI bits from radio links of the serving radio link set

When uplink MIMO is configured, combining TPI bits follows that defined for UL CLTD as defined in section 10.3.

11.4 Operation during discontinuous uplink DPCCH operation

When uplink MIMO is configured, operation during discontinuous uplink DPCCH operation follows that defined for UL CLTD as defined in section 10.4.

11.5 Operation during compressed mode

When uplink MIMO is configured, operation during compressed mode follows that defined for UL CLTD as defined in section 10.5.

11.6 HS-SCCH orders

When uplink MIMO is configured, the HS-SCCH orders as defined for UL CLTD operation in section 10.6 apply.

11.7 Uplink power control

When uplink MIMO is configured, the inner loop power control operates without modifications as defined for non-MIMO operation.

12 MIMO operation of HS-DSCH with four transmit antennas

This section applies only when a UE is configured in MIMO mode with four transmit antennas.

The general transmitter structure to support MIMO operation of HS-PDSCH transmission with four transmit antennas is shown in Figure 11. For each transport block channel coding, interleaving, spreading and scrambling are done as in non-MIMO mode. Symbol level interleaving between symbols modulated from the primary and the fourth transport blocks is applied. Similarly, symbol level interleaving between symbols modulated from the second and the third transport block. The detailed operation for symbol level interleaving is described in section 12.2. The Node B scheduler can decide to transmit one or two or three or four transport blocks to a UE in one TTI in the serving HS-DSCH cell. The spread complex valued signals are fed to all TX antenna branches, and weighted with precoding weights w_{mn} , where $m = 0, 1, 2, 3$, and $n = 0$ to number of transport blocks decided. The precoding weights w_{mn} is the m^{th} row and n^{th} column of the precoding matrix $W_n^{\{s\}}$ defined in Table 14B.7 of [2]. The Node B can dynamically schedule the UE with one or two or three or four transport blocks.

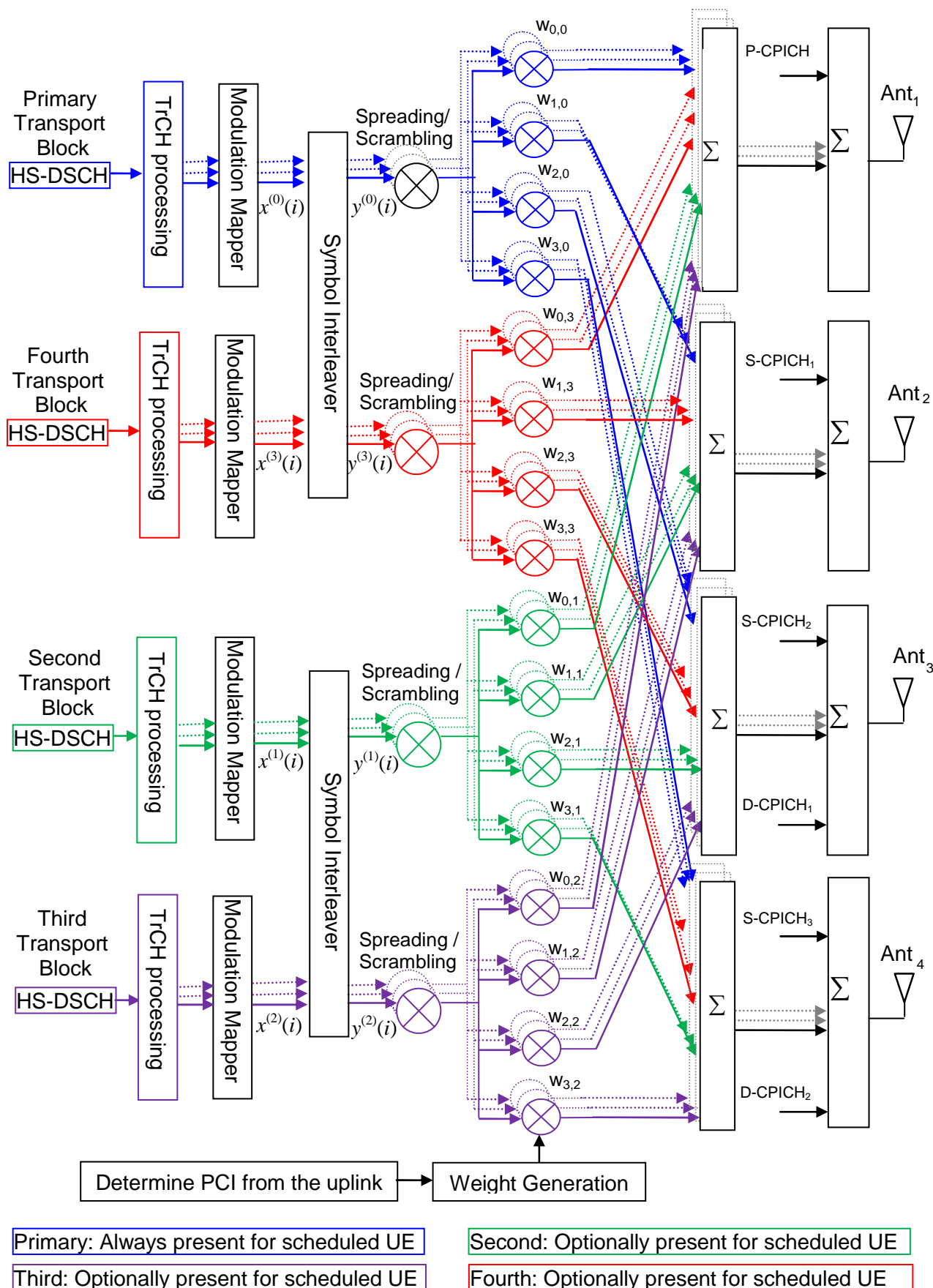

Figure 11: The generic downlink transmitter structure to support MIMO mode with four transmit antennas operation for HS-PDSCH transmission.

12.1 General procedure

The UE uses the CPICH to separately estimate the channels seen from each antenna. One of the antennas will transmit the Antenna 1 modulation pattern of the P-CPICH as defined in subclause 5.3.3.1 of [1]. The other antennas will transmit the Antenna 1 modulation pattern of a S-CPICH. If D-CPICHs are activated, the Antenna 3 and Antenna 4 will transmit the Antenna 1 modulation pattern of a D-CPICH within TTIs in which the HS-PDSCH is scheduled for a UE configured for MIMO mode with 4 transmit antennas. If D-CPICHs are activated, in addition to P-CPICH and S-CPICHs, the UE uses the D-CPICHs as additional phase references on antenna 3 and antenna 4 to estimate the channels for the HS-PDSCH demodulation. The Pilot configuration in support of MIMO mode with four transmit antennas operation of HS-DSCH in the cell is signalled by higher layers.

The UE determines number of transport block preferred a preferred precoding matrix and signals it to the Node B. The signalled information about the number of transport block preferred (NTBP) also called rank information (RI), preferred precoding matrix is termed precoding control indication (PCI) and is defined in subclause 6A.4.2. The PCI is signalled to the Node B together with channel quality indication (CQI) and number of transport block preferred (NTBP) as a composite NTBP/PCI/CQI report according to the procedure defined in subclause 6A.1.2.3. The UE transmits the composite NTBP/PCI/CQI report to the Node B using the CQI field on the HS-DPCCH as defined in [1]. Based on the composite NTBP/PCI/CQI reports, the Node B scheduler decides whether to schedule one, two, three or four transport blocks in a cell to a UE in one TTI and what transport block size(s) and modulation scheme(s) to use for each of them.

The Node B signals to the UE the transport blocks scheduled, the precoding weights applied on the HS-PDSCH sub-frame using the precoding weight indication bits of part 1 of the corresponding HS-SCCH sub-frame. The precoding weight adjustment of each HS-PDSCH is done at the HS-PDSCH sub-frame border. For an UE with dual stream capability the Node B should not schedule more than two transport blocks.

12.2 Symbol level interleaving

Symbol level interleaving is applied between symbols modulated from the second and the third transport block when the Node B schedules three transport blocks. Symbol level interleaving is applied between symbols modulated from the primary and the fourth transport blocks, similarly between symbols modulated from the second and the third transport block when the Node B schedules four transport blocks. Table 11 shows the operation of symbol level interleaving, where $x^{(p)}(i)$ and $y^{(p)}(i)$, $p = 0,1,2$ and 3 are the symbol interleaver input and output symbols respectively.

Table 11: Operation of symbol level interleaving

Number of transport blocks	Symbol level interleaving output
1	$y^{(0)}(i) = x^{(0)}(i)$
2	$y^{(0)}(i) = x^{(0)}(i)$ $y^{(1)}(i) = x^{(1)}(i)$
3	$y^{(0)}(i) = x^{(0)}(i)$ $y^{(1)}(i) = \begin{cases} x^{(1)}(i), & i \text{ is odd} \\ x^{(2)}(i), & i \text{ is even} \end{cases}$ $y^{(2)}(i) = \begin{cases} x^{(2)}(i), & i \text{ is odd} \\ x^{(1)}(i), & i \text{ is even} \end{cases}$
4	$y^{(0)}(i) = \begin{cases} x^{(0)}(i), & i \text{ is odd} \\ x^{(3)}(i), & i \text{ is even} \end{cases}$

	$y^{(3)}(i) = \begin{cases} x^{(3)}(i), & i \text{ is odd} \\ x^{(0)}(i), & i \text{ is even} \end{cases}$
	$y^{(1)}(i) = \begin{cases} x^{(1)}(i), & i \text{ is odd} \\ x^{(2)}(i), & i \text{ is even} \end{cases}$
	$y^{(2)}(i) = \begin{cases} x^{(2)}(i), & i \text{ is odd} \\ x^{(1)}(i), & i \text{ is even} \end{cases}$

12.3 Retransmission Procedures

If the Node B schedules three transport blocks in any transmission, for retransmissions the second transport block and the third transport block are re-transmitted with the same HARQ process identifier as defined in [2]. If the Node B schedules four transport blocks in any transmission, for retransmissions the primary transport block and the fourth transport blocks are re-transmitted with the same HARQ process identifier as defined in [2], retransmissions the second transport block and the third transport block are re-transmitted with the same HARQ process identifier as defined in [2].

- If the Node B schedules two or three transport blocks, the transport block size information of the primary transport block is set to "111111" and if X_{rvpb} is set to 0, then the primary transport block is not transmitted.
- If the Node B schedules two transport blocks, the transport block size information of the second transport block is set to "111111" and if X_{rvsb} is set to 0, then the second transport block is not transmitted.
- If the Node B schedules three or four transport blocks, the transport block size information of the second and the third transport block is set to "111111" and if X_{rvsb} is set to 0, then the second and the third transport block are not transmitted.
- If the Node B schedules four transport blocks, the transport block size information of the primary transport block and fourth transport block is set to "111111" and if X_{rvpb} is set to 0, then the primary and the fourth transport block are not transmitted.
- When the number of transport blocks is equal to 2 or 3, $X_{rvpb} = 0$ and if the transport block size information of the primary transport block is equal to "111111" the UE shall discard the received data on the primary transport block, should assume that the primary transport block had been successfully decoded and generate a positive acknowledgement for the primary transport block in this HARQ process. Node B should assume positive acknowledgement has been received for this HARQ process.
- When the number of transport blocks is equal to 2, $X_{rvsb} = 0$ and if the transport block size information of the second transport block is equal to "111111" the UE shall discard the received data on the second transport block, should assume that the second transport block had been successfully decoded and generate a positive acknowledgement for the second transport block in this HARQ process. Node B should assume positive acknowledgement has been received for this HARQ process.
- When the number of transport blocks is equal to 3 or 4, $X_{rvsb} = 0$ and if the transport block size information of the second and the third transport block is equal to "111111" the UE shall discard the received data on the second and the third transport blocks, should assume that the second and the third transport blocks had been successfully decoded and generate a positive acknowledgement for the second and the third transport blocks in this HARQ process. Node B should assume positive acknowledgement has been received for this HARQ process.
- When the number of transport blocks is equal to 4, $X_{rvpb} = 0$ and if the transport block size information of the primary and the fourth transport block is equal to "111111" the UE shall discard the received data on the primary and the fourth transport blocks, should assume that the primary and the fourth transport blocks had been successfully decoded and generate a positive acknowledgement for the primary and the fourth transport blocks in this HARQ process. Node B should assume positive acknowledgement has been received for this HARQ process.

12.4 Precoding weight restriction

A UE is restricted to report PCI, and NTBP within a precoder codebook subset specified by a bitmap parameter *PrecodingWeightRestriction* configured by higher layer signalling. The bitmap can specify all possible precoder codebook subsets from which the UE can assume the Node B may be using when the UE is configured in MIMO mode

with four transmit antennas. The bitmap forms the bit sequence $a_{63}, \dots, a_3, a_2, a_1, a_0$ where a_0 is the LSB and a_{63} is the MSB and where a bit value of zero indicates that the precoding indices reporting is not allowed in the NTBP/PCI/CQI report.

12.5 HS-SCCH Orders

The Node B may activate or deactivate D-CPICH on 3rd and 4th antennas through HS-SCCH orders as described in [2].

The UE can assume the initial activation status of D-CPICH as set by the network through RRC signalling.

Annex A (informative): (no title)

A.1 Antenna verification

In closed loop mode 1, if channel estimates are taken from the Primary CPICH, the performance will also suffer if the UE cannot detect errors since the channel estimates will be taken for the incorrect phase settings. To mitigate this problem, antenna verification can be done, which can make use of antenna specific pilot patterns of the dedicated physical channel. The antenna verification can be implemented with several different algorithms. A straightforward algorithm can use a 4-hypothesis test per slot. Alternatively, a simplified beam former verification (SBV) requiring only a 2-hypothesis test per slot can be used.

Consider

$$2 \sum_{i=1}^{N_{path}} \frac{1}{\sigma_i^2} \left\{ \sqrt{2} \operatorname{Re}(\gamma h_{2,i}^{(d)} h_{2,i}^{(p)*}) \right\} > \ln \left(\frac{\bar{P}(\phi_{Rx} = \pi)}{\bar{P}(\phi_{Rx} = 0)} \right)$$

Then define the variable x_0 as 0 if the above inequality holds good and $x_0 = \pi$ otherwise.

Similarly consider

$$-2 \sum_{i=1}^{N_{path}} \frac{1}{\sigma_i^2} \left\{ \sqrt{2} \operatorname{Im}(\gamma h_{2,i}^{(d)} h_{2,i}^{(p)*}) \right\} > \ln \left(\frac{\bar{P}(\phi_{Rx} = \pi/2)}{\bar{P}(\phi_{Rx} = -\pi/2)} \right)$$

then define the variable x_1 as $-\pi/2$ if the above inequality holds good and $x_1 = \pi/2$ otherwise.

Whether x_0 or x_1 is to be calculated for each slot is given by the following table, where the first row contains the UL slot index of the feedback bit to be verified.

UL	0	1	2	3	4	5	6	7	8	9	10	11	12	13	14
	x_0	x_1	x_0	x_1	x_0	x_1	x_0	x_1	x_0	x_1	x_0	x_1	x_0	x_1	x_0

The estimate for the transmitted phase is now obtained from

$$\sin(\phi_{Tx}) + j \cos(\phi_{Tx}) = \frac{\sum_{i=0}^1 \sin(x_i)}{\sqrt{2}} + j \frac{\sum_{i=0}^1 \cos(x_i)}{\sqrt{2}}$$

where:

- the x_i values are used corresponding to the current slot and the previous slot taking into account the end-of-frame adjustment and the used CL timing adjustment delay
- $h_{2,i}^{(p)}$ is the i 'th estimated channel tap of antenna 2 using the CPICH;
- $h_{2,i}^{(d)}$ is the i 'th estimated channel tap of antenna 2 using the DPCCCH;
- γ^2 is the DPCH Pilot SNIR/ CPICH SNIR;
- σ_i^2 is the noise plus interference power on the i 'th path.

In normal operation the *a priori* probability for selected pilot pattern is assumed to be 96% (assuming there are 4% of errors in the feedback channel for power control and antenna selection).

A.2 Computation of feedback information for closed loop mode 1 transmit diversity

In non-soft handover case, the computation of feedback information can be accomplished by e.g. solving for weight vector, \underline{w} , that maximises.

$$P = \underline{w}^H H^H H \underline{w} \quad (1)$$

where

$$H = [\underline{h}_1 \quad \underline{h}_2] \text{ and } \underline{w} = [w_1, w_2]^T$$

and where the column vectors \underline{h}_1 and \underline{h}_2 represent the estimated channel impulse responses for the transmission antennas 1 and 2, of length equal to the length of the channel impulse response. The elements of \underline{w} correspond to the adjustments computed by the UE.

During soft handover, the antenna weight vector, \underline{w} can be, for example, determined so as to maximise the criteria function:

$$P = \underline{w}^H (H_1^H H_1 + H_2^H H_2 + \dots) \underline{w} \quad (2)$$

where H_i is an estimated channel impulse response for BS#i. In regular SHO, the set of BS#i corresponds to the active set.

If HS-PDSCH is present, the UE may emphasize the HS-PDSCH serving cell. In this case the antenna weight vector, \underline{w} can be, for example, determined so as to maximise the criteria function:

$$P = \underline{w}^H (\alpha (H_1^H H_1) + (1-\alpha)(H_2^H H_2 + \dots)) \underline{w}$$

where BS#1 is the HS-PDSCH serving cell and coefficient α is less than or equal to 1. For example $\alpha = 0.7$ enhances HS-DSCH performance while ensuring that there is only a small degradation on the DPCH.

Annex B (Informative): Power control

B.1 Downlink power control timing

The power control timing described in this annex should be seen as an example on how the control bits have to be placed in order to permit a short TPC delay.

In order to maximise the cell radius distance within which one-slot control delay is achieved, the frame timing of an uplink DPCH is delayed by 1024 chips from that of the corresponding downlink DPCH measured at the UE antenna.

Responding to a downlink TPC command, the UE shall change its uplink DPCH output power at the beginning of the first uplink pilot field after the TPC command reception. Responding to an uplink TPC command, the UTRAN access point shall change its DPCH output power at the beginning of the next downlink pilot field after the reception of the whole TPC command. Note that in soft handover, the TPC command is sent over one slot when DPC_MODE is 0 and over three slots when DPC_MODE is 1. Note also that the delay from the uplink TPC command reception to the power change timing is not specified for UTRAN. The UE shall decide and send TPC commands on the uplink based on the downlink SIR measurement. For the DPCH, the TPC command field on the uplink starts, when measured at the UE antenna, 512 chips after the end of the downlink pilot field. The UTRAN access point shall decide and send TPC commands based on the uplink SIR measurement. However, the SIR measurement periods are not specified either for UE nor UTRAN.

Figure B.1 illustrates an example of transmitter power control timings when a DPCH is configured on the downlink.

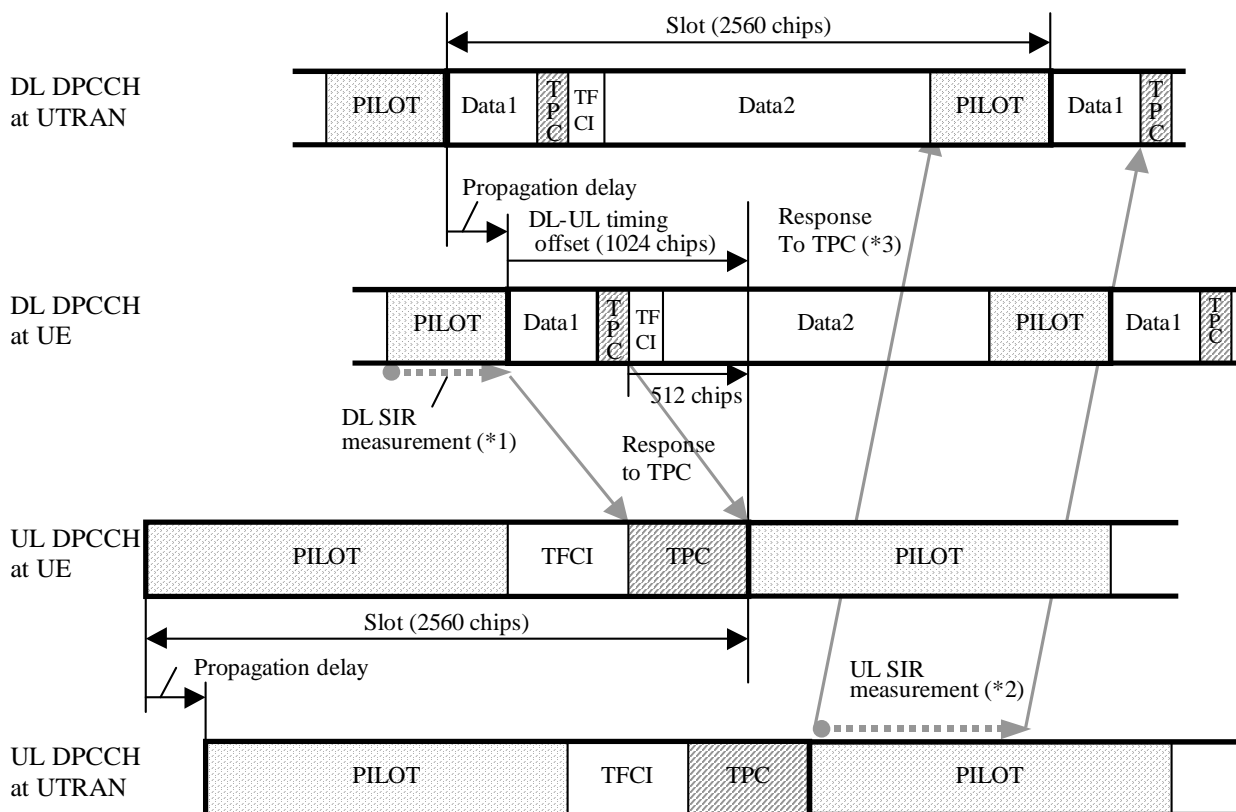

*1,2 The SIR measurement periods illustrated here are examples. Other ways of measurement are allowed to achieve accurate SIR estimation.

*3 If there is not enough time for UTRAN to respond to the TPC, the action can be delayed until the next slot.

Figure B.1: Transmitter power control timing for DPCH

Figure B.2 illustrates an example of transmitter power control timings when the F-DPCH is configured on the downlink and the F-DPCH TPC offset N_{OFF1} of all the radio links in the RLS is 0 or 2(see Table 16C of [1]). Figure B.2a illustrates an example of transmitter power control timings for the radio link whose F-DPCH TPC offset $N_{OFF1} = 0$ or 2, when the F-DPCH is configured on the downlink, and the F-DPCH TPC offset N_{OFF1} of at least one other radio link in the RLS is > 2 . Figure B.3 illustrates an example of transmitter power control timings when the F-DPCH is configured on the downlink and the F-DPCH TPC offset N_{OFF1} of the radio link is larger than 2. Figure B.4 illustrates an example of transmitter power control timings when the F-DPCH is configured on the downlink and the F-DPCH TPC offset N_{OFF1} of the radio link is larger than 14 when uplink DPCCH slot format #4 is used.

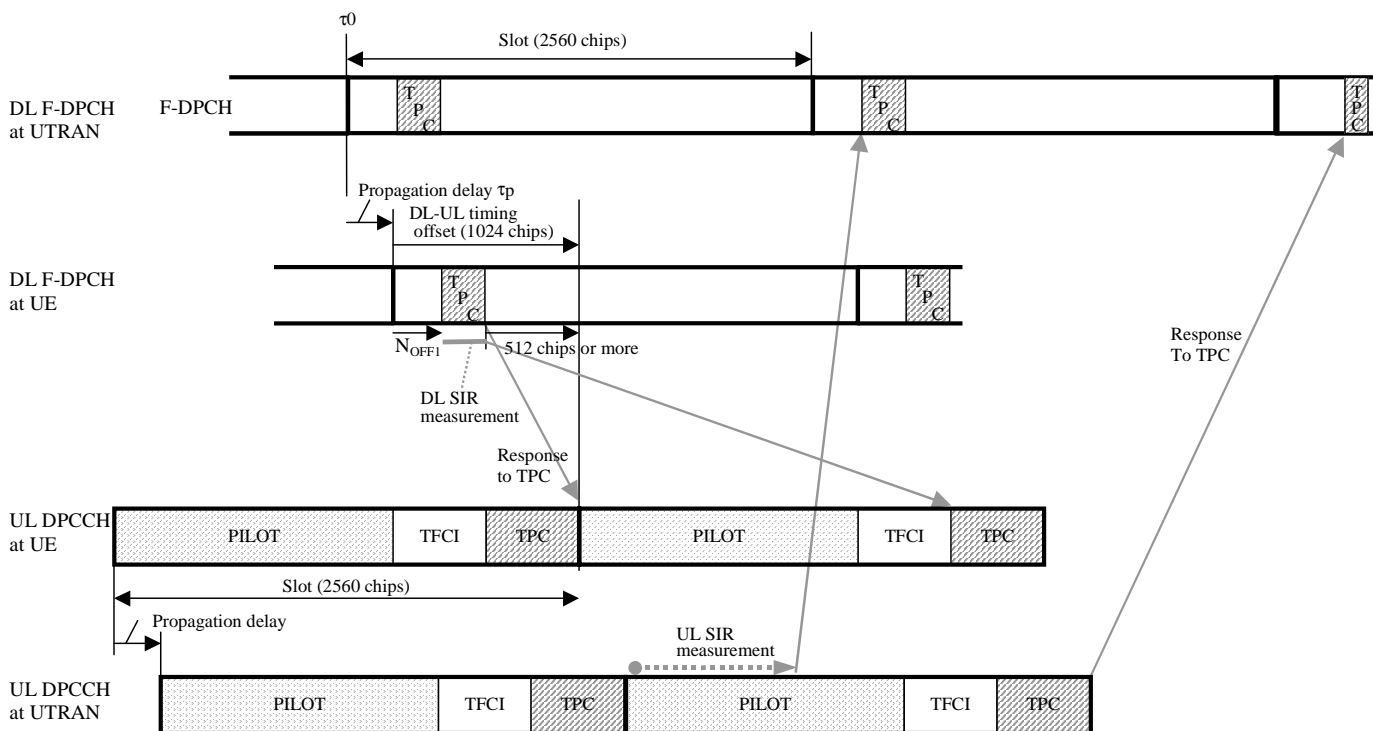

Figure B.2: Transmitter power control timing for F-DPCH with TPC offsets N_{OFF1} of 0 or 2 when F-DPCH TPC offset N_{OFF1} of all the radio links in the RLS is 0 or 2

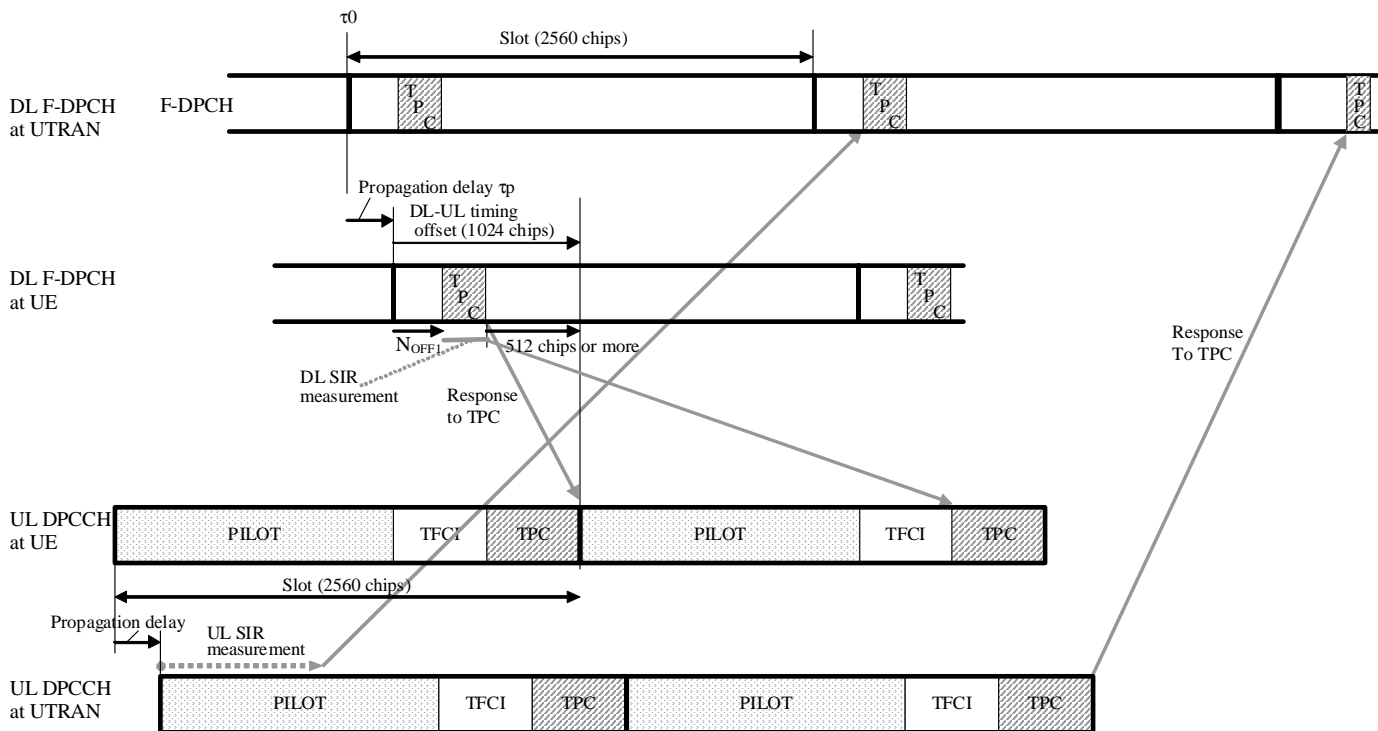

Figure B.2a: Transmitter power control timing for F-DPCH with TPC offsets N_{OFF1} of 0 or 2 when the F-DPCH TPC offset N_{OFF1} of at least one other radio link in the RLS is > 2

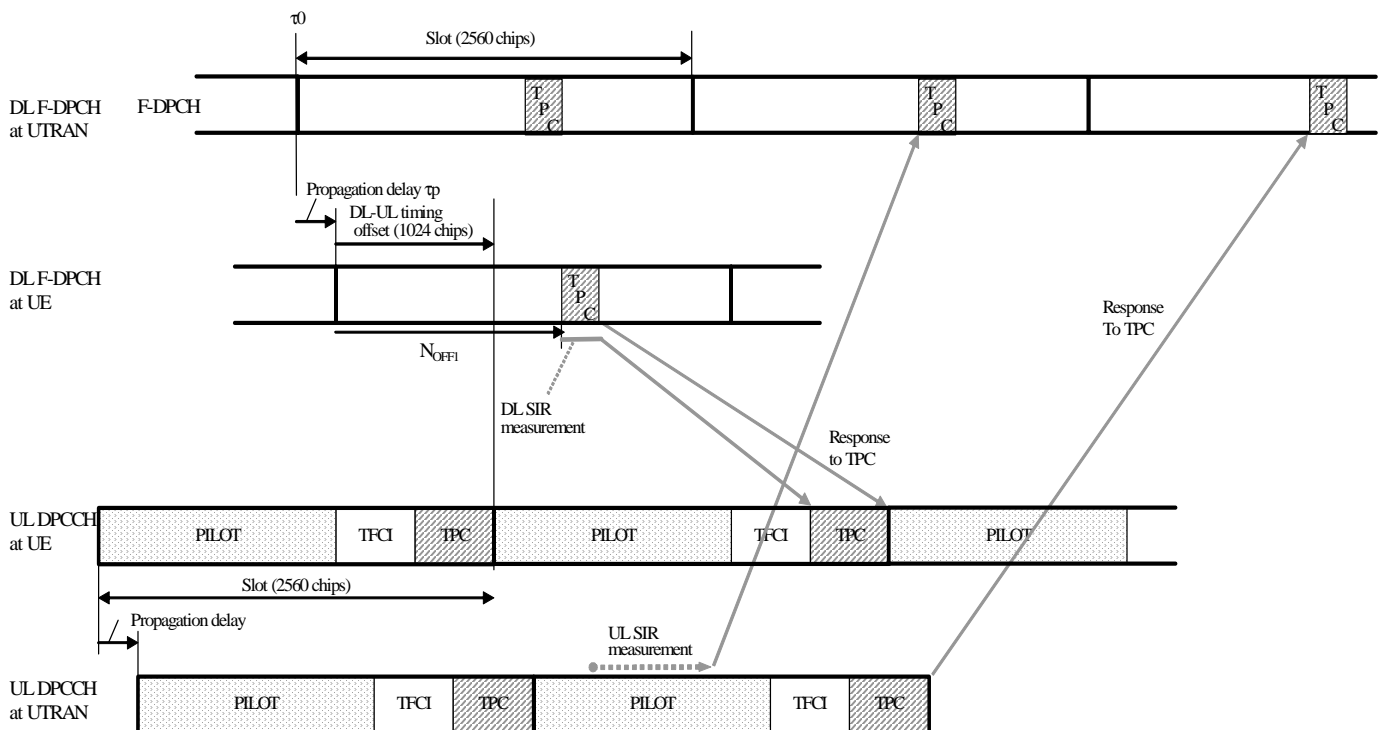

Figure B.3: Transmitter power control timing for F-DPCH with a TPC offset N_{OFF1} larger than 2

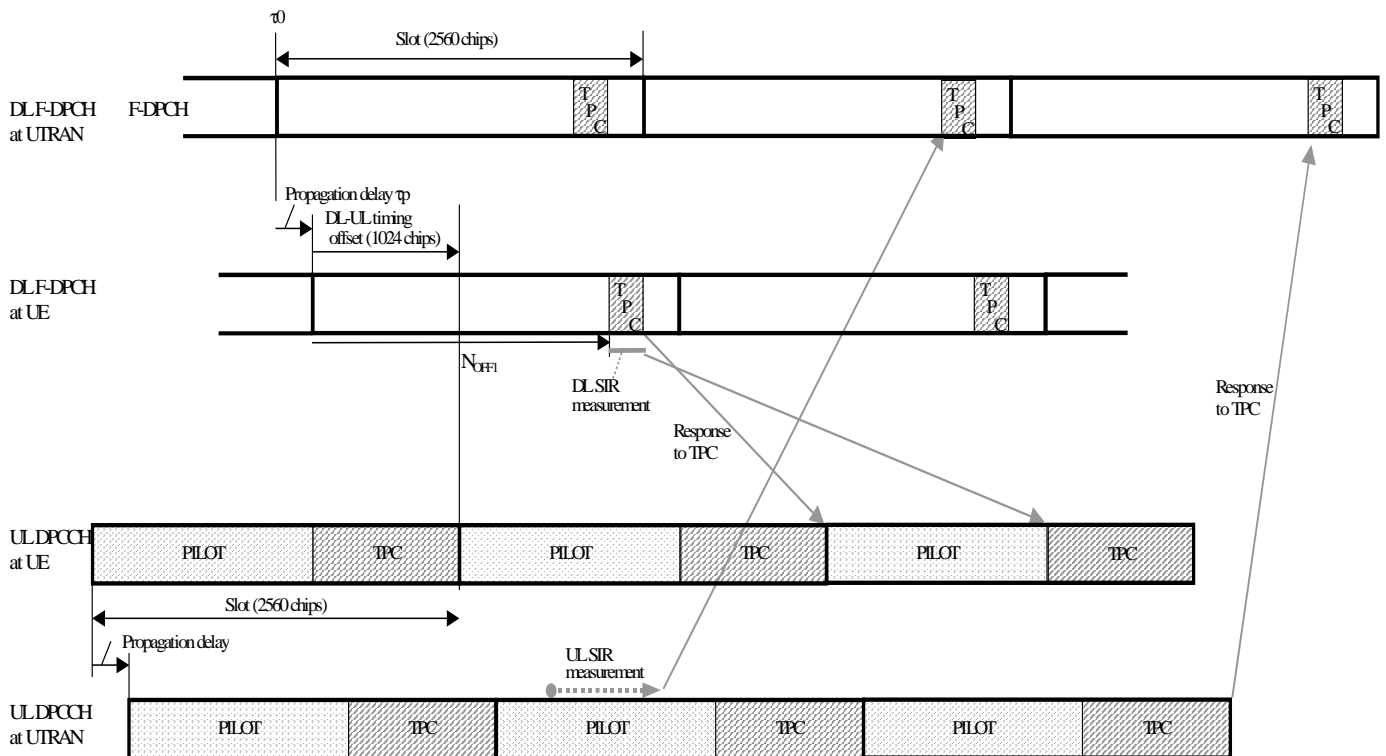

Figure B.4: Transmitter power control timing for F-DPCH with a TPC offset N_{OFF1} larger than 14 with uplink DPCCH slot format #4

B.2 Example of implementation in the UE

The downlink inner-loop power control adjusts the network transmit power in order to keep the received downlink SIR at a given SIR target, SIR_{target} . A higher layer outer loop adjusts SIR_{target} independently for each connection.

The UE should estimate the received downlink DPCCH/DPDCH power of the connection to be power controlled. Simultaneously, the UE should estimate the received interference and calculate the signal-to-interference ratio, SIR_{est} . SIR_{est} can be calculated as $RSCP/ISCP$, where RSCP refers to the received signal code power on one code and ISCP refers to the non-orthogonal interference signal code power of the received signal on one code. Note that due to the specific SIR target offsets described in [5] that can be applied during compressed frames, the spreading factor shall not be considered in the calculation of SIR_{est} .

The obtained SIR estimate SIR_{est} is then used by the UE to generate TPC commands according to the following rule: if $SIR_{est} > SIR_{target}$ then the TPC command to transmit is "0", requesting a transmit power decrease, while if $SIR_{est} < SIR_{target}$ then the TPC command to transmit is "1", requesting a transmit power increase.

When the UE is in soft handover, the UE should estimate SIR_{est} from the downlink signals of all cells in the active set.

B.3 UL power control when losing UL synchronisation

Each Node B operates the uplink power control independently of the other Node Bs that may be providing RLS to the same UE. In case of multiple RLS the UE derives the decision on power adjustment based on all the commands received according the rules specified in section 5.1.2. In this scenario, transmission of a down command by one or more of the involved Node Bs will likely result in the UE decreasing its transmit power.

Consequently, if and when, after successful initial RL synchronisation, the Node B loses UL synchronisation for a UE and if the current number of RLS configured for that UE is greater than one and if the Node B reverts to a TPC pattern in such situation (i.e. generates DL TPC commands independently of actual RL measurements), the Node B should not use TPC commands '0' in the TPC pattern.

Annex C (Informative): Cell search procedure

During the cell search, the UE searches for a cell and determines the downlink scrambling code and frame synchronisation of that cell. The cell search is typically carried out in three steps:

Step 1: Slot synchronisation

During the first step of the cell search procedure the UE uses the SCH's primary synchronisation code to acquire slot synchronisation to a cell. This is typically done with a single matched filter (or any similar device) matched to the primary synchronisation code which is common to all cells. The slot timing of the cell can be obtained by detecting peaks in the matched filter output.

Step 2: Frame synchronisation and code-group identification

During the second step of the cell search procedure, the UE uses the SCH's secondary synchronisation code to find frame synchronisation and identify the code group of the cell found in the first step. This is done by correlating the received signal with all possible secondary synchronisation code sequences, and identifying the maximum correlation value. Since the cyclic shifts of the sequences are unique the code group as well as the frame synchronisation is determined.

Step 3: Scrambling-code identification

During the third and last step of the cell search procedure, the UE determines the exact primary scrambling code used by the found cell. The primary scrambling code is typically identified through symbol-by-symbol correlation over the CPICH with all codes within the code group identified in the second step. After the primary scrambling code has been identified, the Primary CCPCH can be detected. And the system- and cell specific BCH information can be read.

If the UE has received information about which scrambling codes to search for, steps 2 and 3 above can be simplified.

Annex D (Informative): F-TPICH Transmission

The F-TPICH transmission timing described in this annex should be seen as an example on how the TPI bits have to be placed in order to ensure a short TPI delay.

In response to the reception of the TPI bits on the F-TPICH channel, the UE shall apply the precoding weights indicated by the TPI bits at the first UL DPCH slot that is transmitted at least 512 bits after the reception of the last of the two TPI symbols. The reliability of the received TPI bit is determined by the UE based on the downlink SIR measurement on the F-TPICH channel.

Figure D.1 illustrates an example of F-TPICH timing for UL CLTD operation when the F-TPICH frame starts 512 chips after the start of the DPCH/F-DPCH frame.

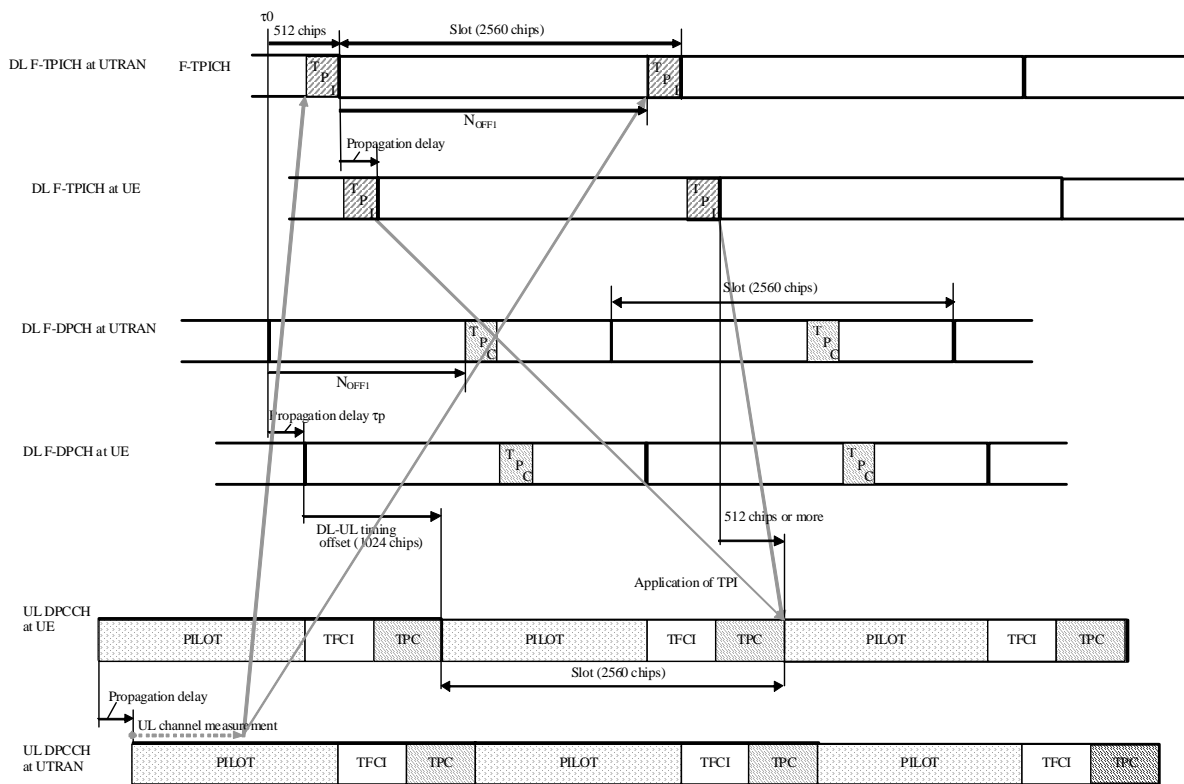

Figure D.1: F-TPICH Transmission timing for UL CLTD when F-TPICH frame starts 512 chips after the start of DPCH/F-DPCH frame

Annex E (informative): Change history

Change history							
Date	TSG #	TSG Doc.	CR	Rev	Subject/Comment	Old	New
	RAN_05	RP-99531	-		Approved at TSG RAN #5 and placed under Change Control	-	3.0.0
14/01/00	RAN_06	RP-99686	003	2	Flexible timing of UTRAN response to uplink closed loop Tx diversity feedback commands	3.0.0	3.1.0
14/01/00	RAN_06	RP-99686	006	2	CPCH power control preamble length	3.0.0	3.1.0
14/01/00	RAN_06	RP-99686	007	-	Removal of open loop power control	3.0.0	3.1.0
14/01/00	RAN_06	RP-99687	008	-	Power offset of AICH and PICH	3.0.0	3.1.0
14/01/00	RAN_06	RP-99686	009	1	Update of Random Access Procedure	3.0.0	3.1.0
14/01/00	RAN_06	RP-99686	010	1	oft symbol combining for uplink power control	3.0.0	3.1.0
14/01/00	RAN_06	RP-99685	011	-	Clarification of closed loop transmit diversity figure in clause 8 and closed loop operation in compressed mode for mode 2 in subclause 8.3 of TS 25.214	3.0.0	3.1.0
14/01/00	RAN_06	RP-99686	012	-	Uplink power control maximum TX power	3.0.0	3.1.0
14/01/00	RAN_06	RP-99686	013	1	Setting of beta values for multi-code	3.0.0	3.1.0
14/01/00	RAN_06	RP-99686	014	-	Consolidation of CPCH Power Control Preamble Information	3.0.0	3.1.0
14/01/00	RAN_06	RP-99686	015	1	Consolidation of Power Control Information for DCH Initialisation	3.0.0	3.1.0
14/01/00	RAN_06	RP-99686	016	-	Uplink power control in compressed mode	3.0.0	3.1.0
14/01/00	RAN_06	RP-99686	018	1	Timing for initialisation procedures	3.0.0	3.1.0
14/01/00	RAN_06	RP-99687	021	-	20 ms RACH message length	3.0.0	3.1.0
14/01/00	RAN_06	RP-99684	023	1	Maximum Tx Power at uplink compressed Mode	3.0.0	3.1.0
14/01/00	RAN_06	RP-99687	024	2	Setting of power in uplink compressed mode	3.0.0	3.1.0
14/01/00	RAN_06	RP-99687	025	-	Cleanup of synchronisation procedures	3.0.0	3.1.0
14/01/00	RAN_06	RP-99686	026	2	Downlink power control	3.0.0	3.1.0
14/01/00	RAN_06	RP-99687	029	-	Out-of-synch handling	3.0.0	3.1.0
14/01/00	RAN_06	RP-99687	030	2	State update rule addition to SSDT specification	3.0.0	3.1.0
14/01/00	RAN_06	RP-99687	033	-	Uplink TX timing adjustment	3.0.0	3.1.0
14/01/00	RAN_06	RP-99687	036	-	Inclusion of idle periods for the IPDL LCS	3.0.0	3.1.0
14/01/00	RAN_06	RP-99686	041	-	Revision of power control timing text	3.0.0	3.1.0
14/01/00	RAN_06	RP-99687	042	1	Inclusion of adjustment loop in downlink power control	3.0.0	3.1.0
14/01/00	-	-	-	-	Change history was added by the editor	3.1.0	3.1.1
31/03/00	RAN_07	RP-000064	043	1	Optimum ID Codes for SSDT Power Control	3.1.1	3.2.0
31/03/00	RAN_07	RP-000064	044	-	Editorial clarification to subclause 5.1.2.2.2	3.1.1	3.2.0
31/03/00	RAN_07	RP-000064	047	1	Additional description of TX diversity for PDSCH	3.1.1	3.2.0
31/03/00	RAN_07	RP-000064	048	-	Power offset on S-CCPCH	3.1.1	3.2.0
31/03/00	RAN_07	RP-000064	050	2	Corrections to uplink power control	3.1.1	3.2.0
31/03/00	RAN_07	RP-000064	055	-	Correction of Adjustment loop description	3.1.1	3.2.0
31/03/00	RAN_07	RP-000064	056	1	Clarification of TPC command combining for Algorithm 1	3.1.1	3.2.0
31/03/00	RAN_07	RP-000064	057	-	Clarification of TPC command combining for Algorithm 2	3.1.1	3.2.0
31/03/00	RAN_07	RP-000064	059	2	CPCH:CD subslot-related additions to 6.2	3.1.1	3.2.0
31/03/00	RAN_07	RP-000064	061	1	CPCH: editorial changes and clarifications of 6.2	3.1.1	3.2.0
31/03/00	RAN_07	RP-000064	062	-	Editorial corrections	3.1.1	3.2.0
31/03/00	RAN_07	RP-000064	064	1	Editorial improvement of the IPDL section	3.1.1	3.2.0
31/03/00	RAN_07	RP-000064	065	1	PRACH power offset definition	3.1.1	3.2.0
31/03/00	RAN_07	RP-000064	066	1	Radio link synchronisation in UTRA/FDD	3.1.1	3.2.0
31/03/00	RAN_07	RP-000064	068	-	Definition for maximum and minimum DL power	3.1.1	3.2.0
31/03/00	RAN_07	RP-000064	069	4	Channel assignment and UE channel selection methods of CPCH	3.1.1	3.2.0
31/03/00	RAN_07	RP-000064	071	-	Channelization code allocation method for PCPCH message part	3.1.1	3.2.0
31/03/00	RAN_07	RP-000064	072	1	Limited power raise used -parameter in DL PC	3.1.1	3.2.0
31/03/00	RAN_07	RP-000064	080	-	Downlink power control	3.1.1	3.2.0
31/03/00	RAN_07	RP-000064	081	-	Editorial improvement on SSDT power control section	3.1.1	3.2.0
31/03/00	RAN_07	RP-000065	082	2	Emergency Stop of CPCH transmission and Start of Message Indicator	3.1.1	3.2.0
31/03/00	RAN_07	RP-000065	083	-	Clean up of USTS related specifications	3.1.1	3.2.0
26/06/00	RAN_08	RP-000268	084	-	Addition of CSICH power parameter	3.2.0	3.3.0
26/06/00	RAN_08	RP-000268	085	-	Correction to power control in compressed mode recovery period	3.2.0	3.3.0
26/06/00	RAN_08	RP-000268	086	1	Revisions to power control for CPCH	3.2.0	3.3.0
26/06/00	RAN_08	RP-000268	087	-	Corrections to uplink DCH power control sections	3.2.0	3.3.0
26/06/00	RAN_08	RP-000268	090	3	Level of specification of downlink power control	3.2.0	3.3.0
26/06/00	RAN_08	RP-000268	091	1	Clarification of TX diversity power setting	3.2.0	3.3.0
26/06/00	RAN_08	RP-000268	092	-	PICH undefined bits	3.2.0	3.3.0
26/06/00	RAN_08	RP-000268	095	1	DPDCH/DPCCH gain factors	3.2.0	3.3.0
26/06/00	RAN_08	RP-000268	096	3	Correction to RACH subchannel definition	3.2.0	3.3.0
26/06/00	RAN_08	RP-000268	097	1	The power setting of the CCC field of DL DPCCH for CPCH	3.2.0	3.3.0
26/06/00	RAN_08	RP-000268	098	4	Procedure for end of transmission indicator in CPCH	3.2.0	3.3.0

Change history							
Date	TSG #	TSG Doc.	CR	Rev	Subject/Comment	Old	New
26/06/00	RAN_08	RP-000268	099	-	Downlink inner-loop power control in compressed mode	3.2.0	3.3.0
26/06/00	RAN_08	RP-000268	100	-	Definition of vector transmission weight entity	3.2.0	3.3.0
26/06/00	RAN_08	RP-000268	101	1	Number of slots for DPCCH power control preamble	3.2.0	3.3.0
26/06/00	RAN_08	RP-000268	102	-	Clarification of UTRAN Tx diversity response timing description in 25.214	3.2.0	3.3.0
26/06/00	RAN_08	RP-000268	103	2	Corrections to transmit diversity section	3.2.0	3.3.0
26/06/00	RAN_08	RP-000268	104	1	Corrections to uplink power control in compressed mode	3.2.0	3.3.0
26/06/00	RAN_08	RP-000268	105	-	Clarification of downlink power control mode	3.2.0	3.3.0
26/06/00	RAN_08	RP-000268	106	-	Clarification of radio link set	3.2.0	3.3.0
26/06/00	RAN_08	RP-000268	107	1	Clarification of radio link synchronisation procedure	3.2.0	3.3.0
26/06/00	RAN_08	RP-000269	108	-	Correctly quantized gain factors for uplink compressed mode	3.2.0	3.3.0
23/09/00	RAN_09	RP-000342	110	4	Downlink inner-loop power control in compressed mode	3.3.0	3.4.0
23/09/00	RAN_09	RP-000342	112	-	Adding reference for power offset variation text in TS 25.214	3.3.0	3.4.0
23/09/00	RAN_09	RP-000342	113	-	Combining TPC commands in soft handover	3.3.0	3.4.0
23/09/00	RAN_09	RP-000342	115	1	Corrections to power control	3.3.0	3.4.0
23/09/00	RAN_09	RP-000342	116	-	Corrections to 25.214	3.3.0	3.4.0
23/09/00	RAN_09	RP-000342	117	-	Clarification to downlink power control	3.3.0	3.4.0
23/09/00	RAN_09	RP-000342	118	3	Clarification of power control at maximum and minimum power	3.3.0	3.4.0
23/09/00	RAN_09	RP-000342	119	-	Clarification of SSdT text	3.3.0	3.4.0
23/09/00	RAN_09	RP-000342	120	-	Corrections to CL transmit diversity mode 1	3.3.0	3.4.0
23/09/00	RAN_09	RP-000342	121	1	Clarification of SSdT ID code bit transmission order	3.3.0	3.4.0
23/09/00	RAN_09	RP-000342	122	1	Clarification on RACH and CPCH subchannel definition	3.3.0	3.4.0
23/09/00	RAN_09	RP-000342	123	1	DPCH initialisation procedure	3.3.0	3.4.0
23/09/00	RAN_09	RP-000342	124	-	Clarification of closed loop mode TX diversity initialisation	3.3.0	3.4.0
23/09/00	RAN_09	RP-000342	127	2	Uplink power control in compressed mode	3.3.0	3.4.0
15/12/00	RAN_10	RP-000540	128	1	Clarification of downlink quality measurement in SSdT	3.4.0	3.5.0
15/12/00	RAN_10	RP-000540	129	-	Formula typography and reference corrections	3.4.0	3.5.0
15/12/00	RAN_10	RP-000540	130	1	Radio link establishment and sync status reporting	3.4.0	3.5.0
15/12/00	RAN_10	RP-000540	133	-	Correction of RACH/CPCH physical random access procedure	3.4.0	3.5.0
15/12/00	RAN_10	RP-000540	134	-	Correction of uplink power control algorithm 2	3.4.0	3.5.0
15/12/00	RAN_10	RP-000540	135	1	TPC command generation on downlink during RLS initialization	3.4.0	3.5.0
15/12/00	RAN_10	RP-000540	136	1	Clarification of RACH behavior at maximum and minimum power	3.4.0	3.5.0
15/12/00	RAN_10	RP-000540	137	-	Clarifications on the description of the radio link establishment procedure (when no radio link exists)	3.4.0	3.5.0
15/12/00	RAN_10	RP-000540	138	1	Corrections on power control preambles	3.4.0	3.5.0
15/12/00	RAN_10	RP-000540	139	1	Clarification of RACH procedure	3.4.0	3.5.0
15/12/00	RAN_10	RP-000540	140	-	Uplink power control in compressed mode	3.4.0	3.5.0
15/12/00	RAN_10	RP-000540	141	1	Revision of the abbreviation list	3.4.0	3.5.0
16/03/01	RAN_11	-	-	-	Approved as Release 4 specification (v4.0.0) at TSG RAN #11	3.5.0	4.0.0
16/03/01	RAN_11	RP-010060	142	1	Uplink power control in compressed mode	3.5.0	4.0.0
16/03/01	RAN_11	RP-010060	144	-	Removal of the power balancing algorithm from TS 25.214	3.5.0	4.0.0
16/03/01	RAN_11	RP-010254	145	2	Clarification of Nid parameter – when SSdT and uplink compressed mode are in operation	3.5.0	4.0.0
16/03/01	RAN_11	RP-010060	146	-	Clarification of closed loop transmit diversity mode 1 and mode 2 operation during compressed mode	3.5.0	4.0.0
16/03/01	RAN_11	RP-010060	148	1	Clarification of UE SIR estimation	3.5.0	4.0.0
16/03/01	RAN_11	RP-010060	150	1	Clarification of the order of SSdT signalling in 2 bit FBI	3.5.0	4.0.0
16/03/01	RAN_11	RP-010244	154	2	Uplink power control preamble	3.5.0	4.0.0
16/03/01	RAN_11	RP-010060	155	-	Correction of limited power raise	3.5.0	4.0.0
16/03/01	RAN_11	RP-010060	156	-	Clarification of initialization procedure	3.5.0	4.0.0
16/03/01	RAN_11	RP-010060	158	-	Definition of power control step size for algorithm 2	3.5.0	4.0.0
16/03/01	RAN_11	RP-010060	161	1	Correction of the UE behavior in SSdT mode	3.5.0	4.0.0
16/03/01	RAN_11	RP-010060	163	-	Correction on downlink synchronization primitives	3.5.0	4.0.0
16/03/01	RAN_11	RP-010074	149	1	DSCH Power Control Improvement in soft handover	3.5.0	4.0.0
15/06/01	RAN_12	RP-010334	166	1	Limited power raise: aligning of terminology with TS25.433	4.0.0	4.1.0
15/06/01	RAN_12	RP-010334	167	1	Correction of IPDL burst parameters	4.0.0	4.1.0
15/06/01	RAN_12	RP-010334	169	1	Correction of synchronisation primitives	4.0.0	4.1.0
15/06/01	RAN_12	RP-010334	177	1	Clarification on TPC command generation on downlink during RL initialisation	4.0.0	4.1.0
15/06/01	RAN_12	RP-010482	181	4	Clarification of synchronisation procedures	4.0.0	4.1.0
15/06/01	RAN_12	RP-010334	183	-	Clarification of initialisation of closed loop mode 1 and 2 during compressed mode	4.0.0	4.1.0
15/06/01	RAN_12	RP-010334	186	-	DL maximum power level in compressed mode	4.0.0	4.1.0
15/06/01	RAN_12	RP-010341	164	1	Clarification on the usage of SSdT signaling in uplink	4.0.0	4.1.0
21/09/01	RAN_13	RP-010520	192	-	Corrections and Clarifications for calculation of idle period position in subclause 8.3 in 25.214	4.1.0	4.2.0
21/09/01	RAN_13	RP-010520	194	1	Minor modifications to the CPCH access procedure	4.1.0	4.2.0
21/09/01	RAN_13	RP-010520	197	-	Downlink power control in compressed mode	4.1.0	4.2.0
21/09/01	RAN_13	RP-010520	199	1	Improvements of closed loop TX diversity description	4.1.0	4.2.0
21/09/01	RAN_13	RP-010520	201	1	Correction to Random access procedure (Primitive from MAC)	4.1.0	4.2.0

Change history							
Date	TSG #	TSG Doc.	CR	Rev	Subject/Comment	Old	New
21/09/01	RAN_13	RP-010677	205	1	Proposed CR to TS25.214: Clarification of the SSDD behaviour with beam forming	4.1.0	4.2.0
21/09/01	RAN_13	RP-010527	195	1	Enhanced PDSCH power control clarification	4.1.0	4.2.0
14/12/01	RAN_14	RP-010739	207	1	Power control in compressed mode when DPC_MODE=1	4.2.0	4.3.0
14/12/01	RAN_14	RP-010739	209	-	Clarification of closed loop mode 1 and 2 Tx diversity operation during compressed mode	4.2.0	4.3.0
14/12/01	RAN_14	RP-010739	211	-	Downlink phase reference reconfiguration	4.2.0	4.3.0
14/12/01	RAN_14	RP-010739	219	1	Downlink power control for channels supporting CPCH	4.2.0	4.3.0
14/12/01	RAN_14	RP-010739	223	-	Removal of slow power control from TS 25.214	4.2.0	4.3.0
14/12/01	RAN_14	RP-010775	216	-	Uplink TPC command processing in SHO with SSDD	4.2.0	4.3.0
14/12/01	RAN_14	RP-010744	217	2	DSCH power control clarification	4.2.0	4.3.0
14/12/01	RAN_14	RP-010933	229	-	Restriction to SSDD and closed loop mode transmit diversity combination	4.2.0	4.3.0
08/03/02	RAN_15	RP-020047	227	-	Clarification on DPCCH dedicated pilot bits with closed loop mode1	4.3.0	4.4.0
08/03/02	RAN_15	RP-020261	231	3	Qth threshold parameter in SSDD	4.3.0	4.4.0
08/03/02	RAN_15	RP-020047	240	1	TPC procedure in UE when SSDD is activated	4.3.0	4.4.0
08/03/02	RAN_15	RP-020053	236	1	Clarification of closed loop transmit diversity during soft handover	4.3.0	4.4.0
08/03/02	RAN_15	RP-020054	250	1	Description of SSDD operation for TFCI power control in hard split mode	4.3.0	5.0.0
08/03/02	RAN_15	RP-020058	237	2	Introduction of HSDPA feature to TS25.214	4.3.0	5.0.0
08/03/02	RAN_15	RP-020058	251	-	Introduction of power control aspects for HSDPA feature in TS25.214	4.3.0	5.0.0
07/06/02	RAN_16	RP-020316	255	2	Correction on the operation of HSDPA during compressed mode	5.0.0	5.1.0
07/06/02	RAN_16	RP-020316	259	1	Clarification of UE transmission timing adjustment with HS-DPCCH	5.0.0	5.1.0
07/06/02	RAN_16	RP-020316	260	4	Definition of CQI reporting	5.0.0	5.1.0
07/06/02	RAN_16	RP-020316	266	-	Correction to the setting of DPCCH/HS-DPCCH power difference	5.0.0	5.1.0
07/06/02	RAN_16	RP-020316	267	-	Inclusion of CQI table	5.0.0	5.1.0
07/06/02	RAN_16	RP-020318	265	1	Definition of Qth threshold parameter in SSDD	5.0.0	5.1.0
17/09/02	RAN_17	RP-020584	263	-	Clarification of total HS-SCCH/HS-PDSCH power	5.1.0	5.2.0
17/09/02	RAN_17	RP-020571	272	-	Reversal of unwanted corrections resulting from CR 25.211-122 & CR 25.214-226	5.1.0	5.2.0
17/09/02	RAN_17	RP-020584	273	2	Clarification of total HS-PDSCH power in CQI reporting procedure	5.1.0	5.2.0
17/09/02	RAN_17	RP-020584	274	1	Closed loop transmit diversity mode 2 with antenna verification	5.1.0	5.2.0
17/09/02	RAN_17	RP-020589	279	-	Correction of maximum power adjustment in case of compressed mode	5.1.0	5.2.0
17/09/02	RAN_17	RP-020574	282	1	Enhanced DSCH power control parameter name change	5.1.0	5.2.0
17/09/02	RAN_17	RP-020584	287	2	Correction of CQI definition	5.1.0	5.2.0
17/09/02	RAN_17	RP-020587	288	-	Inclusion of closed loop transmit diversity for HSDPA	5.1.0	5.2.0
17/09/02	RAN_17	RP-020588	289	-	Correction of timing of CQI reporting	5.1.0	5.2.0
17/09/02	RAN_17	RP-020529	294	-	Correction of reference linked to approval of CR 25.133-471	5.1.0	5.2.0
17/09/02	RAN_17	RP-020584	296	-	The clarification of CQI feedback parameter k value	5.1.0	5.2.0
17/09/02	RAN_17	RP-020584	298	-	Clarification of CQI definition and reference period	5.1.0	5.2.0
17/09/02	RAN_17	RP-020584	286	1	Numbering corrections	5.1.0	5.2.0
20/12/02	RAN_18	RP-020847	300	1	Corrections and clarifications to FDD CQI description	5.2.0	5.3.0
20/12/02	RAN_18	RP-020847	301	1	Criterion to determine primary cell for DSCH power control improvement	5.2.0	5.3.0
20/12/02	RAN_18	RP-020851	304	2	Introduction of Transport Block Size signaling procedure reference.	5.2.0	5.3.0
20/12/02	RAN_18	RP-020841	307	-	Clarification of closed loop timing adjustment mode	5.2.0	5.3.0
26/03/03	RAN_19	RP-030136	299	5	CQI reporting with TxD	5.3.0	5.4.0
26/03/03	RAN_19	RP-030136	313	1	On closed loop transmit diversity mode 1 verification algorithm	5.3.0	5.4.0
26/03/03	RAN_19	RP-030136	315	2	Clarification of SSDD and HSDPA	5.3.0	5.4.0
26/03/03	RAN_19	RP-030132	318	-	Correction on verification algorithm in Annex 1	5.3.0	5.4.0
23/06/03	RAN_20	RP-030273	314	1	Correction of TPC command combining in SHO	5.4.0	5.5.0
23/06/03	RAN_20	RP-030273	319	-	Correction for HS-DPCCH gain factor in compressed frame	5.4.0	5.5.0
23/06/03	RAN_20	RP-030273	320	1	Clarification of HS-SCCH reception in case of minimum interTTI interval is not 1	5.4.0	5.5.0
23/06/03	RAN_20	RP-030273	321	-	Correction of description of CQI transmission timing calculation	5.4.0	5.5.0
23/06/03	RAN_20	RP-030273	322	1	Clarification of the reference power for HS-DPCCH	5.4.0	5.5.0
21/09/03	RAN_21	RP-030458	325	-	Correction of CQI definition table	5.5.0	5.6.0
21/09/03	RAN_21	RP-030462	326	-	Removal of the combination of TxAA Mode 1 with HS-SCCH	5.5.0	5.6.0
21/09/03	RAN_21	RP-030458	328	2	Clarification of power scaling with HS-DPCCH	5.5.0	5.6.0
21/09/03	RAN_21	RP-030458	329	3	Correction of CQI reporting in DL compressed mode	5.5.0	5.6.0
21/09/03	RAN_21	RP-030458	330	1	Clarification of HS-SCCH reception	5.5.0	5.6.0
21/09/03	RAN_21	RP-030458	333	1	Clarification on CQI repetition behaviour	5.5.0	5.6.0
21/09/03	RAN_21	RP-030547	335	3	TPC pattern during loss of RL synchronisation	5.5.0	5.6.0
06/01/04	RAN_22	RP-030649	335	1	Clarification of HS-SCCH reception	5.6.0	5.7.0
06/01/04	RAN_22	RP-030649	336	1	Clarification of CQI definition	5.6.0	5.7.0
06/01/04	RAN_22	RP-030649	337	1	Clarification of the HS-SCCH detection	5.6.0	5.7.0

Change history							
Date	TSG #	TSG Doc.	CR	Rev	Subject/Comment	Old	New
06/01/04	RAN_22	RP-030661	338	-	Remove inconsistency among specifications on signalling support for power control during loss of RL synchronisation	5.6.0	5.7.0
06/01/04	RAN_22	RP-030712	339	-	Alignment of "Soft channel bits" terminology with 25.306	5.6.0	5.7.0
13/01/04	RAN_22	-	-	-	Created for M.1457 update	5.7.0	6.0.0
23/03/04	RAN_23	RP-040086	341	-	Beta values for HS-DPCCH in compressed mode	6.0.0	6.1.0
23/03/04	RAN_23	RP-040086	346	1	ACK/NACK repetition factor	6.0.0	6.1.0
09/06/04	RAN_24	RP-040257	350	3	Clarification of UE procedure in case of HHO failure	6.1.0	6.2.0
28/09/04	RAN_25	RP-040318	352	1	Clarification of SS DT uplink only signalling	6.2.0	6.3.0
13/12/04	RAN_26	RP-040449	361	1	Introduction of E-DCH	6.3.0	6.4.0
13/12/04	RAN_26	RP-040450	351	-	Introduction of MICH	6.3.0	6.4.0
13/12/04	RAN_26	RP-040448	356	1	Introduction of MBMS Soft Combining	6.3.0	6.4.0
13/12/04	RAN_26	RP-040447	360	-	Correction of downlink transmit power control in compressed mode	6.3.0	6.4.0
13/12/04	RAN_26	RP-040527	358	1	Preamble and Postamble to reduce HS-DPCCH transmit power	6.3.0	6.4.0
14/03/05	RAN_27	RP-050048	362	2	Gain factor setting for E-DCH	6.4.0	6.5.0
14/03/05	RAN_27	RP-050049	364	1	Reliable E-RGCH/E-HICH Detection	6.4.0	6.5.0
14/03/05	RAN_27	RP-050088	368	1	Introduction of F-DPCH without pilot field	6.4.0	6.5.0
14/03/05	RAN_27	RP-050140	369	3	DL/UL timing association of E-DCH operation	6.4.0	6.5.0
16/06/05	RAN_28	RP-050254	354	4	Timing Maintained Hard Handover	6.5.0	6.6.0
16/06/05	RAN_28	RP-050253	355	4	Faster L1 DCH synchronization	6.5.0	6.6.0
16/06/05	RAN_28	RP-050252	363	4	Power control at the maximum power limit	6.5.0	6.6.0
16/06/05	RAN_28	RP-050252	372	4	Support of different HARQ profiles	6.5.0	6.6.0
16/06/05	RAN_28	RP-050252	373	-	Lowest reference E-TFC for the gain factor setting for E-DCH	6.5.0	6.6.0
16/06/05	RAN_28	RP-050250	375	1	Feature Clean Up: Removal of 'CPCH'	6.5.0	6.6.0
16/06/05	RAN_28	RP-050248	377	1	Feature Clean Up: Removal of DSCH (FDD mode)	6.5.0	6.6.0
16/06/05	RAN_28	RP-050333	378	1	F-DPCH Downlink Power Control Behaviour in SHO	6.5.0	6.6.0
16/06/05	RAN_28	RP-050256	379	-	Correction to DL synchronization	6.5.0	6.6.0
16/06/05	RAN_28	RP-050252	380	3	Clarification on E-DCH timing	6.5.0	6.6.0
16/06/05	RAN_28	RP-050252	381	1	DPCCH gain factor with no DPDCH configured	6.5.0	6.6.0
16/06/05	RAN_28	RP-050252	382	2	Compressed mode operation for the Enhanced Uplink	6.5.0	6.6.0
16/06/05	RAN_28	RP-050244	384	-	Feature Clean Up: Removal of 'SSDT'	6.5.0	6.6.0
16/06/05	RAN_28	RP-050247	387	1	Feature clean up: Removal of the 'TX diversity closed loop mode 2'	6.5.0	6.6.0
16/06/05	RAN_28	RP-050249	389	1	Feature clean up: Removal of the 'compressed mode by puncturing'	6.5.0	6.6.0
16/06/05	RAN_28	RP-050246	391	1	Feature Clean Up: Removal of dedicated pilot as sole phase reference	6.5.0	6.6.0
16/06/05	RAN_28	RP-050251	392	1	Removal of MBMS Rake Combining	6.5.0	6.6.0
16/06/05	RAN_28	RP-050242	394	1	HS-DPCCH transmissions on discarding HS-SCCH	6.5.0	6.6.0
16/06/05	RAN_28	RP-050345	395	-	Removal of E-RGCH non-serving radio link set	6.5.0	6.6.0
26/09/05	RAN_29	RP-050449	0398	-	Power control annex for F-DPCH	6.6.0	6.7.0
26/09/05	RAN_29	RP-050447	0399	2	Faster L1 DCH Synchronisation	6.6.0	6.7.0
26/09/05	RAN_29	RP-050449	0400	1	F-DPCH Quality Estimate	6.6.0	6.7.0
26/09/05	RAN_29	RP-050450	0401	2	Downlink compressed mode and E-HICH, E-RGCH and E-AGCH	6.6.0	6.7.0
26/09/05	RAN_29	RP-050440	0403	-	Downlink HS total power limitation	6.6.0	6.7.0
26/09/05	RAN_29	RP-050450	0404	1	Clarification on power offset quantization	6.6.0	6.7.0
26/09/05	RAN_29	RP-050450	0405	-	Clarification on computation of gain factors	6.6.0	6.7.0
26/09/05	RAN_29	RP-050450	0406	1	E-DPCH power scaling at the maximum power limit	6.6.0	6.7.0
26/09/05	RAN_29	RP-050547	0407	2	Clarification on E-RGCH detection	6.6.0	6.7.0
26/09/05	RAN_29	RP-050645	0408	4	PRACH preamble power at minimum power transmission	6.6.0	6.7.0
26/09/05	RAN_29	RP-050450	0412	-	Clarification on E-AGCH, EHICH, E-RGCH power control	6.6.0	6.7.0
12/12/05	RAN_30	-	-	-	Editorial revision to the header format change of the chapter 6B.3	6.7.0	6.7.1
20/03/06	RAN_31	RP-060076	0416	-	Correction to number of configured DPDCHs in relation to E-DPCH power scaling	6.7.1	6.8.0
20/03/06	RAN_31	-	-	-	Creation of Release 7 specification (v7.0.0) at RAN#31	6.8.0	7.0.0
12/06/06	RAN_32	RP-060293	0418	1	Correction of synchronisation procedure	7.0.0	7.1.0
12/06/06	RAN_32	RP-060370	0420	-	Clarification of E-TFCl terminology	7.0.0	7.1.0
29/09/06	RAN_33	RP-060490	0423	1	Clarification of E-DPCH gain factor quantization	7.1.0	7.2.0
11/12/06	RAN_34	RP-060727	0432	3	Correction to E-DCH gain factor calculation in relation to compressed mode	7.2.0	7.3.0
08/03/07	RAN_35	RP-070114	0430	10	Definition of MIMO operation on HS-PDSCH, preferred precoding and CQI reporting procedures, modified CQI tables	7.3.0	7.4.0
08/03/07	RAN_35	RP-070115	0421	13	Support of CPC feature	7.3.0	7.4.0
08/03/07	RAN_35	RP-070116	0434	2	Introduction of 64QAM for HSDPA	7.3.0	7.4.0
30/05/07	RAN_36	RP-070388	0435	5	Introduction of 16-QAM for HSUPA	7.4.0	7.5.0
30/05/07	RAN_36	RP-070392	0437	2	Enhanced F-DPCH	7.4.0	7.5.0
30/05/07	RAN_36	RP-070389	0438	6	Clarification to the CPC feature	7.4.0	7.5.0
30/05/07	RAN_36	RP-070387	0440	-	Setting of the uplink HS-DPCCH power relative to DPCCH power for MIMO	7.4.0	7.5.0
30/05/07	RAN_36	RP-070392	0446	1	Enhanced F-DPCH and CPC DL PC timing	7.4.0	7.5.0
30/05/07	RAN_36	RP-070384	0449	-	Support for DL only SFN operation for MBMS FDD	7.4.0	7.5.0
30/05/07	RAN_36	RP-070392	0450	-	Clarification on power control operation for F-DPCH enhancement	7.4.0	7.5.0

Change history							
Date	TSG #	TSG Doc.	CR	Rev	Subject/Comment	Old	New
30/05/07	RAN_36	RP-070390	0451	1	Enhanced CELL_FACH Procedure	7.4.0	7.5.0
11/09/07	RAN_37	RP-070641	0452	2	CPC preamble and postamble clarification for CQI transmission	7.5.0	7.6.0
11/09/07	RAN_37	RP-070641	0453	-	Removal of Inactivity_Threshold_for_UE_Grant_Monitoring definition	7.5.0	7.6.0
11/09/07	RAN_37	RP-070643	0454	2	Corrections to HS-DSCH procedures for CELL_FACH and MIMO	7.5.0	7.6.0
11/09/07	RAN_37	RP-070644	0456	3	Correction to Rel-7 E-DPDCH gain factor calculation	7.5.0	7.6.0
11/09/07	RAN_37	RP-070645	0458	1	Correction of 64QAM CQI tables	7.5.0	7.6.0
11/09/07	RAN_37	RP-070641	0459	-	Clarification of CPC	7.5.0	7.6.0
11/09/07	RAN_37	RP-070644	0460	2	E-DPDCH scaling when UE is at max power	7.5.0	7.6.0
11/09/07	RAN_37	RP-070642	0462	1	Correction of MIMO CQI tables	7.5.0	7.6.0
27/11/07	RAN_38	RP-070945	0463	-	Timing of CQI vs DTX priority change	7.6.0	7.7.0
27/11/07	RAN_38	RP-070945	0465	-	Grant Monitoring clarification	7.6.0	7.7.0
27/11/07	RAN_38	RP-070947	0467	1	Clarification on CQI tables in Rel-7	7.6.0	7.7.0
27/11/07	RAN_38	RP-070945	0469	2	Addition of TFR1 to list of abbreviations	7.6.0	7.7.0
27/11/07	RAN_38	RP-070944	0470	-	Correction to Rel-7 E-DPDCH gain factor calculation	7.6.0	7.7.0
27/11/07	RAN_38	RP-070941	0471	2	Clarification of CQI definition	7.6.0	7.7.0
27/11/07	RAN_38	RP-070947	0473	2	Clarification on HSDPA UE category in Rel-7	7.6.0	7.7.0
27/11/07	RAN_38	RP-070911	0474	-	Clarification on E-DPDCH power extrapolation/interpolation	7.6.0	7.7.0
28/11/07	RAN_38	RP-070948	0476	-	Removing the constraint that the same HS-SCCH should be used in contiguous TTIs	7.7.0	8.0.0
28/11/07	RAN_38	RP-070950	0477	-	Inclusion of CQI tables for the combination of 64QAM and MIMO	7.7.0	8.0.0
04/03/08	RAN_39	RP-080143	0480	1	Correction to UE grant monitoring	8.0.0	8.1.0
28/05/08	RAN_40	RP-080350	0482	2	CPC DTX cycle change clarification	8.1.0	8.2.0
28/05/08	RAN_40	RP-080440	0483	3	HS-SCCH orders for HS-SCCH-less operation	8.1.0	8.2.0
28/05/08	RAN_40	RP-080439	0485	-	Correction to E-DPCCH gain factor calculation	8.1.0	8.2.0
28/05/08	RAN_40	RP-080351	0492	1	Correction to E-DCH control channel timing	8.1.0	8.2.0
09/09/08	RAN_41	RP-080672	0490	1	Introduction of the Enhanced Uplink for CELL_FACH state	8.2.0	8.3.0
09/09/08	RAN_41	RP-080673	0498	3	Introduction of HS-PDSCH Serving Cell Change Enhancements	8.2.0	8.3.0
03/12/08	RAN_42	RP-080989	0497	4	Introduction of Dual-Cell HSDPA Operation on Adjacent Carriers	8.3.0	8.4.0
03/12/08	RAN_42	RP-080974	0502	1	Clarification of F-DPCH TPC Combining Rule of cells in the same RLS	8.3.0	8.4.0
03/12/08	RAN_42	RP-080988	0503	1	Introduction of HS-PDSCH Serving Cell Change Enhancements	8.3.0	8.4.0
03/12/08	RAN_42	RP-080986	0504	1	Corrections in the physical random access procedure for Enhanced Uplink in CELL_FACH State and Idle mode	8.3.0	8.4.0
03/12/08	RAN_42	RP-080974	0506	2	Correction to the description of CPC procedures	8.3.0	8.4.0
03/12/08	RAN_42	RP-080990	0508	2	Improved EUL power control at UE power limitation	8.3.0	8.4.0
03/12/08	RAN_42	RP-080979	0509	1	Typographical error correction in a parameter name in HS-PDSCH reception	8.3.0	8.4.0
03/12/08	RAN_42	RP-080986	0513	-	Support of HS-DPCCH for Enhanced uplink in CELL_FACH state	8.3.0	8.4.0
03/12/08	RAN_42	RP-080978	0515	-	Clarification of NIR setting in CQI mapping tables	8.3.0	8.4.0
03/12/08	RAN_42	RP-080975	0517	3	Correction to E-DPDCH gain factor interpolation in compressed mode	8.3.0	8.4.0
03/12/08	RAN_42	RP-080989	0519	-	References to CQI tables for DC-HSDPA	8.3.0	8.4.0
03/12/08	RAN_42	RP-080975	0523	-	Correction to E-DPDCH gain factor calculation	8.3.0	8.4.0
03/12/08	RAN_42	RP-080974	0524	-	Clarification of CQI repetition in case of UE DTX	8.3.0	8.4.0
03/12/08	RAN_42	RP-080989	0528	-	Clarifications to Dual-Cell HSDPA Operation	8.3.0	8.4.0
03/03/09	RAN_43	RP-090227	0531	-	Editorial correction to UE transmit power control behaviour in case of DTX/DRX	8.4.0	8.5.0
03/03/09	RAN_43	RP-090242	0534	2	Corrections of HS-SCCH orders for DC-HSDPA	8.4.0	8.5.0
03/03/09	RAN_43	RP-090227	0535	-	Clarification of CQI preamble length when switching UE DTX cycle	8.4.0	8.5.0
03/03/09	RAN_43	RP-090229	0538	1	Clarification of the source of parameters to HS-DSCH physical layer	8.4.0	8.5.0
26/05/09	RAN_44	RP-090525	0545	1	Clarification to the transmission of a combination of ACK and NACK	8.5.0	8.6.0
26/05/09	RAN_44	RP-090532	0546	-	HS-DSCH serving cell change enhancements with preconfigured secondary cell	8.5.0	8.6.0
15/09/09	RAN_45	RP-090885	0550	1	Clarification of CQI transmission when CQI priority changes	8.6.0	8.7.0
15/09/09	RAN_45	RP-090886	0553	1	Clarification to support of HS-DSCH related procedures according to MAC-ehs	8.6.0	8.7.0
15/09/09	RAN_45	RP-090885	0557	1	Clarification of CPC Enabling Delay	8.6.0	8.7.0
15/09/09	RAN_45	RP-090885	0559	1	Clarification of DTX Cycle transitions and UL DPCCH burst transmissions	8.6.0	8.7.0
15/09/09	RAN_45	RP-090885	0561	1	Clarification of the start of the CQI_DTX_Timer	8.6.0	8.7.0
15/09/09	RAN_45	RP-090883	0563	1	Unequal Power Setting of P-CPICH and S-CPICH	8.6.0	8.7.0
15/09/09	RAN_45	RP-090889	0568	1	HS-DPCCH ACK/NACK Power Offset setting for DC-HSDPA	8.6.0	8.7.0
18/09/09	RAN_45	RP-090975	0548	4	Introduction of TxAA extension for non-MIMO UEs	8.7.0	9.0.0
18/09/09	RAN_45	RP-090974	0569	-	Combination of DC-HSDPA with MIMO	8.7.0	9.0.0
01/12/09	RAN_46	RP-091170	0570	5	Introduction of DC-HSUPA	9.0.0	9.1.0
01/12/09	RAN_46	RP-091171	0574	3	MIMO configuration per downlink frequency in DC-MIMO operation	9.0.0	9.1.0
01/12/09	RAN_46	RP-091174	0578	1	Clarification to TxAA extension in dual cell	9.0.0	9.1.0

Change history							
Date	TSG #	TSG Doc.	CR	Rev	Subject/Comment	Old	New
01/12/09	RAN_46	RP-091164	0580	-	Clarification of HS-SCCH monitoring	9.0.0	9.1.0
01/12/09	RAN_46	RP-091163	0582	-	Clarification of CQI nominal timer and CQI DTX TIMER	9.0.0	9.1.0
01/12/09	RAN_46	RP-091165	0589	-	Table Index Correction	9.0.0	9.1.0
16/03/10	RAN_47	RP-100199	0592	3	HSDPA MIMO codebook restriction	9.1.0	9.2.0
16/03/10	RAN_47	RP-100200	0594	-	Correction to HS-DSCH and HS-SCCH reception in the URA_PCH and CELL_PCH states	9.1.0	9.2.0
16/03/10	RAN_47	RP-100206	0596	1	Clarification of MIMO configuration per downlink frequency in DC-MIMO operation	9.1.0	9.2.0
16/03/10	RAN_47	RP-100207	0597	-	Correction to Applicability of CQI Mapping Table	9.1.0	9.2.0
16/03/10	RAN_47	RP-100208	0599	1	Decrease DC-HSPA carrier activation application time to 18 slots	9.1.0	9.2.0
14/09/10	RAN_49	RP-100893	0604	5	Clarification of the CQI definition when the UE is configured in MIMO mode	9.2.0	9.3.0
14/09/10	RAN_49	RP-100883	0607	3	Clarification of HS-DSCH and HS-SCCH reception in CELL_FACH, CELL_PCH and URA_PCH states	9.2.0	9.3.0
14/09/10	RAN_49	RP-100894	0614	-	Clarification of E-AGCH/E-RGCH monitoring in a CM gap when DL_DRX_Active is TRUE	9.2.0	9.3.0
14/09/10	RAN_49	RP-100898	0615	2	Clarification on the interruption time for DB-HSDPA due to HS-SCCH order (de)activation	9.2.0	9.3.0
14/09/10	RAN_49	RP-100897	0616	-	Clarification on Secondary_EDCH_Cell_Active upon reception of redundant HS-SCCH order	9.2.0	9.3.0
16/09/10	RAN_49	RP-100902	0611	3	Release 10 created with the introduction of 4C HSDPA	9.3.0	10.0.0
07/12/10	RAN_50	RP-101318	621	1	Correction of number of received HS-DSCH and HS-SCCH in DC-HSDPA-MIMO and 4C-HSDPA	10.0.0	10.1.0
07/12/10	RAN_50	RP-101318	622	1	Clarification on the interruption time for 4C-HSDPA due to HS-SCCH ordered (de)activation	10.0.0	10.1.0
07/12/10	RAN_50	RP-101312	627	-	Further clarification of E-AGCH/E-RGCH monitoring in CM gap when DL_DRX_Active is TRUE	10.0.0	10.1.0
07/12/10	RAN_50	RP-101313	631	2	Clarification of E-DPCCH gain factor calculation in compressed mode	10.0.0	10.1.0
07/12/10	RAN_50	RP-101312	637	1	Clarification of discontinuous uplink DPCCH transmission and compressed mode	10.0.0	10.1.0
07/12/10	RAN_50	RP-101311	641	2	Correction to the single stream CQI reporting in MIMO mode	10.0.0	10.1.0
07/12/10	RAN_50	RP-101310	650	-	Clarification of the applicability of the IE Number of PCCH transmissions in CELL_PCH state	10.0.0	10.1.0
15/03/11	RAN_51	RP-110251	633	5	Correction to CPC procedure for DC-HSUPA	10.1.0	10.2.0
01/06/11	RAN_52	RP-110816	653	-	Clarification of activation status when Secondary_Cell_Enabled is changed from 0 to a value not equal to 0	10.2.0	10.3.0
15/09/11	RAN_53	RP-111224	656	-	Clarification of when to use Sync A procedure when UE transitions from CELL_FACH to CELL_DCH	10.3.0	10.4.0
05/12/11	RAN_54	RP-111670	658	2	CQI reporting for frequency specific compressed mode	10.4.0	10.5.0
05/12/11	RAN_54	RP-111671	652	8	Introduction of 8C-HSDPA	10.5.0	11.0.0
05/12/11	RAN_54	RP-111672	663	-	Introduction of Uplink Closed Loop Transmit Diversity for HSPA	10.5.0	11.0.0
28/02/12	RAN_55	RP-120282	669	-	Clarification of UL DPCCH Slot Format when DPC_MODE is 1 and CPC is not Enabled	11.0.0	11.1.0
28/02/12	RAN_55	RP-120288	670	-	Corrections to Uplink Closed Loop Transmit Diversity	11.0.0	11.1.0
28/02/12	RAN_55	RP-120281	671	-	Further Clarification of when to use Sync A procedure when UE transitions from CELL_FACH to CELL_DCH	11.0.0	11.1.0
13/06/12	RAN_56	RP-120741	677	1	Clarification of CLTD Features	11.1.0	11.2.0
13/06/12	RAN_56	RP-120741	678	5	Introduction of Timing Diagrams for F-TPICH Operation in UL CLTD	11.1.0	11.2.0
13/06/12	RAN_56	RP-120741	679	2	Clarification of TPI timing and F-TPICH transmission for UL CLTD	11.1.0	11.2.0
04/09/12	RAN_57	RP-121271	685	2	Introduction of Multiflow	11.2.0	11.3.0
04/09/12	RAN_57	RP-121384	686	1	Correction of F-TPICH transmission	11.2.0	11.3.0
04/09/12	RAN_57	RP-121384	687	1	Correction to the gain factor definition for S-DPCCH	11.2.0	11.3.0
04/09/12	RAN_57	RP-121270	690	-	Introduction of Further Enhancements to CELL_FACH	11.2.0	11.3.0
04/09/12	RAN_57	RP-121384	691	-	Clarification to F-TPICH transmission	11.2.0	11.3.0
04/09/12	RAN_58	RP-121845	688	5	Introduction of uplink MIMO and 64QAM	11.3.0	11.4.0
04/09/12	RAN_58	RP-121843	689	5	Introduction of 4Tx_HSDPA in 25.214	11.3.0	11.4.0
04/09/12	RAN_58	RP-121841	692	-	Clarification of UE procedure for receiving HS-SCCH orders in the CELL_DCH state	11.3.0	11.4.0
04/09/12	RAN_58	RP-121841	695	-	Clarification of F-TPICH configuration	11.3.0	11.4.0
04/09/12	RAN_58	RP-121842	697	2	Clarification to the procedure of NodeB Triggered HS-DPCCH	11.3.0	11.4.0
04/09/12	RAN_58	RP-121844	699	2	Clarifications and corrections to HSDPA Multiflow	11.3.0	11.4.0
04/09/12	RAN_58	RP-121842	700	1	Clarification of the some aspects of Further Enhancements to CELL_FACH	11.3.0	11.4.0
04/09/12	RAN_58	RP-121836	701	-	Power scaling handling for Multi-RAB	11.3.0	11.4.0
26/02/13	RAN_59	RP-130250	702	1	Correction of HS-DPCCH power offset for four-branch MIMO	11.4.0	11.5.0
26/02/13	RAN_59	RP-130359	703	2	Correction to the referenced variable for CELL-FACH enhancement	11.4.0	11.5.0

History

Document history		
V11.3.0	September 2012	Publication
V11.4.0	January 2013	Publication
V11.5.0	April 2013	Publication