

ETSI TS 125 224 V3.5.0 (2000-12)

Technical Specification

**Universal Mobile Telecommunications System (UMTS);
Physical Layer Procedures (TDD)
(3GPP TS 25.224 version 3.5.0 Release 1999)**



Reference

RTS/TSGR-0125224UR4

Keywords

UMTS

ETSI

650 Route des Lucioles
F-06921 Sophia Antipolis Cedex - FRANCE

Tel.: +33 4 92 94 42 00 Fax: +33 4 93 65 47 16

Siret N° 348 623 562 00017 - NAF 742 C
Association à but non lucratif enregistrée à la
Sous-Préfecture de Grasse (06) N° 7803/88

Important notice

Individual copies of the present document can be downloaded from:

<http://www.etsi.org>

The present document may be made available in more than one electronic version or in print. In any case of existing or perceived difference in contents between such versions, the reference version is the Portable Document Format (PDF). In case of dispute, the reference shall be the printing on ETSI printers of the PDF version kept on a specific network drive within ETSI Secretariat.

Users of the present document should be aware that the document may be subject to revision or change of status. Information on the current status of this and other ETSI documents is available at <http://www.etsi.org/tb/status/>

If you find errors in the present document, send your comment to:
editor@etsi.fr

Copyright Notification

No part may be reproduced except as authorized by written permission.
The copyright and the foregoing restriction extend to reproduction in all media.

© European Telecommunications Standards Institute 2000.

All rights reserved.

Intellectual Property Rights

IPRs essential or potentially essential to the present document may have been declared to ETSI. The information pertaining to these essential IPRs, if any, is publicly available for **ETSI members and non-members**, and can be found in ETSI SR 000 314: "*Intellectual Property Rights (IPRs); Essential, or potentially Essential, IPRs notified to ETSI in respect of ETSI standards*", which is available from the ETSI Secretariat. Latest updates are available on the ETSI Web server (<http://www.etsi.org/ipr>).

Pursuant to the ETSI IPR Policy, no investigation, including IPR searches, has been carried out by ETSI. No guarantee can be given as to the existence of other IPRs not referenced in ETSI SR 000 314 (or the updates on the ETSI Web server) which are, or may be, or may become, essential to the present document.

Foreword

This Technical Specification (TS) has been produced by the ETSI 3rd Generation Partnership Project (3GPP).

The present document may refer to technical specifications or reports using their 3GPP identities, UMTS identities or GSM identities. These should be interpreted as being references to the corresponding ETSI deliverables.

The cross reference between GSM, UMTS, 3GPP and ETSI identities can be found under www.etsi.org/key.

Contents

| | |
|--|-----------|
| Foreword..... | 5 |
| 1 Scope..... | 6 |
| 2 References..... | 6 |
| 3 Abbreviations..... | 6 |
| 4 Physical layer procedures (TDD)..... | 7 |
| 4.1 General..... | 7 |
| 4.2 Transmitter Power Control..... | 7 |
| 4.2.1 General Parameters..... | 7 |
| 4.2.2 Uplink Control..... | 7 |
| 4.2.2.1 General Limits..... | 7 |
| 4.2.2.2 PRACH..... | 8 |
| 4.2.2.3 DPCH, PUSCH..... | 8 |
| 4.2.2.3.1 Gain Factors..... | 8 |
| 4.2.2.3.2 Power Control Loop..... | 9 |
| 4.2.2.3.3 Out of synchronisation handling..... | 9 |
| 4.2.3 Downlink Control..... | 10 |
| 4.2.3.1 P-CCPCH..... | 10 |
| 4.2.3.2 S-CCPCH, PICH..... | 10 |
| 4.2.3.3 DPCH, PDSCH..... | 10 |
| 4.2.3.3.1 Out of synchronisation handling..... | 11 |
| 4.3 Timing Advance..... | 11 |
| 4.3.1 Timing advance with UL Synchronization..... | 11 |
| 4.4 Synchronisation procedures..... | 11 |
| 4.4.1 Cell Search..... | 11 |
| 4.4.2 Dedicated channel synchronisation..... | 12 |
| 4.4.2.1 Synchronisation primitives..... | 12 |
| 4.4.2.1.1 General..... | 12 |
| 4.4.2.1.2 Downlink synchronisation primitives..... | 12 |
| 4.4.2.1.3 Uplink synchronisation primitives..... | 13 |
| 4.4.2.2 Radio link monitoring..... | 13 |
| 4.4.2.2.1 Downlink radio link failure..... | 13 |
| 4.4.2.2.2 Uplink radio link failure/restore..... | 13 |
| 4.5 Discontinuous transmission (DTX) of Radio Frames..... | 13 |
| 4.5.1 Use of Special Bursts fo DTX..... | 13 |
| 4.5.2 Use of Special Bursts for Initial Establishment..... | 14 |
| 4.6 Downlink Transmit Diversity..... | 14 |
| 4.6.1 Transmit Diversity for DPCH..... | 14 |
| 4.6.2 Transmit Diversity for SCH..... | 14 |
| 4.6.2.1 SCH Transmission Scheme..... | 14 |
| 4.6.3 Transmit Diversity for P-CCPCH..... | 15 |
| 4.6.3.1 P-CCPCH Transmission Scheme..... | 15 |
| 4.7 Random access procedure..... | 16 |
| 4.7.1 Physical random access procedure..... | 16 |
| 4.8 DSCH procedure..... | 18 |
| 4.8.1 DSCH procedure with TFCI indication..... | 18 |
| 4.8.2 DSCH procedure with midamble indication..... | 18 |
| Annex A (informative): Power Control..... | 19 |
| A.1 An Example for Calculating α | 19 |
| A.2 Example Implementation of Downlink Power Control in the UE..... | 19 |
| Annex B (informative): Determination of Weight Information..... | 20 |
| B.1 STD Weights..... | 20 |
| B.2 TxAA Weights..... | 20 |

Annex C (informative): Cell search procedure.....21
Annex D (informative): Change history22

Foreword

This Technical Specification (TS) has been produced by the 3rd Generation Partnership Project (3GPP).

The contents of the present document are subject to continuing work within the TSG and may change following formal TSG approval. Should the TSG modify the contents of the present document, it will be re-released by the TSG with an identifying change of release date and an increase in version number as follows:

Version x.y.z

where:

- x the first digit:
 - 1 presented to TSG for information;
 - 2 presented to TSG for approval;
 - 3 or greater indicates TSG approved document under change control.
- y the second digit is incremented for all changes of substance, i.e. technical enhancements, corrections, updates, etc.
- z the third digit is incremented when editorial only changes have been incorporated in the document.

1 Scope

The present document describes the Physical Layer Procedures in the TDD mode of UTRA.

2 References

The following documents contain provisions which, through reference in this text, constitute provisions of the present document.

- References are either specific (identified by date of publication, edition number, version number, etc.) or non-specific.
- For a specific reference, subsequent revisions do not apply.
- For a non-specific reference, the latest version applies.

- [1] 3GPP TS 25.201: "Physical layer - general description".
- [2] 3GPP TS 25.102: "UE physical layer capabilities".
- [3] 3GPP TS 25.211: "Physical channels and mapping of transport channels onto physical channels (FDD)".
- [4] 3GPP TS 25.212: "Multiplexing and channel coding (FDD)".
- [5] 3GPP TS 25.213: "Spreading and modulation (FDD)".
- [6] 3GPP TS 25.214: "Physical layer procedures (FDD)".
- [7] 3GPP TS 25.215: "Physical Layer - Measurements (FDD)".
- [8] 3GPP TS 25.221: "Physical channels and mapping of transport channels onto physical channels (TDD)".
- [9] 3GPP TS 25.222: "Multiplexing and channel coding (TDD)".
- [10] 3GPP TS 25.223: "Spreading and modulation (TDD)".
- [11] 3GPP TS 25.225: "Physical Layer - Measurements (TDD)".
- [12] 3GPP TS 25.301: "Radio Interface Protocol Architecture".
- [13] 3GPP TS 25.302: "Services Provided by the Physical Layer".
- [14] 3GPP TS 25.401: "UTRAN Overall Description".
- [15] 3GPP TS 25.331: "RRC Protocol Specification"
- [16] 3GPP TS 25.433: " UTRAN Iub Interface NBAP Signalling"
- [17] 3GPP TS 25.105: " UTRA (BS) TDD; Radio transmission and Reception"
- [18] 3GPP TS 25.321: " MAC protocol specification"
- [19] 3GPP TS 25.303: " Interlayer Procedures in Connected Mode"

3 Abbreviations

For the purposes of the present document, the following abbreviations apply:

BCCH Broadcast Control Channel

| | |
|---------|---|
| BCH | Broadcast Channel |
| CCTrCH | Coded Composite Transport Channel |
| DCA | Dynamic Channel Allocation |
| DPCH | Dedicated Physical Channel |
| DTX | Discontinuous Transmission |
| FACH | Forward Access Channel |
| NRT | Non-Real Time |
| P-CCPCH | Primary Common Control Physical Channel |
| PRACH | Physical Random Access Channel |
| RACH | Random Access Channel |
| RT | Real Time |
| RU | Resource Unit |
| S-CCPCH | Secondary Common Control Physical Channel |
| SCH | Synchronisation Channel |
| SFN | System Frame Number |
| SSCH | Secondary Synchronisation Channel |
| STD | Selective Transmit Diversity |
| TA | Timing Advance |
| TPC | Transmit Power Control |
| TSTD | Time Switched Transmit Diversity |
| TxAA | Transmit Adaptive Antennas |
| UE | User Equipment |
| VBR | Variable Bit Rate |

4 Physical layer procedures (TDD)

4.1 General

4.2 Transmitter Power Control

4.2.1 General Parameters

Power control is applied for the TDD mode to limit the interference level within the system thus reducing the intercell interference level and to reduce the power consumption in the UE.

All codes within one timeslot allocated to the same CCTrCH use the same transmission power, in case they have the same spreading factor.

Table 1: Transmit Power Control characteristics

| | Uplink | Downlink |
|---------------------------|---|---|
| Power control rate | Variable 1-7 slots delay (2 slot SCH) 1-14 slots delay (1 slot SCH) | Variable, with rate depending on the slot allocation. |
| Step size | | 1, 2, 3 dB |
| Remarks | All figures are without processing and measurement times | Within one timeslot the powers of all active codes may be balanced to within a range of 20 dB |

4.2.2 Uplink Control

4.2.2.1 General Limits

By means of higher layer signalling, the `Maximum_Allowed_UL_TX_` power for uplink may be set to a value lower than what the terminal power class is capable of. The total transmit power shall not exceed the allowed maximum. If

this would be the case, then the transmit power of all uplink physical channels in a timeslot is reduced by the same amount in dB.

4.2.2.2 PRACH

The transmit power for the PRACH is set by higher layers based on open loop power control as described in [15].

4.2.2.3 DPCH, PUSCH

4.2.2.3.1 Gain Factors

Two or more transport channels may be multiplexed onto a CCTrCH as described in [9]. These transport channels undergo rate matching which involves repetition or puncturing. This rate matching affects the transmit power required to obtain a particular E_b/N_0 . Thus, the transmission power of the CCTrCH shall be weighted by a gain factor β .

There are two ways of controlling the gain factors for different TFC's within a CCTrCH transmitted in a radio frame:

- β is signalled for the TFC, or
- β is computed for the TFC, based upon the signalled settings for a reference TFC.

Combinations of the two above methods may be used to associate β values to all TFC's in the TFCS for a CCTrCH. The two methods are described in sections 4.2.2.3.1.1 and 4.2.2.3.1.2 respectively. Several reference TFC's for several different CCTrCH's may be signalled from higher layers.

The weight and gain factors may vary on a radio frame basis depending upon the current SF and TFC used. The setting of weight and gain factors is independent of any other form of power control. That means that the transmit power P_{UL} is calculated according to the formula given below in section 4.2.2.3.2 and then the weight and gain factors are applied on top of that, cf. [10].

4.2.2.3.1.1 Signalled Gain Factors

When the gain factor β_j is signalled by higher layers for a certain TFC, the signalled values are used directly for weighting DPCH(s). Exact values are given in [10].

4.2.2.3.1.2 Computed Gain Factors

The gain factor β_j may also be computed for certain TFCs, based on the signalled settings for a reference TFC:

Let β_{ref} denote the signalled gain factor for the reference TFC. Further, let β_j denote the gain factor used for the j -th TFC.

Define the variable:
$$K_{ref} = \sum_i RM_i \cdot N_i$$

where RM_i is the semi-static rate matching attribute for transport channel i , N_i is the number of bits output from the radio frame segmentation block for transport channel i and the sum is taken over all the transport channels i in the reference TFC.

Similarly, define the variable
$$K_j = \sum_i RM_i \cdot N_i$$

where the sum is taken over all the transport channels i in the j -th TFC.

Moreover, define the variable
$$L_{ref} = \sum_i \frac{1}{SF_i}$$

where SF_i is the spreading factor of DPCH i and the sum is taken over all DPCH i used in the reference TFC.

Similarly, define the variable $L_j = \sum_i \frac{1}{SF_i}$

where the sum is taken over all DPCH i used in the j -th TFC.

Then the variable A_j , called the nominal power relation for TFC j , is computed as:

$$A_j = \sqrt{\frac{L_j}{L_{ref}}} \times \sqrt{\frac{K_{ref}}{K_j}}$$

The gain factors β_j for the j -th TFC are then computed as follows:

- If $A_j > 1$, then β_j is the largest quantized β -value, for which the condition $\beta_j \leq 1 / A_j$ holds.
- If $A_j \leq 1$, then β_j is the smallest quantized β -value, for which the condition $\beta_j \geq 1 / A_j$ holds.

The quantized β -values are given in [10].

4.2.2.3.2 Power Control Loop

After the synchronisation between UTRAN and UE is established, the UE transits into open-loop transmitter power control (TPC).

The power setting for each uplink DPCH in one CCTrCH shall be calculated by the following equation:

$$P_{UL} = \alpha L_{P-CCPCH} + (1-\alpha)L_0 + I_{BTS} + SIR_{TARGET} + \text{Constant value}$$

where

- P_{UL} : Power setting in dBm, cf. section "Combination of physical channels in uplink" in [10]; This value corresponds to a particular CCTrCH (due to CCTrCH-specific SIR_{TARGET}) and a particular timeslot (due to possibly timeslot-specific α and I_{BTS}).
- $L_{P-CCPCH}$: Measure representing path loss in dB (reference transmit power is broadcast on BCH).
- L_0 : Long term average of path loss in dB.
- I_{BTS} : Interference signal power level at cell's receiver in dBm, which is broadcast on BCH.
- α : α is a weighting parameter which represents the quality of path loss measurements. α may be a function of the time delay between the uplink time slot and the most recent down link time slot containing a beacon channel, see [8]. α shall be calculated autonomously at the UE, subject to a maximum allowed value which shall be signalled by higher layers. An example for calculating α as a function of the time delay is given in annex A.1.
- SIR_{TARGET} : Target SIR in dB. A higher layer outer loop adjusts the target SIR.
- Constant value: This value shall be set by higher Layer (operator matter). and is broadcast on BCH.

If the midamble is used in the evaluation of $L_{P-CCPCH}$ and L_0 , and the Tx diversity scheme used for the P-CCPCH involves the transmission of different midambles from the diversity antennas, the received power of the different midambles from the different antennas shall be combined prior to evaluation of these variables.

4.2.2.3.3 Out of synchronisation handling

As stated in 4.2.3.3, the association between TPC commands sent on uplink DPCH and PUSCH, with the power controlled downlink DPCH and PDSCH is signaled by higher layers. In the case of multiple DL CCTrCHs it is possible that an UL CCTrCH will provide TPC commands to more than one DL CCTrCH.

In the second phase of synchronisation evaluation, as defined in 4.4.2.1.2, the UE shall shut off the transmission of an UL CCTrCH if the following criteria are fulfilled for any one of the DL CCTrCHs commanded by its TPC:

- The UE estimates the received dedicated channel burst quality over the last 160 ms period to be worse than a threshold Q_{out} , and in addition, no special burst, as defined in 4.5, is detected with quality above a threshold, Q_{sbout} . Q_{out} and Q_{sbout} are defined implicitly by the relevant tests in [2]. If the UE detects the beacon channel reception level [10 dB] above the handover triggering level, then the UE shall use a 320 ms estimation period for the burst quality evaluation and for the Special Burst detection window.

UE shall subsequently resume the uplink transmission of the CCTrCH if the following criteria are fulfilled:

- The UE estimates the received dedicated CCTrCH burst reception quality over the last 160 ms period to be better than a threshold Q_{in} or the UE detects a burst with quality above threshold Q_{sbin} and TFCI decoded to be that of the Special Burst. Q_{in} and Q_{sbin} are defined implicitly by the relevant tests in [2]. If the UE detects the beacon channel reception level [10 dB] above the handover triggering level, then the UE shall use a 320 ms estimation period for the burst quality evaluation and for the Special Burst detection window.

4.2.3 Downlink Control

4.2.3.1 P-CCPCH

The Primary CCPCH transmit power is set by higher layer signalling and can be changed based on network determination on a slow basis. The reference transmit power of the P-CCPCH is signalled on the BCH.

4.2.3.2 S-CCPCH, PICH

The relative transmit power of the Secondary CCPCH and the PICH compared to the P-CCPCH transmit power are set by higher layer signalling. The PICH power offset relative to the P-CCPCH reference power is signalled on the BCH.

4.2.3.3 DPCH, PDSCH

The initial transmission power of the downlink DPCH and the PDSCH is set by the network. After the initial transmission, the UTRAN transits into SIR-based inner loop power control.

The UE shall generate TPC commands to control the network transmit power and send them in the TPC field of the uplink DPCH and PUSCH. An example on how to derive the TPC commands is given in Annex A.2

The association between TPC commands sent on uplink DPCH and PUSCH, with the power controlled downlink DPCH and PDSCH is signaled by higher layers.

In the case that no associated downlink data is scheduled within 15 timeslots before the transmission of a TPC command then this is regarded as a transmission pause. The TPC commands in this case shall be derived from measurements on the P-CCPCH. An example solution for the generation of the TPC command is given in Annex A.2.

Each TPC command shall always be based on all associated downlink transmissions received since the previous related TPC command. Related TPC commands are defined as TPC commands associated with the same downlink CCTrCHs. If there are no associated downlink transmissions between two or more uplink transmissions carrying related TPC commands, then these TPC commands shall be identical and they shall be regarded by the UTRAN as a single TPC command. This rule applies both to the case where the measurements are based on a CCTrCH or, in the case of a pause, on the P-CCPCH.

As a response to the received TPC command, UTRAN may adjust the transmit power. When the TPC command is judged as "down", the transmission power may be reduced by one step, whereas if judged as "up", the transmission power may be raised by one step. The UTRAN may apply an individual offset to the transmission power in each timeslot according to the downlink interference level at the UE. The transmission power of one DPCH or PDSCH shall not exceed the limits set by higher layer signalling by means of Maximum_DL_Power (dB) and Minimum_DL_Power (dB). The transmission power is defined as the average power of the complex QPSK symbols of a single DPCH before spreading.

During a downlink transmission pause, the UTRAN may accumulate the TPC commands received. The initial UTRAN transmission power for the first data transmission after the pause may then be set to the sum of transmission power before the pause and a power offset according to the accumulated TPC commands. Additionally this sum may include a constant set by the operator and a correction term due to uncertainties in the reception of the TPC bits.

The total downlink transmission power at the nodeB within one timeslot shall not exceed Maximum Transmission Power set by higher layer signalling. In case the total power of the sum of all transmissions would exceed this limit, then the transmission power of all downlink DPCHs is reduced by the amount that allows fulfilling the requirement. The same amount of power reduction is applied to all DPCHs.

A higher layer outer loop adjusts the target SIR.

4.2.3.3.1 Out of synchronisation handling

When the dedicated physical channel out of sync criteria based on the received burst quality is as given in the subclause 4.4.2 then the UE shall set the uplink TPC command = "up". The CRC based criteria shall not be taken into account in TPC bit value setting.

4.3 Timing Advance

UTRAN may adjust the UE transmission timing with timing advance. The initial value for timing advance (TA_{phys}) will be determined in the UTRAN by measurement of the timing of the PRACH. The required timing advance will be represented as an 6 bit number (0-63) 'UL Timing Advance' TA_{ul} , being the multiplier of 4 chips which is nearest to the required timing advance (i.e. $TA_{phys} = TA_{ul} \times 4$ chips).

When Timing Advance is used the UTRAN will continuously measure the timing of a transmission from the UE and send the necessary timing advance value. On receipt of this value the UE shall adjust the timing of its transmissions accordingly in steps of ± 4 chips. The transmission of TA values is done by means of higher layer messages. Upon receiving the TA command the UE shall adjust its transmission timing according to the timing advance command at the frame number specified by higher layer signaling. The UE is signaled the TA value in advance of the specified frame activation time to allow for local processing of the command and application of the TA adjustment on the specified frame. Node-B is also signaled the TA value and radio frame number that the TA adjustment is expected to take place.

If TA is enabled by higher layers, after handover the UE shall transmit in the new cell with timing advance TA adjusted by the relative timing difference Δt between the new and the old cell:

$$TA_{new} = TA_{old} + 2\Delta t.$$

4.3.1 Timing advance with UL Synchronization

If UL Synchronization is used, the timing advance is sub-chip granular and with high accuracy in order to enable synchronous CDMA in the UL. The required timing advance will be represented as a multiple of 1/4 chips.

The UTRAN will continuously measure the timing of a transmission from the UE and send the necessary timing advance value. On receipt of this value the UE will adjust the timing of its transmissions accordingly in steps of $\pm 1/4$ chips.

Support of UL synchronisation is optional for the UE.

4.4 Synchronisation procedures

4.4.1 Cell Search

During the cell search, the UE searches for a cell and determines the downlink scrambling code, basic midamble code and frame synchronisation of that cell. How cell search is typically done is described in Annex C.

4.4.2 Dedicated channel synchronisation

4.4.2.1 Synchronisation primitives

4.4.2.1.1 General

For the dedicated channels, synchronisation primitives are used to indicate the synchronisation status of radio links, both in uplink and downlink. The definition of the primitives is given in the following subclauses.

4.4.2.1.2 Downlink synchronisation primitives

Layer 1 in the UE shall check the synchronization status of each DL CCTrCH individually in every radio frame. All bursts and transport channels of a CCTrCH shall be taken into account. Synchronisation status is indicated to higher layers, using the CPHY-Sync-IND or CPHY-Out-of-Sync-IND primitives. For dedicated physical channels configured with Repetition Periods [15] only the configured active periods shall be taken into account in the estimation. The status check shall also include detection of the Special Bursts defined in 4.5 for DTX.

The criteria for reporting synchronization status are defined in two different phases.

The first phase lasts until 160 ms after the downlink CCTrCH is considered to be established by higher layers. During this time, Out-of-sync shall not be reported. In-sync shall be reported using the CPHY-Sync-IND primitive if any one of the following three criteria is fulfilled.

- a) The UE estimates the burst reception quality over the previous 40 ms period to be better than a threshold Q_{in} . This criterion shall be assumed not to be fulfilled before 40 ms of burst reception quality measurement have been collected.
- b) At least one transport block with a CRC attached is received in a TTI ending in the current frame with correct CRC.
- c) The UE detects at least one Special Burst. Special Burst detection shall be successful if the burst is detected with quality above a threshold, Q_{sbin} , and the TFCI is decoded to be that of the Special Burst.

The second phase starts 160 ms after the downlink dedicated channel is considered established by higher layers. During this phase both Out-of-Sync and In-Sync are reported as follows.

Out-of-sync shall be reported using the CPHY-Out-of-Sync-IND primitive if all three of the following criteria are fulfilled:

- the UE estimates the received dedicated channel burst quality over the last 160 ms period to be worse than a threshold Q_{out} . The value, Q_{out} is defined implicitly by the relevant tests in [2];
- no Special Burst is detected with quality above a threshold Q_{sbout} . The value Q_{sbout} is defined implicitly by the relevant tests in [2];
- over the previous 160 ms, no transport block has been received with a correct CRC

If the UE detects the beacon channel reception level [10 dB] above the handover triggering level, the UE shall use 320 ms estimation period for the burst quality evaluation and for the Special Burst and CRC detection window.

In-sync shall be reported using the CPHY-Sync-IND primitive if any one of the following criteria is fulfilled:

- the UE estimates the received burst reception quality over the last 160 ms period to be better than a threshold Q_{in} . The value, Q_{in} is defined implicitly by the relevant tests in [2].
- the UE detects at least one Special Burst with quality above a threshold Q_{sbin} . The value, Q_{sbin} , is defined implicitly by the relevant tests in [2].
- at least one transport block with a CRC attached is received in a TTI ending in the current frame with correct CRC.

If the UE detects the beacon channel reception level [10 dB] above the handover triggering level, the UE uses 320 ms estimation period for the burst quality evaluation and for the Special Burst and CRC detection window.

If no data are provided by higher layers for transmission during the second phase on the downlink dedicated channel then DTX shall be applied as defined in section 4.5.

How the primitives are used by higher layers is described in [15]. The above definitions may lead to radio frames where neither the In-Sync or Out-of-Sync primitives are reported.

4.4.2.1.3 Uplink synchronisation primitives

Layer 1 in the Node B shall every radio frame check synchronisation status, individually for each UL CCTrCH of the radio link. Synchronisation status is indicated to the RL Failure/Restored triggering function using either the CPHY-Sync-IND or CPHY-Out-of-Sync-IND primitive.

The exact criteria for indicating in-sync/out-of-sync is not subject to specification, but could e.g. be based on received burst quality or CRC checks. One example would be to have the same criteria as for the downlink synchronisation status primitives.

4.4.2.2 Radio link monitoring

4.4.2.2.1 Downlink radio link failure

The downlink CCTrCHs are monitored by the UE, to trigger radio link failure procedures. The downlink CCTrCH failure status is specified in [15], and is based on the synchronisation status primitives CPHY-Sync-IND and CPHY-Out-of-Sync-IND, indicating in-sync and out-of-sync respectively. These primitives shall provide status for each DL CCTrCH separately.

4.4.2.2.2 Uplink radio link failure/restore

The uplink CCTrCHs are monitored by the Node B in order to trigger CCTrCH failure/restore procedures. The uplink CCTrCH failure/restore status is reported using the synchronisation status primitives CPHY-Sync-IND and CPHY-Out-of-Sync-IND, indicating in-sync and out-of-sync respectively.

When the CCTrCH is in the in-sync state, Node B shall start timer T_RLFAILURE after receiving N_OUTSYNC_IND consecutive out-of-sync indications. Node B shall stop and reset timer T_RLFAILURE upon receiving successive N_INSYNC_IND in-sync indications. If T_RLFAILURE expires, Node B shall indicate to higher layers which CCTrCHs are out-of-sync using the synchronization status primitives. Furthermore, the CCTrCH state shall be changed to the out-of-sync state.

When a CCTrCH is in the out-of-sync state, after receiving N_INSYNC_IND successive in-sync indications Node B shall indicate that the CCTrCH has re-established synchronisation and the CCTrCH's state shall be changed to the in-sync-state. The specific parameter settings (values of T_RLFAILURE, N_OUTSYNC_IND, and N_INSYNC_IND) are configurable, see [16].

4.5 Discontinuous transmission (DTX) of Radio Frames

Discontinuous transmission (DTX) is applied in up- and downlink individually for each CCTrCH in case the total bit rate after transport channel multiplexing differs from the total channel bit rate of the dedicated physical channels allocated to a CCTrCH.

Rate matching is used in order to fill resource units completely, that are only partially filled with data. In the case that after rate matching and multiplexing no data at all is to be transmitted in a resource unit the complete resource unit is discarded from transmission. This applies also to the case where only one resource unit is allocated and no data has to be transmitted.

4.5.1 Use of Special Bursts for DTX

In case there are no transport blocks provided for transmission by higher layers for any given CCTrCH after link establishment, then a Special Burst shall be transmitted in the first allocated frame of the transmission pause. If there is a consecutive period of $\lceil N_OUTSYNC_IND/2-1 \rceil$ frames without transport blocks provided by higher layers, then another special burst shall be generated and transmitted at the next possible frame. This pattern shall be continued until transport blocks are provided for the CCTrCH by the higher layers.

This special burst shall have the same slot format as the burst used for data provided by higher layers. The special burst is filled with an arbitrary bit pattern, contains a TFCI and TPC bits if inner loop PC is applied and is transmitted for each CCTrCH individually on the physical channel which is defined to carry the TFCI. The TFCI of the special burst shall indicate that there were no transport blocks provided for transmission by higher layers as defined in [15]. The transmission power of the special burst shall be the same as that of the substituted physical channel of the CCTrCH carrying the TFCI.

4.5.2 Use of Special Bursts for Initial Establishment

Upon initial establishment and either 160 ms following detection of in-sync, or until the first transport block is received from higher layers, both the UE and the Node B shall transmit the special burst for each CCTrCH for each assigned resource which was scheduled to include a TFCI.

4.6 Downlink Transmit Diversity

Downlink transmit diversity for DPCH, P-CCPCH, and SCH is optional in UTRAN. Its support is mandatory at the UE.

4.6.1 Transmit Diversity for DPCH

The transmitter structure to support transmit diversity for DPCH transmission is shown in figure 1. Channel coding, interleaving and spreading are done as in non-diversity mode. The spread complex valued signal is fed to both TX antenna branches, and weighted with antenna specific weight factors w_1 and w_2 . The weight factors are complex valued signals (i.e., $w_i = a_i + jb_i$), in general. These weight factors are calculated on a per slot and per user basis.

The weight factors are determined by the UTRAN. Examples of transmit diversity schemes are given in annex B.

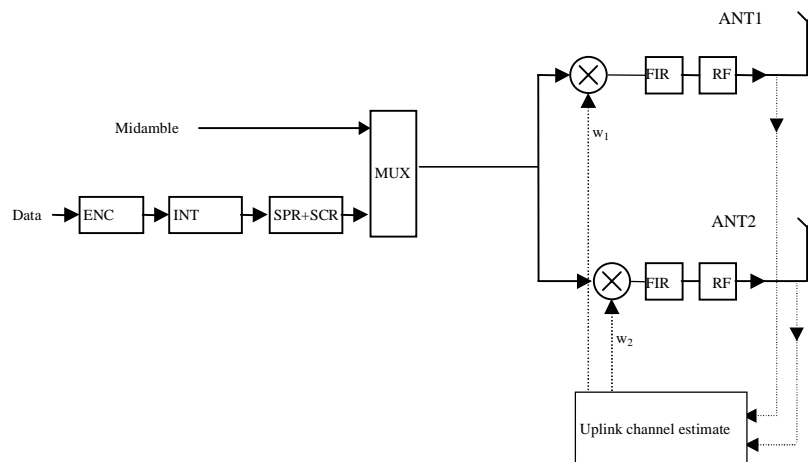

Figure 1: Downlink transmitter structure to support Transmit Diversity for DPCH transmission (UTRAN Access Point)

4.6.2 Transmit Diversity for SCH

Time Switched Transmit Diversity (TSTD) can be employed as transmit diversity scheme for the synchronisation channel.

4.6.2.1 SCH Transmission Scheme

The transmitter structure to support transmit diversity for SCH transmission is shown in figure 2. P-SCH and S-SCH are transmitted from antenna 1 and antenna 2 alternatively. An example for the antenna switching pattern is shown in figure 3.

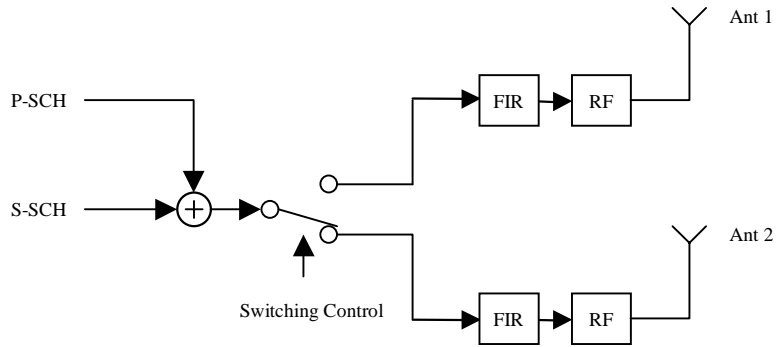

Figure 2: Downlink transmitter structure to support Transmit Diversity for SCH transmission (UTRAN Access Point)

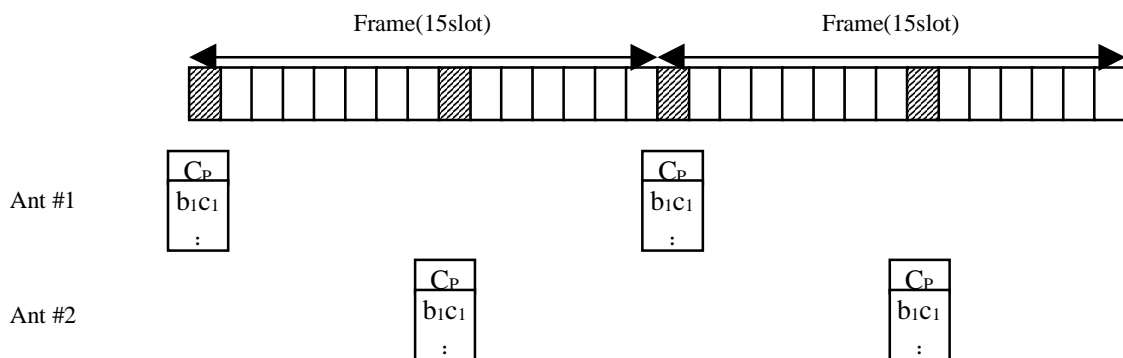

Figure 3: Antenna Switching Pattern (Case 2)

4.6.3 Transmit Diversity for P-CCPCH

Block Space Time Transmit Diversity (Block STTD) may be employed as transmit diversity scheme for the Primary Common Control Physical Channels (P-CCPCH).

4.6.3.1 P-CCPCH Transmission Scheme

The open loop downlink transmit diversity employs a Block Space Time Transmit Diversity scheme (Block STTD).

A block diagram of the Block STTD transmitter is shown in figure 4. Before Block STTD encoding, channel coding, rate matching, interleaving and bit-to-symbol mapping are performed as in the non-diversity mode.

Block STTD encoding is separately performed for each of the two data fields present in a burst (each data field contains N data symbols). For each data field at the encoder input, 2 data fields are generated at its output, corresponding to each of the diversity antennas. The Block STTD encoding operation is illustrated in figure 5, where the superscript * stands for complex conjugate. If N is an odd number, the first symbol of the block shall not be STTD encoded and the same symbol will be transmitted with equal power from both antennas.

After Block STTD encoding both branches are separately spread and scrambled as in the non-diversity mode.

The use of Block STTD encoding will be indicated by higher layers.

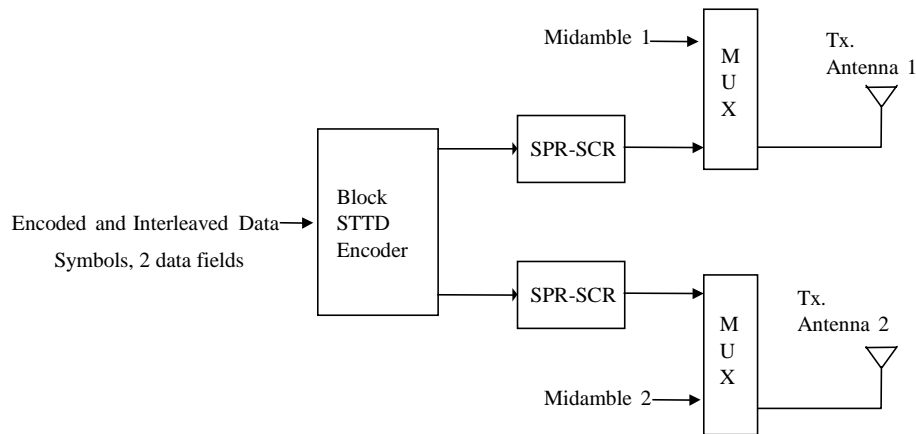

Figure 4: Block Diagram of the transmitter (STTD)

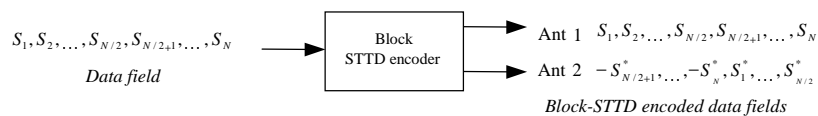

Figure 5: Block Diagram of Block STTD encoder. The symbols S_i are QPSK. N is the length of the block to be encoded

4.7 Random access procedure

The physical random access procedure described below is invoked whenever a higher layer requests transmission of a message on the RACH. The physical random access procedure is controlled by primitives from RRC and MAC. Retransmission on the RACH in case of failed transmission (e.g. due to a collision) is controlled by higher layers. Thus, the backoff algorithm and associated handling of timers is not described here. The definition of the RACH in terms of PRACH sub-channels and associated Access Service Classes is broadcast on the BCH in each cell. Parameters for common physical channel uplink outer loop power control are also broadcast on the BCH in each cell. The UE needs to decode this information prior to transmission on the RACH.

4.7.1 Physical random access procedure

The physical random access procedure described in this subclause is initiated upon request of a PHY-Data-REQ primitive from the MAC sublayer (see [18] and [19]).

Before the physical random-access procedure can be initiated, Layer 1 shall receive the following information by a CPHY-TrCH-Config-REQ from the RRC layer:

- the available PRACH sub-channels for each Access Service Class (ASC);
- the timeslot, spreading factor, channelisation code, midamble, repetition period and offset for each PRACH sub-channel. (There is a 1:1 mapping between spreading code and midamble as defined by RRC);
- the set of Transport Format parameters;
- the set of parameters for common physical channel uplink outer loop power control.

NOTE: The above parameters may be updated from higher layers before each physical random access procedure is initiated. At each initiation of the physical random access procedure, Layer 1 shall receive the following information from the higher layers (MAC):

- the Transport Format to be used for the PRACH message;
- the ASC of the PRACH transmission;
- the data to be transmitted (Transport Block Set).

The physical random-access procedure shall be performed as follows.

- 1 Randomly select the PRACH sub-channel from the available ones for the given ASC. The random function shall be such that each of the allowed selections is chosen with equal probability.
- 2 Derive the available access slots in the next N frames, defined by SFN, SFN+1, ..., SFN+N-1 for the selected PRACH sub-channel with the help of SFN (where N is the repetition period of the selected PRACH sub-channel). Randomly select an uplink access slot from the available access slots in the next frame, defined by SFN, if there is one available. If there is no access slot available in the next frame, defined by SFN then, randomly select one access slot from the available access slots in the following frame, defined by SFN+1. This search is performed for all frames in increasing order, defined by SFN, SFN+1, ..., SFN+N-1, until an available access slot is found. The random function shall be such that each of the allowed selections is chosen with equal probability.
- 3 Randomly select a spreading code from the available ones for the given ASC. The random function shall be such that each of the allowed selections is chosen with equal probability. The midamble is derived from the selected spreading code.
- 4 Set the PRACH message transmission power level according to the specification for common physical channels in uplink (see subclause 4.2.2.2).
- 5 Transmit the random access message with no timing advance.

4.8 DSCH procedure

The physical downlink shared channel procedure described below shall be applied by the UE when the physical layer signalling either with the midamble based signalling or TFCI based signalling is used to indicate for the UE the need for PDSCH detection. There is also a third alternative to indicate to the UE the need for the PDSCH detection and this is done by means of higher layer signalling, already described in [8].

4.8.1 DSCH procedure with TFCI indication

When the UE has been allocated by higher layers to receive data on DSCH using the TFCI, the UE shall decode the PDSCH in the following cases:

- In case of a standalone PDSCH the TFCI is located on the PDSCH itself, then the UE shall decode the TFCI and based on which data rate was indicated by the TFCI, the decoding shall be performed. The UE shall decode PDSCH only if the TFCI word decode corresponds to the TFC part of the TFCS given to the UE by higher layers.
- In case that the TFCI is located on the DCH, the UE shall decode the PDSCH frame or frames if the TFCI on the DCH indicates the need for PDSCH reception. Upon reception of the DCH time slot or time slots, the PDSCH slot (or first PDSCH slot) shall start $SFN\ n+2$ after the DCH frame containing the TFCI, where n indicates the SFN on which the DCH is received. In the case that the TFCI is repeated over several frames, the PDSCH slot shall start $SFN\ n+2$ after the frame having the DCH slot which contains the last part of the repeated TFCI.

4.8.2 DSCH procedure with midamble indication

When the UE has been allocated by higher layers to receive PDSCH based on the midamble used on the PDSCH (midamble based signalling described in [8]), the UE shall operate as follows:

- The UE shall test the midamble it received and if the midamble received was the same as indicated by higher layers to correspond to PDSCH reception, the UE shall detect the PDSCH data according to the TF given by the higher layers for the UE.
- In case of multiple time slot allocation for the DSCH indicated to be part of the TF for the UE, the UE shall receive all timeslots if the midamble of the first timeslot of PDSCH was the midamble indicated to the UE by higher layers.
- In case the standalone PDSCH (no associated DCH) contains the TFCI the UE shall detect the TF indicated by the TFCI on PDSCH.

Annex A (informative): Power Control

A.1 An Example for Calculating α

This annex presents an example for calculating the path loss weighting parameter for open loop power control α .

α can be calculated as $\alpha = 1-(D-1)/6$ where D is the delay, expressed in number of slots, between the uplink slot and the most recent downlink slot. Note that $\alpha=1$ for a delay of one slot (minimal delay), and $\alpha=0$ for a delay of 7 slots (maximal delay).

A.2 Example Implementation of Downlink Power Control in the UE

The measurement of received SIR shall be carried out periodically at the UE. When the measured value is higher than the target SIR value, TPC command = "down". When this is lower than or equal to the target SIR value, TPC command = "up".

In case of a downlink transmission pause on the DPCH or PDSCH, the receive power (RSCP) of the data can no longer be used for inner loop SIR calculations in the UE. In this case the UE should trace the fluctuations of the pathloss based on the P-CCPCH and use these values instead for generating the TPC commands. This pathloss together with the timeslot ISCP measurement in the data timeslot, which is ongoing, should be used to calculate a virtual SIR value:

$$SIR_{virt}(i) = RSCP_{virt}(i) - ISCP(i),$$

$$RSCP_{virt}(i) = RSCP_0 + L_0 - L(i) + \sum_{k=1}^{i-1} TPC(k),$$

| | |
|------------|---|
| RSCP: | Received signal code power in dB |
| ISCP: | Interference signal code power in the DPCH / PDSCH timeslot in dB |
| L: | pathloss in dB measured on the P-CCPCH. The same weighting of the long- and short-term pathloss should be used as for uplink open loop power control, see Annex A.1 |
| i: | index for the frames during a transmission pause, $1 \leq i \leq$ number of frames in the pause |
| L_0 : | weighted pathloss in the last frame before the transmission pause |
| $RSCP_0$: | RSCP of the data that was used in the SIR calculation of the last frame before the pause |
| TPC (k): | \pm power control stepsize in dB according to the TPC bit generated and transmitted in frame k, TPC bit "up" = +stepsize, TPC bit "down" = -stepsize |

Annex B (informative): Determination of Weight Information

Selective Transmit Diversity (STD) and Transmit Adaptive Antennas (TxAA) are examples of transmit diversity schemes for dedicated physical channels.

B.1 STD Weights

The weight vector will take only two values depending on the signal strength received by each antenna in the uplink slot. For each user, the antenna receiving the highest power will be selected (i.e. the corresponding weight will be set to 1).

Table 2: STD weights for two TX antennas

| | w_1 | w_2 |
|-----------------------------------|-------|-------|
| Antenna 1 receiving highest power | 1 | 0 |
| Antenna 2 receiving highest power | 0 | 1 |

B.2 TxAA Weights

In a generic sense, the weight vector to be applied at the transmitter is the \underline{w} that maximises:

$$P = \underline{w}^H H^H H \underline{w} \quad (1)$$

where

$$H = [\underline{h}_1 \quad \underline{h}_2] \text{ and } \underline{w} = [w_1, w_2]^T$$

and where the column vector \underline{h}_i represents the estimated uplink channel impulse response for the i 'th transmission antenna, of length equal to the length of the channel impulse response.

Annex C (informative): Cell search procedure

During the cell search, the UE searches for a cell and determines the downlink scrambling code, basic midamble code and frame synchronisation of that cell. The cell search is typically carried out in three steps:

Step 1: Primary synchronisation code acquisition

During the first step of the cell search procedure, the UE uses the SCH's primary synchronisation code to find a cell. This is typically done with a single matched filter (or any similar device) matched to the primary synchronisation code which is common to all cells. A cell can be found by detecting peaks in the matched filter output.

Note that for a cell of SCH slot configuration case 1, the SCH can be received periodically every 15 slots. In case of a cell of SCH slot configuration case 2, the following SCH slot can be received at offsets of either 7 or 8 slots from the previous SCH slot.

Step 2: Code group identification and slot synchronisation

During the second step of the cell search procedure, the UE uses the SCH's secondary synchronisation codes to identify 1 out of 32 code groups for the cell found in the first step. This is typically done by correlating the received signal with the secondary synchronisation codes at the detected peak positions of the first step. The primary synchronisation code provides the phase reference for coherent detection of the secondary synchronisation codes. The code group can then uniquely be identified by detection of the maximum correlation values.

Each code group indicates a different t_{offset} parameter and 4 specific cell parameters. Each of the cell parameters is associated with one particular downlink scrambling code and one particular long and short basic midamble code. When the UE has determined the code group, it can unambiguously derive the slot timing of the found cell from the detected peak position in the first step and the t_{offset} parameter of the found code group in the second step.

Note that the modulation of the secondary synchronisation codes also indicates the position of the SCH slot within a 2 frames period, e.g. a frame with even or odd SFN. Additionally, in the case of SCH slot configuration following case 2, the SCH slot position within one frame, e.g. first or last SCH slot, can be derived from the modulation of the secondary synchronisation codes.

Step 3: Downlink scrambling code, basic midamble code identification and frame synchronisation

During the third and last step of the cell search procedure, the UE determines the exact downlink scrambling code, basic midamble code and frame timing used by the found cell. The long basic midamble code can be identified by correlation over the P-CCPCH (or any other beacon channel) with the 4 possible long basic midamble codes of the code group found in the second step. A P-CCPCH (or any other beacon channel) always uses the midamble $m^{(1)}$ (and in case of Block-STTD also midamble $m^{(2)}$) derived from the long basic midamble code and always uses a fixed and pre-assigned channelisation code.

When the long basic midamble code has been identified, downlink scrambling code and cell parameter are also known. The UE can read system and cell specific BCH information and acquire frame synchronisation.

Note that even for an initial cell parameter assignment, a cell cycles through a set composed of 2 different cell parameters according to the SFN of a frame, e.g. the downlink scrambling code and the basic midamble code of a cell alternate for frames with even and odd SFN. Cell parameter cycling leaves the code group of a cell unchanged.

If the UE has received information about which cell parameters or SCH configurations to search for, cell search can be simplified.

Annex D (informative): Change history

| Change history | | | | | | | |
|----------------|--------|-----------|-----|-----|---|-------|-------|
| Date | TSG # | TSG Doc. | CR | Rev | Subject/Comment | Old | New |
| 14/01/00 | RAN_05 | RP-99594 | - | | Approved at TSG RAN #5 and placed under Change Control | - | 3.0.0 |
| 14/01/00 | RAN_06 | RP-99698 | 001 | 01 | Primary and Secondary CCPCH in TDD | 3.0.0 | 3.1.0 |
| 14/01/00 | RAN_06 | RP-99698 | 002 | - | Measurement procedure of received reference power for OL-TPC in TDD | 3.0.0 | 3.1.0 |
| 14/01/00 | RAN_06 | RP-99699 | 004 | 1 | STTD capability for P-CCPCH, TDD component | 3.0.0 | 3.1.0 |
| 14/01/00 | RAN_06 | RP-99697 | 005 | 1 | Alignment of Terminology Regarding Spreading for TDD Mode | 3.0.0 | 3.1.0 |
| 14/01/00 | - | - | - | | Change history was added by the editor | 3.1.0 | 3.1.1 |
| 31/03/00 | RAN_07 | RP-000070 | 003 | 2 | Cycling of cell parameters | 3.1.1 | 3.2.0 |
| 31/03/00 | RAN_07 | RP-000070 | 007 | 2 | Clarifications on the UL synchronisation and Timing advance | 3.1.1 | 3.2.0 |
| 31/03/00 | RAN_07 | RP-000070 | 008 | - | Modification of SIR threshold on setting TPC | 3.1.1 | 3.2.0 |
| 31/03/00 | RAN_07 | RP-000070 | 009 | 1 | New section describing the random access procedure | 3.1.1 | 3.2.0 |
| 31/03/00 | RAN_07 | RP-000070 | 011 | - | Removal of Synchronisation Case 3 in TDD | 3.1.1 | 3.2.0 |
| 31/03/00 | RAN_07 | RP-000070 | 012 | 1 | Clarifications on power control procedures | 3.1.1 | 3.2.0 |
| 31/03/00 | RAN_07 | RP-000070 | 013 | - | Signal Point Constellation | 3.1.1 | 3.2.0 |
| 31/03/00 | RAN_07 | RP-000070 | 014 | 2 | Out-of-sync handling for UTRA TDD | 3.1.1 | 3.2.0 |
| 31/03/00 | RAN_07 | RP-000070 | 015 | - | Removal of ODMA from the TDD specifications | 3.1.1 | 3.2.0 |
| 26/06/00 | RAN_08 | RP-000274 | 016 | - | Editorial correction for the power control section in 25.224 | 3.2.0 | 3.3.0 |
| 26/06/00 | RAN_08 | RP-000274 | 017 | - | Power control for TDD during DTX | 3.2.0 | 3.3.0 |
| 26/06/00 | RAN_08 | RP-000274 | 018 | 1 | Power Control for PDSCH | 3.2.0 | 3.3.0 |
| 26/06/00 | RAN_08 | RP-000274 | 020 | 1 | Editorial modification of 25.224 | 3.2.0 | 3.3.0 |
| 26/06/00 | RAN_08 | RP-000274 | 021 | - | Clarifications on TxDiversity for UTRA TDD | 3.2.0 | 3.3.0 |
| 26/06/00 | RAN_08 | RP-000274 | 022 | 1 | Introduction of the TDD DSCH detection procedure in TS 25.224 | 3.2.0 | 3.3.0 |
| 26/06/00 | RAN_08 | RP-000274 | 023 | - | Downlink power control on timeslot basis | 3.2.0 | 3.3.0 |
| 23/09/00 | RAN_09 | RP-000347 | 019 | 1 | Gain Factors for TDD Mode | 3.3.0 | 3.4.0 |
| 23/09/00 | RAN_09 | RP-000347 | 025 | - | Terminology regarding the beacon function | 3.3.0 | 3.4.0 |
| 23/09/00 | RAN_09 | RP-000347 | 026 | 1 | Synchronisation of timing advance adjustment and timing deviation measurement | 3.3.0 | 3.4.0 |
| 23/09/00 | RAN_09 | RP-000347 | 027 | 1 | CCTrCH UL/DL pairing for DL inner loop power control | 3.3.0 | 3.4.0 |
| 23/09/00 | RAN_09 | RP-000347 | 028 | 1 | RACH timing in TDD mode | 3.3.0 | 3.4.0 |
| 23/09/00 | RAN_09 | RP-000347 | 030 | 1 | TDD Access Bursts for HOV | 3.3.0 | 3.4.0 |
| 23/09/00 | RAN_09 | RP-000347 | 032 | - | Removal of ODMA related abbreviations and correction of references | 3.3.0 | 3.4.0 |
| 23/09/00 | RAN_09 | RP-000347 | 033 | - | Clarifications on the Out-of-sync handling for UTRA TDD | 3.3.0 | 3.4.0 |
| 15/12/00 | RAN_10 | RP-000544 | 035 | 1 | Radio Link establishment and sync status reporting | 3.4.0 | 3.5.0 |
| 15/12/00 | RAN_10 | RP-000544 | 040 | - | Clarification on PICH power setting | 3.4.0 | 3.5.0 |
| 15/12/00 | RAN_10 | RP-000544 | 042 | - | Correction to TDD timing advance description | 3.4.0 | 3.5.0 |
| 15/12/00 | RAN_10 | RP-000544 | 043 | - | Limit on maximum value of alpha used for open loop power control | 3.4.0 | 3.5.0 |
| | | | | | | | |
| | | | | | | | |
| | | | | | | | |
| | | | | | | | |
| | | | | | | | |
| | | | | | | | |
| | | | | | | | |
| | | | | | | | |
| | | | | | | | |
| | | | | | | | |
| | | | | | | | |
| | | | | | | | |
| | | | | | | | |
| | | | | | | | |
| | | | | | | | |
| | | | | | | | |
| | | | | | | | |
| | | | | | | | |
| | | | | | | | |

History

| Document history | | |
|-------------------------|----------------|-------------|
| V3.1.1 | January 2000 | Publication |
| V3.2.0 | March 2000 | Publication |
| V3.3.0 | June 2000 | Publication |
| V3.4.0 | September 2000 | Publication |
| V3.5.0 | December 2000 | Publication |