

# ETSI TS 125 224 V5.8.0 (2004-09)

---

*Technical Specification*

## **Universal Mobile Telecommunications System (UMTS); Physical layer procedures (TDD) (3GPP TS 25.224 version 5.8.0 Release 5)**

---



---

**Reference**

RTS/TSGR-0125224v580

---

**Keywords**

UMTS

**ETSI**

650 Route des Lucioles  
F-06921 Sophia Antipolis Cedex - FRANCE

---

Tel.: +33 4 92 94 42 00 Fax: +33 4 93 65 47 16

Siret N° 348 623 562 00017 - NAF 742 C  
Association à but non lucratif enregistrée à la  
Sous-Préfecture de Grasse (06) N° 7803/88

---

**Important notice**

---

Individual copies of the present document can be downloaded from:

<http://www.etsi.org>

The present document may be made available in more than one electronic version or in print. In any case of existing or perceived difference in contents between such versions, the reference version is the Portable Document Format (PDF). In case of dispute, the reference shall be the printing on ETSI printers of the PDF version kept on a specific network drive within ETSI Secretariat.

Users of the present document should be aware that the document may be subject to revision or change of status. Information on the current status of this and other ETSI documents is available at

<http://portal.etsi.org/tb/status/status.asp>

If you find errors in the present document, please send your comment to one of the following services:

[http://portal.etsi.org/chaicor/ETSI\\_support.asp](http://portal.etsi.org/chaicor/ETSI_support.asp)

---

**Copyright Notification**

---

No part may be reproduced except as authorized by written permission.  
The copyright and the foregoing restriction extend to reproduction in all media.

© European Telecommunications Standards Institute 2004.  
All rights reserved.

**DECT**<sup>TM</sup>, **PLUGTESTS**<sup>TM</sup> and **UMTS**<sup>TM</sup> are Trade Marks of ETSI registered for the benefit of its Members.  
**TIPHON**<sup>TM</sup> and the **TIPHON logo** are Trade Marks currently being registered by ETSI for the benefit of its Members.  
**3GPP**<sup>TM</sup> is a Trade Mark of ETSI registered for the benefit of its Members and of the 3GPP Organizational Partners.

---

## Intellectual Property Rights

IPRs essential or potentially essential to the present document may have been declared to ETSI. The information pertaining to these essential IPRs, if any, is publicly available for **ETSI members and non-members**, and can be found in ETSI SR 000 314: *"Intellectual Property Rights (IPRs); Essential, or potentially Essential, IPRs notified to ETSI in respect of ETSI standards"*, which is available from the ETSI Secretariat. Latest updates are available on the ETSI Web server (<http://webapp.etsi.org/IPR/home.asp>).

Pursuant to the ETSI IPR Policy, no investigation, including IPR searches, has been carried out by ETSI. No guarantee can be given as to the existence of other IPRs not referenced in ETSI SR 000 314 (or the updates on the ETSI Web server) which are, or may be, or may become, essential to the present document.

---

## Foreword

This Technical Specification (TS) has been produced by ETSI 3rd Generation Partnership Project (3GPP).

The present document may refer to technical specifications or reports using their 3GPP identities, UMTS identities or GSM identities. These should be interpreted as being references to the corresponding ETSI deliverables.

The cross reference between GSM, UMTS, 3GPP and ETSI identities can be found under <http://webapp.etsi.org/key/queryform.asp>.

# Contents

Intellectual Property Rights .....	2
Foreword.....	2
Foreword.....	6
1 Scope .....	7
2 References .....	7
3 Abbreviations .....	8
4 Physical layer procedures for the 3,84 Mcps option .....	9
4.1 General .....	9
4.2 Transmitter Power Control .....	9
4.2.1 General Parameters .....	9
4.2.2 Uplink Control .....	9
4.2.2.1 General Limits.....	9
4.2.2.2 PRACH .....	9
4.2.2.3 DPCH, PUSCH and HS-SICH .....	9
4.2.2.3.1 Gain Factors .....	10
4.2.2.3.2 Out of synchronisation handling.....	11
4.2.3 Downlink Control .....	11
4.2.3.1 P-CCPCH.....	11
4.2.3.2 S-CCPCH, PICH .....	11
4.2.3.3 SCH.....	11
4.2.3.3A PNBSCH .....	11
4.2.3.4 DPCH, PDSCH .....	11
4.2.3.4.1 Out of synchronisation handling.....	12
4.2.3.5 HS-PDSCH .....	12
4.2.3.6 HS-SCCH.....	12
4.3 Timing Advance .....	13
4.4 Synchronisation procedures.....	13
4.4.1 Cell Search.....	13
4.4.2 Dedicated channel synchronisation.....	13
4.4.2.1 Synchronisation primitives.....	13
4.4.2.1.1 General .....	13
4.4.2.1.2 Downlink synchronisation primitives.....	13
4.4.2.1.3 Uplink synchronisation primitives.....	14
4.4.2.2 Radio link monitoring .....	14
4.4.2.2.1 Downlink radio link failure .....	14
4.4.2.2.2 Uplink radio link failure/restore .....	14
4.5 Discontinuous transmission (DTX) procedure .....	15
4.5.0 Description of Special Bursts.....	15
4.5.1 Use of Special Bursts during DTX .....	15
4.5.2 Use of Special Bursts for Initial Establishment / Reconfiguration .....	16
4.5.3 Use of Special Bursts for DTX on Beacon Channels .....	16
4.6 Downlink Transmit Diversity.....	16
4.6.1 Transmit Diversity for PDSCH, DPCH, HS-SCCH and HS-PDSCH .....	16
4.6.2 Transmit Diversity for SCH.....	17
4.6.2.1 SCH Transmission Scheme .....	17
4.6.3 Transmit Diversity for Beacon Channels.....	17
4.6.3.1 SCTD Transmission Scheme .....	18
4.7 Random access procedure .....	18
4.7.1 Physical random access procedure.....	18
4.8 DSCH procedure .....	19
4.8.1 DSCH procedure with TFCI indication .....	19
4.8.2 DSCH procedure with midamble indication .....	19
4.9 Node B Synchronisation Procedure over the Air .....	20

4.9.1	Frequency Acquisition Phase.....	20
4.9.2	Initial Synchronisation.....	20
4.9.3	Steady-State Phase.....	20
4.9.4	Late entrant cells.....	20
4.10	Idle periods for IPDL location method.....	21
4.10.1	General.....	21
4.10.2	Parameters of IPDL.....	21
4.10.3	Calculation of idle period position.....	21
4.11	HS-DSCH Procedure.....	22
4.11.1	Link Adaptation Procedure.....	22
4.11.2	HS-DSCH Channel Quality Indication Procedure.....	23
5	Physical layer procedures for the 1.28 Mcps option.....	24
5.1	Transmitter Power Control.....	24
5.1.1	Uplink Control.....	24
5.1.1.1	General limits.....	24
5.1.1.2	UpPCH.....	25
5.1.1.3	PRACH.....	25
5.1.1.4	DPCH and PUSCH.....	25
5.1.1.4.1	Gain Factors.....	25
5.1.1.4.2	Out of synchronization handling.....	25
5.1.1.5	HS-SICH.....	25
5.1.2	Downlink Control.....	25
5.1.2.1	P-CCPCH.....	26
5.1.2.2	The power of the FPACH.....	26
5.1.2.3	S-CCPCH, PICH.....	26
5.1.2.4	DPCH, PDSCH.....	26
5.1.2.4.1	Out of synchronisation handling.....	26
5.1.2.5	HS-PDSCH.....	26
5.1.2.6	HS-SCCH.....	26
5.2	UL Synchronisation.....	26
5.2.1	General Description.....	26
5.2.1.1	Preparation of uplink synchronization (downlink synchronization).....	27
5.2.1.2	Establishment of uplink synchronization.....	27
5.2.1.3	Maintenance of uplink synchronisation.....	27
5.2.2	UpPCH.....	27
5.2.3	PRACH.....	27
5.2.4	DPCH and PUSCH.....	28
5.2.4.1	Out of synchronization handling.....	28
5.2.5	HS-SICH.....	28
5.3	Synchronisation procedures.....	28
5.3.1	Cell search.....	28
5.3.2	DCH synchronization.....	29
5.4	Discontinuous transmission (DTX) procedure.....	29
5.5	Downlink Transmit Diversity.....	29
5.5.1	Transmit Diversity for PDSCH, DPCH, HS-SCCH, and HS-PDSCH.....	29
5.5.1.1	TSTD for PDSCH and DPCH.....	29
5.5.1.2	Closed Loop Tx Diversity for PDSCH, DPCH, HS-SCCH, and HS-PDSCH.....	30
5.5.2	Transmit Diversity for DwPCH.....	30
5.5.3	Transmit Diversity for P-CCPCH.....	31
5.5.3.1	TSTD Transmission Scheme for P-CCPCH.....	31
5.5.4	SCTD Transmission Scheme for Beacon Channels.....	31
5.6	Random Access Procedure.....	32
5.6.1	Definitions.....	32
5.6.2	Preparation of random access.....	33
5.6.3	Random access procedure.....	33
5.6.3.1	The use and generation of the information fields transmitted in the FPACH.....	35
5.6.3.1.1	Signature Reference Number.....	35
5.6.3.1.2	Relative Sub-Frame Number.....	35
5.6.3.1.3	Received starting position of the UpPCH (UpPCH <sub>POS</sub> ).....	35
5.6.3.1.4	Transmit Power Level Command for the RACH message.....	35
5.6.4	Random access collision.....	35

5.7	Node B Synchronisation Procedure over the Air .....	36
5.7.1	Initial Synchronisation.....	36
5.7.2	Steady-State Phase.....	36
5.7.3	Late entrant cells.....	36
5.8	Idle periods for IPDL location method.....	36
5.8.1	General.....	36
5.8.2	Parameters of IPDL .....	36
5.8.3	Calculation of idle period position.....	37
5.9	HS-DSCH Procedure.....	37
<b>Annex A (informative): Power Control .....</b>		<b>38</b>
A.1	Example Implementation of Downlink Power Control in the UE.....	38
A.2	Example Implementation of Closed Loop Uplink Power Control in Node B for 1.28 Mcps TDD .....	38
A.3	Example Implementation of Downlink Power Control in UE for 1.28 Mcps TDD when TSTD is used.....	38
A.4	Example Implementation of open Loop Power Control for access procedure for 1.28 Mcps TDD .....	39
<b>Annex B (informative): Determination of Weight Information.....</b>		<b>40</b>
B.1	STD Weights .....	40
B.2	TxAA Weights .....	40
<b>Annex C (informative): Cell search procedure for 3.84 Mcps TDD .....</b>		<b>41</b>
<b>Annex CA (informative): Cell search procedure for 1.28 Mcps TDD .....</b>		<b>42</b>
<b>Annex CB (informative): Examples random access procedure for 1.28 Mcps TDD.....</b>		<b>43</b>
<b>Annex D (informative): Change history .....</b>		<b>45</b>
History .....		47

---

## Foreword

This Technical Specification (TS) has been produced by the 3<sup>rd</sup> Generation Partnership Project (3GPP).

The contents of the present document are subject to continuing work within the TSG and may change following formal TSG approval. Should the TSG modify the contents of the present document, it will be re-released by the TSG with an identifying change of release date and an increase in version number as follows:

Version x.y.z

where:

- x the first digit:
  - 1 presented to TSG for information;
  - 2 presented to TSG for approval;
  - 3 or greater indicates TSG approved document under change control.
- y the second digit is incremented for all changes of substance, i.e. technical enhancements, corrections, updates, etc.
- z the third digit is incremented when editorial only changes have been incorporated in the document.

---

# 1 Scope

The present document describes the Physical Layer Procedures in the TDD mode of UTRA.

---

# 2 References

The following documents contain provisions which, through reference in this text, constitute provisions of the present document.

- References are either specific (identified by date of publication, edition number, version number, etc.) or non-specific.
- For a specific reference, subsequent revisions do not apply.
- For a non-specific reference, the latest version applies. In the case of a reference to a 3GPP document (including a GSM document), a non-specific reference implicitly refers to the latest version of that document *in the same Release as the present document*.

- [1] 3GPP TS 25.201: "Physical layer - general description".
- [2] 3GPP TS 25.102: "UE physical layer capabilities".
- [3] 3GPP TS 25.211: "Physical channels and mapping of transport channels onto physical channels (FDD)".
- [4] 3GPP TS 25.212: "Multiplexing and channel coding (FDD)".
- [5] 3GPP TS 25.213: "Spreading and modulation (FDD)".
- [6] 3GPP TS 25.214: "Physical layer procedures (FDD)".
- [7] 3GPP TS 25.215: "Physical Layer - Measurements (FDD)".
- [8] 3GPP TS 25.221: "Physical channels and mapping of transport channels onto physical channels (TDD)".
- [9] 3GPP TS 25.222: "Multiplexing and channel coding (TDD)".
- [10] 3GPP TS 25.223: "Spreading and modulation (TDD)".
- [11] 3GPP TS 25.225: "Physical Layer - Measurements (TDD)".
- [12] 3GPP TS 25.301: "Radio Interface Protocol Architecture".
- [13] 3GPP TS 25.302: "Services Provided by the Physical Layer".
- [14] 3GPP TS 25.401: "UTRAN Overall Description".
- [15] 3GPP TS 25.331: "RRC Protocol Specification"
- [16] 3GPP TS 25.433: "UTRAN Iub Interface NBAP Signalling"
- [17] 3GPP TS 25.105: "UTRA (BS) TDD; Radio transmission and Reception"
- [18] 3GPP TS 25.321: "MAC protocol specification"
- [19] 3GPP TS 25.303: "Interlayer Procedures in Connected Mode"
- [20] 3GPP TS 25.402: "Synchronisation in UTRAN Stage 2"



## 3 Abbreviations

For the purposes of the present document, the following abbreviations apply:

ACK	Acknowledgement
ASC	Access Service Class
BCCH	Broadcast Control Channel
BCH	Broadcast Channel
CCTrCH	Coded Composite Transport Channel
CDMA	Code Division Multiple Access
CQI	Channel Quality Information
CRC	Cyclic Redundancy Check
DCA	Dynamic Channel Allocation
DL	Downlink
DPCH	Dedicated Physical Channel
DTX	Discontinuous Transmission
FACH	Forward Access Channel
FDD	Frequency Division Duplex
HS-DSCH	High Speed Downlink Shared Channel
HS-PDSCH	High Speed Physical Downlink Shared Channel
HS-SCCH	Shared Control Channel for HS-DSCH
HS-SICH	Shared Information Channel for HS-DSCH
ISCP	Interference Signal Code Power
MAC	Medium Access Control
NACK	Negative Acknowledgement
NRT	Non-Real Time
P-CCPCH	Primary Common Control Physical Channel
PC	Power Control
PDSCH	Physical Downlink Shared Channel
PRACH	Physical Random Access Channel
PUSCH	Physical Uplink Shared Channel
RACH	Random Access Channel
RL	Radio Link
RRC	Radio Resource Control
RSCP	Received Signal Code Power
RT	Real Time
RU	Resource Unit
SBGP	Special Burst Generation Gap
SBP	Special Burst Period
SBSP	Special Burst Scheduling Period
S-CCPCH	Secondary Common Control Physical Channel
SCH	Synchronisation Channel
SCTD	Space Code Transmit Diversity
SFN	System Frame Number
SIR	Signal-to-Interference Ratio
SSCH	Secondary Synchronisation Channel
STD	Selective Transmit Diversity
TA	Timing Advance
TDD	Time Division Duplex
TF	Transport Format
TFC	Transport Format Combination
TFCI	Transport Format Combination Indicator
TFCS	Transport Format Combination Set
TFRI	Transport Format Resource Indicator
TPC	Transmit Power Control
TSTD	Time Switched Transmit Diversity
TTI	Transmission Time Interval
TxAA	Transmit Adaptive Antennas
UE	User Equipment
UL	Uplink
UMTS	Universal Mobile Telecommunications System

UTRAN            UMTS Radio Access Network  
VBR              Variable Bit Rate

## 4 Physical layer procedures for the 3,84 Mcps option

### 4.1 General

### 4.2 Transmitter Power Control

#### 4.2.1 General Parameters

Power control is applied for the TDD mode to limit the interference level within the system thus reducing the intercell interference level and to reduce the power consumption in the UE.

All codes within one timeslot allocated to the same CCTrCH use the same transmission power, in case they have the same spreading factor.

**Table 1: Transmit Power Control characteristics**

	<b>Uplink</b>	<b>Downlink</b>
<b>Power control rate</b>	Variable 1-7 slots delay (2 slot SCH) 1-14 slots delay (1 slot SCH)	Variable, with rate depending on the slot allocation.
<b>TPC Step size</b>	--	1dB or 2 dB or 3 dB
<b>Remarks</b>	All figures are without processing and measurement times	

#### 4.2.2 Uplink Control

##### 4.2.2.1 General Limits

During the operation of the uplink power control procedure the UE transmit power shall not exceed a maximum allowed value which is the lower out of the maximum output power of the terminal power class and a value which may be set by higher layer signalling.

Uplink power control shall be performed while the total UE transmit power is below the maximum allowed output power. In some cases the total UE transmit power in a timeslot after uplink power control calculation might exceed the maximum allowed output power. In these cases the calculated transmit power of all uplink physical channels in this timeslot shall be scaled by the same amount in dB before transmission. The total UE transmission power used shall be the maximum allowed output power.

The UTRAN may not expect the UE to be capable of reducing its total transmit power below the minimum level specified in [2].

##### 4.2.2.2 PRACH

The transmit power for the PRACH is set by higher layers based on open loop power control as described in [15].

##### 4.2.2.3 DPCH, PUSCH and HS-SICH

The transmit power for DPCH, PUSCH and HS-SICH is set by higher layers based on open loop power control as described in [15].

In the case that an ACK is being transmitted on the HS-SICH, the UE shall apply a power offset to the transmit power of the entire HS-SICH. This power offset shall be signalled by higher layers.

#### 4.2.2.3.1 Gain Factors

Two or more transport channels may be multiplexed onto a CCTrCH as described in [9]. These transport channels undergo rate matching which involves repetition or puncturing. This rate matching affects the transmit power required to obtain a particular  $E_b/N_0$ . Thus, the transmission power of the CCTrCH shall be weighted by a gain factor  $\beta$ .

There are two ways of controlling the gain factors for different TFC"s within a CCTrCH transmitted in a radio frame:

- $\beta$  is signalled for the TFC, or
- $\beta$  is computed for the TFC, based upon the signalled settings for a reference TFC.

Combinations of the two above methods may be used to associate  $\beta$  values to all TFC"s in the TFCS for a CCTrCH. The two methods are described in sections 4.2.2.3.1.1 and 4.2.2.3.1.2 respectively. Several reference TFC"s for several different CCTrCH"s may be signalled from higher layers.

The weight and gain factors may vary on a radio frame basis depending upon the current SF and TFC used. The setting of weight and gain factors is independent of any other form of power control. That means that the transmit power  $P_{UL}$  is calculated according to the formula given in [15] and then the weight and gain factors are applied on top of that, cf. [10].

##### 4.2.2.3.1.1 Signalled Gain Factors

When the gain factor  $\beta_j$  is signalled by higher layers for a certain TFC, the signalled values are used directly for weighting DPCH or PUSCH within a CCTrCH. Exact values are given in [10].

##### 4.2.2.3.1.2 Computed Gain Factors

The gain factor  $\beta_j$  may also be computed for certain TFCs, based on the signalled settings for a reference TFC:

Let  $\beta_{ref}$  denote the signalled gain factor for the reference TFC. Further, let  $\beta_j$  denote the gain factor used for the  $j$ -th TFC.

Define the variable: 
$$K_{ref} = \sum_i RM_i \cdot N_i$$

where  $RM_i$  is the semi-static rate matching attribute for transport channel  $i$ ,  $N_i$  is the number of bits output from the radio frame segmentation block for transport channel  $i$  and the sum is taken over all the transport channels  $i$  in the reference TFC.

Similarly, define the variable 
$$K_j = \sum_i RM_i \cdot N_i$$

where the sum is taken over all the transport channels  $i$  in the  $j$ -th TFC.

Moreover, define the variable 
$$L_{ref} = \sum_i \frac{1}{SF_i}$$

where  $SF_i$  is the spreading factor of DPCH or PUSCH  $i$  and the sum is taken over all DPCH or PUSCH  $i$  used in the reference TFC.

Similarly, define the variable 
$$L_j = \sum_i \frac{1}{SF_i}$$

where the sum is taken over all DPCH or PUSCH  $i$  used in the  $j$ -th TFC.

The gain factors  $\beta_j$  for the  $j$ -th TFC are then computed as follows:

$$\beta_j = \beta_{ref} \cdot \sqrt{\frac{L_{ref}}{L_j}} \sqrt{\frac{K_j}{K_{ref}}}$$

No quantisation of  $\beta_j$  is performed and as such, values other than the quantised  $\beta_j$  given in [10] may be used.

#### 4.2.2.3.2 Out of synchronisation handling

As stated in 4.2.3.4, the association between TPC commands sent on uplink DPCH and PUSCH, with the power controlled downlink DPCH and PDSCH is signaled by higher layers. In the case of multiple DL CCTrCHs it is possible that an UL CCTrCH will provide TPC commands to more than one DL CCTrCH.

In the second phase of synchronisation evaluation, as defined in 4.4.2.1.2, the UE shall shut off the transmission of an UL CCTrCH if the following criteria are fulfilled for any one of the DL CCTrCHs commanded by its TPC:

- The UE estimates the received dedicated channel burst quality over the last 160 ms period to be worse than a threshold  $Q_{out}$ , and in addition, no special burst, as defined in 4.5, is detected with quality above a threshold,  $Q_{sburst}$ .  $Q_{out}$  and  $Q_{sburst}$  are defined implicitly by the relevant tests in [2]. If the UE detects the beacon channel reception level [10 dB] above the handover triggering level, then the UE shall use a 320 ms estimation period for the burst quality evaluation and for the Special Burst detection window.

UE shall subsequently resume the uplink transmission of the CCTrCH if the following criteria are fulfilled:

- The UE estimates the received dedicated CCTrCH burst reception quality over the last 160 ms period to be better than a threshold  $Q_{in}$  or the UE detects a burst with quality above threshold  $Q_{sbin}$  and TFCI decoded to be that of the Special Burst.  $Q_{in}$  and  $Q_{sbin}$  are defined implicitly by the relevant tests in [2]. If the UE detects the beacon channel reception level [10 dB] above the handover triggering level, then the UE shall use a 320 ms estimation period for the burst quality evaluation and for the Special Burst detection window.

### 4.2.3 Downlink Control

#### 4.2.3.1 P-CCPCH

The Primary CCPCH transmit power is set by higher layer signalling and can be changed based on network conditions on a slow basis. The reference transmit power of the P-CCPCH is broadcast on BCH or individually signalled to each UE.

#### 4.2.3.2 S-CCPCH, PICH

The relative transmit power of the Secondary CCPCH and the PICH compared to the P-CCPCH transmit power are set by higher layer signalling. The PICH power offset relative to the P-CCPCH reference power is signalled on the BCH.

#### 4.2.3.3 SCH

The SCH transmit power is set by higher layer signalling [16]. The value is given relative to the power of the P-CCPCH.

#### 4.2.3.3A PNBSCH

The PNBSCH transmit power is set by higher layer signalling [16]. The value given is relative to the power of the P-CCPCH

#### 4.2.3.4 DPCH, PDSCH

The initial transmission power of the downlink DPCH and the PDSCH shall be set by higher layer signalling. If associated uplink CCTrCHs for TPC commands are signalled to the UE by higher layers (mandatory for a DPCH), the network shall transit into inner loop power control after the initial transmission. The UE shall then generate TPC commands to control the network transmit power and send them in the TPC field of the associated uplink CCTrCHs. If the physical channel power should be increased, the TPC command is set to 'up' whereas if the power should be reduced the TPC command is set to 'down'. An example on how to derive the TPC commands and the definition of the inner loop power control are given in Annex A.1. A TPC command sent in an uplink CCTrCH controls all downlink DPCHs or PDSCHs to which the associated downlink CCTrCH is mapped to.

If a PDSCH does not have associated uplink CCTrCHs configured for TPC power control, its power shall be controlled by higher layer signalling.

In the case that no associated downlink data is scheduled within 15 timeslots before the transmission of a TPC command then this is regarded as a transmission pause. The TPC commands in this case shall be derived from measurements on beacon function physical channels. An example solution for the generation of the TPC command for this case is given in Annex A 1.

When not in a transmission pause each TPC command shall always be based on all associated downlink transmissions received since the previous related TPC command. Related TPC commands are defined as TPC commands associated with the same downlink CCTrCHs. If there are no associated downlink transmissions (or equivalently no beacon transmissions when in a transmission pause) between two or more uplink transmissions carrying related TPC commands, then these TPC commands shall be identical and they shall be regarded by the UTRAN as a single TPC command.

UTRAN may decide how to adjust the transmit power in response to the received TPC command.

The UTRAN may apply an individual offset to the transmission power in each timeslot according to the downlink interference level at the UE.

The transmission power of one DPCH or PDSCH shall not exceed the limits set by higher layer signalling by means of `Maximum_DL_Power` (dB) and `Minimum_DL_Power` (dB). The transmission power is defined as the average power over one timeslot of the complex QPSK symbols of a single DPCH or PDSCH before spreading relative to the power of the P-CCPCH.

During a downlink transmission pause, both UE and Node B shall use the same TPC step size which is signalled by higher layers. The UTRAN may accumulate the TPC commands received during the pause. TPC commands that shall be regarded as identical may only be counted once. The initial UTRAN transmission power for the first data transmission after the pause may then be set to the sum of transmission power before the pause and a power offset according to the accumulated TPC commands. Additionally this sum may include a constant set by the operator and a correction term due to uncertainties in the reception of the TPC bits. The total downlink transmission power at the Node B within one timeslot shall not exceed Maximum Transmission Power set by higher layer signalling. If the total transmit power of all channels in a timeslot exceeds this limit, then the transmission power of all downlink DPCHs and PDSCHs shall be reduced by the same amount in dB. The value for this power reduction is determined, so that the total transmit power of all channels in this timeslot is equal to the maximum transmission power.

#### 4.2.3.4.1 Out of synchronisation handling

When the dedicated physical channel out of sync criteria based on the received burst quality is as given in the subclause 4.4.2 then the UE shall set the uplink TPC command = "up". The CRC based criteria shall not be taken into account in TPC bit value setting.

#### 4.2.3.5 HS-PDSCH

The HS-PDSCH power control is under the control of the NodeB.

#### 4.2.3.6 HS-SCCH

Higher layers shall indicate the initial transmit power of the HS-SCCH. How exactly this information is taken into account in the power setting is at the discretion of the NodeB.

Following the initial transmission, the NodeB may optionally power control the HS-SCCH. This may be done using TPC commands sent by the UE in the HS-SICH.

The UE shall set the TPC commands in the HS-SICH in order to control the transmit power of the HS-SCCH. The TPC commands shall be set in order to meet the HS-SCCH target BLER.

The accuracy of the received HS-SCCH BLER estimate made by the UE may be enhanced by a suitable use of the HCSN field received within the HS-SCCH itself [9]. This field shall initially be set to zero and shall be incremented by the NodeB each time an HS-SCCH is transmitted to the UE.

## 4.3 Timing Advance

UTRAN may adjust the UE transmission timing with timing advance. The initial value for timing advance ( $TA_{\text{phys}}$ ) will be determined in the UTRAN by measurement of the timing of the PRACH. The required timing advance will be represented as an 6 bit number (0-63) 'UL Timing Advance'  $TA_{\text{ul}}$ , being the multiplier of 4 chips which is nearest to the required timing advance (i.e.  $TA_{\text{phys}} = TA_{\text{ul}} \times 4$  chips).

When Timing Advance is used the UTRAN will continuously measure the timing of a transmission from the UE and send the necessary timing advance value. On receipt of this value the UE shall adjust the timing of its transmissions accordingly in steps of  $\pm 4$  chips. The transmission of TA values is done by means of higher layer messages. Upon receiving the TA command the UE shall adjust its transmission timing according to the timing advance command at the frame number specified by higher layer signaling. The UE is signaled the TA value in advance of the specified frame activation time to allow for local processing of the command and application of the TA adjustment on the specified frame. Node-B is also signaled the TA value and radio frame number that the TA adjustment is expected to take place.

If TA is enabled by higher layers, after handover the UE shall transmit in the new cell with timing advance TA adjusted by the relative timing difference  $\Delta t$  between the new and the old cell:

$$TA_{\text{new}} = TA_{\text{old}} + 2\Delta t.$$

## 4.4 Synchronisation procedures

### 4.4.1 Cell Search

During the cell search, the UE searches for a cell and determines the downlink scrambling code, basic midamble code and frame synchronisation of that cell. How cell search is typically done is described in Annex C.

### 4.4.2 Dedicated channel synchronisation

#### 4.4.2.1 Synchronisation primitives

##### 4.4.2.1.1 General

For the dedicated channels, synchronisation primitives are used to indicate the synchronisation status of radio links, both in uplink and downlink. The definition of the primitives is given in the following subclauses.

##### 4.4.2.1.2 Downlink synchronisation primitives

Layer 1 in the UE shall check the synchronization status of each DL CCTrCH individually in every radio frame. All bursts and transport channels of a CCTrCH shall be taken into account. Synchronisation status is indicated to higher layers, using the CPHY-Sync-IND or CPHY-Out-of-Sync-IND primitives. For dedicated physical channels configured with Repetition Periods [15] only the configured active periods shall be taken into account in the estimation. The status check shall also include detection of the Special Bursts defined in 4.5 for DTX.

The criteria for reporting synchronization status are defined in two different phases.

The first phase lasts until 160 ms after the downlink CCTrCH is considered to be established by higher layers. During this time, Out-of-sync shall not be reported. In-sync shall be reported using the CPHY-Sync-IND primitive if any one of the following three criteria is fulfilled.

- a) The UE estimates the burst reception quality over the previous 40 ms period to be better than a threshold  $Q_{\text{in}}$ . This criterion shall be assumed not to be fulfilled before 40 ms of burst reception quality measurement have been collected.
- b) At least one transport block with a CRC attached is received in a TTI ending in the current frame with correct CRC.
- c) The UE detects at least one Special Burst. Special Burst detection shall be successful if the burst is detected with quality above a threshold,  $Q_{\text{sbin}}$ , and the TFCI is decoded to be that of the Special Burst.

The second phase starts 160 ms after the downlink dedicated channel is considered established by higher layers.. During this phase both Out-of-Sync and In-Sync are reported as follows.

Out-of-sync shall be reported using the CPHY-Out-of-Sync-IND primitive if all three of the following criteria are fulfilled:

- the UE estimates the received dedicated channel burst quality over the last 160 ms period to be worse than a threshold  $Q_{out}$ . The value,  $Q_{out}$  is defined implicitly by the relevant tests in [2];
- no Special Burst is detected with quality above a threshold  $Q_{sbout}$  within the last 160 ms period. The value  $Q_{sbout}$  is defined implicitly by the relevant tests in [2];
- over the previous 160 ms, no transport block has been received with a correct CRC

If the UE detects the beacon channel reception level [10 dB] above the handover triggering level, the UE shall use 320 ms estimation period for the burst quality evaluation and for the Special Burst and CRC detection window.

In-sync shall be reported using the CPHY-Sync-IND primitive if any of the following criteria is fulfilled:

- the UE estimates the received burst reception quality over the last 160 ms period to be better than a threshold  $Q_{in}$ . The value,  $Q_{in}$  is defined implicitly by the relevant tests in [2].
- the UE detects at least one Special Burst with quality above a threshold  $Q_{sbin}$  within the last 160 ms period. The value,  $Q_{sbin}$ , is defined implicitly by the relevant tests in [2].
- at least one transport block with a CRC attached is received in a TTI ending in the current frame with correct CRC.

If the UE detects the beacon channel reception level [10 dB] above the handover triggering level, the UE uses 320 ms estimation period for the burst quality evaluation and for the Special Burst detection window.

If no data are provided by higher layers for transmission during the second phase on the downlink dedicated channel then DTX shall be applied as defined in section 4.5.

How the primitives are used by higher layers is described in [15]. The above definitions may lead to radio frames where neither the In-Sync or Out-of-Sync primitives are reported.

#### 4.4.2.1.3 Uplink synchronisation primitives

Layer 1 in the Node B shall every radio frame check synchronisation status, individually for each UL CCTrCH of the radio link. Synchronisation status is indicated to the RL Failure/Restored triggering function using either the CPHY-Sync-IND or CPHY-Out-of-Sync-IND primitive.

The exact criteria for indicating in-sync/out-of-sync is not subject to specification, but could e.g. be based on received burst quality or CRC checks. One example would be to have the same criteria as for the downlink synchronisation status primitives.

#### 4.4.2.2 Radio link monitoring

##### 4.4.2.2.1 Downlink radio link failure

The downlink CCTrCHs are monitored by the UE, to trigger radio link failure procedures. The downlink CCTrCH failure status is specified in [15], and is based on the synchronisation status primitives CPHY-Sync-IND and CPHY-Out-of-Sync-IND, indicating in-sync and out-of-sync respectively. These primitives shall provide status for each DL CCTrCH separately.

##### 4.4.2.2.2 Uplink radio link failure/restore

The uplink CCTrCHs are monitored by the Node B in order to trigger CCTrCH failure/restore procedures. The uplink CCTrCH failure/restore status is reported using the synchronisation status primitives CPHY-Sync-IND and CPHY-Out-of-Sync-IND, indicating in-sync and out-of-sync respectively.

When the CCTrCH is in the in-sync state, Node B shall start timer  $T_{RLFAILURE}$  after receiving  $N_{OUTSYNC\_IND}$  consecutive out-of-sync indications. Node B shall stop and reset timer  $T_{RLFAILURE}$  upon receiving successive

N\_INSYNC\_IND in-sync indications. If T\_RLFAILURE expires, Node B shall indicate to higher layers which CCTrCHs are out-of-sync using the synchronization status primitives. Furthermore, the CCTrCH state shall be changed to the out-of-sync state.

When a CCTrCH is in the out-of-sync state, after receiving N\_INSYNC\_IND successive in-sync indications Node B shall indicate that the CCTrCH has re-established synchronisation and the CCTrCH's state shall be changed to the in-sync-state. The specific parameter settings (values of T\_RLFAILURE, N\_OUTSYNC\_IND, and N\_INSYNC\_IND) are configurable, see [16].

## 4.5 Discontinuous transmission (DTX) procedure

The DTX procedure shall be applied for CCTrCHs mapped to S-CCPCH, UL DPCH, DL DPCH, PUSCH and PDSCH, if the total bit rate of the CCTrCH differs from the total channel bit rate of the physical channels allocated to this CCTrCH.

The DTX procedure shall also be applied to HS-PDSCHs and HS-SCCHs if no data is to be transmitted on these physical channels in a given TTI.

Rate matching is used in order to fill resource units completely, that are only partially filled with data. In the case that after rate matching and multiplexing no data at all is to be transmitted in a resource unit the complete resource unit shall be discarded from transmission (DTX), unless a Special Burst is transmitted in the RU. This applies also to the case where only one resource unit is allocated and no data has to be transmitted.

### 4.5.0 Description of Special Bursts

For S-CCPCH, UL DPCH, DL DPCH, PUSCH and PDSCH, the Special Burst has the same timeslot format as the burst used for data provided by higher layers. If the timeslot format contains a TFCI field, then the TFCI field shall be filled with '0' bits. The Special Burst may also carry layer 1 control symbols such as TPC bits for the purposes of inner-loop power control. The data portions of the Special Burst are filled with an arbitrary bit pattern.

For S-CCPCH, UL DPCH, DL DPCH, PUSCH and PDSCH, the transmission power of the special burst shall be the same as that of the substituted physical channel of the CCTrCH. In the case of uplink physical channels where autonomous spreading factor change by the UE is permitted by higher layers, the substituted physical channel is considered to be that which would have been employed for the lowest non-zero rate TFC within the set of allowed TFC's and the transmission power of the Special Burst shall again correspond to that of the physical channel substituted.

For HS-PDSCH, the Special Burst shall use the timeslot format #0 from table 7a, see section 5.3.9.5 in [8]. For HS-SCCH, the Special Burst shall use timeslot format #0 from table 5a, see section 5.2.2.6.1 in [8]. The Special Burst is filled with an arbitrary bit pattern. The transmission power of the Special Burst shall be the same as that of the substituted Beacon channel.

### 4.5.1 Use of Special Bursts during DTX

In the case that after link establishment there are no transport blocks provided for transmission by higher layers for a given CCTrCH mapped to UL DPCH, DL DPCH, PUSCH or PDSCH physical channels, then a Special Burst shall be transmitted in the first allocated frame of the transmission pause. If, including the first frame, there is a consecutive period of Special Burst Period (SBP) frames without transport blocks provided by higher layers, then another special burst shall be generated and transmitted at the next possible frame. This pattern shall be continued until transport blocks are provided for the CCTrCH by the higher layers. SBP shall be provided by higher layers. The value of SBP shall be independently specified for uplink and for downlink and shall be designated as

SBGP (special burst generation period) for uplink transmissions

SBSP (special burst scheduling parameter) for downlink transmissions

The default value for both SBGP and SBSP shall be 8.



The Special Burst shall be transmitted using the physical channel with the lowest physical channel sequence number ( $p$ ) as defined by the rate matching function in [9].

Special Bursts shall not be transmitted for HS-SCCH and for CCTrCHs mapped to S-CCPCH or HS-PDSCH in non-Beacon locations, i.e. only DTX shall be applied to these physical channels.

#### 4.5.2 Use of Special Bursts for Initial Establishment / Reconfiguration

Upon initial establishment or reconfiguration for either 160 ms following detection of in-sync, or until the first transport block is received from higher layers, both the UE and the Node B shall transmit the special burst for each CCTrCH mapped to UL DPCH, DL DPCH, PUSCH and PDSCH physical channels.

The Special Burst shall be transmitted using the physical channel with the lowest physical channel sequence number ( $p$ ) as defined by the rate matching function in [9].

#### 4.5.3 Use of Special Bursts for DTX on Beacon Channels

In the case that a beacon-function physical channel (S-CCPCH or PDSCH) would be DTX'd, then a Special Burst shall be transmitted on the Beacon Channel in that frame instead in order to maintain the beacon functionality.

### 4.6 Downlink Transmit Diversity

Downlink transmit diversity for PDSCH, DPCH, P-CCPCH, S-CCPCH, PICH, HS-SCCH, HS-PDSCH, and SCH is optional in UTRAN. Its support is mandatory at the UE.

#### 4.6.1 Transmit Diversity for PDSCH, DPCH, HS-SCCH and HS-PDSCH

The transmitter structure to support transmit diversity for PDSCH, DPCH, HS-SCCH, and HS-PDSCH transmission is shown in figure 1. Channel coding, interleaving and spreading are done as in non-diversity mode. The spread complex valued signal is fed to both TX antenna branches, and weighted with antenna specific weight factors  $w_1$  and  $w_2$ . The weight factors are complex valued signals (i.e.,  $w_i = a_i + jb_i$ ), in general. These weight factors are calculated on a per slot and per user basis.

The weight factors are determined by the UTRAN. Examples of transmit diversity schemes are given in annex B.

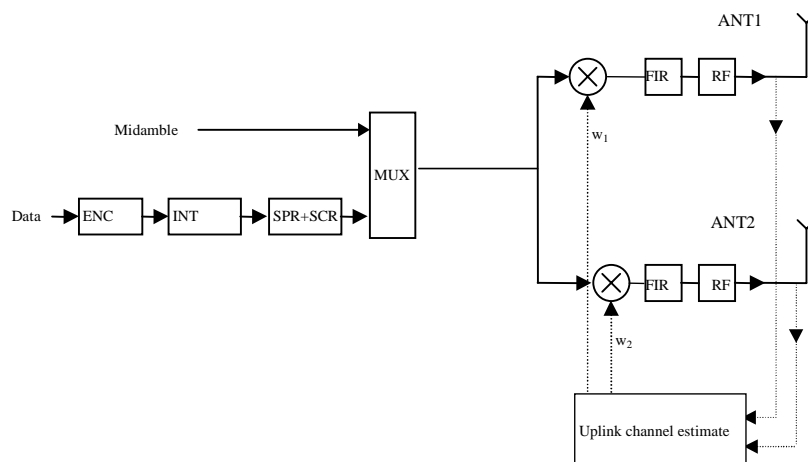

**Figure 1: Downlink transmitter structure to support Transmit Diversity for PDSCH, DPCH, HS-SCCH, and HS-PDSCH transmission (UTRAN Access Point)**

### 4.6.2 Transmit Diversity for SCH

Time Switched Transmit Diversity (TSTD) can be employed as transmit diversity scheme for the synchronisation channel.

#### 4.6.2.1 SCH Transmission Scheme

The transmitter structure to support transmit diversity for SCH transmission is shown in figure 2. P-SCH and S-SCH are transmitted from antenna 1 and antenna 2 alternatively. An example for the antenna switching pattern is shown in figure 3.

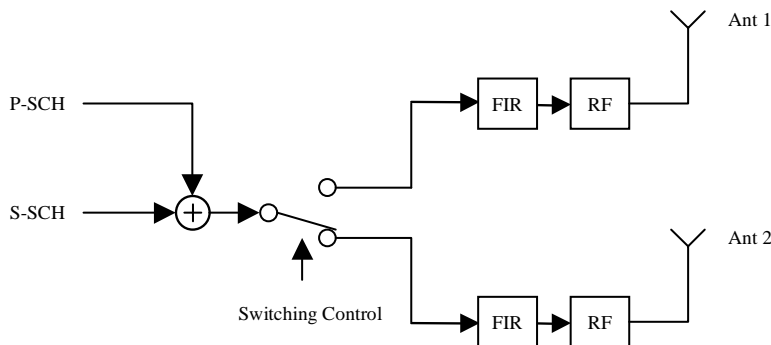

**Figure 2: Downlink transmitter structure to support Transmit Diversity for SCH transmission (UTRAN Access Point)**

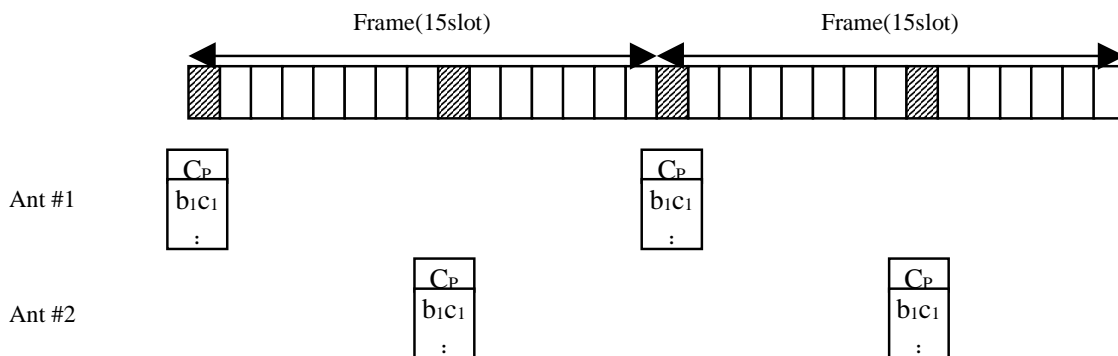

**Figure 3: Antenna Switching Pattern (Case 2)**

### 4.6.3 Transmit Diversity for Beacon Channels

Space Code Transmit Diversity (SCTD) for beacon channels may be employed optionally in the UTRAN. The support is mandatory in the UE. The use of SCTD will be indicated by higher layers. If SCTD is active within a cell :-

- SCTD shall be applied to any beacon channel, and
- the maximum number  $K_{Cell}$  of midambles for burst type 1 that are supported in this cell may be 8 or 16, see [8]. The case of  $K_{Cell} = 4$  midambles is not allowed for this burst type.

### 4.6.3.1 SCTD Transmission Scheme

The open loop downlink transmit diversity scheme for beacon channels is shown in figure 4. Channel coding, rate matching, interleaving and bit-to-symbol mapping are performed as in the non-diversity mode. In Space Code Transmit Diversity mode the data sequence is spread with the channelisation codes  $c_{16}^{(k=1)}$  and  $c_{16}^{(k=2)}$  and scrambled with the cell specific scrambling code. The spread sequence on code  $c_{16}^{(k=2)}$  is then transmitted on the diversity antenna. The power applied to each antenna shall be equal.

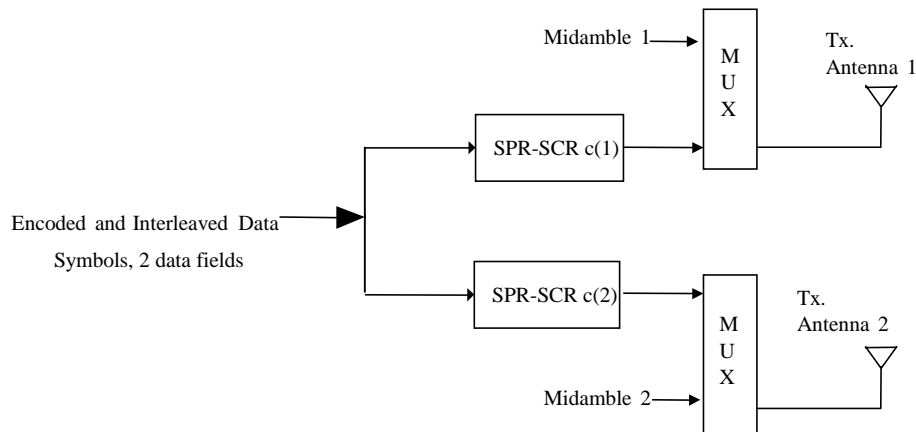

Figure 4: Block Diagram of the transmitter SCTD

## 4.7 Random access procedure

The physical random access procedure described below is invoked whenever a higher layer requests transmission of a message on the RACH. The physical random access procedure is controlled by primitives from RRC and MAC. Retransmission on the RACH in case of failed transmission (e.g. due to a collision) is controlled by higher layers. Thus, the backoff algorithm and associated handling of timers is not described here. The definition of the RACH in terms of PRACH Access Service Classes is broadcast on the BCH in each cell. Parameters for common physical channel uplink outer loop power control are also broadcast on the BCH in each cell. The UE needs to decode this information prior to transmission on the RACH. Higher layer signalling may indicate, that in some frames a timeslot shall be blocked for RACH uplink transmission.

### 4.7.1 Physical random access procedure

The physical random access procedure described in this subclause is initiated upon request from the MAC sublayer (see [18] and [19]).

Note: The selection of a PRACH is done by the RRC Layer.

Before the physical random-access procedure can be initiated, Layer 1 shall receive the following information from the RRC layer using the primitives CPHY-TrCH-Config-REQ and CPHY-RL-Setup/Modify-REQ.

- the available PRACH channelization codes (There is a 1-1 mapping between the channelization code and the midamble shift as defined by RRC) for each Access Service Class (ASC) of the selected PRACH (the selection of a PRACH is done by the RRC ). CPHY-RL-Setup/Modify-REQ);
- the timeslot, spreading factor, and midamble type(direct or inverted) for the selected PRACH (CPHY-RL-Setup/Modify-REQ);
- the RACH Transport Format (CPHY-TrCH-Config-REQ);
- the RACH transport channel identity (CPHY-TrCH-Config-REQ)
- the set of parameters for common physical channel uplink outer loop power control(CPHY-RL-Setup/Modify-REQ).

NOTE: The above parameters may be updated from higher layers before each physical random access procedure is initiated.

At each initiation of the physical random access procedure, Layer 1 shall receive the following information from the MAC:

- the ASC of the PRACH transmission;
- the data to be transmitted (Transport Block Set).

the selected ASC sub-channel. The ASC subchannel is defined in reference [18]. The value is passed in the PHY-Data-REQ is the  $CFN_{CELL}$ .

In addition, Layer 1 may receive information from higher layers, that a timeslot in certain frames shall be blocked for PRACH uplink transmission.

The physical random-access procedure shall be performed as follows:

- 1 Randomly select one channelization code from the set of available codes for the selected ASC. The random function shall be such that each code is chosen with equal probability.
- 2 Determine the midamble shift to use, based on the selected channelization code.
- 3 Set the PRACH message transmission power level according to the specification for common physical channels in uplink (see subclause 4.2.2.2).
- 4 Transmit the RACH Transport Block Set (the random access message) with no timing advance in the selected sub-channel using the selected channelization code.

## 4.8 DSCH procedure

The physical downlink shared channel procedure described below shall be applied by the UE when the physical layer signalling either with the midamble based signalling or TFCI based signalling is used to indicate for the UE the need for PDSCH detection. There is also a third alternative to indicate to the UE the need for the PDSCH detection and this is done by means of higher layer signalling, already described in [8].

### 4.8.1 DSCH procedure with TFCI indication

When the UE has been allocated by higher layers to receive data on DSCH using the TFCI, the UE shall decode the PDSCH in the following cases:

- In case of a standalone PDSCH the TFCI is located on the PDSCH itself, then the UE shall decode the TFCI and based on which data rate was indicated by the TFCI, the decoding shall be performed. The UE shall decode PDSCH only if the TFCI word decode corresponds to the TFC part of the TFCS given to the UE by higher layers.
- In case that the TFCI is located on the DCH, the UE shall decode the PDSCH frame or frames if the TFCI on the DCH indicates the need for PDSCH reception. Upon reception of the DCH time slot or time slots, the PDSCH slot (or first PDSCH slot) shall start  $SFN\ n+2$  after the DCH frame containing the TFCI, where n indicates the SFN on which the DCH is received. In the case that the TFCI is repeated over several frames, the PDSCH slot shall start  $SFN\ n+2$  after the frame having the DCH slot which contains the last part of the repeated TFCI.

### 4.8.2 DSCH procedure with midamble indication

When the UE has been allocated by higher layers to receive PDSCH based on the midamble used on the PDSCH (midamble based signalling described in [8]), the UE shall operate as follows:

- The UE shall test the midamble it received and if the midamble received was the same as indicated by higher layers to correspond to PDSCH reception, the UE shall detect the PDSCH data according to the TF given by the higher layers for the UE.

- In case of multiple time slot allocation for the DSCH indicated to be part of the TF for the UE, the UE shall receive all timeslots if the midamble of the first timeslot of PDSCH was the midamble indicated to the UE by higher layers.
- In case the standalone PDSCH (no associated DCH) contains the TFCI the UE shall detect the TF indicated by the TFCI on PDSCH.

## 4.9 Node B Synchronisation Procedure over the Air

An option exists to use cell sync bursts to achieve and maintain Node B synchronisation [20]. This optional procedure is based on transmissions of cell synchronisation bursts [10] in predetermined timeslots normally assigned to contain PRACH, according to an RNC schedule. Such soundings between neighbouring cells facilitate timing offset measurements by the cells. The timing offset measurements are reported back to the RNC for processing. The RNC generates cell timing updates that are transmitted to the Node Bs and cells for implementation.

When Cell Sync Bursts are used to achieve and maintain intercell Synchronisation there are three distinct phases, with a potential additional sub-phase involving late entrant cells.

### 4.9.1 Frequency Acquisition Phase

The frequency acquisition phase is used to bring cells of an RNS area to within frequency limits prior to initial synchronisation. No traffic is supported during this phase. In this phase cell(s) identified as master time reference shall transmit cell sync bursts [10] specified by higher layers continuously, i. e. one in every timeslot. All other cells shall listen for transmissions and shall perform frequency locking to the transmissions received. They shall signal completion of frequency acquisition to the RNC and begin continuous transmission of cell sync bursts specified by higher layers.

### 4.9.2 Initial Synchronisation

For Initial Phase, where no traffic is supported, the following procedure for initial synchronisation may be used to bring cells of an RNS area into synchronisation at network start up. In this phase each cell shall transmit cell sync bursts [10] according to the higher layer command. All cells use the same cell sync burst code and code offset. Each cell shall listen for transmissions from other cells. Each cell shall report the timing and received SIR of successfully detected cell sync bursts to the RNC. The RNC uses these measurements to adjust the timing of each cell to achieve the required synchronisation accuracy.

### 4.9.3 Steady-State Phase

The steady-state phase is used to maintain the required synchronisation accuracy. With the start of the steady-state phase, traffic is supported in a cell. A procedure that may be used for the steady-state phase involves cell sync bursts [10] that are transmitted and received without effect on existing traffic. Higher layers signal the transmit parameters, i.e., when to transmit which code and code offset, and which transmit power to use. The higher layers also signal to appropriate cells the receive parameters i. e. which codes and code offsets to measure in a certain timeslot. Upon determination of errors in timing, the RNC may adjust the timing of a cell or cells.

### 4.9.4 Late entrant cells

A procedure that may be used for introducing new cells into an already synchronised RNS involves the one time transmission of a single cell sync burst [10] (scheduled by higher layers) by all neighbour cells of the late entrant cell. and received by the late entrant cell. The RNC may use this information to adjust the late entrant cell sufficiently to allow the cell to enter steady state phase.

## 4.10 Idle periods for IPDL location method

### 4.10.1 General

To support time difference measurements for location services, idle periods can be created in the downlink (hence the name IPDL) during which time transmission of all channels from a Node B is temporarily ceased, except for the SCH transmission. During these idle periods the visibility of neighbour cells from the UE is improved.

The idle periods are arranged in a determined pattern according to higher layer parameters. An idle period has a duration of one time slot. During idle periods only the SCH is transmitted. No attempt is made to prevent data loss.

In general there are two modes for these idle periods:

- Continuous mode, and
- Burst mode.

In continuous mode the idle periods are active all the time. In burst mode the idle periods are arranged in bursts where each burst contains enough idle periods to allow a UE to make sufficient measurements for its location to be calculated. The bursts are separated by a period where no idle periods occur.

The time difference measurements can be performed on any channel. If the P-CCPCH falls in an idle slot, UTRAN may decide not to transmit the P-CCPCH in two consecutive frames, the first of these two frames containing the idle slot. This option is signalled by higher layers.

### 4.10.2 Parameters of IPDL

The following parameters are signalled to the UE via higher layers:

- IP\_Status:** This is a logic value that indicates if the idle periods are arranged in continuous or burst mode.
- IP\_Spacing:** The number of 10 ms radio frames between the start of a radio frame that contains an idle period and the next radio frame that contains the next idle period. Note that there is at most one idle period in a radio frame.
- IP\_Start:** The number of the first frame with idle periods. In case of continuous mode IP\_Start is the SFN of the first frame with idle periods and in case of burst mode IP\_Start defines the number of frames after Burst\_Start with the first frame with idle periods.
- IP\_Slot:** The number of the slot that has to be idle [0..14].
- IP\_PCCPCH:** This logic value indicates, if the P-CCPCH is switched off in two consecutive frames. The first of these two frames contains the idle period.

Additionally in the case of burst mode operation the following parameters are also communicated to the UE.

- Burst\_Start:** Specifies the start of the first burst of idle periods.  $256 \times \text{Burst\_Start}$  is the SFN where the first burst of idle periods starts.
- Burst\_Length:** The number of idle periods in a burst of idle periods.
- Burst\_Freq:** Specifies the time between the start of a burst and the start of the next burst.  $256 \times \text{Burst\_Freq}$  is the number of radio frames between the start of a burst and the start of the next burst.

### 4.10.3 Calculation of idle period position

In burst mode, burst #0 starts in the radio frame with SFN =  $256 \times \text{Burst\_Start}$ . Burst #n starts in the radio frame with SFN =  $256 \times \text{Burst\_Start} + n \times 256 \times \text{Burst\_Freq}$  ( $n = 0, 1, 2, \dots$ ). The sequence of bursts according to this formula continues up to and including the radio frame with SFN = 4095. At the start of the radio frame with SFN = 0, the burst sequence is terminated (no idle periods are generated) and at SFN =  $256 \times \text{Burst\_Start}$  the burst sequence is restarted with burst #0 followed by burst #1 etc., as described above.

Continuous mode is equivalent to burst mode, with only one burst spanning the whole SFN cycle of 4096 radio frames, this burst starts in the radio frame with SFN = 0. In case of continuous mode the parameter IP\_Start defines the first frame with idle periods.

The position of an idle period is defined by two values: IP\_Frame(x) and IP\_Slot. IP\_Frame(x) defines the x<sup>th</sup> frame within a burst that contains the idle period. IP\_Slot defines the slot in that frame during which no transmission takes place except for the SCH.

The actual frame with idle periods within a burst is calculated as follows:

$$IP\_Frame(x) = IP\_Start + (x-1) \times IP\_Spacing \text{ with } x = 1, 2, 3, \dots$$

If the parameter IP\_PCCPCH is set to 1, then the P-CCPCH will not be transmitted in the frame IP\_Frame(x) + 1 within a burst.

Figure 5 below illustrates the idle periods for the burst mode case, if the IP\_P-CCPCH parameter is set to 0.

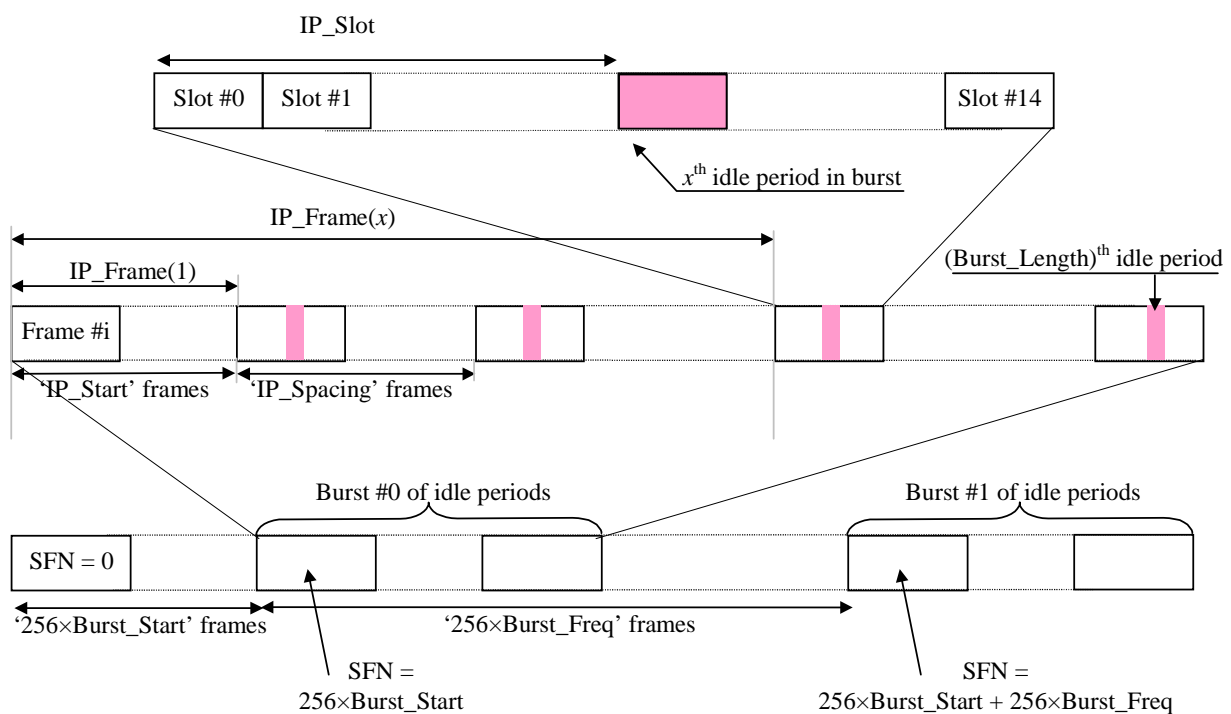

Figure 5: Idle Period placement in the case of burst mode operation with IP\_P-CCPCH parameter set to 0

## 4.11 HS-DSCH Procedure

### 4.11.1 Link Adaptation Procedure

For HS-DSCH, the modulation scheme and effective code rate shall be selected by higher layers located within the NodeB. This shall be achieved by appropriate selection of an HS-DSCH transport block size, modulation format and resources by higher layers. Selection of these parameters may be based on CQI reports from the UE.

The overall HS-DSCH link adaptation procedure consists of *two parts*:

*Node B procedure:*

- 1) The NodeB shall transmit HS-SCCH carrying a UE identity identifying the UE for which HS-DSCH TTI allocation has been given. In the case of HS-DSCH transmissions in consecutive TTIs to the same UE, the same HS-SCCH shall be used for associated signalling.
- 2) The NodeB transmits HS-DSCH to the UE using the resources indicated in the HS-SCCH.
- 3) Upon receiving the HS-SICH from the respective UE, the status report (ACK/NACK and CQI) shall be passed to higher layers.

*UE procedure:*

- 1) When indicated by higher layers, the UE shall start monitoring all HS-SCCHs that are in its HS-SCCH set as signalled to it by higher layers. The information carried on the HS-SCCH is described in [8].
- 2) In the case that a HS-SCCH is identified to be correct by its CRC, the UE shall read the HS-PDSCHs indicated by the HS-SCCH. In the case that a HS-SCCH is identified to be incorrect, the UE shall discard the data on the HS-SCCH and return to monitoring.
- 3) After reading the HS-PDSCHs, the UE shall generate an ACK/NACK message and transmit this to the NodeB in the associated HS-SICH, along with the most recently derived CQI.

The mapping of HS-PDSCH channelisation code set and timeslot information carried by the HS-SCCH for a given HS-DSCH TTI is described in [9].

For a given allocation of HS-PDSCH resources to a UE for a specific HS-DSCH TTI, the following shall apply:

- If timeslot information on HS-SCCH indicates two or more timeslots, none of these timeslots shall comprise a beacon channel.
- If timeslot information on HS-SCCH indicates a single timeslot and this timeslot comprises a beacon channel then:
  - The Node-B shall not indicate SF=1 for any HS-PDSCH resource.
  - The set of HS-PDSCH resources allocated by the Node-B to a UE shall exclusively comprise either beacon function or non-beacon function physical channels. The Node B shall therefore not allocate both beacon function and non-beacon function physical channels within the beacon timeslot to the UE. If the HS-DSCH for a specific HS-DSCH TTI is mapped to the beacon channel, this shall be signalled using  $k_{start} = 1$  and  $k_{stop} = 1$ . For a definition of the first and last allocated channelisation code indices  $k_{start}$  and  $k_{stop}$  on HS-SCCH refer to [9].
  - When SCTD antenna diversity is applied to the beacon channel, then the presence of channelisation code  $C_{16}^{(1)}$  within the channelisation code set information on HS-SCCH shall implicitly indicate the presence of channelisation code  $C_{16}^{(2)}$ .

#### 4.11.2 HS-DSCH Channel Quality Indication Procedure

The channel quality indicator (CQI) provides the NodeB with an estimate of the code rate that would have maximised the single-transmission throughput of the previous HS-DSCH transmission if decoded in isolation. The CQI report requires to be referenced to a given set of HS-PDSCH resources by the NodeB, but note that the UE is not restricted to making measurements only on these reference resources when deriving a given CQI. The reference resources for a CQI report shall be a set of HS-PDSCH resources that were received by the UE in a single TTI, and contain a complete transport block. These resources will be known to the NodeB from the relative timings of the HS-SICH carrying the CQI and previous HS-DSCH transmissions to the UE.

The CQI consists of two fields; a Recommended Transport Block Size (RTBS) and a Recommended Modulation Format (RMF). The UE shall use the same mapping table for these fields as is being used for the time slot information and modulation scheme information fields respectively of the HS-SCCH [18].

The reporting procedure is as follows:

1. The UE receives a message on an HS-SCCH telling it which resources have been allocated to it for the next associated HS-DSCH transmission.



2. The UE reads the associated HS-DSCH transmission, and makes the necessary measurements to derive a CQI that it estimates would have given it the highest single-transmission throughput for the allocated resources whilst achieving a BLER of no more than 10 %.

BLER, in this context, is defined as the probability that a transport block transmitted using the RTBS and RMF is received in error if decoded in isolation. For the purposes of this calculation, it shall be assumed that the transport block that would be transmitted with these parameters would use redundancy version parameters  $s = 1$  and  $r = 0$ . Note that, by this definition, a UE shall never report a CQI that corresponds to a code rate greater than unity.

Using this definition of BLER, single-transmission throughput shall be defined as follows :

$$\text{single-transmission throughput} = (1 - \text{BLER}) \times \text{RTBS}$$

3. The CQI report derived from a given HS-DSCH transmission shall be reported to the NodeB in the next HS-SICH available to the UE following that HS-DSCH transmission, unless that HS-SICH immediately follows the last allocated HS-DSCH timeslot, in which case the subsequent available HS-SICH shall be used by the UE. This HS-SICH may not necessarily be the same HS-SICH that carries the ACK/NACK information for that HS-DSCH transmission. The UE shall always transmit the most recently derived CQI in any given HS-SICH, which may mean that some CQI reports are discarded without being transmitted to the NodeB.

## 5 Physical layer procedures for the 1.28 Mcps option

### 5.1 Transmitter Power Control

The basic purpose of power control is to limit the interference level within the system thus reducing the intercell interference level and to reduce the power consumption in the UE.

The main characteristics of power control are summarized in the following table.

**Table 2: Transmit Power Control characteristics**

	Uplink	Downlink
Power control rate	Variable Closed loop: 0-200 cycles/sec. Open loop: (about 200us – 3575us delay )	Variable Closed loop: 0-200 cycles/sec.
Step size	1,2,3 dB (closed loop)	1,2,3 dB (closed loop)
Remarks	All figures are without processing and measurement times	

Note: All codes within one timeslot allocated to the same CCTrCH use the same transmission power in case they have the same Spreading Factor.

#### 5.1.1 Uplink Control

##### 5.1.1.1 General limits

By means of higher layer signalling, the Maximum\_Allowed\_UL\_TX\_power for uplink may be set to a value lower than what the terminal power class is capable of. Uplink power control shall be performed while the total UE transmit power is below the maximum allowed output TX power. In some cases the total requested UE transmit power in a timeslot after uplink power control calculation might exceed the maximum allowed output power. In these cases the calculated transmit power of all uplink physical channels in this timeslot shall be scaled by the same amount in dB before transmission in order that the total UE transmission power used shall be the maximum allowed output power.

The UTRAN may not expect the UE to be capable of reducing its total transmit power below the minimum level specified in [2].

#### 5.1.1.2 UpPCH

The transmit power for the UpPCH is set by higher layers based on open loop power control as described in [15]

#### 5.1.1.3 PRACH

The transmit power for the PRACH is set by higher layers based on open loop power control as described in [15].

#### 5.1.1.4 DPCH and PUSCH

The initial transmission power for uplink DPCH and PUSCH is set by higher layers based on open loop power control as described in [15]. The UE then transmits into closed loop power control. The node B shall generate TPC commands according to a quality target set by higher layers in order to instruct an increase or decrease in the level of transmission power from the UE and send them in the TPC field of associated downlink CCTrCHs (see [8] for a description of the mapping between DL associated TPC symbols and UL controlled CCTrCH/timeslots). If the physical channel power shall be increased, the TPC command is set to 'up', whereas if the power shall be reduced the command is set to 'down'. A TPC command sent in a downlink CCTrCH controls all uplink DPCHs and PUSCHs in the associated uplink CCTrCH and timeslot. An example of SIR based UL power control is given in annex A2

At the UE when the TPC command is judged as "down", the mobile transmit power shall be reduced by one power control step, whereas if it is judged as "up", the mobile transmit power shall be raised by one power control step.

The closed loop power control procedure for UL DPCH and PUSCH is not affected by the use of TSTD.

In the event of no associated uplink data being transmitted between two related downlink TPC commands, the UE shall ignore the resulting TPC command. The transmit power for the next instance of the timeslot/CCTrCH pair shall then be set using the open loop procedure as for initial transmissions.

##### 5.1.1.4.1 Gain Factors

Same as that of 3.84 Mcps TDD, cf. [4.2.2.3.1 Gain Factors].

##### 5.1.1.4.2 Out of synchronization handling

Same as that of 3.84 Mcps TDD, cf. [4.2.2.3.2 Out of synchronisation handling].

#### 5.1.1.5 HS-SICH

The transmit power of the HS-SICH shall be set by the UE according to the procedures described below. In the case that an ACK is being transmitted on the HS-SICH, the UE shall apply a power offset to the transmit power of the entire HS-SICH. This power offset shall be signalled by higher layers.

On receipt of a TPC command in the HS-SCCH, the UE shall adjust the HS-SICH transmit power according to the power control step size specified by higher layers. However, for the first HS-SICH transmission following the first detected HS-SCCH transmission, or the first HS-SICH transmission following a gap of one or more detected HS-SCCH transmissions to the UE, the UE shall use open loop power control to set the HS-SICH transmit power for that transmission. In this case, the transmission power for HS-SICH is set by higher layers based on open loop power control as described in [15]

### 5.1.2 Downlink Control

The total downlink transmission power at the Node B within one timeslot shall not exceed the Maximum Transmission Power set by higher layer signalling.

### 5.1.2.1 P-CCPCH

Same as that of 3.84 Mcps TDD, cf.[4.2.3.1 P-CCPCH].

### 5.1.2.2 The power of the FPACH

The transmit power for the FPACH is set by the higher layer signalling [16].

### 5.1.2.3 S-CCPCH, PICH

Same as that of 3.84 Mcps TDD, cf.[4.2.3.2 S-CCPCH , PICH].

### 5.1.2.4 DPCH, PDSCH

The initial transmission power of the downlink Dedicated Physical Channel is signalled by higher layers. After the initial transmission, the node B transits into closed-loop TPC. The UE shall generate TPC commands according to a quality target set by higher layers in order to control the level of transmission power from the node B and send them in the TPC field of associated uplink CCTrCHs (see [8] for a description of the mapping between UL associated TPC symbols and DL controlled CCTrCH/timeslots). If the physical channel power should be increased, the TPC command is set to 'up', whereas if the power should be reduced the command is set to 'down'. A TPC command sent in an uplink CCTrCH controls all downlink DPCHs or PDSCHs in the associated downlink CCTrCH and timeslot.

UTRAN may decide how to adjust the transmit power in response to the received TPC command

When TSTD is applied, the UE can use two consecutive measurements of the received SIR in two consecutive sub-frames to generate the power control command. An example implementation of DL power control procedure for 1.28 Mcps TDD when TSTD is applied is given in Annex A.3.

The transmission power of one DPCH or PDSCH shall not exceed the limits set by higher layer signalling by means of Maximum\_DL\_Power (dB) and Minimum\_DL\_Power (dB). The transmission power is defined as the average power over one timeslot of the complex QPSK (or 8PSK respectively) symbols of a single DPCH or PDSCH before spreading relative to the power of the P-CCPCH.

Each TPC command shall be based on all associated downlink transmissions since the previous related TPC command.

In the event of no associated downlink data being transmitted between two related TPC commands, the UTRAN should ignore the resulting TPC command.

#### 5.1.2.4.1 Out of synchronisation handling

Same as that of 3.84 Mcps TDD, cf.[4.2.3.4.1 Out of synchronisation handling].

### 5.1.2.5 HS-PDSCH

The power control for HS-PDSCH for 1.28 Mcps TDD is the same as for 3.84 Mcps, see section 4.2.3.5

### 5.1.2.6 HS-SCCH

The power control for HS-SCCH for 1.28 Mcps TDD is the same as for 3.84 Mcps, see section 4.2.3.6

## 5.2 UL Synchronisation

### 5.2.1 General Description

Support of UL synchronization is mandatory for the UE.

### 5.2.1.1 Preparation of uplink synchronization (downlink synchronization)

When a UE is powered on, it first needs to establish the downlink synchronisation with the cell. Only after the UE has established the downlink synchronisation, it shall start the uplink synchronisation procedure.

### 5.2.1.2 Establishment of uplink synchronization

The establishment of uplink synchronization is done during the random access procedure and involves the UpPCH and the PRACH.

Although the UE can receive the downlink signal from the Node B, the distance to Node B is still uncertain. This would lead to unsynchronised uplink transmission. Therefore, the first transmission in the uplink direction is performed in a special time-slot UpPTS to reduce interference in the traffic time-slots.

The timing used for the UpPCH is set e.g., according to the received power level of DwPCH and/or P-CCPCH.

After the detection of the SYNC-UL sequence in the searching window, the Node B will evaluate the timing, and reply by sending the adjustment information to the UE to modify its timing for next transmission. This is done with the FPACH within the following 4 sub-frames. After sending the PRACH the uplink synchronization is established. The uplink synchronisation procedure shall also be used for the re-establishment of the uplink synchronisation when uplink is out of synchronisation.

### 5.2.1.3 Maintenance of uplink synchronisation

Uplink synchronization is maintained in 1.28 Mcps TDD by sending the uplink advanced in time with respect to the timing of the received downlink.

For the maintenance of the uplink synchronization, the midamble field of each uplink burst can be used.

In each uplink time slot the midamble for each UE is different. The Node B may estimate the timing by evaluating the channel impulse response of each UE in the same time slot. Then, in the next available downlink time slot, the Node B will signal Synchronisation Shift (SS) commands to enable the UE to properly adjust its Tx timing.

## 5.2.2 UpPCH

Open loop uplink synchronisation control is used for UpPCH.

The UE may estimate the propagation delay  $\Delta t_p$  based upon the path loss using the received P-CCPCH and/or DwPCH power.

The UpPCH is sent to the Node B advanced in time according to the timing of the received DwPCH. The time of the beginning of the UpPCH  $T_{TX-UPPCH}$  is given by:

$$T_{TX-UPPCH} = T_{RX-DWPCH} - 2\Delta t_p + 12 \cdot 16 T_C$$

in multiple of 1/8 chips, where

$T_{TX-UPPCH}$  is the beginning time of UpPCH transmission with the UE's timing,

$T_{RX-DWPCH}$  is the received beginning time of DwPCH with the UE's timing,

$2\Delta t_p$  is the timing advance of the UpPCH ( $UpPCH_{ADV}$ ).

## 5.2.3 PRACH

The Node B shall measure the received SYNC-UL timing deviation  $UpPCH_{POS}$ .  $UpPCH_{POS}$  is sent in the FPACH and is represented as an 11 bit number (0-2047) being the multiple of 1/8 chips which is nearest to received position of the UpPCH.

Time of the beginning of the PRACH  $T_{TX-PRACH}$  is given by:

$$T_{TX-PRACH} = T_{RX-PRACH} - (UpPCH_{ADV} + UpPCH_{POS} - 8 \cdot 16 T_C)$$

in multiple of 1/8 chips, where

$T_{TX-PRACH}$  is the beginning time of PRACH transmission with the UE's timing,

$T_{RX-PRACH}$  is the beginning time of PRACH reception with the UE's timing if the PRACH was a DL channel.

## 5.2.4 DPCH and PUSCH

The closed loop uplink synchronisation control uses layer 1 symbols (SS commands) for DPCH and PUSCH. After establishment of the uplink synchronisation, NodeB and UE start to use the closed loop UL synchronisation control procedure. This procedure is continuous during connected mode.

The Node B will continuously measure the timing of the UE and send the necessary synchronisation shift commands in each sub-frame. The UE shall derive a single SS command separately for each controlled uplink timeslot by combining all received SS commands that are related to the controlled time slot (cf. [8]) and that are received within the last up to M sub-frames. The value of the 'Uplink synchronisation frequency' M (1..8) is configured by higher layers.

When the combined SS command is judged as "down", the UE transmit timing for the controlled UL timeslot shall be delayed by one timing adjustment step of k/8 chips. When the command is judged as "up", the UE transmit timing for the controlled UL timeslot shall be advanced by one timing adjustment step of k/8 chips. When the command is judged as "do nothing", the timing shall not be changed. The value of the 'Uplink synchronisation step size' k (1..8) is configured by higher layers.

The timing adjustment shall take place in each sub-frame satisfying the following equation:

$$SFN' \bmod M = 0$$

where

SFN" is the system frame number counting the sub-frames. The system frame number of the radio frames (SFN) can be derived from SFN" by

$SFN = SFN" \text{ div } 2$ , where div is the remainder free division operation.

During a 1.28 Mcps TDD to 1.28 Mcps TDD hand-over the UE shall transmit in the new cell with timing advance TA adjusted by the relative timing difference  $\Delta t$  between the new and the old cell if indicated by higher layers:

$$TA_{\text{new}} = TA_{\text{old}} + 2\Delta t.$$

### 5.2.4.1 Out of synchronization handling

Same as that of 3,84 Mcps TDD, cf.[ 4.2.2.3.2 Out of synchronisation handling.]

## 5.2.5 HS-SICH

The initial transmit timing for the HS-SICH shall be taken from that of the associated uplink DPCH. The UE shall then adjust the timing of the HS-SICH according to SS commands transmitted to it on the HS-SCCH. The step size for these commands shall be signalled to the UE by higher layers. In the case that there is a gap of one or more subframes during which no HS-SCCH transmissions, and thus no SS commands, are received by the UE, the UE shall adjust the timing of the HS-SICH according to SS commands received on the associated downlink DPCH until such time as another HS-SCCH transmission is received.

## 5.3 Synchronisation procedures

### 5.3.1 Cell search

During the initial cell search, the UE searches for a cell. It then determines the DwPTS synchronisation, scrambling code and basic midamble code, control multi-frame synchronisation and then reads the BCH. How cell search is typically done is described in Annex CA.

### 5.3.2 DCH synchronization

The DPCH synchronisation is the same as that of 3,84 Mcps TDD, cf. [4.4.2 Dedicated channel synchronisation].

## 5.4 Discontinuous transmission (DTX) procedure

DTX is the same as in the 3,84 Mcps TDD option, cf. [4.5 Discontinuous transmission (DTX) procedure]. The special burst is transmitted in both consecutive subframes (subframe#1 and #2). SS Bits may be transmitted in Special Bursts.

## 5.5 Downlink Transmit Diversity

Downlink transmit diversity for PDSCH, DPCH, P-CCPCH, S-CCPCH, PICH, HS-SCCH, HS-PDSCH, and DwPCH is optional in UTRAN. Its support is mandatory at the UE.

### 5.5.1 Transmit Diversity for PDSCH, DPCH, HS-SCCH, and HS-PDSCH

Time Switched Transmit Diversity (TSTD) may be employed as transmit diversity scheme for downlink DPCH and PDSCH. Closed loop Transmit Diversity may be employed as transmit diversity scheme for downlink DPCH, HS-SCCH, and HS-PDSCH.

#### 5.5.1.1 TSTD for PDSCH and DPCH

TSTD can be employed as transmit diversity scheme for PDSCH and downlink DPCH. An example for the transmitter structure of the TSTD transmitter is shown in figure 6. Channel coding, rate matching, interleaving, bit-to-symbol mapping, spreading, and scrambling are performed as in the non-diversity mode. Then the data is time multiplexed with the midamble sequence. Then, after pulse shaping, modulation and amplification, DPCH and/or PDSCH is transmitted from antenna 1 and antenna 2 alternately every sub-frame. Not all DPCHs and/or PDSCHs in the sub-frame need to be transmitted on the same antenna and not all DPCHs and/or PDSCHs within a sub-frame have to use TSTD. Figure 7 shows an example for the antenna switching pattern for the transmission of DPCH/PDSCH for the case that all physical channels are transmitted with TSTD and are using the same antenna in the sub-frame.

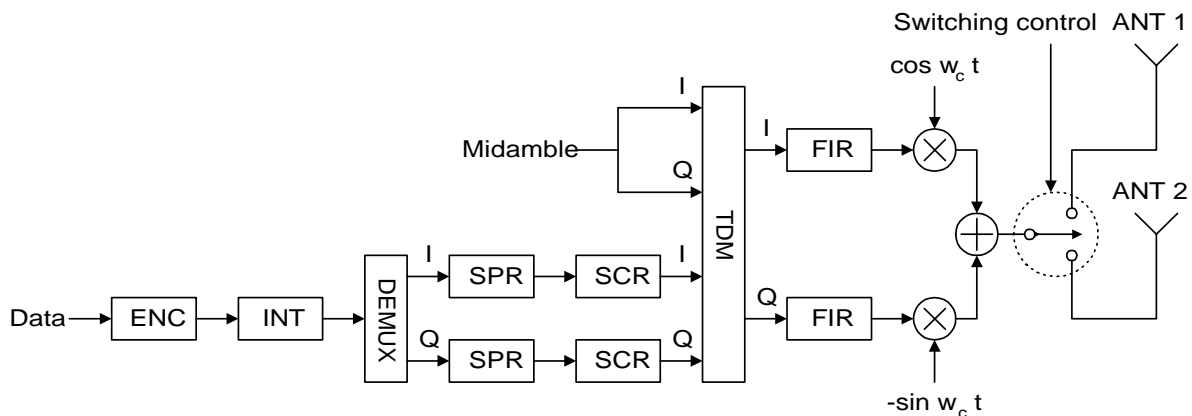
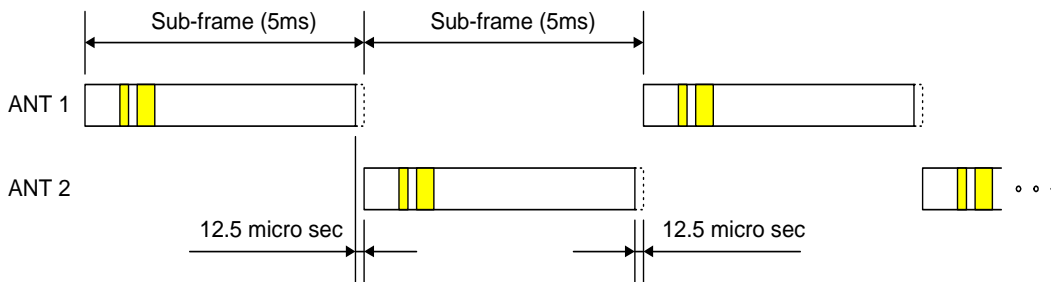

Figure 6: Example for TSTD Transmitter structure for DPCH/PDSCH and P-CCPCH.

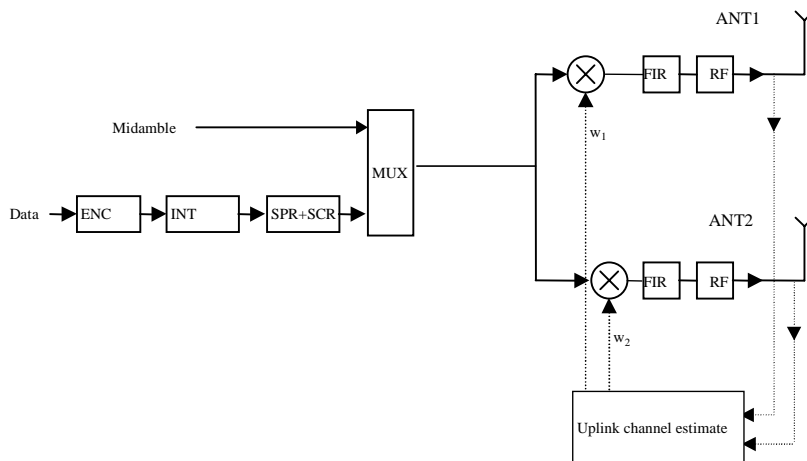

**Figure 7: Example for the antenna swithing pattern for TSTD transmission of DPCH/PDSCH and P-CCPCH: all physical channels are transmitted with TSTD and are using the same antenna in the sub-frame.**

5.5.1.2 Closed Loop Tx Diversity for PDSCH, DPCH, HS-SCCH, and HS-PDSCH

The transmitter structure to support transmit diversity for DPCH, PDSCH, HS-SCCH, and HS-PDSCH transmission is shown in figure 8. Channel coding, interleaving and spreading are done as in non-diversity mode. The spread complex valued signal is fed to both TX antenna branches, and weighted with antenna specific weight factors  $w_1$  and  $w_2$ . The weight factors are complex valued signals (i.e.,  $w_i = a_i + jb_i$ ), in general. These weight factors are calculated on a per slot and per user basis.

The weight factors are determined by the UTRAN.



**Figure 8: Downlink transmitter structure to support Transmit Diversity for DPCH, PDSCH, HS-SCCH, and HS-PDSCH transmission (UTRAN Access Point) in 1.28 Mcps TDD**

5.5.2 Transmit Diversity for DwPCH

The transmitter structure to support transmit diversity for DwPCH transmission is shown in figure 9. DwPCH is transmitted from antenna 1 and antenna 2 alternatively.

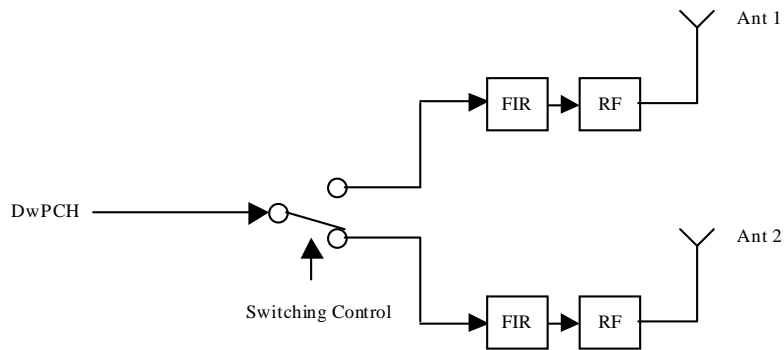

**Figure 9: Downlink transmitter structure to support Transmit Diversity for DwPCH transmission (UTRAN Access Point) in 1.28 Mcps TDD**

### 5.5.3 Transmit Diversity for P-CCPCH

TSTD or Space Code Transmit Diversity (SCTD) can be employed as transmit diversity scheme for the Primary Common Control Physical Channel (P-CCPCH)

#### 5.5.3.1 TSTD Transmission Scheme for P-CCPCH

A block diagram of an example of a TSTD transmitter is shown in figure 6. Channel coding, rate matching, interleaving, bit-to-symbol mapping, spreading, and scrambling are performed as in the non-diversity mode. Then the data is time multiplexed with the midamble sequence. Then, after pulse shaping and modulation and amplification, P-CCPCH is transmitted from antenna 1 and antenna 2 alternately every sub-frame. If there is a DPCH that uses TSTD, TSTD is also applied to P-CCPCH. An example of the antenna-switching pattern is shown in figure 7. If TSTD is applied to P-CCPCH, it shall also be applied to other beacon channels.

#### 5.5.4 SCTD Transmission Scheme for Beacon Channels

The use of SCTD will be indicated by higher layers. If SCTD is active within a cell, SCTD shall be applied to any beacon channel.

The SCTD open loop downlink transmit diversity scheme for beacon channels is shown in figure 10, exemplary for the P-CCPCH. Channel coding, rate matching, interleaving and bit-to-symbol mapping are performed as in the non-diversity mode. In TxDiversity mode the beacon channel that is allocated to code  $c_{16}^{(k=1)}$  is spread with the channelisation codes  $c_{16}^{(k=1)}$  and  $c_{16}^{(k=3)}$  and scrambled with the cell specific scrambling code. The beacon channel that is allocated to code  $c_{16}^{(k=2)}$  is spread with the channelisation codes  $c_{16}^{(k=2)}$  and  $c_{16}^{(k=4)}$  and scrambled with the cell specific scrambling code. The spread sequences on code  $c_{16}^{(k=3)}$  and code  $c_{16}^{(k=4)}$  are then transmitted on the diversity antenna. The power applied to each antenna shall be equal.

The use of SCTD will be indicated by higher layers.



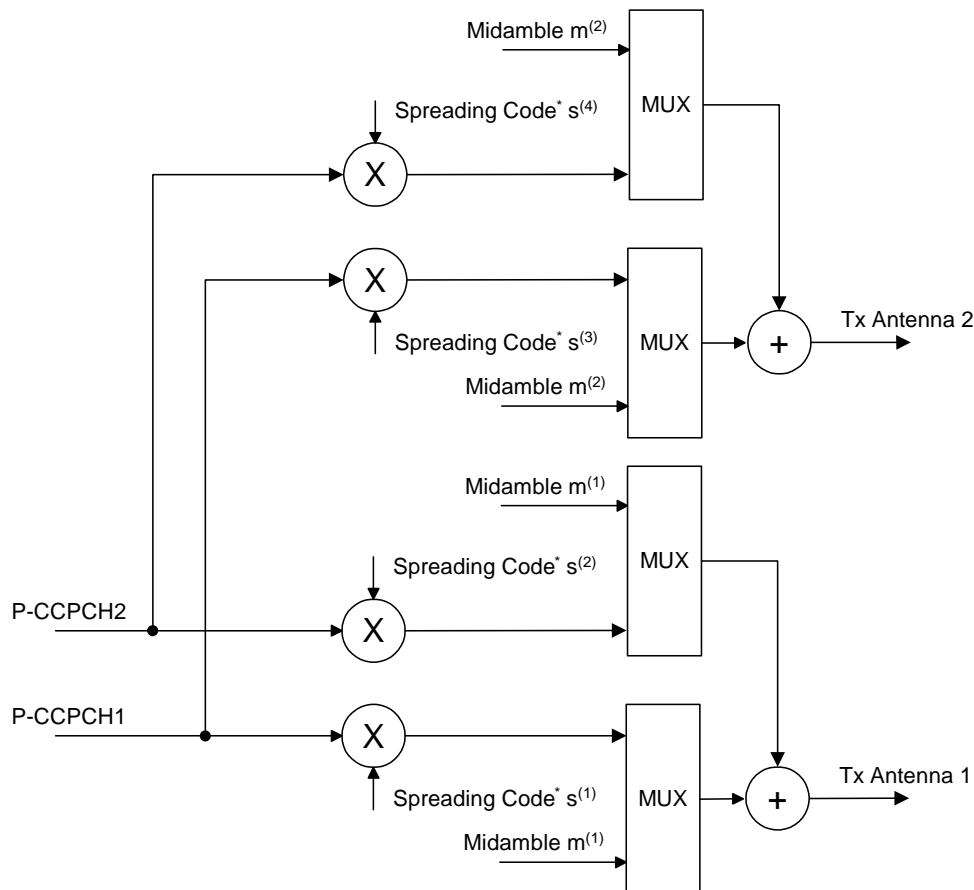

\* Spreading by  $s^{(k)}$  means channelisation by  $c^{(k)}$  and cell specific scrambling

Figure 10: Block Diagram of the transmitter (SCTD) in 1.28 Mcps TDD, exemplary for the P-CCPCH

## 5.6 Random Access Procedure

The physical random access procedure described below is invoked whenever a higher layer requests transmission of a message on the RACH. The physical random access procedure is controlled by primitives from RRC and MAC.

### 5.6.1 Definitions

$FPACH_i$  : The  $i^{\text{th}}$  FPACH number parameter  $i$  indicates the position of the FPACH, the first position is corresponding to the first instance defined in IE 'PRACH system information list' (see [15]).

$L_i$  : Length of RACH transport blocks associated to  $FPACH_i$  in sub-frames

$N_{RACH_i}$  : The number of PRACHs associated to the  $i^{\text{th}}$  FPACH

$n_{RACH_i}$  : The number of a PRACH associated to the  $i^{\text{th}}$  FPACH ranging from 0 to  $N_{RACH_i}-1$

$M$  : Maximum number transmissions in the UpPCH

$WT$  : Maximum number of sub-frames to wait for the network acknowledgement to a sent signature

$SFN''$  : The sub-frame number counting the sub-frames. At the beginning of the frame with the system frame number  $SFN=0$  the sub-frame number is set to zero.

## 5.6.2 Preparation of random access

When the UE is in idle mode, it will keep the downlink synchronisation and read the system information. From the used SYNC-DL code in DwPCH, the UE will get the code set of 8 SYNC-UL codes (signatures) assigned to UpPCH for random access.

The description (codes, spreading factor, midambles, time slots) of the P-RACH, FPACH, S-CCPCH (carrying the FACH transport channel) channel; mapping relation of RACH and FPACH; ASC (available SYNC-UL sequences and available sub-channels) sets for each RACH are broadcast on the BCH.

Thus, when sending a SYNC-UL sequence, the UE knows which FPACH resource, P-RACH resources and S-CCPCH resources will be used for the access.

The physical random access procedure described in this sub-clause is initiated upon request from the MAC sub-layer (see [18] and [19]).

Before the physical random-access procedure can be initiated, Layer 1 shall receive the following information by a CPHY-TrCH-Config-REQ from the RRC layer:

- The association between which signatures and which FPACHs; which FPACHs and which PRACHs; which PRACHs and which S-CCPCHs; including the parameter values for each listed physical channel.
- The length  $L_i$  of a RACH message associated to  $FPACH_i$  can be configured to be either 1 or 2 or 4 sub-frames corresponding to a length in time of either 5 ms or 10 ms or 20 ms.

NOTE 1:  $N_{RACH_i}$  PRACHs can be associated with to  $FPACH_i$ . The maximum allowed

$N_{RACH_i}$  is  $L_i$ .

- The available UpPCH sub-channels for each Access Service Class (ASC);

NOTE 2: An UpPCH sub-channel is defined by a (sub-set of) signature(s) and sub-frame numbers.

- The set of Transport Format parameters for the PRACH message;
- The "M" maximum number transmissions in the UpPCH;
- The "WT" maximum number of sub-frames to wait for the network acknowledgement to a sent signature; (1..4) the maximum value supported by Layer 1 is 4 sub-frames.
- The initial signature power "Signature\_Initial\_Power";
- The power-ramping factor Power Ramp Step [Integer];

The above parameters may be updated from higher layers before each physical random access procedure is initiated.

At each initiation of the physical random access procedure, Layer 1 shall receive the following information from the higher layers (MAC):

- The Transport Format to be used for the specific PRACH message;
- The ASC for the specific Random Access procedure;
- The data to be transmitted (Transport Block Set).

## 5.6.3 Random access procedure

The physical random-access procedure shall be performed as follows:

UE side:

- 1 Set the Signature Re-Transmission Counter to M.
- 2 Set the Signature transmission power to Signature\_Initial\_Power.

- 3 Based on the transport format indicated by MAC layer, a unique RACH used for the radio access is chosen, and then randomly select the UpPCH sub-channel from the available ones for the given ASC. The random function shall be such that each of the allowed selections is chosen with equal probability.
- 4 Transmit a signature using the selected UpPCH sub-channel at the signature transmission power. In the case that the Commanded Signature transmission Power exceeds the maximum allowed value, set the Signature transmission Power to the maximum allowed power.
- 5 After sending a signature, listen to the relevant FPACH for the next WT sub-frames to get the network acknowledgement. The UE will read the FPACH<sub>i</sub> associated to the transmitted UpPCH only in the sub-frames fulfilling the following relation:

$(SFN \bmod L_i) = n_{RACH_i}$  ;  $n_{RACH_i} = 0, \dots, N_{RACH_i} - 1$ , Here, FPACH to which UE should listen is decided according to the following formula:

$$FPACH_i = N \bmod M,$$

Where, N denotes the signature number (0..7) and M denotes the maximum number of FPACHs that defined in the cell.

- 6 In case no valid answer is detected in the due time: Increase the Signature transmission power by  $\Delta P_0 = \text{Power Ramp Step [dB]}$ , decrease the Signature Re-transmission counter by one and if it is still greater than 0, then repeat from step 3; else report a random access failure to the MAC sub-layer.
- 7 In case a valid answer is detected in the due time
  - a) set the timing and power level values according to the indication received by the network in the FPACH<sub>i</sub>
  - b) send at the sub-frame coming 2 sub-frames after the one carrying the signature acknowledgement, the RACH message on the relevant PRACH. In case  $L_i$  is bigger than one and the sub-frame number of the acknowledgement is odd the UE will wait one more sub-frame. The relevant PRACH is the  $n_{RACH_i}^{\text{th}}$  PRACH associated to the FPACH<sub>i</sub> if the following equation ifs fulfilled:

$$(SFN \bmod L_i) = n_{RACH_i} ;$$

Here SFN" is the sub-frame number of the arrival of the acknowledgement.

Both on the UpPCH and on the PRACH, the transmit power level shall never exceed the indicated value signalled by the network.

Network side:

- The node B will transmit the FPACH<sub>i</sub> associated with the received UpPCH only in the sub-frames fulfilling the following relation:

$$(SFN \bmod L) = n_{RACH_i} ; n_{RACH_i} = 0, \dots, N_{RACH_i} - 1,$$

Here, FPACH number i is selected according to the following formula based on acknowledged signature:

$$FPACH_i = N \bmod M,$$

Where, N denotes the signature number (0..7) and M denotes the maximum number of FPACH that defined in the cell.

- The Node B will not acknowledge UpPCHs transmitted more than WT sub-frames ago

At the reception of a valid signature:

- Measure the timing deviation with respect to the reference time  $T_{ref}$  of the received first path in time from the UpPCH and acknowledge the detected signature sending the FPACH burst on the relevant FPACH.

For examples on the random access procedure refer to Annex CB.

### 5.6.3.1 The use and generation of the information fields transmitted in the FPACH

The Fast Physical Access CHannel (FPACH) is used by the Node B to carry, in a single burst, the acknowledgement of a detected signature with timing and power level adjustment indication to a user equipment.

The length and coding of the information fields is explained in TS25.221 sub-clause 5A.3.3.1 .

#### 5.6.3.1.1 Signature Reference Number

The Signature Reference Number field contains the number of the acknowledged signature. The user equipment shall use this information to verify whether it is the recipient of the FPACH message.

#### 5.6.3.1.2 Relative Sub-Frame Number

The Relative Sub-Frame Number field indicates the current sub-frame number with respect to the sub-frame at which the acknowledged signature has been detected.

The user equipment shall use this information to verify whether it is the recipient of the FPACH message.

#### 5.6.3.1.3 Received starting position of the UpPCH ( $UpPCH_{POS}$ )

The *received starting position of the UpPCH ( $UpPCH_{POS}$ )* field indirectly indicates to the user equipment the timing adjustment it has to implement for the following transmission to the network. The node B computes the proper value for this parameter according to the following rules:  $UpPCH_{POS} = UpPTS_{R_{path}} - UpPTS_{TS}$

where

$UpPTS_{R_{path}}$ : time of the reception in the Node B of the SYNC-UL to be used in the uplink synchronization process

$UpPTS_{TS}$ : time instance two symbols prior to the end of the DwPCH according to the Node B internal timing

This information shall be used by the UE to adjust its timing when accessing the network, as described in section [5.2 'Uplink Synchronisation'] .

#### 5.6.3.1.4 Transmit Power Level Command for the RACH message

This field indicates to the user equipment the power level to use for the RACH message transmission on the FPACH associated P-RACH.

The network may set this value based on the measured interference level (I) (in dBm) on the specific PRACH and on the desired signal to interference ratio (SIR) (in dB) on this channel as follows:

$$\text{Transmit Power Level Command for the PRACH}(\text{PRX}_{\text{PRACH,des}})$$

$\text{PRX}_{\text{PRACH,des}}$  is the desired receive power level on the PRACH.

The UE shall add to this value the estimated path-loss to compute the power level to transmit for the PRACH.

## 5.6.4 Random access collision

When a collision is very likely or in bad propagation environment, the Node B does not transmit the FPACH or cannot receive the SYNC-UL. In this case, the UE will not get any response from the Node B. Thus the UE will have to adjust its Tx time and Tx power level based on a new measurement and send a SYNC-UL again after a random delay.

Note that at each (re-)transmission, the SYNC-UL sequence will be randomly selected again by the UE.

Note: Due to the two-step approach a collision most likely happens on the UpPCH. The resources allocated to PRACH are virtually collision free. This two-step approach will guarantee that the RACH resources can be handled with conventional traffic on the same UL time slots.

## 5.7 Node B Synchronisation Procedure over the Air

An option exists to use the regular DwPCH transmissions to achieve and maintain Node B synchronisation [20]. This optional procedure is based on measurements of DwPCHs from neighbouring cells according to an RNC schedule. The timing offset measurements are reported back to the RNC for processing. The RNC generates cell timing updates that are transmitted to the Node Bs and cells for implementation (common with the 3.84 Mcps TDD option). Alternatively the RNC may indicate that the NodeB shall autonomously adjust the cell timings. Two distinct phases can be distinguished for Node B synchronisation over the air, with a potential additional sub-phase involving late entrant cells.

### 5.7.1 Initial Synchronisation

Common with 3.84 Mcps TDD, see [4.9.2 Initial Synchronisation], however, the regular DwPCHs are used as cell sync bursts.

### 5.7.2 Steady-State Phase

Common with 3.84 Mcps TDD, see [4.9.3 Steady-State Phase], however, the regular DwPCHs are used as cell sync bursts. If the NodeB adjusts the cell timings autonomously, it shall take into account the propagation delay, signaled by the RNC.

### 5.7.3 Late entrant cells

A procedure that may be used for introducing new cells into an already synchronised RNS involves the continuous measurement of the DwPCHs of the neighbouring cells by the late entrant cell. The RNC may use this information to adjust the late entrant cell sufficiently to allow the cell to enter steady state phase.

## 5.8 Idle periods for IPDL location method

### 5.8.1 General

To support time difference measurements for location services, idle periods can be created in the downlink (hence the name IPDL) during which time transmission of the DwPCH from a Node B is temporarily ceased. During these idle periods the visibility of neighbour cells from the UE is improved.

The idle periods are arranged in a determined pattern according to higher layer parameters. An idle period has a duration of one DwPTS.

In general there are two modes for these idle periods:

- Continuous mode, and
- Burst mode

In continuous mode, the idle periods are active all the time. In burst mode the idle periods are arranged in bursts where each burst contains enough idle periods to allow a UE to make sufficient measurements for its location to be calculated. The bursts are separated by a period where no idle periods occur. The time difference measurements can be performed on any channel.

### 5.8.2 Parameters of IPDL

The following parameters are signalled to the UE via higher layers:

**IP\_Status:** This is a logic value that indicates if the idle periods are arranged in continuous or burst mode.

**IP\_Spacing:** The number of 10 ms radio frames between the start of a radio frame that contains an idle period and the next radio frame that contains the next idle period.

**IP\_Start:** The number of the first frame with idle periods. In case of continuous mode IP\_Start is the SFN of the first frame with idle periods and in case of burst mode IP\_Start defines the number of frames after Burst\_Start with the first frame with idle periods.

**IP\_Sub:** Indicates whether the idle period is to occur in the odd, the even or both the odd and even 5 ms sub-frames of the 10 ms idle frame.

Additionally in the case of burst mode operation the following parameters are also communicated to the UE.

**Burst\_Start:** Specifies the start of the first burst of idle periods.  $256 \times \text{Burst\_Start}$  is the SFN where the first burst of idle periods starts.

**Burst\_Length:** The number of idle periods in a burst of idle periods.

**Burst\_Freq:** Specifies the time between the start of a burst and the start of the next burst.  $256 \times \text{Burst\_Freq}$  is the number of radio frames between the start of a burst and the start of the next burst.

### 5.8.3 Calculation of idle period position

In burst mode, burst #0 starts in the radio frame with SFN =  $256 \times \text{Burst\_Start}$ . Burst #n starts in the radio frame with SFN =  $256 \times \text{Burst\_Start} + n \times 256 \times \text{Burst\_Freq}$  ( $n = 0, 1, 2, \dots$ ). The sequence of bursts according to this formula continues up to and including the radio frame with SFN = 4095. At the start of the radio frame with SFN = 0, the burst sequence is terminated (no idle periods are generated) and at SFN =  $256 \times \text{Burst\_Start}$  the burst sequence is restarted with burst #0 followed by burst #1 etc., as described above.

Continuous mode is equivalent to burst mode, with only one burst spanning the whole SFN cycle of 4096 radio frames, this burst starts in the radio frame with SFN = 0. In case of continuous mode the parameter IP\_Start defines the first frame with idle periods.

The DwPTS, that has to be idle, is defined by two values: IP\_Frame(x) and IP\_Sub. IP\_Frame(x) defines the  $x^{\text{th}}$  frame within a burst in which subframe with the number IP\_Sub has to be switched off.

The actual frame with idle periods within a burst is calculated as follows:

$$\text{IP\_Frame}(x) = \text{IP\_Start} + (x-1) \times \text{IP\_Spacing} \text{ with } x = 1, 2, 3, \dots$$

Figure 11 below illustrates the idle periods for the burst mode which shows the case that both subframes within each frame have DwPTS as an idle period.

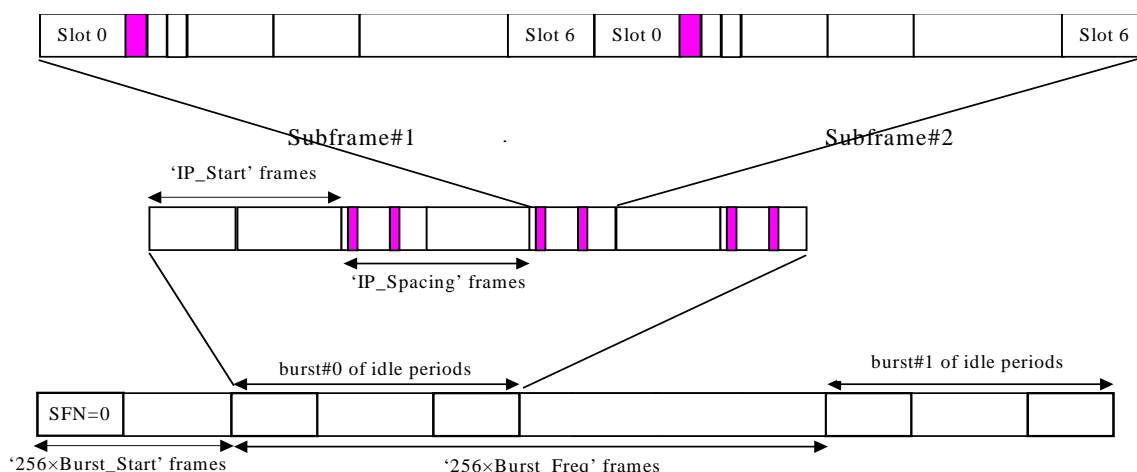

Figure 11: Idle periods of burst mode for 1.28Mcps TDD

## 5.9 HS-DSCH Procedure

The HS-DSCH procedure is the same as that of 3.84 Mcps TDD, cf. 4.11 HS-DSCH Procedure.

---

## Annex A (informative): Power Control

### A.1 Example Implementation of Downlink Power Control in the UE

The power control may be realized by two cascaded control loops. The outer loop controls the transmission quality, whose reference value is set by higher layers [15], by providing the reference value for the inner loop. This reference value should be the SIR at the UE [15]. The inner loop controls the physical quantity for which the outer loop produces the reference value (e. g. the SIR) by generating TPC commands. This may be done by comparing the measured SIR to its reference value. When the measured value is higher than the target SIR value, TPC command = "down". When this is lower than or equal to the target SIR value, TPC command = "up".

In case of a downlink transmission pause on the DPCH or PDSCH, the receive power (RSCP) of the data can no longer be used for inner loop SIR calculations in the UE. In this case the UE should trace the fluctuations of the pathloss based on the P-CCPCH and use these values instead for generating the TPC commands. This pathloss together with the timeslot ISCP measurement in the data timeslot, which is ongoing, should be used to calculate a virtual SIR value:

$$SIR_{virt}(i) = RSCP_{virt}(i) - ISCP(i),$$

$$RSCP_{virt}(i) = RSCP_0 + L_0 - L(i) + \sum_{k=1}^{i-1} TPC(k),$$

RSCP:	Received signal code power in dBm
ISCP:	Interference signal code power in the DPCH / PDSCH timeslot in dBm
L:	pathloss in dB measured on the P-CCPCH. The same weighting of the long- and short-term pathloss should be used as for uplink open loop power control, see Annex A.1
i:	index for the frames during a transmission pause, $1 \leq i \leq$ number of frames in the pause
$L_0$ :	weighted pathloss in the last frame before the transmission pause in dB
$RSCP_0$ :	RSCP of the data that was used in the SIR calculation of the last frame before the pause in dBm
TPC (k):	$\pm$ power control stepsize in dB according to the TPC bit generated and transmitted in frame k, TPC bit "up" = +stepsize, TPC bit "down" = -stepsize

---

### A.2 Example Implementation of Closed Loop Uplink Power Control in Node B for 1.28 Mcps TDD

Uplink power control is based on a quality target, set by higher layers. An example implementation for a Node B TPC calculation algorithm is SIR based. In this algorithm, an outer loop sets a target SIR value,  $SIR_{target}$ , which may be adjusted from time to time in order to ensure that the quality target is met. In the meantime, as part of an inner loop a calculation of SIR in associated uplink transmissions may be carried out. When the measured value is higher than the target SIR value, TPC command = "down". When the measurement is lower than or equal to the target SIR, TPC command = "up".

---

### A.3 Example Implementation of Downlink Power Control in UE for 1.28 Mcps TDD when TSTD is used

Downlink power control is based on a quality target, set by higher layers. An example implementation for a UE TPC calculation algorithm is SIR based. In this algorithm, an outer loop sets a target SIR value,  $SIR_{target}$ , which may be adjusted from time to time in order to ensure that the quality target is met. In the meantime, as part of an inner loop a

calculation of SIR in associated downlink transmissions may be carried out. When the measured value is higher than the target SIR value, TPC command = "down". When the measurement is lower than or equal to the target SIR, TPC command = "up".

When TSTD is applied, the UE can use the consecutive measurements of SIR to calculate  $SIR_{AVG}$ :

$$SIR_{AVG}(i) = w_1 SIR(i-1) + w_2 SIR(i),$$

where,  $w_1 + w_2 = 1$ ,  $w_1 \geq 0$ ,  $w_2 \geq 0$ , and  $SIR(i)$  is the measurement of SIR in sub-frame  $i$  and  $SIR_{AVG}(i)$  is the measurement of  $SIR_{AVG}$  in sub-frame  $i$ . If  $SIR_{AVG}$  is greater than the target SIR value, TPC command = "down". If the  $SIR_{AVG}$  is smaller than the target SIR value, TPC command = "up".

In case of a downlink transmission pause on the DPCH, the example in Annex A.1 can be used for DL power control with  $RSCP_{virt}(i)$  and  $ISCP(i)$  replaced by  $RSCP_{AVG}(i)$  and  $ISCP_{AVG}(i)$ , where

$$RSCP_{AVG}(i) = w_1 RSCP_{virt}(i-1) + w_2 RSCP_{virt}(i),$$

$$ISCP_{AVG}(i) = w_1 ISCP(i-1) + w_2 ISCP(i).$$

---

## A.4 Example Implementation of open Loop Power Control for access procedure for 1.28 Mcps TDD

The higher layer signals (on BCH) a power increment that is applied to the SYNC-UL burst only for the access procedure. At each new transmission of a SYNC-UL burst during the access procedure, the transmit power level can be increased by this power increment.



---

## Annex B (informative): Determination of Weight Information

Selective Transmit Diversity (STD) and Transmit Adaptive Antennas (TxAA) are examples of transmit diversity schemes for dedicated physical channels.

---

### B.1 STD Weights

The weight vector will take only two values depending on the signal strength received by each antenna in the uplink slot. For each user, the antenna receiving the highest power will be selected (i.e. the corresponding weight will be set to 1).

**Table B.1: STD weights for two TX antennas**

	$W_1$	$W_2$
Antenna 1 receiving highest power	1	0
Antenna 2 receiving highest power	0	1

---

### B.2 TxAA Weights

In a generic sense, the weight vector to be applied at the transmitter is the  $\underline{w}$  that maximises:

$$P = \underline{w}^H H^H H \underline{w} \quad (1)$$

where

$$H = [\underline{h}_1 \quad \underline{h}_2] \text{ and } \underline{w} = [w_1, w_2]^T$$

and where the column vector  $\underline{h}_i$  represents the estimated uplink channel impulse response for the  $i$ 'th transmission antenna, of length equal to the length of the channel impulse response.

---

## Annex C (informative): Cell search procedure for 3.84 Mcps TDD

During the cell search, the UE searches for a cell and determines the downlink scrambling code, basic midamble code and frame synchronisation of that cell. The cell search is typically carried out in three steps:

### Step 1: Primary synchronisation code acquisition

During the first step of the cell search procedure, the UE uses the SCH's primary synchronisation code to find a cell. This is typically done with a single matched filter (or any similar device) matched to the primary synchronisation code which is common to all cells. A cell can be found by detecting peaks in the matched filter output.

Note that for a cell of SCH slot configuration case 1, the SCH can be received periodically every 15 slots. In case of a cell of SCH slot configuration case 2, the following SCH slot can be received at offsets of either 7 or 8 slots from the previous SCH slot.

### Step 2: Code group identification and slot synchronisation

During the second step of the cell search procedure, the UE uses the SCH's secondary synchronisation codes to identify 1 out of 32 code groups for the cell found in the first step. This is typically done by correlating the received signal with the secondary synchronisation codes at the detected peak positions of the first step. The primary synchronisation code provides the phase reference for coherent detection of the secondary synchronisation codes. The code group can then uniquely be identified by detection of the maximum correlation values.

Each code group indicates a different  $t_{\text{offset}}$  parameter and 4 specific cell parameters. Each of the cell parameters is associated with one particular downlink scrambling code and one particular long and short basic midamble code. When the UE has determined the code group, it can unambiguously derive the slot timing of the found cell from the detected peak position in the first step and the  $t_{\text{offset}}$  parameter of the found code group in the second step.

Note that the modulation of the secondary synchronisation codes also indicates the position of the SCH slot within a 2 frames period, e.g. a frame with even or odd SFN. Additionally, in the case of SCH slot configuration following case 2, the SCH slot position within one frame, e.g. first or last SCH slot, can be derived from the modulation of the secondary synchronisation codes.

### Step 3: Downlink scrambling code, basic midamble code identification and frame synchronisation

During the third and last step of the cell search procedure, the UE determines the exact downlink scrambling code, basic midamble code and frame timing used by the found cell. The long basic midamble code can be identified by correlation over the P-CCPCH (or any other beacon channel) with the 4 possible long basic midamble codes of the code group found in the second step. A P-CCPCH (or any other beacon channel) always uses the midamble  $m^{(1)}$  (and in case of SCTD also midamble  $m^{(2)}$ ) derived from the long basic midamble code and always uses a fixed and pre-assigned channelisation code.

When the long basic midamble code has been identified, downlink scrambling code and cell parameter are also known. The UE can read system and cell specific BCH information and acquire frame synchronisation.

Note that even for an initial cell parameter assignment, a cell cycles through a set composed of 2 different cell parameters according to the SFN of a frame, e.g. the downlink scrambling code and the basic midamble code of a cell alternate for frames with even and odd SFN. Cell parameter cycling leaves the code group of a cell unchanged.

If the UE has received information about which cell parameters or SCH configurations to search for, cell search can be simplified.

---

## Annex CA (informative): Cell search procedure for 1.28 Mcps TDD

During the initial cell search, the UE searches for a cell. It then determines the DwPTS synchronization, scrambling and basic midamble code identification, control multi-frame synchronisation and then reads the contents in BCH. This initial cell search is carried out in 4 steps:

### Step 1: Search for DwPTS

During the first step of the initial cell search procedure, the UE uses the SYNC-DL (in DwPTS) to acquire DwPTS synchronization to a cell. This is typically done with one or more matched filters (or any similar device) matched to the received SYNC-DL which is chosen from PN sequences set. A single or more matched filter (or any similar device) is used for this purpose. During this procedure, the UE needs to identify which of the 32 possible SYNC-DL sequences is used.

### Step 2: Scrambling and basic midamble code identification

During the second step of the initial cell search procedure, the UE receives the midamble of the P-CCPCH. The P-CCPCH is followed by the DwPTS. In the 1.28 Mcps TDD each DwPTS code corresponds to a group of 4 different basic midamble code. Therefore there are total 128 midamble codes and these codes are not overlapping with each other. Basic midamble code number divided by 4 gives the SYNC-DL code number. Since the SYNC-DL and the group of basic midamble codes of the P-CCPCH are related one by one (i.e, once the SYNC-DL is detected, the 4 midamble codes can be determined), the UE knows which 4 basic midamble codes are used. Then the UE can determine the used basic midamble code using a try and error technique. The same basic midamble code will be used throughout the frame. As each basic midamble code is associated with a scrambling code, the scrambling code is also known by that time. According to the result of the search for the right midamble code, UE may go to next step or go back to step 1.

### Step 3: Control multi-frame synchronisation

During the third step of the initial cell search procedure, the UE searches for the MIB( Master Indication Block) of multi-frame of the BCH in the P-CCPCH indicated by QPSK phase modulation of the DwPTS with respect to the P-CCPCH midamble. The control multi-frame is positioned by a sequence of QPSK symbols modulated on the DwPTS. [n] consecutive DwPTS are sufficient for detecting the current position in the control multi-frame. According to the result of the control multi-frame synchronisation for the right midamble code, UE may go to next step or go back to step 2.

### Step 4: Read the BCH

The (complete) broadcast information of the found cell in one or several BCHs is read. According to the result the UE may move back to previous steps or the initial cell search is finished.

# Annex CB (informative): Examples random access procedure for 1.28 Mcps TDD

**Table CB.1: One PRACH, TTI=5ms, WT=4, L =1, SF4 PRACH**

Sub-frame Number	0	1	2	3	4	5	6	7	8	9	10
Users sending on UpPCH	1	3	5	7							
	2	4	6	8							
Acknowledged user on FPACH		1	2	3	4	5	6	7			
User sending on PRACH 0				1	2	3	4	5	6	7	

User 8 is not granted because more than 5 sub-frames would have passed since the UpPCH.

**Table CB.2: Two PRACHs, TTI=10ms, WT=4, L =2, SF8 PRACH**

Sub-frame Number	0	1	2	3	4	5	6	7	8	9	10	11
Users sending on UpPCH	1	3	5	7								
	2	4	6	8								
Acknowledged user on FPACH		1	2	3	4	5	6	7				
User sending on PRACH 0					2	2	4	4	6	6		
User sending on PRACH 1					1	1	3	3	5	5	7	7

User 8 is not granted because more than 5 sub-frames would have passed since the UpPCH.

**Table CB.3: Four PRACHs, TTI=20ms, WT=4, L =4, SF16 PRACH**

Sub-frame Number	0	1	2	3	4	5	6	7	8	9	10	11	12	13
Users sending on UpPCH	1	3	5	7										
	2	4	6	8										
Acknowledged user on FPACH		1	2	3	4	5	6	7						
User sending on PRACH 0							4	4	4	4				
User sending on PRACH 1					1	1	1	1	5	5	5	5		
User sending on PRACH 2					2	2	2	2	6	6	6	6		
User sending on PRACH 3							3	3	3	3	7	7	7	7

User 8 is not granted because more than 5 sub-frames would have passed since the UpPCH.

**Table CB.4: Two PRACHs, TTI=20ms, WT=4, L =4, SF16 PRACH**

Sub-frame Number	0	1	2	3	4	5	6	7	8	9	10	11	12
Users sending on UpPCH	1	3	5	7									
	2	4	6	8									
Acknowledged user on FPACH	X	1			2	3			X	X			
User sending on PRACH 0							2	2	2	2			
User sending on PRACH 1					1	1	1	1	3	3	3	3	

The FPACH is used ONLY in sub-frames 0, 1, 4, 5, 8, 9,... because they correspond to the used RACH resources.

The FPACH in sub-frame 0 is not used because no UpPCH is preceding.

The FPACH in sub-frames 8,9 is not used because no UpPCH is preceding in the last 4 sub-frames.

In contrast to the previous examples users 4,5,6,7 are not granted because they would not lead to a RACH anyway. In this example their grant would come too late.

User 8 is not granted because more than 4 sub-frames would have passed since the UpPCH.

## Annex D (informative): Change history

Change history							
Date	TSG #	TSG Doc.	CR	Rev	Subject/Comment	Old	New
14/01/00	RAN_05	RP-99594	-		Approved at TSG RAN #5 and placed under Change Control	-	3.0.0
14/01/00	RAN_06	RP-99698	001	01	Primary and Secondary CCPCH in TDD	3.0.0	3.1.0
14/01/00	RAN_06	RP-99698	002	-	Measurement procedure of received reference power for OL-TPC in TDD	3.0.0	3.1.0
14/01/00	RAN_06	RP-99699	004	1	STTD capability for P-CCPCH, TDD component	3.0.0	3.1.0
14/01/00	RAN_06	RP-99697	005	1	Alignment of Terminology Regarding Spreading for TDD Mode	3.0.0	3.1.0
14/01/00	-	-	-	-	Change history was added by the editor	3.1.0	3.1.1
31/03/00	RAN_07	RP-000070	003	2	Cycling of cell parameters	3.1.1	3.2.0
31/03/00	RAN_07	RP-000070	007	2	Clarifications on the UL synchronisation and Timing advance	3.1.1	3.2.0
31/03/00	RAN_07	RP-000070	008	-	Modification of SIR threshold on setting TPC	3.1.1	3.2.0
31/03/00	RAN_07	RP-000070	009	1	New section describing the random access procedure	3.1.1	3.2.0
31/03/00	RAN_07	RP-000070	011	-	Removal of Synchronisation Case 3 in TDD	3.1.1	3.2.0
31/03/00	RAN_07	RP-000070	012	1	Clarifications on power control procedures	3.1.1	3.2.0
31/03/00	RAN_07	RP-000070	013	-	Signal Point Constellation	3.1.1	3.2.0
31/03/00	RAN_07	RP-000070	014	2	Out-of-sync handling for UTRA TDD	3.1.1	3.2.0
31/03/00	RAN_07	RP-000070	015	-	Removal of ODMA from the TDD specifications	3.1.1	3.2.0
26/06/00	RAN_08	RP-000274	016	-	Editorial correction for the power control section in 25.224	3.2.0	3.3.0
26/06/00	RAN_08	RP-000274	017	-	Power control for TDD during DTX	3.2.0	3.3.0
26/06/00	RAN_08	RP-000274	018	1	Power Control for PDSCH	3.2.0	3.3.0
26/06/00	RAN_08	RP-000274	020	1	Editorial modification of 25.224	3.2.0	3.3.0
26/06/00	RAN_08	RP-000274	021	-	Clarifications on Tx Diversity for UTRA TDD	3.2.0	3.3.0
26/06/00	RAN_08	RP-000274	022	1	Introduction of the TDD DSCH detection procedure in TS 25.224	3.2.0	3.3.0
26/06/00	RAN_08	RP-000274	023	-	Downlink power control on timeslot basis	3.2.0	3.3.0
23/09/00	RAN_09	RP-000347	019	1	Gain Factors for TDD Mode	3.3.0	3.4.0
23/09/00	RAN_09	RP-000347	025	-	Terminology regarding the beacon function	3.3.0	3.4.0
23/09/00	RAN_09	RP-000347	026	1	Synchronisation of timing advance adjustment and timing deviation measurement	3.3.0	3.4.0
23/09/00	RAN_09	RP-000347	027	1	CCTrCH UL/DL pairing for DL inner loop power control	3.3.0	3.4.0
23/09/00	RAN_09	RP-000347	028	1	RACH timing in TDD mode	3.3.0	3.4.0
23/09/00	RAN_09	RP-000347	030	1	TDD Access Bursts for HOV	3.3.0	3.4.0
23/09/00	RAN_09	RP-000347	032	-	Removal of ODMA related abbreviations and correction of references	3.3.0	3.4.0
23/09/00	RAN_09	RP-000347	033	-	Clarifications on the Out-of-sync handling for UTRA TDD	3.3.0	3.4.0
15/12/00	RAN_10	RP-000544	035	1	Radio Link establishment and sync status reporting	3.4.0	3.5.0
15/12/00	RAN_10	RP-000544	040	-	Clarification on PICH power setting	3.4.0	3.5.0
15/12/00	RAN_10	RP-000544	042	-	Correction to TDD timing advance description	3.4.0	3.5.0
15/12/00	RAN_10	RP-000544	043	-	Limit on maximum value of alpha used for open loop power control	3.4.0	3.5.0
16/03/01	RAN_11	-	-	-	Approved as Release 4 specification (v4.0.0) at TSG RAN #11	3.5.0	4.0.0
16/03/01	RAN_11	RP-010065	036	-	DTX and Special Burst Scheduling	3.5.0	4.0.0
16/03/01	RAN_11	RP-010065	037	1	RACH random access procedure	3.5.0	4.0.0
16/03/01	RAN_11	RP-010065	045	-	Introduction of closed-loop Tx diversity for the PDSCH and DTX for the PUSCH/PDSCH	3.5.0	4.0.0
16/03/01	RAN_11	RP-010065	046	2	Corrections of TDD power control sections	3.5.0	4.0.0
16/03/01	RAN_11	RP-010065	050	-	Use of a special burst in reconfiguration	3.5.0	4.0.0
16/03/01	RAN_11	RP-010065	053	-	Known TFCI for the TDD special burst	3.5.0	4.0.0
16/03/01	RAN_11	RP-010073	044	2	Layer 1 procedure for Node B synchronisation	3.5.0	4.0.0
16/03/01	RAN_11	RP-010071	047	1	Inclusion of 1,28 Mcps TDD in TS 25.224	3.5.0	4.0.0
16/03/01	RAN_11	RP-010072	048	1	Idle periods for IPDL location method	3.5.0	4.0.0
15/06/01	RAN_12	RP-010338	057	-	Correction of Timing Advance section for 3.84 Mcps TDD	4.0.0	4.1.0
15/06/01	RAN_12	RP-010338	059	-	Addition to the abbreviation list	4.0.0	4.1.0
15/06/01	RAN_12	RP-010343	049	-	Clarification of IP_Frame(x) definition	4.0.0	4.1.0
15/06/01	RAN_12	RP-010343	055	1	Correction of IPDL burst parameters	4.0.0	4.1.0
21/09/01	RAN_13	RP-010525	064	1	Correction of criteria for OOS indication	4.1.0	4.2.0
21/09/01	RAN_13	RP-010531	060	-	Corrections for TS 25.224	4.1.0	4.2.0
21/09/01	RAN_13	RP-010531	062	1	Corrections of Annex E in 25.224	4.1.0	4.2.0
21/09/01	RAN_13	RP-010531	061	-	Corrections and Clarifications for calculation of idle period position in subclause 4.10.3 in 25.224	4.1.0	4.2.0
14/12/01	RAN_14	RP-010742	066	-	Removal of the remark on power control	4.2.0	4.3.0
14/12/01	RAN_14	RP-010742	068	1	Transmit Diversity for P-CCPCH and PICH	4.2.0	4.3.0
14/12/01	RAN_14	RP-010742	070	1	Correction to random access procedure (Primitive from MAC)	4.2.0	4.3.0
14/12/01	RAN_14	RP-010749	073	1	Random access procedure for 1.28Mcps TDD	4.2.0	4.3.0
14/12/01	RAN_14	RP-010749	074	-	Transmit diversity for P-CCPCH and PICH	4.2.0	4.3.0
14/12/01	RAN_14	RP-010749	075	-	Correction of Annex A.3 in 25.224	4.2.0	4.3.0

Change history							
Date	TSG #	TSG Doc.	CR	Rev	Subject/Comment	Old	New
14/12/01	RAN_14	RP-010749	076	-	Removal of the remark on power control	4.2.0	4.3.0
14/12/01	RAN_14	RP-010749	077	-	Corrections to DL-PC sections for 1.28 Mcps TDD	4.2.0	4.3.0
08/03/02	RAN_15	RP-020052	079	1	Removal of quantisation of bj gain factor when calculated from a reference TFC	4.3.0	4.4.0
08/03/02	RAN_15	RP-020052	084	1	TDD MAC layer subchannel assignment	4.3.0	4.4.0
08/03/02	RAN_15	RP-020052	086	-	Transmit diversity on PICH	4.3.0	4.4.0
08/03/02	RAN_15	RP-020057	080	-	Introduction of 'UE Positioning Enhancements for 1.28 Mcps TDD'	4.3.0	5.0.0
08/03/02	RAN_15	RP-020055	082	1	Introduction of 'Node B synchronization for 1.28 Mcps TDD'	4.3.0	5.0.0
08/03/02	RAN_15	RP-020058	081	1	Power Control and Procedures for HSDPA	4.3.0	5.0.0
07/06/02	RAN_16	RP-020315	088	-	Clarification on power control and TxDiversity procedure for 1.28 Mcps TDD	5.0.0	5.1.0
07/06/02	RAN_16	RP-020317	089	-	TxDiversity for HSDPA in TDD	5.0.0	5.1.0
07/06/02	RAN_16	RP-020317	090	-	Correction to HS-SCCH Power Control (TDD)	5.0.0	5.1.0
20/09/02	RAN_17	RP-020586	091	1	Corrections to 25.224 for HSDPA	5.1.0	5.2.0
20/09/02	RAN_17	RP-020572	094	2	Corrections to transmit diversity mode for TDD beacon-function physical channels	5.1.0	5.2.0
20/09/02	RAN_17	RP-020577	097	1	Corrections to uplink synchronisation procedure	5.1.0	5.2.0
20/09/02	RAN_17	RP-020577	099	-	Correction to the PRACH open loop power control procedure for 1.28 Mcps TDD	5.1.0	5.2.0
20/09/02	RAN_17	RP-020579	101	1	Corrections to transmit diversity mode for TDD beacon-function physical channels	5.1.0	5.2.0
15/10/02	-	-	-	-	Separate subclause 5.1.1.3, which was by accident merged into the header of subclause 5.1.1.4	5.2.0	5.2.1
22/12/02	RAN_18	RP-020854	102	1	Corrections and clarifications to TDD CQI description	5.2.1	5.3.0
22/12/02	RAN_18	RP-020852	105	-	Editorial modification to the section numberings	5.2.1	5.3.0
24/03/03	RAN_19	RP-030141	109	1	Corrections to TPC Procedures During a DL Transmission Pause	5.3.0	5.4.0
24/03/03	RAN_19	RP-030141	114	1	Corrections to link adaptation procedure for UTRA TDD (3.84 Mcps Option)	5.3.0	5.4.0
24/03/03	RAN_19	RP-030141	115	2	Minimum timing requirement for CQI transmission on HS-SICH in UTRA TDD	5.3.0	5.4.0
24/03/03	RAN_19	RP-030141	117	2	Clarification of downlink closed loop power control procedures for 3.84 Mcps TDD	5.3.0	5.4.0
24/03/03	RAN_19	RP-030133	119	2	Corrections to the LCR power control procedure	5.3.0	5.4.0
24/06/03	RAN_20	RP-030277	120	-	Clarifications for the 1.28Mcps TDD power control procedure	5.4.0	5.5.0
22/09/03	RAN_21	RP-030460	121	3	Clarification on PDSCH Downlink Power Control Procedures	5.5.0	5.6.0
22/09/03	RAN_21	RP-030476	125	1	DTX and Special Bursts in case of no data on S-CCPCH and Beacon Channels	5.5.0	5.6.0
06/01/04	RAN_22	RP-030698	128	1	Correction to computed gain factors with signalled reference gain factor values	5.6.0	5.7.0
07/09/04	RAN_25	RP-040316	133	-	Transmit diversity usage for beacon channels in LCR TDD	5.7.0	5.8.0
07/09/04	RAN_25	RP-040319	136	1	Corrections of radio access procedure for 1.28McpsTDD	5.7.0	5.8.0

---

## History

<b>Document history</b>		
V5.0.0	March 2002	Publication
V5.1.0	June 2002	Publication
V5.2.0	September 2002	Publication (Withdrawn)
V5.2.1	December 2002	Publication
V5.3.0	December 2002	Publication
V5.4.0	March 2003	Publication
V5.5.0	June 2003	Publication
V5.6.0	September 2003	Publication
V5.7.0	December 2003	Publication
V5.8.0	September 2004	Publication