

ETSI TS 125 301 V3.5.0 (2000-06)

Technical Specification

Universal Mobile Telecommunications System (UMTS); Radio Interface Protocol Architecture (3G TS 25.301 version 3.5.0 Release 1999)



Reference

RTS/TSGR-0225301UR2

Keywords

UMTS

ETSI

650 Route des Lucioles
F-06921 Sophia Antipolis Cedex - FRANCE

Tel.: +33 4 92 94 42 00 Fax: +33 4 93 65 47 16

Siret N° 348 623 562 00017 - NAF 742 C
Association à but non lucratif enregistrée à la
Sous-Préfecture de Grasse (06) N° 7803/88

Important notice

Individual copies of the present document can be downloaded from:

<http://www.etsi.org>

The present document may be made available in more than one electronic version or in print. In any case of existing or perceived difference in contents between such versions, the reference version is the Portable Document Format (PDF).

In case of dispute, the reference shall be the printing on ETSI printers of the PDF version kept on a specific network drive within ETSI Secretariat.

Users of the present document should be aware that the document may be subject to revision or change of status.

Information on the current status of this and other ETSI documents is available at <http://www.etsi.org/tb/status/>

If you find errors in the present document, send your comment to:
editor@etsi.fr

Copyright Notification

No part may be reproduced except as authorized by written permission.
The copyright and the foregoing restriction extend to reproduction in all media.

© European Telecommunications Standards Institute 2000.

All rights reserved.

Intellectual Property Rights

IPRs essential or potentially essential to the present document may have been declared to ETSI. The information pertaining to these essential IPRs, if any, is publicly available for **ETSI members and non-members**, and can be found in ETSI SR 000 314: *"Intellectual Property Rights (IPRs); Essential, or potentially Essential, IPRs notified to ETSI in respect of ETSI standards"*, which is available from the ETSI Secretariat. Latest updates are available on the ETSI Web server (<http://www.etsi.org/ipr>).

Pursuant to the ETSI IPR Policy, no investigation, including IPR searches, has been carried out by ETSI. No guarantee can be given as to the existence of other IPRs not referenced in ETSI SR 000 314 (or the updates on the ETSI Web server) which are, or may be, or may become, essential to the present document.

Foreword

This Technical Specification (TS) has been produced by the ETSI 3rd Generation Partnership Project (3GPP).

The present document may refer to technical specifications or reports using their 3GPP identities, UMTS identities or GSM identities. These should be interpreted as being references to the corresponding ETSI deliverables.

The cross reference between GSM, UMTS, 3GPP and ETSI identities can be found under www.etsi.org/key .

Contents

Foreword.....	5
1 Scope.....	6
2 References.....	6
3 Definitions and abbreviations	7
3.1 Definitions	7
3.2 Abbreviations.....	7
4 Assumed UMTS Architecture	8
5 Radio interface protocol architecture.....	10
5.1 Overall protocol structure	10
5.1.1 Service access points and service primitives.....	12
5.2 Layer 1 Services and Functions	13
5.2.1 L1 Services.....	13
5.2.1.1 Transport channels.....	13
5.2.2 L1 Functions.....	14
5.3 Layer 2 Services and Functions	14
5.3.1 MAC Services and Functions.....	14
5.3.1.1 MAC Services to upper layers.....	15
5.3.1.1.1 Logical channels	15
5.3.1.1.2 Mapping between logical channels and transport channels	16
5.3.1.2 MAC functions	18
5.3.2 RLC Services and Functions	19
5.3.2.1 Services provided to the upper layer	19
5.3.2.2 RLC Functions.....	20
5.3.3 PDCP Services and Function	20
5.3.3.1 PDCP Services provided to upper layers.....	20
5.3.3.2 PDCP Functions	21
5.3.4 Broadcast/Multicast Control - Services and functions	21
5.3.4.1 BMC Services.....	21
5.3.4.2 BMC Functions	21
5.3.5 Data flows through Layer 2.....	21
5.3.5.1 Data flow for BCCH mapped to BCH.....	24
5.3.5.2 Data flow for BCCH mapped to FACH.....	24
5.3.5.3 Data flow for PCCH mapped to PCH.....	24
5.3.5.4 Data flow for CCCH mapped to FACH/RACH	24
5.3.5.5 Data flow for SHCCH mapped to USCH.....	24
5.3.5.6 Data flow for SHCCH mapped to FACH/RACH.....	24
5.3.5.7 Data flow for DCCH mapped to FACH/RACH	25
5.3.5.8 Data flow for DCCH mapped to DSCH	25
5.3.5.9 Data flow for DCCH mapped to USCH	25
5.3.5.10 Data flow for DCCH mapped to CPCH	25
5.3.5.11 Data flow for DTCH (non-transparent RLC) mapped to FACH/RACH	25
5.3.5.12 Data flow for DTCH (non-transparent RLC) mapped to DSCH	25
5.3.5.13 Data flow for DTCH (non-transparent RLC) mapped to USCH	25
5.3.5.14 Data flow for DTCH (transparent RLC) mapped to DCH.....	25
5.3.5.15 Data flow for DTCH (non-transparent RLC) mapped to DCH	25
5.3.5.16 Data flow for DTCH (non-transparent RLC) mapped to CPCH.	25
5.3.5.17 Data flow for DCCH mapped to DCH	26
5.3.5.18 Data flow for CTCH mapped to FACH.....	26
5.4 Layer 3 - Uu Stratum Services and Functions	26
5.4.1 Uu Stratum services	26
5.4.1.1 General Control	26
5.4.1.2 Notification.....	26
5.4.1.3 Dedicated Control.....	26
5.4.2 RRC functions.....	27

5.5	Interactions between RRC and lower layers in the C plane	29
5.6	Protocol termination	30
5.6.1	Protocol termination for DCH	30
5.6.2	Protocol termination for RACH/FACH	30
5.6.3	Protocol termination for FAUSCH	32
5.6.4	Protocol termination for CPCH	32
5.6.5	Protocol termination for DSCH	32
5.6.5.1	DSCH definition	32
5.6.5.2	Resource allocation and UE identification on DSCH	33
5.6.5.2.1	Case A (UE requires a downlink TFCI on a DPCH)	33
5.6.5.2.2	Case B (UE requires a downlink SHCCH) (TDD only)	33
5.6.5.3	Model of DSCH in UTRAN	33
5.6.5.4	Protocol termination	34
5.6.6	Protocol termination for transport channel of type USCH	35
5.6.6.1	USCH definition	35
5.6.6.2	Resource allocation and UE identification on USCH	35
5.6.6.3	Model of USCH in UTRAN	35
5.6.6.4	Protocol termination	36
5.6.7	Protocol termination for transport channel of type BCH	37
5.6.8	Protocol termination for transport channel of type PCH	37
5.6.9	Protocol termination for ODCH	38
5.6.10	Protocol termination for ORACH	38
6	User Identification and RRC Connection Mobility	39
6.1	UE identification on the radio interface	39
6.2	UE connection to UTRAN	39
7	UE modes	40
Annex A (informative): Protocol termination		41
A.1	Alternative protocol termination for DCH	41
A.2	Protocol termination for RACH/FACH	41
Annex B (informative): Change history		44

Foreword

This Technical Specification (TS) has been produced by the 3rd Generation Partnership Project (3GPP).

The contents of the present document are subject to continuing work within the TSG and may change following formal TSG approval. Should the TSG modify the contents of the present document, it will be re-released by the TSG with an identifying change of release date and an increase in version number as follows:

Version x.y.z

where:

- x the first digit:
 - 1 presented to TSG for information;
 - 2 presented to TSG for approval;
 - 3 or greater indicates TSG approved document under change control.
- y the second digit is incremented for all changes of substance, i.e. technical enhancements, corrections, updates, etc.
- z the third digit is incremented when editorial only changes have been incorporated in the document.

1 Scope

The present document shall provide an overview and overall description of the UE-UTRAN radio interface protocol architecture as agreed within the 3GPP TSG RAN working group 2. Details of the radio protocols will be specified in companion documents.

UMTS Release 99 shall support the features and functions described in this document generally. However, some specific logical channels and transport channels which initially were considered for Release 99, but which were deferred to a future UMTS release, have been kept in this specification.

The channels that are not considered for Release 99 are listed as follows:

- Fast Uplink Signalling Channel (FAUSCH);
- ODMA Random Access Channel (ORACH);
- ODMA Dedicated Channel (ODCH);
- ODMA Common Control Channel (OCCCH);
- ODMA Dedicated Control Channel (ODCCH);
- ODMA Dedicated Traffic Channel (ODTCH).

2 References

The following documents contain provisions which, through reference in this text, constitute provisions of the present document.

- References are either specific (identified by date of publication, edition number, version number, etc.) or non-specific.
- For a specific reference, subsequent revisions do not apply.
- For a non-specific reference, the latest version applies.

- [1] 3G TS 23.110: "UMTS Access Stratum; Services and Functions".
- [2] 3G TS 25.401: "RAN Overall Description".
- [3] 3G TR 25.990: "Vocabulary for the UTRAN".
- [4] 3G TS 25.302: "Services provided by the Physical Layer".
- [5] 3G TS 25.303: "Interlayer Procedures in Connected Mode".
- [6] 3G TS 25.304: "UE Procedures in Idle Mode and Procedures for Cell Reselection in Connected Mode".
- [7] 3G TS 25.321: "MAC Protocol Specification".
- [8] 3G TS 25.322: "RLC Protocol Specification".
- [9] 3G TS 25.323: "PDCP Protocol Specification".
- [10] 3G TS 25.324: "BMC Protocol Specification".
- [11] 3G TS 25.331: "RRC Protocol Specification".
- [12] 3G TS 25.224: "Physical Layer Procedures (TDD)".
- [13] 3G TS 24.007: "Mobile radio interface signalling layer 3; General aspects".

- [14] 3G TS 33.105: "Cryptographic Algorithm Requirements".
 [15] 3G TS 33.102: "Security Architecture".

3 Definitions and abbreviations

3.1 Definitions

For the purposes of the present document, the terms and definitions given in [3] apply.

3.2 Abbreviations

For the purposes of the present document, the following abbreviations apply:

ARQ	Automatic Repeat Request
ASC	Access Service Class
BCCH	Broadcast Control Channel
BCH	Broadcast Channel
BMC	Broadcast/Multicast Control
C-	Control-
CC	Call Control
CCCH	Common Control Channel
CCH	Control Channel
CCTrCH	Coded Composite Transport Channel
CN	Core Network
CPCH	Common Packet channel
CRC	Cyclic Redundancy Check
CTCH	Common Traffic Channel
DC	Dedicated Control (SAP)
DCA	Dynamic Channel Allocation
DCCH	Dedicated Control Channel
DCH	Dedicated Channel
DL	Downlink
DRNC	Drift Radio Network Controller
DSCH	Downlink Shared Channel
DTCH	Dedicated Traffic Channel
FACH	Forward Link Access Channel
FAUSCH	Fast Uplink Signalling Channel
FCS	Frame Check Sequence
FDD	Frequency Division Duplex
GC	General Control (SAP)
HO	Handover
ITU	International Telecommunication Union
kbps	kilo-bits per second
L1	Layer 1 (physical layer)
L2	Layer 2 (data link layer)
L3	Layer 3 (network layer)
LAC	Link Access Control
LAI	Location Area Identity
MAC	Medium Access Control
MM	Mobility Management
Nt	Notification (SAP)
OCCCH	ODMA Common Control Channel
ODCCH	ODMA Dedicated Control Channel
ODCH	ODMA Dedicated Channel
ODMA	Opportunity Driven Multiple Access
ORACH	ODMA Random Access Channel
ODTCH	ODMA Dedicated Traffic Channel
PCCH	Paging Control Channel

PCH	Paging Channel
PDCP	Packet Data Convergence Protocol
PDU	Protocol Data Unit
PHY	Physical layer
PhyCH	Physical Channels
PU	Payload Unit
RAB	Radio Access Bearer
RACH	Random Access Channel
RB	Radio Bearer
RLC	Radio Link Control
RNC	Radio Network Controller
RNS	Radio Network Subsystem
RNTI	Radio Network Temporary Identity
RRC	Radio Resource Control
SAP	Service Access Point
SDU	Service Data Unit
SHCCH	Shared Channel Control Channel
SRNC	Serving Radio Network Controller
SRNS	Serving Radio Network Subsystem
TCH	Traffic Channel
TDD	Time Division Duplex
TFCI	Transport Format Combination Indicator
TFI	Transport Format Indicator
TMSI	Temporary Mobile Subscriber Identity
TPC	Transmit Power Control
U-	User-
UE	User Equipment
UE _R	User Equipment with ODMA relay operation enabled
UL	Uplink
UMTS	Universal Mobile Telecommunications System
URA	UTRAN Registration Area
USCH	Uplink Shared Channel
UTRA	UMTS Terrestrial Radio Access
UTRAN	UMTS Terrestrial Radio Access Network

4 Assumed UMTS Architecture

Figure 1a shows the assumed UMTS architecture as outlined in TS 23.110 [1]. The figure shows the UMTS architecture in terms of its entities User Equipment (UE), UTRAN and Core Network. The respective reference points Uu (Radio Interface) and Iu (CN-UTRAN interface) are shown. The figure illustrates furthermore the high-level functional grouping into the Access Stratum and the Non-Access Stratum.

The Access Stratum offers services through the following Service Access Points (SAP) to the Non-Access Stratum:

- General Control (GC) SAPs;
- Notification (Nt) SAPs; and
- Dedicated Control (DC) SAPs.

The SAPs are marked with circles in Figure 1a.

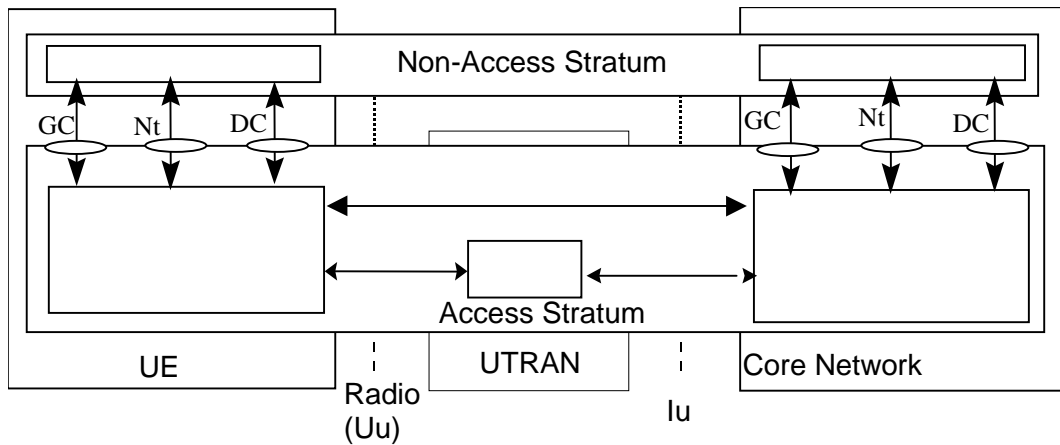

Figure 1a: Assumed UMTS Architecture

This model can be further refined to distinguish the end AS entities, which provide the services to higher layers, from the local entities, which provide services over respectively the Uu and the Iu reference point. Figure 1b presents the refined model.

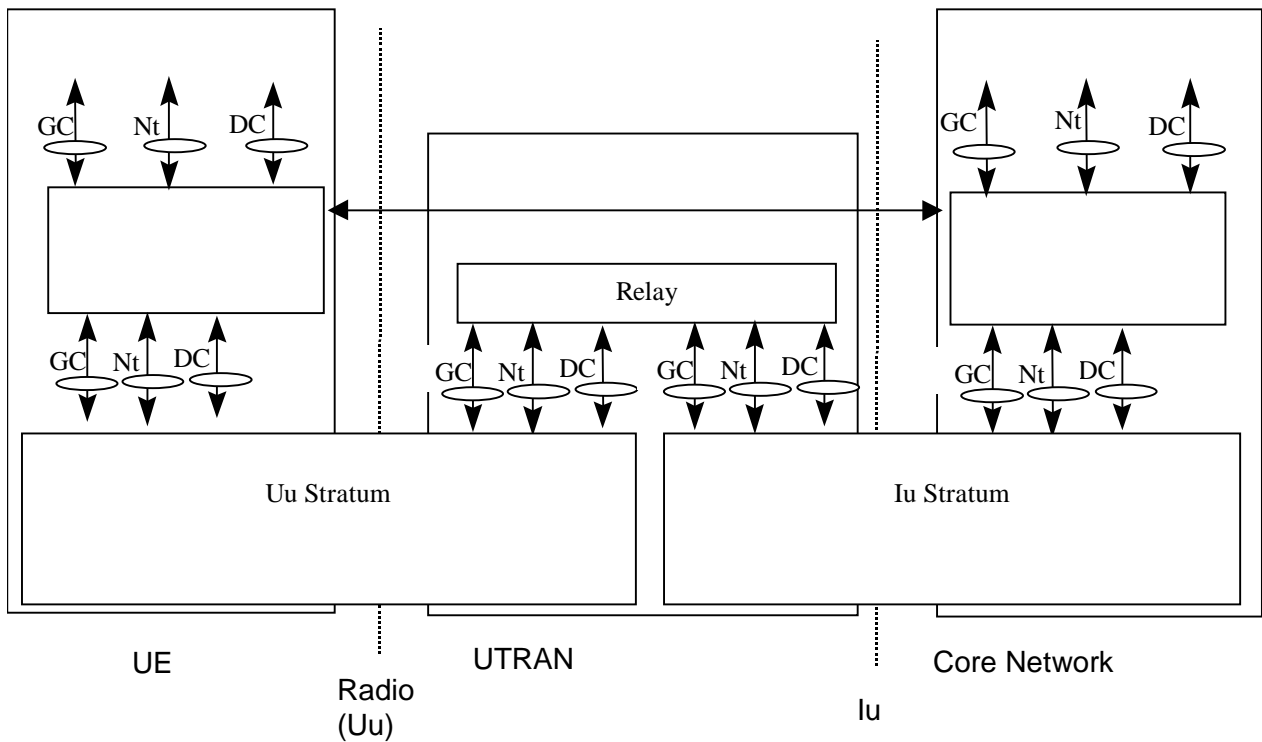

Figure 1b: Assumed UTRAN Model

The Uu Stratum block can be further refined as shown in Figure 1c.

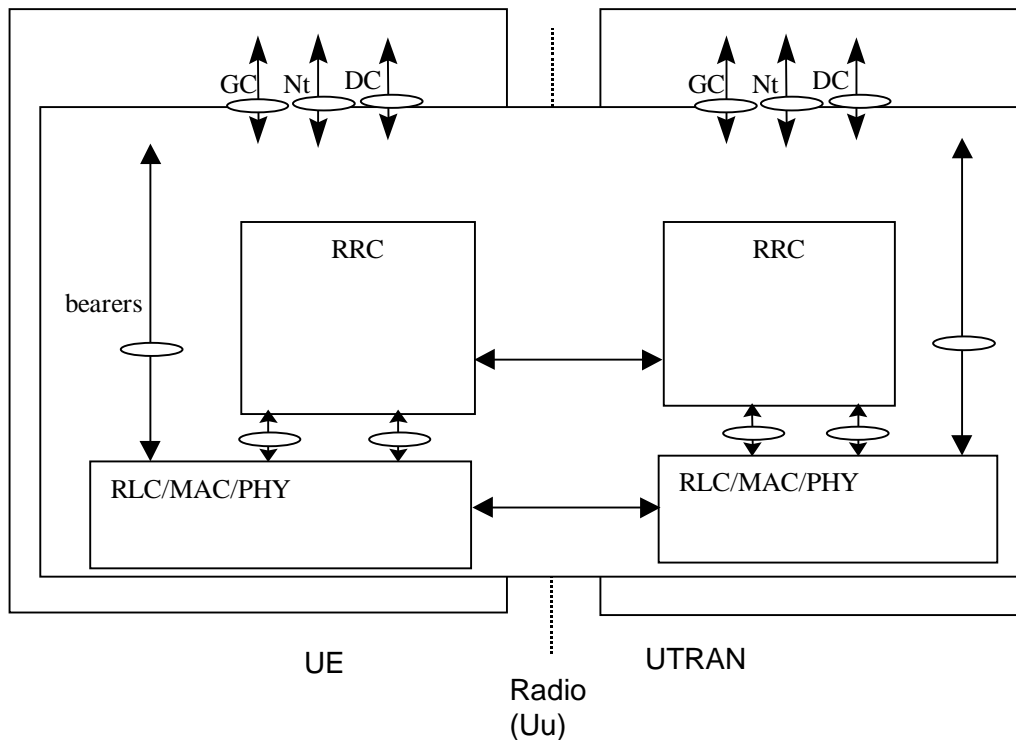

Figure 1c: Assumed Uu Stratum Model

5 Radio interface protocol architecture

5.1 Overall protocol structure

The radio interface is layered into three protocol layers:

- the physical layer (L1);
- the data link layer (L2);
- network layer (L3).

Layer 2 is split into following sublayers: Medium Access Control (MAC), Radio Link Control (RLC), Packet Data Convergence Protocol (PDCP) and Broadcast/Multicast Control (BMC).

Layer 3 and RLC are divided into Control (C-) and User (U-) planes. PDCP and BMC exist in the U-plane only.

In the C-plane, Layer 3 is partitioned into sublayers where the lowest sublayer, denoted as Radio Resource Control (RRC), interfaces with layer 2 and terminates in the UTRAN. The next sublayer provides 'Duplication avoidance' functionality as specified in [13]. It terminates in the CN but is part of the Access Stratum; it provides the Access Stratum Services to higher layers. The higher layer signalling such as Mobility Management (MM) and Call Control (CC) are assumed to belong to the non-access stratum, and therefore not in the scope of 3GPP TSG RAN. On the general level, the protocol architecture is similar to the current ITU-R protocol architecture, ITU-R M.1035.

Figure 2 shows the radio interface protocol architecture. Each block in Figure 2 represents an instance of the respective protocol. Service Access Points (SAP) for peer-to-peer communication are marked with circles at the interface between sublayers. The SAP between MAC and the physical layer provides the transport channels (cf. subclause 5.2.1.1). The SAPs between RLC and the MAC sublayer provide the logical channels (cf. subclause 5.3.1.1.1). In the C-plane, the interface between 'Duplication avoidance' and higher L3 sublayers (CC, MM) is defined by the General Control (GC), Notification (Nt) and Dedicated Control (DC) SAPs.

Also shown in the figure are connections between RRC and MAC as well as RRC and L1 providing local inter-layer control services. An equivalent control interface exists between RRC and the RLC sublayer, between RRC and the

PDCP sublayer and between RRC and BMC sublayer. These interfaces allow the RRC to control the configuration of the lower layers. For this purpose separate Control SAPs are defined between RRC and each lower layer (PDCP, RLC, MAC, and L1).

The RLC sublayer provides ARQ functionality closely coupled with the radio transmission technique used. There is no difference between RLC instances in C and U planes.

The UTRAN can be requested by the CN to prevent all loss of data (i.e. independently of the handovers on the radio interface), as long as the Iu connection point is not modified. This is a basic requirement to be fulfilled by the UTRAN retransmission functionality as provided by the RLC sublayer.

However, in case of the Iu connection point is changed (e.g. SRNS relocation, streamlining), the prevention of the loss of data may not be guaranteed autonomously by the UTRAN but relies on 'Duplication avoidance' functions in the CN.

There are primarily two kinds of signalling messages transported over the radio interface - RRC generated signalling messages and NAS messages generated in the higher layers. On establishment of the signalling connection between the peer RRC entities three or four signalling radio bearers may be set up. Two of these bearers are set up for transport of RRC generated signalling messages - one for transferring messages through an unacknowledged mode RLC entity [see section 5.3.2. for details on RLC modes] and the other for transferring messages through an acknowledged mode RLC entity. One signalling radio bearer is set up for transferring NAS messages set to "high priority" by the higher layers. An optional signalling radio bearer may be set up for transferring NAS messages set to "low priority" by the higher layers. Subsequent to the establishment of the signalling connection a further signalling radio bearer may be set up for transferring RRC generated signalling messages using transparent mode RLC.

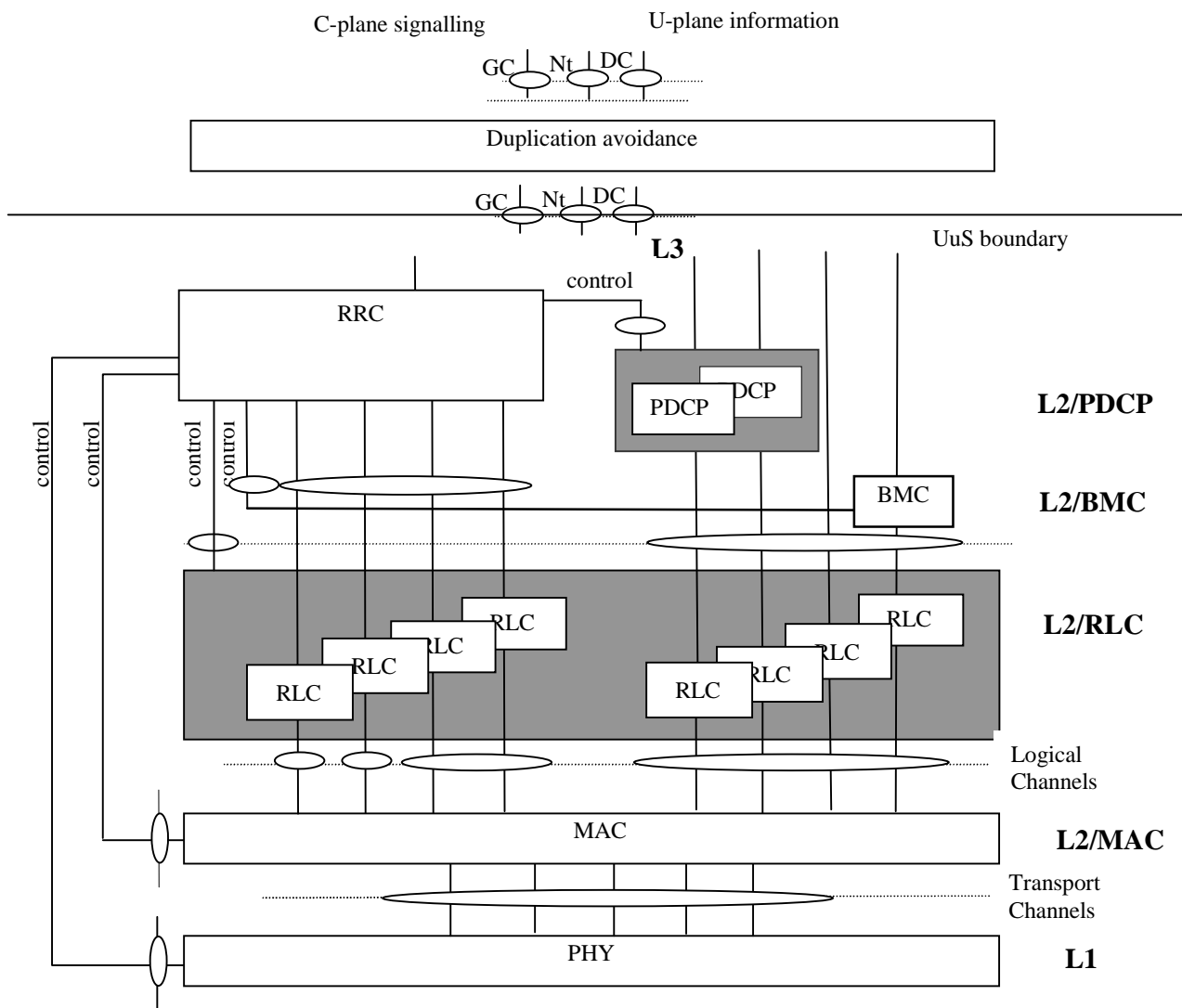

Figure 2: Radio Interface protocol architecture (Service Access Points marked by circles)

5.1.1 Service access points and service primitives

Each layer provides services at Service Access Points (SAPs). A service is defined by a set of service primitives (operations) that a layer provides to upper layer(s).

Control services, allowing the RRC layer to control lower layers locally (i.e. not requiring peer-to-peer communication) are provided at Control SAPs (C-SAP). Note that C-SAP primitives can bypass one or more sublayers, see Figure 2.

In the radio interface protocol specifications, the following naming conventions for primitives shall be applicable:

- Primitives provided by SAPs between adjacent layers shall be prefixed with the name of the service-providing layer, i.e. PHY, MAC, RLC, PDCP, BMC or UUS.
- Primitives provided by SAPs to an application shall be prefixed with the name of the service-providing layer, i.e. RRC.
- Primitives provided by Control SAPs, in addition to the name of the service-providing layer, shall be prefixed with a "C", i.e. CPHY, CMAC, CRLC, CPDCP or CBMC.

This principle leads to the following notations, where <Type> corresponds to request, indication, response or confirm type of primitives:

Primitives between PHY and MAC:

PHY- <Generic name> - <Type>

Primitives between PHY and RRC (over C-SAP):

CPHY- <Generic name> - <Type>

Primitives between MAC and RLC:

MAC- <Generic name> - <Type>

Primitives between MAC and RRC (over C-SAP):

CMAC- <Generic name> - <Type>

Primitives between RLC and upper layers, between RLC and RRC for data transfer and between RLC and PDCP:

RLC- <Generic name> - <Type>

Primitives between RLC and RRC for control of RLC (over C-SAP):

CRLC- <Generic name> - <Type>

Primitives above Uu Stratum:

UUS- <Generic name> - <Type>

Primitives between PDCP and non-access stratum:

PDCP- <Generic name> - <Type>

Primitives between PDCP and RRC (over C-SAP):

CPDCP- <Generic name> - <Type>

Primitives between BMC and upper layer:

BMC- <Generic name> - <Type>

Primitives between BMC and RRC for control of BMC (over C-SAP):

CBMC- <Generic name> - <Type>

In this model, some UUS primitives map directly to RLC primitives without intervening function.

5.2 Layer 1 Services and Functions

This subclause shall provide an overview on services and functions provided by the physical layer. A detailed description of Layer 1 general requirements can be found in 3GPP TS 25.302 [4].

5.2.1 L1 Services

The physical layer offers information transfer services to MAC and higher layers. The physical layer transport services are described by *how* and with what characteristics data are transferred over the radio interface. An adequate term for this is 'Transport Channel'.

NOTE: This should be clearly separated from the classification of *what* is transported, which relates to the concept of logical channels. Thus DCH is used to denote that the physical layer offers the same type of service for both control and traffic.

5.2.1.1 Transport channels

A general classification of transport channels is into two groups:

- common transport channels (where there is a need for inband identification of the UEs when particular UEs are addressed); and
- dedicated transport channels (where the UEs are identified by the physical channel, i.e. code and frequency for FDD and code, time slot and frequency for TDD).

Common transport channel types are (a more detailed description can be found in [4]):

- **Random Access Channel (RACH)**

A contention based uplink channel used for transmission of relatively small amounts of data, e.g. for initial access or non-real-time dedicated control or traffic data.

- **ODMA Random Access Channel (ORACH)**

A contention based channel used in relay link.

- **Common Packet Channel (CPCH)**

A contention based channel used for transmission of bursty data traffic. This channel only exists in FDD mode and only in the uplink direction. The common packet channel is shared by the UEs in a cell and therefore, it is a common resource. The CPCH is fast power controlled.

- **Forward Access Channel (FACH)**

Common downlink channel without closed-loop power control used for transmission of relatively small amount of data.

- **Downlink Shared Channel (DSCH)**

A downlink channel shared by several UEs carrying dedicated control or traffic data.

- **Uplink Shared Channel (USCH)**

An uplink channel shared by several UEs carrying dedicated control or traffic data, used in TDD mode only.

- **Broadcast Channel (BCH)**

A downlink channel used for broadcast of system information into an entire cell.

- **Paging Channel (PCH)**

A downlink channel used for broadcast of control information into an entire cell allowing efficient UE sleep mode procedures. Currently identified information types are paging and notification. Another use could be UTRAN notification of change of BCCH information.

Dedicated transport channel types are:

- **Dedicated Channel (DCH)**

A channel dedicated to one UE used in uplink or downlink.

- **Fast Uplink Signalling Channel (FAUSCH)**

An uplink channel used to allocate dedicated channels in conjunction with FACH.

- **ODMA Dedicated Channel (ODCH)**

A channel dedicated to one UE used in relay link.

To each transport channel (except for the FAUSCH, since it only conveys a reservation request), there is an associated Transport Format (for transport channels with a fixed or slow changing rate) or an associated Transport Format Set (for transport channels with fast changing rate). A Transport Format is defined as a combination of encodings, interleaving, bit rate and mapping onto physical channels (see 3GPP TS 25.302 [4] for details). A Transport Format Set is a set of Transport Formats. E.g., a variable rate DCH has a Transport Format Set (one Transport Format for each rate), whereas a fixed rate DCH has a single Transport Format.

5.2.2 L1 Functions

The physical layer performs the following main functions:

- Macrodiversity distribution/combining and soft handover execution;
- Error detection on transport channels and indication to higher layers;
- FEC encoding/decoding and interleaving/deinterleaving of transport channels;
- Multiplexing of transport channels and demultiplexing of coded composite transport channels;
- Rate matching;
- Mapping of coded composite transport channels on physical channels;
- Power weighting and combining of physical channels;
- Modulation and spreading/demodulation and despreading of physical channels;
- Frequency and time (chip, bit, slot, frame) synchronisation;
- Measurements and indication to higher layers (e.g. FER, SIR, interference power, transmit power, etc.);
- Closed-loop power control;
- RF processing;
- Support of timing advance on uplink channels (TDD only);
- Support of Uplink Synchronisation as defined in [12] (TDD only).

5.3 Layer 2 Services and Functions

5.3.1 MAC Services and Functions

This subclause provides an overview on services and functions provided by the MAC sublayer. A detailed description of the MAC protocol is given in 3GPP TS 25.321 [7].

5.3.1.1 MAC Services to upper layers

- **Data transfer.** This service provides unacknowledged transfer of MAC SDUs between peer MAC entities. This service does not provide any data segmentation. Therefore, segmentation/reassembly function should be achieved by upper layer.
- **Reallocation of radio resources and MAC parameters.** This service performs on request of RRC execution of radio resource reallocation and change of MAC parameters, i.e. reconfiguration of MAC functions such as change of identity of UE, change of transport format (combination) sets, change of transport channel type. In TDD mode, in addition, the MAC can handle resource allocation autonomously.
- **Reporting of measurements.** Local measurements such as traffic volume and quality indication are reported to RRC.

5.3.1.1.1 Logical channels

The MAC layer provides data transfer services on logical channels. A set of logical channel types is defined for different kinds of data transfer services as offered by MAC. Each logical channel type is defined by what type of information is transferred.

A general classification of logical channels is into two groups:

- Control Channels (for the transfer of control plane information);
- Traffic Channels (for the transfer of user plane information).

The configuration of logical channel types is depicted in Figure 3.

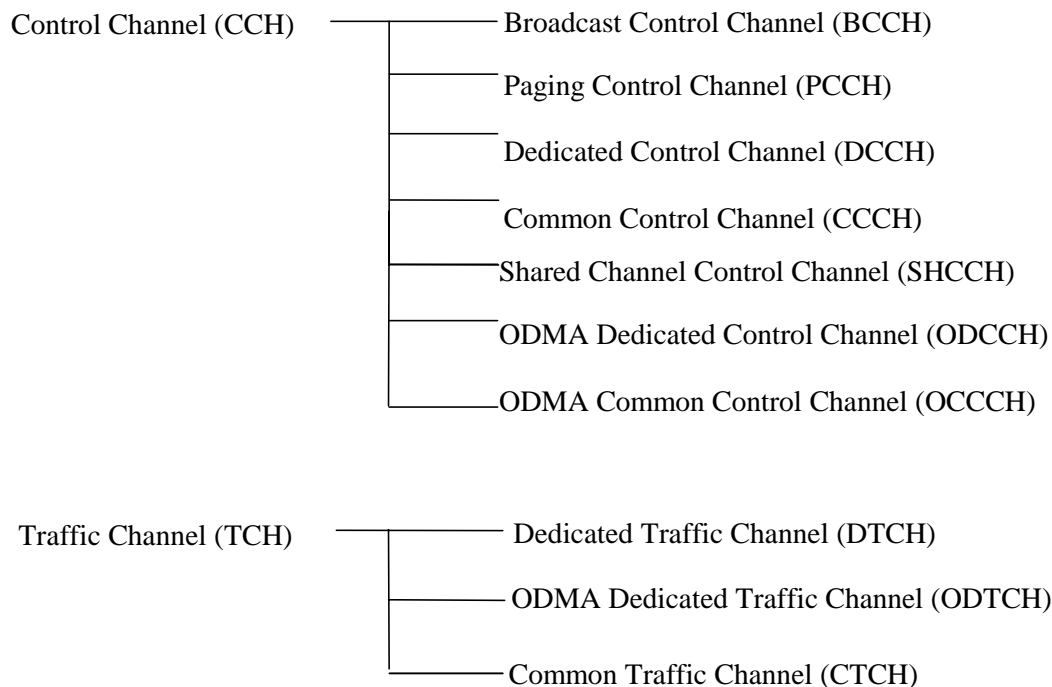

Figure 3: Logical channel structure

Control Channels

Control channels are used for transfer of control plane information only.

Broadcast Control Channel (BCCH)

A downlink channel for broadcasting system control information.

Paging Control Channel (PCCH)

A downlink channel that transfers paging information. This channel is used when the network does not know the location cell of the UE, or, the UE is in the cell connected state (utilising UE sleep mode procedures).

Common Control Channel (CCCH)

Bi-directional channel for transmitting control information between network and UEs. This channel is commonly used by the UEs having no RRC connection with the network and by the UEs using common transport channels when accessing a new cell after cell reselection.

Dedicated Control Channel (DCCH)

A point-to-point bi-directional channel that transmits dedicated control information between a UE and the network. This channel is established through RRC connection setup procedure.

Shared Channel Control Channel (SHCCH)

Bi-directional channel that transmits control information for uplink and downlink shared channels between network and UEs. This channel is for TDD only.

ODMA Common Control Channel (OCCCH)

Bi-directional channel for transmitting control information between UEs.

ODMA Dedicated Control Channel (ODCCH)

A point-to-point bi-directional channel that transmits dedicated control information between UEs. This channel is established through RRC connection setup procedure.

Traffic Channels

Traffic channels are used for the transfer of user plane information only.

Dedicated Traffic Channel (DTCH)

A Dedicated Traffic Channel (DTCH) is a point-to-point channel, dedicated to one UE, for the transfer of user information. A DTCH can exist in both uplink and downlink.

ODMA Dedicated Traffic Channel (ODTCH)

An ODMA Dedicated Traffic Channel (ODTCH) is a point-to-point channel, dedicated to one UE, for the transfer of user information between UEs. An ODTCH exists in relay link.

Common Traffic Channel (CTCH)

A point-to-multipoint unidirectional channel for transfer of dedicated user information for all or a group of specified UEs.

5.3.1.1.2 Mapping between logical channels and transport channels

The following connections between logical channels and transport channels exist:

- BCCH is connected to BCH and may also be connected to FACH;
- PCCH is connected to PCH;
- CCCH is connected to RACH and FACH;
- SHCCH is connected to RACH and USCH/FACH and DSCH;
- DTCH can be connected to either RACH and FACH, to RACH and DSCH, to DCH and DSCH, to a DCH, a CPCH (FDD only) or to USCH (TDD only);
- CTCH is connected to FACH;
- DCCH can be connected to either RACH and FACH, to RACH and DSCH, to DCH and DSCH, to a DCH, a CPCH (FDD only) to FAUSCH, CPCH (FDD only), or to USCH (TDD only).

The mappings as seen from the UE and UTRAN sides are shown in Figure 4 and Figure 5 respectively. Figure 6 illustrates the mapping from the UE in relay operation. Note that ODMA logical channels and transport channels are employed only in relay link transmissions (i.e. not used for uplink or downlink transmissions on the UE-UTRAN radio interface).

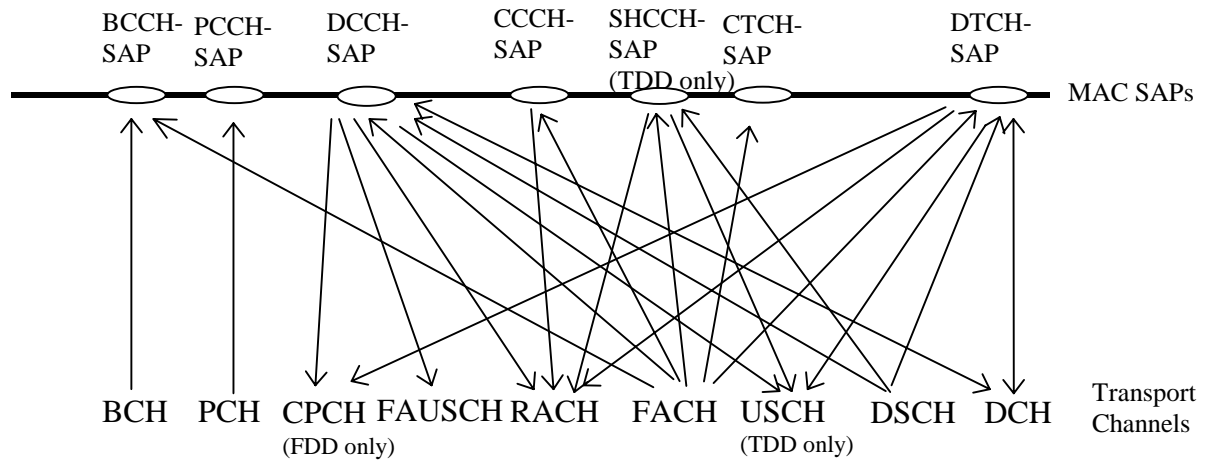

Figure 4: Logical channels mapped onto transport channels, seen from the UE side

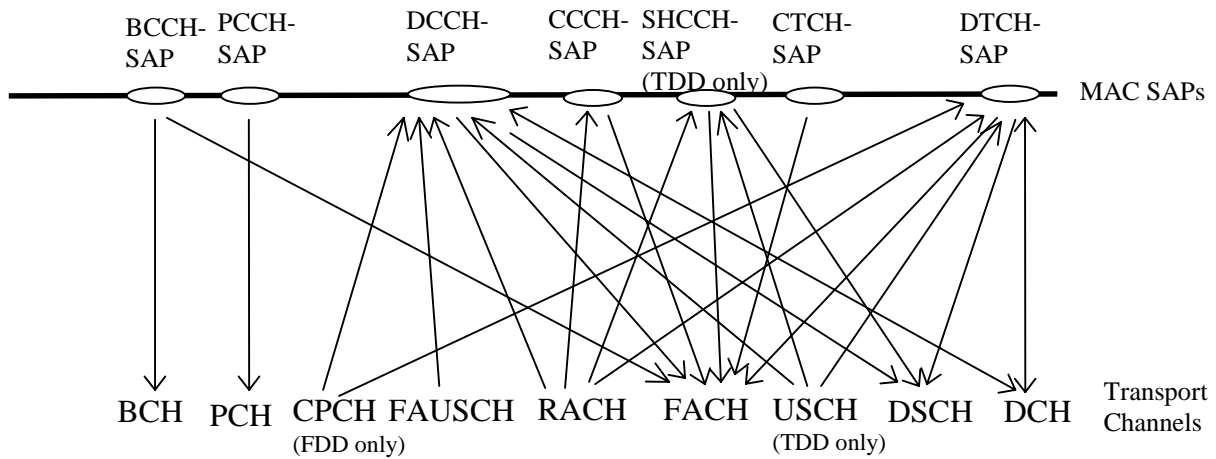

Figure 5: Logical channels mapped onto transport channels, seen from the UTRAN side

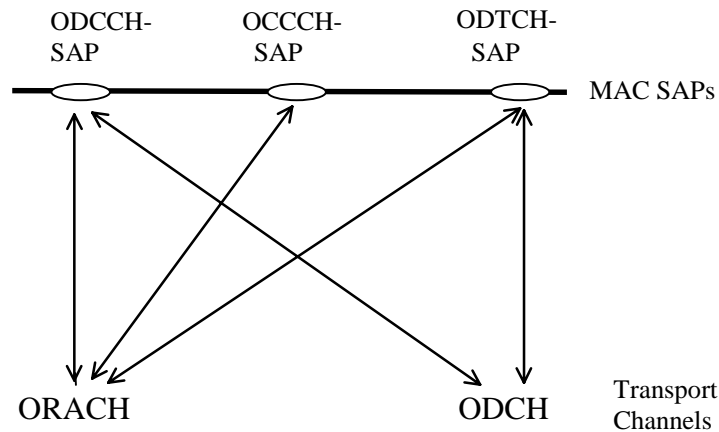

Figure 6: Logical channels mapped onto transport channels, seen from the UE side (relay only)

5.3.1.2 MAC functions

The functions of MAC include:

- **Mapping between logical channels and transport channels.** The MAC is responsible for mapping of logical channel(s) onto the appropriate transport channel(s).
- **Selection of appropriate Transport Format for each Transport Channel depending on instantaneous source rate.** Given the Transport Format Combination Set assigned by RRC, MAC selects the appropriate transport format within an assigned transport format set for each active transport channel depending on source rate. The control of transport formats ensures efficient use of transport channels.
- **Priority handling between data flows of one UE.** When selecting between the Transport Format Combinations in the given Transport Format Combination Set, priorities of the data flows to be mapped onto the corresponding Transport Channels can be taken into account. Priorities are e.g. given by attributes of Radio Bearer services and RLC buffer status. The priority handling is achieved by selecting a Transport Format Combination for which high priority data is mapped onto L1 with a "high bit rate" Transport Format, at the same time letting lower priority data be mapped with a "low bit rate" (could be zero bit rate) Transport Format. Transport format selection may also take into account transmit power indication from Layer 1.
- **Priority handling between UEs by means of dynamic scheduling.** In order to utilise the spectrum resources efficiently for bursty transfer, a dynamic scheduling function may be applied. MAC realises priority handling on common and shared transport channels. Note that for dedicated transport channels, the equivalent of the dynamic scheduling function is implicitly included as part of the reconfiguration function of the RRC sublayer.

NOTE: In the TDD mode the data to be transported are represented in terms of sets of resource units.

- **Identification of UEs on common transport channels.** When a particular UE is addressed on a common downlink channel, or when a UE is using the RACH, there is a need for inband identification of the UE. Since the MAC layer handles the access to, and multiplexing onto, the transport channels, the identification functionality is naturally also placed in MAC.
- **Multiplexing/demultiplexing of higher layer PDUs into/from transport blocks delivered to/from the physical layer on common transport channels.** MAC should support service multiplexing for common transport channels, since the physical layer does not support multiplexing of these channels.
- **Multiplexing/demultiplexing of higher layer PDUs into/from transport block sets delivered to/from the physical layer on dedicated transport channels.** The MAC allows service multiplexing for dedicated transport channels. This function can be utilised when several upper layer services (e.g. RLC instances) can be mapped efficiently on the same transport channel. In this case the identification of multiplexing is contained in the MAC protocol control information.
- **Traffic volume monitoring.** Measurement of traffic volume on logical channels and reporting to RRC. Based on the reported traffic volume information, RRC performs transport channel switching decisions.

- **Dynamic Transport Channel type switching.** Execution of the switching between common and dedicated transport channels based on a switching decision derived by RRC.
- **Ciphering.** This function prevents unauthorised acquisition of data. Ciphering is performed in the MAC layer for transparent RLC mode. Details of the security architecture are specified in [15].
- **Access Service Class selection for RACH transmission.** The RACH resources (i.e. access slots and preamble signatures for FDD, timeslot and channelisation code for TDD) may be divided between different Access Service Classes in order to provide different priorities of RACH usage. In addition it is possible for more than one ASC or for all ASCs to be assigned to the same access slot/signature space. Each access service class will also have a set of back-off parameters associated with it, some or all of which may be broadcast by the network. The MAC function applies the appropriate back-off and indicates to the PHY layer the RACH partition associated to a given MAC PDU transfer.

5.3.2 RLC Services and Functions

This subclause provides an overview on services and functions provided by the RLC sublayer. A detailed description of the RLC protocol is given in 3GPP TS 25.322 [8].

5.3.2.1 Services provided to the upper layer

- **RLC connection establishment/release.** This service performs establishment/release of RLC connections.
- **Transparent data transfer.** This service transmits higher layer PDUs without adding any protocol information, possibly including segmentation/reassembly functionality.
- **Unacknowledged data transfer.** This service transmits higher layer PDUs without guaranteeing delivery to the peer entity. The unacknowledged data transfer mode has the following characteristics:
 - Detection of erroneous data: The RLC sublayer shall deliver only those SDUs to the receiving higher layer that are free of transmission errors by using the sequence-number check function.
 - Unique delivery: The RLC sublayer shall deliver each SDU only once to the receiving upper layer using duplication detection function.
 - Immediate delivery: The receiving RLC sublayer entity shall deliver a SDU to the higher layer receiving entity as soon as it arrives at the receiver.
- **Acknowledged data transfer.** This service transmits higher layer PDUs and guarantees delivery to the peer entity. In case RLC is unable to deliver the data correctly, the user of RLC at the transmitting side is notified. For this service, both in-sequence and out-of-sequence delivery are supported. In many cases a higher layer protocol can restore the order of its PDUs. As long as the out-of-sequence properties of the lower layer are known and controlled (i.e. the higher layer protocol will not immediately request retransmission of a missing PDU) allowing out-of-sequence delivery can save memory space in the receiving RLC. The acknowledged data transfer mode has the following characteristics:
 - Error-free delivery: Error-free delivery is ensured by means of retransmission. The receiving RLC entity delivers only error-free SDUs to the higher layer.
 - Unique delivery: The RLC sublayer shall deliver each SDU only once to the receiving upper layer using duplication detection function.
 - In-sequence delivery: RLC sublayer shall provide support for in-order delivery of SDUs, i.e., RLC sublayer should deliver SDUs to the receiving higher layer entity in the same order as the transmitting higher layer entity submits them to the RLC sublayer.
 - Out-of-sequence delivery: Alternatively to in-sequence delivery, it shall also be possible to allow that the receiving RLC entity delivers SDUs to higher layer in different order than submitted to RLC sublayer at the transmitting side.
- **QoS setting.** The retransmission protocol shall be configurable by layer 3 to provide different levels of QoS. This can be controlled.

- **Notification of unrecoverable errors.** RLC notifies the upper layer of errors that cannot be resolved by RLC itself by normal exception handling procedures, e.g. by adjusting the maximum number of retransmissions according to delay requirements.

There is a single RLC connection per Radio Bearer.

5.3.2.2 RLC Functions

- **Segmentation and reassembly.** This function performs segmentation/reassembly of variable-length higher layer PDUs into/from smaller RLC Payload Units (PUs). The RLC PDU size is adjustable to the actual set of transport formats.

NOTE: Multiple PUs in a RLC PDU is not supported in Release 99. For Release 99 an RLC PDU will include only a single RLC PU.

- **Concatenation.** If the contents of an RLC SDU do not fill an integer number of RLC PUs, the first segment of the next RLC SDU may be put into the RLC PU in concatenation with the last segment of the previous RLC SDU.
- **Padding.** When concatenation is not applicable and the remaining data to be transmitted does not fill an entire RLC PDU of given size, the remainder of the data field shall be filled with padding bits.
- **Transfer of user data.** This function is used for conveyance of data between users of RLC services. RLC supports acknowledged, unacknowledged and transparent data transfer. QoS setting controls transfer of user data.
- **Error correction.** This function provides error correction by retransmission (e.g. Selective Repeat, Go Back N, or a Stop-and-Wait ARQ) in acknowledged data transfer mode.
- **In-sequence delivery of higher layer PDUs.** This function preserves the order of higher layer PDUs that were submitted for transfer by RLC using the acknowledged data transfer service. If this function is not used, out-of-sequence delivery is provided.
- **Duplicate Detection.** This function detects duplicated received RLC PDUs and ensures that the resultant higher Layer PDU is delivered only once to the upper layer.
- **Flow control.** This function allows an RLC receiver to control the rate at which the peer RLC transmitting entity may send information.
- **Sequence number check (Unacknowledged data transfer mode).** This function guarantees the integrity of reassembled PDUs and provides a mechanism for the detection of corrupted RLC SDUs through checking sequence number in RLC PDUs when they are reassembled into a RLC SDU. A corrupted RLC SDU will be discarded.
- **Protocol error detection and recovery.** This function detects and recovers from errors in the operation of the RLC protocol.
- **Ciphering.** This function prevents unauthorised acquisition of data. Ciphering is performed in RLC layer for non-transparent RLC mode. Details of the security architecture are specified in [15].
- **Suspend/resume function.** Suspension and resumption of data transfer as in e.g. LAPDm (cf. GSM 04.05).

5.3.3 PDCP Services and Function

This subclause provides an overview on services and functions provided by the Packet Data Convergence Protocol (PDCP). A detailed description of the PDCP is given in 3GPP TS 25.323 [10].

5.3.3.1 PDCP Services provided to upper layers

- Transmission and reception of Network PDUs in acknowledged, unacknowledged and transparent RLC mode.

5.3.3.2 PDCP Functions

- Mapping of Network PDUs from one network protocol to one RLC entity.
- Compression in the transmitting entity and decompression in the receiving entity of redundant Network PDU control information (header compression/ decompression). This may include TCP/IP header compression and decompression.

5.3.4 Broadcast/Multicast Control - Services and functions

This subclause provides an overview on services and functions provided by the BMC sublayer. A detailed description of the BMC protocol is given in 3GPP TS 25.324 [10].

5.3.4.1 BMC Services

The BM-SAP provides a broadcast/multicast transmission service in the user plane on the radio interface for common user data in transparent or unacknowledged mode.

5.3.4.2 BMC Functions

- **Storage of Cell Broadcast Messages**
The BMC stores the Cell Broadcast messages received over the CBC-RNC interface for scheduled transmission.
- **Traffic volume monitoring and radio resource request for CBS**
At the UTRAN side, the BMC calculates the required transmission rate for Cell Broadcast Service based on the messages received over the CBC-RNC interface, and requests for appropriate CTCH/FACH resources from RRC.
- **Scheduling of BMC messages**
The BMC receives scheduling information together with each Cell Broadcast message over the CBC-RNC-interface. Based on this scheduling information, at the UTRAN side, BMC generates schedule messages and schedules BMC message sequences accordingly. At the UE side, BMC evaluates the schedule messages and indicates scheduling parameters to RRC, which are used by RRC to configure the lower layers for CBS discontinuous reception.
- **Transmission of BMC messages to UE**
This function transmits the BMC messages (Scheduling and Cell Broadcast messages) according to schedule.
- **Delivery of Cell Broadcast messages to upper layer (NAS)**
This functions delivers the received Cell Broadcast messages to upper layer (NAS) in the UE. Only non-corrupted Cell Broadcast messages are delivered.

5.3.5 Data flows through Layer 2

Data flows through layer 2 are characterised by the applied data transfer modes on RLC (acknowledged, unacknowledged and transparent transmission) in combination with the data transfer type on MAC, i.e. whether or not a MAC header is required. The case where no MAC header is required is referred to as "transparent" MAC transmission. Acknowledged and unacknowledged RLC transmissions both require a RLC header. In unacknowledged transmission, only one type of unacknowledged data PDU is exchanged between peer RLC entities. In acknowledged transmission, both (acknowledged) data PDUs and control PDUs are exchanged between peer RLC entities.

The resulting different data flow cases are illustrated in Figures 7 - 10. On the level of detail presented here, differences between acknowledged and unacknowledged RLC transmission are not visible. Acknowledged and unacknowledged RLC transmission is shown as one case, referred to as non-transparent RLC.

NOTE: The term "transparent transmission" is used here to characterise the case where a protocol, MAC or RLC, does not require any protocol control information (e.g. header). In transparent transmission mode, however, some protocol functions may still be applied. In this case an entity of the respective protocol must be present even when the protocol is transparent. For the RLC protocol the segmentation/reassembly function may be applied. This can be performed without segmentation header when a given higher layer PDU fits into a fixed number of RLC PDUs to be transferred in a given transmission time interval. In this case segmentation/reassembly follows predefined rules known to sending and receiving RLC entities. For instance in the user plane, the segmentation/reassembly function is needed for the case of real-time services using high and possibly variable bit rates. For such services higher layer PDUs shall be segmented into reasonably sized RLC PDUs of fixed length allowing efficient FCS error detection on the physical layer. The higher layer PDU can be reassembled by simply concatenating all RLC PDUs included in a transport block set as implied by the used transport format.

Figure 7 and Figure 8 illustrate the data flows for transparent RLC with transparent and non-transparent MAC transmission, respectively.

Figure 9 and Figure 10 illustrate the data flows for non-transparent RLC with transparent and non-transparent MAC transmission, respectively.

For acknowledged RLC transmission mode, a single RLC PDU may include more than one segment (referred to as Payload Unit, cf. TS 25.322 [8]) of RLC SDU. The feature of including multiple PUs into a PDU is not shown here in the data flow, as it is not supported for Release 99.

A number of MAC PDUs shown in the figures shall comprise a transport block set. Note, however, that in all cases a transport block set must not necessarily match with a RLC SDU. The span of a transport block set can be smaller or larger than an RLC SDU.

Each mapping between a logical channel and a transport channel as defined in Figure 4 and Figure 5 in combination with the respective RLC transmission mode implies a certain data flow which is specified on a general level in the following.

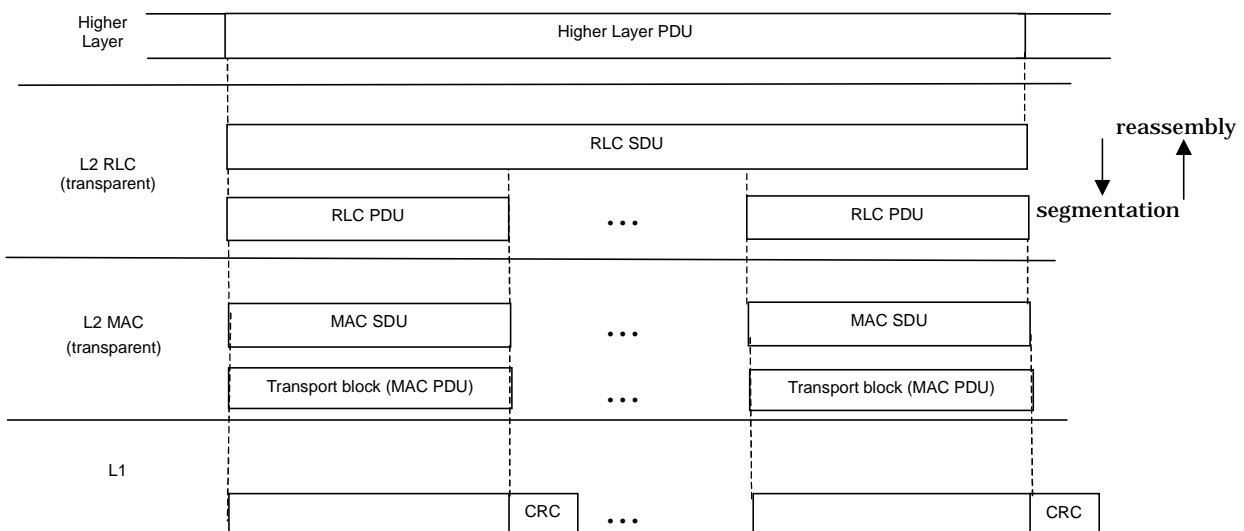

Figure 7: Data flow for transparent RLC and MAC

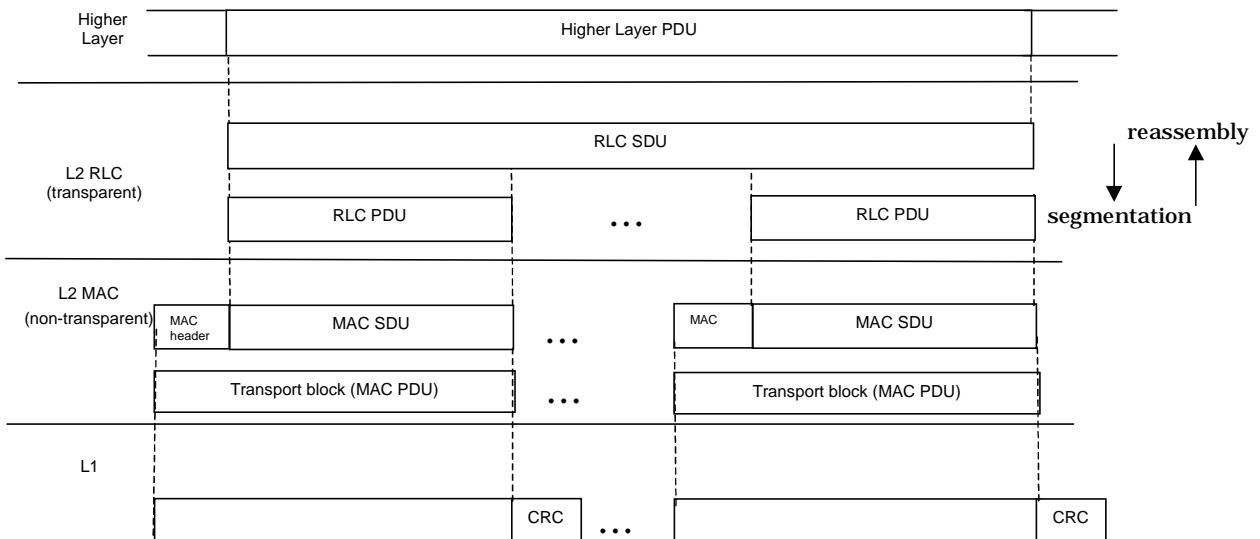

Figure 8: Data flow for transparent RLC and non-transparent MAC

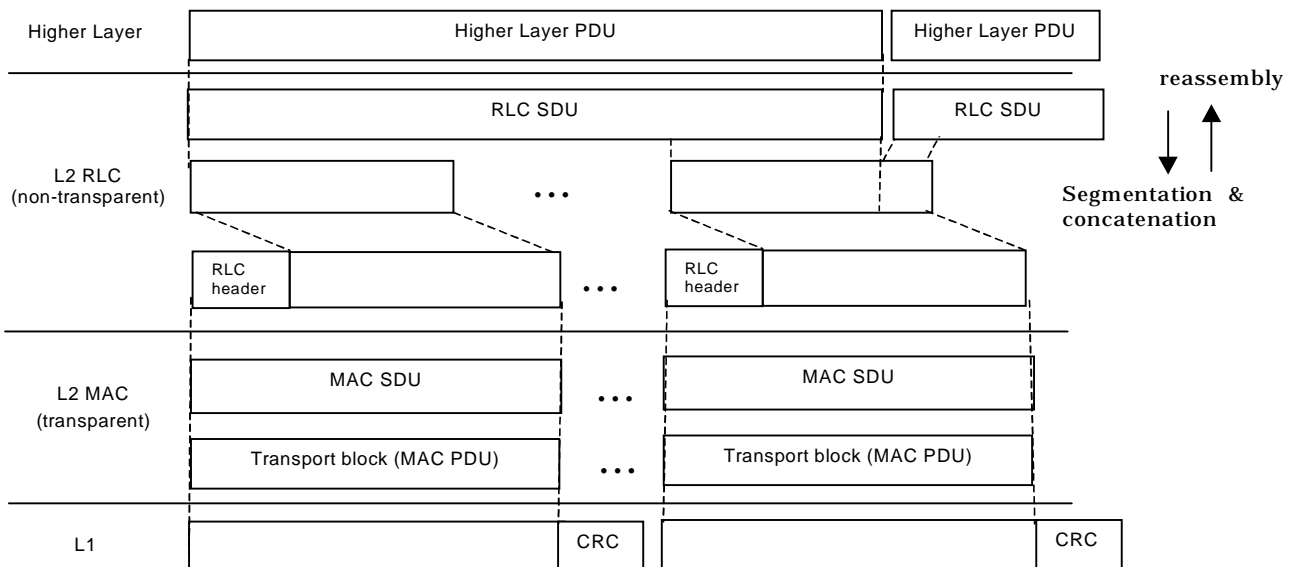

Figure 9: Data flow for non-transparent RLC and transparent MAC

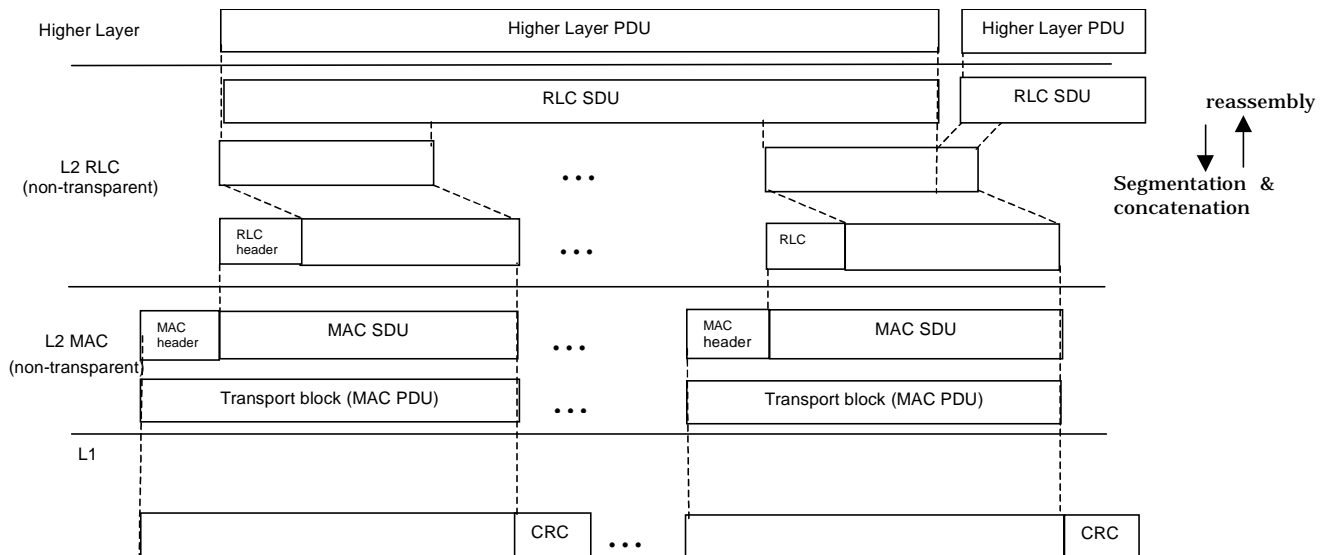

Figure 10: Data flow for non-transparent RLC and MAC

5.3.5.1 Data flow for BCCH mapped to BCH

All RRC PDUs transmitted on BCCH have a fixed length and fit into one RLC PDU (and, equivalently, MAC PDU, as defined by the transport format). No RLC header is needed, i.e. the transparent data transfer mode of RLC is applied.

No MAC header is needed since only one BCCH logical channel is mapped onto a BCH. Figure 7 is applicable.

5.3.5.2 Data flow for BCCH mapped to FACH

No RLC header is needed, i.e. the transparent data transfer mode of RLC is applied. A MAC header is required for identification of the logical channel carried by the FACH. The data flow shown in Figure 8 is applicable.

5.3.5.3 Data flow for PCCH mapped to PCH

No RLC or MAC header is needed, i.e. the data flow in Figure 7 is applicable.

5.3.5.4 Data flow for CCCH mapped to FACH/RACH

For CCCH, transparent transmission mode on RLC is employed on the uplink (when mapped to RACH). Unacknowledged transmission mode on RLC is employed on the downlink (when mapped to FACH). A MAC header is used for logical channel identification (CCCH, CTCH, SHCCH, DCCH, DTCH). If the transparent RLC transfer mode is applied, the data flow Figure 8 is applicable. If the unacknowledged RLC transfer mode is applied, the data flow Figure 10 is applicable.

5.3.5.5 Data flow for SHCCH mapped to USCH

For SHCCH, transparent or unacknowledged transmission mode on RLC is employed. A MAC header may be used for logical channel identification (SHCCH, DCCH, DTCH). When no MAC header is used, SHCCH must be the only channel mapped to USCH/DSCH. If the transparent RLC transfer mode is applied, depending on whether the MAC header is needed or not, either the data flow Figure 7 or Figure 8 is applicable. If the unacknowledged RLC transfer mode is applied, depending on whether the MAC header is needed or not, either the data flow Figure 9 or Figure 10 is applicable.

5.3.5.6 Data flow for SHCCH mapped to FACH/RACH

For SHCCH, transparent or unacknowledged transmission mode on RLC is employed. A MAC header may be used for logical channel identification (CCCH, CTCH, SHCCH, DCCH, DTCH). When no MAC header is used, SHCCH must be the only channel mapped to RACH/FACH. If the transparent RLC transfer mode is applied, depending on whether

the MAC header is needed or not, either the data flow Figure 7 or Figure 8 is applicable. If the unacknowledged RLC transfer mode is applied, depending on whether the MAC header is needed or not, either the data flow Figure 9 or Figure 10 is applicable.

5.3.5.7 Data flow for DCCH mapped to FACH/RACH

For DCCH, both unacknowledged and acknowledged transmission mode on RLC is employed. A MAC header is mandatory for FACH/RACH carrying DCCH. The data flow shown in Figure 10 is applicable.

5.3.5.8 Data flow for DCCH mapped to DSCH

For DCCH, both unacknowledged and acknowledged transmission mode on RLC is employed. A MAC header is mandatory when DCCH is mapped to a DSCH for FDD mode, i.e. the data flow in Figure 10 is applicable. For TDD a MAC header is optional, i.e. either the data flow in Figure 9 or Figure 10 is applicable.

5.3.5.9 Data flow for DCCH mapped to USCH

For DCCH, both unacknowledged and acknowledged transmission mode on RLC is employed. A MAC header is needed if DCCH and DTCH logical channels are multiplexed in MAC before mapping to a USCH, i.e. either the data flow in Figure 9 or Figure 10 is applicable.

5.3.5.10 Data flow for DCCH mapped to CPCH

For DCCH mapped to CPCH, unacknowledged or acknowledged transmission modes on RLC are employed. The MAC header is needed for logical channel service multiplexing. Figure 10 is the applicable data flow to this case.

5.3.5.11 Data flow for DTCH (non-transparent RLC) mapped to FACH/RACH

Mapping to FACH/RACH implies a DTCH with acknowledged or unacknowledged transmission on RLC. A MAC header is mandatory for FACH/RACH when carrying DTCH. The data flow shown in Figure 10 is applicable.

5.3.5.12 Data flow for DTCH (non-transparent RLC) mapped to DSCH

Mapping to DSCH implies a DTCH with acknowledged or unacknowledged transmission on RLC. A MAC header is mandatory when DTCH is mapped to a DSCH in FDD mode, i.e. the data flow in Figure 10 is applicable. In TDD mode a MAC header is optional, i.e. either the data flow in Figure 9 or Figure 10 is applicable.

5.3.5.13 Data flow for DTCH (non-transparent RLC) mapped to USCH

Mapping to USCH implies a DTCH with acknowledged or unacknowledged transmission on RLC. A MAC header is needed if DCCH and DTCH logical channels are multiplexed in MAC before mapping to a USCH, i.e. either the data flow in Figure 9 or Figure 10 is applicable.

5.3.5.14 Data flow for DTCH (transparent RLC) mapped to DCH

Continuous DTCH data stream is segmented into transport blocks on RLC and mapped on a DCH transport channel on MAC. The transport block size is naturally implied by the data rate. Both RLC and MAC sublayers are transparent, i.e. no protocol control information is added, when no multiplexing of DTCH on MAC is applied. The data flow shown in Figure 7 is applicable. If multiplexing on MAC is performed, a MAC header is needed, and Figure 8 applies.

5.3.5.15 Data flow for DTCH (non-transparent RLC) mapped to DCH

In this case acknowledged or unacknowledged transmission on RLC is applied. A MAC header is needed only if multiple DTCH logical channels are multiplexed in MAC before mapping to a DCH, i.e. either the data flow in Figure 9 or Figure 10 is applicable.

5.3.5.16 Data flow for DTCH (non-transparent RLC) mapped to CPCH.

This case requires both non-transparent RLC and MAC operations. The data flow shown in Figure 10 is applicable.

5.3.5.17 Data flow for DCCH mapped to DCH

In this case non-transparent or transparent transmission mode on RLC is applied. A MAC header is needed only if DCCH and DTCH logical channels are multiplexed in MAC before mapping to a DCH, i.e. either the data flow in Figure 9 or Figure 10 is applicable.

5.3.5.18 Data flow for CTCH mapped to FACH

For CTCH, unacknowledged transmission mode on RLC is employed. A MAC header is used for logical channel identification (CCCH, CTCH, DCCH, DTCH). The data flow shown in Figure 10 is applicable.

5.4 Layer 3 - Uu Stratum Services and Functions

This subclause provides an overview on Layer 3 services and functions provided by the Uu Stratum as a whole. A detailed description of the RRC protocol is given in 3GPP TS 25.331 [11]. Examples of structured procedures involving RRC in Idle Mode and Connected Mode are described in 3GPP TS 25.303 [5] and 3GPP TS 25.304 [6], respectively.

5.4.1 Uu Stratum services

5.4.1.1 General Control

The GC SAP provides an information broadcast service. This service broadcasts information to all UEs in a certain geographical area. The basic requirements from such service are:

- It should be possible to broadcast non-access stratum information in a certain geographical area.
- The information is transferred on an unacknowledged mode link. Unacknowledged mode means that the delivery of the broadcast information can not be guaranteed (typically no retransmission scheme is used). It seems reasonable to use an unacknowledged mode link since the information is broadcast to a lot of UEs and since broadcast information often is repeated periodically.
- It should be possible to do repeated transmissions of the broadcast information (how it is repeated is controlled by the non-access stratum).
- The point where the UE received the broadcast information should be included, when the access stratum delivers broadcast information to the non-access stratum.

5.4.1.2 Notification

The Nt SAP provides paging and notification broadcast services. The paging service sends information to a specific UE(s). The information is broadcast in a certain geographical area but addressed to a specific UE(s). The basic requirements from such service are:

- It should be possible to broadcast paging information to a number of UEs in a certain geographical area.
- The information is transferred on an unacknowledged mode link. It is assumed that the protocol entities in non-access stratum handle any kind of retransmission of paging information.

The notification broadcast service broadcasts information to all UEs in a certain geographical. The basic requirements from this service are typically the same as for the information broadcast service of the GC SAP:

- It should be possible to broadcast notification information in a certain geographical area.
- The information is transferred on an unacknowledged mode link.

5.4.1.3 Dedicated Control

The DC SAP provides services for establishment/release of a connection and transfer of messages using this connection. It should also be possible to transfer a message during the establishment phase. The basic requirements from the establishment/release services are:

- It should be possible to establish connections (both point and group connections).
- It should be possible to transfer an initial message during the connection establishment phase. This message transfer has the same requirements as the information transfer service.
- It should be possible to release connections.

The information transfer service sends a message using the earlier established connection. According to [1] it is possible to specify the quality of service requirements for each message. A finite number of quality of service classes will be specified in [1], but currently no class has been specified. In order to get an idea of the basic requirements, the CC and MM protocols in GSM are used as a reference. A GSM based core network is chosen since it is one main option for UMTS. Considering the existing GSM specification of CC and MM the basic requirements from the information transfer service provided by the 'Duplication avoidance' function are (these are some of the services provided by the combination of a duplication layer, RR and the data link layer in GSM):

- In-sequence transfer of messages
Messages are delivered to the NAS on the receiver side exactly in the order they have been submitted by the NAS on the sending side, without loss or duplication, except possibly for the loss of last messages in case of connection abortion.
- Priority handling
If SMS messages should be transported through the control plane it should be possible to give higher priority to signalling messages.

The CC and MM protocols also expect other services, which can not be supported by the current primitives of the DC SAP, e.g. indication of radio link failure.

The information transfer service is provided by a combination of the services provided by the data link layer, RNC and the 'Duplication avoidance' function.

5.4.2 RRC functions

The Radio Resource Control (RRC) layer handles the control plane signalling of Layer 3 between the UEs and UTRAN. The RRC performs the following functions:

- **Broadcast of information provided by the non-access stratum (Core Network).** The RRC layer performs system information broadcasting from the network to all UEs. The system information is normally repeated on a regular basis. The RRC layer performs the scheduling, segmentation and repetition. This function supports broadcast of higher layer (above RRC) information. This information may be cell specific or not. As an example RRC may broadcast Core Network location service area information related to some specific cells.
- **Broadcast of information related to the access stratum.** The RRC layer performs system information broadcasting from the network to all UEs. The system information is normally repeated on a regular basis. The RRC layer performs the scheduling, segmentation and repetition. This function supports broadcast of typically cell-specific information.
- **Broadcast of ODMA relay node neighbour information.** The RRC layer performs probe information broadcasting to allow ODMA routing information to be collected.
- **Establishment, re-establishment, maintenance and release of an RRC connection between the UE and UTRAN.** The establishment of an RRC connection is initiated by a request from higher layers at the UE side to establish the first Signalling Connection for the UE. The establishment of an RRC connection includes an optional cell re-selection, an admission control, and a layer 2 signalling link establishment. The release of an RRC connection can be initiated by a request from higher layers to release the last Signalling Connection for the UE or by the RRC layer itself in case of RRC connection failure. In case of connection loss, the UE requests re-establishment of the RRC connection. In case of RRC connection failure, RRC releases resources associated with the RRC connection.
- **Collating ODMA neighbour list and gradient information.** The ODMA relay node neighbour lists and their respective gradient information will be maintained by the RRC.
- **Maintenance of number of ODMA relay node neighbours.** The RRC will adjust the broadcast powers used for probing messages to maintain the desired number of neighbours.

- **Establishment, maintenance and release of a route between ODMA relay nodes.** The establishment of an ODMA route and RRC connection based upon the routing algorithm.
- **Interworking between the Gateway ODMA relay node and the UTRAN.** The RRC layer will control the interworking with the standard TDD or FDD communication link between the Gateway ODMA relay node and the UTRAN.
- **Establishment, reconfiguration and release of Radio Bearers.** The RRC layer can, on request from higher layers, perform the establishment, reconfiguration and release of Radio Bearers in the user plane. A number of Radio Bearers can be established to an UE at the same time. At establishment and reconfiguration, the RRC layer performs admission control and selects parameters describing the Radio Bearer processing in layer 2 and layer 1, based on information from higher layers.
- **Assignment, reconfiguration and release of radio resources for the RRC connection.** The RRC layer handles the assignment of radio resources (e.g. codes, CPCH channels) needed for the RRC connection including needs from both the control and user plane. The RRC layer may reconfigure radio resources during an established RRC connection. This function includes coordination of the radio resource allocation between multiple radio bearers related to the same RRC connection. RRC controls the radio resources in the uplink and downlink such that UE and UTRAN can communicate using unbalanced radio resources (asymmetric uplink and downlink). RRC signals to the UE to indicate resource allocations for purposes of handover to GSM or other radio systems.
- **RRC connection mobility functions.** The RRC layer performs evaluation, decision and execution related to RRC connection mobility during an established RRC connection, such as handover, preparation of handover to GSM or other systems, cell re-selection and cell/paging area update procedures, based on e.g. measurements done by the UE.
- **Paging/notification.** The RRC layer can broadcast paging information from the network to selected UEs. Higher layers on the network side can request paging and notification. The RRC layer can also initiate paging during an established RRC connection.
- **Routing of higher layer PDUs.** This function performs at the UE side routing of higher layer PDUs to the correct higher layer entity, at the UTRAN side to the correct RANAP entity.
- **Control of requested QoS.** This function shall ensure that the QoS requested for the Radio Bearers can be met. This includes the allocation of a sufficient number of radio resources.
- **UE measurement reporting and control of the reporting.** The measurements performed by the UE are controlled by the RRC layer, in terms of what to measure, when to measure and how to report, including both UMTS air interface and other systems. The RRC layer also performs the reporting of the measurements from the UE to the network.
- **Outer loop power control.** The RRC layer controls setting of the target of the closed loop power control.
- **Control of ciphering.** The RRC layer provides procedures for setting of ciphering (on/off) between the UE and UTRAN. Details of the security architecture are specified in [15].
- **Slow DCA.** Allocation of preferred radio resources based on long-term decision criteria. It is applicable only in TDD mode.
- **Arbitration of radio resources on uplink DCH.** This function controls the allocation of radio resources on uplink DCH on a fast basis, using a broadcast channel to send control information to all involved users.

NOTE: This function is implemented in the CRNC.

- **Initial cell selection and re-selection in idle mode.** Selection of the most suitable cell based on idle mode measurements and cell selection criteria.
- **Integrity protection.** This function adds a Message Authentication Code (MAC-I) to those RRC messages that are considered sensitive and/or contain sensitive information. The mechanism how the MAC-I is calculated is described in TS 33.105 [14].
- **Initial Configuration for CBS**
This function performs the initial configuration of the BMC sublayer.

- **Allocation of radio resources for CBS**
 This function allocates radio resources for CBS based on traffic volume requirements indicated by BMC. The radio resource allocation set by RRC (i.e. the schedule for mapping of CTCH onto FACH/S-CCPCH) is indicated to BMC to enable generation of schedule messages. The resource allocation for CBS shall be broadcast as system information.
- **Configuration for CBS discontinuous reception**
 This function configures the lower layers (L1, L2) of the UE when it shall listen to the resources allocated for CBS based on scheduling information received from BMC.
- **Timing advance control.** The RRC controls the operation of timing advance. It is applicable only in TDD mode.

5.5 Interactions between RRC and lower layers in the C plane

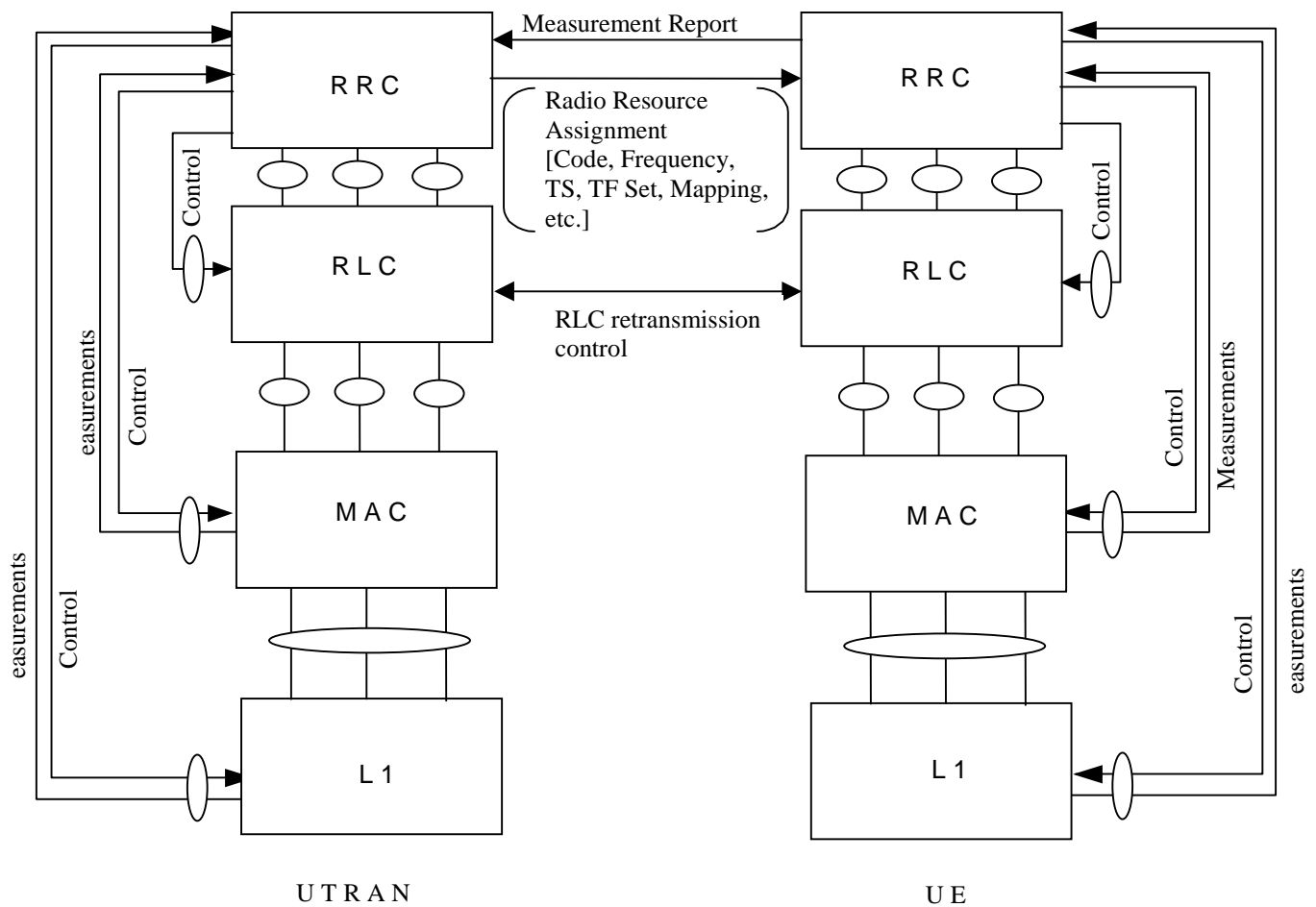

Figure 11: Interactions between RRC and lower layers

The RRC protocol controls and signals the allocation of radio resources to the UE. RRC allows MAC to arbitrate between users and Radio Bearers within the radio resource allocation. The RRC uses the measurements done by the lower layers to determine which radio resources that are available. Therefore it is a need for a measurement report from the UE RRC to the UTRAN RRC. Figure 11 illustrates the principle. The local control and local measurements reporting is handled through the control SAPs between RRC and the lower layers.

5.6 Protocol termination

This subclause specifies in which node of the UTRAN the radio interface protocols are terminated, i.e. where within UTRAN the respective protocol services are accessible. Dashed lines indicate those protocols whose presence is dependent on the service provided to upper layers.

5.6.1 Protocol termination for DCH

Figure 12 and Figure 13 show the protocol termination for DCH for the control and user planes, respectively. The part of physical layer terminating in the Serving RNC is the topmost macro-diversity combining and splitting function for the FDD mode. If no macrodiversity applies, the physical layer is terminated in Node B.

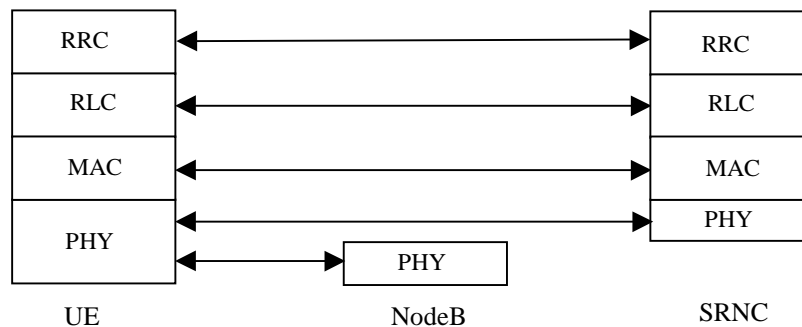

Figure 12: Protocol Termination for DCH, control plane

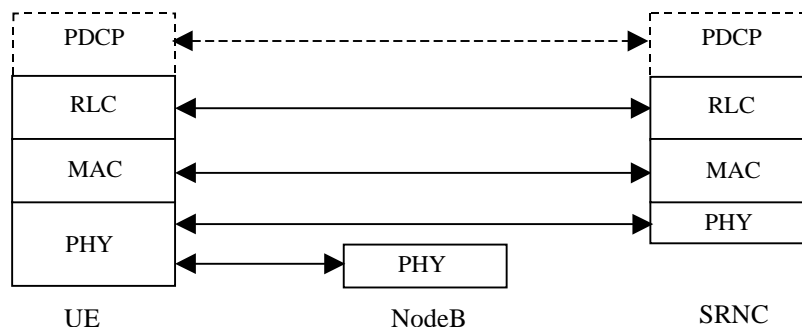

Figure 13: Protocol Termination for DCH, user plane

5.6.2 Protocol termination for RACH/FACH

Figure 14 and Figure 15 show the protocol termination for RACH/FACH for the control and user planes, respectively. Control plane termination refers to the case where RACH/FACH carry dedicated, common or shared control information (i.e. CCCH, DCCH or SHCCH, and in the downlink possibly also BCCH). User plane termination refers to the case where RACH/FACH carry dedicated user data (DTCH) (two alternatives cases, referred to as case B and C, are described in the Annex) or common user data (CTCH).

It is assumed that macrodiversity/soft handover is not applied for RACH/FACH. Therefore, the physical layer terminates in Node B. For RACH/FACH carrying DCCH, MAC is split between Controlling and Serving RNC. RLC, and in the C plane also RRC terminate in the Serving RNC. Since Iur can support common channel data streams, the users of that common channel can depend on different SRNCs. However, they depend on the same Controlling RNC. Therefore, for a given user, the Controlling RNC and the Serving RNC can be separate RNCs.

For FACH carrying BCCH, MAC, RLC and RRC are terminated in the CRNC.

For RACH/FACH carrying SHCCH, MAC, RLC and RRC are terminated in the Controlling RNC (TDD only).

For RACH/FACH carrying CCCH, MAC, RLC and RRC are terminated in the RNC.

BCCH :

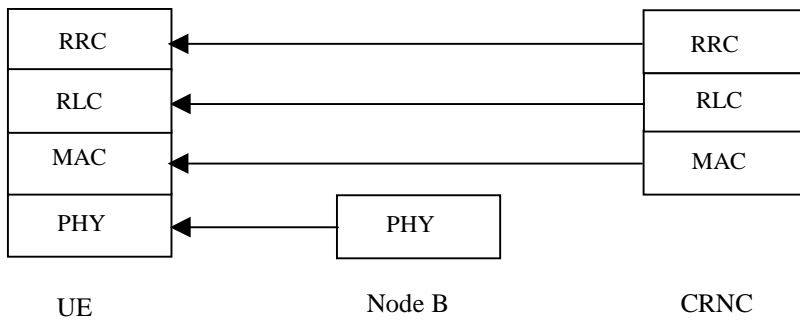

CCCH :

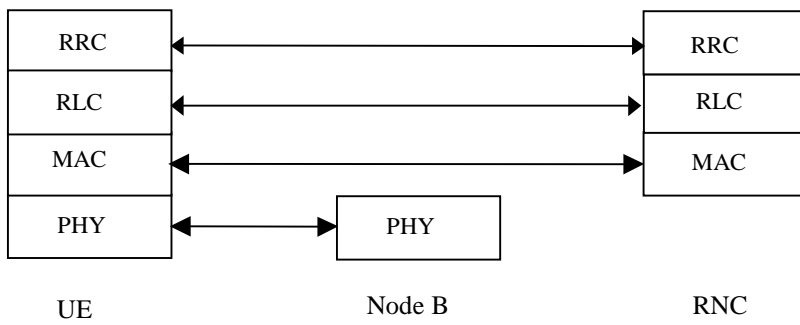

SHCCH:
(TDD only)

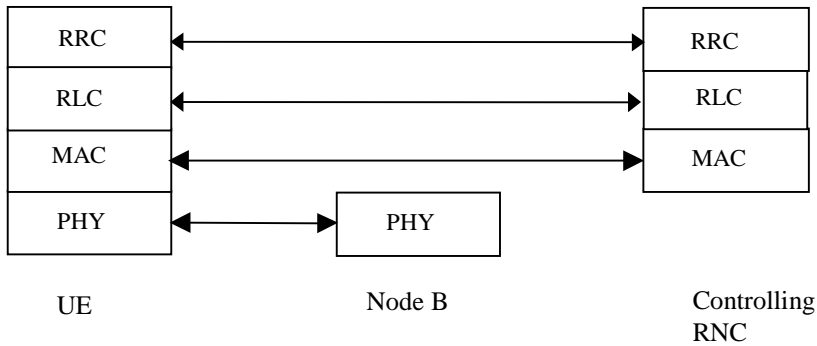

DCCH:

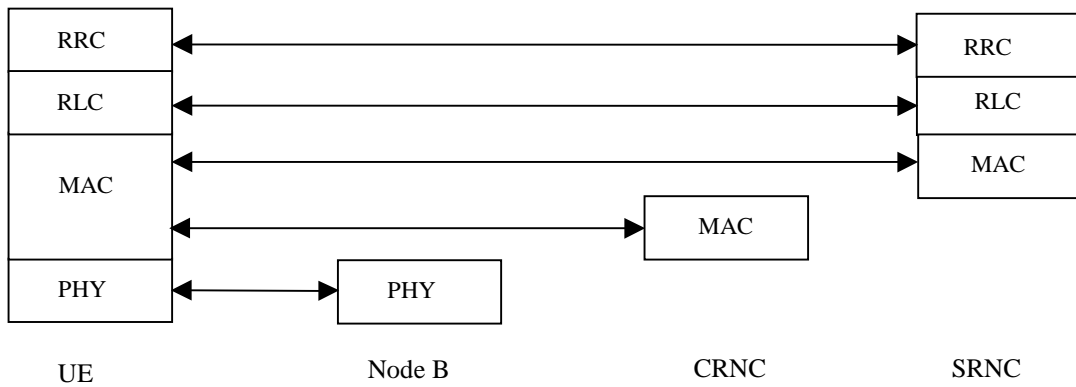

Figure 14: Protocol Termination for RACH/FACH, control plane

CTCH:**DTCH:**

Figure 15: Protocol Termination for RACH/FACH, user plane

5.6.3 Protocol termination for FAUSCH

Protocol termination for the FAUSCH is the same as for the RACH in the control plane (see Figure 14), since FAUSCH is for control purposes only.

5.6.4 Protocol termination for CPCH

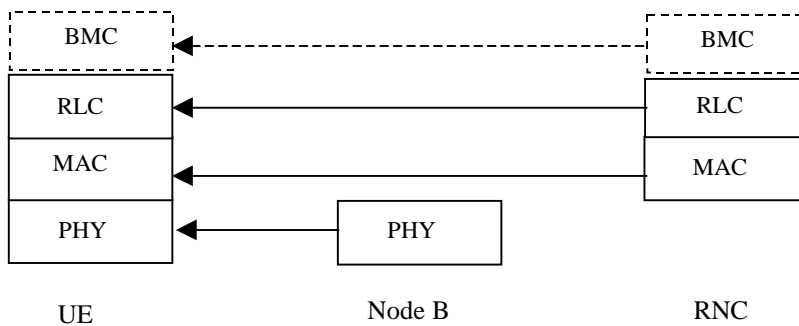
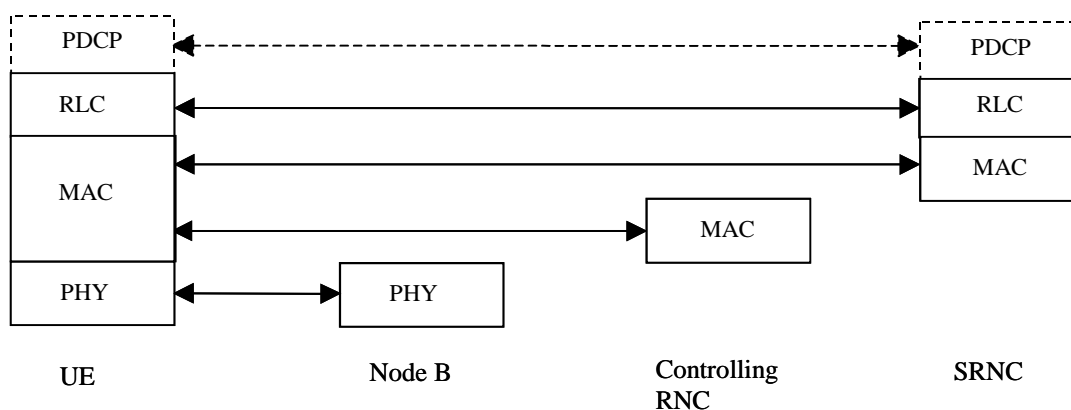
The protocol termination for CPCH is identical to the termination for RACH. Figure 14 (for DCCH) presents the control plane protocol termination. Figure 15 presents the user plane protocol termination.

5.6.5 Protocol termination for DSCH

5.6.5.1 DSCH definition

The DSCH is a resource that exists in downlink only. It has only impact on the physical and transport channel levels, so there is no definition of shared channel in the logical channels provided by MAC.

The DSCH is a transport channel shared dynamically between several UEs. The DSCH is mapped to one or several physical channels such that a specified part of the downlink resources is employed. For the DSCH no macrodiversity is applied, i.e. a specific DSCH is transmitted in a single cell only.

The following two DSCH cases are supported in Release 99, in the following denoted as cases A and B:

- **Case A:** The DSCH is defined as an extension to DCH transmission. DSCH related resource allocation is signalled utilising the transport format indication field (TFI) that will be mapped to the TFCI of the associated DCH.

- **Case B:** The DSCH is defined as a shared downlink channel for which resource allocation is performed by RRC in Controlling RNC. The allocation messages, including UE identification, are transmitted on SHCCH, which is mapped on RACH/FACH. Several DSCH can be multiplexed on a CCTrCH in the physical layer, the transport formats of the DSCHs have to be selected from the transport format combination set of this CCTrCH. Each CCTrCH is mapped on one or more PDSCHs. If the transport format combination subset of a CCTrCH contains more than one transport format combination, a TFCI can be transmitted inside the PDSCH, or blind detection can be applied in the UE. This case is supported for TDD only.

NOTE: Cases A and B of DSCH can be employed concurrently for TDD (at the same time on a single PDSCH).

Interleaving for the DSCH may be applied over a multiplicity of radio frames. Nevertheless, here the basic case is considered where the interleaving is rectangular for a given MAC PDU, and equal to one radio frame (10 ms). The framing is synchronised on the SCH.

In every radio frame, one or several PDSCHs can be used in the downlink. Therefore, the DSCH supports code multiplexing. MAC multiplexing of different UEs shall not be applied within a radio frame, i.e. within one radio frame a PDSCH is assigned to a single UE. However, MAC multiplexing is allowed on a frame by frame basis, i.e. one PDSCH may be allocated to different UEs at each frame.

Transport blocks on the DSCH may be of constant size, so that the Transport Block Set may be derived from the code allocated to each UE on the DSCH. For case B, the transport format combination set can change with each transmission time interval.

5.6.5.2 Resource allocation and UE identification on DSCH

The principles of capacity allocation and UE identification on the DSCH are described in more detail below.

5.6.5.2.1 Case A (UE requires a downlink TFCI on a DPCCH)

The TFCI of the dedicated physical channel may carry the information that a given code of the DSCH must be listened to by the UE. Fast power control can be applied per code based on the dedicated physical control channel, DPCCH.

Alternatively, a UE may be requested on the DCH to listen to a DSCH for a given period of time, and to decode the data so that the address of the destination UE can be decoded. This does not require more TFCI values because signalling is done in layers 2 and 3.

5.6.5.2.2 Case B (UE requires a downlink SHCCH) (TDD only)

The information which physical downlink shared channels to listen to and when, is sent by RRC on the SHCCH logical channel which is mapped on RACH and USCH/FACH and DSCH. The transmitted Layer 3 messages contain information about the used PDSCHs and the timing of the allocation.

5.6.5.3 Model of DSCH in UTRAN

Figure 16 captures the working assumption on the Downlink Shared Channel (DSCH). The two RLCs point to logical channel (DTCH) specific RLC-entities of specific users while MAC refers to the provision of MAC sublayer functions for all users.

The MAC sublayer of a DSCH is split between the Controlling RNC and SRNC. For a given user, the RLC sublayer is terminated in its SRNC. Since Iur can support DSCH data streams, the users on that DSCH can depend on different SRNCs. For a given user, the Controlling RNC and the Serving RNC can be separate RNCs. The MAC in the network takes care of mapping downlink data either to a common channel (FACH, not shown in this figure), or to a DCH and/or the DSCH.

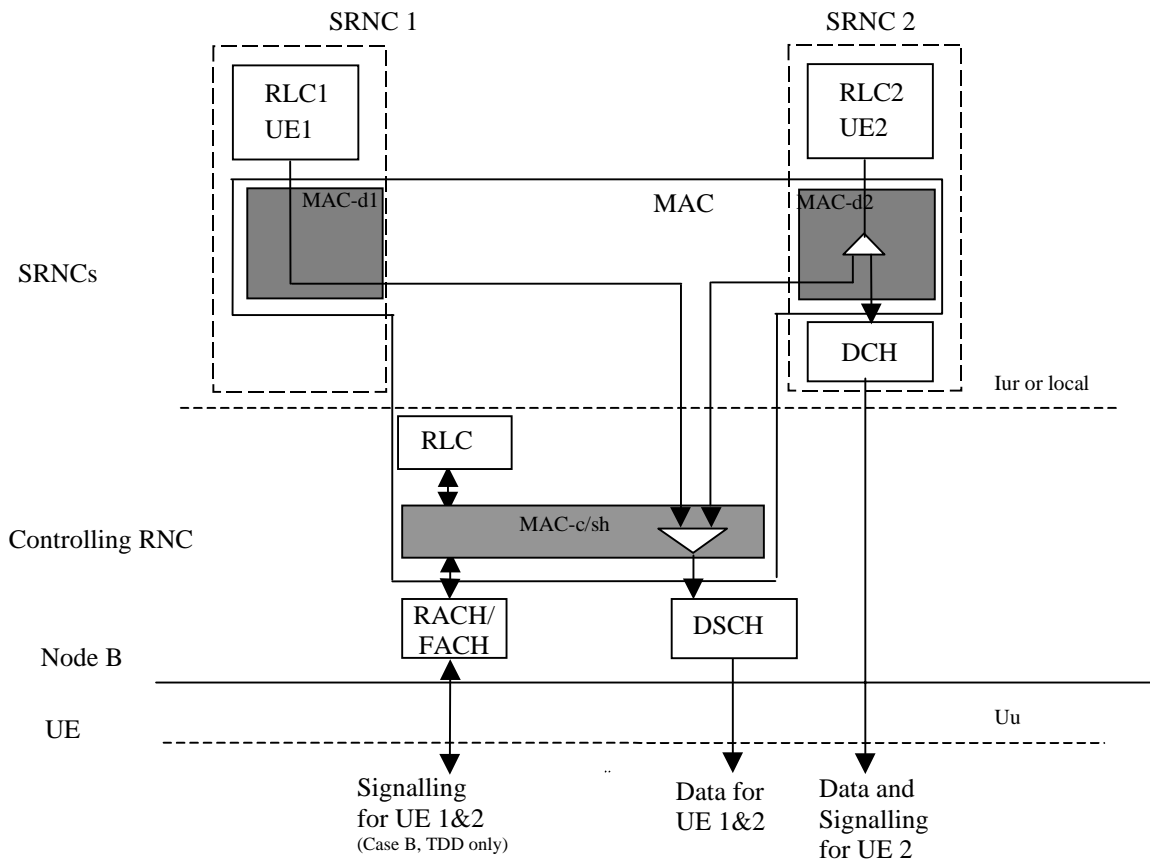

Figure 16: Model of downlink shared channel (DSCH) in UTRAN

5.6.5.4 Protocol termination

The protocol termination points for DSCH in control and user planes are presented in Figure 17 and Figure 18, respectively.

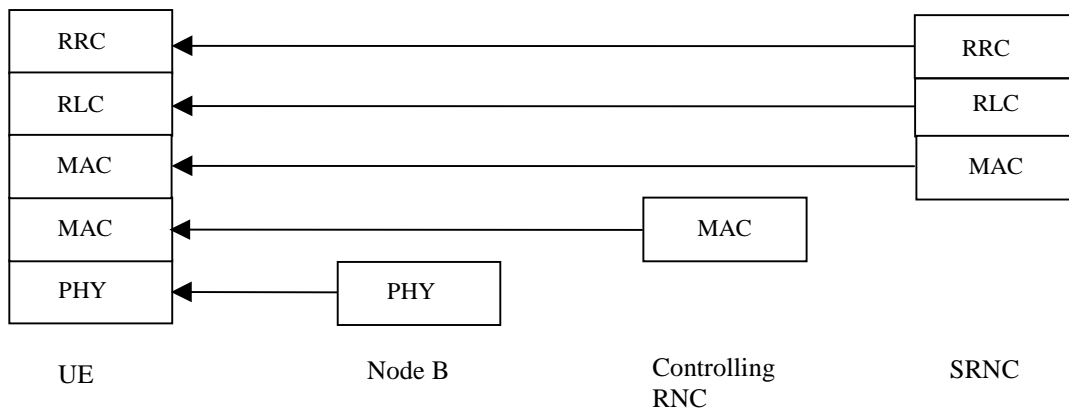

Figure 17: Protocol termination points for DSCH, control plane.

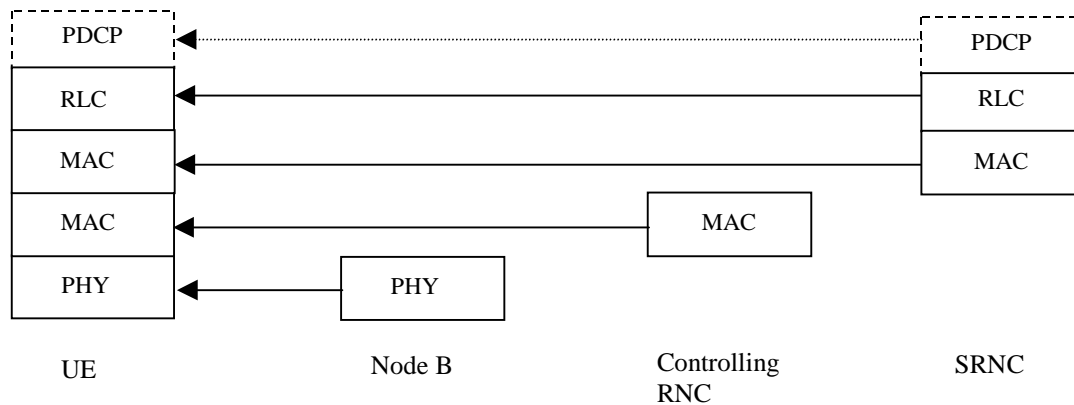

Figure 18: Protocol termination points for DSCH, user plane

5.6.6 Protocol termination for transport channel of type USCH

5.6.6.1 USCH definition

The USCH is only supported for TDD. It is a resource that exists in uplink only. It has only impact on the physical and transport channel levels, so there is no definition of shared channel in the logical channels provided by MAC.

The USCH is a transport channel shared dynamically between several UEs. The USCH is mapped to one or several physical channels such that a specified part of the uplink resources is employed.

The USCH is defined as a shared uplink channel for which resource allocation is performed by RRC in Controlling RNC. The allocation requests and allocation messages, including UE identification, are transmitted on SHCCH, which is mapped on RACH and USCH/FACH and DSCH. Several USCHs can be multiplexed on a CCTrCH in the physical layer, the transport formats of the USCHs have to be selected from the transport format combination set of this CCTrCH. Each CCTrCH is mapped on one or more PUSCHs. If the transport format combination subset of a CCTrCH contains more than one transport format combination, a TFCI can be transmitted inside the PUSCH, or blind detection can be applied in the Node B.

Interleaving for the USCH may be applied over a multiplicity of radio frames.

In every radio frame, one or several PUSCHs can be used in the uplink. Therefore, the USCH supports physical channel multiplexing. MAC multiplexing of different UEs shall not be applied within a radio frame, i.e. within one radio frame a PUSCH is assigned to a single UE. However, MAC multiplexing is allowed on a frame by frame basis, i.e. one PUSCH may be allocated to different UEs at each frame.

The transport format combination set on the USCH can change with each transmission time interval.

5.6.6.2 Resource allocation and UE identification on USCH

The information which physical uplink shared channels to transmit on and when is sent by RRC on the SHCCH logical channel which is mapped on RACH and USCH/FACH and DSCH. The transmitted Layer 3 messages contain information about the assigned PUSCHs and the timing of the allocation.

5.6.6.3 Model of USCH in UTRAN

Figure 19 captures the working assumption on the Uplink Shared Channel (USCH). The two RLCs point to logical channel (DTCH) specific RLC-entities of specific users while MAC refers to the provision of MAC sublayer functions for all users.

The MAC sublayer of a USCH is split between the Controlling RNC and SRNC. For a given user, the RLC sublayer is terminated in its SRNC. Since Iur can support USCH data streams, the users on that USCH can depend on different SRNCs. For a given user, the Controlling RNC and the Serving RNC can be separate RNCs. The MAC in the network takes care of mapping uplink data either from a common channel (RACH, not shown in this figure), DCH or the USCH.

Allocations of uplink capacity are requested by the UEs and signaled to the UEs on the SHCCH (Shared channel control channel) which is mapped on RACH and USCH/FACH and DSCH.

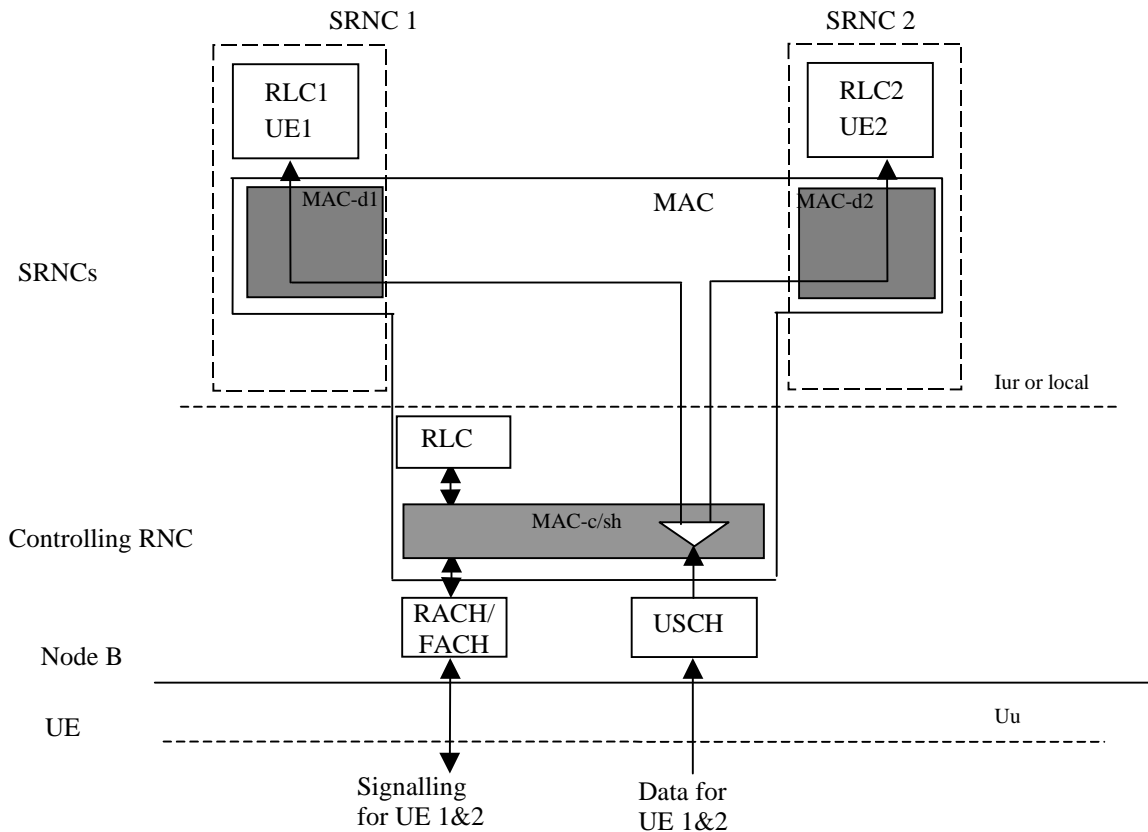

Figure 19: Model of uplink shared channel (USCH) in UTRAN (TDD only)

5.6.6.4 Protocol termination

The protocol termination points for USCH in control and user planes are presented in Figure 20 and Figure 21, respectively. The USCH is for TDD only.

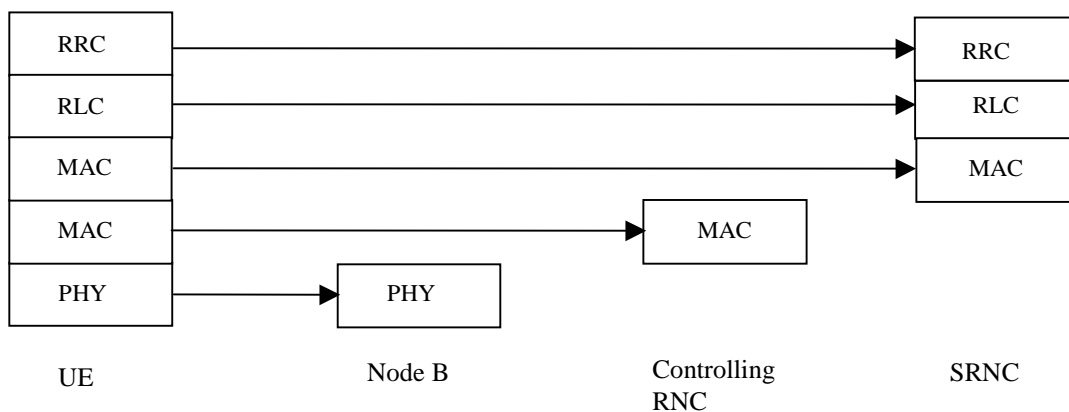

Figure 20: Protocol termination points for USCH, control plane (TDD only)

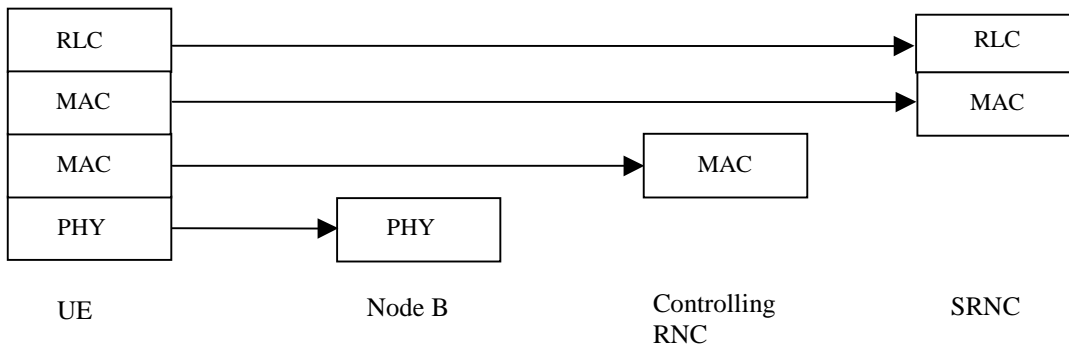

Figure 21: Protocol termination points for USCH, user plane (TDD only)

5.6.7 Protocol termination for transport channel of type BCH

System information on BCH can include information which is available only in Node B, and need to be updated very frequently (each 20-100 ms), such as uplink interference in the cell. Also, for the system information originating from the RNC, it is assumed that the updating of system information is at least one magnitude less (minutes) than the repetition frequency on the BCH (in the order of 1s). The system information originating from the CRNC should be sent transparently to Node B, which then handles the repetition. Protocol termination for the BCH shall therefore be distributed between the Node B and the CRNC, resulting in less signalling on Iub and lower processor load. Note that the RLC sublayer is transparent for this transport channel type.

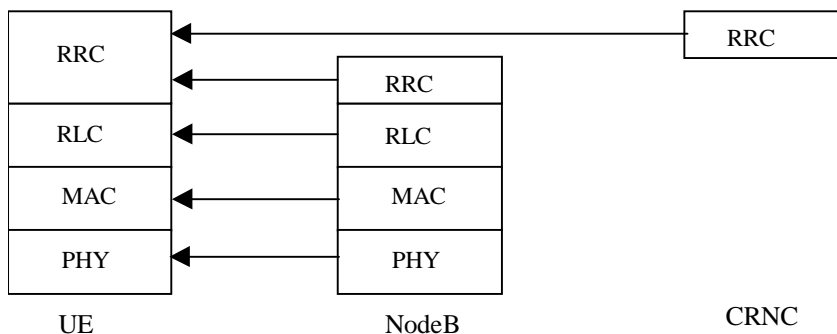

Figure 22: Protocol termination for BCH

5.6.8 Protocol termination for transport channel of type PCH

In order to enable co-ordinated scheduling between PCH and FACH/DSCH the corresponding MAC scheduling functions shall be allocated in the same node. MAC-c/sh is terminated in CRNC. A natural implication is that RLC and RRC also are terminated in CRNC.

Note that the RLC sublayer is transparent for this channel.

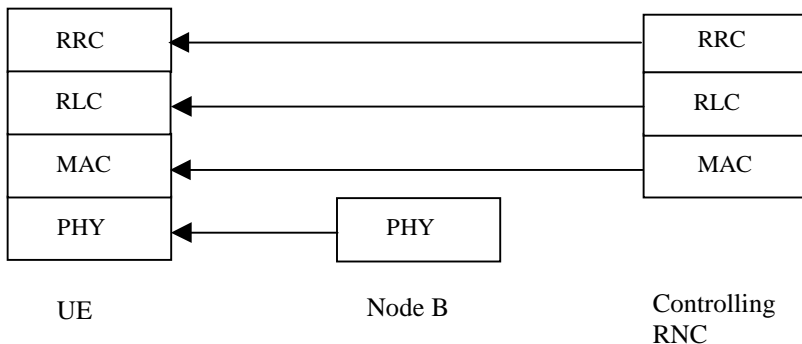

Figure 23: Protocol termination for PCH

5.6.9 Protocol termination for ODCH

Figure 24 and Figure 25 show the protocol termination for ODCH in the control and user planes, respectively.

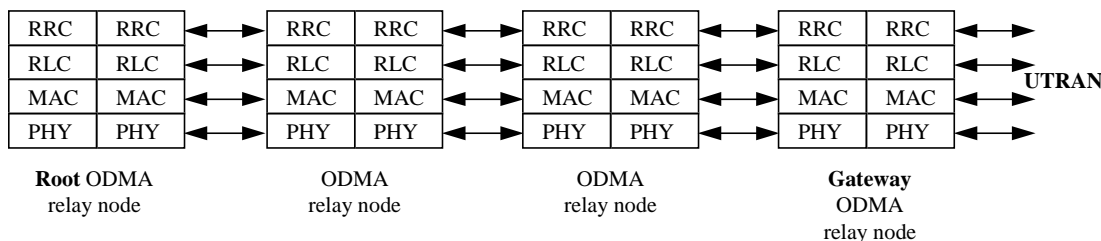

Figure 24: Protocol Termination for the ODCH in the Control Plane

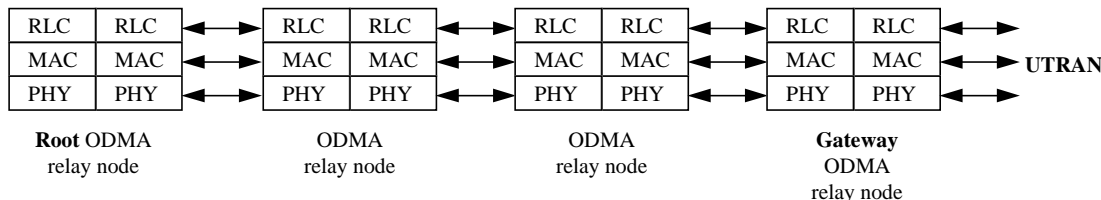

Figure 25: Protocol Termination for the ODCH in the User Plane

NOTE: The current mechanisms and procedures carried out by the RLC and the MAC for the DCH will require modifications to enable them to handle the ODCH.

5.6.10 Protocol termination for ORACH

The protocol termination for ORACH for the control and user planes is illustrated in Figure 26 and Figure 27, respectively. The shown ODMA relay nodes may be either UE_R, Seed, Root, or Gateway.

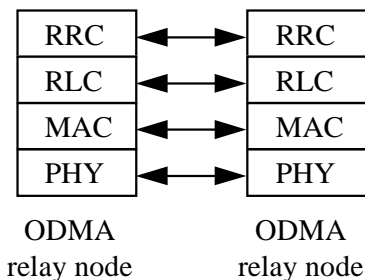

Figure 26: Protocol Termination for ORACH control plane

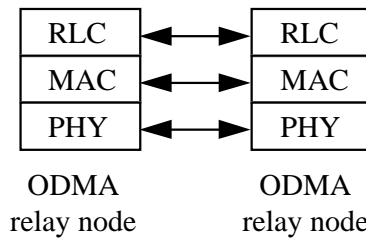

Figure 27: Protocol Termination for ORACH user plane

6 User Identification and RRC Connection Mobility

6.1 UE identification on the radio interface

A Radio Network Temporary Identity (RNTI) is used as an UE identifier on RACH/FACH, RACH+CPCH/FACH or, for FDD mode, also on DSCH by the MAC protocol, or on PCH by the RRC, when a RRC connection exists.

Definition of UE identifiers

Two types of RNTIs exist. One is used within the Serving RNC and it is denoted by Serving RNC RNTI (S-RNTI), the other is used within a cell controlled by a CRNC, when applicable, and it is denoted by Cell RNTI (C-RNTI).

S-RNTI is allocated for all UEs having a RRC connection. It is allocated by the Serving RNC and it is unique within the Serving RNC. S-RNTI is reallocated always when the Serving RNC for the RRC connection is changed and deallocated when the RRC connection is released.

In addition for each UE having an RRC connection, there is an identifier of its current serving RNC, which is denoted as SRNC identifier. The SRNC identifier together with S-RNTI is a unique identifier of the RRC connection within PLMN. The combination of SRNC identifier and S-RNTI is referred to as U-RNTI (UTRAN Radio Network Temporary Identity) which is used on the radio interface.

C-RNTI for an UE is allocated by a controlling RNC and it is unique within one cell controlled by the allocating CRNC. C-RNTI can be reallocated when a UE accesses a new cell with the cell update procedure.

Usage of UE identifiers

U-RNTI is allocated to an UE having a RRC connection. It identifies the UE within UTRAN and is used as a UE identifier in cell update, URA update, RRC connection reestablishment and (UTRAN originated) paging messages and associated responses on the radio interface. The SRNC identifier within the U-RNTI is used by the Controlling RNC to route the received uplink messages towards the Serving RNC.

C-RNTI is used as a UE identifier in all other DCCH/DTCH common channel messages on the radio interface.

NAS identifiers are used as the UE identifier in the initial access CCCH message on the radio interface.

6.2 UE connection to UTRAN

The different levels of UE connection to UTRAN are listed below:

- No signalling connection exist
The UE has no relation to UTRAN, only to CN. For data transfer, a signalling connection has to be established.
- Signalling connection exist
There is a RRC connection between UE and UTRAN. The UE position can be known on different levels:
 - UTRAN Registration Area (URA) level
The UE position is known on UTRAN registration area level. URA is a specified set of cell, which can be identified on the BCCH.

- Cell level
The UE position is known on cell level. Different channel types can be used for data transfer:
 - Common transport channels (RACH, FACH, CPCH, DSCH);
 - Dedicated transport channels (DCH); note that FAUSCH can be used to allocate a dedicated channel for data transmission.

7 UE modes

Two modes of operation are currently defined for the UE, idle mode and connected mode [5, 6].

After power on, the UE stays in idle mode until it transmits a request to establish an RRC connection. In idle mode the UE is identified by non-access stratum identities such as IMSI, TMSI and P-TMSI. In addition, the UTRAN has no own information about the individual idle mode UEs, and can only address e.g. all UEs in a cell or all UEs monitoring a specific paging occasion.

The connected mode is entered when the RRC connection is established. A RRC connection is established between the UE and a RNC called SRNC. The UE is assigned a radio network temporary identity (U-RNTI and possibly in addition C-RNTI) to be used as UE identity on common transport channels. RRC connection is within a UTRAN identified with the U-RNTI.

The UE leaves the connected mode and returns to idle mode when the RRC connection is released or at RRC connection failure.

Reception of SMS cell broadcast can be done in both idle and connected mode.

Annex A (informative): Protocol termination

This Annex describes protocol termination cases, which have been excluded from the initial UMTS release. These cases are captured here for information. They potentially may be considered for future releases.

A.1 Alternative protocol termination for DCH

Figure A.1 and Figure A.2 show an alternative protocol termination case for DCH for the control and user planes, respectively, referred to as Case B. This case would be applicable when macrodiversity at RNC level is not applied, i.e. especially for DCH in the TDD mode.

Case B:

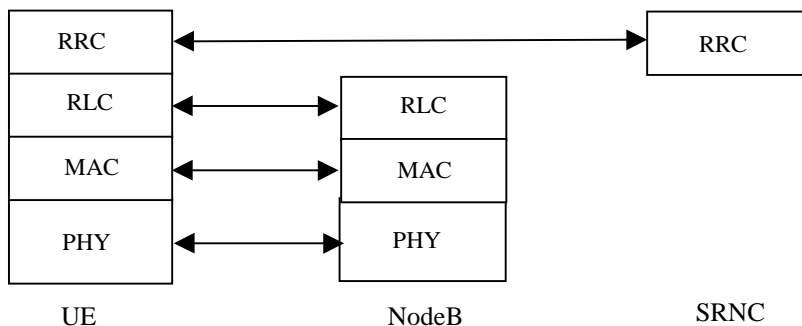

Figure A.1: Protocol Termination for DCH, control plane

Case B:

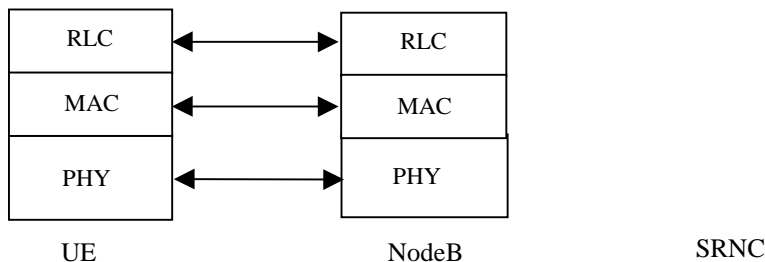

Figure A.2: Protocol Termination for DCH, user plane

A.2 Protocol termination for RACH/FACH

Figure A.3 and Figure A.4 show two alternative protocol termination cases for RACH/FACH for the control and user planes, respectively, referred to as Case B and Case C.

In case B, the physical layer, MAC and RLC terminate in Node B.

In case C, the MAC sublayer is split between Node B, Controlling and Serving RNC. This would be the preferred solution when MAC in Node B shall provide acknowledgements to RACH messages and perform scheduling of FACH transmissions.

Case B:

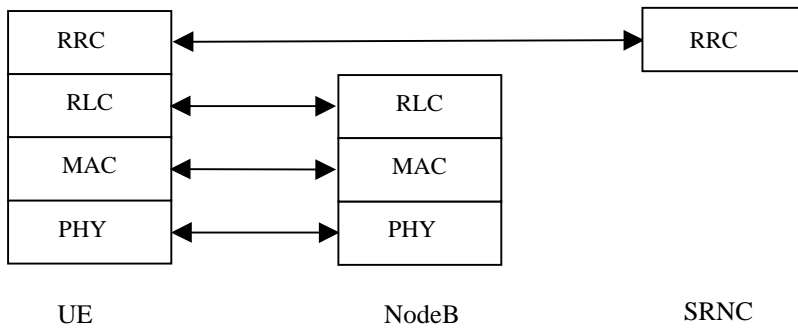

Case C:

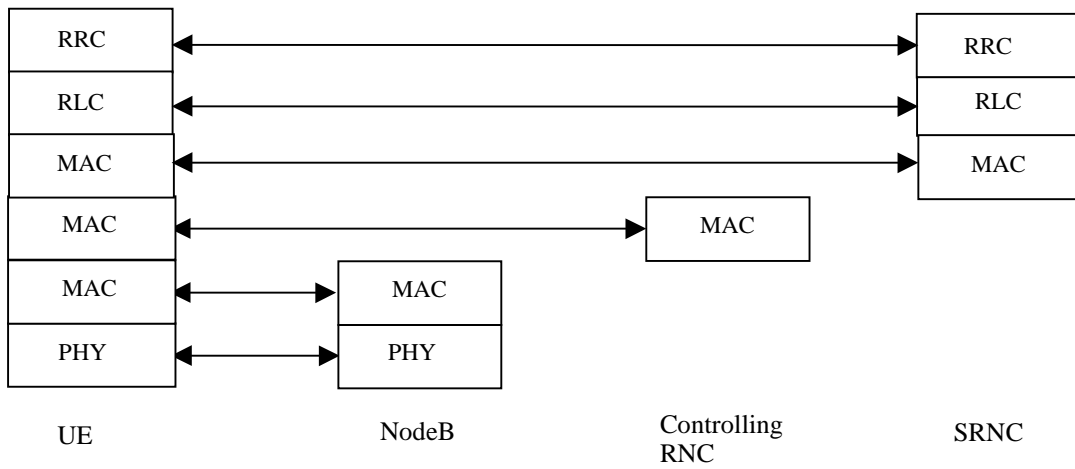
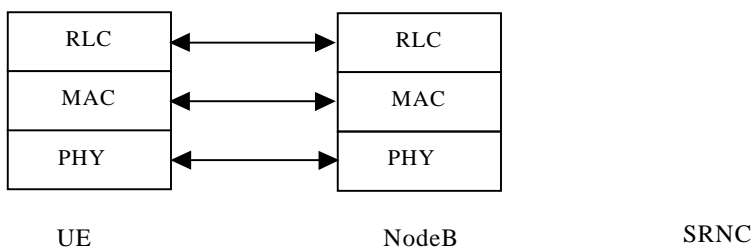

Figure A.3: Protocol Termination for RACH/FACH, control plane

Case B:



Case C:

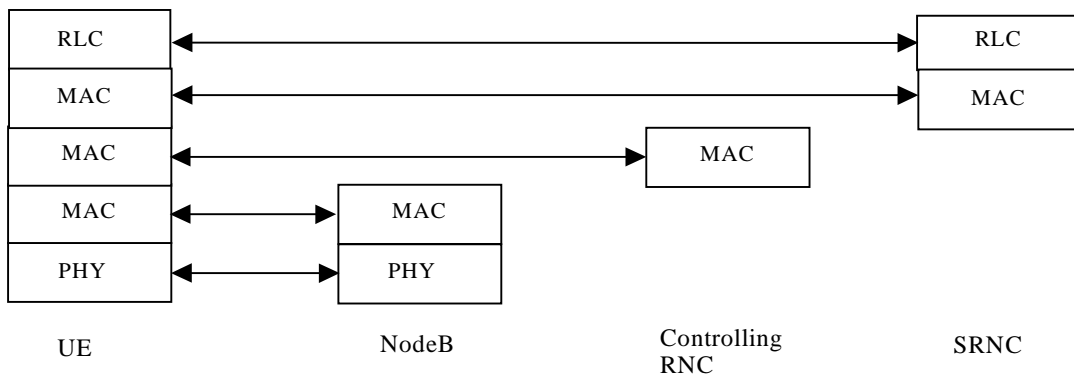

Figure A.4: Protocol Termination for RACH/FACH, user plane

Annex B (informative): Change history

Change history					
TSG-RAN#	Version	CR	Tdoc RAN	New Version	Subject/Comment
RAN_03	-	-	RP-99259	3.0.0	(04/99) Approved at TSG-RAN #3 and placed under Change Control
RAN_04	3.0.0	001	RP-99331	3.1.0	(06/99) Addition of Common Packet Channel (CPCH)
RAN_04	3.0.0	002	RP-99332	3.1.0	Proposed modification of MAC functions
RAN_04	3.0.0	003	RP-99399	3.1.0	Addition of ciphering model description
RAN_05	3.1.0	004	RP-99460	3.2.0	(10/99) Modification of C-RNTI definition
RAN_05	3.1.0	005	RP-99460	3.2.0	Addition of integrity protection function on RRC
RAN_05	3.1.0	006	RP-99460	3.2.0	Clarification on the usage of CCCH vs DCCH logical channels
RAN_05	3.1.0	007	RP-99460	3.2.0	Removal of Quick repeat function from RLC
RAN_05	3.1.0	008	RP-99575	3.2.0	Introduction of Packet Data Convergence Protocol (PDCP) in the protocol architecture
RAN_05	3.1.0	009	RP-99460	3.2.0	Deletion of Annex B (informative)
RAN_05	3.1.0	010	RP-99460	3.2.0	Correction of Ciphering specification (editorial correction)
RAN_05	3.1.0	011	RP-99460	3.2.0	Broadcast/Multicast functions
RAN_05	3.1.0	012	RP-99460	3.2.0	Description of Timing Advance mechanism for TDD
RAN_05	3.1.0	013	RP-99460	3.2.0	MAC primitives addition and modification (harmonization of TDD with FDD)
RAN_05	3.1.0	014	RP-99460	3.2.0	Impact of two cipher key solution on multiplexing at RLC and MAC level
RAN_05	3.1.0	015	RP-99460	3.2.0	Support of Different Access Service Classes (clarification of present text)
RAN_05	3.1.0	016	RP-99460	3.2.0	Support of USCH/DSCH signalling (introduction of SHCCH, see TS 25.321)
RAN_05	3.1.0	017	RP-99460	3.2.0	DCCH mapped to DCH in RLC transparent mode
RAN_05	3.1.0	018	RP-99576	3.2.0	Mapping of BCCH logical channel onto FACH transport channel
RAN_05	3.1.0	019	RP-99460	3.2.0	MAC PDU format for PCCH
RAN_05	3.1.0	020	RP-99460	3.2.0	Editorial changes regarding shared channels for TDD
RAN_05	3.1.0	021	RP-99460	3.2.0	Support of Uplink Synchronization Feature in UL channels (TDD only)
RAN_05	3.1.0	022	RP-99460	3.2.0	RRC functions
RAN_05	3.1.0	023	RP-99460	3.2.0	Modification of termination point for BCH
RAN_05	3.1.0	024	RP-99460	3.2.0	Updated description of UE modes
RAN_05	3.1.0	025	RP-99460	3.2.0	Enhanced protocol architecture
RAN_06	3.2.0	026	RP-99621	3.3.0	(12/99) Support of shared channel operation in TDD
RAN_06	3.2.0	027	RP-99620	3.3.0	Alignment to MAC-c/sh merge
RAN_06	3.2.0	028	RP-99621	3.3.0	Radio Interface Functions for Cell Broadcast
RAN_06	3.2.0	030	RP-99620	3.3.0	Editorial issues
RAN_06	3.2.0	031	RP-99621	3.3.0	Definition of ciphering unit
RAN_07	3.3.0	032	RP-000034	3.4.0	(03/00) Correction of the CFN length
RAN_07	3.3.0	034	RP-000034	3.4.0	Removal of SCH
RAN_08	3.4.0	036	RP-000214	3.5.0	(06/00) Ciphering related corrections
RAN_08	3.4.0	037	RP-000214	3.5.0	Clarification of ciphering parameters
RAN_08	3.4.0	038	RP-000214	3.5.0	Signalling radio bearers
RAN_08	3.4.0	040	RP-000214	3.5.0	Replacement of duplicated information on ciphering description by references

History

Document history		
V3.3.0	January 2000	Publication
V3.4.0	March 2000	Publication
V3.5.0	June 2000	Publication