

ETSI TS 125 302 V4.0.0 (2001-03)

Technical Specification

**Universal Mobile Telecommunications System (UMTS);
Services provided by the Physical Layer
(3GPP TS 25.302 version 4.0.0 Release 4)**



Reference

RTS/TSGR-0225302Uv4

Keywords

UMTS

ETSI

650 Route des Lucioles
F-06921 Sophia Antipolis Cedex - FRANCE

Tel.: +33 4 92 94 42 00 Fax: +33 4 93 65 47 16

Siret N° 348 623 562 00017 - NAF 742 C
Association à but non lucratif enregistrée à la
Sous-Préfecture de Grasse (06) N° 7803/88

Important notice

Individual copies of the present document can be downloaded from:

<http://www.etsi.org>

The present document may be made available in more than one electronic version or in print. In any case of existing or perceived difference in contents between such versions, the reference version is the Portable Document Format (PDF). In case of dispute, the reference shall be the printing on ETSI printers of the PDF version kept on a specific network drive within ETSI Secretariat.

Users of the present document should be aware that the document may be subject to revision or change of status. Information on the current status of this and other ETSI documents is available at <http://www.etsi.org/tb/status/>

If you find errors in the present document, send your comment to:
editor@etsi.fr

Copyright Notification

No part may be reproduced except as authorized by written permission.
The copyright and the foregoing restriction extend to reproduction in all media.

© European Telecommunications Standards Institute 2001.

All rights reserved.

Intellectual Property Rights

IPRs essential or potentially essential to the present document may have been declared to ETSI. The information pertaining to these essential IPRs, if any, is publicly available for **ETSI members and non-members**, and can be found in ETSI SR 000 314: "*Intellectual Property Rights (IPRs); Essential, or potentially Essential, IPRs notified to ETSI in respect of ETSI standards*", which is available from the ETSI Secretariat. Latest updates are available on the ETSI Web server (<http://www.etsi.org/ipr>).

Pursuant to the ETSI IPR Policy, no investigation, including IPR searches, has been carried out by ETSI. No guarantee can be given as to the existence of other IPRs not referenced in ETSI SR 000 314 (or the updates on the ETSI Web server) which are, or may be, or may become, essential to the present document.

Foreword

This Technical Specification (TS) has been produced by the ETSI 3rd Generation Partnership Project (3GPP).

The present document may refer to technical specifications or reports using their 3GPP identities, UMTS identities or GSM identities. These should be interpreted as being references to the corresponding ETSI deliverables.

The cross reference between GSM, UMTS, 3GPP and ETSI identities can be found under www.etsi.org/key.

Contents

Foreword.....	6
1 Scope	7
2 References	7
3 Definitions and abbreviations.....	7
3.1 Definitions.....	7
3.2 Abbreviations.....	7
4 Interfaces to the physical layer.....	9
4.1 Interface to MAC	9
4.2 Interface to RRC	9
5 Services and functions of the physical layer	9
5.1 General.....	9
5.2 Overview of L1 functions	10
5.3 L1 interactions with L2 retransmission functionality.....	10
6 Model of physical layer of the UE	11
6.1 Uplink models.....	11
6.2 Downlink models	12
7 Formats and configurations for L1 data transfer	15
7.1 General concepts about Transport Channels	15
7.1.1 Transport Block.....	15
7.1.2 Transport Block Set.....	15
7.1.3 Transport Block Size	15
7.1.4 Transport Block Set Size	15
7.1.5 Transmission Time Interval.....	15
7.1.6 Transport Format.....	16
7.1.7 Transport Format Set.....	17
7.1.8 Transport Format Combination	17
7.1.9 Transport Format Combination Set	17
7.1.10 Transport Format Indicator (TFI).....	18
7.1.11 Transport Format Combination Indicator (TFCI).....	18
7.1.12 Rate matching.....	19
7.2 Types of Transport Channels	19
7.3 Compressed Mode.....	21
8 UE Simultaneous Physical Channels combinations	22
8.1 FDD Uplink.....	22
8.2 FDD Downlink.....	23
8.3 TDD Uplink	25
8.3.1 3.84 Mcps TDD Uplink.....	25
8.3.2 1.28 Mcps TDD Uplink.....	26
8.4 TDD Downlink.....	28
8.4.1 3.84 Mcps TDD Downlink	28
8.4.2 1.28 Mcps TDD Downlink	29
9 Measurements provided by the physical layer	30
9.1 Model of physical layer measurements.....	31
9.2 UE Measurements	32
9.2.1 SFN-CFN observed time difference	32
9.2.2 Observed time difference to GSM cell.....	32
9.2.3 CPICH E_c/N_0	33
9.2.4 Void.....	33
9.2.5 CPICH RSCP	33
9.2.6 P-CCPCH RSCP.....	33
9.2.7 Timeslot ISCP	33

9.2.8	Void	33
9.2.9	SIR	33
9.2.10	UTRA carrier RSSI	34
9.2.11	GSM carrier RSSI	34
9.2.12	Transport channel BLER	34
9.2.13	UE transmitted power	34
9.2.14	UE Rx-Tx time difference	34
9.2.15	SFN-SFN Observed time difference	35
9.2.16	UE GPS Timing of Cell Frames for UE positioning	35
9.3	UTRAN Measurements	35
9.3.1	Received total wide band power	35
9.3.2	Transmitted carrier power	35
9.3.3	Transmitted code power	36
9.3.4	Void	36
9.3.5	Physical channel BER	36
9.3.6	Transport channel BER	36
9.3.7	RX timing deviation	36
9.3.8	Timeslot ISCP	36
9.3.9	RSCP	37
9.3.10	Round Trip Time	37
9.3.11	Void	37
9.3.12	Acknowledged PRACH preambles	37
9.3.13	Detected PCPCH access preambles	37
9.3.14	Acknowledged PCPCH access preambles	37
9.3.15	SIR	38
9.3.16	PRACH/PCPCH Propagation Delay	38
9.3.17	UTRAN GPS Timing of Cell Frames for UE positioning	38
9.3.18	SIR ERROR	38
9.3.19	Received SYNC_UL Timing Deviation	38
9.3.20	Cell Sync Burst Timing	39
9.3.21	Cell Sync Burst SIR	39
10	Primitives of the physical layer	39
10.1	Generic names of primitives between layers 1 and 2	40
10.1.1	PHY-Access-REQ	40
10.1.2	PHY-Access-CNF	40
10.1.3	PHY-Data-REQ	40
10.1.4	PHY-Data-IND	41
10.1.5	PHY-CPCH_Status-REQ	41
10.1.6	PHY-CPCH_Status-CNF	41
10.1.7	PHY-Status-IND	41
10.2	Generic names of primitives between layers 1 and 3	42
10.2.1	STATUS PRIMITIVES	42
10.2.1.1	CPHY-Sync-IND	42
10.2.1.2	CPHY-Out-of-Sync-IND	42
10.2.1.3	CPHY-Measurement-REQ	42
10.2.1.4	CPHY-Measurement-IND	42
10.2.1.5	CPHY-ERROR-IND	43
10.2.1.6	CPHY-CPCH-EOT-IND	43
10.2.2	CONTROL PRIMITIVES	43
10.2.2.1	CPHY-TrCH-Config-REQ	44
10.2.2.2	CPHY-TrCH-Config-CNF	44
10.2.2.3	CPHY-TrCH-Release-REQ	44
10.2.2.4	CPHY-TrCH-Release-CNF	44
10.2.2.5	CPHY-RL-Setup-REQ	44
10.2.2.6	CPHY-RL-Setup-CNF	44
10.2.2.7	CPHY-RL-Release-REQ	45
10.2.2.8	CPHY-RL-Release-CNF	45
10.2.2.9	CPHY-RL-Modify-REQ	45
10.2.2.10	CPHY-RL-Modify-CNF	45
10.2.2.11	CPHY-Commit-REQ	45
10.2.2.12	CPHY-CPCH-Estop-IND	45

10.2.2.13	CPHY-CPCH-Estop-Resp	46
10.2.2.14	CPHY-CPCH-Estop-REQ	46
10.2.2.15	CPHY-CPCH-Estop-CNF.....	46
10.2.2.16	CPHY-Out-of-Sync-Config-REQ	46
10.2.2.17	CPHY-Out-of-Sync-Config-CNF	46
10.3	Parameter definition	46
10.3.1	Error code	46
10.3.2	Event value	47
10.3.3	Access Information.....	47
10.3.4	Transport Format Subset	47
10.3.5	Physical channel description	47
10.3.5.1	Primary SCH.....	47
10.3.5.2	Secondary SCH.....	47
10.3.5.3	Primary CCPCH	47
10.3.5.4	Secondary CCPCH.....	48
10.3.5.5	PRACH	48
10.3.5.6	Uplink DPDCH+DPCCH	49
10.3.5.7	Uplink DPCH.....	49
10.3.5.8	Downlink DPCH.....	49
10.3.5.9	PCPCH (Physical Common Packet Channel)	49
10.3.5.10	PICH	50
10.3.5.11	AICH.....	50
10.3.5.12	AP-AICH	50
10.3.5.13	CD-ICH.....	50
10.3.5.14	CD/CA-ICH	51
10.3.5.15	CSICH.....	51
10.3.5.16	PDSCH	51
10.3.5.17	PUSCH	51
10.3.5.18	DwPCH (1.28 Mcps TDD only)	52
10.3.5.19	UpPCH (1.28 Mcps TDD only)	52
10.3.5.20	FPACH (1.28 Mcps TDD only).....	52
10.3.5.21	PNBSCH (Physical Node B Synchronisation channel)	52
11	Transport block transmission	52
Annex A (normative): Description of Transport Formats.....		53
Annex B (informative): Example of Transport format attributes for AMR speech codec.....		55
Annex C (informative): Change history		56

Foreword

This Technical Specification (TS) has been produced by the 3rd Generation Partnership Project (3GPP).

The contents of the present document are subject to continuing work within the TSG and may change following formal TSG approval. Should the TSG modify the contents of the present document, it will be re-released by the TSG with an identifying change of release date and an increase in version number as follows:

Version x.y.z

where:

- x the first digit:
 - 1 presented to TSG for information;
 - 2 presented to TSG for approval;
 - 3 or greater indicates TSG approved document under change control.
- y the second digit is incremented for all changes of substance, i.e. technical enhancements, corrections, updates, etc.
- z the third digit is incremented when editorial only changes have been incorporated in the document.

1 Scope

The present document is a technical specification of the services provided by the physical layer of UTRA to upper layers.

2 References

The following documents contain provisions which, through reference in this text, constitute provisions of the present document.

- References are either specific (identified by date of publication, edition number, version number, etc.) or non-specific.
- For a specific reference, subsequent revisions do not apply.
- For a non-specific reference, the latest version applies. In the case of a reference to a 3GPP document (including a GSM document), a non-specific reference implicitly refers to the latest version of that document *in the same Release as the present document*.

- [1] 3GPP TS 23.110: "UMTS Access Stratum; Services and Functions".
- [2] 3GPP TS 25.301: "Radio Interface Protocol Architecture".
- [3] 3GPP TS 25.212: "Multiplexing and channel coding (FDD)".
- [4] 3GPP TS 25.222: "Multiplexing and channel coding (TDD)".
- [5] 3GPP TS 25.224: "Physical Layer Procedures (TDD)".
- [6] 3GPP TS 25.215: "Physical Layer – Measurements (FDD)".
- [7] 3GPP TS 25.213: "Spreading and modulation (FDD)".
- [8] 3GPP TS 25.214: "Physical layer procedures (FDD)".
- [9] 3GPP TS 25.123: "Requirements for Support of Radio Resource Management (TDD)".
- [10] 3GPP TS 25.133: "Requirements for Support of Radio Resource Management (FDD)".
- [11] 3GPP TS 25.225: "Physical Layer – Measurements (TDD)".
- [12] 3GPP TS 25.221: "Physical channels and mapping of transport channels onto physical channels (TDD)".

3 Definitions and abbreviations

3.1 Definitions

For the purposes of the present document, the terms and definitions given in [3] apply.

3.2 Abbreviations

For the purposes of the present document, the following abbreviations apply:

ARQ	Automatic Repeat Request
BCCH	Broadcast Control Channel
BCH	Broadcast Channel

C-	Control-
CC	Call Control
CCC	CPCH Control Command
CCCH	Common Control Channel
CCH	Control Channel
CCTrCH	Coded Composite Transport Channel
CN	Core Network
CRC	Cyclic Redundancy Check
DC	Dedicated Control (SAP)
DCA	Dynamic Channel Allocation
DCCH	Dedicated Control Channel
DCH	Dedicated Channel
DL	Downlink
DRNC	Drift Radio Network Controller
DSCH	Downlink Shared Channel
DTCH	Dedicated Traffic Channel
FACH	Forward Link Access Channel
FAUSCH	Fast Uplink Signalling Channel
FCS	Fame Check Sequence
FDD	Frequency Division Duplex
GC	General Control (SAP)
HO	Handover
ITU	International Telecommunication Union
kbps	kilo-bits per second
L1	Layer 1 (physical layer)
L2	Layer 2 (data link layer)
L3	Layer 3 (network layer)
LAC	Link Access Control
LAI	Location Area Identity
MAC	Medium Access Control
MM	Mobility Management
Nt	Notification (SAP)
PCCH	Paging Control Channel
PCH	Paging Channel
PDU	Protocol Data Unit
PHY	Physical layer
PhyCH	Physical Channels
RACH	Random Access Channel
RLC	Radio Link Control
RNC	Radio Network Controller
RNS	Radio Network Subsystem
RNTI	Radio Network Temporary Identity
RRC	Radio Resource Control
SAP	Service Access Point
SDU	Service Data Unit
SRNC	Serving Radio Network Controller
SRNS	Serving Radio Network Subsystem
TCH	Traffic Channel
TDD	Time Division Duplex
TFCI	Transport Format Combination Indicator
TFI	Transport Format Indicator
TMSI	Temporary Mobile Subscriber Identity
TPC	Transmit Power Control
U-	User-
UE	User Equipment
UL	Uplink
UMTS	Universal Mobile Telecommunications System
URA	UTRAN Registration Area
UTRA	UMTS Terrestrial Radio Access
UTRAN	UMTS Terrestrial Radio Access Network

4 Interfaces to the physical layer

The physical layer (layer 1) is the lowest layer in the OSI Reference Model and it supports all functions required for the transmission of bit streams on the physical medium.

The physical layer interfaces the Medium Access Control (MAC) Layer and the Radio Resource Control (RRC) Layer as depicted in figure 1.

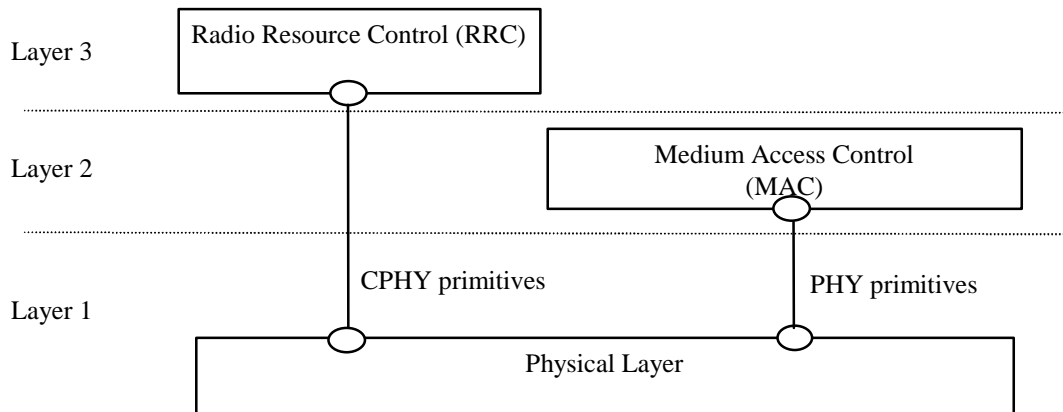

Figure 1: Interfaces with the Physical Layer

4.1 Interface to MAC

The physical layer interfaces the MAC entity of layer 2. Communication between the Physical Layer and MAC is in an abstract way performed by means of PHY-primitives defined which do not constrain implementations.

NOTE: The terms physical layer and layer 1, will be used synonymously in this description.

The PHY-primitives exchanged between the physical layer and the data link layer provide the following functions:

- transfer of transport blocks over the radio interface;
- indicate the status of the layer 1 to layer 2.

4.2 Interface to RRC

The physical layer interfaces the RRC entity of layer 3 in the UE and in the network.

Communication is performed in an abstract way by means of CPHY-primitives. They do not constrain implementations.

The CPHY-primitives exchanged between the physical layer and the Network layer provide the following function:

- control of the configuration of the physical layer.

The currently identified exchange of information across that interface has only a local significance to the UE or Network.

5 Services and functions of the physical layer

5.1 General

The physical layer offers data transport services to higher layers. The access to these services is through the use of transport channels via the MAC sub-layer. The characteristics of a transport channel are defined by its transport format

(or format set), specifying the physical layer processing to be applied to the transport channel in question, such as convolutional channel coding and interleaving, and any service-specific rate matching as needed.

The physical layer operates exactly according to the L1 radio frame timing. A transport block is defined as the data accepted by the physical layer to be jointly encoded. The transmission block timing is then tied exactly to this L1 frame timing, e.g. every transmission block is generated precisely every 10ms, or a multiple of 10 ms.

A UE can set up multiple transport channels simultaneously, each having own transport characteristics (e.g. offering different error correction capability). Each transport channel can be used for information stream transfer of one radio bearer or for layer 2 and higher layer signalling messages.

The multiplexing of these transport channels onto the same or different physical channels is carried out by L1. In addition, the Transport Format Combination Indication field (TFCI) shall uniquely identify the transport format used by each transport channel of the Coded Composite Transport Channel within the current radio frame.

5.2 Overview of L1 functions

The physical layer performs the following main functions:

- FEC encoding/decoding of transport channels;
- measurements and indication to higher layers (e.g. FER, SIR, interference power, transmission power, etc...);
- macrodiversity distribution/combining and soft handover execution;
- error detection on transport channels;
- multiplexing of transport channels and demultiplexing of coded composite transport channels;
- rate matching;
- mapping of coded composite transport channels on physical channels;
- modulation and spreading/demodulation and despreading of physical channels;
- frequency and time (chip, bit, slot, frame) synchronisation;
- closed-loop power control;
- power weighting and combining of physical channels;
- RF processing;
- support of Uplink Synchronisation as defined in [5] (TDD only);
- timing advance on uplink channels (TDD only).

5.3 L1 interactions with L2 retransmission functionality

Provided that the RLC PDUs are mapped one-to-one onto the Transport Blocks, Error indication may be provided by L1 to L2. For that purpose, the L1 CRC can be used for individual error indication of each RLC PDU. The L1 CRC will then serve multiple purposes:

- error indication for uplink macro diversity selection combining (L1);
- error indication for each erroneous Transport Block in transparent and unacknowledged mode RLC;
- quality indication;
- error indication for each erroneous Transport Block in acknowledged mode RLC.

Regardless of the result of the CRC check, all Transport Blocks are delivered to L2 along with the associated error indications.

6 Model of physical layer of the UE

6.1 Uplink models

Figure 2 shows models of the UE's physical layer in the uplink for both FDD and TDD mode. It shows the models for DCH, RACH, CPCH (the latter two used in FDD mode only) and USCH (TDD only). Some restriction exist for the use of different types of transport channel at the same time, these restrictions are described in the clause "UE Simultaneous Physical Channel combinations". More details can be found in [3] and [4].

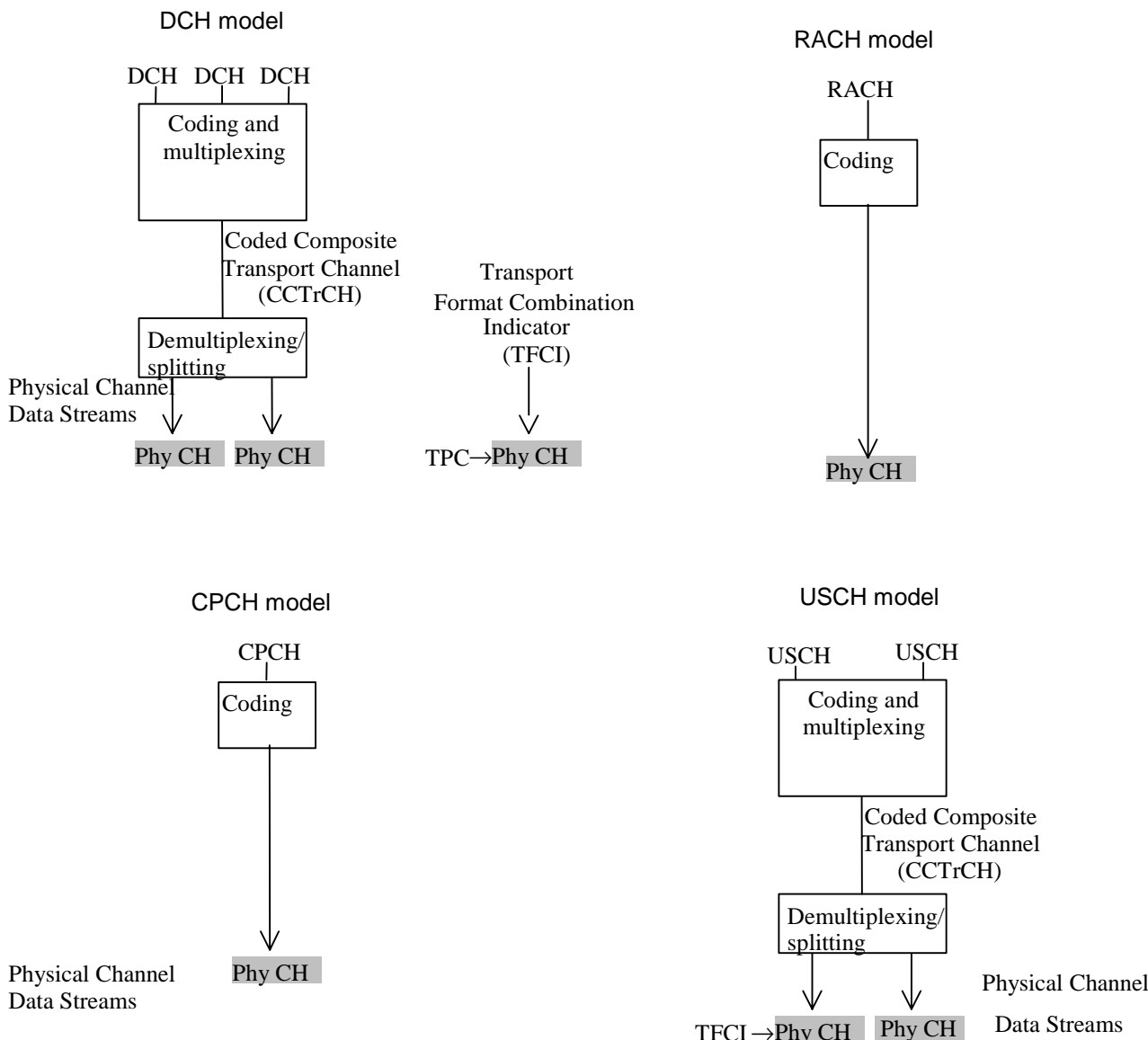

NOTE 1: CPCH is for FDD only.

NOTE 2: USCH is for TDD only.

Figure 2: Model of the UE's physical layer - uplink

The DCH model shows that one or several DCHs can be processed and multiplexed together by the same coding and multiplexing unit. The detailed functions of the coding and multiplexing unit are not defined in the present document but in [3] and [4]. The single output data stream from the coding and multiplexing unit is denoted *Coded Composite Transport Channel (CCTrCH)*.

The bits on a CCTrCH Data Stream can be mapped on the same Physical Channel and should have the same C/I requirement.

On the downlink, multiple CCTrCH can be used simultaneously with one UE. In the case of FDD, only one fast power control loop is necessary for these different CCTrCH, but the different CCTrCH can have different C/I requirements to provide different QoS on the mapped Transport Channels. In the case of TDD, different power control loops can be applied for different CCTrCH. One physical channel can only have bits coming from the same CCTrCH.

On the uplink and in the case of FDD, only one CCTrCH can be used simultaneously. On the uplink and in the case of TDD, multiple CCTrCH can be used simultaneously.

When multiple CCTrCH are used by one UE, one or several TFCI can be used, but each CCTrCH has only zero or one corresponding TFCI. In the case of FDD, these different words are mapped on the same DPCCCH. In the case of TDD, these different TFCI can be mapped on different DPCH.

The data stream of the CCTrCH is fed to a data demultiplexing/splitting unit that demultiplexes/splits the CCTrCH's data stream onto one or several *Physical Channel Data Streams*.

The current configuration of the coding and multiplexing unit is either signalled to, or optionally blindly detected by, the network for each 10 ms frame. If the configuration is signalled, it is represented by the *Transport Format Combination Indicator (TFCI)* bits. Note that the TFCI signalling only consists of pointing out the current transport format combination within the already configured transport format combination set. In the uplink there is only one TFCI representing the current transport formats on all DCHs of one CCTrCH simultaneously. In FDD mode, the physical channel data stream carrying the TFCI is mapped onto the physical channel carrying the power control bits and the pilot. In TDD mode the TFCI is time multiplexed onto the same physical channel(s) as the DCHs. The exact locations and coding of the TFCI are signalled by higher layers.

The DCH and USCH have the possibility to perform Timing Advance in TDD mode.

The model for the RACH case shows that RACH is a common type transport channel in the uplink. RACHs are always mapped one-to-one onto physical channels (PRACHs), i.e. there is no physical layer multiplexing of RACHs. Service multiplexing is handled by the MAC layer. In one cell several RACHs/PRACHs may be configured. If more than one PRACH is configured in a cell, the UE performs PRACH selection as specified in [4].

In FDD, the RACHs mapped to the PRACHs may all employ the same Transport Format and Transport Format Combination Sets, respectively. It is however also possible that individual RACH Transport Format Sets are applied on each available RACH/PRACH.

In TDD, there is no TFCI transmitted in the burst, and therefore each RACH is configured with a single transport format within its TFS. The RACHs mapped to the PRACHs may all employ the same Transport Format. It is however also possible that individual RACH Transport Formats are applied on each available RACH/PRACH combination.

The available pairs of RACH and PRACHs and their parameters are indicated in system information. In FDD mode, the various PRACHs are distinguished either by employing different preamble scrambling codes, or by using a common scrambling code but distinct (non-overlapping) partitions of available signatures and available subchannels. In TDD mode, the various PRACHs are distinguished either by employing different timeslots, or by using a common timeslot but distinct (non-overlapping) partitions of available channelisation codes and available subchannels. Examples of RACH/PRACH configurations are given in [6].

The CPCH, which is another common type transport channel, has a physical layer model as shown in figure2. There is always a single CPCH transport channel mapped to a PCPCH physical channel which implies a one-to-one correspondence between a CPCH TFI and the TFCI conveyed on PCPCH. A CPCH transport channel belongs to a CPCH set which is identified by the application of a common, CPCH set-specific scrambling code for access preamble and collision detection, and multiple PCPCH physical channels. Each PCPCH shall employ a subset of the Transport Format Combinations implied by the Transport Format Set of the CPCH set. A UE can request access to CPCH transport channels of a CPCH set, which is assigned when the service is configured for CPCH transmission.

6.2 Downlink models

Figure 3 and figure 4 show the model of the UE's physical layer for the downlink in FDD and TDD mode, respectively. Note that there is a different model for each transport channel type.

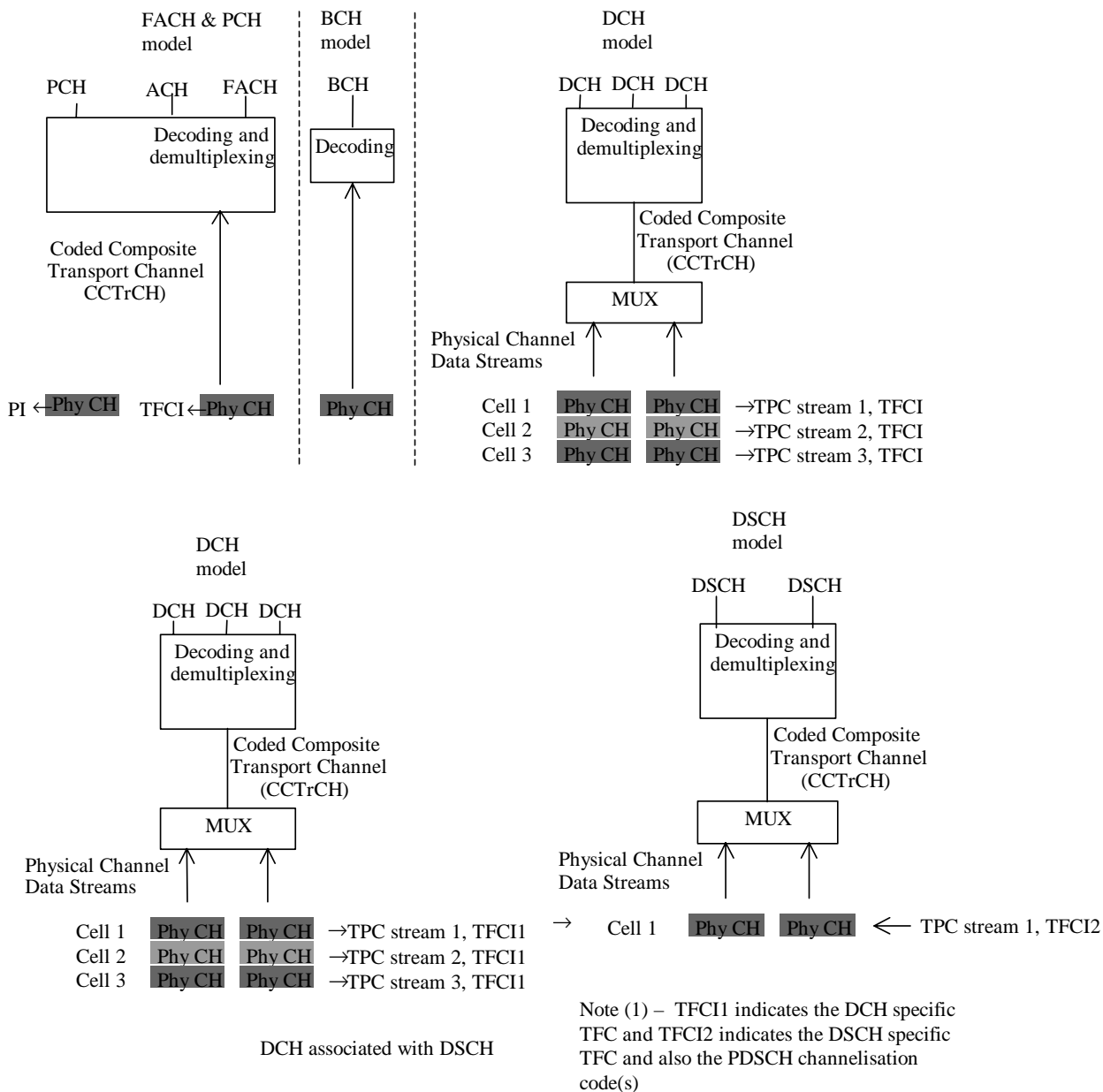

Figure 3: Model of the UE's physical layer - downlink FDD mode

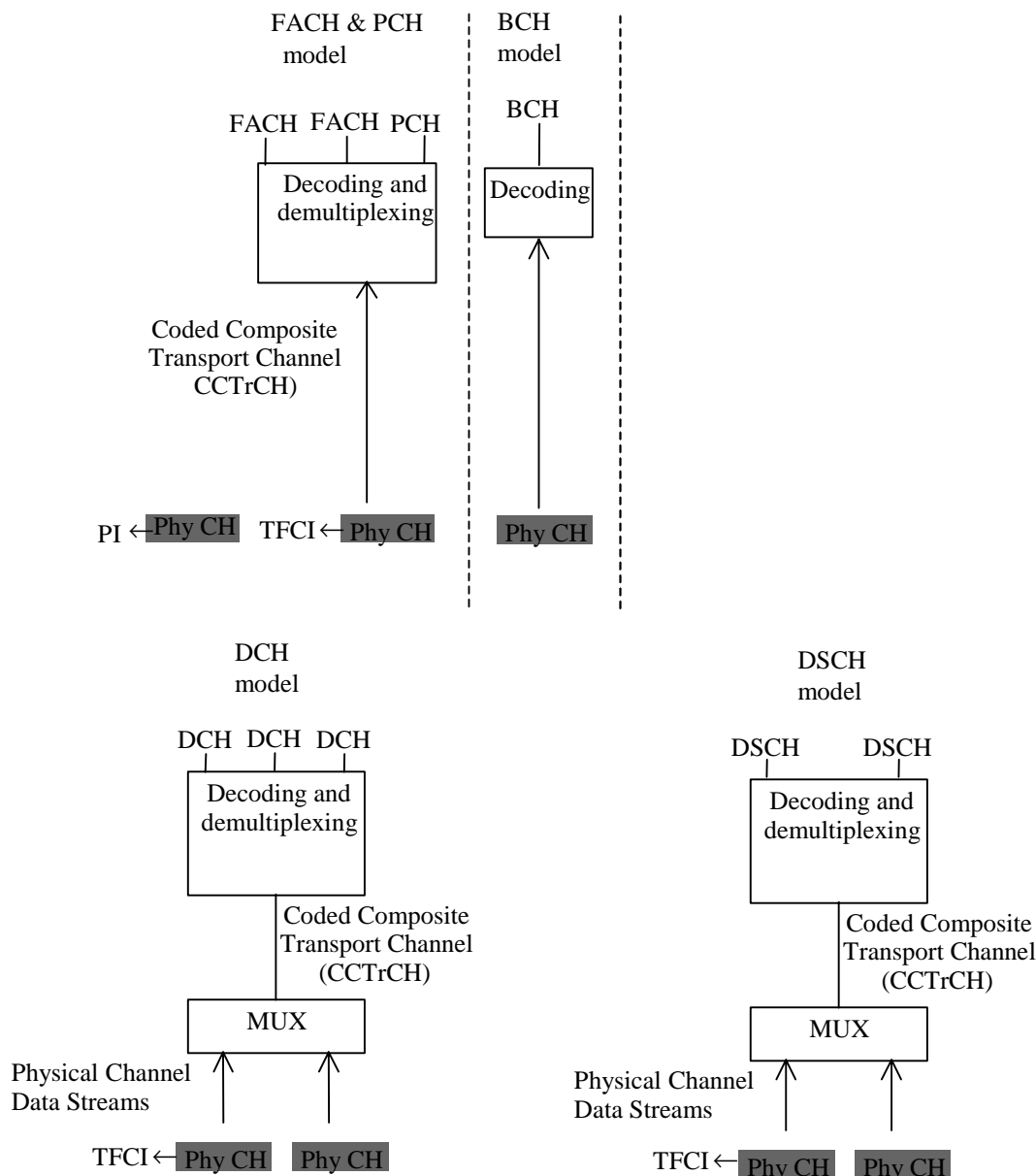

Figure 4: Model of the UE's physical layer – downlink TDD mode

For the DCH case, the mapping between DCHs and physical channel data streams works in the same way as for the uplink. Note however, that the number of DCHs, the coding and multiplexing etc. may be different in uplink and downlink.

In the FDD mode, the differences are mainly due to the soft and softer handover. Further, the pilot, TPC bits and TFCI are time multiplexed onto the same physical channel(s) as the DCHs. Further, the definition of physical channel data stream is somewhat different from the uplink. In TDD mode the TFCI is time multiplexed onto the same physical channel(s) as the DCHs. The exact locations and coding of the TFCI are signalled by higher layers.

Note that it is logically one and the same physical data stream in the active set of cells, even though physically there is one stream for each cell. The same processing and multiplexing is done in each cell. The only difference between the cells is the actual codes, and these codes correspond to the same spreading factor.

The physical channels carrying the same physical channel data stream are combined in the UE receiver, excluding the pilot, and in some cases the TPC bits. TPC bits received on certain physical channels may be combined provided that UTRAN has informed the UE that the TPC information on these channels is identical.

A PCH and one or several FACH can be encoded and multiplexed together forming a CCTrCH. Similarly as in the DCH model there is one TFCI for each CCTrCH for indication of the transport formats used on each PCH and FACH. The PCH is associated with a separate physical channel carrying page indicators (PIs) which are used to trigger UE reception of the physical channel that carries PCH. A FACH or a PCH can also be individually mapped onto a separate physical channel. The BCH is always mapped onto one physical channel without any multiplexing with other transport channels.

7 Formats and configurations for L1 data transfer

7.1 General concepts about Transport Channels

Layer 2 is responsible for the mapping of data onto L1 via the L1/L2 interface that is formed by the transport channels. In order to describe how the mapping is performed and how it is controlled, some definitions and terms are required. The required definitions are given in the following subclauses. Note that the definitions are generic for all transport channel types, i.e. not only for DCHs.

All Transport Channels are defined as unidirectional (i.e. uplink, downlink, or relay-link). This means that a UE can have simultaneously (depending on the services and the state of the UE) one or several transport channels in the downlink, and one or more Transport Channel in the uplink.

7.1.1 Transport Block

This is the basic unit exchanged between L1 and MAC, for L1 processing.

Layer 1 adds a CRC for each Transport Block.

7.1.2 Transport Block Set

This is defined as a set of Transport Blocks, which are exchanged between L1 and MAC at the same time instance using the same transport channel.

7.1.3 Transport Block Size

This is defined as the number of bits in a Transport Block. The Transport Block Size is always fixed within a given Transport Block Set, i.e. all Transport Blocks within a Transport Block Set are equally sized.

7.1.4 Transport Block Set Size

This is defined as the number of bits in a Transport Block Set.

7.1.5 Transmission Time Interval

This is defined as the inter-arrival time of Transport Block Sets, and is equal to the periodicity at which a Transport Block Set is transferred by the physical layer on the radio interface. It is always a multiple of the minimum interleaving period (e.g. 10ms, the length of one Radio Frame). The MAC delivers one Transport Block Set to the physical layer every TTI.

Figure 6 shows an example where Transport Block Sets, at certain time instances, are exchanged between MAC and L1 via three parallel transport channels. Each Transport Block Set consists of a number of Transport Blocks. The Transmission Time Interval, i.e. the time between consecutive deliveries of data between MAC and L1, is also illustrated.

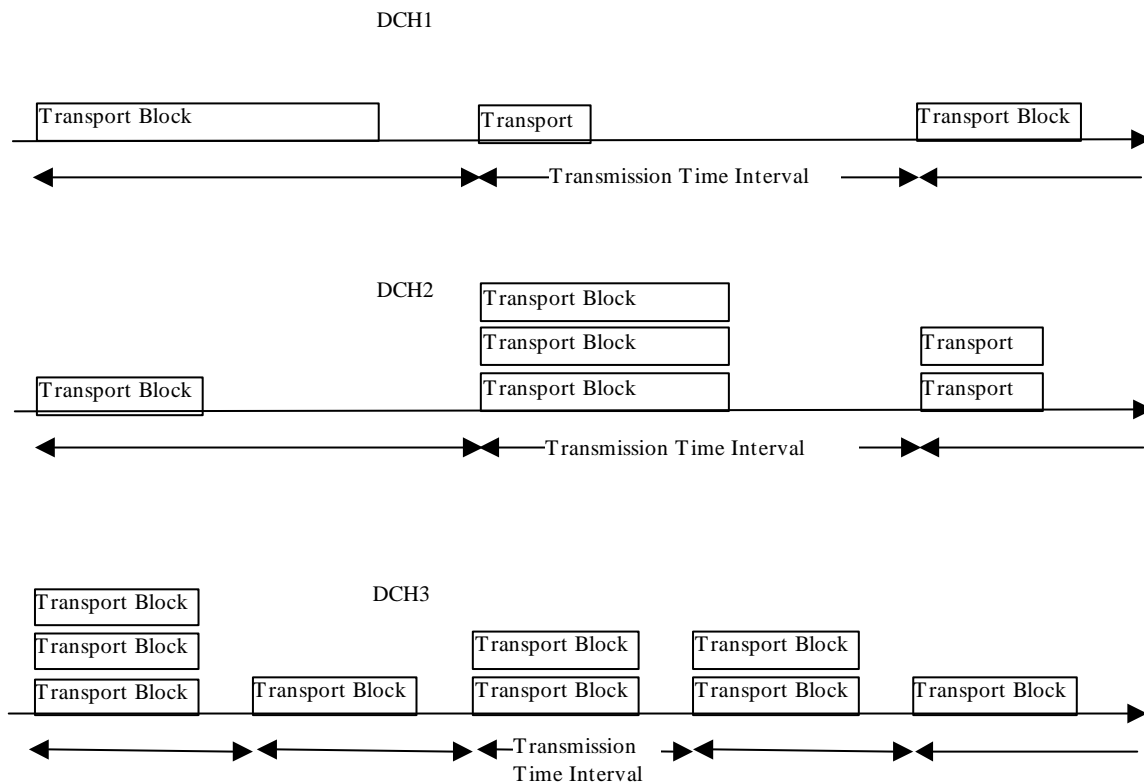

Figure 6: Exchange of data between MAC and L1

7.1.6 Transport Format

This is defined as a format offered by L1 to MAC (and vice versa) for the delivery of a Transport Block Set during a Transmission Time Interval on a Transport Channel. The Transport Format constitutes of two parts – one *dynamic* part and one *semi-static* part.

Attributes of the dynamic part are:

- Transport Block Size;
- Transport Block Set Size;
- Transmission Time Interval (optional dynamic attribute for TDD only);

Attributes of the semi-static part are:

- Transmission Time Interval (mandatory for FDD, optional for the dynamic part of TDD NRT bearers);
- error protection scheme to apply:
 - type of error protection, turbo code, convolutional code or no channel coding;
 - coding rate;
 - static rate matching parameter;
- size of CRC.

In the following example, the Transmission Time Interval is seen as a semi-static part.

EXAMPLE:

Dynamic part: {320 bits, 640 bits}, Semi-static part: {10ms, convolutional coding only, static rate matching parameter = 1}.

7.1.7 Transport Format Set

This is defined as the set of Transport Formats associated to a Transport Channel.

The semi-static parts of all Transport Formats are the same within a Transport Format Set.

Effectively the first two attributes of the dynamic part form the instantaneous bit rate on the Transport Channel. Variable bit rate on a Transport Channel may, depending on the type of service, which is mapped onto the transport channel, be achieved by changing between each Transmission Time Interval one of the following:

1. the Transport Block Set Size only;
2. both the Transport Block Size and the Transport Block Set Size Example 1:
 - dynamic part: {20 bits, 20 bits}; {40 bits, 40 bits}; {80 bits, 80 bits}; {160 bits, 160 bits}.
 - Semi-static part: {10ms, Convolutional coding only, static rate matching parameter = 1} Example 2:
 - dynamic part: {320 bits, 320 bits}; {320 bits, 640 bits}; {320 bits, 1 280 bits}.
 - Semi-static part: {10ms, Convolutional coding only, static rate matching parameter = 2}.

The first example may correspond to a Transport Channel carrying a speech service, requiring blocks delivered on a constant time basis. In the second example, which illustrates the situation where a non-real time service is carried by the Transport Channel, the number of blocks delivered per Transmission Time Interval varies between the different Transport Formats within the Transport Format Set. Referring to figure 6, the Transport Block Size is varied on DCH1 and DCH2. That is, a Transport Format Set where the dynamic part has a variable Transport Block Size has been assigned for DCH1. On DCH3 it is instead only the Transport Block Set Size that is varied. That is, the dynamic parts of the corresponding Transport Format Sets only include variable Transport Block Set Sizes.

7.1.8 Transport Format Combination

The layer 1 multiplexes one or several Transport Channels, and for each Transport Channel, there exists a list of transport formats (Transport Format Set) which are applicable. Nevertheless, at a given point of time, not all combinations may be submitted to layer 1 but only a subset, the Transport Format Combination. This is defined as an authorised combination of the combination of currently valid Transport Formats that can be submitted simultaneously to the layer 1 for transmission on a Coded Composite Transport Channel of a UE, i.e. containing one Transport Format from each Transport Channel.

EXAMPLE:

DCH1:

Dynamic part: {20 bits, 20 bits}, Semi-static part: {10ms, Convolutional coding only, static rate matching parameter = 2};

DCH2:

Dynamic part: {320 bits, 1 280 bits}, Semi-static part: {10ms, Convolutional coding only, static rate matching parameter = 3};

DCH3:

Dynamic part: {320 bits, 320 bits}, Semi-static part: {40ms, Turbo coding, static rate matching parameter = 2}.

7.1.9 Transport Format Combination Set

This is defined as a set of Transport Format Combinations on a Coded Composite Transport Channel.

EXAMPLE:

- dynamic part:
 - combination 1: DCH1: {20 bits, 20 bits}, DCH2: {320 bits, 1280 bits}, DCH3: {320 bits, 320 bits};
 - combination 2: DCH1: {40 bits, 40 bits}, DCH2: {320 bits, 1280 bits}, DCH3: {320 bits, 320 bits};

- combination 3: DCH1: {160 bits, 160 bits}, DCH2: {320 bits, 320 bits}, DCH3: {320 bits, 320 bits}
- semi-static part:
 - DCH1: {10ms, Convolutional coding only, static rate matching parameter = 1};
 - DCH2: {10ms, Convolutional coding only, static rate matching parameter = 1};
 - DCH3: {40ms, Turbo coding, static rate matching parameter = 2}.

The Transport Format Combination Set is what is given to MAC for control. However, the assignment of the Transport Format Combination Set is done by L3. When mapping data onto L1, MAC chooses between the different Transport Format Combinations given in the Transport Format Combination Set. Since it is only the dynamic part that differ between the Transport format Combinations, it is in fact only the dynamic part that MAC has any control over.

The semi-static part, together with the target value for the L1 closed loop power control, correspond to the service attributes:

- quality (e.g. BER);
- transfer delay.

These service attributes are then offered by L1. However, it is L3 that guarantees that the L1 services are fulfilled since it is in charge of controlling the L1 configuration, i.e. the setting of the semi-static part of the Transport Formats. Furthermore, L3 controls the target for the L1 closed loop power control through the outer loop power control (which actually is a quality control rather than a power control).

Note that a Transport Format Combination Set need not contain all possible Transport Format Combinations that can be formed by Transport Format Sets of the corresponding Transport Channels. It is only the allowed combinations that are included. Thereby a maximum total bit rate of all transport channels of a Code Composite Transport Channel can be set appropriately. That can be achieved by only allowing Transport Format Combinations for which the included Transport Formats (one for each Transport Channel) do not correspond to high bit rates simultaneously.

The selection of Transport Format Combinations can be seen as a fast part of the radio resource control. The dedication of these fast parts of the radio resource control to MAC, close to L1, means that the flexible variable rate scheme provided by L1 can be fully utilised. These parts of the radio resource control should be distinguished from the slower parts, which are handled by L3. Thereby the bit rate can be changed very fast, without any need for L3 signalling.

7.1.10 Transport Format Indicator (TFI)

The TFI is a label for a specific transport format within a transport format set. It is used in the inter-layer communication between MAC and L1 each time a transport block set is exchanged between the two layers on a transport channel.

When the DSCH is associated with a DCH, the TFI of the DSCH also indicates the physical channel (i.e. the channelisation code) of the DSCH that has to be listened to by the UE.

7.1.11 Transport Format Combination Indicator (TFCI)

This is a representation of the current Transport Format Combination.

There is a one-to-one correspondence between a certain value of the TFCI and a certain Transport Format Combination. The TFCI is used in order to inform the receiving side of the currently valid Transport Format Combination, and hence how to decode, de-multiplex and deliver the received data on the appropriate Transport Channels.

MAC indicates the TFI to Layer 1 at each delivery of Transport Block Sets on each Transport Channel. Layer 1 then builds the TFCI from the TFIs of all parallel transport channels of the UE, processes the Transport Blocks appropriately and appends the TFCI to the physical control signalling. Through the detection of the TFCI the receiving side is able to identify the Transport Format Combination. For FDD, in case of limited Transport Format Combination Sets the TFCI signalling may be omitted, instead relying on blind detection. Nevertheless, from the assigned Transport Format Combinations, the receiving side has all information it needs in order to decode the information and transfer it to MAC on the appropriate Transport Channels.

The multiplexing and exact rate matching patterns follow predefined rules and may therefore be derived (given the Transport Format Combinations) by transmitter and receiver without signalling over the radio interface.

When the meaning of the TFCI field needs to be reconfigured, two procedures can be used depending on the level of reconfiguration:

- **complete reconfiguration of TFCI:** in this procedure all TFCI values are reinitialised and new values are defined instead. The complete reconfiguration requires an explicit synchronisation between the UE and UTRAN regarding when the reconfiguration becomes valid.
- **incremental reconfiguration of TFCI:** in this procedure, a part of the TFCI values before and after the reconfiguration remain identical (note that this must be true for at least a TFCI that carry the signalling connection). This procedure supports addition, removal or redefinition of TFCI values. This procedure does not require an explicit execution time. This procedure may imply the loss of some user-plane data.

7.1.12 Rate matching

Two levels of rate matching are defined on the radio interface:

- a static rate matching per Transport Channel. The static rate matching is part of the semi-static attributes of the Transport Channel;
- a dynamic rate matching per CCTrCH. The dynamic rate matching adjusts the size of the physical layer data payload to the physical channel as requested by RRC.

The static rate matching and the dynamic rate matching to be applied by the physical layer are indicated by RRC to the physical layer.

In FDD, RRC is also responsible for configuring the physical layer on whether:

- Blind Rate Detection or TFCI is used;
- dynamic rate matching is applied or not on the downlink.

7.2 Types of Transport Channels

A general classification of transport channels is into two groups:

- common channels; and
- dedicated channels (where the UEs can be unambiguously identified by the physical channel, i.e. code and frequency).

Common transport channel types are:

1. Random Access Channel(s) (RACH) characterised by:
 - existence in uplink only;
 - limited data field;
 - collision risk;
 - open loop power control.
2. Forward Access Channel(s) (FACH) characterised by:
 - existence in downlink only;
 - possibility to use beam forming;
 - possibility to use slow power control;
 - possibility to change rate fast (each 10ms); and

- lack of fast power control.
3. Broadcast Channel (BCH) characterised by:
- existence in downlink only;
 - low fixed bit rate; and
 - requirement to be broadcast in the entire coverage area of the cell.
4. Paging Channel (PCH) characterised by:
- existence in downlink only;
 - association with a physical layer signal, the Page Indicator, to support efficient sleep mode procedures; and
 - requirement to be broadcast in the entire coverage area of the cell.
5. Downlink Shared Channel(s) (DSCH) characterised by:
- existence in downlink only;
 - possibility to use beamforming;
 - possibility to use slow power control;
 - possibility to use fast power control, when associated with dedicated channel(s);
 - possibility to be broadcast in the entire cell;
 - always associated with another channel (DCH or FACH (TDD)).
6. CPCH Channel characterised by:
- existence in FDD only;
 - existence in uplink only;
 - fast power control on the message part;
 - possibility to use beam forming;
 - possibility to change rate fast;
 - collision detection;
 - open loop power estimate for pre-amble power ramp-up.
7. Uplink Shared channel (USCH) characterised by:
- used in TDD only;
 - existence in uplink only;
 - possibility to use beam forming;
 - possibility to use power control;
 - possibility to change rate fast;
 - possibility to use Uplink Synchronisation.

Possibility to use Timing advance Dedicated transport channel types are:

1. Dedicated Channel (DCH) characterised by:
- existing in uplink or downlink;
 - possibility to use beam forming;

- possibility to change rate fast (each 10ms);
 - fast power control;
 - possibility to use timing advance in uplink (TDD only);
 - possibility to use Uplink Synchronisation.
2. Fast Uplink Signalling Channel (FAUSCH) to allocate, in conjunction with FACH, dedicated channels; the FAUSCH is characterised by:
- existing in uplink only;
 - inherent addressing of a UE by a unique time-offset (indicating to a UE when to send an uplink signalling code, USC) related to the beginning of the 10 ms frame;
 - allowing for a UE to notify (by sending an USC) a request for a DCH, the allocation of which is messaged via the FACH. No further information is conveyed via the FAUSCH.

NOTE: Applicability for TDD mode is FFS.

To each transport channel, there is an associated Transport Format (for transport channels with a fixed or slow changing rate) or an associated Transport Format Set (for transport channels with fast changing rate).

7.3 Compressed Mode

Compressed Mode is defined as the mechanism whereby certain idle periods are created in radio frames so that the UE can perform measurements during these periods (more details can be found in [3]).

Compressed Mode is obtained by layer 2 using transport channels provided by the layer 1 as follows:

- compressed mode is controlled by the RRC layer, which configures the layer 2 and the physical layer;
- the number of occurrences of compressed frames is controlled by RRC, and can be modified by RRC signalling;
- it is under the responsibility of the layer 2 if necessary and if possible to either buffer some layer 2 PDUs (typically at the RLC layer for NRT services) or to rate-adapt the data flow (similarly to GSM) so that there is no loss of data because of compressed mode. This will be service dependent and controlled by the RRC layer.

For measurements in compressed mode, a transmission gap pattern sequence is defined. A transmission gap pattern sequence consists of alternating transmission gap patterns 1 and 2, and each of these patterns in turn consists of one or two transmission gaps. The transmission gap pattern structure, position and repetition are defined with physical channel parameters described in [3]. In addition, the UTRAN configures compressed mode pattern sequences with the following parameters:

- **TGMP:** Transmission Gap pattern sequence Measurement Purpose: This parameter defines the purpose this transmission gap pattern sequence is intended for. The following values are used:
 - for TDD measurements, one compressed mode pattern sequence can be configured with purpose 'TDD measurement',
 - for FDD measurements, one compressed mode pattern sequence can be configured with purpose 'FDD measurement',
 - for GSM measurements, three simultaneous compressed mode pattern sequences can be configured with purposes 'GSM carrier RSSI measurement', 'Initial BSIC identification' and 'BSIC re-confirmation',
- **TGPSI:** Transmission Gap Pattern Sequence Identifier selects the compressed mode pattern sequence for which the parameters are to be set. The range of TGPSI is [1 to <MaxTGPS>].

The UE shall support a total number of simultaneous compressed mode pattern sequences, which is determined by the UE's capability to support each of the measurement types categorised by the TGMP. For example, a UE supporting FDD and GSM shall support four simultaneous compressed mode pattern sequences and a UE supporting FDD and TDD shall support two simultaneous compressed mode pattern sequences.

When using simultaneous pattern sequences, it is the responsibility of the NW to ensure that the compressed mode gaps do not overlap and are not scheduled to overlap the same frame. Gaps exceeding the maximum gap length shall not be processed by the UE and shall interpreted as a faulty message. If the UE detects overlapping gaps, it shall process the gap from the pattern sequence having the lowest TGPSI.

8 UE Simultaneous Physical Channels combinations

This clause describes the requirements from the UE to send and receive on multiple Transport Channels, which are mapped on different physical channels simultaneously depending on the service capabilities and requirements. The clause will describe the impacts on the support for multiple services (e.g. speech call and SMS-CB) depending on the UE capabilities.

8.1 FDD Uplink

The table describes the possible combinations of FDD physical channels that can be supported in the uplink on the same frequency by one UE simultaneously.

Table 1: FDD Uplink

	Physical Channel Combination	Transport Channel Combination	Mandatory or dependent on UE radio access capabilities	Comment
1	PRACH	RACH	Mandatory	The PRACH physical channel includes the preambles and the message.
2	PCPCH consisting of one control and one data part during the message portion	CPCH	Depending on UE radio access capabilities	The PCPCH physical channel includes the preambles and the message. The maximum channel bit rate is dependant on UE radio access capabilities.
3	PCPCH consisting of one control and more than one data part during the message portion	CPCH	Depending on UE radio access capabilities	The PCPCH physical channel includes the preambles and the message. The maximum channel bit rate is dependant on UE radio access capabilities.
4	DPCCH+DPDCH	One or more DCH coded into a single CCTrCH	Mandatory	The maximum number of DCHs and the maximum channel bit rate are dependant on UE radio access capabilities.
5	DPCCH+ more than one DPDCH	One or more DCH coded into a single CCTrCH	Depending on UE radio access capabilities	The maximum number of DCHs and the maximum channel bit rate are dependant on UE radio access capabilities.

8.2 FDD Downlink

The table describes the possible combinations of FDD physical channels that can be supported in the downlink on the same frequency by one UE simultaneously.

Table 2: FDD Downlink

	Physical Channel Combination	Transport Channel Combination	Mandatory dependent on UE radio access capabilities	Comment
1	PCCPCH	BCH	Mandatory	
2	SCCPCH	FACH Or PCH Or FACH + PCH	Mandatory	The maximum channel bit rate that can be supported is dependent on the UE radio access capabilities. The PCH is included when the UE needs to receive paging on the SCCPCH. The reception of (FACH + PCH) is to enable the reception of broadcast services on the CTCH, mapped to the FACH.
3	PCCPCH + SCCPCH	BCH + (FACH or PCH or (FACH + PCH))	Mandatory	Simultaneous reception of PCCPCH and SCCPCH is only needed at occurrences when the UE needs to read system information on BCH while being in CELL_FACH state, i.e. continuous reception of both PCCPCH and SCCPCH at the same time is not required. The requirement holds for PCCPCH and SCCPCH sent in different cells or in the same cell. The PCH is included when the UE needs to receive paging on the SCCPCH. The reception of (FACH + PCH) is to enable the reception of broadcast services on the CTCH, mapped to the FACH.
4	SCCPCH + AICH	(FACH or PCH or (FACH + PCH))+ RACH in uplink Or (FACH or PCH or (FACH + PCH))+ CPCH in uplink	Mandatory	The maximum channel bit rate that can be supported is dependent on the UE radio access capabilities. The PCH is included when the UE needs to receive paging on the SCCPCH. The reception of (FACH + PCH) is to enable the reception of broadcast services on the CTCH, mapped to the FACH. This physical channel combination facilitates the preamble portion of the CPCH in the uplink
5	SCCPCH + DPCCH	(FACH or PCH or (FACH + PCH))+ CPCH in uplink	Depending on UE radio access capabilities	This physical channel combination facilitates the message portion of the CPCH in the uplink The PCH is included when the UE needs to receive paging on the SCCPCH. The reception of (FACH + PCH) is to enable the reception of broadcast services on the CTCH, mapped to the FACH.
6	More than one SCCPCH	More than one (FACH or PCH or (FACH + PCH))	Depending on UE radio access capabilities	The PCH is included when the UE needs to receive paging on the SCCPCH. The reception of (FACH + PCH) is to enable the reception of broadcast services on the CTCH, mapped to the FACH.
7	PICH	N/A	Mandatory	
8	DPCCH + DPDCH	One or more DCH coded into a single CTrCH	Mandatory	The maximum number of DCHs and the maximum channel bit rate are dependent on UE radio access capabilities.
9	DPCCH + more than one DPDCH	One or more DCH coded into a single CTrCH	Depending on UE radio access capabilities	The maximum number of DCHs and the maximum channel bit rate are dependent on UE radio access capabilities.

	Physical Channel Combination	Transport Channel Combination	Mandatory dependent on UE radio access capabilities	Comment
10	One or more PDSCH + DPCCH + one or more DPDCH	One or more DSCH coded into a single CCTrCH + one or more DCH coded into a single CCTrCH	Depending on UE radio access capabilities	The maximum number of DCHs and the maximum channel bit rate are dependent on UE radio access capabilities.
11	SCCPCH + DPCCH + one or more DPDCH	FACH + one or more DCH coded into a single CCTrCH	Depending on UE radio access capabilities	The maximum number of DCHs and the maximum channel bit rate are dependent on UE radio access capabilities. This combination of physical channels is used for DRAC control of an uplink DCH and for receiving services such as cell broadcast or multicast whilst in connected mode. NOTE 1
12	SCCPCH + one or more PDSCH + DPCCH + one or more DPDCH	FACH + one or more DSCH coded into a single CCTrCH + one or more DCH coded into a single CCTrCH	Depending on UE radio access capabilities	The maximum number of DCHs and the maximum channel bit rate are dependent on UE radio access capabilities. This combination of physical channels is used for simultaneous DSCH and DRAC control of an uplink DCH. NOTE 1
13	One DPCCH + more than one DPDCH	More than one DCH coded into one or more CCTrCH	Depending on UE radio access capabilities	
14	PCCPCH (neighbour cell) + DPCCH + one or more DPDCH + zero, one, or more PDSCH	BCH (neighbour cell) + one or more DCHs + zero, one or more DSCH	Mandatory	This combination is required by a UE in CELL_DCH state to be able to read the SFN of a neighbouring cell to support timing maintained hard hand over

NOTE 1: When both DRAC and CTCH are configured in one cell, the UTRAN should transmit DRAC info and CTCH info on the same S-CCPCH in order to minimize the number of S-CCPCH to be read by the UE. A UE which supports the simultaneous reception of S-CCPCH and DPCH, shall be capable of switching between different S-CCPCH in order to listen to DRAC info and CTCH info that are not scheduled in the same time intervals. If the UE is ordered to listen to CTCH and DRAC info on different S-CCPCH in the same time interval, it shall listen to DRAC info in priority.

8.3 TDD Uplink

8.3.1 3.84 Mcps TDD Uplink

The table addresses the possible combinations of 3.84Mcps TDD physical channels that can be supported in the uplink by one UE simultaneously on the same frequency in any one 10ms frame. In 3.84Mcps TDD a physical channel corresponds to one code, one timeslot and one frequency.

Table 3: 3.84Mcps TDD Uplink

	Physical Channel Combination	Transport Channel Combination	Mandatory or dependent on UE radio access capabilities	Comment
1	PRACH	RACH	Mandatory	
2	DPCH	One or more DCH coded into a single CCTrCH	Mandatory	The maximum number of DCHs and the maximum channel bit rate are dependent on UE radio access capabilities. This combination is used as reference measurement channel.
3	One or more than one DPCH	One or more DCH coded into one or more CCTrCH	Depending on UE radio access capabilities	The maximum number of DCHs and the maximum channel bit rate are dependent on UE radio access capabilities.
4	PRACH + one or more DPCH	RACH + one or more DCH coded into one or more CCTrCH	Depending on UE radio access capabilities	The maximum number of DCHs and the maximum channel bit rate are dependent on UE radio access capabilities. This combination may be used for shared channel operation only. At least the usage of two timeslots is required.
5	One or more PUSCH	One or more USCH coded onto one or more CCTrCH	Depending on UE radio access capabilities	This combination is used for shared channel operation.
6	PRACH + one or more PUSCH	RACH + One or more USCH coded onto one or more CCTrCH	Depending on UE radio access capabilities	This combination may be used for shared channel operation only. At least the usage of two timeslots is required.
7	One or more PUSCH + one or more DPCH	One or more USCH coded onto one or more CCTrCH + one or more DCH coded into one or more CCTrCH	Depending on UE radio access capabilities	The maximum number of DCHs and the maximum channel bit rate are dependent on UE radio access capabilities. This combination may be used for shared channel operation.
8	PRACH + one or more PUSCH + one or more DPCH	RACH + one or more USCH coded onto one or more CCTrCH + one or more DCH coded into one or more CCTrCH	Depending on UE radio access capabilities	The maximum number of DCHs and the maximum channel bit rate are dependent on UE radio access capabilities. This combination may be used for shared channel operation. At least the usage of two timeslots is required.

8.3.2 1.28 Mcps TDD Uplink

The table addresses the possible combinations of 1.28 Mcps TDD physical channels that can be supported in the uplink by one UE simultaneously on the same frequency in the TDD 1.28 Mcps option in any one 5 ms subframe. In 1.28Mcps TDD a physical channel corresponds to one code, one timeslot, one frequency.

Table 4: 1.28 Mcps TDD Uplink

	Physical Channel Combination	Transport Channel Combination	Mandatory or dependent on UE radio access capabilities	Comment
1	UpPCH	N/A	Mandatory	UpPCH is used to establish the uplink synchronisation.
2	PRACH	RACH	Mandatory	
3	UpPCH + One DPCH	One or more DCH coded into a single CCTrCH	Mandatory	One DPCH is needed as reference measurement channel. UpPCH transmission to target cell in case of handover.
4	One DPCH	One or more DCH coded into a single CCTrCH	Mandatory	The maximum number of DCHs and the maximum channel bit rate are dependent on UE radio access capabilities This combination is required for the reference measurement channel.
5	More than one DPCH	One or more DCH coded into one or more CCTrCH	Depending on UE radio access capabilities	The maximum number of DCHs, the maximum number of CCTrCH and the maximum channel bit rate are dependent on UE radio access capabilities.
6	UpPCH+ one or more DPCH	One or more DCH coded into one or more CCTrCH	Depending on UE radio access capabilities	The maximum number of DCHs, the maximum number of CCTrCH and the maximum channel bit rate are dependent on UE radio access capabilities. This configuration is required for UE that operate shared channels and dedicated channels simultaneously.
7	PRACH + one or more DPCHs	RACH + one or more DCH coded into one or more than one CCTrCH	Depending on UE radio access capabilities	The maximum number of DCHs, the maximum number of CCTrCH and the maximum channel bit rate are dependent on UE radio access capabilities. This configuration is required for UE that operate shared channels and dedicated channels simultaneously.
8	One or more PUSCH	One or more USCH coded onto one or more CCTrCH	Depending on UE radio access capabilities	This configuration is required for UE that operate shared channels.
9	UpPCH + one or more PUSCH	One or more USCH coded onto one or more CCTrCH	Depending on UE radio access capabilities	This combination may be used for shared channel operation only.
10	PRACH + one or more PUSCH	RACH + One or more USCH coded onto one or more CCTrCH	Depending on UE radio access capabilities	This combination may be used for shared channel operation only
11	One or more PUSCH + one or more DPCH	One or more USCH coded onto one or more CCTrCH + one or more DCH coded onto one or more CCTrCH	Depending on UE radio access capabilities	The maximum number of DCHs and the maximum channel bit rate are dependent on UE radio access capabilities. This configuration is required for UE that operate shared channels and dedicated channels simultaneously

	Physical Channel Combination	Transport Channel Combination	Mandatory or dependent on UE radio access capabilities	Comment
12	UpPCH + one or more PUSCH + one or more DPCH	One or more USCH coded onto one or more CCTrCH + one or more DCH coded into one or more CCTrCH	Depending on UE radio access capabilities	The maximum number of DCHs and the maximum channel bit rate are dependent on UE radio access capabilities. This combination may be used for shared channel operation.
13	PRACH + one or more PUSCH + one or more DPCH	RACH + one or more USCH coded onto one or more CCTrCH + one or more DCH coded into one or more CCTrCH	Depending on UE radio access capabilities	The maximum number of DCHs and the maximum channel bit rate are dependent on UE radio access capabilities. This combination may be used for shared channel operation.

8.4 TDD Downlink

8.4.1 3.84 Mcps TDD Downlink

The table describes the possible combinations of 3.84Mcps TDD physical channels that can be supported in the downlink by one UE simultaneously on the same frequency in any one 10ms frame, where a 3.84Mcps TDD physical channel corresponds to one code, one timeslot and one frequency.

Depending on UE radio capabilities UEs may be required to occasionally decode P-CCPCH of its own cell in the following Physical Channel Combinations to maintain open loop power control and/or acquire parameters for RACH access: 4, 6, 7, 8, 9, 10, 11, 12.

Depending on UE radio capabilities UEs may be required to occasionally decode one P-CCPCH of neighbour cells in the following Physical Channel Combinations for handover: 6, 8, 11, 12.

Table 5: 3.84Mcps TDD Downlink

	Physical Channel Combination	Transport Channel Combination	Mandatory or dependent on UE radio access capabilities	Comment
1	P-CCPCH + One S-CCPCH	BCH and PCH and/or one or more FACH	Mandatory	
2	P-CCPCH	BCH	Mandatory	
3	S-CCPCH	FACH or/and PCH	Mandatory	
4	More than one S-CCPCH	one or more FACH+ one or more PCH	Depending on UE capabilities	
5	PICH	N/A	Mandatory	
6	Three or more DPCH	One or more DCH coded into one or more CCTrCH	Depending on UE radio access capabilities	The maximum number of DCHs and the maximum channel bit rate are dependent on UE radio access capabilities.
7	One or two DPCH	One or more DCH coded into a single CCTrCH	Mandatory	This combination is used for reference measurement channel.
8	One or more S-CCPCH + one or more DPCH	PCH and/or one or more FACH + one or more DCH coded into one or more CCTrCH	Depending on UE radio access capabilities	The number of DCHs and the maximum channel bit rate are dependent on the UE radio access capabilities. This combination is used for shared channel operation only.
9	One or more PDSCH	One or more DSCH coded onto one or more CCTrCH	Depending on UE radio access capabilities	This combination is used for shared channel operation.
10	One or more PDSCH + one or more S-CCPCH	PCH and/or one or more FACH + one or more DSCH coded onto one or more CCTrCH	Depending on UE radio access capabilities	This combination is used for shared channel operation.
11	One or more PDSCH + one or more DPCH	One or more DSCH coded onto one or more CCTrCH + one or more DCH coded into one or more CCTrCH	Depending on UE radio access capabilities	The maximum number of DCHs and the maximum channel bit rate are dependent on UE radio access capabilities. This combination is used for shared channel operation.

	Physical Channel Combination	Transport Channel Combination	Mandatory or dependent on UE radio access capabilities	Comment
12	One or more PDSCH + one or more S-CCPCH + one or more DPCH	PCH and/or one or more FACH + one or more DSCH coded onto one or more CCTrCH + one or more DCH coded into one or more CCTrCH	Depending on UE radio access capabilities	The maximum number of DCHs and the maximum channel bit rate are dependent on UE radio access capabilities. This combination is used for shared channel operation.
NOTE: Reference: [12].				

8.4.2 1.28 Mcps TDD Downlink

The table addresses the possible combinations of 1.28 Mcps TDD physical channels that can be supported in the downlink by one UE simultaneously on the same frequency in any one 5ms subframe. In 1.28Mcps TDD a physical channel corresponds to one code, one timeslot, one frequency.

Depending on UE radio capabilities UEs may be required to occasionally decode P-CCPCH of its own cell in the following Physical Channel Combinations: 5, 11,12,13,14,15,16,17.

To support handover it depends on UE capabilities if a UE can support the occasional decoding of neighbour cell P-CCPCH in the physical channel combinations 8, 9, 10, 11, 15,16, 17

Table 6: 1.28 Mcps TDD Downlink

	Physical Channel Combination	Transport Channel Combination	Mandatory or dependent on UE radio access capabilities	Comment
1	FPACH	N/A	Mandatory	FPACH is used to answer the UE and to adjust the timing and synchronization shift of the UE
2	P-CCPCH	BCH	Mandatory	
3	S-CCPCH	FACH or/and PCH	Mandatory	
4	P-CCPCH +S-CCPCH	BCH + (FACH or/and PCH)	Mandatory	
5	More than one S-CCPCH	one or more FACH+ one ore more PCH	Depending on UE capabilities	
6	PICH	N/A	Mandatory	
7	FPACH + P-CCPCH + none, one or more S-CCPCH	BCH + (none, one or more FACH+ none, one ore more PCH)	Depending on UE capabilities	
8	2 DPCH	One or more DCH coded into a single CCTrCH	Mandatory	The maximum number of DCH and the maximum channel bit rate are dependent on UE radio access capabilities This channel is used as reference measurement channel
9	One or more DPCH	One or more DCH coded into one or more CCTrCH	Depending on UE radio access capabilities	The maximum number of DCHs, the maximum number of CCTrCH and the maximum channel bit rate are dependent on UE radio access capabilities.

	Physical Channel Combination	Transport Channel Combination	Mandatory or dependent on UE radio access capabilities	Comment
10	FPACH + one or more DPCH	One or more DCH coded into one or more CCTrCH	Depending on UE radio access capabilities	FPACH is used to answer the UE and to adjust the timing and synchronization shift of the UE. The maximum number of DCHs, the maximum number of CCTrCH and the maximum channel bit rate are dependent on UE radio access capabilities. This configuration is required for UE that operate shared channels and dedicated channels simultaneously.
11	One or more S-CCPCH + one or more DPCH	(One or more FACH or/and PCH) + one or more DCH coded into one or more CCTrCH	Depending on UE radio access capabilities	The maximum number of DCHs, the maximum number of CCTrCH and the maximum channel bit rate are dependent on UE radio access capabilities. This configuration is required for UE that operate shared channels and dedicated channels simultaneously.
12	One or more PDSCH	One or more DSCH coded onto one or more CCTrCH	Depending on UE radio access capabilities	This configuration is required for UE that operate shared channels.
13	FPACH + one or more PDSCH	One or more DSCH coded onto one or more CCTrCH	Depending on UE radio access capabilities	This configuration is desirable but not essential for UE supporting shared channels.
14	One or more S-CCPCH + one or more PDSCH	(One or more FACH and/or PCH) + One or more DSCH coded onto one or more CCTrCH	Depending on UE radio access capabilities	This configuration is desirable but not essential for UE supporting shared channels.
15	One or more PDSCH + one or more DPCH	One or more DSCH coded onto one or more CCTrCH + one or more DCH coded into one or more CCTrCH	Depending on UE radio access capabilities	This configuration is required for UE that operate shared channels and dedicated channels simultaneously.
16	FPACH + one or more PDSCH + one or more DPCH	one or more DSCH coded onto one or more CCTrCH + one or more DCH coded into one or more CCTrCH	Depending on UE radio access capabilities.	FPACH is used to answer the UE and to adjust the timing and synchronization shift of the UE. This configuration is desirable but not essential for UE supporting shared channels and dedicated channels simultaneously.
17	One or more S-CCPCH + one or more PDSCH + one or more DPCH	(One or more FACH and/or PCH) + one or more DSCH coded onto one or more CCTrCH + one or more DCH coded into one or more CCTrCH	Depending on UE radio access capabilities.	This configuration is desirable but not essential for UE supporting shared channels and dedicated channels simultaneously.

9 Measurements provided by the physical layer

One of the key services provided by the physical layer is the measurement of various quantities, which are used to trigger or perform a multitude of functions. Both the UE and the UTRAN are required to perform a variety of measurements. The standard will not specify the method to perform these measurements or stipulate that the list of

measurements provided in this clause must all be performed. While some of the measurements are critical to the functioning of the network and are mandatory for delivering the basic functionality (e.g., handover measurements, power control measurements), others may be used by the network operators in optimising the network (e.g., radio environment).

Measurements may be made periodically and reported to the upper layers or may be event-triggered (e.g., primary CCPCH becomes better than the previous best primary CCPCH). Another reporting strategy may combine the event triggered and the periodical approach (e.g. falling of link quality below a certain threshold initiates periodical reporting). The measurements are tightly coupled with the service primitives in that the primitives' parameters may constitute some of the measurements.

The list and frequency of measurements, which the physical layer reports to higher layers, is described in this clause. The detailed definition of measurement control and abilities is contained in [6] for FDD and [11] for TDD. The measurement performance requirements together with accuracy, range and mapping is specified in [9] for TDD and in [10] for FDD.

The measurement quantities measured by the physical layer shall be such that the following principles are applied:

- for handover measurements, the decoding of parameters on the BCCH logical channel of monitored neighbouring cells, should not, in general, be needed for calculating the measurement result. If there is a need to adjust the measurement result with parameters broadcast on the PCCPCH, these parameters shall be provided by the UTRAN in inband measurement control messages. There may be some exceptions to this rule;

EXAMPLE:

It may be necessary to decode the SFN of the measured neighbouring cell for time difference measurements.

- in idle mode or in RRC connected mode using common Transport Channels, the UE shall be able to monitor cells for cell reselection, without being required to frequently decode parameters on the BCCH logical channel of the monitored neighbouring cells. The decoding frequency of these parameters, set by the cell reselection algorithm, should be such that UE standby times are not significantly decreased.

9.1 Model of physical layer measurements

This subclause describes a model for how the physical layer measurements are performed. This model applies both to the UE and Node B measurements.

The measurement model for physical layer measurements is represented in the figure 7.

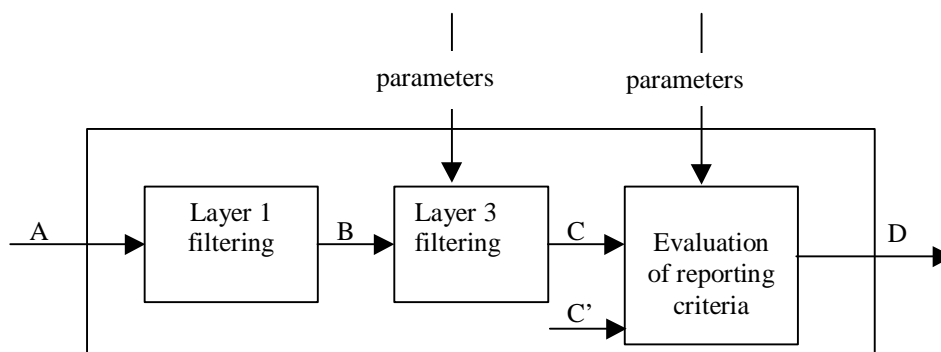

Figure 7: Measurement model

The model is described below:

- **A:** measurements (samples) internal to the physical layer in support to the measurements to be provided to higher layers;
- **Layer 1 filtering:** internal layer 1 filtering of the inputs measured at point A. Exact filtering is implementation dependant. How the measurements are actually executed in the physical layer by an implementation (inputs A and Layer 1 filtering) is not constrained by the standard i.e. the model does not state a specific sampling rate or even if the sampling is periodic or not. What the standard specifies is the performance objective and reporting

rate at point B in the model. The performance objectives for the physical layer measurements are specified in [9] and [10];

- **B:** A measurement reported by layer 1 after layer 1 filtering. The reporting rate at point B is defined by the standard and is measurement type specific. It is chosen to be equal to the measurement period over which performance objectives are defined in [9] and [10]. As a consequence, by setting the layer 3 filtering to "no filtering", the performance of the layer 1 implementation can be tested. This means that the physical layer can organise its internal measurements between these reporting at point B to meet the performance requirements;
- **Layer 3 filtering:** Filtering performed on the measurements provided at point B. The Layer 3 filters are standardised and the configuration of the layer 3 filters is provided by RRC signalling (UE measurements) or NBAP signalling (Node B measurements);
- **C:** A measurement after processing in the layer 3 filter. The reporting rate is identical to the reporting rate at point B and is therefore also measurement type specific. Although this is not shown in the figure, one measurement can be used by a multiplicity of evaluation of reporting criteria;
- **Evaluation of reporting criteria:** This checks whether actual measurement reporting is necessary at point D i.e. whether a message need to be sent to higher layers on the radio interface or Iub interface. The evaluation can be based on more than one flow of measurements at reference point C e.g. to compare between different measurements. This is illustrated by input C, C', etc. The UE shall evaluate the reporting criteria at least every time a new measurement result is reported at point C, C' etc. The reporting criteria are standardised and the configuration is provided by RRC signalling (UE measurements) or NBAP signalling (Node B measurements). Examples are periodic reporting and event based reporting. In case periodical reporting is in use and if the reporting interval is different from the filtering period defined by the layer 3 filter, the last measurement result filtered by the L3 filter shall be used as the value of the reported result. In case event triggered reporting is in use and the reporting criteria is fulfilled, the last measurement result filtered by the L3 filter shall be used as the value for reporting criteria evaluation and as the value of the reported result. This applies also for any additional measurements that shall be reported as a consequence of the event;
- **D:** a measurement report information (message) sent on the radio or Iub interface.

9.2 UE Measurements

For definitions of the measurements, see [6] and [11].

9.2.1 SFN-CFN observed time difference

This measure is mandatory for UE.

Measurement	SFN-CFN observed time difference
Source	L1 (UE)
Destination	RRC (RNC) for handover
Reporting Trigger	On-demand, Event-triggered
Description	Time difference between the SFN of the target neighbouring cell and the CFN in the UE.

9.2.2 Observed time difference to GSM cell

This measure is mandatory for UE capable of handover to GSM.

Measurement	Observed time difference to GSM cell
Source	L1 (UE)
Destination	RRC (RNC) for maintenance and handover to GSM
Reporting Trigger	On-demand, Event-triggered
Description	Time difference between a UTRA cell and a GSM cell.

9.2.3 CPICH E_c/N_0

This measure is mandatory for UE with FDD mode capability.

Measurement	CPICH E_c/N_0
Source	L1(UE)
Destination	RRC (UE, RNC)
Reporting Trigger	Periodic, on demand and event triggered
Description	The received energy per chip of the CPICH divided by the power density in the frequency band.

9.2.4 Void

9.2.5 CPICH RSCP

This measure is mandatory for UE with FDD mode capability.

Measurement	CPICH RSCP
Source	L1(UE)
Destination	RRC (UE, RNC)
Reporting Trigger	periodic or event triggered
Description	Received signal code power of the CPICH.

9.2.6 P-CCPCH RSCP

This measure is mandatory for UE with TDD mode capability.

Measurement	P-CCPCH RSCP
Source	L1(UE)
Destination	RRC (UE, RNC)
Reporting Trigger	periodic or event triggered
Description	Received signal code power of the P-CCPCH

9.2.7 Timeslot ISCP

This measure is mandatory for UE with TDD mode capability.

Measurement	Timeslot ISCP
Source	L1(UE)
Destination	RRC (UE, RNC)
Reporting Trigger	periodic or event triggered
Description	Interference Signal Code Power is the interference on the received signal in a specified timeslot.

9.2.8 Void

9.2.9 SIR

This measure is mandatory for UE with TDD mode capability.

Measurement	SIR
Source	L1(UE)
Destination	RRC (UE,RNC)
Reporting Trigger	Periodic, once every power control cycle , event triggered
Description	Signal to Interference Ratio

9.2.10 UTRA carrier RSSI

This measure is mandatory for UE.

Measurement	UTRA carrier RSSI
Source	L1(UE)
Destination	RRC (RNC)
Reporting Trigger	Periodic, event triggered, on demand
Description	Received Signal Strength Indicator, the wideband received power within the relevant channel bandwidth. For TDD this is measured in specified timeslots.

9.2.11 GSM carrier RSSI

This measure is mandatory for UE with GSM capability.

Measurement	GSM carrier RSSI
Source	L1(UE)
Destination	RRC (RNC)
Reporting Trigger	Periodic, event triggered, on demand
Description	Received Signal Strength Indicator, the wide-band received power within the relevant channel bandwidth. Details are specified in the GSM specification 05.08

9.2.12 Transport channel BLER

This measure is mandatory for UE.

Measurement	Transport channel BLER (Block Error Rate)
Source	L1(UE)
Destination	RRC (RNC,UE)
Reporting Trigger	Periodic, on demand
Description	Estimation of the transport channel block error rate (BLER).

9.2.13 UE transmitted power

This measure is mandatory for UE.

Measurement	UE transmitted power
Source	L1(UE)
Destination	RRC (UE,RNC)
Reporting Trigger	On-demand, periodic, Event-triggered
Description	Total transmitted power on one carrier. For TDD this is measured in specified timeslots.

9.2.14 UE Rx-Tx time difference

This measure is mandatory for UE with FDD mode capability.

Measurement	UE Rx-Tx time difference
Source	L1 (UE)
Destination	RRC (RNC)
Reporting Trigger	On-demand, periodic, event-triggered
Description	Time difference between the UE uplink DPCCH/DPDCH frame transmission and the first detected path (in time) of the downlink DPCH frame from the measured radio link. Type 1 and Type 2 are defined.

9.2.15 SFN-SFN Observed time difference

This measure is mandatory for UE.

Measurement	SFN-SFN observed time difference
Source	L1 (UE)
Destination	RRC (RNC)
Reporting Trigger	On-demand, Event-triggered
Description	Time difference between a specific reference UTRA cell and a target UTRA cell. Type 1 and Type 2 are defined.

9.2.16 UE GPS Timing of Cell Frames for UE positioning

This measure is mandatory for UE that has the capability to measure GPS reference time.

Measurement	UE GPS Timing of Cell Frames for UE positioning
Source	L1 (UE)
Destination	RRC (RNC-UE positioning)
Reporting Trigger	On-demand, Event-triggered, Periodic
Description	The timing between UTRA cell and GPS Time Of Week.

9.3 UTRAN Measurements

9.3.1 Received total wide band power

Measurement	Received total wide band power
Source	L1 (Node B)
Destination	RRC(RNC)
Reporting Trigger	On-demand, Event-triggered, Periodic
Description	The received wide band power including noise generated in the receiver, within the bandwidth defined by the pulse shaping filter. For TDD mode, this is measured in specified timeslots.

9.3.2 Transmitted carrier power

Measurement	Transmitted carrier power
Source	L1(Node B)
Destination	RRC (RNC)
Reporting Trigger	On-demand, periodic, Event-triggered
Description	Transmitted carrier power is the ratio between the total transmitted power on one DL carrier from one UTRAN access point, compared to the maximum power possible to use on that DL carrier at this moment of time. For TDD mode, this is measured in specified timeslots.

9.3.3 Transmitted code power

Measurement	Transmitted code power
Source	L1(Node B)
Destination	RRC (RNC)
Reporting Trigger	On-demand, periodic, Event-triggered
Description	Transmitted Code Power is the transmitted power on one carrier, one scrambling and one channelisation code. For TDD mode, this is measured in specified timeslots.

9.3.4 Void

9.3.5 Physical channel BER

Measurement	Physical channel BER
Source	L1(Node B)
Destination	RRC (RNC)
Reporting Trigger	On-demand, Event-triggered, periodic
Description	The Physical channel BER is an estimation of the average bit error rate (BER) on the DPCCCH of a Radio Link Set. This measurement applies to FDD mode only.

9.3.6 Transport channel BER

Measurement	Transport channel BER
Source	L1(Node B)
Destination	RRC (RNC)
Reporting Trigger	On-demand, Event-triggered, periodic
Description	The transport channel BER is an estimation of the average bit error rate (BER) data part.

9.3.7 RX timing deviation

Measurement	RX timing deviation
Source	L1 (Node B)
Destination	RRC (RNC)
Reporting Trigger	Periodic, event triggered
Description	The difference of the time of arrival of the UL transmissions in relation to the arrival time of a signal with zero propagation delay. This measurement is applicable for TDD mode.

9.3.8 Timeslot ISCP

Measurement	Timeslot ISCP
Source	L1(Node B)
Destination	RRC (RNC)
Reporting Trigger	periodic or event triggered
Description	Interference on Signal Code Power, is the interference on the received signal in a specified timeslot. This measurement is applicable is applicable to TDD mode only.

9.3.9 RSCP

Measurement	RSCP
Source	L1(Node B)
Destination	RRC (RNC)
Reporting Trigger	periodic or event triggered
Description	Received Signal Code Power is the received power on DPCH or PRACH or PUSCH. This measurement is applicable for TDD mode only.

9.3.10 Round Trip Time

Measurement	Round Trip Time
Source	L1(Node B or LMU)
Destination	RRC (RNC-UE positioning)
Reporting Trigger	on demand, event triggered
Description	This is an estimate of the round trip time of signals between the Node B and the UE This measurement is applicable for FDD mode only.

9.3.11 Void

9.3.12 Acknowledged PRACH preambles

Measurement	Acknowledged PRACH preambles
Source	L1(Node B)
Destination	RRC (RNC)
Reporting Trigger	Periodic, event triggered, On demand
Description	This measurement indicates the number of positive acquisition indicators transmitted per access frame on each AICH. This measurement is applicable for FDD mode only.

9.3.13 Detected PCPCH access preambles

Measurement	Detected PCPCH Access preambles
Source	L1(Node B)
Destination	RRC (RNC)
Reporting Trigger	Periodic, event triggered, On demand
Description	This measurement indicates the total number of detected access preambles per access frame on the PCPCHs belonging to a CPCH set. This measurement is applicable for FDD mode only.

9.3.14 Acknowledged PCPCH access preambles

Measurement	Acknowledged PCPCH access preambles
Source	L1(Node B)
Destination	RRC (RNC)
Reporting Trigger	Periodic, event triggered, On demand
Description	This measurement indicates the total number of acknowledged PCPCH access preambles per access frame on the PCPCHs. where an access frame consists of fifteen access slots from access slot #0 to access slot #14. This measurement is applicable for FDD mode only.

9.3.15 SIR

Measurement	SIR
Source	L1(Node B)
Destination	RRC (RNC)
Reporting Trigger	Periodic, event triggered
Description	Signal to Interference Ratio.

9.3.16 PRACH/PCPCH Propagation Delay

Measurement	Propagation delay
Source	L1 (Node B)
Destination	RRC (RNC)
Reporting Trigger	Event triggered, periodic
Description	The one-way propagation delay as measured during either PRACH or PCPCH access. This measurement is applicable for FDD mode only.

9.3.17 UTRAN GPS Timing of Cell Frames for UE positioning

Measurement	UTRAN GPS Timing of Cell Frames for UE positioning
Source	L1 (LMU)
Destination	RRC (RNC-UE positioning)
Reporting Trigger	On-demand, Event-triggered, Periodic
Description	This is the absolute time reference measurement in respect to GPS Time Of Week for the transmission of a particular frame.

9.3.18 SIR ERROR

Measurement	SIR ERROR
Source	L1(Node B)
Destination	RRC (RNC)
Reporting Trigger	Periodic, event triggered
Description	Signal to Interference Ratio Error This measurement is applicable for FDD cells only.

9.3.19 Received SYNC_UL Timing Deviation

Measurement	Received SYNC_UL Timing Deviation
Source	L1 (Node B)
Destination	RRC (RNC)
Reporting Trigger	Event triggered
Definition	'Received SYNC_UL Timing Deviation' is the time difference $UpPCH_{POS} = UpPTS_{Rxpath} - UpPTS_{TS}$ Where $UpPTS_{Rxpath}$: time of the reception in the Node B of the SYNC_UL to be used in the uplink synchronization process $UpPTS_{TS}$: time instance two symbols prior to the end of the DwPCH according to the Node B internal timing

9.3.20 Cell Sync Burst Timing

Measurement	Cell Sync Burst Timing
Source	L1(Node B)
Destination	RRC (RNC)
Reporting Trigger	Periodic, event triggered
Definition	Cell sync burst timing is the time of start (defined by the first detected path in time) of the cell sync burst of a neighbouring cell. Type 1 is used for the initial phase of Node B synchronization. Type 2 is used for the steady-state phase of Node B synchronization.

9.3.21 Cell Sync Burst SIR

Measurement	Cell Sync Burst SIR
Source	L1(Node B)
Destination	RRC (RNC)
Reporting Trigger	Periodic, event triggered
Definition	Signal to Interference Ratio for the cell sync burst, defined as: $RSCP/Interference$, where:

10 Primitives of the physical layer

The Physical layer interacts with other entities as illustrated in figure 1. The interactions with the MAC layer and the RRC layer are shown in terms of primitives where the primitives represent the logical exchange of information and control between the physical layer and higher layers. They do not specify or constrain implementations. The (adjacent) layers connect to each other through Service Access Points (SAPs). Primitives, therefore, are the conveyers of the information exchange and control through SAPs.

Three types of primitives are used for the present document, as follows.

- **REQUEST:**
 - This type is used when a higher layer is requesting a service from a lower layer.
- **INDICATION:**
 - This type is used by a lower layer providing a service to notify its higher layer of activities concerning that higher layer.
- **CONFIRM:**
 - This type is used by a lower layer providing the requested service to confirm to the higher layer that the activity has been completed.

The primitives defined below are for local communications between MAC and L1, as well as RRC and L1 in the same protocol stack.

For the physical layer two sets of primitives are defined:

- **Primitives between layer 1 and 2:**
 - PHY - Generic name - Type: Parameters.
- **Primitives between layer 1 and the RRC entity:**
 - CPHY - Generic name - Type: Parameters.

NOTE: This is a logical description of the primitives and does not cover addressing aspects (e.g. Transport Channel ID, Physical Channel ID, start frame number or disconnect frame number).

10.1 Generic names of primitives between layers 1 and 2

The primitives between layer 1 and layer 2 are shown in table 7.

Table 7: Primitives between layer 1 and 2

Generic Name	Parameters
PHY-ACCESS-REQ	transport format subset (NOTE 1)
PHY-ACCESS-CNF	Access Information (NOTE 1)
PHY-DATA-REQ	TFI, TBS
PHY-DATA-IND	TFI, TBS, CRC result, TD (NOTE 2)
PHY-CPCH_STATUS-REQ	transport format subset
PHY-CPCH_STATUS-CNF	transport format subset
PHY-STATUS-IND	Event value

NOTE 1: FDD only

NOTE 2: TDD only.

10.1.1 PHY-Access-REQ

The PHY-ACCESS-REQ primitive is used to request access to either a RACH or a CPCH transport channel from the physical layer. A PHY-ACCESS primitive is submitted once before the actual data for peer-to-peer communication is passed to the physical layer using the PHY-Data primitive. This primitive is used in FDD only.

Primitive Type: request.

Parameters:

- Transport Format subset.

10.1.2 PHY-Access-CNF

The PHY-ACCESS-CNF primitive is used to confirm that physical layer synchronisation has been established and that the physical layer is ready for data transmission using the PHY-Data primitive. This primitive is used in FDD only.

Primitive Type: confirm.

Parameters:

- access information.

10.1.3 PHY-Data-REQ

The PHY-DATA primitives are used to request SDUs used for communications passed to and from the physical layer. One PHY-DATA primitive is submitted every Transmission Time Interval for each Transport Channel.

Primitive Type: request.

Parameters:

- TFI;
- Transport Block Set;
- FN_{CELL} ;
- Page indicators (PIs) (PCH only).

- ASC selected for that Transport Block Set (RACH only)

10.1.4 PHY- Data-IND

The PHY-DATA primitives are used to indicate SDUs used for Layer 2 passed to and from the physical layer. One PHY-DATA primitive is submitted every Transmission Time Interval for each Transport Channel.

Primitive Type: indicate.

Parameters:

- TFI;
- Transport Block Set;
- CRC check result;
- TD (RX Timing Deviation measurement) (optional, TDD only).

10.1.5 PHY-CPCH_Status-REQ

The PHY-CPCH_STATUS-REQ primitive is used by MAC to request CPCH status information which is broadcast on CSICH. The parameter Transport Format subset allows to restrict the CPCH status information request to a limited number of CPCH channels of the given CPCH set.

Primitive Type: request.

Parameters:

- Transport Format subset.

10.1.6 PHY-CPCH_Status-CNF

The PHY-CPCH_STATUS-CNF primitive is used by L1 to indicate CPCH status information which is broadcast on CSICH. Status information is represented in terms of a Transport format subset which is permitted to be employed by the UE.

Primitive Type: Confirm

Parameters:

- Transport Format subset

10.1.7 PHY-Status-IND

The PHY-Status-IND primitive can be used by the layer 1 to notify higher layers of an event that has occurred.

Primitive Type: indication

Parameters:

- Event value:
 - CPCH Emergency stop was completed;
 - CPCH Start of Message Indicator was received;
 - CPCH Start of Message Indicator was not received;
 - L1 hardware failure has occurred.
 - CPCH End of Transmission was received

10.2 Generic names of primitives between layers 1 and 3

The status primitives between layer 1 and 3 are shown in table 8.

Table 8: Status primitives between layer 1 and 3

Generic Name	Parameters
CPHY-Sync-IND	none
CPHY-Out-of-Sync-IND	none
CPHY-Measurement-REQ	Measurement parameters
CPHY-Measurement-IND	Measurement parameters
CPHY-ERROR-IND	Error Code
CPHY-CPCH-EOT-IND	none

10.2.1 STATUS PRIMITIVES

10.2.1.1 CPHY-Sync-IND

This primitive is used for L1 to indicate to RRC that synchronisation of a certain physical channel has been done in the receiver. In FDD synchronisation is based on reception of the DPCCH, and in TDD synchronisation is based on Special Burst, TB reception, and burst quality estimation.

Primitive Type: indication.

Parameters:

- CCTrCH ID (TDD only).

10.2.1.2 CPHY-Out-of-Sync-IND

Primitive sent from L1 to RRC indicating that synchronisation of a previously configured connection has been lost in the receiver. In FDD synchronisation is based on reception of the DPCCH, and in TDD synchronisation is based on Special Burst, TB reception, and burst quality estimation.

Primitive Type: indication.

Parameters:

- CCTrCH ID (TDD only).

10.2.1.3 CPHY-Measurement-REQ

The Request primitive is used for RRC to configure L1 measurements.

Primitive Type: request.

Parameters:

- transmission power threshold;
- refer to clause 9 for measurement parameters.

10.2.1.4 CPHY-Measurement-IND

The Indication primitive is used to report the measurement results.

Primitive Type: indication.

Parameters:

- refer to clause 9 for measurement parameters.

10.2.1.5 CPHY-ERROR-IND

The CPHY-ERROR primitive is used to indicate to the management entity that an error has occurred as a result of a physical layer fault.

Primitive Type: indication.

Parameters:

- error code.

10.2.1.6 CPHY-CPCH-EOT-IND

The CPHY-CPCH-EOT-IND primitive is used by L1 to indicate RRC of an end of CPCH transmission event has occurred.

Primitive Type: indication.

Parameters:

- none.

10.2.2 CONTROL PRIMITIVES

The control primitives between layer 1 and 3 are shown in table 9.

Table 9: Control primitives between layer 1 and 3

Generic Name	Parameters
CPHY-TrCH-Config-REQ	Transport channel description,
CPHY-TrCH-Config-CNF	
CPHY-TrCH_Release-REQ	
CPHY-TrCH_Release-CNF	
CPHY-RL-Setup-REQ	Physical channel description
CPHY-RL-Setup-CNF	none
CPHY-RL-Release-REQ	none
CPHY-RL-Release-CNF	none
CPHY-RL-Modify-REQ	Physical channel description
CPHY-RL-Modify-CNF	none
CPHY-Commit-REQ	Activation Time
CPHY-CPCH-Estop-IND	none
CPHY-CPCH-Estop-Resp	none
CPHY-CPCH-Estop-REQ	none
CPHY-CPCH-Estop-CNF	none
CPHY-Out-of-Sync-Config-REQ	Out of sync detection parameters
CPHY-Out-of-Sync-Config-CNF	none

10.2.2.1 CPHY-TrCH-Config-REQ

This primitive is used for setting up and configuring a transport channel, and also to modify an existing transport channel.

Primitive Type: request.

Parameters:

- transport channel description.

10.2.2.2 CPHY-TrCH-Config-CNF

This primitive is used for confirming the setting up and configuring a transport channel, and also modifying an existing transport channel.

Primitive Type: confirm.

Parameters:

- none.

10.2.2.3 CPHY-TrCH-Release-REQ

This primitive is used for releasing a transport channel.

Primitive Type: request.

Parameters:

- none.

10.2.2.4 CPHY-TrCH-Release-CNF

This primitive is used for confirming the releasing a transport channel.

Primitive Type: confirm.

Parameters:

- none.

10.2.2.5 CPHY-RL-Setup-REQ

The Request primitive is sent from RRC to L1 for establishment of a Radio link to a certain UE.

Primitive Type: request.

Parameters:

- physical channel description.

10.2.2.6 CPHY-RL-Setup-CNF

The Confirm primitive is returned from L1 to RRC when the Radio link is established. In case L1 is unable to execute the request, this is indicated in the confirm primitive.

Primitive Type: confirm.

Parameters:

- none.

10.2.2.7 CPHY-RL-Release-REQ

The Request primitive is sent from RRC to L1 for release of a Radio link to a certain UE.

Primitive Type: request.

Parameters:

- none.

10.2.2.8 CPHY-RL-Release-CNF

The Confirm primitive is returned from L1 to RRC when the radio link is released.

Primitive Type: confirm.

Parameters:

- none.

10.2.2.9 CPHY- RL-Modify-REQ

The Request primitive is sent from RRC to L1 for modification of a Radio link to a certain UE.

Primitive Type: request.

Parameters:

- physical channel description.

10.2.2.10 CPHY-RL-Modify-CNF

The Confirm primitive is returned from L1 to RRC when the radio link is modified. In case L1 is unable to execute the request, this is indicated in the confirm primitive.

Primitive Type: confirm.

Parameters:

- none.

10.2.2.11 CPHY-Commit-REQ

This primitive is sent from RRC to L1 to synchronise UE and NW for the physical channel modification.

Primitive Type: request.

Parameters:

- activation time.

10.2.2.12 CPHY-CPCH-Estop-IND

The CPHY-CPCH-Estop-IND primitive is used by L1 to notify RRC of a CPCH emergency stop message has been received.

Primitive Type: indication.

Parameters:

- none.

10.2.2.13 CPHY-CPCH-Estop-Resp

This primitive is sent from UE RRC to L1 for emergency stop of the CPCH transmission. After receiving this primitive, UE L1 stopping its transmission on the related CPCH.

Primitive Type: response.

Parameters:

- none.

10.2.2.14 CPHY-CPCH-Estop-REQ

This primitive is sent from RRC to L1 for CPCH Emergency Stop. This primitive is sent for triggering of a CPCH emergency stop. After receiving this primitive, Node B L1 sends CPCH Estop Command to UE. This CPCH Estop Command is all 1 bits pattern in the CCC field of DL DPCCH for CPCH.

Primitive Type: request.

Parameters:

- none.

10.2.2.15 CPHY-CPCH-Estop-CNF

This primitive is sent from Node B L1 to RRC for confirming the emergency stop of the CPCH.

Primitive Type: confirm.

Parameters:

- none.

10.2.2.16 CPHY-Out-of-Sync-Config-REQ

This primitive is sent from RRC to Node B L1 to reconfigure the parameters to detect "in sync" and "out of sync" conditions of uplink physical channel transmission.

Primitive Type: request.

Parameters:

- Out of Sync detection parameters

10.2.2.17 CPHY-Out-of-Sync-Config-CNF

This primitive is sent from Node B L1 to RRC for confirming the Reconfiguration of the Out-of-Sync parameters on Node B L1.

Primitive Type: confirm.

Parameters:

- none.

10.3 Parameter definition

10.3.1 Error code

- Hardware failure.

10.3.2 Event value

- Maximum transmission power has been reached.
- Allowable transmission power has been reached.
- Average transmission power is below allowable transmission power.
- Loss of DL DPCH.
- Completion of CPCH Emergency stop.
- CPCH Start of Message Indicator was received.
- CPCH Start of Message Indicator was not received.
- Maximum number of frames for CPCH transmission has been reached.
- End of Frame for CPCH transmission has been received.

10.3.3 Access Information

- Ready for RACH data transmission (in case of FDD mode: when Ack on AICH has been received, in case of 1.28 Mcps TDD: when Ack on FPACH has been received);
- timeout, no response on AICH (FDD only) or AP-AICH (FDD only) or FPACH (1.28 Mcps TDD only) has been received while maximum number of access preamble transmissions (FDD only) /synchronisation attempts (1.28 Mcps TDD only) has been performed.

The following values of this parameter apply to FDD only:

- NACK on AICH or AP-AICH has been received;
- ready for CPCH data transmission (CD or CD/CA information received on CD/CA-ICH);
- mismatch of CD/CA-ICH signatures;
- no response on CD/CA-ICH received;
- timeout, no CD/CA-ICH received.

10.3.4 Transport Format Subset

- A subset of the Transport Format set of a Transport Channel.

10.3.5 Physical channel description

10.3.5.1 Primary SCH

- Tx diversity mode.

10.3.5.2 Secondary SCH

- Tx diversity mode.

10.3.5.3 Primary CCPCH

- Frequency info.
- DL scrambling code.
- Tx diversity mode.

- Timeslot (TDD only).
- Burst type (3.84 Mcps TDD only).
- Offset (TDD only).
- Repetition period (TDD only).
- Repetition length (TDD only).

10.3.5.4 Secondary CCPCH

- DL scrambling code.
- Channelisation code.
- Tx diversity mode.
- Timeslot (TDD only).
- Burst type (3.84 Mcps TDD only).
- Midamble shift (TDD only).
- Offset (TDD only).
- Repetition period (TDD only).
- Repetition length (TDD only).
- TFCI presence (TDD only).

10.3.5.5 PRACH

- Access Slot (FDD only).
- Preamble scrambling code (FDD only).
- Available preamble signatures (FDD only).
- Spreading factor for data part.
- Power control info:
 - UL target SIR;
 - primary CCPCH DL TX Power;
 - UL interference;
 - power offset (Power ramping) (FDD only).
- Access Service Class Information (PRACH Partitioning):
 - Available signatures for each ASC (FDD only).
 - Available Channelisation codes for each ASC (TDD only).
 - Available Subchannels for each ASC.
- AICH transmission timing parameter (FDD only).
- Timeslots (TDD only).
- Available Channelisation Codes (TDD only)
- Spreading Factor (TDD only).

- Midamble Type (TDD only).

10.3.5.6 Uplink DPDCH+DPCCH

- UL scrambling code.
- DPCCH slot structure (N_{pilot} , N_{TPC} , N_{TFCI} , N_{FBI}).
- Transmission Time offset value.

10.3.5.7 Uplink DPCH

- Timing Advance (TDD only).
- DPCH channelisation code (TDD only).
- Burst Type (3.84 Mcps TDD only).
- DPCH midamble shift (TDD only).
- Timeslot (TDD only).
- Offset (TDD only).
- Repetition Period (TDD only).
- Repetition length (TDD only).
- TFCI presence (TDD only).

10.3.5.8 Downlink DPCH

- Transmission Time offset value.
- DL scrambling code:
 - DL Channelisation code.
- Tx diversity mode:
 - FB mode (FDD only).
- Slot structure (N_{pilot} , N_{TPC} , N_{TFCI} , N_{FBI} , N_{data1} , N_{data2}) (FDD only).
- Special slot structure only for CPCH (N_{pilot} , N_{TPC} , N_{TFCI} , N_{CCC}) (FDD only)
- Burst Type (3.84 Mcps TDD only).
- DPCH midamble shift (TDD only).
- Timeslot (TDD only).
- Offset (TDD only).
- Repetition period (TDD only).
- Repetition length (TDD only).
- TFCI presence (TDD only).

10.3.5.9 PCPCH (Physical Common Packet Channel)

- CPCH Set ID to which this PCPCH belongs.
- Parameters related to the AP preamble:

- Access Preamble (AP) scrambling code;
- available AP signatures/subchannels for access request;
- Parameters related to the CD preamble:
 - CD preamble scrambling code;
 - available CD signatures/subchannels;
- Parameters related to PCPCH message part:
 - PCPCH scrambling code;
 - PCPCH Channelisation code;
 - data rate (spreading factor);
 - N_frames_max: Maximum length of CPCH message in radio frames.

10.3.5.10 PICH

- Scrambling code.
- Channelisation code.
- Timeslot (TDD only).
- Burst Type (3.84 Mcps TDD only).
- Midamble shift (TDD only).
- Offset (TDD only).
- Repetition period (TDD only).
- Repetition length (TDD only).

10.3.5.11 AICH

- Scrambling code.
- Channelisation code.
- Tx diversity mode.

NOTE: The value for the parameters needs to be consistent with the corresponding PRACH.

10.3.5.12 AP-AICH

- CPCH Set ID.
- Scrambling code.
- Channelisation code.
- Tx diversity mode.

10.3.5.13 CD-ICH

- CPCH Set ID.
- Scrambling code.
- Channelisation code.

- Tx diversity mode.

NOTE: This physical channel is used in conjunction with PCPCH when UE Channel Selection is active.

10.3.5.14 CD/CA-ICH

- CPCH Set ID.
- Scrambling code.
- Channelisation code.
- Tx diversity mode.

NOTE: This physical channel is used in conjunction with PCPCH when Channel Assignment is active.

10.3.5.15 CSICH

- CPCH Set ID.
- Scrambling code.
- Channelisation code.
- Tx diversity mode.

NOTE: The values for the parameters need to be consistent with the AP-AICH which is time-multiplexed with this CSICH.

10.3.5.16 PDSCH

- Scrambling code.
- Channelisation code.
- Tx diversity mode:
 - FB mode (FDD only).
- DL channelisation code (TDD only).
- Burst Type (3.84 Mcps TDD only).
- PDSCH Midamble shift (TDD only).
- Timeslot (TDD only).
- Offset (TDD only).
- Repetition period (TDD only).
- Repetition length (TDD only).
- TFCI presence (TDD only).

10.3.5.17 PUSCH

- PUSCH channelisation code.
- Burst Type (3.84 Mcps TDD only).
- PUSCH midamble shift (TDD only).
- Timeslot (TDD only).
- Offset (TDD only).

- Repetition period (TDD only).
- Repetition length (TDD only).
- TFCI presence (TDD only).
- Timing Advance (TDD only).

10.3.5.18 DwPCH (1.28 Mcps TDD only)

- Tx diversity mode.
- SYNC_DL code ID.

10.3.5.19 UpPCH (1.28 Mcps TDD only)

- SYNC_UL code ID.

10.3.5.20 FPACH (1.28 Mcps TDD only)

- Scrambling code
- Channelisation code
- Timeslot
- Midamble shift
- Tx diversity mode.

10.3.5.21 PNBSCH (Physical Node B Synchronisation channel)

- Node B - Node B over the air communication.
- Only for TDD cells.
- Repetition period.
- Concatenated periodically Extended Complementary sequences.

11 Transport block transmission

Data exchange between MAC and the physical layer, is defined in terms of Transport Block Sets (TBS). On a Transport Channel, one Transport Block Set can be transmitted for every Transmission Time Interval. A TBS consists of one or several Transport Blocks which shall be numbered $1, \dots, m, \dots, M$ and is delivered in the order of the index m . A Transport Block is identical with a MAC PDU. A Transport Block (MAC PDU) is a bit string ordered from first to last, where the first and last bits are numbered 1 and A , respectively, where A is the number of bits of the Transport Block. In case of Transport Block size=0 bit, only parity bits are sent and $A=0$.

The bits of the m th Transport Block in a TBS, are denoted as a_{im1}, \dots, a_{imA} for a Transport Channel identified by an index i (cf. [3] and [4]).

Annex A (normative): Description of Transport Formats

The following table describes the characterisation of a Transport Format.

Table A.1: Characterisation of Transport Format

		Attribute values	BCH	PCH	FACH	RACH
Dynamic part	Transport Block Size	0 to 5 000 1 bit granularity	246	1 to 5000 1 bit granularity	0 to 5 000 1 bit granularity	0 to 5 000 1 bit granularity
	Transport Block Set Size	0 to 200 000 1 bit granularity	246	1 to 200 000 1 bit granularity	0 to 200 000 1 bit granularity	0 to 200 000 1 bit granularity
	Transmission Time Interval (option for TDD only)	10, 20 ms, 40 and 80 ms				
Semi-static part	Transmission Time Interval (FDD, option for TDD NRT bearers)	10, 20 ms, 40 and 80 ms	20 ms	10ms for FDD, 20ms for TDD	10, 20 ms, 40 and 80 ms	10 ms and 20 ms for FDD, 10 ms for TDD
	Type of channel coding	No Coding Turbo coding Convolutional coding	Convolutional coding	Convolutional coding	No coding Turbo coding Convolutional coding	Convolutional coding
	code rates	1/2, 1/3	1/2	1/2	1/2, 1/3	1/2
	CRC size	0, 8, 12, 16, 24	16	0, 8, 12, 16, 24	0, 8, 12, 16, 24	0, 8, 12, 16, 24
	Resulting ratio after static rate matching	0,5 to 4				

		Attribute values	CPCH	DCH	DSCH	USCH
Dynamic part	Transport Block Size	0 to 5 000 1 bit granularity	0 to 5 000 1 bit granularity	0 to 5 000 1 bit granularity	0 to 5 000 1 bit granularity	0 to 5 000 1 bit granularity
	Transport Block Set Size	0 to 200 000 1 bit granularity	0 to 200 000 1 bit granularity	0 to 200 000 1 bit granularity	0 to 200 000 1 bit granularity	0 to 200 000 1 bit granularity
	Transmission Time Interval (option for TDD only)	10, 20 ms, 40 and 80 ms		10, 20 ms, 40 and 80 ms	10, 20 ms, 40 and 80 ms	10, 20 ms, 40 and 80 ms
Semi-static part	Transmission Time Interval (FDD, option for TDD NRT bearers)	10, 20 ms, 40 and 80 ms		10, 20 ms, 40 and 80 ms	10, 20 ms, 40 and 80 ms	10, 20 ms, 40 and 80 ms
	Type of channel coding	No coding Turbo coding Convolutional coding	No coding Turbo coding Convolutional coding	No coding Turbo coding Convolutional coding	No coding Turbo coding Convolutional coding	No coding Turbo coding Convolutional coding
	code rates (in case of convolutional coding)	1/2, 1/3	1/2, 1/3	1/2, 1/3	1/2, 1/3	1/2, 1/3
	CRC size	0, 8, 12, 16, 24		0, 8, 12, 16, 24	0, 8, 12, 16, 24	0, 8, 12, 16, 24
	Resulting ratio after static rate matching	0,5 to 4				

NOTE 1: The maximum size of the Transport Block has been chosen so as to avoid any need for segmentation in the physical layer into sub-blocks (segmentation should be avoided in the physical layer).

NOTE 2: Code rate is fixed to 1/3 in case of Turbo coding.

NOTE 3: All channels using the same resources as the BCH (i.e. the same timeslot and code, e.g. in a multiframe pattern) have to use different Transport Formats than the BCH to allow the identification of the BCH channel by physical layer parameters. Due to the differing parameters, decoding of other transport channels than BCH will result in an erroneous CRC.

Annex B (informative): Example of Transport format attributes for AMR speech codec

The support for the AMR speech codec is exemplified below. On the radio interface, one Transport Channel is established per class of bits i.e. DCH A for class A, DCH B for class B and DCH C for class C. Each DCH has a different transport format combination set which corresponds to the necessary protection for the corresponding class of bits as well as the size of these class of bits for the various AMR codec modes.

With this principle, the AMR codec mode which is used during a given TTI can be deduced from the format of the transport channels DCH A, DCH B and DCH C for that particular TTI.

Note that a similar principle can also be applied for other source codecs e.g. other speech codecs or video codecs.

An example of transport channel description for each class of bits is given in table B.1.

Table B.1

	Attribute	Value		
		Class A	Class B	Class C
Dynamic part	Transport Block Size	81	103	60
		65	99	40
		75	84	0
		61	87	0
		58	76	0
		55	63	0
		49	54	0
		42	53	0
		39	0	0
	Transport Block Set Size	Same as the transport block sizes		
Semi-static part	Transmission Time Interval	20 ms		
	Type of channel coding	Convolutional coding		
	code rates	1/2, 1/3 + class-specific rate matching	None, 1/2, 1/3 + class-specific rate matching	None, 1/2 , 1/3 + class-specific rate matching
	CRC size	8	0	0
	Resulting ratio after static rate matching	0.5 to 4 (with no coding the rate matching ratio needs to be >1)		

Annex C (informative): Change history

Change history							
Date	TSG #	TSG Doc.	CR	Rev	Subject/Comment	Old	New
08/1999	RP-04	RP-99309	-		Approved after TSG-RAN #4 and TSG-RAN WG2 #6 (08/1999) by correspondence and placed under Change Control	-	3.0.0
10/1999	RP-05	RP-99461	001		Making all transport block equally sized within a transport block set	3.0.0	3.1.0
	RP-05	RP-99461	002	1	UE Simultaneous Physical Channel Combinations in TDD Mode	3.0.0	3.1.0
	RP-05	RP-99461	004		Timing advance (TDD only)	3.0.0	3.1.0
	RP-05	RP-99461	005		Measurements for TDD provided by physical layer	3.0.0	3.1.0
	RP-05	RP-99461	006		Change of the Downlink model of the UE in relation to PCH	3.0.0	3.1.0
	RP-05	RP-99461	007		Physical channel description for TDD	3.0.0	3.1.0
	RP-05	RP-99461	008		Attributes of the semi-static part and coding terminology	3.0.0	3.1.0
	RP-05	RP-99461	009		Editorial changes following LS received from WG1	3.0.0	3.1.0
	RP-05	RP-99461	010		Support of Uplink Synchronization Feature in UL channels (TDD only)	3.0.0	3.1.0
	RP-05	RP-99461	011		Simultaneous reception of AICH and S-CCPCH	3.0.0	3.1.0
	RP-05	RP-99461	012		Removal of Measurement Precision Requirements	3.0.0	3.1.0
	RP-05	RP-99461	013		Compressed mode	3.0.0	3.1.0
	RP-05	RP-99461	014		Change of the model of the UE with respect to shared channel multiplexing	3.0.0	3.1.0
12/1999	RP-06	RP-99624	015		Alignment of measurement names with RAN	3.1.0	3.2.0
	RP-06	RP-99623	018		Compressed Mode description	3.1.0	3.2.0
	RP-06	RP-99624	022		Alignment with TDD layer 1	3.1.0	3.2.0
	RP-06	RP-99624	023	1	Physical Channel Parameters	3.1.0	3.2.0
	RP-06	RP-99624	025		Addition of PICH and Corrections for Primary	3.1.0	3.2.0
	RP-06	RP-99624	026		Removal of compressed mode inband signalling	3.1.0	3.2.0
	RP-06	RP-99624	028	1	Measurement of Transmitted carrier power	3.1.0	3.2.0
	RP-06	RP-99623	030	1	Editorial issues	3.1.0	3.2.0
	RP-06	RP-99624	031		Measurement of Physical Channel BER	3.1.0	3.2.0
01/2000	-	-	-		E-mail approval by TSG-RAN WG2 of different implementation of CR 015 and CR 028 according to authors' intentions	3.2.0	3.3.0
03/2000	RP-07	RP-000035	032	2	Revision of CPCH model	3.3.0	3.4.0
	RP-07	RP-000035	033	1	Error Correction Coding for FACH	3.3.0	3.4.0
	RP-07	RP-000035	034	3	Revision of compressed mode description	3.3.0	3.4.0
	RP-07	RP-000035	036		TrBLK size	3.3.0	3.4.0
	RP-07	RP-000035	037		PDSCCH multi-code	3.3.0	3.4.0
	RP-07	RP-000035	038	1	Primitives for CPCH Abnormal Situation Handling	3.3.0	3.4.0
	RP-07	RP-000035	039		Physical channel BER	3.3.0	3.4.0
	RP-07	RP-000035	041		Editorial modification on AMR trblk size	3.3.0	3.4.0
	RP-07	RP-000035	042	1	Corrections and clarifications on L1 and L2 functionality descriptions	3.3.0	3.4.0
	RP-07	RP-000035	043	1	Transport Block Transmission	3.3.0	3.4.0
	RP-07	RP-000035	044		Clarification to layer 1 model regarding transport blocks received by UE with CRC failure	3.3.0	3.4.0
	RP-07	RP-000035	045		Removal of SCH and SCCH	3.3.0	3.4.0
	RP-07	RP-000035	046		Replacement of Time of Arrival Measurement by RTT	3.3.0	3.4.0
	RP-07	RP-000035	047	1	Incorporation of Measurement filtering model	3.3.0	3.4.0
	RP-07	RP-000035	048		Separation of physical channel BER measurements	3.3.0	3.4.0
06/2000	RP-08	RP-000215	049	1	Maximum number of simultaneous compressed mode pattern sequences per measurement purpose	3.4.0	3.5.0
	RP-08	RP-000215	050	1	Removal of CPICH SIR measurement quantity	3.4.0	3.5.0
	RP-08	RP-000215	051		Measurements	3.4.0	3.5.0
	RP-08	RP-000215	052	1	End of CPCH transmission	3.4.0	3.5.0
	RP-08	RP-000215	053	1	Measurements of RACH and CPCH	3.4.0	3.5.0
	RP-08	RP-000215	056		Editorial modification on Transport Block Size	3.4.0	3.5.0
	RP-08	RP-000215	057	3	CPCH correction	3.4.0	3.5.0
	RP-08	RP-000215	058	1	SFN Transmission Rate and the Need to Maintain CFN in TDD Mode	3.4.0	3.5.0
	RP-08	RP-000215	059		Addition of out-of-sync-configuration control primitives	3.4.0	3.5.0
	RP-08	RP-000215	060		Addition of propagation delay measurement	3.4.0	3.5.0
	RP-08	RP-000215	061	2	Layer 1 LCS measurements	3.4.0	3.5.0
	RP-08	RP-000215	062	1	Refinement of the definition of a Transport Block	3.4.0	3.5.0
	RP-08	RP-000215	063	1	Corrections of CPCH Emergency stop and start of message Indicator	3.4.0	3.5.0
	RP-08	RP-000215	064		BLER	3.4.0	3.5.0
09/2000	RP-09	RP-000353	065		Filtering period in case of periodical reporting	3.5.0	3.6.0

Change history							
Date	TSG #	TSG Doc.	CR	Rev	Subject/Comment	Old	New
	RP-09	RP-000353	066		UE simultaneous Physical and Transport channel combinations for PDSCH and DSCH	3.5.0	3.6.0
	RP-09	RP-000353	067		Inclusion of SIR ERROR measurement	3.5.0	3.6.0
	RP-09	RP-000353	068	1	Simultaneous reception of PCCPCH and SCCPCH	3.5.0	3.6.0
	RP-09	RP-000353	070		Removal of puncturing limit from the transport format definition	3.5.0	3.6.0
	RP-09	RP-000353	071		Clarification of the Timeslot ISCP Measurements	3.5.0	3.6.0
12/2000	RP-10	RP-000563	072		RACH model	3.6.0	3.7.0
	RP-10	RP-000563	073		Clarification of UTRAN SIR measurement	3.6.0	3.7.0
	RP-10	RP-000563	074		Removal of compressed mode measurement purpose "other"	3.6.0	3.7.0
	RP-10	RP-000563	075		Removal of compressed mode measurement purpose "GSM"	3.6.0	3.7.0
	RP-10	RP-000563	076		Removal of physical channel BER measurement for TDD	3.6.0	3.7.0
	RP-10	RP-000563	077		CPCH model correction	3.6.0	3.7.0
	RP-10	RP-000563	078	1	Removal of FAUSCH and ODMA	3.6.0	3.7.0
	RP-10	RP-000563	080	2	Correction to transport channel mapping	3.6.0	3.7.0
	RP-10	RP-000563	081		Alignment of measurement reference description	3.6.0	3.7.0
	RP-10	RP-000563	082		Changing the name of "RSSI" to "Received total wide band power"	3.6.0	3.7.0
03/2001	RP-11	RP-010020	084	2	Additional physical channel combination for FDD downlink to allow COUNT-C-SFN difference measurement	3.7.0	3.8.0
	RP-11	RP-010020	087		In & Out of Sync Indications per CCTrCH in TDD	3.7.0	3.8.0
	RP-11	RP-010020	088		Correction & Clarification to TDD RACH Model and Primitives	3.7.0	3.8.0
	RP-11	RP-010020	089	1	Alignment of measurements provided by the physical layer	3.7.0	3.8.0
	RP-11	RP-010020	092	1	Physical channel combinations in TDD	3.7.0	3.8.0
	RP-11	RP-010020	094		Measurement model clarifications	3.7.0	3.8.0
	RP-11	RP-010020	095		Removal of DPCCH Gating from Release 99	3.7.0	3.8.0
	RP-11	RP-010020	096	1	Clarification of simultaneous operation of DRAC and CTCH	3.7.0	3.8.0
	RP-11	RP-010037	090	2	1.28Mcps TDD	3.8.0	4.0.0
	RP-11	RP-010041	093	1	Measurements for Node B synchronisation	3.8.0	4.0.0

History

Document history		
V4.0.0	March 2001	Publication