

# ETSI TS 125 304 V3.2.0 (2000-03)

---

*Technical Specification*

## **Universal Mobile Telecommunications System (UMTS); UE Procedures in Idle Mode and Procedures for Cell Reselection in Connected Mode (3G TS 25.304 version 3.2.0 Release 1999)**



---

**Reference**

RTS/TSGR-0225304UR1

---

**Keywords**

UMTS

**ETSI**

650 Route des Lucioles  
F-06921 Sophia Antipolis Cedex - FRANCE

---

Tel.: +33 4 92 94 42 00 Fax: +33 4 93 65 47 16

Siret N° 348 623 562 00017 - NAF 742 C  
Association à but non lucratif enregistrée à la  
Sous-Préfecture de Grasse (06) N° 7803/88

---

**Important notice**

---

Individual copies of the present document can be downloaded from:

<http://www.etsi.org>

The present document may be made available in more than one electronic version or in print. In any case of existing or perceived difference in contents between such versions, the reference version is the Portable Document Format (PDF).

In case of dispute, the reference shall be the printing on ETSI printers of the PDF version kept on a specific network drive within ETSI Secretariat.

Users of the present document should be aware that the document may be subject to revision or change of status.

Information on the current status of this and other ETSI documents is available at <http://www.etsi.org/tb/status/>

If you find errors in the present document, send your comment to:

editor@etsi.fr

---

**Copyright Notification**

---

No part may be reproduced except as authorized by written permission.  
The copyright and the foregoing restriction extend to reproduction in all media.

© European Telecommunications Standards Institute 2000.

All rights reserved.

---

## Intellectual Property Rights

IPRs essential or potentially essential to the present document may have been declared to ETSI. The information pertaining to these essential IPRs, if any, is publicly available for **ETSI members and non-members**, and can be found in SR 000 314: "*Intellectual Property Rights (IPRs); Essential, or potentially Essential, IPRs notified to ETSI in respect of ETSI standards*", which is available from the ETSI Secretariat. Latest updates are available on the ETSI Web server (<http://www.etsi.org/ipr>).

Pursuant to the ETSI IPR Policy, no investigation, including IPR searches, has been carried out by ETSI. No guarantee can be given as to the existence of other IPRs not referenced in SR 000 314 (or the updates on the ETSI Web server) which are, or may be, or may become, essential to the present document.

---

## Foreword

This Technical Specification (TS) has been produced by the ETSI 3<sup>rd</sup> Generation Partnership Project (3GPP).

The present document may refer to technical specifications or reports using their 3GPP identities, UMTS identities or GSM identities. These should be interpreted as being references to the corresponding ETSI deliverables.

The cross reference between GSM, UMTS, 3GPP and ETSI identities can be found under [www.etsi.org/key](http://www.etsi.org/key) .

# Contents

Foreword .....	5
1 Scope.....	6
2 References.....	6
3 Definitions, symbols and abbreviations .....	7
3.1 Definitions .....	7
3.2 Abbreviations.....	8
4 General description of Idle mode.....	8
4.1 Overview.....	8
4.2 Functional division between AS and NAS in Idle mode .....	10
4.3 Service type in Idle mode .....	11
5 Process descriptions .....	13
5.1 PLMN selection and reselection .....	13
5.2 Cell selection and reselection in idle mode.....	13
5.2.1 General .....	13
5.2.2 UTRA Radio access technology.....	17
5.2.2.1 Cell Selection Procedures .....	17
5.2.2.1.1 Description.....	17
5.2.2.1.2 Criteria .....	17
5.2.2.2 Immediate Cell Evaluation Procedure .....	18
5.2.2.2.1 Description.....	18
5.2.2.2.2 Criteria .....	18
5.2.2.3 Camped Normally.....	19
5.2.2.4 Cell Reselection Procedure.....	19
5.2.2.4.1 Triggers for cell re-selection .....	19
5.2.2.4.2 Measurements for cell re-selection when HCS is not used .....	19
5.2.2.4.3 Measurements for cell re-selection when HCS is used .....	20
5.2.2.4.4 Non-suitable cells with $S>0$ .....	20
5.2.2.4.5 Cell Reselection Criteria .....	20
5.2.2.4.6 Cell reselection parameters in system information broadcasts.....	22
5.2.2.5 Cell Selection when leaving connected mode .....	23
5.2.2.6 Any Cell Selection.....	24
5.2.2.7 Camped on Any Cell .....	24
5.2.2.8 Any Cell Reselection .....	24
5.2.2.9 ODMA probing sub-process.....	24
5.2.2.6.1 ODMA probing state machines.....	24
5.2.3 GSM Radio access technology.....	26
5.2.3.1 Cell Selection Procedures.....	26
5.2.3.2 Immediate Cell Evaluation Procedure .....	26
5.2.3.3 Cell Reselection Procedure.....	26
5.2.3.3.1 Description.....	26
5.2.3.3.2 Cell Reselection Criteria .....	26
5.2.3.3.3 Inter-Radio Access Technology Cell Reselection Procedure.....	26
5.2.3.3.4 Cell reselection parameters in system information broadcasts.....	27
5.2.3.4 Cell Selection when leaving connected mode .....	27
5.2.3.5 Any Cell Selection.....	27
5.2.3.6 Camped on Any Cell .....	27
5.2.3.7 Any Cell Reselection .....	27
5.2.4 Barred Cells and Access Control.....	27
5.2.5 Regional Provision of Service .....	28
5.3 Cell Reselection in Connected Mode.....	28
5.3.1 UTRA Radio Access Technology .....	28
5.3.1.1 General .....	28
5.3.1.2 Initial Cell Reselection Procedure .....	29
5.3.1.2.1 Description.....	29

5.3.1.2.2	Criteria .....	30
5.3.1.3	Immediate Cell Evaluation Procedure .....	30
5.3.1.3.1	Description.....	30
5.3.1.4	Cell Reselection Procedure.....	30
5.4	Location Registration.....	30
6	Broadcast information receiving.....	31
6.1	Reception of System Information .....	31
6.2	Cell Broadcast.....	31
7	Measurements for cell selection / reselection .....	31
7.1	Use of Mapping Functions.....	31
7.2	Network control of UE measurement activities .....	31
7.2.1	Intra-frequency cell measurements .....	31
7.2.2	Inter-frequency cell measurements .....	32
7.2.3	Inter-Radio Access Technology measurements .....	32
8	Discontinuous Reception .....	32
9	Multicast services .....	33
9.1	State diagram between the multicast service and DSCH .....	33
9.1.1	MT_Null State.....	34
9.1.2	MT_Monitor State.....	34
9.1.3	MT_Saving State.....	34
9.1.4	MT_Active State .....	35
10	Examples of Procedures.....	35
10.1	NAS initiated change of system information.....	35
10.2	System Information Update to NAS .....	36
10.3	CN originated paging in idle mode.....	37
10.4	PLMN Selection, automatic mode, normal case.....	38
10.5	PLMN Reselection, automatic mode .....	39
10.6	PLMN Reselection, manual mode .....	40
10.7	PLMN Selection, automatic mode, selected PLMN not found.....	41
10.8	NAS Controlled Cell Selection.....	42
10.8.1	Execution in Access Stratum.....	42
10.8.2	Execution in Non-Access Stratum .....	43
<b>Annex A (informative): Change history.....</b>		<b>44</b>

---

# Foreword

This Technical Specification (TS) has been produced by the 3<sup>rd</sup> Generation Partnership Project (3GPP).

The contents of the present document are subject to continuing work within the TSG and may change following formal TSG approval. Should the TSG modify the contents of the present document, it will be re-released by the TSG with an identifying change of release date and an increase in version number as follows:

Version x.y.z

where:

- x the first digit:
  - 1 presented to TSG for information;
  - 2 presented to TSG for approval;
  - 3 or greater indicates TSG approved document under change control.
- y the second digit is incremented for all changes of substance, i.e. technical enhancements, corrections, updates, etc.
- z the third digit is incremented when editorial only changes have been incorporated in the document.

---

# 1 Scope

The present document shall specify the overall idle mode process for the UE and the functional division between the non-access stratum and access stratum in the UE. The non-access stratum part is specified in [5] and the access stratum part in the present document. The UE is in idle mode when there is no RRC connection. In idle mode the UE is identified by non-access stratum identities such as IMSI, TMSI and P-TMSI. In addition, the UTRAN has no own information about the individual idle mode UEs, and can only address e.g. all UEs in a cell or all UEs monitoring a specific paging occasion.

The present document applies to UEs that support at least UTRA and possibly also other radio access technologies, for instance GSM.

In addition to the specification of the idle mode process, there is a specification of the cell selection and reselection procedures applicable to UEs in connected mode in some cases, which are specified in [4].

The present document presents also examples of inter-layer procedures related to the idle mode processes and describes idle mode functionality of a dual RAT UTRA/GSM UE.

Following items are considered for releases beyond Release 1999:

- 1) State diagram between the multicast service and DSCH (subclause 9.1);
- 2) ODMA probing sub-process (subclause 5.2.2.6).

Support for radio access technology priority list is not included in Release 1999.

---

# 2 References

The following documents contain provisions which, through reference in this text, constitute provisions of the present document.

- References are either specific (identified by date of publication, edition number, version number, etc.) or non-specific.
- For a specific reference, subsequent revisions do not apply.
- For a non-specific reference, the latest version applies.

- [1] GSM TS 03.22: "Functions related to Mobile Station in idle mode and group receive mode".
- [2] 3G TS 25.301: "Radio Interface Protocol Architecture".
- [3] 3G TS 25.303: "Interlayer Procedures in Connected Mode".
- [4] 3G TS 25.331: "RRC Protocol Specification".
- [5] 3G TS 23.022: "Functions related to MS in idle mode and group receive mode".
- [6] 3G TR 25.922: "Radio Resource Management Strategies".
- [7] 3G TS 25.211: "Physical channels and mapping of transport channels onto physical channels (FDD)".
- [8] 3G TS 25.221: "Physical channels and mapping of transport channels onto physical channels (TDD)".

## 3 Definitions, symbols and abbreviations

### 3.1 Definitions

For the purposes of the present document, the following terms and definitions apply.

**Acceptable Cell:** a cell that the UE may camp on to make emergency calls. It shall satisfy certain conditions.

**Allowable PLMN:** a PLMN, which is not in the list of forbidden PLMNs in the UE.

**Available PLMN:** a PLMN where the UE has found a cell that satisfies certain conditions.

**Camped on a cell:** UE is in idle mode and has completed the cell selection/reselection process and has chosen a cell. The UE monitors system information and (in most cases) paging information.

NOTE: The services may be limited, and that the PLMN may not be aware of the existence of the UE within the chosen cell.

**DRX cycle:** individual time interval between monitoring Paging Occasion for a specific UE.

**Home PLMN:** a PLMN where the Mobile Country Code (MCC) and Mobile Network Code (MNC) of the PLMN identity are the same as the MCC and MNC of the IMSI.

**Location Registration (LR):** UE registers its presence in a registration area, for instance regularly or when entering a new registration area.

**LSA:** Localised Service Area. A LSA is an operator-defined group of cells for which specific access conditions applies. This may correspond to an area in which the Core Network offers specific services. A LSA may be defined within a PLMN or globally. Therefore, a LSA may offer non-contiguous radio coverage.

**LSA exclusive access cell:** UE may only camp on this cell if the cell belongs to the LSAs to which the user has subscribed. Nevertheless, if no other cells are available, the UE of non-LSA users may originate emergency calls from this cell.

**LSA ID:** Localised Service Area Identity.

**LSA only access:** when LSA only access applies to the user, the UE can only access cells that belong to the LSAs to which the user has subscribed. Outside the coverage area of the subscribed LSAs, the UE may camp on other cells and limited services apply.

**LSA preferential access cell:** LSA preferential access cell is a cell, which is part of the LSA. UEs of users that have subscribed to a LSA of an LSA-preferential-access cell have higher priority to resources than non-LSA users in the same cell. The availability of LSA preferential access cells impacts the radio resource allocation (controlled by UTRAN-Access Stratum). This function is out of the scope of the standards.

**Maximum DRX cycle:** time interval for the longest possible DRX cycle in a cell.

**Paging Block Periodicity (PBP):** period of the occurrence of Paging Blocks. (For FDD, PBP = 1).

**Paging Message Receiving Occasion:** frame where the UE receives actual paging message.

**Paging occasion:**

(FDD) The frame where the UE monitors the PICH.

(TDD) The paging block, which consists of several frames. The value of Paging Occasion is equal to the first frame of the Paging Block.

**Radio Access Mode:** radio access mode of the cell, FDD or TDD.

**Radio Access Technology:** type of technology used for radio access, for instance UTRA or GSM.

**Registered PLMN (RPLMN):** this is the PLMN on which the UE has performed a location registration successfully.

**Registration Area:** (NAS) registration area is an area in which the UE may roam without a need to perform location registration, which is a NAS procedure.



**Selected PLMN:** this is the PLMN that has been selected by the non-access stratum, either manually or automatically.

**Suitable Cell:** a cell on which an UE may camp. It shall satisfy certain conditions, see subclause 4.3.

**Visited PLMN of home country:** a PLMN, different from the home PLMN, where the MCC part of the PLMN identity is the same as the MCC of the IMSI.

## 3.2 Abbreviations

For the purposes of the present document, the following abbreviations apply:

AS	Access Stratum
BCCH	Broadcast Control Channel
CN	Core Network
DRX	Discontinuous Reception
DSCH	Downlink Shared Channel
FDD	Frequency Division Duplex
GC	General Control (SAP)
GPRS	General Packet Radio System
GSM	Global System for Mobile
IMSI	International Mobile Subscriber Identity
MCC	Mobile Country Code
MM	Mobility Management
MNC	Mobile Network Code
NAS	Non-Access Stratum
ODMA	Opportunity Driven Multiple Access
ORACH	ODMA Random Access Channel
PCH	Paging Channel
PI	Page Indicator
PICH	Page Indication Channel
PLMN	Public Land Mobile Network
RAT	Radio Access Technology
RRC	Radio Resource Control
SAP	Service Access Point
TDD	Time Division Duplex
UE	User Equipment
UE <sub>R</sub>	User Equipment with ODMA relay operation enabled
UMTS	Universal Mobile Telecommunications System
UTRA	UMTS Terrestrial Radio Access
UTRAN	UMTS Terrestrial Radio Access Network

---

## 4 General description of Idle mode

### 4.1 Overview

When a multi-RAT UE is switched on, it attempts to make contact with a public land mobile network (PLMN) using a certain radio access technology. In addition to radio access technology, the core network type may differ as well. In this specification, the term PLMN is used as a generic term covering both GSM MAP and ANSI-41 type of PLMNs. According to the type of PLMN, the way to identify it can be different. If the PLMN type is GSM, the PLMN is identified by 'PLMN identity'. and if the PLMN type is ANSI-41, the PLMN is identified by 'SID'

The UE looks for a suitable cell of the chosen PLMN and chooses that cell to provide available services, and tunes to its control channel. This choosing is known as "camping on the cell". The UE will then register its presence, by means of a NAS registration procedure, in the registration area of the chosen cell, if necessary.

If the UE finds a more suitable cell, it reselects onto that alternative cell of the selected PLMN and camps on that cell. If the new cell is in a different registration area, location registration is performed.

If necessary, the UE will look for more suitable cells on other PLMNs at regular time intervals, which is referred to as PLMN-reselection. Particularly, in the home country of the UE, the UE will try to get back to its Home PLMN.

If the UE loses coverage of a PLMN, either a new PLMN is selected automatically (automatic mode), or an indication of which PLMNs are available is given to the user, so that a manual selection can be made (manual mode).

Registration is not performed by UEs only capable of services that need no registration.

The purpose of camping on a cell in idle mode is fourfold:

- a) It enables the UE to receive system information from the PLMN.
- b) When registered and if the UE wishes to initiate a call, it can do this by initially accessing the network on the control channel of the cell on which it is camped.
- c) If the PLMN receives a call for the registered UE, it knows (in most cases) the registration area of the cell in which the UE is camped. It can then send a "paging" message for the UE on control channels of all the cells in the registration area. The UE will then receive the paging message because it is tuned to the control channel of a cell in that registration area and the UE can respond on that control channel.
- d) It enables the UE to receive cell broadcast messages.

If the UE is unable to find a suitable cell to camp on, or the USIM is not inserted, or if the location registration failed, it attempts to camp on a cell irrespective of the PLMN identity, and enters a "limited service" state in which it can only attempt to make emergency calls.

The idle mode tasks can be subdivided into three processes:

- PLMN selection and reselection;
- Cell selection and reselection;
- Location registration.

The relationship between these processes is illustrated in Figure 1.

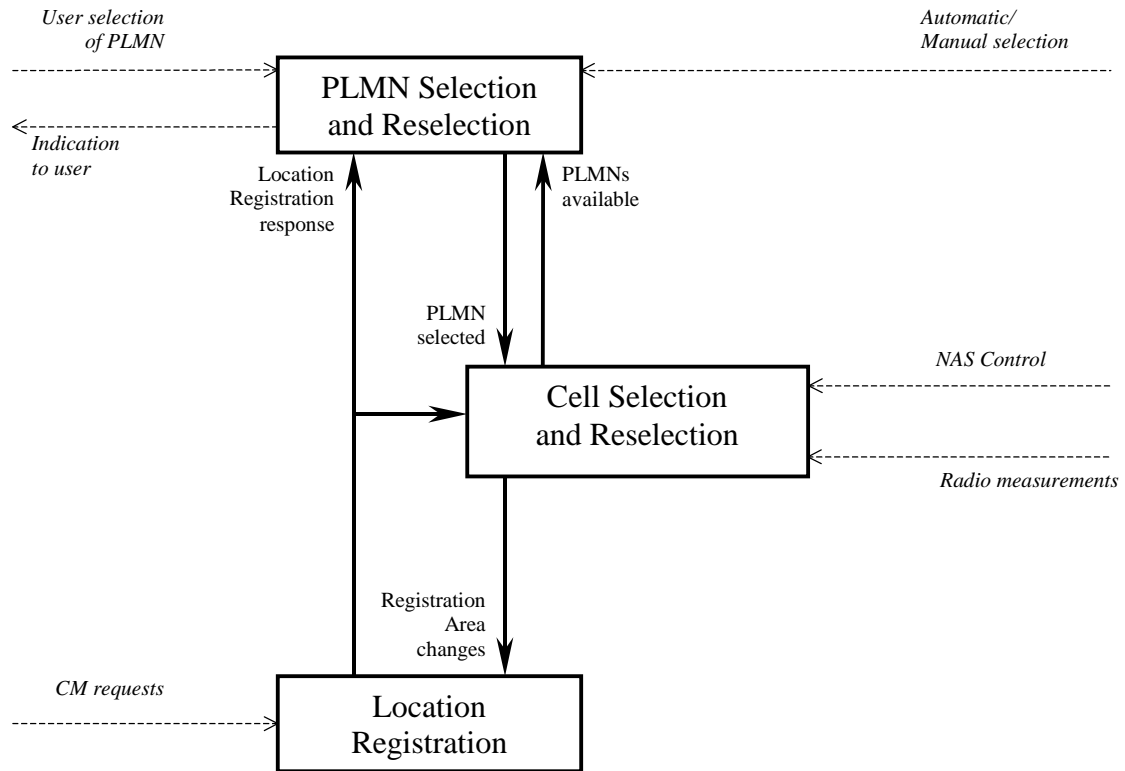

**Figure 1: Overall Idle Mode process**

NOTE: The impact of NAS defined service areas is FFS.

## 4.2 Functional division between AS and NAS in Idle mode

Table 1 presents the functional division between UE non-access stratum (NAS) and UE access stratum (AS) in idle mode. The non-access stratum part is specified in [5] and the access stratum part in the present document. Examples of different idle mode procedures are presented in Clause 10.

**Table 1: Functional division between AS and NAS in idle mode**

Idle Mode Process	UE Non-Access Stratum	UE Access Stratum
PLMN Selection and Reselection	<p>Maintain the list of allowed PLMN types. It can be GSM-MAP only, ANSI-41 only or both.</p> <p>Maintain a list of PLMNs in priority order. Request AS to select a cell either belonging to the PLMN having the highest priority (in automatic mode) or belonging to the manually selected PLMN.</p> <p>In automatic mode, if a PLMN with higher priority is found, request AS to select a cell belonging to that PLMN.</p>	<p>Report available PLMNs with associated PLMN type to NAS on request from NAS or autonomously.</p> <p>It must respect allowed PLMN types indications from NAS.</p>
Cell Selection	Control cell selection by for example, maintaining lists of forbidden registration areas and a list of NAS defined service areas in priority order.	<p>Perform measurements needed to support cell selection.</p> <p>Detect and synchronise to a broadcast channel. Receive and handle broadcast information. Forward NAS system information to NAS.</p> <p>Search for a suitable cell belonging to the PLMN requested by NAS. The cells are identified with 'PLMN identity' (GSM-MAP) or 'SID' in the system information. Respond to NAS whether such cell is found or not.</p> <p>If such a cell is found, the cell is selected to camp on.</p>
Cell Reselection	Control cell reselection by for example, maintaining lists of forbidden registration areas and a list of NAS defined service areas in priority order.	<p>Perform measurements needed to support cell reselection.</p> <p>Detect and synchronise to a broadcast channel. Receive and handle broadcast information. Forward NAS system information to NAS.</p> <p>Change cell if a more suitable cell is found.</p> <p>Perform ODMA probing in an ODMA Relay Node.</p>
Location registration	<p>Register the UE as active after power on.</p> <p>Register the UE's presence in a registration area, for instance regularly or when entering a new registration area.</p> <p>Deregister UE when shutting down.</p>	Report registration area information to NAS.

### 4.3 Service type in Idle mode

This chapter defines the level of service that may be provided by the UTRAN to an UE in Idle mode.

The action of camping on a cell is mandatory to receive some service from the cell. Three levels of services are defined for UEs in idle mode:

- Limited service (emergency calls)
- Normal service (for public use)

- Operator related services (for operators only)

Furthermore, the cells are categorised according to which services they offer:

acceptable cell:

An "acceptable cell" is a cell on which the UE may camp to obtain limited service (originate emergency calls). Such a cell shall fulfil the following requirements, which is the minimum set of requirements to initiate an emergency call in a UTRAN network:

- The cell selection criteria are fulfilled, see subclause 5.2.2.1;
- The cell is not reserved for operator use only.

suitable cell:

A "suitable cell" is a cell on which the UE may camp on to obtain normal service. Such a cell shall fulfil all the following requirements.

- The cell is part of the selected PLMN.
- The cell is not barred except for [details are FFS]:
  - emergency calls; and/or
  - operator only use; and/or
  - SoLSA exclusive access.
- The cell is not part of a forbidden registration area [details are FFS].
- The cell selection criteria are fulfilled, see subclause 5.2.2.1.
- The SoLSA criteria are fulfilled [FFS].
- The cell is not an operator-only cell, unless the UE has those access rights.

barred cell:

An UE shall not camp on this kind of cell for normal services, but may camp on this cell for limited service if no other suitable cell is available.

Whether or not the cell is barred, is indicated in the system information.

operator-only cell:

The aim of this type of cells is to allow the operator using and test newly deployed cells without being disturbed by normal traffic. A UE shall not camp on this cell for any service, except for some classes of UE as indicated on the USIM.

Whether or not the cell is reserved for operator use only, is indicated in the system information.

Table 2 summarises all the different cases above as well as the level of service provided by UTRAN, as seen from the UE in Idle mode.

**Table 2: Summary of service levels provided by UTRAN**

	Acceptable cell	Suitable cell	Barred cell	Operator-only cell
Limited service	Y	Y	Y	N
Normal service	N	Y	N	N
Operator-related service	N	Y	N	Y

## 5 Process descriptions

### 5.1 PLMN selection and reselection

In the UE, the access stratum shall report available PLMNs to the non-access stratum on request from the non-access stratum or autonomously.

UE shall maintain a list of allowed PLMN types. The allowed PLMN type can be GSM-MAP only, ANSI-41 only or both. During PLMN selection and reselection, based on the list of allowed PLMN types and a list of PLMN identities in priority order, the particular PLMN may be selected either automatically or manually. Each PLMN in the list of PLMN identities can be identified by either 'PLMN identity' (GSM-MAP) or 'SID'. In the system information on the broadcast channel, the UE can receive identities of multiple PLMNs of either or both types, i.e. a 'PLMN identity' (GSM-MAP) or a 'SID' or a 'PLMN identity' (GSM-MAP) and a 'SID', in a given cell. The result of the PLMN selection is an identifier of the chosen PLMN, the choice being based on the allowed PLMN types, UE capability or other factors. This identifier is one of either 'PLMN identity' for GSM-MAP type of PLMNs or 'SID' for ANSI-41 type of PLMNs.

In case that the list of allowed PLMN types includes GSM-MAP, the non-access part of the PLMN selection and reselection process is specified in [5].

### 5.2 Cell selection and reselection in idle mode

#### 5.2.1 General

As stated in clause 1, the present document applies to UEs that support at least UTRA and possibly also other radio access technologies, for instance GSM. The following subclauses specify the details for idle mode cell selection and reselection.

- The general part for all radio access technologies, currently UTRA and GSM, this subclause.
- UTRA radio access technologies, see subclause 5.2.2.
- GSM radio access technologies, see subclause 5.2.3.

As an example, consider a UE supporting both UTRA and GSM radio access technologies. It shall follow the specification in this subclause at all times, the specification in 5.2.2 while in UTRA and 5.2.3 while in GSM radio access technology (in addition to the GSM specifications).

Different types of measurements are used in different radio access technologies and modes for the cell selection and reselection. Whenever a direct comparison of these measurements is required, mapping functions will be applied that are defined in [4]. The use of the mapping functions is defined in subclause 7.1. Measured values are marked with the index 'meas', whereas the index 'map' is used whenever mapping functions have been applied onto a measured value.

The UE shall select a suitable cell and the radio access mode based on idle mode measurements and cell selection criteria. The non-access stratum can control the cell selection, for instance in terms of a list of forbidden registration area(s) and a list of NAS defined service area(s) in priority order.

When camped on a cell, the UE shall regularly search for a better cell according to the cell reselection criteria. If a better cell is found, that cell is selected.

The non-access stratum is informed if the cell selection and reselection results in changes in the received system information.

For normal service, the UE has to camp on a suitable cell, tune to that cell's control channel(s) so that the UE can:

- Receive system information from the PLMN;
- Receive registration area information from the PLMN, e.g., location area and routing area; and
- Identify the NAS defined service area(s) to which the serving cell belongs;
- Receive other AS and NAS Information;

- If registered:
  - receive paging and notification messages from the PLMN; and
  - initiate call setup for outgoing calls or other actions from the UE.

Figure 2 shows the states and procedures in the cell selection and reselection process.

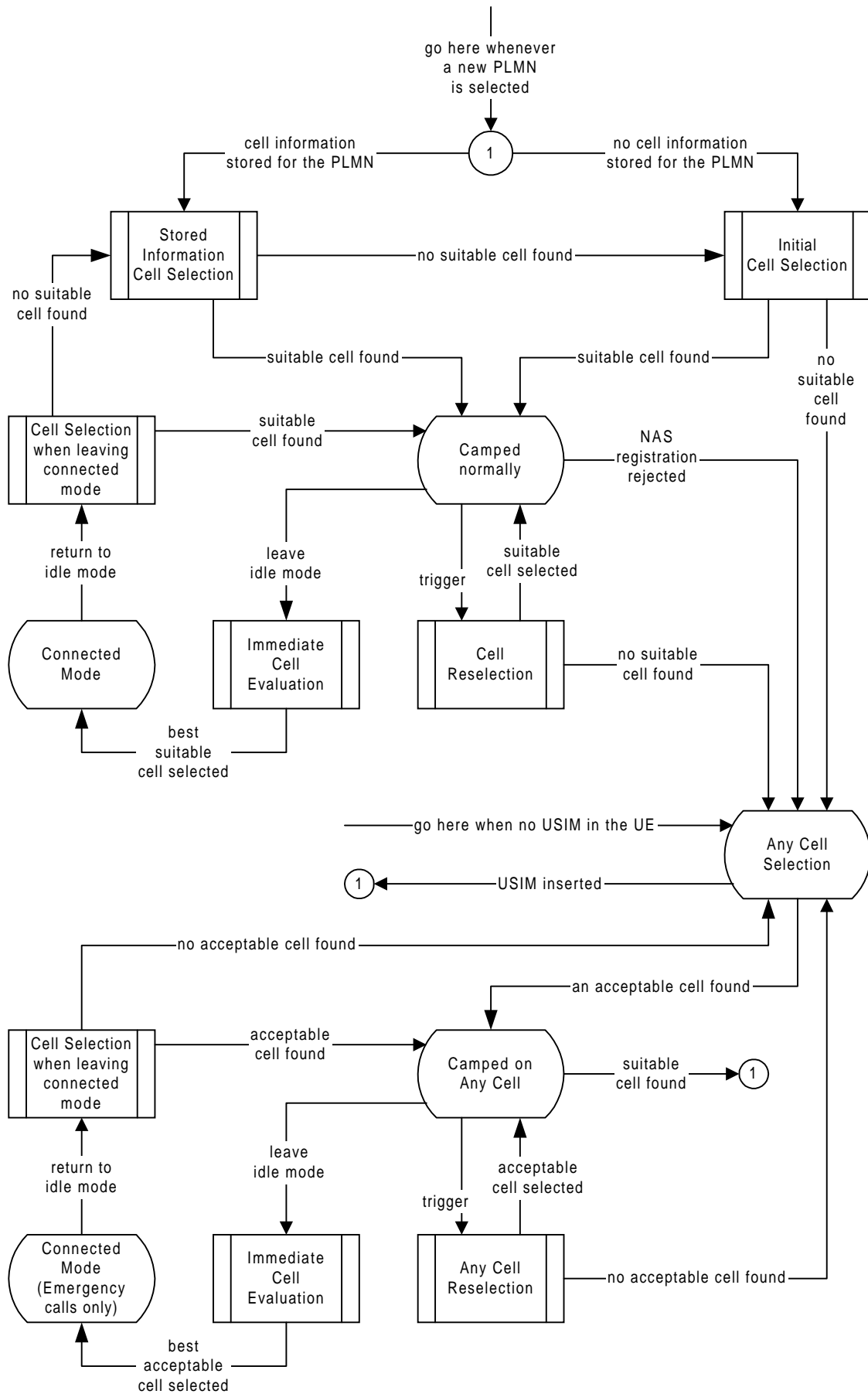

**Figure 2: Idle Mode Cell Selection and Reselection**  
 In any state, a new PLMN selection causes an exit to number 1



Whenever a PLMN has been selected, the UE shall attempt to find a suitable cell to camp on using one of the two procedures, *Initial cell selection* or *Stored information cell selection*. The *Initial cell selection* procedure requires no knowledge about the selected PLMN, but the *Stored information cell selection* procedure requires information about the selected PLMN previously stored. This information makes the search for a suitable cell faster. The non-access stratum may control the cell selection by for example, maintaining lists of forbidden registration areas and a list of NAS defined service areas in priority order.

In the *Initial cell selection* procedure), the UE shall select one radio access technology and search for a suitable cell. If no suitable cell is found, the UE shall select another radio access technology and search for a suitable cell, and so on. In the *Stored information cell selection* procedure, the UE may use stored information about the selected PLMN. The information may contain information from several radio access technologies.

When a suitable cell has been found, the UE shall perform necessary NAS registration procedures. When the UE has registered successfully (assuming a service that requires registration), the UE shall camp on the cell, state *Camped normally*. In this state, the UE shall monitor paging information, monitor system information and perform radio measurements. The measurements shall be used in evaluation of the cell selection, immediate cell evaluation (UTRA only) and reselection criteria. The network controls what the UE shall measure by sending measurement control information in the system information. The measurement control information may contain intra-frequency, inter-frequency and inter-radio-access- technology measurements.

When a cell reselection is triggered, the UE shall evaluate the cell reselection criteria based on radio measurements, and if a better cell is found that cell is selected, procedure *Cell reselection*. The change of cell may imply a change of radio access technology.

When UE leaves idle mode, state *Camped normally*, in order to enter connected mode, state *Connected mode*, the UE shall use the *Immediate cell evaluation* procedure (UTRA only) in order to select the best cell on the current frequency for the access attempt. This procedure allows the UE to reduce power consumption spent on radio measurements, still enabling the UE to select the best cell for access, thus minimising the interference in the system. If no suitable cell is found, the UE shall use the *Cell reselection* procedure. When returning to idle mode, the UE shall use the procedure *Cell selection when leaving connected mode* in order to find a suitable cell to camp on, state *Camped normally*. If no suitable cell is found, the *Stored information cell selection* procedure shall be used.

If no suitable cell is found, the UE shall attempt to find an acceptable cell of any PLMN, state *Any cell selection*. This state is also entered if a non-access stratum registration procedure is rejected, see [5], or if there is no USIM in the UE. If an acceptable cell is found, the UE shall camp on this cell and obtain limited service, state *Camped on any cell*. In this state, the UE shall behave as specified for state *Camped normally*, but typically with a different PLMN. Additionally, the UE shall regularly attempt to find a suitable cell using stored information, trying all radio access technologies that are supported by the UE. If a suitable cell is found, the PLMN is reselected which causes an exit to number 1.

When a cell reselection is triggered, the UE shall evaluate the cell reselection criteria based on radio measurements, and if a better cell is found that cell is selected, procedure *Any cell reselection*. The change of cell may imply a change of radio access technology.

When UE leaves idle mode, state *Camped on any cell*, in order to make an emergency call in connected mode, state *Connected mode (emergency calls only)*, the UE shall use the *Immediate cell evaluation* procedure (UTRA only) in order to select the best cell on the current frequency for the access attempt. If no suitable cell is found, the UE shall use the *Any cell reselection* procedure. When returning to idle mode, the UE shall use the procedure *Cell selection when leaving connected mode* in order to find a suitable cell to camp on, state *Camped on any cell*.

If no acceptable cell is found, the UE shall continue to search for an acceptable cell of any PLMN in state *Any cell selection*. trying all radio access technologies that are supported by the UE.

NOTE: The 'PLMN selection and reselection' process may select a new PLMN at any time in idle mode, which in Figure 2 causes an exit to number 1.

## 5.2.2 UTRA Radio access technology

### 5.2.2.1 Cell Selection Procedures

#### 5.2.2.1.1 Description

Whenever a PLMN is selected, the UE shall attempt to find a suitable cell of that PLMN to camp on according to the following steps.

- 1) Create a candidate list of potential cells to camp on. Two searching procedures are possible.

- a) Initial Cell Selection

This procedure requires no prior knowledge of which RF channels are UTRA carriers. The UE shall scan all RF channels in the UTRA band to find a suitable cell. On each carrier, the UE searches first for the strongest cell and reads its system information, in order to find out which PLMNs are available. If the selected PLMN is found, the search of the rest of carriers may be stopped. After the UE has found one suitable cell for the selected PLMN, the UE shall create a candidate list consisting of this cell and its neighbouring cells, as received in measurement control information via the selected cell.

- b) Stored Information Cell Selection

This procedure requires stored information of carrier frequencies and optionally also information on cell parameters, e.g. scrambling codes, from previously received measurement control information elements. After the UE has found one suitable cell for a selected PLMN the UE shall create the candidate list consisting of this cell and its neighbouring cells, as received in measurement control information via the selected cell.

NOTE: Setting the priorities of PLMN search and selection are FFS.

- 2) For each cell on the candidate list calculate the cell selection value,  $S$ , and the quality value,  $Q_{\text{meas}}$ , defined in subclause 5.2.2.1.2.
- 3) Rank the cells with  $S > 0$  from the highest  $Q_{\text{meas}}$  value.
- 4) Check if the cell with the highest  $Q_{\text{meas}}$  value fulfils all requirements for a suitable cell. If so, choose this cell to camp on. If this cell does not fulfil all requirements for a suitable cell, this cell and all cells on the same frequency shall be removed as candidates for cell selection (see also subclause 5.2.4), and step 3 shall be repeated.

If different radio access modes are involved in the procedure, mapping functions shall be applied. For each radio access mode, such a mapping function is defined and its parameters are broadcast in system information. The mapping function maps a certain range of measurement values  $Q_{\text{meas}}$  to a representing quality value  $Q_{\text{map}}$  that can have values between 0 and 99 (step size 1). These quality values  $Q_{\text{map}}$  can then be compared with each other and the cell with the highest  $Q_{\text{map}}$  value is chosen (among those cells with  $S > 0$ ).

If no suitable cells are found and the stored information cell selection procedure was used in step 1, the Initial cell selection procedure shall be started and the steps are repeated. If the UE is unable to find any suitable cell using the Initial cell selection procedure, it shall attempt to camp on any acceptable cell and enter the Camped on any cell state, where it can only obtain limited service.

NOTE: In PLMN selection, automatic mode, this would normally result in a new PLMN selection.

#### 5.2.2.1.2 Criteria

The cell selection value,  $S$ , is defined as follows.

$$S = Q - Q_{\min} - P_{\text{compensation}}$$

S	Cell Selection value, (dB)
Cell_selection_and_reselecti on_quality_measure (FDD only)	Choice of measurement (CPICH Rx $E_c/N_0$ or CPICH Rx SIR) to use as quality measure $Q_{\text{meas}}$ (read in system information) (see NOTE)
$Q_{\text{meas}}$	Quality value. The quality of the received signal, CPICH Rx $E_c/N_0$ or CPICH Rx SIR, (dB) for FDD, P-CCPCH for TDD (dBm). In FDD, the measurement to use for the quality value is set by the Cell_selection_and_reselection_quality_measure information element.
$Q_{\min}$	Minimum required quality level in the cell (read in system information and dependent on the quantity to measure), (FDD: dB, TDD: dBm).
Pcompensation	$\max(\text{UE\_TXPWR\_MAX\_RACH} - P_{\text{MAX}}, 0)$ , (FDD: dB, TDD: dBm)
UE_TXPWR_MAX_RACH	Maximum TX power level an UE may use when accessing the cell on RACH (read in system information), (dBm)
P_MAX	Maximum RF output power of the UE, (dBm)
NOTE:	The work in order to support the CPICH Rx SIR measurement is in progress in TSG-RAN WG4 and may impact the use of that measurement in the present document.

The cell selection criterion is fulfilled if:

$$S > 0$$

### 5.2.2.2 Immediate Cell Evaluation Procedure

NOTE: Conditions on the use of the immediate cell evaluation procedure are FFS. Specifically, the time needed to perform the procedure is to be considered.

#### 5.2.2.2.1 Description

The Immediate Cell Evaluation procedure is used by the UE to perform a quick evaluation of the quality of the intra-frequency cells. Based on this information, the UE shall select the best cell among the cells on the same frequency, according to the criteria defined in the next subclause.

The immediate cell evaluation shall be triggered prior to RACH transmission.

The following steps shall be carried out when an immediate cell evaluation has been triggered.

- 1) The candidate list of potential cells to camp on consists of the cells in the current registration area listed for intra-frequency measurements in system information of the serving cell.
- 2) Calculate the  $Q_{\text{map}}$  value and the S value for each cell on the candidate list.
- 3) Select the neighbouring cell that fulfils the criteria in 5.2.2.2.2 best.  
If the best cell does not fulfil all other requirements for a suitable cell, UE shall trigger cell re-selection (see also subclause 5.2.4).

NOTE: Whether the calculation of the  $Q_{\text{map}}$  value should require the immediate decoding (e.g. in case the UL load value is used for the calculation) of a set of neighbouring cell BCHs is FFS.

#### 5.2.2.2.2 Criteria

The UE shall select a new cell if the following criteria are fulfilled.

$$S_n > 0$$

$$Q_n > Q_s + Q_{\text{offset}_{s,n}}$$

$S_n$	Cell Selection value of the neighbouring cell, (dB).
Cell_selection_and_reselecti on_quality_measure (FDD only)	Choice of measurement (CPICH Rx Ec/N0 or CPICH Rx SIR) that is used to derive $Q_{\text{map},n}$ and $Q_{\text{map},s}$ , (read in system information) (see NOTE).
$Q_{\text{map},n}$	Quality of the neighbouring cell, derived from CPICH Rx $E_c/N_0$ or CPICH Rx SIR in FDD and from P-CCPCH RSCP in TDD. In FDD, the measurement that is used to derive the quality value is set by the Cell_selection_and_reselection_quality_measure information element.
$Q_{\text{map},s}$	Quality of the serving cell. In FDD, the measurement that is used to derive the quality value is set by the Cell_selection_and_reselection_quality_measure information element.
$Q_{\text{offset}_{s,n}}$	Offset between the two cells considered in the evaluation (read in system information).
NOTE:	The work in order to support the CPICH Rx SIR measurement is in progress in TSG-RAN WG4 and may impact the use of that measurement in the present document.

The quality values  $Q_{\text{map},n}$  and  $Q_{\text{map},s}$  are determined by mapping functions. The parameters for these mapping functions are broadcast in system information. The mapping function maps a certain range of measurement values to a representing quality value.  $Q_{\text{map},n}$  and  $Q_{\text{map},s}$  can have values between 0 and 99 (step size 1).

If more than one neighbouring cell fulfils the criteria, the UE shall choose the cell where the difference between  $Q_{\text{map},n}$  and ( $Q_{\text{map},s} + Q_{\text{offset}}$ ) is highest. If no neighbouring cell fulfils the criteria, the UE shall keep the serving cell.

### 5.2.2.3 Camped Normally

When camped normally, the UE shall perform the following tasks:

- monitor PICH and PCH of the cell as specified in clause 8 according to information sent in system information;
- monitor relevant System Information;
- prior to RACH transmission, the UE shall perform an immediate cell evaluation, according to 5.2.2.2.

### 5.2.2.4 Cell Reselection Procedure

#### 5.2.2.4.1 Triggers for cell re-selection

The cell reselection procedure shall be triggered in the following cases:

- 1) better cell is found;
- 2)  $S \leq 0$ ;
- 3) downlink signalling failure [details are FFS];
- 4) cell has become barred or forbidden.

In case 2), 3) and 4) the parameters  $Q_{\text{hyst}}$  and  $T_{\text{reselection}}$  shall not be considered in the criteria.

#### 5.2.2.4.2 Measurements for cell re-selection when HCS is not used

If hierarchical cell structures are not used in the network, UE shall follow the rules for network control of UE measurement activities in subclause 7.1.

#### 5.2.2.4.3 Measurements for cell re-selection when HCS is used

If hierarchical cell structures are used in the network, the following rules for intra- and inter-frequency measurements, depending on the quality of serving cell  $S_S$ , apply:

- 1) If  $S_S > S_{\text{intraserch}}$  UE need not perform intra-frequency measurements.
- 2) If  $S_S > S_{\text{interserch}}$ , UE need not perform inter-frequency measurements.
- 3) If  $S_{\text{searchHCS}} < S_S \leq S_{\text{intraserch}}$ , UE shall measure on all intra-frequency neighbouring cells, which have equal or higher HCS priority level than the serving cell.
- 4) If  $S_{\text{searchHCS}} < S_S \leq S_{\text{interserch}}$ , UE shall measure on all inter-frequency neighbouring cells, which have equal or higher HCS priority level than the serving cell.
- 5) If  $S_S \leq S_{\text{searchHCS}}$ , UE shall measure on all intra- and inter-frequency neighbouring cells of the serving cell.
- 6) If the number of cell reselections during time period  $T_{\text{CRmax}}$  exceeds  $N_{\text{CR}}$ , high-mobility has been detected. In this high-mobility state, UE shall measure intra- and inter-frequency neighbouring cells, which have equal or lower HCS priority than serving cell. Furthermore, UE shall prioritise re-selection of intra- and inter-frequency neighbouring cells on lower HCS priority level before neighbouring cells on same HCS priority level.

When the number of cell reselections during time period  $T_{\text{CRmax}}$  no longer exceeds  $N_{\text{CR}}$ , UE shall continue these measurements during time period  $T_{\text{CRmaxHyst}}$ . Then, UE shall revert to measure all intra- and inter-frequency neighbouring cells, which have equal or higher HCS priority level than the serving cell.

If hierarchical cell structures are used in the network, the following rules for inter-RAT measurements, depending on the quality of serving cell  $S_S$ , apply:

- 1) If  $S_S > S_{\text{SearchRATm}}$ , UE need not measure on RATm neighbouring cells.
- 2) If  $S_{\text{HCS,RATm}} < S_S \leq S_{\text{Search,RATm}}$ , UE shall measure on RATm neighbouring cells according to the following rules:
  - If the number of cell reselections during time period  $T_{\text{CRmax}}$  does not exceed  $N_{\text{CR}}$ , the UE shall measure RATm neighbouring cells, which have an equal or higher HCS priority than the serving cell.
  - If the number of cell reselections during time period  $T_{\text{CRmax}}$  exceeds  $N_{\text{CR}}$ , high-mobility has been detected. In this high-mobility state, UE shall measure RATm neighbouring cells, which have an equal or lower HCS priority than the serving cell. Furthermore, UE shall prioritise re-selection of RATm neighbouring cells on lower HCS priority level before RATm neighbouring cells on same HCS priority level.

When the number of cell reselections during time interval  $T_{\text{CRmax}}$  no longer exceeds  $N_{\text{CR}}$ , UE shall continue these measurements during time period  $T_{\text{CRmaxHyst}}$ . Then, UE shall revert to measure all intra- and inter-frequency neighbouring cells, which have equal or higher HCS priority level than the serving cell.
- 3) If  $S_S \leq S_{\text{search,RATm}}$ , UE shall measure on all RATm neighbouring cells.

#### 5.2.2.4.4 Non-suitable cells with $S > 0$

If the best cell according to cell reselection criteria specified in subclause 5.2.2.4.4, does not fulfil all requirements for a suitable cell, that cell, together with all cells on that frequency shall be removed as candidate for cell re-selection (see also subclause 5.2.4).

#### 5.2.2.4.5 Cell Reselection Criteria

The following cell re-selection criteria are used for intra-frequency cells, inter-frequency cells and inter-RAT cells:

The quality level threshold criterion H for hierarchical cell structures is used to determine whether prioritised hierarchical cell re-selection shall apply, and is defined by:

$$H_s = Q_{\text{map},s} - Q_{\text{hcs}_s}$$

$$H_n = Q_{\text{map},n} - Q_{\text{hcs}_n} - TO_n * L_n$$

The cell-ranking criterion R is defined by:

$$R_s = Q_{\text{map},s} + Q_{\text{hyst}_s}$$

$$R_n = Q_{\text{map},n} - Q_{\text{offset}_{s,n}} - TO_n * (1 - L_n)$$

where:

$$TO_n = \text{TEMP\_OFFSET}_n * W(\text{PENALTY\_TIME}_n - T_n)$$

$$L_n = 0 \quad \text{if } \text{HCS\_PRIO}_n = \text{HCS\_PRIO}_s$$

$$L_n = 1 \quad \text{if } \text{HCS\_PRIO}_n \neq \text{HCS\_PRIO}_s$$

$$W(x) = 0 \quad \text{for } x < 0$$

$$W(x) = 1 \quad \text{for } x \geq 0$$

$T_n$  is a timer implemented for each neighbouring cell.  $T_n$  shall be started from zero when following conditions becomes true:

$$Q_{\text{map},n} > Q_{\text{hcs}_n} \quad \text{if } \text{HCS\_PRIO}_n \neq \text{HCS\_PRIO}_s$$

$$Q_{\text{map},n} > Q_{\text{map},s} + Q_{\text{offset}_{s,n}} \quad \text{if } \text{HCS\_PRIO}_n = \text{HCS\_PRIO}_s$$

$T_n$  shall be stopped as soon as these conditions are no longer fulfilled.

At cell-reselection, a timer  $T_n$  is stopped only if the corresponding cell is not a neighbour cell of the new serving cell, or if the criterion given above for starting timer  $T_n$  for the corresponding cell is no longer fulfilled with the parameters of the new serving cell.

$\text{TEMP\_OFFSET}_n$  applies an offset to H and R criteria for the duration of  $\text{PENALTY\_TIME}_n$  after the timer  $T_n$  has started for that cell.

$S_n$	Cell Selection value of the neighbouring cell, (dB)
Cell_selection_and_reselecti on_quality_measure (FDD only)	Choice of measurement (CPICH Rx $E_c/N_0$ or CPICH Rx SIR) that is used to derive quality measures $Q_{map,n}$ and $Q_{map,s}$ , (read in system information) (see NOTE).
$Q_{map,n}$	Quality of the neighbouring cell, derived from CPICH Rx $E_c/N_0$ or CPICH Rx SIR in FDD, from P-CCPCH in TDD and from RXLEV in GSM. In FDD, the measurement that is used to derive the quality value is set by the Cell_selection_and_reselection_quality_measure information element.
$Q_{map,s}$	Quality of the serving cell, derived from CPICH Rx $E_c/N_0$ or CPICH Rx SIR in FDD, from P-CCPCH in TDD and from RXLEV in GSM. The measurement that is used to derive the quality value is set by the Cell_selection_and_reselection_quality_measure information element.
$Q_{offset,s,n}$	Offset between the two cells considered in the evaluation (read in system information).
$Q_{hyst,s}$	Hysteresis value of the serving cell.
HCS_PRIO <sub>s</sub> , HCS_PRIO <sub>n</sub>	HCS priority level (0-7) for serving cell and neighbouring cells
PENALTY_TIME <sub>n</sub>	Duration for applying TEMP_OFFSET <sub>n</sub> to H and R criteria (s)
$Q_{hcs,s}$ , $Q_{hcs,n}$	Quality threshold level for applying prioritised hierarchical cell re-selection
TEMP_OFFSET <sub>n</sub>	Offset to H and R criteria for the duration of PENALTY_TIME <sub>n</sub>
$T_{maxCR}$	Duration for evaluating allowed amount of cell reselections (s).
$N_{CR}$	Maximum number of cell reselections
$T_{CrmaxHyst}$	Additional time period before UE reverts to low-mobility measurements (s)
Treselection <sub>s</sub>	Time-to-trigger for cell reselection, (s)
NOTE:	The work in order to support the CPICH Rx SIR measurement is in progress in RAN WG4 and may impact the use of that measurement in the present document.

The quality values  $Q_{map,n}$  and  $Q_{map,s}$  are determined by mapping functions. The parameters for these mapping functions are broadcast in system information. The mapping function maps a certain range of measurement values to a representing quality value.  $Q_{map,n}$  and  $Q_{map,s}$  can have values between 0 and 99 (step size 1).

The UE shall perform a cell re-selection if a non-serving cell is evaluated to be better than the serving cell. The best cell is the cell with the highest R value and  $S > 0$  among

- those cells that have the highest HCS\_PRIO among those cells that fulfil the criterion  $H \geq 0$ . Note that this rule is not valid when UE high-mobility is detected (see subclause 5.2.2.4.3).
- all cells, not considering HCS priority levels, if no cell fulfil the criterion  $H \geq 0$  or HCS is not applied.

The UE shall reselect the new cell, if the cell reselection criteria are fulfilled during a time interval Treselection.

#### 5.2.2.4.6 Cell reselection parameters in system information broadcasts

The selection of values for network controlled parameters can be optimised by means of different methods. Examples of methods are described in [6]. Cell reselection parameters are broadcast in system information as follows:

##### **Q<sub>offset,s,n</sub>**

The offset between the two cells considered in the evaluation ( $Q_{offset,s,n}$ ) can be conveyed in two different ways:

Alternative 1. Offsets can be included for each neighbouring cell in the intra-frequency neighbouring cell list, which is read in system information of the serving cell.

Alternative 2. The offset can be broadcast in each cell, and the UE decodes it from system information broadcasts in the neighbouring cell. In the case, this offset is applied for all cell relations towards that neighbouring cell (i.e. for each value on the subscript s). Decoding is done only when the cell measurement exceeds the neighbour cell decoding range. The offset is broadcast together with an offset expiration timer, which indicates how long the offset value is valid.

NOTE 1: Whether both 1 and 2 could be used or if only one of these alternatives is used is FFS.

##### **Q<sub>hyst,s</sub>**

The hysteresis value ( $Q_{hyst}$ ) is read in system information of the serving cell.

**HCS\_PRIO<sub>s</sub>, HCS\_PRIO<sub>n</sub>**

HCS priority level (0-7) for serving cell and neighbouring cells are read in system information of serving cell.

**Qhcs<sub>s</sub>, Qhcs<sub>n</sub>**

Quality threshold levels for applying prioritised hierarchical cell re-selection are read in system information of serving cell.

**PENALTY\_TIME<sub>n</sub>**

Time duration for which the TEMPORARY\_OFFSET<sub>n</sub> is applied for a neighbouring cell is read in system information of serving cell.

**TEMPORARY\_OFFSET<sub>n</sub>**

Applies an offset to the H and R criteria for a neighbouring cell for the duration of PENALTY\_TIME<sub>n</sub>. The parameter is read in system information of serving cell.

**T<sub>CRmax</sub>**

Duration for evaluating allowed amount of cell reselection(s) is read in system information of serving cell.

**N<sub>CR</sub>**

Maximum number of cell reselections is read in system information of serving cell.

**T<sub>CRmaxHyst</sub>**

Additional time period before UE reverts to low-mobility measurements is read in system information of serving cell.

**T<sub>reselection<sub>s</sub></sub>**

The cell reselection timer value is read in system information of the serving cell.

**Decoding range**

The decoding range is read in system information of the serving cell.

NOTE 2: This parameter is only applicable for Alternative 2, see above.

**OffsetExp**

The offset expiration timer is read in system information of the neighbouring cell.

NOTE 3: This parameter is only applicable for Alternative 2, see above.

**S<sub>searchHCS</sub>**

Below this limit in the serving cell, the UE shall initiate measurements of all neighbouring cells of the serving cell. The value is read in system information of the serving cell.

**S<sub>searchRAT 1</sub> - S<sub>searchRAT k</sub>**

Below this RAT specific threshold in the serving UTRA cell, the UE shall initiate measurements of inter-radio access technology cells. The values are read in system information of the serving cell.

**Mapping Info**

Mapping Info contains all the information that is necessary to define the mapping function that is used for mapping a certain range of measurement values to a representing quality value (0..99, step size 1).

**5.2.2.5 Cell Selection when leaving connected mode**

When returning to idle mode from connected mode, the UE shall select a suitable cell to camp on. Candidate cells for this selection are the cell(s) used immediately before leaving connected mode. If no suitable cell is found, the UE shall use the Stored information cell selection procedure in order to find a suitable cell to camp on.



When returning to idle mode after an emergency call on any PLMN, the UE shall select an acceptable cell to camp on. Candidate cells for this selection are the cell(s) used immediately before leaving connected mode. If no acceptable cell is found, the UE shall continue to search for an acceptable cell of any PLMN in state Any cell selection.

#### 5.2.2.6 Any Cell Selection

In this state, the UE shall attempt to find an acceptable cell to camp on, trying all radio access technologies that are supported by the UE.

If no acceptable cell is found, the UE shall continue to search for an acceptable cell in this state.

#### 5.2.2.7 Camped on Any Cell

If an acceptable cell is found, the UE shall camp on this cell and obtain limited service, state Camped on any cell. In this state, the UE shall behave as specified for state Camped normally, but typically with a different PLMN. Additionally, the UE shall regularly attempt to find a suitable cell trying all radio access technologies that are supported by the UE. If a suitable cell is found, this causes an exit to number 1 in Figure 2.

#### 5.2.2.8 Any Cell Reselection

The Any cell reselection procedure is identical to the cell reselection procedure. However, the requirement of selecting a suitable cell is relaxed to selecting an acceptable cell.

#### 5.2.2.9 ODMA probing sub-process

In addition to UE cell selection process the  $UE_R$  will initiate or continue to evaluate the relay link via probing. The ODMA probing process state machine controls the rate of ODMA relay node probing. The ODMA probing state machines and mechanisms for controlling the rate of ODMA probing are discussed in the following subclause.

##### 5.2.2.6.1 ODMA probing state machines

Probing is a mechanism used by the ODMA relay node to build a neighbour list which should contain at least a predefined minimum number of neighbours. The probing activity levels of an ODMA relay node may also be influenced by a number of key system parameters such as:

- number of neighbours;
- gradient information;
- path loss to neighbours;
- speed of the terminal;
- battery power level.

The probing state machines are characterised by the level of probing opportunities. The objective of the probing state machines is to optimise ORACH activity to provide reduced interference and regulate power consumption. The difference between these state machines can generally be characterised by the number of ORACH channels that may be used for probing. Thus the probing opportunities within one  $N$  multiframe may vary depending upon the active state machine. Additionally, the ratio of probe transmission to reception is controlled by a probing activity parameter  $K$ . The state machines are full probing, duty maintained probing, and relay prohibited. The function of each of these state machines is described below:

##### Full probing

Full probing is the case where probing is allowed on every ORACH timeslot within a  $N$  multiframe. The  $UE_R$  will probe on the ORACH at a rate defined by the probing activity parameter  $K$ .

##### Duty Maintained probing

The duty maintained probing is the case where probing is allowed on  $M$  slots of an  $N$  multiframe. The  $UE_R$  will probe on the  $M$  ORACH slots in an  $N$  multiframe at a rate defined by the probing activity parameter  $K$ .

Relay Prohibited

In this mode the UE<sub>R</sub> would cease all of its ODMA probing activities and will fall into standard TDD or FDD operation.

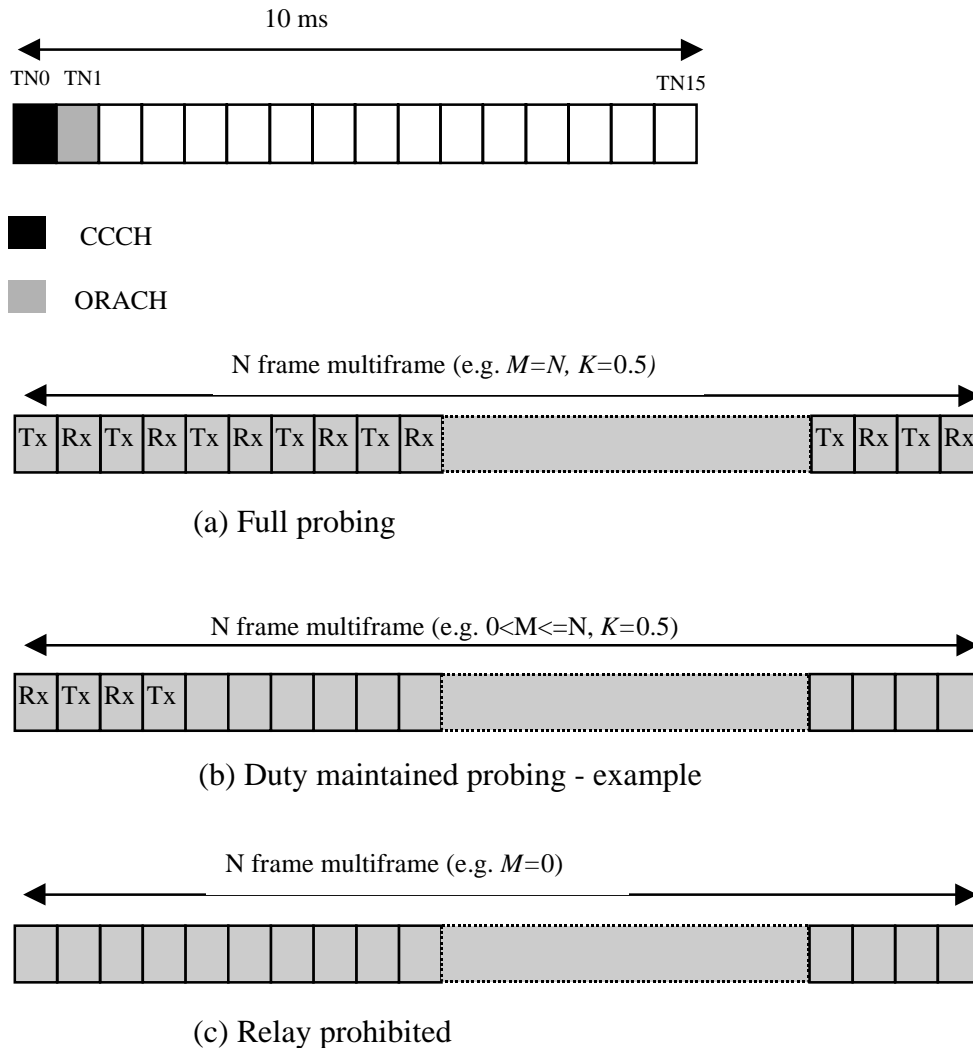

**Figure 3: Probing state machines and mechanism**

The probing activity levels for given state machines are illustrated in Figure 3 for a system with an ORACH for M slots per  $N \times 16$  multiframe.

NOTE: The distribution of probing opportunities within a multiframe may not necessarily be consecutive and located at the beginning of a multiframe.

A practical illustration of these probing state machines within the ODMA system is shown in Figure 4.

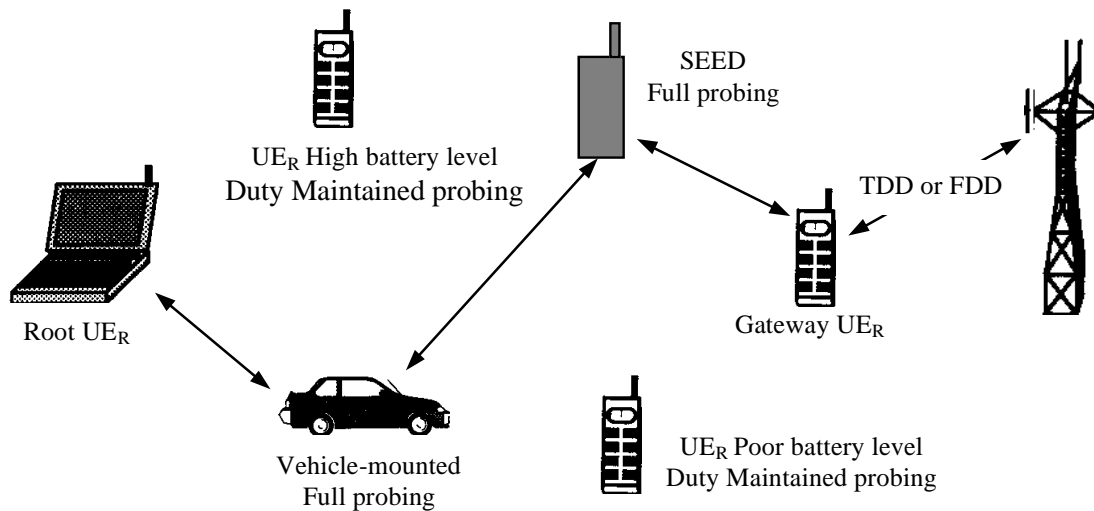

Figure 4: Illustration of probing process assignment

## 5.2.3 GSM Radio access technology

### 5.2.3.1 Cell Selection Procedures

The cell selection procedures in GSM are specified in [1].

### 5.2.3.2 Immediate Cell Evaluation Procedure

Immediate Cell Evaluation procedure is not applicable for GSM.

### 5.2.3.3 Cell Reselection Procedure

#### 5.2.3.3.1 Description

The cell reselection procedure in GSM is specified in [1].

#### 5.2.3.3.2 Cell Reselection Criteria

The cell reselection criteria in GSM are specified in [1].

#### 5.2.3.3.3 Inter-Radio Access Technology Cell Reselection Procedure

The criteria for a better UTRA cell are:

$$Q_s < Q_{\text{search}_s}$$

$$Q_n > Q_{\text{accept}_{s,n}}$$

$Q_s$	Quality of the serving cell, (dB or dBm). NOTE: Exact unit is FFS.
$Q_n$	Quality of the neighbouring cell, (dB or dBm). NOTE: Exact unit is FFS.
$Q_{search_s}$	Below this limit in the serving cell, the UE shall take measurements of UTRA cells if such entries exist in the measurement control information elements (dB or dBm). NOTE: Exact unit is FFS.
$Q_{accept_{s,n}}$	Minimum quality required for a UTRA cell. (dB or dBm). NOTE: Exact unit is FFS.

Measurements on UTRA cells are not carried out unless the quality of the serving cell is lower than a threshold,  $Q_{search}$ .

The UE shall select a UTRA cell that fulfils the criteria  $Q_n > Q_{accept_{s,n}}$ . If more than one cell fulfils the criteria, the UE shall select the cell with the highest quality  $Q$ .

$Q_{accept}$  and  $Q_{search}$  are included in the system information of the serving cell.

If no cells of the other technologies fulfil the criteria, the UE shall stay on the current cell and continue to perform measurements as long as  $Q_s < Q_{search_s}$ .

#### 5.2.3.3.4 Cell reselection parameters in system information broadcasts

The selection of values for network controlled parameters can be optimised by means of different methods. Examples of methods are described in [6]. Inter-radio access technology cell reselection parameters are broadcast in GSM system information as follows:

##### **$Q_{search_s}$**

When the  $Q$  value of the serving GSM cell is below this value, the UE shall perform measurements of UTRA cells.

##### **$Q_{accept_{s,n}}$**

Minimum quality of the UTRA cell required for selecting the UTRA cell.

#### 5.2.3.4 Cell Selection when leaving connected mode

Cell selection when leaving connected mode in GSM is specified in [1].

#### 5.2.3.5 Any Cell Selection

The any cell selection state in GSM is specified in [1].

#### 5.2.3.6 Camped on Any Cell

The camped on any cell state in GSM is specified in [1].

#### 5.2.3.7 Any Cell Reselection

The any cell reselection procedure in GSM is specified in [1].

### 5.2.4 Barred Cells and Access Control

The barred case of cell status is used to bar completely a cell against access by all normal subscribers. This barred status is indicated in the information broadcast by the cell, in the Cell Access Restriction information element, which has 4 cases:

1. Cell not Barred;
2. Cell Barred for normal users - allows Operator access;
3. Cell Barred for normal users – allows Emergency access;

4. Cell Barred for normal users – allows SoLSA access.

Additionally, combinations of cases 2, 3, and 4 are allowed in one cell.

If UE, during the cell selection, immediate cell evaluation and cell re-selection procedures, detects UTRA cell  $i$ , that fulfil the cell selection criteria  $S > 0$ , but not all other requirements for a suitable cell, all cells on same frequency as cell  $i$  shall be removed as candidates for cell selection. Specific actions performed by the UE are described for each procedure.

UE shall regard that the cell barred condition of cell  $i$  is valid during time interval  $T_{\text{barred}}$ .  $T_{\text{barred}}$  is sent via system information of cell  $i$ .

NOTE: Access Control is FFS

FFS

## 5.2.5 Regional Provision of Service

FFS

## 5.3 Cell Reselection in Connected Mode

### 5.3.1 UTRA Radio Access Technology

#### 5.3.1.1 General

This subclause specifies cell reselection procedures in UTRAN connected mode.

The UE shall select a suitable cell and radio access technology based on connected mode radio measurements and cell reselection criteria.

Figure 5 shows the states and procedures in the cell reselection process in connected mode.

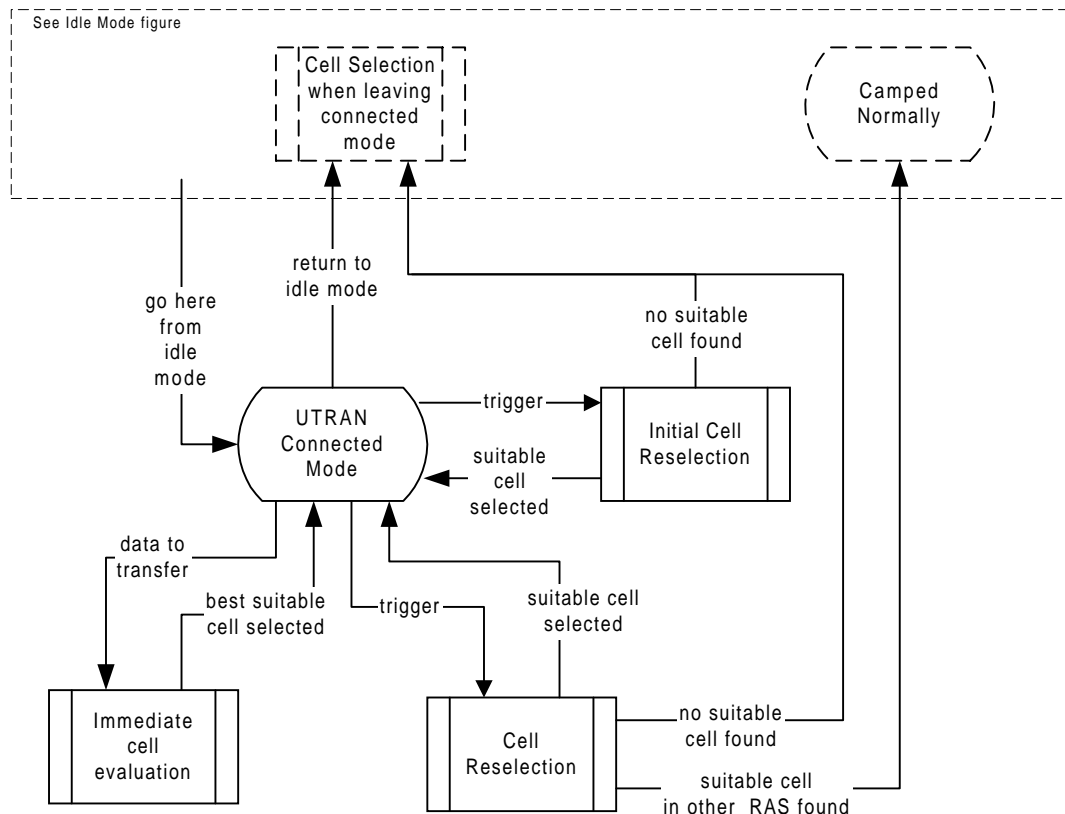

**Figure 5: UTRAN Connected mode cell reselection**

Transition from idle mode to connected mode is described in subclause 5.2.

For UTRAN connected mode, RRC connection mobility tasks are specified in [25.331]. In some states the UE shall perform cell reselection procedures.

When a cell reselection is triggered, the UE shall evaluate the cell reselection criteria based on radio measurements, and if a better cell is found that cell is selected, procedure *Cell reselection* (see subclause 5.3.1.4). If the change of cell implies a change of radio access technology, the RRC connection is released, and the UE enters idle mode. If no suitable cell is found in the cell reselection procedure, the RRC connection is released, and the UE enters idle mode.

When the UE has data to transmit, and there is no restriction for the UE to reselect cell (see [25.331]), the UE shall use the *Immediate cell evaluation* procedure (see subclause 5.3.1.3) to select the best suitable cell prior to the access attempt, according to the immediate cell evaluation criteria. Constraints on the use of this procedure are specified in [25.331].

When an immediate cell reselection is triggered, the UE shall use the *Initial cell reselection* procedure (see subclause 5.3.1.2) to find a suitable cell. The cases where this may be triggered are specified in [25.331]. One example where this procedure is triggered is at radio link failure, where the UE may trigger an initial cell reselection in order to request re-establishment of the RRC connection. If the UE is unable to find a suitable cell, the UE shall release the RRC connection and enter idle mode.

### 5.3.1.2 Initial Cell Reselection Procedure

#### 5.3.1.2.1 Description

Triggers for the Initial cell re-selection procedure are specified in [25.331].

When the Initial cell reselection procedure is triggered, the UE shall attempt to find a suitable cell belonging to the selected PLMN according to the following steps:

- 1) The UE shall scan all RF channels of the UTRA band to find a suitable cell. The UE may optimise this search by using stored information of carrier frequencies and optionally also information on cell parameters, e.g.

scrambling codes, from previously received measurement control information elements. If UE, during the initial cell re-selection procedure, detects UTRA cell  $i$ , that fulfil the cell selection criteria  $S > 0$ , but not all other requirements for a suitable cell, all cells on same frequency as cell  $i$  shall be removed as candidates for cell selection (see also subclause 5.2.4).

- 2) After the UE has found one suitable cell for the selected PLMN, the UE shall create a candidate list consisting of this cell and its neighbouring UTRA cells, as received in measurement control information via the selected cell.
- 3) For each cell on the candidate list fulfilling all criteria for a suitable cell, see subclause 5.2.2.1, except the cell selection criteria, calculate the cell selection value,  $S$ , and the quality value,  $Q_{\text{meas}}$ , defined in subclause 5.3.1.2.2.
- 4) Among the cells with  $S > 0$  select the cell with the highest  $Q_{\text{meas}}$  value.

If different radio access modes are involved in the procedure, mapping functions shall be applied. For each radio access mode, such a mapping function is defined and its parameters are broadcast in system information. The mapping function maps a certain range of measurement values to a representing quality value  $Q_{\text{map}}$  that can have values between 0 and 99 (step size 1). These quality values  $Q_{\text{map}}$  can then be compared with each other and the cell with the highest  $Q_{\text{map}}$  value is chosen (among those cells with  $S > 0$ ).

If the UE is unable to find any suitable cell, the UE shall release the RRC connection and enter idle mode.

#### 5.3.1.2.2 Criteria

The criteria for initial cell reselection is specified in subclause 5.2.2.1.2.

#### 5.3.1.3 Immediate Cell Evaluation Procedure

##### 5.3.1.3.1 Description

The Immediate Cell Evaluation procedure is used by the UE to perform a quick evaluation of the quality of the intra-frequency cells. Based on this information, the UE shall select the best cell among the cells on the same frequency, according to the criteria defined in the next subclause.

The immediate cell evaluation procedure shall be triggered prior to RACH and CPCH (FFS) transmission, if not restrictions specified in [4] inhibits use of the procedure.

The immediate cell evaluation procedure in UTRA access technology Connected Mode is the same as used for idle mode, described in subclause 5.2.2.2, with the following differences:

- 1) The potential cells for selection at immediate cell evaluation in Connected Mode consists of the cells for intra-frequency measurements in system information of the serving cell. However, if UE dedicated measurements control information has been assigned to the UE in the serving cell, the candidate list consists of the cells for intra-frequency measurements included in this UE dedicated measurement control information.

##### 5.3.1.4 Cell Reselection Procedure

The cell reselection procedure in UTRA access technology Connected Mode is the same as used for idle mode, described in subclause 5.2.2.4.

## 5.4 Location Registration

In the UE, the access stratum shall report registration area information to the non-access stratum.

The non-access part of the location registration process is specified in [5].

---

## 6 Broadcast information receiving

### 6.1 Reception of System Information

The UE shall read the BCCH to acquire valid system information. For each acquisition, the UE will need different combinations of system information blocks broadcast on BCCH. Thus, the scheduling of the broadcast channel is done in such way that the UE knows exactly when the needed information can be found.

When any of the system information blocks are modified, the corresponding scheduling information is updated to reflect the changes in system information transmitted on BCCH. Further, a message is sent to all UEs on PCCH to indicate that a new master information block is available in the cell. Then the UE shall read the updated master information block on BCCH and if the changes are applicable for the UE, the modified system information block(s) are read as well.

### 6.2 Cell Broadcast

A UE supporting Cell Broadcast Service (CBS) shall be capable to receive BMC messages in the Idle mode.

---

## 7 Measurements for cell selection / reselection

### 7.1 Use of Mapping Functions

Different types of measurements are used in different radio access technologies and modes for the cell selection and reselection (CPICH Ec/N0 or CPICH SIR in UTRA FDD, P-CCPCH RSCP in UTRA TDD, RXLEV in GSM). Whenever a direct comparison of these measurements is required, mapping functions shall be applied.

Mapping functions are used for mapping a certain range of measurement values  $Q_{meas}$  to a representing quality value  $Q_{map}$  (0..99, step size 1).

For each radio access technology and mode, one mapping function is defined. It may be defined over one or several consecutive intervals of the measurement values  $Q_{meas}$ .

The size of the consecutive intervals is sufficiently defined by their upper limit (given by parameter *Upper\_limit*). In case of only one interval specified, the parameter *Upper\_limit* is not needed and the interval is equivalent to the measurement range defined for that radio access technology. In case of more than one interval specified, the upper limit of the last interval defined is equivalent to the upper limit of the defined measurement range. The lower limit of an interval is equivalent to the upper limit of the interval before that interval. For the first interval, the lower limit is equivalent to the lower limit of the defined measurement range.

Within each interval, one function type is defined (given by parameter *Function\_type*) and the according function is defined by two parameters *Map\_parameter\_1* and *Map\_parameter\_2*. If  $Q_{meas}$  is the measured value and  $Q_{map}$  is the representing quality value, the following relation is defined over a certain interval:

Function type:

linear:  $Q_{map} = \text{Map\_parameter\_1} * Q_{meas} + \text{Map\_parameter\_2}$ .

The parameters defined for each interval (*Function\_type*, *Map\_parameter\_1*, *Map\_parameter\_2* and *Upper\_limit*) are broadcast in system information.

### 7.2 Network control of UE measurement activities

#### 7.2.1 Intra-frequency cell measurements

The optional parameter *Sintrasearch* provides means for the network to control the UE Intra-frequency measurement activities in idle mode. The parameter is included in the system information of the serving cell.



Depending on the presence of the parameter, and the quality of the serving cell,  $S_s$ , the following 2 cases are possible.

- 1) Parameter  $S_{intrasearch}$  is available for serving cell:

$S_s > S_{intrasearch}$	UE need not perform Intra-frequency measurements
$S_s \leq S_{intrasearch}$	UE shall perform Intra-frequency measurements

- 2) Parameter  $S_{intrasearch}$  is not available for serving cell:  
UE shall perform Intra-frequency measurements.

## 7.2.2 Inter-frequency cell measurements

The optional parameters  $S_{intersearch}$  provide means for the network to control the UE Inter-frequency measurement activities in idle mode. The parameters is included in the system information of the serving cell.

Depending on the presence of the parameters, and the quality of the serving cell,  $S_s$ , the following cases are possible:

- 1) Parameter  $S_{intersearch}$  is available for serving cell:

$S_s > S_{intersearch}$	UE need not perform Inter-frequency measurements
$S_s \leq S_{intersearch}$	UE shall perform Inter-frequency measurements

- 2) Parameter  $S_{intersearch}$  is not available for serving cell:  
UE shall perform Inter-frequency measurements.

## 7.2.3 Inter-Radio Access Technology measurements

The parameter  $S_{search}$  provides means for the network to control the UE Inter-Radio Access Technology measurement activities in idle mode. The parameter is included in the system information of the serving cell.

$S_s > S_{search}$	UE need not perform Inter-RAT measurements
$S_s \leq S_{search}$	UE shall perform Inter-RAT measurements

---

# 8 Discontinuous Reception

The UE may use Discontinuous Reception (DRX) in idle mode in order to reduce power consumption. When DRX is used the UE needs only to monitor one Page Indicator, PI, (see definition in [7] and [8]) in one Paging Occasion per DRX cycle.

The DRX cycle length shall be  $2^k \cdot \text{PBP}$  frames, where  $k$  is an integer and PBP is the Paging Block Periodicity. PBP is only applicable for TDD and is equal to the PICH repetition period that is broadcast in system information. For FDD,  $\text{PBP}=1$ .

The UE may be attached to different CN domains with different CN domain specific DRX cycle lengths. The UE shall store each CN domain specific DRX cycle length for each CN domain the UE is attached to and use the shortest of those DRX cycle lengths. The DRX cycle lengths to use for each CN domain are given in system information.

The DRX cycle lengths to use for UTRAN connected mode is the shortest of the following:

- UTRAN DRX cycle length;
- any of the stored CN domain specific DRX cycle length for the CN domains the UE is only attached to with no signalling connection established.

The UE shall use the IMSI, the Cell System Frame Number (SFN),  $N_p$  (number of page indicators within a frame), Frame offset (For FDD, Frame offset = 0; for TDD, PICH frame offset values are given in system information), PBP and the DRX cycle length to determine the Paging Occasions.

The value of the Paging Occasion (i.e. the SFN of the first frame of the Paging Block) is determined as follows:

Paging Occasion=  $\{ \text{IMSI mod (DRX cycle length div PBP)} \} * \text{PBP} + n * \text{DRX cycle length} + \text{Frame Offset}$

Where  $n = 0, 1, 2, \dots$  as long as SFN is below its maximum value.

The actual Page Indicator within a Paging Occasion that the UE shall read is similarly determined based on IMSI.

The Page Indicator to use is calculated by using the following formula:

$\text{PI} = \text{DRX Index mod } N_p$

where  $\text{DRX Index} = \{ \text{IMSI div (DRX cycle length div PBP)} \}$

In FDD mode,  $N_p = (18, 36, 72, 144)$  is the number of Page Indicators per frame, and is given in IE "Number of PI per frame", part of system information in FDD mode. In TDD mode,  $N_p$  is the number of Page Indicators per paging block and is calculated by the Paging Indicator Length  $L_{PI}$ , the Burst Type (long or short midamble) and the PICH repetition length, which are given in system information..

If the UE has no IMSI, for instance when making an emergency call without USIM, the UE shall use a default number,  $\text{IMSI} = 0$ , in the formulas above.

For FDD, see [7] for details about the timing between a PICH frame and when the paging message is transmitted on the PCH in the associated S-CCPCH frame. In TDD mode, the Paging Message Receiving Occasion is calculated using the following formula:

$\text{Paging Message Receiving Occasion} = \text{Paging Occasion} + N_{\text{PICH}} + N_{\text{GAP}} + \{ (\text{DRX Index div } N_p) \text{ mod } N_{\text{PCH}} \} * 2$

The value  $N_{\text{PICH}}$  is the number of frames for PICH transmission and is equal to the PICH repetition length given in system information. The value  $N_{\text{GAP}}$  is the number of frames between the last frame carrying PICH for this Paging Occasion and the first frame carrying paging messages for this Paging Occasion. The value  $N_{\text{PCH}}$  is the number of Paging Groups.  $N_{\text{PCH}}$  and  $N_{\text{GAP}}$  are given in system information.

## 9 Multicast services

### 9.1 State diagram between the multicast service and DSCH

NOTE: The use of DSCH for multicast services is FFS.

The multicast service relative to the DSCH consists of the following states:

- MT\_Null State;
- MT\_Monitor State;
- MT\_Saving State;
- MT\_Active State.

Figure 6 shows the multicast state diagram relative to the DSCH. The MT\_Monitor State is a state for decoding the DSCH in order to monitor its multicast control data and the MT\_Saving State is a state in which the UE savings for the supporting power saving feature.

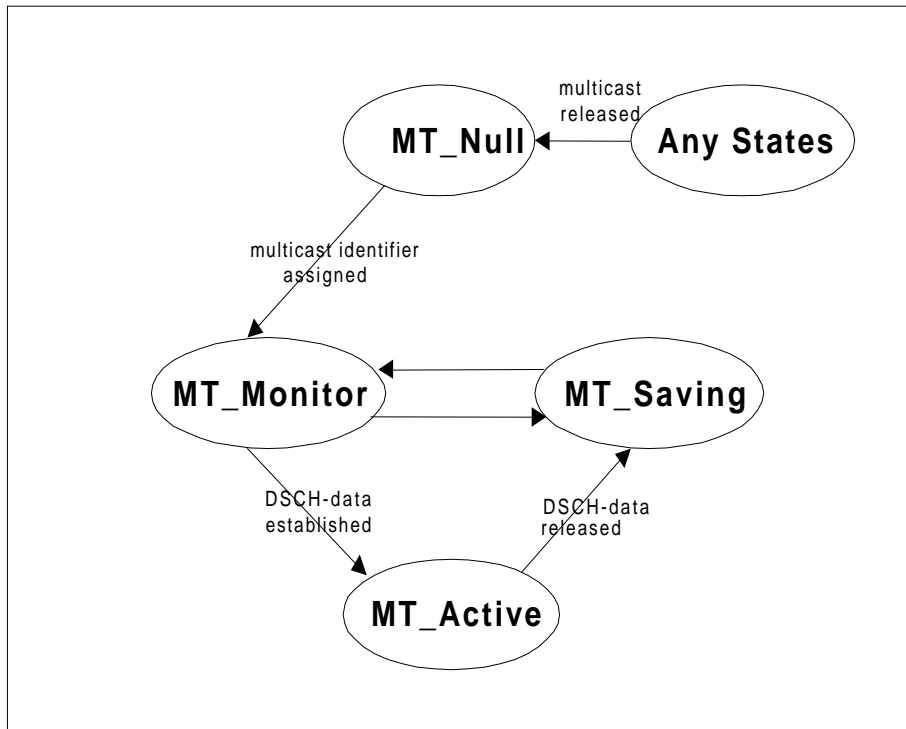

**Figure 6: Multicast State Diagram relative to the DSCH, MT=MULTicast service**

### 9.1.1 MT\_Null State

#### a) Attributes

- Multicast service has not been activated.
- DSCH is not established.

#### b) Behaviour

- Waits for activation of multicast service.

### 9.1.2 MT\_Monitor State

#### a) Attributes

- DSCH is monitored in order to decode the multicast control data that contains the assigned multicast identifier.

#### b) Behaviour

- Receives the DSCH control data on DSCH and confirms the assigned multicast identifier.

### 9.1.3 MT\_Saving State

#### a) Attributes

- DSCH is not monitored for the control or the user data.

#### b) Behaviour

- FFS

### 9.1.4 MT\_Active State

- a) Attributes
  - DSCH is not monitored for the control data.
  - DSCH is monitored for the user data.
- b) Behaviour
  - Receives the multicast user data on the established DSCH.

## 10 Examples of Procedures

### 10.1 NAS initiated change of system information

The sequence in Figure 7 shows the change of broadcast system information initiated from the non-access stratum (NAS).

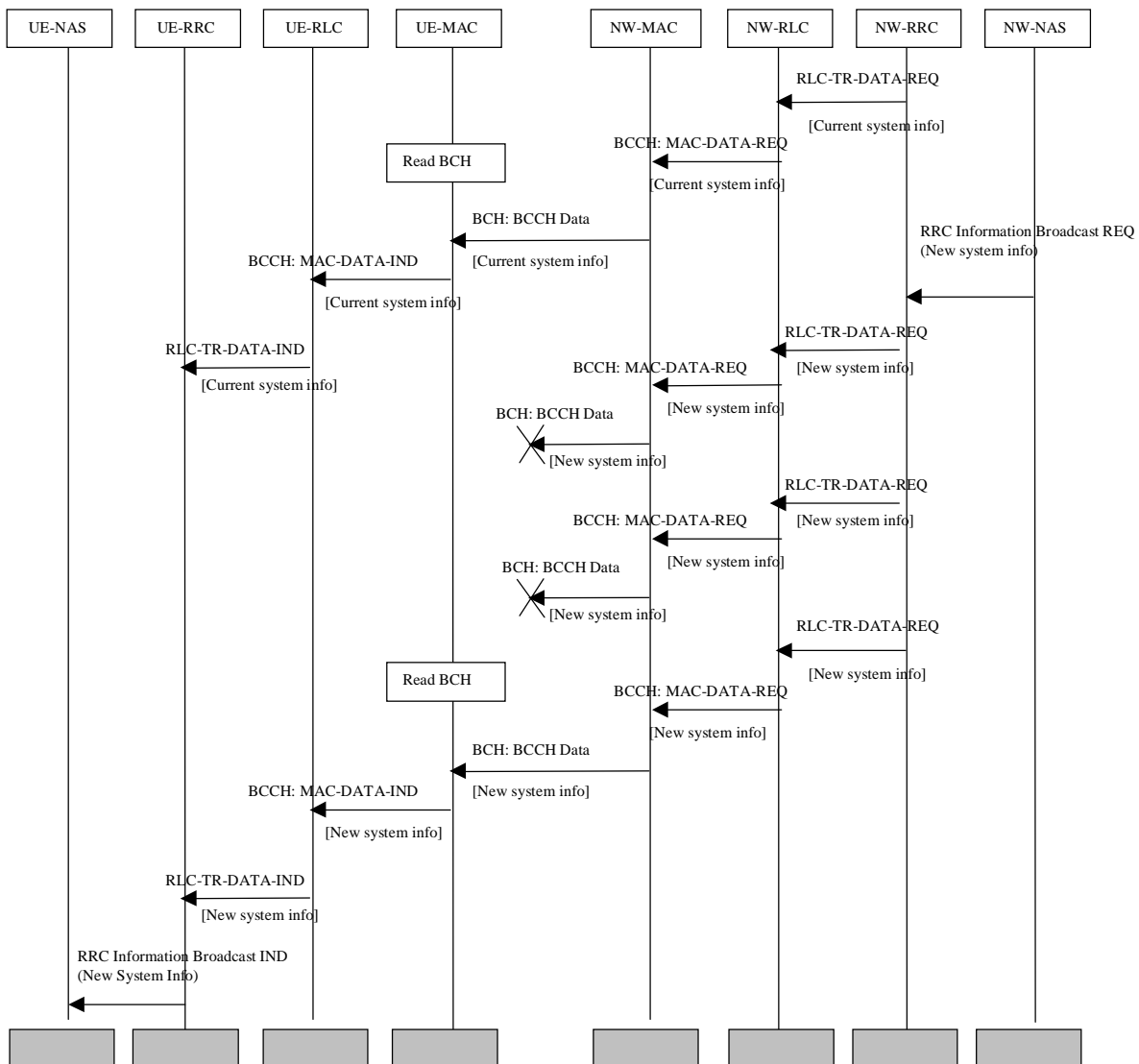

Figure 7: Example sequence, non-access stratum initiated change of broadcast system info

A non-access stratum entity in the network issues a request for change of the broadcast system information, by issuing a RRC Information Broadcast REQ primitive over the General Control (GC) SAP.

The change in system information in this example is such that it is not necessary for the UEs to be forced to receive BCCH immediately after the change. All UEs will eventually read the new system information either at e.g. cell reselection or at UE state change.

When the UE reads system information on BCCH and the RRC layer finds out that the non-access part of the information has been changed, an RRC Information Broadcast IND primitive is issued to the non-access stratum entity in the UE over the General Control (GC) SAP.

**NOTE:** The network may force the UEs in a paging group to read system information by sending a page request message, but this is not shown in the example above.

## 10.2 System Information Update to NAS

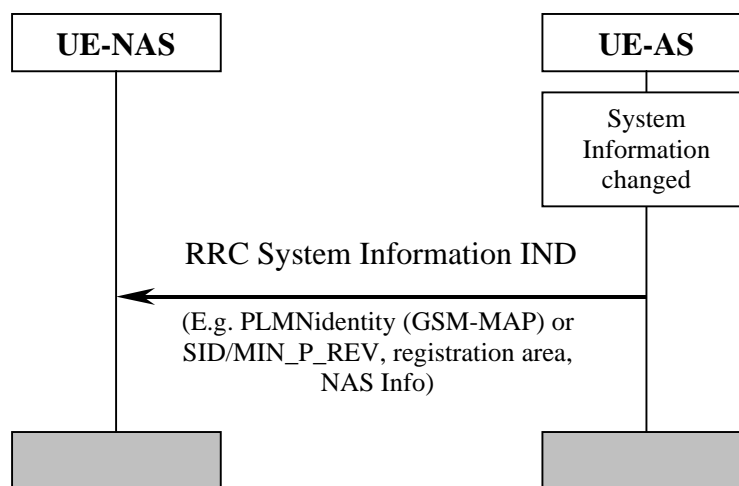

**Figure 8: System Information Update to NAS**

AS sends system information to NAS when a change of system information is detected in the cell currently camped on. This happens for instance when a new cell is selected due to cell reselection. The information sent can include PLMN identity (GSM-MAP or SID, registration area and NAS information. The NAS information includes the identity of the NAS defined service area.

### 10.3 CN originated paging in idle mode

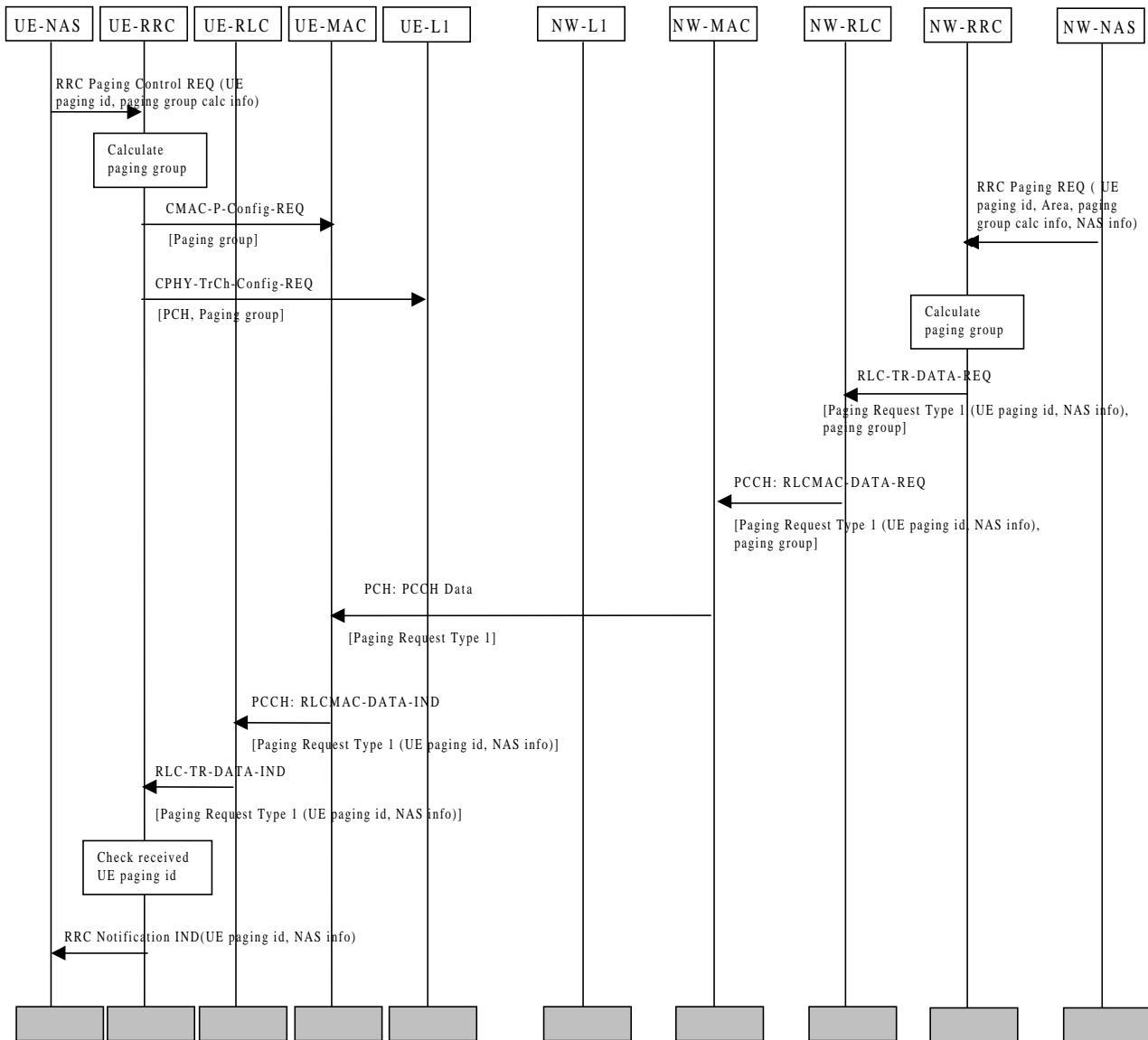

**Figure 9: Example sequence of CN initiated paging request in idle mode**

Figure 9 illustrates a CN originated paging request when the UE is in idle mode.

In the UE, a NAS entity issues the primitive RRC Paging Control REQ, which tells RRC to listen to paging and notifications addressed to a given UE paging identity and on a paging group which can be calculated using information given from NAS.

NOTE: The paging group calculation info can e.g. be the IMSI of the UE.

A NAS entity on the network side requests paging of an UE using the RRC Paging REQ primitive over the Nt-SAP. The primitive contains a UE paging identity, an area where the page request is to be broadcast, information for calculation of the paging group and NAS information to be transparently transmitted to the UE by the paging request.

The RRC layer calculates the paging group, and formats a Paging Request Type 1 message containing the UE paging identity and the NAS information. The RRC layer then requests MAC to transmit the message on the PCH on the selected paging group.

In the UE, the RRC layer continuously monitors the paging group, compares the UE paging identities in received paging request messages with its own identities. A match occurs, and in this case the UE paging identity and the NAS information is forwarded to the NAS entity of the UE.

## 10.4 PLMN Selection, automatic mode, normal case

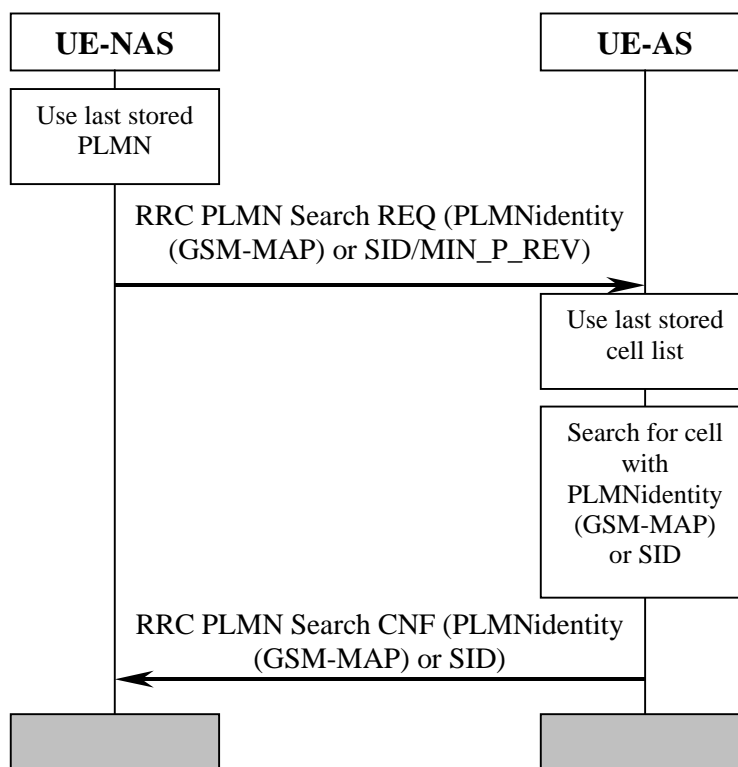

**Figure 10: PLMN Selection, automatic mode, normal case**

At power-on, the non-access stratum (NAS) selects the PLMN with highest priority, possibly the last PLMN stored prior to previous power off. The access stratum (AS) is requested to find a cell belonging to that PLMN. When searching for the requested PLMN and in order to speed up the search, AS may use a list of cell information stored prior to previous power-off. When a cell belonging to the requested PLMN is found, that cell is selected and NAS is notified that the PLMN was found.

## 10.5 PLMN Reselection, automatic mode

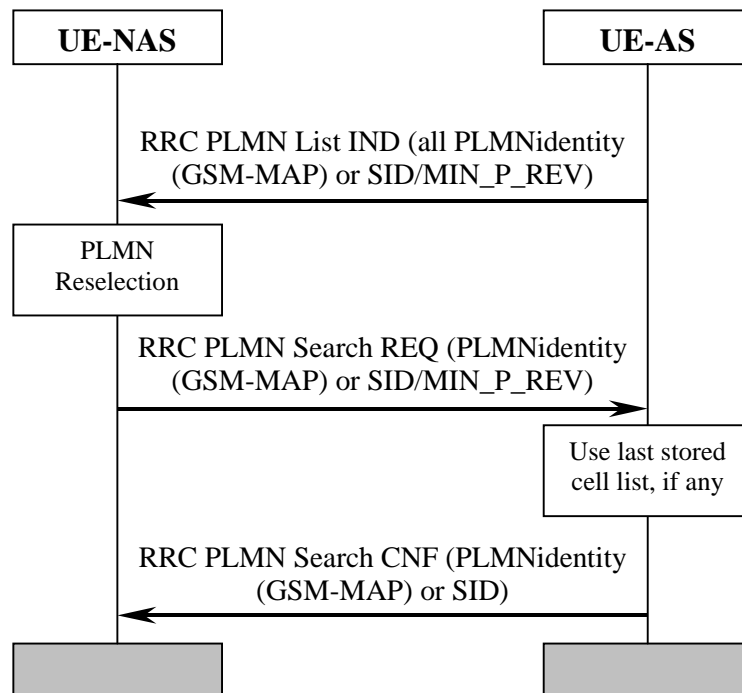
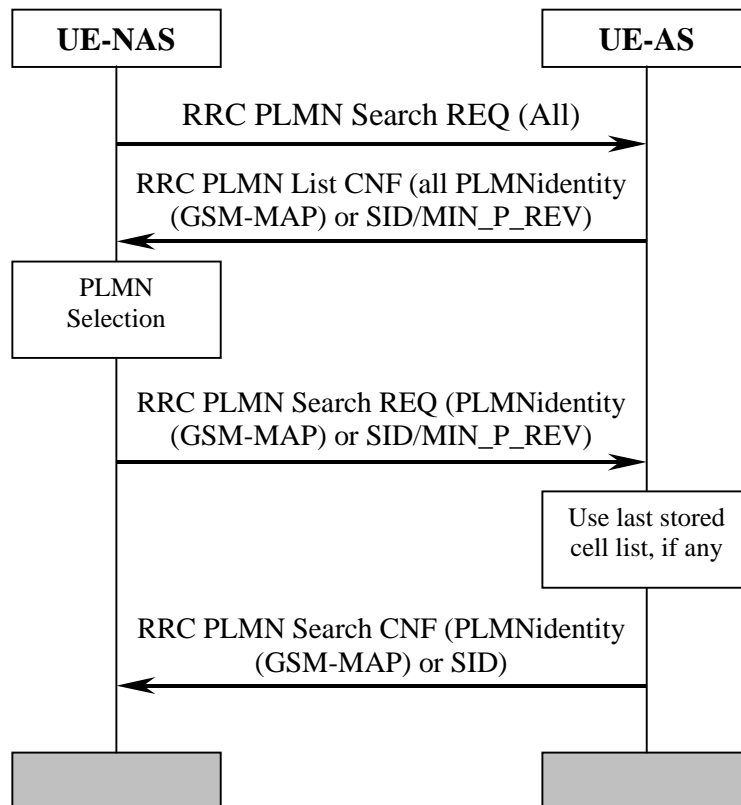

**Figure 11: PLMN Reselection, automatic mode**

Triggered by, for instance, a timer, AS sends a list to NAS with all PLMNs currently available. The list includes the identities of available PLMNs and possibly information about their NAS defined service area(s). Assuming that a PLMN with higher priority is found, NAS requests AS to select a cell belonging to the PLMN with highest priority. When searching for the requested PLMN and in order to speed up the search, AS may use a list of cell information previously stored, if any. When a cell belonging to the requested PLMN is found, that cell is selected and NAS is notified that the PLMN was found.



## 10.6 PLMN Reselection, manual mode



**Figure 12: PLMN Reselection, manual mode**

NAS requests AS to report all PLMNs currently available, for instance as a response to a user request. AS sends a list to NAS with all PLMNs currently available. The list includes the identities of available PLMNs and possibly information about their NAS defined service area(s). Assuming that a PLMN with higher priority is selected by for instance the user, NAS requests AS to select a cell belonging to the PLMN with highest priority. When searching for the requested PLMN and in order to speed up the search, AS may use a list of cell information previously stored, if any. When a cell belonging to the requested PLMN is found, that cell is selected and NAS is notified that the PLMN was found.

## 10.7 PLMN Selection, automatic mode, selected PLMN not found

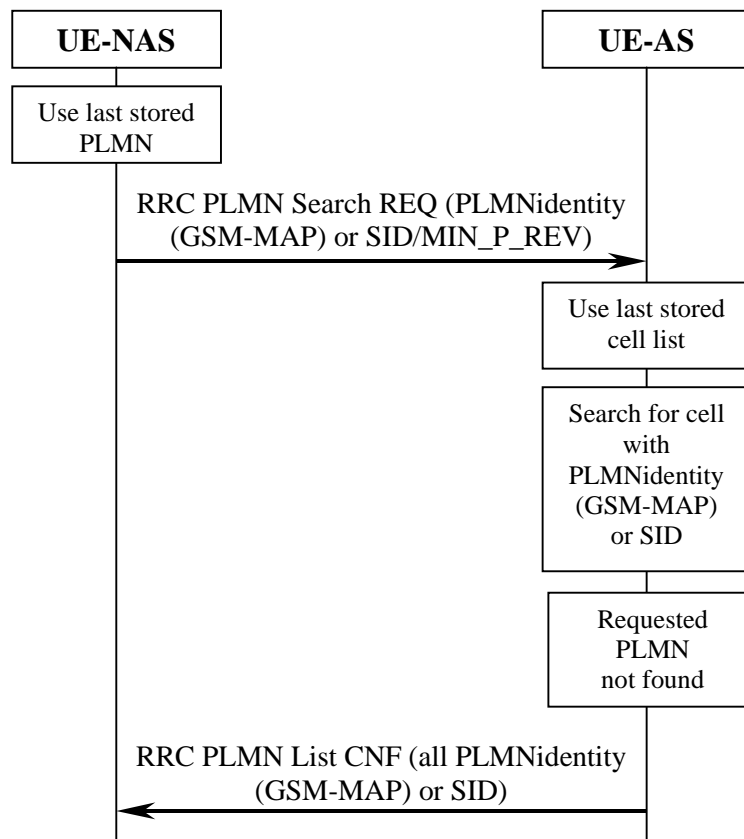
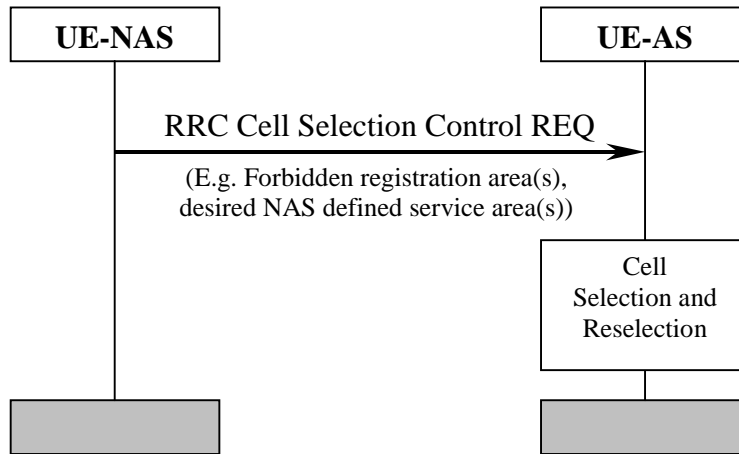

**Figure 13: PLMN Selection, automatic mode, selected PLMN not found**

At power-on, the non-access stratum selects the PLMN with highest priority, possibly from the list of PLMNs stored prior to previous power off. The access stratum is requested to find a cell belonging to that PLMN. When searching for the requested PLMN and in order to speed up the search, AS may use a list of cell information stored prior to previous power-off. If no cell is found belonging to the requested PLMN, a list of available PLMNs is sent to NAS, indicating which PLMN has been temporarily chosen by AS.

## 10.8 NAS Controlled Cell Selection

### 10.8.1 Execution in Access Stratum

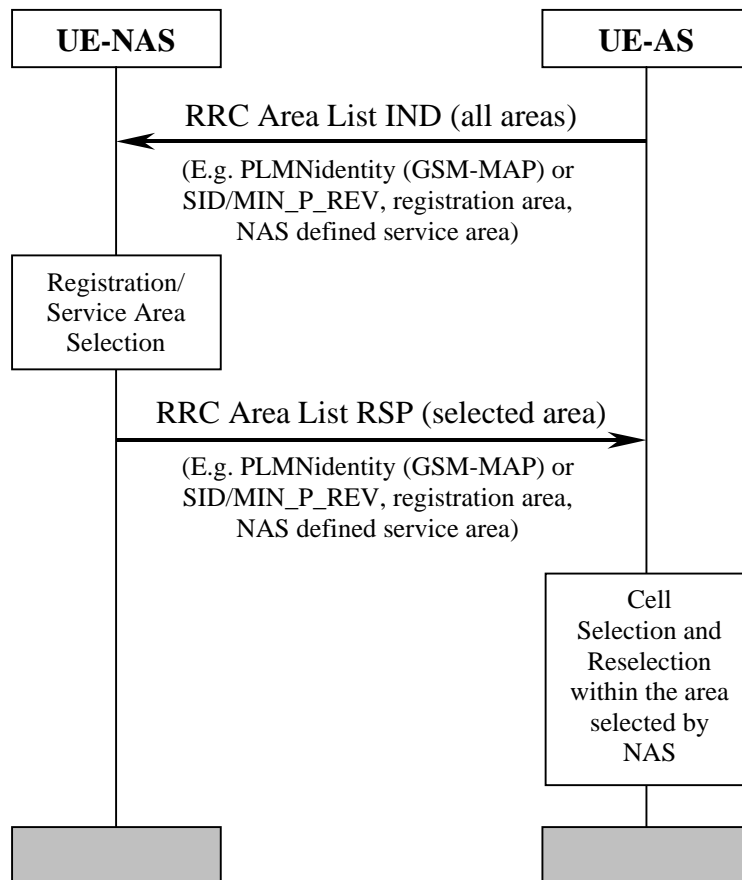

**Figure 14: NAS Controlled Cell Selection, execution in AS**

NAS may influence the cell selection and reselection by sending control information to AS. This information can include, for example, lists of forbidden registration areas and a list of NAS defined service areas in priority order. The control information is used by AS in cell selection and reselection:

- Cells belonging to a forbidden registration area will only be selected if no better cell is found. At this point, the services provided the UE might be limited.
- Cells belonging to a NAS defined service area with higher priority than current service area will be considered better than the cell currently camped on. Depending on radio access mode, the most suitable cell in idle mode may not be the most suitable cell in connected mode.

## 10.8.2 Execution in Non-Access Stratum



**Figure 15: NAS Controlled Cell Selection, execution in NAS**

As an alternative to the example in subclause 11.8.1, AS sends cell selection information to NAS. This information can include PLMN identity (GSM-MAP) or SID, registration area and NAS defined service area. The information contains the full set of available registration areas and NAS defined service areas. The information is typically sent when there is a change of available areas, for instance when a neighbour cell belonging to a new registration area/NAS defined service area is found. Correspondingly, a new list of available areas is sent from AS to NAS when for instance coverage is lost from the cell currently camped on and that is the only cell belonging to the current NAS defined service area.

AS performs cell selection and reselection for the selected registration area/NAS defined service area without interaction with NAS. However, before reselecting a cell in another registration area/NAS defined service area, AS must check with NAS.

## Annex A (informative): Change history

Change history					
TSG-RAN#	Version	CR	Tdoc RAN	New Version	Subject/Comment
RAN_05	-	-	RP-99464	3.0.0	(10/99) Approved at TSG-RAN #5 and placed under Change Control
RAN_06	3.0.0	001	RP-99632	3.1.0	(12/99) Modification and editorial changes
RAN_06	3.0.0	002	RP-99633	3.1.0	Specification of Cell reselection procedures in
RAN_06	3.0.0	003	RP-99633	3.1.0	Integration of Cell Broadcast Service (CBS)
RAN_06	3.0.0	004	RP-99633	3.1.0	Measurement used as a quality estimate for cell
RAN_06	3.0.0	006	RP-99632	3.1.0	Discontinuous reception
RAN_06	3.0.0	008	RP-99633	3.1.0	Barred Cells and Access Control
RAN_06	3.0.0	009	RP-99633	3.1.0	Introduction of network control of UE measurement
RAN_06	3.0.0	011	RP-99631	3.1.0	Editorial issues
RAN_07	3.1.0	007	RP-000037	3.2.0	(03/00) Cell Selection for DS-41 mode
RAN_07	3.1.0	014	RP-000037	3.2.0	Modified description of cell search procedure
RAN_07	3.1.0	018	RP-000037	3.2.0	UE individual DRX cycles in CELL_PCH and URA_PCH states
RAN_07	3.1.0	019	RP-000037	3.2.0	Cell re-selection criteria including HCS
RAN_07	3.1.0	021	RP-000037	3.2.0	Modified description of DRX

---

# History

<b>Document history</b>		
V3.2.0	March 2000	Publication