

ETSI TS 125 321 V3.5.0 (2000-09)

Technical Specification

Universal Mobile Telecommunications System (UMTS); MAC protocol specification (3GPP TS 25.321 version 3.5.0 Release 1999)



Reference

RTS/TSGR-0225321UR3

Keywords

UMTS

ETSI

650 Route des Lucioles
F-06921 Sophia Antipolis Cedex - FRANCE

Tel.: +33 4 92 94 42 00 Fax: +33 4 93 65 47 16

Siret N° 348 623 562 00017 - NAF 742 C
Association à but non lucratif enregistrée à la
Sous-Préfecture de Grasse (06) N° 7803/88

Important notice

Individual copies of the present document can be downloaded from:

<http://www.etsi.org>

The present document may be made available in more than one electronic version or in print. In any case of existing or perceived difference in contents between such versions, the reference version is the Portable Document Format (PDF). In case of dispute, the reference shall be the printing on ETSI printers of the PDF version kept on a specific network drive within ETSI Secretariat.

Users of the present document should be aware that the document may be subject to revision or change of status. Information on the current status of this and other ETSI documents is available at <http://www.etsi.org/tb/status/>

If you find errors in the present document, send your comment to:
editor@etsi.fr

Copyright Notification

No part may be reproduced except as authorized by written permission.
The copyright and the foregoing restriction extend to reproduction in all media.

© European Telecommunications Standards Institute 2000.

All rights reserved.

Intellectual Property Rights

IPRs essential or potentially essential to the present document may have been declared to ETSI. The information pertaining to these essential IPRs, if any, is publicly available for **ETSI members and non-members**, and can be found in ETSI SR 000 314: "*Intellectual Property Rights (IPRs); Essential, or potentially Essential, IPRs notified to ETSI in respect of ETSI standards*", which is available from the ETSI Secretariat. Latest updates are available on the ETSI Web server (<http://www.etsi.org/ipr>).

Pursuant to the ETSI IPR Policy, no investigation, including IPR searches, has been carried out by ETSI. No guarantee can be given as to the existence of other IPRs not referenced in ETSI SR 000 314 (or the updates on the ETSI Web server) which are, or may be, or may become, essential to the present document.

Foreword

This Technical Specification (TS) has been produced by the ETSI 3rd Generation Partnership Project (3GPP).

The present document may refer to technical specifications or reports using their 3GPP identities, UMTS identities or GSM identities. These should be interpreted as being references to the corresponding ETSI deliverables.

The cross reference between GSM, UMTS, 3GPP and ETSI identities can be found under www.etsi.org/key .

Contents

Foreword.....	5
1 Scope.....	6
2 References.....	6
3 Definitions and abbreviations.....	7
3.1 Definitions.....	7
3.2 Abbreviations.....	7
4 General.....	8
4.1 Objective.....	8
4.2 MAC architecture.....	8
4.2.1 MAC Entities.....	8
4.2.2 MAC-b.....	8
4.2.3 Traffic Related Architecture - UE Side.....	9
4.2.3.1 MAC-c/sh entity – UE Side.....	10
4.2.3.2 MAC-d entity – UE Side.....	11
4.2.4 Traffic Related Architecture - UTRAN Side.....	12
4.2.4.1 MAC-c/sh entity – UTRAN Side.....	13
4.2.4.2 MAC-d entity – UTRAN Side.....	14
4.3 Channel structure.....	15
4.3.1 Transport channels.....	16
4.3.2 Logical Channels.....	16
4.3.2.1 Logical channel structure.....	16
4.3.2.2 Control Channels.....	16
4.3.2.3 Traffic Channels.....	17
4.3.3 Mapping between logical channels and transport channels.....	17
5 Services provided to upper layers.....	17
5.1 Description of Services provided to upper layers.....	17
6 Functions.....	17
6.1 Description of the MAC functions.....	17
6.2 Relation between MAC Functions / Transport Channels and UE.....	18
6.2.1 Relation between MAC Functions and Transport Channels.....	18
6.2.2 Relation of UE MAC functions corresponding to the Transport Channel MAC Functions and Transport Channels.....	19
7 Services expected from physical layer.....	19
8 Elements for layer-to-layer communication.....	19
8.1 Primitives between layers 1 and 2.....	19
8.2 Primitives between MAC and RLC.....	20
8.2.1 Primitives.....	20
8.2.2 Parameters.....	20
8.3 Primitives between MAC and RRC.....	21
8.3.1 Primitives.....	21
8.3.2 Parameters.....	21
9 Elements for peer-to-peer communication.....	22
9.1 Protocol data units.....	22
9.1.1 General.....	22
9.1.2 MAC Data PDU.....	23
9.2 Formats and parameters.....	23
9.2.1 MAC Data PDU: Parameters of the MAC header.....	23
9.2.1.1 MAC header for DTCH and DCCH.....	25
9.2.1.2 MAC header for BCCH.....	26
9.2.1.3 MAC header for PCCH.....	26
9.2.1.4 MAC header for CCCH.....	26

9.2.1.5	MAC Header for CTCH.....	27
9.2.1.6	MAC Header for SHCCH.....	27
10	Handling of unknown, unforeseen and erroneous protocol data.....	27
11	Elementary procedures.....	27
11.1	Traffic volume measurement for dynamic radio bearer control.....	27
11.2	Control of RACH transmissions.....	29
11.2.1	Access Service Class selection.....	29
11.2.2	Control of RACH transmissions for FDD mode.....	30
11.2.3	Control of RACH transmissions for TDD.....	32
11.3	Control of CPCH transmissions for FDD.....	33
11.4	Transport format combination selection in UE.....	37
Annex A (informative): Change history.....		39

Foreword

This Technical Specification (TS) has been produced by the 3rd Generation Partnership Project (3GPP).

The contents of the present document are subject to continuing work within the TSG and may change following formal TSG approval. Should the TSG modify the contents of the present document, it will be re-released by the TSG with an identifying change of release date and an increase in version number as follows:

Version x.y.z

where:

- x the first digit:
 - 1 presented to TSG for information;
 - 2 presented to TSG for approval;
 - 3 or greater indicates TSG approved document under change control.
- y the second digit is incremented for all changes of substance, i.e. technical enhancements, corrections, updates, etc.
- z the third digit is incremented when editorial only changes have been incorporated in the document.

1 Scope

The present document specifies the MAC protocol.

The specification describes:

- MAC architecture;
- MAC entities;
- channel structure;
- services provided to upper layers;
- MAC functions;
- services expected from the physical layer;
- elements for layer-to-layer communication including primitives between MAC and RLC;
- elements for peer-to-peer communication;
- protocol data units, formats and parameters;
- elementary procedures.

2 References

The following documents contain provisions which, through reference in this text, constitute provisions of the present document.

- References are either specific (identified by date of publication, edition number, version number, etc.) or non-specific.
- For a specific reference, subsequent revisions do not apply.
- For a non-specific reference, the latest version applies.

- [1] 3GPP TR 21.905: "Vocabulary for 3GPP Specifications".
- [2] 3GPP TS 25.301: "Radio Interface Protocol Architecture".
- [3] 3GPP TS 25.302: "Services provided by the Physical Layer".
- [4] 3GPP TS 25.303: "Interlayer Procedures in Connected Mode".
- [5] 3GPP TS 25.304: "UE Procedures in Idle Mode and Procedures for Cell Reselection in Connected Mode".
- [6] 3GPP TS 25.322: "RLC Protocol Specification".
- [7] 3GPP TS 25.331: "RRC Protocol Specification".
- [8] 3GPP TS 25.921: "Guidelines and Principles for Protocol Description and Error Handling".
- [9] 3GPP TR 25.990: "Vocabulary for the UTRAN".
- [10] 3GPP TS 33.102: "Security architecture".
- [11] 3GPP TS 25.425: "UTRAN Iur Interface User Plane Protocols for Common Transport Channel Data Streams".

3 Definitions and abbreviations

3.1 Definitions

For the purposes of the present document, the terms and definitions given in [9] and [1] apply.

3.2 Abbreviations

For the purposes of the present document, the following abbreviations apply:

ASC	Access Service Class
BCCH	Broadcast Control Channel
BCH	Broadcast Channel
C-	Control-
CCCH	Common Control Channel
CPCH	Common Packet Channel (UL)
DCCH	Dedicated Control Channel
DCH	Dedicated Channel
DL	Downlink
DSCH	Downlink Shared Channel
DTCH	Dedicated Traffic Channel
FACH	Forward Link Access Channel
FAUSCH	Fast Uplink Signalling Channel
FDD	Frequency Division Duplex
L1	Layer 1 (physical layer)
L2	Layer 2 (data link layer)
L3	Layer 3 (network layer)
MAC	Medium Access Control
PCCH	Paging Control Channel
PCH	Paging Channel
PDU	Protocol Data Unit
PHY	Physical layer
PhyCH	Physical Channels
RACH	Random Access Channel
RLC	Radio Link Control
RNC	Radio Network Controller
RNS	Radio Network Subsystem
RNTI	Radio Network Temporary Identity
RRC	Radio Resource Control
SAP	Service Access Point
SDU	Service Data Unit
SHCCH	Shared Channel Control Channel
SRNC	Serving Radio Network Controller
SRNS	Serving Radio Network Subsystem
TDD	Time Division Duplex
TFCI	Transport Format Combination Indicator
TFI	Transport Format Indicator
U-	User-
UE	User Equipment
UL	Uplink
UMTS	Universal Mobile Telecommunications System
USCH	Uplink Shared Channel
UTRA	UMTS Terrestrial Radio Access
UTRAN	UMTS Terrestrial Radio Access Network

4 General

4.1 Objective

The objective is to describe the MAC architecture and the different MAC entities from a functional point of view.

NOTE: FAUSCH is not part of release 99.

4.2 MAC architecture

The description in this subclause is a model and does not specify or restrict implementations.

According to the RRC functions the RRC is generally in control of the internal configuration of the MAC.

4.2.1 MAC Entities

The diagrams that describe the MAC architecture are constructed from MAC entities.

The entities are assigned the following names.

- MAC-b is the MAC entity that handles the following transport channels:
 - broadcast channel (BCH)
- MAC-c/sh, is the MAC entity that handles the following transport channels:
 - paging channel (PCH)
 - forward access channel (FACH)
 - random access channel (RACH)
 - common packet channel (UL CPCH). The CPCH exists only in FDD mode.
 - downlink shared channel (DSCH)
 - uplink shared channel (USCH). The USCH exists only in TDD mode.
- MAC-d is the MAC entity that handles the following transport channels:
 - dedicated transport channels (DCH)

The exact functions completed by the entities are different in the UE from those completed in the UTRAN.

NOTE: When a UE is allocated resources for exclusive use by the bearers that it supports the MAC-d entities dynamically share the resources between the bearers and are responsible for selecting the TFI/ TFCI that is to be used in each transmission time interval.

4.2.2 MAC-b

The following diagram illustrates the connectivity of the MAC-b entity in a UE and in each cell of the UTRAN.

MAC-b represents the control entity for the broadcast channel (BCH).

There is one MAC-b entity in each UE and one MAC-b in the UTRAN for each cell.

The MAC Control SAP is used to transfer Control information to MAC-b.

The MAC-b entity is located in the Node B.

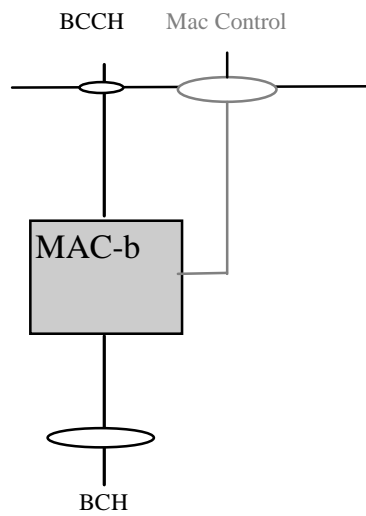

Figure 4.2.2.1: UE side and UTRAN side architecture

4.2.3 Traffic Related Architecture - UE Side

Figure 4.2.3.1 illustrates the connectivity of MAC entities.

The MAC-c/sh controls access to common transport channels.

The MAC-d controls access to dedicated transport channels.

If logical channels of dedicated type are mapped to common channels then MAC-d passes the data to MAC-c/sh via the illustrated connection between the functional entities.

The mapping of logical channels on transport channels depends on the multiplexing that is configured by RRC.

The MAC Control SAP is used to transfer Control information to each MAC entity.

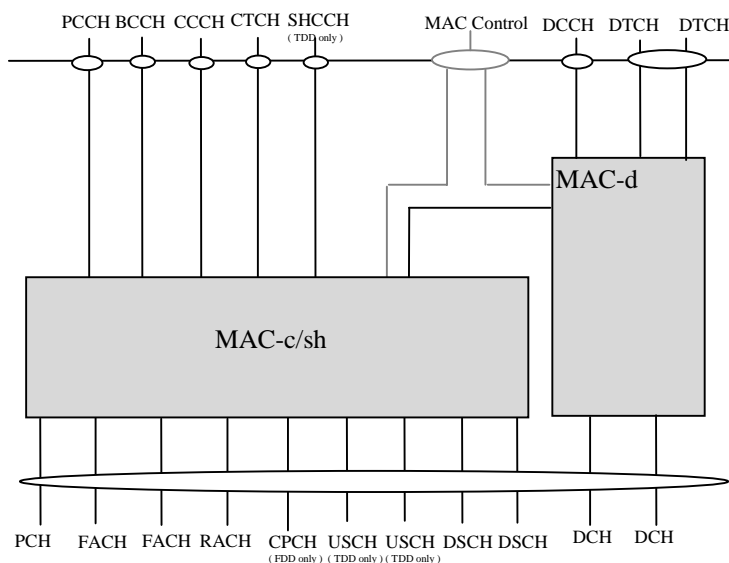

Figure 4.2.3.1: UE side MAC architecture

4.2.3.1 MAC-c/sh entity – UE Side

Figure 4.2.3.1.1 shows the UE side MAC-c/sh entity.

The following functionality is covered:

- TCTF MUX:
 - this function represents the handling (insertion for uplink channels and detection and deletion for downlink channels) of the TCTF field in the MAC header, and the respective mapping between logical and transport channels.
The TCTF field indicates the common logical channel type, or if a dedicated logical channel is used;
- add/read UE Id:
 - the UE Id is added for CPCH and RACH transmissions
 - the UE Id, when present, identifies data to this UE.
- UL: TF selection:
 - in the uplink, the possibility of transport format selection exists.
In case of CPCH transmission, a TF is selected based on TF availability determined from status information on the CSICH;
- ASC selection:
 - For RACH, MAC indicates the ASC associated with the PDU to the physical layer. For CPCH, MAC may indicate the ASC associated with the PDU to the Physical Layer. This is to ensure that RACH and CPCH messages associated with a given Access Service Class (ASC) are sent on the appropriate signature(s) and time slot(s). MAC also applies the appropriate back-off parameter(s) associated with the given ASC;
- scheduling /priority handling
 - this functionality is used to transmit the information received from MAC-d on RACH and CPCH based on logical channel priorities. This function is related to TF selection.
- TFC selection
 - transport format and transport format combination selection according to the transport format combination set (or transport format combination subset) configured by RRC is performed,

The RLC provides RLC-PDUs to the MAC, which fit into the available transport blocks on the transport channels.

There is one MAC-c/sh entity in each UE.

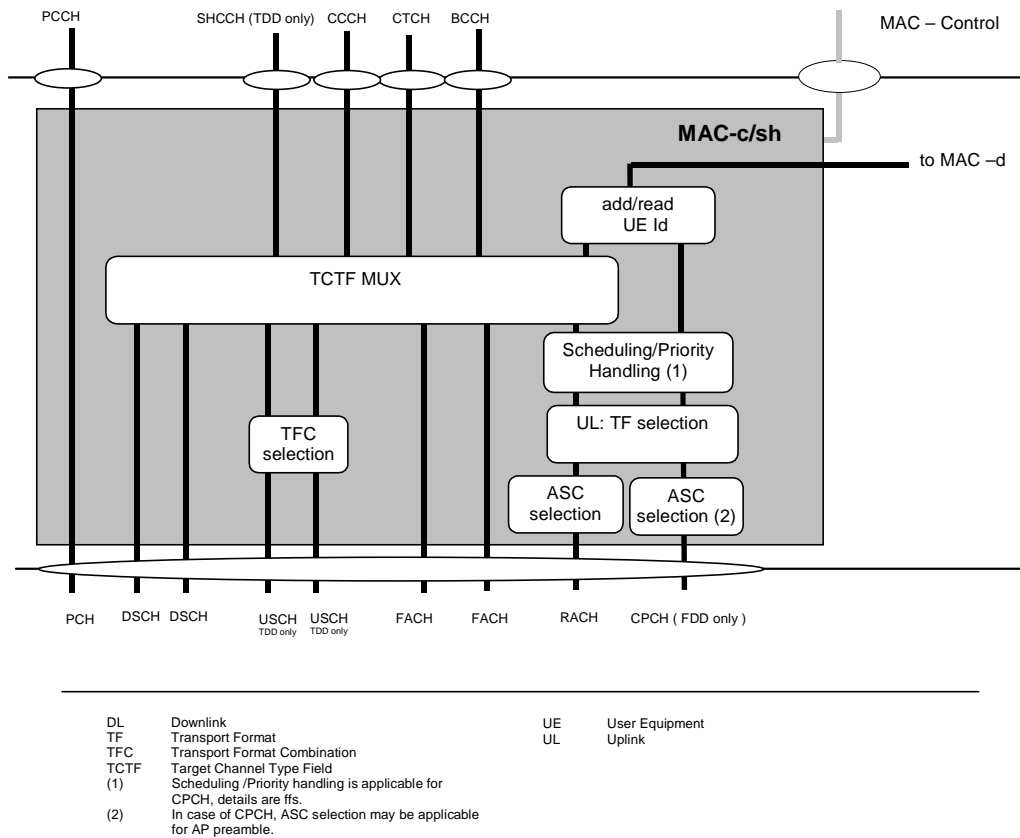

Figure 4.2.3.1.1: UE side MAC architecture / MAC-c/sh details

4.2.3.2 MAC-d entity – UE Side

Figure 4.2.3.2.1 shows the UE side MAC-d entity.

The following functionality is covered:

- Channel switching
- dynamic transport channel type switching is performed by this entity, based on decision taken by RRC. This is usually related to a change of radio resources.
- C/T MUX:
 - the C/T MUX is used when multiplexing of several dedicated logical channels onto one transport channel is used. An unambiguous identification of the logical channel is included.
- Ciphering:
 - Ciphering for transparent mode data to be ciphered is performed in MAC-d. Details about ciphering can be found in [10].
- Deciphering:
 - Deciphering for ciphered transparent mode data is performed in MAC-d. Details about ciphering can be found in [10].
- UL TFC selection:
 - transport format and transport format combination selection according to the transport format combination set (or transport format combination subset) configured by RRC is performed.
- FAUSCH Handling:

- this function handles the FAUSCH transport channels, details are ffs.

The MAC-d entity is responsible for mapping dedicated logical channels for the uplink either onto dedicated transport channels or to transfer data to MAC-c/sh to be transmitted via common channels.

One dedicated logical channel can be mapped simultaneously onto DCH and DSCH;

The MAC-d entity has a connection to the MAC-c/sh entity. This connection is used to transfer data to the MAC-c/sh to transmit data on transport channels that are handled by MAC-c/sh (uplink) or to receive data from transport channels that are handled by MAC-c/sh (downlink).

There is one MAC-d entity in the UE.

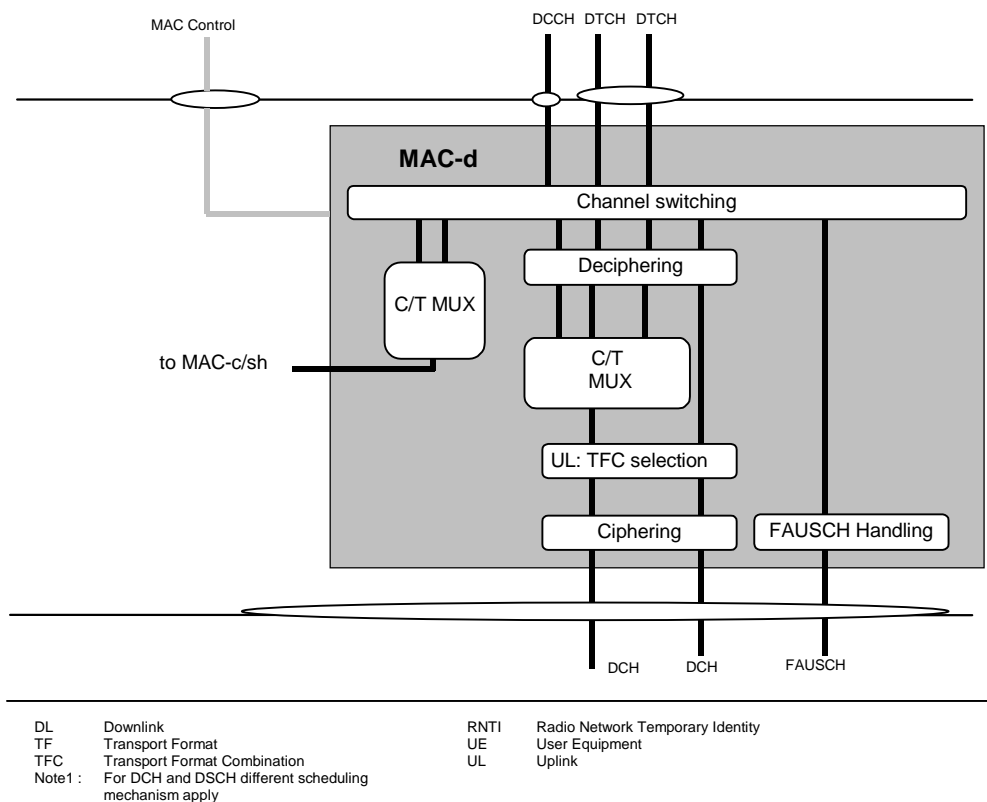

Figure 4.2.3.2.1: UE side MAC architecture / MAC-d details

4.2.4 Traffic Related Architecture - UTRAN Side

Figure 4.2.4.1 illustrates the connectivity between the MAC entities from the UTRAN side.

It is similar to the UE case with the exception that there will be one MAC-d for each UE and each UE (MAC-d) that is associated with a particular cell may be associated with that cell's MAC-c/sh.

MAC-c/sh is located in the controlling RNC while MAC-d is located in the serving RNC.

The MAC Control SAP is used to transfer Control information to each MAC entity belongs to one UE.

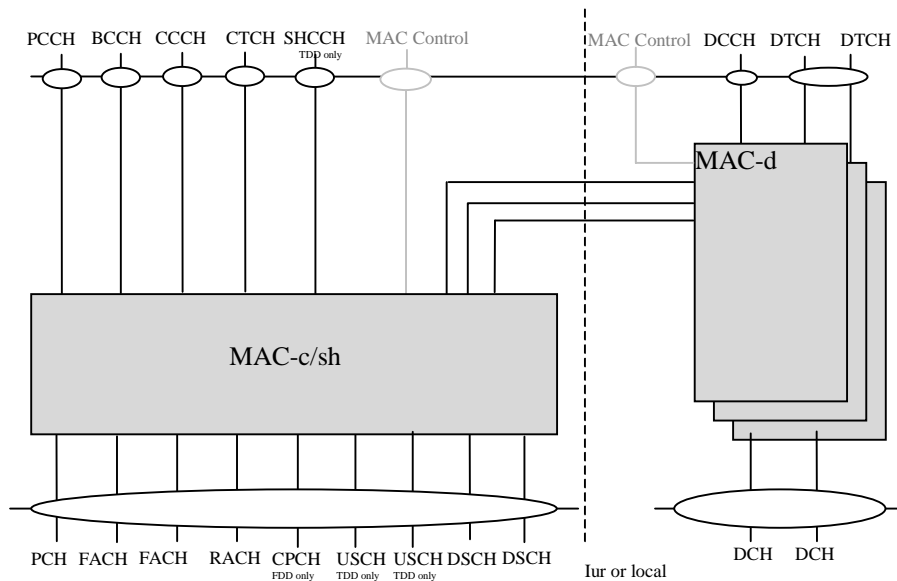

Figure 4.2.4.1: UTRAN side MAC architecture

4.2.4.1 MAC-c/sh entity – UTRAN Side

Figure 4.2.4.1.1 shows the UTRAN side MAC-c/sh entity. The following functionality is covered:

- the Scheduling – Priority Handling;
 - this function manages FACH and DSCH resources between the UE's and between data flows according to their priority.
- TCTF MUX
 - this function represents the handling (insertion for downlink channels and detection and deletion for uplink channels) of the TCTF field in the MAC header, and the respective mapping between logical and transport channels.
 - The TCTF field indicates the common logical channel type, or if a dedicated logical channel is used;
- UE Id Mux;
 - for dedicated type logical channels, the UE Id field in the MAC header is used to distinguish between UEs;
- TFC selection;
 - in the downlink, transport format combination selection is done for FACH and PCH and DSCHs;
- demultiplex;
 - for TDD operation the demultiplex function is used to separate USCH data from different UEs, i.e. to be transferred to different MAC-d entities;
- DL code allocation;
 - this function is used to indicate the code used on the DSCH;

Flow control is provided to MAC-d.

The RLC provides RLC-PDUs to the MAC, which fit into the available transport blocks on the transport channels.

There is one MAC-c/sh entity in the UTRAN for each cell;

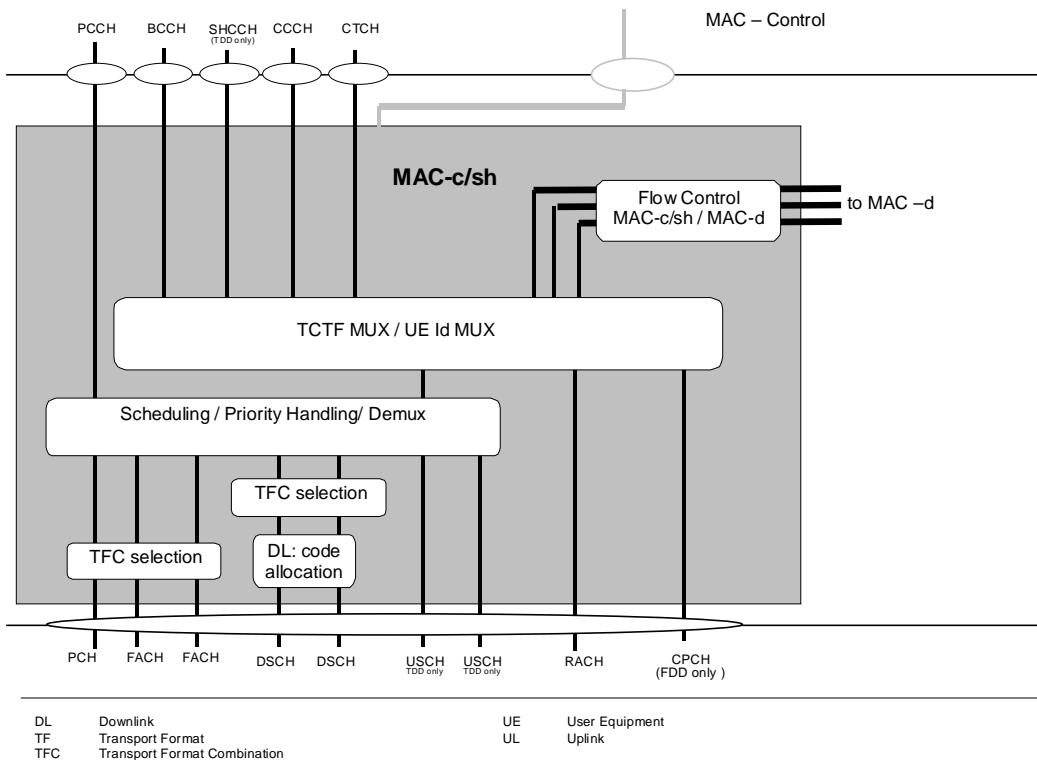

Figure 4.2.4.1.1: UTRAN side MAC architecture / MAC-c/sh details

4.2.4.2 MAC-d entity – UTRAN Side

Figure 4.2.4.2.1 shows the UTRAN side MAC-d entity.

The following functionality is covered:

- channel switching:
 - dynamic transport channel type switching is performed by this entity, based on decision taken by RRC;
- C/T MUX box;
 - the function includes the C/T field when multiplexing of several dedicated logical channels onto one transport channel is used.
- Priority setting;
 - This function is responsible for priority setting on data received from DCCH / DTCH;
- Ciphering;
 - Ciphering for transparent mode data to be ciphered is performed in MAC-d. Details about ciphering can be found in [10].
- Deciphering;
 - Deciphering for ciphered transparent mode data is performed in MAC-d. Details about ciphering can be found in [10].
- DL Scheduling/Priority handling;
 - in the downlink, scheduling and priority handling of transport channels is performed within the allowed transport format combinations of the TFCs assigned by the RRC.

- Flow Control;
 - a flow control function exists toward MAC-c/sh to limit buffering between MAC-d and MAC-c/sh entities. This function is intended to limit layer 2 signalling latency and reduce discarded and retransmitted data as a result of FACH or DSCH congestion. For the Iur interface this is specified in [11].
- FAUSCH control;
 - FAUSCH Handling indicates the function in the MAC-d supports the FAUSCH, details are ffs;

A MAC-d entity using common channels is connected to a MAC-c/sh entity that handles the scheduling of the common channels to which the UE is assigned and DL (FACH) priority identification to MAC-c/sh;

A MAC-d entity using downlink shared channel is connected to a MAC-c/sh entity that handles the shared channels to which the UE is assigned and indicates the level of priority of each PDU to MAC-c/sh;

A MAC-d entity is responsible for mapping dedicated logical channels onto the available dedicated transport channels or routing the data received on a DCCH or DTCH to MAC-c/sh.

One dedicated logical channel can be mapped simultaneously on DCH and DSCH. Different scheduling mechanisms apply for DCH and DSCH.

There is one MAC-d entity in the UTRAN for each served UE.

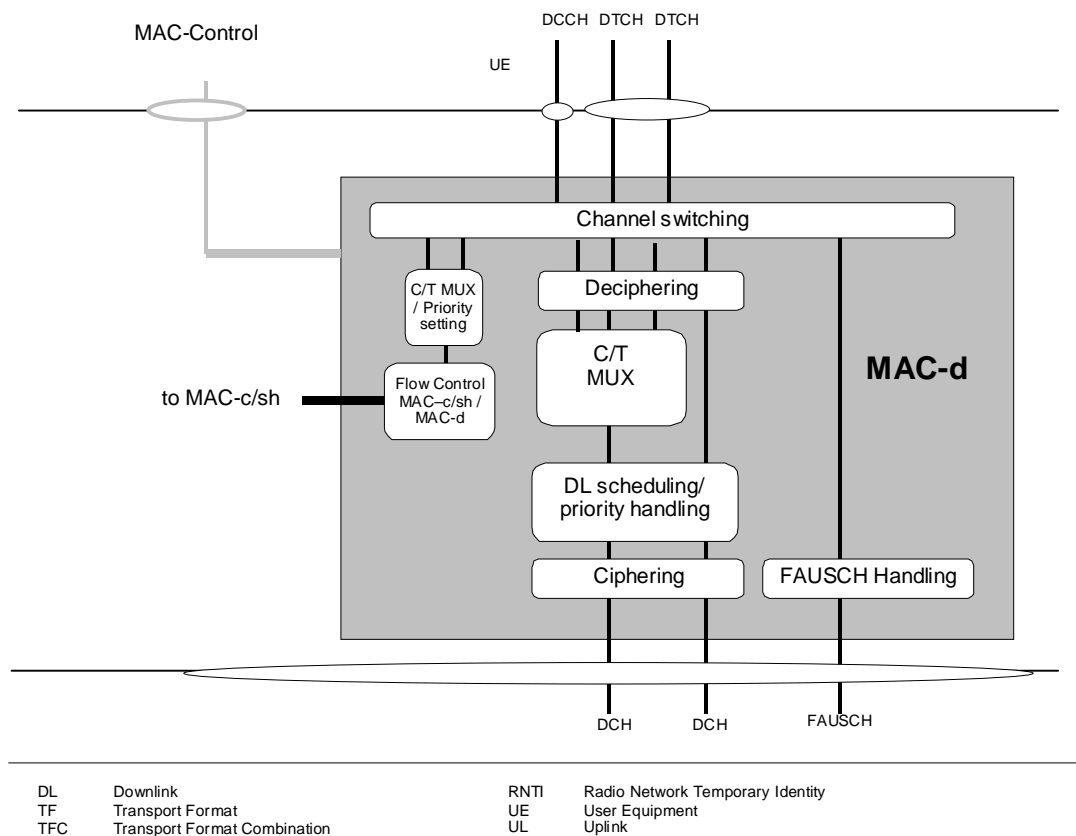

Figure 4.2.4.2.1: UTRAN side MAC architecture / MAC-d details

4.3 Channel structure

The MAC operates on the channels defined below; the transport channels are described between MAC and Layer 1, the logical channels are described between MAC and RLC.

The following subclauses provide an overview, the normative description can be found in [2] and [3] respectively.

4.3.1 Transport channels

Common transport channel types are:

- Random Access Channel(s) (RACH);
- Forward Access Channel(s) (FACH);
- Downlink Shared Channel(s) (DSCH);
- Common Packet Channel(s) (CPCH) for UL FDD operation only;
- Uplink Shared Channel(s) (USCH), for TDD operation only;
- Broadcast Channel (BCH);
- Paging Channel (PCH).

Dedicated transport channel types are:

- Dedicated Channel (DCH);
- Fast Uplink Signalling Channel (FAUSCH);

4.3.2 Logical Channels

The MAC layer provides data transfer services on logical channels. A set of logical channel types is defined for different kinds of data transfer services as offered by MAC.

Each logical channel type is defined by what type of information is transferred.

4.3.2.1 Logical channel structure

The configuration of logical channel types is depicted in figure 4.3.2.1.

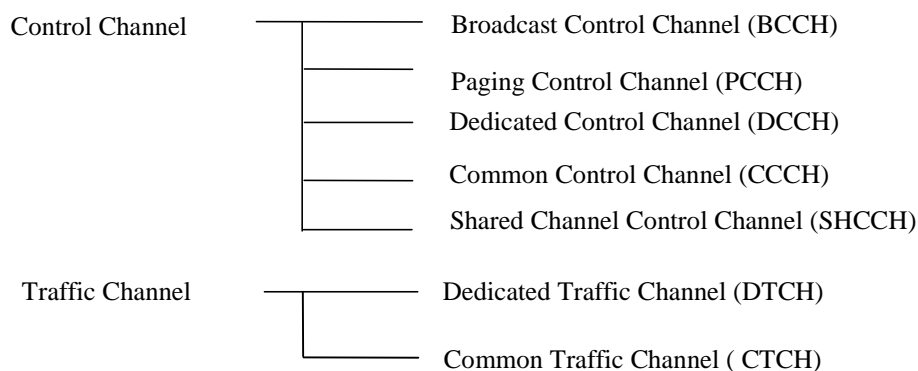

Figure 4.3.2.1: Logical channel structure

4.3.2.2 Control Channels

Following control channels are used for transfer of control plane information only:

- Broadcast Control Channel (BCCH);
- Paging Control Channel (PCCH);
- Common Control Channel (CCCH);
- Dedicated Control Channel (DCCH);

- Shared Channel Control Channel (SHCCH).

4.3.2.3 Traffic Channels

Following traffic channels are used for the transfer of user plane information only:

- Dedicated Traffic Channel (DTCH);
- Common Traffic Channel (CTCH).

4.3.3 Mapping between logical channels and transport channels

The following connections between logical channels and transport channels exist:

- BCCH is connected to BCH and may also be connected to FACH;
- PCCH is connected to PCH;
- CCCH is connected to RACH and FACH;
- DCCH and DTCH can be connected to either RACH and FACH, to CPCH and FACH, to RACH and DSCH, to DCH and DSCH, or to a DCH, the DCCH can be connected to FAUSCH; DCCH and DTCH can be mapped to the USCH (TDD only);
- CTCH is connected to FACH;
- SHCCH is connected to RACH and USCH/FACH and DSCH.

5 Services provided to upper layers

This clause describes the different services provided by the MAC to higher layers. For a detailed description of the following functions see [2].

5.1 Description of Services provided to upper layers

- Data transfer: This service provides unacknowledged transfer of MAC SDUs between peer MAC entities without data segmentation.
- Reallocation of radio resources and MAC parameters: This service performs on request of RRC execution of radio resource reallocation and change of MAC parameters.
- Reporting of measurements: Local measurements are reported to RRC.

6 Functions

6.1 Description of the MAC functions

The functions of MAC include:

- mapping between logical channels and transport channels;
- selection of appropriate Transport Format for each Transport Channel depending on instantaneous source rate;
- priority handling between data flows of one UE;
- priority handling between UEs by means of dynamic scheduling;
- priority handling between data flows of several users on the DSCH and FACH;

- identification of UEs on common transport channels;
- multiplexing/demultiplexing of higher layer PDUs into/from transport blocks delivered to/from the physical layer on common transport channels;
- multiplexing/demultiplexing of higher layer PDUs into/from transport block sets delivered to/from the physical layer on dedicated transport channels;
- traffic volume monitoring;
- Dynamic Transport Channel type switching;
- ciphering for transparent RLC;
- Access Service Class selection for RACH and CPCH transmission.

6.2 Relation between MAC Functions / Transport Channels and UE

6.2.1 Relation between MAC Functions and Transport Channels

Table 6.2.1.1: UTRAN MAC functions corresponding to the transport channel

Associated MAC Functions	Logical Ch	Transport Ch	TF Selection	Priority handling between users	Priority handling (one user)	Scheduling	Identification of UEs	Mux/ Demux on common transport CH	Mux/ Demux on dedicated transport CH	Dynamic transport CH switching
Uplink (Rx)	CCCH	RACH						X		
	DCCH	RACH					X	X		
	DCCH	CPCH					X	X		X
	DCCH	DCH							X	
	DTCH	RACH					X	X		
	DTCH	CPCH					X	X		X
	DTCH	DCH							X	
	SHCCH	RACH					X	X		
	SHCCH	USCH						X		X
	DTCH	USCH	X					X		X
Downlink (Tx)	DCCH	USCH	X					X		X
	BCCH	BCH				X				
	BCCH	FACH	X			X		X		
	PCCH	PCH	X			X				
	CCCH	FACH	X	X		X		X		
	CTCH	FACH	X			X		X		
	DCCH	FACH	X	X		X	X	X		
	DCCH	DSCH	X	X				X		
	DCCH	DCH	X		X				X	
	DTCH	FACH	X	X		X	X	X		X
	DTCH	DSCH	X	X				X		X
	DTCH	DCH	X		X				X	X
SHCCH	FACH	X	X		X		X			
SHCCH	DSCH	X	X					X	X	

6.2.2 Relation of UE MAC functions corresponding to the Transport Channel MAC Functions and Transport Channels

Table 6.2.2.1: UE MAC functions corresponding to the transport channel

Functions	Logical Ch	Transport Ch	TF Selection	Priority handling data of one user	Identification	Mux/Demux on common transport channels	Mux/Demux on dedicated transport channels	Dynamic transport channel type switching	
Uplink (Tx)	CCCH	RACH				X			
	DCCH	RACH	X	X	X	X			
	DCCH	CPCH	X	X	X	X		X	
	DCCH	DCH	X	X			X		
	DTCH	RACH	X	X	X	X		X	
	DTCH	CPCH	X	X	X	X		X	
	DTCH	DCH	X	X			X	X	
	SHCCH	RACH				X			
	SHCCH	USCH	X	X		X		X	
	DCCH	USCH	X	X		X		X	
	DTCH	USCH	X	X		X		X	
	Downlink (Rx)	BCCH	BCH						
		BCCH	FACH				X		
PCCH		PCH							
CCCH		FACH				X			
CTCH		FACH				X			
DCCH		FACH			X	X			
DCCH		DSCH				X			
DCCH		DCH					X		
DTCH		FACH			X	X			
DTCH		DSCH				X			
DTCH		DCH					X		
SHCCH		FACH				X			
SHCCH	DSCH				X				

7 Services expected from physical layer

The physical layer offers information transfer services to MAC. For detailed description, see [3].

8 Elements for layer-to-layer communication

The interaction between the MAC layer and other layers are described in terms of primitives where the primitives represent the logical exchange of information and control between the MAC layer and other layers. The primitives shall not specify or constrain implementations. The MAC is connected to layer 1, RLC and RRC. The following subclauses describe the primitives between these layers.

8.1 Primitives between layers 1 and 2

The primitives are described in [3].

8.2 Primitives between MAC and RLC

8.2.1 Primitives

The primitives between MAC layer and RLC layer are shown in table 8.2.1.1.

Table 8.2.1.1: Primitives between MAC layer and RLC layer

Generic Name	Type				Parameters
	Request	Indication	Response	Confirm	
MAC-DATA	X	X			Data, Number of transmitted RLC PDUs, BO, UE-ID type indicator, TD (note)
MAC-STATUS		X	X		No_PDU, PDU_Size, BO
NOTE: TDD only.					

MAC-DATA-Req/Ind:

- MAC-DATA-Req primitive is used to request that an upper layer PDU be sent using the procedures for the information transfer service;
- MAC-DATA-Ind primitive indicates the arrival of upper layer PDUs received within one transmission time interval by means of the information transfer service.

MAC-STATUS-Ind/Resp:

- MAC-STATUS-Ind primitive indicates to RLC for each logical channel the rate at which it may transfer data to MAC. Parameters are the number of PDUs that can be transferred in each transmission time interval and the PDU size; it is possible that MAC would use this primitive to indicate that it expects the current buffer occupancy of the addressed logical channel in order to provide for optimised TFC selection on transport channels with long transmission time interval.
- MAC-STATUS-Resp primitive enables RLC to acknowledge a MAC-STATUS-Ind. It is possible that RLC would use this primitive to indicate that it has nothing to send or that it is in a suspended state or to indicate the current buffer occupancy to MAC.

8.2.2 Parameters

a) Data:

- it contains the RLC layer messages (RLC-PDU) to be transmitted, or the RLC layer messages that have been received by the MAC sub-layer.

b) Number of transmitted RLC PDUs (indication only):

- indicates the number of RLC PDUs transmitted within the transmission time interval, based on the TFI value.

c) Buffer Occupancy (BO):

- the parameter Buffer Occupancy (BO) indicates for each logical channel the amount of data that is currently queued for transmission (or retransmission) in RLC layer.

d) RX Timing Deviation (TD), TDD only:

- it contains the RX Timing Deviation as measured by the physical layer for the physical resources carrying the data of the Message Unit. This parameter is optional and only for Indication. It is needed for the transfer of the RX Timing Deviation measurement of RACH transmissions carrying CCCH data to RRC.

e) Number of PDU (No_PDU):

- specifies the number of PDUs that the RLC is permitted to transfer to MAC within a transmission time interval.
- f) PDU Size (PDU_Size):
- specifies the size of PDU that can be transferred to MAC within a transmission time interval.
- g) UE-ID Type Indicator:
- indicates the UE-ID type to be included on MAC for a DCCH when it is mapped onto a common transport channel (i.e. FACH, RACH or CPCH).

8.3 Primitives between MAC and RRC

8.3.1 Primitives

The primitives between MAC and RRC are shown in table 8.3.1.1.

Table 8.3.1.1: Primitives between MAC sub-layer and RRC

Generic Name	Type				Parameters
	Request	Indication	Response	Confirm	
CMAC-CONFIG	X				UE information elements RAB information elements TrCH information elements RACH transmission control elements Ciphering elements CPCH transmission control elements
CMAC-MEASUREMENT	X	X			Measurement information elements (for Request), Measurement result (for Indication)
CMAC-STATUS		X			Status info.

CMAC-CONFIG-Req:

- CMAC-CONFIG-Req is used to request for setup, release and configuration of a logical channel, e.g. RNTI allocation, switching the connection between logical channels and transport channels, TFCS update or scheduling priority of logical channel.

CMAC-MEASUREMENT-Req/Ind:

- CMAC-MEASUREMENT-Req is used by RRC to request MAC to perform measurements, e.g. traffic volume measurements;
- CMAC-MEASUREMENT-Ind is used to notify RRC of the measurement result.

CMAC-STATUS-Ind:

- CMAC-STATUS-Ind primitive notifies RRC of status information.

8.3.2 Parameters

See TS 25.331 for a detailed description of the UE, RB and TrCH information elements.

- a) UE information elements
- S-RNTI
 - SRNC identity
 - C-RNTI
 - Activation time

- b) RB information elements
 - RB multiplexing info (Transport channel identity, Logical channel identity, MAC logical channel priority)
- c) TrCH information elements
 - Transport Format Combination Set
- d) Measurement information elements
 - Mode (periodic, event-triggered or both)
 - THU
 - THL
 - Measurement quantity identifiers
 - Report Interval
- e) Measurement result
 - Mode
 - Reporting Quantities
 - Event ID (4a or 4b)
- f) Status info
 - Maximum number of preamble ramping cycles reached.
- g) RACH transmission control elements
 - Set of ASC parameters (identifier for PRACH partitions, persistence values)
 - Maximum number of preamble ramping cycles M_{\max}
 - Minimum and maximum number of time units between two preamble ramping cycles, N_{BO1min} and N_{BO1max}
- h) Ciphering elements
 - Ciphering mode
 - Ciphering key
 - Ciphering sequence number
- i) CPCH transmission control elements
 - CPCH persistency value, P for each Transport Format
 - Maximum number of preamble ramping cycles $N_{\text{access_fails}}$
 - NF_max (Maximum number of frames for CPCH transmission for each Transport Format)
 - N_EOT (Number of EOT for release of CPCH transmission)
 - Backoff control timer parameters
 - Transport Format Set
 - Initial Priority Delays
 - Channel Assignment Active indication

9 Elements for peer-to-peer communication

9.1 Protocol data units

9.1.1 General

A MAC PDU is a bit string, with a length not necessarily a multiple of 8 bits. In the drawings in clause 9.1, bit strings are represented by tables in which the first bit is the leftmost one on the first line of the table, the last bit is the rightmost on the last line of the table, and more generally the bit string is to be read from left to right and then in the reading order of the lines.

Depending on the provided service, MAC SDUs are bit strings, with any non null length, or bit strings with an integer number of octets in length. An SDU is included into a MAC PDU from first bit onward.

In the UE for the uplink, all MAC PDUs delivered to the physical layer within one TTI are defined as Transport Block Set (TBS). It consists of one or several Transport Blocks, each containing one MAC PDU. The Transport Blocks, shall be transmitted in the order as delivered from RLC. When multiplexing of RLC PDUs from different logical channels is performed on MAC, the order of all Transport Blocks originating from the same logical channel shall be the same as the

order of the sequence delivered from RLC. The order of the different logical channels in a TBS is set by the MAC protocol.

9.1.2 MAC Data PDU

MAC PDU consists of an optional MAC header and a MAC Service Data Unit (MAC SDU), see figure 9.1.2.1. Both the MAC header and the MAC SDU are of variable size.

The content and the size of the MAC header depends on the type of the logical channel, and in some cases none of the parameters in the MAC header are needed.

The size of the MAC-SDU depends on the size of the RLC-PDU, which is defined during the setup procedure.

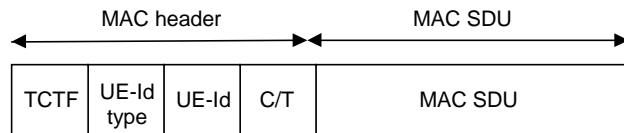

Figure 9.1.2.1: MAC data PDU

9.2 Formats and parameters

NOTE: MAC header field encodings as specified in this clause with designation "Reserved" are forbidden to be used by a sender in this version of the protocol.

9.2.1 MAC Data PDU: Parameters of the MAC header

The following fields are defined for the MAC header:

- Target Channel Type Field

The TCTF field is a flag that provides identification of the logical channel class on FACH and RACH transport channels, i.e. whether it carries BCCH, CCCH, CTCH, SHCCH or dedicated logical channel information. The size and coding of TCTF for FDD and TDD are shown in tables 9.2.1.1, 9.2.1.2 and 9.2.1.3. Note that the size of the TCTF field of FACH for FDD is either 2 or 8 bits depending of the value of the 2 most significant bits and for TDD is either 3 or 5 bits depending on the value of the 3 most significant bits. The TCTF of the RACH for TDD is either 2 or 4 bits depending on the value of the 2 most significant bits.

Table 9.2.1.1: Coding of the Target Channel Type Field on FACH for TDD

TCTF	Designation
000	BCCH
001	CCCH
010	CTCH
01100	DCCH or DTCH over FACH
01101-01111	Reserved (PDUs with this coding will be discarded by this version of the protocol)
100	SHCCH
101-111	Reserved (PDUs with this coding will be discarded by this version of the protocol)

Table 9.2.1.2: Coding of the Target Channel Type Field on FACH for FDD

TCTF	Designation
00	BCCH
01000000	CCCH
01000001- 01111111	Reserved (PDUs with this coding will be discarded by this version of the protocol)
10000000	CTCH
10000001- 10111111	Reserved (PDUs with this coding will be discarded by this version of the protocol)
11	DCCH or DTCH over FACH

Table 9.2.1.3: Coding of the Target Channel Type Field on USCH or DSCH (TDD only)

TCTF	Designation
0	SHCCH
1	DCCH or DTCH over USCH or DSCH

Table 9.2.1.4: Coding of the Target Channel Type Field on RACH for FDD

TCTF	Designation
00	CCCH
01	DCCH or DTCH over RACH
10-11	Reserved (PDUs with this coding will be discarded by this version of the protocol)

Table 9.2.1.5: Coding of the Target Channel Type Field on RACH for TDD

TCTF	Designation
00	CCCH
0100	DCCH or DTCH Over RACH
0101- 0111	Reserved (PDUs with this coding will be discarded by this version of the protocol)
10	SHCCH
11	Reserved (PDUs with this coding will be discarded by this version of the protocol)

- C/T field

The C/T field provides identification of the logical channel instance when multiple logical channels are carried on the same transport channel. The C/T field is used also to provide identification of the logical channel type on dedicated transport channels and on FACH and RACH when used for user data transmission. The size of the C/T field is fixed to 4 bits for both common transport channels and dedicated transport channels. Table 9.2.1.5a shows the 4-bit C/T field.

Table 9.2.1.5a: Structure of the C/T field

C/T field	Designation
0000	Logical channel 1
0001	Logical channel 2
...	...
1110	Logical channel 15
1111	Reserved (PDUs with this coding will be discarded by this version of the protocol)

- UE-Id

The UE-Id field provides an identifier of the UE on common transport channels. The following types of UE-Id used on MAC are defined:

- UTRAN Radio Network Temporary Identity (U-RNTI) may be used in the MAC header of DCCH when mapped onto common transport channels;
- Cell Radio Network Temporary Identity (C-RNTI) is used on DTCH, DSCH in FDD mode, and may be used on DCCH, when mapped onto common transport channels;
- the UE id to be used by MAC is configured through the MAC control SAP. The lengths of the UE-id field of the MAC header are given in table 9.2.1.6.

Table 9.2.1.6: Lengths of UE Id field

UE Id type	Length of UE Id field
U-RNTI	32 bits
C-RNTI	16 bits

- UE-Id Type

The UE-Id Type field is needed to ensure correct decoding of the UE-Id field in MAC Headers.

Table 9.2.1.7: UE-Id Type field definition

UE-Id Type field 2 bits	UE-Id Type
00	U-RNTI
01	C-RNTI
10	Reserved (PDUs with this coding will be discarded by this version of the protocol)
11	Reserved (PDUs with this coding will be discarded by this version of the protocol)

9.2.1.1 MAC header for DTCH and DCCH

- a) DTCH or DCCH mapped to DCH, no multiplexing of dedicated channels on MAC:
 - no MAC header is required.
- b) DTCH or DCCH mapped to DCH, with multiplexing of dedicated channels on MAC:
 - C/T field is included in MAC header.
- c) DTCH or DCCH mapped to RACH/FACH:
 - TCTF field, C/T field, UE-Id type field and UE-Id are included in the MAC header.

d) DTCH or DCCH mapped to DSCH or USCH:

- the TCTF field is included in the MAC header for TDD only. The UE-Id type and UE-Id are included in the MAC header for FDD only. The C/T field is included if multiplexing on MAC is applied.

e) DTCH or DCCH mapped to DSCH or USCH where DTCH or DCCH are the only logical channels:

- the UE-Id type and UE-Id are included in the MAC header for FDD only. The C/T field is included in the MAC header if multiplexing on MAC is applied.

f) DTCH or DCCH mapped to CPCH:

- UE-Id type field and UE-Id are included in the MAC header. The C/T field is included in the MAC header if multiplexing on MAC is applied.

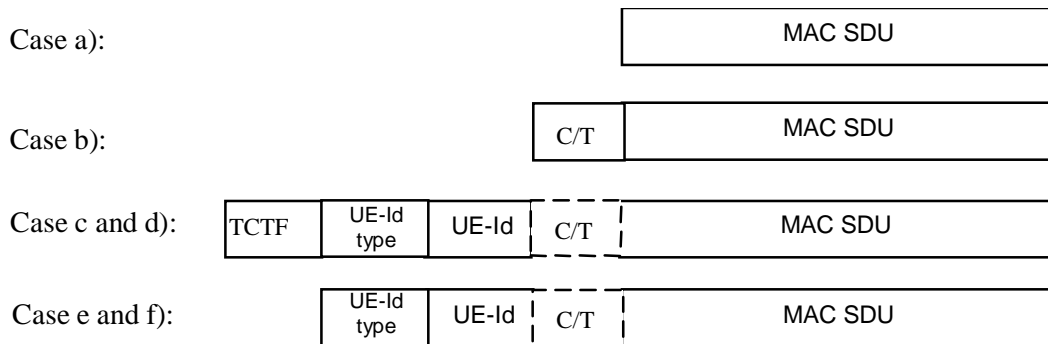

Figure 9.2.1.1.1: MAC Data PDU formats for DTCH and DCCH

9.2.1.2 MAC header for BCCH

a) BCCH mapped to BCH:

- no MAC header is included.

b) BCCH mapped to FACH:

- the TCTF field is included in MAC header.

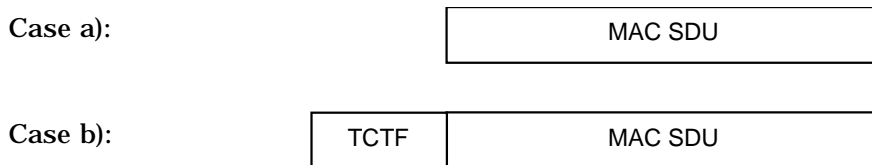

Figure 9.2.1.2.1: MAC Data PDU formats for BCCH

9.2.1.3 MAC header for PCCH

There is no MAC header for PCCH.

9.2.1.4 MAC header for CCCH

CCCH mapped to RACH/FACH:

- TCTF field is included in MAC header.

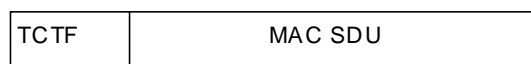

Figure 9.2.1.4.1: MAC Data PDU formats for CCCH

9.2.1.5 MAC Header for CTCH

The TCTF field is included as MAC header for CTCH as shown in figure 9.2.1.5.1.

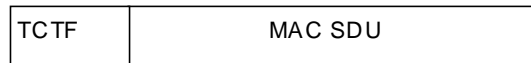

Figure 9.2.1.5.1: MAC Data PDU format for CTCH

9.2.1.6 MAC Header for SHCCH

The MAC header for SHCCH is as shown in figure 9.2.1.6.1.

- a) SHCCH mapped to RACH and USCH/FACH and DSCH:
 - TCTF has to be included.
- b) SHCCH mapped to RACH and USCH/FACH and DSCH, where SHCCH is the only channel.

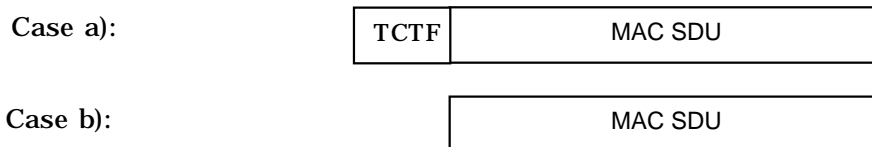

Figure 9.2.1.6.1: MAC Data PDU format for SHCCH

10 Handling of unknown, unforeseen and erroneous protocol data

Basic requirements for handling unknown, unforeseen and erroneous protocol data are described in [8].

11 Elementary procedures

11.1 Traffic volume measurement for dynamic radio bearer control

Dynamic radio bearer control is performed in RRC, based on the traffic volume measurement reported by MAC. Traffic volume information is gathered and measured in MAC layer and the result is reported from MAC layer to RRC layer.

Traffic volume monitoring procedure in MAC is shown in figure 11.1.1. MAC receives RLC PDUs together with information of RLC transmission buffer. Every TTI, MAC compares the amount of data corresponding to a Transport Channel with the thresholds set by RRC. If the value is out of range, MAC indicates the measurement reports on traffic volume status to RRC. Thereby, RRC can be informed the traffic volume status of each transport channel, and therefore can take proper action for new radio bearer configuration accordingly.

RRC requests MAC measurement report with the primitive CMAC-Measure-REQ including following parameters.

Measurement information elements.

- Mode
Indicates whether the report should be periodic, or event-triggered
- THU (If Event ID = 4a, then Reporting Threshold is Upper Threshold.)
Upper threshold value for every transport channel, applicable when mode is event-triggered

- THL (If Event ID = 4b, then Reporting Threshold is Lower Threshold.)
Lower threshold value for every transport channel, applicable when mode is event-triggered
- Measurement quantity identifiers
Indicates what should be reported to RRC layer
For each RB, Buffer Occupancy (mandatory), Variance (optional), or Average (optional)
- Report Interval
Indicates the report interval, applicable when report mode is periodic

MAC receives RLC PDUs with the primitive MAC-Data-REQ including following parameters.

- Data (RLC PDU)
- Buffer Occupancy (BO)
The parameter Buffer Occupancy (BO) indicates the amount of data that is currently queued for transmission (or retransmission)

MAC receives measurement information elements with the primitive CMAC-Measure-REQ that includes parameters such as Mode, report interval, and THL and THU for each transport channel. Whenever MAC receives RLC PDUs from different RLC entities, it is notified by RLC amount of data queued in RLC transmission buffer. If the mode is event-triggered, MAC compares the amount of data to be transmitted on a transport channel with threshold values passed by RRC, THL and THU. In case that the measured value is out of range, MAC reports the status of result of comparison and status of each RB to RRC. On the other hand, if the mode is periodic, MAC reports measurement result to RRC periodically. Measurement result can contain average and variance as well as amount of data for each RB as follows.

Measurement result.

- Mode
Periodic, or event-triggered
- Reporting Quantity
For each RB, Buffer Occupancy (mandatory), Variance (optional), and Average (optional)
- Event ID
Indicates overflow or underflow for each transport channel, applicable when mode is event-triggered
 - Event 4a: RLC buffer payload exceeds an absolute threshold
 - Event 4b: RLC buffer payload becomes smaller than an absolute threshold

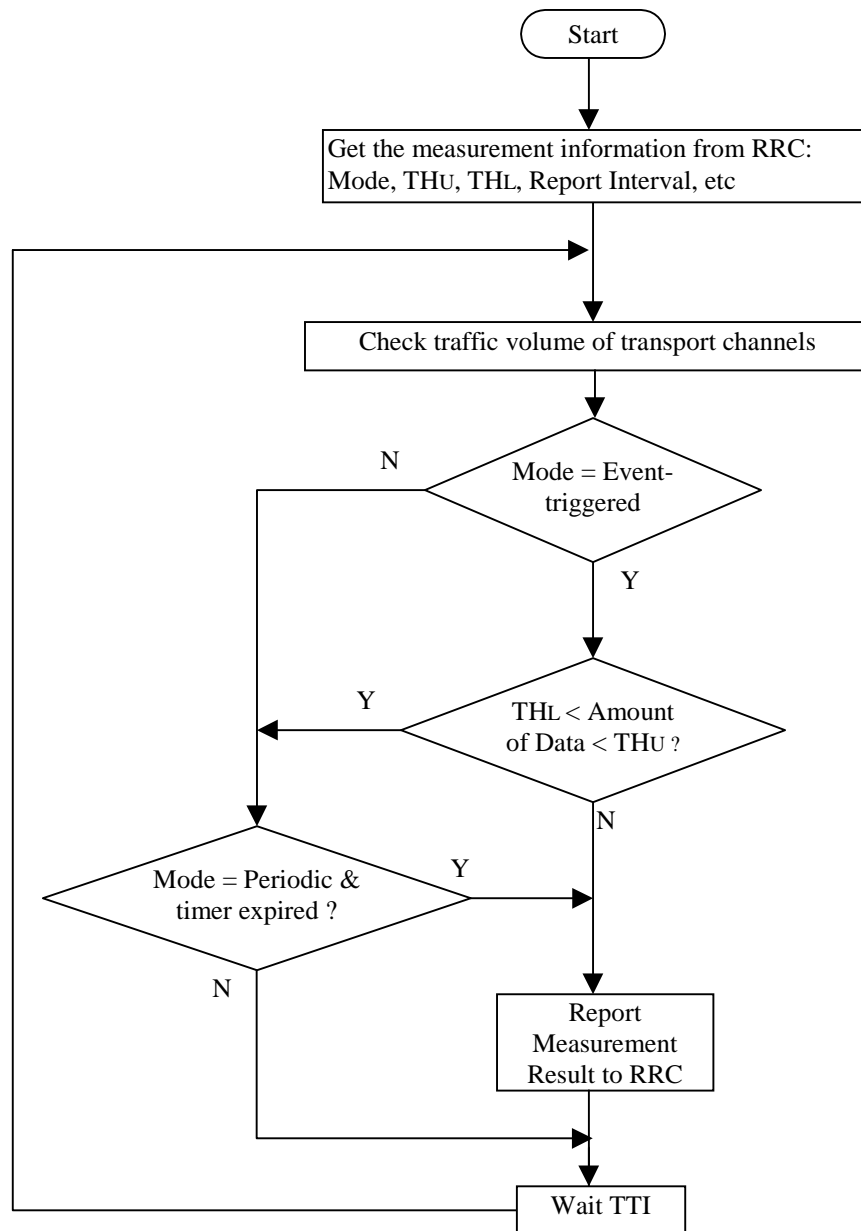

Figure 11.1.1: Traffic volume measurement/report procedure in MAC

11.2 Control of RACH transmissions

The MAC sublayer is in charge of controlling the timing of RACH transmissions on transmission time interval level (i.e. on 10 ms-radio frame level; the timing on access slot level is controlled by L1). Note that retransmissions in case of erroneously received RACH message part are under control of higher layers, i.e. RLC, or RRC for CCCH (and SHCCH for TDD).

11.2.1 Access Service Class selection

The physical RACH resources (i.e. access slots and preamble signatures for FDD, timeslot and channelisation code for TDD) may be divided between different Access Service Classes in order to provide different priorities of RACH usage. It is possible for more than one ASC or for all ASCs to be assigned to the same access slot/signature space.

Access Service Classes are numbered in the range $0 \leq i \leq \text{NumASC} \leq 7$ (i.e. the maximum number of ASCs is $\text{NumASC}+1 = 8$). An ASC is defined by an identifier i that defines a certain partition of the PRACH resources and an associated persistence value P_i . A set of ASC parameters consists of $\text{NumASC}+1$ such parameters (i, P_i) , $i = 0, \dots, \text{NumASC}$. The PRACH partitions and the persistence values P_i are derived by the RRC protocol from system information (see TS 25.331 [7]). The set of ASC parameters is provided to MAC with the CMAC-Config-REQ primitive. The ASC enumeration is such that it corresponds to the order of priority (ASC 0 = highest priority, ASC 7 = lowest priority). ASC 0 shall be used in case of Emergency Call or for reasons with equivalent priority.

At radio bearer setup/reconfiguration each involved logical channel is assigned a MAC Logical channel Priority (MLP) in the range 1, ..., 8. When the MAC sublayer is configured for RACH transmission in the UE, these MLP levels shall be employed for ASC selection on MAC.

The following ASC selection scheme shall be applied, where NumASC is the highest available ASC number and MinMLP the highest logical channel priority assigned to one logical channel:

- in case all TBs in the TB set have the same MLP, select $\text{ASC} = \min(\text{NumASC}, \text{MLP})$;
- in case TBs in a TB set have different priority, determine the highest priority level MinMLP and select $\text{ASC} = \min(\text{NumASC}, \text{MinMLP})$.

11.2.2 Control of RACH transmissions for FDD mode

The RACH transmissions are controlled by the UE MAC sublayer as outlined in figure 11.2.2.1.

NOTE: The figure shall illustrate the operation of the transmission control procedure as specified below. It shall not impose restrictions on implementation. MAC controls the timing of each initial preamble ramping cycle as well as successive preamble ramping cycles in case that none or a negative acknowledgement is received on AICH.

MAC receives the following RACH transmission control parameters from RRC with the CMAC-Config-REQ primitive:

- a set of Access Service Class (ASC) parameters, which includes for each ASC, $i=0, \dots, \text{NumASC}$ an identification of a PRACH partition and a persistence value P_i (transmission probability);
- maximum number of preamble ramping cycles M_{max} ;
- range of backoff interval for timer T_{BO1} , given in terms of numbers of transmission 10 ms time intervals N_{BO1max} and N_{BO1min} , applicable when negative acknowledgement on AICH is received.

When there is data to be transmitted, MAC selects the ASC from the available set of ASCs, which consists of an identifier i of a certain PRACH partition and an associated persistence value P_i . The procedure to be applied for ASC selection is described in subclause 11.2.1.

Based on the persistence value P_i , the UE decides whether to start the L1 PRACH transmission procedure (see TS 25.214) in the present transmission time interval or not. If transmission is allowed, the PRACH transmission procedure (starting with a preamble power ramping cycle) is initiated by sending of a PHY-ACCESS-REQ primitive. MAC then waits for access information from L1 via PHY-ACCESS-CNF primitive. If transmission is not allowed, a new persistency check is performed in the next transmission time interval. The persistency check is repeated until transmission is permitted.

When the preamble has been acknowledged on AICH, L1 access information with parameter value "ready for data transmission" is indicated to MAC with PHY-ACCESS-CNF primitive. Then data transmission is requested with PHY-DATA-REQ primitive, and the PRACH transmission procedure shall be completed with transmission of the PRACH message part according to L1 specifications.

When PHY indicates that no acknowledgement on AICH is received while the maximum number of preamble retransmissions is reached (defined by parameter $\text{Preamble_Retrans_Max}$ on L1), a new persistency test is performed in the next transmission time interval. The timer T_2 ensures that two successive persistency tests are separated by at least one 10 ms time interval.

In case that a negative acknowledgement has been received on AICH a backoff timer T_{BO1} is started. After expiry of the timer, persistence check is performed again. Backoff timer T_{BO1} is set to an integer number N_{BO1} of 10 ms time intervals, randomly drawn within an interval $0 \leq N_{BO1min} \leq N_{BO1} \leq N_{BO1max}$ (with uniform distribution). N_{BO1min} and N_{BO1max} may be set equal when a fixed delay is desired, and even to zero when no delay other than the one due to persistency is desired.

Before a persistency test is performed it shall be checked whether any new RACH transmission control parameters have been received from RRC with CMAC-Config-REQ primitive. The latest set of RACH transmission control parameters shall be applied.

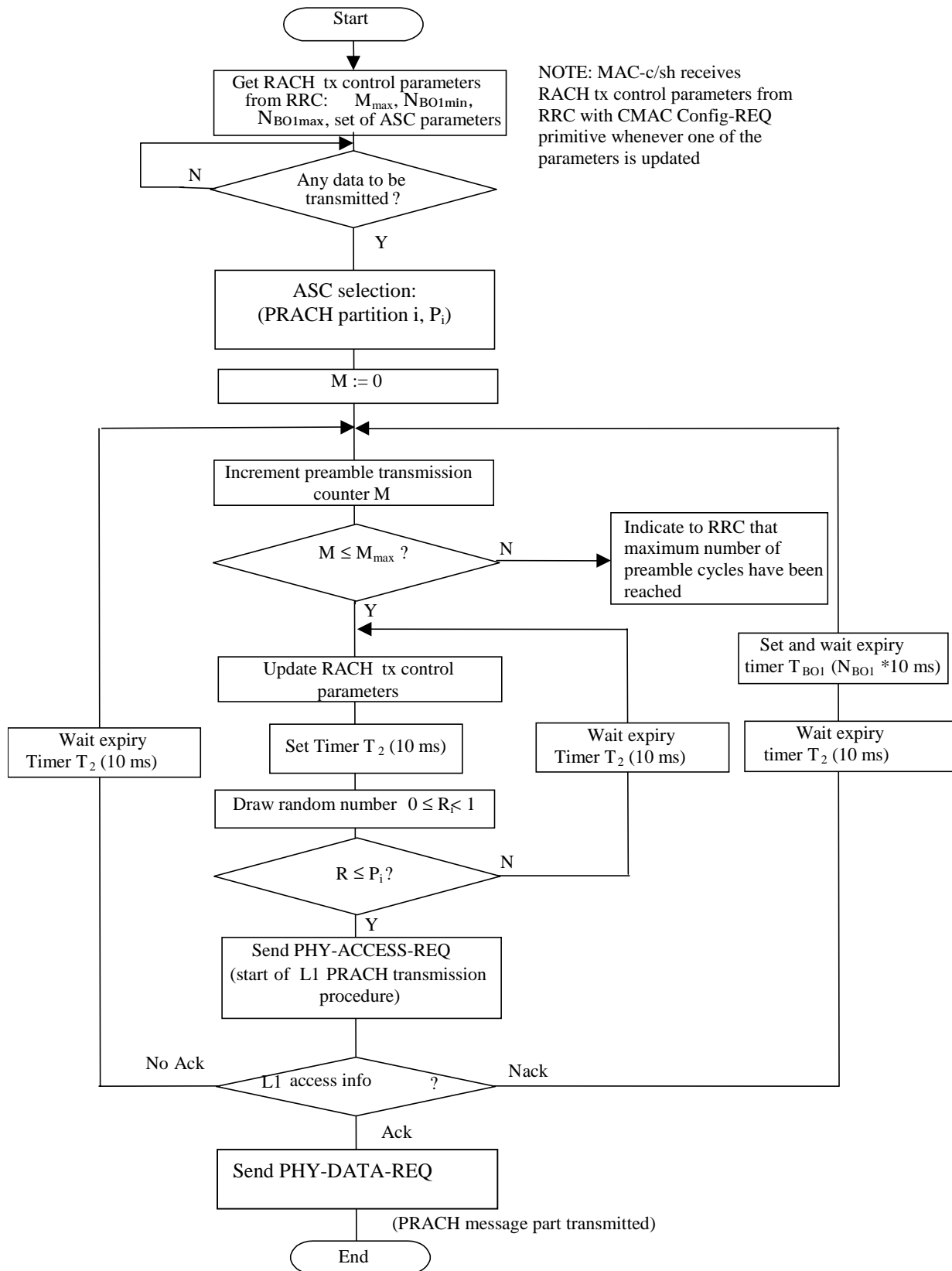

Figure 11.2.2.1: RACH transmission control procedure (UE side, informative)

11.2.3 Control of RACH transmissions for TDD

The RACH transmissions are performed by the UE as shown in figure 11.2.3.1.

NOTE: The figure shall illustrate the operation of the transmission control procedure as specified below. It shall not impose restrictions on implementation.

MAC receives the following RACH transmission control parameters from RRC with the CMAC-Config-REQ primitive:

- a set of Access Service Class (ASC) parameters, which includes for each ASC, $i=0, \dots, \text{NumASC}$ an identification of a PRACH partition and a persistence value P_i (transmission probability).

When there is data to be transmitted, MAC selects the ASC from the available set of ASCs, which consists of an identifier i of a certain PRACH partition and an associated persistence value P_i . The procedure to be applied for ASC selection is described in subclause 11.2.1.

Based on the persistence value P , the UE decides whether to send the message on the RACH. If transmission is allowed, the PRACH transmission procedure is initiated by sending of a PHY-Data-REQ primitive. If transmission is not allowed, a new persistency check is performed in the next transmission time interval. The persistency check is repeated until transmission is permitted.

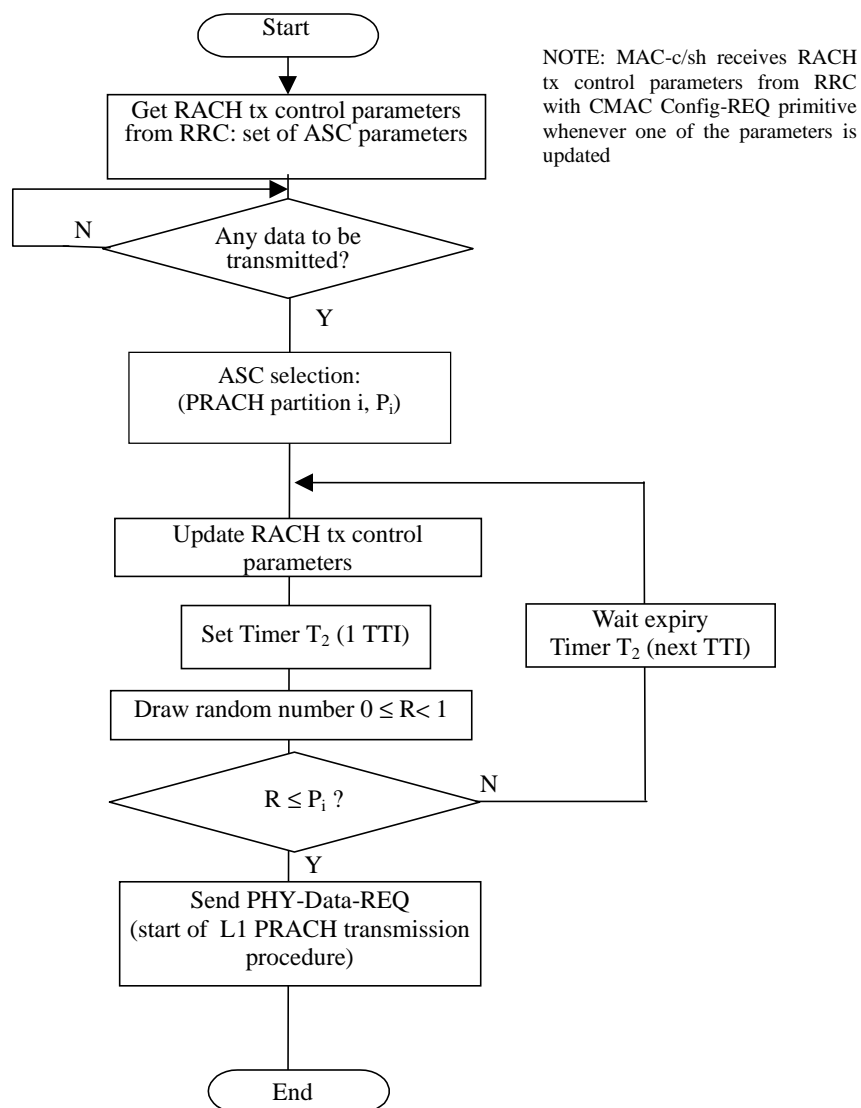

Figure 11.2.3.1: RACH transmission control procedure for TDD (UE side, informative)

11.3 Control of CPCH transmissions for FDD

The MAC layer controls the timing of CPCH transmissions on transmission time interval level (i.e. on 10, 20, 40 or 80 ms level); the timing on access slot level is controlled by L1. MAC controls the timing of each initial preamble ramping

cycle as well as successive preamble ramping cycles. Note that retransmissions in case of erroneously received CPCH message part are under control of higher layers. The CPCH transmissions are performed by the UE as illustrated in figures 11.3.1 and 11.3.2. Figure 11.3.1 procedure is used for initial access to CPCH channel. Figure 11.3.2 procedure is used for each TTI transmission while the UE continues to transmit on the CPCH channel obtained using the initial access procedure.

MAC receives the following CPCH transmission control parameters from RRC with the CMAC-Config-REQ primitive:

- persistence values, P (transmission probability for each Transport Format (TF));
- N_access_fails, maximum number of preamble ramping cycles;
- NF_max, maximum number of frames for CPCH transmission for each TF;
- N_EOT (Number of EOT for release of CPCH transmission);
- Backoff control timer parameters;
- Transport Format Set;
- Initial Priority Delays;
- Channel Assignment Active indication.

The MAC procedure for transmission control of initial CPCH access shall be invoked when the UE has data to transmit and the UE is not currently transmitting on a previously accessed CPCH channel. The steps for this procedure are listed here:

1. the UE shall get all UL transmit parameters (CPCH Set Info, P values, Initial Priority Delays, N_access_fails, NF_max, N_EOT etc) from RRC;
2. the UE shall reset counter M, EOT counter and Frame Count Transmitted (FCT) upon entry to the initial access procedure;
3. the UE shall send a PHY-CPCH_Status-REQ to Layer 1 to obtain CPCH TF subset status. If Layer 1 returns an error message, the UE shall increment counter M. If counter M is equal to N_access_fails, the UE shall execute an access failure error procedure and the CPCH access procedure ends. If counter M is less than N_access_fails, the procedure shall continue from step 3. If Layer 1 returns a PHY-CPCH_Status-CNF message, which includes a TF subset indicating the currently available TFs of the requested TF subset, the procedure shall continue from step 4;
4. the UE shall initialise the Busy Table with the CPCH TF subset status from Layer 1. Those TFs in the TF subset of the Layer 1 PHY-CPCH_Status-CNF response will be marked available. All other TFs will be marked busy;
5. if all TFs are marked busy, the UE shall reset and start timer Tboc1, wait until timer expiry, and increment counter M. If counter M is equal to N_access_fails, the UE shall execute an access failure error procedure and the CPCH access procedure ends. If counter M is less than N_access_fails, the procedure shall continue from step 3;
6. the UE shall update all UL transmit parameters from RRC;
7. UE shall select a TF from the set of available TFs listed in the Busy Table. UE shall use the CPCH channel capacity (transport block set size, NF_max, and TTI interval), and Busy Table information to select one CPCH TF for L1 to access. The UE may select a TF, which uses a lower data rate and a lower UL Tx power than the maximum UL Tx power allowed;
8. UE shall implement a test based on the Persistence value (P) to determine whether to attempt access to the selected CPCH TF. If access is allowed, the UE may implement an initial delay based on ASC of the data to be transmitted, then shall send a PHY-Access-REQ with the selected TF to L1 for CPCH access. If the P test does not allow access, the selected CPCH TF shall be marked busy in the Busy Table. If all TFs are marked busy, the UE shall reset and start timer Tboc1, wait until timer expiry, and increment counter M. If counter M is equal to N_access_fails, the UE shall execute an access failure error procedure and the CPCH access procedure ends. If counter M is less than N_access_fails, the procedure shall continue from step 3. If all TFs are not marked busy, the UE shall resume the procedure from step 6;

9. after the UE has sent the access request to L1, L1 shall return a PHY-Access-CNF including one of five access indications to MAC as shown in figure 11.3.1. If the L1 access indication is that access is granted, then UE shall execute the transmission control procedure for the Nth TTI using the selected TF and the initial access procedure ends;
10. if L1 access indication is no AP-AICH received or no CD-AICH received, the UE shall reset and start timer T_{boc3}, wait until timer expiry, and increment counter M. If counter M is equal to N_{access_fails}, the UE shall execute an access failure error procedure and the CPCH access procedure ends. If counter M is less than N_{access_fails}, the UE shall proceed from step 3;
11. if L1 access indication is AP-AICH_{nak} received and Channel Assignment (CA) is active, the UE shall proceed from step 13. If L1 access indication is AP-AICH_{nak} received and Channel Assignment (CA) is not active, the UE shall reset and start timer T_{boc2}, wait until timer expiry, and mark the selected channel busy in the Busy Table. If all channels are marked busy, the UE shall reset and start timer T_{boc1}, wait until timer expiry, and increment counter M. If counter M is equal to N_{access_fails}, the UE shall execute an access failure error procedure and the CPCH access procedure ends. If counter M is less than N_{access_fails}, the procedure shall continue from step 3. If all channels are not marked busy, the UE shall resume the procedure from step 6;
12. if L1 access indication is CD-AICH signature mismatch, the UE shall reset and start timer T_{boc4}, wait until timer expiry, and increment counter M. If counter M is equal to N_{access_fails}, the UE shall execute an access failure error procedure and the CPCH access procedure ends. If counter M is less than N_{access_fails}, the procedure shall continue from step 3;
13. the UE shall reset and start timer T_{boc2}, wait until timer expiry, and increment counter M. If counter M is equal to N_{access_fails}, the UE shall execute an access failure error procedure and the CPCH access procedure ends. If counter M is less than N_{access_fails}, the procedure shall continue from step 3.

The MAC procedure for transmission control of Nth TTI shall be invoked when the UE has data to transmit and the UE is currently transmitting on a previously accessed CPCH channel. The steps for this procedure are listed here:

1. the UE shall build a transport block set for the next TTI;
2. if the sum of the Frame Count Transmitted counter plus the number of frames in the next TTI is greater than NF_{max}, the UE shall exit this procedure and start the MAC procedure for CPCH transmission of the first TTI. This shall release the CPCH channel in use and the UE will contend again for a new CPCH channel to continue transmission. If the sum of the Frame Count Transmitted counter plus the number of frames in the next TTI is less than or equal to NF_{max}, the UE shall send a PHY-Data-REQ with the transport block set to L1 to continue transmission on the CPCH channel which has previously been accessed;
3. if the UE has no data to transmit and the sum of the Frame Count Transmitted counter plus the number of frames in the next TTI is less than NF_{max}, the UE shall send a PHY-Data-REQ with zero sized transport block to L1 to stop transmission on the CPCH channel which has previously been accessed.
4. if L1 returns PHY-Status-IND indicating abnormal situation the UE shall execute an abnormal situation handling procedure and the CPCH Nth TTI procedure ends. Reasons for abnormal situation may include the following:
 - emergency stop was received;
 - start of Message Indicator was not received;
 - L1 hardware failure has occurred;
 - out of synch has occurred
5. if the L1 returns PHY-Status-IND indicating normal transmission, then the UE shall increment the Frame Count Transmitted counter by the length of the TTI just transmitted and the procedure ends.

Table 11.3: CPCH Backoff Delay Timer Values

Timer	Based on parameter	Fixed/random
T _{BOC1} (all Busy)	NF _{bo_all_busy}	Random
T _{BOC2} (channel Busy)	NS _{bo_busy}	Fixed
T _{BOC3} (no AICH)	NF _{bo_no_aich}	Fixed
T _{BOC4} (mismatch)	NF _{bo_mismatch}	Random

For T_{BOC4} , UE shall randomly select a timer value at each execution of the timer. A uniform random draw shall be made to select an integer number of frames within the range $[0, NF_bo_mismatch]$. For T_{BOC1} , UE would randomly select a timer value at each execution of the timer. A uniform random draw shall be made to select an integer number of frames within the range $[0, NF_bo_all\ busy]$.

NOTE: Backoff parameter range and units are specified in TS 25.331, RRC Protocol Specification.

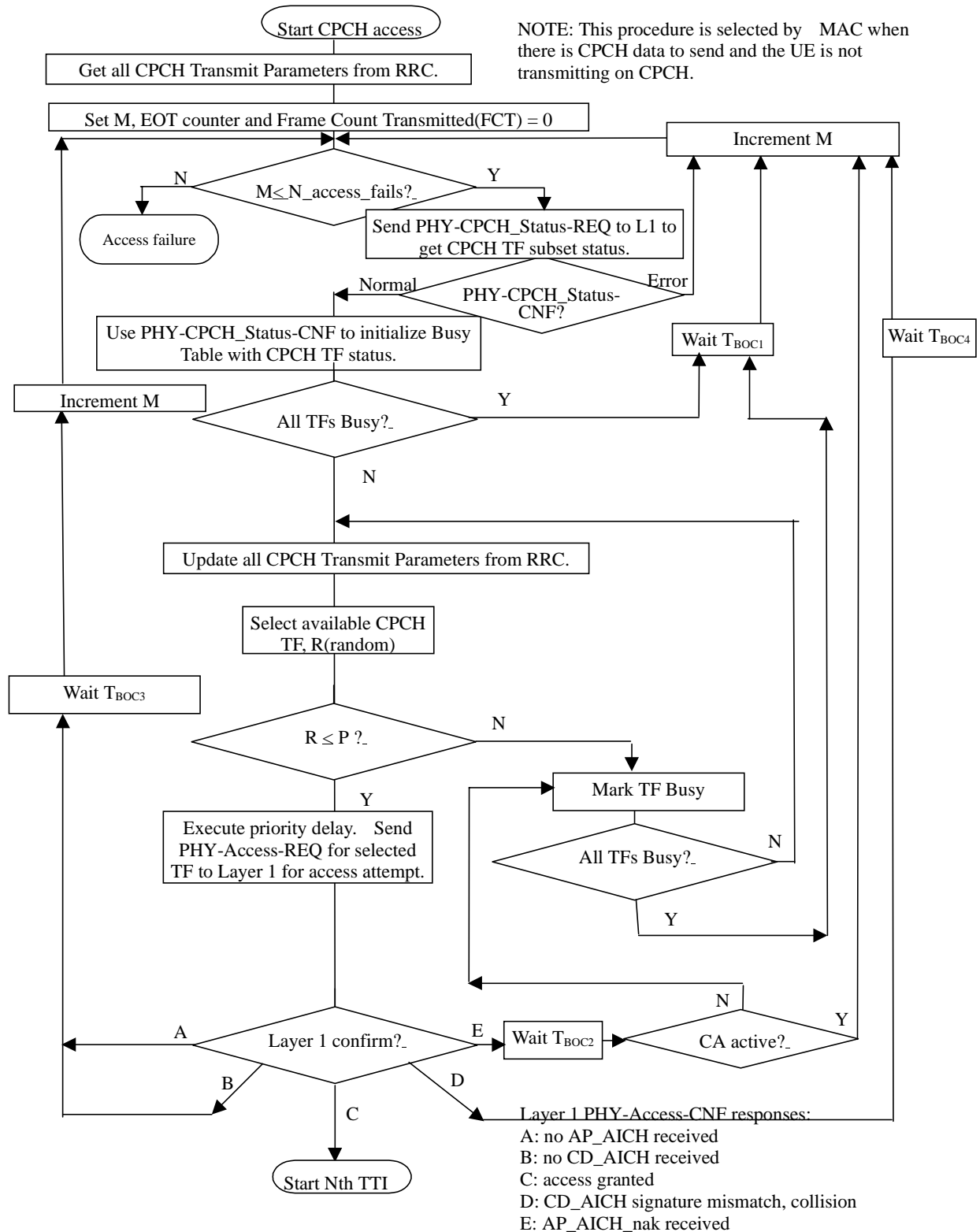

Figure 11.3.1: CPCH transmission control procedure for initial access (informative)

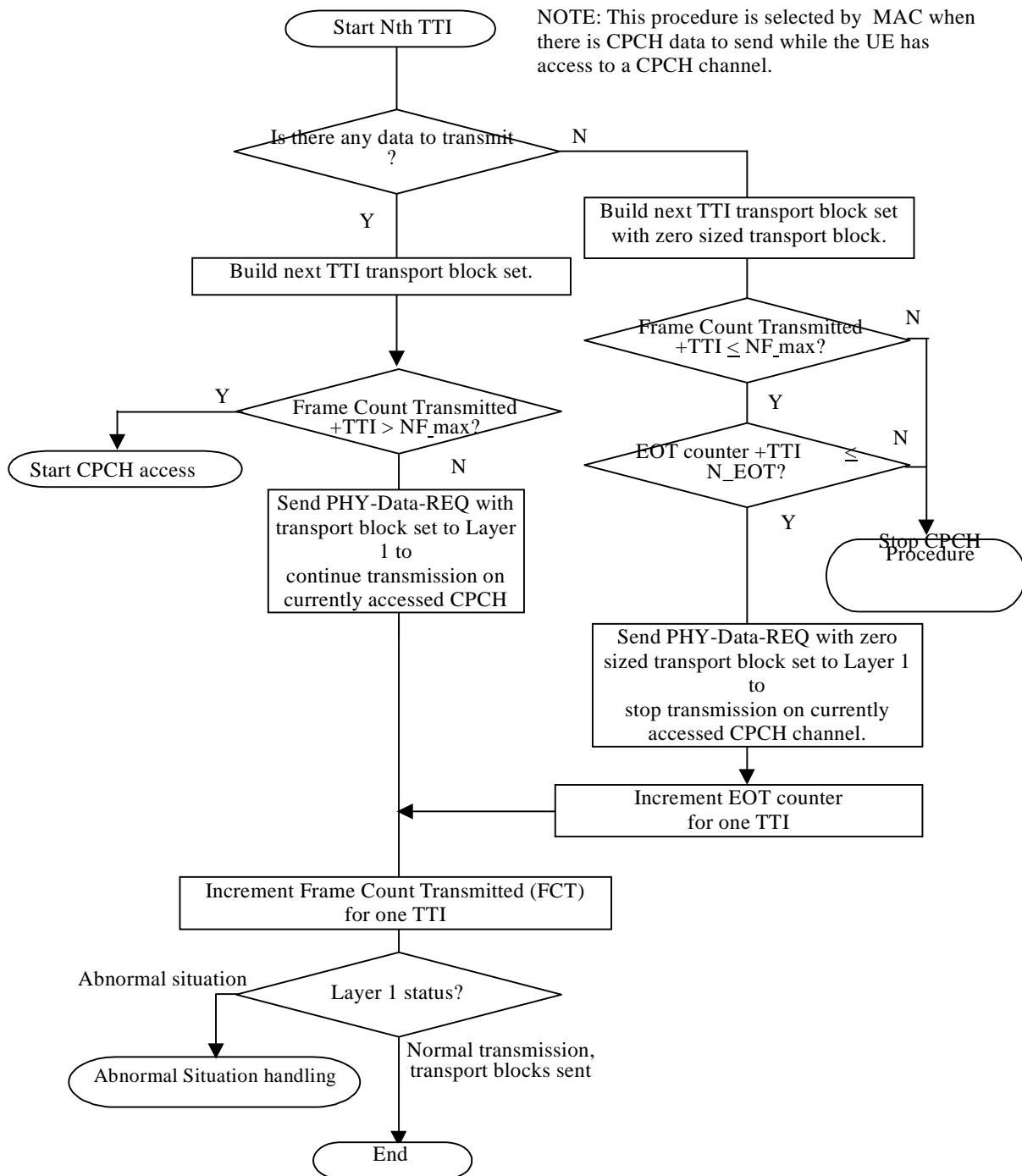

Figure 11.3.2: CPCH transmission control procedure for Nth TTI (informative)

11.4 Transport format combination selection in UE

RRC can control the scheduling of uplink data by giving a priority value between 1 and 8 for each logical channel where 1 is the highest priority and 8 the lowest. The selection of TFC in the UE shall be done according to the priorities between logical channels indicated by RRC. Logical channels have relative priority i.e. data with a given priority may occasionally be transmitted even if it prevents data with a higher priority from being transmitted.

A fraction of the transport blocks on a logical channel may be blocked for transmission in favour of data from a logical channel with the next lower used priority. If the fraction is set to zero, the priority scheme will be absolute priority, i.e. no transport blocks on the logical channel shall be blocked for transmission in favour of lower priority data.

The maximum fraction of transport blocks on a logical channel that may be blocked for transmission in favour of data with the next lower priority is given by RRC signalling. The blocked transport blocks shall be selected in a periodical manner, with the shortest possible periodicity. If the shortest periodicity can be achieved in more than one way, the minimum distance between two blocked transport block shall be as large as possible, to assure that the blocked frames are distributed uniformly. The rules for TFC selection in the above section shall apply to TF selection when RACH or CPCH is used.

When the UE output power is approaching the UE maximum transmit power and the inner loop for power control can no longer be maintained for coverage reasons, the UE shall adapt to the TFC corresponding to the next lower bit rate, i.e. the TFC with the present total bit rate shall not be used. If the bit rate of a logical channel carrying data from a codec supporting variable-rate operation is impacted, the codec data rate shall be adopted accordingly.

The UE shall continuously estimate whether the maximum transmitter power is sufficient to support the temporarily blocked TFC. When the maximum transmitter power is sufficient, the temporarily blocked TFC shall again be considered in the TFC selection.

The maximum UE power is defined in [25.331].

Annex A (informative): Change history

Change history					
TSG-RAN#	Version	CR	Tdoc RAN	New Version	Subject/Comment
RAN_04	-	-	RP-99312	3.0.0	Approved at TSG-RAN #4 and placed under Change Control
RAN_05	3.0.0	001	RP-99463	3.1.0	Modified MAC handling of PCH and FACH
RAN_05	3.0.0	002	RP-99463	3.1.0	Modifications of MAC primitives
RAN_05	3.0.0	003	RP-99463	3.1.0	RACH/FACH MAC header – Channel type identification
RAN_05	3.0.0	004	RP-99463	3.1.0	Support for USCH/DSCH signalling in TDD
RAN_05	3.0.0	006	RP-99463	3.1.0	Clarification on RACH partitioning and prioritization via access service class (ASC) and relation to back-off algorithm
RAN_05	3.0.0	010	RP-99463	3.1.0	Modifications on UE-Id formats
RAN_05	3.0.0	011	RP-99463	3.1.0	CPCH primitives
RAN_05	3.0.0	012	RP-99463	3.1.0	Timing advance for TDD
RAN_05	3.0.0	013	RP-99463	3.1.0	Traffic volume measurement report procedure
RAN_05	3.0.0	014	RP-99463	3.1.0	Mapping of BCCH logical channel onto FACH transport channel
RAN_05	3.0.0	015	RP-99463	3.1.0	MAC PDU formats for DCCH/DTCH on DSCH and for PCCH
RAN_05	3.0.0	016	RP-99463	3.1.0	Informative parts that shall not specify or constrain implementations
RAN_05	3.0.0	017	RP-99463	3.1.0	Modification of RACH transmission control procedure
RAN_05	3.0.0	018	RP-99463	3.1.0	Removal of MAC function for system information and paging scheduling
RAN_05	3.0.0	019	RP-99463	3.1.0	RACH transmission control procedure on MAC for TDD mod
RAN_05	3.0.0	021	RP-99463	3.1.0	Removal of Annex A and B of TS 25.321
RAN_06	3.1.0	022	RP-99638	3.2.0	Modified MAC header field sizes
RAN_06	3.1.0	023	RP-99638	3.2.0	MAC: Multiple shared channels (DSCH/USCH)
RAN_06	3.1.0	024	RP-99638	3.2.0	Parameters for Status Primitive
RAN_06	3.1.0	025	RP-99638	3.2.0	Support of shared channel operation in TDD
RAN_06	3.1.0	028	RP-99638	3.2.0	Modification of Cell Broadcast Service (CBS)
RAN_06	3.1.0	030	RP-99637	3.2.0	Editorial changes
RAN_06	3.1.0	031	RP-99638	3.2.0	Simultaneous mapping of logical channels on
RAN_07	3.2.0	032	RP-000039	3.3.0	(03/00) Bit Aligned TDD MAC Headers
RAN_07	3.2.0	035	RP-000039	3.3.0	CPCH including Channel Assignment
RAN_07	3.2.0	036	RP-000039	3.3.0	UE-ID type indication
RAN_07	3.2.0	037	RP-000039	3.3.0	RACH transmission control procedure
RAN_07	3.2.0	039	RP-000039	3.3.0	CPCH start of message indication
RAN_07	3.2.0	040	RP-000039	3.3.0	Removal of SCH and SCCH
RAN_07	3.2.0	041	RP-000039	3.3.0	Clarification of bit order
RAN_08	3.3.0	042	RP-000219	3.4.0	(06/00) CPCH correction
RAN_08	3.3.0	043	RP-000219	3.4.0	End of CPCH transmission
RAN_08	3.3.0	044	RP-000219	3.4.0	Clarification of prioritisation of logical channels in UE
RAN_08	3.3.0	045	RP-000219	3.4.0	CPCH MAC procedures
RAN_08	3.3.0	046	RP-000219	3.4.0	Traffic Volume Measurement for dynamic radio bearer control
RAN_09	3.4.0	047	RP-000357	3.5.0	(09/00) Movement of primitives text to the correct section
RAN_09	3.4.0	048	RP-000357	3.5.0	Corrections to RACH procedure
RAN_09	3.4.0	049	RP-000357	3.5.0	Clarification on the parameters of the MAC-RLC primitives
RAN_09	3.4.0	051	RP-000357	3.5.0	Editorial Cleanup

History

Document history		
V3.2.0	January 2000	Publication
V3.3.0	March 2000	Publication
V3.4.0	June 2000	Publication
V3.5.0	September 2000	Publication