

ETSI TS 125 323 V4.2.0 (2001-09)

Technical Specification

Universal Mobile Telecommunications System (UMTS); Packet Data Convergence Protocol (PDCP) Specification (3GPP TS 25.323 version 4.2.0 Release 4)



Reference

RTS/TSGR-0225323Uv4R2

Keywords

UMTS

ETSI

650 Route des Lucioles
F-06921 Sophia Antipolis Cedex - FRANCE

Tel.: +33 4 92 94 42 00 Fax: +33 4 93 65 47 16

Siret N° 348 623 562 00017 - NAF 742 C
Association à but non lucratif enregistrée à la
Sous-Préfecture de Grasse (06) N° 7803/88

Important notice

Individual copies of the present document can be downloaded from:

<http://www.etsi.org>

The present document may be made available in more than one electronic version or in print. In any case of existing or perceived difference in contents between such versions, the reference version is the Portable Document Format (PDF). In case of dispute, the reference shall be the printing on ETSI printers of the PDF version kept on a specific network drive within ETSI Secretariat.

Users of the present document should be aware that the document may be subject to revision or change of status. Information on the current status of this and other ETSI documents is available at

<http://portal.etsi.org/tb/status/status.asp>

If you find errors in the present document, send your comment to:

editor@etsi.fr

Copyright Notification

No part may be reproduced except as authorized by written permission.
The copyright and the foregoing restriction extend to reproduction in all media.

© European Telecommunications Standards Institute 2001.
All rights reserved.

Intellectual Property Rights

IPRs essential or potentially essential to the present document may have been declared to ETSI. The information pertaining to these essential IPRs, if any, is publicly available for **ETSI members and non-members**, and can be found in ETSI SR 000 314: "*Intellectual Property Rights (IPRs); Essential, or potentially Essential, IPRs notified to ETSI in respect of ETSI standards*", which is available from the ETSI Secretariat. Latest updates are available on the ETSI Web server (<http://www.etsi.org/legal/home.htm>).

Pursuant to the ETSI IPR Policy, no investigation, including IPR searches, has been carried out by ETSI. No guarantee can be given as to the existence of other IPRs not referenced in ETSI SR 000 314 (or the updates on the ETSI Web server) which are, or may be, or may become, essential to the present document.

Foreword

This Technical Specification (TS) has been produced by ETSI 3rd Generation Partnership Project (3GPP).

The present document may refer to technical specifications or reports using their 3GPP identities, UMTS identities or GSM identities. These should be interpreted as being references to the corresponding ETSI deliverables.

The cross reference between GSM, UMTS, 3GPP and ETSI identities can be found under www.etsi.org/key.

Contents

Intellectual Property Rights	2
Foreword.....	2
Foreword.....	4
1 Scope	5
2 References	5
3 Definitions and Abbreviations.....	5
3.1 Definitions	5
3.2 Abbreviations	5
4 General	6
4.1 Objective	6
4.2 Overview on sublayer architecture	6
5 Functions	7
5.1 Header Compression	7
5.1.1 Mapping of PID values	7
5.1.2 IP Header Compression (RFC 2507)	8
5.1.2.1 Context identifiers	8
5.1.2.2 Mapping of PID values for RFC 2507	9
5.1.3 Robust Header Compression (RFC 3095)	9
5.1.3.1 Context identifiers	9
5.1.3.2 Mapping of PID values for RFC 3095 with CIDs in PDCP PDU Header	9
5.1.3.3 Mapping of PID values for RFC 3095 with CIDs within ROHC packet format	9
5.1.3.4 RFC 3095 Segmentation	10
5.1.3.5 Protocol Parameters	10
5.2 Void.....	11
5.3 Data Transfer	11
5.3.1 Data transfer over acknowledged mode RLC	11
5.3.2 Data transfer over unacknowledged and transparent mode RLC	12
5.4 SRNS Relocation.....	12
5.4.1 Lossless SRNS Relocation.....	12
5.4.1.1 PDCP Sequence Numbering	12
5.4.1.2 PDCP Sequence Number synchronization	13
5.4.1.3 Sequence Number and Data Forwarding.....	13
6 Services	14
6.1 Services provided to upper layers.....	14
6.2 Services expected from RLC layer.....	14
7 Elements for layer-to-layer communication.....	14
7.1 Primitives between PDCP and upper layers	14
8 Elements for peer-to-peer communication	15
8.1 Protocol data units	15
8.2 Formats.....	15
8.2.1 PDCP-No-Header PDU	16
8.2.2 PDCP Data PDU.....	16
8.2.3 PDCP SeqNum PDU	16
8.3 Parameters	16
8.3.1 PDU Type	17
8.3.2 PID.....	17
8.3.3 Data.....	17
8.3.4 Sequence number.....	17
9 Handling of unknown, unforeseen and erroneous protocol data	18
9.1 Invalid PDU type.....	18
9.2 Invalid PID value.....	18
Annex A (informative): Change history	19
History	20

Foreword

This Technical Specification (TS) has been produced by the 3rd Generation Partnership Project (3GPP).

The contents of the present document are subject to continuing work within the TSG and may change following formal TSG approval. Should the TSG modify the contents of the present document, it will be re-released by the TSG with an identifying change of release date and an increase in version number as follows:

Version x.y.z

where:

- x the first digit:
 - 1 presented to TSG for information;
 - 2 presented to TSG for approval;
 - 3 or greater indicates TSG approved document under change control.
- y the second digit is incremented for all changes of substance, i.e. technical enhancements, corrections, updates, etc.
- z the third digit is incremented when editorial only changes have been incorporated in the document.

1 Scope

The present document provides the description of the Packet Data Convergence Protocol (PDCP).

2 References

The following documents contain provisions which, through reference in this text, constitute provisions of the present document.

- References are either specific (identified by date of publication, edition number, version number, etc.) or non-specific.
- For a specific reference, subsequent revisions do not apply.
- For a non-specific reference, the latest version applies. In the case of a reference to a 3GPP document (including a GSM document), a non-specific reference implicitly refers to the latest version of that document *in the same Release as the present document*.

- [1] 3GPP TS 23.060: "General Packet Radio Service (GPRS); Service description; Stage 2".
- [2] 3GPP TS 25.331: "Radio Resource Control".
- [3] 3GPP TS 25.301: "Radio Interface Protocol Architecture".
- [4] 3GPP TS 25.303: "Interlayer Procedures in Connected Mode".
- [5] 3GPP TS 25.322: "RLC Protocol Specification".
- [6] IETF RFC 2507: "IP Header Compression".
- [7] 3GPP TR 21.905: "Vocabulary for 3GPP Specifications".
- [8] IETF RFC 3095: "RObust Header Compression (ROHC): Framework and four profiles: RTP, UDP, ESP, and uncompressed".
- [9] IETF RFC 3096: "Requirements for robust IP/UDP/RTP header compression".

3 Definitions and Abbreviations

3.1 Definitions

For the purposes of the present document, the terms and definitions given in [7] apply.

3.2 Abbreviations

For the purposes of the present document, the following abbreviations apply:

AS	Access Stratum
CID	Context Identifier
C-SAP	Control Service Access Point
HC	Header Compression
IETF	Internet Engineering Task Force
IP	Internet Protocol
L2	Layer 2 (data link layer)
L3	Layer 3 (network layer)
NAS	Non Access Stratum
PDCP	Packet Data Convergence Protocol

PDU	Protocol Data Unit
PID	Packet Identifier
PPP	Point-to-Point Protocol
RB	Radio Bearer
RFC	Request For Comments
RLC	Radio Link Control
RNC	Radio Network Controller
ROHC	RObust Header Compression
RTP	Real Time Protocol
SDU	Service Data Unit
TCP	Transmission Control Protocol
UDP	User Datagram Protocol
UE	User Equipment
UMTS	Universal Mobile Telecommunications System
UTRA	UMTS Terrestrial Radio Access
UTRAN	UMTS Terrestrial Radio Access Network

4 General

4.1 Objective

The present document describes the functionality of the PDCP.

4.2 Overview on sublayer architecture

Figure 1 shows the model of the PDCP within the radio interface protocol architecture. The radio interface protocol architecture is defined in [3]. The PDCP sublayer is defined for the PS domain only.

Every PS domain RAB is associated with one RB, which in turn is associated with one PDCP entity. Each PDCP entity is associated with one RLC entity. The PDCP entities are located in the PDCP sublayer.

Every PDCP entity uses zero, one or several different header compression protocol types. Several PDCP entities may be defined for a UE with each using the same or different protocol type. In this version of the specification, only two header compression protocol types, RFC 2507 [6] and RFC 3095[8], are supported.

The PDCP sublayer is configured by upper layer [2] through the PDCP-C-SAP.

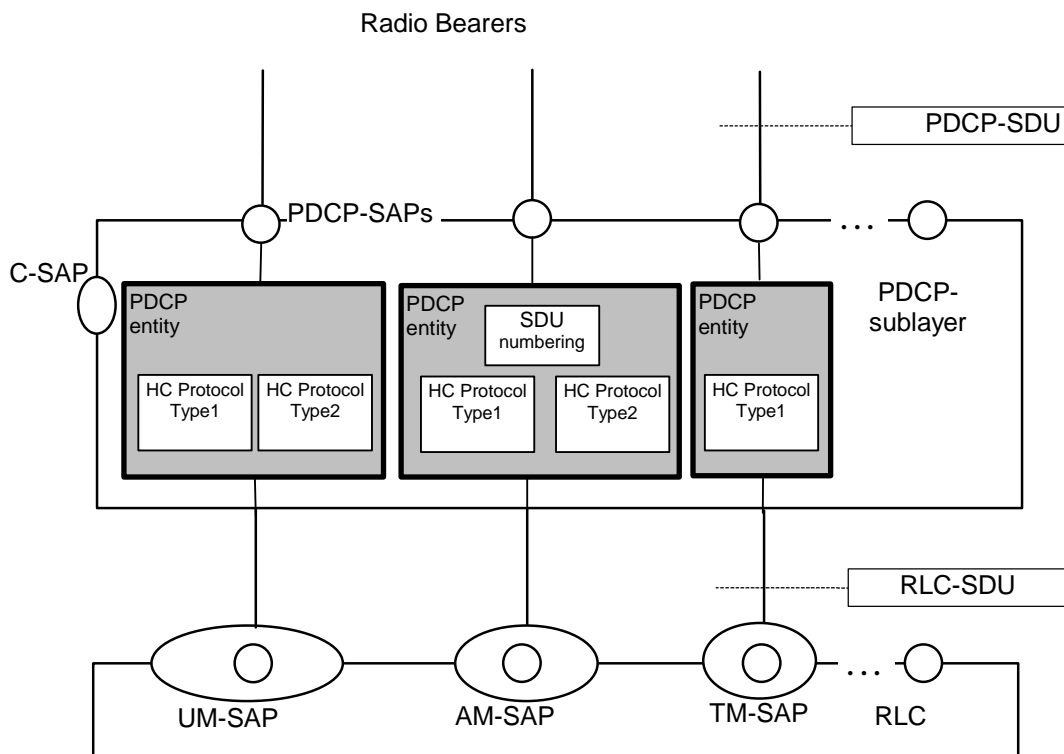

Figure 1: PDCP structure

Figure 1 represents one possible structure for the PDCP sublayer and should not restrict implementation.

5 Functions

PDCP provides its services to the NAS at the UE or the relay at the Radio Network Controller (RNC).

The Packet Data Convergence Protocol shall perform the following functions:

- header compression and decompression of IP data streams (e.g., TCP/IP and RTP/UDP/IP headers for IPv4 and IPv6) at the transmitting and receiving entity, respectively.
- transfer of user data. This function is used for conveyance of data between users of PDCP services.
- maintenance of PDCP sequence numbers for radio bearers that are configured to support lossless SRNS Relocation.

PDCP uses the services provided by the Radio Link Control (RLC) sublayer.

5.1 Header Compression

The header compression protocol is specific to the particular network layer, transport layer or upper layer protocol combinations e.g. TCP/IP and RTP/UDP/IP. The network layer protocol type, e.g. IP or PPP, is indicated during PDP context activation as defined in [1]. The header compression protocols and their parameters are configured by upper layers for each PDCP entity. Compressor and decompressor initiated signalling between peer PDCP entities, during operation, is accomplished through in-band signalling.

5.1.1 Mapping of PID values

Depending on the configuration by upper layers (i.e. PDCP PDU type to be used and header compressor protocol), the PDCP sublayer shall be able to:

- identify different types of header compression protocols;
- identify different header compression protocol packet types within a header compression protocol; and
- identify different contexts for a header compression protocol.

The above requirements are realised by utilising the PID field in the PDCP PDU.

The mapping of the PID values shall follow the general rules listed below:

- PID values shall be mapped to the different packet types independently at each PDCP entity;
- PID value "0" shall indicate "no compression". PID value "0" shall be used in a PDCP PDU containing in its Data field a PDCP SDU that is unchanged by the Sender and that shall not be decompressed by the Receiver.;
- PID values are mapped in ascending order, starting from 1, for every configured header compression protocol, in the order of configuration by upper layer. The first available PID value is assigned to the first packet type of the header compression protocol as defined in the specification for this header compression protocol. PID values are mapped for all the specified packet types defined for the header compression protocol and in the order defined in subclause 5.1.2.1 for the respective header compression protocol;
- PID values are re-mapped for the PDCP entity after any reconfiguration of the header compression protocols for that entity.

The following table illustrates an example of the PID value mapping to the packet types when five arbitrary header compression methods are configured for one PDCP entity: RFC 2507[6], Methods A and B, RFC 3095 [8] and Method C. Method A, Method B and Method C are imaginary header compression protocols introduced for the purpose of illustration.

Table 1: Example of the PID value mapping table

PID Value	Optimisation method	Packet type
0	No header compression	-
1	RFC 2507	Full header
2	RFC 2507	Compressed TCP
3	RFC 2507	Compressed TCP nondelta
4	RFC 2507	Compressed non TCP
5	RFC 2507	Context state
6	Method A	Packet Type 1 of Method A
7	Method A	Packet Type 2 of Method A
8	Method B	Packet Type 1 of Method B
9	Method B	Packet Type 2 of Method B
10	RFC 3095	CID 0
11	RFC 3095	CID 1
12	RFC 3095	CID 2
13	Method C	Packet Type 1 of Method C
14	Method C	Packet Type 2 of Method C
15...31	Unassigned value	-

5.1.2 IP Header Compression (RFC 2507)

The detailed operation of the RFC 2507 header compression protocol is specified in IETF RFC 2507 [6]. The mechanisms related to error recovery and packet reordering are also described in RFC 2507. These mechanisms shall be included in the functionality of the header compression supported by PDCP. The implementation of the RFC 2507 header compression functionality is not covered in this specification and is left to the implementation.

5.1.2.1 Context identifiers

Context identifiers for RFC 2507 shall only be included in the RFC 2507 packet types format, as defined in [6].

5.1.2.2 Mapping of PID values for RFC 2507

PID values shall be mapped to the RFC 2507 header compression packet types in the order presented in Table 2 below where "n" is the number of PID values already mapped to other protocol packet types.

Table 2: Mapping of PID values for RFC 2507 header compression protocol

PID value	Optimisation method	Packet type
n+1	RFC 2507	Full header
n+2	RFC 2507	Compressed TCP
n+3	RFC 2507	Compressed TCP non-delta
n+4	RFC 2507	Compressed non-TCP
n+5	RFC 2507	Context state

5.1.3 Robust Header Compression (RFC 3095)

The detailed operation of the, "RObust Header Compression (ROHC)" protocol is specified in IETF RFC 3095 [8].

5.1.3.1 Context identifiers

The context of the RFC 3095 protocol is defined in [8]. RFC 3095 can be configured to support one or several contexts. Each context is identified by a value known as the context identifier (CID). If CIDs are to be used, then the CID shall be either:

- included in the PDCP header; or
- included in the RFC 3095 packet format [8].

The choice of which of the above two methods to use is configured by upper layers. The mapping of the PID values is specified in subclauses 5.1.3.2 and 5.1.3.3, respectively for the above two methods.

5.1.3.2 Mapping of PID values for RFC 3095 with CIDs in PDCP PDU Header

The following PID values shall be mapped to the RFC 3095 header compression protocol in the order presented in the table where n is the number of PID values already mapped to other protocol packet types. As shown in the Table 3 below, the mapping of PID values for the RFC 3095 map to the CID values used by RFC 3095. The maximum CID value (CID_x) is configured by upper layers. If this method is configured by upper layers, PDCP shall not introduce CIDs in the ROHC packet format.

Table 3: Mapping of PID values for RFC 3095 header compression protocol

PID value	Optimisation method	Packet type
n+1	RFC 3095	CID1
n+2	RFC 3095	CID2
...	RFC 3095	...
...	RFC 3095	...
n+x	RFC 3095	CID _x

5.1.3.3 Mapping of PID values for RFC 3095 with CIDs within ROHC packet format

The following PID value shall be mapped to the RFC 3095 header compression protocol as presented in the table where n is the number of PID values already assigned to other protocol packet types.

Table 4: Mapping of PID values for RFC 3095 header compression protocol

PID value	Optimisation method	Packet type
n+1	RFC 3095	RFC 3095 packet format

If this method is configured by upper layers,, PDCP shall not be configured to accommodate ROHC CIDs in the PDCP PDU header .

5.1.3.4 RFC 3095 Segmentation

The RFC 3095 protocol supports segmentation. The segmentation:

- can vary on a packet-by-packet basis; and
- does not add any overhead to packets that are not segmented.

The Segmentation option of RFC 3095 shall:

- not be used when RLC is configured in non-transparent mode [5], in which case the MRRU (maximum reconstructed reception unit) shall be set equal to 0;
- only be used when RLC is configured in transparent mode and the PACKET_SIZES_ALLOWED is used to configure ROHC packet sizes;
- be applied if the produced packet does not fit the largest packet as indicated by PACKET_SIZES_ALLOWED.

5.1.3.5 Protocol Parameters

RFC 3095 has two types of parameters [8]:

- configuration parameters: these are mandatory and must be configured between compressor and decompressor peers.
- implementation parameters: these are optional and, when used, stipulate how RFC 3095 operates.

These parameters are categorized in four different groups, as defined below:

- M: Mandatory and configured by upper layers.
- MO: Parameters that must be supported and when used can only be configured or triggered by upper layers.
- O: Optional RFC 3095 parameters that are not configured by upper layers. They may be used locally (i.e. UTRAN and/or in UE) for RFC 3095.
- N/A: These are not used in RFC 3095.

The usage and definition of the parameters shall be as specified below.

- CID_INCLUSION_INFO (M): This defines whether RFC3095 CID values are transferred within PDCP headers or RFC3095 packet format. See chapter 5.1.3.1 for more information.
- MAX_CID (M): This is the maximum CID value that can be used. One CID value shall always be reserved for uncompressed flows.
- LARGE_CIDS: This is not configured by upper layers but inferred from the configured value of MAX_CID according to the following rule:

If MAX_CID > 15 then LARGE_CIDS = TRUE else LARGE_CIDS = FALSE.

- PROFILES (M): Profiles are used to define which profiles are allowed to be used by the UE in uplink. All profiles defined in [8] shall be supported by the UE.
- FEEDBACK_FOR (N/A):
- MRRU (M): Segmentation is not used by default.
- NO_OF_PACKET_SIZES_ALLOWED (O).
- PACKET_SIZES_ALLOWED (MO): This parameter, if configured, governs which packet sizes in bytes may be used by RFC 3095. Thus, packet sizes not in the set of values for this parameter shall not be used.

- PAYLOAD_SIZES (O).
- NO_OF_PACKET_SIZES_USED (O).
- PACKET_SIZES_USED (O).
- CONTEXT_REINITIALIZATION (MO).
- MODE (O).
- CLOCK_RESOLUTION (O).
- REVERSE_DECOMPRESSION_DEPTH (M): Default value is that reverse decompression is not used.

5.2 Void

5.3 Data Transfer

If header compression is configured the PDCP entity in the Sender shall:

- perform header compression upon reception of a PDCP SDU from upper layers;
- if the radio bearer is configured for lossless SRNS Relocation:
 - maintain PDCP sequence numbering as specified in subclause 5.4.1.1;
- submit the PDCP PDU to lower layer in the sequence received from the upper layer.

When the PDCP entity at the Receiver receives the PDCP PDU from lower layers, it shall:

- perform header decompression (if header compression is configured) of the PDCP PDU to obtain the PDCP SDU; and
- deliver the PDCP SDU to the upper layer in the order received from the lower layer;
- if the received PDCP PDU is of type SeqNum PDU:
 - follow the procedure in subclause 5.4.1.2.

5.3.1 Data transfer over acknowledged mode RLC

Figure 2 shows the PDCP data transfer over acknowledged mode RLC.

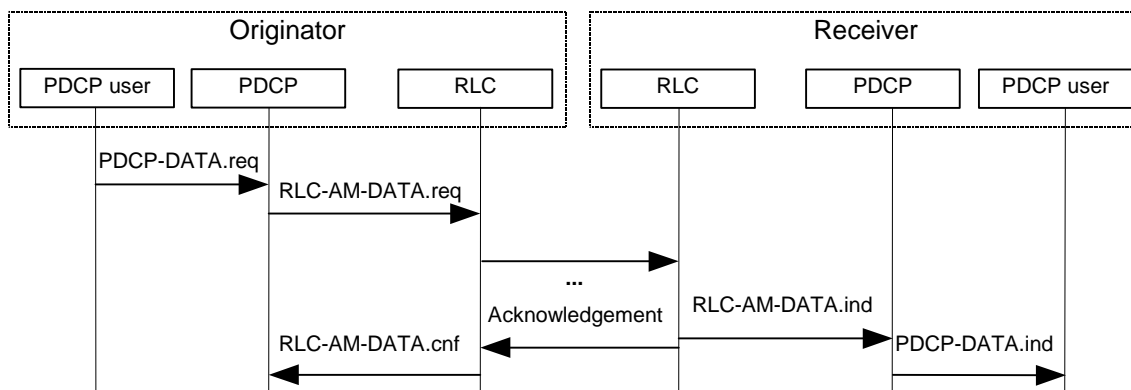

Figure 2: PDCP data transfer over acknowledged mode RLC

5.3.2 Data transfer over unacknowledged and transparent mode RLC

Figure 3 shows the PDCP data transfer over unacknowledged or transparent mode RLC.

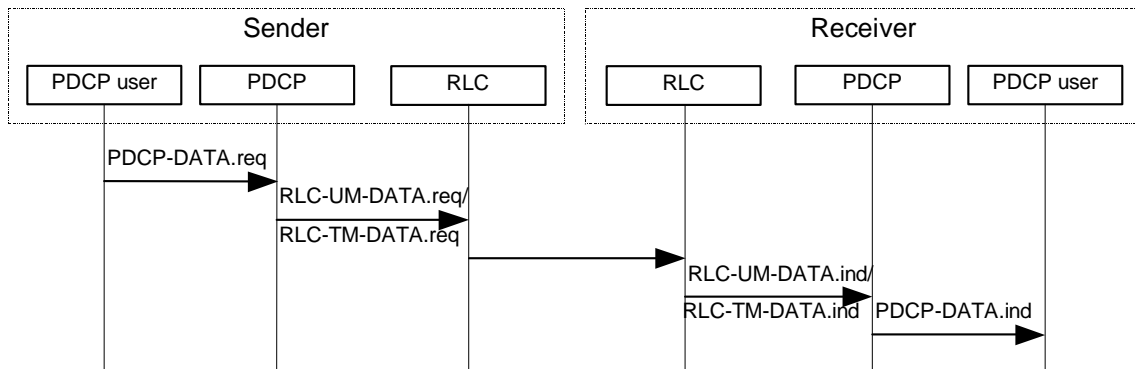

Figure 3: PDCP data transfer over unacknowledged or transparent mode RLC

5.4 SRNS Relocation

In case of SRNS Relocation upper layer indicates to PDCP to perform the re-initialisation of all compression entities of a RB. This entails the following:

- Configured compression parameters remain valid during re-initialisation.
- All compression state information is initialised, e.g. header compression contexts. Therefore, the first 'compressed' packet type after SRNS Relocation is a full header.
- The PDCP sequence numbers are not changed due to the PDCP header compression protocol re-initialisation.

5.4.1 Lossless SRNS Relocation

Lossless SRNS Relocation is only applicable when RLC is configured for in-sequence delivery and acknowledged mode. The support of lossless SRNS Relocation is configured by upper layer.

For the support of lossless SRNS Relocation PDCP maintains sequence numbers for PDCP SDUs, as described in subclause 5.4.1.1. These sequence numbers are synchronised between PDCP Sender and Receiver, as described in subclause 5.4.1.2. When a lossless SRNS Relocation is performed sequence numbers are exchanged between UE and UTRAN. They are used to confirm PDCP SDUs successfully received by the Receiver but not yet acknowledged to have been received by the lower layer, as described in subclause 5.4.1.3. After relocation the data transfer begins with the first unconfirmed PDCP SDU.

5.4.1.1 PDCP Sequence Numbering

PDCP sequence numbering shall be applied when lossless SRNS Relocation is to be supported. PDCP Sequence Numbers serve to acknowledge previously sent PDCP SDUs prior to relocation. The value of the PDCP sequence number ranges from 0 to 65535. The PDCP SN window size indicates the maximum number of PDCP SDUs, not confirmed to have been successfully transmitted to the peer entity by lower layer, that can be numbered at any given time. The PDCP SN window size is configured by upper layers. PDCP sequence numbers are set to "0" when the PDCP entity is set-up for the first time.

In the following the "submission/reception of a PDCP SDU to/from lower layer" is used as a synonym for the submission/reception of a PDCP Data PDU or a PDCP SeqNum PDU to/from lower layer that carries in its Data field a compressed or uncompressed PDCP SDU. In case PDCP sequence numbers are applied, for each radio bearer:

- in the UE:
 - the UL_Send PDCP sequence number shall be set to "0" for the first PDCP SDU submitted to lower layer;

- the UL_Send PDCP sequence number shall be incremented by "1" when a PDCP SDU is submitted to lower layer;
- the DL_Receive PDCP sequence number is set to "0" for the first received PDCP SDU;
- the DL_Receive PDCP sequence number is incremented by "1" when a PDCP Data SDU is received from lower layer.
- in the UTRAN:
 - the DL_Send PDCP sequence number shall be set to "0" for the first PDCP SDU submitted to lower layer;
 - the DL_Send PDCP sequence number shall be incremented by "1" when a PDCP SDU is submitted to lower layer;
 - the UL_Receive PDCP sequence number shall be set to "0" for the first received PDCP SDU;
 - the UL_Receive PDCP sequence number is incremented by "1" when a PDCP Data SDU is received from lower layer.

PDCP sequence numbers shall not be decremented in a PDCP entity.

5.4.1.2 PDCP Sequence Number synchronization

For radio bearers that are configured to support lossless SRNS Relocation, the PDCP entity shall:

- if upper layer indicates to a PDCP entity that it should synchronise the PDCP SN following a RLC reset or RB reconfiguration; and
- if the PDCP entity receives an invalid "next expected UL/DL Receive PDCP Sequence Number" for upper layer after Relocation:
 - trigger the Synchronization of PDCP SN by submitting one PDCP SeqNum PDU to lower layer;
 - consider that the synchronisation procedure is complete on confirmation by lower layer of the successful transmission of the PDCP SeqNum PDU.

In the UE, the next expected UL_Receive_SN is considered invalid if its value is less than the PDCP SN of the first sent but unacknowledged PDCP SDU or greater than the first unsent PDCP SDU.

On receiving a PDCP SeqNum PDU, the PDCP entity shall:

- set the value of the Receive PDCP sequence number (i.e. UL_Receive or DL_Receive) to the value indicated in the PDCP SeqNum PDU.

5.4.1.3 Sequence Number and Data Forwarding

In case of a lossless SRNS Relocation procedure, as described in [1]:

- the UTRAN should send to the UE the next expected UL PDCP Sequence Number; and
- the UE shall send to the UTRAN the next expected DL Receive PDCP Sequence Number.

This information exchange synchronises the Sequence Numbers at the UE and UTRAN PDCP entities.

When requested by the upper layer, for each radio bearer configured to support lossless SRNS Relocation, the PDCP sublayer in the source RNC should forward the following to the target RNC:

- the Receive PDCP Sequence Number of the next PDCP SDU expected to be received from the UE;
- the Send PDCP sequence number of the first PDCP SDU forwarded to the target SRNC;
- the PDCP-SDUs not confirmed to have been received by the peer PDCP entity.

6 Services

6.1 Services provided to upper layers

The following services are provided by PDCP to upper layers:

- transfer of user data;
- maintenance of PDCP PDU sequence numbers.

6.2 Services expected from RLC layer

For a detailed description of the following functions see [5].

- transparent data transfer Service;
- unacknowledged data transfer Service;
- acknowledged data transfer Service.

7 Elements for layer-to-layer communication

The interaction between the PDCP layer and other layers are described in terms of primitives where the primitives represent the logical exchange of information and control between the PDCP layer and other layers. The primitives shall not specify or constrain implementations.

7.1 Primitives between PDCP and upper layers

The primitives between PDCP and upper layers are shown in Table 5.

Table 5: Primitives between PDCP and upper layers

Generic Name	Parameter			
	Req.	Ind.	Resp.	Conf.
PDCP-DATA	Data	Data	Not Defined	Not Defined
CPDCP-CONFIG	PDCP-Info, RLC-SAP SN_Sync, R/I	Not Defined	Not Defined	Not Defined
CPDCP-RELEASE	RLC-SAP	Not Defined	Not Defined	Not Defined
CPDCP-SN	PDCP SN	Not Defined	Not Defined	Not Defined
CPDCP-RELOC	Receive_SN	Not Defined	Not Defined	Receive_SN, Send_SN

Each Primitive is defined as follows:

- a) PDCP-DATA-Req./Ind.
 - PDCP-DATA-Req is used by upper user-plane protocol layers to request a transmission of upper layer PDU.
 - PDCP-DATA-Ind is used to deliver PDCP SDU that has been received to upper user plane protocol layers.
- b) CPDCP-CONFIG-Req.
 - CPDCP-CONFIG Req is used to configure and – in case of already existing PDCP entity – to reconfigure a PDCP entity and to assign it to the radio bearer associated with that entity.
- c) CPDCP-RELEASE-Req.
 - CPDCP-RELEASE-Req is used by upper layers to release a PDCP entity.

d) CPDCP-SN-Req.

- This primitive is used at the UTRAN. CPDCP-SN-Req is used to transfer the PDCP SN to PDCP.

e) CPDCP-RELOC-Req/Conf.

- CPDCP-RELOC-Req initiates the SRNS Relocation procedure in PDCP for those radio bearers that are configured to support lossless SRNS Relocation. The Receive_SN is only included at the UE side.
- CPDCP-RELOC-Conf is used to transfer the Receive_SN and/or Send_SN to upper layers for lossless SRNS Relocation. The Send_SN is only included at the source RNC.

The following parameters are used in the primitives:

1) PDCP-Info:

- Contains the parameters for each of the header compression protocols configured to be used by one PDCP entity.

2) RLC-SAP:

- The RLC-SAP (TM/UM/AM) used by PDCP entity when communicating with RLC sublayer.

3) SN_Sync:

- Indicates that PDCP should start PDCP sequence number synchronization

4) Send_SN:

- The send PDCP sequence number of the next PDCP SDU to be sent. There is one in the uplink (UL_Send_SN) and one in the downlink (DL_Send_SN). Refer to subclause 5.4.1.

5) Receive_SN:

- The receive PDCP sequence number of the next PDCP SDU expected to be received. There is one in the uplink (UL_Receive_SN) and one in the downlink (DL_Receive_SN). Refer to subclause 5.4.1.

6) PDCP SN:

- This includes a PDCP sequence number.

7) R/I:

- Indicates that PDCP should Re-initialise/Initialise the header compression protocols.

8 Elements for peer-to-peer communication

8.1 Protocol data units

Different PDU formats are defined for the PDCP protocol, one not introducing any overhead to the (compressed) PDCP SDU, others introducing such overhead.

8.2 Formats

A PDCP PDU shall be a multiple of 8 bits, if the RLC entity is configured for unacknowledged or acknowledged mode. Otherwise, if the RLC entity is configured for transparent mode, it is bit-aligned. In Tables 6, 7 and 8, bit strings are represented as follows: the first bit is the leftmost one on the first line of the table, the last bit is the rightmost on the last line of the table, and more generally the bit string is to be read from left to right and then in the reading order of the lines.

SDUs are bit strings, with any non-null length. If not compressed within PDCP an SDU is included from first bit onward.

8.2.1 PDCP-No-Header PDU

The PDCP-No-Header PDU does not introduce any overhead to the PDCP SDU. The use of the PDCP-No-header PDU is configured by the upper layer.

The format of the PDCP-No-Header-PDU is shown in Table 6.

Table 6: PDCP-No-Header PDU

Data

8.2.2 PDCP Data PDU

The PDCP Data PDU is used to convey:

- data containing an uncompressed PDCP SDU; or
- header compression related control signalling; or
- data that has been obtained from PDCP SDU after header compression.

The format of the PDCP Data PDU is shown in Table 7.

Table 7: PDCP Data PDU format

PDU type	PID
Data	

8.2.3 PDCP SeqNum PDU

The PDCP SeqNum PDU is used to convey a PDCP SDU sequence number and:

- data containing an uncompressed PDCP SDU; or
- header compression related control signalling; or
- data that has been obtained from PDCP SDU after header compression.

The format of the PDCP –SeqNum PDU is shown in Table 8.

Table 8: PDCP –SeqNum PDU format

PDU type	PID
Sequence number	
Data	

8.3 Parameters

If not otherwise mentioned in the definition of each field then the bits in the parameters shall be interpreted as follows: the left most bit string is the first and most significant and the right most bit is the last and least significant bit.

Unless otherwise mentioned, integers are encoded in standard binary encoding for unsigned integers. In all cases the bits appear ordered from MSB to LSB when read in the PDU.

8.3.1 PDU Type

Length: 3 bits.

The PDU type field indicates the PDCP Data PDU type.

Bit	PDU Type
000	PDCP Data PDU (Table 7)
001	PDCP SeqNum PDU (Table 8)
010-111	Reserved (PDUs with this encoding are invalid for this version of the protocol)

8.3.2 PID

Length: 5 bits.

The PID field indicates the used header compression and packet type or a context identifier.

Bit	Description
00000	No header compression
00001-11111	Dynamically negotiated header compression identifier, as described in subclause 5.1.1

The PID field value indicates the used header compression protocol type and packet type or CID. A specific header compression protocol may utilize a certain range of consecutive values from the PID field value space for different packet types. The Receiving PDCP entity performs the necessary operation (e.g. header decompression) according to the PID field value. There is no fixed relationship between the PID field value and the used optimisation / packet type; PID field values are mapped on PDCP set-up and re-configuration.

The PID field can also be used to represent context identifier values, as specified in subclause 5.1.1.

8.3.3 Data

If:

- header compression is configured; and
- PDU type = PDCP Data PDU, or PDU type = PDCP SeqNum PDU:
 - PDCP SDUs with headers compressed; or
 - Header compression protocol feedback information shall be mapped to the "Data" field.

Else:

- if header compression is not configured; and
- if RB is configured for "lossless Relocation"; and
- if PDU type = PDCP No-header PDU:
 - uncompressed PDCP SDUs shall be mapped to the "Data" field.

8.3.4 Sequence number

Length: 16 bits

PDCP SDU sequence number.

9 Handling of unknown, unforeseen and erroneous protocol data

9.1 Invalid PDU type

If a PDCP entity receives a PDCP PDU with a PDU Type set to Reserved (see subclause 8.3.1), it shall:

- discard the PDCP PDU.

If a PDCP entity is not configured for lossless SRNS Relocation and receives a PDCP SeqNum PDU, it shall:

- ignore the Sequence number field of the PDCP SeqNum PDU.

9.2 Invalid PID value

If a PDCP entity receives a PDCP PDU with a PID value that is not mapped with a valid packet type (see subclause 5.1.1), it shall:

- discard the PDCP PDU.

Annex A (informative): Change history

Change history							
Date	TSG #	TSG Doc.	CR	Rev	Subject/Comment	Old	New
12/1999	RP-06	RP-99645	-		Approved at TSG-RAN #6 and placed under Change Control	-	3.0.0
03/2000	RP-07	RP-000041	004		Bit order of PDCP PDUs	3.0.0	3.1.0
	RP-07	RP-000041	005		Changes to PDCP	3.0.0	3.1.0
06/2000	RP-08	RP-000221	006	4	Changes in PDCP PDU format due to PDCP sequence numbering	3.1.0	3.2.0
09/2000	RP-09	RP-000359	009	3	Clarification of PDCP Sequence Numbering	3.1.0	3.2.0
	RP-09	RP-000359	011		Clarification on how to handle invalid PDUs	3.2.0	3.3.0
	RP-09	RP-000359	012	2	Primitives required for SRNS relocation	3.2.0	3.3.0
	RP-09	RP-000359	015		Handling of invalid PDCP PDU sequence number	3.2.0	3.3.0
03/2001	RP-11	RP-010027	018	1	Editorial Corrections	3.3.0	3.4.0
	RP-11	RP-010027	019	1	Updates necessary for Rel-4 specification	3.3.0	3.4.0
	RP-11	RP-010039	017	2	Robust Header Compression	3.4.0	4.0.0
06/2001	RP-12	RP-010310	021		Clarification on PDCP Sequence numbering	4.0.0	4.1.0
09/2001	RP-13	RP-010543	028		Header compression protocol reinitialisation during SRNS relocation	4.1.0	4.2.0
	RP-13	RP-010543	030		PDCP SDU Sequence Numbering	4.1.0	4.2.0
	RP-13	RP-010543	036		Corrections to PDCP	4.1.0	4.2.0
	RP-13	RP-010553	026		Selection of the RFC 3095 CID transmission	4.1.0	4.2.0

History

Document history		
V4.0.0	March 2001	Publication
V4.1.0	June 2001	Publication
V4.2.0	September 2001	Publication