

ETSI TS 125 401 V3.1.0 (2000-01)

Technical Specification

Universal Mobile Telecommunications System (UMTS); UTRAN Overall Description (3G TS 25.401 version 3.1.0 Release 1999)



Reference

DTS/TSGR-0325401U

Keywords

UMTS

ETSI

Postal address

F-06921 Sophia Antipolis Cedex - FRANCE

Office address

650 Route des Lucioles - Sophia Antipolis
Valbonne - FRANCE
Tel.: +33 4 92 94 42 00 Fax: +33 4 93 65 47 16
Siret N° 348 623 562 00017 - NAF 742 C
Association à but non lucratif enregistrée à la
Sous-Préfecture de Grasse (06) N° 7803/88

Internet

secretariat@etsi.fr
Individual copies of this ETSI deliverable
can be downloaded from
<http://www.etsi.org>
If you find errors in the present document, send your
comment to: editor@etsi.fr

Important notice

This ETSI deliverable may be made available in more than one electronic version or in print. In any case of existing or perceived difference in contents between such versions, the reference version is the Portable Document Format (PDF). In case of dispute, the reference shall be the printing on ETSI printers of the PDF version kept on a specific network drive within ETSI Secretariat.

Copyright Notification

No part may be reproduced except as authorized by written permission.
The copyright and the foregoing restriction extend to reproduction in all media.

© European Telecommunications Standards Institute 2000.
All rights reserved.

Intellectual Property Rights

IPRs essential or potentially essential to the present document may have been declared to ETSI. The information pertaining to these essential IPRs, if any, is publicly available for **ETSI members and non-members**, and can be found in SR 000 314: *"Intellectual Property Rights (IPRs); Essential, or potentially Essential, IPRs notified to ETSI in respect of ETSI standards"*, which is available from the ETSI Secretariat. Latest updates are available on the ETSI Web server (<http://www.etsi.org/ipr>).

Pursuant to the ETSI IPR Policy, no investigation, including IPR searches, has been carried out by ETSI. No guarantee can be given as to the existence of other IPRs not referenced in SR 000 314 (or the updates on the ETSI Web server) which are, or may be, or may become, essential to the present document.

Foreword

This Technical Specification (TS) has been produced by the ETSI 3rd Generation Partnership Project (3GPP).

The present document may refer to technical specifications or reports using their 3GPP identities or GSM identities. These should be interpreted as being references to the corresponding ETSI deliverables. The mapping of document identities is as follows:

For 3GPP documents:

3G TS | TR nn.nnn "<title>" (with or without the prefix 3G)

is equivalent to

ETSI TS | TR 1nn nnn "[Digital cellular telecommunications system (Phase 2+) (GSM);] Universal Mobile Telecommunications System; <title>

For GSM document identities of type "GSM xx.yy", e.g. GSM 01.04, the corresponding ETSI document identity may be found in the Cross Reference List on www.etsi.org/key

Contents

Foreword	5
1 Scope	6
2 References	6
3 Definitions, symbols and abbreviations	6
3.1 Definitions	6
3.2 Abbreviations	8
3.3 Notation	8
4 General principles	8
5 UMTS General architecture	9
5.1 Overview	9
5.2 General protocols architecture	9
5.2.1 User plane	10
5.2.2 Control plane	10
6 UTRAN Architecture	11
6.1 UTRAN Identifiers	12
6.1.1 PLMN Identifier	12
6.1.2 CN Domain Identifier	12
6.1.3 RNC Identifier	12
6.1.4 Service Area Identifier	12
6.1.5 Cell Identifier	12
6.1.6 Local Cell Identifier	12
6.1.7 UE Identifiers	13
6.1.7.1 Usage of RNTI	14
6.1.8 Identifiers for dedicated resources within UTRAN	14
6.1.8.1 Radio Network Control Plane identifiers	14
6.1.8.2 Transport Network Control Plane identifiers	14
6.1.8.3 Binding identifier	14
6.2 Transport Addresses	15
7 UTRAN Functions description	16
7.1 List of functions	16
7.2 Functions description	16
7.2.1 Functions related to overall system access control	16
7.2.1.1 Admission Control	17
7.2.1.2 Congestion Control	17
7.2.1.3 System information broadcasting	17
7.2.2 Radio channel ciphering and deciphering	17
7.2.3 Functions related to Mobility	17
7.2.3.1 Handover	17
7.2.3.2 SRNS Relocation	17
7.2.4 Functions related to radio resource management and control	18
7.2.4.1 Radio resource configuration and operation	18
7.2.4.2 Radio environment survey	18
7.2.4.3 [FDD - Macro-diversity control]	19
7.2.4.4 Radio bearer connection set-up and release (Radio Bearer Control)	19
7.2.4.5 Allocation and deallocation of Radio Bearers	19
7.2.4.6 [TDD - Dynamic Channel Allocation (DCA)]	19
7.2.4.7 Radio protocols function	19
7.2.4.8 RF power control	19
7.2.4.8.1 UL OUTER LOOP POWER CONTROL	20
7.2.4.8.2 DL OUTER LOOP POWER CONTROL	20
7.2.4.8.3 UL INNER LOOP POWER CONTROL	20
7.2.4.8.4 DL INNER LOOP POWER CONTROL	20
7.2.4.8.5 UL OPEN LOOP POWER CONTROL	20

7.2.4.8.6	DL OPEN LOOP POWER CONTROL.....	20
7.2.4.9	Radio channel coding	21
7.2.4.10	Radio channel decoding.....	21
7.2.4.11	Channel coding control.....	21
7.2.4.12	Initial (random) access detection and handling	21
7.2.4.13	CN Distribution function for Non Access Stratum messages.....	21
7.2.4.14	[TDD - Timing Advance]	21
7.2.4.15	Service specific function for Non Access Stratum messages	21
8	Mobility Management.....	22
8.1	Signalling connection	22
8.2	Consequences for Mobility Handling	22
9	Synchronisation	22
9.1	SYNCHRONISATION MODEL	22
10	UTRAN O&M Requirements	23
10.1	O&M of Node B	23
10.1.1	Implementation Specific O&M	24
10.1.2	Logical O&M	24
11	UTRAN Interfaces	25
11.1	General Protocol Model for UTRAN Interfaces.....	25
11.1.1	General	25
11.1.2	Horizontal Layers.....	25
11.1.3	Vertical Planes	25
11.1.3.1	Control Plane.....	25
11.1.3.2	User Plane.....	26
11.1.3.3	Transport Network Control Plane.....	26
11.1.3.4	Transport Network User Plane	26
11.2	Protocol Model (Informative).....	26
11.2.1	RACH Transport Channel.....	26
11.2.2	FACH Transport Channel	27
11.2.3	DCH Transport Channel.....	29
11.2.4	DSCH Transport Channel	30
11.2.5	USCH Transport Channel	31
12	UTRAN Performance Requirements	32
12.1	UTRAN delay requirements	32
Annex A (informative): Change History		33
History.....		34

Foreword

This Technical Specification has been produced by the 3GPP.

The contents of the present document are subject to continuing work within the TSG and may change following formal TSG approval. Should the TSG modify the contents of this TS, it will be re-released by the TSG with an identifying change of release date and an increase in version number as follows:

Version 3.y.z

where:

- x the first digit:
 - 1 presented to TSG for information;
 - 2 presented to TSG for approval;
 - 3 Indicates TSG approved document under change control.
- y the second digit is incremented for all changes of substance, i.e. technical enhancements, corrections, updates, etc.
- z the third digit is incremented when editorial only changes have been incorporated in the specification;

1 Scope

This document describes the overall architecture of the UTRAN, including internal interfaces and assumptions on the radio and Iu interfaces.

2 References

The following documents contain provisions which, through reference in this text, constitute provisions of the present document.

- References are either specific (identified by date of publication, edition number, version number, etc.) or non-specific.
- For a specific reference, subsequent revisions do not apply.
- For a non-specific reference, the latest version applies.

- [1] Merged UTRAN Architecture Description V0.0.2
- [2] UMTS 23.10 : UMTS Access Stratum Services and Functions
- [3] UMTS 25.211: Physical channels and mapping of transport channels onto physical channels (FDD)
- [4] TS 25.442: Implementation Specific O&M Transport
- [5] TS 25.402:Synchronisation in UTRAN, Stage 2

NOTE : [1] is a temporary reference only to ease the definition of what should be in the different sections of this document.

3 Definitions, symbols and abbreviations

3.1 Definitions

NOTE: Cleaned version of section 5.1 from [1] with a reference to a more general vocabulary document

ALCAP: Generic name for the transport signalling protocols used to set-up and tear-down transport bearers.

Cell: A cell is a geographical area that can be identified by a User Equipment from a (cell) identification that is broadcast from one *UTRAN Access Point*
A Cell is either FDD or TDD mode.

Iu: Interconnection point between the RNS and the Core Network. It is also considered as a reference point.

Iub: Interface between the RNC and the Node B.

Iur: A logical interface between two RNCs. Whilst logically representing a point to point link between RNCs, the physical realisation may not be a point to point link.

Logical Model: A Logical Model defines an abstract view of a network or network element by means of information objects representing network element, aggregations of network elements, the topological relationship between the elements, endpoints of connections (termination points), and transport entities (such as connections) that transport information between two or more termination points.

The information objects defined in the Logical Model are used, among others, by connection management functions. In this way, a physical implementation independent management is achieved.

Node B: A logical node responsible for radio transmission / reception in one or more cells to/from the UE. Terminates

the Iub interface towards the RNC.

Radio Network Controller: This equipment in the RNS is in charge of controlling the use and the integrity of the radio resources.

Controlling RNC: A role an RNC can take with respect to a specific set of Node B's. There is only one Controlling RNC for any Node B. The Controlling RNC has the overall control of the logical resources of its node B's.

Radio Network Subsystem: Either a full network or only the access part of a UMTS network offering the allocation and the release of specific radio resources to establish means of connection in between an UE and the UTRAN. A Radio Network Subsystem contains one RNC and is responsible for the resources and transmission/reception in a set of cells.

Serving RNS: A role an RNS can take with respect to a specific connection between an UE and UTRAN. There is one Serving RNS for each UE that has a connection to UTRAN. The Serving RNS is in charge of the radio connection between a UE and the UTRAN. The Serving RNS terminates the Iu for this UE.

Drift RNS: The role an RNS can take with respect to a specific connection between an UE and UTRAN. An RNS that supports the Serving RNS with radio resources when the connection between the UTRAN and the UE need to use cell(s) controlled by this RNS is referred to as Drift RNS

Radio Access Network Application Part: Radio Network Signalling over the Iu.

Radio Network Subsystem Application Part: Radio Network Signalling over the Iur.

RRC Connection: A point-to-point bi-directional connection between RRC peer entities on the UE and the UTRAN sides, respectively. An UE has either zero or one RRC connection.

User Equipment: A Mobile Equipment with one or several UMTS Subscriber Identity Module(s).

UMTS Terrestrial Radio Access Network: UTRAN is a conceptual term identifying that part of the network which consists of RNCs and Node Bs between Iu and Uu. The concept of UTRAN instantiation is currently undefined.

UTRAN Access Point: A conceptual point within the UTRAN performing radio transmission and reception. A UTRAN access point is associated with one specific *cell*, i.e. there exists one UTRAN access point for each cell. It is the UTRAN-side end point of a *radio link*.

Radio Link: A "radio link" is a logical association between a single User Equipment and a single UTRAN access point. Its physical realization comprises one or more radio bearer transmissions.

Uu: The Radio interface between UTRAN and the User Equipment.

RAB sub-flows: A Radio Access Bearer can be realised by UTRAN through several sub-flows. These sub-flows correspond to the NAS service data streams that have QoS characteristics that differ in a predefined manner within a RAB e.g. different reliability classes.

RAB sub-flows have the following characteristics:

- 1) The sub-flows of a RAB are established and released at the RAB establishment and re-lease, respectively
- 2) The sub-flows of a RAB are submitted and delivered together at the RAB SAP
- 3) The sub-flows of a RAB are carried over the same Iu transmission connection
- 4) The sub-flows of a RAB are organised in a predefined manner at the SAP and over the Iu interface. The organisation is imposed by the NAS as part of its co-ordination responsibility.

Coordinated DCHs: Dedicated transport channels transporting information for different RAB subflows belonging to one and the same RAB. Coordinated DCHs are always established and released in combination. Coordinated DCHs cannot be operated on individually e.g. if the establishment of one DCH fails, the establishment of all other coordinated DCHs shall be terminated unsuccessfully and the establishment of the RAB fails.

3.2 Abbreviations

CN	Core Network
DCH	Dedicated Channel
DL	Downlink
DRNS	Drift RNS
FACH	Forward Access Channel
GTP	GPRS Tunnelling Protocol
MAC	Medium Access Control
NAS	Non Access Stratum
NBAP	Node B Application Protocol
PCH	Paging Channel
QoS	Quality of Service
RAB	Radio Access Bearer
RACH	Random Access Channel
RANAP	Radio Access Network Application Part
RNC	Radio Network Controller
RNS	Radio Network Subsystem
RNSAP	Radio Network Subsystem Application Part
RNTI	Radio Network Temporary Identity
SRNS	Serving RNS
UE	User Equipment
UL	Uplink
UMTS	Universal Mobile Telecommunication System
USIM	UMTS Subscriber Identity Module
UTRAN	UMTS Terrestrial Radio Access Network

3.3 Notation

Parts of the document apply only to one mode, FDD or TDD. Any such area will be tagged by [FDD — xxxxxxxxx] and [TDD — yyyyyyyyyy] respectively. The tag applies to the text until the closing bracket.

4 General principles

The general principles guiding the definition of UTRAN Architecture as well as the UTRAN interfaces are the following:

- Logical separation of signalling and data transport networks
- UTRAN and CN functions are fully separated from transport functions. Addressing scheme used in UTRAN and CN shall not be tied to the addressing schemes of transport functions. The fact that some UTRAN or CN function resides in the same equipment as some transport functions does not make the transport functions part of the UTRAN or the CN.
- Macro diversity (FDD only) is fully handled in the UTRAN
- Mobility for RRC connection is fully controlled by the UTRAN.
Note : Handover to other Access Networks is FFS.
- When defining the UTRAN interfaces the following principles were followed :The functional division across the interfaces shall have as few options as possible.
- Interfaces should be based on a logical model of the entity controlled through this interface

Transport Network Control Plane is a functional plane in the interfaces protocol structure that is used for the transport bearer management. The actual signalling protocol that is in use within the Transport Network Control Plane depends on the underlying transport layer technology. The intention is not to specify a new UTRAN specific Application Part for the Transport Network Control Plane but to use signalling protocols standardised in other groups (if needed) for the applied transport layer technology.

5 UMTS General architecture

5.1 Overview

Figure 1 shows a simplified UMTS architecture with the external reference points and interfaces to the UTRAN. The architecture is based on document [1].

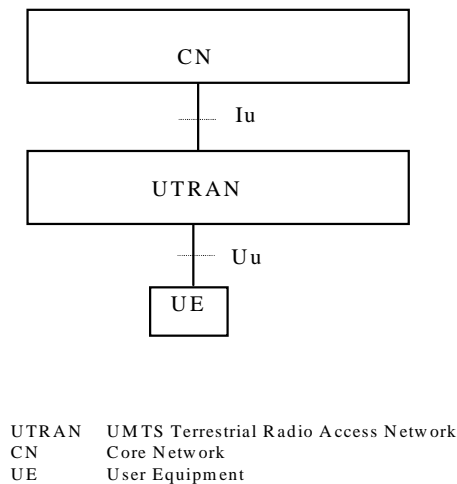

Figure 1: UMTS Architecture

5.2 General protocols architecture

The protocols over Uu and Iu interfaces are divided into two structures:

- **User plane protocols**
These are the protocols implementing the actual radio access bearer service, i.e. carrying user data through the access stratum.
- **Control plane protocols**
These are the protocols for controlling the radio access bearers and the connection between the UE and the network from different aspects (including requesting the service, controlling different transmission resources, handover & streamlining etc.). Also a mechanism for transparent transfer of NAS messages is included.

5.2.1 User plane

The radio access bearer service is offered from SAP to SAP by the Access Stratum. The figure below shows the protocols on the Uu and Iu interfaces that linked together provide this radio access bearer service.

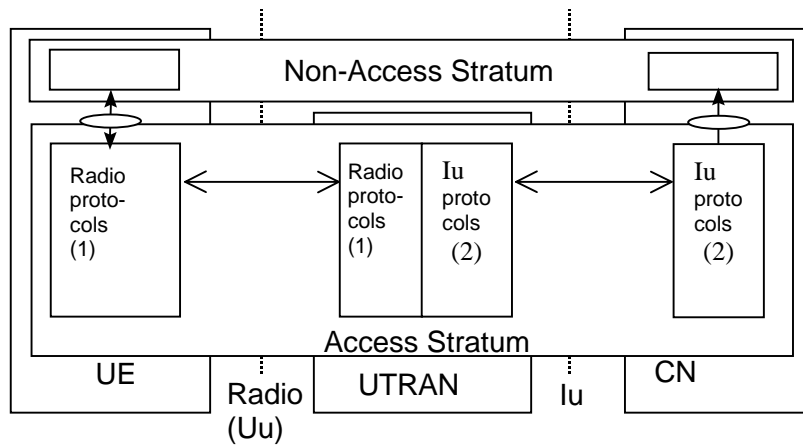

- (1) To be defined by TSG RAN WG2
- (2) The protocols are defined in documents S3.1x (description of Iu interface).

Figure 2: Iu and Uu User plane

5.2.2 Control plane

The figure below shows the control plane (signalling) protocol stacks on Iu and Uu interfaces.

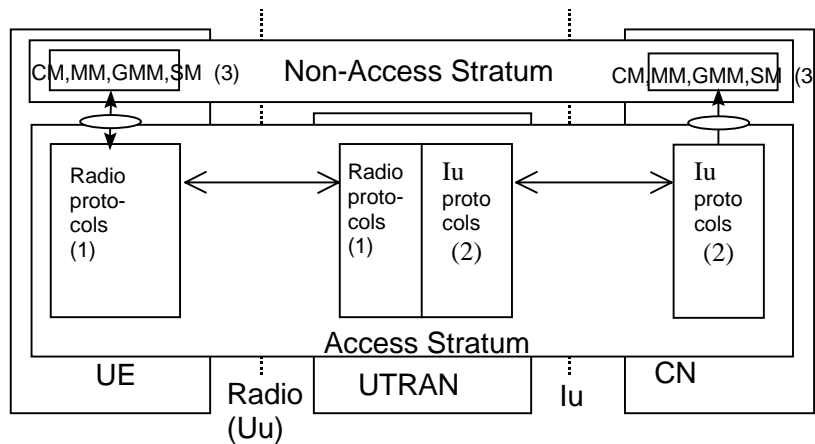

- (1) To be defined by TSG RAN WG2 group
- (2) The protocol is defined in documents S3.1x.(Description of Iu interface).
- (3) **CM,MM,GMM,SM:** This exemplifies a set of NAS control protocols between UE and CN. There may be different NAS protocol stacks in parallel. The evolution of the protocol architecture for these protocols is FFS.

Figure 3: Iu and Uu Control plane

NOTE: Both the Radio protocols and the Iu protocols contain a mechanism to transparently transfer NAS messages.

6 UTRAN Architecture

The UTRAN consists of a set of Radio Network Subsystems connected to the Core Network through the Iu.

A RNS consists of a Radio Network Controller and one or more Node Bs. A Node B is connected to the RNC through the Iub interface.

A Node B can support FDD mode, TDD mode or dual-mode operation.

The RNC is responsible for the Handover decisions that require signalling to the UE.

The RNC comprises a combining/splitting function to support macro diversity between different Node B.

A RNC supporting the FDD mode may include a combining/splitting function to support macro diversity between different Node B.

Inside the UTRAN, the RNCs of the Radio Network Subsystems can be interconnected together through the Iur. Iu(s) and Iur are logical interfaces. Iur can be conveyed over physical direct connection between RNCs or via any suitable transport network.

The UTRAN architecture is shown in figure 4.

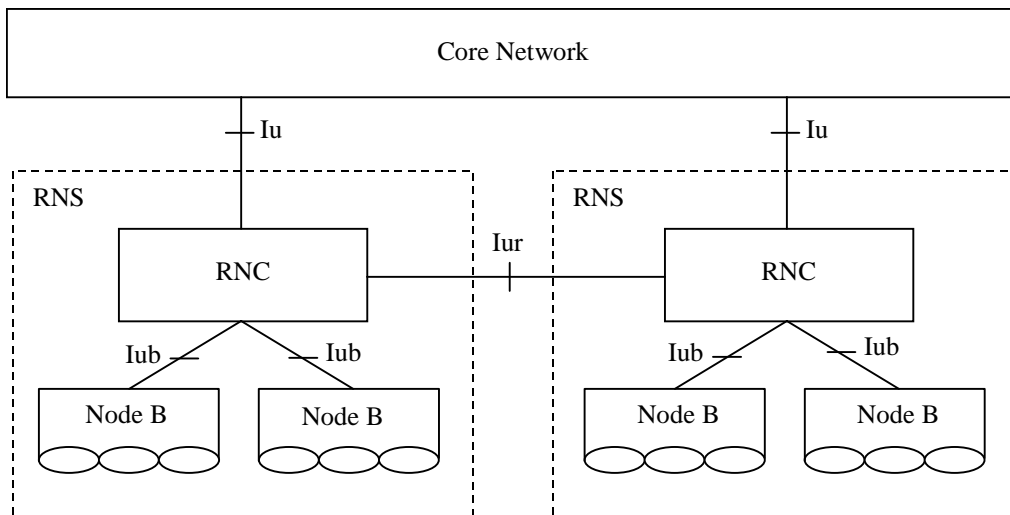

Figure 4: UTRAN Architecture

Each RNS is responsible for the resources of its set of cells.

For each connection between a User Equipment and the UTRAN, One RNS is the Serving RNS. When required, Drift RNSs support the Serving RNS by providing radio resources as shown in figure 5. The role of an RNS (Serving or Drift) is on a per connection basis between a UE and the UTRAN.

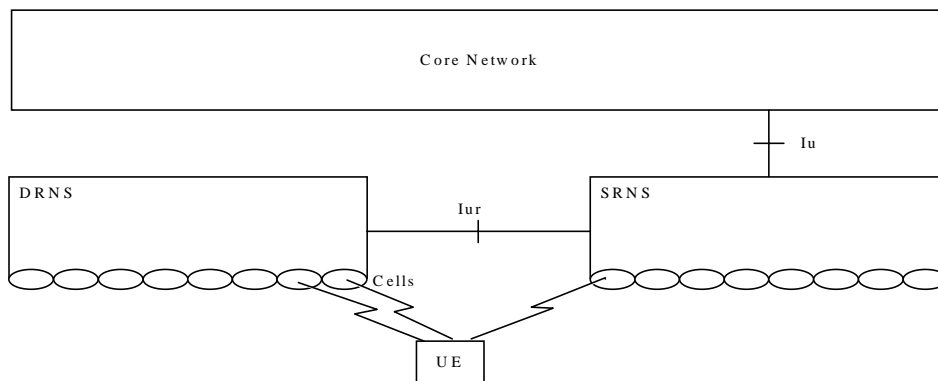

Figure 5: Serving and Drift RNS

6.1 UTRAN Identifiers

6.1.1 PLMN Identifier

A Public Land Mobile Network is uniquely identified by its PLMN identifier. PLMN-Id is made of Mobile Country Code (MCC) and Mobile Network Code (MNC).

- **PLMN-Id = MCC + MNC**

The MCC and MNC are predefined within a UTRAN, and set in the RNC via O&M.

6.1.2 CN Domain Identifier

A CN Domain Edge Node is identified within UTRAN by its CN Domain Identifier. The CN Domain identifier is used over UTRAN interfaces to identify a particular CN Domain Edge Node for relocation purposes. The CN Domain identifier is made of the PLMN-Id and of the LAC or RAC of the first accessed cell in the target RNS.

The two following CN Domains Identifiers are defined:

- **CN CS Domain-Id = PLMN-Id + LAC**
- **CN PS Domain-Id = PLMN-Id + LAC+ RAC**

The LAC and RAC are defined by the operator, and set in the RNC via O&M.

6.1.3 RNC Identifier

An RNC node is uniquely identified within UTRAN by its RNC Identifier (RNC-Id). RNC-Id together with the PLMN identifier is used to globally identify the RNC. RNC-Id or the RNC-Id together with the PLMN-Id is used as RNC identifier in UTRAN Iub, Iur and Iu interfaces. SRNC-Id is the RNC-Id of the SRNC. C-RNC-Id is the RNC-Id of the controlling RNC. D-RNC-Id is the RNC Id of the drift RNC.

- **Global RNC-Id = PLMN-Id + RNC-Id**

The RNC-Id is defined by the operator, and set in the RNC via O&M.

6.1.4 Service Area Identifier

The Service Area Identifier (SAI) is used to uniquely identify an area consisting of one or more cells belonging to the same Location Area. Such an area is called a Service Area and can be used for indicating the location of a UE to the CN.

The Service Area Code (SAC) together with the PLMN-Id and the LAC will constitute the Service Area Identifier.

- **SAI = PLMN-Id + LAC + SAC**

The SAC is defined by the operator, and set in the RNC via O&M.

6.1.5 Cell Identifier

The Cell identifier (C-Id) is used to uniquely identify a cell within an RNS. The Cell-Id together with the identifier of the controlling RNC (CRNC-Id) constitutes the UTRAN Cell Identity (UC-Id) and is used to identify the cell uniquely within UTRAN. UC-Id or C-Id is used to identify a cell in UTRAN Iub, Iur and Iu interfaces.

- **UC-Id = RNC-Id + C-Id**

The C-Id is defined by the operator, and set in the RNC via O&M. The C-Id is set in a Node B by its C-RNC.

6.1.6 Local Cell Identifier

The Local Cell identifier is used to uniquely identify the set of resources within a Node B required to support a cell (as

identified by a C-Id). As a minimum it shall be unique within the Node B, but it is also capable of supporting uniqueness within the UTRAN for management system purposes.

The Local Cell Identifier is used for the initial configuration of a Node B when no C-Id is defined. The Local Cell identifier is defined by the operator, and set in both the Node B and its C-RNC via O&M. The relationship between the Local Cell Identifier and C-Id is set in the C-RNC via O&M.

6.1.7 UE Identifiers

NOTE: This RNTI definition and usage needs to be confirmed by 3GPP TSG RAN WG2.

Radio Network Temporary Identities (RNTI) are used as UE identifiers within UTRAN and in signalling messages between UE and UTRAN.

Four types of RNTI exist;

- 1) Serving RNC RNTI (s-RNTI)
- 2) Drift RNC RNTI (d-RNTI)
- 3) Cell RNTI(c-RNTI)
- 4) UTRAN RNTI (u-RNTI)

s-RNTI is used

- by UE to identify itself to the Serving RNC
- by SRNC to address the UE
- by DRNC to identify the UE to Serving RNC.

s-RNTI is allocated for all UEs having a RRC connection, it is allocated by the Serving RNC and it is unique within the Serving RNC. s-RNTI is reallocated always when the Serving RNC for the RRC connection is changed.

d-RNTI is used

- by serving RNC to identify the UE to Drift RNC.

NOTE: The d-RNTI is never used on Uu.

d-RNTI is allocated by drift RNC upon drift UE contexts establishment and it shall be unique within the drift RNC. Serving RNC shall know the mapping between s-RNTI and the d-RNTIs allocated in Drift RNCs for the same UE. Drift RNC shall know the s-RNTI and SRNC-ID related to existing d-RNTI within the drift RNC.

c-RNTI is used

- by UE to identify itself to the controlling RNC
- by controlling RNC to address the UE.

c-RNTI is allocated by controlling RNC upon UE accessing a new cell. C-RNTI shall be unique within the accessed cell. Controlling RNC shall know the d-RNTI associated to the c-RNTI within the same logical RNC (if any).

u-RNTI

The u-RNTI is allocated to an UE having a RRC connection and identifies the UE within UTRAN.

u-RNTI is composed of

- SRNC identity
- s-RNTI

Each RNC has a unique identifier within the UTRAN part of the PLMN, denoted by RNC identifier (RNC-ID). This

identifier is used to route UTRAN interface messages to correct RNC. RNC-ID of the serving RNC together with the s-RNTI is a unique identifier of the UE in the UTRAN part of the PLMN.

6.1.7.1 Usage of RNTI

S-RNTI together with the RNC-ID is used as a UE identifier for the first cell access (at cell change) when a RRC connection exists for this UE and for UTRAN originated paging including associated response messages on the air interface. RNC-ID is used by Controlling RNC to route the received uplink messages towards the Serving RNC.

NOTE: For the initial access two different methods of identification, a random number and a unique core network UE identifier are under consideration.

C-RNTI is used as a UE identifier in all other DCCH/DTCH common channel messages on air interface.

6.1.8 Identifiers for dedicated resources within UTRAN

6.1.8.1 Radio Network Control Plane identifiers

Each addressable object in each reference point has an application part level identifier. This identifier is allocated autonomously by the entity responsible for initiation of the setup of the object. This application part identifier will be used as a reference to the object that is setup. Both ends of the reference point shall memorise the AP Identifier during the lifetime of the object. Application part identifier can be related to a specific ALCAP identifier and that relationship shall also be memorised by both ends.

Table below lists the basic AP level identifiers in each reference point.

Object	Identifier	Abbreviation	Valid for
Radio Access Bearer	Radio Access Bearer ID	RAB-ID	lu
Dedicated Transport channel	DCH-ID	DCH-ID	lur, lub

6.1.8.2 Transport Network Control Plane identifiers

ALCAP identifier is used only in Transport Network Control plane (ALCAP protocol, if exist) and may be used in User Plane in the actual data transmission using the transport link. ALCAP identifier identifies the transport link according to the naming conventions defined for the transport link type in question. Both ends of the reference point of the ALCAP shall memorise the ALCAP identifier during the lifetime of the transport link. Each ALCAP identifier can be binded to an Application Part identifier.

Following table indicates examples of the identifiers used for different transmission link types.

Transmission link type	ALCAP Identifier
AAL2	AAL2 Path ID + CID
GTP over IP	IP address + GTP identifier (ffs.)

6.1.8.3 Binding identifier

Binding Identifier is used to initialise the linkage between ALCAP and Application Part (RANAP, RNSAP, NBAP) identifiers. Binding identifier can be used both in Radio Network Control plane Application Part protocols and in Transport Network Control Plane's ALCAP protocol.

Binding ID binds the Radio and Transport Network Control plane identifiers together. To ensure maximal independence of those two planes, the binding ID should be used only when necessary: Binding ID shall thus be used only in Radio Network Control plane Application Part messages in which a new association between the planes is created and in ALCAP messages creating new transmission links.

Binding ID for each transmission link shall be allocated before the setup of that transmission link. Reserved Binding IDs and the associated transport link shall be memorised by both peers of each reference point.

The Binding ID is sent on one direction using the Application Part protocol and is return in the other direction by the

ALCAP protocol.

The binding identity shall already be assigned and tied to a radio application procedure when the first ALCAP message is received in a node.

Figure 6 illustrates how application instances of the Radio Network Control Plane and instances of the Transport Network Plane are linked together through the Binding Identifier in the set-up phase:

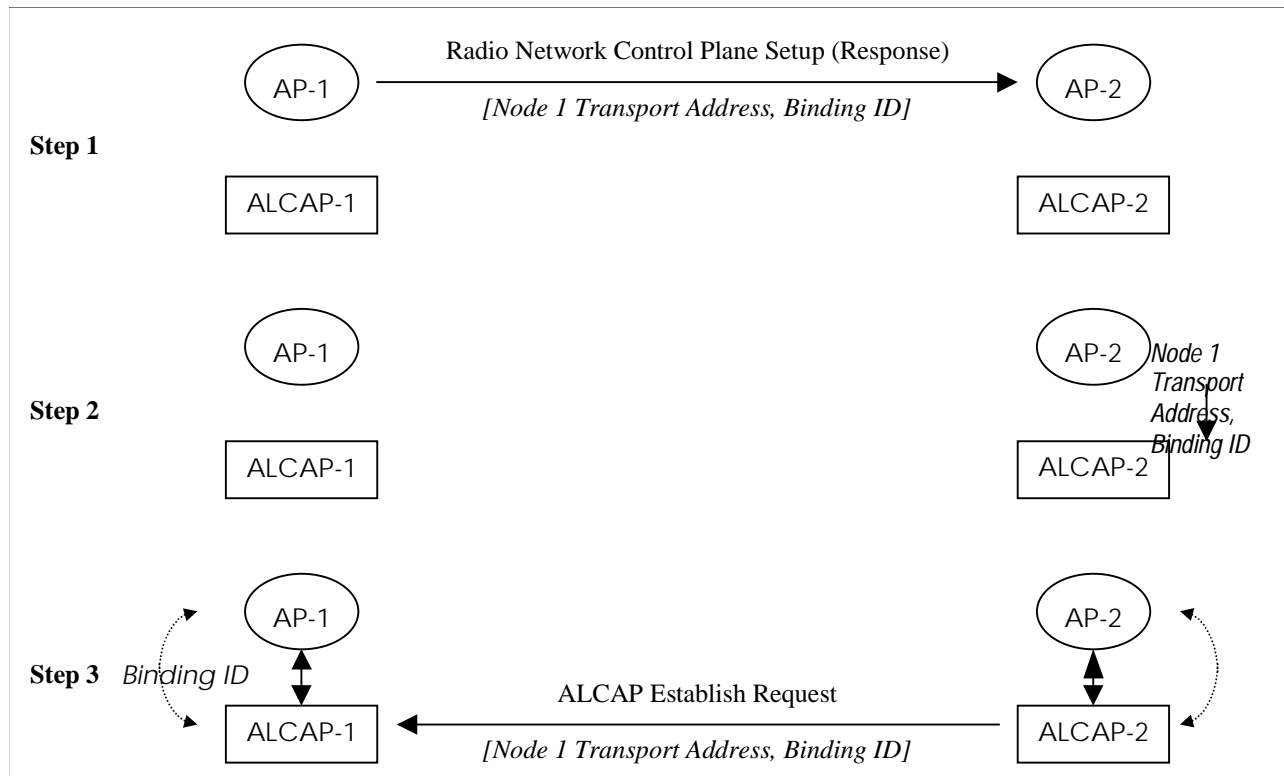

Figure 6: Usage of Binding ID

- Step 1: Application Part AP-1 assign the Binding Identifier and sends a Radio Network Control Plane Set-up (Response) message (which of the two messages depends on the involved interface - Iu/Iur or Iub). The message contains the originating node Transport layer address and the Binding Identifier.
- Step 2: Among reception of the Radio Network Control Plane Set-up message, the peer entity AP-2 requests to ALCAP-2 to establish a transmission link. The Binding Identifier is passed to ALCAP-2
- Step 3: ALCAP-2 sends an ALCAP Establish Request to the peer entity ALCAP-1. The message contains the Binding Identifier. The Binding Identifier allows correlating the incoming transport connection with the Application Part transaction in step 1.

The following table indicates the binding identifier allocating entity in each interface.

Reference point	Allocating entity	Application part message including Binding-ID
Iu	CN	Request from CN
Iur	DRNC	Response to the request from SRNC
Iub	Node-B	Response to the request from DRNC

6.2 Transport Addresses

The transport layer address parameter is transported in the radio network application signalling procedures that result in establishment of transport bearer connections.

The transport layer address parameter shall not be interpreted in the radio network application pro-tocols and reveal the

addressing format used in the transport layer.

7 UTRAN Functions description

7.1 List of functions

NOTE: This list of functions, their classification and definitions is an initial list, classification and definitions that will be further refined.

- Functions related to overall system access control
 - Admission Control
 - Congestion Control
 - System information broadcasting
- Radio channel ciphering and deciphering
- Functions related to mobility
 - Handover
 - SRNS Relocation
- Functions related to radio resource management and control
 - Radio resource configuration and operation
 - Radio environment survey
 - [FDD - Macro-diversity control]
 - Radio bearer connection set-up and release (Radio Bearer Control)
 - Allocation and deallocation of Radio Bearers
 - [TDD - Dynamic Channel Allocation (DCA)]
 - Radio protocols function
 - RF power control
 - RF power setting
 - [TDD - Timing Advance]
 - Radio channel coding
 - Radio channel decoding
 - Channel coding control
 - Initial (random) access detection and handling
 - CN Distribution function for Non Access Stratum messages

7.2 Functions description

7.2.1 Functions related to overall system access control

System access is the means by which a UMTS user is connected to the UMTS in order to use UMTS services and/or

facilities. User system access may be initiated from either the mobile side, e.g. a mobile originated call, or the network side, e.g. a mobile terminated call.

7.2.1.1 Admission Control

The purpose of the admission control is to admit or deny new users, new radio access bearers or new radio links (for example due to handover). The admission control should try to avoid overload situations and base its decisions on interference and resource measurements. The admission control is employed at for example initial UE access, RAB assignment/reconfiguration and at handover. These cases may give different answers depending on priority and situation.

The Admission Control function based on UL interference and DL power is located in the Controlling RNC.

The Serving RNC is performing admission Control towards the Iu interface.

7.2.1.2 Congestion Control

The task of congestion control is to monitor, detect and handle situations when the system is reaching a near overload or an overload situation with the already connected users. This means that some part of the network has run out, or will soon run out of resources. The congestion control should then bring the system back to a stable state as seamless as possible.

NOTE: This admission Control function is related to Radio Resources

Congestion control is performed within UTRAN.

7.2.1.3 System information broadcasting

This function provides the mobile station with the Access Stratum and Non Access Stratum information which are needed by the UE for its operation within the network.

The basic control and synchronisation of this function is located in UTRAN.

7.2.2 Radio channel ciphering and deciphering

This function is a pure computation function whereby the radio transmitted data can be protected against a non-authorised third-party. Ciphering and deciphering may be based on the usage of a session-dependent key, derived through signalling and/or session dependent information.

This function is located in the UE and in the UTRAN.

7.2.3 Functions related to Mobility

7.2.3.1 Handover

This function manages the mobility of the radio interface. It is based on radio measurements and it is used to maintain the Quality of Service requested by the Core Network.

Handover may be directed to/from another system (e.g. UMTS to GSM handover).

The handover function may be either controlled by the network, or independently by the UE. Therefore, this function may be located in the SRNC, the UE, or both.

7.2.3.2 SRNS Relocation

The SRNS Relocation function coordinates the activities when the SRNS role is to be taken over by another RNS. The SRNS relocation function manages the Iu interface connection mobility from an RNS to another.

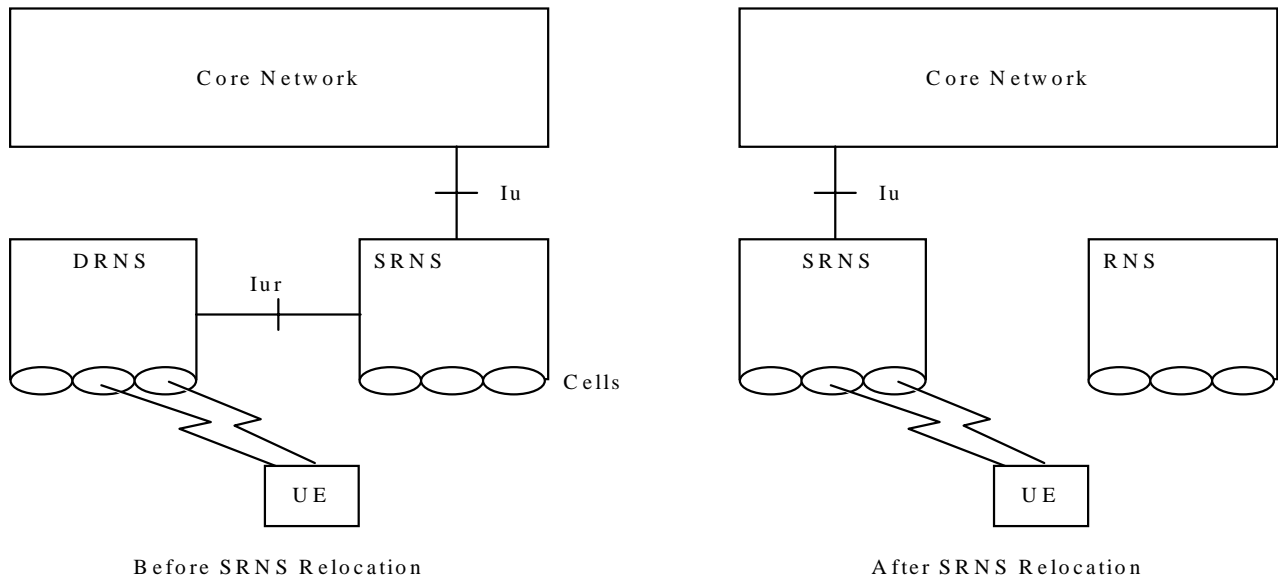

Figure 7: Serving RNS Relocation

The SRNS Relocation is initiated by the SRNC.

This function is located in the RNC and the CN.

7.2.4 Functions related to radio resource management and control

7.2.4.1 Radio resource configuration and operation

This function performs configures the radio network resources, i.e. cells and common transport channels (BCH, RACH, FACH, PCH), and takes the resources into or out of operation.

7.2.4.2 Radio environment survey

This function performs measurements on radio channels (current and surrounding cells) and translates these measurements into radio channel quality estimates. Measurements may include :

- 1) received signal strengths (current and surrounding cells),
- 2) estimated bit error ratios, (current and surrounding cells),
- 3) estimation of propagation environments (e.g. high-speed, low-speed, satellite, etc.),
- 4) transmission range (e.g. through timing information),
- 5) Doppler shift,
- 6) synchronisation status,
- 7) Received interference level,
- 8) Total DL transmission power per cell.

This function is located in the UE and in the UTRAN.

Radio resource management is concerned with the allocation and maintenance of radio communication resources. UMTS radio resources must be shared between circuit transfer mode services and packet transfer modes services (i.e. Connection-oriented and/or connectionless-oriented services).

7.2.4.3 [FDD - Macro-diversity control]

This function controls the duplication/ replication of information streams to receive/ transmit the same information through multiple physical channels (possibly in different cells) from/ towards a single mobile terminal.

This function also controls the combining of information streams generated by a single source (diversity link), but conveyed via several parallel physical channels (diversity sub-links). Macro diversity control should interact with channel coding control in order to reduce the bit error ratio when combining the different information streams. In some cases, depending on physical network configuration, there may be several entities which combine the different information streams, i.e there may be combining/splitting at the SRNC, DRNC or Node B level.

This function is located in the UTRAN.

7.2.4.4 Radio bearer connection set-up and release (Radio Bearer Control)

This function is responsible for the control of connection element set-up and release in the radio access sub network. The purpose of this function is

- 1) to participate in the processing of the end-to-end connection set-up and release,
- 2) and to manage and maintain the element of the end-to-end connection, which is located in the radio access sub network.

In the former case, this function will be activated by request from other functional entities at call set-up/release. In the latter case, i.e. when the end-to-end connection has already been established, this function may also be invoked to cater for in-call service modification or at handover execution.

This function is located both in the UE and in the RNC.

7.2.4.5 Allocation and deallocation of Radio Bearers

This function consists of translating the connection element set-up (resp. release) requests into physical radio channel allocation (resp. deallocation) accordingly to the QoS of the Radio Access Bearer.

This function may be activated during the call since e.g. the user service request may vary, or macro diversity may be used.

This function is located in the CRNC and SRNC.

7.2.4.6 [TDD - Dynamic Channel Allocation (DCA)]

DCA is used in the TDD mode. It includes Fast DCA and Slow DCA. Slow DCA is the process of assigning radio resources, including time slots, to different TDD cells according to the varying cell load. Fast DCA is the process of assigning resources to Radio Bearers, and is related to Admission Control.

7.2.4.7 Radio protocols function

This function provides user data and signalling transfer capability across the UMTS radio interface by adapting the services (according to the QoS of the Radio Access Bearer) to the Radio transmission. This function includes amongst other:

- Multiplexing of services and multiplexing of UEs on Radio bearers
- Segmentation and reassembly
- Acknowledged/Unacknowledged delivery according to the Radio Access Bearer QoS

7.2.4.8 RF power control

This group of functions controls the level of the transmitted power in order to minimise interference and keep the quality of the connections. It consist of the following functions: UL Outer Loop Power Control, DL Outer Loop Power Control, UL Inner Loop Power Control, DL Inner Loop Power Control, UL Open Loop Power Control and DL Open Loop Power Control.

7.2.4.8.1 UL OUTER LOOP POWER CONTROL

The UL Outer Loop Power Control located in the SRNC sets the target quality value for the UL Inner Loop Power Control which is located in Node B for FDD and is located in the UE for TDD. It receives input from quality estimates of the transport channel. The UL outer loop power control is mainly used for a long-term quality control of the radio channel.

In FDD this function is located in the UTRAN, in TDD the function is performed in UTRAN and the target quality value is sent to the UE by the SRNC.

In FDD, if the connection involves both a SRNS and a DRNS the function UL Outer Loop Power Control (located in the SRNC) sets the target quality for the UL Inner Loop Power Control function (located in Node B). Additional quality information for the case when macro diversity combining is performed in DRNC is for further study.

NOTE: Some additional function is needed for resource negotiation between the SRNS and the DRNS across the Iur. This is FFS.

7.2.4.8.2 DL OUTER LOOP POWER CONTROL

The DL Outer Loop Power Control sets the target quality value for the DL inner loop power control. It receives input from quality estimates of the transport channel, measured in the UE. The DL outer loop power control is mainly used for a long-term quality control of the radio channel.

This function is located mainly in the UE, but some control parameters are set by the UTRAN.

The SRNC, regularly (or under some algorithms), sends the target down link power range based on the measurement report from UE.

7.2.4.8.3 UL INNER LOOP POWER CONTROL

The UL Inner Loop Power Control sets the power of the uplink dedicated physical channels.

In FDD, it is a closed loop process. It receives the quality target from UL Outer Loop Power Control and quality estimates of the uplink dedicated physical control channel. The power control commands are sent on the downlink dedicated physical control channel to the UE. This function is located in both the UTRAN and the UE.

In TDD it is an open loop process, it receives the quality target from the UL Outer Loop Power Control and uses the quality target and quality estimates of downlink channels to set the transmit power. This function is located in the UE.

7.2.4.8.4 DL INNER LOOP POWER CONTROL

The DL Inner Loop Power Control sets the power of the downlink dedicated physical channels. It receives the quality target from DL Outer Loop Power Control and quality estimates of the downlink dedicated physical control channel. The power control commands are sent on the uplink dedicated physical control channel to the UTRAN.

This function is located in both the UTRAN and the UE.

7.2.4.8.5 UL OPEN LOOP POWER CONTROL

The UL Open Loop Power Control sets the initial power of the UE, i.e. at random access. The function uses UE measurements and broadcasted cell/system parameters as input.

This function is located in both the UTRAN and the UE.

7.2.4.8.6 DL OPEN LOOP POWER CONTROL

The DL Open Loop Power Control sets the initial power of downlink channels. It receives downlink measurement reports from the UE.

This function is located in both the UTRAN and the UE.

7.2.4.9 Radio channel coding

This function introduces redundancy into the source data flow, increasing its rate by adding information calculated from the source data, in order to allow the detection or correction of signal errors introduced by the transmission medium. The channel coding algorithm(s) used and the amount of redundancy introduced may be different for the different types of logical channels and different types of data.

This function is located in both the UE and in the UTRAN.

7.2.4.10 Radio channel decoding

This function tries to reconstruct the source information using the redundancy added by the channel coding function to detect or correct possible errors in the received data flow. The channel decoding function may also employ a priori error likelihood information generated by the demodulation function to increase the efficiency of the decoding operation. The channel decoding function is the complement function to the channel coding function.

This function is located in both the UE and in the UTRAN.

7.2.4.11 Channel coding control

This function generates control information required by the channel coding/ decoding execution functions. This may include channel coding scheme, code rate, etc.

This function is located in both the UE and in the UTRAN.

7.2.4.12 Initial (random) access detection and handling

This function will have the ability to detect an initial access attempt from a mobile station and will respond appropriately. The handling of the initial access may include procedures for a possible resolution of colliding attempts, etc. The successful result will be the request for allocation of appropriate resources for the requesting mobile station.

This function is located in the UTRAN.

7.2.4.13 CN Distribution function for Non Access Stratum messages

In the RRC protocol, messages from the NAS shall be transparently transferred within the Access Stratum using the Direct Transfer procedure. A distribution function in the UE and the SRNC shall handle a CN domain indicator, Service Descriptor, and Flow ID being part of the AS message to direct messages to the appropriate NAS entity i.e. the appropriate Mobility Management instance in the UE domain and the appropriate CN domain.

In the downlink direction the UE shall be provided by the SRNC with the information on the originating CN domain for the individual NAS message.

In the uplink direction, the process performed by the distribution function in the UE consists in inserting the appropriate values for CN domain indicator, Service Descriptor, and Flow ID IEs in the AS message and the process performed by the SRNC consists in evaluating the CN domain indicator, Service Descriptor, and Flow ID contained in the AS message and distribute the NAS message to the corresponding RANAP instance for transfer over Iu interface.

This distribution function is located in both the UE and in the SRNC.

7.2.4.14 [TDD - Timing Advance]

This function is used in uplink to align the uplink radio signals from the UE to the UTRAN. Timing advance is based on uplink burst timing measurements performed by the Node B L1, and on Timing Advance commands sent downlink to the UE.

7.2.4.15 Service specific function for Non Access Stratum messages

A service specific function in the UE provides a SAP for a particular service (e.g. a given priority). In the downlink direction, the SRNC may base the routing on this SAP.

This service specific function is located in both the UE and the SRNC.

8 Mobility Management

NOTE: Location based services have not been yet considered and need further studies.

8.1 Signalling connection

Based on [2], the UE may either have or not have a signalling connection:

- 1) There exists a signalling connection established over the Dedicated Control Service Access Point (DC-SAP) from the Access Stratum.
In this case, the CN can reach the UE by the dedicated connection SAP on the CN side, and the UTRAN has a context with the UE and CN for this particular connection. This context is erased when the connection is released. The *dedicated connection* can be initiated from the UE only.

NOTE: A dedicated connection is currently defined as Signalling Connection in [2]. Note that in the radio interface, dedicated or common channels can be used.

Depending on the activity of a UE, the location of the UE is known either on cell level (higher activity) or in a larger area consisting of several cells (lower activity). This will (i) minimise the number of location update messages for moving UEs with low activity and (ii) remove the need for paging for UEs known on cell level.

- 2) There does not exist a dedicated connection.
In this case, the CN must reach the UE via the Notification SAP. The message sent to the UE can be a request to the UE to establish a dedicated connection. The UE is addressed with a user/terminal identity and a 'geographical area'.

8.2 Consequences for Mobility Handling

It is generally agreed [1] to contain radio access specific procedures within UTRAN. This means that all cell level mobility should be handled within UTRAN. Also the cell structure of the radio network should not necessarily be known outside the UTRAN.

When there exists a dedicated connection to the UE, the UTRAN shall handle the radio interface mobility of the UE. This includes procedures such as soft handover, and procedures for handling mobility in the RACH/PCH substate.

NOTE: Some reference will be necessary to a 3GPP TSG RAN WG2 document that defines that substate.

When there does not exist a dedicated connection to the UE, no UE information in UTRAN is needed. In this case, the mobility is handled directly between UE and CN outside access stratum (e.g. by means of registration procedures). When paging the UE, the CN indicates a 'geographical area' that is translated within UTRAN to the actual cells that shall be paged. A 'geographical area' shall be identified in a cell-structure independent way. One possibility is the use of 'Location Area identities'.

During the lifetime of the dedicated connection, the registrations to the CN are suppressed by the UE. When a dedicated connection is released, the UE performs a new registration to the CN, if needed.

Thus, the UTRAN does not contain any permanent 'location registers' for the UE, but only temporary contexts for the duration of the dedicated connection. This context may typically contain location information (e.g. current cell(s) of the UE) and information about allocated radio resources and related connection references.

9 Synchronisation

9.1 SYNCHRONISATION MODEL

Different synchronisation issues are identified within UTRAN, i.e.:

- Network Synchronisation

- Node Synchronisation
- Transport Channel synchronisation
- Radio Interface Synchronisation
- Time Alignment handling

The Nodes involved by the above mentioned synchronisation issues (with exception of Network and Node Synchronisation) are shown by the Synchronisation Issues Model of Figure 7

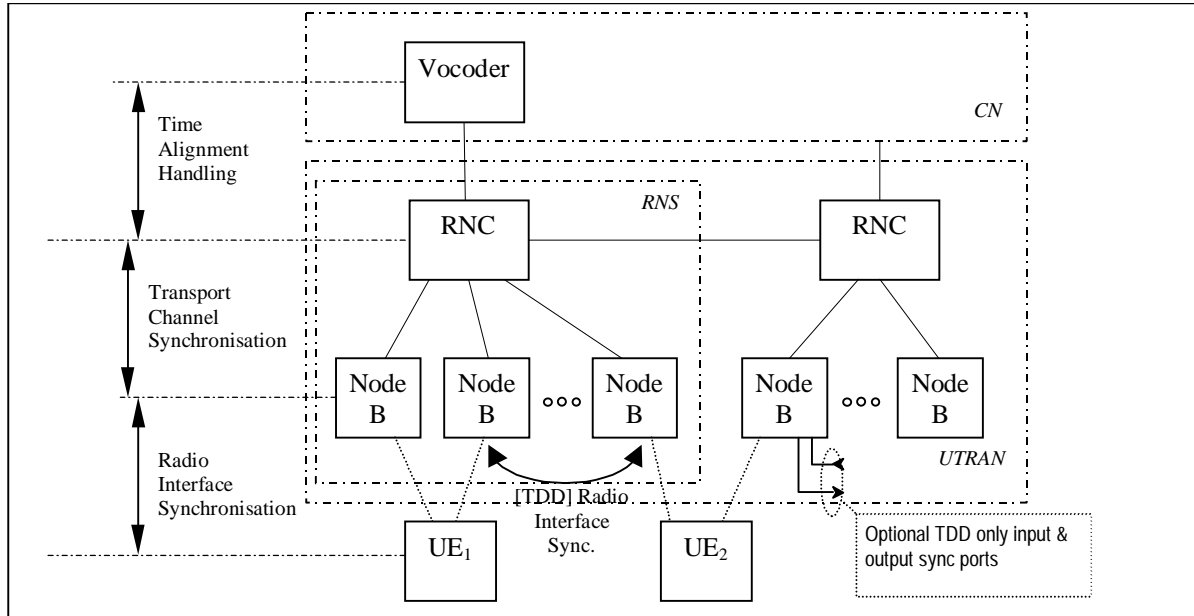

Figure 8: Synchronisation issues model

10 UTRAN O&M Requirements

10.1 O&M of Node B

The O&M of Node B is separated in two parts : the O&M linked to the actual implementation of Node B, denoted as Implementation Specific O&M, and the O&M which impacts on the traffic carrying resources in Node B controlled from the RNC, denoted *logical O&M*. The RNS architecture with the O&M interfaces is shown in figure 9.

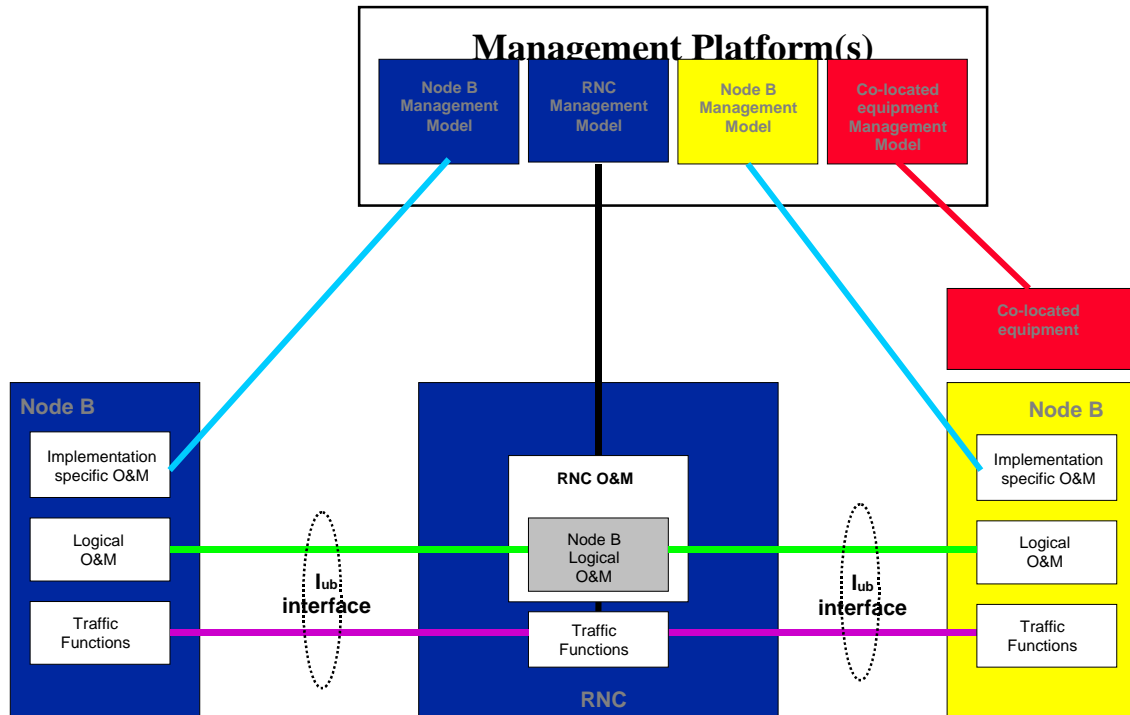

Figure 9: RNS architecture with O&M interfaces

NOTE 1: The concept of an interface from the RNC to the management system is shown for clarity only. It's definition is outside the scope of 3GPP-TSG-RAN-WG3.

NOTE 2: The presentation of the O&M functions within the management system is shown for clarity only. Their actual implementation is outside the scope of 3GPP-TSG-RAN-WG3.

NOTE 3: The standardisation of the Implementation Specific O&M is outside the scope of 3GPP-TSG-RAN-WG3. The 3GPP-TSG-RAN-WG3 should only address the bearer for the Implementation Specific O&M.

NOTE 4: The figure shows only logical connections and does not intend to mandate any physical interfaces.

10.1.1 Implementation Specific O&M

The Implementation Specific O&M functions are heavily dependent on the implementation of Node B, both for its hardware components and for the management of the software components. It needs therefore to be implementation dependent, and be performed between Node B and the management system.

One solution for the transport of Implementation Specific O&M is to route from Node B to the management system via the RNC. In this case, the Implementation Specific O&M interface and Iub interface share the same physical bearer, and [4] specifies the routing function and the transport bearer for this scenario. The deployment of the routing across the RNC in the UTRAN is optional. Where signalling between co-located equipment and its management system is required, this may be carried over the same bearer as Implementation Specific O&M.

10.1.2 Logical O&M

Logical O&M is the signalling associated with the control of logical resources (channels, cells,...) owned by the RNC but physically implemented in the Node B. The RNC controls these logical resources. A number of O&M procedures physically implemented in Node B impact on the logical resources and therefore require an information exchange between RNC and Node B. All messages needed to support this information exchange are classified as Logical O&M forming an integral part of NBAP.

11 UTRAN Interfaces

11.1 General Protocol Model for UTRAN Interfaces

11.1.1 General

The general protocol model for UTRAN Interfaces is depicted in figure 10, and described in detail in the following sub-sections. The structure is based on the principle that the layers and planes are logically independent of each other, and if needed, protocol layers, or the whole protocol stack in a plane may be changed in the future by decisions in the standardisation.

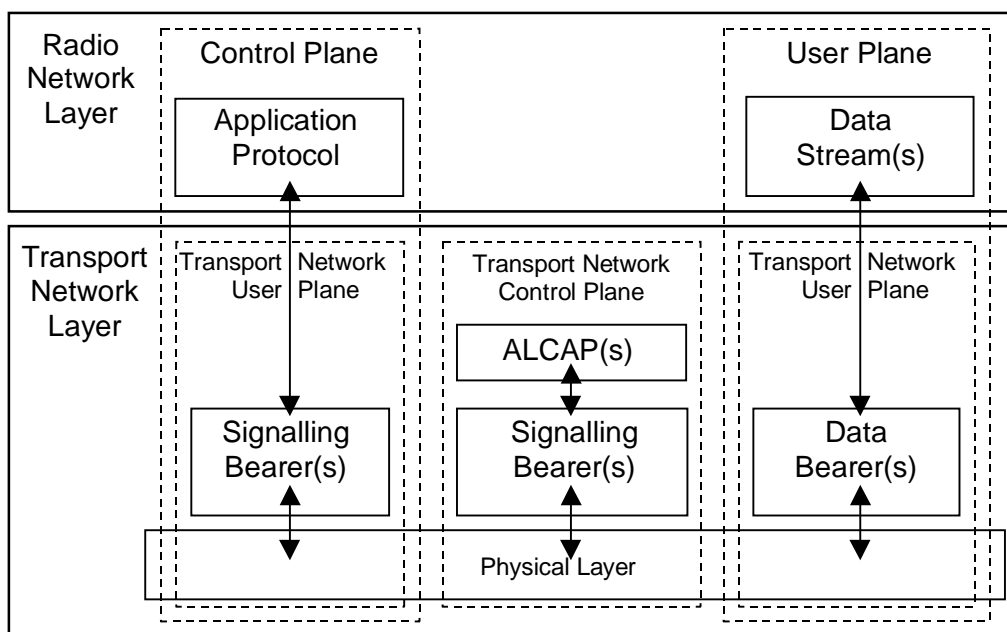

Figure 10: General Protocol Model for UTRAN Interfaces

11.1.2 Horizontal Layers

The Protocol Structure consists of two main layers, Radio Network Layer, and Transport Network Layer. All UTRAN related issues are visible only in the Radio Network Layer, and the Transport Network Layer represents standard transport technology that is selected to be used for UTRAN, but without any UTRAN specific requirements.

11.1.3 Vertical Planes

11.1.3.1 Control Plane

The Control Plane Includes the Application Protocol, i.e. RANAP, RNSAP or NBAP, and the Signalling Bearer for transporting the Application Protocol messages.

Among other things, the Application Protocol is used for setting up bearers for (i.e. Radio Access Bearer or Radio Link) in the Radio Network Layer. In the three plane structure the bearer parameters in the Application Protocol are not directly tied to the User Plane technology, but are rather general bearer parameters.

The Signalling Bearer for the Application Protocol may or may not be of the same type as the Signalling Protocol for the ALCAP. The Signalling Bearer is always set up by O&M actions.

11.1.3.2 User Plane

The User Plane Includes the Data Stream(s) and the Data Bearer(s) for the Data Stream(s). The Data Stream(s) is/are characterised by one or more frame protocols specified for that interface.

11.1.3.3 Transport Network Control Plane

The Transport Network Control Plane does not include any Radio Network Layer information, and is completely in the Transport Layer. It includes the ALCAP protocol(s) that is/are needed to set up the transport bearers (Data Bearer) for the User Plane. It also includes the appropriate Signalling Bearer(s) needed for the ALCAP protocol(s).

The Transport Network Control Plane is a plane that acts between the Control Plane and the User Plane. The introduction of Transport Network Control Plane makes it possible for the Application Protocol in the Radio Network Control Plane to be completely independent of the technology selected for Data Bearer in the User Plane.

When Transport Network Control Plane is used, the transport bearers for the Data Bearer in the User Plane are set up in the following fashion. First there is a signalling transaction by the Application Protocol in the Control Plane, which triggers the set up of the Data Bearer by the ALCAP protocol that is specific for the User Plane technology.

The independence of Control Plane and User Plane assumes that ALCAP signalling transaction takes place. It should be noted that ALCAP might not be used for all types Data Bearers. If there is no ALCAP signalling transaction, the Transport Network Control Plane is not needed at all. This is the case when pre-configured Data Bearers are used.

It should also be noted that the ALCAP protocol(s) in the Transport Network Control Plane is/are not used for setting up the Signalling Bearer for the Application Protocol or for the ALCAP during real time operation.

The Signalling Bearer for the ALCAP may or may not be of the same type as the Signalling Bearer for the Application Protocol. The Signalling Bearer for ALCAP is always set up by O&M actions.

11.1.3.4 Transport Network User Plane

The Data Bearer(s) in the User Plane, and the Signalling Bearer(s) for Application Protocol, belong also to Transport Network User Plane. As described in the previous section, the Data Bearers in Transport Network User Plane are directly controlled by Transport Network Control Plane during real time operation, but the control actions required for setting up the Signalling Bearer(s) for Application Protocol are considered O&M actions.

11.2 Protocol Model (Informative)

The following section is a informative section which aim is to provide an overall picture of how the MAC layer is distributed over Uu, Iub and Iur for the RACH, FACH and DCH.

11.2.1 RACH Transport Channel

Figure 11 shows the protocol stack model for the RACH transport channel when the Controlling and Serving RNC are co-incident.

For the RACH transport channel, Dedicated MAC (MAC-d) uses the services of Common MAC (MAC-c).

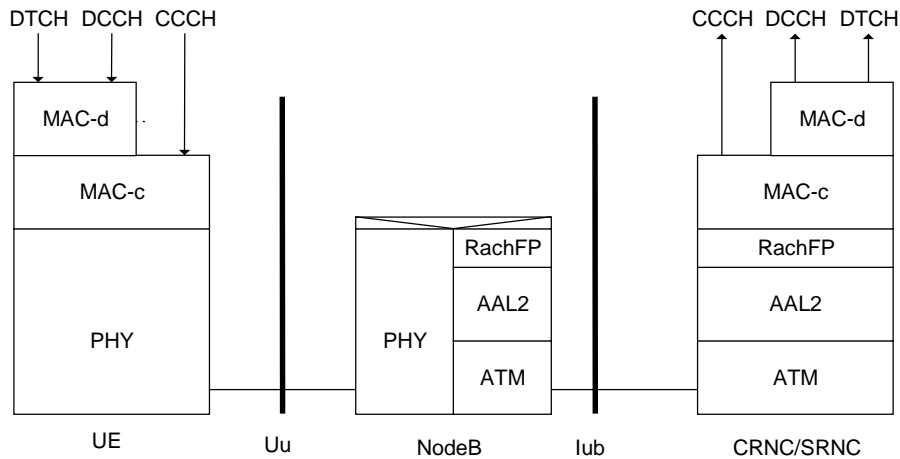

Figure 11: RACH: Coincident Controlling and Serving RNC

The Common MAC (MAC-c) entity in the UE transfers MAC-c PDU to the peer MAC-c entity in the RNC using the services of the Physical Layer.

An Interworking Function (IWF) in the NodeB interworks the RACH frame received by the PHY entity into the RACH Frame Protocol (RACH FP) entity.

The RACH Frame Protocol entity adds header information to form a RACH FP PDU which is transported to the RNC over an AAL2 (or AAL5) connection.

At the RNC, the RACH FP entity delivers the MAC-c PDU to the MAC-c entity.

Figure 12 shows the protocol model for the RACH transport channel with separate Controlling and Serving RNC. In this case, Iur RACH Frame Protocol (DchFP) is used to interwork the Common MAC (MAC-c) at the Controlling RNC with the Dedicated MAC (MAC-d) at the Serving RNC (The exact Iur FACH Frame Protocol is FFS)

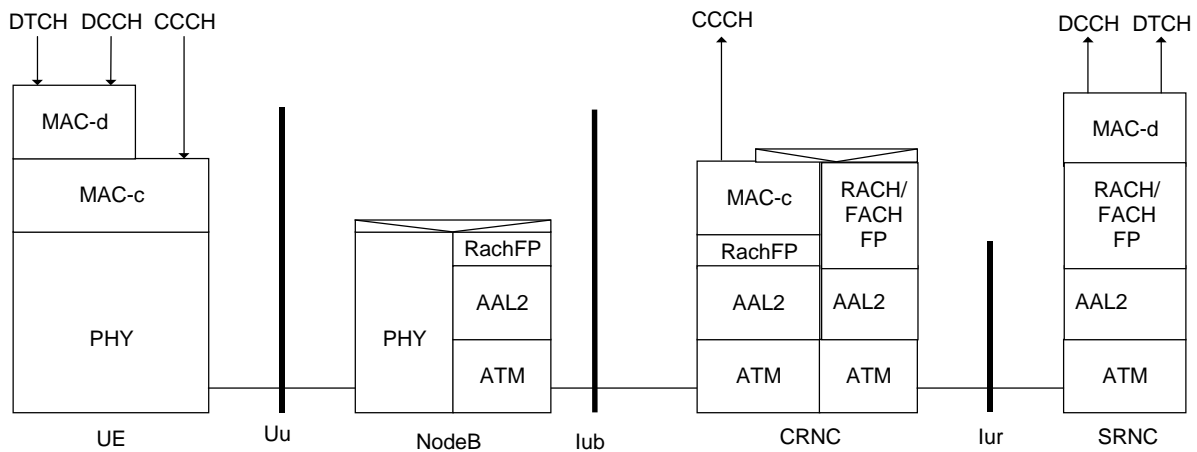

Figure 12: RACH: Separate Controlling and Serving RNC

11.2.2 FACH Transport Channel

Figure 13 shows the protocol model for the FACH transport channel when the Controlling and Serving RNC are coincident.

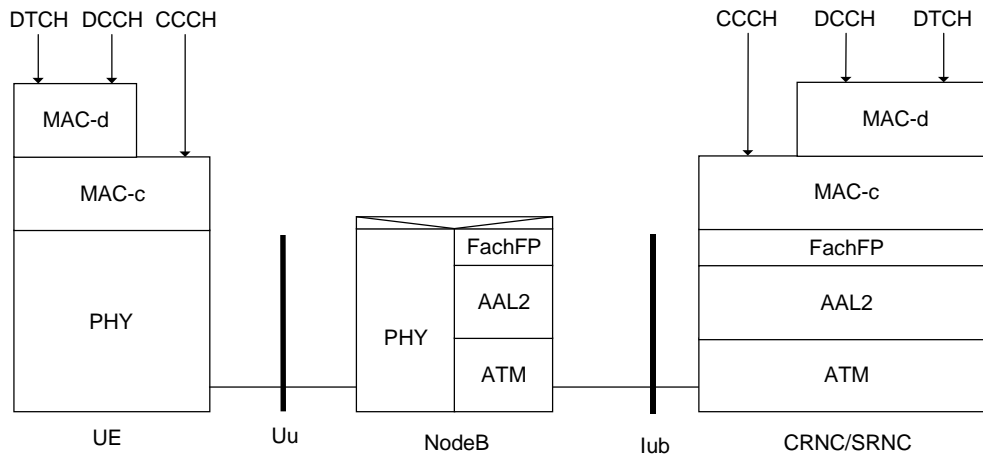

Figure 13: FACH Co-incident Controlling and Serving RNC

The Common MAC (MAC-c) entity in the RNC transfers MAC-c PDU to the peer MAC-c entity in the UE using the services of the FACH Frame Protocol (FACH FP) entity.

The FACH Frame Protocol entity adds header information to form a FACH FP PDU which is transported to the NodeB over an AAL2 (or AAL5) connection.

An Interworking Function (IWF) in the NodeB interworks the FACH frame received by FACH Frame Protocol (FACH FP) entity into the PHY entity.

FACH scheduling is performed by MAC-c in the CRNC.

Figure 14 shows the protocol model for the FACH transport channel with separate Controlling and Serving RNC. In this case, Iur FACH Frame Protocol is used to interwork the Common MAC (MAC-c) at the Controlling RNC with the Dedicated MAC (MAC-d) at the Serving RNC (The exact Iur FACH Frame Protocol is FFS)

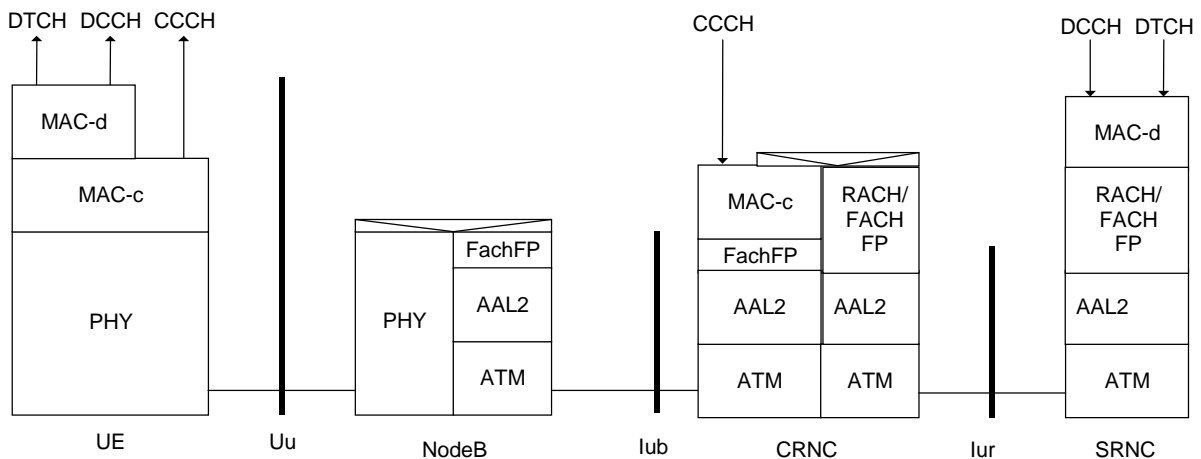

Figure 14: FACH: Separate Controlling and Serving RNC

11.2.3 DCH Transport Channel

Figure 15 shows the protocol model for the DCH transport channel when the Controlling and Serving RNC are co-incident.

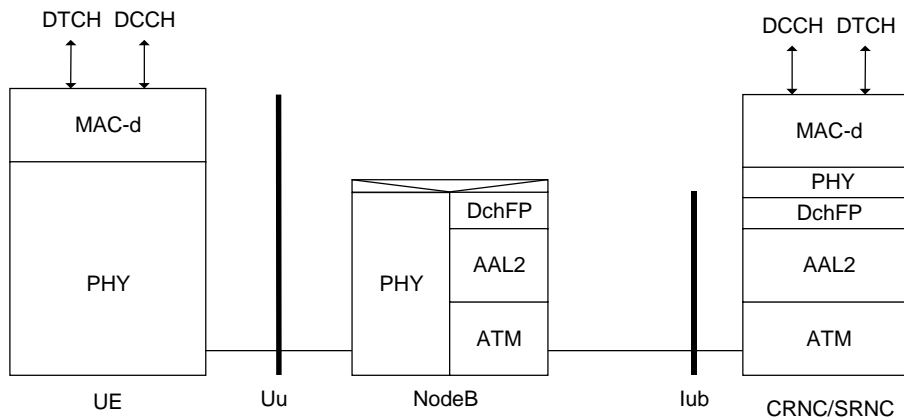

Figure 15: DCH: Co-incident Controlling and Serving RNC

The DCH transport channel introduces the concept of distributed PHY layer.

An Interworking Function (IWF) in the NodeB interworks between the DCH Frame Protocol (DCH FP) entity and the PHY entity.

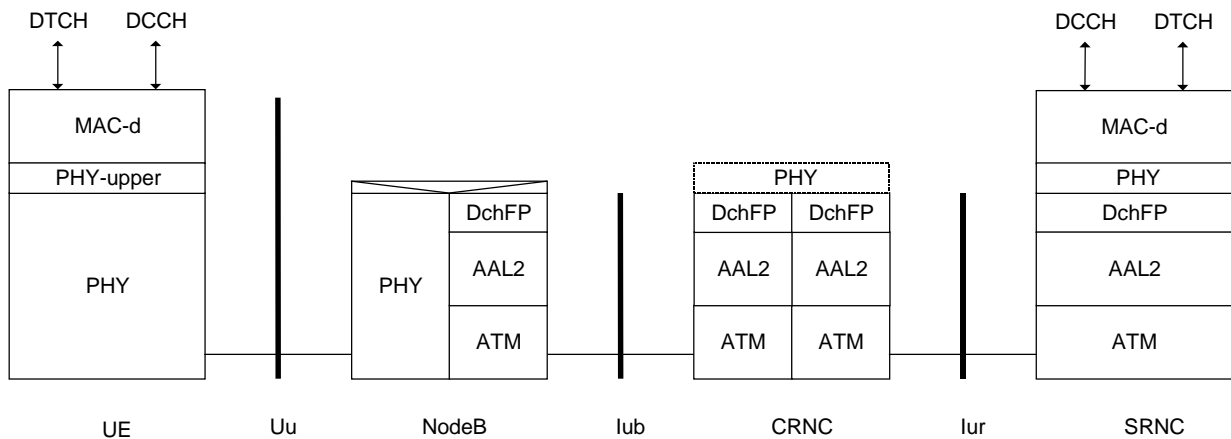

Figure 16: DCH: Separate Controlling and Serving RNC

Figure 16 shows the protocol model for the DCH transport channel with separate Controlling and Serving RNC. In this case, the Iub DCH FP is terminated in the CRNC and interworked with the Iur DCH FP through a PHY function. This function performs optional soft handover or can be a null function.

11.2.4 DSCH Transport Channel

Figure 17 shows the protocol model for the DSCH transport channel when the Controlling and Serving RNC are co-incident.

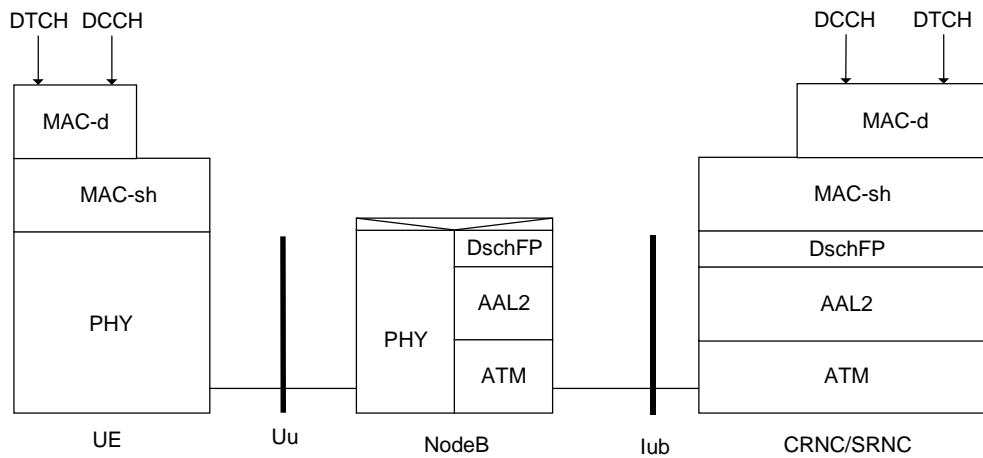

Figure 17: DSCH Co-incident Controlling and Serving RNC

The Shared MAC (MAC-sh) entity in the RNC transfers MAC-sh PDU to the peer MAC-sh entity in the UE using the services of the DSCH Frame Protocol (DSCH FP) entity. The DSCH FP entity adds header information to form a DSCH FP PDU which is transported to the Node B over an AAL2 (or AAL5) connection.

An Interworking Function (IWF) in the Node B interworks the DSCH frame received by DSCH FP entity into the PHY entity. DSCH scheduling is performed by MAC-sh in the CRNC.

Figure 18 shows the protocol model for the DSCH transport channel with separate Controlling and Serving RNC. In this case, Iur DSCH Frame Protocol is used to interwork the MAC-sh at the Controlling RNC with the MAC-d at the Serving RNC.

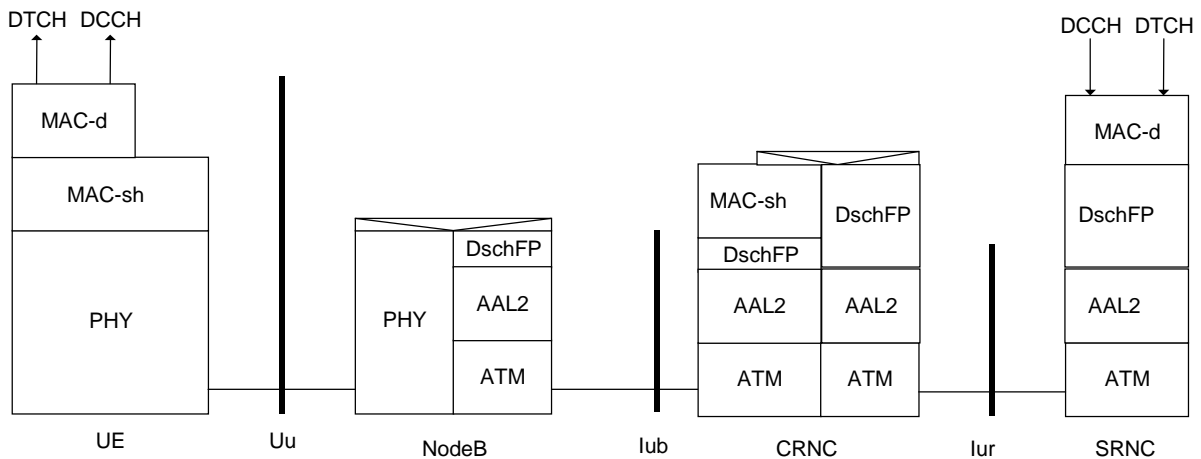

Figure 18: DSCH: Separate Controlling and Serving RNC

11.2.5 USCH Transport Channel

Figure 19 shows the protocol model for the USCH transport channel when the Controlling and Serving RNC are co-incident.

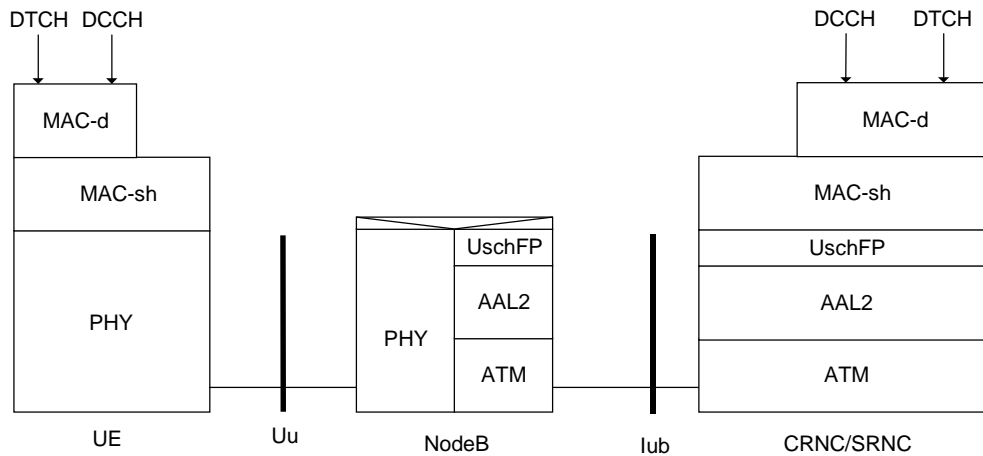

Figure 19: USCH Co-incident Controlling and Serving RNC

The Shared MAC (MAC-sh) entity in the RNC *receives* MAC-sh PDU *from* the peer MAC-sh entity in the UE using the services of the Interworking Function in the NodeB, and the USCH Frame Protocol (USCH FP) entity. The USCH FP entity *in the NodeB* adds header information to form a USCH FP PDU which is transported to the RNC over an AAL2 (or AAL5) connection.

An Interworking Function (IWF) in the Node B interworks *the received USCH PHY entity into an USCH frame to be transmitted by the USCH FP entity over the Iub interface*. USCH scheduling is performed by MAC-sh in UE and by C-RRC in the CRNC.

Figure 20 shows the protocol model for the USCH transport channel with separate Controlling and Serving RNC. In this case, Iur USCH Frame Protocol is used to interwork the MAC-sh at the Controlling RNC with the MAC-d at the Serving RNC.

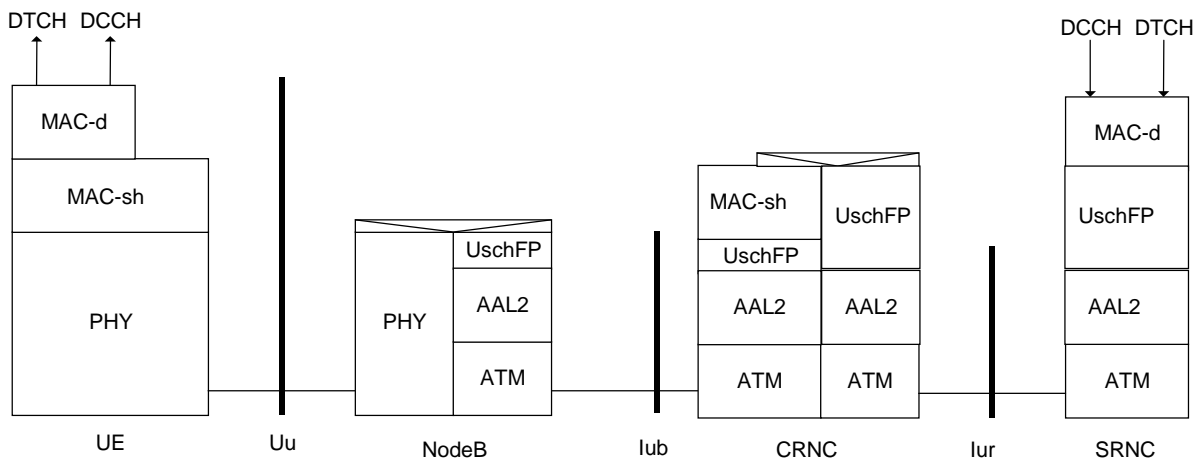

Figure 20: USCH: Separate Controlling and Serving RNC

12 UTRAN Performance Requirements

12.1 UTRAN delay requirements

The maximum transmission delay of a diversity branch and the maximum processing delay introduced by single UTRAN network elements shall be defined.

Annex A (informative): Change History

Change history					
TSG RAN#	Version	CR	Tdoc RAN	New Version	Subject/Comment
RAN_05	-	-	-	3.0.0	Approved at TSG RAN #5 and placed under Change Control
RAN_06	3.0.0	-	RP-99735	3.1.0	Approved at TSG RAN #6
RAN_06	3.0.0	-	RP-99736	3.1.0	Approved at TSG RAN #6
RAN_06	3.0.0	-	RP-99737	3.1.0	Approved at TSG RAN #6
RAN_06	3.0.0	-	RP-99738	3.1.0	Approved at TSG RAN #6

Rapporteur for TS25.401 is:
Pierre Lescuyer
Nortel Networks
Tel. : +33 1 39 44 44 86
Fax : +33 1 39 44 50 02
Email : lescuyer@nortelnetworks.com

History

Document history		
V3.1.0	January 2000	Publication