

ETSI TS 125 420 V4.2.0 (2002-03)

Technical Specification

Universal Mobile Telecommunications System (UMTS); UTRAN Iur Interface General Aspects and Principles (3GPP TS 25 420 version 4.2.0 Release 4)



Reference

RTS/TSGR-0325420Uv4R2

Keywords

UMTS

ETSI

650 Route des Lucioles
F-06921 Sophia Antipolis Cedex - FRANCE

Tel.: +33 4 92 94 42 00 Fax: +33 4 93 65 47 16

Siret N° 348 623 562 00017 - NAF 742 C
Association à but non lucratif enregistrée à la
Sous-Préfecture de Grasse (06) N° 7803/88

Important notice

Individual copies of the present document can be downloaded from:

<http://www.etsi.org>

The present document may be made available in more than one electronic version or in print. In any case of existing or perceived difference in contents between such versions, the reference version is the Portable Document Format (PDF). In case of dispute, the reference shall be the printing on ETSI printers of the PDF version kept on a specific network drive within ETSI Secretariat.

Users of the present document should be aware that the document may be subject to revision or change of status. Information on the current status of this and other ETSI documents is available at

<http://portal.etsi.org/tb/status/status.asp>

If you find errors in the present document, send your comment to:

editor@etsi.fr

Copyright Notification

No part may be reproduced except as authorized by written permission.
The copyright and the foregoing restriction extend to reproduction in all media.

© European Telecommunications Standards Institute 2002.
All rights reserved.

DECT™, PLUGTESTS™ and UMTS™ are Trade Marks of ETSI registered for the benefit of its Members.
TIPHON™ and the TIPHON logo are Trade Marks currently being registered by ETSI for the benefit of its Members.
3GPP™ is a Trade Mark of ETSI registered for the benefit of its Members and of the 3GPP Organizational Partners.

Intellectual Property Rights

IPRs essential or potentially essential to the present document may have been declared to ETSI. The information pertaining to these essential IPRs, if any, is publicly available for **ETSI members and non-members**, and can be found in ETSI SR 000 314: "*Intellectual Property Rights (IPRs); Essential, or potentially Essential, IPRs notified to ETSI in respect of ETSI standards*", which is available from the ETSI Secretariat. Latest updates are available on the ETSI Web server (<http://webapp.etsi.org/IPR/home.asp>).

Pursuant to the ETSI IPR Policy, no investigation, including IPR searches, has been carried out by ETSI. No guarantee can be given as to the existence of other IPRs not referenced in ETSI SR 000 314 (or the updates on the ETSI Web server) which are, or may be, or may become, essential to the present document.

Foreword

This Technical Specification (TS) has been produced by ETSI 3rd Generation Partnership Project (3GPP).

The present document may refer to technical specifications or reports using their 3GPP identities, UMTS identities or GSM identities. These should be interpreted as being references to the corresponding ETSI deliverables.

The cross reference between GSM, UMTS, 3GPP and ETSI identities can be found under www.etsi.org/key.

Contents

Intellectual Property Rights	2
Foreword.....	2
Foreword.....	5
1 Scope	6
2 References	6
3 Definitions and abbreviations.....	6
3.1 Definitions	6
3.2 Abbreviations	7
3.3 Specification Notations	7
4 General Aspects.....	8
4.1 Introduction	8
4.2 Iur Interface General Principles.....	8
4.3 Iur Interface Specification Objectives	8
4.3.1 General.....	8
4.3.2 Addressing of RNSs over the Iur Interface	9
4.4 Iur Interface Capabilities	9
4.4.1 Radio application related signalling.....	9
4.4.2 Iub/Iur DCH data streams	9
4.4.3 Iur RACH/CPCH [FDD] data streams.....	9
4.4.4 Iur DSCH data streams	9
4.4.5 Iur USCH data streams [TDD]	9
4.4.6 Iur FACH data streams	10
4.5 Iur Interface Characteristics	10
4.5.1 Uses of SCCP	10
4.5.1.1 General	10
4.5.1.2 SCCP connection establishment.....	10
4.5.1.3 Establishment procedure initiated from the SRNC	10
4.5.1.3A Establishment procedure initiated from an RNC requesting common measurements or information.....	11
4.5.1.4 SCCP connection release	12
4.5.1.5 General SCCP Abnormal Conditions.....	12
4.5.1.5.1 SCCP bearer failure	12
4.5.1.5.2 SCCP connection failure	12
4.5.2 SCCP Addressing Scheme.....	13
4.5.2.1 General	13
5 Functions of the I _{ur} Interface Protocols	13
5.1 Functional List.....	13
5.2 Functional Split over Iur.....	13
5.2.1 Combining/Splitting.....	13
5.2.2 Control of Combining/Splitting Topology.....	14
5.2.3 Handling of DRNS Hardware Resources.....	14
5.2.4 Allocation of Physical Channels.....	14
5.2.5 UpLink Power Control.....	14
5.2.6 Down-Link Power Control	14
5.2.7 Admission Control.....	14
5.2.8 Radio Protocol Functional Split.....	14
6 I _{ur} Interface Protocols	15
6.1 General	15
6.2 Radio Signalling Protocols.....	15
6.2.1 RNSAP Protocol.....	15
6.3 User Plane Frame Protocols	16
6.3.1 Iub/Iur DCH Frame Protocol	16

6.3.2	Iur DSCH Frame Protocol	16
6.3.3	Iur USCH Frame Protocol [TDD].....	16
6.3.4	Iur RACH/CPCH [FDD] Frame Protocol.....	17
6.3.5	Iur FACH Frame Protocol	17
6.4	Mapping of Frame Protocols onto transport bearers	17
7	DRNS logical Model over I _{ur}	17
7.1	Overview	17
7.2	Logical Model Elements	18
7.2.1	Radio Link	18
7.2.2	Cell.....	18
7.2.3	Iur DCH Data Port	18
7.2.4	Iur DSCH Data Port.....	18
7.2.5	Iur USCH Data Port [TDD]	18
7.2.6	Iur RACH/CPCH [FDD]/FACH Data Port.....	19
7.2.7	Iur Control Port.....	19
8	I _{ur} Interface Protocol Structure	19
9	Other I _{ur} Interface Specifications.....	20
9.1	UTRAN Iur Interface: Layer 1 (TS 25.421).....	20
9.2	UTRAN Iur Interface: Signalling Transport (TS 25.422)	20
9.3	UTRAN Iur Interface: RNSAP Specification (TS 25.423)	20
9.4	UTRAN Iur Interface: Data Transport and Transport Signalling for Common Transport Channel Data Streams (TS 25.424).....	20
9.5	UTRAN Iur Interface: User Plane Protocols for Common Transport Channel Data Streams (TS 25.425)	20
9.6	UTRAN Iur & Iub Interface: Data Transport and Transport Signalling for DCH Data Streams (TS 25.426).....	20
9.7	UTRAN Iur & Iub Interface: User Plane Protocols for DCH Data Streams (TS 25.427)	20
9.8	Summary of UTRAN Iur Interface Technical Specifications.....	20
Annex A (informative): Change history		22
History		23

Foreword

This Technical Specification (TS) has been produced by the 3rd Generation Partnership Project (3GPP).

The contents of the present document are subject to continuing work within the TSG and may change following formal TSG approval. Should the TSG modify the contents of the present document, it will be re-released by the TSG with an identifying change of release date and an increase in version number as follows:

Version x.y.z

where:

- x the first digit:
 - 1 presented to TSG for information;
 - 2 presented to TSG for approval;
 - 3 or greater indicates TSG approved document under change control.
- y the second digit is incremented for all changes of substance, i.e. technical enhancements, corrections, updates, etc.
- z the third digit is incremented when editorial only changes have been incorporated in the document.

1 Scope

The present document is an introduction to the TSG RAN TS 25.42x series of UMTS Technical Specifications that define the Iur Interface. It is a logical interface for the interconnection of two Radio Network Controller (RNC) components of the UMTS Terrestrial Radio Access Network (UTRAN) for the UMTS system.

2 References

The following documents contain provisions which, through reference in this text, constitute provisions of the present document.

- References are either specific (identified by date of publication, edition number, version number, etc.) or non-specific.
- For a specific reference, subsequent revisions do not apply.
- For a non-specific reference, the latest version applies. In the case of a reference to a 3GPP document (including a GSM document), a non-specific reference implicitly refers to the latest version of that document *in the same Release as the present document*.

- [1] 3GPP TS 25.427: "UTRAN Iub/Iur Interface User Plane Protocol for DCH Data Streams".
- [2] 3GPP TS 25.425: "UTRAN Iur Interface: User Plane Protocols for Common Transport Channel Data Streams".
- [3] 3GPP TS 25.421: "UTRAN Iur Interface: Layer 1".
- [4] 3GPP TS 25.422: "UTRAN Iur Interface: Signalling Transport".
- [5] 3GPP TS 25.423: "UTRAN Iur Interface: RNSAP Signalling".
- [6] 3GPP TS 25.424: "UTRAN Iur Interface: Data Transport & Transport Signalling".
- [7] 3GPP TS 25.401: "UTRAN Overall Description".
- [8] 3GPP TS 25.426: "UTRAN Iur & Iub Interface: Data Transport & Transport Signalling for DCH Data Streams".
- [9] ITU-T Recommendation Q.711 (7/96): "Functional description of the signalling connection control part".
- [10] ITU-T Recommendation Q.712 (7/96): "Definition and function of signalling connection control part messages".
- [11] ITU-T Recommendation Q.713 (7/96): "Signalling connection control part formats and codes".
- [12] ITU-T Recommendation Q.714 (7/96): "Signalling connection control part procedures".
- [13] 3GPP TS 23.003: "Numbering, Addressing and Identification".
- [14] ITU-T Recommendation Q.2630.1 (12/99): "AAL type 2 Signalling Protocol (Capability Set 1)".

3 Definitions and abbreviations

3.1 Definitions

None

3.2 Abbreviations

For the purposes of the present document, the following abbreviations apply:

AAL2	ATM Adaptation Layer type 2
AAL5	ATM Adaptation Layer type 5
ALCAP	Access Link Control Application Part
ATM	Asynchronous Transfer Mode
CPCH	Common Packet Channel
CRNC	Controlling RNC
CTP	Common Transport Protocol
DCH	Dedicated Transport Channel
DL	Downlink
DRNC	Drift Radio Network Controller
DRNS	Drift Radio Network Subsystem
DSCH	Downlink Shared Channel
FACH	Forward Access Channel
GT	Global Title
IP	Internet Protocol
MAC	Medium Access Control
MTP3-B	Message Transfer Part level 3 (for Q.2140)
PLMN	Public Land Mobile Network
QoS	Quality of Service
RACH	Random Access Channel
RF	Radio Frequency
RNC	Radio Network Controller
RNS	Radio Network Subsystem
RNSAP	Radio Network Subsystem Application Part
RRC	Radio Resource Control
SCCP	Signalling Connection Control Part
SPC	Signalling Point Code
SRNC	Serving Radio Network Controller
SRNS	Serving Radio Network Subsystem
SS7	Signalling System N° 7
SSCF-NNI	Service Specific Co-ordination Function – Network Node Interface
SSCOP	Service Specific Connection Oriented Protocol
SSN	Sub-System Number
STC	Signalling Transport Converter
UE	User Equipment
UL	Up-link
UMTS	Universal Mobile Telecommunication System
URA	UTRAN Registration Area
USCH	Uplink Shared Channel
UTRAN	UMTS Terrestrial Radio Access Network

3.3 Specification Notations

For the purposes of the present document, the following notations apply:

- [FDD] This tagging of a word indicates that the word preceding the tag "[FDD]" applies only to FDD. This tagging of a heading indicates that the heading preceding the tag "[FDD]" and the section following the heading applies only to FDD.
- [TDD] This tagging of a word indicates that the word preceding the tag "[TDD]" applies only to TDD, including 3.84Mcps TDD and 1.28Mcps TDD. This tagging of a heading indicates that the heading preceding the tag "[TDD]" and the section following the heading applies only to TDD, including 3.84Mcps TDD and 1.28Mcps TDD.
- [3.84Mcps TDD] This tagging of a word indicates that the word preceding the tag "[3.84Mcps TDD]" applies only to 3.84Mcps TDD. This tagging of a heading indicates that the heading preceding the tag "[3.84Mcps TDD]" and the section following the heading applies only to 3.84Mcps TDD.

[1.28Mcps TDD]	This tagging of a word indicates that the word preceding the tag "[1.28Mcps TDD]" applies only to 1.28Mcps TDD. This tagging of a heading indicates that the heading preceding the tag "[1.28Mcps TDD]" and the section following the heading applies only to 1.28Mcps TDD.
[FDD - ...]	This tagging indicates that the enclosed text following the "[FDD - " applies only to FDD. Multiple sequential paragraphs applying only to FDD are enclosed separately to enable insertion of TDD specific (or common) paragraphs between the FDD specific paragraphs.
[TDD - ...]	This tagging indicates that the enclosed text following the "[TDD - " applies only to TDD including 3.84Mcps TDD and 1.28Mcps TDD. Multiple sequential paragraphs applying only to TDD are enclosed separately to enable insertion of FDD specific (or common) paragraphs between the TDD specific paragraphs.
[3.84Mcps TDD - ...]	This tagging indicates that the enclosed text following the "[3.84Mcps TDD - " applies only to 3.84Mcps TDD. Multiple sequential paragraphs applying only to 3.84Mcps TDD are enclosed separately to enable insertion of FDD and TDD specific (or common) paragraphs between the 3.84Mcps TDD specific paragraphs.
[1.28Mcps TDD - ...]	This tagging indicates that the enclosed text following the "[1.28Mcps TDD - " applies only to 1.28Mcps TDD. Multiple sequential paragraphs applying only to 1.28Mcps TDD are enclosed separately to enable insertion of FDD and TDD specific (or common) paragraphs between the 1.28Mcps TDD specific paragraphs.
Procedure	When referring to a procedure in the specification, the Procedure Name is written with the first letters in each word in upper case characters followed by the word "procedure", e.g. RNSAP Basic Mobility Procedures.
Message	When referring to a message in the specification, the MESSAGE NAME is written with all letters in upper case characters followed by the word "message", e.g. RADIO LINK SETUP REQUEST message.
Frame	When referring to a control or data frame in the specification, the CONTROL/DATA FRAME NAME is written with all letters in upper case characters followed by the words "control/data frame", e.g. DCH data frame.

4 General Aspects

4.1 Introduction

The logical connection that exists between any two RNCs within the UTRAN is referred to as the I_{ur} interface.

4.2 I_{ur} Interface General Principles

The general principles for the specification of the I_{ur} interface are as follows:

- The I_{ur} interface should be open;
- The I_{ur} interface shall support the exchange of signalling information between two RNCs, in addition the interface may need to support one or more I_{ur} data streams;
- From a logical standpoint, the I_{ur} is a point-to-point interface between two RNCs within the UTRAN. A point-to-point logical interface should be feasible even in the absence of a physical direct connection between the two RNCs.

4.3 I_{ur} Interface Specification Objectives

4.3.1 General

The I_{ur} interface specifications shall facilitate the following:

- inter-connection of RNCs supplied by different manufacturers;
- support of continuation between RNSs of the UTRAN services offered via the Iu interface;
- separation of I_{ur} interface Radio Network functionality and Transport Network functionality to facilitate introduction of future technology.

4.3.2 Addressing of RNSs over the Iur Interface

- For an RRC connection using a dedicated channel, the Iur standard shall allow the addition / deletion of radio links supported by cells belonging to any RNS within the PLMN.
- The specification of the Iur interface shall allow an RNC to address any other RNC within the PLMN for establishing a signalling bearer over Iur.
- The specification of the Iur interface shall allow an RNC to address any other RNC within the PLMN for establishing user data bearers for Iur data streams.

RNSAP shall allow different kinds of addressing schemes to be used for the signalling bearer.

4.4 Iur Interface Capabilities

4.4.1 Radio application related signalling

The Iur interface provides capability to support radio interface mobility between RNSs, of UEs having a connection with UTRAN. This capability includes the support of handover, radio resource handling and synchronisation between RNSs.

4.4.2 Iub/Iur DCH data streams

The Iur interface provides the means for transport of uplink and downlink Iub/Iur DCH frames carrying user data and control information between SRNC and Node B (DRNS), via the DRNC.

In the UTRAN, one DCH data stream always corresponds to a bi-directional transport channel. Although the TFS is configured separately for each DCH direction and a DCH could be configured with e.g. only a zero-bit transport format in one direction, the DCH is always treated as a bi-directional transport channel in the UTRAN. As a result, two uni-directional Uu DCH transport channels with opposite directions can be mapped to either one or two DCH transport channels in the UTRAN.

4.4.3 Iur RACH/CPCH [FDD] data streams

The Iur interface provides the means for transport of uplink RACH and [FDD - CPCH] transport frames between DRNC and SRNC.

4.4.4 Iur DSCH data streams

An Iur DSCH data stream corresponds to the data carried on one DSCH transport channel for one UE. A UE may have multiple Iur DSCH data streams.

The Iur interface provides a means of transporting down link MAC-c/sh SDUs. In addition, the interface provides a means to the SRNC for queue reporting and a means for the DRNC to allocate capacity to the SRNC.

4.4.5 Iur USCH data streams [TDD]

An Iur USCH data stream corresponds to the data carried on one USCH transport channel for one UE. A UE may have multiple Iur USCH data streams.

4.4.6 Iur FACH data streams

The Iur interface provides the means for transport of downlink FACH transport frames between SRNC and DRNC.

4.5 Iur Interface Characteristics

4.5.1 Uses of SCCP

4.5.1.1 General

The SCCP is used to support signalling messages between two RNCs. One user function of the SCCP, called Radio Network Subsystem Application Part (RNSAP), is defined. The RNSAP uses one signalling connection per DRNC and UE where a UE is having one or more active radio links for the transfer of layer 3 messages. RNSAP also uses one signalling connection per RNC providing common measurements and information to a particular RNC (i.e. if measurements and information are transferred in both directions between a pair of RNCs, then two SCCP connections are used).

Both connectionless and connection-oriented procedures are used to support the RNSAP. TS 25.423 explain whether connection oriented or connectionless services should be used for a layer 3 procedure.

The following subclauses describe the use of SCCP connections for RNSAP transactions. Subclause 4.5.1.2 describes the connection establishment procedures. Subclause 4.5.1.3 describes the connection establishment procedures initiated from SRNC. Subclause 4.5.1.4 describes the connection release procedures. Subclause 4.5.1.5 describes abnormal conditions.

4.5.1.2 SCCP connection establishment

A new SCCP connection is established when information related to the communication between a UE and the network has to be exchanged between two RNCs, and no SCCP connection exists between the two RNCs involved, for the concerned UE.

In this case, the SCCP connection is established by the SRNC.

A new SCCP connection is established when a request for common measurements or information is made towards a particular RNC and no SCCP connection for common measurements and information transfer has been established from the RNC requesting the measurements or information towards the one providing the measurements or the information.

In this case, the SCCP connection is established by the RNC requesting the measurements or the information.

4.5.1.3 Establishment procedure initiated from the SRNC

The SCCP signalling connection establishment is initiated, by the SRNC, when the SRNC needs to request dedicated resources, i.e. a DCH, from a DRNC.

Initiation

- The SRNC sends the SCCP: CR message to the DRNC. The RADIO LINK SETUP REQUEST message may be included in the user data field of an SCCP Connection Request message.

Termination

1. Successful outcome:
 - The SCCP Connection Confirm message, which may optionally contain a connection oriented RNSAP message in the user data field, is returned to the SRNC.
2. Unsuccessful outcome:
 - If the SCCP signalling connection establishment fails, an SCCP Connection Refusal message will be sent back to the SRNC. This message may optionally contain a connection oriented RNSAP message.

For more information on how the RNSAP procedure Radio Link Setup is handled, please see the procedure Radio Link Setup in TS 25.423 [5].

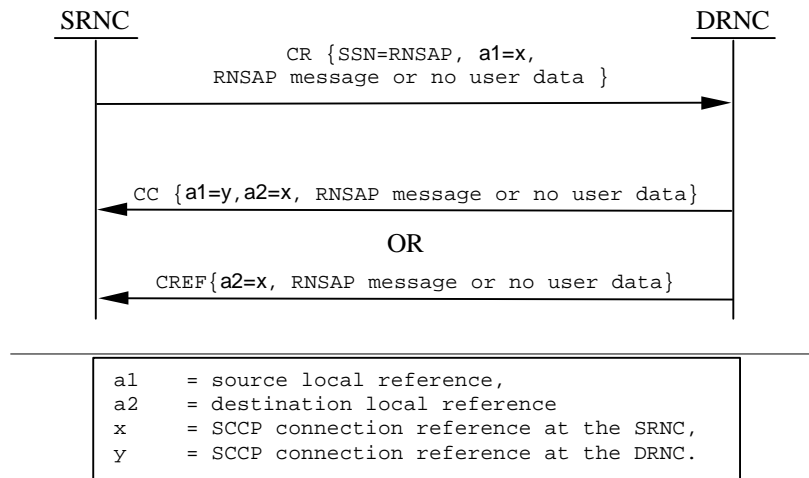

Figure 1: Setting-up of SCCP Signalling Connection

4.5.1.3A Establishment procedure initiated from an RNC requesting common measurements or information

The SCCP signalling connection establishment is initiated, by an RNC, when the RNC needs to request common measurements or provision of information from another RNC and there is no signalling bearer existing for this purpose. For the description below, the RNC requesting the measurements or the information is called RNC1 and the RNC being requested to provide the measurements or the information is called RNC2.

Initiation

- The RNC1 sends the SCCP: CR message to the RNC2. The COMMON MEASUREMENT INITIATION REQUEST or the INFORMATION EXCHANGE INITIATION REQUEST message shall be included in the user data field of the SCCP Connection Request message.

Termination

1. Successful outcome:
 - The SCCP Connection Confirm message, which may optionally contain a connection oriented RNSAP message in the user data field, is returned to the RNC1.
2. Unsuccessful outcome:
 - If the SCCP signalling connection establishment fails, an SCCP Connection Refusal message will be sent back to the RNC1. This message may optionally contain a connection oriented RNSAP message.

RNSAP Common Measurement Initiation and Information Exchange Initiation procedures are described in [5].

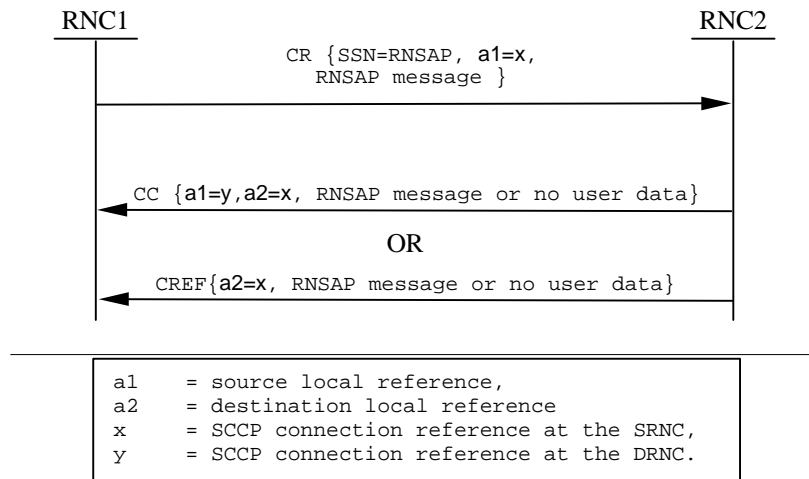

Figure 1a: Setting-up of SCCP Signalling Connection

4.5.1.4 SCCP connection release

An SCCP connection related to a specific UE is released in all normal release cases when the SRNC realises that a given signalling connection is no longer required.

The SRNC sends an SCCP Released message.

The procedure may be initiated at the SRNC side and the DRNC side in any abnormal release case.

An SCCP connection used for common measurements and information exchanges is released in all normal release cases when the RNC1 (see 4.5.1.3A) determines that a given signalling connection is no longer required. The RNC1 sends an SCCP Released message.

The procedure may be initiated at the RNC 1 side and the RNC 2 side in any abnormal release case.

4.5.1.5 General SCCP Abnormal Conditions

4.5.1.5.1 SCCP bearer failure

If a user-out-of-service information or signalling-point-inaccessible information is received by the RNSAP, no new attempt to establish SCCP connections or to send SCCP Connectionless messages towards the affected signalling point (indicated by the affected signalling point code) will be started until the corresponding user-in-service information or signalling-point-accessible information is received.

When a user-out-of-service information or signalling-point-inaccessible is received by an RNC, an optional timer may be started. When the timer expires, the RNC shall take actions as described in [5] Annex X. When the user-in-service or signalling-point-accessible is received, the timer is stopped.

4.5.1.5.2 SCCP connection failure

If for any reason an SCCP connection is released, the optional timer expires or a connection refusal is received while any of the RNSAP procedures are being performed or while a dedicated resource is still allocated, this shall be handled by the RNC as described in [5] Annex X.2.

4.5.2 SCCP Addressing Scheme

4.5.2.1 General

RNSAP may use SSN, SPC and/or GT and any combination of them as addressing schemes for the SCCP. Which of the available addressing schemes to use for the SCCP is an operator matter.

When GT addressing is utilised, the following settings shall be used:

- SSN Indicator = 1 (RNSAP SSN as defined in [13] shall always be included);
- Global Title Indicator = 0100 (GT includes translation type, numbering plan, encoding scheme and nature of address indicator);
- Translation Type = 0000 0000 (not used);
- Numbering Plan = 0001 (E.163/4);
- Nature of Address Indicator = 000 0100 (International Significant Number);
- Encoding Scheme = 0001 or 0010 (BCD, odd or even);
- Routing indicator = 0 or 1 (route on GT or PC/SSN).

When used, the GT shall be the E.164 address of the relevant node.

5 Functions of the I_{ur} Interface Protocols

5.1 Functional List

The list of functions on the I_{ur} interface is the following:

1. Transport Network Management.
2. Traffic management of Common Transport Channels:
 - Preparation of Common Transport Channel resources;
 - Paging.
3. Traffic Management of Dedicated Transport Channels:
 - Radio Link Setup/ Addition/ Deletion;
 - Measurement Reporting.
4. Traffic Management of Downlink Shared Transport Channels and [TDD - Uplink Shared Transport Channels]:
 - Radio Link Setup/ Addition/ Deletion;
 - Capacity Allocation.
5. Measurement reporting for common and dedicated measurement objects.

5.2 Functional Split over I_{ur}

5.2.1 Combining/Splitting

DRNS may perform combining/splitting of data streams communicated via its cells. SRNS performs combining/splitting of I_{ur} data streams received from/sent to DRNS(s), and data streams communicated via its own cells.

The UL combining of information streams may be performed using any suitable algorithm, for example:

- [FDD - based on maximum ratio algorithm (maximum ratio combining)];
- [FDD - based on quality information associated to each TBS (selection-combining)];
- [TDD - based on the presence/absence of the signal (selection)].

The internal DRNS handling of combining (respectively splitting) of Iub (respectively Iur) DCH frames is controlled by the DRNS.

5.2.2 Control of Combining/Splitting Topology

When requesting the addition of a new cell for a UE-UTRAN connection, the RNC of the SRNS (i.e. the SRNC) can explicitly request to the RNC of the DRNS (i.e. the DRNC) a new Iur data stream, in which case the combining and splitting function within the DRNS is not used for that cell. The SRNC can also explicitly request from the DRNC the use of the combining and splitting function inside the DRNS for that cell. Otherwise, the DRNS takes the decision whether combining and splitting function is used inside the DRNS for that cell i.e. whether a new Iur data stream shall be added or not.

5.2.3 Handling of DRNS Hardware Resources

Allocation and control of DRNS hardware resources, used for Iur data streams and radio interface transmission/reception in DRNS is performed by DRNS.

5.2.4 Allocation of Physical Channels

Allocation of physical channels in cells belonging to DRNS is performed in DRNS.

5.2.5 UpLink Power Control

This group of functions controls the level of the uplink transmitted power in order to minimise uplink interference and keep the quality of the connections. If the connection involves both a SRNS and a DRNS the function UL Outer Loop Power Control (located in the SRNC) sets the target quality for the UL Inner Loop Power Control function (located in Node B [FDD]).

5.2.6 Down-Link Power Control

This group of functions controls the level of the downlink transmitted power. In FDD it is also used to correct the downlink power drifting between several radio links. SRNC regularly (or under some algorithms) sends the target down link power reference based on the measurement report from UE.

5.2.7 Admission Control

Admission control in a DRNC is implicitly invoked during radio link setup/modify.

Information on UL interference and DL power on cells controlled by the DRNC should be available across Iur.

Additional information exchanges between admission control functions located in different RNCs are for further study.

5.2.8 Radio Protocol Functional Split

Iur supports the radio protocol functional split between SRNC and DRNC.

6 I_{ur} Interface Protocols

6.1 General

There shall exist a clear separation between the Radio Network Layer and the Transport Layer. Therefore, the radio network signalling and Iur data streams are separated from the data transport resource and traffic handling as shown in Figure 2. Data transport resource and traffic handling is controlled by Transport Signalling. The Transport Signalling is carried by a Signalling Bearer over the Iur interface.

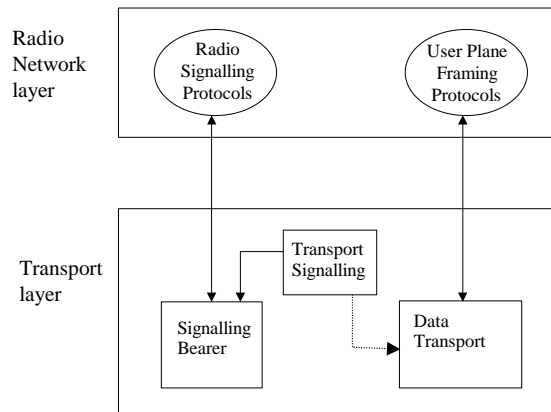

Figure 2: Separation of Radio Network Protocols and transport over Iur

6.2 Radio Signalling Protocols

6.2.1 RNSAP Protocol

The protocol responsible for providing signalling information across the Iur interface is called the Radio Network Subsystem Application Part (RNSAP).

The RNSAP is terminated by the two RNCs inter-connected via the Iur interface RNSAP Procedure Modules.

RNSAP procedures are divided into four modules as follows:

1. RNSAP Basic Mobility Procedures;
2. RNSAP DCH Procedures;
3. RNSAP Common Transport Channel Procedures;
4. RNSAP Global Procedures.

The Basic Mobility Procedures module contains procedures used to handle the mobility within UTRAN.

The DCH Procedures module contains procedures that are used to handle DCHs, DSCH and [TDD - USCHs] between two RNSs. If procedures from this module are not used in a specific Iur, then the usage of DCH, DSCH and [TDD - USCH] traffic between corresponding RNSs is not possible.

The Common Transport Channel Procedures module contains procedures that are used to control common transport channel data streams (excluding the DSCH and USCH) over Iur interface.

The Global Procedures module contains procedures that are not related to a specific UE. The procedures in this module are in contrast to the above modules involving two peer CRNCs.

6.3 User Plane Frame Protocols

6.3.1 Iub/Iur DCH Frame Protocol

There are two types of Iub/Iur DCH FP frames:

- DCH data frame;
- DCH control frame.

The contents of the Iub/Iur DCH data frame include:

- Transport Block Sets;
- Quality estimate.

The contents of the Iur DCH control frame include:

- Measurement reports;
- Power control information;
- Synchronisation information.

For a more detailed description of the Iur/Iub DCH frame protocol refer to 'UTRAN Iur & Iub Interface User Plane Protocol for DCH Data Streams' [1].

6.3.2 Iur DSCH Frame Protocol

There are two types of Iur DSCH FP frames:

- DSCH data frame;
- DSCH control frames.

The contents of the Iur DSCH data frame include:

- MAC-c/sh SDUs;
- User Buffer Status.

The contents of the Iur DSCH control frame include:

- Flow control Information (UL);
- Capacity Request Information (DL).

For a more detailed description of the Iur DSCH frame protocol refer to 'UTRAN Iur Interface User Plane protocols for Common Transport Channel Data Streams' [2].

6.3.3 Iur USCH Frame Protocol [TDD]

There is one type of Iur USCH FP frames:

- USCH data frame.

The contents of the Iur USCH data frame include:

- MAC-c/sh SDUs.

For a more detailed description of the Iur USCH frame protocol refer to 'UTRAN Iur Interface User Plane protocols for Common Transport Channel Data Streams' [2].

6.3.4 Iur RACH/CPCH [FDD] Frame Protocol

For a more detailed description of the Iur RACH framing protocol refer to 'UTRAN Iur Interface User Plane protocols for Common Transport Channel Data Streams' [2].

6.3.5 Iur FACH Frame Protocol

For a more detailed description of the Iur FACH framing protocol refer to 'UTRAN Iur Interface User Plane protocols for Common Transport Channel Data Streams' [2].

6.4 Mapping of Frame Protocols onto transport bearers

- DCH** One Iur DCH data stream is carried on one transport bearer except in the case of co-ordinated DCHs in which case a set of co-ordinated DCHs are multiplexed onto the same transport bearer.
- DSCH** One Iur DSCH data stream is carried on one transport bearer
- [TDD - USCH** One Iur USCH data stream is carried on one transport bearer.]
- RACH/CPCH[FDD]** Multiple RACH/CPCH[FDD] data streams may be carried on one transport bearer.
- FACH** Multiple FACH data streams may be carried on one transport bearer.

RACH/CPCH[FDD] and FACH data streams for one UE are carried on same transport bearer.

7 DRNS logical Model over I_{ur}

7.1 Overview

The model in Figure 3 shows the Drift Radio Network System as seen from the SRNC. It is modelled as a «black box» with a set of Radio Links on the Uu side of the box and another set of User Plane access ports on the Iur side of the box. The Radio Links are connected to the Iur user ports via the internal transport mechanisms of the DRNS. Operations for controlling the connections between ports are sent from the SRNC to the DRNC via an Iur Control Plane port.

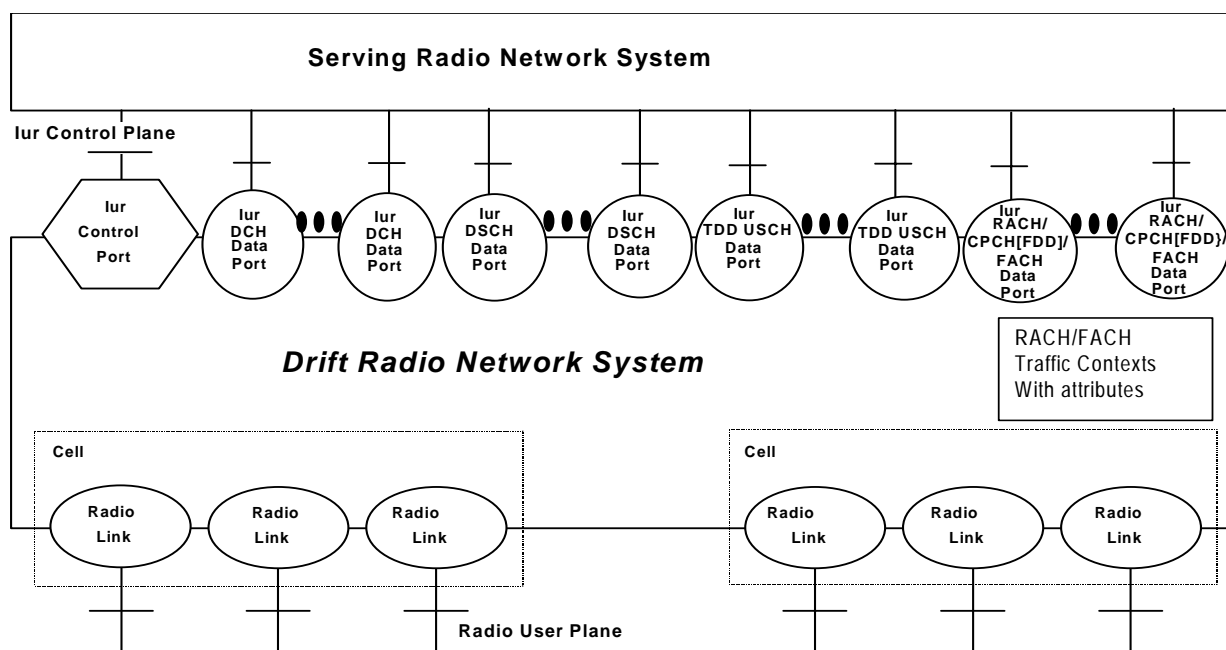

Figure 3: Drift RNS Logical Model

7.2 Logical Model Elements

7.2.1 Radio Link

A Radio Link represents a User Plane access point on the UTRAN side of the Uu interface between the User Equipment and the UTRAN.

The semantics of a Radio Link include the following:

- It is created, destroyed, and added by SRNC.
- It can be attached to one or more Iur Data Ports at any given time.
- Its resources are allocated and controlled by the DRNS.

7.2.2 Cell

It is defined by:

- A Cell identifier.

The semantics of a Cell include the following:

- It is created and destroyed by administrative procedures.

7.2.3 Iur DCH Data Port

One Iur DCH Data port represents one user plane transport bearer. One user plane transport bearer will carry only one DCH data stream except in the case of co-ordinated DCHs, in which case the data streams of all co-ordinated DCHs shall be multiplexed on one and the same user plane transport bearer.

The semantics of an Iur DCH Data Port include the following:

- It is created and destroyed by administrative procedures when transport facilities are added to, or deleted from, the Iur interface between the SRNS and DRNS. It can also be created and destroyed dynamically using dynamically setup transport bearers to add or remove transport facilities.
- It is assigned and released by the SRNC in reaction to requests for bearer services from the UE.
- It may be attached to one or more Radio Links. When attached to Radio Links in the downlink direction, it acts as a point-to-multipoint connection for diversity transmission. When attached to multiple Radio Links in the uplink direction, it acts as a multipoint-to-point connection for diversity reception [FDD].
- The transmit and receive combining/splitting resources required to implement the point-to-multipoint and multipoint-to-point connections are controlled by the DRNS [FDD].
- The Iur DCH Data Stream emanating from the Iur DCH Data Port terminates in the SRNS connected to DRNS.

7.2.4 Iur DSCH Data Port

One Iur DSCH Data port represents one bi-directional Iur user plane transport bearer. One Iur user plane transport bearer will carry only one DSCH data stream.

7.2.5 Iur USCH Data Port [TDD]

One Iur USCH Data port represents one Iur user plane transport bearer. One Iur user plane transport bearer will carry only one USCH data stream.

7.2.6 Iur RACH/CPCH [FDD]/FACH Data Port

The Iur RACH/CPCH [FDD]/FACH data port represents a transport bearer and is identified with a transport bearer identity.

7.2.7 Iur Control Port

An Iur Control Port represents the Control Plane access point on the Iur interface between the SRNS and the DRNS. It is defined by:

- A transport bearer channel identifier.

The semantics of an Iur Control Port include the following:

- It is created via administrative procedures when the Iur interface is created.

8 I_{ur} Interface Protocol Structure

The Iur interface protocol architecture consists of two functional layers:

- Radio Network Layer, defines the procedures related to the interaction of two RNCs within a PLMN. The radio network layer consists of a Radio Network Control Plane and a Radio Network User Plane.
- Transport layer, defines procedures for establishing physical connections between two RNCs within a PLMN.

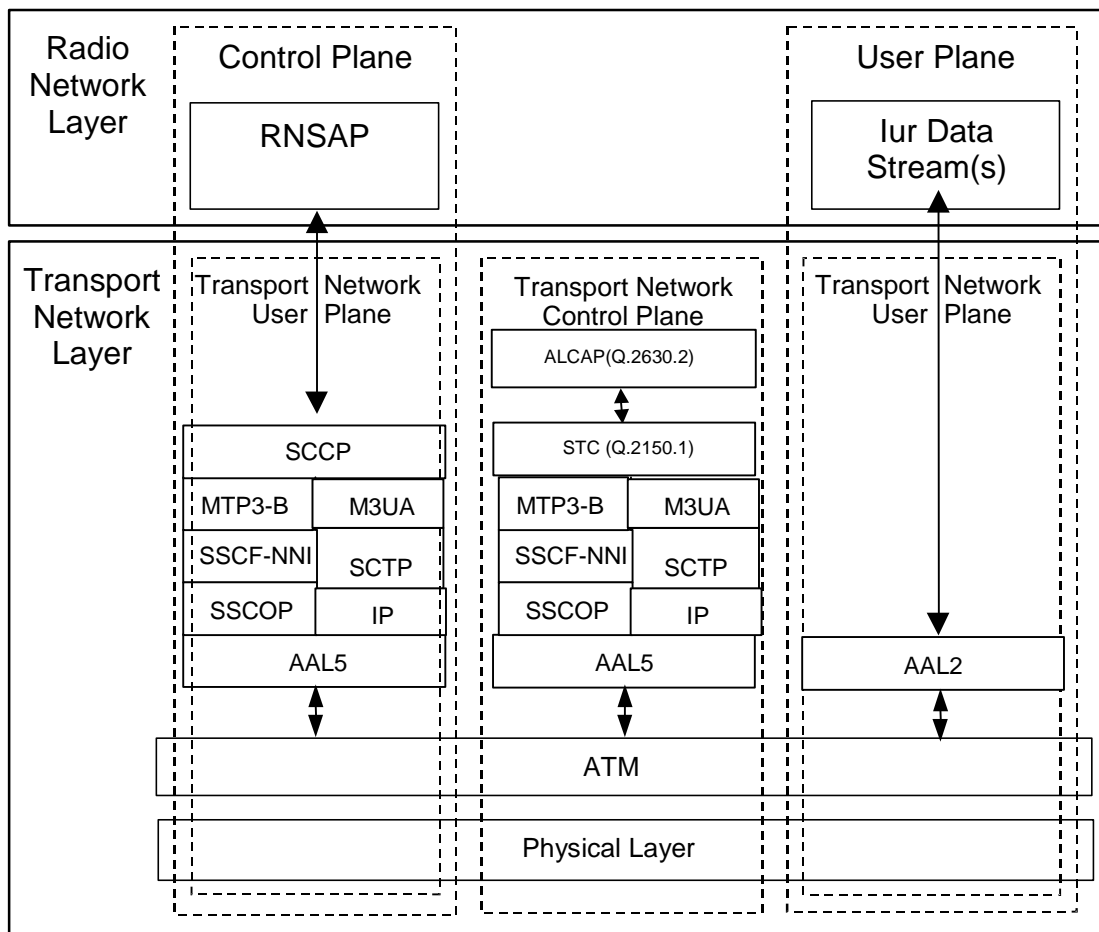

Figure 4: Iur Interface Protocol Structure

9 Other I_{ur} Interface Specifications

9.1 UTRAN Iur Interface: Layer 1 (TS 25.421)

3GPP TS 25.421 specifies the range of physical layer technologies that may be used to support the Iur interface.

9.2 UTRAN Iur Interface: Signalling Transport (TS 25.422)

3GPP TS 25.422 specifies the signalling bearers for the RNSAP for Iur Interface.

9.3 UTRAN Iur Interface: RNSAP Specification (TS 25.423)

3GPP TS 25.423 specifies the RNSAP protocol for radio network control plane signalling over the Iur interface.

9.4 UTRAN Iur Interface: Data Transport and Transport Signalling for Common Transport Channel Data Streams (TS 25.424)

3GPP TS 25.424 specifies the transport bearers for the user plane of the Iur interface. It also specifies the ALCAP protocol used to control these transport bearers.

9.5 UTRAN Iur Interface: User Plane Protocols for Common Transport Channel Data Streams (TS 25.425)

3GPP TS 25.425 specifies the user plane frame handling protocol for the common channels on Iur interface.

9.6 UTRAN Iur & Iub Interface: Data Transport and Transport Signalling for DCH Data Streams (TS 25.426)

3GPP TS 25.426 specifies the transport bearers for the user plane of the Iub/Iur interface. It also specifies the ALCAP protocol used to control these transport bearers.

9.7 UTRAN Iur & Iub Interface: User Plane Protocols for DCH Data Streams (TS 25.427)

3GPP TS 25.427 specifies the user plane frame handling protocol for the dedicated channels on Iub/Iur interface.

9.8 Summary of UTRAN Iur Interface Technical Specifications

The relationship between the technical specifications that define the UTRAN Iur interface is shown in Figure 5.

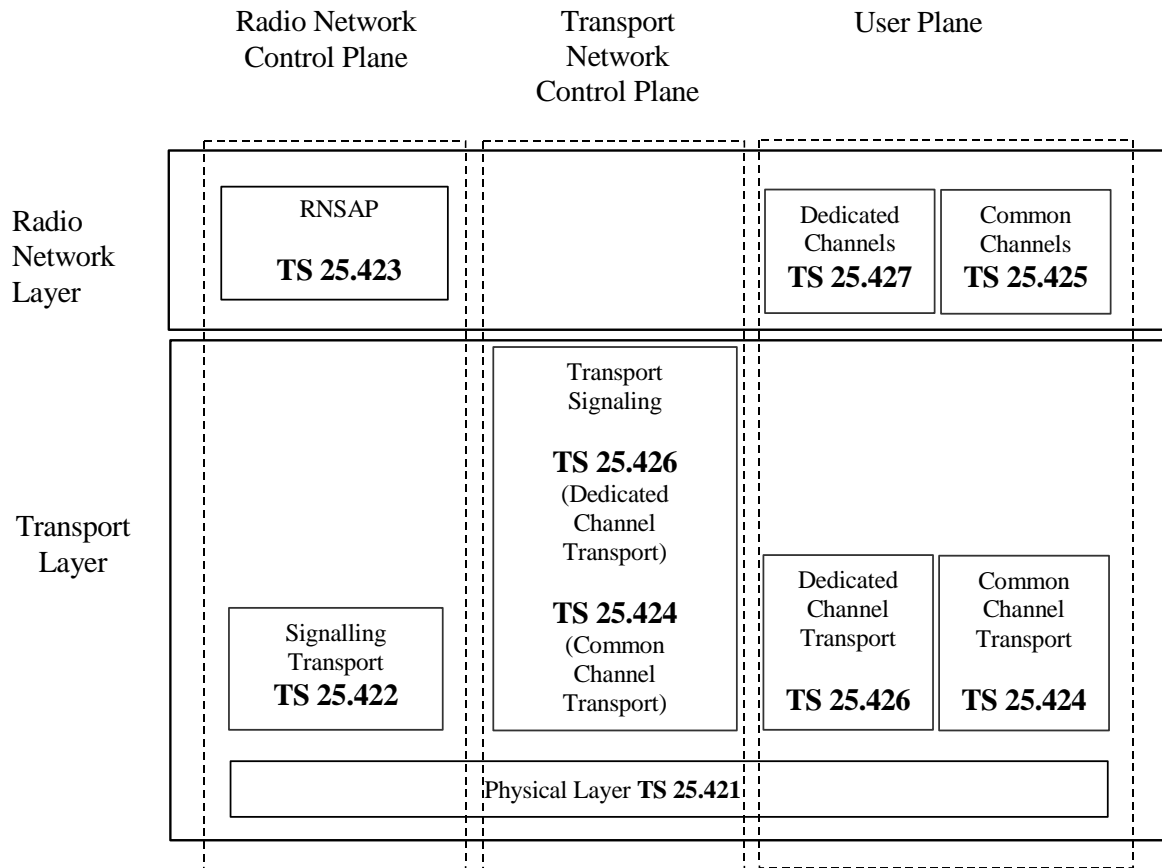

Figure 5: Iur Interface Technical Specifications

Annex A (informative): Change history

Change history					
TSG RAN#	Version	CR	Tdoc RAN	New Version	Subject/Comment
RAN_06	-	-	RP-99796	3.0.0	Approved at TSG RAN #6 and placed under Change Control
RAN_07	3.0.0	-	RP-000097	3.1.0	Approved at TSG RAN #7 (6 approved CRs)
RAN_09	3.1.0	008	RP-000378	3.2.0	Approved at TSG RAN #9
RAN_11	3.2.0	009	RP-010115	3.3.0	Approved at TSG RAN #11

Change history							
Date	TSG #	TSG Doc.	CR	Rev	Subject/Comment	Old	New
March 01	11	RP-010160	012		Approved at TSG RAN #11 and placed under Change Control	-	4.0.0
March 01	11	RP-010162	011		Approved at TSG RAN #11 and placed under Change Control	-	4.0.0
March 01	11	RP-010163	010		Approved at TSG RAN #11 and placed under Change Control	-	4.0.0
March 01	11	RP-010159	014		Approved at TSG RAN #11 and placed under Change Control	-	4.0.0
12/2001	14	RP-010853	016		Reference corrections	4.0.0	4.1.0
12/2001	14	RP-010853	018		25.420 v4.0.0 CR Clarification of the Combining/Splitting function	4.0.0	4.1.0
12/2001	14	RP-010853	020	1	Addition of "Specification Notations" Section	4.0.0	4.1.0
12/2001	14	RP-010853	022	2	Behaviour of the RNC in case of Iur transmission failure	4.0.0	4.1.0
03/2002	15	RP-020168	026	1	SCCP Connection Release Initiated by RNC in Abnormal case	4.1.0	4.2.0

History

Document history		
V4.0.0	March 2001	Publication
V4.1.0	December 2001	Publication
V4.2.0	March 2002	Publication