

ETSI TS 125 422 V11.0.0 (2012-10)



**Universal Mobile Telecommunications System (UMTS);
UTRAN Iur interface signalling transport
(3GPP TS 25.422 version 11.0.0 Release 11)**



Reference

RTS/TSGR-0325422vb00

Keywords

UMTS

ETSI

650 Route des Lucioles
F-06921 Sophia Antipolis Cedex - FRANCE

Tel.: +33 4 92 94 42 00 Fax: +33 4 93 65 47 16

Siret N° 348 623 562 00017 - NAF 742 C
Association à but non lucratif enregistrée à la
Sous-Préfecture de Grasse (06) N° 7803/88

Important notice

Individual copies of the present document can be downloaded from:

<http://www.etsi.org>

The present document may be made available in more than one electronic version or in print. In any case of existing or perceived difference in contents between such versions, the reference version is the Portable Document Format (PDF). In case of dispute, the reference shall be the printing on ETSI printers of the PDF version kept on a specific network drive within ETSI Secretariat.

Users of the present document should be aware that the document may be subject to revision or change of status. Information on the current status of this and other ETSI documents is available at

<http://portal.etsi.org/tb/status/status.asp>

If you find errors in the present document, please send your comment to one of the following services:

http://portal.etsi.org/chaicor/ETSI_support.asp

Copyright Notification

No part may be reproduced except as authorized by written permission.
The copyright and the foregoing restriction extend to reproduction in all media.

© European Telecommunications Standards Institute 2012.
All rights reserved.

DECT™, PLUGTESTS™, UMTS™ and the ETSI logo are Trade Marks of ETSI registered for the benefit of its Members.
3GPP™ and LTE™ are Trade Marks of ETSI registered for the benefit of its Members and
of the 3GPP Organizational Partners.
GSM® and the GSM logo are Trade Marks registered and owned by the GSM Association.

Intellectual Property Rights

IPRs essential or potentially essential to the present document may have been declared to ETSI. The information pertaining to these essential IPRs, if any, is publicly available for **ETSI members and non-members**, and can be found in ETSI SR 000 314: *"Intellectual Property Rights (IPRs); Essential, or potentially Essential, IPRs notified to ETSI in respect of ETSI standards"*, which is available from the ETSI Secretariat. Latest updates are available on the ETSI Web server (<http://ipr.etsi.org>).

Pursuant to the ETSI IPR Policy, no investigation, including IPR searches, has been carried out by ETSI. No guarantee can be given as to the existence of other IPRs not referenced in ETSI SR 000 314 (or the updates on the ETSI Web server) which are, or may be, or may become, essential to the present document.

Foreword

This Technical Specification (TS) has been produced by ETSI 3rd Generation Partnership Project (3GPP).

The present document may refer to technical specifications or reports using their 3GPP identities, UMTS identities or GSM identities. These should be interpreted as being references to the corresponding ETSI deliverables.

The cross reference between GSM, UMTS, 3GPP and ETSI identities can be found under <http://webapp.etsi.org/key/queryform.asp>.

Contents

Intellectual Property Rights	2
Foreword.....	2
Foreword.....	4
1 Scope	5
2 References	5
3 Abbreviations	6
4 Data Link Layer	7
4.1 ATM Transport Option	7
4.2 IP Transport Option.....	7
5 RNSAP Signalling Bearer	7
5.1 Introduction	7
5.2 Signalling Bearer.....	8
5.2.1 ATM Option 1	8
5.2.2 ATM Option 2	8
5.2.3 IP Transport Option	9
5.3 Services Provided by the Signalling Bearer	9
Annex A (informative): Change history	10
History	11

Foreword

This Technical Specification (TS) has been produced by the 3rd Generation Partnership Project (3GPP).

The contents of the present document are subject to continuing work within the TSG and may change following formal TSG approval. Should the TSG modify the contents of the present document, it will be re-released by the TSG with an identifying change of release date and an increase in version number as follows:

Version x.y.z

where:

- x the first digit:
 - 1 presented to TSG for information;
 - 2 presented to TSG for approval;
 - 3 or greater indicates TSG approved document under change control.
- y the second digit is incremented for all changes of substance, i.e. technical enhancements, corrections, updates, etc.
- z the third digit is incremented when editorial only changes have been incorporated in the document.

1 Scope

The present document specifies the standards for Signalling Transport to be used across Iur Interface. Iur Interface is a logical interface between the two RNC of the UMTS Terrestrial Radio Access Network (UTRAN) for the UMTS system. The present document describes how the RNSAP signalling messages are transported between the two RNCs.

2 References

The following documents contain provisions which, through reference in this text, constitute provisions of the present document.

- References are either specific (identified by date of publication, edition number, version number, etc.) or non-specific.
- For a specific reference, subsequent revisions do not apply.
- For a non-specific reference, the latest version applies. In the case of a reference to a 3GPP document (including a GSM document), a non-specific reference implicitly refers to the latest version of that document *in the same Release as the present document*.

- [1] ITU-T Recommendation Q.2100 (1994-07): "B-ISDN Signalling ATM Adaptation Layer (SAAL) - Overview description".
- [2] ITU-T Recommendation Q.2110 (1994-07): "B-ISDN ATM adaptation layer - Service Specific Connection Oriented Protocol (SSCOP)".
- [3] ITU-T Recommendation Q.2140 (1995-02): "B-ISDN ATM adaptation layer - Service Specific Co-ordination Function for signalling at the Network Node Interface (SSCF AT NNI)".
- [4] ITU-T Recommendation Q.2210 (1996-07): "Message transfer part level 3 functions and messages using the services of ITU-T Recommendation Q.2140".
- [5] ITU-T Recommendation I.361 (1995-11): "B-ISDN ATM layer specification".
- [6] ITU-T Recommendation I.363.5 (1996-08): "B-ISDN ATM Adaptation Layer specification: Type 5 AAL".
- [7] ITU-T Recommendation Q.711 (1996-07): "Functional description of the signalling connection control part".
- [8] ITU-T Recommendation Q.712 (1996-07): "Definition and function of Signalling connection control part messages".
- [9] ITU-T Recommendation Q.713 (1996-07): Signalling connection control part formats and codes.
- [10] ITU-T Recommendation Q.714 (1996-07): "Signalling connection control part procedures".
- [11] ITU-T Recommendation Q.715 (1996-07): "Signalling connection control part user guide".
- [12] ITU-T Recommendation Q.716 (1993-03): "Signalling System No. 7 - Signalling Connection Control Part (SCCP) performance".
- [13] IETF RFC 791 (September 1981): "Internet Protocol".
- [14] IETF RFC 1483 (July 1993): "Multi protocol Encapsulation over ATM Adaptation Layer 5".
- [15] IETF RFC 2225 (April 1998): "Classical IP and ARP over ATM".
- [16] IETF RFC 2960 (October 2000): "Stream Control Transmission Protocol".
- [17] IETF RFC 3332(2002-09): "Signalling System 7 (SS7) Message Transfer Part 3 (MTP3) – User Adaptation Layer (M3UA)"

- [18] IETF STD 51, RFC 1661 (1994-07): "The Point-To-Point Protocol (PPP)".
- [19] IETF STD 51, RFC 1662 (1994-07): "PPP in HDLC-like Framing".
- [20] IETF RFC 2507 (1999-02): "IP header compression".
- [21] IETF RFC 1990 (1996-08): "The PPP Multilink Protocol (MP)".
- [22] IETF RFC 2686 (1999-09): "The Multi-Class Extension to Multi-Link PPP".
- [23] IETF RFC 2509 (1999-02): "IP Header Compression over PPP".
- [24] IETF RFC 2460 (1998-12): "Internet Protocol, Version 6 (Ipv6) Specification".
- [25] IETF RFC 2474 (1998-12): "Definition of the Differentiated Services Field (DS Field) in the IPv4 and IPv6 Headers".
- [26] Void [27] IETF RFC 3153 (2001-08): "PPP Multiplexing".
- [28] IETF RFC 2364 (1998-07): "PPP over AAL5".
- [29] IETF RFC 3031 (2001-01): "Multiprotocol Label Switching Architecture".
- [30] IETF RFC 3309 (2002-09): "SCTP Checksum Change".
- [31] ANSI T1.111-2001: "Signalling System Number 7 (SS7) - Message Transfer Part (MTP)".
- [32] ANSI T1.112-2001: "Signaling System Number 7 (SS7) -- Signaling Connection Control Part (SCCP)".
- [33] ANSI T1.645-1995 (R2003): "B-ISDN Signaling ATM Adaptation Layer - Service Specific Coordination Function for Support of Signaling at the Network Node Interface (SSCF at the NNI)".

3 Abbreviations

For the purposes of the present document, the following abbreviations apply:

AAL	ATM Adaptation Layer
AAL2	ATM Adaptation Layer 2
AAL5	ATM Adaptation Layer 5
ATM	Asynchronous Transfer Mode
DiffServ	Differentiated Services
HDLC	High level Data Link Control
IP	Internet Protocol
IPv4	Internet Protocol, version 4
IPv6	Internet Protocol, version 6
M3UA	SS7 MTP3 User Adaptation layer
ML/MC-PPP	Muti-Link/Multi-Class PPP
MPLS	Multiprotocol Label Switching
MTP3-B	Message Transfer Part level 3 for Q.2140
PLMN	Public Land Mobile Network
PPP	Point-to-Point protocol
PPPMux	PPP Multiplexing
QoS	Quality of Service
RNC	Radio Network Controller
RNSAP	Radio Network Subsystem Application Part
SAAL-NNI	Signalling ATM Adaptation Layer - Network Node Interface
SCCP	Signalling Connection Control Part
SCTP	Stream Control Transmission Protocol
SSCF	Service Specific Co-ordination Function
SSCOP	Service Specific Connection Oriented Protocol
UE	User Equipment

4 Data Link Layer

4.1 ATM Transport Option

ATM shall be used in the radio network control plane according to ITU-T Rec. I.361 [5]. The structure of the cell header used in the UTRAN Iur interface is the cell header format and encoding at NNI (see figure 3 of ITU-T Rec. I.361 [5]).

4.2 IP Transport Option

A UTRAN Node supporting IP transport option shall support PPP protocol with HDLC framing IETF RFC 1661 [18], IETF RFC 1662 [19].

Note: This does not preclude the single implementation and use of any other data link layer protocols (e.g. PPPMux/AAL5/ATM (IETF RFC 3153 [27], IETF RFC 2364 [28]), PPP/AAL2/ATM, Ethernet, MPLS/ATM (IETF RFC 3031 [29]), etc.) fulfilling the UTRAN requirements toward the upper layers.

An RNC using IP transport option having interfaces connected via slow bandwidth PPP links like E1/T1/J1 shall also support IP Header Compression IETF RFC 2507 [20] and the PPP extensions ML/MC-PPP IETF RFC 1990 [21], IETF RFC 2686 [22]. In this case, negotiation of header compression IETF RFC 2507 [20] over PPP shall be performed via IETF RFC 2509 [23].

5 RNSAP Signalling Bearer

5.1 Introduction

This subclause specifies the Signalling Bearer protocol stack that supports the RNSAP signalling protocol.

The following requirements on the RNSAP signalling bearer can be stated:

- provide reliable transfer of control plane signalling messages in both connectionless mode and connection-oriented mode;
- provide separate independent connections for distinguishing transactions with individual UEs;
- supervise the "UE connections" and provide connection status information to the Upper Layers for individual UEs;
- provide networking and routing functions;
- provide redundancy in the signalling network;
- provide load sharing.

5.2 Signalling Bearer

This subclause refers to specifications of the Signalling Bearer for the Radio Network Layer protocols. As shown in figure 1, the standard allows operators to choose one out of three protocol suites for transport of SCCP messages.

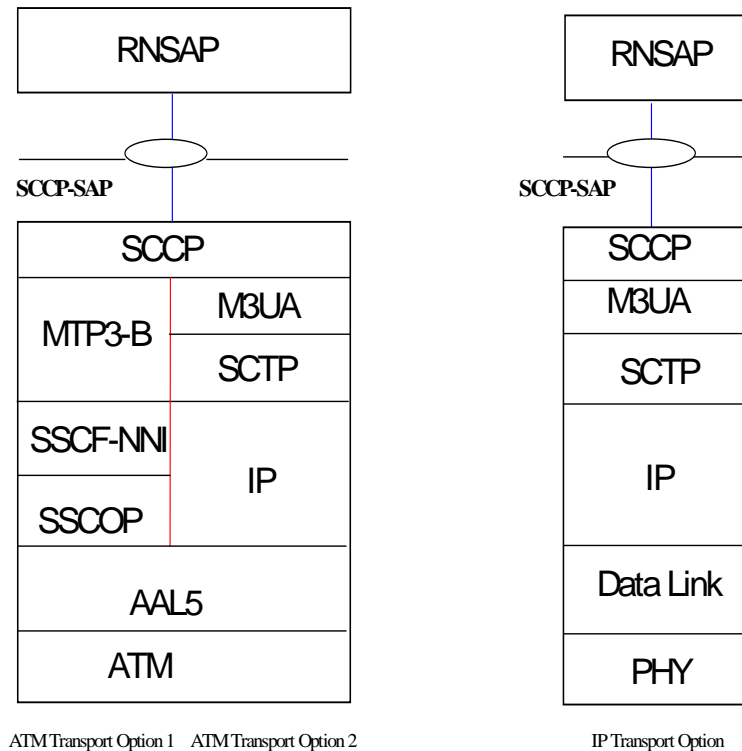

Figure 1: Signalling bearer for RNSAP

5.2.1 ATM Option 1

1. **SCCP** ITU-T Rec. Q.711 [7] /ITU-T Rec. Q.712 [8]/ ITU-T Rec. Q.713 [9]/ ITU-T Rec. Q.714 [10]/ ITU-T Rec. Q.715 [11]/ ITU-T Rec. Q.716[12] or ANSI T1.112-2001 [32] provides connectionless service, class 0, connection oriented service, class 2, separation of the connections mobile by mobile basis on the connection oriented link and establishment of a connection oriented link mobile by mobile basis.
2. **MTP3-B** ITU-T Rec. Q.2210 [4] or ANSI T1.111-2001 [31] provides message routing, discrimination and distribution (for point-to-point link only), signalling link management load sharing and changeover/back between link within one link-set. The need for multiple link-sets is precluded.
3. **SAAL-NNI** ITU-T Rec. Q.2100 [1] consists of the following sub-layers: - **SSCF** ITU-T Rec. Q.2140 [3] or ANSI T1.645-1995 [33], - **SSCOP** ITU-T Rec. Q.2110 [2] and - **AAL5** ITU-T Rec. I.363.5 [6]. The SSCF maps the requirements of the layer above to the requirements of SSCOP. Also SAAL connection management, link status and remote processor status mechanisms are provided. SSCOP provides mechanisms for the establishment and release of connections and the reliable exchange of signalling information between signalling entities. Adapts the upper layer protocol to the requirements of the Lower ATM cells.
4. **ATM** ITU-T Rec. I.361 [5].

5.2.2 ATM Option 2

1. **SCCP**. See subclause 5.2.1
2. **M3UA** refers to the SCCP adaptation layer "SS7 MTP3 - User Adaptation Layer" IETF RFC 3332 [17] also developed by the Sigtran working group of the IETF. An RNC equipped with the M3UA stack option shall

support both the client and the server functionality towards another RNC. This enables the RNC to report to another RNC when it is a newly introduced entity in the network.

3. **SCTP** refers to the Stream Control Transmission Protocol IETF RFC 2960 [16] developed by the Sigtran working group of the IETF for the purposes of transporting various signalling protocols over IP networks. The checksum method specified in RFC 3309 IETF RFC 3309 [30] shall be used instead of the method specified in IETF RFC 2960 [16].
4. **IP** IETF RFC 791 [13] over ATM is defined in IETF RFC 1483 [14] and IETF RFC 2225 [15].
5. **ATM** ITU-T Rec. I.361 [5].

5.2.3 IP Transport Option

1. **SCCP**. See subclause 5.2.1.
2. **M3UA**: See subclause 5.2.2.
3. **SCTP**. See subclause 5.2.2. In addition, Multi-homing is a way to achieve redundancy with SCTP between two endpoints, of which one or both is assigned with multiple IP addresses. SCTP endpoints shall support a multi-homed remote SCTP endpoint.
4. **IP**. An IP UTRAN Node shall support IPv6 IETF RFC 2460 [24]. The support of IPv4 IETF RFC 791 [13] is optional.

NOTE: This does not preclude single implementation of IPv4.

IP dual stack support is recommended for the potential transition period from IPv4 to IPv6 in the transport network

IP Differentiated Services code point marking IETF RFC 2474 [25] shall be supported. The Diffserv code point may be determined from the application parameters.

5. Data link layer is as specified in chapter 4.2.

5.3 Services Provided by the Signalling Bearer

When considering the requirements that the upper layers, i.e. RNSAP, have on the Signalling Bearer, there are a number of services it has to provide and a number of functions to perform. These numbers of services that the signalling bearer shall provide, to the upper layers, are stated in the references ITU-T Rec. Q.711 [7] /ITU-T Rec. Q.712 [8]/ ITU-T Rec. Q.713 [9]/ ITU-T Rec. Q.714 [10]/ ITU-T Rec. Q.715 [11]/ ITU-T Rec. Q.716 [12] or ANSI T1.112-2001 [32].

Annex A (informative): Change history

Date	TSG #	TSG Doc.	CR	Rev	Subject/Comment	New
12/2008	-	-	-	-	Creation of Rel-8 version based on v7.1.0	8.0.0
12/2009	-	-	-	-	Creation of Rel-9 version based on v8.0.0	9.0.0
03/2011	SP-49	SP-100629			Clarification on the use of References (TS 21.801 CR#0030)	9.0.1
03/2011					Creation of Rel-10 version based on v9.0.1	10.0.0
06/2011	52	RP-110684	0024	-	Correction of references.	10.1.0
09/2012					Update to Rel-11 version (MCC)	11.0.0

History

Document history		
V11.0.0	October 2012	Publication