

# ETSI TS 125 430 V16.0.0 (2020-08)



## **Universal Mobile Telecommunications System (UMTS); UTRAN Iub Interface: general aspects and principles (3GPP TS 25.430 version 16.0.0 Release 16)**



---

**Reference**

RTS/TSGR-0325430vg00

---

**Keywords**

UMTS

**ETSI**

650 Route des Lucioles  
F-06921 Sophia Antipolis Cedex - FRANCE

---

Tel.: +33 4 92 94 42 00 Fax: +33 4 93 65 47 16

Siret N° 348 623 562 00017 - NAF 742 C  
Association à but non lucratif enregistrée à la  
Sous-Préfecture de Grasse (06) N° 7803/88

---

**Important notice**

---

The present document can be downloaded from:

<http://www.etsi.org/standards-search>

The present document may be made available in electronic versions and/or in print. The content of any electronic and/or print versions of the present document shall not be modified without the prior written authorization of ETSI. In case of any existing or perceived difference in contents between such versions and/or in print, the prevailing version of an ETSI deliverable is the one made publicly available in PDF format at [www.etsi.org/deliver](http://www.etsi.org/deliver).

Users of the present document should be aware that the document may be subject to revision or change of status.

Information on the current status of this and other ETSI documents is available at

<https://portal.etsi.org/TB/ETSIDeliverableStatus.aspx>

If you find errors in the present document, please send your comment to one of the following services:

<https://portal.etsi.org/People/CommitteeSupportStaff.aspx>

---

**Copyright Notification**

---

No part may be reproduced or utilized in any form or by any means, electronic or mechanical, including photocopying and microfilm except as authorized by written permission of ETSI.

The content of the PDF version shall not be modified without the written authorization of ETSI.

The copyright and the foregoing restriction extend to reproduction in all media.

© ETSI 2020.

All rights reserved.

**DECT™**, **PLUGTESTS™**, **UMTS™** and the ETSI logo are trademarks of ETSI registered for the benefit of its Members.

**3GPP™** and **LTE™** are trademarks of ETSI registered for the benefit of its Members and of the 3GPP Organizational Partners.

**oneM2M™** logo is a trademark of ETSI registered for the benefit of its Members and of the oneM2M Partners.

**GSM®** and the GSM logo are trademarks registered and owned by the GSM Association.

---

## Intellectual Property Rights

### Essential patents

IPRs essential or potentially essential to normative deliverables may have been declared to ETSI. The information pertaining to these essential IPRs, if any, is publicly available for **ETSI members and non-members**, and can be found in ETSI SR 000 314: "*Intellectual Property Rights (IPRs); Essential, or potentially Essential, IPRs notified to ETSI in respect of ETSI standards*", which is available from the ETSI Secretariat. Latest updates are available on the ETSI Web server (<https://ipr.etsi.org/>).

Pursuant to the ETSI IPR Policy, no investigation, including IPR searches, has been carried out by ETSI. No guarantee can be given as to the existence of other IPRs not referenced in ETSI SR 000 314 (or the updates on the ETSI Web server) which are, or may be, or may become, essential to the present document.

### Trademarks

The present document may include trademarks and/or tradenames which are asserted and/or registered by their owners. ETSI claims no ownership of these except for any which are indicated as being the property of ETSI, and conveys no right to use or reproduce any trademark and/or tradename. Mention of those trademarks in the present document does not constitute an endorsement by ETSI of products, services or organizations associated with those trademarks.

---

## Legal Notice

This Technical Specification (TS) has been produced by ETSI 3rd Generation Partnership Project (3GPP).

The present document may refer to technical specifications or reports using their 3GPP identities. These shall be interpreted as being references to the corresponding ETSI deliverables.

The cross reference between 3GPP and ETSI identities can be found under <http://webapp.etsi.org/key/queryform.asp>.

---

## Modal verbs terminology

In the present document "**shall**", "**shall not**", "**should**", "**should not**", "**may**", "**need not**", "**will**", "**will not**", "**can**" and "**cannot**" are to be interpreted as described in clause 3.2 of the [ETSI Drafting Rules](#) (Verbal forms for the expression of provisions).

"**must**" and "**must not**" are **NOT** allowed in ETSI deliverables except when used in direct citation.

# Contents

Intellectual Property Rights .....	2
Legal Notice .....	2
Modal verbs terminology.....	2
Foreword.....	5
1 Scope .....	6
2 References .....	6
3 Definitions and abbreviations.....	6
3.1 Definitions .....	6
3.2 Abbreviations .....	7
3.3 Specification Notations .....	8
4 General Aspects.....	9
4.1 Introduction .....	9
4.2 Iub Interface General Principles .....	9
4.3 Iub Interface Specification Objectives .....	9
4.4 Iub Interface Capabilities .....	9
4.4.1 Radio application related signalling.....	9
4.4.2 Iub/Iur DCH data stream.....	10
4.4.3 Iub RACH data stream.....	10
4.4.4 Iub CPCH data stream [FDD].....	10
4.4.5 Iub FACH data stream .....	10
4.4.6 Iub DSCH data stream [TDD] .....	10
4.4.7 Iub USCH data stream [TDD] .....	10
4.4.8 Iub PCH data stream .....	10
4.4.9 Iub FDD TFCI2 data stream .....	10
4.4.10 Iub HS-DSCH data stream.....	11
4.4.11 Iub E-DCH data stream.....	11
4.5 Iub Interface Characteristics.....	11
4.5.1 Mapping of Iub data streams.....	11
4.6 Iub Protocols .....	11
5 Functions of the I <sub>ub</sub> Interface Protocols.....	12
5.1 Iub Functions.....	12
5.2 Functional split over Iub.....	13
5.2.1 Management of Iub Transport Resources .....	13
5.2.2 Logical O&M of Node B .....	13
5.2.2.1 Handling of Node B Hardware Resources .....	13
5.2.3 Implementation Specific O&M Transport .....	13
5.2.4 System Information Management.....	13
5.2.5 Traffic management of Common Channels .....	14
5.2.6 Traffic management of Dedicated Channels.....	14
5.2.6.1 Combining/Splitting and Control .....	14
5.2.6.2 Handover Decision.....	14
5.2.6.3 Allocation of Physical Channel Resources .....	14
5.2.6.4 UpLink Power Control.....	14
5.2.6.5 Down-Link Power Control.....	15
5.2.6.6 Admission Control .....	15
5.2.6.7 Power and Interference Reporting.....	15
5.2.7 Traffic management of Shared Channels [TDD].....	15
5.2.7A Traffic management of High Speed Shared Channels .....	15
5.2.8 Timing and Synchronization Management .....	15
6 Node B logical Model over Iub.....	15
6.1 Overview .....	15
6.2 Elements of the logical model .....	16

6.2.1	Node B Communication Contexts for Dedicated and Shared Channels .....	16
6.2.2	Common Transport Channels .....	17
6.2.3	Transport network logical resources .....	17
6.2.3.1	Node B Control Port.....	17
6.2.3.2	Communication Control Port .....	17
6.2.3.3	Traffic Termination Point .....	17
6.2.3.4	Iub DCH Data Port.....	18
6.2.3.5	Iub RACH Data Port .....	18
6.2.3.6	Iub CPCH Data Port [FDD] .....	18
6.2.3.7	Iub FACH Data Port.....	18
6.2.3.8	Iub DSCH Data Port [TDD].....	18
6.2.3.8A	Iub HS-DSCH Data Port .....	18
6.2.3.9	Iub USCH Data Port [TDD].....	18
6.2.3.10	Iub PCH Data Port .....	18
6.2.3.11	Iub FDD TFCI2 Data Port.....	18
6.2.3.12	Iub E-DCH Data Port.....	18
6.2.4	Radio Network Logical resources.....	19
6.2.4.1	Common Resources .....	19
6.2.4.2	Cell .....	19
6.2.4.3	Common Physical Channels and Common Transport Channels.....	21
6.2.4.4	Physical Shared Channels .....	22
7	Iub Interface Protocol Structure .....	23
8	Other Iub Interface Specifications.....	23
8.1	UTRAN Iub Interface: Layer 1 (TSG RAN 25.431).....	23
8.2	UTRAN Iub Interface: Signalling Transport (TSG RAN 25.432) .....	23
8.3	NBAP Specification (TSG RAN 25.433).....	24
8.4	UTRAN Iub Interface: Data Transport & Transport Signalling for Common Transport Channel Data Streams (TSG RAN 25.434).....	24
8.5	UTRAN Iub Interface: User Plane Protocols for Common Transport Channel Data Streams (TSG RAN 25.435).....	24
8.6	UTRAN Iur/Iub Interface: Data Transport & Transport Signalling for DCH Data Streams (TSG RAN 25.426) .....	24
8.7	UTRAN Iur/Iub Interface: User Plane Protocol for DCH Data Streams (TSG RAN 25.427) .....	24
8.8	Summary of UTRAN Iub Interface Technical Specifications .....	25
<b>Annex A (informative): Change history .....</b>		<b>26</b>
History .....		27

---

# Foreword

This Technical Specification (TS) has been produced by the 3<sup>rd</sup> Generation Partnership Project (3GPP).

The contents of the present document are subject to continuing work within the TSG and may change following formal TSG approval. Should the TSG modify the contents of the present document, it will be re-released by the TSG with an identifying change of release date and an increase in version number as follows:

Version x.y.z

where:

- x the first digit:
  - 1 presented to TSG for information;
  - 2 presented to TSG for approval;
  - 3 or greater indicates TSG approved document under change control.
- y the second digit is incremented for all changes of substance, i.e. technical enhancements, corrections, updates, etc.
- z the third digit is incremented when editorial only changes have been incorporated in the document.

---

# 1 Scope

The present document is an introduction to the TSG RAN TS 25.43x series of UMTS Technical Specifications that define the Iub Interface. The Iub interface is a logical interface for the interconnection of Node B and Radio Network Controller (RNC) components of the UMTS Terrestrial Radio Access Network (UTRAN) for the UMTS system.

---

# 2 References

The following documents contain provisions which, through reference in this text, constitute provisions of the present document.

- References are either specific (identified by date of publication, edition number, version number, etc.) or non-specific.
- For a specific reference, subsequent revisions do not apply.
- For a non-specific reference, the latest version applies. In the case of a reference to a 3GPP document (including a GSM document), a non-specific reference implicitly refers to the latest version of that document *in the same Release as the present document*.

- [1] 3GPP TS 25.401: "UTRAN overall description".
- [2] 3GPP TS 25.442: "UTRAN implementation-specific O&M transport".
- [3] 3GPP TS 25.432: "UTRAN Iub interface: signalling transport".
- [4] 3GPP TS 25.302: "Services provided by the physical layer".
- [5] 3GPP TS 25.431: "UTRAN Iub interface layer 1".
- [6] Void
- [7] 3GPP TS 25.433: "UTRAN Iub interface Node B Application Part (NBAP) signalling".
- [8] 3GPP TS 25.434: "UTRAN Iub Interface Data Transport and Transport Signalling for Common Transport Channel Data Streams".
- [9] 3GPP TS 25.435: "UTRAN Iub Interface user plane protocols for Common Transport Channel data streams".
- [10] 3GPP TS 25.426: "UTRAN Iur and Iub Interface data transport & transport signalling for DCH data streams".
- [11] 3GPP TS 25.427: "UTRAN Iur/Iub Interface user plane protocol for DCH data streams".
- [12] 3GPP TS 25.402: "Synchronization in UTRAN Stage 2".
- [13] ITU-T Recommendation Q.2630.2 (1999-12): "AAL type 2 Signalling Protocol (Capability Set 2)".
- [14] 3GPP TS 25.319: "Enhanced Uplink; Overall description; Stage 2".

---

# 3 Definitions and abbreviations

## 3.1 Definitions

For the purposes of the present document, the following terms and definitions apply:

**Propagation delay (PD):** it is the round trip propagation delay of the radio signal from the Node B to the UE and back to the BS in one chip resolution.

**Timing Advance (TA):** it is the amount of time, expressed in number of chips, by which the transmission of an uplink burst is anticipated by the UE in order to be received by the cell inside the corresponding time slot.

## 3.2 Abbreviations

For the purposes of the present document, the following abbreviations apply:

AAL2	ATM Adaptation Layer type 2
AAL5	ATM Adaptation Layer type 5
AICH	Acquisition Indication Channel
ALCAP	Access Link Control Application Part
ATM	Asynchronous Transfer Mode
BCH	Broadcast Channel
BCCH	Broadcast Control Channel
CCH	Control Channel
CPCId	Common Physical Channel Identifier
CPICH	Common Pilot Channel
CTCId	Common Transport Channel Identifier
CRNC	Controlling Radio Network Controller
DCH	Dedicated Transport Channel
DPCCH	Dedicated Physical Control Channel
DPCH	Dedicated Physical Channel
DSCH	Down-link Shared Channel
E-DCH	Enhanced Dedicated Channel
FACH	Forward Access Channel
FAUSCH	Fast Up-link Signalling Channel
FDD	Frequency Division Duplex
F-DPCH	Fractional DPCH
HARQ	Hybrid Automatic Repeat Request
HS-DSCH	High Speed Downlink Shared Channel
IP	Internet Protocol
MICH	MBMS notification Indicator Channel
NBAP	Node B Application Part
O&M	Operation and Maintenance
PICH	Page Indication Channel
PCCH	Paging Control Channel
PCCPCH	Primary Common Control Physical Channel
PCPICH	Primary Common Pilot Channel
PCH	Paging Channel
PDSCH	Physical Downlink Shared Channel
PLCCH	Physical Layer Common Control Channel
PRACH	Physical Random Access Channel
PUSCH	Physical Uplink Shared Channel
RACH	Random Access Channel
RNC	Radio Network Controller
RNS	Radio Network Subsystem
SCH	Synchronization Channel
SCCPCH	Secondary Common Control Physical Channel
SCPICH	Secondary Common Pilot Channel
SCTP	Stream Control Transmission Protocol
SRNC	Serving Radio Network Controller
SSCF-UNI	Service Specific Co-ordination Function - User Network Interface
SSCOP	Service Specific Connection Oriented Protocol
TDD	Time Division Duplex
UE	User Equipment
UC-ID	UTRAN Cell Identifier
UDP	User Datagram Protocol
UMTS	Universal Mobile Telecommunication System
USCH	Up-link Shared Channel
UTRAN	UMTS Terrestrial Radio Access Network



### 3.3 Specification Notations

For the purposes of the present document, the following notations apply:

- [FDD] This tagging of a word indicates that the word preceding the tag "[FDD]" applies only to FDD. This tagging of a heading indicates that the heading preceding the tag "[FDD]" and the section following the heading applies only to FDD.
- [TDD] This tagging of a word indicates that the word preceding the tag "[TDD]" applies only to TDD, including 7.68 Mcps TDD, 3.84Mcps TDD and 1.28Mcps TDD. This tagging of a heading indicates that the heading preceding the tag "[TDD]" and the section following the heading applies only to TDD, including 7.68 Mcps TDD, 3.84Mcps TDD and 1.28Mcps TDD.
- [7.68Mcps TDD] This tagging of a word indicates that the word preceding the tag "[7.68Mcps TDD]" applies only to 7.68Mcps TDD. This tagging of a heading indicates that the heading preceding the tag "[7.68Mcps TDD]" and the section following the heading applies only to 7.68Mcps TDD.
- [3.84Mcps TDD] This tagging of a word indicates that the word preceding the tag "[3.84Mcps TDD]" applies only to 3.84Mcps TDD. This tagging of a heading indicates that the heading preceding the tag "[3.84Mcps TDD]" and the section following the heading applies only to 3.84Mcps TDD.
- [1.28Mcps TDD] This tagging of a word indicates that the word preceding the tag "[1.28Mcps TDD]" applies only to 1.28Mcps TDD. This tagging of a heading indicates that the heading preceding the tag "[1.28Mcps TDD]" and the section following the heading applies only to 1.28Mcps TDD.
- [FDD - ...] This tagging indicates that the enclosed text following the "[FDD - " applies only to FDD. Multiple sequential paragraphs applying only to FDD are enclosed separately to enable insertion of TDD specific (or common) paragraphs between the FDD specific paragraphs.
- [TDD - ...] This tagging indicates that the enclosed text following the "[TDD - " applies only to TDD, including 7.68 Mcps TDD, 3.84Mcps TDD and 1.28Mcps TDD. Multiple sequential paragraphs applying only to TDD are enclosed separately to enable insertion of FDD specific (or common) paragraphs between the TDD specific paragraphs.
- [7.68Mcps TDD - ...] This tagging indicates that the enclosed text following the "[7.68Mcps TDD - " applies only to 7.68Mcps TDD. Multiple sequential paragraphs applying only to 7.68Mcps TDD are enclosed separately to enable insertion of FDD and TDD specific (or common) paragraphs between the 7.68Mcps TDD specific paragraphs.
- [3.84Mcps TDD - ...] This tagging indicates that the enclosed text following the "[3.84Mcps TDD - " applies only to 3.84Mcps TDD. Multiple sequential paragraphs applying only to 1.28Mcps TDD are enclosed separately to enable insertion of FDD and TDD specific (or common) paragraphs between the 3.84Mcps TDD specific paragraphs.
- [1.28Mcps TDD - ...] This tagging indicates that the enclosed text following the "[1.28Mcps TDD - " applies only to 1.28Mcps TDD. Multiple sequential paragraphs applying only to 1.28Mcps TDD are enclosed separately to enable insertion of FDD and TDD specific (or common) paragraphs between the 1.28Mcps TDD specific paragraphs.
- Procedure When referring to a procedure in the specification the Procedure Name is written with the first letters in each word in upper case characters followed by the word "procedure", e.g. Radio Network Layer procedures.
- Message When referring to a message in the specification the MESSAGE NAME is written with all letters in upper case characters followed by the word "message", e.g. RADIO LINK SETUP REQUEST message.
- Frame When referring to a control or data frame in the specification the CONTROL/DATA FRAME NAME is written with all letters in upper case characters followed by the words "control/data frame", e.g. DCH transport frame.

---

## 4 General Aspects

### 4.1 Introduction

The logical interface between a RNC and a Node B is called the Iub interface.

### 4.2 Iub Interface General Principles

The general principles for the specification of the Iub interface are as follows:

- Transmission sharing between the GSM/GPRS Abis interface and the Iub interface shall not be precluded.
- The functional division between RNC and Node B shall have as few options as possible.
- Iub should be based on a logical model of Node B.
- Node B controls a number of cells and can be ordered to add/remove radio links in those cells.
- Neither the physical structure nor any internal protocols of the Node B shall be visible over Iub and are thus not limiting factors, e.g., when introducing future technology.
- Only the logical O&M (TS 25.401 [1]) of Node B is supported by the Iub.
- Complex functionality shall as far as possible be avoided over Iub. Advanced optimisation solutions may be added in later versions of the standard.
- The Iub functional split shall take into account the probability of frequent switching between different channel types.

### 4.3 Iub Interface Specification Objectives

The I<sub>ub</sub> interface specifications shall facilitate the following:

- Inter-connection of RNCs and Node Bs from different manufacturers.
- Separation of I<sub>ub</sub> interface Radio Network functionality and Transport Network functionality to facilitate introduction of future technology.

The Iub parts to be standardised are:

1. User data transport.
2. Signalling for handling the user data.
3. Node B Logical O&M (TS 25.401 [1]).

Note: It should be possible to transport the Implementation Specific O&M (TS 25.401 [1]) interface via the same transport bearer as the Iub interface and, hence, the lower layer transport mechanisms should be standardised to this effect. The application level content of the Implementation Specific O&M interface is out of scope of UTRAN standardization. Where the implementation specific O&M interface shares the same bearer as the Iub interface, the transport layers shall be as specified in TS 25.442 [2] and TS 25.432 [3] respectively.

### 4.4 Iub Interface Capabilities

#### 4.4.1 Radio application related signalling

The Iub interface allows the RNC and the Node B to negotiate about radio resources, for example to add and delete cells controlled by the Node B to support communication of the dedicated connection between UE and SRNC.

Information used to control the broadcast channel and information to be transported on the broadcast channel belongs to this category also. In addition, logical O&M (TS 25.401 [1]) between the Node B and RNC shall also be included in this category.

#### 4.4.2 Iub/Iur DCH data stream

The Iub interface provides the means for transport of uplink and downlink DCH transport frames between RNC and Node B. An Iub/Iur DCH data stream corresponds to the data carried on one DCH transport channel.

In the UTRAN, one DCH data stream always corresponds to a bi-directional transport channel. Although the TFS is configured separately for each DCH direction and a DCH could be configured with e.g. only a zero-bit transport format in one direction, the DCH is always treated as a bi-directional transport channel in the UTRAN. As a result, two uni-directional Uu DCH transport channels with opposite directions can be mapped to either one or two DCH transport channels in the UTRAN.

#### 4.4.3 Iub RACH data stream

The Iub interface provides the means for transport of uplink RACH transport frames between Node B and RNC. An Iub RACH data stream corresponds to the data carried on one RACH transport channel.

#### 4.4.4 Iub CPCH data stream [FDD]

Void.

#### 4.4.5 Iub FACH data stream

The Iub interface provides the means for transport of downlink FACH transport frames between RNC and Node B. An Iub FACH data stream corresponds to the data carried on one FACH transport channel.

#### 4.4.6 Iub DSCH data stream [TDD]

The Iub interface provides the means for transport of downlink shared channel, DSCH, data frames between RNC and Node B. An Iub DSCH data stream corresponds to the data carried on one DSCH transport channel for one UE. A UE may have multiple DSCH data streams.

#### 4.4.7 Iub USCH data stream [TDD]

The Iub interface provides the means for transport of uplink shared channel, USCH, data frames between Node B and RNC. An Iub USCH data stream corresponds to the data carried on one USCH transport channel for one UE. A UE may have multiple USCH data streams.

#### 4.4.8 Iub PCH data stream

The Iub interface provides the means for transport of PCH transport frames between RNC and Node B. An Iub PCH data stream corresponds to the data carried on one PCH transport channel.

#### 4.4.9 Iub FDD TFCI2 data stream

Void.

#### 4.4.10 Iub HS-DSCH data stream

The Iub interface provides the means for transport of high speed downlink shared channel, HS-DSCH, data frames between RNC and Node B. An Iub HS-DSCH data stream corresponds to the data carried on one MAC-d flow for one UE. A UE may have multiple HS-DSCH data streams.

#### 4.4.11 Iub E-DCH data stream

The Iub interface provides the means for transport of uplink E-DCH transport frames between Node B and RNC. An Iub E-DCH data stream corresponds to the data carried on one MAC-d flow for one UE. A UE may have multiple E-DCH data streams.

In addition, the interface provides the following:

- A means for the Node B to indicate the number of HARQ retransmissions to the SRNC (TS 25.427 [11]);
- A means to indicate to the SRNC, for the purposes of re-ordering, the CFN and Subframe Number that have been added by the Node B (TS 25.427 [11]).

### 4.5 Iub Interface Characteristics

#### 4.5.1 Mapping of Iub data streams

- |                     |   |
|---------------------|---|
| <b>DCH</b>          | One Iub DCH data stream is carried on one transport bearer. For each DCH data stream a transport bearer must be established over Iub, except in the case of coordinated DCHs in which case a set of coordinated DCHs are multiplexed onto the same transport bearer.  |
| <b>RACH</b>         | One Iub RACH data stream is carried on one transport bearer. For each RACH in a cell, a transport bearer must be established over the Iub interface.  |
| <b>FACH</b>         | One Iub FACH data stream is carried on one transport bearer. For each FACH in a cell, a transport bearer must be established over the Iub Interface, except in case of transport bearer sharing for MBMS, where only one transport bearer is established at the Iub interface for several FACHs belonging to different cells. |
| <b>[TDD - DSCH]</b> | One Iub DSCH data stream is carried on one transport bearer. For each DSCH data stream, a transport bearer must be established over the Iub interface.]   |
| <b>HS-DSCH</b>      | One Iub HS-DSCH data stream is carried on one transport bearer. For each HS-DSCH data stream, a transport bearer must be established over the Iub interface.  |
| <b>E-DCH</b>        | One Iub E-DCH data stream is carried on one transport bearer. For each E-DCH data stream, a transport bearer must be established over the Iub interface.]   |
| <b>[TDD - USCH]</b> | One Iub USCH data stream is carried on one transport bearer. For each USCH data stream, a transport bearer must be established over the Iub interface.]   |
| <b>PCH</b>          | One Iub PCH data stream is carried on one transport bearer.   |

### 4.6 Iub Protocols

There shall exist a clear separation between the radio network layer and the transport layer. Therefore, the radio network signalling and Iub data streams are separated from the data transport resource and traffic handling as shown in figure 1. This resource and traffic handling is controlled by the Transport Signalling. The Transport Signalling is carried by a Signalling Bearer over the Iub interface.

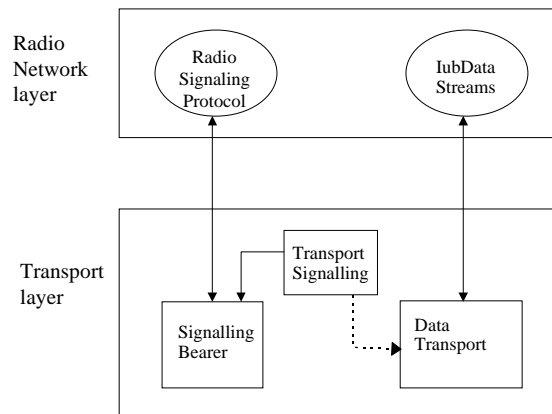

**Figure 1: Separation of Radio Network protocols and transport over Iub**

## 5 Functions of the I<sub>ub</sub> Interface Protocols

### 5.1 Iub Functions

The list of functions on the Iub interface is the following:

1. Management of Iub Transport Resources;
2. Logical O&M of Node B:
  - Iub Link Management;
  - Cell Configuration Management;
  - Radio Network Performance Measurements;
  - Resource Event Management;
  - Common Transport Channel Management;
  - Radio Resource Management;
  - Radio Network Configuration Alignment;
3. Implementation Specific O&M Transport;
4. System Information Management;
5. Traffic Management of Common Channels:
  - Admission Control;
  - Power Management;
  - Data Transfer;
6. Traffic Management of Dedicated Channels:
  - Radio Link Management;
  - Radio Link Supervision;
  - Channel Allocation / De-allocation;
  - Power Management;
  - Measurement Reporting;

- Dedicated Transport Channel Management;
  - Data Transfer;
7. Traffic Management of Shared Channels:
- Channel Allocation / De-allocation;
  - Power Management;
  - Transport Channel Management;
  - Dynamic Physical Channel Assignment;
  - Radio Link Management;
  - Data Transfer;
8. Timing and Synchronization Management:
- Transport Channel Synchronization (Frame synchronization);
  - Node B - RNC node Synchronization;
  - Inter Node B node Synchronization.

## 5.2 Functional split over Iub

### 5.2.1 Management of Iub Transport Resources

The underlying transport resources (AAL2 and UDP/IP transport bearers) shall be set up and controlled by the RNC. Further information on these functions is provided in the transport layer specifications (TS 25.432 [3], TS 25.434 [8], TS 25.426 [10]).

### 5.2.2 Logical O&M of Node B

Logical O&M is the signalling associated with the control of logical resources (channels, cells,...) owned by the RNC but physically implemented in the Node B. The RNC controls these logical resources. A number of O&M procedures physically implemented in Node B impact on the logical resources and therefore require an information exchange between RNC and Node B. All messages needed to support this information exchange are classified as Logical O&M forming an integral part of NBAP over the Iub interface.

#### 5.2.2.1 Handling of Node B Hardware Resources

Mapping of Node B logical resources onto Node B hardware resources, used for Iub data streams and radio interface transmission/reception, is performed by Node B.

### 5.2.3 Implementation Specific O&M Transport

The Iub interface may support the transport of Implementation specific O&M information. Further detail on this can be found in the UMTS technical specification on Implementation Specific O&M Transport (TS 25.442 [2]).

### 5.2.4 System Information Management

System Information is sent by the CRNC to a Node B. CRNC can also request the Node B to autonomously create and update certain Node B related system information. Scheduling of system broadcast information is carried out in the CRNC. Scheduling information is always sent by the CRNC to the Node B. The Node B is responsible for transmitting the received system information according to the scheduling parameters provided. If requested by the CRNC, the Node B is also responsible for autonomously creating and updating the Node B related system information according to the scheduling parameters provided.

## 5.2.5 Traffic management of Common Channels

The common channels need to be controlled from the RNC. This is typically the control of the RACH and FACH channels, the information that is broadcast on the Broadcast control channel, and the control and request for sending information on the paging channels.

## 5.2.6 Traffic management of Dedicated Channels

These functions are related to the activation of logical resources (e.g. Radio Links, Iub ports), and the connection of these various resources together.

[FDD - Some freedom may be left for Node B implementation on some functions like soft combining within Node B, since soft combining has merits for being executed as close as possible to the radio (both in terms of transmission cost and efficiency).]

### 5.2.6.1 Combining/Splitting and Control

Node B may perform combining/splitting of DCH data streams communicated via its cells. RNC performs combining/splitting of Iub data streams received from/sent to several Node B(s).

The UL combining of information streams may be performed using any suitable algorithm, for example:

- [FDD - based on maximum ratio algorithm (maximum ratio combining)];
- [FDD - based on quality information associated to each TBS (selection-combining)];
- [TDD - based on the presence/absence of the signal (selection)].

When requesting the addition of a new cell for a UE-UTRAN connection, the RNC can explicitly request to the Node B a new Iub data stream, in which case the combining and splitting function within the Node B is not used for that cell. Otherwise, the Node B takes the decision whether combining and splitting function is used inside the Node B for that cell i.e. whether a new Iub data stream shall be added or not.

The internal Node B handling of the combining/splitting of radio frames is controlled by the Node B.

For E-DCH combining of UL streams in the Node B is mandatory as described in TS 25.319 [14].

### 5.2.6.2 Handover Decision

To support mobility of the UE to UTRAN connection between cells, UTRAN uses measurement reports from the UE and detectors at the cells.

The RNC takes the decision to add or delete cells from the connection.

### 5.2.6.3 Allocation of Physical Channel Resources

In FDD allocation of downlink channelisation codes of cells belonging to Node B is performed in the CRNC.

In TDD allocation of uplink and downlink physical channel resources of cells belonging to Node B is performed in the CRNC.

### 5.2.6.4 UpLink Power Control

This function controls the level of the transmitted power in order to minimise interference and keep the quality of the connections. The function uplink Outer Loop Power Control located in the SRNC sets the target quality for the uplink Inner Loop Power Control function, for E-DCH the Node B reports the number of HARQ retransmissions to the SRNC as an input to the Outer Loop Power Control function. In FDD and 1.28Mcps TDD, Inner Loop Power Control Function is located in Node B, while in 3.84Mcps TDD it is located in the UE.

### 5.2.6.5 Down-Link Power Control

This function controls the level of the downlink transmitted power. In FDD it is also used to correct the downlink power drifting between several radio links. A SRNC regularly (or under some algorithms) shall send the target down link power range based on the measurement report from UE.

### 5.2.6.6 Admission Control

The Admission Control function based on uplink interference and downlink power is located in the CRNC.

Node B shall report uplink interference measurements and downlink power information over the Iub.

The CRNC controls this reporting function, i.e. if this information needs to be reported and the period of these reports.

### 5.2.6.7 Power and Interference Reporting

A threshold for reporting may be given to Node B from the CRNC to prevent frequent reporting over the Iub. Node B shall have a function to measure "uplink interference level and downlink TX Power" and a function to compare the averaged "uplink interference level and downlink TX power" with the threshold value. Node B shall also have a function to report when the average measured value exceeds the threshold value. The CRNC shall have a function to modify the "threshold value" for neighbour cell co-ordination.

An indication of exceeding uplink interference threshold or downlink TX power may be included as a cause of failure when a Node B is requested to set-up a radio link or add to an existing radio link. This may be used when a number of radio links set-up requests or additions are received on the Iub during the reporting interval.

## 5.2.7 Traffic management of Shared Channels [TDD]

The shared channels shall be controlled from the RNC. This is typically the control of the TDD DSCH channels and the TDD USCH channels.

### 5.2.7A Traffic management of High Speed Shared Channels

The high speed shared channels shall be controlled from the Node B. This includes the control of the HS-DSCH channels as well as the required control channels on the radio interface.

## 5.2.8 Timing and Synchronization Management

The Iub interface shall support timing and synchronization management functions. Further detail regarding these functions can be found in the UMTS technical specification on UTRAN synchronization (TS 25.402 [12]).

---

# 6 Node B logical Model over Iub

## 6.1 Overview

The model described in figure 2 shows the Node B as seen from the controlling RNC. The model includes:

- The logical resources provided by Node B to UTRAN (via its Controlling RNC) - depicted as "cells" which include the physical channel resources DPCH, [FDD – F-DPCH] [TDD - PDSCH and PUSCH];
- The dedicated channels which have been established on Node B;
- The common transport channels that Node B provides to the RNC.

The procedures for controlling the connections between radio links and Iub DCH data ports are sent from the RNC to the Node B via the Communication Control Ports.



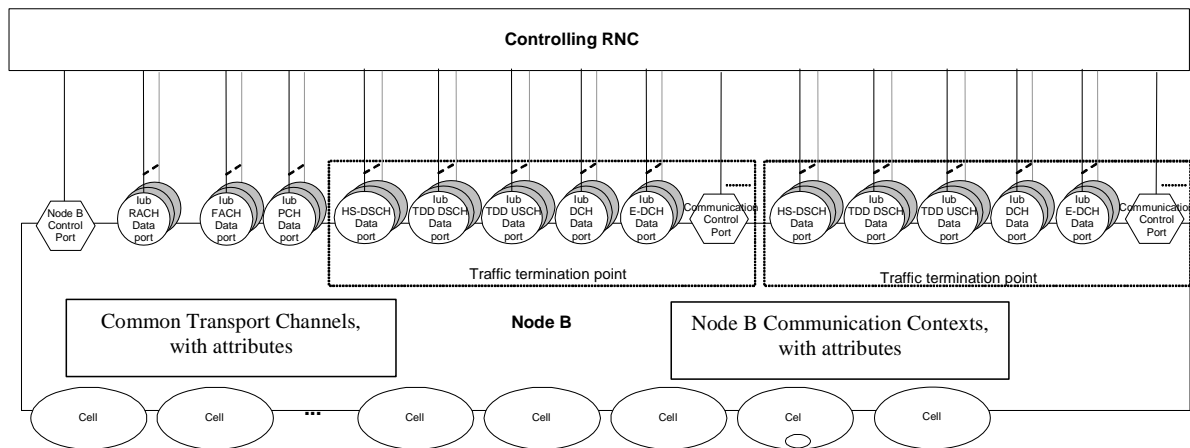

Figure 2: Logical Model of Node B

## 6.2 Elements of the logical model

### 6.2.1 Node B Communication Contexts for Dedicated and Shared Channels

A Node B Communication Context corresponds to all the dedicated resources that are necessary for a user in dedicated mode and using dedicated and/or shared channels as restricted to a given Node B. [TDD - The Node B Communication Context also exists for users in Cell\_FACH mode (i.e. non-dedicated mode) provided a USCH and/or DSCH and/or HS-DSCH has been allocated to these users.]

There are a number of Node B Communication Contexts inside a given Node B.

The attributes to a Node B Communication Context shall include the following (not exhaustive):

- The list of Cells where dedicated and/or shared physical resources are used.
- The list of DCH which are mapped on the dedicated physical resources for that Node B Communication Context.
- [TDD - The list of DSCH and USCH which are used by the respective UE.]
- The list of HS-DSCH MAC-d flows which are used by the respective UE.
- The list of E-DCH MAC-d flows which are used by the respective UE.]
- The complete DCH characteristics for each DCH, identified by its DCH-identifier (TS 25.302 [4]).
- [TDD - The complete Transport Channel characteristics for each DSCH and USCH, identified by its Shared Channel identifier (TS 25.302 [4]).]
- The complete HS-DSCH characteristics for each HS-DSCH MAC-d Flow, identified by its HS-DSCH MAC-d Flow identifier (TS 25.302 [4]).
- The complete E-DCH characteristics for each E-DCH MAC-d Flow, identified by its E-DCH MAC-d Flow identifier (TS 25.302 [4]).]
- The list of Iub DCH Data Ports.
- [TDD - The list of Iub DSCH Data ports and Iub USCH data ports.]
- The list of Iub HS-DSCH Data ports.
- The list of Iub E-DCH Data ports.]
- For each Iub DCH Data Port, the corresponding DCH and cells which are carried on this data port.

- [TDD - For each Iub DSCH and USCH data port, the corresponding DSCH or USCH and cell which serves that DSCH or USCH.]
- For each Iub HS-DSCH data port, the corresponding HS-DSCH data stream and cell which serves that HS-DSCH data stream.
- Physical layer parameters (outer loop power control, etc).

## 6.2.2 Common Transport Channels

Common Transport Channels are defined in TS 25.435 [9]. A Common Transport Channel is configured in the Node B, on request of the CRNC.

The BCH is carried directly on the Node B control port using NBAP procedures. This Common Channel will not be mapped to an individual data port.

The RACH has an associated Iub RACH Data Port and the FACH has an associated Iub FACH Data Port.

[TDD - The Iub DSCH data port is associated to one DSCH and to one Node B Communication Context.]

[TDD - the Iub USCH data port is associated to one USCH and to one Node B Communication Context.]

The attributes of a Common transport channel shall include (not exhaustive):

- Type (RACH, FACH, DSCH [TDD], USCH [TDD], PCH).
- Associated Iub RACH Data Port for a RACH, Iub FACH Data Port for a FACH, Iub PCH Data Port for the PCH.
- Physical parameters.

[TDD - The DSCHs used by one UE are multiplexed to one or several CCTrCHs where each CCTrCH is mapped to a set of PDSCH ("PDSCH Set"). These PDSCH Sets are included in the Common Transport Channel data base. The same applies for the USCHs and the corresponding PUSCH Sets.]

## 6.2.3 Transport network logical resources

### 6.2.3.1 Node B Control Port

The Node B Control Port is used to exchange the signalling information for the logical O&M of Node B, the creation of Node B Communication Contexts, the configuration of the common transport channels that Node B provides in a given cell, PCH and BCH control information between the RNC and the Node B. The Node B Control Port corresponds to one signalling bearer between the controlling RNC and the Node B. There is one Node B Control Port per Node B.

### 6.2.3.2 Communication Control Port

A Communication Control Port corresponds to one signalling bearer between the RNC and Node B for the control of Node B Communication Contexts. One signalling bearer between RNC and Node B can at most correspond to one Communication Control Port. Node B may have multiple Communication Control Ports (one per Traffic Termination Point). The Communication Control Port is selected at creation of the Node B Communication Context. The Communication Control Port is re-selected when the signalling bearer for the control of Node B Communication is rearranged.

### 6.2.3.3 Traffic Termination Point

Traffic Termination Point represents DCH, DSCH [TDD], USCH [TDD], HS-DSCH and E-DCH data streams belonging to one or more Node B Communication Contexts (UE contexts), which are controlled via one Communication Control Port. The Traffic Termination Point is thus a descriptive entity which neither is controlled over Iub nor by O&M.

#### 6.2.3.4 Iub DCH Data Port

One Iub DCH Data port represents one user plane transport bearer. One user plane transport bearer will carry only one DCH data stream except in the case of coordinated DCHs, in which case the data streams of all combined DCHs shall be multiplexed on one and the same user plane transport bearer.

#### 6.2.3.5 Iub RACH Data Port

An Iub RACH Data Port represents a user plane bearer carrying one Iub RACH Data Stream between the Node B and the RNC. There is one RACH Data Port for each RACH channel of Node B.

#### 6.2.3.6 Iub CPCH Data Port [FDD]

Void.

#### 6.2.3.7 Iub FACH Data Port

An Iub FACH Data Port represents a user plane bearer carrying one Iub FACH Data Stream between the Node B and the RNC. There is one FACH Data Port for each FACH channel of Node B.

#### 6.2.3.8 Iub DSCH Data Port [TDD]

An Iub DSCH Data Port represents a user plane bearer carrying one Iub DSCH Data Stream between the Node B and the RNC. For each DSCH, that is used by an individual UE, there is one Iub DSCH Data Port per Node B exclusively assigned to the communication context of that UE.

#### 6.2.3.8A Iub HS-DSCH Data Port

An Iub HS-DSCH Data Port represents a user plane bearer carrying one Iub HS-DSCH Data Streams between the Node B and the RNC.

#### 6.2.3.9 Iub USCH Data Port [TDD]

An Iub USCH Data Port represents a user plane bearer carrying one Iub USCH Data Stream between the Node B and the RNC. For each USCH, that is used by an individual UE, there is one Iub USCH Data Port with data exclusively assigned to the Node B communication context of that UE.

#### 6.2.3.10 Iub PCH Data Port

An Iub PCH Data Port represents an Iub PCH Data Stream between the Node B and the RNC.

#### 6.2.3.11 Iub FDD TFCI2 Data Port

Void.

#### 6.2.3.12 Iub E-DCH Data Port

An Iub E-DCH Data Port represents a user plane bearer carrying one Iub E-DCH Data Stream between the Node B and the RNC.

## 6.2.4 Radio Network Logical resources

### 6.2.4.1 Common Resources

The CRNC manages logical radio network resources in Node B and needs to use both common and dedicated resources in a Node B to run a radio network. Therefore, it is the CRNC that orders the Node B to configure, reconfigure and delete these resources. However, if the equipment in Node B cannot fully support the configuration that the CRNC requests, or the equipment breaks down, then Node B can indicate the availability of the common resources (i.e. both downgrade and upgrade).

The common resources are the Cell, the common physical channels and the common transport channels.

In Node B these common resources have an operational state, that indicates whether they are operational or not, i.e. whether they can carry traffic or not.

Figure 3 shows the common resources that a CRNC is managing in a Node B to be able to run a radio network.

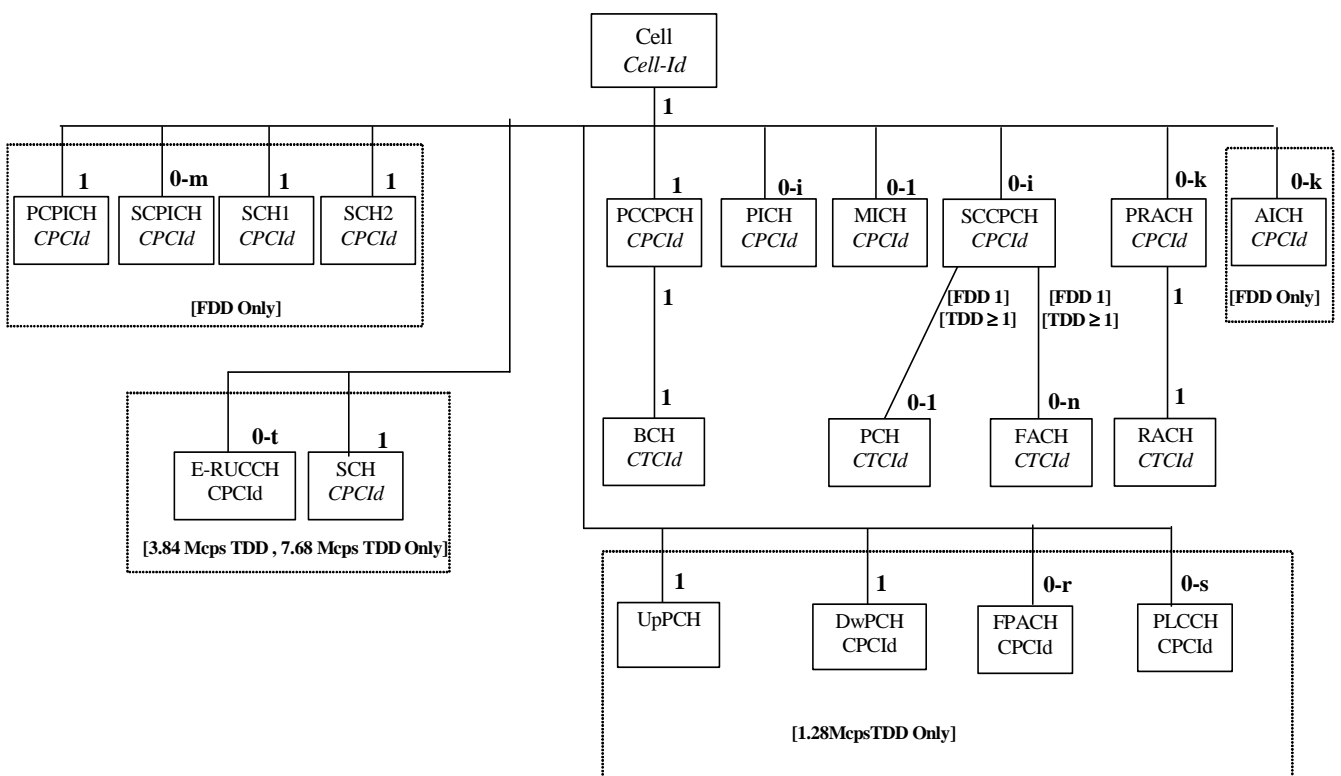

The number or range above each box indicates how many of the channels named in that box can exist as "children" under one instant of a "parent" box to which the "child" box is connected.

The number or range beneath each box indicates how many of the channels named in that box can exist as "parent" boxes for one instant of a "child" channel to which the "parent" box is connected.

CPCId = Common Physical Channel Identifier

CTCId = Common Transport Channel Identifier

[TDD - The number of PICH = the number of PCH]

[FDD - The number of AICH = the number of PRACH]

[TDD - PCH and FACHs can be mapped on one or more SCCPCH]

**Figure 3: Common resources in a Node B that are managed by the CRNC**

### 6.2.4.2 Cell

A Cell is identified by a UTRAN Cell identifier (UC-id) (TS 25.401 [1]).

The semantics of a Cell include the following:

- The Cell can be created and removed by administrative procedures. When a Local Cell, i.e. equipment in a Node B, is made available to the CRNC for configuration of a cell, the CRNC can configure the cell with configuration

data, common physical channels and common transport channels in Node B. In so doing a Local cell is added to the RNS.

- If any Iub transport bearers for common or dedicated transport channels exist when the cell is deleted, the Node B shall initiate the release of those transport bearers.
- Node B may support one or more cells. [1.28Mcps TDD - A cell may support one or more frequencies. If multiple frequencies are configured in one cell, the cell is called the multi-frequency cell.]
- Configuration of a cell over the Iub interface cannot be successful unless Node B has reported a Local Cell Id (TS 25.401 [1]) as available to the CRNC.
- Once a Local Cell is configured to support a cell, it cannot be deleted without the CRNC first deleting the cell.

Figure 4 illustrates the state diagram for a Local Cell in Node B, as seen over the Iub interface.

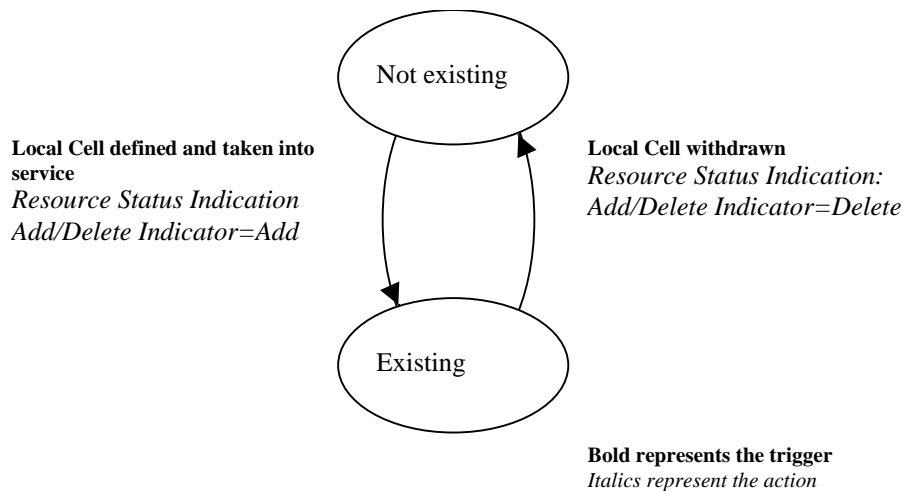

**Figure 4: States for a Local Cell that are seen over the Iub interface**

Cells in Node B have a resource operational state.

Figure 5 illustrates the state diagram for the states of a cell, as seen over the Iub interface.

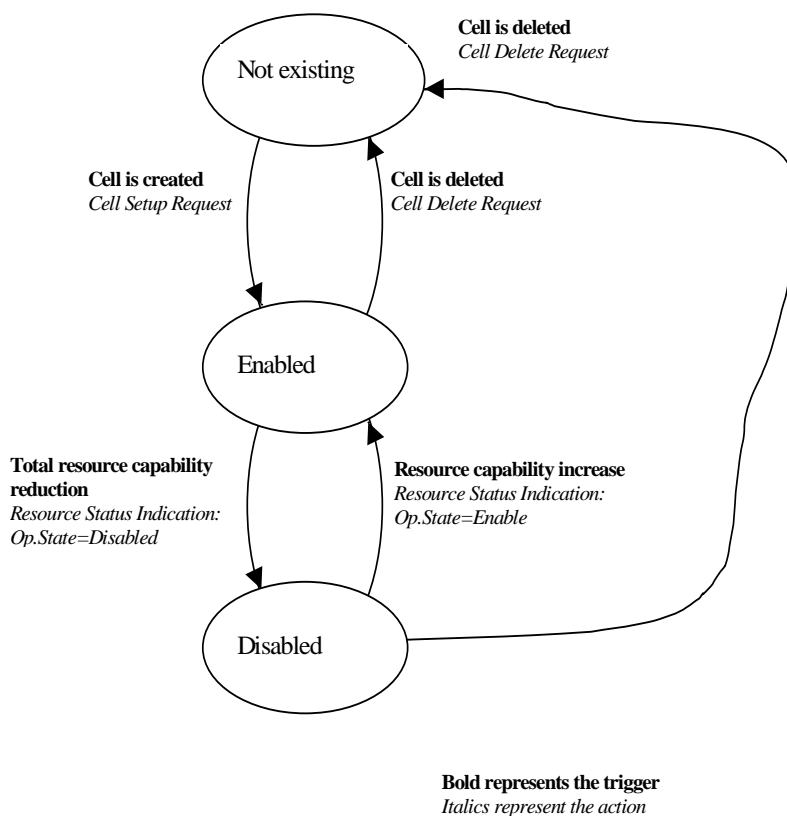

**Figure 5: States for a cell in Node B, as reported to the CRNC**

There are three states seen over the Iub interface:

1. Not existing, meaning that the cell does not exist in Node B.
2. Enabled, meaning that the resource can be used by the RNC.
3. Disabled, meaning that the resource cannot be used by the RNC.

When a cell becomes disabled in Node B, that shall be reported to the CRNC together with the cause.

### 6.2.4.3 Common Physical Channels and Common Transport Channels

Common physical channels and common transport channels in Node B have a resource operational state.

Figure 6 illustrates the state diagram for common physical channels and common transport channels in Node B, as seen over the Iub interface.

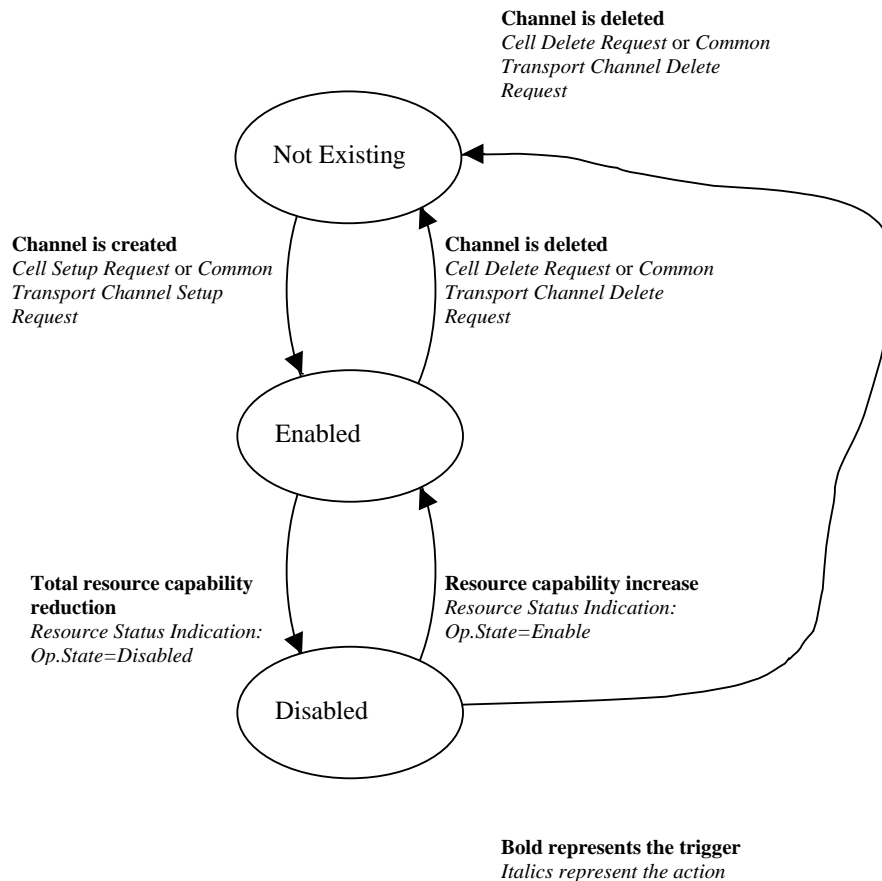

**Figure 6: States for a common channel in Node B, as reported to the CRNC**

There are three states seen over the Iub interface:

1. Not existing, meaning that the resource does not exist in Node B;
2. Enabled, meaning that the resource can be used by the RNC;
3. Disabled, meaning that the resource cannot be used by the RNC.

When a channel becomes disabled in the Node B, this shall be reported to the CRNC together with the cause.

#### 6.2.4.4 Physical Shared Channels

Physical Shared Channels includes [TDD - the Physical Downlink Shared Channels (PDSCH), the Physical Uplink Shared Channels (PUSCH) and] the High Speed Physical Shared Channels (HS-PDSCH). [TDD - These PDSCH and PUSCH [TDD] are special cases of the Common Physical Channels].

[FDD - A HS-PDSCH is defined by a channelisation code within a code subtree that is configured within a specific Communication Context. The HS-PDSCH is activated dynamically as part of the HS-DSCH scheduling.]

[TDD - A PDSCH is defined by a channelisation code, a time slot and other Physical Channel parameters. Several PDSCH may be grouped into a PDSCH Set, which is given a "PDSCH Set Id". The PDSCH Sets are configured in the Node B in the "Common Transport Channel" data base by Common NBAP messages. These PDSCH Sets are available to carry DSCH data. The PDSCH Sets are dynamically activated to carry DSCH data, as part of the DSCH scheduling.]

[TDD - A HS-PDSCH is defined by a channelisation code, a time slot and other Physical Channel parameters. The HS-PDSCH is activated dynamically as part of the HS-DSCH scheduling.]

[TDD - A PUSCH is defined by a channelisation code, a time slot and other Physical Channel parameters. Several PUSCH may be grouped into a PUSCH Set, which is given a "PUSCH Set Id". The PUSCH Sets are configured in the Node B in the "Common Transport Channel" data base by Common NBAP messages. These PUSCH Sets are available to carry USCH data. The PUSCH Sets are dynamically activated to carry USCH data, as part of the USCH scheduling.]

# 7 Iub Interface Protocol Structure

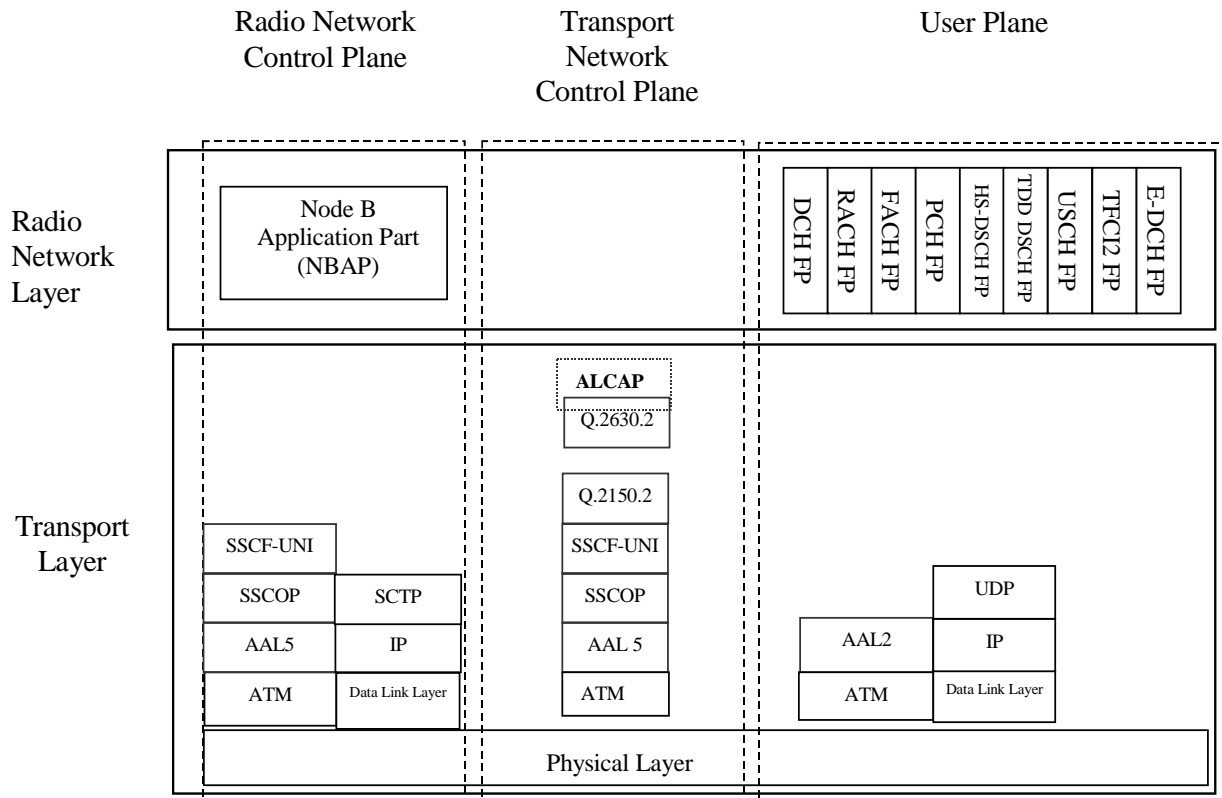

**Figure 7: Iub Interface Protocol Structure.**

The Iub interface protocol architecture consists of two functional layers:

1. Radio Network Layer, defines procedures related to the operation of Node B. The radio network layer consists of a radio network control plane and a radio network user plane.
2. Transport Layer, defines procedures for establishing physical connections between Node B and the RNC with AAL type 2 Signalling Protocol (Capability Set 2) (ITU-T Rec. Q.2630.2 [13]).

There shall be one dedicated AAL2 or UDP/IP transport bearer for each RACH, and one for each FACH transport channel or for each set of FACH transport channels in case of transport bearer sharing (see section 4.5.1).

## 8 Other Iub Interface Specifications

### 8.1 UTRAN Iub Interface: Layer 1 (TSG RAN 25.431)

This document (TS 25.431 [5]) specifies the standards allowed for the implement of Layer 1 (physical layer) on the I<sub>ub</sub> interface.

### 8.2 UTRAN Iub Interface: Signalling Transport (TSG RAN 25.432)

This document (TS 25.432 [3]) specifies the signalling transport related to NBAP signalling to be used across the Iub Interface.



### 8.3 NBAP Specification (TSG RAN 25.433)

This document (TS 25.433 [7]) specifies the standards for NBAP specification to be used over Iub Interface.

### 8.4 UTRAN Iub Interface: Data Transport & Transport Signalling for Common Transport Channel Data Streams (TSG RAN 25.434)

This document (TS 25.434 [8]) provides a specification of the UTRAN RNC-Node B (Iub) interface Data Transport and Transport Signalling for Common Transport Channel data streams.

### 8.5 UTRAN Iub Interface: User Plane Protocols for Common Transport Channel Data Streams (TSG RAN 25.435)

This document (TS 25.435 [9]) provides a specification of the UTRAN RNC-Node B (Iub) interface user plane protocols for Common Transport Channel data streams.

### 8.6 UTRAN Iur/Iub Interface: Data Transport & Transport Signalling for DCH Data Streams (TSG RAN 25.426)

This Technical Specification (TS 25.426 [10]) specifies the transport bearers for the DCH data streams on UTRAN Iur and Iub interfaces. The corresponding Transport Network Control plane is also specified.

### 8.7 UTRAN Iur/Iub Interface: User Plane Protocol for DCH Data Streams (TSG RAN 25.427)

This document (TS 25.427 [11]) provides a specification of the UTRAN Iur and Iub interfaces user plane protocols for Dedicated Transport Channel data streams.

## 8.8 Summary of UTRAN Iub Interface Technical Specifications

The relationship between the technical specifications that define the UTRAN Iub interface is shown in figure 8.

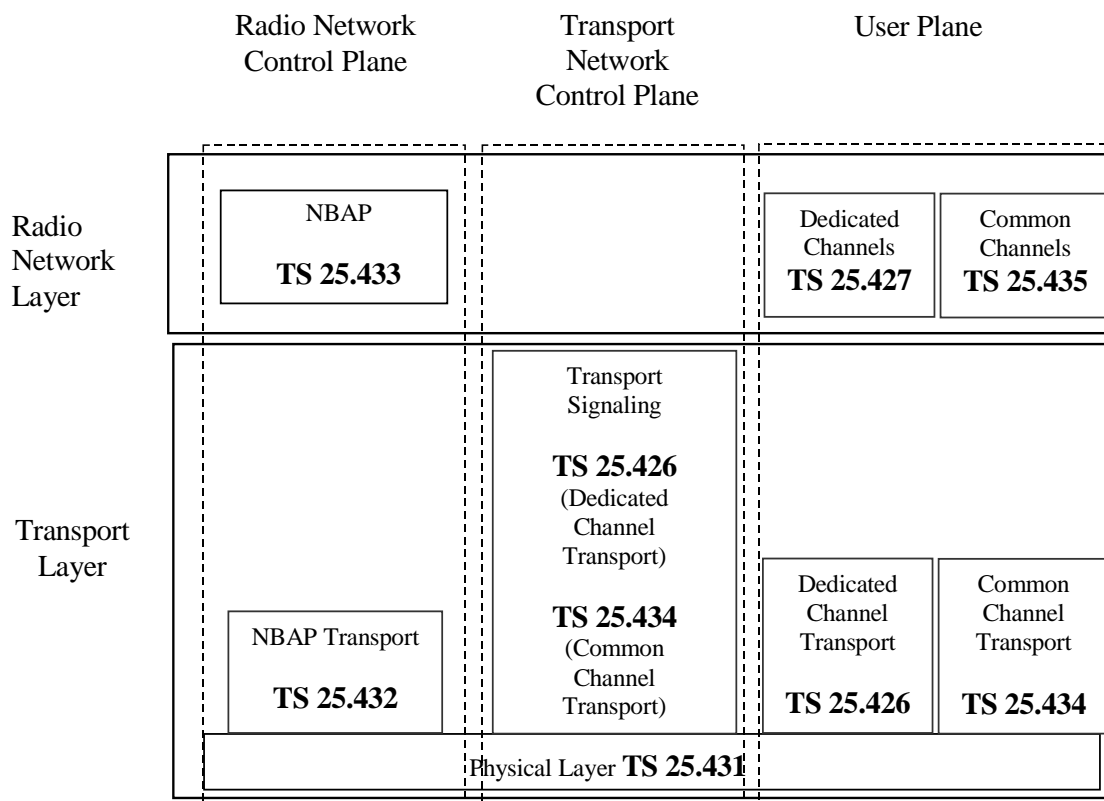

**Figure 8: Iub Interface Technical Specifications.**

## Annex A (informative): Change history

Date / TSG	TSG Doc.	CR	Rev	Subject/Comment	New
12/2008	-	-	-	Creation of Rel-8 version based on v7.5.0	8.0.0
12/2009	-	-	-	Creation of Rel-9 version based on v8.0.0	9.0.0
SP-49	SP-100629			Clarification on the use of References (TS 21.801 CR#0030)	9.0.1
03/2011				Creation of Rel-10 version based on v9.0.1	10.0.0
52	RP-110685	0074	1	Correction to the References	10.1.0
09/2012				Update to Rel-11 version (MCC)	11.0.0
09/2014				Update to Rel-12 version (MCC)	12.0.0
12/2015				Update to Rel-13 version (MCC)	13.0.0

Change history							
Date	Meeting	TDoc	CR	Rev	Cat	Subject/Comment	New version
2017-03	SA#75					Promotion to Release 14 without technical change	14.0.0
2018-07	SA#80	-	-	-	-	Promotion to Release 15 without technical change	15.0.0
2020-07	SA#88-e	-	-	-	-	Update to Rel-16 version (MCC)	16.0.0

---

# History

<b>Document history</b>		
V16.0.0	August 2020	Publication