

ETSI TS 125 442 V4.0.0 (2001-03)

Technical Specification

Universal Mobile Telecommunications System (UMTS); UTRAN Implementation Specific O&M Transport (3GPP TS 25.442 version 4.0.0 Release 4)



Reference

RTS/TSGR-0325442Uv4

Keywords

UMTS

ETSI

650 Route des Lucioles
F-06921 Sophia Antipolis Cedex - FRANCE

Tel.: +33 4 92 94 42 00 Fax: +33 4 93 65 47 16

Siret N° 348 623 562 00017 - NAF 742 C
Association à but non lucratif enregistrée à la
Sous-Préfecture de Grasse (06) N° 7803/88

Important notice

Individual copies of the present document can be downloaded from:

<http://www.etsi.org>

The present document may be made available in more than one electronic version or in print. In any case of existing or perceived difference in contents between such versions, the reference version is the Portable Document Format (PDF). In case of dispute, the reference shall be the printing on ETSI printers of the PDF version kept on a specific network drive within ETSI Secretariat.

Users of the present document should be aware that the document may be subject to revision or change of status. Information on the current status of this and other ETSI documents is available at <http://www.etsi.org/tb/status/>

If you find errors in the present document, send your comment to:
editor@etsi.fr

Copyright Notification

No part may be reproduced except as authorized by written permission.
The copyright and the foregoing restriction extend to reproduction in all media.

© European Telecommunications Standards Institute 2001.

All rights reserved.

Intellectual Property Rights

IPRs essential or potentially essential to the present document may have been declared to ETSI. The information pertaining to these essential IPRs, if any, is publicly available for **ETSI members and non-members**, and can be found in ETSI SR 000 314: "*Intellectual Property Rights (IPRs); Essential, or potentially Essential, IPRs notified to ETSI in respect of ETSI standards*", which is available from the ETSI Secretariat. Latest updates are available on the ETSI Web server (<http://www.etsi.org/ipr>).

Pursuant to the ETSI IPR Policy, no investigation, including IPR searches, has been carried out by ETSI. No guarantee can be given as to the existence of other IPRs not referenced in ETSI SR 000 314 (or the updates on the ETSI Web server) which are, or may be, or may become, essential to the present document.

Foreword

This Technical Specification (TS) has been produced by the ETSI 3rd Generation Partnership Project (3GPP).

The present document may refer to technical specifications or reports using their 3GPP identities, UMTS identities or GSM identities. These should be interpreted as being references to the corresponding ETSI deliverables.

The cross reference between GSM, UMTS, 3GPP and ETSI identities can be found under www.etsi.org/key.

Contents

Foreword	4
1 Scope.....	5
2 References.....	5
3 Definitions and abbreviations	5
3.1 Definitions	5
3.2 Abbreviations.....	5
4 Implementation Specific O&M Transport.....	6
4.1 Requirements	6
4.2 Routing.....	6
4.3 Transport Bearer	7
Annex A (informative): Change History	8

Foreword

This Technical Specification (TS) has been produced by the 3rd Generation Partnership Project (3GPP).

The contents of this informal TS may be subject to continuing work within the 3GPP and may change following formal TSG-S4 approval. Should TSG-S4 modify the contents of the present document, it will be re-released with an identifying change of release date and an increase in version number as follows:

Version x.y.z

where:

- x the first digit:
 - 1 presented to TSG for information;
 - 2 presented to TSG for approval;
 - 3 or greater indicates TSG approved document under change control.
- y the second digit is incremented for all changes of substance, i.e. technical enhancements, corrections, updates, etc.
- z the third digit is incremented when editorial only changes have been incorporated in the document.

1 Scope

The present document specifies the transport of implementation specific O&M signalling between Node B and the Management Platform in case that the transport is routed via the RNC.

2 References

The following documents contain provisions which, through reference in this text, constitute provisions of the present document.

- References are either specific (identified by date of publication, edition number, version number, etc.) or non-specific.
- For a specific reference, subsequent revisions do not apply.
- For a non-specific reference, the latest version applies. In the case of a reference to a 3GPP document (including a GSM document), a non-specific reference implicitly refers to the latest version of that document *in the same Release as the present document*.

- [1] 3GPP TS 25.431: "UTRAN Iub interface Layer 1".
- [2] 3GPP TS 25.401: "UTRAN Overall Description".
- [3] ITU-T Recommendation I.363.5 (8/1996): "B-ISDN ATM Adaptation Layer Type 5 Specification".
- [4] IETF RFC 2225 (4/1998): "Classical IP and ARP over ATM".
- [5] IETF RFC 2684 (9/1999): "Multiprotocol Encapsulation over ATM Adaptation Layer 5".
- [6] IETF RFC 791 (9/1981): "Internet Protocol".

3 Definitions and abbreviations

3.1 Definitions

For the purposes of the present document, the following terms and definitions apply:

Logical O&M: Logical O&M is the signalling associated with the control of logical resources owned by the RNC but physically implemented in Node B.

Implementation Specific O&M: Implementation Specific O&M functions depend on the implementation of the Node B, both for its hardware and software components.

3.2 Abbreviations

For the purposes of the present document, the following abbreviations apply:

AAL5	ATM Adaptation Layer type 5
ATM	Asynchronous Transfer Mode
ARP	Address Resolution Protocol
RFC	Request For Comment
IP	Internet Protocol
O&M	Operation and Maintenance
RNC	Radio Network Controller

4 Implementation Specific O&M Transport

4.1 Requirements

While this specification only addresses the transport of Node B Implementation Specific O&M signalling, many of the following requirements are derived from generic requirements for O&M of UMTS network elements:

- Common O&M infrastructure for all network elements.
- Independence from various data link protocols.
- Support of various higher layer protocols and applications.
- Secure transmission.
- No Impact of O&M transport on traffic transport and signalling.
- Re-use of existing transport facilities, i.e. co-existence of Iub and Implementation Specific O&M on the same bearer.

4.2 Routing

It is the responsibility of the RNC to route Implementation Specific O&M signalling traffic. The traffic exchanged over this signalling link is completely transparent to the RNC. Both RNC and Node B have to support the routing of Implementation specific O&M via the RNC.

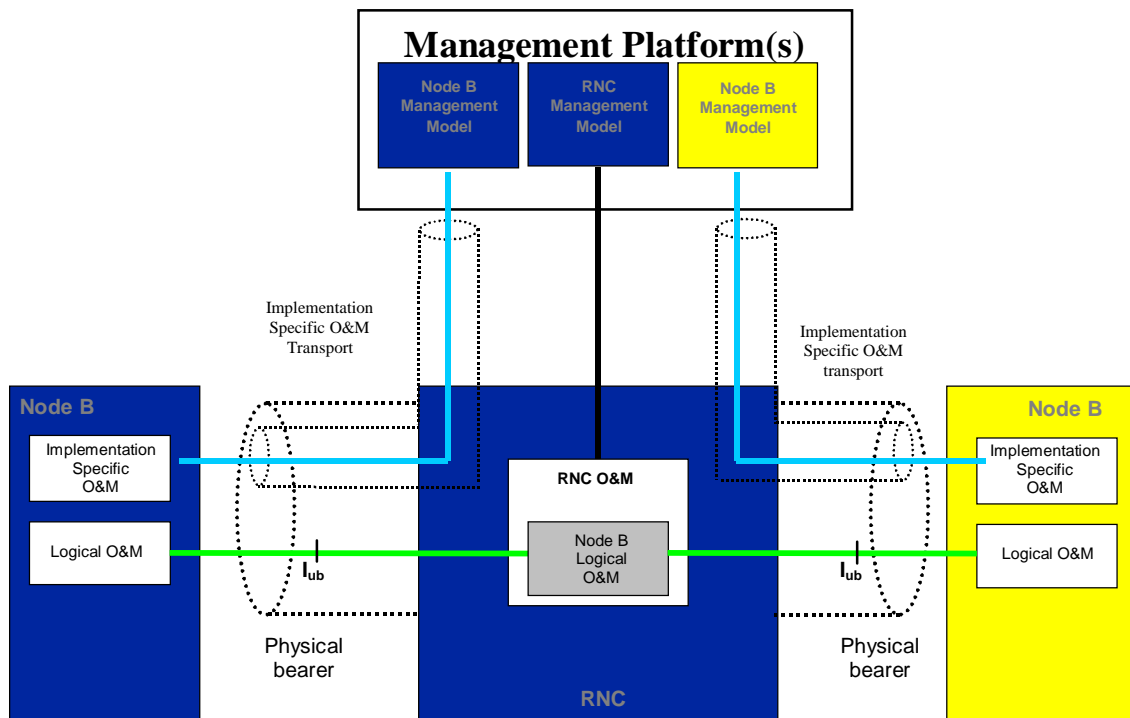

Figure 1: Implementation Specific O&M Transport via RNC

4.3 Transport Bearer

An appropriate transport bearer for Implementation Specific O&M should consider the requirements listed in subclause 4.1. IP [6] should be the transport mechanism in order to allow a data link independent support of a variety of O&M applications and protocols for the Implementation Specific O&M of the Node B.

IP datagrams containing O&M signalling have to be carried over the same bearer as Iub. Since ATM will be used on Iub, IP over ATM should be the bearer for O&M signalling.

The following figure shows the protocol stack for Implementation Specific O&M transport between Node B and RNC:

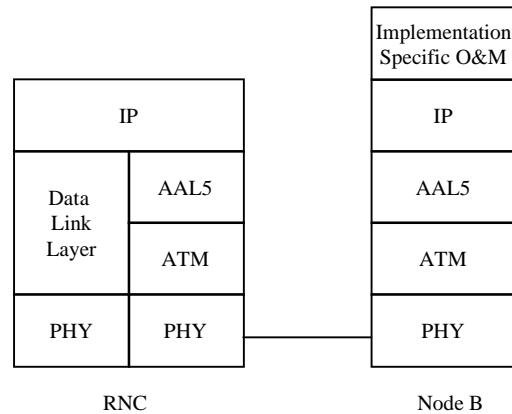

Figure 2: Protocol Stack for Implementation Specific O&M Transport

AAL5 shall be used according to ITU-T Recommendation I.363.5.

AAL5 virtual circuits are used to transport the IP packets containing Implementation Specific O&M signalling data between Node B and RNC. Multiple VCs can be used over the interface. An association shall be made between a VC and the IP addresses that are related to this VC in the peer node side. This association can be made using O&M or using ATM Inverse ARP according to Classical IP over ATM.

Classical IP over ATM protocols are used to carry the IP packets over the ATM transport network. Classical IP over ATM is specified in IETF RFC 2225. Multiprotocol Encapsulation over AAL5 is specified in IETF RFC 2684.

Annex A (informative): Change History

Change history					
TSG RAN#	Version	CR	Tdoc RAN	New Version	Subject/Comment
RAN_05		-	-	3.0.0	A Approved at TSG RAN #5 by correspondence and placed under Change Control
RAN_07	3.0.0	-	-	3.1.0	Approved at TSG RAN #7

Change history							
Date	TSG #	TSG Doc.	CR	Rev	Subject/Comment	Old	New
March 01	11	-	-		Approved at TSG RAN #11 and placed under Change Control	-	4.0.0

History

Document history		
V4.0.0	March 2001	Publication