

ETSI TS 125 453 V6.11.0 (2007-03)

Technical Specification

Universal Mobile Telecommunications System (UMTS); UTRAN Iu-PS interface Positioning Calculation Application Part (PCAP) signalling (3GPP TS 25.453 version 6.11.0 Release 6)



Reference

RTS/TSGR-0325453v6b0

Keywords

UMTS

ETSI

650 Route des Lucioles
F-06921 Sophia Antipolis Cedex - FRANCE

Tel.: +33 4 92 94 42 00 Fax: +33 4 93 65 47 16

Siret N° 348 623 562 00017 - NAF 742 C
Association à but non lucratif enregistrée à la
Sous-Préfecture de Grasse (06) N° 7803/88

Important notice

Individual copies of the present document can be downloaded from:

<http://www.etsi.org>

The present document may be made available in more than one electronic version or in print. In any case of existing or perceived difference in contents between such versions, the reference version is the Portable Document Format (PDF). In case of dispute, the reference shall be the printing on ETSI printers of the PDF version kept on a specific network drive within ETSI Secretariat.

Users of the present document should be aware that the document may be subject to revision or change of status. Information on the current status of this and other ETSI documents is available at

<http://portal.etsi.org/tb/status/status.asp>

If you find errors in the present document, please send your comment to one of the following services:

http://portal.etsi.org/chaicor/ETSI_support.asp

Copyright Notification

No part may be reproduced except as authorized by written permission.
The copyright and the foregoing restriction extend to reproduction in all media.

© European Telecommunications Standards Institute 2007.
All rights reserved.

DECTTM, **PLUGTESTS**TM and **UMTS**TM are Trade Marks of ETSI registered for the benefit of its Members.
TIPHONTM and the **TIPHON logo** are Trade Marks currently being registered by ETSI for the benefit of its Members.
3GPPTM is a Trade Mark of ETSI registered for the benefit of its Members and of the 3GPP Organizational Partners.

Intellectual Property Rights

IPRs essential or potentially essential to the present document may have been declared to ETSI. The information pertaining to these essential IPRs, if any, is publicly available for **ETSI members and non-members**, and can be found in ETSI SR 000 314: *"Intellectual Property Rights (IPRs); Essential, or potentially Essential, IPRs notified to ETSI in respect of ETSI standards"*, which is available from the ETSI Secretariat. Latest updates are available on the ETSI Web server (<http://webapp.etsi.org/IPR/home.asp>).

Pursuant to the ETSI IPR Policy, no investigation, including IPR searches, has been carried out by ETSI. No guarantee can be given as to the existence of other IPRs not referenced in ETSI SR 000 314 (or the updates on the ETSI Web server) which are, or may be, or may become, essential to the present document.

Foreword

This Technical Specification (TS) has been produced by ETSI 3rd Generation Partnership Project (3GPP).

The present document may refer to technical specifications or reports using their 3GPP identities, UMTS identities or GSM identities. These should be interpreted as being references to the corresponding ETSI deliverables.

The cross reference between GSM, UMTS, 3GPP and ETSI identities can be found under <http://webapp.etsi.org/key/queryform.asp>.

Contents

Intellectual Property Rights	2
Foreword.....	2
Foreword.....	6
1 Scope	7
2 References	7
3 Definitions and abbreviations.....	8
3.1 Definitions	8
3.2 Abbreviations	8
4 General	9
4.1 Procedure Specification Principles.....	9
4.2 Forwards and Backwards Compatibility	9
4.3 Specification Notations	9
5 PCAP Services	10
6 Services Expected from Signalling Transport.....	10
7 Functions of PCAP	10
8 PCAP Procedures	11
8.1 Elementary Procedures.....	11
8.2 Position Calculation	11
8.2.1 General.....	11
8.2.2 Successful Operation	11
8.2.3 Unsuccessful Operation	12
8.2.4 Abnormal Conditions.....	12
8.3 Information Exchange Initiation.....	13
8.3.1 General.....	13
8.3.2 Successful Operation	13
8.3.3 Unsuccessful Operation	15
8.3.4 Abnormal Conditions.....	15
8.4 Information Reporting.....	15
8.4.1 General.....	15
8.4.2 Successful Operation	16
8.4.3 Abnormal Conditions.....	16
8.5 Information Exchange Termination	16
8.5.1 General.....	16
8.5.2 Successful Operation	16
8.5.3 Abnormal Conditions.....	17
8.6 Information Exchange Failure.....	17
8.6.1 General.....	17
8.6.2 Successful Operation	17
8.7 Error Indication	17
8.7.1 General.....	17
8.7.2 Successful Operation	18
8.7.3 Abnormal Conditions.....	18
9 Elements for PCAP Communication.....	18
9.1 Message Functional Definition and Content	18
9.1.1 General.....	18
9.1.2 Message Contents	19
9.1.2.1 Presence	19
9.1.2.2 Criticality	19
9.1.2.3 Range	19
9.1.2.4 Assigned Criticality.....	19

9.1.3	Position Calculation Request	20
9.1.4	Position Calculation Response.....	21
9.1.5	POSITION CALCULATION FAILURE	21
9.1.6	Information Exchange Initiation Request	21
9.1.7	Information Exchange Initiation Response.....	22
9.1.8	Information Exchange Initiation Failure.....	22
9.1.9	Information Report	22
9.1.10	Information Exchange Termination Request	22
9.1.11	Information Exchange Failure Indication	23
9.1.12	Error Indication.....	23
9.2	Information Element Functional Definitions and Contents	23
9.2.1	General.....	23
9.2.2	Radio Network Layer Related IEs	23
9.2.2.1	Almanac and Satellite Health SIB.....	23
9.2.2.2	Altitude and direction.....	24
9.2.2.3	Cause.....	24
9.2.2.4	Criticality Diagnostics.....	27
9.2.2.5	DGPS Corrections.....	29
9.2.2.6	Geographical Area	30
9.2.2.7	Geographical Coordinates	32
9.2.2.8	GPS Acquisition Assistance.....	32
9.2.2.9	GPS Almanac and Satellite Health.....	33
9.2.2.10	GPS Clock and Ephemeris Parameters	34
9.2.2.11	GPS Ionospheric Model	36
9.2.2.12	GPS Measured Results	37
9.2.2.13	GPS Navigation Model	38
9.2.2.14	GPS Real Time Integrity	39
9.2.2.15	GPS Reference Time.....	39
9.2.2.16	GPS Transmission TOW	40
9.2.2.17	GPS UTC Model.....	40
9.2.2.18	GPS-UTRAN Time Relationship Uncertainty	40
9.2.2.19	Information Exchange ID.....	40
9.2.2.20	Information Exchange Object Type	40
9.2.2.21	Information Report Characteristics	41
9.2.2.22	Information Type	42
9.2.2.23	Message Structure	43
9.2.2.24	Message Type	43
9.2.2.25	Method Type.....	44
9.2.2.26	Requested Data Value.....	44
9.2.2.27	Requested Data Value Information	44
9.2.2.28	Transaction ID.....	44
9.2.2.29	Transmission TOW Indicator.....	45
9.2.2.30	Uncertainty Ellipse.....	45
9.2.2.31	Cell-ID Measured Results Info List	45
9.2.2.32	OTDOA Measured Results Info List	46
9.2.2.33	OTDOA Neighbour Cell Info	48
9.2.2.34	OTDOA Reference Cell Info	49
9.2.2.35	UE Positioning Measurement Quality.....	50
9.2.2.36	UTRAN Access Point Position with Altitude	51
9.2.2.37	UTRAN Cell Identifier (UC-ID).....	51
9.2.2.38	Horizontal Accuracy Code.....	51
9.2.2.39	Vertical Accuracy Code	51
9.2.2.40	Accuracy Fulfilment Indicator	52
9.3	Message and Information Element Abstract Syntax (with ASN.1).....	53
9.3.0	General.....	53
9.3.1	Usage of private message mechanism for non-standard use.....	53
9.3.2	Elementary Procedure Definitions	53
9.3.3	PDU Definitions	56
9.3.4	Information Element Definitions	62
9.3.5	Common Definitions.....	79
9.3.6	Constant Definitions	79
9.3.7	Container Definitions.....	80

9.4	Message Transfer Syntax	82
10	Handling of Unknown, Unforeseen and Erroneous Protocol Data	83
10.1	General	83
10.2	Transfer Syntax Error	83
10.3	Abstract Syntax Error	83
10.3.1	General	83
10.3.2	Criticality Information	84
10.3.3	Presence Information	84
10.3.4	Not comprehended IE/IE group	85
10.3.4.1	Procedure Code	85
10.3.4.1A	Type of Message	85
10.3.4.2	IEs other than the Procedure Code and Type of Message	85
10.3.5	Missing IE or IE group	86
10.3.6	IEs or IE groups received in wrong order or with too many occurrences or erroneously present	87
10.4	Logical Error	88
10.5	Exceptions	88
Annex A (informative): Guidelines for Usage of the Criticality Diagnostics IE		89
A.1	EXAMPLE MESSAGE Layout	89
A.2	Example on a Received EXAMPLE MESSAGE	89
A.3	Content of Criticality Diagnostics	91
A.3.1	Example 1	91
A.3.2	Example 2	92
A.3.3	Example 3	93
A.3.4	Example 4	94
A.3.5	Example 5	95
A.4	ASN.1 of EXAMPLE MESSAGE	96
Annex B (informative): Change history		98
History		99

Foreword

This Technical Specification has been produced by the 3rd Generation Partnership Project (3GPP).

The contents of the present document are subject to continuing work within the TSG and may change following formal TSG approval. Should the TSG modify the contents of the present document, it will be re-released by the TSG with an identifying change of release date and an increase in version number as follows:

Version x.y.z

where:

- x the first digit:
 - 1 presented to TSG for information;
 - 2 presented to TSG for approval;
 - 3 or greater indicates TSG approved document under change control.
- y the second digit is incremented for all changes of substance, i.e. technical enhancements, corrections, updates, etc.
- z the third digit is incremented when editorial only changes have been incorporated in the document.

1 Scope

The present document specifies the *Positioning Calculation Application Part (PCAP)* between the Radio Network Controller (RNC) and the Stand-Alone SMLC (SAS). It fulfills the RNC-SAS communication requirements specified in [6] and thus defines the Iupc interface and its associated signaling procedures.

2 References

The following documents contain provisions which, through reference in this text, constitute provisions of the present document.

- References are either specific (identified by date of publication, edition number, version number, etc.) or non-specific.
- For a specific reference, subsequent revisions do not apply.
- For a non-specific reference, the latest version applies. In the case of a reference to a 3GPP document (including a GSM document), a non-specific reference implicitly refers to the latest version of that document *in the same Release as the present document*.

- [1] 3GPP TS 25.450: "UTRAN Iupc interface general aspects and principles".
- [2] 3GPP TS 25.451: "UTRAN Iupc interface layer 1".
- [3] 3GPP TS 25.452: "UTRAN Iupc interface signalling transport".
- [4] 3GPP TS 25.331: "Radio Resource Control (RRC) Protocol Specification".
- [5] 3GPP TS 25.401: "UTRAN Overall Description".
- [6] 3GPP TS 25.305: "Stage 2 functional specification of UE positioning in UTRAN".
- [7] ITU-T Recommendation X.680 (07/2002): "Information technology - Abstract Syntax Notation One (ASN.1): Specification of basic notation".
- [8] ITU-T Recommendation X.681 07/2002): "Information technology - Abstract Syntax Notation One (ASN.1): Information object specification".
- [9] ITU-T Recommendation X.691 (07/2002): "Information technology - ASN.1 encoding rules: Specification of Packed Encoding Rules (PER)".
- [10] ICD-GPS-200: (12 April 2000) "Navstar GPS Space Segment/Navigation User Interface".
- [11] 3GPP TS 23.032: "Universal Geographical Area Description (GAD)".
- [12] 3GPP TR 25.921: "Guidelines and principles for protocol description and error handling".
- [13] 3GPP TS 25.133: "Requirements for support of Radio Resource management (FDD)".
- [14] 3GPP TS 25.123: "Requirements for support of Radio Resource management (TDD)".

3 Definitions and abbreviations

3.1 Definitions

For the purposes of the present document, the following terms and definitions apply:

Stand-Alone SMLC (SAS): logical node that interconnects to the RNC over the Iupc interface via the PCAP protocol. An SAS performs the following procedures:

- provide GPS related data to the RNC;
- performs the position calculation function based upon UE Positioning measurement data.

Elementary Procedure: PCAP consists of Elementary Procedures (EPs)

An Elementary Procedure is a unit of interaction between the RNC and the SAS. An EP consists of an initiating message and possibly a response message. Two kinds of EPs are used:

- **Class 1:** Elementary Procedures with response (success or failure).
- **Class 2:** Elementary Procedures without response.

For Class 1 EPs, the types of responses can be as follows:

Successful:

- A signalling message explicitly indicates that the elementary procedure successfully completed with the receipt of the response.

Unsuccessful:

- A signalling message explicitly indicates that the EP failed.

Class 2 EPs are considered always successful.

Information Exchange Context: Information Exchange Context is created by the first Information Exchange Initiation Procedure initiated by the RNC and requested from the SAS.

The Information Exchange Context is deleted after the Information Exchange Termination or the Information Exchange Failure procedure when there is no more Information Exchange to be provided by the RNC to the SAS. The Information Exchange Context is identified by an SCCP connection as, for Information Exchanges, only the connection oriented mode of the signalling bearer is used.

3.2 Abbreviations

For the purposes of the present document, the following abbreviations apply:

A-GPS	Assisted GPS
ASN.1	Abstract Syntax Notation One
CN	Core Network
CRNC	Controlling RNC
DGPS	Differential GPS
EP	Elementary Procedure
FDD	Frequency Division Duplex
GPS	Global Positioning System
MSC	Mobile services Switching Center
OTDOA	Observed Time Difference Of Arrival
PCAP	Positioning Calculation Application Part
PRC	Pseudorange Correction
RNC	Radio Network Controller
RNS	Radio Network Subsystem
RRC	Radio Resource Control
SAS	Stand-Alone SMLC
SCCP	Signalling Connection Control Part

SIB	System Information Block
SMLC	Serving Mobile Location Center
SRNC	Serving RNC
SRNS	Serving RNS
TDD	Time Division Duplex
TOW	Time of Week
UE	User Equipment
UTRAN	Universal Terrestrial Radio Access Network

4 General

4.1 Procedure Specification Principles

The principle for specifying the procedure logic is to specify the functional behaviour of the SAS exactly and completely. The RNC functional behaviour is left unspecified.

The following specification principles have been applied for the procedure text in clause 8:

- The procedure text discriminates between:
 - 1) Functionality which "shall" be executed:
 - The procedure text indicates that the receiving node "shall" perform a certain function Y under a certain condition. If the receiving node supports procedure X but cannot perform functionality Y requested in the REQUEST message of a Class 1 EP, the receiving node shall respond with the message used to report unsuccessful outcome for this procedure, containing an appropriate cause value.
 - 2) Functionality which "shall, if supported" be executed:
 - The procedure text indicates that the receiving node "shall, if supported," perform a certain function Y under a certain condition. If the receiving node supports procedure X, but does not support functionality Y, the receiving node shall proceed with the execution of the EP, possibly informing the requesting node about the not supported functionality.
- Any required inclusion of an optional IE in a response message is explicitly indicated in the procedure text. If the procedure text does not explicitly indicate that an optional IE shall be included in a response message, the optional IE shall not be included.

4.2 Forwards and Backwards Compatibility

The forwards and backwards compatibility of the protocol is assured by mechanism where all current and future messages, and IEs or groups of related IEs, include Id and criticality fields that are coded in a standard format that will not be changed in the future. These parts can always be decoded regardless of the standard version.

4.3 Specification Notations

For the purposes of the present document, the following notations apply:

Procedure	When referring to an elementary procedure in the specification the Procedure Name is written with the first letters in each word in upper case characters followed by the word "procedure", e.g. Position Calculation procedure.
Message	When referring to a message in the specification the MESSAGE NAME is written with all letters in upper case characters followed by the word "message", e.g. POSITION CALCULATION REQUEST message.
IE	When referring to an information element (IE) in the specification the <i>Information Element Name</i> is written with the first letters in each word in upper case characters and all letters in Italic font followed by the abbreviation "IE", e.g. <i>Request Type</i> IE.

Value of an IE When referring to the value of an information element (IE) in the specification the "Value" is written as it is specified in clause 9.2 enclosed by quotation marks, e.g. "Abstract Syntax Error (Reject)" or "Geographical Coordinates".

5 PCAP Services

PCAP provides the signalling services between RNC and SAS that are required to fulfill the PCAP functions described in clause 7. PCAP services are categorized as follows:

1. Position Calculation Service: They are related to a single UE and involve the transfer of UE Positioning measurement data and UE position estimate data over the Iupc interface between the SRNC and the SAS. They utilise connectionless signalling transport provided by the Iupc signalling bearer.
2. Information Exchange Service: They involve the transfer of GPS related data over the Iupc interface between the RNC and the SAS on demand, on modification, or at regular intervals. They utilise connection-oriented signalling transport provided by the Iupc signalling bearer.

6 Services Expected from Signalling Transport

Signalling transport [3] shall provide the following service for the PCAP.

1. Connection oriented data transfer service. This service is supported by a signalling connection between the RNC and the SAS. It shall be possible to dynamically establish and release signalling connections based on the need. Each point-to-point operation shall have its own signalling connection. The signalling connection shall provide in sequence delivery of PCAP messages. PCAP shall be notified if the signalling connection breaks.
2. Connectionless data transfer service. PCAP shall be notified in case a PCAP message did not reach the intended peer PCAP entity.

7 Functions of PCAP

PCAP has the following functions:

- Position Calculation. This function enables the SRNC to interact with an SAS in the process of performing a position estimate of a UE.
- Information Exchange. This function enables the RNC to obtain GPS related data from an SAS.
- Reporting of General Error Situations. This function allows reporting of general error situations for which function specific error messages have not been defined.

The mapping between the above functions and PCAP elementary procedures is shown in the table 1.

Table 1: Mapping between functions and PCAP elementary procedures

Function	Elementary Procedure(s)
Position Calculation	a) Position Calculation
Information Exchange	a) Information Exchange Initiation b) Information Reporting c) Information Exchange Termination d) Information Exchange Failure
Reporting of General Error Situations	a) Error Indication

8 PCAP Procedures

8.1 Elementary Procedures

In the following tables, all EPs are divided into class 1 and class 2 EPs (see clause 3.1 for explanation of the different classes).

Table 2: Class 1

Elementary Procedure	Initiating Message	Successful Outcome	Unsuccessful Outcome
		Response message	Response message
Position Calculation	POSITION CALCULATION REQUEST	POSITION CALCULATION RESPONSE	POSITION CALCULATION FAILURE
Information Exchange Initiation	IIINFORMATION EXCHANGE INITIATION REQUEST	INFORMATION EXCHANGE INITIATION RESPONSE	INFORMATION EXCHANGE INITIATION FAILURE

Table 3: Class 2

Elementary Procedure	Message
Information Reporting	INFORMATION REPORT
Information Exchange Termination	INFORMATION EXCHANGE TERMINATION REQUEST
Information Exchange Failure	INFORMATION EXCHANGE FAILURE INDICATION
Error Indication	ERROR INDICATION

8.2 Position Calculation

8.2.1 General

The purpose of the Position Calculation procedure is to enable an SRNC to query an SAS for a position estimate of a UE. The procedure uses connectionless signalling.

8.2.2 Successful Operation

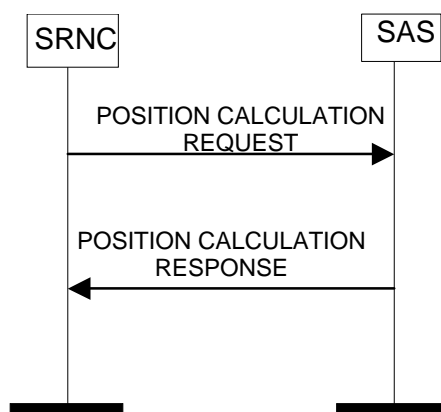

Figure 1: Position Calculation procedure, Successful Operation

The procedure is initiated with a POSITION CALCULATION REQUEST message sent from the SRNC to the SAS. When the SAS receives the POSITION CALCULATION REQUEST message, it shall calculate the UE position based on the provided measurement data.

If the *Initial UE Position Estimate* IE is included in the POSITION CALCULATION REQUEST message, the SAS shall use this value for the calculation of the UE Position Estimate in case of A-GPS positioning methods are used. The SAS may use this value for the calculation of the UE Position when any other methods are used.

If the *Horizontal Accuracy Code* IE and possibly the *Vertical Accuracy Code* IE are included in the POSITION CALCULATION REQUEST message, the SAS shall use these values in order to assess whether the resulting position estimation fulfills the requested accuracy.

Response Message:

If the SAS was able to calculate the position estimate, it shall respond with a POSITION CALCULATION RESPONSE message.

If at least the *Horizontal Accuracy Code* IE was included in the POSITION CALCULATION REQUEST message and the calculated position estimate fulfils the requested accuracy, the *Accuracy Fulfilment Indicator* IE with the value "requested accuracy fulfilled" shall be included in the POSITION CALCULATION RESPONSE message. If the calculated position estimate does not fulfil the requested accuracy, the *Accuracy Fulfilment Indicator* IE with the value "requested accuracy not fulfilled" shall be included in the POSITION CALCULATION RESPONSE message.

8.2.3 Unsuccessful Operation

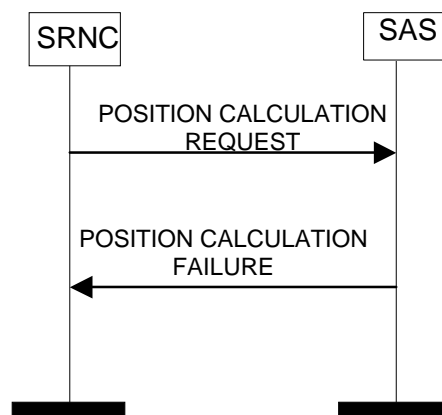

Figure 2: Position Calculation procedure, Unsuccessful Operation

If the SAS is unable to perform the position estimate for any reason, it shall return a POSITION CALCULATION FAILURE message to the SRNC.

Typical cause values are:

- Invalid reference information;
- Position calculation error: invalid GPS measured results;
- Initial UE Position Estimate missing;
- Processing Overload;
- Hardware Failure;
- O&M Intervention.

8.2.4 Abnormal Conditions

If the *Vertical Accuracy Code* IE is included and the *Horizontal Accuracy Code* IE is not included in the POSITION CALCULATION REQUEST message, the SAS shall reject the procedure.

If the *GPS Measured Results* IE is included in the POSITION CALCULATION REQUEST message but the *Initial UE Position Estimate* IE is not, the SAS shall return the POSITION CALCULATION FAILURE message to the SRNC.

If neither of the *GPS Measurement Results* IE, the *Cell-ID Measured Results Sets* IE nor the *OTDOA Measurement Group* IE is included in the POSITION CALCULATION REQUEST message, the SAS shall return the POSITION CALCULATION FAILURE message to the SRNC.

8.3 Information Exchange Initiation

8.3.1 General

This procedure is used by a RNC to request the initiation of an information exchange with a SAS.

This procedure uses the signalling bearer connection for the Information Exchange Context.

8.3.2 Successful Operation

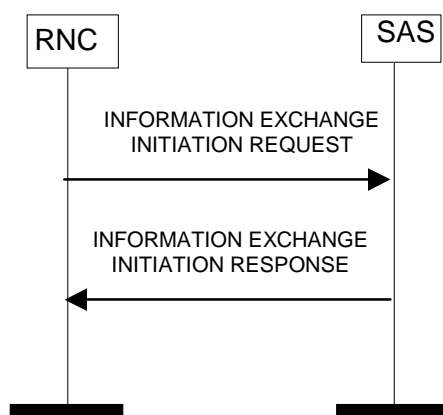

Figure 3: Information Exchange Initiation procedure, Successful Operation

The procedure is initiated with an INFORMATION EXCHANGE INITIATION REQUEST message sent from RNC to SAS.

If the *Information Type* IE is set to 'Implicit', the SAS is responsible for selecting the type of assistance data.

Upon reception, the SAS shall provide the requested information according to the parameters given in the request. Unless specified below, the meaning of the parameters are given in other specifications.

Information Report Characteristics:

The *Information Report Characteristics* IE indicates how the reporting of the information shall be performed.

If the *Information Report Characteristics* IE is set to 'On-Demand', the SAS shall report the requested information immediately.

If the *Information Report Characteristics* IE is set to "Periodic", the SAS shall report the requested information immediately and then shall periodically initiate the Information Reporting procedure for all the requested information, with the requested report frequency.

If the *Information Report Characteristics* IE is set to "On-Modification", the SAS shall report the requested information immediately if available. If the requested information is not available at the moment of receiving the INFORMATION EXCHANGE INITIATION REQUEST message, but expected to become available after some acquisition time, the SAS shall initiate the Information Reporting procedure when the requested information becomes available. The SAS shall then initiate the Information Reporting procedure in accordance to the following conditions:

- If the *Information Type* IE is set to "Explicit" and the *Explicit Information Item* IE includes "Almanac and Satellite Health", the SAS shall initiate the Information Reporting procedure for this specific Explicit

Information Type when a change in the t_{oa} or WN_a parameter has occurred in almanac/health information for at least one visible satellite.

- If the *Information Type* IE is set to "Explicit" and the *Explicit Information Item* IE includes "UTC Model", the SAS shall initiate the Information Reporting procedure for this specific Explicit Information Type when a change in the t_{ot} or WN_t parameter has occurred in the GPS UTC model.
 - If the *Transmission TOW Indicator* IE is set to "requested", then the SAS shall include the *GPS Transmission TOW* IE in the INFORMATION REPORT message.
- If the *Information Type* IE is set to 'Explicit' and the *Explicit Information Item* IE includes "Ionospheric Model", the SAS shall initiate the Information Reporting procedure for this specific Explicit Information Type when a change has occurred in the GPS ionospheric model.
 - If the *Transmission TOW Indicator* IE is set to "requested", then the SAS shall include the *GPS Transmission TOW* IE in the INFORMATION REPORT message.
- If the *Information Type* IE is set to "Explicit" and the *Explicit Information Item* IE includes "Navigation Model", the SAS shall initiate the Information Reporting procedure for this specific Explicit Information Type when a change has occurred in the clock/ephemeris information for at least one visible satellite or in the list of visible satellites.
 - If the *Transmission TOW Indicator* IE is set to "requested", then the SAS shall include the *GPS Transmission TOW* IE in the INFORMATION REPORT message.
- If the *Information Type* IE is set to "Explicit" and the *Explicit Information Item* IE includes "DGPS Corrections", the SAS shall initiate the Information Reporting procedure for this specific Explicit Information Type when a change has occurred in the quality of the DGPS corrections information for at least one visible satellite or in the list of visible satellites.
- If the *Information Type* IE is set to "Explicit" and the *Explicit Information Item* IE includes "Reference Time", the SAS shall initiate the Information Reporting procedure for this specific Explicit Information Type when a change has occurred in the time-of-week assistance information for at least one visible satellite or in the list of visible satellites.
- If the *Information Type* IE is set to "Explicit" and the *Explicit Information Item* IE includes "Acquisition Assistance", the SAS shall initiate the Information Reporting procedure for this specific Explicit Information Type when a change has occurred in acquisition assistance information for at least one visible satellite or in the list of visible satellites.
- If the *Information Type* IE is set to "Explicit" and the *Explicit Information Item* IE includes "Real Time Integrity", the SAS shall initiate the Information Reporting procedure for this specific Explicit Information Type when a change has occurred in the real-time integrity status of at least one visible satellite.
- If the *Information Type* IE is set to "Explicit" and the *Explicit Information Item* IE includes "Almanac and Satellite Health SIB", the SAS shall initiate the Information Reporting procedure for this specific Explicit Information Type when a change has occurred in almanac/health information for at least one visible satellite.
 - If the *Transmission TOW Indicator* IE is set to "requested", then the SAS shall include the *GPS Transmission TOW* IE in the INFORMATION REPORT message.
- If any of the above *Information Type* IEs becomes temporarily unavailable, the SAS shall initiate the Information Reporting procedure for this specific Information Item by indicating "Information Not Available" in the *Requested Data Value Information* IE. If the Information becomes available again, the SAS shall initiate the Information Reporting procedure for this specific Information.

Response message:

If the SAS is able to determine the information requested by the RNC, it shall respond with the INFORMATION EXCHANGE INITIATION RESPONSE message. The message shall include the same Information Exchange ID that was included in the INFORMATION EXCHANGE INITIATION REQUEST message. When the *Report Characteristics* IE is set to "On Modification" or "Periodic", the INFORMATION EXCHANGE INITIATION RESPONSE message shall contain the *Requested Data Value* IE if the data are available. When the *Report Characteristics* IE is set to "On Demand", the INFORMATION EXCHANGE INITIATION RESPONSE message shall contain the *Requested Data Value* IE.

When the response message includes data to be reported (see above), the SAS shall include at least one IE in the *Requested Data Value* IE.

8.3.3 Unsuccessful Operation

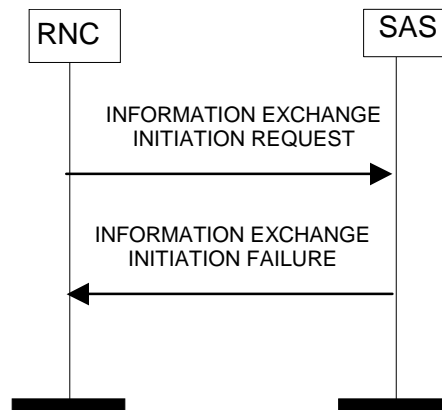

Figure 4: Information Exchange Initiation procedure, Unsuccessful Operation

If the requested Information Type received in the *Information Type* IE indicates a type of information that SAS cannot provide, the SAS shall regard the Information Exchange Initiation procedure as failed.

If the requested information provision cannot be carried out, the SAS shall send the INFORMATION EXCHANGE INITIATION FAILURE message. The message shall include the same Information Exchange ID that was used in the INFORMATION EXCHANGE INITIATION REQUEST message and the *Cause* IE set to an appropriate value.

Typical cause values are as follows:

- Information temporarily not available;
- Information Provision not supported for the object;
- Processing Overload;
- Hardware Failure;
- O&M Intervention.

8.3.4 Abnormal Conditions

-

8.4 Information Reporting

8.4.1 General

This procedure is used by a SAS to report the result of information requested by a RNC using the Information Exchange Initiation.

This procedure uses the signalling bearer connection for the Information Exchange Context.

8.4.2 Successful Operation

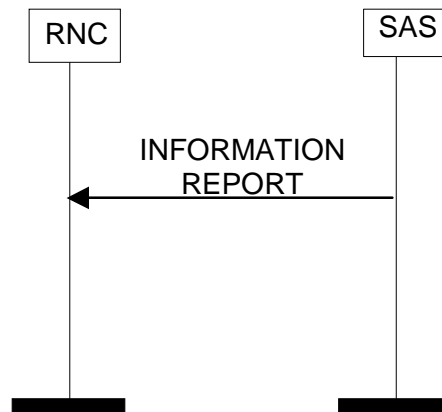

Figure 5: Information Reporting procedure, Successful Operation

If the requested information reporting criteria are met, the SAS shall initiate an Information Reporting procedure. Unless specified below, the meaning of the parameters are given in other specifications.

The *Information Exchange ID* IE shall be set to the Information Exchange ID provided by the RNC when initiating the information exchange with the Information Exchange Initiation procedure.

The *Requested Data Value* IE shall include at least one IE containing the data to be reported.

8.4.3 Abnormal Conditions

-

8.5 Information Exchange Termination

8.5.1 General

This procedure is used by a RNC to terminate the information exchange requested using the Information Exchange Initiation.

This procedure uses the signalling bearer connection for the Information Exchange Context.

8.5.2 Successful Operation

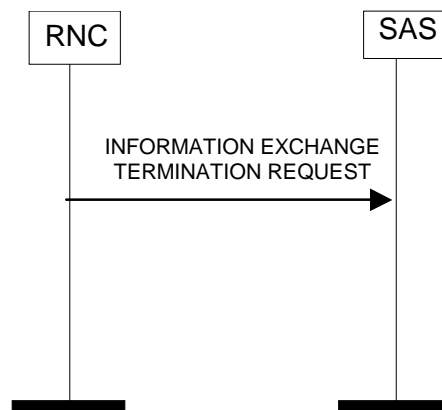

Figure 6: Information Exchange Termination procedure, Successful Operation

This procedure is initiated with an INFORMATION EXCHANGE TERMINATION REQUEST message.

Upon reception, the SAS shall terminate the information exchange corresponding to the Information Exchange ID.

8.5.3 Abnormal Conditions

-

8.6 Information Exchange Failure

8.6.1 General

This procedure is used by a SAS to notify a RNC that the information exchange it previously requested using the Information Exchange Initiation can no longer be reported.

This procedure uses the signalling bearer connection for the Information Exchange Context.

8.6.2 Successful Operation

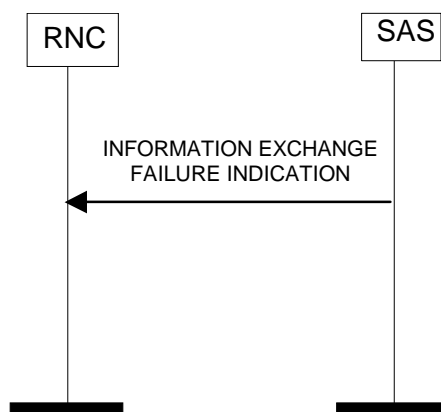

Figure 7: Information Exchange Failure procedure, Successful Operation

This procedure is initiated with a INFORMATION EXCHANGE FAILURE INDICATION message, sent from the SAS to the RNC, to inform the RNC that information previously requested by the Information Exchange Initiation procedure can no longer be reported. The message shall include the same Information Exchange ID that was used in the INFORMATION EXCHANGE INITIATION REQUEST message and the *Cause* IE set to an appropriate value.

Typical cause values are as follows:

- Information temporarily not available.

8.7 Error Indication

8.7.1 General

The Error Indication procedure is used by a node to report detected errors in one incoming message, provided they cannot be reported by an appropriate failure message.

8.7.2 Successful Operation

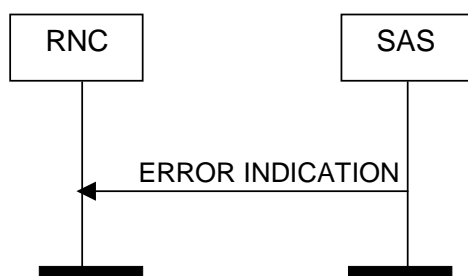

Figure 8: Error Indication procedure, SAS Originated, Successful Operation

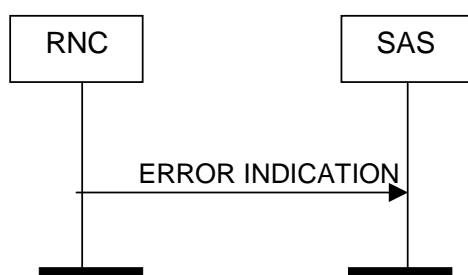

Figure 9: Error Indication procedure, RNC Originated, Successful Operation

When the conditions defined in clause 10 are fulfilled, the Error Indication procedure is initiated by an ERROR INDICATION message sent from the receiving node. This message shall use the same mode of the signalling bearer and the same signalling bearer connection (if connection oriented) as the message that triggers the procedure.

The ERROR INDICATION message shall include either the *Cause IE*, or the *Criticality Diagnostics IE*, or both the *Cause IE* and the *Criticality Diagnostics IE*.

Typical cause values are as follows:

- Transfer Syntax Error;
- Abstract Syntax Error (Reject);
- Abstract Syntax Error (Ignore and Notify);
- Message not Compatible with Receiver State;
- Unspecified.

8.7.3 Abnormal Conditions

-

9 Elements for PCAP Communication

9.1 Message Functional Definition and Content

9.1.1 General

Clause 9.1 presents the contents of PCAP messages in tabular format. The corresponding ASN.1 definitions are presented in clause 9.3. In case there is contradiction between the tabular format in clause 9.1 and the ASN.1 definition, the ASN.1 shall take precedence, except for the definition of conditions for the presence of conditional IEs, where the tabular format shall take precedence.

NOTE: The messages have been defined in accordance to the guidelines specified in [12].

9.1.2 Message Contents

9.1.2.1 Presence

All information elements in the message descriptions below are marked mandatory, optional or conditional according to table 4.

Table 4: Meaning of abbreviations used in PCAP messages

Abbreviation	Meaning
M	IEs marked as Mandatory (M) shall always be included in the message.
O	IEs marked as Optional (O) may or may not be included in the message.
C	IEs marked as Conditional (C) shall be included in a message only if the condition is satisfied. Otherwise the IE shall not be included.

9.1.2.2 Criticality

Each Information Element or Group of Information Elements may have a criticality information applied to it. Following cases are possible.

Table 5: Meaning of content within "Criticality" column

Abbreviation	Meaning
–	No criticality information is applied explicitly.
YES	Criticality information is applied. This is usable only for non-repeatable IEs
GLOBAL	The IE and all its repetitions together have one common criticality information. This is usable only for repeatable IEs.
EACH	Each repetition of the IE has its own criticality information. It is not allowed to assign different criticality values to the repetitions. This is usable only for repeatable IEs.

9.1.2.3 Range

The Range column indicates the allowed number of copies of repetitive IEs/IE groups.

9.1.2.4 Assigned Criticality

This column provides the actual criticality information as defined in clause 10.3.2, if applicable.

9.1.3 Position Calculation Request

Table 6

IE/Group Name	Presence	Range	IE type and reference	Semantics description	Criticality	Assigned Criticality
Message Type	M		9.2.2.24		YES	reject
Transaction ID	M		9.2.2.28		–	
Initial UE Position Estimate	O		Geographical Area 9.2.2.6		YES	reject
GPS Measured Results		<i>0..<maxNoOfSets ></i>			GLOBAL	reject
>GPS Measured Results	M		9.2.2.12		–	
Cell-ID Measured Results Sets		<i>0..<maxNoOfMeasurements></i>			GLOBAL	reject
>Cell-ID Measured Results Info List	M		9.2.2.31		–	
OTDOA Measurement Group		<i>0..1</i>			YES	reject
>OTDOA Reference Cell Info	M		9.2.2.34		–	
>OTDOA Neighbour Cell Info List		<i>1..<maxNoOfMeasNC ell ></i>			–	
>>OTDOA Neighbour Cell Info	M		9.2.2.33		–	
>OTDOA Measured Results Sets		<i>1..<maxNoOfMeasurements></i>			–	
>>OTDOA Measured Results Info List	M		9.2.2.32		–	
Horizontal Accuracy Code	O		9.2.2.38		YES	ignore
Vertical Accuracy Code	O		9.2.2.39		YES	ignore

Table 7

Range bound	Explanation
maxNoOfMeasNCell	Maximum number of neighbouring cells on which information can be reported. The value of maxNoOfMeasCell is 32.
maxNoOfSets	Maximum number of sets of Measured Results included in the Position Calculation Request message. The value for maxNoOfSets is 3.
maxNoOfMeasurements	Maximum number of Measurements of Cell-ID Measured Results Info List and OTDOA Measured Results Info List included in the Position Calculation Request message. The value for maxNoOfMeasurements is 16.

9.1.4 Position Calculation Response

Table 8

IE/Group Name	Presence	Range	IE type and reference	Semantics description	Criticality	Assigned Criticality
Message Type	M		9.2.2.24		YES	reject
Transaction ID	M		9.2.2.28		–	
UE Position Estimate	M		Geographical Area 9.2.2.6		YES	ignore
Criticality Diagnostics	O		9.2.2.4		YES	ignore
Accuracy Fulfilment Indicator	O		9.2.2.40		YES	ignore

9.1.5 POSITION CALCULATION FAILURE

Table 9

IE/Group Name	Presence	Range	IE type and reference	Semantics description	Criticality	Assigned Criticality
Message Type	M		9.2.2.24		YES	reject
Transaction ID	M		9.2.2.28		–	
Cause	M		9.2.2.3		YES	ignore
Criticality Diagnostics	O		9.2.2.4		YES	ignore

9.1.6 Information Exchange Initiation Request

Table 10

IE/Group Name	Presence	Range	IE Type and Reference	Semantics Description	Criticality	Assigned Criticality
Message Type	M		9.2.2.24		YES	reject
Transaction ID	M		9.2.2.28		–	
Information Exchange ID	M		9.2.2.19		YES	reject
CHOICE <i>Information Exchange Object Type</i>	M				YES	reject
> <i>Reference Position</i>					–	
>> <i>Reference Position Estimate/UE Initial Position</i>	M		Geographical Area 9.2.2.6		–	
Information Type	M		9.2.2.22		YES	reject
Information Report Characteristics	M		9.2.2.21		YES	reject
GPS-UTRAN Time Relationship Uncertainty	C-GPS		9.2.2.18		YES	reject

Table 11

Condition	Explanation
GPS	The IE shall be present if the information requested in the <i>Information Type</i> IE contains GPS-related data

9.1.7 Information Exchange Initiation Response

Table 12

IE/Group Name	Presence	Range	IE Type and Reference	Semantics Description	Criticality	Assigned Criticality
Message Type	M		9.2.2.24		YES	reject
Transaction ID	M		9.2.2.28		–	
Information Exchange ID	M		9.2.2.19		YES	ignore
CHOICE <i>Information Exchange Object Type</i>	O				YES	ignore
> <i>Reference Position</i>					–	
>>Requested Data Value	M		9.2.2.26		–	
Criticality Diagnostics	O		9.2.2.4		YES	ignore

9.1.8 Information Exchange Initiation Failure

Table 13

IE/Group Name	Presence	Range	IE Type and Reference	Semantics Description	Criticality	Assigned Criticality
Message Type	M		9.2.2.24		YES	reject
Transaction ID	M		9.2.2.28		–	
Information Exchange ID	M		9.2.2.19		YES	ignore
Cause	M		9.2.2.3		YES	ignore
Criticality Diagnostics	O		9.2.2.4		YES	ignore

9.1.9 Information Report

Table 14

IE/Group Name	Presence	Range	IE Type and Reference	Semantics Description	Criticality	Assigned Criticality
Message Type	M		9.2.2.24		YES	ignore
Transaction ID	M		9.2.2.28		–	
Information Exchange ID	M		9.2.2.19		YES	ignore
CHOICE <i>Information Exchange Object Type</i>	M				YES	ignore
> <i>Reference Position</i>					–	
>>Requested Data Value Information	M		9.2.2.27		–	

9.1.10 Information Exchange Termination Request

Table 15

IE/Group Name	Presence	Range	IE Type and Reference	Semantics Description	Criticality	Assigned Criticality
Message Type	M		9.2.2.24		YES	ignore
Transaction ID	M		9.2.2.28		–	
Information Exchange ID	M		9.2.2.19		YES	ignore

9.1.11 Information Exchange Failure Indication

Table 16

IE/Group Name	Presence	Range	IE Type and Reference	Semantics Description	Criticality	Assigned Criticality
Message Type	M		9.2.2.24		YES	ignore
Transaction ID	M		9.2.2.28		–	
Information Exchange ID	M		9.2.2.19		YES	ignore
Cause	M		9.2.2.3		YES	ignore

9.1.12 Error Indication

Table 17

IE/Group Name	Presence	Range	IE type and reference	Semantics description	Criticality	Assigned Criticality
Message Type	M		9.2.2.24		YES	ignore
Transaction ID	M		9.2.2.28		–	
Cause	O		9.2.2.3		YES	ignore
Criticality Diagnostics	O		9.2.2.4		YES	ignore

9.2 Information Element Functional Definitions and Contents

9.2.1 General

Clause 9.2 presents the PCAP IE definitions in tabular format. The corresponding ASN.1 definitions are presented in clause 9.3. In case there is contradiction between the tabular format in clause 9.2 and the ASN.1 definition, the ASN.1 shall take precedence, except for the definition of conditions for the presence of conditional elements, where the tabular format shall take precedence.

When specifying information elements which are to be represented by bitstrings, if not otherwise specifically stated in the semantics description of the concerned IE or elsewhere, the following principle applies with regards to the ordering of bits:

- The first bit (leftmost bit) contains the most significant bit (MSB);
- The last bit (rightmost bit) contains the least significant bit (LSB);
- When importing bitstrings from other specifications, the first bit of the bitstring contains the first bit of the concerned information;

9.2.2 Radio Network Layer Related IEs

9.2.2.1 Almanac and Satellite Health SIB

Table 18

IE/Group Name	Presence	Range	IE Type and Reference	Semantics Description
GPS Almanac and Satellite Health	M		9.2.2.9	
SatMask	M		BIT STRING(1..32)	indicates the satellites that contain the pages being broadcast in this data set
LSB TOW	M		BIT STRING (8)	

9.2.2.2 Altitude and direction

Table 19

IE/Group Name	Presence	Range	IE type and reference	Semantics description
Direction of Altitude	M		ENUMERATED (Height, Depth)	
Altitude	M		INTEGER (0..2 ¹⁵ -1)	The relation between the value (N) and the altitude (a) in meters it describes is $N \leq a < N+1$, except for $N=2^{15}-1$ for which the range is extended to include all greater values of (a).

9.2.2.3 Cause

The purpose of the cause information element is to indicate the reason for a particular event for the whole protocol.

Table 20

IE/Group Name	Presence	Range	IE Type and Reference	Semantics Description
CHOICE Cause Group				
<i>>Radio Network Layer</i>				
>>Radio Network Layer Cause	M		ENUMERATED (invalid reference information, information temporarily not available, information provision not supported for the object, position calculation error: invalid GPS measured results, ..., position calculation error: invalid Cell- ID measured results, position calculation error: invalid OTDOA measured results, position calculation error: A-GPS positioning method not supported, position calculation error: Cell-ID positioning method not supported, position calculation error: OTDOA positioning method not supported, Initial UE Position Estimate missing)	
<i>>Transport Layer</i>				
>>Transport Layer Cause	M		ENUMERATED (Transport Resource Unavailable, Unspecified, ...)	
<i>>Protocol</i>				
>>Protocol Cause	M		ENUMERATED (Transfer Syntax Error, Abstract Syntax Error (Reject), Abstract Syntax Error (Ignore and Notify), Message not Compatible with Receiver State, Semantic Error, Unspecified, Abstract Syntax Error (Falsely Constructed Message), ...)	
<i>> Misc</i>				
>>Misc Cause	M		ENUMERATED (Processing Overload, Hardware Failure, O&M Intervention, Unspecified, ...)	

The meaning of the different cause values is described in the following table. In general, "not supported" cause values indicate that the concerning capability is missing. On the other hand, "not available" cause values indicate that the concerning capability is present, but insufficient resources were available to perform the requested action.

Table 21

Radio Network Layer cause	Meaning
Invalid reference information	The reference information (GPS-UTRAN Time Relationship Uncertainty and/or Initial UE Position Estimate) provided by the RNC are invalid
Information temporarily not available	The information requested by RNC is temporarily not available
Information Provision not supported for the object	The SAS does not support provision of the requested information for the concerned object types
Position calculation error: invalid GPS measured results	The SAS cannot calculate position due to invalid GPS measured results
Position calculation error: invalid Cell-ID measured results	The SAS cannot calculate position due to invalid Cell-ID measured results
Position calculation error: invalid OTDOA measured results	The SAS cannot calculate position due to invalid OTDOA measured results
Position calculation error: A-GPS positioning method not supported	The SAS cannot calculate position because it does not support the A-GPS positioning method
Position calculation error: Cell-ID positioning method not supported	The SAS cannot calculate position because it does not support the Cell-ID positioning method
Position calculation error: OTDOA positioning method not supported	The SAS cannot calculate position because it does not support the OTDOA positioning method

Table 22

Transport Network Layer cause	Meaning
Transport resource unavailable	The required transport resources are not available
Unspecified	Sent when none of the above cause values applies but still the cause is Transport Network Layer related

Table 23

Protocol cause	Meaning
Abstract Syntax Error (Reject)	The received message included an abstract syntax error and the concerning criticality indicated "reject" (see clause 10.3)
Abstract Syntax Error (Ignore and Notify)	The received message included an abstract syntax error and the concerning criticality indicated "ignore and notify" (see clause 10.3)
Abstract syntax error (falsely constructed message)	The received message contained IEs or IE groups in wrong order or with too many occurrences (see clause 10.3)
Message not Compatible with Receiver State	The received message was not compatible with the receiver state (see clause 10.4)
Semantic Error	The received message included a semantic error (see clause 10.4)
Transfer Syntax Error	The received message included a transfer syntax error (see clause 10.2)
Unspecified	Sent when none of the above cause values applies but still the cause is Protocol related

Table 24

Miscellaneous cause	Meaning
Processing Overload	RNC/SAS processing overload
Hardware Failure	RNC/SAS hardware failure
O&M Intervention	Operation and Maintenance intervention related to RNC/SAS equipment
Unspecified	Sent when none of the above cause values applies and the cause is not related to any of the categories Radio Network Layer, Transport Network Layer or Protocol

9.2.2.4 Criticality Diagnostics

The *Criticality Diagnostics* IE is sent by the RNC or the SAS when parts of a received message have not been comprehended or are missing. It contains information about which IE was not comprehended or is missing.

For further details on how to use the *Criticality Diagnostics* IE, see annex A.

Table 25

IE/Group Name	Presence	Range	IE type and reference	Semantics description
Procedure Code	O		INTEGER (0..255)	
Triggering Message	O		ENUMERATED (initiating message, successful outcome, unsuccessful outcome, outcome)	The Triggering Message is used only if the Criticality Diagnostics is part of Error Indication.
Procedure Criticality	O		ENUMERATED (reject, ignore, notify)	This Procedure Criticality is used for reporting the Criticality of the Triggering message (Procedure).
Transaction ID	O		9.2.2.28	
Information Element Criticality Diagnostics		<i>0..<maxnoof errors></i>		
>IE Criticality	M		ENUMERATED (reject, ignore, notify)	The IE Criticality is used for reporting the criticality of the triggering IE. The value 'Ignore' shall never be used.
>IE Id	M		INTEGER (0..65535)	The IE Id of the not understood or missing IE as defined in the ASN.1 part of the specification.
>Repetition Number	O		INTEGER (0..255)	<p>The <i>Repetition Number</i> IE gives</p> <ul style="list-style-type: none"> - in case of a not understood IE: The number of occurrences of the reported IE up to and including the not understood occurrence - in case of a missing IE: The number of occurrences up to but not including the missing occurrence. <p>Note: All the counted occurrences of the reported IE must have the same top-down hierarchical message structure of IEs with assigned criticality above them.</p>
>Message Structure	O		9.2.2.23	The <i>Message Structure</i> IE describes the structure where the not understood or missing IE was detected. This IE is included if the not understood IE is not the top level of the message.
>Type of Error	M		ENUMERATED (not understood, missing, ...)	

Table 26

Range bound	Explanation
maxnooferrors	Maximum number of IE errors allowed to be reported with a single message. The value for maxnooferrors is 256.

9.2.2.5 DGPS Corrections

This IE contains DGPS corrections, which may be employed to compensate for ranging errors due to atmospheric delay, orbital modelling, and satellite clock drift.

Table 27

IE/Group Name	Presence	Range	IE Type and Reference	Semantics Description
GPS TOW sec	M		INTEGER (0..604799)	In seconds GPS time-of-week when the DGPS corrections were calculated
Status/Health	M		ENUMERATED (UDRE scale 1.0, UDRE scale 0.75, UDRE scale 0.5, UDRE scale 0.3, UDRE scale 0.2, UDRE scale 0.1, no data, invalid data)	
DPGS information	C- Status/Health	$1..<maxSat >$		
>SatID	M		INTEGER (0..63)	Identifies the satellite and is equal to (SV ID No - 1) where SV ID No is defined in [10].
>IODE	M		INTEGER (0..255)	
>UDRE	M		ENUMERATED (UDRE \leq 1.0 m, 1.0m < UDRE \leq 4.0m, 4.0m < UDRE \leq 8.0m, 8.0m < UDRE)	The value in this field shall be multiplied by the UDRE Scale Factor in the IE Status/Health to determine the final UDRE estimate for the particular satellite.
>PRC	M		INTEGER (-2047..2047.)	Scaling factor 0.32 Meters
>Range Rate Correction	M		INTEGER (-127..127)	Scaling factor 0.032 meters/sec

Table 28

Condition	Explanation
Status/Health	This IE shall be present if the <i>Status/Health</i> IE is not equal to "no data" or "invalid data"

Table 29

Range bound	Explanation
maxSat	Maximum number of satellites for which data is included in this IE. The value for maxSat is 16.

9.2.2.6 Geographical Area

Geographical Area IE is used to identify an area using geographical coordinates. The reference system is the same as the one used in [11].

Table 30

IE/Group Name	Presence	Range	IE type and reference	Semantics description
CHOICE <i>Geographical Area</i>				
> <i>Point</i>				Ellipsoid point
>>Geographical Coordinates	M		9.2.2.7	
> <i>Point With Uncertainty</i>				Ellipsoid point with uncertainty circle
>>Geographical Coordinates	M		9.2.2.7	
>>Uncertainty Code	M		INTEGER (0..127)	The uncertainty "r" expressed in meters is derived from the "Uncertainty Code" k by $r = 10x(1.1^{k-1})$
> <i>Polygon</i>				List of Ellipsoid points
>> Polygon		1..<maxnoofPoints>		
>>>Geographical Coordinates	M		9.2.2.7	
> <i>Ellipsoid point with uncertainty Ellipse</i>				
>>Geographical Coordinates	M		9.2.2.7	
>>Uncertainty Ellipse	M		9.2.2.30	
>>Confidence	M		INTEGER (0..100)	In percentage
> <i>Ellipsoid point with altitude</i>				
>>Geographical Coordinates	M		9.2.2.7	
>>Altitude and direction	M		9.2.2.2	
> <i>Ellipsoid point with altitude and uncertainty Ellipsoid</i>				
>>Geographical Coordinates	M		9.2.2.7	
>>Altitude and direction	M		9.2.2.2	
>>Uncertainty Ellipse	M		9.2.2.30	
>>Uncertainty Altitude	M		INTEGER (0..127)	The uncertainty altitude 'h' expressed in metres is derived from the 'Uncertainty Altitude' k, by: $h=45x(1.025^k-1)$
>>Confidence	M		INTEGER (0..100)	In percentage
> <i>Ellipsoid Arc</i>				
>>Geographical Coordinates	M		9.2.2.7	
>>Inner radius	M		INTEGER (0..2 ¹⁶ -1)	The relation between the value (N) and the radius (r) in meters it describes is $5N \leq r < 5(N+1)$, except for $N=2^{16}-1$ for which the range is extended to include all greater values of (r).
>>Uncertainty radius	M		INTEGER (0..127)	The uncertainty "r" is derived from the "Uncertainty radius" k by $r = 10x(1.1^{k-1})$

IE/Group Name	Presence	Range	IE type and reference	Semantics description
>>Offset angle	M		INTEGER (0..179)	The relation between the value (N) and the angle (a) in degrees it describes is $2N \leq a < 2(N+1)$
>>Included angle	M		INTEGER (0..179)	The relation between the value (N) and the angle (a) in degrees it describes is $2N < a \leq 2(N+1)$
>>Confidence	M		INTEGER (0..100)	

Table 31

Range bound	Explanation
maxnoofPoints	Maximum no. of points in polygon. Value is 15.

9.2.2.7 Geographical Coordinates

This IE contains the geographical coordinates.

Table 32

IE/Group Name	Presence	Range	IE type and reference	Semantics description
Latitude Sign	M		ENUMERATED (North, South)	
Degrees Of Latitude	M		INTEGER (0.. $2^{23}-1$)	The IE value (N) is derived by this formula: $N \leq 2^{23} X / 90 < N+1$ X being the latitude in degree (0°.. 90°)
Degrees Of Longitude	M		INTEGER (-2^{23} .. $2^{23}-1$)	The IE value (N) is derived by this formula: $N \leq 2^{24} X / 360 < N+1$ X being the longitude in degree (-180°..+180°)

9.2.2.8 GPS Acquisition Assistance

This IE contains parameters that enable fast acquisition of the GPS signals in UE-assisted GPS positioning.

Table 33

IE/Group Name	Presence	Range	IE Type and Reference	Semantics Description
GPS TOW msec	M		INTEGER (0..6.048*10 ⁸ -1)	GPS Time of Week in milliseconds (rounded down to the nearest millisecond unit).
Satellite information		<i>1..<maxSat</i> >		
>SatID	M		INTEGER (0..63)	Identifies the satellite and is equal to (SV ID No - 1) where SV ID No is defined in [10].
>Doppler (0 th order term)	M		INTEGER (-2048..2047)	Scaling factor 2.5Hz
>Extra Doppler		<i>0..1</i>		
>>Doppler (1 st order term)	M		INTEGER (-42..21)	Scaling factor 1/42
>>Doppler Uncertainty	M		ENUMERATED (12.5,25,50,100,200,...)	In Hz
>Code Phase	M		INTEGER (0..1022)	In Chips, specifies the centre of the search window
>Integer Code Phase	M		INTEGER (0..19)	Number of 1023 chip segments
>GPS Bit number	M		INTEGER (0..3)	Specifies GPS bit number (20 1023 chip segments)
>Code Phase Search Window	M		ENUMERATED (1023,1,2,3,4,6,8,12,16,24,32,48,64,96,128,192)	Specifies the width of the search window.
>Azimuth and Elevation		<i>0..1</i>		
>>Azimuth	M		INTEGER (0..31)	Scaling factor 11.25 Degrees
>>Elevation	M		INTEGER (0..7)	Scaling factor 11.25 Degrees

Table 34

Range bound	Explanation
maxSat	Maximum number of satellites for which data is included in this IE. The value of maxSat is 16.

9.2.2.9 GPS Almanac and Satellite Health

This IE contains a reduced-precision subset of the clock and ephemeris parameters.

Table 35

IE/Group Name	Presence	Range	IE Type and Reference	Semantics Description
WN _a	M		BIT STRING (8)	
Satellite information		<i>1..<maxSat Almanac></i>		
>DataID	M		BIT STRING (2)	See [10]
>SatID	M		INTEGER (0..63)	Identifies the satellite and is equal to (SV ID No - 1) where SV ID No is defined in [10].
>e	M		BIT STRING (16)	Eccentricity [10]
>t _{oa}	M		BIT STRING (8)	Reference Time of Almanac [10]
>δi	M		BIT STRING (16)	Correction to Inclination (semi-circles) [10]
>OMEGADOT	M		BIT STRING (16)	Rate of Right Ascension (semi-circles/sec) [10]
>SV Health	M		BIT STRING (8)	[10]
>A ^{1/2}	M		BIT STRING (24)	Semi-Major Axis (meters) ^{1/2} [10]
>OMEGA ₀	M		BIT STRING (24)	Longitude of Ascending Node of Orbit Plane at Weekly Epoch (semi-circles) [10]
>M ₀	M		BIT STRING (24)	Mean Anomaly at Reference Time (semi-circles) [10]
>ω	M		BIT STRING (24)	Argument of Perigee (semi-circles) [10]
>af ₀	M		BIT STRING (11)	apparent clock correction [10]
>af ₁	M		BIT STRING (11)	apparent clock correction [10]
SV Global Health	O		BIT STRING (364)	This enables GPS time recovery and possibly extended GPS correlation intervals

Table 36

Range bound	Explanation
maxSatAlmanac	Maximum number of satellites for which data is included in this IE. The value of maxSatAlmanac is 32.

9.2.2.10 GPS Clock and Ephemeris Parameters

The IE contains the GPS clock information and GPS Ephemeris.

Table 37

IE/Group Name	Presence	Range	IE Type and Reference	Semantics Description
C/A or P on L2	M		BIT STRING (2)	Code(s) on L2 Channel [10]
URA Index	M		BIT STRING (4)	User Range Accuracy [10]
SV Health	M		BIT STRING (6)	[10]
IODC	M		BIT STRING (10)	Issue of Data, Clock [10]
L2 P Data Flag	M		BIT STRING (1)	[10]
SF 1 Reserved	M		BIT STRING (87)	[10]
T _{GD}	M		BIT STRING (8)	Estimated group delay differential [10]
t _{oc}	M		BIT STRING (16)	apparent clock correction [10]
af ₂	M		BIT STRING (8)	apparent clock correction [10]
af ₁	M		BIT STRING (16)	apparent clock correction [10]
af ₀	M		BIT STRING (22)	apparent clock correction [10]
C _{rs}	M		BIT STRING (16)	Amplitude of the Sine Harmonic Correction Term to the Orbit Radius (meters) [10]
Δn	M		BIT STRING (16)	Mean Motion Difference From Computed Value (semi-circles/sec) [10]
M ₀	M		BIT STRING (32)	Mean Anomaly at Reference Time (semi-circles) [10]
C _{uc}	M		BIT STRING (16)	Amplitude of the Cosine Harmonic Correction Term To The Argument Of Latitude (radians) [10]
e	M		BIT STRING (32)	Eccentricity [10]
C _{us}	M		BIT STRING (16)	Amplitude of the Sine Harmonic Correction Term To The Argument Of Latitude (radians) [10]
(A) ^{1/2}	M		BIT STRING (32)	Semi-Major Axis (meters) ^{1/2} [10]
t _{oe}	M		BIT STRING (16)	Reference Time Ephemeris [10]
Fit Interval Flag	M		BIT STRING (1)	[10]
AODO	M		BIT STRING (5)	Age Of Data Offset [10]
C _{ic}	M		BIT STRING (16)	Amplitude of the Cosine Harmonic Correction Term To The Angle Of Inclination (radians) [10]
OMEGA ₀	M		BIT STRING (32)	Longitude of Ascending Node of Orbit Plane at Weekly Epoch (semi-circles) [10]
C _{is}	M		BIT STRING (16)	Amplitude of the Sine Harmonic Correction Term To The Angle Of Inclination (radians) [10]
i ₀	M		BIT STRING (32)	Inclination Angle at Reference Time (semi-circles) [10]
C _{rc}	M		BIT STRING (16)	Amplitude of the Cosine Harmonic Correction Term to the Orbit Radius (meters) [10]

ω	M		BIT STRING (32)	Argument of Perigee (semi-circles) [10]
OMEGAdot	M		BIT STRING (24)	Rate of Right Ascension (semi-circles/sec) [10]
ldot	M		BIT STRING (14)	Rate of Inclination Angle (semi-circles/sec) [10]

9.2.2.11 GPS Ionospheric Model

The IE contains fields needed to model the propagation delays of the GPS signals through the ionosphere.

Table 38

IE/Group Name	Presence	Range	IE Type and Reference	Semantics Description
α_0	M		BIT STRING (8)	NOTE 1
α_1	M		BIT STRING (8)	NOTE 1
α_2	M		BIT STRING (8)	NOTE 1
α_3	M		BIT STRING (8)	NOTE 1
β_0	M		BIT STRING (8)	NOTE 2
β_1	M		BIT STRING (8)	NOTE 2
β_2	M		BIT STRING (8)	NOTE 2
β_3	M		BIT STRING (8)	NOTE 2

NOTE 1: The parameters α_n are the coefficients of a cubic equation representing the amplitude of the vertical delay [10].

NOTE 2: The parameters β_n are the coefficients of a cubic equation representing the period of the ionospheric model [10].

9.2.2.12 GPS Measured Results

The purpose of this information element is to provide reported GPS measurement information from the SRNC to the SAS.

Table 39

IE/Group Name	Presence	Range	IE Type and Reference	Semantics Description
GPS TOW msec	M		INTEGER (0..6.048*10 ⁸ -1)	GPS Time of Week in milliseconds (rounded down to the nearest millisecond unit).
Measurement Parameters		1..<maxSat >		
>Satellite ID	M		INTEGER (0..63)	Identifies the satellite and is equal to (SV ID No - 1) where SV ID No is defined in [10].
>C/N ₀	M		INTEGER (0..63)	The estimate of the carrier-to-noise ratio of the received signal from the particular satellite used in the measurement. It is given in units of dB-Hz (Typical levels will be in the range of 20 – 50 dB-Hz).
>Doppler	M		INTEGER (-32768..-32768)	Hz, scale factor 0.2.
>Whole GPS Chips	M		INTEGER (0..1022)	Unit in GPS chips
>Fractional GPS Chips	M		INTEGER (0..(2 ¹⁰ -1))	Scale factor 2 ⁻¹⁰
>Multipath Indicator	M		ENUMERATED (NM, low, medium, high)	See NOTE 1
>Pseudorange RMS Error	M		INTEGER (0..63)	See NOTE 2

NOTE 1: Table 41 gives the mapping of the multipath indicator field.

NOTE 2: Table 42 gives the bitmapping of the Pseudorange RMS Error field.

Table 40

Range bound	Explanation
maxSat	Maximum number of satellites for which data is included in this IE. The value of maxSat is 16.

Table 41

Value	Multipath Indication
NM	Not measured
Low	MP error < 5m
Medium	5m < MP error < 43m
High	MP error > 43m

Table 42

Value	Mantissa	Exponent	Floating-Point value, x_i	Pseudorange value, P
0	000	000	0.5	$P < 0.5$
1	001	000	0.5625	$0.5 \leq P < 0.5625$
i	X	Y	$0.5 * (1 + x/8) * 2^y$	$x_{i-1} \leq P < x_i$
62	110	111	112	$104 \leq P < 112$
63	111	111	--	$112 \leq P$

9.2.2.13 GPS Navigation Model

This IE contain information required to manage the transfer of precise navigation data to the GPS-capable UE.

Table 43

IE/Group Name	Presence	Range	IE Type and Reference	Semantics Description
Satellite information		$1..<maxSat>$		
>SatID	M		INTEGER (0..63)	Identifies the satellite and is equal to (SV ID No - 1) where SV ID No is defined in [10].
>Satellite Status	M		ENUMERATED (NS_NN, ES_SN, ES_NN, REVD)	See NOTE
>GPS Clock and Ephemeris parameters	C-Satellite status		9.2.2.10	

NOTE: The UE shall interpret enumerated symbols as follows.

Table 44

Value	Indication
NS_NN	New satellite, new Navigation Model
ES_SN	Existing satellite, same Navigation Model
ES_NN	Existing satellite, new Navigation Model
REVD	Reserved

Table 45

Condition	Explanation
Satellite status	The IE shall be present if the <i>Satellite Status</i> IE is not set to ES_SN

Table 46

Range bound	Explanation
maxSat	Maximum number of satellites for which data is included in this IE. The value of maxSat is 16.

9.2.2.14 GPS Real Time Integrity

Table 47

IE/Group Name	Presence	Range	IE Type and Reference	Semantics Description
CHOICE <i>Bad Satellites Presence</i>				
> <i>Bad Satellites</i>				
>> Satellite information		1..<maxNoSat>		
>>>BadSatID	M		INTEGER (0..63)	Identifies the satellite and is equal to (SV ID No - 1) where SV ID No is defined in [10].
> <i>No Bad Satellites</i>			NULL	

Table 48

Range bound	Explanation
maxNoSat	Maximum number of satellites for which data is included in this IE. The value of maxNoSat is 16.

9.2.2.15 GPS Reference Time

Table 49

IE/Group Name	Presence	Range	IE Type and Reference	Semantics Description
GPS Week	M		INTEGER (0..1023)	
GPS TOW msec	M		INTEGER (0..6.048*10 ⁸ -1)	GPS Time of Week in milliseconds (rounded down to the nearest millisecond unit).
GPS TOW Assist		0..<maxSat>		
>SatID	M		INTEGER (0..63)	Identifies the satellite and is equal to (SV ID No - 1) where SV ID No is defined in [10].
>TLM Message	M		BIT STRING (14)	
>Anti-Spoof	M		BOOLEAN	
>Alert	M		BOOLEAN	
>TLM Reserved	M		BIT STRING (2)	

Table 50

Range bound	Explanation
maxSat	Maximum number of satellites for which data is included in this IE. The value of maxSat is 16.

9.2.2.16 GPS Transmission TOW

Table 51

IE/Group Name	Presence	Range	IE Type and Reference	Semantics Description
GPS Transmission TOW			INTEGER (0..604799)	The GPS time-of-week in seconds

9.2.2.17 GPS UTC Model

The UTC Model field contains a set of parameters needed to relate GPS time to Universal Time Coordinate (UTC).

Table 52

IE/Group Name	Presence	Range	IE Type and Reference	Semantics Description
A_1	M		BIT STRING (24)	sec/sec [10]
A_0	M		BIT STRING (32)	seconds [10]
t_{ot}	M		BIT STRING (8)	seconds [10]
Δt_{LS}	M		BIT STRING (8)	seconds [10]
WN_t	M		BIT STRING (8)	weeks [10]
WN_{LSF}	M		BIT STRING (8)	weeks [10]
DN	M		BIT STRING (8)	days [10]
Δt_{LSF}	M		BIT STRING (8)	seconds [10]

9.2.2.18 GPS-UTRAN Time Relationship Uncertainty

This IE contains the uncertainty of the GPS and UTRAN time relationship.

Table 53

IE/Group Name	Presence	Range	IE Type and Reference	Semantics Description
GPS-UTRAN Time Relationship Uncertainty			ENUMERATED (50ns, 500ns, 1us, 10us, 1ms, 10ms, 100ms, unreliable,...)	RNC estimate of uncertainty in GPS-UTRAN time relationship

9.2.2.19 Information Exchange ID

The Information Exchange ID uniquely identifies any requested information per RNC-SAS pair.

Table 54

IE/Group Name	Presence	Range	IE Type and Reference	Semantics Description
Information Exchange ID			INTEGER (0 .. 2^20-1)	

9.2.2.20 Information Exchange Object Type

Void.

9.2.2.21 Information Report Characteristics

The information report characteristics define how the reporting shall be performed.

Table 56

IE/Group Name	Presence	Range	IE Type and Reference	Semantics Description
Information Report Characteristics Type	M		ENUMERATED(On Demand, Periodic, On Modification, ...)	
CHOICE <i>Information Report Periodicity</i>	C-Periodic			Indicates the frequency with which the SAS shall send broadcast data reports.
> <i>Min</i>				
>>Minutes	M		INTEGER (1..60, ...)	
> <i>Hour</i>				
>>Hours	M		INTEGER (1..24, ...)	

Table 57

Condition	Explanation
Periodic	This IE shall be present if the <i>Information Report Characteristics Type</i> IE indicates 'periodic'

9.2.2.22 Information Type

The Information Type indicates which kind of information the SAS shall provide.

Table 58

IE/Group Name	Presence	Range	IE Type and Reference	Semantics Description
CHOICE <i>Information Type</i>				
> <i>Implicit</i>				
>>Method Type	M		9.2.2.25	
> <i>Explicit</i>				
>> Explicit Information		1..<maxnoofExplInfo>		
>>>CHOICE <i>Explicit Information Item</i>	M			
>>>>Almanac and Satellite Health			NULL	
>>>>UTC Model				
>>>>>Transmission TOW Indicator	M		9.2.2.29	
>>>>Ionospheric Model				
>>>>>Transmission TOW Indicator	M		9.2.2.29	
>>>>Navigation Model				
>>>>>Transmission TOW Indicator	M		9.2.2.29	
>>>>> Nav. Model Additional Data		0..1		
>>>>>>GPS Week	M		INTEGER (0..1023)	
>>>>>>GPS_Toe	M		INTEGER (0..167)	GPS time of ephemeris in hours of the latest ephemeris set
>>>>>>T-Toe limit	M		Integer (0..10)	ephemeris age tolerance in hours
>>>>>> Satellite related data		0..<maxSat>		
>>>>>>>SatID	M		INTEGER (0..63)	Identifies the satellite and is equal to (SV ID No - 1) where SV ID No is defined in [10].
>>>>>>>IODE	M		INTEGER (0..255)	Issue of Data Ephemeris for SatID
>>>>DGPS Corrections			NULL	
>>>>Reference Time			NULL	
>>>>Acquisition Assistance			NULL	
>>>>Real Time Integrity			NULL	
>>>>Almanac and Satellite Health SIB				
>>>>>Transmission TOW Indicator	M		9.2.2.29	

Table 59

Range Bound	Explanation
maxnoofExplInfo	Maximum number of Explicit Information supported in one Information Exchange. The value of maxnoofExplInfo is 32.
maxSat	Maximum number of satellites for which data is included in this IE. The value of maxSat is 16.

9.2.2.23 Message Structure

The *Message Structure* IE gives information for each level with assigned criticality in an hierarchical message structure from top level down to the lowest level above the reported level for the occurred error (reported in the *Information Element Criticality Diagnostics* IE).

Table 60

IE/Group Name	Presence	Range	IE type and reference	Semantics description
Message structure		<i>1..<maxnooflevels></i>		The first repetition of the <i>Message Structure</i> IE corresponds to the top level of the message. The last repetition of the <i>Message Structure</i> IE corresponds to the level above the reported level for the occurred error of the message.
>IE ID	M		INTEGER (0..65535)	The IE ID of this level's IE containing the not understood or missing IE.
>Repetition Number	O		INTEGER (1..256)	The <i>Repetition Number</i> IE gives, if applicable, the number of occurrences of this level's reported IE up to and including the occurrence containing the not understood or missing IE. Note: All the counted occurrences of the reported IE must have the same top-down hierarchical message structure of IEs with assigned criticality above them.

Table 61

Range bound	Explanation
maxnooflevels	Maximum no. of message levels to report. The value for maxnooflevels is 256.

9.2.2.24 Message Type

Message Type IE uniquely identifies the message being sent. It is mandatory for all messages.

Table 62

IE/Group Name	Presence	Range	IE Type and Reference	Semantics Description
Procedure Code	M		INTEGER(0..255)	'1' = Position Calculation '2' = Information Exchange Initiation '3' = Information Reporting '4' = Information Exchange Termination, '5' = Information Exchange Failure '6' = Error Indication,
Type of Message	M		ENUMERATED (Initiating Message, Successful Outcome, Unsuccessful Outcome, Outcome)	

9.2.2.25 Method Type

Table 63

IE/Group Name	Presence	Range	IE Type and Reference	Semantics Description
Method Type			ENUMERATED (UE_Assisted, UE_Based)	

9.2.2.26 Requested Data Value

The Requested Data Value contains the relevant data concerning the ongoing information exchange.

Table 64

IE/Group Name	Presence	Range	IE Type and Reference	Semantics Description
GPS Almanac and Satellite Health	O		9.2.2.9	
GPS UTC Model	O		9.2.2.17	
GPS Ionospheric Model	O		9.2.2.11	
GPS Navigation Model	O		9.2.2.13	
DGPS Corrections	O		9.2.2.5	
GPS Reference Time	O		9.2.2.15	
GPS Acquisition Assistance	O		9.2.2.8	
GPS Real Time Integrity	O		9.2.2.14	
Almanac and Satellite Health SIB	O		9.2.2.1	
GPS Transmission TOW	O		9.2.2.16	

9.2.2.27 Requested Data Value Information

The *Requested Data Value Information* IE provides information on whether or not the Requested Data Value is available in the message and also the Requested Data Value itself if available.

In case of "Periodic" and "On Modification" reporting, "Information Not Available" shall be used when at least one part of the requested information was not available at the moment of initiating the Information Reporting procedure.

Table 65

IE/Group Name	Presence	Range	IE Type and Reference	Semantics Description	Criticality	Assigned Criticality
CHOICE <i>Information Availability Indicator</i>	M				–	
> <i>Information Available</i>					–	
>>Requested Data Value	M		9.2.2.26		–	
> <i>Information not Available</i>			NULL		–	

9.2.2.28 Transaction ID

The Transaction ID is used to associate all the messages belonging to the same procedure. Messages belonging to the same procedure shall use the same Transaction ID.

The Transaction ID is determined by the initiating peer of a procedure.

The Transaction ID shall uniquely identify a procedure among all ongoing parallel procedures using the same procedure code, and initiated by the same protocol peer.

Table 66

IE/Group Name	Presence	Range	IE Type and Reference	Semantics Description
CHOICE <i>Transaction ID Length</i>				The Transaction ID shall be interpreted for its integer value, not for the type of encoding ("short" or "long").
> <i>Short</i>				
>>Transaction ID Value	M		INTEGER (0..127)	
> <i>Long</i>				
>>Transaction ID Value	M		INTEGER (0..32767)	

9.2.2.29 Transmission TOW Indicator

Table 67

IE/Group Name	Presence	Range	IE Type and Reference	Semantics Description
Transmission TOW Indicator			ENUMERATED (requested, not requested)	

9.2.2.30 Uncertainty Ellipse

This IE contains the uncertainty ellipse of a geographical area.

Table 68

IE/Group Name	Presence	Range	IE type and reference	Semantics description
Uncertainty semi-major	M		INTEGER (0..127)	The uncertainty "r" is derived from the "uncertainty code" k by $r = 10 \times (1.1^k - 1)$
Uncertainty semi-minor	M		INTEGER (0..127)	The uncertainty "r" is derived from the "uncertainty code" k by $r = 10 \times (1.1^k - 1)$
Orientation of major axis	M		INTEGER (0..89)	The relation between the IE value (N) and the angle (a) in degrees it describes is $2N \leq a < 2(N+1)$

9.2.2.31 Cell-ID Measured Results Info List

This IE contains the Cell-ID measurements of signals associated with one or more cells.

Table 69

IE/Group Name	Presence	Range	IE Type and Reference	Semantics Description
Cell-ID Measured Results Info		<i>1..<maxNoOfMeasNCell></i>		
>UC-ID	M		9.2.2.37	The identifier of the measured cell.
>UTRAN Access Point Position with Altitude	M		9.2.2.36	Exact geographical position of the base station antenna.
>Geographical Area	O		9.2.2.6	
>Round Trip Time Info		<i>0..1</i>		FDD only
>>UE Rx-Tx Time Difference Type 2	M		INTEGER (0..8191)	According to mapping in [13].
>>UE Positioning Measurement Quality	M		9.2.2.35	Quality of the UE Rx-Tx time difference measurement.
>>Round Trip Time	M		INTEGER (0..32766)	According to mapping in [13].
>Rx Timing Deviation Info		<i>0..1</i>		3.84Mcps TDD only
>>Rx Timing Deviation	M		INTEGER (0..8191)	According to mapping in [14].
>>Timing Advance	M		INTEGER (0..63)	According to [4].
>Rx Timing Deviation LCR Info		<i>0..1</i>		1.28Mcps TDD only
>>Rx Timing Deviation LCR	M		INTEGER (0..511)	According to mapping in [14].
>>Timing Advance LCR	M		INTEGER (0..2047)	According to mapping in [14].
>Pathloss	O		INTEGER (46..158)	Unit: dB downlink pathloss as defined in [4] subclause 10.3.7.3

Table 70

Range bound	Explanation
maxNoOfMeasNCell	Maximum number of neighbour cells on which information can be reported. The value of maxNoOfMeasNCell is 32.

9.2.2.32 OTDOA Measured Results Info List

This IE contains the OTDOA measurements of signals sent from the reference and neighbour cells.

Table 71

IE/Group Name	Presence	Range	IE Type and Reference	Semantics Description
OTDOA Measured Results Info		1..<MaxnoofMeasNCell>		
>UC-ID	M		9.2.2.37	The identifier of the neighbour cell.
>UE SFN-SFN Observed Time Difference Type 2 Info		1		
>>SFN-SFN Observed Time Difference Type 2	M		INTEGER (0..40961)	Gives the observed timing of the neighbour cell relative to the reference cell.
>>UE Positioning Measurement Quality	M		9.2.2.35	Quality of the observed time difference measurement.
>>Measurement Delay	M		INTEGER (0..65535)	The interval of time, in units of 10ms frames, spanning the following two events: 1) Time of applicability of the SFN-SFN Value or TUTRAN-GPS/SFN relationship provided for the corresponding neighbour cell in 9.2.2.33. 2) The point in time when this corresponding SFN-SFN observed time difference measurement was captured by the UE.

Table 72

Range bound	Explanation
MaxNoOfMeasNCell	Maximum number of neighbouring cells on which information can be reported. The value of MaxNoOfMeasNCell is 32.

9.2.2.33 OTDOA Neighbour Cell Info

Table 73

IE/Group Name	Presence	Range	IE Type and Reference	Semantics Description
UC-ID	M		9.2.2.37	The identifier of the neighbour cell.
UTRAN Access Point Position with Altitude	M		9.2.2.36	Exact geographical position of the base station antenna.
CHOICE <i>Relative Timing Difference Info</i>	M			
> <i>SFN-SFN Measurement Value Information</i>				
>>SFN-SFN Value	M		INTEGER (0..614399)	
>>SFN-SFN Quality	O		INTEGER (0..255)	Indicates the standard deviation (std) of the SFN-SFN otd (observed time difference) measurements in 1/16 chip. SFN-SFN Quality = $\sqrt{E[(x-\mu)^2]}$ = std of reported SFN-SFN Value, where x is the reported SFN-SFN Value and $\mu = E[x]$ is the expectation value of x.
>>SFN-SFN Drift Rate	M		INTEGER (-100..+100)	Indicates the SFN-SFN drift rate in 1/256 chip per second. A positive value indicates that the Reference cell clock is running at a greater frequency than the measured neighbouring cell.
>>SFN-SFN Drift Rate Quality	O		INTEGER (0..100)	Indicates the standard deviation (std) of the SFN-SFN drift rate measurements in 1/256 chip per second. SFN-SFN Drift Rate Quality = $\sqrt{E[(x-\mu)^2]}$ = std of reported SFN-SFN Drift Rate, where x is the reported SFN-SFN Drift Rate and $\mu = E[x]$ is the expectation value of x.
> <i>T_{UTRAN-GPS} Measurement Value Information</i>				
>>SFN	M		INTEGER (0..4095)	SFN during which the T _{UTRAN-GPS} measurement was performed
>>T _{UTRAN-GPS}		1		Indicates the UTRAN GPS Timing of Cell Frame for LCS.
>>>MS	M		INTEGER (0..16383)	Most significant part
>>>LS	M		INTEGER (0..4294967295)	Least significant part
>>T _{UTRAN-GPS} Quality	O		INTEGER (0..255)	Indicates the standard deviation (std) of the T _{UTRAN-GPS} measurements in 1/16 chip. T _{UTRAN-GPS} Quality = $\sqrt{E[(x-\mu)^2]}$ = std of reported T _{UTRAN-GPS} Value, where x is the reported T _{UTRAN-GPS} Value and $\mu = E[x]$ is the expectation value of x.
>>T _{UTRAN-GPS} Drift Rate	M		INTEGER (-50..+50)	Indicates the T _{UTRAN-GPS} drift rate in 1/256 chip per second. A positive value indicates that

				the UTRAN clock is running at a lower frequency than GPS clock.
>>T _{UTRAN-GPS} Drift Rate Quality	O		INTEGER (0..50)	Indicates the standard deviation (std) of the T _{UTRAN-GPS} drift rate measurements in 1/256 chip per second. T _{UTRAN-GPS} Drift Rate Quality = $\sqrt{E[(x-\mu)^2]}$ = std of reported T _{UTRAN-GPS} Drift Rate, where x is the reported T _{UTRAN-GPS} Drift Rate and $\mu = E[x]$ is the expectation value of x.

9.2.2.34 OTDOA Reference Cell Info

Table 74

IE/Group Name	Presence	Range	IE Type and Reference	Semantics Description
UC-ID	M		9.2.2.37	The identifier of the reference cell.
UTRAN Access Point Position with Altitude	M		9.2.2.36	Exact geographical position of the base station antenna.
T_{UTRAN-GPS} Measurement Value Information		0..1		
>SFN	M		INTEGER (0..4095)	SFN during which the T _{UTRAN-GPS} measurement was performed
>T _{UTRAN-GPS}		1		Indicates the UTRAN GPS Timing of Cell Frame for LCS.
>>MS	M		INTEGER (0..16383)	Most significant part
>>LS	M		INTEGER (0..4294967295)	Least significant part
>T _{UTRAN-GPS} Quality	O		INTEGER (0..255)	Indicates the standard deviation (std) of the T _{UTRAN-GPS} measurements in 1/16 chip. T _{UTRAN-GPS} Quality = $\sqrt{E[(x-\mu)^2]}$ = std of reported T _{UTRAN-GPS} Value, where x is the reported T _{UTRAN-GPS} Value and $\mu = E[x]$ is the expectation value of x.
>T _{UTRAN-GPS} Drift Rate	M		INTEGER (-50..+50)	Indicates the T _{UTRAN-GPS} drift rate in 1/256 chip per second. A positive value indicates that the UTRAN clock is running at a lower frequency than GPS clock.
>T _{UTRAN-GPS} Drift Rate Quality	O		INTEGER (0..50)	Indicates the standard deviation (std) of the T _{UTRAN-GPS} drift rate measurements in 1/256 chip per second. T _{UTRAN-GPS} Drift Rate Quality = $\sqrt{E[(x-\mu)^2]}$ = std of reported T _{UTRAN-GPS} Drift Rate, where x is the reported T _{UTRAN-GPS} Drift Rate and $\mu = E[x]$ is the expectation value of x.

9.2.2.35 UE Positioning Measurement Quality

Table 75

IE/Group Name	Presence	Range	IE Type and Reference	Semantics Description
Std Resolution	M		BIT STRING (2)	Std Resolution field includes the resolution used in Std of Measurements field. Encoding on two bits as follows: '00' 10 meters '01' 20 meters '10' 30 meters '11' Reserved
Number of Measurements	M		BIT STRING (3)	The 'Number of Measurements' field indicates how many measurements have been used in the UE to determine the sample standard deviation of the measurements. Following 3 bit encoding is used: '001' 5-9 '010' 10-14 '011' 15-24 '100' 25-34 '101' 35-44 '110' 45-54 '111' 55 or more Special case: '000': In this case the field 'Std of Measurements' contains the std of the reported measurement value = $\sqrt{E[(x-\mu)^2]}$, where x is the reported value and $\mu = E[x]$ is the expectation value (i.e. the true value) of x. This std can be used irrespective of the number of measurements and reporting of the number of measurements is not needed. Also other measurements such as Ec/No or Rx levels can be utilised in this case to evaluate the 'Std of Measurements' reported in this IE.
Std of Measurements	M		BIT STRING (5)	Std of Measurements field includes sample standard deviation of measurements (when number of measurements is reported in "Number of Measurements" field) or standard deviation of the reported measurement value = $\sqrt{E[(x-\mu)^2]}$, where x is the reported value and $\mu = E[x]$ is the expectation value (i.e. the true value) of x (when '000' is given in 'Number of Measurements' field). Following linear 5 bit encoding is used: '00000' 0 - (R*1-1) meters '00001' R*1 - (R*2-1) meters

				'00010' R*2 – (R*3-1) meters ... '11111' R*31 meters or more where R is the resolution defined by Std Resolution field. E.g. R=20 m corresponds to 0-19 m, 20-39 m,...,620+ m.
--	--	--	--	---

9.2.2.36 UTRAN Access Point Position with Altitude

The UTRAN Access Point Position with Altitude indicates the exact geographical position of the base station antenna. The altitude shall be included when available.

Table 76

IE/Group Name	Presence	Range	IE Type and Reference	Semantics Description
Geographical Coordinates	M		9.2.2.7	
Altitude and direction	O		9.2.2.2	

9.2.2.37 UTRAN Cell Identifier (UC-ID)

The UC-ID (UTRAN Cell identifier) is the identifier of a cell in one UTRAN.

Table 77

IE/Group Name	Presence	Range	IE Type and Reference	Semantics Description
RNC-ID	M		INTEGER (0..4095)	The identifier of one RNC in UTRAN.
C-ID	M		INTEGER (0..65535)	The identifier of a cell in one RNS.

9.2.2.38 Horizontal Accuracy Code

Table 78

IE/Group Name	Presence	Range	IE Type and Reference	Semantics Description
Horizontal Accuracy Code	M		INTEGER(0..127)	The requested accuracy "r" is derived from the "Horizontal Accuracy Code" k by $r = 10x(1.1^k - 1)$

9.2.2.39 Vertical Accuracy Code

Table 79

IE/Group Name	Presence	Range	IE Type and Reference	Semantics Description
Vertical Accuracy Code	M		INTEGER(0..127)	The requested accuracy "v" is derived from the "Vertical Accuracy Code" k by $v = 45x(1.025^k - 1)$.

9.2.2.40 Accuracy Fulfilment Indicator

This IE indicates whether the returned position estimate satisfies the requested accuracy or not.

Table 80

IE/Group Name	Presence	Range	IE Type and Reference	Semantics Description
Accuracy Fulfilment Indicator	M		ENUMERATED (requested accuracy fulfilled, requested accuracy not fulfilled, ...)	

9.3 Message and Information Element Abstract Syntax (with ASN.1)

9.3.0 General

PCAP ASN.1 definition conforms with [7], [8], and [9].

The ASN.1 definition specifies the structure and content of PCAP messages. PCAP messages can contain any IEs specified in the object set definitions for that message without the order or number of occurrence being restricted by ASN.1. However, for this version of the standard, a sending entity shall construct a PCAP message according to the PDU definitions module and with the following additional rules (Note that in the following IE means an IE in the object set with an explicit id. If one IE needed to appear more than once in one object set, then the different occurrences have different IE ids):

- IEs shall be ordered (in an IE container) in the order they appear in object set definitions.
- Object set definitions specify how many times IEs may appear. An IE shall appear exactly once if the presence field in an object has value "mandatory". An IE may appear at most once if the presence field in an object has value "optional" or "conditional". If in a tabular format there is multiplicity specified for an IE (i.e. an IE list) then in the corresponding ASN.1 definition the list definition is separated into two parts. The first part defines an IE container list where the list elements reside. The second part defines list elements. The IE container list appears as an IE of its own. For this version of the standard an IE container list may contain only one kind of list elements.

If a PCAP message that is not constructed as defined above is received, this shall be considered as Abstract Syntax Error, and the message shall be handled as defined for Abstract Syntax Error in clause 10.3.6.

Clause 9.3 presents the Abstract Syntax of PCAP protocol with ASN.1. In case there is contradiction between the ASN.1 definition in this clause and the tabular format in clauses 9.1 and 9.2, the ASN.1 shall take precedence, except for the definition of conditions for the presence of conditional elements, where the tabular format shall take precedence.

9.3.1 Usage of private message mechanism for non-standard use

The private message mechanism for non-standard use may be used:

- for special operator- (and/or vendor) specific features considered not to be part of the basic functionality, i.e. the functionality required for a complete and high-quality specification in order to guarantee multivendor interoperability;
- by vendors for research purposes, e.g. to implement and evaluate new algorithms/features before such features are proposed for standardisation.

The private message mechanism shall not be used for basic functionality. Such functionality shall be standardised.

9.3.2 Elementary Procedure Definitions

```
-- *****
--
-- Elementary Procedure definitions
--
-- *****

PCAP-PDU-Descriptions {
itu-t (0) identified-organization (4) etsi (0) mobileDomain (0)
umts-Access (20) modules (3) pcap(4) version1 (1) pcap-PDU-Descriptions (0)}

DEFINITIONS AUTOMATIC TAGS ::=

BEGIN

-- *****
--
-- IE parameter types from other modules.
--
```

```

-- *****
IMPORTS
    Criticality,
    ProcedureCode,
    TransactionID
FROM PCAP-CommonDataTypes

    PositionCalculationRequest,
    PositionCalculationResponse,
    PositionCalculationFailure,
    InformationExchangeInitiationRequest,
    InformationExchangeInitiationResponse,
    InformationExchangeInitiationFailure,
    InformationReport,
    InformationExchangeTerminationRequest,
    InformationExchangeFailureIndication,
    ErrorIndication,
    PrivateMessage
FROM PCAP-PDU-Contents

    id-PositionCalculation,
    id-InformationExchangeInitiation,
    id-InformationReporting,
    id-InformationExchangeTermination,
    id-InformationExchangeFailure,
    id-ErrorIndication,
    id-privateMessage
FROM PCAP-Constants;

-- *****
--
-- Interface Elementary Procedure Class
--
-- *****

PCAP-ELEMENTARY-PROCEDURE ::= CLASS {
    &InitiatingMessage          ,
    &SuccessfulOutcome          OPTIONAL,
    &UnsuccessfulOutcome        OPTIONAL,
    &Outcome                    OPTIONAL,
    &procedureCode              ProcedureCode  UNIQUE,
    &criticality                Criticality   DEFAULT ignore
}

WITH SYNTAX {
    INITIATING MESSAGE          &InitiatingMessage
    [SUCCESSFUL OUTCOME         &SuccessfulOutcome]
    [UNSUCCESSFUL OUTCOME       &UnsuccessfulOutcome]
    [OUTCOME                    &Outcome]
    PROCEDURE CODE              &procedureCode
    [CRITICALITY                &criticality]
}

-- *****
--
-- Interface PDU definitions
--
-- *****

PCAP-PDU ::= CHOICE {
    initiatingMessage          InitiatingMessage,
    successfulOutcome          SuccessfulOutcome,
    unsuccessfulOutcome        UnsuccessfulOutcome,
    outcome                    Outcome,
    ...
}

InitiatingMessage ::= SEQUENCE {
    procedureCode              PCAP-ELEMENTARY-PROCEDURE.&procedureCode      ({PCAP-ELEMENTARY-PROCEDURES}),
    criticality                PCAP-ELEMENTARY-PROCEDURE.&criticality        ({PCAP-ELEMENTARY-PROCEDURES}{@procedureCode}),
    transactionID              TransactionID,
    value                      PCAP-ELEMENTARY-PROCEDURE.&InitiatingMessage  ({PCAP-ELEMENTARY-PROCEDURES}{@procedureCode})
}

```

```

SuccessfulOutcome ::= SEQUENCE {
    procedureCode    PCAP-ELEMENTARY-PROCEDURE.&procedureCode    ({PCAP-ELEMENTARY-PROCEDURES}),
    criticality      PCAP-ELEMENTARY-PROCEDURE.&criticality      ({PCAP-ELEMENTARY-
PCAP-ELEMENTARY-PROCEDURES}{@procedureCode}),
    transactionID   TransactionID,
    value           PCAP-ELEMENTARY-PROCEDURE.&SuccessfulOutcome ({PCAP-ELEMENTARY-
PCAP-ELEMENTARY-PROCEDURES}{@procedureCode})
}

UnsuccessfulOutcome ::= SEQUENCE {
    procedureCode    PCAP-ELEMENTARY-PROCEDURE.&procedureCode    ({PCAP-ELEMENTARY-PROCEDURES}),
    criticality      PCAP-ELEMENTARY-PROCEDURE.&criticality      ({PCAP-ELEMENTARY-
PCAP-ELEMENTARY-PROCEDURES}{@procedureCode}),
    transactionID   TransactionID,
    value           PCAP-ELEMENTARY-PROCEDURE.&UnsuccessfulOutcome ({PCAP-ELEMENTARY-
PCAP-ELEMENTARY-PROCEDURES}{@procedureCode})
}

Outcome ::= SEQUENCE {
    procedureCode    PCAP-ELEMENTARY-PROCEDURE.&procedureCode    ({PCAP-ELEMENTARY-PROCEDURES}),
    criticality      PCAP-ELEMENTARY-PROCEDURE.&criticality      ({PCAP-ELEMENTARY-
PCAP-ELEMENTARY-PROCEDURES}{@procedureCode}),
    transactionID   TransactionID,
    value           PCAP-ELEMENTARY-PROCEDURE.&Outcome          ({PCAP-ELEMENTARY-
PCAP-ELEMENTARY-PROCEDURES}{@procedureCode})
}

-- *****
--
-- Interface Elementary Procedure List
--
-- *****

PCAP-ELEMENTARY-PROCEDURES PCAP-ELEMENTARY-PROCEDURE ::= {
    PCAP-ELEMENTARY-PROCEDURES-CLASS-1 |
    PCAP-ELEMENTARY-PROCEDURES-CLASS-2 ,
    ...
}

PCAP-ELEMENTARY-PROCEDURES-CLASS-1 PCAP-ELEMENTARY-PROCEDURE ::= {
    positionCalculation |
    informationExchangeInitiation,
    ...
}

PCAP-ELEMENTARY-PROCEDURES-CLASS-2 PCAP-ELEMENTARY-PROCEDURE ::= {
    informationReporting |
    informationExchangeTermination |
    informationExchangeFailure |
    errorIndication |
    privateMessage,
    ...
}

-- *****
--
-- Interface Elementary Procedures
--
-- *****

positionCalculation PCAP-ELEMENTARY-PROCEDURE ::= {
    INITIATING MESSAGE      PositionCalculationRequest
    SUCCESSFUL OUTCOME      PositionCalculationResponse
    UNSUCCESSFUL OUTCOME    PositionCalculationFailure
    PROCEDURE CODE          id-PositionCalculation
    CRITICALITY             reject
}

informationExchangeInitiation PCAP-ELEMENTARY-PROCEDURE ::= {
    INITIATING MESSAGE      InformationExchangeInitiationRequest
    SUCCESSFUL OUTCOME      InformationExchangeInitiationResponse
    UNSUCCESSFUL OUTCOME    InformationExchangeInitiationFailure
    PROCEDURE CODE          id-InformationExchangeInitiation
    CRITICALITY             reject
}

```



```

informationReporting PCAP-ELEMENTARY-PROCEDURE ::= {
    INITIATING MESSAGE      InformationReport
    PROCEDURE CODE          id-InformationReporting
    CRITICALITY             ignore
}

informationExchangeTermination PCAP-ELEMENTARY-PROCEDURE ::= {
    INITIATING MESSAGE      InformationExchangeTerminationRequest
    PROCEDURE CODE          id-InformationExchangeTermination
    CRITICALITY             ignore
}

informationExchangeFailure PCAP-ELEMENTARY-PROCEDURE ::= {
    INITIATING MESSAGE      InformationExchangeFailureIndication
    PROCEDURE CODE          id-InformationExchangeFailure
    CRITICALITY             ignore
}

errorIndication PCAP-ELEMENTARY-PROCEDURE ::= {
    INITIATING MESSAGE      ErrorIndication
    PROCEDURE CODE          id-ErrorIndication
    CRITICALITY             ignore
}

privateMessage PCAP-ELEMENTARY-PROCEDURE ::= {
    INITIATING MESSAGE      PrivateMessage
    PROCEDURE CODE          id-privateMessage
    CRITICALITY             ignore
}

```

END

9.3.3 PDU Definitions

```

-- *****
--
-- PDU definitions for PCAP.
--
-- *****

PCAP-PDU-Contents {
    itu-t (0) identified-organization (4) etsi (0) mobileDomain (0)
    umts-Access (20) modules (3) pcap(4) version1 (1) pcap-PDU-Contents (1) }

DEFINITIONS AUTOMATIC TAGS ::=

BEGIN

-- *****
--
-- IE parameter types from other modules.
--
-- *****

IMPORTS
    Cause,
    CriticalityDiagnostics,
    GPS-UTRAN-TRU,
    InformationExchangeID,
    InformationReportCharacteristics,
    InformationType,
    MeasuredResultsList,
    RequestedDataValue,
    RequestedDataValueInformation,
    UE-PositionEstimate,
    CellId-MeasuredResultsSets,
    OTDOA-MeasurementGroup,
    AccuracyFulfilmentIndicator,
    HorizontalAccuracyCode,
    VerticalAccuracyCode
FROM PCAP-IEs

```

```

TransactionID
FROM PCAP-CommonDataTypes

ProtocolExtensionContainer{},
ProtocolIE-ContainerList{},
ProtocolIE-Container{},
PrivateIE-Container{},
PCAP-PRIVATE-IES,
PCAP-PROTOCOL-EXTENSION,
PCAP-PROTOCOL-IES
FROM PCAP-Containers

id-Cause,
id-CriticalityDiagnostics,
id-GPS-UTRAN-TRU,
id-InformationExchangeID,
id-InformationExchangeObjectType-InfEx-Rprt,
id-InformationExchangeObjectType-InfEx-Rqst,
id-InformationExchangeObjectType-InfEx-Rsp,
id-InformationReportCharacteristics,
id-InformationType,
id-GPS-MeasuredResultsList,
id-RequestedDataValue,
id-RequestedDataValueInformation,
id-TransactionID,
id-UE-PositionEstimate,
id-CellId-MeasuredResultsSets,
id-OTDOA-MeasurementGroup,
id-AccuracyFulfilmentIndicator,
id-HorizontalAccuracyCode,
id-VerticalAccuracyCode
FROM PCAP-Constants;

-- *****
--
-- POSITION CALCULATION REQUEST
--
-- *****

PositionCalculationRequest ::= SEQUENCE {
    protocolIEs          ProtocolIE-Container          { {PositionCalculationRequestIEs} },
    protocolExtensions   ProtocolExtensionContainer    { {PositionCalculationRequestExtensions} }
    OPTIONAL,
    ...
}

PositionCalculationRequestIEs PCAP-PROTOCOL-IES ::= {
    { ID id-UE-PositionEstimate          CRITICALITY reject  TYPE UE-PositionEstimate
      PRESENCE optional } |
    { ID id-GPS-MeasuredResultsList      CRITICALITY reject  TYPE MeasuredResultsList
      PRESENCE optional },
    ...
}

PositionCalculationRequestExtensions PCAP-PROTOCOL-EXTENSION ::= {
    { ID id-CellId-MeasuredResultsSets    CRITICALITY reject  EXTENSION CellId-MeasuredResultsSets
      PRESENCE optional } |
    { ID id-OTDOA-MeasurementGroup        CRITICALITY reject  EXTENSION OTDOA-MeasurementGroup
      PRESENCE optional } |
    { ID id-HorizontalAccuracyCode        CRITICALITY ignore  EXTENSION HorizontalAccuracyCode
      PRESENCE optional } |
    { ID id-VerticalAccuracyCode         CRITICALITY ignore  EXTENSION VerticalAccuracyCode
      PRESENCE optional },
    ...
}

-- *****
--
-- POSITION CALCULATION RESPONSE
--
-- *****

PositionCalculationResponse ::= SEQUENCE {
    protocolIEs          ProtocolIE-Container          { {PositionCalculationResponseIEs} },
    protocolExtensions   ProtocolExtensionContainer    { {PositionCalculationResponseExtensions} }
    OPTIONAL,

```

```

    ...
}

PositionCalculationResponseIEs PCAP-PROTOCOL-IES ::= {
  { ID id-UE-PositionEstimate          CRITICALITY ignore  TYPE UE-PositionEstimate          PRESENCE
  mandatory } |
  { ID id-CriticalityDiagnostics       CRITICALITY ignore  TYPE CriticalityDiagnostics       PRESENCE
  optional },
  ...
}

PositionCalculationResponseExtensions PCAP-PROTOCOL-EXTENSION ::= {
  { ID id-AccuracyFulfilmentIndicator CRITICALITY ignore  EXTENSION AccuracyFulfilmentIndicator
  PRESENCE optional},
  ...
}

-- *****
--
-- POSITION CALCULATION FAILURE
--
-- *****

PositionCalculationFailure ::= SEQUENCE {
  protocolIEs          ProtocolIE-Container    { {PositionCalculationFailureIEs} },
  protocolExtensions  ProtocolExtensionContainer { {PositionCalculationFailureExtensions} }
  OPTIONAL,
  ...
}

PositionCalculationFailureIEs PCAP-PROTOCOL-IES ::= {
  { ID id-Cause          CRITICALITY ignore  TYPE Cause          PRESENCE
  mandatory} |
  { ID id-CriticalityDiagnostics CRITICALITY ignore  TYPE CriticalityDiagnostics PRESENCE
  optional },
  ...
}

PositionCalculationFailureExtensions PCAP-PROTOCOL-EXTENSION ::= {
  ...
}

-- *****
--
-- INFORMATION EXCHANGE INITIATION REQUEST
--
-- *****

InformationExchangeInitiationRequest ::= SEQUENCE {
  protocolIEs          ProtocolIE-Container    {{InformationExchangeInitiationRequest-IEs}},
  protocolExtensions  ProtocolExtensionContainer {{InformationExchangeInitiationRequest-
  Extensions}}
  OPTIONAL,
  ...
}

InformationExchangeInitiationRequest-IEs PCAP-PROTOCOL-IES ::= {
  { ID id-InformationExchangeID          CRITICALITY reject  TYPE
  InformationExchangeID          PRESENCE  mandatory }|
  { ID id-InformationExchangeObjectType-InfEx-Rqst CRITICALITY reject  TYPE
  InformationExchangeObjectType-InfEx-Rqst PRESENCE  mandatory }|
  -- This IE represents both the Information Exchange Object Type IE and the choice based on the
  Information Exchange Object Type
  -- as described in the tabular message format in clause 9.1.
  { ID id-InformationType          CRITICALITY reject  TYPE InformationType
  PRESENCE  mandatory }|
  { ID id-InformationReportCharacteristics CRITICALITY reject  TYPE
  InformationReportCharacteristics PRESENCE  mandatory }|
  { ID id-GPS-UTRAN-TRU          CRITICALITY reject  TYPE GPS-UTRAN-TRU
  PRESENCE conditional },
  -- This IE shall be present if the information requested in the Information Type IE contains
  GPS-related data
  ...
}

InformationExchangeInitiationRequest-Extensions PCAP-PROTOCOL-EXTENSION ::= {
  ...
}

```

```

InformationExchangeObjectType-InfEx-Rqst ::= CHOICE {
    referencePosition          RefPosition-InfEx-Rqst,
    ...
}

RefPosition-InfEx-Rqst ::= SEQUENCE {
    referencePositionEstimate  UE-PositionEstimate,
    iE-Extensions             ProtocolExtensionContainer { { RefPositionItem-InfEx-Rqst-
ExtIEs} } OPTIONAL,
    ...
}

RefPositionItem-InfEx-Rqst-ExtIEs PCAP-PROTOCOL-EXTENSION ::= {
    ...
}

-- *****
--
-- INFORMATION EXCHANGE INITIATION RESPONSE
--
-- *****

InformationExchangeInitiationResponse ::= SEQUENCE {
    protocolIEs                ProtocolIE-Container {{InformationExchangeInitiationResponse-IEs}},
    protocolExtensions         ProtocolExtensionContainer {{InformationExchangeInitiationResponse-
Extensions}} OPTIONAL,
    ...
}

InformationExchangeInitiationResponse-IEs PCAP-PROTOCOL-IES ::= {
    { ID id-InformationExchangeID                CRITICALITY ignore TYPE
InformationExchangeID                PRESENCE mandatory }|
    { ID id-InformationExchangeObjectType-InfEx-Rsp CRITICALITY ignore TYPE
InformationExchangeObjectType-InfEx-Rsp PRESENCE optional }|
    { ID id-CriticalityDiagnostics                CRITICALITY ignore TYPE
CriticalityDiagnostics                PRESENCE optional },
    ...
}

InformationExchangeInitiationResponse-Extensions PCAP-PROTOCOL-EXTENSION ::= {
    ...
}

InformationExchangeObjectType-InfEx-Rsp ::= CHOICE {
    referencePosition          RefPosition-InfEx-Rsp,
    ...
}

RefPosition-InfEx-Rsp ::= SEQUENCE {
    requestedDataValue         RequestedDataValue,
    iE-Extensions             ProtocolExtensionContainer { { RefPositionItem-InfEx-Rsp-
ExtIEs} } OPTIONAL,
    ...
}

RefPositionItem-InfEx-Rsp-ExtIEs PCAP-PROTOCOL-EXTENSION ::= {
    ...
}

-- *****
--
-- INFORMATION EXCHANGE INITIATION FAILURE
--
-- *****

InformationExchangeInitiationFailure ::= SEQUENCE {
    protocolIEs                ProtocolIE-Container {{InformationExchangeInitiationFailure-IEs}},
    protocolExtensions         ProtocolExtensionContainer {{InformationExchangeInitiationFailure-
Extensions}} OPTIONAL,
    ...
}

InformationExchangeInitiationFailure-IEs PCAP-PROTOCOL-IES ::= {

```

```

    { ID      id-InformationExchangeID      CRITICALITY ignore  TYPE InformationExchangeID
    PRESENCE  mandatory }|
    { ID      id-Cause                      CRITICALITY ignore  TYPE Cause
    PRESENCE  mandatory }|
    { ID      id-CriticalityDiagnostics     CRITICALITY ignore  TYPE CriticalityDiagnostics
    PRESENCE  optional   },
    ...
}

InformationExchangeInitiationFailure-Extensions PCAP-PROTOCOL-EXTENSION ::= {
    ...
}

-- *****
--
-- INFORMATION REPORT
--
-- *****

InformationReport ::= SEQUENCE {
    protocolIEs          ProtocolIE-Container          {{InformationReport-IEs}},
    protocolExtensions   ProtocolExtensionContainer    {{InformationReport-Extensions}}
    OPTIONAL,
    ...
}

InformationReport-IEs PCAP-PROTOCOL-IES ::= {
    { ID      id-InformationExchangeID      CRITICALITY ignore  TYPE
InformationExchangeID                      PRESENCE  mandatory }|
    { ID      id-InformationExchangeObjectType-InfEx-Rprt CRITICALITY ignore  TYPE
InformationExchangeObjectType-InfEx-Rprt  PRESENCE  mandatory },
    ...
}

InformationReport-Extensions PCAP-PROTOCOL-EXTENSION ::= {
    ...
}

InformationExchangeObjectType-InfEx-Rprt ::= CHOICE {
    referencePosition          RefPosition-InfEx-Rprt,
    ...
}

RefPosition-InfEx-Rprt ::= SEQUENCE {
    requestedDataValueInformation RequestedDataValueInformation,
    iE-Extensions              ProtocolExtensionContainer {{ RefPositionItem-InfEx-Rprt-ExtIEs
}}
    OPTIONAL,
    ...
}

RefPositionItem-InfEx-Rprt-ExtIEs PCAP-PROTOCOL-EXTENSION ::= {
    ...
}

-- *****
--
-- INFORMATION EXCHANGE TERMINATION REQUEST
--
-- *****

InformationExchangeTerminationRequest ::= SEQUENCE {
    protocolIEs          ProtocolIE-Container          {{InformationExchangeTerminationRequest-
IEs}},
    protocolExtensions   ProtocolExtensionContainer    {{InformationExchangeTerminationRequest-
Extensions}}
    OPTIONAL,
    ...
}

InformationExchangeTerminationRequest-IEs PCAP-PROTOCOL-IES ::= {
    { ID      id-InformationExchangeID      CRITICALITY ignore  TYPE InformationExchangeID
    PRESENCE  mandatory},
    ...
}

InformationExchangeTerminationRequest-Extensions PCAP-PROTOCOL-EXTENSION ::= {
    ...
}

```

```

}

-- *****
--
-- INFORMATION EXCHANGE FAILURE INDICATION
--
-- *****

InformationExchangeFailureIndication ::= SEQUENCE {
    protocolIEs          ProtocolIE-Container      {{InformationExchangeFailureIndication-
    IEs}},
    protocolExtensions   ProtocolExtensionContainer {{InformationExchangeFailureIndication-
    Extensions}} OPTIONAL,
    ...
}

InformationExchangeFailureIndication-IEs PCAP-PROTOCOL-IES ::= {
    { ID id-InformationExchangeID          CRITICALITY ignore      TYPE
InformationExchangeID          PRESENCE   mandatory   }|
    { ID id-Cause                          CRITICALITY ignore      TYPE Cause
    PRESENCE   mandatory   },
    ...
}

InformationExchangeFailureIndication-Extensions PCAP-PROTOCOL-EXTENSION ::= {
    ...
}

-- *****
--
-- ERROR INDICATION
--
-- *****

ErrorIndication ::= SEQUENCE {
    protocolIEs          ProtocolIE-Container      { {ErrorIndicationIEs} },
    protocolExtensions   ProtocolExtensionContainer { {ErrorIndicationExtensions} } OPTIONAL,
    ...
}

ErrorIndicationIEs PCAP-PROTOCOL-IES ::= {
    { ID id-Cause          CRITICALITY ignore      TYPE Cause          PRESENCE
optional } |
    { ID id-CriticalityDiagnostics          CRITICALITY ignore      TYPE CriticalityDiagnostics          PRESENCE
optional },
    ...
}

ErrorIndicationExtensions PCAP-PROTOCOL-EXTENSION ::= {
    ...
}

-- *****
--
-- PRIVATE MESSAGE
--
-- *****

PrivateMessage ::= SEQUENCE {
    privateIEs          PrivateIE-Container      {{PrivateMessage-IEs}},
    ...
}

PrivateMessage-IEs PCAP-PRIVATE-IES ::= {
    ...
}

END

```

9.3.4 Information Element Definitions

```

-- *****
--
-- Information Element Definitions
--
-- *****

PCAP-IEs {
itu-t (0) identified-organization (4) etsi (0) mobileDomain (0)
umts-Access (20) modules (3) pcap(4) version1 (1) pcap-IEs (2) }

DEFINITIONS AUTOMATIC TAGS ::=

BEGIN

IMPORTS
    maxNrOfErrors,
    maxSat,
    maxSatAlmanac,
    maxNrOfLevels,
    maxNrOfMeasNCell,
    maxNrOfMeasurements,
    maxNrOfPoints,
    maxNrOfExpInfo,
    maxNrOfSets
FROM PCAP-Constants

    Criticality,
    ProcedureCode,
    ProtocolIE-ID,
    TransactionID,
    TriggeringMessage
FROM PCAP-CommonDataTypes

    ProtocolExtensionContainer{},
    PCAP-PROTOCOL-EXTENSION
FROM PCAP-Containers;

-- *****
--
-- Accuracy Fulfilment Indicator
--
-- *****

AccuracyFulfilmentIndicator ::= ENUMERATED{
    requested-Accuracy-Fulfilled,
    requested-Accuracy-Not-Fulfilled,
    ...
}

-- *****
--
-- Almanac and Satellite Health SIB
--
-- *****

AlmanacAndSatelliteHealthSIB ::= SEQUENCE {
    gpsAlmanacAndSatelliteHealth    GPS-AlmanacAndSatelliteHealth,
    satMask                          BIT STRING (SIZE (1..32)),
    lsbTOW                            BIT STRING (SIZE (8)),
    iE-Extensions                    ProtocolExtensionContainer { { AlmanacAndSatelliteHealthSIB-
ExtIEs } } OPTIONAL,
    ...
}

AlmanacAndSatelliteHealthSIB-ExtIEs PCAP-PROTOCOL-EXTENSION ::= {
    ...
}

-- *****
--
-- Cause IE
--
-- *****

```

```

Cause ::= CHOICE {
    radioNetwork          CauseRadioNetwork,
    transport             CauseTransport,
    protocol              CauseProtocol,
    misc                  CauseMisc,
    ...
}
CauseRadioNetwork ::= ENUMERATED {
    invalid-reference-information,
    information-temporarily-not-available,
    information-provision-not-supported-for-the-object,
    position-calculation-error-invalid-GPS-measured-results,
    ...,
    position-calculation-error-invalid-CellID-measured-results,
    position-calculation-error-invalid-OTDOA-measured-results,
    position-calculation-error-AGPS-positioning-method-not-supported,
    position-calculation-error-CellID-positioning-method-not-supported,
    position-calculation-error-OTDOA-positioning-method-not-supported,
    initial-UE-position-estimate-missing
}
CauseTransport ::= ENUMERATED {
    transport-resource-unavailable,
    unspecified,
    ...
}
CauseProtocol ::= ENUMERATED {
    transfer-syntax-error,
    abstract-syntax-error-reject,
    abstract-syntax-error-ignore-and-notify,
    message-not-compatible-with-receiver-state,
    semantic-error,
    unspecified,
    abstract-syntax-error-falsely-constructed-message,
    ...
}
CauseMisc ::= ENUMERATED {
    processing-overload,
    hardware-failure,
    o-and-m-intervention,
    unspecified,
    ...
}
-- *****
--
-- Cell Id Measured Results Sets
--
-- *****

CellId-MeasuredResultsSets ::=          SEQUENCE (SIZE (1..maxNrOfMeasurements)) OF
    CellId-MeasuredResultsInfoList

CellId-MeasuredResultsInfoList ::=      SEQUENCE (SIZE (1..maxNrOfMeasNCell)) OF
    CellId-MeasuredResultsInfo

CellId-MeasuredResultsInfo ::=          SEQUENCE {
    uC-ID                               UC-ID,
    uTRANAccessPointPositionAltitude    UTRANAccessPointPositionAltitude,
    ue-PositionEstimate                  UE-PositionEstimate                OPTIONAL,
    roundTripTimeInfo                    RoundTripTimeInfo                    OPTIONAL, -- FDD only
    rxTimingDeviationInfo                RxTimingDeviationInfo                OPTIONAL, -- 3.84Mcps TDD only
    rxTimingDeviationLCRInfo             RxTimingDeviationLCRInfo             OPTIONAL, -- 1.28Mcps TDD only
    pathloss                              Pathloss                              OPTIONAL,
    iE-Extensions                         ProtocolExtensionContainer { { CellId-MeasuredResultsInfo-
ExtIEs } }                            OPTIONAL,
    ...
}

CellId-MeasuredResultsInfo-ExtIEs PCAP-PROTOCOL-EXTENSION ::= {
    ...
}

RoundTripTimeInfo ::=                    SEQUENCE {

```



```

    ue-RxTxTimeDifferenceType2          UE-RxTxTimeDifferenceType2,
    ue-PositioningMeasQuality           UE-PositioningMeasQuality,
    roundTripTime                       RoundTripTime,
    iE-Extensions                       ProtocolExtensionContainer { { RoundTripTimeInfo-ExtIEs } }
        OPTIONAL,
    ...
}

RoundTripTimeInfo-ExtIEs PCAP-PROTOCOL-EXTENSION ::= {
    ...
}

UE-RxTxTimeDifferenceType2 ::=          INTEGER (0..8191)

UE-PositioningMeasQuality ::=          SEQUENCE {
    stdResolution                       BIT STRING (SIZE (2)),
    numberOfMeasurements                BIT STRING (SIZE (3)),
    stdOfMeasurements                   BIT STRING (SIZE (5)),
    iE-Extensions                       ProtocolExtensionContainer { { UE-PositioningMeasQuality-
ExtIEs } }          OPTIONAL,
    ...
}

UE-PositioningMeasQuality-ExtIEs PCAP-PROTOCOL-EXTENSION ::= {
    ...
}

RoundTripTime ::=                      INTEGER (0..32766)
-- Actual value RoundTripTime = IE value * 0.0625 + 876

UTRANAccessPointPositionAltitude ::=  SEQUENCE {
    geographicalCoordinates              GeographicalCoordinates,
    ga-AltitudeAndDirection              GA-AltitudeAndDirection
        OPTIONAL,
    iE-Extensions                       ProtocolExtensionContainer { {
UTRANAccessPointPositionAltitude-ExtIEs } }          OPTIONAL,
    ...
}

UTRANAccessPointPositionAltitude-ExtIEs PCAP-PROTOCOL-EXTENSION ::= {
    ...
}

RxTimingDeviationInfo ::=              SEQUENCE {
    rxTimingDeviation                   RxTimingDeviation,
    timingAdvance                       TimingAdvance,
    iE-Extensions                       ProtocolExtensionContainer { { RxTimingDeviationInfo-ExtIEs
} }          OPTIONAL,
    ...
}

RxTimingDeviationInfo-ExtIEs PCAP-PROTOCOL-EXTENSION ::= {
    ...
}

RxTimingDeviationLCRInfo ::=           SEQUENCE {
    rxTimingDeviationLCR                 RxTimingDeviationLCR,
    timingAdvanceLCR                     TimingAdvanceLCR,
    iE-Extensions                       ProtocolExtensionContainer { { RxTimingDeviationLCRInfo-
ExtIEs } }          OPTIONAL,
    ...
}

RxTimingDeviationLCRInfo-ExtIEs PCAP-PROTOCOL-EXTENSION ::= {
    ...
}

RxTimingDeviation ::=                  INTEGER (0..8191)

RxTimingDeviationLCR ::=                INTEGER (0..511)

TimingAdvance ::=                       INTEGER (0..63)

TimingAdvanceLCR ::=                    INTEGER (0..2047)

Pathloss ::=                            INTEGER (46..158)
-- Unit: dB; as defined in [4] subclause 10.3.7.3

```

```

-- *****
--
-- CriticalityDiagnostics
--
-- *****

CriticalityDiagnostics ::= SEQUENCE {
    procedureCode          ProcedureCode
    OPTIONAL,
    triggeringMessage      TriggeringMessage
    OPTIONAL,
    procedureCriticality   Criticality
    OPTIONAL,
    transactionID         TransactionID
    OPTIONAL,
    iEsCriticalityDiagnostics CriticalityDiagnostics-IE-List OPTIONAL,
    iE-Extensions         ProtocolExtensionContainer { {CriticalityDiagnostics-ExtIEs} }
    OPTIONAL,
    ...
}

CriticalityDiagnostics-IE-List ::= SEQUENCE (SIZE (1..maxNrOfErrors)) OF
SEQUENCE {
    iECriticality          Criticality,
    iE-ID                 ProtocolIE-ID,
    repetitionNumber      CriticalityDiagnosticsRepetition
    OPTIONAL,
    messageStructure      MessageStructure
    OPTIONAL,
    typeOfError           TypeOfError,
    iE-Extensions         ProtocolExtensionContainer { {CriticalityDiagnostics-IE-List-ExtIEs} }
    OPTIONAL,
    ...
}

CriticalityDiagnostics-IE-List-ExtIEs PCAP-PROTOCOL-EXTENSION ::= {
    ...
}

CriticalityDiagnostics-ExtIEs PCAP-PROTOCOL-EXTENSION ::= {
    ...
}

CriticalityDiagnosticsRepetition ::= INTEGER (0..255)

TypeOfError ::= ENUMERATED {
    not-understood,
    missing,
    ...
}

-- *****
--
-- DGPSCorrections
--
-- *****

DGPSCorrections ::=
SEQUENCE {
    gps-TOW-sec          INTEGER (0..604799),
    statusHealth         DiffCorrectionStatus,
    dgps-CorrectionSatInfoList DGPS-CorrectionSatInfoList
    OPTIONAL,
    -- not included if satelliteHealth is equal to noData or invalidData
    iE-Extensions         ProtocolExtensionContainer { { DGPSCorrections-ExtIEs } }
    OPTIONAL,
    ...
}

DGPSCorrections-ExtIEs PCAP-PROTOCOL-EXTENSION ::= {
    ...
}

DiffCorrectionStatus ::=
ENUMERATED {

```

```

        udre-1-0, udre-0-75, udre-0-5, udre-0-3,
        udre-0-2, udre-0-1, noData, invalidData }

DGPS-CorrectionSatInfoList ::= SEQUENCE (SIZE (1..maxSat)) OF
    DGPS-CorrectionSatInfo

DGPS-CorrectionSatInfo ::= SEQUENCE {
    satID          INTEGER (0..63),
    iode           INTEGER (0..255),
    udre           UDRE,
    prc            PRC,
    rrc            RRC,
    iE-Extensions ProtocolExtensionContainer { { DGPS-CorrectionSatInfo-ExtIEs
} } OPTIONAL,
    ...
}

DGPS-CorrectionSatInfo-ExtIEs PCAP-PROTOCOL-EXTENSION ::= {
    ...
}

UDRE ::= ENUMERATED {
    lessThan1,
    between1-and-4,
    between4-and-8,
    over8 }

PRC ::= INTEGER (-2047..2047)

RRC ::= INTEGER (-127..127)

-- *****
--
-- UE-PositionEstimate (i.e., Geographical Area)
--
-- *****

-- UE-PositionEstimate is based on Geographical Area Description in 23.032

UE-PositionEstimate ::= CHOICE {
    point                GA-Point,
    pointWithUncertainty GA-PointWithUncertainty,
    polygon              GA-Polygon,
    pointWithUncertaintyEllipse GA-PointWithUncertaintyEllipse,
    pointWithAltitude    GA-PointWithAltitude,
    pointWithAltitudeAndUncertaintyEllipsoid GA-PointWithAltitudeAndUncertaintyEllipsoid,
    ellipsoidArc         GA-EllipsoidArc,
    ...
}

GeographicalCoordinates ::= SEQUENCE {
    latitudeSign    ENUMERATED {north, south},
    latitude        INTEGER (0..8388607),
    longitude       INTEGER (-8388608..8388607),
    iE-Extensions  ProtocolExtensionContainer { {GeographicalCoordinates-ExtIEs} }
OPTIONAL,
    ...
}

GeographicalCoordinates-ExtIEs PCAP-PROTOCOL-EXTENSION ::= {
    ...
}

GA-AltitudeAndDirection ::= SEQUENCE {
    directionOfAltitude ENUMERATED {height, depth},
    altitude             INTEGER (0..32767),
    ...
}

GA-EllipsoidArc ::= SEQUENCE {
    geographicalCoordinates GeographicalCoordinates,
    innerRadius             INTEGER (0..65535),
    uncertaintyRadius       INTEGER (0..127),
}

```

```

offsetAngle          INTEGER (0..179),
includedAngle        INTEGER (0..179),
confidence            INTEGER (0..100),
iE-Extensions        ProtocolExtensionContainer { { GA-EllipsoidArc-ExtIEs } } OPTIONAL,
...
}

GA-EllipsoidArc-ExtIEs PCAP-PROTOCOL-EXTENSION ::= {
...
}

GA-Point ::= SEQUENCE {
geographicalCoordinates GeographicalCoordinates,
iE-Extensions           ProtocolExtensionContainer { {GA-Point-ExtIEs} } OPTIONAL,
...
}

GA-Point-ExtIEs PCAP-PROTOCOL-EXTENSION ::= {
...
}

GA-PointWithAltitude ::= SEQUENCE {
geographicalCoordinates GeographicalCoordinates,
altitudeAndDirection    GA-AltitudeAndDirection,
iE-Extensions           ProtocolExtensionContainer { { GA-PointWithAltitude-ExtIEs } }
OPTIONAL,
...
}

GA-PointWithAltitude-ExtIEs PCAP-PROTOCOL-EXTENSION ::= {
...
}

GA-PointWithAltitudeAndUncertaintyEllipsoid ::= SEQUENCE {
geographicalCoordinates GeographicalCoordinates,
altitudeAndDirection    GA-AltitudeAndDirection,
uncertaintyEllipse      GA-UncertaintyEllipse,
uncertaintyAltitude     INTEGER (0..127),
confidence               INTEGER (0..100),
iE-Extensions           ProtocolExtensionContainer { { GA-
PointWithAltitudeAndUncertaintyEllipsoid-ExtIEs } } OPTIONAL,
...
}

GA-PointWithAltitudeAndUncertaintyEllipsoid-ExtIEs PCAP-PROTOCOL-EXTENSION ::= {
...
}

GA-PointWithUnCertainty ::=SEQUENCE {
geographicalCoordinates GeographicalCoordinates,
uncertaintyCode         INTEGER (0..127),
iE-Extensions           ProtocolExtensionContainer { {GA-PointWithUnCertainty-ExtIEs} }
OPTIONAL,
...}

GA-PointWithUnCertainty-ExtIEs PCAP-PROTOCOL-EXTENSION ::= {
...
}

GA-PointWithUnCertaintyEllipse ::= SEQUENCE {
geographicalCoordinates GeographicalCoordinates,
uncertaintyEllipse      GA-UncertaintyEllipse,
confidence               INTEGER (0..100),
iE-Extensions           ProtocolExtensionContainer { { GA-PointWithUnCertaintyEllipse-
ExtIEs } } OPTIONAL,
...
}

GA-PointWithUnCertaintyEllipse-ExtIEs PCAP-PROTOCOL-EXTENSION ::= {
...
}

GA-Polygon ::= SEQUENCE (SIZE (1..maxNrOfPoints)) OF
SEQUENCE {
geographicalCoordinates GeographicalCoordinates,
iE-Extensions           ProtocolExtensionContainer { {GA-Polygon-ExtIEs} } OPTIONAL,
...
}

```

```

GA-Polygon-ExtIEs PCAP-PROTOCOL-EXTENSION ::= {
    ...
}

GA-UncertaintyEllipse ::= SEQUENCE {
    uncertaintySemi-major      INTEGER (0..127),
    uncertaintySemi-minor     INTEGER (0..127),
    orientationOfMajorAxis    INTEGER (0..89),
    ...
}

-- *****
--
-- GPS-AcquisitionAssistance:
--
-- *****

GPS-AcquisitionAssistance ::= SEQUENCE {
    gps-TOW-lmsec              INTEGER (0..604799999),
    satelliteInformationList   AcquisitionSatInfoList,
    iE-Extensions              ProtocolExtensionContainer { { GPS-AcquisitionAssistance-
ExtIEs } } OPTIONAL,
    ...
}

GPS-AcquisitionAssistance-ExtIEs PCAP-PROTOCOL-EXTENSION ::= {
    ...
}

AcquisitionSatInfoList ::= SEQUENCE (SIZE (1..maxSat)) OF
    AcquisitionSatInfo

AcquisitionSatInfo ::= SEQUENCE {
    satID                      INTEGER (0..63),
    doppler0thOrder            INTEGER (-2048..2047),
    extraDopplerInfo           ExtraDopplerInfo
    OPTIONAL,
    codePhase                  INTEGER (0..1022),
    integerCodePhase           INTEGER (0..19),
    gps-BitNumber              INTEGER (0..3),
    codePhaseSearchWindow     CodePhaseSearchWindow,
    azimuthAndElevation       AzimuthAndElevation
    OPTIONAL,
    iE-Extensions              ProtocolExtensionContainer { { AcquisitionSatInfo-ExtIEs } }
    OPTIONAL,
    ...
}

AcquisitionSatInfo-ExtIEs PCAP-PROTOCOL-EXTENSION ::= {
    ...
}

ExtraDopplerInfo ::= SEQUENCE {
    doppler1stOrder            INTEGER (-42..21),
    dopplerUncertainty         DopplerUncertainty,
    iE-Extensions              ProtocolExtensionContainer { { ExtraDopplerInfo-ExtIEs } }
    OPTIONAL,
    ...
}

ExtraDopplerInfo-ExtIEs PCAP-PROTOCOL-EXTENSION ::= {
    ...
}

DopplerUncertainty ::= ENUMERATED {
    hz12-5, hz25, hz50, hz100, hz200, ...}

CodePhaseSearchWindow ::= ENUMERATED {
    w1023, w1, w2, w3, w4, w6, w8,
    w12, w16, w24, w32, w48, w64,
    w96, w128, w192 }

```

```

AzimuthAndElevation ::= SEQUENCE {
    azimuth          INTEGER (0..31),
    elevation        INTEGER (0..7),
    iE-Extensions   ProtocolExtensionContainer { { AzimuthAndElevation-ExtIEs } }
} OPTIONAL,
...
}

```

```

AzimuthAndElevation-ExtIEs PCAP-PROTOCOL-EXTENSION ::= {
    ...
}

```

```

-- *****
--
-- GPS Almanac and Satellite Health
--
-- *****

```

```

GPS-AlmanacAndSatelliteHealth ::= SEQUENCE {
    wn-a          BIT STRING (SIZE (8)),
    almanacSatInfoList  AlmanacSatInfoList,
    svGlobalHealth BIT STRING (SIZE (364)) OPTIONAL,
    iE-Extensions ProtocolExtensionContainer { { GPS-
AlmanacAndSatelliteHealth-ExtIEs } } OPTIONAL,
    ...
}

```

```

GPS-AlmanacAndSatelliteHealth-ExtIEs PCAP-PROTOCOL-EXTENSION ::= {
    ...
}

```

```

AlmanacSatInfoList ::= SEQUENCE (SIZE (1..maxSatAlmanac)) OF
    AlmanacSatInfo

```

```

AlmanacSatInfo ::= SEQUENCE {
    dataID        BIT STRING (SIZE (2)),
    satID         INTEGER (0..63),
    e             BIT STRING (SIZE (16)),
    t-oa         BIT STRING (SIZE (8)),
    deltaI       BIT STRING (SIZE (16)),
    omegaDot     BIT STRING (SIZE (16)),
    satHealth    BIT STRING (SIZE (8)),
    a-Sqrt       BIT STRING (SIZE (24)),
    omega0       BIT STRING (SIZE (24)),
    m0           BIT STRING (SIZE (24)),
    omega        BIT STRING (SIZE (24)),
    af0          BIT STRING (SIZE (11)),
    af1          BIT STRING (SIZE (11)),
    iE-Extensions ProtocolExtensionContainer { { AlmanacSatInfo-ExtIEs } }
    OPTIONAL,
    ...
}

```

```

AlmanacSatInfo-ExtIEs PCAP-PROTOCOL-EXTENSION ::= {
    ...
}

```

```

-- *****
--
-- GPS Clock And Ephemeris Parameters
--
-- *****

```

```

GPS-ClockAndEphemerisParameters ::= SEQUENCE {
    codeOnL2     BIT STRING (SIZE (2)),
    uraIndex     BIT STRING (SIZE (4)),
    satHealth    BIT STRING (SIZE (6)),
    iodc         BIT STRING (SIZE (10)),
    l2Pflag     BIT STRING (SIZE (1)),
    sflRevD     SubFrame1Reserved,

```

```

t-GD                BIT STRING (SIZE (8)),
t-oc                BIT STRING (SIZE (16)),
af2                 BIT STRING (SIZE (8)),
af1                 BIT STRING (SIZE (16)),
af0                 BIT STRING (SIZE (22)),
c-rs                BIT STRING (SIZE (16)),
delta-n             BIT STRING (SIZE (16)),
m0                  BIT STRING (SIZE (32)),
c-uc                BIT STRING (SIZE (16)),
e                   BIT STRING (SIZE (32)),
c-us                BIT STRING (SIZE (16)),
a-Sqrt              BIT STRING (SIZE (32)),
t-oe                BIT STRING (SIZE (16)),
fitInterval         BIT STRING (SIZE (1)),
aodo                BIT STRING (SIZE (5)),
c-ic                BIT STRING (SIZE (16)),
omega0              BIT STRING (SIZE (32)),
c-is                BIT STRING (SIZE (16)),
i0                  BIT STRING (SIZE (32)),
c-rc                BIT STRING (SIZE (16)),
omega               BIT STRING (SIZE (32)),
omegaDot            BIT STRING (SIZE (24)),
iDot                BIT STRING (SIZE (14)),
iE-Extensions       ProtocolExtensionContainer { { GPS-
ClockAndEphemerisParameters-ExtIEs } } OPTIONAL,
...
}

GPS-ClockAndEphemerisParameters-ExtIEs PCAP-PROTOCOL-EXTENSION ::= {
...
}

SubFrameReserved ::= SEQUENCE {
reserved1           BIT STRING (SIZE (23)),
reserved2           BIT STRING (SIZE (24)),
reserved3           BIT STRING (SIZE (24)),
reserved4           BIT STRING (SIZE (16))
}

-- *****
--
-- GPS Ionospheric Model
--
-- *****

GPS-Ionospheric-Model ::= SEQUENCE {
alfa0               BIT STRING (SIZE (8)),
alfa1               BIT STRING (SIZE (8)),
alfa2               BIT STRING (SIZE (8)),
alfa3               BIT STRING (SIZE (8)),
beta0               BIT STRING (SIZE (8)),
beta1               BIT STRING (SIZE (8)),
beta2               BIT STRING (SIZE (8)),
beta3               BIT STRING (SIZE (8)),
iE-Extensions       ProtocolExtensionContainer { { GPS-Ionospheric-Model-ExtIEs
} } OPTIONAL,
...
}

GPS-Ionospheric-Model-ExtIEs PCAP-PROTOCOL-EXTENSION ::= {
...
}

-- *****
--
-- GPS Measured Results
--
-- *****

MeasuredResultsList ::= SEQUENCE (SIZE (1..maxNrOfSets)) OF
GPS-MeasuredResults

GPS-MeasuredResults ::= SEQUENCE {
gps-TOW-lmsec       INTEGER (0..604799999),

```

```

    gps-MeasurementParamList      GPS-MeasurementParamList,
    iE-Extensions                 ProtocolExtensionContainer { { GPS-MeasuredResults-ExtIEs }
} OPTIONAL,
...
}

GPS-MeasuredResults-ExtIEs PCAP-PROTOCOL-EXTENSION ::= {
...
}

GPS-MeasurementParamList ::=      SEQUENCE (SIZE (1..maxSat)) OF
                                   GPS-MeasurementParam

GPS-MeasurementParam ::=          SEQUENCE {
    satelliteID                    INTEGER (0..63),
    c-N0                           INTEGER (0..63),
    doppler                        INTEGER (-32768..32768),
    wholeGPS-Chips                 INTEGER (0..1022),
    fractionalGPS-Chips            INTEGER (0..1023),
    multipathIndicator             MultipathIndicator,
    pseudorangeRMS-Error          INTEGER (0..63),
    iE-Extensions                 ProtocolExtensionContainer { { GPS-MeasurementParam-ExtIEs }
} OPTIONAL,
...
}

MultipathIndicator ::=            ENUMERATED {
                                   nm,
                                   low,
                                   medium,
                                   high }

GPS-MeasurementParam-ExtIEs PCAP-PROTOCOL-EXTENSION ::= {
...
}

-- *****
--
-- GPS Navigation Model
--
-- *****

GPS-NavigationModel ::=          SEQUENCE (SIZE (1..maxSat)) OF
                                   NavigationModelSatInfo

NavigationModelSatInfo ::=       SEQUENCE {
    satID                          INTEGER (0..63),
    satelliteStatus                 SatelliteStatus,
    gps-clockAndEphemerisParms     GPS-ClockAndEphemerisParameters
    OPTIONAL,
    -- This IE is not present if satelliteStatus is es-SN
    iE-Extensions                 ProtocolExtensionContainer { { NavigationModelSatInfo-ExtIEs
} } OPTIONAL,
...
}

NavigationModelSatInfo-ExtIEs PCAP-PROTOCOL-EXTENSION ::= {
...
}

SatelliteStatus ::=             ENUMERATED {
                                   ns-NN,
                                   es-SN,
                                   es-NN,
                                   rev2,
                                   rev }

-- *****
--
-- GPS Real Time Integrity
--

```



```

-- *****
GPS-RealTimeIntegrity ::= CHOICE {
    badSatellites      BadSatList,
    noBadSatellites    NoBadSatellites,
    ...
}

BadSatList ::=
    SEQUENCE (SIZE (1..maxSat)) OF
        INTEGER (0..63)

NoBadSatellites ::= NULL

-- *****
--
-- GPS Reference Time
--
-- *****

GPS-ReferenceTime ::=
    SEQUENCE {
        gps-Week          INTEGER (0..1023),
        gps-TOW-lmsec     INTEGER (0..604799999),
        gps-TOW-AssistList GPS-TOW-AssistList
        OPTIONAL,
        iE-Extensions     ProtocolExtensionContainer { { GPS-ReferenceTime-ExtIEs } }
        OPTIONAL,
        ...
    }

GPS-ReferenceTime-ExtIEs PCAP-PROTOCOL-EXTENSION ::= {
    ...
}

GPS-TOW-AssistList ::=
    SEQUENCE (SIZE (1..maxSat)) OF
        GPS-TOW-Assist

GPS-TOW-Assist ::=
    SEQUENCE {
        satID             INTEGER (0..63),
        tlm-Message       BIT STRING (SIZE (14)),
        antiSpoof         BOOLEAN,
        alert              BOOLEAN,
        tlm-Reserved      BIT STRING (SIZE (2)),
        iE-Extensions     ProtocolExtensionContainer { { GPS-TOW-Assist-ExtIEs } }
        OPTIONAL,
        ...
    }

GPS-TOW-Assist-ExtIEs PCAP-PROTOCOL-EXTENSION ::= {
    ...
}

-- *****
--
-- GPS Transmission TOW
--
-- *****

GPS-Transmission-TOW ::= INTEGER (0..604799)

-- *****
--
-- GPS UTC Model
--
-- *****

GPS-UTC-Model ::=
    SEQUENCE {
        a1                BIT STRING (SIZE (24)),
        a0                BIT STRING (SIZE (32)),
        t-ot              BIT STRING (SIZE (8)),
        delta-t-LS        BIT STRING (SIZE (8)),
        wn-t              BIT STRING (SIZE (8)),
        wn-lsf            BIT STRING (SIZE (8)),
        dn                BIT STRING (SIZE (8)),
    }

```

```

    delta-t-LSF                BIT STRING (SIZE (8)),
    iE-Extensions              ProtocolExtensionContainer { { GPS-UTCmodel-ExtIEs } }
    OPTIONAL,
    ...
}

GPS-UTCmodel-ExtIEs PCAP-PROTOCOL-EXTENSION ::= {
    ...
}

-- *****
--
-- GPS UTRAN Time Relationship Uncertainty
-- nsec=nanosecond, usec=microsecond, msec=millisecond, sec=second
--
-- *****

GPS-UTRAN-TRU ::= ENUMERATED {
    nsec-50,
    nsec-500,
    usec-1,
    usec-10,
    msec-1,
    msec-10,
    msec-100,
    unreliable,
    ...}

-- *****
--
-- Information Exchange ID
--
-- *****

InformationExchangeID ::= INTEGER (0..1048575)

-- *****
--
-- Information Report Characteristics
--
-- *****

InformationReportCharacteristics ::= SEQUENCE {
    type                InformationReportCharacteristicsType,
    periodicity          InformationReportPeriodicity            OPTIONAL,
    -- present if type indicates periodic
    ...
}

InformationReportCharacteristicsType ::= ENUMERATED {
    onDemand,
    periodic,
    onModification,
    ...
}

InformationReportPeriodicity ::= CHOICE {
    min                INTEGER (1..60, ...),
    -- Unit min, Step lmin
    hour               INTEGER (1..24, ...),
    -- Unit hour, Step lhour
    ...
}

-- *****
--
-- Information Type
--
-- *****

InformationType ::= CHOICE {
    implicitInformation
    MethodType,

```

```

    explicitInformation      ExplicitInformationList,
    ...
}

ExplicitInformationList ::= SEQUENCE (SIZE (1..maxNrOfExpInfo)) OF ExplicitInformation

ExplicitInformation ::= CHOICE {
    almanacAndSatelliteHealth      AlmanacAndSatelliteHealth,
    utcModel                       UtcModel,
    ionosphericModel               IonosphericModel,
    navigationModel                NavigationModel,
    dgpsCorrections                DgpsCorrections,
    referenceTime                  ReferenceTime,
    acquisitionAssistance           AcquisitionAssistance,
    realTimeIntegrity              RealTimeIntegrity,
    almanacAndSatelliteHealthSIB    AlmanacAndSatelliteHealthSIB-InfoType,
    ...
}

AlmanacAndSatelliteHealth ::= NULL

UtcModel ::= SEQUENCE {
    transmissionTOWIndicator      TransmissionTOWIndicator,
    iE-Extensions                 ProtocolExtensionContainer { { UtcModel-ExtIEs } } OPTIONAL,
    ...
}

UtcModel-ExtIEs PCAP-PROTOCOL-EXTENSION ::= {
    ...
}

IonosphericModel ::= SEQUENCE {
    transmissionTOWIndicator      TransmissionTOWIndicator,
    iE-Extensions                 ProtocolExtensionContainer { { IonosphericModel-ExtIEs } } OPTIONAL,
    ...
}

IonosphericModel-ExtIEs PCAP-PROTOCOL-EXTENSION ::= {
    ...
}

NavigationModel ::= SEQUENCE {
    transmissionTOWIndicator      TransmissionTOWIndicator,
    navModelAdditionalData        NavModelAdditionalData OPTIONAL,
    iE-Extensions                 ProtocolExtensionContainer { { NavigationModel-ExtIEs } }
    OPTIONAL,
    ...
}

NavigationModel-ExtIEs PCAP-PROTOCOL-EXTENSION ::= {
    ...
}

NavModelAdditionalData ::= SEQUENCE {
    gps-Week                      INTEGER (0..1023),
    gps-TOE                       INTEGER (0..167),
    t-TOE-limit                   INTEGER (0..10),
    satRelatedDataList            SatelliteRelatedDataList,
    iE-Extensions                 ProtocolExtensionContainer { { NavModelAdditionalData-ExtIEs } }
    OPTIONAL,
    ...
}

NavModelAdditionalData-ExtIEs PCAP-PROTOCOL-EXTENSION ::= {
    ...
}

SatelliteRelatedDataList ::= SEQUENCE (SIZE (0..maxSat)) OF SatelliteRelatedData

SatelliteRelatedData ::= SEQUENCE {
    satID                         INTEGER (0..63),
    iode                          INTEGER (0..255),
    iE-Extensions                 ProtocolExtensionContainer { { SatelliteRelatedData-ExtIEs } }
    OPTIONAL,
    ...
}

```

```

SatelliteRelatedData-ExtIEs PCAP-PROTOCOL-EXTENSION ::= {
  ...
}

DgpsCorrections ::= NULL

ReferenceTime ::= NULL

AcquisitionAssistance ::= NULL

RealTimeIntegrity ::= NULL

AlmanacAndSatelliteHealthSIB-InfoType ::= SEQUENCE {
  transmissionTOWIndicator      TransmissionTOWIndicator,
  iE-Extensions                 ProtocolExtensionContainer { { AlmanacAndSatelliteHealthSIB-
InfoType-ExtIEs } } OPTIONAL,
  ...
}

AlmanacAndSatelliteHealthSIB-InfoType-ExtIEs PCAP-PROTOCOL-EXTENSION ::= {
  ...
}

TransmissionTOWIndicator ::= ENUMERATED {
  requested,
  not-Requested
}

-- *****
--
-- Message Structure
--
-- *****

MessageStructure ::= SEQUENCE (SIZE (1..maxNrOfLevels)) OF
  SEQUENCE {
    iE-ID                ProtocolIE-ID,
    repetitionNumber     MessageStructureRepetition
  } OPTIONAL,
  iE-Extensions         ProtocolExtensionContainer { {MessageStructure-ExtIEs} }
OPTIONAL,
  ...
}

MessageStructureRepetition ::= INTEGER (1..256)

MessageStructure-ExtIEs PCAP-PROTOCOL-EXTENSION ::= {
  ...
}

-- *****
--
-- Method Type
--
-- *****

MethodType ::= ENUMERATED {
  ue-assisted,
  ue-based
}

-- *****
--
-- OTDOA Measurement Group
--
-- *****

OTDOA-MeasurementGroup ::= SEQUENCE {
  otdoa-ReferenceCellInfo      OTDOA-ReferenceCellInfo,
  otdoa-NeighbourCellInfoList  OTDOA-NeighbourCellInfoList,
  otdoa-MeasuredResultsSets    OTDOA-MeasuredResultsSets,
  iE-Extensions                ProtocolExtensionContainer { { OTDOA-MeasurementGroup-ExtIEs
} } OPTIONAL,
  ...
}

```

```

}

OTDOA-MeasurementGroup-ExtIEs PCAP-PROTOCOL-EXTENSION ::= {
  ...
}

OTDOA-ReferenceCellInfo ::=
  uC-ID                SEQUENCE {
                        UC-ID,
                        UTRANAccessPointPositionAltitude,
                        TUTRANGPSMeasurementValueInfo
                        OPTIONAL,
                        iE-Extensions                ProtocolExtensionContainer { { OTDOA-ReferenceCellInfo-
ExtIEs } }          OPTIONAL,
  ...
}

OTDOA-ReferenceCellInfo-ExtIEs PCAP-PROTOCOL-EXTENSION ::= {
  ...
}

OTDOA-NeighbourCellInfoList ::=
  OTDOA-NeighbourCellInfo                SEQUENCE (SIZE (1..maxNrOfMeasNCell)) OF

OTDOA-NeighbourCellInfo ::=
  uC-ID                SEQUENCE {
                        UC-ID,
                        UTRANAccessPointPositionAltitude,
                        relativeTimingDifferenceInfo,
                        iE-Extensions                ProtocolExtensionContainer { { OTDOA-NeighbourCellInfo-
ExtIEs } }          OPTIONAL,
  ...
}

OTDOA-NeighbourCellInfo-ExtIEs PCAP-PROTOCOL-EXTENSION ::= {
  ...
}

OTDOA-MeasuredResultsSets ::=
  OTDOA-MeasuredResultsInfoList          SEQUENCE (SIZE (1..maxNrOfMeasurements)) OF

OTDOA-MeasuredResultsInfoList ::=
  OTDOA-MeasuredResultsInfo              SEQUENCE (SIZE (1..maxNrOfMeasNCell)) OF

OTDOA-MeasuredResultsInfo ::=
  uC-ID                SEQUENCE {
                        UC-ID,
                        ue-SFNSFNTimeDifferenceType2Info,
                        iE-Extensions                ProtocolExtensionContainer { { OTDOA-MeasuredResultsInfo-
ExtIEs } }          OPTIONAL,
  ...
}

OTDOA-MeasuredResultsInfo-ExtIEs PCAP-PROTOCOL-EXTENSION ::= {
  ...
}

UE-SFNSFNTimeDifferenceType2Info ::=
  ue-SFNSFNTimeDifferenceType2          SEQUENCE {
                        INTEGER (0..40961),
                        ue-PositioningMeasQuality    UE-PositioningMeasQuality,
                        measurementDelay              INTEGER (0..65535),
                        iE-Extensions                ProtocolExtensionContainer { { UE-SFNSFNTimeDifferenceInfo-
ExtIEs } }          OPTIONAL,
  ...
}

UE-SFNSFNTimeDifferenceInfo-ExtIEs PCAP-PROTOCOL-EXTENSION ::= {
  ...
}

UC-ID ::=
  rNC-ID                SEQUENCE {
                        INTEGER (0..4095),
                        c-ID                INTEGER (0..65535),
                        iE-Extensions                ProtocolExtensionContainer { { UC-ID-ExtIEs } }
                        OPTIONAL,
  ...
}

UC-ID-ExtIEs PCAP-PROTOCOL-EXTENSION ::= {
  ...
}

```

```

RelativeTimingDifferenceInfo ::= CHOICE {
    sFNFSNMeasurementValueInfo SFNSFNMeasurementValueInfo,
    tUTRANGPSMeasurementValueInfo TUTRANGPSMeasurementValueInfo,
    ...
}

SFNSFNMeasurementValueInfo ::= SEQUENCE {
    sFNFSNValue SFNSFNValue,
    sFNFSNQuality SFNSFNQuality
    OPTIONAL,
    sFNFSNDriftRate SFNSFNDriftRate,
    sFNFSNDriftRateQuality SFNSFNDriftRateQuality
    OPTIONAL,
    iE-Extensions ProtocolExtensionContainer { { SFNSFNMeasurementValueInfo-
ExtIEs } } OPTIONAL,
    ...
}

SFNSFNMeasurementValueInfo-ExtIEs PCAP-PROTOCOL-EXTENSION ::= {
    ...
}

SFNSFNValue ::= INTEGER (0..614399)

SFNSFNQuality ::= INTEGER (0..255)
-- Unit chip, Step 1/16 chip, Range 0.. 255/16 chip

SFNSFNDriftRate ::= INTEGER (-100..100)
-- Unit chip/s, Step 1/256 chip/s, Range -100/256..+100/256 chip/s

SFNSFNDriftRateQuality ::= INTEGER (0..100)
-- Unit chip/s, Step 1/256 chip/s, Range 0..100/256 chip/s

TUTRANGPSMeasurementValueInfo ::= SEQUENCE {
    sFN SFN,
    tUTRANGPS TUTRANGPS,
    tUTRANGPSQuality TUTRANGPSQuality
    OPTIONAL,
    tUTRANGPSDriftRate TUTRANGPSDriftRate,
    tUTRANGPSDriftRateQuality TUTRANGPSDriftRateQuality
    OPTIONAL,
    iE-Extensions ProtocolExtensionContainer { {
TUTRANGPSMeasurementValueInfo-ExtIEs } } OPTIONAL,
    ...
}

TUTRANGPSMeasurementValueInfo-ExtIEs PCAP-PROTOCOL-EXTENSION ::= {
    ...
}

SFN ::= INTEGER (0..4095)

TUTRANGPS ::= SEQUENCE {
    ms-part INTEGER (0..16383),
    ls-part INTEGER (0..4294967295)
}

TUTRANGPSQuality ::= INTEGER (0..255)
-- Unit chip, Step 1/16 chip, Range 0.. 255/16 chip

TUTRANGPSDriftRate ::= INTEGER (-50..50)
-- Unit chip/s, Step 1/256 chip/s, Range -50/256..+50/256 chip/s

TUTRANGPSDriftRateQuality ::= INTEGER (0..50)
-- Unit chip/s, Step 1/256 chip/s, Range 0..50/256 chip/s

-- *****
--
-- Requested Data Value
--
-- *****

RequestedDataValue ::= SEQUENCE {
    gpsAlmanacAndSatelliteHealth GPS-AlmanacAndSatelliteHealth
    OPTIONAL,

```

```

gps-UTC-Model                GPS-UTC-Model
OPTIONAL,
gps-Ionospheric-Model        GPS-Ionospheric-Model
OPTIONAL,
gps-NavigationModel          GPS-NavigationModel
OPTIONAL,
dgpsCorrections              DGPSCorrections
OPTIONAL,
referenceTime                 GPS-ReferenceTime
OPTIONAL,
gps-AcquisitionAssistance    GPS-AcquisitionAssistance
OPTIONAL,
gps-RealTime-Integrity       GPS-RealTimeIntegrity
OPTIONAL,
almanacAndSatelliteHealthSIB AlmanacAndSatelliteHealthSIB
OPTIONAL,
gps-Transmission-TOW        GPS-Transmission-TOW
OPTIONAL,
iE-Extensions                ProtocolExtensionContainer { { RequestedDataValue-ExtIEs } }
OPTIONAL,
...
}

```

--at least one of the above IEs shall be present in the requested data value

```

RequestedDataValue-ExtIEs PCAP-PROTOCOL-EXTENSION ::= {
    ...
}

```

```

-- *****
--
-- Requested Data Value Information
--
-- *****

```

```

RequestedDataValueInformation ::= CHOICE {
    informationAvailable      InformationAvailable,
    informationNotAvailable    InformationNotAvailable
}

```

```

InformationAvailable ::= SEQUENCE {
    requestedDataValue        RequestedDataValue,
    iE-Extensions             ProtocolExtensionContainer { { InformationAvailable-ExtIEs } }
OPTIONAL,
    ...
}

```

```

InformationAvailable-ExtIEs PCAP-PROTOCOL-EXTENSION ::= {
    ...
}

```

```

InformationNotAvailable ::= NULL

```

```

-- *****
--
-- Horizontal Accuracy Code
--
-- *****

```

```

HorizontalAccuracyCode      ::= INTEGER (0..127)

```

```

-- *****
--
-- Vertical Accuracy Code
--
-- *****

```

```

VerticalAccuracyCode        ::= INTEGER (0..127)

```

END

9.3.5 Common Definitions

```

-- *****
--
-- Common definitions
--
-- *****

PCAP-CommonDataTypes {
itu-t (0) identified-organization (4) etsi (0) mobileDomain (0)
umts-Access (20) modules (3) pcap(4) version1 (1) pcap-CommonDataTypes (3) }

DEFINITIONS AUTOMATIC TAGS ::=

BEGIN

-- *****
--
-- Extension constants
--
-- *****

maxPrivateIEs                INTEGER ::= 65535
maxProtocolExtensions        INTEGER ::= 65535
maxProtocolIEs               INTEGER ::= 65535

-- *****
--
-- Common Data Types
--
-- *****
Criticality ::= ENUMERATED { reject, ignore, notify }

Presence ::= ENUMERATED { optional, conditional, mandatory }

PrivateIE-ID ::= CHOICE {
    local          INTEGER (0..65535),
    global         OBJECT IDENTIFIER
}

ProcedureCode ::= INTEGER (0..255)

ProtocolIE-ID ::= INTEGER (0..maxProtocolIEs)

TransactionID ::= CHOICE {
    shortTID      INTEGER (0..127),
    longTID       INTEGER (0..32767)
}

TriggeringMessage ::= ENUMERATED { initiating-message, successful-outcome, unsuccessful-outcome,
outcome }

END

```

9.3.6 Constant Definitions

```

-- *****
--
-- Constant definitions
--
-- *****

PCAP-Constants {
itu-t (0) identified-organization (4) etsi (0) mobileDomain (0)
umts-Access (20) modules (3) pcap(4) version1 (1) pcap-Constants (4) }

DEFINITIONS AUTOMATIC TAGS ::=

BEGIN

IMPORTS
    ProcedureCode,
    ProtocolIE-ID

```



```

FROM PCAP-CommonDataTypes;

-- *****
--
-- Elementary Procedures
--
-- *****

id-PositionCalculation           ProcedureCode ::= 1
id-InformationExchangeInitiation ProcedureCode ::= 2
id-InformationReporting          ProcedureCode ::= 3
id-InformationExchangeTermination ProcedureCode ::= 4
id-InformationExchangeFailure    ProcedureCode ::= 5
id-ErrorIndication              ProcedureCode ::= 6
id-privateMessage                ProcedureCode ::= 7

-- *****
--
-- Lists
--
-- *****

maxNrOfErrors                    INTEGER ::= 256
maxSat                           INTEGER ::= 16
maxSatAlmanac                    INTEGER ::= 32
maxNrOfLevels                    INTEGER ::= 256
maxNrOfPoints                    INTEGER ::= 15
maxNrOfExpInfo                   INTEGER ::= 32
maxNrOfMeasNCell                 INTEGER ::= 32
maxNrOfMeasurements              INTEGER ::= 16
maxNrOfSets                      INTEGER ::= 3

-- *****
--
-- IEs
--
-- *****

id-Cause                        ProtocolIE-ID ::= 1
id-CriticalityDiagnostics       ProtocolIE-ID ::= 2
id-GPS-UTRAN-TRU               ProtocolIE-ID ::= 3
id-InformationExchangeID        ProtocolIE-ID ::= 4
id-InformationExchangeObjectType-InfEx-Rprt ProtocolIE-ID ::= 5
id-InformationExchangeObjectType-InfEx-Rqst ProtocolIE-ID ::= 6
id-InformationExchangeObjectType-InfEx-Rsp  ProtocolIE-ID ::= 7
id-InformationReportCharacteristics ProtocolIE-ID ::= 8
id-InformationType              ProtocolIE-ID ::= 9
id-GPS-MeasuredResultsList      ProtocolIE-ID ::= 10
id-MethodType                   ProtocolIE-ID ::= 11
id-RefPosition-InfEx-Rqst       ProtocolIE-ID ::= 12
id-RefPosition-InfEx-Rsp       ProtocolIE-ID ::= 13
id-RefPosition-Inf-Rprt        ProtocolIE-ID ::= 14
id-RequestedDataValue           ProtocolIE-ID ::= 15
id-RequestedDataValueInformation ProtocolIE-ID ::= 16
id-TransactionID                ProtocolIE-ID ::= 17
id-UE-PositionEstimate          ProtocolIE-ID ::= 18
id-CellId-MeasuredResultsSets   ProtocolIE-ID ::= 20
id-OTDOA-MeasurementGroup       ProtocolIE-ID ::= 22
id-AccuracyFulfilmentIndicator  ProtocolIE-ID ::= 23
id-HorizontalAccuracyCode       ProtocolIE-ID ::= 24
id-VerticalAccuracyCode         ProtocolIE-ID ::= 25

END

```

9.3.7 Container Definitions

```

-- *****
--
-- Container definitions
--
-- *****

PCAP-Containers {

```

```
itu-t (0) identified-organization (4) etsi (0) mobileDomain (0)
umts-Access (20) modules (3) pcap(4) version1 (1) pcap-Containers (5) }
```

```
DEFINITIONS AUTOMATIC TAGS ::=
```

```
BEGIN
```

```
-- *****
--
-- IE parameter types from other modules.
--
-- *****
```

```
IMPORTS
```

```
    Criticality,
    Presence,
    PrivateIE-ID,
    ProtocolIE-ID,
    maxPrivateIEs,
    maxProtocolExtensions,
    maxProtocolIEs
```

```
FROM PCAP-CommonDataTypes;
```

```
-- *****
--
-- Class Definition for Protocol IEs
--
-- *****
```

```
PCAP-PROTOCOL-IES ::= CLASS {
    &id          ProtocolIE-ID          UNIQUE,
    &criticality Criticality,
    &Value,
    &presence    Presence
}
```

```
WITH SYNTAX {
    ID          &id
    CRITICALITY &criticality
    TYPE        &Value
    PRESENCE    &presence
}
```

```
-- *****
--
-- Class Definition for Protocol Extensions
--
-- *****
```

```
PCAP-PROTOCOL-EXTENSION ::= CLASS {
    &id          ProtocolIE-ID UNIQUE,
    &criticality Criticality,
    &Extension,
    &presence    Presence
}
```

```
WITH SYNTAX {
    ID          &id
    CRITICALITY &criticality
    EXTENSION   &Extension
    PRESENCE    &presence
}
```

```
-- *****
--
-- Class Definition for Private IEs
--
-- *****
```

```
PCAP-PRIVATE-IES ::= CLASS {
    &id          PrivateIE-ID,
    &criticality Criticality,
    &Value,
    &presence    Presence
}
```

```
WITH SYNTAX {
    ID          &id
    CRITICALITY &criticality
    TYPE        &Value
    PRESENCE    &presence
}
```

```

}

-- *****
--
-- Container for Protocol IES
--
-- *****

ProtocolIE-Container {PCAP-PROTOCOL-IES : IESSetParam} ::=
  SEQUENCE (SIZE (0..maxProtocolIEs)) OF
    ProtocolIE-Field {{IESSetParam}}

ProtocolIE-Field {PCAP-PROTOCOL-IES : IESSetParam} ::= SEQUENCE {
  id                PCAP-PROTOCOL-IES.&id                ({IESSetParam}),
  criticality       PCAP-PROTOCOL-IES.&criticality       ({IESSetParam}{@id}),
  value            PCAP-PROTOCOL-IES.&Value            ({IESSetParam}{@id})
}

-- *****
--
-- Container Lists for Protocol IE Containers
--
-- *****

ProtocolIE-ContainerList {INTEGER : lowerBound, INTEGER : upperBound, PCAP-PROTOCOL-IES :
IESSetParam} ::=
  SEQUENCE (SIZE (lowerBound..upperBound)) OF
    ProtocolIE-Container {{IESSetParam}}

-- *****
--
-- Container for Protocol Extensions
--
-- *****

ProtocolExtensionContainer {PCAP-PROTOCOL-EXTENSION : ExtensionSetParam} ::=
  SEQUENCE (SIZE (1..maxProtocolExtensions)) OF
    ProtocolExtensionField {{ExtensionSetParam}}

ProtocolExtensionField {PCAP-PROTOCOL-EXTENSION : ExtensionSetParam} ::= SEQUENCE {
  id                PCAP-PROTOCOL-EXTENSION.&id                ({ExtensionSetParam}),
  criticality       PCAP-PROTOCOL-EXTENSION.&criticality       ({ExtensionSetParam}{@id}),
  extensionValue    PCAP-PROTOCOL-EXTENSION.&Extension        ({ExtensionSetParam}{@id})
}

-- *****
--
-- Container for Private IES
--
-- *****

PrivateIE-Container {PCAP-PRIVATE-IES : IESSetParam } ::=
  SEQUENCE (SIZE (1.. maxPrivateIEs)) OF
    PrivateIE-Field {{IESSetParam}}

PrivateIE-Field {PCAP-PRIVATE-IES : IESSetParam} ::= SEQUENCE {
  id                PCAP-PRIVATE-IES.&id                ({IESSetParam}),
  criticality       PCAP-PRIVATE-IES.&criticality       ({IESSetParam}{@id}),
  value            PCAP-PRIVATE-IES.&Value            ({IESSetParam}{@id})
}

END

```

9.4 Message Transfer Syntax

PCAP shall use the ASN.1 Basic Packed Encoding Rules (BASIC-PER) Aligned Variant as transfer syntax, as specified in [9].

10 Handling of Unknown, Unforeseen and Erroneous Protocol Data

10.1 General

Protocol Error cases can be divided into three classes:

- Transfer Syntax Error.
- Abstract Syntax Error.
- Logical Error.

Protocol errors can occur in the following functions within a receiving node.

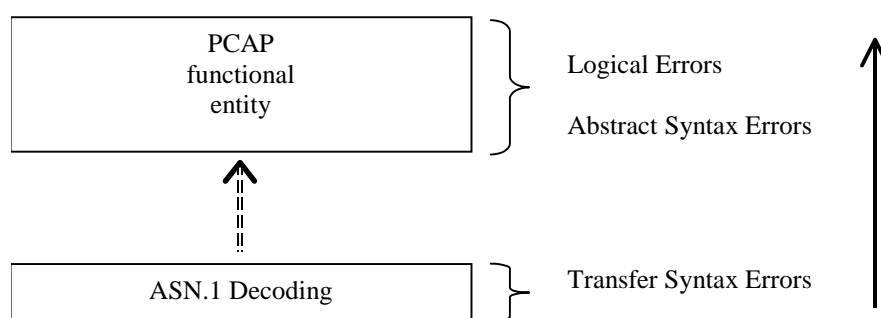

Figure 10: Protocol Errors in PCAP

The information stated in subclauses 10.2, 10.3 and 10.4, to be included in the message used when reporting an error, is what at minimum shall be included. Other optional information elements within the message may also be included, if available. This is also valid for the case when the reporting is done with a response message. The latter is an exception to what is stated in subclause 4.1.

10.2 Transfer Syntax Error

A Transfer Syntax Error occurs when the receiver is not able to decode the received physical message. Transfer syntax errors are always detected in the process of ASN.1 decoding. If a Transfer Syntax Error occurs, the receiver should initiate Error Indication procedure with appropriate cause value for the Transfer Syntax protocol error.

Examples for Transfer Syntax Errors are:

- Violation of value ranges in ASN.1 definition of messages. e.g.: If an IE has a defined value range of 0 to 10 (ASN.1: INTEGER (0..10)), and 12 will be received, then this will be treated as a transfer syntax error.
- Violation in list element constraints. e.g.: If a list is defined as containing 1 to 10 elements, and 12 elements will be received, than this case will be handled as a transfer syntax error.
- Missing mandatory elements in ASN.1 SEQUENCE definitions (as sent by the originator of the message).
- Wrong order of elements in ASN.1 SEQUENCE definitions (as sent by the originator of the message).

10.3 Abstract Syntax Error

10.3.1 General

An Abstract Syntax Error occurs when the receiving functional PCAP entity:

- 1) receives IEs or IE groups that cannot be understood (unknown IE id);

- 2) receives IEs for which the logical range is violated (e.g.: ASN.1 definition: 0 to 15, the logical range is 0 to 10 (values 11 to 15 are undefined), and 12 will be received; this case will be handled as an abstract syntax error using criticality information sent by the originator of the message);
- 3) does not receive IEs or IE groups but according to the specified presence of the concerning object, the IEs or IE groups should have been present in the received message;
- 4) receives IEs or IE groups that are defined to be part of that message in wrong order or with too many occurrences of the same IE or IE group;
- 5) receives IEs or IE groups but according to the conditional presence of the concerning object and the specified condition, the IEs or IE groups should not have been present in the received message.

Cases 1 and 2 (not comprehended IE/IE group) are handled based on received Criticality information. Case 3 (missing IE/IE group) is handled based on Criticality information and Presence information for the missing IE/IE group specified in the version of the specification used by the receiver. Case 4 (IEs or IE groups in wrong order or with too many occurrences) and Case 5 (erroneously present conditional IEs or IE groups) result in rejecting the procedure.

If an Abstract Syntax Error occurs, the receiver shall read the remaining message and shall then for each detected Abstract Syntax Error that belong to cases 1-3 act according to the Criticality Information and Presence Information for the IE/IE group due to which Abstract Syntax Error occurred in accordance with subclauses 10.3.4 and 10.3.5. The handling of cases 4 and 5 is specified in subclause 10.3.6.

10.3.2 Criticality Information

In the PCAP messages there is criticality information set for individual IEs and/or IE groups. This criticality information instructs the receiver how to act when receiving an IE or an IE group that is not comprehended, i.e. the entire item (IE or IE group) which is not (fully or partially) comprehended shall be treated in accordance with its own criticality information as specified in subclause 10.3.4.

In addition, the criticality information is used in case of the missing IE/IE group abstract syntax error (see subclause 10.3.5).

The receiving node shall take different actions depending on the value of the Criticality Information. The three possible values of the Criticality Information for an IE/IE group are:

- Reject IE.
- Ignore IE and Notify Sender.
- Ignore IE.

The following rules restrict when a receiving entity may consider an IE, an IE group, or an EP not comprehended (not implemented), and when action based on criticality information is applicable:

1. IE or IE group: When one new or modified IE or IE group is implemented for one EP from a standard version, then other new or modified IEs or IE groups specified for that EP in that standard version shall be considered comprehended by a receiving entity (some may still remain unsupported).
2. EP: The comprehension of different EPs within a standard version or between different standard versions is not mandated. Any EP that is not supported may be considered not comprehended, even if another EP from that standard version is comprehended, and action based on criticality shall be applied.

10.3.3 Presence Information

For many IEs/IE groups which are optional according to the ASN.1 transfer syntax, PCAP specifies separately if the presence of these IEs/IE groups is optional or mandatory with respect to RNS application by means of the presence field of the concerning object of class PCAP-PROTOCOL-IES, PCAP-PROTOCOL-IES-PAIR, PCAP-PROTOCOL-EXTENSION or PCAP-PRIVATE-IES.

The presence field of the indicated classes supports three values:

1. Optional;

2. Conditional;
3. Mandatory.

If an IE/IE group is not included in a received message and the presence of the IE/IE group is mandatory or the presence is conditional and the condition is true according to the version of the specification used by the receiver, an abstract syntax error occurs due to a missing IE/IE group.

If an IE/IE group is included in a received message and the presence of the IE/IE group is conditional and the condition is false according to the version of the specification used by the receiver, an abstract syntax error occurs due to this erroneously present conditional IE/IE group.

10.3.4 Not comprehended IE/IE group

10.3.4.1 Procedure Code

The receiving node shall treat the different types of received criticality information of the *Procedure Code* IE according to the following:

Reject IE:

- If a message is received with a *Procedure Code* IE marked with "*Reject IE*" which the receiving node does not comprehend, the receiving node shall reject the procedure using the Error Indication procedure.

Ignore IE and Notify Sender:

- If a message is received with a *Procedure Code* IE marked with "*Ignore IE and Notify Sender*" which the receiving node does not comprehend, the receiving node shall ignore the procedure and initiate the Error Indication procedure.

Ignore IE:

- If a message is received with a *Procedure Code* IE marked with "*Ignore IE*" which the receiving node does not comprehend, the receiving node shall ignore the procedure.

When using the Error Indication procedure to reject a procedure or to report an ignored procedure it shall include the *Procedure Code* IE, the *Triggering Message* IE, and the *Procedure Criticality* IE in the *Criticality Diagnostics* IE.

10.3.4.1A Type of Message

When the receiving node cannot decode the *Type of Message* IE, the Error Indication procedure shall be initiated with an appropriate cause value.

10.3.4.2 IEs other than the Procedure Code and Type of Message

The receiving node shall treat the different types of received criticality information of an IE/IE group other than the *Procedure Code* IE and *Type of Message* IE according to the following:

Reject IE:

- If a message *initiating* a procedure is received containing one or more IEs/IE groups marked with "*Reject IE*" which the receiving node does not comprehend; none of the functional requests of the message shall be executed. The receiving node shall reject the procedure and report the rejection of one or more IEs/IE groups using the message normally used to report unsuccessful outcome of the procedure. In case the information received in the initiating message was insufficient to determine a value for all IEs that are required to be present in the message used to report the unsuccessful outcome of the procedure, the receiving node shall instead terminate the procedure and initiate the Error Indication procedure.
- If a message *initiating* a procedure that does not have a message to report unsuccessful outcome is received containing one or more IEs/IE groups marked with "*Reject IE*" which the receiving node does not comprehend, the receiving node shall terminate the procedure and initiate the Error Indication procedure.

- If a *response* message is received containing one or more IEs/IE groups marked with "*Reject IE*", that the receiving node does not comprehend, the receiving node shall consider the procedure as unsuccessfully terminated and initiate local error handling.

Ignore IE and Notify Sender:

- If a message *initiating* a procedure is received containing one or more IEs/IE groups marked with "*Ignore IE and Notify Sender*" which the receiving node does not comprehend, the receiving node shall ignore the content of the not comprehended IEs/IE groups, continue with the procedure as if the not comprehended IEs/IE groups were not received (except for the reporting) using the understood IEs/IE groups, and report in the response message of the procedure that one or more IEs/IE groups have been ignored. In case the information received in the initiating message was insufficient to determine a value for all IEs that are required to be present in the response message, the receiving node shall instead terminate the procedure and initiate the Error Indication procedure.
- If a message *initiating* a procedure that does not have a message to report the outcome of the procedure is received containing one or more IEs/IE groups marked with "*Ignore IE and Notify Sender*" which the receiving node does not comprehend, the receiving node shall ignore the content of the not comprehended IEs/IE groups, continue with the procedure as if the not comprehended IEs/IE groups were not received (except for the reporting) using the understood IEs/IE groups, and initiate the Error Indication procedure to report that one or more IEs/IE groups have been ignored.
- If a *response* message is received containing one or more IEs/IE groups marked with "*Ignore IE and Notify Sender*" which the receiving node does not comprehend, the receiving node shall ignore the content of the not comprehended IEs/IE groups, continue with the procedure as if the not comprehended IEs/IE groups were not received (except for the reporting) using the understood IEs/IE groups and initiate the Error Indication procedure.

Ignore IE:

- If a message *initiating* a procedure is received containing one or more IEs/IE groups marked with "*Ignore IE*" which the receiving node does not comprehend, the receiving node shall ignore the content of the not comprehended IEs/IE groups and continue with the procedure as if the not comprehended IEs/IE groups were not received using the understood IEs/IE groups.
- If a *response* message is received containing one or more IEs/IE groups marked with "*Ignore IE*" which the receiving node does not comprehend, the receiving node shall ignore the content of the not comprehended IEs/IE groups.

When reporting not comprehended IEs/IE groups marked with "*Reject IE*" or "*Ignore IE and Notify Sender*" using a response message defined for the procedure, the *Information Element Criticality Diagnostics* IE shall be included in the *Criticality Diagnostics* IE for each reported IE/IE group. The *Repetition Number* IE shall be included in the *Information Element Criticality Diagnostics* IE if the reported IE/IE group was part of a "SEQUENCE OF" definition.

When reporting not comprehended IEs/IE groups marked with "*Reject IE*" or "*Ignore IE and Notify Sender*" using the Error Indication procedure, the *Procedure Code* IE, the *Triggering Message* IE, *Procedure Criticality* IE, the *Transaction Id* IE, and the *Information Element Criticality Diagnostics* IE shall be included in the *Criticality Diagnostics* IE for each reported IE/IE group. The *Repetition Number* IE shall be included in the *Information Element Criticality Diagnostics* IE if the reported IE/IE group was part of a "SEQUENCE OF" definition.

10.3.5 Missing IE or IE group

The receiving node shall treat the missing IE/IE group according to the criticality information for the missing IE/IE group in the received message specified in the version of the present document used by the receiver:

Reject IE:

- If a received message *initiating* a procedure is missing one or more IEs/IE groups with specified criticality "*Reject IE*"; none of the functional requests of the message shall be executed. The receiving node shall reject the procedure and report the missing IEs/IE groups using the message normally used to report unsuccessful outcome of the procedure. In case the information received in the initiating message was insufficient to determine a value for all IEs that are required to be present in the message used to report the unsuccessful outcome of the procedure, the receiving node shall instead terminate the procedure and initiate the Error Indication procedure.

- If a received message *initiating* a procedure that does not have a message to report unsuccessful outcome is missing one or more IEs/IE groups with specified criticality "*Reject IE*", the receiving node shall initiate the Error Indication procedure.
- If a received *response* message is missing one or more IEs/IE groups with specified criticality "*Reject IE*", the receiving node shall consider the procedure as unsuccessfully terminated and initiate local error handling.

Ignore IE and Notify Sender:

- If a received message *initiating* a procedure is missing one or more IEs/IE groups with specified criticality "*Ignore IE and Notify Sender*", the receiving node shall ignore that those IEs are missing and continue with the procedure based on the other IEs/IE groups present in the message and report in the response message of the procedure that one or more IEs/IE groups were missing. In case the information received in the initiating message was insufficient to determine a value for all IEs that are required to be present in the response message, the receiving node shall instead terminate the procedure and initiate the Error Indication procedure.
- If a received message *initiating* a procedure that does not have a message to report the outcome of the procedure is missing one or more IEs/IE groups with specified criticality "*Ignore IE and Notify Sender*", the receiving node shall ignore that those IEs are missing and continue with the procedure based on the other IEs/IE groups present in the message and initiate the Error Indication procedure to report that one or more IEs/IE groups were missing.
- If a received *response* message is missing one or more IEs/IE groups with specified criticality "*Ignore IE and Notify Sender*", the receiving node shall ignore that those IEs are missing and continue with the procedure based on the other IEs/IE groups present in the message and initiate the Error Indication procedure to report that one or more IEs/IE groups were missing.

Ignore IE:

- If a received message *initiating* a procedure is missing one or more IEs/IE groups with specified criticality "*Ignore IE*", the receiving node shall ignore that those IEs are missing and continue with the procedure based on the other IEs/IE groups present in the message.
- If a received *response* message is missing one or more IEs/IE groups with specified criticality "*Ignore IE*", the receiving node shall ignore that those IEs/IE groups are missing.

When reporting missing IEs/IE groups with specified criticality "*Reject IE*" or "*Ignore IE and Notify Sender*" using a response message defined for the procedure, the *Information Element Criticality Diagnostics* IE shall be included in the *Criticality Diagnostics* IE for each reported IE/IE group.

When reporting missing IEs/IE groups with specified criticality "*Reject IE*" or "*Ignore IE and Notify Sender*" using the Error Indication procedure, the *Procedure Code* IE, the *Triggering Message* IE, *Procedure Criticality* IE, the *Transaction Id* IE, and the *Information Element Criticality Diagnostics* IE shall be included in the *Criticality Diagnostics* IE for each reported IE/IE group.

10.3.6 IEs or IE groups received in wrong order or with too many occurrences or erroneously present

If a message with IEs or IE groups in wrong order or with too many occurrences is received or if IEs or IE groups with a conditional presence are present when the condition is not met (i.e. erroneously present), the receiving node shall behave according to the following:

- If a message *initiating* a procedure is received containing IEs or IE groups in wrong order or with too many occurrences or erroneously present, none of the functional requests of the message shall be executed. The receiving node shall reject the procedure and report the cause value "Abstract Syntax Error (Falsely Constructed Message)" using the message normally used to report unsuccessful outcome of the procedure. In case the information received in the initiating message was insufficient to determine a value for all IEs that are required to be present in the message used to report the unsuccessful outcome of the procedure, the receiving node shall instead terminate the procedure and initiate the Error Indication.
- If a message *initiating* a procedure that does not have a message to report unsuccessful outcome is received containing IEs or IE groups in wrong order or with too many occurrences or erroneously present, the receiving node shall terminate the procedure and initiate the Error Indication procedure, and use cause value "Abstract Syntax Error (Falsely Constructed Message)".

- If a *response* message is received containing IEs or IE groups in wrong order or with too many occurrences or erroneously present, the receiving node shall consider the procedure as unsuccessfully terminated and initiate local error handling.

10.4 Logical Error

Logical error situations occur when a message is comprehended correctly, but the information contained within the message is not valid (i.e. semantic error), or describes a procedure which is not compatible with the state of the receiver. In these conditions, the following behaviour shall be performed (unless otherwise specified) as defined by the class of the elementary procedure, irrespective of the criticality of the IEs/IE groups containing the erroneous values.

Class 1:

Protocol Causes:

Where the logical error occurs in a request message of a class 1 procedure, and the procedure has a message to report this unsuccessful outcome, this message shall be sent with an appropriate cause value. Typical cause values are:

1. Semantic Error.
2. Message not compatible with receiver state.

Where the logical error is contained in a request message of a class 1 procedure, and the procedure does not have a message to report this unsuccessful outcome, the procedure shall be terminated and the Error Indication procedure shall be initiated with an appropriate cause value.

Where the logical error exists in a response message of a class 1 procedure, the procedure shall be considered as unsuccessfully terminated and local error handling shall be initiated.

Class 2:

Where the logical error occurs in a message of a class 2 procedure, the procedure shall be terminated and the Error Indication procedure shall be initiated with an appropriate cause value.

10.5 Exceptions

The error handling for all the cases described hereafter shall take precedence over any other error handling described in the other subclasses of clause 10.

- If any type of error (Transfer Syntax Error, Abstract Syntax Error or Logical Error) is detected in the ERROR INDICATION message, it shall not trigger the Error Indication procedure in the receiving Node but local error handling.
- In case a response message or Error Indication message needs to be returned, but the information necessary to determine the receiver of that message is missing, the procedure shall be considered as unsuccessfully terminated and local error handling shall be initiated.
- If an error that terminates a procedure occurs, the returned cause value shall reflect the error that caused the termination of the procedure even if one or more abstract syntax errors with criticality 'ignore and notify' have earlier occurred within the same procedure.

Annex A (informative): Guidelines for Usage of the Criticality Diagnostics IE

A.1 EXAMPLE MESSAGE Layout

Assume the following message format:

Table A.1

IE/Group Name	Presence	Range	IE type and reference	Semantics description	Criticality	Assigned Criticality
Message Type	M				YES	Reject
Transaction ID	M				-	
A	M				YES	reject
B	M				YES	reject
>E		1..<maxE>			EACH	ignore
>>F		1..<maxF>			-	
>>>G		0..3, ...			EACH	ignore
>>H		1..<maxH>			EACH	ignore
>>>G		0..3, ...			EACH	ignore and notify
>>G	M				YES	reject
>>J		1..<maxJ>			-	
>>>G		0..3, ...			EACH	reject
C	M				YES	reject
>K		1..<maxK>			EACH	ignore and notify
>>L		1..<maxL>			-	
>>>M	O				-	
D	M				YES	reject

NOTE: The IEs F, J, and L do not have assigned criticality. The IEs F, J, and L are consequently realised as the ASN.1 type SEQUENCE OF of "ordinary" ASN.1 type, e.g. INTEGER. On the other hand, the repeatable IEs with assigned criticality are realised as the ASN.1 type SEQUENCE OF of an IE object, e.g. ProtocolIE-Single-Container.

For the corresponding ASN.1 layout, see clause A.4.

A.2 Example on a Received EXAMPLE MESSAGE

Assume further more that a received message based on the above tabular format is according to figure A.1.

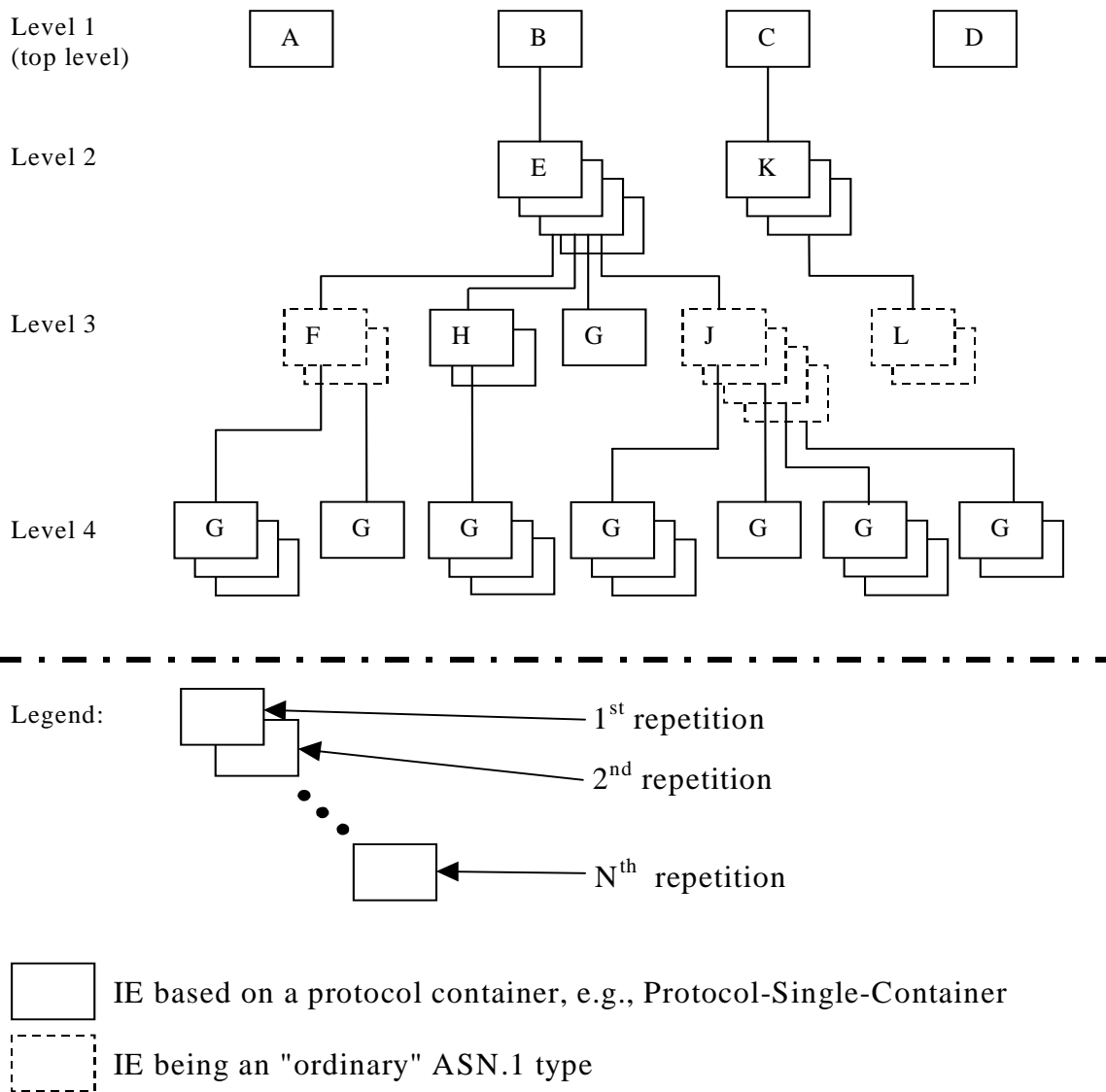

Figure A.1: Example of content of a received PCAP message based on the EXAMPLE MESSAGE

A.3 Content of Criticality Diagnostics

A.3.1 Example 1

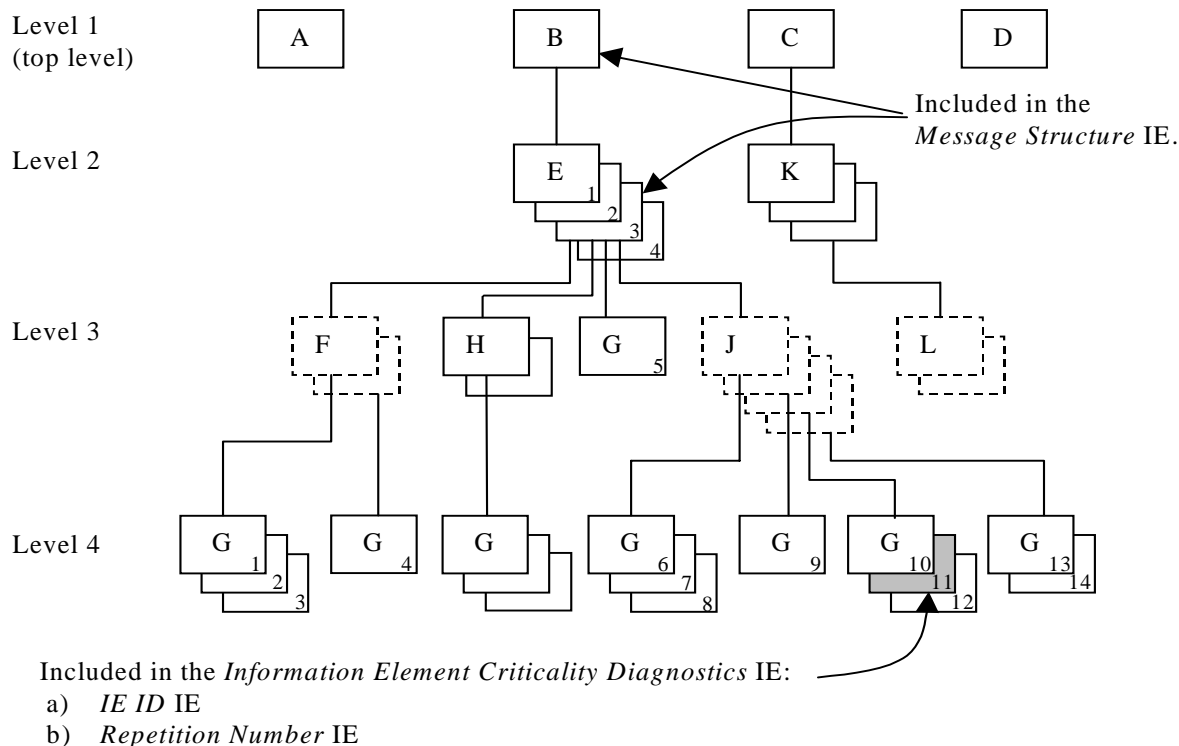

Figure A.2: Example of a received PCAP message containing a not comprehended IE

If there is an error within the instance marked as grey in the IE G in the IE J shown in the figure A.2, this will be reported within the *Information Element Criticality Diagnostics* IE within the *Criticality Diagnostics* IEas in table A.2.

Table A.2

IE name	Value	Comment
IE Criticality	Reject	Criticality for IE on the reported level, i.e. level 4.
IE ID	id-G	IE ID from the reported level, i.e. level 4.
Repetition Number	11	Repetition number on the reported level, i.e. level 4. (Since the IE E (level 2) is the lowest level included in the <i>Message Structure</i> IE this is the eleventh occurrence of IE G within the IE E (level 2).
Type of Error	not understood	
<i>Message Structure, first repetition</i>		
>IE ID	id-B	IE ID from level 1.
<i>Message Structure, second repetition</i>		
>IE ID	id-E	IE ID from the lowest level above the reported level, i.e. level 2.
>Repetition Number	3	Repetition number from the lowest level above the reported level, i.e. level 2.

NOTE 1: The IE J on level 3 cannot be included in the *Message Structure* IE since they have no criticality of their own.

NOTE 2: The repetition number of the reported IE indicates the number of repetitions of IE G received up to the detected erroneous repetition, counting all occurrences of the IE G below the same instance of the previous level with assigned criticality (instance 3 of IE E on level 2).

A.3.2 Example 2

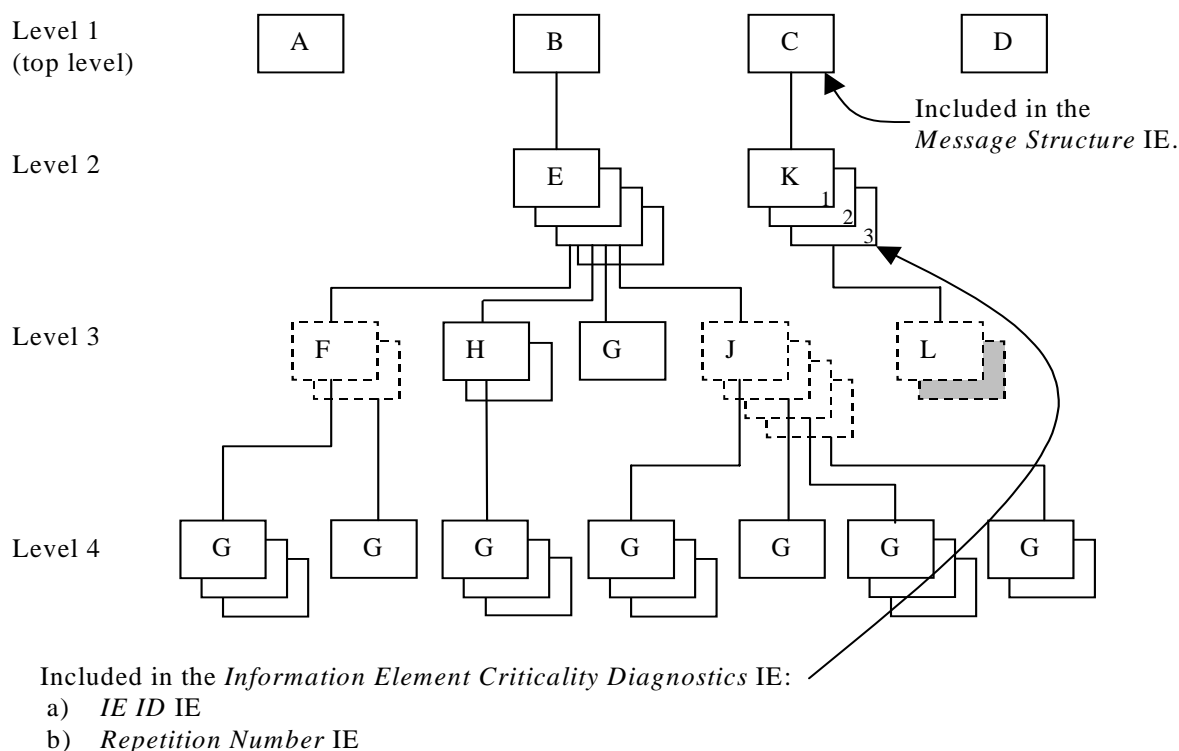

Figure A.3: Example of a received PCAP message containing a not comprehended IE

If there is an error within the second instance (marked as grey) in the sequence (IE L in the tabular format) on level 3 below IE K in the structure shown in the figure A.3, this will be reported within the *Information Element Criticality Diagnostics IE* within the *Criticality Diagnostics IE*s in table A.3.

Table A.3

IE name	Value	Comment
IE Criticality	ignore and notify	Criticality for IE on the reported level, i.e. level 2.
IE ID	id-K	IE ID from the reported level, i.e. level 2.
Repetition Number	3	Repetition number on the reported level, i.e. level 2.
Type of Error	not understood	
<i>Message Structure, first repetition</i>		
>IE ID	id-C	IE ID from the lowest level above the reported level, i.e. level 1.

NOTE: The IE L on level 3 cannot be reported individually included in the *Message Structure IE* since it has no criticality of its own.

A.3.3 Example 3

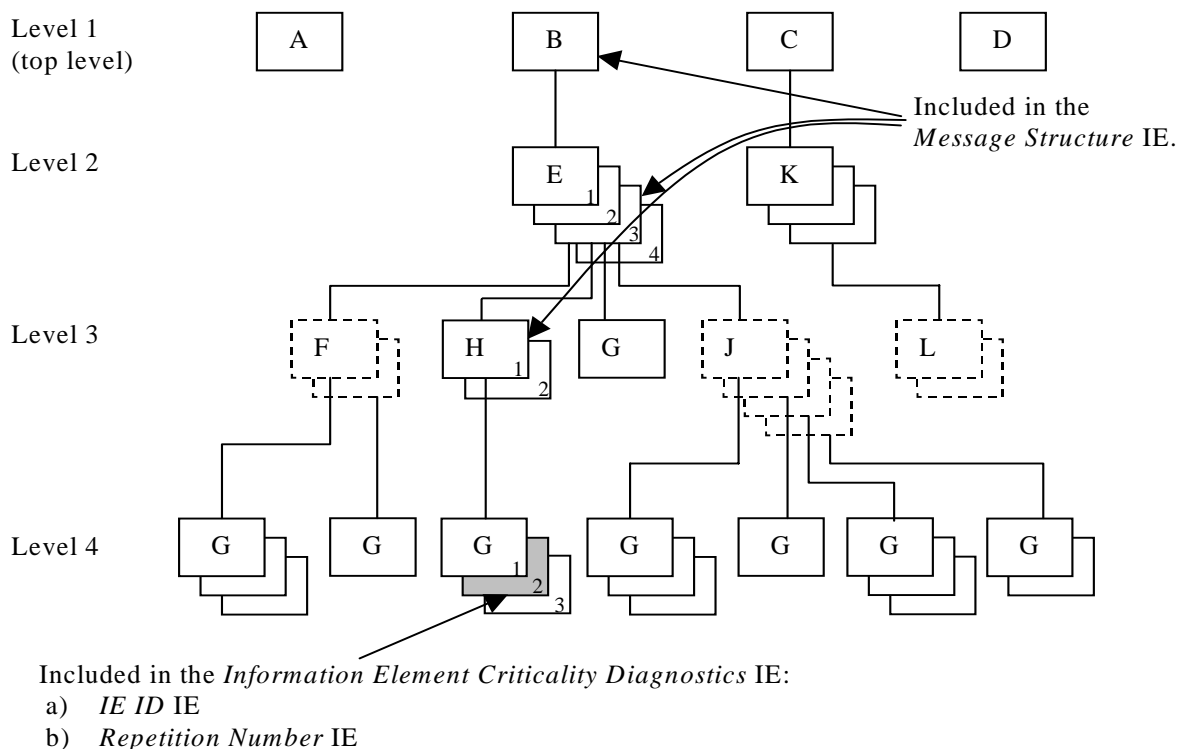

Figure A.4: Example of a received PCAP message containing a not comprehended IE

If there is an error within the instance marked as grey in the IE G in the IE H shown in the figure A.4, this will be reported within the *Information Element Criticality Diagnostics IE* within the *Criticality Diagnostics IE*s in table A.4.

Table A.4

IE name	Value	Comment
IE Criticality	ignore and notify	Criticality for IE on the reported level, i.e. level 4.
IE ID	id-G	IE ID from the reported level, i.e. level 4.
Repetition Number	2	Repetition number on the reported level, i.e. level 4.
Type of Error	not understood	
<i>Message Structure, first repetition</i>		
>IE ID	id-B	IE ID from level 1.
<i>Message Structure, second repetition</i>		
>IE ID	id-E	IE ID from level 2.
>Repetition Number	3	Repetition number from level 2.
<i>Message Structure, third repetition</i>		
>IE ID	id-H	IE ID from the lowest level above the reported level, i.e. level 3.
>Repetition Number	1	Repetition number from the lowest level above the reported level, i.e. level 3.

NOTE: The repetition number of level 4 indicates the number of repetitions of IE G received up to the detected erroneous repetition, counted below the same instance of the previous level with assigned criticality (instance 1 of IE H on level 3).

A.3.4 Example 4

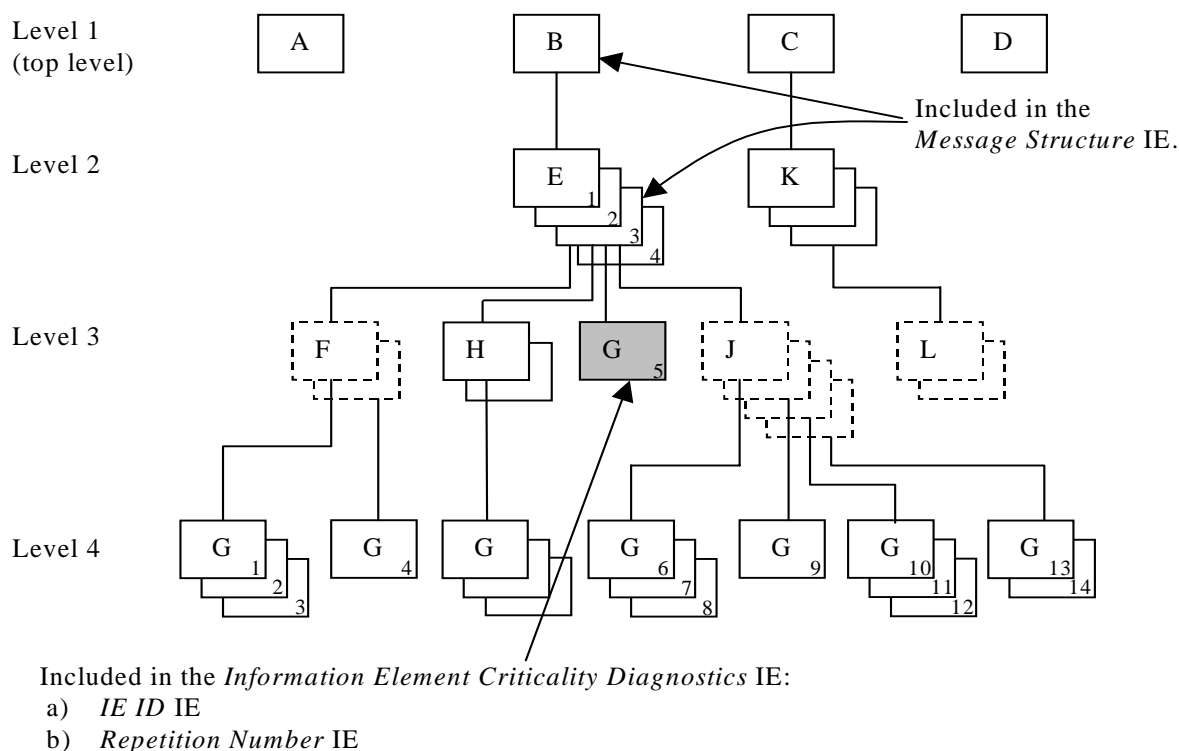

Figure A.5: Example of a received PCAP message containing a not comprehended IE

If there is an error within the instance marked as grey in the IE G in the IE E shown in the figure A.5, this will be reported within the *Information Element Criticality Diagnostics* IE within the *Criticality Diagnostics* IE, as in table A.5.

Table A.5

IE name	Value	Comment
IE Criticality	Reject	Criticality for IE on the reported level, i.e. level 3.
IE ID	id-G	IE ID from the reported level, i.e. level 3.
Repetition Number	5	Repetition number on the reported level, i.e. level 3. (Since the IE E (level 2) is the lowest level included in the <i>Message Structure</i> IE this is the fifth occurrence of IE G within the IE E (level 2).
Type of Error	not understood	
Message Structure, <i>first repetition</i>		
>IE ID	id-B	IE ID from level 1.
Message Structure, <i>second repetition</i>		
>IE ID	id-E	IE ID from the lowest level above the reported level, i.e. level 2.
>Repetition Number	3	Repetition number from the lowest level above the reported level, i.e. level 2.

NOTE: The repetition number of the reported IE indicates the number of repetitions of IE G received up to the detected erroneous repetition, counting all occurrences of the IE G below the same instance of the previous level with assigned criticality (instance 3 of IE E on level 2).

A.3.5 Example 5

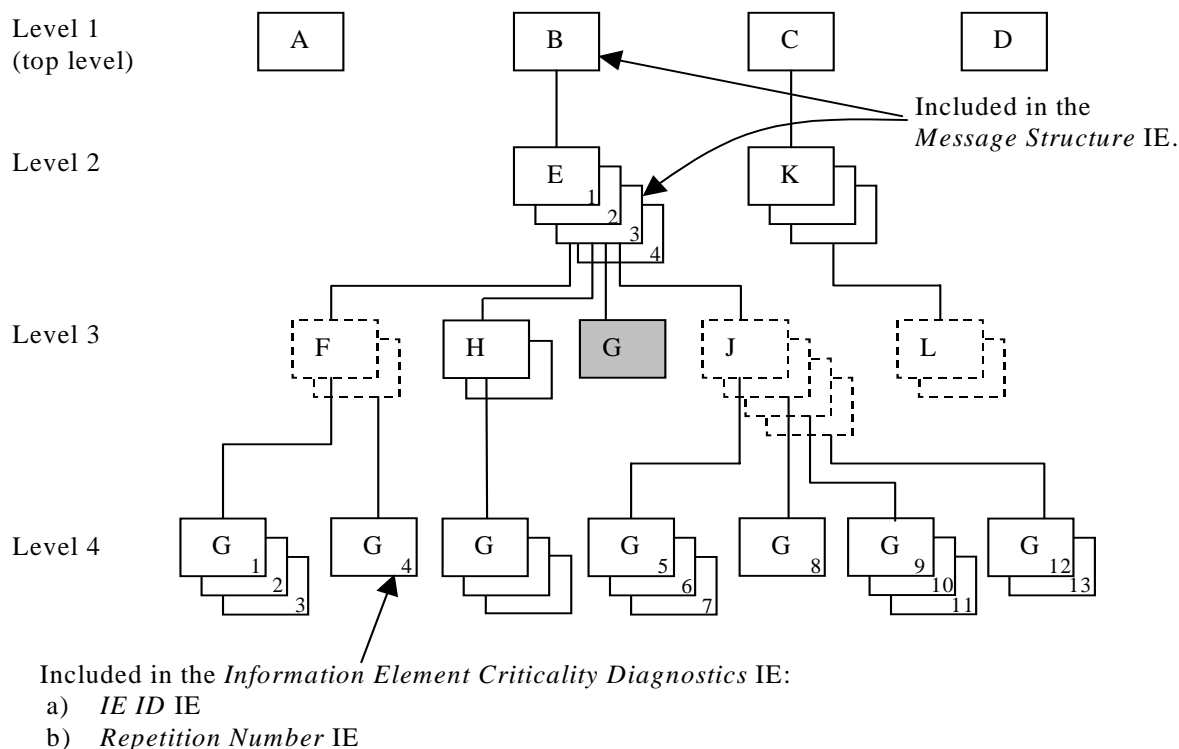

Figure A.6: Example of a received PCAP message with a missing IE

If the instance marked as grey in the IE G in the IE E shown in the figure A.6, is missing this will be reported within the *Information Element Criticality Diagnostics* IE within the *Criticality Diagnostics* IE, as in table A.6.

Table A.6

IE name	Value	Comment
IE Criticality	reject	Criticality for IE on the reported level, i.e. level 3.
IE ID	id-G	IE ID from the reported level, i.e. level 3.
Repetition Number	4	Repetition number up to the missing IE on the reported level, i.e. level 3. (Since the IE E (level 2) is the lowest level included in the <i>Message Structure</i> IE there have been four occurrences of IE G within the IE E (level 2) up to the missing occurrence.
Type of Error	missing	
<i>Message Structure, first repetition</i>		
>IE ID	id-B	IE ID from level 1.
<i>Message Structure, second repetition</i>		
>IE ID	id-E	IE ID from the lowest level above the reported level, i.e. level 2.
>Repetition Number	3	Repetition number from the lowest level above the reported level, i.e. level 2.

NOTE: The repetition number of the reported IE indicates the number of repetitions of IE G received up to but not including the missing occurrence, counting all occurrences of the IE G below the same instance of the previous level with assigned criticality (instance 3 of IE E on level 2).

A.4 ASN.1 of EXAMPLE MESSAGE

```

ExampleMessage ::= SEQUENCE {
    ProtocolIEs          ProtocolIE-Container          {{ExampleMessage-IEs}},
    ProtocolExtensions  ProtocolExtensionContainer  {{ExampleMessage-Extensions}}  OPTIONAL,
    ...
}

ExampleMessage-IEs PCAP-PROTOCOL-IES ::= {
    { ID id-A    CRITICALITY reject  TYPE A  PRESENCE mandatory } |
    { ID id-B    CRITICALITY reject  TYPE B  PRESENCE mandatory } |
    { ID id-C    CRITICALITY reject  TYPE C  PRESENCE mandatory } |
    { ID id-D    CRITICALITY reject  TYPE D  PRESENCE mandatory } ,
    ...
}

B ::= SEQUENCE {
    e          E-List,
    iE-Extensions  ProtocolExtensionContainer { {B-ExtIEs} }  OPTIONAL,
    ...
}

B-ExtIEs PCAP-PROTOCOL-EXTENSION ::= {
    ...
}

E-List ::= SEQUENCE (SIZE (1..maxE)) OF ProtocolIE-Single-Container { {E-IEs} }

E-IEs PCAP-PROTOCOL-IES ::= {
    { ID id-E    CRITICALITY ignore  TYPE E  PRESENCE mandatory }
}

E ::= SEQUENCE {
    f          F-List,
    h          H-List,
    g          G-List1,
    j          J-List,
    iE-Extensions  ProtocolExtensionContainer { {E-ExtIEs} }  OPTIONAL,
    ...
}

E-ExtIEs PCAP-PROTOCOL-EXTENSION ::= {
    ...
}

F-List ::= SEQUENCE (SIZE (1..maxF)) OF F

F ::= SEQUENCE {
    g          G-List2 OPTIONAL,
    iE-Extensions  ProtocolExtensionContainer { {F-ExtIEs} }  OPTIONAL,
    ...
}

F-ExtIEs PCAP-PROTOCOL-EXTENSION ::= {
    ...
}

G-List2 ::= SEQUENCE (SIZE (1..3, ...)) OF ProtocolIE-Single-Container { {G2-IEs} }

G2-IEs PCAP-PROTOCOL-IES ::= {
    { ID id-G    CRITICALITY ignore  TYPE G  PRESENCE mandatory }
}

H-List ::= SEQUENCE (SIZE (1..maxH)) OF ProtocolIE-Single-Container { {H-IEs} }

H-IEs PCAP-PROTOCOL-IES ::= {
    { ID id-H    CRITICALITY ignore  TYPE H  PRESENCE mandatory }
}

H ::= SEQUENCE {
    g          G-List3 OPTIONAL,
    iE-Extensions  ProtocolExtensionContainer { {H-ExtIEs} }  OPTIONAL,
    ...
}

H-ExtIEs PCAP-PROTOCOL-EXTENSION ::= {
    ...
}

```

```

}

G-List3 ::= SEQUENCE (SIZE (1..3, ...)) OF ProtocolIE-Single-Container { {G3-IEs} }

G3-IEs PCAP-PROTOCOL-IES ::= {
  { ID id-G    CRITICALITY notify  TYPE G  PRESENCE mandatory }
}

G-List1 ::= ProtocolIE-Single-Container { {G1-IEs} }

G1-IEs PCAP-PROTOCOL-IES ::= {
  { ID id-G    CRITICALITY reject  TYPE G  PRESENCE mandatory }
}

J-List ::= SEQUENCE (SIZE (1..maxJ)) OF J

J ::= SEQUENCE {
  g          G-List4 OPTIONAL,
  iE-Extensions ProtocolExtensionContainer { {J-ExtIEs} } OPTIONAL,
  ...
}

J-ExtIEs PCAP-PROTOCOL-EXTENSION ::= {
  ...
}

G-List4 ::= SEQUENCE (SIZE (1..3, ...)) OF ProtocolIE-Single-Container { {G4-IEs} }

G4-IEs PCAP-PROTOCOL-IES ::= {
  { ID id-G    CRITICALITY reject  TYPE G  PRESENCE mandatory }
}

C ::= SEQUENCE {
  k          K-List,
  iE-Extensions ProtocolExtensionContainer { {C-ExtIEs} } OPTIONAL,
  ...
}

C-ExtIEs PCAP-PROTOCOL-EXTENSION ::= {
  ...
}

K-List ::= SEQUENCE (SIZE (1..maxK)) OF ProtocolIE-Single-Container { {K-IEs} }

K-IEs PCAP-PROTOCOL-IES ::= {
  { ID id-K    CRITICALITY notify  TYPE K  PRESENCE mandatory }
}

K ::= SEQUENCE {
  l          L-List,
  iE-Extensions ProtocolExtensionContainer { {K-ExtIEs} } OPTIONAL,
  ...
}

K-ExtIEs PCAP-PROTOCOL-EXTENSION ::= {
  ...
}

L-List ::= SEQUENCE (SIZE (1..maxL)) OF L

L ::= SEQUENCE {
  m          M OPTIONAL,
  iE-Extensions ProtocolExtensionContainer { {L-ExtIEs} } OPTIONAL,
  ...
}

L-ExtIEs PCAP-PROTOCOL-EXTENSION ::= {
  ...
}

ExampleMessage-Extensions PCAP-PROTOCOL-EXTENSION ::= {
  ...
}

```

Annex B (informative): Change history

Change history							
Date	TSG #	TSG Doc.	CR	Rev	Subject/Comment	Old	New
06/2001	12	RP-010402			Approved at TSG RAN #12 and placed under Change Control	-	5.0.0
09/2001	13	RP-010603	002	1	Correction to the Error handling of the ERROR INDICATION message	5.0.0	5.1.0
09/2001	13	RP-010603	003		Proposed CR to 25.453 on Semantics Description of C/No	5.0.0	5.1.0
09/2001	13	RP-010603	004		Proposed CR to 25.453 on Clause 10	5.0.0	5.1.0
09/2001	13	RP-010603	005	1	Error handling of the Erroneously Present Conditional Ies	5.0.0	5.1.0
09/2001	13	RP-010603	006	1	Clarification of chapter 10	5.0.0	5.1.0
09/2001	13	RP-010603	007		PCAP Criticality	5.0.0	5.1.0
12/2001	14	RP-010875	008	1	Bitstrings ordering	5.1.0	5.2.0
12/2001	14	RP-010875	009	1	Reference corrections	5.1.0	5.2.0
12/2001	14	RP-010875	010	1	Clarification for the definition of the ASN.1 constants	5.1.0	5.2.0
12/2001	14	RP-010875	012	1	Procedure Code Criticality in Error Indication	5.1.0	5.2.0
12/2001	14	RP-010875	013	2	Addition of amendment to clarify the PER encoding of bitstrings	5.1.0	5.2.0
12/2001	14	RP-010875	014	1	Clarification of the Transaction ID	5.1.0	5.2.0
12/2001	14	RP-010875	015		Correction the Clause 10 Error Handling	5.1.0	5.2.0
-3/2002	15	RP-020211	016		Modification on the Object Identifier	5.2.0	5.3.0
06/2002	16	RP-020432	017	2	Criticality Information Decoding Failure Handling	5.3.0	5.4.0
06/2002	16	RP-020432	018	1	Clarification for the usage of the cause value	5.3.0	5.4.0
03/2003	19	RP-030065	023		CR on GPS Almanac and Satellite Health	5.4.0	5.5.0
03/2003	19	RP-030065	024		CR on GPS Measured Results	5.4.0	5.5.0
03/2003	19	RP-030067	026		Alignment of 'Uncertainty Ellipse' with RRC	5.4.0	5.5.0
03/2003	19	RP-030070	027		Correction for the Information Exchange Initiation procedure	5.4.0	5.5.0
03/2003	19	RP-030084	022	2	CR on revising the position calculation function and definition of SAS to support all REL-4 UE positioning methods	5.5.0	6.0.0
06/2003	20	RP-030324	032	1	Alignment of the Requested Data Value Information IE description	6.0.0	6.1.0
06/2003	20	RP-030325	034		GPS trigger condition	6.0.0	6.1.0
06/2003	20	RP-030341	035		Position Calculation Extension for TDD	6.0.0	6.1.0
06/2003	20	RP-030322	037	1	'On Modification' and 'Periodic' reporting alignment for Information Exchange procedures	6.0.0	6.1.0
06/2003	20	RP-030322	044		CR on Criticality Aspects	6.0.0	6.1.0
06/2003	20	RP-030322	045		CR on Information Exchange Initiation Request for GPS Navigation Model	6.0.0	6.1.0
06/2003	20	RP-030322	046		CR on DGPS Parameters	6.0.0	6.1.0
06/2003	20	RP-030322	047		CR on Removal of Information Exchange Object Type	6.0.0	6.1.0
06/2003	20	RP-030322	048		CR on Information Report of GPS Almanac and Satellite Health	6.0.0	6.1.0
06/2003	20	RP-030326	050		Correction of Failure message used for logical errors	6.0.0	6.1.0
09/2003	21	RP-030442	052		Correction to an incorrect implementation in the Requested Data Value Information IE	6.1.0	6.2.0
09/2003	21	RP-030445	054		Alignment of title and sub-clause text of chapter 10.3.4.2	6.1.0	6.2.0
09/2003	21	RP-030446	059		Removal of the note in chapter 10	6.1.0	6.2.0
09/2003	21	RP-030454	060		Improvement of position calculation with pathloss	6.1.0	6.2.0
12/2003	22	RP-030697	061		Improvement of position calculation through set enlargement	6.2.0	6.3.0
12/2003	22	RP-030683	064		Information Exchange Initiation behavior correction	6.2.0	6.3.0
03/2004	23	RP-040053	068		Alignment with 23.032 correction of Included Angle for Ellipsoid Arc	6.3.0	6.4.0
03/2004	23	RP-040075	069		Initial UE Position IE only mandatory necessary for GPS	6.3.0	6.4.0
03/2004	23	RP-040072	071		PCAP Review	6.3.0	6.4.0
06/2004	24	RP-040184	072	1	Correction to usage of INITIAL UE POSITION	6.4.0	6.5.0
09/2004	25	RP-040306	074	1	Introduction of the requested accuracy and an indication of achieved accuracy in Position Calculation procedure over lupc interface	6.5.0	6.6.0
12/2004	26	RP-040441	076		outdated ITU-T reference	6.6.0	6.7.0
03/2005	27	RP-050055	078	1	Corrections to descriptions of GPS Almanac and Ephemeris fields	6.7.0	6.8.0
06/2005	28	RP-050217	082	2	Correction of deletion of Information Exchange Context	6.8.0	6.9.0
12/2005	30	RP-050701	085		PCAP Review	6.9.0	6.10.0
03/2007	35	RP-070052	100	1	Presence inconsistency	6.10.0	6.11.0

History

Document history		
V6.3.0	December 2003	Publication
V6.4.0	March 2004	Publication
V6.5.0	June 2004	Publication
V6.6.0	September 2004	Publication
V6.7.0	December 2004	Publication
V6.8.0	March 2005	Publication
V6.9.0	June 2005	Publication
V6.10.0	December 2005	Publication
V6.11.0	March 2007	Publication