

ETSI TS 126 348 V17.1.0 (2022-07)



**LTE ;
5G ;
Northbound Application Programming Interface (API)
for Multimedia Broadcast/Multicast Service (MBMS)
at the xMB reference point
(3GPP TS 26.348 version 17.1.0 Release 17)**



Reference

RTS/TSGS-0426348vh10

Keywords

5G,LTE

ETSI

650 Route des Lucioles
F-06921 Sophia Antipolis Cedex - FRANCE

Tel.: +33 4 92 94 42 00 Fax: +33 4 93 65 47 16

Siret N° 348 623 562 00017 - APE 7112B
Association à but non lucratif enregistrée à la
Sous-Préfecture de Grasse (06) N° w061004871

Important notice

The present document can be downloaded from:

<http://www.etsi.org/standards-search>

The present document may be made available in electronic versions and/or in print. The content of any electronic and/or print versions of the present document shall not be modified without the prior written authorization of ETSI. In case of any existing or perceived difference in contents between such versions and/or in print, the prevailing version of an ETSI deliverable is the one made publicly available in PDF format at www.etsi.org/deliver.

Users of the present document should be aware that the document may be subject to revision or change of status.

Information on the current status of this and other ETSI documents is available at

<https://portal.etsi.org/TB/ETSIDeliverableStatus.aspx>

If you find errors in the present document, please send your comment to one of the following services:

<https://portal.etsi.org/People/CommitteeSupportStaff.aspx>

If you find a security vulnerability in the present document, please report it through our
Coordinated Vulnerability Disclosure Program:

<https://www.etsi.org/standards/coordinated-vulnerability-disclosure>

Notice of disclaimer & limitation of liability

The information provided in the present deliverable is directed solely to professionals who have the appropriate degree of experience to understand and interpret its content in accordance with generally accepted engineering or other professional standard and applicable regulations.

No recommendation as to products and services or vendors is made or should be implied.

No representation or warranty is made that this deliverable is technically accurate or sufficient or conforms to any law and/or governmental rule and/or regulation and further, no representation or warranty is made of merchantability or fitness for any particular purpose or against infringement of intellectual property rights.

In no event shall ETSI be held liable for loss of profits or any other incidental or consequential damages.

Any software contained in this deliverable is provided "AS IS" with no warranties, express or implied, including but not limited to, the warranties of merchantability, fitness for a particular purpose and non-infringement of intellectual property rights and ETSI shall not be held liable in any event for any damages whatsoever (including, without limitation, damages for loss of profits, business interruption, loss of information, or any other pecuniary loss) arising out of or related to the use of or inability to use the software.

Copyright Notification

No part may be reproduced or utilized in any form or by any means, electronic or mechanical, including photocopying and microfilm except as authorized by written permission of ETSI.

The content of the PDF version shall not be modified without the written authorization of ETSI.

The copyright and the foregoing restriction extend to reproduction in all media.

© ETSI 2022.
All rights reserved.

Intellectual Property Rights

Essential patents

IPRs essential or potentially essential to normative deliverables may have been declared to ETSI. The declarations pertaining to these essential IPRs, if any, are publicly available for **ETSI members and non-members**, and can be found in ETSI SR 000 314: "*Intellectual Property Rights (IPRs); Essential, or potentially Essential, IPRs notified to ETSI in respect of ETSI standards*", which is available from the ETSI Secretariat. Latest updates are available on the ETSI Web server (<https://ipr.etsi.org/>).

Pursuant to the ETSI Directives including the ETSI IPR Policy, no investigation regarding the essentiality of IPRs, including IPR searches, has been carried out by ETSI. No guarantee can be given as to the existence of other IPRs not referenced in ETSI SR 000 314 (or the updates on the ETSI Web server) which are, or may be, or may become, essential to the present document.

Trademarks

The present document may include trademarks and/or tradenames which are asserted and/or registered by their owners. ETSI claims no ownership of these except for any which are indicated as being the property of ETSI, and conveys no right to use or reproduce any trademark and/or tradename. Mention of those trademarks in the present document does not constitute an endorsement by ETSI of products, services or organizations associated with those trademarks.

DECT™, **PLUGTESTS™**, **UMTS™** and the ETSI logo are trademarks of ETSI registered for the benefit of its Members. **3GPP™** and **LTE™** are trademarks of ETSI registered for the benefit of its Members and of the 3GPP Organizational Partners. **oneM2M™** logo is a trademark of ETSI registered for the benefit of its Members and of the oneM2M Partners. **GSM®** and the GSM logo are trademarks registered and owned by the GSM Association.

Legal Notice

This Technical Specification (TS) has been produced by ETSI 3rd Generation Partnership Project (3GPP).

The present document may refer to technical specifications or reports using their 3GPP identities. These shall be interpreted as being references to the corresponding ETSI deliverables.

The cross reference between 3GPP and ETSI identities can be found under <http://webapp.etsi.org/key/queryform.asp>.

Modal verbs terminology

In the present document "**shall**", "**shall not**", "**should**", "**should not**", "**may**", "**need not**", "**will**", "**will not**", "**can**" and "**cannot**" are to be interpreted as described in clause 3.2 of the [ETSI Drafting Rules](#) (Verbal forms for the expression of provisions).

"**must**" and "**must not**" are **NOT** allowed in ETSI deliverables except when used in direct citation.

Contents

| | |
|---|-----------|
| Intellectual Property Rights | 2 |
| Legal Notice | 2 |
| Modal verbs terminology..... | 2 |
| Foreword..... | 5 |
| Introduction | 5 |
| 1 Scope | 6 |
| 2 References | 6 |
| 3 Definitions and abbreviations..... | 7 |
| 3.1 Definitions | 7 |
| 3.2 Abbreviations | 7 |
| 4 Architecture..... | 7 |
| 4.1 General | 7 |
| 4.2 xMB reference point..... | 9 |
| 5 Procedure..... | 9 |
| 5.1 General | 9 |
| 5.2 Authentication and Authorization | 10 |
| 5.2.1 Introduction..... | 10 |
| 5.2.2 Authentication Procedure | 10 |
| 5.2.3 Authorization Procedure | 11 |
| 5.3 Service Management Procedures | 12 |
| 5.3.1 Introduction..... | 12 |
| 5.3.2 Create Service..... | 12 |
| 5.3.3 Get Service Properties | 12 |
| 5.3.4 Update Service Properties..... | 12 |
| 5.3.5 Terminate a Service | 13 |
| 5.3.6 Service Notifications..... | 13 |
| 5.3.7 List of Service Properties..... | 14 |
| 5.4 Session Management Procedures | 16 |
| 5.4.1 Introduction..... | 16 |
| 5.4.2 Create Session..... | 17 |
| 5.4.3 Get Session Properties | 17 |
| 5.4.4 Update Session Properties | 18 |
| 5.4.5 Terminate a Session..... | 18 |
| 5.4.6 Session Properties..... | 19 |
| 5.4.7 Geographical area for mission critical services | 31 |
| 5.5 User Plane Procedures..... | 32 |
| 5.5.1 Introduction..... | 32 |
| 5.5.2 File Distribution | 32 |
| 5.5.3 RTP Streaming..... | 32 |
| 5.5.4 Transport..... | 33 |
| 5.5.5 Notification Messages..... | 33 |
| 5.6 File Delivery Manifest..... | 34 |
| 5.6.1 General..... | 34 |
| 5.6.2 File Delivery Manifest..... | 34 |
| 5.6.3 JSON Schema for File Delivery Manifest | 36 |
| Annex A (informative): xMB User Plane (xMB-U) | 39 |
| A.0 General | 39 |
| A.1 Generic File Delivery | 39 |
| A.1.1 Introduction | 39 |
| A.1.2 File ingestion with Pull..... | 39 |

| | | |
|--|--|-----------|
| A.1.3 | File ingestion with Push | 41 |
| A.2 | DASH Media Presentation Delivery | 42 |
| A.2.1 | Introduction | 42 |
| A.2.2 | DASH Content ingestion with Pull | 43 |
| A.2.3 | DASH Content ingestion with Push | 45 |
| A.3 | MBMS Streaming (with RTP) | 46 |
| A.4 | Transparent Delivery | 47 |
| A.5 | HLS Media Presentation Delivery | 49 |
| A.5.1 | Introduction | 49 |
| A.5.2 | Segment and Playlist Order Guarantee | 49 |
| A.5.3 | HLS Content Ingestion with Pull | 49 |
| A.5.3.1 | Introduction | 49 |
| A.5.3.2 | Content ingestion steps | 49 |
| A.5.4 | HLS Content Ingestion with Push | 50 |
| A.5.4.1 | Introduction | 50 |
| A.5.4.2 | Content ingestion steps | 50 |
| Annex B (informative): Change history | | 51 |
| History | | 52 |

Foreword

This Technical Specification has been produced by the 3rd Generation Partnership Project (3GPP).

The contents of the present document are subject to continuing work within the TSG and may change following formal TSG approval. Should the TSG modify the contents of the present document, it will be re-released by the TSG with an identifying change of release date and an increase in version number as follows:

Version x.y.z

where:

x the first digit:

- 1 presented to TSG for information;
- 2 presented to TSG for approval;
- 3 or greater indicates TSG approved document under change control.

Y the second digit is incremented for all changes of substance, i.e. technical enhancements, corrections, updates, etc.

z the third digit is incremented when editorial only changes have been incorporated in the document.

Introduction

The present document defines a northbound interface between the BM-SC and the content provider. The interface is called xMB. Both external (3rd party) content providers and 3GPP defined API invokers e.g. GCS AS can use the xMB reference point to access BM-SC provided delivery services.

The xMB reference point supports different session types, such as generic file delivery e.g. for MCDATA, application streaming, including DASH streaming, RTP ingest and ingest for transparent delivery. The xMB reference point supports unicast delivery of content, e.g. for devices outside of the MBMS coverage area.

The xMB reference point is fully integrated into the Common API Framework for 3GPP Northbound APIs (CAPIF).

1 Scope

The present document provides interaction methods and interfaces between a BM-SC and a content provider. The purpose of the document is the definition of enablers for the usage of MBMS delivery.

2 References

The following documents contain provisions which, through reference in this text, constitute provisions of the present document.

- References are either specific (identified by date of publication, edition number, version number, etc.) or non-specific.
- For a specific reference, subsequent revisions do not apply.
- For a non-specific reference, the latest version applies. In the case of a reference to a 3GPP document (including a GSM document), a non-specific reference implicitly refers to the latest version of that document *in the same Release as the present document*.

- [1] 3GPP TR 21.905: "Vocabulary for 3GPP Specifications".
- [2] 3GPP TS 26.346: "Multimedia Broadcast/Multicast Service (MBMS); Protocols and codecs".
- [3] 3GPP TS 26.234: "Transparent end-to-end Packet-switched Streaming Service (PSS); Protocols and codecs".
- [4] 3GPP TS 26.247: "Transparent end-to-end Packet-switched Streaming Service (PSS); Progressive Download and Dynamic Adaptive Streaming over HTTP (3GP-DASH)".
- [5] 3GPP TS 33.310: "Network Domain Security (NDS); Authentication Framework (AF)".
- [6] IETF RFC 6347: "Datagram Transport Layer Security Version 1.2", E. Rescorla, N. Modadugu.
- [7] IETF RFC 4918: "HTTP Extensions for Web Distributed Authoring and Versioning (WebDAV)", L. Dusseault.
- [8] IETF RFC 5795: "The Robust Header Compression (ROHC) Framework".
- [9] IETF RFC 3095: "RObust Header Compression (ROHC): Framework and four profiles: RTP, UDP, ESP, and uncompressed".
- [10] 3GPP TS 23.222: "Common API Framework for 3GPP Northbound APIs".
- [11] IETF Internet-Draft: "JSON Schema: A Media Type for Describing JSON Documents", draft-wright-json-schema-01, April 15, 2017.
- [12] 3GPP TS 23.280, "Common functional architecture to support mission critical services; Stage 2".
- [13] 3GPP TS 29.061: "Interworking between the Public Land Mobile Network (PLMN) supporting packet based services and Packet Data Networks (PDN)".
- [14] 3GPP TS 29.468: "Group Communication System Enablers for LTE (GCSE_LTE); MB2 reference point; Stage 3".
- [15] IETF RFC 5234 (January 2008): "Augmented BNF for Syntax Specifications: ABNF", D. Crocker and P. Overell.
- [16] 3GPP TS 23.246: "Multimedia Broadcast/Multicast Service (MBMS); Architecture and functional description".
- [17] 3GPP TS 26.501: "5G Media Streaming (5GMS); General description and architecture".

3 Definitions and abbreviations

3.1 Definitions

For the purposes of the present document, the terms and definitions given in 3GPP TR 21.905 [1] and the following apply. A term defined in the present document takes precedence over the definition of the same term, if any, in 3GPP TR 21.905 [1].

3.2 Abbreviations

For the purposes of the present document, the abbreviations given in 3GPP TR 21.905 [1] and the following apply. An abbreviation defined in the present document takes precedence over the definition of the same abbreviation, if any, in 3GPP TR 21.905 [1].

| | |
|-------|--------------------------------------|
| 5GMS | 5G Media Streaming |
| ARP | Allocation and Retention Priority |
| BM-SC | Broadcast-Multicast - Service Centre |
| DASH | Dynamic Adaptive Streaming over HTTP |
| DTLS | Datagram Transport Layer Security |
| FEC | Forward Error Correction |
| GBR | Guaranteed Bitrate |
| HLS | HTTP Live Streaming |
| MPD | Media Presentation Description |
| QCI | QOS Class Identifier |
| QOS | Quality of Service |
| QOE | Quality of Experience |
| ROM | Receive Only Mode |
| RTSP | Real-Time Streaming Protocol |
| RTP | Real Time Transport Protocol |
| RTCP | Real Time Transport Control Protocol |
| SACH | Service Announcement Channel |
| SAI | Service Area Identity |
| SCEF | Service Capability Exposure Function |
| SDP | Session Description protocol |
| TLS | Transport Layer Security |
| TV | Television |
| UE | User Equipment |
| UDP | User Datagram Protocol |
| URL | Uniform Resource Locator |
| UTC | Universal Time Coordinated |

4 Architecture

4.1 General

As shown in Figure 4.1-1, the reference point between Content Provider and BM-SC is called the xMB interface. Using the xMB reference point, content provider can invoke procedures supported by BM-SC(s) to set up and manage MBMS user service from BM-SC to the MBMS Clients. BM-SC defines an endpoint with all supported procedures on the xMB interface, which can then be converted to SGmb procedures for the interface between BM-SC and MBMS GW (not depicted).

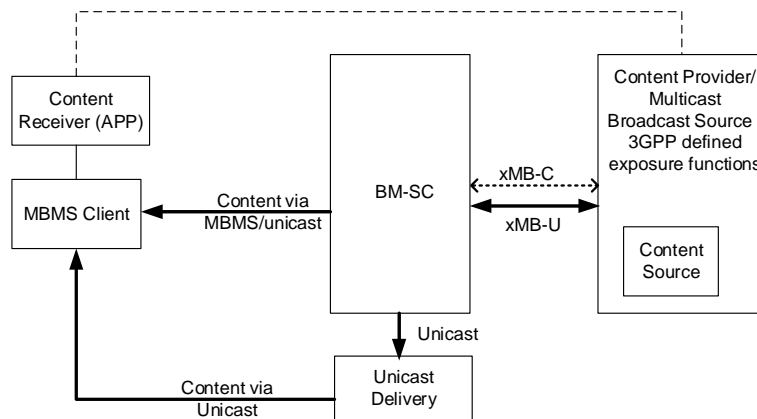

Figure 4.1-1: The xMB reference model

The BM-SC may forward the received content for unicast delivery for appropriate functions (e.g., MBMS user service fallback).

The control plane (xMB-C) and the user plane (xMB-U) may be optionally terminated by 3GPP defined enabler / exposure functions such as an SCEF, which exposes the same or a different interface to content providers. The exposed API such as SCEF is not specified in the present document.

The content provider may optionally exchange application level information like service metadata (e.g. serviceIds or URL(s) of USD(s) or other service identifier(s)) directly with the application.

The BM-SC may support CAPIF [10]. When CAPIF is supported, then:

- the BM-SC shall support the CAPIF API provider domain functions (i.e. CAPIF-2/2e (xMB), CAPIF-3, CAPIF-4 and CAPIF-5 as specified in TS 23.222 [10]);
- the BM-SC xMB authentication and authorization functions (as defined in Clause 5.2) are replaced by CAPIF equivalent core domain functions (i.e. CAPIF-1/1e).

The CAPIF and associated API provider domain functions are specified in TS 23.222 [10].

The content provider may be a mission critical service provider ([12]), which is arranging MC Services to Mission Critical Organizations. Providing MC Services may require additional control of the resource allocation (QoS, coverage area). For this purpose, the interface can be extended with the xMB mission critical extension. The xMB mission critical extension consists in:

- additional properties within the control plane procedures (Table 5.4-6),
- specific semantic and syntax for the geographical area (Clause 5.4.7).

The Content Provider may be a 5GMS Application Provider as defined in clause 4.6 of TS 26.501 [17], providing 5G Media Streaming services to a 5GMS System, as shown in Figure 4.1.2. In this case, *Content Receiver <APP>* includes a 5GMS Client that can be served at least partially by the MBMS Client. The 5GMS Application Function (5GMS AF) invokes xMB-C control plane procedures on the BM-SC as specified in clauses 5.3 and 5.4 and, as a result, content is ingested by the BM-SC from the 5GMS Application Server (5GMS AS) using the xMB-U File Distribution procedures specified in clause 5.5.2 to support delivery of xMB-C Session types *Application* or *Files*. Procedures for 5GMS content delivery via eMBMS, including communication of the 5GMS AF and 5GMS AS with the BM-SC are defined in clause 5.10 of TS 26.501 [17].

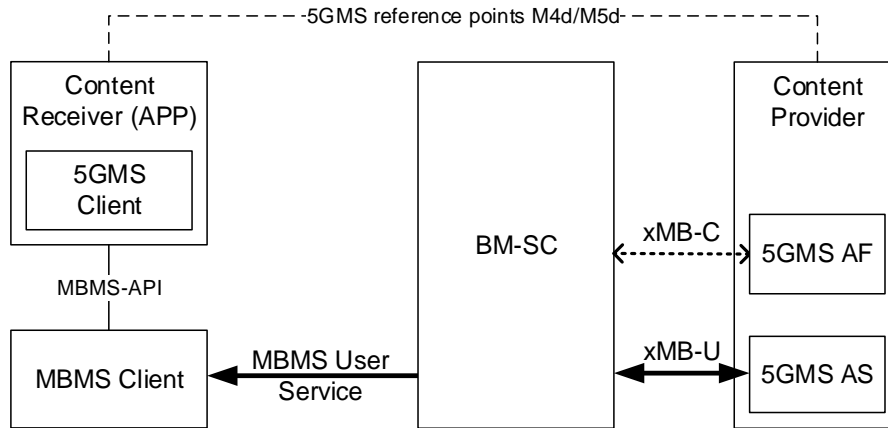

Figure 4.1-2: 5GMS over eMBMS

4.2 xMB reference point

The xMB reference point exists between the content provider and the BM-SC directly or via 3GPP defined enabler / exposure functions such as SCEF. When the BM-SC connects to content provider via a 3GPP defined enabler / exposure function, the xMB-C interface (and optionally also the xMB-U) is terminated at the 3GPP defined enabler / exposure function.

The xMB reference point provides the ability for the content provider to:

- authenticate and authorize BM-SC(s).
- create, modify and terminate a service.
- create, modify and terminate a session.
- query information.
- deliver content to the BM-SC(s)

The xMB reference point provides the ability for the BM-SC to:

- authenticate and authorize a content provider.
- notify the content provider of the status of an MBMS user service usage.
- retrieve content from the content provider.

The xMB reference point shall support security function for confidentiality protection of both control plane (xMB-C) and user plane (xMB-U).

5 Procedure

5.1 General

The xMB reference point defines procedures between a BM-SC and a content provider. The content provider may be external (i.e. 3rd party provider) or 3GPP defined API invokers.

The following procedures are available:

- Authentication and Authorization

NOTE: When CAPIF is used, the CAPIF 1 / CAPIF 1e procedures are used.

- Service Management Procedures

- Session Management Procedures

By default the BM-SC announces all the services including the different eMBMS parameters to MBMS Clients so that MBMS Clients can activate reception of the announced MBMS services. It is also possible that the Content Provider /API invoker is doing the service announcement by itself.

A set of different session types are supported, namely:

- Streaming: the BM-SC may use the MBMS Streaming delivery method for content distribution to MBMS Clients
- Files: the BM-SC may use the MBMS Download delivery method for content distribution to MBMS Clients
- Application: the BM-SC may use the MBMS Download delivery method for content distribution to MBMS Clients.

Figure 4.1-2: 5GMS over eMBMS

- Transport-Mode: the BM-SC is transparent to the stream and passed data via MBMS bearers to UEs.

5.2 Authentication and Authorization

5.2.1 Introduction

The content provider and the BM-SC shall follow the procedures in this clause for authentication and authorization over the xMB.

When the content provider (API invoker) uses CAPIF to discover the BM-SC (xMB provider) and to interact with the BM-SC, then the xMB security procedures (as defined in this clauses) are replaced by CAPIF-1 / CAPIF-1e [10] security procedures.

Before provisioning of services at the BM-SC, the content provider has to be authenticated and authorized to perform service management functions using xMB. If the content provider wants to modify or remove the provisioned services, it can do so by using a valid access token.

The content provider may have multiple and different end-points for xMB-C and xMB-U. Each connection may have different entitlements based on the roles assigned to the requesting connecting party.

While authentication is performed based on standard (D)TLS connection and certificate exchange, authorization is performed using either the "domain-based" or "user-based" mode as described in clause 5.2.3.

In the user-based mode, fine-grained authorization shall be performed prior to any transaction to allow the BM-SC to check the access rights of the content provider user (either a human or a machine). Such authorization procedure, if successful, shall result in the creation of an "access token" that the server will return to the content provider for subsequent requests made on the xMB interface.

In the domain-based mode, additional authorization steps shall not be performed. Users within a content provider domain are not further separated.

5.2.2 Authentication Procedure

The authentication procedure is used by the content provider and the BM-SC to authenticate each other. The content provider shall be authenticated with the BM-SC when the content provider wants to provision new services or manage existing services. Similarly, the BM-SC shall be authenticated by the content provider when the BM-SC needs to send reports and notifications to the content provider. Authentication is also required for all user plane procedures.

Figure 5.2-1 shows the authentication procedure used between the content provider and the BM-SC.

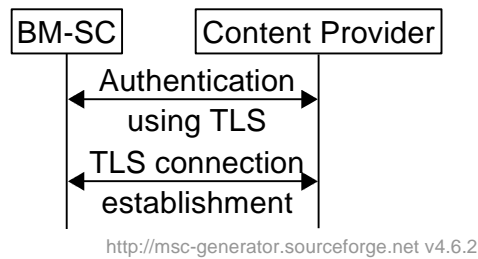

Figure 5.2-1: Authentication Procedure

1. The content provider and the BM-SC authenticate each other for performing service management and status reporting and notification respectively. During this authentication step, the content provider and BM-SC exchange their X.509 certificates using TLS as defined in TS 33.310 [5] and independently verify the validity of each other's certificate.
2. The TLS connection is established.

5.2.3 Authorization Procedure

Before using any of the MBMS xMB procedure, the Content Provider shall first use the following authorization procedure to retrieve its authorization. After successful authorization based on the content provider's representative's credentials, operations such as service and session creation within the granted permissions become possible.

In this version of the specification, the BM-SC shall support at least one of the two following modes of authorization: *domain-based* or *user-based*.

Upon a successful authentication procedure, the absence of an access token provided to the content provider in response to an authorization request is an indication that the BM-SC only supports domain-based authorization, based on the previously-established (D)TLS connection between the Content Provider server and the BM-SC. This means that the same access rights to service or session resource requests across the xMB interface will be granted at the level of the business entity represented by the sender, independent of the end-user representative of that entity or administrative domain submitting the request. This requires the network operator to have already created and provided a unique certificate for storage by the BM-SC. If the certificate of the content provider is not contained in the BM-SC, then the authorization procedure shall fail.

Presence of an access token in the authorization response is an indication that the BM-SC supports user-based authorization, i.e., fine-grained authorization at the end-user representative level, of xMB resource requests. In this case, the content provider representative shall include this access token in each subsequent resource request made on xMB.

NOTE 1: It is up to the BM-SC to decide whether it supports domain-based or user-based authorization.

NOTE 2: In Figure 5-3 and subsequent clauses on Service Management and Session Management procedures and the associated message sequence diagrams, it is assumed that user-based authorization is supported by the BM-SC.

Figure 5.2-2 shows the procedure for content provider authorization by the BM-SC.

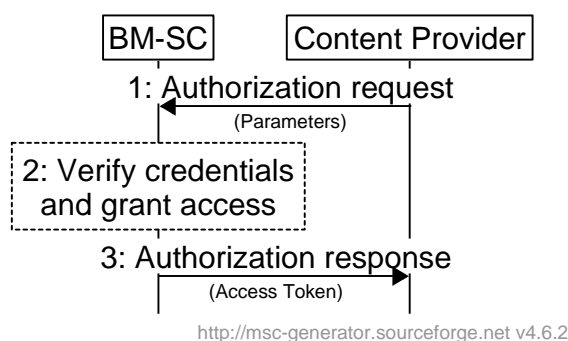

Figure 5.2-2: Authorization Procedure

- 1) If the content provider's representative is not in possession of a valid access token, it shall connect to the BM-SC using the authenticated TLS connection and perform the authorization procedure to retrieve the access token.
- 2) The BM-SC checks the credentials of the content provider and upon successful verification it will generate an access token that will be returned to the content provider. The link between the access token and the entitlement is outside of the scope of the specification.
- 3) The content provider may then use the access token on subsequent calls to the xMB interface.

5.3 Service Management Procedures

5.3.1 Introduction

The service management procedures allow the content provider to create, modify and delete services on the BM-SC. Each service may contain multiple sequential sessions.

5.3.2 Create Service

The procedure allows a content provider to create a new the service. Service configuration and service sessions are added in subsequent procedures.

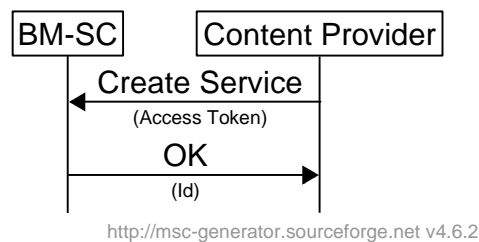

Figure 5.3-1: Service Creation

1. The service is created. The content provider provides a valid access token.
2. On successful creation, the BM-SC responds with the resource id of the service. Service properties are fetched and modified with subsequent transactions.

5.3.3 Get Service Properties

The procedure allows a content provider to fetch the current configuration of the service.

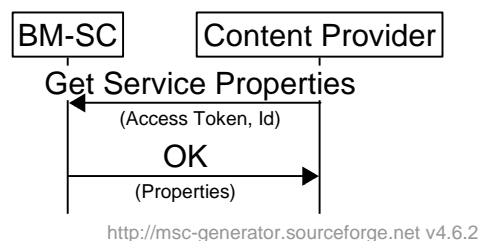

Figure 5.3-2: Get current service properties

1. The content provider sends along with the service property request, the access token and the resource id of the service.
2. The BM-SC provides the service properties in response.

5.3.4 Update Service Properties

The procedure allows a content provider to update the current configuration of the service.

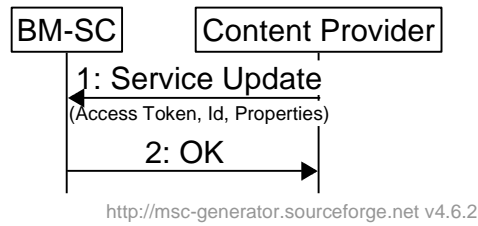

Figure 5.3-3: Service Update

The content provider may first fetch the current service configuration using the Get Service Configuration procedure.

1. The content provider modifies the properties of the service resource. The procedure may allow modification of individual properties or all properties.
2. The content provider updates the resource identified by the id of the service.

5.3.5 Terminate a Service

The content provider may terminate a service. All sessions, including those which are being created or are already active will be deleted automatically with the termination of the service.

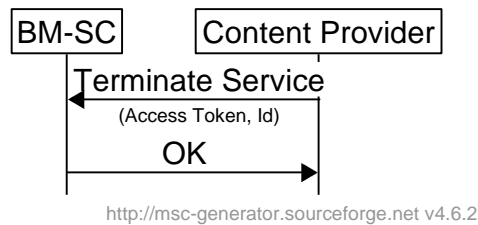

Figure 5.3-4: Service Termination

1. The content provider sends the service termination command. The access token and the resource id of the service is provided as input.
2. The BM-SC terminates the service and deletes all associated sessions, and acknowledges the reception of this request.

5.3.6 Service Notifications

Service Notifications can be pushed to the content provider, when the content provider has provided a value for the Push Notification URL property through a Service Update procedure transaction. The content provider can always initiate request for the delivery of notifications using the URL for notification resources.

The content provider may configure a push notification end-point within the service properties. When present, the BM-SC notifies the content provider whenever appropriate.

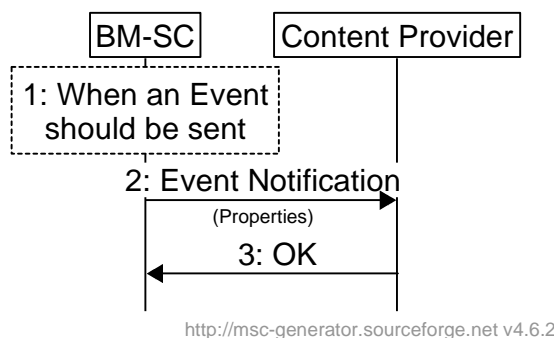

Figure 5.3-5: Event Push Notification

1. When an event occurs, the BM-SC determines whether an event notification should be sent to the content provider.
2. The BM-SC sends a notification, containing details around the event, to the content provider.
3. The content provider acknowledges the reception.

The content provider may initiate periodical "pull"-based reception of notifications.

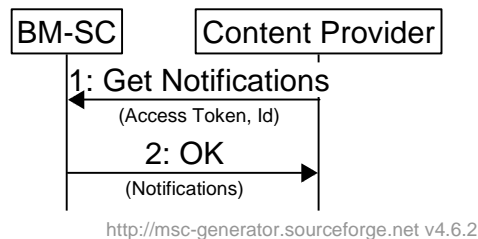

Figure 5.3-6: Event Pull Notification

1. The content provider sends along with the notification request, the access token and may additionally provide the service id as a filter.
2. The BM-SC provides all the notifications in response which occurred during a BM-SC-defined past period prior to the time of reception of the request.

5.3.7 List of Service Properties

All Service Properties, except for the resource id, are always carried in a HTTPS message body. The access-token is always carried as part of HTTP Headers. Except for the service creation request (where the id is not present), the resource id shall be present in the URL of all requests that relate to a specific service.

In the Table 5.3-1, the following assertions are made:

- Table header: C stands for Create Service Procedure, G is for Get Service Procedure, U is for Update Service Procedure and T is for Terminate Service Procedure. "I", and "O" respectively denote "request" (going Into the BM-SC), and response (going Out of the BM-SC).
- Optional ("O") means that the property may or may not be sent/received during a REST transaction. It does not necessarily mean that the property is optional. It is possible, for example, that a session is not yet started because the Content Provider has not set the property in any previous Update transaction using the PUT or PATCH HTTP method, as opposed to representing a hint on the importance of the property for the BM-SC.
- A property marked as optional (O) in a request message may be present in the request. When not present in the request body, the property, if present in the BM-SC, will not be updated.
- A property marked as optional (O) in a response message is only present in the response when a value is assigned by the BM-SC.
- A property marked as mandatory (M) in a response message is always present in the response. The BM-SC provides defaults, which may be modified subsequently by the content provider.
- A blank cell in the table means "forbidden" (the property cannot be added to the request or returned by the BM-SC, depending on the transaction direction).

Table 5.3-1: List of Service Properties

| Property Name | Property Description | C I | C O | G I | G O | U I | U O | T I |
|---------------|--|--------|--------|--------|--------|--------|--------|--------|
| id | Identifier of the Service Resource. Shall be systematically present in the message URL to identify the resource in the BM-SC. | | M | | | | | |

| Property Name | Property Description | | | C | C | G | G | U | U | T |
|---------------------------|--|---------|----------------------------|---|---|---|---|---|---|---|
| | Type | Unit | Default | | | | | | | |
| | Integer | None | N/A | | | | | | | |
| ServiceID | ServiceID, set by the BM-SC to identify the MBMS User Service as defined in Clause 11.2.1.1 of TS 26.346 [2]. | | | | | | M | | | |
| | String | None | N/A | | | | | | | |
| Service Class | The service class that service belongs to (see <i>serviceClass</i> element in Clause 11.2.1.2) of TS 26.346 [2]. | | | | | | M | O | | |
| | String | None | (operator defined default) | | | | | | | |
| Service Languages | List of languages of the service content (see <i>serviceLanguage</i> element in Clause 11.2.1.1) of TS 26.346 [2]. | | | | | | O | O | | |
| | List of String | None | Empty list | | | | | | | |
| Service Names | List of Service Names (see <i>name</i> element in Clause 11.2.1.1) of TS 26.346 [2]. | | | | | | O | O | | |
| | List of String | None | Empty List | | | | | | | |
| Receive Only Mode | When set to 'true', the Content Provider indicates that the service is a Receive Only Mode service. | | | | | | | O | | |
| | Boolean | Enabled | False | | | | | | | |
| Service Announcement Mode | <p>Enumeration of Service Announcement Mode.</p> <p>Additional service announcement modes may be added in future.</p> <ul style="list-style-type: none"> - SACH: BM-SC performs the Service Announcement for the current service using the SACH channel (cf. Annex L.2, L3 of TS 26.346 [2]). - Content Provider: Content Provider performs the Service Announcement to an (not necessarily 3GPP-defined) MBMS User Agent function in the UE. The MBMS User Agent performs a similar role to but is a separate entity from the MBMS client, the latter of which is not involved in Service Announcement reception. The BM-SC shall provide the service announcement information to content provider. | | | | | | M | O | | |
| | String | None | SACH | | | | | | | |

| Property Name | Property Description | C | C | G | G | U | U | T | | | | | | | | | | | |
|-------------------------------------|---|-------------------|---------|---------|---------|----------|-------|---------|-------------------|-----------|---------|--------------------|-------------------|--|--|--|--|--|--|
| | | I | O | I | O | I | O | I | | | | | | | | | | | |
| Consumption Reporting Configuration | The content provider wishes to collect consumption reports. | | | | O | O | | | | | | | | | | | | | |
| | <table border="1"> <thead> <tr> <th>Type</th> <th>Name</th> <th>Default</th> </tr> </thead> <tbody> <tr> <td>Boolean</td> <td>Enabled</td> <td>False</td> </tr> <tr> <td>Integer</td> <td>Sample Percentage</td> <td>10 (in %)</td> </tr> <tr> <td>Integer</td> <td>Reporting Interval</td> <td>3600 (in seconds)</td> </tr> </tbody> </table> | Type | Name | Default | Boolean | Enabled | False | Integer | Sample Percentage | 10 (in %) | Integer | Reporting Interval | 3600 (in seconds) | | | | | | |
| | Type | Name | Default | | | | | | | | | | | | | | | | |
| | Boolean | Enabled | False | | | | | | | | | | | | | | | | |
| Integer | Sample Percentage | 10 (in %) | | | | | | | | | | | | | | | | | |
| Integer | Reporting Interval | 3600 (in seconds) | | | | | | | | | | | | | | | | | |
| Push Notification URL | The content provider provides Notification URL over which it will receive notifications "pushed" by the BM-SC. The Notification procedure is described in Clause 5.4.6 of TS 26.346 [2]. | | | | O | O | | | | | | | | | | | | | |
| | <table border="1"> <thead> <tr> <th>Type</th> <th>Unit</th> <th>Default</th> </tr> </thead> <tbody> <tr> <td>String</td> <td>- None -</td> <td>""</td> </tr> </tbody> </table> | Type | Unit | Default | String | - None - | "" | | | | | | | | | | | | |
| Type | Unit | Default | | | | | | | | | | | | | | | | | |
| String | - None - | "" | | | | | | | | | | | | | | | | | |
| Push Notification Configuration | <p>If the content provider enables push delivery of notifications, then the content provider may provide notification filters.</p> <p>This parameter contains a comma separated list of Classes it wishes to receive among the following options: Critical, Warning, Information, Service, Session, or All to get all types of notification.</p> <p>The notification message shall be sent immediately to the content provider upon becoming available.</p> | | | | O | O | | | | | | | | | | | | | |
| | <table border="1"> <thead> <tr> <th>Type</th> <th>Unit</th> <th>Default</th> </tr> </thead> <tbody> <tr> <td>String</td> <td>None</td> <td>All</td> </tr> </tbody> </table> | Type | Unit | Default | String | None | All | | | | | | | | | | | | |
| Type | Unit | Default | | | | | | | | | | | | | | | | | |
| String | None | All | | | | | | | | | | | | | | | | | |

NOTE: It is assumed that the BM-SC can derive the required UE capabilities from the provided service and session properties.

5.4 Session Management Procedures

5.4.1 Introduction

Session management procedures allow the content provider to create, modify and terminate sessions. Each session is time bound (i.e. has a start and stop time) and is associated with a target broadcast area (which can be used to derive the MBMS Service Area). The stop time may be absent in case of 24/7 sessions.

The MBMS Bearer is active between start and stop time of the session independently whether the content provider is sending data. The BM-SC automatically terminates the MBMS bearer at stop time. The content provider may proactively terminate the session before the stop time.

A session has one of the following states. The BM-SC may only allow state transition, when the mandatory session properties according to the service type is configure. The BM-SC may reject modification of properties depending on the session state.

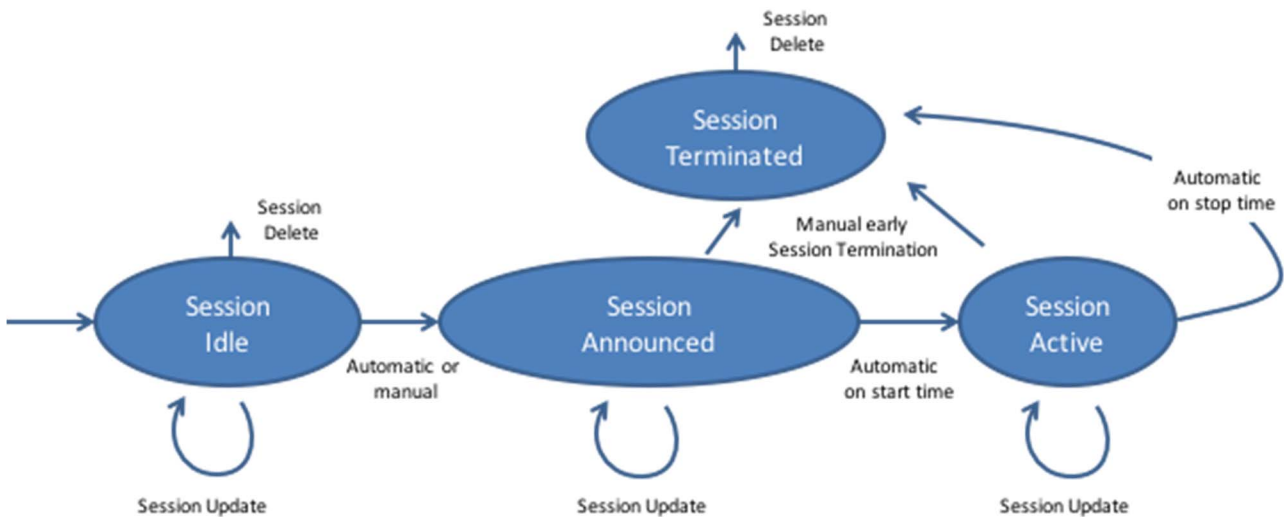

Figure 5.4-1: Session State Diagram

State description of the BM-SC for a session. The BM-SC may reject state transitions when mandatory properties are missing. The BM-SC may send error notifications to the content provider.

- Session Idle: The Session is under preparation. Typically, the content provider needs multiple session updates in order to configure all session properties and retrieve the needed information for content provider user-plane entities.
- Session Announced: The session properties have been announced and MBMS Clients may become aware that the session is about to start.
- Session Active: The session is active according to the Session Schedule.

5.4.2 Create Session

This procedure allows the content provider to create a session for an available service.

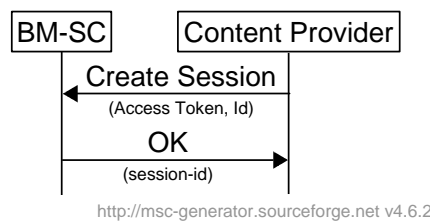

Figure 5.4-2: Session Creation

- 1) The Content Provider wishes to create a new session and sends the Create Session command. The content provider provides the access token and the resource id of the service with the input.
- 2) The BM-SC creates the session resources and provides the session resource id in response. The session properties are defined in subsequent transactions.

5.4.3 Get Session Properties

This procedure allows the content provider to get the current session configuration.

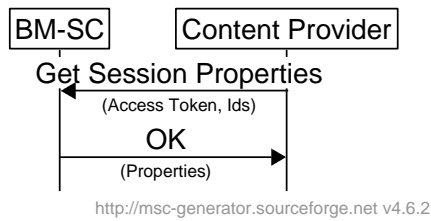

Figure 5.4-3: Get Current Session Properties

1. The content provider requests the session configuration information. The content provider provides the access token, the resource ids the service and the session with the request.
2. The BM-SC provides the session configuration in response.

5.4.4 Update Session Properties

This procedure allows the content provider to update session properties.

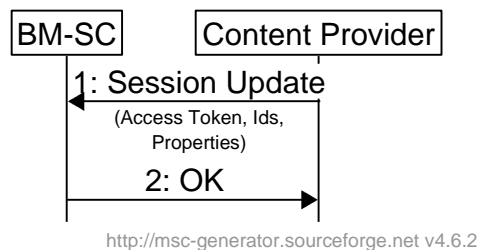

Figure 5.4-4: Session Properties Update

The content provider may first fetch the current session properties configuration using the Get Session Properties procedure:

1. The content provider requests updating of the properties of the session resource associated with a service. The access token and the resource ids of the service and the session are provided as input. The procedure may allow modification of individual properties or all properties for the named session.
2. The BM-SC updates the session properties for the indicated service and returns an acknowledgment to the content provider.

5.4.5 Terminate a Session

The content provider terminates a session during any session state.

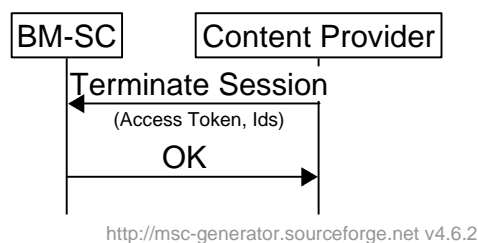

Figure 5.4-5: Session Termination

1. The content provider sends the service termination command. The access token and the id of the service and the session id are provided as input.
2. The BM-SC terminates the session and deletes all associated resources and acknowledges the reception of this command.

5.4.6 Session Properties

All Session properties, except for the resource id, are carried in the HTTPS message body. The access-token is always carried as part of HTTP Headers. Except for the session creation request (where the resource id is not present), the resource id shall be present in the URL of all requests that relate to a specific session.

In the table below, the following assertions are made:

- Table header: C stands for Create Session, G is for Get Session, U is for Update Session and T is for Terminate Session. "I", and "O" respectively denote "request" (going Into the BM-SC), and response (going Out of the BM-SC).
- Optional ("O") means that the property may or may not be sent/received during a REST transaction. It does not necessarily mean that the property is optional. It is possible, for example, that a session is not yet started because the Content Provider has not set it in any Update transaction using the PUT or PATCH HTTP method as opposed to representing a hint on the importance of the property for the BM-SC.
- A property marked as optional (O) in a request message may be present in the request. When not present in the request body, the property, if present in the BM-SC, will not be updated.
- A property marked as optional (O) in a response message is only present in the response when a value is assigned in the BM-SC.
- A property marked as mandatory (M) in a response message is always present in the response. The BM-SC provides default values for the session, which may be modified subsequently by the content provider.
- A blank cell in the cell shall means "forbidden" (the property cannot be added to the request or returned by the BM-SC, depending on the transaction direction).

Table 5.4-1: List of Session Properties

| Property Name | Property Description | | | C I | C O | G I | G O | U I | U O | T I |
|---------------|--|--|----------------------------|--------|--------|--------|--------|--------|--------|--------|
| id | Resource Id of the Session. | | | | M | | | | | |
| | Type | Unit | Default | | | | | | | |
| | Integer | None | N/A | | | | | | | |
| Session start | Start time when the MBMS Bearer become active. | | | | | | M | O | | |
| | Type | Unit | Default | | | | | | | |
| | Integer | UTC Date timestamp (with second precision) | Session creation date + 1h | | | | | | | |
| Session stop | End time at which the MBMS bearer becomes inactive. | | | | | | M | O | | |
| | Type | Unit | Default | | | | | | | |
| | Integer | UTC Date timestamp (with second precision) | Session start + 1h | | | | | | | |
| Max Bitrate | The requested bitrate excludes FEC overhead and transport overhead. The BM-SC calculates the MBMS Bearer bitrate from it, considering overhead like FEC and other transport overheads. The session | | | | | | M | O | | |

| Property Name | Property Description | C | C | G | G | U | U | T | | | | | | |
|---------------------------------|--|------------|------|---------|----------------|--|------------|---|--|--|---|---|--|--|
| | | I | O | I | O | I | O | I | | | | | | |
| | bitrate is always larger or equal to the payload bitrate. <table border="1"> <thead> <tr> <th>Type</th> <th>Unit</th> <th>Default</th> </tr> </thead> <tbody> <tr> <td>Integer</td> <td>kbps</td> <td>0</td> </tr> </tbody> </table> | Type | Unit | Default | Integer | kbps | 0 | | | | | | | |
| Type | Unit | Default | | | | | | | | | | | | |
| Integer | kbps | 0 | | | | | | | | | | | | |
| Max Delay | Specifies the maximum delay the MBMS System should add, i.e. from the time a packet is received by the BM-SC to the time by when the packet is received by the MBMS client. <table border="1"> <thead> <tr> <th>Type</th> <th>Unit</th> <th>Default</th> </tr> </thead> <tbody> <tr> <td>Integer</td> <td>ms</td> <td>-1</td> </tr> </tbody> </table> Note, that the value -1 indicates that the content provider has no specific delay requirement. | Type | Unit | Default | Integer | ms | -1 | | | | O | O | | |
| Type | Unit | Default | | | | | | | | | | | | |
| Integer | ms | -1 | | | | | | | | | | | | |
| Session State | The BM-SC may automatically change the state of the session. Possible states: Session Idle, Session Announced, Session Active <table border="1"> <thead> <tr> <th>Type</th> <th>Unit</th> <th>Default</th> </tr> </thead> <tbody> <tr> <td>String</td> <td>None</td> <td>Idle</td> </tr> </tbody> </table> | Type | Unit | Default | String | None | Idle | | | | M | | | |
| Type | Unit | Default | | | | | | | | | | | | |
| String | None | Idle | | | | | | | | | | | | |
| Service Announcement start time | When present, this time at which the BM-SC shall start service announcement. If absent, the BM-SC may automatically start service announcement when it has all data needed to perform such service announcement. <table border="1"> <thead> <tr> <th>Type</th> <th>Unit</th> <th>Default</th> </tr> </thead> <tbody> <tr> <td>Integer</td> <td>UTC Date timestamp (with second precision)</td> <td>None</td> </tr> </tbody> </table> | Type | Unit | Default | Integer | UTC Date timestamp (with second precision) | None | | | | O | O | | |
| Type | Unit | Default | | | | | | | | | | | | |
| Integer | UTC Date timestamp (with second precision) | None | | | | | | | | | | | | |
| Geographical Area | Geographical Area, at which the service is to be provided, either through unicast or through MBMS Bearers. The BM-SC derives the MBMS Service Area and the SAI list for the availability information from Geographical Area as provided by the content provider. The Geographical Area contains the following information: <table border="1"> <thead> <tr> <th>Type</th> <th>Unit</th> <th>Default</th> </tr> </thead> <tbody> <tr> <td>List of String</td> <td>None</td> <td>Empty list</td> </tr> </tbody> </table> The content of each string item is left to the business agreement between the Content Provider and the Operator. | Type | Unit | Default | List of String | None | Empty list | | | | M | O | | |
| Type | Unit | Default | | | | | | | | | | | | |
| List of String | None | Empty list | | | | | | | | | | | | |

| Property Name | Property Description | C | C | G | G | U | U | T | | | | | |
|----------------|---|---------------------------|---------|---------|--------|------|---------------------------|---|--|--|--|--|--|
| | | I | O | I | O | I | O | I | | | | | |
| QoE Reporting | List of QoE metrics that the content provider recommends the BM-SC to collect. The QoE metrics shall be derived from the QoE metrics in Clause 8.4 of TS 26.346 [2] and in Clause 10.2 of 26.247 [4] and depend on the delivery method that is used for the session. | | | | O | O | | | | | | | |
| QoE Report URL | Resource location at which the BM-SC will provide the QoE reports. | | | | O | | | | | | | | |
| | <table border="1"> <thead> <tr> <th>Type</th> <th>Unit</th> <th>Default</th> </tr> </thead> <tbody> <tr> <td>String</td> <td>None</td> <td>Operator selected default</td> </tr> </tbody> </table> | Type | Unit | Default | String | None | Operator selected default | | | | | | |
| | Type | Unit | Default | | | | | | | | | | |
| String | None | Operator selected default | | | | | | | | | | | |
| | | | | | | | | | | | | | |
| Session Type | <p>The Session Type represents the method used by the content provider in providing content to the BM-SC (via xMB-U). The BM-SC shall select the appropriate delivery method based on the Session Type value.</p> <p>Valid values: Streaming, Files, Application, Transport-Mode</p> <p>When Session Type is set to Streaming, the BM-SC expects a Streaming type input (RTP) whose format is compliant to MBMS streaming (as defined in TS 26.346).</p> <p>When Session Type is set to Files, the BM-SC expects generic files as input. The files can be provided either by on-request pull interactions or continuous push ingest.</p> <p>When Session Type is set to Application, then the ingest method depends on the application service description.</p> <p>When the Application Service Description pertains to DASH, the BM-SC expects an MPD and optionally one or more Initialization Segments. The content is assumed to be 3GP-DASH compliant (as defined by 26.247 [4]). The BM-SC may either pull the media segments from the content provider or the content provider continuously pushes segments into the BM-SC.</p> <p>When Session Type is set to Transport-Mode, the BM-SC shall provide transport of data/TV content according to the Transparent delivery method as described in clause 8B of TS 26.346[2]. The content provider may provide some of the session properties for the broadcast distribution.</p> <p>The Session Type shall be extensible for further session types.</p> | | | | M | O | | | | | | | |
| | <table border="1"> <thead> <tr> <th>Type</th> <th>Unit</th> <th>Default</th> </tr> </thead> <tbody> <tr> <td>String</td> <td>None</td> <td>Files</td> </tr> </tbody> </table> | Type | Unit | Default | String | None | Files | | | | | | |
| | Type | Unit | Default | | | | | | | | | | |
| | String | None | Files | | | | | | | | | | |
| | | | | | | | | | | | | | |
| | | | | | | | | | | | | | |

| Property Name | Property Description | C | C | G | G | U | U | T | | | | | |
|--------------------|---|--|------|---------|---------|------|--|---|--|--|---|---|--|
| | | I | O | I | O | I | O | I | | | | | |
| Header Compression | <p>Requests the BM-SC to enable ROHC [8] and [9] on the input flow to save overhead space.</p> <p>When this property is present, then header compression shall be processed on each described input flow. Each flow to be processed shall contain following parameters:</p> <ul style="list-style-type: none"> - Flow Description: Typically the IP/port of the input flow. - Periodicity: number denoting the target periodicity for ROHC full header packets in units of seconds. - Profile: Applicable ROHC profile (see IETF RFC 5795 [8].When the Content Provider does not explicitly set this property, the BM-SC decides on the usage. | | | | O | O | | | | | | | |
| FEC | <p>When present, requests the BM-SC to perform FEC protection of the input flow(s) when transmitting over the MBMS channel using the provided SDP.</p> <p>The SDP should include FEC scheme according to the used delivery method as defined in TS 26.346.</p> <table border="1"> <thead> <tr> <th>Type</th> <th>Unit</th> <th>Default</th> </tr> </thead> <tbody> <tr> <td>String</td> <td>None</td> <td>SDP description of FEC framework configuration information</td> </tr> </tbody> </table> <p>When the Content Provider does not explicitly set the property, the BM-SC decides on the usage and amount of FEC redundancy.</p> | Type | Unit | Default | String | None | SDP description of FEC framework configuration information | | | | O | O | |
| Type | Unit | Default | | | | | | | | | | | |
| String | None | SDP description of FEC framework configuration information | | | | | | | | | | | |
| Get Sharing ID | <p>When present and set to "true", request the BM-SC to provide a unique identifier so that the transmission resources can be shared with other sessions.</p> <p>Note, that other sessions will use the same Max Bitrate, Geographical Area and (in case of MC Services) QoS-Information.</p> <table border="1"> <thead> <tr> <th>Type</th> <th>Unit</th> <th>Default</th> </tr> </thead> <tbody> <tr> <td>Boolean</td> <td>None</td> <td>False</td> </tr> </tbody> </table> | Type | Unit | Default | Boolean | None | False | | | | O | O | |
| Type | Unit | Default | | | | | | | | | | | |
| Boolean | None | False | | | | | | | | | | | |
| Sharing ID | <p>When present, the value of the field identifies an already existing session to share the transmission, where Max Bitrate, Geographical Area and (in case of MC Services) QoS-Information are re-used</p> <p>Note, the Max Bitrate, Geographical Area and (in case of MC Services)</p> | | | | O | O | | | | | | | |

| Property Name | Property Description | C | C | G | G | U | U | T | | | | | |
|---------------|--|---------|------|---------|--------|------|----|---|--|--|--|--|--|
| | | I | O | I | O | I | O | I | | | | | |
| | QoS-Information cannot be changed since the values from the original session will be used. | | | | | | | | | | | | |
| | <table border="1"> <thead> <tr> <th>Type</th> <th>Unit</th> <th>Default</th> </tr> </thead> <tbody> <tr> <td>String</td> <td>None</td> <td>""</td> </tr> </tbody> </table> | Type | Unit | Default | String | None | "" | | | | | | |
| Type | Unit | Default | | | | | | | | | | | |
| String | None | "" | | | | | | | | | | | |

When the Session Type is set to "Transport-Mode", then the additional properties as defined in Table 5.4-2 apply. The properties in Table 5.4-2 are only present when the Session Type is set to "Transport-Mode".

Table 5.4-2: Additional properties for Transport-Mode

| Property Name | Property Description | C | C | G | G | U | U | T |
|---|---|---|---|---|---|---|---|---|
| | | I | O | I | O | I | O | I |
| Session Description Parameters for User Plane | <p>This property provides information to the BM-SC on where and how to access the user plane content from the content provider, and comprises one or more of the following components:</p> <ul style="list-style-type: none"> - Type: the type of the content associated with the target resource, for example the Internet Media Type of the resource as identified by an HTTP/S URL. Type with the value "embedded" is defined in this version of the specification, as an indication that the xMB-U user plane parameters are embedded in the User Plane Parameters object described below. - Access URL: A URL that enables BM-SC access to and possibly control of the ingest session. The URL could be, for example, a) an RTSP URL, b) a reference to an SDP that describes a multicast stream associated with the ingest session, or c) an HTTP/S URL to retrieve an already-packaged MPEG2-TS stream. - User Plane Parameters: Object provided by the Content Provider to the BM-SC, which when set to "embedded", contains the session description information for the following purposes: <ul style="list-style-type: none"> - If the <i>property</i> Delivery Mode Configuration for user plane is set to Forward Only, the User Plane Parameters object may contain a ready-made Session Description and the indication of a single xMB-U reception UDP port, in which case the BM-SC shall use it for Service Announcement over SACH. - If such Session Description is not present in this object, the Content Provider is directly performing the Service Announcement, i.e., it corresponds to the case where | | | | O | O | | |

| Property Name | Property Description | C | C | G | G | U | U | T | | | | | |
|--|---|--------------|------|---------|--------|----------|--------------|---|--|--|---|---|--|
| | | I | O | I | O | I | O | I | | | | | |
| | <p><i>Service Announcement Mode</i> property, as defined in Table 5.3-1, is set to Content Provider.</p> <ul style="list-style-type: none"> - If this property <i>Delivery Mode Configuration for user plane</i> is set to Proxy, the object shall contain a Session Description template and a list of the transmitted UDP flows to be forwarded on the established MBMS bearer for the session. For each list entry, the content provider shall indicate whether a) this UDP flow is directly associated with a media description entry in the Session Description Template – i.e., an "m=" line is present in the template and which contains a port field, or b) this UDP flow is related to a media description entry – e.g., it corresponds to an RTCP flow affiliated with the RTP flow as described by the RTP/AVP profile). If the flow is directly associated with a media description entry, then the BM-SC shall modify the port field of the media description entry in the Session Description Template. If the flow is related to a media description entry, then the BM-SC shall simply forward the flow onto a port whose value is equal to the port of the related media session plus an offset. <p>Note the BM-SC may get input on session properties from the content provider, e.g. bitrate, depending on the ingest session.</p> | | | | | | | | | | | | |
| Delivery Mode Configuration for user plane | <p>This property defines how the session needs to be delivered to the application, i.e. it basically establishes the delivery mode.</p> <ul style="list-style-type: none"> - Mode Enumeration: Specifies the delivery mode. - Forward-only: The BM-SC receives complete IP Multicast packets for to be forwarded. The content provider will create the IP multicast packets. - Proxy: The BM-SC proxies the incoming UDP payloads to the outgoing UDP payloads. The BM-SC will create the IP multicast packets. <table border="1"> <thead> <tr> <th>Type</th> <th>Unit</th> <th>Default</th> </tr> </thead> <tbody> <tr> <td>String</td> <td>– None –</td> <td>Forward-only</td> </tr> </tbody> </table> | Type | Unit | Default | String | – None – | Forward-only | | | | M | O | |
| Type | Unit | Default | | | | | | | | | | | |
| String | – None – | Forward-only | | | | | | | | | | | |
| Delivery Session Description Parameters | <p>The contents of this property depend on the setting of the <i>Service Announcement Mode</i> property as defined in Table 5.3-1. If <i>Service Announcement Mode</i> is set to Content Provider, then at minimum the following</p> | | | | O | | | | | | | | |

| Property Name | Property Description | C | C | G | G | U | U | T |
|---------------|--|---|---|---|---|---|---|---|
| | | I | O | I | O | I | O | I |
| | session parameters shall be provided by the BM-SC: - TMGI of the MBMS Bearer Note that additional parameters may be provided, based on the configuration options of the delivery method when <i>Session Type</i> is set to Transport-Mode . | | | | | | | |

When the Session Type is set to "Streaming", then the additional properties as defined in Table 5.4-3 apply. The properties in Table 5.4-3 are only present when the Session Type is set to "Streaming".

Table 5.4-3: Additional properties for Streaming

| Property Name | Property Description | C | C | G | G | U | U | T | | | | | |
|---------------|--|---------|------|---------|---------|----------|----|---|--|--|---|---|--|
| | | I | O | I | O | I | O | I | | | | | |
| SDP URL | A URL to the SDP that describes the streaming session between the content provider and the BM-SC which will be used for ingesting the streaming session via xMB-U. The SDP shall include the RTSP links for every media session as part of the "a=control" attribute to enable RTSP control of the session. The SDP shall also contain the required bitrate for each of the media sessions. The content shall conform to the constraints of the present document. <table border="1"> <tr> <td>Type</td> <td>Unit</td> <td>Default</td> </tr> <tr> <td>String</td> <td>– None –</td> <td>""</td> </tr> </table> Note that the session will not be activated without a valid SDP URL. | Type | Unit | Default | String | – None – | "" | | | | M | O | |
| Type | Unit | Default | | | | | | | | | | | |
| String | – None – | "" | | | | | | | | | | | |
| TimeShifting | Indicates if and for how long time shifting access to the content (using unicast) may be provided for this session. <table border="1"> <tr> <td>Type</td> <td>Unit</td> <td>Default</td> </tr> <tr> <td>Integer</td> <td>second</td> <td>0</td> </tr> </table> If not set (so defaulted to 0), there shall be no time shifting access. | Type | Unit | Default | Integer | second | 0 | | | | O | O | |
| Type | Unit | Default | | | | | | | | | | | |
| Integer | second | 0 | | | | | | | | | | | |

The BM-SC starts the streaming session when the session state becomes active. When the BM-SC adds FEC redundancy, then the BM-SC may start the ingest session sufficiently earlier.

When the Session Type is set to "Application", then the additional properties as defined in Table 5.4-4 apply. The properties in Table 5.4-4 are only present when the Session Type is set to "Application".

Table 5.4-4: Additional properties for Application, incl. DASH Service Descriptions

| Property Name | Property Description | CI | CO | GI | G | U | U | T |
|---------------------------------|---|----|----|----|---|---|---|---|
| | | I | O | I | O | I | O | I |
| Application Service Description | MIME type of the Application Service, for example application/dash+xml for DASH or application/vnd.apple.mpegurl for HLS. | | | | M | O | | |

| Property Name | Property Description | | | CI | CO | GI | G O | U I | U O | T I |
|--|--|-----------|----------------------|----|----|----|--------|--------|--------|--------|
| | Type | Unit | Default | | | | | | | |
| | String | MIME type | application/dash+xml | | | | | | | |
| | To refer to 5GMS DASH content, the MIME content type may include a profiles parameter as defined in DASH, including the profile for 5G Media Streaming as defined by clause 7.3.11 of TS 26.247 [4], as ""urn:3GPP:5GMS:iop:DASH". | | | | | | | | | |
| Alternative ApplicationService Description | Alternative MIME type of the Application Service, for services which can be described by different MIME types, as DASH/HLS hybrid services. This parameter is only used for DASH/HLS hybrid services. | | | | | | O | O | | |
| | String | MIME type | "" | | | | | | | |
| Ingest Mode | The ingest mode enumerates how resources are ingested into the BM-SC via xMB-U. Pull: The BM-SC pulls the resources as described by the application entry point document. Push: The content provider pushes resources. The BM-SC needs to provide a push URL. In case of DASH, resources are media segments: Pull: The BM-SC pulls the media segments as described by the segment availability start time from a DASH MPD. Push: The content provider pushes media segments, so that the media segment is available on the BM-SC according to segment availability start time. The BM-SC needs to provide a push URL. In the case of HLS, resources are media playlists and media segments: Pull: The BM-SC pulls the media playlists as described by the master playlist and pulls the media segments as described by the pulled media playlists. Push: The content provider pushes media playlists and media segments. The BM-SC needs to provide a push URL. In the case of a DASH/HLS hybrid service, resources are HLS media playlists and DASH/HLS media segments. Only the Push mode is authorized. Push: The content provider pushes HLS media playlists and media segments. The BM-SC needs to provide a push URL. | | | | | | M | O | | |

| Property Name | Property Description | | | CI | CO | GI | G O | U I | U O | T I | | | | | | |
|---|--|---------|---------|------|------|---------|--------|--------|--------|--------|--|--|---|---|--|--|
| | Type | Unit | Default | | | | | | | | | | | | | |
| | String | None | Push | | | | | | | | | | | | | |
| Application Entry Point URL | <p>The application entry point refers to an MPD when Application Service Description pertains to DASH or to a master playlist when Application Service Description pertains to HLS.</p> <p>When the Ingest Mode is set to Push for a DASH service,, then the MPD Url refers to a DASH MPD which should be fetched, optionally conditioned and inserted into Service Announcement.</p> <p>When the Ingest Mode is set to Push for a HLS service, then the master playlist Url refers to a HLS master playlist which should be fetched, optionally conditioned and inserted into Service Announcement.</p> <p>When the Ingest Mode is set to Pull, then the BM-SC starts fetching the segments using unicast.</p> <table border="1"> <thead> <tr> <th>Type</th> <th>Unit</th> <th>Default</th> </tr> </thead> <tbody> <tr> <td>String</td> <td>None</td> <td>""</td> </tr> </tbody> </table> <p>Note that if not set to a valid URL, the session will not be started.</p> | | | Type | Unit | Default | String | None | "" | | | | M | O | | |
| Type | Unit | Default | | | | | | | | | | | | | | |
| String | None | "" | | | | | | | | | | | | | | |
| Alternative Application Entry Point URL | <p>The alternative application Entry Point provides the application entry point with respect to the MIME type given by the Alternative Service Description parameter.</p> <p>This parameter is only used for DASH/HLS hybrid services.</p> <table border="1"> <thead> <tr> <th>Type</th> <th>Unit</th> <th>Default</th> </tr> </thead> <tbody> <tr> <td>String</td> <td>None</td> <td>""</td> </tr> </tbody> </table> <p>Note that if not set to a valid URL, the session will not be started.</p> <p>The alternative application Entry Point should be added to the service Announcement.</p> | | | Type | Unit | Default | String | None | "" | | | | O | O | | |
| Type | Unit | Default | | | | | | | | | | | | | | |
| String | None | "" | | | | | | | | | | | | | | |
| Push URL | <p>A resource locator for ingesting media segments using HTTPS via xMB-U. The content provider may create additional sub-resources using WebDAV procedures.</p> <p>This is a read-only property managed by the BM-SC and only present when Ingest Mode is set to Push.</p> <table border="1"> <thead> <tr> <th>Type</th> <th>Unit</th> <th>Default</th> </tr> </thead> <tbody> <tr> <td>String</td> <td>None</td> <td>""</td> </tr> </tbody> </table> <p>This property is mandatory if the Session type is set to Application and Ingest Mode is set to Push.</p> | | | Type | Unit | Default | String | None | "" | | | | O | | | |
| Type | Unit | Default | | | | | | | | | | | | | | |
| String | None | "" | | | | | | | | | | | | | | |

| Property Name | Property Description | CI | CO | GI | GO | UI | UO | TI | | | | | | |
|------------------|---|------------|------|---------|----------------|------|------------|----|--|--|---|---|--|--|
| Unicast Delivery | <p>Indicator whether the content is also available for unicast retrieval.</p> <p>If set true, the application client may access the content referenced in the application entry point from a unicast content server or a 5GMS AS.</p> <table border="1"> <tr> <td>Type</td> <td>Unit</td> <td>Default</td> </tr> <tr> <td>Boolean</td> <td>None</td> <td>False</td> </tr> </table> | Type | Unit | Default | Boolean | None | False | | | | M | O | | |
| Type | Unit | Default | | | | | | | | | | | | |
| Boolean | None | False | | | | | | | | | | | | |
| Components | <p>List of Components of the application, which are recommended to be made available on MBMS Bearers.</p> <p>If the value of the Application Service Description parameter is set to "application/dash+xml", each component is identified by a representation identifier.</p> <p>If the value of the Application Service Description parameter is set to "application/vnd.apple.mpegurl", each component is identified by the URL of the Media Playlist.</p> <table border="1"> <tr> <td>Type</td> <td>Unit</td> <td>Default</td> </tr> <tr> <td>List of String</td> <td>None</td> <td>Empty list</td> </tr> </table> | Type | Unit | Default | List of String | None | Empty list | | | | O | O | | |
| Type | Unit | Default | | | | | | | | | | | | |
| List of String | None | Empty list | | | | | | | | | | | | |

When the Session Type is set to "Files", then the additional properties as defined in Table 5.4-5 apply. The properties in Table 5.4-5 are only present when the Session Type is set to "Files".

Table 5.4-5: Additional properties for Files

| Property Name | Property Description | CI | CO | GI | GO | UI | UO | TI | | | | | |
|---------------|--|---------|------|---------|--------|------|------|----|--|--|---|---|--|
| Ingest Mode | <p>The ingest mode enumerates how resources are ingested into the BM-SC via xMB-U.</p> <ul style="list-style-type: none"> - Push: The Content Provider shall push the file to the BM-SC that will immediately process and deliver as soon as it is ready. The BM-SC may be configured to ignore all files that are pushed before session active time, or stage them. In case of Push mode, the BM-SC shall provide back to the content provider the URL the Content Provider shall use to push the files. - Pull: In this case, the Content Provider provides the resource location from which the BM-SC will fetch the file. The Content Provider may tell the BM-SC when to start fetching the file <table border="1"> <tr> <td>Type</td> <td>Unit</td> <td>Default</td> </tr> <tr> <td>String</td> <td>None</td> <td>Pull</td> </tr> </table> | Type | Unit | Default | String | None | Pull | | | | M | O | |
| Type | Unit | Default | | | | | | | | | | | |
| String | None | Pull | | | | | | | | | | | |

| Property Name | Property Description | C I | C O | G I | G O | U I | U O | T I |
|---------------|--|--------|--------|--------|--------|--------|--------|--------|
| File List | <p>List of files to be sent.</p> <p>In the Push mode, the file list is not used since the BM-SC will monitor its push folder and send the files it receives on a first-come first-served basis.</p> <p>In Pull mode, the file list contains the following information per file entry:</p> <ul style="list-style-type: none"> - file URL: the URL to the file the BM-SC will use to fetch the content - file display URL: the URL to the file as seen by the UE - file earliest fetch time: The BM-SC shall fetch the file no sooner than this UTC timestamp. If absent, then the file shall be present on the Content Provider server and the BM-SC may fetch it at a time of its choosing. - file latest fetch time: The BM-SC shall fetch the file no later than this UTC timestamp. If absent, then the file shall be present on the Content Provider server and the BM-SC may fetch it at a time of its choosing. - file size (optional): The content provider may provide the precise or a file size estimate as input. The BM-SC may update the file size once it has started to fetch the file. - file status: Enumeration stating the state of the file. Possible values are pending, fetching, fetched, fetch failed, preparing, prepared, prepare failed, in transmission queue, transmitting, transmission failed, sent. - Target reception completion time (on the MBMS Client): hint on the target time, when the file should be completely received by the UE. The BM-SC should schedule and order the transmission etc accordingly. - Keep Update Interval: The BM-SC checks the file resources with the given interval for changes. - Unicast availability: Indication that the file is also available for unicast retrieval by the application at a Content Provider server whose location is given by the HTTP(S) URL corresponding to the value of "file display URL". - byteRange (optional): If present and set to "true", indicates that the HTTP(S) URL given in the fileDisplayURL parameter can be used for Byte-Range-Based file repair (subclause 9.3) otherwise fileDisplayURL | | | | O | O | | |

| Property Name | Property Description | C | C | G | G | U | U | T | | | | | | |
|-----------------------------|---|---------|------|---------|---------|---------|------|---|--|--|---|---|--|--|
| | | I | O | I | O | I | O | I | | | | | | |
| | <p>parameter should not be used for Byte-Range-Based file repair</p> <ul style="list-style-type: none"> - ETag (optional): represents the value of the ETag as defined in RFC 2616 [18] which may also serve as the version identifier for the file in the Byte-Range-Based file repair requests. The ETag should only be supplied by the 3rd party content provider if it is expected that it is different from the one provided over xMB-U when fetching the file. - File repetition (optional): The number of times the file shall be sent on the session (a value of 1 means the file shall be sent only once). This counter shall be decreased each time the file has been transmitted. When equals to zero, no more file repeat is scheduled. The BM-SC may send FEC instead of source information. Default value is 1. - Note that the expected behavior is that the BM-SC will first send all files in the order of the File List, then decrement the file repetition counter for each file, and subsequently retransmit the list again (only files with counter > 0 are transmitted). This is repeated until all repetitions are completed, or the session stop time has elapsed, whichever event occurring first. | | | | | | | | | | | | | |
| Carousel Mode | <p>Provides information on carousel activation and mode. Possible values are none, back-to-back, scheduled.</p> <p>When carousel is enabled, file repetition is ignored.</p> <table border="1"> <thead> <tr> <th>Type</th> <th>Unit</th> <th>Default</th> </tr> </thead> <tbody> <tr> <td>String</td> <td>None</td> <td>none</td> </tr> </tbody> </table> | Type | Unit | Default | String | None | none | | | | O | O | | |
| Type | Unit | Default | | | | | | | | | | | | |
| String | None | none | | | | | | | | | | | | |
| Carousel Scheduled Interval | <p>When carousel mode is set to Scheduled, time interval between two consecutive sessions.</p> <table border="1"> <thead> <tr> <th>Type</th> <th>Unit</th> <th>Default</th> </tr> </thead> <tbody> <tr> <td>Integer</td> <td>Seconds</td> <td>3600</td> </tr> </tbody> </table> | Type | Unit | Default | Integer | Seconds | 3600 | | | | O | O | | |
| Type | Unit | Default | | | | | | | | | | | | |
| Integer | Seconds | 3600 | | | | | | | | | | | | |
| File delivery manifest URL | <p>Alternative to the file list. The resource may additionally describe scheduling information for the file.</p> <table border="1"> <thead> <tr> <th>Type</th> <th>Unit</th> <th>Default</th> </tr> </thead> <tbody> <tr> <td>String</td> <td>None</td> <td>""</td> </tr> </tbody> </table> | Type | Unit | Default | String | None | "" | | | | O | O | | |
| Type | Unit | Default | | | | | | | | | | | | |
| String | None | "" | | | | | | | | | | | | |
| Push URL | <p>A resource locator for ingesting content using HTTPS via xMB-U.</p> <p>This is a read-only property managed by the BM-SC and only present when Ingest Mode is set to Push.</p> | | | | O | | | | | | | | | |

| Property Name | Property Description | | | C | C | G | G | U | U | T |
|------------------|--|------|---------|---|---|---|---|---|---|---|
| | | | | I | O | I | O | I | O | I |
| | Type | Unit | Default | | | | | | | |
| | String | None | "" | | | | | | | |
| Display Base URL | When ingest mode is set to Push, the Base URL is seen by the UE. | | | | | | O | O | | |
| | Type | Unit | Default | | | | | | | |
| | String | None | "" | | | | | | | |
| SA file URL | When the service announcement mode is set to "Content provider", the BM-SC returns the URL of the SA file announcing the session. The BM-SC shall follow the profile 1c (Annex L.3 of 3GPP 26.346 [2]) | | | | | | O | | | |

For the xMB mission critical extension, the additional properties as defined in Table 5.4-6 apply. The properties *TMGI* and *QoS-Information* in Table 5.4-6 are only present when the *MC-Extension* property is set to true.

Table 5.4-6: Additional properties in the xMB mission critical extension

| Property Name | Property Description | | | C | C | G | G | U | U | T |
|-----------------|--|------|---------|---|---|---|---|---|---|---|
| | | | | I | O | I | O | I | O | I |
| MC-Extension | (Optional) Set to true to use the mission critical extension. | | | O | | | O | | | |
| | Type | Unit | Default | | | | | | | |
| | Boolean | None | False | | | | | | | |
| TMGI | TMGI of the MBMS session, as returned by the MBMS Session start procedure (3GPP TS 29.061 [13]). | | | | | | M | | | |
| QoS-Information | Provides the QoS parameters for the MBMS bearer. The list of QoS parameters matches the composition of the QoS Information AVP specified in 3GPP TS 29.468 [14]: GBR, ARP, QCI. The difference between the Max Bitrate (Table 5.4-1) and GBR can be used by the BM-SC as a budget for FEC. | | | | | | M | O | | |

5.4.7 Geographical area for mission critical services

The BM-SC derives the MBMS Service Area and the SAI list for the availability information from the Geographical Area property, provided as a list of strings by the content provider. How the derivation is done is left to a business agreement between the content provider and the operator, as specified in Table 5.4-1.

This subclause specifies syntax and semantic for the geographical area, when the *MC-Extension* property is set to true.

A string included in the Geographical Area property represent either a MBMS service area or a cell id, according the following syntax, in ABNF [15]:

geographical_area_string = cell_string / sai_string

cell_string = "ECGI-" 1*HEXDIG; Hexadecimal representation of an ECGI

sai_string = "SAI-" 1*DIGIT; MBMS SAI

If the Geographical Area property contains both a list of cells and a list of MBMS service areas, then the provided MBMS service areas shall be a complete set of the MBMS service areas that contains all the provided cells.

If the Geographical Area property contains only a list of cells, the BM-SC shall derive the list of MBMS service areas from the list of cells based on operator policy.

The BM-SC shall provide the list of MBMS service areas and the list of cells in the Session Start procedure defined in 3GPP TS 23.246 [16].

5.5 User Plane Procedures

5.5.1 Introduction

The xMB-U user plane procedures cover the transmission of service data from the content provider to the BM-SC. Only authorized and authenticated content provider sources shall be able to ingest user plane data over xMB-U to the BM-SC. The following data transfer modes are supported:

- File Push: the content provider uploads or transmits files to the BM-SC either as soon as they become available, or in advance.
- File Pull: the content provider makes files available prior to the session start and at least during the lifetime of a session. The BM-SC will retrieve the files when it needs to deliver them.
- RTP Streaming: the BM-SC establishes an RTSP session to the content provider and starts the streaming session to relay media streams.
- Transport: the BM-SC listens on one IP address and one port number to receive UDP packets.

The details of these procedures are provided in the following clauses.

5.5.2 File Distribution

Provisioning files for file distribution shall use one of the following options:

- WebDAV as described in RFC 4918 [7] over HTTP over TLS. The Content Provider shall provide an authorization access token with every HTTPS transaction.
- HTTP over TLS for file retrieval. The BM-SC shall use at least HTTP Version 1.1.

The content provider shall ensure that content is available at the BM-SC prior to its scheduled transmission time. For instance, for DASH segments, the segment shall be pushed to the BM-SC considering the timing requirements indicated in the MPD. For HLS segments, the segments shall be pushed to the BM-SC prior to their inclusion in a Media Playlist available to the BM-SC.

Also for all files that are declared as part of the file list of a session, all declared files shall be available before their indicated availability time, or if not provided, prior to the session start.

As an alternative to providing the properties and transport-related requirements of a file-based service, for delivery over the MBMS bearer service, via the 'File List' property of the 'Session' resource in subclause 5.4.6, the Content Provider may elect to convey the same information via the File Delivery Manifest, as described in clause 5.6.

5.5.3 RTP Streaming

The content provider shall support PSS server functionality according to PSS as described in Clause 5.3 of 3GPP TS 26.234 [3]. The streaming session shall be accessible prior to the start of the session. When the user plane data is provided via UDP, then SRTP over DTLS [6] shall be used for user plane protection. Establishment of TCP based user plane sessions with PSS is not supported.

5.5.4 Transport

For Transport sessions, the BM-SC shall activate the receivers on the indicated IP address and port number. All traffic shall use DTLS as specified in RFC 4347 [6] where both client and server certificates are verified.

5.5.5 Notification Messages

When the content provider wants to receive notifications, then the content provider shall provide a HTTPS URL using which the BM-SC will send, via push delivery, service and session related notification to the content provider. The BM-SC shall use HTTPS to send notifications to the content provider. The content of the notification message shall be provided as part of the body part of the HTTP message. Upon successful reception, the content provider shall reply with a 200 OK response.

The format of the notification message shall contain the following parameters, the corresponding details of which are specified in Table 5.5-1:

- Message Name (String): The unique identifier of the message.
- Message Class (enumeration): Enumeration with the following values (may be expanded in the future):
 - **Critical:** When some event drastically prevent the proper delivery of content, such as when the network is down, the data ingestion is interrupted, BM-SC data delivery function stopped,
 - **Warning:** When the service can be partially delivered but quality is reduced. The reason can be that the service is partly down because the data bitrate is too high, the packet loss rate is too high, ...
 - **Information:** When the service is properly delivered but some interesting event occurred. The reason can be the presence of reporting information for the service, the correct transmission of the service announcement.
 - **Session/Service:** Service/Session related parameters, such as service/session started, service/session terminated, Content file send, file fetching error, etc.
- Message Information (Dictionary): A dictionary of key values containing information linked to the notification.
- Message Source: The ids are stored in the key "**source**" in a hierarchical dot separated format (e.g. Service 1 => "1", Session 2 of service 3 => "3.2"). When Source is empty, then the notification is system wide.
- Message Information (Dictionary): A dictionary of key values containing information linked to the notification. Common keys in the dictionary, which shall be always present:
 - **Date:** Every message information dictionary contains the UTC timestamp (in ms) of the date of the event, accessible using the key "**date**". It also contains the ids of the service/session that triggered the message (necessary since in PUSH mode, the URL will not contain such identifiers).

Table 5.5-1: List of Additional Notification Message

| Message Class | Message Name | Additional Key Value Pairs |
|---------------|--|---|
| Critical | NetworkIsDown | – None – |
| | ServiceBadlyConfigured | badOrMissingParameters: [<property name>, ..] |
| | SessionBadlyConfigured | badOrMissingParameters: [<property name>, ..] |
| Warning | IncomingBitrateExceedSessionCapacity | incomingBitRate:<value in kbps> |
| | NoIncomingData | None |
| Information | QoEReportAvailable | None |
| | ConsumptionReportsAvailable | None |
| | ReceptionReportsAvailable | None |
| Service | ServiceAnnouncementChange (only when in session state Session Announced or Session Active) | None |
| Session | SessionStateChange | Session State Enumerates: Session Idle, Session Announced, Session Active, Session Terminated |
| | FileReadyForTransmission (only when Session Type is "Files") | fileUrl:<file URL>, fileSize: <integer>, transmission size: <integer> |
| | FileDownloadStarted (only when Session Type is "Files") | fileUrl: <file URL> |
| | FileSuccessfullySent (only when Session Type is "Files") | fileUrl:<file URL> |
| | FileFetchError | fileUrl:<file URL>, httpErrorCode: <integer> |

5.6 File Delivery Manifest

5.6.1 General

File-based services originating from 3rd party Content Providers may be ingested over the xMB interface and delivered to UEs using the download delivery method. This clause specifies the File Delivery Manifest, which represents an alternative to the *FileList* property and its subordinate parameters of the “session” resource whose stage 2 text is described in subclause 5.4.6.

5.6.2 File Delivery Manifest

The fields and description of the File Delivery Manifest, assuming such document is delivered as a JSON-encoded document, are shown in Table 5.6-1.

Table 5.6-1: Description of File Delivery Manifest

| Field Name | JSON Value Type | Default | | | | Description |
|------------|-----------------|-----------------------|-----------------|--------------------------------------|-------|---|
| | | Child Parameter | | Units | Value | |
| | | | Child Parameter | | | |
| FileList | array | | | | | <p>Container for the set of files, for delivery over MBMS, whose properties or transport parameters are given in the File Delivery Manifest. This field may contain the following child parameters:</p> <ul style="list-style-type: none"> - fileURL - fileDisplayURL - fileEarliestFetchTime - fileLatestFetchTime - fileSize - targetReceptionCompletionTime - keepUpdatedInterval - unicastAvailability - byteRange - ETag - fileRepetition |
| | string | fileURL | - | - | - | In the case of pull-based content ingestion, the resource location of the file, as an HTTP(S) URL, at the Content Provider server from which the BM-SC can request the file. |
| | string | fileDisplayURL | - | - | - | HTTP(S) URL of the file as provided to the MBMS-aware application. |
| | integer | fileEarliestFetchTime | - | UTC time with second-level precision | - | In the case of pull-based content ingestion, the absolute time, expressed as the 32-bit integer portion of an NTP time stamp, representing the earliest time that the BM-SC can request the file from the Content Provider server. Absence of this parameter is an indication that the BM-SC may submit a request for the file at a time of its choosing. |
| | integer | fileLatestFetchTime | - | UTC time with second-level precision | - | In the case of pull-based content ingestion, the absolute time, expressed as the 32-bit integer portion of an NTP time stamp, representing the latest time that the BM-SC can request the file from the Content Provider server. Absence of this parameter is an indication that the BM-SC may submit a request for the file at a time of its choosing. |
| | integer | fileSize | - | bytes | - | Precise or estimated size of the file in units of bytes. If this parameter is absent, it means that the file size is not known to the Content Provider. |

| Field Name | JSON Value Type | Default | | | | Description |
|------------|-----------------|-------------------------------|-----------------|--------------------------------------|-------|--|
| | | Child Parameter | | Units | Value | |
| | | | Child Parameter | | | |
| | integer | targetReceptionCompletionTime | - | UTC time with second-level precision | - | A hint from the CP to the BM-SC on the nominally expected time, expressed as the 32-bit integer portion of an NTP time stamp, at which the file should be completely received by the MBMS client and made available to the MBMS-aware application. The BM-SC is expected to schedule and order transmission of the file in accordance to this attribute. Absence of this parameter is an indication that there is no explicit requirement by the CP on when the reception of the file at the MBMS client should occur, other than it should not be earlier than <i>earliestReceptionCompletionTime</i> , if present, in the File Delivery Manifest. |
| | integer | keepUpdateInterval | | milliseconds | - | Interval that the BM-SC is expected to check for update of the file if it belongs to a Keep-Updated Service. |
| | boolean | unicastAvailability | - | - | false | Indication that the file is also available for unicast acquisition by the application at a Content Provider server whose location is given by the HTTP(S) URL corresponding to the value of the parameter <i>fileDisplayURL</i> . |
| | boolean | byteRange | -- | -- | false | If present and set to "true", indicates that the HTTP(S) URL given in the <i>fileDisplayURL</i> parameter can be used for Byte-Range-Based file repair (subclause 9.3) otherwise <i>fileDisplayURL</i> parameter should not be used for Byte-Range-Based file repair. |
| | string | ETag | -- | -- | -- | represents the value of the ETag as defined in RFC 2616 [18] which may also serve as the version identifier for the file in the Byte-Range-Based file repair requests. The ETag should only be supplied by the 3rd party content provider if it is expected that it is different from the one provided over xMB-U when fetching the file. |
| | number | fileRepetition | - | - | - | The number of times the file shall be sent on the session (a value of 1 means the file shall be sent only once). This counter shall be decremented each time the file has been transmitted. When the counter reaches zero, the file shall cease to be delivered. The BM-SC may send FEC repair symbols instead of source symbols. Default value is 1. Note that the expected behaviour is that the BM-SC first sends all the files as ordered in "FileList", then decrements the counter for each file, and subsequently retransmits the list of files again (only those files whose counter > 0 are transmitted). This process is repeated until either the counter reaches '0', or the session stop time has elapsed, whichever event occurs first. |

5.6.3 JSON Schema for File Delivery Manifest

When encoded as a JSON document, the schema of the File Delivery Manifest, whose description is provided in clause 5.6.2, and specified according to JSON Schema [11], is shown below.

```

{
  "FileManifest": {
    "type": "object",
    "description": "Refer to Table 5.6-1 for detailed description.",
    "properties": {
      "FileList": {
        "type": "array",
        "description": "Refer to Table 5.6-1 for detailed description.",
        "items": {
          "type": "object",
          "properties": {
            "fileURL": {
              "type": "string",
              "description": "Refer to Table 5.6-1 for detailed
description."
            },
            "fileDisplayURL": {
              "type": "string",
              "description": "Refer to Table 5.6-1 for detailed
description."
            },
            "fileEarliestFetchTime": {
              "type": "integer",
              "format": "int32",
              "description": "Refer to Table 5.6-1 for detailed
description."
            },
            "fileLatestFetchTime": {
              "type": "integer",
              "format": "int32",
              "description": "Refer to Table 5.6-1 for detailed
description."
            },
            "fileSize": {
              "type": "integer",
              "format": "int32",
              "description": "Refer to Table 5.6-1 for detailed
description."
            },
            "targetReceptionCompletionTime": {
              "type": "integer",
              "format": "int32",
              "description": "Refer to Table 5.6-1 for detailed
description."
            },
            "keepUpdatedInterval": {
              "type": "integer",
              "format": "int32",
              "description": "Refer to Table 5.6-1 for detailed
description."
            },
            "unicastAvailability": {
              "type": "boolean",
              "description": "Refer to Table 5.6-1 for detailed
description."
            },
            "byteRange": {
              "type": "boolean",
              "description": "Refer to Table 5.6-1 for detailed
description."
            },
            "ETag": {
              "type": "string",
              "description": "Refer to Table 5.6-1 for detailed
description."
            },
            "fileRepetition": {
              "type": "number",
              "description": "Refer to Table 5.6-1 for detailed
description."
            }
          }
        }
      }
    }
  }
}

```

```
}  
  }  
    }  
      }  
        }  
          }  
            }
```

Annex A (informative): xMB User Plane (xMB-U)

A.0 General

This annex provides an overview of the different xMB User Plane (xMB-U) protocol stacks for the various xMB delivery options. The xMB Control Plane is used to select the correct version.

A.1 Generic File Delivery

A.1.1 Introduction

This clause illustrates the various xMB-U options for generic file delivery. A file may be a large file like a video on demand file or a small file. Files can also be regarded as messages e.g. a plain text file or with header and body.

A.1.2 File ingestion with Pull

The Content Provider delegates all MBMS related complexity to the operator and provides files for delivery using HTTP to the BM-SC. The Content Provider provides the file URLs to the BM-SC and the BM-SC fetches the files using HTTP. The BM-SC is handling all MBMS related complexity, e.g. converting the HTTP payload into an IP Multicast suitable protocols, adding AL-FEC, etc. The Content Provider delegates the delivery of MBMS of Service Announcement Metadata (i.e. IP Multicast protocol details, etc) to the MBMS Client to the BM-SC.

Figure A.1.2-1 illustrates a setup, where the BM-SC pulls files from a File Server. The xMB-C is used to provide the file URLs to the BM-SC.

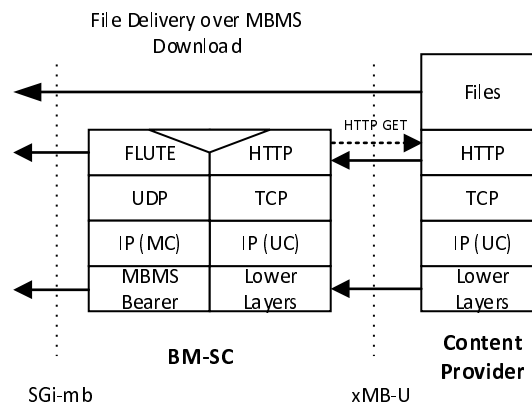

Figure A.1.2-1: File Delivery using Pull Mode (HTTP GET)

The following Session Properties allow the configuration of this xMB-U mode:

- *Session Type* is set by the Content Provider to Files.
- *Ingest Mode* (Session Type specific property) is set by the Content Provider to Pull.
- The *File List* (Session Type specific property) is updated by the Content Provider with File URLs to be fetched by the BM-SC and then send. The BM-SC updates Service Announcement according to the File List information.

Procedure

The following flow diagram illustrates the message flow. During provisioning phase, the according xMB Service and Sessions are created. Some lead time is needed to secure that all intended receiving UEs are capable of receiving the content.

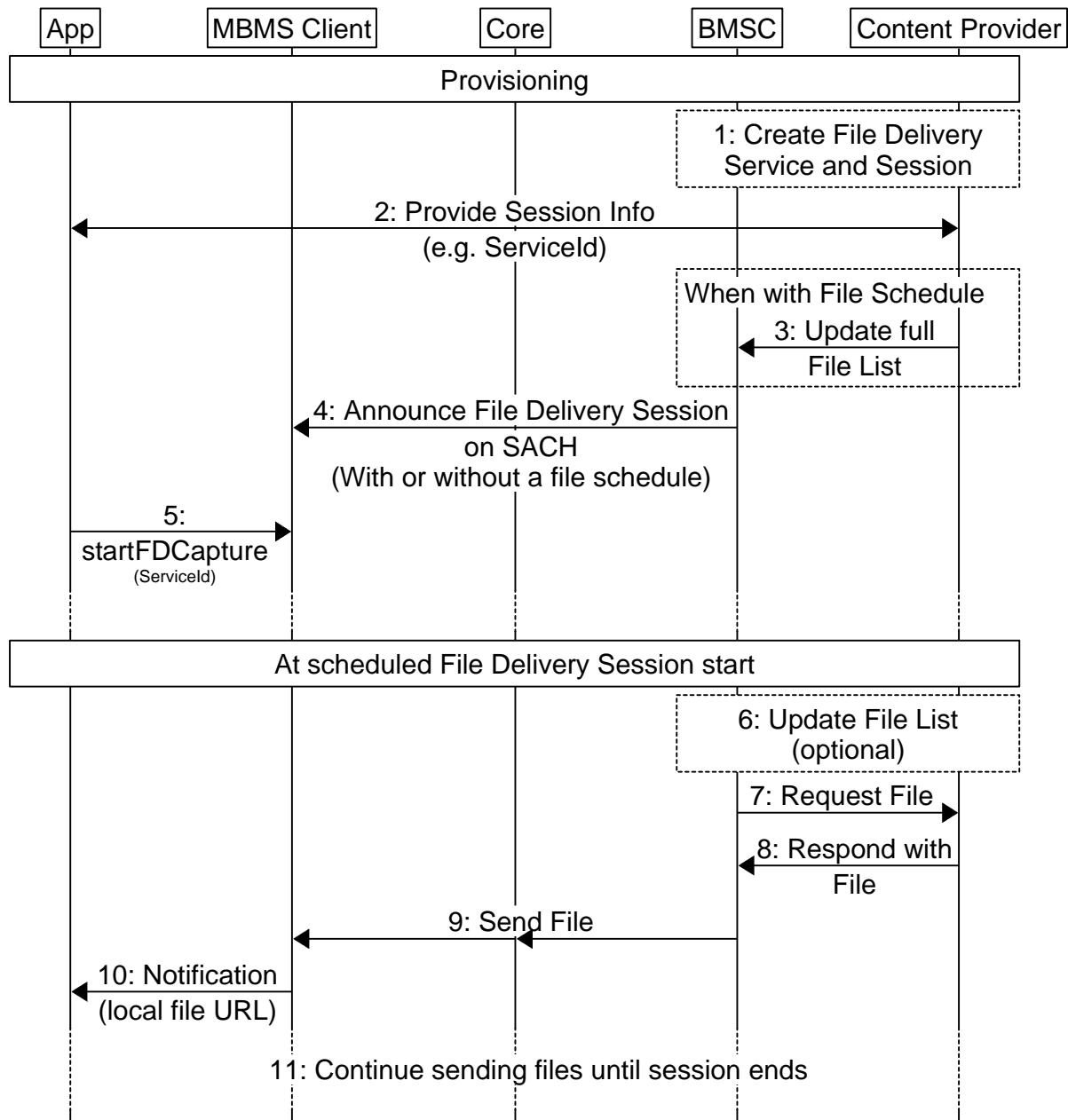

<http://msc-generator.sourceforge.net v6.3.7>

Figure A.1.2-2: Call Flow

Provisioning

- 1: The Content Provider creates the File Delivery Service and Session using xMB procedures.
- 2: As result of the Service and Session provisioning procedure, the Content Provider gets the service identification information (e.g. ServiceId), which needs to be used by the App to request the reception activation from the MBMS Client.
- 3: When a File Schedule should be inserted into service announcement, the content provider provides the full file list well in advance. The BM-SC determines the file sizes and creates the resulting file schedule entry.
- 4: The MBMS client receives the service access information via SACH.

5: When the App is interested in the service, the App requests the MBMS client to activate reception using the appropriate MBMS Client API call. The App uses the ServiceId as identification for the interested service.

At scheduled File Delivery Session start time.

6: When not all file URLs to be sent during the file delivery session are provided, the Content Provider updates the File List and adds additional file entries.

7: The BM-SC fetches the file according to the file list.

8: The BM-SC receives the requested file and wraps it into MBMS Download Delivery Objects.

9: The BM-SC sends the file as MBMS Download Delivery Object. When the MBMS Client has activated the reception for that service and is located inside of the broadcast coverage, the MBMS client receives the file (potentially after correcting packet losses).

10: When the MBMS Client has successfully received the file, it notifies the App.

11: Step 6 can be repeated multi times, independent from steps 7 to 9. Steps 7 to 9 are repeated (as sequence) for every file in the file list until the session schedule end time is reached.

A.1.3 File ingestion with Push

The Content Provider delegates all MBMS related complexity to the operator and provides files for delivery using HTTP to the BM-SC. The Content Provider pushes the files using HTTP. The BM-SC is handling all MBMS related complexity, e.g. converting the HTTP payload into an IP Multicast suitable protocols, adding AL-FEC, etc. The Content Provider delegates the delivery of MBMS of Service Announcement Metadata (i.e. DASH MPD, IP Multicast protocol details, etc) to the MBMS Client to the BM-SC.

Figure A.1.3-1 illustrates a setup, where a File Server pushes files using HTTP PUT into the BM-SC.

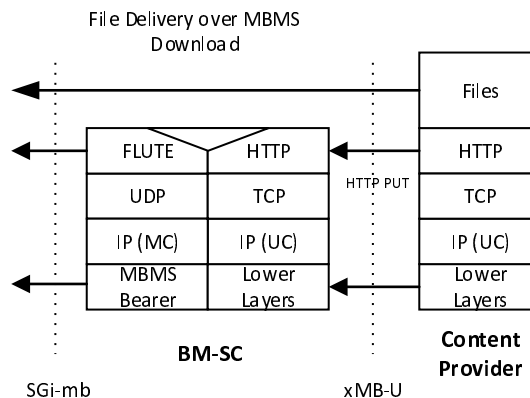

Figure A.1.3-1: File Delivery using Push Mode (HTTP PUT)

The following Session Properties allow the configuration of this xMB-U mode:

- *Session Type* is set by the Content Provider to Files.
- *Ingest Mode* (Session Type specific property) is set by the Content Provider to Push.
- The BM-SC provides the *Push URL* (Session Type specific property) to the Content Provider. The value of this property is configured to the File Server.
- *Display Base URL* contains the base URL for the files. In the URLs, used in the FLUTE FDT instances and (in some cases) in Service Announcement, the BM-SC replaces the Push URL part of the file URL with the value of the *Display Base URL*.

Procedure

The following flow diagram illustrates the message flow. During provisioning phase, the according xMB Service and Sessions are created. Some lead time is needed to secure that all intended receiving UEs are capable of receiving the content

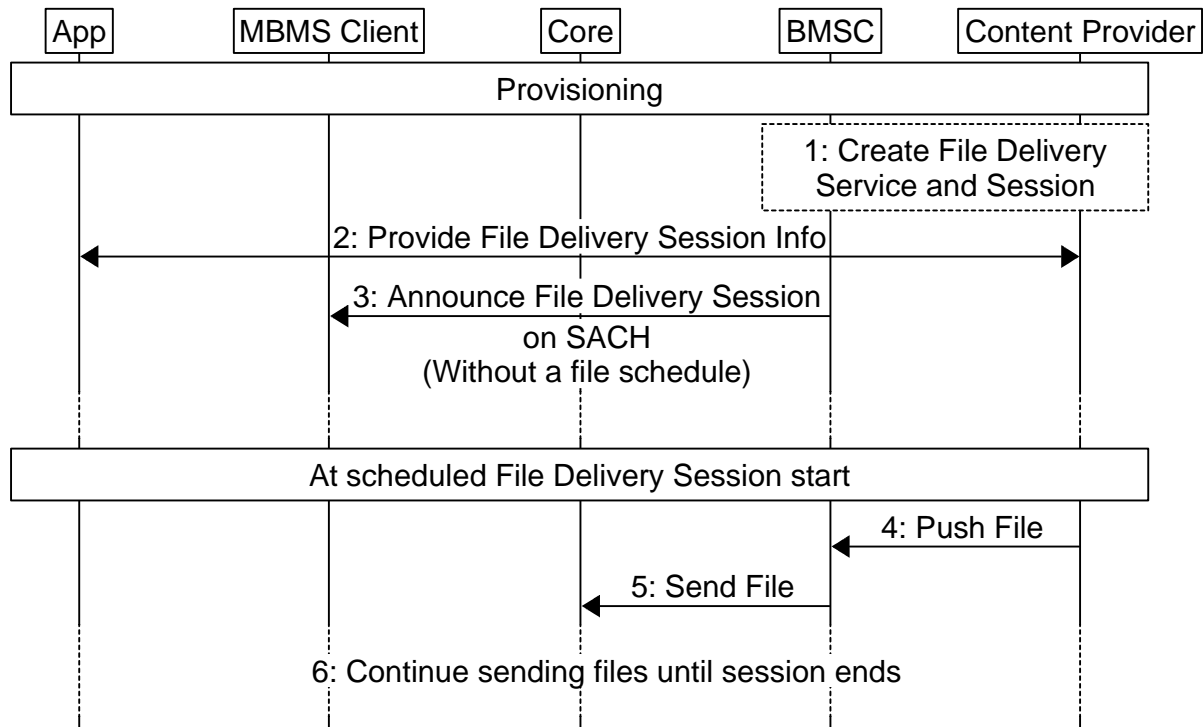

<http://msc-generator.sourceforge.net> v6.3.7

Figure A.1.3-2: Call Flow

Provisioning:

- 1: The Content Provider creates the File Delivery Service and Session using xMB procedures.
- 2: As result of the Service and Session provisioning procedure, the Content Provider gets the service identification information, which needs to be used by the App to request the reception activation from the MBMS Client.
- 3: The MBMS client receives the service access information via SACH.

At scheduled DASH Session start time.

- 4: The content provider starts pushing files to the BM-SC, which wraps the received file into MBMS Download Delivery Objects.
- 5: The BM-SC sends the File as MBMS Download Delivery Object.
- 6: Step 5 and 6 are repeated for every file until the session schedule end time is reached.

A.2 DASH Media Presentation Delivery

A.2.1 Introduction

This clause illustrates the various xMB-U options for DASH Media Presentation delivery. A DASH Media Presentation consists of a Media Presentation Description (MPD), one or more initialization segments and sequences of media segments, containing the media data. A segment is a small file, containing a defined duration of media time, like 2sec of media time.

The Media Presentation Description (MPD) and Initialization Segments (IS) are typically provided with the SACH before the actual DASH media segment reception so that the UE has all access information available for tuning in to the DASH stream. The media segments and MPD updates are ingested using xMB-U.

A.2.2 DASH Content ingestion with Pull

The Content Provider delegates all MBMS related complexity to the operator and provides DASH compliant content using HTTP to the BM-SC. The Content Provider provides a MPD to the BM-SC and the BM-SC fetches the DASH content according to the MPD description using HTTP. The BM-SC is handling all MBMS related complexity, e.g. converting the HTTP payload into an IP Multicast suitable protocols, adding AL-FEC, etc. The Content Provider delegates the delivery of MBMS of Service Announcement Metadata (i.e. DASH MPD, IP Multicast protocol details, etc) to the MBMS Client to the BM-SC.

Figure A.2.2-1 illustrates a setup, where the BM-SC fetches DASH Content using HTTP GET according to a DASH MPD from a Content Server.

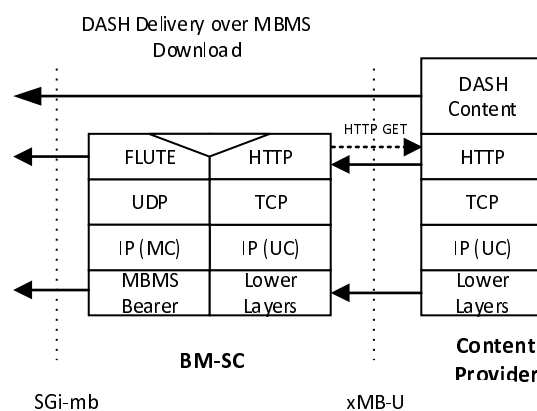

Figure A.2.2-1: Segment Delivery using Pull Mode (HTTP GET)

The following Session Properties allow the configuration of this xMB-U mode.

- *Session Type* is set by the Content Provider to Application.
- *Ingest Mode* (Session Type specific property) is set by the Content Provider to Pull.
- *Application Service Description* (Session Type specific property) is set to application/dash+xml.
- *Application Entry Point URL* contains the URL to the DASH MPD. The BM-SC will fetch the DASH MPD using the value of the *Application Entry Point URL* and start fetching segments. Further, the BM-SC will fetch the DASH MPD using the value of the *Application Entry Point URL* and embed the MPD into the Service Announcement File (SACH).
- *Unicast Delivery* is set to *false*. Indicating that the operation is not allowed to use Mood, e.g. because of content distribution rights.

Procedure

The following flow diagram illustrates the message flow. During provisioning phase, the according xMB Service and Sessions are created. Some lead time is needed to secure that all intended receiving UEs are capable of receiving the content.

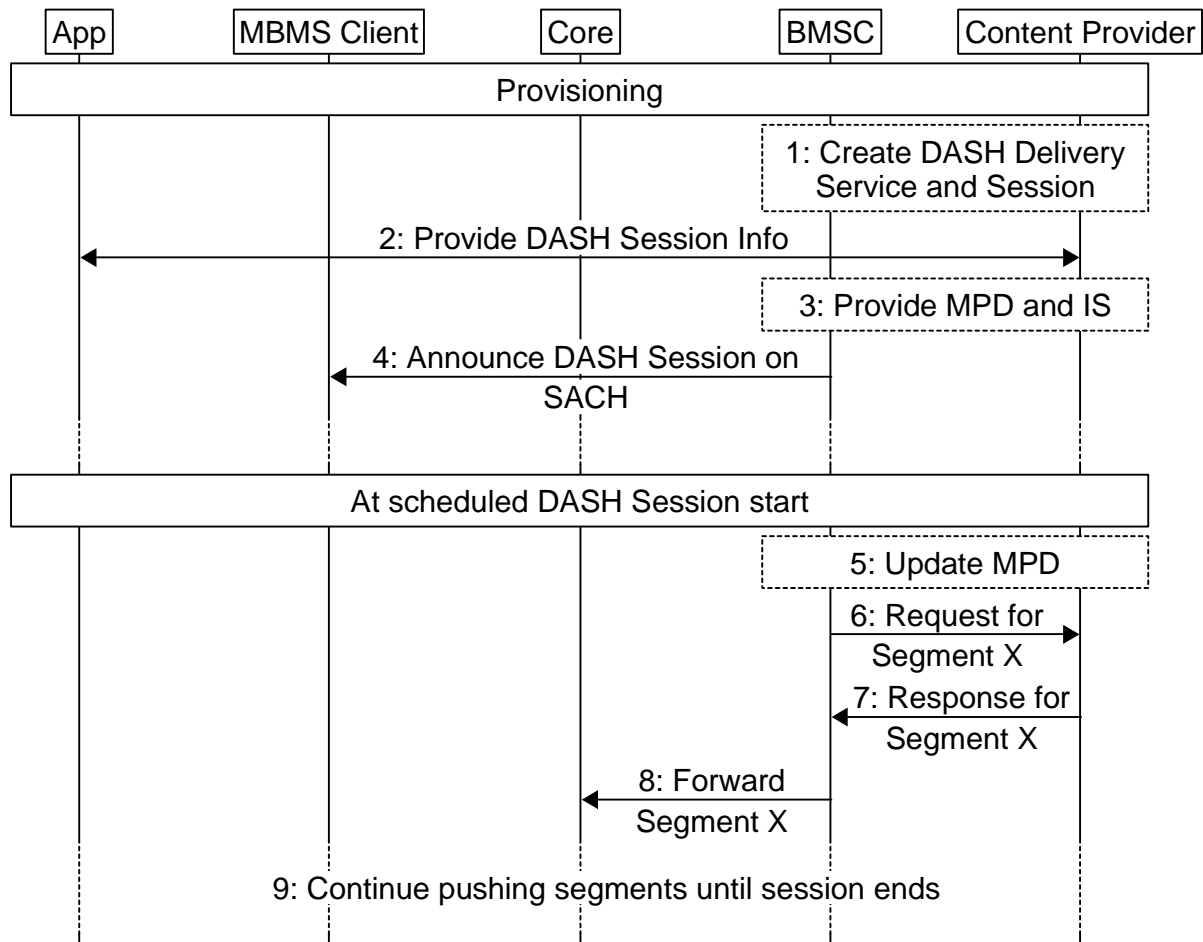

<http://msc-generator.sourceforge.net> v4.6.2

Figure A.2.2-2: Call Flow

Provisioning

- 1: The Content Provider creates the DASH Delivery Service and Session using xMB procedures.
- 2: As result of the Service and Session provisioning procedure, the Content provider gets the service identification information, which needs to be used by the App to request the reception activation from the MBMS Client.
- 3: The content provider provides the MPD and IS, which should be provided together with other access information using the SACH to the MBMS Client.
- 4: The MBMS client receives the service access information. At scheduled DASH Session start time.
- 5: The BM-SC updates the MPD according to the MPD update instructions.
- 6: The BM-SC uses the provided MPD to determine the segment availability start times for the different segments. Here, Segment X is the next segment to send and the BM-SC segments a segment request to the Content Provider.
- 7: The BM-SC receives the requested Segment X and wraps it into MBMS Download Delivery Objects.
- 8: The BM-SC sends the DASH Segment as MBMS Download Delivery Object.
- 9: Steps 5 to 8 are repeated for every DASH media segment until the session schedule end time is reached.

A.2.3 DASH Content ingestion with Push

The Content Provider delegates all MBMS related complexity to the operator and provides DASH compliant content using HTTP to the BM-SC. The Content Provider pushes the DASH Content as soon as new DASH Content is available using HTTP. The BM-SC is handling all MBMS related complexity, e.g. converting the HTTP payload into an IP Multicast suitable protocols, adding AL-FEC, etc. The Content Provider delegates the delivery of MBMS of Service Announcement Metadata (i.e. DASH MPD, IP Multicast protocol details, etc) to the MBMS Client to the BM-SC.

Figure A.2.3-1 illustrates a setup, where a DASH packager pushes DASH Content using HTTP PUT into the BM-SC, once the segment (or MPD update) becomes available.

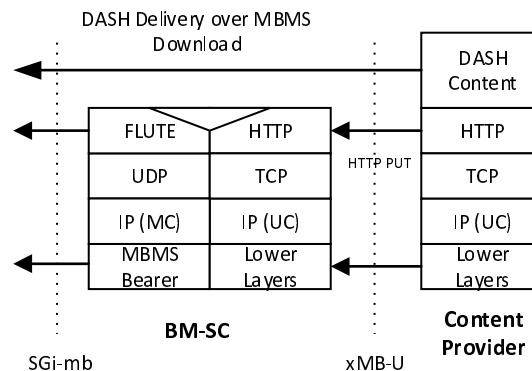

Figure A.2.3-1: DASH Content Delivery using Push (HTTP PUT)

The following Session Properties allow the configuration of this xMB-U mode.

- *Session Type* is set by the Content Provider to Application.
- *Ingest Mode* (Session Type specific property) is set by the Content Provider to Push.
- The BM-SC provides the *Push URL* (Session Type specific property) to the Content Provider. The value of this property is configured to the DASH packager.
- *Application Service Description* (Session Type specific property) is set to application/dash+xml.
- *Application Entry Point URL* contains the URL to the DASH MPD. The BM-SC will fetch the DASH MPD using the value of the *Application Entry Point URL* and embed the MPD into the Service Announcement File (SACH).
- *Unicast Delivery* is set to *false*. Indicating that the operation is not allowed to use MoD, e.g. because of content distribution rights.

Procedure

The following flow diagram illustrates the message flow. During provisioning phase, the according xMB Service and Sessions are created. Some lead time is needed to secure that all intended receiving UEs are capable of receiving the content.

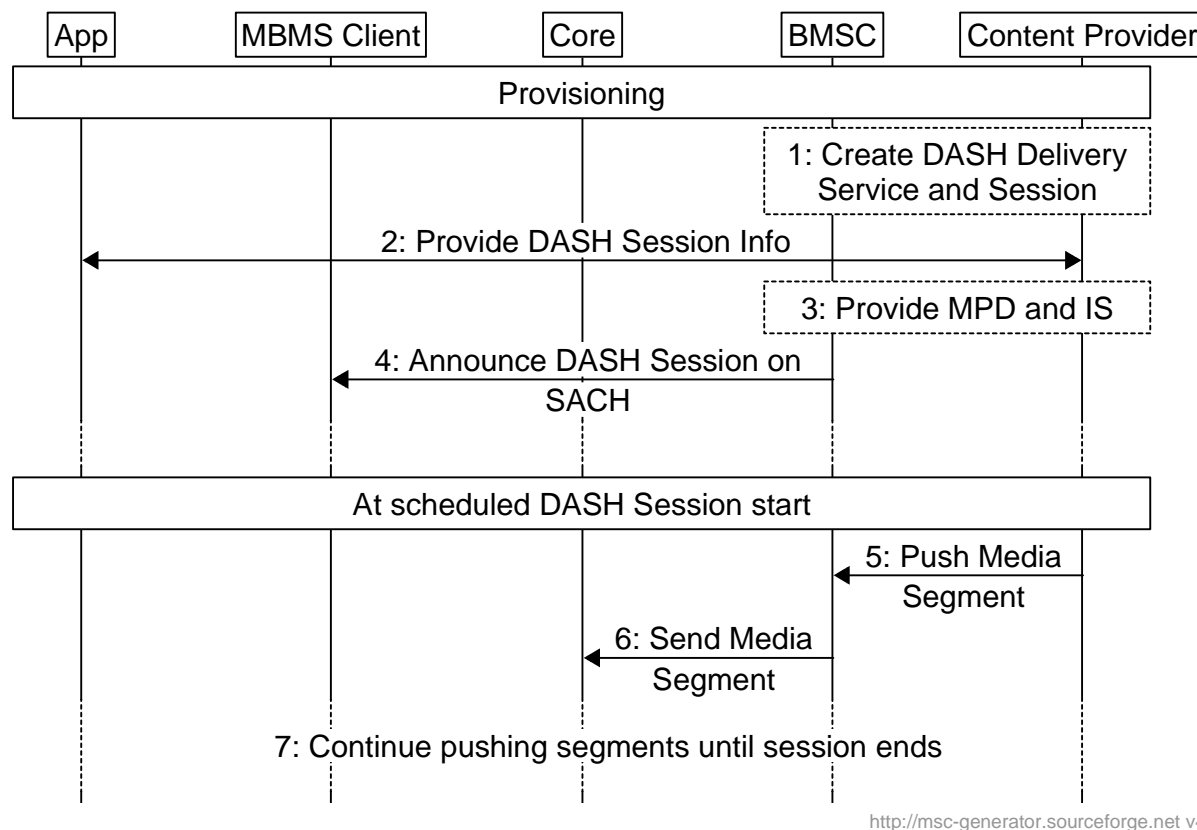

Figure A.2.3-2: Call Flow

Provisioning

Steps 1 to 4 are identical as in Figure A.2.2-2.

At scheduled DASH Session start time.

5: The content provider starts pushing DASH media segments to the BM-SC, which wraps the DASH Media Segments into MBMS Download Delivery Objects.

6: The BM-SC sends the File as MBMS Download Delivery Object.

7: Steps 5 and 6 are repeated for every DASH media segment until the session schedule end time is reached.

A.3 MBMS Streaming (with RTP)

This clause illustrates the various xMB-U options for MBMS Streaming with RTP. The BM-SC receives here the RTP stream from the content provider.

Figure A.3-1 illustrates a setup, where the BM-SC receives an RTP stream from the content provider. The xMB-C is used to provide the RTPS URL to the BM-SC.

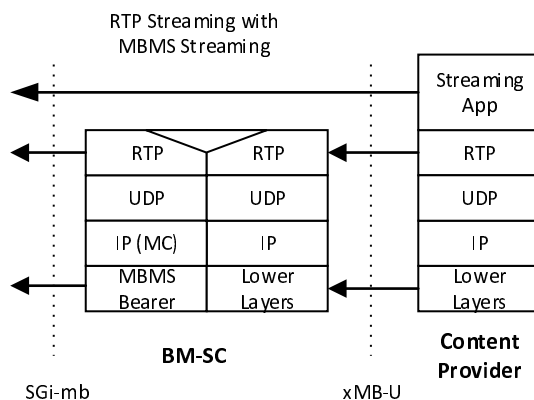

Figure A.3-1: MBMS Streaming with RTP

The following Session Properties allow the configuration of this xMB-U mode:

- *Session Type* is set by the Content Provider to *Streaming*.
- *SDP URL* (Session Type specific property) is set by the Content Provider and points to the RTSP server hosting the content. The BM-SC establishes the RTSP session to control the RTP flow.

A.4 Transparent Delivery

This clause illustrates the various xMB-U options for Transparent Delivery Mode. The BM-SC handles the streams in a transparent manner.

Figure A.4-1 illustrates a setup of Transparent Delivery with Proxy. The xMB-C is used to provide the necessary information to the BM-SC.

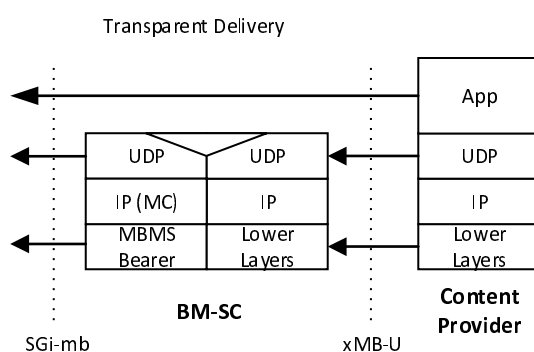

Figure A.4-1: Transparent Delivery with Proxy mode

The following Session Properties allow the configuration of this xMB-U mode:

- *Session Type* is set by the Content Provider to *Transport-Mode*.
- *Delivery Mode Configuration for user plane* (Session Type specific property) is set by the Content Provider to *Proxy*.
- *Session Description Parameters for User Plane* (Session Type specific property) is set by the Content Provider and contains the UDP flow mapping descriptions.

- When *Session Announcement Mode* (Session Type specific property) is set by the Content Provider to *SACH*, the BM-SC will add according session description into the SACH. In this case the MBMS Client (cf. TS 26.347) will offer the service to an application.
- When *Session Announcement Mode* (Session Type specific property) is set by the Content Provider to *Content Provider* then the Content Provider is responsible to announce services to UEs (e.g. using GC1). The BM-SC provides at least the TMGIs as value of the *Delivery Session Description Parameters* property.

Figure A.4-2 illustrates a setup of Transparent Delivery with Forward-Only. The xMB-C is used to provide the necessary information to the BM-SC.

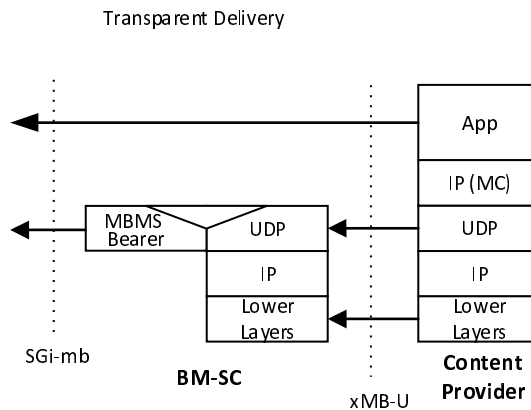

Figure A.4-2: Transparent Delivery with Forward-Only

The following Session Properties allow the configuration of this xMB-U mode:

- *Session Type* is set by the Content Provider to *Transport-Mode*.
- *Delivery Mode Configuration for user plane* (Session Type specific property) is set by the Content Provider to *Forward-only*.
- *Session Description Parameters for User Plane* (Session Type specific property) is set by the Content Provider and contains the UDP flow mapping descriptions.
- When *Session Announcement Mode* (Session Type specific property) is set by the Content Provider to *SACH*, the BM-SC will add according session description into the SACH. In this case the MBMS Client (cf. TS 26.347) will offer the service to an application.
- When *Session Announcement Mode* (Session Type specific property) is set by the Content Provider to *Content Provider* then the Content Provider is responsible to announce services to UEs (e.g. using GC1). The BM-SC provides at least the TMGIs as value of the *Delivery Session Description Parameters* property.

A.5 HLS Media Presentation Delivery

A.5.1 Introduction

This subclause illustrates the xMB-U constraints and options for HLS delivery.

An HLS presentation typically consists of a single Master Playlist and multiple Media Playlists, one for each media Rendition. Media Playlists specify a sequence of media segments, each containing media data. A Media Playlist may also specify, by way of an EXT-MAP tag, a segment containing only the subsequent sequences' CMAF Header. These header-only segments are also referred to as Initialization Segments (IS) or Media Initialization Sections.

A.5.2 Segment and Playlist Order Guarantee

As mentioned in subclause 5.5.2, media segments should be made available to the BM-SC, and ingested using xMB-U, prior to the ingestion of the Media Playlists that specify those segments. This ordering is the responsibility of the Content Provider, irrespective of ingest mode, as detailed below.

A.5.3 HLS Content Ingestion with Pull

A.5.3.1 Introduction

The Content Provider delegates all MBMS related complexity to the operator and provides HLS compliant content using an HTTP GET method to the BM-SC. The Content Provider is responsible for ensuring the required ordering of media segments and Media Playlist availability to the requesting BM-SC. Using the Pull ingest mode the BM-SC should parse the supplied Media Playlist, at each update, to discover new media segment URIs.

The following Session Properties allow the configuration of this xMB-U mode.

- *Session Type* is set by the Content Provider to Application.
- *Ingest Mode* (Session Type specific property) is set by the Content Provider to Pull.
- *Application Service Description* (Session Type specific property) is set to application/vnd.apple.mpegurl.
- *Application Entry Point URL* contains the URL to the HLS Master Playlist. The BM-SC will fetch the Master Playlist using the value of the Application Entry Point URL and embed the Master Playlist into the Service Announcement File (via SACH).

A.5.3.2 Content ingestion steps

- 1: The Content Provider creates the HLS Delivery Service and Session using xMB procedures.
- 2: As a result of the Service and Session provisioning procedure, the Content Provider gets the service identification information, which needs to be used by the Application to request the reception activation from the MBMS Client.
- 3: The Content Provider provides the Master Playlist. It also provides the IS, with identifying source URI, for each Media Playlist to be broadcast. The source URI should match the EXT-MAP tag within the corresponding Media Playlist. Note that the Master Playlist and the collection of IS will be provided via the SACH to the MBMS Client.
- 4: The MBMS client receives the service access information.
- 5: At Playlist reload intervals as specified by RFC 8216 section 6.3.4, the BM-SC Pulls, via HTTP GET, Media Playlist updates, which specify all segment(s) currently available. Following this the BM-SC Pulls any media segments it has not yet ingested. The BM-SC then wraps the Media Playlist and the new media segment(s) into MBMS Download Delivery Objects.
- 6: The BM-SC sends the CMAF Segment(s) as MBMS Download Delivery Objects together with the corresponding Media Playlists.

7: Steps 5 and 6 are repeated until the session schedule end time is reached.

A.5.4 HLS Content Ingestion with Push

A.5.4.1 Introduction

The Content Provider delegates all MBMS related complexity to the operator and provides HLS compliant content using an HTTP PUT method to the BM-SC. The Content Provider is responsible for ensuring the order of media segments and Media Playlist availability to the BM-SC over the xMB-U.

The following Session Properties allow the configuration of this xMB-U mode.

- *Session Type* is set by the Content Provider to Application.
- *Ingest Mode* (Session Type specific property) is set by the Content Provider to Push.
- The BM-SC provides the *Push URL* (Session Type specific property) to the Content Provider. The value of this property is configured to the HLS packager.
- *Application Service Description* (Session Type specific property) is set to application/vnd.apple.mpegurl.
- *Application Entry Point URL* contains the URL to the HLS Master Playlist. The BM-SC will fetch the Master Playlist using the value of the Application Entry Point URL and embed the Master Playlist into the Service Announcement File (SACH).

A.5.4.2 Content ingestion steps

Steps 1 to 4 are identical to clause A.5.3.

5: At segment Duration intervals, the Content Provider pushes a new media segment to the BM-SC. The BM-SC then wraps it into an MBMS Download Delivery Object.

6: Following each segment push, the Content Provider pushes to the BM-SC a Media Playlist update that now specifies the segment made available in step 5. The BM-SC then wraps it into an MBMS Download Delivery Object.

7: The BM-SC sends the CMAF segment(s) together with the corresponding Media Playlist update as MBMS Download Delivery Objects.

8: Steps 5 to 7 are repeated until the session schedule end time is reached.

Annex B (informative): Change history

| Change history | | | | | | | |
|----------------|---------|-----------|------|-----|-----|---|-------------|
| Date | Meeting | TDoc | CR | Rev | Cat | Subject/Comment | New version |
| 2018-09 | SA#81 | SP-180654 | | | | Presented to TSG SA#81 (for information) | 1.0.0 |
| 2018-12 | SA#82 | SP-180980 | | | | Presented to TSG SA#82 (for approval) | 2.0.0 |
| 2018-12 | SA#82 | | | | | Approved at SA#82 | 16.0.0 |
| 2019-03 | SA#83 | SP-190033 | 0002 | 2 | B | Support of profile 1c | 16.1.0 |
| 2019-06 | SA#84 | SP-190340 | 0003 | 1 | B | Support for Multiplexing MCDATA Sessions on one MBMS Bearer | 16.2.0 |
| 2019-06 | SA#84 | SP-190340 | 0005 | - | F | Correction of xMB Guidelines | 16.2.0 |
| 2020-03 | SA#87-e | SP-200039 | 0006 | 1 | B | Guidelines for HLS Media Presentation Delivery | 16.2.0 |
| 2020-03 | SA#87-e | SP-200039 | 0007 | 1 | B | Support of hybrid HLS/DASH services | 16.3.0 |
| 2022-04 | - | - | - | - | - | Update to Rel-17 version (MCC) | 17.0.0 |
| 2022-06 | SA#96 | SP-220597 | 0008 | | | [5MBP3] xMB Extensions for 5GMS via eMBMS | 17.1.0 |

History

| Document history | | |
|-------------------------|-----------|-------------|
| V17.0.0 | May 2022 | Publication |
| V17.1.0 | July 2022 | Publication |
| | | |
| | | |
| | | |