

ETSI TS 126 501 V18.5.0 (2024-05)



**5G;**  
**5G Media Streaming (5GMS);**  
**General description and architecture**  
**(3GPP TS 26.501 version 18.5.0 Release 18)**



---

**Reference**

RTS/TSGS-0426501vi50

---

**Keywords**

5G

**ETSI**

---

650 Route des Lucioles  
F-06921 Sophia Antipolis Cedex - FRANCE

Tel.: +33 4 92 94 42 00 Fax: +33 4 93 65 47 16

Siret N° 348 623 562 00017 - APE 7112B  
Association à but non lucratif enregistrée à la  
Sous-Préfecture de Grasse (06) N° w061004871

---

**Important notice**

The present document can be downloaded from:

<https://www.etsi.org/standards-search>

The present document may be made available in electronic versions and/or in print. The content of any electronic and/or print versions of the present document shall not be modified without the prior written authorization of ETSI. In case of any existing or perceived difference in contents between such versions and/or in print, the prevailing version of an ETSI deliverable is the one made publicly available in PDF format at [www.etsi.org/deliver](http://www.etsi.org/deliver).

Users of the present document should be aware that the document may be subject to revision or change of status.

Information on the current status of this and other ETSI documents is available at

<https://portal.etsi.org/TB/ETSIDeliverableStatus.aspx>

If you find errors in the present document, please send your comment to one of the following services:

<https://portal.etsi.org/People/CommitteeSupportStaff.aspx>

If you find a security vulnerability in the present document, please report it through our  
Coordinated Vulnerability Disclosure Program:

<https://www.etsi.org/standards/coordinated-vulnerability-disclosure>

---

**Notice of disclaimer & limitation of liability**

The information provided in the present deliverable is directed solely to professionals who have the appropriate degree of experience to understand and interpret its content in accordance with generally accepted engineering or other professional standard and applicable regulations.

No recommendation as to products and services or vendors is made or should be implied.

No representation or warranty is made that this deliverable is technically accurate or sufficient or conforms to any law and/or governmental rule and/or regulation and further, no representation or warranty is made of merchantability or fitness for any particular purpose or against infringement of intellectual property rights.

In no event shall ETSI be held liable for loss of profits or any other incidental or consequential damages.

Any software contained in this deliverable is provided "AS IS" with no warranties, express or implied, including but not limited to, the warranties of merchantability, fitness for a particular purpose and non-infringement of intellectual property rights and ETSI shall not be held liable in any event for any damages whatsoever (including, without limitation, damages for loss of profits, business interruption, loss of information, or any other pecuniary loss) arising out of or related to the use of or inability to use the software.

---

**Copyright Notification**

No part may be reproduced or utilized in any form or by any means, electronic or mechanical, including photocopying and microfilm except as authorized by written permission of ETSI.

The content of the PDF version shall not be modified without the written authorization of ETSI.

The copyright and the foregoing restriction extend to reproduction in all media.

© ETSI 2024.  
All rights reserved.

---

# Intellectual Property Rights

## Essential patents

IPRs essential or potentially essential to normative deliverables may have been declared to ETSI. The declarations pertaining to these essential IPRs, if any, are publicly available for **ETSI members and non-members**, and can be found in ETSI SR 000 314: "*Intellectual Property Rights (IPRs); Essential, or potentially Essential, IPRs notified to ETSI in respect of ETSI standards*", which is available from the ETSI Secretariat. Latest updates are available on the ETSI Web server (<https://ipr.etsi.org/>).

Pursuant to the ETSI Directives including the ETSI IPR Policy, no investigation regarding the essentiality of IPRs, including IPR searches, has been carried out by ETSI. No guarantee can be given as to the existence of other IPRs not referenced in ETSI SR 000 314 (or the updates on the ETSI Web server) which are, or may be, or may become, essential to the present document.

## Trademarks

The present document may include trademarks and/or tradenames which are asserted and/or registered by their owners. ETSI claims no ownership of these except for any which are indicated as being the property of ETSI, and conveys no right to use or reproduce any trademark and/or tradename. Mention of those trademarks in the present document does not constitute an endorsement by ETSI of products, services or organizations associated with those trademarks.

**DECT™**, **PLUGTESTS™**, **UMTS™** and the ETSI logo are trademarks of ETSI registered for the benefit of its Members. **3GPP™** and **LTE™** are trademarks of ETSI registered for the benefit of its Members and of the 3GPP Organizational Partners. **oneM2M™** logo is a trademark of ETSI registered for the benefit of its Members and of the oneM2M Partners. **GSM®** and the GSM logo are trademarks registered and owned by the GSM Association.

---

# Legal Notice

This Technical Specification (TS) has been produced by ETSI 3rd Generation Partnership Project (3GPP).

The present document may refer to technical specifications or reports using their 3GPP identities. These shall be interpreted as being references to the corresponding ETSI deliverables.

The cross reference between 3GPP and ETSI identities can be found under <https://webapp.etsi.org/key/queryform.asp>.

---

# Modal verbs terminology

In the present document "**shall**", "**shall not**", "**should**", "**should not**", "**may**", "**need not**", "**will**", "**will not**", "**can**" and "**cannot**" are to be interpreted as described in clause 3.2 of the [ETSI Drafting Rules](#) (Verbal forms for the expression of provisions).

"**must**" and "**must not**" are **NOT** allowed in ETSI deliverables except when used in direct citation.

# Contents

Intellectual Property Rights .....	2
Legal Notice .....	2
Modal verbs terminology.....	2
Foreword.....	9
1 Scope .....	10
2 References .....	10
3 Definition of terms, symbols and abbreviations.....	11
3.1 Terms.....	11
3.2 Symbols.....	13
3.3 Abbreviations .....	14
4 Media Streaming architecture .....	15
4.0 Media Streaming features (informative).....	15
4.0.1 Introduction.....	15
4.0.2 Content hosting .....	16
4.0.3 Content publishing.....	16
4.0.4 Content preparation.....	17
4.0.5 Network assistance .....	18
4.0.6 Dynamic policies .....	19
4.0.7 Remote control.....	21
4.0.8 Consumption reporting .....	21
4.0.9 QoE metrics reporting.....	22
4.0.10 Edge processing .....	22
4.0.11 eMBMS delivery .....	22
4.0.12 Data collection, reporting and exposure .....	22
4.0.13 Service URL handling .....	22
4.1 General service architecture .....	23
4.1.1 Definition of 5G Media Streaming architecture.....	23
4.1.2 Generalized Media Delivery architecture .....	24
4.1.2.1 Generalized Media Delivery in the 5G System.....	24
4.1.2.2 Reference architecture for Media Delivery .....	26
4.1.2.3 Network Functions and UE entities .....	26
4.1.2.4 Reference points.....	27
4.1.2.5 Interfaces and APIs .....	28
4.1.2.5.1 Interfaces and APIs supporting media session handling.....	28
4.1.2.5.2 Interfaces and APIs supporting media transport.....	28
4.1.2.5.3 Interfaces and APIs supporting application functionality.....	29
4.2 5G unicast downlink Media Streaming architecture .....	29
4.2.1 Standalone – Non-Roaming .....	29
4.2.2 5GMSd UE functions.....	32
4.2.3 Service Access Information for downlink media streaming .....	35
4.3 Uplink 5G Media Streaming architecture.....	37
4.3.1 Media architecture .....	37
4.3.2 UE 5GMSu functions.....	39
4.3.3 Service Access Information for uplink media streaming.....	41
4.4 Network Slicing for Downlink Media Streaming.....	42
4.5 5G Media Streaming architecture extensions for Edge Computing .....	43
4.5.1 Introduction.....	43
4.5.2 5G Media Streaming combined with Edge Computing .....	43
4.5.3 Provisioning and Service Information .....	44
4.5.4 Edge application context for 5GMS functions.....	45
4.5.4.1 5GMS AF context .....	45
4.5.4.2 5GMS AS context .....	45
4.6 5G Downlink Media Streaming via eMBMS .....	46
4.6.1 Architecture for 5G Downlink Media Streaming over eMBMS.....	46

4.6.2	Usage of 5GMS reference points for eMBMS-based delivery .....	47
4.6.2.1	Usage of M1d.....	47
4.6.2.2	Usage of M2d.....	47
4.6.2.3	Usage of M3d.....	47
4.6.2.4	Usage of M4d.....	47
4.6.2.5	Usage of M5d.....	47
4.6.2.6	Usage of M6d.....	48
4.6.2.7	Usage of M7d.....	48
4.6.2.8	Usage of M8d.....	48
4.6.3	Usage of MBMS reference points and interfaces .....	48
4.6.3.1	Usage of xMB-C .....	48
4.6.3.2	Usage of xMB-U .....	48
4.6.3.3	Usage of MBMS User Services and Delivery Methods .....	48
4.6.3.4	Usage of MBMS-API-C.....	48
4.6.3.5	Usage of MBMS-API-U .....	48
4.7	Data collection, reporting and exposure for 5GMS.....	49
4.7.1	Reference architecture instantiation.....	49
4.7.2	UE data reporting for 5GMS.....	50
4.7.2.1	UE data reporting procedures for downlink media streaming.....	50
4.7.2.2	UE data reporting procedures for uplink media streaming.....	51
4.7.2.3	UE data reporting of ANBR-based Network Assistance invocations .....	51
4.7.3	UE data processing for 5GMS .....	52
4.7.3.1	UE data processing procedures for downlink media streaming .....	52
4.7.3.2	UE data processing procedures for uplink media streaming .....	53
4.7.4	Event exposure of 5GMS UE data.....	53
4.7.4.1	Event exposure for downlink media streaming UE data .....	53
4.7.4.2	Event exposure for uplink media streaming UE data .....	53
4.7.4.3	Common baseline parameters for event exposure.....	54
4.7.4.4	Event exposure of QoE metrics UE data.....	55
4.7.4.5	Event exposure of consumption reporting UE data.....	57
4.7.4.6	Event exposure of dynamic policy invocation UE data .....	58
4.7.4.7	Event exposure of Network Assistance UE data.....	60
4.7.4.8	Event exposure of media streaming access activity UE data .....	63
4.8	Downlink media streaming to Media Players with multiple formats .....	64
4.9	Downlink 5G Media Streaming via MBS .....	65
4.9.1	Architecture for downlink 5G Media Streaming over MBS.....	65
4.9.2	Usage of 5GMS reference points for MBS-based delivery.....	67
4.9.2.1	Usage of M1 .....	67
4.9.2.2	Usage of M2d.....	67
4.9.2.3	Usage of M3d.....	67
4.9.2.4	Usage of M4d.....	67
4.9.2.5	Usage of M5.....	67
4.9.2.6	Usage of M6d.....	68
4.9.2.7	Usage of M7d.....	68
4.9.2.8	Usage of M8d.....	68
4.9.3	Usage of MBS reference points and interfaces .....	68
4.9.3.1	Usage of Nmbsf service at Nmb10 and Nmb5+N33.....	68
4.9.3.2	Usage of Nmb8 .....	68
4.9.3.3	Usage of MBS User Services and Distribution Methods .....	68
4.9.3.4	Usage of MBS-6.....	68
4.9.3.5	Usage of MBS-7.....	68
4.10	3GPP Service URL handling.....	69
4.10.1	General.....	69
4.10.2	Baseline parameters of 3GPP Service URL for 5G Media Streaming.....	69
5	Procedures for downlink Media Streaming.....	70
5.1	General .....	70
5.2	Baseline procedure for unicast downlink Media Streaming session establishment.....	72
5.2.1	General.....	72
5.2.2	Progressive download of on-demand content .....	72
5.2.3	DASH streaming.....	74
5.2.4	Procedures for downlink streaming to Media Players with different presentation manifests .....	75

5.3	Provisioning Session for Media Streaming .....	77
5.3.1	Domain model .....	77
5.3.2	Baseline provisioning procedure.....	79
5.4	Content Hosting Configuration for downlink Media Streaming .....	81
5.4.1	General.....	81
5.4.2	Media ingest procedure.....	82
5.5	Metrics collection and reporting.....	83
5.5.1	General.....	83
5.5.2	RAN-based reporting procedure .....	83
5.5.3	5GMSd AF-based reporting procedure.....	86
5.5.4	Metrics reporting configuration parameters.....	88
5.6	Consumption reporting.....	89
5.6.1	Consumption reporting procedure .....	89
5.6.2	Consumption reporting parameters.....	91
5.6.3	Triggering consumption reporting .....	91
5.7	Establishing a Unicast Downlink Media Streaming Session with 5GMSd AF interactions for dynamic policy updates.....	91
5.7.1	General.....	91
5.7.2	Provisioning.....	92
5.7.3	Progressive Download of On-Demand Content.....	93
5.7.4	DASH Streaming .....	96
5.7.5	Parameters for dynamic policy invocation configuration .....	98
5.7.6	Dynamic Policy selection for downlink media streaming based on Service Operation Point signalling .....	99
5.7.7	Use of Service Operation Point signalling to optimise delivery of low-latency live media streaming services (informative) .....	100
5.7.7.1	5GMS System acts as a CDN.....	100
5.7.7.2	5GMSd AS deployed in an external DN.....	101
5.7.8	Downlink Background Data Transfer using dynamic policy invocation .....	102
5.8	Dynamic Policy based on Network Slicing for Downlink Media Streaming .....	107
5.8.1	Procedure .....	107
5.9	Downlink Network Assistance .....	108
5.9.1	Introduction.....	108
5.9.2	5GMSd AF-based downlink Network Assistance .....	108
5.9.3	ANBR-based downlink Network Assistance .....	109
5.10	5GMS via eMBMS.....	110
5.10.1	General.....	110
5.10.2	Procedures for 5GMS content delivered exclusively via eMBMS .....	110
5.10.3	5GMS Consumption Reporting procedures for eMBMS.....	112
5.10.4	5GMS Metrics Reporting procedures for eMBMS.....	114
5.10.5	Procedures for Hybrid Services: 5GMS content delivery via 5G System and eMBMS .....	116
5.10.5.1	General .....	116
5.10.5.2	Interactive service .....	119
5.10.5.3	Session continuity .....	119
5.10.5.4	Time-shifted viewing .....	119
5.10.5.5	Content or component replacement.....	119
5.10.6	Procedures for dynamic provisioning of 5GMS content delivery via eMBMS .....	120
5.10.6.1	General .....	120
5.10.6.2	Operation modes .....	123
5.10.7	Service URL handling procedures for 5GMSd via eMBMS in Receive-Only Mode (ROM) .....	123
5.11	Procedures for downlink media streaming data collection, reporting and exposure .....	125
5.11.1	Configuration of 5GMSd AS data collection client for downlink media streaming access reporting .....	125
5.11.2	Downlink media streaming access activity reporting by 5GMSd AS.....	125
5.11.3	Downlink media streaming access event exposure.....	126
5.11.4	Downlink media streaming access reporting parameters.....	127
5.11.5	Triggering downlink media streaming access reporting .....	127
5.12	5GMS via MBS.....	127
5.12.1	General.....	127
5.12.2	Procedures for 5GMS content delivered exclusively via MBS.....	128
5.12.3	5GMS consumption reporting procedures for MBS .....	131
5.12.4	5GMS content delivery via 5G System and MBS .....	133
5.12.4.1	General .....	133

5.12.4.2	Interactive service .....	136
5.12.4.3	Session continuity .....	136
5.12.4.4	Time-shifted viewing .....	136
5.12.4.5	Content or component replacement.....	136
5.12.5	Procedures for dynamic provisioning of 5GMS content delivery via MBS .....	137
5.12.5.1	General .....	137
5.12.5.2	Operation modes .....	140
6	Procedures for uplink Media Streaming.....	140
6.1	General .....	140
6.2	Preparing for uplink Media Streaming .....	142
6.2.1	Introduction.....	142
6.2.2	Provisioning session for uplink streaming .....	142
6.2.2.1	Domain model.....	142
6.2.2.2	Baseline provisioning procedure .....	145
6.2.3	Content Publishing Configuration for uplink streaming .....	147
6.2.3.1	General .....	147
6.2.3.2	Media egest procedure .....	148
6.3	Establishment of an uplink Media Streaming session .....	149
6.4	Termination of an uplink Media Streaming session .....	150
6.5	Providing 5GMSu AF-based Network Assistance .....	150
6.6	Providing Remote Control.....	151
6.7	RAN Signalling based Support for Uplink Network Assistance.....	152
6.8	Procedures for uplink media streaming data collection, reporting and exposure .....	153
6.8.1	Configuration of 5GMSu AS data collection client for uplink media streaming access reporting .....	153
6.8.2	Uplink media streaming access reporting by 5GMSu AS.....	154
6.8.3	Uplink media streaming access event exposure.....	154
6.8.4	Uplink media streaming access reporting parameters.....	155
6.8.5	Triggering uplink media streaming access reporting .....	155
6.9	Establishing an uplink streaming session with 5GMSu AF interactions for dynamic policy invocation and updates.....	156
6.9.1	General.....	156
6.9.2	Provisioning.....	156
6.9.3	Uplink streaming with dynamic policy invocation .....	158
6.9.4	Parameters for dynamic policy invocation configuration .....	159
6.9.5	Dynamic Policy selection for uplink media streaming based on Service Operation Point signalling.....	160
6.9.6	Dynamic Policy based on Network Slicing for uplink media streaming .....	161
6.9.7	Uplink Background Data Transfer using dynamic policy invocation.....	162
7	5GMS network media processing .....	166
7.1	General .....	166
7.2	Media processing procedures for downlink media streaming .....	166
7.3	Media processing procedures for uplink media streaming .....	168
8	Procedures for 5GMS Edge Processing .....	169
8.1	Procedure for client-driven management of 5GMS Edge Processing .....	169
8.2	Procedure for AF-driven management of 5GMS Edge Processing .....	172
9	Procedures for Service URL handling.....	173
9.1	Baseline procedure .....	173
<b>Annex A (informative): Usage Guidelines for collaboration scenarios.....</b>		<b>175</b>
A.0	General .....	175
A.1	Downlink media streaming with AS deployed in an external Data Network (OTT).....	175
A.2	Downlink media streaming with both AF and AS deployed in the trusted Data Network .....	176
A.3	Downlink media streaming with both AF and AS deployed in an external Data Network (OTT).....	177
A.4	Downlink media streaming with AF deployed in the trusted Data Network and AS deployed in an external Data Network.....	177

A.5	Downlink media streaming with AS deployed in an external Data Network, provisioned by AF deployed in the trusted Data Network.....	178
A.6	Downlink media streaming with AS deployed in the trusted Data Network, provisioned by AF deployed in an external Data Network.....	179
A.7	Downlink media streaming with both AF and AS deployed in the trusted Data Network and AF interaction with PCF.....	179
A.8	Downlink media streaming with AFs deployed in two separate trusted Data Networks sharing AS in an external Data Network.....	180
A.9	Downlink media streaming with both AF and AS deployed in external Data Network and AS delivering content through two trusted Data Networks (OTT) .....	180
A.10	Uplink media streaming using content preparation with both AF and AS deployed in the trusted Data Network .....	181
A.11	Uplink media streaming using content preparation (media plane only) with both AF and AS deployed in the trusted Data Network.....	184
A.12	Uplink media streaming using content preparation (media plane only) with provisioning and AS in the external domain .....	186
A.13	Uplink media streaming using content preparation with AF in the trusted Data Network and AS in the external domain .....	188
A.14	Uplink media streaming using content preparation with AF and AS in the external domain .....	190
A.15	Cascaded uplink and downlink media streaming using content preparation.....	193
A.15.1	Introduction .....	193
A.15.2	Cascaded uplink and downlink media streaming using content preparation with external content re-ingestion .....	193
A.15.3	Cascaded uplink and downlink media streaming using content preparation with direct content re-ingestion .....	196
A.15.4	Cascaded uplink and downlink media streaming using content preparation with internal content re-ingestion .....	199
<b>Annex B (informative):</b>	<b>MNO-specific Service Access Information acquisition.....</b>	<b>200</b>
B.1	General .....	200
B.2	Deployment with DNS-based resolution.....	200
B.3	Deployment with HTTPS-based resolution.....	202
<b>Annex C (informative):</b>	<b>Collaboration Models for 5GMS via eMBMS.....</b>	<b>204</b>
C.1	Introduction .....	204
C.2	Collaboration 5GMS-MBMS 1: 5GMS Content Provider uses different delivery networks.....	204
C.3	Collaboration 5GMS-MBMS 2: 5GMS Network Operator offloads to 5G Broadcast Network Operator.....	205
C.4	Collaboration 5GMS-MBMS 3: 5GMS Service Operator includes MBMS network.....	205
C.5	Collaboration 5GMS-MBMS 4: 5G Broadcast Service Provider offloads to 5G MNO .....	206
<b>Annex D (informative):</b>	<b>Use Cases for 5GMS event exposure.....</b>	<b>208</b>
D.1	Introduction .....	208
D.2	Controlling Event exposure.....	208
D.2.1	Data exposure restrictions .....	208
D.2.2	Event subscription filters.....	208
D.3	QoE metrics for downlink media streaming.....	208



D.4	Consumption of downlink media streaming.....	208
D.5	Invocation of dynamic policies .....	209
D.6	Invocation of Network Assistance .....	209
D.7	Media streaming access activity.....	210
D.7.1	Downlink media streaming access activity .....	210
<b>Annex E (informative):</b>	<b>Change history .....</b>	<b>211</b>
History .....		214

---

# Foreword

This Technical Specification has been produced by the 3rd Generation Partnership Project (3GPP).

The contents of the present document are subject to continuing work within the TSG and may change following formal TSG approval. Should the TSG modify the contents of the present document, it will be re-released by the TSG with an identifying change of release date and an increase in version number as follows:

Version x.y.z

where:

- x the first digit:
  - 1 presented to TSG for information;
  - 2 presented to TSG for approval;
  - 3 or greater indicates TSG approved document under change control.
- y the second digit is incremented for all changes of substance, i.e. technical enhancements, corrections, updates, etc.
- z the third digit is incremented when editorial only changes have been incorporated in the document.

---

# 1 Scope

The present document specifies the 5G Media Streaming (5GMS) architecture. The 5GMS supported services include MNO and third-party Downlink Media Streaming Services, and MNO and third-party Uplink Media Streaming Services. The 5GMS architecture supports related network and UE functions and APIs, backwards compatible functions for EUTRAN deployments (with and without MBMS) and 5G specific features.

NOTE: Support of 5G Media Streaming over MBMS with 5GC is not considered in the current version of the present document.

The 5GMS architecture is functionally divided into independent components enabling different deployments with various degrees of integration between 5G MNOs and Content Providers. It is specified as a set of extensions to TS 23.501 "System Architecture for the 5G System".

---

# 2 References

The following documents contain provisions which, through reference in this text, constitute provisions of the present document.

- References are either specific (identified by date of publication, edition number, version number, etc.) or non-specific.
- For a specific reference, subsequent revisions do not apply.
- For a non-specific reference, the latest version applies. In the case of a reference to a 3GPP document (including a GSM document), a non-specific reference implicitly refers to the latest version of that document *in the same Release as the present document*.

- [1] 3GPP TR 21.905: "Vocabulary for 3GPP Specifications".
- [2] 3GPP TS 23.501: "System architecture for the 5G System (5GS)".
- [3] 3GPP TS 23.502: "Procedures for the 5G System (5GS)".
- [4] 3GPP TS 23.503: "Policy and charging control framework for the 5G System (5GS); Stage 2".
- [5] Void
- [6] 3GPP TS 26.307: "Presentation layer for 3GPP services".
- [7] 3GPP TS 26.247: "Transparent end-to-end Packet-switched Streaming Service (PSS); Progressive Download and Dynamic Adaptive Streaming over HTTP (3GP-DASH)".
- [8] 3GPP TS 26.234: "Transparent end-to-end Packet-switched Streaming Service (PSS); Protocols and codecs".
- [9] 3GPP TS 23.003: "Technical Specification Group Core Network and Terminals; Numbering, addressing and identification".
- [10] 3GPP TS 28.530: "Management and orchestration; Concepts, use cases and requirements".
- [11] 3GPP TS 28.531: "Management and orchestration; Provisioning".
- [12] 3GPP TS 28.541: "Management and orchestration; 5G Network Resource Model (NRM); Stage 2 and stage 3".
- [13] 3GPP TS 23.222: "Common API Framework for 3GPP Northbound APIs".
- [14] IETF RFC 1034: "Domain names - concepts and facilities".
- [15] 3GPP TS 23.548: "5G System Enhancements for Edge Computing; Stage 2".
- [16] 3GPP TS 23.558: "Architecture for enabling Edge Applications".

- [17] 3GPP TS 28.538: "Management and orchestration; Edge Computing Management".
- [18] 3GPP TS 23.246: "Multimedia Broadcast/Multicast Service (MBMS); Architecture and functional description".
- [19] 3GPP TS 26.346: "Multimedia Broadcast/Multicast Service (MBMS); Protocols and codecs".
- [20] 3GPP TS 26.347: "Multimedia Broadcast/Multicast Service (MBMS); Application Programming Interface and URL".
- [21] 3GPP TS 26.348: "Northbound Application Programming Interface (API) for Multimedia Broadcast/Multicast Service (MBMS) at the xMB reference point".
- [22] 3GPP TS 26.531: "Data collection and reporting; General description and architecture".
- [23] 3GPP TS 23.288: "Architecture enhancements for 5G System (5GS) to support network data analytics services".
- [24] 3GPP TS 27.007: "AT command set for User Equipment (UE)".
- [25] CTA-5005: "Web Application Video Ecosystem – DASH-HLS Interoperability Specification".
- [26] 3GPP TS 26.511: "5G Media Streaming (5GMS); Profiles, Codecs and Formats".
- [27] ISO/IEC 23000-19: "Information Technology Multimedia Application Format (MPEG-A) – Part 19: Common Media Application Format (CMAF) for segmented media".
- [28] IETF RFC 8216: "HTTP Live Streaming".
- [29] ISO/IEC 23009-1: "Information Technology – Dynamic Adaptive Streaming Over HTTP (DASH) – Part 1: Media Presentation Description and Segment Formats".
- [30] 3GPP TS 26.502: "5G Multicast-Broadcast User Service Architecture".
- [31] Void.
- [32] 3GPP TS 26.506: "5G Real-time Media Communication Architecture".

---

## 3 Definition of terms, symbols and abbreviations

### 3.1 Terms

For the purposes of the present document, the terms given in TR 21.905 [1] and the following apply. A term defined in the present document takes precedence over the definition of the same term, if any, in TR 21.905 [1].

**5GMS System:** An assembly of Application Functions, Application Servers and interfaces from the 5G Media Streaming architecture that support either downlink media streaming services or uplink media streaming services, or both.

NOTE 1: The components of a 5GMS System may be provided by an MNO as part of a 5GS and/or by a 5GMS Application Provider.

**5GMS Application Provider:** A party that interacts with functions of the 5GMS System and supplies a 5GMS-Aware Application that interacts with functions of the 5GMS System.

**5GMS-Aware Application:** Application in the UE, provided by the 5GMS Application Provider, that contains the service logic of the 5GMS application service, and interacts with other 5GMS Client and Network functions via the interfaces and APIs defined in the 5GMS architecture.

NOTE 2: Functionality of the 5GMS-Aware Application is outside the scope of this specification.

NOTE 3: A 5GMS-Aware Application associated with the delivery of either a downlink or uplink related 5GMS service is referred to as a 5GMSd-Aware Application or a 5GMSu-Aware Application, respectively.

**5GMS Client:** A UE function that is either a 5GMSd Client or a 5GMSu Client, or both.

**5G Media Streaming Client for downlink (5GMSd Client):** UE function that includes at least a 5G Media Streaming Player and a Media Session Handler for downlink streaming and that may be accessed through well-defined interfaces/APIs.

**5G Media Streaming Client for uplink (5GMSu Client):** Originator of 5GMSu service that includes at least a Media Streamer and a Media Session Handler for uplink streaming and that may be accessed through well-defined interfaces/APIs.

**5GMSu Media Streamer:** UE function that enables uplink delivery of streaming media content to an Application Server function of the 5GMS Application Provider, and which interacts with both the 5GMSu-Aware Application for media capture and subsequent streaming, and the Media Session Handler for media session control.

NOTE 4: The 5GMSu Media Streamer receives a Media Streamer Entry to initiate an uplink streaming session.

NOTE 5: The 5GMSu Media Streamer captures the media on the provided input devices. The 5GMSu Media Streamer exposes some basic controls such as capture, pause, and stop to the 5GMSu-Aware Application.

**Dynamic policy:** A Dynamic PCC Rule (c.f. TS 23.503 [4]) for an uplink or downlink application flow during a media session.

**Egest Session:** An uplink media streaming session from the 5GMSu AS towards the 5GMSu Application Provider.

**Ingest Session:** A session to upload the media content into a 5GMSd AS.

**Policy Template:** A collection of (semi-static) PCF/NEF API parameters which are specific to the 5GMS Application Provider and also the resulting PCC Rule.

**Policy Template Id:** Identifies the desired policy template, which is used by 5GMSd AF to select the appropriate PCF/NEF API towards the 5G System so that the PCF can compile the desired PCC Rule.

**Media Entry Point:** A Media Player Entry for downlink media streaming or a Media Streamer Entry for uplink media streaming intended to be consumed by a 5GMS Media Stream Handler.

**Media Player Entry:** A document or a pointer to a document that defines a downlink media streaming presentation e.g. MPD for DASH content or URL to a video clip file intended to be consumed by a 5GMSd Media Player.

**Media Session Handler:** UE function that communicates with the 5GMS AF in order to establish and control the delivery of a streaming media session in the downlink or uplink direction, and which also exposes APIs to the 5GMS-Aware Application and to the Media Player (for downlink streaming) or the Media Streamer (for uplink streaming).

**Media Streamer Entry:** A pointer (e.g. in the form of a URL) that defines an entry point of an uplink media streaming session intended to be consumed by a 5GMSu Media Streamer.

**media streaming session:** A session initiated by a 5GMS-Aware Application that involves one or more media streams being delivered between the 5GMS AS and the 5GMS Client via reference point M4.

**presentation entry:** A document or a pointer to a document that defines an application presentation e.g. an HTML5 document as defined in e.g. TS 26.307 [6].

**Provisioning Session:** A data structure supplied at interface M1 by a 5GMS Application Provider that configures the 5GMS features relevant to a set of 5GMS-Aware Applications.

**5GMSd Media Player:** UE function that enables playback and rendering of a media presentation based on a Media Player Entry and exposing some basic controls such as play, pause, seek, stop to the 5GMSd-Aware Application.

NOTE 6: A 5GMSd Media Player is expected to include a Media Access Client, Media Decoders, Media rendering/presentation, and possibly also a DRM Client a Consumption Measurement and Logging Client and a Metrics Measurement and Logging Client. The 5GMSd Media Player's Media Access Client receives a Media Player Entry. The 5GMSd Media Player renders the media on the provided output devices, such as a display in case of video.

NOTE 7: The 5GMSd Media Player is functionally similar to the combination of a TS 26.247 [7] 3GP-DASH client and a TS 26.234 [8] PSS media decoder and renderer.

**Service Access Information:** Set of parameters and addresses that are needed by a 5GMS Client to activate the reception of a downlink media streaming session or the transmission on an uplink media streaming session, perform dynamic policy invocation, consumption reporting and/or metrics reporting, and request AF-based network assistance.

**Service and Content Discovery:** Functionality and procedures provided by a 5GMSd Application Provider to a 5GMS-Aware Application that enables the end user to discover the available streaming service and content offerings and select a specific service or content item for access.

NOTE 8: The Service and Content Discovery functionality and procedures are outside the scope of this specification.

**Service Announcement:** Procedures conducted between the 5GMS-Aware Application and the 5GMS Application Provider such that the 5GMS-Aware Application is able to obtain 5GMS Service Access Information, either directly or in the form of a reference to that information.

**Service Data Flow:** As defined in TS 23.503 [4] ("An aggregate set of packet flows carried through the UPF that matches a service data flow template").

**Service Data Flow Description:** A set of parameters and/or parameter ranges used by the 5GMS AF to create a Service Data Flow Template.

**Service Description:** A set of parameters and/or parameter ranges describing the requirements of the streaming service, used by the Media Stream Handler to follow the service requirements and associated with a Service Operation Point.

**Service Operation Point:** An abstract set of parameters and/or parameter ranges defining service requirements for media streaming that may be supported by a Dynamic Policy in the 5GMS System and described as part of a Service Description or provided as information to the Media Stream Handler.

**third party player:** Part of an application that uses APIs to exercise selected 5GMSd functions to play back media content.

NOTE 9: Such APIs are for example defined in TS 26.307 [6] when using the Media Source Extensions for media playback. This type of player is downloaded by or built into an application, or it is downloaded with the Presentation Entry (e.g. as a JavaScript library).

**third party uplink streamer:** Part of an application that uses APIs to exercise selected 5GMSu functions to capture and stream media content.

NOTE 10: This type of streamer is typically implemented as downloadable software.

## 3.2 Symbols

Void.

### 3.3 Abbreviations

For the purposes of the present document, the abbreviations given in TR 21.905 [1] and the following apply. An abbreviation defined in the present document takes precedence over the definition of the same abbreviation, if any, in TR 21.905 [1].

5GC	5G Core Network
5GMS	5G Media Streaming
5GMSd	5G Media Streaming downlink
5GMSu	5G Media Streaming uplink
5GS	5G Systems
AF	Application Function
ABR	Adaptive Bit Rate
AMF	Access and Mobility Function
ANBR	Access Network Bit rate Recommendation
API	Application Programming Interface
App	Application
AS	Application Server
CAPIF	Common API Framework
CDN	Content Delivery Network
DASH	Dynamic and Adaptive Streaming over HTTP
DN	Data Network
DNAI	Data Network Application Identifier
DNN	Data Network Name
DRM	Digital Rights Management
EPC	Evolved Packet Core
EPS	Evolved Packet System
EUTRAN	Evolved Universal Terrestrial Radio Access Network
FLUS	Framework for Live Uplink Streaming
FQDN	Fully-Qualified Domain Name
GPU	Graphics Processing Unit
GSM	Global System for Mobile communication
HPLMN	Home Public Land Mobile Network
HTTP	HyperText Transfer Protocol
HTTPS	HyperText Transfer Protocol Secure
LTE	Long-Term Evolution
MBMS	Multimedia Broadcast Multicast System
MNO	Mobile Network Operator
MPD	Media Presentation Description
MSISDN	Mobile Station International Subscriber Directory Number
NA	Network Assistance
NEF	Network Exposure Function
NR	New Radio
NSMF	Network Slice Management Function
NSSAI	Network Slice Selection Assistance Information
NSSP	Network Slice Selection Policy
OAM	Operations, Administration and Maintenance
OTT	Over-The-Top
PCC	Policy and Charging Control
PCF	Policy and Charging Function
PDU	Packet Data Unit
PSS	Packet-switched Streaming Service
RAN	Radio Access Network
RTC	Real-Time media Communication
SBA	Service based Architecture
SLA	Service Level Agreement
TCP	Transmission Control Protocol
UPF	User Plane Function
URL	Unique Resource Identifier
URSP	UE Route Selection Policy

## 4 Media Streaming architecture

### 4.0 Media Streaming features (informative)

#### 4.0.1 Introduction

This clause defines a set of high-level features for supporting enhanced media streaming in the 5G System. The functional architecture of this 5G Media Streaming (5GMS) System is defined in clause 4.1 and is further specialised for downlink media streaming (clause 4.2) and uplink media streaming (clause 4.3). Procedures for downlink media streaming are defined in clause 5 and those for uplink media streaming in clause 6.

In the context of the present document, streaming is defined as the delivery of time-continuous media as the predominant media. Streaming points to the fact that the media is predominantly sent only in a single direction and consumed as it is received. Additionally, the media content may be streamed as it is produced, referred to as live streaming. If content is streamed that is already produced, it is referred to as on-demand streaming. Streaming content may also be delivered in non-real time and stored for later consumption on demand.

References to Dynamic Adaptive Streaming over HTTP (MPEG-DASH) [29] in the present document apply equally to HTTP Live Streaming (HLS) [28] except where noted otherwise. The term *Media Entry Point* is used to refer generically to an MPEG-DASH Media Presentation Description (MPD) but may be taken to apply equally to alternative media presentation description formats such as an HLS master playlist, unless noted otherwise.

Table 4.0.1-1 lists the principal features of the 5GMS architecture along with cross-references to relevant clauses defining its functions and procedures.

**Table 4.0.1-1: 5G Media Streaming feature index**

Feature	Feature description clause	Procedure definition clause(s)	
		Downlink media streaming	Uplink media streaming
Content hosting	4.0.2	5.4	Not applicable
Content publishing	4.0.3	Not applicable	6.2.3
Content preparation	4.0.4	Not defined	Not defined
Network assistance	4.0.5	5.9	6.5, 6.7
Dynamic policies	4.0.6	5.8, 5.7.6	6.9
Remote control	4.0.7	Not applicable	6.6
Consumption reporting	4.0.8	5.6	Not applicable
QoE metrics reporting	4.0.9	5.5	Not applicable
Edge processing	4.0.10	8	
eMBMS delivery	4.0.11	5.10	Not applicable
Data collection, reporting and exposure	4.0.12	5.11	6.8
Service URL handling	4.0.13	9, 5.10.7	9

The following clauses introduce these features in terms of network-side components ("5GMS network services") and a UE-side client component referred to variously as the *5GMSd Client* (for downlink media streaming), *5GMSu Client* (for uplink media streaming), or simply *5GMS Client* (in the case of features applicable to either downlink media streaming or uplink media streaming).



## 4.0.2 Content hosting

The content hosting feature is applicable to downlink media streaming only. It provides a service equivalent to a Content Delivery Network (CDN) deployed inside or outside the Trusted DN. High-level procedures for this feature are defined in clause 5.4.

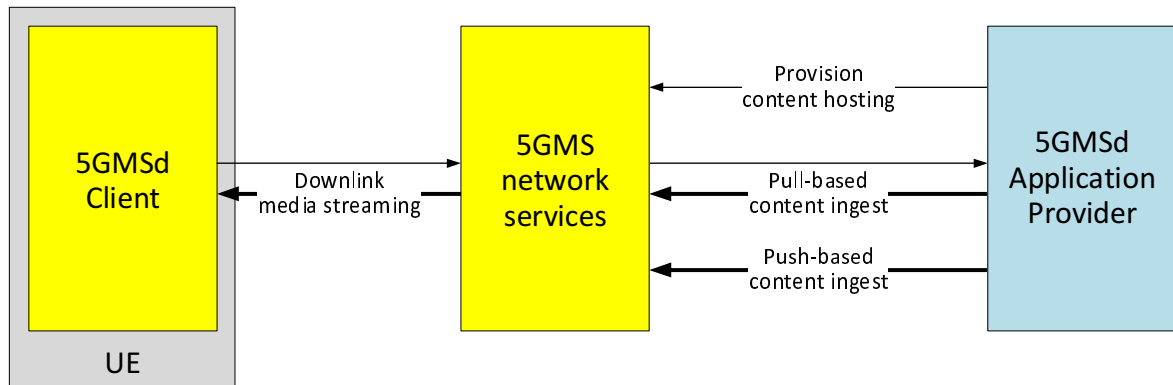

**Figure 4.0.2-1: High-level arrangement for content hosting feature**

When a 5GMSd Application Provider has provisioned the content hosting feature for downlink media streaming:

1. Media content is either retrieved by a network-side component of the 5GMS System from a media origin at the 5GMSd Application Provider (pull-based content ingest) or else it is published to a network-side component of the 5GMS System by the 5GMSd Application Provider (push-based content ingest).
2. The network-side component of the 5GMS System may cache this content for a configurable period of time.
3. Network-side components of the 5GMS System may manipulate the content according to rules provisioned in Content Preparation Templates (see clause 4.0.4).
4. The 5GMSd Client in the UE subsequently retrieves the (possibly manipulated) media content as part of a downlink media streaming session. The security of the content served to the 5GMSd Client by network-side components of the 5GMS System may be guaranteed by a provisioned Server Certificate.

In addition, the use of content hosting by 5GMSd Clients is logged by the 5GMS System and, if suitably provisioned, is exposed by it to subscribing 5GMSd Application Providers in the form of events. This information is equivalent to that contained in CDN access logs (see also clause 4.0.12).

## 4.0.3 Content publishing

The content publication feature is applicable to uplink media streaming only. High-level procedures for this feature are defined in clause 6.2.3.

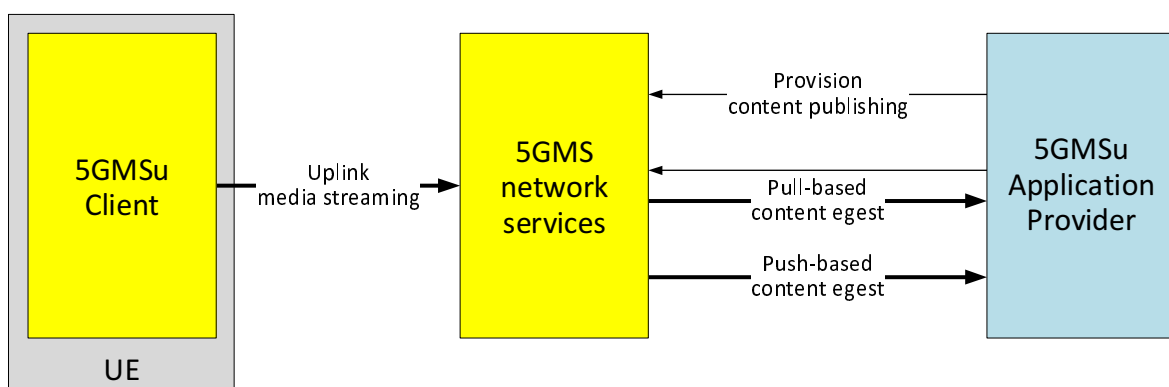

**Figure 4.0.3-1: High-level arrangement for content publishing feature**

When a 5GMSu Application Provider has provisioned the content publishing feature for uplink media streaming:

1. Media content is published by the 5GMSu Client in the UE to a network-side component of the 5GMS System as part of an uplink media streaming session. The security of the content published to the 5GMS System may be guaranteed by a provisioned Server Certificate.
2. The network-side component of the 5GMS System may cache this content for a configurable period of time.
3. Network-side components of the 5GMS System may manipulate the content according to rules provisioned in Content Preparation Templates (see clause 4.0.4).
4. A network-side component of the 5GMS System makes the media content available for retrieval by the 5GMSu Application Provider (pull-based content egest) or publishes it directly to the 5GMSu Application Provider (push-based content egest).

#### 4.0.4 Content preparation

The content preparation feature is applicable to both downlink media streaming (where it is provisioned as part of the content hosting feature introduced in clause 4.0.2) and uplink media streaming (where it is provisioned as part of the content publishing feature introduced in clause 4.0.3). The content preparation feature enables a 5GMS Application Provider to specify content manipulation by network-side components of the 5GMS System according to provisioned Content Preparation Templates.

When a 5GMSd Application Provider has provisioned the content preparation feature for downlink media streaming:

1. Network-side components of the 5GMS System may manipulate ingested media content and may cache the manipulated content prior to serving it to the 5GMSd Client in the UE.

When a 5GMSu Application Provider has provisioned the content preparation feature for uplink media streaming:

1. Network-side components of the 5GMS System may manipulate the media content ingested from the 5GMSu Client in the UE and may cache the manipulated content prior to egesting it to the 5GMSu Application Provider.

## 4.0.5 Network assistance

The network assistance feature is applicable to both downlink media streaming and uplink media streaming. It enables the 5GMS Client in the UE to interrogate or manipulate the network Quality of Service for an ongoing media streaming session.

High-level procedures for this feature are defined in clause 5.9 (downlink media streaming) and in clauses 6.1, 6.5 and 6.7 (uplink media streaming). The network assistance feature is not explicitly provisioned by the 5GMS Application Provider. It is either available for a particular media streaming session or not, depending on system pre-configuration and/or policy.

Two mechanisms for obtaining network assistance are defined in the present document: one based on interactions with the PCF via network-based components of the 5GMS System (*AF-based network assistance*), the other based on ANBR signalling interactions between the UE modem and the RAN (*ANBR-based network assistance*).

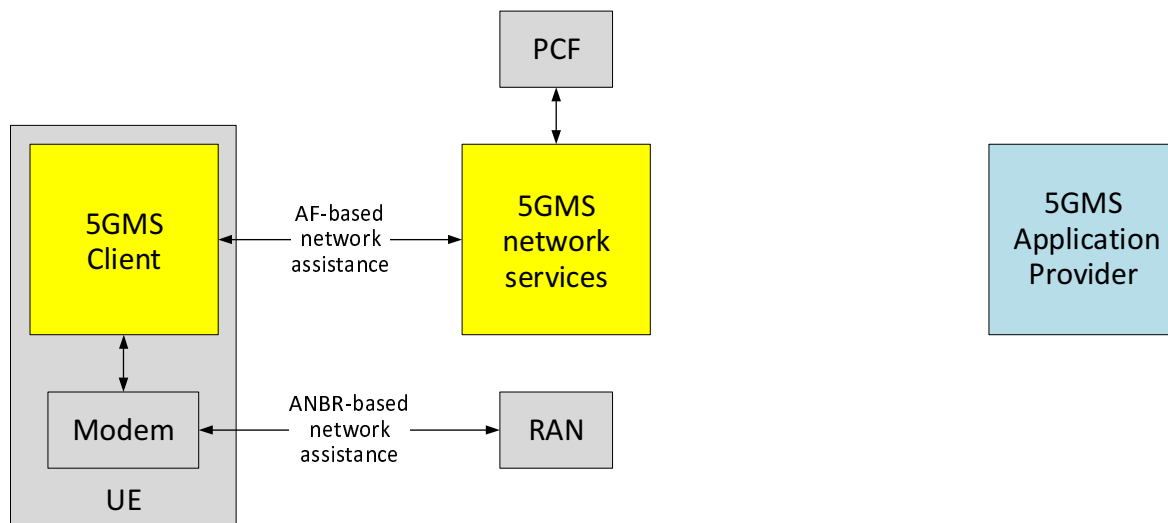

**Figure 4.0.5-1: High-level arrangement for network assistance feature**

The following network assistance sub-features are defined in this release for both the AF-based and ANBR-based mechanisms:

1. *Bit rate recommendation (or throughput estimation)*. The 5GMS Client requests an estimate from a network-side component of the 5GMS System of the bit rate that can currently be offered by a media streaming session. The network-side component interrogates the PCF on behalf of the 5GMS Client to obtain this information about the PDU session corresponding to the media streaming session.

The 5GMS Client uses this information to adjust its own streaming bit rate to fit within the Quality of Service (QoS) envelope that the network is able to offer, for example by switching to a different representation listed in its Media Entry Point, or by adjusting the encoding bit rate for uplink streaming to fit within this bit rate budget. The media streaming Quality of Experience (QoE) is more stable and consistent as a consequence.

2. *Delivery boost*. The 5GMS Client speculatively requests a temporary boost to the bit rate of a media streaming session from a network-side component of the 5GMS System. The network-side component requests a modification to the PDU session corresponding to the media streaming session from the PCF on behalf of the 5GMS Client. If there is sufficient spare network capacity to accommodate the requested bit rate, it is granted by the 5GMS System on a temporary basis.

The 5GMS Client uses this temporary boost to speed up media streaming data transfer, for example to replenish a depleted downlink streaming buffer or to complete a download/upload faster than would otherwise be possible.

In addition, the use of network assistance by 5GMS Clients is logged by the 5GMS System and, if suitably provisioned, is exposed by it to subscribing 5GMS Application Providers in the form of events (see also clause 4.0.12).

### 4.0.6 Dynamic policies

The dynamic policies feature is applicable to both downlink media streaming and uplink media streaming. It enables the 5GMS Client in the UE to manipulate the network traffic handling policies for an ongoing media streaming session.

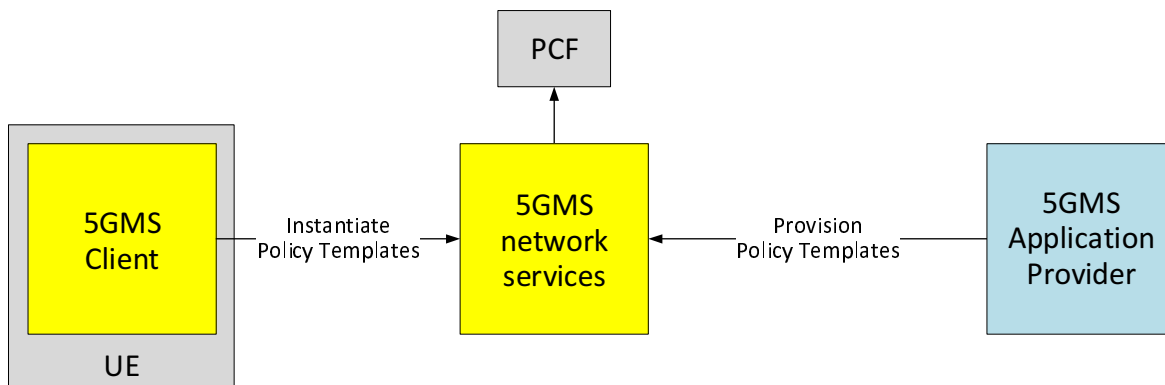

NOTE: The PCF is accessed via the NEF when the 5GMS network services are deployed outside the Trusted DN.

**Figure 4.0.6-1: High-level arrangement for dynamic policies**

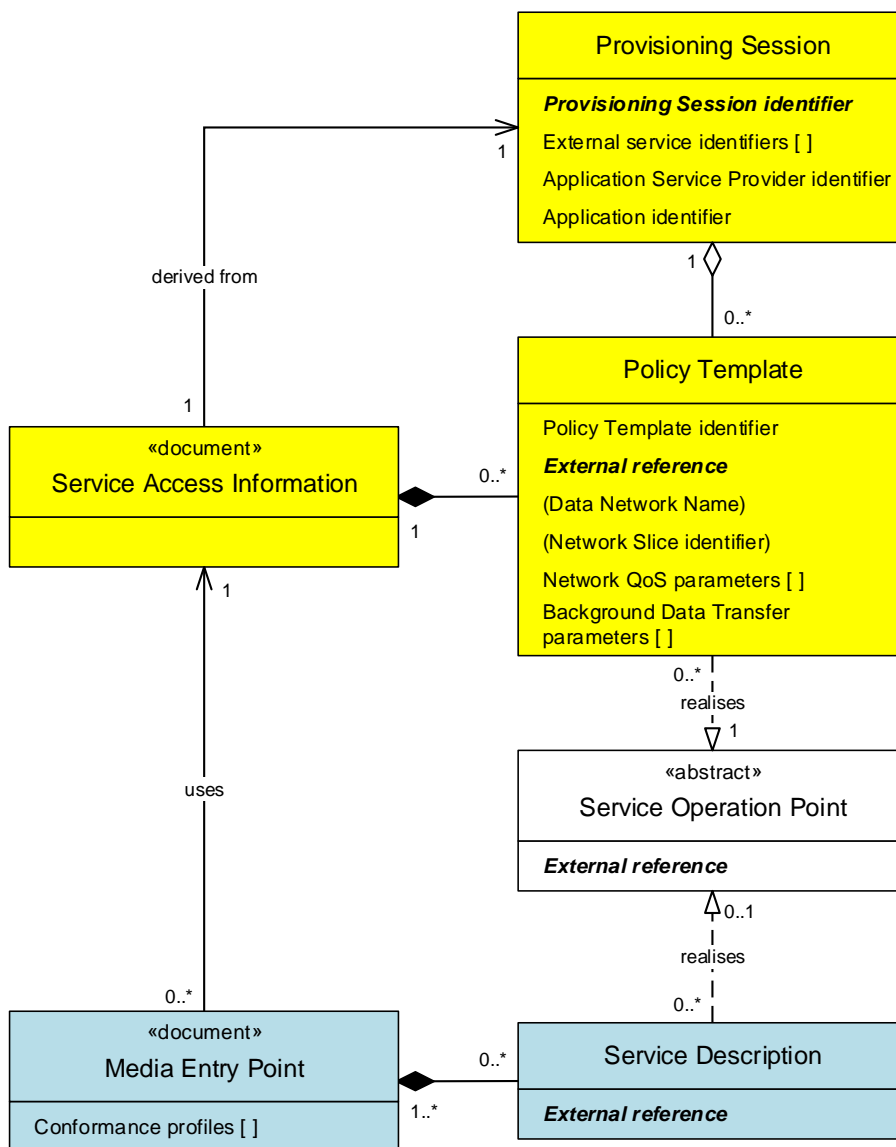

**Figure 4.0.6-2: Domain model for dynamic policies**

With reference to figure 4.0.6-2, dynamic policies work as follows:

1. A conceptual *Service Operation Point* is an abstract set of requirements that support a media streaming service (e.g., SD, HD, UHD). It is identified by an *External reference* that is used to tag *Policy Template* resources provisioned in the 5GMS System and *Service Descriptions* included in *Media Entry Point* documents.
2. The Service Operation Point is embodied in the 5G System by a *Policy Template* which is provisioned in the 5GMS network services by the 5GMS Application Provider within the scope of an umbrella *Provisioning Session*. A Policy Template may be defined as being applicable to a particular Data Network and/or Network Slice. The Policy Template carries the *External reference* and Network QoS parameters corresponding to a single Service Operation Point. (Any number of Policy Templates provisioned for different Data Networks and/or Network Slices may reference the same Service Operation Point.) The 5GMS network services may reject attempts to provision a Policy Template that specifies Network QoS parameters outside acceptable bounds imposed by local system configuration.

In addition, the Policy Template may include a reference to an existing Background Data Transfer policy. If no previously defined Background Data Transfer policy exists, the Policy Template may instead include the parameters that are used by the 5GMS network services to provision a Background Data Transfer policy for the current Provisioning Session. These parameters may include desired time windows when Background Data Transfer may be advertised to 5GMS Clients, a quota representing the maximum number of 5GMS Clients that are permitted to take advantage of Background Data Transfers in each such time window and a quota representing a ceiling for the aggregate volume of data that all 5GMS Clients are permitted to transfer in each Background Data Transfer window. Hence, an advertised time window is not a guarantee that a request for Background Data Transfer will actually be granted by the 5GMS System.

3. The 5GMS Application Provider makes one or more *Media Entry Point* documents (e.g., DASH MPDs) available for use by the 5GMS Client. To take advantage of the dynamic policies feature, a Media Entry Point document includes one or more *Service Descriptions*, each identifying the streaming requirements of a presentation that correspond to a single Service Operation Point (e.g., SD, HD, UHD) and identified by means of an *External reference*. The same Service Description may be included in more than one Media Entry Point document in case a common Service Operation Point is applicable to multiple media presentations.
4. When a Media Entry Point is selected by the 5GMS Client at the start of a media streaming session, the 5GMS Client retrieves Service Access Information from a network-side component of the 5GMS System describing the set of available Policy Templates provisioned in step 2 and exposes this to a controlling application on the UE.
  - 4a. If Background Data Transfer was provisioned as part of any Policy Templates in step 2 above, the Service Access Information includes details of the advertised time windows when Background Data Transfers are available and the data volume quota (if any). Maximum bit rates for the 5GMS Client in either or both the uplink and downlink direction may also be nominated by the 5G System and signalled to the 5GMS Client in the Service Access Information. Finally, an endpoint in the 5GMS network services may be provided allowing the 5GMS Client to subscribe to receive real-time notifications of Background Data Transfer warning notifications.
5. At the start of a media streaming session, the controlling application on the UE selects one of the Service Descriptions listed in the Media Entry Point document that realises its preferred Service Operation Point. Either the Media Player (when the Service Descriptions are within the Media Entry Point document) or the controlling application (when the Service Descriptions are not within the Media Entry Point document) informs the 5GMS Client of its choice by passing the corresponding External reference to it.
6. If there is a Policy Template available for the current media streaming session with the indicated External reference, the 5GMS Client instantiates this Policy Template by interacting with a network-side component of the 5GMS System in order to realise the Service Operation Point described by the Policy Template and the Service Description. The effect of this is that the corresponding network Quality of Service is applied to the media streaming session.
7. At any point during one of the advertised Background Data Transfer time windows the 5GMS Client may request a Background Data Transfer by instantiating a Policy Template with a Background Data Transfer specification in the 5GMS network services, including an estimate of the data volume it intends to transfer. The 5GMS network services may grant the request for the Background Data Transfer if the data volume estimate is acceptable and if the quota of requests for the time window in question has not already been exceeded. If the request is granted, the 5GMS network services apply the appropriate Background Data Transfer Quality of Service policy to the media streaming session from the Policy Template in question. The Background Data Transfer grant returned to the 5GMS Client includes an estimate of the time period for which Background Data Transfer is available for the 5GMS Client to use and an indication of the maximum data volume that it is

permitted to transfer. After this period has expired, the 5GMS network services automatically revert the network Quality of Service back to its state before the grant.

8. The 5GMS media services also subscribe to receive Background Data Transfer warning notifications from the PCF related to the individual Background Data Transfer policy as defined in clause 4.16.7.3 of TS 23 502 [3]. The 5GMS media services shall notify the 5GMS Client when the network performance of that particular media streaming session degrades below the Background Data Transfer policy currently in force or when the aggregate data volume for all data transfers during the current Background Data Transfer time window has been reached.

In addition, the use of dynamic policies by 5GMS Clients is logged by the 5GMS System and, if suitably provisioned, is exposed by it to subscribing 5GMS Application Providers in the form of events (see also clause 4.0.12).

## 4.0.7 Remote control

The remote control feature is applicable to uplink media streaming only. While high-level procedures for integrating this feature into 5G Media Streaming are specified in clause 6.6 of the present document, it is not further defined in this release.

## 4.0.8 Consumption reporting

The consumption reporting feature is applicable to downlink media streaming only in this release. It allows consumption of downlink media streaming to be logged by the 5GMS System and exposed for analysis.

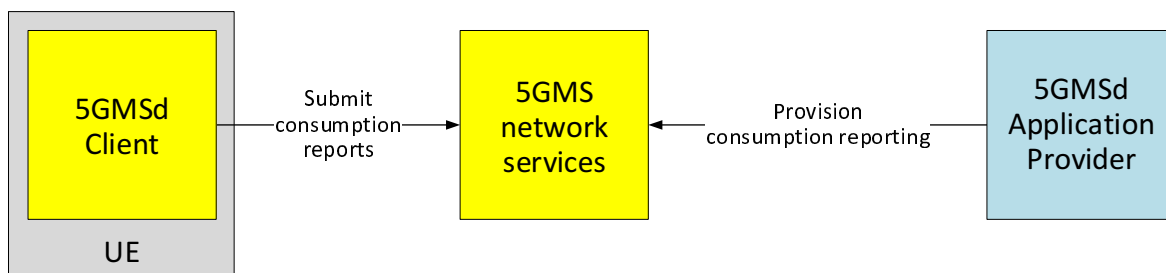

**Figure 4.0.8-1: High-level arrangement for consumption reporting feature**

When a 5GMSd Application Provider has provisioned the consumption reporting feature for downlink media streaming:

1. The 5GMSd Client reports consumption of media that is part of downlink media streaming sessions to a network-side component of the 5GMS System.

In addition, the data contained in consumption reports may be exposed by the 5GMS System in the form of events to subscribing 5GMS Application Providers (see also clause 4.0.12).

## 4.0.9 QoE metrics reporting

The QoE metrics reporting feature is applicable to downlink media streaming only in this release. It allows the Quality of Experience of media streaming sessions to be logged by the 5GMS System and exposed for analysis.

Two mechanisms for reporting downlink QoE metrics are defined in the present document: one that involves reports being sent to the OAM via the RAN (*RAN-based QoE metrics reporting*, see clause 5.5.2), the other involving reports sent to the network-based components of the 5GMS System (*AF-based QoE metrics reporting*, see clause 5.5.3).

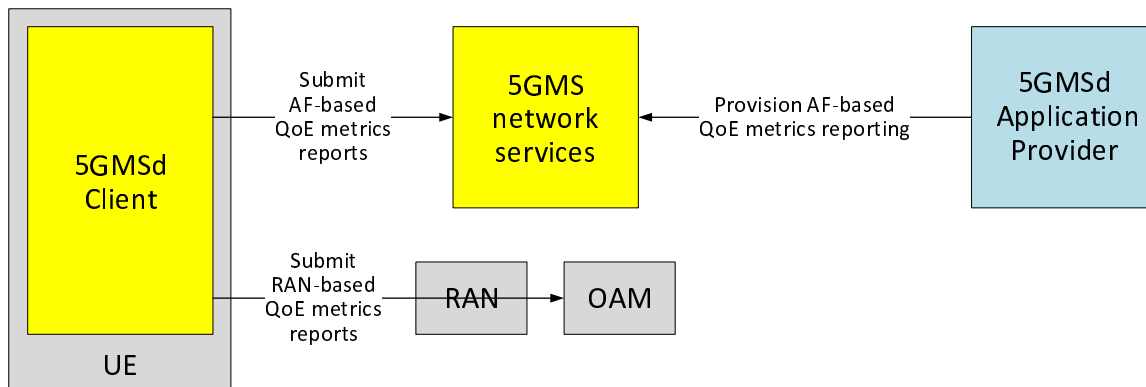

**Figure 4.0.9-1: High-level arrangement for QoE metrics reporting feature**

When a 5GMS Application Provider has provisioned the QoE metrics reporting feature for media streaming:

1. The 5GMS Client reports QoE metrics that it has collected during media streaming sessions to a network-side component of the 5GMS System.

In addition, the data contained in AF-based QoE metrics reports may be exposed by the 5GMS System to subscribing 5GMS Application Providers in the form of events (see also clause 4.0.12).

## 4.0.10 Edge processing

The edge processing feature is applicable to both downlink media streaming and uplink media streaming. It enables the 5GMS Client in the UE to take advantage of edge computing capabilities in the 5GMS System to support media streaming. This feature is defined in clause 4.5 and high-level procedures are defined in clause 8.

## 4.0.11 eMBMS delivery

The eMBMS delivery feature is applicable to downlink media streaming only. It enables the 5GMS System to provision the delivery of downlink media streaming content via eMBMS User Services sessions. This feature is defined in clause 4.6 and high-level procedures are defined in clause 5.10.

## 4.0.12 Data collection, reporting and exposure

The data collection, reporting and exposure feature is applicable to both downlink media streaming and uplink media streaming. It enables the 5GMS System to log data relating to media streaming sessions and to expose this to subscribers in the form of *Events*. This feature is defined in clause 4.7 and high-level procedures are defined in clause 5.11 (for downlink media streaming) and clause 6.8 (for uplink media streaming).

## 4.0.13 Service URL handling

Service URL handling is applicable to downlink and uplink media streaming. This feature is defined in clause 4.10 and high-level procedures are defined in clause 9.

The intent of 3GPP Service URL handling is to launch UE functions based on the execution of a URL. This enables 5G Media Streaming services to be announced within a third-party application, a general web page, a messaging service or shared via social messages using a 3GPP Service URL for 5GMS. When a service is launched using a 3GPP Service

URL for 5GMS, a 5GMS Client function for media session handling is expected to be launched implicitly alongside, for example, a primary media stream handling function.

## 4.1 General service architecture

### 4.1.1 Definition of 5G Media Streaming architecture

The overall 5G Media Streaming Architecture is shown in Figure 4.1.1-1 below.

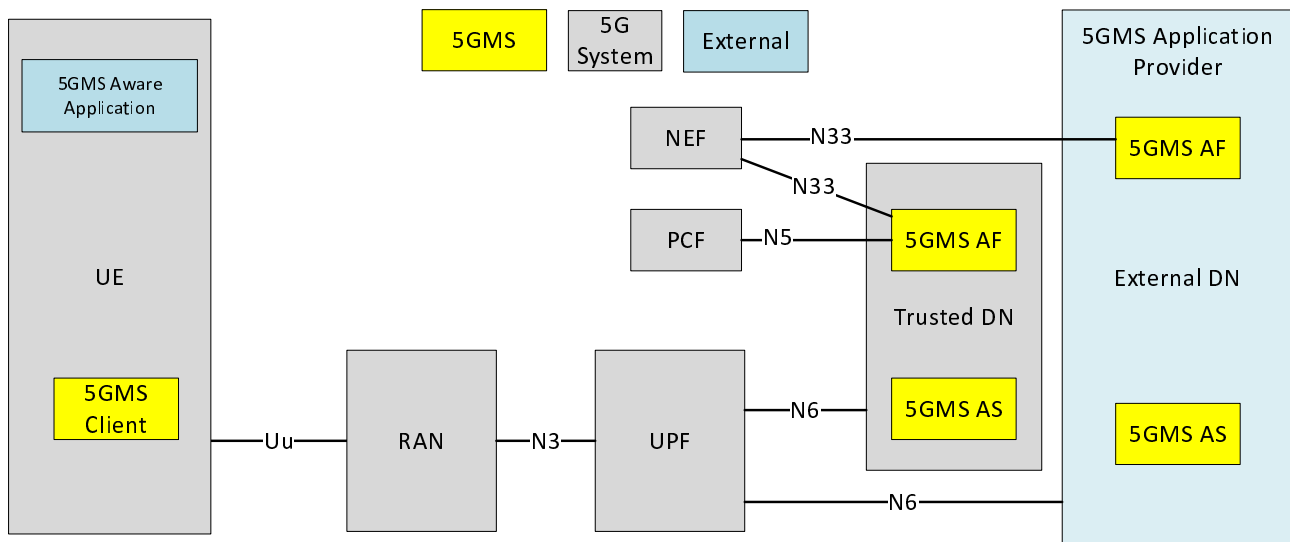

NOTE: The functions indicated by the yellow filled boxes are in scope of stage 3 specifications for 5GMS. The functions indicated by the grey boxes are defined in 5G System specifications. The functions indicated by the blue boxes are neither in scope of 5G Media Streaming nor 5G System specifications.

**Figure 4.1.1-1: 5G Media Streaming within the 5G System**

The 5GMS Application Provider uses 5GMS for streaming services. It provides a 5GMS Aware-Application on the UE to make use of 5GMS Client and network functions using interfaces and APIs defined in 5GMS.

The architecture in Figure 4.1.1-1 represents the specified 5GMS functions within the 5G System (5GS) as defined in TS 23.501 [2]. Three main functions are defined:

- **5GMS AF:** An Application Function as defined in TS 23.501 [2] clause 6.2.10, dedicated to 5G Media Streaming.
- **5GMS AS:** An Application Server dedicated to 5G Media Streaming.
- **5GMS Client:** A UE internal function dedicated to 5G Media Streaming. The 5GMS Client is a logical function and its subfunctions may be distributed within the UE according to implementation choice.

5GMS AF and 5GMS AS are Data Network (DN) functions and communicate with the UE via N6 as defined in TS 23.501 [2].

Functions in trusted DNs, e.g. a 5GMS AF in the Trusted DN, are trusted by the operator's network as illustrated in Figure 4.2.3-5 of TS 23.501 [2]. Therefore, such AFs may directly communicate with the relevant 5G Core functions.

Functions in external DNs, e.g. a 5GMS AF in the External DN, may only communicate with 5G Core functions via the NEF using N33.

The present document specifies the according network architectures for 5GS. The 5GMS architecture may be applied to an EPS although such an application is not specified in the present document and is left to the discretion of deployments and implementations.

The 5G Media Services Architecture maps the overall high-level architecture shown in Figure 4.1-1 above to the general architecture shown in Figure 4.1-2 below.



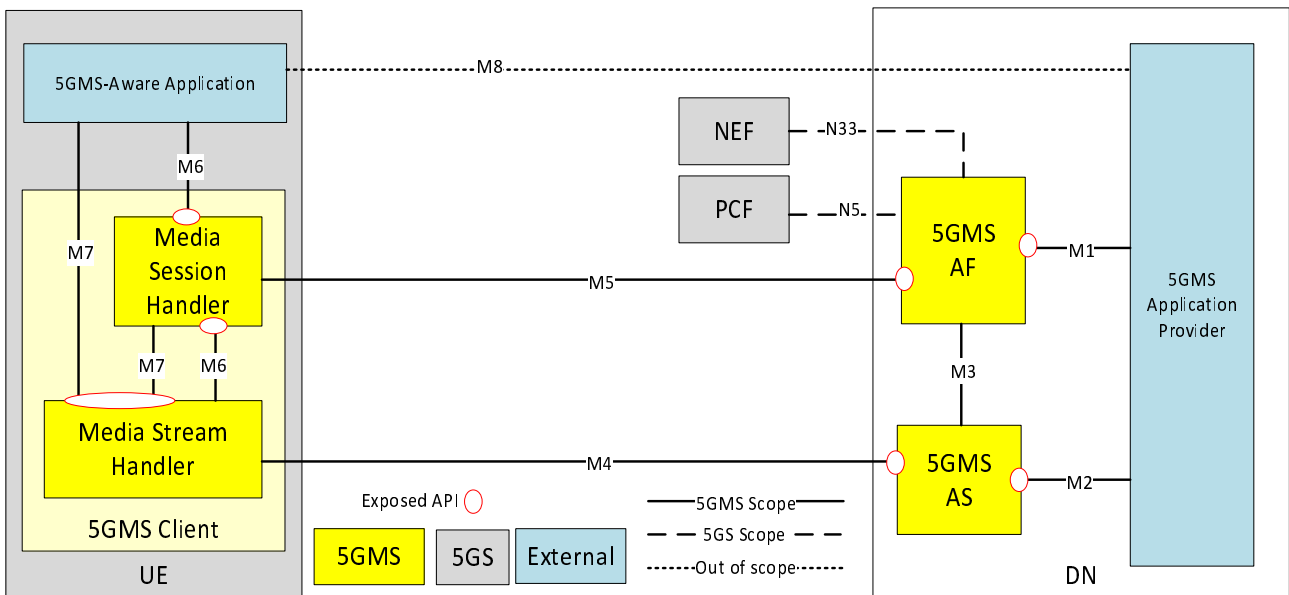

NOTE: The 5GMS Client in the UE is depicted in the form of Media Session Handler and Media Stream Handler constituent functions which expose APIs to one another in the same way that those APIs are exposed to 5GMS-Aware Applications. This UE architecture is not applicable generally; it is just as valid to implement a 5GMS Client that does not expose interfaces M6 and M7 within the 5GMS Client. It is also valid for a 5GMS Client inside a UE to be completely self-contained, such that all functionality typically implemented in the 5GMS-Aware Application is embedded in the UE and thus interfaces M6 and M7 are not exposed at all.

Figure 4.1.1-2: 5G Media Streaming general architecture

The remainder of the present document specifies stage 2 aspects of the media streaming functional entities shown in the general architecture of Figure 4.1.1-2.

This architecture specification addresses two main scenarios as concerns each individual media streaming operation:

- **Downlink streaming:** The network is the origin of the media and the UE acts as the consumption device.
- **Uplink streaming:** The UE is the origin of the media and the network acts as the consumption entity.

The functional entities and interfaces of the media streaming general architecture need to be elaborated with specificities relating to downlink and uplink streaming. For this purpose, corresponding descriptions add the suffix "d" for downlink and "u" for uplink functionality as appropriate in each case.

Clause 4.2 introduces the 5G Unicast Downlink Media Streaming architecture.

Clause 4.3 introduces the 5G Unicast Uplink Media Streaming architecture.

## 4.1.2 Generalized Media Delivery architecture

### 4.1.2.1 Generalized Media Delivery in the 5G System

This clause and subsequent subclauses of clause 4.1.2 define a generalized Media Delivery architecture of which the architecture for 5G Media Streaming (5GMS) defined elsewhere in the present document is one possible realisation. In case of any misalignment between the two, the 5GMS architecture has precedence over this generalised architecture.

Due to the similarity of the 5GMS architecture (as defined in the present document) to the architecture for Real-Time media Communication (RTC) defined in TS 26.506 [32], the RTC functions and 5GMS functions may share or may make use of many common functionalities for both media session handling and media delivery. A generalized Media Delivery architecture that integrates 5GMS and RTC functionality in the 5G System is defined in figure 4.1.2.1-1.

NOTE: Full integration of 5GMS and RTC is not addressed in the present document.

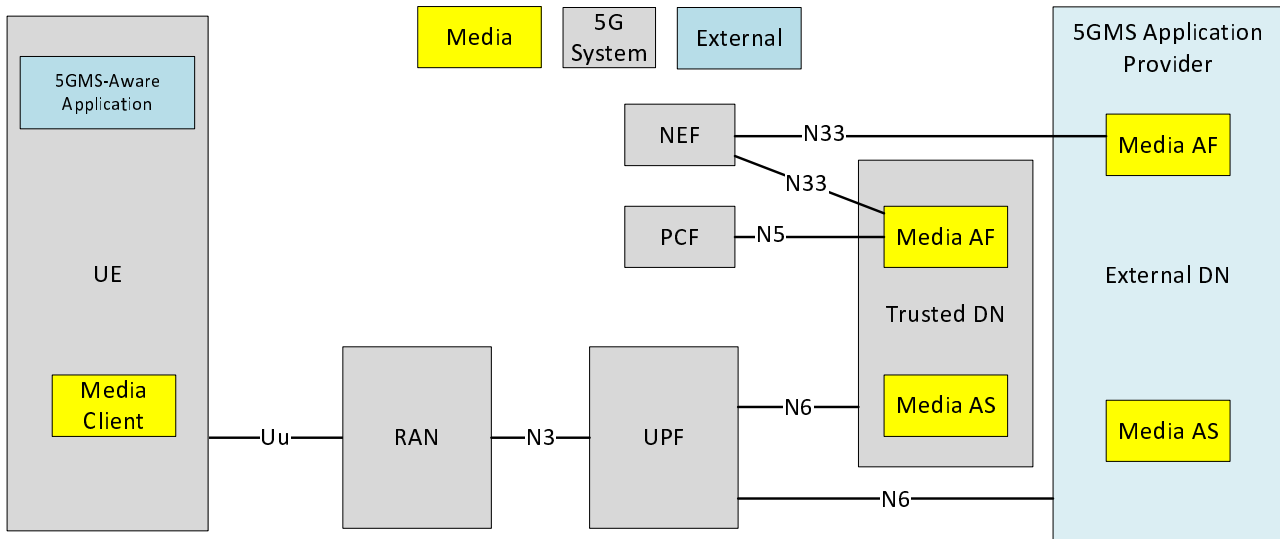

**Figure 4.1.2.1-1: Generalized Media Delivery architecture within the 5G System**

In this representation:

- The *Media Application Provider* plays the role of the 5GMS Application Provider.
- The *Media-aware Application* plays the role of the 5GMS-Aware Application.
- The 5GMS AF is one possible realisation of the general Media AF.
- The 5GMS AS is one possible realisation of the general Media AS.
- The 5GMS Client is part of the general Media Client.

### 4.1.2.2 Reference architecture for Media Delivery

A functional description with additional details as well as reference points is provided below, as illustrated in figure 4.1.2.2-1.

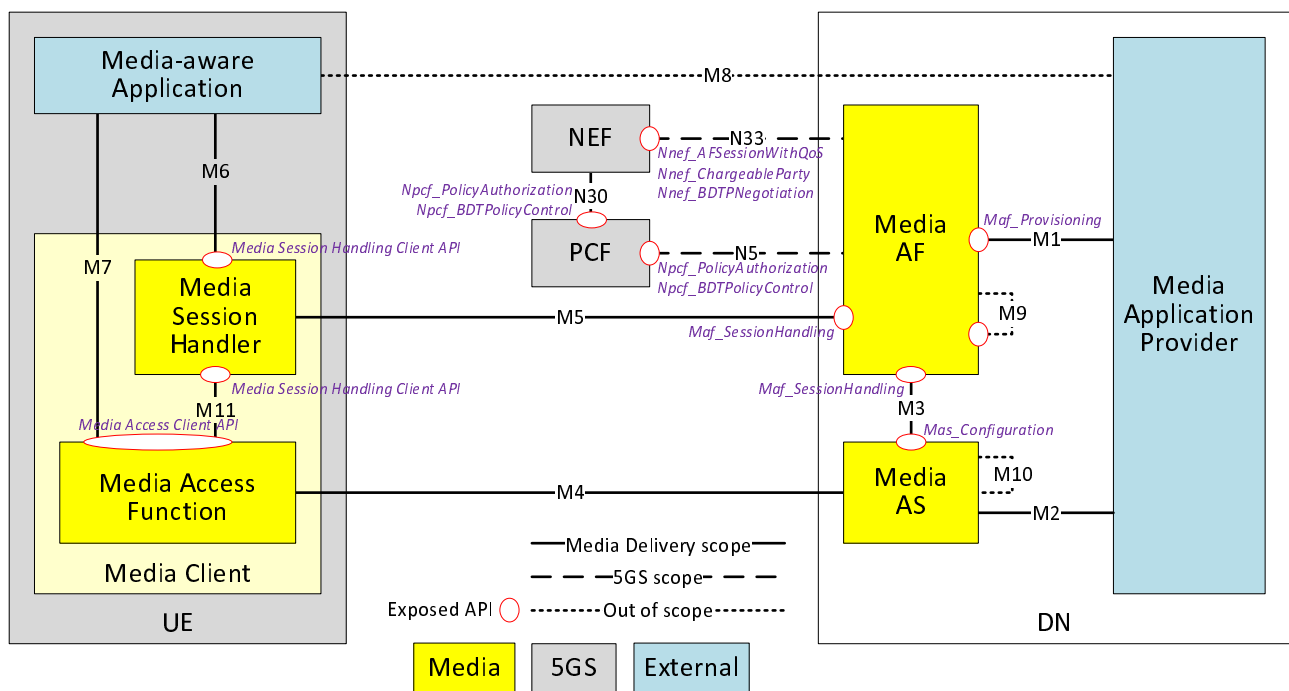

NOTE 1: Exposed APIs are named in *italics*.

NOTE 2: If the Media Client is deployed as a monolithic functional block, it may choose not to expose interfaces externally at reference point M11.

**Figure 4.1.2.2-1: Generalized Media Delivery architecture**

### 4.1.2.3 Network Functions and UE entities

Functional definitions may be generalized as follows:

- **Media AF:** An Application Function as defined in clause 6.2.10 of TS 23.501 [2] dedicated to Media Delivery.
- **Media AS:** An Application Server dedicated to Media Delivery.
- **Media Client:** A UE internal function dedicated to Media Delivery comprising:
  - **Media Session Handler:** An entity on the UE that communicates with the Media AF in order to establish, control and support the delivery of a media session.
  - **Media Access Function:** An entity on the UE that communicates with the Media AS in order to access and deliver media content. The media access function for example may be further sub-divided into content delivery protocols, codecs, media types and metadata representation.
- **Media-aware Application:** An application entity on the UE that makes use of 3GPP-defined APIs to invoke the Media Session Handler and/or the Media Access Function in order to support Media Delivery.

NOTE: An application (e.g., a web browser application) that does not invoke either the Media Session Handler or the Media Access Function using 3GPP-defined APIs is not considered a Media-aware Application and is not mapped into the generalized Media Delivery reference architecture.

**Table 4.1.2.3-1 Mapping of 5GMS functions to generalized Media Delivery architecture**

Generalized media architecture function	5GMSd function	5GMSu function
Media AF	5GMSd AF	5GMSu AF
Media AS	5GMSd AS	5GMSu AS
Media Client	5GMSd Client	5GMSu Client
Media Session Handler	Media Session Handler	
Media Access Function	Media Stream Handler (Media Player)	Media Stream Handler (Media Streamer)
Media Application Provider	5GMSd Application Provider	5GMSu Application Provider
Media-aware Application	5GMSd-Aware Application	5GMSu-Aware Application

#### 4.1.2.4 Reference points

The following reference points are defined for Media Delivery:

- M1:** Reference point between the Media Application Provider and the Media AF for the provisioning of Media Delivery.
- M2:** Reference point between the Media Application Provider and the Media AS for the purposes of ingesting media into the Media AS or egesting media from the Media AS.
- M3:** Reference point between the Media AF and the Media AS for the purposes of Media AS configuration and/or for media session handling in relation to Media Delivery.
- M4:** Reference point between the Media AS and the Media Access Function in the UE for the purpose of downlink transport of media from the Media AS to the Media Access Function ("content distribution") or uplink transport of media from the Media Access Function to the Media AS ("content contribution").
- M5:** Reference point between the Media AF and the Media Session Handler in the Media Client for the purpose of media session handling in relation to Media Delivery.
- M6:** Reference point between the Media-aware Application and the Media Session Handler for the purpose of configuring the Media Session Handler.
- M7:** Reference point between the Media-aware Application and the Media Access Function for the purpose of media access control.
- M8:** Reference point between the Media-aware Application and the Media Application Provider.

NOTE 1: Reference point M8 is private and therefore beyond the scope of standardisation.

- M9:** Reference point between one instance of the Media AF and another for the purpose of Media AF instance chaining.

NOTE 2: Reference point M9 is not defined by the 5GMS architecture.

- M10:** Reference point between one instance of the Media AS and another for the purpose of peer-to-peer media transport between different Media Clients.

NOTE 3: Reference point M10 is not defined by the 5GMS architecture.

- M11:** Reference point between the Media Session Handler and the Media Access Function (both in the Media Client) for the purpose of configuring the Media Session Handler and/or media access control.

Table 4.1.2.4-1 Mapping of 5GMS reference points to generalized Media Delivery architecture

Generalized Media Delivery architecture reference point	5GMSd reference point	5GMSu reference point
M1	M1d	M1u
M2	M2d	M2u
M3	M3d	M3u
M4	M4d	M4u
M5	M5d	M5u
M6	M6d	M6u
M7	M7d	M7u
M8	M8d	M8u
M9	Not defined	Not defined
M10	Not defined	Not defined
M11	M6d, M7d	M6u, M7u

## 4.1.2.5 Interfaces and APIs

### 4.1.2.5.1 Interfaces and APIs supporting media session handling

The Media AF exposes the following network service interfaces for media session handling:

- *Provisioning API (Maf\_Provisioning)*: External API, exposed to the Media Application Provider by the Media AF at reference point M1 to provision the usage of the Media Delivery and to obtain feedback.
- *Media Session Handling API (Maf\_SessionHandling)* exposed by a Media AF to the Media Session Handler at reference point M5 and/or to the Media AS at reference point M3 for media session handling, control, reporting and assistance that also include appropriate security mechanisms, e.g. authorization and authentication.

The Media Session Handler exposes the following UE APIs for media session handling:

- *Media Session Handling Client API*: exposed by the Media Session Handler to the Media-aware Application at reference point M6 and to the Media Access Function at reference point M11, for configuring media session handling, including service launch.

### 4.1.2.5.2 Interfaces and APIs supporting media transport

The Media AS exposes the following network service interfaces to support media transport:

- *Media Application Server Configuration API (Mas\_Configuration)* used by the Media AF at reference point M3 to configure the Media AS.

The Media AS exposes the following media transport interfaces:

- *Application Provider media transport interface* between the Media AS and the Media Application Provider, used to exchange media data using a media transport protocol at reference point M2.
- *Client-facing media transport interface* between the Media Access Function and the Media AS, used to exchange media data using a media transport protocol at reference point M4.

The Media Access Client exposes the following UE APIs for media access control:

- *Media Access Control API* exposed by the Media Access Function to the Media-aware Application at reference point M7 and to the Media Session Handler at reference point M11, in order to configure and communicate with the Media Access Function.

### 4.1.2.5.3 Interfaces and APIs supporting application functionality

The Media Application Provider exposes the following network service interfaces to support application functionality:

- *Application-private API* used for information exchange between the Media-aware Application and the Media Application Provider at reference point M8.

## 4.2 5G unicast downlink Media Streaming architecture

### 4.2.1 Standalone – Non-Roaming

The 5GMSd Application Provider uses 5GMSd functions for downlink streaming services. It provides a 5GMSd-Aware Application on the UE the ability to make use of 5GMSd Client and network functions using 5GMSd interfaces and APIs.

The architecture in Figure 4.2.1-1 below represents the specified 5GMSd functions within the 5G System (5GS) as defined in TS 23.501 [2]. Three main functions are defined:

- **5GMSd AF:** An Application Function similar to that defined in TS 23.501 [2] clause 6.2.10, dedicated to 5G Downlink Media Streaming.
- **5GMSd AS:** An Application Server dedicated to 5G Downlink Media Streaming.

NOTE 0: When a 5GMSd AS ingests content directly from a 5GMSu AS, the 5GMSd AS plays the role of a 5GMSu Application Provider. For more details of this scenario, see clause A.15.3.

- **5GMSd Client:** A UE internal function dedicated to 5G Downlink Media Streaming. The 5GMSd Client is a logical function and its subfunctions may be distributed within the UE according to implementation choice.

5GMSd AF and 5GMSd AS are Data Network (DN) functions and communicate with the UE via the User Plane Function (UPF) using the N6 reference point as defined in TS 23.501 [2].

Functions in trusted DNs are trusted by the operator's network as illustrated in Figure 4.2.3-5 of TS 23.501 [2]. Therefore, AFs in trusted DNs may directly communicate with relevant 5G Core functions.

Functions in external DNs, i.e. 5GMSd AFs in external DNs, may only communicate with 5G Core functions via the NEF using N33.

NOTE 1: The 5GMS architecture may be applied to an EPS although such an application is not specified in the present document and is left to the discretion of deployments and implementations.

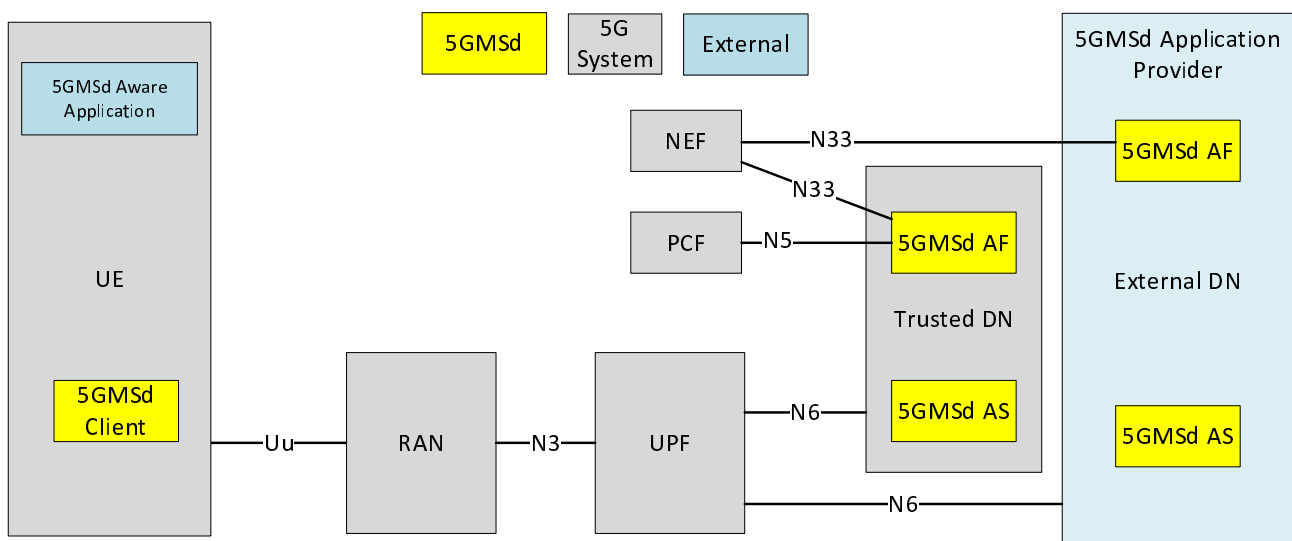

Figure 4.2.1-1: Downlink 5G Media Streaming within 5G System



session to be established. The 5GMSd-Aware Application is not defined within the 5G Media Streaming specifications, but the function makes use of 5GMSd Client and network functions using 5GMSd interfaces and APIs.

- **5GMSd AS:** An Application Server which hosts 5G media functions. Note that there may be different realizations of the 5GMSd AS, including the distribution of 5GMSd AS functionality between different physical hosts, for example in a Content Delivery Network (CDN).

The 5GMSd AS in this release supports the following features:

i. **Content Hosting**, including:

- Ingesting media content from a 5GMSd Application Provider at reference point M2d.
- Caching media content to reduce the need to ingest the same content repeatedly at reference point M2d.
- A generic framework for content preparation.
- Geographic restrictions on content access by the Media Player at reference point M4d ("geofencing").
- Domain Name aliasing at reference point M4d.
- Support for server certificates at reference point M4d.
- URL path rewriting at reference point M4d.
- URL signing at reference point M4d.

NOTE 6a: The features of the 5GMSd AS cater primarily for media streaming content. However, many of these features may also be used to support the delivery of other types of content, for example web content.

- **5GMSd Application Provider:** External application or content-specific media functionality, e.g., media creation, encoding and formatting that uses 5GMSd interfaces to stream media to 5GMSd-Aware Applications.
- **5GMSd AF:** An Application Function that provides various control functions to the Media Session Handler on the UE and/or to the 5GMSd Application Provider. It may relay or initiate a request for different Policy or Charging Function (PCF) treatment or interact with other network functions via the NEF.

NOTE 7: There may be multiple 5GMSd AFs present in a deployment and residing within the Data Network, each exposing one or more APIs.

The following interfaces are defined for 5G Downlink Media Streaming:

- M1d (5GMSd Provisioning API): External API, exposed by the 5GMSd AF which enables the 5GMSd Application Provider to provision the usage of the 5G Media Streaming System for downlink media streaming and to obtain feedback.
- M2d (5GMSd Ingest API): Optional External API exposed by the 5GMSd AS used when the 5GMSd AS in the trusted DN is selected to host content for the streaming service.
- M3d: Internal API used by a 5GMSd AF to configure and manage a 5GMSd AS instance.
- M4d (Media Streaming APIs): APIs exposed by a 5GMSd AS to the Media Player to stream media content in real time or download media content in non-real time.
- M5d (Media Session Handling API): APIs exposed by a 5GMSd AF to the Media Session Handler for media session handling, control, reporting and assistance that also include appropriate security mechanisms, e.g. authorization and authentication.
- M6d (UE Media Session Handling APIs): APIs exposed by a Media Session Handler to the Media Player for client-internal communication, and exposed to the 5GMSd-Aware Application enabling it to make use of 5GMS functions. This API may be supported by a 3GPP-defined Service URL (see clause 4.10).
- M7d (UE Media Player APIs): APIs exposed by a Media Player to the 5GMSd-Aware Application and Media Session Handler to make use of the Media Player.



- M8d: (Application API): application interface used for information exchange between the 5GMSd-Aware Application and the 5GMSd Application Provider, for example to provide Service Access Information to the 5GMSd-Aware Application. This API is external to the 5G System and not specified by 5GMS.

NOTE 8: Non-Standalone, Roaming, Non-3GPP Access and EPC-5GC interworking aspects are FFS.

The following subfunctions are identified as a part of a more detailed breakdown of the 5GMSd AS for stage 3 specifications:

- Adaptive Bit Rate (ABR) Encoder, Encryption and Encapsulator.
- Manifest (e.g. MPD) Generator and Segment (e.g. DASH) Packager.
- Origin Server.
- CDN Server (e.g. Edge Servers).
- DRM Server (e.g. DRM License Server).
- Service Directory.
- Content Guide Server.
- Replacement content server (e.g. Ad content server).
- Manifest Proxy, i.e. MPD modification server.
- App Server.
- Session Management Server.

A breakdown of 5GMSd functions in the UE is provided in clause 4.2.2 below.

## 4.2.2 5GMSd UE functions

The UE may include many detailed subfunctions that can be used individually or controlled individually by the 5GMSd-Aware Application. This clause breaks down several relevant identified subfunctions for which stage 3 specification is available.

NOTE: This UE architecture is logical; the realization of reference points M6 and M7 inside the logical 5GMS Client is subject to implementation choice.

The 5GMSd-Aware Application itself may include many functions that are not provided by the 5GMSd Client or by the 5G UE. Examples include service and content discovery, notifications and social network integration. The 5GMSd-Aware Application may also include functions that are equivalent to ones provided by the 5GMSd Client and may only use a subset of the 5GMSd client functions. The 5GMSd-Aware Application may act based on user input or may for example also receive remote control commands from the 5GMSd Application Provider through M8d.

With respect to Media Player functions, Figure 4.2.2-1 below shows more detailed functional components of a UE for media player functions to access the 5GMSd AS.

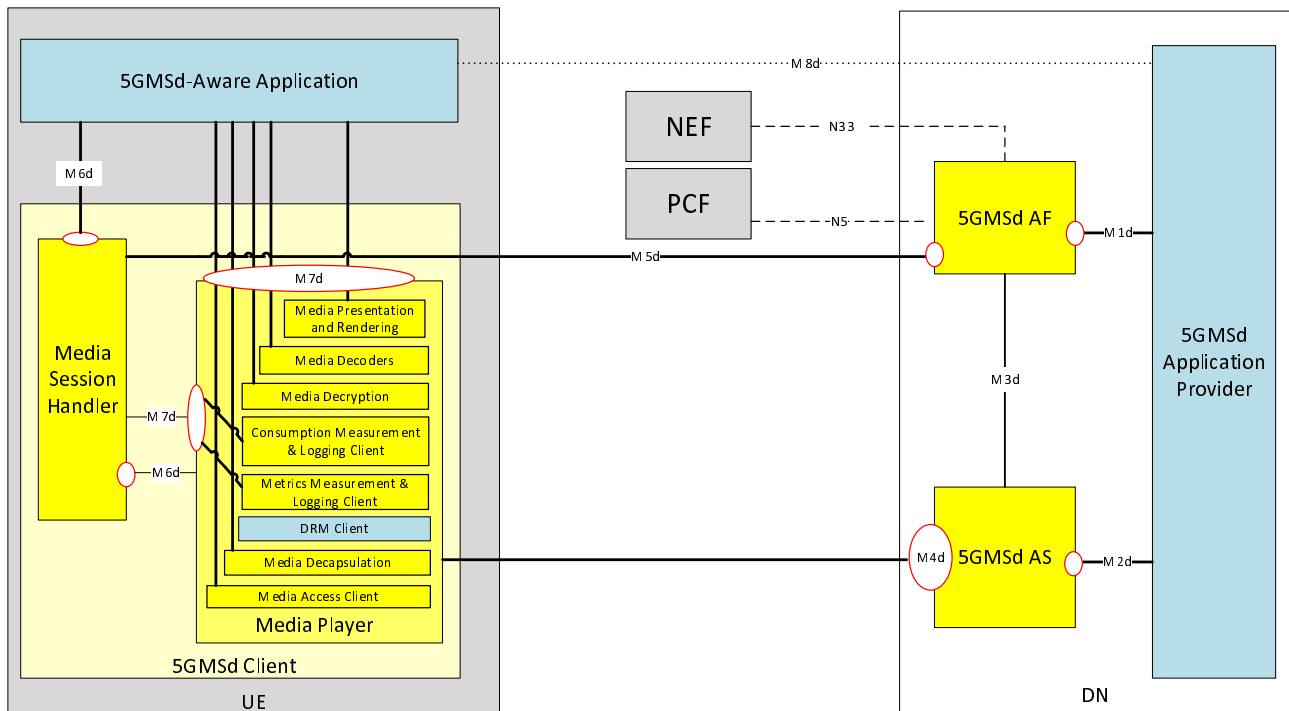
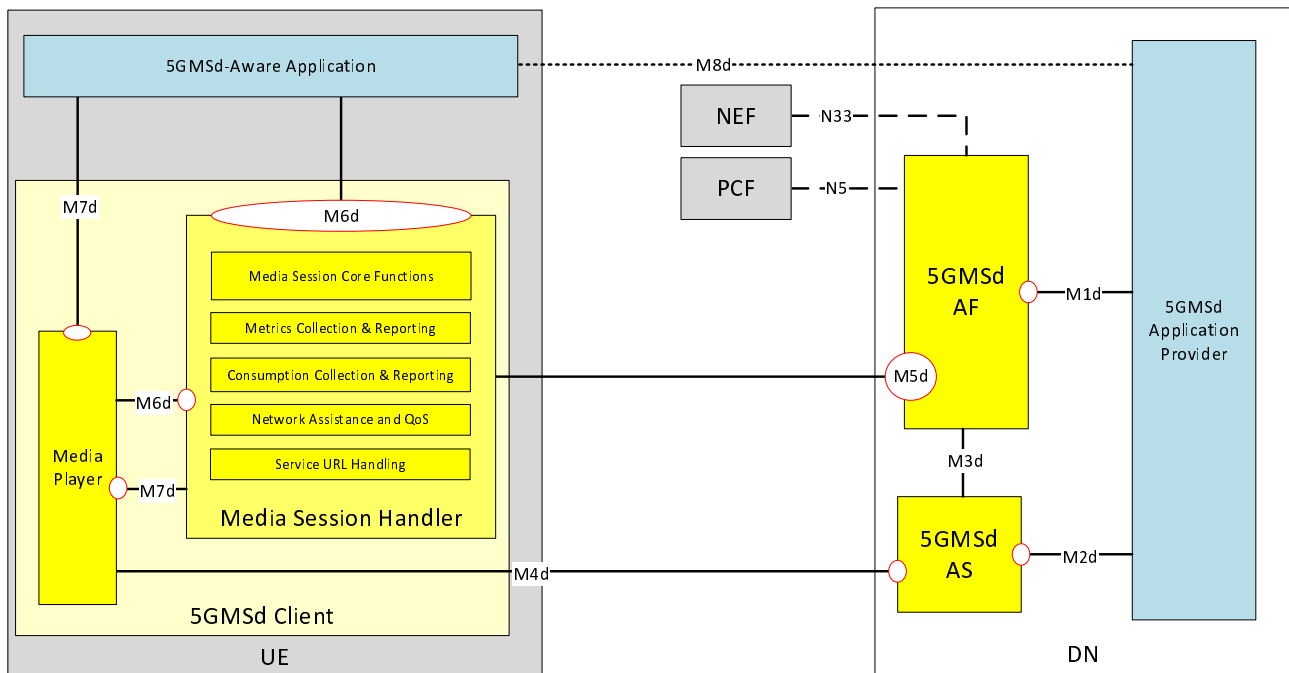

**Figure 4.2.2-1: Downlink 5G Media Streaming UE functions (Media Player centric)**

The following subfunctions are identified as part of a more detailed breakdown of the Media Player function:

- **Media Access Client:** Accesses media content, such as DASH-formatted media segments, for immediate or delayed consumption.
- **Media Decapsulation:** Extracts the elementary media streams for decoding and provides media system related functions such as time synchronization, capability signalling, accessibility signalling, etc.
- **Consumption Measurement and Logging Client:** Performs the measurement and logging of content consumption-related information in accordance with the Consumption Reporting Configuration part of provisioning data, supplied by the 5GMSd Application Provider to the 5GMSd AF, and forwarded by the 5GMSd AF to the Media Player via the Media Session Handler.
- **Metrics Measurement and Logging Client:** Performs the measurement and logging of QoE metrics in accordance with the Metrics Reporting Configuration part of provisioning data, supplied by the 5GMSd Application Provider to the 5GMSd AF, and forwarded by the 5GMSd AF to the Media Player via the Media Session Handler.
- **DRM Client (optional):** When present, the DRM client might or might not be a part of the Media Player. It provides a content protection mechanism with its unique key management and key delivery system, authentication/authorization, policy enforcement and entitlement check. The DRM Client is not defined within 5G Media Streaming specifications.
- **Media Decryption (optional):** When present, media decryption is responsible to decrypt the media samples using the keys provided in the DRM license, and further passing to the Media Decoder to enable playback of encrypted media. The media decryption and media decoding could be implemented on a general-purpose processor in software or hardware or, for a more secure and robust architecture, the decryption, decoding and rendering could be implemented on the hardware of secure processors.
- **Media Decoder:** Decodes the media, such as audio or video.
- **Media Presentation and Rendering:** Presents the media using an appropriate output device and enables possible interaction with the media.

With respect to the Media Session Handler, Figure 4.2.2-2 below shows more detailed functional components of a UE to access the 5GMSd AF.



**Figure 4.2.2-2: Downlink 5G Media Streaming UE functions (control-centric)**

NOTE 1: The yellow colour indicates here that the 3GPP has created specifications for the function.

NOTE 2: A UE is a logical device which may correspond to the tethering of multiple physical devices or other types of realizations.

The following subfunctions are identified as part of a more detailed breakdown of Media Session Handler:

- **Core Functions:** Realization of a "session" concept for media communications, optionally spanning multiple stateless sessions. May optionally interact with network-based 5GMSd AFs.
- **Metrics Collection and Reporting:** executes the collection of QoE metrics measurement logs from the Media Player and sending of metrics reports to the 5GMSd AF for the purpose of metrics analysis or to enable potential transport optimizations by the network.
- **Consumption Collection and Reporting:** executes the collection of content consumption measurement logs from the Media Player and sending of consumption reports to a 5GMSd AF about the currently consumed media within the available presentation, about the UE capabilities and about the environment of the media session for potential transport optimizations by the network or consumption report analysis.
- **Dynamic Policy:** involves interacting with the 5GMSd AF to instantiate Policy Templates that change the network Quality of Service for a media streaming session. Policy Templates may be selected based on interactions with the Media Player.
- **Network Assistance:** downlink streaming delivery assisting functions provided by the network to the 5GMSd Client and Media Player in the form of bit rate recommendation (or throughput estimation) and/or delivery boost. Network Assistance functionality may be supported by 5GMSd AF or ANBR-based RAN signalling mechanisms. This function also includes the logging of ANBR-based Network Assistance invocations and their reporting via reference point R2, as defined in clause 4.7.1.
- **Service URL Handling:** a UE function that handles 3GPP Service URLs (see clause 4.10) to support the launch of 5GMSd services and associated functions in the UE and in the network.

NOTE 2a: While this function may not be exclusive to 5GMS, this specification only defines Service URL handling for 5GMS.

NOTE 3: Based on such a decomposition, additional interfaces and APIs may exist in inside the UE:

- Media control interface(s) to configure and interact with the different UE media functions.
- Media control interface for media session management.
- Control interface for collection of logged QoE metrics measurements.
- Control interface for collection of logged content consumption measurements.
- Decoded media samples are handed over to the media renderer.
- Decrypted, compressed media samples are handed over to a trusted media decoder.
- In the case of encryption, the encrypted, compressed media samples are handed over to the DRM Client.

NOTE 4: Non-Standalone, Roaming, Non-3GPP Access and EPC-5GC interworking aspects are FFS.

### 4.2.3 Service Access Information for downlink media streaming

The Service Access Information is the set of parameters and addresses which are needed by the 5GMSd Client to activate and control the reception of a downlink streaming session, and to report service/content consumption and/or QoE metrics.

The Service Access Information may be provided together with other service announcement information using M8d. Alternatively, the 5GMSd Client fetches the Service Access Information from the 5GMSd AF. The Service Access Information may be provided as, or may be accessed via, a 3GPP-defined Service URL that provides a unique resolvable identifier to the 5GMSd Provisioning Session and that may also include a reference to the Media Player Entry. Regardless of how it is provided, the Service Access Information contains different information, depending on the collaboration model between the 5GMS System and the 5GMSd Application Provider, and also depending on offered features. Baseline parameters are listed in Table 4.2.3-1 below:

**Table 4.2.3-1: Parameters of baseline Service Access Information**

Parameters	Description
Provisioning Session identifier	Unique identification of the M1d Provisioning Session.

When the content hosting feature is activated for a downlink streaming session, the parameters from Table 4.2.3-1a below can additionally be present.

**Table 4.2.3-1a: Streaming Access parameters**

Parameters	Description
Media Player Entries	<p>A set of pointers to documents that each define an equivalent media presentation (see NOTE), e.g. MPD for DASH content or URL to a video clip file.</p> <p>Each member of the set may specify additional details to aid selection by the 5GMS Client, including content type, profile indicators and precedence.</p> <p>A Media Player Entry document may additionally include Service Descriptions, each one identified by an <i>External reference</i> that enables it to be matched with a Policy Template, and each describing the set of media streaming parameters (e.g., bit rate, target latency) that realise a Service Operation Point.</p> <p>A Media Player Entry URL may be embedded in a 3GPP Service URL.</p>
NOTE:	An equivalent media presentation is one which has the same content but may result in a different Quality of Experience.

When the consumption reporting feature is activated for a downlink streaming session, the parameters from Table 4.2.3-2 below are additionally present.

**Table 4.2.3-2: Parameters for consumption reporting configuration**

Parameters	Description
Reporting interval	Identifies the interval between consumption reports being sent by the Media Session Handler.
Server address	A list of 5GMSd AF addresses where the consumption reports are sent by the Media Session Handler.
Sample percentage	The proportion of clients that shall report media consumption. If not specified, all clients shall send reports.
Location reporting	Identify whether the Media Session Handler provides location data to the 5GMSd AF (in case of MNO or trusted third parties)

When the dynamic policy invocation feature is activated for a downlink streaming session the parameters from Table 4.2.3-3 below are additionally present.

**Table 4.2.3-3: Parameters for dynamic policy invocation configuration**

Parameters	Description
Server address	A list of 5GMSd AF addresses (in the form of opaque URLs) which offer the APIs for dynamic policy invocation sent by the 5GMS Media Session Handler.
Valid Policy Template Ids	A list of Policy Template identifiers which the 5GMSd Client is authorized to use.
Service Data Flow Methods	A list of recommended Service Data Flow description methods (descriptors), e.g. 5-Tuple, ToS, 2-Tuple, etc, which should be used by the Media Session Handler to describe the Service Data Flows for the traffic to be policed.
External reference	Additional identifier for this Policy Template, unique within the scope of its Provisioning Session, that can be cross-referenced with external metadata about the streaming session.

When the metrics collection and reporting feature is activated for a downlink streaming session, one or more parameter sets for metrics configuration, according to Table 4.2.3-4, are additionally present. Each metrics configuration set contains specific settings valid for that configuration, which is typically metric scheme dependent, and collection and reporting shall be done separately for each set.

**Table 4.2.3-4: Parameters for each metrics configuration set**

Parameters	Description
Scheme	The scheme associated with this metrics configuration set. A scheme may be associated with 3GPP or with a non-3GPP entity. If not specified, a default 3GPP metrics scheme shall apply. Metrics schemes shall be uniquely identified by URIs.
Server address	A list of 5GMSd AF addresses to which metric reports shall be sent for this metrics configuration set.
DNN	The Data Network Name (DNN) which shall be used when sending metrics report for this metrics configuration set. If not specified, the default DNN shall be used.
Slice scope	A list of network slice(s) for which metrics collection and reporting shall be executed for this metrics configuration set. If not specified, the metrics collection and reporting shall be done for all network slices.
Reporting interval	The sending interval between metrics reports for this metrics configuration set. If not specified, a single final report shall be sent after the streaming session has ended.
Sample percentage	The proportion of streaming sessions that shall report metrics for this metrics configuration set. If not specified, reports shall be sent for all sessions.
Streaming source filter	A list of content URL patterns for which metrics reporting shall be done for this metrics configuration set. If not specified, reporting shall be done for all URLs.
Metrics	A list of metrics which shall be collected and reported for this metrics configuration set. For progressive download and DASH streaming services, the listed metrics are associated with the 3GPP metrics scheme and shall correspond to one or more of the metrics as specified in clauses 10.3 and 10.4, respectively, of TS 26.247 [7]. In addition, for the 3GPP metrics scheme as applied to DASH streaming, the quality reporting scheme and quality reporting protocol as defined in clauses 10.5 and 10.6, respectively, of [7] shall be used. If not specified, a complete (or default if applicable) set of metrics will be collected and reported.

When 5GMSd AF-based Network Assistance is activated for a downlink streaming session the parameters from Table 4.2.3-5 below shall be additionally present.

**Table 4.2.3-5: Parameters for 5GMSd AF-based Network Assistance configuration**

Parameters	Description
Server address	5GMSd AF address that offers the APIs for 5GMSd AF-based Network Assistance, accessed by the 5GMSd Media Session Handler. The server address shall be an opaque URL, following the 5GMS URL format.

## 4.3 Uplink 5G Media Streaming architecture

### 4.3.1 Media architecture

The 5GMSu Application Provider uses 5GMSu functions for uplink streaming services. It provides a 5GMSu-Aware Application on the UE the ability to make use of 5GMSu Client and network functions using 5GMSu interfaces and APIs.

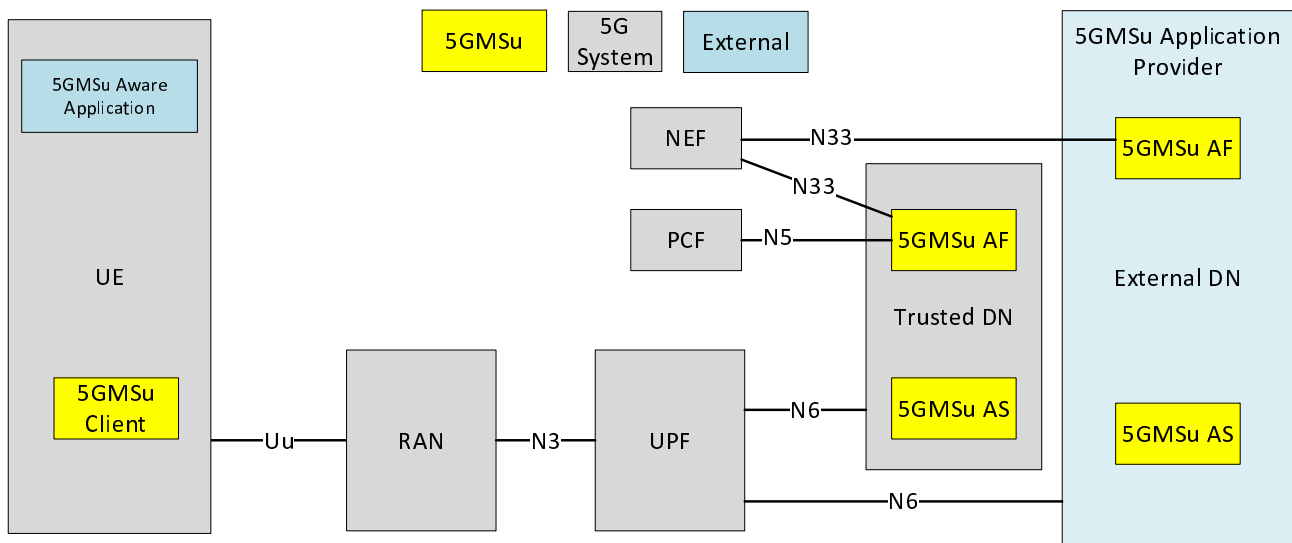

**Figure 4.3.1-1: Media architecture for unicast uplink media streaming**

NOTE 1: The functions indicated by the yellow filled boxes are in scope of stage 3 specifications for 5GMS. The functions indicated by the grey boxes are defined in 5G System specifications. The functions indicated by the blue boxes are neither in scope of 5G Media Streaming nor 5G System specifications.

The architecture in Figure 4.3.1-1 above represents the specified 5GMSu functions within the 5G System (5GS) as defined in TS 23.501 [2]. Three main functions are defined:

- **5GMSu AF:** An Application Function similar to that defined in TS 23.501 [2] clause 6.2.10, dedicated to 5G Uplink Media Streaming.
- **5GMSu AS:** An Application Server dedicated to 5G Uplink Media Streaming.

NOTE 2: When a 5GMSd AS ingests content directly from a 5GMSu AS, the 5GMSu AS plays the role of a 5GMSd Application Provider. For more details of this scenario, see clause A.15.3.

- **5GMSu Client:** A UE-internal function dedicated to 5G Uplink Media Streaming.

5GMSu AF and 5GMSu AS are Data Network (DN) functions and communicate with the UE via N6 as defined in TS 23.501 [2].

Functions in trusted DNs, e.g., a 5GMSu AF in the Trusted DN, are trusted by the operator's network as illustrated in Figure 4.2.3-5 of TS 23.501 [2]. Therefore, such AFs may directly communicate with relevant 5G Core functions.

Functions in external DNs, e.g., a 5GMSu AF in the External DN, may only communicate with 5G Core functions via the NEF using N33.

The architecture in Figure 4.3.1-2 below represents the media architecture connecting UE internal functions and related network functions for 5G Uplink Media Streaming.

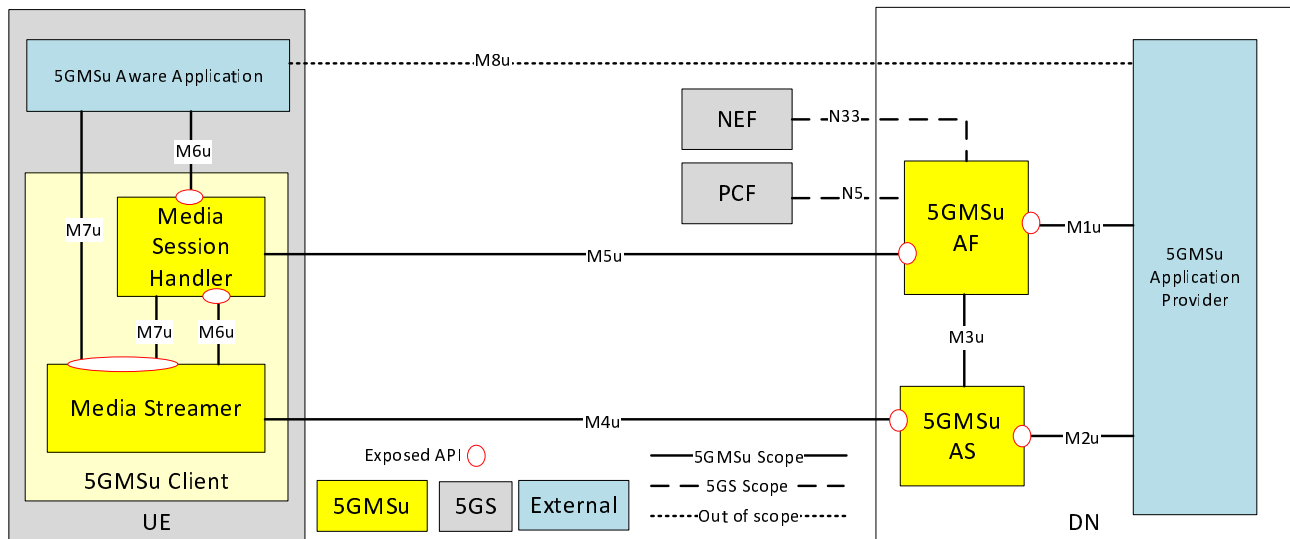

**Figure 4.3.1-2: Media architecture for unicast uplink media streaming**

NOTE 2: The functions indicated by the yellow filled boxes are in scope of stage 3 for 5GMSu. The functions indicated by the grey boxes are defined in 5GS. The interfaces indicated by solid lines are in scope of stage 3 for 5GMSu. The interfaces indicated by dashed lines are defined in 5GS. The interfaces indicated by dotted lines are neither in scope of 5GS nor 5GMSu, but are considered as part of informative call flows.

NOTE 3: Red ovals indicate API provider functions.

NOTE 4: The 5GMSu AF may also interact with the NEF for NEF-enabled API access. However, within Release 16, the NEF is only used by the 5GMSu AF to interact with the Policy and Charging Function (PCF) in 5GMS specifications.

NOTE 5: Some information might also be exchanged between 5GMSu entities and the OAM, although the OAM is not explicitly shown in the architecture.

The following functions are defined:

- 5G Media Streaming Client for uplink (**5GMSu Client**) on UE: Originator of 5GMSu service that may be accessed through well-defined interfaces/APIs. The UE may also be implemented in a self-contained manner such that interfaces M6u and M7u are not exposed at all.
- The 5GMSu Client contains two subfunctions:
  - **Media Session Handler:** A function on the UE that communicates with the 5GMSu AF in order to establish, control and support the delivery of a media session, and that may perform QoE metrics reporting. The Media Session Handler exposes APIs that can be used by the 5GMSu-Aware Application. The Media Session Handler may be launched by a 3GPP-defined Service URL (see clause 4.10).
  - **Media Streamer:** A function on the UE that communicates with the 5GMSu AS in order to perform real-time or non-real-time uplink streaming of media content and provides a service to both the 5GMSu-Aware Application for media capturing and uplink streaming and the Media Session Handler for media session control.
- **5GMSu-Aware Application:** The 5GMSu Client is typically controlled by an external media application, e.g. an App, which implements external application or content service provider specific logic and enables a media session to be established. The 5GMSu-Aware Application is not defined within the 5G Media Streaming specifications, but the function makes use of 5GMSu Client and network functions using 5GMSu interfaces and APIs.

- **5GMSu AS:** An Application Server which hosts 5G media functions. Note that there may be different realizations of a 5GMSu AS, for example a Content Delivery Network (CDN) server.
- **5GMSu Application Provider:** External application or content-specific media functionality, e.g., media storage, consumption, transcoding and redistribution that uses 5GMSu interfaces to receive streaming media from 5GMSu Aware Applications.
- **5GMSu AF:** An Application Function that provides various control functions to the Media Session Handler on the UE and/or to the 5GMSu Application Provider. It may relay or initiate a request for different Policy or Charging Function (PCF) treatment or interact with other network functions via the NEF.

NOTE 6: There may be multiple 5GMSu AFs present in a deployment and residing within the Data, each exposing one or more APIs.

The following interfaces are defined for 5G Uplink Media Streaming:

- M1u (5GMSu Provisioning API): External API, exposed by the 5GMSu AF and which enables the 5GMSu Application Provider to provision the usage of the 5G Media Streaming system for uplink media streaming and to obtain feedback.
- M2u (5GMSu Publish API): Optional External API exposed by the 5GMSu AS used when the 5GMSu AS in the trusted DN is selected to receive the content for the streaming service.
- M3u: Internal API used by a 5GMSu AF to configure and manage a 5GMSu AS instance.
- M4u (Uplink Media Streaming APIs): APIs exposed by a 5GMSu AS to the Media Streamer to stream media content.
- M5u (Media Session Handling API): APIs exposed by a 5GMSu AF to the Media Session Handler for media session handling, control and assistance that also include appropriate security mechanisms e.g. authorization and authentication, and QoE metrics reporting.
- M6u (UE Media Session Handling APIs): APIs that may be exposed by a Media Session Handler to the Media Streamer for client-internal communication, and to the 5GMSu-Aware Application to make use of 5GMSu functions. This API may be supported by a 3GPP-defined Service URL (see clause 4.10).
- M7u (UE Media Streamer APIs): APIs that may be exposed by a Media Streamer to the 5GMSu-Aware Application and Media Session Handler to make use of the Media Streamer, including configuration of QoE metrics to be measured and logged, and the collection of metrics measurement logs.
- M8u: (Application API): application interface used for information exchange between the 5GMSu-Aware Application and the 5GMSu Application Provider, for example to provide Service Access Information to the 5GMSu-Aware Application. This API is external and not specified in the 5GMS architecture.

NOTE 7: Non-Standalone, Roaming, Non-3GPP Access and EPC-5GC interworking aspects are FFS.

### 4.3.2 UE 5GMSu functions

The UE may include many detailed subfunctions that can be used individually or controlled individually by the 5GMSu-Aware Application. This clause breaks down several relevant identified subfunctions for which stage 3 specification is available.

The 5GMSu-Aware Application itself may include many functions that are not provided by the 5GMSu Client or to the 5G UE. Examples include peripheral discovery, notifications and social network integration. The 5GMSu-Aware Application may also include functions that are equivalent to ones provided by the 5GMSu Client and may only use a subset of the 5GMSu Client functions.



With respect to the Media Streamer and Media Handler functions, Figure 4.3.2-1 shows more detailed functional components of a 5GMSu Client.

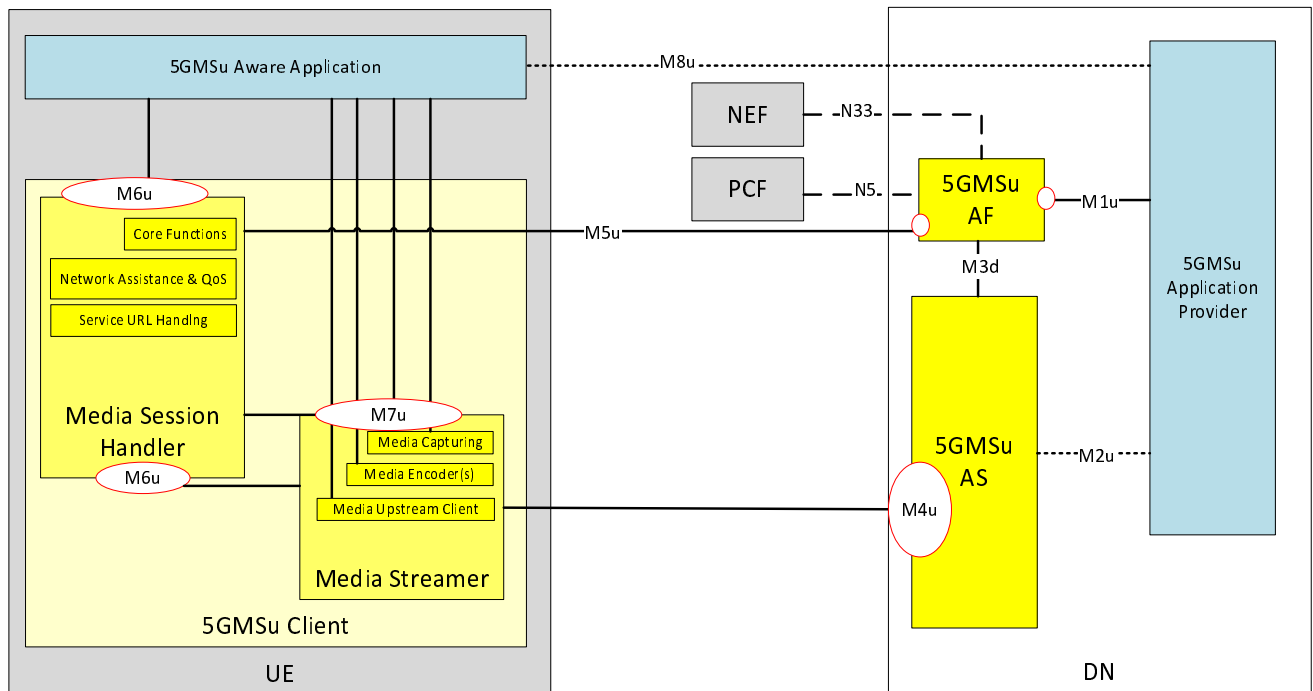

**Figure 4.3.2-1: Uplink 5G Media Streaming UE functions**

NOTE 1: A UE is a logical device which may correspond to the tethering of multiple physical devices or other types of realizations.

The following subfunctions are identified as part of a more detailed breakdown of the UE 5G Uplink Media Streaming functions:

- **5GMSu-Aware Application:** application which is out of scope of the present specification and which uses the UE 5G Uplink Media Streaming functions and APIs.
- **Media Capturing:** Devices such as video cameras or microphones that transform an analogue media signal into digital media data.
- **Media Encoder(s):** Compresses the media data.
- **Media Upstream Client:** encapsulates encoded media data and pushes it upstream to the 5GMSu AS in real time or non-real time.
- **Network Assistance:** uplink streaming delivery assisting functions provided by the network to the 5GMSu Client and Media Streamer in the form of bit rate recommendation (or throughput estimation) and/or delivery boost. Network Assistance functionality may be supported by 5GMSu AF or ANBR-based RAN signalling mechanisms.
- **Dynamic Policy:** involves interacting with the 5GMSu AF to instantiate Policy Templates that change the network Quality of Service for an uplink media streaming session. Policy Templates may be selected based on interactions with the Media Streamer.
- **Core Functions:** configures the 5GMSu AS for uplink streaming reception.
- **Service URL Handling:** a UE function that handles 3GPP Service URLs (see clause 4.10) to support the launch of 5GMSu services and associated functions in the UE and in the network.

NOTE 2: While this function may not be exclusive to 5GMS, the present document only defines Service URL handling for 5GMS.

Here are the roles of the different APIs of the UE 5G Uplink Media Streaming functions:

- M6u: API used to control the Core Functions and the Media Remote Control function.
- M7u: API used to configure, activate and stop the Media Capturing, Media Encoding(s) and Media Upstream Client functions, and also to support metrics configuration and collection functionality.

### 4.3.3 Service Access Information for uplink media streaming

The Service Access Information is the set of parameters and addresses which are needed by the 5GMSu Client to activate and control the uplink streaming session.

The Service Access Information may be provided by the 5GMSu Application Provider to the 5GMSu-Aware Application together with other service announcement information using M8u. Alternatively, the 5GMSu Client fetches the Service Access Information from the 5GMSu AF at reference point M5u. Regardless of how it is provided, the Service Access Information contains different information, depending on the collaboration model between the 5GMS System and the 5GMSu Application Provider (which are assumed to be independent entities), and also depending on offered features. The Service Access Information may be provided as, or may be accessed via, a 3GPP-defined Service URL that provides a unique resolvable identifier to the 5GMSu media session and that may also include a reference to the Media Entry Point.

Baseline parameters are listed in table 4.3.3-1 below:

**Table 4.3.3-1: Parameters of baseline Service Access Information**

Parameters	Description
Provisioning Session identifier	Unique identification of the M1u Provisioning Session.

The parameters from table 4.3.3-2 below shall also be present.

**Table 4.3.3-2: Streaming Access parameters**

Parameters	Description
Media Streamer Entries	<p>A set of entry points. Each entry point consists of one of the following:</p> <ol style="list-style-type: none"> <li>A URL endpoint on the 5GMSu AS to which media can be streamed directly at M4u and its associated data, or</li> <li>The URL of a document that can be downloaded from the 5GMSu AS which contains the parameters for uplink media streaming at M4u.</li> </ol> <p>A Media Streamer Entry document may additionally include Service Descriptions, each one identified by an <i>External reference</i> that enables it to be matched with a Policy Template, and each describing the set of media streaming parameters (e.g., bit rate, target latency) that realise a Service Operation Point.</p> <p>A Media Streamer Entry URL may be embedded in a 3GPP Service URL.</p>

Each entry point is defined by its parameters and identifiers. The set shall have at least one member.

When the dynamic policy invocation feature is activated for an uplink streaming session the parameters from table 4.3.3-3 below are additionally present.

**Table 4.3.3-3: Parameters for dynamic policy invocation configuration**

Parameters	Description
Server address	A list of 5GMSu AF addresses (in the form of opaque URLs) which offer the APIs for dynamic policy invocation sent by the 5GMS Media Session Handler.
Valid Policy Template Ids	A list of Policy Template identifiers which the 5GMSu Client is authorized to use.
Service Data Flow Methods	A list of recommended Service Data Flow description methods (descriptors), e.g. 5-Tuple, ToS, 2-Tuple, etc, which should be used by the Media Session Handler to describe the Service Data Flows for the traffic to be policed.
External reference	Additional identifier for this Policy Template, unique within the scope of its Provisioning Session, that can be cross-referenced with external metadata about the streaming session.

When 5GMSu AF-based Network Assistance is activated for an uplink streaming session the parameters from table 4.3.3-4 below shall be additionally present.

**Table 4.3.3-4: Parameters for 5GMSu AF-based Network Assistance configuration**

Parameters	Description
Server address	5GMSu AF address that offers the APIs for 5GMSu AF-based Network Assistance, accessed by the 5GMSu Media Session Handler. The server address shall be an opaque URL, following the 5GMS URL format.

## 4.4 Network Slicing for Downlink Media Streaming

The 5GMS architecture offers the option to create a Content Hosting Configuration for external 5GMSd AS(s) through a provisioning interface, as described in clause 5.4. A Content Hosting Configuration is a 5GMS-optimized configuration that is tailored to a third-party content or service provider to leverage the capabilities of the 5G System to achieve optimized delivery of media content.

Upon successful setup of a Content Hosting Configuration, the 5GMSd AF uses the NSaaS to create or use an existing corresponding network slice, and assigns the Content Hosting Configuration domain as the network slice selection assistance information rule. This allows any traffic to and from the Content Hosting Configuration domain to be mapped to the correct network slice instance.

The concept of Network Slice as a Service (NSaaS) is defined in TS 28.530 [10]. NSaaS can be offered by an MNO to third-party providers in the form of a service. This service allows the providers to use the network slice instance as the end user and to manage the network slice instance via a management interface exposed by the MNO. In turn, these providers offer their own services, e.g. OTT service, on top of the network slice instance obtained from the MNO.

The NSaaS offered by the MNO can be characterized by certain properties (capabilities to satisfy service level requirements), e.g.

- radio access technology,
- bandwidth,
- end-to-end latency,
- reliability,
- mobility,
- density,
- guaranteed / non-guaranteed QoS,
- security level, etc.

The interface that is used for the creation and management of network slices is defined in TS 28.531 [11] and the information elements are defined in TS 28.541 [12].

The network (HPLMN) may provision the UE with Network Slice Selection Policy (NSSP) as part of the UE Route Selection Policy rules as described in TS 23.503 [4]. This ensures that the UE will request a particular network slice when establishing the PDU session. Note that this mapping can also be established through associating an Application with the Content Hosting Configuration and the network slice, which in turn will be associated with a PDU session that includes the Content Hosting Configuration domain as a matching domain.

Once the PDU session is established using the network slice instance that corresponds to the Content Hosting Configuration, the media distribution to the UE may start. The network slice instance may be provisioned to support processing and edge computing in addition to the appropriate QoS allocation. The 5GMSd AF is responsible for ensuring appropriate traffic routing, e.g. request the routing of traffic to a local access to a Data Network (identified by a DNAI) that hosts the media processing compute instances.

## 4.5 5G Media Streaming architecture extensions for Edge Computing

### 4.5.1 Introduction

This clause defines an architecture that enables a 5GMS Application Provider to provision resources in the Edge DN for an application through the M1 interface by configuring an *edge processing resource template*.

Media processing in the edge may be achieved in one of two different ways at the application layer:

1. *Client-driven management.* 5GMS-Aware Applications that are aware of the edge processing can directly request an edge resource and discover the EAS that is best suited to serve the application.
2. *AF-driven management.* The 5GMS AF automatically allocates edge resources for new media streaming sessions on behalf of the application using information in the 5GMS Provisioning Session.

An Edge-enabled 5GMS Client as defined in this clause leverages the SA6 Edge Computing capabilities defined in TS 23.558 [16]. Other realizations are possible, but are outside the scope of the present document.

### 4.5.2 5G Media Streaming combined with Edge Computing

The 5GMS architecture is extended to add support for media processing in the edge. The extended architecture is an integration of the 5GMS architecture defined in the present document with the architecture for enabling Edge Applications defined in TS 23.558 [16], and the Edge Computing management architecture defined in TS 28.538 [17]. The extended architecture is depicted in figure 8.2-1.

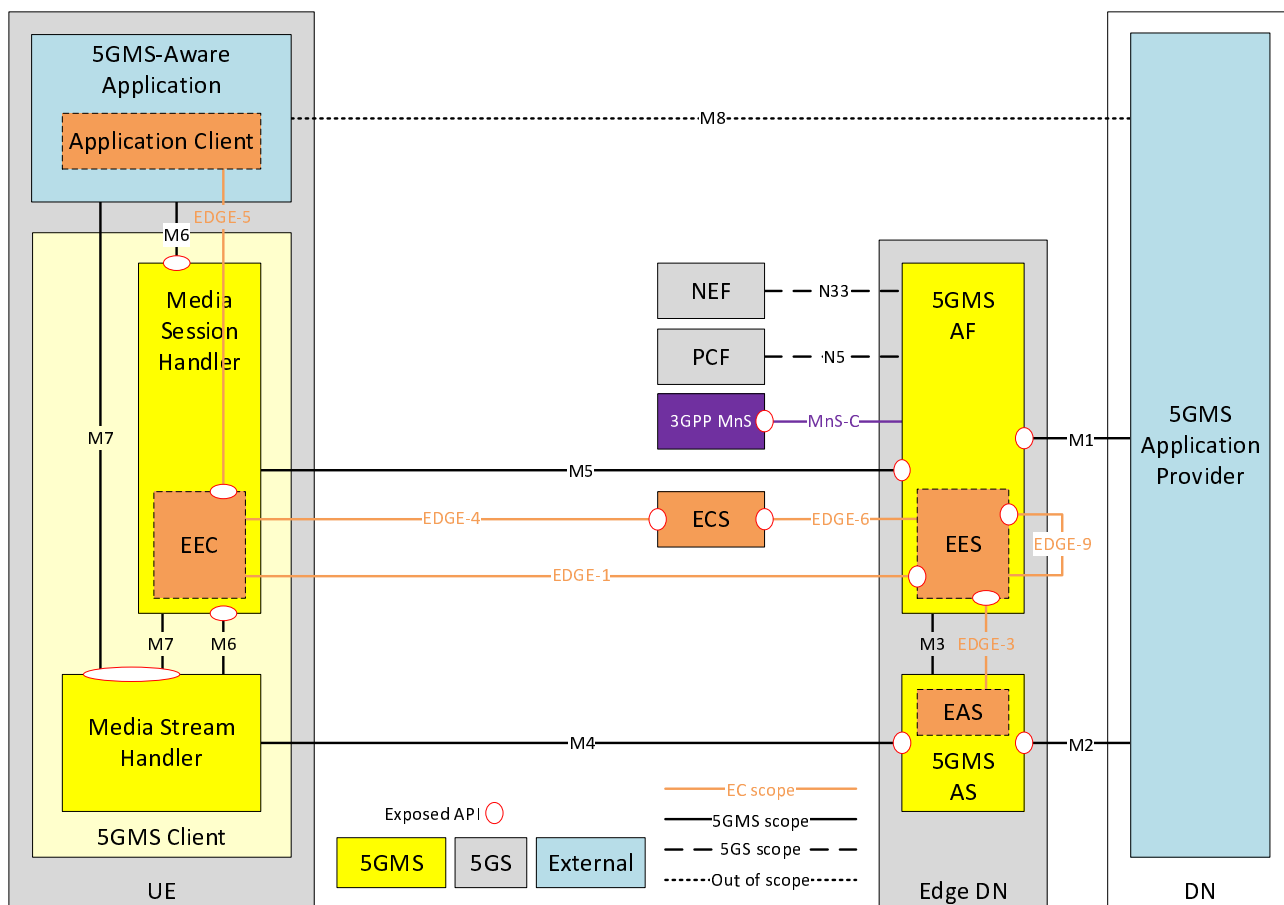

Figure 4.5.2-1: Reference edge-enabled 5GMS media architecture

Based on the extended architecture, the following assumptions shall apply:

1. A 5GMS AF that is edge-enabled shall support EES functionality including:
  - EDGE-1 API for supporting registration and provisioning of EEC functions, and discovery by them of EAS instances.
  - EDGE-3 API towards the EAS function of 5GMS AS instances.
  - EDGE-6 API for registering with an ECS function.
  - EDGE-9 API for media session relocation.
2. A 5GMS AF that is edge-enabled shall be capable of determining (using information in the 5GMS Provisioning Session) whether a media streaming session meets the eligibility criteria for using edge resources.
3. A 5GMS AF that is edge-enabled may perform compute resource allocation using the MnS-C interface.
4. A 5GMS AS that is edge-enabled shall support EAS functionality including the EDGE-3 API for registration with the EES.
5. A Media Session Handler that is edge-enabled should support EEC functionality including:
  - Invoking the EES function using the EDGE-1 API.
  - Invoking the ECS function using the EDGE-4 API.
  - EDGE-5 API exposed to the Application Client.
6. A Media Session Handler that is edge-enabled shall be capable of determining (using 5GMS Service Access Information) whether a media streaming session meets the eligibility criteria for requesting edge resources.
7. A 5GMS-Aware Application that is edge-enabled shall support Application Client functionality and should invoke the ECS function using the EDGE-5 API.

The extended 5GMS architecture supports both client-driven as well as AF-driven management of the edge processing session.

The 5GMS Application Provider may request the deployment of edge resources as part of the Provisioning Session.

- In the client-driven approach, the 5GMS-Aware Application and/or the Media Session Handler cover and locate a suitable 5GMS AS instance in the Edge DN. is aware of the support of edge processing in the network and takes steps, such as using the EDGE-5 APIs, to discover and locate a suitable 5GMS AS instance in the Edge DN.
- In the AF-driven approach, the 5GMS Application Provider configures the 5GMS AF to automatically deploy edge processing for the media sessions of the corresponding Provisioning Session based on the provisioned edge processing resource template. The 5GMS-Aware Application may not be aware of the edge deployment and the EAS is discovered through other means, such as DNS resolution with support from the EASDF as specified in [15].

### 4.5.3 Provisioning and Service Information

The provisioning step allows a 5GMS Application Provider to configure information about its edge processing requirements for media streaming sessions.

The following information shall be configurable by the 5GMS Application Provider over reference point M1:

- Condition for activation of edge processing, e.g. the traffic descriptors, application identifier, geographic location of the UE, etc.
- Selection of client-driven or AF-driven management.
- EAS profile information for each EAS that will serve the application, such as the service KPIs, geographical location, and service continuity support. The EAS profile is defined in clause 8.2.4 of TS 23.558 [16].

- Application context relocation tolerance and requirements.

For client-driven edge processing, an edge-enabled 5GMS AF shall support sharing any required configuration information about edge processing with the Media Session Handler through Service Access Information at reference point M5, and the EEC embedded in the Media Session Handler shall support processing this configuration information. This enables the EEC embedded in the Media Session Handler to request edge processing for a streaming session from the EES embedded in the 5GMS AF, realising reference point EDGE-1.

## 4.5.4 Edge application context for 5GMS functions

### 4.5.4.1 5GMS AF context

The following application state may be subject to transfer during the application context relocation of an edge-deployed 5GMS AF instance:

- The EEC context maintained by the EES, as defined in clause 8.2.8 of TS 23.558 [16].
- The session context maintained by the 5GMS AF, including the currently selected dynamic QoS and charging policy, any associated event subscriptions, the associated edge configuration, the consumption reporting configuration, QoE reporting configuration.
- Other internal context information such as traffic identification and steering information to support dynamic QoS and charging policies, history of network assistance and dynamic policy.

NOTE: Not all context data needs to be transferred during every context relocation operation.

### 4.5.4.2 5GMS AS context

The following application state may be subject to transfer during the application context relocation of an edge-deployed 5GMS AS instance:

- The media stream context maintained by the 5GMS AS, which includes configuration for uplink streaming endpoint and any collected QoE reports.

## 4.6 5G Downlink Media Streaming via eMBMS

### 4.6.1 Architecture for 5G Downlink Media Streaming over eMBMS

Figure 4.6.1-1 below depicts an architecture for downlink 5G Media Streaming via eMBMS that combines the functions and reference points of the 5GMS System with those of the MBMS System.

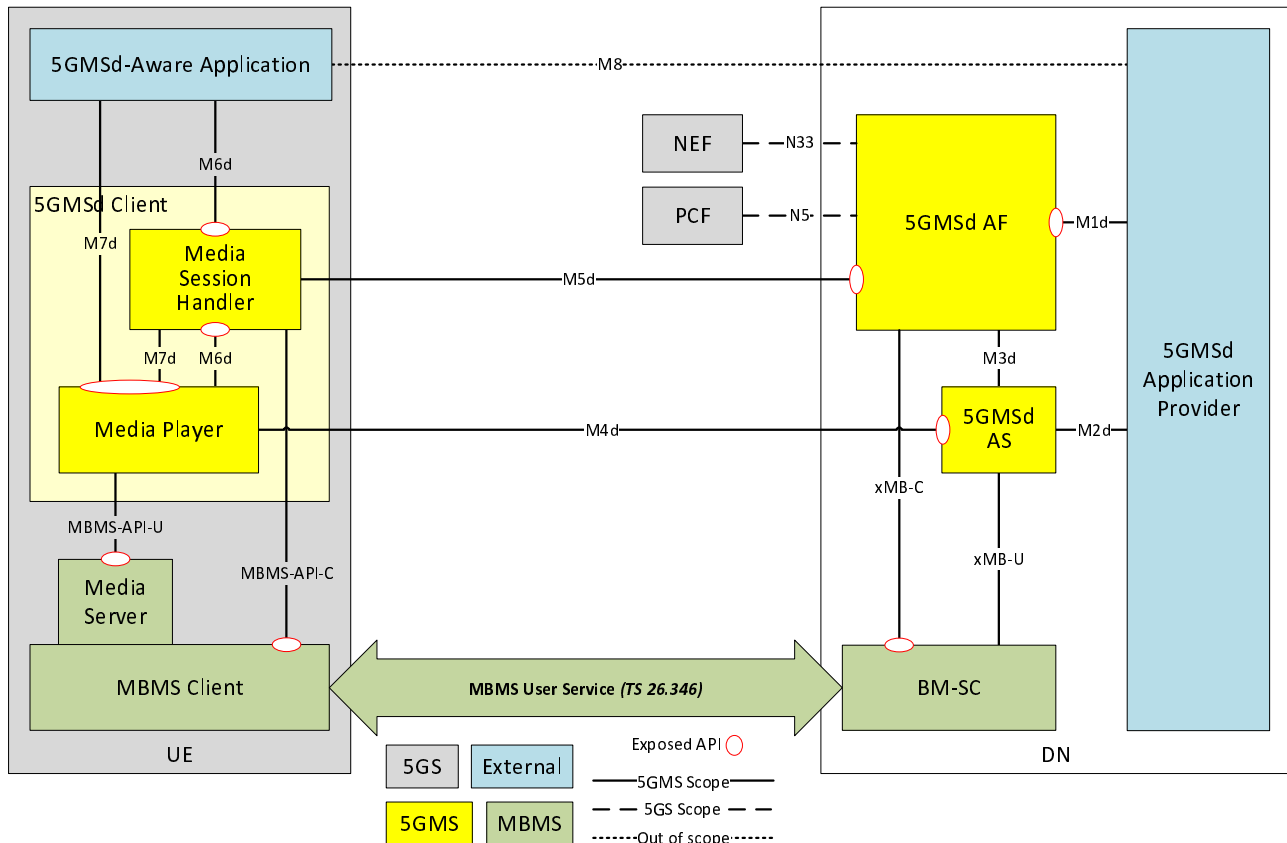

**Figure 4.6.1-1: Architecture for downlink 5G Media Streaming over eMBMS**

This arrangement allows 5GMS-based downlink media streaming to be deployed as an MBMS-aware Application on top of eMBMS as defined in TS 23.246 [18], TS 26.346 [19], TS 26.347 [20] and TS 26.348 [21].

In this case:

1. The 5GMSd AF configures the delivery of 5GMSd content to an MBMS Client in the UE by creating a Service as defined in TS 26.348 [21], clause 5.3. In order to additionally deliver this content over an MBMS User Service, the 5GMSd AF invokes xMB-C control plane procedures on the BM SC as specified in clauses 5.3 and 5.4 of TS 26.348 [21] and, as a result, content is ingested by the BM-SC from the 5GMSd AS using the xMB-U File Distribution procedures specified in clause 5.5.2 of TS 26.348 [21] to allow xMB-C Session types *Application* and *Files*.
2. The 5GMSd Client acts as eMBMS-Aware Application (as defined in TS 26.347 [20]) for the MBMS Client. Thus, the *MBMS Client* is controlled by the 5GMSd Client via the Media Streaming Service API specified in clause 6.3 of TS 26.347 [20] or via the File Delivery Application Service API specified in clause 6.2 of TS 26.347 [20]. (This interaction is labelled MBMS-API-C in figure 4.6.1-1 above.)
3. The MBMS Client receives media and other objects from the BM-SC according to the MBMS Download Delivery Method specified in clause 7 of TS 26.346 [19]. If an uplink is available to the MBMS Client, and if associated delivery procedures as specified in clause 9.3 of TS 26.346 [19] are activated, the MBMS Client uses the associated delivery procedures to recover damaged media objects received from the BM-SC for xMB-C Session type *Files*.

4. The *Media Server* function interfaces with the MBMS Client per figure 5.1 of TS 26.347 [20], and shall expose the content received (and possibly repaired) by the MBMS Client to the 5GMSd Client via the HTTP client-to-application interface specified in clause 7.2 of TS 26.347 [20]. (This interaction is labelled MBMS-API-U in figure 4.6.1-1 above.)
5. The media player sends requests according to the signalled object availability times in the manifest. In case a media object transmitted via the MBMS User Service is not received by the MBMS Client by the object availability times, or if it cannot be repaired in time for consumption by the 5GMS Client, the Media Server returns an error or a partial object in response to the Media Player's request for the media object, and the Media Player may instead attempt to retrieve the media object, or ranges of it, from the 5GMSd AS at reference point M4d, if available. The object shall be available for the application for a well-defined time duration.

NOTE: Details on determining the availability time requirements of the application are deferred to stage-3.

The usage of existing reference points to support these scenarios is documented in the following clauses. Procedures for 5GMS via eMBMS are defined in clause 5.10.

## 4.6.2 Usage of 5GMS reference points for eMBMS-based delivery

### 4.6.2.1 Usage of M1d

Reference point M1d is used as defined in clauses 4.1 to 4.4.

In addition, the content provider shall authorize via M1d that 5GMS content may be distributed via eMBMS.

The translation of M1d information to eMBMS delivery provisioning is left to implementation.

NOTE: The 5GMS Application Provider may provision specific use-cases (high velocity, specific reception area, indoor/outdoor/mobile users) at reference point M1d. These service requirements are translated by the 5GMSd AF into specific xMB-C calls to provision the BM-SC with a service that has the correct parameters for a specific location.

### 4.6.2.2 Usage of M2d

Reference point M2d is be used as defined in clauses 4.1 to 4.4.

### 4.6.2.3 Usage of M3d

Reference point M3d is used as defined in clauses 4.1 to 4.4.

### 4.6.2.4 Usage of M4d

Reference point M4d is used as defined in clauses 4.1 to 4.4.

### 4.6.2.5 Usage of M5d

Reference point M5d is used as defined in sub-clauses 4.1 to 4.4.

In addition, for 5GMS content to be distributed via eMBMS:

- The 5GMS Service Access Information shall include the relevant information of the eMBMS Service Announcement in order to bootstrap reception of the MBMS service, typically via a service identifier (i.e., the *serviceId* attribute of the *bundleDescription.userServiceDescription* element of the USD - see TS 26.346 [19]). This is passed by the Media Session Handler to the MBMS Client via reference point MBMS-API-C [20].

When this information is present in the Service Access Information and when the UE is MBMS-capable, the 5GMSd Client shall invoke the MBMS Client to initiate reception of the corresponding MBMS User Service.

- The 5GMS Service Access Information shall include relevant information from the eMBMS Service Announcement in order for the Media Session Handler to:



- i) Collect metrics of the MBMS service from the MBMS Client and report them to the 5GMSd AF using an appropriate metrics reporting scheme.
- ii) Collect media consumption information from the MBMS Client and submit it to the 5GMSd AF in 5GMS consumption reports..

#### 4.6.2.6 Usage of M6d

Reference point M6d is used as defined in clauses 4.1 to 4.4.

#### 4.6.2.7 Usage of M7d

Reference point M7d is used as defined in clauses 4.1 to 4.4.

#### 4.6.2.8 Usage of M8d

Reference point M8d is used as defined in clauses 4.1 to 4.4.

### 4.6.3 Usage of MBMS reference points and interfaces

#### 4.6.3.1 Usage of xMB-C

The 5GMSd AF provisions MBMS User Services in the BM-SC as defined in clauses 5.3 and 5.4 of TS 26.348 [21].

#### 4.6.3.2 Usage of xMB-U

The BM-SC ingests content from the 5GMSd AS using the push-based ingest method.

#### 4.6.3.3 Usage of MBMS User Services and Delivery Methods

The MBMS User Service Announcement as defined in TS 26.346 is used to advertise the availability of 5GMS content delivered via eMBMS.

A *Generic application service* (as defined in clause 5.7 of TS 26.346 [19]) is provisioned in the BM-SC and the application service entry point instance is a downlink 5GMS streaming manifest, for example a DASH MPD or HLS playlist.

NOTE: The support of multiple manifests for the same media streaming session is not covered in 5GMS. Hybrid DASH/HLS is supported in eMBMS. Usage together with 5GMS is left to implementation.

#### 4.6.3.4 Usage of MBMS-API-C

The MBMS Client operates according to the procedures defined in clause 6.3 of TS 26.347 [20] at reference point MBMS-API-C when communicating with the 5GMSd Client.

The MBMS Client exposes information to the Media Session Handler to manage the reception of MBMS User Services.

The Media Session Handler configures the MBMS Client for consumption and QoE metrics reporting.

The MBMS Client provides consumption and QoE metrics reports to the Media Session Handler.

#### 4.6.3.5 Usage of MBMS-API-U

The MBMS Client operates according to the procedures defined in clause 7 of TS 26.347 [20] at reference point MBMS-API-U when communicating with the 5GMSd Client.

The MBMS Client provides the streaming manifest, as well as updates of the manifest, to the 5GMSd Client and implements policies for hybrid services based on clause 7 of TS 26.347 [20].

The MBMS Client exposes fully- and partially-received media objects to the Media Player in the 5GMSd Client.

## 4.7 Data collection, reporting and exposure for 5GMS

### 4.7.1 Reference architecture instantiation

The abstract data collection and reporting architecture defined in clause 4 of TS 26.531 [22] and depicted in figure 4.2-1 of TS 26.531 [22] is instantiated in the 5G Media Streaming architecture as shown in figure 4.7.1-1 and as defined below.

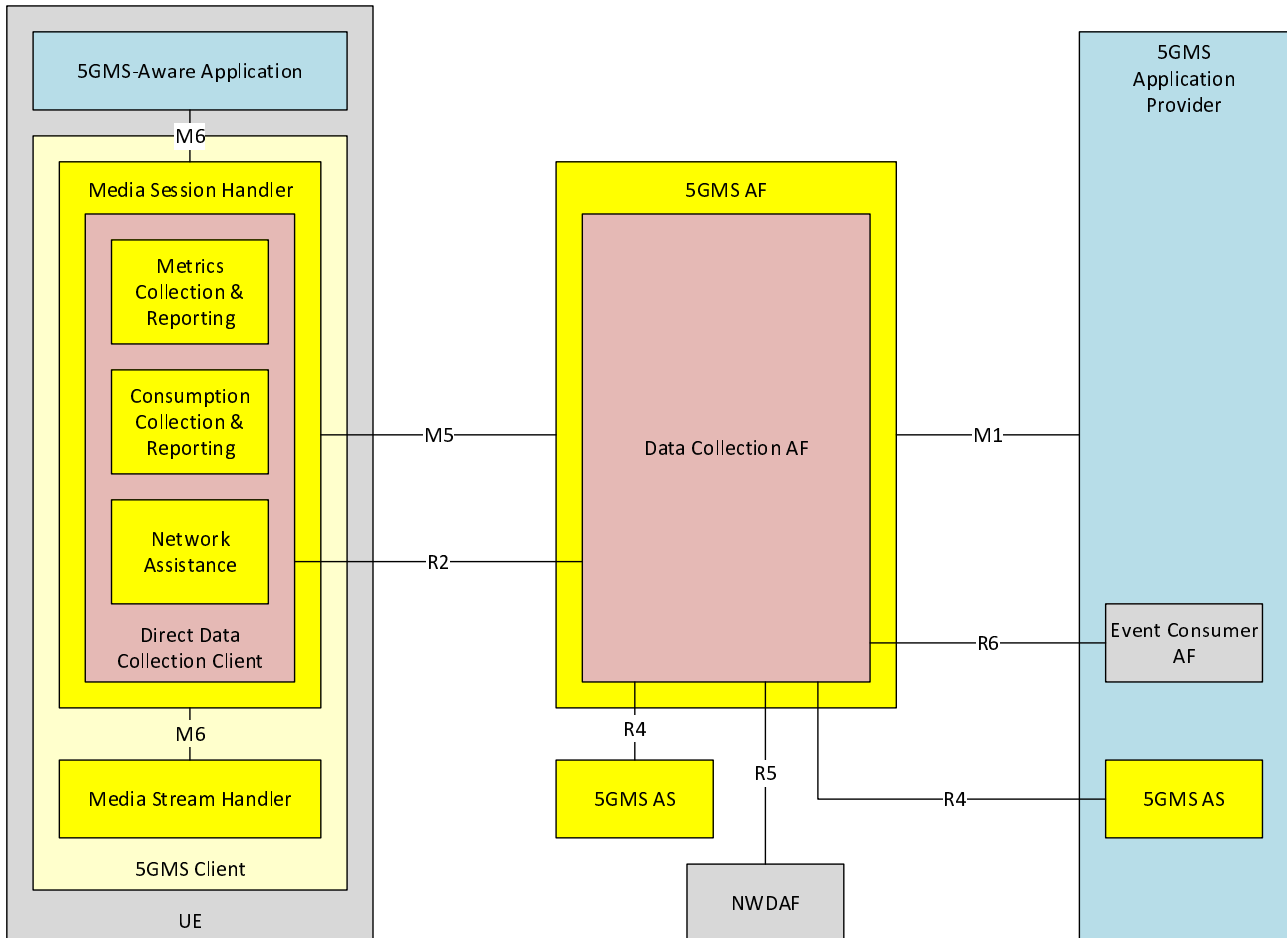

**Figure 4.7.1-1: Data collection and reporting architecture instantiation for 5G Media Streaming**

The functional elements in this instantiation are defined as follows:

- The role of the *Application Service Provider* in the abstract architecture is played by the 5GMS Application Provider.
- The *Data Collection AF* for 5G Media Streaming is instantiated in the 5GMS AF.
- The *Direct Data Collection Client* for 5G Media Streaming is instantiated in the Media Session Handler. This takes logical responsibility for the UE data collection activities of the *Metrics Collection & Reporting* and *Consumption Collection & Reporting* subfunctions and the subsequent reporting of this UE data via reference point M5. It also takes logical responsibility for the logging of ANBR-based Network Assistance invocations by the *Network Assistance* subfunction and their subsequent reporting to the Data Collection AF instantiated in the 5GMS AF via reference point R2.
- The *Provisioning AF* of the Application Service Provider is not instantiated in the 5GMS architecture. Data collection and reporting is instead provisioned using the procedures defined in the present document.
- The *Indirect Data Collection Client* is not instantiated in the 5GMS architecture. Indirect reporting of UE data is outside the scope of 5G Media Streaming.

- The role of the *AS* data collection client in the abstract reference architecture is played by 5GMS AS. This may be deployed as a trusted AS within the 5G System or deployed externally.
- The *Event Consumer AF* is instantiated in the 5GMS Application Provider as a consumer of 5G Media Streaming events from the Data Collection AF.

The reference points as defined as follows in this instantiation:

- R1** This reference point is not instantiated in the 5GMS architecture.
- M1** Provisioning of data collection and reporting features in the Data Collection AF.
- R2** Direct data reporting by the Direct Data Collection Client to the Data Collection AF of ANBR-based Network Assistance invocations.  
For the provision of QoE metrics and consumption reports, R2 is instead logically realised by the combination of the following components:
  - Internal interfaces between the Direct Data Reporting Client and its subordinate functions, namely Metrics Collection & Reporting and Consumption Reporting & Reporting.,
  - Internal interface between the Media Session Handler and its subordinate Direct Data Collection Client function.
  - Reference point M5, as defined below.
  - Internal interface between the 5GMS AF and its subordinate Data Collection AF function.
- M5** Direct data reporting by the Direct Data Collection Client to the Data Collection AF, via the Media Session Handler and 5GMS AF.
- R3** This reference point is not instantiated in the 5GMS architecture.
- R4** Media streaming access reporting by the 5GMS AS to the Data Collection AF.
- R5** Event exposure by the Data Collection AF to subscribing NWDAF [23] instances.
- R6** Event exposure by the Data Collection AF to subscribing Event Consumer AF instances in the 5GMS Application Provider.
- R7** This reference point is not instantiated in the 5GMS architecture.
- M6** Configuration of 5GMS-related data reporting by the 5GMS-Aware Application.
- R8** This reference point is not instantiated in the 5GMS architecture.

## 4.7.2 UE data reporting for 5GMS

### 4.7.2.1 UE data reporting procedures for downlink media streaming

The following UE data reporting procedures are in scope for the instantiation of the abstract data collection and reporting architecture in the downlink 5GMS architecture:

1. The procedures defined in clause 5.5 shall be used by the Direct Data Collection Client instantiated in the Media Session Handler to report *QoE metrics for downlink media streaming* to the Data Collection AF instantiated in the 5GMSd AF.
2. The procedures defined in clause 5.6 shall be used by the Direct Data Collection Client instantiated in the Media Session Handler to report *consumption of downlink media streaming* to the Data Collection AF instantiated in the 5GMSd AF.
- 3.- Invocations of the *downlink dynamic policy* procedures defined in clause 5.8 shall be logged by the 5GMSd AF and reported to its subordinate Data Collection AF.
4. Invocations of the *AF-based downlink Network Assistance* procedures defined in clause 5.9.2 shall be logged by the 5GMSd AF and reported to its subordinate Data Collection AF during active AF-based Network Assistance sessions.
5. The procedures defined in clause 5.11.1 and 5.11.2 shall be used by the 5GMSd AS to report *downlink media streaming access activity* to the Data Collection AF instantiated in the 5GMSd AF via reference point R4.
6. The procedures defined in clause 4.7.2.3 shall be used by the Direct Data Collection Client instantiated in the Media Session Handler to report invocations of the *ANBR-based downlink Network Assistance* procedures to the Data Collection AF instantiated in the 5GMSd AF via reference point R2.

#### 4.7.2.2 UE data reporting procedures for uplink media streaming

The following UE data reporting procedures are in scope for the instantiation of the abstract data collection and reporting architecture in the uplink 5GMS architecture:

1. Invocations of the *AF-based uplink Network Assistance* procedures defined in clause 6.5 shall be logged by the 5GMSu AF and reported to its subordinate Data Collection AF during active AF-based Network Assistance sessions.
2. The procedures defined in clause 4.7.2.3 shall be used by the Direct Data Collection Client instantiated in the Media Session Handler to report invocations of the *ANBR-based uplink Network Assistance* procedures to the Data Collection AF instantiated in the 5GMSu AF via reference point R2. .
3. The procedures defined in clause 6.8.1 and 6.8.2 shall be used by the 5GMSu AS to report *uplink media streaming access activity* to the Data Collection AF instantiated in the 5GMSu AF via reference point R4.

#### 4.7.2.3 UE data reporting of ANBR-based Network Assistance invocations

Invocations of ANBR-based Network Assistance by the Media Session Handler for both downlink and uplink media streaming shall be reported by the Network Assistance subfunction of the Direct Data Collection Client to the Data Collection AF at reference point R2 according to the reporting requirements indicated in a data collection client configuration it has previously obtained at this reference point.

ANBR-based Network Assistance invocation reports shall contain the following parameters:

- Timestamp of the invocation.
- UE identification, e.g. the GPSI or current IP address.
- The DNN and S-NSSAI.
- UE location.
- Recommended bit rate.

## 4.7.3 UE data processing for 5GMS

### 4.7.3.1 UE data processing procedures for downlink media streaming

The following restriction dimensions and aggregation functions defined in clause 4.5.2 of TS 26.531 [22] may be provisioned in a Data Access Profile as part of a 5GMSd Provisioning Session and shall, as a consequence, be applied to reported UE data prior to exposing it to event consumers.

**Table 4.7.3.1-1: Valid processing of downlink media streaming UE data by the Data Collection AF**

	Restriction dimension			Aggregation function					
	Time	User	Location	None	Count	Mean	Maximum	Minimum	Sum
QoE metrics for downlink media streaming	Yes	Yes	Yes	Yes	Yes (NOTE 1)	Yes (NOTE 1)	Yes (NOTE 1)	Yes (NOTE 1)	Yes (NOTE 1)
Consumption of downlink media streaming	Yes	Yes	Yes	Yes	Yes (NOTE 2)	No	No	No	No
Downlink dynamic policy invocations	Yes	Yes	Yes	Yes	Yes (NOTE 3)	No	No	No	No
AF-based downlink Network Assistance invocations	Yes	Yes	Yes	Yes	Yes (NOTE 3)	Yes (NOTE 4)	Yes (NOTE 4)	Yes (NOTE 4)	No
ANBR-based downlink Network Assistance invocations	Yes	Yes	Yes	Yes	Yes (NOTE 3)	Yes (NOTE 4)	Yes (NOTE 4)	Yes (NOTE 4)	No
Downlink media streaming access activity	Yes	Yes	Yes	Yes	Yes (NOTE 2)	No	No	No	No
NOTE 1: Aggregation functions applied individually to all exposed metrics within the scope of the applicable restriction dimension(s).									
NOTE 2: Number of downlink media streaming sessions within the scope of the applicable restriction dimension(s).									
NOTE 3: Number of invocations within the scope of the applicable restriction dimension(s).									
NOTE 4: Aggregation functions applied to bit rate recommendations within the scope of the applicable restriction dimension(s).									

### 4.7.3.2 UE data processing procedures for uplink media streaming

The following restriction dimensions and aggregation functions defined in clause 4.5.2 of TS 26.531 [22] may be provisioned in a Data Access Profile as part of a 5GMSu Provisioning Session and shall, as a consequence, be applied to reported UE data prior to exposing it to event consumers.

**Table 4.7.3.2-1: Valid processing of uplink media streaming UE data by the Data Collection AF**

	Restriction dimension			Aggregation function					
	Time	User	Location	None	Count	Mean	Maximum	Minimum	Sum
AF-based uplink Network Assistance invocations	Yes	Yes	Yes	Yes	Yes (NOTE 1)	Yes (NOTE 2)	Yes (NOTE 2)	Yes (NOTE 2)	No
ANBR-based uplink Network Assistance invocations	Yes	Yes	Yes	Yes	Yes (NOTE 1)	Yes (NOTE 2)	Yes (NOTE 2)	Yes (NOTE 2)	No
Uplink media streaming access activity	Yes	Yes	Yes	Yes	Yes (NOTE 3)	No	No	No	No
NOTE 1: Number of invocations within the scope of the applicable restriction dimension(s).									
NOTE 2: Aggregation functions applied to bit rate recommendations within the scope of the applicable restriction dimension(s).									
NOTE 3: Number of uplink media streaming sessions within the scope of the applicable restriction dimension(s).									

## 4.7.4 Event exposure of 5GMS UE data

### 4.7.4.1 Event exposure for downlink media streaming UE data

The following types of events are exposed by the Data Collection AF instantiated in the 5GMSd AF:

1. *QoE metrics for downlink media streaming* reported by the Media Session Handler to the Data Collection AF instantiated in the 5GMSd AF, as defined in clauses 4.7.4.3 and 4.7.4.4.
2. *Consumption of downlink media streaming* reported by the Media Session Handler to the Data Collection AF instantiated in the 5GMSd AF, as defined in clauses 4.7.4.3 and 4.7.4.5.
- 3.- Invocations of *downlink dynamic policies* in the 5GMSd AF by the Media Session Handler, as defined in clauses 4.7.4.3 and 4.7.4.6.
4. Invocations of *AF-based downlink Network Assistance* in the 5GMSd AF by the Media Session Handler, as defined in clauses 4.7.4.3 and 4.7.4.7.
5. *Downlink media streaming access activity* reported by the 5GMSd AS to the Data Collection AF instantiated in the 5GMSd AF, as defined in clauses 4.7.4.3 and 4.7.4.8.
6. Invocations of *ANBR-based downlink Network Assistance* reported by the Direct Data Collection Client instantiated in the Media Session Handler to the Data Collection AF instantiated in the 5GMSd AF, as defined in clauses 4.7.4.3 and 4.7.4.7.

High-level procedures for downlink media streaming event exposure are defined in clause 5.11.3.

### 4.7.4.2 Event exposure for uplink media streaming UE data

The following types of events are exposed by the Data Collection AF instantiated in the 5GMSd AF:

1. Invocations of *AF-based uplink Network Assistance* in the 5GMSd AF by the Media Session Handler, as defined in clauses 4.7.4.3 and 4.7.4.7.

2. Invocations of *ANBR-based uplink Network Assistance* reported by the Direct Data Collection Client instantiated in the Media Session Handler to the Data Collection AF instantiated in the 5GMSu AF, as defined in clauses 4.7.4.3 and 4.7.4.7.
3. *Uplink media streaming access activity* reported by the 5GMSu AS to the Data Collection AF instantiated in the 5GMSu AF, as defined in clauses 4.7.4.3 and 4.7.4.8.

High-level procedures for uplink media streaming event exposure are defined in clause 6.8.3.

#### 4.7.4.3 Common baseline parameters for event exposure

The Data Collection AF shall include the following common baseline parameters in each event it exposes to event consumers:

**Table 4.7.4.3-1: Common baseline parameters for event collections**

Parameter	Cardinality	Description
Collection timestamp	1..1	The date–time at which this collection was exposed by the Data Collection AF as an event to its subscribed event consumers.
Start timestamp	1..1	Date–time of earliest data sample included in or summarised by this collection.
End timestamp	1..1	Date–time of latest data sample included in or summarised by this collection.
Sample count	1..1	The number of data samples included in or summarised by this collection. (Where summary records are included in the collection, the number of records in the collection differs from this number.)
Media streaming direction	1..1	Indicating whether this collection relates to downlink media streaming sessions or to uplink media streaming sessions.
Record summarisation descriptor	1..*	Nature of the records included in this collection. One or more of the following aggregation functions are used to generate records: <ul style="list-style-type: none"> <li>- <i>None</i>: Collection includes a separate record for each data sample.</li> <li>- <i>Count</i>: collection describes only the number of data samples between <i>Start timestamp</i> and <i>End timestamp</i> with no individual records provided.</li> <li>- <i>Mean</i>: Collection includes a record summarising the mean average value of data samples over a certain time period.</li> <li>- <i>Minimum</i>: Collection includes a record summarising the smallest value of data samples over a certain time period.</li> <li>- <i>Maximum</i>: Collection includes a record summarising the largest value of data samples over a certain time period.</li> <li>- <i>Sum</i>: Collection includes a record summarising the sum of data sample values over a certain time period.</li> </ul> As specified in the following clauses, not all aggregation functions are applicable to all types of media streaming event.
Records	0..*	A set of records, each one describing a UE data sample or summarising a set of UE data samples.

And for each record in the collection:

**Table 4.7.4.3-2: Common baseline parameters for event records**

Parameter	Cardinality	Description
Record type	1..1	Indicating the nature of information carried in this record: <ul style="list-style-type: none"> <li>- Individual data sample record.</li> <li>- Mean parameter values summary record.</li> <li>- Minimum parameter values summary record.</li> <li>- Maximum parameter values summary record.</li> <li>- Sum parameter values summary record.</li> </ul> Not all record types are applicable to all types of media streaming event.
Record timestamp	1..1	The date–time at which the UE data carried in this record was sampled or summarised.
Provisioning Session identifier	0..1	The Provisioning Session to which this record pertains. Present only for individual data sample record type.
Media streaming session identifier	0..1	A value synthesised by the 5GMS System that uniquely identifies the media streaming session to which this record pertains.

		Present only for individual data sample record type.
UE identification	0..1	GPSI of the requesting UE or a stable globally unique string identifying the requesting Media Session Handler. Present only for individual data sample record type and only when exposure is permitted by the data exposure restrictions in force for the event type in question.
Data Network Name	0..1	Identifying the Data Network of the M4 media streaming session. Present only for individual data sample record type.
Slice identification	0..1	The S-NSSAI identifying the Network Slice of the M4 media streaming session. Present only for individual data sample record type.
UE location	0..1	The location of the UE for the data sample described by this record. Present only for individual data sample record type and only when exposure is permitted by the data exposure restrictions in force for the event type in question.

#### 4.7.4.4 Event exposure of QoE metrics UE data

For QoE metrics reported to the 5GMSd AF by the Media Session Handler, the Data Collection AF shall include the following parameters (derived from the baseline parameters defined in table 4.7.4.3-1) in each event it exposes to event consumers:

**Table 4.7.4.4-1: Parameters for QoE metrics collection**

Parameter	Cardinality	Description
Collection timestamp	1..1	The date–time at which the collection was exposed by the Data Collection AF as an event to its subscribed event consumers.
Start timestamp	1..1	Date–time of the earliest QoE metrics report included in or summarised by this collection.
End timestamp	1..1	Date–time of the latest QoE metrics report included in or summarised by this collection.
Sample count	1..1	The number of QoE metrics reports included in or summarised by this collection. (Where summary records are included in the collection, the number of records in the collection differs from this number.)
Media streaming direction	1..1	Collections of QoE metrics records only apply to downlink media streaming.
Record summarisation descriptor	1..*	Nature of the records included in this collection. One or more of the following aggregation functions are used to generate records: <ul style="list-style-type: none"> <li>- <i>None</i>: Collection includes a separate record for each QoE metrics report.</li> <li>- <i>Count</i>: Collection describes only the number of QoE metrics reports between <i>Start timestamp</i> and <i>End timestamp</i> with no individual records provided.</li> <li>- <i>Mean</i>: Collection includes a record summarising the mean average value of each QoE metric over a certain time period.</li> <li>- <i>Minimum</i>: Collection includes a record summarising the smallest value of each QoE metric over a certain time period.</li> <li>- <i>Maximum</i>: Collection includes a record summarising the largest value of each QoE metric over a certain time period.</li> <li>- <i>Sum</i>: Collection includes a record summarising the sum of the QoE metric values over a certain time period.</li> </ul>
Records	0..*	A set of QoE metrics events, each one describing a QoE metrics report or summarising a set of QoE metrics reports.



And for each record in the collection the following parameters shall be included, extending the baseline parameter set defined in table 4.7.4.3-2:

**Table 4.7.4.4-2: Parameters for QoE metrics event**

Parameter	Cardinality	Description
Record type	1..1	Indicating the nature of information carried in this QoE metrics event: <ul style="list-style-type: none"> <li>- Individual QoE metrics report record.</li> <li>- Mean parameter values summary record.</li> <li>- Minimum parameter values summary record.</li> <li>- Maximum parameter values summary record.</li> <li>- Sum parameter values summary record.</li> </ul>
Record timestamp	1..1	For individual QoE metrics report records, the date–time at which the parent QoE metrics report was generated by the Media Session Handler. Otherwise, the date–time at which the summary record was generated by the Data Collection AF instantiated in the 5GMS AF.
Provisioning Session identifier	0..1	The Provisioning Session to which this QoE metrics record pertains. Present only for individual QoE metrics report record type.
Media streaming session identifier	0..1	A value synthesised by the 5GMS System that uniquely identifies the media streaming session to which this QoE metrics record pertains. Present only for individual QoE metrics report record type.
UE identification	0..1	GPSI of the UE or a stable globally unique string identifying the Media Session Handler that reported QoE metrics, corresponding to the reporting client identifier described in clause 4.7.5. Present only for individual QoE metrics report record type, and only when exposure is permitted by the data exposure restrictions in force.
Data Network Name	0..1	Identifying the Data Network of the M4 media streaming session for which the QoE metrics were reported. Present only for individual QoE metrics report record type.
Slice identification	0..1	The S-NSSAI identifying the Network Slice of the M4 media streaming session for which the QoE metrics were reported. Present only for individual QoE metrics report record type.
UE location	0..1	The location of the UE when the QoE metrics were collected. Present only for individual QoE metrics report record type, and only when exposure is permitted by the data exposure restrictions in force.
Record subtype	1..1	A fully-qualified URI that uniquely identifies the QoE metrics reporting scheme and QoE metrics event described by this record. This is formed by concatenating a metrics reporting scheme identifier (such as the URN specified in clause 10.5 of TS 26.247 [7]) with a term identifier discriminating the type of QoE metric.
QoE metrics list	1..1	A list of QoE metrics of a single type derived from a single UE data report.
Sample timestamp	0..1	The moment in time at which this QoE metric was sampled.
Sample duration	0..1	The time duration over which this QoE metric was sampled.
Media timestamp	0..1	The time point in the media at which this QoE metric was sampled.
QoE metrics	1..1	A set of name–value pairs associated with this QoE metric.
Metric key	1..1	A token that uniquely identifies the type of metric within the scope of the <i>Record subtype</i> .
Metric value	0..1	The value of the metric.

#### 4.7.4.5 Event exposure of consumption reporting UE data

For media consumption reported to the 5GMSd AF by the Media Session Handler, the Data Collection AF shall include the following parameters (derived from the baseline parameters defined in table 4.7.4.3-1) in each event it exposes to event consumers:

**Table 4.7.4.5-1: Parameters for consumption reporting units collection**

Parameter	Cardinality	Description
Collection timestamp	1..1	The date–time at which the collection was exposed by the Data Collection AF as an event to its subscribed event consumers.
Start timestamp	1..1	Date–time of the earliest consumption reporting unit included in or summarised by this collection.
End timestamp	1..1	Date–time of the latest consumption reporting unit included in or summarised by this collection.
Sample count	1..1	The number of consumption reporting unit records included in or summarised by this collection. (Where summary records are included in the collection, the number of records in the collection differs from this number.)
Media streaming direction	1..1	Collections of consumption reporting units only apply to downlink media streaming.
Record summarisation descriptor	1..*	Nature of the records included in this collection. One or more of the following aggregation functions are used to generate records: <ul style="list-style-type: none"> <li>- <i>None</i>: Collection includes a separate record for each consumption reporting unit.</li> <li>- <i>Count</i>: Collection describes only the number of consumption reporting units between <i>Start timestamp</i> and <i>End timestamp</i> with no individual records provided.</li> <li>- <i>Mean</i>: Not applicable to consumption reporting.</li> <li>- <i>Minimum</i>: Not applicable to consumption reporting.</li> <li>- <i>Maximum</i>: Not applicable to consumption reporting.</li> <li>- <i>Sum</i>: Not applicable to consumption reporting.</li> </ul>
Records	0..*	A set of consumption reporting events, each one describing a consumption reporting unit.

And for each record in the collection the following parameters shall be included, extending the baseline parameter set defined in table 4.7.4.3-2:

**Table 4.7.4.5-2: Parameters for consumption reporting event**

Parameter	Cardinality	Description
Record type	1..1	Indicating the nature of information carried in this consumption reporting event: <ul style="list-style-type: none"> <li>- Individual consumption reporting unit record.</li> </ul>
Record timestamp	1..1	The date–time at which this consumption reporting unit began.
Provisioning Session identifier	0..1	The Provisioning Session to which this consumption reporting unit record pertains. Present only for individual consumption reporting unit record type.
Media streaming session identifier	0..1	A value synthesised by the 5GMS System that uniquely identifies the media streaming session to which this consumption reporting unit record pertains. Present only for individual consumption reporting unit record type.
UE identification	0..1	GPSI of the UE or a stable globally unique string identifying the Media Session Handler that reported media consumption, corresponding to the reporting client identifier described in clause 4.7.4. Present only for individual consumption reporting unit record type, and only when exposure is permitted by the data exposure restrictions in force.
Data Network Name	0..1	Identifying the Data Network of the M4 media streaming session for which media consumption was reported. Present only for individual consumption reporting unit record type.
Slice identification	0..1	The S-NSSAI identifying the Network Slice of the M4 media streaming session for which media consumption was reported. Present only for individual consumption reporting unit record type.
UE location	0..1	The location of the UE when media was consumed. Present only for individual consumption reporting unit record type, and only when exposure is permitted by the data exposure restrictions in force.

Duration	1..1	The duration of this consumption reporting unit.
Media endpoint identifier	0..1	The IP address and port number of the M4d endpoint used to access the media during this consumption reporting unit. Present only when exposure is permitted by the data exposure restrictions in force for the event in question.
Media Player Entry URL	1..1	The Media Player Entry URL to which this consumption reporting unit pertains.
Media component identifier	1..1	A token (e.g., an MPEG-DASH representation identifier) identifying the media component of the Media Player Entry that was consumed during this consumption reporting unit.

#### 4.7.4.6 Event exposure of dynamic policy invocation UE data

For dynamic policy invocations on the 5GMS AF by the Media Session Handler, the Data Collection AF shall include the following parameters (derived from the baseline parameters defined in table 4.7.4.3-1) in each event it exposes to event consumers:

**Table 4.7.4.6-1: Parameters for dynamic policy invocations collection**

Parameter	Cardinality	Description
Collection timestamp	1..1	The date–time at which the collection was exposed by the Data Collection AF as an event to its subscribed event consumers.
Start timestamp	1..1	Date–time of the earliest dynamic policy invocation included in or summarised by this collection.
End timestamp	1..1	Date–time of the latest dynamic policy invocation included in or summarised by this collection.
Sample count	1..1	The number of dynamic policy invocations included in or summarised by this collection. (Where summary records are included in the collection, the number of records in the collection differs from this number.)
Media streaming direction	1..1	Indicating whether this collection of dynamic policy invocations relates to downlink media streaming sessions or to uplink media streaming sessions.
Record summarisation descriptor	1..*	Nature of the records included in this collection. One or more of the following aggregation functions are used to generate records: <ul style="list-style-type: none"> <li>- <i>None</i>: Collection includes a separate record for each dynamic policy invocation.</li> <li>- <i>Count</i>: Collection describes only the number of dynamic policy invocations between <i>Start timestamp</i> and <i>End timestamp</i> with no individual records provided.</li> <li>- <i>Mean</i>: Not applicable to dynamic policy invocations.</li> <li>- <i>Minimum</i>: Not applicable to dynamic policy invocations.</li> <li>- <i>Maximum</i>: Not applicable to dynamic policy invocations.</li> <li>- <i>Sum</i>: Not applicable to dynamic policy invocations.</li> </ul>
Records	0..*	A set of dynamic policy invocation events, each one describing a dynamic policy invocation.

And for each record in the collection the following parameters shall be included, extending the baseline parameter set defined in table 4.7.4.3-2:

**Table 4.7.4.6-2: Parameters for dynamic policy invocation event**

Parameter	Cardinality	Description
Record type	1..1	Indicating the nature of information carried in this dynamic policy invocation event: - Individual dynamic policy invocation record.
Record timestamp	1..1	The date–time at which the dynamic policy was invoked by the Media Session Handler.
Provisioning Session identifier	0..1	The Provisioning Session to which this record pertains. Present only for individual dynamic policy invocation record type.
Media streaming session identifier	0..1	A value synthesised by the 5GMS System that uniquely identifies the media streaming session to which this record pertains. Present only for individual dynamic policy invocation record type.
UE identification	0..1	GPSI of the UE or a stable globally unique string identifying the Media Session Handler that instantiated the dynamic policy. Present only for individual dynamic policy invocation record type and only when exposure is permitted by the data exposure restrictions in force.
Data Network Name	0..1	Identifying the Data Network of the M4 media streaming session for which the dynamic policy was instantiated. Present only for individual dynamic policy invocation record type.
Slice identification	0..1	The S-NSSAI identifying the Network Slice of the M4 media streaming session on which the dynamic policy was instantiated. Present only for individual dynamic policy invocation record type.
UE location	0..1	The location of the UE when the dynamic policy was instantiated. Present only for individual dynamic policy invocation record type and only when exposure is permitted by the data exposure restrictions in force.
Policy Template identifier	1..1	Identifying the Policy Template instantiated by the Media Session Handler.
Service Data Flow descriptions	0..*	The set of Service Data Flows to which the Media Session Handler requested that the Policy Template be applied. Present only for individual dynamic policy invocation record type and only when exposure is permitted by the data exposure restrictions in force. If present, at least a domain name or one packet filter shall be populated.
Domain name	0..1	A set of Service Data Flows described in terms of a target 5GMS AS host name at reference point M4.
Packet filters	0..*	A set of Service Data Flows identified in terms of their layer 3 and/or layer 4 protocol parameters at reference point M4.
Source IP address	0..1	An IP address from which layer 3 packets are sent.
Destination IP address	0..1	An IP address to which layer 3 packets are addressed.
Protocol number	0..1	A layer 4 protocol number encapsulated by IP packets (e.g., TCP, UDP).
Source port	0..1	A source port of layer 4 protocol data units (e.g., TCP segments, UDP datagrams).
Destination port	0..1	A destination port of layer 4 protocol data units (e.g., TCP segments, UDP datagrams).
Type of Service or Traffic Class	0..1	An IPv4 Type of Service or IPv6 Traffic Class, including mask.
Flow label	0..1	An IPv6 flow label.
Security Parameter Index	0..1	An IPsec Security Parameter Index.

Requested QoS parameters	0..1	The network QoS parameters (if any) requested by the Media Session Handler.
Maximum requested bit rate	1..1	The maximum bit rate requested.
Minimum desired bit rate	0..1	The minimum bit rate desired.
Minimum requested bit rate	1..1	The minimum bit rate requested.
Desired packet latency	0..1	The packet latency requested.
Desired packet loss rate	0..1	The packet loss rate requested.
Enforcement method	0..1	The policy enforcement method indicated by the 5GMS AF.
Enforcement bit rate	0..1	The enforcement bit rate (if any) indicated by the 5GMS AF.

#### 4.7.4.7 Event exposure of Network Assistance UE data

For invocations of both AF-based Network Assistance and ANBR-based Network Assistance on the 5GMS AF by the Media Session Handler, the Data Collection AF shall include the following parameters (derived from the baseline parameters defined in table 4.7.4.3-1) in each event it exposes to event consumers:

**Table 4.7.4.7-1: Parameters for Network Assistance invocations collection**

Parameter	Cardinality	Description
Collection timestamp	1..1	The date–time at which the collection was exposed by the Data Collection AF as an event to its subscribed event consumers.
Start timestamp	1..1	Date–time of the earliest Network Assistance invocation included in or summarised by this collection.
End timestamp	1..1	Date–time of the latest Network Assistance invocation included in or summarised by this collection.
Sample count	1..1	The number of Network Assistance invocations included in or summarised by this collection. (Where summary records are included in the collection, the number of records in the collection differs from this number.)
Media streaming direction	1..1	Indicating whether this collection of Network Assistance invocations relates to downlink media streaming sessions or to uplink media streaming sessions.
Record summarisation descriptor	1..*	Nature of the records included in this collection. One or more of the following aggregation functions are used to generate records: <ul style="list-style-type: none"> <li>- <i>None</i>: Collection includes a separate record for each Network Assistance invocation.</li> <li>- <i>Count</i>: Collection describes only the number of Network Assistance invocations between <i>Start timestamp</i> and <i>End timestamp</i> with no individual records provided.</li> <li>- <i>Mean</i>: Collection includes a record summarising the mean average value of each QoS parameter over a certain time period.</li> <li>- <i>Minimum</i>: Collection includes a record summarising the smallest value of each QoS parameter over a certain time period.</li> <li>- <i>Maximum</i>: Collection includes a record summarising the largest value of each QoS parameter over a certain time period.</li> <li>- <i>Sum</i>: Not applicable to Network Assistance invocations.</li> </ul>
Records	0..*	A set of Network Assistance invocation events, each one describing a Network Assistance invocation or summarising a set of Network Assistance invocations.

And for each record in the collection the following parameters shall be included, extending the baseline parameter set defined in table 4.7.4.3-2:

**Table 4.7.4.7-2: Parameters for Network Assistance invocation event**

Parameter	Cardinality	Description
Record type	1..1	Indicating the nature of information carried in this Network Assistance invocation event: <ul style="list-style-type: none"> <li>- Individual Network Assistance invocation record.</li> <li>- Mean parameter values summary record.</li> <li>- Minimum parameter values summary record.</li> <li>- Maximum parameter values summary record.</li> </ul>
Record timestamp	1..1	For individual records, the date–time at which Network Assistance was invoked by the Media Session Handler. Otherwise, the date–time at which the summary record was generated by the Data Collection AF instantiated in the 5GMS AF.
Provisioning Session identifier	0..1	The Provisioning Session to which this record pertains. Present only for individual Network Assistance invocation record type.
Media streaming session identifier	0..1	A value synthesised by the 5GMS System that uniquely identifies the media streaming session to which this record pertains. Present only for individual Network Assistance invocation record type.
UE identification	0..1	GPSI of the UE or a stable globally unique string identifying the Media Session Handler that requested Network Assistance.. Present only for individual Network Assistance invocation record type and only when exposure is permitted by the data exposure restrictions in force.
Data Network Name	0..1	Identifying the Data Network of the M4 media streaming session for which Network Assistance was sought. Present only for individual Network Assistance invocation record type.
Slice identification	0..1	The S-NSSAI identifying the Network Slice of the M4 media streaming session on which Network Assistance was sought. Present only for individual Network Assistance invocation record type.
UE location	0..1	The location of the UE when Network Assistance was sought. Present only for individual Network Assistance invocation record type and only when exposure is permitted by the data exposure restrictions in force.
Record subtype	1..1	Indicating which of the following Network Assistance features was invoked by the UE: <ul style="list-style-type: none"> <li>- Bit rate recommendation solicited from 5GMS AF by Media Session Handler.</li> <li>- Delivery boost requested from 5GMS AF by Media Session Handler.</li> <li>- Bit rate recommendation solicited from RAN modem by Media Session Handler.</li> <li>- Delivery boost requested from RAN modem by Media Session Handler.</li> </ul>
Policy Template identifier	0..1	Identifying the Policy Template (if any) referenced by the Media Session Handler in the Network Assistance Session.

Service Data Flow descriptions	1..*	The set of Service Data Flows for which the Media Session Handler sought Network Assistance. Present only for individual Network Assistance invocation record type and only when exposure is permitted by the data exposure restrictions in force. If present, at least a domain name or one packet filter shall be populated.
Domain name	0..1	A set of Service Data Flows described in terms of a target 5GMS AS host name at reference point M4.
Packet filters	0..*	A set of Service Data Flows identified in terms of their layer 3 and/or layer 4 protocol parameters at reference point M4.
Source IP address	0..1	An IP address from which layer 3 packets are sent.
Destination IP address	0..1	An IP address to which layer 3 packets are addressed.
Protocol number	0..1	A layer 4 protocol number encapsulated by IP packets (e.g., TCP, UDP).
Source port	0..1	A source port of layer 4 protocol data units (e.g., TCP segments, UDP datagrams).
Destination port	0..1	A destination port of layer 4 protocol data units (e.g., TCP segments, UDP datagrams).
Type of Service or Traffic Class	0..1	An IPv4 Type of Service or IPv6 Traffic Class, including mask.
Flow label	0..1	An IPv6 flow label.
Security Parameter Index	0..1	An IPsec Security Parameter Index.
Requested QoS parameters	0..1	The network QoS parameters (if any) requested from the 5GMS AF or RAN by the Media Session Handler.
Maximum requested bit rate	1..1	The maximum bit rate requested.
Minimum desired bit rate	0..1	The minimum bit rate desired.
Minimum requested bit rate	1..1	The minimum bit rate requested.
Desired packet latency	0..1	The packet latency requested.
Desired packet loss rate	0..1	The packet loss rate requested.
Recommended QoS parameters	0..1	The network QoS parameters (if any) recommended by the 5GMS AF or RAN to the Media Session Handler.
Maximum recommended bit rate	1..1	The maximum bit rate recommended by the 5GMS AF or RAN.
Minimum recommended bit rate	1..1	The minimum bit rate recommended by the 5GMS AF or RAN.

#### 4.7.4.8 Event exposure of media streaming access activity UE data

For media streaming access reported by the 5GMS AS, the Data Collection AF shall include the following parameters (derived from the baseline parameters defined in table 4.7.4.3-1) in each event it exposes to event consumers:

**Table 4.7.4.8-1: Parameters for media streaming accesses collection**

Parameter	Cardinality	Description
Collection timestamp	1..1	The date–time at which the collection was exposed by the Data Collection AF as an event to its subscribed event consumers.
Start timestamp	1..1	Date–time of the earliest media streaming access record included in or summarised by this collection.
End timestamp	1..1	Date–time of the latest media streaming access record included in or summarised by this collection.
Sample count	1..1	The number of media streaming access records included in or summarised by this collection. (Where summary records are included in the collection, the number of records in the collection differs from this number.)
Media streaming direction	1..1	Indicating whether this collection of media access records relates to downlink media streaming sessions or to uplink media streaming sessions.
Record summarisation descriptor	1..*	Nature of the records included in this collection. One or more of the following aggregation functions are used to generate records: <ul style="list-style-type: none"> <li>- <i>None</i>: Collection includes a separate record for each media streaming access.</li> <li>- <i>Count</i>: Collection describes only the number of media streaming accesses between <i>Start timestamp</i> and <i>End timestamp</i> with no individual records provided.</li> <li>- <i>Mean</i>: Not applicable to media streaming access.</li> <li>- <i>Minimum</i>: Not applicable to media streaming access.</li> <li>- <i>Maximum</i>: Not applicable to media streaming access.</li> <li>- <i>Sum</i>: Not applicable to media streaming access.</li> </ul>
Records	0..*	A set of media streaming access events, each one describing a media streaming access.

And for each record in the collection the following parameters shall be included, extending the baseline parameter set defined in table 4.7.4.3-2:

**Table 4.7.4.8-2: Parameters for media streaming access event**

Parameter	Cardinality	Description
Record type	1..1	Indicating the nature of information carried in this media streaming access event: <ul style="list-style-type: none"> <li>- Individual media streaming access record.</li> </ul>
Record timestamp	1..1	The date–time at which media was accessed by the Media Stream Handler (Media Player or Media Streamer).
Provisioning Session identifier	0..1	The Provisioning Session to which this media streaming access record pertains. Present only for individual media streaming access record type.
Media streaming session identifier	0..1	A value synthesised by the 5GMS System that uniquely identifies the media streaming session to which this media streaming access record pertains. Present only for individual media streaming access record type.
UE identification	0..1	GPSI of the UE or a stable globally unique string identifying the 5GMS Client that accessed media. Present only for individual media streaming access record type, and only when exposure is permitted by the data exposure restrictions in force.
Data Network Name	0..1	Identifying the Data Network of the M4 media streaming session for which media streaming access was reported. Present only for individual media streaming access record type.
Slice identification	0..1	The S-NSSAI identifying the Network Slice of the M4 media streaming session for which media streaming access was reported. Present only for individual media streaming access record type.
UE location	0..1	The location of the UE when media was accessed. Present only for individual media streaming access record type, and only when exposure is permitted by the data exposure restrictions in force.



Media Stream Handler endpoint address	1..1	The endpoint address of the Media Stream Handler that accessed the 5GMS AS.
Application Server endpoint address	1..1	The endpoint address of the 5GMS AS that was accessed.
Request message	1..1	Details of the Media Stream Handler request message for this media access.
Request method	1..1	The request method.
Request URL	1..1	The URL of the requested resource representation.
Protocol version	1..1	The protocol version.
Range	0..1	The range of the resource representation requested, if any.
Size	1..1	The total size of the request message.
Body size	1..1	The size of the request message body, which may be zero.
Media content type	0..1	The media content type of the request message body, if any.
User agent	0..1	The user agent identifying the requesting Media Stream Handler, if any.
User identity	0..1	A token identifying the user that made the request, if any.
Referer	0..1	A URL that the Media Stream Handler reported being referred from, if any.
Cache status	0..1	An indication of whether the response was present in the 5GMS AS cache (if implemented) and, if so, whether the cache item was fresh or stale. Applicable to downlink media streaming only.
Response message	1..1	Details of the 5GMS AS response message for this media access.
Response code	1..1	The response code.
Size	1..1	The total size of the response message.
Body size	1..1	The size of the response message body, which may be zero.
Media content type	0..1	The media content type of the response message body, if any.
Processing latency	1..1	The time that was taken for the 5GMS AS to service the request and send the response message.
Connection metrics	0..1	Cumulative metrics about the performance of the transport connection at reference point M4.
Mean network round-trip time	1..1	A rolling mean average of the network round-trip time measured for media accesses at reference point M4.
Network round-trip time variation	1..1	The variation in <i>Mean network round-trip time</i> during its averaging period.
Congestion window size	1..1	The sampled size of the connection window for the underlying transport connection at reference point M4 when the request was processed by the 5GMS AS.

## 4.8 Downlink media streaming to Media Players with multiple formats

This clause considers downlink streaming in which a 5GMSd Application Provider publishes the same service in different media formats, all to be ingested by the same logical 5GMSd AS. The different media formats of the service are described by different presentation manifests (e.g. Dynamic Adaptive Streaming over HTTP [29] and HTTP Live Streaming [28]) but are described by a common Content Hosting Configuration (see clause 5.4) under a single Provisioning Session (see clause 5.3). The different media formats may or may not share the media resources described by their respective presentation manifests.

Where the different media formats do share the same media objects (for example, an ISO MPEG Common Media Application Format (CMAF) presentation [27] according to the content format specified in TS 26.511 [26]) the same CMAF content may then be provided to different kinds of Media Player, for example HTTP Live Streaming [28] and Dynamic Adaptive Streaming over HTTP [29], requiring different presentation manifest formats. This approach is aligned with CTA-5005 [25], which primarily focusses on creating interoperable CMAF content such that it can be used at the same time with DASH and HLS to the greatest possible extent.

The deployment architecture for this scenario is documented in figure 4.8-1. In this case, the 5GMSd Application Provider provisions a single downlink media streaming session and triggers the content to be served to 5GMS Clients that consume different media formats, indicated in the figure with an asterisk.

- Provisioning and content ingest shall support the ability to serve different formats.
- Provisioning and content ingest shall support the possibility that different formats may share common media files, for example CMAF to be used for DASH and HLS.

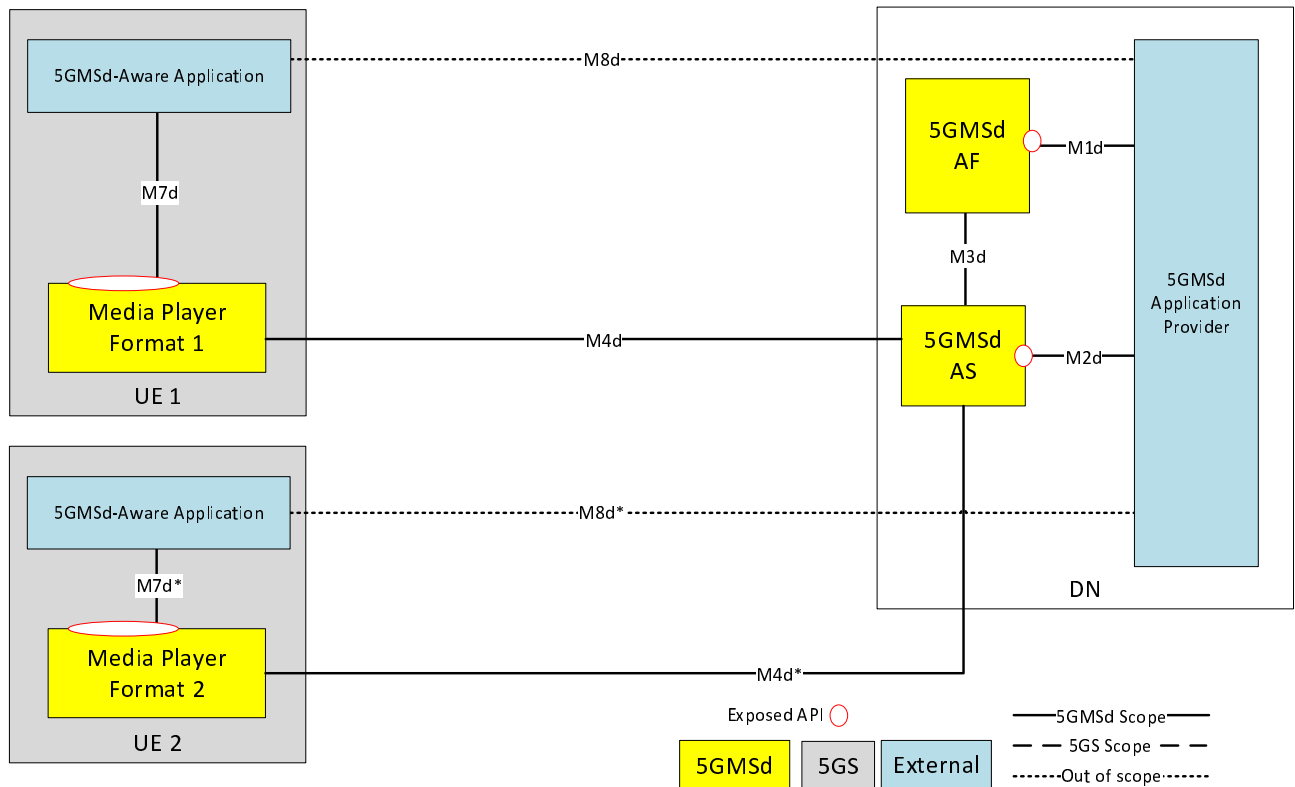
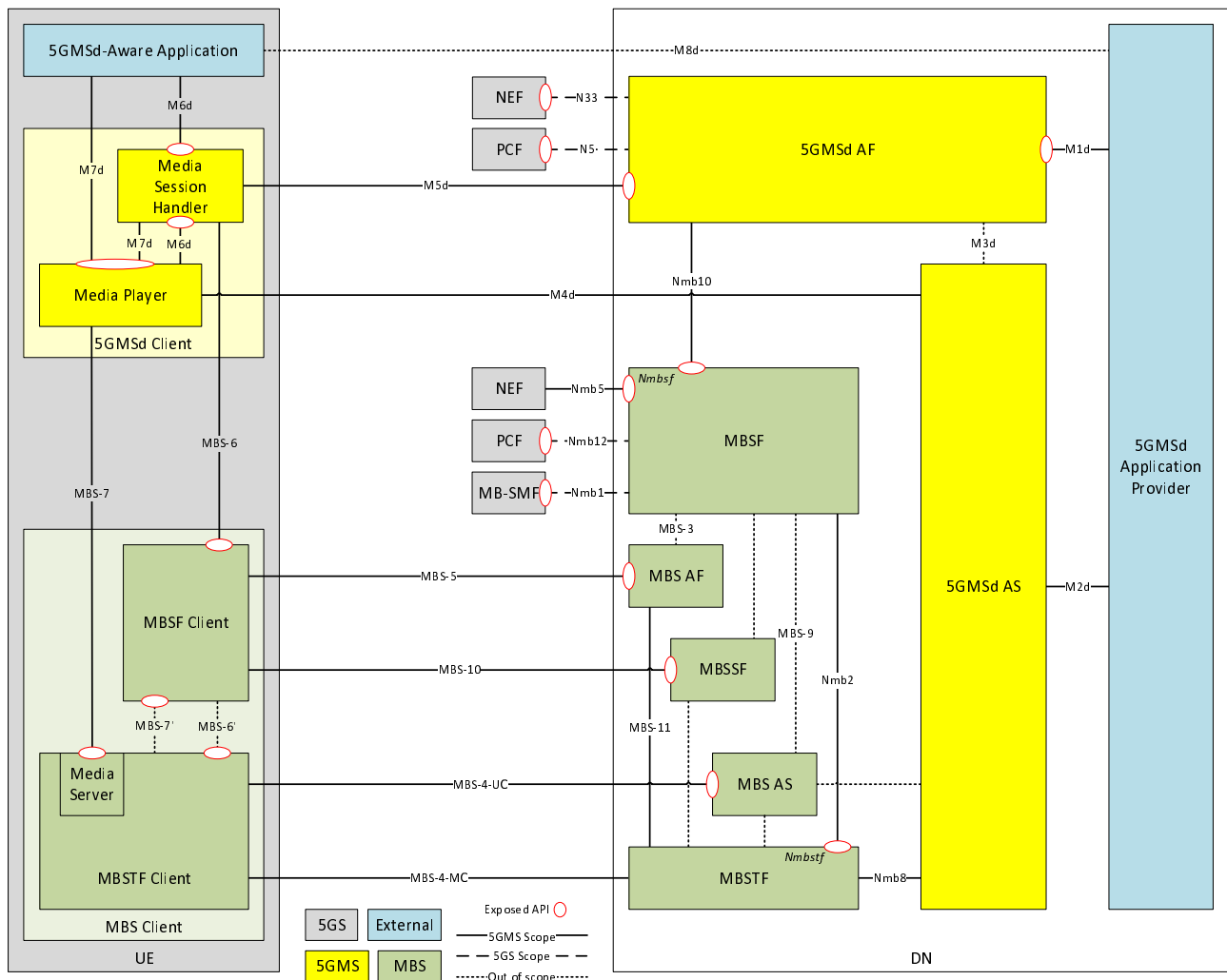

**Figure 4.8-1: Deployment architecture for downlink media streaming to Media Players with different formats**

## 4.9 Downlink 5G Media Streaming via MBS

### 4.9.1 Architecture for downlink 5G Media Streaming over MBS

Figure 4.9.1-1 below depicts an architecture for downlink 5G Media Streaming via MBS as defined in TS 26.502 [30] that combines the functions and reference points of the 5GMS System with those of the MBS System. In the simple case, the 5GMSd AF is deployed in a Trusted DN together with the MBS System according to the collaboration model in clause A.3 of [30] and *Nmbsf* service operations on the MBSF are invoked by the 5GMSd AF directly at reference point Nmb10. In other deployments, as for example shown in clauses A.4 and A.5 of [30], the 5GMS System may be external to the MBS System. In this case, the service operations on the MBSF are instead invoked on the NEF at reference point N33, and the NEF then communicates with the MBSF at reference point Nmb5.



**Figure 4.9.1-1: Architecture for 5G Media Streaming over MBS**

This arrangement allows 5GMS-based downlink media streaming to be deployed as an MBS-Aware Application on top of the MBS System as defined in TS 26.502 [30].

In this case:

1. The 5GMSd AF configures the delivery of 5GMSd content to an MBS Client in the UE by provisioning an MBS User Service as defined in clause 4.5.1 of TS 26.502 [30]. In order to additionally deliver this content over one or more MBS Distribution Session, the 5GMSd AF invokes control plane procedures on the MBSF as specified in clause 7.2 of [30] and, as a result, content is ingested by the MBSTF from the 5GMSd AS using the pull-based object ingest procedures at reference point Nmb8 specified in clause 6.1 of [30].

NOTE 1: Push-based ingest of 5GMS content by the MBSTF at reference point Nmb8 is not enabled in the current release. 5GMS only supports pull based content acquisition at reference point M4.

NOTE 2: 5GMSd AS and MBS AS share similar functions and may be deployed in a single physical node.

2. The 5GMSd Client acts as MBS-Aware Application (as defined in TS 26.502 [30]) for the MBS Client. Thus, the *MBS Client* is controlled by the 5GMSd Client via the MBS-6 API.
3. The MBSTF Client receives media and other objects from the MBSTF according to the Object Distribution Method specified in clause 6.1 of TS 26.502 [30]. If Object Repair as specified in clause 4.2.6 of TS 26.502 [30] is available in the MBS System, the MBS Client uses the unicast repair delivery procedures to recover damaged objects received from the MBSTF by interacting at reference point MBS-4-UC.
4. The *Media Server* subfunction of the MBSTF Client provides a media server interface and shall expose the content received (and possibly repaired) by the MBS Client to the Media Player in the 5GMSd Client via reference point MBS-7 using interactions equivalent to those defined at reference point M4d.

5. The Media Player sends requests according to the signalled object availability times in the manifest. In case a media object transmitted via an MBS Distribution Session is not received by the MBS Client by the object availability times, or if it cannot be repaired in time for consumption by the 5GMSd Client, the Media Server in the MBS Client returns either an error or else a partial object in response to the Media Player's request for the media object. In this case, the Media Player may instead attempt to retrieve the media object, or ranges of it, from the 5GMSd AS at reference point M4d, if available. The object shall be available for download from the 5GMSd AS for a well-defined time period.

NOTE 3: Details on determining the availability time requirements of the application are deferred to stage 3.

The usage of existing reference points to support these scenarios is documented in the following clauses. Procedures for 5GMS via MBS are defined in clause 5.12.

## 4.9.2 Usage of 5GMS reference points for MBS-based delivery

### 4.9.2.1 Usage of M1

Reference point M1 is used as defined in clauses 4.1 to 4.4.

In addition, the 5GMSd Application Provider shall authorize via M1 that 5GMS content may be distributed via MBS.

The translation of M1 information to MBS delivery provisioning by the 5GMSd AF is left to implementation.

NOTE: The 5GMS Application Provider may provision specific use-cases (high velocity, specific reception area, indoor/outdoor/mobile users) at reference point M1d. These service requirements are translated by the 5GMSd AF into specific *Nmbsf* service operations to provision the MBSF with a service that has the correct parameters for a specific location.

### 4.9.2.2 Usage of M2d

Reference point M2d is be used as defined in clauses 4.1 to 4.4.

### 4.9.2.3 Usage of M3d

Reference point M3d is used as defined in clauses 4.1 to 4.4.

### 4.9.2.4 Usage of M4d

Reference point M4d is used as defined in clauses 4.1 to 4.4.

### 4.9.2.5 Usage of M5

Reference point M5 is used as defined in clauses 4.1 to 4.4.

When 5GMS content is distributed via MBS, the 5GMSd Service Access Information shall additionally include:

1. Relevant information of the MBS Service Announcement in order to bootstrap reception of the MBS service, typically via an external service identifier. This is passed by the Media Session Handler to the MBS Client via reference point MBS-6.

When this information is present in the Service Access Information and when the UE is MBS-capable, the 5GMSd Client shall invoke the MBS Client to initiate reception of the corresponding MBS User Service.

2. Relevant information from the MBS Service Announcement in order for the Media Session Handler to:
  - a) Collect metrics of the MBS User Service from the MBS Client and report them to the 5GMSd AF using an appropriate metrics reporting scheme.
  - b) Collect media consumption information from the MBS Client and submit it to the 5GMSd AF in 5GMS consumption reports.

#### 4.9.2.6 Usage of M6d

Reference point M6d is used as defined in clauses 4.1 to 4.4.

#### 4.9.2.7 Usage of M7d

Reference point M7d is used as defined in clauses 4.1 to 4.4.

#### 4.9.2.8 Usage of M8d

Reference point M8d is used as defined in clauses 4.1 to 4.4.

### 4.9.3 Usage of MBS reference points and interfaces

#### 4.9.3.1 Usage of Nmbsf service at Nmb10 and Nmb5+N33

The 5GMSd AF provisions MBS User Services in the MBSF as defined in clauses 5.3 of TS 26.502 [30]. In case the 5GMSd AF is in a Trusted DN together with the MBS System according to the collaboration model in clause A.3 of [30], *Nmbsf* service operations shall be invoked directly at reference point Nmb10. Where the 5GMSd AF is deployed outside the Trusted DN, as for example shown in *Nmbsf* service operations shall instead be invoked via the NEF at reference points N33+Nmb5.

#### 4.9.3.2 Usage of Nmb8

The MBSTF ingests content from the 5GMSd AS using the pull-based ingest method at reference point Nmb8.

#### 4.9.3.3 Usage of MBS User Services and Distribution Methods

Real-time object streaming as defined in clause 6.1 of TS 26.502 [30] is provisioned in the MBSTF by the MBSF acting on the provisioning instructions of the 5GMSd AF. The application service entry point instance is a downlink 5GMS streaming manifest, for example a DASH MPD or HLS playlist.

The MBS User Service Announcement as defined in clause 4.2.4 of TS 26.502 [30] is used to advertise the availability of 5GMS content delivered via MBS.

#### 4.9.3.4 Usage of MBS-6

The 5GMSd Client plays the role of an MBS-Aware Application and operates according to the procedures defined in clauses 5.2 and 5.5 of TS 26.502 [30] when communicating with the MBSF Client at reference point MBS-6.

The MBSF Client exposes information to the Media Session Handler at this reference point to manage the reception of MBS User Services.

The Media Session Handler configures the MBSF Client for reception reporting.

The MBSF Client provides reception reports to the Media Session Handler.

#### 4.9.3.5 Usage of MBS-7

The 5GMSd Client plays the role of an MBS-Aware Application and operates according to the procedures defined in clause 5.2 of TS 26.502 [30] when communicating with the MBSTF Client at reference point MBS-7.

The MBSTF Client provides the entry point document, as well as updates of the entry point document, to the 5GMSd Client at this reference point.

The MBSTF Client exposes fully- and partially-received media objects to the Media Player in the 5GMSd Client.

## 4.10 3GPP Service URL handling

### 4.10.1 General

Where there is a facility for an application or service to launch a UE function on the same UE via a URL request, it is convenient to use such a mechanism to launch media session handling for a 5G Media Streaming session. In this case, the Media Session Handler can be launched implicitly as a result of a request for a URL with a prefix that matches a value previously registered with the UE Operating System by the Media Session Handler. Media streaming may also be launched as a by-product of the URL request by embedding a Media Entry Point in the URL. This enables 5G Media Streaming sessions to be launched by any UE application (not just a 5GMS-Aware Application), or from a link in a web page.

If the Media Session Handler is not available on the UE, or if the Media Session Handler is not able to resolve the service, then the 3GPP Service URL shall resolve to an endpoint on the 5GMS AF which may respond to the URL request, for example by redirecting the application to a Media Entry Point.

This clause defines the baseline requirements for a 3GPP Service URL that can be used to activate a 5G Media Streaming session in line with step 5 of clause 5.1 (for downlink Media Streaming), and steps 4 and 6 of clause 6.1 (for uplink Media Streaming). The detailed baseline procedure for handling these 3GPP Service URLs is defined in clause 9.

### 4.10.2 Baseline parameters of 3GPP Service URL for 5G Media Streaming

The parameters in table 4.10.2-1 may be included explicitly or implicitly in the 3GPP Service URL when it is used to launch a 5G Media Streaming session:

**Table 4.10.2-1: Baseline parameters of 3GPP Service URL for 5G Media Streaming**

Parameter	Use	Description
Service type	M	Uniquely indicating either downlink 5G Media Streaming or uplink 5G Media Streaming.
External service identifier	M	A globally unique service identifier nominated by the 5GMS Application Provider that resolves to a Provisioning Session in the 5GMS System.
5GMS AF endpoint addresses	0..N	Endpoint address(es) for 5GMS AF instance(s) to be used by the Media Session Handler at reference point M5. Any of the provided addresses may be used for media session handling of this 3GPP Service URL. Present only in the case where the 5GMS AF is deployed outside the Trusted DN.
Media Entry Point URLs	0..N	URLs of Media Entry Points on a 5GMS AS to be launched by the Media Session Handler after successful initiation of media session handling and establishment of communication with the Media Stream Handler (Media Player or Media Streamer).
Acceptable media types	C	Indicating a set of media types acceptable to the 5GMS-Aware Application for a 5G Media Streaming session. Present if no Media Entry Point is provided. This value is used by the Media Session Handler to select the appropriate Media Entry Point provided by the 5GMS AF.
Acceptable media profiles	C	Indicating a set of acceptable conformance profiles for a 5G Media Streaming session. Present if no Media Entry Point is provided. This value is used by the Media Session Handler to select the appropriate Media Entry Point provided by the 5GMS AF.

The 3GPP Service URL for 5G Media Streaming may also include information to support handling of eMBMS or MBS delivery.

# 5 Procedures for downlink Media Streaming

## 5.1 General

The downlink streaming procedures follow the general high-level workflow depicted in Figure 5.1-1 below, starting from provisioning and ingest session preparation to the actual content streaming sessions. The **Ingest Session** refers to the time interval during which media content is uploaded to the 5GMSd AS. The **Provisioning Session** refers to the time interval during which the 5GMSd Client can access the media content and the 5GMSd Application Provider can control and monitor the media content and its delivery. Interactions between the 5GMSd AF and the 5GMSd Application Provider may occur at any time while the Provisioning Session is active.

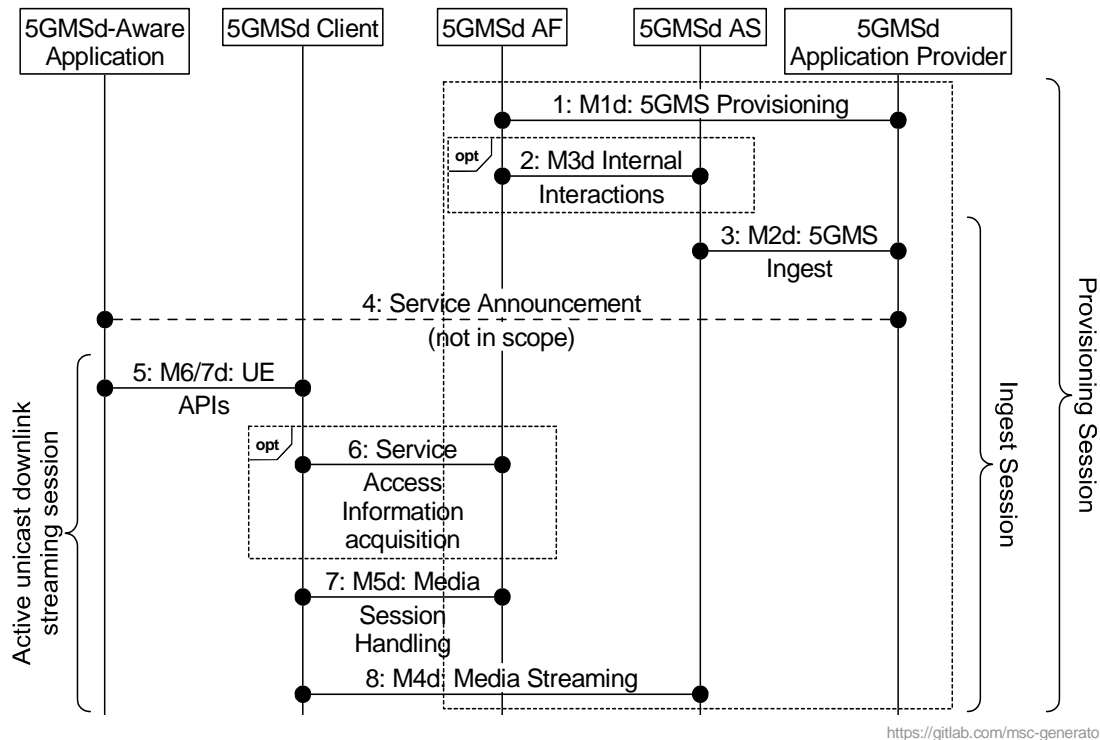

**Figure 5.1-1: High-level procedure for downlink media streaming**

The 5GMSd provisioning API at M1d allows selection of media session handling (M5d) and media streaming (M4d) options, including whether the media content is hosted on trusted 5GMSd AS instances. of provisioned 5GMSd features is captured in a Provisioning Session (see clause 5.3) that is uniquely identified in the 5GMS System by a Provisioning Session identifier. The Provisioning Session information may include Content Hosting Configurations, Content Preparation Templates, Server Certificates, Policy Templates, a Consumption Reporting Configuration, Metrics Reporting Configurations, Edge Resources Configurations and Event Data Processing Configurations.

The Consumption Reporting and/or Metrics Reporting Configuration information provisioned over M1d and passed to the 5GMSd Client by the 5GMSd AF over M5d determines the UE data to be collected by the 5GMSd Client and subsequently reported to the 5GMSd AF. The 5GMSd Application Provider is additionally able to provision Event Data Processing Configurations that specify data processing instructions for subsequent manipulation by the 5GMSd AF of UE data, whether reported by the 5GMSd Client or otherwise obtained, and rules for restricting the subsequent exposure by the 5GMSd AF of UE data to event consumers including the NWDAF defined in TS 23.288 [23] and/or the 5GMSd Application Provider.

The 5GMSd AF selects the M5d interface features according to the provisioning option. The Media Session Handling interface exposed by the 5GMSd AF can be used for core session handling; configuring content consumption measurement, logging, collection and reporting; configuring QoE metrics measurement, logging collection and reporting; requesting different policy and charging treatments; or 5GMSd AF-based Network Assistance.

When the media content is hosted by trusted 5GMSd AS instances, then the 5GMSd AF selects and configures the 5GMSd AS. Interactions between a 5GMSd AF and a 5GMSd AS (M3d interactions) take place for content hosting

configuration, including 5GMS Ingest (M2d) and Media Streaming (M4d) resource reservations. The 5GMSd AS allocates M2d and M4d resources and communicates resource identifiers back to the 5GMSd AF. The 5GMSd AF provides information about the provisioned resources (in form of resource identifiers) for Media Session Handling (M5d), the 5GMSd Ingest (M2d) and the Media Streaming (M4d), to the 5GMSd Application Provider. The resource identifiers for Media Session Handling and Media Streaming are needed by the 5GMSd Client to access the 5GMSd functions.

When Content Hosting is provided by a 5GMSd AS in the external DN, then the M3d interface is not used and the 5GMSd AF does not provide 5GMS Ingest (M2d) and Media Streaming (M4d) resource reservations. M3d procedures are not standardized.

5GMSd Clients can (in principle) start streaming media as soon as the corresponding content is ingested by activating a unicast downlink streaming session. However, it may take some time until the media content is available for Media Streaming (via the Media Streaming API) or the distribution availability might be based on a provisioned schedule. The unicast downlink streaming session for a given UE (or "for each UE") is active from the time at which the 5GMSd-Aware Application activates the reception of a streaming service until its termination.

The 5GMSd-Aware Application receives application data from the 5GMSd Application Provider before receiving the downlink streaming media. The application data contains Service Access Information, which acts as an entry point for the 5GMSd Client to start the downlink streaming session. The 5GMSd Client may either receive a reference to that Service Access Information or the full Service Access Information from the 5GMSd Application Provider.

Steps:

1. The 5GMSd Application Provider creates a Provisioning Session with the 5GMSd AF and starts provisioning the usage of the 5G Media Streaming System. During the establishment phase, the used features are negotiated and detailed configurations are exchanged. The 5GMSd AF receives Service Access Information for M5d (Media Session Handling) and, where media content hosting is negotiated, Service Access Information for M2d (Ingestion) and M4d (Media Streaming) as well. This information is needed by the 5GMSd Client to access the service. Depending on the provisioning, only a reference to the Service Access Information might be supplied.
2. When Content Hosting is offered and selected there may be interactions between the 5GMSd AF and the 5GMSd AS at reference point M3d, e.g., to configure Server Certificates and/or Content Preparation Templates and to allocate 5GMSd content ingest and distribution resources by providing a Content Hosting Configuration. The 5GMSd AS provides resource identifiers for the allocated resources to the 5GMSd AF, which then provides the information to the 5GMSd Application Provider.
3. The 5GMSd Application Provider starts the Ingest Session by ingesting content. In case of live services, the content is continuously ingested. In case of on-demand streaming services, the content may be uploaded once and then updated later on.

NOTE 1: A 5GMSd AS in the external Data Network may provide the Content Hosting.

4. The 5GMSd Application Provider provides the Service Announcement Information to the 5GMSd-Aware Application. The service announcement includes either the whole Service Access Information (i.e. details for Media Session Handling (M5d) and for Media Streaming access (M4d)) or a reference to the Service Access Information or pre-configured information. When only a reference is included, the 5GMSd Client fetches (in step 6) the Services Access Information when needed. In a specific case, the 5GMSd service may be announced using a 3GPP Service URL (see clause 4.10) that will launch the service as defined in clause 9.
5. When the 5GMSd-Aware Application decides to begin streaming, the Service Access Information (all or a reference) is provided to the 5GMSd Client. The 5GMSd Client activates the unicast downlink streaming session.
6. (Optional) In case the 5GMSd Client received only a reference to the Service Access Information, then it acquires the Service Access Information from the 5GMSd AF.

NOTE 2: Pre-caching of Service Access Information may also be supported by the 5GMS Client to speed up the activation of the service.

7. The 5GMSd Client uses the Media Session Handling API exposed by the 5GMSd AF at M5d. The Media Session Handling API is used for configuring content consumption measurement, logging, collection and reporting; configuring QoE metrics measurement, logging, collection and reporting; requesting different policy



and charging treatments; or 5GMSd AF-based Network Assistance. The actual time of API usage depends on the feature and interactions that may be used during the media content reception.

- 8. The 5GMSd Client activates reception of the media content.

## 5.2 Baseline procedure for unicast downlink Media Streaming session establishment

### 5.2.1 General

This clause describes the baseline procedure for establishing a unicast downlink media streaming session. This baseline procedure assumes that the 5GMSd AF and the 5GMSd AS both reside in the external DN and that there are no interactions between the 5GMSd AF and the 5G System.

### 5.2.2 Progressive download of on-demand content

This baseline procedure describes the establishment of a unicast downlink streaming session. A streaming session may use 3GP File Format (Progressive Download), 3GP Timed Text or other (potentially non-3GPP defined) formats.

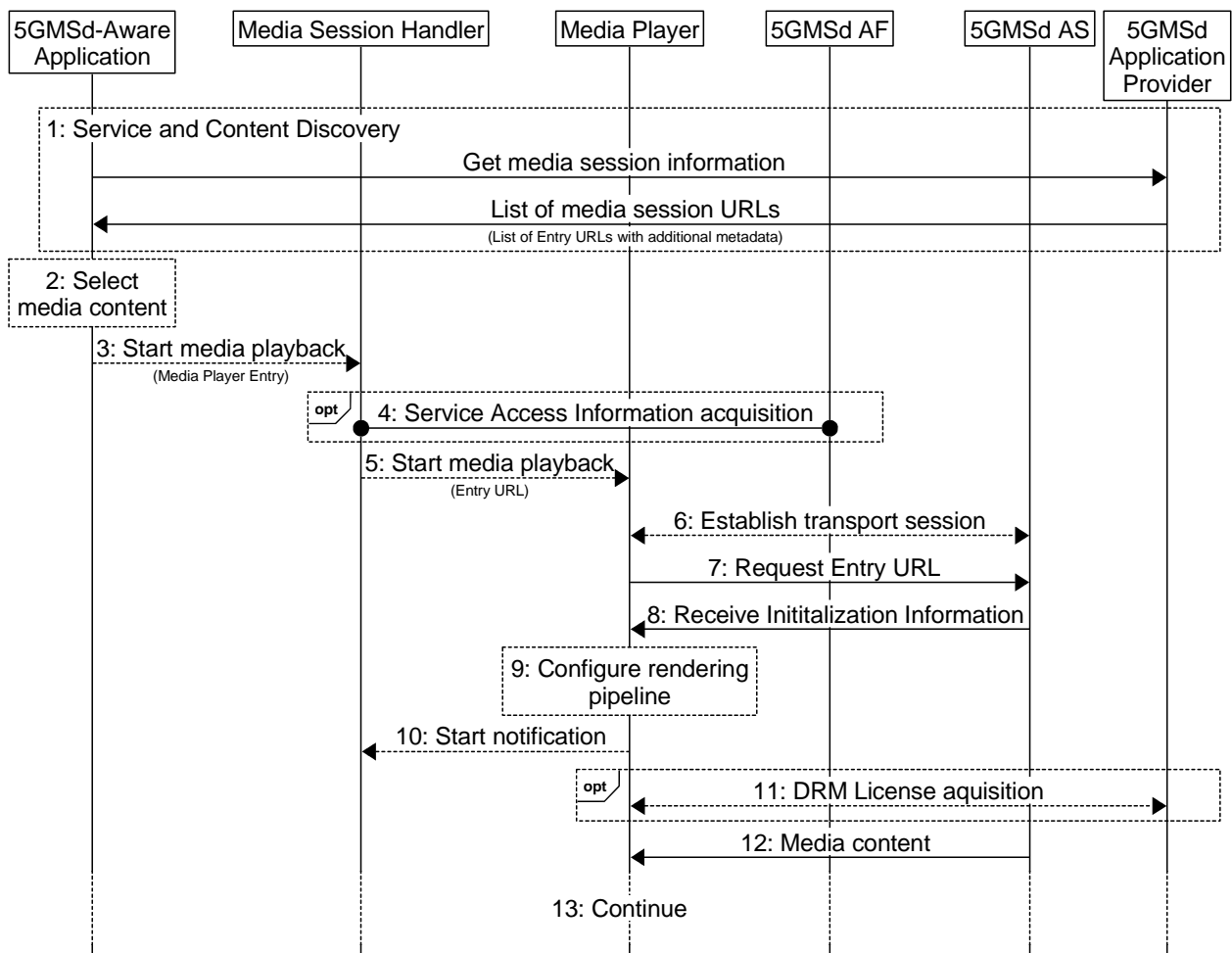

<http://msc-generator.sourceforge.net v6.3.8>

Figure 5.2-1: High Level Procedure for progressive download for on-demand media

## Prerequisites:

- The 5GMSd Application Provider has provisioned the 5G Media Streaming System and has set up content ingest.
- The 5GMSd-Aware Application has received the service announcement from the 5GMSd Application Provider.

## Steps:

- 1: The 5GMSd-Aware Application triggers the Service Announcement and Service and Content Discovery procedure. The Service Announcement includes either the whole Service Access Information (i.e. details for Media Session Handling (M5d) and for Media Streaming access (M4d)) or a reference to the Service Access Information.

NOTE: The Service and Content Discovery procedure only involves the 5GMSd-Aware Application and the 5GMSd Application Provider and hence is out of scope of the present document.

- 2: A Media Player Entry is selected.
- 3: The 5GMSd-Aware Application triggers the Media Session Handler to start the playback. The Media Player Entry is provided to the Media Session Handler.
- 4: When the 5GMS-Aware Application has received only a reference to the Service Access Information (see step 1), the Media Session Handler interacts with the 5GMSd AF to acquire the whole Service Access Information.
- 5: The Media Session Handler triggers the Media Player to start the session.
- 6: The Media Player establishes the transport session.
- 7: The Media Player sends the request for the progressive download content.
- 8: The Media Player receives the initialization information of the progressive download content. The initialization information contains configuration parameters for reception of the media and, optionally, also DRM information.
- 9: The Media Player configures the rendering pipeline for media playback.
- 10: The Media Player notifies the Media Session Handler, providing the transport session information and some media content related information.
- 11: Optional: The Media Player acquires a DRM License from the 5GMSd Application Provider.
- 12: The Media Player receives media content and puts it into the rendering pipeline.
- 13: The Media Player continuously receives and plays back the media content.

### 5.2.3 DASH streaming

It is assumed here that the key information to initialize the media decoding and rendering pipeline is present in the Media Player Entry (or referenced by the Media Player Entry). The intention is to provide the 5GMSd Client with information to set up the media decoding and rendering pipeline in such a way that no pipeline reset is needed during the session. Implementations need to consider that parts of the information are provided with the initialization segments.

It is assumed that the client is enabled to use the same media decoding and rendering pipeline during the session.

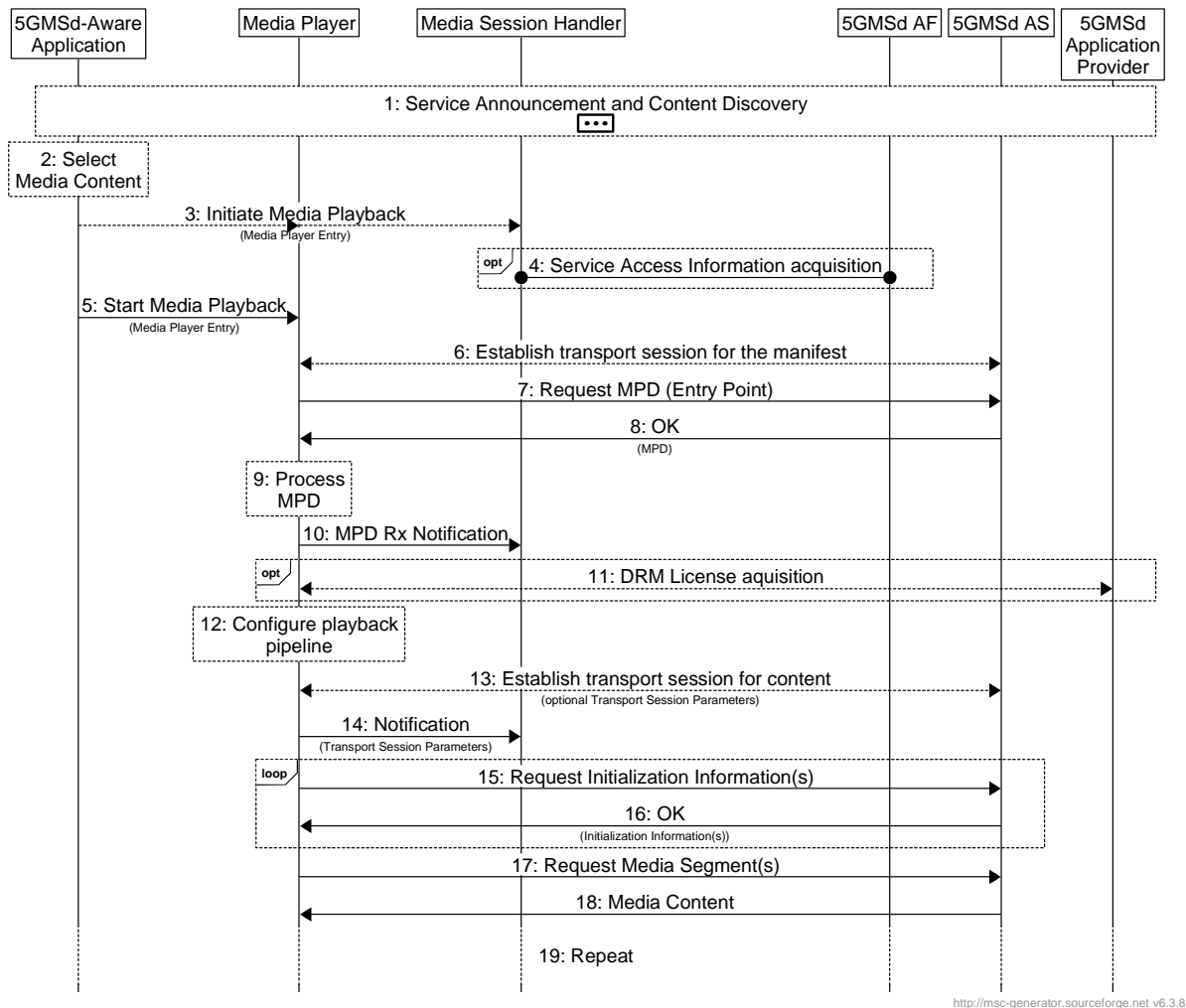

Figure 5.2-2: High-level procedure for DASH content

Prerequisites:

- The 5GMSd Application Provider has provisioned the 5G Media Streaming System and has setup content ingest.
- The 5GMSd Aware Application has received the service announcement from the 5GMS Application Provider.

Steps:

- 1: The 5GMSd Aware Application triggers the Service Announcement and Service and Content Discovery procedure. The Service and Content Discovery procedure only involves the App and the external Application Server. The Service Announcement includes either the whole Service Access Information (i.e. details for Media Session Handling (M5d) and for Media Streaming access (M4d)) or a reference to the service access information.
- 2: A media content item is selected.
- 3: The 5GMSd-Aware Application triggers the 5GMSd Client to start media playback. The Media Player Entry is provided to the 5GMSd Client.

- 4: When the 5GMS-Aware Application has received only a reference to the Service Access Information (see step 1), the Media Session Handler interacts with the 5GMSd AF to acquire the whole Service Access Information.
- 5: In parallel, the Media Player is invoked to start media access and playback.
- 6: The Media Player establishes the transport session for acquiring the MPD referenced by the Media Player Entry.
- 7: The Media Player requests the MPD.
- 8: The Media Player receives the MPD.
- 9: The Media Player processes the MPD. It determines for example the number of needed transport sessions for media acquisition. The Media Player should be able to use the MPD information to initialize the media pipelines for each media stream. The MPD should also contain information to initialize the DRM client, when DRM is used.
- 10: The Media Player notifies the Media Session Handler about the MPD. The notification may contain parameters from the MPD.
- 11: Optional: the Media Player acquires the necessary DRM information, for example a DRM License.
- 12: The Media Player configures the media playback pipeline.
- 13: The Media Player establishes the necessary transport sessions for the content. For example, the Media Player may establish one transport session for each media component (audio, video, etc) and possibly additional transport sessions for other media representations.
- 14: The Media Player notifies the Media Session Handler that it is ready to commence playback and optionally provides transport session parameters.
- 15: The Media Player requests initialization information. The Media Player repeats this step for each required initialization segment.
- 16: The Media Player receives the initialization information.
- 17: The Media Player requests media segments according to the MPD.
- 18: the Media Player receives media segments and puts the information into the appropriate media rendering pipeline.
- 19: Previous steps are repeated according to the MPD information.

NOTE: The Media Player can interact with multiple instances of the 5GMSd AS. The Media Player can be made aware of the 5GMSd AS instances via the manifest.

## 5.2.4 Procedures for downlink streaming to Media Players with different presentation manifests

Figure 5.2.4-1 illustrates a high-level procedure for downlink streaming to Media Players with different presentation manifests. The extensions compared to the DASH streaming in clause 5.2.3 are indicated in bold.

The procedure makes the following assumptions:

- Common media segments (e.g. based on CMAF [27]) are shared between multiple Media Players requiring different presentation formats (see clause 4.8).
- Key information to initialize the media decoding and rendering pipeline is present in the Media Player Entries (or referenced by the Media Player Entries).

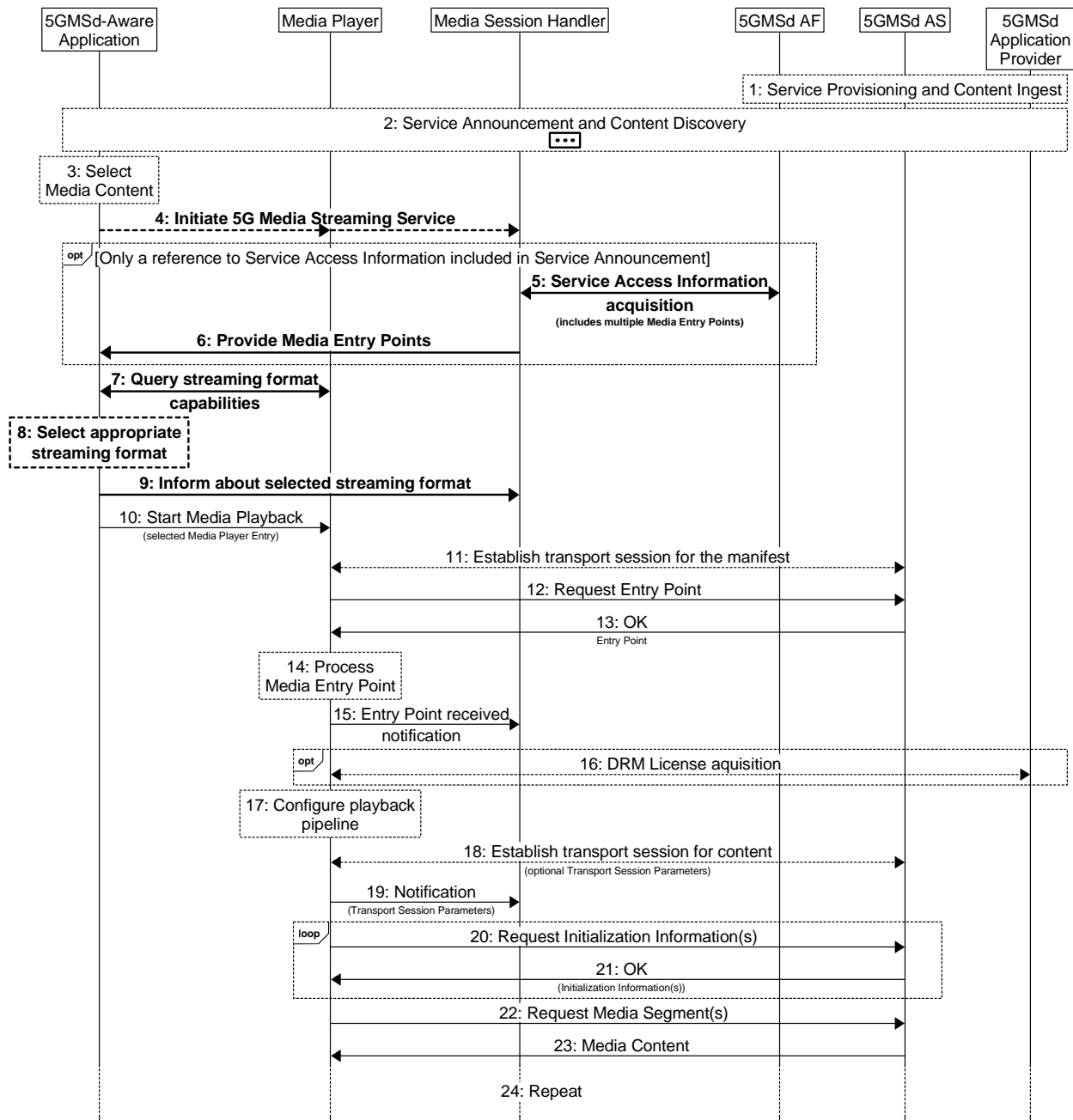

<https://gitlab.com/msc-generator v8.0>

**Figure 5.2.4-1: High-level procedure for CMAF content shared by different Media Players**

Steps:

- 1: The 5GMSd Application Provider provisions the 5G Media Streaming System, including content hosting.
- 2: The 5GMSd-Aware Application triggers the Service Announcement and Service and Content Discovery procedure with the 5GMSd Application Provider. The Service Announcement includes either the whole Service Access Information (i.e. details for Media Session Handling (M5d) and for Media Streaming access (M4d) **which may include a Media Entry Point URL for each of the different available presentation manifests, or a reference to the Service Access Information.**
- 3: A media content item is selected.
- 4: The 5GMSd-Aware Application triggers the 5GMSd Client to initiate the **5G Media Streaming Service.**

When the 5GMS-Aware Application has received only a reference to the Service Access Information (see step 1):

- 5: The Media Session Handler interacts with the 5GMSd AF to acquire the whole Service Access Information. **The Service Access Information may include a Media Entry Point URL for each of the different available presentation manifests.**
- 6: **The Media Session Handler provides the Media Entry Points to the 5GMS-Aware Application. The information may indicate a precedence order for these Media Entry Points.**

Then:

- 7: **The 5GMSd-Aware Application queries the Media Player capabilities for different manifests. If multiple streaming formats are supported, a preferred one may be indicated in the response.**
- 8: **The 5GMSd-Aware Application selects one of the Media Entry Points based on the information provided in steps 5 and 6 above.**
- 9: **The 5GMSd-Aware Application informs the Media Session Handler about the streaming format of the chosen Media Entry Point, for example for Consumption Reporting purposes.**
- 10: In parallel, the Media Player is invoked with the **selected Media Entry Point** to start media access and playback.

Steps 11 to 24 are identical to steps 6 to 19, respectively, in clause 5.2.3.

## 5.3 Provisioning Session for Media Streaming

### 5.3.1 Domain model

The M1d baseline domain model is depicted in Figure 5.3.1-1 overleaf. It consists of a Provisioning Session, which contains at least one of the following:

- A Content Hosting Configuration,
- A Consumption Reporting Configuration which defines consumption measurement, logging, collection and reporting functionality,
- A Policy Template,
- A Metrics Reporting Configuration which defines QoE metrics measurement, logging, collection and reporting functionality,
- An *Edge Resources Configuration* specifying the requirements for edge processing as defined in TS 23.548 [15] and TS 23.558 [16] in support of the Provisioning Session, including eligibility criteria that indicate the circumstances in which edge computing is to be used for Media Streaming sessions associated with this Provisioning Session and parameters indicating the tolerance of the application for relocation of the Edge AS, or
- An *Event Data Processing Configuration* which contains data manipulation instructions to be performed on UE data by the Data Collection AF including, but not limited to, reporting format conversion, data normalisation, domain-specific anonymisation of data and (dis)aggregation of data into exposed events. This entity includes one or more *Data Access Profiles*, each one defining a specific access level for controlling the event information exposed to an event consumer.

Each Provisioning Session is uniquely identified within the 5GMS System by a Provisioning Session identifier.

When a certain 5GMS feature is selected, the 5GMSd AF compiles the resulting Service Access Information so that the 5GMSd Client can access the services via M4d and/or M5d.

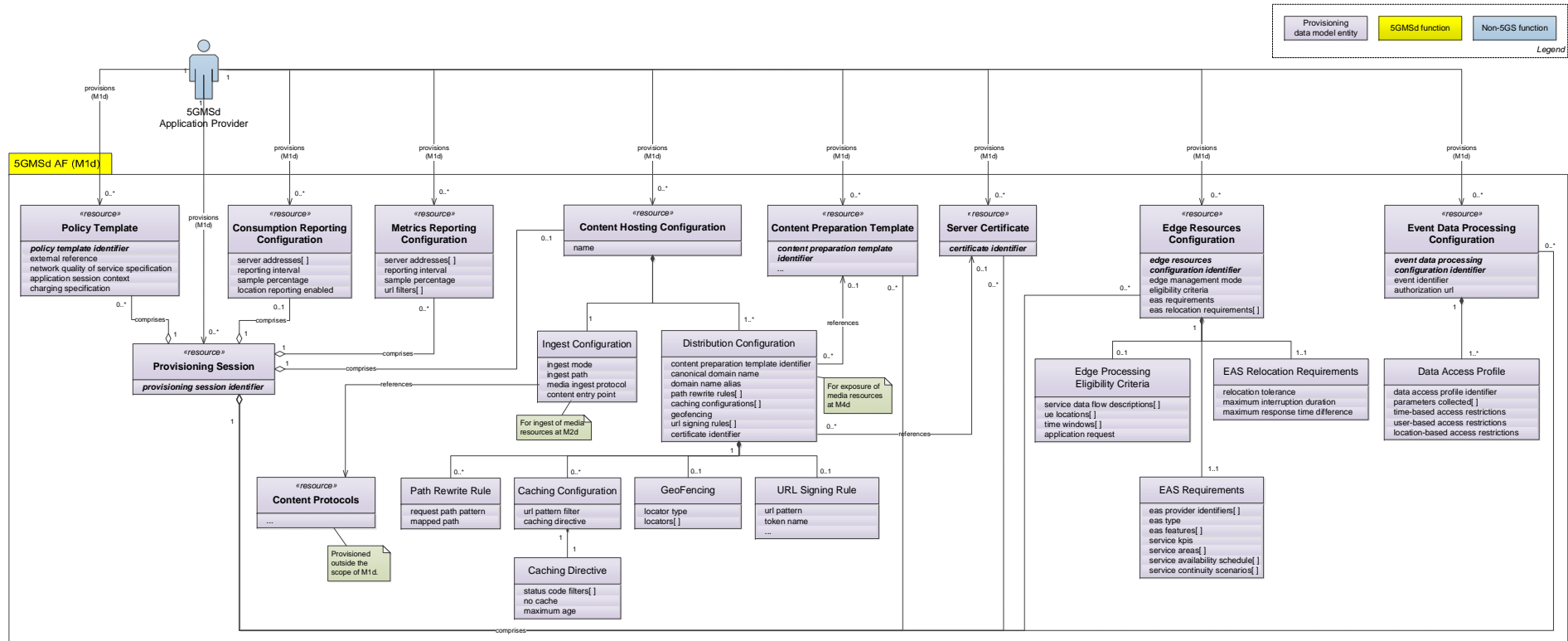
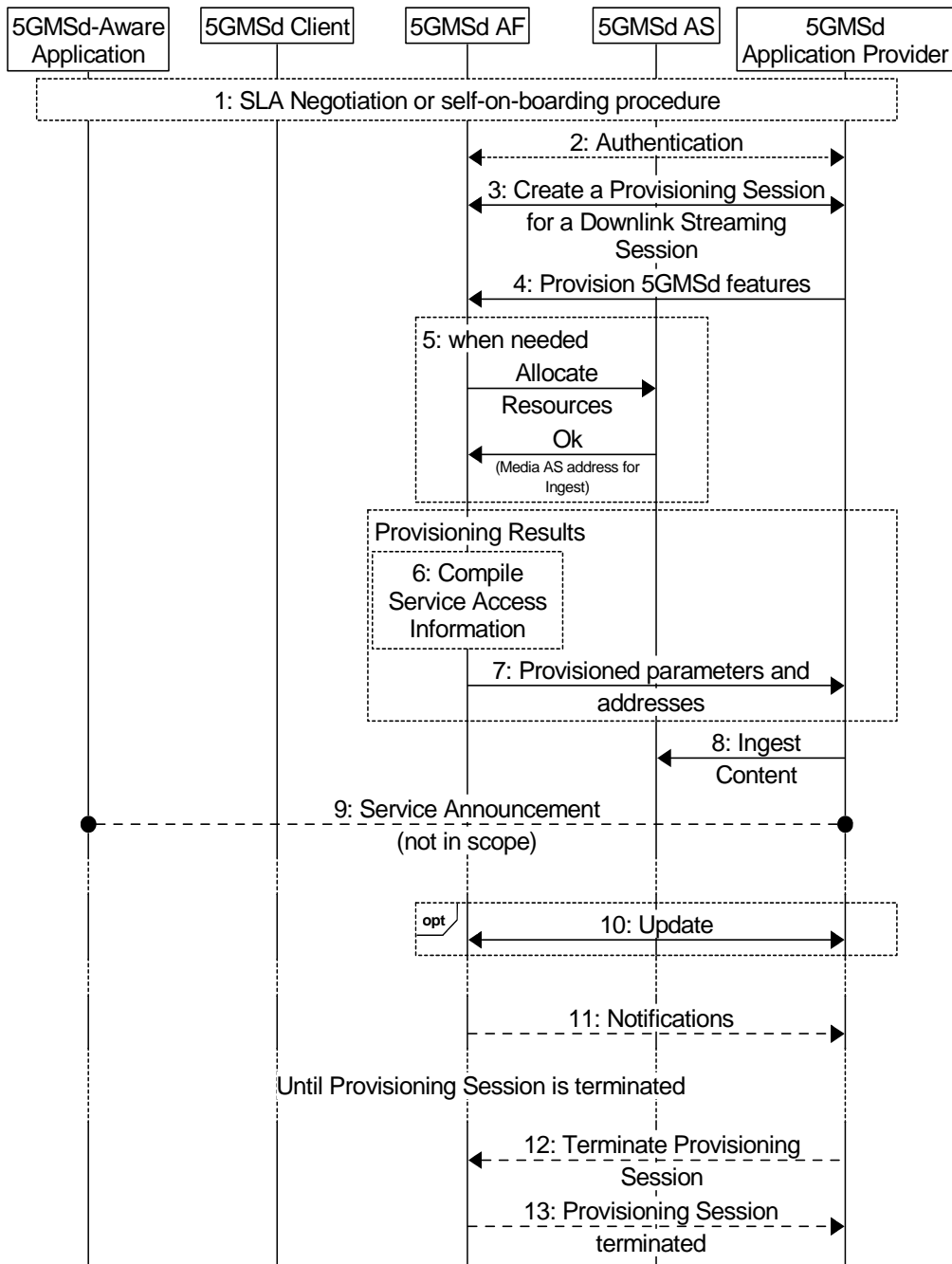

Figure 5.3.1-1: M1d provisioning domain model

### 5.3.2 Baseline provisioning procedure

The present clause describes the baseline procedure to provision the features using the 5GMS System.

NOTE 1: SLA negotiations between the 5GMSd Application Provider and the 5GMS System provider are outside the scope of the present specification and are included in the figure below for illustrative purposes only.



<http://msc-generator.sourceforge.net> v6.3.8

**Figure 5.3.2-1: High-level procedure for provisioning the 5GMS System for downlink media streaming sessions**



Steps:

1. The 5GMSd Application Provider discovers the address (URL) of the 5GMSd AF (M1d) for Session Provisioning.
2. The 5GMSd Application Provider authenticates itself with the system. This procedure reuses existing authentication/authorization procedures, e.g. as defined for CAPIF [13].
3. The 5GMSd Application Provider creates a Provisioning Session, providing its 5GMSd Application Provider identifier as input. 5GMSd Application Provider queries the capabilities and authorized features.
4. The 5GMSd Application Provider specifies one or more 5GMSd features in the Provisioning Session. A set of authorized features is activated, such as content consumption measurement, logging, collection and reporting; QoE metrics measurement, logging, collection and reporting; dynamic policy; network assistance; and content hosting (including ingest).

One or more *External service identifiers* are supplied by the 5GMSd Application Provider to support the later retrieval of Service Access Information from the 5GMSd AF by the Media Session Handler.

When the content hosting feature is offered and selected, the 5GMS Application Provider configures the content hosting behaviour of the 5GMSd AS. This Content Hosting Configuration is specified in clause 5.4 and includes selecting the ingest protocol and format, caching and proxying of media objects, content preparation, access protection (e.g. URL signing) and indicating a target distribution area (e.g. through geofencing).

When the dynamic policy feature is offered and selected, the 5GMSd Application Provider specifies a set of policies which can be invoked for the unicast downlink streaming session. The UE becomes aware of the selected policies in the form of a list of valid Policy Template Ids.

When the content consumption measurement, logging, collection and reporting feature is offered and selected, the 5GMSd Application Provider indicates the desired reporting interval. When the 5GMSd Application Provider has delegated Service Access Information handling to the 5GMS System, then location reporting is also selected or de-selected.

When the QoE metrics measurement, logging, collection and reporting feature is offered and selected, the 5GMSd Application Provider provides configuration input on the QoE post processing. When the 5GMSd Application Provider has delegated Service Access Information handling to the 5GMS System, then more detailed metrics reporting is configured.

When the edge computing feature is offered and selected, the 5GMSd Application Provider provides one or more Edge Resources Configurations that can be used to support either client-driven management or Application Provider-driven management of edge resources associated with the Provisioning Session.

When the event data processing feature is offered and selected, the 5GMSd Application Provider provides one or more Event Data Processing Configurations that determine how, in the scope of the Provisioning Session, content consumption and QoE metrics collected from the UE and application logs collected from the 5GMSd AS are processed into events and exposed to subscribers.

5. When content hosting is desired, the 5GMSd AF interacts with the 5GMSd AS at reference point M3d to allocate M2d resources and to configure the ingest format by means of a Content Hosting Configuration (defined in clause 5.4) which may reference Server Certificates and Content Preparation Templates, as required. The 5GMSd AS responds with the M2d content ingest address.
6. The 5GMSd AF compiles the Service Access Information. The Service Access Information contains access details and options such as the Provisioning Session identifier, M5d (Media Session Handling) addresses for content consumption reporting, QoE metrics reporting, dynamic policy, network assistance, etc. When content hosting is offered and has been selected in step 4, then also M4d (Media Streaming) information such as the DASH MPD is included.
7. The 5GMSd AF provides the results to the 5GMSd Application Provider.
  - a. When the 5GMSd Application Provider has selected full Service Access Information, then the results are provided in the form of addresses and configurations for M2d (Ingest), M5d (Media Session Handling) and M4d (Media Streaming).

- b. When the 5GMSd Application Provider delegated the Service Access Information handling to the 5GMS System, then a reference to the Service Access Information (e.g., a URL) is provided. The Media Session Handler fetches the full Service Access Information later from the 5GMSd AF.
8. When content hosting is offered and has been selected in step 4, the 5GMSd Application Provider can start supplying content at the M2d ingest interface. In the case of progressive download or on-demand DASH sessions, the 5GMSd Application Provider makes the content assets available. In the case of Live DASH streaming sessions, the 5GMSd Application Provider starts supplying the live content.
9. The 5GMSd Application Provider executes Service Announcement and updates the UEs (during the lifetime of the Provisioning Session).

Optional:

10. The 5GMSd Application Provider may update the Provisioning Session.

Depending on the parameters of the Provisioning Session:

11. The 5GMSd AF may send event-related or periodic notifications to the 5GMSd Application Provider.

According to schedule, or upon request:

12. The 5GMSd Application Provider may manually terminate the Provisioning Session (at any time). All associated resources are released. Content may be removed from the 5GMSd AS. The 5GMSd Application Provider may configure a schedule for Provisioning Session termination.
13. The 5GMSd AF sends a notification upon Provisioning Session termination.

The 5GMSd AF may request the creation or reuse of one or more network slices for distributing the content of the provisioned session. If more than one network slice is provisioned for the distribution of the content of a session, the list of allowed S-NSSAIs shall be conveyed to the target UEs (e.g. through URSP or through M5d or M8d).

NOTE 2: The 5GMSd AS(s) serving the content are only accessible through the DNN(s) used by the network slice(s) provisioned for the distribution of that content.

## 5.4 Content Hosting Configuration for downlink Media Streaming

### 5.4.1 General

The 5G Media Streaming architecture defines an interface (M1d) for provisioning which offers the procedures to configure content ingest for downlink media streaming over 5G. Once a Provisioning Session is established using the API at interface M1d, content hosting can be configured. The control part of the ingest interface may be performed through the NEF. Ingested content is accessible from the 5GMSd AS at interface M4d through a new location identifier.

The M2d interface supports the ingest of the following types of content:

- Live streaming content.
- On-demand streaming content.
- Static files such as images, scene descriptions, etc.

The 5GMSd AF provides an API at interface M1d that allows a 5GMSd Application Provider to create/update/delete a Content Hosting Configuration. A Content Hosting Configuration contains all the parameters for a particular content ingest and distribution setup.

NOTE: In the current version of the present document, the M2d ingest interface only supports unicast downlink streaming.

## 5.4.2 Media ingest procedure

The media ingest procedure is illustrated in figure 5.4-1:

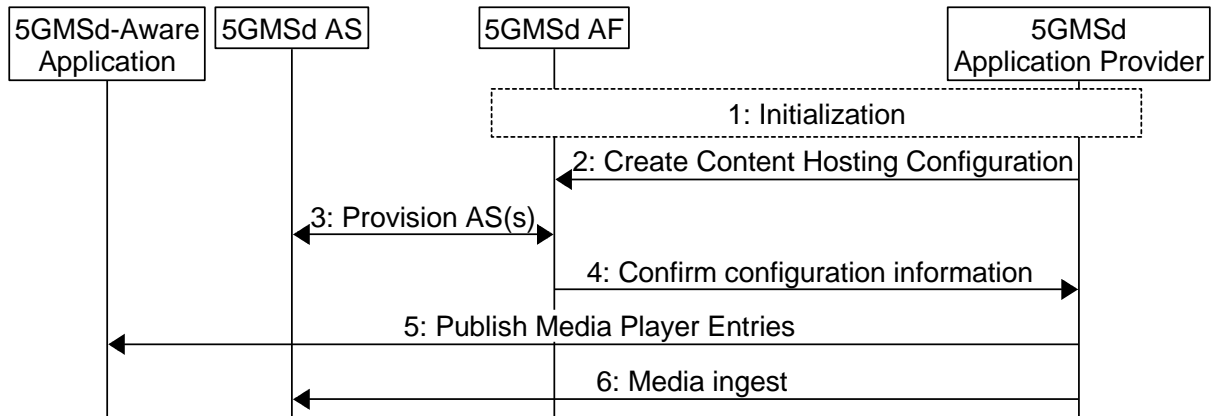

**Figure 5.4-1: Media ingest procedure**

The steps are as follows:

- 1: *Initialization*: the 5GMSd Application Provider discovers the entry point and authenticates itself with the 5GMSd AF.
- 2: *Create Content Hosting Configuration*: the 5GMSd Application Provider creates a new Content Hosting Configuration for all media formats of its content through the 5GMSd AF. The configuration specifies a domain name, supplies a certificate for HTTPS access to the content, sets the caching rules per media type, indicates the distribution area (e.g. through geofencing), distribution protocol, the desired content preparation, URL signing, etc. Upon successful configuration, the 5GMSd AF responds with a Content Hosting Configuration identifier, and the location of the 5GMSd AS to which to send the content (if using the push mode).
- 3: *Provision 5GMSd AS instance(s)*: The 5GMSd AF configures the related 5GMSd AS instance(s) to prepare for media ingest for that particular Content Hosting Configuration. As well as configuring any necessary Server Certificates and/or Content Preparation Templates, this step may involve instructing the 5GMSd AS instance(s) to set appropriate caching rules, to perform URL signature validation and to limit access through geofencing. The 5GMSd AS(s) responds indicating whether the configuration was successful or not.  
  
In case of partial failure, the configuration shall be removed from all 5GMS AS(s) that succeeded.
- 4: *Confirm configuration information*: The 5GMSd AF communicates the Content Hosting Configuration of the 5GMSd AS(s) back to the 5GMSd Application Provider for further media push or pull.  
  
In the case where not all requested media formats could be accommodated during the previous step, the 5GMSd AF shall indicate these in the failure response.
- 5: *Publish Media Player Entries*: The 5GMSd Application Provider shall then publish the Media Player Entries to the 5GMSd-Aware Application to enable access to the content, possibly in different formats.
- 6: *Media ingest*: The 5GMSd AS(s) may start pulling or receiving content (if using push mode) from the 5GMSd Application Provider. The 5GMSd AS performs the requested content preparation prior to providing access to the content.

NOTE: Pull of media content from the external 5GMSd AS(s) may be triggered by a request from the 5GMSd Client.

The 5GMSd Application Provider may update a Content Hosting Configuration subsequently to modify some of its parameters. The subset of parameters that can be updated may be limited by the 5GMSd AF.

## 5.5 Metrics collection and reporting

### 5.5.1 General

Metrics collection and reporting can be done in different ways, depending on the relationship between the Application Provider and the 5GMS System operator. The following clauses show simplified signalling examples for two different use-cases.

### 5.5.2 RAN-based reporting procedure

In the first use-case, shown in Figure 5.5.2-1 below, the 5GMS System operator controls the metrics collection and reporting using the RAN-based configuration method. In this case the metrics are configured via the RAN and the control plane, independent of 5GMS functional support.

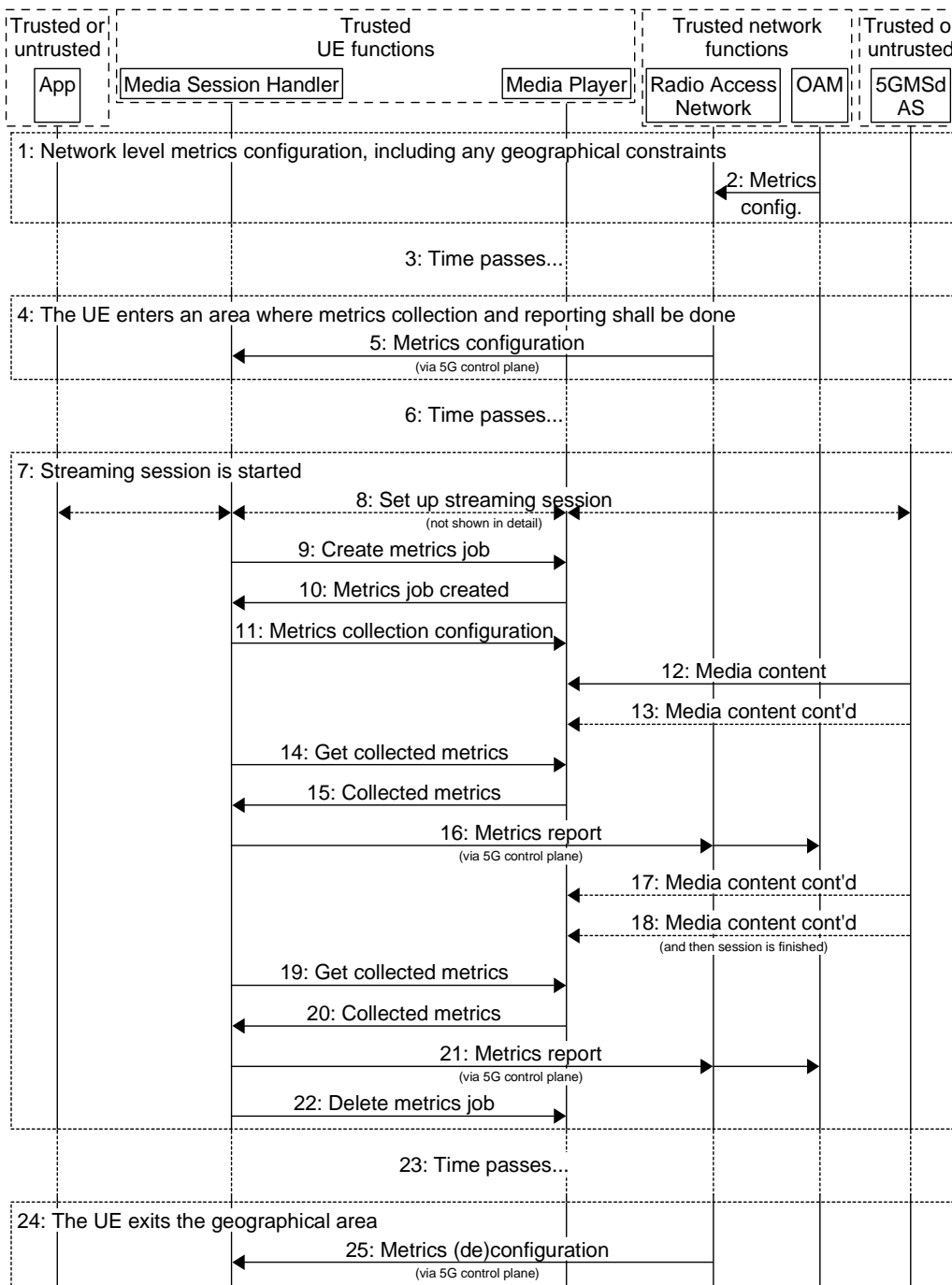

<http://msc-generator.sourceforge.net v6.3.8>

**Figure 5.5.2-1: Metrics collection and reporting via RAN-based configuration**

The different steps are explained below:

- 1: Overall metrics configuration is done on the network level, for instance defining which geographical areas that shall have metrics collection active, which metrics to collect, and how metrics shall be reported. If per-slice metrics collection and reporting is supported, a slice scope may be present in the metrics configuration, indicating the specific slice instance(s) for metrics collection and reporting.
- 2: The metrics configuration(s) is/are sent from the OAM to the RAN, which does not forward that information to the UE at this stage.
- 3: Time passes, and it is assumed that the UE moves around during that period.
- 4: The UE enters an area (cell, location area, etc..) which is inside the geographical constraint. This is discovered by the RAN, and it now needs to activate metrics collection and reporting for the UE.
- 5: The actual metrics configuration is sent from the RAN to the Media Session Handler, via the control plane.
- 6: Additional time passes, and the UE has a metrics configuration, but no streaming session has started.
- 7: A streaming session is started.
- 8: The session setup is done in conjunction with signalling transactions (not shown here).
- 8a: If a slice scope is included in the metrics configuration set, the Media Session Handler shall check the running slice which is carrying the current media streaming (e.g. via the AT Command +CGDCONT [24] or the specific traffic mapping with URSP [4]). If the running slice is within the slice scope, the metrics collection and reporting shall be executed. Additionally, the running slice shall also be included into the metrics reports.
- 9: A new metrics collection job is created in the Media Player.
- 10: A reference to the new metrics collection job is returned.
- 11: The configuration for the metrics collection job is sent to the Media Player (i.e. which metrics should be measured) along with the measurement resolution interval). The metrics reporting interval timer is activated in the Media Session Handler.
- 12: Media is delivered and rendered, and...
- 13: ...more media is delivered...
- 14: The configured metrics reporting interval has elapsed, and the Media Session Handler now requests the collected metrics from the Media Player.
- 15: The Media Player returns the collected metrics.
- 16: The metrics are reported via the control plane.
- 17: The session continues...
- 18: more media is delivered, and then the session is finished.
- 19: The Media Session Handler requests the final metrics collected.
- 20: The Media Player returns the final collected metrics.
- 21: The metrics are reported to the OAM via the control plane.
- 21a: The OAM may determine the per-slice QoE metrics based on the metrics reports and the slice scope.
- 22: The metrics collection job is deleted.
- 23: Time passes, the UE moves around.
- 24: The UE leaves the geographical area specified by the metrics configuration.

25: The RAN sends metrics (de)configuration to the UE, to stop future metrics collection.

### 5.5.3 5GMSd AF-based reporting procedure

The second use-case, shown in figure 5.5.3-1 below, illustrates a scenario where the metrics collection and reporting is configured by the 5GMSd AF. In this example, it is assumed that the metrics configuration provided by the 5GMSd AF comprises instructions/rules regarding metrics collection (i.e. measurement and logging) and reporting for two different schemes - one that is non-3GPP-defined and initially sourced from the 5GMSd AS, and the other scheme that is defined by 3GPP and initially sourced from an OAM Server belonging to the 5GMS System operator. Each metrics scheme requires the 5GMSd Client to perform metrics collection and subsequent metrics reporting to the 5GMSd AF according to the configuration rules of that scheme. Furthermore, it is assumed that the 5GMSd AF is required to deliver metrics reports obtained from the 5GMSd Client to separate destination entities, upon optionally having performed post-processing of the original report information, according to the configuration rules of each metrics scheme. The 5GMSd AF and 5GMSd AS functions can be either trusted or untrusted.

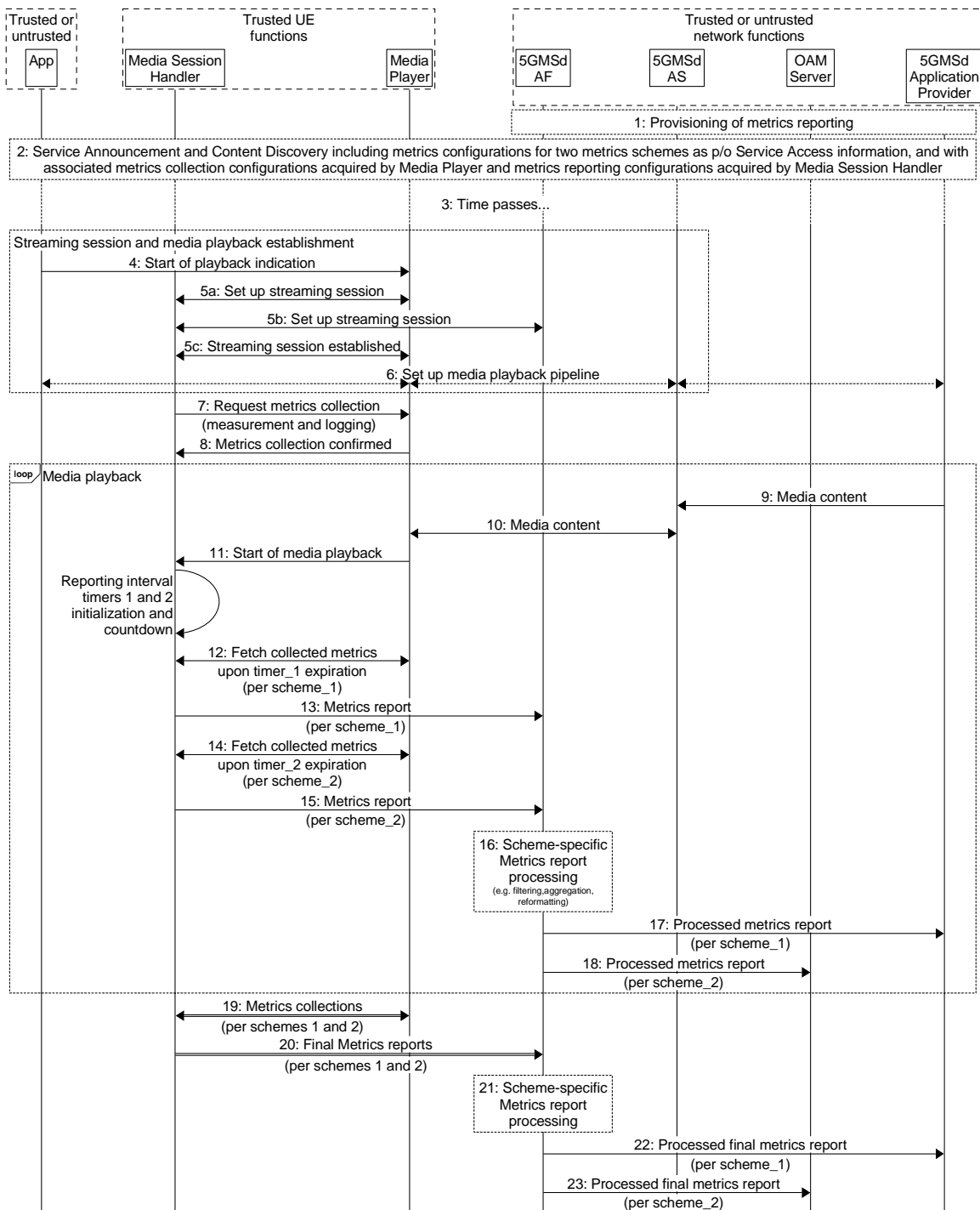

<http://msc-generator.sourceforge.net v6.3.8>

Figure 5.5.3-1: Metrics collection and reporting via 5GMSd AF-based configuration

The message sequence steps are described below:

- 1: The 5GMSd AF is provisioned with two separate sets of metrics reporting configuration information - metrics scheme\_1 as defined by the 5GMSd Application Provider and metrics scheme\_2 as defined by 3GPP, each pertaining to metrics collection by the Media Player, retrieval of those collected metrics from the Media Player by the Media Session Handler, and the generation and delivery of metrics reports from the Media Session Handler to the 5GMSd AF. The 5GMSd AF is similarly provisioned with two separate sets of metrics reporting configuration information, associated with the metrics schemes 1 and 2, regarding required post-processing functionality and subsequent and separate delivery of processed metrics reports to the 5GMSd Application Provider and to the OAM Server.
- 2: The 5GMSd-Aware Application triggers the Service Announcement and Content Discovery procedure. The Service Announcement includes the whole Service Access Information that contains metric configuration info for metrics schemes 1 and 2, with their associated metrics collection configurations acquired by the Media Player and metrics collection configurations acquired by the Media Session Handler.
- 3: Time passes until the 5GMSd UE initiates session establishment and media playback.
- 4: The 5GMSd-Aware Application informs the Media Player of impending media playback.
- 5a: The Media Player requests the establishment of a streaming session with the Media Session Handler which acknowledges the request.
- 5b: The Media Session Handler requests the establishment of a streaming session with the 5GMSd AF which confirms the streaming session establishment.
- 5c: The Media Session Handler informs the Media Player the successful set-up of the streaming session.
- 6: Media playback pipeline is set up between the Media Player, the 5GMSd AS and the 5GMSd Application Provider.
- 7: The Media Session Handler queries the Media Player on its capability to perform metrics collection (measurement and logging function) in accordance with both schemes 1 and 2 as defined by its metrics configuration.
- 8: The Media Player acknowledges its support for the collection of the required metrics of all configured schemes.

During the course of media playback, steps 9-18 below may be repeated, depending on the duration of the playback and the frequency of metrics reporting as set by the metrics configuration for each of the two schemes.

- 9: Assuming a live streaming service, media content is delivered via push ingest from the 5GMSd Application Provider to the 5GMSd AS.
- 10: The Media Player fetches media content from the 5GMSd AS and begins media playback.
- 11: The Media Player notifies the Media Session Handler of the start of media playback, causing the Media Session Handler to initialize and begin countdown of separate metrics reporting interval timers for schemes 1 and 2.
- 12: Upon expiration of timer\_1 (associated with scheme\_1), the Media Session Handler retrieves the logged metrics measurements from the Media Player according to scheme\_1.
- 13: In accordance with its metrics reporting configuration as provisioned in step 2, a metrics report for scheme\_1 is sent from the Media Session Handler to the 5GMSd AF.
- 14: Upon expiration of timer\_2 (associated with scheme\_2), the Media Session Handler retrieves the logged metrics measurements from the Media Player according to scheme\_2.
- 15: In accordance with its metrics reporting configuration as provisioned in step 2, a metrics report for scheme\_2 is sent from the Media Session Handler to the 5GMSd AF.
- 16: In accordance with its metrics reporting configuration as provisioned in step 1, the 5GMSd AF performs separate post-processing in accordance with schemes 1 and 2 (e.g. filtering, aggregation, reformatting) of the received types of metrics reports.



Furthermore, in accordance with its metrics reporting configuration as provisioned in step 1:

17: The 5GMSd AF sends a processed metrics report in accordance with scheme\_1 to the 5GMSd Application Provider.

18: The 5GMSd AF sends a processed metrics report in accordance with scheme\_2 to the OAM Server.

Upon the termination of media playback (as notified by the 5GMSd-Aware Application to the Media Player) a final round of metrics collection and reporting is performed:

19: The Media Session Handler obtains the latest metrics measurements from the Media Player in accordance with schemes 1 and 2. These procedures might occur prior to the nominal expiration of the metrics reporting interval timers.

20: Final metrics reports, in accordance with schemes 1 and 2 are sent by the Media Session Handler to the 5GMSd AF. These procedures might occur prior to the expiration of the nominal metrics reporting intervals.

21: The 5GMSd AF performs post-processing of the received final metrics reports in accordance with schemes 1 and 2.

22: Same as step 17.

23: Same as step 18.

**NOTE:** Although not explicitly shown or described in Figure 5.3.3-1, should the 5GMSd AF represent an untrusted network entity and the OAM Server represent a trusted network entity, the delivery of processed metrics reports from the 5GMSd AF to the OAM Server, as depicted in steps 18 and 23, must be mediated by the NEF (Network Exposure Function).

## 5.5.4 Metrics reporting configuration parameters

Table 4.2.3-4 in clause 4.2.3 describes the metrics reporting configuration parameters used in step 5 of Figure 5.5.2-1 and step 3a of Figure 5.5.3-1. Note that some of the parameters are only relevant for a specific reporting option, as shown in Table 5.5.4-1 below.

**Table 5.5.4-1: Metrics reporting configuration parameters and options**

Parameters	Relevance in RAN-based reporting?	Relevance in 5GMSd AF-based reporting?
Server address	No	Yes
Scheme	No (default 3GPP)	Yes
DNN	No	Yes
Reporting interval	Yes	Yes
Sample percentage	Yes	Yes
Streaming source filter	Yes	Yes
Slice scope	Yes	No
Metrics	Yes (3GPP-defined)	Yes (3GPP-defined or non-3GPP defined)

## 5.6 Consumption reporting

### 5.6.1 Consumption reporting procedure

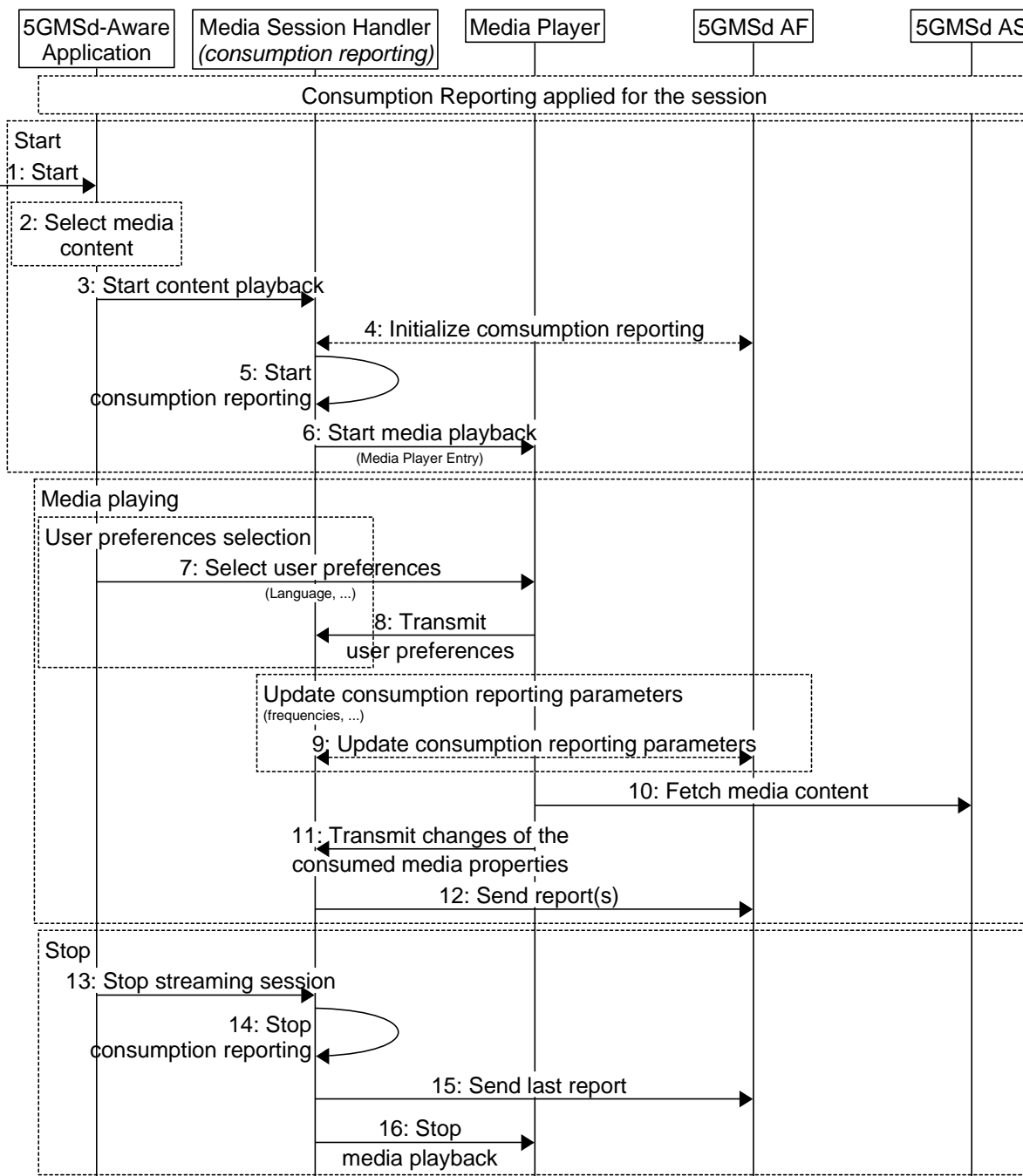

<http://msc-generator.sourceforge.net> v6.3.8

Figure 5.6-1: Consumption reporting

Steps:

The first phase is the initialisation phase:

- 1: The 5GMSd-Aware Application is started.
- 2: A media content item is selected.
- 3: The 5GMSd-Aware Application triggers the Media Session Handler to start content playback. The Media Player Entry is provided.
- 4: The 5GMSd AF initializes the parameters for the consumption reporting configuration (e.g. frequency).
- 5: The Media Session Handler triggers consumption reporting.
- 6: The Media Session Handler starts the Media Player with the Media Player Entry.

The second phase is media playback:

The user preferences may be changed:

- 7: The 5GMSd-Aware Application selects/changes the user preferences.
- 8: The Media Player transmits consumption reporting user preferences to the Media Session Handler.

When media is playing, the consumption reporting parameters may be updated.

- 9: The 5GMSd AF updates the consumption reporting parameters.

When media is playing:

- 10: The Media Player regularly accesses to the media content.
- 11: In case of changes to the consumed media properties, the Media Player transmits the changes to the Media Session Handler.
- 12: The Media Session Handler regularly sends report(s) to the 5GMSd AF.

The last phase is to stop the media:

- 13: The 5GMSd-Aware Application triggers the Media Session Handler to stop content playback.
- 14: The Media Session Handler stops consumption reporting.
- 15: The Media Session Handler may send final consumption report(s) to the 5GMSd AF.
- 17: The Media Session Handler stops the Media Player.

## 5.6.2 Consumption reporting parameters

Table 4.2.3-2 describes the parameters used in step 4 of clause 5.6.1.

Table 5.6.2-2 below describes the additional parameters used in steps 13 or 16 of clause 5.6.1.

**Table 5.6.2-2: Additional consumption reporting parameters**

Parameters	Description
Media Player Entry pointer	Identify the Media Player Entry. In the case of DASH, the Media Player Entry pointer can be a URL of the MPD.
Consumption reporting client ID	Identify the identifier of the UE that consumes the data.
Location type	Identify the UE location type. This parameter is only used when the location reporting is enabled for the UE or for the Downlink Streaming session with a condition that the UE allows to share its location within operator's trust domain. The location type can be CGI, ECGI or NCGI as defined in TS 23.003 [9].
Location	Identify the UE location. This parameter is only used when location reporting is enabled for the UE or for the Downlink Streaming session, and when the UE allows its location to be shared within the Network Operator's trust domain.
Media consumed	Identifies the media consumed. In the case of DASH, the AdaptationSet@id may be used.
Start time	The time when media consumption started.
Duration	The duration of media consumption relative to the start time.

## 5.6.3 Triggering consumption reporting

If consumption reporting is supported and activated, the 5GMSd Client shall send a consumption report when any of the following conditions is met:

- Start of 5GMS consumption of a Downlink Streaming session;
- Stop of 5GMS consumption of a Downlink Streaming session;
- Upon determining the need to report ongoing 5GMS consumption
  - Reports are sent at periodic intervals determined by the reporting interval attribute of the consumption reporting configuration specified in Table 4.2.3-2.
- Upon determining a location change if location reporting is requested by the 5GMSd AF and is allowed to be reported by the UE.

NOTE: Whenever a consumption report is sent, the 5GMSd Client is expected to reset its corresponding reporting interval timer to the value of that attribute and begin countdown of the timer. Whenever the 5GMSd Client stops consumption of the same session, it is expected to disable its corresponding reporting interval timer.

## 5.7 Establishing a Unicast Downlink Media Streaming Session with 5GMSd AF interactions for dynamic policy updates

### 5.7.1 General

This clause describes the provisioning for dynamic policy invocation and the establishment of a unicast downlink streaming session using the dynamic policy API. The establishment of the unicast downlink media streaming session uses 5GMSd AF interactions, as described in steps 4 to 8 of clause 5.1. The dynamic policy API allows separate handling of Service Data Flows within the same PDU Session. The Media Session Handler provides a Policy Template

Id together with Service Data Flow Descriptions when requesting a dynamic policy. An example Policy Template Id value is "background\_data".

The Media Session Handler provides needed information to the 5GMSd AF, so that the 5GMSd AF can combine the semi-static parameters from a Policy Template (which is associated with the Policy Template Id) with the API parameters to trigger a dynamic PCC rule update using the NEF or PCF.

The 5GMSd AF may trigger, for example, the "AF session with required QoS procedure" (see TS 23.502 [3] clause 4.15.6.6) for updating QoS related dynamic PCC rules. For changing charging related rules, the 5GMSd AF may trigger the "Change the chargeable party during the session" procedure (see TS 23.502 [3] clause 4.15.6.5).

### 5.7.2 Provisioning

The provisioning for the dynamic policy procedure follows generally the procedure from clause 5.3. Specifically, the Dynamic Policy feature is activated and, as result, the 5GMSd Application Provider is able to provision one or more Policy Templates.

The domain model of M1d and M5d APIs is depicted in Figure 5.7.2-1. Realization of the dependencies between M1d and M5d data entries are up to implementation.

NOTE: Multiple M5d 5GMSd AF nodes may reference the same M1d resource.

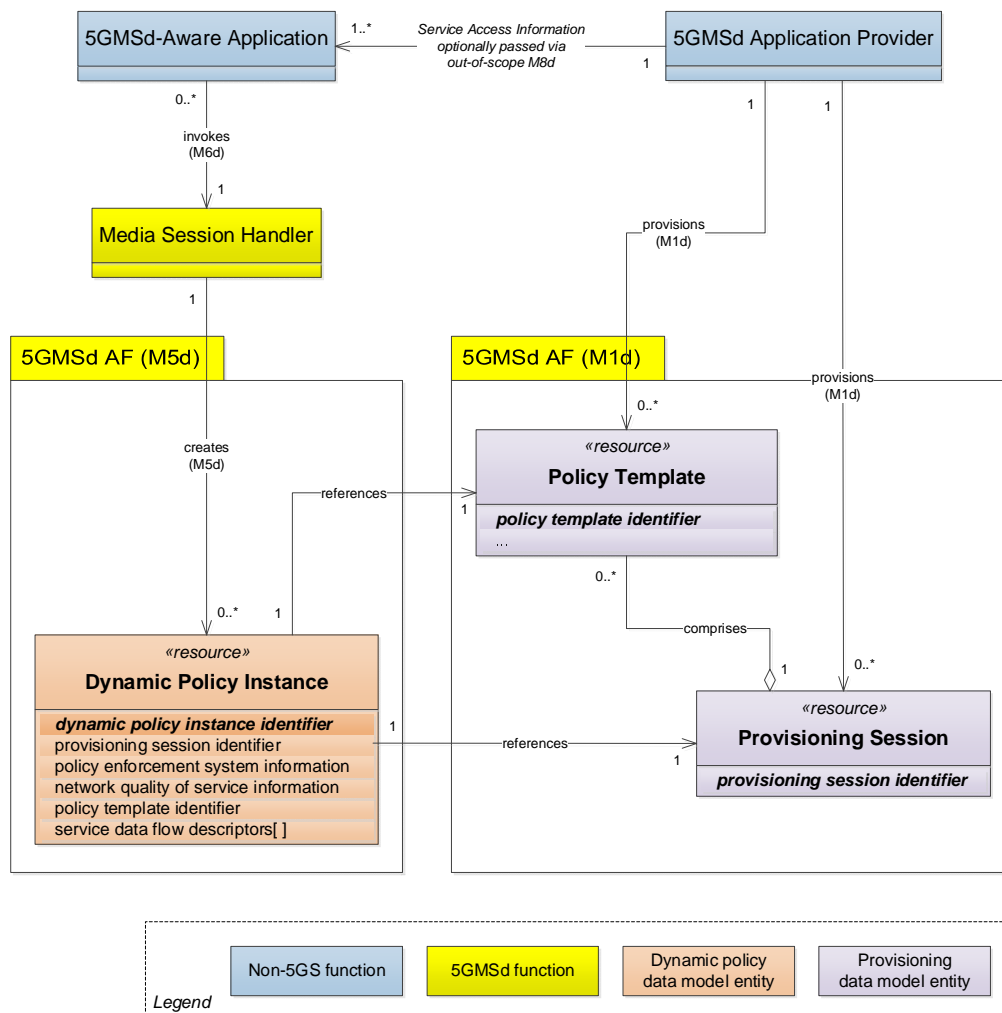

Figure 5.7.2-1: Domain model for dynamic policies

A Policy Template is identified by a Policy Template Id and contains semi-static parameters, including the API entry for the PCF/NEF interactions. The list of provisioned Policy Template Ids is communicated as valid Policy Template

Ids to the Media Session Handler. The Media Session Handler uses one of the valid Policy Template Ids when invoking a dynamic policy.

### 5.7.3 Progressive Download of On-Demand Content

This procedure describes the establishment of a unicast downlink media streaming session with 5GMSd AF interactions for dynamic policy updates. A streaming session may use 3GP File Format (Progressive Download), 3GP Timed Text or other (potentially non-3GPP defined) formats.

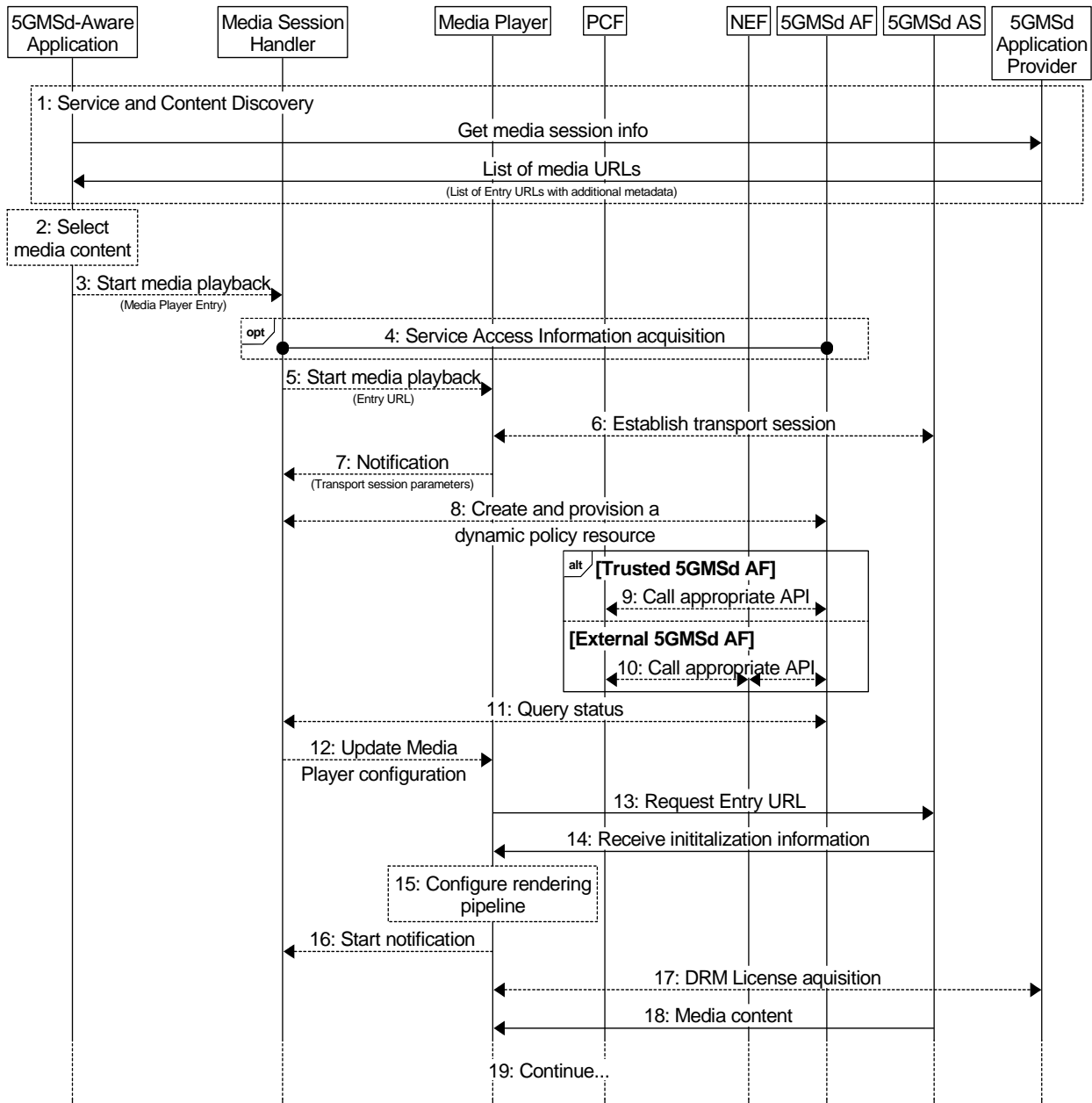

http://msc-generator.sourceforge.net v6.3.8

Figure 5.7-1: High Level Procedure for progressive download for on-demand media

Prerequisites:

- The 5GMSd Application Provider has provisioned the 5G Media Streaming System and has set up content ingest.
- The 5GMSd-Aware Application has received the Service Announcement from the 5GMSd Application Provider.

- The Service Access Information contains detailed information for the policy related interactions. Specifically, the information includes URL(s) for the 5GMSd AF, an identifier of the 5GMS Provisioning Session and a list of authorized Policy Type indications for that specific application.
- The 5GMSd Application Provider has agreed an SLA with the Network Operator defining the possible QoS levels and their charging rates (see TS 23.503 [4] clause 6.1.3.22). The PCF is configured with the corresponding QoS parameters and charging information.

Steps:

- 1: The 5GMSd-Aware Application triggers the Service Announcement and Content Discovery procedure. The Service Announcement includes either the whole Service Access Information (i.e. details for Media Session Handling (M5d) and for Media Streaming access (M4d)) or a reference to the Service Access Information. The configuration parameters are listed in Table 5.7.4-1.

NOTE: The Service and Content Discovery procedure only involves the 5GMSd-Aware Application and the external Application Server, and hence is out of scope of the present document.

- 2: A Media Player Entry is selected.
- 3: The 5GMSd-Aware Application triggers the Media Session Handler to start media playback. The Media Player Entry is provided to the Media Session Handler.
- 4: When the 5GMSd-Aware Application has received a reference to the Service Access Information (see step 1), the Media Session Handler interacts with the 5GMSd AF to acquire the whole Service Access Information.
- 5: The Media Session Handler triggers the Media Player to start the session.
- 6: The Media Player establishes the transport session, e.g. a TCP connection.
- 7: The Media Player notifies the Media Session Handler about the Service Data Flow Description(s) of the transport session established in the previous step (see TS 23.502 [3]), as defined in the Service Access Information. This can be for example 5-tuples.
- 8: The Media Session Handler requests that a dynamic policy be applied to the media session. The request includes at least the Provisioning Session identifier, the Service Data Flow Description(s) and the Policy Template identifier (see Table 5.7.4-1) to be applied to the described transport session. In some cases, a QoS specification is also provided, containing desired QoS information. The 5GMSd AF uses the Policy Template indication for the related procedure and to identify the related network function.
- 9: This step applies when the 5GMSd AF resides in the trusted Data Network. Depending on the Policy Template, the step is executed either:
  - a. When the Policy Template relates to QoS, the 5GMSd AF may either directly interact with the PCF or may use a NEF service:
    - when directly interacting with the PCF, the 5GMSd AF uses the Npcf\_PolicyAuthorization Service as defined in TS 23.502 [3] clause 5.2.5.3).
    - when interacting via the NEF with the PCF, continue at step 10a.
  - b. When the Policy Template relates to a different charging scheme, the 5GMSd AF may either directly interact with the PCF or may use a NEF service:
    - when directly interacting with the PCF, the 5GMSd AF uses the Npcf\_PolicyAuthorization Service as defined in TS 23.502 [3] clause 5.2.5.3).
    - when interacting via the NEF with the PCF, continue at step 10b.
- 10: This step applies when the 5GMSd AF resides in the external Data Network. Depending on the Policy Template, the step is executed either:
  - a. When the Policy Template relates to QoS, the 5GMSd AF may use the Nnef\_AFsessionWithQoS service as defined in TS 23.502 [3] clause 5.2.6.9. (The complete call flow is described in TS 23.502 [3] clause 4.15.6.6.)

- b. When the Policy Template relates to a different charging scheme, the 5GMSd AF may use the Nnef\_ChargeableParty service as defined in TS 23.502 [3] clause 5.2.6.8. (The complete call flow is described in TS 23.502 [3] clause 4.15.6.4 and clause 4.15.6.5.) The Policy Template may contain the Sponsor Information (values, based on SLA negotiation) and Background Data Transfer Reference ID. The Flow description is provided by the Media Session Handler at API invocation.
- 11: The Media Session Handler queries the status of the dynamic policy invocation. The response contains status information (policy accepted, rejected, etc) and information on policy enforcement such as the enforcement method and enforcement bit rate.
- 12: The Media Session Handler notifies the Media Player according to the response from the 5GMSd AF (see Table 5.6.4-2).
- 13: The Media Player sends the request for the progressive download content.
- 14: The Media Player receives the initialization information of the progressive download content. The initialization information contains configuration parameters for reception of the media, and optionally also DRM information.
- 15: The Media Player configures the rendering pipeline for media playback.
- 16: The Media Player notifies the Media Session Handler, providing the transport session information and some media content related information.
- 17: Optional: Media Player acquires a DRM License from as the 5GMSd Application Provider.
- 18: The Media Player receives media content and puts it into the rendering pipeline.
- 19: The Media Player continues to receive and play back the media content.



### 5.7.4 DASH Streaming

It is assumed here that the key information to initialize the media decoding and rendering pipeline is present in the Media Player Entry (or referenced by the Media Player Entry). The intention is to provide the client with information to setup the media decoding and rendering pipeline in such a way that no pipeline reset is needed during the session. Implementations need to consider that parts of the information are provided with the initialization segments.

It is assumed that the client is enabled to use the same media decoding and rendering pipeline during the session.

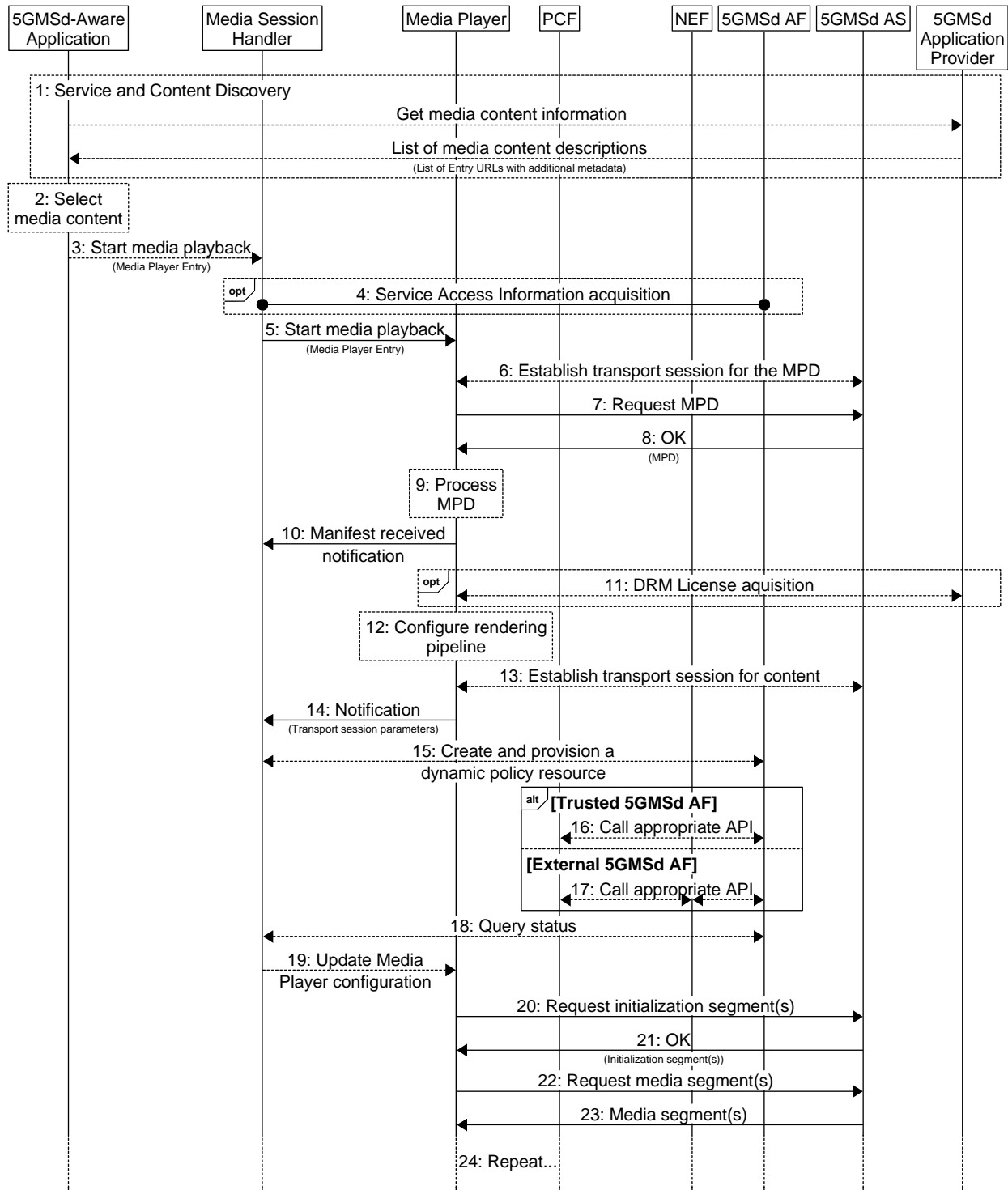

http://msc-generator.sourceforge.net v6.3.8

Figure 5.7-2: High Level Procedure for DASH content

## Prerequisites:

- The 5GMSd Application Provider has provisioned the 5G Media Streaming System and has set up content ingest.
- The 5GMSd-Aware Application has received the service announcement from the 5GMSd Application Provider.
- The Service Announcement Information contains detailed information for the policy related interactions. Specifically, the information includes URLs for the 5GMSd AF, an identifier of the Provisioning Session and a list of authorized Policy Type indications for that specific application.
- The 5GMSd Application Provider has agreed an SLA with the Network Operator defining the possible QoS levels and their charging rates (see TS 23.503 [4] clause 6.1.3.22). The PCF is configured with the corresponding QoS parameters and charging information.

## Steps:

- 1: The 5GMSd-Aware Application triggers the Service Announcement and Content Discovery procedure. The Content Discovery procedure only involves the App 5GMSd-Aware Application and the 5GMSd Application Provider. The Service Announcement includes either the whole Service Access Information (i.e. details for Media Session Handling (M5d) and for Media Streaming access (M4d)) or a reference to the Service Access Information. The configuration parameters are listed in Table 5.7.4-1.
- 2: A media content item is selected.
- 3: The 5GMSd-Aware Application triggers the Media Session Handler to start media playback. The Media Player Entry is provided to the Media Session Handler.
- 4: When the 5GMS-Aware Application has received only a reference to the Service Access Information (see step 1), the Media Session Handler interacts with the 5GMSd AF to acquire the whole Service Access Information.
- 5: The Media Session Handler triggers the Media Player to start the session.
- 6: The Media Player establishes a transport session for acquiring the MPD referenced by the Media Player Entry.
- 7: The Media Player requests the MPD.
- 8: The Media Player receives the MPD.
- 9: The Media Player processes the MPD. It determines, for example, the number of needed transport sessions for media acquisition. The Media Player should be able to use the MPD information to initialize the media pipelines for each media stream. The MPD should also contain information to start the DRM client initialization, when DRM is used.
- 10: The Media Player notifies the Media Session Handler about the MPD. The notification may contain parameters from the MPD.
- 11: (Optional) the Media Player acquires the necessary DRM information, for example a DRM License.
- 12: The Media Player configures the media rendering pipeline.
- 13: The Media Player establishes the necessary transport session(s) for acquiring the content. For example, the Media Player may establish one transport session for each media component (audio, video, etc) and possibly additional transport sessions for other media representations.
- 14: The Media Session Handler is notified about the established transport session(s) for the content by providing the Service Data Flow Description of the application flows as defined in the Service Access Information. This can be for example 5-tuples.
- 15: The Media Session Handler requests that a dynamic policy be applied to the media session. The request includes at least the Provisioning Session identifier, the Service Data Flow Description(s) and the Policy Template identifier (see Table 5.7.4-1), to be applied to the described transport session. In some cases, a QoS specification is also provided, containing desired QoS information. The 5GMSd AF uses the Policy Template for the related procedure and to identify the related network function.

NOTE: The Media Session Handler may add and remove Service Data Flow description(s) from the dynamic policy resource during the lifetime of the Media Streaming Session.

- 16: This step applies when the 5GMSd AF resides in the trusted Data Network. Depending on the Policy Template, the step is executed either:
- a. When the Policy Template relates to QoS, the 5GMSd AF may either directly interact with the PCF or may use a NEF service:
    - when directly interacting with the PCF, the 5GMSd AF uses the Npcf\_PolicyAuthorization service as defined in TS 23.502 [3] clause 5.2.5.3).
    - when interacting via the NEF with the PCF, continue at step 17a.
  - b. When the Policy Template relates to a different charging scheme, the 5GMSd AF may either directly interact with the PCF or may use a NEF service:
    - when directly interacting with the PCF, the 5GMSd AF uses the Npcf\_PolicyAuthorization service as defined in TS 23.502 [3] clause 5.2.5.3).
    - when interacting via the NEF with the PCF, continue at step 17b.
- 17: This step applies when the 5GMSd AF resides in the external Data Network. Depending on the Policy Template, the step is executed either:
- a. When the Policy Template relates to QoS, the 5GMSd AF may use the Nnef\_AFsessionWithQoS service as defined in TS 23.502 [3] clause 5.2.6.9. (The complete call flow is described in TS 23.502 clause 4.15.6.6.)
  - b. When the Policy Template relates to a different charging scheme, the 5GMSd AF may use the Nnef\_ChargeableParty service as defined in TS 23.502 [3] clause 5.2.6.8. (The complete call flow is described in TS 23.502 clause 4.15.6.4 and clause 4.15.6.5.) The Policy Template may contain the Sponsor Information (values, based on SLA negotiation) and Background Data Transfer Reference ID. The Flow Description is provided by the Media Session Handler at API invocation.
- 18: The Media Session Handler queries the status of the dynamic policy invocation. The response contains status information (policy accepted, rejected, etc) and information on policy enforcement such as the enforcement method and enforcement bit rate.
- 19: The Media Session Handler updates the configuration of the Media Player according to the response from the 5GMSd AF (See Table 5.6.4-2).
- 20: The Media Player requests a DASH initialization segment. The Media Player repeats this step for each required initialization segment.
- 21: The Media Player receives the initialization segments.
- 22: The Media Player requests DASH media segments according to the MPD.
- 23: The Media Player receives media segments and feeds them into the appropriate media rendering pipeline.
- 24: Previous steps are repeated according to the MPD information.

## 5.7.5 Parameters for dynamic policy invocation configuration

**Table 5.7.5-1: Status information dynamic policy**

Parameters	Description
Policy Enforcement	Information about the policy enforcement system.

### 5.7.6 Dynamic Policy selection for downlink media streaming based on Service Operation Point signalling

This clause provides an extension to the general call flow in clause 5.2.3 in order to address the usage of Service Descriptions to select a Dynamic Policy in downlink 5G Media Streaming services that supports the requirements of an abstract Service Operation Point. Details are shown in figure 5.7.6-1.

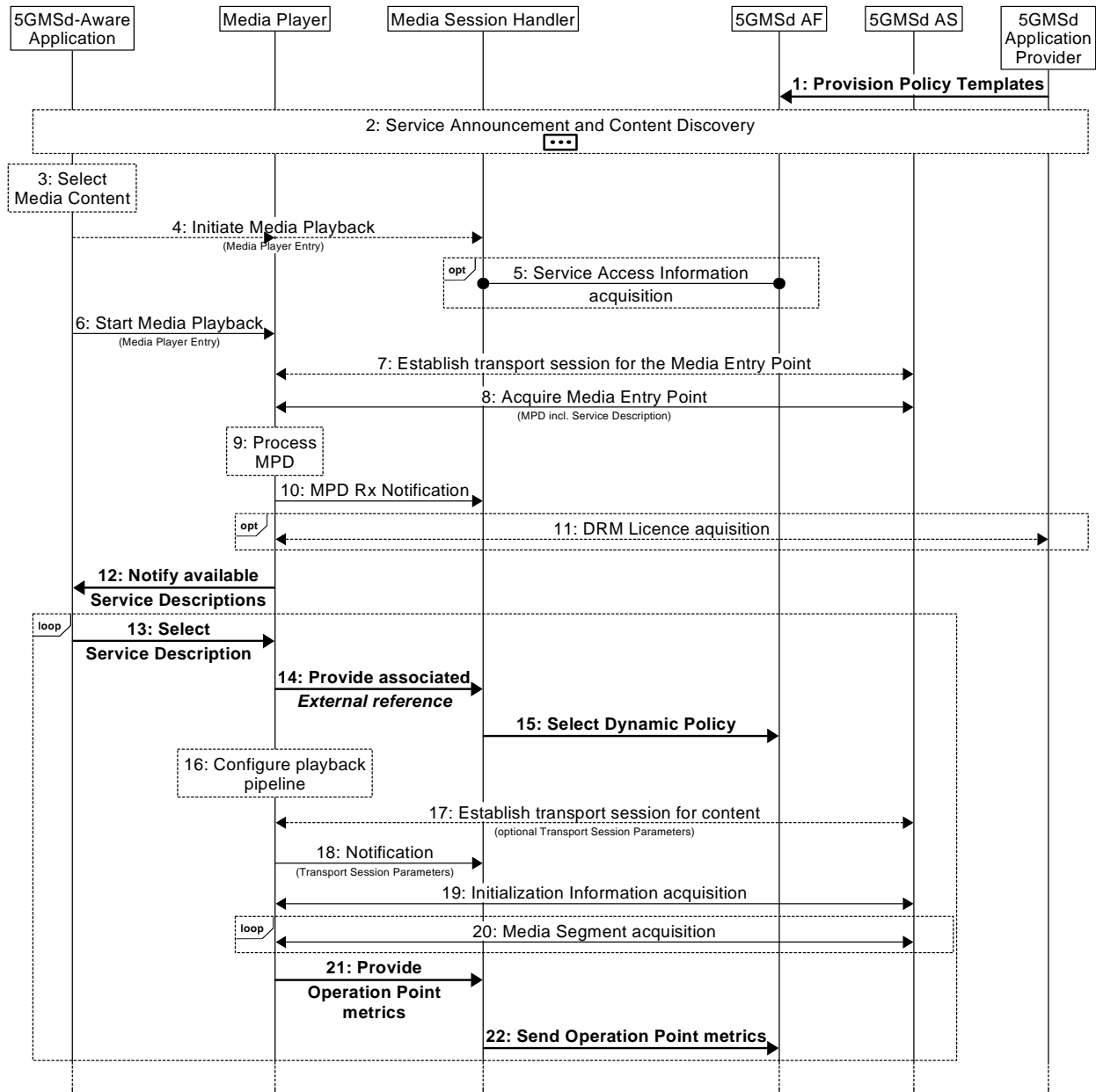

<https://gitlab.com/msc-generator/v8.4>

**Figure 5.7.6-1: High-level procedure for DASH content streaming with Service Operation Point handling**

Prerequisites:

- The 5GMSd Application Provider has provisioned the content hosting feature in the 5G Media Streaming System.
- The 5GMSd-Aware Application has received the Service Announcement from the 5GMSd Application Provider.

Extended Steps:

1. Policy Templates are provisioned in the 5GMSd AF.
12. The Media Player informs the 5GMS-Aware Application about the set of Service Descriptions associated with the Media Player Entry document for the content selected in step 3. Each Service Description is identified by a different *External reference*.
13. The 5GMSd-Aware Application selects one of the available Service Descriptions.
14. The Media Player provides the *External reference* of the selected Service Description to the Media Session Handler.
15. The Media Session Handler selects a Dynamic Policy with a matching *External reference*.
21. The Media Player provides Operation Point metrics to the Media Session Handler.
22. The Media Session Handler sends Service Operation Point measurements and events to the 5GMSd AF.

## 5.7.7 Use of Service Operation Point signalling to optimise delivery of low-latency live media streaming services (informative)

### 5.7.7.1 5GMS System acts as a CDN

In this case, the specific aspects are as follows:

1. A provisioning agreement is struck between the 5GMSd Application Provider and the operator of the 5GMS System in the form of one or several Service Operation Points expressed as Service Descriptions and/or Policy Templates. (Service Descriptions may be derived from Policy Templates if the latter are omitted, or *vice versa*.)
2. DASH or HLS content is provided externally. Media Entry Point documents are annotated with Service Descriptions. The content is published to the 5GMS System for distribution over downlink media streaming.
3. Content is ingested by the 5GMSd AS at reference point M2d such that the latency requirements can be met.
4. The 5GMS System distributes the ingested content according to the provisioning agreement, i.e. meeting bit rate and latency requirements of the agreed Service Operation Point.

NOTE: The path between an (external) 5GMS Application Provider and the 5GMSd AS is subject to a separate transport-level agreement.

5. The Service Operation Point metrics collated by the 5GMSd AF are used by the 5GMS System to determine whether the agreed Service Operation Point has been satisfied, or whether the Policy Templates need to be adjusted so that it can be satisfied.

For low-latency streaming where the 5GMS System acts as a CDN, the basic call flow documented in clause 5.7.6 is extended as follows.

Extended steps:

1. Policy Templates suitable for supporting low-latency media streaming are provisioned in the 5GMSd AF.
2. Media ingest supports a low-latency protocol, e.g. segment content is provided in chunks.
14. 5GMSd-Aware Application selects a low-latency Service Description and provides its *External reference* to the Media Session Handler.
17. The Media Player configures itself for low-latency playback based on the low-latency Service Description selected in step 14.
21. The Media Player operates in a low-latency media delivery mode.

### 5.7.7.2 5GMSd AS deployed in an external DN

In this case, the specific aspects are as follows:

1. A provisioning agreement is struck between the 5GMS Application Provider and the operator of the 5GMS System in the form of one or several Service Operation Points expressed as Service Descriptions and/or Policy Templates. (Service Descriptions may be derived from Policy Templates if the latter are omitted, or *vice versa*.)

NOTE: The path between the externally deployed 5GMSd AS and the 5G System may be subject to a separate transport-level agreement.

2. The 5GMSd AS external.
3. Content ingest by the 5GMSd AS is out of scope.
4. The 5GMS System distributes the content according to the agreed provisioning agreement, i.e. meeting bit rate and latency requirements of the agreed Service Operation Point.
5. The Service Operation Point metrics collated by the 5GMSd AF are used by the 5GMS System to determine whether the agreed Service Operation Point has been satisfied, or whether the Policy Templates need to be adjusted so that it can be satisfied.

For low-latency streaming where the 5GMSd AS is deployed in an external DN, the basic call flow documented in clause 5.7.6 is extended as follows.

Extended steps:

1. Policy Templates suitable for supporting low-latency media streaming are provisioned in the 5GMSd AF.
14. 5GMSd-Aware Application selects a low-latency Service Description.
17. The Media Player configures itself for low-latency playback based on the low-latency Service Description selected in step 14.
21. The Media Player operates in a low-latency media delivery mode.

### 5.7.8 Downlink Background Data Transfer using dynamic policy invocation

Figure 5.7.8-1 shows a high-level call flow for the configuration and usage of a Background Data Transfer session in downlink 5G Media Streaming:

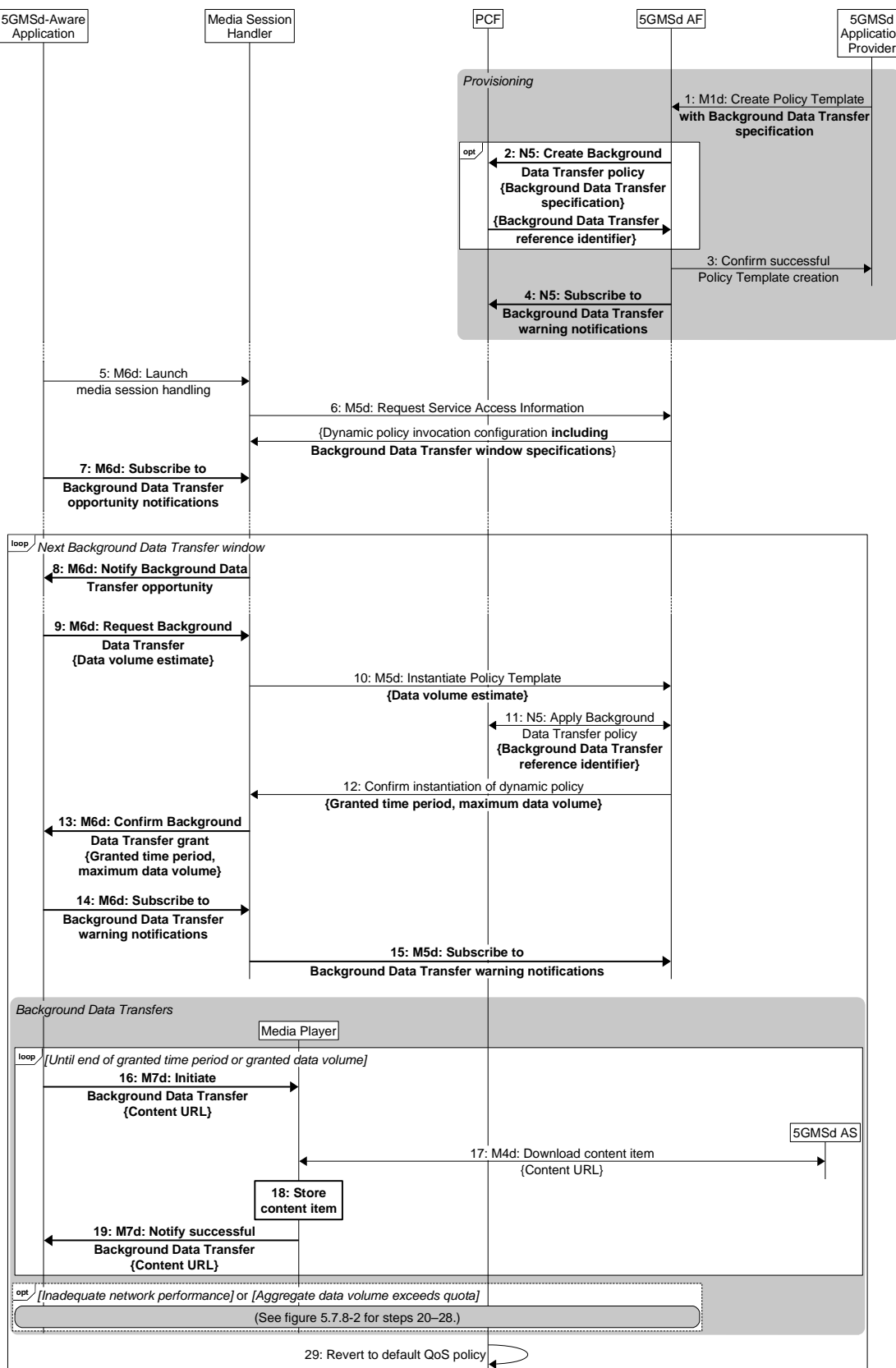

<https://gitlab.com/msc-generator/v8.4>

Figure 5.7.8-1: Call flow for Background Data Transfer session configuration and establishment

Pre-requisites:

1. The 5GMSd Application Provider has negotiated a Service Level Agreement with the 5GMS System operator that includes all or some of the following:
  - a. Time window(s) when Background Data Transfers are available. These may recur on a regular pattern (e.g., daily, weekly, monthly, etc.).
  - b. A quota for the maximum number of 5GMS Clients that may avail themselves of a Background Data Transfer during each such time window.
  - c. A quota for the maximum aggregate volume of data that may be transferred by all 5GMS Clients during each Background Data Transfer window.
2. The 5GMS System operator may have provisioned a Background Data Transfer Policy in the PCF based on the Service Level Agreement, in which case it may share the corresponding Background Data Transfer reference identifier directly with the 5GMSd Application Provider. The steps in the call flow sequence are as follows with differences from the baseline call flow highlighted in **bold**:
  1. The 5GMSd Application Provider provisions a Policy Template in the 5GMSd AF at reference point M1d including network QoS parameters **that either references an existing Background Data Transfer policy already provisioned in the PCF that embodies the aforementioned Service Level Agreement or else directly specifies Background Data Transfer parameters in line with the aforementioned Service Level Agreement.**
  2. **If the supplied Policy Template explicitly declares new Background Data Transfer parameters, the 5GMSd AF creates a corresponding new Background Data Transfer policy in the PCF based on them using the *Npcf\_BDTPolicyControl* service (or, if the 5GMSd AF is deployed outside the Trusted DN, the *Nnef\_BDTPNegotiation* service (see clause 4.16.7.2 of TS 23.502 [3]). The PCF may interact with the UDR as a consequence. The procedure yields a Background Data Transfer reference identifier.**
  3. The 5GMSd AF acknowledges successful creation of the Policy Template to the 5GMSd Application Provider. This confirms that the parameters of the Policy Template (**including the Background Data Transfer parameters**) are acceptable to the 5GMS System.
  4. If it has not already done so, the 5GMSd AF subscribes to receive Background Data Transfer warning notifications from the PCF as defined in clause 4.16.7 of TS 23.502 [3].

At some later point in time:

5. The 5GMSd-Aware Application launches media session handling using an appropriate service launch mechanism at reference point M6d.
6. In response, the Media Session Handler fetches Service Access Information from the 5GMSd AF for the relevant Provisioning Session via reference point M5d. A client dynamic policy invocation configuration is provided that describes the Policy Templates applicable to the requesting 5GMSd Client, **including information about Background Data Transfer windows and endpoint(s) that the Media Session Handler may subscribe to in order to receive Background Data Transfer warning notifications from the 5GMSd AF.**
7. **The 5GMSd-Aware Application also subscribes to receive notifications of Background Data Transfer opportunities from the Media Session Handler by invoking a client API on the latter at reference point M6d.**

At the start of the next Background Data Transfer window:

8. According to its list of current subscriptions (see step 7), **the Media Session Handler notifies its 5GMSd-Aware Application subscriber(s) of the Background Data Transfer opportunity by sending a notification to each one via reference point M6d. The notification indicates the time window of the Background Data Transfer opportunity.**
9. **If it wishes to avail itself of the Background Data Transfer opportunity (immediately or at some later point during the time window indicated in the previous step) a 5GMSd-Aware Application that has received such a notification invokes a suitable client API on the Media Session Handler at reference point M6d. The invocation includes an estimate of the data volume the 5GMSd Client intends to transfer in the background.**



- 10: The Media Session Handler instantiates a dynamic policy resource on the 5GMSd AF based on one of the Policy Templates advertised in the Service Access Information **that includes Background Data Transfer parameters. The request includes an estimate of the data volume the 5GMSd Client intends to transfer in the background.**
11. **If the request falls within a time window for Background Data Transfers advertised in the Service Access Information and if the quota for the number of Background Data Transfers within the current time window has not been exceeded, the Media Session Handler requests a change to the network QoS of the appropriate PDU Session by invoking the *Npcf\_PolicyAuthorization\_Create* operation (either directly or via the NEF) according to clause 4.16.7.1 of TS 23.502 [3] based on the Background Data Transfer parameters described in the appropriate Policy Template and citing the reference identifier of the Background Data Transfer referenced in step 1 or created in step 2.**
12. **The 5GMSd AF responds to the Media Session Handler to grant the Background Data Transfer request. The grant response includes a recommendation from the 5GMSd AF of the maximum time period for which the Background Data Transfer is available and the maximum Background Data Transfer volume granted for the media streaming session during this grant period (which may be smaller than that requested in step 10).**
13. **The Media Session Handler informs the 5GMSd-Aware Application of the Background Data Transfer grant by sending a synchronous response or asynchronous notification to the latter at reference point M7d. This conveys the maximum time period recommendation and maximum data volume indicated by the 5GMSd AF in the previous step.**
- 14: **The 5GMSd-Aware Application subscribes to receive Background Data Transfer warning notifications from the Media Session Handler by invoking a client API on the latter at reference point M6d.**
15. **As a consequence, the Media Session Handler subscribes to receive Background Data Transfer warning notifications from the 5GMSd AF by invoking a network API on the latter at reference point M5d. The subscription endpoint(s) are indicated in the Service Access Information obtained in step 6.**

The following steps are repeated for each content item the 5GMSd-Aware Application would like to download during the granted time period for Background Data Transfers:

16. **The 5GMSd-Aware Application initiates download of a content item in the background by invoking a suitable client API on the Media Player at reference point M7u. The content is identified by a URL that is available on a 5GMSd AS.**
17. **The Media Player acquires the content item from the 5GMSd AS at reference point M4d using the content item URL supplied in the previous step.**
18. **The Media Player stores the acquired content item for later playback.**

NOTE: Ownership of the content store and protection of stored content is out of scope.

19. **The Media Player confirms that the content item has been successfully acquired by sending a notification to the 5GMSd-Aware Application at reference point M7d.**

(Steps 20–28 are described below.)

When the granted time period for Background Data Transfers subsequently expires:

29. **The PCF automatically reverts the network QoS of the media streaming session to its state prior to the Background Data Transfer grant without intervention from the 5GMS System.**

At any time during a Background Data Transfer window the PCF may detect that the network cannot satisfy the requirements of the Background Data Transfer policy at the UE’s current location (as defined in clause 6.1.2.4 of TS 23.503 [4]) or that the volume of data transferred by all UEs in the current Background Data Transfer window has exceeded the quota provisioned in the Background Data Transfer policy. The procedures in this case are summarised in figure 5.7.8-2.

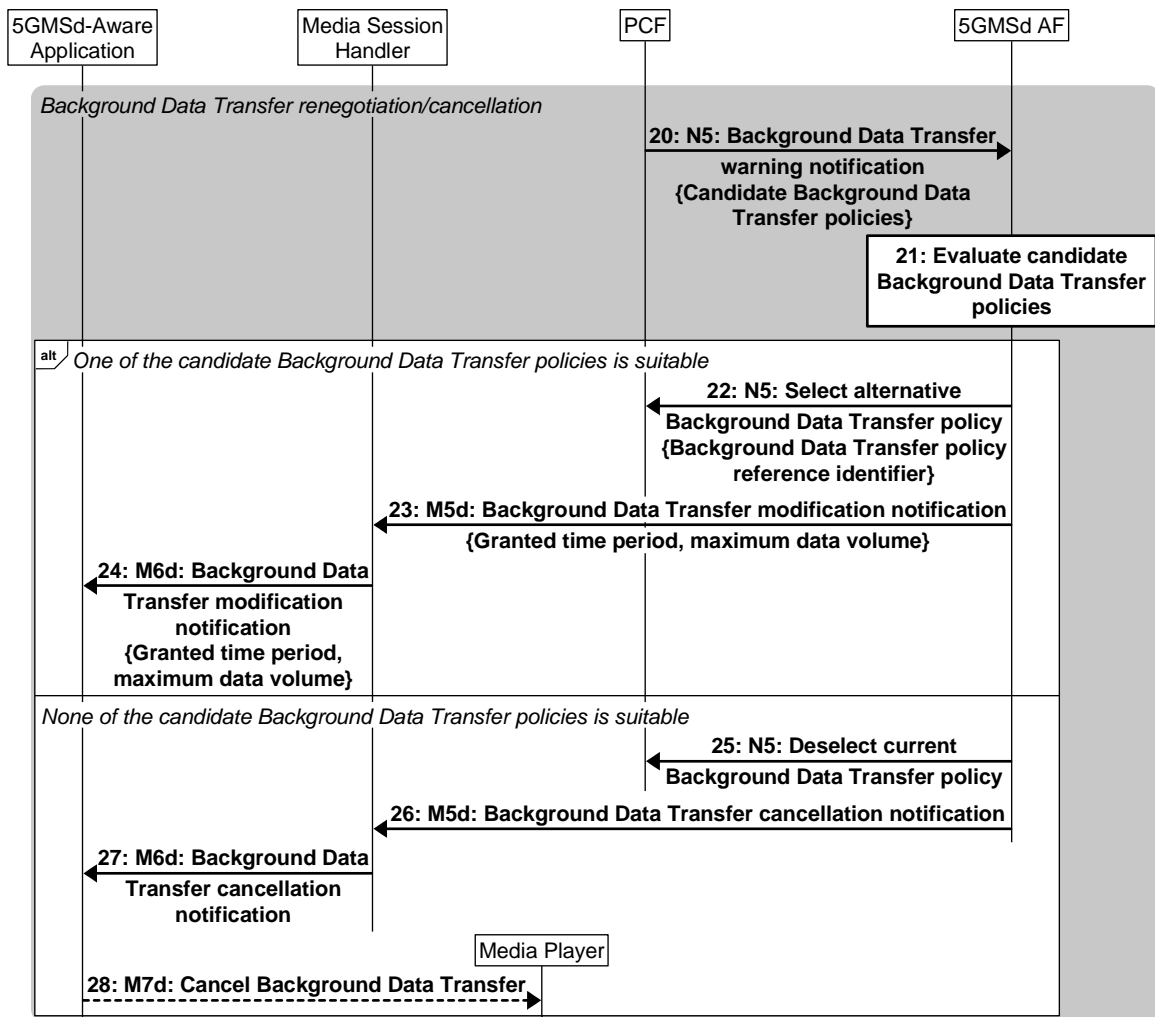

<https://gitlab.com/msc-generator/v8.4>

**Figure 5.7.8-2: Call flow for Background Data Transfer session renegotiation/cancellation**

The steps are as follows:

**20:** If it is able to identify alternative Background Data Transfer policies, the PCF sends a Background Data Transfer warning notification with these candidates to the 5GMSd AF as defined in clause 4.16.7.3 of TS 23.502 [3].

**21:** The 5GMSd AF evaluates the candidate alternative Background Data Transfer policies for suitability.

If the 5GMSd AF determines that one of the candidate alternative Background Data Transfer policies suggested by the PCF is suitable for the media streaming session in question:

- 22: The 5GMSd AF requests that its chosen alternative Background Data Transfer policy is applied, according to step 12 in clause 4.16.7.3 of TS 23.502 [13]. As defined in clause 6.1.2.4 of TS 23.503 [4], in this case the current Background Data Transfer policy remains in force until its natural end (see step 29 above).**
- 23. Using an asynchronous notification mechanism at reference point M5d, the 5GMSd AF notifies the Media Session Handler of the modified Background Data Transfer grant, including the new maximum time period for which the Background Data Transfer is available, and the new maximum Background Data Transfer volume granted for the media streaming session during this grant period (which may be smaller than that requested in step 10).**
- 24: The Media Session Handler informs the 5GMSd-Aware Application of the Background Data Transfer grant by sending an asynchronous notification to the latter at reference point M6d. This conveys the maximum time period recommendation and maximum data volume indicated by the 5GMSd AF in the previous step.**

Otherwise, if none of the candidate Background Data Transfer policies suggested by the PCF deemed suitable by the 5GMSd AF:

- 25: The 5GMSd AF informs the PCF that none of the candidate Background Data Transfer policies is suitable, according to step 13 in clause 4.16.7.3 of TS 23.502 [13].**
- 26: Using an asynchronous notification mechanism at reference point M5d, the 5GMSd AF notifies the Media Session Handler that the Background Data Transfer window has ended prematurely.**
- 27: Using an asynchronous notification mechanism at reference point M6d, the Media Session Handler notifies the 5GMSd-Aware Application that the Background Data Transfer window has ended prematurely.**
- 28: As a consequence, the 5GMSd-Aware Application may choose to cancel an in-progress Background Data Transfer by invoking a suitable client API method on the Media Player at reference point M7d.**

## 5.8 Dynamic Policy based on Network Slicing for Downlink Media Streaming

### 5.8.1 Procedure

The 5GMSd Application Provider requests the assignment of more than one network slice for the distribution of the service. The 5GMSd Application Provider indicates the desired network slice features that correspond to the Service Access Information. Upon successful assignment of the network slices for the service, the 5GMSd AF shall respond with the list of allowed S-NSSAIs to the 5GMSd Application Provider.

Figure 5.8.1-1 is the flowchart diagram for this procedure.

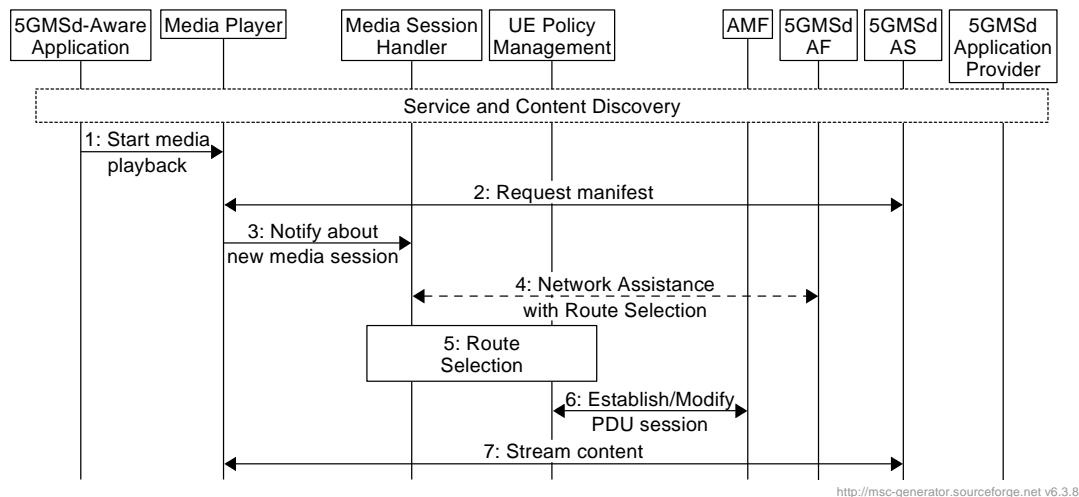

**Figure 5.8.1-1: Dynamic Policy based on Network Slicing for Downlink Streaming**

Pre-requisites:

1. The UE knows how to access the network slice(s) associated with a particular Provisioning Session.
2. The 5GMSd AS(s) serving the content for the particular Provisioning Session shall be accessible through the DNN(s) associated to the network slice(s) provisioned for the distribution of that content.

The steps are as follows:

1. The 5GMSd-Aware Application triggers media playback by invoking the Media Player with the Media Player Entry for the selected content.
2. The Media Player requests the manifest from the 5GMSd AS.
3. The Media Player notifies the Media Session Handler about the upcoming media session and may request specific 5GMSd AF-based Network Assistance for that session, when not already established.
4. The Media Session Handler retrieves information from the 5GMSd AF to assist with the route selection for the session. This may include information about the network slices, the DNNs, any pre-authorized QoS guarantees for that Provisioning Session. The Media Session Handler gets information about the operation point selection from the Media Player as described in step 4.
5. The Media Session Handler and the UE Policy Management in the UE perform the route selection procedure using information such as the playback operation point, the traffic descriptors. The UE Policy Management will use the matching filter to retrieve the Route Selection descriptor, which provides the DNN, and the S-NSSAI(s), identifying the network slice(s) to be used for this Provisioning Session.
6. The UE reuses an existing PDU session with the selected S-NSSAI and DNN from step 5, or requests the establishment of a new PDU session with the identified parameters, if one doesn't exist already.
7. The streaming of the media content at the target operation point starts.

## 5.9 Downlink Network Assistance

### 5.9.1 Introduction

The Network Assistance (NA) feature enables a UE that is receiving a downlink media stream to improve the QoE of the media streaming session, by being able to make use of two distinct facilities.

The first facility is **bit rate recommendation (throughput estimation)**. This enables the UE to start a downlink streaming session at the most appropriate bit rate for the network conditions at hand, or to obtain a recommendation from the network which will remain valid until further notice during a media streaming session. The recommended bit rate is based on network estimations or predictions of available link bandwidth. This function is provided as an additional tool to support the UE, in addition to the common approach of the UE performing its own estimation based on measurement of the downlink traffic in the past.

The second facility is the **delivery boost**. The 5GMSd Client uses this function to indicate to the network that a temporary boost, i.e., a temporary increase of network throughput for this client is needed in order to avoid the risk of media playback stalling due to buffer under-run, which could otherwise occur during the next media segment or soon after. Throughput boosting may also be used at the start of a playback session to shorten the time to start media playback, giving a better experience for the user.

Network Assistance for downlink media streaming may be offered to the UE in one of two ways:

- Based on interaction between the UE and the 5GMSd AF, with a subsequent interaction between the 5GMSd AF and the PCF (or the NEF);
- Based on interaction between the UE and the RAN, re-using the ANBR-based RAN signalling.

The UE shall not use both approaches on the same Network Assistance session.

Figure 5.9.1-1 depicts the Network Assistance feature in the context of the 5GMS architecture, showing the scope of both approaches.

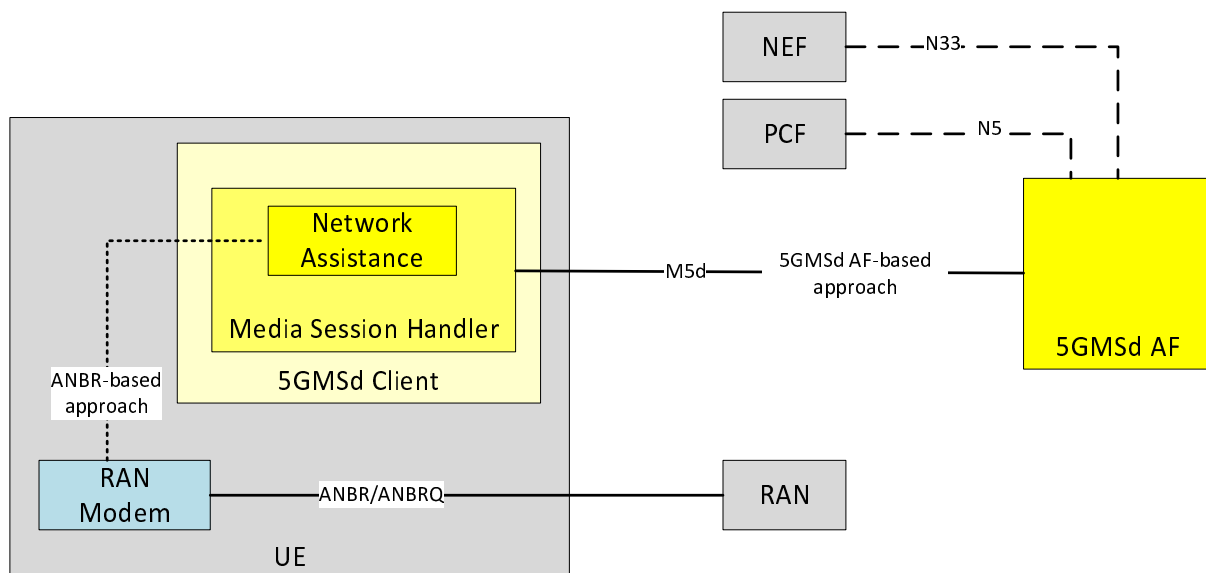

**Figure 5.9.1-1: Downlink Network Assistance alternative approaches**

### 5.9.2 5GMSd AF-based downlink Network Assistance

The Network Assistance (NA) feature enables a UE to receive a bit rate recommendation from the 5GMSd AF that provides the NA server function. The 5GMSd AF provides the response with an estimation of throughput, or the recommendation of a bit rate which will remain valid until further notice. The UE uses this estimation to derive the most suitable bit rate for its downlink content session from the versions that might be available. The network is

expected to commit resources to be able to fulfil the recommendation, although no guarantee for the bandwidth estimation can be assumed. The 5GMSd Client may provide additional information, such as available media versions, in terms of the required bit rates, to the 5GMSd AF.

The second facility is the delivery boost. The 5GMSd Client uses this function to indicate to the network that a temporary boost, i.e. a temporary increase of network throughput for this client, is needed.

Each interaction for the 5GMSd AF-based downlink Network Assistance procedures consists of two steps in sequence:

1. Between the UE (Media Session Handler) and the 5GMSd AF using a 5GMS API at interface M5d;
2. Between the 5GMSd AF and the PCF (or the NEF):
  - using the Npcf\_PolicyAuthorization procedure or Nnef\_AFSessionWithQoS procedure to request modification of the PDU session with the requested QoS information.
  - using the Npcf\_PolicyAuthorization notification service or Nnef Monitoring Event procedure to receive QoS changes. The 5GMSd AF receives these policy change notifications asynchronously.

Network Assistance is performed within dedicated NA sessions that are a part of the Media Session Handler procedures. Only 5GMSd Clients that have been granted an NA session by the 5GMSd AF may execute the NA bit rate recommendation and boost request procedures. This enables the 5GMSd AF to enforce policies that could include the access to NA by certain 5GMSd Clients only, such that authorisation to use NA facilities can be verified once at the granting of an NA session, and does not need to be verified for each NA request from the 5GMSd Client.

The procedures for 5GMSd AF-based downlink Network Assistance are:

1. NA session initiation. The 5GMSd Client requests to initiate an NA session with the 5GMSd AF. If the request fulfils any pre-requisites for access to NA functionality, for example policy and charging, then the 5GMSd AF responds with a confirmation that the NA session has been established.
2. NA throughput estimation. The 5GMSd Client requests a throughput estimation for a downlink media session from the 5GMSd AF. A unique identifier for the downlink media session is provided by the 5GMSd Client.

If the set of available bit rates in the downlink media session is provided with the request then the 5GMSd AF responds with the recommended bit rate based on its throughput estimation. If the throughput estimation is lower than the lowest value from the set of available bit rates, then the actual throughput estimation is provided.

If no set of available bit rates is provided with the request then the 5GMSd AF responds with the throughput estimation.

3. NA delivery boost. The 5GMSd Client requests from the AF a downlink delivery boost. A unique identifier for the downlink media session is provided by the 5GMSd Client.
4. NA session termination. The 5GMSd Client requests to terminate an NA session with the 5GMSd AF. The unique identifier of the NA session to be terminated is provided by the 5GMSd Client.

The AF responds positively if the indicated session could be terminated, and negatively otherwise.

### 5.9.3 ANBR-based downlink Network Assistance

This approach for the downlink Network Assistance feature is based upon the exchange of the bit rate recommendation message and bit rate recommendation query message between the RAN and UE as described in TS 38.321 [9]. In this case the Network Assistance function in the 5GMSd Client utilises a UE-internal facility to access the RAN modem driver to access ANBR signalling operations and to receive corresponding responses from the network. Hence, this control interface is outside the scope of the 5GMS architecture.

The RAN in this architecture contains control plane and user plane entities that interact with peer control plane and user plane entities in the UE.

- The control plane interactions involve the sending by the RAN of downlink bit rate recommendations to the UE, which may occur either independently, or in response to a boost request from the UE, via the exchange of the bit rate recommendation message and bit rate recommendation query message between the RAN and UE as described in TS 38.321 [9]. This control interface is outside the scope of the 5GMS architecture.

- The user plane interaction pertains to downlink streaming media transport over interface M4d.

## 5.10 5GMS via eMBMS

### 5.10.1 General

This clause defines procedures for different use cases and scenarios when 5GMS is using eMBMS for delivery as introduced in clause 4.6.

### 5.10.2 Procedures for 5GMS content delivered exclusively via eMBMS

In this case, 5GMS media data is exclusively delivered via eMBMS, i.e. media content is not delivered via reference point M4d, but only via MBMS User Services. The 5GMSd Client acts as an MBMS-Aware Application.

The call flow in Figure 5.10.2 1 extends the call flow defined in clause 5.3.2 to address the delivery of 5GMS media data exclusively via eMBMS. Aspects specific to this use-case are indicated in bold.

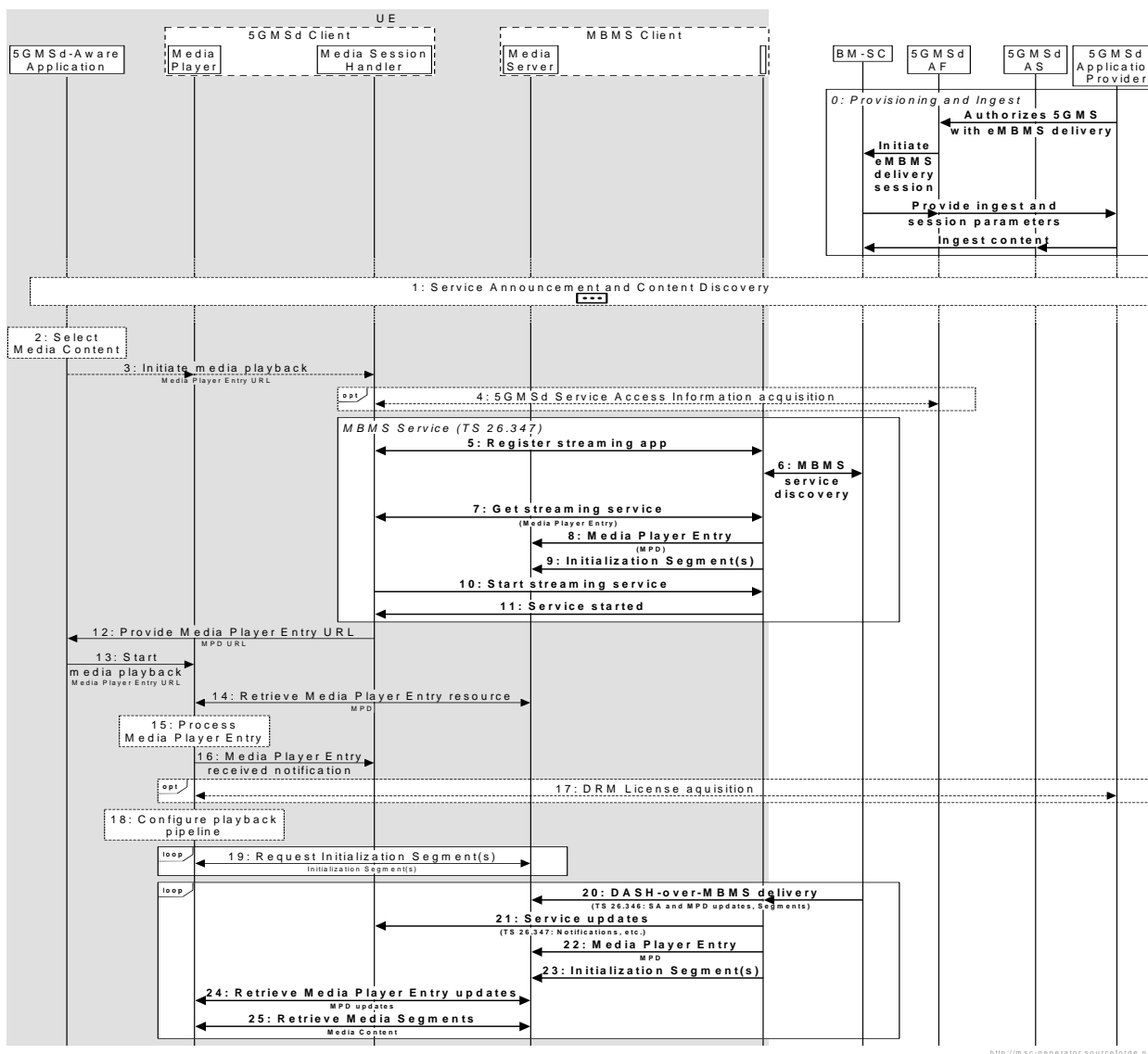

Figure 5.10.2-1: High-level procedure for DASH content delivery via eMBMS

Prerequisites (step 0):

- The 5GMSd Application Provider has provisioned the 5G Media Streaming System, including content ingest **and the authorization to distribute 5GMS content via eMBMS.**
- **The 5GMS AF has informed the BM-SC about the availability of 5GMS content** by provisioning an MBMS service **and has obtained relevant information from the eMBMS Service Announcement (such as the MBMS service identifier).**
- The BM-SC is ingesting content **from the 5GMS AS**, using either pull mode or push mode.
- The BM-SC has broadcast the MBMS Service Announcement, **including an indication that the content is 5GMS content.**

Steps:

- 1: The 5GMSd-Aware Application triggers the Service Announcement procedure and the 5GMS Service and Content Discovery procedure at reference point M8.
- 2: A media content item is selected.
- 3: The 5GMSd-Aware Application triggers the 5GMSd Client to start media playback. The Media Player Entry is provided to the 5GMSd Client.
- 4: If the 5GMS-Aware Application has received only a reference to the Service Access Information (see step 1), the Media Session Handler interacts with the 5GMSd AF to acquire the whole Service Access Information. **This includes relevant information from the eMBMS Service Announcement (such as the MBMS service identifier) in order to bootstrap reception of the MBMS service.**

**5-11: The Media Session Handler acts as an MBMS-Aware Application and initiates service acquisition. For details, see TS 26.347 [18]. This establishes a transport session for the MPD and the Content.**

NOTE: The MPD and Initialization Segment(s) are forwarded by the MBMS Client to the Media Server to enable their subsequent delivery to the Media Player upon request.

12: The Media SessionHandler provides the MPD URL to the Media Player either directly or through the 5GMSd-Aware Application.

13: The Media Player is invoked to start media access and playback.

14: The Media Player retrieves the Media Player Entry resource (an MPD) from the proxy Media Server.

15: The Media Player processes the retrieved MPD. It determines, for example, the number of transport sessions needed for media acquisition. The Media Player should be able to use the MPD information to initialize the media pipelines for each media stream (see step 18). When DRM is used (see step 17) the MPD should also contain sufficient information to initialize the DRM client.

16: The Media Player notifies the Media Session Handler about the start of a new downlink media streaming session. The notification may include parameters from the MPD.

17: Optional: The Media Player acquires any necessary DRM information, for example a DRM License.

18: The Media Player configures the media playback pipeline.

19: The Media Player retrieves initialization segment(s) referenced by the MPD.

**20-25: Content is delivered using DASH-over-MBMS. Session Announcement updates are provided to the MBMS Client as necessary. MPD updates and Segments are pushed to the media server. The Media Player retrieves media segments from the proxy Media Server according to the MPD and forwards them to the appropriate media rendering pipeline.**



### 5.10.3 5GMS Consumption Reporting procedures for eMBMS

In this case, 5GMS consumption reporting is used to report consumption of 5GMSd content via an eMBMS service.

NOTE: eMBMS consumption reporting is disabled in this case.

The call flow in Figure 5.10.3-1 extends the call flow defined in clause 5.6.1 to address consumption reporting. Aspects specific to this use-case are indicated in bold.

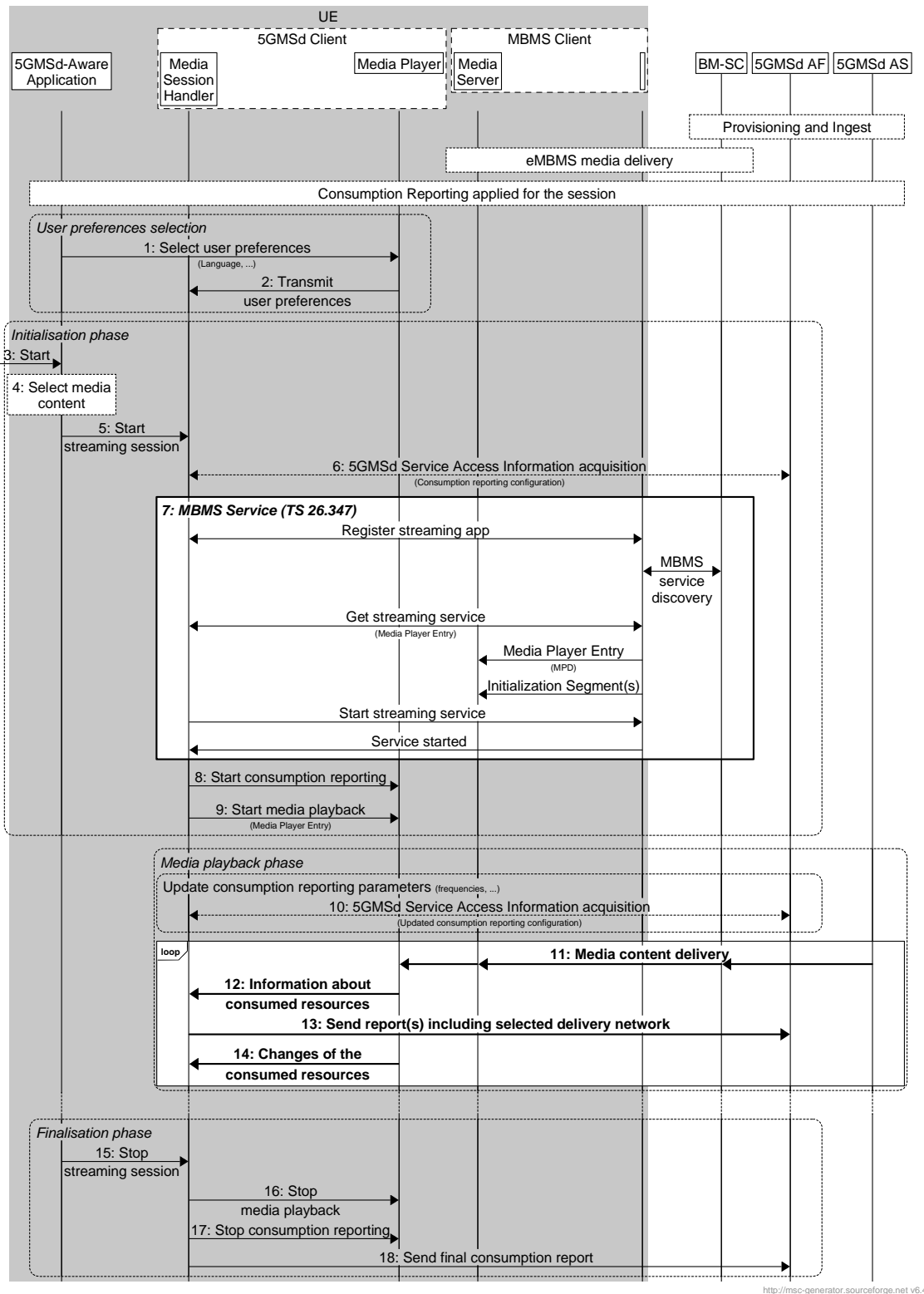

<http://msc-generator.sourceforge.net/v6.4>

Figure 5.10.3-1: Consumption reporting for 5GMS via eMBMS

Prerequisites (step 0):

- The 5GMSd Application Provider has provisioned the 5G Media Streaming System, including content ingest, consumption reporting **and the permission to distribute 5GMS content via eMBMS**.
- The BM-SC is ingesting content **from the 5GMS AS**, using either pull mode or push mode.
- eMBMS media delivery is established.
- Consumption reporting is established.

Steps:

The user preferences relating to consumption reporting may be changed:

- 1: The 5GMSd-Aware Application selects/changes the user preferences.
- 2: The Media Player transmits consumption reporting user preferences to the Media Session Handler.

The first phase is initialisation.

- 3: The 5GMSd-Aware Application is started.
- 4: A media content item is selected.
- 5: The 5GMSd-Aware Application triggers the Media Session Handler to start content playback. The Media Player Entry is provided.
- 6: If the 5GMS-Aware Application has received only a reference to the Service Access Information, the Media Session Handler interacts with the 5GMSd AF to acquire the whole Service Access Information. **This includes a client consumption reporting configuration** including parameters such as reporting frequency.
- 7: The MBMS service is initiated.**
- 8: The Media Session Handler triggers consumption reporting in the Media Player.
- 9: The Media Session Handler starts the Media Player with the Media Player Entry.

The second phase is media playback.

When media is playing, the consumption reporting parameters may be updated by the 5GMSd AF.

- 10: The Media Session Handler acquires updated Service Access Information from the 5GMSd AF including updated consumption reporting parameters.

When media is playing:

- 11: Media content is accessed through different networks, possibly via eMBMS or unicast.**
- 12: The Media Player transmits information about the media streaming resources consumed to the Media Session Handler, **including the source of the media**.
- 13: The Media Session Handler regularly sends consumption report(s) to the 5GMSd AF, **including information about the delivery network from which the media was acquired**.
- 14: The Media Player provides an update to the Media Session Handler about the consumed media streaming resources, for example a change in the delivery network.**

The last phase is to stop the media:

- 15: The 5GMSd-Aware Application triggers the Media Session Handler to stop content playback.
- 16: The Media Session Handler stops the Media Player.
- 17: The Media Session Handler stops consumption reporting in the Media Player.
- 18: The Media Session Handler may send final consumption report(s) to the 5GMSd AF.

### 5.10.4 5GMS Metrics Reporting procedures for eMBMS

In this case, 5GMS metrics reporting is used to report 5GMS and eMBMS metrics to the 5GMSd AF.

NOTE: eMBMS metrics reporting is disabled in this case.

The call flow in Figure 5.10.4-1 extends the call flow defined in clause 5.5.3 to address metrics reporting. Aspects specific to this use-case are indicated in bold.

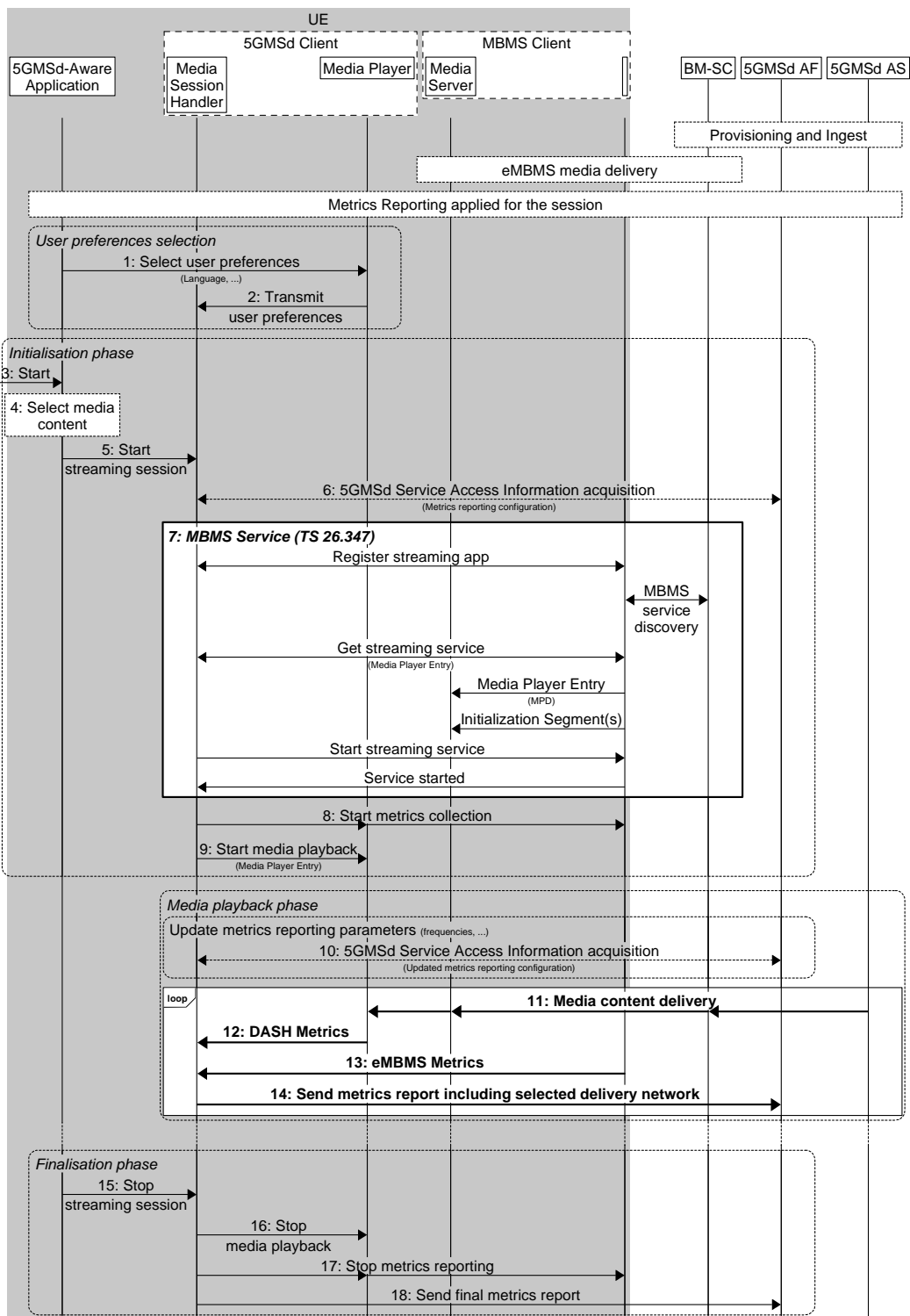

<https://gitlab.com/mso-generator/v8.2>

Figure 5.10.4-1: Metrics reporting for 5GMS via eMBMS

Prerequisites (step 0):

- The 5GMSd Application Provider has provisioned the 5G Media Streaming System, including content ingest, metrics reporting **and the permission to distribute 5GMS content via eMBMS**.
- The BM-SC is ingesting content **from the 5GMS AS**, using either pull mode or push mode.
- eMBMS media delivery is established.
- Metrics reporting is established.

Steps:

The user preferences relating to metrics reporting may be changed:

- 1: The 5GMSd-Aware Application selects/changes the user preferences.
- 2: The Media Player transmits metrics reporting user preferences to the Media Session Handler.

The first phase is initialisation.

- 3: The 5GMSd-Aware Application is started.
- 4: A media content item is selected.
- 5: The 5GMSd-Aware Application triggers the Media Session Handler to start content playback. The Media Player Entry is provided.
- 6: If the 5GMS-Aware Application has received only a reference to the Service Access Information, the Media Session Handler interacts with the 5GMSd AF to acquire the whole Service Access Information. **This includes a client metrics reporting configuration** including parameters such as reporting frequency.
- 7: The MBMS service is initiated.**
- 8: The Media Session Handler **triggers metrics collection by the MBMS Client** and by the Media Player.
- 9: The Media Session Handler starts the Media Player with the Media Player Entry.

The second phase is media playback.

When media is playing, the metrics reporting parameters may be updated by the 5GMSd AF.

- 10: The Media Session Handler acquires updated Service Access Information from the 5GMSd AF including updated metrics reporting parameters.

When media is playing:

- 11: Media content is accessed through different networks, possibly via eMBMS or unicast.**
- 12: The Media Player provides DASH metrics to the Media Session Handler.**
- 13: The MBMS Client provides MBMS metrics to the Media Session Handler using MBMS-API-C.**
- 14: The Media Session Handler regularly sends metrics report(s) to the 5GMSd AF, **including information about the delivery network from which the media was acquired.**

The last phase is to stop the media:

- 15: The 5GMSd-Aware Application triggers the Media Session Handler to stop content playback.
- 16: The Media Session Handler **stops metrics collection in the MBMS Client** and the Media Player.
- 17: The Media Session Handler stops metrics reporting.
- 18: The Media Session Handler may send final metrics report(s) to the 5GMSd AF.

## 5.10.5 Procedures for Hybrid Services: 5GMS content delivery via 5G System and eMBMS

### 5.10.5.1 General

Hybrid services refer to the case for which a basic service is available on eMBMS and at the same time on unicast. The service on unicast may be richer and extended and may provide additional user experiences. For the hybrid use cases, the content is statically provisioned on different delivery networks.

Hybrid services predominantly refer to the case for which the delivery manifest differentiates between resources accessible on unicast via M4d and resources accessible through eMBMS, in this case through MBMS-API-U.

These resources are differentiated in the delivery manifest through different DNs, for example different Base URLs in DASH MPDs, or in HLS by providing different pathways. The 5GMS Client, in particular the Media Player in collaboration with the Media Session Handler and the MBMS Client, dynamically selects the delivery network from which to acquire media content according to reception conditions, user preferences or other policies. Content is provisioned such that the 5GMS Client is able to provide a seamless user experience when switching between different delivery networks.

The call flow in Figures 5.10.5-1, 5.10.5 2 and 5.10.5 3 extends that defined in clause 5.6.1 to address generic hybrid use cases. Specific additional use cases are presented in the remainder of clause 5.10.5.

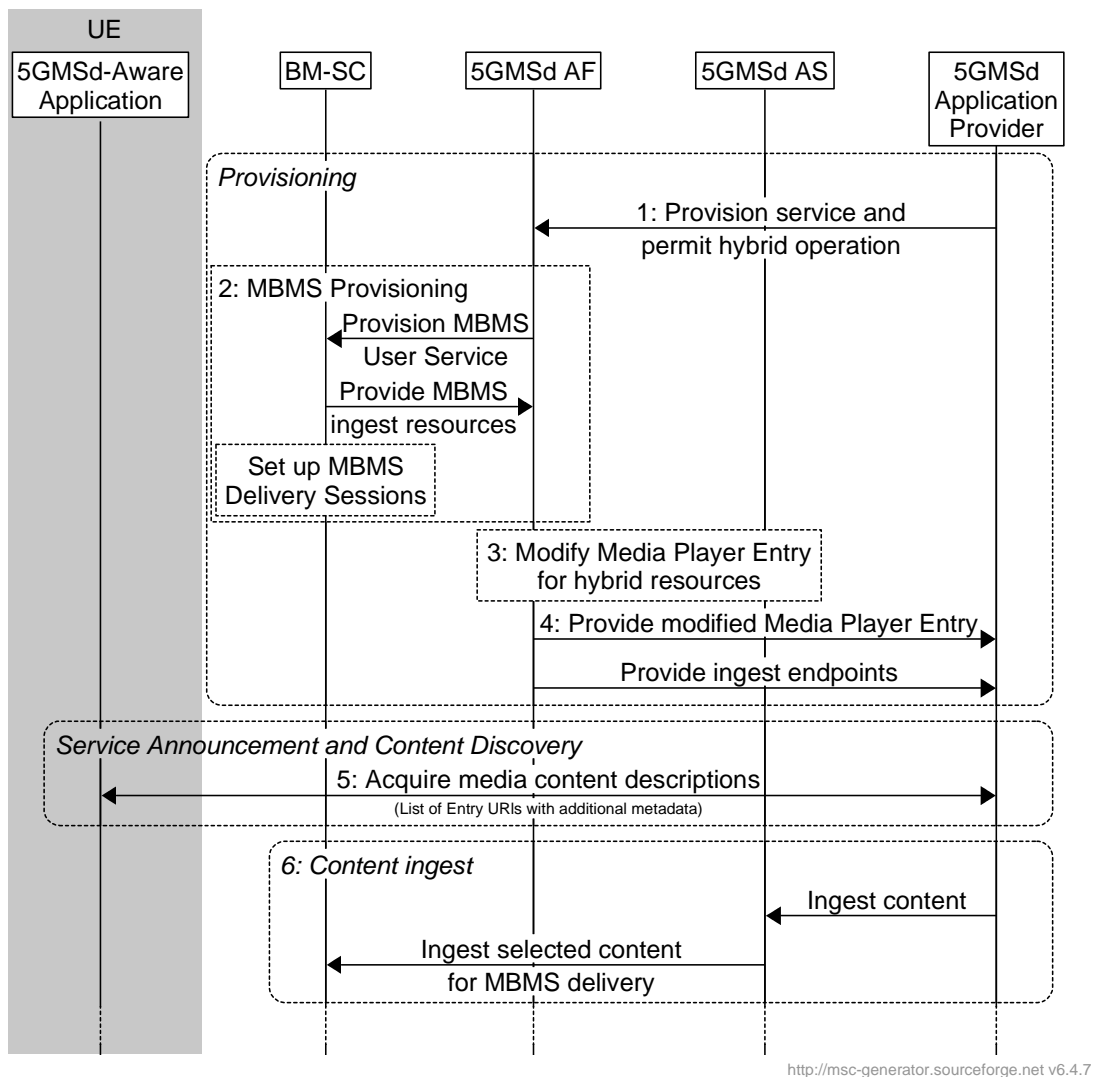

<http://msc-generator.sourceforge.net> v6.4.7

Figure 5.10.5-1: High-level procedure for hybrid delivery of DASH content

Steps:

- 1: The 5GMSd Application Provider triggers 5GMS provisioning and permits hybrid distribution of the media content.
- 2: As a consequence, the 5GMSd AF provisions MBMS delivery. The MBMS Delivery Session is set up, and the BM SC informs the 5GMS AF about the content ingest endpoints.
- 3: The 5GMSd AS modifies the Media Player Entry (typically a media presentation manifest) under the direction of the 5GMSd AF to indicate that content is available either on a the MBMS Client's local Media Server or on 5GMSd AS.
- 4: The modified presentation manifest and the ingest endpoints are provided to the 5GMSd Application Provider. The manifest may also be updated by the 5GMSd Application Service Provider.
- 5: The media content is announced to the 5GMSd-Aware Application and the application requests the entry points for the service.
- 6: The 5GMSd AS begins ingesting content from the 5GMSd Application Provider and the BM SC may, in turn, begin ingesting this content from the 5GMSd AS.

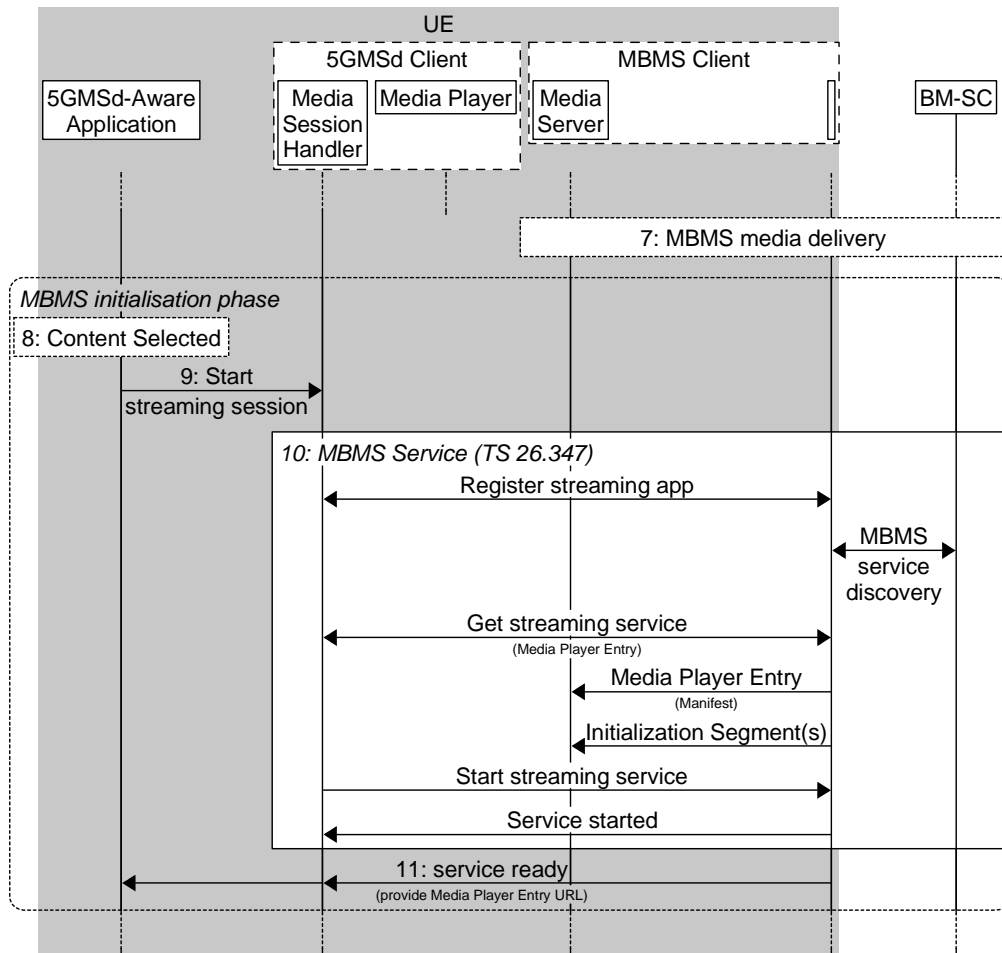

<http://msc-generator.sourceforge.net v6.4.7>

**Figure 5.10.5-2: High-level procedure for hybrid delivery of DASH content (continued)**

- 7: The BM SC starts one or more MBMS Delivery Sessions.
- 8: The media content is selected by the 5GMSd-Aware Application.
- 9: The application initiates the media streaming session through Media Session Handler.
- 10: The Media Session Handler initiates the MBMS streaming services.

11: The media session handler through the information from the MBMS Client informs the 5GMSd-Aware Application that the service is ready.

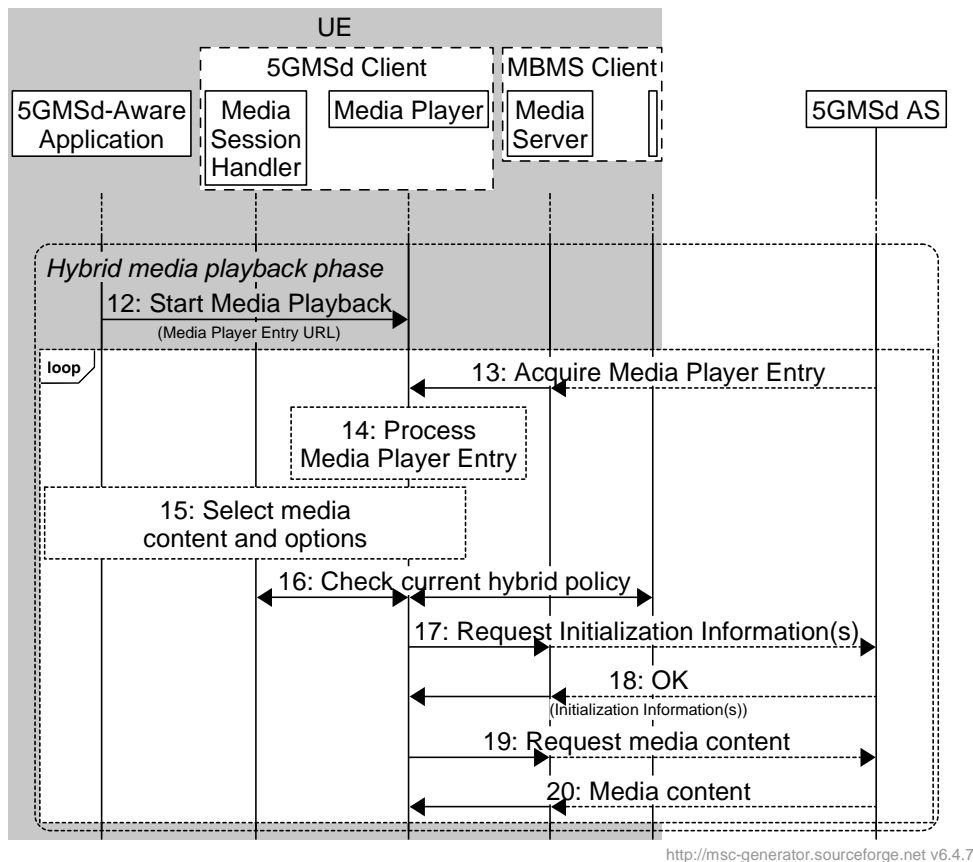

**Figure 5.10.5-3: High-level procedure for hybrid delivery of DASH content (continued)**

- 12: The 5GMSd-Aware Application starts media playback.
  - 13: The Media Player Entry (typically a media presentation manifest ) is acquired by the Media Player. It may be available from the local Media Server (populated by the MBMS Client) or from the 5GMSd AS, or even from both.
  - 14: The Media Player processes the Media Player Entry and identifies that content is available from different data networks (the local Media Server and the 5GMSd AS).
  - 15: Under the control of the 5GMSd-Aware Application, the Media Player selects the content and different content options.
  - 16: The Media Player continuously checks with the Media Session Handler - and possibly forwarded to the MBMS Client if the MBMS User Service data is available - how to use the different content. This depends on the hybrid scenario. Different policies may be considered.
  - 17: The Media Player requests initialization information either from the local Media Server or from the 5GMSd AS. The Media Player repeats this step for each required initialization segment.
  - 18: The Media Player receives the initialization information.
  - 19: The Media Player requests media segments according to the Media Player Entry, either from the local Media Server or from the 5GMSd AS.
  - 20: The Media Player receives media segments and puts the information into the appropriate media rendering pipeline.
- Steps 13-20 are repeated according to the Media Player Entry information.

### 5.10.5.2 Interactive service

In a specific hybrid scenario, an interactive service may be provided via 5GMS while the main media content resources are delivered via eMBMS exclusively. In this case, the following instantiations apply:

- In step 2, the media presentation manifest (MPD) only points to content in the local Media Server.
- Step 13 as well as steps 17-20 are all terminated on the local Media Server.

### 5.10.5.3 Session continuity

In a specific hybrid scenario, the service is made available via both 5GMS and eMBMS delivery networks, but only one Representation of each Adaptation Set is provided via eMBMS. In this case, the following instantiations apply:

- In step 2, one Representation of each Adaptation Set is distributed via eMBMS.
- As long as the streaming service is accessible over eMBMS, the Media Player selects the media content in step 13 as well as steps 17-20 from the local Media Server; content is not available from the 5GMSd AS.
- If the streaming service becomes unavailable via eMBMS, the Media Player switches to accessing the media content in step 13 as well as steps 17-20 from the 5GMSd AS.
- Once the streaming service becomes available again via eMBMS, the Media Player switches back to accessing the media content in step 13 as well as steps 17-20 from the local Media Server.

### 5.10.5.4 Time-shifted viewing

In a specific hybrid scenario, the service is made available via both 5GMS and eMBMS delivery networks, but only one Representation of each Adaptation Set is provided via eMBMS. The content is retained by the 5GMS AS for a period of time to support time shifted access. In this case, the following instantiations apply:

- In step 2, one Representation of each Adaptation Set is distributed via eMBMS.
- If the streaming service is accessible via eMBMS and the user is consuming content at the live edge, the Media Player selects the media content in the step 13 as well as steps 17-20 from the local Media Server; content is not available from the 5GMSd AS.
- If the user switches to time-shift viewing mode or streaming service becomes unavailable via eMBMS, the Media Player switches to accessing the media content in the step 13 as well as steps 17-20 from the 5GMSd AS.
- Once the streaming service becomes available again via eMBMS and the user returns to the live edge, the Media Player switches back to accessing the media content in the step 13 as well as steps 17-20 from the local Media Server.

### 5.10.5.5 Content or component replacement

In a specific hybrid scenario, the service is made available via both 5GMS and eMBMS delivery networks, but only one Representation of selected Adaptation Sets is provided via eMBMS. Some Adaptation Sets are only available via 5GMS. In another case, two or more content alternatives may exist for a period of time, but only one alternative is provided over eMBMS.

In this case, the following instantiations apply:

- In step 2, the MPD is generated to define the different content alternatives.
- If the streaming service is accessible over eMBMS and the user watches content available on broadcast, the Media Player selects the media content in step 13 as well as steps 17-20 from the local Media Server; content is not available from the 5GMSd AS.
- If the user switches content or content components, the Media Player switches to accessing the media content in the step 13 as well as steps 17-20 from the 5GMSd AS. If only a component is replaced, the Media Player accesses media content from the local Media Server and the 5GMSd AS at the same time.



## 5.10.6 Procedures for dynamic provisioning of 5GMS content delivery via eMBMS

### 5.10.6.1 General

In this scenario the same content is distributed via eMBMS (for example using a broadcast network in receive-only mode) and via a 5GMS System. The resources of the broadcast system are statically configured. eMBMS-based distribution may, for example, be used only for services in high demand, and the resources and quality of the service distributed through broadcast may be adjusted according to demand. Demand may be identified through 5GMS Consumption Reporting.

The call flow in Figures 5.10.6 1 and 5.10.6 2 extends that defined in clause 5.6.1 to address generic use cases for broadcast-on-demand. Specific additional use cases are presented in the remainder of clause 5.10.6.

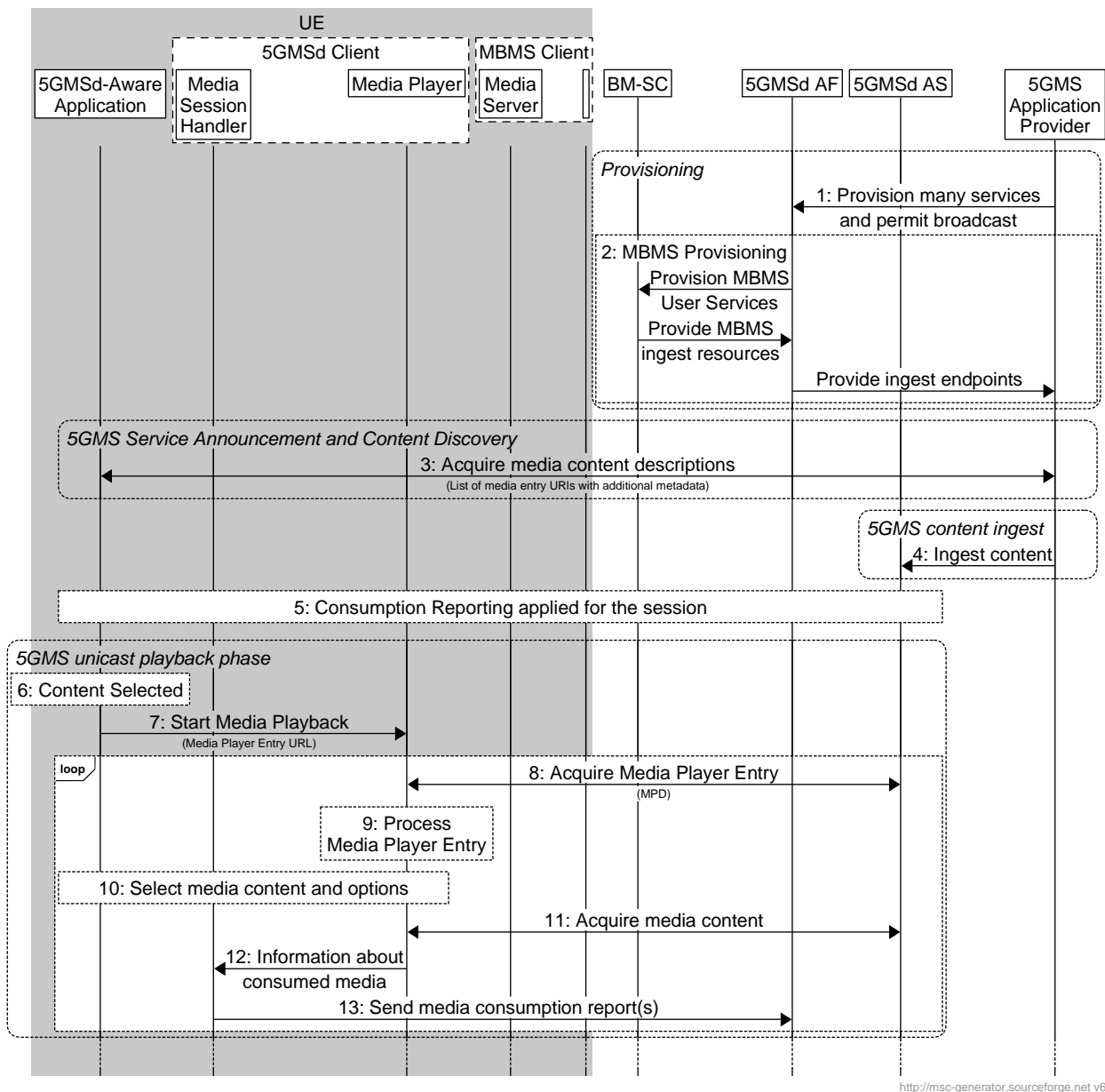

Figure 5.10.6.1-1: High-level procedure for DASH content delivered via eMBMS broadcast-on-demand

## Steps:

- 1: The 5GMS Application Provider provisions one or more MBMS services and permits broadcast distribution of the media content.
- 2: As a consequence, the 5GMSd AF provisions MBMS delivery and the BM SC informs the 5GMS AF about the resources it will use to ingest media content.

NOTE: This step may happen later, up to (and possibly as part of) step 15, for example only when demand is identified.

- 3: The media content is announced to the 5GMSd-Aware Application and the application request the entry points for the service.
- 4: The 5GMSd AS starts to ingest content from the 5GMSd Application Provider.
- 5: Consumption Reporting is applied for the 5GMSd session.

## Media playback initially uses unicast 5G Media Streaming:

- 6: The media content is selected by the 5GMSd-Aware Application.
- 7: The 5GMSd-Aware Application triggers the start of media playback by the Media Player.
- 8: The media presentation manifest (e.g. DASH MPD) is requested by the Media Player from the 5GMSd AS.
- 9: The Media Player processes the media presentation manifest and identifies that the media content is available on the 5GMS AS
- 10: The Media Player, under the control of the application, selects the media content and different content options.
- 11: Media content is received from the 5GMSd AS via reference point M4d.
- 12: The Media Player informs the Media Session Handler about the consumed media content.
- 13: The Media Session Handler sends consumption reports to the 5GMSd AF.

## Subsequently, media playback switches to eMBMS:

- 14: By analysing the consumption reports submitted to it in the previous step, the 5GMSd AF identifies a high level of demand for the service.
- 15: Additional MBMS delivery sessions are provisioned to add delivery of the service via eMBMS.
- 16: The BM SC starts ingesting media content from the 5GMSd AS.
- 17: MBMS delivery starts.
- 18: The 5GMSd AF informs the Media Session Handler that MBMS delivery is initiated and provides the Service Success Information.
- 19: MBMS content reception is initiated by the Media Session Handler.
- 20: Once the service is ready, the content delivered on MBMS is used by the Media Player. Consumption reporting continues. Specific cases may use different policies, similar to the hybrid case in clause 5.10.5.

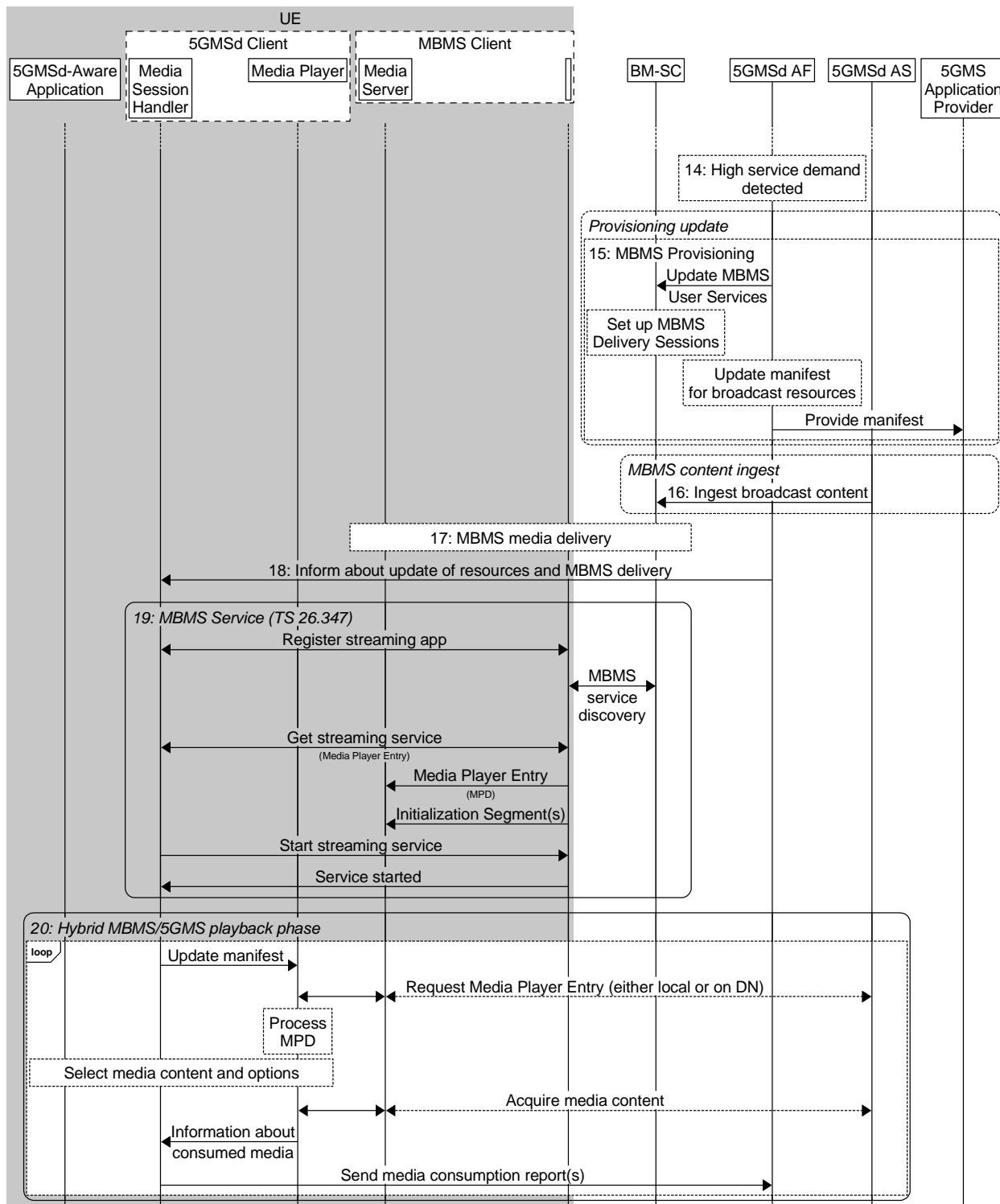

<http://msc-generator.sourceforge.net v6.4.7>

Figure 5.10.6.1-2: High-level procedure for DASH content delivered via eMBMS broadcast-on-demand (continued)

### 5.10.6.2 Operation modes

At least the following operation modes are supported based on the general procedures in clause 5.10.6.1:

1. Every 5GMS media service is mapped to exactly one MBMS User Service. Whether the MBMS User Service is announced and delivered or not depends on service demand. The MBMS Delivery Session is adjusted dynamically - for example the Delivery Session is disabled, or the bit rate is changed - depending on service demand and/or content requirements.
2. A set of MBMS User Services and MBMS Delivery Sessions is defined in the initial provisioning. 5GMS media services are dynamically mapped to statically configured MBMS User Services based on demand and content requirements.
3. Components of the 5GMS User Service, for example audio service components for different languages, are assigned dynamically to MBMS delivery depending on demand.

### 5.10.7 Service URL handling procedures for 5GMSd via eMBMS in Receive-Only Mode (ROM)

In an extension to the procedures provided in clauses 5.10.2 and 9.1, this clause defines a call flow in order to initiate a 5GMSd streaming session delivered via eMBMS without needing to contact the network, for example as done in Receive-Only Mode (ROM).

The call flow in figure 5.13.2-1 extends those defined in clauses 5.10.2 and 9.1 to address 3GPP Service URL handling. Aspects specific to this use-case are indicated in bold.

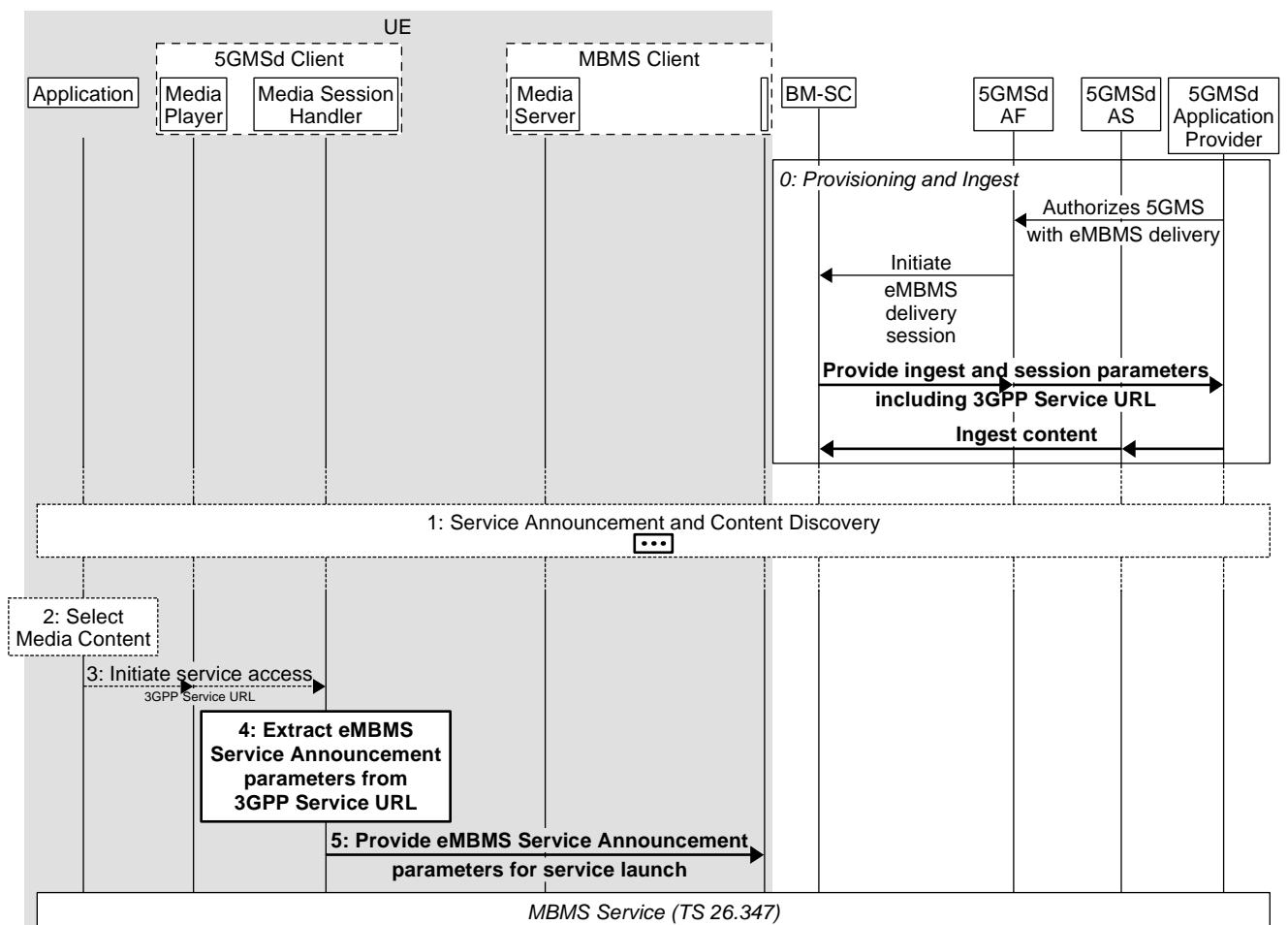

<https://gitlab.com/msc-generator/v8.4>

Figure 5.10.2-1: High-level procedure for DASH content delivery via eMBMS with 3GPP Service URL

Prerequisites (step 0):

- The 5GMSd Application Provider has provisioned the 5GMSd System, including content ingest and the authorization to distribute 5GMSd content via eMBMS.
- The 5GMSd AF has informed the BM-SC about the availability of 5GMSd content by provisioning an MBMS service and has obtained relevant information from the eMBMS Service Announcement (such as the MBMS service identifier).
- **Based on the information, the 5GMSd Application Provider has generated a 3GPP Service URL with sufficient information for the Media Session Handler and MBMS Client to access the service.**
- The BM-SC is ingesting content from the 5GMSd AS.
- The BM-SC has broadcast the MBMS Service Announcement, including an indication that the content is 5GMSd content.

Steps:

- 1: The 5GMSd-Aware Application triggers the Service Announcement procedure and the 5GMS Service and Content Discovery procedure at reference point M8. **The information returned to the 5GMSd-Aware Application includes a 3GPP Service URL indicating a 5GMS-based service and also includes relevant information from the eMBMS Service Announcement (such as the MBMS service identifier).**
- 2: A media content item is selected.
- 3: The 5GMSd-Aware Application triggers the 5GMSd Client to start media playback. **The 3GPP Service URL describing the service is requested and the Media Session Handler handles it.**
- 4: **The Media Session Handler uses the Service URL information to extract relevant information from the eMBMS Service Announcement (such as the MBMS service identifier) in order to bootstrap reception of the MBMS service.**
- 5: **The Media Session Handler provides the Service Access information to the MBMS Client.**

Finally, the MBMS Service is launched as defined in steps 5–25 of clause 5.10.2.

## 5.11 Procedures for downlink media streaming data collection, reporting and exposure

### 5.11.1 Configuration of 5GMSd AS data collection client for downlink media streaming access reporting

The 5GMSd AS obtains its data collection client configuration at reference point R4 as part of its initialisation procedure, as shown in figure 5.11.1-1.

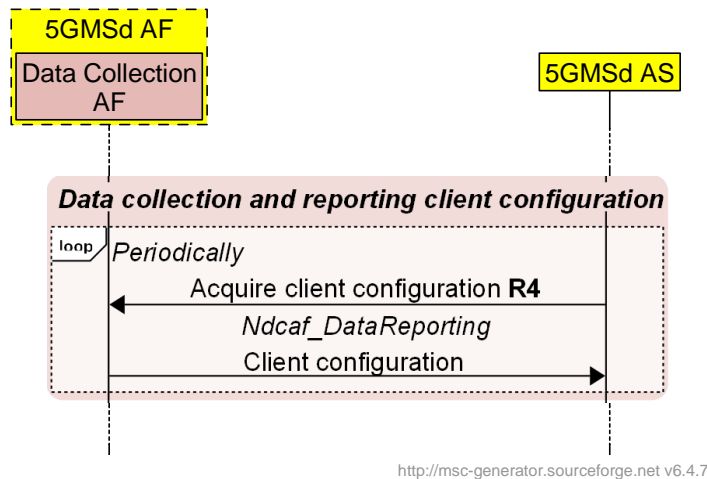
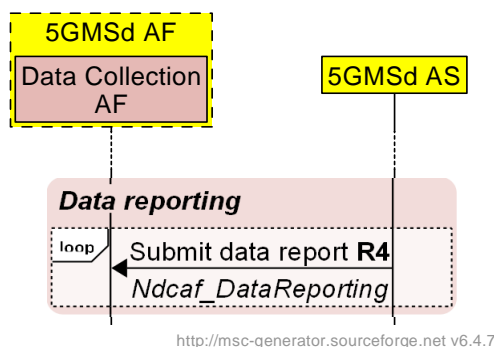

**Figure 5.11.1-1: Data collection client configuration for downlink media streaming access reporting**

The 5GMSd AS shall periodically refresh its data collection client configuration and act appropriately on any changes in the configuration.

### 5.11.2 Downlink media streaming access activity reporting by 5GMSd AS

The 5GMSd AS shall use the procedure shown in figure 5.10.2-1 to report downlink media streaming access to the Data Collection AF instantiated in the 5GMSd AF when the data collection client configuration obtained using the procedure in clause 5.10.1 indicates that it should do so.



**Figure 5.10.2-1: Downlink media streaming access reporting**

The data report defined in clause 4.6.1 of TS 26.531 [22] shall be used by the 5GMSd AS to report the activity of downlink media streaming access by the Media Player. Each downlink access logged by the 5GMSd AS in relation to such activity shall be reported as a single record in a report submitted to the Data Collection AF at reference point R4. The parameters included in the data report are defined in clause 5.11.4. The frequency of reporting is defined in clause 5.11.5.

### 5.11.3 Downlink media streaming access event exposure

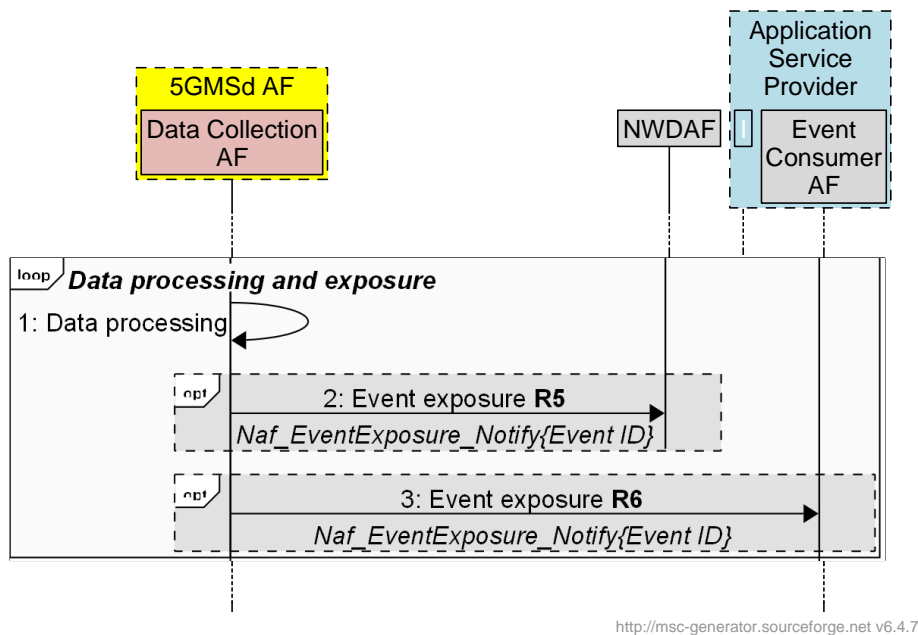

**Figure 5.11.3-1: Downlink media streaming access event exposure**

The 5GMS System shall follow the procedures for event reporting defined in clause 4.15.1 of TS 23.502 [3]. In the context of downlink media streaming:

- The role of *event provider NF* (also referred to in [3] as *event provider NF*, *event provider*, or *NF producer*) is performed by the 5GMSd AF and its subordinate Data Collection AF or the NEF.
- The role of *event consumer NF* (also referred to in [3] as *consumer NF*, *NF service consumer*, or *NF consumer*) is performed by the NWDAF, the NEF and/or the Event Consumer AF of the 5GMSd Application Provider.

When one of the abovementioned event consumer entities subscribes to event reporting at the 5GMSd AF:

- Event subscription parameters contained in *Event Reporting Information* (such as maximum number of reports, maximum duration of reporting, sampling ratio, partitioning criteria, etc. as defined in clause 4.15.1 of [3]) shall be limited or superseded by similar or identical rules optionally set by a 5GMSd Application Provider in the Event Data Processing Configuration of the 5GMSd AF Provisioning Session, as defined in clause 5.3.1 of the present document.
- UE targeting rules contained in the *Target of Event Reporting* (see clause 4.15.1 of [3]) shall be limited or superseded by similar or identical rules optionally set by a 5GMSd Application Provider in Data Access Profiles in the Event Data Processing Configuration of the 5GMSd AF Provisioning Session, as defined in clause 5.3.1 of the present document.

## 5.11.4 Downlink media streaming access reporting parameters

Table 5.11.4-1 below describes the parameters reported by the 5GMSd AS in clause 5.11.2 for each downlink media streaming access.

**Table 5.11.4-1: Downlink media streaming access reporting parameters**

Parameter	Cardinality	Description
Date-time	1..1	The date and time of access.
UE identity	1..1	A unique identifier of the UE accessing the 5GMSd AS, such as the source IP address and port number of the Media Player.
5GMSd AS service endpoint	1..1	The service endpoint on the 5GMSd AS to which the Media Player is connected for this access, such as the server IP address and port number.
Session identifier	0..1	An identifier for the HTTP session on which the Media Player request was made for this access.
HTTP request method	1..1	The HTTP method used for this access.
HTTP request URL	1..1	The URL requested by the Media Player for this access.
HTTP request version	1..1	The HTTP version requested by the Media Player for this access.
HTTP request range	0..1	The value of the Range HTTP request header, if present for this access.
HTTP request size	1..1	The total number of bytes in the HTTP client request message from the Media Player for this access.
HTTP User Agent	0..1	A string describing the Media Player that made this access.
User identity	0..1	A string identifying the user that made the access.
Referrer URL	0..1	The URL that the Media Player reports being referred from.
Cache status	0..1	An indication of whether the 5GMSd AS is able to serve the requested URL from cache for this access (a hit) or whether there is a stale object cached (expired) or the requested URL is not present in cache (miss). For non-caching implementations of the 5GMSd AS, the status is miss for all accesses.
HTTP response code	1..1	The HTTP response code issued by the 5GMSd AS for this access.
HTTP response size	1..1	The total number of bytes returned by the 5GMSd AS in the HTTP response message for this access.
HTTP response body size	1..1	The number of bytes returned by the 5GMSd AS in the HTTP response body for this access.
HTTP response content type	0..1	The MIME content type of the HTTP response message returned by the 5GMSd AS for this access.
Processing latency	1..1	The time taken by the 5GMSd AS to respond to the Media Player request, measured from the first byte of the HTTP request being processed by the 5GMSd AS to the last byte of the response being sent.
Mean network round-trip time	1..1	A rolling mean average of the network round-trip time for the HTTP session on which the access was received.
Network round-trip time variance	1..1	The variance in the average network round-trip time for the HTTP session on which the access was received.
Transport congestion window size	1..1	The current size (in bytes) of the congestion window for the transport connection supporting the HTTP session on which the access was received.

## 5.11.5 Triggering downlink media streaming access reporting

Reports shall be sent by the 5GMSd AS to the Data Collection AS as indicated in the data collection client configuration obtained using the procedure defined in clause 5.11.1.

## 5.12 5GMS via MBS

### 5.12.1 General

This clause defines procedures for different use cases and scenarios when 5GMS uses MBS for delivery as introduced in clause 4.9. In all scenarios, the 5GMSd Client acts as an MBS-Aware Application.

The scenarios presented are not considered to be comprehensive and complete for all possible functionalities. For example, while MBS defines its own metrics reporting, the MBS client may also provide information to the Media



Session Handler that integrates relevant data in 5GMS metrics reporting. MBS and 5GMS metrics reporting may run in parallel.

The MBSTF terminates the MBS Distribution Session and includes a proxy Media Server that it is assumed can be accessed by the Media Player using common methods, typically HTTP GET requests.

### 5.12.2 Procedures for 5GMS content delivered exclusively via MBS

In this scenario, 5GMS content is delivered exclusively via the MBS System, i.e. content is not delivered via reference point M4d, but only via MBS User Services. However, the MBSTF Client may perform unicast object repair operations via reference point MBS-4-UC, if available.

The call flow in figure 5.12.2 1 extends that defined in clause 5.3.2 to address the delivery of 5GMS content exclusively via MBS. Aspects specific to this use-case are indicated in bold.

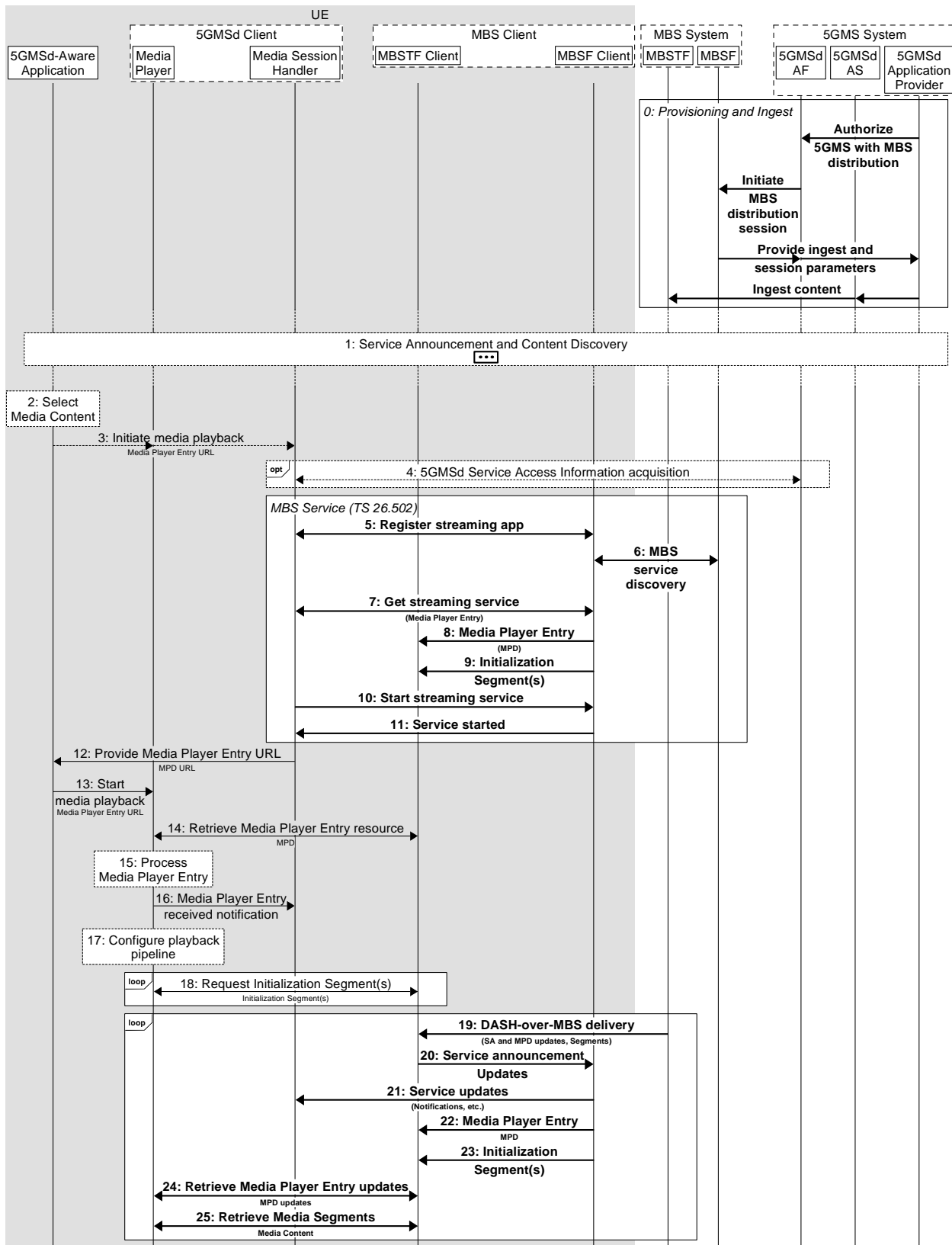

<https://gitlab.com/msc-generator> v8.0

Figure 5.12.2-1: High-level procedure for DASH content delivery via MBS

Prerequisites (step 0):

- The 5GMSd Application Provider has provisioned the 5G Media Streaming System, including content ingest **and the authorization to distribute 5GMS content via MBS.**
- **The 5GMS AF has informed the MBSF about the availability of 5GMS content** by provisioning an MBS service **and has obtained relevant information from the MBS Service Announcement (such as the MBS service identifier).**
- The MBSTF is ingesting content **from the 5GMS AS**, using pull based object acquisition.
- The MBSTF distributes the MBS User Service Announcement via the MBS User Service Announcement Channel at reference point MBS-4-MC, **possibly including an indication that the content is 5GMS content.**

Steps:

- 1: The 5GMSd-Aware Application triggers the Service Announcement procedure and the 5GMS Service and Content Discovery procedure at reference point M8.
- 2: A media content item is selected.
- 3: The 5GMSd-Aware Application triggers the 5GMSd Client to start media playback. The Media Player Entry documents are provided to the 5GMSd Client.
- 4: If the 5GMS-Aware Application has received only a reference to the Service Access Information (see step 1), the Media Session Handler interacts with the 5GMSd AF to acquire the whole Service Access Information. **This includes relevant information from the MBS Service Announcement (such as the MBS service identifier) in order to bootstrap reception of the MBS service.**

**5–11: The 5GMSd Client acts as an MBS-Aware Application and its Media Session Handler initiates service acquisition per TS 26.502 [30]. This establishes a transport session for the Media Player Entry and the Content.**

NOTE: The Media Player Entry and Initialization Segment(s) are made available by the MBSTF Client's proxy Media Server for subsequent request by the Media Player.

- 12: The Media Session Handler provides the Media Player Entry URL to the Media Player either directly or through the 5GMSd-Aware Application.
- 13: The Media Player is invoked by the 5GMSd-Aware Application to start media access and playback.
- 14: The Media Player retrieves the Media Player Entry resource (e.g. MPD) from the proxy Media Server.
- 15: The Media Player processes the retrieved Media Player Entry. It determines, for example, the number of transport sessions needed for media acquisition. The Media Player should be able to use the Media Player Entry information to initialize the media rendering pipeline(s) for each media stream (see step 17).
- 16: The Media Player notifies the Media Session Handler about the start of a new downlink media streaming session. The notification may include parameters from the Media Player Entry.
- 17: The Media Player configures the media rendering pipeline(s).
- 18: The Media Player retrieves initialization segment(s) referenced by the Media Player Entry.

**19-25: Content is delivered using Object Streaming (see clause 6.1 of TS 26.502 [30]). Session Announcement updates are provided to the MBS Client as necessary. The MBSTF receives the MBS User Service Announcement via reference point MBS-4-MC and hands it to the MBSF for processing. MPD updates and media segments received from the MBSTF are made available by the MBSTF Client's proxy Media Server. The Media Player retrieves media segments from the proxy Media Server in the MBSTF Client according to the Media Player Entry and forwards them to the appropriate media rendering pipeline.**

### 5.12.3 5GMS consumption reporting procedures for MBS

In this scenario, 5GMS consumption reporting is used to report consumption of 5GMSd content via an MBS service.

NOTE: MBS User Services Reception Reporting (see clause 4.2.5 of TS 26.502 [30]) may continue in parallel with 5GMS consumption reporting.

The call flow in figure 5.12.3-1 extends the that defined in clause 5.6.1 to address consumption reporting. Aspects specific to this use-case are indicated in bold.

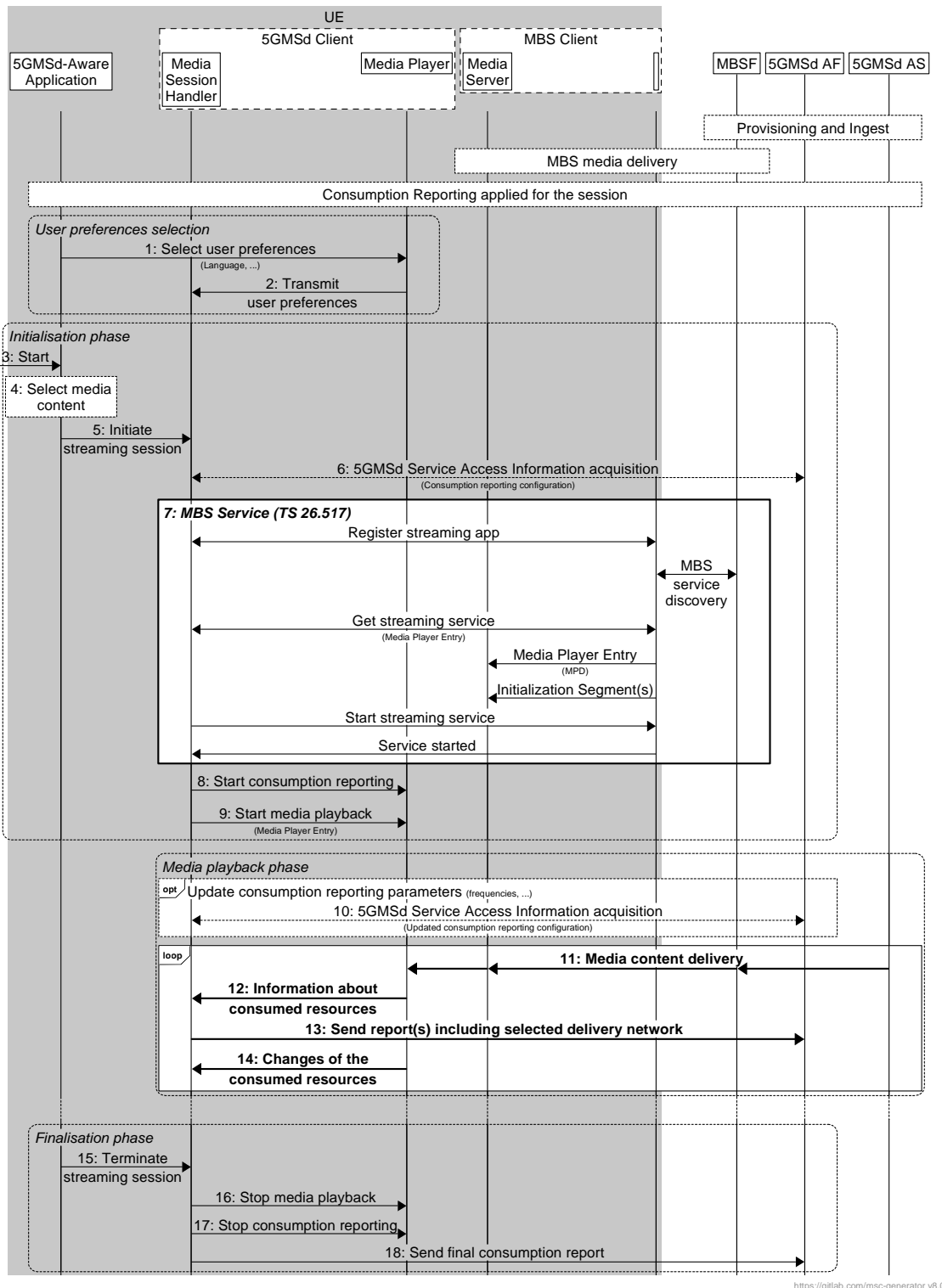

Figure 5.12.3-1: Consumption reporting for 5GMS via MBS

Prerequisites (step 0):

- The 5GMSd Application Provider has provisioned the 5G Media Streaming System, including content ingest, consumption reporting **and the permission to distribute 5GMS content via MBS**.
- The MBSTF is ingesting content **from the 5GMS AS**, using either pull mode or push mode.
- MBS media delivery is established.
- Consumption reporting is established.

Steps:

The user preferences relating to consumption reporting may be changed:

- 1: The 5GMSd-Aware Application selects/changes the user preferences.
- 2: The Media Player transmits consumption reporting user preferences to the Media Session Handler.

The first phase is initialisation.

- 3: The 5GMSd-Aware Application is started.
- 4: A media content item is selected.
- 5: The 5GMSd-Aware Application triggers the Media Session Handler to initiate media session handling and content playback. The Media Player Entry is provided.
- 6: If the 5GMS-Aware Application has received only a reference to the Service Access Information, the Media Session Handler interacts with the 5GMSd AF to acquire the whole Service Access Information. **This includes a client consumption reporting configuration** including parameters such as reporting frequency.
- 7: The MBS service reception is initiated by the Media Session Handler.**
- 8: The Media Session Handler triggers consumption reporting in the Media Player.
- 9: The Media Player is invoked by the 5GMSd-Aware Application to start media access and playback.

The second phase is media playback.

When media is playing, the consumption reporting parameters may be updated by the 5GMSd AF.

- 10: The Media Session Handler acquires updated Service Access Information from the 5GMSd AF including updated consumption reporting parameters.

When media is playing:

- 11: Media content is accessed through different networks, possibly via MBS or unicast.**
- 12: The Media Player transmits information about the media streaming resources consumed to the Media Session Handler, **including the source of the media**.
- 13: The Media Session Handler regularly sends consumption report(s) to the 5GMSd AF, **including information about the delivery network from which the media was acquired**.
- 14: The Media Player provides an update to the Media Session Handler about the consumed media streaming resources, for example a change in the delivery network.**

The last phase is to terminate the media streaming session:

- 15: The 5GMSd-Aware Application triggers the Media Session Handler to stop content playback.
- 16: The Media Session Handler stops the Media Player.
- 17: The Media Session Handler stops consumption reporting in the Media Player.
- 18: The Media Session Handler may send final consumption report(s) to the 5GMSd AF.

## 5.12.4 5GMS content delivery via 5G System and MBS

### 5.12.4.1 General

This clause addresses cases for which a 5GMS service is available on MBS and at the same time on unicast. The service on unicast may be richer and extended and may provide additional user experiences. It is assumed that the content is statically provisioned on either MBS or on unicast.

Services addressed in this clause predominantly refer to the case for which the delivery manifest differentiates between resources accessible via unicast downlink media streaming at reference point M4d and resources accessible through MBS, in this case through MBS-API-U.

These resources are differentiated in the delivery manifest through different Data Networks, for example different Base URLs in DASH MPDs, or in HLS by providing different pathways. The 5GMSd Client, in particular the Media Player in collaboration with the Media Session Handler and the MBS Client, dynamically selects the delivery network from which to acquire media content according to reception conditions, user preferences or other policies. Content is provisioned such that the 5GMSd Client is able to provide a seamless user experience when switching between different delivery networks.

The call flow in figures 5.12.4-1, 5.12.4-2 and 5.12.4-3 extends that defined in clause 5.6.1 to address generic hybrid use cases. Specific additional use cases are presented in the remainder of clause 5.12.4.

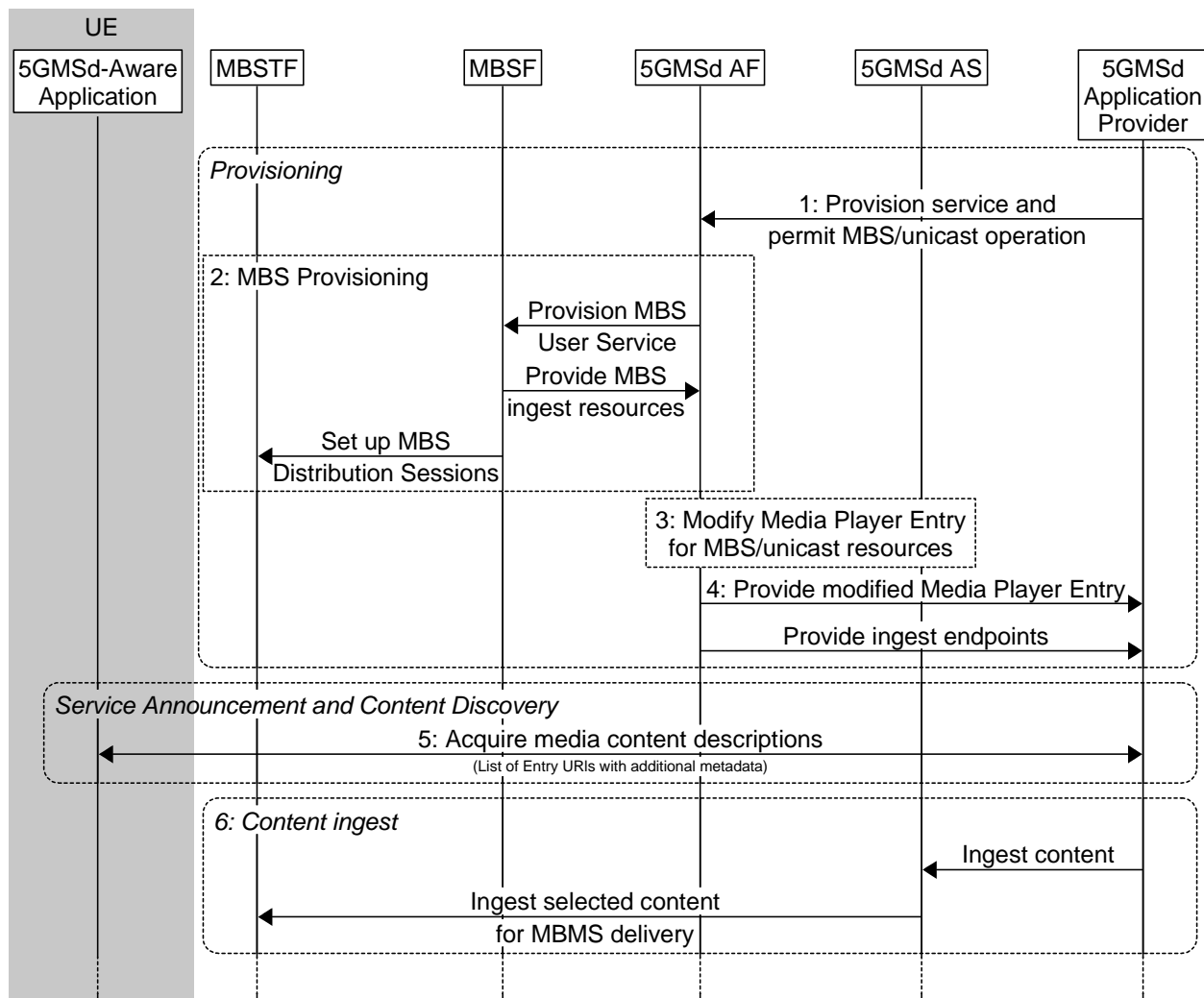
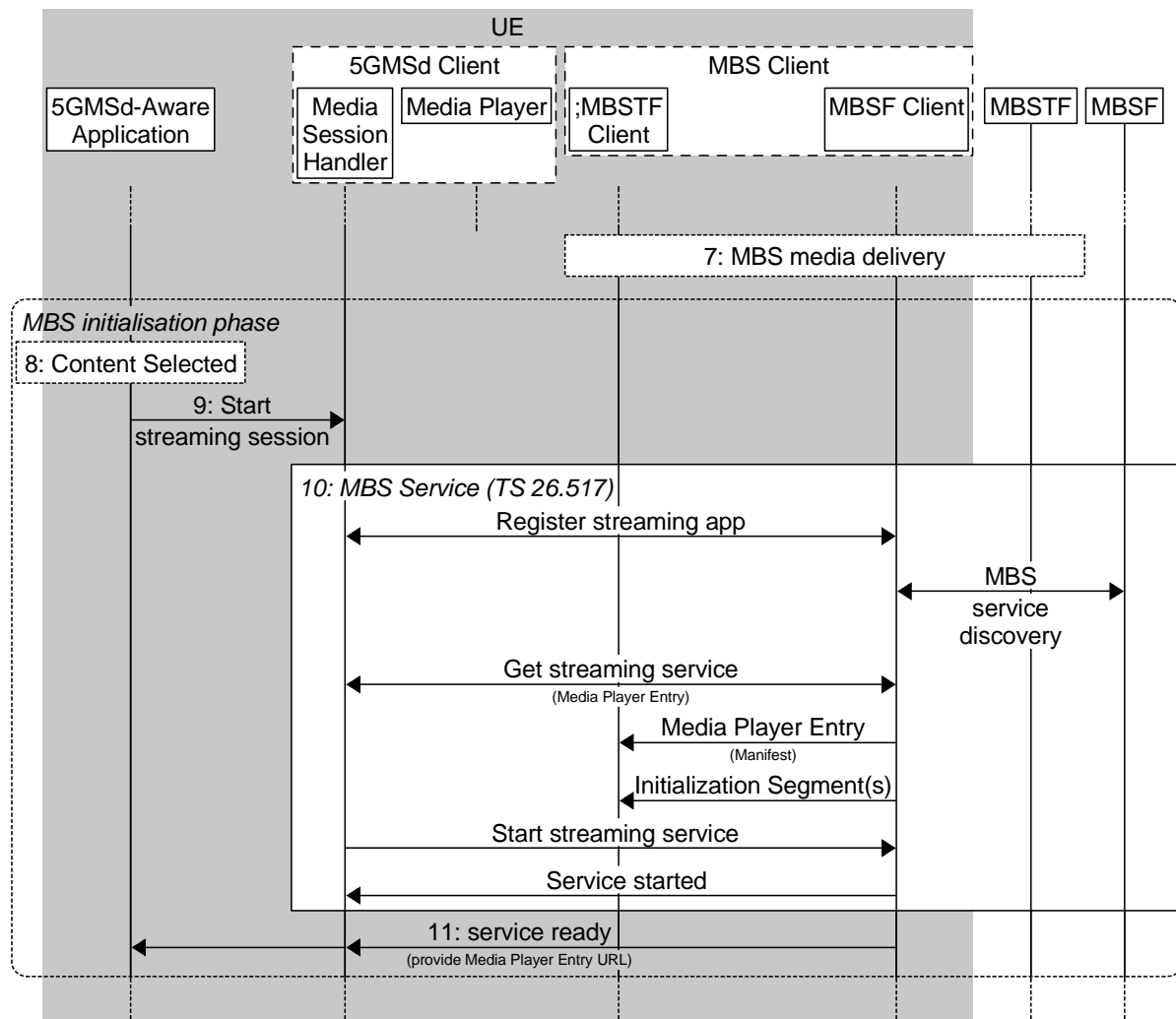

Figure 5.12.4-1: High-level procedure 5GMS content delivery via 5G System and MBS

Steps:

- 1: The 5GMSd Application Provider triggers 5GMS provisioning and permits concurrent 5GMS and MBS distribution of the media content.
- 2: As a consequence, the 5GMSd AF provisions MBS delivery. The MBS Delivery Session is set up, and the MBSF informs the 5GMS AF about the content ingest endpoints.
- 3: The 5GMSd AS modifies the Media Player Entry (typically a media presentation manifest) under the direction of the 5GMSd AF to indicate that content is available either on a the MBS Client's local Media Server or on 5GMSd AS.
- 4: The modified presentation manifest and the ingest endpoints are provided to the 5GMSd Application Provider. The manifest may also be updated by the 5GMSd Application Service Provider.
- 5: The media content is announced to the 5GMSd-Aware Application and the application requests the entry points for the service.
- 6: The 5GMSd AS begins ingesting content from the 5GMSd Application Provider and the MBSTF may, in turn, begin ingesting this content from the 5GMSd AS.

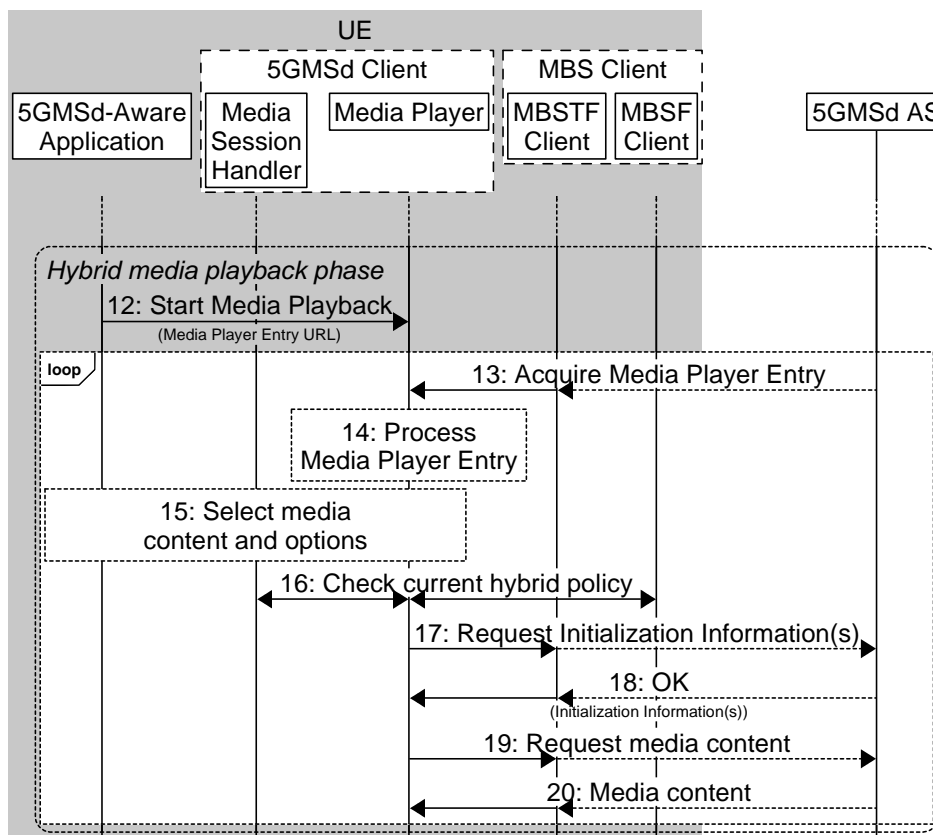

**Figure 5.12.4-2: High-level procedure 5GMS content delivery via 5G System and MBS (continued)**

- 7: The MBSTF starts one or more MBS Delivery Sessions.
- 8: The media content is selected by the 5GMSd-Aware Application.
- 9: The application initiates the media streaming session through Media Session Handler.

10: The Media Session Handler initiates the MBS streaming services.

11: The media session handler through the information from the MBS Client informs the 5GMSd-Aware Application that the service is ready.



**Figure 5.12.4-3: High-level procedure for 5GMS content delivery via 5G System and MBS (continued)**

12: The 5GMSd-Aware Application starts media playback.

13: The Media Player Entry (typically a media presentation manifest) is acquired by the Media Player. It may be available from the local Media Server (populated by the MBS Client) or from the 5GMSd AS, or even from both.

14: The Media Player processes the Media Player Entry and identifies that content is available from different data networks (the local Media Server and the 5GMSd AS).

15: Under the control of the 5GMSd-Aware Application, the Media Player selects the content and different content options.

16: The Media Player continuously checks with the Media Session Handler - and possibly forwarded to the MBS Client if the MBS User Service data is available - how to use the different content. This depends on the hybrid scenario. Different policies may be considered.

17: The Media Player requests initialization information either from the local Media Server or from the 5GMSd AS. The Media Player repeats this step for each required initialization segment.

18: The Media Player receives the initialization information.

19: The Media Player requests media segments according to the Media Player Entry, either from the local Media Server or from the 5GMSd AS.

20: The Media Player receives media segments and puts the information into the appropriate media rendering pipeline.

Steps 13-20 are repeated according to the Media Player Entry information.



#### 5.12.4.2 Interactive service

In a specific 5GMS content delivery via 5G System and MBS scenario, an interactive service may be provided via 5GMS while the main media content resources are delivered via MBS exclusively. In this case, the following instantiations apply:

- In step 2, the Media Entry Point document (e.g. MPD) only points to content in the local proxy Media Server.
- Step 13 as well as steps 17-20 are all terminated on the local proxy Media Server.

#### 5.12.4.3 Session continuity

In a specific 5GMS content delivery via 5G System and MBS scenario, the service is made available via both 5GMS and MBS delivery networks, but only one Representation of each Adaptation Set is provided via MBS. In this case, the following instantiations apply:

- In step 2, one Representation of each Adaptation Set is distributed via MBS.
- As long as the streaming service is accessible over MBS, the Media Player selects the media content in step 13 as well as steps 17–20 from the local proxy Media Server; content is not available from the 5GMSd AS.
- If the streaming service becomes unavailable via MBS, the Media Player switches to accessing the media content in step 13 as well as steps 17–20 from the 5GMSd AS.
- Once the streaming service becomes available again via MBS, the Media Player switches back to accessing the media content in step 13 as well as steps 17–20 from the local proxy Media Server.

#### 5.12.4.4 Time-shifted viewing

In a specific 5GMS content delivery via 5G System and MBS scenario, the service is made available via both 5GMS and MBS delivery networks, but only one Representation of each Adaptation Set is provided via MBS. The content is retained by the 5GMSd AS for a period of time to support time shifted access. In this case, the following instantiations apply:

- In step 2, one Representation of each Adaptation Set is distributed via MBS.
- If the streaming service is accessible via MBS and the user is consuming content at the live edge, the Media Player selects the media content in the step 13 as well as steps 17–20 from the local proxy Media Server; content is not available from the 5GMSd AS.
- If the user switches to time-shift viewing mode or streaming service becomes unavailable via MBS, the Media Player switches to accessing the media content in the step 13 as well as steps 17–20 from the 5GMSd AS.
- Once the streaming service becomes available again via MBS and the user returns to the live edge, the Media Player switches back to accessing the media content in the step 13 as well as steps 17–20 from the local proxy Media Server.

#### 5.12.4.5 Content or component replacement

In a specific 5GMS content delivery via 5G System and MBS scenario, the service is made available via both 5GMS and MBS delivery networks, but only one Representation of selected Adaptation Sets is provided via MBS. Some Adaptation Sets are only available via 5GMS. In another case, two or more content alternatives may exist for a period of time, but only one alternative is provided over MBS.

In this case, the following instantiations apply:

- In step 2, the MPD is generated to define the different content alternatives.
- If the streaming service is accessible over MBS and the user watches content available on broadcast, the Media Player selects the media content in step 13 as well as steps 17–20 from the local proxy Media Server; content is not available from the 5GMSd AS.

- If the user switches content or content components, the Media Player switches to accessing the media content in the step 13 as well as steps 17–20 from the 5GMSd AS. If only a component is replaced, the Media Player accesses media content from the local proxy Media Server and the 5GMSd AS at the same time.

### 5.12.5 Procedures for dynamic provisioning of 5GMS content delivery via MBS

#### 5.12.5.1 General

In this scenario the same content is distributed via MBS and via a 5GMS System. The resources of the MBS System are statically configured. MBS-based distribution may, for example, be used only for services in high demand, and the resources and quality of the service distributed through broadcast may be adjusted according to demand. Demand may be identified through 5GMS Consumption Reporting.

The call flow in figures 5.12.5-1 and 5.12.5-2 extends that defined in clause 5.12.1 to address generic use cases for MBS-on-demand. Specific additional use cases are presented in the remainder of clause 5.12.5.

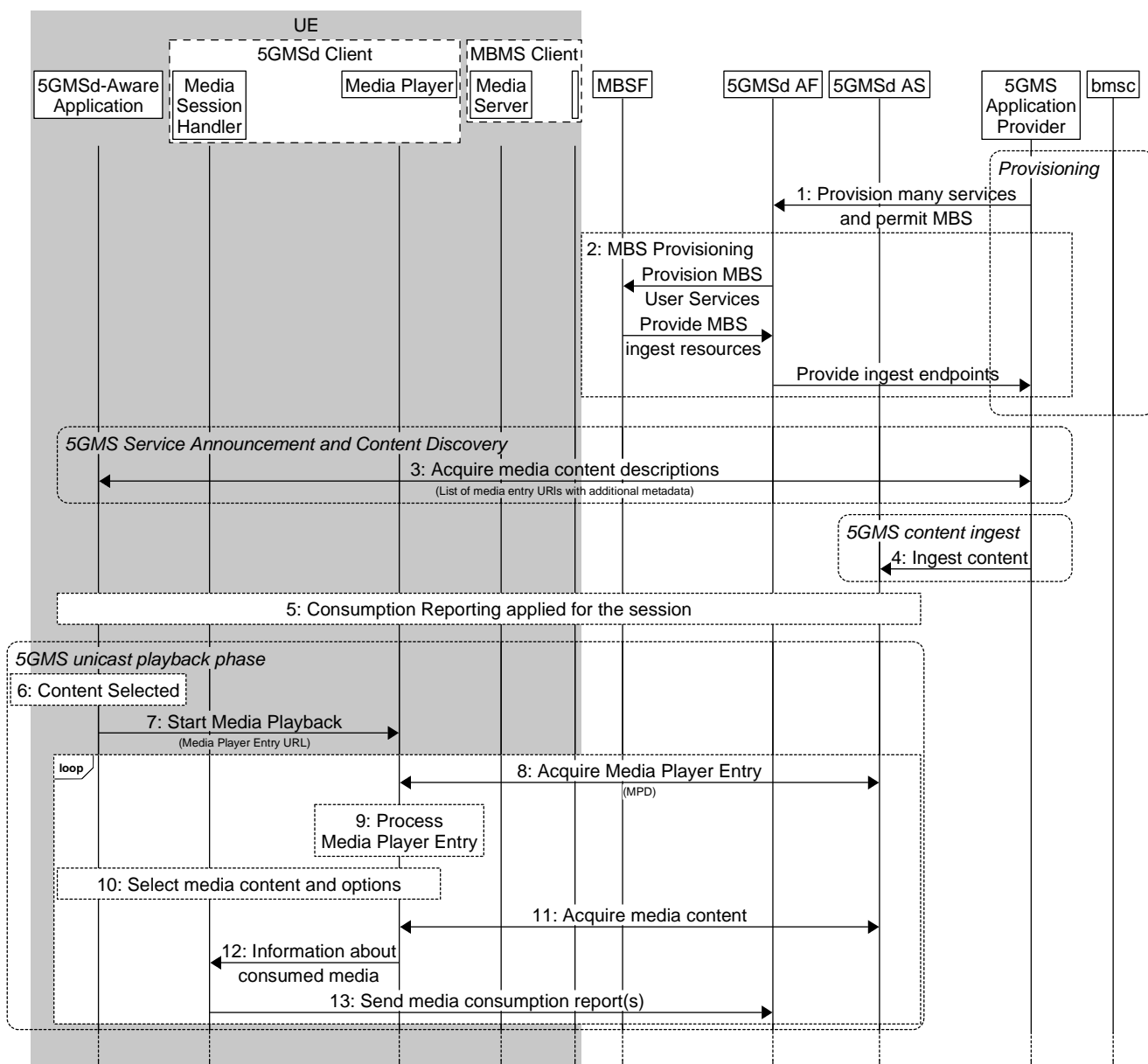

Figure 5.12.5.1-1: High-level procedure for DASH content delivered via MBS-on-demand

## Steps:

- 1: The 5GMS Application Provider provisions one or more 5GMSd services and permits broadcast distribution of the media content.
- 2: As a consequence, the 5GMSd AF provisions MBS delivery and the MBSF informs the 5GMSd AF about the resources it will use to ingest media content.

NOTE: This step may happen later, up to (and possibly as part of) step 15, for example only when demand is identified.

- 3: The media content is announced to the 5GMSd-Aware Application and the application request the entry points for the service.
- 4: The 5GMSd AS starts to ingest content from the 5GMSd Application Provider.
- 5: Consumption Reporting is applied for the downlink media streaming session.

## Media playback initially uses unicast 5G Media Streaming:

- 6: The media content is selected by the 5GMSd-Aware Application.
- 7: The 5GMSd-Aware Application triggers the start of media playback by the Media Player.
- 8: The Media Entry Point document (e.g. DASH MPD) is requested by the Media Player from the 5GMSd AS.
- 9: The Media Player processes the media presentation manifest and identifies that the media content is available on the 5GMSd AS
- 10: The Media Player, under the control of the application, selects the media content and different content options.
- 11: Media content is received from the 5GMSd AS via reference point M4d.
- 12: The Media Player informs the Media Session Handler about the consumed media content.
- 13: The Media Session Handler sends consumption reports to the 5GMSd AF.

## Subsequently, media playback switches to MBS:

- 14: By analysing the consumption reports submitted to it in the previous step, the 5GMSd AF identifies a high level of demand for the service.
- 15: Additional MBS Distribution Sessions are provisioned to add delivery of the service via MBS.
- 16: The MBSTF starts ingesting media content from the 5GMSd AS.
- 17: MBS media distribution starts.
- 18: The 5GMSd AF informs the Media Session Handler that MBS media distribution is initiated by providing updated Service Access Information.
- 19: MBS content reception is initiated by the Media Session Handler.
- 20: Once the service is ready, the content delivered on MBS is used by the Media Player. Consumption reporting continues. Specific cases may use different policies, similar to the hybrid case in clause 5.12.5.

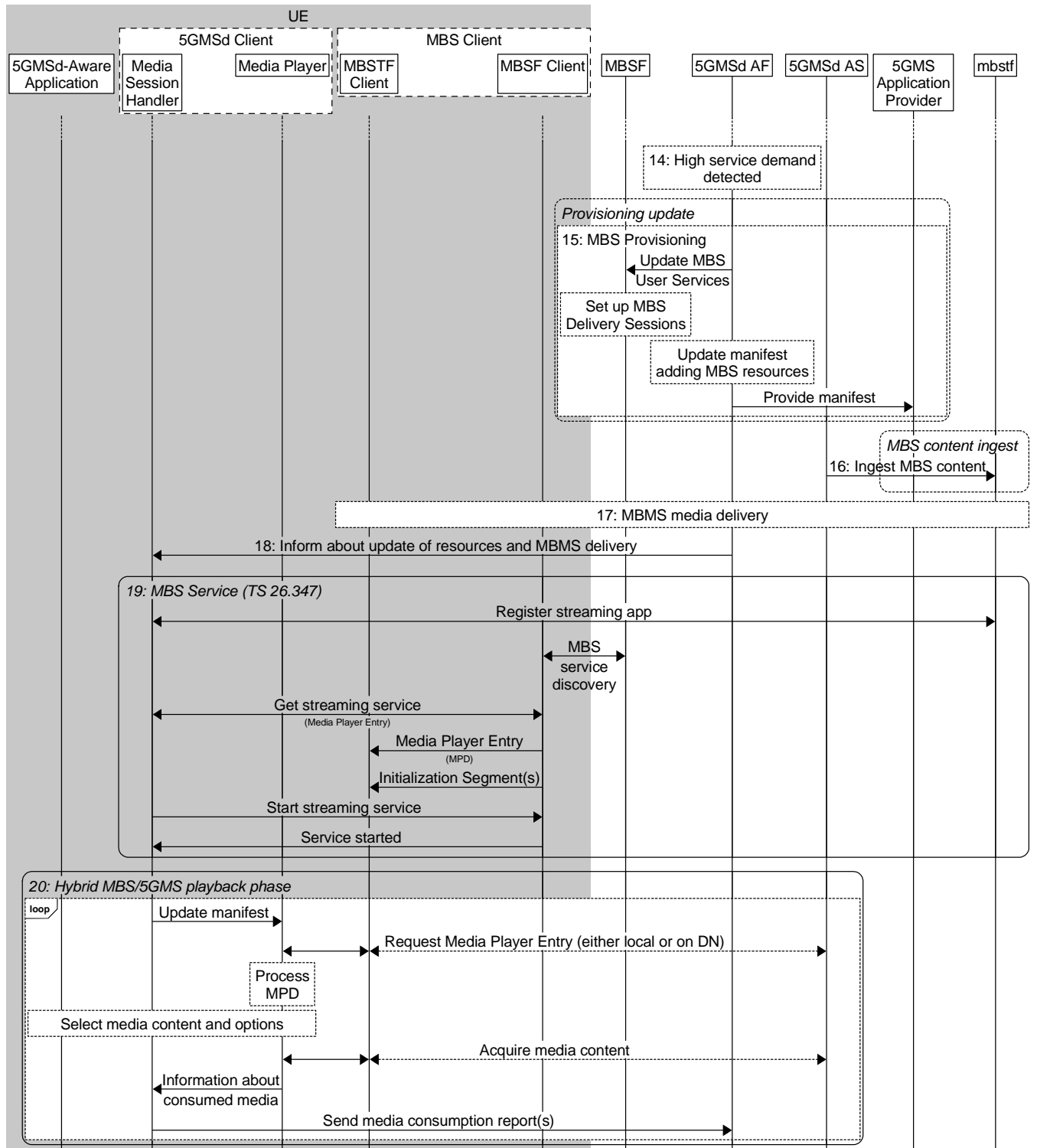

Figure 5.12.5.1-2: High-level procedure for DASH content delivered via MBS-on-demand (continued)

### 5.12.5.2 Operation modes

At least the following operation modes are supported based on the general procedures in clause 5.12.5.1:

1. Every 5GMS media service is mapped to exactly one MBS User Service. Whether the MBS User Service is announced and delivered or not depends on service demand. The MBS Distribution Session is adjusted dynamically – for example the MBS Distribution Session is disabled, or the bit rate is changed – depending on service demand and/or content requirements.
2. A set of MBS User Services and MBS Distribution Sessions is defined in the initial provisioning. Downlink media streaming components are dynamically mapped to statically configured MBS Distribution Services based on demand and content requirements.
3. Components of the downlink media streaming session, for example audio service components for different languages, are assigned dynamically to MBS Distribution Sessions depending on demand.

---

## 6 Procedures for uplink Media Streaming

### 6.1 General

The procedures for uplink media streaming allow a 5GMSu Application Provider to create, modify, establish and delete sessions. Uplink media streaming sessions exist between a 5GMSu Client and a 5GMSu AS.

The uplink streaming procedures follow a general high-level workflow, starting from provisioning to the actual uplink streaming sessions. The Egest Session refers to the time period during which media content is uplink streamed to the 5GMSu AS and optionally egested from there to the 5GMS Application Provider. The Provisioning Session refers to the time period during which the 5GMSu Client is permitted to upload stream media content. Interactions between the 5GMSu AF and the 5GMSu Application Provider may occur at any time while the Provisioning Session is active.

The 5GMSu Provisioning API allows the selection of Media Session Handling (M5u) and Uplink Streaming (M4u) options, including whether the media content is published to trusted 5GMSu ASs. The 5GMSu AF selects the M5u interface according to the provisioning option. The Media Session Handling interface exposed by the 5GMSu AF can be used for metrics reporting, requesting different policy and charging treatments, or 5GMSu AF-based Network Assistance.

When the 5GMSu AF and 5GMSu AS reside in the same DN, then the 5GMSu AF selects the 5GMSu AS. Interactions between a 5GMSu AF and a 5GMSu AS (M3u interactions) take place for Content Egest (M2u) and Uplink Streaming (M4u) resource reservations. The 5GMSu AS allocates M2u and M4u resources and communicates resource identifiers back to the 5GMSu AF. The 5GMSu AF provides information about the provisioned resources (in the form of resource identifiers) for Media Session Handling, Content Egest, and Uplink Streaming to the 5GMSu Application Provider. The resource identifiers for Media Session Handling and Uplink Streaming are needed by the 5GMSu Client to access the selected features.

5GMSu Client can (in principle) start the uplink streaming by activating its uplink streaming session. The uplink streaming session for a given UE (or for each UE) is active from the time at which the 5GMSu-Aware Application activates the transmission of an uplink streaming service until its termination.

The 5GMSu-Aware Application receives application metadata from the 5GMSu Application Provider before transmitting the uplink streaming media. The application metadata contains Service Access Information, which acts as an entry point for the 5GMSu Client to start the uplink streaming session. The 5GMSu Client may either receive the Service Access Information from the 5GMSu Application Provider (using a not standardized interface) or instructions for a remote control session through the 5GMS-Aware Application.

The Network Assistance (NA) feature enables a UE that is receiving an uplink media stream to improve the QoE of the media streaming session, by being able to make use of two distinct facilities.

The first facility is **bit rate recommendation (throughput estimation)**. This enables the UE to start an uplink streaming session at the most appropriate bit rate for the network conditions at hand, or to obtain a recommendation from the network which will remain valid until further notice during a media streaming session. The recommended bit rate is based on network estimations or predictions of available link bandwidth. This function is provided as an

additional tool to support the UE, in addition to the common approach of the UE performing its own estimation based on measurement of the uplink traffic in the past.

The second facility is the **delivery boost**. The 5GMSu Client uses this function to indicate to the network that a temporary boost, i.e., a temporary increase of network throughput for this client is needed, for example in order to prevent the uplink media streaming buffer in the Media Streamer from overflowing.

Network Assistance may be offered to the UE in one of two ways:

- Based on interaction between the UE and the 5GMSu AF, with a subsequent interaction between the 5GMSu AF and the PCF (or the NEF), as defined in clause 6.5.
- Based on interaction between the UE and the RAN, re-using the ANBR-based RAN signalling as defined in clause 6.7.

The UE shall not use both approaches on the same Network Assistance session.

Figure 6.1-1 provides a basic high-level call flow for uplink streaming. The corresponding collaboration scenario is defined in clause A.10.

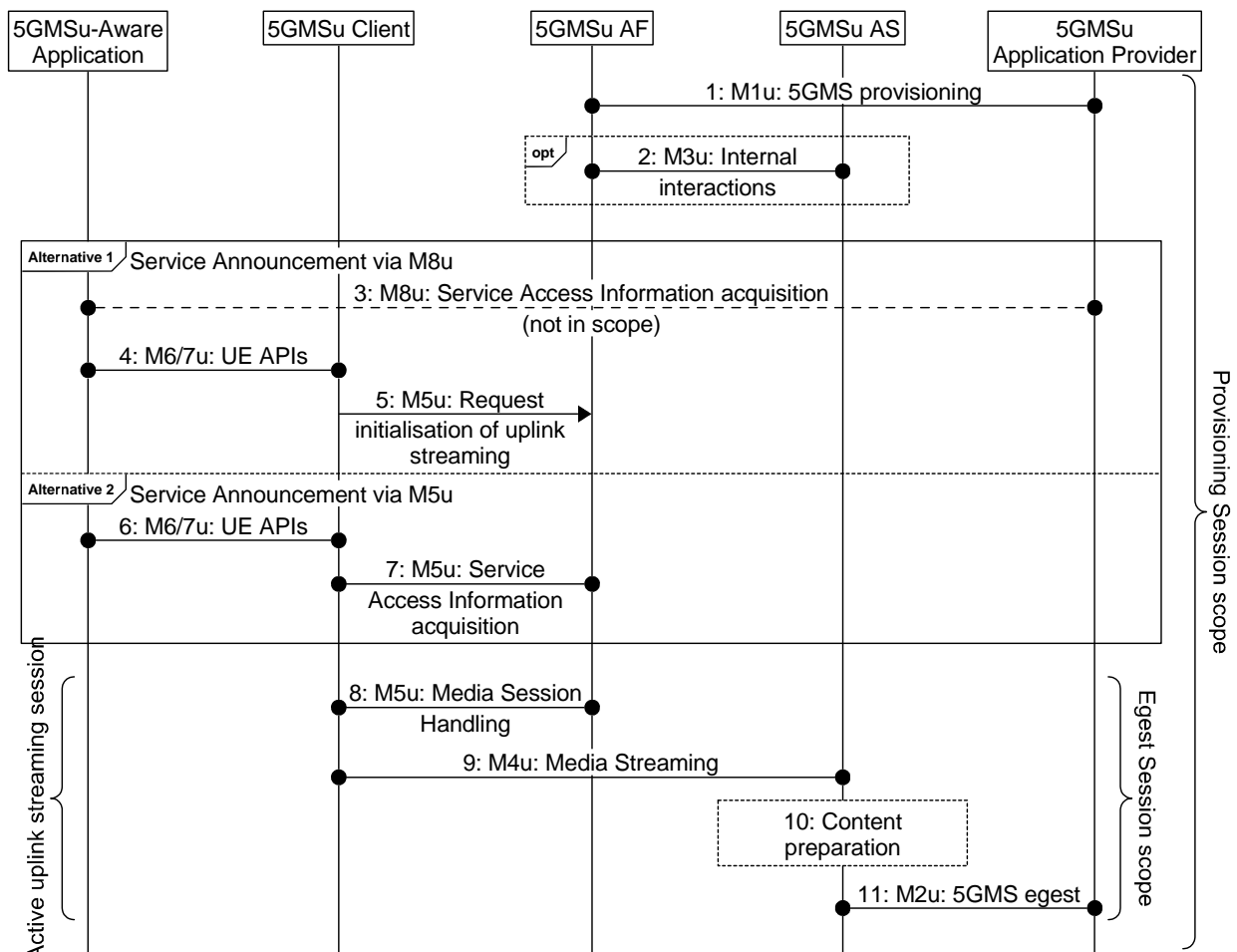

<https://gitlab.com/msc-generator v8.0>

**Figure 6.1-1: High-level call flow for uplink media streaming**

Steps:

1. The 5GMSu Application Provider provisions the 5GMSu AF at reference point M1u, including a Content Publishing Configuration for content egest and, optionally, Content Preparation Templates.
2. When Content Publishing is offered and selected, there may be interactions between the 5GMSu AF and the 5GMSu AS at reference point M3u, e.g., to configure Server Certificates and/or Content Preparation Templates and to confirm the availability of resources for Content Preparation and Content Egest by providing a Content

Publishing Configuration (defined in clause 6.2.3). The 5GMSu AS provides resource identifiers for the allocated resources to the 5GMSu AF, which then provides the information to the 5GMSu Application Provider.

At some later point in time:

3. The 5GMSu Application Provider provides Service Access Information to the 5GMS-Aware Application at reference point M8u.
4. When the 5GMSu-Aware Application decides to activate an uplink media streaming session, the Service Access Information is provided to the 5GMSu Client.
5. The 5GMSu Client requests the 5GMSu AF to initialise uplink media streaming (M5u).

Alternatively:

6. The 5GMS-Aware Application requests the 5GMSu Client to start an uplink streaming session (M6u/M7u).
7. The 5GMSu Client requests Service Access Information from the 5GMSu AF at reference point M5u.

Then:

8. The 5GMSu Client starts the Egest Session by activating the uplink streaming session.
9. Uplink media streaming starts from the 5GMSu Client to the 5GMSu AS via reference point M4u.
10. If content preparation was provisioned in step 1, the uplinked media may be manipulated by the 5GMSu AS prior to egest.
11. Media streaming egest starts from the 5GMSu AS to the 5GMSu Application Provider at reference point M2u.

Clauses A.11 to A.15 define additional collaboration scenarios for uplink streaming. The call flow for each collaboration scenario is also included in each clause.

## 6.2 Preparing for uplink Media Streaming

### 6.2.1 Introduction

Before streaming media data in the uplink direction, a set of parameters are provisioned at the 5GMSu AF/AS and at the 5GMSu Client. On the 5GMSu AF/AS, the M1u API is used for session provisioning. On the UE side, the M8u or M5u API is used for provisioning.

### 6.2.2 Provisioning session for uplink streaming

#### 6.2.2.1 Domain model

The M1u baseline domain model is depicted in figure 6.2.2.1-1 overleaf. It consists of a Provisioning Session, which contains at least one of the following:

- A Content Publishing Configuration,
- A Policy Template,
- One or more Content Preparation Templates,
- An *Edge Resources Configuration* specifying the requirements for edge processing as defined in TS 23.548 [15] and TS 23.558 [16] in support of the Provisioning Session, including eligibility criteria that indicate the circumstances in which edge computing is to be used for Media Streaming sessions associated with this Provisioning Session and parameters indicating the tolerance of the application for relocation of the Edge AS, or

Each Provisioning Session is uniquely identified within the 5GMS System by a Provisioning Session identifier.

When a certain 5GMS feature (such as content publishing configuration, policy template, content preparation template or edge resource configuration) is selected, the 5GMSu AF compiles the resulting Service Access Information that the 5GMSu Client needs to have to access the services via M5u.



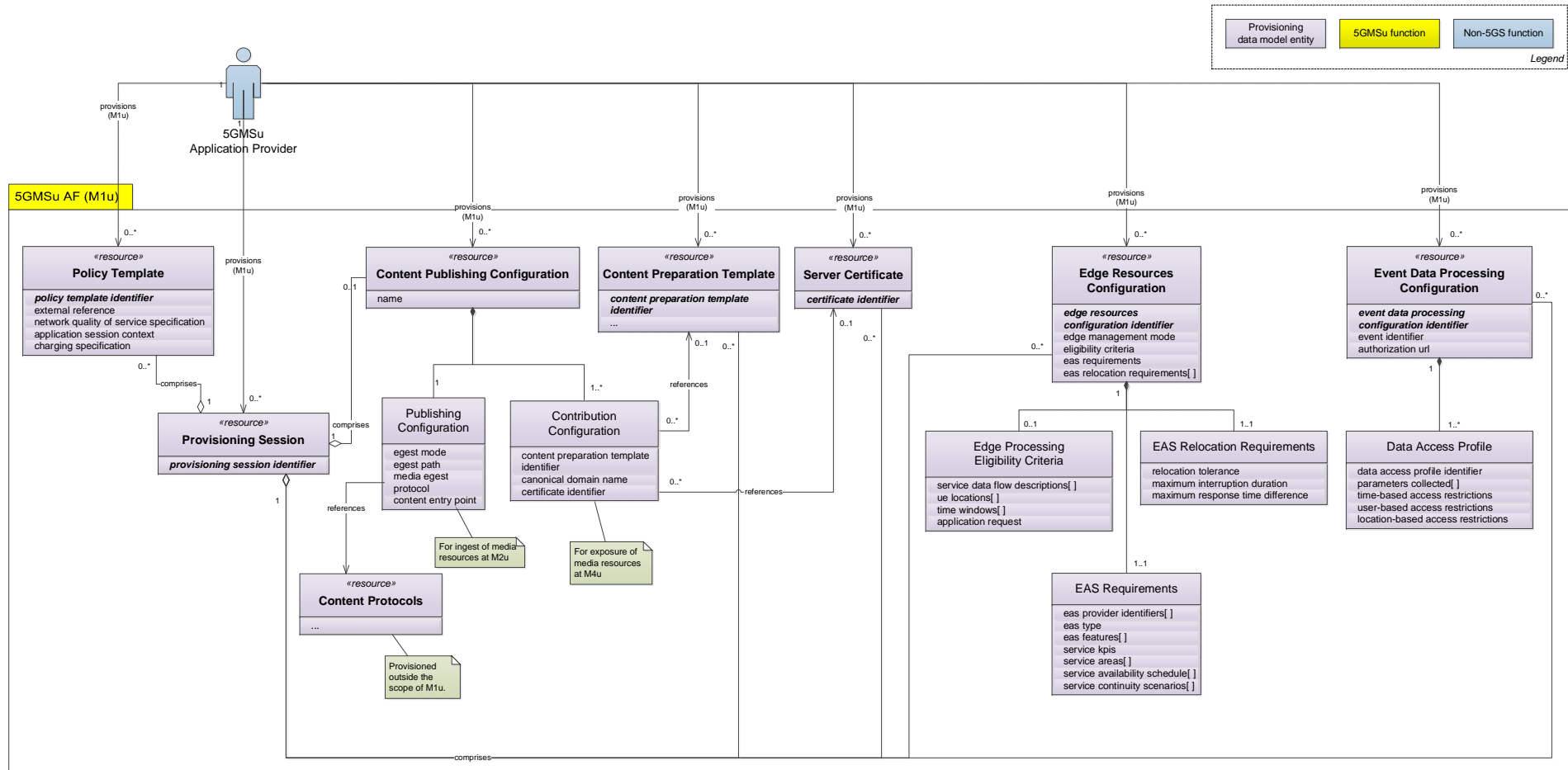
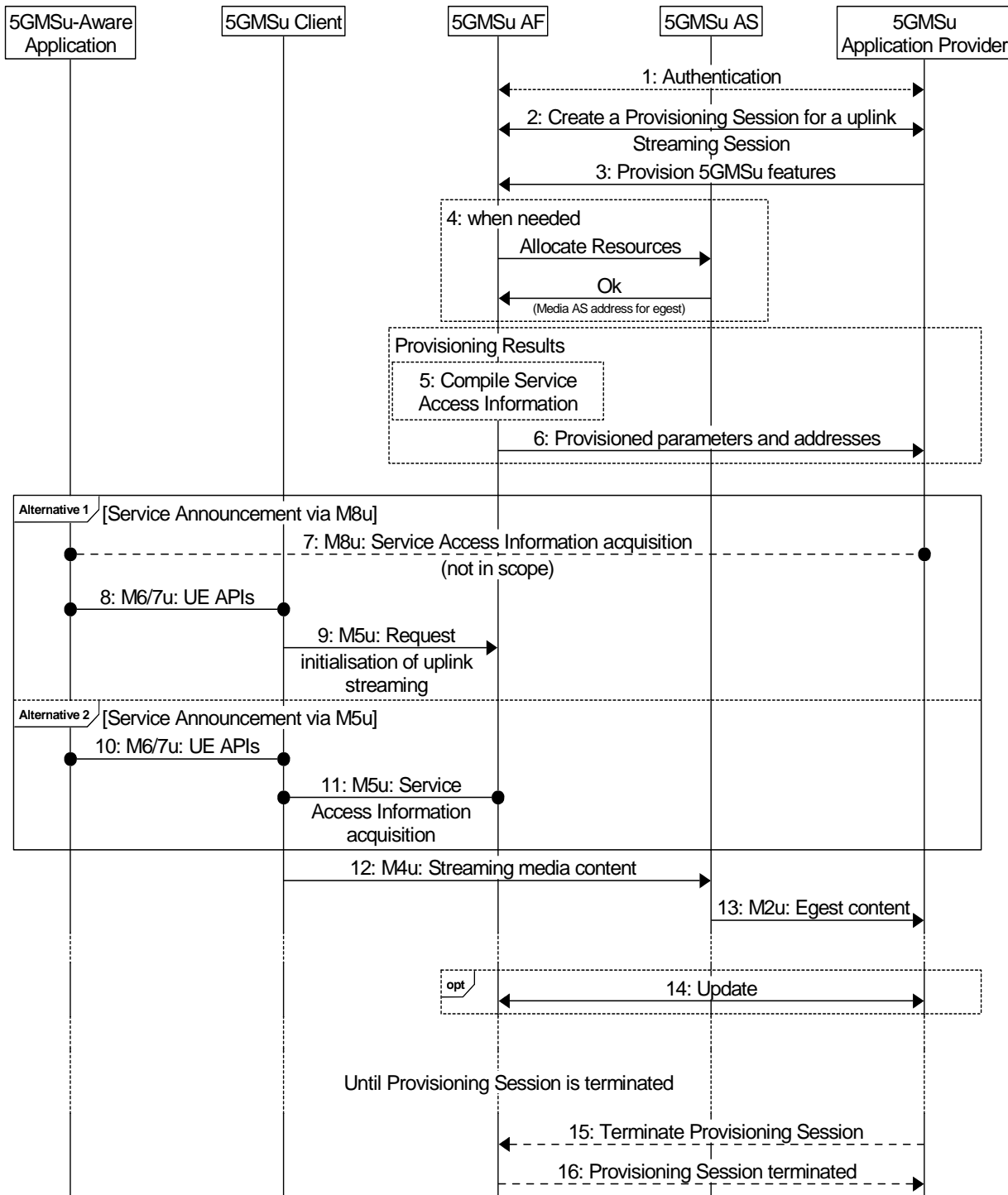

Figure 6.2.2.1-1: M1u provisioning domain model

### 6.2.2.2 Baseline provisioning procedure

This clause describes the baseline procedure to provision the features using the 5GMS System.

NOTE 1: SLA negotiations between the 5GMSu Application Provider and the 5GMS System provider are outside the scope of the present specification and are included in the figure below for illustrative purposes only.



<https://gitlab.com/vmsc-generator/v8.0>

Figure 6.2.2.2-1: High-level procedure for provisioning the 5GMS System for uplink media streaming sessions

Steps:

1. The 5GMSu Application Provider authenticates itself with the system. This procedure reuses existing authentication/authorization procedures, e.g., as defined for CAPIF [13].
2. The 5GMSu Application Provider creates a Provisioning Session, providing its 5GMSu Application Provider identifier as input. 5GMSu Application Provider queries the capabilities and authorized features.
3. The 5GMSu Application Provider specifies one or more 5GMSu features in the Provisioning Session. A set of authorized features is activated, such as content dynamic policy; network assistance; and content publishing (including egest).

When the content publishing feature is offered and selected, the 5GMS Application Provider provides a Content Publishing Configuration to configure the content publishing behaviour of the 5GMSu AS (see next step), including selecting the uplink ingest protocol and format, content preparation and egest protocol and format.

When the dynamic policy feature is offered and selected, the 5GMSu Application Provider specifies a set of policies which can be invoked for the uplink streaming session. The UE becomes aware of the selected policies in the form of a list of valid Policy Template Ids.

When the edge computing feature is offered and selected, the 5GMSu Application Provider provides one or more Edge Resources Configurations that can be used to support either client-driven management or Application Provider-driven management of edge resources associated with the Provisioning Session.

4. When content publication is desired, the 5GMSu AF interacts with the 5GMSu AS at reference point M3u to configure any necessary Server Certificates and/or Content Publishing Templates and to allocate resources for M2u egest protocol and format by means of a Content Publishing Configuration. The 5GMSu AS responds to the 5GMSu AF with the M2u content egest address.
5. The 5GMSu AF compiles the Service Access Information. The Service Access Information contains access details and options such as the Provisioning Session identifier, M5u (Media Session Handling) addresses for uplink entry point, dynamic policy, network assistance, etc.
6. The 5GMSu AF provides the results to the 5GMSu Application Provider.

The following steps:

7. When the 5GMSu Application Provider has selected full Service Access Information, the results are provided in the form of addresses and configurations for M2u (content egest), M5u (Media Session Handling) and M4u (Media Uplink Streaming). The 5GMSu Application Provider provides a subset of this information to the 5GMSu-Aware Application through M8u.
8. When the 5GMSu-Aware Application decides to activate the streaming service transmission, the Service Access Information is provided to the 5GMSu Client.
9. The 5GMSu Client requests the 5GMSu AF to initialise uplink media streaming (M5u), including reservation of any resources required for content preparation.

Or, alternatively:

10. The 5GMS-Aware Application requests the 5GMSu Client to start an uplink streaming session (M6u/M7u).
11. When the 5GMSu Application Provider has delegated Service Access Information handling to the 5GMS System, a reference to the Service Access Information (e.g. an URL) is provided. The Media Session Handler fetches the full Service Access Information later from the 5GMSu AF.

Then:

12. The 5GMSu Client streams the content to the 5GMSu AS.
13. When content publishing is offered and has been selected in step 4, the 5GMSu Application Provider can start retrieving the content from the M2u egest interface.

Optionally:

14. The 5GMSu Application Provider may update the Provisioning Session.

According to schedule, or upon request by the 5GMSu-Aware Application:

15. The 5GMSu Application Provider may manually terminate the Provisioning Session (at any time). All associated resources are released. Content may be removed from the 5GMSu AS. The 5GMSd Application Provider may configure a schedule for Provisioning Session termination.

16. The 5GMSu AF sends a notification to the 5GMSu Client upon Provisioning Session termination.

The 5GMSu AF may request the creation or reuse of one or more network slices for ingesting the content of the provisioned session. If more than one network slice is provisioned for the ingest of the content of a session, the list of allowed S-NSSAIs shall be conveyed to the target UE (e.g. through URSP or through M8u, step 7, or M5u, step 10).

NOTE 2: The 5GMSu AS receiving the content is only accessible through the DNN(s) used by the network slice(s) provisioned for the distribution of that content.

## 6.2.3 Content Publishing Configuration for uplink streaming

### 6.2.3.1 General

The 5G Media Streaming architecture defines a reference point (M1u) for provisioning which offers the procedures to configure content ingest for uplink media streaming over a 5GMS System. Once a Provisioning Session is established using the API at reference point M1u, content publishing may be configured. Content can then be uplink streamed by the Media Streamer in the 5GMSu Client to the 5GMSu AS through reference point M4u. The uploaded (and possibly processed) content is accessible via reference point M2u for egest.

Reference point M2u supports the egest of the following types of content:

- Live streaming content.
- On-demand streaming content. i.e. the content that previously streamed from the UE to 5GMSu AS and is stored in 5GMSu AS.
- Static files such as images, scene descriptions, etc. associated with the uplink streaming content.

The 5GMSu AF provides an API at reference point M1u that allows a 5GMSu Application Provider to create/update/delete a Content Publishing Configuration. A Content Publishing Configuration contains all the parameters for a particular content ingest uplink and egest setup, and optionally references one or more Content Preparation Templates.

### 6.2.3.2 Media egest procedure

The media egest procedure is as follows:

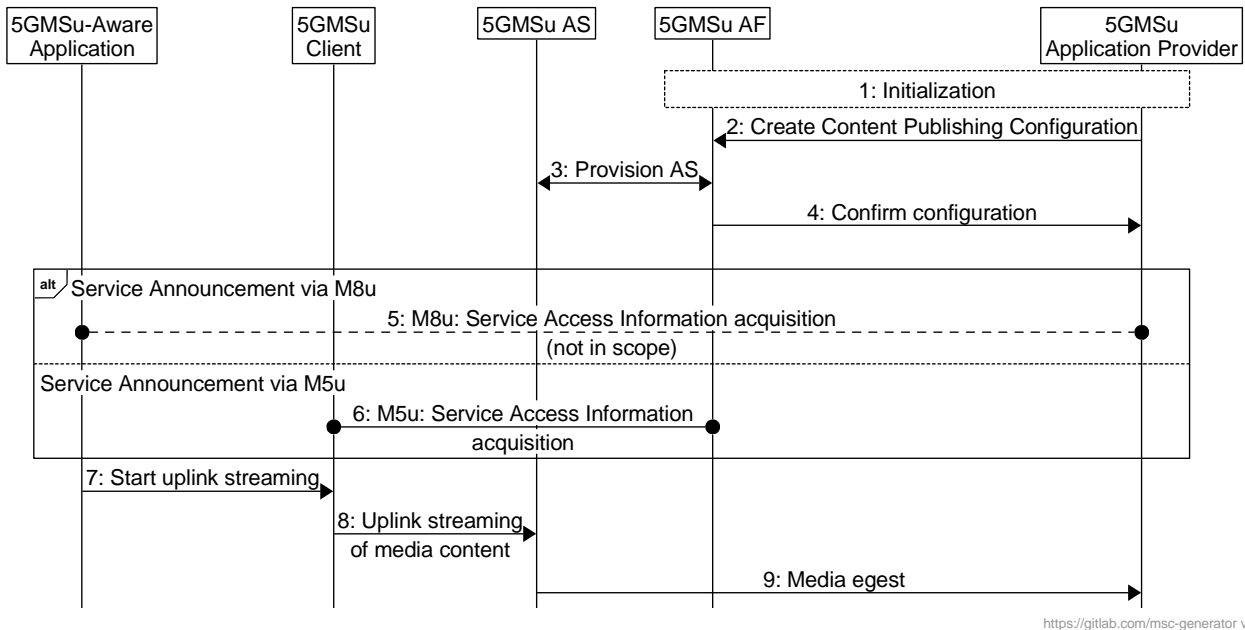

<https://gitlab.com/msc-generator/v8.0>

**Figure 6.2.3-1: Media egest procedure**

The steps are as follows:

- 1: Initialization:** the 5GMSu Application Provider discovers the M1u endpoint address and authenticates itself with the 5GMSu AF.
- 2: Create Content Publishing Configuration:** the 5GMSu Application Provider creates a new Content Publishing Configuration through the 5GMSu AF. The configuration specifies path, protocol, entry point, the egest push/pull mode, and possibly one or more content preparation templates. Upon successful configuration, the 5GMSu AF responds with a Content Publishing Configuration identifier, and the location of the 5GMSu AS from which to pull the content (if using the pull mode).
- 3: Provision 5GMSu AS instance(s):** The 5GMSu AF configures the related 5GMSu AS instance(s) for a particular Content Publishing Configuration via reference point M3u. This step may involve instructing the 5GMSu AS to establish one or more content preparation processes declared in Content Preparation Templates. The 5GMSu AS(s) responds whether the configuration was successful or not.
- 4: Confirm provisioning:** Upon successful provisioning, the 5GMSu AF responds with a Content Publishing Configuration identifier, and the location of the 5GMSu AS from which to pull the content (if using the pull mode).

One of the following steps:

- 5: Provide the uplink entry point:** The 5GMSu Application Provider publishes the uplink entry point to the 5GMSu-Aware Application through reference point M8u to enable it to begin uplink streaming to the 5GMSu AS.

or:

- 6:** The 5GMSu Client acquires the uplink entry point as part of Service Access Information through reference point M5u.
- 7:** The 5GMSu-Aware Application requests the 5GMSu Client to start the uplink streaming.
- 8:** The 5GMSu Client starts uplink streaming of the content to the 5GMSu AS via reference point M4u.

9: *Media egest*: The 5GMSu Application Provider may start pulling or receiving content (if using push mode) from the 5GMSu AS. The 5GMSu AS performs the requested content preparation prior to making the uplink content ready for being pulled by or pushed to the 5GMSu Application Provider.

NOTE: Pulling media content from the 5GMSu AS may be triggered by a request from the 5GMSu Client through M8u.

The 5GMSu Application Provider may update a Content Publishing Configuration subsequently to modify some of its parameters. The subset of parameters that can be updated may be limited by the 5GMSu AF.

## 6.3 Establishment of an uplink Media Streaming session

The procedure allows a Media Streamer to establish an uplink streaming session with a 5GMSu AS.

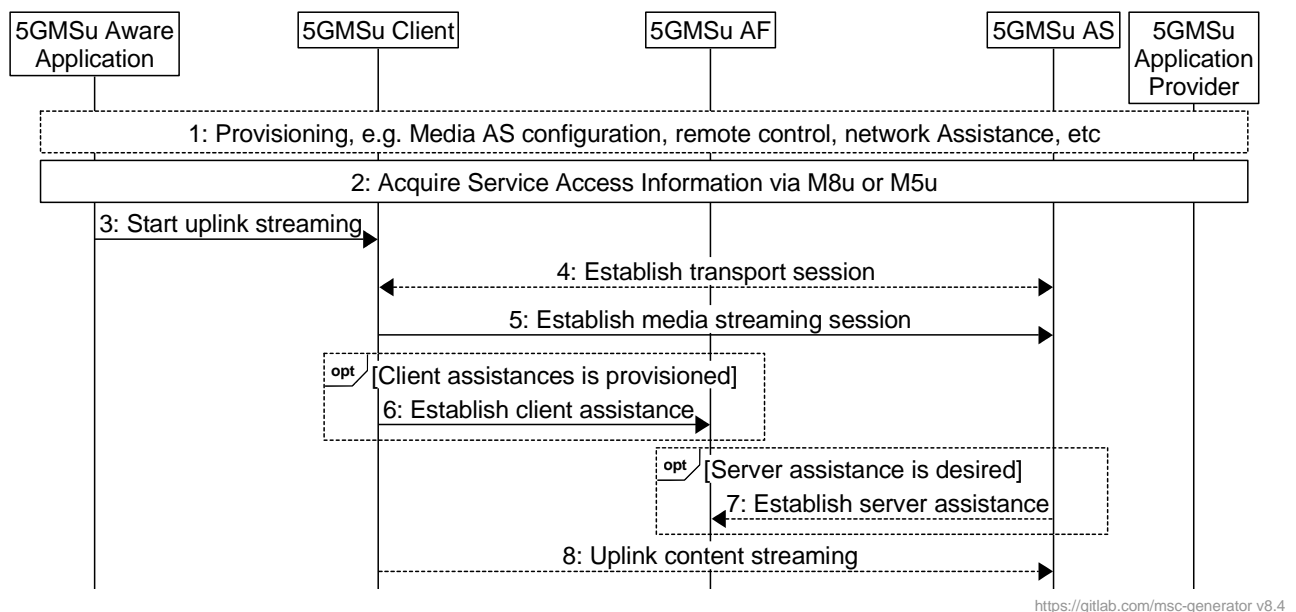

Figure 6.3-1: Uplink Streaming Session Establishment

Steps:

- 1: During provisioning, the Media Streamer component of the 5GMSu Client is provisioned with basic information, such as the 5GMSu AF and 5GMSu AS addresses.
- 2: The 5GMSu-Aware Application acquires Service Access Information via reference point M8u or M5u according to the one of the procedures defined in clause 6.2.2.2.
- 3: The 5GMSu-Aware Application instructs the 5GMSu Client to start uplink media streaming according to one of the procedures defined in clause 6.2.2.2.
- 4: The 5GMSu Client establishes the uplink transport session.
- 5: The 5GMSu Client establishes the uplink media streaming session.

When client assistance is provisioned:

- 6: The 5GMSu Client establishes the assistance channel to the provisioned 5GMSu AF(s).

When server assistance is desired (e.g. for QoS or charging):

- 7: The 5GMSu AS establishes an assistance session with the 5GMSu AF.
- 8: The 5GMSu Client streams the content up to the 5GMSu AS.

## 6.4 Termination of an uplink Media Streaming session

The procedure defines the termination of an uplink media streaming session.

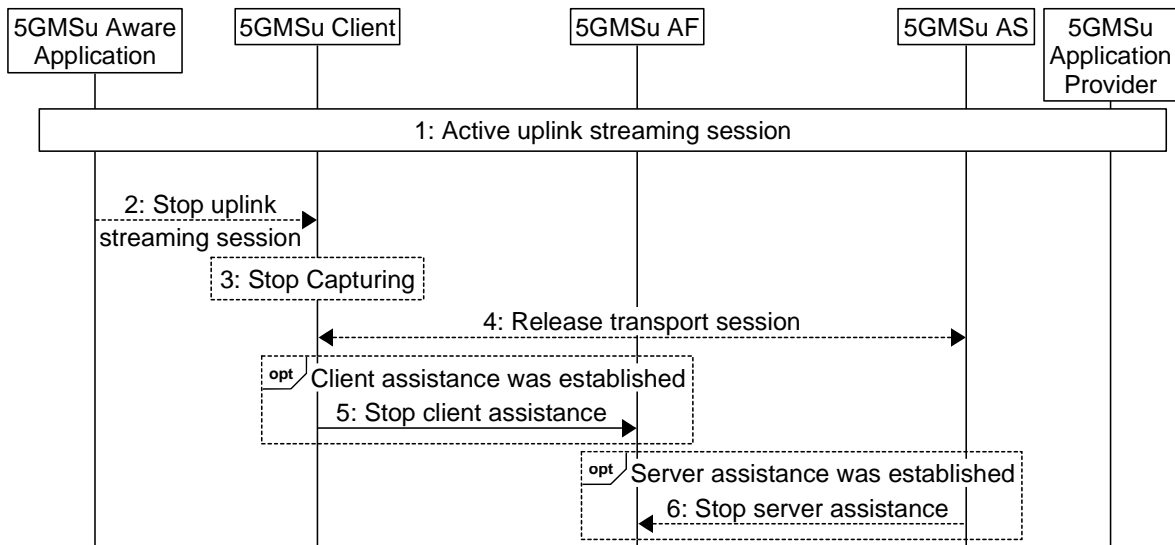

<http://msc-generator.sourceforge.net v7.2>

**Figure 6.4-1: Uplink streaming session teardown**

Steps:

1. An uplink media streaming session is active and should be terminated.
2. The 5GMSu-Aware Application sends a Stop command to the 5GMSu Client.
3. The 5GMSu Client stops the capturing process.
4. The uplink transport session is released.

When client assistance was established:

5. The 5GMSu AF is notified that the uplink media streaming session is terminated.

When server assistance was established:

6. The 5GMSu AS is notified the 5GMSu AF that the uplink media streaming session is terminated.

## 6.5 Providing 5GMSu AF-based Network Assistance

The procedure a 5GMSu Client uses to obtain network assistance from a 5GMSu AF is defined in figure 6.5-1 below.

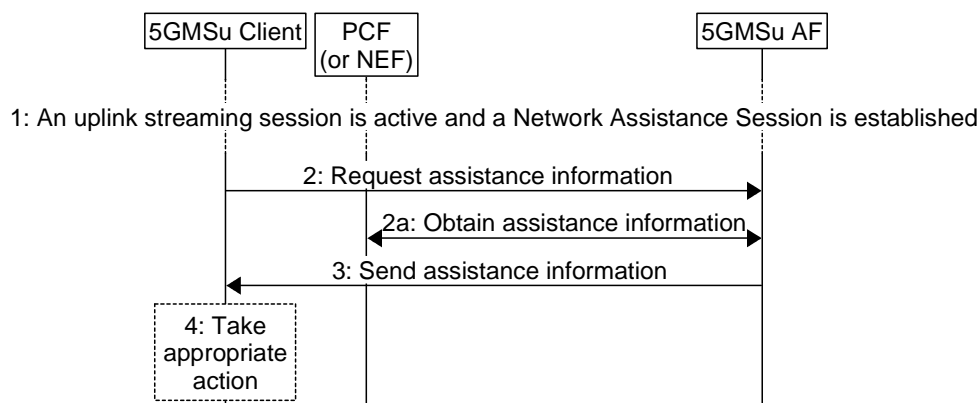

<https://gitlab.com/msc-generator v8.4>

**Figure 6.5-1: Providing 5GMSu AF-based Network Assistance**

Steps:

- 1: An uplink streaming session is active. A Network Assistance Session is established with the 5GMSu AF.
- 2: The Media Session Handler in the 5GMSu Client requests assistance information from the 5GMSu AF.
- 2a: The 5GMSu AF interacts with the PCF (or, if the AF is deployed outside the Trusted DN, with the PCF via the NEF) to obtain the requested assistance information.
- 3: The assistance information is returned to the Media Session Handler in the 5GMSu Client.
- 4: The Media Streamer in the 5GMSu Client takes an appropriate action based on the information received.

## 6.6 Providing Remote Control

The procedure defines the remote control from a Remote Controller through the 5GMSu-Aware Application.

NOTE: The remote controller may be a network-based function or a UE-based function.

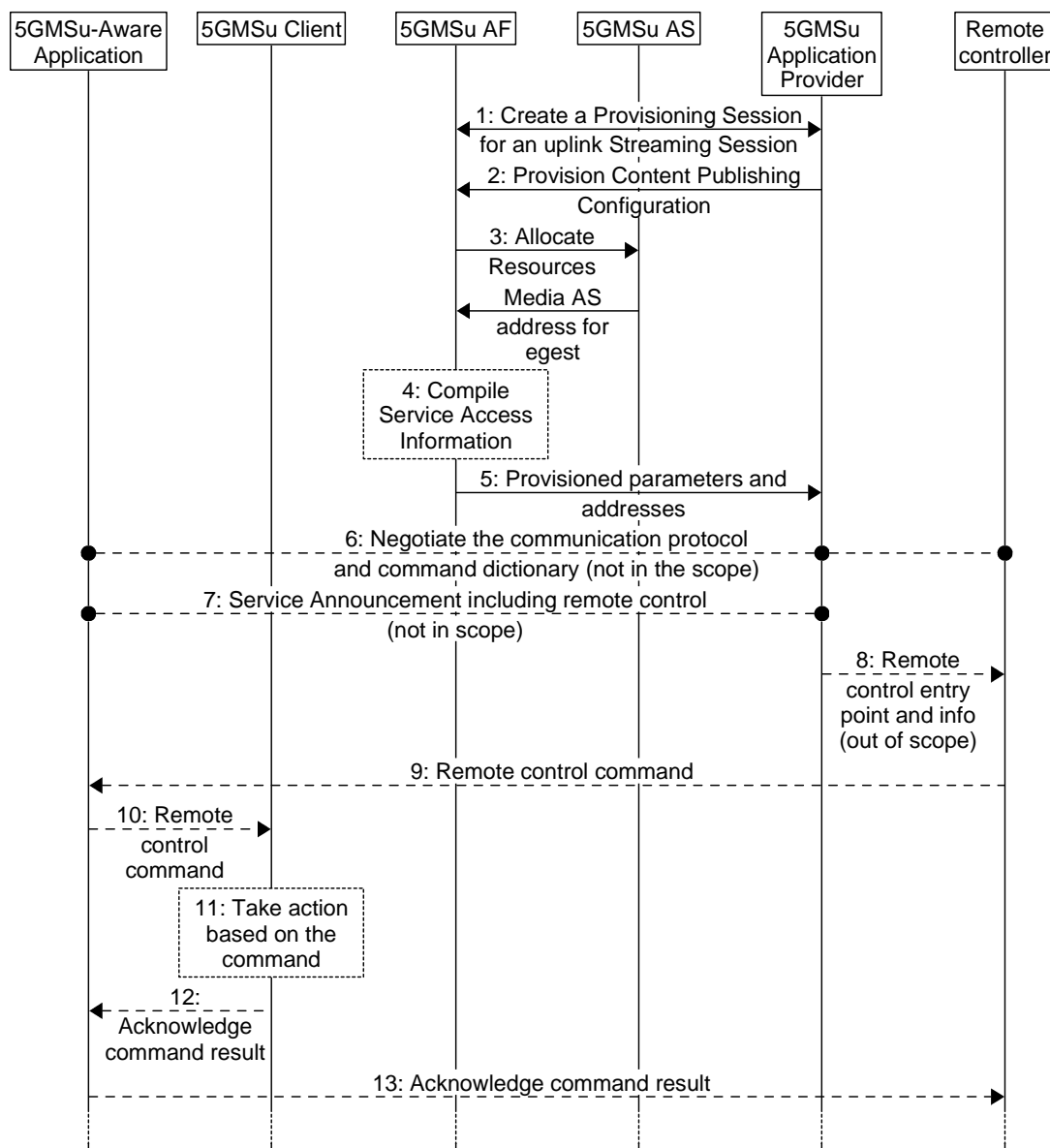

<http://msc-generator.sourceforge.net v7.2>

Figure 6.6-1: High-level procedure for remote control of a 5GMS uplink streaming session



Steps:

1. The 5GMSu Application Provider creates a Provisioning Session at reference point M1u, providing its 5GMSu Application Provider identifier as input. 5GMSu Application Provider queries the capabilities and authorized features.
2. The 5GMSu Application Provider requests Content Publish Configuration provisioning at reference point M1u.
3. The 5GMSu AF interacts with the 5GMSu AS at reference point M3u to allocate resources for the M2u egest protocol and format. Then the 5GMSu AS responds with the M2u address.
4. The 5GMSu AF compiles the Service Access Information. The Service Access Information contains access details and options such as the Provisioning Session identifier, and M5u (Media Session Handling) address for an uplink entry point.
5. The 5GMSu AF provides the results of the provisioning request (step 1) to the 5GMSu Application Provider via reference point M1u.
  - a. When the 5GMSu Application Provider has selected full-Service Access Information, the results are provided in the form of addresses and configurations for M2u (egest), M5u (Media Session Handling), M4u (Media Uplink Streaming).
  - b. When the 5GMSu Application Provider has delegated the Service Access Information handling to the 5GMS System, then a reference to the Service Access Information (e.g. an URL) is provided. The Media Session Handler fetches the full-Service Access Information later from the 5GMSu AF.
6. The 5GMSu-Aware Application, the 5GMSu Application Provider and the third party Remote Controller negotiate the communication protocol and the command dictionary for remote control, and reach an agreement (if any).
7. The 5GMSu Application Provider announces the uplink streaming service to the 5GMSu-Aware Application at reference point M8u (during the lifetime of the Provisioning Session).
8. The 5GMSu Application Provider sends the remote control information to the Remote Controller.
9. The Remote Controller sends a remote control command to the 5GMSu-Aware Application using the protocol negotiated in step 6.
10. Based on the received the remote control command, the 5GMSu-Aware Application sends a corresponding request to the 5GMSu Client.
11. The 5GMSu Client takes the required action based on the received request.
12. The 5GMSu Client acknowledges execution of the received request to the 5GMSu-Aware Application, including the results (if any).
13. The 5GMSu-Aware Application acknowledges execution of the remote control command to the Remote Controller, including the results (if any).

## 6.7 RAN Signalling based Support for Uplink Network Assistance

Figure 6.7-1 depicts an uplink streaming architecture where RAN signalling is employed to support uplink Network Assistance functionality.

The RAN in the architecture contains control plane and user plane entities that interact with peer control and user plane entities in the UE, in the request/response for uplink bit rate recommendations, or boost of the uplink streaming data rate, and subsequent media transport. The user plane functionality as shown in Figure 6.7-1 (solid line going from UE to RAN to 5GMSu AS) illustrates the scheduling/passthrough functionality associated with user plane communications, governed by the RAN, as result of the uplink assistance messaging over the control plane (shown by dotted line between the UE and RAN). It is assumed in this case that 5GMSu AF-based Network Assistance is not utilized.

It should be noted that although the 5GMSu AF is not utilized when RAN signalling based network assistance is performed, it is assumed that there is a higher-level network entity which coordinates and tracks network assistance performed using RAN signalling versus application signalling for individual UEs.

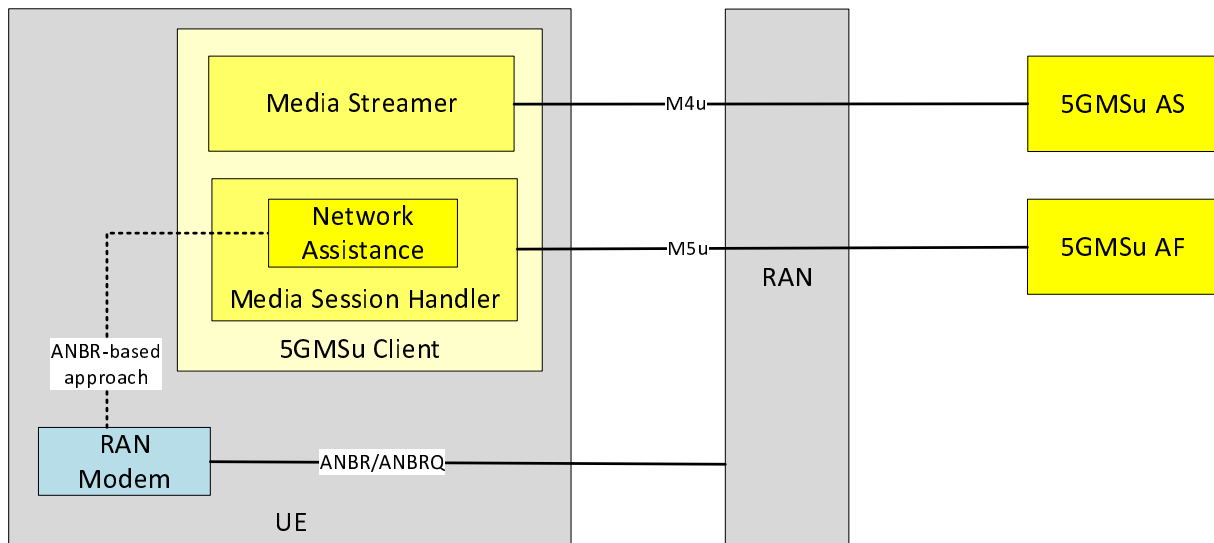

Figure 6.7-1: RAN Signalling based Uplink Network Assistance

## 6.8 Procedures for uplink media streaming data collection, reporting and exposure

### 6.8.1 Configuration of 5GMSu AS data collection client for uplink media streaming access reporting

The 5GMSu AS obtains its data collection client configuration at reference point R4 as part of its initialisation procedure, as shown in figure 6.8.1-1.

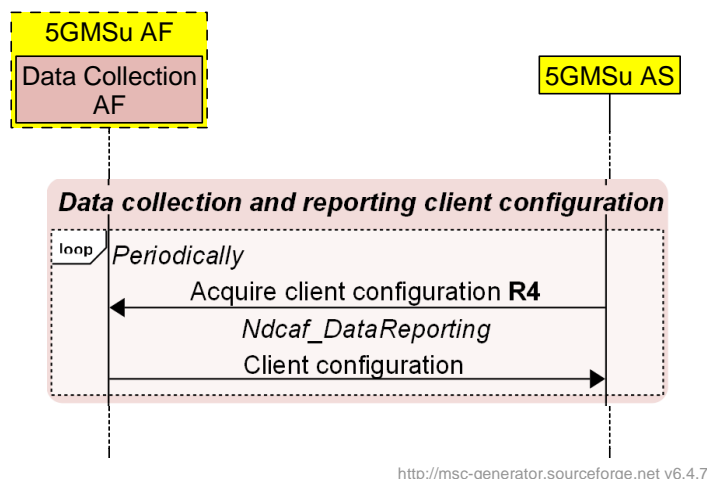

Figure 6.8.1-1: Data collection client configuration for uplink media streaming access reporting

The 5GMSu AS shall periodically refresh its data collection client configuration and act appropriately on any changes in the configuration.

### 6.8.2 Uplink media streaming access reporting by 5GMSu AS

The 5GMSu AS shall use the procedure shown in figure 6.8.2-1 to report uplink media streaming access to the Data Collection AF instantiated in the 5GMSu AF when the data collection client configuration obtained using the procedure in clause 6.8.1 indicates that it should do so.

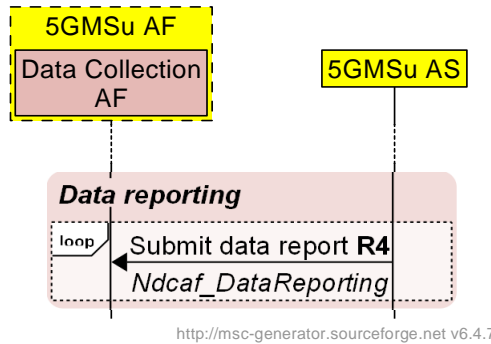

Figure 6.8.2-1: Uplink media streaming access reporting

The data report defined in clause 4.6.1 of TS 26.531 [22] shall be used by the 5GMSu AS to report the activity of uplink media streaming access by the Media Streamer. Each uplink access logged by the 5GMSu AS in relation to such activity shall be reported as a single record in a report submitted to the Data Collection AF at reference point R4. The parameters included in the data report are defined in clause 6.8.4. The frequency of reporting is defined in clause 6.8.5.

### 6.8.3 Uplink media streaming access event exposure

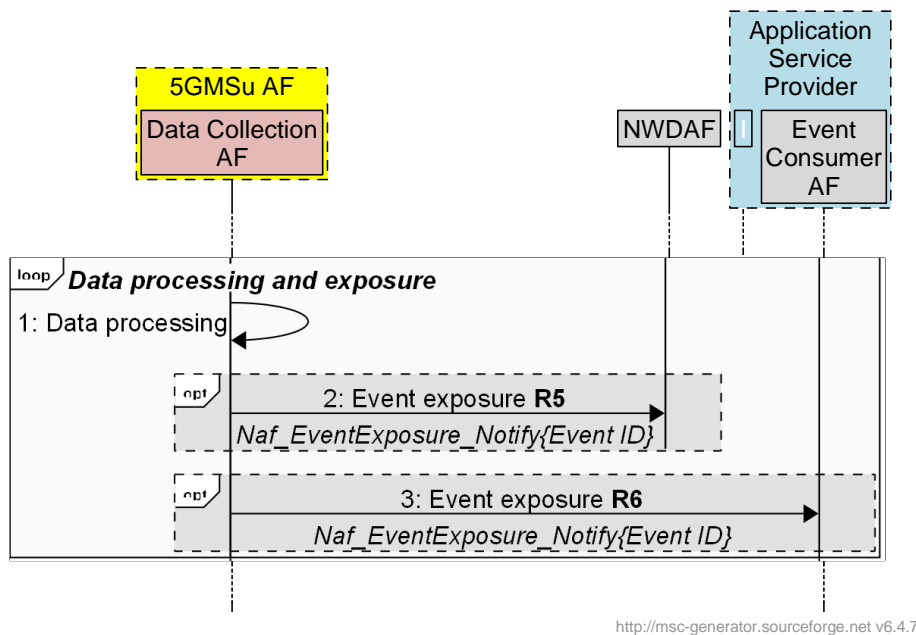

Figure 6.8.3-1: Uplink media streaming access event exposure

The 5GMS System shall follow the procedures for event reporting defined in clause 4.15.1 of TS 23.502 [3]. In the context of uplink media streaming:

- The role of *event provider NF* (also referred to in [3] as *event provider NF*, *event provider*, or *NF producer*) is performed by the 5GMSu AF and its subordinate Data Collection AF.
- The role of *event consumer NF* (also referred to in [3] as *consumer NF*, *NF service consumer*, or *NF consumer*) is performed by the NWDAF, the NEF and/or the Event Consumer AF of the 5GMSd Application Provider.

When one of the abovementioned event consumer entities subscribes to event reporting at the 5GMSu AF:

- Event subscription parameters contained in *Event Reporting Information* (such as maximum number of reports, maximum duration of reporting, sampling ratio, partitioning criteria, etc. as defined in clause 4.15.1 of [3]) shall be limited or superseded by similar or identical rules optionally set by a 5GMSu Application Provider in the Event Data Processing Configuration of the 5GMSu AF Provisioning Session, as defined in clause 5.3.1 of the present document.
- UE targeting rules contained in the *Target of Event Reporting* (see clause 4.15.1 of [3]) shall be limited or superseded by similar or identical rules optionally set by a 5GMSd Application Provider in Data Access Profiles in the Event Data Processing Configuration of the 5GMSd AF Provisioning Session, as defined in clause 5.3.1 of the present document.

## 6.8.4 Uplink media streaming access reporting parameters

Table 6.8.4-1 below describes the parameters reported by the 5GMSu AS in clause 6.8.2 for each downlink media streaming access.

**Table 6.8.4-1: Uplink media streaming access reporting parameters**

Parameter	Cardinality	Description
Date-time	1..1	The date and time of access.
UE identity	1..1	A unique identifier of the UE accessing the 5GMSu AS, such as the source IP address and port number of the Media Streamer.
5GMSu AS service endpoint	1..1	The service endpoint on the 5GMSu AS to which the Media Streamer is connected for this access, such as the server IP address and port number.
Session identifier	0..1	An identifier for the HTTP session on which the Media Streamer request was made for this access.
HTTP request method	1..1	The HTTP method used for this access.
HTTP request URL	1..1	The URL requested by the Media Streamer for this access.
HTTP request version	1..1	The HTTP version requested by the Media Streamer for this access.
HTTP request range	0..1	The value of the Range HTTP request header, if present for this access.
HTTP request size	1..1	The total number of bytes in the HTTP client request message from the Media Streamer for this access.
HTTP request body size	1..1	The number of bytes supplied by the Media Streamer in the HTTP request body for this access.
HTTP request content type	0..1	The MIME content type of the HTTP request message supplied by the Media Streamer for this access.
HTTP User Agent	0..1	A string describing the Media Streamer that made this access.
User identity	0..1	A string identifying the user that made the access.
Referrer URL	0..1	The URL that the Media Streamer reports being referred from.
HTTP response code	1..1	The HTTP response code issued by the 5GMSu AS for this access.
HTTP response size	1..1	The total number of bytes returned by the 5GMSu AS in the HTTP response message for this access.
HTTP response body size	1..1	The number of bytes returned by the 5GMSu AS in the HTTP response body for this access.
HTTP response content type	0..1	The MIME content type of the HTTP response message returned by the 5GMSu AS for this access.
Processing latency	1..1	The time taken by the 5GMSu AS to respond to the Media Streamer request, measured from the first byte of the HTTP request being processed by the 5GMSu AS to the last byte of the response being sent.
Mean network round-trip time	1..1	A rolling mean average of the network round-trip time for the HTTP session on which the access was received.
Network round-trip time variance	1..1	The variance in the average network round-trip time for the HTTP session on which the access was received.
Transport congestion window size	1..1	The current size (in bytes) of the congestion window for the transport connection supporting the HTTP session on which the access was received.

## 6.8.5 Triggering uplink media streaming access reporting

Reports shall be sent by the 5GMSu AS to the Data Collection AF as indicated in the data collection client configuration obtained using the procedure defined in clause 6.8.1.

## 6.9 Establishing an uplink streaming session with 5GMSu AF interactions for dynamic policy invocation and updates

### 6.9.1 General

This clause describes the procedures for provisioning Policy Templates and the establishment of uplink streaming session using dynamic policy invocation. The establishment of the uplink streaming session uses 5GMSu AF interactions, as described in clause 6.1. The Dynamic Policy feature allows separate handling of Service Data Flows within the same PDU Session. The Media Session Handler provides a Policy Template Id together with Service Data Flow Descriptions when requesting a dynamic policy. An example Policy Template Id value is "background\_data".

The Media Session Handler provides needed information to the 5GMSu AF, so that the 5GMSu AF can combine the semi-static parameters from a Policy Template (which is associated with the Policy Template Id) with parameters supplied dynamically by the Media Session Handler to trigger a dynamic PCC rule update using the NEF or PCF.

The 5GMSu AF may trigger, for example, the "AF session with required QoS procedure" (see clause 4.15.6.6 of TS 23.502 [3]) to update QoS-related dynamic PCC rules. For changing charging-related rules, the 5GMSu AF may trigger the "Change the chargeable party during the session" procedure (see clause 4.15.6.5 of TS 23.502 [3]).

### 6.9.2 Provisioning

The provisioning for the dynamic policy procedure follows the general procedure from clause 6.2.2. Specifically, the Dynamic Policy feature is activated and, as result, the 5GMSu Application Provider is able to provision one or more Policy Templates.

The domain model of M1u and M5u APIs is depicted in figure 6.9.2-1. Realization of the dependencies between M1u and M5u data entries are up to implementation.

NOTE: Multiple M5u 5GMSu AF nodes may reference the same M1u resource.

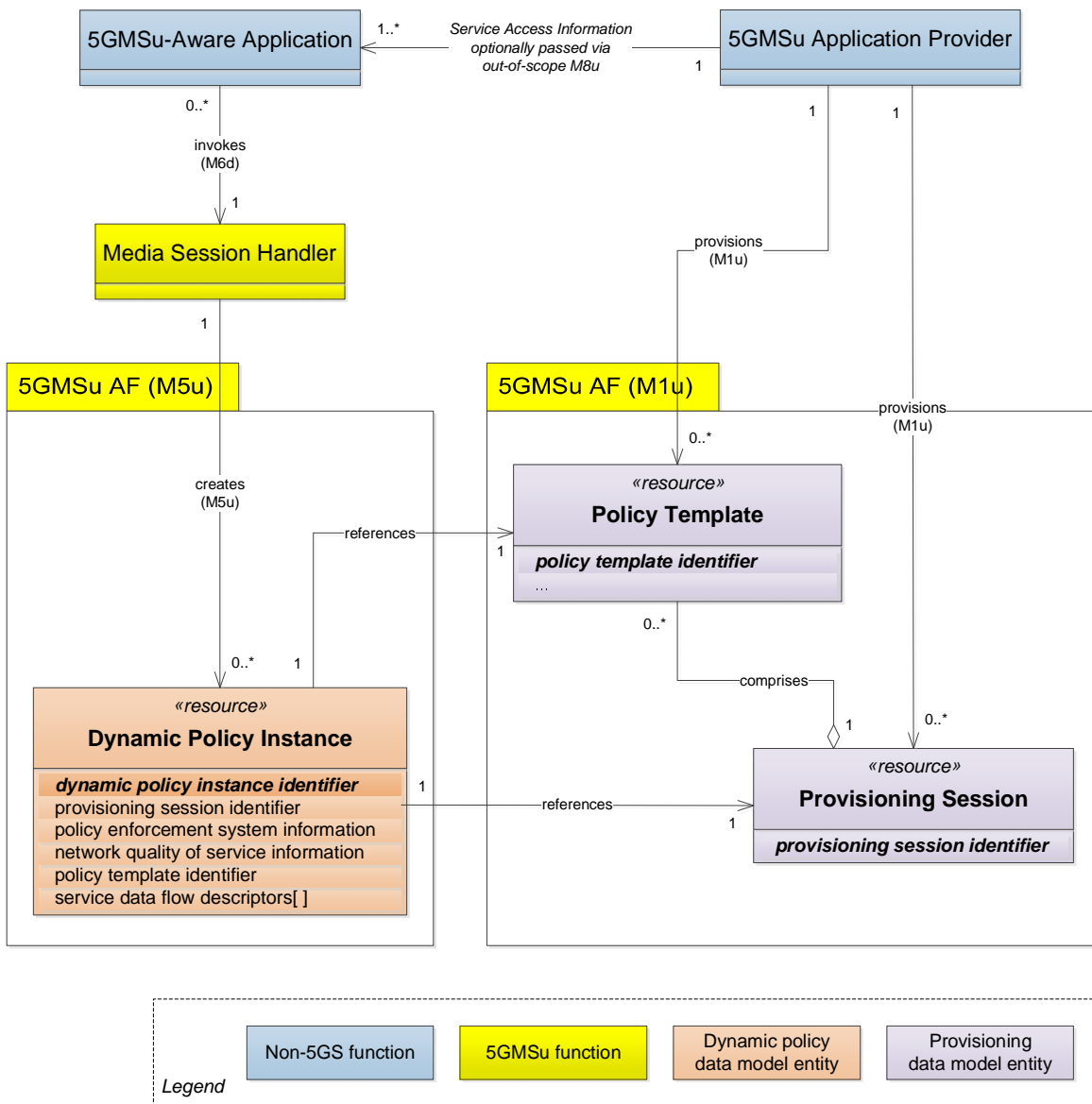
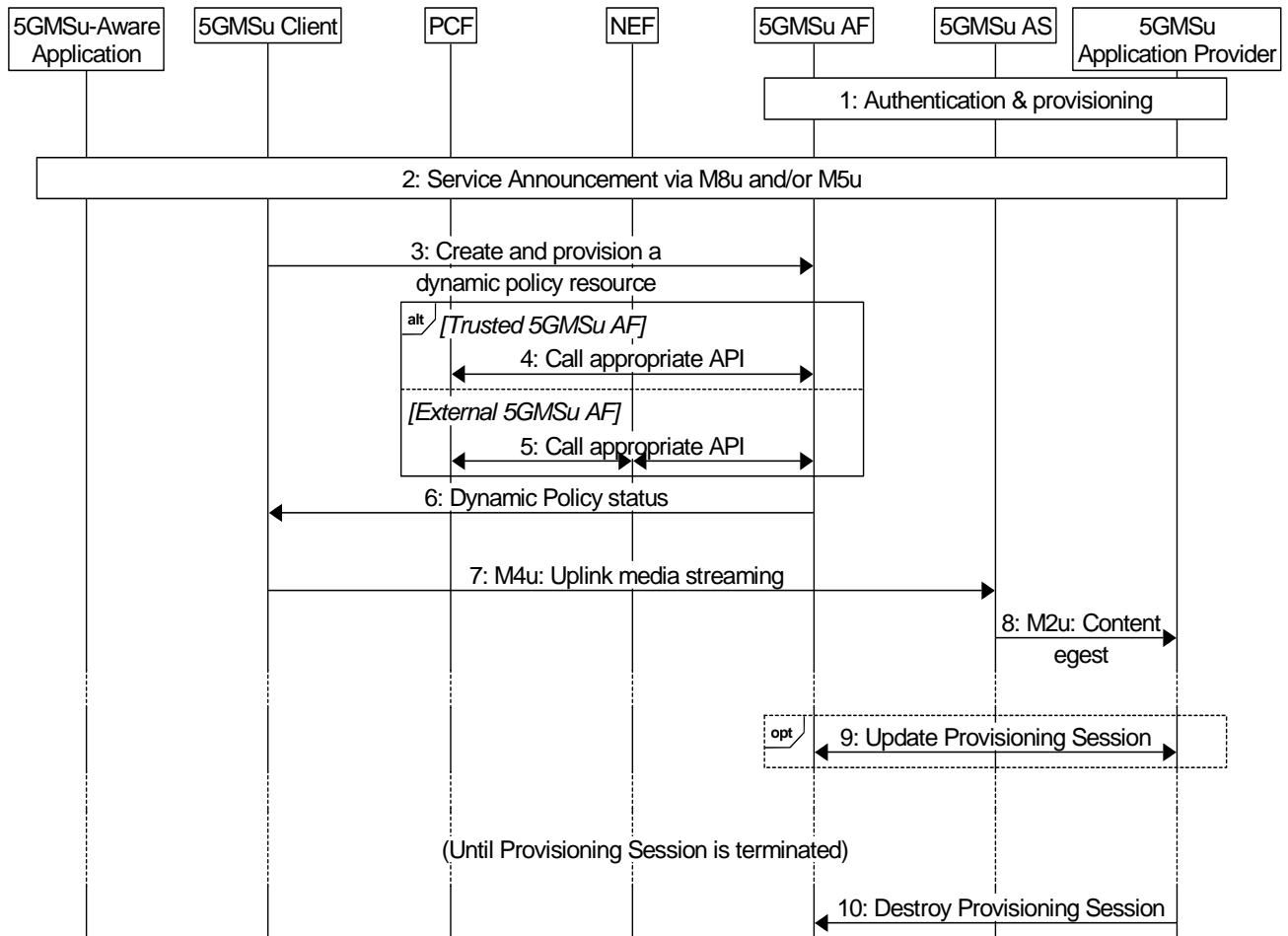

**Figure 6.9.2-1: Domain model for dynamic policies for uplink streaming**

A Policy Template is identified by a Policy Template Id and contains semi-static parameters, including the API entry for the PCF/NEF interactions. The list of provisioned Policy Template Ids is communicated as valid Policy Template Ids to the Media Session Handler. The Media Session Handler uses one of the valid Policy Template Ids when invoking a dynamic policy.

### 6.9.3 Uplink streaming with dynamic policy invocation

This procedure describes the establishment of an uplink streaming session with 5GMSu AF interactions for dynamic policy invocation.



<https://gitlab.com/msc-generator/v8.4>

**Figure 6.9.3-1: High-level procedure for uplink media streaming session with dynamic policy invocation**

Steps:

1. The 5GMSu Application Provider authenticates and provisions the 5GMS System for uplink media streaming.
2. The 5GMSu Application Provider provides the Service Access Information to the 5GMSu-Aware Application via reference point M8u, or alternatively the 5GMSu Client acquires the Services Access Information from 5GMSu AF via reference point M5u.

Then:

3. **The 5GMSu Client requests that a dynamic policy is applied to the media streaming session. The request includes at least the Provisioning Session identifier, the Service Data Flow Description(s) and the Policy Template identifier (see figure 6.9.2-1), to be applied to the described transport session. In some cases, a QoS specification is also provided, containing desired QoS information. The 5GMSu AF uses the Policy Template for the related procedure and to identify the related network function.**

**NOTE:** The 5GMSu Client may add and remove Service Data Flow description(s) from the dynamic policy during the lifetime of the uplink media streaming session.

4. This step applies when the 5GMSu AF resides in the trusted Data Network. Depending on the Policy Template, the step is executed either:
  - a. When the Policy Template relates to QoS, the 5GMSu AF may either directly interact with the PCF or may use a NEF service:
    - when directly interacting with the PCF, the 5GMSu AF uses the *Npcf\_PolicyAuthorization* service as defined in clause 5.2.5.3 of TS 23.502 [3]).
    - when interacting via the NEF with the PCF, continue at step 5a.
  - b. When the Policy Template relates to a different charging scheme, the 5GMSu AF may either directly interact with the PCF or may use a NEF service:
    - when directly interacting with the PCF, the 5GMSu AF uses the *Npcf\_PolicyAuthorization* service as defined in clause 5.2.5.3 of TS 23.502 [3]).
    - when interacting via the NEF with the PCF, continue at step 5b.
5. This step applies when the 5GMSu AF resides in the external Data Network. Depending on the Policy Template, the step is executed either:
  - a. When the Policy Template relates to QoS, the 5GMSu AF uses the *Nnef\_AFsessionWithQoS* service as defined in clause 5.2.6.9 of TS 23.502 [3]. (The complete call flow is described in clause 4.15.6.6 of TS 23.502 [3].)
  - b. When the Policy Template relates to a different charging scheme, the 5GMSu AF uses the *Nnef\_ChargeableParty* service as defined in clause 5.2.6.8 of TS 23.502 [3]. (The complete call flow is described in clause 4.15.6.4 and 4.15.6.5 of TS 23.502 [3].) The Policy Template may contain Sponsor Information (values based on SLA negotiation) and a Background Data Transfer Reference ID. The Flow Description is provided by the Media Session Handler at API invocation.
6. The response to step 3 from the 5GMSu AF contains status information (policy accepted, rejected, etc) and information on policy enforcement such as the enforcement method and enforcement bit rate.
7. The 5GMSu Client streams the content to the 5GMSu AS via reference point M4u.
8. When content publishing is offered and has been selected in step 1, the content contributed to the 5GMSu AS in the previous step is made available to the 5GMSu Application Provider via reference point M2u.

Optionally:

9. The 5GMSu Application Provider may update the Provisioning Session.

According to schedule, or upon request by the 5GMSu-Aware Application:

10. The 5GMSu Application Provider may manually terminate the Provisioning Session (at any time). All associated resources are released. Content may be removed from the 5GMSu AS. The 5GMSu Application Provider may configure a schedule for Provisioning Session termination.

## 6.9.4 Parameters for dynamic policy invocation configuration

**Table 6.9.4-1: Status information dynamic policy**

Parameters	Description
Policy Enforcement	Information about the policy enforcement system.



## 6.9.5 Dynamic Policy selection for uplink media streaming based on Service Operation Point signalling

This clause provides an extension to the general call flow in clause 6.2.3 in order to address the usage of Service Descriptions to select a Dynamic Policy in uplink 5G Media Streaming services that supports the requirements of an abstract Service Operation Point. Details are shown in figure 6.9.5-1.

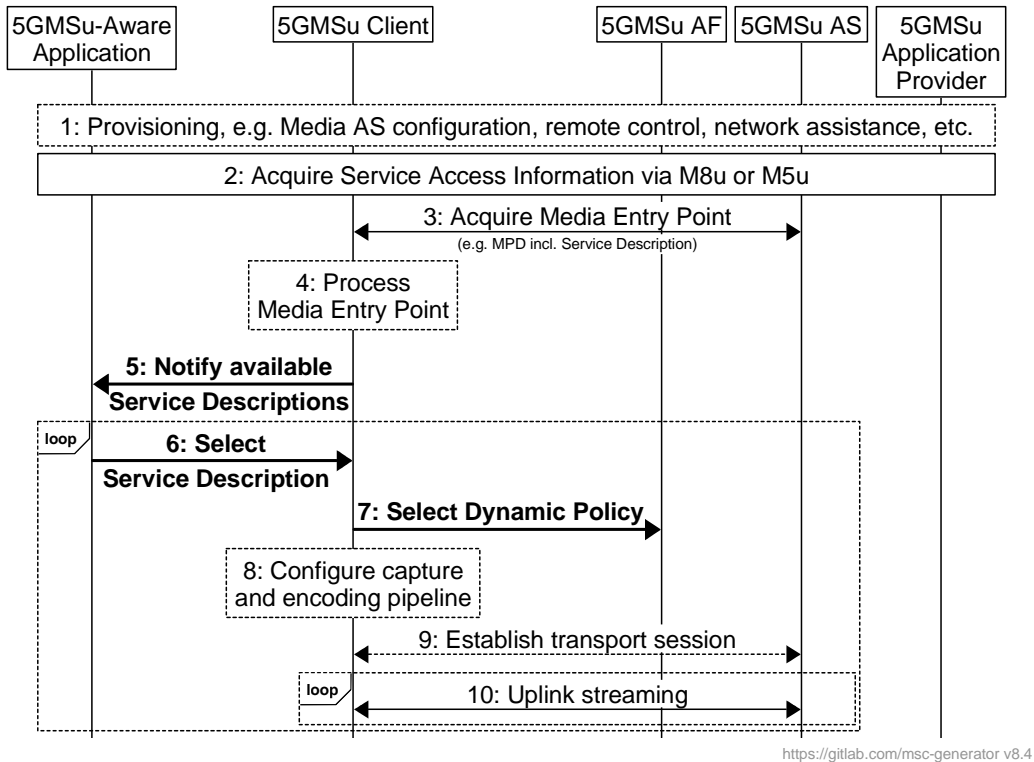

**Figure 6.9.5-1: High-level procedure for uplink media streaming with Service Operation Point handling**

Steps:

1. Policy Templates are provisioned in the 5GMSd AF and various configurations are performed.
2. Either the 5GMSu-Aware Application acquires Service Access Information from the 5GMSu Application Provider via reference point M8u, or else Service Access Information is acquired by the 5GMSu Client from the 5GMSu AF via reference point M5u (as defined in steps 7–11 of figure 6.2.2.2-1).
3. The 5GMSu Client acquires the Media Entry Point from the 5GMSu AS.
4. The 5GMSu Client processes the Media Entry Point to discover the set of available Service Descriptions, each one identified by a different *External reference*.
5. **The 5GMSu Client notifies the 5GMSu Application about the available Service Descriptions.**
6. **The 5GMSu Application selects a Service Description and notifies the 5GMSu Client by supplying its *External reference*.**
7. **The 5GMSu Client selects a Dynamic Policy with a matching *External reference*.**
8. The 5GMSu Client configures its capture and encoding according to the selected Service Description.
9. A transport session is established by the 5GMSu Client for uplink media streaming.
10. Media is streamed to the 5GMSu AS via the uplink.

## 6.9.6 Dynamic Policy based on Network Slicing for uplink media streaming

The 5GMSu Application Provider requests the assignment of more than one network slice for the uplink media streaming service. The 5GMSu Application Provider indicates the desired network slice features that correspond to the Service Access Information. Upon successful assignment of the network slices for the service, the 5GMSu AF shall respond with the list of allowed S-NSSAIs to the 5GMSu Application Provider.

Figure 6.9.6-1 is the sequence diagram for this procedure.

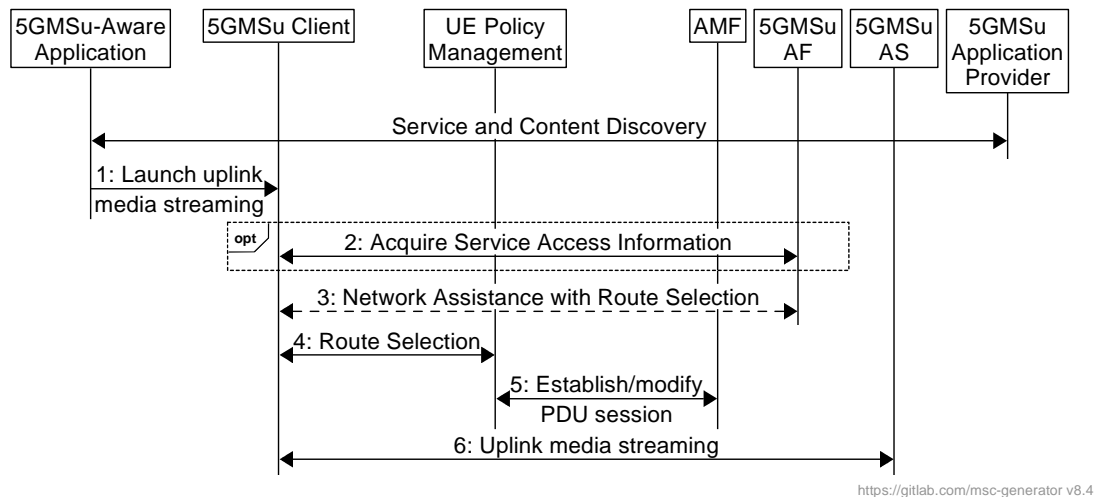

**Figure 6.9.6-1.: Dynamic Policy based on Network Slicing for uplink streaming**

Pre-requisites:

1. The UE knows how to access the network slice(s) associated with a particular Provisioning Session.
2. The 5GMSu AS instance(s) serving the content for the particular Provisioning Session are accessible through the DNN(s) associated with the network slice(s) provisioned for the contribution of that content.

The steps are as follows:

1. The 5GMSu-Aware Application triggers the 5GMSu Client for uplink media streaming of content.
2. If it has not already been provided with the necessary Service Announcement parameters by the 5GMSu-Aware Application in the previous step, the Media Session Handler in the 5GMSu Client retrieves Service Access Information from the 5GMSu AF for the Provisioning Session of interest.
3. **The Media Session Handler in the 5GMSu Client invokes Network Assistance on the 5GMSu AF and receives information in response to assist it with the route selection for the uplink media streaming session. This may include information about the network slices, the DNNs and any pre-authorized QoS guarantees for that Provisioning Session.**
4. **The 5GMSu Client and the UE Policy Management in the UE perform the route selection procedure using information such as the uplink streaming Service Operation Point and the traffic descriptors. The UE Policy Management uses the matching filter to retrieve the Route Selection descriptor, which provides the DNN and the S-NSSAI(s) identifying the network slice(s) to be used for uplink media streaming sessions associated with this Provisioning Session.**
5. **The UE either reuses an existing PDU Session with the selected S-NSSAI and DNN from step 3 or, if one doesn't exist already, it requests the establishment of a new PDU Session with the identified parameters.**
6. The 5GMSu Client contributes media content to the 5GMSu AS at reference point M4u using the PDU Session selected in the previous step and this content is made available to the 5GMSu Application Provider at reference point M2u.

### 6.9.7 Uplink Background Data Transfer using dynamic policy invocation

Figure 6.9.7-1 shows a high-level call flow for the configuration and usage of a Background Data Transfer session in uplink 5G Media Streaming:

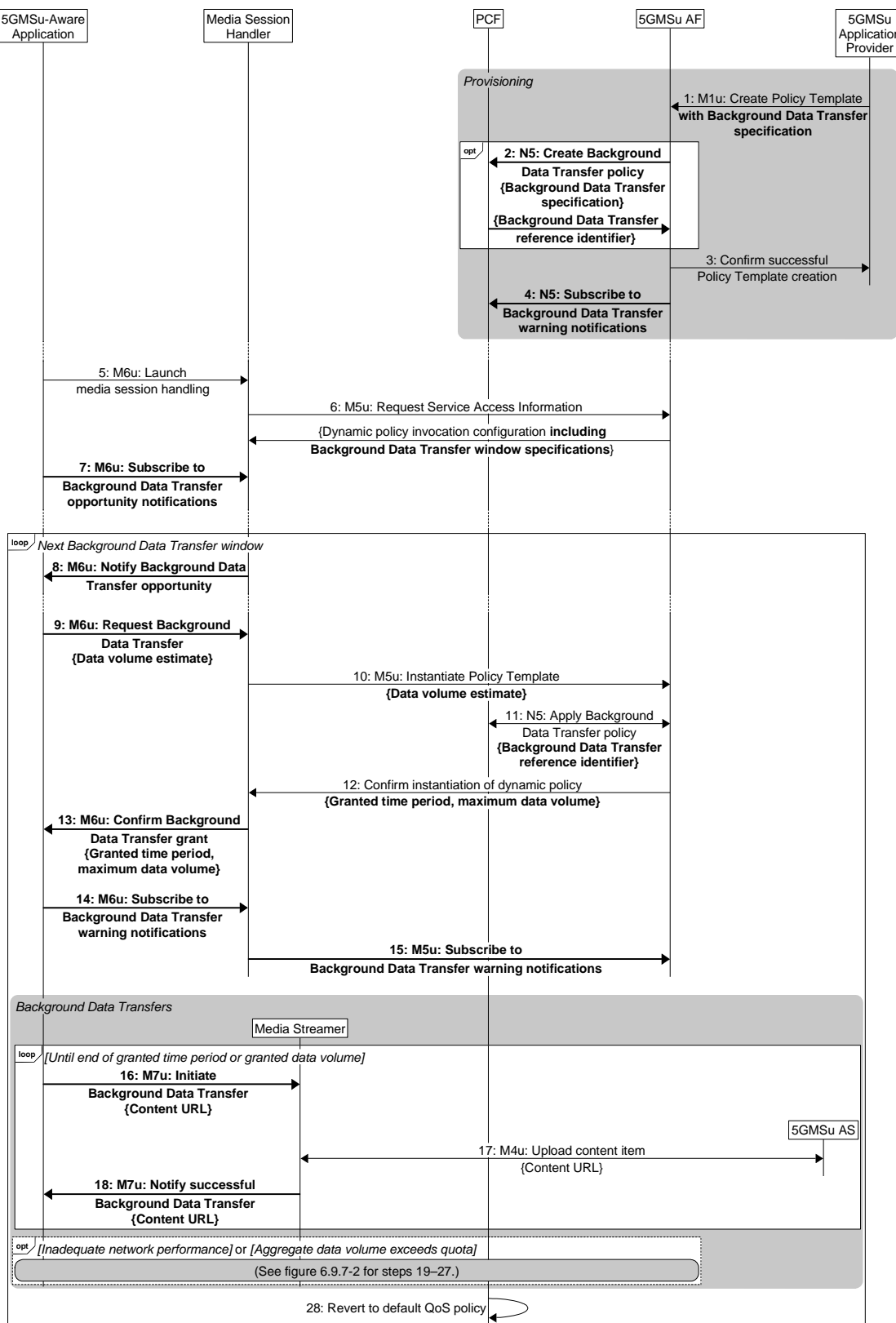

<https://gitlab.com/mmc-generator/v8.4>

Figure 6.9.7-1: Call flow for uplink Background Data Transfer session configuration and establishment

Pre-requisites:

1. The 5GMSu Application Provider has negotiated a Service Level Agreement with the 5GMS System operator that includes all or some of the following:
  - a. Time window(s) when Background Data Transfers are available. These may recur on a regular pattern (e.g., daily, weekly, monthly, etc.).
  - b. A quota for the maximum number of 5GMS Clients that may avail themselves of a Background Data Transfer during each such time window.
  - c. A quota for the maximum aggregate volume of data that may be transferred by all 5GMS Clients during each Background Data Transfer window.
2. The 5GMS System operator may have provisioned a Background Data Transfer Policy in the PCF based on the Service Level Agreement, in which case it may share the corresponding Background Data Transfer reference identifier directly with the 5GMSu Application Provider.

The steps in the call flow sequence are as follows with differences from the baseline call flow highlighted in **bold**:

1. The 5GMSu Application Provider provisions a Policy Template in the 5GMSu AF at reference point M1u including network QoS parameters **that either references an existing Background Data Transfer policy already provisioned in the PCF that embodies the aforementioned Service Level Agreement or else directly specifies Background Data Transfer parameters in line with the aforementioned Service Level Agreement.**
2. **If the supplied Policy Template explicitly declares new Background Data Transfer parameters, the 5GMSu AF creates a corresponding new Background Data Transfer policy in the PCF based on them using the *Npcf\_BDTPolicyControl* service (or, if the 5GMSu AF is deployed outside the Trusted DN, the *Nnef\_BDTPNegotiation* service (see clause 4.16.7.2 of TS 23.502 [3]). The PCF may interact with the UDR as a consequence. The procedure yields a Background Data Transfer reference identifier.**
3. The 5GMSu AF acknowledges successful creation of the Policy Template to the 5GMSu Application Provider. This confirms that the parameters of the Policy Template (**including the Background Data Transfer parameters**) are acceptable to the 5GMS System.
4. If it has not already done so, the 5GMSu AF subscribes to receive Background Data Transfer warning notifications from the PCF as defined in clause 4.16.7 of TS 23.502 [3].

At some later point in time:

5. The 5GMSu-Aware Application launches media session handling using an appropriate service launch mechanism at reference point M6u.
6. In response, the Media Session Handler fetches Service Access Information from the 5GMSu AF for the relevant Provisioning Session via reference point M5u. A client dynamic policy invocation configuration is provided that describes the Policy Templates applicable to the requesting 5GMSu Client, **including information about Background Data Transfer windows and endpoint(s) that the Media Session Handler may subscribe to in order to receive Background Data Transfer warning notifications from the 5GMSu AF.**
7. **The 5GMSu-Aware Application also subscribes to receive notifications of Background Data Transfer opportunities from the Media Session Handler by invoking a client API on the latter at reference point M6u.**

At the start of the next Background Data Transfer window:

8. According to its list of current subscriptions (see step 7), **the Media Session Handler notifies its 5GMSu-Aware Application subscriber(s) of the Background Data Transfer opportunity by sending a notification to each one via reference point M6u. The notification indicates the time window of the Background Data Transfer opportunity.**
9. **If it wishes to avail itself of the Background Data Transfer opportunity (immediately or at some later point during the time window indicated in the previous step) a 5GMSu-Aware Application that has received such a notification invokes a suitable client API on the Media Session Handler at reference point**

**M6u. The invocation includes an estimate of the data volume the 5GMSu Client intends to transfer in the background.**

- 10: The Media Session Handler instantiates a dynamic policy resource on the 5GMSu AF based on one of the Policy Templates advertised in the Service Access Information **that includes Background Data Transfer parameters. The request includes an estimate of the data volume the 5GMSu Client intends to transfer in the background.**
11. **If the request falls within a time window for Background Data Transfers advertised in the Service Access Information and if the quota for the number of Background Data Transfers within the current time window has not been exceeded, the Media Session Handler requests a change to the network QoS of the appropriate PDU Session by invoking the *Npcf\_PolicyAuthorization\_Create* operation (either directly or via the NEF) according to clause 4.16.7.1 of TS 23.502 [3] based on the Background Data Transfer parameters described in the appropriate Policy Template and citing the reference identifier of the Background Data Transfer referenced in step 1 or created in step 2.**
12. **The 5GMSu AF responds to the Media Session Handler to grant the Background Data Transfer request. The grant response includes a recommendation from the 5GMSu AF of the maximum time period for which the Background Data Transfer is available and the maximum Background Data Transfer volume granted for the media streaming session during this grant period (which may be smaller than that requested in step 10).**
13. **The Media Session Handler informs the 5GMSu-Aware Application of the Background Data Transfer grant by sending a synchronous response or asynchronous notification to the latter at reference point M7u. This conveys the maximum time period recommendation and maximum data volume indicated by the 5GMSu AF in the previous step.**
- 14: **The 5GMSu-Aware Application subscribes to receive Background Data Transfer warning notifications from the Media Session Handler by invoking a client API on the latter at reference point M6u.**
15. **As a consequence, the Media Session Handler subscribes to receive Background Data Transfer warning notifications from the 5GMSu AF by invoking a network API on the latter at reference point M5u. The subscription endpoint(s) are indicated in the Service Access Information obtained in step 6.**

The following steps are repeated for each content item the 5GMSu-Aware Application would like to download during the granted time period for Background Data Transfers:

16. **The 5GMSu-Aware Application initiates upload of a content item in the background by invoking a suitable client API on the Media Streamer at reference point M7u. The content is identified by a URL that is available on a 5GMSu AS.**
17. **The Media Streamer uploads the content item from the 5GMSu AS at reference point M4d using the content item URL supplied in the previous step.**
18. **The Media Player confirms that the content item has been successfully uploaded by sending a notification to the 5GMSu-Aware Application at reference point M7u.**

(Steps 19–27 are described below.)

When the granted time period for Background Data Transfers subsequently expires:

28. **The PCF automatically reverts the network QoS of the media streaming session to its state prior to the Background Data Transfer grant without intervention from the 5GMS System.**

At any time during a Background Data Transfer window the PCF may detect that the network cannot satisfy the requirements of the Background Data Transfer policy at the UE’s current location (as defined in clause 6.1.2.4 of TS 23.503 [4]) or that the volume of data transferred by all UEs in the current Background Data Transfer window has exceeded the quota provisioned in the Background Data Transfer policy. The procedures in this case are summarised in figure 6.9.7-2.

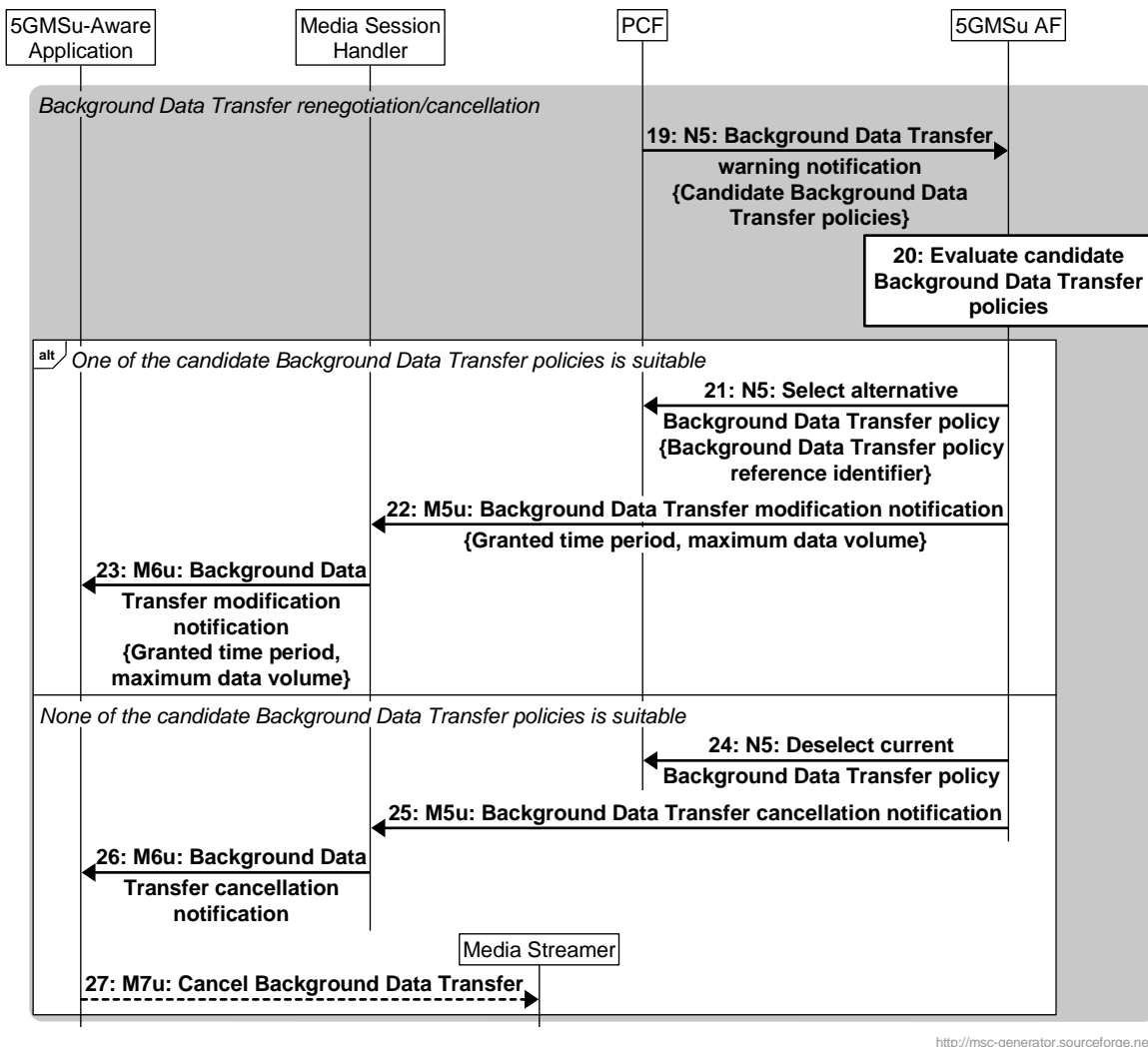

<http://msc-generator.sourceforge.net v7.2>

Figure 6.9.7-2: Call flow for uplink Background Data Transfer session renegotiation/cancellation

The steps are as follows:

**19:** If it is able to identify alternative Background Data Transfer policies, the PCF sends a Background Data Transfer warning notification with these candidates to the 5GMSu AF as defined in clause 4.16.7.3 of TS 23.502 [3].

**20:** The 5GMSu AF evaluates the candidate alternative Background Data Transfer policies for suitability.

If the 5GMSu AF determines that one of the candidate alternative Background Data Transfer policies suggested by the PCF is suitable for the media streaming session in question:

- 21: The 5GMSu AF requests that its chosen alternative Background Data Transfer policy is applied, according to step 12 in clause 4.16.7.3 of TS 23.502 [13]. As defined in clause 6.1.2.4 of TS 23.503 [4], in this case the current Background Data Transfer policy remains in force until its natural end (see step 29 above).**
- 22. Using an asynchronous notification mechanism at reference point M5u, the 5GMSu AF notifies the Media Session Handler of the modified Background Data Transfer grant, including the new maximum time period for which the Background Data Transfer is available, and the new maximum Background Data Transfer volume granted for the media streaming session during this grant period (which may be smaller than that requested in step 10).**
- 23: The Media Session Handler informs the 5GMSu-Aware Application of the Background Data Transfer grant by sending an asynchronous notification to the latter at reference point M6u. This conveys the maximum time period recommendation and maximum data volume indicated by the 5GMSu AF in the previous step.**

Otherwise, if none of the candidate Background Data Transfer policies suggested by the PCF deemed suitable by the 5GMSu AF:

- 24: The 5GMSu AF informs the PCF that none of the candidate Background Data Transfer policies is suitable, according to step 13 in clause 4.16.7.3 of TS 23.502 [13].**
- 25: Using an asynchronous notification mechanism at reference point M5u, the 5GMSu AF notifies the Media Session Handler that the Background Data Transfer window has ended prematurely.**
- 26: Using an asynchronous notification mechanism at reference point M6u, the Media Session Handler notifies the 5GMSu-Aware Application that the Background Data Transfer window has ended prematurely.**
- 27: As a consequence, the 5GMSu-Aware Application may choose to cancel an in-progress Background Data Transfer by invoking a suitable client API method on the Media Player at reference point M7u.**

---

## 7 5GMS network media processing

### 7.1 General

A 5GMS Application Provider may request media processing to be performed on its media data. This can be instantiated as part of the Uplink or Downlink streaming.

The media processing is performed according to one or more Content Preparation Templates by a set of 5GMS AS instances, which may need to build complex media processing workflows. The 5GMS AF coordinates the media processing and ensures that the appropriate QoS and traffic handling for the session are provided.

### 7.2 Media processing procedures for downlink media streaming

As part of setting up a Content Hosting Configuration for downlink media streaming, a 5GMSd Application Provider may request custom processing to be performed.

The following processing operations may be available:

- Adaptive Bit Rate (ABR) Encoding, Encryption and Encapsulation.
- MPD (e.g., MPD) Generator and Segment (e.g., DASH) Packager.
- Content Replacement (e.g., Ad insertion, blackouts, regional content):
  - MPD (e.g., MPD) modification.

- App Server: other content enrichment functions such as Closed Caption insertion, object detection, content filtering, etc.

The procedures are as follows:

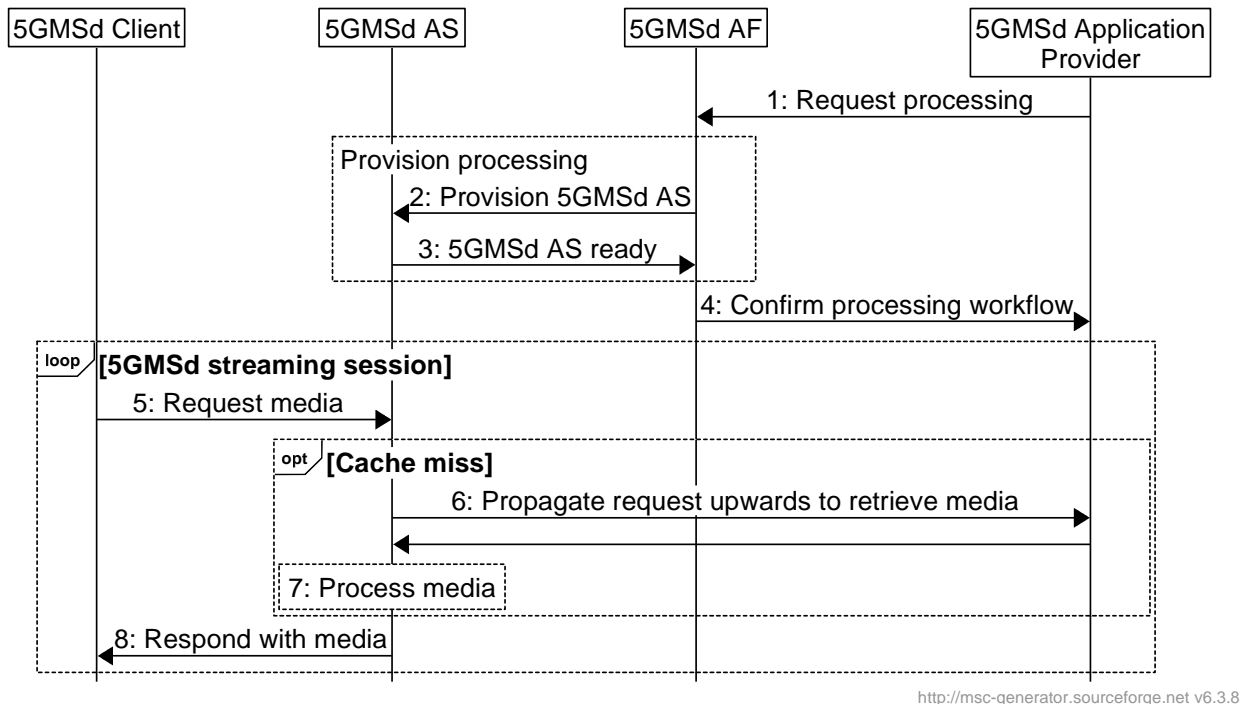

<http://msc-generator.sourceforge.net> v6.3.8

**Figure 7.2-1: Media processing procedures for downlink media streaming**

The steps are as follows:

1. Upon setting up a Content Hosting Configuration, the 5GMSd Application Provider requests media processing to be set up. The 5GMSd Application Provider provides a description of the type and placement of the processing. The 5GMS System may only allow a shortlisted set of media processing functions to be used by the 5GMSd Application Provider.
2. The 5GMSd AF provisions via reference point M3d a selected set of 5GMSd AS instance(s) to fulfil the requested media processing in the appropriate placement by means of one or more Content Preparation Templates references by a Content Hosting Configuration. Depending on the configuration, one or multiple AS instance(s) may be involved. The Content Hosting Configuration may also reference Server Certificates configured at reference point M3d.
3. The 5GMSd AS instance(s) confirm successful provisioning to the 5GMSd AF.
4. The 5GMSd AF confirms the successful creation of the Content Hosting Configuration with the requested media processing to the external Media application server.
5. A 5GMSd Client sends a request for media content to one of the 5GMSd AS instance(s) listed in the provisioned Content Hosting Configuration (see clause 5.4).
6. If it does not already have a copy of the requested media cached, the 5GMSd AS fetches the media from the 5GMSd Application Provider.
7. The 5GMSd AS processes the ingested media based on the media processing workflow configured by the Content Preparation Template(s) provisioned in step 2.
8. The 5GMSd AS serves the requested media to the 5GMSd Client after successful media processing.

Different variants of these procedures may be possible, depending on the type of processing, the placement of the processing, and the characteristics of the Content Hosting Configuration.



## 7.3 Media processing procedures for uplink media streaming

The 5GMSu AF instructs the 5GMSu AS to perform processing of the media according to the provided media processing document.

The procedure is defined as follows:

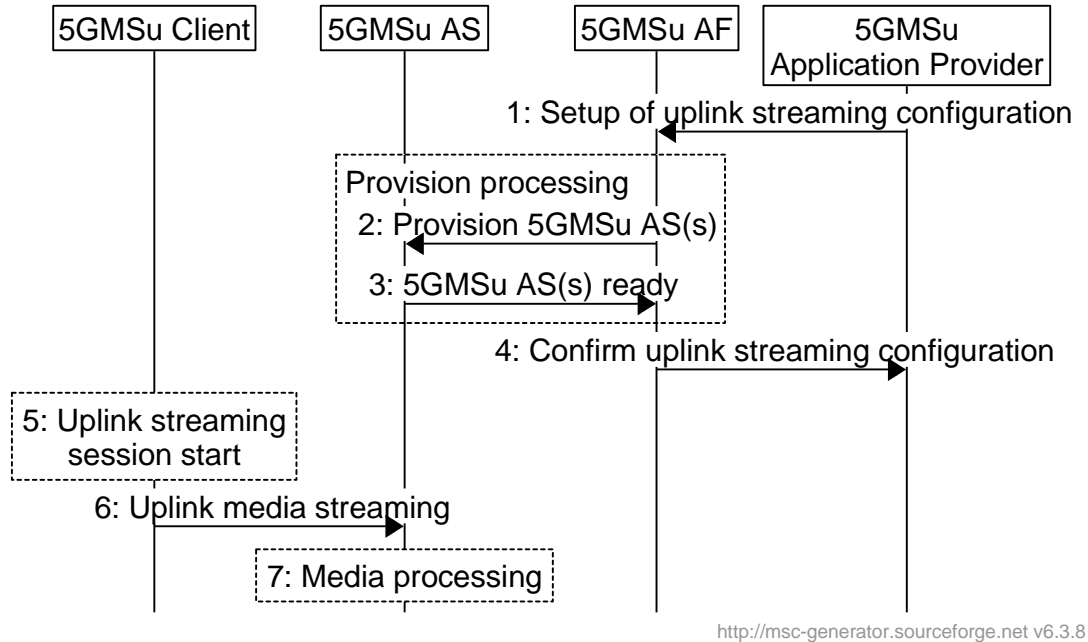

<http://msc-generator.sourceforge.net v6.3.8>

**Figure 7.3-1: Media processing pProcedures for uplink media streaming**

The steps are as follows:

1. *Setup of uplink streaming configuration*: The 5GMSu Application Provider sends a request to start an uplink session to the 5GMSu AF. The request contains a description of the media processing that is to be performed by the 5GMSu AS in the form of one or more Content Preparation Templates referenced by a Content Publishing Configuration. Depending on the configuration one 5GMSu AS may be involved.
2. *Provision 5GMSu AS*: The 5GMSu AF parses the media processing description and provisions the 5GMSu AS that will perform the requested processing via reference point M3u. If the requested processing is not accepted, the session creation fails.
3. *5GMSu AS ready*: The 5GMSu AS confirms the correct configuration and informs the 5GMSu AF that it is ready to receive and process media as requested.
4. *Confirm uplink streaming configuration*: The 5GMSu AF confirms the successful creation of the uplink streaming configuration to the 5GMSu Application Provider.
5. *Uplink streaming session starts*: the session is triggered in the 5GMSu Client.
6. *Uplink media streaming*: Media content is streamed from the 5GMSu Client to the 5GMSu AS.
7. The 5GMSu AS process(es) the received media based on the provisioned media processing workflow configured in step 2.

# 8 Procedures for 5GMS Edge Processing

## 8.1 Procedure for client-driven management of 5GMS Edge Processing

Figure 8.1-1 outlines a detailed call flow for client-driven session establishment.

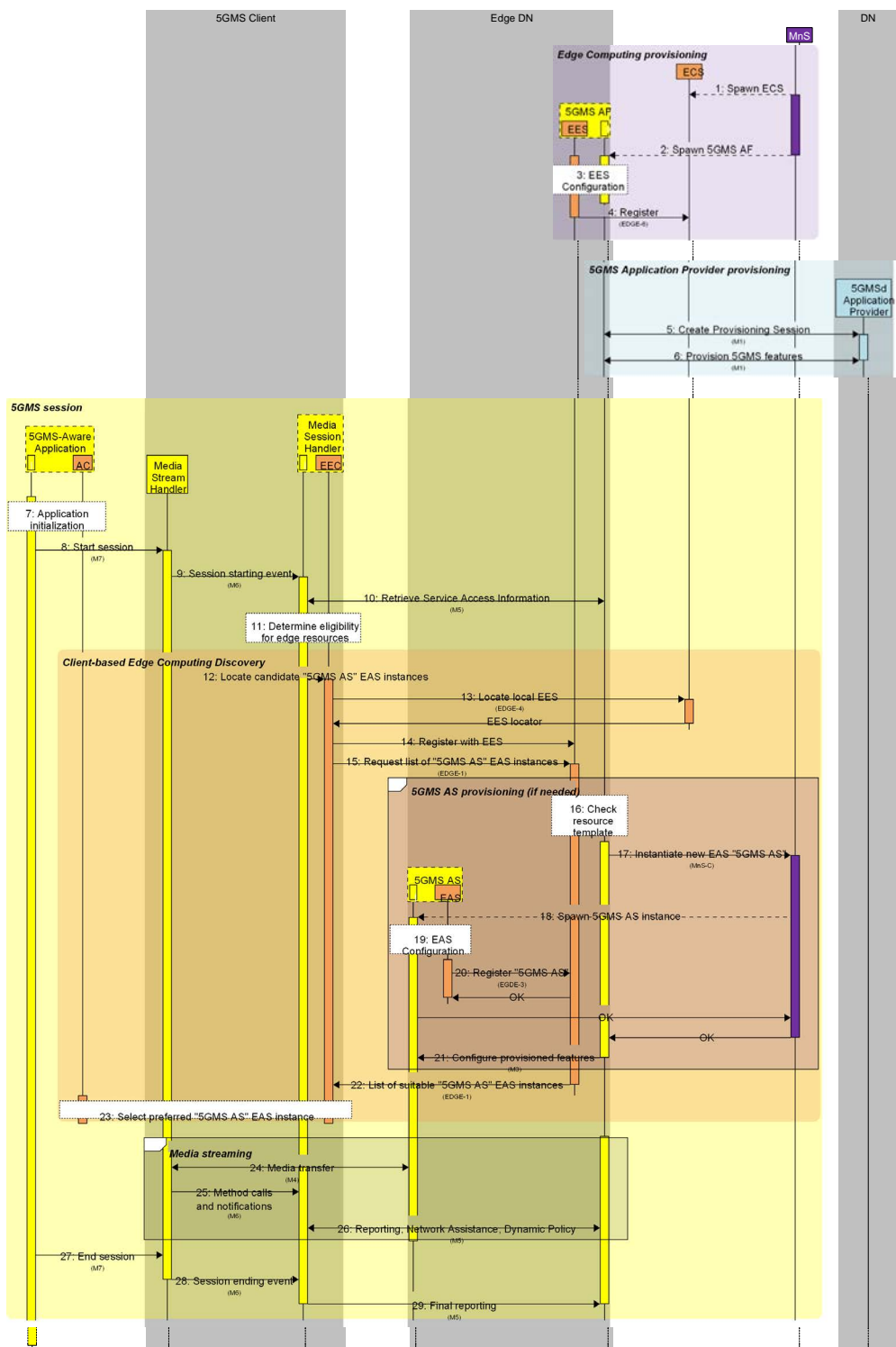

Figure 8.1-1: Client-driven session establishment

The **Edge Computing Provisioning** phase is a provisioning phase, that may be repeated several times (e.g. to extend edge processing coverage to new geographical areas or to increase the capacity of an already provisioned area). All steps in this phase are optional and performed on need basis. The steps are:

1. **Spawn ECS:** In this step, a new ECS is instantiated to manage new or increased demand for edge processing.
2. **Spawn 5GMS AF:** In this step, a new 5GMS AF that is edge-enabled is instantiated to handle new or increased demand for media sessions with edge processing.
3. **EES Configuration:** The EES is configured for a specific Edge Data Network.
4. **EES Registration with ECS:** The EES registers with the ECS that is in authority over the target EDN.

The **5GMS Application Provider Provisioning** phase is performed prior to the establishment of any related media streaming sessions by the 5GMS Application Provider. Subsequent updates to the provisioning session are possible.

5. **Create Provisioning Session:** In this step, the 5GMS Application Provider creates a new provisioning session.
6. **Provision 5GMS features:** In this step, the 5GMS Application Provider may create different configurations such as Content Hosting, Reporting, Edge Processing, etc.

The 5GMS-Aware Application initiates a new media streaming session:

7. **Application Initialization:** The user launches the 5GMS-Aware Application. The application performs any required initialization steps.
8. **Start session:** The 5GMS-Aware Application invokes the Media Streamer with appropriate streaming access parameters.
9. **Session starting event:** The application informs the Media Session Handler about the start of a new 5GMS session.
10. **Retrieve Service Access Information:** The Media Session Handler retrieves Service Access Information from the 5GMS AF appropriate to the 5GMS session.
11. **Determine eligibility for requesting edge resources:** Using information from the Service Access Information, the Media Session Handler determines whether the media streaming session is eligible for requesting edge resources.

If the eligibility criteria are met in the previous step, the UE discovers an EAS instance offering 5GMS AS functionality in the **Client-based Edge Computing Discovery** phase:

12. **Locate candidate "5GMS AS" EAS instances:** The Media Session Handler (potentially triggered by a request from the 5GMS-Aware Application) asks its embedded EEC to discover the location of one or more suitable EAS instances offering the "5GMS AS" capability that are able to serve the application.
13. **Locate local EES:** The EEC queries the ECS for a suitable EES.
14. **Register with EES:** The EEC registers with the selected EES.
15. **Request list of "5GMS AS" EAS instances:** The EEC contacts the EES to query for one or more EAS instances offering the "5GMS AS" capability that can serve the session, using EAS discovery filters (see Table 8.5.4.2-2 in [16]) obtained as a part of the Service Access Information and/or provided by the Application Client, e.g. "5GMS AS" for EAS type, appropriate values for service feature(s), and other EAS characteristics.

The optional sub-flow is for provisioning an additional 5GMS AS instance if a suitable EAS instance offering the "5GMS AS" capability cannot be located. The steps are:

16. **Check resource template:** The 5GMS AF checks the provisioned edge processing resource template for the related application to determine the edge resource requirements of the application.
17. **Instantiate new EAS/5GMS AS:** The 5GMS AF requests the MnS to instantiate a new "5GMS AS" EAS instance using the specified requirements in the provisioned edge processing resource template and parameters provided in the query by the EEC.

18. **Spawn 5GMS AS instance:** The MnS creates a new instance of the EAS offering "5GMS AS" capability with the requested placement and resources.
19. **EAS configuration:** The newly instantiated "5GMS AS" EAS instance is configured, after which it is discoverable through DNS procedures or the discovery procedures as defined in TS 23.558 [16].
20. **Register EAS with EES:** The newly instantiated EAS instance registers itself with the triggering EES.
21. **Configure provisioned features:** This may include configuring and launching the server-side application in the 5GMS AS.

Completion of Client-based Edge Computing Discovery phase:

22. **List of suitable "5GMS AS" EAS instances:** The EES/5GMS AF responds to the EEC with a list of "5GMS AS" EAS instances and their characteristics in an EAS discovery response (see Table 8.5.3.3-1 in [16]). Every EAS instance in the list satisfies the requirements defined in the provisioned edge processing resource template.
23. **Select preferred "5GMS AS" EAS instance:** The AC and/or EEC/Media Session Handler select(s) a "5GMS AS" EAS instance from the provided list, based on the AC's desired criteria.

In the case where the media entry point provided in the Service Access Information includes a host name, the EEC/Media Session Handler inserts a record into the UE's local DNS resolver that resolves this host name to the IP address of the chosen EAS instance.

After the successful discovery of a "5GMS AS" EAS instance, the actual streaming session may start:

24. **Media transfer:** The 5GMS-Aware Application connects to the selected EAS "5GMS AS" and the streaming starts.

In the case where the media entry point provided in the Service Access Information includes a host name, before connecting, the Media Stream Handler first resolves this to the IP address of the EAS instance selected in step 23.

25. **Method calls and notifications:** Supporting information about the 5GMS session is passed from the Media Stream Handler to the Media Session Handler.
26. **Reporting, network assistance, and dynamic policy:** The Media Session Handler exchanges supporting information about the 5GMS session with the 5GMS AF.
27. **End session:** the 5GMS-Aware Application informs the Media Session Handler that the 5GMS session has ended.
28. **Session ending event:** The Media Streamer informs the Media Session Handler about the end of the 5GMS session.
29. **Final reporting:** The Media Session Handler performs any final reporting to the 5GMS AF.

## 8.2 Procedure for AF-driven management of 5GMS Edge Processing

Figure 8.2-1 outlines a detailed call flow for the AF-driven management of edge processing. In clause 8.1, the optional provisioning of an additional 5GMS AS instance occurs in response to an explicit call from the Application Client to an on-board EEC, whereas in this procedure the provisioning of an additional 5GMS AS instance is initiated by the 5GMS AF. This occurs, if needed, as part of and in response to Application Provider provisioning, and subsequently when needed to support the dynamically changing demands of eligible media streaming sessions. The 5GMS AS instance may also be reprovisioned at any time during the lifetime of the 5GMS Provisioning Session in response to changing demand levels (not illustrated for brevity).

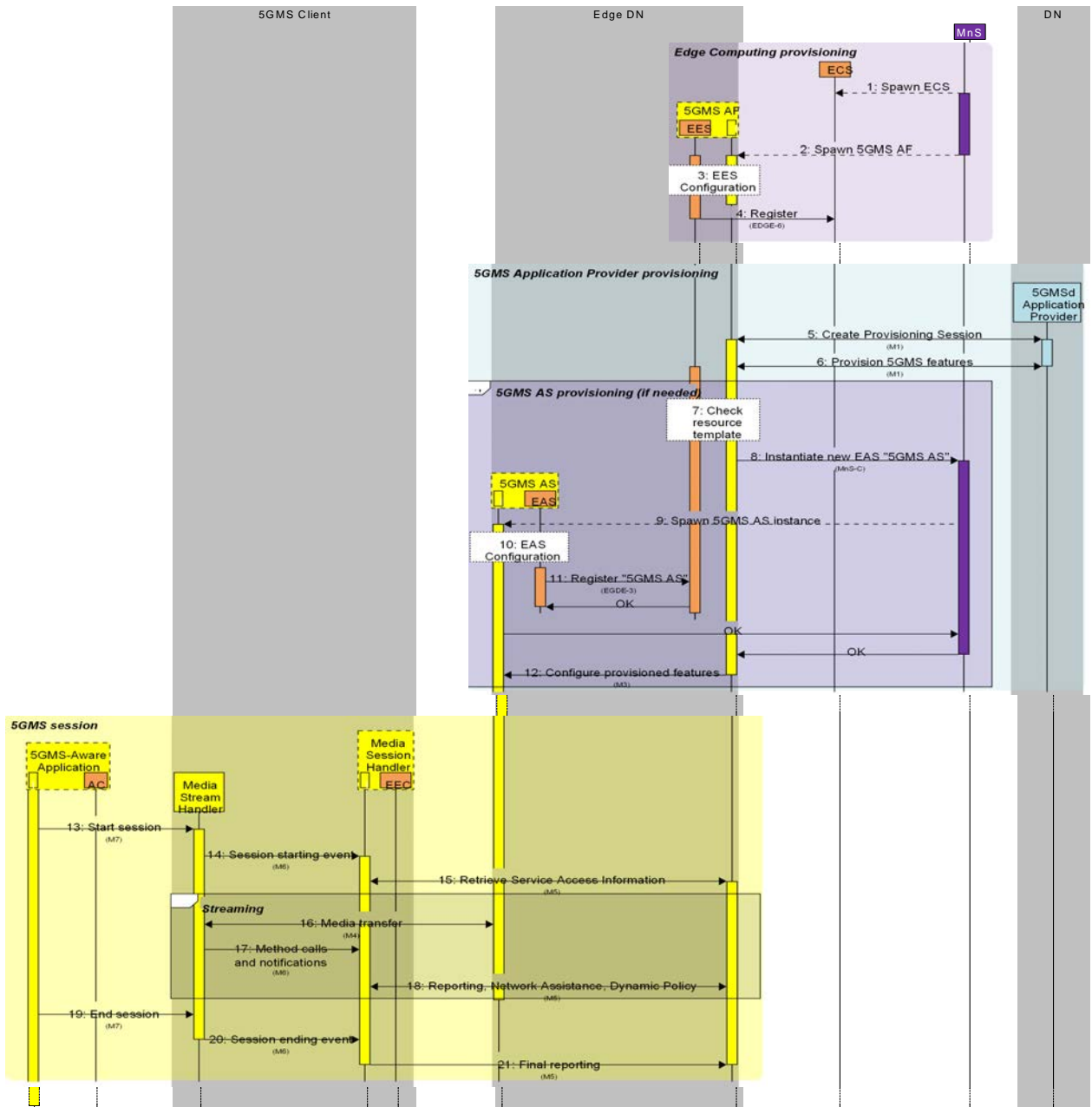

Figure 8.3.2-1: AF-driven management of 5GMS edge processing

The **Edge Computing Provisioning** phase is a provisioning phase, that may be repeated several times (e.g. to extend edge processing coverage to new geographical areas or to increase the capacity of an already provisioned area). All steps in this phase are optional and performed on need basis. Steps 1-4 are identical to those described in clause 8.1 above.

The **5GMS Application Provider Provisioning** phase is performed prior to the establishment of any related media streaming sessions by the 5GMS Application Provider. Subsequent updates to the provisioning session are possible. Steps 5-6 are identical to those described in clause 8.1 above.

The optional sub-flow to provision an additional 5GMS AS instance may be repeated multiple times on need basis to add new capacity, to increase existing capacity for edge processing or to reallocate underused edge processing resources to other tasks. The edge processing capacity is tailored for the specific 5GMS Application Provider based on the information in the Provisioning Session. Steps 7-12 are identical to steps 16-21 described in clause 8.1 above with the following exception:

- In step 7, based on the eligibility criteria in the edge resource template, the 5GMS AF shall determine whether the media streaming session is eligible to use edge resources.

After successful discovery, the actual streaming session may start in the 5GMS Session phase. Steps 13-15 are identical to steps 8-10 described in clause 8.1 above, and steps 16-21 are identical to steps 24-29.

NOTE: In this call flow, the Application Client (AC) and EEC are not used to discover the 5GMS AS location. Instead, a Media Player Entry may be provided to the Media Session Handler by the 5GMS AF in the Service Access Information at M5 (step 15), or otherwise the location of the 5GMS AS is provided directly to the 5GMS-Aware Application via (out of scope) interface M8.

## 9 Procedures for Service URL handling

### 9.1 Baseline procedure

The launch of a 5GMS session using a 3GPP Service URL (see clause 4.10) is shown in figure 9.1-1. In this procedure, the Application is not assumed to be a 5GMS-Aware Application.

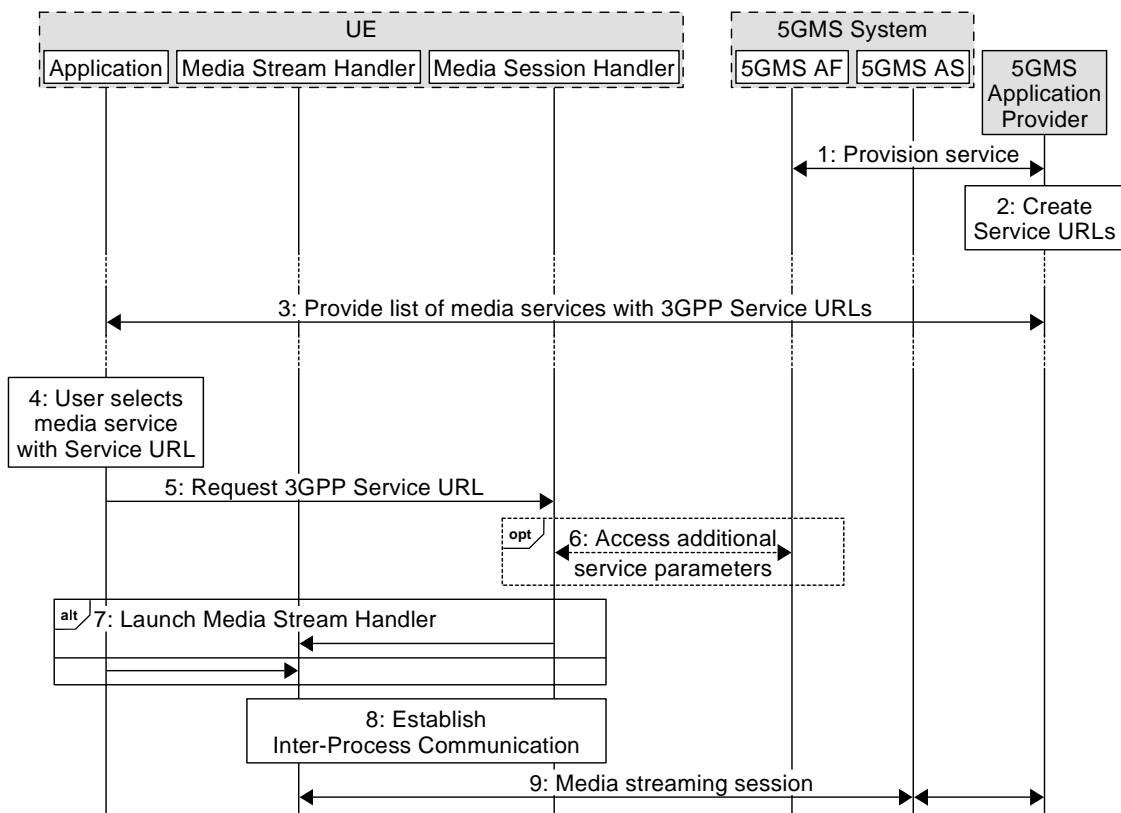

Figure 9.1-1 Baseline procedure for 3GPP Service URL Handling

The call flow is as follows:

1. The 5GMS Application Provider provisions media streaming services at reference point M1 and provides one or more *External service identifiers* to the 5GMS AF as part of the Provisioning Session.
2. The 5GMS Application Provider generates a unique 3GPP Service URL that includes one of the provisioned *External service identifiers*. Additional service announcement parameters, including a Media Entry Point URL, may also be embedded in this 3GPP Service URL.
3. The Application discovers the set of currently available media services at reference point M8.
4. The user selects a media service in the Application that is offered as a 3GPP Service URL.
5. The Application requests the 3GPP Service URL corresponding to the media service. If the Media Session Handler is available, it handles and resolves the URL.

NOTE: If the Media Session Handler is not available, the 3GPP Service URL request may be handled by the 5GMS AF as a fallback. In this case, the 5GMS AF may provide a Media Entry Point corresponding the 3GPP Service URL or reject the request.

6. The Media Session Handler may collect additional service parameters from the 5GMS AF. In particular, Service Access Information may be retrieved from the 5GMS AF using the *External service identifier* extracted from the 3GPP Service URL to identify the Provisioning Session of interest.
7. If the 3GPP Service URL requested in step 4 contains an embedded Media Entry Point URL, or if a Media Entry Point URL was obtained in step 5 or 6 the Media Session Handler launches the Media Stream Handler.

Alternatively, the Application may launch the Media Stream Handler directly itself using any Media Entry Point it obtained in preceding steps that is supported by the 5GMS Client.

8. Inter-Process Communication is established between the Media Stream Handler and the Media Session Handler.
9. Media streaming occurs between the Media Player, 5GMS AS and the 5GMS Application Provider.

---

# Annex A (informative): Usage Guidelines for collaboration scenarios

## A.0 General

This annex describes a set of collaboration scenarios and deployment options of the 5G Media Streaming architecture. The intention is to illustrate different deployment options.

Note that the scenarios focus on the ownership of the functions. Scalability realizations such as a CDN are not illustrated. As result of the scalability considerations, the M4-serving 5GMS AS and/or M5-serving 5GMS AF:

- May consist of multiple (physical) servers, which may be addressed using a single FQDN. A load balancer forwards client requests to one of these servers. Forwarding may be via HTTP redirects or transparent towards the client.
- May consist of multiple (physical) servers, where different servers, or different groups of servers, may be addressed with different FQDNs. The client may be made aware of this via the manifest (i.e. listing multiple base URLs).

NOTE: In this case the servers may be managed by the same or different parties (e.g. MNO and/or 5GMS Application Provider).

- May be addressed with a single FQDN. For example, the MNO AS is mostly transparent and acts as a proxy/cache.

NOTE: In every collaboration scenario of this Annex, any step which differs from the baseline call flow is shown in **bold text**.

---

## A.1 Downlink media streaming with AS deployed in an external Data Network (OTT)

The collaboration scenario shown in figure A.1-1 represents a typical OTT collaboration scenario, where only the 5GMSd AS is deployed and which resides in an external Data Network. In this collaboration scenario, neither the 5GMSd AF nor the Media Session Handler function of the 5GMSd Client is present/necessary for downlink media streaming operation. All Service Announcement Information is delivered at reference point M8d from the 5GMSd Application Provider to the 5GMSd-Aware Application. The latter then passes the Service Access Information contained in the service announcement to the Media Player to enable downstream media streaming session establishment and media transfer. In addition, M8d is used for UE application-level data reporting from the 5GMSd Aware Application to



the 5GMSd Application Provider. The Provisioning API (M1d') and Ingest API (M2d') may follow 5GMS specifications.

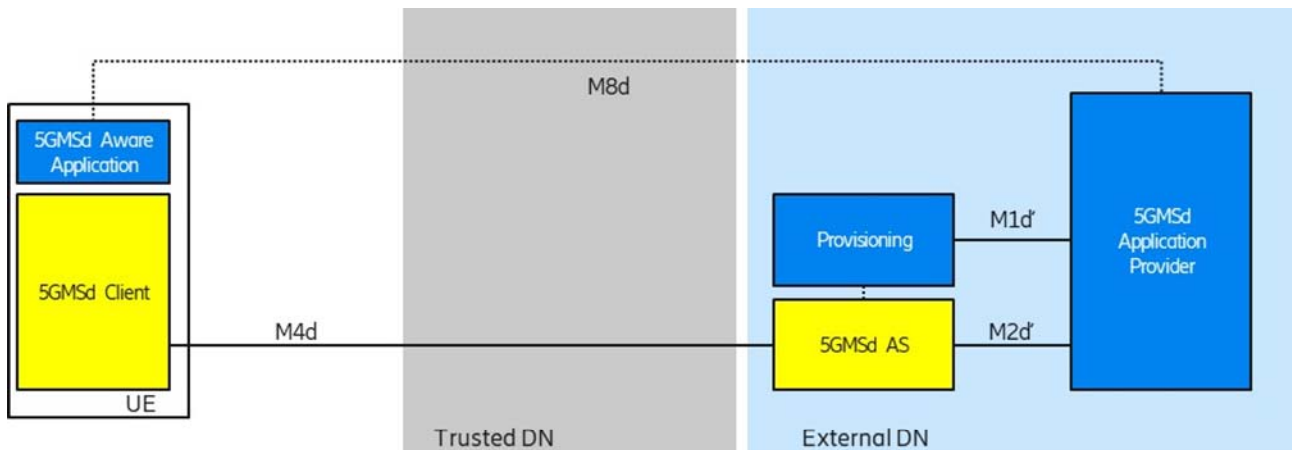

**Figure A.1-1: Downlink media streaming with AF and AS in an external Data Network**

The interfaces M1d' and M2d' may be similar to interfaces M1d and M2d respectively. Interface M4d follows 3GPP specifications.

NOTE: Although a single logical 5GMSd AS exposes both the M2d' (Ingest) and M4d (Downlink Streaming) interfaces, these APIs may, in a real deployment, be implemented on different physical servers (with different FQDNs). Furthermore, a large number of serving nodes, each with its own FQDN may offer the M4d service, following CDN scaling principles.

## A.2 Downlink media streaming with both AF and AS deployed in the trusted Data Network

This collaboration scenario shown in figure A.2-1 represents a MNO CDN scenario, where the CDN is used for ingest and delivery of the content. In this collaboration scenario, similar to that in clause A.1, the Media Session Handler is not present/necessary for downlink media streaming operation since all Service Access Information is delivered at reference point M8d from the 5GMSd Application Provider to the 5GMSd-Aware Application, and in turn the Service Access Information is passed to the Media Player. Similarly, M8d is used for UE application-level data reporting from the 5GMSd-Aware Application to the 5GMSd Application Provider. The 5GMSd AF is present in this scenario to obtain Service Access Information from the 5GMSd Application Provider (at M1d), and in turn, passes that information to the 5GMSd AS.

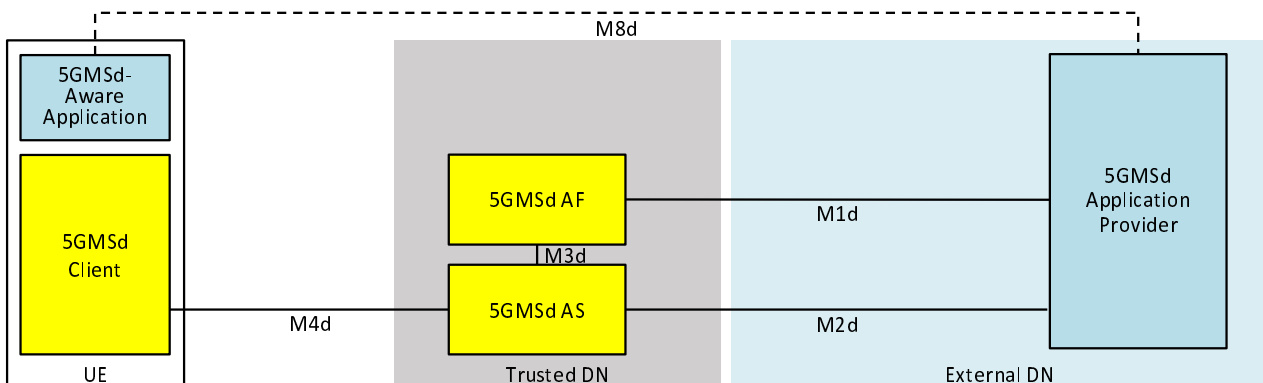

**Figure A.2-1: Downlink media streaming with AF and AS in the trusted Data Network**

### A.3 Downlink media streaming with both AF and AS deployed in an external Data Network (OTT)

The collaboration scenario shown in figure A.3-1 represents a typical OTT collaboration scenario, where the 5GMSd AF and 5GMSd AS are deployed in an external Data Network. The 5GMSd AF interacts with the NEF via N33. The Provisioning API (M1d') and Ingest API (M2d') may follow 5GMS specifications.

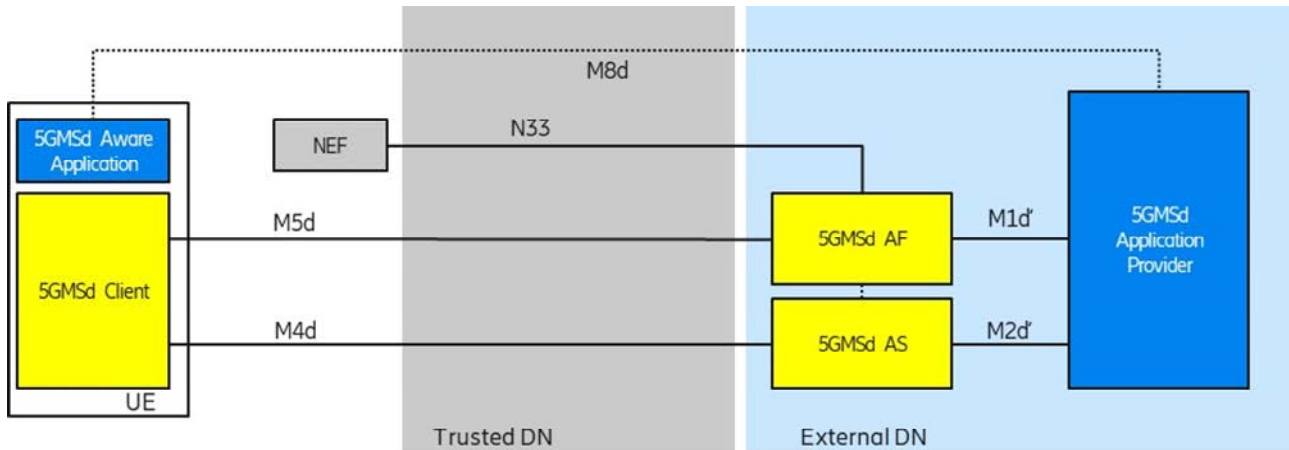

**Figure A.3-1: Downlink media streaming with AF and AS in an external Data Network (OTT)**

NOTE 1: The M5d API may be exposed using a different FQDN than the M1d' API exposing function.

NOTE 2: The M5d API may be exposed using several FQDNs, e.g. for different M5d assistance services.

### A.4 Downlink media streaming with AF deployed in the trusted Data Network and AS deployed in an external Data Network

This collaboration scenario shown in figure A.4-1 depicts a content hosting function in the external Data Network, e.g. using a third-party CDN in collaboration with MNO offered assistance and network services. The Provisioning API (M1d') and Ingest API (M2d') may follow 5GMS specifications.

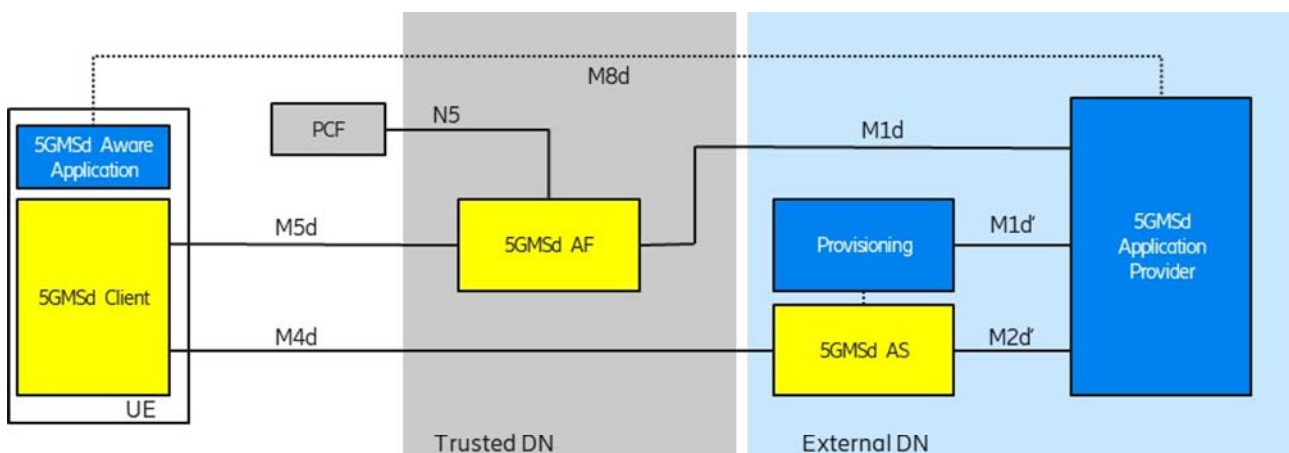
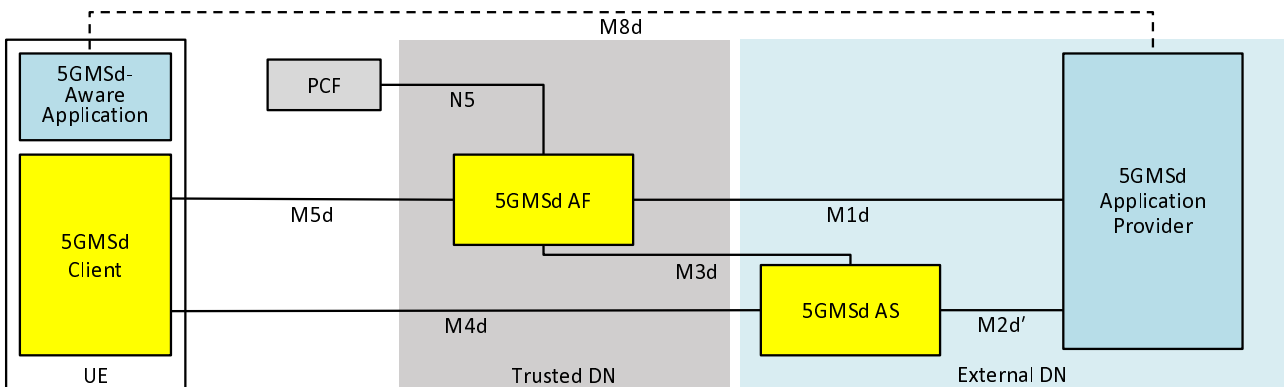

**Figure A.4-1: Downlink media streaming with AF in the trusted Data Network and AS in external Data Network**

Interfaces M1d' and M2d' may be similar to interfaces M1d and M2d respectively. Interface M4d follows 5GMS specifications.

## A.5 Downlink media streaming with AS deployed in an external Data Network, provisioned by AF deployed in the trusted Data Network

The collaboration scenario shown in figure A.5-1 is similar to that depicted in clause A.4 with the difference that the external content hosting function (5GMSd AS) is provisioned from a 5GMSd AF which is located in a trusted Data Network. It is expected that a 5GMSd AF and 5GMSd AS from different providers are interconnected using an M3d interface. The Ingest API (M2d') may follow 5GMS specifications.

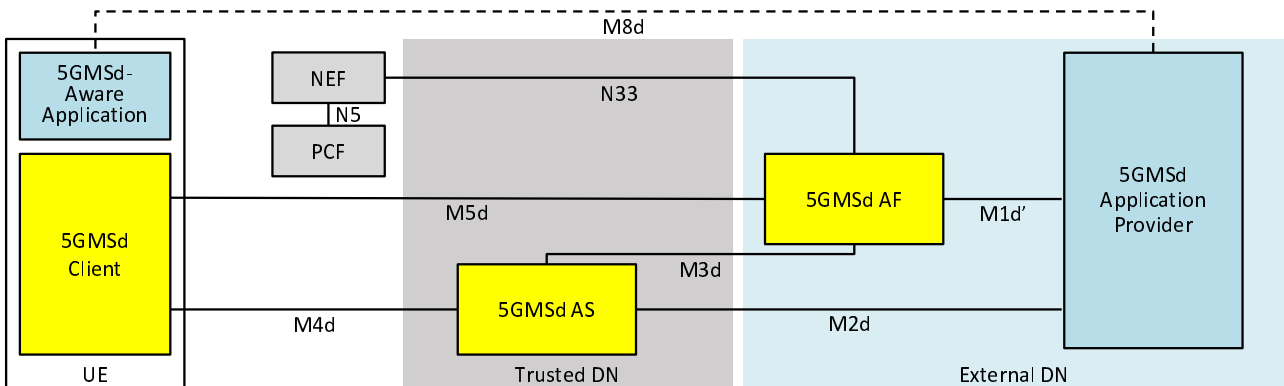

**Figure A.5-1: Downlink media streaming with AS in external Data Network, provisioned by AF in the trusted Data Network**

Interface M2d' may be similar to interface M2d. All other interfaces depicted follow 3GPP specifications.

## A.6 Downlink media streaming with AS deployed in the trusted Data Network, provisioned by AF deployed in an external Data Network

The collaboration scenario shown in figure A.6-1 is similar to those depicted in clauses A.4 and A.5 with the difference that the trusted content hosting function (5GMSd AS) is provisioned from an external 5GMSd AF. It is expected that a 5GMSd AF and 5GMSd AS from different providers are interconnected using an M3d interface. The Provisioning API (M1d') may follow 5GMS specifications. Interactions between the externally-deployed 5GMSd AF and the PCF are proxied via the NEF at reference point N33.

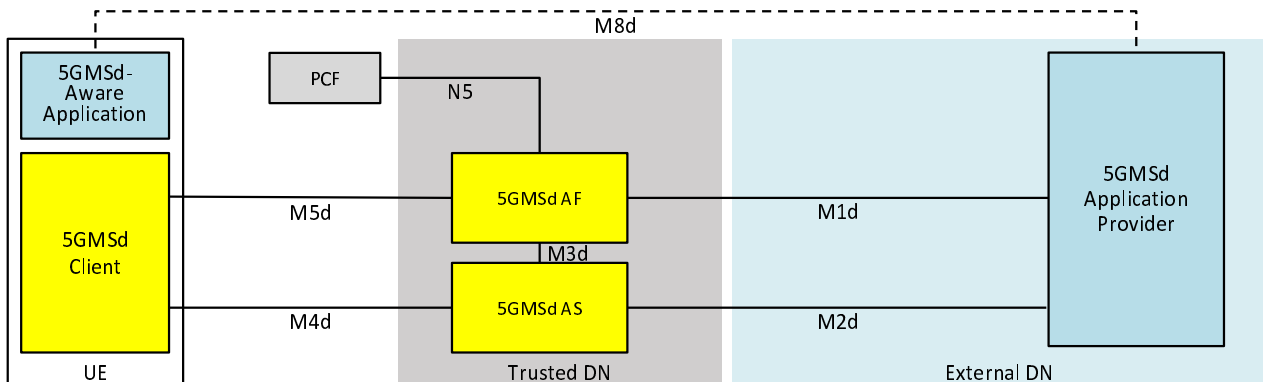

**Figure A.6-1: Downlink media streaming with AS in the trusted Data Network, provisioned by AF in external Data Network**

The interface at reference point M1d' may be similar to that defined at reference point M1d. All other interfaces depicted follow 3GPP specifications.

## A.7 Downlink media streaming with both AF and AS deployed in the trusted Data Network and AF interaction with PCF

The collaboration scenario shown in figure A.7-1 represents a MNO CDN scenario (similar to that in clause A.2) where the CDN is used for ingest and delivery of the content. Additional 5GMS features are used which require interaction with the PCF.



**Figure A.7-1: Downlink media streaming with AF and AS in the trusted Data Network**

## A.8 Downlink media streaming with AFs deployed in two separate trusted Data Networks sharing AS in an external Data Network

The collaboration scenario shown in figure A.8-1 represents a multi-MNO distribution scenario where an external CDN (5GMSd AS) is used to deliver content through multiple 5GMSd capable PLMNs. Additional 5GMSd features are used from the serving 5GMS System which need interactions with the PCF of the serving PLMN. The Provisioning API (M1d') and Ingest API (M2d') may follow 5GMS specifications.

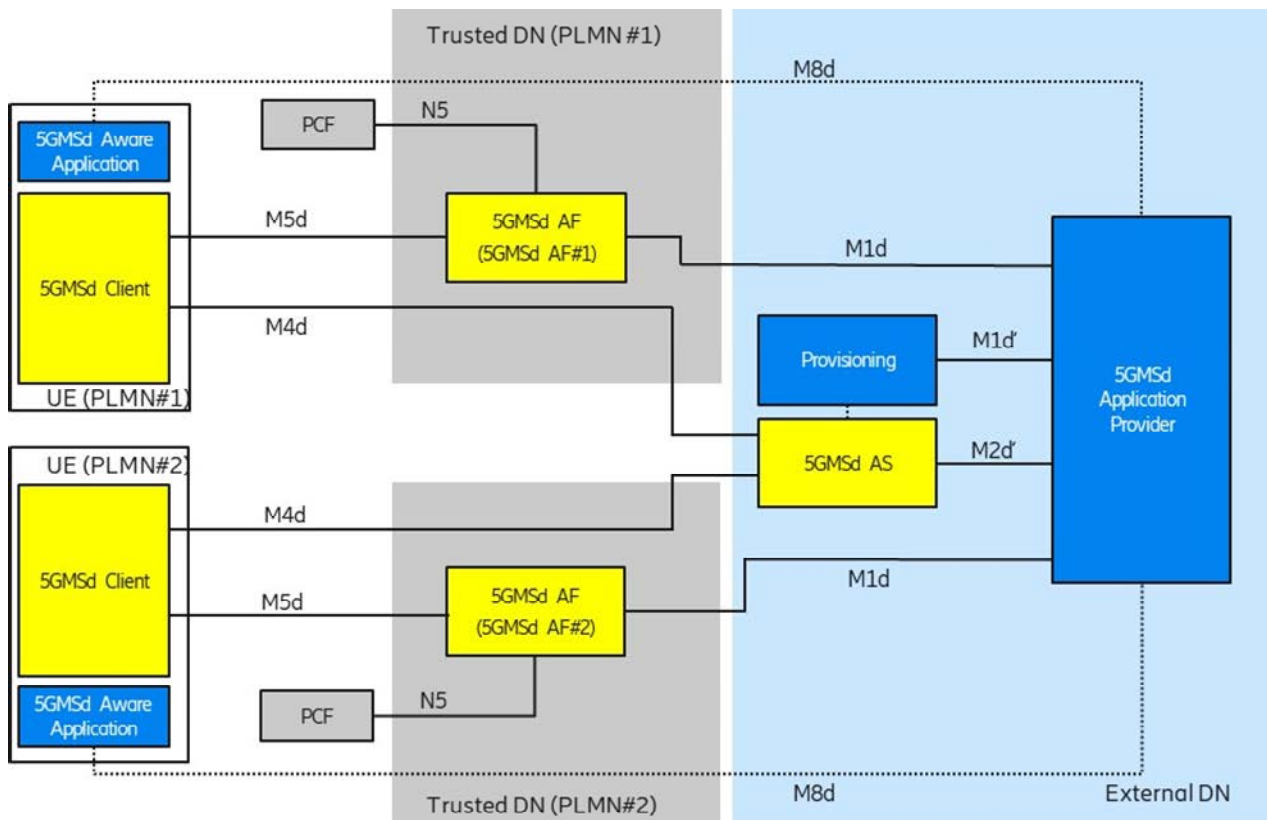

**Figure A.8-1: Downlink media streaming with AFs in two trusted Data Networks sharing AS in external Data Network**

## A.9 Downlink media streaming with both AF and AS deployed in external Data Network and AS delivering content through two trusted Data Networks (OTT)

This collaboration scenario shown in figure A.9-1 represents a multi-MNO distribution scenario where an external CDN (5GMSd AS) is used to deliver content through multiple 5GMSd-capable PLMNs. Additional 5GMSd features are used from the serving 5GMS System which need interactions with the NEF of the serving PLMN. The Provisioning API (M1d') and Ingest API (M2d') may follow 5GMS specifications.

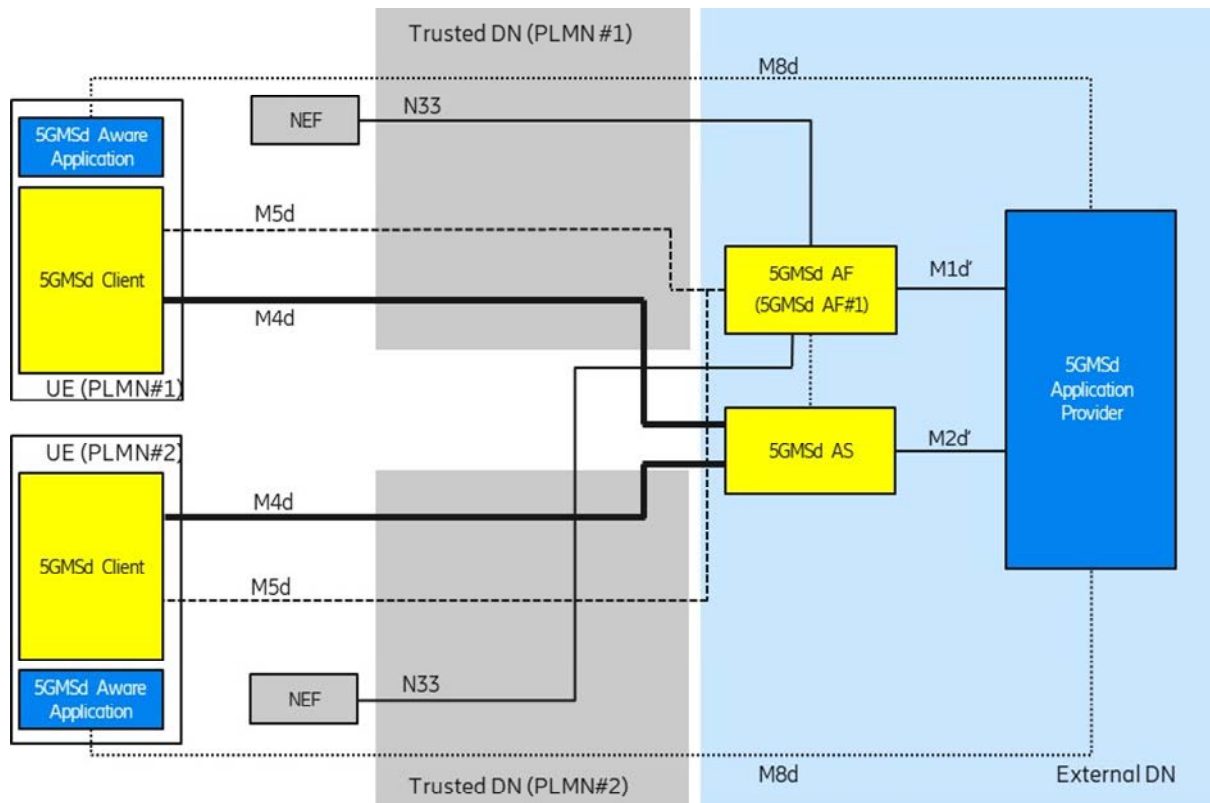

Figure A.9-1: Downlink media streaming with AF and AS in external Data Network delivering through two trusted Data Networks (OTT)

## A.10 Uplink media streaming using content preparation with both AF and AS deployed in the trusted Data Network

In this collaboration scenario shown in figure A.10-1, both the 5GMSu AS and 5GMSu reside in the trusted Data Network. Additionally, reference point M2u is used for content egest to the external 5GMSu Application Provider.

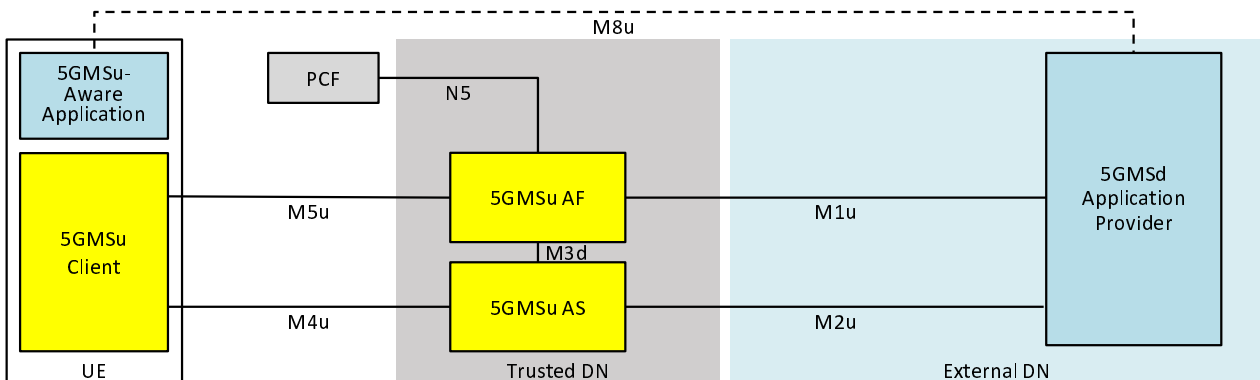
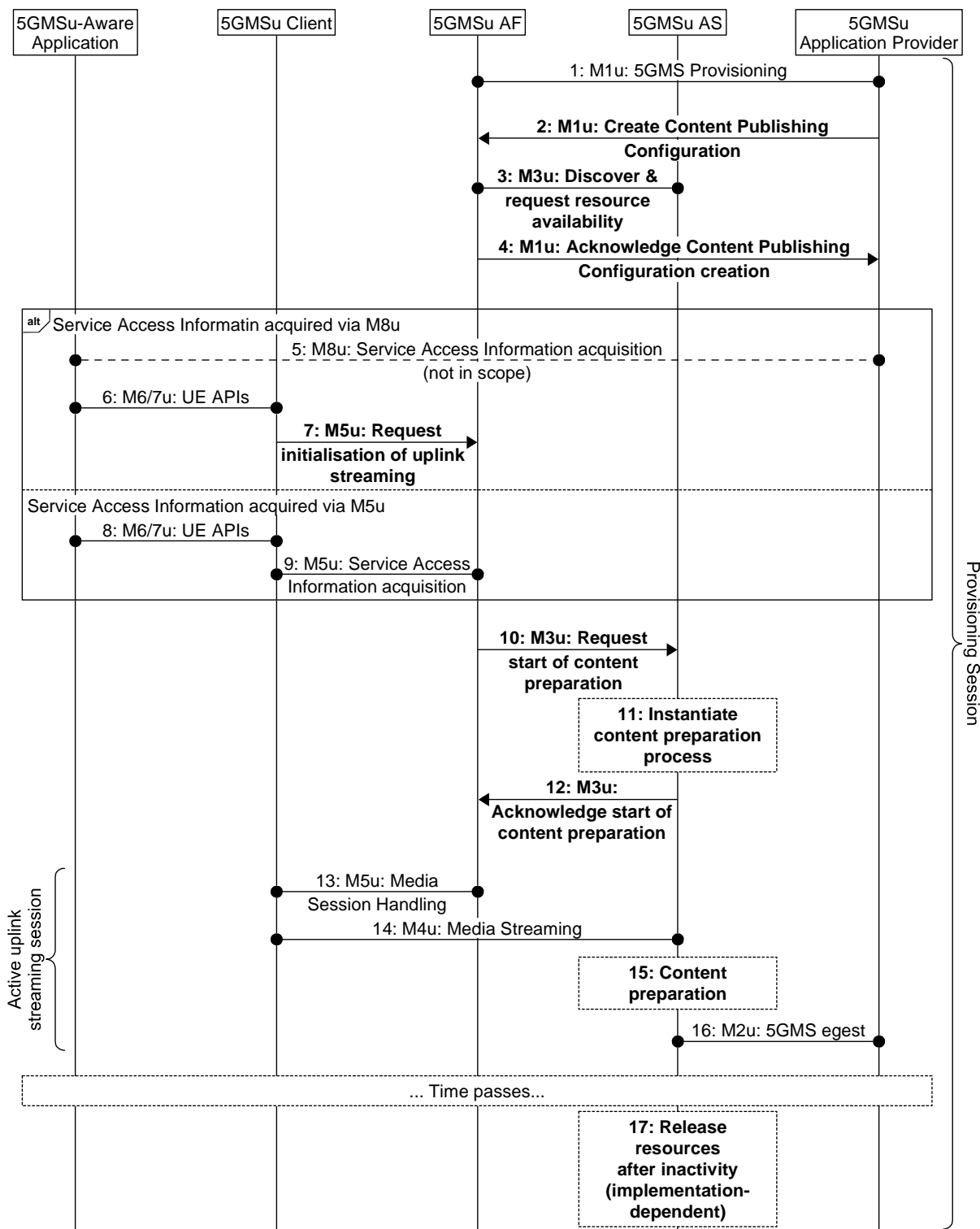

Figure A.10-1: Uplink media streaming with AF and AS in trusted Data Network

Figure A.10-2 provides a high-level call flow for this collaboration scenario.



<https://gitlab.com/msc-generator v8.0>

Figure A.10-2: Call flow for uplink media streaming using content preparation with AF and AS in trusted Data Network

Steps:

1. The 5GMSu Application Provider creates a Provisioning Session with the 5GMSu AF.
2. **The 5GMSu Application Provider requests the 5GMSu AF to create one Content Publishing Configuration that defines the instructions for content egest (M1u).**
3. **The 5GMSu AF, based on the received Content Publishing Configuration, requests the 5GMSu AS to confirm the availability of content resources for content preparation (M3u).**
4. **The 5GMSu AF acknowledges the successful creation of the Content Publishing Configuration to the 5GMSu Application Provider (M1u).**

At some later point in time:

5. The 5GMSu Application Provider provides Service Access Information to the 5GMS-Aware Application at reference point M8u.
6. The 5GMS-Aware Application requests the 5GMSu Client to start an uplink streaming session (M6u/M7u).
7. **The 5GMSu Client requests that the 5GMSu AF initialises uplink media streaming, including any content preparation required by the Content Publishing Configuration (M5u).**

Alternatively:

8. The 5GMS-Aware Application requests the 5GMSu Client to start an uplink streaming session (M6u/M7u).
9. The 5GMSu Client requests Service Access Information from the 5GMSu AF at reference point M5u.

As a consequence:

10. **The 5GMSd AF requests initialisation of the content preparation process by the 5GMSd AS (M3u).**
11. **The 5GMSd AS initialises the content preparation process, if it is not already running.**
12. **The 5GMSd AF acknowledges the initialisation of the content preparation process (M3u).**

Then:

13. The 5GMSu Client performs media session handling for the uplink streaming session (M5u).
14. Uplink media streaming starts from the 5GMSu Client to the 5GMSu AS (M4u).
15. **If content preparation was successfully initialized at step 11 or before, the uplinked media may be manipulated by the 5GMSu AS prior to egest.**
16. Media streaming egest starts from the 5GMSu AS to the 5GMSu Application Provider (M2u).

Finally:

17. **The 5GMSu AS releases its resources after observing a period of interactivity.**

NOTE: This step is implementation dependent.



## A.11 Uplink media streaming using content preparation (media plane only) with both AF and AS deployed in the trusted Data Network

This scenario pertains to a collaboration in the uplink media plane only for which the 5GMSu AS is deployed in the trusted Data Network. Here, the 5GMS System is assumed to offer uplink streaming capabilities as a service to an external 5GMSu Application Provider. This collaboration scenario is analogous to the scenario in clause A.2 in terms of the use of M8u (as opposed to M8d in clause A.2) for the delivery of Service Access Information from the 5GMSu Application Provider to the 5GMSu Client via the 5GMSu Aware Application, and the reporting of UE application data from the 5GMSu-Aware Application to the 5GMSu Application Provider.

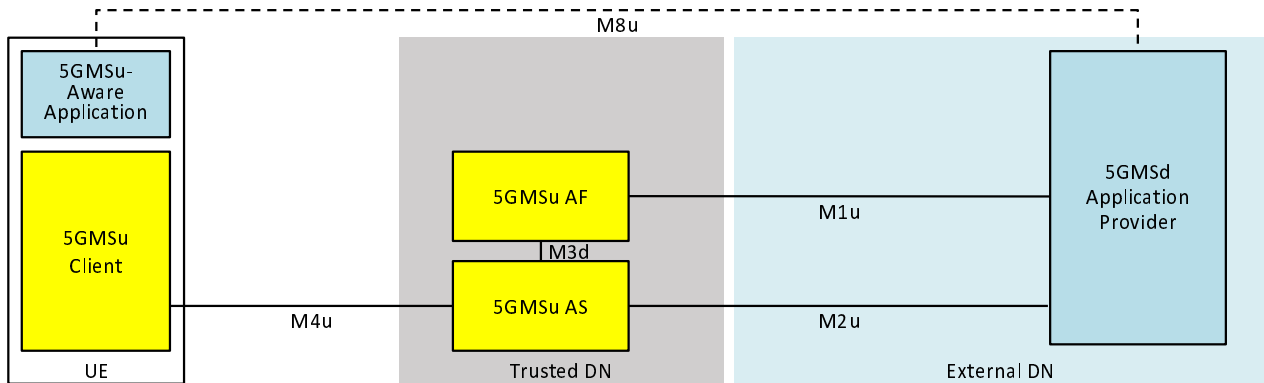

NOTE: Although provisioning at reference point M1u is shown between the (external) 5GMSu Application Provider and the 5GMSu AF, due to the absence of reference point M5u in this collaboration, there is no control interaction between the 5GMSu Client and the 5GMS System during an uplink streaming session.

Figure A.11-1: Uplink media streaming (media plane only) with AF and AS in the trusted Data Network

Figure A.11-2 provides a high-level call flow for this collaboration scenario.

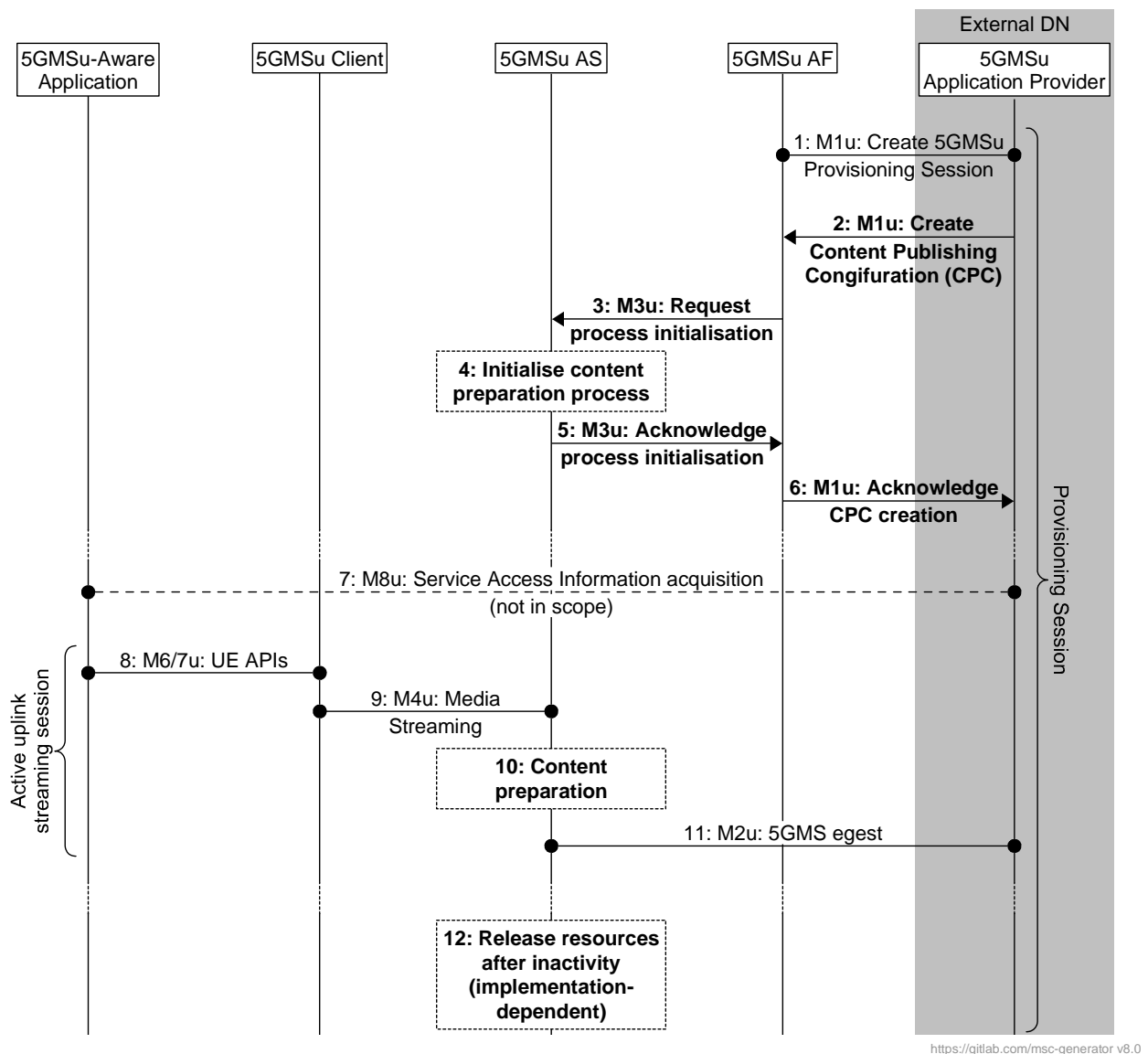

**Figure A.11-2: Uplink media streaming using content preparation (media plane only) with AF and AS in the trusted Data Network**

Steps:

1. The 5GMSu Application Provider creates a Provisioning Session for uplink streaming with the 5GMSu AF.
2. The 5GMSu Application Provider creates a Content Publishing Configuration as part of the Provisioning Session that defines the instructions for content egest (M1u).
3. The 5GMSu AF, based on the received Content Publishing Configuration, requests the 5GMSu AS to instantiate the content preparation process (M3u).
4. The 5GMSu AS initialises the content preparation process.
5. The 5GMSu AS acknowledges the initialisation of the required process (M3u).
6. The 5GMSu AF acknowledges the successful creation of the Content Publishing Configuration to the 5GMSu Application Provider (M1u).

At some later point in time:

7. The 5GMSu Application Provider optionally provides Service Access Information to the 5GMS-Aware Application (M8).
8. The 5GMS-Aware Application requests the 5GMSu Client to start an uplink streaming session (M6u/M7u).
9. Uplink media streaming starts from the 5GMSu Client to the 5GMSu AS (M4u).
- 10. If content preparation was initialized in step 4, the uplinked media may be manipulated by the 5GMSu AS prior to egest.**
11. Media streaming egest starts from the 5GMSu AS to the 5GMSu Application Provider (M2u).

Finally:

- 12. The 5GMSu AS releases its resources after observing a period of inactivity.**

NOTE: This step is implementation-dependent.

## A.12 Uplink media streaming using content preparation (media plane only) with provisioning and AS in the external domain

This scenario pertains to a media plane only collaboration for which the 5GMSu AS is deployed in the external domain and the 5GMSu AF is not involved. Specifically, reference points M1' and/or M2u' do not follow 3GPP specifications. This collaboration scenario is analogous to the scenario in A.1 in that neither the 5GMSu AF nor the Media Session Handler function of the 5GMSu Client is present/necessary for uplink media streaming operation. Similar to the collaboration scenario in A.11, M8u is used for the delivery of Service Access Information from the 5GMSu Application Provider to the 5GMSu Client via the 5GMSu Aware Application, and the reporting of UE application data from the 5GMSu Aware Application to the 5GMSu Application Provider. The Provisioning API (M1u') and Ingest API (M2u') may follow 5GMS specifications.

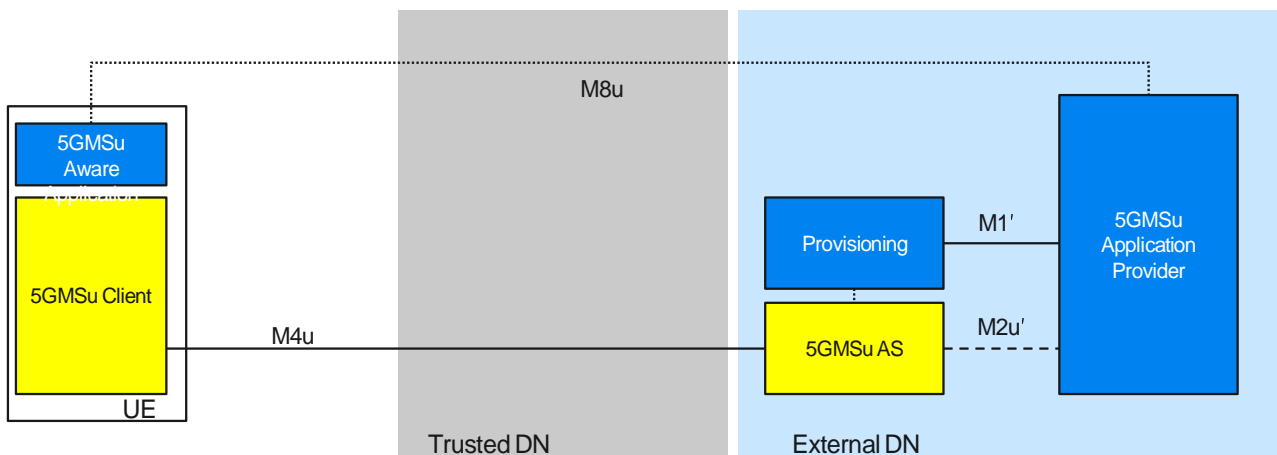

**Figure A.12-1: Uplink media streaming (media plane only) with provisioning and AS in the external domain**

Figure A.12-2 provides a high-level call flow for this collaboration scenario.

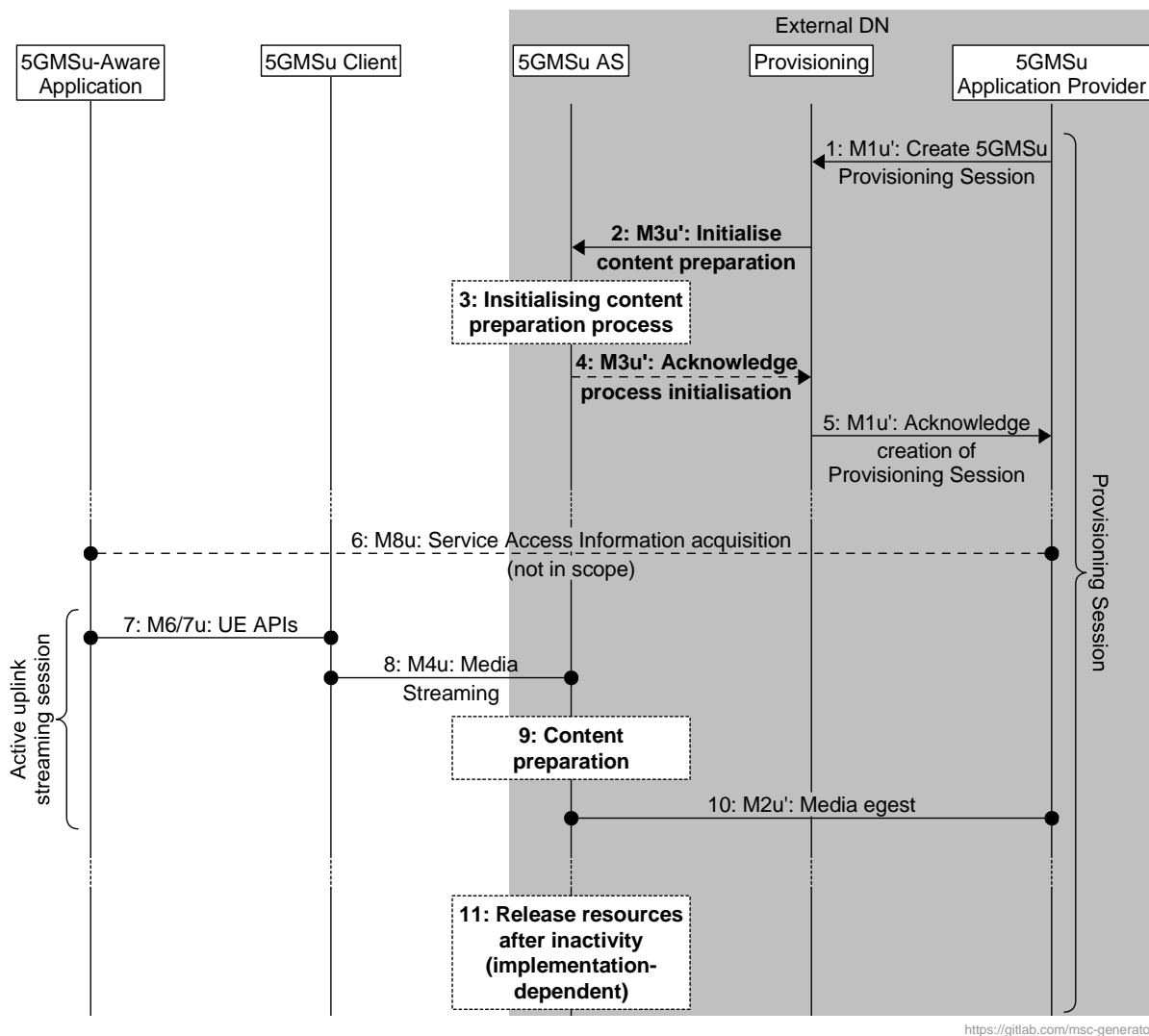

<https://gitlab.com/msc-generator/v8.0>

**Figure A.12-2: Call flow for Uplink media streaming using content preparation (media plane only) with provisioning and AS in the external domain**

Steps:

1. The 5GMSu Application Provider creates a Provisioning Session for uplink streaming with the 5GMSu AF (M1u').
2. **The Provisioning function requests the 5GMSu AS to initialise the required content preparation process (M3u').**
3. **The 5GMSu AS initialises the content preparation process.**
4. **The 5GMSu AS acknowledges the initialisation of the required process (M3u').**
5. The Provisioning function acknowledges the successful creation of the Provisioning Session to the 5GMSu Application Provider (M1u').

At some later point in time:

6. The 5GMSu Application Provider provides Service Access Information to the 5GMS-Aware Application (M8).
7. The 5GMS-Aware Application requests the 5GMSu Client to start an uplink streaming session (M6u/M7u).
8. Uplink media streaming starts from the 5GMSu Client to the 5GMSu AS (M4u).

9. If content preparation was initialized in step 3, the uplinked media may be manipulated by the 5GMSu AS prior to egest.

10. Media streaming egest starts from the 5GMSu AS to the 5GMSu Application Provider (M2u).

Finally:

11. The 5GMSu AS releases its resources after observing a period of inactivity.

NOTE: This step is implementation-dependent.

## A.13 Uplink media streaming using content preparation with AF in the trusted Data Network and AS in the external domain

In this collaboration scenario, both the 5GMSu AS and 5GMSu AF are present. The 5GMSu AS resides in the external domain. While it employs 5GMS protocol and format for uplink media reception from the 5GMSu Client (M4u), norit performs content egest to the 5GMSu Application Provider over a M2u-like (M2u') protocol and format (and therefore it is called 5GMSu-like AS). The 5GMSu AF is used to interact with the 5GMSu Application Provider at the reference point M1 for uplink media streaming provisioning System, and to interact with the Media Session Handler of the 5GMSu Client for providing Service Access Information, dynamic policy invocation and/or other uplink media streaming related functionality such as metrics reporting and network assistance). The Provisioning API (M1u') and Ingest API (M2u') may follow 5GMS specifications.

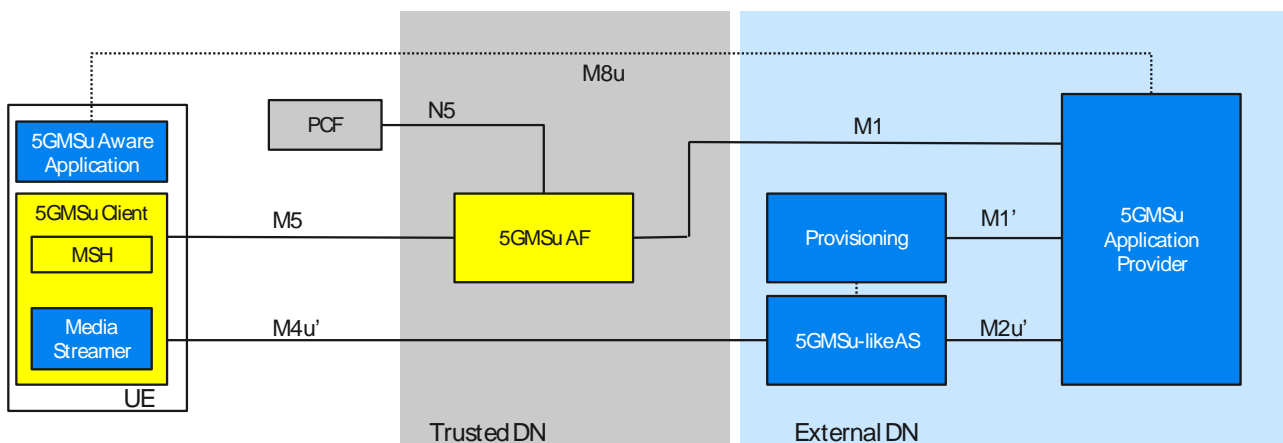
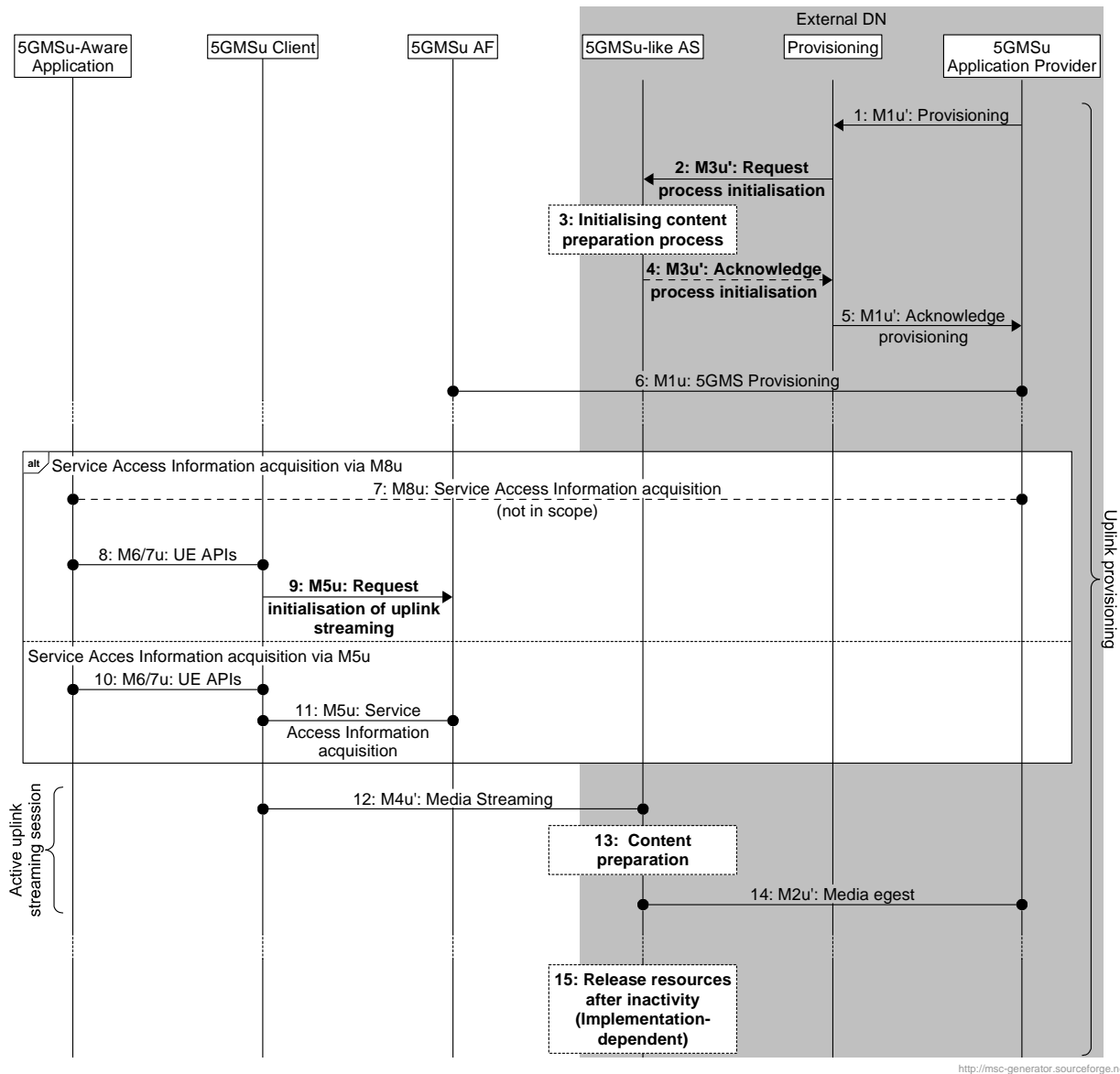

Figure A.13-1: Uplink media streaming AF in the trusted Data Network and AS in the external domain

Figure A.13-2 provides a high-level call flow for this collaboration scenario.



<http://msc-generator.sourceforge.net v7.2>

**Figure A.13-2: Call flow for uplink media streaming using content preparation with AF in the trusted Data Network and AS in the external domain**

Steps:

1. The 5GMSu Application Provider creates a Provisioning Session with its internal Provisioning function (M1u').
2. **The Provisioning function requests the 5GMSu-like AS to initialise the required content preparation process instantiation (M3u').**
3. **The 5GMSu-like AS instantiates the content preparation process.**
4. **The 5GMSu-like AS acknowledges the Provisioning the instantiation of required process (M3u').**
5. The Provisioning function acknowledges successful provisioning to the 5GMSu Application Provider (M1u').
6. The 5GMSu Application Provider creates a Provisioning Session for uplink streaming with the 5GMSu AF.

At some later point in time:

7. The 5GMSu Application Provider provides Service Access Information to the 5GMS-Aware Application at reference point M8u.

8. The 5GMS-Aware Application requests the 5GMSu Client to start an uplink streaming session (M6u/M7u).

**9. The 5GMSu Client requests that the 5GMSu AF initialises uplink media streaming (M5u).**

NOTE: This step is redundant in this collaboration, but occurs in order that other collaborations are supported.

Alternatively:

10. The 5GMS-Aware Application requests the 5GMSu Client to start an uplink streaming session (M6u/M7u).

11. The 5GMSu Client requests Service Access Information from the 5GSMu AF at reference point M5u.

At some later point in time:

12. Uplink media streaming starts from the 5GMSu Client to the 5GMSu-like AS (M4u').

**13. If content preparation was initialized in step 3, the uplinked media may be manipulated by the 5GMSu AS prior to egest.**

14. Media streaming egest starts from the 5GMSu-like AS to the 5GMSu Application Provider (M2u').

Finally:

**15. The 5GMSu AS releases its resources after observing a period of inactivity.**

NOTE: This step is implementation dependent.

## A.14 Uplink media streaming using content preparation with AF and AS in the external domain

In this collaboration scenario, both the 5GMSu AS and 5GMSu AF are present and follow 3GPP specifications. Both the 5GMSu AS and 5GMSu AF reside in the external DN/domain. The Provisioning API (M1u') and Ingest API (M2u') may follow 5GMS specifications.

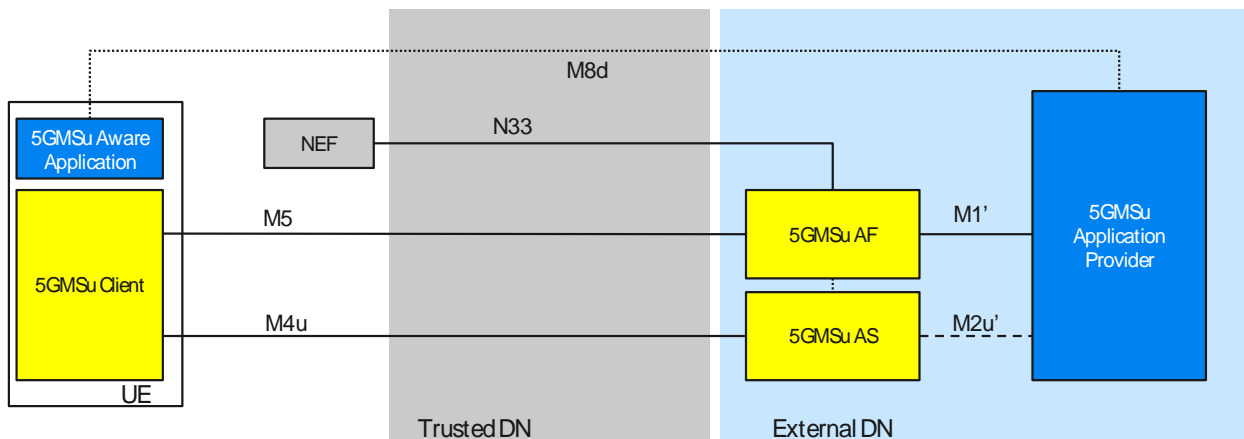
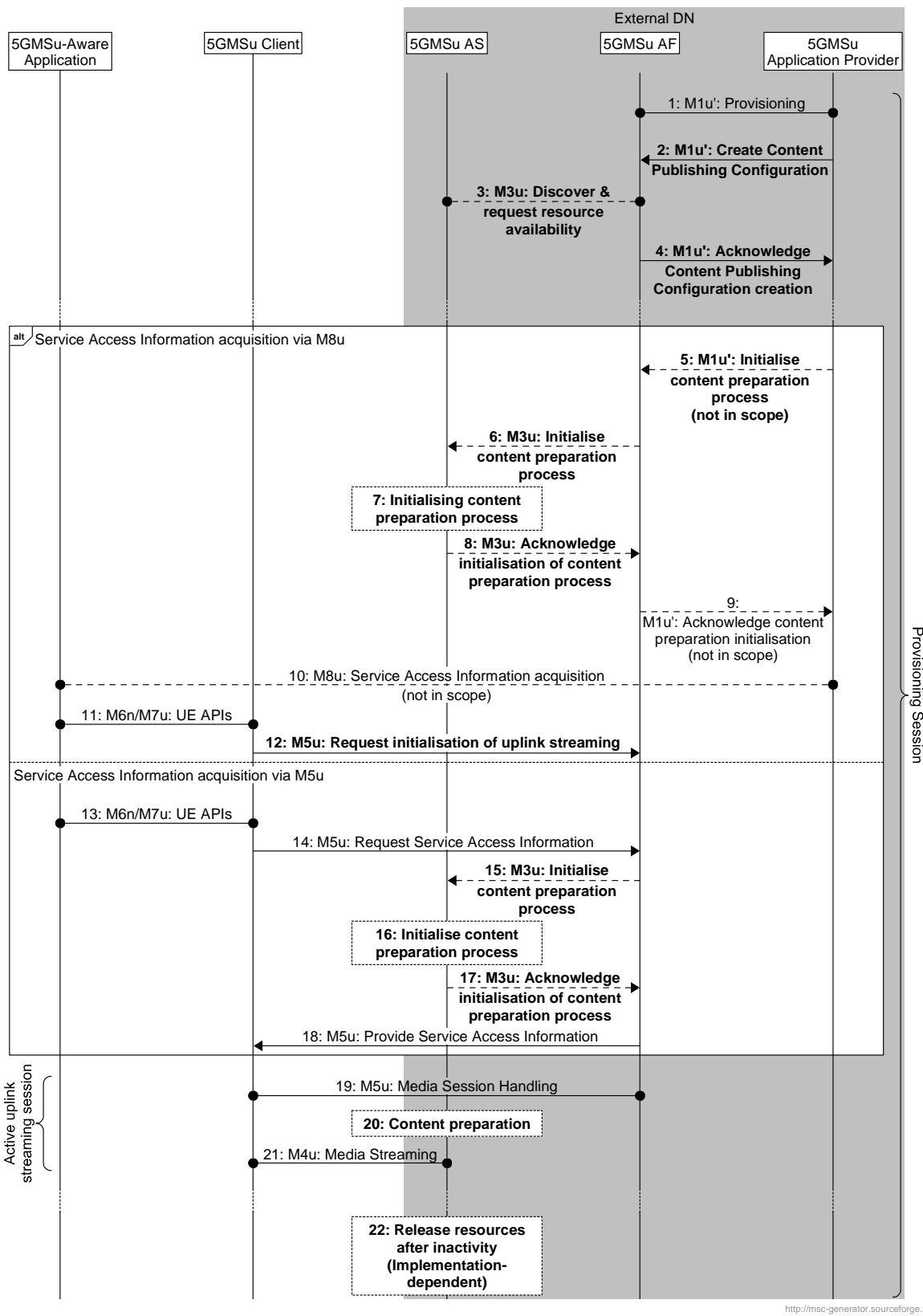

Figure A.13-1: Uplink media streaming with AF and AS in the external domain

Figure A.14-2 provides a high-level call flow for this collaboration scenario.



<http://msc-generator.sourceforge.net v7.2>

Figure A.14-2: Call flow for uplink media streaming using content preparation with AF and AS in the external domain



Steps:

1. The 5GMSu Application Provider creates a Provisioning Session for uplink streaming with the 5GMSu AF (M1u').
2. **The 5GMSu Application Provider creates a Content Publishing Configuration as part of the Provisioning Session that defines the instructions for content egest (M1u').**
3. **The 5GMSu AF, based on the received publishing configuration, requests the 5GMSu AS to confirm the availability of content resources for egest (M3u).**
4. **The 5GMSu AF acknowledges the successful creation of the Content Publishing Configuration to the 5GMSu Application Provider (M1u').**

At some later point in time:

5. **The 5GMSu Application Provider requests that the 5GMSu AF initialises the content preparation process (M1u').**
6. **The 5GMSd AF requests initialisation of the content preparation process (M3u).**
7. **The 5GMSd AS initialises the content preparation process, if is not already running (M3u).**
8. **The 5GMSd AS acknowledges the initialisation of the content preparation process (M3u).**
9. **The 5GMSu AF acknowledges the initialisation of the content preparation process (M1u').**
10. The 5GMSu Application Provider provides Service Access Information to the 5GMS-Aware Application (M8).
11. The 5GMS-Aware Application requests the 5GMSu Client to start an uplink streaming session (M6u/M7u).
12. **The 5GMSu Client requests that the 5GMSu AF initialises uplink media streaming (M5u).**

NOTE: This step is redundant in this collaboration, but occurs in order that other collaborations are supported.

Alternatively:

13. The 5GMS-Aware Application requests the 5GMSu Client to start an uplink streaming session (M6u/M7u).
14. The 5GMSu Client requests Service Access Information from the 5GMSu AF (M5u).
15. **The 5GMSd AF requests initialisation of the content preparation process (M3u).**
16. **The 5GMSd AS initialises the content preparation process, if is not already running (M3u).**
17. **The 5GMSd AF acknowledges the initialisation of the content preparation process (M3u).**
18. The 5GMSu AF provides Service Access Information to the 5GMSu Client (M5u).

Then:

19. Uplink media streaming starts from the 5GMSu Client to the 5GMSu AS via reference point M4u.
20. **If content preparation was initialized in step 7 or 16, the uplinked media may be manipulated by the 5GMSu AS prior to egest.**
21. Media streaming egest starts from the 5GMSu AS to the 5GMSu Application Provider (M2u').

Finally:

22. **The 5GMSu AS releases its resources after observing a period of inactivity.**

NOTE: This step is implementation-dependent.

# A.15 Cascaded uplink and downlink media streaming using content preparation

## A.15.1 Introduction

This scenario represents a hybrid end-to-end form of collaboration across uplink media streaming and downlink media streaming services. An external 5GMS Application Provider relies on the 5GMS System to support both the uplink streaming media transmission by 5GMSu Clients and subsequent redistribution of that content via downlink media streaming for reception by 5GMSd Clients within the same 5GMS System.

Two distinct methods are described in the following clauses.

- In the first method (clause A.15.2) the content contributed to the 5GMSu AS using uplink media streaming is transferred indirectly to the 5GMSd AS via a 5GMS Application Provider for redistribution using downlink media streaming.
- In the second method (clause A.15.3) the content contributed to the 5GMSu AS using uplink media streaming is transferred directly from the 5GMSu AS to the 5GMSd AS without any intermediary.

These two methods are not mutually exclusive. For example, content transferred using the second method may also be egested to a 5GMSu Application Provider for subsequent redistribution by other 5GMS Systems and/or non-3GPP distribution systems.

## A.15.2 Cascaded uplink and downlink media streaming using content preparation with external content re-ingestion

In a first variant of this collaboration scenario, content contributed to the 5GMS System by the 5GMSu Client is egested by the 5GMSu AS at reference point M2u (by either push- or pull-based means) and subsequently ingested by the 5GMSd AS from the 5GMS Application Provider at reference point M2d (by either push- or pull-based means).

NOTE: For redistribution with the lowest possible latency, the provisioning of both push-based egest and push-based ingest are recommended.

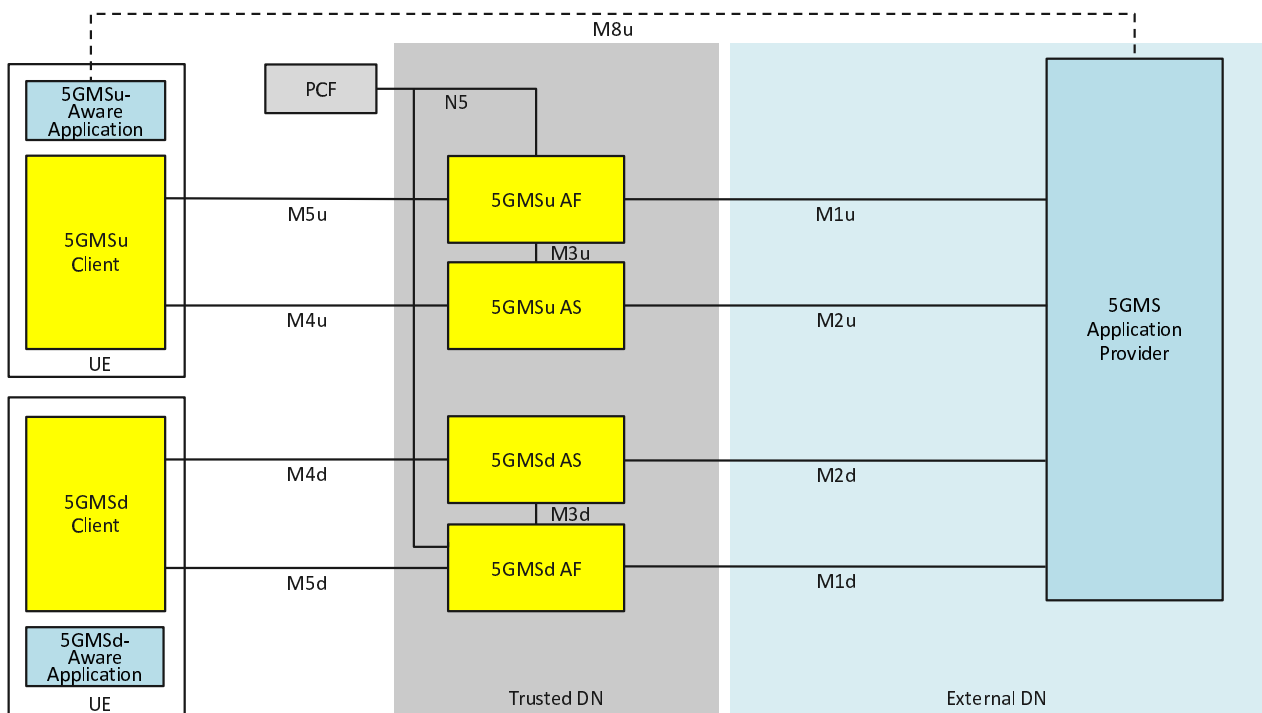
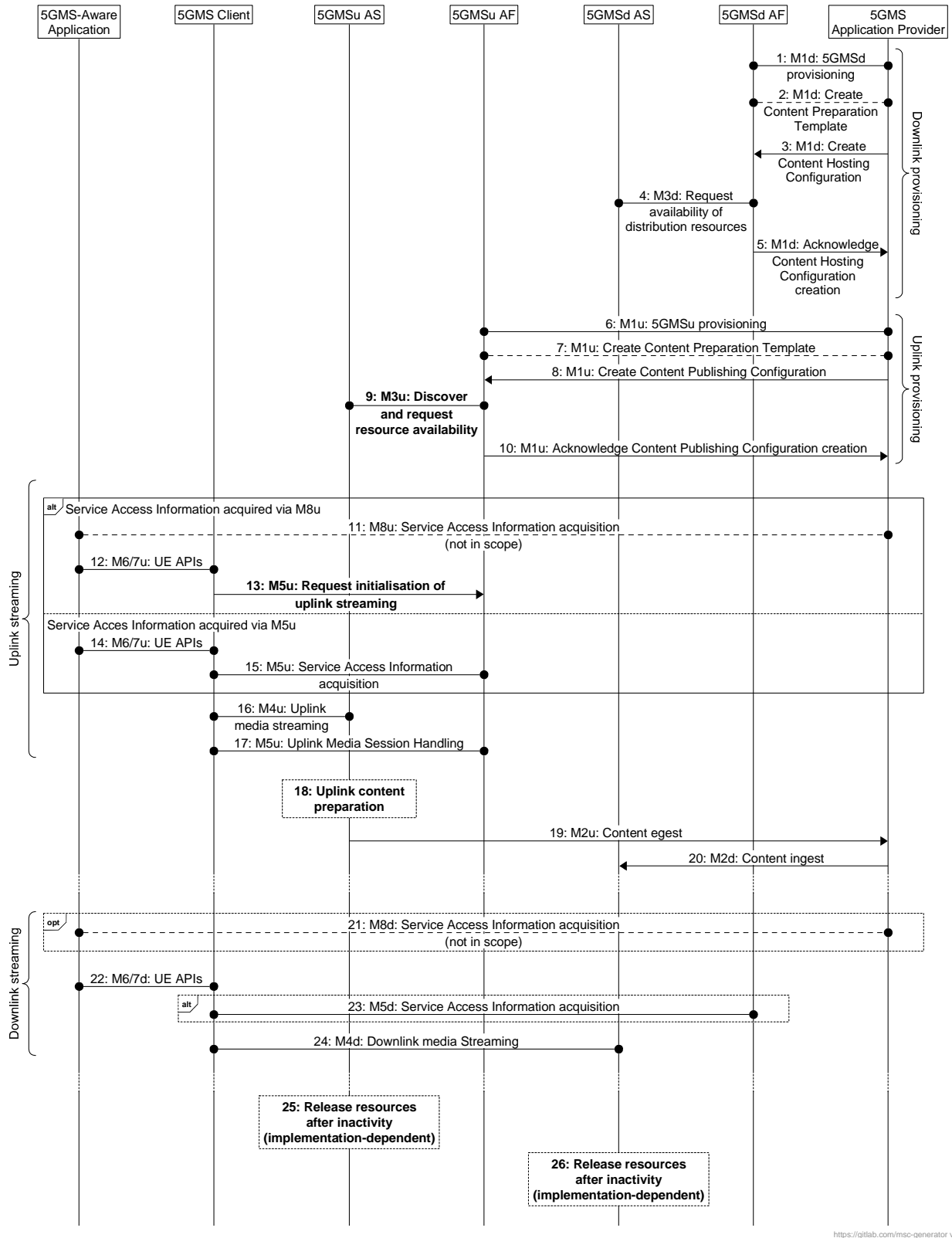

Figure A.15.2-1: Cascaded uplink and downlink media streaming with external content re-ingestion

Figure A.15.2-2 shows the call flow for this scenario. (To simplify the call flow, the details of the content preparation process are omitted.)



<https://gitlab.com/msc-generator/v8.4>

**Figure A.15.2-2: Call flow for cascaded uplink and downlink media streaming using content preparation with external content re-ingestion**

Steps:

1. The 5GMSd Application Provider creates a Provisioning Session with the 5GMSd AF (M1d).

2. The 5GMS Application Provider may provision the 5GMSd AF with a Content Preparation Template (M1d).
3. The 5GMSd Application Provider provisions the 5GMSd AF with a Content Hosting Configuration. The ingest configuration indicates that content will be ingested from the 5GMS Application Provider by either pull- or push-based means. If a Content Preparation Template was provisioned in the previous step, the Content Hosting Configuration may reference it.
4. The 5GMSd AF, based on the provisioned Content Hosting Configuration and Content Preparation Template, requests the 5GMSd AS to confirm the availability of content distribution resources (M3d).
5. The 5GMSd AF acknowledges to the 5GMSd Application Provider the successful creation of the Content Hosting Configuration (M1d).
6. The 5GMS Application Provider creates a Provisioning Session with the 5GMSu AF (M1u).
7. The 5GMS Application Provider may provision the 5GMSu AF with a Content Preparation Template (M1u).
8. The 5GMS Application Provider provisions the 5GMSu AF with a Content Publishing Configuration (M1u). The egest configuration indicates that contributed content will be made available to the 5GMS Application Provider by either pull- or push-based means. If a Content Preparation Template was provisioned in the previous step, the Content Publishing Configuration may reference it.
- 9. The 5GMSu AF, based on the provisioned Content Hosting Configuration and Content Preparation Template (if any) requests the 5GMSu AS to confirm the availability of content contribution resources (M3u).**
10. The 5GMSu AF acknowledges successful provisioning to the 5GMSu Application Provider (M1u).

NOTE: In this variant of the collaboration scenario the order of downlink media streaming provisioning (steps 1–5) and uplink media streaming provisioning (steps 6–10) may be reversed.

At some later point in time:

11. The 5GMSu Application Provider provides Service Access Information for uplink media streaming to the 5GMSu-Aware Application at reference point M8u.
12. The 5GMSu-Aware Application requests the 5GMSu Client to start an uplink streaming session (M6u/M7u).
- 13. The 5GMSu Client requests that the 5GMSu AF initialises uplink media streaming (M5u).**

Alternatively:

14. The 5GMSu-Aware Application requests the 5GMSu Client to start an uplink streaming session (M6u/M7u).
15. The 5GMSu Client requests Service Access Information from the 5GMSu AF at reference point M5u.

At some later point in time:

16. Uplink media streaming starts from the 5GMSu Client to the 5GMSu AS (M4u).
17. The 5GMSu Client invokes media session handling procedures during the uplink media streaming session (M5).
- 18. If content preparation was provisioned in step 7, the uplinked media may be manipulated by the 5GMSu AS prior to being egested by it.**

19. The 5GMSu AS egests the content to the 5GMS Application Provider (M2u) by pull- or push-based means according to the Content Publishing Configuration provisioned in step 8.

NOTE: Steps 16–19 may continue in parallel with steps 20 and 24.

- 20: The 5GMSd AS ingests the content from the 5GMS Application Provider (M2d) by pull- or push-based means according to the Content Hosting Configuration provisioned in step 3.

Steps 21–24 concern the 5GMS downlink streaming process:

21. The 5GMS Application Provider optionally provides Service Access Information for downlink media streaming to the 5GMSd-Aware Application (M8d).

- 22. The 5GMSd-Aware Application requests the 5GMSd Client to start an uplink streaming session (M6d/M7d).
- 23. If Service Access Information was not provided in step 21, the 5GMSd Client requests this information from the 5GSMd AF (M5d).
- 24. Downlink media streaming starts from the 5GMSd AS to the 5GMSd Client (M4d).

Finally:

- 25. The 5GMSu AS releases its uplink content preparation resources after observing a period of interactivity.**
- 26. The 5GMSd AS releases its downlink content preparation resources after observing a period of interactivity.**

NOTE: Steps 25 and 26 are implementation-dependent.

### A.15.3 Cascaded uplink and downlink media streaming using content preparation with direct content re-ingestion

In a second variant of this collaboration scenario, content contributed to the 5GMS System by the 5GMSu Client is egested by the 5GMSu AS at reference point M2u (by either push- or pull-based means) and directly ingested by the 5GMSd AS at reference point M2d (with push- or pull-based content ingest provisioned the same way as for the corresponding content egest). The content thus bypasses the external 5GMS Application Provider altogether.

NOTE 1: Although not depicted, the 5GMSd AS in this collaboration acts as a 5GMSu Application Provider for the 5GMSu AS to target. Conversely, the 5GMSu AS acts as a 5GMSd Application Provider supplying content to the 5GMSd AS.

NOTE 2: For redistribution with lower latency, the provisioning of push-based content egest and ingest is recommended.

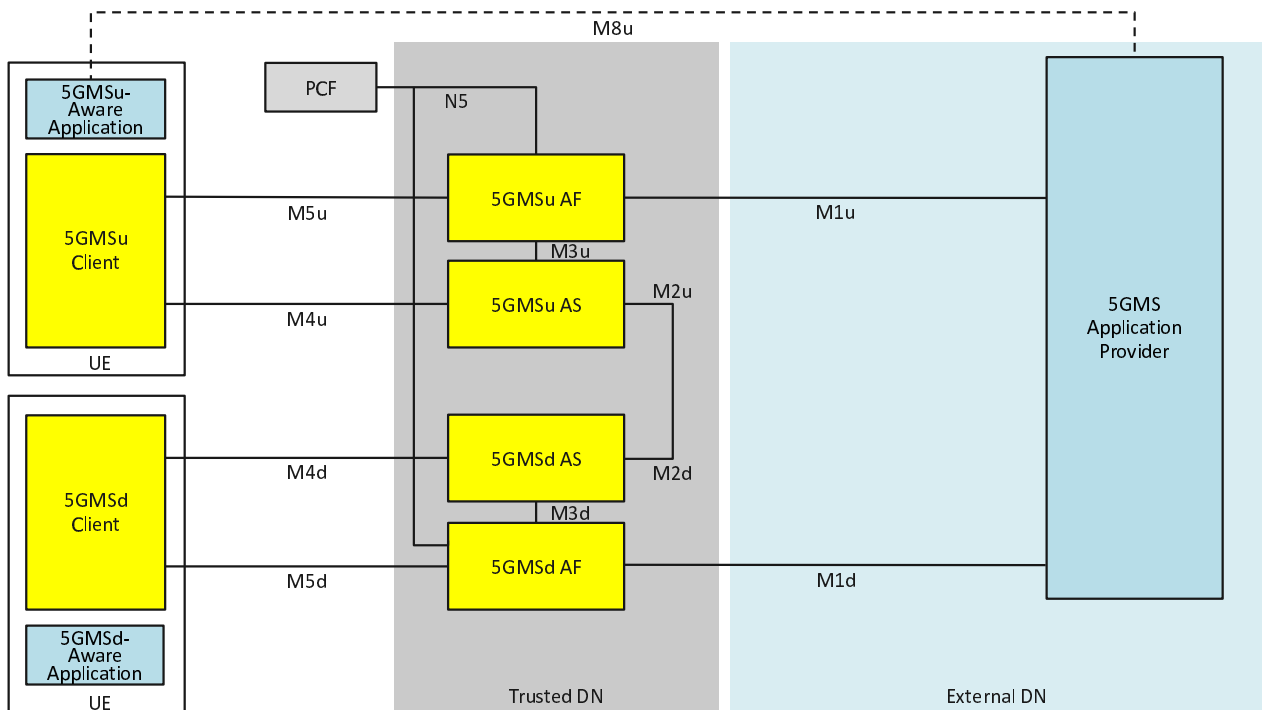

Figure A.15.3-1: Cascaded uplink and downlink media streaming with direct content re-ingestion

Figure A.15.3-2 shows the call flow for this scenario when push-based egest/ingest is used for direct content re-ingestion. (To simplify the call flow, the details of the content preparation process are omitted.)

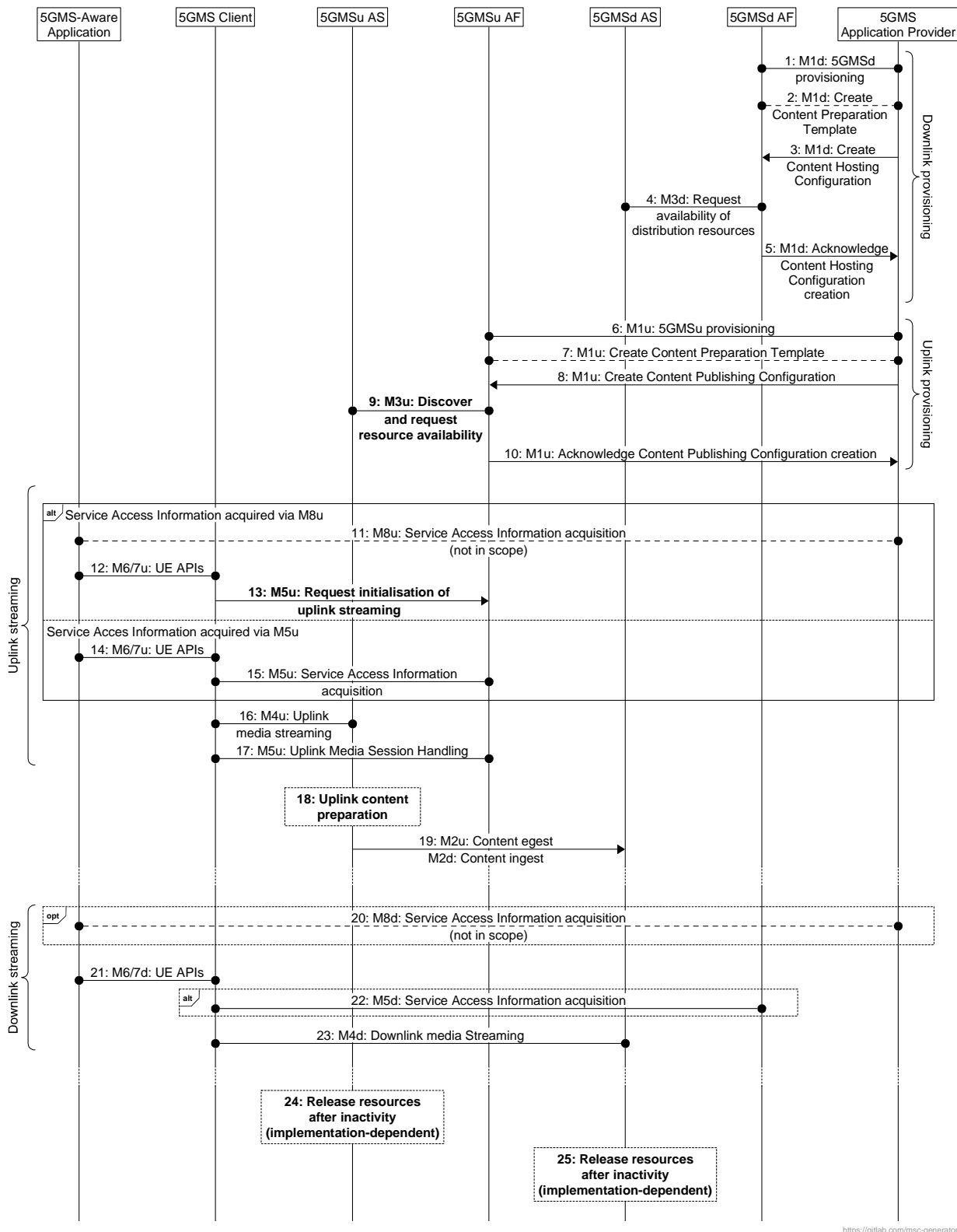
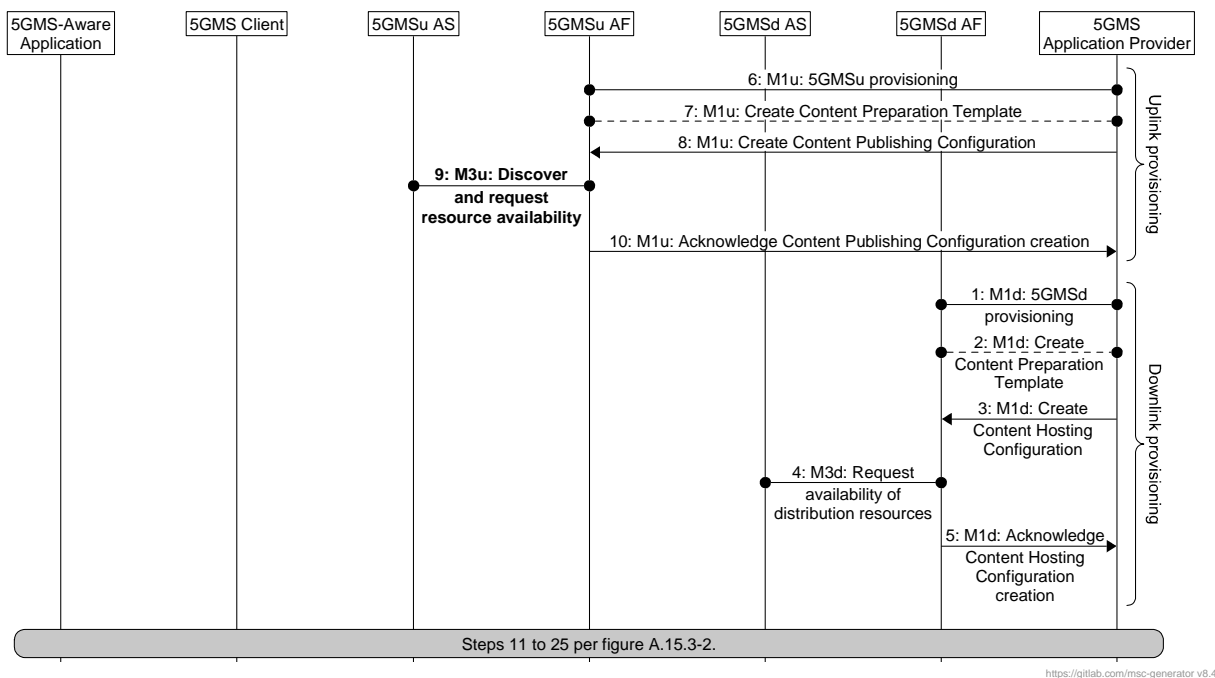

Figure A.15.3-2: Call flow for cascaded uplink and downlink media streaming using content preparation with direct push-based content re-ingestion

The steps for this call flow are identical to those in clause A.15.2 except for the following:

3. The 5GMSd Application Provider provisions the 5GMSd AF with a Content Hosting Configuration. The ingest configuration indicates that content will be ingested from the **5GMSu AS** by push-based means. If a Content Preparation Template was provisioned in the previous step, the Content Hosting Configuration may reference it.
5. The 5GMSd AF acknowledges to the 5GMSd Application Provider the successful creation of the Content Hosting Configuration (M1d). The acknowledgement includes the ingest base URL on the 5GMSd AS to which downlink media streaming content is to be pushed.
8. The 5GMS Application Provider provisions the 5GMSu AF with a Content Publishing Configuration (M1u). The egest configuration indicates that contributed content will be made available to the **5GMSd AS** by push-based means. **The egest destination is specified to be the base URL on the 5GMSd AS returned in prior step 5.** If a Content Preparation Template was provisioned in the previous step, the Content Publishing Configuration may reference it.
19. The 5GMSu AS egests the content (M2u) by push-based means according to the Content Publishing Configuration provisioned in step 8 **and the 5GMSd AS directly ingests the content by the same means (M2d) according to the Content Hosting Configuration provisioned in step 3.**

If pull-based egest/ingest is instead used between the 5GMSu AS and the 5GMSd AS, the order of the provisioning (steps 1–5 and 6–10 of figure A.15.3-2) is reversed to the order shown in figure A.15.3-3 with uplink streaming provisioned before downlink streaming:



**Figure A.15.3-3: Call flow for cascaded uplink and downlink media streaming using content preparation with direct pull-based content re-ingestion**

The steps for this call flow are identical to those in clause A.15.2 except for the following:

8. The 5GMS Application Provider provisions the 5GMSu AF with a Content Publishing Configuration (M1u). The egest configuration indicates that contributed content will be made available to the **5GMSd AS** by pull-based means. If a Content Preparation Template was provisioned in the previous step, the Content Publishing Configuration may reference it.
10. The 5GMSu AF acknowledges successful provisioning to the 5GMSu Application Provider (M1u). **The acknowledgement includes the egest base URL on the 5GMSu AS from which contributed uplink media streaming content will be made available.**
3. The 5GMSd Application Provider provisions the 5GMSd AF with a Content Hosting Configuration. The ingest configuration indicates that content will be ingested from the **5GMSu AS** by pull-based means **from the egest**

base URL on the 5GMSu AS returned in prior step 10. If a Content Preparation Template was provisioned in the previous step, the Content Hosting Configuration may reference it.

- 16. The 5GMSu AS makes the content available for pull-based egest (M2u) according to the Content Publishing Configuration provisioned in step 8 **and the 5GMSd AS directly ingests the content by the same means (M2d) according to the Content Hosting Configuration provisioned in step 3.**

### A.15.4 Cascaded uplink and downlink media streaming using content preparation with internal content re-ingestion

In a third variant of this collaboration scenario, the 5GMS System is provisioned by the 5GMS Application Provider for uplink-downlink content redistribution per clause A.15.3. The 5GMS System recognises this and arranges for content to be transferred directly from the 5GMSu AS to the 5GMSd AS via an internal interface not specified by 3GPP (as an implementation-specific optimisation) instead of egesting the content at reference point M2u and re-ingesting it at M2d.

Content may additionally be egested by the 5GMSu AS at reference point M2u for ingestion by the 5GMS Application Provider and possible redistribution to other 5GMS Systems and/or other destination networks.

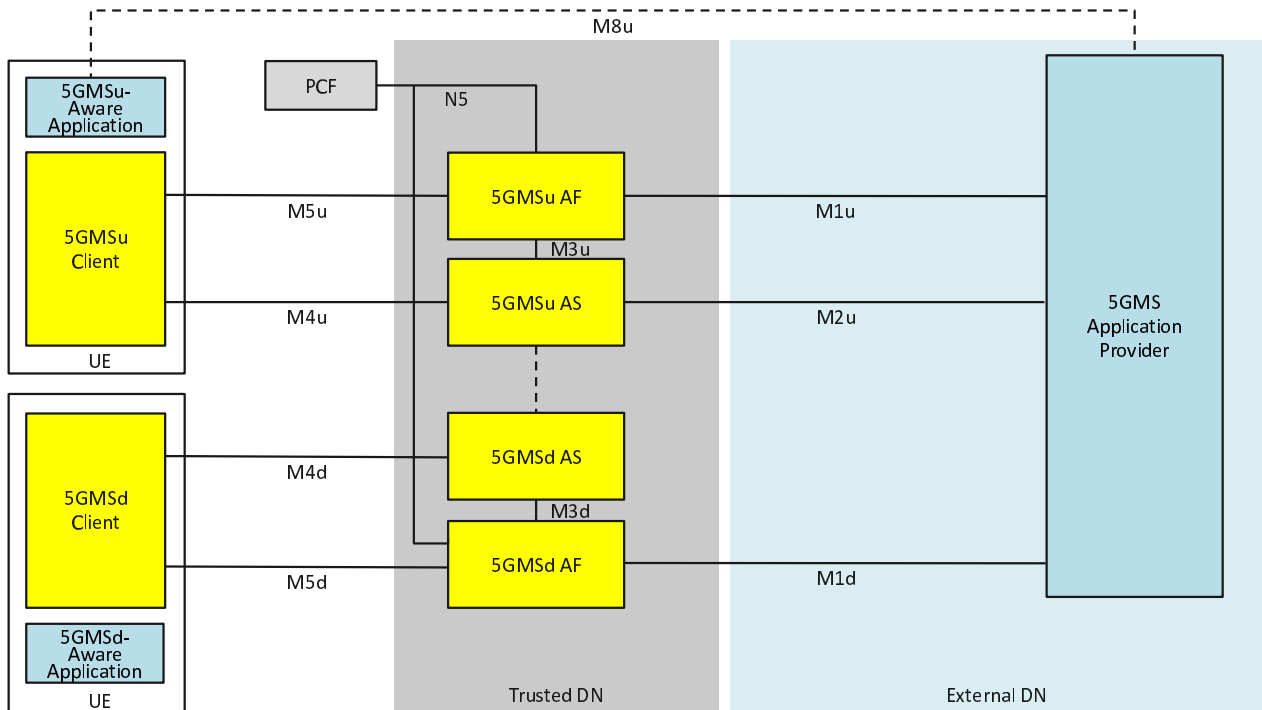

Figure A.15.4-1: Cascaded uplink and downlink media streaming with internal content re-ingestion



## Annex B (informative): MNO-specific Service Access Information acquisition

### B.1 General

A 5GMSd Application Provider may offer its content via multiple Access Networks from different operators. Each access network can consist of a 5G System and one or more 5G Media Streaming Architecture components, in particular its own 5GMSd AFs. The 5GMSd AFs of that access network use their own FQDNs and potentially their own URL root path elements. When a 5GMSd-Aware Application is deployed in different 5G Systems the 5GMSd Client needs to acquire Service Access Information that resolves to the 5GMSd AF endpoint address(es) appropriate for the serving 5G System. The Service Access Information contains the URLs and API parameters of the configured 5GMSd AFs and ASs of that 5G Media Streaming System.

There are different ways to resolve the matching service access information. This annex focuses on two solutions where the 5GMSd Client fetches the Service Access Information from a 5GMSd AF within the Trusted DN of the serving mobile network.

### B.2 Deployment with DNS-based resolution

Figure B.2-1 depicts the deployment for DNS-based resolution of the 5GMSd AF in the Trusted DN of the MNO which is currently providing connectivity to the 5GMSd Client. The DNS functions are defined in RFC 1034 [14].

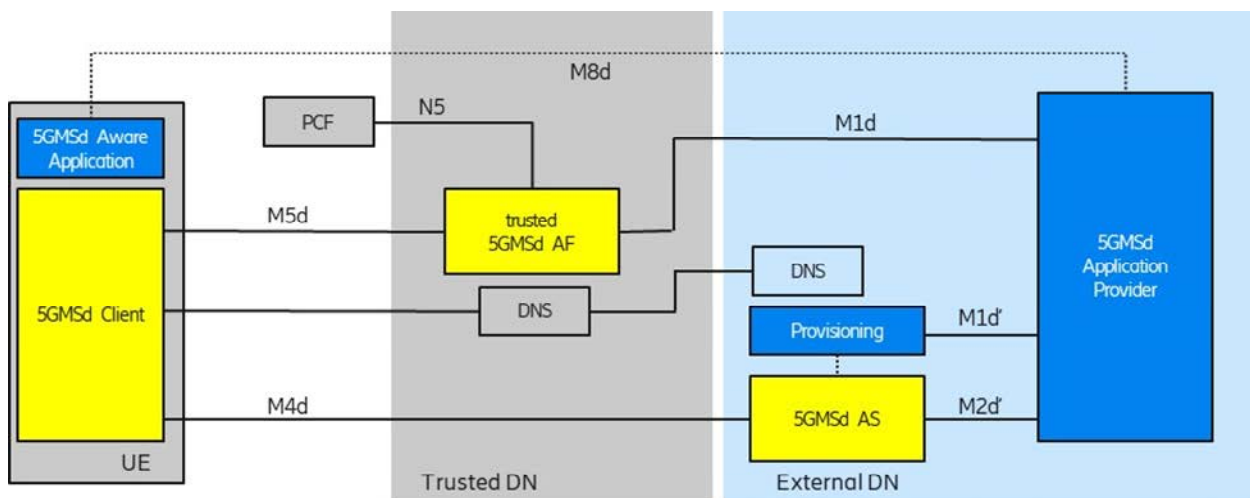

**Figure B.2-1: DNS based resolution of 5GMSd AF in trusted DN**

For the DNS-based resolution mechanism, the 5GMSd Client is provisioned with a Service Access Information URL, for example dynamically via M8d or statically within the code of the 5GMSd-Aware Application. The Service Access Information URL contains an FQDN from the 5GMSd Application Provider or a global URL in the GSMA domain (i.e. in the "3gppnetworks.org" domain).

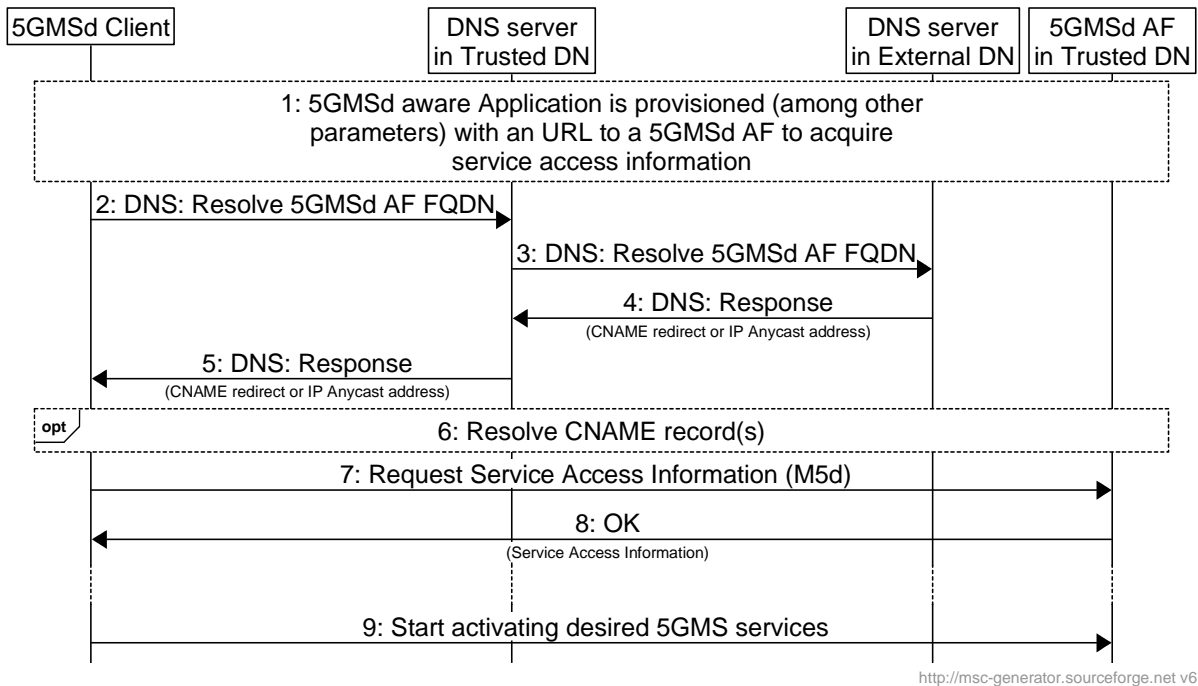

<http://msc-generator.sourceforge.net v6.3.8>

**Figure B.2-2: Message Sequence Chart for DNS-based resolution**

Steps:

- 1: The 5GMSd-Aware Application is provisioned (among other parameters) with a URL of the 5GMSd AF from which to acquire Service Access Information. The 5GMSd-Aware Application provides this URL to the 5GMSd Client upon start.
- 2: The 5GMSd Client uses DNS to resolve the FQDN of the URL. The 5GMSd Client sends a DNS request to the DNS server in the Trusted DN.
- 3: The DNS server in the trusted DN is not responsible for the FQDN and the DNS server forwards the DNS request to a DNS server in the external DN responsible for the FQDN. This may be the DNS server of the 5GMSd Application Provider or a GSMA DNS server.
- 4: Based on information from the originating network, the external DNS creates a response. The response may be a CNAME redirect (i.e. FQDN from the serving mobile network responsibility) or an IP address (preferably an IP Anycast Address).
- 5: The DNS server forwards the DNS response to the 5GMSd Client.
- 6: When the 5GMSd Client received another FQDN with the response (i.e. a CNAME DNS record), then the 5GMSd Client resolves the FQDN to an IP address. The resolved IP address should be an IP address of an 5GMSd AF in the Trusted DN.
- 7: The 5GMSd Client issues a request to the resolved 5GMSd AF in order to acquire the Service Access Information.
- 8: The 5GMSd AF provides the Service Access Information in its response to the 5GMSd Client. The Service Access Information contains URLs and parameters according to provisioned 5GMS features.
- 9: When needed, the 5GMSd Client uses the acquired Service Access Information to activate the needed 5GMSd feature(s).

## B.3 Deployment with HTTPS-based resolution

Figure B.3-1 depicts the deployment for HTTPS-based resolution of the 5GMSd AF in the Trusted DN of the MNO which is currently providing connectivity to the 5GMSd Client.

NOTE: The process of resolving IP addresses from FQDNs is not depicted in this deployment architecture.

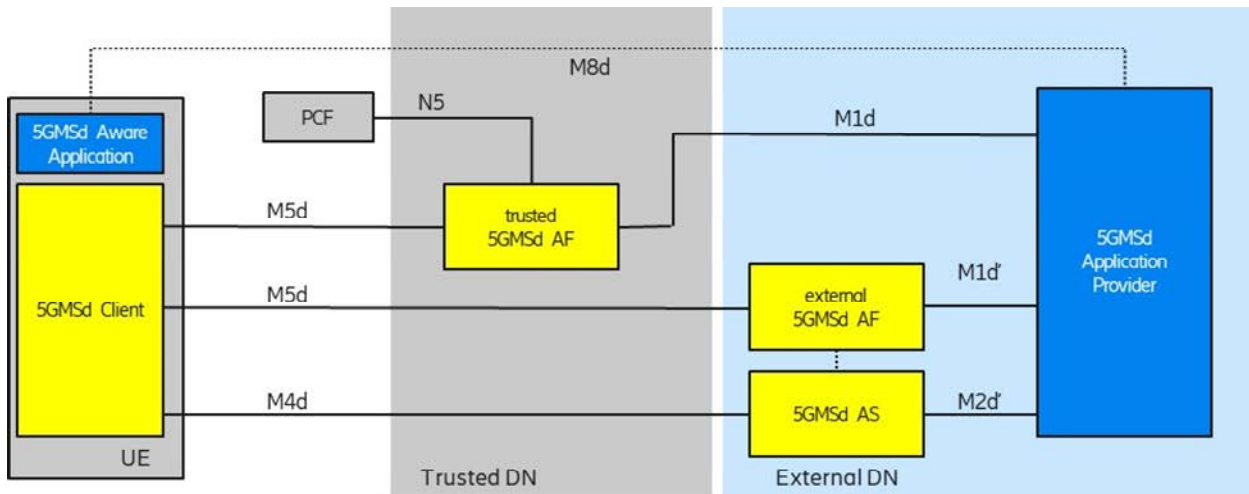

Figure B.3-1: HTTPS based resolution of 5GMSd AF in Trusted DN

For the HTTPS-based resolution mechanism, the 5GMSd Client is provisioned with a Service Access Information URL, for example dynamically via M8d or statically within the code of the 5GMSd-Aware Application. The Service Access Information URL contains an FQDN of a 5GMSd AF within the 5GMSd Application Provider domain, which acts as a request redirector.

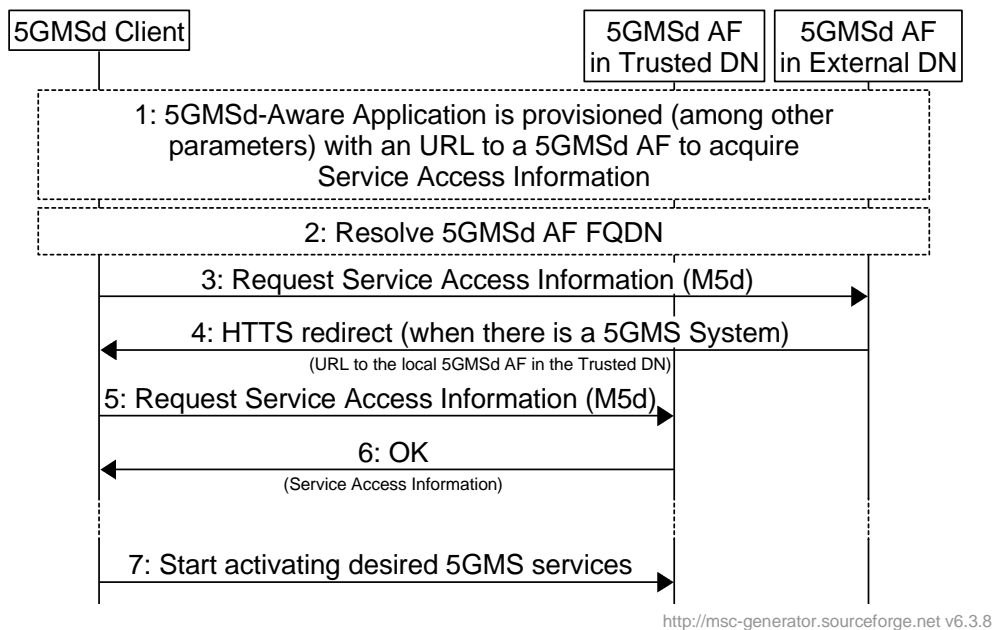

Figure B.3-2: Message Sequence Chart for HTTPS based resolution

Steps:

- 1: The 5GMSd-Aware Application is provisioned (among other parameters) with a URL of the 5GMSd AF from which to acquire Service Access Information. The 5GMSd-Aware Application passes this URL to the 5GMSd Client upon start.
- 2: The 5GMSd Client uses DNS to resolve the FQDN of the URL.

- 3: The 5GMSd Client issues a request to the resolved 5GMSd AF in order to acquire the Service Access Information.
- 4: Based on information from the originating network (e.g. visible IP of the 5GMSd Client), the 5GMSd AF in the External DN creates an HTTPS redirection response. The 5GMSd AF looks up the according FQDN of the 5GMSd AF in the trusted DN and sends an HTTPS redirection response to the 5GMSd Client.

When the 5GMSd AF in the External DN does not offer 5GMS features, or if the 5GMS features are not provisioned it instead provides a response containing an HTTP error message.

**NOTE:** Instead of redirecting a 5GMSd Client to the 5GMSd AF in the Trusted DN, the External 5GMSd AF may directly provide the Service Access Information in the above step. In this case, the 5GMSd Application Provider needs to update its 5GMSd AF according to changes within the Trusted DN, e.g. changes of FQDNs.

- 5: The 5GMSd Client issues a request to the resolved 5GMSd AF in order to acquire the Service Access Information.
- 6: The 5GMSd AF provides the Service Access Information in its response to the 5GMSd Client. The Service Access Information contains URLs and parameters according to provisioned 5GMS features.
- 7: When needed, the 5GMSd Client uses the acquired Service Access Information to activate the needed 5GMSd feature(s).

# Annex C (informative): Collaboration Models for 5GMS via eMBMS

## C.1 Introduction

For 5GMS via eMBMS as introduced in clauses 4.6 and 5.10, different deployment collaboration scenarios of the architecture as provided in clause 4.6 may be considered. In all cases, the same UE architecture is used, but different network side operation modes are considered, including the following parties:

- *5G Mobile Network Operator*: A party that offers 5G System reference points to a content provider.
- *5G Broadcast Network Operator*: A party that offers eMBMS reference points to a third party.
- *5GMS Content Provider*: A party that provides 5GMS content.
- *5GMS Network Operator*: A party that offers 5GMS System reference points to a content provider.
- *5G Broadcast Service Provider*: A party that offers 5GMS content via eMBMS and also provides the same content to a 5G Mobile Network Operator.
- *5GMS Service Provider*: A party that distributes 5GMS content via a 5G System and via eMBMS.

## C.2 Collaboration 5GMS-MBMS 1: 5GMS Content Provider uses different delivery networks

Figures C.2-1 illustrates a collaboration in which the 5GMS Content Provider uses different delivery networks.

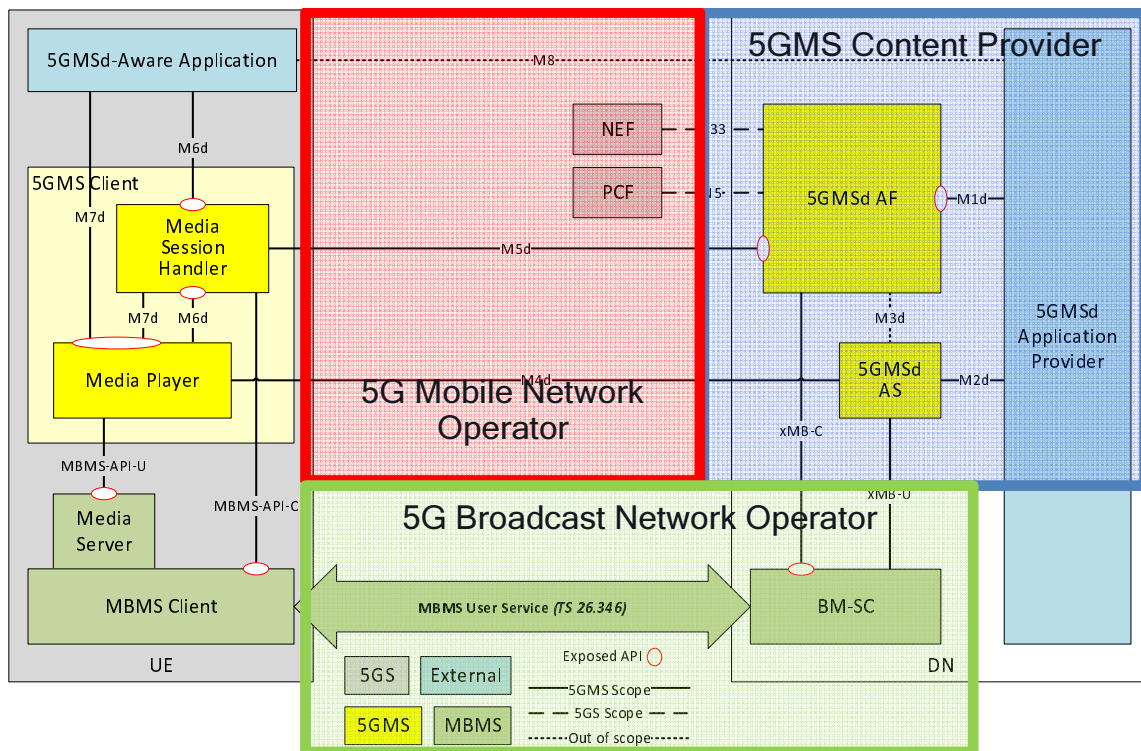

Figure C.2-1: Collaboration 5GMS-MBMS 1: 5GMS Content Provider uses different delivery networks

### C.3 Collaboration 5GMS-MBMS 2: 5GMS Network Operator offloads to 5G Broadcast Network Operator

Figure C.3-1 illustrates a collaboration in which a 5GMS Network Operator offloads to a 5G Broadcast Network Operator.

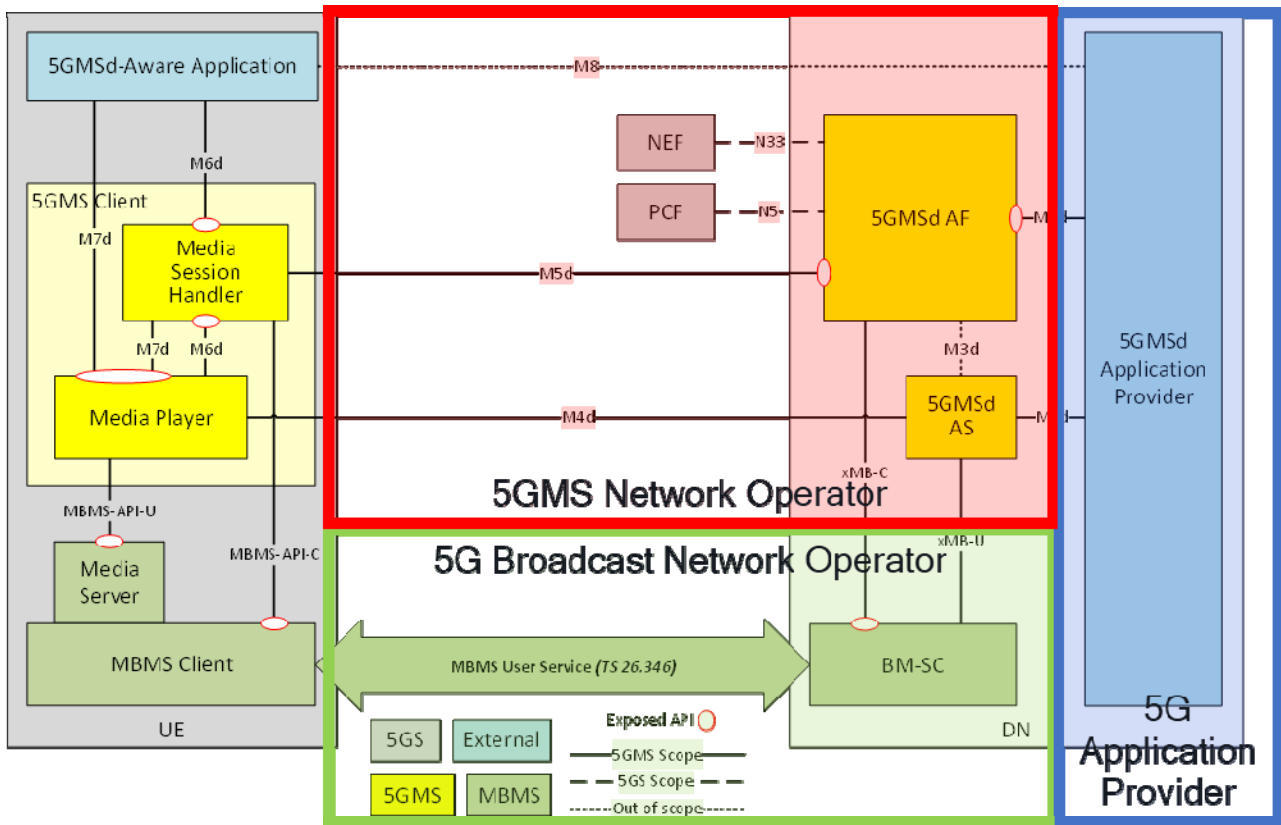

Figure C.3-1: Collaboration 5GMS-MBMS 2: 5GMS Network Operator offloads to 5G Broadcast Network Operator

### C.4 Collaboration 5GMS-MBMS 3: 5GMS Service Operator includes MBMS network

Figure C.4-1 illustrates a collaboration in which a 5GMS Service Operator includes an MBMS network.

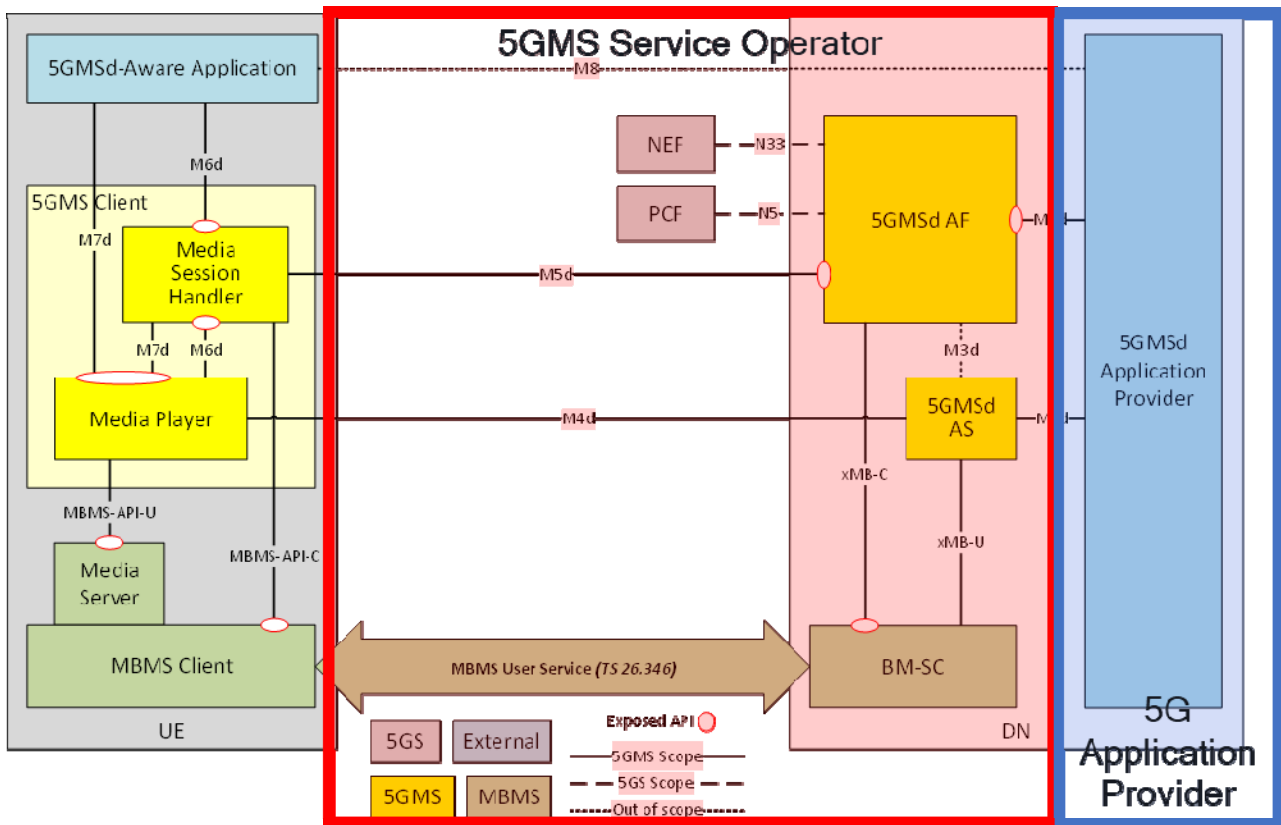

Figure C.4-1: Collaboration 5GMS-MBMS 3: 5GMS Service Operator includes MBMS network

## C.5 Collaboration 5GMS-MBMS 4: 5G Broadcast Service Provider offloads to 5G MNO

Figure C.5-1 illustrates a collaboration in which a 5G Broadcast Service Provider offloads to a 5G Mobile Network Operator.

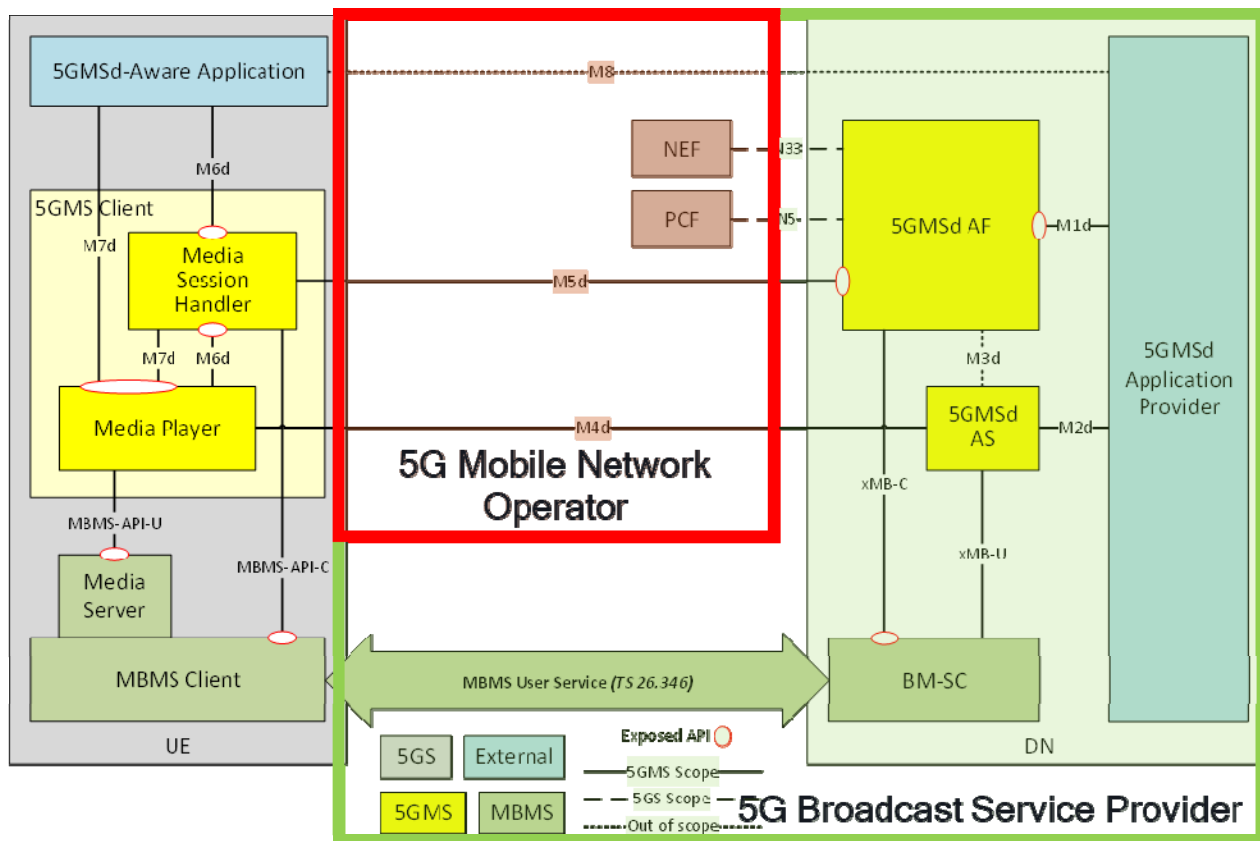

Figure C.5-1: Collaboration 5GMS-MBMS 4: 5G Broadcast Service Provider offloads to 5G MNO



---

# Annex D (informative): Use Cases for 5GMS event exposure

## D.1 Introduction

This annex describes Use Cases related to the exposure of events relating to 5G Media Streaming by the Data Collection AF instantiated in the 5GMS AF.

---

## D.2 Controlling Event exposure

### D.2.1 Data exposure restrictions

The 5GMS Application Provider wishes to limit the level of access that different classes of Event consumer subscribers have to UE data reported to and subsequently exposed by the Data Collection AF. These restrictions are expressed in the form of data processing instructions that it provisions in the Data Collection AF instantiated in the 5GMS AF along the dimensions described below. Each set of data processing instructions applies to a particular Event ID and Event consumer type:

- Time-based restriction determines the granularity of access along the time axis, ranging from the finest granularity which permits Event consumer access to individual events as they occur, to the coarsest granularity which combines all event data into a single aggregated value.
- User-based restriction controls access based on end-user grouping. Such restriction ranges from the fine granularity which permits Event consumer access to individual events related to individual end users, through medium granularity which aggregates collected event data at the level of user groups, to coarse granularity which bundles the data across all users.
- Location-based restriction defines access based on the geographical location of the data collection client at which the UE data was collected. Fine-grained control allows the Event consumer to access individual events, irrespective of the location. Medium-grained control aggregates collected event data for a defined geographical area. Coarse-grained control aggregates all event data to produce a single aggregated value for all locations.

For example, the 5GMS Application Provider decides that its own Event Consumer AF is granted the finest-grained access to event data by all of the above dimensions. On the other hand, according to the "silver" business agreement it has established with the Mobile Network Operator, the NWDAF is granted medium-grained access to event data, while based under a "bronze" business agreement it has established with another Application Service Provider, the Event Consumer AF of that third-party ASP is granted only coarse-grained access to event data.

### D.2.2 Event subscription filters

A certain Event consumer is only interested in receiving events for a specific user or group(s) of users, or a specific application or UEs at a certain location. It expresses these preferences in the form of filters when subscribing to the event at the Data Collection AF.

---

## D.3 QoE metrics for downlink media streaming

The Use Case for exposing QoE metrics for downlink media streaming as an event is in clause 6.4 of TS 23.288 [23].

---

## D.4 Consumption of downlink media streaming

The 5GMSd Client collates feedback reports on currently consumed downlink media streaming content according to a provisioned Consumption Reporting Configuration it obtains from the Service Access Information for its Provisioning

Session. The consumption reports include the media player entry point URL, the start time, duration and UE locations. The Media Session Handler sends the consumption reports to 5GMSd AF for subsequent event exposure to subscribed Event consumers.

The 5GMSd Application Provider subscribes to downlink media streaming consumption events from the Data Collection AF, specifying an appropriate application filter in its subscription request. To drill down into downlink media streaming consumption at a finer geographical granularity, a location filter is also specified as part of the subscription. To analyse use of a new application feature in isolation as part of a beta testing programme, a user group filter corresponding to the test population is also specified. With the exposed event, the 5GMSd Application Provider performs data analytics to determine, for example, which media content is most popular in the 5GMS System, which media content is most popular at a specific location, or which portions of the media content are consumed. This helps the 5GMSd Application Provider to optimise distribution of the most popular media content in the 5GMS System.

Alternatively, the NWDAF subscribes to this event for data analytics, exposing the results to the 5GMSd Application Provider.

---

## D.5 Invocation of dynamic policies

The Media Session Handler invokes the Dynamic Policy API on the 5GMS AF via M5 to request a specific policy and charging treatment to be applied to a particular media streaming application data flow. As a result, the 5GMS AF invokes appropriate service operations on Network Functions in the 5G Core, e.g. Npcf\_PolicyAuthorization or Nnef\_AFSessionWithQoS, to effect the requested network QoS policy change. The 5GMS AF obtains status information (policy accepted, rejected, etc.) about these service operation invocations, and policy enforcement information, such as the enforcement method selected and the enforcement bit rate. After recording the invocation of the dynamic policies, the 5GMS AF reports these records to its subordinate Data Collection AF for exposure to subscribed Event consumers.

The event for invocation of dynamic policies may include the timestamp when the Media Session Handler invokes the dynamic function in 5GMS AF, the requested policy template identifier, the status information, etc.

The Event Consumer AF within the 5GMS Application Provider or the NWDAF subscribes to events of this type from the Data Collection AF, specifying the relevant application filter and any relevant location and/or user filters in its subscription request. Using the details about the invocations for dynamic policies, the 5GMS Application Provider or the NWDAF analyse the network quality provided by the 5G System and the dynamic network requirements for this media streaming service.

Alternatively, the NWDAF subscribes to the event, specifying any relevant filters, and exposes analytics results to the 5GMS Application Provider, enabling the 5GMS Application Provider to optimise the media streaming service, e.g. by provisioning more appropriate policy templates or by negotiating more suitable Service Level Agreement (SLA) with the MNO.

---

## D.6 Invocation of Network Assistance

The AF-based Network Assistance feature enables a UE to receive a bit rate recommendation from a 5GMS AF providing the Network Assistance server function.

The 5GMS AF uses the Npcf\_PolicyAuthorization notification or Nnef\_MonitoringEvent procedure to receive notifications of network QoS changes, e.g. estimation of throughput, recommendation of a bit rate. The 5GMS AF receives these policy change notifications asynchronously.

The 5GMS AF reports the invocation of AF-based network assistance to its subordinate Data Collection AF, including information about requested QoS and recommended QoS. The Data Collection AF subsequently exposes this UE data to the Event Consumer AF within the 5GMS Application Provider. Using this information, the 5GMS Application Provider is able to optimise the use of the 5GMS System, e.g. by performing dynamic congestion window adjustment.

Data collection and reporting may also be used in case the UE implements ANBR-based Network Assistance. In this case the Direct Data Reporting Client reports the invocations of ANBR-based Network Assistance directly to the 5GMS AF's subordinate Data Collection AF.

The NWDAF subscribes to events of this type at the Data Collection AF, specifying the relevant application filter and any relevant location and/or user filters. Based on the requested QoS and recommended QoS in the exposed events, the NWDAF analyses whether the current network deployment or status can support the currently provisioned media streaming services, and exposes these results to the OAM for better network optimization.

---

## D.7 Media streaming access activity

### D.7.1 Downlink media streaming access activity

In downlink 5G Media Streaming, the 5GMSd AS acts as a CDN (e.g., edge server) in the hosting and delivery of streaming media content that it has ingested. The corresponding media streaming access activity (i.e., CDN access logs) available at the 5GMSd AS are reported to the Data Collection AF instantiated in the 5GMSd AF for subsequent event exposure to the Event Consumer AF in the 5GMSd Application Provider.

The 5GMSd Application Provider uses information in the exposed events (e.g. the number of unique users and the access history for different media content items) to improve its CDN content distribution. It specifies the relevant application filter and any relevant location and/or user filters in its subscription request to the Data Collection AF.

Alternatively, the NWDAF subscribes to events of this type, specifying the relevant application filter and any relevant location and/or user filters, and analyses the total volume of data delivered by the 5GMSd AS or the average response time for downlink media requests in order to optimise the 5GMS System deployment or to demonstrate to the 5GMSd Application Provider that the SLA for downlink media streaming has been satisfied.

## Annex E (informative): Change history

Change history							
Date	Meeting	TDoc	CR	Rev	Cat	Subject/Comment	New version
2019-03	SA#83	SP-190037				Presented to TSG SA#83 (for information)	1.0.0
2019-06	SA#84	SP-190333				Presented to TSG SA#84 (for approval)	2.0.0
2019-06	SA#84					Approved at TSG SA#84	16.0.0
2019-09	SA#85	SP-190654	0001	2	F	Clarification of configuration updates when not streaming media data	16.1.0
2019-09	SA#85	SP-190654	0002	3	F	Correction of Architecture, Unicast Streaming Procedure, QoE metrics reporting, Consumption reporting and Session Handling for 5GMS	16.1.0
2019-12	SA#86	SP-190999	0003	-	F	Correction to architecture and procedures	16.2.0
2020-03	SA#87-e	SP-200040	0004	1	B	Triggering conditions for Consumption Reporting	16.3.0
2020-03	SA#87-e	SP-200040	0005	-	F	Correction on downlink media streaming establishment	16.3.0
2020-03	SA#87-e	SP-200040	0006	1	F	Collaboration Scenarios for 5G Media Streaming	16.3.0
2020-03	SA#87-e	SP-200040	0007	1	F	Correction on Provisioning procedures	16.3.0
2020-03	SA#87-e	SP-200040	0008	1	F	Corrections and clarifications for Dynamic Policy Procedures	16.3.0
2020-03	SA#87-e	SP-200040	0009	1	C	Metrics collection parameters	16.3.0
2020-03	SA#87-e	SP-200040	0010	-	C	UE-internal interfaces	16.3.0
2020-03	SA#87-e	SP-200040	0011	-	F	Procedures for Unicast Downlink Streaming with 5GMSd AS interactions	16.3.0
2020-03	SA#87-e	SP-200040	0012	-	F	Network Assistance	16.3.0
2020-03	SA#87-e					Editorial	16.3.1
2020-04	SA4#108-e					Working draft following SA4#108-e as baseline for SA4#109-e draft CRs.	
2020-06	SA#88-e	SP-200388	0018	-	F	Consolidated changes from SA4#108-e and SA4#109-e	16.4.0
2020-06	SA#88-e	SP-200388	0015	-	F	Corrections on network slicing	16.4.0
2020-06	SA#88-e					Editorial Corrections	16.4.1
2020-09	SA#89-e	SP-200663	0019	1	F	Corrections and Clarifications on Network Assistance	16.5.0
2020-12	SA#90-e	SP-200930	0020	2	F	Corrections on Metrics	16.6.0
2020-12	SA#90-e	SP-200930	0022	1	F	Corrections to align with TS 26.512 v16.0.0	16.6.0
2020-12	SA#90-e	SP-200930	0023	-	F	Corrections and Clarifications on Network Assistance	16.6.0
2020-12	SA#90-e	SP-200930	0024	-	F	Corrections on Metrics Configuration and Reporting via 5G control plane	16.6.0
2020-12	SA#90-e	SP-200930	0025	1	F	Corrections and Clarifications on Metrics and Consumption Reporting	16.6.0
2020-12	SA#90-e	SP-200930	0026	-	F	Correction of Dynamic Policy Procedure	16.6.0
2021-01	Post SA#90-e	SP-200930				Editorial Corrections	16.6.1
2021-04	SA#91-e	SP-210037	0027	-	F	CR to TS 26.501 0027 on clarifications and corrections (Rel-16)	16.7.0
2021-06	SA#92-e	SP-210535	0028	1	F	Corrections to TS 26.501	16.8.0
2021-12	SA#94-e	SP-211351	0029	-	F	Aligning Stage 2 Content Hosting function of 5GMSd AS to Stage 3	16.9.0
2021-12	SA#94-e	SP-211351	0030	-	B	CR on the Support of Edge Media Processing in 5GMS	17.0.0
2022-01						Editorials	17.0.1
2022-03	SA#95-e	SP-220037	0033	1	A	Correction 5GMS Client definition and clarification of reference point usage	17.1.0
2022-03	SA#95-e	SP-220039	0034	2	B	5GMS via eMBMS	17.1.0
2022-06	SA#96	SP-220598	0035	-	B	[EVEX] Data collection and reporting for 5G Media Streaming	17.2.0
2022-06	SA#96	SP-220598	0036	-	B	[EVEX] [5GMS_EDGE] Expanded downlink provisioning procedures and domain model	17.2.0
2022-06	SA#96	SP-220598	0037	-	F	CR on use cases for newly defined 5GMS event	17.2.0
2022-06	SA#96	SP-220594	0038	1	F	CR 26.501-0038 rev1 Improved CR on edge provisioning procedures	17.2.0
2022-06	SA#96	SP-220621	0039	-	F	Corrections to 5GMS via eMBMS	17.2.0
2022-09	SA#97-e	SP-220757	0040	1	F	CR on subscription filters for 5GMS event	17.3.0
2022-12	SA#98-e	SP-221054	0047	2	F	CR to TS 26.501 Add slice scope into the metrics configuration	17.4.0
2022-12	SA#98-e	SP-221057	0041	1	B	[5GMSA_Ph2] Uplink high level procedure	18.0.0
2022-12	SA#98-e	SP-221057	0042	1	B	[5GMSA_Ph2] Uplink streaming: removing FLUS and updating the workflows	18.0.0
2023-03	SA#99	SP-230255	0058	1	A	Correction of metrics reporting for eMBMS	18.1.0
2023-03	SA#99	SP-230252	0046	4	B	[5GMSA_Ph2] Downlink Streaming to Media Players with Different Manifests	18.1.0
2023-03	SA#99	SP-230252	0050	1	C	[5GMS_Ph2] Uplink high Remote Control- General	18.1.0
2023-03	SA#99	SP-230252	0051	1	C	[5GMS_Ph2] Uplink Remote Control- procedure	18.1.0
2023-03	SA#99	SP-230252	0052	1	C	[5GMS_Ph2] Uplink Remote Control- procedure	18.1.0
2023-03	SA#99	SP-230252	0055	1	C	[5GMS_Ph2] UE data processing for AF-based NA	18.1.0
2023-06	SA#100	SP-230545	0044	13	B	[5GMS_Ph2] Feature description, dynamic policies and Service URL handling	18.2.0
2023-06	SA#100	SP-230545	0045	9	B	[5GMSA_Ph2] 5GMS over 5MBS	18.2.0
2023-06	SA#100	SP-230545	0056	5	B	[5GMS_Ph2] Data collection for ANBR-based NA	18.2.0
2023-06	SA#100	SP-230545	0059	5	B	[5GMS_Ph2] 5GMS AS configuration via M3	18.2.0

2023-06	SA#100	SP-230545	0061	3	D	[5GMS_Ph2] Improvements on the multiple manifest downlink streaming call flow	18.2.0
2023-06	SA#100	SP-230545	0063	1	D	[5GMS_Ph2] Uplink Streaming: editorial correction	18.2.0
2023-09	SA#101	SP-230917	0069	4	C	[5GMS_Ph2] Event exposure	18.3.0
2023-09	SA#101	SP-230917	0070	2	C	[5GMS_Ph2] Additional baseline parameter for 3GPP Service URL	18.3.0
2023-09	SA#101	SP-230917	0071	1	F	[5GMS_Ph2] Update to 5GMS+MBS architecture	18.3.0
2023-09	SA#101	SP-230919	0066	5	F	[5GMSA, TE118] Clarifications to Network Assistance feature	18.3.0
2023-09						Editorial corrections	18.3.1
2023-12	SA#102	SP-231363	0077	5	F	[5GMS_Ph2] Addition of Background Data Transfer feature	18.4.0
2023-12	SA#102	SP-231363	0078	3	F	[5GMS_Ph2] Cascaded uplink-downlink media streaming collaboration	18.4.0
2023-12	SA#102	SP-231363	0079	1	F	[5GMS_Ph2] Adjustment of baseline parameters for 3GPP Service URL	18.4.0
2023-12	SA#102	SP-231363	0080	2	A	[5GMSA] ANBR-based NA	18.4.0
2023-12	SA#102	SP-231363	0081	2	F	[5GMS_Ph2] Addition the dynamic policies invocation for uplink streaming	18.4.0
2024-03	SA#103	SP-240039	0074	3	F	5GMS Functions are general Media Functions	18.5.0
2024-03	SA#103	SP-240041	0086		A	[5GMSA] ANBR abbreviation	18.5.0

---

# History

<b>Document history</b>		
V18.5.0	May 2024	Publication