

ETSI TS 126 502 V17.0.0 (2022-05)



5G;
5G Multicast-Broadcast User Service Architecture
(3GPP TS 26.502 version 17.0.0 Release 17)



Reference

DTS/TSGS-0426502vh00

Keywords

5G

ETSI

650 Route des Lucioles
F-06921 Sophia Antipolis Cedex - FRANCE

Tel.: +33 4 92 94 42 00 Fax: +33 4 93 65 47 16

Siret N° 348 623 562 00017 - APE 7112B
Association à but non lucratif enregistrée à la
Sous-Préfecture de Grasse (06) N° w061004871

Important notice

The present document can be downloaded from:

<http://www.etsi.org/standards-search>

The present document may be made available in electronic versions and/or in print. The content of any electronic and/or print versions of the present document shall not be modified without the prior written authorization of ETSI. In case of any existing or perceived difference in contents between such versions and/or in print, the prevailing version of an ETSI deliverable is the one made publicly available in PDF format at www.etsi.org/deliver.

Users of the present document should be aware that the document may be subject to revision or change of status.

Information on the current status of this and other ETSI documents is available at

<https://portal.etsi.org/TB/ETSIDeliverableStatus.aspx>

If you find errors in the present document, please send your comment to one of the following services:

<https://portal.etsi.org/People/CommitteeSupportStaff.aspx>

If you find a security vulnerability in the present document, please report it through our
Coordinated Vulnerability Disclosure Program:

<https://www.etsi.org/standards/coordinated-vulnerability-disclosure>

Notice of disclaimer & limitation of liability

The information provided in the present deliverable is directed solely to professionals who have the appropriate degree of experience to understand and interpret its content in accordance with generally accepted engineering or other professional standard and applicable regulations.

No recommendation as to products and services or vendors is made or should be implied.

No representation or warranty is made that this deliverable is technically accurate or sufficient or conforms to any law and/or governmental rule and/or regulation and further, no representation or warranty is made of merchantability or fitness for any particular purpose or against infringement of intellectual property rights.

In no event shall ETSI be held liable for loss of profits or any other incidental or consequential damages.

Any software contained in this deliverable is provided "AS IS" with no warranties, express or implied, including but not limited to, the warranties of merchantability, fitness for a particular purpose and non-infringement of intellectual property rights and ETSI shall not be held liable in any event for any damages whatsoever (including, without limitation, damages for loss of profits, business interruption, loss of information, or any other pecuniary loss) arising out of or related to the use of or inability to use the software.

Copyright Notification

No part may be reproduced or utilized in any form or by any means, electronic or mechanical, including photocopying and microfilm except as authorized by written permission of ETSI.

The content of the PDF version shall not be modified without the written authorization of ETSI.

The copyright and the foregoing restriction extend to reproduction in all media.

© ETSI 2022.
All rights reserved.

Intellectual Property Rights

Essential patents

IPRs essential or potentially essential to normative deliverables may have been declared to ETSI. The declarations pertaining to these essential IPRs, if any, are publicly available for **ETSI members and non-members**, and can be found in ETSI SR 000 314: "*Intellectual Property Rights (IPRs); Essential, or potentially Essential, IPRs notified to ETSI in respect of ETSI standards*", which is available from the ETSI Secretariat. Latest updates are available on the ETSI Web server (<https://ipr.etsi.org/>).

Pursuant to the ETSI Directives including the ETSI IPR Policy, no investigation regarding the essentiality of IPRs, including IPR searches, has been carried out by ETSI. No guarantee can be given as to the existence of other IPRs not referenced in ETSI SR 000 314 (or the updates on the ETSI Web server) which are, or may be, or may become, essential to the present document.

Trademarks

The present document may include trademarks and/or tradenames which are asserted and/or registered by their owners. ETSI claims no ownership of these except for any which are indicated as being the property of ETSI, and conveys no right to use or reproduce any trademark and/or tradename. Mention of those trademarks in the present document does not constitute an endorsement by ETSI of products, services or organizations associated with those trademarks.

DECT™, **PLUGTESTS™**, **UMTS™** and the ETSI logo are trademarks of ETSI registered for the benefit of its Members. **3GPP™** and **LTE™** are trademarks of ETSI registered for the benefit of its Members and of the 3GPP Organizational Partners. **oneM2M™** logo is a trademark of ETSI registered for the benefit of its Members and of the oneM2M Partners. **GSM®** and the GSM logo are trademarks registered and owned by the GSM Association.

Legal Notice

This Technical Specification (TS) has been produced by ETSI 3rd Generation Partnership Project (3GPP).

The present document may refer to technical specifications or reports using their 3GPP identities. These shall be interpreted as being references to the corresponding ETSI deliverables.

The cross reference between 3GPP and ETSI identities can be found under <http://webapp.etsi.org/key/queryform.asp>.

Modal verbs terminology

In the present document "**shall**", "**shall not**", "**should**", "**should not**", "**may**", "**need not**", "**will**", "**will not**", "**can**" and "**cannot**" are to be interpreted as described in clause 3.2 of the [ETSI Drafting Rules](#) (Verbal forms for the expression of provisions).

"**must**" and "**must not**" are **NOT** allowed in ETSI deliverables except when used in direct citation.

Contents

Intellectual Property Rights	2
Legal Notice	2
Modal verbs terminology.....	2
Foreword.....	5
1 Scope	7
2 References	7
3 Definitions of terms, symbols and abbreviations	7
3.1 Terms.....	7
3.2 Symbols.....	8
3.3 Abbreviations	8
4 Reference architecture for 5G Multicast–Broadcast User Services	9
4.1 General	9
4.2 System description	9
4.2.1 Network architecture.....	9
4.2.2 User Services network architecture	10
4.2.3 User Services Distribution methods.....	10
4.2.4 User Service Announcement.....	11
4.2.5 User Services Consumption Reporting	11
4.3 Functional entities	11
4.3.1 General.....	11
4.3.2 MBSF.....	12
4.3.3 MBSTF	12
4.3.3.1 General	12
4.3.3.2 MBSTF subfunctions to support Object Distribution Method	13
4.3.3.3 MBSTF subfunctions to support Packet Distribution Method	14
4.3.4 MBS AS.....	14
4.3.5 MBS Client	14
4.3.6 MBS-Aware Application	15
4.4 Reference points and interfaces.....	15
4.4.1 Overview	15
4.5 Domain model	16
4.5.1 User Services domain model	16
4.5.2 Static information model	17
4.5.3 MBS User Service parameters	19
4.5.4 MBS Consumption Reporting Configuration parameters	19
4.5.5 MBS User Data Ingest Session parameters.....	19
4.5.6 MBS Distribution Session parameters	20
4.5.7 MBS User Service Announcement parameters.....	22
4.6 Dynamic model	23
4.6.1 MBS Distribution Session life-cycle	23
4.7 QoS model.....	25
4.8 Security	25
4.9 Interworking with eMBMS	25
5 Procedures for 5G Multicast–Broadcast User Services.....	27
5.1 General	27
5.2 High-level baseline procedures	27
5.3 Procedures for User Service discovery/announcement	28
5.4 Procedures for User Service initiation/termination	28
5.5 Procedures for User Service data transfer	28
5.6 Associated delivery procedures.....	29
6 MBS User Services distribution methods.....	29
6.1 Object Distribution Method.....	29

6.2	Packet Distribution Method.....	29
7	Network Function services.....	30
7.1	General.....	30
7.2	MBSF Services.....	30
7.2.1	General.....	30
7.2.2	Nmbssf MBS User Service operations.....	30
7.2.2.1	Nmbssf_MBSUserService_Create service operation.....	30
7.2.2.2	Nmbssf_MBSUserService_Retrieve service operation.....	30
7.2.2.3	Nmbssf_MBSUserService_Update service operation.....	31
7.2.2.4	Nmbssf_MBSUserService_Destroy service operation.....	31
7.2.3	Nmbssf MBS User Data Ingest Session operation.....	31
7.2.3.1	Nmbssf_MBSUserDataIngestSession_Create service operation.....	31
7.2.3.2	Nmbssf_MBSUserDataIngestSession_Retrieve service operation.....	31
7.2.3.3	Nmbssf_MBSUserDataIngestSession_Update service operation.....	31
7.2.2.4	Nmbssf_MBSUserDataIngestSession_Destroy service operation.....	32
7.2.2.5	Nmbssf_MBSUserDataIngestSession_StatusSubscribe operation.....	32
7.2.2.6	Nmbssf_MBSUserDataIngestSession_StatusUnsubscribe operation.....	32
7.2.2.7	Nmbssf_MBSUserDataIngestSession_StatusNotify operation.....	32
7.3	MBSTF Services.....	32
7.3.1	General.....	32
7.3.2	Nmbstf_MBSDistributionSession service.....	33
7.3.2.1	Nmbstf_MBSDistributionSession_Create service operation.....	33
7.3.2.2	Nmbstf_MBSDistributionSession_Retrieve service operation.....	33
7.3.2.3	Nmbstf_MBSDistributionSession_Update service operation.....	33
7.3.2.4	Nmbstf_MBSDistributionSession_Destroy service operation.....	33
7.3.2.5	Nmbstf_MBSDistributionSession_StatusSubscribe operation.....	33
7.3.2.6	Nmbstf_MBSDistributionSession_StatusUnsubscribe operation.....	34
7.3.2.7	Nmbstf_MBSDistributionSession_StatusNotify operation.....	34
Annex A (informative): Deployment and Collaboration Models.....		35
A.1	Group Communication.....	35
A.2	5G Media Streaming.....	35
A.3	MBS Application Provider (AF/AS) in Trusted DN.....	35
A.4	MBS Application Provider (AF/AS) in external DN.....	36
A.5	MBSF/MBSTF-like functions in External DN.....	37
Annex B (informative): Nmb8 User Plane ingest examples.....		38
B.1	General.....	38
B.2	Object Distribution Method.....	38
B.2.1	Object Distribution Method with pull-based ingest.....	38
B.2.2	Object Distribution Method with push-based ingest.....	39
B.3	Packet Distribution Method.....	40
B.3.1	Proxy mode.....	40
B.3.2	Forward-only mode.....	41
Annex X (informative): Change history.....		42
History.....		43

Foreword

This Technical Specification has been produced by the 3rd Generation Partnership Project (3GPP).

The contents of the present document are subject to continuing work within the TSG and may change following formal TSG approval. Should the TSG modify the contents of the present document, it will be re-released by the TSG with an identifying change of release date and an increase in version number as follows:

Version x.y.z

where:

- x the first digit:
 - 1 presented to TSG for information;
 - 2 presented to TSG for approval;
 - 3 or greater indicates TSG approved document under change control.
- y the second digit is incremented for all changes of substance, i.e. technical enhancements, corrections, updates, etc.
- z the third digit is incremented when editorial only changes have been incorporated in the document.

In the present document, modal verbs have the following meanings:

- shall** indicates a mandatory requirement to do something
- shall not** indicates an interdiction (prohibition) to do something

The constructions "shall" and "shall not" are confined to the context of normative provisions, and do not appear in Technical Reports.

The constructions "must" and "must not" are not used as substitutes for "shall" and "shall not". Their use is avoided insofar as possible, and they are not used in a normative context except in a direct citation from an external, referenced, non-3GPP document, or so as to maintain continuity of style when extending or modifying the provisions of such a referenced document.

- should** indicates a recommendation to do something
- should not** indicates a recommendation not to do something
- may** indicates permission to do something
- need not** indicates permission not to do something

The construction "may not" is ambiguous and is not used in normative elements. The unambiguous constructions "might not" or "shall not" are used instead, depending upon the meaning intended.

- can** indicates that something is possible
- cannot** indicates that something is impossible

The constructions "can" and "cannot" are not substitutes for "may" and "need not".

- will** indicates that something is certain or expected to happen as a result of action taken by an agency the behaviour of which is outside the scope of the present document
- will not** indicates that something is certain or expected not to happen as a result of action taken by an agency the behaviour of which is outside the scope of the present document
- might** indicates a likelihood that something will happen as a result of action taken by some agency the behaviour of which is outside the scope of the present document

might not indicates a likelihood that something will not happen as a result of action taken by some agency the behaviour of which is outside the scope of the present document

In addition:

is (or any other verb in the indicative mood) indicates a statement of fact

is not (or any other negative verb in the indicative mood) indicates a statement of fact

The constructions "is" and "is not" do not indicate requirements.

1 Scope

The present document defines an architecture and high-level procedures for User Services conveyed using the 5G multicast–broadcast capabilities of the 5G System defined in TS 23.501 [2], TS 23.502 [3] and TS 23.247 [5].

2 References

The following documents contain provisions which, through reference in this text, constitute provisions of the present document.

- References are either specific (identified by date of publication, edition number, version number, etc.) or non-specific.
- For a specific reference, subsequent revisions do not apply.
- For a non-specific reference, the latest version applies. In the case of a reference to a 3GPP document (including a GSM document), a non-specific reference implicitly refers to the latest version of that document *in the same Release as the present document*.

- [1] 3GPP TR 21.905: "Vocabulary for 3GPP Specifications".
- [2] 3GPP TS 23.501: "System architecture for the 5G System (5GS)".
- [3] 3GPP TS 23.502: "Procedures for the 5G System (5GS)".
- [4] 3GPP TS 23.503: "Policy and charging control framework for the 5G System (5GS); Stage 2".
- [5] 3GPP TS 23.247: "Architectural enhancements for 5G multicast-broadcast services; Stage 2".
- [6] 3GPP TS 26.348: "Northbound Application Programming Interface (API) for Multimedia Broadcast/Multicast Service (MBMS) at the xMB reference point".
- [7] 3GPP TS 26.501: "5G Media Streaming (5GMS); General description and architecture".
- [8] IETF RFC 3500: "RTP: A Transport Protocol for Real-Time Applications".
- [9] IETF RFC 2250: "RTP Payload Format for MPEG1/MPEG2 Video".
- [10] 3GPP TS 26.247: "Transparent end-to-end Packet-switched Streaming Service (PSS); Progressive Download and Dynamic Adaptive Streaming over HTTP (3GP-DASH)".
- [11] 3GPP TS 26.531: "Data Collection and Reporting; General Description and Architecture".
- [12] 3GPP TS 23.468: "Group Communication System Enablers for LTE (GCSE_LTE)".

3 Definitions of terms, symbols and abbreviations

3.1 Terms

For the purposes of the present document, the terms given in 3GPP TR 21.905 [1], TS 23.501 [2], TS 23.502 [3], TS 23.247 [5] and the following apply. A term defined in the present document takes precedence over the definition of the same term, if any, in 3GPP TR 21.905 [1].

Broadcast MBS session: an MBS session to deliver the broadcast communication service, as defined in TS 23.247 [4].

distribution method: a mechanism (comprising the Object Distribution Method and Packet Distribution Method) used by the MBSTF to deliver data to the MBS Client as part of a User Service.

MBS Application Data Session: time, protocols and protocol state (i.e. parameters) provided by the MBSTF Client to the MBS-Aware Application.

MBS Application Service: an end-user service for which parts or all of the data are accessible by activating the reception of an MBS User Service.

MBS-Aware Application: a UE-based application that consumes User Services by invoking with MBS Client APIs.

MBS Client: the UE function that consumes User Services defined in the present document.

MBS Distribution Session: time, protocols and protocol state (i.e. parameters) which define sender and receiver configuration and which use an MBS Session for the delivery of an MBS User Data Ingest Session.

MBS Session: a multicast session or a broadcast session, as defined in TS 23.247 [4].

MBS User Service: an abstract transport-level service configured by the MBSF and using one or more MBS Distribution Sessions, possibly in combination with unicast, for the purpose of supporting an MBS-Aware Application via a set of APIs that allows the MBS Client to activate and deactivate reception of the MBS Session.

MBS User Data Ingest Session: time, protocols and protocol state (i.e. parameters) provided by an MBS Application Provider for distribution over an MBS User Service, and provided to the MBS-Aware Application as an MBS Application Data Session.

MBS User Service Announcement: a list of available MBS User Services and metadata associated with their delivery.

MBS User Service Control: control of an MBS User Service by an MBS-Aware Application interacting with an MBSF Client.

MBS User Service Provisioning: provisioning of an MBS User Service in the MBSF by an MBS Application Provider.

MBS User Service Session: an instance of an MBS User Service.

Multicast MBS session: an MBS session to deliver the multicast communication service, as defined in TS 23.247 [4].

Object Distribution Method: the distribution method supporting real-time and non-real-time distribution of discrete binary objects, including media segments, to MBS Clients as part of an MBS Session.

Packet Distribution Method: the distribution method supporting transparent delivery of Application Data Units to MBS Clients as part of an MBS Session.

3.2 Symbols

Void.

3.3 Abbreviations

For the purposes of the present document, the abbreviations given in 3GPP TR 21.905 [1], TS 23.501 [2], TS 23.502 [3], TS 23.247 [4] and the following apply. An abbreviation defined in the present document takes precedence over the definition of the same abbreviation, if any, in 3GPP TR 21.905 [1].

5QI	5G QoS Identifier
DN	Data Network
FEC	Forward Erasure Correction
MBS	Multicast–Broadcast Services
MB-SMF	Multicast–Broadcast Session Management Function
MB-UPF	Multicast–Broadcast User Plane Function
MBSF	Multicast–Broadcast Service Function
MBSTF	Multicast–Broadcast Service Transport Function
LTE	Long Term Evolution
NEF	Network Exposure Function
PCF	Policy and Charging Function
PDU	Protocol Data Unit
QoS	Quality of Service
SDU	Service Data Unit
UE	User Equipment

4 Reference architecture for 5G Multicast–Broadcast User Services

4.1 General

This clause defines a reference architecture for 5G Multicast–Broadcast User Services, including the logical functions involved and the logical reference points between them.

Interworking with LTE is specified in clause 5.2 of TS 23.247 [5] and its use in the context of MBS User Services is further specified in clauses 4.9 and A.1 of the present document.

4.2 System description

4.2.1 Network architecture

Figure 4.2.1-1 depicts the MBS network architecture defined in clause 5.1 of TS 23.247 [5] using the reference point representation.

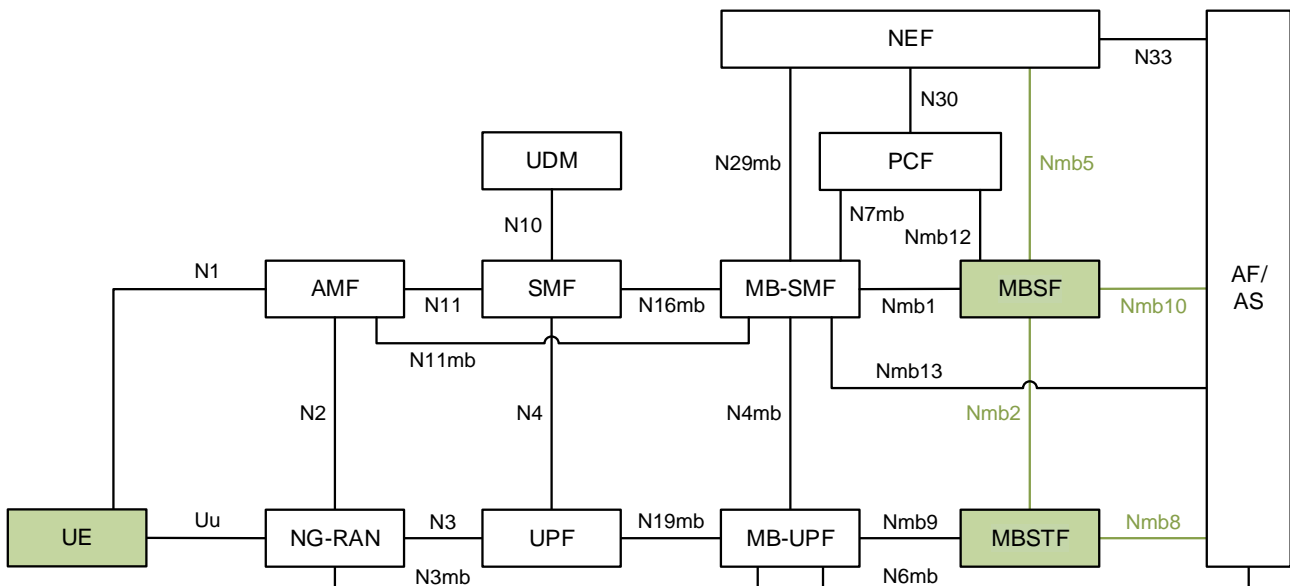

Figure 4.2.1-1: Network architecture for MBS User Services delivery and control

The functions and reference points involved in providing MBS User Services within the MBS System are highlighted in green. In particular:

- Reference point Nmb10 is used by the AF/AS to provision MBS User Services in the MBSF by invoking the *Nmbmf* service defined in clause 7.2.
- Reference point Nmb2 is used by the MBSF to configure and control MBS User Services distribution methods in the MBSTF by invoking the *Nmbstf* service defined in clause 7.3.
- Reference point Nmb8 is used by the MBSTF to ingest content from the AF/AS.

4.2.2 User Services network architecture

MBS User Services enable high-level applications to make use of the low-level features of the MBS System. An MBS User Service is provided by the MBSF and MBSTF working in combination to support configuration option 2 and configuration option 3 defined in annex A of TS 23.247 [5]. It enables a complete service offering to an end-user, via a set of APIs that allows the MBS Client to activate or deactivate reception of the service.

The MBS User Services architecture depicted in figure 4.2.2-1 shows the MBS-related entities involved in providing MBS User Services delivery and control. These are described in the following clauses. The MBS Application Provider plays the role of the AF/AS.

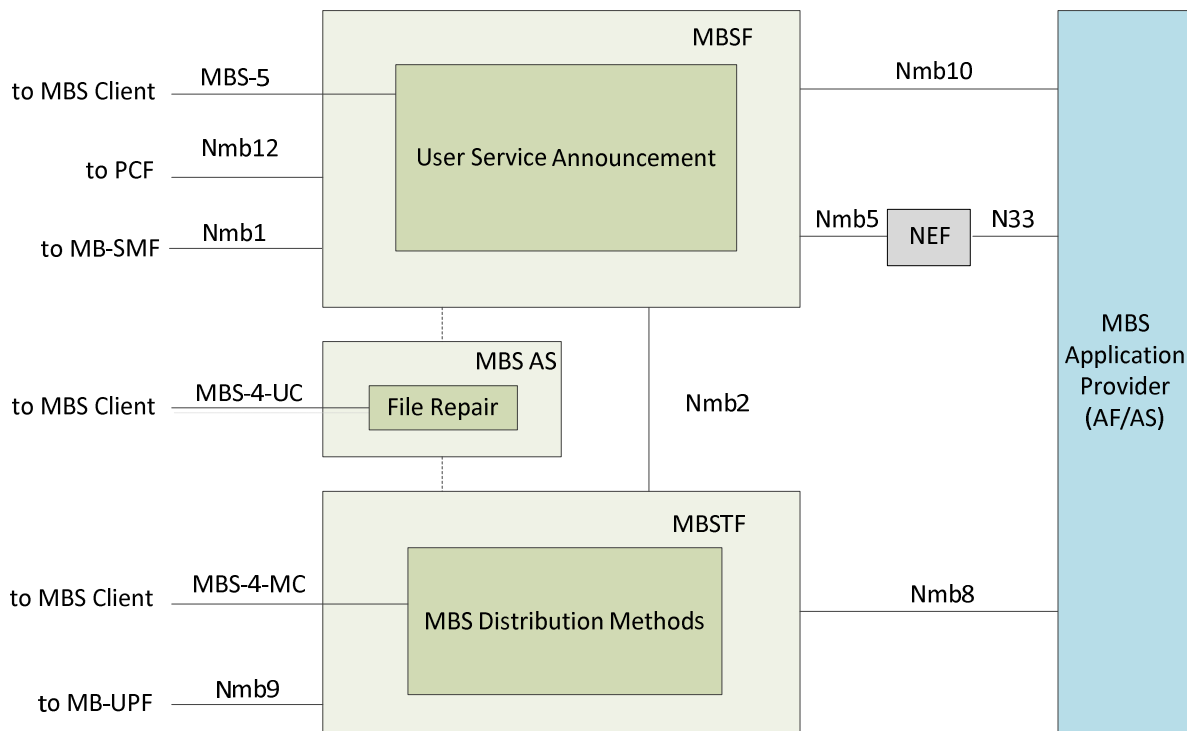

Figure 4.2.2-1: MBS User Services network architecture

4.2.3 User Services Distribution methods

The MBS User Services distribution methods defined in clause 6 of the present document make use of MBS Sessions (see clause 4.1 of TS 23.247 [5]) to deliver data to the MBS Client. The distribution methods may use either a multicast MBS Session or a broadcast MBS Session. A set of MBS distribution methods is provided by the MBSTF. These provide functionality such as security and key distribution, reliability control (by means of FEC techniques) and associated delivery procedures.

- **Object Distribution Method:** A distribution method that delivers discrete binary objects over an MBS Session. This may be used to support real-time distribution of media segments (as special objects) including Low-Latency CMAF segments.

The use of MBS Sessions by the Object Distribution Method is specified in clause 6.1.

- **Packet Distribution Method:** A distribution method that supports streaming of packetised media data over an MBS Session where Service Data Units (SDUs) are conveyed to the UE as part of Protocol Data Units (PDUs) or IP flows. Examples of upper layer SDUs are generic IP/UDP datagrams.

The use of MBS Sessions by the Packet Distribution Method is specified in clause 6.2.

The above distribution methods may use either a multicast MBS Session or a broadcast MBS Session to distribute content to an MBS Client and may also make use of a set of MBS associated delivery procedures.

4.2.4 User Service Announcement

The User Service Announcement provides information needed by the MBS Client to discover and activate the reception of one or more MBS User Services. User Service Announcement information may be delivered via MBS Distribution Sessions or via a regular PDU Session.

The baseline information conveyed in User Service Announcements is defined in clause 4.5.7.

4.2.5 User Services Consumption Reporting

Reporting by the MBS Client to the MBSF is for further study and may be realised by instantiating the data collection and reporting architecture specified in TS 26.531 [11]. This may include, for example, dynamically adjusting the Application Layer FEC redundancy level in the MBSTF according to the Packet Error Rate (PER) reported by the MBS Client.

4.3 Functional entities

4.3.1 General

The MBSF and MBSTF offer service layer functionality for sending data via MBS Sessions. The MBSF (clause 4.3.2) offers control plane functionality while the MBSTF (clause 4.3.3) offers user plane functionality. The MBSTF acts as a User Plane anchor when it sources IP multicast traffic. Reference point Nmb2 provides the means for the MBSF to configure the delivery methods in the MBSTF.

Figure 4.3.1-1 shows the complete set of functional entities involved in supporting MBS User Services when the MBS Application Provider is deployed in the Trusted DN, including client functions in the UE.

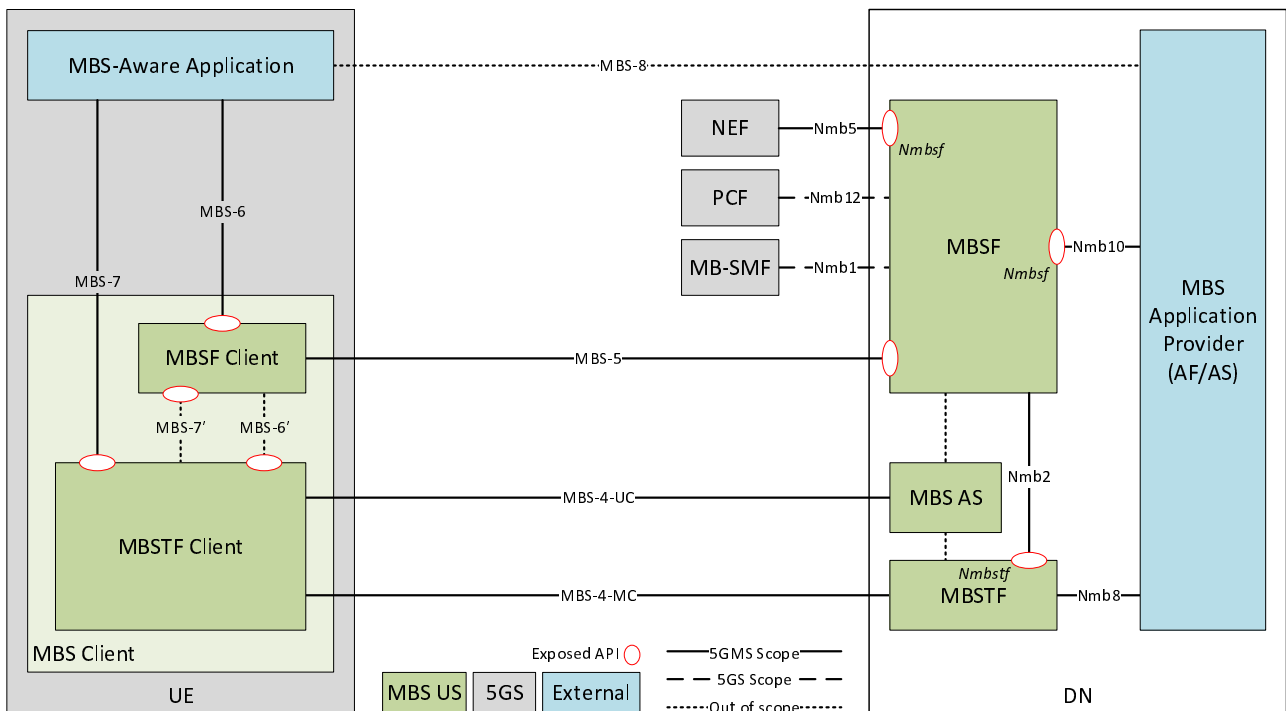

NOTE: When the MBS Application Provider is deployed outside the Trusted DN, it interacts with the MBSF via the NEF at reference point N33, as shown in figure 4.2.2-1, instead of via Nmb10.

Figure 4.3.1-1 MBS User Service reference architecture

In the above architecture, MBS-specific functions such as the MBS AS and MBSF are shown as independent and standalone. In deployments, they may be co-located on physical devices with other functions. As an example, the MBS AS may be hosted in the MBS Application Provider domain, or it may be hosted in a 5GMS AS.

4.3.2 MBSF

The functionality of the MBSF is defined in clause 5.3.2.11 of TS 23.247 [5]. It receives provisioning and control commands either directly at reference point Nmb10 or at reference point Nmb5 (via the NEF). The MBSF invokes MBS Session operations on the MB-SMF at reference point Nmb1. The MBSF configures the MBSTF at reference point Nmb2.

The User Service Announcement function of the MBSF provides session access information which is consumed by the MBS Client and subsequently used to discover and initiate the reception of one or multiple MBS User Services. The session access information may contain information for presentation to the end-user, as well as application parameters used in generating service content for consumption by the MBS Client.

The present document defines additional Control Plane functionalities of the MBSF to support MBS User Services including:

1. Generating the User Service Announcement for each MBS Session.
2. Managing User Service Announcement updates.
3. Providing the User Service Announcement information to the MBS Client in a timely manner using one or more of the following mechanisms:
 - a) Unicast User Service Announcement via reference point MBS-5, including the possible use of push- or notification-based update mechanisms.
 - b) User Service Announcement via an MBS Distribution Session at reference point MBS-4-MC, optionally in the same MBS Distribution Session as the content it is advertising.
 - c) User Service Announcement via application-private means at reference point MBS-8.

4.3.3 MBSTF

4.3.3.1 General

The functionality of the MBSTF is defined in clause 5.3.2.12 of TS 23.247 [5]. It receives User Plane data traffic at reference point Nmb8 and sends MBS data packets to the MB-UPF via reference point Nmb9.

NOTE: The MBSTF may not be present in all deployments of the MBS System. However, the MBSTF is an integral and necessary component of MBS User Services and the present document is not concerned with deployments in which it is absent.

The present document defines additional User Plane functionalities of the MBSTF to support MBS User Services as follows:

1. Receiving MBS Distribution Session configurations from the MBSF at reference point Nmb2.
2. Sending notification events to the MBSF, e.g. data ingest failure, session terminated, delivery started via reference point Nmb2.
3. Based on the MBS Distribution Session configuration:
 - a) MBS delivery of ingested objects or sequences of objects to the MBS Client using the Object Distribution Method (see clause 6.1). This may be used to support real-time distribution of media segments (as special objects) including CMAF segments.
 - b) MBS delivery of ingested packet streams to the MBS Client using the Packet Distribution Method (see clause 6.2).
 - c) Delivery of MBS User Service Announcement information (including updates as necessary) within the MBS Session.

4.3.3.2 MBSTF subfunctions to support Object Distribution Method

The MBSTF subfunctions supporting the Object Distribution Method are depicted in figure 4.3.3.2-1 below.

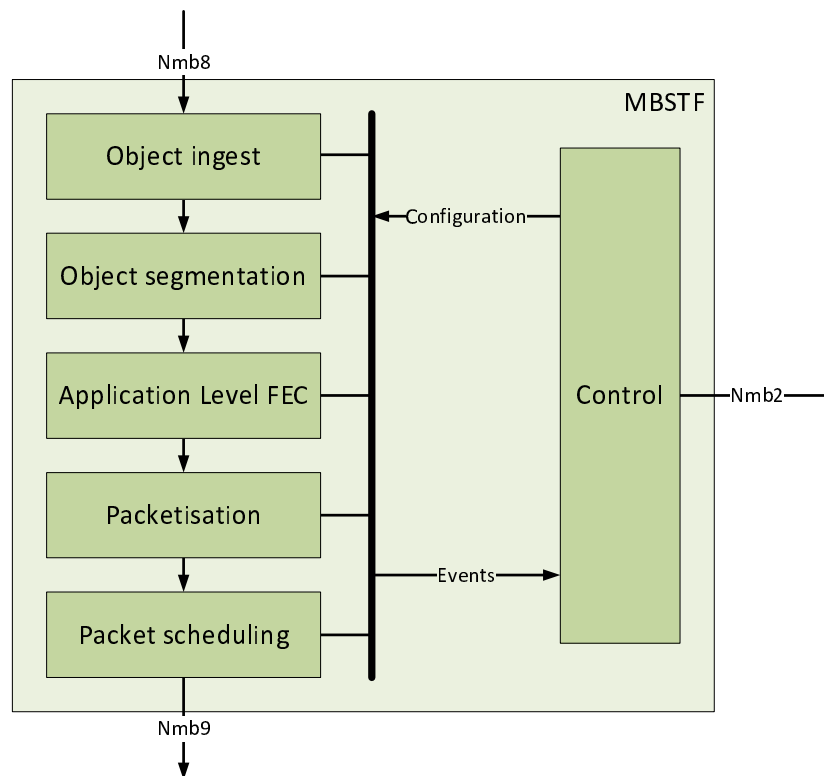

Figure 4.3.3.2-1: MBSTF architecture overview for Object Distribution Method

The *Object ingest* subfunction supports:

- Pull-based ingest at reference point Nmb8: The Object ingest subfunction in this case fetches one or more objects from the MBS Application Provider (AF/AS) using HTTPS.
- Push-based ingest at reference point Nmb8: The Object ingest subfunction receives one or more objects from the MBS Application Provider (AF/AS) using HTTPS.

The *Object segmentation subfunction* supports the partitioning of an object into payload units suitable for MBS transmission.

The optional *Application Layer FEC* subfunction supports object recovery when some packets are not received by the MBMS Client.

The *Packetisation* subfunction places the payload units (and, optionally, the FEC data) into Nmb9 transmission packets according to clause 6.1.

The *Packet scheduling* subfunction schedules the outgoing packet stream according to target bit rate configuration.

The *Control subfunction* offers support for MBSTF service configuration, status query and notifications at reference point Nmb2.

4.3.3.3 MBSTF subfunctions to support Packet Distribution Method

The MBSTF subfunctions supporting the Packet Distribution Method are depicted in figure 4.3.3.3-1 below.

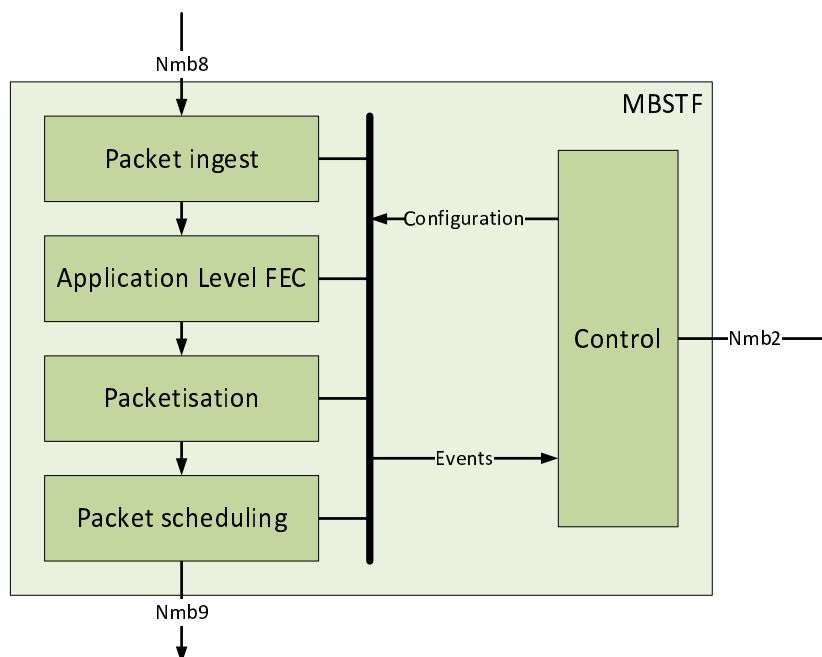

Figure 4.3.3.3-1: MBSTF architecture overview for Packet Distribution Method

The *Packet ingest* subfunction supports the reception of a packet sequence at reference point Nmb2 from authorized sources.

The optional *Application Layer FEC* subfunction to support object recovery when some packets are not received by the MBMS Client.

The *Packetisation* subfunction places the ingested packets (and, optionally, the FEC data) into Nmb9 transmission packets. Depending on the transmission mode, ingested packets may be reformatted suitable for MBS transmission.

The *Packet scheduling* subfunction schedules the outgoing data stream according to target bit rate configuration.

The *Control subfunction* offers support for MBSTF service configuration and service notifications at reference point Nmb2.

4.3.4 MBS AS

The MBS AS performs the following functions to support MBS User Services:

- Providing a byte-range file repair service for use with the Object Distribution Method.

4.3.5 MBS Client

The MBS Client function is part of the UE. The functionality of the UE is defined in clause 5.3.2.8 of TS 23.247 [5].

The MBS Client is further divided into the following subfunctions:

- *MBSF Client*: Communicates with the MBSF on MBS User Service control aspects.
- *MBSTF Client*: Communicates with the MBSTF or MBS AS in order to provide an MBS Application Data Session to the MBS-Aware Application.

The MBS Client performs the following functions to support MBS User Services:

- Reception of IP multicast data from either a Multicast MBS Session or a Broadcast MBS Session.
- Exposure of MBS Application Data Sessions towards an 5MBS-Aware Application.
- Using AL-FEC to recover packets or objects , if this optional feature is provisioned for the MBS Session.
- Unicast recovery of the application payload data carried in multicast/broadcast packets that are not successfully received via MBS-4, if unicast repair is provisioned for the MBS Session.

NOTE: Roaming of the MBS Client is for further study.

4.3.6 MBS-Aware Application

The MBS Client is typically controlled by an external application which triggers the establishment of an MBS User Services session. The MBS-Aware Application is not defined within the present document, but the function makes use of the MBS Client and (indirectly) the Network Functions supporting MBS User Services (MBSF, MBSTF and MBS AS) via reference points MBS-6 and MBS-7.

4.4 Reference points and interfaces

4.4.1 Overview

The following reference points defined in clause 5.1 of TS 23.247 [5] are relevant to MBS User Services architecture: Nmb1, Nmb2, Nmb5, Nmb8, Nmb9, Nmb10 and Nmb12.

The following additional reference points are defined by the present document:

- **MBS-4-MC**: Unidirectional multicast distribution of content from the MBSTF to the MBS Client.
- **MBS-4-UC**: File-based unicast repair between the MBS Client and the MBS AS.
- **MBS-5**: Interactions between the MBS Client and the MBSF for the purpose of MBS control plane and service handling.
- **MBS-6**: API exposed by the MBS Client and used by the MBS-Aware Application to manage and control MBS User Services.
- **MBS-7**: API exposed by the MBS Client and used by the MBS-Aware Application to receive user data information distributed using MBS User Services.
- **MBS-8**: Announcement of MBS User Services to the MBS-Aware Application by the MBS Application Provider.

In addition, the following reference points are defined inside the MBS Client function:

- **MBS-6'**: API exposed by the MBSTF Client and used by the MBSF Client to (de)activate reception of an MBS Session by the MBSTF. The reception parameters are supplied by the MBSF Client.

This reference point is outside the scope of MBS User Services and is not described further in the present document.

- **MBS-7'**: API exposed by the MSTF Client and used by the MBSTF to supply MBS Session configuration information that has been received from reference point MBS-4-MC.

This reference point is outside the scope of MBS User Services and is not described further in the present document.

4.5 Domain model

4.5.1 User Services domain model

The domain model for MBS User Services addresses different service and session concepts that are established between the different functional entities of the MBS User Services architecture, as shown in figure 4.5.1-1.

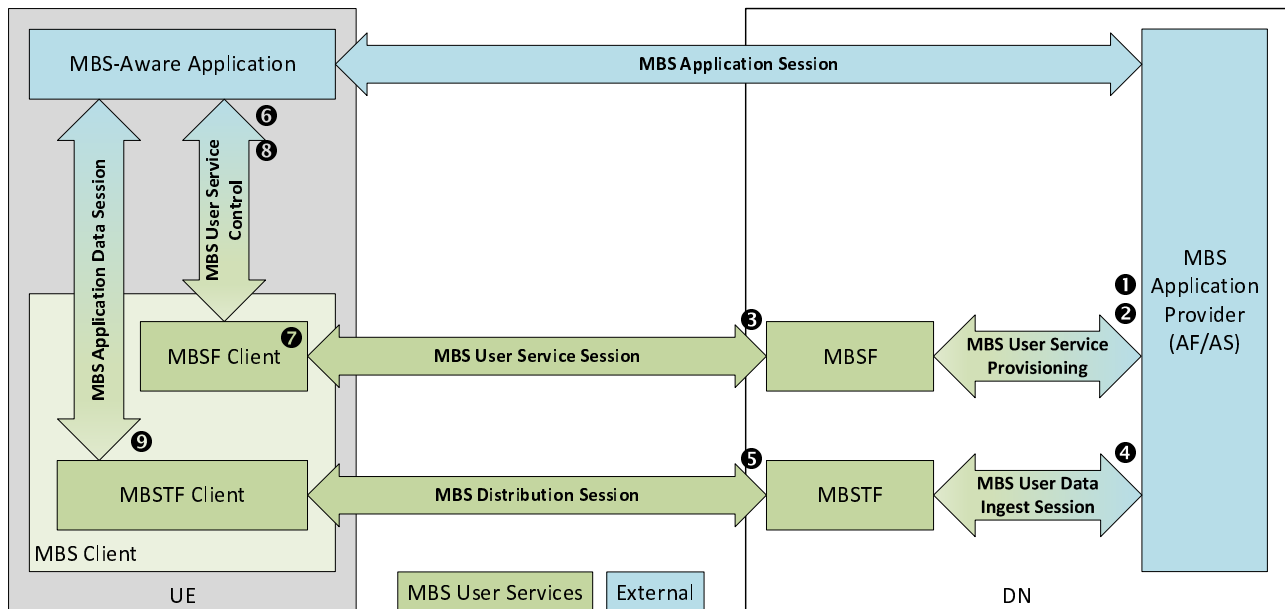

Figure 4.5.1-1: MBS User Services domain model

In the above figure:

1. The MBS Application Provider initiates *MBS User Service Provisioning* with the MBSF to provision an *MBS User Service*.
2. Subsequently, the MBS Application Provider provisions a number of time-bound *MBS User Data Ingest Sessions* within the scope of the newly provisioned *MBS User Service*, also by means of *MBS User Service Provisioning*.

When the current time enters the time window of a provisioned *MBS User Data Ingest Session*:

3. The MBSF establishes an *MBS User Service Session* of the parent *MBS User Service* by establishing an *MBS Session* in the MBS System. The reception parameters of the *MBS Session* are advertised in an *MBS User Service Announcement*, as defined in clause 4.5.2 below. The *MBS User Service Announcement* is optionally passed back to the MBS Application Provider by means of *MBS User Service Provisioning* (see step 7bis).
4. The MBSTF establishes an *MBS User Data Ingest Session* between itself and the MBS Application Provider for the purpose of ingesting objects or packets, according to the type of distribution method provisioned.
5. The MBSTF establishes an *MBS Distribution Session* and begins to transmit objects or packets on it according to the configured distribution method as and when they are available from the *MBS User Data Ingest Session*.

When an *MBS User Service* is established:

6. The MBS-Aware Application instructs the MBSF Client to activate an *MBS User Service* by means of *MBS User Service Control*.
7. The MBSF Client may acquire the *MBS User Service Announcement* from the MBSF via the *MBS User Service* [or via the *MBS Distribution Session*] and pass selected application-facing parameters (such as the service class and service names) up to the MBS-Aware Application by means of *MBS User Service Control*.

- 7bis. Alternatively, the MBS User Service Announcement may be made available to the MBS Application Provider, in which case the MBS-Aware Application obtains it via an application-private *MBS Application Service* and then provides it to the MBSF Client by means of MBS User Service Control.
8. The MBS-Aware Application selects the announced MBS User Service via MBS User Service Control and, as a result, the MBSF Client activates reception of the corresponding MBS Distribution Session in the MBSTF Client.
 9. An *MBS Application Data Session* is established between the MBSTF Client and the MBS-Aware Application to supply the latter with received (and possibly repaired) user data.

4.5.2 Static information model

Figure 4.5.2-1 shows how the different service and session concepts depicted in figure 4.5.1-1 above relate to each other. In this figure:

1. The MBS Application Provider provisions the parameters of a new MBS User Service by invoking the *Nmbsf* service either directly, or via the NEF.
2. The MBS Application Provider provisions a number of time-bound MBS User Data Ingest Sessions within the scope of the MBS User Service by invoking the *Nmbsf* service either directly, or via an equivalent service provided by the NEF. Each MBS User Data Ingest Session includes the details of one or more MBS Distribution Sessions. The MBSF provisions additional MBS Distribution Session parameters (denoted in table 4.5.6-1 as assigned by the MBSF) and exposes some of them back to the MBS Application Provider (as indicated by the NOTE to table 4.5.6-1).

NOTE: The MBSF typically allocates a Temporary Mobile Group Identity (TMGI) for each MBS Distribution session (see step 4 below), but it is also possible for the *Nmbsf* service invoker to nominate a particular value during this provisioning step if TMGI allocations are managed externally to the MBSF.

[3. The MBS Application Provider may additionally provision an MBS Consumption Reporting Configuration within the scope of the MBS User Service by invoking the *Nmbsf* service either directly, or via the NEF.]

Shortly before the current time enters the time window of a provisioned MBS User Data Ingest Session:

4. The MBSF provisions an MBS Session in the MBS System by invoking the *NmbSMF* service on the MB-SMF (see clause 9 of TS 23.247 [5]) to allocate a TMGI (if one has not already been allocated) for each MBS Distribution Session and to create an MBS Session Context for each one. In response, the MB-SMF provides the MB-UPF ingest information (specifically, the MB-UPF tunnel endpoint address and traffic flow information to be used by the MBSTF) to the MBSF.
5. The MBSF provisions an MBS Distribution Session in the MBSTF by invoking the *NmbSTF* service at reference point Nmb2 using the parameters from the newly created MBS Session Context.
6. Using the parameters from the MBS Distribution Session and from the newly created MBS Session Context, the MBSF compiles an MBS User Service Announcement to advertise the availability of the MBS User Service.

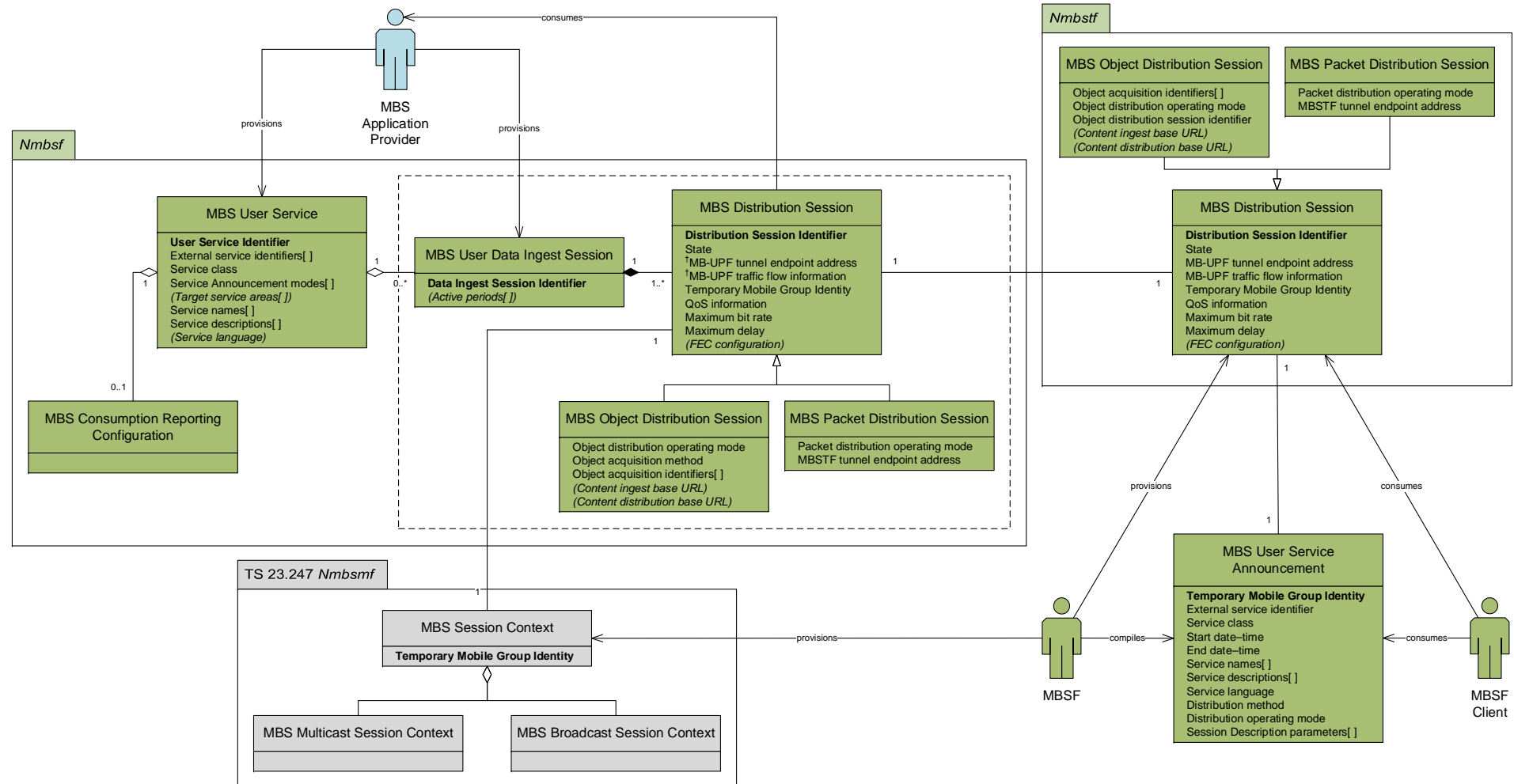

NOTE: Parameters not exposed to the MBS Application Provider via the Nmbssf service at reference point Nmb10 are annotated with the dagger symbol †.

Figure 4.5.2-1: MBS User Services static information model

4.5.3 MBS User Service parameters

This entity models an MBS User Service, as provisioned by the MBS Application Provider and as managed by the MBSF. The baseline parameters of an MBS User Service are listed in table 4.5.3-1 below:

Table 4.5.3-1: Baseline parameters of MBS User Service entity

Parameter	Cardinality	Assigner	Description
User Service Identifier	1..1	MBSF	A unique identifier for this MBS User Service in the MBSF.
External service identifiers	1..*	MBS Application Provider	A unique identifier for this MBS User Service that is also present in the MBS User Service Announcement. If assigned in a globally unique manner, this identifier may be useful in correlating this MBS User Service with the same service delivered by a different system.
Service class	1..1		The class of this MBS User Service, expressed as a term identifier from a controlled vocabulary.
Service announcement modes	1..*		Determines whether the MBS User Service Announcement compiled by the MBSF is advertised to the MBSF Client at reference point MBS-5[, and/or advertised to the MBSF Client via the MBS Session] and/or passed back to the MBS Application Provider.
Target service areas	0..*		The service areas in which this MBS User Service is to be made available.
Service names	1..*		A set of distinguishing names for this MBS User Service, one per language.
Service descriptions	1..*		A set of descriptions of this MBS User Service, one per language.
Service language	0..1		The main language of this MBS User Service.

MBS User Data Ingest Sessions (see clause 4.5.5) are separately provisioned within the scope of an MBS User Service. It is valid for an MBS User Service to have no MBS User Data Ingest Sessions currently provisioned.

[An MBS Consumption Reporting Configuration (see clause 4.5.4 below) may be separately provisioned within the scope of an MBS User Service.]

4.5.4 MBS Consumption Reporting Configuration parameters

Consumption reporting for MBS User Services is for future study.

4.5.5 MBS User Data Ingest Session parameters

This entity models an MBS User Data Ingest Session, as provisioned by the MBS Application Provider and as managed by the MBSF. The baseline parameters for an MBS User Data Ingest Session are listed in table 4.5.5-1 below:

Table 4.5.5-1: Baseline parameters of MBS User Data Ingest Session entity

Parameter	Cardinality	Assigner	Description
Data Ingest Session Identifier	1..1	MBSF	An identifier for this MBS User Data Ingest Session that is unique in the scope of the parent MBS User Service (see clause 4.5.3).
Active periods	0..*	MBS Application Provider	Periods of time during which the MBS User Data Ingest Session is active in the MBS System. If omitted, the session is active until further notice.

The MBS User Data Ingest Session is composed of one or more MBS Distribution Sessions (see clause 4.5.6 below) and these shall be provisioned in the same operation as the enclosing MBS User Data Ingest Session. It is not valid for an MBS User Data Ingest Session to have no MBS Distribution Sessions defined.

4.5.6 MBS Distribution Session parameters

This entity models an MBS Distribution Session, as provisioned by the MBS Application Provider and as managed by the MBSF. This MBSF subsequently uses this information to provision a corresponding MBS Distribution Session in the MBSTF.

The baseline parameters for an MBS Distribution Session that are common to all distribution methods are listed in table 4.5.6-1 below. All parameters are exposed to the MBS Application Provider except where noted otherwise.

Table 4.5.6-1: Common baseline parameters of MBS Distribution Session entity

Parameter	Cardinality	Assigner	Description
Distribution Session Identifier	1..1	MBSF	An identifier for this MBS Distribution Session that is unique within the scope of the MBS User Service (see clause 4.5.3).
State	1..1		The current state of the MBS Distribution Session: <i>INACTIVE</i> , <i>ESTABLISHED</i> , <i>ACTIVE</i> or <i>DEACTIVATING</i> (see clause 4.6.1).
MBS Session Context	1..1		As defined in clause 6.9 of TS 23.247 [5] (see NOTE).
MB-UPF tunnel endpoint address	1..1		The tunnel endpoint address of the MB-UPF that supports this MBS Distribution Session at reference point Nmb9 (see NOTE).
MB-UPF traffic flow information	1..1		Details of the traffic flow to be used by the MBSTF for this MBS Distribution Session, including the multicast group destination address and port number (see NOTE).
Temporary Mobile Group Identity	0..1	MBSF or MBS Application Provider	The Temporary Mobile Group Identity (TMGI) of the MBS Session supporting this MBS Distribution Session. Allocated by the MBSF in conjunction with the MB-SMF unless supplied by the MBS Application Provider at the time of provisioning.
QoS information	1..1	MBS Application Provider	A 5G QoS Identifier (5QI) [2] to be applied to the traffic flow for this MBS Distribution Session.
Maximum bit rate	1..1		The maximum bit rate for this MBS Distribution Session.
Maximum delay	0..1		The maximum end-to-end distribution delay that is tolerated for this MBS Distribution Session by the MBS Application Provider.
Distribution method	1..1		The distribution method for this MBS Distribution Session, as defined in clause 6.
Distribution operating mode	0..1		The operating mode in the case where multiple modes are defined in clause 6 for the indicated distribution method.
FEC configuration	0..1		Configuration for FEC information added by the MBSTF to protect this MBS Distribution Session.
NOTE: Internal parameter not exposed to the MBS Application Provider.			

An MBS User Service Announcement (see clause 4.5.7 below) shall be associated with an MBS Distribution Session when the latter is in the *ESTABLISHED* or *ACTIVE* state.

The following MBS Distribution Session parameters are additionally relevant when the distribution method is the Object Distribution Method:

Table 4.5.6-2: Additional MBS Distribution Session parameters for Object Distribution Method

Parameter	Cardinality	Assigner	Description
Object acquisition method	1..1	MBS Application Provider	Indicates whether the objects(s) are to be pushed into the MBSTF by the MBS Application Provider or whether they are to be pulled from the MBS Application Provider by the MBSTF.
Object acquisition identifiers	1..1		Identifies the object(s) to be ingested and distributed by the MBSTF during this MBS Distribution Session. This could be the ingest URL of the object, or the ingest URL of a manifest describing a set of objects, or a reference into a manifest describing a set of objects.
Content ingest base URL	0..1		A prefix substituted by the MBSTF with the content distribution base URL prior to distribution of ingested objects.
Content distribution base URL	0..1		A prefix substituted by the MBSTF in place of the content ingest base URL prior to distribution of ingested objects.

The following parameters are additionally relevant when the distribution method is the Packet Distribution Method:

Table 4.5.6-3: Additional MBS Distribution Session parameters for Packet Distribution Method

Parameter	Cardinality	Assigner	Description
MBSTF tunnel endpoint address	1..1	MBSF	An endpoint address to which an MBS Application Provider establishes a unicast tunnel at reference point Nmb8 prior to the commencement of this MBS User Data Ingest Session.
MBSTF traffic flow information	1..1		Details of the User Plane data traffic flow to be used by the MBS Application Provider for this MBS Distribution Session, including the multicast group destination address and port number.

4.5.7 MBS User Service Announcement parameters

This entity models an MBS User Service Announcement, which is compiled by the MBSF and used to advertise the current or imminent availability of an MBS User Service in the MBS System. The baseline parameters for an MBS User Service Announcement are listed in table 4.5.7-1 below:

Table 4.5.7-1: Baseline parameters of MBS User Service Announcement entity

Parameter	Cardinality	Assigner	Description
Temporary Mobile Group Identity	1..1	MB-SMF	The Temporary Mobile Group Identity (TMGI) of the MBS Session supporting the parent MBS Distribution Session.
External service identifiers	1..*	MBS Application Provider	A unique identifier used by the MBSF Client to distinguish between MBS User Services. If assigned in a globally unique manner, this identifier may be useful to the MBSF Client in correlating the MBS User Service with the same service delivered by a different system.
Service class	1..1		The class of the MBS User Service, expressed as a term identifier from a controlled vocabulary.
Start date–time	0..1		The point in time from which this MBS User Service Announcement is valid. If not present, the announcement is already valid.
End date–time	0..1		The point in time after which this MBS User Service Announcement is no longer valid. If not present, the announcement is valid indefinitely.
Service names	1..*		A set of distinguishing names for the MBS User Service, one per language.
Service descriptions	1..*		A set of descriptions of the MBS User Service, one per language.
Service language	0..1		The main language of the MBS User Service.
Distribution method	1..1		The distribution method for this MBS User Service, as defined in clause 6.
Distribution operating mode	0..1		The operating mode in the case where multiple modes are defined in clause 6 for the indicated distribution method.
Session Description parameters[]	1..1	MBSF	Additional parameters needed to receive the MBS Session supporting this MBS User Service, including relevant User Plane traffic flow parameters.

4.6 Dynamic model

4.6.1 MBS Distribution Session life-cycle

The life-cycle model for the MBS Distribution Session is depicted in figure 4.6.1-1 below. The current state of a provisioned MBS Distribution Session is reflected in the *state* parameter of the information entities maintained by the MBSF and the MBSTF, and is exposed to the MBS Application Provider via the *Nmbsf* service.

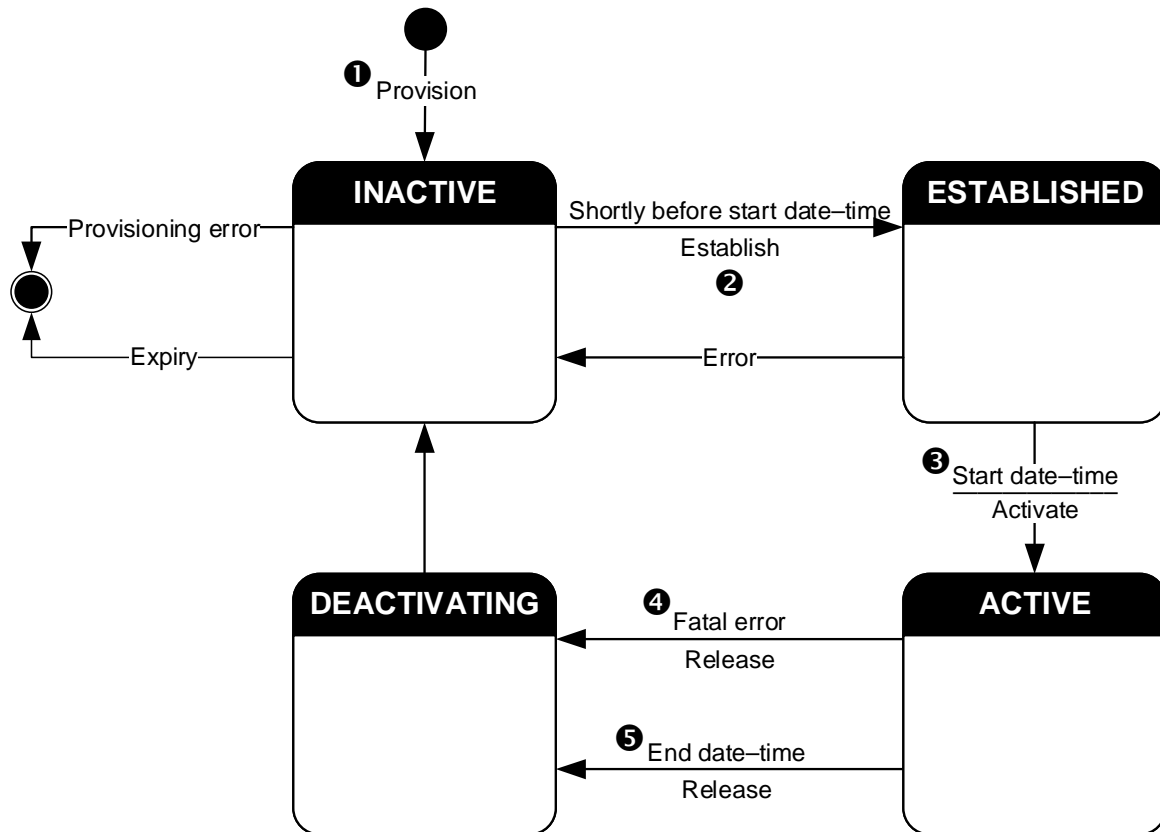

Figure 4.6.1-1: Life-cycle model for MBS Distribution Session

1. An MBS Distribution Session shall be in the *INACTIVE* state when it is first provisioned in the MBSF by the MBS Application Provider. The MBSF shall provision a corresponding MBS Distribution Session entity in the MBSTF. This replica of the MBS Distribution Session shall also be in the *INACTIVE* state.

If the provisioned end date–time of the parent MBS User Data Ingest Session is in the past, the MBS Distribution Session shall immediately expire and shall transition to a state in which it is no longer provisioned.

It is an error for the end date–time of the parent MBS User Data Ingest Session to be prior to the start date–time. The MBSF shall reject such a configuration at the time of provisioning.

2. Shortly before the provisioned start date–time of the parent MBS User Data Ingest Session (or immediately if the start date–time is in the past at the point of provisioning) the MBS Distribution Session shall transition into the *ESTABLISHED* state.

At this point:

- a. The MBSF shall reserve resources for the MBS Distribution Session in the MBS System by interacting with the MB-SMF at reference point Nmb1 using the procedures defined in clause 7.1.1 of TS 23.247 [5].
- b. The MBSF shall establish the MBS Distribution Session in the MBSTF by invoking the MBS Distribution Session establishment procedure on the *Nmbsf* service at reference point Nmb2 using the procedures defined in clause 5.4 of the present document. As a result, the MBSTF shall attempt to establish an MBS User Data

Ingest Session with the upstream data source at reference point Nmb8 and may commence ingesting data (but not distributing it).

NOTE: Successfully establishing the MBS User Data Ingest Session requires, in the case of the Object Distribution Method, successful retrieval of at least an initial object from the MBS Application Provider via reference point Nmb8. In the case of the Packet Distribution Method, successful establishment of the MBS User Data Ingest Session may require a data ingest tunnel to be established successfully with the MBS Application Provider at reference point Nmb8 and receipt of at least one data packet through that tunnel.

If either of these procedures fail, a suitable error shall be returned to the MBSF. Any successfully reserved resources in the MBS System shall be released and the MBS Distribution Session shall return to the *INACTIVE* state.

Otherwise, the MBSF shall advertise the successfully established MBS Distribution Session to MBSF Clients (either directly via MBS-5, or indirectly via MBS-8, depending on the provisioned advertisement mode) by means of an MBS User Service Announcement that it has compiled. An MBS Client in receipt of this advertisement may activate reception of the established MBS Distribution Session at this point (but will not yet receive any MBS data packets).

3. At the provisioned start date–time of the parent MBS User Data Ingest Session (or immediately if the start date–time is in the past at the point of provisioning) the MBS Distribution Session shall transition into the *ACTIVE* state.

The MBSF shall inform the MBSTF of this state transition by invoking the MBS Distribution Session activation procedure on the *Nmbstf* service at reference point Nmb2, as specified in clause 5.4 of the present document. As a result, the MBSTF shall commence sending MBS data packets to the MB-UPF at reference point Nmb9, and any MBS Clients that have activated reception of the previously advertised MBS Distribution Session in step 2 above may start to receive MBS data packets at reference point MBS-4-MC.

4. If the MBSTF encounters any error conditions when the MBS Distribution Session is in the *ACTIVE* state it shall notify the MBSF by invoking the MBS Distribution Session notification procedure defined by the *Nmbstf* service at reference point Nmb2 per clause 5.4.

If the MBSF determines that the error is of such a severity that the MBS Distribution Session cannot continue, it shall transition to the *DEACTIVATING* state.

- a. The MBSF shall stop advertising the MBS Distribution Session by means of an MBS User Service Announcement.
 - b. The MBSF shall inform the MBSTF of this state transition by invoking the MBS Distribution Session deactivation procedure on the *Nmbstf* service at reference point Nmb2 using the procedures defined in clause 5.4 of the present document. As a result, the MBSTF shall cease sending MBS data packets to the MB-UPF at reference point Nmb9.
 - c. The MBSF shall release the MBS Distribution Session in the MBSTF by invoking the MBS Distribution Session release procedure on the *Nmbstf* service at reference point Nmb2 using the procedures defined in clause 5.4 of the present document. As a result, the MBSTF shall stop ingesting data at reference point Nmb8 from the upstream data source. As a result of this procedure, the MBSTF shall automatically transition to the *INACTIVE* state.
 - d. The MBSF shall release resources in the MBS System associated with the MBS Distribution Session by interacting with the MB-SMF at reference point Nmb1 using the procedures defined in clause 7.1.1 of TS 23.247 [5]. As a result of this procedure, the MBSF shall automatically transition to the *INACTIVE* state.
5. At the provisioned end date–time of the parent MBS User Data Ingest Session (or immediately if the MBS Distribution Session or its parent MBS User Data Ingest Session are destroyed by the MBS Application Provider earlier than the provisioned end date–time) an MBS Distribution Session in the *ACTIVE* state shall transition into the *DEACTIVATING* state and the deactivation procedure described in steps 4a to 4d inclusive shall be followed.

Once the deactivation procedure is complete, the expired MBS Distribution Session shall transition automatically to a state in which it is no longer provisioned.

4.7 QoS model

How MBS User Services make use of the network Quality of Service primitives defined in TS 23.247 [5] is for further study.

4.8 Security

How MBS User Services makes use of the security primitives studied in TR 33.850 is for further study.

4.9 Interworking with eMBMS

Interworking between MBS and eMBMS is described in clause 5.2 of TS 23.247 [5] and applies at the service layer in cases where the same Multicast/Broadcast service is provided simultaneously via eMBMS and MBS. Figure 4.9-1 depicts a combined network architecture based on figure 4.2.1-1 in the present document and figure 5.2-1 in TS 23.247 [5].

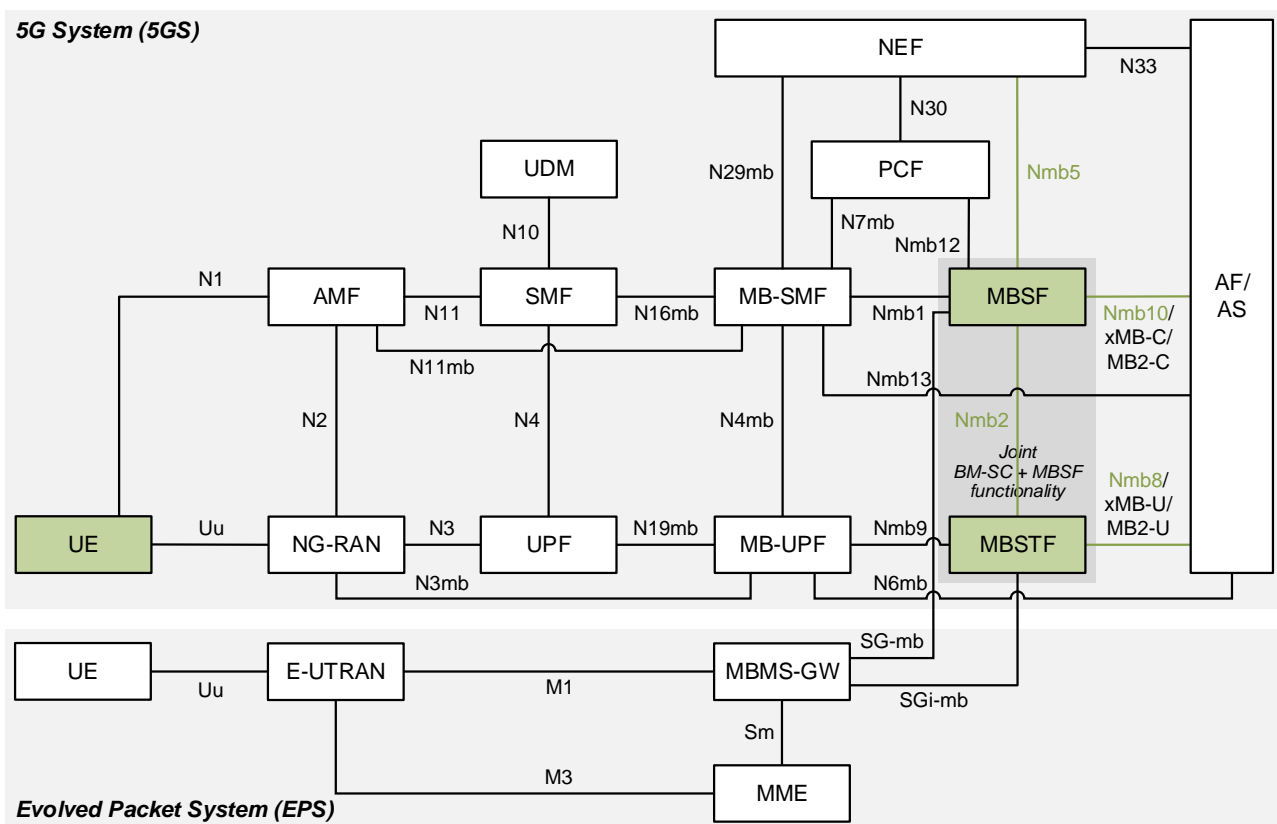

Figure 4.9-1: MBS-eMBMS interworking system architecture

To support MBS-eMBMS interworking according to the description in clause 5.2 of TS 23.247 [5], the MBS User Services architecture supports the following functionality:

1. MBS User Services are provisioned via reference point Nmb8 per the present document. eMBMS User Services are separately provisioned at xMB-C per TS 26.348 [6] or MB2-C per TS 23.468 [12]. A common TMGI is used in the MBS System and in the eMBMS System. The two User Services should be provisioned to ingest the same content if service continuity between the MBS System and the eMBMS System is required.
2. Signalling from the MBSF to the MBS Client is present in the MBS User Service Announcement indicating that the equivalent User Service is also available via eMBMS. By this, a UE that implements both an MBS Client and an eMBMS Client may choose to receive the service from either network, and may dynamically switch between them according to varying reception conditions. Such an architecture is shown in figure 4.9-2.

3. Content for the provisioned MBS User Service is ingested logically by the MBTSF at reference point Nmb8 per the present document. Content for the provisioned eMBMS User Service is ingested logically by the MBSTF at reference point xMB-U per TS 26.348 [6] or MB-2 per TS 23.468 [12]. If these reference points are compatible, the content is ingested once to satisfy both logical ingestions.
4. MBS User Services distribution methods are compatible with eMBMS delivery methods such that the same ingested content can be delivered to an MBS Client and to an eMBMS Client. UEs only supporting only eMBMS are served by this architecture as well.

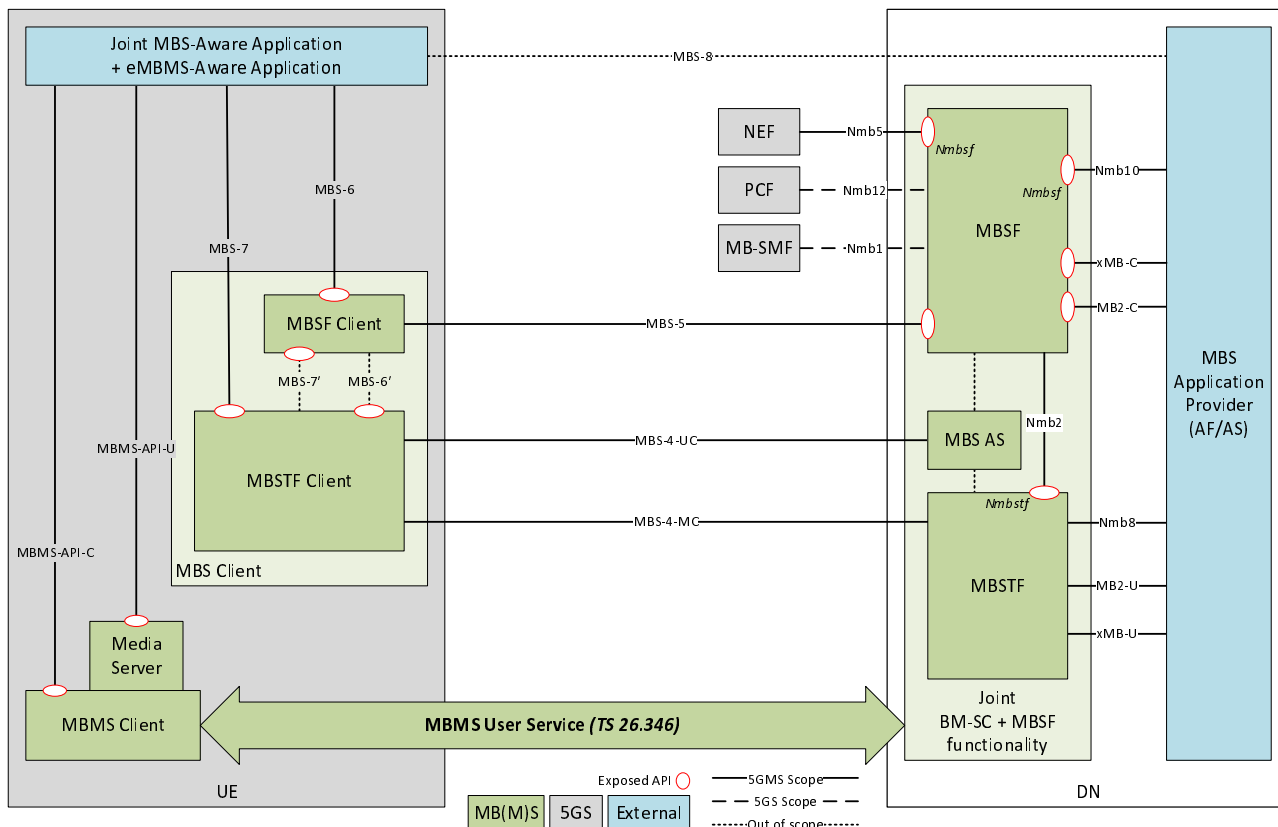

Figure 4.9-2: MBS–eMBMS interworking reference architecture

5 Procedures for 5G Multicast–Broadcast User Services

5.1 General

This clause defines the high-level procedures for 5G Multicast–Broadcast User Services.

5.2 High-level baseline procedures

The high-level baseline procedures for MBS User Services are shown in figure 5.2-1.

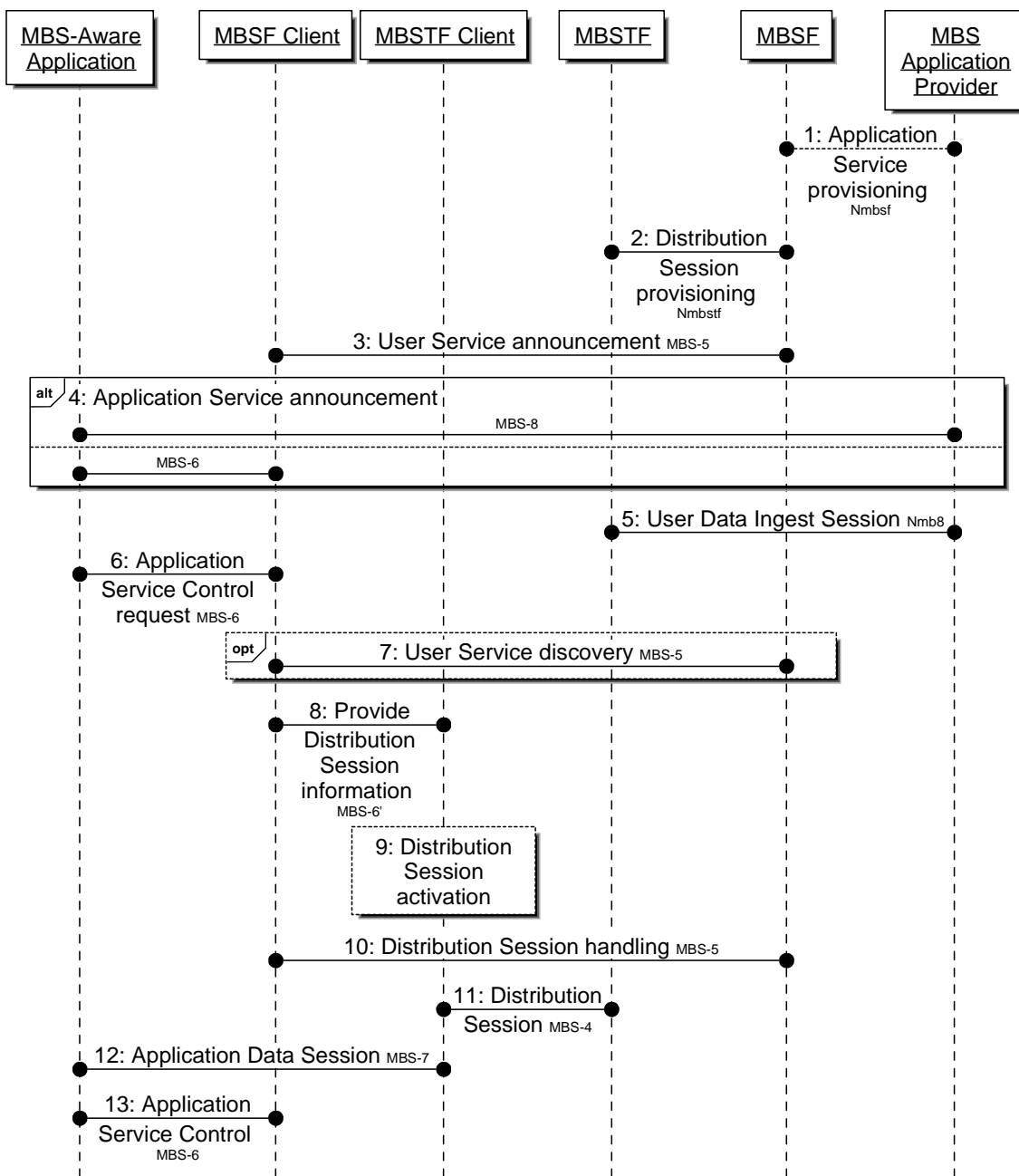

<http://msc-generator.sourceforge.net> v6.3.7

NOTE: In the interests of brevity, the prefix MBS is omitted from the numbered steps in the figure.

Figure 5.2-1: MBS User Service high-level baseline procedures

The basic procedures are as follows:

1. The MBS Application Provider provisions an Application Service as an MBS User Service by invoking the *Nmbsf* service on the MBSF.
2. The MBSF provisions one or more MBS Distribution Session by invoking the *Nmbstf* on the MBSTF.
3. The MBSF creates a User Service Announcement that may be accessed by the MBS Client of interested UEs.
4. The MBS Application Provider informs the MBS-Aware Application via MBS-8 that the specific Application Service can be accessed via an MBS User Service by means of an Application Service Announcement.

[Alternatively, the MBSF Client synthesises the Application Service Announcement from the User Service Announcement received in step 3 and informs the MBS-Aware Application via MBS-6 that the Application Service can be accessed via an MBS User Service.]
5. The MBS Application Provider creates an MBS User Data Ingest Session with the MBSTF (via the MBSF) and the latter ingests the user data via *Nmb8*.
6. The MBS-Aware Application requests the MBS Client to access a specific MBS User Service by invoking procedures at MBS-6.
7. Optional: If it has not already been received in step 3 above, the MBSF Client may discover additional access information about this MBS User Service by querying the MBSF via MBS-5.
8. The MBSF Client provides the MBS Distribution Session information acquired as part of the User Service Announcement information to the MBSTF Client via MBS-6'.
9. The MBSTF Client activates reception of the MBS Distribution Session.
10. The MBSF Client continuously handles the MBS Distribution Session data based on updates received via MBS-5.
11. The MBSTF Client receives MBS Distribution Session data via MBS-4-MC as part of the MBS Distribution Session.
12. The MBSTF provides the MBS Distribution Session data to the MBS-Aware Application via MBS-7 in an MBS Application Data Session.
13. The MBS-Aware Application controls the MBS User Service by invoking MBS Application Service Control procedures on the MBSF Client via MBS-6.

5.3 Procedures for User Service discovery/announcement

5.4 Procedures for User Service initiation/termination

5.5 Procedures for User Service data transfer

5.6 Associated delivery procedures

6 MBS User Services distribution methods

6.1 Object Distribution Method

The Object Distribution Method is used to deliver binary objects to the MBS Client over an MBS Session that have been received from the MBS Application Provider over reference point Nmb8.

The following Use Cases are supported:

- Single file delivery.
- Delivering a root object and its dependent objects as a collection, e.g. a web page and all the assets needed to render it.
- Object carouselling for file delivery, including updates of files.
- Real-time object streaming, for example for regular-latency or low-latency streaming delivery. In the latter case, the objects distributed may be CMAF segments as defined by the 5G Media Streaming DASH Interoperability Point specified in clause 7.3.11 of TS 26.247 [10].

Based on the configuration received from the MBSF via reference point Nmb2, the objects are ingested by the MBSTF from the MBS Application Provider via pull-based or push-based method. As defined in clause 4, the MBSTF segments the objects into appropriate payloads, adds the FEC redundancy and schedule packet transmission to the MBS Client.

File repair functionality may be utilized to repair object fragments transmitted by the MBSTF using the Object Distribution Method but lost or corrupted in transit. In such cases, the MBS Client may request the missing object fragments from the MBS AS. File repair may be done during an ongoing MBS User Services Session or after an MBS User Services Session.

6.2 Packet Distribution Method

The Packet Distribution Method is used to deliver *packet* streams to the MBS Client over an MBS Session that have been received from the MBS Application Provider over reference point Nmb8. This distribution method is particularly useful for multicast and broadcast of IP-based services for which the content delivery protocols are defined outside the scope of the MBS specification.

The MBSTF receives packet streams from the MBS Application Provider, typically in the form of UDP/IP packets, and sends them to the configured MBS Session. Optionally, packet sequence numbering and/or FEC redundancy may be added by the MBSTF.

The Packet Distribution Session may be operated in one of two different modes:

- In *Forward-only mode*, the transport protocol on top of IP is opaque to the MBS System. The User Service Announcement may be handled by the MBS Application Provider via external means at reference point MBS-8.
- In *Proxy mode*, the UDP packet payload of the UDP streams is opaque to the MBS Session. An MBS Client is expected to make the UDP Payloads available directly to the MBS-Aware Application, without further knowledge of the content carried.

7 Network Function services

7.1 General

The Network Function Services exposed by the MBSF and the MBSTF are defined in this clause.

7.2 MBSF Services

7.2.1 General

The following table illustrates the set of Network Function services exposed by the MBSF.

Table 7.2-1: NF services provided by MBSF

Service name	Service operation name	Operation semantics	Example consumer(s) (see NOTE)
<i>Nmbf_MBSUserService</i>	<i>Create</i>	Request/Response	AF, NEF
	<i>Retrieve</i>	Request/Response	AF, NEF
	<i>Update</i>	Request/Response	AF, NEF
	<i>Destroy</i>	Request/Response	AF, NEF
<i>Nmbf_MBSUserDataIngestSession</i>	<i>Create</i>	Request/Response	AF, NEF
	<i>Retrieve</i>	Request/Response	AF, NEF
	<i>Update</i>	Request/Response	AF, NEF
	<i>Destroy</i>	Request/Response	AF, NEF
	<i>StatusSubscribe</i>	Subscribe/Notify	AF, NEF
	<i>StatusUnsubscribe</i>		AF, NEF
	<i>StatusNotify</i>		AF, NEF
NOTE: Service exposure to the AF is for further study.			

7.2.2 Nmbf MBS User Service operations

7.2.2.1 Nmbf_MBSUserService_Create service operation

Service operation name: *Nmbf_MBSUserService_Create*

Description: Provision a new MBS User Service. The general data model is illustrated in figure 4.5.2-1.

Input (Required, Optional): Parameters in table 4.5.3-1 assigned by the MBS Application Provider.

Output (Required, Optional): Parameters in table 4.5.3-1.

7.2.2.2 Nmbf_MBSUserService_Retrieve service operation

Service operation name: *Nmbf_MBSUserService_Retrieve*

Description: Used by the NF/NEF to retrieve the properties of an existing MBS User Service.

Input (Required, Optional): MBS User Service Identifier

Output (Required, Output): Parameters in table 4.5.3-1.

7.2.2.3 Nmbsf_MBSUserService_Update service operation

Service operation name: *Nmbsf_MBSUserService_Update*

Description: Update the properties of an existing MBS User Service.

Input (Required, Optional): MBS User Service Identifier. Parameters in table 4.5.3-1 assigned by the MBS Application Provider.

Output (Required, Optional): Result indication. Parameters in table 4.5.3-1.

7.2.2.4 Nmbsf_MBSUserService_Destroy service operation

Service operation name: *Nmbsf_MBSUserService_Destroy*

Description: Release the resources of the associated MBS User Service.

Input (Required, Optional): MBS User Service Identifier.

Output (Required, Optional): Result indication.

7.2.3 Nmbsf MBS User Data Ingest Session operation

7.2.3.1 Nmbsf_MBSUserDataIngestSession_Create service operation

Service operation name: *Nmbsf_MBSUserDataIngestSession_Create*

Description: Create an MBS User Data Ingest Session, including a set of subordinate MBS Distribution Session(s).

Input (Required, Optional): Parameters in table 4.5.5-1 and table 4.5.6-1, and either table 4.5.6-2 or table 4.5.6-3 assigned by the MBS Application Provider, depending on the distribution method.

Output (Required, Optional): Result indication. MBS User Data Ingest Session Identifier.

7.2.3.2 Nmbsf_MBSUserDataIngestSession_Retrieve service operation

Service operation name: *Nmbsf_MBSUserDataIngestSession_Retrieve*

Description: Used by the AF/NEF to retrieve the properties of an existing MBS User Data Ingest Session.

Input (Required, Optional): MBS User Data Ingest Session Identifier.

Output (Required, Optional): Result indication. Parameters in table 4.5.5-1 and table 4.5.6-1, and either table 4.5.6-2 or table 4.5.6-3, depending on the distribution method.

7.2.3.3 Nmbsf_MBSUserDataIngestSession_Update service operation

Service operation name: *Nmbsf_MBSUserDataIngestSession_Update*

Description: Update the properties of an existing MBS User Data Ingest Session and its set of subordinate MBS Distribution Session(s).

Input (Required, Optional): MBS User Data Ingest Session Identifier. Parameters in table 4.5.5-1 and table 4.5.6-1, and either table 4.5.6-2 or table 4.5.6-3, depending on the distribution method.

Output (Required, Optional): Result indication.

7.2.2.4 Nmbf_MBSUserDataIngestSession_Destroy service operation

Service operation name: *Nmbf_MBSUserDataIngestSession_Destroy*

Description: Destroy an MBS User Data Ingest Session along with its subordinate MBS Distribution Session(s).

Input (Required, Optional): MBSUser Data Ingest Session Identifier.

Output (Required, Optional): Result indication.

7.2.2.5 Nmbf_MBSUserDataIngestSession_StatusSubscribe operation

Service operation name: *Nmbf_MBSUserDataIngestSession_StatusSubscribe*

Description: Invoked by AF/NEF on the MBSF when it needs to create a subscription to monitor at least one event relevant to the MBS User Data Ingest Session. The AF may subscribe to multiple events in a subscription.

Input (Required, Optional): MBS User Data Ingest Session Identifier, Event ID(s), notification target address.

Output (Required, Optional): When the subscription is accepted: Subscription correlation ID.

7.2.2.6 Nmbf_MBSUserDataIngestSession_StatusUnsubscribe operation

Service operation name: *Nmbf_MBSUserDataIngestSession_StatusUnsubscribe*

Description: Remove an existing subscription.

Input, Required: Subscription correlation ID.

Output, Required: Result Indication.

7.2.2.7 Nmbf_MBSUserDataIngestSession_StatusNotify operation

Service operation name: *Nmbf_MBSUserDataIngestSession_StatusNotify*

Description: Used by the MBSF to notify AF/NEF about the status change of the MBS User Data Ingest Session or the status of a file.

Input (Required, Optional): MBS User Data Ingest Session Identifier, Event ID(s).

Output, Required: Result indication.

7.3 MBSTF Services

7.3.1 General

The following table illustrates the set of NF services exposed by the MBSTF.

Table 8.3-1: NF services provided by MBSTF

Service name	Service operation name	Operation semantics	Example consumer(s)
<i>Nmbstf_MBSDistributionSession</i>	<i>Create</i>	Request/Response	MBSF
	<i>Retrieve</i>	Request/Response	MBSF
	<i>Update</i>	Request/Response	MBSF
	<i>Destroy</i>	Request/Response	MBSF
	<i>StatusSubscribe</i>	Subscribe/Notify	MBSF
	<i>StatusUnsubscribe</i>		MBSF
	<i>StatusNotify</i>		MBSF

7.3.2 Nmbstf_MBSDistributionSession service

7.3.2.1 Nmbstf_MBSDistributionSession_Create service operation

Service operation name: *Nmbstf_MBSDistributionSession_Create*

Description: Create a new MBS Distribution Session within the MBSTF.

Input (Required, Optional): Parameters in table 4.5.6-1 and either table 4.5.6-2 or table 4.5.6-3, depending on the distribution method.

Output, Required: Result indication.

7.3.2.2 Nmbstf_MBSDistributionSession_Retrieve service operation

Service operation name: *Nmbstf_MBSSession_Retrieve*

Description: Retrieve the parameters of an existing MBS Distribution Session.

Input (Required, Optional): MBS Distribution Session Identifier.

Output, Required: Parameters in table 4.5.6-1 and either table 4.5.6-2 or table 4.5.6-3, depending on the distribution method.

7.3.2.3 Nmbstf_MBSDistributionSession_Update service operation

Service operation name: *Nmbstf_MBSDistributionSession_Update*

Description: Update an existing MBS Distribution Session, for example to change the session stop time, object delivery session, application session, packets delivery session, files, and ancillary information.

Input (Required, Optional): MBS Distribution Session Identifier. Parameters in table 4.5.6-1 and either table 4.5.6-2 or table 4.5.6-3, depending on the distribution method.

Output, Required: Result indication.

7.3.2.4 Nmbstf_MBSDistributionSession_Destroy service operation

Service operation name: *Nmbstf_MBSDistributionSession_Destroy*

Description: Destroy an existing MBS Distribution Session.

Input (Required, Optional): MBS Distribution Session Identifier.

Output, Required: Result indication.

7.3.2.5 Nmbstf_MBSDistributionSession_StatusSubscribe operation

Service operation name: *Nmbstf_MBSDistributionSession_StatusSubscribe*

Description: Invoked by MBSF on the MBSTF when it needs to monitor at least one event relevant to the MBS Distribution session. The MBSF may subscribe to multiple events in a subscription.

Input (Required, Optional): MBS Distribution Session Identifier, Event ID(s), notification target address.

Output: When the subscription is accepted: Subscription correlation ID.

7.3.2.6 Nmbstf_MBSDistributionSession_StatusUnsubscribe operation

Service operation name: *Nmbstf_MBSDistributionSession_StatusUnsubscribe*

Description: Remove an existing subscription.

Input (Required, Optional): Subscription correlation ID.

Output: Result indication.

7.3.2.7 Nmbstf_MBSDistributionSession_StatusNotify operation

Service operation name: *Nmbstf_MBSDistributionSession_StatusNotify*

Description: Used by the MBSTF to notify the MBSF about the status change of the MBS Distribution Session or the status of the file.

Input (Required, Optional): MBS Distribution Session Identifier, Event ID(s).

Output: Result indication.

Annex A (informative): Deployment and Collaboration Models

A.1 Group Communication

The use of MBS User Services in collaboration with Group Communication services [12] is for further study.

A.2 5G Media Streaming

The use of MBS User Services in collaboration with the 5G Media Streaming architecture [7] is for further study.

A.3 MBS Application Provider (AF/AS) in Trusted DN

Figure A.3-1 depicts a collaboration in which the MBS Application Provider (AF/AS) is deployed within the Trusted DN.

1. The AF/AS uses the *Nmbssf* service directly at reference point Nmb10.
2. The MBSTF injects packets into the MB-UPF via reference point Nmb9.

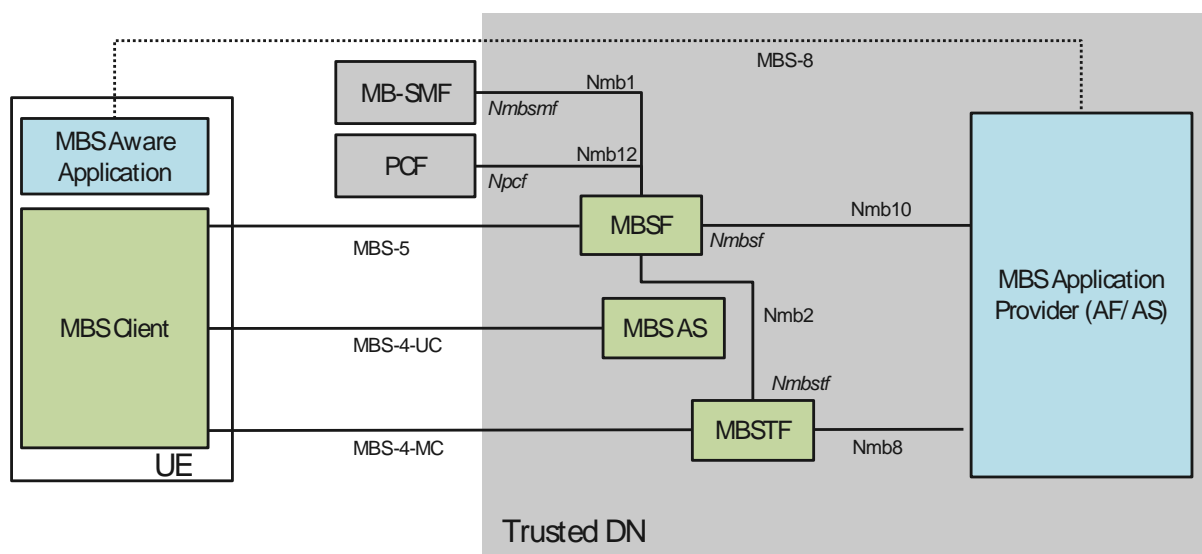

NOTE: Italic type is used to annotate service-based interactions.

Figure A.3-1: Deployment with MBS Application Provider (AF/AS) in Trusted DN

A.4 MBS Application Provider (AF/AS) in external DN

Figure A.4-1 depicts a collaboration in which the MBS Application Provider (AF/AS) is deployed within the External DN.

1. The AF/AS invokes the *Nnef* service at reference point N33 to access the MBSF via the NEF. The NEF, in turn, invokes the *Nmbmf* service on the MBSF at reference point Nmb5 on behalf of the AF/AS.
2. The MBSTF injects packets into the MB-UPF via reference point Nmb9.

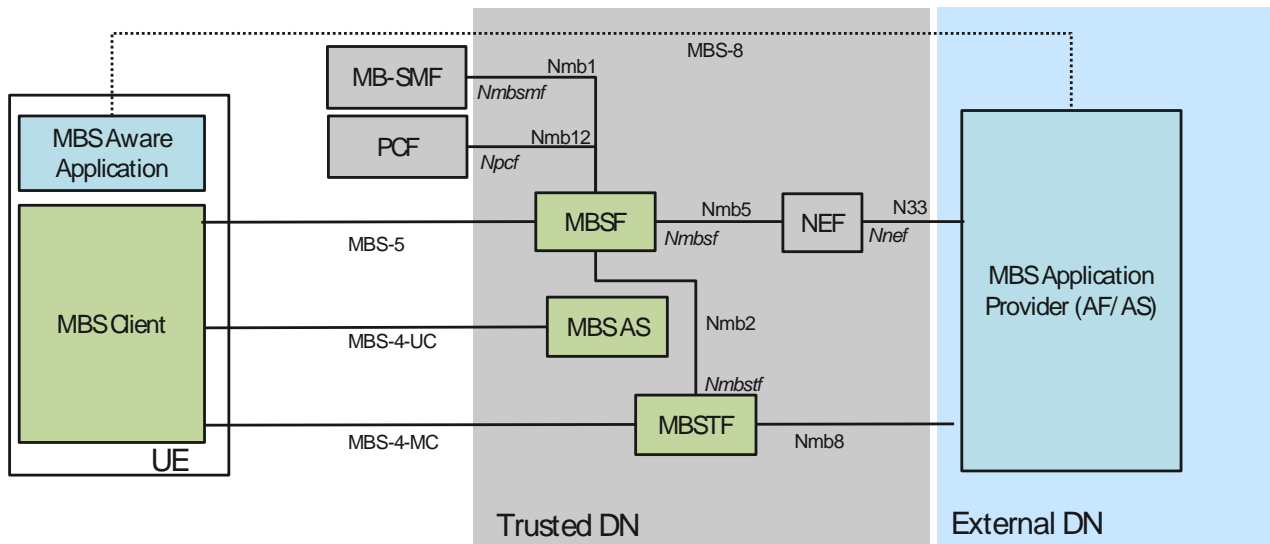

NOTE: Italic type is used to annotate service-based interactions.

Figure A.4-1: Deployment with MBS Application Provider (AF/AS) in External DN

A.5 MBSF/MBSTF-like functions in External DN

Figure A.5-1 depicts a transport-only deployment.

1. The MBSF-like function provisions MBS Services in the MB-SMF via the *Nnef* service at reference point N33.
2. The MBS Application Provider (AF/AS) uses an MBSTF-like function to produce packet data compliant with reference point MBS-4-MC. The packets are injected directly into the MB-UPF at reference point N6mb (not shown).
3. An MBS Application Provider (AF/AS) in an External DN uses an MBSF-like function to generate a Service Announcement for MBS User Services.
4. The MBS Application Provider (AF/AS) makes file repair available from an MBS AS-like function that is compliant with reference point MBS-4-UC.

The MBSF-like, MBSTF-like and MBS AS-like functions produce data streams which are compliant with the present document. Although the 5G System sets up a Transport-only Mode (see configuration option 1 in annex A of TS 23.247 [5]), the MBS Client in the UE follows the procedures defined in the present document.

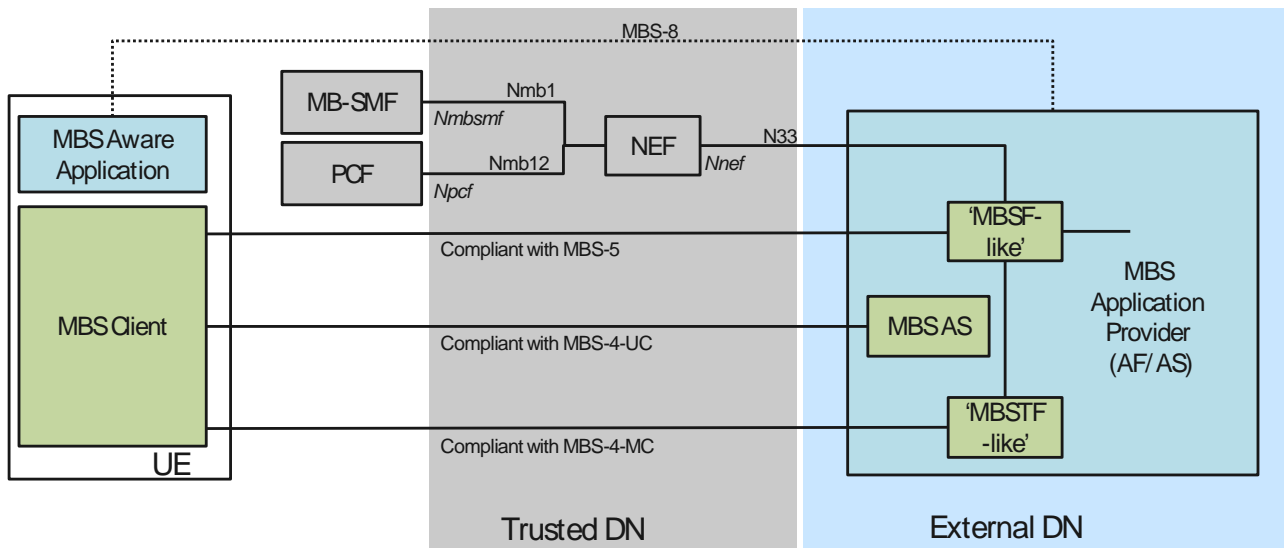

NOTE: Italic type is used to annotate service-based interfaces.

Figure A.5-1: Deployment with MBSF/MBSTF-like functions in External DN

Annex B (informative): Nmb8 User Plane ingest examples

B.1 General

This annex provides an overview of the different Nmb8 User Plane protocol stacks for the distribution methods defined in clause 6. The distribution method is selected and configured at reference point Nmb2 based on Nmb10 provisioning.

B.2 Object Distribution Method

B.2.1 Object Distribution Method with pull-based ingest

Figure B.2.1-1 illustrates a setup in which the MBS Application Provider (AF/AS) provides an object manifest to the MBSF listing the URLs of objects to be ingested and distributed. This is passed to the MBSTF at reference point Nmb2, and the MBSTF then fetches these objects using HTTP. The MBSTF handles all MBS-related complexity, e.g. converting the HTTP message payload into an IP multicast suitable protocol, adding AL-FEC, etc. The AF/AS delegates to the MBSF the delivery of MBS Service Announcement metadata to the MBS Client (i.e. IP multicast protocol details, etc).

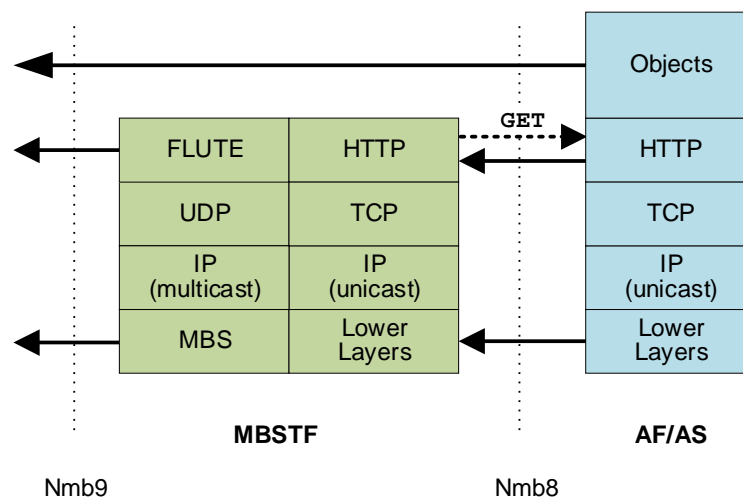

Figure B.2.1-1: Object Distribution Method using Pull ingest mode (HTTP GET)

The following Parameters are used by the MBS Application Provider (AF/AS) at reference point Nmb10 to provision this setup:

- *Distribution method* is set to *Object*.
- *Distribution operating mode* is set to *File* or *Collection* or *Carousel* or *Real-time*, as appropriate.
- *Object acquisition method* (property specific to the distribution method) is set to *Pull*.
- The *Object acquisition identifiers*, which refers to a manifest here, describing the set of objects.

B.2.2 Object Distribution Method with push-based ingest

Figure B.2.2-1 illustrates a setup in which the MBS Application Provider (AF/AS) pushes objects directly into the MBSTF at Nmb8 using HTTP PUT. The MBSTF handles all MBS-related complexity, e.g. converting the HTTP message payload into an IP multicast suitable protocol, adding AL-FEC, etc. The AF/AS delegates MBS delivery of Service Announcement metadata destined for the MBS Client (i.e. DASH MPD, IP multicast protocol details, etc.) to the MBSTF via MBSF.

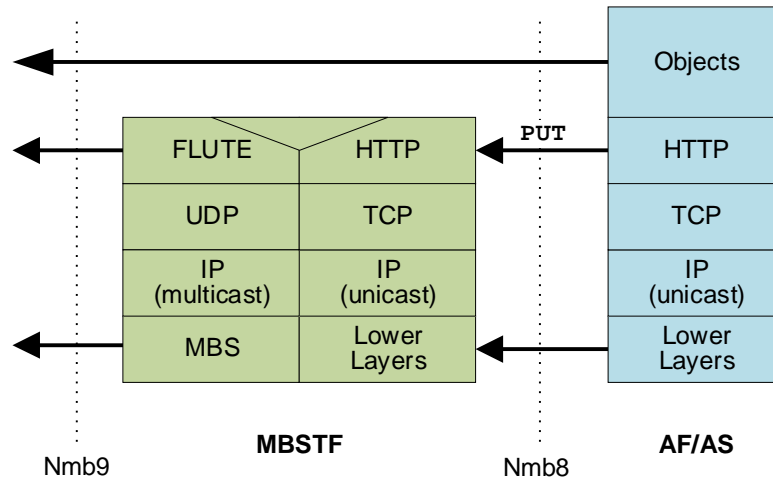

Figure B.2.2-1: Object Distribution Method using Push ingest mode (HTTP PUT)

The following MBS Distribution Session properties are used by the MBS Application Provider (AF/AS) at reference point Nmb10 to provision this setup:

- *Distribution method* is set to *Object*.
- *Distribution operating mode* is set to *File* or *Collection* or *Carousel* or *Real-time*, as appropriate.
- *Object acquisition method* is set to *Push*.
- The *Object acquisition identifiers* contains here the Push base URL, which is used to ingest objects. The MBSF provides the *Push base URL* (property specific to the distribution method) to the MBS Application Provider (AF/AS).
- *Distribution base URL* contains the base URL for the objects. The MBSF replaces the Push base URL part of the object ingest URL with the value of the *Distribution base URL* for inclusion in FLUTE FDT instance(s) and (in some cases) in the Service Announcement.

B.3 Packet Distribution Method

B.3.1 Proxy mode

Figure B.3.1-1 illustrates a setup in which the MBS Application Provider (AF/AS) injects UDP datagrams directly into the MBSTF at reference point Nmb8. The MBSTF handles all MBS-related complexity, e.g. restamping the UDP datagram headers and/or the IP packet headers, as required for distribution.

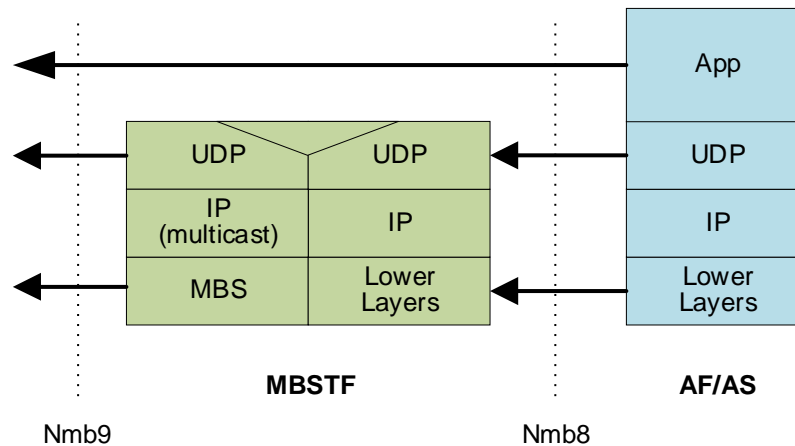

Figure B.3.1-1: Packet Distribution Method using Proxy mode

The following MBS Distribution Session properties are used by the MBS Application Provider (AF/AS) at reference point Nmb10 to provision this setup:

- *Distribution method* is set to *Packet*.
- *Distribution operating mode* is set to *Proxy*.
- *Session Description Parameters for User Plane* (property specific to the distribution method) indicates UDP flow mapping descriptions. The MBSTF provides the *MBSTF tunnel endpoint address* (property specific to the distribution method) to the MBS Application Provider (AF/AS) and joins the multicast group in the *MBSTF traffic flow information* (property specific to the distribution method) in order to receive the UDP datagram stream.

B.3.2 Forward-only mode

Figure B.3.2-1 illustrates a setup in which the MBS Application Provider (AF/AS) injects multicast IP packets encapsulated in a unicast UDP/IP tunnel directly into the MBSTF. The MBSTF decapsulates the multicast IP packets from the tunnel and forwards them unmodified to the MBS Session at reference point Nmb9.

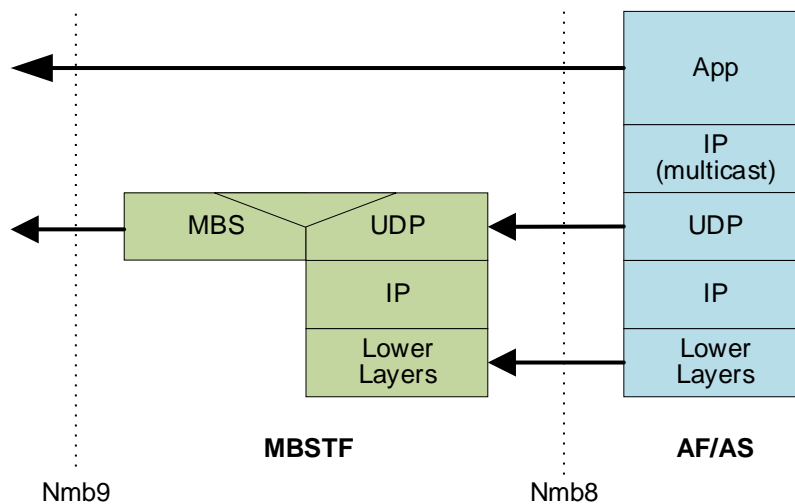

Figure B.3.2-1: Packet Distribution Method using Forward-only mode

The following MBS Distribution Session properties are used by the MBS Application Provider (AF/AS) at reference point Nmb10 to provision this setup:

- *Distribution method* is set to *Packet*.
- *Distribution operating mode* is set to *Forward-only*.
- *Session Description Parameters for User Plane* (property specific to the distribution method) indicates UDP flow mapping descriptions. The MBSTF provides the *MBSTF tunnel endpoint address* (property specific to the distribution method) to the MBS Application Provider (AF/AS) so that it can establish the UDP/IP tunnel with the MBSTF and start sending tunnelled IP packets.

Annex X (informative): Change history

Change history							
Date	Meeting	TDoc	CR	Rev	Cat	Subject/Comment	New version
2021-07	Post-SA4#114-e ad hoc	S4al211206				Initial skeleton document.	0.0.1
2021-08	SA4#115-e	S4-211270				Implemented agreements at SA4#115-e	0.1.0
2021-11	SA4#116-e	S4-211663				Implemented agreements at SA4#115-e: S4-211588: Service/session model and high-level procedures. S4-211597: Reference architecture and reference points. S4-211657: Definitions of functional entities. S4-211661: Definitions of two distribution methods. S4-211662: Collaboration scenarios.	0.2.0
2021-12	SA#94-e	SP-211343				Presentation to plenary for information	1.0.0
2022-02	SA4#117-e	S4-220235				Implemented agreements at SA4#115-e: S4-220056r05: Static domain model and baseline parameters. S4-220057: MBS Distribution Session life-cycle model. S4-220149r01: Network Function services. S4-220150r03: Nmb8 User Plane ingest examples. S4-220112r03: Interworking with eMBMS and updates on User Service Announcement carriage. S4-220123r08: Support of interworking with LTE-MBMS.	1.1.0
2022-03	SA#95-e	SP-220297				Presentation to SA for approval	2.0.0
2022-03	SA#95-e					Under change control	17.0.0

History

Document history		
V17.0.0	May 2022	Publication