

ETSI TS 128 305 V17.0.0 (2022-04)



**Digital cellular telecommunications system (Phase 2+) (GSM);
Universal Mobile Telecommunications System (UMTS);
LTE;
5G;
Control and monitoring of
Power, Energy and Environmental (PEE)
parameters Integration Reference Point (IRP);
Information Service (IS)
(3GPP TS 28.305 version 17.0.0 Release 17)**



Reference

RTS/TSGS-0528305vh00

Keywords

5G,GSM,LTE,UMTS

ETSI

650 Route des Lucioles
F-06921 Sophia Antipolis Cedex - FRANCE

Tel.: +33 4 92 94 42 00 Fax: +33 4 93 65 47 16

Siret N° 348 623 562 00017 - APE 7112B
Association à but non lucratif enregistrée à la
Sous-Préfecture de Grasse (06) N° w061004871

Important notice

The present document can be downloaded from:

<http://www.etsi.org/standards-search>

The present document may be made available in electronic versions and/or in print. The content of any electronic and/or print versions of the present document shall not be modified without the prior written authorization of ETSI. In case of any existing or perceived difference in contents between such versions and/or in print, the prevailing version of an ETSI deliverable is the one made publicly available in PDF format at www.etsi.org/deliver.

Users of the present document should be aware that the document may be subject to revision or change of status.

Information on the current status of this and other ETSI documents is available at

<https://portal.etsi.org/TB/ETSIDeliverableStatus.aspx>

If you find errors in the present document, please send your comment to one of the following services:

<https://portal.etsi.org/People/CommitteeSupportStaff.aspx>

If you find a security vulnerability in the present document, please report it through our
Coordinated Vulnerability Disclosure Program:

<https://www.etsi.org/standards/coordinated-vulnerability-disclosure>

Notice of disclaimer & limitation of liability

The information provided in the present deliverable is directed solely to professionals who have the appropriate degree of experience to understand and interpret its content in accordance with generally accepted engineering or other professional standard and applicable regulations.

No recommendation as to products and services or vendors is made or should be implied.

No representation or warranty is made that this deliverable is technically accurate or sufficient or conforms to any law and/or governmental rule and/or regulation and further, no representation or warranty is made of merchantability or fitness for any particular purpose or against infringement of intellectual property rights.

In no event shall ETSI be held liable for loss of profits or any other incidental or consequential damages.

Any software contained in this deliverable is provided "AS IS" with no warranties, express or implied, including but not limited to, the warranties of merchantability, fitness for a particular purpose and non-infringement of intellectual property rights and ETSI shall not be held liable in any event for any damages whatsoever (including, without limitation, damages for loss of profits, business interruption, loss of information, or any other pecuniary loss) arising out of or related to the use of or inability to use the software.

Copyright Notification

No part may be reproduced or utilized in any form or by any means, electronic or mechanical, including photocopying and microfilm except as authorized by written permission of ETSI.

The content of the PDF version shall not be modified without the written authorization of ETSI.

The copyright and the foregoing restriction extend to reproduction in all media.

© ETSI 2022.
All rights reserved.

Intellectual Property Rights

Essential patents

IPRs essential or potentially essential to normative deliverables may have been declared to ETSI. The declarations pertaining to these essential IPRs, if any, are publicly available for **ETSI members and non-members**, and can be found in ETSI SR 000 314: "*Intellectual Property Rights (IPRs); Essential, or potentially Essential, IPRs notified to ETSI in respect of ETSI standards*", which is available from the ETSI Secretariat. Latest updates are available on the ETSI Web server (<https://ipr.etsi.org/>).

Pursuant to the ETSI Directives including the ETSI IPR Policy, no investigation regarding the essentiality of IPRs, including IPR searches, has been carried out by ETSI. No guarantee can be given as to the existence of other IPRs not referenced in ETSI SR 000 314 (or the updates on the ETSI Web server) which are, or may be, or may become, essential to the present document.

Trademarks

The present document may include trademarks and/or tradenames which are asserted and/or registered by their owners. ETSI claims no ownership of these except for any which are indicated as being the property of ETSI, and conveys no right to use or reproduce any trademark and/or tradename. Mention of those trademarks in the present document does not constitute an endorsement by ETSI of products, services or organizations associated with those trademarks.

DECT™, **PLUGTESTS™**, **UMTS™** and the ETSI logo are trademarks of ETSI registered for the benefit of its Members. **3GPP™** and **LTE™** are trademarks of ETSI registered for the benefit of its Members and of the 3GPP Organizational Partners. **oneM2M™** logo is a trademark of ETSI registered for the benefit of its Members and of the oneM2M Partners. **GSM®** and the GSM logo are trademarks registered and owned by the GSM Association.

Legal Notice

This Technical Specification (TS) has been produced by ETSI 3rd Generation Partnership Project (3GPP).

The present document may refer to technical specifications or reports using their 3GPP identities. These shall be interpreted as being references to the corresponding ETSI deliverables.

The cross reference between 3GPP and ETSI identities can be found under <http://webapp.etsi.org/key/queryform.asp>.

Modal verbs terminology

In the present document "**shall**", "**shall not**", "**should**", "**should not**", "**may**", "**need not**", "**will**", "**will not**", "**can**" and "**cannot**" are to be interpreted as described in clause 3.2 of the [ETSI Drafting Rules](#) (Verbal forms for the expression of provisions).

"**must**" and "**must not**" are **NOT** allowed in ETSI deliverables except when used in direct citation.

Contents

Intellectual Property Rights	2
Legal Notice	2
Modal verbs terminology.....	2
Foreword.....	6
Introduction	6
1 Scope	7
2 References	7
3 Definitions and abbreviations.....	7
3.1 Definitions	7
3.2 Abbreviations	8
4 System overview	8
4.1 System Context	8
5 Model	9
5.1 Model for solution 1	9
5.1.0 Introduction.....	9
5.1.1 Imported and associated information entities	10
5.1.1.1 Imported information entities and local labels	10
5.1.1.2 Associated information entities and local labels	10
5.1.2 Class diagrams	10
5.1.2.1 Relationships.....	10
5.1.2.2 Inheritance.....	10
5.1.3 Class definitions.....	10
5.1.4 Attribute definitions.....	10
5.1.5 Common notifications.....	10
5.2 Model for solution 2	10
5.2.0 Introduction.....	10
5.2.1 Imported and associated information entities	11
5.2.1.1 Imported information entities and local labels	11
5.2.1.2 Associated information entities and local labels	11
5.2.2 Class diagrams	11
5.2.2.1 Relationships.....	11
5.2.2.2 Inheritance.....	11
5.2.3 Class definitions.....	11
5.2.3.1 PEEMonitoredEntity	11
5.2.3.1.1 Definition.....	11
5.2.3.1.2 Attributes	11
5.2.3.1.3 Attribute constraints	12
5.2.3.1.4 Notifications	12
5.2.3.1.5 State diagram	12
5.2.3.2 PEEMEDescription	12
5.2.3.2.1 Definition.....	12
5.2.3.2.2 Attributes	12
5.2.3.2.3 Attribute constraints	12
5.2.3.2.4 Notifications	12
5.2.3.2.5 State diagram	12
5.2.3.3 PEEMeasurementData	13
5.2.3.3.1 Definition.....	13
5.2.3.3.2 Attributes	13
5.2.3.3.3 Attribute constraints	13
5.2.3.3.4 Notifications	13
5.2.3.3.5 State diagram	13
5.2.3.4 PEEAlarmInformation	13

5.2.3.4.1	Definition.....	13
5.2.3.4.2	Attributes	13
5.2.3.4.3	Attribute constraints	14
5.2.3.4.4	Notifications	14
5.2.3.4.5	State diagram	14
5.2.3.5	PEEConfigInformation	14
5.2.3.5.1	Definition.....	14
5.2.3.5.2	Attributes	14
5.2.3.5.3	Attribute constraints	14
5.2.3.5.4	Notifications	14
5.2.3.5.5	State diagram	14
5.2.3.6	PEECMONIRP	14
5.2.3.6.1	Definition.....	14
5.2.3.6.2	Attributes	14
5.2.3.6.3	Attribute constraints	14
5.2.3.6.4	Notifications	15
5.2.3.6.5	State diagram	15
5.2.4	Attribute definitions	15
5.2.4.1	Attribute properties	15
5.2.4.2	Constraints	17
5.2.5	Common notifications.....	17
6	Interface Definition	17
6.1	Interface definition for solution 1	17
6.1.1	Class diagram.....	17
6.2	Interface definition for solution 2	17
6.2.1	Class diagram.....	17
6.2.2	Generic rules	18
6.2.3	CMONOperations_1 Interface (M).....	18
6.2.3.1	Operation readMEDescription (M).....	18
6.2.3.1.1	Definition.....	18
6.2.3.1.2	Input parameters	19
6.2.3.1.3	Output parameters	19
6.2.3.1.4	Pre-condition	19
6.2.3.1.5	Post-condition.....	19
6.2.3.1.6	Exception.....	19
6.2.3.2	Operation writeMEDescription (M).....	19
6.2.3.2.1	Definition.....	19
6.2.3.2.2	Input parameters	20
6.2.3.2.3	Output parameters	20
6.2.3.2.4	Pre-condition	20
6.2.3.2.5	Post-condition.....	20
6.2.3.2.6	Exception.....	20
6.2.4	CMONOperations_2 Interface (M).....	20
6.2.4.1	Operation readMEConfiguration (M).....	20
6.2.4.1.1	Definition.....	20
6.2.4.1.2	Input parameters	21
6.2.4.1.3	Output parameters	21
6.2.4.1.4	Pre-condition	21
6.2.4.1.5	Post-condition.....	21
6.2.4.1.6	Exception.....	21
6.2.4.2	Operation writeMEConfiguration (M).....	22
6.2.4.2.1	Definition.....	22
6.2.4.2.2	Input parameters	22
6.2.4.2.3	Output parameters	22
6.2.4.2.4	Pre-condition	22
6.2.4.2.5	Post-condition.....	22
6.2.4.2.6	Exception.....	23
6.2.5	CMONOperations_3 Interface (M).....	23
6.2.5.1	Operation createCMONPMJob (M).....	23
6.2.5.1.1	Definition.....	23

6.2.5.1.2	Input parameters	23
6.2.5.1.3	Output parameters	24
6.2.5.1.4	Pre-condition	24
6.2.5.1.5	Post-condition.....	24
6.2.5.1.6	Exception.....	24
6.2.5.1.7	Constraints.....	24
6.2.5.2	Operation stopCMONPMJob (M).....	24
6.2.5.2.1	Definition.....	24
6.2.5.2.2	Input parameters	24
6.2.5.2.3	Output parameters	25
6.2.5.2.4	Pre-condition	25
6.2.5.2.5	Post-condition.....	25
6.2.5.2.6	Exception.....	25
6.2.5.2.7	Constraints.....	25
6.2.6	CMONNotifications_1 Interface (M).....	25
6.2.6.1	Notification notifyMeasurementData (M)	25
6.2.6.1.1	Definition.....	25
6.2.6.1.2	Input parameters	26
6.2.7	CMONNotifications_2 Interface (M).....	27
6.2.7.1	Notification notifyAlarm (M)	27
6.2.7.1.1	Definition.....	27
6.2.7.1.2	Input parameters	27
6.2.8	CMONNotifications_3 Interface (M).....	27
6.2.8.1	Notification notifyConfigurationChange (M).....	27
6.2.8.1.1	Definition.....	27
6.2.8.1.2	Input parameters	28
6.2.9	CMONNotifications_4 Interface (M).....	28
6.2.9.1	Notification notifyThresholdCrossingOrReaching (M).....	28
6.2.9.1.1	Definition.....	28
6.2.9.1.2	Input parameters	28
Annex A (informative):	Change history	29
History		30

Foreword

This Technical Specification has been produced by the 3rd Generation Partnership Project (3GPP).

The contents of the present document are subject to continuing work within the TSG and may change following formal TSG approval. Should the TSG modify the contents of the present document, it will be re-released by the TSG with an identifying change of release date and an increase in version number as follows:

Version x.y.z

where:

- x the first digit:
 - 1 presented to TSG for information;
 - 2 presented to TSG for approval;
 - 3 or greater indicates TSG approved document under change control.
- y the second digit is incremented for all changes of substance, i.e. technical enhancements, corrections, updates, etc.
- z the third digit is incremented when editorial only changes have been incorporated in the document.

Introduction

The present document is part of a TS-family covering the 3rd Generation Partnership Project; Technical Specification Group Services and System Aspects; Telecommunication management; as identified below:

- | | |
|---------------|---|
| 28.304 | Control and monitoring of Power, Energy and Environmental (PEE) parameters Integration Reference Point (IRP); Requirements |
| 28.305 | Control and monitoring of Power, Energy and Environmental (PEE) parameters Integration Reference Point (IRP): Information Service (IS) |
| 28.306 | Control and monitoring of Power, Energy and Environmental (PEE) parameters Integration Reference Point (IRP); Solution Set (SS) definitions |

1 Scope

The present document specifies the control and monitoring of Power, Energy and Environmental (PEE) parameters Integration Reference Point (IRP) Information Service (IS).

It specifies the semantics and behaviour of operations, notifications and their parameters visible across Itf-N in a protocol and technology neutral way. It does not define their syntax and encoding.

2 References

The following documents contain provisions which, through reference in this text, constitute provisions of the present document.

- References are either specific (identified by date of publication, edition number, version number, etc.) or non-specific.
- For a specific reference, subsequent revisions do not apply.
- For a non-specific reference, the latest version applies. In the case of a reference to a 3GPP document (including a GSM document), a non-specific reference implicitly refers to the latest version of that document *in the same Release as the present document*.

- [1] 3GPP TR 21.905: "Vocabulary for 3GPP Specifications".
- [2] ETSI ES 202 336-12 (V1.1.1) (2015-06): " Environmental Engineering (EE); Monitoring and control interface for infrastructure equipment (power, cooling and building environment systems used in telecommunication networks); Part 12: ICT equipment power, energy and environmental parameters monitoring information model".
- [3] 3GPP TS 32.150: "Integration Reference Point (IRP) Concept and definitions".
- [4] 3GPP TS 28.622: "Telecommunication management; Generic Network Resource Model (NRM) Integration Reference Point (IRP); Information Service (IS)".
- [5] 3GPP TS 32.602: "Telecommunication management; Configuration Management (CM); Basic CM Integration Reference Point (IRP); Information Service (IS)".
- [6] 3GPP TS 32.612: "Telecommunication management; Configuration Management (CM); Bulk CM Integration Reference Point (IRP): Information Service (IS)".
- [7] 3GPP TS 32.412: "Telecommunication management; Performance Management (PM) Integration Reference Point (IRP): Information Service (IS)".
- [8] 3GPP TS 32.111-2: "Telecommunication management; Fault Management; Part 2: Alarm Integration Reference Point (IRP): Information Service (IS)".
- [9] 3GPP TS 28.304: "Control and monitoring of Power, Energy and Environmental (PEE) parameters Integration Reference Point (IRP); Requirements".
- [10] ITU-T Recommendation X.733: "Information Technology – Open Systems Interconnection – Systems Management: Alarm Reporting Function".

3 Definitions and abbreviations

3.1 Definitions

For the purposes of the present document, the terms and definitions given in 3GPP TR 21.905 [1] and the following apply. A term defined in the present document takes precedence over the definition of the same term, if any, in 3GPP TR 21.905 [1].

3.2 Abbreviations

For the purposes of the present document, the abbreviations given in 3GPP TR 21.905 [1] and the following apply. An abbreviation defined in the present document takes precedence over the definition of the same abbreviation, if any, in 3GPP TR 21.905 [1].

CU	Control Unit
DGU	Digital Gathering Unit
NM-RMS	Network Management layer RMS
PEE	Power, Energy and Environmental
PEECMON	PEE Control and Monitoring
RMS	Remote Management Server
VSE	Vendor-Specific Extension
VS-RMS	Vendor Specific RMS
XCU	XML enabled CU

4 System overview

4.1 System Context

The general definition of the System Context for the present IRP is found in 3GPP TS 32.150 [3], sub-clause 4.7.

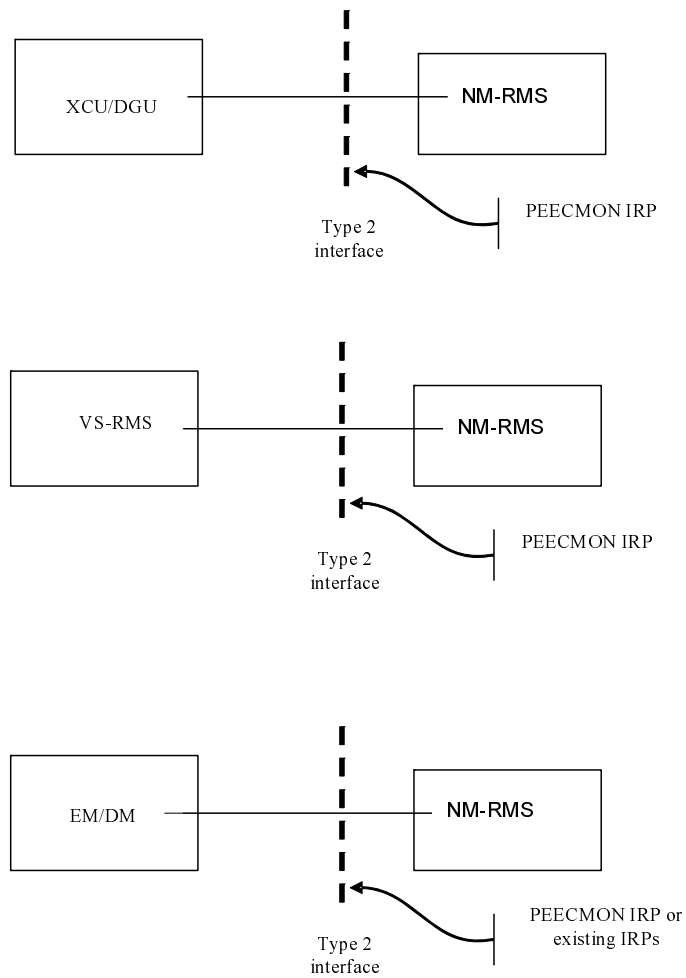

Figure 4.1.1: System Context

5 Model

5.1 Model for solution 1

5.1.0 Introduction

NOTE: Void.

Due to the fact that existing CM, PM, and FM interface IRPs are applicable to solution 1, the model definition of this solution can refer to model definitions from Basic CM IRP (TS 32.602 [5]), Bulk CM IRP (TS 32.612 [6]), PM IRP (TS 32.412 [7]) and Alarm IRP (TS 32.111-2 [8]).

Use cases and requirement for Solution 1 are described in 28.304 [9].

5.1.1 Imported and associated information entities

5.1.1.1 Imported information entities and local labels

None.

5.1.1.2 Associated information entities and local labels

None.

5.1.2 Class diagrams

5.1.2.1 Relationships

Due to the fact that existing CM, PM, and FM interface IRPs are applicable to solution 1, the model definition of this solution can refer to model definitions from Basic CM IRP (TS 32.602 [5]), Bulk CM IRP (TS 32.612 [6]), PM IRP (TS 32.412 [7]) and Alarm IRP (TS 32.111-2 [8]).

5.1.2.2 Inheritance

Due to the fact that existing CM, PM, and FM interface IRPs are applicable to solution 1, the model definition of this solution can refer to model definitions from Basic CM IRP (TS 32.602 [5]), Bulk CM IRP (TS 32.612 [6]), PM IRP (TS 32.412 [7]) and Alarm IRP (TS 32.111-2 [8]).

5.1.3 Class definitions

Due to the fact that existing CM, PM, and FM interface IRPs are applicable to solution 1, the model definition of this solution can refer to model definitions from Basic CM IRP (TS 32.602 [5]), Bulk CM IRP (TS 32.612 [6]), PM IRP (TS 32.412 [7]) and Alarm IRP (TS 32.111-2 [8]).

5.1.4 Attribute definitions

NOTE: Void.

Attributes related to the control and monitoring of power, energy and environmental parameters in radio access networks are defined in `IOC ManagedFunction` – cf. 3GPP TS 28.622 [4].

5.1.5 Common notifications

No additional notifications compared to those applicable to `IOC ManagedFunction` – cf. 3GPP TS 28.622 [4].

5.2 Model for solution 2

5.2.0 Introduction

This clause introduces the set of classes (i.e. IOCs, SupportIOCs) that encapsulate information used by the CMON IRP for the control and monitoring of PEE parameters in radio access networks. The intent is to identify the information required for the CMONIRP implementation of its operations and notification emission. This clause provides the

overview of all support object classes in UML. Subsequent clauses provide more detailed specification of various aspects of these support object classes.

5.2.1 Imported and associated information entities

5.2.1.1 Imported information entities and local labels

There is no imported information entity.

5.2.1.2 Associated information entities and local labels

There is no associated information entity.

5.2.2 Class diagrams

5.2.2.1 Relationships

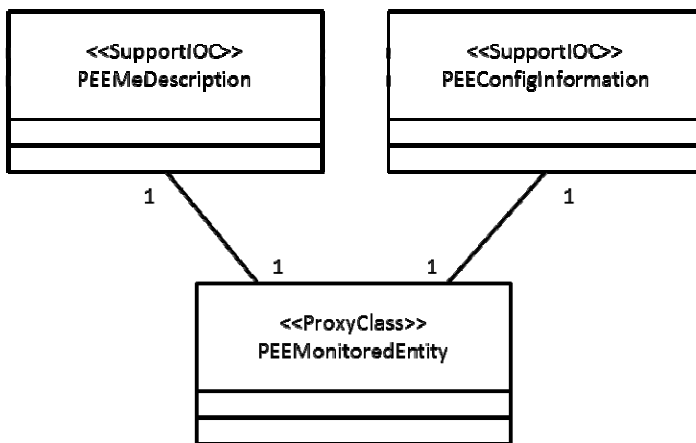

Figure 5.2.2.1.1: Information model for solution 2 - Relationships

5.2.2.2 Inheritance

There is no inheritance defined.

5.2.3 Class definitions

5.2.3.1 PEEMonitoredEntity

5.2.3.1.1 Definition

This IOC represents the monitoring of a base station whose Power, Energy and Environmental (PEE) parameters are monitored. It can apply to a GERAN, UTRAN or E-UTRAN base station. It can apply to a base station with either a built-in sensor or an external sensor.

5.2.3.1.2 Attributes

Attribute name	Support Qualifier	isReadable	isWritable	isInvariant	isNotifiable
mEId	M	M	-	M	-

5.2.3.1.3 Attribute constraints

None.

5.2.3.1.4 Notifications

None.

5.2.3.1.5 State diagram

None.

5.2.3.2 PEEMEDescription

5.2.3.2.1 Definition

This IOC provides a description of the monitored entity.

5.2.3.2.2 Attributes

Attribute name	Support Qualifier	isReadable	isWritable	isInvariant	isNotifyable
siteIdentification	M	M	M	-	M
siteLatitude	CM	M	M	-	M
siteLongitude	CM	M	M	-	M
siteDescription	M	M	M	-	M
equipmentType	M	M	M	-	M
environmentType	M	M	M	-	M
powerInterface	M	M	M	-	M
xcuDguDescription	CM	M	M	-	M
sensorDescription	CM	M	M	-	M
vSRmsDescription	CM	M	M	-	M

5.2.3.2.3 Attribute constraints

Name	Definition
xcuDguDescription	It shall be supported only in case of base stations with external sensors.
sensorDescription	It shall be supported only in case of base stations with external sensors.
vSRmsDescription	It shall be supported only in case of base stations with external sensors monitored via VS-RMS.
siteLatitude	It shall be supported only in case of UTRAN or E-UTRAN base stations.
siteLongitude	It shall be supported only in case of UTRAN or E-UTRAN base stations.

5.2.3.2.4 Notifications

None.

5.2.3.2.5 State diagram

None.

5.2.3.3 PEEMeasurementData

5.2.3.3.1 Definition

This IOC represents the PEE measurements of the monitored entity.

5.2.3.3.2 Attributes

Attribute name	Support Qualifier	isReadable	isWritable	isInvariant	isNotifyable
powerAverage	M	M	-	M	-
powerMin	M	M	-	M	-
powerMax	M	M	-	M	-
energyConsumption	M	M	-	M	-
temperatureAverage	M	M	-	M	-
temperatureMin	M	M	-	M	-
temperatureMax	M	M	-	M	-
voltageAverage	M	M	-	M	-
voltageMin	M	M	-	M	-
voltageMax	M	M	-	M	-
currentAverage	M	M	-	M	-
currentMin	M	M	-	M	-
currentMax	M	M	-	M	-
humidityAverage	M	M	-	M	-
humidityMin	M	M	-	M	-
humidityMax	M	M	-	M	-
collectionBeginTime	M	M	-	M	-
collectionEndTime	M	M	-	M	-

5.2.3.3.3 Attribute constraints

None.

5.2.3.3.4 Notifications

None.

5.2.3.3.5 State diagram

None.

5.2.3.4 PEEAlarmInformation

5.2.3.4.1 Definition

This IOC represents the alarm information of the monitored entity.

5.2.3.4.2 Attributes

Attribute name	Support Qualifier	isReadable	isWritable	isInvariant	isNotifyable
alarmId	M	M	-	M	-
alarmTime	M	M	-	M	-
alarmType	M	M	-	M	-
perceivedSeverity	M	M	-	M	-
probableCause	M	M	-	M	-
additionaltext	O	M	-	M	-

5.2.3.4.3 Attribute constraints

None.

5.2.3.4.4 Notifications

None.

5.2.3.4.5 State diagram

None.

5.2.3.5 PEEConfigInformation

5.2.3.5.1 Definition

This IOC represents the PEE related configuration information of the monitored entity.

5.2.3.5.2 Attributes

Attribute name	Support Qualifier	isReadable	isWritable	isInvariant	isNotifyable
powerMinThreshold	M	M	-	M	-
powerMaxThreshold	M	M	-	M	-
temperatureMinThreshold	M	M	-	M	-
temperatureMaxThreshold	M	M	-	M	-
voltageMinThreshold	M	M	-	M	-
voltageMaxThreshold	M	M	-	M	-
currentMinThreshold	M	M	-	M	-
currentMaxThreshold	M	M	-	M	-
humidityMinThreshold	M	M	-	M	-
humidityMaxThreshold	M	M	-	M	-

5.2.3.5.3 Attribute constraints

None.

5.2.3.5.4 Notifications

None.

5.2.3.5.5 State diagram

None.

5.2.3.6 PEECMONIRP

5.2.3.6.1 Definition

PEECMONIRP is the representation of the Power, Energy and Environmental (PEE) parameters management capabilities specified by the present document.

5.2.3.6.2 Attributes

None.

5.2.3.6.3 Attribute constraints

None.

5.2.3.6.4 Notifications

None.

5.2.3.6.5 State diagram

None.

5.2.4 Attribute definitions

5.2.4.1 Attribute properties

Attribute Name	Documentation and Allowed Values	Properties
currentMinThreshold	It indicates the minimum current threshold value to be used for raising alarms. allowedValues: see ETSI ES 202 336-12 [2] – Clauses 4.4.3.3, 4.4.3.4, Annex B	type: Real multiplicity: 1 isOrdered: N/A isUnique: N/A defaultValue: Null isNullable: True
currentMaxThreshold	It indicates the maximum current threshold value to be used for raising alarms. allowedValues: see ETSI ES 202 336-12 [2] – Clauses 4.4.3.3, 4.4.3.4, Annex B	type: Real multiplicity: 1 isOrdered: N/A isUnique: N/A defaultValue: Null isNullable: True
environmentType	It indicates the type of environment of the monitored entity. allowedValues: see ETSI ES 202 336-12 [2] – Clause 4.4.1.	type: <<enumeration>> multiplicity: 1 isOrdered: N/A isUnique: N/A defaultValue: False isNullable: False
equipmentType	It indicates the type of equipment of the monitored entity. allowedValues: see ETSI ES 202 336-12 [2] – Clause 4.4.1.	type: <<enumeration>> multiplicity: 1 isOrdered: N/A isUnique: N/A defaultValue: False isNullable: False
humidityMinThreshold	It indicates the minimum humidity threshold value to be used for raising alarms. allowedValues: see ETSI ES 202 336-12 [2] – clause 4.4.3.3, Annex B	type: Real multiplicity: 1 isOrdered: N/A isUnique: N/A defaultValue: Null isNullable: True
humidityMaxThreshold	It indicates the maximum humidity threshold value to be used for raising alarms. allowedValues: see ETSI ES 202 336-12 [2] – clause 4.4.3.3, Annex B	type: Real multiplicity: 1 isOrdered: N/A isUnique: N/A defaultValue: Null isNullable: True
mEId	It identifies the monitored entity. allowedValues: N/A	type: Integer multiplicity: 1 isOrdered: N/A isUnique: N/A defaultValue: False isNullable: False
powerInterface	It indicates the type of power interface of the monitored entity. allowedValues: see ETSI ES 202 336-12 [2] – Clause 4.4.1.	type: <<enumeration>> multiplicity: 1 isOrdered: N/A isUnique: N/A defaultValue: False isNullable: False
powerMinThreshold	It indicates the minimum power threshold value to be used for raising alarms.	type: Real multiplicity: 1 isOrdered: N/A

Attribute Name	Documentation and Allowed Values	Properties
	allowedValues: see ETSI ES 202 336-12 [2] – clauses 4.4.3.1, 4.4.3.4, Annex A	isUnique: N/A defaultValue: Null isNullable: True
powerMaxThreshold	It indicates the maximum power threshold value to be used for raising alarms. allowedValues: see ETSI ES 202 336-12 [2] – clauses 4.4.3.1, 4.4.3.4, Annex A	type: Real multiplicity: 1 isOrdered: N/A isUnique: N/A defaultValue: Null isNullable: True
sensorDescription	It gives a description of the sensor. allowedValues: N/A	type: String multiplicity: 1 isOrdered: N/A isUnique: N/A defaultValue: False isNullable: False
siteDescription	It gives a description of the site of the monitored entity. allowedValues: N/A	type: String multiplicity: 1 isOrdered: N/A isUnique: N/A defaultValue: False isNullable: False
siteIdentification	It gives an identification of the site of the monitored entity. allowedValues: N/A	type: String multiplicity: 1 isOrdered: N/A isUnique: N/A defaultValue: False isNullable: False
siteLatitude	The latitude of the site location based on the World Geodetic System (1984 version) global reference frame (WGS 84). Positive values correspond to north of 0 degrees latitude (northern hemisphere). allowedValues: -90.0000 to +90.0000	type: Real multiplicity: 1 isOrdered: N/A isUnique: N/A defaultValue: False isNullable: False
siteLongitude	The longitude of the site location based on the World Geodetic System (1984 version) global reference frame (WGS 84). Positive values correspond to east of 0 degrees longitude. allowedValues: -180.0000 to +180.0000	type: Real multiplicity: 1 isOrdered: N/A isUnique: N/A defaultValue: False isNullable: False
temperatureMinThreshold	It indicates the minimum temperature threshold value to be used for raising alarms. allowedValues: see ETSI ES 202 336-12 [2] – clause 4.4.3.4, Annex B	type: Real multiplicity: 1 isOrdered: N/A isUnique: N/A defaultValue: Null isNullable: True
temperatureMaxThreshold	It indicates the maximum temperature threshold value to be used for raising alarms. allowedValues: see ETSI ES 202 336-12 [2] – clause 4.4.3.4, Annex B	type: Real multiplicity: 1 isOrdered: N/A isUnique: N/A defaultValue: Null isNullable: True
voltageMinThreshold	It indicates the minimum voltage threshold value to be used for raising alarms. allowedValues: see ETSI ES 202 336-12 [2] – Clauses 4.4.3.3, 4.4.3.4, Annex B	type: Real multiplicity: 1 isOrdered: N/A isUnique: N/A defaultValue: Null isNullable: True
voltageMaxThreshold	It indicates the maximum voltage threshold value to be used for raising alarms.	type: Real multiplicity: 1 isOrdered: N/A isUnique: N/A

Attribute Name	Documentation and Allowed Values	Properties
	allowedValues: see ETSI ES 202 336-12 [2] – Clauses 4.4.3.3, 4.4.3.4, Annex B	defaultValue: Null isNullable: True
vSRmsDescription	It gives a description of the VS-RMS. allowedValues: N/A	type: String multiplicity: 1 isOrdered: N/A isUnique: N/A defaultValue: False isNullable: False
xcuDguDescription	It gives a description of the XCU/DGU. allowedValues: N/A	type: String multiplicity: 1 isOrdered: N/A isUnique: N/A defaultValue: False isNullable: False

5.2.4.2 Constraints

Name	Affected attribute(s)	Definition
inv_TimerConstraints	ntfTimeTickTimer	The ntfTimeTickTimer is lower than or equal to ntfTimeTick.

5.2.5 Common notifications

None.

6 Interface Definition

6.1 Interface definition for solution 1

6.1.1 Class diagram

None.

6.2 Interface definition for solution 2

6.2.1 Class diagram

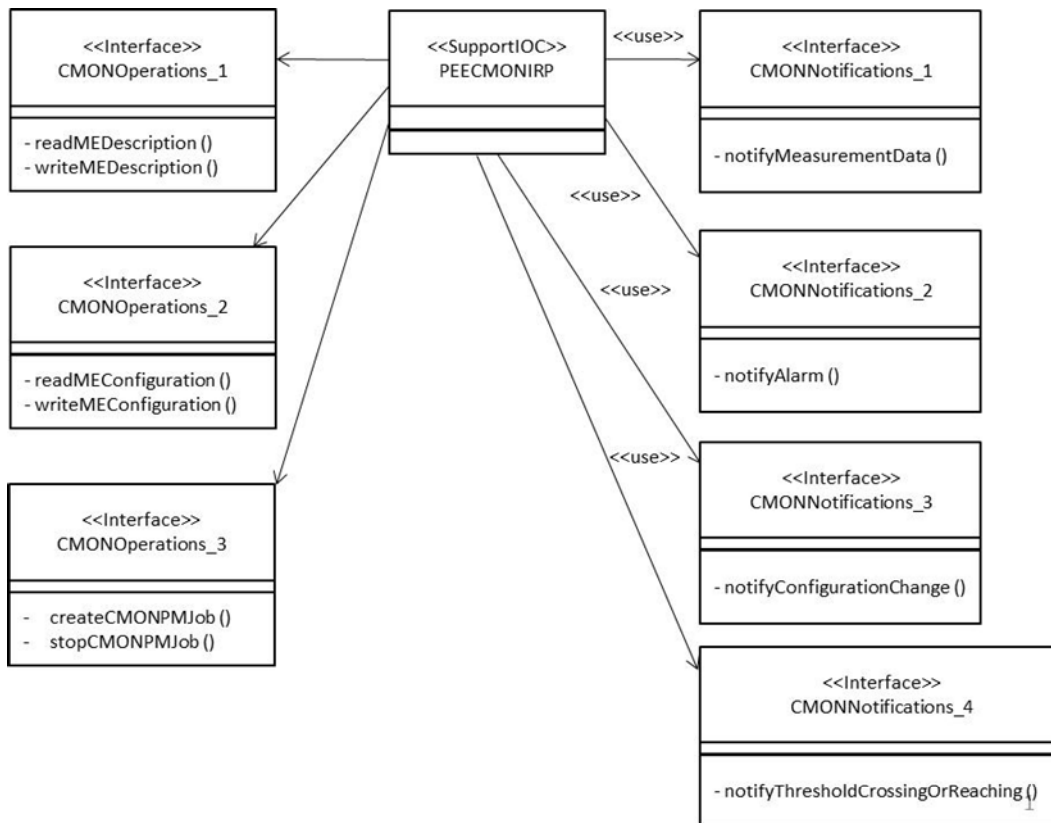

Figure 6.2.1.1: Class diagram representing interfaces for solution 2

6.2.2 Generic rules

Rule 1: each operation with at least one input parameter supports a pre-condition `valid_input_parameter` which indicates that all input parameters shall be valid with regards to their information type. Additionally, each such operation supports an exception `operation_failed_invalid_input_parameter` which is raised when pre-condition `valid_input_parameter` is false. The exception has the same entry and exit state.

Rule 2: Each operation with at least one optional input parameter supports a set of pre-conditions `supported_optional_input_parameter_yyy` where "yyy" is the name of the optional input parameter and the pre-condition indicates that the operation supports the named optional input parameter. Additionally, each such operation supports an exception `operation_failed_unsupported_optional_input_parameter_yyy` which is raised when (a) the pre-condition `supported_optional_input_parameter_yyy` is false and (b) the named optional input parameter is carrying information. The exception has the same entry and exit state.

Rule 3: each operation shall support a generic exception `operation_failed_internal_problem` which is raised when an internal problem occurs and that the operation cannot be completed. The exception has the same entry and exit state.

6.2.3 CMONOperations_1 Interface (M)

6.2.3.1 Operation `readMEDescription` (M)

6.2.3.1.1 Definition

The IRPManager invokes this operation to read description data of the monitored entity.

Referenced TS	Requirement label	Comment
3GPP TS 28.304 [9]	REQ-EECMON-CON-001 REQ-EECMON-CON-002 REQ-EECMON-CON-003	

6.2.3.1.2 Input parameters

Name	Qualifier	Matching Type	Comment
mEId	M	mEId of the PEEMonitoredEntity instance.	This parameter contains the identification of the monitored entity.
attributeNameList	O	List of attribute names (in PEEMEDescription).	This parameter contains the list of names of attributes of the monitored entity, from PEEMEDescription. If the list is not provided, name+value pairs for all attributes of the monitored entity shall be returned.

6.2.3.1.3 Output parameters

Name	Qualifier	Matching Information	Comment
mEId	M	mEId of the PEEMonitoredEntity instance.	This parameter contains the identification of the monitored entity.
attNameValueList	M	List of attribute name (in PEEMEDescription) and value pairs	This parameter contains a list of attribute name+value of the monitored entity.
status	M	ENUM (OperationSucceeded, OperationFailed)	If allInformationReturned is true, status = OperationSucceeded. If operation_failed is true, status = OperationFailed.

6.2.3.1.4 Pre-condition

None.

6.2.3.1.5 Post-condition

allInformationReturned.

Assertion Name	Definition
allInformationReturned	For all attributes of the input parameter attributeNameList, their names and values are returned. All their values remain unchanged as the result of this operation.

6.2.3.1.6 Exception

Assertion Name	Definition
operation_failed	Condition: One of the input parameters is invalid or the post-condition is not true. Returned Information: The output parameter status. Exit state: Entry state.

6.2.3.2 Operation writeMEDescription (M)

6.2.3.2.1 Definition

The IRPManager invokes this operation to modify description data of the monitored entity.

Referenced TS	Requirement label	Comment
3GPP TS 28.304 [9]	REQ-EECMON-CON-007 REQ-EECMON-CON-008 REQ-EECMON-CON-009	

6.2.3.2.2 Input parameters

Name	Qualifier	Matching Type	Comment
mEId	M	mEId of the PEEMonitoredEntity instance.	This parameter contains the identification of the monitored entity.
attNameValueList	M	List of attribute name (in PEEMEDescription) and value pairs	This parameter contains the list of attribute name+value of the monitored entity, for attributes in PEEMEDescription.

6.2.3.2.3 Output parameters

Name	Qualifier	Matching Information	Comment
mEId	M	mEId of the PEEMonitoredEntity instance.	This parameter contains the identification of the monitored entity.
attNameValueList	M	List of attribute name (in PEEMEDescription) and value pairs	This parameter contains a list of attribute name+value of the modified attributes of the monitored entity after the operation has been achieved.
status	M	ENUM (OperationSucceeded, OperationFailed)	If allInformationReturned is true, status = OperationSucceeded. If operation_failed is true, status = OperationFailed.

6.2.3.2.4 Pre-condition

None .

6.2.3.2.5 Post-condition

allAttributesCorrectlyModified.

Assertion Name	Definition
allAttributesCorrectlyModified	All attributes of the input parameter attributeNameList have been correctly modified as requested by this operation. All their modified values are returned.

6.2.3.2.6 Exception

Assertion Name	Definition
operation_failed	Condition: One of the input parameters is invalid or the post-condition is not true. Returned Information: The output parameter status. Exit state: Entry state.

6.2.4 CMONOperations_2 Interface (M)

6.2.4.1 Operation readMEConfiguration (M)

6.2.4.1.1 Definition

The IRPManager invokes this operation to read threshold values on PEE parameters for one monitored entity.

Referenced TS	Requirement label	Comment
3GPP TS 28.304 [9]	REQ-EECMON-CON-007 REQ-EECMON-CON-008 REQ-EECMON-CON-009	

6.2.4.1.2 Input parameters

Parameter Name	Support Qualifier	Information Type / Legal Values	Comment
mEId	M	PEEMonitoredEntity.mEId	This parameter contains the mEId of the PEEMonitoredEntity instance.
thresholdNameList	O	List of threshold names (in PEEMConfiguration)	This parameter contains the list of threshold names for the monitored entity instances, where threshold name corresponds to an attribute name in PEEConfigInformation. If the list is not provided, name+value pairs for all thresholds of the monitored entity shall be returned.

6.2.4.1.3 Output parameters

Parameter Name	Support Qualifier	Matching Information / Information Type / Legal Values	Comment
mEId	M	PEEMonitoredEntity.mEId	This parameter contains the mEId of the PEEMonitoredEntity instance whose threshold(s) have been read.
thresholdNameValueList	M	List of threshold name and value pairs	This parameter contains the list of threshold name+value pairs set for the monitored entity instance, where threshold name corresponds to an attribute name in PEEConfigInformation.
status	M	ENUM (OperationSucceeded, OperationFailed)	If allInformationReturned is true, status = OperationSucceeded. If operation_failed is true, status = OperationFailed.

6.2.4.1.4 Pre-condition

None.

6.2.4.1.5 Post-condition

allInformationReturned.

Assertion Name	Definition
allInformationReturned	For all thresholds of the input parameter thresholdNameList, their names and values are returned. All their values remain unchanged as the result of this operation.

6.2.4.1.6 Exception

Assertion Name	Definition
operation_failed	Condition: One of the input parameters is invalid or the post-condition is not true. Returned Information: The output parameter status. Exit state: Entry state.

6.2.4.2 Operation writeMEConfiguration (M)

6.2.4.2.1 Definition

The IRPManager invokes this operation to write threshold values on PEE parameters of one monitored entity.

Referenced TS	Requirement label	Comment
3GPP TS 28.304 [9]	REQ-EECMON-CON-007 REQ-EECMON-CON-008 REQ-EECMON-CON-009	

6.2.4.2.2 Input parameters

Parameter Name	Support Qualifier	Information Type / Legal Values	Comment
mEId	M	List of <PEEMonitoredEntity.mEId>	This parameter contains the Id of PEEMonitoredEntity instance whose threshold(s) are to be written.
thresholdNameValueList	M	List of threshold name and value pairs	This parameter contains the list of threshold name+value pairs for the monitored entity instance, where threshold name corresponds to an attribute name in PEEConfigInformation. Each threshold name+value pair defines the value of the monitored threshold. If the value is (a) crossed or (b) reached, a thresholdCrossing notification shall be emitted by the PEECMONIRP Agent.

6.2.4.2.3 Output parameters

Parameter Name	Support Qualifier	Matching Information / Information Type / Legal Values	Comment
mEId	M	PEEMonitoredEntity.mEId	This parameter contains the Id of the PEEMonitoredEntity instance whose threshold(s) have been written.
thresholdNameValueList	M	List of threshold name and value pairs	This parameter contains the list of threshold name+value pairs set for the monitored entity instance, where threshold name corresponds to an attribute name in PEEConfigInformation.
status	M	ENUM (OperationSucceeded, OperationFailed)	If allInformationReturned is true, status = OperationSucceeded. If operation_failed is true, status = OperationFailed.

6.2.4.2.4 Pre-condition

None.

6.2.4.2.5 Post-condition

allThresholdsCorrectlyModified.

Assertion Name	Definition
allThresholdsCorrectlyModified	All thresholds of the input parameter thresholdNameValueList have been correctly modified as requested by this operation. All their values are returned.

6.2.4.2.6 Exception

Assertion Name	Definition
operation_failed	Condition: One of the input parameters is invalid or the post-condition is not true. Returned Information: The output parameter status. Exit state: Entry state.

6.2.5 CMONOperations_3 Interface (M)

6.2.5.1 Operation createCMONPMJob (M)

6.2.5.1.1 Definition

The IRPManager invokes this operation to create a PEE measurement job on one or more monitored entity(ies). The PEE measurement job starts immediately and run indefinitely until a stopCMONPMJob request is received by IRPAgent.

The way the address of the entity to which notifications containing measurement data are sent is provisioned, is not in the scope of this document.

Referenced TS	Requirement label	Comment
3GPP TS 28.304 [9]	REQ-EECMON-CON-001 REQ-EECMON-CON-002 REQ-EECMON-CON-003	

6.2.5.1.2 Input parameters

Parameter Name	Support Qualifier	Information Type / Legal Values	Comment
mEIdList	M	List of <PEEMonitoredEntity.mEId>	This parameter contains the list of mEIds of PEEMonitoredEntity instances whose measurement(s) are to be collected.
measurementNameList	M	List of measurement names	This parameter contains the list of names of measurements to be collected. Each measurement name shall correspond to an attribute name of PEEMeasurementData.
granularityPeriod	M	A number of minutes. See Comment for legal values	It specifies the period between two successive measurements. The value can be 5 minutes, 15 minutes, 30 minutes, 1 hour, 12 hours and 24 hours. The minimum granularity period is 5 minutes in most cases, but for some measurements it may only make sense to collect data in a larger granularity period. It also specifies the period between two successive emissions of notifyMeasurementData notifications.

6.2.5.1.3 Output parameters

Parameter Name	Support Qualifier	Matching Information / Information Type / Legal Values	Comment
jobId	M	Measurement job id	Unique identifier of the measurement job among all the existing measurement jobs in a PEECMONIRP Agent (located in XCU/DGU or in VS-RMS or in EM/DM). The uniqueness is guaranteed by the Operator.
status	M	ENUM (Success, Failure, PartialSuccess)	An operation may fail because of a specified (e.g. invalid granularity period, invalid measurement name) or unspecified reason.

6.2.5.1.4 Pre-condition

None.

6.2.5.1.5 Post-condition

None.

6.2.5.1.6 Exception

Assertion Name	Definition
operation_failed	Condition: One of the input parameters is invalid. Returned Information: The output parameter status. Exit state: Entry state.

6.2.5.1.7 Constraints

None.

6.2.5.2 Operation stopCMONPMJob (M)

6.2.5.2.1 Definition

The IRPManager invokes this operation to stop an ongoing PEE measurement job on one or more monitored entity(ies). The PEE measurement job stops immediately.

Referenced TS	Requirement label	Comment
3GPP TS 28.304 [9]	REQ-EECMON-CON-001 REQ-EECMON-CON-002 REQ-EECMON-CON-003	

6.2.5.2.2 Input parameters

Parameter Name	Support Qualifier	Information Type / Legal Values	Comment
jobId	M	Measurement job id	Identifier of the measurement job among all the existing measurement jobs in a PEECMONIRP Agent (located in XCU/DGU or in VS-RMS or in EM/DM).

6.2.5.2.3 Output parameters

Parameter Name	Support Qualifier	Matching Information / Information Type / Legal Values	Comment
status	M	ENUM (Success, Failure, PartialSuccess)	An operation may fail because of a specified (e.g. unknown job, job cannot be stopped) or unspecified reason.

6.2.5.2.4 Pre-condition

None.

6.2.5.2.5 Post-condition

cMONPMJobStopped.

Assertion Name	Definition
cMONPMJobStopped	The PM job has been stopped.

6.2.5.2.6 Exception

Assertion Name	Definition
operation_failed	Condition: One of the input parameters is invalid or the post-condition is not true. Returned Information: The output parameter status. Exit state: Entry state.

6.2.5.2.7 Constraints

None.

6.2.6 CMONNotifications_1 Interface (M)

6.2.6.1 Notification notifyMeasurementData (M)

6.2.6.1.1 Definition

The PEECMONIRP Agent notifies the PEECMONIRP Manager with measurement data.

Referenced TS	Requirement label	Comment
3GPP TS 28.304 [9]	REQ-EECMON-CON-004 REQ-EECMON-CON-005 REQ-EECMON-CON-006	

6.2.6.1.2 Input parameters

Parameter Name	Support Qualifier	Information Type / Legal Values	Comment
notificationId	M		Unique identifier of the notification among all the notifications issued by the PEECMONIRP Agent (located in XCU/DGU or in VS-RMS or in EM/DM).
notificationHeader	M		This is the notification header to be inserted in each such notification. It includes a version indicator, the name, type and vendor name of the sending network node, and a time stamp indicating the time at which the notification is sent by PEECMONIRP Agent.
notificationType	M	"Measurement data"	
jobId	M	Measurement job id	Unique identifier of the measurement job.
measHeader			This is the measurement result notification header to be inserted in each such notification. It includes a version indicator, the name, type and vendor name of the sending network node, and a time stamp ("collectionBeginTime"). The "collectionBeginTime" is a time stamp that refers to the start of the first measurement collection interval (granularity period) that is covered by the collected measurement results that are sent in this notification.
measData	M	Measurement data	It represents the sequence of zero or more measurement result items. It can be empty in case no measurement data can be provided. The individual "measData" elements can appear in any order. Each "measData" element contains the mEId of the PEEMonitoredEntity instance, and the list of measurement results pertaining to that PEEMonitoredEntity instance ("measInfo"). Each "measInfo" is a pair of measurement name ("measName") and the corresponding result(s) ("measValues"). "measName" shall correspond to an attribute name in PEEMeasurementData. "measValues" contains the list of measurement results for the resource being measured.
measFooter	M		The measurement result notification footer to be inserted in each notification. It includes a time stamp, which refers to the end of the overall measurement collection interval that is covered by the collected measurement results being sent in this notification.

6.2.7 CMONNotifications_2 Interface (M)

6.2.7.1 Notification notifyAlarm (M)

6.2.7.1.1 Definition

The PEECMONIRP Agent notifies the PEECMONIRP Manager of a new alarm.

Referenced TS	Requirement label	Comment
3GPP TS 28.304 [9]	REQ-EECMON-CON-010 REQ-EECMON-CON-011 REQ-EECMON-CON-012	

6.2.7.1.2 Input parameters

Parameter Name	Support Qualifier	Information Type / Legal Values	Comment
notificationId	M		Unique identifier of the notification among all the notifications issued by the PEECMONIRP Agent (located in XCU/DGU or in VS-RMS or in EM/DM).
notificationHeader	M		This is the notification header to be inserted in each such notification. It includes a version indicator, the name, type and vendor name of the sending network node, and a time stamp indicating the time at which the notification is sent by PEECMONIRP Agent.
notificationType	M	"Alarm notification"	
alarmId	M		Unique alarm id among alarm ids generated by the PEECMONIRP Agent.
alarmTime	M	All values indicating valid time.	It indicates the date and time when the alarm is raised by the alarmed PEEMonitoredEntity instance.
alarmType	M		See Event Types in TS 32.111-2 [8] – Annex A.
perceivedSeverity	M		Critical, Major, Minor, Warning, Indeterminate, Cleared: see [10].
probableCause	M		See Probable Causes in TS 32.111-2 [8] – Annex B.
additionalText	O	N/A	It can carry semantics that is outside the scope of this IRP specification. It may provide the identification of the site from which the alarm has been originated. It may contain further information on the alarm.

6.2.8 CMONNotifications_3 Interface (M)

6.2.8.1 Notification notifyConfigurationChange (M)

6.2.8.1.1 Definition

The PEECMONIRP Agent notifies the PEECMONIRP Manager of a change of configuration.

Referenced TS	Requirement label	Comment
3GPP TS 28.304 [9]	REQ-EECMON-CON-013 REQ-EECMON-CON-014 REQ-EECMON-CON-015	

6.2.8.1.2 Input parameters

Parameter Name	Support Qualifier	Information Type / Legal Values	Comment
notificationId	M		Unique identifier of the notification among all the notifications issued by the PEECMONIRP Agent (located in XCU/DGU or in VS-RMS or in EM/DM).
notificationHeader	M		This is the notification header to be inserted in each such notification. It includes a version indicator, the name, type and vendor name of the sending network node, and a time stamp indicating the time at which the notification is sent by PEECMONIRP Agent.
notificationType	M	"Configuration Change notification"	
mEId	M	mEId of the PEEMonitoredEntity instance.	This parameter contains the identification of the monitored entity.
attNameValueList	M	List of attribute name (in PEEMEDescription) and value pairs	This parameter contains a list of attribute name+value pairs of the monitored entity, for which a value change happened.

6.2.9 CMONNotifications_4 Interface (M)

6.2.9.1 Notification notifyThresholdCrossingOrReaching (M)

6.2.9.1.1 Definition

The PEECMONIRP Agent notifies the PEECMONIRP Manager of a threshold crossing.

Referenced TS	Requirement label	Comment
3GPP TS 28.304 [9]	REQ-EECMON-CON-013 REQ-EECMON-CON-014 REQ-EECMON-CON-015	

6.2.9.1.2 Input parameters

Parameter Name	Support Qualifier	Information Type / Legal Values	Comment
notificationId	M		Unique identifier of the notification among all the notifications issued by the PEECMONIRP Agent (located in XCU/DGU or in VS-RMS or in EM/DM).
notificationHeader	M		This is the notification header to be inserted in each such notification. It includes a version indicator, the name, type and vendor name of the sending network node, and a time stamp indicating the time at which the notification is sent by PEECMONIRP Agent.
notificationType	M	"Threshold crossing or reaching notification"	
mEId	M	mEId of the PEEMonitoredEntity instance.	This parameter contains the identification of the monitored entity.
thresholdInfo	M		It indicates crossed threshold information such as: <ul style="list-style-type: none"> The name of the threshold (corresponding to an attribute of PEEConfigInformation) whose value has crossed a threshold, The threshold value, The observed value that have crossed or reached the threshold value.

Annex A (informative): Change history

Change history							
Date	Meeting	TDoc	CR	Rev	Cat	Subject/Comment	New version
2018-03	SA#79					Upgrade to change control version	15.0.0
2018-12	SA#82	SP-181039	000 1	1	F	Include information about referencers to CM, PM and FM IRPs	15.1.0
2020-07	-	-	-	-	-	Update to Rel-16 version (MCC)	16.0.0
2022-03	-	-	-	-	-	Update to Rel-17 version (MCC)	17.0.0

History

Document history		
V17.0.0	April 2022	Publication