

ETSI TS 128 541 V15.3.0 (2019-06)



**5G;  
Management and orchestration;  
5G Network Resource Model (NRM);  
Stage 2 and stage 3  
(3GPP TS 28.541 version 15.3.0 Release 15)**



---

Reference

RTS/TSGS-0528541vf30

---

Keywords

5G

**ETSI**

650 Route des Lucioles  
F-06921 Sophia Antipolis Cedex - FRANCE

Tel.: +33 4 92 94 42 00 Fax: +33 4 93 65 47 16

Siret N° 348 623 562 00017 - NAF 742 C  
Association à but non lucratif enregistrée à la  
Sous-Préfecture de Grasse (06) N° 7803/88

---

**Important notice**

The present document can be downloaded from:

<http://www.etsi.org/standards-search>

The present document may be made available in electronic versions and/or in print. The content of any electronic and/or print versions of the present document shall not be modified without the prior written authorization of ETSI. In case of any existing or perceived difference in contents between such versions and/or in print, the prevailing version of an ETSI deliverable is the one made publicly available in PDF format at [www.etsi.org/deliver](http://www.etsi.org/deliver).

Users of the present document should be aware that the document may be subject to revision or change of status.

Information on the current status of this and other ETSI documents is available at

<https://portal.etsi.org/TB/ETSIDeliverableStatus.aspx>

If you find errors in the present document, please send your comment to one of the following services:

<https://portal.etsi.org/People/CommitteeSupportStaff.aspx>

---

**Copyright Notification**

No part may be reproduced or utilized in any form or by any means, electronic or mechanical, including photocopying and microfilm except as authorized by written permission of ETSI.

The content of the PDF version shall not be modified without the written authorization of ETSI.

The copyright and the foregoing restriction extend to reproduction in all media.

© ETSI 2019.

All rights reserved.

**DECT™**, **PLUGTESTS™**, **UMTS™** and the ETSI logo are trademarks of ETSI registered for the benefit of its Members.

**3GPP™** and **LTE™** are trademarks of ETSI registered for the benefit of its Members and of the 3GPP Organizational Partners.

**oneM2M™** logo is a trademark of ETSI registered for the benefit of its Members and of the oneM2M Partners.

**GSM®** and the GSM logo are trademarks registered and owned by the GSM Association.

---

## Intellectual Property Rights

### Essential patents

IPRs essential or potentially essential to normative deliverables may have been declared to ETSI. The information pertaining to these essential IPRs, if any, is publicly available for **ETSI members and non-members**, and can be found in ETSI SR 000 314: "*Intellectual Property Rights (IPRs); Essential, or potentially Essential, IPRs notified to ETSI in respect of ETSI standards*", which is available from the ETSI Secretariat. Latest updates are available on the ETSI Web server (<https://ipr.etsi.org/>).

Pursuant to the ETSI IPR Policy, no investigation, including IPR searches, has been carried out by ETSI. No guarantee can be given as to the existence of other IPRs not referenced in ETSI SR 000 314 (or the updates on the ETSI Web server) which are, or may be, or may become, essential to the present document.

### Trademarks

The present document may include trademarks and/or tradenames which are asserted and/or registered by their owners. ETSI claims no ownership of these except for any which are indicated as being the property of ETSI, and conveys no right to use or reproduce any trademark and/or tradename. Mention of those trademarks in the present document does not constitute an endorsement by ETSI of products, services or organizations associated with those trademarks.

---

## Legal Notice

This Technical Specification (TS) has been produced by ETSI 3rd Generation Partnership Project (3GPP).

The present document may refer to technical specifications or reports using their 3GPP identities. These shall be interpreted as being references to the corresponding ETSI deliverables.

The cross reference between 3GPP and ETSI identities can be found under <http://webapp.etsi.org/key/queryform.asp>.

---

## Modal verbs terminology

In the present document "**shall**", "**shall not**", "**should**", "**should not**", "**may**", "**need not**", "**will**", "**will not**", "**can**" and "**cannot**" are to be interpreted as described in clause 3.2 of the [ETSI Drafting Rules](#) (Verbal forms for the expression of provisions).

"**must**" and "**must not**" are **NOT** allowed in ETSI deliverables except when used in direct citation.

# Contents

Intellectual Property Rights .....	2
Legal Notice .....	2
Modal verbs terminology.....	2
Foreword.....	15
Introduction .....	15
1 Scope .....	16
2 References .....	16
3 Definitions and abbreviations.....	18
3.1 Definitions .....	18
3.2 Abbreviations .....	18
4 Information model definitions for NR NRM.....	19
4.1 Imported and associated information .....	19
4.1.1 Imported information entities and local labels.....	19
4.1.2 Associated information entities and local labels.....	19
4.2 Class diagram .....	19
4.2.1 Class diagram for gNB and en-gNB .....	19
4.2.1.1 Relationships.....	19
4.2.1.2 Inheritance.....	21
4.3 Class definitions .....	22
4.3.1 GNBDUFunction .....	22
4.3.1.1 Definition .....	22
4.3.1.2 Attributes.....	23
4.3.1.3 Attribute constraints .....	23
4.3.1.4 Notifications.....	23
4.3.2 GNBCUCPFunction .....	23
4.3.2.1 Definition .....	23
4.3.2.2 Attributes.....	23
4.3.2.3 Attribute constraints .....	23
4.3.2.4 Notifications.....	24
4.3.3 GNBCUUPFunction .....	24
4.3.3.1 Definition .....	24
4.3.3.2 Attributes.....	24
4.3.3.3 Attribute constraints .....	24
4.3.3.4 Notifications.....	24
4.3.4 NRCellCU .....	24
4.3.4.1 Definition .....	24
4.3.4.2 Attributes.....	25
4.3.4.3 Attribute constraints .....	25
4.3.4.4 Notifications.....	25
4.3.5 NRCellDU .....	25
4.3.5.1 Definition .....	25
4.3.5.2 Attributes.....	26
4.3.5.3 Attribute constraints .....	26
4.3.5.4 Notifications.....	26
4.3.6 NRSectorCarrier .....	26
4.3.6.1 Definition .....	26
4.3.6.2 Attributes.....	27
4.3.6.3 Attribute constraints .....	27
4.3.6.4 Notifications.....	27
4.3.7 BWP .....	27
4.3.7.1 Definition .....	27
4.3.7.2 Attributes.....	27
4.3.7.3 Attribute constraints .....	27

4.3.7.4	Notifications.....	27
4.3.8	EP_E1 .....	28
4.3.8.1	Definition .....	28
4.3.8.2	Attributes.....	28
4.3.8.3	Attribute constraints .....	28
4.3.8.4	Notifications.....	28
4.3.9	EP_XnU.....	28
4.3.9.1	Definition .....	28
4.3.9.2	Attributes.....	28
4.3.9.3	Attribute constraints .....	28
4.3.9.4	Notifications.....	28
4.3.10	EP_NgC.....	28
4.3.10.1	Definition .....	28
4.3.10.2	Attributes.....	29
4.3.10.3	Attribute constraints .....	29
4.3.10.4	Notifications.....	29
4.3.11	EP_NgU.....	29
4.3.11.1	Definition .....	29
4.3.11.2	Attributes.....	29
4.3.11.3	Attribute constraints .....	29
4.3.11.4	Notifications.....	29
4.3.12	EP_F1C.....	29
4.3.12.1	Definition .....	29
4.3.12.2	Attributes.....	30
4.3.12.3	Attribute constraints .....	30
4.3.12.4	Notifications.....	30
4.3.13	EP_F1U.....	30
4.3.13.1	Definition .....	30
4.3.13.2	Attributes.....	30
4.3.13.3	Attribute constraints .....	30
4.3.13.4	Notifications.....	30
4.3.14	EP_S1U.....	30
4.3.14.1	Definition .....	30
4.3.14.2	Attributes.....	30
4.3.14.3	Attribute constraints .....	30
4.3.14.4	Notifications.....	31
4.3.15	EP_X2C.....	31
4.3.15.1	Definition .....	31
4.3.15.2	Attributes.....	31
4.3.15.3	Attribute constraints .....	31
4.3.15.4	Notifications.....	31
4.3.16	EP_X2U.....	31
4.3.16.1	Definition .....	31
4.3.16.2	Attributes.....	31
4.3.16.3	Attribute constraints .....	31
4.3.16.4	Notifications.....	31
4.3.17	EP_XnC.....	31
4.3.17.1	Definition .....	31
4.3.17.2	Attributes.....	32
4.3.17.3	Attribute constraints .....	32
4.3.17.4	Notifications.....	32
4.3.18	ExternalGNBCUCPFfunction .....	32
4.3.18.1	Definition .....	32
4.3.18.2	Attributes.....	32
4.3.18.3	Attribute constraints .....	32
4.3.18.4	Notifications.....	32
4.3.19	ExternalGNBCUUPFunction .....	32
4.3.19.1	Definition .....	32
4.3.19.2	Attributes.....	32
4.3.19.3	Attribute constraints .....	32
4.3.19.4	Notifications.....	32

4.3.20	ExternalGNBDUFunction .....	33
4.3.20.1	Definition .....	33
4.3.20.2	Attributes.....	33
4.3.20.3	Attribute constraints .....	33
4.3.20.4	Notifications.....	33
4.3.21	ExternalUPFFunction.....	33
4.3.21.1	Definition .....	33
4.3.21.2	Attributes.....	33
4.3.21.3	Attribute constraints .....	33
4.3.21.4	Notifications.....	33
4.3.22	ExternalAMFFunction.....	33
4.3.22.1	Definition .....	33
4.3.22.2	Attributes.....	33
4.3.22.3	Attribute constraints .....	33
4.3.22.4	Notifications.....	34
4.3.23	ExternalMFs <<ProxyClass>> .....	34
4.3.23.1	Definition .....	34
4.3.23.2	Attributes.....	34
4.3.23.3	Attribute constraints .....	34
4.3.23.4	Notifications.....	34
4.3.24	ENBFunction <<ProxyClass>> .....	34
4.3.24.1	Definition .....	34
4.3.24.2	Attributes.....	34
4.3.24.3	Attribute constraints .....	34
4.3.24.4	Notifications.....	34
4.3.25	GNBCUCPFunction <<ProxyClass>>.....	34
4.3.25.1	Definition .....	34
4.3.25.2	Attributes.....	34
4.3.25.3	Attribute constraints .....	35
4.3.25.4	Notifications.....	35
4.3.26	GNBCUUPFunction <<ProxyClass>>.....	35
4.3.26.1	Definition .....	35
4.3.26.2	Attributes.....	35
4.3.26.3	Attribute constraints .....	35
4.3.26.4	Notifications.....	35
4.3.27	GNBDUFunction <<ProxyClass>> .....	35
4.3.27.1	Definition .....	35
4.3.27.2	Attributes.....	35
4.3.27.3	Attribute constraints .....	35
4.3.27.4	Notifications.....	35
4.3.28	ServingGWFFunction <<ProxyClass>>.....	35
4.3.28.1	Definition .....	35
4.3.28.2	Attributes.....	35
4.3.28.3	Attribute constraints .....	36
4.3.28.4	Notifications.....	36
4.3.29	UPFFunction <<ProxyClass>> .....	36
4.3.29.1	Definition .....	36
4.3.29.2	Attributes.....	36
4.3.29.3	Attribute constraints .....	36
4.3.29.4	Notifications.....	36
4.3.30	AMFFunction <<ProxyClass>> .....	36
4.3.30.1	Definition .....	36
4.3.30.2	Attributes.....	36
4.3.30.3	Attribute constraints .....	36
4.3.30.4	Notifications.....	36
4.3.31	Void.....	36
4.3.32	NRCellRelation.....	36
4.3.32.1	Definition .....	36
4.3.32.2	Attributes.....	37
4.3.32.3	Attribute constraints .....	37
4.3.32.4	Notifications.....	37

4.3.33	NRFreqRelation.....	37
4.3.33.1	Definition .....	37
4.3.33.2	Attributes.....	37
4.3.33.3	Attribute constraints .....	37
4.3.33.4	Notifications.....	37
4.3.34	EutranFreqRelation .....	37
4.3.34.1	Definition .....	37
4.3.34.2	Attributes.....	37
4.3.34.3	Attribute constraints .....	37
4.3.34.4	Notifications.....	37
4.3.35	ExternalNRCellCU .....	38
4.3.35.1	Definition .....	38
4.3.35.2	Attributes.....	38
4.3.35.3	Attribute constraints .....	38
4.3.35.4	Notifications.....	38
4.3.36	RRMPolicyRatio2 .....	38
4.3.36.1	Definition .....	38
4.3.36.2	Attributes.....	38
4.4	Attribute definitions .....	39
4.4.1	Attribute properties .....	39
4.5	Common notifications .....	47
5	Information model definitions for 5GC NRM.....	47
5.1	Imported information entities and local labels .....	47
5.2	Class diagram .....	47
5.2.1	Class diagram of 5GC NFs .....	47
5.2.1.1	Relationships.....	47
5.2.1.2	Inheritance.....	54
5.2.2	Class diagram of AMF Region/AMF Set .....	55
5.2.2.1	Relationships.....	55
5.2.2.2	Inheritance.....	56
5.3	Class definitions .....	56
5.3.1	AMFFunction.....	56
5.3.1.1	Definition .....	56
5.3.1.2	Attributes.....	57
5.3.1.3	Attribute constraints .....	57
5.3.1.4	Notifications.....	57
5.3.2	SMFFunction.....	57
5.3.2.1	Definition .....	57
5.3.2.2	Attributes.....	57
5.3.2.3	Attribute constraints .....	57
5.3.2.4	Notifications.....	57
5.3.3	UPFFunction.....	57
5.3.3.1	Definition .....	57
5.3.3.2	Attributes.....	58
5.3.3.3	Attribute constraints .....	58
5.3.3.4	Notifications.....	58
5.3.4	N3IWFFunction .....	58
5.3.4.1	Definition .....	58
5.3.4.2	Attributes.....	58
5.3.4.3	Attribute constraints .....	58
5.3.4.4	Notifications.....	58
5.3.5	PCFFunction.....	58
5.3.5.1	Definition .....	58
5.3.5.2	Attributes.....	58
5.3.5.3	Attribute constraints .....	58
5.3.5.4	Notifications.....	58
5.3.6	AUSFFunction.....	59
5.3.6.1	Definition .....	59
5.3.6.2	Attributes.....	59
5.3.6.3	Attribute constraints .....	59

5.3.6.4	Notifications.....	59
5.3.7	UDMFunction.....	59
5.3.7.1	Definition .....	59
5.3.7.2	Attributes.....	59
5.3.5.3	Attribute constraints .....	59
5.3.5.4	Notifications.....	59
5.3.8	UDRFunction.....	59
5.3.8.1	Definition .....	59
5.3.8.2	Attributes.....	60
5.3.8.3	Attribute constraints .....	60
5.3.8.4	Notifications.....	60
5.3.9	UDSFunction.....	60
5.3.9.1	Definition .....	60
5.3.9.2	Attributes.....	60
5.3.9.3	Attribute constraints .....	60
5.3.9.4	Notifications.....	60
5.3.10	NRFunction.....	60
5.3.10.1	Definition .....	60
5.3.10.2	Attributes.....	61
5.3.10.3	Attribute constraints .....	61
5.3.10.4	Notifications.....	61
5.3.11	NSSFunction.....	61
5.3.11.1	Definition .....	61
5.3.11.2	Attributes.....	61
5.3.11.3	Attribute constraints .....	61
5.3.11.4	Notifications.....	61
5.3.12	AFunction.....	61
5.3.12.1	Definition .....	61
5.3.13	DNFunction.....	61
5.3.13.1	Definition .....	61
5.3.14	SMSFunction.....	62
5.3.14.1	Definition .....	62
5.3.14.2	Attributes.....	62
5.3.14.3	Attribute constraints .....	62
5.3.14.4	Notifications.....	62
5.3.15	LMFunction.....	62
5.3.15.1	Definition .....	62
5.3.15.2	Attributes.....	62
5.3.15.3	Attribute constraints .....	62
5.3.15.4	Notifications.....	62
5.3.16	NGEIRFunction.....	62
5.3.16.1	Definition .....	62
5.3.16.2	Attributes.....	63
5.3.16.3	Attribute constraints .....	63
5.3.16.4	Notifications.....	63
5.3.17	SEPPFunction.....	63
5.3.17.1	Definition .....	63
5.3.17.2	Attributes.....	63
5.3.17.3	Attribute constraints .....	63
5.3.17.4	Notifications.....	63
5.3.18	NWDAFunction.....	63
5.3.18.1	Definition .....	63
5.3.18.2	Attributes.....	63
5.3.18.3	Attribute constraints .....	63
5.3.18.4	Notifications.....	63
5.3.19	EP_N2.....	64
5.3.19.1	Definition .....	64
5.3.19.2	Attributes.....	64
5.3.19.3	Attribute constraints .....	64
5.3.19.4	Notifications.....	64
5.3.20	EP_N3.....	64



5.3.20.1	Definition .....	64
5.3.20.2	Attributes.....	64
5.3.20.3	Attribute constraints .....	64
5.3.20.4	Notifications.....	64
5.3.21	EP_N4 .....	64
5.3.21.1	Definition .....	64
5.3.21.2	Attributes.....	64
5.3.21.3	Attribute constraints .....	64
5.3.21.4	Notifications.....	65
5.3.22	EP_N5 .....	65
5.3.22.1	Definition .....	65
5.3.22.2	Attributes.....	65
5.3.22.3	Attribute constraints .....	65
5.3.22.4	Notifications.....	65
5.3.23	EP_N6 .....	65
5.3.23.1	Definition .....	65
5.3.23.2	Attributes.....	65
5.3.23.3	Attribute constraints .....	65
5.3.23.4	Notifications.....	65
5.3.24	EP_N7 .....	65
5.3.24.1	Definition .....	65
5.3.24.2	Attributes.....	66
5.3.24.3	Attribute constraints .....	66
5.3.24.4	Notifications.....	66
5.3.25	EP_N8 .....	66
5.3.25.1	Definition .....	66
5.3.25.2	Attributes.....	66
5.3.25.3	Attribute constraints .....	66
5.3.25.4	Notifications.....	66
5.3.26	EP_N9 .....	66
5.3.26.1	Definition .....	66
5.3.26.2	Attributes.....	66
5.3.26.3	Attribute constraints .....	66
5.3.26.4	Notifications.....	66
5.3.27	EP_N10 .....	67
5.3.27.1	Definition .....	67
5.3.27.2	Attributes.....	67
5.3.27.3	Attribute constraints .....	67
5.3.27.4	Notifications.....	67
5.3.28	EP_N11 .....	67
5.3.28.1	Definition .....	67
5.3.28.2	Attributes.....	67
5.3.28.3	Attribute constraints .....	67
5.3.28.4	Notifications.....	67
5.3.29	EP_N12 .....	67
5.3.29.1	Definition .....	67
5.3.29.2	Attributes.....	67
5.3.29.3	Attribute constraints .....	67
5.3.29.4	Notifications.....	68
5.3.30	EP_N13 .....	68
5.3.30.1	Definition .....	68
5.3.30.2	Attributes.....	68
5.3.30.3	Attribute constraints .....	68
5.3.30.4	Notifications.....	68
5.3.31	EP_N14 .....	68
5.3.31.1	Definition .....	68
5.3.31.2	Attributes.....	68
5.3.31.3	Attribute constraints .....	68
5.3.31.4	Notifications.....	68
5.3.32	EP_N15 .....	68
5.3.32.1	Definition .....	68

5.3.32.2	Attributes.....	69
5.3.32.3	Attribute constraints .....	69
5.3.32.4	Notifications.....	69
5.3.33	EP_N16 .....	69
5.3.33.1	Definition .....	69
5.3.33.2	Attributes.....	69
5.3.33.3	Attribute constraints .....	69
5.3.33.4	Notifications.....	69
5.3.34	EP_N17 .....	69
5.3.34.1	Definition .....	69
5.3.34.2	Attributes.....	69
5.3.34.3	Attribute constraints .....	69
5.3.34.4	Notifications.....	69
5.3.35	EP_N20 .....	70
5.3.35.1	Definition .....	70
5.3.35.2	Attributes.....	70
5.3.35.3	Attribute constraints .....	70
5.3.35.4	Notifications.....	70
5.3.36	EP_N21 .....	70
5.3.36.1	Definition .....	70
5.3.36.2	Attributes.....	70
5.3.36.3	Attribute constraints .....	70
5.3.36.4	Notifications.....	70
5.3.37	EP_N22 .....	70
5.3.37.1	Definition .....	70
5.3.37.2	Attributes.....	70
5.3.37.3	Attribute constraints .....	70
5.3.37.4	Notifications.....	71
5.3.38	EP_N26 .....	71
5.3.38.1	Definition .....	71
5.3.38.2	Attributes.....	71
5.3.38.3	Attribute constraints .....	71
5.3.38.4	Notifications.....	71
5.3.39	EP_SBI_X .....	71
5.3.39.1	Definition .....	71
5.3.39.2	Attributes.....	71
5.3.39.3	Attribute constraints .....	71
5.3.39.4	Notifications.....	71
5.3.40	EP_SBI_IPX .....	71
5.3.40.1	Definition .....	71
5.3.40.2	Attributes.....	72
5.3.40.3	Attribute constraints .....	72
5.3.40.4	Notifications.....	72
5.3.41	EP_S5C.....	72
5.3.41.1	Definition .....	72
5.3.41.2	Attributes.....	72
5.3.41.3	Attribute constraints .....	72
5.3.41.4	Notifications.....	72
5.3.42	EP_S5U.....	72
5.3.42.1	Definition .....	72
5.3.42.2	Attributes.....	72
5.3.42.3	Attribute constraints .....	72
5.3.42.4	Notifications.....	72
5.3.43	EP_Rx .....	73
5.3.43.1	Definition .....	73
5.3.43.2	Attributes.....	73
5.3.43.3	Attribute constraints .....	73
5.3.43.4	Notifications.....	73
5.3.44	EP_MAP_SMSC.....	73
5.3.44.1	Definition .....	73
5.3.44.2	Attributes.....	73

5.3.44.3	Attribute constraints .....	73
5.3.44.4	Notifications .....	73
5.3.45	EP_NLS .....	73
5.3.45.1	Definition .....	73
5.3.45.2	Attributes .....	73
5.3.45.3	Attribute constraints .....	73
5.3.45.4	Notifications .....	74
5.3.46	EP_NLG .....	74
5.3.46.1	Definition .....	74
5.3.46.2	Attributes .....	74
5.3.46.3	Attribute constraints .....	74
5.3.46.4	Notifications .....	74
5.3.47	EP_N27 .....	74
5.3.47.1	Definition .....	74
5.3.47.2	Attributes .....	74
5.3.47.3	Attribute constraints .....	74
5.3.47.4	Notifications .....	74
5.3.48	EP_N31 .....	74
5.3.48.1	Definition .....	74
5.3.48.2	Attributes .....	75
5.3.48.3	Attribute constraints .....	75
5.3.48.4	Notifications .....	75
5.3.49	ExternalNRFFunction .....	75
5.3.49.1	Definition .....	75
5.3.49.2	Attributes .....	75
5.3.49.3	Attribute constraints .....	75
5.3.49.4	Notifications .....	75
5.3.50	ExternalNSSFFunction .....	75
5.3.50.1	Definition .....	75
5.3.50.2	Attributes .....	75
5.3.50.3	Attribute constraints .....	75
5.3.50.4	Notifications .....	75
5.3.51	AMFSet .....	76
5.3.51.1	Definition .....	76
5.3.51.2	Attributes .....	76
5.3.51.3	Attribute constraints .....	76
5.3.51.4	Notifications .....	76
5.3.52	AMFRegion .....	76
5.3.52.1	Definition .....	76
5.3.52.2	Attributes .....	76
5.3.52.3	Attribute constraints .....	76
5.3.52.4	Notifications .....	76
5.3.53	ExternalAMFFunction .....	77
5.3.53.1	Definition .....	77
5.3.53.2	Attributes .....	77
5.3.53.3	Attribute constraints .....	77
5.3.53.4	Notifications .....	77
5.4	Attribute definitions .....	77
5.4.1	Attribute properties .....	77
5.5	Common notifications .....	79
6	Information model definitions for network slice NRM .....	79
6.1	Imported information entities and local labels .....	79
6.2	Class diagram .....	80
6.2.1	Relationships .....	80
6.2.2	Inheritance .....	80
6.3	Class definitions .....	81
6.3.1	NetworkSlice .....	81
6.3.1.1	Definition .....	81
6.3.1.2	Attributes .....	81
6.3.1.3	Attribute constraints .....	81

6.3.1.4	Notifications.....	81
6.3.2	NetworkSliceSubnet .....	81
6.3.2.1	Definition .....	81
6.3.2.2	Attributes.....	81
6.3.2.3	Attribute constraints .....	81
6.3.2.4	Notifications.....	81
6.3.3	ServiceProfile.....	82
6.3.3.1	Definition .....	82
6.3.3.2	Attributes.....	82
6.3.3.3	Attribute constraints .....	82
6.3.3.4	Notifications.....	82
6.3.4	SliceProfile.....	82
6.3.4.1	Definition .....	82
6.3.4.2	Attributes.....	82
6.3.4.3	Attribute constraints .....	82
6.3.4.4	Notifications.....	83
6.4	Attribute definition .....	84
6.4.1	Attribute properties .....	84
6.5	Common notifications .....	87
7	Solution Set (SS) .....	87
<b>Annex A (normative): Cell state handling .....</b>		<b>89</b>
A.1	Relation between the administrative state and the "Pre-operation state of the gNB-DU Cell" .....	89
A.2	Combined state diagram for gNB cell.....	89
<b>Annex B (normative): NSI and NSSI state handling .....</b>		<b>94</b>
B.1	NSI state handling .....	94
B.2	State handling of NSSI.....	95
<b>Annex C (normative): XML definitions for NR NRM.....</b>		<b>98</b>
C.1	General .....	98
C.2	Architectural features .....	98
C.3	Mapping .....	98
C.3.1	General mapping .....	98
C.3.2	Information Object Class (IOC) mapping .....	98
C.4	Solution Set definitions .....	98
C.4.1	XML definition structure.....	98
C.4.2	Graphical representation.....	98
C.4.3	XML schema "nRNrm.xsd" .....	98
<b>Annex D (normative): JSON definitions for NR NRM.....</b>		<b>107</b>
D.1	General .....	107
D.2	Architectural features .....	107
D.3	Mapping .....	107
D.3.1	IOC mapping.....	107
D.3.2	Attributes mapping.....	107
D.4	Solution Set (SS) definitions .....	108
D.4.1	JSON definition structure.....	108
D.4.2	Graphical representation.....	108
D.4.3	JSON schema "nrNrm.json" .....	108
<b>Annex E (normative): YANG definitions for NR NRM .....</b>		<b>117</b>
E.1	General .....	117

E.2	Architectural features .....	117
E.3	Mapping .....	117
E.3.1	IOC mapping.....	117
E.3.2	Attributes mapping.....	118
E.4	Solution Set (SS) definitions .....	118
E.4.1	YANG definition structure .....	118
E.4.2	Graphical representation.....	118
E.4.3	YANG schema .....	122
E.4.3.1	General type definition "nrm-types-3gpp.yang" .....	122
E.4.3.2	Basic IOC definition which can be reused by specific ManagedFunction. "Top.yang", "ManagedElement.yang", "ManagedFunction.yang", "EP_RP.yang", "Subnetwork.yang", "vsDataContainer.yang", "MeContext.yang", "ManagementNode.yang" .....	129
E.4.3.3	NGRAN, composition of all gNB ManagedFunctions in "ngran.yang" .....	138
E.4.3.4	NGRAN submodule, "ngran-gNBCUCPFunction.yang" .....	139
E.4.3.5	NGRAN submodule, "ngran-gNBCUUPFunction.yang" .....	140
E.4.3.6	NGRAN submodule, "ngran-gNBDFunction.yang" .....	141
E.4.3.7	NGRAN submodule, "ngran-nRCellCU.yang" .....	141
E.4.3.8	NGRAN submodule, "ngran-nRCellDU.yang" .....	142
E.4.3.9	NGRAN submodule, "ngran-nRSectorCarrier.yang" .....	144
E.4.3.10	NGRAN submodule, "ngran-bWP.yang" .....	145
<b>Annex F (normative): XML definitions for 5GC NRM .....</b>		<b>146</b>
F.1	General .....	146
F.2	Architectural features .....	146
F.3	Mapping .....	146
F.3.1	General mapping .....	146
F.3.2	Information Object Class (IOC) mapping .....	146
F.4	Solution Set definitions .....	146
F.4.1	XML definition structure.....	146
F.4.2	Graphical representation.....	146
F.4.3	XML schema "ngcNrm.xsd" .....	146
<b>Annex G (normative): JSON definitions for 5GC NRM.....</b>		<b>166</b>
G.1	General .....	166
G.2	Architectural features .....	166
G.3	Mapping .....	166
G.3.1	IOC mapping.....	166
G.3.2	Attributes mapping.....	167
G.4	Solution Set definitions .....	168
G.4.1	JSON definition structure.....	168
G.4.2	Graphical representation.....	168
G.4.3	JSON schema "ngcNrm.json" .....	168
<b>Annex H (normative): YANG definitions for 5GC.....</b>		<b>188</b>
H.1	General .....	188
H.2	Architectural features .....	188
H.3	Mapping .....	188
H.3.1	IOC mapping.....	188
H.3.2	Attributes mapping.....	188
H.4	Solution Set definitions .....	189
H.4.1	YANG definition structure .....	189
H.4.2	Graphical representation.....	189
H.4.3	YANG schema .....	204

H.4.3.1	General type definition "nrm-types-3gpp.yang" .....	204
H.4.3.2	Basic IOC definition which can be reused by specific ManagedFunction. "Top.yang", "ManagedElement.yang", "ManagedFunction.yang", "EP_RP.yang", "SubNetwork" .....	204
H.4.3.3	NGC module, composition of all 5GC ManagedFunctions in "ngc.yang" .....	204
H.4.3.4	NGC submodule, "ngc-AMFFunction.yang", "ngc-AMFRegion.yang", "ngc-AMFSet.yang" .....	205
H.4.3.5	NGC submodule, "ngc-AUSFFunction.yang" .....	207
H.4.3.6	NGC submodule, "ngc-LMFFunction.yang" .....	208
H.4.3.7	NGC submodule, "ngc-N3IWFFunction.yang" .....	209
H.4.3.8	NGC submodule, "ngc-NGEIRFunction.yang" .....	209
H.4.3.9	NGC submodule, "ngc-NRFFunction.yang" .....	210
H.4.3.10	NGC submodule, "ngc-NSSFFunction.yang" .....	215
H.4.3.11	NGC submodule, "ngc-NWDFunction.yang" .....	216
H.4.3.12	NGC submodule, "ngc-PCFFunction.yang" .....	217
H.4.3.13	NGC submodule, "ngc-SEPPFunction.yang" .....	218
H.4.3.14	NGC submodule, "ngc-SMFFunction.yang" .....	219
H.4.3.15	NGC submodule, "ngc-SMSFFunction.yang" .....	220
H.4.3.16	NGC submodule, "ngc-UDMFunction.yang" .....	220
H.4.3.17	NGC submodule, "ngc-UDRFunction.yang" .....	221
H.4.3.18	NGC submodule, "ngc-UDSFFunction.yang" .....	222
H.4.3.19	NGC submodule, "ngc-UPFFunction.yang" .....	223
<b>Annex I (normative): XML definitions for network slice.....</b>		<b>224</b>
I.1	General .....	224
I.2	Architectural features .....	224
I.3	Mapping .....	224
I.3.1	General mapping .....	224
I.3.2	Information Object Class (IOC) mapping .....	224
I.4	Solution Set (SS) definitions .....	224
I.4.1	XML definition structure.....	224
I.4.2	Graphical representation.....	224
I.4.3	XML schema "sliceNrm.xsd" .....	224
<b>Annex J (normative): JSON definitions for network slice.....</b>		<b>228</b>
J.1	General .....	228
J.2	Architectural features .....	228
J.3	Mapping .....	228
J.3.1	IOC mapping.....	228
J.3.2	Attributes mapping .....	228
J.4	Solution Set (SS) definitions .....	229
J.4.1	JSON definition structure.....	229
J.4.2	Graphical representation.....	229
J.4.3	JSON schema "sliceNrm.json" .....	229
<b>Annex K (normative): YANG definitions for Network Slice NRM .....</b>		<b>234</b>
K.1	General .....	234
K.2	Architectural features .....	234
K.3	Mapping .....	234
K.3.1	IOC mapping.....	234
K.3.2	Attributes mapping .....	234
K.4	Solution Set definitions .....	234
K.4.1	YANG definition structure.....	234
K.4.2	Graphical representation.....	234
K.4.3	YANG schema .....	236
K.4.3.1	General type definition "nrm-types-3gpp.yang" .....	236

K.4.3.2	Basic IOC definition which can be reused by specific ManagedFuncion. "Top.yang", "ManagedElement.yang", "ManagedFunction.yang", "EP_RP.yang", "SubNetwork" .....	236
K.4.3.3	NetworkSlice Module, "NetworkSlice.yang" .....	236
K.4.3.4	ServiceProfile Submodule, "ServiceProfile.yang" .....	237
K.4.3.5	NetworkSliceSubnet Module, "NetworkSliceSubnet.yang" .....	238
K.4.3.6	SliceProfile Submodule, "SliceProfile.yang" .....	239
K.4.3.7	perfReq Module, "perfReq.yang" .....	240
<b>Annex L (informative):</b>	<b>Change history</b> .....	<b>241</b>
History .....		244

---

# Foreword

This Technical Specification has been produced by the 3rd Generation Partnership Project (3GPP).

The contents of the present document are subject to continuing work within the TSG and may change following formal TSG approval. Should the TSG modify the contents of the present document, it will be re-released by the TSG with an identifying change of release date and an increase in version number as follows:

Version x.y.z

where:

- x the first digit:
  - 1 presented to TSG for information;
  - 2 presented to TSG for approval;
  - 3 or greater indicates TSG approved document under change control.
- y the second digit is incremented for all changes of substance, i.e. technical enhancements, corrections, updates, etc.
- z the third digit is incremented when editorial only changes have been incorporated in the document.

---

# Introduction

The present document is part of a TS-family covering the 3rd Generation Partnership Project Technical Specification Group Services and System Aspects Management and orchestration of networks, as identified below:

TS 28.540: Management and orchestration of 5G networks; Network Resource Model (NRM); Stage 1.

**TS 28.541: Management and orchestration of 5G networks; Network Resource Model (NRM); Stage 2 and stage 3.**



---

# 1 Scope

The present document specifies the Information Model and Solution Set for the Network Resource Model (NRM) definitions of NR, NG-RAN, 5G Core Network (5GC) and network slice, to fulfil the requirements identified in 3GPP TS 28.540 [10].

The Information Model defines the semantics and behaviour of information object class attributes and relations visible on the management interfaces in a protocol and technology neutral way. And Solution Set defines one or more solution set(s) with specific protocol(s) according to the Information Model definitions.

---

# 2 References

The following documents contain provisions which, through reference in this text, constitute provisions of the present document.

- References are either specific (identified by date of publication, edition number, version number, etc.) or non-specific.
- For a specific reference, subsequent revisions do not apply.
- For a non-specific reference, the latest version applies. In the case of a reference to a 3GPP document (including a GSM document), a non-specific reference implicitly refers to the latest version of that document *in the same Release as the present document*.

- [1] 3GPP TR 21.905: "Vocabulary for 3GPP Specifications".
- [2] 3GPP TS 23.501: "System Architecture for the 5G System".
- [3] 3GPP TS 38.300: "NR; Overall description; Stage-2".
- [4] 3GPP TS 38.401: "NG-RAN; Architecture description".
- [5] 3GPP TS 38.413: "NG-RAN; NG Application Protocol (NGAP)".
- [6] 3GPP TS 38.420: "NG-RAN; Xn general aspects and principles".
- [7] 3GPP TS 38.470: "NG-RAN; F1 general aspects and principles".
- [8] 3GPP TS 38.473: "NG-RAN; F1 application protocol (F1AP)".
- [9] 3GPP TS 37.340: "NR; Multi-connectivity; Overall description; Stage 2".
- [10] 3GPP TS 28.540: "Management and orchestration; 5G Network Resource Model (NRM); Stage 1".
- [11] 3GPP TS 28.662: "Telecommunication management; Generic Radio Access Network (RAN) Network Resource Model (NRM) Integration Reference Point (IRP); Information Service (IS)".
- [12] 3GPP TS 38.104: "NR; Base Station (BS) radio transmission and reception".
- [13] 3GPP TS 23.003: "Numbering, Addressing and Identification".
- [14] 3GPP TS 36.410: "Evolved Universal Terrestrial Radio Access Network (E-UTRAN); S1 general aspects and principles".
- [15] 3GPP TS 36.423: "Evolved Universal Terrestrial Radio Access Network (E-UTRAN); X2 application protocol".
- [16] 3GPP TS 36.425: "Evolved Universal Terrestrial Radio Access Network (E-UTRAN); X2 interface user plane protocol".
- [17] 3GPP TS 28.625: "State Management Data Definition Integration Reference Point (IRP); Information Service (IS)".

- [18] ITU-T Recommendation X.731: "Information technology - Open Systems Interconnection - Systems Management: State management function".
- [19] 3GPP TS 28.658: "Telecommunications management; Evolved Universal Terrestrial Radio Access Network (E-UTRAN) Network Resource Model (NRM) Integration Reference Point (IRP): Information Service (IS)".
- [20] 3GPP TS 28.702: "Core Network (CN) Network Resource Model (NRM) Integration Reference Point (IRP); Information Service (IS)".
- [21] 3GPP TS 28.708: "Telecommunication management; Evolved Packet Core (EPC) Network Resource Model (NRM) Integration Reference Point (IRP): Information Service (IS)".
- [22] 3GPP TS 23.040: "Technical realization of the Short Message Service (SMS)".
- [23] 3GPP TS 29.510: "5G system; Network Function Repository Services; Stage 3".
- [24] 3GPP TS 29.531: "5G System; Network Slice Selection Services Stage 3".
- [25] Void.
- [26] 3GPP TS 28.531: "Management and orchestration; Provisioning".
- [27] 3GPP TS 28.554: "Management and orchestration; 5G End to end Key Performance Indicators (KPI)".
- [28] 3GPP TS 22.261: "Service requirements for next generation new services and markets".
- [29] ETSI GS NFV-IFA 013 V2.4.1 (2018-02) "Network Function Virtualisation (NFV); Management and Orchestration; Os-Ma-nfvo Reference Point - Interface and Information Model Specification".
- [30] 3GPP TS 28.622: "Telecommunication management; Generic Network Resource Model (NRM) Integration Reference Point (IRP); Information Service (IS)".
- [31] Void.
- [32] 3GPP TS 38.211: "NR; Physical channels and modulation".
- [33] 3GPP TS 32.616: "Telecommunication management; Configuration Management (CM); Bulk CM Integration Reference Point (IRP); Solution Set (SS) definitions".
- [34] 3GPP TS 28.623: "Telecommunication management; Generic Network Resource Model (NRM) Integration Reference Point (IRP); Solution Set (SS) definitions".
- [35] 3GPP TS 28.532: "Management and orchestration; Management services".
- [36] Void.
- [37] IETF RFC 791: "Internet Protocol".
- [38] IETF RFC 2373: "IP Version 6 Addressing Architecture".
- [39] IEEE 802.1Q: "Media Access Control Bridges and Virtual Bridged Local Area Networks".
- [40] ETSI GS NFV-IFA 015 (V2.4.1): "Network Function Virtualisation (NFV); Management and Orchestration; Report on NFV Information Model".
- [41] 3GPP TS 38.213: "NR; Physical layer procedures for control".
- [42] 3GPP TS 38.101-1: "NR; User Equipment (UE) radio transmission and reception; Part 1: Range 1 Standalone".
- [43] 3GPP TS 32.156: "Telecommunication management; Fixed Mobile Convergence (FMC) model repertoire".

---

## 3 Definitions and abbreviations

### 3.1 Definitions

For the purposes of the present document, the terms and definitions given in 3GPP TR 21.905 [1], 3GPP TS 28.540 [10] and the following apply. A term defined in the present document takes precedence over the definition of the same term, if any, in 3GPP TR 21.905 [1] and 3GPP TS 28.540 [10].

### 3.2 Abbreviations

For the purposes of the present document, the abbreviations given in 3GPP TR 21.905 [1], 3GPP TS 23.501 [2], 3GPP TS 38.401 [4], 3GPP TS 28.540 [10] and the following apply. An abbreviation defined in the present document takes precedence over the definition of the same abbreviation, if any, in 3GPP TR 21.905 [1], 3GPP TS 23.501 [2], 3GPP TS 38.401 [4] and 3GPP TS 28.540 [10].

BWP	Bandwidth part
CM	Configuration Management
DN	Distinguished Name
IOC	Information Object Class
JSON	JavaScript Object Notation
NFV	Network Functions Virtualisation
NRM	Network Resource Model
NS	Network Service
NSI	Network Slice Instance
NSSAI	Network Slice Selection Assistance Information
NSSI	Network Slice Subnet Instance
PNF	Physical Network Function
SBA	Service Based Architecture
SS	Solution Set
TN	Transport Network
VNF	Virtualised Network Function

## 4 Information model definitions for NR NRM

### 4.1 Imported and associated information

#### 4.1.1 Imported information entities and local labels

Label reference	Local label
3GPP TS 28.622 [30], IOC, ManagedFunction	ManagedFunction
3GPP TS 28.622 [30], IOC, EP_RP	EP_RP
3GPP TS 28.662 [11], IOC, SectorEquipmentFunction	SectorEquipmentFunction
3GPP TS 28.658 [19], IOC, ExternalENBFunction	ExternalENBFunction
3GPP TS 28.708 [21], IOC, ServingGWFunction	ServingGWFunction
3GPP TS 28.658 [19], IOC, EUTranCellFDD	EUTranCellFDD
3GPP TS 28.658 [19], IOC, EUTranCellTDD	EUTranCellTDD
3GPP TS 28.658 [19], dataType, PLMNId	PLMNId

#### 4.1.2 Associated information entities and local labels

Label reference	Local label
3GPP TS 28.622 [30], IOC, ManagedElement	ManagedElement
3GPP TS 28.622 [30], IOC, SubNetwork	SubNetwork

## 4.2 Class diagram

### 4.2.1 Class diagram for gNB and en-gNB

#### 4.2.1.1 Relationships

This clause depicts the set of classes (e.g. IOCs) that encapsulates the information relevant for this gNB and en-gNB. For the UML semantics, see 3GPP TS 32.156 [43]. Subsequent clauses provide more detailed specification of various aspects of these classes.

The model fragments are for the representation of gNB and en-gNB.

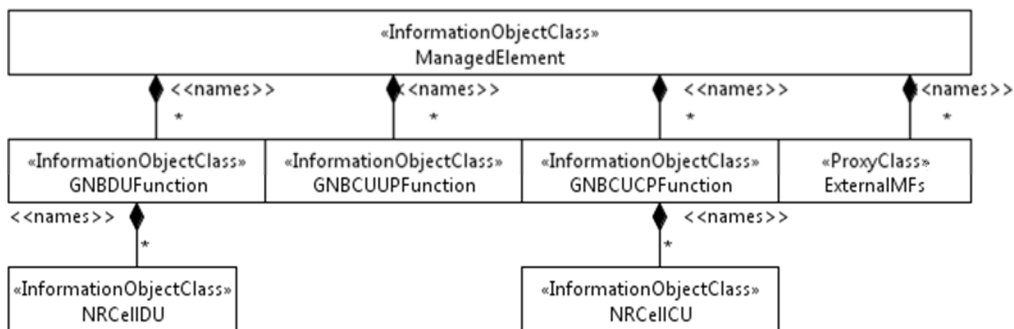

Figure 4.2.1.1-1: NRM for all deployment scenarios

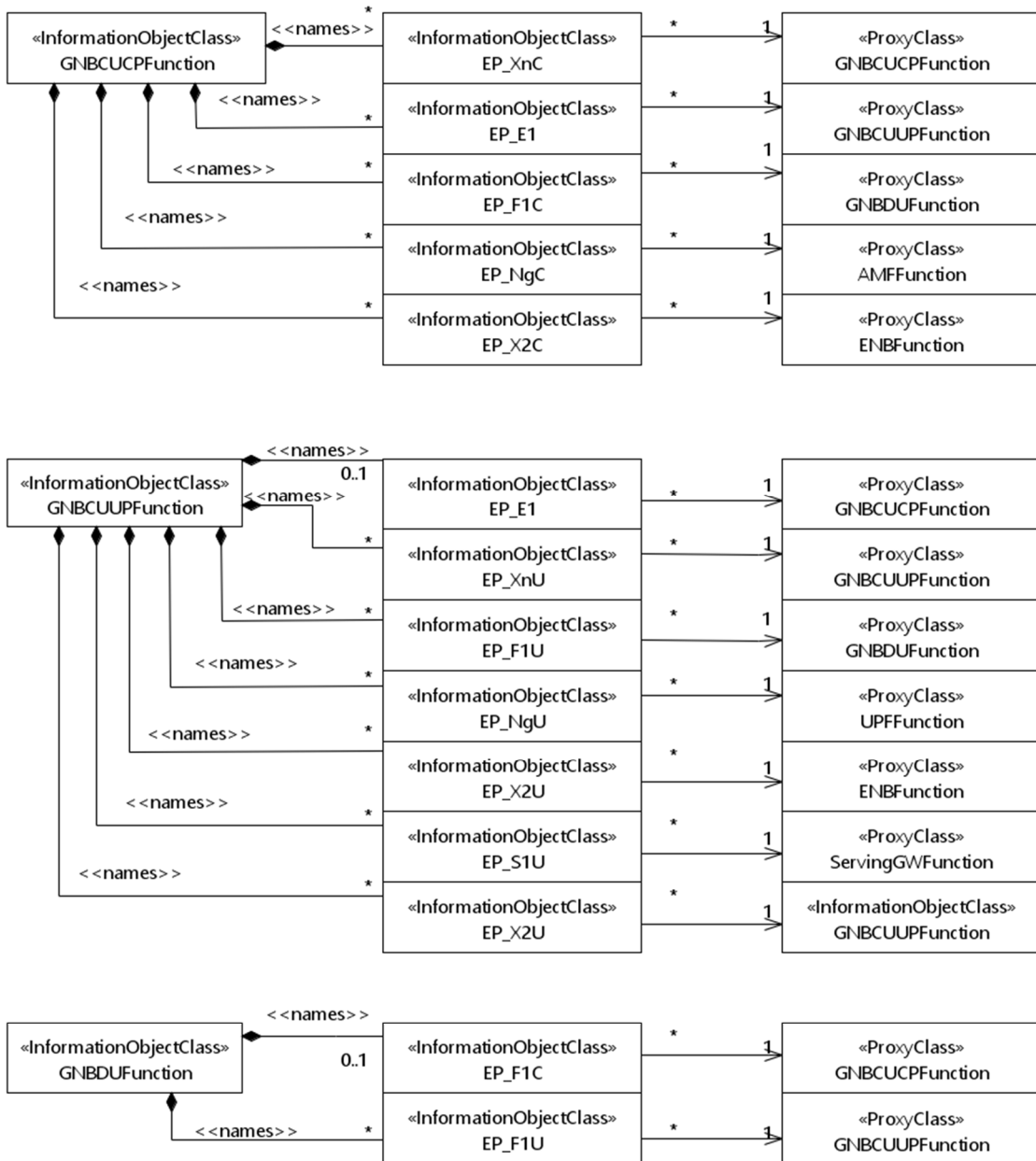

Figure 4.2.1.1-2: NRM for EPs for all deployment scenarios



Figure 4.2.1.1-3: NRM for <<IOC>>NRSectorCarrier and <<IOC>>BWP for all deployment scenarios

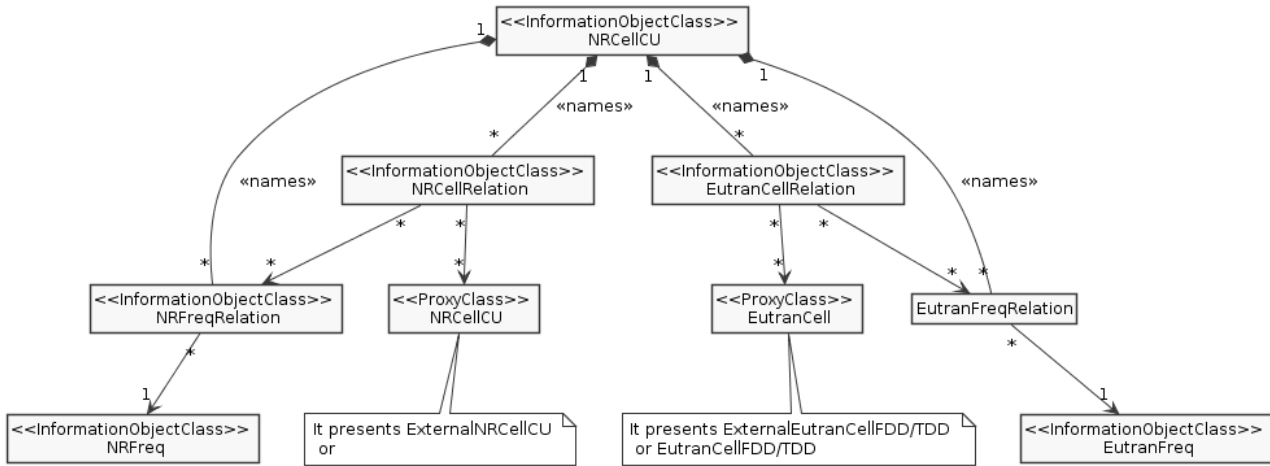

Figure 4.2.1.1-4: Cell Relation view for all deployment scenarios

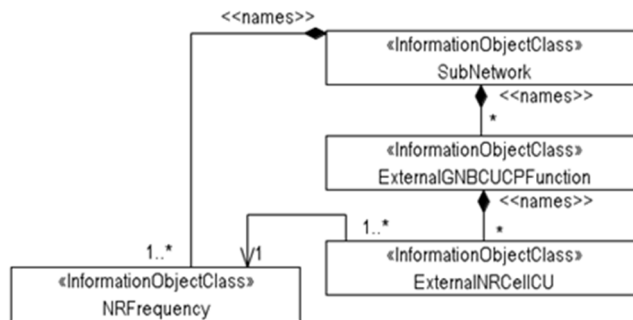

Figure 4.2.1.1-5: View on frequencies and external entities

4.2.1.2 Inheritance

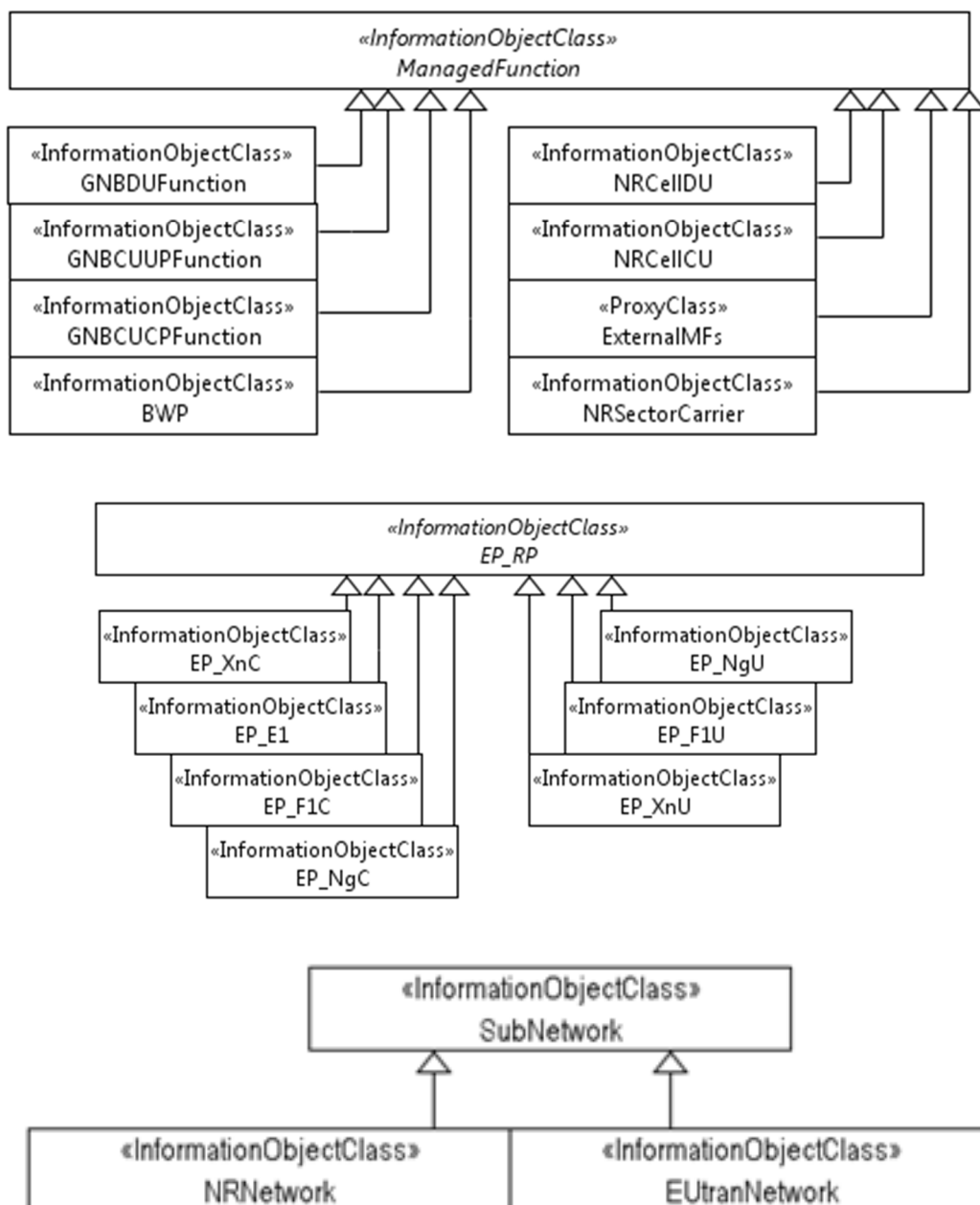

Figure 4.2.1.2-1: Inheritance Hierarchy

## 4.3 Class definitions

### 4.3.1 GNBDUFunction

#### 4.3.1.1 Definition

This IOC represents the logical function DU of gNB or en-gNB defined in 3GPP TS 38.401 [4].

The following table identifies the necessary end points required for the representation of gNB and en-gNB, of all deployment scenarios.

Role	Req	End point requirement for 3-split deployment scenario	End point requirement for 2-split deployment scenario	End point requirement for Non-split deployment scenario
gNB		<<IOC>>EP_F1C, <<IOC>>EP_F1U	<<IOC>>EP_F1C, <<IOC>>EP_F1U	None.
en-gNB		<<IOC>>EP_F1C, <<IOC>>EP_F1U	<<IOC>>EP_F1C, <<IOC>>EP_F1U	None.

#### 4.3.1.2 Attributes

Attribute name	Support Qualifier	isReadable	isWritable	isInvariant	isNotifiable
gNBDUIId	M	T	T	F	T
gNBDUName	O	T	T	F	T
gNBId	M	T	F	F	T
gNBIdLength	M	T	T	F	T
pLMNId	M	T	T	T	T

#### 4.3.1.3 Attribute constraints

None.

#### 4.3.1.4 Notifications

The common notifications defined in subclause 4.5 are valid for this IOC, without exceptions or additions.

### 4.3.2 GNBCUCPFunction

#### 4.3.2.1 Definition

This IOC represents the logical function CU-CP of gNB and en-gNB defined in 3GPP TS 38.401 [4].

The following table identifies the necessary end points required for the representation of gNB and en-gNB, of all deployment scenarios.

Role	Req	End point requirement for 3-split deployment scenario	End point requirement for 2-split deployment scenario	End point requirement for Non-split deployment scenario
gNB		<<IOC>>EP_XnC, <<IOC>>EP_NgC, <<IOC>>EP_F1C, <<IOC>>EP_E1.	<<IOC>>EP_XnC, <<IOC>>EP_NgC, <<IOC>>EP_F1C <<IOC>>EP_F1U.	<<IOC>>EP_XnC, <<IOC>>EP_NgC.
en-gNB		<<IOC>>EP_X2C, <<IOC>>EP_F1C, <<IOC>>EP_E1.	<<IOC>>EP_X2C, <<IOC>>EP_F1C.	<<IOC>>EP_X2C.

#### 4.3.2.2 Attributes

Attribute name	Support Qualifier	isReadable	isWritable	isInvariant	isNotifiable
gNBId	M	T	T	F	T
gNBIdLength	M	T	T	F	T
gNBCUName	O	T	T	F	T
pLMNId	M	T	T	T	T

#### 4.3.2.3 Attribute constraints

None.



#### 4.3.2.4 Notifications

The common notifications defined in subclause 4.5 are valid for this IOC, without exceptions or additions.

### 4.3.3 GNBCUUPFunction

#### 4.3.3.1 Definition

This IOC represents the logical function CU-UP of gNB or en-gNB defined in 3GPP TS 38.401 [4].

The following table identifies the necessary end points required for the representation of gNB and en-gNB, of all deployment scenarios.

Req Role	End point requirement for 3-split deployment scenario	End point requirement for 2-split deployment scenario	End point requirement for Non-split deployment scenario
gNB	<<IOC>>EP_XnU, <<IOC>>EP_NgU, <<IOC>>EP_F1U, <<IOC>>EP_E1.	<<IOC>>EP_XnU, <<IOC>>EP_NgU, <<IOC>>EP_F1U.	<<IOC>>EP_XnU, <<IOC>>EP_NgU.
en-gNB	<<IOC>>EP_X2U, <<IOC>>EP_S1U, <<IOC>>EP_F1U, <<IOC>>EP_E1.	<<IOC>>EP_X2U, <<IOC>>EP_S1U, <<IOC>>EP_F1U.	<<IOC>>EP_X2U, <<IOC>>EP_S1U.

#### 4.3.3.2 Attributes

Attribute name	Support Qualifier	isReadable	isWritable	isInvariant	isNotifiable
pLMNIdList	M	T	T	F	T
gNBId	M	T	T	F	T
gNBIdLength	M	T	T	F	T

#### 4.3.3.3 Attribute constraints

None.

#### 4.3.3.4 Notifications

The common notifications defined in subclause 4.5 are valid for this IOC, without exceptions or additions.

### 4.3.4 NRCellCU

#### 4.3.4.1 Definition

This IOC represents the information required by CU that is responsible for the management of inter-cell mobility and neighbour relations via ANR.

#### 4.3.4.2 Attributes

Attribute name	Support Qualifier	isReadable	isWritable	isInvariant	isNotifiable
cellLocalId	M	T	T	F	T
pLMNIdList	M	T	T (Note)	F	T
sNSSAIdList	CM	T	T	F	T
rRMPolicyType	CM	T	T	F	T
rRMPolicyNSSIId	CM	T	T	F	T
rRMPolicyRatio	CM	T	T	F	T
rRMPolicyRatio2	CM	T	T	F	T
rRMPolicy	CM	T	T	F	T
<b>Attribute related to role</b>					
Note: Whether the attribute "pLMNIdList" can be writable depends on the implementation.					

NOTE 1: Void.

NOTE 2: Void.

#### 4.3.4.3 Attribute constraints

Name	Definition
sNSSAIdList Support Qualifier	Condition: Network slicing feature is supported.
rRMPolicyRatio2 Support Qualifier	Condition: Network slicing feature is supported and rRMPolicyType is 2.
rRMPolicyType Support Qualifier	Condition: RRM policy for network slicing feature is supported.
rRMPolicyNSSIId Support Qualifier	Condition: RRM policy for network slicing feature is supported and rRMPolicyType is 1.
rRMPolicyRatio Support Qualifier	Condition: RRM policy for network slicing feature is supported and rRMPolicyType is 1.
rRMPolicy Support Qualifier	Condition: RRM policy for network slicing feature is supported and rRMPolicyType is 0.

#### 4.3.4.4 Notifications

The common notifications defined in subclause 4.5 are valid for this IOC, without exceptions or additions.

### 4.3.5 NRCellDU

#### 4.3.5.1 Definition

This IOC represents the information of a cell known by DU. The procedure for cell setup is initiated from the DU, thus requiring a notion of a cell. The DU owns the resources realizing the cell, thus requiring a notion of a cell owning the specific resources instances.

An NR cell transmits SS/PBCH block and always requires downlink transmission at a certain carrier frequency with a certain channel bandwidth. Transmission may be performed from multiple sector-carriers using different transmission points, and these may be configured with different carrier frequencies and channel bandwidths, as long as they are aligned to the cell's downlink resource grids as defined in subclause 4.4 in TS 38.211 [32]. The values of `arfcnDL` and `bSChannelBwDL` attributes define the resource grids which each sector-carrier needs to be aligned to. See subclauses 5.3 and 5.4.2 of TS 38.104 for definitions of BS channel bandwidth and NR-ARFCN, respectively.

An NR cell requires an uplink in order to provide initial access. In case of TDD, the values of `arfcnUL` and `bSChannelBwUL` have to always be set to the same values as for the corresponding DL attributes. For both FDD and TDD, the `arfcnUL` and `bSChannelBwUL` define uplink resource grids to which each sector-carrier needs to align to.

An NR cell can in addition be configured with a supplementary uplink, which has its own `arfcnSUL` and `bSChannelBwSUL`, which define resource grids for supplementary uplink sector-carriers.

Each of downlink, uplink and supplementary uplink (if configured) need an initial bandwidth part (BWP), which defines resources to be used by UEs during and immediately after initial access. Additional BWPs can be either

configured or calculated by gNB internally and be applied to UEs dynamically by gNB based on e.g. UE capability and bandwidth need of each UE.

#### 4.3.5.2 Attributes

Attribute name	Support Qualifier	isReadable	isWritable	isInvariant	isNotifyable
cellLocalId	M	T	T	F	T
operationalState	M	T	F	F	T (see Note 2)
administrativeState	M	T	T	F	T (see Note 2)
cellState	M	T	F	F	T (see Note 2)
pLMNIdList	M	T	T	F	T
sNSSAList	CM	T	T	F	T
nRPCI	M	T	T	F	T
nRTAC	CM	T	T	F	T
arfcnDL	M	T	T	F	T
arfcnUL	CM	T	T	F	T
arfcnSUL	CM	T	T	F	T
bSchannelBwDL	M	T	T	F	T
ssbFrequency	M	T	T	F	T
ssbPeriodicity	M	T	T	F	T
ssbSubCarrierSpacing	M	T	T	F	T
ssbOffset	M	T	T	F	T
ssbDuration	M	T	T	F	T
bSchannelBwUL	CM	T	T	F	T
bSchannelBwSUL	CM	T	T	F	T
<b>Attribute related to role</b>					
nRSectorCarrier	M	T	T	F	T
bWP	M	T	T	F	T
NOTE 1: No state propagation is implied.					
NOTE 2: The attribute value change is conveyed by the notifyStateChange notification.					

#### 4.3.5.3 Attribute constraints

Name	Definition
sNSSAList Support Qualifier	Condition: Network slicing feature is supported.
arfcnUL Support Qualifier	Condition: The cell has an uplink (FDD or TDD)
arfcnSUL Support Qualifier	Condition: The cell has a supplementary uplink
bSchannelBwUL Support Qualifier	Condition: The cell has an uplink (FDD or TDD)
bSchannelBwSUL Support Qualifier	Condition: The cell has a supplementary uplink
nrTAC Support Qualifier	Condition: 5G Standalone solution is supported.

#### 4.3.5.4 Notifications

The common notifications defined in subclause 4.5 are valid for this IOC, without exceptions or additions.

### 4.3.6 NRSectorCarrier

#### 4.3.6.1 Definition

This <<IOC>>NRSectorCarrier represents the resources of each transmission point included in the cell. These in general have different physical locations (of the antennae), and possibly different frequencies or bandwidths. The UE is not directly aware of which NRSectorCarrier resources the network uses for its connection.

An NR sector-carrier can have downlink, uplink or both as specified by txDirection. **Attributes related to unavailable direction (DL or UL) shall not be set.**

Additional NRSectorCarriers not directly associated to one cell only can also be configured.

If a value of arfcnDL, arfcnUL, bSchannelBwDL or bSchannelBwUL can be derived unambiguously from the referring cell, then that attribute needs not be present. That will not be possible if the NRSectorCarrier is used for

supplementary uplink, if it is not directly associated to a cell, or if the sector-carrier uses only a part of the cell's channel bandwidth. Thus, at least in those cases the applicable attributes have to be present and their values need to be set.

#### 4.3.6.2 Attributes

Attribute name	Support Qualifier	isReadable	isWritable	isInvariant	isNotifiable
txDirection	M	T	T	F	T
configuredMaxTxPower	CM	T	T	F	T
arfcnDL	CM	T	T	F	T
arfcnUL	CM	T	T	F	T
bSChannelBwDL	CM	T	T	F	T
bSChannelBwUL	CM	T	T	F	T
<b>attribute related to role</b>					
sectorEquipmentFunction	M	T	T	F	T

#### 4.3.6.3 Attribute constraints

Name	Definition
configuredMaxTxPower	Condition: The sector-carrier has a downlink.
arfcnDL	Condition: The sector-carrier has a downlink AND the value differs from the referring cell's value of arfcnDL.
arfcnUL	Condition: The sector-carrier has an uplink AND the value differs from the referring cell's value of arfcnUL.
bSChannelBwDL	Condition: The sector-carrier has a downlink AND the value differs from the referring cell's value of bSChannelBwDL.
bSChannelBwUL	Condition: The sector-carrier has an uplink AND the value differs from the referring cell's value of bSChannelBwUL.

#### 4.3.6.4 Notifications

The common notifications defined in subclause 4.5 are valid for this IOC, without exceptions or additions.

### 4.3.7 BWP

#### 4.3.7.1 Definition

This IOC represents a bandwidth part (BWP) defined in 3GPP TS 38.211 [32], subclause 4.4.5. A bandwidth part is related to downlink, uplink or supplementary uplink resource grids, and is defined by its subcarrier spacing (SCS), cyclic prefix and location and size related to the common resource grid for the applicable SCS.

A BWP can be either an initial BWP used for initial access, or other ("regular") BWP configured for relevant UEs that support the BWP's characteristics.

#### 4.3.7.2 Attributes

Attribute name	Support Qualifier	isReadable	isWritable	isInvariant	isNotifiable
bwpContext	M	T	T	F	T
isInitialBwp	M	T	T	F	T
subCarrierSpacing	M	T	T	F	T
cyclicPrefix	M	T	T	F	T
startRB	M	T	T	F	T
numberOfRBs	M	T	T	F	T

#### 4.3.7.3 Attribute constraints

None.

#### 4.3.7.4 Notifications

The common notifications defined in subclause 4.5 are valid for this IOC, without exceptions or additions.

## 4.3.8 EP\_E1

### 4.3.8.1 Definition

This IOC represents the local end point of the logical link, supporting E1 interface between gNB-CU-CP and gNB-CU-UP. The E1 interface is defined in 3GPP TS 38.401 [4].

### 4.3.8.2 Attributes

Attribute name	Support Qualifier	isReadable	isWritable	isInvariant	isNotifiable
localAddress	O	T	T	F	T
remoteAddress	O	T	T	F	T

### 4.3.8.3 Attribute constraints

None.

### 4.3.8.4 Notifications

The common notifications defined in subclause 4.5 are valid for this IOC, without exceptions or additions.

## 4.3.9 EP\_XnU

### 4.3.9.1 Definition

This IOC represents the one end-point of a logical link supporting the Xn user plane (Xn-U) interface. The Xn-U interface provides non-guaranteed delivery of user plane PDUs between two NG-RAN nodes. The user plane PDUs are carried on GTP-U/UDP/IP/Data link layer/Physical layer stack. See subclause 7.2 of 3GPP TS 38.420 [6].

### 4.3.9.2 Attributes

Attribute name	Support Qualifier	isReadable	isWritable	isInvariant	isNotifiable
localAddress	O	T	T	F	T
remoteAddress	O	T	T	F	T

### 4.3.9.3 Attribute constraints

None.

### 4.3.9.4 Notifications

The common notifications defined in subclause 4.5 are valid for this IOC, without exceptions or additions.

## 4.3.10 EP\_NgC

### 4.3.10.1 Definition

This IOC represents the local end point of the control plane interface (NG-C) between the gNB and NG-Core entity. The transport network layer is built on IP transport. For the reliable transport of signalling messages, SCTP is added on top of IP. The application layer signalling protocol is referred to as NG-AP (NG Application Protocol).

3GPP TS 38.470 [7] noted that "one gNB-CU and a set of gNB-DUs are visible to other logical nodes as a gNB or an en-gNB where the gNB terminates the Xn and the NG interfaces, and the en-gNB terminates the X2 and the S1-U interfaces".

### 4.3.10.2 Attributes

Attribute name	Support Qualifier	isReadable	isWritable	isInvariant	isNotifiable
localAddress	O	T	T	F	T
remoteAddress	O	T	T	F	T

### 4.3.10.3 Attribute constraints

None.

### 4.3.10.4 Notifications

The common notifications defined in subclause 4.5 are valid for this IOC, without exceptions or additions.

## 4.3.11 EP\_NgU

### 4.3.11.1 Definition

This IOC represents the local end point of the NG user plane (NG-U) interface between the gNB and the UPGW. The interface provides non-guaranteed delivery of user plane PDUs between the gNB and the UPGW. GTP-U is baseline for this interface.

3GPP TS 38.470 [7] noted that "one gNB-CU and a set of gNB-DUs are visible to other logical nodes as a gNB or an en-gNB where the gNB terminates the Xn and the NG interfaces, and the en-gNB terminates the X2 and the S1-U interfaces".

### 4.3.11.2 Attributes

Attribute name	Support Qualifier	isReadable	isWritable	isInvariant	isNotifiable
localAddress	O	T	T	F	T
remoteAddress	O	T	T	F	T

### 4.3.11.3 Attribute constraints

None.

### 4.3.11.4 Notifications

The common notifications defined in subclause 4.5 are valid for this IOC, without exceptions or additions.

## 4.3.12 EP\_F1C

### 4.3.12.1 Definition

This IOC represents the local end point of the control plane interface (F1-C) between the DU and CU or CU-CP. The transport network layer is based on IP transport with the SCTP on top of IP. The application layer signalling protocol is referred to as NG-AP (NG Application Protocol). See subclause 7.1 of 3GPP TS 38.470 [7].

3GPP TS 38.470 [7] noted that "one gNB-CU and a set of gNB-DUs are visible to other logical nodes as a gNB or an en-gNB where the gNB terminates the Xn and the NG interfaces, and the en-gNB terminates the X2 and the S1-U interfaces".

#### 4.3.12.2 Attributes

Attribute name	Support Qualifier	isReadable	isWritable	isInvariant	isNotifiable
localAddress	O	T	T	F	T
remoteAddress	O	T	T	F	T

#### 4.3.12.3 Attribute constraints

None.

#### 4.3.12.4 Notifications

The common notifications defined in subclause 4.5 are valid for this IOC, without exceptions or additions.

### 4.3.13 EP\_F1U

#### 4.3.13.1 Definition

This IOC represents the local end point of the user plane interface (F1-U) between the DU and CU or CU-UP. The transport network layer is based on IP transport, with the UDP and GTP-U on top of IP.

3GPP TS 38.470 [7] noted that "one gNB-CU and a set of gNB-DUs are visible to other logical nodes as a gNB or an en-gNB where the gNB terminates the Xn and the NG interfaces, and the en-gNB terminates the X2 and the S1-U interfaces".

#### 4.3.13.2 Attributes

Attribute name	Support Qualifier	isReadable	isWritable	isInvariant	isNotifiable
localAddress	O	T	T	F	T
remoteAddress	O	T	T	F	T

#### 4.3.13.3 Attribute constraints

None.

#### 4.3.13.4 Notifications

The common notifications defined in subclause 4.5 are valid for this IOC, without exceptions or additions.

### 4.3.14 EP\_S1U

#### 4.3.14.1 Definition

This IOC represents the local end point of the logical link, supporting S1-U interface towards a S-GW node. The S1-U interface is defined in 3GPP TS 36.410 [14].

#### 4.3.14.2 Attributes

Attribute name	Support Qualifier	isReadable	isWritable	isInvariant	isNotifiable
localAddress	O	T	T	F	T
remoteAddress	O	T	T	F	T

#### 4.3.14.3 Attribute constraints

None.

#### 4.3.14.4 Notifications

The common notifications defined in subclause 4.5 are valid for this IOC, without exceptions or additions.

### 4.3.15 EP\_X2C

#### 4.3.15.1 Definition

This IOC represents the local end point of the logical link, supporting X2-C application protocols used in EN-DC, to a neighbour eNB or en-gNB node, which is defined in 3GPP TS 36.423 [15]. EN-DC is defined in 3GPP TS 37.340 [9].

#### 4.3.15.2 Attributes

Attribute name	Support Qualifier	isReadable	isWritable	isInvariant	isNotifiable
localAddress	O	T	T	F	T
remoteAddress	O	T	T	F	T

#### 4.3.15.3 Attribute constraints

None.

#### 4.3.15.4 Notifications

The common notifications defined in subclause 4.5 are valid for this IOC, without exceptions or additions.

### 4.3.16 EP\_X2U

#### 4.3.16.1 Definition

This IOC represents the local end-point of a logical link supporting the X2 user plane (X2-U) interface used in EN-DC, which is defined in 3GPP TS 36.425 [16].

#### 4.3.16.2 Attributes

Attribute name	Support Qualifier	isReadable	isWritable	isInvariant	isNotifiable
localAddress	O	T	T	F	T
remoteAddress	O	T	T	F	T

#### 4.3.16.3 Attribute constraints

None.

#### 4.3.16.4 Notifications

The common notifications defined in subclause 4.5 are valid for this IOC, without exceptions or additions.

### 4.3.17 EP\_XnC

#### 4.3.17.1 Definition

This IOC represents the local gNB node end point of the logical link, supporting Xn Application protocols, to a neighbour gNB node. The Xn Application PDUs are carried over SCTP/IP/Data link layer/Physical layer stack. See subclause 7 of 3GPP TS 38.420 [6].



#### 4.3.17.2 Attributes

Attribute name	Support Qualifier	isReadable	isWritable	isInvariant	isNotifiable
localAddress	O	T	T	F	T
remoteAddress	O	T	T	F	T

#### 4.3.17.3 Attribute constraints

None

#### 4.3.17.4 Notifications

The common notifications defined in subclause 4.5 are valid for this IOC, without exceptions or additions.

### 4.3.18 ExternalGNBCUCPFunction

#### 4.3.18.1 Definition

This IOC represents the properties, known by the management function, of a `GNBCUCPFunction` managed by another management function. For more information about `GNBCUCPFunction`, see subclause 4.3.2.

#### 4.3.18.2 Attributes

Attribute name	Support Qualifier	isReadable	isWritable	isInvariant	isNotifiable
gNBId	M	T	T	F	T
gNBIdLength	M	T	T	F	T

#### 4.3.18.3 Attribute constraints

None.

#### 4.3.18.4 Notifications

The common notifications defined in subclause 4.5 are valid for this IOC, without exceptions or additions.

### 4.3.19 ExternalGNBCUUPFunction

#### 4.3.19.1 Definition

This IOC represents the properties, known by the management function, of a `GNBCUUPFunction` managed by another management function. For more information about `GNBCUUPFunction`, see subclause 4.3.3.

#### 4.3.19.2 Attributes

Attribute name	Support Qualifier	isReadable	isWritable	isInvariant	isNotifiable
gNBId	M	T	T	F	T
gNBIdLength	M	T	T	F	T

#### 4.3.19.3 Attribute constraints

None.

#### 4.3.19.4 Notifications

The common notifications defined in subclause 4.5 are valid for this IOC, without exceptions or additions.

## 4.3.20 ExternalGNBDUFunction

### 4.3.20.1 Definition

This IOC represents the properties, known by the management function, of a GNBDUFunction managed by another management function. For more information about GNBDUFunction, see subclause 4.3.1.

### 4.3.20.2 Attributes

Attribute name	Support Qualifier	isReadable	isWritable	isInvariant	isNotifiable
gNBId	M	T	T	T	T
gNBIdLength	M	T	T	F	T

### 4.3.20.3 Attribute constraints

None.

### 4.3.20.4 Notifications

The common notifications defined in subclause 4.5 are valid for this IOC, without exceptions or additions.

## 4.3.21 ExternalUPFFunction

### 4.3.21.1 Definition

This IOC represents the properties, known by the management function, of a UPFFunction managed by another management function. For more information about UPFFunction, see subclause 5.3.3.

### 4.3.21.2 Attributes

Attribute name	Support Qualifier	isReadable	isWritable	isInvariant	isNotifiable

### 4.3.21.3 Attribute constraints

None.

### 4.3.21.4 Notifications

The common notifications defined in subclause 4.5 are valid for this IOC, without exceptions or additions.

## 4.3.22 ExternalAMFFunction

### 4.3.22.1 Definition

This IOC represents the properties, known by the management function, of an AMFFunction managed by another management function. For more information about AMFFunction, see subclause 5.3.

### 4.3.22.2 Attributes

Attribute name	Support Qualifier	isReadable	isWritable	isInvariant	isNotifiable

### 4.3.22.3 Attribute constraints

None

#### 4.3.22.4 Notifications

The common notifications defined in subclause 4.5 are valid for this IOC, without exceptions or additions.

### 4.3.23 ExternalMFs <<ProxyClass>>

#### 4.3.23.1 Definition

This represents the following IOCs:

```
<<IOC>>ExternalAMFFunction, <<IOC>>ExternalGNBCUUPFunction,  
<<IOC>>ExternalGNBDUFunction, <<IOC>>ExternalServingGWFunction,  
<<IOC>>ExternalUPFFunction.
```

#### 4.3.23.2 Attributes

See respective IOCs.

#### 4.3.23.3 Attribute constraints

See respective IOCs.

#### 4.3.23.4 Notifications

See respective IOCs.

### 4.3.24 ENBFunction <<ProxyClass>>

#### 4.3.24.1 Definition

This IOC represents an <<IOC>>ENBFunction and <<IOC>>ExternalENBFunction.

#### 4.3.24.2 Attributes

See that defined in <<IOC>>ENBFunction and <<IOC>>ExternalENBFunction.

#### 4.3.24.3 Attribute constraints

See that defined in <<IOC>>ENBFunction and <<IOC>>ExternalENBFunction.

#### 4.3.24.4 Notifications

See respective IOCs.

### 4.3.25 GNBCUCPFunction <<ProxyClass>>

#### 4.3.25.1 Definition

This IOC represents an <<IOC>>GNBCUCPFunction and <<IOC>>ExternalGNBCUCPFunction.

#### 4.3.25.2 Attributes

See that defined in <<IOC>>GNBCUCPFunction and <<IOC>>ExternalGNBCUCPFunction.

#### 4.3.25.3 Attribute constraints

See respective IOCs.

#### 4.3.25.4 Notifications

See respective IOCs.

### 4.3.26 GNBCUUPFunction <<ProxyClass>>

#### 4.3.26.1 Definition

This IOC represents an <<IOC>>GNBCUUPFunction and <<IOC>>ExternalGNBCUUPFunction.

#### 4.3.26.2 Attributes

See that defined in <<IOC>>GNBCUUPFunction and <<IOC>>ExternalGNBCUUPFunction.

#### 4.3.26.3 Attribute constraints

See that defined in <<IOC>>GNBCUUPFunction and <<IOC>>ExternalGNBCUUPFunction.

#### 4.3.26.4 Notifications

See respective IOCs.

### 4.3.27 GNBDUFunction <<ProxyClass>>

#### 4.3.27.1 Definition

This IOC represents an <<IOC>>GNBDUFunction and <<IOC>>ExternalGNBDUFunction.

#### 4.3.27.2 Attributes

See that defined in <<IOC>>GNBDUFunction and <<IOC>>ExternalGNBDUFunction.

#### 4.3.27.3 Attribute constraints

See that defined in <<IOC>>GNBDUFunction and <<IOC>>ExternalGNBDUFunction.

#### 4.3.27.4 Notifications

See respective IOCs.

### 4.3.28 ServingGWFFunction <<ProxyClass>>

#### 4.3.28.1 Definition

This IOC represents an <<IOC>>ServingGWFFunction and <<IOC>>ExternalServingGWFFunction.

#### 4.3.28.2 Attributes

See that defined in <<IOC>>ServingGWFFunction and <<IOC>>ExternalServingGWFFunction.

### 4.3.28.3 Attribute constraints

See that defined in <<IOC>>ServingGWFunction and <<IOC>>ExternalServingGWFunction.

### 4.3.28.4 Notifications

See respective IOCs.

## 4.3.29 UPFFunction <<ProxyClass>>

### 4.3.29.1 Definition

This IOC represents an <<IOC>>UPFFunction and <<IOC>>ExternalUPFFunction.

### 4.3.29.2 Attributes

See that defined in <<IOC>>UPFFunction and <<IOC>>ExternalUPFFunction.

### 4.3.29.3 Attribute constraints

See that defined in <<IOC>>UPFFunction and <<IOC>>ExternalUPFFunction.

### 4.3.29.4 Notifications

See respective IOCs.

## 4.3.30 AMFFunction <<ProxyClass>>

### 4.3.30.1 Definition

This IOC represents an <<IOC>>AMFFunction and <<IOC>>ExternalAMFFunction.

### 4.3.30.2 Attributes

See that defined in <<IOC>>AMFFunction and <<IOC>>ExternalAMFFunction.

### 4.3.30.3 Attribute constraints

See that defined in <<IOC>>AMFFunction and <<IOC>>ExternalAMFFunction.

### 4.3.30.4 Notifications

See respective IOCs.

## 4.3.31 Void

## 4.3.32 NRCellRelation

### 4.3.32.1 Definition

This IOC represents a neighbour cell relation from a source cell to a target cell, where the target cell is an NRCellCU or ExternalNRCellCU instance.

Neighbour cell relations are unidirectional.

#### 4.3.32.2 Attributes

Attribute name	Support Qualifier	isReadable	isWritable	isInvariant	isNotifyable
Id	M	T	T	T	F
nRTCI	O	T	T	F	T
adjacentCell	M	T	T	F	T

#### 4.3.32.3 Attribute constraints

#### 4.3.32.4 Notifications

The common notifications defined in subclause 4.5 are valid for this IOC, without exceptions or additions.

### 4.3.33 NRFreqRelation

#### 4.3.33.1 Definition

This IOC represents a neighbour frequency relation for one or more NRCellRelations.

#### 4.3.33.2 Attributes

Attribute name	Support Qualifier	isReadable	isWritable	isInvariant	isNotifyable

#### 4.3.33.3 Attribute constraints

#### 4.3.33.4 Notifications

The common notifications defined in subclause 4.5 are valid for this IOC, without exceptions or additions.

### 4.3.34 EutranFreqRelation

#### 4.3.34.1 Definition

This IOC represents a neighbour frequency relation for one or more EutranCellRelations.

#### 4.3.34.2 Attributes

Attribute name	Support Qualifier	isReadable	isWritable	isInvariant	isNotifyable

#### 4.3.34.3 Attribute constraints

#### 4.3.34.4 Notifications

The common notifications defined in subclause 4.5 are valid for this IOC, without exceptions or additions.

## 4.3.35 ExternalNRCellCU

### 4.3.35.1 Definition

This abstract IOC represents the properties of an NRCellCU controlled by another Management Service Provider. This IOC contains necessary attributes for inter-system and intra-system handover. It also contains a subset of the attributes of related IOCs controlled by Management Service Provider. The way to maintain consistency between the attribute values of these IOCs is outside the scope of the present document.

### 4.3.35.2 Attributes

Attribute name	Support Qualifier	isReadable	isWritable	isInvariant	isNotifiable
cellLocalId	M	T	T	F	T
nRPCI	M	T	T	F	T
arfcnDL	M	T	T	F	T

### 4.3.35.3 Attribute constraints

None.

### 4.3.35.4 Notifications

The common notifications defined in subclause 4.5 are valid for this IOC, without exceptions or additions.

## 4.3.36 RRMPolicyRatio2

### 4.3.36.1 Definition

This <<DataType>> represents the properties of RRMPolicyRatio2. The RRM policy setting the ratios for the split of the Radio resources between the supported S-NSSALists. in average over time. RRMPolicyRation2 is a list and each item of the list has seven attributes. Four of them specify the percentage of radio resources to be allocated to the corresponding sNSSAList. The attribute rRMPolicyMaxRatio defines the maximum resource limitation for the sNSSAList. The attribute rRMPolicyMarginMaxRatio defines the safety margin that allows for maximum float limit use with other sNSSAIs borrowing free resources while keeping safety margin to ensure that resources are available for quota specific sNSSAList. The attribute rRMPolicyMinRatio defines the minimum resource limitation for the sNSSAList. The attribute rRMPolicyMarginMinRatio defines the safety margin that allows for minimum float limit use with other sNSSAIs borrowing free resources while keeping safety margin to ensure that resources are available for quota specific sNSSAList.

### 4.3.36.2 Attributes

Attribute name	Support Qualifier	isReadable	isWritable	isInvariant	isNotifiable
groupId	M	T	F	T	F
sNSSAList	M	T	T	F	T
quotaType	M	T	T	F	T
rRMPolicyMaxRatio	M	T	T	F	T
rRMPolicyMarginMaxRatio	O	T	T	F	T
rRMPolicyMinRatio	M	T	T	F	T
rRMPolicyMarginMinRatio	O	T	T	F	T

## 4.4 Attribute definitions

### 4.4.1 Attribute properties



Attribute Name	Documentation and Allowed Values	Properties
administrativeState	<p>It indicates the administrative state of the NRCellDU. It describes the permission to use or prohibition against using the cell, imposed through the OAM services.</p> <p>allowedValues: "LOCKED", "SHUTTING DOWN", "UNLOCKED". The meaning of these values is as defined in ITU-T Recommendation X.731 [18].</p> <p>See Annex A for Relation between the "Pre-operation state of the gNB-DU Cell" and administrative state relevant in case of 2-split and 3-split deployment scenarios.</p>	<p>type: ENUM multiplicity: 1 isOrdered: N/A isUnique: N/A defaultValue: Locked isNullable: False</p>
operationalState	<p>It indicates the operational state of the NRCellDU instance. It describes whether the resource is installed and partially or fully operable (Enabled) or the resource is not installed or not operable (Disabled).</p> <p>allowedValues: "ENABLED", "DISABLED".</p>	<p>type: ENUM multiplicity: 1 isOrdered: N/A isUnique: N/A defaultValue: None isNullable: False</p>
cellState	<p>It indicates the usage state of the NRCellDU instance. It describes whether the cell is not currently in use (Idle), or currently in use but not configured to carry traffic (Inactive) or is currently in use and is configured to carry traffic (Active).</p> <p>The Inactive and Active definitions are in accordance with TS 38.401 [4]: "Inactive: the cell is known by both the gNB-DU and the gNB-CU. The cell shall not serve UEs; Active: the cell is known by both the gNB-DU and the gNB-CU. The cell should be able to serve UEs."</p> <p>"allowedValues: "IDLE", "INACTIVE", "ACTIVE".</p>	<p>type: ENUM multiplicity: 1 isOrdered: N/A isUnique: N/A defaultValue: None isNullable: False</p>
arfcnDL	<p>NR Absolute Radio Frequency Channel Number (NR-ARFCN) for downlink</p> <p>allowedValues: See TS 38.104 [12] subclause 5.4.2. Note that allowed values of NR-ARFCN are specified for each band in subclause 5.4.2.3.</p>	<p>type: Integer multiplicity: 1 isOrdered: N/A isUnique: N/A defaultValue: None isNullable: False</p>
arfcnUL	<p>NR Absolute Radio Frequency Channel Number (NR-ARFCN) for uplink</p> <p>allowedValues: See TS 38.104 [12] subclause 5.4.2. Note that allowed values of NR-ARFCN are specified for each band in subclause 5.4.2.3.</p>	<p>type: Integer multiplicity: 1 isOrdered: N/A isUnique: N/A defaultValue: None isNullable: False</p>
arfcnSUL	<p>NR Absolute Radio Frequency Channel Number (NR-ARFCN) for supplementary uplink</p> <p>allowedValues: See TS 38.104 [12] subclause 5.4.2. Note that allowed values of NR-ARFCN are specified for each band in subclause 5.4.2.3.</p>	<p>type: Integer multiplicity: 1 isOrdered: N/A isUnique: N/A defaultValue: None isNullable: False</p>
bSChannelBwDL	<p>BS Channel BW in MHz. for downlink</p> <p>allowedValues: See BS Channel BW in TS 38.104 [12], subclause 5.3.</p>	<p>type: Integer multiplicity: 1 isOrdered: N/A isUnique: N/A defaultValue: None isNullable: False</p>

bSChannelBwUL	BS Channel BW in MHz.for uplink  allowedValues: See BS Channel BW in TS 38.104 [12], subclause 5.3.	type: Integer multiplicity: 1 isOrdered: N/A isUnique: N/A defaultValue: None isNullable: False
bSChannelBwSUL	BS Channel BW in MHz.for supplementary uplink  allowedValues: See BS Channel BW in TS 38.104 [12], subclause 5.3.	type: Integer multiplicity: 1 isOrdered: N/A isUnique: N/A defaultValue: None isNullable: False
configuredMaxTxPower	This is the maximum number of milliwatt possible for all downlink channels, used simultaneously in a sector-carrier, added together.  allowedValues: N/A	type: Integer multiplicity: 1 isOrdered: N/A isUnique: N/A defaultValue: None isNullable: False
cyclicPrefix	Cyclic prefix as defined in TS 38.211 [32], subclause 4.2.  allowedValues: "NORMAL", "EXTENDED".	type: enumeration multiplicity: 1 isOrdered: N/A isUnique: N/A defaultValue: None isNullable: False
localAddress	This parameter specifies the localAddress including IP address and VLAN ID used for initialization of the underlying transport.  First string is IP address, IP address can be an IPv4 address (See RFC 791 [37]) or an IPv6 address (See RFC 2373 [38]). Second string is VLAN Id. (See IEEE 802.1Q [39]),	type: String multiplicity: 2 isOrdered: True isUnique: N/A defaultValue: None isNullable: False
remoteAddress	Remote address including IP address used for initialization of the underlying transport.  IP address can be an IPv4 address (See RFC 791 [37]) or an IPv6 address (See RFC 2373 [38]).	type: String multiplicity: 1 isOrdered: N/A isUnique: N/A defaultValue: None isNullable: False
gNBId	It identifies a gNB within a PLMN. The gNB ID is part of the NR Cell Identifier (NCI) of the gNB cells. See "gNB Identifier (gNB ID)" of subclause 8.2 of TS 38.300 [3]. See "Global gNB ID" in subclause 9.3.1.6 of TS 38.413 [5].  allowedValues: 0 .. 4294967295	type: Integer multiplicity: 1 isOrdered: N/A isUnique: N/A defaultValue: None isNullable: False
gNBIdLength	This indicates the number of bits for encoding the gNB ID. See "Global gNB ID" in subclause 9.3.1.6 of TS 38.413 [5].  allowedValues: 22 .. 32.	type: Integer multiplicity: 1 isOrdered: N/A isUnique: N/A defaultValue: None isNullable: False
gNBDUId	It uniquely identifies the DU at least within a gNB. See 'gNB-DU ID' in subclause 9.3.1.9 of 3GPP TS 38.473 [8].  allowedValues: Not applicable	type: Integer multiplicity: 1 isOrdered: N/A isUnique: N/A defaultValue: None isNullable: False

gNBCUName	<p>It identifies the Central Entity of a NR node, see subclause 9.2.1.4 of 3GPP TS 38.473 [8].</p> <p>allowedValues: Not applicable</p>	<p>type: String multiplicity: 1 isOrdered: N/A isUnique: N/A defaultValue: None isNullable: False</p>
gNBDUName	<p>It identifies the Distributed Entity of a NR node, see subclause 9.2.1.5 of 3GPP TS 38.473 [8].</p> <p>allowedValues: Not applicable</p>	<p>type: String multiplicity: 1 isOrdered: N/A isUnique: N/A defaultValue: None isNullable: False</p>
cellLocalId	<p>It identifies a NR cell of a gNB.</p> <p>It, together with the gNB Identifier (using gNBId of the parent GNBCUCPFunction or GNBDFunction or ExternalCUCPFunction), identifies a NR cell within a PLMN. This is the NR Cell Identity (NCI). See subclause 8.2 of TS 38.300 [3].</p> <p>The NCI can be constructed by encoding the gNB Identifier using gNBId (of the parent GNBCUCPFunction or GNBDFunction or ExternalCUCPFunction) and cellLocalId where the gNB Identifier field is of length specified by gNBIdLength (of the parent GNBCUCPFunction or GNBDFunction or ExternalCUCPFunction). See "Global gNB ID" in subclause 9.3.1.6 of TS 38.413 [5].</p> <p>The NR Cell Global identifier (NCGI) is constructed from the PLMN identity the cell belongs to and the NR Cell Identifier (NCI) of the cell. See relation between NCI and NCGI subclause 8.2 of TS 38.300 [3].</p> <p>allowedValues: Not applicable</p>	<p>type: Integer multiplicity: 1 isOrdered: N/A isUnique: True defaultValue: None isNullable: False</p>
nRPCI	<p>This holds the Physical Cell Identity (PCI) of the NR cell.</p> <p>allowedValues: See 3GPP TS 36.211 subclause 6.11 for legal values of pci.</p>	<p>type: Integer multiplicity: 1 isOrdered: N/A isUnique: N/A defaultValue: None isNullable: False</p>
nRTAC	<p>This holds the identity of the common Tracking Area Code for the PLMNs.</p> <p>allowedValues: a) It is the TAC or Extended-TAC. b) A cell can only broadcast one TAC or Extended-TAC. See TS 36.300, subclause 10.1.7 (PLMNID and TAC relation). c) TAC is defined in subclause 19.4.2.3 of 3GPP TS 23.003 [13] and Extended-TAC is defined in subclause 9.3.1.29 of 3GPP TS 38.473 [8].</p>	<p>type: Bitstring multiplicity: 1 isOrdered: N/A isUnique: N/A defaultValue: None isNullable: False</p>
GNBCUCPFunction.pLMNid	<p>It specifies the PLMN identifier to be used as part of the global RAN node identity.</p> <p>allowedValues: Not applicable.</p>	<p>Type: PLMNid multiplicity: 1 isOrdered: N/A isUnique: N/A defaultValue: None isNullable: False</p>

GNBDUFunction.pLMNId	It specifies the PLMN identifier to be used as part of the NR Cell Global Identity (NCGI).  allowedValues: Not applicable.	type: PLMNId multiplicity: 1 isOrdered: N/A isUnique: N/A defaultValue: None isNullable: False
NRCellCU.pLMNIdList	It defines which PLMNs that can be served by the NR cell.  allowedValues: Not applicable.	type: PLMNId multiplicity: 1..12 isOrdered: N/A isUnique: True defaultValue: None isNullable: False
GNBCUUPFunction.pLMNIdList	This is a list of PLMN identifiers. It defines from which set of PLMNs an UE must have as its serving PLMN to be allowed to use the GNB-CU-UP.  allowedValues: Not applicable.	type: PLMNId multiplicity: 1..12 isOrdered: N/A isUnique: True defaultValue: None isNullable: False
NRCellDU.pLMNIdList	It defines which PLMNs that can be served by the NR cell. The first entry of the list is the PLMN used to construct the nCGI for the NR cell.  allowedValues: Not applicable.	type: PLMNId multiplicity: 1..12 isOrdered: N/A isUnique: True defaultValue: None isNullable: False
ExternalNRCellCU.pLMNIdList	It defines which PLMNs that are assumed to be served by the NR Cell in another gNB-CU-CP. This list is either updated by the managed element itself (e.g. due to ANR, signalling over Xn etc) or by consumer over the standard interface.  allowedValues: Not applicable.	Type: PLMNId multiplicity: 1..12 isOrdered: N/A isUnique: True defaultValue: None isNullable: False
sNSSAIIList	It represents the list of S-NSSAI the managed object is supporting, NSSAI is a set of supported S-NSSAI(s), an S-NSSAI is comprised of a SST (Slice/Service type) and an optional SD (Slice Differentiator) field, (See 3GPP TS 23.003 [13]).  allowedValues: See 3GPP TS 23.003 [13]	type: <<S-NSSAI>> multiplicity: * isOrdered: N/A isUnique: N/A defaultValue: None allowedValues: N/A isNullable: False
rRMPolicyType	Type of the RRM policy. The value 0 denotes use of the rRMPolicy. The value 1 denotes use of the rRMPolicyNSSIId, rRMPolicyRatio The value 2 denotes use of the rRMPolicyRatio2.  allowedValues: 0 : 65535.	type: Integer multiplicity: 1 isOrdered: N/A isUnique: N/A defaultValue: None isNullable: False
rRMPolicyNSSIId	The list of S-NSSAIs for which a rRMPolicyRatio value is specified  allowedValues: Not applicable.	type: DN multiplicity: 1..* isOrdered: N/A isUnique: N/A defaultValue: None allowedValues: N/A isNullable: False

rRMPolicyRatio	<p>The RRM policy setting the ratio for the split of the Radio resources between the supported S-NSSAI lists A S-NSSAI list is defined in rRMPolicyNSSAIId. rRMPolicyRatio is the list of target percentage values assigned to the corresponding rRMPolicyNSSAIId values. Every value specifies the percentage of PRBs to be allocated to the corresponding S-NSSAIs, in average over time. The sum of the values shall be less or equal 100.</p> <p>allowedValues: 0 : 100</p> <p>See NOTE 3 and NOTE 4</p>	<p>type: Integer multiplicity: 1..* isOrdered: N/A isUnique: N/A defaultValue: None allowedValues: N/A isNullable: False</p>
rRMPolicyRatio2	<p>The attribute specifies a list of RRMPolicyRatio2 which defined as datatype. The attribute is used to set the ratios for the split of the Radio resources between the sNSSAIs for radio resources (e.g. RRC connected users, PDCP resource, etc.) in average time (see NOTE 3 and NOTE 2).</p> <p>The sum of the values included in the item of rRMPolicyRatio2 shall be less or equal 100 (see NOTE 4).</p> <p>allowedValues: Not applicable.</p>	<p>type: &lt;&lt; dataType &gt;&gt; multiplicity: 1..* isOrdered: N/A isUnique: N/A defaultValue: None allowedValues: N/A isNullable: False</p>
groupId	<p>The attribute identifies one sNSSAIsList group inside NRCellCU. The rRMPolicyRatio2 is configured for each group. The value of the groupId is unique inside one NRCellCU instance</p>	<p>type: Integer multiplicity: 1 isOrdered: N/A isUnique: N/A defaultValue: None allowedValues: N/A isNullable: False</p>
quotaType	<p>The attribute indicates the type of the quota which allows to allocate resources as strictly usable for defined slice(s) ( "strict quota") or allows that resources to be used by other slice(s) when defined slice(s) do not need them ( "float quota").</p> <p>allowedValues: "STRICT", "FLOAT".</p>	<p>type: ENUM multiplicity: 1 isOrdered: N/A isUnique: N/A defaultValue: None isNullable: False</p>
rRMPolicyMaxRatio	<p>The RRM policy setting the maximum percentage of radio resources to be allocated to the corresponding S-NSSAIsList. This quota can be strict or float quota. Strict quota means resources are not allowed for other sNSSAIs even when they are not used by the defined sNSSAIsList. Float quota resources can be used by other sNSSAIs when the defined sNSSAIsList do not need them.</p> <p>Value 0 indicates that there is no maximum limit.</p> <p>allowedValues: 0 : 100</p>	<p>type: Integer multiplicity: 0..1 isOrdered: N/A isUnique: N/A defaultValue: None allowedValues: N/A isNullable: False</p>
rRMPolicyMarginMaxRatio	<p>Maximum quota margin ratio is applicable when maximum quota policy ratio is of type "float quota". It defines the resource quota within maximum quota to reserve buffers for new resource requirements for the specified S-NSSAIsList. With the margin ratio, unused resources of the maximum resource quota can be allocated to other S-NSSAIs when the free resources are more than resource amount indicated by the margin. The margin resource quota can only be used for the specific S-NSSAIsList.</p> <p>Value 0 indicates that no margin is used.</p> <p>allowedValues: 0 : 100</p>	<p>type: Integer multiplicity: 0..1 isOrdered: N/A isUnique: N/A defaultValue: None allowedValues: N/A isNullable: False</p>

rRMPolicyMinimumRatio	<p>The RRM policy setting the minimum percentage of radio resources to be allocated to the corresponding S-NSSAList. This quota can be strict or float quota. Strict quota means resources are not allowed for other sNSSAIs even when they are not used by the defined sNSSAList. Float quota resources can be used by other sNSSAIs when the defined sNSSAList do not need them.</p> <p>Value 0 indicates that there is no minimum limit.</p> <p>allowedValues: 0 : 100</p> <p>NOTE: The averaging time interval is implementation dependent.</p>	<p>type: Integer multiplicity: 0..1 isOrdered: N/A isUnique: N/A defaultValue: None allowedValues: N/A isNullable: False</p>
rRMPolicyMarginMinimumRatio	<p>Minimum quota margin ratio is applicable when minimum quota policy ratio is of type "float quota". It defines the resource quota within minimum quota to reserve buffers for new resource requirements for the specified S-NSSAList. With the margin ratio, unused resources of the minimum resource quota can be allocated to other S-NSSAIs when the free resources are more than resource amount indicated by the margin. The margin resource quota can only be used for the specific S-NSSAList.</p> <p>Value 0 indicates that no margin is used.</p> <p>allowedValues: 0 : 100</p>	<p>type: Integer multiplicity: 0..1 isOrdered: N/A isUnique: N/A defaultValue: None allowedValues: N/A isNullable: False</p>
rRMPolicy	<p>It represents RRM policy which includes guidance for split of radio resources between the S-NSSAIs that the cell supports in case when the rRMPolicyType is absent or equal to 0. The RRM policy is implementation dependent.</p> <p>allowedValues: Not applicable</p>	<p>type: String multiplicity: 1 isOrdered: N/A isUnique: N/A defaultValue: None isNullable: False</p>
subcarrierSpacing	<p>Subcarrier spacing configuration for a BWP. See subclause 5 in TS 38.104 [12].</p> <p>AllowedValues: [15, 30, 60, 120] depending on the frequency range FR1 or FR2.</p>	<p>type: Integer multiplicity: 1 isOrdered: N/A isUnique: N/A defaultValue: None isNullable: False</p>
txDirection	<p>Indicates if the transmission direction is downlink (DL), uplink (UL) or both downlink and uplink (DL and UL).</p> <p>allowedValues: "DL", "UL", "DL and UL"</p>	<p>type: Enum multiplicity: 1 isOrdered: N/A isUnique: N/A defaultValue: None isNullable: False</p>
bwpContext	<p>It identifies whether the object is used for downlink, uplink or supplementary uplink.</p> <p>allowedValues: "DL", "UL", "SUL"</p>	<p>type: Enum multiplicity: 1 isOrdered: N/A isUnique: N/A defaultValue: None isNullable: False</p>
isInitialBwp	<p>It identifies whether the object is used for initial or other BWP.</p> <p>allowedValues: "INITIAL", "OTHER"</p>	<p>type: Enum multiplicity: 1 isOrdered: N/A isUnique: N/A defaultValue: None isNullable: False</p>

startRB	<p>Offset in common resource blocks to common resource block 0 for the applicable subcarrier spacing for a BWP. This corresponds to N_BWP_start, see subclause 4.4.5 in TS 38.211 [32].</p> <p>allowedValues: 0 to N_grid_size – 1, where N_grid_size equals the number of resource blocks for the BS channel bandwidth, given the subcarrier spacing of the BWP.</p>	<p>type: Integer multiplicity: 1 isOrdered: N/A isUnique: N/A defaultValue: None isNullable: False</p>
numberOfRBs	<p>Number of physical resource blocks for a BWP. This corresponds to N_BWP_size, see subclause 4.4.5 in TS 38.211 [32].</p> <p>allowedValues: 1 to N_grid_size – startRB of the BWP. Se startRB for definition of N_grid_size.</p>	<p>type: Integer multiplicity: 1 isOrdered: N/A isUnique: N/A defaultValue: None isNullable: False</p>
nRTCI	<p>This is the Target NR Cell Identifier. It consists of NR Cell Identifier (NCI) and Physical Cell Identifier of the target NR cell (nRPCI).</p> <p>The NRRelation.nRTCI identifies the target cell from the perspective of the NRCell, the name-containing instance of the subject NRCellCU instance.</p>	<p>type: Integer multiplicity: 1 isOrdered: N/A isUnique: N/A defaultValue: None isNullable: False</p>
adjacentCell	<p>This attribute contains the DN of an AdjacentNRCell (NRCellCU or ExternalNRCellCU) or AdjacentEutranCell (EutranCellFDD or EutranCellTDD or ExternalEutranCellFDD or ExternalEutranCellTDD)</p> <p>allowedValues: Not applicable.</p>	<p>type: DN multiplicity: 1 isOrdered: N/A isUnique: True defaultValue: None isNullable: False</p>
ssbFrequency	<p>Indicates cell defining SSB frequency domain position</p> <p>Frequency of the cell defining SSB transmission. The frequency provided in this attribute identifies the position of resource element RE=#0 (subcarrier #0) of resource block RB#10 of the SS block. The frequency must be positioned on the NR global frequency raster, as defined in TS 38.101 [42] subclause 5.4.2. and within bSChannelBwDL.</p> <p>allowedValues: 0..3279165</p>	<p>type: Integer multiplicity: 1 isOrdered: N/A isUnique: N/A defaultValue: None isNullable: False</p>
ssbPeriodicity	<p>Indicates cell defined SSB periodicity in number of subframes (ms).</p> <p>The SSB periodicity in msec is used for the rate matching purpose.</p> <p>allowedValues: 5, 10, 20, 40, 80, 160.</p>	<p>type: Integer multiplicity: 1 isOrdered: N/A isUnique: N/A defaultValue: None isNullable: False</p>
ssbSubCarrierSpacing	<p>Subcarrier spacing of SSB. See subclause 7.4.3.1 of TS 38.211 [32].</p> <p>allowedValues: Only the values 15kHz or 30 kHz (&lt;6GHz), 120 kHz or 240 kHz (&gt;6GHz) are applicable.</p>	<p>type: Integer multiplicity: 1 isOrdered: N/A isUnique: N/A defaultValue: None isNullable: False</p>
ssbOffset	<p>Indicates cell defining SSB time domain position. Defined as the offset of the measurement window, in number of subframes (ms), in which to receive SS/PBCH blocks, where allowed values depend on the ssbPeriodicity.</p> <p>allowedValues: ssbPeriodicity5 ms 0..4, ssbPeriodicity10 ms 0..9, ssbPeriodicity20 ms 0..19, ssbPeriodicity40 ms 0..39, ssbPeriodicity80 ms 0..79, ssbPeriodicity160 ms 0..159.</p>	<p>type: Integer multiplicity: 1 isOrdered: N/A isUnique: N/A defaultValue: None isNullable: False</p>

ssbDuration	Duration of the measurement window in which to receive SS/PBCH blocks. It is given in number of subframes (ms) (see 38.213 [41], subclause 4.1.  allowedValues: 1, 2, 3, 4, 5.	type: Integer multiplicity: 1 isOrdered: N/A isUnique: N/A defaultValue: None isNullable: False
NOTE 1: Void NOTE 2: The radio resource can be signaling resources (e.g. RRC connected users) or user plane resources (e.g. PDCP). The detail resource and how to map the ratio to exact number of resources is implementation dependant. NOTE 3: The averaging time interval is implementation dependent. NOTE 4: How to cacluate the sum of the ratio is implementation dependent.		

## 4.5 Common notifications

This subclause presents a list of notifications, defined in [35], that provisioning management service consumer can receive. The notification parameter `objectClass/objectInstance`, defined in [26], would capture the DN of an instance of an IOC defined in the present document.

Name	Qualifier	Notes
notifyMOIAttributeValueChanges	O	
notifyMOICreation	O	
notifyMOIDeletion	O	

# 5 Information model definitions for 5GC NRM

## 5.1 Imported information entities and local labels

Label reference	Local label
TS 28.622 [30], IOC, SubNetwork	SubNetwork
TS 28.622 [30], IOC, ManagedElement	ManagedElement
TS 28.622 [30], IOC, ManagedFunction	ManagedFunction
TS 28.622 [30], IOC, EP_RP	EP_RP
TS 28.708 [21], IOC, ServingGWFunction	ServingGWFunction
TS 28.702 [20], IOC, SmsIwmscFunction	SmsIwmscFunction
TS 28.702 [20], IOC, SmsGmscFunction	SmsGmscFunction
TS 28.702 [20], IOC, GmlcFunction	GmlcFunction
3GPP TS 28.658 [19], dataType, PLMNId	PLMNId

## 5.2 Class diagram

### 5.2.1 Class diagram of 5GC NFs

#### 5.2.1.1 Relationships

This clause depicts the set of classes (e.g. IOCs) that encapsulates the information relevant for NRM of 5GC NFs definitions. This clause provides the overview of the relationships of relevant classes in UML. Subsequent clauses provide more detailed specification of various aspects of these classes.

The Figure 5.2.1.1-1 shows the 5GC NF NRM containment/naming relationship.



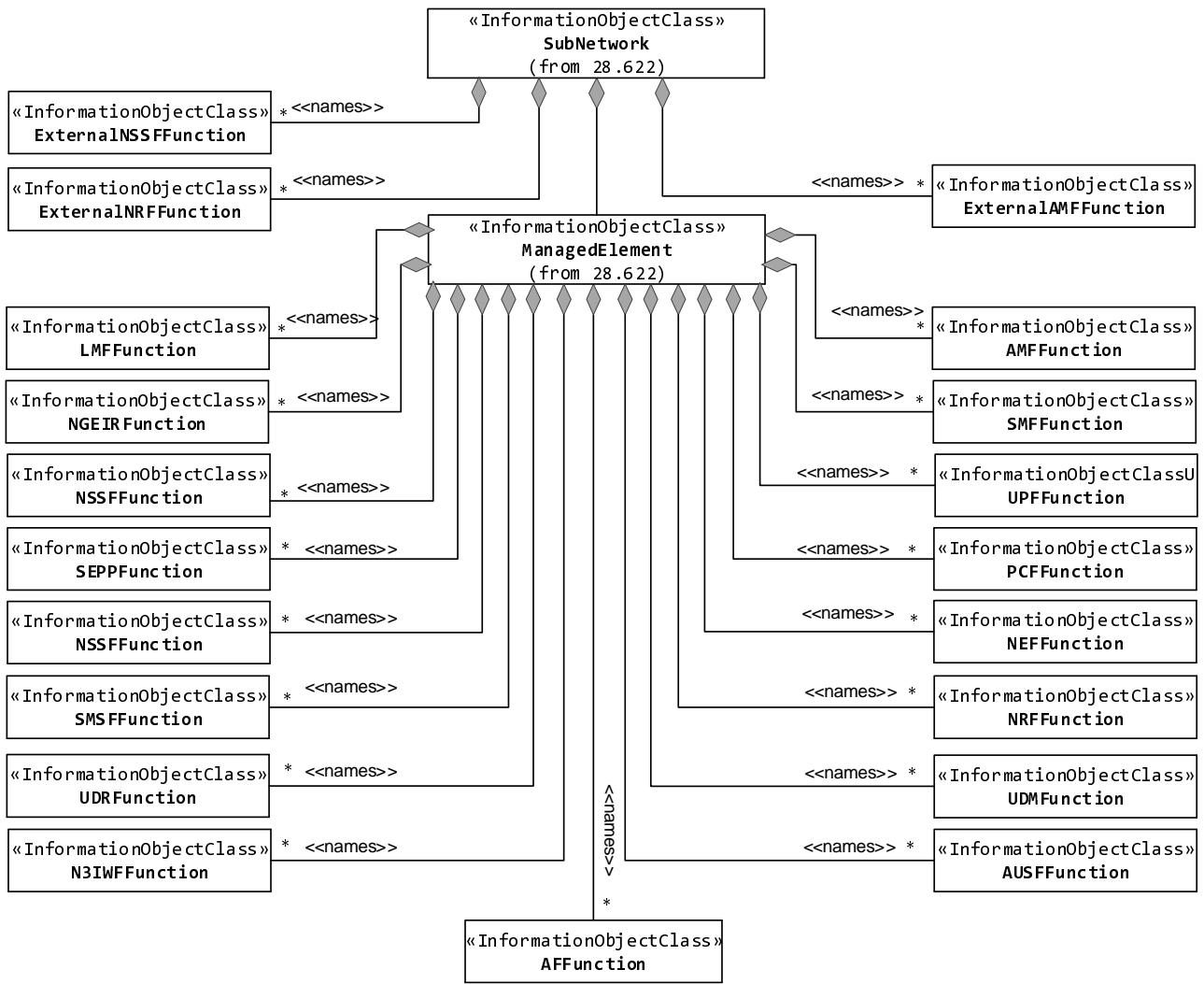

Figure 5.2.1.1-1: 5GC NRM containment/naming relationship

The Figure 5.2.1.1-2 shows the transport view of AMF NRM.

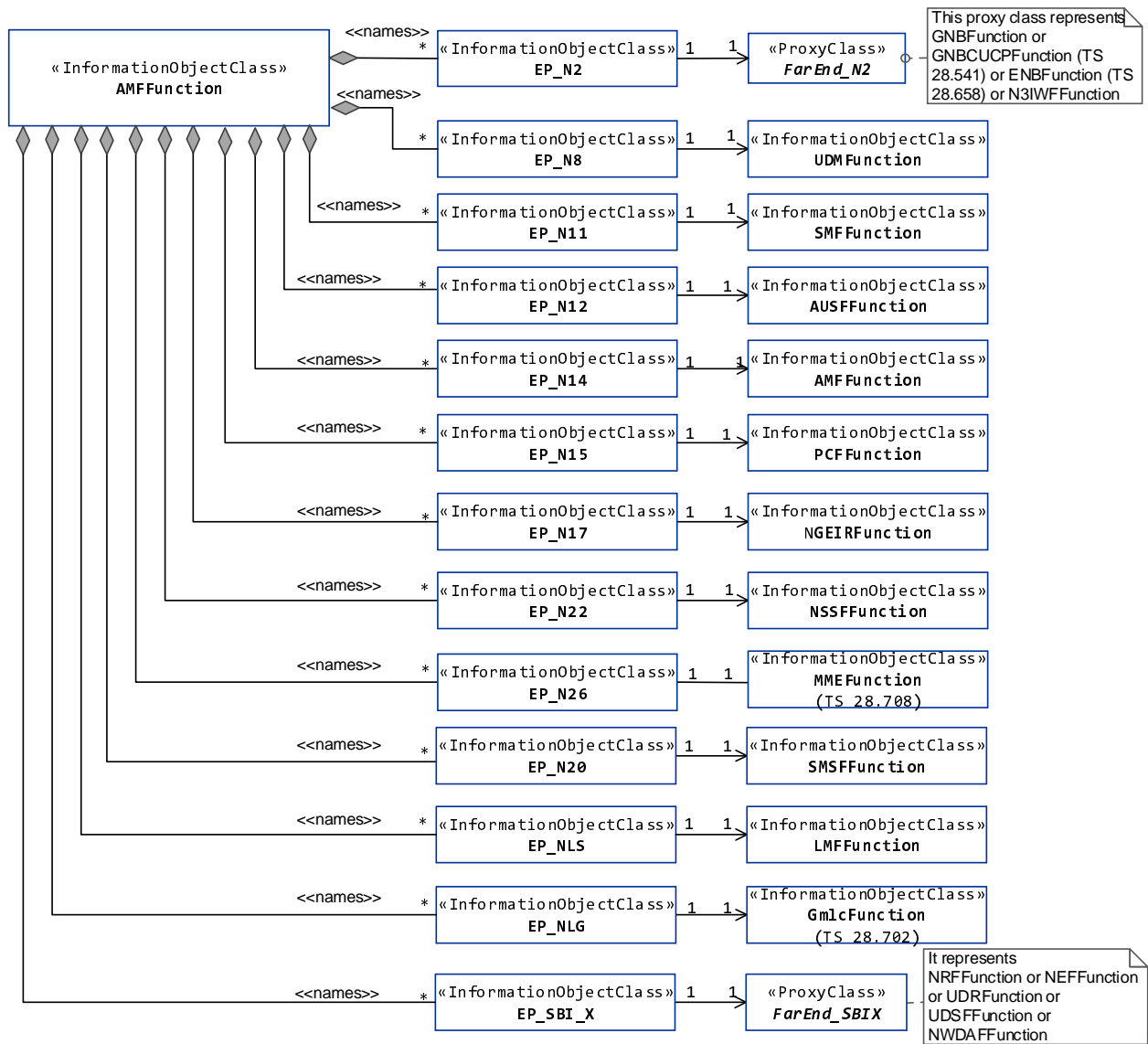

Figure 5.2.1.1-2: Transport view of AMF NRM

The Figure 5.2.1.1-3 shows the transport view of SMF NRM.

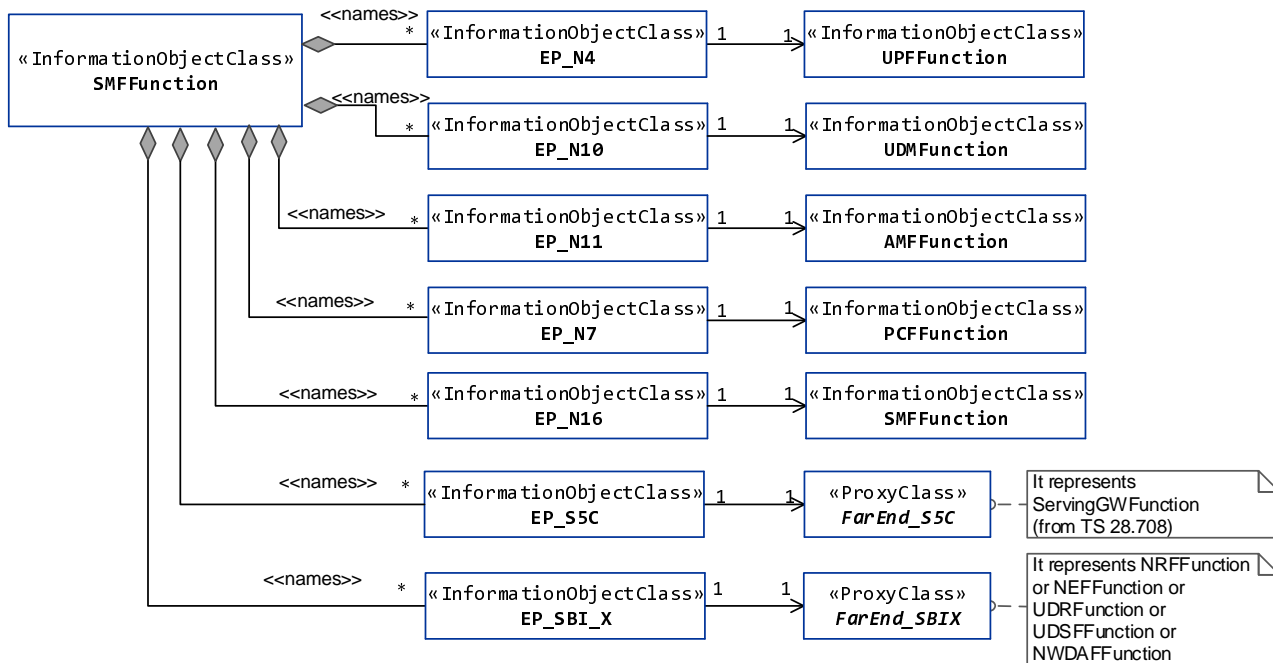

Figure 5.2.1.1-3: Transport view of SMF NRM

The Figure 5.2.1.1-4 shows the transport view of UPF NRM.

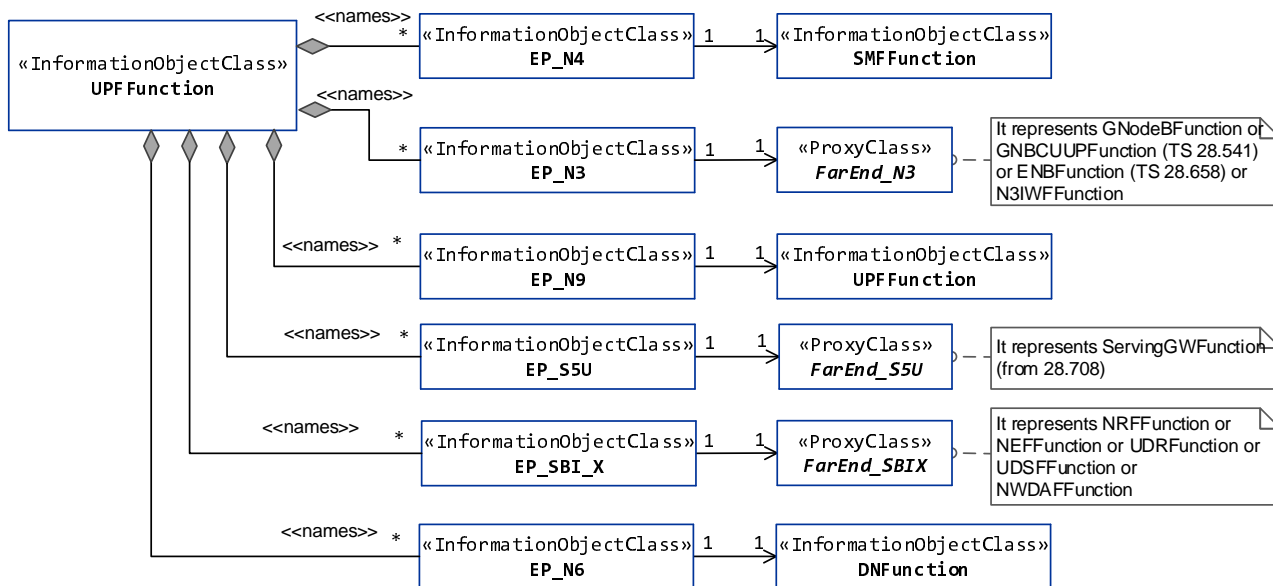

Figure 5.2.1.1-4: Transport view of UPF NRM

The Figure 5.2.1.1-5 shows the transport view of N3IWF NRM.

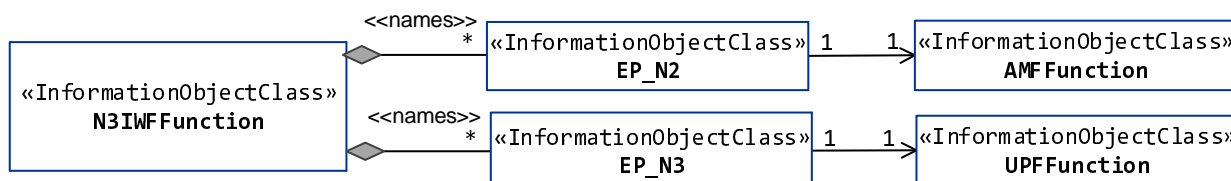

Figure 5.2.1.1-5: Transport view of N3IWF NRM

The Figure 5.2.1.1-6 shows the transport view of PCF NRM.

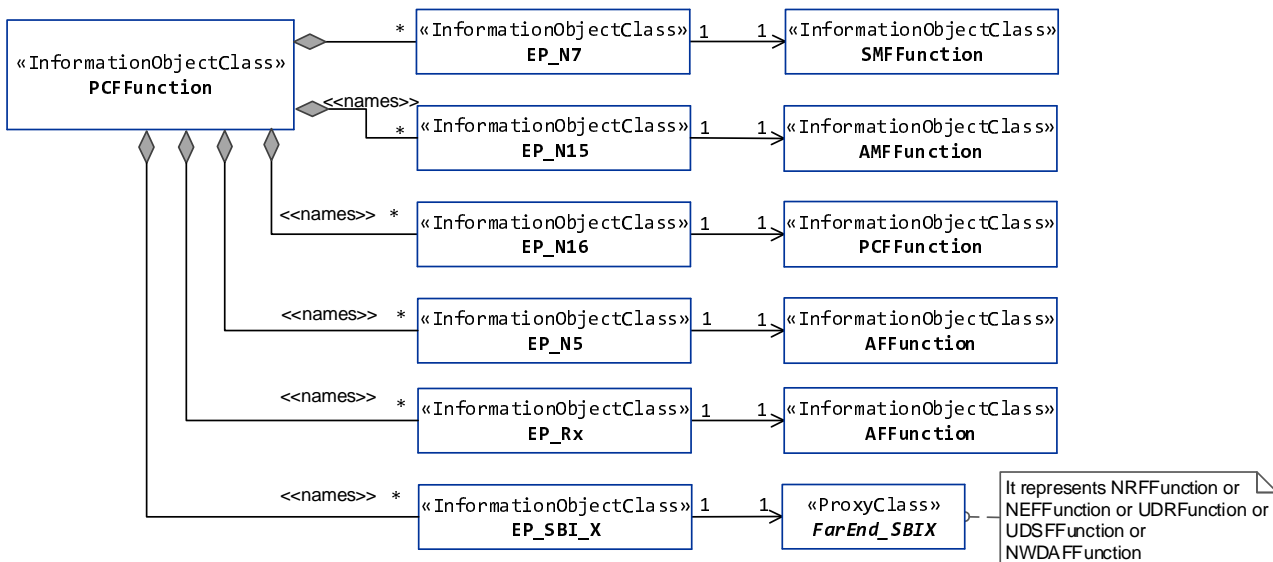

Figure 5.2.1.1-6: Transport view of PCF NRM

The Figure 5.2.1.1-7 shows the transport view of AUSF NRM.

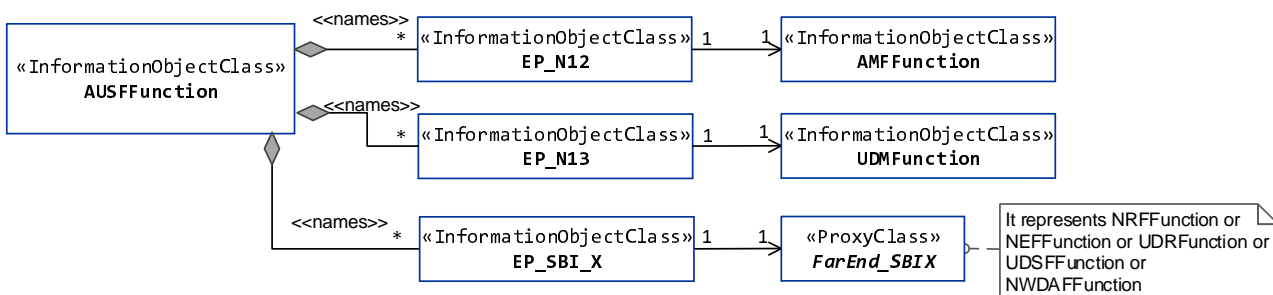

Figure 5.2.1.1-7: Transport view of AUSF NRM

The Figure 5.2.1.1-8 shows the transport view of UDM NRM.

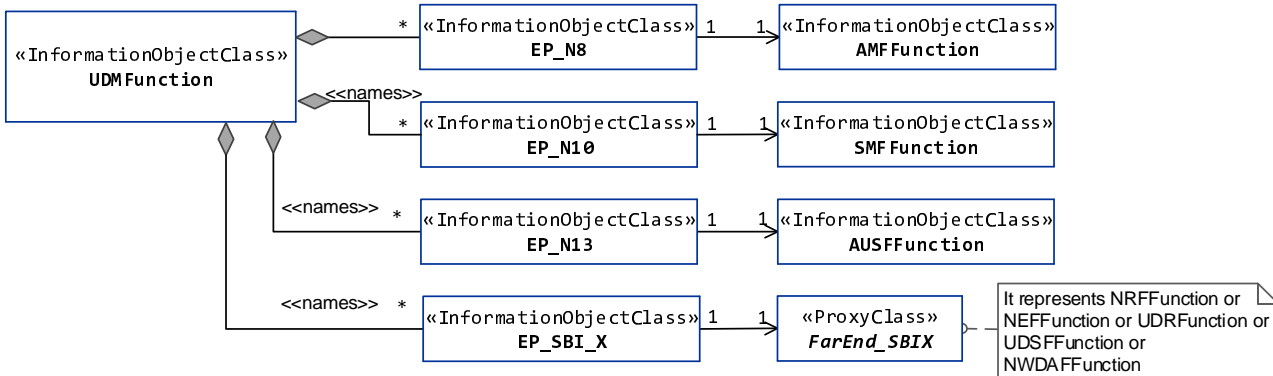

Figure 5.2.1.1-8: Transport view of UDM NRM

The Figure 5.2.1.1-9 shows the transport view of UDR NRM.

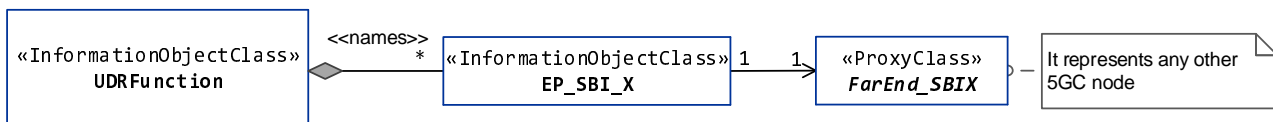

Figure 5.2.1.1-9: Transport view of UDR NRM

The Figure 5.2.1.1-10 shows the transport view of UDSF NRM.

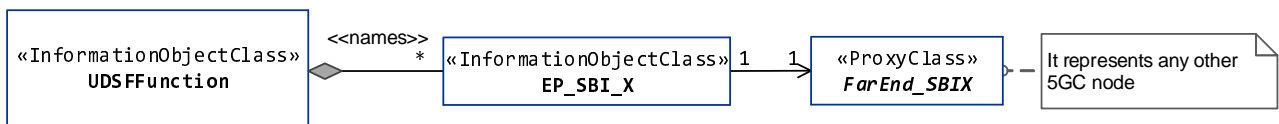

Figure 5.2.1.1-10: Transport view of UDSF NRM

The Figure 5.2.1.1-11 shows the transport view of NWDAF NRM.

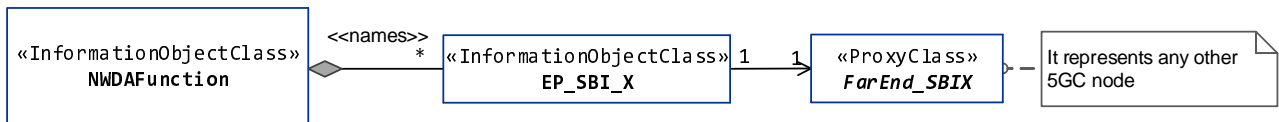

Figure 5.2.1.1-11: Transport view of NWDAF NRM

The Figure 5.2.1.1-12 shows the transport view of NRF NRM.

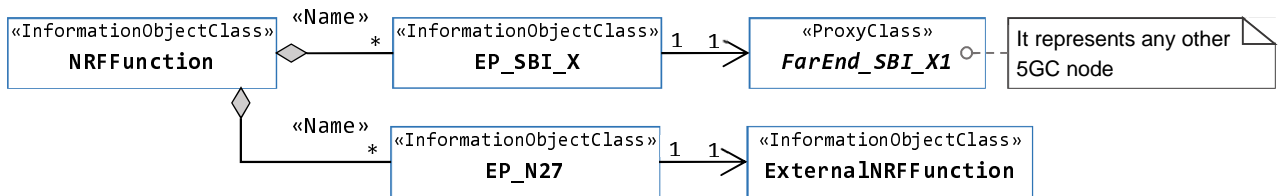

Figure 5.2.1.1-12: Transport view of NRF NRM

The Figure 5.2.1.1-13 shows the transport view of NSSF NRM.

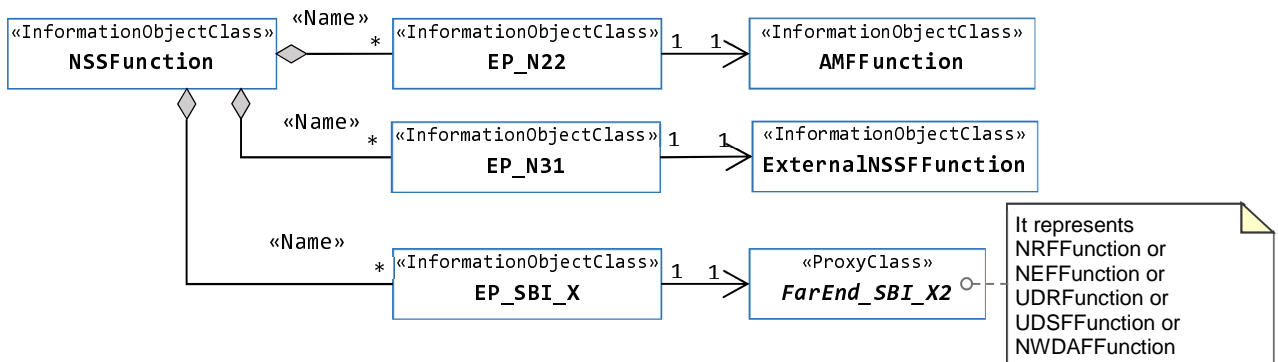

Figure 5.2.1.1-13: Transport view of NSSF NRM

The Figure 5.2.1.1-14 shows the transport view of SMSF NRM.

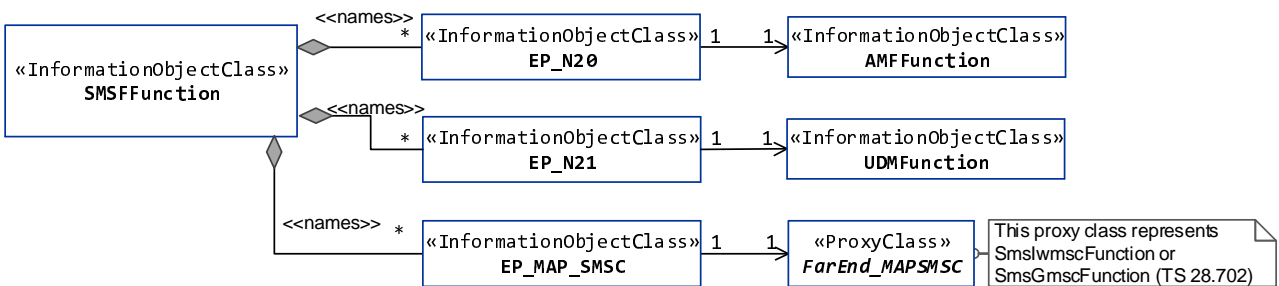

Figure 5.2.1.1-14: Transport view of SMSF NRM

The Figure 5.2.1.1-15 shows the transport view of 5G location service related NRM.

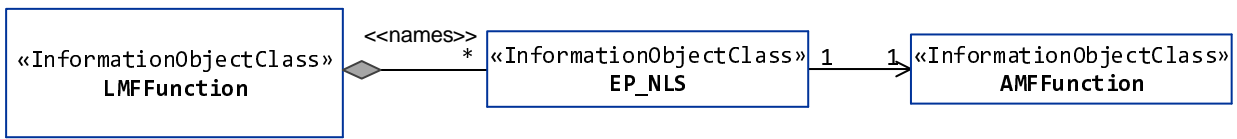

Figure 5.2.1.1-15: Transport view of LMF NRM

The Figure 5.2.1.1-16 shows the transport view of 5G-EIR NRM.

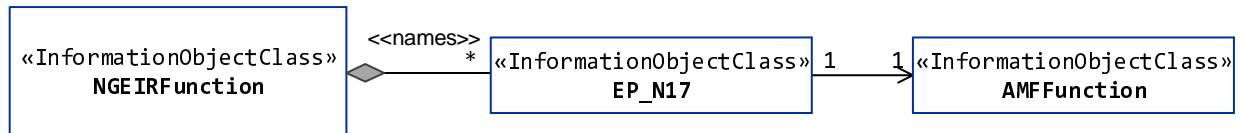

Figure 5.2.1.1-16: Transport view of 5G-EIR NRM

The Figure 5.2.1.1-17 shows the transport view of SEPP NRM.

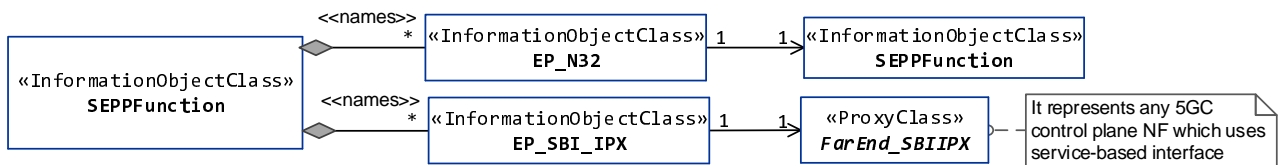

Figure 5.2.1.1-17: Transport view of SEPP NRM

### 5.2.1.2 Inheritance

This clause depicts the inheritance relationships that exist between IOCs.

Figure 5.2.1.2-1 shows the inheritance hierarchy from IOC ManagedFunction related to the 5GC NF NRM.

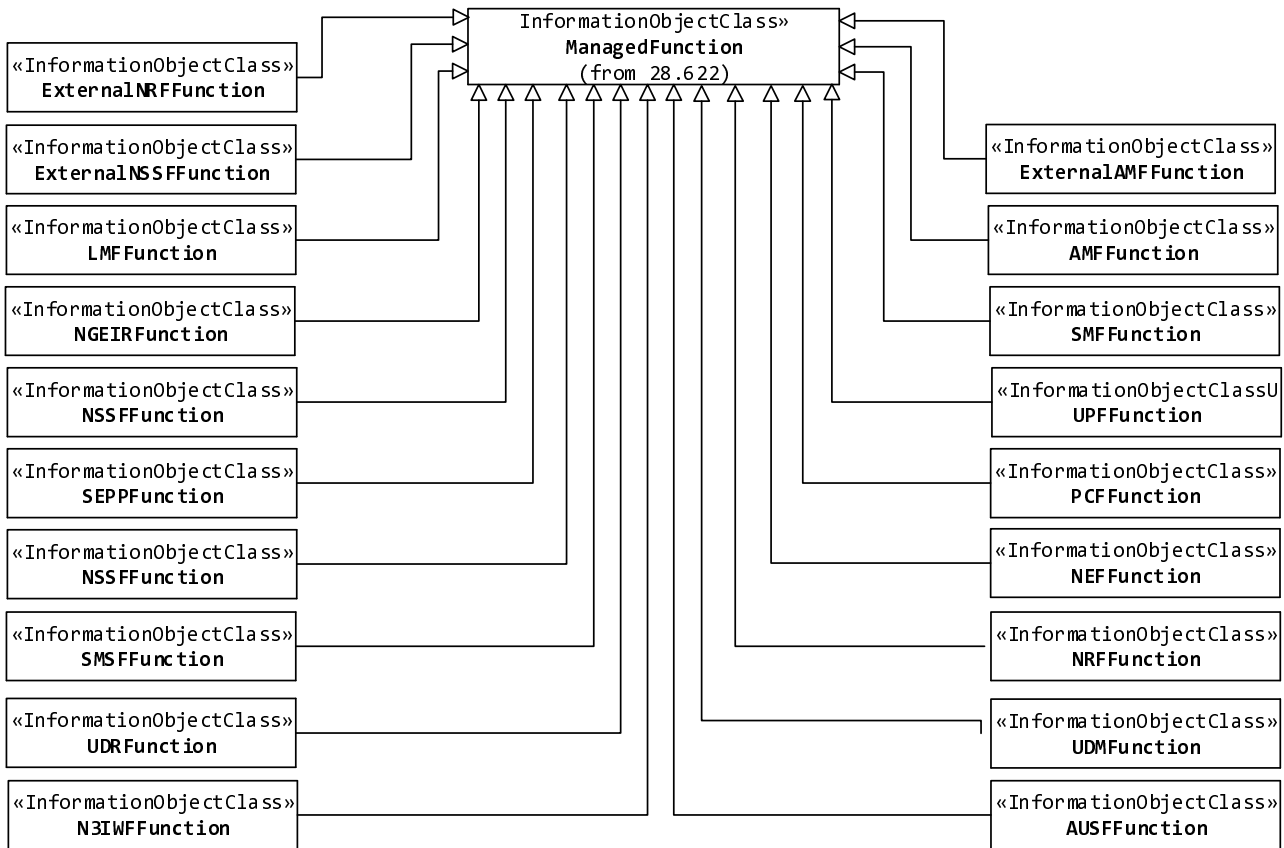

Figure 5.2.1.2-1: Inheritance hierarchy from IOC ManagedFunction related to the 5GC NF NRM

Figure 5.2.1.2-2 shows the inheritance hierarchy from IOC EP\_RP related to 5GC NF NRM.

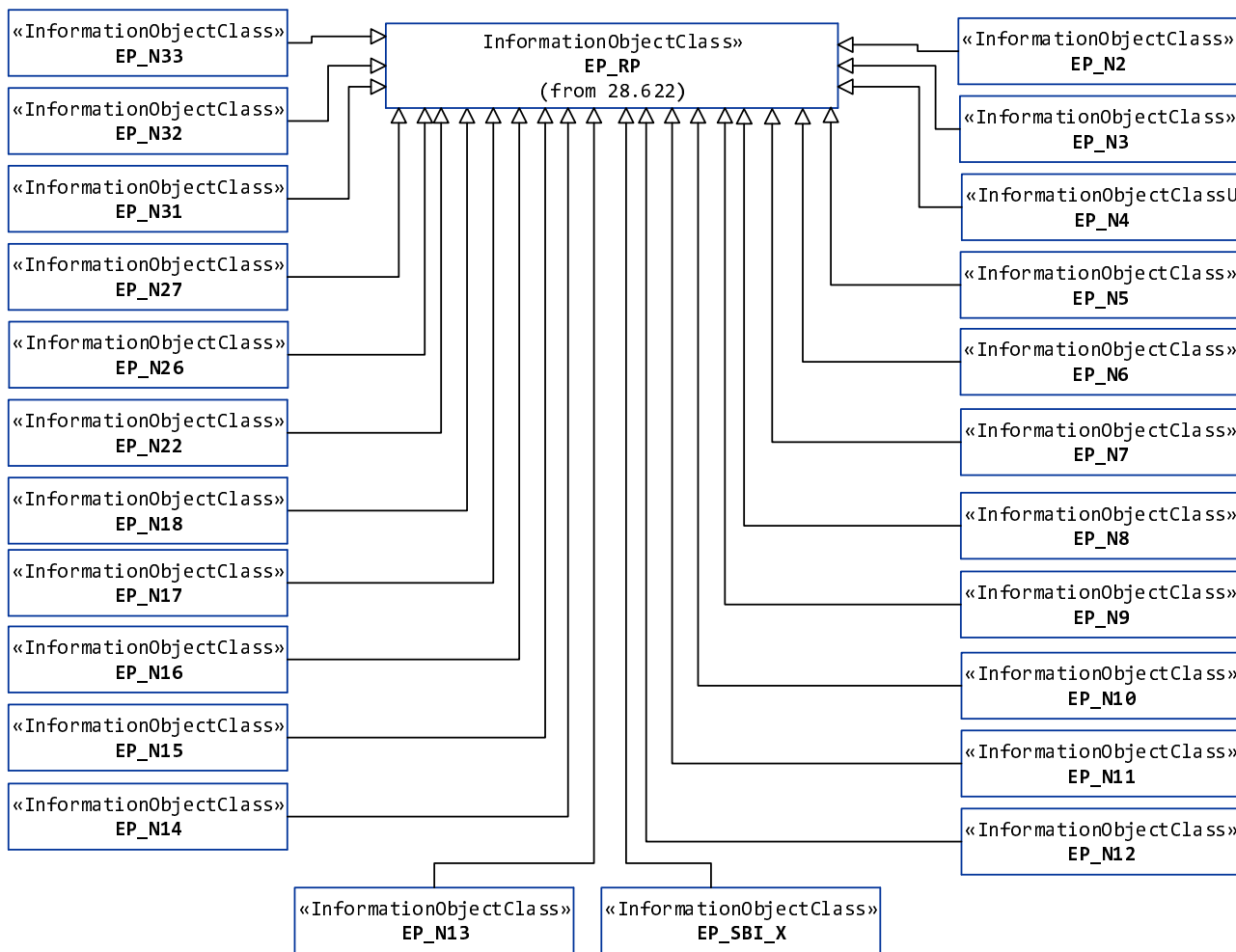

Figure 5.2.1.2-2: Inheritance hierarchy from IOC EP\_RP related to the 5GC NF NRM

## 5.2.2 Class diagram of AMF Region/AMF Set

### 5.2.2.1 Relationships

This clause depicts the set of classes (e.g. IOCs) that encapsulates the information relevant for NRM of AMF Region/AMF Set definitions. This clause provides the overview of the relationships of relevant classes in UML. Subsequent clauses provide more detailed specification of various aspects of these classes.

The Figure 5.2.2.1-1 shows the AMF Region/AMF Set NRM containment/naming relationship.



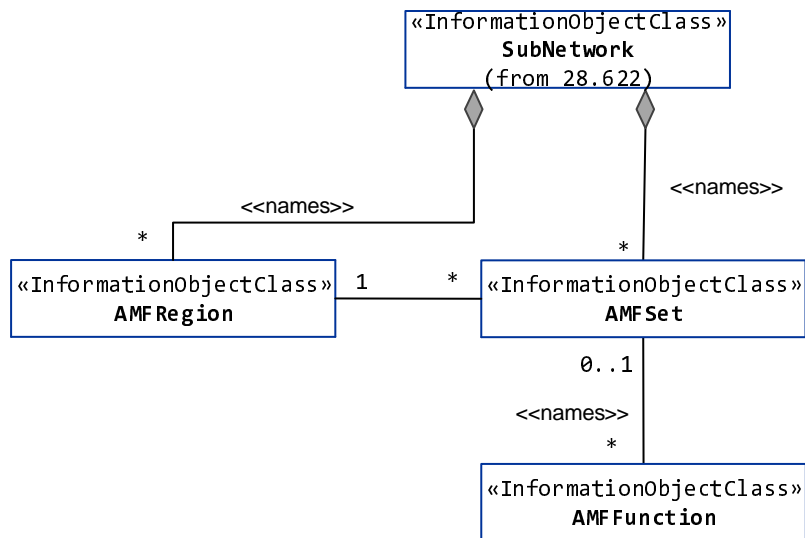

Figure 5.2.2.1-1: AMF Region/AMF Set NRM

### 5.2.2.2 Inheritance

This clause depicts the inheritance relationships that exist between IOCs.

Figure 5.2.2.2-1 shows the inheritance hierarchy from IOC ManagedFunction related to the AMF Region/AMF Set NRM.

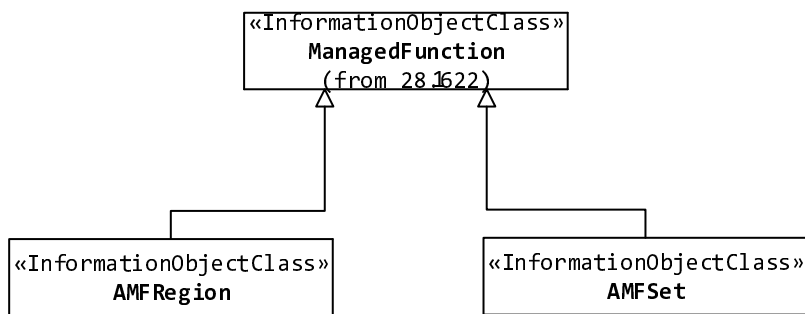

Figure 5.2.2.2-1: AMF Region/AMF Set Inheritance

## 5.3 Class definitions

### 5.3.1 AMFFunction

#### 5.3.1.1 Definition

This IOC represents the AMF functionality in 5GC. For more information about the AMF, see 3GPP TS 23.501 [2].

### 5.3.1.2 Attributes

Attribute name	Support Qualifier	isReadable	isWritable	isInvariant	isNotifiable
pLMNidList	M	T	T	F	T
aMFIdentifier	M	T	T	F	T
sBIFQDN	M	T	T	F	T
sBIServiceList	M	T	F	F	T
weightFactor	M	T	T	F	T
sNSSAList	CM	T	F	F	T

### 5.3.1.3 Attribute constraints

Name	Definition
sNSSAList Support Qualifier	Condition: Network slicing feature is supported.

### 5.3.1.4 Notifications

The common notifications defined in subclause 5.5 are valid for this IOC, without exceptions or additions.

## 5.3.2 SMFFunction

### 5.3.2.1 Definition

This IOC represents the SMF function in 5GC. For more information about the SMF, see 3GPP TS 23.501 [2].

### 5.3.2.2 Attributes

Attribute name	Support Qualifier	isReadable	isWritable	isInvariant	isNotifiable
pLMNidList	M	T	T	F	T
nRTAclList	M	T	T	F	T
sBIFQDN	M	T	T	F	T
sBIServiceList	M	T	F	F	T
sNSSAList	CM	T	T	F	T

### 5.3.2.3 Attribute constraints

Name	Definition
sNSSAList Support Qualifier	Condition: Network slicing feature is supported.

### 5.3.2.4 Notifications

The common notifications defined in subclause 5.5 are valid for this IOC, without exceptions or additions.

## 5.3.3 UPFFunction

### 5.3.3.1 Definition

This IOC represents the UPF function in 5GC. For more information about the UPF, see 3GPP TS 23.501 [2].

### 5.3.3.2 Attributes

Attribute name	Support Qualifier	isReadable	isWritable	isInvariant	isNotifiable
pLMNidList	M	T	T	F	T
nRTACList	M	T	T	F	T
sNSSAList	CM	T	T	F	T

### 5.3.3.3 Attribute constraints

Name	Definition
sNSSAList CM Support Qualifier	The condition is "network slicing feature is supported".

### 5.3.3.4 Notifications

The common notifications defined in subclause 5.5 are valid for this IOC, without exceptions or additions.

## 5.3.4 N3IWFFunction

### 5.3.4.1 Definition

This IOC represents the N3IWF function which is used to enable non-3GPP access networks connected to the 5GC. For more information about the N3IWF, see 3GPP TS 23.501 [2].

### 5.3.4.2 Attributes

Attribute name	Support Qualifier	isReadable	isWritable	isInvariant	isNotifiable
pLMNidList	M	T	T	F	T

### 5.3.4.3 Attribute constraints

None.

### 5.3.4.4 Notifications

The common notifications defined in subclause 5.5 are valid for this IOC, without exceptions or additions.

## 5.3.5 PCFFunction

### 5.3.5.1 Definition

This IOC represents the PCF function in 5GC. For more information about the PCF, see 3GPP TS 23.501 [2].

### 5.3.5.2 Attributes

Attribute name	Support Qualifier	isReadable	isWritable	isInvariant	isNotifiable
pLMNidList	M	T	T	F	T
sBIFQDN	M	T	T	F	T
sBIServiceList	M	T	F	F	T
sNSSAList	CM	T	T	F	T

### 5.3.5.3 Attribute constraints

Name	Definition
sNSSAList Support Qualifier	Condition: network slicing feature is supported.

### 5.3.5.4 Notifications

The common notifications defined in subclause 5.5 are valid for this IOC, without exceptions or additions.

## 5.3.6 AUSFunction

### 5.3.6.1 Definition

This IOC represents the AUSF function in 5GC. For more information about the AUSF, see 3GPP TS 23.501 [2].

### 5.3.6.2 Attributes

Attribute name	Support Qualifier	isReadable	isWritable	isInvariant	isNotifyable
pLMNidList	M	T	T	F	T
sBIFQDN	M	T	T	F	T
sBIServiceList	M	T	F	F	T
sNSSAList	CM	T	T	F	T

### 5.3.6.3 Attribute constraints

Name	Definition
sNSSAList Support Qualifier	Condition: Network slicing feature is supported.

### 5.3.6.4 Notifications

The common notifications defined in subclause 5.5 are valid for this IOC, without exceptions or additions.

## 5.3.7 UDMFunction

### 5.3.7.1 Definition

This IOC represents the UDM function in 5GC. For more information about the UDM, see 3GPP TS 23.501 [2].

### 5.3.7.2 Attributes

Attribute name	Support Qualifier	isReadable	isWritable	isInvariant	isNotifyable
pLMNidList	M	T	T	F	T
sBIFQDN	M	T	T	F	T
sBIServiceList	M	T	F	F	T
sNSSAList	CM	T	T	F	T

### 5.3.5.3 Attribute constraints

Name	Definition
sNSSAList Support Qualifier	Condition: network slicing feature is supported.

### 5.3.5.4 Notifications

The common notifications defined in subclause 5.5 are valid for this IOC, without exceptions or additions.

## 5.3.8 UDRFunction

### 5.3.8.1 Definition

This IOC represents the UDR function in 5GC. For more information about the UDR, see 3GPP TS 23.501 [2].

### 5.3.8.2 Attributes

Attribute name	Support Qualifier	isReadable	isWritable	isInvariant	isNotifyable
pLMNidList	M	T	T	F	T
sBIFQDN	M	T	T	F	T
sBIServiceList	M	T	F	F	T
sNSSAIIList	CM	T	T	F	T

### 5.3.8.3 Attribute constraints

Name	Definition
sNSSAIIList Support Qualifier	Condition: Network slicing feature is supported.

### 5.3.8.4 Notifications

The common notifications defined in subclause 5.5 are valid for this IOC, without exceptions or additions.

## 5.3.9 UDSFFunction

### 5.3.9.1 Definition

This IOC represents the UDSF function which can be interacted with any other 5GC NF defined in 3GPP TS 23.501 [2]. For more information about the UDSF, see 3GPP TS 23.501 [2].

### 5.3.9.2 Attributes

Attribute name	Support Qualifier	isReadable	isWritable	isInvariant	isNotifyable
pLMNidList	M	T	T	F	T
sBIFQDN	M	T	T	F	T
sBIServiceList	M	T	F	F	T
sNSSAIIList	CM	T	T	F	T

### 5.3.9.3 Attribute constraints

Name	Definition
sNSSAIIList Support Qualifier	Condition: Network slicing feature is supported.

### 5.3.9.4 Notifications

The common notifications defined in subclause 5.5 are valid for this IOC, without exceptions or additions.

## 5.3.10 NRFFunction

### 5.3.10.1 Definition

This IOC represents the NRF function in 5GC. For more information about the NRF, see 3GPP TS 23.501 [2].

### 5.3.10.2 Attributes

Attribute name	Support Qualifier	isReadable	isWritable	isInvariant	isNotifiable
pLMNidList	M	T	T	F	T
sBIFQDN	M	T	T	F	T
sNSSAIIList	CM	T	T	F	T
nfProfileList	CM	T	T	F	T
nSIIdList	O	T	T	F	T

### 5.3.10.3 Attribute constraints

Name	Definition
sNSSAIIList Support Qualifier	Condition: network slicing feature is supported.
nfProfileList Support Qualifier	Condition: NF profile is registered and deregistered by management system.
nSIIdList Support Qualifier	Condition: Network slicing feature is supported.

### 5.3.10.4 Notifications

The common notifications defined in subclause 5.5 are valid for this IOC, without exceptions or additions.

## 5.3.11 NSSFunction

### 5.3.11.1 Definition

This IOC represents the NSSF function in 5GC. For more information about the NSSF, see 3GPP TS 23.501 [2].

### 5.3.11.2 Attributes

Attribute name	Support Qualifier	isReadable	isWritable	isInvariant	isNotifiable
pLMNidList	M	T	T	F	T
sBIFQDN	M	T	T	F	T
sNSSAIIList	M	T	T	F	T
nSIIdList	O	T	T	F	T

### 5.3.11.3 Attribute constraints

None.

### 5.3.11.4 Notifications

The common notifications defined in subclause 5.5 are valid for this IOC, without exceptions or additions.

## 5.3.12 AFFunction

### 5.3.12.1 Definition

This IOC is defined for only purpose to describe the IOCs representing its interaction interface with 5GC (i.e. EP\_Rx and EP\_N5). It has no any attributes defined.

## 5.3.13 DNFunction

### 5.3.13.1 Definition

This IOC is defined for only purpose to describe the IOCs representing Data Network (DN) interaction interface with 5GC (i.e. EP\_N6). It has no any attributes defined.

## 5.3.14 SMSFunction

### 5.3.14.1 Definition

This IOC represents the SMSF function defined in 3GPP TS 23.501 [2].

### 5.3.14.2 Attributes

Attribute name	Support Qualifier	isReadable	isWritable	isInvariant	isNotifyable
pLMNIdList	M	T	T	F	T
sBIFQDN	M	T	T	F	T
sBIServiceList	M	T	F	F	T

### 5.3.14.3 Attribute constraints

None.

### 5.3.14.4 Notifications

The common notifications defined in subclause 5.5 are valid for this IOC, without exceptions or additions.

## 5.3.15 LMFunction

### 5.3.15.1 Definition

This IOC represents the LMF function defined in 3GPP TS 23.501 [2].

### 5.3.15.2 Attributes

Attribute name	Support Qualifier	isReadable	isWritable	isInvariant	isNotifyable
pLMNIdList	M	T	T	F	T

### 5.3.15.3 Attribute constraints

None.

### 5.3.15.4 Notifications

The common notifications defined in subclause 5.5 are valid for this IOC, without exceptions or additions.

## 5.3.16 NGEIRFunction

### 5.3.16.1 Definition

This IOC represents the 5G-EIR function in 5GC. For more information about the 5G-EIR, see 3GPP TS 23.501 [2].

### 5.3.16.2 Attributes

Attribute name	Support Qualifier	isReadable	isWritable	isInvariant	isNotifiable
pLMNidList	M	T	T	F	T
sBIFQDN	M	T	T	F	T
sBIServiceList	M	T	F	F	T
sNSSAIIList	CM	T	T	F	T

### 5.3.16.3 Attribute constraints

Name	Definition
sNSSAIIList Support Qualifier	Condition: network slicing feature is supported.

### 5.3.16.4 Notifications

The common notifications defined in subclause 5.5 are valid for this IOC, without exceptions or additions.

## 5.3.17 SEPPFunction

### 5.3.17.1 Definition

This IOC represents the SEPP function which support message filtering and policing on inter-PLMN control plane interface. For more information about the SEPP, see 3GPP TS 23.501 [2].

### 5.3.17.2 Attributes

Attribute name	Support Qualifier	isReadable	isWritable	isInvariant	isNotifiable
pLMNidList	M	T	T	F	T

### 5.3.17.3 Attribute constraints

None.

### 5.3.17.4 Notifications

The common notifications defined in subclause 5.5 are valid for this IOC, without exceptions or additions.

## 5.3.18 NWDAFFunction

### 5.3.18.1 Definition

This IOC represents the NWDAF function in 5GC. For more information about the NWDAF, see 3GPP TS 23.501 [2].

### 5.3.18.2 Attributes

Attribute name	Support Qualifier	isReadable	isWritable	isInvariant	isNotifiable
pLMNidList	M	T	T	F	T
sBIFQDN	M	T	T	F	T
sBIServiceList	M	T	F	F	T
sNSSAIIList	CM	T	T	F	T

### 5.3.18.3 Attribute constraints

Name	Definition
sNSSAIIList Support Qualifier	Condition: Network slicing feature is supported.

### 5.3.18.4 Notifications

The common notifications defined in subclause 5.5 are valid for this IOC, without exceptions or additions.



### 5.3.19 EP\_N2

#### 5.3.19.1 Definition

This IOC represents the N2 interface between (R)AN and AMF, which is defined in 3GPP TS 23.501 [2].

#### 5.3.19.2 Attributes

Attribute name	Support Qualifier	isReadable	isWritable	isInvariant	isNotifiable
localAddress	O	T	T	F	T
remoteAddress	O	T	T	F	T

#### 5.3.19.3 Attribute constraints

None.

#### 5.3.19.4 Notifications

The common notifications defined in subclause 5.5 are valid for this IOC, without exceptions or additions.

### 5.3.20 EP\_N3

#### 5.3.20.1 Definition

This IOC represents the N3 interface between (R)AN and UPF, which is defined in 3GPP TS 23.501 [2].

#### 5.3.20.2 Attributes

Attribute name	Support Qualifier	isReadable	isWritable	isInvariant	isNotifiable
localAddress	O	T	T	F	T
remoteAddress	O	T	T	F	T

#### 5.3.20.3 Attribute constraints

None.

#### 5.3.20.4 Notifications

The common notifications defined in subclause 5.5 are valid for this IOC, without exceptions or additions.

### 5.3.21 EP\_N4

#### 5.3.21.1 Definition

This IOC represents the N4 interface between SMF and UPF, which is defined in 3GPP TS 23.501 [2].

#### 5.3.21.2 Attributes

Attribute name	Support Qualifier	isReadable	isWritable	isInvariant	isNotifiable
localAddress	O	T	T	F	T
remoteAddress	O	T	T	F	T

#### 5.3.21.3 Attribute constraints

None.

### 5.3.21.4 Notifications

The common notifications defined in subclause 5.5 are valid for this IOC, without exceptions or additions.

## 5.3.22 EP\_N5

### 5.3.22.1 Definition

This IOC represents the N5 interface between PCF and AF, which is defined in 3GPP TS 23.501 [2].

### 5.3.22.2 Attributes

Attribute name	Support Qualifier	isReadable	isWritable	isInvariant	isNotifyable
localAddress	O	T	T	F	T
remoteAddress	O	T	T	F	T

### 5.3.22.3 Attribute constraints

None.

### 5.3.22.4 Notifications

The common notifications defined in subclause 5.5 are valid for this IOC, without exceptions or additions.

## 5.3.23 EP\_N6

### 5.3.23.1 Definition

This IOC represents the N6 interface between UPF and DN, which is defined in 3GPP TS 23.501 [2].

### 5.3.23.2 Attributes

Attribute name	Support Qualifier	isReadable	isWritable	isInvariant	isNotifyable
localAddress	O	T	T	F	T
remoteAddress	O	T	T	F	T

### 5.3.23.3 Attribute constraints

None.

### 5.3.23.4 Notifications

The common notifications defined in subclause 5.5 are valid for this IOC, without exceptions or additions.

## 5.3.24 EP\_N7

### 5.3.24.1 Definition

This IOC represents the N7 interface between SMF and PCF, which is defined in 3GPP TS 23.501 [2].

### 5.3.24.2 Attributes

Attribute name	Support Qualifier	isReadable	isWritable	isInvariant	isNotifyable
localAddress	O	T	T	F	T
remoteAddress	O	T	T	F	T

### 5.3.24.3 Attribute constraints

None.

### 5.3.24.4 Notifications

The common notifications defined in subclause 5.5 are valid for this IOC, without exceptions or additions.

## 5.3.25 EP\_N8

### 5.3.25.1 Definition

This IOC represents the N8 interface between AMF and UDM, which is defined in 3GPP TS 23.501 [2].

### 5.3.25.2 Attributes

Attribute name	Support Qualifier	isReadable	isWritable	isInvariant	isNotifyable
localAddress	O	T	T	F	T
remoteAddress	O	T	T	F	T

### 5.3.25.3 Attribute constraints

None.

### 5.3.25.4 Notifications

The common notifications defined in subclause 5.5 are valid for this IOC, without exceptions or additions.

## 5.3.26 EP\_N9

### 5.3.26.1 Definition

This IOC represents the N7 interface between two UPFs, which is defined in 3GPP TS 23.501 [2].

### 5.3.26.2 Attributes

Attribute name	Support Qualifier	isReadable	isWritable	isInvariant	isNotifyable
localAddress	O	T	T	F	T
remoteAddress	O	T	T	F	T

### 5.3.26.3 Attribute constraints

None.

### 5.3.26.4 Notifications

The common notifications defined in subclause 5.5 are valid for this IOC, without exceptions or additions.

## 5.3.27 EP\_N10

### 5.3.27.1 Definition

This IOC represents the N10 interface between SMF and UDM, which is defined in 3GPP TS 23.501 [2].

### 5.3.27.2 Attributes

Attribute name	Support Qualifier	isReadable	isWritable	isInvariant	isNotifiable
localAddress	O	T	T	F	T
remoteAddress	O	T	T	F	T

### 5.3.27.3 Attribute constraints

None.

### 5.3.27.4 Notifications

The common notifications defined in subclause 5.5 are valid for this IOC, without exceptions or additions.

## 5.3.28 EP\_N11

### 5.3.28.1 Definition

This IOC represents the N11 interface between AMF and SMF, which is defined in 3GPP TS 23.501 [2].

### 5.3.28.2 Attributes

Attribute name	Support Qualifier	isReadable	isWritable	isInvariant	isNotifiable
localAddress	O	T	T	F	T
remoteAddress	O	T	T	F	T

### 5.3.28.3 Attribute constraints

None.

### 5.3.28.4 Notifications

The common notifications defined in subclause 5.5 are valid for this IOC, without exceptions or additions.

## 5.3.29 EP\_N12

### 5.3.29.1 Definition

This IOC represents the N12 interface between AMF and AUSF, which is defined in 3GPP TS 23.501 [2].

### 5.3.29.2 Attributes

Attribute name	Support Qualifier	isReadable	isWritable	isInvariant	isNotifiable
localAddress	O	T	T	F	T
remoteAddress	O	T	T	F	T

### 5.3.29.3 Attribute constraints

None.

### 5.3.29.4 Notifications

The common notifications defined in subclause 5.5 are valid for this IOC, without exceptions or additions.

## 5.3.30 EP\_N13

### 5.3.30.1 Definition

This IOC represents the N13 interface between AUSF and UDM, which is defined in 3GPP TS 23.501 [2].

### 5.3.30.2 Attributes

Attribute name	Support Qualifier	isReadable	isWritable	isInvariant	isNotifyable
localAddress	O	T	T	F	T
remoteAddress	O	T	T	F	T

### 5.3.30.3 Attribute constraints

None.

### 5.3.30.4 Notifications

The common notifications defined in subclause 5.5 are valid for this IOC, without exceptions or additions.

## 5.3.31 EP\_N14

### 5.3.31.1 Definition

This IOC represents the N14 interface between two AMFs, which is defined in 3GPP TS 23.501 [2].

### 5.3.31.2 Attributes

Attribute name	Support Qualifier	isReadable	isWritable	isInvariant	isNotifyable
localAddress	O	T	T	F	T
remoteAddress	O	T	T	F	T

### 5.3.31.3 Attribute constraints

None.

### 5.3.31.4 Notifications

The common notifications defined in subclause 5.5 are valid for this IOC, without exceptions or additions.

## 5.3.32 EP\_N15

### 5.3.32.1 Definition

This IOC represents the N15 interface between AMF and PCF, which is defined in 3GPP TS 23.501 [2].

### 5.3.32.2 Attributes

Attribute name	Support Qualifier	isReadable	isWritable	isInvariant	isNotifiable
localAddress	O	T	T	F	T
remoteAddress	O	T	T	F	T

### 5.3.32.3 Attribute constraints

None.

### 5.3.32.4 Notifications

The common notifications defined in subclause 5.5 are valid for this IOC, without exceptions or additions.

## 5.3.33 EP\_N16

### 5.3.33.1 Definition

This IOC represents the N16 interface between two SMFs, which is defined in 3GPP TS 23.501 [2].

### 5.3.33.2 Attributes

Attribute name	Support Qualifier	isReadable	isWritable	isInvariant	isNotifiable
localAddress	O	T	T	F	T
remoteAddress	O	T	T	F	T

### 5.3.33.3 Attribute constraints

None.

### 5.3.33.4 Notifications

The common notifications defined in subclause 5.5 are valid for this IOC, without exceptions or additions.

## 5.3.34 EP\_N17

### 5.3.34.1 Definition

This IOC represents the N17 interface between AMF and 5G-EIR, which is defined in 3GPP TS 23.501 [2].

### 5.3.34.2 Attributes

Attribute name	Support Qualifier	isReadable	isWritable	isInvariant	isNotifiable
localAddress	O	T	T	F	T
remoteAddress	O	T	T	F	T

### 5.3.34.3 Attribute constraints

None.

### 5.3.34.4 Notifications

The common notifications defined in subclause 5.5 are valid for this IOC, without exceptions or additions.

### 5.3.35 EP\_N20

#### 5.3.35.1 Definition

This IOC represents the N20 interface between AMF and SMSF, which is defined in 3GPP TS 23.501 [2].

#### 5.3.35.2 Attributes

Attribute name	Support Qualifier	isReadable	isWritable	isInvariant	isNotifiable
localAddress	O	T	T	F	T
remoteAddress	O	T	T	F	T

#### 5.3.35.3 Attribute constraints

None.

#### 5.3.35.4 Notifications

The common notifications defined in subclause 5.5 are valid for this IOC, without exceptions or additions.

### 5.3.36 EP\_N21

#### 5.3.36.1 Definition

This IOC represents the N21 interface between SMSF and UDM, which is defined in 3GPP TS 23.501 [2].

#### 5.3.36.2 Attributes

Attribute name	Support Qualifier	isReadable	isWritable	isInvariant	isNotifiable
localAddress	O	T	T	F	T
remoteAddress	O	T	T	F	T

#### 5.3.36.3 Attribute constraints

None.

#### 5.3.36.4 Notifications

The common notifications defined in subclause 5.5 are valid for this IOC, without exceptions or additions.

### 5.3.37 EP\_N22

#### 5.3.37.1 Definition

This IOC represents the N22 interface between AMF and NSSF, which is defined in 3GPP TS 23.501 [2].

#### 5.3.37.2 Attributes

Attribute name	Support Qualifier	isReadable	isWritable	isInvariant	isNotifiable
localAddress	O	T	T	F	T
remoteAddress	O	T	T	F	T

#### 5.3.37.3 Attribute constraints

None.

### 5.3.37.4 Notifications

The common notifications defined in subclause 5.5 are valid for this IOC, without exceptions or additions.

## 5.3.38 EP\_N26

### 5.3.38.1 Definition

This IOC represents the N26 interface between AMF and MME, which is defined in 3GPP TS 23.501 [2].

### 5.3.38.2 Attributes

Attribute name	Support Qualifier	isReadable	isWritable	isInvariant	isNotifyable
localAddress	O	T	T	F	T
remoteAddress	O	T	T	F	T

### 5.3.38.3 Attribute constraints

None.

### 5.3.38.4 Notifications

The common notifications defined in subclause 5.5 are valid for this IOC, without exceptions or additions.

## 5.3.39 EP\_SBI\_X

### 5.3.39.1 Definition

This IOC represents the service-based interfaces from any 5GC NF towards UDSF, UDR, NEF, NRF and NWDAF, as these NFs can be interacted with any other 5GC NF, see detail in 3GPP TS 23.501 [2].

### 5.3.39.2 Attributes

Attribute name	Support Qualifier	isReadable	isWritable	isInvariant	isNotifyable
localAddress	O	T	T	F	T
remoteAddress	O	T	T	F	T
sBIserviceList	O	T	T	F	T

### 5.3.39.3 Attribute constraints

None.

### 5.3.39.4 Notifications

The common notifications defined in subclause 5.5 are valid for this IOC, without exceptions or additions.

## 5.3.40 EP\_SBI\_IPX

### 5.3.40.1 Definition

This IOC represents the inter-connection interface from any 5GC control plane NF to SEPP, see detail in 3GPP TS 23.501 [2].



### 5.3.40.2 Attributes

Attribute name	Support Qualifier	isReadable	isWritable	isInvariant	isNotifiable
localAddress	O	T	T	F	T
remoteAddress	O	T	T	F	T
sBIserviceList	O	T	T	F	T

### 5.3.40.3 Attribute constraints

None.

### 5.3.40.4 Notifications

The common notifications defined in subclause 5.5 are valid for this IOC, without exceptions or additions.

## 5.3.41 EP\_S5C

### 5.3.41.1 Definition

This IOC represents the S5-C interface between SGW and SMF/PGW-C, which is defined in 3GPP TS 23.501 [2].

### 5.3.41.2 Attributes

Attribute name	Support Qualifier	isReadable	isWritable	isInvariant	isNotifiable
localAddress	O	T	T	F	T
remoteAddress	O	T	T	F	T

### 5.3.41.3 Attribute constraints

None.

### 5.3.41.4 Notifications

The common notifications defined in subclause 5.5 are valid for this IOC, without exceptions or additions.

## 5.3.42 EP\_S5U

### 5.3.42.1 Definition

This IOC represents the S5-U interface between SGW and UPF/PGW-U, which is defined in 3GPP TS 23.501 [2].

### 5.3.42.2 Attributes

Attribute name	Support Qualifier	isReadable	isWritable	isInvariant	isNotifiable
localAddress	O	T	T	F	T
remoteAddress	O	T	T	F	T

### 5.3.42.3 Attribute constraints

None.

### 5.3.42.4 Notifications

The common notifications defined in subclause 5.5 are valid for this IOC, without exceptions or additions.

### 5.3.43 EP\_Rx

#### 5.3.43.1 Definition

This IOC represents the Rx interface between PCF and AF, which is defined in 3GPP TS 23.501 [2].

#### 5.3.43.2 Attributes

Attribute name	Support Qualifier	isReadable	isWritable	isInvariant	isNotifyable
localAddress	O	T	T	F	T
remoteAddress	O	T	T	F	T

#### 5.3.43.3 Attribute constraints

None.

#### 5.3.43.4 Notifications

The common notifications defined in subclause 5.5 are valid for this IOC, without exceptions or additions.

### 5.3.44 EP\_MAP\_SMSC

#### 5.3.44.1 Definition

This IOC represents the MAP interface between SMSF and MSC-IW MSC/GMSC, which is defined in 3GPP TS 23.040 [22].

#### 5.3.44.2 Attributes

Attribute name	Support Qualifier	isReadable	isWritable	isInvariant	isNotifyable
localAddress	O	T	T	F	T
remoteAddress	O	T	T	F	T

#### 5.3.44.3 Attribute constraints

None.

#### 5.3.44.4 Notifications

The common notifications defined in subclause 5.5 are valid for this IOC, without exceptions or additions.

### 5.3.45 EP-NLS

#### 5.3.45.1 Definition

This IOC represents the NLS interface between AMF and LMF, which is defined in 3GPP TS 23.501 [2].

#### 5.3.45.2 Attributes

Attribute name	Support Qualifier	isReadable	isWritable	isInvariant	isNotifyable
localAddress	O	T	T	F	T
remoteAddress	O	T	T	F	T

#### 5.3.45.3 Attribute constraints

None.

### 5.3.45.4 Notifications

The common notifications defined in subclause 5.5 are valid for this IOC, without exceptions or additions.

## 5.3.46 EP\_NLG

### 5.3.46.1 Definition

This IOC represents the NLg interface between AMF and GMLC, which is defined in 3GPP TS 23.501 [2].

### 5.3.46.2 Attributes

Attribute name	Support Qualifier	isReadable	isWritable	isInvariant	isNotifyable
localAddress	O	T	T	F	T
remoteAddress	O	T	T	F	T

### 5.3.46.3 Attribute constraints

None.

### 5.3.46.4 Notifications

The common notifications defined in subclause 5.5 are valid for this IOC, without exceptions or additions.

## 5.3.47 EP\_N27

### 5.3.47.1 Definition

This IOC represents an end point of N27 interface between vNRF and hNRF, which is defined in 3GPP TS 29.510 [10].

### 5.3.47.2 Attributes

Attribute name	Support Qualifier	isReadable	isWritable	isInvariant	isNotifyable
localAddress	O	T	T	F	T
remoteAddress	O	T	T	F	T

### 5.3.47.3 Attribute constraints

None.

### 5.3.47.4 Notifications

The common notifications defined in subclause 5.5 are valid for this IOC, without exceptions or additions.

## 5.3.48 EP\_N31

### 5.3.48.1 Definition

This IOC represents an end point of N31 interface between vNSSF and hNSSF, which is defined in 3GPP TS 29.531 [11].

### 5.3.48.2 Attributes

Attribute name	Support Qualifier	isReadable	isWritable	isInvariant	isNotifyable
localAddress	O	T	T	F	T
remoteAddress	O	T	T	F	T

### 5.3.48.3 Attribute constraints

None.

### 5.3.48.4 Notifications

The common notifications defined in subclause 5.5 are valid for this IOC, without exceptions or additions.

## 5.3.49 ExternalNRFFunction

### 5.3.49.1 Definition

This IOC represents external NRF function controlled by another management domain. For more information about the NRF, see 3GPP TS 23.501 [2].

### 5.3.49.2 Attributes

Attribute name	Support Qualifier	isReadable	isWritable	isInvariant	isNotifyable
id	M	T	F	F	T
pLMNidList	M	T	T	F	T

### 5.3.49.3 Attribute constraints

None.

### 5.3.49.4 Notifications

The common notifications defined in subclause 5.5 are valid for this IOC, without exceptions or additions.

## 5.3.50 ExternalNSSFFunction

### 5.3.50.1 Definition

This IOC represents external NSSF function controlled by another management domain. For more information about the NSSF, see 3GPP TS 23.501 [2].

### 5.3.50.2 Attributes

Attribute name	Support Qualifier	isReadable	isWritable	isInvariant	isNotifyable
id	M	T	F	F	T
pLMNidList	M	T	T	F	T

### 5.3.50.3 Attribute constraints

None.

### 5.3.50.4 Notifications

The common notifications defined in subclause 5.5 are valid for this IOC, without exceptions or additions.

## 5.3.51 AMFSet

### 5.3.51.1 Definition

This IOC represents the AMF Set which consists of some AMFs that serve a given area and Network Slice. For more information about the AMF Set, see 3GPP TS 23.501 [2].

### 5.3.51.2 Attributes

Attribute name	Support Qualifier	isReadable	isWritable	isInvariant	isNotifiable
pLMNidList	M	T	T	F	T
nRTAClist	M	T	T	F	T
aMFSetId	M	T	T	F	T
sNSSAIlList	CM	T	T	F	T
<b>Attribute related to role</b>					
aMFRegion	M	T	T	F	T
aMFSetMemberList	M	T	T	F	T

### 5.3.51.3 Attribute constraints

Name	Definition
sNSSAIlList Support Qualifier	Condition: Network slicing feature is supported.

### 5.3.51.4 Notifications

The common notifications defined in subclause 5.5 are valid for this IOC, without exceptions or additions.

## 5.3.52 AMFRegion

### 5.3.52.1 Definition

This IOC represents the AMF Region which consists one or multiple AMF Sets. For more information about the AMF Region, see 3GPP TS 23.501 [2].

### 5.3.52.2 Attributes

Attribute name	Support Qualifier	isReadable	isWritable	isInvariant	isNotifiable
pLMNidList	M	T	T	F	T
nRTAClist	M	T	T	F	T
aMFRegionId	M	T	T	F	T
sNSSAIlList	CM	T	T	F	T
<b>Attribute related to role</b>					
aMFSet	M	T	T	F	T

### 5.3.52.3 Attribute constraints

Name	Definition
sNSSAIlList Support Qualifier	Condition: Network slicing feature is supported.

### 5.3.52.4 Notifications

The common notifications defined in subclause 5.5 are valid for this IOC, without exceptions or additions.

## 5.3.53 ExternalAMFFunction

### 5.3.53.1 Definition

This IOC represents an external AMF functionality used in EN-DC. For more information about the AMF, see 3GPP TS 23.501 [2].

### 5.3.53.2 Attributes

Attribute name	Support Qualifier	isReadable	isWritable	isInvariant	isNotifyable
Id	M	T	F	F	T
pLMNIdList	M	T	T	F	T
aMFIdentifier	M	T	T	F	T

### 5.3.53.3 Attribute constraints

None.

### 5.3.53.4 Notifications

The common notifications defined in subclause 5.5 are valid for this IOC, without exceptions or additions.

## 5.4 Attribute definitions

### 5.4.1 Attribute properties

The following table defines the attributes that are present in several Information Object Classes (IOCs) of the present document.

Attribute Name	Documentation and Allowed Values	Properties
amfIdentifier	The AMFI is constructed from an AMF Region ID, an AMF Set ID and an AMF Pointer. The AMF Region ID identifies the region, the AMF Set ID uniquely identifies the AMF Set within the AMF Region, and the AMF Pointer uniquely identifies the AMF within the AMF Set. (Ref. 3GPP TS 23.003 [13])	type: Integer multiplicity: 1 isOrdered: N/A isUnique: N/A defaultValue: None allowedValues: N/A isNullable: False
amfSetId	It represents the AMF Set ID, which is uniquely identifies the AMF Set within the AMF Region. allowedValues: defined in subclause 2.10.1 of 3GPP TS 23.003 [13].	type: Integer multiplicity: 1 isOrdered: N/A isUnique: N/A defaultValue: None allowedValues: N/A isNullable: False
amfSetMemberList	It is the list of DNs of AMFFunction instances of the AMFSet. allowedValues: N/A	type: DN multiplicity: 1 isOrdered: N/A isUnique: True defaultValue: None isNullable: False
amfRegionId	It represents the AMF Region ID, which identifies the region. allowedValues: defined in subclause 2.10.1 of 3GPP TS 23.003 [13].	type: Integer multiplicity: 1 isOrdered: N/A isUnique: N/A defaultValue: None allowedValues: N/A isNullable: False
localAddress	This parameter specifies the localAddress including IP address and VLAN ID used for initialization of the underlying transport.  First string is IP address, IP address can be an IPv4 address (See RFC 791 [37]) or an IPv6 address (See RFC 2373 [38]). Second string is VLAN Id (See IEEE 802.1Q [39]).	type: String multiplicity: 2 isOrdered: True isUnique: N/A defaultValue: None isNullable: False
remoteAddress	Remote address including IP address used for initialization of the underlying transport.  IP address can be an IPv4 address (See RFC 791 [37]) or an IPv6 address (See RFC 2373 [38]).	type: String multiplicity: 1 isOrdered: N/A isUnique: N/A defaultValue: None isNullable: False
nfProfileList	It is a set of NFProfile(s) to be registered in the NRF instance. NFProfile is defined in 3GPP TS 29.510 [23].	type: <<dataType>> multiplicity: * isOrdered: N/A isUnique: N/A defaultValue: None allowedValues: N/A isNullable: False
nSIIdList	It is a set of NSI Id. The NSI ID is defined in subclause 6.1.6.2.8 of 3GPP TS 29.531 [24].	type: String multiplicity: * isOrdered: N/A isUnique: N/A defaultValue: None allowedValues: N/A isNullable: False
sNSSAList	See subclause 4.4.1.	
sBIFQDN	It is used to indicate the FQDN of the registered NF instance in service-based interface, for example, NF instance FQDN structure is: nftype<nfnum>.slicetype<sliceid>.mnc<MNC>.mcc<MCC>.3gppnetwork.org	type: String multiplicity: 1 isOrdered: N/A isUnique: N/A defaultValue: None allowedValues: N/A isNullable: False

sBIServiceList	It is used to indicate the all supported NF services registered on service-based interface.	type: String multiplicity: * isOrdered: N/A isUnique: N/A defaultValue: None allowedValues: N/A isNullable: False
nRTACLlist	It is the list of Tracking Area Code (either legacy TAC or extended TAC) where the represented management function serving.  allowedValues: Legacy TAC and Extended TAC are defined in clause 9.3.3.10 of TS 38.413 [5].	type: Integer multiplicity: 1..* isOrdered: N/A isUnique: N/A defaultValue: None allowedValues: N/A isNullable: False
weightFactor	The weight factor is typically set according to the capacity of local node (AMF) relative to other nodes in the same type. And it is used to achieve load balancing among a set of same type of network functions. (Ref. 3GPP TS 23.501 [2])	type: Integer multiplicity: 1 isOrdered: N/A isUnique: N/A defaultValue: None allowedValues: N/A isNullable: False

## 5.5 Common notifications

This subclause presents a list of notifications, defined in [35], that provisioning management service consumer can receive. The notification parameter `objectClass/objectInstance`, defined in [26], would capture the DN of an instance of an IOC defined in the present document.

Name	Qualifier	Notes
notifyMOIAttributeValueChanges	O	
notifyMOICreation	O	
notifyMOIDeletion	O	

---

## 6 Information model definitions for network slice NRM

### 6.1 Imported information entities and local labels

Label reference	Local label
3GPP TS 28.622 [30], IOC, Top	Top
3GPP TS 28.622 [30], IOC, SubNetwork	SubNetwork
3GPP TS 28.622 [30], IOC, ManagedFunction	ManagedFunction
3GPP TS 28.658 [19], dataType, PLMNId	PLMNId



## 6.2 Class diagram

### 6.2.1 Relationships

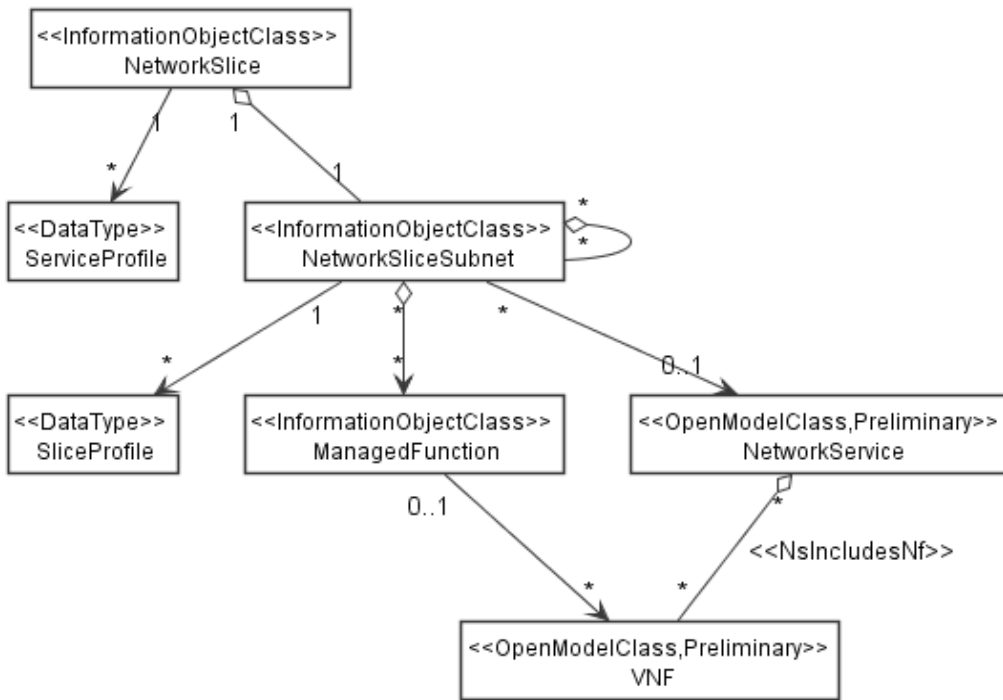
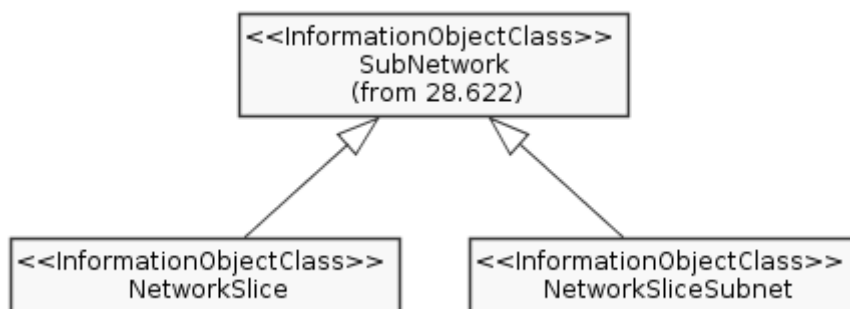

**Figure 6.2.1-1: Network slice NRM fragment relationship**

NOTE 1: The <<OpenModelClass>> NetworkService and <<OpenModelClass>> VNF are defined in [40].

NOTE 2: The target Network Service (NS) instance represents a group of VNFs and PNFs that are supporting the source network slice subnet instance.

### 6.2.2 Inheritance



**Figure 6.2.2-1: Network slice inheritance relationship**

## 6.3 Class definitions

### 6.3.1 NetworkSlice

#### 6.3.1.1 Definition

This IOC represents the properties of a network slice instance in a 5G network. For more information about the network slice instance, see 3GPP TS 28.531 [26].

#### 6.3.1.2 Attributes

Attribute name	Support Qualifier	isReadable	isWritable	isInvariant	isNotifyable
operationalState	M	T	F	F	T
administrativeState	M	T	T	F	T
serviceProfileList	M	T	T	F	T
<b>Attribute related to role</b>					
nSSIId	M	T	F	F	T

#### 6.3.1.3 Attribute constraints

None.

#### 6.3.1.4 Notifications

The common notifications defined in subclause 6.5 are valid for this IOC, without exceptions or additions.

### 6.3.2 NetworkSliceSubnet

#### 6.3.2.1 Definition

This IOC represents the properties of a network slice subnet instance in a 5G network. For more information about the network slice subnet instance, see 3GPP TS 28.531 [26].

#### 6.3.2.2 Attributes

Attribute name	Support Qualifier	isReadable	isWritable	isInvariant	isNotifyable
mFidList	M	T	F	F	T
constituentNSSIIdList	M	T	F	F	T
operationalState	M	T	F	F	T
administrativeState	M	T	T	F	T
nsInfo	CM	T	F	F	T
sliceProfileList	M	T	T	F	T

#### 6.3.2.3 Attribute constraints

Name	Definition
nsInfo Support Qualifier	Condition: It shall be supported if the NSS instance is realized in the virtualized environment. Otherwise this attribute shall be absent.

#### 6.3.2.4 Notifications

The common notifications defined in subclause 6.5 are valid for this IOC, without exceptions or additions.

### 6.3.3 ServiceProfile

#### 6.3.3.1 Definition

This <<DataType>> represents the properties of network slice related requirement that should be supported by the network slice instance in 5G network.

#### 6.3.3.2 Attributes

Attribute name	Support Qualifier	isReadable	isWritable	isInvariant	isNotifyable
serviceProfileId	M	T	F	T	T
sNSSAList	M	T	T	F	T
pLMNIdList	M	T	T	F	T
perfReq	M	T	T	F	T
maxNumberOfUEs	O	T	T	F	T
coverageAreaTAList	O	T	T	F	T
latency	O	T	T	F	T
uEMobilityLevel	O	T	T	F	T
resourceSharingLevel	O	T	T	F	T
sST	M	T	T	F	T
availability	O	T	T	F	T

#### 6.3.3.3 Attribute constraints

None.

#### 6.3.3.4 Notifications

Not applicable.

### 6.3.4 SliceProfile

#### 6.3.4.1 Definition

This <<DataType>> represents the properties of network slice subnet related requirement that should be supported by the network slice subnet instance in a 5G network.

#### 6.3.4.2 Attributes

Attribute name	Support Qualifier	isReadable	isWritable	isInvariant	isNotifyable
sliceProfileId	M	T	F	T	T
sNSSAList	M	T	T	F	T
pLMNIdList	M	T	T	F	T
perfReq	M	T	T	F	T
maxNumberOfUEs	O	T	T	F	T
coverageAreaTAList	O	T	T	F	T
latency	O	T	T	F	T
uEMobilityLevel	O	T	T	F	T
resourceSharingLevel	O	T	T	F	T

#### 6.3.4.3 Attribute constraints

None.

#### 6.3.4.4 Notifications

Not applicable

## 6.4 Attribute definition

### 6.4.1 Attribute properties

Attribute Name	Documentation and Allowed Values	Properties
availability	This parameter specifies the availability requirement for an network slice instance, expressed as a percentage.	type: Float multiplicity: 1 isOrdered: N/A isUnique: N/A defaultValue: None allowedValues: N/A isNullable: True
nSSIIId	It is the DN of the MOI for the NSSI associated with the network slice instance.	type: DN multiplicity: 1 isOrdered: N/A isUnique: N/A defaultValue: None allowedValues: N/A isNullable: False
serviceProfileId	A unique identifier of property of network slice related requirement should be supported by the network slice instance.	type: String multiplicity: 1 isOrdered: N/A isUnique: N/A defaultValue: None isNullable: True
sliceProfileId	A unique identifier of the property of network slice subnet related requirement should be supported by the network slice subnet instance.	type: String multiplicity: 1 isOrdered: N/A isUnique: N/A defaultValue: None isNullable: True
constituentNSSIIIdList	It is a list of DN of MOI(s) for the constituent NSSI associated with the network slice subnet instance.	type: DN multiplicity: * isOrdered: N/A isUnique: N/A defaultValue: None allowedValues: N/A isNullable: False
mFidList	It is a list of DN of the MOI(s) for the NF instances associated with the network slice subnet instance.	type: DN multiplicity: * isOrdered: N/A isUnique: N/A defaultValue: None allowedValues: N/A isNullable: False
operationalState	It indicates the operational state of the network slice instance or the network slice subnet instance. It describes whether or not the resource is physically installed and working.  allowedValues: "ENABLED", "DISABLED". The meaning of these values is as defined in 3GPP TS 28.625 [17] and ITU-T X.731 [18].	type: ENUM multiplicity: 1 isOrdered: N/A isUnique: N/A defaultValue: None allowedValues: N/A isNullable: False
administrativeState	It indicates the administrative state of the network slice instance or the network slice subnet instance. It describes the permission to use or prohibition against using the instance, imposed through the OAM services.  allowedValues: "LOCKED", "UNLOCKED", "SHUTTINGDOWN" The meaning of these values is as defined in 3GPP TS 28.625 [17] and ITU-T X.731 [18].	type: ENUM multiplicity: 1 isOrdered: N/A isUnique: N/A defaultValue: None allowedValues: N/A isNullable: False
nsInfo	This attribute contains the NsInfo of the NS instance corresponding to the network slice subnet instance. The NsInfo is described in clause 8.3.3.2.2 of ETSI GS NFV-IFA 013 [29]. The NsInfo contains: - nsInstancelId. - nsName (optional). - description (optional).	type: <<dataType>> multiplicity: 1 isOrdered: N/A isUnique: True defaultValue: No default value isNullable: True

perfReq	<p>This parameter specifies the requirements to the NSI in terms of the scenarios defined in the TS 22.261 [28], such as Experienced data rate, Area traffic capacity (density) information of UE density.</p> <p>It is a structure containing the following elements:</p> <ul style="list-style-type: none"> <li>- list of perfRequirements</li> </ul> <p>Depending on the sST value, the list of perfRequirements will be</p> <ul style="list-style-type: none"> <li>- list of eMBBPerfReq</li> </ul> <p>or</p> <ul style="list-style-type: none"> <li>- list of uRLLCPerfReq</li> </ul> <p>or</p> <ul style="list-style-type: none"> <li>- list of mIoTPerfReq</li> </ul> <p>NOTE: the list of mIoTPerfReq is not addressed in the present document.</p> <p>allowedValues:</p> <ul style="list-style-type: none"> <li>- list of eMBBPerfReq is a list of entries where an entry identifies the performance requirements to the NSI in terms of the scenarios defined in the Table 7.1-1 of TS 22.261 [28]. An entry has the following attributes: expDataRateDL (Integer), expDataRateUL (Integer), areaTrafficCapDL (Integer), areaTrafficCapUL (Integer), userDensity (Integer), activityFactor (Integer), uESpeed (Integer), coverage (String) (see Table 7.1-1 of TS 22.261 [28]).</li> <li>- list of uRLLCPerfReq is a list of entries where an entry identifies the performance requirements to the NSI in terms of the scenarios defined in the Table 7.2.2-1 of TS 22.261 [28]. An entry has the following attributes: e2eLatency (Integer), jitter (Integer), survivalTime (Integer), cSAvailability (Float), reliability (Float), expDataRate (Integer), payloadSize (String), trafficDensity (Integer), connDensity (Integer), serviceAreaDimension (String) (see Table 7.2-1 of TS 22.261 [28]).</li> </ul> <p>NOTE: Limitation on attribute values in instances of <i>ServiceProfile</i> is not addressed in the present document.</p>	<p>type: &lt;&lt;dataType&gt;&gt;  multiplicity: *  isOrdered: N/A  isUnique: N/A  defaultValue: None  allowedValues: N/A  isNullable: False</p>
sNSSAIList	<p>This parameter specifies the S-NSSAI list to be supported by the new NSI to be created or the existing NSI to be re-used.</p> <p>sNSSAIList is defined in subclause 4.4.1</p>	
maxNumberOfUEs	<p>An attribute specifies the maximum number of UEs may simultaneously access the network slice instance.</p>	<p>type: Integer  multiplicity: 1  isOrdered: N/A  isUnique: N/A  defaultValue: None  allowedValues: N/A  isNullable: False</p>
coverageAreaTAList	<p>An attribute specifies a list of &lt;TrackingArea&gt; where the NSI can be selected.</p>	<p>type: &lt;&lt;dataType&gt;&gt;  multiplicity: 1..*  isOrdered: N/A  isUnique: N/A  defaultValue: None  allowedValues: N/A  isNullable: False</p>
latency	<p>An attribute specifies the packet transmission latency (millisecond) through the RAN, CN, and TN part of 5G network and is used to evaluate utilization performance of the end-to-end network slice instance. See clause 6.3.1 of 28.554 [27].</p>	<p>type: Integer  multiplicity: 1  isOrdered: N/A  isUnique: N/A  defaultValue: None  allowedValues: N/A  isNullable: False</p>
uEMobilityLevel	<p>An attribute specifies the mobility level of UE accessing the network slice instance. See 6.2.1 of TS 22.261 [28].</p> <p>allowedValues: stationary, nomadic, restricted mobility, fully mobility.</p>	<p>type: Enum  multiplicity: 1  isOrdered: N/A  isUnique: N/A  defaultValue: None  allowedValues: N/A  isNullable: True</p>

<code>serviceProfile.resourceSharingLevel</code>	An attribute specifies whether the resources to be allocated to the network slice instance may be shared with another network slice instance(s).  allowedValues: shared, non-shared.	type: Enum multiplicity: 1 isOrdered: N/A isUnique: N/A defaultValue: None allowedValues: Yes isNullable: True
<code>sliceProfile.resourceSharingLevel</code>	An attribute specifies whether the resources to be allocated to the network slice subnet instance may be shared with another network slice subnet instance(s).  allowedValues: shared, non-shared.	type: Enum multiplicity: 1 isOrdered: N/A isUnique: N/A defaultValue: None allowedValues: Yes isNullable: True
<code>serviceProfileList</code>	An attribute specifies a list of ServiceProfile (see clause 6.3.3) supported by the network slice instance	type: << dataType >> multiplicity: * isOrdered: N/A isUnique: N/A defaultValue: None allowedValues: N/A isNullable: False
<code>sliceProfileList</code>	An attribute specifies a list of SliceProfile (see clause 6.3.4) supported by the network slice subnet instance	type: << dataType >> multiplicity: * isOrdered: N/A isUnique: N/A defaultValue: None allowedValues: N/A isNullable: False
<code>sST</code>	This parameter specifies the slice/service type for a ServiceProfile..  See clause 5.15.2 of 3GPP TS 23.501 [2].	type: Integer multiplicity: 1 isOrdered: N/A isUnique: N/A defaultValue: None allowedValues: N/A isNullable: False

## 6.5 Common notifications

This subclause presents a list of notifications, defined in [35], that provisioning management service consumer can receive. The notification parameter `objectClass/objectInstance`, defined in [26], would capture the DN of an instance of an IOC defined in the present document.

Name	Qualifier	Notes
<code>notifyMOIAttributeValueChanges</code>	O	
<code>notifyMOICreation</code>	O	
<code>notifyMOIDeletion</code>	O	

## 7 Solution Set (SS)

The present document defines the following NRM Solution Set definitions for NR and NG-RAN:

- XML based 3GPP NR and NG-RAN NRM Solution Set (Annex C).
- JSON based 3GPP NR and NG-RAN NRM Solution Set (Annex D).
- YANG based 3GPP NR and NG-RAN NRM Solution Set (Annex E).

The present document defines the following NRM Solution Set definitions for 5GC:

- XML based 3GPP 5GC NRM Solution Set (Annex F).



- JSON based 3GPP 5GC NRM Solution Set (Annex G).
- YANG based 3GPP 5GC NRM Solution Set (Annex H).

The present document defines the following NRM Solution Set definitions for network slice and network slice subnet:

- XML based 3GPP Network Slice NRM Solution Set (Annex I).
- JSON based 3GPP Network Slice NRM Solution Set (Annex J).
- YANG based 3GPP Network Slice NRM Solution Set (Annex K).

# Annex A (normative): Cell state handling

## A.1 Relation between the administrative state and the "Pre-operation state of the gNB-DU Cell"

The administrative state indicates the permission to use or prohibition against using the cell, imposed through the OAM services. The administrative state has three values: "LOCKED", "SHUTTING DOWN" or "UNLOCKED"

The meanings of these values are defined in ITU-T Recommendation X.731 [18].

The relation between the administrative state and the "Pre-operation state of the gNB-DU Cell" is defined in subclause 8.5 of TS 38.401 [4]. See below an extract from subclause 8.5 of TS 38.401 [4] on the F1 startup and cell activation.

If the `operationalState` is "ENABLED" (i.e. the resource is physically installed and working) and if the `administrativeState` is "UNLOCKED", the step "0: Pre-operational state" will exit and the step "1: F1 Setup Request" will be executed."

### 8.5 F1 Startup and cells activation

This function allows to setup the F1 interface between a gNB-DU and a gNB-CU and it allows to activate the gNB-DU cells.

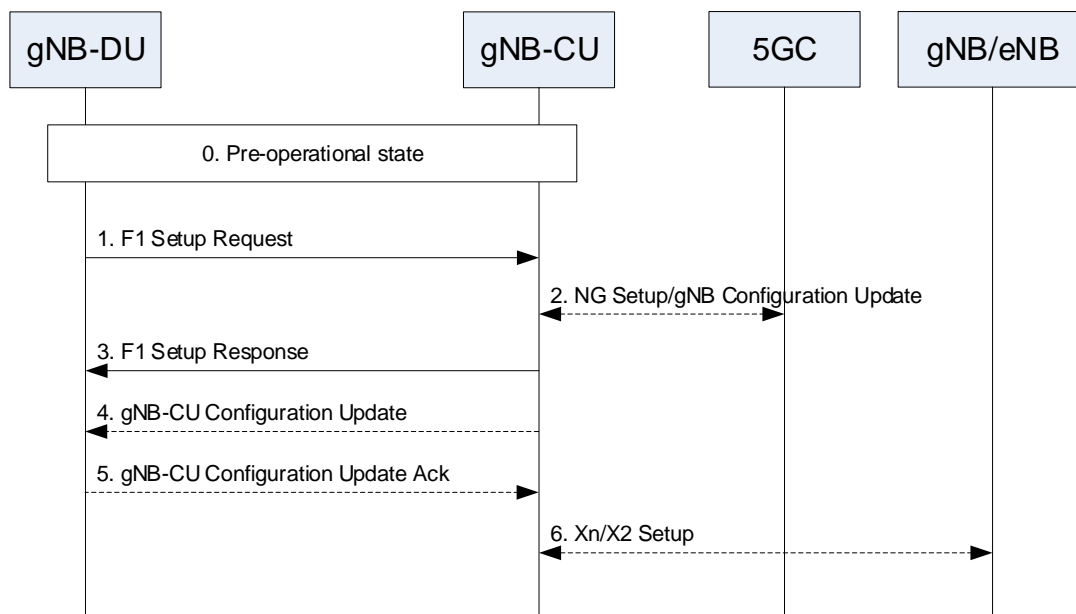
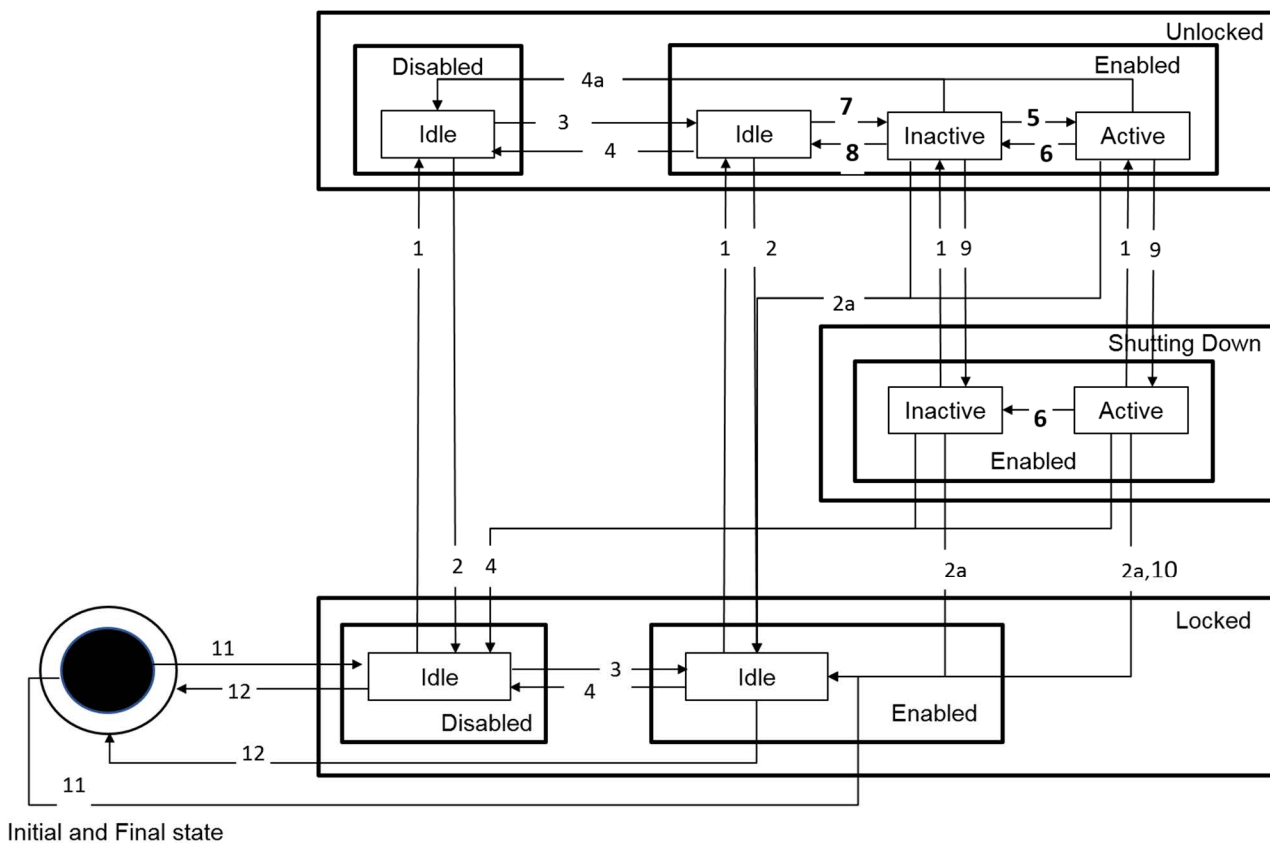

Figure 8.5-1: F1 startup and cell activation

## A.2 Combined state diagram for gNB cell

This is the Combined state diagram for gNB cell.



**Figure A.2-1: Combined gNB cell state diagram**

The gNB-DU maintains cell states. The following table is the gNB cell state transition table.

In 3-split and 2-split deployment scenarios, the interactions between gNB-CU and gNB-DU are standardized. The interactions specified under the column "The state transition events and actions" of "The gNB Cell state transition table" below shall be present for the state transition.

In the non-split deployment scenarios, the interactions between gNB-CU and gNB-DU are not standardized. The interactions between gNB-CU and gNB-DU specified under the column "The state transition events and actions" of "The gNB Cell state transition table" can be replaced by other means that is not standardized.

**Table A.2-1: The gNB Cell state transition table**

Transition number	The state transition event and actions
1	Event: Receive request to unlock. Action: None.
2	Event: Receive request to lock. Action: None.
2a	Event: Receive request to lock Action: Send to gNB-CU the "gNB-DU Configuration Update message" with served cell to delete.
3	Event: When the required cell resource is physically installed and working. Action: none.
4	Event: When the required cell resource is not physically installed or is not working. Action: Send to gNB-CU the "gNB-DU Configuration update message" with cell to delete.
4a	Event: When the required cell resource is physically uninstalled or is not working. Action: Send to gNB-CU the "GNB-DU Configuration Update message" with served cell to delete.
5	Event: Receive from gNB-CU the "F1 Setup Response message" (identifying the cell to be activated). The cell is activated successfully. Actions: Do nothing or send gNB-CU the "gNB-DU Configuration Update message" with Cell stated as active'  ----- or ----- Event: Receive from gNB-CU the "gNB-CU Configuration Update message" (identifying cell to be activated e.g., in case that the cell was not activated using the "F1 Setup Response message"). Actions: The cell is activated successfully. Send to gNB-CU the "gNB-CU Configuration Update Response" to confirm the cell is in active state.  ----- or ----- Event: Receive from gNB-CU the "gNB-DU Configuration Update Acknowledge message" (identifying cell to be activated e.g., in case that the cell was not activated using the "F1 Setup Response message") and the cell is activated successfully Actions: Do nothing.
6	Event: Receive from gNB-CU the "gNB-CU Configuration Update message" and responds with gNB-CU Configuration Update Acknowledge messages. Actions: Respond with gNB-CU Configuration Update Acknowledge messages.  ----- or ----- Event: Event: DU experiences an internal failure and decided to place the cell into inactive state. Actions: Send to gNB-CU the "gNB-DU Cell status Update message"
7	Event: Send to gNB-CU the "F1 Setup request" (identifying the cell that is configured and ready to be activated). Actions: none.  ----- or ----- Send to gNB-CU the "gNB-DU Configuration Update message" with the served cell to add. Actions: none.
8	Event: Sends to gNB-CU the "gNB-DU Configuration Update message" with served cell to delete. Receive response from gNB-CU the "gNB-DU Configuration Update Acknowledge message". Actions: None.
9	Event: Receive request to shut down. Actions: None.
10	Event: Last user quit. Actions: Send to gNB-CU the "GNB-DU Configuration Update message" with served cell to delete.
11	Event: When a cell is created and is configured. Actions: None

12	Event: When a cell is deleted. Action: None.
----	---

# Annex B (normative): NSI and NSSI state handling

## B.1 NSI state handling

An NSI is a logical object in the management system that represents a complex grouping of resources that may be in various states. At any time, the management system needs to know the state of an NSI.

The ITU-T X.731 [18], to which [17] refers, has defined the inter-relation between the administrative state, operational state and usage state of systems in general.

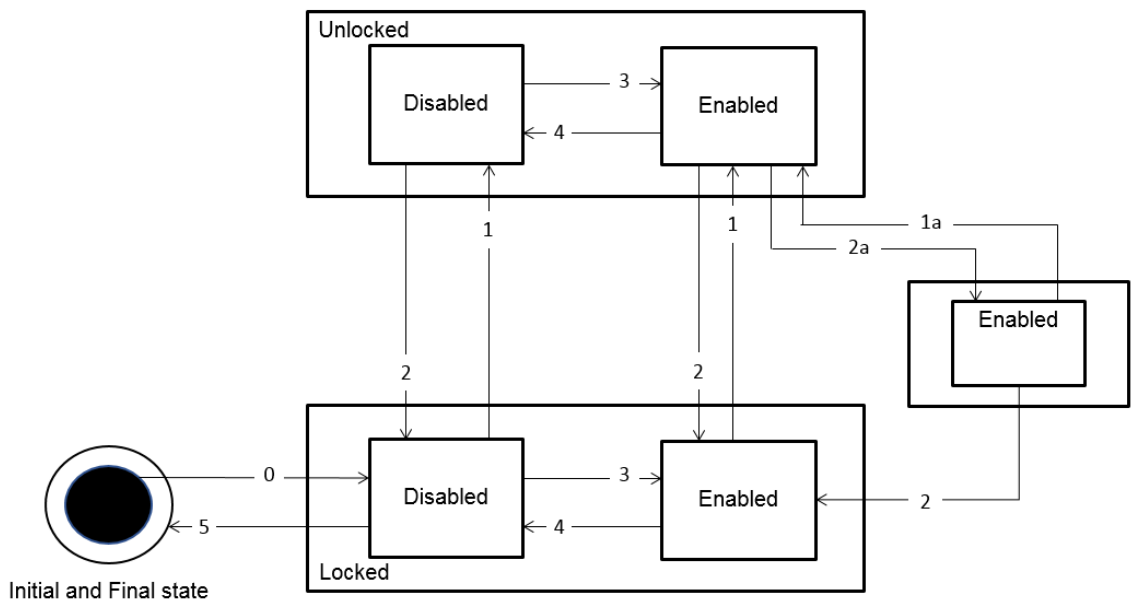

**Figure B.1: Combined NSI state diagram**

In an NSI deployment scenario, the interactions between communication service management function, network slice management function and network slice subnet management function are standardized. The interactions specified under the column "The state transition events and actions" of "NSI state transition table" below shall be present for the state transition.

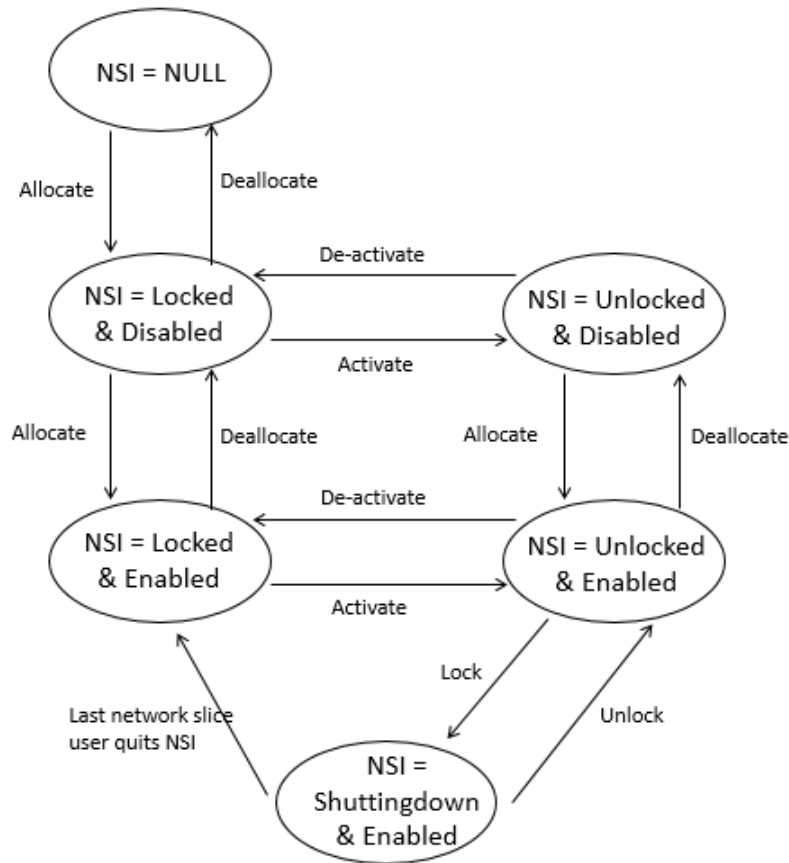

Figure B.2: NSI state diagram with state transition triggers

Table B.1: The NSI state transition table

Trigger number	The state transition events and actions
0	NSMF responds positively to the "Create NSI request" message, the NSI is created and the state is set to Locked
1	NSMF responds positively to the "Activate NSI request" message (identifying the NSI to be activated). ----- or ----- CM operation to set administrative state to Unlocked.
1a	CM Operation to set administrative state to Unlocked
2	The last user of the NSI stops using the NSI
2a	CM Operation to set administrative state to Shutting down
3	When the NSI and its constituents are installed and working NSMF receives positive response to the "Allocate NSSI" message (applicable to the NSI to be enabled).
4	When the NSI or its constituents are not installed or not working NSMF receives positive response to the "Deallocate NSSI" message (applicable to the NSI to be disabled)
5	NSMF responds positively to the "Deallocate NSI request" message, the NSI is deleted and the state is set to NULL

## B.2 State handling of NSSI

An NSSI is a logical object in the management system that represents a complex grouping of resources that may be in various states. At any time the management system needs to know the state of an NSSI.



The ITU-T X.731 [18], to which [17] refers, has defined the inter-relation between the administrative state, operational state and usage state of systems in general.

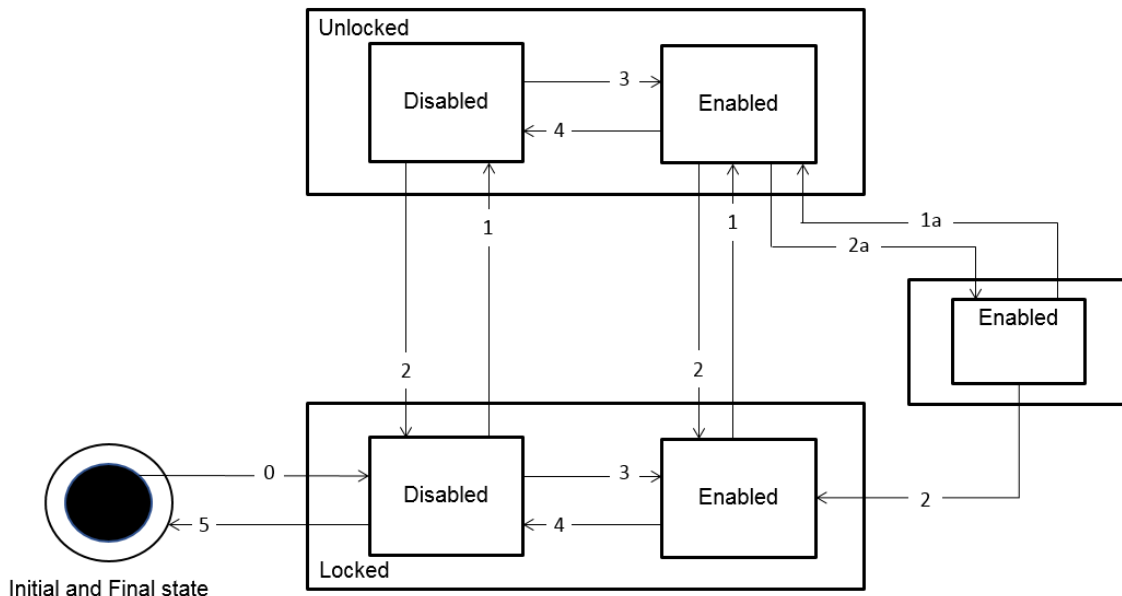

Figure B.2.1: Combined NSSI state diagram

In an NSSI deployment scenario, the interactions between CSMF, NSMF and NSSMF are standardized. The interactions specified under the column "The state transition events and actions" of "NSSI state transition table" below shall be present for the state transition.

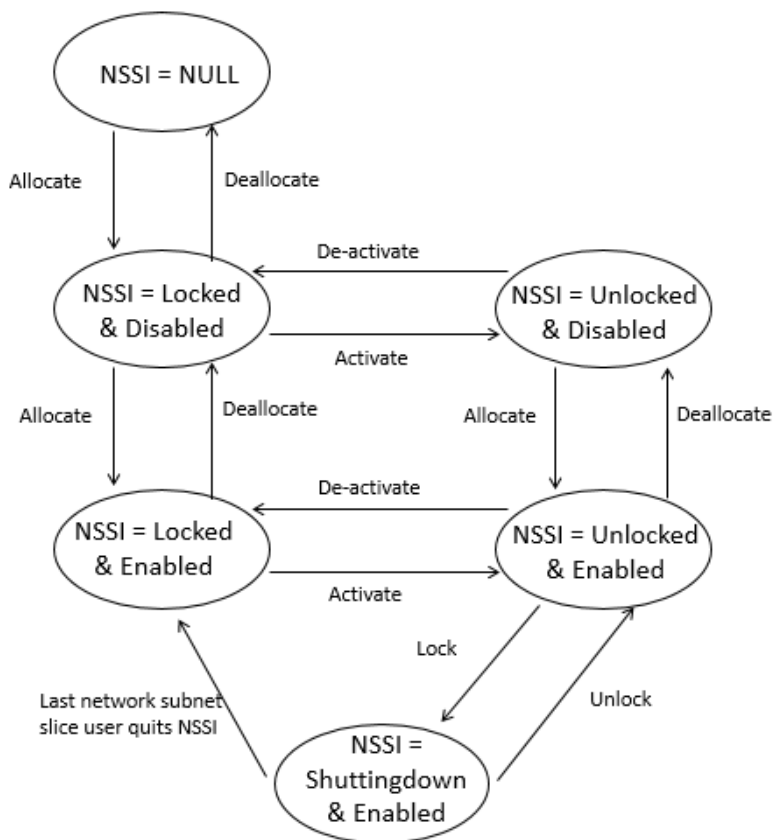

Figure B.2.2: NSSI state diagram with state transition triggers

**Table B.2.1: The NSSI state transition table**

Trigger number	The state transition events and actions
0	NSSMF responds positively to the "Create NSSI request" message, the NSSI is created and the state is set to Locked
1	NSSMF responds positively to the "Activate NSSI request" message (identifying the NSSI to be activated).  ----- or -----  CM operation to set administrative state to Unlocked.
1a	CM Operation to set administrative state to Unlocked
2	The last user of the NSSI stops using the NSSI
2a	CM Operation to set administrative state to Shutting down
3	When the NSSI constituents are installed and working NSSMF receives positive response to the "Create NSSI constituent" message (applicable to the NSSI to be enabled).
4	When the NSSI constituents are not installed or not working NSSMF receive positive response to the "Delete NSSI constituent" message (applicable to the NSSI to be disabled)
5	NSSMF responds positively to the "Delete NSSI request" message, the NSSI is deleted and the state is set to NULL.

---

## Annex C (normative): XML definitions for NR NRM

### C.1 General

This annex contains the XML definitions for the NR and NG-RAN NRM, in accordance with NR and NG-RAN NRM Information Model definitions specified in clause 4.

---

### C.2 Architectural features

The overall architectural feature of NR NRM information model is specified in clause 4, this clause specifies features that are specific to the Schema definitions.

The XML definitions of the present document specify the schema for a configuration content, which can be included in a configuration file for Bulk configuration management operations

---

### C.3 Mapping

#### C.3.1 General mapping

An IOC maps to an XML element of the same name as the IOC's name in the Information Model. An IOC attribute maps to a sub-element of the corresponding IOC's XML element, and the name of this sub-element is the same as the attribute's name in the Information Model.

#### C.3.2 Information Object Class (IOC) mapping

The mapping is not present in the current version of the present document.

---

### C.4 Solution Set definitions

#### C.4.1 XML definition structure

The overall description of the file format of configuration data XML files is provided by 3GPP TS 32.616 [33].

The present document defines the NRM-specific XML schema nrNrm.xsd for the NR NRM Information Model defined in clause 4.

XML schema nrNrm.xsd explicitly declares NRM-specific XML element types for the related NRM.

The definition of those NRM-specific XML element types complies with the generic mapping rules defined in 3GPP TS 32.616 [33].

#### C.4.2 Graphical representation

The graphical representation is not present in the current version of the present document.

#### C.4.3 XML schema "nrNrm.xsd"

```
<?xml version="1.0" encoding="UTF-8"?>
```

```

<!--
 3GPP TS 28.541 NR Network Resource Model
 XML schema definition
 nrNrm.xsd
-->
<schema xmlns="http://www.w3.org/2001/XMLSchema"
  xmlns:xn="http://www.3gpp.org/ftp/specs/archive/28_series/28.623#genericNrm"
  xmlns:nn="http://www.3gpp.org/ftp/specs/archive/28_series/28.541#nrNrm"
  xmlns:en="http://www.3gpp.org/ftp/specs/archive/28_series/28.659#eutranNrm"
  xmlns:epc="http://www.3gpp.org/ftp/specs/archive/28_series/28.709#epcNrm"
  xmlns:sm="http://www.3gpp.org/ftp/specs/archive/28_series/28.626#stateManagementIRP"
  xmlns:ngc="http://www.3gpp.org/ftp/specs/archive/28_series/28.541#ngcNrm"
  xmlns:sp="http://www.3gpp.org/ftp/specs/archive/28_series/28.629#sonPolicyNrm"

  targetNamespace="http://www.3gpp.org/ftp/specs/archive/28_series/28.541#nrNrm"
  elementFormDefault="qualified">
  <import namespace="http://www.3gpp.org/ftp/specs/archive/28_series/28.623#genericNrm"/>
  <import namespace="http://www.3gpp.org/ftp/specs/archive/28_series/28.709#epcNrm"/>
  <import namespace="http://www.3gpp.org/ftp/specs/archive/28_series/28.626#stateManagementIRP"/>
  <import namespace="http://www.3gpp.org/ftp/specs/archive/28_series/28.541#ngcNrm"/>
  <import namespace="http://www.3gpp.org/ftp/specs/archive/28_series/28.629#sonPolicyNrm"/>

  <simpleType name="GnbId">
    <restriction base="unsignedLong">
      <maxInclusive value="4294967295"/>
    </restriction>
  </simpleType>
  <simpleType name="GnbIdLength">
    <restriction base="integer">
      <minLength value="22"/>
      <maxLength value="32"/>
    </restriction>
  </simpleType>
  <simpleType name="Nci">
    <restriction base="unsignedLong">
      <maxInclusive value="68719476735"/>
    </restriction>
  </simpleType>

  <simpleType name="Pci">
    <restriction base="unsignedShort">
      <maxInclusive value="503"/>
      <!-- Minimum value is 0, maximum value is 3x167+2=503 -->
    </restriction>
  </simpleType>
  <simpleType name="NrTac">
    <restriction base="unsignedLong">
      <maxInclusive value="16777215"/>
      <!-- 5G TAC is 3-octets length -->
    </restriction>
  </simpleType>
  <simpleType name="GnbDuId">
    <restriction base="unsignedLong">
      <maxInclusive value="68719476735"/>
      <!-- Minimum value is 0, maximum value is 2^36-1=68719476735 -->
    </restriction>
  </simpleType>
  <simpleType name="GnbName">
    <restriction base="string">
      <minLength value="1"/>
      <maxLength value="150"/>
    </restriction>
  </simpleType>
  <simpleType name="CyclicPrefix">
    <restriction base="integer">
      <enumeration value="15"/>
      <enumeration value="30"/>
      <enumeration value="60"/>
      <enumeration value="120"/>
    </restriction>
  </simpleType>
  <simpleType name="QuotaType">
    <restriction base="string">
      <enumeration value="STRICT"/>
      <enumeration value="FLOAT"/>
    </restriction>
  </simpleType>
  <complexType name="IpEndPoint">

```

```

    <sequence>
      <element name="ipv4Address" type="string"/>
      <element name="ipv6Address" type="string"/>
      <element name="ipv6Prefix" type="string"/>
      <element name="vlanId" type="integer"/>
    </sequence>
  </complexType>
<simpleType name="CellState">
  <restriction base="string">
    <enumeration value="IDLE"/>
    <enumeration value="INACTIVE"/>
    <enumeration value="ACTIVE"/>
  </restriction>
</simpleType>
<simpleType name="BwpContext">
  <restriction base="string">
    <enumeration value="DL"/>
    <enumeration value="UL"/>
    <enumeration value="SUL"/>
  </restriction>
</simpleType>
<simpleType name="IsInitialBwp">
  <restriction base="string">
    <enumeration value="INITIAL"/>
    <enumeration value="OTHER"/>
  </restriction>
</simpleType>
<complexType name="RRMPolicyRation2">
  <sequence>
    <element name="groupId" type="integer"/>
    <element name="sNSSAList" type="ngc:SnsaiList"/>
    <element name="quotaType" type="QuotaType"/>
    <element name="rRMPolicyMaxRation" type="integer"/>
    <element name="rRMPolicyMarginMaxRation" type="integer"/>
    <element name="rRMPolicyMinRation" type="integer"/>
    <element name="rRMPolicyMarginMinRation" type="integer"/>
  </sequence>
</complexType>
<element name="GNBDUFunction" substitutionGroup="xn:ManagedElementOptionallyContainedNrmClass">
  <complexType>
    <complexContent>
      <extension base="xn:NrmClass">
        <sequence>
          <element name="attributes">
            <complexType>
              <all>
                <element name="userLabel" type="string"/>
                <element name="vnfParametersList" type="xn:vnfParametersListType" minOccurs="0"/>
                <element name="peeParametersList" type="xn:peeParametersListType" minOccurs="0"/>
                <element name="gnbId" type="nn:GnbId"/>
                <element name="gnbIdLength" type="nn:GnbIdLength"/>
                <element name="gnbDUId" type="nn:GnbDUId"/>
                <element name="gnbDuName" type="nn:GnbName" minOccurs="0"/>
              </all>
            </complexType>
          </element>
          <choice minOccurs="0" maxOccurs="unbounded">
            <element ref="nn:NRCellDU"/>
            <element ref="nn:BWP"/>
            <element ref="nn:NRSectorCarrier"/>
            <element ref="nn:EP_FLIC"/>
            <element ref="nn:EP_FLU"/>
          </choice>
        </sequence>
      </extension>
    </complexContent>
  </complexType>
</element>
<element name="GNBCUCPFunction" substitutionGroup="xn:ManagedElementOptionallyContainedNrmClass">
  <complexType>
    <complexContent>
      <extension base="xn:NrmClass">
        <sequence>
          <element name="attributes">
            <complexType>
              <all>
                <element name="userLabel" type="string"/>
                <element name="vnfParametersList" type="xn:vnfParametersListType" minOccurs="0"/>
              </all>
            </complexType>
          </element>
        </sequence>
      </extension>
    </complexContent>
  </complexType>
</element>

```

```

        <element name="peeParametersList" type="xn:peeParametersListType" minOccurs="0"/>
        <element name="gnbId" type="nn:GnbId" />
        <element name="gnbIdLength" type="nn:GnbIdLength"/>
        <element name="gnbCuName" type="nn:GnbName" minOccurs="0"/>
        <element name="pLMNIdList" type="en:PLMNIdList" />
    </all>
</complexType>
</element>
<choice minOccurs="0" maxOccurs="unbounded">
    <element ref="nn:NRCCellCU"/>
    <element ref="nn:EP_FLIC"/>
    <element ref="nn:EP_E1"/>
    <element ref="nn:EP_XnC"/>
    <element ref="nn:EP_X2C"/>
    <element ref="nn:EP_NgC"/>
    <element ref="xn:VsDataContainer"/>
</choice>
</sequence>
</extension>
</complexContent>
</complexType>
</element>
<element name="GNBCUUPFunction" substitutionGroup="xn:ManagedElementOptionallyContainedNrmClass">
    <complexType>
        <complexContent>
            <extension base="xn:NrmClass">
                <sequence>
                    <element name="attributes">
                        <complexType>
                            <all>
                                <element name="userLabel" type="string"/>
                                <element name="vnfParametersList" type="xn:vnfParametersListType" minOccurs="0"/>
                                <element name="peeParametersList" type="xn:peeParametersListType" minOccurs="0"/>
                                <element name="pLMNIdList" type="en:PLMNIdList"/>
                                <element name="gNBId" type="nn:GnbId"/>
                                <element name="gnbIdLength" type="nn:GnbIdLength"/>
                            </all>
                        </complexType>
                    </element>
                    <choice minOccurs="0" maxOccurs="unbounded">
                        <element ref="nn:EP_E1"/>
                        <element ref="nn:EP_FLU"/>
                        <element ref="nn:EP_XnU"/>
                        <element ref="nn:EP_NgU"/>
                        <element ref="nn:EP_X2U"/>
                        <element ref="nn:EP_S1U"/>
                        <element ref="xn:VsDataContainer"/>
                    </choice>
                </sequence>
            </extension>
        </complexContent>
    </complexType>
</element>
<element name="NRCCellCU">
    <complexType>
        <complexContent>
            <extension base="xn:NrmClass">
                <sequence>
                    <element name="attributes">
                        <complexType>
                            <all>
                                <element name="userLabel" type="string"/>
                                <element name="vnfParametersList" type="xn:vnfParametersListType" minOccurs="0"/>
                                <element name="nCGI" type="nn:Ncgi"/>
                                <element name="pLMNIdList" type="en:PLMNIdList"/>
                                <element name="sNSSAIIList" type="ngc:SnssaiList" minOccurs="0"/>
                                <element name="rRMPolicyType" type="integer" minOccurs="0"/>
                                <element name="rRMPolicyNSSIIId" type="xn:dn" minOccurs="0"/>
                                <element name="rRMPolicyRatio" type="integer" minOccurs="0"/>
                                <element name="rRMPolicy" type="string" minOccurs="0"/>
                                <element name="rRMPolicyRatio2" type="RRMPolicyRation2" minOccurs="0"/>
                            </all>
                        </complexType>
                    </element>
                    <choice minOccurs="0" maxOccurs="unbounded">
                        <element ref="xn:VsDataContainer"/>
                    </choice>
                </sequence>
            </extension>
        </complexContent>
    </complexType>
</element>
</choice minOccurs="0" maxOccurs="1">

```

```

        <element ref="sp:EnergySavingProperties"/>
        <element ref="sp:ESPolicies"/>
    </choice>
</sequence>
</extension>
</complexContent>
</complexType>
</element>
<element name="NRCellDU">
    <complexType>
        <complexContent>
            <extension base="xn:NrmClass">
                <sequence>
                    <element name="attributes">
                        <complexType>
                            <all>
                                <element name="userLabel" type="string"/>
                                <element name="vnfParametersList" type="xn:vnfParametersListType" minOccurs="0"/>
                                <element name="nCGI" type="nn:Ncgi" minOccurs="0"/>
                                <element name="operationalState" type="sm:operationalStateType" minOccurs="0"/>
                                <element name="administrativeState" type="sm:administrativeStateType"
                                    minOccurs="0"/>
                                <element name="cellState" type="nn:CellState"/>
                                <element name="pLMNidList" type="en:PLMNidList"/>
                                <element name="sNSSAIIList" type="ngc:SnssaiList" minOccurs="0"/>
                                <element name="nRpci" type="nn:Pci" />
                                <element name="nRTac" type="nn:NrTac" />
                                <element name="arfcnDL" type="integer"/>
                                <element name="arfcnUL" type="integer" minOccurs="0"/>
                                <element name="arfcnSUL" type="integer" minOccurs="0"/>
                                <element name="bsChannelBwDL" type="integer"/>
                                <element name="bsChannelBwUL" type="integer" minOccurs="0"/>
                                <element name="bsChannelBwSUL" type="integer" minOccurs="0"/>
                            </all>
                        </complexType>
                    </element>
                    <choice minOccurs="0" maxOccurs="unbounded">
                        <element ref="xn:VsDataContainer"/>
                        <element name="nRSectorCarrier" type="xn:dn" minOccurs="0"/>
                        <element name="bWP" type="xn:dn" minOccurs="0"/>
                    </choice>
                    <choice minOccurs="0" maxOccurs="1">
                        <element ref="sp:EnergySavingProperties"/>
                        <element ref="sp:ESPolicies"/>
                    </choice>
                </sequence>
            </extension>
        </complexContent>
    </complexType>
</element>
<element name="NRSectorCarrier">
    <complexType>
        <complexContent>
            <extension base="xn:NrmClass">
                <sequence>
                    <element name="attributes">
                        <complexType>
                            <all>
                                <element name="userLabel" type="string"/>
                                <element name="vnfParametersList" type="xn:vnfParametersListType" minOccurs="0"/>
                                <element name="txDirection" type="nn:TxDirection"/>
                                <element name="configuredMaxTxPower" type="integer"/>
                                <element name="arfcnDL" type="integer" minOccurs="0"/>
                                <element name="arfcnUL" type="integer" minOccurs="0"/>
                                <element name="bsChannelBwDL" type="integer" minOccurs="0"/>
                                <element name="bsChannelBwUL" type="integer" minOccurs="0"/>
                            </all>
                        </complexType>
                    </element>
                    <choice minOccurs="0" maxOccurs="unbounded">
                        <element ref="xn:VsDataContainer"/>
                        <element name="sectorEquipmentFunction" type="xn:dn" minOccurs="0"/>
                    </choice>
                    <choice minOccurs="0" maxOccurs="1">
                        <element ref="sp:EnergySavingProperties"/>
                        <element ref="sp:ESPolicies"/>
                    </choice>
                </sequence>
            </extension>
        </complexContent>
    </complexType>
</element>

```

```

    </extension>
  </complexType>
</element>
<element name="BWP">
  <complexType>
    <complexContent>
      <extension base="xn:NrmClass">
        <sequence>
          <element name="attributes">
            <complexType>
              <all>
                <element name="userLabel" type="string"/>
                <element name="vnfParametersList" type="xn:vnfParametersListType" minOccurs="0"/>
                <element name="bwpContext" type="nn:BwpContext"/>
                <element name="isInitialBwp" type="nn:IsInitialBwp"/>
                <element name="subCarrierSpacing" type="integer"/>
                <element name="cyclicPrefix" type="nn:CyclicPrefix"/>
                <element name="startRB" type="integer"/>
                <element name="numberOfRBs" type="integer"/>
              </all>
            </complexType>
          </element>
          <choice minOccurs="0" maxOccurs="unbounded">
            <element ref="xn:VsDataContainer"/>
          </choice>
        </sequence>
      </extension>
    </complexContent>
  </complexType>
</element>
<element name="EP_E1">
  <complexType>
    <complexContent>
      <extension base="xn:NrmClass">
        <sequence>
          <element name="attributes" minOccurs="0">
            <complexType>
              <all>
                <!-- Inherited attributes from EP_RP -->
                <element name="farEndEntity" type="xn:dn" minOccurs="0"/>
                <element name="userLabel" type="string" minOccurs="0"/>
                <!-- End of inherited attributes from EP_RP -->
                <element name="localAddress" type="nn:IpEndPoint" minOccurs="0"/>
                <element name="remoteAddress" type="nn:IpEndPoint" minOccurs="0"/>
              </all>
            </complexType>
          </element>
          <choice minOccurs="0" maxOccurs="unbounded">
            <element ref="xn:VsDataContainer"/>
          </choice>
        </sequence>
      </extension>
    </complexContent>
  </complexType>
</element>
<element name="EP_XnC">
  <complexType>
    <complexContent>
      <extension base="xn:NrmClass">
        <sequence>
          <element name="attributes" minOccurs="0">
            <complexType>
              <all>
                <!-- Inherited attributes from EP_RP -->
                <element name="farEndEntity" type="xn:dn" minOccurs="0"/>
                <element name="userLabel" type="string" minOccurs="0"/>
                <!-- End of inherited attributes from EP_RP -->
                <element name="localAddress" type="nn:IpEndPoint" minOccurs="0"/>
                <element name="remoteAddress" type="nn:IpEndPoint" minOccurs="0"/>
              </all>
            </complexType>
          </element>
          <choice minOccurs="0" maxOccurs="unbounded">
            <element ref="xn:VsDataContainer"/>
          </choice>
        </sequence>
      </extension>
    </complexContent>
  </complexType>
</element>

```



```

    </complexContent>
  </complexType>
</element>
<element name="EP_XnU">
  <complexType>
    <complexContent>
      <extension base="xn:NrmClass">
        <sequence>
          <element name="attributes" minOccurs="0">
            <complexType>
              <all>
                <!-- Inherited attributes from EP_RP -->
                <element name="farEndEntity" type="xn:dn" minOccurs="0"/>
                <element name="userLabel" type="string" minOccurs="0"/>
                <!-- End of inherited attributes from EP_RP -->
                <element name="localAddress" type="nn:IpEndPoint" minOccurs="0"/>
                <element name="remoteAddress" type="nn:IpEndPoint" minOccurs="0"/>
              </all>
            </complexType>
          </element>
          <choice minOccurs="0" maxOccurs="unbounded">
            <element ref="xn:VsDataContainer"/>
          </choice>
        </sequence>
      </extension>
    </complexContent>
  </complexType>
</element>
<element name="EP_NgC">
  <complexType>
    <complexContent>
      <extension base="xn:NrmClass">
        <sequence>
          <element name="attributes" minOccurs="0">
            <complexType>
              <all>
                <!-- Inherited attributes from EP_RP -->
                <element name="farEndEntity" type="xn:dn" minOccurs="0"/>
                <element name="userLabel" type="string" minOccurs="0"/>
                <!-- End of inherited attributes from EP_RP -->
                <element name="localAddress" type="nn:IpEndPoint" minOccurs="0"/>
                <element name="remoteAddress" type="nn:IpEndPoint" minOccurs="0"/>
              </all>
            </complexType>
          </element>
          <choice minOccurs="0" maxOccurs="unbounded">
            <element ref="xn:VsDataContainer"/>
          </choice>
        </sequence>
      </extension>
    </complexContent>
  </complexType>
</element>
<element name="EP_NgU">
  <complexType>
    <complexContent>
      <extension base="xn:NrmClass">
        <sequence>
          <element name="attributes" minOccurs="0">
            <complexType>
              <all>
                <!-- Inherited attributes from EP_RP -->
                <element name="farEndEntity" type="xn:dn" minOccurs="0"/>
                <element name="userLabel" type="string" minOccurs="0"/>
                <!-- End of inherited attributes from EP_RP -->
                <element name="localAddress" type="nn:IpEndPoint" minOccurs="0"/>
                <element name="remoteAddress" type="nn:IpEndPoint" minOccurs="0"/>
              </all>
            </complexType>
          </element>
          <choice minOccurs="0" maxOccurs="unbounded">
            <element ref="xn:VsDataContainer"/>
          </choice>
        </sequence>
      </extension>
    </complexContent>
  </complexType>
</element>

```

```

<element name="EP_FLIC">
  <complexType>
    <complexContent>
      <extension base="xn:NrmClass">
        <sequence>
          <element name="attributes" minOccurs="0">
            <complexType>
              <all>
                <!-- Inherited attributes from EP_RP -->
                <element name="farEndEntity" type="xn:dn" minOccurs="0"/>
                <element name="userLabel" type="string" minOccurs="0"/>
                <!-- End of inherited attributes from EP_RP -->
                <element name="localAddress" type="nn:IpEndPoint" minOccurs="0"/>
                <element name="remoteAddress" type="nn:IpEndPoint" minOccurs="0"/>
              </all>
            </complexType>
          </element>
          <choice minOccurs="0" maxOccurs="unbounded">
            <element ref="xn:VsDataContainer"/>
          </choice>
        </sequence>
      </extension>
    </complexContent>
  </complexType>
</element>
<element name="EP_FLIU">
  <complexType>
    <complexContent>
      <extension base="xn:NrmClass">
        <sequence>
          <element name="attributes" minOccurs="0">
            <complexType>
              <all>
                <!-- Inherited attributes from EP_RP -->
                <element name="farEndEntity" type="xn:dn" minOccurs="0"/>
                <element name="userLabel" type="string" minOccurs="0"/>
                <!-- End of inherited attributes from EP_RP -->
                <element name="localAddress" type="nn:IpEndPoint" minOccurs="0"/>
                <element name="remoteAddress" type="nn:IpEndPoint" minOccurs="0"/>
              </all>
            </complexType>
          </element>
          <choice minOccurs="0" maxOccurs="unbounded">
            <element ref="xn:VsDataContainer"/>
          </choice>
        </sequence>
      </extension>
    </complexContent>
  </complexType>
</element>
<element name="EP_S1U">
  <complexType>
    <complexContent>
      <extension base="xn:NrmClass">
        <sequence>
          <element name="attributes" minOccurs="0">
            <complexType>
              <all>
                <!-- Inherited attributes from EP_RP -->
                <element name="farEndEntity" type="xn:dn" minOccurs="0"/>
                <element name="userLabel" type="string" minOccurs="0"/>
                <!-- End of inherited attributes from EP_RP -->
                <element name="localAddress" type="nn:IpEndPoint" minOccurs="0"/>
                <element name="remoteAddress" type="nn:IpEndPoint" minOccurs="0"/>
              </all>
            </complexType>
          </element>
          <choice minOccurs="0" maxOccurs="unbounded">
            <element ref="xn:VsDataContainer"/>
          </choice>
        </sequence>
      </extension>
    </complexContent>
  </complexType>
</element>
<element name="EP_X2C">
  <complexType>
    <complexContent>

```

```

<extension base="xn:NrmClass">
  <sequence>
    <element name="attributes" minOccurs="0">
      <complexType>
        <all>
          <!-- Inherited attributes from EP_RP -->
          <element name="farEndEntity" type="xn:dn" minOccurs="0"/>
          <element name="userLabel" type="string" minOccurs="0"/>
          <!-- End of inherited attributes from EP_RP -->
          <element name="localAddress" type="nn:IpEndPoint" minOccurs="0"/>
          <element name="remoteAddress" type="nn:IpEndPoint" minOccurs="0"/>
        </all>
      </complexType>
    </element>
    <choice minOccurs="0" maxOccurs="unbounded">
      <element ref="xn:VsDataContainer"/>
    </choice>
  </sequence>
</extension>
</complexContent>
</complexType>
</element>
<element name="EP_X2U">
  <complexType>
    <complexContent>
      <extension base="xn:NrmClass">
        <sequence>
          <element name="attributes" minOccurs="0">
            <complexType>
              <all>
                <!-- Inherited attributes from EP_RP -->
                <element name="farEndEntity" type="xn:dn" minOccurs="0"/>
                <element name="userLabel" type="string" minOccurs="0"/>
                <!-- End of inherited attributes from EP_RP -->
                <element name="localAddress" type="nn:IpEndPoint" minOccurs="0"/>
                <element name="remoteAddress" type="nn:IpEndPoint" minOccurs="0"/>
              </all>
            </complexType>
          </element>
          <choice minOccurs="0" maxOccurs="unbounded">
            <element ref="xn:VsDataContainer"/>
          </choice>
        </sequence>
      </extension>
    </complexContent>
  </complexType>
</element>
</schema>

```

## Annex D (normative): JSON definitions for NR NRM

### D.1 General

This annex contains the JSON definitions for the NR and NG-RAN NRM, in accordance with NR and NG-RAN NRM information model definitions specified in clause 4.

### D.2 Architectural features

### D.3 Mapping

#### D.3.1 IOC mapping

Mapping from the IOCs defined in the information model to SS equivalent definitions are listed in the following table.

IOC Name	JSON definitions' Name	JSON Type
GNBDUFunction	gnbDuFunction	object
GNBCUCPFunction	gnbCuCpFunction	object
GNBCUUPFunction	gnbCuUpFunction	object
NRCellCU	nrCellCu	object
NRCellDU	nrCellDu	object
NRSectorCarrier	nrSectorCarrier	object
BWP	bwp	object
EP_E1	ep_E1	object
EP_XnC	ep_XnC	object
EP_XnU	ep_XnU	object
EP_NgC	ep_NgC	object
EP_NgU	ep_NgU	object
EP_F1C	ep_F1C	object
EP_F1U	ep_F1U	object
EP_S1U	ep_S1U	object
EP_X2C	ep_X2C	object
EP_X2U	ep_X2U	object

#### D.3.2 Attributes mapping

Mapping from the attributes of IOCs defined in the information model to SS equivalent definitions are listed in the following table.

Object Attributes	JSON definitions' Name	JSON Type
cellState	cellState	CellState
txDirection	txDirection	TxDirection
bwpContext	BwpContext	bwpContext
isInitialBwp	isInitialBwp	IsInitialBwp
configuredMaxTxPower	configuredMaxTxPower	ConfiguredMaxTxPower
fddCenterFrequencyUL	fddCenterFrequencyUL	FddCenterFrequencyUL
fddCenterFrequencyDL	fddCenterFrequencyDL	FddCenterFrequencyDL
fddbBandwidthUL	fddbBandwidthUL	FddBandwidthUL
fddbBandwidthDL	fddbBandwidthDL	FddBandwidthDL
localAddress	localAddress	IpEndPoint
remoteAddress	remoteAddress	IpEndPoint
gnbId	gnbId	GnbId
gnbDUId	gnbDuId	GnbDUId
gnbCuName	gnbCuName	gnbName
gnbDUName	gnbDuName	gnbName
nCI	nCi	NCi
nrPCI	nrPci	NrPCI
nrTac	nrTac	NrTac
snssaiList	snssaiList	SnssaiList
pointAarfcnULFDD	pointAarfcnULFDD	PointAarfcnULFDD
pointAarfcnDLFDD	pointAarfcnDLFDD	PointAarfcnDLFDD
pointAarfcnTDD	pointAarfcnTDD	PointAarfcnTDD
rrmPolicy	rrmPolicy	RrmPolicy
RRMPolicyRation2	rrmPolicyRation2	RrmPolicyRation2
plmnId	plmnId	PlmnId
plmnIdList	plmnIdList	PlmnIdList

## D.4 Solution Set (SS) definitions

### D.4.1 JSON definition structure

JSON is used as resource representations format carried in the HTTP request and HTTP response message bodies. The properties (key-value pairs) on an object are defined using the properties keyword.

### D.4.2 Graphical representation

The graphical representation is not present in the current version of the present document.

### D.4.3 JSON schema "nrNrm.json"

```
{
  "$schema": "http://json-schema.org/draft-05/schema#",
  "id": "http://3gpp.org/28541/nrNrm.json",
  "description": "JSON based solution set definitions for NR NRM",
  "_referenced_schema": "http://3gpp.org/28623/genericNrm.json",
  "_referenced_schema": "http://3gpp.org/28626/stateManagementNrm.json",
  "_referenced_schema": "http://3gpp.org/28541/ngcNrm.json",
  "definitions": {
    "gnbDuFunction": {
      "type": "object",
      "properties": {
        "userLabel": {
          "type": "string"
        },
        "vnfParametersList": {
          "$ref": "http://3gpp.org/28623/genericNrm.json#/definitions/VnfParametersList"
        },
        "peeParametersList": {
          "$ref": "http://3gpp.org/28623/genericNrm.json#/definitions/PeeParametersList"
        },
        "gnbDuId": {
          "$ref": "#/definitions/GnbDuId"
        }
      }
    }
  }
}
```

```

    },
    "gnbDuName": {
      "$ref": "#/definitions/GnbName"
    },
    "gnbId": {
      "$ref": "#/definitions/GnbId"
    },
    "gnbIdLength": {
      "$ref": "#/definitions/GnbIdLength"
    }
  },
  "required": [
    "userLabel",
    "gnbDuId",
    "gnbId",
    "gnbIdLength"
  ]
},
"gnbCuCpFunction": {
  "type": "object",
  "properties": {
    "userLabel": {
      "type": "string"
    },
    "vnfParametersList": {
      "$ref": "http://3gpp.org/28623/genericNrm.json#/definitions/VnfParametersList"
    },
    "peeParametersList": {
      "$ref": "http://3gpp.org/28623/genericNrm.json#/definitions/PeeParametersList"
    },
    "gnbId": {
      "$ref": "#/definitions/GnbId"
    },
    "gnbIdLength": {
      "$ref": "#/definitions/GnbIdLength"
    },
    "gnbCuName": {
      "$ref": "#/definitions/GnbName"
    },
    "plmnIdList": {
      "$ref": "#/definitions/PlmnIdList"
    }
  },
  "required": [
    "userLabel",
    "gnbId",
    "gnbIdLength",
    "plmnIdList"
  ]
},
"gnbCuUpFunction": {
  "type": "object",
  "properties": {
    "userLabel": {
      "type": "string"
    },
    "vnfParametersList": {
      "$ref": "http://3gpp.org/28623/genericNrm.json#/definitions/VnfParametersList"
    },
    "peeParametersList": {
      "$ref": "http://3gpp.org/28623/genericNrm.json#/definitions/PeeParametersList"
    },
    "gnbId": {
      "$ref": "#/definitions/GnbId"
    },
    "gnbIdLength": {
      "$ref": "#/definitions/GnbIdLength"
    },
    "plmnIdList": {
      "$ref": "#/definitions/PlmnIdList"
    }
  },
  "required": [
    "userLabel",
    "gnbId",

```

```

        "gnbIdLength",
        "plmnIdList"
    ]
},
"nrCellCu": {
    "type": "object",
    "properties": {
        "userLabel": {
            "type": "string"
        },
        "vnfParametersList": {
            "$ref": "http://3gpp.org/28623/genericNrm.json#/definitions/VnfParametersList"
        },
        "nCi": {
            "$ref": "#/definitions/NCi"
        },
        "plmnIdList": {
            "$ref": "#/definitions/PlmnIdList"
        },
        "snssaiList": {
            "$ref": "#/definitions/SnssaiList"
        },
        "rrmPolicyType": {
            "type": "integer"
        },
        "rrmPolicyNSSIId": {
            "$ref": "http://3gpp.org/28623/genericNrm.json#/definitions/Dn"
        },
        "rrmPolicyRatio": {
            "type": "integer"
        },
        "rrmPolicy": {
            "$ref": "#/definitions/RrmPolicy"
        },
        "rrmPolicyRatio2": {
            "$ref": "#/definitions/RrmPolicyRatio2"
        }
    },
    "required": [
        "userLabel",
        "nCI",
        "plmnIdList"
    ]
},
"nrCellDu": {
    "type": "object",
    "properties": {
        "userLabel": {
            "type": "string"
        },
        "vnfParametersList": {
            "$ref": "http://3gpp.org/28623/genericNrm.json#/definitions/VnfParametersList"
        },
        "administrativeState": {
            "$ref":
"http://3gpp.org/28626/stateManagementNrm.json#/definitions/AdministrativeState"
        },
        "operationalState": {
            "$ref":
"http://3gpp.org/28626/stateManagementNrm.json#/definitions/OperationalState"
        },
        "cellState": {
            "$ref": "#/definitions/CellState"
        },
        "nCi": {
            "$ref": "#/definitions/NCi"
        },
        "plmnIdList": {
            "$ref": "#/definitions/PlmnIdList"
        },
        "snssaiList": {
            "$ref": "#/definitions/SnssaiList"
        },
        "nrPci": {
            "$ref": "#/definitions/NrPci"
        },
        "nrTac": {

```

```

        "$ref": "#/definitions/NrTac"
    },
    "arfcnDL": {
        "type": "integer"
    },
    "arfcnUL": {
        "type": "integer"
    },
    "arfcnSUL": {
        "type": "integer"
    },
    "bSChannelBwDL": {
        "type": "integer"
    },
    "bSChannelBwUL": {
        "type": "integer"
    },
    "bSChannelBwSUL": {
        "type": "integer"
    }
    },
    "required": [
        "userLabel",
        "ngi",
        "plmnIdList",
        "nrPci",
        "nrTac",
        "arfcnDL",
        "bSChannelBwDL"
    ]
},
"nrSectorCarrier": {
    "type": "object",
    "properties": {
        "userLabel": {
            "type": "string"
        },
        "vnfParametersList": {
            "$ref": "http://3gpp.org/28623/genericNrm.json#/definitions/VnfParametersList"
        },
        "txDirection": {
            "$ref": "#/definitions/TxDirection"
        },
        "configuredMaxTxPower": {
            "type": "integer"
        },
        "arfcnDL": {
            "type": "integer"
        },
        "arfcnUL": {
            "type": "integer"
        },
        "bSChannelBwDL": {
            "type": "integer"
        },
        "bSChannelBwUL": {
            "type": "integer"
        }
    },
    "required": [
        "userLabel",
        "configuredMaxTxPower",
        "txDirection"
    ]
},
"bwp": {
    "type": "object",
    "properties": {
        "userLabel": {
            "type": "string"
        },
        "vnfParametersList": {
            "$ref": "http://3gpp.org/28623/genericNrm.json#/definitions/VnfParametersList"
        },
        "bwpContext": {
            "$ref": "#/definitions/BwpContext"
        },
        "isInitialBwp": {

```



```

        "$ref": "#/definitions/IsInitialBwp"
    },
    "subCarrierSpacing": {
        "type": "integer"
    },
    "cyclicPrefix": {
        "$ref": "#/definitions/CyclicPrefix"
    },
    "startRB": {
        "type": "integer"
    },
    "numberOfRBs": {
        "type": "integer"
    },
    },
    "required": [
        "userLabel",
        "bwpContext",
        "isInitialBwp",
        "subCarrierSpacing",
        "cyclicPrefix",
        "startRB",
        "numberOfRBs"
    ]
},
"eP_E1": {
    "type": "object",
    "properties": {
        "userLabel": {
            "type": "string"
        },
        "farEndEntity": {
            "type": "string"
        },
        "localAddress": {
            "$ref": "#/definitions/IpEndPoint"
        },
        "remoteAddress": {
            "$ref": "#/definitions/IpEndPoint"
        }
    },
},
"eP_XnC": {
    "type": "object",
    "properties": {
        "userLabel": {
            "type": "string"
        },
        "farEndEntity": {
            "type": "string"
        },
        "localAddress": {
            "$ref": "#/definitions/IpEndPoint"
        },
        "remoteAddress": {
            "$ref": "#/definitions/IpEndPoint"
        }
    },
},
"eP_XnU": {
    "type": "object",
    "properties": {
        "userLabel": {
            "type": "string"
        },
        "farEndEntity": {
            "type": "string"
        },
        "localAddress": {
            "$ref": "#/definitions/IpEndPoint"
        },
        "remoteAddress": {
            "$ref": "#/definitions/IpEndPoint"
        }
    },
},
"eP_NgC": {
    "type": "object",

```

```

    "properties": {
      "userLabel": {
        "type": "string"
      },
      "farEndEntity": {
        "type": "string"
      },
      "localAddress": {
        "$ref": "#/definitions/IpEndPoint"
      },
      "remoteAddress": {
        "$ref": "#/definitions/IpEndPoint"
      }
    },
  },
  "eP_NgU": {
    "type": "object",
    "properties": {
      "userLabel": {
        "type": "string"
      },
      "farEndEntity": {
        "type": "string"
      },
      "localAddress": {
        "$ref": "#/definitions/IpEndPoint"
      },
      "remoteAddress": {
        "$ref": "#/definitions/IpEndPoint"
      }
    },
  },
  "eP_FlC": {
    "type": "object",
    "properties": {
      "userLabel": {
        "type": "string"
      },
      "farEndEntity": {
        "type": "string"
      },
      "localAddress": {
        "$ref": "#/definitions/IpEndPoint"
      },
      "remoteAddress": {
        "$ref": "#/definitions/IpEndPoint"
      }
    },
  },
  "eP_FlU": {
    "type": "object",
    "properties": {
      "userLabel": {
        "type": "string"
      },
      "farEndEntity": {
        "type": "string"
      },
      "localAddress": {
        "$ref": "#/definitions/IpEndPoint"
      },
      "remoteAddress": {
        "$ref": "#/definitions/IpEndPoint"
      }
    },
  },
  "eP_SlU": {
    "type": "object",
    "properties": {
      "userLabel": {
        "type": "string"
      },
      "farEndEntity": {
        "type": "string"
      },
      "localAddress": {
        "$ref": "#/definitions/IpEndPoint"
      },
    },
  },

```

```

        "remoteAddress": {
          "$ref": "#/definitions/IpEndPoint"
        }
      },
    },
    "eP_X2C": {
      "type": "object",
      "properties": {
        "userLabel": {
          "type": "string"
        },
        "farEndEntity": {
          "type": "string"
        },
        "localAddress": {
          "$ref": "#/definitions/IpEndPoint"
        },
        "remoteAddress": {
          "$ref": "#/definitions/IpEndPoint"
        }
      }
    },
    "eP_X2U": {
      "type": "object",
      "properties": {
        "userLabel": {
          "type": "string"
        },
        "farEndEntity": {
          "type": "string"
        },
        "localAddress": {
          "$ref": "#/definitions/IpEndPoint"
        },
        "remoteAddress": {
          "$ref": "#/definitions/IpEndPoint"
        }
      }
    },
    "GnbId": {
      "type": "string",
      "description": "gNBID identifies a gNB within a PLMN."
    },
    "GnbIdLength": {
      "type": "integer",
      "description": "This indicates the number of bits for encoding the gNB ID.",
      "minimum": 22,
      "maximum": 32
    },
    "GnbName": {
      "type": "string",
      "maxLength": 150
    },
    "GnbDuId": {
      "type": "number",
      "description": "GnbDuId represents the NB-DU ID defined in TS 38.473.",
      "minimum": 0,
      "maximum": 68719476735
    },
    "NCi": {
      "type": "object",
      "description": "NCgi uniquely identifies a NR cell within a PLMN.",
      "properties": {
        "plmnId": {
          "$ref": "#/definitions/PlmnId"
        },
        "nCI": {
          "$ref": "#/definitions/NrCellId"
        }
      }
    },
    "SnssaiList": {
      "type": "array",
      "item": {
        "$ref": "#/definitions/Snssai"
      }
    }
  },
}

```

```

    "RrmPolicy": {
      "type": "string",
      "description": "RrmPolicy represents RRM policy which includes guidance for split of
radio resources between multiple slices the cell supports. The RRM policy is implementation
dependent.",
    },
    "IpEndPoint": {
      "type": "object",
      "properties": {
        "ipv4Address": {
          "type": "string"
        },
        "ipv6Address": {
          "type": "string"
        },
        "ipv6Prefix": {
          "type": "string"
        },
        "transport": {
          "type": "string"
        },
        "vlanId": {
          "type": "integer"
        }
      }
    },
    "NrPci": {
      "type": "integer",
      "maximum": 503
    },
    "NrTac": {
      "type": "integer",
      "maximum": 16777215
    },
    "NrCellId": {
      "type": "integer",
      "maximum": 68719476735
    },
    "Sst": {
      "type": "integer",
      "maximum": 255
    },
    "Snssai": {
      "type": "object",
      "properties": {
        "sst": {
          "$ref": "#/definitions/Sst"
        },
        "sd": {
          "type": "string"
        }
      }
    },
    "CellState": {
      "enum": ["IDLE", "INACTIVE", "ACTIVE"]
    },
    "CyclicPrefix": {
      "enum": ["15", "30", "60", "120"]
    },
    "TxDirection": {
      "enum": ["DL", "UL", "DL and UL"]
    },
    "BwpContext": {
      "enum": ["DL", "UL", "SUL"]
    },
    "IsInitialBwp": {
      "enum": ["INITIAL", "OTHER", "SUL"]
    },
    "QuotaType": {
      "enum": ["STRICT", "FLOAT"]
    },
    "RrmPolicyRatio2": {
      "type": "object",
      "properties": {
        "groupId": {
          "type": "integer"
        },
        "sNSSAIList": {

```

```

        "$ref": "#/definitions/SnssaiList"
      },
      "quotaType": {
        "$ref": "#/definitions/QuotaType"
      },
      "rRMPolicyMaxRation": {
        "type": "integer"
      },
      "rRMPolicyMarginMaxRation": {
        "type": "integer"
      },
      "rRMPolicyMinRation": {
        "type": "integer"
      },
      "rRMPolicyMarginMinRation": {
        "type": "integer"
      }
    }
  },
  "Mcc": {
    "type": "string",
    "pattern": "[02-79][0-9][0-9]"
  },
  "Mnc": {
    "type": "string",
    "pattern": "[0-9]{3}|[0-9]{2}"
  },
  "PlmnId": {
    "type": "object",
    "properties": {
      "mcc": {
        "$ref": "#/definitions/Mcc"
      },
      "mnc": {
        "$ref": "#/definitions/Mnc"
      }
    }
  },
  "PlmnIdList": {
    "type": "array",
    "item": {
      "$ref": "#/definitions/PlmnId"
    }
  }
}

```

# Annex E (normative): YANG definitions for NR NRM

## E.1 General

This annex contains the YANG definitions for the NR and NG-RAN NRM, in accordance with NR and NG-RAN NRM information model definitions specified in clause 4.

## E.2 Architectural features

## E.3 Mapping

### E.3.1 IOC mapping

Mapping from the IOCs defined in the information model to SS equivalent definitions are listed in the following table.

IOC Name	YANG definitions' Name	YANG Type
ManagedElement	ManagedElement	Container in module
GNBDUFunction	GNBDUFunction	Container in submodule
GNBCUCPFunction	GNBCUCPFunction	Container in submodule
GNBCUUPFunction	GNBCUUPFunction	Container in submodule
NRCellCU	NRCellCU	Container in submodule
NRCellDU	NRCellDU	Container in submodule
NRSectorCarrier	NRSectorCarrier	Container in submodule
BWP	BWP	Container in submodule
EP_E1	EP_E1	Container in module
EP_XnC	EP_XnC	Container in module
EP_XnU	EP_XnU	Container in module
EP_NgC	EP_NgC	Container in module
EP_NgU	EP_NgU	Container in module
EP_F1C	EP_F1C	Container in module
EP_F1U	EP_F1U	Container in module
EP_S1U	EP_S1U	Container in module
EP_X2C	EP_X2C	Container in module
EP_X2U	EP_X2U	Container in module

NOTE 1: Modularize (include module and submodules) the data model design to be easier to maintain and extend.

NOTE 2: Facilitate the reusability. Technically use grouping statement of YANG to define common node.

NOTE 3: The YANG definitions' Name is identical to object's name in information model.

NOTE 4: Define a ngran module which included/imported other modules/submodules to constitute a completed NG-RAN system. The module augments the ManagedElement IoC to add required ManagedFunctions

NOTE 5: Reflect the class hierarchy in Inheritance view. Define basic IOCs such as Top, ManagedFunction, EP\_RP, etc., and inherit xxxFunction, EP\_xxx, etc., from the parent IOCs.

IOC Name	YANG definitions' Name	YANG Type
NOTE 6: To simplify, only define common IoC in 28.622 [30] as base class, and integrate attributes of common IoCs in 28.620 into the common classes.		

## E.3.2 Attributes mapping

Mapping from the attributes of IOCs defined in the information model to SS equivalent definitions are listed in the following table.

Object Attributes	YANG definitions' Name	YANG Type
Simple Type Attributes	Same to the Name in Stage 2	leaf
Complex Type Attribute	Same to the Name in Stage 2	Reusable Container
Simple Type List	Same to the Name in Stage 2 with removing List/s at the end of the attribute	leaf-list
Complex Type List	Same to the Name in Stage 2 with removing List/s at the end of the attribute	list
NOTE: Basically, use Leaf to define Attributes, and use typedef/grouping to define specific/complex type if required.		

## E.4 Solution Set (SS) definitions

### E.4.1 YANG definition structure

TBD

### E.4.2 Graphical representation

```

module: ngran
  +--rw ManagedElement
    +--ro objectClass          string
    +--ro objectInstance      nrm-type:t_dn
    +--ro id                   nrm-type:t_dn
    +--ro vendorName          string
    +--rw userDefinedState     string
    +--ro swVersion            string
    +--ro dnPrefix             string
    +--rw userLabel            string
    +--ro locationName         string
    +--ro managedBy*           nrm-type:t_dn
    +--ro managedElementTypeList* string
    +--rw GNBDFunction
      +--ro objectClass          string
      +--ro objectInstance      nrm-type:t_dn
      +--ro id                   nrm-type:t_dn
      +--rw userLabel            string
      +--rw vnfParametersList
        +--rw vnfInstanceId      string
        +--rw vnfId              string
        +--rw flavourId          string
        +--rw autoScalable       boolean
      +--rw peeParametersList
        +--rw siteIdentification string
        +--rw siteLatitude       decimal64
        +--rw siteLongitude      decimal64
        +--rw siteDescription    string
        +--rw equipmentType      enumeration
        +--rw environmentType    enumeration
        +--rw powerInterface     enumeration

```

```

+--rw gNBUID                               uint32
+--rw gNBUName                             string
+--ro gNBID                                 uint32
+--ro gNBIDLength                           uint32
+--rw EP_FL_C
| +--ro objectClass                         string
| +--ro objectInstance                     nrm-type:t_dn
| +--rw id                                 nrm-type:t_dn
| +--rw userLabel                           string
| +--rw farEndEntity                       nrm-type:t_dn
| +--rw localAddress
| | +--rw ip_address                       inet:ip-address
| | +--rw vlan_id                         uint16
| +--rw remoteAddress                     inet:ip-address
+--rw EP_FL_U
| +--ro objectClass                         string
| +--ro objectInstance                     nrm-type:t_dn
| +--rw id                                 nrm-type:t_dn
| +--rw userLabel                           string
| +--rw farEndEntity                       nrm-type:t_dn
| +--rw localAddress
| | +--rw ip_address                       inet:ip-address
| | +--rw vlan_id                         uint16
| +--rw remoteAddress                     inet:ip-address
+--rw NRCellDU* [k_nCI]
| +--rw k_nCI                               string
| +--ro objectClass                         string
| +--ro objectInstance                     nrm-type:t_dn
| +--ro id                                 nrm-type:t_dn
| +--rw userLabel                           string
| +--rw vnfParametersList
| | +--rw vnfInstanceId                     string
| | +--rw vnfdId                           string
| | +--rw flavourId                       string
| | +--rw autoScalable                     boolean
| +--rw peeParametersList
| | +--rw siteIdentification               string
| | +--rw siteLatitude                     decimal64
| | +--rw siteLongitude                    decimal64
| | +--rw siteDescription                  string
| | +--rw equipmentType                    enumeration
| | +--rw environmentType                 enumeration
| | +--rw powerInterface                   enumeration
| +--rw nCI                               t_NCI
+--rw pLMNId* [MCC]
| +--rw MCC                               t_mcc
| +--rw MNC                               t_mnc
+--rw s-NSSAI*                             nrm-type:t_s-NSSAI
+--ro operationalState                       nrm-type:t_operationalState
+--rw administrativeState                   nrm-type:t_administrativeState
+--ro cellState                             nrm-type:t_cellState
+--rw nRPCI                                 nrm-type:t_nRPCI
+--rw nRTAC                                 nrm-type:t_tAC
+--rw bsChannelBw                           uint16
+--rw fDDCarrierDL                          uint16
+--rw fDDCarrierUL                          uint16
+--rw tDDCarrier                            uint16
+--rw subcarrierSpacingDL                   nrm-type:t_subcarrierSpacing
+--rw subcarrierSpacingUL                   nrm-type:t_subcarrierSpacing
+--rw cyclicPrefixDL                        nrm-type:t_cyclicPrefix
+--rw cyclicPrefixUL                        nrm-type:t_cyclicPrefix
+--rw fDDBwpCommonCarrierFreqDL            uint16
+--rw fDDBwpCommonCarrierFreqUL            uint16
+--rw fDDBwpCommonChannelBwDL              uint16
+--rw fDDBwpCommonChannelBwUL              uint16
+--rw tDDBwpCommonCarrierFreq              uint16
+--rw tDDBwpCommonChannelBw                uint16
+--rw fDDBwpDedicatedCarrierFreqDL         uint16
+--rw fDDBwpDedicatedCarrierFreqUL        uint16
+--rw fDDBwpDedicatedChannelBwDL           uint16
+--rw fDDBwpDedicatedChannelBwUL          uint16
+--rw tDDBwpDedicatedCarrierFreq           uint16
+--rw tDDBwpDedicatedChannelBw             uint16
+--rw NRSectorCarrier*                     nrm-type:t_dn
+--rw NRSectorCarrier* [sectorEquipmentFunction]
+--ro configuredMaxTxPower                  uint16
+--ro pointAArfcnDLFDD                     uint32
+--ro pointAArfcnULFDD                     uint32

```



```

    +--ro pointAArfcnTDD          uint32
    +--ro fDDBwpTxStartDL        uint16
    +--ro fDDBwpTxStartUL        uint16
    +--ro fDDBwpTxBwDL           uint16
    +--ro fDDBwpTxBwUL           uint16
    +--ro tDDBwpTxStart          uint16
    +--ro tDDBwpTxBw             uint16
    +--rw sectorEquipmentFunction nrm-type:t_dn
+--rw GNBCUCPFunction
  +--ro objectClass              string
  +--ro objectInstance           nrm-type:t_dn
  +--ro id                       nrm-type:t_dn
  +--rw userLabel                string
  +--rw vnfParametersList
    | +--rw vnfInstanceId         string
    | +--rw vnfdId               string
    | +--rw flavourId            string
    | +--rw autoScalable         boolean
  +--rw peeParametersList
    | +--rw siteIdentification   string
    | +--rw siteLatitude         decimal64
    | +--rw siteLongitude        decimal64
    | +--rw siteDescription      string
    | +--rw equipmentType        enumeration
    | +--rw environmentType      enumeration
    | +--rw powerInterface       enumeration
  +--rw gNBCUName                string
  +--ro gNBID                    uint32
  +--ro gNBIDLength              uint32
  +--rw pLMNId* [MCC MNC]
    | +--rw MCC                  t_mcc
    | +--rw MNC                  t_mnc
  +--rw (gNB-type)
    +--:(gNB)
      | +--rw EP-NgC
      | | +--ro objectClass      string
      | | +--ro objectInstance   nrm-type:t_dn
      | | +--ro id                nrm-type:t_dn
      | | +--rw userLabel        string
      | | +--rw farEndEntity     nrm-type:t_dn
      | | +--rw localAddress
      | | | +--rw ip_address     inet:ip-address
      | | | +--rw vlan_id        uint16
      | | +--rw remoteAddress    inet:ip-address
      | +--rw EP-XnC
      | | +--ro objectClass      string
      | | +--ro objectInstance   nrm-type:t_dn
      | | +--ro id                nrm-type:t_dn
      | | +--rw userLabel        string
      | | +--rw farEndEntity     nrm-type:t_dn
      | | +--rw localAddress
      | | | +--rw ip_address     inet:ip-address
      | | | +--rw vlan_id        uint16
      | | +--rw remoteAddress    inet:ip-address
      +--:(en-gNB)
        +--rw EP-X2C
        | +--ro objectClass      string
        | +--ro objectInstance   nrm-type:t_dn
        | +--ro id                nrm-type:t_dn
        | +--rw userLabel        string
        | +--rw farEndEntity     nrm-type:t_dn
        | +--rw localAddress
        | | +--rw ip_address     inet:ip-address
        | | +--rw vlan_id        uint16
        | +--rw remoteAddress    inet:ip-address
  +--rw EP_F1C
  | +--ro objectClass            string
  | +--ro objectInstance         nrm-type:t_dn
  | +--ro id                     nrm-type:t_dn
  | +--rw userLabel              string
  | +--rw farEndEntity           nrm-type:t_dn
  | +--rw localAddress
  | | +--rw ip_address           inet:ip-address
  | | +--rw vlan_id             uint16
  | +--rw remoteAddress          inet:ip-address
+--rw EP_E1
  +--ro objectClass              string
  +--ro objectInstance           nrm-type:t_dn

```

```

| | +-rw id nrm-type:t_dn
| | +-rw userLabel string
| | +-rw farEndEntity nrm-type:t_dn
| | +-rw localAddress
| | | +-rw ip_address inet:ip-address
| | | +-rw vlan_id uint16
| | +-rw remoteAddress inet:ip-address
+--rw NRCellCU* [k_nCI]
| +-rw k_nCI string
| +-ro objectClass string
| +-ro objectInstance nrm-type:t_dn
| +-ro id nrm-type:t_dn
| +-rw userLabel string
| +-rw vnfParametersList
| | +-rw vnfInstanceId string
| | +-rw vnfdId string
| | +-rw flavourId string
| | +-rw autoScalable boolean
| +-rw peeParametersList
| | +-rw siteIdentification string
| | +-rw siteLatitude decimal64
| | +-rw siteLongitude decimal64
| | +-rw siteDescription string
| | +-rw equipmentType enumeration
| | +-rw environmentType enumeration
| | +-rw powerInterface enumeration
| +-rw nCGI t_NCI
| | +-rw pLMNid* [MCC]
| | +-rw MCC t_mcc
| | +-rw MNC t_mnc
| +-rw s-NSSAI* nrm-type:t_s-NSSAI
| +-rw rRMPolicy string
+--rw GNBCUUPFunction
| +-ro objectClass string
| +-ro objectInstance nrm-type:t_dn
| +-ro id nrm-type:t_dn
| +-rw userLabel string
| +-rw vnfParametersList
| | +-rw vnfInstanceId string
| | +-rw vnfdId string
| | +-rw flavourId string
| | +-rw autoScalable boolean
| +-rw peeParametersList
| | +-rw siteIdentification string
| | +-rw siteLatitude decimal64
| | +-rw siteLongitude decimal64
| | +-rw siteDescription string
| | +-rw equipmentType enumeration
| | +-rw environmentType enumeration
| | +-rw powerInterface enumeration
+--ro gNBid uint32
| +-ro gNBidLength uint32
+--rw pLMNid* [MCC MNC]
| +-rw MCC t_mcc
| +-rw MNC t_mnc
+--rw EP_FLU
| +-ro objectClass string
| +-ro objectInstance nrm-type:t_dn
| +-rw id nrm-type:t_dn
| +-rw userLabel string
| +-rw farEndEntity nrm-type:t_dn
| +-rw localAddress
| | +-rw ip_address inet:ip-address
| | +-rw vlan_id uint16
| +-rw remoteAddress inet:ip-address
+--rw EP_E1
| +-ro objectClass string
| +-ro objectInstance nrm-type:t_dn
| +-rw id nrm-type:t_dn
| +-rw userLabel string
| +-rw farEndEntity nrm-type:t_dn
| +-rw localAddress
| | +-rw ip_address inet:ip-address
| | +-rw vlan_id uint16
| +-rw remoteAddress inet:ip-address
+--rw (gNB-type)
| +-rw EP_NgU

```

```

| | +--ro objectClass      string
| | +--ro objectInstance  nrm-type:t_dn
| | +--rw id              nrm-type:t_dn
| | +--rw userLabel      string
| | +--rw farEndEntity    nrm-type:t_dn
| | +--rw localAddress
| | | +--rw ip_address    inet:ip-address
| | | +--rw vlan_id      uint16
| | +--rw remoteAddress  inet:ip-address
+--rw EP_XnU
| | +--ro objectClass      string
| | +--ro objectInstance  nrm-type:t_dn
| | +--rw id              nrm-type:t_dn
| | +--rw userLabel      string
| | +--rw farEndEntity    nrm-type:t_dn
| | +--rw localAddress
| | | +--rw ip_address    inet:ip-address
| | | +--rw vlan_id      uint16
| | +--rw remoteAddress  inet:ip-address
+--:(en-gNB)
+--rw EP_X2U
| | +--ro objectClass      string
| | +--ro objectInstance  nrm-type:t_dn
| | +--rw id              nrm-type:t_dn
| | +--rw userLabel      string
| | +--rw farEndEntity    nrm-type:t_dn
| | +--rw localAddress
| | | +--rw ip_address    inet:ip-address
| | | +--rw vlan_id      uint16
| | +--rw remoteAddress  inet:ip-address
+--rw EP_SlU
| | +--ro objectClass      string
| | +--ro objectInstance  nrm-type:t_dn
| | +--rw id              nrm-type:t_dn
| | +--rw userLabel      string
| | +--rw farEndEntity    nrm-type:t_dn
| | +--rw localAddress
| | | +--rw ip_address    inet:ip-address
| | | +--rw vlan_id      uint16
| | +--rw remoteAddress  inet:ip-address

```

## E.4.3 YANG schema

### E.4.3.1 General type definition "nrm-types-3gpp.yang"

```

module nrm-types-3gpp {

  namespace "urn:3gpp:tsg:sa5:nrm:types";
  prefix "nrm-type";
  import ietf-inet-types { prefix inet; revision-date "2010-09-24"; }
  import ietf-yang-types { prefix yang; revision-date "2010-09-24"; }

  revision 2018-07-31 {
    description
      "Initial revision.";
  }

  typedef t_dn {
    type string;
    description
      "The dn type represents a Distinguish Name of the object.";
  }

  typedef t_mcc {
    description "The mobile country code consists of three decimal digits, The first digit of the
mobile country code identifies the geographic region (the digits 1 and 8 are not used):";
    type string {
      pattern '[02-79][0-9][0-9]';
    }
  }

  typedef t_mnc {

```

```

        description "the mobile network code consists of two or three decimal digits (for example: MNC
of 001 is not the same as MNC of 01)";
        type string {
            pattern '[0-9][0-9][0-9]|[0-9][0-9]';
        }
    }

    grouping pLMNid {
        leaf MCC {
            type t_mcc;
        }
        leaf MNC {
            type t_mnc;
        }
    }

    typedef t_NCI {
        description "The NCI shall be of fixed length of 36 bits and shall be coded using full
hexadecimal representation. The exact coding of the NCI is the responsibility of each PLMN
operator";
        reference "23.003";
        type union {
            type string {
                length 36;
                pattern '[01]*';
            }
            type string {
                length 9;
                pattern '[a-fA-F0-9]*';
            }
        }
    }

    typedef t_operationalState {
        type enumeration {
            enum "Enabled";
            enum "Disabled";
        }
    }

    typedef t_administrativeState {
        type enumeration {
            enum "Locked";
            enum "Shutdown";
            enum "Unlocked";
        }
    }

    typedef t_availabilityStatus {
        type enumeration {
            enum "IN TEST";
            enum "FAILED";
            enum "POWER OFF";
            enum "OFF LINE";
            enum "OFF DUTY";
            enum "DEPENDENCY";
            enum "DEGRADED";
            enum "NOT INSTALLED";
            enum "LOG FULL";
        }
    }

    typedef t_cellState {
        type enumeration {
            enum "Idle";
            enum "Inactive";
            enum "Active";
        }
    }

    typedef t_s-NSSAI {
        type union {
            type uint8;
            type uint32;
        }
    }
}

```

```
typedef t_SST {
    type uint8;
}

typedef t_nRPCI {
    type uint32;
}

typedef t_tAC {
    type union {
        type string {
            length 4;
            pattern '[a-fA-F0-9]*';
        }
        type string {
            length 6;
            pattern '[a-fA-F0-9]*';
        }
    }
}

typedef t_subcarrierSpacing {
    type enumeration {
        enum 15;
        enum 30;
        enum 60;
        enum 120;
    }
}

typedef t_cyclicPrefix {
    type enumeration {
        enum "Normal";
        enum "Extended";
    }
}

typedef t_aMF-Region-id {
    type string {
        length 8;
        pattern '[01]*';
    }
}

typedef t_aMF-Set-id {
    type string {
        length 10;
        pattern '[01]*';
    }
}

typedef t_aMF-Pointer {
    type string {
        length 6;
        pattern '[01]*';
    }
}

grouping aMFI {
    leaf AMF-Region-id {
        type t_aMF-Region-id;
    }
    leaf AMF-Set-id {
        type t_aMF-Set-id;
    }
    leaf AMF-Pointer {
        type t_aMF-Pointer;
    }
}

typedef t_TransportProtocol {
    type enumeration {
        enum "TCP";
        enum "STCP";
        enum "UDP";
    }
}
```

```
    }  
  }  
  
  // type definition especially for core NF  
  
  typedef NFType {  
    type enumeration {  
      enum "NRF";  
      enum "UDM";  
      enum "AMF";  
      enum "SMF";  
      enum "AUSF";  
      enum "NEF";  
      enum "PCF";  
      enum "SMSF";  
      enum "NSSF";  
      enum "UDR";  
      enum "LMF";  
      enum "GMLC";  
      enum "5G_EIR";  
      enum "SEPP";  
      enum "UPF";  
      enum "N3IWF";  
      enum "AF";  
      enum "UDSF";  
      enum "BSF";  
      enum "CHF";  
    }  
  }  
  
  typedef NFStatus {  
    type enumeration {  
      enum "REGISTERED";  
      enum "SUSPENDED";  
    }  
  }  
  
  typedef NotificationType {  
    type enumeration {  
      enum "N1_MESSAGES";  
      enum "N2_INFORMATION";  
      enum "LOCATION_NOTIFICATION";  
    }  
  }  
  
  typedef NotificationEventType {  
    type enumeration {  
      enum "NF_REGISTERED";  
      enum "NF_DEREGISTERED";  
      enum "NF_PROFILE_CHANGED";  
    }  
  }  
  
  typedef DataSetId {  
    type enumeration {  
      enum "SUBSCRIPTION";  
      enum "POLICY";  
      enum "EXPOSURE";  
      enum "APPLICATION";  
    }  
  }  
  
  typedef UPInterfaceType {  
    type enumeration {  
      enum "N3";  
      enum "N6";  
      enum "N9";  
    }  
  }  
  
  typedef N1MessageClass {  
    type enumeration {  
      enum "5GMM";  
      enum "SM";  
      enum "LPP";  
      enum "SMS";  
    }  
  }  
}
```

```
typedef N2InformationClass {
    type enumeration {
        enum "SM";
        enum "NRPPa";
        enum "PWS";
        enum "PWS-BCAL";
        enum "PWS-RF";
    }
}

typedef t_Load {
    description "Latest known load information of the NF ranged from 0 to 100 in percentage ";
    type uint8 {
        range 0..100;
    }
}

typedef SupportedFeatures {
    type string {
        pattern '[A-Fa-f0-9]*';
    }
}

grouping SupiRange {
    leaf start {
        type string;
    }

    leaf end {
        type string;
    }

    leaf pattern {
        type string;
    }
}

grouping IdentityRange {
    leaf start {
        type string;
    }

    leaf end {
        type string;
    }

    leaf pattern {
        type string;
    }
}

grouping Guami {
    container plmnId { uses pLMNid; }
    container amfId { uses aMFI; }
}

grouping Tai {
    container plmnId { uses pLMNid; }
    leaf tac { type t_tAC; }
}

typedef t_Dnn {
    type string;
}

grouping DnnUpfInfoItem {
    leaf dnn {
        type t_Dnn;
    }
}

grouping SnsaiUpfInfoItem {
    leaf sNssai {
        type t_s-NSSAI;
    }

    list dnnUpfInfo {
```

```
        key dnn;
        uses DnnUpfInfoItem;
    }
}

grouping NFServiceVersion {
    description "";
    leaf apiVersionInUri {
        description "";
        type string;
    }

    leaf apiFullVersion {
        type string;
        description "";
    }

    leaf expiry {
        description "";
        type yang:date-and-time;
    }
}

grouping ipEndPoint {
    choice address {
        leaf ipv4Address {
            type inet:ipv4-address;
        }
        leaf ipv6Address {
            type inet:ipv6-address;
        }
        leaf ipv6Prefix {
            type inet:ipv6-prefix;
        }
    }

    leaf transport {
        type t_TransportProtocol;
    }

    leaf port {
        type uint16;
    }
}

grouping defaultNotificationSubscription {

    leaf notificationType {
        type NotificationType;
    }

    leaf callbackUri {
        type inet:uri;
    }

    leaf n1MessageClass {
        type N1MessageClass;
    }

    leaf n2InformationClass {
        type N2InformationClass;
    }
}

grouping InterfaceUpfInfoItem {

    leaf interfaceType {
        type UPInterfaceType;
    }

    choice address {
        leaf ipv4Address {
            type inet:ipv4-address;
        }
        leaf ipv6Address {
            type inet:ipv6-address;
        }
    }
}
```



```
    }
    leaf ipv6Prefix {
      type inet:ipv6-prefix;
    }
    leaf endpointFqdn {
      type inet:domain-name;
    }
  }

  leaf networkInstance {
    type string;
  }
}

grouping Ipv4AddressRange {
  leaf start {
    type inet:ipv4-address;
  }
  leaf end {
    type inet:ipv4-address;
  }
}

grouping Ipv6PrefixRange {
  leaf start {
    type inet:ipv6-prefix;
  }
  leaf end {
    type inet:ipv6-prefix;
  }
}

typedef t_NsiId {
  type string;
}

typedef t_uEMobilityLevel {
  type enumeration {
    enum "stationary";
    enum "nomadic";
    enum "restricted mobility";
    enum "fully mobility";
  }
}

typedef t_resourceSharingLevel {
  type enumeration {
    enum "shared";
    enum "not-shared";
  }
}

typedef TxDirection {
  type enumeration {
    enum "DL";
    enum "UL";
    enum "DL and UL";
  }
}

typedef BwpContext {
  type enumeration {
    enum "DL";
    enum "UL";
    enum "SUL";
  }
}

typedef IsInitialBwp {
  type enumeration {
    enum "INITIAL";
    enum "OTHER";
  }
}

typedef t_quotaType {
  type enumeration {
```

```

        enum "strict";
        enum "float";
    }
}

grouping RRMPolicyRatio2{
    leaf groupId {
        type uint16;
    }
    leaf-list sNSSAI {
        type t_s-NSSAI;
    }
    leaf quotaType {
        type t_quotaType;
    }
    leaf rRMPolicyMaxRation {
        type uint8;
    }
    leaf rRMPolicyMarginMaxRation {
        type uint8;
    }
    leaf rRMPolicyMinRation {
        type uint8;
    }
    leaf rRMPolicyMarginMinRation {
        type uint8;
    }
}
}
}

```

#### E.4.3.2 Basic IOC definition which can be reused by specific ManagedFuncion. "Top.yang", "ManagedElement.yang", "ManagedFunction.yang", "EP\_RP.yang", "Subnetwork.yang", "vsDataContainer.yang", "MeContext.yang", "ManagementNode.yang"

```

module Top {
    namespace "urn:3gpp:tsg:sa5:nrm:Top";
    prefix "top";
    import nrm-types-3gpp { prefix nrm-type; revision-date "2018-07-31"; }
    organization "3gpp SA5";
    description "root class to be inherited/reused by other child class including ME, MF, EP, etc.";
    reference "28.622";

    revision 2018-07-31 {
        description "Initial revision";
    }

    grouping Top {
        leaf objectClass {
            mandatory "true";
            config "false";
            description "";
            type string;
        }
        leaf objectInstance {
            mandatory "true";
            config "false";
            description "";
            type nrm-type:t_dn;
        }

        description "";
    }
}

module SubNetwork {
    namespace "urn:3gpp:tsg:sa5:nrm:SubNetwork";
    prefix "subnet";
    import nrm-types-3gpp { prefix nrm-type; revision-date "2018-07-31"; }
    import Top { prefix top; revision-date "2018-07-31"; }
    import VsDataContainer {prefix vsData; revision-date "2018-12-18"; }
    organization "3gpp SA5";
}

```

```

description "define basic SubNetwork which will be augmented by other IOCs";

revision 2018-07-31 {
    description "Initial revision";
}

grouping SubNetwork {
    uses top:Top;
    leaf id {
        mandatory "true";
        config "false";
        description "derived from top_";
        type nrm-type:t_dn;
    }
    leaf dnPrefix {
        mandatory "true";
        config "false";
        description "derived from domain_";
        type string;
    }

    leaf userLabel {
        description "derived from domain_";
        mandatory "true";
        config "true";
        type string;
    }
    leaf userDefinedNetworkType {
        description "derived from domain_";
        mandatory "true";
        config "true";
        type string;
    }

    }
    leaf-list setOfMcc {
        min-elements "0";
        description "";

        config "false";
        type nrm-type:t_mcc;
    }

    }
    list vsDataContainer {
        min-elements "0";
        uses vsData:VsDataContainer;
    }
}

container SubNetwork {
    uses SubNetwork;
}

}

module ManagedElement {
    namespace "urn:3gpp:tsg:sa5:nrm:ManagedElement";
    prefix "me";
    import nrm-types-3gpp { prefix nrm-type; revision-date "2018-07-31"; }
    import Top { prefix top; revision-date "2018-07-31"; }
    import VsDataContainer {prefix vsData; revision-date "2018-12-18"; }
    organization "3gpp SA5";
    description "define basic ManagedElement which will be augmented by other IOCs";

    revision 2018-07-31 {
        description "Initial revision";
    }

    grouping ManagedElement {
        uses top:Top;
        leaf id {
            mandatory "true";
            config "false";
            description "";
            type nrm-type:t_dn;
        }
        leaf vendorName {
            mandatory "true";
            config "false";
        }
    }
}

```

```

        description "";
        type string;
    }
    leaf userDefinedState {
        mandatory "true";
        config "true";
        description "";
        type string;
    }
    leaf swVersion {
        mandatory "true";
        config "false";
        description "";
        type string;
    }
    leaf dnPrefix {
        mandatory "true";
        config "false";
        description "";
        type string;
    }
    leaf userLabel {
        description "";
        mandatory "true";
        config "true";
        type string;
    }
    leaf locationName {
        mandatory "true";
        config "false";
        type string;
    }
    leaf-list managedBy {
        description "";
        config "false";
        type nrm-type:t_dn;
    }
    leaf-list managedElementTypeList {
        min-elements "1";
        config "false";
        description "";
        type string;
    }
    list vsDataContainer {
        min-elements "0";
        uses vsData:VsDataContainer;
    }
}
}
}

```

```

module ManagedFunction {
    namespace "urn:3gpp:tsg:sa5:nrm:ManagedFunction";
    prefix "mf";
    import Top { prefix top; revision-date "2018-07-31"; }
    import nrm-types-3gpp { prefix nrm-type; revision-date "2018-07-31"; }
    import VsDataContainer {prefix vsData; revision-date "2018-12-18"; }
    description "common/basic MF class to be inherited/reused by other child MF classes ";

    revision 2018-07-31 {
        description "Initial revision";
    }

    grouping ManagedFunction {
        description "";

        uses top:Top;
        leaf id {
            description "";
            mandatory "true";
            config "false";
            type nrm-type:t_dn;
        }
        leaf userLabel {
            mandatory "false";
            config "true";
            type string;
        }
    }
}

```

```

    }
    container vnfParametersList {
      description "It shall be supported if the MF instance is realized by one or more VNF
instance(s). Otherwise this attribute shall be absent ";
      leaf vnfInstanceId {
        mandatory "true";
        type string;
      }
      leaf vnfdId {
        type string;
      }
      leaf flavourId {
        description "Identifier of the VNF Deployment Flavour applied to this VNF instance";
        reference "clause 9.4.3 of ETSI GS NFV-IFA 008 ";
        type string;
      }
      leaf autoScalable {
        description "Indicator of whether the auto-scaling of this VNF instance is enabled
or disabled. The type is Boolean";
        type boolean;
      }
    }
    container peeParametersList {
      description "It shall be supported if the control and monitoring of PEE parameters is
supported by the ManagedFunction or sub-class instance.";
      leaf siteIdentification {
        mandatory "true";
        description "The identification of the site where the ManagedFunction resides.";
        type string;
      }
      leaf siteLatitude {
        description "The latitude of the site where the ManagedFunction instance resides,
based on World Geodetic System (1984 version) global referenceframe (WGS 84). Positive values
correspond to the northern hemisphere. This attribute is optional in case of BTSFunction and
RNCFUNCTION instance(s). allowedValues: -90.0000 to +90.0000 ";
        when "contains(..../objectClass,'BTSFunction') or
contains(..../objectClass,'RNCFUNCTION')";
        type decimal64 {
          fraction-digits 4;
          range "-90.0000 .. 90.0000";
        }
      }
      leaf siteLongitude {
        description "The longitude of the site where the ManagedFunction instance resides,
based on World Geodetic System (1984 version) global reference frame (WGS 84). Positive values
correspond to degrees east of 0 degrees longitude. This attribute is optional in case of BTSFunction
and RNCFUNCTION instance(s). allowedValues: -180.0000to +180.0000 ";
        when "contains(..../objectClass,'BTSFunction') or
contains(..../objectClass,'RNCFUNCTION')";
        type decimal64 {
          fraction-digits 4;
          range "-180.0000 .. 180.0000";
        }
      }
      leaf siteDescription {
        mandatory "true";
        description "An operator defined description of the site where the ManagedFunction
instance resides.";
        type string;
      }
      leaf equipmentType {
        mandatory "true";
        description "The type of equipment where the managedFunction instance resides.
allowedValues: see clause 4.4.1 of ETSI ES 202 336-12 [18]. ";
        type enumeration {
          enum RRU;
          enum BBU;
          enum Wide-area-BS-cabinet;
          enum Medium-range-BS;
        }
      }
      leaf environmentType {
        mandatory "true";
        description "The type of environment where the managedFunction instance resides.
allowedValues: see clause 4.4.1 of ETSI ES 202 336-12 [18]. ";
        type enumeration {
          enum Indoor;
          enum Outdoor;
        }
      }
    }
  }

```

```

    }
    leaf powerInterface {
        mandatory "true";
        description "The type of power. allowedValues: see clause 4.4.1 of ETSI ES202 336-12
[18]. ";
        type enumeration {
            enum AC;
            enum DC;
        }
    }
}
list vsDataContainer {
    min-elements "0";
    uses vsData:VsDataContainer;
}
}
}

```

```

module EP_RP {
    namespace "urn:3gpp:tsg:sa5:nrm:EP_RP";
    prefix "ep-rp";

    import Top { prefix top; revision-date "2018-07-31"; }
    import nrm-types-3gpp { prefix nrm-type; revision-date "2018-07-31"; }
    import ietf-inet-types { prefix inet; revision-date "2010-09-24"; }
    import VsDataContainer {prefix vsData; revision-date "2018-12-18"; }
    description "common/basic MF class to be inherited/reused by other child MF classes ";

    revision 2018-07-31 {
        description "Initial revision";
    }

    grouping local-address {
        leaf ip_address {
            type inet:ip-address;
        }
        leaf vlan_id {
            type uint16;
        }
    }

    grouping EP_RP {
        description "";
        uses top:Top;
        leaf id {
            description "";
            mandatory "true";
            type nrm-type:t_dn;
        }
        leaf userLabel {
            description "";
            mandatory "false";
            type string;
        }
        leaf farEndEntity {
            mandatory "false";
            type nrm-type:t_dn;
        }
        list vsDataContainer {
            min-elements "0";
            uses vsData:VsDataContainer;
        }
    }

    grouping EP_XX {
        description "as all EPs defined in NGRAN and 5GC have same attributes, define a common EP
for all endpoints for reusing";
        uses EP_RP;
        container localAddress {
            presence "true";
            description "";
            uses local-address;
        }
        leaf remoteAddress {
            description "";
            mandatory "false";

```

```
        type inet:ip-address;
    }
}

grouping EP_E1 {
    description "";
    uses EP_XX;
}

grouping EP_F1C {
    description "";
    uses EP_XX;
}

grouping EP_F1U {
    description "";
    uses EP_XX;
}

grouping EP_XnC {
    description "";
    uses EP_XX;
}

grouping EP_XnU {
    description "";
    uses EP_XX;
}

grouping EP_NgC {
    description "";
    uses EP_XX;
}

grouping EP_NgU {
    description "";
    uses EP_XX;
}

grouping EP_X2C {
    description "";
    uses EP_XX;
}

grouping EP_X2U {
    description "";
    uses EP_XX;
}

grouping EP_S1U {
    description "";
    uses EP_XX;
}

grouping EP_N2 {
    description "";
    uses EP_XX;
}

grouping EP_N3 {
    description "";
    uses EP_XX;
}

grouping EP_N4 {
    description "";
    uses EP_XX;
}

grouping EP_N5 {
    description "";
    uses EP_XX;
}

grouping EP_N6 {
    description "";
    uses EP_XX;
}
}
```

```
grouping EP_N7 {
    description "";
    uses EP_XX;
}

grouping EP_N8 {
    description "";
    uses EP_XX;
}

grouping EP_N9 {
    description "";
    uses EP_XX;
}

grouping EP_N10 {
    description "";
    uses EP_XX;
}

grouping EP_N11 {
    description "";
    uses EP_XX;
}

grouping EP_N12 {
    description "";
    uses EP_XX;
}

grouping EP_N13 {
    description "";
    uses EP_XX;
}

grouping EP_N14 {
    description "";
    uses EP_XX;
}

grouping EP_N15 {
    description "";
    uses EP_XX;
}

grouping EP_N16 {
    description "";
    uses EP_XX;
}

grouping EP_N17 {
    description "";
    uses EP_XX;
}

grouping EP_N20 {
    description "";
    uses EP_XX;
}

grouping EP_N21 {
    description "";
    uses EP_XX;
}

grouping EP_N22 {
    description "";
    uses EP_XX;
}

grouping EP_N26 {
    description "";
    uses EP_XX;
}

grouping EP_S5C {
    description "";
}
```



```

    uses EP_XX;
}

grouping EP_S5U {
    description "";
    uses EP_XX;
}

grouping EP_Rx {
    description "";
    uses EP_XX;
}

grouping EP_MAP_SMSC {
    description "";
    uses EP_XX;
}

grouping EP_NLS {
    description "";
    uses EP_XX;
}

grouping EP_NLG {
    description "";
    uses EP_XX;
}

grouping EP_N27 {
    description "";
    uses EP_XX;
}

grouping EP_N31 {
    description "";
    uses EP_XX;
}

grouping EP_N32 {
    description "";
    uses EP_XX;
}

grouping EP_SBI_X {
    description "It's used for the services consumed by the control plane function. Far entity
and remoteAddress are required for this endpoint";
    uses EP_XX;
    leaf-list sBIService {
        min-elements "1";
        config "false";
        type string;
    }
}

grouping EP_SBI_IPX {
    description "It's used for the SEPP services consumed by the control plane function. Far
entity and remoteAddress are required for this endpoint";
    uses EP_XX;
    leaf-list sBIService {
        min-elements "1";
        config "false";
        type string;
    }
}

grouping SAP {
    leaf dn {
        type inet:domain-name;
    }
    leaf port {
        type uint16;
    }
}

grouping EP_NBI_X {
    description "The service access point of the control plane function. It's used for the
services (including SEPP service) provided by the control plane function. Far entity and remoteAddress
are necessary for this endpoint ";

```

```

    uses EP_RP;
    container localsAP {
        presence "true";
        description "";
        uses SAP;
    }
    leaf-list sBIService {
        min-elements "1";
        config "false";
        type string;
    }
}

module ManagementNode {
    namespace "urn:3gpp:tsg:sa5:nrm:ManagedElement";
    prefix "managementNode";
    import nrm-types-3gpp { prefix nrm-type; revision-date "2018-07-31"; }
    import Top { prefix top; revision-date "2018-07-31"; }
    import VsDataContainer {prefix vsData; revision-date "2018-12-18"; }
    organization "3gpp SA5";

    revision 2018-12-18 {
        description "15.1.0";
    }

    container ManagementNode {
        uses top:Top;
        leaf id {
            mandatory "true";
            config "false";
            description "";
            type nrm-type:t_dn;
        }
        leaf userLabel {
            description "";
            mandatory "true";
            config "true";
            type string;
        }
        leaf-list managedElements {
            description "";
            config "false";
            type nrm-type:t_dn;
        }
        leaf vendorName {
            mandatory "true";
            config "false";
            description "";
            type string;
        }
        leaf locationName {
            mandatory "true";
            config "false";
            type string;
        }
        leaf userDefinedState {
            mandatory "true";
            config "true";
            description "";
            type string;
        }
        leaf swVersion {
            mandatory "true";
            config "false";
            description "";
            type string;
        }
        list vsDataContainer {
            min-elements "0";
            uses vsData:VsDataContainer;
        }
    }
}

module MeContext {
    namespace "urn:3gpp:tsg:sa5:nrm:MeContext";
    prefix "meContext";

```

```

import nrm-types-3gpp { prefix nrm-type; revision-date "2018-07-31"; }
import Top { prefix top; revision-date "2018-07-31"; }
organization "3gpp SA5";

revision 2018-12-18 {
    description "Initial Version";
}

container MeContext {
    uses top:Top;
    leaf id {
        mandatory "true";
        config "false";
        description "derived from top_";
        type nrm-type:t_dn;
    }
    leaf dnPrefix {
        mandatory "true";
        config "false";
        description "derived from domain_";
        type string;
    }
}

}

module VsDataContainer {
    namespace "urn:3gpp:tsg:sa5:nrm::VsDataContainer";
    prefix "vsData";
    import Top { prefix top; revision-date "2018-07-31"; }
    import nrm-types-3gpp { prefix nrm-type; revision-date "2018-07-31"; }

    revision 2018-12-18 {
        description "Initial revision";
    }
    grouping VsDataContainer {
        uses top:Top;
        leaf id {
            mandatory "true";
            config "false";
            description "derived from top_";
            type nrm-type:t_dn;
        }
        leaf vsDataType {
            mandatory "true";
            config "true";
            description "";
            type string;
        }
        leaf vsDataFormatVersion {
            mandatory "true";
            config "false";
            description "";
            type string;
        }
        anydata vsData;
        list vsDataContainer {
            min-elements "0";
            uses VsDataContainer;
        }
    }
}
}

```

### E.4.3.3 NGRAN, composition of all gNB ManagedFunctions in "ngran.yang"

```

module ngran {

    namespace "urn:3gpp:tsg:sa5:nrm:ngran";
    prefix "ngran";

    import ManagedElement { prefix me; revision-date "2018-07-31"; }

    include ngran-nRCellCU;
    include ngran-nRCellDU;
    include ngran-nRSectorCarrier;
    include ngran-gNBDFFunction;
    include ngran-gNBCUCPFunction;
}

```

```

include ngran-gNBCUUPFunction;

organization "3gpp SA5";
description "Main YANG module for the NRM NG-RAN Defined gNB as ManagedElement
(subclass of ME) for overaching all other functions supported
nggran Define constituted MFs and EPs as container in submodule";

revision 2018-07-27 {
    description "15.0.2";
}

container ManagedElement {
    description "list constituted MF and EP below, let's discuss if umbrella ManagedElement
needed for NR
    if it's not required, we can just remove the me and keep the container below";
    uses me:ManagedElement;
    list GNBDUFunction { uses GNBDUFunction; }
    list GNBCUCPFunction { uses GNBCUCPFunction; }
    list GNBCUUPFunction { uses GNBCUUPFunction; }
}
}

```

#### E.4.3.4 NGRAN submodule, "nggran-gNBCUCPFunction.yang"

```

submodule ngran-gNBCUCPFunction {

    belongs-to ngran { prefix ngran; }

    import EP_RP { prefix ep-rp; revision-date "2018-07-31"; }
    import ManagedFunction { prefix mf; revision-date "2018-07-31"; }
    import nrm-types-3gpp { prefix nrm-type; revision-date "2018-07-31"; }

    include ngran-nRCellCU;

    description "GNBCUCPFunction derived from basic ManagedFunction, for 3 split deployment mode
only";

    revision 2018-08-02 {
        description "15.0.2";
    }

    grouping GNBCUCPFunction {
        uses mf:ManagedFunction;

        leaf gNBCUName {
            description "PrintableString(SIZE(1..150,))";
            mandatory "false";
            config "true";
            type string {
                length "1..150";
            }
        }
        leaf gNBId {
            description "It identifies a gNB within a PLMN. See gNB Identifier (gNB ID) of
subclause 8.2 of 3GPP TS 38.300 [3]). See Global gNB ID in subclause 9.3.1.6 of 3GPP TS 38.413 [5].
";
            mandatory "true";
            config "false";
            type uint32;
        }
        leaf gNBIdLength {
            description "It indicates the number of bits for encoding the gNB ID.";
            mandatory "true";
            config "false";
            type uint32 {
                range "22..32";
            }
        }
    }

    list pLMNId {
        min-elements "1";
        description "a list of PLMN-Id, PLMN-Id= Mobile Country Codes (MCC)|| Mobile Network
Codes(MNC) ";
        config "true";
        key "MCC MNC";
        uses nrm-type:pLMNId;
    }
}

```

```

    choice gNB-type {
      case gNB {
        list EP-NgC { uses ep-rp:EP_NgC; }
        list EP-XnC { uses ep-rp:EP_XnC; }
      }
      case en-gNB {
        container EP-X2C { uses ep-rp:EP_X2C; }
      }
    }

    list EP_F1C { uses ep-rp:EP_F1C; }
    list EP_E1 { uses ep-rp:EP_E1; }

    list NRCellCU { uses NRCellCU; }
  }
}

```

### E.4.3.5 NGRAN submodule, "ngran-gNBCUUPFunction.yang"

```

submodule ngran-gNBCUUPFunction {

  belongs-to ngran { prefix ngran; }

  import EP_RP { prefix ep-rp; revision-date "2018-07-31"; }
  import ManagedFunction { prefix mf; revision-date "2018-07-31"; }
  import nrm-types-3gpp { prefix nrm-type; revision-date "2018-07-31"; }

  description "GNBCUUPFunction derived from basic ManagedFunction, for 3 split deployment mode
  only";

  revision 2018-08-02 {
    description "15.0.2";
  }

  grouping GNBCUUPFunction {
    uses mf:ManagedFunction;

    leaf gNBId {
      description "It identifies a gNB within a PLMN. See gNB Identifier (gNB ID) of
      subclause 8.2 of 3GPP TS 38.300 [3]). See Global gNB ID in subclause 9.3.1.6 of 3GPP TS 38.413 [5].
      ";
      mandatory "true";
      config "false";
      type uint32;
    }
    leaf gNBIdLength {
      description "It indicates the number of bits for encoding the gNB ID.";
      mandatory "true";
      config "false";
      type uint32 {
        range "22..32";
      }
    }
  }

  list pLMNId {
    description "a list of PLMN-Id, PLMN-Id= Mobile Country Codes (MCC)|| Mobile Network
    Codes(MNC) ";
    config "true";
    key "MCC MNC";
    uses nrm-type:pLMNId;
  }
  list EP_F1U { uses ep-rp:EP_F1U; }
  container EP_E1 { uses ep-rp:EP_E1; }
  choice gNB-type {
    case gNB {
      list EP_NgU { uses ep-rp:EP_NgU; }
      list EP_XnU { uses ep-rp:EP_XnU; }
    }
    case en-gNB {
      list EP_X2U { uses ep-rp:EP_X2U; }
      list EP_S1U { uses ep-rp:EP_S1U; }
    }
  }
}

```

}

### E.4.3.6 NGRAN submodule, "ngran-gNBDUFunction.yang"

```

submodule ngran-gNBDUFunction {
    belongs-to ngran { prefix ngran; }

    import EP_RP { prefix ep-rp; revision-date "2018-07-31"; }
    import ManagedFunction { prefix mf; revision-date "2018-07-31"; }

    include ngran-nRCellDU;
    include ngran-nRSectorCarrier;

    description "GNBDUFunction derived from basic ManagedFunction, for 3 split deployment mode
only";

    revision 2018-08-02 {
        description "15.0.2";
    }

    grouping GNBDUFunction {
        uses mf:ManagedFunction;

        leaf gNBIDid {
            description "It uniquely identifies the DU at least within a gNB. See gNB-DU ID in
subclause 9.3.1.9 of 3GPP TS 38.473 ";
            mandatory "true";
            config "true";
            type uint32;
        }
        leaf gNBDUName {
            description "PrintableString(SIZE(1..150,))";
            mandatory "false";
            config "true";
            type string {
                length "1..150";
            }
        }
        leaf gNBId {
            description "It identifies a gNB within a PLMN. See gNB Identifier (gNB ID) of
subclause 8.2 of 3GPP TS 38.300 [3]). See Global gNB ID in subclause 9.3.1.6 of 3GPP TS 38.413 [5].
";
            mandatory "true";
            config "false";
            type uint32;
        }
        leaf gNBIdLength {
            description "It indicates the number of bits for encoding the gNB ID.";
            mandatory "true";
            config "false";
            type uint32 {
                range " 22..32";
            }
        }
    }

    container EP_F1C { uses ep-rp:EP_F1C; }
    list EP_FLU { uses ep-rp:EP_FLU; }

    list NRCellDU {
        uses NRCellDU;
    }
    list NRSectorCarrier {
        uses NRSectorCarrier;
    }
    list BWP {
        uses BWP;
    }
}

```

### E.4.3.7 NGRAN submodule, "ngran-nRCellCU.yang"

```

submodule ngran-nRCellCU {

```

```

belongs-to ngran { prefix ngran; }

import ManagedFunction { prefix mf; revision-date "2018-07-31"; }
import nrm-types-3gpp { prefix nrm-type; revision-date "2018-07-31"; }

description "NRCellCU derived from basic ManagedFunction";

revision 2018-08-02 {
  description "Initial revision";
}

grouping NRCellCU {
  uses mf:ManagedFunction;

  leaf nCI {
    config "true";
    description "It uniquely identifies a NR cell within a PLMN.";
    reference "See NR Cell identifier (NCI) subclause 8.2 of 3GPP
              TS 38.300 [3].";
    type nrm-type:t_NCI;
  }

  list pLMNId {
    min-elements "1";
    description "a list of PLMN-Id, PLMN-Id= Mobile Country Codes (MCC)|| Mobile Network
Codes(MNC) ";
    config "true";
    key MCC;
    uses nrm-type:pLMNId;
  }

  leaf-list s-NSSAI {
    min-elements "0";
    config "true";
    description "It represents the list of S-NSSAI the managed object is capable of
supporting, an S-NSSAI is comprised of a SST (Slice/Service
type) and an optional SD (Slice Differentiator) field, (Ref. 3GPPTS 23.003
[13]). ";
    reference "3GPP TS 23.003";
    type nrm-type:t_s-NSSAI;
  }

  leaf rRMPolicyType {
    config "true";
    type uint16;
  }

  leaf rRMPolicyNSSIId {
    config "true";
    type nrm-type:t_dn;
  }

  leaf rRMPolicyRatio {
    config "true";
    type uint8 { range 0..100; }
  }

  leaf rRMPolicy {
    description "It represents RRM policy which includes guidance for split of radio
resources between multiple slices the cell supports. The RRM policy is implementation dependent.";
    config "true";
    type string;
  }

  container rRMPolicyRatio2 {
    presence "true";
    config "true";
    uses nrm-type:RRMPolicyRatio2;
  }
}
}

```

#### E.4.3.8 NGRAN submodule, "ngran- nRCellDU.yang"

```

submodule ngran-nRCellDU {
  belongs-to ngran { prefix ngran; }

```

```

import ManagedFunction { prefix mf; revision-date "2018-07-31"; }
import nrm-types-3gpp { prefix nrm-type; revision-date "2018-07-31"; }

description "NRCellDU derived from basic ManagedFunction";

revision 2018-08-02 {
  description "Initial revision";
}

grouping NRCellDU {
  uses mf:ManagedFunction;

  leaf nCI {
    config "true";
    description "It uniquely identifies a NR cell within a PLMN.";
    reference "See NR Cell identifier (NCI) subclause 8.2 of 3GPP TS 38.300 [3].";
    type nrm-type:t_NCI;
  }

  list pLMNId {
    min-elements "1";
    description "a list of PLMN-Id, PLMN-Id= Mobile Country Codes (MCC)|| Mobile Network
Codes(MNC) ";
    config "true";
    key MCC;
    uses nrm-type:pLMNId;
  }

  leaf-list s-NSSAI {
    min-elements "0";
    config "true";
    type nrm-type:t_s-NSSAI;
  }

  leaf operationalState {
    config "false";
    description "CM, It indicates the operational state of the NRCellDU instance. It
describes whether the resource is installed and partially or fully operable (Enabled) or the
resource is not installed or not operable (Disabled).";
    type nrm-type:t_operationalState;
  }

  leaf administrativeState {
    description "CM, It indicates the administrative state of the NRCellDU. It describes the
permission to use or prohibition against using the cell, imposed through the OAM services.";
    config "true";
    type nrm-type:t_administrativeState;
  }

  leaf cellState {
    description "It indicates the usage state of the NRCellDU instance. It describes whether
the cell is not currently in use (Idle), or currently in use but not configured to carry traffic
(Inactive) or is currently in use and is configured to carry traffic (Active)";
    mandatory "true";
    config "false";
    type nrm-type:t_cellState;
  }

  leaf nRPCI {
    description "";
    mandatory "true";
    config "true";
    type nrm-type:t_nRPCI;
  }

  leaf nRTAC {
    mandatory "true";
    config "true";
    type nrm-type:t_tAC;
  }

  leaf arfcnDL {
    mandatory "true";
    config "true";
    type uint32;
  }

  leaf arfcnUL {
    config "true";
    type uint32;
  }

  leaf arfcnSUL {
    config "true";
    type uint32;
  }
}

```



```

    }
    leaf bSChannelBwDL {
        mandatory "true";
        config "true";
        type uint32;
    }
    leaf bSChannelBwUL {
        config "true";
        type uint32;
    }
    leaf bSChannelBwSUL {
        config "true";
        type uint32;
    }
    }

    //refer to nRSectorCarrier
    leaf-list NRSectorCarrier {
        min-elements "0";
        description "";
        config "true";
        type nrm-type:t_dn;
    }
    //refer to bwp
    leaf-list bWP {
        min-elements "0";
        description "";
        config "true";
        type nrm-type:t_dn;
    }
    }
}

```

### E.4.3.9 NGRAN submodule, "ngran-nRSectorCarrier.yang"

```

submodule ngran-nRSectorCarrier {

    belongs-to ngran { prefix ngran; }

    import nrm-types-3gpp { prefix nrm-type; revision-date "2018-07-31"; }
    import ManagedFunction { prefix mf; revision-date "2018-07-31"; }

    description "NRSectorCarrier";

    revision 2018-08-02 {
        description "Initial revision";
    }

    grouping NRSectorCarrier {
        description "";
        uses mf:ManagedFunction;

        leaf txDirection {
            mandatory "true";
            config "true";
            type nrm-type:TxDirection;
        }
        leaf configuredMaxTxPower {
            mandatory "true";
            config "false";
            description "";
            type uint16;
        }
        leaf arfcnDL {
            config "true";
            type uint32;
        }
        leaf arfcnUL {
            config "true";
            type uint32;
        }
        leaf bSChannelBwDL {
            config "true";
            type uint32;
        }
        leaf bSChannelBwUL {
            config "true";
            type uint32;
        }
    }
}

```

```
    leaf sectorEquipmentFunction {
      mandatory "true";
      config "true";
      description "fqBand for NR should be defined";
      reference "23.622";
      type nrm-type:t_dn;
    }
  }
}
```

### E.4.3.10 NGRAN submodule, "ngran-bWP.yang"

```
submodule ngran-bWP {
  belongs-to ngran { prefix ngran; }

  import nrm-types-3gpp { prefix nrm-type; revision-date "2018-07-31"; }
  import ManagedFunction { prefix mf; revision-date "2018-07-31"; }

  description "BWP";

  revision 2018-09-28 {
    description "Initial revision";
  }

  grouping BWP {
    description "";
    uses mf:ManagedFunction;

    leaf bwpContext {
      mandatory "true";
      config "true";
      type nrm-type:BwpContext;
    }
    leaf isInitialBwp {
      mandatory "true";
      config "false";
      description "";
      type nrm-type:IsInitialBwp;
    }
    leaf subCarrierSpacing {
      mandatory "true";
      config "true";
      type uint32;
    }
    leaf cyclicPrefix {
      mandatory "true";
      config "true";
      type nrm-type:t_cyclicPrefix;
    }
    leaf startRB {
      mandatory "true";
      config "true";
      type uint32;
    }
    leaf numberOfRBs {
      mandatory "true";
      config "true";
      type uint32;
    }
  }
}
```

---

## Annex F (normative): XML definitions for 5GC NRM

### F.1 General

This annex contains the XML definitions for the 5GC NRM, in accordance with 5G NRM Information Model definitions specified in clause 4.

---

### F.2 Architectural features

The overall architectural feature of 5GC NRM information model is specified in clause 4, this clause specifies features that are specific to the Schema definitions.

The XML definitions of the present document specify the schema for a configuration content, which can be included in a configuration file for Bulk configuration management operations.

---

### F.3 Mapping

#### F.3.1 General mapping

An IOC maps to an XML element of the same name as the IOC's name in the Information Model. An IOC attribute maps to a sub-element of the corresponding IOC's XML element, and the name of this sub-element is the same as the attribute's name in the Information Model.

#### F.3.2 Information Object Class (IOC) mapping

The mapping is not present in the current version of the present document.

---

### F.4 Solution Set definitions

#### F.4.1 XML definition structure

The overall description of the file format of configuration data XML files is provided by 3GPP TS 32.616 [33].

The present document defines the NRM-specific XML schema `ngcNrm.xsd` for the 5GC NRM Information Model defined in clause 4.

XML schema `ngcNrm.xsd` explicitly declares NRM-specific XML element types for the related NRM.

The definition of those NRM-specific XML element types complies with the generic mapping rules defined in 3GPP TS 32.616 [33].

#### F.4.2 Graphical representation

The graphical representation is not present in the current version of the present document.

#### F.4.3 XML schema "`ngcNrm.xsd`"

```
<?xml version="1.0" encoding="UTF-8"?>
```

```

<!--
 3GPP TS 28.541 5GC Network Resource Model
 XML schema definition
 ngcNrm.xsd
-->

<schema
  targetNamespace="http://www.3gpp.org/ftp/specs/archive/28_series/28.541#ngcNrm"
  elementFormDefault="qualified"
  attributeFormDefault="unqualified"
  xmlns="http://www.w3.org/2001/XMLSchema"
  xmlns:xn="http://www.3gpp.org/ftp/specs/archive/28_series/28.623#genericNrm"
  xmlns:nn="http://www.3gpp.org/ftp/specs/archive/28_series/28.541#nrNrm"
  xmlns:en="http://www.3gpp.org/ftp/specs/archive/28_series/28.659#eutranNrm"
  xmlns:ngc="http://www.3gpp.org/ftp/specs/archive/28_series/28.541#ngcNrm"
>

  <import namespace="http://www.3gpp.org/ftp/specs/archive/28_series/28.623#genericNrm"/>
<import namespace="http://www.3gpp.org/ftp/specs/archive/28_series/28.659#eutranNrm"/>
<import namespace="http://www.3gpp.org/ftp/specs/archive/28_series/28.541#nrNrm"/>

  <!--NGC NRM IM class associated XML elements -->
  <complexType name="AmfIdentifier">
    <sequence>
      <element name="amfRegionId" type="ngc:AmfRegionId"/>
      <element name="amfSetId" type="ngc:AmfSetId"/>
      <element name="amfPointer" type="ngc:AmfPointer"/>
    </sequence>
  </complexType>
  <simpleType name="AmfRegionId">
    <restriction base="integer">
      <maxInclusive value="255"/>
      <!-- The AMF Region ID is 8-bitslength, defined in 23.003 -->
    </restriction>
  </simpleType>
  <simpleType name="AmfSetId">
    <restriction base="integer">
      <maxInclusive value="1023"/>
      <!-- The AMF Region ID is 10-bits length, defined in 23.003 -->
    </restriction>
  </simpleType>
  <simpleType name="AmfPointer">
    <restriction base="integer">
      <maxInclusive value="63"/>
      <!-- The AMF Pointer is 6-bits length, defined in 23.003 -->
    </restriction>
  </simpleType>
  <complexType name="NrTACLList">
    <sequence>
      <element name="tac" type="nn:NrTac" minOccurs="0" maxOccurs="unbounded"/>
    </sequence>
  </complexType>
  <complexType name="NFProfileList">
    <sequence>
      <element name="nfProfile" type="ngc:NfProfile"/>
    </sequence>
  </complexType>
  <complexType name="NfProfile">
    <sequence>
      <element name="nfInstanceId" type="string"/>
      <!-- nfInstanceId is uuid of NF instance -->
      <element name="nfType" type="ngc:NfType"/>
      <element name="nfStatus" type="ngc:NfStatus"/>
      <element name="plmn" type="en:PLMNId"/>
      <element name="nfType" type="ngc:NfType"/>
      <element name="sNssais" type="ngc:SnsaiList"/>
      <element name="fqdn" type="string"/>
      <element name="interPlmnFqdn" type="string"/>
      <element name="fqdn" type="string"/>
      <element name="ipv4Addresses" type="string"/>
      <element name="ipv6Addresses" type="string"/>
      <element name="ipv6Prefixes" type="string"/>
      <element name="capacity" type="string"/>
      <element name="udrInfo" type="ngc:UdrInfo"/>
      <element name="amfInfo" type="ngc:AmfInfo"/>
      <element name="smfInfo" type="ngc:SmfInfo"/>
      <element name="upfInfo" type="ngc:UpfInfo"/>
    </sequence>
  </complexType>

```

```

    <element name="nfServices" type="ngc:NfServices"/>
  </sequence>
</complexType>
<complexType name="NfServices">
  <sequence>
    <element name="serviceInstanceId" type="string"/>
    <element name="serviceName" type="string"/>
    <element name="version" type="string"/>
    <element name="schema" type="string"/>
    <element name="fqdn" type="string"/>
    <element name="interPlmnFqdn" type="string"/>
      <element name="ipEndPoints" type="ngc:IpEndpoints"/>
      <element name="apiPrefix" type="string"/>
    <element name="defaultNotificationSubscriptions" type="ngc:DefaultNotificationSubscriptions"/>
      <element name="allowedPlmns" type="en:PLMNIdList"/>
      <element name="allowedNfTypes" type="ngc:NfTypeList"/>
    <element name="allowedNssais" type="ngc:Nssai"/>
      <element name="capacity" type="string"/>
      <element name="supportedFeatures" type="string"/>
    </sequence>
  </complexType>
<simpleType name="NfType">
  <restriction base="string">
    <!-- NF name is defined in TS 23.501 -->
    <enumeration value="NRF"/>
    <enumeration value="UDM"/>
    <enumeration value="AMF"/>
    <enumeration value="SMF"/>
    <enumeration value="AUSF"/>
    <enumeration value="NEF"/>
    <enumeration value="PCF"/>
    <enumeration value="SMSF"/>
    <enumeration value="NSSF"/>
    <enumeration value="UDR"/>
    <enumeration value="LMF"/>
    <enumeration value="GMLC"/>
    <enumeration value="5GEIR"/>
    <enumeration value="SEPP"/>
    <enumeration value="UPF"/>
    <enumeration value="N3IWF"/>
    <enumeration value="AF"/>
    <enumeration value="UDSF"/>
    <enumeration value="DN"/>
  </restriction>
</simpleType>
<complexType name="NfTypeList">
  <sequence>
    <element name="NfType" type="ngc:NfType"/>
  </sequence>
</complexType>
<complexType name="IpEndpoints">
  <sequence>
    <element name="ipEndPoint" type="nn:IpEndPoint"/>
  </sequence>
</complexType>
<complexType name="UdrInfo">
  <sequence>
    <element name="supiRange" type="ngc:SupiRange"/>
  </sequence>
</complexType>
<complexType name="SupiRange">
  <sequence>
    <element name="start" type="string"/>
    <element name="end" type="string"/>
    <element name="pattern" type="string"/>
  </sequence>
</complexType>
<complexType name="AmfInfo">
  <sequence>
    <element name="amfSetId" type="ngc:AmfSetId"/>
  </sequence>
</complexType>
<complexType name="SmfInfo">
  <sequence>
    <element name="dnn" type="string"/>
  </sequence>
</complexType>
<complexType name="UpfInfo">

```

```

    <sequence>
      <element name="snssaiUpfInfo" type="ngc:SnssaiUpfInfo"/>
    </sequence>
  </complexType>
</complexType name="SnssaiUpfInfo">
  <sequence>
    <element name="sNssai" type="ngc:SNssai"/>
    <element name="dnnUpfInfoList" type="ngc:DnnUpfInfoList"/>
  </sequence>
</complexType>
<complexType name="DnnUpfInfoList">
  <sequence>
    <element name="dnn" type="string"/>
  </sequence>
</complexType>
<complexType name="DefaultNotificationSubscription">
  <sequence>
    <element name="notificationType" type="ngc:NotificationType"/>
    <element name="callbackUri" type="string"/>
    <element name="nlMessageClass" type="string"/>
    <element name="n2InformationClass" type="string"/>
  </sequence>
</complexType>
<simpleType name="NotificationType">
  <restriction base="string">
    <enumeration value="N1_MESSAGES"/>
    <enumeration value="N2_INFORMATION"/>
    <enumeration value="LOCATION_NOTIFICATION"/>
  </restriction>
</simpleType>
<simpleType name="TransportProtocol">
  <restriction base="string">
    <enumeration value="TCP"/>
  </restriction>
</simpleType>
<simpleType name="NfStatus">
  <restriction base="string">
    <enumeration value="REGISTERED"/>
    <enumeration value="SUSPENDED"/>
  </restriction>
</simpleType>
<complexType name="NfRegistrationData">
  <sequence>
    <element name="heartBeatTimer" type="integer"/>
    <element name="nfProfile" type="ngc:NfProfile"/>
  </sequence>
</complexType>
<complexType name="NSILdList">
  <sequence>
    <element name="nSIId" type="string"/>
    <!-- NSI Id is defined in TS 29.531 -->
  </sequence>
</complexType>
<complexType name="SnssaiList">
  <sequence>
    <element name="sNssai" type="ngc:SNssai"/>
  </sequence>
</complexType>
<complexType name="SNssai">
  <sequence>
    <element name="sst" type="ngc:Sst" minOccurs="0"/>
    <element name="sd" type="ngc:Sd"/>
  </sequence>
</complexType>
<simpleType name="Sst">
  <restriction base="integer">
    <maxInclusive value="255"/>
    <!-- SST is 1-octets length and defined in TS 23.003 -->
  </restriction>
</simpleType>
<simpleType name="Sd">
  <restriction base="integer">
    <maxInclusive value="65535"/>
    <!-- SST is 2-octets length and defined in TS 23.003 -->
  </restriction>
</simpleType>
<complexType name="SBIServiceList">
  <sequence>

```

```

    <element name="nfServices" type="ngc:NfServices"/>
  </sequence>
</complexType>
<simpleType name="WeightFactor">
  <restriction base="integer">
  </restriction>
</simpleType>

<element name="AMFFunction" substitutionGroup="xn:ManagedElementOptionallyContainedNrmClass">
  <complexType>
    <complexContent>
      <extension base="xn:NrmClass">
        <sequence>
          <element name="attributes">
            <complexType>
              <all>
                <element name="userLabel" type="string"/>
                <element name="vnfParametersList" type="xn:vnfParametersListType" minOccurs="0"/>
                <element name="pLMNIdList" type="en:PLMNIdList"/>
                <element name="aMFIdentifier" type="ngc:aMFIdentifier"/>
                <element name="sBIFqdn" type="string"/>
                <element name="sBIServceList" type="ngc:SBIServiceList"/>
                <element name="weightFactor" type="ngc:WeightFactor"/>
                <element name="snssaiList" type="ngc:SnssaiList" minOccurs="0"/>
                <element name="aMFSet" type="xn:dn" minOccurs="0"/>
              </all>
            </complexType>
          </element>
          <choice minOccurs="0" maxOccurs="unbounded">
            <element ref="ngc:EP_N2"/>
            <element ref="ngc:EP_N8"/>
            <element ref="ngc:EP_N11"/>
            <element ref="ngc:EP_N12"/>
            <element ref="ngc:EP_N14"/>
            <element ref="ngc:EP_N15"/>
            <element ref="ngc:EP_N17"/>
            <element ref="ngc:EP_N22"/>
            <element ref="ngc:EP_N26"/>
            <element ref="ngc:EP_N20"/>
            <element ref="ngc:EP_NLS"/>
            <element ref="ngc:EP_NLG"/>
            <element ref="ngc:EP_SBI_X"/>
            <element ref="xn:VsDataContainer"/>
          </choice>
        </sequence>
      </extension>
    </complexContent>
  </complexType>
</element>

<element name="SMFFunction" substitutionGroup="xn:ManagedElementOptionallyContainedNrmClass">
  <complexType>
    <complexContent>
      <extension base="xn:NrmClass">
        <sequence>
          <element name="attributes">
            <complexType>
              <all>
                <element name="userLabel" type="string"/>
                <element name="vnfParametersList" type="xn:vnfParametersListType" minOccurs="0"/>
                <element name="pLMNIdList" type="en:PLMNIdList"/>
                <element name="nRTACList" type="ngc:NrTACList"/>
                <element name="sBIFqdn" type="string"/>
                <element name="sBIServceList" type="ngc:SBIServiceList"/>
                <element name="snssaiList" type="ngc:SnssaiList" minOccurs="0"/>
              </all>
            </complexType>
          </element>
          <choice minOccurs="0" maxOccurs="unbounded">
            <element ref="ngc:EP_N4"/>
            <element ref="ngc:EP_N10"/>
            <element ref="ngc:EP_N11"/>
            <element ref="ngc:EP_N7"/>
            <element ref="ngc:EP_N16"/>
            <element ref="ngc:EP_S5C"/>
            <element ref="ngc:EP_SBI_X"/>
            <element ref="xn:VsDataContainer"/>
          </choice>
        </sequence>
      </extension>
    </complexContent>
  </complexType>
</element>

```

```

    </extension>
  </complexType>
</element>
<element name="UPFFFunction" substitutionGroup="xn:ManagedElementOptionallyContainedNrmClass">
  <complexType>
    <complexContent>
      <extension base="xn:NrmClass">
        <sequence>
          <element name="attributes">
            <complexType>
              <all>
                <element name="userLabel" type="string"/>
                <element name="vnfParametersList" type="xn:vnfParametersListType" minOccurs="0"/>
                <element name="pLMNidList" type="en:PLMNidList"/>
                <element name="nRTACList" type="ngc:NrTACList"/>
                <element name="snssaiList" type="ngc:SnssaiList" minOccurs="0"/>
              </all>
            </complexType>
          </element>
          <choice minOccurs="0" maxOccurs="unbounded">
            <element ref="ngc:EP_N4"/>
            <element ref="ngc:EP_N3"/>
            <element ref="ngc:EP_N9"/>
            <element ref="ngc:EP_S5U"/>
            <element ref="ngc:EP_SBI_X"/>
            <element ref="ngc:EP_N6"/>
            <element ref="xn:VsDataContainer"/>
          </choice>
        </sequence>
      </extension>
    </complexContent>
  </complexType>
</element>
<element name="N3IWFFunction" substitutionGroup="xn:ManagedElementOptionallyContainedNrmClass">
  <complexType>
    <complexContent>
      <extension base="xn:NrmClass">
        <sequence>
          <element name="attributes">
            <complexType>
              <all>
                <element name="userLabel" type="string"/>
                <element name="vnfParametersList" type="xn:vnfParametersListType" minOccurs="0"/>
                <element name="pLMNidList" type="en:PLMNidList"/>
              </all>
            </complexType>
          </element>
          <choice minOccurs="0" maxOccurs="unbounded">
            <element ref="ngc:EP_N2"/>
            <element ref="ngc:EP_N3"/>
            <element ref="xn:VsDataContainer"/>
          </choice>
        </sequence>
      </extension>
    </complexContent>
  </complexType>
</element>
<element name="PCFFFunction" substitutionGroup="xn:ManagedElementOptionallyContainedNrmClass">
  <complexType>
    <complexContent>
      <extension base="xn:NrmClass">
        <sequence>
          <element name="attributes">
            <complexType>
              <all>
                <element name="userLabel" type="string"/>
                <element name="vnfParametersList" type="xn:vnfParametersListType" minOccurs="0"/>
                <element name="pLMNidList" type="en:PLMNidList" />
                <element name="sBIFqdn" type="string" />
                <element name="sBIServceList" type="ngc:SBIServiceList"/>
                <element name="snssaiList" type="ngc:SnssaiList" minOccurs="0"/>
              </all>
            </complexType>
          </element>
          <choice minOccurs="0" maxOccurs="unbounded">
            <element ref="ngc:EP_N7"/>
            <element ref="ngc:EP_N15"/>
          </choice>
        </sequence>
      </extension>
    </complexContent>
  </complexType>
</element>

```



```

        <element ref="ngc:EP_N16"/>
        <element ref="ngc:EP_N5"/>
        <element ref="ngc:EP_Rx"/>
        <element ref="ngc:EP_SBI_X"/>
        <element ref="xn:VsDataContainer"/>
    </choice>
</sequence>
</extension>
</complexContent>
</complexType>
</element>
<element name="AUSFFunction" substitutionGroup="xn:ManagedElementOptionallyContainedNrmClass">
    <complexType>
        <complexContent>
            <extension base="xn:NrmClass">
                <sequence>
                    <element name="attributes">
                        <complexType>
                            <all>
                                <element name="userLabel" type="string"/>
                                <element name="vnfParametersList" type="xn:vnfParametersListType" minOccurs="0"/>
                                <element name="pLMNidList" type="en:PLMNidList"/>
                                <element name="sBIFqdn" type="string"/>
                                <element name="sBIServivceList" type="ngc:SBIServiceList"/>
                                <element name="snssaiList" type="ngc:SnssaiList" minOccurs="0"/>
                            </all>
                        </complexType>
                    </element>
                    <choice minOccurs="0" maxOccurs="unbounded">
                        <element ref="ngc:EP_N12"/>
                        <element ref="ngc:EP_N13"/>
                        <element ref="ngc:EP_SBI_X"/>
                        <element ref="xn:VsDataContainer"/>
                    </choice>
                </sequence>
            </extension>
        </complexContent>
    </complexType>
</element>
<element name="UDMFunction" substitutionGroup="xn:ManagedElementOptionallyContainedNrmClass">
    <complexType>
        <complexContent>
            <extension base="xn:NrmClass">
                <sequence>
                    <element name="attributes">
                        <complexType>
                            <all>
                                <element name="userLabel" type="string"/>
                                <element name="vnfParametersList" type="xn:vnfParametersListType" minOccurs="0"/>
                                <element name="pLMNidList" type="en:PLMNidList"/>
                                <element name="sBIFqdn" type="string"/>
                                <element name="sBIServivceList" type="ngc:SBIServiceList"/>
                                <element name="snssaiList" type="ngc:SnssaiList" minOccurs="0"/>
                            </all>
                        </complexType>
                    </element>
                    <choice minOccurs="0" maxOccurs="unbounded">
                        <element ref="ngc:EP_N8"/>
                        <element ref="ngc:EP_N10"/>
                        <element ref="ngc:EP_N13"/>
                        <element ref="ngc:EP_SBI_X"/>
                        <element ref="xn:VsDataContainer"/>
                    </choice>
                </sequence>
            </extension>
        </complexContent>
    </complexType>
</element>
<element name="UDRFunction" substitutionGroup="xn:ManagedElementOptionallyContainedNrmClass">
    <complexType>
        <complexContent>
            <extension base="xn:NrmClass">
                <sequence>
                    <element name="attributes">
                        <complexType>
                            <all>
                                <element name="userLabel" type="string"/>
                                <element name="vnfParametersList" type="xn:vnfParametersListType" minOccurs="0"/>
                            </all>
                        </complexType>
                    </element>
                </sequence>
            </extension>
        </complexContent>
    </complexType>
</element>

```

```

        <element name="pLMNidList" type="en:PLMNidList"/>
        <element name="sBIFqdn" type="string"/>
        <element name="sBIServceList" type="ngc:SBIServiceList"/>
        <element name="snssaiList" type="ngc:SnssaiList" minOccurs="0"/>
    </all>
</complexType>
</element>
<choice minOccurs="0" maxOccurs="unbounded">
    <element ref="ngc:EP_SBI_X"/>
    <element ref="xn:VsDataContainer"/>
</choice>
</sequence>
</extension>
</complexContent>
</complexType>
</element>
<element name="UDSFFunction" substitutionGroup="xn:ManagedElementOptionallyContainedNrmClass">
    <complexType>
        <complexContent>
            <extension base="xn:NrmClass">
                <sequence>
                    <element name="attributes">
                        <complexType>
                            <all>
                                <element name="userLabel" type="string"/>
                                <element name="vnfParametersList" type="xn:vnfParametersListType" minOccurs="0"/>
                                <element name="pLMNidList" type="en:PLMNidList"/>
                                <element name="sBIFqdn" type="string"/>
                                <element name="sBIServceList" type="ngc:SBIServiceList"/>
                                <element name="snssaiList" type="ngc:SnssaiList" minOccurs="0"/>
                            </all>
                        </complexType>
                    </element>
                    <choice minOccurs="0" maxOccurs="unbounded">
                        <element ref="ngc:EP_SBI_X"/>
                        <element ref="xn:VsDataContainer"/>
                    </choice>
                </sequence>
            </extension>
        </complexContent>
    </complexType>
</element>
<element name="NRFFFunction" substitutionGroup="xn:ManagedElementOptionallyContainedNrmClass">
    <complexType>
        <complexContent>
            <extension base="xn:NrmClass">
                <sequence>
                    <element name="attributes">
                        <complexType>
                            <all>
                                <element name="userLabel" type="string"/>
                                <element name="vnfParametersList" type="xn:vnfParametersListType" minOccurs="0"/>
                                <element name="pLMNidList" type="en:PLMNidList"/>
                                <element name="sBIFqdn" type="string"/>
                                <element name="nSIidList" type="ngc:NSIidList" minOccurs="0"/>
                                <element name="nFProfileList" type="ngc:NFProfileList" minOccurs="0"/>
                                <element name="snssaiList" type="ngc:SnssaiList" minOccurs="0"/>
                            </all>
                        </complexType>
                    </element>
                    <choice minOccurs="0" maxOccurs="unbounded">
                        <element ref="ngc:EP_N27"/>
                        <element ref="ngc:EP_SBI_X"/>
                        <element ref="xn:VsDataContainer"/>
                    </choice>
                </sequence>
            </extension>
        </complexContent>
    </complexType>
</element>
<element name="NSSFFunction" substitutionGroup="xn:ManagedElementOptionallyContainedNrmClass">
    <complexType>
        <complexContent>
            <extension base="xn:NrmClass">
                <sequence>
                    <element name="attributes">
                        <complexType>
                            <all>

```

```

        <element name="userLabel" type="string"/>
        <element name="vnfParametersList" type="xn:vnfParametersListType" minOccurs="0"/>
        <element name="pLMNIdList" type="en:PLMNIdList"/>
        <element name="sBIFqdn" type="string"/>
        <element name="nSIIdList" type="ngc:NSIIdList"/>
        <element name="snssaiList" type="ngc:SnssaiList" minOccurs="0"/>
    </all>
</complexType>
</element>
<choice minOccurs="0" maxOccurs="unbounded">
    <element ref="ngc:EP_N27"/>
    <element ref="ngc:EP_N31"/>
    <element ref="ngc:EP_SBI_X"/>
    <element ref="xn:VsDataContainer"/>
</choice>
</sequence>
</extension>
</complexContent>
</complexType>
</element>
<element name="SMSFunction" substitutionGroup="xn:ManagedElementOptionallyContainedNrmClass">
    <complexType>
        <complexContent>
            <extension base="xn:NrmClass">
                <sequence>
                    <element name="attributes">
                        <complexType>
                            <all>
                                <element name="userLabel" type="string"/>
                                <element name="vnfParametersList" type="xn:vnfParametersListType" minOccurs="0"/>
                                <element name="pLMNIdList" type="en:PLMNIdList"/>
                                <element name="sBIFqdn" type="string"/>
                                <element name="sBIServceList" type="ngc:SBIServiceList"/>
                            </all>
                        </complexType>
                    </element>
                    <choice minOccurs="0" maxOccurs="unbounded">
                        <element ref="ngc:EP_N20"/>
                        <element ref="ngc:EP_N21"/>
                        <element ref="ngc:EP_MAP_SMSC"/>
                        <element ref="xn:VsDataContainer"/>
                    </choice>
                </sequence>
            </extension>
        </complexContent>
    </complexType>
</element>
<element name="LMFFunction" substitutionGroup="xn:ManagedElementOptionallyContainedNrmClass">
    <complexType>
        <complexContent>
            <extension base="xn:NrmClass">
                <sequence>
                    <element name="attributes">
                        <complexType>
                            <all>
                                <element name="userLabel" type="string"/>
                                <element name="vnfParametersList" type="xn:vnfParametersListType" minOccurs="0"/>
                                <element name="pLMNIdList" type="en:PLMNIdList"/>
                            </all>
                        </complexType>
                    </element>
                    <choice minOccurs="0" maxOccurs="unbounded">
                        <element ref="ngc:EP_NLS"/>
                        <element ref="xn:VsDataContainer"/>
                    </choice>
                </sequence>
            </extension>
        </complexContent>
    </complexType>
</element>
<element name="NGEIRFunction" substitutionGroup="xn:ManagedElementOptionallyContainedNrmClass">
    <complexType>
        <complexContent>
            <extension base="xn:NrmClass">
                <sequence>
                    <element name="attributes">
                        <complexType>
                            <all>

```

```

        <element name="userLabel" type="string"/>
        <element name="vnfParametersList" type="xn:vnfParametersListType" minOccurs="0"/>
        <element name="pLMNidList" type="en:PLMNidList"/>
        <element name="sBIFqdn" type="string"/>
        <element name="sBISerivceList" type="ngc:SBIServiceList"/>
        <element name="snssaiList" type="ngc:SnssaiList" minOccurs="0"/>
    </all>
</complexType>
</element>
<choice minOccurs="0" maxOccurs="unbounded">
    <element ref="ngc:EP_N17"/>
    <element ref="xn:VsDataContainer"/>
</choice>
</sequence>
</extension>
</complexContent>
</complexType>
</element>
<element name="SEPPFunction" substitutionGroup="xn:ManagedElementOptionallyContainedNrmClass">
    <complexType>
        <complexContent>
            <extension base="xn:NrmClass">
                <sequence>
                    <element name="attributes">
                        <complexType>
                            <all>
                                <element name="userLabel" type="string"/>
                                <element name="vnfParametersList" type="xn:vnfParametersListType" minOccurs="0"/>
                                <element name="pLMNidList" type="en:PLMNidList"/>
                            </all>
                        </complexType>
                    </element>
                    <choice minOccurs="0" maxOccurs="unbounded">
                        <element ref="ngc:EP_N32"/>
                        <element ref="ngc:EP_SBI_IPX"/>
                        <element ref="xn:VsDataContainer"/>
                    </choice>
                </sequence>
            </extension>
        </complexContent>
    </complexType>
</element>
<element name="NWDAFFunction" substitutionGroup="xn:ManagedElementOptionallyContainedNrmClass">
    <complexType>
        <complexContent>
            <extension base="xn:NrmClass">
                <sequence>
                    <element name="attributes">
                        <complexType>
                            <all>
                                <element name="userLabel" type="string"/>
                                <element name="vnfParametersList" type="xn:vnfParametersListType" minOccurs="0"/>
                                <element name="pLMNidList" type="en:PLMNidList"/>
                                <element name="sBIFqdn" type="string"/>
                                <element name="sBISerivceList" type="ngc:SBIServiceList"/>
                                <element name="snssaiList" type="ngc:SnssaiList" minOccurs="0"/>
                            </all>
                        </complexType>
                    </element>
                    <choice minOccurs="0" maxOccurs="unbounded">
                        <element ref="ngc:EP_SBI_X"/>
                        <element ref="xn:VsDataContainer"/>
                    </choice>
                </sequence>
            </extension>
        </complexContent>
    </complexType>
</element>
<element name="EP_N2">
    <complexType>
        <complexContent>
            <extension base="xn:NrmClass">
                <sequence>
                    <element name="attributes" minOccurs="0">
                        <complexType>
                            <all>
                                <!-- Inherited attributes from EP_RP -->

```

```

        <element name="farEndEntity" type="xn:dn" minOccurs="0"/>
        <element name="userLabel" type="string" minOccurs="0"/>
        <!-- End of inherited attributes from EP_RP -->
        <element name="localAddress" type="nn:IpEndPoint" minOccurs="0"/>
        <element name="remoteAddress" type="nn:IpEndPoint" minOccurs="0"/>
    </all>
  </complexType>
</element>
<choice minOccurs="0" maxOccurs="unbounded">
  <element ref="xn:VsDataContainer"/>
</choice>
</sequence>
</extension>
</complexContent>
</complexType>
</element>
<element name="EP_N3">
  <complexType>
    <complexContent>
      <extension base="xn:NrmClass">
        <sequence>
          <element name="attributes" minOccurs="0">
            <complexType>
              <all>
                <!-- Inherited attributes from EP_RP -->
                <element name="farEndEntity" type="xn:dn" minOccurs="0"/>
                <element name="userLabel" type="string" minOccurs="0"/>
                <!-- End of inherited attributes from EP_RP -->
                <element name="localAddress" type="nn:IpEndPoint" minOccurs="0"/>
              </all>
            </complexType>
          </element>
          <choice minOccurs="0" maxOccurs="unbounded">
            <element ref="xn:VsDataContainer"/>
          </choice>
        </sequence>
      </extension>
    </complexContent>
  </complexType>
</element>
<element name="EP_N4">
  <complexType>
    <complexContent>
      <extension base="xn:NrmClass">
        <sequence>
          <element name="attributes" minOccurs="0">
            <complexType>
              <all>
                <!-- Inherited attributes from EP_RP -->
                <element name="farEndEntity" type="xn:dn" minOccurs="0"/>
                <element name="userLabel" type="string" minOccurs="0"/>
                <!-- End of inherited attributes from EP_RP -->
                <element name="localAddress" type="nn:IpEndPoint" minOccurs="0"/>
                <element name="remoteAddress" type="nn:IpEndPoint" minOccurs="0"/>
              </all>
            </complexType>
          </element>
          <choice minOccurs="0" maxOccurs="unbounded">
            <element ref="xn:VsDataContainer"/>
          </choice>
        </sequence>
      </extension>
    </complexContent>
  </complexType>
</element>
<element name="EP_N5">
  <complexType>
    <complexContent>
      <extension base="xn:NrmClass">
        <sequence>
          <element name="attributes" minOccurs="0">
            <complexType>
              <all>
                <!-- Inherited attributes from EP_RP -->
                <element name="farEndEntity" type="xn:dn" minOccurs="0"/>
                <element name="userLabel" type="string" minOccurs="0"/>
                <!-- End of inherited attributes from EP_RP -->
                <element name="localAddress" type="nn:IpEndPoint" minOccurs="0"/>
              </all>
            </complexType>
          </element>
          <choice minOccurs="0" maxOccurs="unbounded">
            <element ref="xn:VsDataContainer"/>
          </choice>
        </sequence>
      </extension>
    </complexContent>
  </complexType>
</element>

```

```

        <element name="remoteAddress" type="nn:IpEndPoint" minOccurs="0"/>
      </all>
    </complexType>
  </element>
  <choice minOccurs="0" maxOccurs="unbounded">
    <element ref="xn:VsDataContainer"/>
  </choice>
</sequence>
</extension>
</complexContent>
</complexType>
</element>
<element name="EP_N6">
  <complexType>
    <complexContent>
      <extension base="xn:NrmClass">
        <sequence>
          <element name="attributes" minOccurs="0">
            <complexType>
              <all>
                <!-- Inherited attributes from EP_RP -->
                <element name="farEndEntity" type="xn:dn" minOccurs="0"/>
                <element name="userLabel" type="string" minOccurs="0"/>
                <!-- End of inherited attributes from EP_RP -->
                <element name="localAddress" type="nn:IpEndPoint" minOccurs="0"/>
                <element name="remoteAddress" type="nn:IpEndPoint" minOccurs="0"/>
              </all>
            </complexType>
          </element>
          <choice minOccurs="0" maxOccurs="unbounded">
            <element ref="xn:VsDataContainer"/>
          </choice>
        </sequence>
      </extension>
    </complexContent>
  </complexType>
</element>
<element name="EP_N7">
  <complexType>
    <complexContent>
      <extension base="xn:NrmClass">
        <sequence>
          <element name="attributes" minOccurs="0">
            <complexType>
              <all>
                <!-- Inherited attributes from EP_RP -->
                <element name="farEndEntity" type="xn:dn" minOccurs="0"/>
                <element name="userLabel" type="string" minOccurs="0"/>
                <!-- End of inherited attributes from EP_RP -->
                <element name="localAddress" type="nn:IpEndPoint" minOccurs="0"/>
                <element name="remoteAddress" type="nn:IpEndPoint" minOccurs="0"/>
              </all>
            </complexType>
          </element>
          <choice minOccurs="0" maxOccurs="unbounded">
            <element ref="xn:VsDataContainer"/>
          </choice>
        </sequence>
      </extension>
    </complexContent>
  </complexType>
</element>
<element name="EP_N8">
  <complexType>
    <complexContent>
      <extension base="xn:NrmClass">
        <sequence>
          <element name="attributes" minOccurs="0">
            <complexType>
              <all>
                <!-- Inherited attributes from EP_RP -->
                <element name="farEndEntity" type="xn:dn" minOccurs="0"/>
                <element name="userLabel" type="string" minOccurs="0"/>
                <!-- End of inherited attributes from EP_RP -->
                <element name="localAddress" type="nn:IpEndPoint" minOccurs="0"/>
                <element name="remoteAddress" type="nn:IpEndPoint" minOccurs="0"/>
              </all>
            </complexType>
          </element>
        </sequence>
      </extension>
    </complexContent>
  </complexType>
</element>

```

```

        </element>
        <choice minOccurs="0" maxOccurs="unbounded">
          <element ref="xn:VsDataContainer" />
        </choice>
      </sequence>
    </extension>
  </complexContent>
</complexType>
</element>
<element name="EP_N9">
  <complexType>
    <complexContent>
      <extension base="xn:NrmClass">
        <sequence>
          <element name="attributes" minOccurs="0">
            <complexType>
              <all>
                <!-- Inherited attributes from EP_RP -->
                <element name="farEndEntity" type="xn:dn" minOccurs="0"/>
                <element name="userLabel" type="string" minOccurs="0"/>
                <!-- End of inherited attributes from EP_RP -->
                <element name="localAddress" type="nn:IpEndPoint" minOccurs="0"/>
              </all>
            </complexType>
          </element>
          <choice minOccurs="0" maxOccurs="unbounded">
            <element ref="xn:VsDataContainer" />
          </choice>
        </sequence>
      </extension>
    </complexContent>
  </complexType>
</element>
<element name="EP_N10">
  <complexType>
    <complexContent>
      <extension base="xn:NrmClass">
        <sequence>
          <element name="attributes" minOccurs="0">
            <complexType>
              <all>
                <!-- Inherited attributes from EP_RP -->
                <element name="farEndEntity" type="xn:dn" minOccurs="0"/>
                <element name="userLabel" type="string" minOccurs="0"/>
                <!-- End of inherited attributes from EP_RP -->
                <element name="localAddress" type="nn:IpEndPoint" minOccurs="0"/>
                <element name="remoteAddress" type="nn:IpEndPoint" minOccurs="0"/>
              </all>
            </complexType>
          </element>
          <choice minOccurs="0" maxOccurs="unbounded">
            <element ref="xn:VsDataContainer" />
          </choice>
        </sequence>
      </extension>
    </complexContent>
  </complexType>
</element>
<element name="EP_N11">
  <complexType>
    <complexContent>
      <extension base="xn:NrmClass">
        <sequence>
          <element name="attributes" minOccurs="0">
            <complexType>
              <all>
                <!-- Inherited attributes from EP_RP -->
                <element name="farEndEntity" type="xn:dn" minOccurs="0"/>
                <element name="userLabel" type="string" minOccurs="0"/>
                <!-- End of inherited attributes from EP_RP -->
                <element name="localAddress" type="nn:IpEndPoint" minOccurs="0"/>
                <element name="remoteAddress" type="nn:IpEndPoint" minOccurs="0"/>
              </all>
            </complexType>
          </element>
          <choice minOccurs="0" maxOccurs="unbounded">
            <element ref="xn:VsDataContainer" />
          </choice>
        </sequence>
      </extension>
    </complexContent>
  </complexType>
</element>

```

```

    </sequence>
  </extension>
</complexContent>
</complexType>
</element>
<element name="EP_N12">
  <complexType>
    <complexContent>
      <extension base="xn:NrmClass">
        <sequence>
          <element name="attributes" minOccurs="0">
            <complexType>
              <all>
                <!-- Inherited attributes from EP_RP -->
                <element name="farEndEntity" type="xn:dn" minOccurs="0"/>
                <element name="userLabel" type="string" minOccurs="0"/>
                <!-- End of inherited attributes from EP_RP -->
                <element name="localAddress" type="nn:IpEndPoint" minOccurs="0"/>
                <element name="remoteAddress" type="nn:IpEndPoint" minOccurs="0"/>
              </all>
            </complexType>
          </element>
          <choice minOccurs="0" maxOccurs="unbounded">
            <element ref="xn:VsDataContainer"/>
          </choice>
        </sequence>
      </extension>
    </complexContent>
  </complexType>
</element>
<element name="EP_N13">
  <complexType>
    <complexContent>
      <extension base="xn:NrmClass">
        <sequence>
          <element name="attributes" minOccurs="0">
            <complexType>
              <all>
                <!-- Inherited attributes from EP_RP -->
                <element name="farEndEntity" type="xn:dn" minOccurs="0"/>
                <element name="userLabel" type="string" minOccurs="0"/>
                <!-- End of inherited attributes from EP_RP -->
                <element name="localAddress" type="nn:IpEndPoint" minOccurs="0"/>
                <element name="remoteAddress" type="nn:IpEndPoint" minOccurs="0"/>
              </all>
            </complexType>
          </element>
          <choice minOccurs="0" maxOccurs="unbounded">
            <element ref="xn:VsDataContainer"/>
          </choice>
        </sequence>
      </extension>
    </complexContent>
  </complexType>
</element>
<element name="EP_N14">
  <complexType>
    <complexContent>
      <extension base="xn:NrmClass">
        <sequence>
          <element name="attributes" minOccurs="0">
            <complexType>
              <all>
                <!-- Inherited attributes from EP_RP -->
                <element name="farEndEntity" type="xn:dn" minOccurs="0"/>
                <element name="userLabel" type="string" minOccurs="0"/>
                <!-- End of inherited attributes from EP_RP -->
                <element name="localAddress" type="nn:IpEndPoint" minOccurs="0"/>
                <element name="remoteAddress" type="nn:IpEndPoint" minOccurs="0"/>
              </all>
            </complexType>
          </element>
          <choice minOccurs="0" maxOccurs="unbounded">
            <element ref="xn:VsDataContainer"/>
          </choice>
        </sequence>
      </extension>
    </complexContent>
  </complexType>
</element>

```



```

    </complexType>
  </element>
  <element name="EP_N15">
    <complexType>
      <complexContent>
        <extension base="xn:NrmClass">
          <sequence>
            <element name="attributes" minOccurs="0">
              <complexType>
                <all>
                  <!-- Inherited attributes from EP_RP -->
                  <element name="farEndEntity" type="xn:dn" minOccurs="0"/>
                  <element name="userLabel" type="string" minOccurs="0"/>
                  <!-- End of inherited attributes from EP_RP -->
                  <element name="localAddress" type="nn:IpEndPoint" minOccurs="0"/>
                  <element name="remoteAddress" type="nn:IpEndPoint" minOccurs="0"/>
                </all>
              </complexType>
            </element>
            <choice minOccurs="0" maxOccurs="unbounded">
              <element ref="xn:VsDataContainer"/>
            </choice>
          </sequence>
        </extension>
      </complexContent>
    </complexType>
  </element>
  <element name="EP_N16">
    <complexType>
      <complexContent>
        <extension base="xn:NrmClass">
          <sequence>
            <element name="attributes" minOccurs="0">
              <complexType>
                <all>
                  <!-- Inherited attributes from EP_RP -->
                  <element name="farEndEntity" type="xn:dn" minOccurs="0"/>
                  <element name="userLabel" type="string" minOccurs="0"/>
                  <!-- End of inherited attributes from EP_RP -->
                  <element name="localAddress" type="nn:IpEndPoint" minOccurs="0"/>
                  <element name="remoteAddress" type="nn:IpEndPoint" minOccurs="0"/>
                </all>
              </complexType>
            </element>
            <choice minOccurs="0" maxOccurs="unbounded">
              <element ref="xn:VsDataContainer"/>
            </choice>
          </sequence>
        </extension>
      </complexContent>
    </complexType>
  </element>
  <element name="EP_N17">
    <complexType>
      <complexContent>
        <extension base="xn:NrmClass">
          <sequence>
            <element name="attributes" minOccurs="0">
              <complexType>
                <all>
                  <!-- Inherited attributes from EP_RP -->
                  <element name="farEndEntity" type="xn:dn" minOccurs="0"/>
                  <element name="userLabel" type="string" minOccurs="0"/>
                  <!-- End of inherited attributes from EP_RP -->
                  <element name="localAddress" type="nn:IpEndPoint" minOccurs="0"/>
                  <element name="remoteAddress" type="nn:IpEndPoint" minOccurs="0"/>
                </all>
              </complexType>
            </element>
            <choice minOccurs="0" maxOccurs="unbounded">
              <element ref="xn:VsDataContainer"/>
            </choice>
          </sequence>
        </extension>
      </complexContent>
    </complexType>
  </element>
  <element name="EP_N20">

```

```

<complexType>
  <complexContent>
    <extension base="xn:NrmClass">
      <sequence>
        <element name="attributes" minOccurs="0">
          <complexType>
            <all>
              <!-- Inherited attributes from EP_RP -->
              <element name="farEndEntity" type="xn:dn" minOccurs="0"/>
              <element name="userLabel" type="string" minOccurs="0"/>
              <!-- End of inherited attributes from EP_RP -->
              <element name="localAddress" type="nn:IpEndPoint" minOccurs="0"/>
              <element name="remoteAddress" type="nn:IpEndPoint" minOccurs="0"/>
            </all>
          </complexType>
        </element>
        <choice minOccurs="0" maxOccurs="unbounded">
          <element ref="xn:VsDataContainer"/>
        </choice>
      </sequence>
    </extension>
  </complexContent>
</complexType>
</element>
<element name="EP_N21">
  <complexType>
    <complexContent>
      <extension base="xn:NrmClass">
        <sequence>
          <element name="attributes" minOccurs="0">
            <complexType>
              <all>
                <!-- Inherited attributes from EP_RP -->
                <element name="farEndEntity" type="xn:dn" minOccurs="0"/>
                <element name="userLabel" type="string" minOccurs="0"/>
                <!-- End of inherited attributes from EP_RP -->
                <element name="localAddress" type="nn:IpEndPoint" minOccurs="0"/>
                <element name="remoteAddress" type="nn:IpEndPoint" minOccurs="0"/>
              </all>
            </complexType>
          </element>
          <choice minOccurs="0" maxOccurs="unbounded">
            <element ref="xn:VsDataContainer"/>
          </choice>
        </sequence>
      </extension>
    </complexContent>
  </complexType>
</element>
<element name="EP_N22">
  <complexType>
    <complexContent>
      <extension base="xn:NrmClass">
        <sequence>
          <element name="attributes" minOccurs="0">
            <complexType>
              <all>
                <!-- Inherited attributes from EP_RP -->
                <element name="farEndEntity" type="xn:dn" minOccurs="0"/>
                <element name="userLabel" type="string" minOccurs="0"/>
                <!-- End of inherited attributes from EP_RP -->
                <element name="localAddress" type="nn:IpEndPoint" minOccurs="0"/>
                <element name="remoteAddress" type="nn:IpEndPoint" minOccurs="0"/>
              </all>
            </complexType>
          </element>
          <choice minOccurs="0" maxOccurs="unbounded">
            <element ref="xn:VsDataContainer"/>
          </choice>
        </sequence>
      </extension>
    </complexContent>
  </complexType>
</element>
<element name="EP_N26">
  <complexType>
    <complexContent>
      <extension base="xn:NrmClass">

```

```

    <sequence>
      <element name="attributes" minOccurs="0">
        <complexType>
          <all>
            <!-- Inherited attributes from EP_RP -->
            <element name="farEndEntity" type="xn:dn" minOccurs="0"/>
            <element name="userLabel" type="string" minOccurs="0"/>
            <!-- End of inherited attributes from EP_RP -->
            <element name="localAddress" type="nn:IpEndPoint" minOccurs="0"/>
            <element name="remoteAddress" type="nn:IpEndPoint" minOccurs="0"/>
          </all>
        </complexType>
      </element>
      <choice minOccurs="0" maxOccurs="unbounded">
        <element ref="xn:VsDataContainer"/>
      </choice>
    </sequence>
  </extension>
</complexContent>
</complexType>
</element>
<element name="EP_N27">
  <complexType>
    <complexContent>
      <extension base="xn:NrmClass">
        <sequence>
          <element name="attributes" minOccurs="0">
            <complexType>
              <all>
                <!-- Inherited attributes from EP_RP -->
                <element name="farEndEntity" type="xn:dn" minOccurs="0"/>
                <element name="userLabel" type="string" minOccurs="0"/>
                <!-- End of inherited attributes from EP_RP -->
                <element name="localAddress" type="nn:IpEndPoint" minOccurs="0"/>
                <element name="remoteAddress" type="nn:IpEndPoint" minOccurs="0"/>
              </all>
            </complexType>
          </element>
          <choice minOccurs="0" maxOccurs="unbounded">
            <element ref="xn:VsDataContainer"/>
          </choice>
        </sequence>
      </extension>
    </complexContent>
  </complexType>
</element>
<element name="EP_N31">
  <complexType>
    <complexContent>
      <extension base="xn:NrmClass">
        <sequence>
          <element name="attributes" minOccurs="0">
            <complexType>
              <all>
                <!-- Inherited attributes from EP_RP -->
                <element name="farEndEntity" type="xn:dn" minOccurs="0"/>
                <element name="userLabel" type="string" minOccurs="0"/>
                <!-- End of inherited attributes from EP_RP -->
                <element name="localAddress" type="nn:IpEndPoint" minOccurs="0"/>
                <element name="remoteAddress" type="nn:IpEndPoint" minOccurs="0"/>
              </all>
            </complexType>
          </element>
          <choice minOccurs="0" maxOccurs="unbounded">
            <element ref="xn:VsDataContainer"/>
          </choice>
        </sequence>
      </extension>
    </complexContent>
  </complexType>
</element>
<element name="EP_N32">
  <complexType>
    <complexContent>
      <extension base="xn:NrmClass">
        <sequence>
          <element name="attributes" minOccurs="0">
            <complexType>

```

```

    <all>
      <!-- Inherited attributes from EP_RP -->
      <element name="farEndEntity" type="xn:dn" minOccurs="0"/>
      <element name="userLabel" type="string" minOccurs="0"/>
      <!-- End of inherited attributes from EP_RP -->
      <element name="localAddress" type="nn:IpEndPoint" minOccurs="0"/>
      <element name="remoteAddress" type="nn:IpEndPoint" minOccurs="0"/>
    </all>
  </complexType>
</element>
<choice minOccurs="0" maxOccurs="unbounded">
  <element ref="xn:VsDataContainer"/>
</choice>
</sequence>
</extension>
</complexContent>
</complexType>
</element>
<element name="EP_SBI_X">
  <complexType>
    <complexContent>
      <extension base="xn:NrmClass">
        <sequence>
          <element name="attributes" minOccurs="0">
            <complexType>
              <all>
                <!-- Inherited attributes from EP_RP -->
                <element name="farEndEntity" type="xn:dn" minOccurs="0"/>
                <element name="userLabel" type="string" minOccurs="0"/>
                <!-- End of inherited attributes from EP_RP -->
                <element name="localAddress" type="nn:IpEndPoint" minOccurs="0"/>
                <element name="remoteAddress" type="nn:IpEndPoint" minOccurs="0"/>
              </all>
            </complexType>
          </element>
          <choice minOccurs="0" maxOccurs="unbounded">
            <element ref="xn:VsDataContainer"/>
          </choice>
        </sequence>
      </extension>
    </complexContent>
  </complexType>
</element>
<element name="EP_SBI_IPX">
  <complexType>
    <complexContent>
      <extension base="xn:NrmClass">
        <sequence>
          <element name="attributes" minOccurs="0">
            <complexType>
              <all>
                <!-- Inherited attributes from EP_RP -->
                <element name="farEndEntity" type="xn:dn" minOccurs="0"/>
                <element name="userLabel" type="string" minOccurs="0"/>
                <!-- End of inherited attributes from EP_RP -->
                <element name="localAddress" type="nn:IpEndPoint" minOccurs="0"/>
                <element name="remoteAddress" type="nn:IpEndPoint" minOccurs="0"/>
              </all>
            </complexType>
          </element>
          <choice minOccurs="0" maxOccurs="unbounded">
            <element ref="xn:VsDataContainer"/>
          </choice>
        </sequence>
      </extension>
    </complexContent>
  </complexType>
</element>
<element name="EP_S5C">
  <complexType>
    <complexContent>
      <extension base="xn:NrmClass">
        <sequence>
          <element name="attributes" minOccurs="0">
            <complexType>
              <all>
                <!-- Inherited attributes from EP_RP -->
                <element name="farEndEntity" type="xn:dn" minOccurs="0"/>

```

```

        <element name="userLabel" type="string" minOccurs="0"/>
        <!-- End of inherited attributes from EP_RP -->
        <element name="localAddress" type="nn:IpEndPoint" minOccurs="0"/>
        <element name="remoteAddress" type="nn:IpEndPoint" minOccurs="0"/>
    </all>
    </complexType>
</element>
<choice minOccurs="0" maxOccurs="unbounded">
    <element ref="xn:VsDataContainer"/>
</choice>
</sequence>
</extension>
</complexContent>
</complexType>
</element>
<element name="EP_S5U">
    <complexType>
        <complexContent>
            <extension base="xn:NrmClass">
                <sequence>
                    <element name="attributes" minOccurs="0">
                        <complexType>
                            <all>
                                <!-- Inherited attributes from EP_RP -->
                                <element name="farEndEntity" type="xn:dn" minOccurs="0"/>
                                <element name="userLabel" type="string" minOccurs="0"/>
                                <!-- End of inherited attributes from EP_RP -->
                                <element name="localAddress" type="nn:IpEndPoint" minOccurs="0"/>
                            </all>
                        </complexType>
                    </element>
                    <choice minOccurs="0" maxOccurs="unbounded">
                        <element ref="xn:VsDataContainer"/>
                    </choice>
                </sequence>
            </extension>
        </complexContent>
    </complexType>
</element>
<element name="EP_Rx">
    <complexType>
        <complexContent>
            <extension base="xn:NrmClass">
                <sequence>
                    <element name="attributes" minOccurs="0">
                        <complexType>
                            <all>
                                <!-- Inherited attributes from EP_RP -->
                                <element name="farEndEntity" type="xn:dn" minOccurs="0"/>
                                <element name="userLabel" type="string" minOccurs="0"/>
                                <!-- End of inherited attributes from EP_RP -->
                                <element name="localAddress" type="nn:IpEndPoint" minOccurs="0"/>
                                <element name="remoteAddress" type="nn:IpEndPoint" minOccurs="0"/>
                            </all>
                        </complexType>
                    </element>
                    <choice minOccurs="0" maxOccurs="unbounded">
                        <element ref="xn:VsDataContainer"/>
                    </choice>
                </sequence>
            </extension>
        </complexContent>
    </complexType>
</element>
<element name="EP_MAP_SMSC">
    <complexType>
        <complexContent>
            <extension base="xn:NrmClass">
                <sequence>
                    <element name="attributes" minOccurs="0">
                        <complexType>
                            <all>
                                <!-- Inherited attributes from EP_RP -->
                                <element name="farEndEntity" type="xn:dn" minOccurs="0"/>
                                <element name="userLabel" type="string" minOccurs="0"/>
                                <!-- End of inherited attributes from EP_RP -->
                                <element name="localAddress" type="nn:IpEndPoint" minOccurs="0"/>
                                <element name="remoteAddress" type="nn:IpEndPoint" minOccurs="0"/>
                            </all>
                        </complexType>
                    </element>
                </sequence>
            </extension>
        </complexContent>
    </complexType>
</element>

```

```

        </all>
      </complexType>
    </element>
    <choice minOccurs="0" maxOccurs="unbounded">
      <element ref="xn:VsDataContainer" />
    </choice>
  </sequence>
</extension>
</complexContent>
</complexType>
</element>
<element name="EP_NLS">
  <complexType>
    <complexContent>
      <extension base="xn:NrmClass">
        <sequence>
          <element name="attributes" minOccurs="0">
            <complexType>
              <all>
                <!-- Inherited attributes from EP_RP -->
                <element name="farEndEntity" type="xn:dn" minOccurs="0"/>
                <element name="userLabel" type="string" minOccurs="0"/>
                <!-- End of inherited attributes from EP_RP -->
                <element name="localAddress" type="nn:IpEndPoint" minOccurs="0"/>
                <element name="remoteAddress" type="nn:IpEndPoint" minOccurs="0"/>
              </all>
            </complexType>
          </element>
          <choice minOccurs="0" maxOccurs="unbounded">
            <element ref="xn:VsDataContainer" />
          </choice>
        </sequence>
      </extension>
    </complexContent>
  </complexType>
</element>
<element name="EP_NLG">
  <complexType>
    <complexContent>
      <extension base="xn:NrmClass">
        <sequence>
          <element name="attributes" minOccurs="0">
            <complexType>
              <all>
                <!-- Inherited attributes from EP_RP -->
                <element name="farEndEntity" type="xn:dn" minOccurs="0"/>
                <element name="userLabel" type="string" minOccurs="0"/>
                <!-- End of inherited attributes from EP_RP -->
                <element name="localAddress" type="nn:IpEndPoint" minOccurs="0"/>
                <element name="remoteAddress" type="nn:IpEndPoint" minOccurs="0"/>
              </all>
            </complexType>
          </element>
          <choice minOccurs="0" maxOccurs="unbounded">
            <element ref="xn:VsDataContainer" />
          </choice>
        </sequence>
      </extension>
    </complexContent>
  </complexType>
</element>
</schema>

```

---

## Annex G (normative): JSON definitions for 5GC NRM

### G.1 General

This annex contains the JSON definitions for the 5GC NRM, in accordance with 5GC NRM information model definitions specified in clause 5.

---

### G.2 Architectural features

The overall architectural feature of 5GC NRM information model is specified in clause 5, this annex specifies features that are specific to the Schema definitions.

---

### G.3 Mapping

#### G.3.1 IOC mapping

Mapping from the IOCs defined in the information model to SS equivalent definitions are listed in the following table.

IOC Name	JSON definitions' Name	JSON Type
AMFFunction	amfFunction	object
SMFFunction	smfFunction	object
UPFFunction	upfFunction	object
N3IWFunction	n3wifFunction	object
PCFFunction	pcrfFunction	object
AUSFFunction	ausfunction	object
UDMFunction	udmFunction	object
UDRFunction	udrFunction	object
UDSFFunction	udsfFunction	object
NRFFunction	nrfFunction	object
NSSFFunction	nssfFunction	object
SMSFFunction	smsfFunction	object
LMFFunction	lmfFunction	object
NGEIRFunction	ngeirFunction	object
SEPPFunction	seppFunction	object
NWDAFFunction	nwdafFunction	object
EP_N2	eP_N2	object
EP_N3	eP_N3	object
EP_N4	eP_N4	object
EP_N5	eP_N5	object
EP_N6	eP_N6	object
EP_N7	eP_N7	object
EP_N8	eP_N8	object
EP_N9	eP_N9	object
EP_N10	eP_N10	object
EP_N11	eP_N11	object
EP_N12	eP_N12	object
EP_N13	eP_N13	object
EP_N14	eP_N14	object
EP_N15	eP_N15	object
EP_N16	eP_N16	object
EP_N17	eP_N17	object
EP_N20	eP_N20	object
EP_N21	eP_N21	object
EP_N22	eP_N22	object
EP_N26	eP_N26	object
EP_SBI_X	eP_SBI_X	object
EP_SBI_IPX	eP_SBI_IPX	object
EP_S5C	eP_S5C	object
EP_S5U	eP_S5U	object
EP_Rx	eP_Rx	object
EP_MAP_SMSC	eP_MAP_SMSC	object
EP_NLC	eP_NLC	object
EP_NLG	eP_NLG	object
EP_N27	eP_N27	object
EP_N31	eP_N31	object
ExternalNRFFunction	externalNrfFunction	object
ExternalNSSFFunction	externalNssfFunction	object
AMFSet	amfSet	object
AMFRegion	amfRegion	object
ExternalAMFFunction	externalAmfFunction	object

## G.3.2 Attributes mapping

Mapping from the attributes of IOCs defined in the information model to SS equivalent definitions are listed in the following table.



Object Attributes	JSON definitions' Name	JSON Type
amfIdentifier	amfIdentifier	AmfIdentifier
amfSetId	amfSetId	AmfSetId
amfRegionId	amfRegionId	AmfRegionId
localAddress	localAddress	nrNrm:IPEndPoint
remoteAddress	remoteAddress	nrNrm:IPEndPoint
nfProfileList	nfProfileList	NfProfileList
nSIIdList	nSIIdList	NSIIdList
sNSSAIList	snssaiList	nrNrm:SnssaiList
plmnIdList	plmnIdList	nrNrm:PlmnIdList
sBIFQDN	sBIFQDN	SBIFqdn
sBIServiceList	sBIServiceList	SBIServiceList
nRTACLlist	tACLlist	TACLlist
weightFactor	weightFactor	WeightFactor

## G.4 Solution Set definitions

### G.4.1 JSON definition structure

JSON is used as resource representations format carried in the HTTP request and HTTP response message bodies. The properties (key-value pairs) on an object are defined using the properties keyword.

### G.4.2 Graphical representation

The graphical representation is not present in the current version of the present document.

### G.4.3 JSON schema "ngcNrm.json"

```
{
  "$schema": "http://json-schema.org/draft-05/schema#",
  "id": "http://3gpp.org/28541/ngcNrm.json",
  "description": "JSON based solution set definitions for 5GC",
  "_referenced_schema": "http://3gpp.org/28623/genericNrm.json",
  "_referenced_schema": "http://3gpp.org/28626/stateManagementNrm.json",
  "_referenced_schema": "http://3gpp.org/28541/nrNrm.json",
  "definitions": {
    "amfFunction": {
      "type": "object",
      "properties": {
        "id": {
          "type": "string"
        },
        "userLabel": {
          "type": "string"
        },
        "vnfParametersList": {
          "$ref": "http://3gpp.org/28623/genericNrm.json#/definitions/VnfParametersList"
        },
        "plmnIdList": {
          "$ref": "http://3gpp.org/28541/nrNrm.json#/definitions/PlmnIdList"
        },
        "amfIdentifier": {
          "$ref": "#/definitions/AmfIdentifier"
        },
        "sBIFqdn": {
          "type": "string"
        },
        "sBIServiceList": {
          "$ref": "#/definitions/SBIServiceList"
        },
        "weightFactor": {
```

```

        "$ref": "#/definitions/WeightFactor"
    },
    "snssaiList": {
        "$ref": "http://3gpp.org/28541/nrNrm.json#/definitions/SnssaiList"
    },
    "amfSet": {
        "$ref": "http://3gpp.org/28623/genericNrm.json#/definitions/Dn"
    }
},
"required": [
    "userLabel",
    "plmnIdList",
    "amfIdentifier",
    "sBIFqdn",
    "SBIServiceList",
    "weightFactor"
]
},
"smfFunction": {
    "type": "object",
    "properties": {
        "id": {
            "type": "string"
        },
        "userLabel": {
            "type": "string"
        },
        "vnfParametersList": {
            "$ref": "http://3gpp.org/28623/genericNrm.json#/definitions/VnfParametersList"
        },
        "plmnIdList": {
            "$ref": "http://3gpp.org/28541/nrNrm.json#/definitions/PlmnIdList"
        },
        "nRTACLList": {
            "$ref": "#/definitions/TACLList"
        },
        "sBIFqdn": {
            "type": "string"
        },
        "SBIServivceList": {
            "$ref": "#/definitions/SBIServiceList"
        },
        "snssaiList": {
            "$ref": "http://3gpp.org/28541/nrNrm.json#/definitions/SnssaiList"
        }
    },
    "required": [
        "userLabel",
        "plmnIdList",
        "nRTACLList",
        "sBIFqdn",
        "SBIServiceList"
    ]
},
"upfFunction": {
    "type": "object",
    "properties": {
        "id": {
            "type": "string"
        },
        "userLabel": {
            "type": "string"
        },
        "vnfParametersList": {
            "$ref": "http://3gpp.org/28623/genericNrm.json#/definitions/VnfParametersList"
        },
        "plmnIdList": {
            "$ref": "http://3gpp.org/28541/nrNrm.json#/definitions/PlmnIdList"
        },
        "nRTACLList": {
            "$ref": "#/definitions/TACLList"
        },
        "snssaiList": {
            "$ref": "http://3gpp.org/28541/nrNrm.json#/definitions/SnssaiList"
        }
    },
    "required": [

```

```

        "userLabel",
        "plmnIdList",
        "nRTACLList"
    ]
},
"n3iwfFunction": {
    "type": "object",
    "properties": {
        "id": {
            "type": "string"
        },
        "userLabel": {
            "type": "string"
        },
        "vnfParametersList": {
            "$ref": "http://3gpp.org/28623/genericNrm.json#/definitions/VnfParametersList"
        },
        "plmnIdList": {
            "$ref": "http://3gpp.org/28541/nrNrm.json#/definitions/PlmnIdList"
        }
    },
    "required": [
        "userLabel",
        "plmnIdList"
    ]
},
"pcfFunction": {
    "type": "object",
    "properties": {
        "id": {
            "type": "string"
        },
        "userLabel": {
            "type": "string"
        },
        "vnfParametersList": {
            "$ref": "http://3gpp.org/28623/genericNrm.json#/definitions/VnfParametersList"
        },
        "plmnIdList": {
            "$ref": "http://3gpp.org/28541/nrNrm.json#/definitions/PlmnIdList"
        },
        "sBIFqdn": {
            "type": "string"
        },
        "SBIServceList": {
            "$ref": "#/definitions/SBIServiceList"
        },
        "snssaiList": {
            "$ref": "http://3gpp.org/28541/nrNrm.json#/definitions/SnssaiList"
        }
    },
    "required": [
        "userLabel",
        "plmnIdList",
        "sBIFqdn",
        "SBIServiceList"
    ]
},
"ausfFunction": {
    "type": "object",
    "properties": {
        "id": {
            "type": "string"
        },
        "userLabel": {
            "type": "string"
        },
        "vnfParametersList": {
            "$ref": "http://3gpp.org/28623/genericNrm.json#/definitions/VnfParametersList"
        },
        "plmnIdList": {
            "$ref": "http://3gpp.org/28541/nrNrm.json#/definitions/PlmnIdList"
        },
        "sBIFqdn": {
            "type": "string"
        },
        "SBIServceList": {
            "$ref": "#/definitions/SBIServiceList"
        }
    }
}

```

```

    },
    "snssaiList": {
      "$ref": "http://3gpp.org/28541/nrNrm.json#/definitions/SnssaiList"
    }
  },
  "required": [
    "userLabel",
    "plmnIdList",
    "sBIFqdn",
    "SBIServiceList"
  ]
},
]
},
"udmFunction": {
  "type": "object",
  "properties": {
    "id": {
      "type": "string"
    },
    "userLabel": {
      "type": "string"
    },
    "vnfParametersList": {
      "$ref": "http://3gpp.org/28623/genericNrm.json#/definitions/VnfParametersList"
    },
    "plmnIdList": {
      "$ref": "http://3gpp.org/28541/nrNrm.json#/definitions/PlmnIdList"
    },
    "sBIFqdn": {
      "type": "string"
    },
    "SBIServiceList": {
      "$ref": "#/definitions/SBIServiceList"
    },
    "snssaiList": {
      "$ref": "http://3gpp.org/28541/nrNrm.json#/definitions/SnssaiList"
    }
  },
  "required": [
    "userLabel",
    "plmnIdList",
    "sBIFqdn",
    "SBIServiceList"
  ]
},
]
},
"udrFunction": {
  "type": "object",
  "properties": {
    "id": {
      "type": "string"
    },
    "userLabel": {
      "type": "string"
    },
    "vnfParametersList": {
      "$ref": "http://3gpp.org/28623/genericNrm.json#/definitions/VnfParametersList"
    },
    "plmnIdList": {
      "$ref": "http://3gpp.org/28541/nrNrm.json#/definitions/PlmnIdList"
    },
    "sBIFqdn": {
      "type": "string"
    },
    "SBIServiceList": {
      "$ref": "#/definitions/SBIServiceList"
    },
    "snssaiList": {
      "$ref": "http://3gpp.org/28541/nrNrm.json#/definitions/SnssaiList"
    }
  },
  "required": [
    "userLabel",
    "plmnIdList",
    "sBIFqdn",
    "SBIServiceList"
  ]
},
]
},
"udsfFunction": {
  "type": "object",

```

```

"properties": {
  "id": {
    "type": "string"
  },
  "userLabel": {
    "type": "string"
  },
  "vnfParametersList": {
    "$ref": "http://3gpp.org/28623/genericNrm.json#/definitions/VnfParametersList"
  },
  "plmnIdList": {
    "$ref": "http://3gpp.org/28541/nrNrm.json#/definitions/PlmnIdList"
  },
  "sBIFqdn": {
    "type": "string"
  },
  "sBIServiceList": {
    "$ref": "#/definitions/SBIServiceList"
  },
  "snssaiList": {
    "$ref": "http://3gpp.org/28541/nrNrm.json#/definitions/SnssaiList"
  }
},
"required": [
  "userLabel",
  "plmnIdList",
  "sBIFqdn",
  "sBIServiceList"
]
},
"nrfFunction": {
  "type": "object",
  "properties": {
    "id": {
      "type": "string"
    },
    "userLabel": {
      "type": "string"
    },
    "vnfParametersList": {
      "$ref": "http://3gpp.org/28623/genericNrm.json#/definitions/VnfParametersList"
    },
    "plmnIdList": {
      "$ref": "http://3gpp.org/28541/nrNrm.json#/definitions/PlmnIdList"
    },
    "sBIFqdn": {
      "type": "string"
    },
    "nSIIdList": {
      "$ref": "#/definitions/NSIIdList"
    },
    "nFProfileList": {
      "$ref": "#/definitions/NFProfileList"
    },
    "snssaiList": {
      "$ref": "http://3gpp.org/28541/nrNrm.json#/definitions/SnssaiList"
    }
  },
  "required": [
    "userLabel",
    "plmnIdList",
    "sBIFqdn"
  ]
},
"nssfFunction": {
  "type": "object",
  "properties": {
    "id": {
      "type": "string"
    },
    "userLabel": {
      "type": "string"
    },
    "vnfParametersList": {
      "$ref": "http://3gpp.org/28623/genericNrm.json#/definitions/VnfParametersList"
    },
    "plmnIdList": {
      "$ref": "http://3gpp.org/28541/nrNrm.json#/definitions/PlmnIdList"
    }
  }
}

```

```

    },
    "sBIFqdn": {
      "type": "string"
    },
    "nSIIdList": {
      "$ref": "#/definitions/NSIIdList"
    },
    "nFProfileList": {
      "$ref": "#/definitions/NFProfileList"
    },
    "snssaiList": {
      "$ref": "http://3gpp.org/28541/nrNrm.json#/definitions/SnssaiList"
    }
  },
  "required": [
    "userLabel",
    "plmnIdList",
    "sBIFqdn"
  ]
},
"smsfFunction": {
  "type": "object",
  "properties": {
    "id": {
      "type": "string"
    },
    "userLabel": {
      "type": "string"
    },
    "vnfParametersList": {
      "$ref": "http://3gpp.org/28623/genericNrm.json#/definitions/VnfParametersList"
    },
    "plmnIdList": {
      "$ref": "http://3gpp.org/28541/nrNrm.json#/definitions/PlmnIdList"
    },
    "sBIFqdn": {
      "type": "string"
    },
    "SBIServivceList": {
      "$ref": "#/definitions/SBIServiceList"
    }
  },
  "required": [
    "userLabel",
    "plmnIdList",
    "sBIFqdn",
    "SBIServiceList"
  ]
},
"lmfFunction": {
  "type": "object",
  "properties": {
    "id": {
      "type": "string"
    },
    "userLabel": {
      "type": "string"
    },
    "vnfParametersList": {
      "$ref": "http://3gpp.org/28623/genericNrm.json#/definitions/VnfParametersList"
    },
    "plmnIdList": {
      "$ref": "http://3gpp.org/28541/nrNrm.json#/definitions/PlmnIdList"
    }
  },
  "required": [
    "userLabel",
    "plmnIdList"
  ]
},
"ngeirFunction": {
  "type": "object",
  "properties": {
    "id": {
      "type": "string"
    },
    "userLabel": {
      "type": "string"
    }
  }
}

```

```

    },
    "vnfParametersList": {
      "$ref": "http://3gpp.org/28623/genericNrm.json#/definitions/VnfParametersList"
    },
    "plmnIdList": {
      "$ref": "http://3gpp.org/28541/nrNrm.json#/definitions/PlmnIdList"
    },
    "sBIFqdn": {
      "type": "string"
    },
    "sBIServicelist": {
      "$ref": "#/definitions/SBIServiceList"
    },
    "snssaiList": {
      "$ref": "http://3gpp.org/28541/nrNrm.json#/definitions/SnssaiList"
    }
  },
  "required": [
    "userLabel",
    "plmnIdList",
    "sBIFqdn",
    "SBIServiceList"
  ]
},
"seppFunction": {
  "type": "object",
  "properties": {
    "id": {
      "type": "string"
    },
    "userLabel": {
      "type": "string"
    },
    "vnfParametersList": {
      "$ref": "http://3gpp.org/28623/genericNrm.json#/definitions/VnfParametersList"
    },
    "plmnIdList": {
      "$ref": "http://3gpp.org/28541/nrNrm.json#/definitions/PlmnIdList"
    }
  },
  "required": [
    "userLabel",
    "plmnIdList"
  ]
},
"nwdafFunction": {
  "type": "object",
  "properties": {
    "id": {
      "type": "string"
    },
    "userLabel": {
      "type": "string"
    },
    "vnfParametersList": {
      "$ref": "http://3gpp.org/28623/genericNrm.json#/definitions/VnfParametersList"
    },
    "plmnIdList": {
      "$ref": "http://3gpp.org/28541/nrNrm.json#/definitions/PlmnIdList"
    },
    "sBIFqdn": {
      "type": "string"
    },
    "sBIServicelist": {
      "$ref": "#/definitions/SBIServiceList"
    },
    "snssaiList": {
      "$ref": "http://3gpp.org/28541/nrNrm.json#/definitions/SnssaiList"
    }
  },
  "required": [
    "userLabel",
    "plmnIdList",
    "sBIFqdn",
    "SBIServiceList"
  ]
},
"eP_N2": {

```

```

    "type": "object",
    "properties": {
      "id": {
        "type": "string"
      },
      "userLabel": {
        "type": "string"
      },
      "farEndEntity": {
        "$ref": "http://3gpp.org/28623/genericNrm.json#/definitions/Dn"
      },
      "localAddress": {
        "$ref": "http://3gpp.org/28541/nrNrm.json#/definitions/IPEndPoint"
      },
      "remoteAddress": {
        "$ref": "http://3gpp.org/28541/nrNrm.json#/definitions/IPEndPoint"
      }
    }
  },
  "eP_N3": {
    "type": "object",
    "properties": {
      "id": {
        "type": "string"
      },
      "userLabel": {
        "type": "string"
      },
      "farEndEntity": {
        "$ref": "http://3gpp.org/28623/genericNrm.json#/definitions/Dn"
      },
      "localAddress": {
        "$ref": "http://3gpp.org/28541/nrNrm.json#/definitions/IPEndPoint"
      }
    }
  },
  "eP_N4": {
    "type": "object",
    "properties": {
      "id": {
        "type": "string"
      },
      "userLabel": {
        "type": "string"
      },
      "farEndEntity": {
        "$ref": "http://3gpp.org/28623/genericNrm.json#/definitions/Dn"
      },
      "localAddress": {
        "$ref": "http://3gpp.org/28541/nrNrm.json#/definitions/IPEndPoint"
      },
      "remoteAddress": {
        "$ref": "http://3gpp.org/28541/nrNrm.json#/definitions/IPEndPoint"
      }
    }
  },
  "eP_N5": {
    "type": "object",
    "properties": {
      "id": {
        "type": "string"
      },
      "userLabel": {
        "type": "string"
      },
      "farEndEntity": {
        "$ref": "http://3gpp.org/28623/genericNrm.json#/definitions/Dn"
      },
      "localAddress": {
        "$ref": "http://3gpp.org/28541/nrNrm.json#/definitions/IPEndPoint"
      },
      "remoteAddress": {
        "$ref": "http://3gpp.org/28541/nrNrm.json#/definitions/IPEndPoint"
      }
    }
  },
  "eP_N6": {
    "type": "object",

```



```

    "properties": {
      "id": {
        "type": "string"
      },
      "userLabel": {
        "type": "string"
      },
      "farEndEntity": {
        "$ref": "http://3gpp.org/28623/genericNrm.json#/definitions/Dn"
      },
      "localAddress": {
        "$ref": "http://3gpp.org/28541/nrNrm.json#/definitions/IPEndPoint"
      },
      "remoteAddress": {
        "$ref": "http://3gpp.org/28541/nrNrm.json#/definitions/IPEndPoint"
      }
    }
  },
  "eP_N7": {
    "type": "object",
    "properties": {
      "id": {
        "type": "string"
      },
      "userLabel": {
        "type": "string"
      },
      "farEndEntity": {
        "$ref": "http://3gpp.org/28623/genericNrm.json#/definitions/Dn"
      },
      "localAddress": {
        "$ref": "http://3gpp.org/28541/nrNrm.json#/definitions/IPEndPoint"
      },
      "remoteAddress": {
        "$ref": "http://3gpp.org/28541/nrNrm.json#/definitions/IPEndPoint"
      }
    }
  },
  "eP_N8": {
    "type": "object",
    "properties": {
      "id": {
        "type": "string"
      },
      "userLabel": {
        "type": "string"
      },
      "farEndEntity": {
        "$ref": "http://3gpp.org/28623/genericNrm.json#/definitions/Dn"
      },
      "localAddress": {
        "$ref": "http://3gpp.org/28541/nrNrm.json#/definitions/IPEndPoint"
      },
      "remoteAddress": {
        "$ref": "http://3gpp.org/28541/nrNrm.json#/definitions/IPEndPoint"
      }
    }
  },
  "eP_N9": {
    "type": "object",
    "properties": {
      "id": {
        "type": "string"
      },
      "userLabel": {
        "type": "string"
      },
      "farEndEntity": {
        "$ref": "http://3gpp.org/28623/genericNrm.json#/definitions/Dn"
      },
      "localAddress": {
        "$ref": "http://3gpp.org/28541/nrNrm.json#/definitions/IPEndPoint"
      }
    }
  },
  "eP_N10": {
    "type": "object",
    "properties": {

```

```

        "id": {
          "type": "string"
        },
        "userLabel": {
          "type": "string"
        },
        "farEndEntity": {
          "$ref": "http://3gpp.org/28623/genericNrm.json#/definitions/Dn"
        },
        "localAddress": {
          "$ref": "http://3gpp.org/28541/nrNrm.json#/definitions/IPEndPoint"
        },
        "remoteAddress": {
          "$ref": "http://3gpp.org/28541/nrNrm.json#/definitions/IPEndPoint"
        }
      }
    },
    "eP_N11": {
      "type": "object",
      "properties": {
        "id": {
          "type": "string"
        },
        "userLabel": {
          "type": "string"
        },
        "farEndEntity": {
          "$ref": "http://3gpp.org/28623/genericNrm.json#/definitions/Dn"
        },
        "localAddress": {
          "$ref": "http://3gpp.org/28541/nrNrm.json#/definitions/IPEndPoint"
        },
        "remoteAddress": {
          "$ref": "http://3gpp.org/28541/nrNrm.json#/definitions/IPEndPoint"
        }
      }
    },
    "eP_N12": {
      "type": "object",
      "properties": {
        "id": {
          "type": "string"
        },
        "userLabel": {
          "type": "string"
        },
        "farEndEntity": {
          "$ref": "http://3gpp.org/28623/genericNrm.json#/definitions/Dn"
        },
        "localAddress": {
          "$ref": "http://3gpp.org/28541/nrNrm.json#/definitions/IPEndPoint"
        },
        "remoteAddress": {
          "$ref": "http://3gpp.org/28541/nrNrm.json#/definitions/IPEndPoint"
        }
      }
    },
    "eP_N13": {
      "type": "object",
      "properties": {
        "id": {
          "type": "string"
        },
        "userLabel": {
          "type": "string"
        },
        "farEndEntity": {
          "$ref": "http://3gpp.org/28623/genericNrm.json#/definitions/Dn"
        },
        "localAddress": {
          "$ref": "http://3gpp.org/28541/nrNrm.json#/definitions/IPEndPoint"
        },
        "remoteAddress": {
          "$ref": "http://3gpp.org/28541/nrNrm.json#/definitions/IPEndPoint"
        }
      }
    },
    "eP_N14": {

```

```

    "type": "object",
    "properties": {
      "id": {
        "type": "string"
      },
      "userLabel": {
        "type": "string"
      },
      "farEndEntity": {
        "$ref": "http://3gpp.org/28623/genericNrm.json#/definitions/Dn"
      },
      "localAddress": {
        "$ref": "http://3gpp.org/28541/nrNrm.json#/definitions/IPEndPoint"
      },
      "remoteAddress": {
        "$ref": "http://3gpp.org/28541/nrNrm.json#/definitions/IPEndPoint"
      }
    }
  },
  "eP_N15": {
    "type": "object",
    "properties": {
      "id": {
        "type": "string"
      },
      "userLabel": {
        "type": "string"
      },
      "farEndEntity": {
        "$ref": "http://3gpp.org/28623/genericNrm.json#/definitions/Dn"
      },
      "localAddress": {
        "$ref": "http://3gpp.org/28541/nrNrm.json#/definitions/IPEndPoint"
      },
      "remoteAddress": {
        "$ref": "http://3gpp.org/28541/nrNrm.json#/definitions/IPEndPoint"
      }
    }
  },
  "eP_N16": {
    "type": "object",
    "properties": {
      "id": {
        "type": "string"
      },
      "userLabel": {
        "type": "string"
      },
      "farEndEntity": {
        "$ref": "http://3gpp.org/28623/genericNrm.json#/definitions/Dn"
      },
      "localAddress": {
        "$ref": "http://3gpp.org/28541/nrNrm.json#/definitions/IPEndPoint"
      },
      "remoteAddress": {
        "$ref": "http://3gpp.org/28541/nrNrm.json#/definitions/IPEndPoint"
      }
    }
  },
  "eP_N17": {
    "type": "object",
    "properties": {
      "id": {
        "type": "string"
      },
      "userLabel": {
        "type": "string"
      },
      "farEndEntity": {
        "$ref": "http://3gpp.org/28623/genericNrm.json#/definitions/Dn"
      },
      "localAddress": {
        "$ref": "http://3gpp.org/28541/nrNrm.json#/definitions/IPEndPoint"
      },
      "remoteAddress": {
        "$ref": "http://3gpp.org/28541/nrNrm.json#/definitions/IPEndPoint"
      }
    }
  }
}

```

```

    },
    "eP_N20": {
      "type": "object",
      "properties": {
        "id": {
          "type": "string"
        },
        "userLabel": {
          "type": "string"
        },
        "farEndEntity": {
          "$ref": "http://3gpp.org/28623/genericNrm.json#/definitions/Dn"
        },
        "localAddress": {
          "$ref": "http://3gpp.org/28541/nrNrm.json#/definitions/IPEndPoint"
        },
        "remoteAddress": {
          "$ref": "http://3gpp.org/28541/nrNrm.json#/definitions/IPEndPoint"
        }
      }
    },
    "eP_N21": {
      "type": "object",
      "properties": {
        "id": {
          "type": "string"
        },
        "userLabel": {
          "type": "string"
        },
        "farEndEntity": {
          "$ref": "http://3gpp.org/28623/genericNrm.json#/definitions/Dn"
        },
        "localAddress": {
          "$ref": "http://3gpp.org/28541/nrNrm.json#/definitions/IPEndPoint"
        },
        "remoteAddress": {
          "$ref": "http://3gpp.org/28541/nrNrm.json#/definitions/IPEndPoint"
        }
      }
    },
    "eP_N22": {
      "type": "object",
      "properties": {
        "id": {
          "type": "string"
        },
        "userLabel": {
          "type": "string"
        },
        "farEndEntity": {
          "$ref": "http://3gpp.org/28623/genericNrm.json#/definitions/Dn"
        },
        "localAddress": {
          "$ref": "http://3gpp.org/28541/nrNrm.json#/definitions/IPEndPoint"
        },
        "remoteAddress": {
          "$ref": "http://3gpp.org/28541/nrNrm.json#/definitions/IPEndPoint"
        }
      }
    },
    "eP_N26": {
      "type": "object",
      "properties": {
        "id": {
          "type": "string"
        },
        "userLabel": {
          "type": "string"
        },
        "farEndEntity": {
          "$ref": "http://3gpp.org/28623/genericNrm.json#/definitions/Dn"
        },
        "localAddress": {
          "$ref": "http://3gpp.org/28541/nrNrm.json#/definitions/IPEndPoint"
        },
        "remoteAddress": {
          "$ref": "http://3gpp.org/28541/nrNrm.json#/definitions/IPEndPoint"
        }
      }
    }
  }

```

```

    }
  },
  "eP_SBI_X": {
    "type": "object",
    "properties": {
      "id": {
        "type": "string"
      },
      "userLabel": {
        "type": "string"
      },
      "farEndEntity": {
        "$ref": "http://3gpp.org/28623/genericNrm.json#/definitions/Dn"
      },
      "localAddress": {
        "$ref": "http://3gpp.org/28541/nrNrm.json#/definitions/IPEndPoint"
      },
      "remoteAddress": {
        "$ref": "http://3gpp.org/28541/nrNrm.json#/definitions/IPEndPoint"
      }
    }
  },
  "eP_SBI_IPX": {
    "type": "object",
    "properties": {
      "id": {
        "type": "string"
      },
      "userLabel": {
        "type": "string"
      },
      "farEndEntity": {
        "$ref": "http://3gpp.org/28623/genericNrm.json#/definitions/Dn"
      },
      "localAddress": {
        "$ref": "http://3gpp.org/28541/nrNrm.json#/definitions/IPEndPoint"
      },
      "remoteAddress": {
        "$ref": "http://3gpp.org/28541/nrNrm.json#/definitions/IPEndPoint"
      }
    }
  },
  "eP_S5C": {
    "type": "object",
    "properties": {
      "id": {
        "type": "string"
      },
      "userLabel": {
        "type": "string"
      },
      "farEndEntity": {
        "$ref": "http://3gpp.org/28623/genericNrm.json#/definitions/Dn"
      },
      "localAddress": {
        "$ref": "http://3gpp.org/28541/nrNrm.json#/definitions/IPEndPoint"
      },
      "remoteAddress": {
        "$ref": "http://3gpp.org/28541/nrNrm.json#/definitions/IPEndPoint"
      }
    }
  },
  "eP_S5U": {
    "type": "object",
    "properties": {
      "id": {
        "type": "string"
      },
      "userLabel": {
        "type": "string"
      },
      "farEndEntity": {
        "$ref": "http://3gpp.org/28623/genericNrm.json#/definitions/Dn"
      },
      "localAddress": {
        "$ref": "http://3gpp.org/28541/nrNrm.json#/definitions/IPEndPoint"
      }
    }
  }
}

```

```

    }
  },
  "eP_Rx": {
    "type": "object",
    "properties": {
      "id": {
        "type": "string"
      },
      "userLabel": {
        "type": "string"
      },
      "farEndEntity": {
        "$ref": "http://3gpp.org/28623/genericNrm.json#/definitions/Dn"
      },
      "localAddress": {
        "$ref": "http://3gpp.org/28541/nrNrm.json#/definitions/IPEndPoint"
      },
      "remoteAddress": {
        "$ref": "http://3gpp.org/28541/nrNrm.json#/definitions/IPEndPoint"
      }
    }
  },
  "eP_MAP_SMSC": {
    "type": "object",
    "properties": {
      "id": {
        "type": "string"
      },
      "userLabel": {
        "type": "string"
      },
      "farEndEntity": {
        "$ref": "http://3gpp.org/28623/genericNrm.json#/definitions/Dn"
      },
      "localAddress": {
        "$ref": "http://3gpp.org/28541/nrNrm.json#/definitions/IPEndPoint"
      },
      "remoteAddress": {
        "$ref": "http://3gpp.org/28541/nrNrm.json#/definitions/IPEndPoint"
      }
    }
  },
  "eP_NLS": {
    "type": "object",
    "properties": {
      "id": {
        "type": "string"
      },
      "userLabel": {
        "type": "string"
      },
      "farEndEntity": {
        "$ref": "http://3gpp.org/28623/genericNrm.json#/definitions/Dn"
      },
      "localAddress": {
        "$ref": "http://3gpp.org/28541/nrNrm.json#/definitions/IPEndPoint"
      },
      "remoteAddress": {
        "$ref": "http://3gpp.org/28541/nrNrm.json#/definitions/IPEndPoint"
      }
    }
  },
  "eP_NLG": {
    "type": "object",
    "properties": {
      "id": {
        "type": "string"
      },
      "userLabel": {
        "type": "string"
      },
      "farEndEntity": {
        "$ref": "http://3gpp.org/28623/genericNrm.json#/definitions/Dn"
      },
      "localAddress": {
        "$ref": "http://3gpp.org/28541/nrNrm.json#/definitions/IPEndPoint"
      },
      "remoteAddress": {

```

```

        "$ref": "http://3gpp.org/28541/nrNrm.json#/definitions/IPEndPoint"
    }
},
"amfSet": {
    "type": "object",
    "properties": {
        "id": {
            "type": "string"
        },
        "userLabel": {
            "type": "string"
        },
        "plmnIdList": {
            "$ref": "http://3gpp.org/28541/nrNrm.json#/definitions/PlmnIdList"
        },
        "nRTACLList": {
            "$ref": "#/definitions/TACLList"
        },
        "amfSetId": {
            "$ref": "#/definitions/AmfSetId"
        },
        "snssaiList": {
            "$ref": "http://3gpp.org/28541/nrNrm.json#/definitions/SnssaiList"
        }
    },
    "required": [
        "plmnIdList",
        "nRTACLList",
        "amfSetId"
    ]
},
"amfRegion": {
    "type": "object",
    "properties": {
        "id": {
            "type": "string"
        },
        "userLabel": {
            "type": "string"
        },
        "plmnIdList": {
            "$ref": "http://3gpp.org/28541/nrNrm.json#/definitions/PlmnIdList"
        },
        "nRTACLList": {
            "$ref": "#/definitions/TACLList"
        },
        "amfRegionId": {
            "$ref": "#/definitions/AmfRegionId"
        },
        "snssaiList": {
            "$ref": "http://3gpp.org/28541/nrNrm.json#/definitions/SnssaiList"
        }
    },
    "required": [
        "plmnIdList",
        "nRTACLList",
        "amfRegionId"
    ]
},
"AmfIdentifier": {
    "type": "object",
    "description": "AmfIdentifier comprise of amfRegionId, amfSetId and amfPointer",
    "properties": {
        "amfRegionId": {
            "$ref": "#/definitions/AmfRegionId"
        },
        "amfSetId": {
            "$ref": "#/definitions/AmfSetId"
        },
        "amfPointer": {
            "$ref": "#/definitions/AmfPointer"
        }
    }
},
"AmfRegionId": {
    "type": "integer",

```

```

    "description": "AmfRegionId is defined in TS 23.003",
    "maximum": 255
  },
  "AmfSetId": {
    "type": "string",
    "description": "AmfSetId is defined in TS 23.003",
    "maximum": 1023
  },
  "AmfPointer": {
    "type": "integer",
    "description": "AmfPointer is defined in TS 23.003",
    "maximum": 63
  },
  "nFProfileList": {
    "type": "array",
    "description": "List of NF profile",
    "items": {
      "$ref": "#/definitions/NFProfile"
    }
  },
  "NFProfile": {
    "type": "object",
    "description": "NF profile stored in NRF, defined in TS 29.510",
    "properties": {
      "nFInstanceId": {
        "type": "string",
        "description": "uuid of NF instance"
      },
      "NFType": {
        "$ref": "#/definitions/NFType"
      },
      "NFStatus": {
        "$ref": "#/definitions/NFStatus"
      },
      "plmn": {
        "$ref": "http://3gpp.org/28541/nrNrm.json#/definitions/PlmnId"
      },
      "sNssais": {
        "$ref": "http://3gpp.org/28541/nrNrm.json#/definitions/Snssai"
      },
      "fqdn": {
        "$ref": "#/definitions/Fqdn"
      },
      "interPlmnFqdn": {
        "$ref": "#/definitions/Fqdn"
      },
      "ipv4Addresses": {
        "type": "array",
        "item": {
          "$ref": "#/definitions/Ipv4Addr"
        }
      },
      "ipv6Addresses": {
        "type": "array",
        "item": {
          "$ref": "#/definitions/Ipv6Addr"
        }
      },
      "ipv6Prefixes": {
        "type": "array",
        "item": {
          "$ref": "#/definitions/Ipv6Prefix"
        }
      },
      "capacity": {
        "$ref": "#/definitions/Capacity"
      },
      "udrInfo": {
        "$ref": "#/definitions/UdrInfo"
      },
      "amfInfo": {
        "$ref": "#/definitions/amfInfo"
      },
      "smfInfo": {
        "$ref": "#/definitions/SmfInfo"
      },
      "upfInfo": {
        "$ref": "#/definitions/UpfInfo"
      }
    }
  }

```



```

    },
    "nfServices": {
      "type": "array",
      "item": {
        "$ref": "#/definitions/NFService"
      }
    }
  },
  "NFService": {
    "type": "object",
    "description": "NF Service is defined in TS 29.510",
    "properties": {
      "serviceInstanceId": {
        "type": "string",
      },
      "serviceName": {
        "type": "string",
      },
      "version": {
        "type": "string",
      },
      "schema": {
        "type": "string",
      },
      "fqdn": {
        "$ref": "#/definitions/Fqdn"
      },
      "interPlmnFqdn": {
        "$ref": "#/definitions/Fqdn"
      },
      "ipEndPoints": {
        "type": "array",
        "item": {
          "$ref": "#/definitions/IpEndPoint"
        }
      },
      "apiPrefix": {
        "type": "string",
      },
      "defaultNotificationSubscriptions": {
        "type": "array",
        "item": {
          "$ref": "#/definitions/DefaultNotificationSubscriptions"
        }
      },
      "allowedPlmns": {
        "$ref": "http://3gpp.org/28541/nrNrm.json#/definitions/PlmnId"
      },
      "allowedNfTypes": {
        "type": "array",
        "item": {
          "$ref": "#/definitions/NFType"
        }
      },
      "allowedNssais": {
        "type": "array",
        "item": {
          "$ref": "#/definitions/Snssai"
        }
      },
      "capacity": {
        "$ref": "#/definitions/Capacity"
      },
      "supportedFeatures": {
        "$ref": "#/definitions/SupportedFeatures"
      }
    }
  },
  "NFType": {
    "type": "string",
    "description": "NF name defined in TS 23.501",
    "enum": [
      "NRF",
      "UDM",
      "AMF",
      "SMF",
      "AUSF",
    ]
  }
}

```

```

        "NEF",
        "PCF",
        "SMF",
        "NSSF",
        "UDR",
        "LMF",
        "GMLC",
        "5G_EIR",
        "SEPP",
        "UPF",
        "N3IWF",
        "AF",
        "UDSF",
        "DN"
    ]
},
"Fqdn": {
    "type": "string"
},
"EndPoint": {
    "type": "object",
    "properties": {
        "ipv4Address": {
            "$ref": "#/definitions/Ipv4Addr"
        },
        "ipv6Address": {
            "$ref": "#/definitions/Ipv6Addr"
        },
        "ipv6Prefix": {
            "$ref": "#/definitions/Ipv6Prefix"
        },
        "transport": {
            "$ref": "#/definitions/TransportProtocol"
        },
        "port": {
            "type": "integer"
        }
    }
},
"UdrInfo": {
    "type": "object",
    "properties": {
        "supiRanges": {
            "type": "array",
            "items": {
                "$ref": "#/definitions/SupiRange"
            }
        }
    }
},
"SupiRange": {
    "type": "object",
    "properties": {
        "start": {
            "type": "string"
        },
        "end": {
            "type": "string"
        },
        "pattern": {
            "type": "string"
        }
    }
},
"AmfInfo": {
    "type": "object",
    "properties": {
        "amfSetId": {
            "$ref": "#/definitions/AmfSetId"
        }
    }
},
"SmfInfo": {
    "type": "object",
    "properties": {
        "dnnList": {
            "type": "array",
            "items": {

```

```

        "$ref": "#/definitions/Dnn"
      }
    }
  },
  "UpfInfo": {
    "type": "object",
    "properties": {
      "sNssaiUpfInfoList": {
        "type": "array",
        "items": {
          "$ref": "#/definitions/SnssaiUpfInfoItem"
        }
      }
    }
  },
  "SnssaiUpfInfoItem": {
    "type": "object",
    "properties": {
      "sNssai": {
        "$ref": "#/definitions/Snssai"
      },
      "dnnUpfInfoList": {
        "type": "array",
        "items": {
          "$ref": "#/definitions/DnnUpfInfoListInfo"
        }
      }
    }
  },
  "DnnUpfInfoItem": {
    "type": "object",
    "properties": {
      "dnn": {
        "$ref": "#/definitions/Dnn"
      }
    }
  },
  "DefaultNotificationSubscription": {
    "type": "object",
    "properties": {
      "notificationType": {
        "$ref": "#/definitions/NotificationType"
      },
      "callbackUri": {
        "$ref": "#/definitions/Uri"
      },
      "n1MessageClass": {
        "$ref": "#/definitions/N1MessageClass"
      },
      "n2InformationClass": {
        "$ref": "#/definitions/n2InformationClass"
      }
    }
  },
  "NotificationType": {
    "type": "string",
    "description": "any of enumerated value",
    "enum": [
      "N1_MESSAGES",
      "N2_INFORMATION",
      "LOCATION_NOTIFICATION"
    ]
  },
  "TransportProtocol": {
    "type": "string",
    "description": "any of enumerated value",
    "enum": [
      "TCP"
    ]
  },
  "NFStatus": {
    "type": "string",
    "description": "any of enumerated value",
    "enum": [
      "REGISTERED",
      "SUSPENDED"
    ]
  }
]

```

```
    },
    "NFRegistrationData": {
      "type": "object",
      "properties": {
        "heartBeatTimer": {
          "type": "integer"
        },
        "nfProfile": {
          "$ref": "#/definitions/NFProfile"
        }
      }
    },
    "NSIIdList": {
      "type": "array",
      "items": {
        "nSIId": {
          "$ref": "#/definitions/NSIId"
        }
      }
    },
    "NSIId": {
      "type": "string",
      "description": "NSI Id is defined in TS 29.531"
    },
    "NrCellId": {
      "type": "string",
    },
    "SBIFqdn": {
      "$ref": "#/definitions/Fqdn"
    },
    "SBIServiceList": {
      "type": "array",
      "item": {
        "$ref": "#/definitions/NFService"
      }
    },
    "TACLlist": {
      "type": "array",
      "item": {
        "$ref": "http://3gpp.org/28541/nrNrm.json#/definitions/NrTac"
      }
    },
    "weightFactor": {
      "type": "integer"
    }
  }
}
```

# Annex H (normative): YANG definitions for 5GC

## H.1 General

This annex contains the YANG definitions for the 5GC NRM, in accordance with 5GC information model definitions specified in clause 4.

## H.2 Architectural features

## H.3 Mapping

### H.3.1 IOC mapping

Mapping from the IOCs defined in the information model to SS equivalent definitions are listed in the following table.

IOC Name	YANG definitions' Name	YANG Type
SubNetwork	SubNetwork	Container in module
ManagedElement	ManagedElement	Container in module
AMFFunction	AMFFunction	Container in submodule
SMFFunction	SMFFunction	Container in submodule
UPFFunction	UPFFunction	Container in submodule
N3IWFFunction	N3IWFFunction	Container in submodule
PCFFunction	PCFFunction	Container in submodule
AUSFFunction	AUSFFunction	Container in submodule
UDMFunction	UDMFunction	Container in submodule
UDRFunction	UDRFunction	Container in submodule
UDSFFunction	UDSFFunction	Container in submodule
NRFFunction	NRFFunction	Container in submodule
NSSFFunction	NSSFFunction	Container in submodule
SMSFFunction	SMSFFunction	Container in submodule
LMFFunction	LMFFunction	Container in submodule
NGEIRFunction	NGEIRFunction	Container in submodule
SEPPFunction	SEPPFunction	Container in submodule
NWDAFFunction	NWDAFFunction	Container in submodule
EP_***	EP_***	Reusable container in module

### H.3.2 Attributes mapping

Mapping from the attributes of IOCs defined in the information model to SS equivalent definitions are listed in the following table.

Object Attributes	YANG definitions' Name	YANG Type
Simple Type Attributes	Same to the Name in Stage 2	leaf
Complex Type Attribute	Same to the Name in Stage 2	Reusable Container
Simple Type List	Same to the Name in Stage 2 with removing List/s at the end of the attribute	leaf-list
Complex Type List	Same to the Name in Stage 2 with removing List/s at the end of the attribute	list

## H.4 Solution Set definitions

### H.4.1 YANG definition structure

### H.4.2 Graphical representation

```

module: ngc
  +--rw SubNetwork
    +--ro objectClass          string
    +--ro objectInstance      nrm-type:t_dn
    +--ro id                   nrm-type:t_dn
    +--ro dnPrefix            string
    +--rw userLabel            string
    +--rw userDefinedNetworkType string
    +--ro setOfMcc*           nrm-type:t_mcc
    +--rw ManagedElement
      +--ro objectClass          string
      +--ro objectInstance      nrm-type:t_dn
      +--ro id                   nrm-type:t_dn
      +--ro vendorName          string
      +--rw userDefinedState    string
      +--ro swVersion           string
      +--ro dnPrefix            string
      +--rw userLabel            string
      +--ro locationName        string
      +--ro managedBy*          nrm-type:t_dn
      +--ro managedElementList* string
    +--rw AMFFunction
      | +--ro objectClass          string
      | +--ro objectInstance      nrm-type:t_dn
      | +--ro id                   nrm-type:t_dn
      | +--rw userLabel            string
      | +--rw vnfParametersList
      | | +--rw vnfInstanceId    string
      | | +--rw vnfId            string
      | | +--rw flavourId        string
      | | +--rw autoScalable     boolean
      | +--rw peeParametersList
      | | +--rw siteIdentification string
      | | +--rw siteLatitude      decimal64
      | | +--rw siteLongitude     decimal64
      | | +--rw siteDescription   string
      | | +--rw equipmentType     enumeration
      | | +--rw environmentType   enumeration
      | | +--rw powerInterface    enumeration
      | +--rw pLMNid* [MCC MNC]
      | | +--rw MCC              t_mcc
      | | +--rw MNC              t_mnc
      | +--rw aMFIdentifier
      | | +--rw AMF-Region-id    t_aMF-Region-id
      | | +--rw AMF-Set-id       t_aMF-Set-id
      | | +--rw AMF-Pointer      t_aMF-Pointer
      | +--rw sBIFQDN            inet:domain-name
      +--ro sBIService*         string

```

```

+--rw weightFactor          uint8
+--rw s-NSSAI*              nrm-type:t_s-NSSAI
+--rw EP_N2
| +--ro objectClass         string
| +--ro objectInstance     nrm-type:t_dn
| +--rw id                  nrm-type:t_dn
| +--rw userLabel          string
| +--rw farEndEntity       nrm-type:t_dn
| +--rw localAddress
| | +--rw ip_address       inet:ip-address
| | +--rw vlan_id         uint16
| +--rw remoteAddress      inet:ip-address
+--rw EP_N8
| +--ro objectClass         string
| +--ro objectInstance     nrm-type:t_dn
| +--rw id                  nrm-type:t_dn
| +--rw userLabel          string
| +--rw farEndEntity       nrm-type:t_dn
| +--rw localAddress
| | +--rw ip_address       inet:ip-address
| | +--rw vlan_id         uint16
| +--rw remoteAddress      inet:ip-address
+--rw EP_N11
| +--ro objectClass         string
| +--ro objectInstance     nrm-type:t_dn
| +--rw id                  nrm-type:t_dn
| +--rw userLabel          string
| +--rw farEndEntity       nrm-type:t_dn
| +--rw localAddress
| | +--rw ip_address       inet:ip-address
| | +--rw vlan_id         uint16
| +--rw remoteAddress      inet:ip-address
+--rw EP_N12
| +--ro objectClass         string
| +--ro objectInstance     nrm-type:t_dn
| +--rw id                  nrm-type:t_dn
| +--rw userLabel          string
| +--rw farEndEntity       nrm-type:t_dn
| +--rw localAddress
| | +--rw ip_address       inet:ip-address
| | +--rw vlan_id         uint16
| +--rw remoteAddress      inet:ip-address
+--rw EP_N14
| +--ro objectClass         string
| +--ro objectInstance     nrm-type:t_dn
| +--rw id                  nrm-type:t_dn
| +--rw userLabel          string
| +--rw farEndEntity       nrm-type:t_dn
| +--rw localAddress
| | +--rw ip_address       inet:ip-address
| | +--rw vlan_id         uint16
| +--rw remoteAddress      inet:ip-address
+--rw EP_N15
| +--ro objectClass         string
| +--ro objectInstance     nrm-type:t_dn
| +--rw id                  nrm-type:t_dn
| +--rw userLabel          string
| +--rw farEndEntity       nrm-type:t_dn
| +--rw localAddress
| | +--rw ip_address       inet:ip-address
| | +--rw vlan_id         uint16
| +--rw remoteAddress      inet:ip-address
+--rw EP_N17
| +--ro objectClass         string
| +--ro objectInstance     nrm-type:t_dn
| +--rw id                  nrm-type:t_dn
| +--rw userLabel          string
| +--rw farEndEntity       nrm-type:t_dn
| +--rw localAddress
| | +--rw ip_address       inet:ip-address
| | +--rw vlan_id         uint16
| +--rw remoteAddress      inet:ip-address
+--rw EP_N20
| +--ro objectClass         string
| +--ro objectInstance     nrm-type:t_dn
| +--rw id                  nrm-type:t_dn
| +--rw userLabel          string
| +--rw farEndEntity       nrm-type:t_dn

```

```

| | +--rw localAddress
| | | +--rw ip_address      inet:ip-address
| | | +--rw vlan_id        uint16
| | +--rw remoteAddress    inet:ip-address
+--rw EP_N22
| | +--ro objectClass      string
| | +--ro objectInstance   nrm-type:t_dn
| | +--rw id               nrm-type:t_dn
| | +--rw userLabel        string
| | +--rw farEndEntity     nrm-type:t_dn
| | +--rw localAddress
| | | +--rw ip_address      inet:ip-address
| | | +--rw vlan_id        uint16
| | +--rw remoteAddress    inet:ip-address
+--rw EP_N26
| | +--ro objectClass      string
| | +--ro objectInstance   nrm-type:t_dn
| | +--rw id               nrm-type:t_dn
| | +--rw userLabel        string
| | +--rw farEndEntity     nrm-type:t_dn
| | +--rw localAddress
| | | +--rw ip_address      inet:ip-address
| | | +--rw vlan_id        uint16
| | +--rw remoteAddress    inet:ip-address
+--rw EP_NLS
| | +--ro objectClass      string
| | +--ro objectInstance   nrm-type:t_dn
| | +--rw id               nrm-type:t_dn
| | +--rw userLabel        string
| | +--rw farEndEntity     nrm-type:t_dn
| | +--rw localAddress
| | | +--rw ip_address      inet:ip-address
| | | +--rw vlan_id        uint16
| | +--rw remoteAddress    inet:ip-address
+--rw EP_NLG
| | +--ro objectClass      string
| | +--ro objectInstance   nrm-type:t_dn
| | +--rw id               nrm-type:t_dn
| | +--rw userLabel        string
| | +--rw farEndEntity     nrm-type:t_dn
| | +--rw localAddress
| | | +--rw ip_address      inet:ip-address
| | | +--rw vlan_id        uint16
| | +--rw remoteAddress    inet:ip-address
+--rw EP_SBI_X* [id]
| | +--ro objectClass      string
| | +--ro objectInstance   nrm-type:t_dn
| | +--rw id               nrm-type:t_dn
| | +--rw userLabel        string
| | +--rw farEndEntity     nrm-type:t_dn
| | +--rw localAddress
| | | +--rw ip_address      inet:ip-address
| | | +--rw vlan_id        uint16
| | +--rw remoteAddress    inet:ip-address
| | +--ro sBIService*     string
+--rw SMFFunction
| | +--ro objectClass      string
| | +--ro objectInstance   nrm-type:t_dn
| | +--ro id               nrm-type:t_dn
| | +--rw userLabel        string
+--rw vnfParametersList
| | +--rw vnfInstanceId    string
| | +--rw vnfId            string
| | +--rw flavourId        string
| | +--rw autoScalable     boolean
+--rw peeParametersList
| | +--rw siteIdentification string
| | +--rw siteLatitude      decimal64
| | +--rw siteLongitude     decimal64
| | +--rw siteDescription   string
| | +--rw equipmentType     enumeration
| | +--rw environmentType   enumeration
| | +--rw powerInterface    enumeration
+--rw pLMNId* [MCC MNC]
| | +--rw MCC               t_mcc
| | +--rw MNC               t_mnc
+--rw sBIFQDN                inet:domain-name
+--ro sBIService*           string

```



```

+--ro tAC*                nrm-type:t_tAC
+--rw s-NSSAI*            nrm-type:t_s-NSSAI
+--rw EP_N4
| +--ro objectClass        string
| +--ro objectInstance    nrm-type:t_dn
| +--rw id                 nrm-type:t_dn
| +--rw userLabel         string
| +--rw farEndEntity      nrm-type:t_dn
| +--rw localAddress
| | +--rw ip_address      inet:ip-address
| | +--rw vlan_id        uint16
| +--rw remoteAddress     inet:ip-address
+--rw EP_N7
| +--ro objectClass        string
| +--ro objectInstance    nrm-type:t_dn
| +--rw id                 nrm-type:t_dn
| +--rw userLabel         string
| +--rw farEndEntity      nrm-type:t_dn
| +--rw localAddress
| | +--rw ip_address      inet:ip-address
| | +--rw vlan_id        uint16
| +--rw remoteAddress     inet:ip-address
+--rw EP_N10
| +--ro objectClass        string
| +--ro objectInstance    nrm-type:t_dn
| +--rw id                 nrm-type:t_dn
| +--rw userLabel         string
| +--rw farEndEntity      nrm-type:t_dn
| +--rw localAddress
| | +--rw ip_address      inet:ip-address
| | +--rw vlan_id        uint16
| +--rw remoteAddress     inet:ip-address
+--rw EP_N11
| +--ro objectClass        string
| +--ro objectInstance    nrm-type:t_dn
| +--rw id                 nrm-type:t_dn
| +--rw userLabel         string
| +--rw farEndEntity      nrm-type:t_dn
| +--rw localAddress
| | +--rw ip_address      inet:ip-address
| | +--rw vlan_id        uint16
| +--rw remoteAddress     inet:ip-address
+--rw EP_N16
| +--ro objectClass        string
| +--ro objectInstance    nrm-type:t_dn
| +--rw id                 nrm-type:t_dn
| +--rw userLabel         string
| +--rw farEndEntity      nrm-type:t_dn
| +--rw localAddress
| | +--rw ip_address      inet:ip-address
| | +--rw vlan_id        uint16
| +--rw remoteAddress     inet:ip-address
+--rw EP_S5C
| +--ro objectClass        string
| +--ro objectInstance    nrm-type:t_dn
| +--rw id                 nrm-type:t_dn
| +--rw userLabel         string
| +--rw farEndEntity      nrm-type:t_dn
| +--rw localAddress
| | +--rw ip_address      inet:ip-address
| | +--rw vlan_id        uint16
| +--rw remoteAddress     inet:ip-address
+--rw EP_SBI_X* [id]
| +--ro objectClass        string
| +--ro objectInstance    nrm-type:t_dn
| +--rw id                 nrm-type:t_dn
| +--rw userLabel         string
| +--rw farEndEntity      nrm-type:t_dn
| +--rw localAddress
| | +--rw ip_address      inet:ip-address
| | +--rw vlan_id        uint16
| +--rw remoteAddress     inet:ip-address
+--ro sBIService*        string
+--rw UPFFunction
| +--ro objectClass        string
| +--ro objectInstance    nrm-type:t_dn
| +--ro id                 nrm-type:t_dn
| +--rw userLabel         string

```

```

+--rw vnfParametersList
|   +--rw vnfInstanceId string
|   +--rw vnfId        string
|   +--rw flavourId   string
|   +--rw autoScalable boolean
+--rw peeParametersList
|   +--rw siteIdentification string
|   +--rw siteLatitude      decimal64
|   +--rw siteLongitude     decimal64
|   +--rw siteDescription   string
|   +--rw equipmentType    enumeration
|   +--rw environmentType  enumeration
|   +--rw powerInterface   enumeration
+--rw pLMNid* [MCC MNC]
|   +--rw MCC t_mcc
|   +--rw MNC t_mnc
+--ro tAC* nrm-type:t_tAC
+--rw s-NSSAI* nrm-type:t_s-NSSAI
+--rw EP_N3
|   +--ro objectClass string
|   +--ro objectInstance nrm-type:t_dn
|   +--rw id nrm-type:t_dn
|   +--rw userLabel string
|   +--rw farEndEntity nrm-type:t_dn
|   +--rw localAddress
|   |   +--rw ip_address inet:ip-address
|   |   +--rw vlan_id uint16
|   +--rw remoteAddress inet:ip-address
+--rw EP_N4
|   +--ro objectClass string
|   +--ro objectInstance nrm-type:t_dn
|   +--rw id nrm-type:t_dn
|   +--rw userLabel string
|   +--rw farEndEntity nrm-type:t_dn
|   +--rw localAddress
|   |   +--rw ip_address inet:ip-address
|   |   +--rw vlan_id uint16
|   +--rw remoteAddress inet:ip-address
+--rw EP_N9
|   +--ro objectClass string
|   +--ro objectInstance nrm-type:t_dn
|   +--rw id nrm-type:t_dn
|   +--rw userLabel string
|   +--rw farEndEntity nrm-type:t_dn
|   +--rw localAddress
|   |   +--rw ip_address inet:ip-address
|   |   +--rw vlan_id uint16
|   +--rw remoteAddress inet:ip-address
+--rw EP_N6
|   +--ro objectClass string
|   +--ro objectInstance nrm-type:t_dn
|   +--rw id nrm-type:t_dn
|   +--rw userLabel string
|   +--rw farEndEntity nrm-type:t_dn
|   +--rw localAddress
|   |   +--rw ip_address inet:ip-address
|   |   +--rw vlan_id uint16
|   +--rw remoteAddress inet:ip-address
+--rw EP_S5U
|   +--ro objectClass string
|   +--ro objectInstance nrm-type:t_dn
|   +--rw id nrm-type:t_dn
|   +--rw userLabel string
|   +--rw farEndEntity nrm-type:t_dn
|   +--rw localAddress
|   |   +--rw ip_address inet:ip-address
|   |   +--rw vlan_id uint16
|   +--rw remoteAddress inet:ip-address
+--rw N3IWFFunction
|   +--ro objectClass string
|   +--ro objectInstance nrm-type:t_dn
|   +--ro id nrm-type:t_dn
|   +--rw userLabel string
+--rw vnfParametersList
|   +--rw vnfInstanceId string
|   +--rw vnfId        string
|   +--rw flavourId   string
|   +--rw autoScalable boolean

```

```

+--rw peeParametersList
| +--rw siteIdentification      string
| +--rw siteLatitude           decimal64
| +--rw siteLongitude          decimal64
| +--rw siteDescription        string
| +--rw equipmentType          enumeration
| +--rw environmentType        enumeration
| +--rw powerInterface          enumeration
+--rw pLMNid* [MCC MNC]
| +--rw MCC      t_mcc
| +--rw MNC      t_mnc
+--rw EP_N2
| +--ro objectClass            string
| +--ro objectInstance        nrm-type:t_dn
| +--rw id                    nrm-type:t_dn
| +--rw userLabel              string
| +--rw farEndEntity           nrm-type:t_dn
| +--rw localAddress
| | +--rw ip_address          inet:ip-address
| | +--rw vlan_id            uint16
| +--rw remoteAddress          inet:ip-address
+--rw EP_N3
| +--ro objectClass            string
| +--ro objectInstance        nrm-type:t_dn
| +--rw id                    nrm-type:t_dn
| +--rw userLabel              string
| +--rw farEndEntity           nrm-type:t_dn
| +--rw localAddress
| | +--rw ip_address          inet:ip-address
| | +--rw vlan_id            uint16
| +--rw remoteAddress          inet:ip-address
+--rw PCFFunction
| +--ro objectClass            string
| +--ro objectInstance        nrm-type:t_dn
| +--ro id                    nrm-type:t_dn
| +--rw userLabel              string
+--rw vnfParametersList
| +--rw vnfInstanceId          string
| +--rw vnfId                 string
| +--rw flavourId             string
| +--rw autoScalable          boolean
+--rw peeParametersList
| +--rw siteIdentification      string
| +--rw siteLatitude           decimal64
| +--rw siteLongitude          decimal64
| +--rw siteDescription        string
| +--rw equipmentType          enumeration
| +--rw environmentType        enumeration
| +--rw powerInterface          enumeration
+--rw pLMNid* [MCC MNC]
| +--rw MCC      t_mcc
| +--rw MNC      t_mnc
+--rw sBIFQDN                  inet:domain-name
+--ro sBIService*              string
+--rw s-NSSAI*                 nrm-type:t_s-NSSAI
+--rw EP_N5
| +--ro objectClass            string
| +--ro objectInstance        nrm-type:t_dn
| +--rw id                    nrm-type:t_dn
| +--rw userLabel              string
| +--rw farEndEntity           nrm-type:t_dn
| +--rw localAddress
| | +--rw ip_address          inet:ip-address
| | +--rw vlan_id            uint16
| +--rw remoteAddress          inet:ip-address
+--rw EP_N7
| +--ro objectClass            string
| +--ro objectInstance        nrm-type:t_dn
| +--rw id                    nrm-type:t_dn
| +--rw userLabel              string
| +--rw farEndEntity           nrm-type:t_dn
| +--rw localAddress
| | +--rw ip_address          inet:ip-address
| | +--rw vlan_id            uint16
| +--rw remoteAddress          inet:ip-address
+--rw EP_N15
| +--ro objectClass            string
| +--ro objectInstance        nrm-type:t_dn

```

```

| | +--rw id nrm-type:t_dn
| | +--rw userLabel string
| | +--rw farEndEntity nrm-type:t_dn
| | +--rw localAddress
| | | +--rw ip_address inet:ip-address
| | | +--rw vlan_id uint16
| | +--rw remoteAddress inet:ip-address
+--rw EP_N16
| | +--ro objectClass string
| | +--ro objectInstance nrm-type:t_dn
| | +--rw id nrm-type:t_dn
| | +--rw userLabel string
| | +--rw farEndEntity nrm-type:t_dn
| | +--rw localAddress
| | | +--rw ip_address inet:ip-address
| | | +--rw vlan_id uint16
| | +--rw remoteAddress inet:ip-address
+--rw EP_Rx
| | +--ro objectClass string
| | +--ro objectInstance nrm-type:t_dn
| | +--rw id nrm-type:t_dn
| | +--rw userLabel string
| | +--rw farEndEntity nrm-type:t_dn
| | +--rw localAddress
| | | +--rw ip_address inet:ip-address
| | | +--rw vlan_id uint16
| | +--rw remoteAddress inet:ip-address
+--rw EP_SBI_X* [id]
| | +--ro objectClass string
| | +--ro objectInstance nrm-type:t_dn
| | +--rw id nrm-type:t_dn
| | +--rw userLabel string
| | +--rw farEndEntity nrm-type:t_dn
| | +--rw localAddress
| | | +--rw ip_address inet:ip-address
| | | +--rw vlan_id uint16
| | +--rw remoteAddress inet:ip-address
| | +--ro sBIService* string
+--rw AUSFunction
| | +--ro objectClass string
| | +--ro objectInstance nrm-type:t_dn
| | +--ro id nrm-type:t_dn
| | +--rw userLabel string
| | +--rw vnfParametersList
| | | +--rw vnfInstanceId string
| | | +--rw vnfId string
| | | +--rw flavourId string
| | | +--rw autoScalable boolean
| | +--rw peeParametersList
| | | +--rw siteIdentification string
| | | +--rw siteLatitude decimal64
| | | +--rw siteLongitude decimal64
| | | +--rw siteDescription string
| | | +--rw equipmentType enumeration
| | | +--rw environmentType enumeration
| | | +--rw powerInterface enumeration
+--rw pLMNId* [MCC MNC]
| | +--rw MCC t_mcc
| | +--rw MNC t_mnc
+--rw sBIFQDN inet:domain-name
+--ro sBIService* string
+--rw s-NSSAI* nrm-type:t_s-NSSAI
+--rw EP_N12
| | +--ro objectClass string
| | +--ro objectInstance nrm-type:t_dn
| | +--rw id nrm-type:t_dn
| | +--rw userLabel string
| | +--rw farEndEntity nrm-type:t_dn
| | +--rw localAddress
| | | +--rw ip_address inet:ip-address
| | | +--rw vlan_id uint16
| | +--rw remoteAddress inet:ip-address
+--rw EP_N13
| | +--ro objectClass string
| | +--ro objectInstance nrm-type:t_dn
| | +--rw id nrm-type:t_dn
| | +--rw userLabel string
| | +--rw farEndEntity nrm-type:t_dn

```

```

| | +--rw localAddress
| | | +--rw ip_address      inet:ip-address
| | | +--rw vlan_id         uint16
| | +--rw remoteAddress    inet:ip-address
+--rw EP_SBI_X* [id]
| +--ro objectClass       string
| +--ro objectInstance    nrm-type:t_dn
| +--rw id                 nrm-type:t_dn
| +--rw userLabel         string
| +--rw farEndEntity      nrm-type:t_dn
| +--rw localAddress
| | +--rw ip_address      inet:ip-address
| | +--rw vlan_id         uint16
| +--rw remoteAddress    inet:ip-address
| +--ro sBIService*      string
+--rw UDMFunction
| +--ro objectClass       string
| +--ro objectInstance    nrm-type:t_dn
| +--ro id                 nrm-type:t_dn
| +--rw userLabel         string
+--rw vnfParametersList
| +--rw vnfInstanceId     string
| +--rw vnfId             string
| +--rw flavourId        string
| +--rw autoScalable     boolean
+--rw peeParametersList
| +--rw siteIdentification string
| +--rw siteLatitude      decimal64
| +--rw siteLongitude     decimal64
| +--rw siteDescription   string
| +--rw equipmentType     enumeration
| +--rw environmentType   enumeration
| +--rw powerInterface    enumeration
+--rw pLMNid* [MCC MNC]
| +--rw MCC               t_mcc
| +--rw MNC               t_mnc
+--rw sBIFQDN             inet:domain-name
+--ro sBIService*        string
+--rw s-NSSAI*           nrm-type:t_s-NSSAI
+--rw EP_N8
| +--ro objectClass       string
| +--ro objectInstance    nrm-type:t_dn
| +--rw id                 nrm-type:t_dn
| +--rw userLabel         string
| +--rw farEndEntity      nrm-type:t_dn
| +--rw localAddress
| | +--rw ip_address      inet:ip-address
| | +--rw vlan_id         uint16
| +--rw remoteAddress    inet:ip-address
+--rw EP_N10
| +--ro objectClass       string
| +--ro objectInstance    nrm-type:t_dn
| +--rw id                 nrm-type:t_dn
| +--rw userLabel         string
| +--rw farEndEntity      nrm-type:t_dn
| +--rw localAddress
| | +--rw ip_address      inet:ip-address
| | +--rw vlan_id         uint16
| +--rw remoteAddress    inet:ip-address
+--rw EP_N13
| +--ro objectClass       string
| +--ro objectInstance    nrm-type:t_dn
| +--rw id                 nrm-type:t_dn
| +--rw userLabel         string
| +--rw farEndEntity      nrm-type:t_dn
| +--rw localAddress
| | +--rw ip_address      inet:ip-address
| | +--rw vlan_id         uint16
| +--rw remoteAddress    inet:ip-address
+--rw EP_SBI_X* [id]
| +--ro objectClass       string
| +--ro objectInstance    nrm-type:t_dn
| +--rw id                 nrm-type:t_dn
| +--rw userLabel         string
| +--rw farEndEntity      nrm-type:t_dn
| +--rw localAddress
| | +--rw ip_address      inet:ip-address
| | +--rw vlan_id         uint16

```

```

|      +--rw remoteAddress      inet:ip-address
|      +--ro sBIService*       string
+--rw UDRFunction
|      +--ro objectClass       string
|      +--ro objectInstance    nrm-type:t_dn
|      +--ro id                nrm-type:t_dn
|      +--rw userLabel        string
|      +--rw vnfParametersList
|      |      +--rw vnfInstanceId string
|      |      +--rw vnfdId       string
|      |      +--rw flavourId    string
|      |      +--rw autoScalable boolean
|      +--rw peeParametersList
|      |      +--rw siteIdentification string
|      |      +--rw siteLatitude     decimal64
|      |      +--rw siteLongitude    decimal64
|      |      +--rw siteDescription  string
|      |      +--rw equipmentType    enumeration
|      |      +--rw environmentType  enumeration
|      |      +--rw powerInterface   enumeration
|      +--rw pLMNId* [MCC MNC]
|      |      +--rw MCC      t_mcc
|      |      +--rw MNC      t_mnc
|      +--rw sBIFQDN           inet:domain-name
|      +--ro sBIService*       string
|      +--rw s-NSSAI*          nrm-type:t_s-NSSAI
|      +--rw EP_SBI_X* [id]
|      |      +--ro objectClass    string
|      |      +--ro objectInstance nrm-type:t_dn
|      |      +--ro id             nrm-type:t_dn
|      |      +--rw userLabel     string
|      |      +--rw farEndEntity   nrm-type:t_dn
|      |      +--rw localAddress
|      |      |      +--rw ip_address inet:ip-address
|      |      |      +--rw vlan_id   uint16
|      |      +--rw remoteAddress  inet:ip-address
|      |      +--ro sBIService*    string
+--rw UDSFFunction
|      +--ro objectClass       string
|      +--ro objectInstance    nrm-type:t_dn
|      +--ro id                nrm-type:t_dn
|      +--rw userLabel        string
|      +--rw vnfParametersList
|      |      +--rw vnfInstanceId string
|      |      +--rw vnfdId       string
|      |      +--rw flavourId    string
|      |      +--rw autoScalable boolean
|      +--rw peeParametersList
|      |      +--rw siteIdentification string
|      |      +--rw siteLatitude     decimal64
|      |      +--rw siteLongitude    decimal64
|      |      +--rw siteDescription  string
|      |      +--rw equipmentType    enumeration
|      |      +--rw environmentType  enumeration
|      |      +--rw powerInterface   enumeration
|      +--rw pLMNId* [MCC MNC]
|      |      +--rw MCC      t_mcc
|      |      +--rw MNC      t_mnc
|      +--rw sBIFQDN           inet:domain-name
|      +--ro sBIService*       string
|      +--rw s-NSSAI*          nrm-type:t_s-NSSAI
|      +--rw EP_SBI_X* [id]
|      |      +--ro objectClass    string
|      |      +--ro objectInstance nrm-type:t_dn
|      |      +--ro id             nrm-type:t_dn
|      |      +--rw userLabel     string
|      |      +--rw farEndEntity   nrm-type:t_dn
|      |      +--rw localAddress
|      |      |      +--rw ip_address inet:ip-address
|      |      |      +--rw vlan_id   uint16
|      |      +--rw remoteAddress  inet:ip-address
|      |      +--ro sBIService*    string
+--rw NRFFunction
|      +--ro objectClass       string
|      +--ro objectInstance    nrm-type:t_dn
|      +--ro id                nrm-type:t_dn
|      +--rw userLabel        string
|      +--rw vnfParametersList

```

```

| | +--rw vnfInstanceId      string
| | +--rw vnfdId           string
| | +--rw flavourId       string
| | +--rw autoScalable    boolean
| | +--rw peeParametersList
| | | +--rw siteIdentification  string
| | | +--rw siteLatitude       decimal64
| | | +--rw siteLongitude      decimal64
| | | +--rw siteDescription    string
| | | +--rw equipmentType      enumeration
| | | +--rw environmentType    enumeration
| | | +--rw powerInterface     enumeration
| | +--rw plmnId* [MCC MNC]
| | | +--rw MCC      t_mcc
| | | +--rw MNC      t_mnc
| | +--rw sBIFQDN          inet:domain-name
| | +--ro sBIService*     string
| | +--rw s-NSSAI*        nrm-type:t_s-NSSAI
| | +--rw nFProfile* [nfInstanceId]
| | | +--rw nfInstanceId      string
| | | +--rw nfType           nrm-type:NFType
| | | +--rw nfStatus        nrm-type:NFStatus
| | | +--rw plmn
| | | | +--rw MCC      t_mcc
| | | | +--rw MNC      t_mnc
| | | +--rw sNssais*        nrm-type:t_s-NSSAI
| | | +--rw nsi*           string
| | | +--rw fqdn           inet:domain-name
| | | +--rw interPlmnFqdn  inet:domain-name
| | | +--rw ipv4Address*   inet:ipv4-address
| | | +--rw ipv6Address*   inet:ipv6-address
| | | +--rw ipv6Prefix*   inet:ipv6-prefix
| | | +--rw capacity       uint8
| | | +--rw load           nrm-type:t_Load
| | | +--rw locality       string
| | | +--rw priority       uint8
| | +--rw udrInfo
| | | +--rw groupId         string
| | | +--rw supiRange* [start end pattern]
| | | | +--rw start        string
| | | | +--rw end          string
| | | | +--rw pattern      string
| | | +--rw gpsiRange* [start end pattern]
| | | | +--rw start        string
| | | | +--rw end          string
| | | | +--rw pattern      string
| | | +--rw externalGroupIdentifiersRange* [start end pattern]
| | | | +--rw start        string
| | | | +--rw end          string
| | | | +--rw pattern      string
| | | +--rw supportedDataSet*          nrm-type:DataSetId
| | +--rw udmInfo
| | | +--rw groupId         string
| | | +--rw supiRange* [start end pattern]
| | | | +--rw start        string
| | | | +--rw end          string
| | | | +--rw pattern      string
| | | +--rw gpsiRange* [start end pattern]
| | | | +--rw start        string
| | | | +--rw end          string
| | | | +--rw pattern      string
| | | +--rw externalGroupIdentifiersRange* [start end pattern]
| | | | +--rw start        string
| | | | +--rw end          string
| | | | +--rw pattern      string
| | | +--rw routingIndicator          string
| | +--rw ausfInfo
| | | +--rw groupId         string
| | | +--rw supiRange* [start end pattern]
| | | | +--rw start        string
| | | | +--rw end          string
| | | | +--rw pattern      string
| | | +--rw routingIndicator          string
| | +--rw amfInfo
| | | +--rw amfRegionId     string
| | | +--rw amfSetId       string
| | | +--rw guami* [k_id]
| | | | +--rw k_id         string

```

```

+--rw plmnId
|   +--rw MCC      t_mcc
|   +--rw MNC      t_mnc
+--rw amfId
|   +--rw AMF-Region-id  t_aMF-Region-id
|   +--rw AMF-Set-id     t_aMF-Set-id
|   +--rw AMF-Pointer    t_aMF-Pointer
+--rw tai* [k_id]
|   +--rw k_id      string
|   +--rw plmnId
|   |   +--rw MCC      t_mcc
|   |   +--rw MNC      t_mnc
|   +--rw tac      t_tAC
+--rw backupInfoAmfFailure* [k_id]
|   +--rw k_id      string
|   +--rw plmnId
|   |   +--rw MCC      t_mcc
|   |   +--rw MNC      t_mnc
|   +--rw amfId
|   |   +--rw AMF-Region-id  t_aMF-Region-id
|   |   +--rw AMF-Set-id     t_aMF-Set-id
|   |   +--rw AMF-Pointer    t_aMF-Pointer
+--rw backupInfoAmfRemoval* [k_id]
|   +--rw k_id      string
|   +--rw plmnId
|   |   +--rw MCC      t_mcc
|   |   +--rw MNC      t_mnc
|   +--rw amfId
|   |   +--rw AMF-Region-id  t_aMF-Region-id
|   |   +--rw AMF-Set-id     t_aMF-Set-id
|   |   +--rw AMF-Pointer    t_aMF-Pointer
+--rw smfInfo
+--rw dnn*      nrm-type:t_Dnn
+--rw tai* [k_id]
|   +--rw k_id      string
|   +--rw plmnId
|   |   +--rw MCC      t_mcc
|   |   +--rw MNC      t_mnc
|   +--rw tac      t_tAC
+--rw pgwFqdn  inet:domain-name
+--rw upfInfo
+--rw sNssaiUpfInfo* [sNssai]
|   +--rw sNssai      t_s-NSSAI
|   +--rw dnnUpfInfo* [dnn]
|   |   +--rw dnn      t_Dnn
+--rw smfServingArea  string
+--rw interfaceUpfInfo* [k_id]
|   +--rw k_id      string
|   +--rw interfaceType  UPIInterfaceType
|   +--rw (address)
|   |   +--:(ipv4Address)
|   |   |   +--rw ipv4Address      inet:ipv4-address
|   |   +--:(ipv6Address)
|   |   |   +--rw ipv6Address      inet:ipv6-address
|   |   +--:(ipv6Prefix)
|   |   |   +--rw ipv6Prefix      inet:ipv6-prefix
|   |   +--:(endpointFqdn)
|   |   |   +--rw endpointFqdn    inet:domain-name
|   +--rw networkInstance  string
+--rw pcfInfo
|   +--rw dnn*      nrm-type:t_Dnn
+--rw bsfInfo
+--rw ipv4AddressRange* [start end]
|   +--rw start      inet:ipv4-address
|   +--rw end        inet:ipv4-address
+--rw ipv6PrefixRange* [start end]
|   +--rw start      inet:ipv6-prefix
|   +--rw end        inet:ipv6-prefix
+--rw nfService* [serviceInstanceID]
+--rw serviceInstanceID      string
+--rw serviceName            string
+--rw version
|   +--rw apiVersionInUri    string
|   +--rw apiFullVersion    string
|   +--rw expiry            yang:date-and-time
+--rw schema                string
+--rw fqdn                  inet:domain-name
+--rw interPlmnFqdn        inet:domain-name

```



```

+--rw ipEndPoint* [k_id]
|   +--rw k_id          string
|   +--rw (address)
|   |   +--:(ipv4Address)
|   |   |   +--rw ipv4Address  inet:ipv4-address
|   |   +--:(ipv6Address)
|   |   |   +--rw ipv6Address  inet:ipv6-address
|   |   +--:(ipv6Prefix)
|   |   |   +--rw ipv6Prefix   inet:ipv6-prefix
|   +--rw transport    t_TransportProtocol
|   +--rw port         uint16
+--rw apiPrefix          string
+--rw defaultNotificationSubscription* [notificationType]
|   +--rw notificationType  NotificationType
|   +--rw callbackUri       inet:uri
|   +--rw n1MessageClass    N1MessageClass
|   +--rw n2InformationClass N2InformationClass
+--rw allowedPlmn* [MCC MNC]
|   +--rw MCC    t_mcc
|   +--rw MNC    t_mnc
+--rw allowedNfType*          nrm-type:NfType
+--rw allowedDomain*         string
+--rw allowedNssais*         nrm-type:t_s-NSSAI
+--rw capacity                uint8
+--rw load                    nrm-type:t_Load
+--rw supportedFeatures       nrm-type:SupportedFeatures
+--ro nSIId*                  nrm-type:t_NsiId
+--rw EP_N27
|   +--ro objectClass          string
|   +--ro objectInstance      nrm-type:t_dn
|   +--rw id                  nrm-type:t_dn
|   +--rw userLabel           string
|   +--rw farEndEntity        nrm-type:t_dn
|   +--rw localAddress
|   |   +--rw ip_address      inet:ip-address
|   |   +--rw vlan_id        uint16
|   +--rw remoteAddress       inet:ip-address
+--rw EP_SBI_X* [id]
|   +--ro objectClass          string
|   +--ro objectInstance      nrm-type:t_dn
|   +--rw id                  nrm-type:t_dn
|   +--rw userLabel           string
|   +--rw farEndEntity        nrm-type:t_dn
|   +--rw localAddress
|   |   +--rw ip_address      inet:ip-address
|   |   +--rw vlan_id        uint16
|   +--rw remoteAddress       inet:ip-address
+--ro SBIService*            string
+--rw NSSFunction
|   +--ro objectClass          string
|   +--ro objectInstance      nrm-type:t_dn
|   +--ro id                  nrm-type:t_dn
|   +--rw userLabel           string
|   +--rw vnfParametersList
|   |   +--rw vnfInstanceId    string
|   |   +--rw vnfId           string
|   |   +--rw flavourId       string
|   |   +--rw autoScalable    boolean
|   +--rw peeParametersList
|   |   +--rw siteIdentification  string
|   |   +--rw siteLatitude       decimal64
|   |   +--rw siteLongitude      decimal64
|   |   +--rw siteDescription    string
|   |   +--rw equipmentType      enumeration
|   |   +--rw environmentType    enumeration
|   |   +--rw powerInterface     enumeration
+--rw pLMNId* [MCC MNC]
|   +--rw MCC    t_mcc
|   +--rw MNC    t_mnc
+--rw sBIFQDN                inet:domain-name
+--ro SBIService*            string
+--rw s-NSSAI*               nrm-type:t_s-NSSAI
+--ro nSIId*                  nrm-type:t_NsiId
+--rw EP_N22
|   +--ro objectClass          string
|   +--ro objectInstance      nrm-type:t_dn
|   +--rw id                  nrm-type:t_dn
|   +--rw userLabel           string

```

```

| | +--rw farEndEntity      nrm-type:t_dn
| | +--rw localAddress
| | | +--rw ip_address    inet:ip-address
| | | +--rw vlan_id      uint16
| | +--rw remoteAddress   inet:ip-address
+--rw EP_N31
| | +--ro objectClass     string
| | +--ro objectInstance  nrm-type:t_dn
| | +--rw id              nrm-type:t_dn
| | +--rw userLabel       string
| | +--rw farEndEntity    nrm-type:t_dn
| | +--rw localAddress
| | | +--rw ip_address    inet:ip-address
| | | +--rw vlan_id      uint16
| | +--rw remoteAddress   inet:ip-address
+--rw EP_SBI_X* [id]
| | +--ro objectClass     string
| | +--ro objectInstance  nrm-type:t_dn
| | +--rw id              nrm-type:t_dn
| | +--rw userLabel       string
| | +--rw farEndEntity    nrm-type:t_dn
| | +--rw localAddress
| | | +--rw ip_address    inet:ip-address
| | | +--rw vlan_id      uint16
| | +--rw remoteAddress   inet:ip-address
| | +--ro sBIService*     string
+--rw SMSFunction
| | +--ro objectClass     string
| | +--ro objectInstance  nrm-type:t_dn
| | +--ro id              nrm-type:t_dn
| | +--rw userLabel       string
+--rw vnfParametersList
| | +--rw vnfInstanceId   string
| | +--rw vnfId           string
| | +--rw flavourId      string
| | +--rw autoScalable    boolean
+--rw peeParametersList
| | +--rw siteIdentification string
| | +--rw siteLatitude      decimal64
| | +--rw siteLongitude     decimal64
| | +--rw siteDescription   string
| | +--rw equipmentType     enumeration
| | +--rw environmentType   enumeration
| | +--rw powerInterface    enumeration
+--rw pLMNid* [MCC MNC]
| | +--rw MCC      t_mcc
| | +--rw MNC      t_mnc
+--rw EP_N20
| | +--ro objectClass     string
| | +--ro objectInstance  nrm-type:t_dn
| | +--rw id              nrm-type:t_dn
| | +--rw userLabel       string
| | +--rw farEndEntity    nrm-type:t_dn
| | +--rw localAddress
| | | +--rw ip_address    inet:ip-address
| | | +--rw vlan_id      uint16
| | +--rw remoteAddress   inet:ip-address
+--rw EP_N21
| | +--ro objectClass     string
| | +--ro objectInstance  nrm-type:t_dn
| | +--rw id              nrm-type:t_dn
| | +--rw userLabel       string
| | +--rw farEndEntity    nrm-type:t_dn
| | +--rw localAddress
| | | +--rw ip_address    inet:ip-address
| | | +--rw vlan_id      uint16
| | +--rw remoteAddress   inet:ip-address
+--rw EP_MAP_SMSC
| | +--ro objectClass     string
| | +--ro objectInstance  nrm-type:t_dn
| | +--rw id              nrm-type:t_dn
| | +--rw userLabel       string
| | +--rw farEndEntity    nrm-type:t_dn
| | +--rw localAddress
| | | +--rw ip_address    inet:ip-address
| | | +--rw vlan_id      uint16
| | +--rw remoteAddress   inet:ip-address
+--rw LMFFunction

```

```

|   +---ro objectClass          string
|   +---ro objectInstance      nrm-type:t_dn
|   +---ro id                   nrm-type:t_dn
|   +---rw userLabel           string
|   +---rw vnfParametersList
|   |   +---rw vnfInstanceId    string
|   |   +---rw vnfId           string
|   |   +---rw flavourId       string
|   |   +---rw autoScalable    boolean
|   +---rw peeParametersList
|   |   +---rw siteIdentification string
|   |   +---rw siteLatitude     decimal64
|   |   +---rw siteLongitude    decimal64
|   |   +---rw siteDescription  string
|   |   +---rw equipmentType    enumeration
|   |   +---rw environmentType  enumeration
|   |   +---rw powerInterface   enumeration
|   +---rw pLMNid* [MCC MNC]
|   |   +---rw MCC              t_mcc
|   |   +---rw MNC              t_mnc
|   +---rw EP_NLS
|   |   +---ro objectClass      string
|   |   +---ro objectInstance  nrm-type:t_dn
|   |   +---ro id               nrm-type:t_dn
|   |   +---rw userLabel        string
|   |   +---rw farEndEntity     nrm-type:t_dn
|   |   +---rw localAddress
|   |   |   +---rw ip_address   inet:ip-address
|   |   |   +---rw vlan_id     uint16
|   |   +---rw remoteAddress    inet:ip-address
+---rw NGEIRFunction
|   +---ro objectClass          string
|   +---ro objectInstance      nrm-type:t_dn
|   +---ro id                   nrm-type:t_dn
|   +---rw userLabel           string
|   +---rw vnfParametersList
|   |   +---rw vnfInstanceId    string
|   |   +---rw vnfId           string
|   |   +---rw flavourId       string
|   |   +---rw autoScalable    boolean
|   +---rw peeParametersList
|   |   +---rw siteIdentification string
|   |   +---rw siteLatitude     decimal64
|   |   +---rw siteLongitude    decimal64
|   |   +---rw siteDescription  string
|   |   +---rw equipmentType    enumeration
|   |   +---rw environmentType  enumeration
|   |   +---rw powerInterface   enumeration
|   +---rw pLMNid* [MCC MNC]
|   |   +---rw MCC              t_mcc
|   |   +---rw MNC              t_mnc
|   +---rw sBIFQDN              inet:domain-name
|   +---ro sBIService*          string
|   +---rw s-NSSAI*             nrm-type:t_s-NSSAI
|   +---rw EP_N17
|   |   +---ro objectClass      string
|   |   +---ro objectInstance  nrm-type:t_dn
|   |   +---ro id               nrm-type:t_dn
|   |   +---rw userLabel        string
|   |   +---rw farEndEntity     nrm-type:t_dn
|   |   +---rw localAddress
|   |   |   +---rw ip_address   inet:ip-address
|   |   |   +---rw vlan_id     uint16
|   |   +---rw remoteAddress    inet:ip-address
|   +---rw EP_SBI_X* [id]
|   |   +---ro objectClass      string
|   |   +---ro objectInstance  nrm-type:t_dn
|   |   +---ro id               nrm-type:t_dn
|   |   +---rw userLabel        string
|   |   +---rw farEndEntity     nrm-type:t_dn
|   |   +---rw localAddress
|   |   |   +---rw ip_address   inet:ip-address
|   |   |   +---rw vlan_id     uint16
|   |   +---rw remoteAddress    inet:ip-address
|   |   +---ro sBIService*      string
+---rw SEPPFunction
|   +---ro objectClass          string
|   +---ro objectInstance      nrm-type:t_dn

```

```

| +--ro id nrm-type:t_dn
| +--rw userLabel string
| +--rw vnfParametersList
| | +--rw vnfInstanceId string
| | +--rw vnfdId string
| | +--rw flavourId string
| | +--rw autoScalable boolean
| +--rw peeParametersList
| | +--rw siteIdentification string
| | +--rw siteLatitude decimal64
| | +--rw siteLongitude decimal64
| | +--rw siteDescription string
| | +--rw equipmentType enumeration
| | +--rw environmentType enumeration
| | +--rw powerInterface enumeration
| +--rw pLMNid* [MCC MNC]
| | +--rw MCC t_mcc
| | +--rw MNC t_mnc
| +--rw sBIFQDN inet:domain-name
| +--ro sBIService* string
| +--rw EP_N32
| | +--ro objectClass string
| | +--ro objectInstance nrm-type:t_dn
| | +--rw id nrm-type:t_dn
| | +--rw userLabel string
| | +--rw farEndEntity nrm-type:t_dn
| | +--rw localAddress
| | | +--rw ip_address inet:ip-address
| | | +--rw vlan_id uint16
| | +--rw remoteAddress inet:ip-address
| +--rw EP_SBI_IPX* [id]
| | +--ro objectClass string
| | +--ro objectInstance nrm-type:t_dn
| | +--rw id nrm-type:t_dn
| | +--rw userLabel string
| | +--rw farEndEntity nrm-type:t_dn
| | +--rw localAddress
| | | +--rw ip_address inet:ip-address
| | | +--rw vlan_id uint16
| | +--rw remoteAddress inet:ip-address
| | +--ro sBIService* string
+--rw NWDAFunction
| +--ro objectClass string
| +--ro objectInstance nrm-type:t_dn
| +--ro id nrm-type:t_dn
| +--rw userLabel string
| +--rw vnfParametersList
| | +--rw vnfInstanceId string
| | +--rw vnfdId string
| | +--rw flavourId string
| | +--rw autoScalable boolean
| +--rw peeParametersList
| | +--rw siteIdentification string
| | +--rw siteLatitude decimal64
| | +--rw siteLongitude decimal64
| | +--rw siteDescription string
| | +--rw equipmentType enumeration
| | +--rw environmentType enumeration
| | +--rw powerInterface enumeration
| +--rw pLMNid* [MCC MNC]
| | +--rw MCC t_mcc
| | +--rw MNC t_mnc
| +--rw sBIFQDN inet:domain-name
| +--ro sBIService* string
| +--rw s-NSSAI* nrm-type:t_s-NSSAI
| +--rw EP_SBI_X* [id]
| | +--ro objectClass string
| | +--ro objectInstance nrm-type:t_dn
| | +--rw id nrm-type:t_dn
| | +--rw userLabel string
| | +--rw farEndEntity nrm-type:t_dn
| | +--rw localAddress
| | | +--rw ip_address inet:ip-address
| | | +--rw vlan_id uint16
| | +--rw remoteAddress inet:ip-address
| | +--ro sBIService* string

```

## H.4.3 YANG schema

### H.4.3.1 General type definition "nrm-types-3gpp.yang"

Refer to Annex E.4.3.1.

### H.4.3.2 Basic IOC definition which can be reused by specific ManagedFuncion. "Top.yang", "ManagedElement.yang", "ManagedFunction.yang", "EP\_RP.yang", "SubNetwork"

Refer to Annex G.

### H.4.3.3 NGC module, composition of all 5GC ManagedFunctions in "ngc.yang"

```

module ngc {
  namespace "urn:3gpp:tsg:sa5:nrm:ngc";
  prefix "ngc";
  import SubNetwork { prefix subnet; revision-date "2018-07-31"; }
  import ManagedElement { prefix me; revision-date "2018-07-31"; }
  include ngc-AMFFunction;
  include ngc-SMFFunction;
  include ngc-UPFFunction;
  include ngc-N3IWFFunction;
  include ngc-PCFFunction;
  include ngc-AUSFFunction;
  include ngc-UDMFunction;
  include ngc-UDRFunction;
  include ngc-UDSFunction;
  include ngc-NRFFunction;
  include ngc-NSSFunction;
  include ngc-SMSFunction;
  include ngc-LMFFunction;
  include ngc-NGEIRFunction;
  include ngc-SEPPFunction;
  include ngc-NWDAFunction;
  include NFProfile;

  revision 2018-08-07 {
    description "Initial revision";
  }

  container SubNetwork {

    uses subnet:SubNetwork;
    list ManagedElement {
      uses me:ManagedElement;
      list AMFFunction { uses AMFFunction; }
      list SMFFunction { uses SMFFunction; }
      list UPFFunction { uses UPFFunction; }
      list N3IWFFunction { uses N3IWFFunction; }
      list PCFFunction { uses PCFFunction; }
      list AUSFFunction { uses AUSFFunction; }
      list UDMFunction { uses UDMFunction; }
      list UDRFunction { uses UDRFunction; }
      list UDSFunction { uses UDSFunction; }
      list NRFFunction { uses NRFFunction; }
      list NSSFunction { uses NSSFunction; }
      list SMSFunction { uses SMSFunction; }
      list LMFFunction { uses LMFFunction; }
      list NGEIRFunction { uses NGEIRFunction; }
      list SEPPFunction { uses SEPPFunction; }
      list NWDAFunction { uses NWDAFunction; }
    }
    list AMFSet { uses AMFSet; }
    list AMFRegion { uses AMFRegion; }
  }
}

```

### H.4.3.4 NGC submodule, "ngc-AMFFunction.yang", "ngc-AMFRegion.yang", "ngc-AMFSet.yang"

```

submodule ngc-AMFFunction {

  belongs-to ngc { prefix ngc; }

  import EP_RP { prefix ep-rp; revision-date "2018-07-31"; }
  import ManagedFunction { prefix mf; revision-date "2018-07-31"; }
  import nrm-types-3gpp { prefix nrm-type; revision-date "2018-07-31"; }
  import ietf-inet-types { prefix inet; revision-date "2010-09-24"; }

  description "AMFFunction derived from basic ManagedFunction";

  revision 2018-08-07 {
    description "Initial revision";
  }

  grouping AMFFunction {
    uses mf:ManagedFunction;

    list pLMNId {
      min-elements "1";
      description "a list of PLMN-Id, PLMN-Id= Mobile Country Codes (MCC)|| Mobile Network
Codes(MNC) ";
      config "true";
      key "MCC MNC";
      uses nrm-type:pLMNId;
    }

    container aMFIdentifier {
      presence "true";
      config "true";
      description "";
      uses nrm-type:aMFI;
    }

    leaf sBIFQDN {
      mandatory "true";
      config "true";
      description " ";
      type inet:domain-name;
    }

    leaf-list sBIService {
      description "";
      min-elements "1";
      config "false";
      type string;
    }

    leaf weightFactor {
      mandatory "true";
      config "true";
      description "";
      type uint8;
    }

    leaf-list s-NSSAI {
      min-elements "0";
      config "true";
      description "It represents the list of S-NSSAI the managed object is capable
of supporting, an S-NSSAI is comprised of a SST (Slice/Service
type) and an optional SD (Slice Differentiator) field, (Ref. 3GPP
TS 23.003 [13]). ";
      reference "3GPP TS 23.003";
      type nrm-type:t_s-NSSAI;
    }

    list EP_N2 { uses ep-rp:EP_N2; }
    list EP_N8 { uses ep-rp:EP_N8; }
    list EP_N11 { uses ep-rp:EP_N11; }
    list EP_N12 { uses ep-rp:EP_N12; }
    list EP_N14 { uses ep-rp:EP_N14; }
    list EP_N15 { uses ep-rp:EP_N15; }
  }
}

```

```

    list EP_N17 { uses ep-rp:EP_N17; }
    list EP_N20 { uses ep-rp:EP_N20; }
    list EP_N22 { uses ep-rp:EP_N22; }
    list EP_N26 { uses ep-rp:EP_N26; }
    list EP_NLS { uses ep-rp:EP_NLS; }
    list EP_NLG { uses ep-rp:EP_NLS; }
    list EP_SBI_X {
        uses ep-rp:EP_SBI_X;
    }
}
}

submodule ngc-AMFRegion {

    belongs-to ngc { prefix ngc; }

    import ManagedFunction { prefix mf; revision-date "2018-07-31"; }
    import nrm-types-3gpp { prefix nrm-type; revision-date "2018-07-31"; }
    import ietf-inet-types { prefix inet; revision-date "2010-09-24"; }

    revision 2018-12-18 {
        description "initial verison";
    }

    grouping AMFRegion {
        uses mf:ManagedFunction;

        list pLMNId {
            min-elements "1";
            description "a list of PLMN-Id, PLMN-Id= Mobile Country Codes (MCC)|| Mobile Network
Codes(MNC) ";
            config "true";
            key "MCC MNC";
            uses nrm-type:pLMNId;
        }

        leaf aMFRegionId {
            config "true";
            description "";
            type nrm-type:t_aMF-Region-id;
        }

        leaf-list tAC {
            min-elements "1";
            config "false";
            type nrm-type:t_tAC;
        }

        leaf-list s-NSSAI {
            min-elements "0";
            config "true";
            description "It represents the list of S-NSSAI the managed object is capable
of supporting, an S-NSSAI is comprised of a SST (Slice/Service
type) and an optional SD (Slice Differentiator) field, (Ref. 3GPP
TS 23.003 [13]). ";
            reference "3GPP TS 23.003";
            type nrm-type:t_s-NSSAI;
        }

        leaf-list aMFSet {
            description "AMF Set list in the aMFRegion";
            min-elements "0";
            config "true";
            type nrm-type:t_dn;
        }
    }
}

submodule ngc-AMFSet {

    belongs-to ngc { prefix ngc; }

    import ManagedFunction { prefix mf; revision-date "2018-07-31"; }

```

```

import nrm-types-3gpp { prefix nrm-type; revision-date "2018-07-31"; }
import ietf-inet-types { prefix inet; revision-date "2010-09-24"; }

revision 2018-12-18 {
  description "initial verison";
}

grouping AMFSet {
  uses mf:ManagedFunction;

  list pLMNId {
    min-elements "1";
    description "a list of PLMN-Id, PLMN-Id= Mobile Country Codes (MCC)|| Mobile Network
Codes(MNC) ";
    config "true";
    key "MCC MNC";
    uses nrm-type:pLMNId;
  }

  leaf aMFSetId {
    config "true";
    description "";
    type nrm-type:t_aMF-Set-id;
  }

  leaf-list tAC {
    min-elements "1";
    config "false";
    type nrm-type:t_tAC;
  }

  leaf-list s-NSSAI {
    min-elements "0";
    config "true";
    description "It represents the list of S-NSSAI the managed object is capable
of supporting, an S-NSSAI is comprised of a SST (Slice/Service
type) and an optional SD (Slice Differentiator) field, (Ref. 3GPP
TS 23.003 [13]). ";
    reference "3GPP TS 23.003";
    type nrm-type:t_s-NSSAI;
  }

  leaf-list aMFSetMember {
    description "AMF funciton list in the aMFSet";
    min-elements "0";
    config "true";
    type nrm-type:t_dn;
  }

  leaf aMFRegion {
    description "associated aMFRegion the aMFSet belong to";
    type nrm-type:t_dn;
  }
}
}

```

#### H.4.3.5 NGC submodule, "ngc-AUSFFunction.yang"

```

submodule ngc-AUSFFunction {

  belongs-to ngc { prefix ngc; }

  import EP_RP { prefix ep-rp; revision-date "2018-07-31"; }
  import ManagedFunction { prefix mf; revision-date "2018-07-31"; }
  import nrm-types-3gpp { prefix nrm-type; revision-date "2018-07-31"; }
  import ietf-inet-types { prefix inet; revision-date "2010-09-24"; }

  description "AUSFFunction derived from basic ManagedFunction";

  revision 2018-08-07 {
    description "Initial revision";
  }

  grouping AUSFFunction {
    uses mf:ManagedFunction;
  }
}

```



```

    list pLMNId {
      min-elements "1";
      description "a list of PLMN-Id, PLMN-Id= Mobile Country Codes (MCC)|| Mobile Network
Codes(MNC) ";
      config "true";
      key "MCC MNC";
      uses nrm-type:pLMNId;
    }

    leaf sBIFQDN {
      mandatory "true";
      config "true";
      description "";
      type inet:domain-name;
    }

    leaf-list sBIService {
      min-elements "1";
      config "false";
      type string;
    }

    leaf-list s-NSSAI {
      min-elements "0";
      config "true";
      description "It represents the list of S-NSSAI the managed object is capable
of supporting, an S-NSSAI is comprised of a SST (Slice/Service
type) and an optional SD (Slice Differentiator) field, (Ref. 3GPP
TS 23.003 [13]). ";
      reference "3GPP TS 23.003";
      type nrm-type:t_s-NSSAI;
    }

    list EP_N12 { uses ep-rp:EP_N12; }
    list EP_N13 { uses ep-rp:EP_N13; }
    list EP_SBI_X {
      key id;
      uses ep-rp:EP_SBI_X;
    }
  }
}

```

#### H.4.3.6 NGC submodule, "ngc-LMFFunction.yang"

```

submodule ngc-LMFFunction {

  belongs-to ngc { prefix ngc; }

  import EP_RP { prefix ep-rp; revision-date "2018-07-31"; }
  import ManagedFunction { prefix mf; revision-date "2018-07-31"; }
  import nrm-types-3gpp { prefix nrm-type; revision-date "2018-07-31"; }

  description "LMFFunction derived from basic ManagedFunction";

  revision 2018-12-18 {
    description "15.1.0";
  }

  grouping LMFFunction {
    uses mf:ManagedFunction;

    list pLMNId {
      min-elements "1";
      description "a list of PLMN-Id, PLMN-Id= Mobile Country Codes (MCC)|| Mobile Network
Codes(MNC) ";
      config "true";
      key "MCC MNC";
      uses nrm-type:pLMNId;
    }

    list EP-NLS { uses ep-rp:EP-NLS; }
  }
}

```

}

### H.4.3.7 NGC submodule, "ngc-N3IWFFunction.yang"

```

submodule ngc-N3IWFFunction {

  belongs-to ngc { prefix ngc; }

  import EP_RP { prefix ep-rp; revision-date "2018-07-31"; }
  import ManagedFunction { prefix mf; revision-date "2018-07-31"; }
  import nrm-types-3gpp { prefix nrm-type; revision-date "2018-07-31"; }

  description "N3IWFFunction derived from basic ManagedFunction";

  revision 2018-08-07 {
    description "Initial revision";
  }

  grouping N3IWFFunction {
    uses mf:ManagedFunction;

    list pLMNid {
      min-elements "1";
      description "a list of PLMN-Id, PLMN-Id= Mobile Country Codes (MCC)|| Mobile Network
Codes(MNC) ";
      config "true";
      key "MCC MNC";
      uses nrm-type:pLMNid;
    }

    list EP_N2 { uses ep-rp:EP_N2; }
    list EP_N3 { uses ep-rp:EP_N3; }
  }
}

```

### H.4.3.8 NGC submodule, "ngc-NGEIRFunction.yang"

```

submodule ngc-NGEIRFunction {

  belongs-to ngc { prefix ngc; }

  import EP_RP { prefix ep-rp; revision-date "2018-07-31"; }
  import ManagedFunction { prefix mf; revision-date "2018-07-31"; }
  import nrm-types-3gpp { prefix nrm-type; revision-date "2018-07-31"; }
  import ietf-inet-types { prefix inet; revision-date "2010-09-24"; }

  description "NGEIRFunction derived from basic ManagedFunction";

  revision 2018-08-07 {
    description "Initial revision";
  }

  grouping NGEIRFunction {
    uses mf:ManagedFunction;

    list pLMNid {
      min-elements "1";
      description "a list of PLMN-Id, PLMN-Id= Mobile Country Codes (MCC)|| Mobile Network
Codes(MNC) ";
      config "true";
      key "MCC MNC";
      uses nrm-type:pLMNid;
    }

    leaf sBIFQDN {
      mandatory "true";
      config "true";
      description "";
      type inet:domain-name;
    }

    leaf-list sBIService {
      min-elements "1";
      config "false";
      type string;
    }
  }
}

```

```

leaf-list s-NSSAI {
  min-elements "0";
  config "true";
  description "It represents the list of S-NSSAI the managed object is capable
    of supporting, an S-NSSAI is comprised of a SST (Slice/Service
    type) and an optional SD (Slice Differentiator) field, (Ref. 3GPP
    TS 23.003 [13]). ";
  reference "3GPP TS 23.003";
  type nrm-type:t_s-NSSAI;
}

list EP_N17 { uses ep-rp:EP_N17; }
list EP_SBI_X {
  key id;
  uses ep-rp:EP_SBI_X;
}
}
}
}

```

### H.4.3.9 NGC submodule, "ngc-NRFFunction.yang"

```

submodule ngc-NRFFunction {

  belongs-to ngc { prefix ngc; }

  import EP_RP { prefix ep-rp; revision-date "2018-07-31"; }
  import ManagedFunction { prefix mf; revision-date "2018-07-31"; }
  import nrm-types-3gpp { prefix nrm-type; revision-date "2018-07-31"; }
  import ietf-inet-types { prefix inet; revision-date "2010-09-24"; }
  include NFProfile;

  description "NRFFunction derived from basic ManagedFunction";

  revision 2018-08-07 {
    description "Initial revision";
  }

  grouping NRFFunction {
    uses mf:ManagedFunction;

    list pLMNId {
      min-elements "1";
      description "a list of PLMN-Id, PLMN-Id= Mobile Country Codes (MCC)|| Mobile Network
Codes(MNC) ";
      config "true";
      key "MCC MNC";
      uses nrm-type:pLMNId;
    }

    leaf sBIFQDN {
      mandatory "true";
      config "true";
      description " ";
      type inet:domain-name;
    }

    leaf-list sBIService {
      description " ";
      min-elements "1";
      config "false";
      type string;
    }

    leaf-list s-NSSAI {
      min-elements "0";
      config "true";
      description "It represents the list of S-NSSAI the managed object is capable
        of supporting, an S-NSSAI is comprised of a SST (Slice/Service
        type) and an optional SD (Slice Differentiator) field, (Ref. 3GPP
        TS 23.003 [13]). ";
      reference "3GPP TS 23.003";
      type nrm-type:t_s-NSSAI;
    }
  }
}

```

```
list nFProfile {
  description "CM only required when NF profile is registered and deregistered by
management system.";
  min-elements "1";
  config "true";
  key nfInstanceId;
  uses NFProfile;
}

leaf-list nSIId {
  description "Is it really needed if network slicing feature enabled Seems it's only
required for NSSF";
  min-elements "1";
  config "false";
  type nrm-type:t_NsiId;
}

list EP_N27 { uses ep-rp:EP_N26; }
list EP_SBI_X {
  key id;
  uses ep-rp:EP_SBI_X;
}
}

}
submodule NFProfile {
  belongs-to ngc { prefix ngc; }

  import nrm-types-3gpp { prefix nrm-type; revision-date "2018-07-31"; }
  import ietf-inet-types { prefix inet; revision-date "2010-09-24"; }

  revision 2018-08-08 {
    description "Initial revision";
  }

  grouping UdrInfo {
    leaf groupId {
      type string;
    }

    list supiRange {
      key "start end pattern";
      uses nrm-type:SupiRange;
    }

    list gpsiRange {
      key "start end pattern";
      uses nrm-type:IdentityRange;
    }

    list externalGroupIdentifiersRange {
      key "start end pattern";
      uses nrm-type:IdentityRange;
    }

    leaf-list supportedDataSet {
      type nrm-type:DataSetId;
    }
  }

  grouping UdmInfo {
    leaf groupId {
      type string;
    }

    list supiRange {
      key "start end pattern";
      uses nrm-type:SupiRange;
    }
  }
}
```

```
list gpsiRange {
    key "start end pattern";
    uses nrm-type:IdentityRange;
}

list externalGroupIdentifiersRange {
    key "start end pattern";
    uses nrm-type:IdentityRange;
}

leaf routingIndicator {
    type string;
}
}

grouping AusfInfo {
    leaf groupId {
        type string;
    }

    list supiRange {
        key "start end pattern";
        uses nrm-type:SupiRange;
    }

    leaf routingIndicator {
        type string;
    }
}

grouping AmfInfo {
    leaf amfRegionId {
        type string;
    }

    leaf amfSetId {
        type string;
    }

    list guami {
        //FFS to use embedded identifier
        key k_id;
        leaf k_id {
            type string;
        }
        uses nrm-type:Guami;
    }

    list tai {
        //FFS to use embedded identifier
        key k_id;
        leaf k_id {
            type string;
        }
        uses nrm-type:Tai;
    }

    list backupInfoAmfFailure {
        //FFS to use embedded identifier
        key k_id;
        leaf k_id {
            type string;
        }
        uses nrm-type:Guami;
    }

    list backupInfoAmfRemoval {
        //FFS to use embedded identifier
        key k_id;
        leaf k_id {
            type string;
        }
        uses nrm-type:Guami;
    }
}
}
```

```
grouping SmfInfo {
  leaf-list dnn {
    type nrm-type:t_Dnn;
  }

  list tai {
    //FFS to use embedded identifier
    key k_id;
    leaf k_id {
      type string;
    }
    uses nrm-type:Tai;
  }

  leaf pgwFqdn {
    type inet:domain-name;
  }
}

grouping UpfInfo {
  list sNssaiUpfInfo {
    key sNssai;
    uses nrm-type:SnssaiUpfInfoItem;
  }

  leaf smfServingArea {
    type string;
  }

  list interfaceUpfInfo {
    //FFS to use "choiced" identifier
    key k_id;
    leaf k_id {
      type string;
    }
    //key "interfaceType address";
    uses nrm-type:InterfaceUpfInfoItem;
  }
}

grouping PcfInfo {
  leaf-list dnn {
    type nrm-type:t_Dnn;
  }
}

grouping BsfInfo {
  list ipv4AddressRange {
    key "start end";
    uses nrm-type:Ipv4AddressRange;
  }
  list ipv6PrefixRange {
    key "start end";
    uses nrm-type:Ipv6PrefixRange;
  }
}

grouping NFService {
  leaf serviceInstanceID {
    description "";
    mandatory "true";
    type string;
  }

  leaf serviceName {
    mandatory "true";
    type string;
  }

  container version { uses nrm-type:NFServiceVersion; }

  leaf schema {
    mandatory "true";
    type string;
  }
}
```

```
leaf fqdn {
    type inet:domain-name;
}

leaf interPlmnFqdn {
    type inet:domain-name;
}

list ipEndPoint {
    //FFS to use "choiced" identifier
    key k_id;
    leaf k_id {
        type string;
    }
    // key "address port";
    uses nrm-type:ipEndPoint;
}

leaf apiPrefix {
    type string;
}

list defaultNotificationSubscription {
    key notificationType;
    uses nrm-type:defaultNotificationSubscription;
}

list allowedPlmn {
    key "MCC MNC";
    uses nrm-type:pLMNId;
}

leaf-list allowedNfType {
    type nrm-type:NfType;
}

leaf-list allowedDomain {
    type string;
}

leaf-list allowedNssais {
    type nrm-type:t_s-NSSAI;
}

leaf capacity {
    type uint8;
}

leaf load {
    type nrm-type:t_Load;
}

leaf supportedFeatures {
    type nrm-type:SupportedFeatures;
}

}

grouping NFProfile {

    leaf nfInstanceId {
        mandatory "true";
        type string;
    }

    leaf nfType {
        mandatory "true";
        type nrm-type:NfType;
    }

    leaf nfStatus {
        mandatory "true";
        type nrm-type:NFStatus;
    }

    container plmn {
        uses nrm-type:pLMNId;
    }
}
```

```

    }

    leaf-list sNssais {
        type nrm-type:t_s-NSSAI;
    }

    leaf-list nsi {
        type string;
    }

    leaf fqdn {
        type inet:domain-name;
    }

    leaf interPlmnFqdn {
        type inet:domain-name;
    }

    leaf-list ipv4Address {
        type inet:ipv4-address;
    }

    leaf-list ipv6Address {
        type inet:ipv6-address;
    }

    leaf-list ipv6Prefix {
        type inet:ipv6-prefix;
    }

    leaf capacity {
        type uint8;
    }

    leaf load {
        type nrm-type:t_Load;
    }

    leaf locality {
        type string;
    }

    leaf priority {
        type uint8;
    }

    container udrInfo { uses UdrInfo; }
    container udmInfo { uses UdmInfo; }
    container ausfInfo { uses AusfInfo; }
    container amfInfo { uses AmfInfo; }
    container smfInfo { uses SmfInfo; }
    container upfInfo { uses UpfInfo; }
    container pcfInfo { uses PcfInfo; }
    container bsfInfo { uses BsfInfo; }

    list nfService {
        min-elements "0";
        description "";
        key serviceInstanceID;
        uses NFService;
    }
}
}

```

#### H.4.3.10 NGC submodule, "ngc-NSSFFunction.yang"

```

submodule ngc-NSSFFunction {

    belongs-to ngc { prefix ngc; }

    import EP_RP { prefix ep-rp; revision-date "2018-07-31"; }
    import ManagedFunction { prefix mf; revision-date "2018-07-31"; }
    import nrm-types-3gpp { prefix nrm-type; revision-date "2018-07-31"; }
    import ietf-inet-types { prefix inet; revision-date "2010-09-24"; }

    description "NSSFFunction derived from basic ManagedFunction";
}

```



```

revision 2018-08-07 {
    description "Initial revision";
}

grouping NSSFFunction {
    uses mf:ManagedFunction;

    list pLMNid {
        min-elements "1";
        description "a list of PLMN-Id, PLMN-Id= Mobile Country Codes (MCC)|| Mobile Network
Codes(MNC) ";
        config "true";
        key "MCC MNC";
        uses nrm-type:pLMNid;
    }

    leaf sBIFQDN {
        mandatory "true";
        config "true";
        description " ";
        type inet:domain-name;
    }

    leaf-list sBIService {
        description " ";
        min-elements "1";
        config "false";
        type string;
    }

    leaf-list s-NSSAI {
        min-elements "0";
        config "true";
        description "It represents the list of S-NSSAI the managed object is capable
of supporting, an S-NSSAI is comprised of a SST (Slice/Service
type) and an optional SD (Slice Differentiator) field, (Ref. 3GPP
TS 23.003 [13]). ";
        reference "3GPP TS 23.003";
        type nrm-type:t_s-NSSAI;
    }

    leaf-list nSIId {
        description "Is it really needed if network slicing feature enabled Seems it's only
required for NSSF";
        min-elements "1";
        config "false";
        type nrm-type:t_NsiId;
    }

    list EP_N22 { uses ep-rp:EP_N22; }
    list EP_N31 { uses ep-rp:EP_N31; }
    list EP_SBI_X {
        key id;
        uses ep-rp:EP_SBI_X;
    }
}
}

```

#### H.4.3.11 NGC submodule, "ngc-NWDAFunction.yang"

```

submodule ngc-NWDAFunction {

    belongs-to ngc { prefix ngc; }

    import EP_RP { prefix ep-rp; revision-date "2018-07-31"; }
    import ManagedFunction { prefix mf; revision-date "2018-07-31"; }
    import nrm-types-3gpp { prefix nrm-type; revision-date "2018-07-31"; }
    import ietf-inet-types { prefix inet; revision-date "2010-09-24"; }

    description "NWDAFunction derived from basic ManagedFunction";

    revision 2018-08-07 {

```

```

        description "Initial revision";
    }

    grouping NWDAFunction {
        uses mf:ManagedFunction;

        list pLMNId {
            min-elements "1";
            description "a list of PLMN-Id, PLMN-Id= Mobile Country Codes (MCC)|| Mobile Network
Codes(MNC) ";
            config "true";
            key "MCC MNC";
            uses nrm-type:pLMNId;
        }

        leaf sBIFQDN {
            mandatory "true";
            config "true";
            description "";
            type inet:domain-name;
        }

        leaf-list sBIService {
            min-elements "1";
            config "false";
            type string;
        }

        leaf-list s-NSSAI {
            min-elements "0";
            config "true";
            description "It represents the list of S-NSSAI the managed object is capable
of supporting, an S-NSSAI is comprised of a SST (Slice/Service
type) and an optional SD (Slice Differentiator) field, (Ref. 3GPP
TS 23.003 [13]). ";
            reference "3GPP TS 23.003";
            type nrm-type:t_s-NSSAI;
        }

        list EP_SBI_X {
            key id;
            uses ep-rp:EP_SBI_X;
        }
    }
}

```

#### H.4.3.12 NGC submodule, "ngc-PCFFunction.yang"

```

submodule ngc-PCFFunction {

    belongs-to ngc { prefix ngc; }

    import EP_RP { prefix ep-rp; revision-date "2018-07-31"; }
    import ManagedFunction { prefix mf; revision-date "2018-07-31"; }
    import nrm-types-3gpp { prefix nrm-type; revision-date "2018-07-31"; }
    import ietf-inet-types { prefix inet; revision-date "2010-09-24"; }

    description "PCFFunction derived from basic ManagedFunction";

    revision 2018-08-07 {
        description "Initial revision";
    }

    grouping PCFFunction {
        uses mf:ManagedFunction;

        list pLMNId {
            min-elements "1";
            description "a list of PLMN-Id, PLMN-Id= Mobile Country Codes (MCC)|| Mobile Network
Codes(MNC) ";
            config "true";
            key "MCC MNC";
            uses nrm-type:pLMNId;
        }
    }
}

```

```

leaf sBIFQDN {
    mandatory "true";
    config "true";
    description "";
    type inet:domain-name;
}

leaf-list sBIService {
    min-elements "1";
    config "false";
    type string;
}

leaf-list s-NSSAI {
    min-elements "0";
    config "true";
    description "It represents the list of S-NSSAI the managed object is capable
of supporting, an S-NSSAI is comprised of a SST (Slice/Service
type) and an optional SD (Slice Differentiator) field, (Ref. 3GPP
TS 23.003 [13]). ";
    reference "3GPP TS 23.003";
    type nrm-type:t_s-NSSAI;
}

list EP_N5 { uses ep-rp:EP_N5; }
list EP_N7 { uses ep-rp:EP_N7; }
list EP_N15 { uses ep-rp:EP_N15; }
list EP_N16 { uses ep-rp:EP_N16; }
list EP_Rx { uses ep-rp:EP_Rx; }
list EP_SBI_X {
    key id;
    uses ep-rp:EP_SBI_X;
}
}
}

```

### H.4.3.13 NGC submodule, "ngc-SEPPFunction.yang"

```

submodule ngc-SEPPFunction {

    belongs-to ngc { prefix ngc; }

    import EP_RP { prefix ep-rp; revision-date "2018-07-31"; }
    import ManagedFunction { prefix mf; revision-date "2018-07-31"; }
    import nrm-types-3gpp { prefix nrm-type; revision-date "2018-07-31"; }
    import ietf-inet-types { prefix inet; revision-date "2010-09-24"; }

    description "SEPPFunction derived from basic ManagedFunction";

    revision 2018-08-07 {
        description "Initial revision";
    }

    grouping SEPPFunction {
        uses mf:ManagedFunction;

        list pLMNId {
            min-elements "1";
            description "a list of PLMN-Id, PLMN-Id= Mobile Country Codes (MCC)|| Mobile Network
Codes(MNC) ";
            config "true";
            key "MCC MNC";
            uses nrm-type:pLMNId;
        }

        leaf sBIFQDN {
            mandatory "true";
            config "true";
            description "";
            type inet:domain-name;
        }

        leaf-list sBIService {
            min-elements "1";
            config "false";

```

```

        type string;
    }
    container EP_N32 { uses ep-rp:EP_N32; }
    list EP_SBI_IPX {
        key id;
        uses ep-rp:EP_SBI_IPX;
    }
}
}

```

#### H.4.3.14 NGC submodule, "ngc-SMFFunction.yang"

```

submodule ngc-SMFFunction {

    belongs-to ngc { prefix ngc; }

    import EP_RP { prefix ep-rp; revision-date "2018-07-31"; }
    import ManagedFunction { prefix mf; revision-date "2018-07-31"; }
    import nrm-types-3gpp { prefix nrm-type; revision-date "2018-07-31"; }
    import ietf-inet-types { prefix inet; revision-date "2010-09-24"; }

    description "SMFFunction derived from basic ManagedFunction";

    revision 2018-08-07 {
        description "Initial revision";
    }

    grouping SMFFunction {
        uses mf:ManagedFunction;

        list pLMNid {
            min-elements "1";
            description "a list of PLMN-Id, PLMN-Id= Mobile Country Codes (MCC)|| Mobile Network
Codes(MNC) ";
            config "true";
            key "MCC MNC";
            uses nrm-type:pLMNid;
        }

        leaf sBIFQDN {
            mandatory "true";
            config "true";
            description "";
            type inet:domain-name;
        }

        leaf-list sBIService {
            min-elements "1";
            config "false";
            type string;
        }

        leaf-list tAC {
            min-elements "1";
            config "false";
            type nrm-type:t_tAC;
        }

        leaf-list s-NSSAI {
            min-elements "0";
            config "true";
            description "It represents the list of S-NSSAI the managed object is capable
of supporting, an S-NSSAI is comprised of a SST (Slice/Service
type) and an optional SD (Slice Differentiator) field, (Ref. 3GPP
TS 23.003 [13]). ";
            reference "3GPP TS 23.003";
            type nrm-type:t_s-NSSAI;
        }

        list EP_N4 { uses ep-rp:EP_N4; }
        list EP_N7 { uses ep-rp:EP_N7; }
    }
}

```

```

list EP_N10 { uses ep-rp:EP_N10; }
list EP_N11 { uses ep-rp:EP_N11; }
list EP_N16 { uses ep-rp:EP_N16; }
list EP_S5C { uses ep-rp:EP_S5C; }
list EP_SBI_X {
    key id;
    uses ep-rp:EP_SBI_X;
}
}

```

#### H.4.3.15 NGC submodule, "ngc-SMSFunction.yang"

```

submodule ngc-SMSFunction {

    belongs-to ngc { prefix ngc; }

    import EP_RP { prefix ep-rp; revision-date "2018-07-31"; }
    import ManagedFunction { prefix mf; revision-date "2018-07-31"; }
    import nrm-types-3gpp { prefix nrm-type; revision-date "2018-07-31"; }

    description "SMSFunction derived from basic ManagedFunction";

    revision 2018-08-07 {
        description "Initial revision";
    }

    grouping SMSFunction {
        uses mf:ManagedFunction;

        list pLMNId {
            min-elements "1";
            description "a list of PLMN-Id, PLMN-Id= Mobile Country Codes (MCC)|| Mobile Network
Codes(MNC) ";
            config "true";
            key "MCC MNC";
            uses nrm-type:pLMNId;
        }

        list EP_N20 { uses ep-rp:EP_N20; }
        list EP_N21 { uses ep-rp:EP_N21; }
        list EP_MAP_SMSC { uses ep-rp:EP_MAP_SMSC; }
    }
}

```

#### H.4.3.16 NGC submodule, "ngc-UDMFunction.yang"

```

submodule ngc-UDMFunction {

    belongs-to ngc { prefix ngc; }

    import EP_RP { prefix ep-rp; revision-date "2018-07-31"; }
    import ManagedFunction { prefix mf; revision-date "2018-07-31"; }
    import nrm-types-3gpp { prefix nrm-type; revision-date "2018-07-31"; }
    import ietf-inet-types { prefix inet; revision-date "2010-09-24"; }

    description "UDMFunction derived from basic ManagedFunction";

    revision 2018-08-07 {
        description "Initial revision";
    }

    grouping UDMFunction {
        uses mf:ManagedFunction;

        list pLMNId {
            min-elements "1";
            description "a list of PLMN-Id, PLMN-Id= Mobile Country Codes (MCC)|| Mobile Network
Codes(MNC) ";
            config "true";
            key "MCC MNC";
            uses nrm-type:pLMNId;
        }

        leaf sBIFQDN {
            mandatory "true";
        }
    }
}

```

```

        config "true";
        description "";
        type inet:domain-name;
    }

    leaf-list sBIService {
        min-elements "1";
        config "false";
        type string;
    }

    leaf-list s-NSSAI {
        min-elements "0";
        config "true";
        description "It represents the list of S-NSSAI the managed object is capable
                    of supporting, an S-NSSAI is comprised of a SST (Slice/Service
                    type) and an optional SD (Slice Differentiator) field, (Ref. 3GPP
                    TS 23.003 [13]). ";
        reference "3GPP TS 23.003";
        type nrm-type:t_s-NSSAI;
    }

    list EP_N8 { uses ep-rp:EP_N8; }
    list EP_N10 { uses ep-rp:EP_N10; }
    list EP_N13 { uses ep-rp:EP_N13; }
    list EP_SBI_X {
        key id;
        uses ep-rp:EP_SBI_X;
    }
}
}
}

```

### H.4.3.17 NGC submodule, "ngc-UDRFunction.yang"

```

submodule ngc-UDRFunction {

    belongs-to ngc { prefix ngc; }

    import EP_RP { prefix ep-rp; revision-date "2018-07-31"; }
    import ManagedFunction { prefix mf; revision-date "2018-07-31"; }
    import nrm-types-3gpp { prefix nrm-type; revision-date "2018-07-31"; }
    import ietf-inet-types { prefix inet; revision-date "2010-09-24"; }

    description "UDRFunction derived from basic ManagedFunction";

    revision 2018-08-07 {
        description "Initial revision";
    }

    grouping UDRFunction {
        uses mf:ManagedFunction;

        list pLMNId {
            min-elements "1";
            description "a list of PLMN-Id, PLMN-Id= Mobile Country Codes (MCC)|| Mobile Network
Codes(MNC) ";
            config "true";
            key "MCC MNC";
            uses nrm-type:pLMNId;
        }

        leaf sBIFQDN {
            mandatory "true";
            config "true";
            description "";
            type inet:domain-name;
        }

        leaf-list sBIService {
            min-elements "1";
            config "false";
            type string;
        }

    }

    leaf-list s-NSSAI {

```

```

    min-elements "0";
    config "true";
    description "It represents the list of S-NSSAI the managed object is capable
      of supporting, an S-NSSAI is comprised of a SST (Slice/Service
      type) and an optional SD (Slice Differentiator) field, (Ref. 3GPP
      TS 23.003 [13]). ";
    reference "3GPP TS 23.003";
    type nrm-type:t_s-NSSAI;
  }
  list EP_SBI_X {
    key id;
    uses ep-rp:EP_SBI_X;
  }
}
}
}

```

#### H.4.3.18 NGC submodule, "ngc-UDSFFunction.yang"

```

submodule ngc-UDSFFunction {

  belongs-to ngc { prefix ngc; }

  import EP_RP { prefix ep-rp; revision-date "2018-07-31"; }
  import ManagedFunction { prefix mf; revision-date "2018-07-31"; }
  import nrm-types-3gpp { prefix nrm-type; revision-date "2018-07-31"; }
  import ietf-inet-types { prefix inet; revision-date "2010-09-24"; }

  description "UDSFFunction derived from basic ManagedFunction";

  revision 2018-08-07 {
    description "Initial revision";
  }

  grouping UDSFFunction {
    uses mf:ManagedFunction;

    list pLMNid {
      min-elements "1";
      description "a list of PLMN-Id, PLMN-Id= Mobile Country Codes (MCC)|| Mobile Network
Codes(MNC) ";
      config "true";
      key "MCC MNC";
      uses nrm-type:pLMNid;
    }

    leaf sBIFQDN {
      mandatory "true";
      config "true";
      description "";
      type inet:domain-name;
    }

    leaf-list sBIService {
      min-elements "1";
      config "false";
      type string;
    }

    leaf-list s-NSSAI {
      min-elements "0";
      config "true";
      description "It represents the list of S-NSSAI the managed object is capable
        of supporting, an S-NSSAI is comprised of a SST (Slice/Service
        type) and an optional SD (Slice Differentiator) field, (Ref. 3GPP
        TS 23.003 [13]). ";
      reference "3GPP TS 23.003";
      type nrm-type:t_s-NSSAI;
    }
    list EP_SBI_X {
      key id;
      uses ep-rp:EP_SBI_X;
    }
  }
}
}

```

### H.4.3.19 NGC submodule, "ngc-UPFFunction.yang"

```

submodule ngc-UPFFunction {

  belongs-to ngc { prefix ngc; }

  import EP_RP { prefix ep-rp; revision-date "2018-07-31"; }
  import ManagedFunction { prefix mf; revision-date "2018-07-31"; }
  import nrm-types-3gpp { prefix nrm-type; revision-date "2018-07-31"; }

  description "UPFFunction derived from basic ManagedFunction";

  revision 2018-08-07 {
    description "Initial revision";
  }

  grouping UPFFunction {
    uses mf:ManagedFunction;

    list pLMNId {
      min-elements "1";
      description "a list of PLMN-Id, PLMN-Id= Mobile Country Codes (MCC)|| Mobile Network
Codes(MNC) ";
      config "true";
      key "MCC MNC";
      uses nrm-type:pLMNId;
    }

    leaf-list tAC {
      min-elements "1";
      config "false";
      type nrm-type:t_tAC;
    }

    leaf-list s-NSSAI {
      min-elements "0";
      config "true";
      description "It represents the list of S-NSSAI the managed object is capable
of supporting, an S-NSSAI is comprised of a SST (Slice/Service
type) and an optional SD (Slice Differentiator) field, (Ref. 3GPP
TS 23.003 [13]). ";
      reference "3GPP TS 23.003";
      type nrm-type:t_s-NSSAI;
    }

    list EP_N3 { uses ep-rp:EP_N4; }
    list EP_N4 { uses ep-rp:EP_N7; }
    list EP_N9 { uses ep-rp:EP_N10; }
    list EP_N6 { uses ep-rp:EP_N11; }
    list EP_S5U { uses ep-rp:EP_S5C; }
  }
}

```



---

# Annex I (normative): XML definitions for network slice

## I.1 General

This annex contains the XML definitions for the network slice NRM, in accordance with network slice NRM Information Model definitions specified in clause 6.

---

## I.2 Architectural features

The overall architectural feature of network slice information model is specified in clause 6, this clause specifies features that are specific to the Schema definitions.

The XML definitions of the present document specify the schema for a configuration content, which can be included in a configuration file for Bulk configuration management operations.

---

## I.3 Mapping

### I.3.1 General mapping

An IOC maps to an XML element of the same name as the IOC's name in the Information Model. An IOC attribute maps to a sub-element of the corresponding IOC's XML element, and the name of this sub-element is the same as the attribute's name in the Information Model.

### I.3.2 Information Object Class (IOC) mapping

The mapping is not present in the current version of the present document.

---

## I.4 Solution Set (SS) definitions

### I.4.1 XML definition structure

The overall description of the file format of configuration data XML files is provided by 3GPP TS 32.616 [33].

This annex defines the NRM-specific XML schema `sliceNrm.xsd` for the network slice Information Model defined in clause 6.

XML schema `sliceNrm.xsd` explicitly declares NRM-specific XML element types for the related NRM.

The definition of those NRM-specific XML element types complies with the generic mapping rules defined in 3GPP TS 32.616 [33].

### I.4.2 Graphical representation

The graphical representation is not present in the current version of the present document.

### I.4.3 XML schema "`sliceNrm.xsd`"

```
<?xml version="1.0" encoding="UTF-8"?>
```

```

<!--
3GPP TS 28.541 network slice Network Resource Model
XML schema definition
sliceNrm.xsd
-->
<schema xmlns="http://www.w3.org/2001/XMLSchema"
xmlns:xn="http://www.3gpp.org/ftp/specs/archive/28_series/28.623#genericNrm"
xmlns:sl="http://www.3gpp.org/ftp/specs/archive/28_series/28.541#sliceNrm"
xmlns:nn="http://www.3gpp.org/ftp/specs/archive/28_series/28.541#nrNrm"
xmlns:ngc="http://www.3gpp.org/ftp/specs/archive/28_series/28.541#ngcNrm"
xmlns:en="http://www.3gpp.org/ftp/specs/archive/28_series/28.659#eutranNrm"
xmlns:sm="http://www.3gpp.org/ftp/specs/archive/28_series/28.626#stateManagementIRP"
targetNamespace="http://www.3gpp.org/ftp/specs/archive/28_series/28.541#sliceNrm"
elementFormDefault="qualified">
  <import namespace="http://www.3gpp.org/ftp/specs/archive/28_series/28.623#genericNrm"/>
  <import namespace="http://www.3gpp.org/ftp/specs/archive/28_series/28.541#nrNrm"/>
  <import namespace="http://www.3gpp.org/ftp/specs/archive/28_series/28.541#ngcNrm"/>
  <import namespace="http://www.3gpp.org/ftp/specs/archive/28_series/28.659#eutranNrm"/>
  <import namespace="http://www.3gpp.org/ftp/specs/archive/28_series/28.626#stateManagementIRP"/>

  <simpleType name="MobilityLevel">
    <restriction base="string">
      <enumeration value="STATIONARY"/>
      <enumeration value="NOMADIC"/>
      <enumeration value="RESTRICTED MOBILITY"/>
      <enumeration value="FULLY MOBILITY"/>
    </restriction>
  </simpleType>
  <simpleType name="SharingLevel">
    <restriction base="string">
      <enumeration value="SHARED"/>
      <enumeration value="NON-SHARED"/>
    </restriction>
  </simpleType>

  <complexType name="PerfReq">
    <!-- Refer to definitions in TS 22.261-->
    <sequence>
      <choice minOccurs="0" maxOccurs="1">
        <element name="perfReqEMBB" type="sl:PerfReqEmbb"/>
        <element name="perfReqUrllc" type="sl:PerfReqUrllc"/>
      </choice>
    </sequence>
  </complexType>
  <complexType name="PerfReqEmbb">
    <sequence>
      <element name="expDataRateDL" type="integer" minOccurs="0"/>
      <element name="expDataRateUL" type="integer" minOccurs="0"/>
      <element name="areaTrafficCapDL" type="integer" minOccurs="0"/>
      <element name="areaTrafficCapUL" type="integer" minOccurs="0"/>
      <element name="userDensity" type="integer" minOccurs="0"/>
      <element name="activityFactor" type="integer" minOccurs="0"/>
      <element name="uESpeed" type="integer" minOccurs="0"/>
      <element name="coverage" type="string" minOccurs="0"/>
    </sequence>
  </complexType>
  <complexType name="PerfReqUrllc">
    <sequence>
      <element name="e2eKatency" type="integer" minOccurs="0"/>
      <element name="jitter" type="integer" minOccurs="0"/>
      <element name="survivalTime" type="integer" minOccurs="0"/>
      <element name="cSAvailability" type="float" minOccurs="0"/>
      <element name="reliability" type="float" minOccurs="0"/>
      <element name="expDataRate" type="integer" minOccurs="0"/>
      <element name="payloadSize" type="integer" minOccurs="0"/>
      <element name="trafficDensity" type="string" minOccurs="0"/>
      <element name="connDensity" type="float" minOccurs="0"/>
      <element name="serviceDimension" type="string" minOccurs="0"/>
    </sequence>
  </complexType>
  <complexType name="ServiceProfile">
    <sequence>
      <element name="serviceProfileId" type="string"/>
      <element name="sNSSAIIList" type="ngc:SnsaiList"/>
      <element name="pLMNIdList" type="en:PLMNIdList"/>
      <element name="perfReq" type="sl:PerfReq"/>
      <element name="maxNumberOfUEs" type="long" minOccurs="0"/>
      <element name="coverageAreaTAList" type="ngc:NrTACLList" minOccurs="0"/>
    </sequence>
  </complexType>

```

```

    <element name="latency" type="integer" minOccurs="0"/>
    <element name="uEMobilityLevel" type="integer" minOccurs="0"/>
    <element name="resourceSharingLevel" type="integer" minOccurs="0"/>
    <element name="sst" type="ngc:Sst"/>
    <element name="availability" type="float" minOccurs="0"/>
  </sequence>
</complexType>
<complexType name="ServiceProfileList">
  <sequence>
    <element name="serviceProfile" type="sl:ServiceProfile"/>
  </sequence>
</complexType>

<complexType name="SliceProfile">
  <sequence>
    <element name="sliceProfileId" type="string"/>
    <element name="sNSSAList" type="ngc:SnssaiList"/>
    <element name="pLMNIdList" type="en:PLMNIdList"/>
    <element name="perfReq" type="sl:PerfReq"/>
    <element name="maxNumberOfUEs" type="long" minOccurs="0"/>
    <element name="coverageAreaTAList" type="ngc:NrTACList" minOccurs="0"/>
    <element name="latency" type="integer" minOccurs="0"/>
    <element name="uEMobilityLevel" type="sl:MobilityLevel" minOccurs="0"/>
    <element name="resourceSharingLevel" type="integer" minOccurs="0"/>
  </sequence>
</complexType>
<complexType name="SliceProfileList">
  <sequence>
    <element name="sliceProfile" type="sl:SliceProfile"/>
  </sequence>
</complexType>
<complexType name="NsInfo">
  <!-- Refer to definitions in subclause 8.3.3.2.2 of ETSI NFV IFA013 -->
  <sequence>
    <element name="nsInstanceId" type="string"/>
    <element name="nsName" type="string"/>
    <element name="description" type="string"/>
  </sequence>
</complexType>

<element name="NetworkSlice" substitutionGroup="xn:SubNetworkOptionallyContainedNrmClass">
  <complexType>
    <complexContent>
      <extension base="xn:NrmClass">
        <sequence>
          <element name="attributes">
            <complexType>
              <all>
                <!-- Inherited attributes from SubNetwork -->
                <element name="dnPrefix" type="string" minOccurs="0"/>
                <element name="userLabel" type="string"/>
                <element name="userDefinedNetworkType" type="string"/>
                <element name="setOfMcc" type="string" minOccurs="0"/>
                <!-- End of inherited attributes from SubNetwork -->
                <element name="nSSIId" type="xn:dn"/>
                <element name="operationalState" type="sm:operationalStateType"/>
                <element name="administrativeState" type="sm:administrativeStateType"/>
                <element name="serviceProfileList" type="sl:ServiceProfileList"/>
              </all>
            </complexType>
          </element>
        </sequence>
      </extension>
    </complexContent>
  </complexType>
</element>
<element name="NetworkSliceSubnet" substitutionGroup="xn:SubNetworkOptionallyContainedNrmClass">
  <complexType>
    <complexContent>
      <extension base="xn:NrmClass">
        <sequence>
          <element name="attributes">
            <complexType>
              <all>
                <!-- Inherited attributes from SubNetwork -->
                <element name="dnPrefix" type="string" minOccurs="0"/>
                <element name="userLabel" type="string"/>
              </all>
            </complexType>
          </element>
        </sequence>
      </extension>
    </complexContent>
  </complexType>
</element>

```

```
<element name="userDefinedNetworkType" type="string"/>
<element name="setOfMcc" type="string" minOccurs="0"/>
<!-- End of inherited attributes from SubNetwork -->
<element name="mFidList" type="xn:dnList"/>
<element name="ConstituentNSSIIDList" type="xn:dnList"/>
<element name="operationalState" type="sm:operationalStateType"/>
<element name="administrativeState" type="sm:administrativeStateType"/>
<element name="nsInfo" type="sl:NsInfo" minOccurs="0"/>
<element name="sliceProfileList" type="sl:SliceProfileList"/>
</all>
</complexType>
</element>
</sequence>
</extension>
</complexContent>
</complexType>
</element>
</schema>
```

---

## Annex J (normative): JSON definitions for network slice

### J.1 General

This annex contains the JSON definitions for the network slice NRM, in accordance with network slice NRM Information Model definitions specified in clause 6.

---

### J.2 Architectural features

The overall architectural feature of network slice information model is specified in clause 6, this clause specifies features that are specific to the Schema definitions.

---

### J.3 Mapping

#### J.3.1 IOC mapping

Mapping from the IOCs defined in the information model to SS equivalent definitions are listed in the following table.

IOC Name	JSON definitions' Name	JSON Type
NetworkSlice	networkSlice	object
NetworkSliceSubnet	networkSliceSubnet	object
ServiceProfile	serviceProfile	object
SliceProfile	sliceProfile	object

#### J.3.2 Attributes mapping

Mapping from the attributes of IOCs defined in the information model to SS equivalent definitions are listed in the following table.

Object Attributes	JSON definitions' Name	JSON Type
nSSIIId	nSSIIId	genericNrm:Dn
serviceProfileId	serviceProfileId	string
sliceProfileId	sliceProfileId	string
constituentNSSIIIdList	constituentNSSIIIdList	genericNrm:DnList
mFIdList	mFIdList	genericNrm:DnList
operationalState	operationalState	stateManagementNrm: operationalStateType
administrativeState	administrativeState	stateManagementNrm: administrativeStateType
nsInfo	nsInfo	NsInfo
plmnIdList	plmnIdList	nrNrm: PlmnIdList
perfReq	perfReq	PerfReq
sNSSAIList	snsasaiList	nrNrm: SnsasaiList
maxNumberOfUEs	maxNumberOfUEs	number
coverageAreaTAList	coverageAreaTAList	ngcNrm:TACLlist
latency	latency	number
uEMobilityLevel	uEMobilityLevel	number
resourceSharingLevel	resourceSharingLevel	number
serviceProfileList	serviceProfileList	object
sliceProfileList	sliceProfileList	object

## J.4 Solution Set (SS) definitions

### J.4.1 JSON definition structure

JSON is used as resource representations format carried in the HTTP request and HTTP response message bodies. The properties (key-value pairs) on an object are defined using the properties keyword.

### J.4.2 Graphical representation

The graphical representation is not present in the current version of the present document.

### J.4.3 JSON schema "sliceNrm.json"

```
{
  "$schema": "http://json-schema.org/draft-04/schema#",
  "id": "http://3gpp.org/28541/sliceNrm.json",
  "description": "JSON based solution set definitions for network slice and network slice subnet",
  "_referenced_schema": "http://3gpp.org/28623/genericNrm.json",
  "_referenced_schema": "http://3gpp.org/28626/stateManagementNrm.json",
  "_referenced_schema": "http://3gpp.org/28541/nrNrm.json",
  "_referenced_schema": "http://3gpp.org/28541/ngcNrm.json",

  "definitions": {
    "networkSlice": {
      "type": "object",
      "properties": {
        "id": {
          "type": "string"
        },
        "dnPrefix": {
          "type": "string"
        },
        "userLabel": {
          "type": "string"
        },
        "userDefinedNetworkType": {
          "type": "string"
        },
        "setOfMcc": {
          "type": "string"
        },
        "nSSIIId": {
          "$ref": "http://3gpp.org/28623/genericNrm.json#/definitions/Dn"
        }
      }
    }
  }
}
```

```

    },
    "operationalState": {
      "$ref":
"http://3gpp.org/28626/stateManagementNrm.json#/definitions/operationalState"
    },
    "administrativeState": {
      "$ref":
"http://3gpp.org/28626/stateManagementNrm.json#/definitions/administrativeState"
    },
    "serviceProfileList": {
      "$ref": "#/definitions/ServiceProfileList"
    }
  },
  "required": [
    "userLabel",
    "userDefinedNetworkType",
    "nSSIID",
    "operationalState",
    "administrativeState",
    "serviceProfileList"
  ]
},
"networkSliceSubnet": {
  "type": "object",
  "properties": {
    "id": {
      "type": "string"
    },
    "dnPrefix": {
      "type": "string"
    },
    "userLabel": {
      "type": "string"
    },
    "userDefinedNetworkType": {
      "type": "string"
    },
    "setOfMcc": {
      "type": "string"
    },
    "mFidList": {
      "$ref": "http://3gpp.org/28623/genericNrm.json#/definitions/DnList"
    },
    "constituentNSSIIDList": {
      "$ref": "http://3gpp.org/28623/genericNrm.json#/definitions/DnList"
    },
    "operationalState": {
      "$ref":
"http://3gpp.org/28626/stateManagementNrm.json#/definitions/OperationalState"
    },
    "administrativeState": {
      "$ref":
"http://3gpp.org/28626/stateManagementNrm.json#/definitions/AdministrativeState"
    },
    "nsInfo": {
      "$ref": "#/definitions/NsInfo"
    },
    "sliceProfileList": {
      "$ref": "#/definitions/ServiceProfileList"
    }
  },
  "required": [
    "userLabel",
    "mFidList",
    "constituentNSSIIDList",
    "operationalState",
    "administrativeState",
    "sliceProfileList"
  ]
},
"MobilityLevel": {
  "type": "string",
  "enum": [
    "STATIONARY",
    "NOMADIC",
    "RESTRICTED MOBILITY",
    "FULLY MOBILITY"
  ]
},
"SharingLevel": {

```

```

        "type": "string",
        "enum": [
            "SHARED",
            "NON-SHARED"
        ]
    },
    "PrefReq": {
        "type": "object",
        "properties": {
            "prefReqEmbb": {
                "$ref": "#/definitions/PrefReqEmbb"
            },
            "prefReqUrrlc": {
                "$ref": "#/definitions/PrefReqUrrlc"
            }
        }
    },
    "PerfReqEmbb": {
        "type": "object",
        "properties": {
            "expDataRateDL": {
                "type": "number"
            },
            "expDataRateUL": {
                "type": "number"
            },
            "areaTrafficCapDL": {
                "type": "number"
            },
            "areaTrafficCapUL": {
                "type": "number"
            },
            "userDensity": {
                "type": "number"
            },
            "activityFactor": {
                "type": "number"
            },
            "uESpeed": {
                "type": "number"
            },
            "coverage": {
                "type": "string"
            }
        }
    },
    "PerfReqUrrlc": {
        "type": "object",
        "properties": {
            "e2eLatency": {
                "type": "number"
            },
            "jitter": {
                "type": "number"
            },
            "survivalTime": {
                "type": "number"
            },
            "areaTrafficCapUL": {
                "type": "number"
            },
            "cSAvailability": {
                "type": "number"
            },
            "reliability": {
                "type": "number"
            },
            "expDataRate": {
                "type": "number"
            },
            "payloadSize": {
                "type": "number"
            },
            "trafficDensity": {
                "type": "string"
            },
            "connDensity": {
                "type": "number"
            }
        }
    }
}

```



```

    },
    "serviceDimension": {
      "type": "string"
    }
  }
},
"ServiceProfile": {
  "type": "object",
  "properties": {
    "serviceProfileId": {
      "type": "string"
    },
    "snssaiList": {
      "$ref": "http://3gpp.org/28541/nrNrm.json#/definitions/SnssaiList"
    },
    "plmnIdList": {
      "$ref": "http://3gpp.org/28541/nrNrm.json#/definitions/PlmnIdList"
    },
    "perfReq": {
      "$ref": "#/definitions/PrefReq"
    },
    "maxNumberOfUEs": {
      "type": "number"
    },
    "coverageAreaTAList": {
      "$ref": "http://3gpp.org/28541/ngcNrm.json#/definitions/TACList"
    },
    "latency": {
      "type": "number"
    },
    "uEMobilityLevel": {
      "type": "number"
    },
    "sst": {
      "$ref": "http://3gpp.org/28541/ngcNrm.json#/definitions/Sst"
    },
    "resourceSharingLevel": {
      "type": "integer"
    },
    "availability": {
      "type": "number"
    }
  }
},
"ServiceProfileList": {
  "type": "array",
  "item": {
    "$ref": "#/definitions/ServiceProfile"
  }
},
"SliceProfile": {
  "type": "object",
  "properties": {
    "sliceProfileId": {
      "type": "string"
    },
    "snssaiList": {
      "$ref": "http://3gpp.org/28541/nrNrm.json#/definitions/SnssaiList"
    },
    "plmnIdList": {
      "$ref": "http://3gpp.org/28541/nrNrm.json#/definitions/PlmnIdList"
    },
    "perfReq": {
      "$ref": "#/definitions/PrefReq"
    },
    "maxNumberOfUEs": {
      "type": "number"
    },
    "coverageAreaTAList": {
      "$ref": "http://3gpp.org/28541/ngcNrm.json#/definitions/TACList"
    },
    "latency": {
      "type": "number"
    },
    "uEMobilityLevel": {
      "type": "number"
    },
    "resourceSharingLevel": {

```

```
        "type": "integer"
      }
    },
    "SliceProfileList": {
      "type": "array",
      "item": {
        "$ref": "#/definitions/SliceProfile"
      }
    },
    "NsInfo": {
      "type": "object",
      "properties": {
        "nsInstanceId": {
          "type": "string"
        },
        "nsName": {
          "type": "string"
        },
        "description": {
          "type": "string"
        }
      }
    }
  }
}
```

## Annex K (normative): YANG definitions for Network Slice NRM

### K.1 General

This annex contains the YANG definitions for the Network Slice NRM, in accordance with Network Slicing information model definitions specified in clause 6.

### K.2 Architectural features

### K.3 Mapping

#### K.3.1 IOC mapping

Mapping from the IOCs defined in the information model to SS equivalent definitions are listed in the following table.

IOC Name	YANG definitions' Name	YANG Type
NetworkSlice	NetworkSlice	Container in module
NetworkSliceSubnet	NetworkSliceSubnet	Container in module
ServiceProfile	serviceProfile	Reusable Container in Module
SliceProfile	SliceProfile	Reusable Container in Module

#### K.3.2 Attributes mapping

Mapping from the attributes of IOCs defined in the information model to SS equivalent definitions are listed in the following table.

Object Attributes	YANG definitions' Name	YANG Type
Simple Type Attributes	Same to the Name in Stage 2	leaf
Complex Type Attribute	Same to the Name in Stage 2	Reusable Container
Simple Type List	Same to the Name in Stage 2 with removing List/s at the end of the attribute	leaf-list
Complex Type List	Same to the Name in Stage 2 with removing List/s at the end of the attribute	list

### K.4 Solution Set definitions

#### K.4.1 YANG definition structure

#### K.4.2 Graphical representation

```

module: NetworkSlice
  +--rw NetworkSlice
    +--ro objectClass          string
    +--ro objectInstance      nrm-type:t_dn
  
```

```

+--ro id nrm-type:t_dn
+--ro dnPrefix string
+--rw userLabel string
+--rw userDefinedNetworkType string
+--ro setOfMcc* nrm-type:t_mcc
+--ro nSSIIId nrm-type:t_dn
+--ro operationalState nrm-type:t_operationalState
+--rw administrativeState nrm-type:t_administrativeState
+--rw serviceProfile* [serviceProfileId]
| +--rw serviceProfileId nrm-type:t_dn
| +--rw s-NSSAI* nrm-type:t_s-NSSAI
| +--rw pLMNId
| | +--rw MCC t_mcc
| | +--rw MNC t_mnc
| +--rw perfReq
| +--rw (SST)
| | +--:(eMBB)
| | | +--rw expDataRateDL uint16
| | | +--rw expDataRateU uint16
| | | +--rw areaTrafficCapDL uint16
| | | +--rw areaTrafficCapUL uint16
| | | +--rw userDensity uint16
| | | +--rw activityFactor uint16
| | | +--rw uESpeed uint16
| | | +--rw coverage string
| | +--:(uRLLC)
| | | +--rw e2eLatency uint16
| | | +--rw jitter uint16
| | | +--rw survivalTime uint16
| | | +--rw cSAvailability decimal64
| | | +--rw reliability decimal64
| | | +--rw expDataRate uint16
| | | +--rw payloadSize string
| | | +--rw trafficDensity uint16
| | | +--rw connDensity uint16
| | | +--rw serviceAreaDimension string
| +--rw maxNumberOfUEs uint64
| +--rw coverageAreaTA* nrm-type:t_tAC
| +--rw latency uint16
| +--rw uEMobilityLevel nrm-type:t_uEMobilityLevel
| +--rw resourceSharingLevel nrm-type:t_resourceSharingLevel
+--rw sST nrm-type:t_SST

```

module: NetworkSliceSubnet

```

+--rw NetworkSliceSubnet
+--ro objectClass string
+--ro objectInstance nrm-type:t_dn
+--ro id nrm-type:t_dn
+--ro dnPrefix string
+--rw userLabel string
+--rw userDefinedNetworkType string
+--ro setOfMcc* nrm-type:t_mcc
+--ro mFId* nrm-type:t_dn
+--ro constituentNSSIIIdList* nrm-type:t_dn
+--rw State string
+--ro nsInfo nrm-type:t_dn
+--rw sliceProfile* [sliceProfileId]
| +--rw sliceProfileId nrm-type:t_dn
| +--rw s-NSSAI* nrm-type:t_s-NSSAI
| +--rw pLMNId
| | +--rw MCC t_mcc
| | +--rw MNC t_mnc
| +--rw perfReq
| +--rw (SST)
| | +--:(eMBB)
| | | +--rw expDataRateDL uint16
| | | +--rw expDataRateU uint16
| | | +--rw areaTrafficCapDL uint16
| | | +--rw areaTrafficCapUL uint16
| | | +--rw userDensity uint16
| | | +--rw activityFactor uint16
| | | +--rw uESpeed uint16
| | | +--rw coverage string
| | +--:(uRLLC)
| | | +--rw e2eLatency uint16
| | | +--rw jitter uint16
| | | +--rw survivalTime uint16
| | | +--rw cSAvailability decimal64

```

```

| |      +--rw reliability          decimal64
| |      +--rw expDataRate         uint16
| |      +--rw payloadSize        string
| |      +--rw trafficDensity      uint16
| |      +--rw connDensity         uint16
| |      +--rw serviceAreaDimension string
| +--rw maxNumberOfUEs           uint64
| +--rw coverageAreaTA*         nrm-type:t_tAC
| +--rw latency                  uint16
| +--rw uEMobilityLevel         nrm-type:t_uEMobilityLevel
| +--rw resourceSharingLevel    nrm-type:t_resourceSharingLevel
+--rw sST                       nrm-type:t_SST

```

## K.4.3 YANG schema

### K.4.3.1 General type definition "nrm-types-3gpp.yang"

Refer to Annex E.4.3.1.

### K.4.3.2 Basic IOC definition which can be reused by specific ManagedFuncion. "Top.yang", "ManagedElement.yang", "ManagedFunction.yang", "EP\_RP.yang", "SubNetwork"

Refer to Annex E.4.3.2.

### K.4.3.3 NetworkSlice Module, "NetworkSlice.yang"

```

module NetworkSlice {
  namespace "urn:3gpp:tsg:sa5:nrm:NetworkSlice";
  prefix "ns";

  import SubNetwork { prefix subnet; revision-date "2018-07-31"; }
  import nrm-types-3gpp { prefix nrm-type; revision-date "2018-07-31"; }
  include ServiceProfile;

  description "";

  revision 2018-08-09 {
    description "Initial revision";
  }

  container NetworkSlice {
    uses subnet:SubNetwork;

    leaf nSSIId {
      mandatory "true";
      config "false";
      description "";
      type nrm-type:t_dn;
    }

    leaf operationalState {
      mandatory "true";
      config "false";
      description "";
      type nrm-type:t_operationalState;
    }

    leaf administrativeState {
      mandatory "true";
      config "true";
      description "";
      type nrm-type:t_administrativeState;
    }

    list serviceProfile {
      min-elements "1";
      config "true";
      description "";
    }
  }
}

```

```

        key serviceProfileId;
        uses ServiceProfile;
    }

}

}

```

#### K.4.3.4 ServiceProfile Submodule, "ServiceProfile.yang"

```

submodule ServiceProfile {

    belongs-to NetworkSlice { prefix ns; }

    import nrm-types-3gpp { prefix nrm-type; revision-date "2018-07-31"; }
    import perfReq { prefix perf; revision-date "2018-08-10"; }

    revision 2018-08-09 {
        description "Initial revision";
    }

    grouping ServiceProfile {

        leaf serviceProfileId {
            mandatory "true";
            description "";
            type nrm-type:t_dn;
        }

        leaf-list s-NSSAI {
            min-elements "1";
            config "true";
            description "";
            type nrm-type:t_s-NSSAI;
        }

        list pLMNid {
            min-elements "1";
            config "true";
            key "MCC MNC";
            uses nrm-type:pLMNid;
        }

        container perfReq {
            config "true";
            description "";
            uses perf:perfReq;
        }

        leaf maxNumberOfUEs {
            mandatory "false";
            config "true";
            description "";
            type uint64;
        }

        leaf-list coverageAreaTA {
            min-elements "1";
            config "true";
            description "";
            type nrm-type:t_tAC;
        }

        leaf latency {
            mandatory "false";
            config "true";
            description "";
            type uint16;
        }

        leaf uEMobilityLevel {
            mandatory "false";
            config "true";
            description "";
            type nrm-type:t_uEMobilityLevel;
        }
    }
}

```

```

    }

    leaf resourceSharingLevel {
        mandatory "false";
        config "true";
        description "";
        type nrm-type:t_resourceSharingLevel;
    }

    leaf sST {
        mandatory "true";
        config "true";
        description "";
        type nrm-type:t_SST;
    }

    leaf availability {
        mandatory "false";
        config "true";
        description "";
        type decimal64;
    }

}

}

```

#### K.4.3.5 NetworkSliceSubnet Module, "NetworkSliceSubnet.yang"

```

module NetworkSliceSubnet {
    namespace "urn:3gpp:tsg:sa5:nrm:NetworkSliceSubnet";
    prefix "nss";

    import SubNetwork { prefix subnet; revision-date "2018-07-31"; }
    import nrm-types-3gpp { prefix nrm-type; revision-date "2018-07-31"; }

    include SliceProfile;

    description "";

    revision 2018-08-09 {
        description "Initial revision";
    }

    container NetworkSliceSubnet {
        uses subnet:SubNetwork;

        leaf-list mFId {
            min-elements "0";
            config "false";
            description "";
            type nrm-type:t_dn;
        }

        leaf-list constituentNSSIIdList {
            min-elements "0";
            config "false";
            description "";
            type nrm-type:t_dn;
        }

        leaf operationalState {
            mandatory "true";
            config "false";
            description "";
            type nrm-type:t_operationalState;
        }

        leaf administrativeState {
            mandatory "true";
            config "true";
            description "";
            type nrm-type:t_administrativeState;
        }
    }
}

```

```

    leaf nsInfo {
      mandatory "false";
      config "false";
      description "";
      type nrm-type:t_dn;
    }

    list sliceProfile {
      min-elements "1";
      config "true";
      description "";
      key sliceProfileId;
      uses SliceProfile;
    }

  }
}

```

### K.4.3.6 SliceProfile Submodule, "SliceProfile.yang"

```

submodule SliceProfile {

  belongs-to NetworkSliceSubnet { prefix nss; }

  import nrm-types-3gpp { prefix nrm-type; revision-date "2018-07-31"; }
  import perfReq { prefix perf; revision-date "2018-08-10"; }

  revision 2018-08-09 {
    description "Initial revision";
  }

  grouping SliceProfile {

    leaf sliceProfileId {
      mandatory "true";
      description "";
      type nrm-type:t_dn;
    }

    leaf-list s-NSSAI {
      min-elements "1";
      config "true";
      description "";
      type nrm-type:t_s-NSSAI;
    }

    list pLMNid {
      min-elements "1";
      config "true";
      key "MCC MNC";
      uses nrm-type:pLMNid;
    }

    container perfReq {
      config "true";
      description "";
      uses perf:perfReq;
    }

    leaf maxNumberOfUEs {
      mandatory "false";
      config "true";
      description "";
      type uint64;
    }

    leaf-list coverageAreaTA {
      min-elements "1";
      config "true";
      description "";
      type nrm-type:t_tAC;
    }
  }
}

```



```

leaf latency {
  mandatory "false";
  config "true";
  description "";
  type uint16;
}

leaf uEMobilityLevel {
  mandatory "false";
  config "true";
  description "";
  type nrm-type:t_uEMobilityLevel;
}

leaf resourceSharingLevel {
  mandatory "false";
  config "true";
  description "";
  type nrm-type:t_resourceSharingLevel;
}

}
}

```

### K.4.3.7 perfReq Module, "perfReq.yang"

```

module perfReq {
  namespace "urn:3gpp:tsg:sa5:nrm:perfReq";
  prefix "perf";

  revision 2018-08-10 {
    description "Initial revision";
  }

  grouping perfReq {
    choice SST {
      case eMBB {
        leaf expDataRateDL { type uint16; }
        leaf expDataRateU { type uint16; }
        leaf areaTrafficCapDL { type uint16; }
        leaf areaTrafficCapUL { type uint16; }
        leaf userDensity { type uint16; }
        leaf activityFactor { type uint16; }
        leaf uESpeed { type uint16; }
        leaf coverage { type string; }
      }
      case uRLLC {
        leaf e2eLatency { type uint16; }
        leaf jitter { type uint16; }
        leaf survivalTime { type uint16; }
        leaf cSAvailability {
          type decimal64 {
            fraction-digits 4;
            range 1..99.9999;
          }
        }
        leaf reliability {
          type decimal64 {
            fraction-digits 4;
            range 1..99.9999;
          }
        }
        leaf expDataRate { type uint16; }
        leaf payloadSize { type string; }
        leaf trafficDensity { type uint16; }
        leaf connDensity { type uint16; }
        leaf serviceAreaDimension { type string; }
      }
    }
  }
}

```

## Annex L (informative): Change history

Change history							
Date	Meeting	TDoc	CR	Rev	Cat	Subject/Comment	New version
2018-09	SA#81					Upgrade to change control version	15.0.0
2018-09	SA#81					EdiHelp review	15.0.1
2018-12	SA#82	SP-181046	0001	1	F	Fix issues raised by EditHelp	15.1.0
2018-12	SA#82	SP-181046	0002	2	F	Update NR Stage 2 definition to align with TS 37.340 for MR-DC	15.1.0
2018-12	SA#82	SP-181046	0003	1	F	Update NRM Stage 2 definition to align with TS 23.501 for 5G architecture	15.1.0
2018-12	SA#82	SP-181046	0005	1	F	Update Stage 3 XML definition of NR to align with Stage 2 content	15.1.0
2018-12	SA#82	SP-181046	0006	1	F	Update Stage 3 JSON definition of NR to align with Stage 2 content	15.1.0
2018-12	SA#82	SP-181046	0007	1	F	Update Stage 3 YANG definition of NR to align with Stage 2 content	15.1.0
2018-12	SA#82	SP-181046	0008	1	F	Update Stage 3 XML definition of 5GC to align with Stage 2 content	15.1.0
2018-12	SA#82	SP-181046	0009	1	F	Update Stage 3 JSON definition of 5GC to align with Stage 2 content	15.1.0
2018-12	SA#82	SP-181046	0011	1	F	Update stage 3 XML definition of NS to align with Stage 2 content	15.1.0
2018-12	SA#82	SP-181046	0012	1	F	Update Stage 3 JSON definition of NS to align with Stage 2 content	15.1.0
2018-12	SA#82	SP-181046	0013	1	F	Update stage 3 YANG definition of NS to align with Stage 2 content	15.1.0
2018-12	SA#82	SP-181046	0014	1	F	Correct the term sNSSAList and nRTAList	15.1.0
2018-12	SA#82	SP-181046	0015	1	F	Update the inheritance hierarchy figure for NR NRM to include BWP IOC and NRSectorCarrier IOC	15.1.0
2018-12	SA#82	SP-181046	0016	1	F	Change the term nCGI to nCI	15.1.0
2018-12	SA#82	SP-181046	0019	1	F	Align properties of cell state	15.1.0
2018-12	SA#82	SP-181046	0021	1	F	Add missing attribute definition and condition	15.1.0
2018-12	SA#82	SP-181047	0022	1	F	Add missing detail definition for attribute	15.1.0
2018-12	SA#82	SP-181047	0023	1	F	Adding missing attribute, and correction of reference	15.1.0
2018-12	SA#82	SP-181043	0025	-	F	Remove NSSF from the abbreviations	15.1.0
2018-12	SA#82	SP-181046	0027	-	F	Replace symbol for network slice state management	15.1.0
2018-12	SA#82	SP-181046	0031	1	F	Remove the ExternalENBFunction definition	15.1.0
2018-12	SA#82	SP-181046	0033	1	F	Align the management of external function and cell with TS 28.658	15.1.0
2018-12	SA#82	SP-181156	0034	1	F	Update NR NRM with Cell Relation	15.1.0
2018-12	SA#82	SP-181156	0038	3	F	RRM Policy enhancements	15.1.0
2018-12	SA#82	SP-181156	0039	1	F	Fix containment issue in YANG definition	15.1.0
2018-12	SA#82	SP-181156	0040	-	F	Implement minor corrections	15.1.0
2018-12	SA#82	SP-181042	0041	-	F	Update Stage 3 NRM for RRM Policy enhancements	15.1.0
2019-03	SA#83	SP-190121	0043	1	F	Align NR attributes definition related to SSB with corresponding NG-RAN IE definition	15.2.0
2019-03	SA#83	SP-190121	0044	1	F	Correct the use of nCI and PLMN	15.2.0
2019-03	SA#83	SP-190121	0045	-	F	Remove duplicate definition for ExternalNRCellCU	15.2.0
2019-03	SA#83	SP-190121	0046	2	F	Correct class diagram for view on external entities	15.2.0
2019-03	SA#83	SP-190121	0047	1	F	Correct the definition for resourceSharingLevel	15.2.0
2019-03	SA#83	SP-190121	0048	1	F	Correction of references	15.2.0
2019-03	SA#83	SP-190121	0052	1	F	Align the term mFIdList and constituentNSSIIdList	15.2.0
2019-03	SA#83	SP-190121	0053	1	F	Correct the definition of nSSIId	15.2.0
2019-03	SA#83	SP-190121	0054	1	F	Add missing attribute constraint for class definition of NSSFFunction	15.2.0
2019-03	SA#83	SP-190121	0055	1	F	Correct attribute constraints for RRMpolicy related attributes in NRCellCU	15.2.0
2019-03	SA#83	SP-190121	0057	-	F	Correct cardinality of End Point (EP) to target	15.2.0
2019-03	SA#83	SP-190121	0058	-	F	Correct Import table	15.2.0
2019-03	SA#83	SP-190121	0059	-	F	Remove ExternalNRCellCU.pLMNIdList	15.2.0
2019-03	SA#83	SP-190121	0060	-	F	Use 'bS' (not 'bs') to prefix all BS (base station) attributes	15.2.0
2019-03	SA#83	SP-190121	0061	1	F	Correction of State attributes descriptions	15.2.0
2019-03	SA#83	SP-190121	0062	-	F	Update 5G JSON Solution Set to align with generic NRM	15.2.0

2019-03	SA#83	SP-190121	0063	1	F	Update YANG Solution Set to align with Stage 2 definition	15.2.0
2019-03	SA#83	SP-190121	0064	1	F	Update Information Service to fix Network Slice modeling issue	15.2.0
2019-03	SA#83	SP-190121	0065	1	F	Update Solution Set to fix Network Slice modeling issue	15.2.0
2019-03	SA#83	SP-190121	0066	1	F	Add availability in service profile of network slice resource model	15.2.0
2019-03	SA#83	SP-190121	0068	1	F	Add sST attribute to ServiceProfile	15.2.0
2019-03	SA#83	SP-190121	0069	1	F	Update to sST attribute stage 3	15.2.0
2019-06	SA#84	SP-190374	0082	-	F	Remove attribute availabilityStatus in NRCellDU IOC	15.3.0
2019-06	SA#84	SP-190374	0084	1	F	Correct the definition for nsInfo	15.3.0
2019-06	SA#84	SP-190374	0087	1	F	Update Information Service of NR to fix unclear Note issue	15.3.0
2019-06	SA#84	SP-190374	0094	-	F	Correct definition of configuredMaxTxPower	15.3.0
2019-06	SA#84	SP-190374	0103	-	F	Fix the implementation errors	15.3.0
2019-06	SA#84	SP-190374	0104	2	F	Correct the use of plmnIdList	15.3.0

---

## History

<b>Document history</b>		
V15.0.1	October 2018	Publication
V15.1.0	April 2019	Publication
V15.2.0	May 2019	Publication
V15.3.0	June 2019	Publication