

ETSI TS 128 541 V15.8.0 (2021-04)



**5G;
Management and orchestration;
5G Network Resource Model (NRM);
Stage 2 and stage 3
(3GPP TS 28.541 version 15.8.0 Release 15)**



Reference

RTS/TSGS-0528541vf80

Keywords

5G

ETSI

650 Route des Lucioles
F-06921 Sophia Antipolis Cedex - FRANCE

Tel.: +33 4 92 94 42 00 Fax: +33 4 93 65 47 16

Siret N° 348 623 562 00017 - APE 7112B
Association à but non lucratif enregistrée à la
Sous-Préfecture de Grasse (06) N° w061004871

Important noticeThe present document can be downloaded from:
<http://www.etsi.org/standards-search>

The present document may be made available in electronic versions and/or in print. The content of any electronic and/or print versions of the present document shall not be modified without the prior written authorization of ETSI. In case of any existing or perceived difference in contents between such versions and/or in print, the prevailing version of an ETSI deliverable is the one made publicly available in PDF format at www.etsi.org/deliver.

Users of the present document should be aware that the document may be subject to revision or change of status. Information on the current status of this and other ETSI documents is available at <https://portal.etsi.org/TB/ETSIDeliverableStatus.aspx>

If you find errors in the present document, please send your comment to one of the following services:
<https://portal.etsi.org/People/CommitteeSupportStaff.aspx>

Notice of disclaimer & limitation of liability

The information provided in the present deliverable is directed solely to professionals who have the appropriate degree of experience to understand and interpret its content in accordance with generally accepted engineering or other professional standard and applicable regulations.

No recommendation as to products and services or vendors is made or should be implied.

No representation or warranty is made that this deliverable is technically accurate or sufficient or conforms to any law and/or governmental rule and/or regulation and further, no representation or warranty is made of merchantability or fitness for any particular purpose or against infringement of intellectual property rights.

In no event shall ETSI be held liable for loss of profits or any other incidental or consequential damages.

Any software contained in this deliverable is provided "AS IS" with no warranties, express or implied, including but not limited to, the warranties of merchantability, fitness for a particular purpose and non-infringement of intellectual property rights and ETSI shall not be held liable in any event for any damages whatsoever (including, without limitation, damages for loss of profits, business interruption, loss of information, or any other pecuniary loss) arising out of or related to the use of or inability to use the software.

Copyright Notification

No part may be reproduced or utilized in any form or by any means, electronic or mechanical, including photocopying and microfilm except as authorized by written permission of ETSI.

The content of the PDF version shall not be modified without the written authorization of ETSI.

The copyright and the foregoing restriction extend to reproduction in all media.

© ETSI 2021.
All rights reserved.

Intellectual Property Rights

Essential patents

IPRs essential or potentially essential to normative deliverables may have been declared to ETSI. The declarations pertaining to these essential IPRs, if any, are publicly available for **ETSI members and non-members**, and can be found in ETSI SR 000 314: "*Intellectual Property Rights (IPRs); Essential, or potentially Essential, IPRs notified to ETSI in respect of ETSI standards*", which is available from the ETSI Secretariat. Latest updates are available on the ETSI Web server (<https://ipr.etsi.org/>).

Pursuant to the ETSI Directives including the ETSI IPR Policy, no investigation regarding the essentiality of IPRs, including IPR searches, has been carried out by ETSI. No guarantee can be given as to the existence of other IPRs not referenced in ETSI SR 000 314 (or the updates on the ETSI Web server) which are, or may be, or may become, essential to the present document.

Trademarks

The present document may include trademarks and/or tradenames which are asserted and/or registered by their owners. ETSI claims no ownership of these except for any which are indicated as being the property of ETSI, and conveys no right to use or reproduce any trademark and/or tradename. Mention of those trademarks in the present document does not constitute an endorsement by ETSI of products, services or organizations associated with those trademarks.

DECT™, **PLUGTESTS™**, **UMTS™** and the ETSI logo are trademarks of ETSI registered for the benefit of its Members. **3GPP™** and **LTE™** are trademarks of ETSI registered for the benefit of its Members and of the 3GPP Organizational Partners. **oneM2M™** logo is a trademark of ETSI registered for the benefit of its Members and of the oneM2M Partners. **GSM®** and the GSM logo are trademarks registered and owned by the GSM Association.

Legal Notice

This Technical Specification (TS) has been produced by ETSI 3rd Generation Partnership Project (3GPP).

The present document may refer to technical specifications or reports using their 3GPP identities. These shall be interpreted as being references to the corresponding ETSI deliverables.

The cross reference between 3GPP and ETSI identities can be found under <http://webapp.etsi.org/key/queryform.asp>.

Modal verbs terminology

In the present document "**shall**", "**shall not**", "**should**", "**should not**", "**may**", "**need not**", "**will**", "**will not**", "**can**" and "**cannot**" are to be interpreted as described in clause 3.2 of the [ETSI Drafting Rules](#) (Verbal forms for the expression of provisions).

"**must**" and "**must not**" are **NOT** allowed in ETSI deliverables except when used in direct citation.

Contents

Intellectual Property Rights	2
Legal Notice	2
Modal verbs terminology.....	2
Foreword.....	14
Introduction	14
1 Scope	15
2 References	15
3 Definitions and abbreviations.....	17
3.1 Definitions	17
3.2 Abbreviations	17
4 Information model definitions for NR NRM.....	18
4.1 Imported and associated information	18
4.1.1 Imported information entities and local labels.....	18
4.1.2 Associated information entities and local labels.....	18
4.2 Class diagram	18
4.2.1 Class diagram for gNB and en-gNB	18
4.2.1.1 Relationships.....	18
4.2.1.2 Inheritance.....	21
4.3 Class definitions	23
4.3.1 GNBDUFunction	23
4.3.1.1 Definition	23
4.3.1.2 Attributes.....	23
4.3.1.3 Attribute constraints	23
4.3.1.4 Notifications.....	23
4.3.2 GNBCUCPFunction	23
4.3.2.1 Definition	23
4.3.2.2 Attributes.....	24
4.3.2.3 Attribute constraints	24
4.3.2.4 Notifications.....	24
4.3.3 GNBCUUPFunction	24
4.3.3.1 Definition	24
4.3.3.2 Attributes.....	25
4.3.3.3 Attribute constraints	25
4.3.3.4 Notifications.....	25
4.3.4 NRCellCU	25
4.3.4.1 Definition	25
4.3.4.2 Attributes.....	25
4.3.4.3 Attribute constraints	26
4.3.4.4 Notifications.....	26
4.3.5 NRCellDU	26
4.3.5.1 Definition	26
4.3.5.2 Attributes.....	26
4.3.5.3 Attribute constraints	27
4.3.5.4 Notifications.....	27
4.3.6 NRSectorCarrier	27
4.3.6.1 Definition	27
4.3.6.2 Attributes.....	28
4.3.6.3 Attribute constraints	28
4.3.6.4 Notifications.....	28
4.3.7 BWP	28
4.3.7.1 Definition	28
4.3.7.2 Attributes.....	28
4.3.7.3 Attribute constraints	28

4.3.7.4	Notifications.....	29
4.3.8	EP_E1	29
4.3.8.1	Definition	29
4.3.8.2	Attributes.....	29
4.3.8.3	Attribute constraints	29
4.3.8.4	Notifications.....	29
4.3.9	EP_XnU.....	29
4.3.9.1	Definition	29
4.3.9.2	Attributes.....	29
4.3.9.3	Attribute constraints	29
4.3.9.4	Notifications.....	29
4.3.10	EP_NgC.....	30
4.3.10.1	Definition	30
4.3.10.2	Attributes.....	30
4.3.10.3	Attribute constraints	30
4.3.10.4	Notifications.....	30
4.3.11	EP_NgU.....	30
4.3.11.1	Definition	30
4.3.11.2	Attributes.....	30
4.3.11.3	Attribute constraints	30
4.3.11.4	Notifications.....	30
4.3.12	EP_F1C.....	31
4.3.12.1	Definition	31
4.3.12.2	Attributes.....	31
4.3.12.3	Attribute constraints	31
4.3.12.4	Notifications.....	31
4.3.13	EP_F1U.....	31
4.3.13.1	Definition	31
4.3.13.2	Attributes.....	31
4.3.13.3	Attribute constraints	31
4.3.13.4	Notifications.....	31
4.3.14	EP_S1U.....	32
4.3.14.1	Definition	32
4.3.14.2	Attributes.....	32
4.3.14.3	Attribute constraints	32
4.3.14.4	Notifications.....	32
4.3.15	EP_X2C.....	32
4.3.15.1	Definition	32
4.3.15.2	Attributes.....	32
4.3.15.3	Attribute constraints	32
4.3.15.4	Notifications.....	32
4.3.16	EP_X2U.....	32
4.3.16.1	Definition	32
4.3.16.2	Attributes.....	33
4.3.16.3	Attribute constraints	33
4.3.16.4	Notifications.....	33
4.3.17	EP_XnC.....	33
4.3.17.1	Definition	33
4.3.17.2	Attributes.....	33
4.3.17.3	Attribute constraints	33
4.3.17.4	Notifications.....	33
4.3.18	ExternalGNBCUCPFfunction	33
4.3.18.1	Definition	33
4.3.18.2	Attributes.....	33
4.3.18.3	Attribute constraints	34
4.3.18.4	Notifications.....	34
4.3.19	ExternalGNBCUUPFunction	34
4.3.19.1	Definition	34
4.3.19.2	Attributes.....	34
4.3.19.3	Attribute constraints	34
4.3.19.4	Notifications.....	34

4.3.20	ExternalGNBDUFunction	34
4.3.20.1	Definition	34
4.3.20.2	Attributes	34
4.3.20.3	Attribute constraints	34
4.3.20.4	Notifications	35
4.3.21	ExternalUPFFunction	35
4.3.21.1	Definition	35
4.3.21.2	Attributes	35
4.3.21.3	Attribute constraints	35
4.3.21.4	Notifications	35
4.3.22	ExternalAMFFunction	35
4.3.22.1	Definition	35
4.3.22.2	Attributes	35
4.3.22.3	Attribute constraints	35
4.3.22.4	Notifications	35
4.3.23	Void	36
4.3.24	ENBFunction <<ProxyClass>>	36
4.3.24.1	Definition	36
4.3.24.2	Attributes	36
4.3.24.3	Attribute constraints	36
4.3.24.4	Notifications	36
4.3.25	GNBCUCPFunction <<ProxyClass>>	36
4.3.25.1	Definition	36
4.3.25.2	Attributes	36
4.3.25.3	Attribute constraints	36
4.3.25.4	Notifications	36
4.3.26	GNBCUUPFunction <<ProxyClass>>	36
4.3.26.1	Definition	36
4.3.26.2	Attributes	36
4.3.26.3	Attribute constraints	36
4.3.26.4	Notifications	37
4.3.27	GNBDUFunction <<ProxyClass>>	37
4.3.27.1	Definition	37
4.3.27.2	Attributes	37
4.3.27.3	Attribute constraints	37
4.3.27.4	Notifications	37
4.3.28	ServingGWFFunction <<ProxyClass>>	37
4.3.28.1	Definition	37
4.3.28.2	Attributes	37
4.3.28.3	Attribute constraints	37
4.3.28.4	Notifications	37
4.3.29	UPFFunction <<ProxyClass>>	37
4.3.29.1	Definition	37
4.3.29.2	Attributes	37
4.3.29.3	Attribute constraints	37
4.3.29.4	Notifications	38
4.3.30	AMFFunction <<ProxyClass>>	38
4.3.30.1	Definition	38
4.3.30.2	Attributes	38
4.3.30.3	Attribute constraints	38
4.3.30.4	Notifications	38
4.3.31	Void	38
4.3.32	NRCellRelation	38
4.3.32.1	Definition	38
4.3.32.2	Attributes	38
4.3.32.3	Attribute constraints	38
4.3.32.4	Notifications	38
4.3.33	NRFreqRelation	39
4.3.33.1	Definition	39
4.3.33.2	Attributes	39
4.3.33.3	Attribute constraints	39

4.3.33.4	Void.....	39
4.3.35	ExternalNRCellCU.....	39
4.3.35.1	Definition.....	39
4.3.35.2	Attributes.....	40
4.3.35.3	Attribute constraints.....	40
4.3.35.4	Notifications.....	40
4.3.36	RRMPolicyRatio2 <<dataType>>.....	40
4.3.36.1	Definition.....	40
4.3.36.2	Attributes.....	40
4.3.37	NRFrequency.....	40
4.3.37.1	Definition.....	40
4.3.37.2	Attributes.....	41
4.3.37.3	Attribute constraints.....	41
4.3.37.4	Notifications.....	41
4.3.38	CommonBeamformingFunction.....	41
4.3.38.1	Definition.....	41
4.3.38.2	Attributes.....	41
4.3.38.3	Attribute constraints.....	41
4.3.38.4	Notifications.....	41
4.3.39	Beam.....	41
4.3.39.1	Definition.....	41
4.3.39.2	Attributes.....	42
4.3.39.3	Attribute constraints.....	42
4.3.39.4	Notifications.....	42
4.4	Attribute definitions.....	43
4.4.1	Attribute properties.....	43
4.5	Common notifications.....	55
5	Information model definitions for 5GC NRM.....	56
5.1	Imported information entities and local labels.....	56
5.2	Class diagram.....	56
5.2.1	Class diagram of 5GC NFs.....	56
5.2.1.1	Relationships.....	56
5.2.1.2	Inheritance.....	63
5.2.2	Class diagram of AMF Region/AMF Set.....	64
5.2.2.1	Relationships.....	64
5.2.2.2	Inheritance.....	65
5.3	Class definitions.....	65
5.3.1	AMFFunction.....	65
5.3.1.1	Definition.....	65
5.3.1.2	Attributes.....	65
5.3.1.3	Attribute constraints.....	66
5.3.1.4	Notifications.....	66
5.3.2	SMFFunction.....	66
5.3.2.1	Definition.....	66
5.3.2.2	Attributes.....	66
5.3.2.3	Attribute constraints.....	66
5.3.2.4	Notifications.....	66
5.3.3	UPFFunction.....	66
5.3.3.1	Definition.....	66
5.3.3.2	Attributes.....	66
5.3.3.3	Attribute constraints.....	67
5.3.3.4	Notifications.....	67
5.3.4	N3IWFFunction.....	67
5.3.4.1	Definition.....	67
5.3.4.2	Attributes.....	67
5.3.4.3	Attribute constraints.....	67
5.3.4.4	Notifications.....	67
5.3.5	PCFFunction.....	67
5.3.5.1	Definition.....	67
5.3.5.2	Attributes.....	67

5.3.5.3	Attribute constraints	68
5.3.5.4	Notifications	68
5.3.6	AUSFFunction	68
5.3.6.1	Definition	68
5.3.6.2	Attributes	68
5.3.6.3	Attribute constraints	68
5.3.6.4	Notifications	68
5.3.7	UDMFunction	68
5.3.7.1	Definition	68
5.3.7.2	Attributes	68
5.3.5.3	Attribute constraints	69
5.3.5.4	Notifications	69
5.3.8	UDRFFunction	69
5.3.8.1	Definition	69
5.3.8.2	Attributes	69
5.3.8.3	Attribute constraints	69
5.3.8.4	Notifications	69
5.3.9	UDSFFunction	69
5.3.9.1	Definition	69
5.3.9.2	Attributes	69
5.3.9.3	Attribute constraints	70
5.3.9.4	Notifications	70
5.3.10	NRFFunction	70
5.3.10.1	Definition	70
5.3.10.2	Attributes	70
5.3.10.3	Attribute constraints	70
5.3.10.4	Notifications	70
5.3.11	NSSFFunction	70
5.3.11.1	Definition	70
5.3.11.2	Attributes	70
5.3.11.3	Attribute constraints	71
5.3.11.4	Notifications	71
5.3.12	AFFunction	71
5.3.12.1	Definition	71
5.3.13	DNFunction	71
5.3.13.1	Definition	71
5.3.14	SMSFFunction	71
5.3.14.1	Definition	71
5.3.14.2	Attributes	71
5.3.14.3	Attribute constraints	71
5.3.14.4	Notifications	71
5.3.15	LMFFunction	72
5.3.15.1	Definition	72
5.3.15.2	Attributes	72
5.3.15.3	Attribute constraints	72
5.3.15.4	Notifications	72
5.3.16	NGEIRFunction	72
5.3.16.1	Definition	72
5.3.16.2	Attributes	72
5.3.16.3	Attribute constraints	72
5.3.16.4	Notifications	72
5.3.17	SEPPFunction	72
5.3.17.1	Definition	72
5.3.17.2	Attributes	73
5.3.17.3	Attribute constraints	73
5.3.17.4	Notifications	73
5.3.18	NWDAFFunction	73
5.3.18.1	Definition	73
5.3.18.2	Attributes	73
5.3.18.3	Attribute constraints	73
5.3.18.4	Notifications	73

5.3.19	EP_N2	73
5.3.19.1	Definition	73
5.3.19.2	Attributes.....	73
5.3.19.3	Attribute constraints	73
5.3.19.4	Notifications.....	74
5.3.20	EP_N3	74
5.3.20.1	Definition	74
5.3.20.2	Attributes.....	74
5.3.20.3	Attribute constraints	74
5.3.20.4	Notifications.....	74
5.3.21	EP_N4	74
5.3.21.1	Definition	74
5.3.21.2	Attributes.....	74
5.3.21.3	Attribute constraints	74
5.3.21.4	Notifications.....	74
5.3.22	EP_N5	74
5.3.22.1	Definition	74
5.3.22.2	Attributes.....	74
5.3.22.3	Attribute constraints	75
5.3.22.4	Notifications.....	75
5.3.23	EP_N6	75
5.3.23.1	Definition	75
5.3.23.2	Attributes.....	75
5.3.23.3	Attribute constraints	75
5.3.23.4	Notifications.....	75
5.3.24	EP_N7	75
5.3.24.1	Definition	75
5.3.24.2	Attributes.....	75
5.3.24.3	Attribute constraints	75
5.3.24.4	Notifications.....	75
5.3.25	EP_N8	76
5.3.25.1	Definition	76
5.3.25.2	Attributes.....	76
5.3.25.3	Attribute constraints	76
5.3.25.4	Notifications.....	76
5.3.26	EP_N9	76
5.3.26.1	Definition	76
5.3.26.2	Attributes.....	76
5.3.26.3	Attribute constraints	76
5.3.26.4	Notifications.....	76
5.3.27	EP_N10	76
5.3.27.1	Definition	76
5.3.27.2	Attributes.....	76
5.3.27.3	Attribute constraints	77
5.3.27.4	Notifications.....	77
5.3.28	EP_N11	77
5.3.28.1	Definition	77
5.3.28.2	Attributes.....	77
5.3.28.3	Attribute constraints	77
5.3.28.4	Notifications.....	77
5.3.29	EP_N12	77
5.3.29.1	Definition	77
5.3.29.2	Attributes.....	77
5.3.29.3	Attribute constraints	77
5.3.29.4	Notifications.....	77
5.3.30	EP_N13	78
5.3.30.1	Definition	78
5.3.30.2	Attributes.....	78
5.3.30.3	Attribute constraints	78
5.3.30.4	Notifications.....	78
5.3.31	EP_N14	78

5.3.31.1	Definition	78
5.3.31.2	Attributes.....	78
5.3.31.3	Attribute constraints	78
5.3.31.4	Notifications.....	78
5.3.32	EP_N15	78
5.3.32.1	Definition	78
5.3.32.2	Attributes.....	78
5.3.32.3	Attribute constraints	79
5.3.32.4	Notifications.....	79
5.3.33	EP_N16	79
5.3.33.1	Definition	79
5.3.33.2	Attributes.....	79
5.3.33.3	Attribute constraints	79
5.3.33.4	Notifications.....	79
5.3.34	EP_N17	79
5.3.34.1	Definition	79
5.3.34.2	Attributes.....	79
5.3.34.3	Attribute constraints	79
5.3.34.4	Notifications.....	79
5.3.35	EP_N20	80
5.3.35.1	Definition	80
5.3.35.2	Attributes.....	80
5.3.35.3	Attribute constraints	80
5.3.35.4	Notifications.....	80
5.3.36	EP_N21	80
5.3.36.1	Definition	80
5.3.36.2	Attributes.....	80
5.3.36.3	Attribute constraints	80
5.3.36.4	Notifications.....	80
5.3.37	EP_N22	80
5.3.37.1	Definition	80
5.3.37.2	Attributes.....	80
5.3.37.3	Attribute constraints	81
5.3.37.4	Notifications.....	81
5.3.38	EP_N26	81
5.3.38.1	Definition	81
5.3.38.2	Attributes.....	81
5.3.38.3	Attribute constraints	81
5.3.38.4	Notifications.....	81
5.3.39	EP_SBI_X	81
5.3.39.1	Definition	81
5.3.39.2	Attributes.....	81
5.3.39.3	Attribute constraints	81
5.3.39.4	Notifications.....	82
5.3.40	EP_SBI_IPX	82
5.3.40.1	Definition	82
5.3.40.2	Attributes.....	82
5.3.40.3	Attribute constraints	82
5.3.40.4	Notifications.....	82
5.3.41	EP_S5C	82
5.3.41.1	Definition	82
5.3.41.2	Attributes.....	82
5.3.41.3	Attribute constraints	82
5.3.41.4	Notifications.....	82
5.3.42	EP_S5U	82
5.3.42.1	Definition	82
5.3.42.2	Attributes.....	83
5.3.42.3	Attribute constraints	83
5.3.42.4	Notifications.....	83
5.3.43	EP_Rx	83
5.3.43.1	Definition	83

5.3.43.2	Attributes.....	83
5.3.43.3	Attribute constraints	83
5.3.43.4	Notifications.....	83
5.3.44	EP_MAP_SMSC.....	83
5.3.44.1	Definition	83
5.3.44.2	Attributes.....	83
5.3.44.3	Attribute constraints	83
5.3.44.4	Notifications.....	84
5.3.45	EP-NLS.....	84
5.3.45.1	Definition	84
5.3.45.2	Attributes.....	84
5.3.45.3	Attribute constraints	84
5.3.45.4	Notifications.....	84
5.3.46	EP_NLG.....	84
5.3.46.1	Definition	84
5.3.46.2	Attributes.....	84
5.3.46.3	Attribute constraints	84
5.3.46.4	Notifications.....	84
5.3.47	EP_N27.....	84
5.3.47.1	Definition	84
5.3.47.2	Attributes.....	85
5.3.47.3	Attribute constraints	85
5.3.47.4	Notifications.....	85
5.3.48	EP_N31.....	85
5.3.48.1	Definition	85
5.3.48.2	Attributes.....	85
5.3.48.3	Attribute constraints	85
5.3.48.4	Notifications.....	85
5.3.49	ExternalNRFFunction.....	85
5.3.49.1	Definition	85
5.3.49.2	Attributes.....	85
5.3.49.3	Attribute constraints	86
5.3.49.4	Notifications.....	86
5.3.50	ExternalNSSFFunction.....	86
5.3.50.1	Definition	86
5.3.50.2	Attributes.....	86
5.3.50.3	Attribute constraints	86
5.3.50.4	Notifications.....	86
5.3.51	AMFSet.....	86
5.3.51.1	Definition	86
5.3.51.2	Attributes.....	86
5.3.51.3	Attribute constraints	87
5.3.51.4	Notifications.....	87
5.3.52	AMFRegion.....	87
5.3.52.1	Definition	87
5.3.52.2	Attributes.....	87
5.3.52.3	Attribute constraints	87
5.3.52.4	Notifications.....	87
5.3.53	ExternalAMFFunction.....	87
5.3.53.1	Definition	87
5.3.53.2	Attributes.....	87
5.3.53.3	Attribute constraints	88
5.3.53.4	Notifications.....	88
5.4	Attribute definitions	88
5.4.1	Attribute properties	88
5.5	Common notifications	90
6	Information model definitions for network slice NRM.....	90
6.1	Imported information entities and local labels	90
6.2	Class diagram	91
6.2.1	Relationships.....	91

6.2.2	Inheritance	91
6.3	Class definitions	92
6.3.1	NetworkSlice	92
6.3.1.1	Definition	92
6.3.1.2	Attributes	92
6.3.1.3	Attribute constraints	92
6.3.1.4	Notifications	92
6.3.2	NetworkSliceSubnet	92
6.3.2.1	Definition	92
6.3.2.2	Attributes	92
6.3.2.3	Attribute constraints	93
6.3.2.4	Notifications	93
6.3.3	ServiceProfile	93
6.3.3.1	Definition	93
6.3.3.2	Attributes	93
6.3.3.3	Attribute constraints	93
6.3.3.4	Notifications	93
6.3.4	SliceProfile	93
6.3.4.1	Definition	93
6.3.4.2	Attributes	94
6.3.4.3	Attribute constraints	94
6.3.4.4	Notifications	94
6.4	Attribute definition	95
6.4.1	Attribute properties	95
6.5	Common notifications	99
7	Solution Set (SS)	99
Annex A (normative): Cell state handling		100
A.1	Relation between the administrative state and the "Pre-operation state of the gNB-DU Cell"	100
A.2	Combined state diagram for gNB cell	100
Annex B (normative): NSI and NSSI state handling		105
B.1	NSI state handling	105
B.2	State handling of NSSI	106
Annex C (normative): XML definitions for NR NRM.....		108
C.1	General	108
C.2	Architectural features	108
C.3	Mapping	108
C.3.1	General mapping	108
C.3.2	Information Object Class (IOC) mapping	108
C.4	Solution Set definitions	108
C.4.1	XML definition structure.....	108
C.4.2	Graphical representation.....	108
C.4.3	XML schema "nrNrm.xsd"	108
Annex D (normative): JSON definitions for NR NRM.....		124
D.1	General	124
D.2	Architectural features	124
D.3	Mapping	124
D.4	Solution Set (SS) definitions	124
D.4.1	JSON definition structure	124
D.4.2	Graphical representation.....	124
D.4.3	JSON schema "nrNrm.json"	124

Annex E (normative):	YANG definitions for NR NRM	148
E.1	General	148
E.2	Void.....	148
E.3	Void.....	148
E.4	Void.....	148
E.5	Modules.....	148
E.6	Graphical representation.....	186
E.7	Mount information	186
Annex F (normative):	XML definitions for 5GC NRM	187
F.1	General	187
F.2	Architectural features	187
F.3	Mapping	187
F.3.1	General mapping	187
F.3.2	Information Object Class (IOC) mapping	187
F.4	Solution Set definitions	187
F.4.1	XML definition structure.....	187
F.4.2	Graphical representation.....	187
F.4.3	XML schema "ngcNrm.xsd"	187
Annex G (normative):	JSON definitions for 5GC NRM.....	209
G.1	General	209
G.2	Architectural features	209
G.3	Mapping	209
G.4	Solution Set definitions	209
G.4.1	JSON definition structure	209
G.4.2	Graphical representation.....	209
G.4.3	JSON schema "ngcNrm.json"	209
Annex H (normative):	YANG definitions for 5GC.....	229
H.1	General	229
H.2	Void.....	229
H.3	Void.....	229
H.4	Void.....	229
H.5	Modules.....	229
H.6	Graphical representation.....	276
H.7	Mount information	310
Annex I (normative):	XML definitions for network slice.....	311
I.1	General	311
I.2	Architectural features	311
I.3	Mapping	311
I.3.1	General mapping	311
I.3.2	Information Object Class (IOC) mapping	311
I.4	Solution Set (SS) definitions	311
I.4.1	XML definition structure.....	311

I.4.2	Graphical representation.....	311
I.4.3	XML schema "sliceNrm.xsd".....	311
Annex J (normative): JSON definitions for network slice.....		315
J.1	General	315
J.2	Architectural features	315
J.3	Mapping	315
J.4	Solution Set (SS) definitions	315
J.4.1	JSON definition structure.....	315
J.4.2	Graphical representation.....	315
J.4.3	JSON schema "sliceNrm.json".....	315
Annex K (normative): Void		320
Annex L (informative): Change history		321
History		324

Foreword

This Technical Specification has been produced by the 3rd Generation Partnership Project (3GPP).

The contents of the present document are subject to continuing work within the TSG and may change following formal TSG approval. Should the TSG modify the contents of the present document, it will be re-released by the TSG with an identifying change of release date and an increase in version number as follows:

Version x.y.z

where:

- x the first digit:
 - 1 presented to TSG for information;
 - 2 presented to TSG for approval;
 - 3 or greater indicates TSG approved document under change control.
- y the second digit is incremented for all changes of substance, i.e. technical enhancements, corrections, updates, etc.
- z the third digit is incremented when editorial only changes have been incorporated in the document.

Introduction

The present document is part of a TS-family covering the 3rd Generation Partnership Project Technical Specification Group Services and System Aspects Management and orchestration of networks, as identified below:

TS 28.540: Management and orchestration of 5G networks; Network Resource Model (NRM); Stage 1.

TS 28.541: Management and orchestration of 5G networks; Network Resource Model (NRM); Stage 2 and stage 3.

1 Scope

The present document specifies the Information Model and Solution Set for the Network Resource Model (NRM) definitions of NR, NG-RAN, 5G Core Network (5GC) and network slice, to fulfil the requirements identified in 3GPP TS 28.540 [10].

The Information Model defines the semantics and behaviour of information object class attributes and relations visible on the management interfaces in a protocol and technology neutral way. And Solution Set defines one or more solution set(s) with specific protocol(s) according to the Information Model definitions.

2 References

The following documents contain provisions which, through reference in this text, constitute provisions of the present document.

- References are either specific (identified by date of publication, edition number, version number, etc.) or non-specific.
- For a specific reference, subsequent revisions do not apply.
- For a non-specific reference, the latest version applies. In the case of a reference to a 3GPP document (including a GSM document), a non-specific reference implicitly refers to the latest version of that document *in the same Release as the present document*.

- [1] 3GPP TR 21.905: "Vocabulary for 3GPP Specifications".
- [2] 3GPP TS 23.501: "System Architecture for the 5G System".
- [3] 3GPP TS 38.300: "NR; Overall description; Stage-2".
- [4] 3GPP TS 38.401: "NG-RAN; Architecture description".
- [5] 3GPP TS 38.413: "NG-RAN; NG Application Protocol (NGAP)".
- [6] 3GPP TS 38.420: "NG-RAN; Xn general aspects and principles".
- [7] 3GPP TS 38.470: "NG-RAN; F1 general aspects and principles".
- [8] 3GPP TS 38.473: "NG-RAN; F1 application protocol (F1AP)".
- [9] 3GPP TS 37.340: "NR; Multi-connectivity; Overall description; Stage 2".
- [10] 3GPP TS 28.540: "Management and orchestration; 5G Network Resource Model (NRM); Stage 1".
- [11] 3GPP TS 28.662: "Telecommunication management; Generic Radio Access Network (RAN) Network Resource Model (NRM) Integration Reference Point (IRP); Information Service (IS)".
- [12] 3GPP TS 38.104: "NR; Base Station (BS) radio transmission and reception".
- [13] 3GPP TS 23.003: "Numbering, Addressing and Identification".
- [14] 3GPP TS 36.410: "Evolved Universal Terrestrial Radio Access Network (E-UTRAN); S1 general aspects and principles".
- [15] 3GPP TS 36.423: "Evolved Universal Terrestrial Radio Access Network (E-UTRAN); X2 application protocol".
- [16] 3GPP TS 36.425: "Evolved Universal Terrestrial Radio Access Network (E-UTRAN); X2 interface user plane protocol".
- [17] 3GPP TS 28.625: "State Management Data Definition Integration Reference Point (IRP); Information Service (IS)".

- [18] ITU-T Recommendation X.731: "Information technology - Open Systems Interconnection - Systems Management: State management function".
- [19] 3GPP TS 28.658: "Telecommunications management; Evolved Universal Terrestrial Radio Access Network (E-UTRAN) Network Resource Model (NRM) Integration Reference Point (IRP): Information Service (IS)".
- [20] 3GPP TS 28.702: "Core Network (CN) Network Resource Model (NRM) Integration Reference Point (IRP); Information Service (IS)".
- [21] 3GPP TS 28.708: "Telecommunication management; Evolved Packet Core (EPC) Network Resource Model (NRM) Integration Reference Point (IRP): Information Service (IS)".
- [22] 3GPP TS 23.040: "Technical realization of the Short Message Service (SMS)".
- [23] 3GPP TS 29.510: "5G system; Network Function Repository Services; Stage 3".
- [24] 3GPP TS 29.531: "5G System; Network Slice Selection Services Stage 3".
- [25] Void.
- [26] 3GPP TS 28.531: "Management and orchestration; Provisioning".
- [27] 3GPP TS 28.554: "Management and orchestration; 5G End to end Key Performance Indicators (KPI)".
- [28] 3GPP TS 22.261: "Service requirements for next generation new services and markets".
- [29] ETSI GS NFV-IFA 013 V2.4.1 (2018-02) "Network Function Virtualisation (NFV); Management and Orchestration; Os-Ma-nfvo Reference Point - Interface and Information Model Specification".
- [30] 3GPP TS 28.622: "Telecommunication management; Generic Network Resource Model (NRM) Integration Reference Point (IRP); Information Service (IS)".
- [31] Void.
- [32] 3GPP TS 38.211: "NR; Physical channels and modulation".
- [33] 3GPP TS 32.616: "Telecommunication management; Configuration Management (CM); Bulk CM Integration Reference Point (IRP); Solution Set (SS) definitions".
- [34] 3GPP TS 28.623: "Telecommunication management; Generic Network Resource Model (NRM) Integration Reference Point (IRP); Solution Set (SS) definitions".
- [35] 3GPP TS 28.532: "Management and orchestration; Management services".
- [36] Void.
- [37] IETF RFC 791: "Internet Protocol".
- [38] IETF RFC 2373: "IP Version 6 Addressing Architecture".
- [39] IEEE 802.1Q: "Media Access Control Bridges and Virtual Bridged Local Area Networks".
- [40] ETSI GR NFV-IFA 015 (V2.4.1): "Network Function Virtualisation (NFV) Release 2; Management and Orchestration; Report on NFV Information Model".
- [41] 3GPP TS 38.213: "NR; Physical layer procedures for control".
- [42] 3GPP TS 38.101-1: "NR; User Equipment (UE) radio transmission and reception; Part 1: Range 1 Standalone".
- [43] 3GPP TS 32.156: "Telecommunication management; Fixed Mobile Convergence (FMC) model repertoire".
- [44] 3GPP TS 38.304: "NR; User Equipment (UE) procedures in Idle mode and RRC Inactive state".

- [45] IETF RFC 8340: "YANG Tree Diagrams".
- [46] 3GPP TS 32.160: "Management and orchestration; Management Service Template".
- [47] IETF RFC 8528: "YANG Schema Mount".
- [48] 3GPP TS 38.463: "NG-RAN; E1 application protocol (E1AP)".
- [49] 3GPP TS 38.901: "Study on channel model for frequencies from 0.5 to 100 GHz".
- [50] 3GPP TS 38.331: "NR; Radio Resource Control (RRC) protocol specification".
- [51] 3GPP TS 38.215: "NR; Physical layer measurements".
- [52] Void.

3 Definitions and abbreviations

3.1 Definitions

For the purposes of the present document, the terms and definitions given in 3GPP TR 21.905 [1], 3GPP TS 28.540 [10] and the following apply. A term defined in the present document takes precedence over the definition of the same term, if any, in 3GPP TR 21.905 [1] and 3GPP TS 28.540 [10].

3.2 Abbreviations

For the purposes of the present document, the abbreviations given in 3GPP TR 21.905 [1], 3GPP TS 23.501 [2], 3GPP TS 38.401 [4], 3GPP TS 28.540 [10] and the following apply. An abbreviation defined in the present document takes precedence over the definition of the same abbreviation, if any, in 3GPP TR 21.905 [1], 3GPP TS 23.501 [2], 3GPP TS 38.401 [4] and 3GPP TS 28.540 [10].

BWP	Bandwidth part
CM	Configuration Management
DN	Distinguished Name
IOC	Information Object Class
JSON	JavaScript Object Notation
NFV	Network Functions Virtualisation
NRM	Network Resource Model
NS	Network Service
NSI	Network Slice Instance
NSSAI	Network Slice Selection Assistance Information
NSSI	Network Slice Subnet Instance
PNF	Physical Network Function
SBA	Service Based Architecture
SS	Solution Set
TN	Transport Network
VNF	Virtualised Network Function

4 Information model definitions for NR NRM

4.1 Imported and associated information

4.1.1 Imported information entities and local labels

Label reference	Local label
3GPP TS 28.622 [30], IOC, ManagedFunction	ManagedFunction
3GPP TS 28.622 [30], IOC, EP_RP	EP_RP
3GPP TS 28.662 [11], IOC, SectorEquipmentFunction	SectorEquipmentFunction
3GPP TS 28.658 [19], IOC, ExternalENBFunction	ExternalENBFunction
3GPP TS 28.658 [19], IOC, ENBFunction	ENBFunction
3GPP TS 28.708 [21], IOC, ServingGWFunction	ServingGWFunction
3GPP TS 28.708 [21], IOC, ExternalServingGWFunction	ExternalServingGWFunction
3GPP TS 28.658 [19], IOC, EUTranCellFDD	EUTranCellFDD
3GPP TS 28.658 [19], IOC, ExternalEUTranCellFDD	ExternalEUTranCellFDD
3GPP TS 28.658 [19], IOC, EUTranCellTDD	EUTranCellTDD
3GPP TS 28.658 [19], IOC, ExternalEUTranCellTDD	ExternalEUTranCellTDD
3GPP TS 28.658 [19], dataType, PLMNId	PLMNId
3GPP TS 28.658 [19], IOC, AdjacentCell	AdjacentEUTranCell
3GPP TS 28.658 [19], IOC, EUTranFrequency	EUTranFrequency
3GPP TS 28.658 [19], IOC, EUTranFreqRelation	EUTranFreqRelation
3GPP TS 28.658 [19], IOC, EUTranRelation	EUTranCellRelation

4.1.2 Associated information entities and local labels

Label reference	Local label
3GPP TS 28.622 [30], IOC, ManagedElement	ManagedElement
3GPP TS 28.622 [30], IOC, SubNetwork	SubNetwork

4.2 Class diagram

4.2.1 Class diagram for gNB and en-gNB

4.2.1.1 Relationships

This clause depicts the set of classes (e.g. IOCs) that encapsulates the information relevant for this gNB and en-gNB. For the UML semantics, see 3GPP TS 32.156 [43]. Subsequent clauses provide more detailed specification of various aspects of these classes.

The models are for the management of gNB and en-gNB for all NG-RAN deployment scenarios as listed below.

- Non-split NG-RAN deployment scenario, represents the gNB defined in TS 38.401[4].
- 2-split NG-RAN deployment scenario, represents the gNB consist of a gNB-CU and gNB-DU defined in TS 38.401[4] clause 6.1.1.
- 3-split NG-RAN deployment scenario, represents the gNB consist of gNB-CU-CP, gNB-CU-UP and gNB-DU defined in TS 38.401[4] clause 6.1.2.

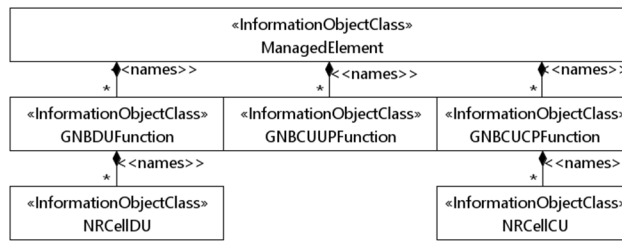

Figure 4.2.1.1-1: NRM for all deployment scenarios

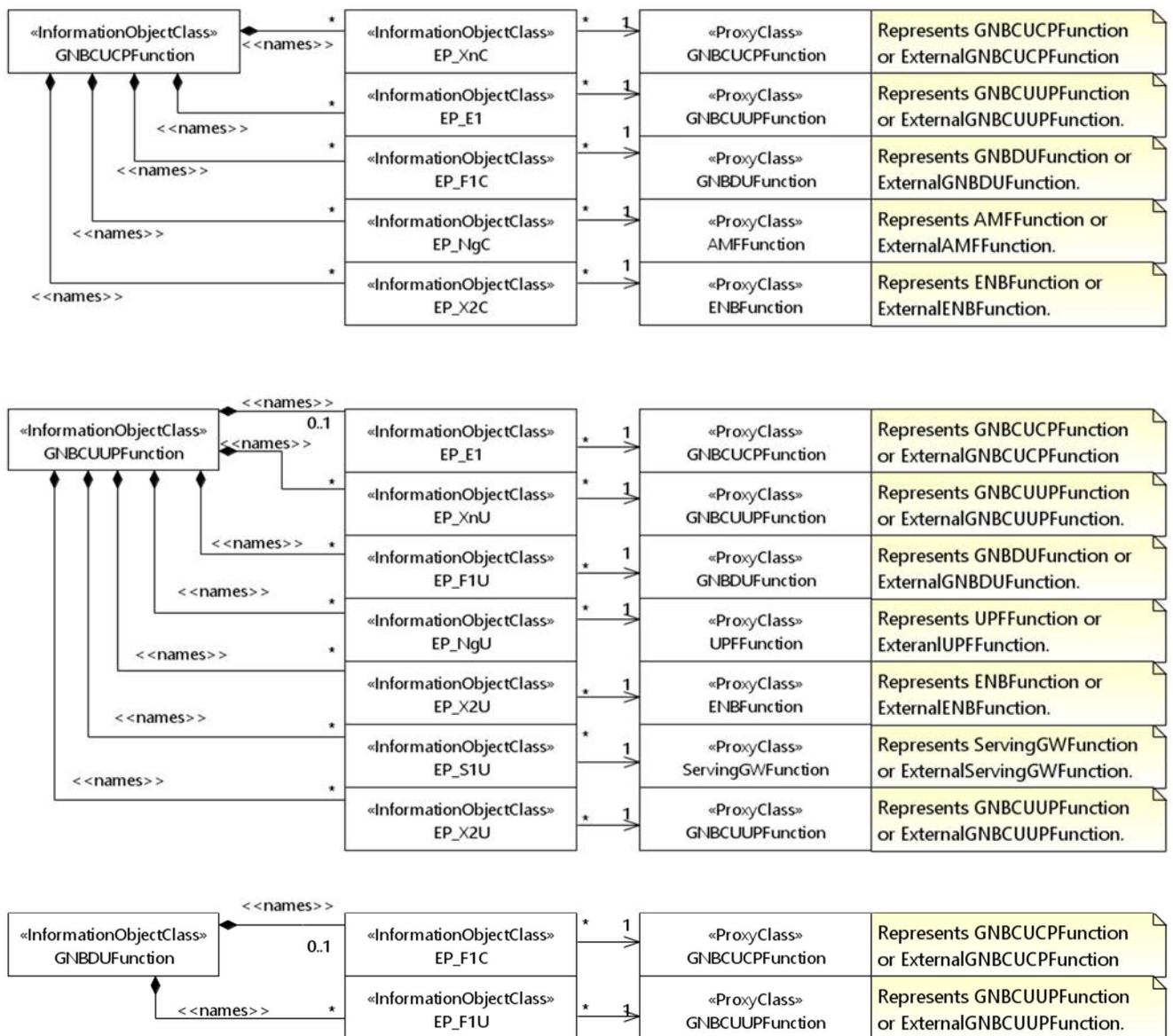

Figure 4.2.1.1-2: NRM for EPs for all deployment scenarios

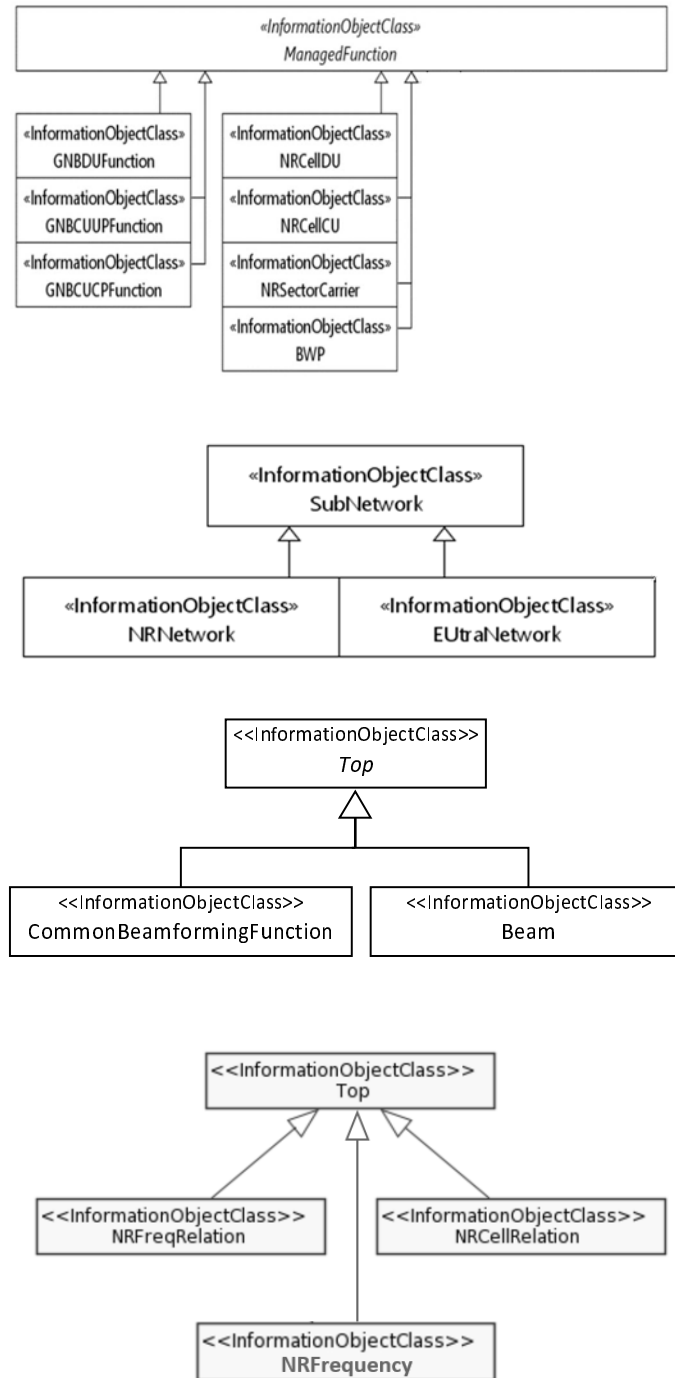

Figure 4.2.1.2-1: Inheritance Hierarchy

4.3 Class definitions

4.3.1 GNBDUFunction

4.3.1.1 Definition

For non-split NG-RAN deployment scenario, this IOC together with GNBCUCPFunction IOC and GNBCUUPFunction IOC provide the management of gNB defined in clause 6.1.1 in 3GPP TS 38.401 [4].

For 2-split and 3-split NG-RAN deployment scenarios, this IOC provides the management representation of the gNB-DU defined in clause 6.1.1 in 3GPP TS 38.401 [4].

The following table identifies the necessary end points required for the representation of gNB and en-gNB, of all deployment scenarios.

Role	Req	End point requirement for 3-split deployment scenario	End point requirement for 2-split deployment scenario	End point requirement for Non-split deployment scenario
gNB		<<IOC>>EP_F1C, <<IOC>>EP_F1U	<<IOC>>EP_F1C, <<IOC>>EP_F1U	None.
en-gNB		<<IOC>>EP_F1C, <<IOC>>EP_F1U	<<IOC>>EP_F1C, <<IOC>>EP_F1U	None.

4.3.1.2 Attributes

The GNBDUFunction IOC includes attributes inherited from ManagedFunction IOC (defined in TS 28.622[30]) and the following attributes:

Attribute name	Support Qualifier	isReadable	isWritable	isInvariant	isNotifiable
gNBDUId	M	T	T	F	T
gNBDUName	O	T	T	F	T
gNBId	M	T	F	F	T
gNBIdLength	M	T	T	F	T

4.3.1.3 Attribute constraints

None.

4.3.1.4 Notifications

The common notifications defined in subclause 4.5 are valid for this IOC, without exceptions or additions.

4.3.2 GNBCUCPFunction

4.3.2.1 Definition

For non-split NG-RAN deployment scenario, this IOC together with GNBCUUPFunction IOC and GNBDUFunction IOC provide the management representation of gNB defined in clause 6.1.1 in 3GPP TS 38.401 [4].

For 2-split NG-RAN deployment scenario, this IOC together with GNBCUUPFunction IOC provide management representation of the gNB-CU defined in clause 6.1.1 in 3GPP TS 38.401 [4].

For 3-split NG-RAN deployment scenario, this IOC provides management representation of gNB-CU-CP defined in clause 6.1.2 in 3GPP TS 38.401 [4].

The following table identifies the necessary end points required for the representation of gNB and en-gNB, of all deployment scenarios.

Role	Req	End point requirement for 3-split deployment scenario	End point requirement for 2-split deployment scenario	End point requirement for Non-split deployment scenario
gNB		<<IOC>>EP_XnC, <<IOC>>EP_NgC, <<IOC>>EP_F1C, <<IOC>>EP_E1.	<<IOC>>EP_XnC, <<IOC>>EP_NgC, <<IOC>>EP_F1C <<IOC>>EP_F1U.	<<IOC>>EP_XnC, <<IOC>>EP_NgC.
en-gNB		<<IOC>>EP_X2C, <<IOC>>EP_F1C, <<IOC>>EP_E1.	<<IOC>>EP_X2C, <<IOC>>EP_F1C.	<<IOC>>EP_X2C.

4.3.2.2 Attributes

The GNBCUCPFunction IOC includes attributes inherited from ManagedFunction IOC (defined in TS 28.622[30]) and the following attributes:

Attribute name	Support Qualifier	isReadable	isWritable	isInvariant	isNotifiable
gNBId	M	T	T	F	T
gNBIdLength	M	T	T	F	T
gNBCUName	O	T	T	F	T
pLMNId	M	T	T	T	T

4.3.2.3 Attribute constraints

None.

4.3.2.4 Notifications

The common notifications defined in subclause 4.5 are valid for this IOC, without exceptions or additions.

4.3.3 GNBCUUPFunction

4.3.3.1 Definition

For non-split NG-RAN deployment scenario, this IOC together with GNBCUCPFunction IOC and GNBDUFunction IOC provide the management representation of gNB as defined in clause 6.1.1 in 3GPP TS 38.401 [4].

For 2-split NG-RAN deployment scenario, this IOC together with GNBCUCPFunction IOC provide management representation of the gNB-CU defined in clause 6.1.1 in 3GPP TS 38.401 [4].

For 3-split NG-RAN deployment scenario, this IOC provides management representation of the gNB-CU-UP defined in clause 6.1.2 in 3GPP TS 38.401 [4].

The following table identifies the necessary end points required for the representation of gNB and en-gNB, of all deployment scenarios.

Req Role	End point requirement for 3-split deployment scenario	End point requirement for 2-split deployment scenario	End point requirement for Non-split deployment scenario
gNB	<<IOC>>EP_XnU, <<IOC>>EP_NgU, <<IOC>>EP_F1U, <<IOC>>EP_E1.	<<IOC>>EP_XnU, <<IOC>>EP_NgU, <<IOC>>EP_F1U.	<<IOC>>EP_XnU, <<IOC>>EP_NgU.
en-gNB	<<IOC>>EP_X2U, <<IOC>>EP_S1U, <<IOC>>EP_F1U, <<IOC>>EP_E1.	<<IOC>>EP_X2U, <<IOC>>EP_S1U, <<IOC>>EP_F1U.	<<IOC>>EP_X2U, <<IOC>>EP_S1U.

4.3.3.2 Attributes

The GNBCUUPFunction IOC includes attributes inherited from ManagedFunction IOC (defined in TS 28.622[30]) and the following attributes:

Attribute name	Support Qualifier	isReadable	isWritable	isInvariant	isNotifiable
gNBCUUPId	M	T	F	T	T
pLMNIdList	M	T	T	F	T
gNBId	M	T	T	F	T
gNBIdLength	M	T	T	F	T

4.3.3.3 Attribute constraints

None.

4.3.3.4 Notifications

The common notifications defined in subclause 4.5 are valid for this IOC, without exceptions or additions.

4.3.4 NRCellCU

4.3.4.1 Definition

This IOC represents the part of the NR cell information that is responsible for the management of inter-cell mobility and neighbour relations via ANR.

4.3.4.2 Attributes

The NRCellCU IOC includes attributes inherited from ManagedFunction IOC (defined in TS 28.622[30]) and the following attributes:

Attribute name	Support Qualifier	isReadable	isWritable	isInvariant	isNotifiable
cellLocalId	M	T	T	F	T
pLMNIdList	M	T	T (Note)	F	T
sNSSAIIList	CM	T	T	F	T
rRMPolicyType	CM	T	T	F	T
rRMPolicyNSSIIId	CM	T	T	F	T
rRMPolicyRatio	CM	T	T	F	T
rRMPolicyRatio2	CM	T	T	F	T
rRMPolicy	CM	T	T	F	T
Attribute related to role					
nRFrequencyRef	M	T	F	F	T

Note: Whether the attribute "pLMNIdList" can be writable depends on the implementation.

NOTE 1: Void.

NOTE 2: Void.

4.3.4.3 Attribute constraints

Name	Definition
sNSSAIList Support Qualifier	Condition: Network slicing feature is supported.
rRMPolicyRatio2 Support Qualifier	Condition: Network slicing feature is supported and rRMPolicyType is 2.
rRMPolicyType Support Qualifier	Condition: RRM policy for network slicing feature is supported.
rRMPolicyNSSIId Support Qualifier	Condition: RRM policy for network slicing feature is supported and rRMPolicyType is 1.
rRMPolicyRatio Support Qualifier	Condition: RRM policy for network slicing feature is supported and rRMPolicyType is 1.
rRMPolicy Support Qualifier	Condition: RRM policy for network slicing feature is supported and rRMPolicyType is 0.

4.3.4.4 Notifications

The common notifications defined in subclause 4.5 are valid for this IOC, without exceptions or additions.

4.3.5 NRCellDU

4.3.5.1 Definition

This IOC represents the part of NR cell information that describes the specific resources instances.

An NR cell transmits SS/PBCH block and always requires downlink transmission at a certain carrier frequency with a certain channel bandwidth. Transmission may be performed from multiple sector-carriers using different transmission points, and these may be configured with different carrier frequencies and channel bandwidths, as long as they are aligned to the cell's downlink resource grids as defined in subclause 4.4 in TS 38.211 [32]. The values of `arfcnDL` and `bSChannelBwDL` attributes define the resource grids which each sector-carrier needs to be aligned to. See subclauses 5.3 and 5.4.2 of TS 38.104 for definitions of BS channel bandwidth and NR-ARFCN, respectively.

An NR cell requires an uplink in order to provide initial access. In case of TDD, the values of `arfcnUL` and `bSChannelBwUL` have to always be set to the same values as for the corresponding DL attributes. For both FDD and TDD, the `arfcnUL` and `bSChannelBwUL` define uplink resource grids to which each sector-carrier needs to align to.

An NR cell can in addition be configured with a supplementary uplink, which has its own `arfcnSUL` and `bSChannelBwSUL`, which define resource grids for supplementary uplink sector-carriers.

Each of downlink, uplink and supplementary uplink (if configured) need an initial bandwidth part (BWP), which defines resources to be used by UEs during and immediately after initial access. Additional BWPs can be either configured or calculated by gNB internally and be applied to UEs dynamically by gNB based on e.g. UE capability and bandwidth need of each UE.

NOTE: The S-NSSAI(s) in the `S-NSSAIList` are common to all PLMNs listed in the `PLMNIdList` attribute for the NRCellDU.

4.3.5.2 Attributes

The NRCellDU IOC includes attributes inherited from ManagedFunction IOC (defined in TS 28.622[30]) and the following attributes:

Attribute name	Support Qualifier	isReadable	isWritable	isInvariant	isNotifiable
cellLocalId	M	T	T	F	T
operationalState	M	T	F	F	T
administrativeState	M	T	T	F	T
cellState	M	T	F	F	T
pLMNIdList	M	T	T	F	T
sNSSAIdList	CM	T	T	F	T
nRPCI	M	T	T	F	T
nRTAC	M	T	T	F	T
arfcnDL	M	T	T	F	T
arfcnUL	CM	T	T	F	T
arfcnSUL	CM	T	T	F	T
bSChannelBwDL	M	T	T	F	T
ssbFrequency	CM	T	T	F	T
ssbPeriodicity	M	T	T	F	T
ssbSubCarrierSpacing	CM	T	T	F	T
ssbOffset	M	T	T	F	T
ssbDuration	M	T	T	F	T
bSChannelBwUL	CM	T	T	F	T
bSChannelBwSUL	CM	T	T	F	T
Attribute related to role					
nRSectorCarrierRef	M	T	T	F	T
bWPRef	M	T	T	F	T
nRFrequencyRef	CO	T	T	F	T
NOTE 1: No state propagation is implied.					
NOTE 2: Void.					

4.3.5.3 Attribute constraints

Name	Definition
sNSSAIdList Support Qualifier	Condition: Network slicing feature is supported.
arfcnUL Support Qualifier	Condition: The cell has an uplink (FDD or TDD)
arfcnSUL Support Qualifier	Condition: The cell has a supplementary uplink
bSChannelBwUL Support Qualifier	Condition: The cell has an uplink (FDD or TDD)
bSChannelBwSUL Support Qualifier	Condition: The cell has a supplementary uplink
nRFrequencyRef Support Qualifier	Condition: Non-split deployment scenario is supported
ssbFrequency Support Qualifier	Condition: nRFrequencyRef is not used.
ssbSubCarrierSpacing Support Qualifier	Condition: nRFrequencyRef is not used.

4.3.5.4 Notifications

The common notifications defined in subclause 4.5 are valid for this IOC, without exceptions or additions.

4.3.6 NRSectorCarrier

4.3.6.1 Definition

This <<IOC>>NRSectorCarrier represents the resources of each transmission point included in the cell. These in general have different physical locations (of the antennae), and possibly different frequencies or bandwidths. The UE is not directly aware of which NRSectorCarrier resources the network uses for its connection.

An NR sector-carrier can have downlink, uplink or both as specified by txDirection. **Attributes related to unavailable direction (DL or UL) shall not be set.**

Additional NRSectorCarriers not directly associated to one cell only can also be configured.

If a value of arfcnDL, arfcnUL, bSChannelBwDL or bSChannelBwUL can be derived unambiguously from the referring cell, then that attribute needs not be present. That will not be possible if the NRSectorCarrier is used for supplementary uplink, if it is not directly associated to a cell, or if the sector-carrier uses only a part of the cell's channel bandwidth. Thus, at least in those cases the applicable attributes have to be present and their values need to be set.

4.3.6.2 Attributes

The NRSectorCarrier IOC includes attributes inherited from ManagedFunction IOC (defined in TS 28.622[30]) and the following attributes:

Attribute name	Support Qualifier	isReadable	isWritable	isInvariant	isNotifiable
txDirection	M	T	T	F	T
configuredMaxTxPower	CM	T	T	F	T
arfcnDL	CM	T	T	F	T
arfcnUL	CM	T	T	F	T
bSChannelBwDL	CM	T	T	F	T
bSChannelBwUL	CM	T	T	F	T
attribute related to role					
sectorEquipmentFunctionRef	M	T	T	F	T

4.3.6.3 Attribute constraints

Name	Definition
configuredMaxTxPower	Condition: The sector-carrier has a downlink.
arfcnDL	Condition: The sector-carrier has a downlink AND the value differs from the referring cell's value of arfcnDL.
arfcnUL	Condition: The sector-carrier has an uplink AND the value differs from the referring cell's value of arfcnUL.
bSChannelBwDL	Condition: The sector-carrier has a downlink AND the value differs from the referring cell's value of bSChannelBwDL.
bSChannelBwUL	Condition: The sector-carrier has an uplink AND the value differs from the referring cell's value of bSChannelBwUL.

4.3.6.4 Notifications

The common notifications defined in subclause 4.5 are valid for this IOC, without exceptions or additions.

4.3.7 BWP

4.3.7.1 Definition

This IOC represents a bandwidth part (BWP) defined in 3GPP TS 38.211 [32], subclause 4.4.5. A bandwidth part is related to downlink, uplink or supplementary uplink resource grids, and is defined by its subcarrier spacing (SCS), cyclic prefix and location and size related to the common resource grid for the applicable SCS.

A BWP can be either an initial BWP used for initial access, or other ("regular") BWP configured for relevant UEs that support the BWP's characteristics.

4.3.7.2 Attributes

The BWP IOC includes attributes inherited from ManagedFunction IOC (defined in TS 28.622[30]) and the following attributes:

Attribute name	Support Qualifier	isReadable	isWritable	isInvariant	isNotifiable
bwpContext	M	T	T	F	T
isInitialBwp	M	T	T	F	T
subCarrierSpacing	M	T	T	F	T
cyclicPrefix	M	T	T	F	T
startRB	M	T	T	F	T
numberOfRBs	M	T	T	F	T

4.3.7.3 Attribute constraints

None.

4.3.7.4 Notifications

The common notifications defined in subclause 4.5 are valid for this IOC, without exceptions or additions.

4.3.8 EP_E1

4.3.8.1 Definition

This IOC represents the local end point of the logical link, supporting E1 interface between gNB-CU-CP and gNB-CU-UP. The E1 interface is defined in 3GPP TS 38.401 [4].

4.3.8.2 Attributes

The EP_E1 IOC includes attributes inherited from EP_RP IOC (defined in TS 28.622[30]) and the following attributes:

Attribute name	Support Qualifier	isReadable	isWritable	isInvariant	isNotifyable
localAddress	O	T	T	F	T
remoteAddress	O	T	T	F	T

4.3.8.3 Attribute constraints

None.

4.3.8.4 Notifications

The common notifications defined in subclause 4.5 are valid for this IOC, without exceptions or additions.

4.3.9 EP_XnU

4.3.9.1 Definition

This IOC represents the one end-point of a logical link supporting the Xn user plane (Xn-U) interface. The Xn-U interface provides non-guaranteed delivery of user plane PDUs between two NG-RAN nodes. The user plane PDUs are carried on GTP-U/UDP/IP/Data link layer/Physical layer stack. See subclause 7.2 of 3GPP TS 38.420 [6].

4.3.9.2 Attributes

The EP_XnU IOC includes attributes inherited from EP_RP IOC (defined in TS 28.622[30]) and the following attributes:

Attribute name	Support Qualifier	isReadable	isWritable	isInvariant	isNotifyable
localAddress	O	T	T	F	T
remoteAddress	O	T	T	F	T

4.3.9.3 Attribute constraints

None.

4.3.9.4 Notifications

The common notifications defined in subclause 4.5 are valid for this IOC, without exceptions or additions.

4.3.10 EP_NgC

4.3.10.1 Definition

This IOC represents the local end point of the control plane interface (NG-C) between the gNB and NG-Core entity. The transport network layer is built on IP transport. For the reliable transport of signalling messages, SCTP is added on top of IP. The application layer signalling protocol is referred to as NG-AP (NG Application Protocol).

3GPP TS 38.470 [7] noted that "one gNB-CU and a set of gNB-DUs are visible to other logical nodes as a gNB or an en-gNB where the gNB terminates the Xn and the NG interfaces, and the en-gNB terminates the X2 and the S1-U interfaces".

4.3.10.2 Attributes

The EP_NgC IOC includes attributes inherited from EP_RP IOC (defined in TS 28.622[30]) and the following attributes:

Attribute name	Support Qualifier	isReadable	isWritable	isInvariant	isNotifyable
localAddress	O	T	T	F	T
remoteAddress	O	T	T	F	T

4.3.10.3 Attribute constraints

None.

4.3.10.4 Notifications

The common notifications defined in subclause 4.5 are valid for this IOC, without exceptions or additions.

4.3.11 EP_NgU

4.3.11.1 Definition

This IOC represents the local end point of the NG user plane (NG-U) interface between the gNB and UPF. The interface provides non-guaranteed delivery of user plane PDUs between the gNB and UPF. GTP-U is baseline for this interface.

3GPP TS 38.470 [7] noted that "one gNB-CU and a set of gNB-DUs are visible to other logical nodes as a gNB or an en-gNB where the gNB terminates the Xn and the NG interfaces, and the en-gNB terminates the X2 and the S1-U interfaces".

4.3.11.2 Attributes

The EP_NgU IOC includes attributes inherited from EP_RP IOC (defined in TS 28.622[30]) and the following attributes:

Attribute name	Support Qualifier	isReadable	isWritable	isInvariant	isNotifyable
localAddress	O	T	T	F	T
remoteAddress	O	T	T	F	T

4.3.11.3 Attribute constraints

None.

4.3.11.4 Notifications

The common notifications defined in subclause 4.5 are valid for this IOC, without exceptions or additions.

4.3.12 EP_F1C

4.3.12.1 Definition

This IOC represents the local end point of the control plane interface (F1-C) between the DU and CU or CU-CP. The transport network layer is based on IP transport with the SCTP on top of IP. The application layer signalling protocol is referred to as NG-AP (NG Application Protocol). See subclause 7.1 of 3GPP TS 38.470 [7].

3GPP TS 38.470 [7] noted that "one gNB-CU and a set of gNB-DUs are visible to other logical nodes as a gNB or an en-gNB where the gNB terminates the Xn and the NG interfaces, and the en-gNB terminates the X2 and the S1-U interfaces".

4.3.12.2 Attributes

The EP_F1C IOC includes attributes inherited from EP_RP IOC (defined in TS 28.622[30]) and the following attributes:

Attribute name	Support Qualifier	isReadable	isWritable	isInvariant	isNotifyable
localAddress	O	T	T	F	T
remoteAddress	O	T	T	F	T

4.3.12.3 Attribute constraints

None.

4.3.12.4 Notifications

The common notifications defined in subclause 4.5 are valid for this IOC, without exceptions or additions.

4.3.13 EP_F1U

4.3.13.1 Definition

This IOC represents the local end point of the user plane interface (F1-U) between the DU and CU or CU-UP. The transport network layer is based on IP transport, with the UDP and GTP-U on top of IP.

3GPP TS 38.470 [7] noted that "one gNB-CU and a set of gNB-DUs are visible to other logical nodes as a gNB or an en-gNB where the gNB terminates the Xn and the NG interfaces, and the en-gNB terminates the X2 and the S1-U interfaces".

4.3.13.2 Attributes

The EP_F1U IOC includes attributes inherited from EP_RP IOC (defined in TS 28.622[30]) and the following attributes:

Attribute name	Support Qualifier	isReadable	isWritable	isInvariant	isNotifyable
localAddress	O	T	T	F	T
remoteAddress	O	T	T	F	T

4.3.13.3 Attribute constraints

None.

4.3.13.4 Notifications

The common notifications defined in subclause 4.5 are valid for this IOC, without exceptions or additions.

4.3.14 EP_S1U

4.3.14.1 Definition

This IOC represents the local end point of the logical link, supporting S1-U interface towards a S-GW node. The S1-U interface is defined in 3GPP TS 36.410 [14].

4.3.14.2 Attributes

The EP_S1U IOC includes attributes inherited from EP_RP IOC (defined in TS 28.622[30]) and the following attributes:

Attribute name	Support Qualifier	isReadable	isWritable	isInvariant	isNotifyable
localAddress	O	T	T	F	T
remoteAddress	O	T	T	F	T

4.3.14.3 Attribute constraints

None.

4.3.14.4 Notifications

The common notifications defined in subclause 4.5 are valid for this IOC, without exceptions or additions.

4.3.15 EP_X2C

4.3.15.1 Definition

This IOC represents the local end point of the logical link, supporting X2-C application protocols used in EN-DC, to a neighbour eNB or en-gNB node, which is defined in 3GPP TS 36.423 [15]. EN-DC is defined in 3GPP TS 37.340 [9].

4.3.15.2 Attributes

The EP_X2C IOC includes attributes inherited from EP_RP IOC (defined in TS 28.622[30]) and the following attributes:

Attribute name	Support Qualifier	isReadable	isWritable	isInvariant	isNotifyable
localAddress	O	T	T	F	T
remoteAddress	O	T	T	F	T

4.3.15.3 Attribute constraints

None.

4.3.15.4 Notifications

The common notifications defined in subclause 4.5 are valid for this IOC, without exceptions or additions.

4.3.16 EP_X2U

4.3.16.1 Definition

This IOC represents the local end-point of a logical link supporting the X2 user plane (X2-U) interface used in EN-DC, which is defined in 3GPP TS 36.425 [16].

4.3.16.2 Attributes

The EP_X2U IOC includes attributes inherited from EP_RP IOC (defined in TS 28.622[30]) and the following attributes:

Attribute name	Support Qualifier	isReadable	isWritable	isInvariant	isNotifiable
localAddress	O	T	T	F	T
remoteAddress	O	T	T	F	T

4.3.16.3 Attribute constraints

None.

4.3.16.4 Notifications

The common notifications defined in subclause 4.5 are valid for this IOC, without exceptions or additions.

4.3.17 EP_XnC

4.3.17.1 Definition

This IOC represents the local gNB node end point of the logical link, supporting Xn Application protocols, to a neighbour gNB node. The Xn Application PDUs are carried over SCTP/IP/Data link layer/Physical layer stack. See subclause 7 of 3GPP TS 38.420 [6].

4.3.17.2 Attributes

The EP_X2C IOC includes attributes inherited from EP_RP IOC (defined in TS 28.622[30]) and the following attributes:

Attribute name	Support Qualifier	isReadable	isWritable	isInvariant	isNotifiable
localAddress	O	T	T	F	T
remoteAddress	O	T	T	F	T

4.3.17.3 Attribute constraints

None

4.3.17.4 Notifications

The common notifications defined in subclause 4.5 are valid for this IOC, without exceptions or additions.

4.3.18 ExternalGNBCUCPFunction

4.3.18.1 Definition

This IOC represents the properties, known by the management function, of a GNBCUCPFunction managed by another management function. For more information about GNBCUCPFunction, see subclause 4.3.2.

4.3.18.2 Attributes

The ExternalGNBCUCPFunction includes attributes inherited from EP_RP IOC (defined in TS 28.622[30]) and the following attributes:

Attribute name	Support Qualifier	isReadable	isWritable	isInvariant	isNotifiable
gNBId	M	T	T	F	T
gNBIdLength	M	T	T	F	T
pLMNId	M	T	T	F	T

4.3.18.3 Attribute constraints

None.

4.3.18.4 Notifications

The common notifications defined in subclause 4.5 are valid for this IOC, without exceptions or additions.

4.3.19 ExternalGNBCUUPFunction

4.3.19.1 Definition

This IOC represents the properties, known by the management function, of a `GNBCUUPFunction` managed by another management function. For more information about `GNBCUUPFunction`, see subclause 4.3.3.

4.3.19.2 Attributes

The `ExternalGNBCUUPFunction` includes attributes inherited from `ManagedFunction` IOC (defined in TS 28.622[30]) and the following attributes:

Attribute name	Support Qualifier	isReadable	isWritable	isInvariant	isNotifiable
gNBId	M	T	T	F	T
gNBIdLength	M	T	T	F	T

4.3.19.3 Attribute constraints

None.

4.3.19.4 Notifications

The common notifications defined in subclause 4.5 are valid for this IOC, without exceptions or additions.

4.3.20 ExternalGNBDUFunction

4.3.20.1 Definition

This IOC represents the properties, known by the management function, of a `GNBDUFunction` managed by another management function. For more information about `GNBDUFunction`, see subclause 4.3.1.

4.3.20.2 Attributes

The `ExternalGNBDUFunction` includes attributes inherited from `ManagedFunction` IOC (defined in TS 28.622[30]) and the following attributes:

Attribute name	Support Qualifier	isReadable	isWritable	isInvariant	isNotifiable
gNBId	M	T	T	T	T
gNBIdLength	M	T	T	F	T

4.3.20.3 Attribute constraints

None.

4.3.20.4 Notifications

The common notifications defined in subclause 4.5 are valid for this IOC, without exceptions or additions.

4.3.21 ExternalUPFFunction

4.3.21.1 Definition

This IOC represents the properties, known by the management function, of a UPFFunction managed by another management function. For more information about UPFFunction, see subclause 5.3.3.

4.3.21.2 Attributes

The ExternalUPFFunction includes attributes inherited from ManagedFunction IOC (defined in TS 28.622[30]) and the following attributes:

Attribute name	Support Qualifier	isReadable	isWritable	isInvariant	isNotifiable

4.3.21.3 Attribute constraints

None.

4.3.21.4 Notifications

The common notifications defined in subclause 4.5 are valid for this IOC, without exceptions or additions.

4.3.22 ExternalAMFFunction

4.3.22.1 Definition

This IOC represents the properties, known by the management function, of an AMFFunction managed by another management function. For more information about AMFFunction, see subclause 5.3.

4.3.22.2 Attributes

The ExternalAMFFunction includes attributes inherited from ManagedFunction IOC (defined in TS 28.622[30]) and the following attributes:

Attribute name	Support Qualifier	isReadable	isWritable	isInvariant	isNotifiable

4.3.22.3 Attribute constraints

None

4.3.22.4 Notifications

The common notifications defined in subclause 4.5 are valid for this IOC, without exceptions or additions.

4.3.23 Void

4.3.24 ENBFunction <<ProxyClass>>

4.3.24.1 Definition

This IOC represents an <<IOC>>ENBFunction and <<IOC>>ExternalENBFunction.

4.3.24.2 Attributes

See that defined in <<IOC>>ENBFunction and <<IOC>>ExternalENBFunction.

4.3.24.3 Attribute constraints

See that defined in <<IOC>>ENBFunction and <<IOC>>ExternalENBFunction.

4.3.24.4 Notifications

See respective IOCs.

4.3.25 GNBCUCPFunction <<ProxyClass>>

4.3.25.1 Definition

This IOC represents an <<IOC>>GNBCUCPFunction and <<IOC>>ExternalGNBCUCPFunction.

4.3.25.2 Attributes

See that defined in <<IOC>>GNBCUCPFunction and <<IOC>>ExternalGNBCUCPFunction.

4.3.25.3 Attribute constraints

See respective IOCs.

4.3.25.4 Notifications

See respective IOCs.

4.3.26 GNBCUUPFunction <<ProxyClass>>

4.3.26.1 Definition

This IOC represents an <<IOC>>GNBCUUPFunction and <<IOC>>ExternalGNBCUUPFunction.

4.3.26.2 Attributes

See that defined in <<IOC>>GNBCUUPFunction and <<IOC>>ExternalGNBCUUPFunction.

4.3.26.3 Attribute constraints

See that defined in <<IOC>>GNBCUUPFunction and <<IOC>>ExternalGNBCUUPFunction.

4.3.26.4 Notifications

See respective IOCs.

4.3.27 GNBDUFunction <<ProxyClass>>

4.3.27.1 Definition

This IOC represents an <<IOC>>GNBDUFunction and <<IOC>>ExternalGNBDUFunction.

4.3.27.2 Attributes

See that defined in <<IOC>>GNBDUFunction and <<IOC>>ExternalGNBDUFunction.

4.3.27.3 Attribute constraints

See that defined in <<IOC>>GNBDUFunction and <<IOC>>ExternalGNBDUFunction.

4.3.27.4 Notifications

See respective IOCs.

4.3.28 ServingGWFFunction <<ProxyClass>>

4.3.28.1 Definition

This IOC represents an <<IOC>>ServingGWFFunction and <<IOC>>ExternalServingGWFFunction.

4.3.28.2 Attributes

See that defined in <<IOC>>ServingGWFFunction and <<IOC>>ExternalServingGWFFunction.

4.3.28.3 Attribute constraints

See that defined in <<IOC>>ServingGWFFunction and <<IOC>>ExternalServingGWFFunction.

4.3.28.4 Notifications

See respective IOCs.

4.3.29 UPFFunction <<ProxyClass>>

4.3.29.1 Definition

This IOC represents an <<IOC>>UPFFunction and <<IOC>>ExternalUPFFunction.

4.3.29.2 Attributes

See that defined in <<IOC>>UPFFunction and <<IOC>>ExternalUPFFunction.

4.3.29.3 Attribute constraints

See that defined in <<IOC>>UPFFunction and <<IOC>>ExternalUPFFunction.

4.3.29.4 Notifications

See respective IOCs.

4.3.30 AMFFunction <<ProxyClass>>

4.3.30.1 Definition

This IOC represents an <<IOC>>AMFFunction and <<IOC>>ExternalAMFFunction.

4.3.30.2 Attributes

See that defined in <<IOC>>AMFFunction and <<IOC>>ExternalAMFFunction.

4.3.30.3 Attribute constraints

See that defined in <<IOC>>AMFFunction and <<IOC>>ExternalAMFFunction.

4.3.30.4 Notifications

See respective IOCs.

4.3.31 Void

4.3.32 NRCellRelation

4.3.32.1 Definition

This IOC represents a neighbour cell relation from a source cell to a target cell, where the target cell is an NRCellCU or ExternalNRCellCU instance.

The source cell can be a NRCellCU instance. This is the case for an Intra-NR neighbour cell relation.

The source cell can be a EUTranGenericCell instance. This is the case for Inter-LTE-NR neighbour cell relation, from E-UTRAN to NR. See 3GPP TS 28.658 [19].

Neighbour cell relations are unidirectional.

4.3.32.2 Attributes

Attribute name	Support Qualifier	isReadable	isWritable	isInvariant	isNotifyable
nRTCI	O	T	T	F	T
cellIndividualOffsetadjacentCell	MM	TT	TT	FF	TT
attribute related to role					
nRFreqRelationRef	M	T	T	F	T
adjacentNRCellRef	M	T	T	F	T

4.3.32.3 Attribute constraints

4.3.32.4 Notifications

The common notifications defined in subclause 4.5 are valid for this IOC, without exceptions or additions.

4.3.33 NRFreqRelation

4.3.33.1 Definition

This IOC, together with the target NRFrequency, represents the frequency properties applicable to the referencing NRCellRelation.

4.3.33.2 Attributes

Attribute name	Support Qualifier	isReadable	isWritable	isInvariant	isNotifyable
offsetMO	O	T	T	F	F
blackListEntry	O	T	T	F	F
blackListEntryIdleMode	O	T	T	F	F
cellReselectionPriority	O	T	T	F	F
cellReselectionSubPriority	O	T	T	F	F
pMax	O	T	T	F	F
qOffsetFreq	O	T	T	F	F
qQualMin	O	T	T	F	F
qRxLevMin	M	T	T	F	F
threshXHighP	M	T	T	F	F
threshXHighQ	CM	T	T	F	F
threshXLowP	M	T	T	F	F
threshXLowQ	CM	T	T	F	F
tReselectionNr	M	T	T	F	F
tReselectionNRSfHigh	O	T	T	F	F
tReselectionNRSfMedium	O	T	T	F	F
attribute related to role					
nRFrequencyRef	M	T	T	F	F

4.3.33.3 Attribute constraints

Name	Definition
threshXHighQ	Condition: RSRQ used in SIB4..
threshXLowQ	Condition: RSRQ used in SIB4.

4.3.33.4 Void

4.3.35 ExternalNRCellCU

4.3.35.1 Definition

This abstract IOC represents the properties of an NRCellCU controlled by another Management Service Provider. This IOC contains necessary attributes for inter-system and intra-system handover. It also contains a subset of the attributes of related IOCs controlled by Management Service Provider. The way to maintain consistency between the attribute values of these IOCs is outside the scope of the present document.

4.3.35.2 Attributes

Attribute name	Support Qualifier	isReadable	isWritable	isInvariant	isNotifiable
cellLocalId	M	T	T	F	T
nRPCI	M	T	T	F	T
plmnIdList	M	T	T	F	T
attribute related to role	M	T	T	F	T
nRFRrequencyRef	M	T	T	F	T

4.3.35.3 Attribute constraints

None.

4.3.35.4 Notifications

The common notifications defined in subclause 4.5 are valid for this IOC, without exceptions or additions.

4.3.36 RRMPolicyRatio2 <<dataType>>

4.3.36.1 Definition

This <<dataType>> represents the properties of RRMPolicyRatio2. The RRM policy setting the ratios for the split of the Radio resources between the supported S-NSSALists. in average over time. RRMPolicyRatio2 is a list and each item of the list has seven attributes. Four of them specify the percentage of radio resources to be allocated to the corresponding sNSSAIList. The attribute rRMPolicyMaxRatio defines the maximum resource limitation for the sNSSAIList. The attribute rRMPolicyMarginMaxRatio defines the safety margin that allows for maximum float limit use with other sNSSAIs borrowing free resources while keeping safety margin to ensure that resources are available for quota specific sNSSAIList. The attribute rRMPolicyMinRatio defines the minimum resource limitation for the sNSSAIList. The attribute rRMPolicyMarginMinRatio defines the safety margin that allows for minimum float limit use with other sNSSAIs borrowing free resources while keeping safety margin to ensure that resources are available for quota specific sNSSAIList.

4.3.36.2 Attributes

Attribute name	Support Qualifier	isReadable	isWritable	isInvariant	isNotifiable
groupId	M	T	F	T	F
sNSSAIList	M	T	T	F	T
quotaType	M	T	T	F	T
rRMPolicyMaxRatio	M	T	T	F	T
rRMPolicyMarginMaxRatio	O	T	T	F	T
rRMPolicyMinRatio	M	T	T	F	T
rRMPolicyMarginMinRatio	O	T	T	F	T

4.3.37 NRFrequency

4.3.37.1 Definition

This IOC represents certain NR frequency properties.

4.3.37.2 Attributes

Attribute name	Support Qualifier	isReadable	isWritable	isInvariant	isNotifiable
absoluteFrequencySSB	M	T	T	F	T
sSBSubCarrierSpacing	M	T	T	F	T
multiFrequencyBandListNR	O	T	F	F	T

4.3.37.3 Attribute constraints

None.

4.3.37.4 Notifications

The common notifications defined in subclause 4.5 are valid for this IOC, without exceptions or additions.

4.3.38 CommonBeamformingFunction

4.3.38.1 Definition

This <<IOC>>CommonBeamformingFunction represents common beamforming functionality (eg: SSB beams) for the NRSectorCarrier.

The beams addressed in this definition are the common beams. There may be more than one beam per CommonBeamformingFunction for the NRSectorCarrier.

4.3.38.2 Attributes

Attribute name	Support Qualifier	isReadable	isWritable	isInvariant	isNotifiable

4.3.38.3 Attribute constraints

None.

4.3.38.4 Notifications

The common notifications defined in subclause 4.5 are valid for this IOC, without exceptions or additions.

4.3.39 Beam

4.3.39.1 Definition

This <<IOC>>Beam represents the per-Beam information required for, e.g. beam performance management utilizing measurements generated in the RAN. TS 38.104 [12] relates to beam transmission, TS 38.215 [51] to beam measurements, and TS 38.331 [50] to reporting of those measurements and associated beam failure Information Elements, clauses 5.5.3, 5.5.5.2, 6.3.2. 6.2.2.

Measurements on common beams may be correlated with associated spatial beam information to assist use cases like troubleshooting performance problems, or SON functions like Coverage & Capacity Optimization.

<<IOC>>Beam can have spatial attributes of horizontal/azimuth (ie: Phi ϕ -axis) and vertical/tilt (ie: Theta θ -axis) beam pointing direction and beam width attributes. There may be more than one beam per CommonBeamformingFunction for an NRSectorCarrier. Informational note, beam direction and width are characteristics—a representation—of directional energy vectors.

4.3.39.2 Attributes

Attribute name	Support Qualifier	isReadable	isWritable	isInvariant	isNotifiable
beamIndex	M	T	F	F	T
beamType	O	T	F	F	T
beamAzimuth	CM	T	F	F	T
beamTilt	CM	T	F	F	T
beamHorizWidth	CM	T	F	F	T
beamVertWidth	CM	T	F	F	T

4.3.39.3 Attribute constraints

Name	Definition
beamAzimuth Support Qualifier	Condition: The beamType is "SSB-BEAM" and Supported by Equipment
beamTilt Support Qualifier	Condition: The beamType is "SSB-BEAM" and Supported by Equipment
beamHorizWidth Support Qualifier	Condition: The beamType is "SSB-BEAM" and Supported by Equipment
beamVertWidth Support Qualifier	Condition: The beamType is "SSB-BEAM" and Supported by Equipment

4.3.39.4 Notifications

The common notifications defined in subclause 4.5 are valid for this IOC, without exceptions or additions.

4.4 Attribute definitions

4.4.1 Attribute properties

Attribute Name	Documentation and Allowed Values	Properties
administrativeState	<p>It indicates the administrative state of the NRCellDU. It describes the permission to use or prohibition against using the cell, imposed through the OAM services.</p> <p>allowedValues: LOCKED, SHUTTING DOWN, UNLOCKED. The meaning of these values is as defined in ITU-T Recommendation X.731 [18].</p> <p>See Annex A for Relation between the "Pre-operation state of the gNB-DU Cell" and administrative state relevant in case of 2-split and 3-split deployment scenarios.</p>	<p>type: enumeration multiplicity: 1 isOrdered: N/A isUnique: N/A defaultValue: Locked isNullable: False</p>
operationalState	<p>It indicates the operational state of the NRCellDU instance. It describes whether the resource is installed and partially or fully operable (Enabled) or the resource is not installed or not operable (Disabled).</p> <p>allowedValues: ENABLED, DISABLED.</p>	<p>type: enumeration multiplicity: 1 isOrdered: N/A isUnique: N/A defaultValue: None isNullable: False</p>
cellState	<p>It indicates the usage state of the NRCellDU instance. It describes whether the cell is not currently in use (Idle), or currently in use but not configured to carry traffic (Inactive) or is currently in use and is configured to carry traffic (Active).</p> <p>The Inactive and Active definitions are in accordance with TS 38.401 [4]: "Inactive: the cell is known by both the gNB-DU and the gNB-CU. The cell shall not serve UEs; Active: the cell is known by both the gNB-DU and the gNB-CU. The cell should be able to serve UEs."</p> <p>allowedValues: IDLE", INACTIVE", ACTIVE.</p>	<p>type: enumeration multiplicity: 1 isOrdered: N/A isUnique: N/A defaultValue: None isNullable: False</p>
arfcnDL	<p>NR Absolute Radio Frequency Channel Number (NR-ARFCN) for downlink</p> <p>allowedValues: See TS 38.104 [12] subclause 5.4.2. Note that allowed values of NR-ARFCN are specified for each band in subclause 5.4.2.3.</p>	<p>type: Integer multiplicity: 1 isOrdered: N/A isUnique: N/A defaultValue: None isNullable: False</p>
arfcnUL	<p>NR Absolute Radio Frequency Channel Number (NR-ARFCN) for uplink</p> <p>allowedValues: See TS 38.104 [12] subclause 5.4.2. Note that allowed values of NR-ARFCN are specified for each band in subclause 5.4.2.3.</p>	<p>type: Integer multiplicity: 1 isOrdered: N/A isUnique: N/A defaultValue: None isNullable: False</p>
beamAzimuth	<p>The azimuth of a beam transmission, which means the horizontal beamforming pointing angle (beam peak direction) in the (Phi) ϕ-axis in 1/10th degree resolution. See subclauses 3.2 in TS 38.104 [12] and 7.3 in TS 38.901 [49] as well as TS 28.662 [11]. The pointing angle is the direction equal to the geometric centre of the half-power contour of the beam relative to the reference plane. Zero degree implies explicit antenna bearing (boresight). Positive angle implies clockwise from the antenna bearing.</p> <p>AllowedValues: [-1800 ..1800] 0.1 degree</p>	<p>type: Integer multiplicity: 1 isOrdered: N/A isUnique: N/A defaultValue: Null isNullable: True</p>

beamHorizWidth	<p>The Horizontal beamWidth of a beam transmission, which means the horizontal beamforming half-power (3dB down) beamwidth in the (Phi) ϕ-axis in 1/10th degree resolution. See subclauses 3.2 in TS 38.104 [12] and 7.3 in TS 38.901 [49].</p> <p>AllowedValues: [0..3599] 0.1 degree</p>	<p>type: Integer multiplicity: 1 isOrdered: N/A isUnique: N/A defaultValue: Null isNullable: True</p>
beamIndex	<p>Index of the beam.</p> <p>For example, please see subclause 6.6.2 of TS 38.331 [50] where the ssb-Index in the rsIndexResults element of MeasResultNR is defined.</p>	<p>type: Integer multiplicity: 1 isOrdered: N/A isUnique: N/A defaultValue: Null isNullable: True</p>
beamTilt	<p>The tilt of a beam transmission, which means the vertical beamforming pointing angle (beam peak direction) in the (Theta) θ-axis in 1/10th degree resolution. See subclauses 3.2 in TS 38.104 [12] and 7.3 in TS 38.901 [49] as well as TS 28.662 [11]. The pointing angle is the direction equal to the geometric centre of the half-power contour of the beam relative to the reference plane. Positive value implies downtilt.</p> <p>AllowedValues: [-900..900] 0.1 degree</p>	<p>type: Integer multiplicity: 1 isOrdered: N/A isUnique: N/A defaultValue: Null isNullable: True</p>
beamType	<p>The type of the beam.</p> <p>allowedValues: "SSB-BEAM"</p>	<p>type: IntegerString multiplicity: 0..1 isOrdered: N/A isUnique: N/A defaultValue: Null isNullable: True</p>
beamVertWidth	<p>The Vertical beamWidth of a beam transmission, which means the vertical beamforming half-power (3dB down) beamwidth in the (Theta) θ-axis in 1/10th degree resolution. See subclauses 3.2 in TS 38.104 [12] and 7.3 in TS 38.901 [49].</p> <p>AllowedValues: [0...1800] 0.1 degree</p>	<p>type: Integer multiplicity: 1 isOrdered: N/A isUnique: N/A defaultValue: Null isNullable: True</p>
arfcnSUL	<p>NR Absolute Radio Frequency Channel Number (NR-ARFCN) for supplementary uplink</p> <p>allowedValues: See TS 38.104 [12] subclause 5.4.2. Note that allowed values of NR-ARFCN are specified for each band in subclause 5.4.2.3.</p>	<p>type: Integer multiplicity: 1 isOrdered: N/A isUnique: N/A defaultValue: None isNullable: False</p>
bSChannelBwDL	<p>BS Channel BW in MHz. for downlink</p> <p>allowedValues: See BS Channel BW in TS 38.104 [12], subclause 5.3.</p>	<p>type: Integer multiplicity: 1 isOrdered: N/A isUnique: N/A defaultValue: None isNullable: False</p>
bSChannelBwUL	<p>BS Channel BW in MHz. for uplink</p> <p>allowedValues: See BS Channel BW in TS 38.104 [12], subclause 5.3.</p>	<p>type: Integer multiplicity: 1 isOrdered: N/A isUnique: N/A defaultValue: None isNullable: False</p>

bSChannelBwSUL	BS Channel BW in MHz.for supplementary uplink allowedValues: See BS Channel BW in TS 38.104 [12], subclause 5.3.	type: Integer multiplicity: 1 isOrdered: N/A isUnique: N/A defaultValue: None isNullable: False
configuredMaxTxPower	This is the maximum transmission power in milliwatt (mW) at the antenna port for all downlink channels, used simultaneously in a sector-carrier, added together. allowedValues: N/A	type: Integer multiplicity: 1 isOrdered: N/A isUnique: N/A defaultValue: None isNullable: False
cyclicPrefix	Cyclic prefix as defined in TS 38.211 [32], subclause 4.2. allowedValues: NORMAL, EXTENDED.	type: enumeration multiplicity: 1 isOrdered: N/A isUnique: N/A defaultValue: None isNullable: False
localAddress	This parameter specifies the localAddress including IP address and VLAN ID used for initialization of the underlying transport. First string is IP address, IP address can be an IPv4 address (See RFC 791 [37]) or an IPv6 address (See RFC 2373 [38]). Second string is VLAN Id. (See IEEE 802.1Q [39]),	type: String multiplicity: 2 isOrdered: True isUnique: N/A defaultValue: None isNullable: False
remoteAddress	Remote address including IP address used for initialization of the underlying transport. IP address can be an IPv4 address (See RFC 791 [37]) or an IPv6 address (See RFC 2373 [38]).	type: String multiplicity: 1 isOrdered: N/A isUnique: N/A defaultValue: None isNullable: False
gNBId	It identifies a gNB within a PLMN. The gNB ID is part of the NR Cell Identifier (NCI) of the gNB cells. See "gNB Identifier (gNB ID)" of subclause 8.2 of TS 38.300 [3]. See "Global gNB ID" in subclause 9.3.1.6 of TS 38.413 [5]. allowedValues: 0..4294967295	type: Integer multiplicity: 1 isOrdered: N/A isUnique: N/A defaultValue: None isNullable: False
gNBIdLength	This indicates the number of bits for encoding the gNB ID. See "Global gNB ID" in subclause 9.3.1.6 of TS 38.413 [5]. allowedValues: 22 .. 32.	type: Integer multiplicity: 1 isOrdered: N/A isUnique: N/A defaultValue: None isNullable: False
gNBDUId	It uniquely identifies the DU at least within a gNB-CU. See 'gNB-DU ID' in subclause 9.3.1.9 of 3GPP TS 38.473 [8]. allowedValues: 0..2 ³⁶ -1	type: Integer multiplicity: 1 isOrdered: N/A isUnique: N/A defaultValue: None isNullable: False
gNBCUUPId	It uniquely identifies the gNB-CU-UP at least within a gNB-CU-CP. See 'gNB-CU-UP ID' in subclause 9.3.1.15 of 3GPP TS 38.463 [48]. allowedValues: 0..2 ³⁶ -1	type: Integer multiplicity: 1 isOrdered: N/A isUnique: N/A defaultValue: None isNullable: False

gNBCUName	It identifies the Central Entity of a NR node, see subclause 9.2.1.4 of 3GPP TS 38.473 [8]. allowedValues: Not applicable	type: String multiplicity: 1 isOrdered: N/A isUnique: N/A defaultValue: None isNullable: False
gNBDUName	It identifies the Distributed Entity of a NR node, see subclause 9.2.1.5 of 3GPP TS 38.473 [8]. allowedValues: Not applicable	type: String multiplicity: 1 isOrdered: N/A isUnique: N/A defaultValue: None isNullable: False
cellLocalId	It identifies a NR cell of a gNB. It, together with the gNB Identifier (using gNBId of the parent GNBCUCPFunctioN OR GNBDFunctioN OR ExternalCUCPFunctioN), identifies a NR cell within a PLMN. This is the NR Cell Identity (NCI). See subclause 8.2 of TS 38.300 [3]. The NCI can be constructed by encoding the gNB Identifier using gNBId (of the parent GNBCUCPFunctioN OR GNBDFunctioN OR ExternalCUCPFunctioN) and cellLocalId where the gNB Identifier field is of length specified by gNBIdLength (of the parent GNBCUCPFunctioN OR GNBDFunctioN OR ExternalCUCPFunctioN). See "Global gNB ID" in subclause 9.3.1.6 of TS 38.413 [5]. The NR Cell Global identifier (NCGI) is constructed from the PLMN identity the cell belongs to and the NR Cell Identifier (NCI) of the cell. See relation between NCI and NCGI subclause 8.2 of TS 38.300 [3]. allowedValues: Not applicable	type: Integer multiplicity: 1 isOrdered: N/A isUnique: True defaultValue: None isNullable: False
nRPCI	This holds the Physical Cell Identity (PCI) of the NR cell. allowedValues: See 3GPP TS 36.211 subclause 6.11 for legal values of pci.	type: Integer multiplicity: 1 isOrdered: N/A isUnique: N/A defaultValue: None isNullable: False
nRTAC	This holds the identity of the common Tracking Area Code for the PLMNs. allowedValues: a) It is the TAC or Extended-TAC. b) A cell can only broadcast one TAC or Extended-TAC. See TS 36.300, subclause 10.1.7 (PLMNID and TAC relation). c) TAC is defined in subclause 19.4.2.3 of 3GPP TS 23.003 [13] and Extended-TAC is defined in subclause 9.3.1.29 of 3GPP TS 38.473 [8]. d) For a 5G SA (Stand Alone), it has a non-null value.	type: Integer multiplicity: 1 isOrdered: N/A isUnique: N/A defaultValue: NULL isNullable: True
GNBCUCPFunctioN.pLMNID	It specifies the PLMN identifier to be used as part of the global RAN node identity. allowedValues: Not applicable.	Type: PLMNID multiplicity: 1 isOrdered: N/A isUnique: N/A defaultValue: None isNullable: False

NRCellCU.pLMNIdList	It defines which PLMNs that can be served by the NR cell. allowedValues: Not applicable.	type: PLMNId multiplicity: 1..12 isOrdered: N/A isUnique: True defaultValue: None isNullable: False
GNBCUUPFunction.pLMNIdList	This is a list of PLMN identifiers. It defines from which set of PLMNs an UE needs to have as its serving PLMN to be allowed to use the GNB-CU-UP. allowedValues: Not applicable.	type: PLMNId multiplicity: 1..12 isOrdered: N/A isUnique: True defaultValue: None isNullable: False
NRCellDU.pLMNIdList	It defines which PLMNs that can be served by the NR cell. The first entry of the list is the PLMN used to construct the nCGI for the NR cell. allowedValues: Not applicable.	type: PLMNId multiplicity: 1..12 isOrdered: N/A isUnique: True defaultValue: None isNullable: False
ExternalNRCellCU.pLMNIdList	It defines which PLMNs that are assumed to be served by the NR Cell in another gNB-CU-CP. This list is either updated by the managed element itself (e.g. due to ANR, signalling over Xn etc) or by consumer over the standard interface. allowedValues: Not applicable.	Type: PLMNId multiplicity: 1..12 isOrdered: N/A isUnique: True defaultValue: None isNullable: False
sNSSAIIList	It represents the list of S-NSSAI the managed object is supporting, NSSAI is a set of supported S-NSSAI(s), an S-NSSAI is comprised of a SST (Slice/Service type) and an optional SD (Slice Differentiator) field, (See 3GPP TS 23.003 [13]). allowedValues: See 3GPP TS 23.003 [13]	type: <<S-NSSAI>> multiplicity: * isOrdered: N/A isUnique: N/A defaultValue: None allowedValues: N/A isNullable: False
rRMPolicyType	Type of the RRM policy. The value 0 denotes use of the rRMPolicy. The value 1 denotes use of the rRMPolicyNSSIId, rRMPolicyRatio The value 2 denotes use of the rRMPolicyRatio2. allowedValues: 0 : 65535.	type: Integer multiplicity: 1 isOrdered: N/A isUnique: N/A defaultValue: None isNullable: False
rRMPolicyNSSIId	The list of S-NSSAIs for which a rRMPolicyRatio value is specified allowedValues: Not applicable.	type: DN multiplicity: 1..* isOrdered: N/A isUnique: N/A defaultValue: None allowedValues: N/A isNullable: False
rRMPolicyRatio	The RRM policy setting the ratio for the split of the Radio resources between the supported S-NSSAI lists A S-NSSAI list is defined in rRMPolicyNSSIId. rRMPolicyRatio is the list of target percentage values assigned to the corresponding rRMPolicyNSSIId values. Every value specifies the percentage of PRBs to be allocated to the corresponding S-NSSAIs, in average over time. The sum of the values shall be less or equal 100. allowedValues: 0 : 100 See NOTE 3 and NOTE 4	type: Integer multiplicity: 1..* isOrdered: N/A isUnique: N/A defaultValue: None allowedValues: N/A isNullable: False

rRMPolicyRatio2	<p>The attribute specifies a list of RRMPolicyRatio2 which defined as datatype. The attribute is used to set the ratios for the split of the Radio resources between the sNSSALists for radio resources (e.g. RRC connected users, PDCP resource, etc.) in average time (see NOTE 3 and NOTE 2).</p> <p>The sum of the values included in the item of rRMPolicyRatio2 shall be less or equal 100 (see NOTE 4).</p> <p>allowedValues: Not applicable.</p>	<p>type: << dataType >> multiplicity: 1..* isOrdered: N/A isUnique: N/A defaultValue: None allowedValues: N/A isNullable: False</p>
groupId	<p>The attribute identifies one sNSSAList group inside NRCellCU. The rRMPolicyRatio2 is configured for each group. The value of the groupId is unique inside one NRCellCU instance.</p>	<p>type: Integer multiplicity: 1 isOrdered: N/A isUnique: N/A defaultValue: None allowedValues: N/A isNullable: False</p>
quotaType	<p>The attribute indicates the type of the quota which allows to allocate resources as strictly usable for defined S-NSSAList ("strict quota") or allows that resources to be used by other S-NSSAList when defined slice(s) do not need them ("float quota").</p> <p>allowedValues: "STRICT", "FLOAT".</p>	<p>type: ENUM multiplicity: 1 isOrdered: N/A isUnique: N/A defaultValue: None isNullable: False</p>
rRMPolicyMaxRatio	<p>The RRM policy setting the maximum percentage of radio resources to be allocated to the corresponding S-NSSAList. This quota can be strict or float quota. Strict quota means the defined S-NSSAList cannot be allocated resource if its used resource reached maxRatio. Float quota means the defined S-NSSAList can use quota from other S-NSSAList even if its resource has reached maxRatio, if there's free quota from other S-NSSAList. In addition, resources of the defined S-NSSAList can be used by other S-NSSAList when the defined S-NSSAList do not need them.</p> <p>Value 0 indicates that there is no maximum limit.</p> <p>allowedValues: 0 : 100</p>	<p>type: Integer multiplicity: 0..1 isOrdered: N/A isUnique: N/A defaultValue: None allowedValues: N/A isNullable: False</p>
rRMPolicyMarginMaxRatio	<p>Maximum quota margin ratio is applicable when maximum quota policy ratio is of type "float quota". It defines the resource quota within maximum quota to reserve buffers for new resource requirements for the defined S-NSSAList. With the margin ratio, unused resources of the maximum resource quota can be allocated to other S-NSSAIs when the free resources are more than resource amount indicated by the margin. The margin resource quota can only be used for the defined S-NSSAList.</p> <p>Value 0 indicates that no margin is used.</p> <p>allowedValues: 0 : 100</p>	<p>type: Integer multiplicity: 0..1 isOrdered: N/A isUnique: N/A defaultValue: None allowedValues: N/A isNullable: False</p>

rRMPolicyMinRatio	<p>The RRM policy setting the minimum percentage of radio resources to be allocated to the corresponding S-NSSAList, especially in congestion situation.</p> <p>This quota can be strict or float quota. Strict quota means resources are not allowed for other S-NSSAList even when they are not used by the defined S-NSSAList. Float quota resources can be used by other S-NSSAList when the defined S-NSSAList do not need them.</p> <p>Value 0 indicates that there is no minimum limit.</p> <p>allowedValues: 0 : 100</p> <p>NOTE: The averaging time interval is implementation dependent.</p>	<p>type: Integer multiplicity: 0..1 isOrdered: N/A isUnique: N/A defaultValue: None allowedValues: N/A isNullable: False</p>
rRMPolicyMarginMinRatio	<p>Minimum quota margin ratio is applicable when minimum quota policy ratio is of type "float quota". It defines the resource quota within minimum quota to reserve buffers for new resource requirements for the defined S-NSSAList. With the margin ratio, unused resources of the minimum resource quota can be allocated to other S-NSSAList when the free resources are more than resource amount indicated by the margin. The margin resource quota can only be used for the defined S-NSSAList.</p> <p>Value 0 indicates that no margin is used.</p> <p>allowedValues: 0 : 100</p>	<p>type: Integer multiplicity: 0..1 isOrdered: N/A isUnique: N/A defaultValue: None allowedValues: N/A isNullable: False</p>
rRMPolicy	<p>It represents RRM policy which includes guidance for split of radio resources between the S-NSSAIs that the cell supports in case when the rRMPolicyType is absent or equal to 0. The RRM policy is implementation dependent.</p> <p>allowedValues: Not applicable</p>	<p>type: String multiplicity: 1 isOrdered: N/A isUnique: N/A defaultValue: None isNullable: False</p>
subCarrierSpacing	<p>Subcarrier spacing configuration for a BWP. See subclause 5 in TS 38.104 [12].</p> <p>AllowedValues: [15, 30, 60, 120] depending on the frequency range FR1 or FR2.</p>	<p>type: Integer multiplicity: 1 isOrdered: N/A isUnique: N/A defaultValue: None isNullable: False</p>
txDirection	<p>Indicates if the transmission direction is downlink (DL), uplink (UL) or both downlink and uplink (DL and UL).</p> <p>allowedValues: DL, UL, DL_AND_UL</p>	<p>type: ENUM multiplicity: 1 isOrdered: N/A isUnique: N/A defaultValue: None isNullable: False</p>
bwpContext	<p>It identifies whether the object is used for downlink, uplink or supplementary uplink.</p> <p>allowedValues:DL, UL, SUL</p>	<p>type: ENUM multiplicity: 1 isOrdered: N/A isUnique: N/A defaultValue: None isNullable: False</p>
isInitialBwp	<p>It identifies whether the object is used for initial or other BWP.</p> <p>allowedValues:INITIAL, OTHER</p>	<p>type: ENUM multiplicity: 1 isOrdered: N/A isUnique: N/A defaultValue: None isNullable: False</p>

startRB	<p>Offset in common resource blocks to common resource block 0 for the applicable subcarrier spacing for a BWP. This corresponds to N_BWP_start, see subclause 4.4.5 in TS 38.211 [32].</p> <p>allowedValues: 0 to N_grid_size – 1, where N_grid_size equals the number of resource blocks for the BS channel bandwidth, given the subcarrier spacing of the BWP.</p>	<p>type: Integer multiplicity: 1 isOrdered: N/A isUnique: N/A defaultValue: None isNullable: False</p>
numberOfRBs	<p>Number of physical resource blocks for a BWP. This corresponds to N_BWP_size, see subclause 4.4.5 in TS 38.211 [32].</p> <p>allowedValues: 1 to N_grid_size – startRB of the BWP. See startRB for definition of N_grid_size.</p>	<p>type: Integer multiplicity: 1 isOrdered: N/A isUnique: N/A defaultValue: None isNullable: False</p>
nRTCI	<p>This is the Target NR Cell Identifier. It consists of NR Cell Identifier (NCI) and Physical Cell Identifier of the target NR cell (nRPCI).</p> <p>The NRRelation.nRTCI identifies the target cell from the perspective of the NRCell, the name-containing instance of the subject NRCellCU instance.</p> <p>allowedValues: Not applicable.</p>	<p>type: Integer multiplicity: 1 isOrdered: N/A isUnique: N/A defaultValue: None isNullable: False</p>
adjacentCell	<p>This attribute contains the DN of an adjacentNRCell (NRCellCU or ExternalNRCellCU).</p> <p>allowedValues: Not applicable.</p>	<p>type: DN multiplicity: 1 isOrdered: N/A isUnique: True defaultValue: None isNullable: False</p>
nRFrequencyRef	<p>This attribute contains the DN of the referenced NRFrequency.</p> <p>allowedValues: Not applicable.</p>	<p>type: DN multiplicity: 1 isOrdered: N/A isUnique: True defaultValue: None isNullable: False</p>
nRSectorCarrierRef	<p>This attribute contains the DN of the referenced NRSectorCarrier.</p> <p>allowedValues: Not applicable.</p>	<p>type: DN multiplicity: 1 isOrdered: N/A isUnique: True defaultValue: None isNullable: False</p>
bWPRef	<p>This attribute contains the DN of the referenced BWP.</p> <p>allowedValues: Not applicable.</p>	<p>type: DN multiplicity: 1 isOrdered: N/A isUnique: True defaultValue: None isNullable: False</p>
sectorEquipmentFunctionRef	<p>This attribute contains the DN of the referenced NSectorEquipmentFunction.</p> <p>allowedValues: Not applicable.</p>	<p>type: DN multiplicity: 1 isOrdered: N/A isUnique: True defaultValue: None isNullable: False</p>
offsetMO	<p>It is a list of offset values applicable to all measured cells with reference signal(s) indicated in this <i>MeasObjectNR</i>. See offsetMO of subclause 5.5.4 of TS 38.331 [50].</p> <p>allowedValues: Not applicable.</p>	<p>type: QOffsetRangeList multiplicity: 1 isOrdered: N/A isUnique: N/A defaultValue: N/A isNullable: False</p>

cellIndividualOffset	<p>It is a list of offset values for the neighbour cell. Used when UE is in connected mode. The unit is 1dB. It is defined for rsrpOffsetSSB, rsrqOffsetSSB, sinrOffsetSSB, rsrpOffsetCSI-RS, rsrqOffsetCSI-RS and sinrOffsetCSI-RS. See TS 38.331 [50].</p> <p>allowedValues: Not applicable.</p>	<p>type: Integer multiplicity: 6 isOrdered: True isUnique: N/A defaultValue: 0 isNullable: False</p>
blackListEntry	<p>It specifies a list of PCI (physical cell identity) that are blacklisted in EUTRAN measurements as described in 3GPP TS 38.331 [50].</p> <p>allowedValues: { 0...1007 }</p>	<p>type: Integer multiplicity: * isOrdered: N/A isUnique: N/A defaultValue: None isNullable: False</p>
blackListEntryIdleMode	<p>It specifies a list of PCI (physical cell identity) that are blacklisted in SIB4 and SIB5.</p> <p>allowedValues: { 0...1007 }</p>	<p>type: Integer multiplicity: 1 isOrdered: N/A isUnique: N/A defaultValue: None isNullable: False</p>
cellReselectionPriority	<p>It is the absolute priority of the carrier frequency used by the cell reselection procedure. See <i>CellReselectionPriority</i> IE in TS 38.331 [50].</p> <p>It corresponds to the parameter priority in 3GPP TS 38.304 [44].</p> <p>Value 0 means lowest priority. The UE behaviour when no value is entered is specified in subclause 5.2.4.1 of 3GPP TS 38.304 [44].</p> <p>The value shall not be already used by other RAT, i.e. equal priorities between RATs are not supported.</p> <p>allowedValues: Not applicable.</p>	<p>type: Integer multiplicity: 1 isOrdered: N/A isUnique: N/A defaultValue: 0None isNullable: False</p>
cellReselectionSubPriority	<p>It indicates a fractional value to be added to the value of cellReselectionPriority to obtain the absolute priority of the concerned carrier frequency for E-UTRA and NR. See <i>CellReselectionSubPriority</i> IE in TS 38.331 [50].</p> <p>allowedValues: { 0.2, 0.4, 0.6, 0.8 }.</p>	<p>type: Short multiplicity: 1 isOrdered: N/A isUnique: N/A defaultValue: None isNullable: False</p>
pMax	<p>It calculates the parameter Pcompensation (defined in 3GPP TS 38.304 [44]), at cell reselection to an Cell. Its unit is 1 dBm. It corresponds to parameter PEMAX in 3GPP TS 38.101-1[42].</p> <p>allowedValues: { -30..33 }.</p>	<p>type: Integer multiplicity: 1 isOrdered: N/A isUnique: N/A defaultValue: None isNullable: False</p>
qOffsetFreq	<p>It is the frequency specific offset applied when evaluating candidates for cell reselection.</p>	<p>type: Real multiplicity: 1 isOrdered: N/A isUnique: N/A defaultValue: 0 isNullable: False</p>

qOffsetRangeList	<p>It is used to indicate a cell, beam or measurement object specific offset to be applied when evaluating candidates for cell re-selection or when evaluating triggering conditions for measurement reporting. The value in dB. Value dB-24 corresponds to -24 dB, dB-22 corresponds to -22 dB and so on.</p> <p>This is a list of enum values representing, in sequence: rsrpOffsetSSB, rsrqOffsetSSB, sinrOffsetSSB, rsrpOffsetCSI-RS, srqOffsetCSI-RS, sinrOffsetCSI-RS.</p> <p>See Q-OffsetRangeList in subclause of subclause 6.3.1 of TS 38.311 [50].</p> <p>allowedValues: { -24, -22, -20, -18, -16, -14, -12, -10, -8, -6, -5, -4, -3, -2, -1, 0, 1, 2, 3, 4, 5, 6, 8, 10, 12, 14, 16, 18, 20, 22, 24 }</p>	<p>type: enumeration multiplicity: 6 isOrdered: True isUnique: N/A defaultValue: 0 isNullable: False</p>
qQualMin	<p>It indicates the minimum required quality level in the cell (dB). See qQualMin in TS 38.304 [44]. Unit is 1 dB.</p> <p>Value 0 means that it is not sent and UE applies in such case the (default) value of negative infinity for Qqualmin. Sent in SIB3 or SIB5.</p> <p>allowedValues: { -34..-3, 0 }</p>	<p>type: Real multiplicity: 1 isOrdered: N/A isUnique: N/A defaultValue: None isNullable: False</p>
qRxLevMin	<p>It indicates the required minimum received Reference Symbol Received Power (RSRP) level in the (E-UTRA) frequency for cell reselection. It corresponds to Qrxlevmin defined in 3GPP TS 38.304 [44]. It is broadcast in SIB3 or SIB5, depending on whether the related frequency is intra- or inter-frequency. Its unit is 1 dBm and resolution is 2.</p> <p>allowedValues: { -140..-44 }.</p>	<p>type: Integer multiplicity: 1 isOrdered: N/A isUnique: N/A defaultValue: None isNullable: False</p>
threshXHighP	<p>This specifies the Srxlev threshold (in dB) used by the UE when reselecting towards a higher priority RAT/ frequency than the current serving frequency. Each frequency of NR and E-UTRAN might have a specific threshold. It corresponds to the Thresh_{X, HighP} in 3GPP TS 38.304 [44]. Its unit is 1 dB and resolution is 2.</p> <p>allowedValues: { 0..62 }</p>	<p>type: Integer multiplicity: 1 isOrdered: N/A isUnique: N/A defaultValue: None isNullable: False</p>
threshXHighQ	<p>This specifies the Squal threshold (in dB) used by the UE when reselecting towards a higher priority RAT/ frequency than the current serving frequency. Each frequency of NR and E-UTRAN might have a specific threshold. It corresponds to the Thresh_{X, HighQ} in TS 38.304 [44]. Its unit is 1 dB.</p> <p>allowedValues: { 0..31 }</p>	<p>type: Integer multiplicity: 1 isOrdered: N/A isUnique: N/A defaultValue: None isNullable: False</p>
threshXLowP	<p>This specifies the Srxlev threshold (in dB) used by the UE when reselecting towards a lower priority RAT/ frequency than the current serving frequency. Each frequency of NR might have a specific threshold. It corresponds to Thresh_{X, LowP} in 3GPP TS 38.304 [44]. Its unit is 1 dB. Its resolution is 2.</p> <p>allowedValues: { 0..62 }</p>	<p>type: Integer multiplicity: 1 isOrdered: N/A isUnique: N/A defaultValue: None isNullable: False</p>

threshXLowQ	<p>This specifies the Squal threshold (in dB) used by the UE when reselecting towards a lower priority RAT/ frequency than the current serving frequency. Each frequency of NR might have a specific threshold. It corresponds to ThreshX,Low in TS 38.304 [44]. Its unit is 1 dB.</p> <p>allowedValues: {0..31}.</p>	<p>type: Integer multiplicity: 1 isOrdered: N/A isUnique: N/A defaultValue: None isNullable: False</p>
tReselectionNr	<p>It is the cell reselection timer and corresponds to parameter TreselectionRAT for NR defined in 38.331 [50]. Its unit is in seconds.</p> <p>allowedValues: {0..7}.</p>	<p>type: Integer multiplicity: 1 isOrdered: N/A isUnique: N/A defaultValue: None isNullable: False</p>
tReselectionNR SfHigh	<p>The attribute t-ReselectionNr (a parameter Treselection_{NR} in TS 38.304 [44]) is multiplied with this factor if the UE is in high mobility state. It corresponds to the parameter Speed dependent ScalingFactor for TreselectionNr for medium high state in 3GPP TS 38.304 [44]. The unit is one %.</p> <p>Value mapping: 25 = 0.25 50 = 0.5 75 = 0.75 100 = 1.0</p> <p>allowedValues: {25, 50, 75, 100}.</p>	<p>type: Integer multiplicity: 1 isOrdered: N/A isUnique: N/A defaultValue: None isNullable: False</p>
tReselectionNR SfMedium	<p>The attribute t-ReselectionNR (a parameter "Treselection_{NR} in TS 38.304 [44]") is multiplied with this factor if the UE is in medium mobility state. It corresponds to the parameter Speed dependent ScalingFactor for TreselectionNr for medium mobility state in 3GPP TS 38.304 [44]. Its unit is one %.</p> <p>Value mapping: 25 = 0.25 50 = 0.5 75 = 0.75 100 = 1.0</p> <p>allowedValues: {25, 50, 75, 100}.</p>	<p>type: Integer multiplicity: 1 isOrdered: N/A isUnique: N/A defaultValue: None isNullable: False</p>
absoluteFrequencySSB	<p>The absolute frequency applicable for a downlink NR carrier frequency associated with the SSB.</p> <p>allowedValues: {0.. 3279165}.</p>	<p>type: Integer multiplicity: 1 isOrdered: N/A isUnique: N/A defaultValue: None isNullable: False</p>
sSSBSubCarrierSpacing	<p>This SSB is used for for synchronization. See subclause 5 in TS 38.104 [12]. Its units are in kHz.</p> <p>allowedValues: {15, 30, 120, 240}.</p> <p>Note that the allowed values of SSB used for representing data, by e.g. a BWP, are: 15, 30, 60 and 120 in units of kHz.</p>	<p>type: Integer multiplicity: 1 isOrdered: N/A isUnique: N/A defaultValue: None isNullable: False</p>
multiFrequencyBandListNR	<p>It is a list of additional frequency bands the frequency belongs to. The list is automatically set by the gNB.</p> <p>allowedValues: {1..256 }</p>	<p>type: Integer multiplicity: 1 isOrdered: N/A isUnique: N/A defaultValue: None isNullable: False</p>

ssbFrequency	Indicates cell defining SSB frequency domain position Frequency of the cell defining SSB transmission. The frequency provided in this attribute identifies the position of resource element RE=#0 (subcarrier #0) of resource block RB#10 of the SS block. The frequency shall be positioned on the NR global frequency raster, as defined in TS 38.101-1 [42] subclause 5.4.2. and within bSChannelBwDL. allowedValues: 0..3279165	type: Integer multiplicity: 1 isOrdered: N/A isUnique: N/A defaultValue: None isNullable: False
ssbPeriodicity	Indicates cell defined SSB periodicity in number of subframes (ms). The SSB periodicity in msec is used for the rate matching purpose. allowedValues: 5, 10, 20, 40, 80, 160.	type: Integer multiplicity: 1 isOrdered: N/A isUnique: N/A defaultValue: None isNullable: False
ssbOffset	Indicates cell defining SSB time domain position. Defined as the offset of the measurement window, in number of subframes (ms), in which to receive SS/PBCH blocks, where allowed values depend on the ssbPeriodicity. allowedValues: ssbPeriodicity5 ms 0..4, ssbPeriodicity10 ms 0..9, ssbPeriodicity20 ms 0..19, ssbPeriodicity40 ms 0..39, ssbPeriodicity80 ms 0..79, ssbPeriodicity160 ms 0..159.	type: Integer multiplicity: 1 isOrdered: N/A isUnique: N/A defaultValue: None isNullable: False
ssbDuration	Duration of the measurement window in which to receive SS/PBCH blocks. It is given in number of subframes (ms) (see 38.213 [41], subclause 4.1). allowedValues: 1, 2, 3, 4, 5.	type: Integer multiplicity: 1 isOrdered: N/A isUnique: N/A defaultValue: None isNullable: False
<p>NOTE 1: Void</p> <p>NOTE 2: The radio resource can be signaling resources (e.g. RRC connected users) or user plane resources (e.g. PDCP). The detail resource and how to map the ratio to exact number of resources is implementation dependant.</p> <p>NOTE 3: The averaging time interval is implementation dependent.</p> <p>NOTE 4: How to cacluate the sum of the ratio is implementation dependent.</p>		

4.5 Common notifications

This subclause presents a list of notifications, defined in TS 28.532 [35], that provisioning management service consumer can receive. The notification parameter `objectClass/objectInstance`, defined in TS 28.531 [26], would capture the DN of an instance of an IOC defined in the present document.

Name	Qualifier	Notes
notifyMOIAttributeValueChanges	O	
notifyMOICreation	O	
notifyMOIDeletion	O	

5 Information model definitions for 5GC NRM

5.1 Imported information entities and local labels

Label reference	Local label
TS 28.622 [30], IOC, SubNetwork	SubNetwork
TS 28.622 [30], IOC, ManagedElement	ManagedElement
TS 28.622 [30], IOC, ManagedFunction	ManagedFunction
TS 28.622 [30], IOC, EP_RP	EP_RP
TS 28.708 [21], IOC, ServingGWFunction	ServingGWFunction
TS 28.702 [20], IOC, SmsIwmscFunction	SmsIwmscFunction
TS 28.702 [20], IOC, SmsGmscFunction	SmsGmscFunction
TS 28.702 [20], IOC, GmlcFunction	GmlcFunction
3GPP TS 28.658 [19], dataType, PLMNId	PLMNId

5.2 Class diagram

5.2.1 Class diagram of 5GC NFs

5.2.1.1 Relationships

This clause depicts the set of classes (e.g. IOCs) that encapsulates the information relevant for NRM of 5GC NFs definitions. This clause provides the overview of the relationships of relevant classes in UML. Subsequent clauses provide more detailed specification of various aspects of these classes.

The Figure 5.2.1.1-1 shows the 5GC NF NRM containment/naming relationship.

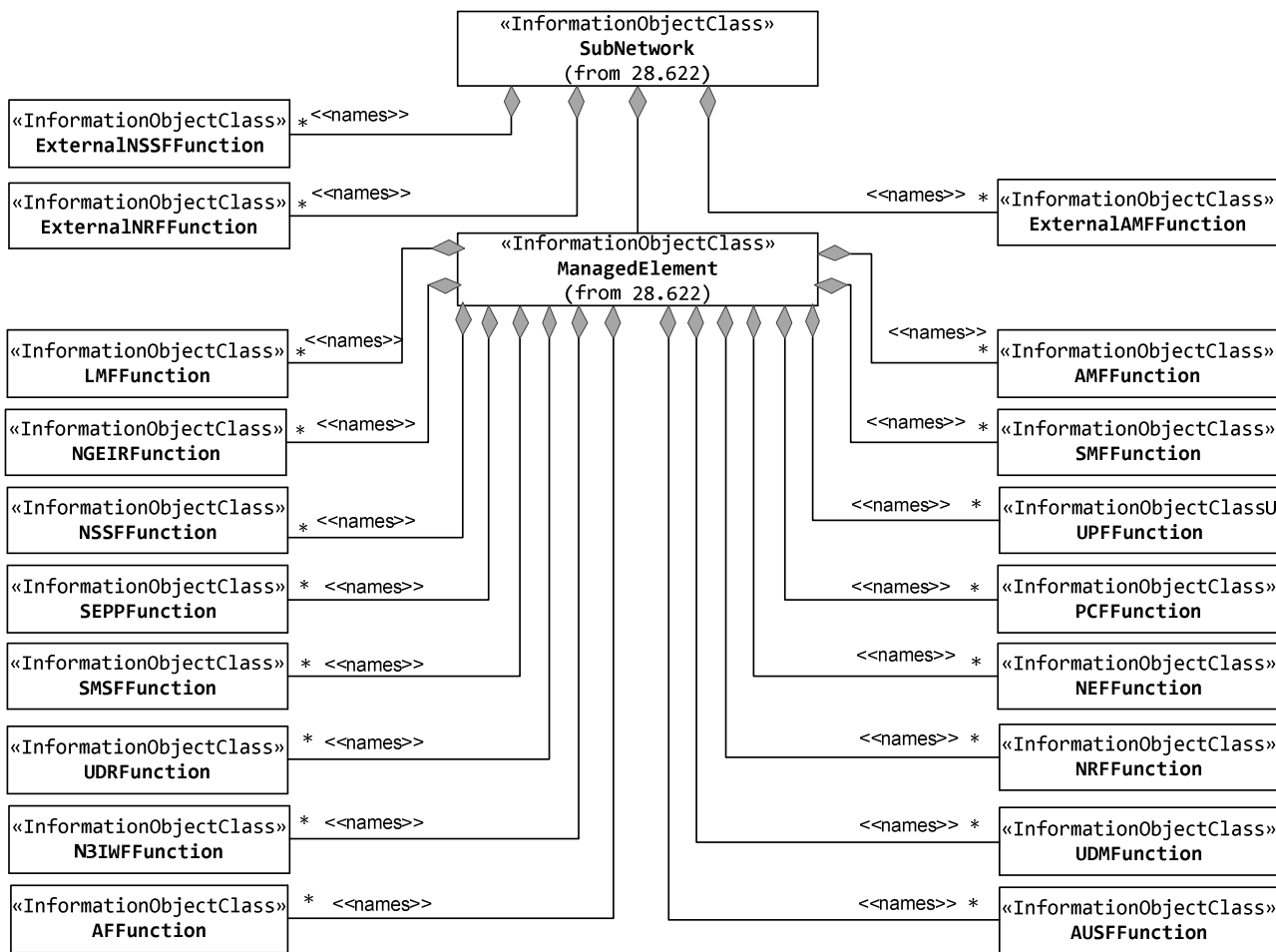

Figure 5.2.1.1-1: 5GC NRM containment/naming relationship

The Figure 5.2.1.1-2 shows the transport view of AMF NRM.

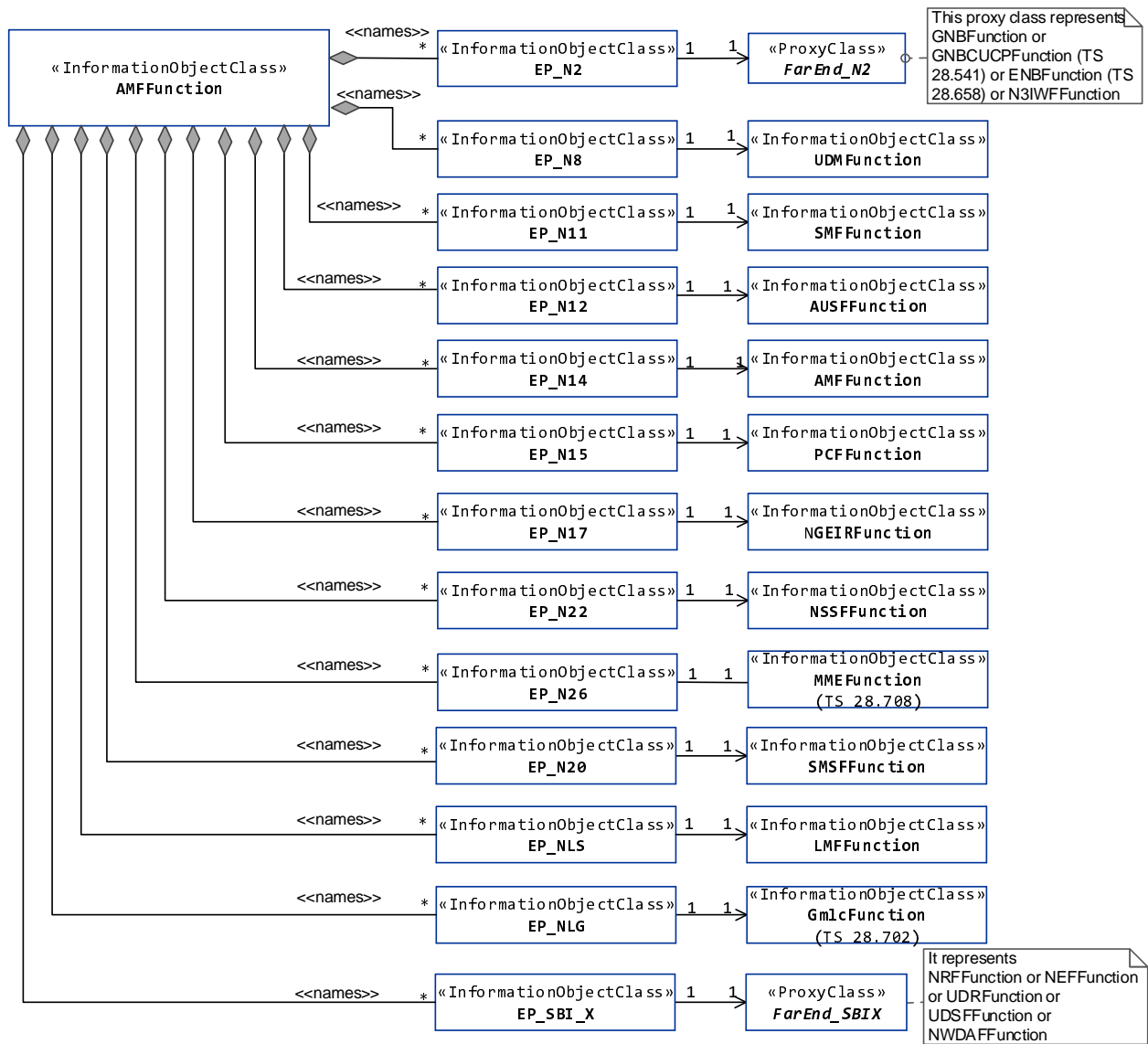

Figure 5.2.1.1-2: Transport view of AMF NRM

The Figure 5.2.1.1-3 shows the transport view of SMF NRM.

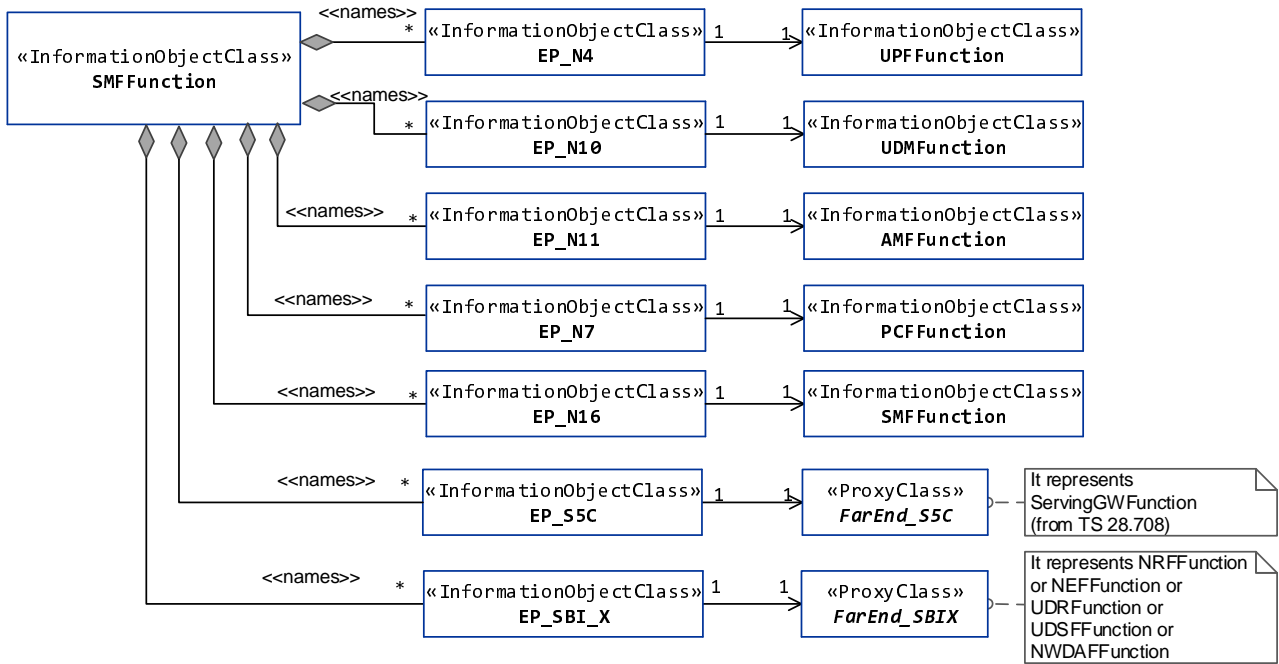

Figure 5.2.1.1-3: Transport view of SMF NRM

The Figure 5.2.1.1-4 shows the transport view of UPF NRM.

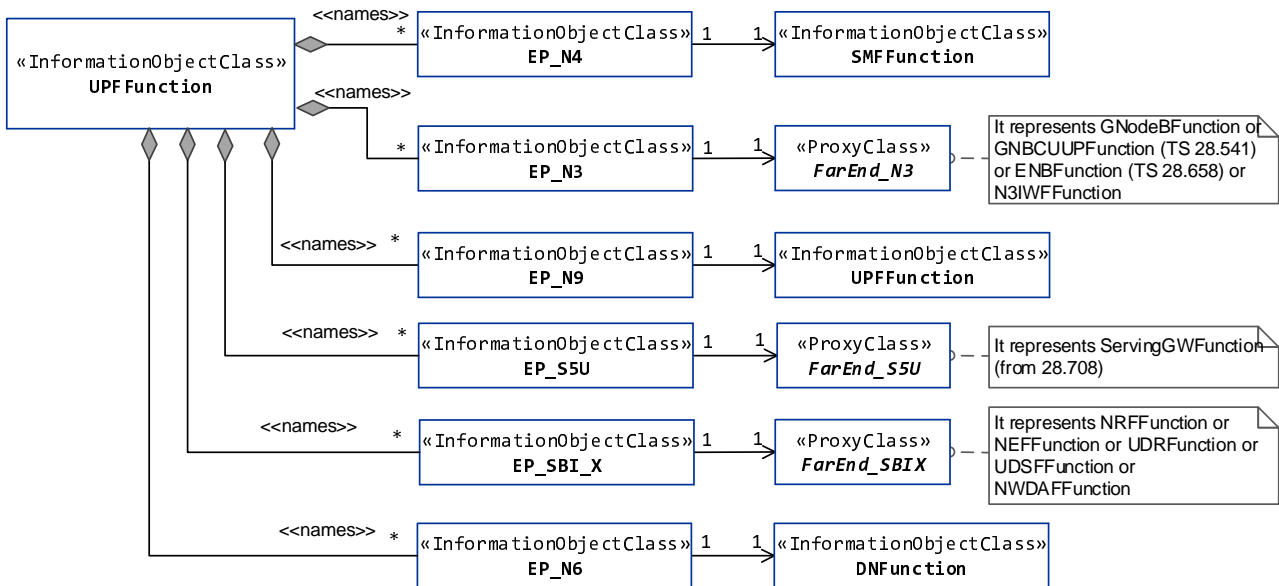

Figure 5.2.1.1-4: Transport view of UPF NRM

The Figure 5.2.1.1-5 shows the transport view of N3IWF NRM.

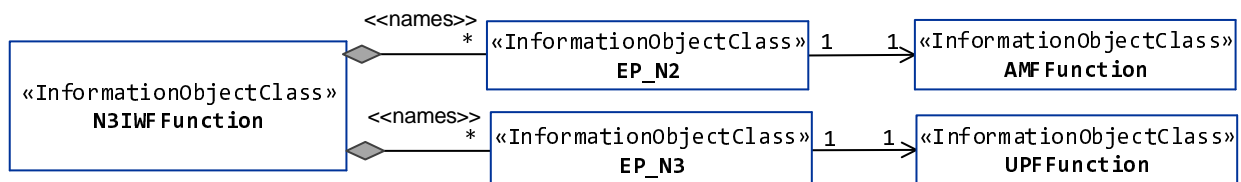

Figure 5.2.1.1-5: Transport view of N3IWF NRM

The Figure 5.2.1.1-6 shows the transport view of PCF NRM.

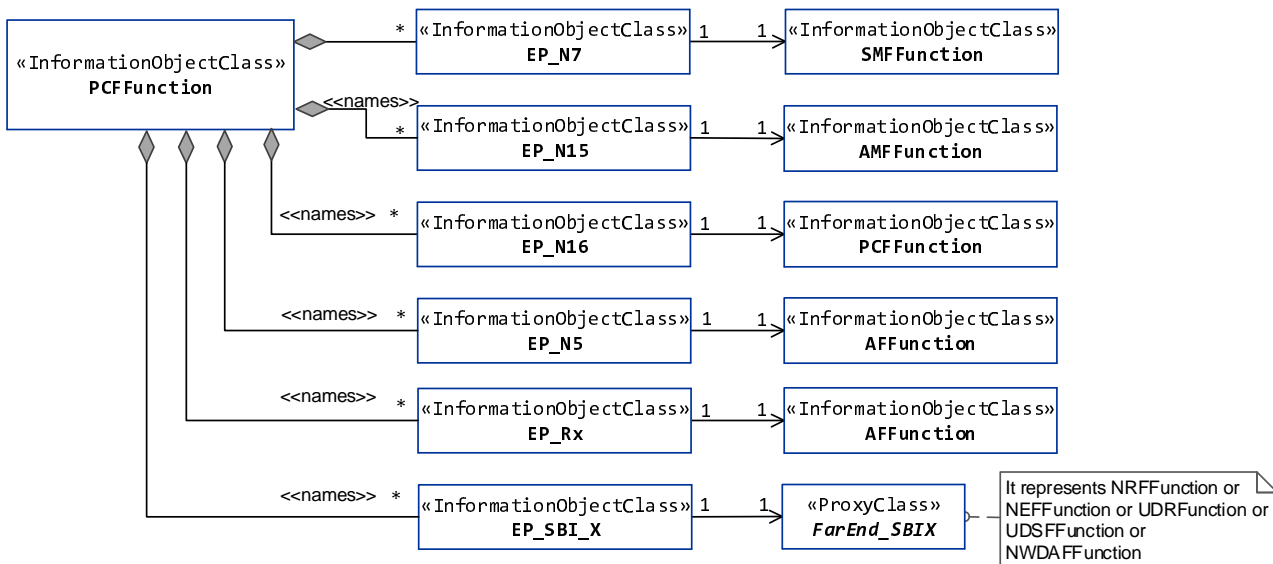

Figure 5.2.1.1-6: Transport view of PCF NRM

The Figure 5.2.1.1-7 shows the transport view of AUSF NRM.

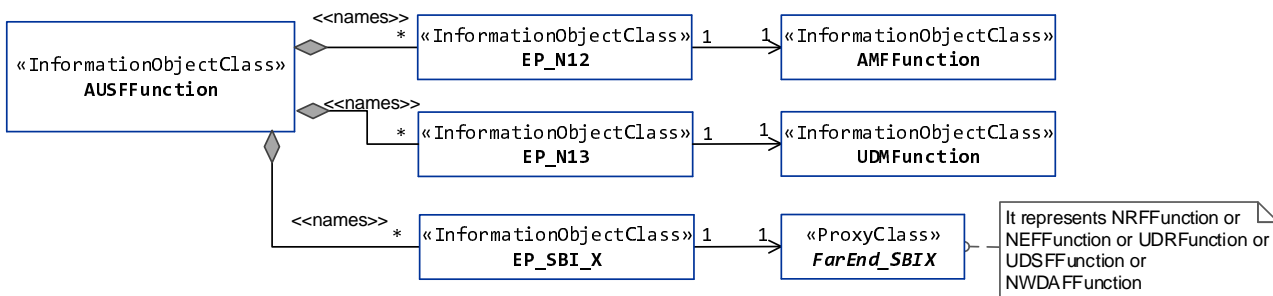

Figure 5.2.1.1-7: Transport view of AUSF NRM

The Figure 5.2.1.1-8 shows the transport view of UDM NRM.

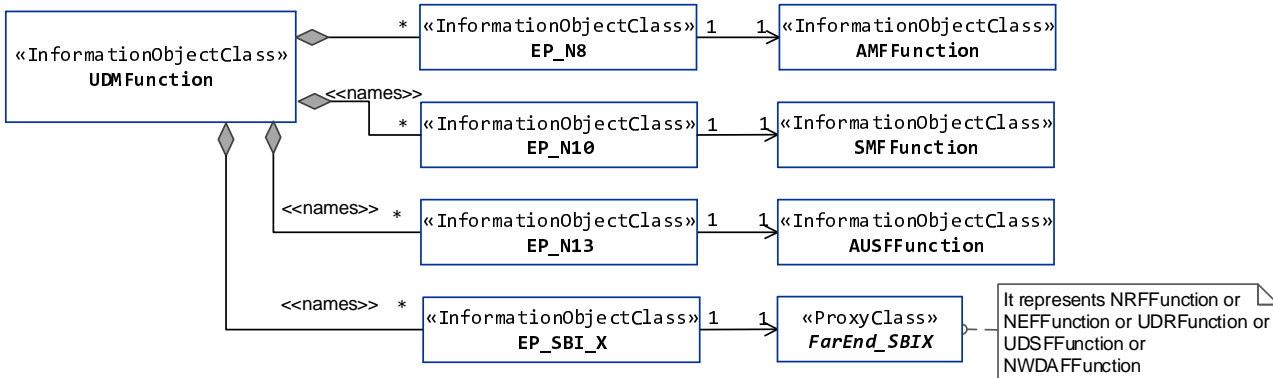

Figure 5.2.1.1-8: Transport view of UDM NRM

The Figure 5.2.1.1-9 shows the transport view of UDR NRM.

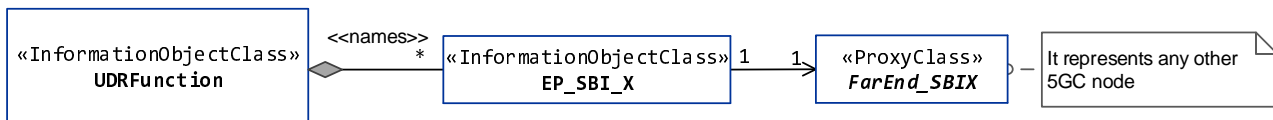

Figure 5.2.1.1-9: Transport view of UDR NRM

The Figure 5.2.1.1-10 shows the transport view of UDSF NRM.

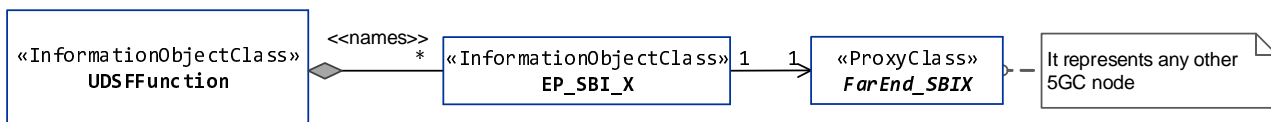

Figure 5.2.1.1-10: Transport view of UDSF NRM

The Figure 5.2.1.1-11 shows the transport view of NWDAF NRM.

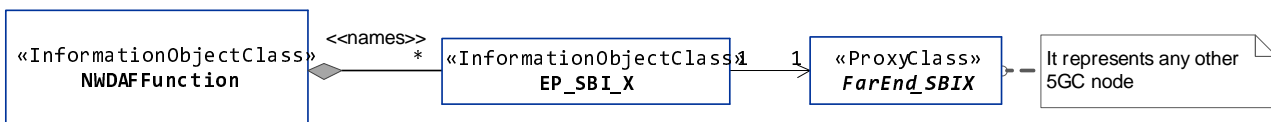

Figure 5.2.1.1-11: Transport view of NWDAF NRM

The Figure 5.2.1.1-12 shows the transport view of NRF NRM.

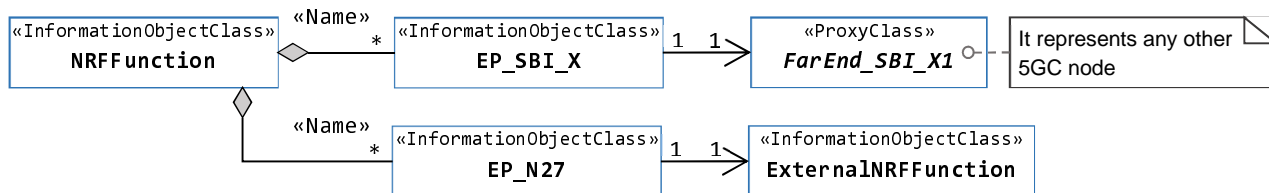

Figure 5.2.1.1-12: Transport view of NRF NRM

The Figure 5.2.1.1-13 shows the transport view of NSSF NRM.

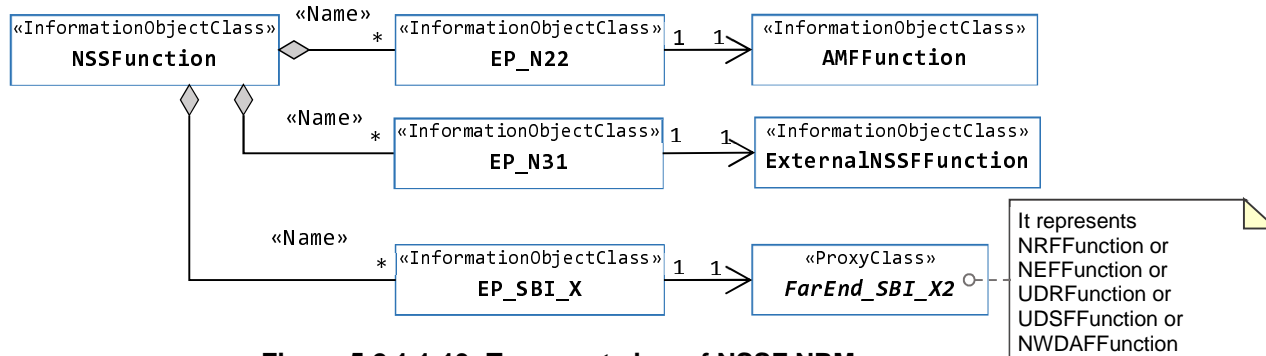

Figure 5.2.1.1-13: Transport view of NSSF NRM

The Figure 5.2.1.1-14 shows the transport view of SMSF NRM.

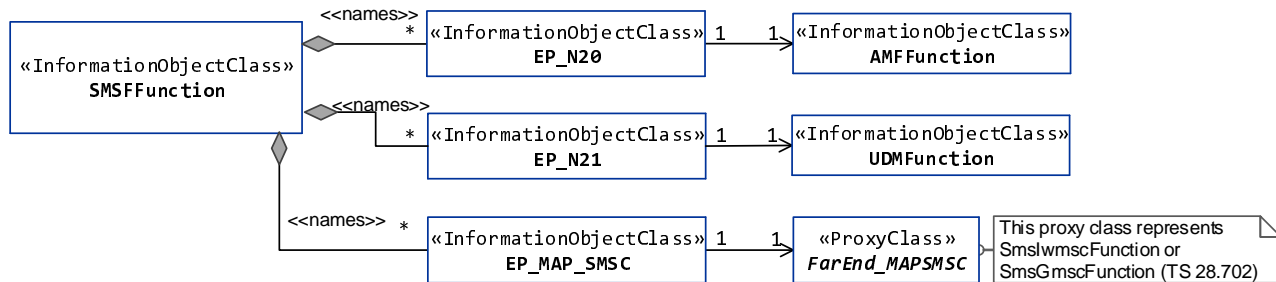

Figure 5.2.1.1-14: Transport view of SMSF NRM

The Figure 5.2.1.1-15 shows the transport view of 5G location service related NRM.

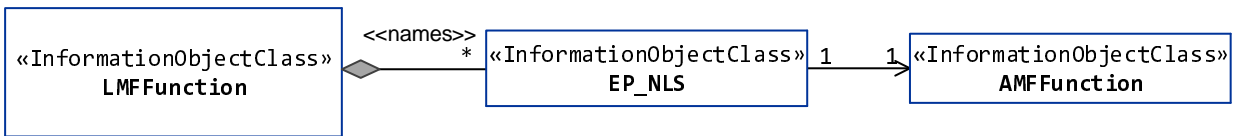

Figure 5.2.1.1-15: Transport view of LMF NRM

The Figure 5.2.1.1-16 shows the transport view of 5G-EIR NRM.

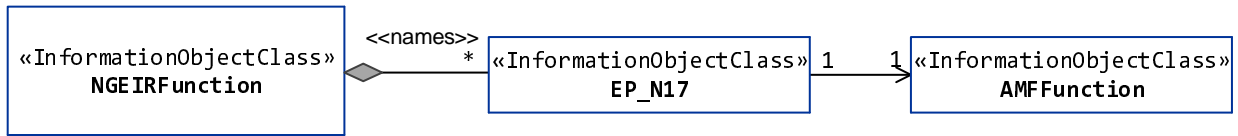

Figure 5.2.1.1-16: Transport view of 5G-EIR NRM

The Figure 5.2.1.1-17 shows the transport view of SEPP NRM.

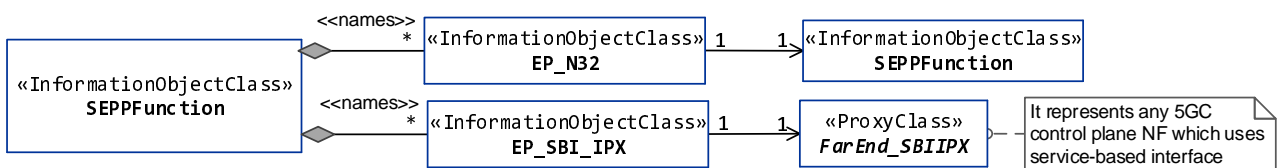

Figure 5.2.1.1-17: Transport view of SEPP NRM

5.2.1.2 Inheritance

This clause depicts the inheritance relationships that exist between IOCs.

Figure 5.2.1.2-1 shows the inheritance hierarchy from IOC ManagedFunction related to the 5GC NF NRM.

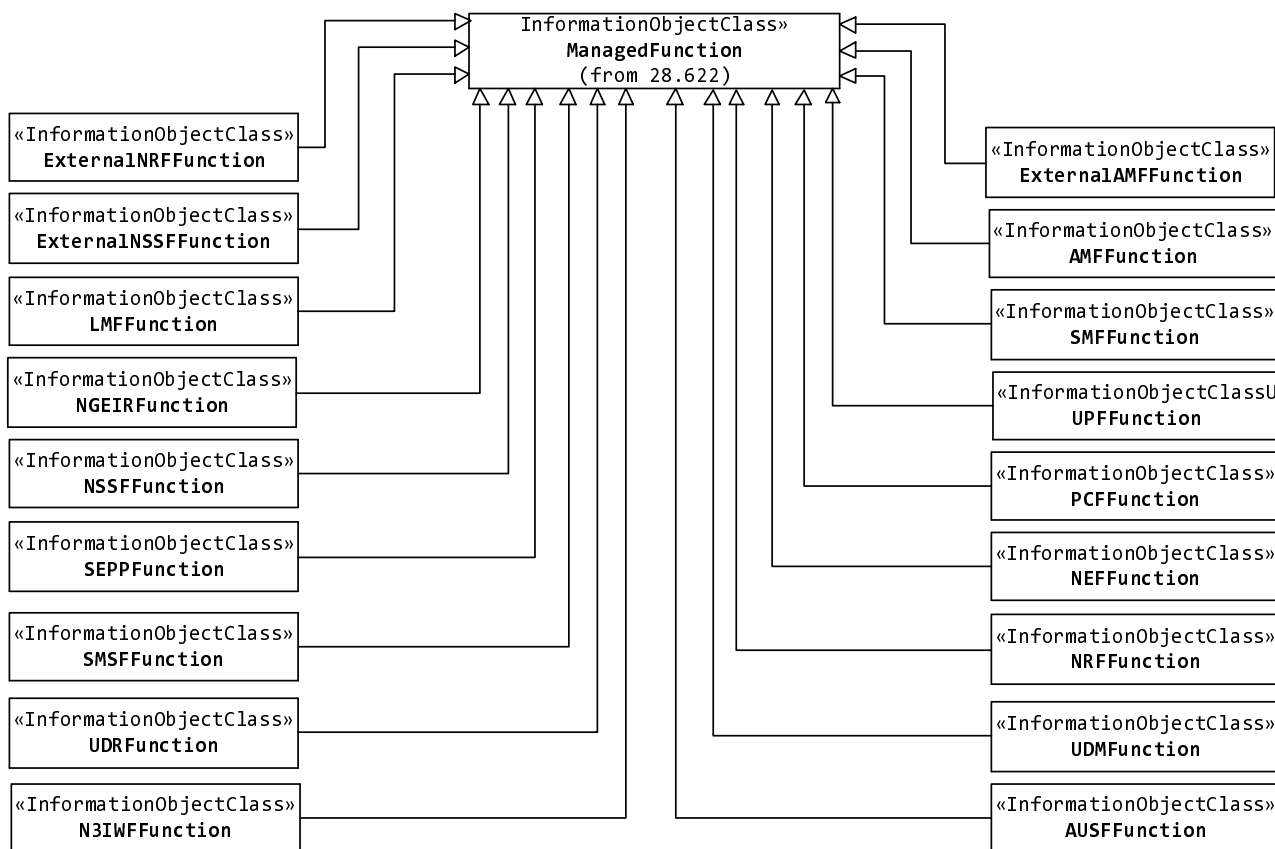

Figure 5.2.1.2-1: Inheritance hierarchy from IOC ManagedFunction related to the 5GC NF NRM

Figure 5.2.1.2-2 shows the inheritance hierarchy from IOC EP_RP related to 5GC NF NRM.

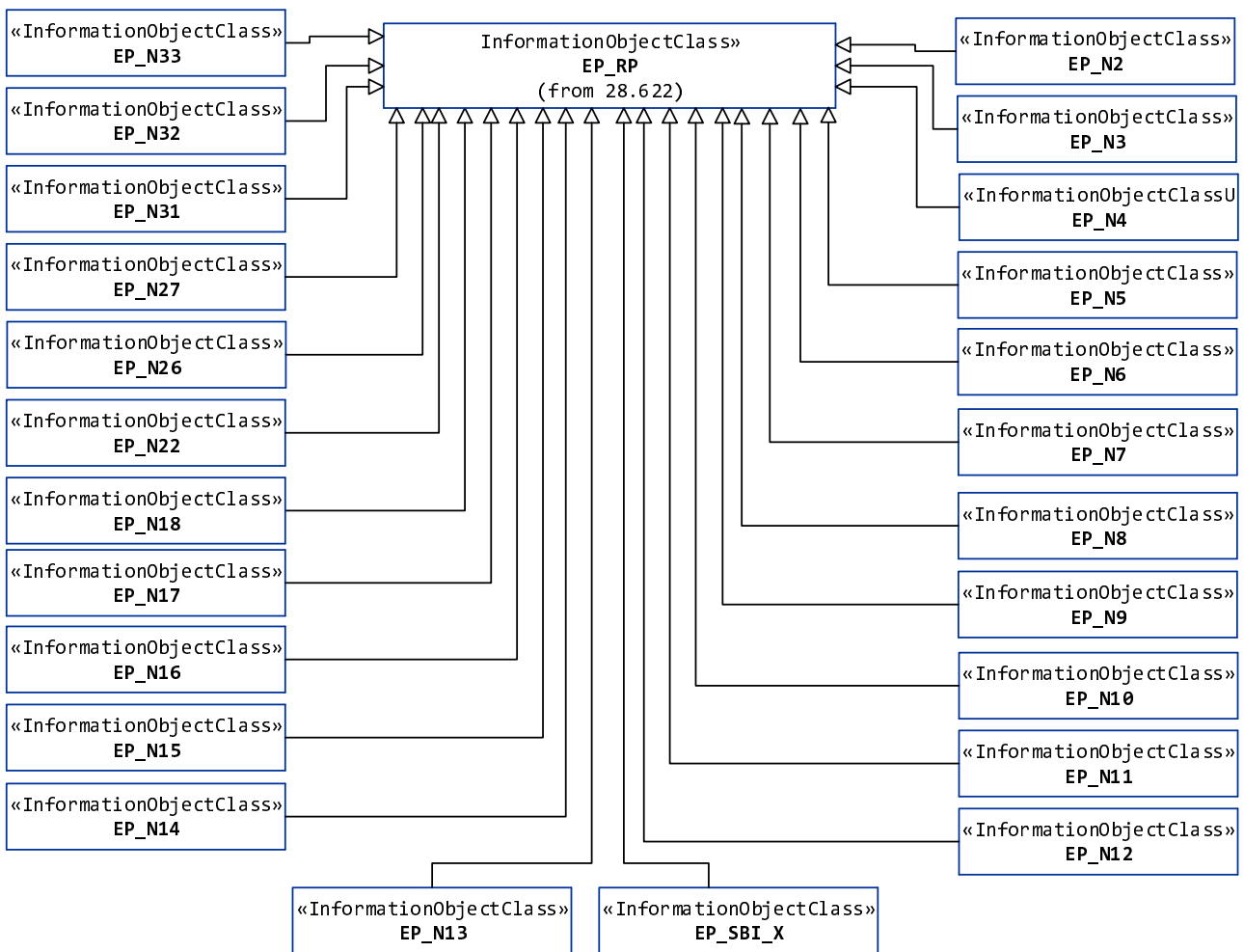

Figure 5.2.1.2-2: Inheritance hierarchy from IOC EP_RP related to the 5GC NF NRM

5.2.2 Class diagram of AMF Region/AMF Set

5.2.2.1 Relationships

This clause depicts the set of classes (e.g. IOCs) that encapsulates the information relevant for NRM of AMF Region/AMF Set definitions. This clause provides the overview of the relationships of relevant classes in UML. Subsequent clauses provide more detailed specification of various aspects of these classes.

The Figure 5.2.2.1-1 shows the AMF Region/AMF Set NRM containment/naming relationship.

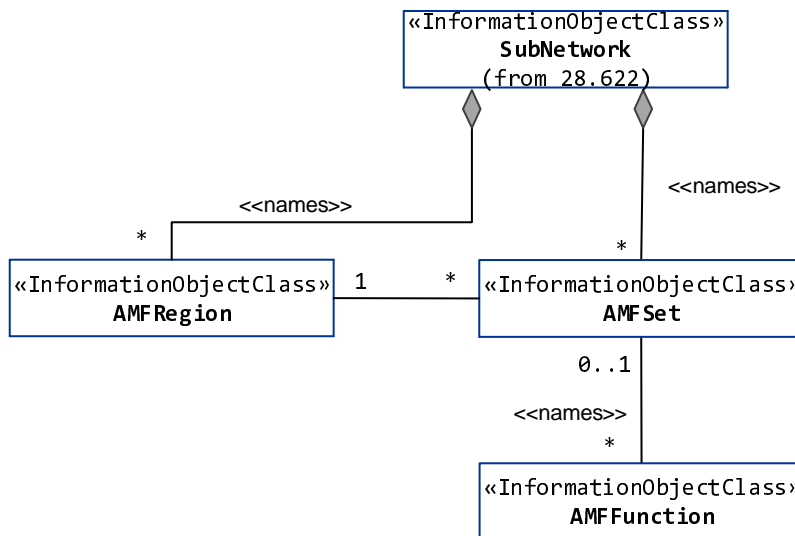

Figure 5.2.2.1-1: AMF Region/AMF Set NRM

5.2.2.2 Inheritance

This clause depicts the inheritance relationships that exist between IOCs.

Figure 5.2.2.2-1 shows the inheritance hierarchy from IOC ManagedFunction related to the AMF Region/AMF Set NRM.

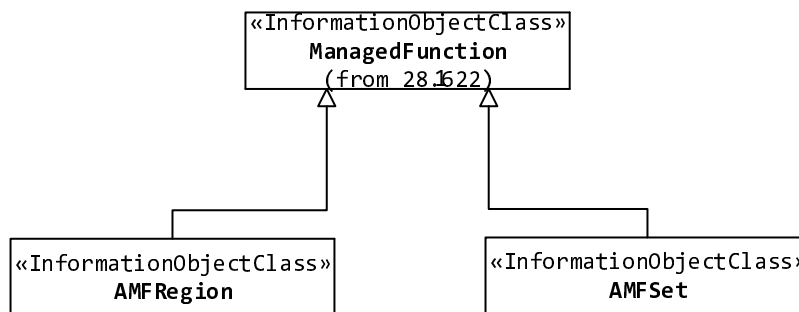

Figure 5.2.2.2-1: AMF Region/AMF Set Inheritance

5.3 Class definitions

5.3.1 AMFFunction

5.3.1.1 Definition

This IOC represents the AMF functionality in 5GC. For more information about the AMF, see 3GPP TS 23.501 [2].

5.3.1.2 Attributes

The AMFFunction IOC includes attributes inherited from ManagedFunction IOC (defined in TS 28.622[30]) and the following attributes:

Attribute name	Support Qualifier	isReadable	isWritable	isInvariant	isNotifiable
pLMNidList	M	T	T	F	T
aMFIIdentifier	M	T	T	F	T
sBIFQDN	M	T	T	F	T
sBIServiceList	M	T	F	F	T
weightFactor	M	T	T	F	T
sNSSAIList	CM	T	F	F	T

5.3.1.3 Attribute constraints

Name	Definition
sNSSAIList Support Qualifier	Condition: Network slicing feature is supported.

5.3.1.4 Notifications

The common notifications defined in subclause 5.5 are valid for this IOC, without exceptions or additions.

5.3.2 SMFFunction

5.3.2.1 Definition

This IOC represents the SMF function in 5GC. For more information about the SMF, see 3GPP TS 23.501 [2].

5.3.2.2 Attributes

The SMFFunction IOC includes attributes inherited from ManagedFunction IOC (defined in TS 28.622[30]) and the following attributes:

Attribute name	Support Qualifier	isReadable	isWritable	isInvariant	isNotifiable
pLMNidList	M	T	T	F	T
nRTAClist	M	T	T	F	T
sBIFQDN	M	T	T	F	T
sBIServiceList	M	T	F	F	T
sNSSAIList	CM	T	T	F	T

5.3.2.3 Attribute constraints

Name	Definition
sNSSAIList Support Qualifier	Condition: Network slicing feature is supported.

5.3.2.4 Notifications

The common notifications defined in subclause 5.5 are valid for this IOC, without exceptions or additions.

5.3.3 UPFFunction

5.3.3.1 Definition

This IOC represents the UPF function in 5GC. For more information about the UPF, see 3GPP TS 23.501 [2].

5.3.3.2 Attributes

The UPFFunction IOC includes attributes inherited from ManagedFunction IOC (defined in TS 28.622[30]) and the following attributes:

Attribute name	Support Qualifier	isReadable	isWritable	isInvariant	isNotifiable
pLMNidList	M	T	T	F	T
nRTAClist	M	T	T	F	T
sNSSAList	CM	T	T	F	T

5.3.3.3 Attribute constraints

Name	Definition
sNSSAList CM Support Qualifier	The condition is "network slicing feature is supported".

5.3.3.4 Notifications

The common notifications defined in subclause 5.5 are valid for this IOC, without exceptions or additions.

5.3.4 N3IWFFunction

5.3.4.1 Definition

This IOC represents the N3IWF function which is used to enable non-3GPP access networks connected to the 5GC. For more information about the N3IWF, see 3GPP TS 23.501 [2].

5.3.4.2 Attributes

The N3IWFFunction IOC includes attributes inherited from ManagedFunction IOC (defined in TS 28.622[30]) and the following attributes:

Attribute name	Support Qualifier	isReadable	isWritable	isInvariant	isNotifiable
pLMNidList	M	T	T	F	T

5.3.4.3 Attribute constraints

None.

5.3.4.4 Notifications

The common notifications defined in subclause 5.5 are valid for this IOC, without exceptions or additions.

5.3.5 PCFFunction

5.3.5.1 Definition

This IOC represents the PCF function in 5GC. For more information about the PCF, see 3GPP TS 23.501 [2].

5.3.5.2 Attributes

The PCFFunction IOC includes attributes inherited from ManagedFunction IOC (defined in TS 28.622[30]) and the following attributes:

Attribute name	Support Qualifier	isReadable	isWritable	isInvariant	isNotifiable
pLMNidList	M	T	T	F	T
sBIFQDN	M	T	T	F	T
sBIServiceList	M	T	F	F	T
sNSSAList	CM	T	T	F	T

5.3.5.3 Attribute constraints

Name	Definition
sNSSAList Support Qualifier	Condition: network slicing feature is supported.

5.3.5.4 Notifications

The common notifications defined in subclause 5.5 are valid for this IOC, without exceptions or additions.

5.3.6 AUSFunction

5.3.6.1 Definition

This IOC represents the AUSF function in 5GC. For more information about the AUSF, see 3GPP TS 23.501 [2].

5.3.6.2 Attributes

The AUSFunction IOC includes attributes inherited from ManagedFunction IOC (defined in TS 28.622[30]) and the following attributes:

Attribute name	Support Qualifier	isReadable	isWritable	isInvariant	isNotifiable
pLMNidList	M	T	T	F	T
sBIFQDN	M	T	T	F	T
sBIServiceList	M	T	F	F	T
sNSSAList	CM	T	T	F	T

5.3.6.3 Attribute constraints

Name	Definition
sNSSAList Support Qualifier	Condition: Network slicing feature is supported.

5.3.6.4 Notifications

The common notifications defined in subclause 5.5 are valid for this IOC, without exceptions or additions.

5.3.7 UDMFunction

5.3.7.1 Definition

This IOC represents the UDM function in 5GC. For more information about the UDM, see 3GPP TS 23.501 [2].

5.3.7.2 Attributes

The UDMFunction IOC includes attributes inherited from ManagedFunction IOC (defined in TS 28.622[30]) and the following attributes:

Attribute name	Support Qualifier	isReadable	isWritable	isInvariant	isNotifiable
pLMNidList	M	T	T	F	T
sBIFQDN	M	T	T	F	T
sBIServiceList	M	T	F	F	T
sNSSAList	CM	T	T	F	T

5.3.5.3 Attribute constraints

Name	Definition
sNSSAList Support Qualifier	Condition: network slicing feature is supported.

5.3.5.4 Notifications

The common notifications defined in subclause 5.5 are valid for this IOC, without exceptions or additions.

5.3.8 UDRFunction

5.3.8.1 Definition

This IOC represents the UDR function in 5GC. For more information about the UDR, see 3GPP TS 23.501 [2].

5.3.8.2 Attributes

The UDRFunction IOC includes attributes inherited from ManagedFunction IOC (defined in TS 28.622[30]) and the following attributes:

Attribute name	Support Qualifier	isReadable	isWritable	isInvariant	isNotifiable
pLMNidList	M	T	T	F	T
sBIFQDN	M	T	T	F	T
sBIServiceList	M	T	F	F	T
sNSSAList	CM	T	T	F	T

5.3.8.3 Attribute constraints

Name	Definition
sNSSAList Support Qualifier	Condition: Network slicing feature is supported.

5.3.8.4 Notifications

The common notifications defined in subclause 5.5 are valid for this IOC, without exceptions or additions.

5.3.9 UDSFFunction

5.3.9.1 Definition

This IOC represents the UDSF function which can be interacted with any other 5GC NF defined in 3GPP TS 23.501 [2]. For more information about the UDSF, see 3GPP TS 23.501 [2].

5.3.9.2 Attributes

The UDSFFunction IOC includes attributes inherited from ManagedFunction IOC (defined in TS 28.622[30]) and the following attributes:

Attribute name	Support Qualifier	isReadable	isWritable	isInvariant	isNotifiable
pLMNIdList	M	T	T	F	T
sBIFQDN	M	T	T	F	T
sBIServiceList	M	T	F	F	T
sNSSAList	CM	T	T	F	T

5.3.9.3 Attribute constraints

Name	Definition
sNSSAList Support Qualifier	Condition: Network slicing feature is supported.

5.3.9.4 Notifications

The common notifications defined in subclause 5.5 are valid for this IOC, without exceptions or additions.

5.3.10 NRFFunction

5.3.10.1 Definition

This IOC represents the NRF function in 5GC. For more information about the NRF, see 3GPP TS 23.501 [2].

5.3.10.2 Attributes

The NRFFunction IOC includes attributes inherited from ManagedFunction IOC (defined in TS 28.622[30]) and the following attributes:

Attribute name	Support Qualifier	isReadable	isWritable	isInvariant	isNotifiable
pLMNIdList	M	T	T	F	T
sBIFQDN	M	T	T	F	T
sNSSAList	CM	T	T	F	T
nfProfileList	CM	T	T	F	T
nSIIdList	O	T	T	F	T

5.3.10.3 Attribute constraints

Name	Definition
sNSSAList Support Qualifier	Condition: network slicing feature is supported.
nfProfileList Support Qualifier	Condition: NF profile is registered and deregistered by management system.
nSIIdList Support Qualifier	Condition: Network slicing feature is supported.

5.3.10.4 Notifications

The common notifications defined in subclause 5.5 are valid for this IOC, without exceptions or additions.

5.3.11 NSSFFunction

5.3.11.1 Definition

This IOC represents the NSSF function in 5GC. For more information about the NSSF, see 3GPP TS 23.501 [2].

5.3.11.2 Attributes

The NSSFFunction IOC includes attributes inherited from ManagedFunction IOC (defined in TS 28.622[30]) and the following attributes:

Attribute name	Support Qualifier	isReadable	isWritable	isInvariant	isNotifiable
pLMNidList	M	T	T	F	T
sBIFQDN	M	T	T	F	T
sNSSAIIList	M	T	T	F	T
nSIIdList	O	T	T	F	T

5.3.11.3 Attribute constraints

None.

5.3.11.4 Notifications

The common notifications defined in subclause 5.5 are valid for this IOC, without exceptions or additions.

5.3.12 AFFunction

5.3.12.1 Definition

This IOC is defined for only purpose to describe the IOCs representing its interaction interface with 5GC (i.e. EP_Rx and EP_N5). It has no any attributes defined.

5.3.13 DNFunction

5.3.13.1 Definition

This IOC is defined for only purpose to describe the IOCs representing Data Network (DN) interaction interface with 5GC (i.e. EP_N6). It has no any attributes defined.

5.3.14 SMSFFunction

5.3.14.1 Definition

This IOC represents the SMSF function defined in 3GPP TS 23.501 [2].

5.3.14.2 Attributes

The SMSFFunction IOC includes attributes inherited from ManagedFunction IOC (defined in TS 28.622[30]) and the following attributes:

Attribute name	Support Qualifier	isReadable	isWritable	isInvariant	isNotifiable
pLMNidList	M	T	T	F	T
sBIFQDN	M	T	T	F	T
sBIServiceList	M	T	F	F	T

5.3.14.3 Attribute constraints

None.

5.3.14.4 Notifications

The common notifications defined in subclause 5.5 are valid for this IOC, without exceptions or additions.

5.3.15 LMFFunction

5.3.15.1 Definition

This IOC represents the LMF function defined in 3GPP TS 23.501 [2].

5.3.15.2 Attributes

The LMFFunction IOC includes attributes inherited from ManagedFunction IOC (defined in TS 28.622[30]) and the following attributes:

Attribute name	Support Qualifier	isReadable	isWritable	isInvariant	isNotifiable
pLMNidList	M	T	T	F	T

5.3.15.3 Attribute constraints

None.

5.3.15.4 Notifications

The common notifications defined in subclause 5.5 are valid for this IOC, without exceptions or additions.

5.3.16 NGEIRFunction

5.3.16.1 Definition

This IOC represents the 5G-EIR function in 5GC. For more information about the 5G-EIR, see 3GPP TS 23.501 [2].

5.3.16.2 Attributes

The NGEIRFunction IOC includes attributes inherited from ManagedFunction IOC (defined in TS 28.622[30]) and the following attributes:

Attribute name	Support Qualifier	isReadable	isWritable	isInvariant	isNotifiable
pLMNidList	M	T	T	F	T
sBIFQDN	M	T	T	F	T
sBIServiceList	M	T	F	F	T
sNSSAList	CM	T	T	F	T

5.3.16.3 Attribute constraints

Name	Definition
sNSSAList Support Qualifier	Condition: network slicing feature is supported.

5.3.16.4 Notifications

The common notifications defined in subclause 5.5 are valid for this IOC, without exceptions or additions.

5.3.17 SEPPFunction

5.3.17.1 Definition

This IOC represents the SEPP function which support message filtering and policing on inter-PLMN control plane interface. For more information about the SEPP, see 3GPP TS 23.501 [2].

5.3.17.2 Attributes

The SEPPFunction IOC includes attributes inherited from ManagedFunction IOC (defined in TS 28.622[30]) and the following attributes:

Attribute name	Support Qualifier	isReadable	isWritable	isInvariant	isNotifiable
pLMNIdList	M	T	T	F	T

5.3.17.3 Attribute constraints

None.

5.3.17.4 Notifications

The common notifications defined in subclause 5.5 are valid for this IOC, without exceptions or additions.

5.3.18 NWDAFFunction

5.3.18.1 Definition

This IOC represents the NWDAF function in 5GC. For more information about the NWDAF, see 3GPP TS 23.501 [2].

5.3.18.2 Attributes

The NWDAFFunction IOC includes attributes inherited from ManagedFunction IOC (defined in TS 28.622[30]) and the following attributes:

Attribute name	Support Qualifier	isReadable	isWritable	isInvariant	isNotifiable
pLMNIdList	M	T	T	F	T
sBIFQDN	M	T	T	F	T
sBIServiceList	M	T	F	F	T
sNSSAList	CM	T	T	F	T

5.3.18.3 Attribute constraints

Name	Definition
sNSSAList Support Qualifier	Condition: Network slicing feature is supported.

5.3.18.4 Notifications

The common notifications defined in subclause 5.5 are valid for this IOC, without exceptions or additions.

5.3.19 EP_N2

5.3.19.1 Definition

This IOC represents the N2 interface between (R)AN and AMF, which is defined in 3GPP TS 23.501 [2].

5.3.19.2 Attributes

The EP_N2 IOC includes attributes inherited from EP_RP IOC (defined in TS 28.622[30]) and the following attributes:

Attribute name	Support Qualifier	isReadable	isWritable	isInvariant	isNotifiable
localAddress	O	T	T	F	T
remoteAddress	O	T	T	F	T

5.3.19.3 Attribute constraints

None.

5.3.19.4 Notifications

The common notifications defined in subclause 5.5 are valid for this IOC, without exceptions or additions.

5.3.20 EP_N3

5.3.20.1 Definition

This IOC represents the N3 interface between (R)AN and UPF, which is defined in 3GPP TS 23.501 [2].

5.3.20.2 Attributes

The EP_N3 IOC includes attributes inherited from EP_RP IOC (defined in TS 28.622[30]) and the following attributes:

Attribute name	Support Qualifier	isReadable	isWritable	isInvariant	isNotifiable
localAddress	O	T	T	F	T
remoteAddress	O	T	T	F	T

5.3.20.3 Attribute constraints

None.

5.3.20.4 Notifications

The common notifications defined in subclause 5.5 are valid for this IOC, without exceptions or additions.

5.3.21 EP_N4

5.3.21.1 Definition

This IOC represents the N4 interface between SMF and UPF, which is defined in 3GPP TS 23.501 [2].

5.3.21.2 Attributes

The EP_N4 IOC includes attributes inherited from EP_RP IOC (defined in TS 28.622[30]) and the following attributes:

Attribute name	Support Qualifier	isReadable	isWritable	isInvariant	isNotifiable
localAddress	O	T	T	F	T
remoteAddress	O	T	T	F	T

5.3.21.3 Attribute constraints

None.

5.3.21.4 Notifications

The common notifications defined in subclause 5.5 are valid for this IOC, without exceptions or additions.

5.3.22 EP_N5

5.3.22.1 Definition

This IOC represents the N5 interface between PCF and AF, which is defined in 3GPP TS 23.501 [2].

5.3.22.2 Attributes

The EP_N5 IOC includes attributes inherited from EP_RP IOC (defined in TS 28.622[30]) and the following attributes:

Attribute name	Support Qualifier	isReadable	isWritable	isInvariant	isNotifiable
localAddress	O	T	T	F	T
remoteAddress	O	T	T	F	T

5.3.22.3 Attribute constraints

None.

5.3.22.4 Notifications

The common notifications defined in subclause 5.5 are valid for this IOC, without exceptions or additions.

5.3.23 EP_N6

5.3.23.1 Definition

This IOC represents the N6 interface between UPF and DN, which is defined in 3GPP TS 23.501 [2].

5.3.23.2 Attributes

The EP_N6 IOC includes attributes inherited from EP_RP IOC (defined in TS 28.622[30]) and the following attributes:

Attribute name	Support Qualifier	isReadable	isWritable	isInvariant	isNotifiable
localAddress	O	T	T	F	T
remoteAddress	O	T	T	F	T

5.3.23.3 Attribute constraints

None.

5.3.23.4 Notifications

The common notifications defined in subclause 5.5 are valid for this IOC, without exceptions or additions.

5.3.24 EP_N7

5.3.24.1 Definition

This IOC represents the N7 interface between SMF and PCF, which is defined in 3GPP TS 23.501 [2].

5.3.24.2 Attributes

The EP_N7 IOC includes attributes inherited from EP_RP IOC (defined in TS 28.622[30]) and the following attributes:

Attribute name	Support Qualifier	isReadable	isWritable	isInvariant	isNotifiable
localAddress	O	T	T	F	T
remoteAddress	O	T	T	F	T

5.3.24.3 Attribute constraints

None.

5.3.24.4 Notifications

The common notifications defined in subclause 5.5 are valid for this IOC, without exceptions or additions.

5.3.25 EP_N8

5.3.25.1 Definition

This IOC represents the N8 interface between AMF and UDM, which is defined in 3GPP TS 23.501 [2].

5.3.25.2 Attributes

The EP_N8 IOC includes attributes inherited from EP_RP IOC (defined in TS 28.622[30]) and the following attributes:

Attribute name	Support Qualifier	isReadable	isWritable	isInvariant	isNotifiable
localAddress	O	T	T	F	T
remoteAddress	O	T	T	F	T

5.3.25.3 Attribute constraints

None.

5.3.25.4 Notifications

The common notifications defined in subclause 5.5 are valid for this IOC, without exceptions or additions.

5.3.26 EP_N9

5.3.26.1 Definition

This IOC represents the N7 interface between two UPFs, which is defined in 3GPP TS 23.501 [2].

5.3.26.2 Attributes

The EP_N9 IOC includes attributes inherited from EP_RP IOC (defined in TS 28.622[30]) and the following attributes:

Attribute name	Support Qualifier	isReadable	isWritable	isInvariant	isNotifiable
localAddress	O	T	T	F	T
remoteAddress	O	T	T	F	T

5.3.26.3 Attribute constraints

None.

5.3.26.4 Notifications

The common notifications defined in subclause 5.5 are valid for this IOC, without exceptions or additions.

5.3.27 EP_N10

5.3.27.1 Definition

This IOC represents the N10 interface between SMF and UDM, which is defined in 3GPP TS 23.501 [2].

5.3.27.2 Attributes

The EP_N10 IOC includes attributes inherited from EP_RP IOC (defined in TS 28.622[30]) and the following attributes:

Attribute name	Support Qualifier	isReadable	isWritable	isInvariant	isNotifiable
localAddress	O	T	T	F	T
remoteAddress	O	T	T	F	T

5.3.27.3 Attribute constraints

None.

5.3.27.4 Notifications

The common notifications defined in subclause 5.5 are valid for this IOC, without exceptions or additions.

5.3.28 EP_N11

5.3.28.1 Definition

This IOC represents the N11 interface between AMF and SMF, which is defined in 3GPP TS 23.501 [2].

5.3.28.2 Attributes

The EP_N11 IOC includes attributes inherited from EP_RP IOC (defined in TS 28.622[30]) and the following attributes:

Attribute name	Support Qualifier	isReadable	isWritable	isInvariant	isNotifiable
localAddress	O	T	T	F	T
remoteAddress	O	T	T	F	T

5.3.28.3 Attribute constraints

None.

5.3.28.4 Notifications

The common notifications defined in subclause 5.5 are valid for this IOC, without exceptions or additions.

5.3.29 EP_N12

5.3.29.1 Definition

This IOC represents the N12 interface between AMF and AUSF, which is defined in 3GPP TS 23.501 [2].

5.3.29.2 Attributes

The EP_N12 IOC includes attributes inherited from EP_RP IOC (defined in TS 28.622[30]) and the following attributes:

Attribute name	Support Qualifier	isReadable	isWritable	isInvariant	isNotifiable
localAddress	O	T	T	F	T
remoteAddress	O	T	T	F	T

5.3.29.3 Attribute constraints

None.

5.3.29.4 Notifications

The common notifications defined in subclause 5.5 are valid for this IOC, without exceptions or additions.

5.3.30 EP_N13

5.3.30.1 Definition

This IOC represents the N13 interface between AUSF and UDM, which is defined in 3GPP TS 23.501 [2].

5.3.30.2 Attributes

The EP_N13 IOC includes attributes inherited from EP_RP IOC (defined in TS 28.622[30]) and the following attributes:

Attribute name	Support Qualifier	isReadable	isWritable	isInvariant	isNotifiable
localAddress	O	T	T	F	T
remoteAddress	O	T	T	F	T

5.3.30.3 Attribute constraints

None.

5.3.30.4 Notifications

The common notifications defined in subclause 5.5 are valid for this IOC, without exceptions or additions.

5.3.31 EP_N14

5.3.31.1 Definition

This IOC represents the N14 interface between two AMFs, which is defined in 3GPP TS 23.501 [2].

5.3.31.2 Attributes

The EP_N14 IOC includes attributes inherited from EP_RP IOC (defined in TS 28.622[30]) and the following attributes:

Attribute name	Support Qualifier	isReadable	isWritable	isInvariant	isNotifiable
localAddress	O	T	T	F	T
remoteAddress	O	T	T	F	T

5.3.31.3 Attribute constraints

None.

5.3.31.4 Notifications

The common notifications defined in subclause 5.5 are valid for this IOC, without exceptions or additions.

5.3.32 EP_N15

5.3.32.1 Definition

This IOC represents the N15 interface between AMF and PCF, which is defined in 3GPP TS 23.501 [2].

5.3.32.2 Attributes

The EP_N15 IOC includes attributes inherited from EP_RP IOC (defined in TS 28.622[30]) and the following attributes:

Attribute name	Support Qualifier	isReadable	isWritable	isInvariant	isNotifiable
localAddress	O	T	T	F	T
remoteAddress	O	T	T	F	T

5.3.32.3 Attribute constraints

None.

5.3.32.4 Notifications

The common notifications defined in subclause 5.5 are valid for this IOC, without exceptions or additions.

5.3.33 EP_N16

5.3.33.1 Definition

This IOC represents the N16 interface between two SMFs, which is defined in 3GPP TS 23.501 [2].

5.3.33.2 Attributes

The EP_N16 IOC includes attributes inherited from EP_RP IOC (defined in TS 28.622[30]) and the following attributes:

Attribute name	Support Qualifier	isReadable	isWritable	isInvariant	isNotifiable
localAddress	O	T	T	F	T
remoteAddress	O	T	T	F	T

5.3.33.3 Attribute constraints

None.

5.3.33.4 Notifications

The common notifications defined in subclause 5.5 are valid for this IOC, without exceptions or additions.

5.3.34 EP_N17

5.3.34.1 Definition

This IOC represents the N17 interface between AMF and 5G-EIR, which is defined in 3GPP TS 23.501 [2].

5.3.34.2 Attributes

The EP_N17 IOC includes attributes inherited from EP_RP IOC (defined in TS 28.622[30]) and the following attributes:

Attribute name	Support Qualifier	isReadable	isWritable	isInvariant	isNotifiable
localAddress	O	T	T	F	T
remoteAddress	O	T	T	F	T

5.3.34.3 Attribute constraints

None.

5.3.34.4 Notifications

The common notifications defined in subclause 5.5 are valid for this IOC, without exceptions or additions.

5.3.35 EP_N20

5.3.35.1 Definition

This IOC represents the N20 interface between AMF and SMSF, which is defined in 3GPP TS 23.501 [2].

5.3.35.2 Attributes

The EP_N20 IOC includes attributes inherited from EP_RP IOC (defined in TS 28.622[30]) and the following attributes:

Attribute name	Support Qualifier	isReadable	isWritable	isInvariant	isNotifiable
localAddress	O	T	T	F	T
remoteAddress	O	T	T	F	T

5.3.35.3 Attribute constraints

None.

5.3.35.4 Notifications

The common notifications defined in subclause 5.5 are valid for this IOC, without exceptions or additions.

5.3.36 EP_N21

5.3.36.1 Definition

This IOC represents the N21 interface between SMSF and UDM, which is defined in 3GPP TS 23.501 [2].

5.3.36.2 Attributes

The EP_N21 IOC includes attributes inherited from EP_RP IOC (defined in TS 28.622[30]) and the following attributes:

Attribute name	Support Qualifier	isReadable	isWritable	isInvariant	isNotifiable
localAddress	O	T	T	F	T
remoteAddress	O	T	T	F	T

5.3.36.3 Attribute constraints

None.

5.3.36.4 Notifications

The common notifications defined in subclause 5.5 are valid for this IOC, without exceptions or additions.

5.3.37 EP_N22

5.3.37.1 Definition

This IOC represents the N22 interface between AMF and NSSF, which is defined in 3GPP TS 23.501 [2].

5.3.37.2 Attributes

The EP_N22 IOC includes attributes inherited from EP_RP IOC (defined in TS 28.622[30]) and the following attributes:

Attribute name	Support Qualifier	isReadable	isWritable	isInvariant	isNotifiable
localAddress	O	T	T	F	T
remoteAddress	O	T	T	F	T

5.3.37.3 Attribute constraints

None.

5.3.37.4 Notifications

The common notifications defined in subclause 5.5 are valid for this IOC, without exceptions or additions.

5.3.38 EP_N26

5.3.38.1 Definition

This IOC represents the N26 interface between AMF and MME, which is defined in 3GPP TS 23.501 [2].

5.3.38.2 Attributes

The EP_N26 IOC includes attributes inherited from EP_RP IOC (defined in TS 28.622[30]) and the following attributes:

Attribute name	Support Qualifier	isReadable	isWritable	isInvariant	isNotifiable
localAddress	O	T	T	F	T
remoteAddress	O	T	T	F	T

5.3.38.3 Attribute constraints

None.

5.3.38.4 Notifications

The common notifications defined in subclause 5.5 are valid for this IOC, without exceptions or additions.

5.3.39 EP_SBI_X

5.3.39.1 Definition

This IOC represents the service-based interfaces from any 5GC NF towards UDSF, UDR, NEF, NRF and NWDAF, as these NFs can be interacted with any other 5GC NF, see detail in 3GPP TS 23.501 [2].

5.3.39.2 Attributes

The EP_SBI_X IOC includes attributes inherited from EP_RP IOC (defined in TS 28.622[30]) and the following attributes:

Attribute name	Support Qualifier	isReadable	isWritable	isInvariant	isNotifiable
localAddress	O	T	T	F	T
remoteAddress	O	T	T	F	T
sBIserviceList	O	T	T	F	T

5.3.39.3 Attribute constraints

None.

5.3.39.4 Notifications

The common notifications defined in subclause 5.5 are valid for this IOC, without exceptions or additions.

5.3.40 EP_SBI_IPX

5.3.40.1 Definition

This IOC represents the inter-connection interface from any 5GC control plane NF to SEPP, see detail in 3GPP TS 23.501 [2].

5.3.40.2 Attributes

The EP_SBI_IPX IOC includes attributes inherited from EP_RP IOC (defined in TS 28.622[30]) and the following attributes:

Attribute name	Support Qualifier	isReadable	isWritable	isInvariant	isNotifyable
localAddress	O	T	T	F	T
remoteAddress	O	T	T	F	T
sBIserviceList	O	T	T	F	T

5.3.40.3 Attribute constraints

None.

5.3.40.4 Notifications

The common notifications defined in subclause 5.5 are valid for this IOC, without exceptions or additions.

5.3.41 EP_S5C

5.3.41.1 Definition

This IOC represents the S5-C interface between SGW and SMF/PGW-C, which is defined in 3GPP TS 23.501 [2].

5.3.41.2 Attributes

The EP_S5C IOC includes attributes inherited from EP_RP IOC (defined in TS 28.622[30]) and the following attributes:

Attribute name	Support Qualifier	isReadable	isWritable	isInvariant	isNotifyable
localAddress	O	T	T	F	T
remoteAddress	O	T	T	F	T

5.3.41.3 Attribute constraints

None.

5.3.41.4 Notifications

The common notifications defined in subclause 5.5 are valid for this IOC, without exceptions or additions.

5.3.42 EP_S5U

5.3.42.1 Definition

This IOC represents the S5-U interface between SGW and UPF/PGW-U, which is defined in 3GPP TS 23.501 [2].

5.3.42.2 Attributes

The EP_S5U IOC includes attributes inherited from EP_RP IOC (defined in TS 28.622[30]) and the following attributes:

Attribute name	Support Qualifier	isReadable	isWritable	isInvariant	isNotifiable
localAddress	O	T	T	F	T
remoteAddress	O	T	T	F	T

5.3.42.3 Attribute constraints

None.

5.3.42.4 Notifications

The common notifications defined in subclause 5.5 are valid for this IOC, without exceptions or additions.

5.3.43 EP_Rx

5.3.43.1 Definition

This IOC represents the Rx interface between PCF and AF, which is defined in 3GPP TS 23.501 [2].

5.3.43.2 Attributes

The EP_Rx IOC includes attributes inherited from EP_RP IOC (defined in TS 28.622[30]) and the following attributes:

Attribute name	Support Qualifier	isReadable	isWritable	isInvariant	isNotifiable
localAddress	O	T	T	F	T
remoteAddress	O	T	T	F	T

5.3.43.3 Attribute constraints

None.

5.3.43.4 Notifications

The common notifications defined in subclause 5.5 are valid for this IOC, without exceptions or additions.

5.3.44 EP_MAP_SMSC

5.3.44.1 Definition

This IOC represents the MAP interface between SMSF and MSC-IWMSC/GMSC, which is defined in 3GPP TS 23.040 [22].

5.3.44.2 Attributes

The EP_MAP_SMSC IOC includes attributes inherited from EP_RP IOC (defined in TS 28.622[30]) and the following attributes:

Attribute name	Support Qualifier	isReadable	isWritable	isInvariant	isNotifiable
localAddress	O	T	T	F	T
remoteAddress	O	T	T	F	T

5.3.44.3 Attribute constraints

None.

5.3.44.4 Notifications

The common notifications defined in subclause 5.5 are valid for this IOC, without exceptions or additions.

5.3.45 EP_NLS

5.3.45.1 Definition

This IOC represents the NLS interface between AMF and LMF, which is defined in 3GPP TS 23.501 [2].

5.3.45.2 Attributes

The EP_NLS IOC includes attributes inherited from EP_RP IOC (defined in TS 28.622[30]) and the following attributes:

Attribute name	Support Qualifier	isReadable	isWritable	isInvariant	isNotifiable
localAddress	O	T	T	F	T
remoteAddress	O	T	T	F	T

5.3.45.3 Attribute constraints

None.

5.3.45.4 Notifications

The common notifications defined in subclause 5.5 are valid for this IOC, without exceptions or additions.

5.3.46 EP_NLG

5.3.46.1 Definition

This IOC represents the NLg interface between AMF and GMLC, which is defined in 3GPP TS 23.501 [2].

5.3.46.2 Attributes

The EP_NLG IOC includes attributes inherited from EP_RP IOC (defined in TS 28.622[30]) and the following attributes:

Attribute name	Support Qualifier	isReadable	isWritable	isInvariant	isNotifiable
localAddress	O	T	T	F	T
remoteAddress	O	T	T	F	T

5.3.46.3 Attribute constraints

None.

5.3.46.4 Notifications

The common notifications defined in subclause 5.5 are valid for this IOC, without exceptions or additions.

5.3.47 EP_N27

5.3.47.1 Definition

This IOC represents an end point of N27 interface between vNRF and hNRF, which is defined in 3GPP TS 29.510 [10].

5.3.47.2 Attributes

The EP_N27 IOC includes attributes inherited from EP_RP IOC (defined in TS 28.622[30]) and the following attributes:

Attribute name	Support Qualifier	isReadable	isWritable	isInvariant	isNotifyable
localAddress	O	T	T	F	T
remoteAddress	O	T	T	F	T

5.3.47.3 Attribute constraints

None.

5.3.47.4 Notifications

The common notifications defined in subclause 5.5 are valid for this IOC, without exceptions or additions.

5.3.48 EP_N31

5.3.48.1 Definition

This IOC represents an end point of N31 interface between vNSSF and hNSSF, which is defined in 3GPP TS 29.531 [11].

5.3.48.2 Attributes

The EP_N31 IOC includes attributes inherited from EP_RP IOC (defined in TS 28.622[30]) and the following attributes:

Attribute name	Support Qualifier	isReadable	isWritable	isInvariant	isNotifyable
localAddress	O	T	T	F	T
remoteAddress	O	T	T	F	T

5.3.48.3 Attribute constraints

None.

5.3.48.4 Notifications

The common notifications defined in subclause 5.5 are valid for this IOC, without exceptions or additions.

5.3.49 ExternalNRFFunction

5.3.49.1 Definition

This IOC represents external NRF function controlled by another management domain. For more information about the NRF, see 3GPP TS 23.501 [2].

5.3.49.2 Attributes

The ExternalNRFFunction IOC includes attributes inherited from ManagedFunction IOC (defined in TS 28.622[30]) and the following attributes:

Attribute name	Support Qualifier	isReadable	isWritable	isInvariant	isNotifiable
id	M	T	F	F	T
pLMNidList	M	T	T	F	T

5.3.49.3 Attribute constraints

None.

5.3.49.4 Notifications

The common notifications defined in subclause 5.5 are valid for this IOC, without exceptions or additions.

5.3.50 ExternalNSSFFunction

5.3.50.1 Definition

This IOC represents external NSSF function controlled by another management domain. For more information about the NSSF, see 3GPP TS 23.501 [2].

5.3.50.2 Attributes

The ExternalNSSFFunction IOC includes attributes inherited from ManagedFunction IOC (defined in TS 28.622[30]) and the following attributes:

Attribute name	Support Qualifier	isReadable	isWritable	isInvariant	isNotifiable
id	M	T	F	F	T
pLMNidList	M	T	T	F	T

5.3.50.3 Attribute constraints

None.

5.3.50.4 Notifications

The common notifications defined in subclause 5.5 are valid for this IOC, without exceptions or additions.

5.3.51 AMFSet

5.3.51.1 Definition

This IOC represents the AMF Set which consists of some AMFs that serve a given area and Network Slice. For more information about the AMF Set, see 3GPP TS 23.501 [2].

5.3.51.2 Attributes

The AMFSet IOC includes attributes inherited from ManagedFunction IOC (defined in TS 28.622[30]) and the following attributes:

Attribute name	Support Qualifier	isReadable	isWritable	isInvariant	isNotifiable
pLMNidList	M	T	T	F	T
nRTAClist	M	T	T	F	T
aMFSetId	M	T	T	F	T
sNSSAIList	CM	T	T	F	T
Attribute related to role					
aMFRegion	M	T	T	F	T
aMFSetMemberList	M	T	T	F	T

5.3.51.3 Attribute constraints

Name	Definition
sNSSAIList Support Qualifier	Condition: Network slicing feature is supported.

5.3.51.4 Notifications

The common notifications defined in subclause 5.5 are valid for this IOC, without exceptions or additions.

5.3.52 AMFRegion

5.3.52.1 Definition

This IOC represents the AMF Region which consists one or multiple AMF Sets. For more information about the AMF Region, see 3GPP TS 23.501 [2].

5.3.52.2 Attributes

The AMFRegion IOC includes attributes inherited from ManagedFunction IOC (defined in TS 28.622[30]) and the following attributes:

Attribute name	Support Qualifier	isReadable	isWritable	isInvariant	isNotifiable
pLMNidList	M	T	T	F	T
nRTAClist	M	T	T	F	T
aMFRegionId	M	T	T	F	T
sNSSAIList	CM	T	T	F	T
Attribute related to role					
aMFSet	M	T	T	F	T

5.3.52.3 Attribute constraints

Name	Definition
sNSSAIList Support Qualifier	Condition: Network slicing feature is supported.

5.3.52.4 Notifications

The common notifications defined in subclause 5.5 are valid for this IOC, without exceptions or additions.

5.3.53 ExternalAMFFunction

5.3.53.1 Definition

This IOC represents an external AMF functionality used in EN-DC. For more information about the AMF, see 3GPP TS 23.501 [2].

5.3.53.2 Attributes

The ExternalAMFFunction IOC includes attributes inherited from ManagedFunction IOC (defined in TS 28.622[30]) and the following attributes:

Attribute name	Support Qualifier	isReadable	isWritable	isInvariant	isNotifyable
Id	M	T	F	F	T
pLMNidList	M	T	T	F	T
aMFIdentifier	M	T	T	F	T

5.3.53.3 Attribute constraints

None.

5.3.53.4 Notifications

The common notifications defined in subclause 5.5 are valid for this IOC, without exceptions or additions.

5.4 Attribute definitions

5.4.1 Attribute properties

The following table defines the attributes that are present in several Information Object Classes (IOCs) of the present document.

Attribute Name	Documentation and Allowed Values	Properties
amfIdentifier	The AMFI is constructed from an AMF Region ID, an AMF Set ID and an AMF Pointer. The AMF Region ID identifies the region, the AMF Set ID uniquely identifies the AMF Set within the AMF Region, and the AMF Pointer uniquely identifies the AMF within the AMF Set. (Ref. 3GPP TS 23.003 [13])	type: Integer multiplicity: 1 isOrdered: N/A isUnique: N/A defaultValue: None allowedValues: N/A isNullable: False
amfSetId	It represents the AMF Set ID, which is uniquely identifies the AMF Set within the AMF Region. allowedValues: defined in subclause 2.10.1 of 3GPP TS 23.003 [13].	type: Integer multiplicity: 1 isOrdered: N/A isUnique: N/A defaultValue: None allowedValues: N/A isNullable: False
amfSetMemberList	It is the list of DNS of AMFFunction instances of the AMFSet. allowedValues: N/A	type: DN multiplicity: 1 isOrdered: N/A isUnique: True defaultValue: None isNullable: False
amfRegionId	It represents the AMF Region ID, which identifies the region. allowedValues: defined in subclause 2.10.1 of 3GPP TS 23.003 [13].	type: Integer multiplicity: 1 isOrdered: N/A isUnique: N/A defaultValue: None allowedValues: N/A isNullable: False
localAddress	This parameter specifies the localAddress including IP address and VLAN ID used for initialization of the underlying transport. First string is IP address, IP address can be an IPv4 address (See RFC 791 [37]) or an IPv6 address (See RFC 2373 [38]). Second string is VLAN Id (See IEEE 802.1Q [39]).	type: String multiplicity: 2 isOrdered: True isUnique: N/A defaultValue: None isNullable: False
remoteAddress	Remote address including IP address used for initialization of the underlying transport. IP address can be an IPv4 address (See RFC 791 [37]) or an IPv6 address (See RFC 2373 [38]).	type: String multiplicity: 1 isOrdered: N/A isUnique: N/A defaultValue: None isNullable: False
nfProfileList	It is a set of NFProfile(s) to be registered in the NRF instance. NFProfile is defined in 3GPP TS 29.510 [23].	type: <<dataType>> multiplicity: * isOrdered: N/A isUnique: N/A defaultValue: None allowedValues: N/A isNullable: False
nSIIdList	It is a set of NSI Id. The NSI ID is defined in subclause 6.1.6.3.2 of 3GPP TS 29.531 [24].	type: String multiplicity: * isOrdered: N/A isUnique: N/A defaultValue: None allowedValues: N/A isNullable: False
sNSSAList	See subclause 4.4.1.	

sBIFQDN	It is used to indicate the FQDN of the registered NF instance in service-based interface, for example, NF instance FQDN structure is: nftype<nfnum>.slicetype<sliceid>.mnc<MNC>.mcc<MCC>.3gppnetwork.org	type: String multiplicity: 1 isOrdered: N/A isUnique: N/A defaultValue: None allowedValues: N/A isNullable: False
sBIServiceList	It is used to indicate the all supported NF services registered on service-based interface.	type: String multiplicity: * isOrdered: N/A isUnique: N/A defaultValue: None allowedValues: N/A isNullable: False
nRTACLlist	It is the list of Tracking Area Code (either legacy TAC or extended TAC) where the represented management function serving. allowedValues: Legacy TAC and Extended TAC are defined in clause 9.3.3.10 of TS 38.413 [5].	type: Integer multiplicity: 1..* isOrdered: N/A isUnique: N/A defaultValue: None allowedValues: N/A isNullable: False
weightFactor	The weight factor is typically set according to the capacity of local node (AMF) relative to other nodes in the same type. And it is used to achieve load balancing among a set of same type of network functions. (Ref. 3GPP TS 23.501 [2])	type: Integer multiplicity: 1 isOrdered: N/A isUnique: N/A defaultValue: None allowedValues: N/A isNullable: False

5.5 Common notifications

This subclause presents a list of notifications, defined in TS 28.532 [35], that provisioning management service consumer can receive. The notification parameter `objectClass/objectInstance`, defined in TS 28.531 [26], would capture the DN of an instance of an IOC defined in the present document.

Name	Qualifier	Notes
notifyMOIAttributeValueChanges	O	
notifyMOICreation	O	
notifyMOIDeletion	O	

6 Information model definitions for network slice NRM

6.1 Imported information entities and local labels

Label reference	Local label
3GPP TS 28.622 [30], IOC, Top	Top
3GPP TS 28.622 [30], IOC, SubNetwork	SubNetwork
3GPP TS 28.622 [30], IOC, ManagedFunction	ManagedFunction
3GPP TS 28.658 [19], dataType, PLMNid	PLMNid

6.2 Class diagram

6.2.1 Relationships

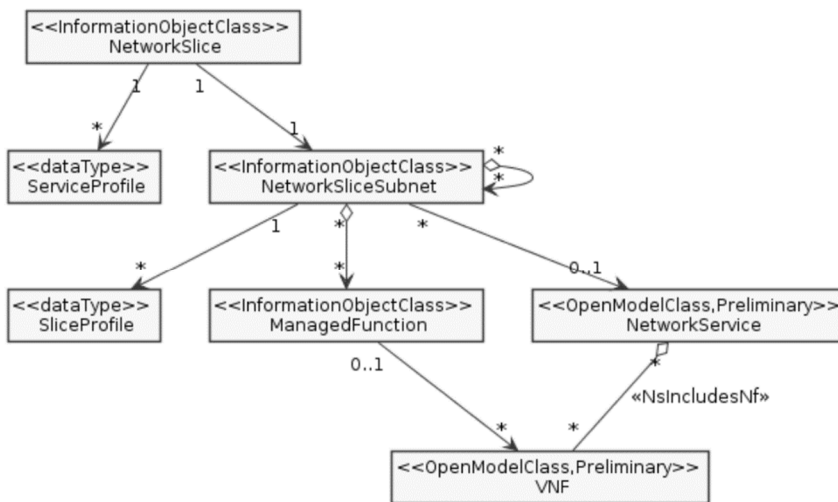

Figure 6.2.1-1: Network slice NRM fragment relationship

NOTE 1: The <<OpenModelClass>> NetworkService and <<OpenModelClass>> VNF are defined in [40].

NOTE 2: The target Network Service (NS) instance represents a group of VNFs and PNFs that are supporting the source network slice subnet instance.

NOTE 3: The instance tree of this NRM fragment would not contain the instances of NetworkService and VNF. However, the NetworkSliceSubNet instances would have an attribute holding the identifiers of NetworkService instances and the ManagedFunction instance would have an attribute holding identifiers of VNF instances.

6.2.2 Inheritance

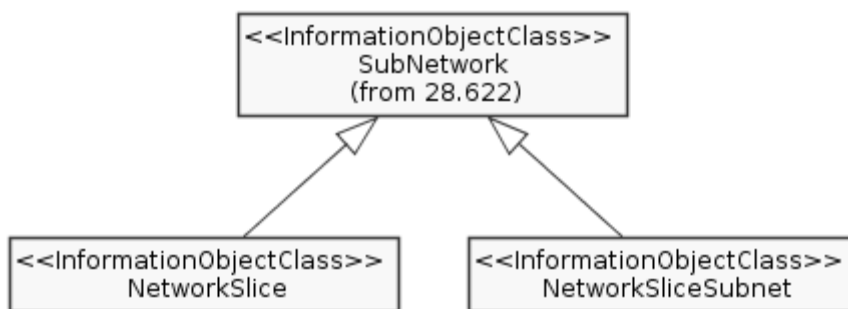

Figure 6.2.2-1: Network slice inheritance relationship

6.3 Class definitions

6.3.1 NetworkSlice

6.3.1.1 Definition

This IOC represents the properties of a network slice instance in a 5G network. For more information about the network slice instance, see 3GPP TS 28.531 [26].

6.3.1.2 Attributes

The NetworkSlice IOC includes attributes inherited from SubNetwork IOC (defined in TS 28.622[30]) and the following attributes:

Attribute name	Support Qualifier	isReadable	isWritable	isInvariant	isNotifyable
operationalState	M	T	F	F	T
administrativeState	M	T	T	F	T
serviceProfileList	M	T	T	F	T
Attribute related to role					
networkSliceSubnetRef	M	T	F	F	T

6.3.1.3 Attribute constraints

None.

6.3.1.4 Notifications

The common notifications defined in subclause 6.5 are valid for this IOC, without exceptions or additions.

6.3.2 NetworkSliceSubnet

6.3.2.1 Definition

This IOC represents the properties of a network slice subnet instance in a 5G network. For more information about the network slice subnet instance, see 3GPP TS 28.531 [26].

6.3.2.2 Attributes

The NetworkSliceSubnet IOC includes attributes inherited from SubNetwork IOC (defined in TS 28.622[30]) and the following attributes:

Attribute name	Support Qualifier	isReadable	isWritable	isInvariant	isNotifiable
operationalState	M	T	F	F	T
administrativeState	M	T	T	F	T
nsInfo	CM	T	F	F	T
sliceProfileList	M	T	T	F	T
Attribute related to role					
managedFunctionRef	M	T	F	F	T
networkSliceSubnetRef	M	T	F	F	T

6.3.2.3 Attribute constraints

Name	Definition
nsInfo Support Qualifier	Condition: It shall be supported if the NSS instance is realized in the virtualized environment. Otherwise this attribute shall be absent.

6.3.2.4 Notifications

The common notifications defined in subclause 6.5 are valid for this IOC, without exceptions or additions.

6.3.3 ServiceProfile

6.3.3.1 Definition

This <<dataType>> represents the properties of network slice related requirement that should be supported by the network slice instance in 5G network.

6.3.3.2 Attributes

Attribute name	Support Qualifier	isReadable	isWritable	isInvariant	isNotifiable
serviceProfileId	M	T	F	T	T
sNSSAList	M	T	T	F	T
pLMNIdList	M	T	T	F	T
perfReq	M	T	T	F	T
maxNumberOfUEs	O	T	T	F	T
coverageAreaTAList	O	T	T	F	T
latency	O	T	T	F	T
uEMobilityLevel	O	T	T	F	T
resourceSharingLevel	O	T	T	F	T
sST	M	T	T	F	T
availability	O	T	T	F	T

6.3.3.3 Attribute constraints

None.

6.3.3.4 Notifications

Not applicable.

6.3.4 SliceProfile

6.3.4.1 Definition

This <<dataType>> represents the properties of network slice subnet related requirement that should be supported by the network slice subnet instance in a 5G network.

6.3.4.2 Attributes

Attribute name	Support Qualifier	isReadable	isWritable	isInvariant	isNotifyable
sliceProfileId	M	T	F	T	T
sNSSAList	M	T	T	F	T
pLMNIdList	M	T	T	F	T
perfReq	M	T	T	F	T
maxNumberOfUEs	O	T	T	F	T
coverageAreaTAList	O	T	T	F	T
latency	O	T	T	F	T
uEMobilityLevel	O	T	T	F	T
resourceSharingLevel	O	T	T	F	T

6.3.4.3 Attribute constraints

None.

6.3.4.4 Notifications

Not applicable

6.4 Attribute definition

6.4.1 Attribute properties

Attribute Name	Documentation and Allowed Values	Properties
availability	This parameter specifies the availability requirement for an network slice instance, expressed as a percentage.	type: Float multiplicity: 1 isOrdered: N/A isUnique: N/A defaultValue: None allowedValues: N/A isNullable: True
serviceProfileId	A unique identifier of property of network slice related requirement should be supported by the network slice instance.	type: String multiplicity: 1 isOrdered: N/A isUnique: N/A defaultValue: None isNullable: True
sliceProfileId	A unique identifier of the property of network slice subnet related requirement should be supported by the network slice subnet instance.	type: String multiplicity: 1 isOrdered: N/A isUnique: N/A defaultValue: None isNullable: True
constituentNSSIIdList	It is a list of DN of MOI(s) for the constituent NSSI associated with the network slice subnet instance.	type: DN multiplicity: * isOrdered: N/A isUnique: N/A defaultValue: None allowedValues: N/A isNullable: False
mFidList	It is a list of DN of the MOI(s) for the NF instances associated with the network slice subnet instance.	type: DN multiplicity: * isOrdered: N/A isUnique: N/A defaultValue: None allowedValues: N/A isNullable: False
operationalState	It indicates the operational state of the network slice instance or the network slice subnet instance. It describes whether or not the resource is physically installed and working. allowedValues: ENABLED, DISABLED. The meaning of these values is as defined in 3GPP TS 28.625 [17] and ITU-T X.731 [18].	type: ENUM multiplicity: 1 isOrdered: N/A isUnique: N/A defaultValue: None allowedValues: N/A isNullable: False
administrativeState	It indicates the administrative state of the network slice instance or the network slice subnet instance. It describes the permission to use or prohibition against using the instance, imposed through the OAM services. allowedValues: LOCKED, UNLOCKED, SHUTTINGDOWN. The meaning of these values is as defined in 3GPP TS 28.625 [17] and ITU-T X.731 [18].	type: ENUM multiplicity: 1 isOrdered: N/A isUnique: N/A defaultValue: LOCKED allowedValues: N/A isNullable: False
nsInfo	This attribute contains the NsInfo of the NS instance corresponding to the network slice subnet instance. The NsInfo is described in clause 8.3.3.2.2 of ETSI GS NFV-IFA 013 [29]. The NsInfo contains: - nsInstancelid. - nsName (optional). - description (optional).	type: <<dataType>> multiplicity: 1 isOrdered: N/A isUnique: True defaultValue: No default value isNullable: True

perfReq	<p>This parameter specifies the requirements to the NSI in terms of the scenarios defined in the TS 22.261 [28], such as Experienced data rate, Area traffic capacity (density) information of UE density.</p> <p>It is a structure containing the following elements:</p> <ul style="list-style-type: none"> - list of perfRequirements <p>Depending on the sST value, the list of perfRequirements will be</p> <ul style="list-style-type: none"> - list of eMBBPerfReq <p>or</p> <ul style="list-style-type: none"> - list of uRLLCPerfReq <p>or</p> <ul style="list-style-type: none"> - list of mIoTPerfReq <p>NOTE: the list of mIoTPerfReq is not addressed in the present document.</p> <p>allowedValues:</p> <ul style="list-style-type: none"> - list of eMBBPerfReq is a list of entries where an entry identifies the performance requirements to the NSI in terms of the scenarios defined in the Table 7.1-1 of TS 22.261 [28]. An entry has the following attributes: expDataRateDL (Integer), expDataRateUL (Integer), areaTrafficCapDL (Integer), areaTrafficCapUL (Integer), userDensity (Integer), activityFactor (Integer), uESpeed (Integer), coverage (String) (see Table 7.1-1 of TS 22.261 [28]). - list of uRLLCPerfReq is a list of entries where an entry identifies the performance requirements to the NSI in terms of the scenarios defined in the Table 7.2.2-1 of TS 22.261 [28]. An entry has the following attributes: e2eLatency (Integer), jitter (Integer), survivalTime (Integer), cSAvailability (Float), reliability (Float), expDataRate (Integer), payloadSize (String), trafficDensity (Integer), connDensity (Integer), serviceAreaDimension (String) (see Table 7.2-1 of TS 22.261 [28]). <p>NOTE: Limitation on attribute values in instances of ServiceProfile is not addressed in the present document.</p>	<p>type: <<dataType>> multiplicity: * isOrdered: N/A isUnique: N/A defaultValue: None allowedValues: N/A isNullable: False</p>
sNSSAIList	<p>This parameter specifies the S-NSSAI list to be supported by the new NSI to be created or the existing NSI to be re-used.</p> <p>sNSSAIList is defined in subclause 4.4.1</p>	
maxNumberOfUEs	<p>An attribute specifies the maximum number of UEs may simultaneously access the network slice instance.</p>	<p>type: Integer multiplicity: 1 isOrdered: N/A isUnique: N/A defaultValue: None allowedValues: N/A isNullable: False</p>
coverageAreaTAList	<p>An attribute specifies a list of <TrackingArea> where the NSI can be selected.</p>	<p>type: <<dataType>> multiplicity: 1..* isOrdered: N/A isUnique: N/A defaultValue: None allowedValues: N/A isNullable: False</p>
latency	<p>An attribute specifies the packet transmission latency (millisecond) through the RAN, CN, and TN part of 5G network and is used to evaluate utilization performance of the end-to-end network slice instance. See clause 6.3.1 of 28.554 [27].</p>	<p>type: Integer multiplicity: 1 isOrdered: N/A isUnique: N/A defaultValue: None allowedValues: N/A isNullable: False</p>

uEMobilityLevel	An attribute specifies the mobility level of UE accessing the network slice instance. See 6.2.1 of TS 22.261 [28]. allowedValues: STATIONARY, NOMADIC, RESTRICTED_MOBILITY, FULLY_MOBILITY	type: ENUM multiplicity: 1 isOrdered: N/A isUnique: N/A defaultValue: None allowedValues: N/A isNullable: True
serviceProfile.resourceSharingLevel	An attribute specifies whether the resources to be allocated to the network slice instance may be shared with another network slice instance(s). allowedValues: SHARED, NON_SHARED.	type: ENUM multiplicity: 1 isOrdered: N/A isUnique: N/A defaultValue: None allowedValues: Yes isNullable: True
sliceProfile.resourceSharingLevel	An attribute specifies whether the resources to be allocated to the network slice subnet instance may be shared with another network slice subnet instance(s). allowedValues: SHARED, NON_SHARED.	type: ENUM multiplicity: 1 isOrdered: N/A isUnique: N/A defaultValue: None allowedValues: Yes isNullable: True
serviceProfileList	An attribute specifies a list of ServiceProfile (see clause 6.3.3) supported by the network slice instance	type: << dataType >> multiplicity: * isOrdered: N/A isUnique: N/A defaultValue: None allowedValues: N/A isNullable: False
sliceProfileList	An attribute specifies a list of SliceProfile (see clause 6.3.4) supported by the network slice subnet instance	type: << dataType >> multiplicity: * isOrdered: N/A isUnique: N/A defaultValue: None allowedValues: N/A isNullable: False
sST	This parameter specifies the slice/service type for a ServiceProfile.. See clause 5.15.2 of 3GPP TS 23.501 [2].	type: Integer multiplicity: 1 isOrdered: N/A isUnique: N/A defaultValue: None allowedValues: N/A isNullable: False
NetworkSlice.networkSliceSubnetRef	This holds a DN of NetworkSliceSubnet relating to the NetworkSlice instance.	type: DN multiplicity: 1 isOrdered: N/A isUnique: N/A defaultValue: None isNullable: False
NetworkSliceSubnet.networkSliceSubnetRef	This holds a list of DN of constituent NetworkSliceSubnet supporting NetworkSliceSubnet instance	type: DN multiplicity: * isOrdered: N/A isUnique: N/A defaultValue: None isNullable: False

managedFunctionRef	This holds a list of DN of ManagedFunction instances supporting the NetworkSliceSubnet instance.	type: DN multiplicity: * isOrdered: N/A isUnique: N/A defaultValue: None allowedValues: N/A isNullable: False
--------------------	--	---

6.5 Common notifications

This subclause presents a list of notifications, defined in [35], that provisioning management service consumer can receive. The notification parameter `objectClass/objectInstance`, defined in [26], would capture the DN of an instance of an IOC defined in the present document.

Name	Qualifier	Notes
notifyMOIAttributeValueChanges	O	
notifyMOICreation	O	
notifyMOIDeletion	O	

7 Solution Set (SS)

The present document defines the following NRM Solution Set definitions for NR and NG-RAN:

- XML based 3GPP NR and NG-RAN NRM Solution Set (Annex C).
- JSON based 3GPP NR and NG-RAN NRM Solution Set (Annex D).
- YANG based 3GPP NR and NG-RAN NRM Solution Set (Annex E).

The present document defines the following NRM Solution Set definitions for 5GC:

- XML based 3GPP 5GC NRM Solution Set (Annex F).
- JSON based 3GPP 5GC NRM Solution Set (Annex G).
- YANG based 3GPP 5GC NRM Solution Set (Annex H).

The present document defines the following NRM Solution Set definitions for network slice and network slice subnet:

- XML based 3GPP Network Slice NRM Solution Set (Annex I).
- JSON based 3GPP Network Slice NRM Solution Set (Annex J).

Annex A (normative): Cell state handling

A.1 Relation between the administrative state and the "Pre-operation state of the gNB-DU Cell"

The administrative state indicates the permission to use or prohibition against using the cell, imposed through the OAM services. The administrative state has three values: "LOCKED", "SHUTTING DOWN" or "UNLOCKED"

The meanings of these values are defined in ITU-T Recommendation X.731 [18].

The relation between the administrative state and the "Pre-operation state of the gNB-DU Cell" is defined in subclause 8.5 of TS 38.401 [4]. See below an extract from subclause 8.5 of TS 38.401 [4] on the F1 startup and cell activation.

If the `operationalState` is "ENABLED" (i.e. the resource is physically installed and working) and if the `administrativeState` is "UNLOCKED", the step "0: Pre-operational state" will exit and the step "1: F1 Setup Request" will be executed."

8.5 F1 Startup and cells activation

This function allows to setup the F1 interface between a gNB-DU and a gNB-CU and it allows to activate the gNB-DU cells.

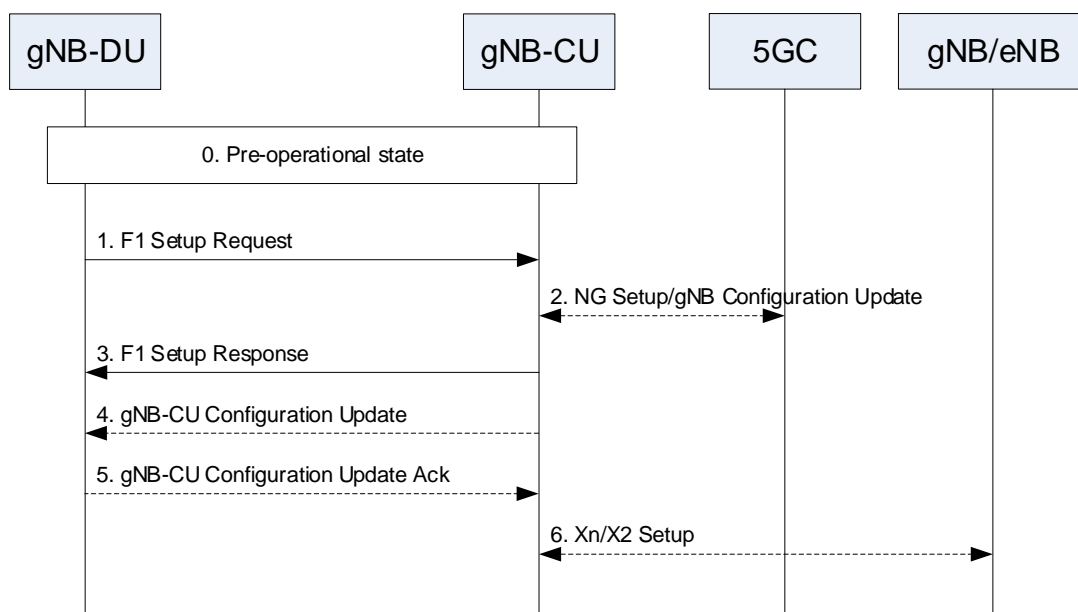

Figure 8.5-1: F1 startup and cell activation

A.2 Combined state diagram for gNB cell

This is the Combined state diagram for gNB cell.

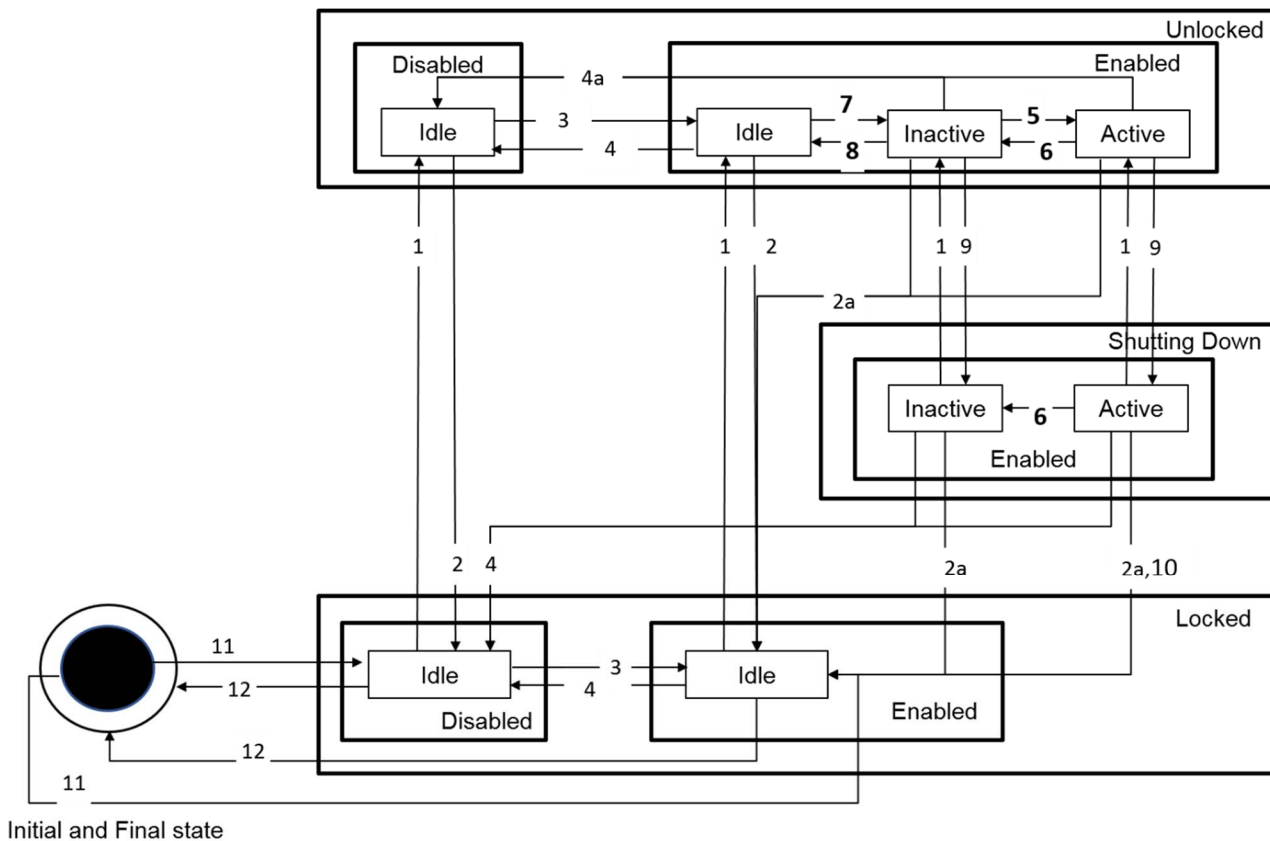

Figure A.2-1: Combined gNB cell state diagram

The gNB-DU maintains cell states. The following table is the gNB cell state transition table.

In 3-split and 2-split deployment scenarios, the interactions between gNB-CU and gNB-DU are standardized. The interactions specified under the column "The state transition events and actions" of "The gNB Cell state transition table" below shall be present for the state transition.

In the non-split deployment scenarios, the interactions between gNB-CU and gNB-DU are not standardized. The interactions between gNB-CU and gNB-DU specified under the column "The state transition events and actions" of "The gNB Cell state transition table" can be replaced by other means that is not standardized.

Table A.2-1: The gNB Cell state transition table

Transition number	The state transition event and actions
1	Event: Receive request to unlock. Action: None.
2	Event: Receive request to lock. Action: None.
2a	Event: Receive request to lock Action: Send to gNB-CU the "gNB-DU Configuration Update message" with served cell to delete.
3	Event: When the required cell resource is physically installed and working. Action: none.
4	Event: When the required cell resource is not physically installed or is not working. Action: Send to gNB-CU the "gNB-DU Configuration update message" with cell to delete.
4a	Event: When the required cell resource is physically uninstalled or is not working. Action: Send to gNB-CU the "GNB-DU Configuration Update message" with served cell to delete.
5	Event: Receive from gNB-CU the "F1 Setup Response message" (identifying the cell to be activated). The cell is activated successfully. Actions: Do nothing or send gNB-CU the "gNB-DU Configuration Update message" with Cell stated as active' ----- or ----- Event: Receive from gNB-CU the "gNB-CU Configuration Update message" (identifying cell to be activated e.g., in case that the cell was not activated using the "F1 Setup Response message"). Actions: The cell is activated successfully. Send to gNB-CU the "gNB-CU Configuration Update Response" to confirm the cell is in active state. ----- or ----- Event: Receive from gNB-CU the "gNB-DU Configuration Update Acknowledge message" (identifying cell to be activated e.g., in case that the cell was not activated using the "F1 Setup Response message") and the cell is activated successfully Actions: Do nothing.
6	Event: Receive from gNB-CU the "gNB-CU Configuration Update message" and responds with gNB-CU Configuration Update Acknowledge messages. Actions: Respond with gNB-CU Configuration Update Acknowledge messages. ----- or ----- Event: Event: DU experiences an internal failure and decided to place the cell into inactive state. Actions: Send to gNB-CU the "gNB-DU Cell status Update message"
7	Event: Send to gNB-CU the "F1 Setup request" (identifying the cell that is configured and ready to be activated). Actions: none. ----- or ----- Send to gNB-CU the "gNB-DU Configuration Update message" with the served cell to add. Actions: none.
8	Event: Sends to gNB-CU the "gNB-DU Configuration Update message" with served cell to delete. Receive response from gNB-CU the "gNB-DU Configuration Update Acknowledge message". Actions: None.
9	Event: Receive request to shut down. Actions: None.
10	Event: Last user quit. Actions: Send to gNB-CU the "GNB-DU Configuration Update message" with served cell to delete.
11	Event: When a cell is created and is configured. Actions: None

12	Event: When a cell is deleted. Action: None.
----	---

Annex B (normative): NSI and NSSI state handling

B.1 NSI state handling

A NetworkSlice instance (NSI) is a logical object in the management system that represents a complex grouping of resources that may be in various states. At any time, the management system needs to know the state of an NSI.

The ITU-T X.731 [18], to which [17] refers, has defined the inter-relation between the administrative state and operational state and usage state of systems in general.

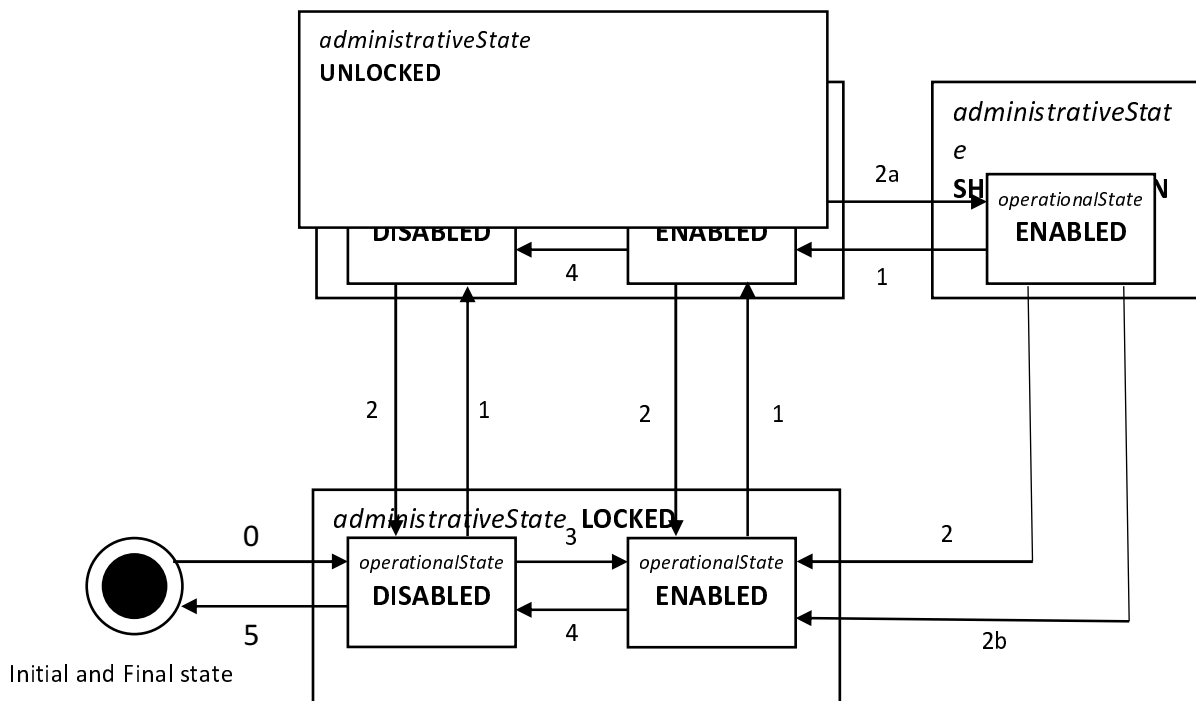

Figure B.1: Combined NSI state diagram

The interactions specified under the column "The state transition events and actions" of "NSI state transition table" below shall be present for the state transition.

Table B.1: The NSI state transition table

Trigger number	The state transition events and actions
0	Operation allocateNsi results in the creation of NSI. and tThe administrative state is set to LOCKED and operationalState is set to DISABLED -- or -- CM operation creates NSI. The administrative state is set to LOCKED and operationalState is set to DISABLED
1	CM operation sets administrative state to UNLOCKED
2	CM operation sets administrative state to LOCKED
2a	CM operation sets administrative state to SHUTTING DOWN
2b	The last user of the NSInetwork slice stops using the NSInetwork slice
3	The related NSSI (identified by NetworkSlice.networkSliceSubnetRef) changes state to UNLOCKED and ENABLED
4	The related NSSI (identified by NetworkSlice.networkSliceSubnetRef) changes state to LOCKED -- or -- The related NSSI (identified by NetworkSlice.networkSliceSubnetRef) changes state to DISABLED
5	Operation deallocateNsi results in the deletion of NSI -- or -- CM operation deletes NSI

B.2 State handling of NSSI

A NetworkSliceSubnet instance (NSSI) is a logical object in the management system that represents a complex grouping of resources that may be in various states. At any time the management system needs to know the state of an NSSI.

The ITU-T X.731 [18], to which [17] refers, has defined the inter-relation between the administrative state, operational state and usage state of systems in general.

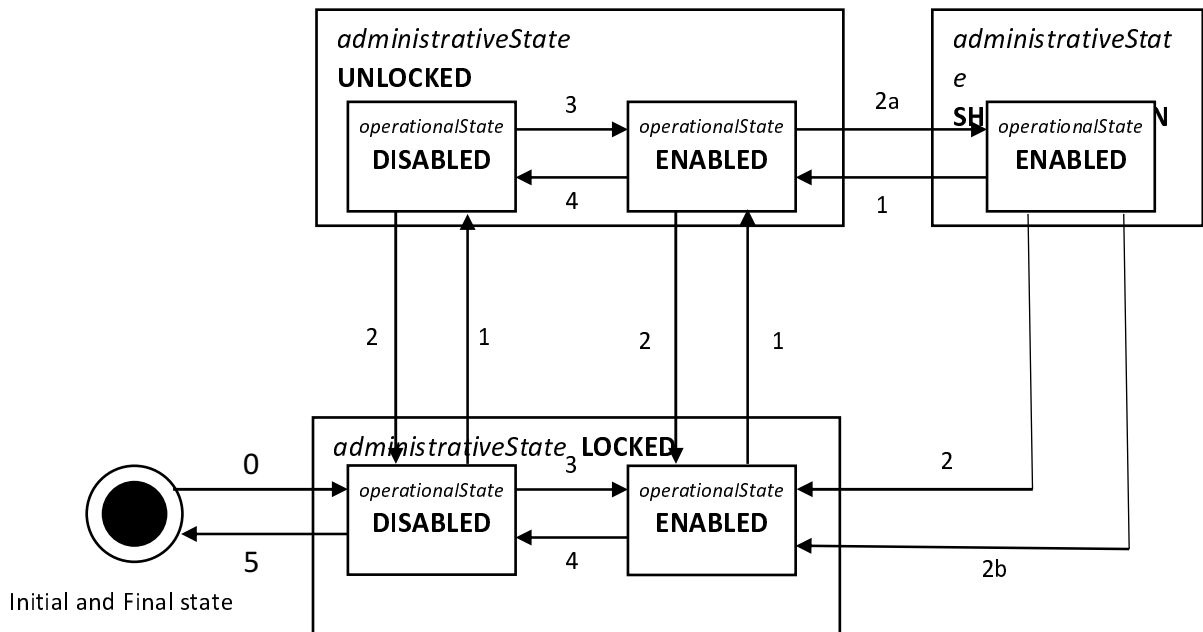

Figure B.2.1: Combined NSSI state diagram

The interactions specified under the column "The state transition events and actions" of "NSSI state transition table" below shall be present for the state transition.

Table B.2.1: The NSSI state transition table

Trigger number	The state transition events and actions
0	Operation allocateNssi results in the creation of NSSI. The administrative state is set to LOCKED and operationalState is set to DISABLED -- or -- CM operation creates NSSI. The administrative state is set to LOCKED and operationalState is set to DISABLED
1	CM operation sets administrative state to UNLOCKED
2	CM operation sets administrative state to LOCKED
2a	CM operation sets administrative state to SHUTTING DOWN
2b	The last user of the NSSInetwork slice subnet stops using the NSSInetwork slice subnet
3	All constituent NSSIs (identified by NetworkSliceSubnet.networkSliceSubnetRef) change state to UNLOCKED and ENABLED
4	At least one constituent NSSI (identified by NetworkSliceSubnet.networkSliceSubnetRef) changes state to LOCKED -- or -- At least one constituent NSSI (identified by NetworkSliceSubnet.networkSliceSubnetRef) changes state to DISABLED
5	Operation deallocateNssi results in the deletion of NSSI -- or -- CM operation deletes NSSI

Annex C (normative): XML definitions for NR NRM

C.1 General

This annex contains the XML definitions for the NR and NG-RAN NRM, in accordance with NR and NG-RAN NRM Information Model definitions specified in clause 4.

C.2 Architectural features

The overall architectural feature of NR NRM information model is specified in clause 4, this clause specifies features that are specific to the Schema definitions.

The XML definitions of the present document specify the schema for a configuration content, which can be included in a configuration file for Bulk configuration management operations

C.3 Mapping

C.3.1 General mapping

An IOC maps to an XML element of the same name as the IOC's name in the Information Model. An IOC attribute maps to a sub-element of the corresponding IOC's XML element, and the name of this sub-element is the same as the attribute's name in the Information Model.

C.3.2 Information Object Class (IOC) mapping

The mapping is not present in the current version of the present document.

C.4 Solution Set definitions

C.4.1 XML definition structure

The overall description of the file format of configuration data XML files is provided by 3GPP TS 32.616 [33].

The present document defines the NRM-specific XML schema nrNrm.xsd for the NR NRM Information Model defined in clause 4.

XML schema nrNrm.xsd explicitly declares NRM-specific XML element types for the related NRM.

The definition of those NRM-specific XML element types complies with the generic mapping rules defined in 3GPP TS 32.616 [33].

C.4.2 Graphical representation

The graphical representation is not present in the current version of the present document.

C.4.3 XML schema "nrNrm.xsd"

```
<?xml version="1.0" encoding="UTF-8"?>
```

```

<!--
  3GPP TS 28.541 NR Network Resource Model
  XML schema definition
  nrNrm.xsd
-->
<schema xmlns="http://www.w3.org/2001/XMLSchema"
  xmlns:xn="http://www.3gpp.org/ftp/specs/archive/28_series/28.623#genericNrm"
  xmlns:nn="http://www.3gpp.org/ftp/specs/archive/28_series/28.541#nrNrm"
  xmlns:en="http://www.3gpp.org/ftp/specs/archive/28_series/28.659#eutranNrm"
  xmlns:epc="http://www.3gpp.org/ftp/specs/archive/28_series/28.709#epcNrm"
  xmlns:sm="http://www.3gpp.org/ftp/specs/archive/28_series/28.626#stateManagementIRP"
  xmlns:ngc="http://www.3gpp.org/ftp/specs/archive/28_series/28.541#ngcNrm"
  xmlns:sp="http://www.3gpp.org/ftp/specs/archive/28_series/28.629#sonPolicyNrm"
  targetNamespace="http://www.3gpp.org/ftp/specs/archive/28_series/28.541#nrNrm"
  elementFormDefault="qualified">
  <import namespace="http://www.3gpp.org/ftp/specs/archive/28_series/28.623#genericNrm"/>
  <import namespace="http://www.3gpp.org/ftp/specs/archive/28_series/28.709#epcNrm"/>
  <import namespace="http://www.3gpp.org/ftp/specs/archive/28_series/28.626#stateManagementIRP"/>
  <import namespace="http://www.3gpp.org/ftp/specs/archive/28_series/28.541#ngcNrm"/>
  <import namespace="http://www.3gpp.org/ftp/specs/archive/28_series/28.629#sonPolicyNrm"/>

  <simpleType name="GnbId">
    <restriction base="unsignedLong">
      <maxInclusive value="4294967295"/>
    </restriction>
  </simpleType>
  <simpleType name="GnbIdLength">
    <restriction base="integer">
      <minLength value="22"/>
      <maxLength value="32"/>
    </restriction>
  </simpleType>
  <simpleType name="Nci">
    <restriction base="unsignedLong">
      <maxInclusive value="68719476735"/>
    </restriction>
  </simpleType>
  <simpleType name="Pci">
    <restriction base="unsignedShort">
      <maxInclusive value="503"/>
      <!-- Minimum value is 0, maximum value is 3x167+2=503 -->
    </restriction>
  </simpleType>
  <simpleType name="NrTac">
    <restriction base="unsignedLong">
      <maxInclusive value="16777215"/>
      <!-- 5G TAC is 3-octets length -->
    </restriction>
  </simpleType>
  <simpleType name="GnbDuId">
    <restriction base="unsignedLong">
      <maxInclusive value="68719476735"/>
      <!-- Minimum value is 0, maximum value is 2^36-1=68719476735 -->
    </restriction>
  </simpleType>
  <simpleType name="GnbCuupId">
    <restriction base="unsignedLong">
      <maxInclusive value="68719476735"/>
      <!-- Minimum value is 0, maximum value is 2^36-1=68719476735 -->
    </restriction>
  </simpleType>
  <simpleType name="GnbName">
    <restriction base="string">
      <minLength value="1"/>
      <maxLength value="150"/>
    </restriction>
  </simpleType>
  <simpleType name="CyclicPrefix">
    <restriction base="integer">
      <enumeration value="15"/>
      <enumeration value="30"/>
      <enumeration value="60"/>
      <enumeration value="120"/>
    </restriction>
  </simpleType>
  <simpleType name="QuotaType">
    <restriction base="string">
      <enumeration value="STRICT"/>
    </restriction>

```

```

        <enumeration value="FLOAT"/>
    </restriction>
</simpleType>
<simpleType name="CellState">
    <restriction base="string">
        <enumeration value="IDLE"/>
        <enumeration value="INACTIVE"/>
        <enumeration value="ACTIVE"/>
    </restriction>
</simpleType>
<simpleType name="BwpContext">
    <restriction base="string">
        <enumeration value="DL"/>
        <enumeration value="UL"/>
        <enumeration value="SUL"/>
    </restriction>
</simpleType>
<simpleType name="IsInitialBwp">
    <restriction base="string">
        <enumeration value="INITIAL"/>
        <enumeration value="OTHER"/>
    </restriction>
</simpleType>
<simpleType name="qOffsetRangeList">
    <restriction base="string">
        <enumeration value="dB-24"/>
        <enumeration value="dB-22"/>
        <enumeration value="dB-20"/>
        <enumeration value="dB-18"/>
        <enumeration value="dB-16"/>
        <enumeration value="dB-14"/>
        <enumeration value="dB-12"/>
        <enumeration value="dB-10"/>
        <enumeration value="dB-8"/>
        <enumeration value="dB-6"/>
        <enumeration value="dB-5"/>
        <enumeration value="dB-4"/>
        <enumeration value="dB-3"/>
        <enumeration value="dB-2"/>
        <enumeration value="dB-1"/>
        <enumeration value="dB0"/>
        <enumeration value="dB1"/>
        <enumeration value="dB2"/>
        <enumeration value="dB3"/>
        <enumeration value="dB4"/>
        <enumeration value="dB5"/>
        <enumeration value="dB6"/>
        <enumeration value="dB8"/>
        <enumeration value="dB10"/>
        <enumeration value="dB12"/>
        <enumeration value="dB14"/>
        <enumeration value="dB16"/>
        <enumeration value="dB18"/>
        <enumeration value="dB20"/>
        <enumeration value="dB22"/>
        <enumeration value="dB24"/>
    </restriction>
</simpleType>
<simpleType name="cellReselectionPriority">
    <restriction base="unsignedLong">
        <minInclusive value="0"/>
        <maxInclusive value="16"/>
        <!--Value 0 means lowest priority-->
    </restriction>
</simpleType>
<simpleType name="cellReselectionSubPriority">
    <restriction base="unsignedLong">
        <minInclusive value="0"/>
        <maxInclusive value="16"/>
        <!--Value 0 means lowest priority-->
    </restriction>
</simpleType>
<simpleType name="PMaxRangeType">
    <restriction base="short">
        <minInclusive value="-30"/>
        <maxInclusive value="33"/>
    </restriction>
</simpleType>

```

```
<simpleType name="qOffsetFreq">
  <restriction base="short">
    <minInclusive value="-24"/>
    <maxInclusive value="24"/>
  </restriction>
</simpleType>
<simpleType name="qQualMin">
  <restriction base="integer">
    <minInclusive value="-34"/>
    <maxInclusive value="0"/>
  </restriction>
</simpleType>
<simpleType name="qRxLevMin">
  <restriction base="integer">
    <minInclusive value="-140"/>
    <maxInclusive value="-44"/>
  </restriction>
</simpleType>
<simpleType name="Threshxhighp">
  <restriction base="integer">
    <minInclusive value="0"/>
    <maxInclusive value="62"/>
  </restriction>
</simpleType>
<simpleType name="Threshxhighq">
  <restriction base="integer">
    <minInclusive value="0"/>
    <maxInclusive value="31"/>
  </restriction>
</simpleType>
<simpleType name="Threshxlowp">
  <restriction base="integer">
    <minInclusive value="0"/>
    <maxInclusive value="62"/>
  </restriction>
</simpleType>
<simpleType name="Threshxlowq">
  <restriction base="integer">
    <minInclusive value="0"/>
    <maxInclusive value="62"/>
  </restriction>
</simpleType>
<simpleType name="Tresselectionnr">
  <restriction base="integer">
    <minInclusive value="0"/>
    <maxInclusive value="7"/>
  </restriction>
</simpleType>
<simpleType name="Tresselectionnrshigh">
  <restriction base="string">
    <enumeration value="25"/>
    <enumeration value="50"/>
    <enumeration value="75"/>
    <enumeration value="100"/>
  </restriction>
</simpleType>
<simpleType name="Tresselectionnrsmmedium">
  <restriction base="string">
    <enumeration value="25"/>
    <enumeration value="50"/>
    <enumeration value="75"/>
    <enumeration value="100"/>
  </restriction>
</simpleType>
<simpleType name="Absolutefrequencyssb">
  <restriction base="integer">
    <minInclusive value="0"/>
    <maxInclusive value="3279165"/>
  </restriction>
</simpleType>
<simpleType name="Ssbsubcarrierspacing">
  <restriction base="string">
    <enumeration value="15"/>
    <enumeration value="30"/>
    <enumeration value="120"/>
    <enumeration value="240"/>
  </restriction>
</simpleType>
```



```

<simpleType name="Multifrequencybandlistnr">
  <restriction base="integer">
    <minInclusive value="1"/>
    <maxInclusive value="256"/>
  </restriction>
</simpleType>
<complexType name="LocalEndPoint">
  <sequence>
    <element name="ipv4Address" type="string"/>
    <element name="ipv6Address" type="string"/>
    <element name="ipv6Prefix" type="string"/>
    <element name="vlanId" type="integer"/>
  </sequence>
</complexType>
<complexType name="RemoteEndPoint">
  <sequence>
    <element name="ipv4Address" type="string"/>
    <element name="ipv6Address" type="string"/>
    <element name="ipv6Prefix" type="string"/>
  </sequence>
</complexType>
<complexType name="blackListEntry">
  <sequence minOccurs="0" maxOccurs="1007" >
    <element name="pci" type="en:PCI" maxOccurs="504"/>
  </sequence>
</complexType>
<complexType name="blackListEntryIdleMode">
  <sequence minOccurs="0" maxOccurs="1007" >
    <element name="pci" type="en:PCI" maxOccurs="504"/>
  </sequence>
</complexType>
<complexType name="RRMPolicyRation2">
  <sequence>
    <element name="groupId" type="integer"/>
    <element name="sNSSAList" type="ngc:SnsaiList"/>
    <element name="quotaType" type="QuotaType"/>
    <element name="rRMPolicyMaxRation" type="integer"/>
    <element name="rRMPolicyMarginMaxRation" type="integer"/>
    <element name="rRMPolicyMinRation" type="integer"/>
    <element name="rRMPolicyMarginMinRation" type="integer"/>
  </sequence>
</complexType>
<complexType name="PLMNidList">
  <sequence>
    <element name="pLMNid" type="en:PLMNid" maxOccurs="6"/>
    <!-- The first pLMNid of the pLMNidList is primary PLMN id -->
  </sequence>
</complexType>
<complexType name="cellIndividualOffset">
  <sequence>
    <element name="rsrpOffsetSSB" type="qOffsetRangeList"/>
    <element name="rsrqOffsetSSB" type="qOffsetRangeList"/>
    <element name="sinrOffsetSSB" type="qOffsetRangeList"/>
    <element name="rsrpOffsetCSI-RS" type="qOffsetRangeList"/>
    <element name="rsrqOffsetCSI-RS" type="qOffsetRangeList"/>
    <element name="sinrOffsetCSI-RS" type="qOffsetRangeList"/>
  </sequence>
</complexType>
<element name="GNBDUFunction" substitutionGroup="xn:ManagedElementOptionallyContainedNrmClass">
  <complexType>
    <complexContent>
      <extension base="xn:NrmClass">
        <sequence>
          <element name="attributes">
            <complexType>
              <all>
                <!-- Inherited attributes from ManagedFunction -->
                <element name="userLabel" type="string" minOccurs="0"/>
                <element name="vnfParametersList" type="xn:vnfParametersListType"
minOccurs="0"/>
                <element name="peeParametersList" type="xn:peeParametersListType"
minOccurs="0"/>
                <element name="priority" type="integer" minOccurs="0"/>
                <element name="measurements" type="xn:MeasurementTypesAndGpsList"
minOccurs="0"/>
                <!--End of inherited attributes from ManagedFunction-->
                <element name="gnbId" type="nn:GnbId"/>
              </all>
            </complexType>
          </element>
        </sequence>
      </extension>
    </complexContent>
  </complexType>

```

```

        <element name="gnbIdLength" type="nn:GnbIdLength" />
        <element name="gnbDUId" type="nn:GnbDuId" />
        <element name="gnbDuName" type="nn:GnbName" minOccurs="0" />
    </all>
</complexType>
</element>
<choice minOccurs="0" maxOccurs="unbounded">
    <element ref="nn:NRCe11DU" />
    <element ref="nn:BWP" />
    <element ref="nn:NRSectorCarrier" />
    <element ref="nn:EP_F1C" />
    <element ref="nn:EP_F1U" />
</choice>
<choice minOccurs="0" maxOccurs="unbounded">
    <element ref="xn:MeasurementControl" />
</choice>
</sequence>
</extension>
</complexContent>
</complexType>
</element>
<element name="GNBCUCPFunction" substitutionGroup="xn:ManagedElementOptionallyContainedNrmClass">
    <complexType>
        <complexContent>
            <extension base="xn:NrmClass">
                <sequence>
                    <element name="attributes">
                        <complexType>
                            <all>
                                <!-- Inherited attributes from ManagedFunction -->
                                <element name="userLabel" type="string" minOccurs="0" />
                                <element name="vnfParametersList" type="xn:vnfParametersListType"
minOccurs="0" />
                                <element name="peeParametersList" type="xn:peeParametersListType"
minOccurs="0" />
                                <element name="priority" type="integer" minOccurs="0" />
                                <element name="measurements" type="xn:MeasurementTypesAndGPsList"
minOccurs="0" />
                                <!--End of inherited attributes from ManagedFunction-->
                                <element name="gnbId" type="nn:GnbId" />
                                <element name="gnbIdLength" type="nn:GnbIdLength" />
                                <element name="gnbCuName" type="nn:GnbName" minOccurs="0" />
                                <element name="pLMNId" type="en:PLMNId" />
                            </all>
                        </complexType>
                    </element>
                    <choice minOccurs="0" maxOccurs="unbounded">
                        <element ref="nn:NRCe11CU" />
                        <element ref="nn:EP_F1C" />
                        <element ref="nn:EP_E1" />
                        <element ref="nn:EP_XnC" />
                        <element ref="nn:EP_X2C" />
                        <element ref="nn:EP_NgC" />
                        <element ref="xn:VsDataContainer" />
                    </choice>
                    <choice minOccurs="0" maxOccurs="unbounded">
                        <element ref="xn:MeasurementControl" />
                    </choice>
                </sequence>
            </extension>
        </complexContent>
    </complexType>
</element>
<element name="GNBCUUPFunction" substitutionGroup="xn:ManagedElementOptionallyContainedNrmClass">
    <complexType>
        <complexContent>
            <extension base="xn:NrmClass">
                <sequence>
                    <element name="attributes">
                        <complexType>
                            <all>
                                <!-- Inherited attributes from ManagedFunction -->
                                <element name="userLabel" type="string" minOccurs="0" />
                                <element name="vnfParametersList" type="xn:vnfParametersListType"
minOccurs="0" />
                                <element name="peeParametersList" type="xn:peeParametersListType"
minOccurs="0" />
                                <element name="priority" type="integer" minOccurs="0" />
                            </all>
                        </complexType>
                    </element>
                </sequence>
            </extension>
        </complexContent>
    </complexType>
</element>

```

```

        <element name="measurements" type="xn:MeasurementTypesAndGPsList"
minOccurs="0"/>
        <!--End of inherited attributes from ManagedFunction-->
        <element name="pLMNIdList" type="en:PLMNIdList"/>
        <element name="gNBId" type="nn:GnbId"/>
        <element name="gnbIdLength" type="nn:GnbIdLength"/>
        <element name="gnbCuupId" type="nn:GnbCuupId"/>
    </all>
</complexType>
</element>
<choice minOccurs="0" maxOccurs="unbounded">
    <element ref="nn:EP_E1"/>
    <element ref="nn:EP_FLU"/>
    <element ref="nn:EP_XnU"/>
    <element ref="nn:EP_NgU"/>
    <element ref="nn:EP_X2U"/>
    <element ref="nn:EP_SLU"/>
    <element ref="xn:VsDataContainer"/>
</choice>
<choice minOccurs="0" maxOccurs="unbounded">
    <element ref="xn:MeasurementControl"/>
</choice>
</sequence>
</extension>
</complexContent>
</complexType>
</element>
<element name="NRCellCU">
    <complexType>
        <complexContent>
            <extension base="xn:NrmClass">
                <sequence>
                    <element name="attributes">
                        <complexType>
                            <all>
                                <!-- Inherited attributes from ManagedFunction -->
                                <element name="userLabel" type="string" minOccurs="0"/>
                                <element name="vnfParametersList" type="xn:vnfParametersListType"
minOccurs="0"/>
                                <element name="peeParametersList" type="xn:peeParametersListType"
minOccurs="0"/>
                                <element name="priority" type="integer" minOccurs="0"/>
                                <element name="measurements" type="xn:MeasurementTypesAndGPsList"
minOccurs="0"/>
                                <!--End of inherited attributes from ManagedFunction-->
                                <element name="nCGI" type="nn:Ncgi"/>
                                <element name="pLMNIdList" type="en:PLMNIdList"/>
                                <element name="sNSSAIIList" type="ngc:SnssaiList" minOccurs="0"/>
                                <element name="rRMPolicyType" type="integer" minOccurs="0"/>
                                <element name="rRMPolicyNSSIIId" type="xn:dn" minOccurs="0"/>
                                <element name="rRMPolicyRatio" type="integer" minOccurs="0"/>
                                <element name="rRMPolicy" type="string" minOccurs="0"/>
                                <element name="rRMPolicyRatio2" type="RRMPolicyRation2" minOccurs="0"/>
                                <element name="nRFrequencyRef" type="xn:dn" minOccurs="0"/>
                            </all>
                        </complexType>
                    </element>
                    <choice minOccurs="0" maxOccurs="unbounded">
                        <element ref="xn:VsDataContainer"/>
                        <element ref="nrCellRelation"/>
                        <element ref="nrFreqRelation"/>
                        <element ref="eUtranCellRelation"/>
                        <element ref="eUtranFreqRelation"/>
                    </choice>
                    <choice minOccurs="0" maxOccurs="unbounded">
                        <element ref="xn:MeasurementControl"/>
                    </choice>
                    <choice minOccurs="0" maxOccurs="1">
                        <element ref="sp:EnergySavingProperties"/>
                        <element ref="sp:ESPolicies"/>
                    </choice>
                </sequence>
            </extension>
        </complexContent>
    </complexType>
</element>
<element name="NRCellDU">
    <complexType>

```

```

    <complexContent>
      <extension base="xn:NrmClass">
        <sequence>
          <element name="attributes">
            <complexType>
              <all>
                <!-- Inherited attributes from ManagedFunction -->
                <element name="userLabel" type="string" minOccurs="0"/>
                <element name="vnfParametersList" type="xn:vnfParametersListType"
minOccurs="0"/>
                <element name="peeParametersList" type="xn:peeParametersListType"
minOccurs="0"/>
                <element name="priority" type="integer" minOccurs="0"/>
                <element name="measurements" type="xn:MeasurementTypesAndGPsList"
minOccurs="0"/>
                <!--End of inherited attributes from ManagedFunction-->
                <element name="nCGI" type="nn:Ncgi" minOccurs="0"/>
                <element name="operationalState" type="sm:operationalStateType" minOccurs="0"/>
                <element name="administrativeState" type="sm:administrativeStateType"
minOccurs="0"/>
                <element name="cellState" type="nn:CellState"/>
                <element name="pLMNIdList" type="en:PLMNIdList"/>
                <element name="sNSSAList" type="ngc:SnsaiList" minOccurs="0"/>
                <element name="nRpci" type="nn:Pci" />
                <element name="nRTac" type="nn:NrTac" />
                <element name="arfcnDL" type="integer"/>
                <element name="arfcnUL" type="integer" minOccurs="0"/>
                <element name="arfcnSUL" type="integer" minOccurs="0"/>
                <element name="bSChannelBwDL" type="integer"/>
                <element name="bSChannelBwUL" type="integer" minOccurs="0"/>
                <element name="bSChannelBwSUL" type="integer" minOccurs="0"/>
                <element name="nRFrequencyRef" type="xn:dn" minOccurs="0"/>
                <element name="nRSectorCarrierRef" type="xn:dn" minOccurs="0"/>
                <element name="bWPRef" type="xn:dn" minOccurs="0"/>
              </all>
            </complexType>
          </element>
          <choice minOccurs="0" maxOccurs="unbounded">
            <element ref="xn:VsDataContainer" />
          </choice>
          <choice minOccurs="0" maxOccurs="unbounded">
            <element ref="xn:MeasurementControl" />
          </choice>
          <choice minOccurs="0" maxOccurs="1">
            <element ref="sp:EnergySavingProperties" />
            <element ref="sp:ESPolicies" />
          </choice>
        </sequence>
      </extension>
    </complexContent>
  </complexType>
</element>
<element name="NRSectorCarrier">
  <complexType>
    <complexContent>
      <extension base="xn:NrmClass">
        <sequence>
          <element name="attributes">
            <complexType>
              <all>
                <!-- Inherited attributes from ManagedFunction -->
                <element name="userLabel" type="string" minOccurs="0"/>
                <element name="vnfParametersList" type="xn:vnfParametersListType"
minOccurs="0"/>
                <element name="peeParametersList" type="xn:peeParametersListType"
minOccurs="0"/>
                <element name="priority" type="integer" minOccurs="0"/>
                <element name="measurements" type="xn:MeasurementTypesAndGPsList"
minOccurs="0"/>
                <!--End of inherited attributes from ManagedFunction-->
                <element name="txDirection" type="nn:TxDirection"/>
                <element name="configuredMaxTxPower" type="integer"/>
                <element name="arfcnDL" type="integer" minOccurs="0"/>
                <element name="arfcnUL" type="integer" minOccurs="0"/>
                <element name="bSChannelBwDL" type="integer" minOccurs="0"/>
                <element name="bSChannelBwUL" type="integer" minOccurs="0"/>
                <element name="sectorEquipmentFunctionRef" type="xn:dn" minOccurs="0"/>
              </all>
            </complexType>
          </element>
        </sequence>
      </extension>
    </complexContent>
  </complexType>
</element>

```

```

        </complexType>
      </element>
      <choice minOccurs="0" maxOccurs="unbounded">
        <element ref="xn:MeasurementControl"/>
      </choice>
      <choice minOccurs="0" maxOccurs="unbounded">
        <element ref="xn:VsDataContainer"/>
      </choice>
      <choice minOccurs="0" maxOccurs="1">
        <element ref="sp:EnergySavingProperties"/>
        <element ref="sp:ESPolicies"/>
      </choice>
    </sequence>
  </extension>
</complexContent>
</complexType>
</element>
<element name="BWP">
  <complexType>
    <complexContent>
      <extension base="xn:NrmClass">
        <sequence>
          <element name="attributes">
            <complexType>
              <all>
                <!-- Inherited attributes from ManagedFunction -->
                <element name="userLabel" type="string" minOccurs="0"/>
                <element name="vnfParametersList" type="xn:vnfParametersListType"
minOccurs="0"/>
                <element name="peeParametersList" type="xn:peeParametersListType"
minOccurs="0"/>
                <element name="priority" type="integer" minOccurs="0"/>
                <element name="measurements" type="xn:MeasurementTypesAndGPsList"
minOccurs="0"/>
                <!--End of inherited attributes from ManagedFunction-->
                <element name="bwpContext" type="nn:BwpContext"/>
                <element name="isInitialBwp" type="nn:IsInitialBwp"/>
                <element name="subCarrierSpacing" type="integer"/>
                <element name="cyclicPrefix" type="nn:CyclicPrefix"/>
                <element name="startRB" type="integer"/>
                <element name="numberOfRBs" type="integer"/>
              </all>
            </complexType>
          </element>
          <choice minOccurs="0" maxOccurs="unbounded">
            <element ref="xn:MeasurementControl"/>
          </choice>
          <choice minOccurs="0" maxOccurs="unbounded">
            <element ref="xn:VsDataContainer"/>
          </choice>
        </sequence>
      </extension>
    </complexContent>
  </complexType>
</element>
<element name="CommonBeamformingFunction">
  <complexType>
    <complexContent>
      <extension base="xn:NrmClass">
        <sequence>
          <element name="attributes">
            <complexType>
              <choice minOccurs="0" maxOccurs="unbounded">
                <element ref="xn:VsDataContainer"/>
              </choice>
              <choice minOccurs="0" maxOccurs="unbounded">
                <element ref="xn:MeasurementControl"/>
              </choice>
              <choice minOccurs="0" maxOccurs="1">
                <element ref="sp:EnergySavingProperties"/>
                <element ref="sp:ESPolicies"/>
              </choice>
            </sequence>
          </extension>
        </complexContent>
      </complexType>
    </element>

```

```

<element name="Beam">
  <complexType>
    <complexContent>
      <extension base="xn:NrmClass">
        <sequence>
          <element name="attributes">
            <complexType>
              <all>
                <element name="beamIndex" type="integer" minOccurs="0"/>
                <element name="beamType" type="beamType" minOccurs="0"/>
                <element name="beamAzimuth" type="beamAzimuth" minOccurs="0"/>
                <element name="beamTilt" type="beamTilt" minOccurs="0"/>
                <element name="beamHorizWidth" type="beamHorizWidth" minOccurs="0"/>
                <element name="beamVertWidth" type="beamVertWidth" minOccurs="0"/>
              </all>
            </complexType>
          </element>
          <choice minOccurs="0" maxOccurs="unbounded">
            <element ref="xn:MeasurementControl"/>
          </choice>
          <choice minOccurs="0" maxOccurs="unbounded">
            <element ref="xn:VsDataContainer"/>
          </choice>
          <choice minOccurs="0" maxOccurs="1">
            <element ref="sp:EnergySavingProperties"/>
            <element ref="sp:ESPolicies"/>
          </choice>
        </sequence>
      </extension>
    </complexContent>
  </complexType>
</element>

<element name="EP_E1">
  <complexType>
    <complexContent>
      <extension base="xn:NrmClass">
        <sequence>
          <element name="attributes" minOccurs="0">
            <complexType>
              <all>
                <!-- Inherited attributes from EP_RP -->
                <element name="farEndEntity" type="xn:dn" minOccurs="0"/>
                <element name="userLabel" type="string" minOccurs="0"/>
                <!-- End of inherited attributes from EP_RP -->
                <element name="localAddress" type="nn:LocalEndPoint" minOccurs="0"/>
                <element name="remoteAddress" type="nn:RemoteEndPoint" minOccurs="0"/>
              </all>
            </complexType>
          </element>
          <choice minOccurs="0" maxOccurs="unbounded">
            <element ref="xn:VsDataContainer"/>
          </choice>
        </sequence>
      </extension>
    </complexContent>
  </complexType>
</element>

<element name="EP_XnC">
  <complexType>
    <complexContent>
      <extension base="xn:NrmClass">
        <sequence>
          <element name="attributes" minOccurs="0">
            <complexType>
              <all>
                <!-- Inherited attributes from EP_RP -->
                <element name="farEndEntity" type="xn:dn" minOccurs="0"/>
                <element name="userLabel" type="string" minOccurs="0"/>
                <!-- End of inherited attributes from EP_RP -->
                <element name="localAddress" type="nn:LocalEndPoint" minOccurs="0"/>
                <element name="remoteAddress" type="nn:RemoteEndPoint" minOccurs="0"/>
              </all>
            </complexType>
          </element>
        </sequence>
      </extension>
    </complexContent>
  </complexType>
</element>

```

```

        </complexType>
      </element>
      <choice minOccurs="0" maxOccurs="unbounded">
        <element ref="xn:VsDataContainer"/>
      </choice>
    </sequence>
  </extension>
</complexContent>
</complexType>
</element>
<element name="EP_XnU">
  <complexType>
    <complexContent>
      <extension base="xn:NrmClass">
        <sequence>
          <element name="attributes" minOccurs="0">
            <complexType>
              <all>
                <!-- Inherited attributes from EP_RP -->
                <element name="farEndEntity" type="xn:dn" minOccurs="0"/>
                <element name="userLabel" type="string" minOccurs="0"/>
                <!-- End of inherited attributes from EP_RP -->
                <element name="localAddress" type="nn:LocalEndPoint" minOccurs="0"/>
                <element name="remoteAddress" type="nn:RemoteEndPoint" minOccurs="0"/>
              </all>
            </complexType>
          </element>
          <choice minOccurs="0" maxOccurs="unbounded">
            <element ref="xn:VsDataContainer"/>
          </choice>
        </sequence>
      </extension>
    </complexContent>
  </complexType>
</element>
<element name="EP_NgC">
  <complexType>
    <complexContent>
      <extension base="xn:NrmClass">
        <sequence>
          <element name="attributes" minOccurs="0">
            <complexType>
              <all>
                <!-- Inherited attributes from EP_RP -->
                <element name="farEndEntity" type="xn:dn" minOccurs="0"/>
                <element name="userLabel" type="string" minOccurs="0"/>
                <!-- End of inherited attributes from EP_RP -->
                <element name="localAddress" type="nn:LocalEndPoint" minOccurs="0"/>
                <element name="remoteAddress" type="nn:RemoteEndPoint" minOccurs="0"/>
              </all>
            </complexType>
          </element>
          <choice minOccurs="0" maxOccurs="unbounded">
            <element ref="xn:VsDataContainer"/>
          </choice>
        </sequence>
      </extension>
    </complexContent>
  </complexType>
</element>
<element name="EP_NgU">
  <complexType>
    <complexContent>
      <extension base="xn:NrmClass">
        <sequence>
          <element name="attributes" minOccurs="0">
            <complexType>
              <all>
                <!-- Inherited attributes from EP_RP -->
                <element name="farEndEntity" type="xn:dn" minOccurs="0"/>
                <element name="userLabel" type="string" minOccurs="0"/>
                <!-- End of inherited attributes from EP_RP -->
                <element name="localAddress" type="nn:LocalEndPoint" minOccurs="0"/>
                <element name="remoteAddress" type="nn:RemoteEndPoint" minOccurs="0"/>
              </all>
            </complexType>
          </element>
          <choice minOccurs="0" maxOccurs="unbounded">

```

```

        <element ref="xn:VsDataContainer"/>
      </choice>
    </sequence>
  </extension>
</complexContent>
</complexType>
</element>
<element name="EP_F1C">
  <complexType>
    <complexContent>
      <extension base="xn:NrmClass">
        <sequence>
          <element name="attributes" minOccurs="0">
            <complexType>
              <all>
                <!-- Inherited attributes from EP_RP -->
                <element name="farEndEntity" type="xn:dn" minOccurs="0"/>
                <element name="userLabel" type="string" minOccurs="0"/>
                <!-- End of inherited attributes from EP_RP -->
                <element name="localAddress" type="nn:LocalEndPoint" minOccurs="0"/>
                <element name="remoteAddress" type="nn:RemoteEndPoint" minOccurs="0"/>
              </all>
            </complexType>
          </element>
          <choice minOccurs="0" maxOccurs="unbounded">
            <element ref="xn:VsDataContainer"/>
          </choice>
        </sequence>
      </extension>
    </complexContent>
  </complexType>
</element>
<element name="EP_F1U">
  <complexType>
    <complexContent>
      <extension base="xn:NrmClass">
        <sequence>
          <element name="attributes" minOccurs="0">
            <complexType>
              <all>
                <!-- Inherited attributes from EP_RP -->
                <element name="farEndEntity" type="xn:dn" minOccurs="0"/>
                <element name="userLabel" type="string" minOccurs="0"/>
                <!-- End of inherited attributes from EP_RP -->
                <element name="localAddress" type="nn:LocalEndPoint" minOccurs="0"/>
                <element name="remoteAddress" type="nn:RemoteEndPoint" minOccurs="0"/>
              </all>
            </complexType>
          </element>
          <choice minOccurs="0" maxOccurs="unbounded">
            <element ref="xn:VsDataContainer"/>
          </choice>
        </sequence>
      </extension>
    </complexContent>
  </complexType>
</element>
<element name="EP_S1U">
  <complexType>
    <complexContent>
      <extension base="xn:NrmClass">
        <sequence>
          <element name="attributes" minOccurs="0">
            <complexType>
              <all>
                <!-- Inherited attributes from EP_RP -->
                <element name="farEndEntity" type="xn:dn" minOccurs="0"/>
                <element name="userLabel" type="string" minOccurs="0"/>
                <!-- End of inherited attributes from EP_RP -->
                <element name="localAddress" type="nn:LocalEndPoint" minOccurs="0"/>
                <element name="remoteAddress" type="nn:RemoteEndPoint" minOccurs="0"/>
              </all>
            </complexType>
          </element>
          <choice minOccurs="0" maxOccurs="unbounded">
            <element ref="xn:VsDataContainer"/>
          </choice>
        </sequence>
      </extension>
    </complexContent>
  </complexType>
</element>

```



```

        </extension>
      </complexContent>
    </complexType>
  </element>
  <element name="EP_X2C">
    <complexType>
      <complexContent>
        <extension base="xn:NrmClass">
          <sequence>
            <element name="attributes" minOccurs="0">
              <complexType>
                <all>
                  <!-- Inherited attributes from EP_RP -->
                  <element name="farEndEntity" type="xn:dn" minOccurs="0"/>
                  <element name="userLabel" type="string" minOccurs="0"/>
                  <!-- End of inherited attributes from EP_RP -->
                  <element name="localAddress" type="nn:LocalEndPoint" minOccurs="0"/>
                  <element name="remoteAddress" type="nn:RemoteEndPoint" minOccurs="0"/>
                </all>
              </complexType>
            </element>
            <choice minOccurs="0" maxOccurs="unbounded">
              <element ref="xn:VsDataContainer"/>
            </choice>
          </sequence>
        </extension>
      </complexContent>
    </complexType>
  </element>
  <element name="EP_X2U">
    <complexType>
      <complexContent>
        <extension base="xn:NrmClass">
          <sequence>
            <element name="attributes" minOccurs="0">
              <complexType>
                <all>
                  <!-- Inherited attributes from EP_RP -->
                  <element name="farEndEntity" type="xn:dn" minOccurs="0"/>
                  <element name="userLabel" type="string" minOccurs="0"/>
                  <!-- End of inherited attributes from EP_RP -->
                  <element name="localAddress" type="nn:LocalEndPoint" minOccurs="0"/>
                  <element name="remoteAddress" type="nn:RemoteEndPoint" minOccurs="0"/>
                </all>
              </complexType>
            </element>
            <choice minOccurs="0" maxOccurs="unbounded">
              <element ref="xn:VsDataContainer"/>
            </choice>
          </sequence>
        </extension>
      </complexContent>
    </complexType>
  </element>
  <element name="NRCellRelation">
    <complexType>
      <complexContent>
        <extension base="xn:NrmClass">
          <sequence>
            <element name="attributes">
              <complexType>
                <all>
                  <!-- Inherited attributes from Top_ -->
                  <element name="userLabel" type="string" minOccurs="0"/>
                  <element name="nRTCI" type="nn:Nrtci"/>
                  <element name="cellIndividualOffset" type="en:CellIndividualOffset"/>
                  <element name="nRFreqRelationRef" type="xn:dn" minOccurs="0"/>
                  <element name="adjacentNRCellRef" type="xn:dn" minOccurs="0"/>
                </all>
              </complexType>
            </element>
            <choice minOccurs="0" maxOccurs="unbounded">
              <element ref="xn:VsDataContainer"/>
            </choice>
            <choice minOccurs="0" maxOccurs="1">
              <element ref="sp:EnergySavingProperties"/>
              <element ref="sp:ESPolicies"/>
            </choice>
          </sequence>
        </extension>
      </complexContent>
    </complexType>
  </element>

```

```

        <choice minOccurs="0" maxOccurs="unbounded">
            <element ref="xn:MeasurementControl"/>
        </choice>
    </sequence>
</extension>
</complexContent>
</complexType>
</element>
<element name="NRFreqRelation">
    <complexType>
        <complexContent>
            <extension base="xn:NrmClass">
                <sequence>
                    <element name="attributes">
                        <complexType>
                            <all>
                                <!-- Inherited attributes from Top_ -->
                                <element name="id" type="string" />
                                <!--End of inherited attributes from Top_ -->
                                <element name="offsetMO" type="en:qOffsetRangeList"/>
                                <element name="blackListEntry" type="en:blackListEntry" minOccurs="0"/>
                                <element name="blackListEntryIdleMode" type="en:blackListEntryIdleMode"
minOccurs="0"/>
                                <element name="cellReselectionPriority" type="en:cellReselectionPriority"/>
                                <element name="cellReselectionSubPriority"
type="en:cellReselectionSubPriority"/>
                                <element name="pMax" type="en:PMaxRangeType" minOccurs="0"/>
                                <element name="qOffserFreq" type="nn:qOffserFreq" minOccurs="0"/>
                                <element name="qQualMin" type="en:qQualMin" minOccurs="0"/>
                                <element name="qRxLevMin" type="en:qRxLevMin" minOccurs="0"/>
                                <element name="threshXHighP" type="en:threshxhighp" minOccurs="0"/>
                                <element name="threshXHighQ" type="en:threshxhighq" minOccurs="0"/>
                                <element name="threshXLowP" type="en:threshxlowp" minOccurs="0"/>
                                <element name="threshXLowQ" type="en:threshxlowp" minOccurs="0"/>
                                <element name="tReselectionNr" type="nn:Treselectionnr" minOccurs="0"/>
                                <element name="tReselectionNRSfHigh" type="nn:Treselectionnrfsfhigh"
minOccurs="0"/>
                                <element name="tReselectionNRSfMedium" type="nn:Treselectionnrfsfmedium"
minOccurs="0"/>
                                <element name="nRFfrequencyRef" type="xn:dn" minOccurs="0"/>
                            </all>
                        </complexType>
                    </element>
                    <choice minOccurs="0" maxOccurs="unbounded">
                        <element ref="xn:VsDataContainer"/>
                    </choice>
                    <choice minOccurs="0" maxOccurs="unbounded">
                        <element ref="xn:MeasurementControl"/>
                    </choice>
                    <choice minOccurs="0" maxOccurs="1">
                        <element ref="sp:EnergySavingProperties"/>
                        <element ref="sp:ESPolicies"/>
                    </choice>
                </sequence>
            </extension>
        </complexContent>
    </complexType>
</element>
<element name="ExternalNRCellCU">
    <complexType>
        <complexContent>
            <extension base="xn:NrmClass">
                <sequence>
                    <element name="attributes">
                        <complexType>
                            <all>
                                <!-- Inherited attributes from ManagedFunction -->
                                <element name="userLabel" type="string" minOccurs="0"/>
                                <element name="vnfParametersList" type="xn:vnfParametersListType"
minOccurs="0"/>
                                <element name="peeParametersList" type="xn:peeParametersListType"
minOccurs="0"/>
                                <element name="priority" type="integer" minOccurs="0"/>
                                <element name="measurements" type="xn:MeasurementTypesAndGPsList"
minOccurs="0"/>
                                <!--End of inherited attributes from ManagedFunction -->
                                <element name="nCGI" type="nn:Ncgi"/>
                                <element name="pLMNIdList" type="en:PLMNIdList"/>
                            </all>
                        </complexType>
                    </element>
                </sequence>
            </extension>
        </complexContent>
    </complexType>
</element>

```

```

        <element name="nRPCI" type="nn:NrpCi" minOccurs="0"/>
        <element name="nRFrequencyRef" type="xn:dn" minOccurs="0"/>
    </all>
</complexType>
</element>
<choice minOccurs="0" maxOccurs="unbounded">
    <element ref="xn:VsDataContainer"/>
</choice>
<choice minOccurs="0" maxOccurs="unbounded">
    <element ref="xn:MeasurementControl"/>
</choice>
<choice minOccurs="0" maxOccurs="1">
    <element ref="sp:EnergySavingProperties"/>
    <element ref="sp:ESPolicies"/>
</choice>
</sequence>
</extension>
</complexContent>
</complexType>
</element>
<element name="ExternalGNBCUCPFFunction" substitutionGroup="xn:SubNetworkOptionallyContainedNrmClass">
    <complexType>
        <complexContent>
            <extension base="xn:NrmClass">
                <sequence>
                    <element name="attributes">
                        <complexType>
                            <all>
                                <!-- Inherited attributes from ManagedFunction -->
                                <element name="userLabel" type="string" minOccurs="0"/>
                                <element name="vnfParametersList" type="xn:vnfParametersListType"
minOccurs="0"/>
                                <element name="peeParametersList" type="xn:peeParametersListType"
minOccurs="0"/>
                                <element name="priority" type="integer" minOccurs="0"/>
                                <element name="measurements" type="xn:MeasurementTypesAndGPsList"
minOccurs="0"/>
                                <!--End of inherited attributes from ManagedFunction -->
                                <element name="gnbId" type="nn:GnbId" />
                                <element name="gnbIdLength" type="nn:GnbIdLength"/>
                                <element name="pLMNId" type="en:PLMNIdList" />
                            </all>
                        </complexType>
                    </element>
                    <choice minOccurs="0" maxOccurs="unbounded">
                        <element ref="xn:VsDataContainer"/>
                    </choice>
                    <choice minOccurs="0" maxOccurs="unbounded">
                        <element ref="xn:MeasurementControl"/>
                    </choice>
                    <choice minOccurs="0" maxOccurs="1">
                        <element ref="sp:EnergySavingProperties"/>
                        <element ref="sp:ESPolicies"/>
                    </choice>
                </sequence>
            </extension>
        </complexContent>
    </complexType>
</element>
<element name="RRMPolicyRatio2">
    <complexType>
        <complexContent>
            <extension base="xn:NrmClass">
                <sequence>
                    <element name="attributes">
                        <complexType>
                            <all>
                                <element name="userLabel" type="string"/>
                                <element name="vnfParametersList" type="xn:vnfParametersListType"
minOccurs="0"/>
                                <element name="groupId" type="integer"/>
                                <element name="sNSSAILList" type="ngc:SnsaiList" minOccurs="0"/>
                                <element name="quotaType" type="nn:quotaType"/>
                                <element name="rRMPolicyMaxRatio" type="integer" minOccurs="0"/>
                                <element name="rRMPolicyMarginMaxRatio" type="integer" minOccurs="0"/>
                                <element name="rRMPolicyMinRatio" type="integer" minOccurs="0"/>
                                <element name="rRMPolicyMarginMinRatio" type="integer" minOccurs="0"/>
                            </all>
                        </complexType>
                    </element>
                </sequence>
            </extension>
        </complexContent>
    </complexType>
</element>

```

```

        </all>
      </complexType>
    </element>
    <choice minOccurs="0" maxOccurs="unbounded">
      <element ref="xn:VsDataContainer"/>
    </choice>
    <choice minOccurs="0" maxOccurs="1">
      <element ref="sp:EnergySavingProperties"/>
      <element ref="sp:ESPolicies"/>
    </choice>
  </sequence>
</extension>
</complexContent>
</complexType>
</element>
<element name="NRFrequency" substitutionGroup="xn:SubNetworkOptionallyContainedNrmClass">
  <complexType>
    <complexContent>
      <extension base="xn:NrmClass">
        <sequence>
          <element name="attributes">
            <complexType>
              <all>
                <!-- Inherited attributes from ManagedFunction -->
                <element name="userLabel" type="string" minOccurs="0"/>
                <element name="vnfParametersList" type="xn:vnfParametersListType"
minOccurs="0"/>
                <element name="peeParametersList" type="xn:peeParametersListType"
minOccurs="0"/>
                <element name="priority" type="integer" minOccurs="0"/>
                <element name="measurements" type="xn:MeasurementTypesAndGPsList"
minOccurs="0"/>
                <!--End of inherited attributes from ManagedFunction -->
                <element name="absoluteFrequencySSB" type="nn:AbsoluteFrequencySSB"
minOccurs="0"/>
                <element name="sBSSubCarrierSpacing" type="nn:SbsSubCarrierSpacing"
minOccurs="0"/>
                <element name="multiFrequencyBandListNR" type="nn:MultiFrequencyBandListNR"
minOccurs="0"/>
              </all>
            </complexType>
          </element>
          <choice minOccurs="0" maxOccurs="unbounded">
            <element ref="xn:VsDataContainer"/>
          </choice>
          <choice minOccurs="0" maxOccurs="1">
            <element ref="sp:EnergySavingProperties"/>
            <element ref="sp:ESPolicies"/>
          </choice>
          <choice minOccurs="0" maxOccurs="unbounded">
            <element ref="xn:MeasurementControl"/>
          </choice>
        </sequence>
      </extension>
    </complexContent>
  </complexType>
</element>
</schema>

```

Annex D (normative): JSON definitions for NR NRM

D.1 General

This annex contains the JSON definitions for the NR and NG-RAN NRM, in accordance with NR and NG-RAN NRM information model definitions specified in clause 4.

D.2 Architectural features

D.3 Mapping

Refer to TS 32.160 [46].

D.4 Solution Set (SS) definitions

D.4.1 JSON definition structure

JSON is used as resource representations format carried in the HTTP request and HTTP response message bodies. The properties (key-value pairs) on an object are defined using the properties keyword.

D.4.2 Graphical representation

None.

D.4.3 JSON schema "nrNrm.json"

```
{
  "openapi": "3.0.1",
  "info": {
    "title": "3GPP NR NRM",
    "version": "15.3.0",
    "description": "OAS 3.0.1 specification compatible schema for 3GPP NR NRM"
  },
  "paths": {},
  "components": {
    "schemas": {
      "GnbId": {
        "type": "string"
      },
      "GnbIdLength": {
        "type": "integer",
        "minimum": 22,
        "maximum": 32
      },
      "GnbName": {
        "type": "string",
        "maxLength": 150
      },
      "GnbDuId": {
        "type": "number",
        "minimum": 0,
        "maximum": 68719476735
      },
      "GnbCuUpId": {
        "type": "number",

```

```

    "minimum": 0,
    "maximum": 68719476735
  },
  "NCi": {
    "type": "object",
    "properties": {
      "plmnId": {
        "$ref": "#/components/schemas/PlmnId"
      },
      "nCI": {
        "$ref": "#/components/schemas/NrCellId"
      }
    }
  },
  "SnssaiList": {
    "type": "array",
    "items": {
      "$ref": "#/components/schemas/Snssai"
    }
  },
  "RrmPolicy": {
    "type": "string"
  },
  "NrPci": {
    "type": "integer",
    "maximum": 503
  },
  "NrTac": {
    "type": "integer",
    "maximum": 16777215
  },
  "NrCellId": {
    "type": "integer",
    "maximum": 68719476735
  },
  "Sst": {
    "type": "integer",
    "maximum": 255
  },
  "Snssai": {
    "type": "object",
    "properties": {
      "sst": {
        "$ref": "#/components/schemas/Sst"
      },
      "sd": {
        "type": "string"
      }
    }
  },
  "CellState": {
    "type": "string",
    "enum": [
      "IDLE",
      "INACTIVE",
      "ACTIVE"
    ]
  },
  "CyclicPrefix": {
    "type": "string",
    "enum": [
      "15",
      "30",
      "60",
      "120"
    ]
  },
  "TxDirection": {
    "type": "string",
    "enum": [
      "DL",
      "UL",
      "DL and UL"
    ]
  },
  "BwpContext": {
    "type": "string",
    "enum": [

```

```

        "DL",
        "UL",
        "SUL"
    ]
},
"IsInitialBwp": {
    "type": "string",
    "enum": [
        "INITIAL",
        "OTHER",
        "SUL"
    ]
},
"QuotaType": {
    "type": "string",
    "enum": [
        "STRICT",
        "FLOAT"
    ]
},
"RrmPolicyRatio2": {
    "type": "object",
    "properties": {
        "groupId": {
            "type": "integer"
        },
        "sNSSAList": {
            "$ref": "#/components/schemas/SnssaiList"
        },
        "quotaType": {
            "$ref": "#/components/schemas/QuotaType"
        },
        "rRMPolicyMaxRation": {
            "type": "integer"
        },
        "rRMPolicyMarginMaxRation": {
            "type": "integer"
        },
        "rRMPolicyMinRation": {
            "type": "integer"
        },
        "rRMPolicyMarginMinRation": {
            "type": "integer"
        }
    }
},
"Mnc": {
    "type": "string",
    "pattern": "[0-9]{3}|[0-9]{2}"
},
"PlmnId": {
    "type": "object",
    "properties": {
        "mcc": {
            "$ref": "genericNrm.json#/components/schemas/Mcc"
        },
        "mnc": {
            "$ref": "#/components/schemas/Mnc"
        }
    }
},
"PlmnIdList": {
    "type": "array",
    "items": {
        "$ref": "#/components/schemas/PlmnId"
    }
},
"LocalAddress": {
    "type": "object",
    "properties": {
        "ipv4Address": {
            "$ref": "genericNrm.json#/components/schemas/Ipv4Addr"
        },
        "ipv6Address": {
            "$ref": "genericNrm.json#/components/schemas/Ipv6Addr"
        },
        "vlanId": {
            "type": "integer",

```

```
        "minimum": 0,
        "maximum": 4096
      },
      "port": {
        "type": "integer",
        "minimum": 0,
        "maximum": 65535
      }
    }
  },
  "RemoteAddress": {
    "type": "object",
    "properties": {
      "ipv4Address": {
        "$ref": "genericNrm.json#/components/schemas/Ipv4Addr"
      },
      "ipv6Address": {
        "$ref": "genericNrm.json#/components/schemas/Ipv6Addr"
      }
    }
  },
  "CellIndividualOffset": {
    "type": "object",
    "properties": {
      "rsrpOffsetSSB": {
        "type": "integer"
      },
      "rsrqOffsetSSB": {
        "type": "integer"
      },
      "sinrOffsetSSB": {
        "type": "integer"
      },
      "rsrpOffsetCSI-RS": {
        "type": "integer"
      },
      "rsrqOffsetCSI-RS": {
        "type": "integer"
      },
      "sinrOffsetCSI-RS": {
        "type": "integer"
      }
    }
  },
  "QOffsetRange": {
    "type": "integer",
    "enum": [
      -24,
      -22,
      -20,
      -18,
      -16,
      -14,
      -12,
      -10,
      -8,
      -6,
      -5,
      -4,
      -3,
      -2,
      -1,
      0,
      24,
      22,
      20,
      18,
      16,
      14,
      12,
      10,
      8,
      6,
      5,
      4,
      3,
      2,
      1
    ]
  }
}
```



```

    ]
  },
  "QOffsetRangeList": {
    "type": "object",
    "properties": {
      "rsrpOffsetSSB": {
        "$ref": "#/components/schemas/QOffsetRange"
      },
      "rsrqOffsetSSB": {
        "$ref": "#/components/schemas/QOffsetRange"
      },
      "sinrOffsetSSB": {
        "$ref": "#/components/schemas/QOffsetRange"
      },
      "rsrpOffsetCSI-RS": {
        "$ref": "#/components/schemas/QOffsetRange"
      },
      "rsrqOffsetCSI-RS": {
        "$ref": "#/components/schemas/QOffsetRange"
      },
      "sinrOffsetCSI-RS": {
        "$ref": "#/components/schemas/QOffsetRange"
      }
    }
  },
  "QOffsetFreq": {
    "type": "number"
  },
  "TReselectionNRSf": {
    "type": "integer",
    "enum": [
      25,
      50,
      75,
      100
    ]
  },
  "SsbPeriodicity": {
    "type": "integer",
    "enum": [
      5,
      10,
      20,
      40,
      80,
      160
    ]
  },
  "SsbDuration": {
    "type": "integer",
    "enum": [
      1,
      2,
      3,
      4,
      5
    ]
  },
  "SsbSubCarrierSpacing": {
    "type": "integer",
    "enum": [
      15,
      30,
      120,
      240
    ]
  },
  "GnbDuFunction": {
    "allOf": [
      {
        "$ref": "genericNrm.json#/components/schemas/Top-Attributes"
      },
      {
        "type": "object",
        "properties": {
          "attributes": {
            "allOf": [

```

```

    "$ref": "genericNrm.json#/components/schemas/ManagedFunction-Attributes"
  },
  {
    "type": "object",
    "properties": {
      "gnbDuId": {
        "$ref": "#/components/schemas/GnbDuId"
      },
      "gnbDuName": {
        "$ref": "#/components/schemas/GnbName"
      },
      "gnbId": {
        "$ref": "#/components/schemas/GnbId"
      },
      "gnbIdLength": {
        "$ref": "#/components/schemas/GnbIdLength"
      }
    }
  }
]
},
{
  "$ref": "genericNrm.json#/components/schemas/ManagedFunction-ContainingObjects"
},
{
  "type": "object",
  "properties": {
    "EP_F1C": {
      "$ref": "#/components/schemas/EP_F1C"
    },
    "EP_F1U": {
      "type": "array",
      "items": {
        "$ref": "#/components/schemas/EP_F1U"
      }
    },
    "NrCellDu": {
      "type": "array",
      "items": {
        "$ref": "#/components/schemas/NrCellDu"
      }
    },
    "NrSectorCarrier": {
      "type": "array",
      "items": {
        "$ref": "#/components/schemas/NrSectorCarrier"
      }
    },
    "Bwp": {
      "type": "array",
      "items": {
        "$ref": "#/components/schemas/Bwp"
      }
    },
    "CommonBeamformingFunction": {
      "type": "array",
      "items": {
        "$ref": "#/components/schemas/CommonBeamformingFunction"
      }
    },
    "Beam": {
      "type": "array",
      "items": {
        "$ref": "#/components/schemas/Beam"
      }
    }
  }
}
],
},
"GnbCuCpFunction": {
  "allOf": [
    {
      "$ref": "genericNrm.json#/components/schemas/Top-Attributes"
    },
    {

```

```

    "type": "object",
    "properties": {
      "attributes": {
        "allOf": [
          {
            "$ref": "genericNrm.json#/components/schemas/ManagedFunction-Attributes"
          },
          {
            "type": "object",
            "properties": {
              "gnbId": {
                "$ref": "#/components/schemas/GnbId"
              },
              "gnbIdLength": {
                "$ref": "#/components/schemas/GnbIdLength"
              },
              "gnbCuName": {
                "$ref": "#/components/schemas/GnbName"
              },
              "plmnId": {
                "$ref": "#/components/schemas/PlmnId"
              }
            }
          }
        ]
      }
    },
    {
      "$ref": "genericNrm.json#/components/schemas/ManagedFunction-ContainingObjects"
    },
    {
      "type": "object",
      "properties": {
        "EP_F1C": {
          "type": "array",
          "items": {
            "$ref": "#/components/schemas/EP_F1C"
          }
        },
        "EP_E1": {
          "type": "array",
          "items": {
            "$ref": "#/components/schemas/EP_E1"
          }
        },
        "EP_XnC": {
          "type": "array",
          "items": {
            "$ref": "#/components/schemas/EP_XnC"
          }
        },
        "EP_X2C": {
          "type": "array",
          "items": {
            "$ref": "#/components/schemas/EP_X2C"
          }
        },
        "EP_NgC": {
          "type": "array",
          "items": {
            "$ref": "#/components/schemas/EP_NgC"
          }
        },
        "NrCellCu": {
          "type": "array",
          "items": {
            "$ref": "#/components/schemas/NrCellCu"
          }
        }
      }
    }
  ],
  "GnbCuUpFunction": {
    "allOf": [
      {
        "$ref": "genericNrm.json#/components/schemas/Top-Attributes"
      }
    ]
  }
}

```

```

    },
    {
      "type": "object",
      "properties": {
        "attributes": {
          "allOf": [
            {
              "$ref": "genericNrm.json#/components/schemas/ManagedFunction-Attributes"
            },
            {
              "type": "object",
              "properties": {
                "gnbId": {
                  "$ref": "#/components/schemas/GnbId"
                },
                "gnbIdLength": {
                  "$ref": "#/components/schemas/GnbIdLength"
                },
                "gnbCuUpId": {
                  "$ref": "#/components/schemas/GnbCuUpId"
                },
                "plmnIdList": {
                  "$ref": "#/components/schemas/PlmnIdList"
                }
              }
            }
          ]
        }
      }
    },
    {
      "$ref": "genericNrm.json#/components/schemas/ManagedFunction-ContainingObjects"
    },
    {
      "type": "object",
      "properties": {
        "EP_E1": {
          "$ref": "#/components/schemas/EP_E1"
        },
        "EP_F1U": {
          "type": "array",
          "items": {
            "$ref": "#/components/schemas/EP_F1U"
          }
        },
        "EP_XnU": {
          "type": "array",
          "items": {
            "$ref": "#/components/schemas/EP_XnU"
          }
        },
        "EP_NgU": {
          "type": "array",
          "items": {
            "$ref": "#/components/schemas/EP_NgU"
          }
        },
        "EP_X2U": {
          "type": "array",
          "items": {
            "$ref": "#/components/schemas/EP_X2U"
          }
        },
        "EP_S1U": {
          "type": "array",
          "items": {
            "$ref": "#/components/schemas/EP_S1U"
          }
        }
      }
    }
  ],
  "NrCellCu": {
    "allOf": [
      {
        "$ref": "genericNrm.json#/components/schemas/Top-Attributes"
      }
    ]
  },

```

```

{
  "type": "object",
  "properties": {
    "attributes": {
      "allOf": [
        {
          "$ref": "genericNrm.json#/components/schemas/ManagedFunction-Attributes"
        },
        {
          "type": "object",
          "properties": {
            "cellLocalId": {
              "type": "integer"
            },
            "plmnIdList": {
              "$ref": "#/components/schemas/PlmnIdList"
            },
            "snssaiList": {
              "$ref": "#/components/schemas/SnssaiList"
            },
            "rrmPolicyType": {
              "type": "integer"
            },
            "rrmPolicyNSSIId": {
              "$ref": "genericNrm.json#/components/schemas/Dn"
            },
            "rrmPolicyRatio": {
              "type": "integer"
            },
            "rrmPolicy": {
              "$ref": "#/components/schemas/RrmPolicy"
            },
            "rrmPolicyRatio2": {
              "$ref": "#/components/schemas/RrmPolicyRatio2"
            },
            "nRFrequencyRef": {
              "$ref": "genericNrm.json#/components/schemas/Dn"
            }
          }
        }
      ]
    }
  },
  "$ref": "genericNrm.json#/components/schemas/ManagedFunction-ContainingObjects"
},
{
  "type": "object",
  "properties": {
    "NRCellRelation": {
      "type": "array",
      "items": {
        "$ref": "#/components/schemas/NRCellRelation"
      }
    },
    "NRFreqRelation": {
      "type": "array",
      "items": {
        "$ref": "#/components/schemas/NRFreqRelation"
      }
    },
    "EUTranCellRelation": {
      "type": "array",
      "items": {
        "$ref": "#/components/schemas/EUTranCellRelation"
      }
    },
    "EUTranFreqRelation": {
      "type": "array",
      "items": {
        "$ref": "#/components/schemas/EUTranFreqRelation"
      }
    }
  }
}
],
},

```

```

"NrCellDu": {
  "allOf": [
    {
      "$ref": "genericNrm.json#/components/schemas/Top-Attributes"
    },
    {
      "type": "object",
      "properties": {
        "attributes": {
          "allOf": [
            {
              "$ref": "genericNrm.json#/components/schemas/ManagedFunction-Attributes"
            },
            {
              "type": "object",
              "properties": {
                "administrativeState": {
                  "$ref": "genericNrm.json#/components/schemas/AdministrativeState"
                },
                "operationalState": {
                  "$ref": "genericNrm.json#/components/schemas/OperationalState"
                },
                "cellLocalId": {
                  "type": "integer"
                },
                "cellState": {
                  "$ref": "#/components/schemas/CellState"
                },
                "plmnIdList": {
                  "$ref": "#/components/schemas/PlmnIdList"
                },
                "snssaiList": {
                  "$ref": "#/components/schemas/SnssaiList"
                },
                "nrPci": {
                  "$ref": "#/components/schemas/NrPci"
                },
                "nrTac": {
                  "$ref": "#/components/schemas/NrTac"
                },
                "arfcnDL": {
                  "type": "integer"
                },
                "arfcnUL": {
                  "type": "integer"
                },
                "arfcnSUL": {
                  "type": "integer"
                },
                "bSChannelBwDL": {
                  "type": "integer"
                },
                "bSChannelBwUL": {
                  "type": "integer"
                },
                "bSChannelBwSUL": {
                  "type": "integer"
                },
                "ssbFrequency": {
                  "type": "integer",
                  "minimum": 0,
                  "maximum": 3279165
                },
                "ssbPeriodicity": {
                  "$ref": "#/components/schemas/SsbPeriodicity"
                },
                "ssbSubCarrierSpacing": {
                  "$ref": "#/components/schemas/SsbSubCarrierSpacing"
                },
                "ssbOffset": {
                  "type": "integer",
                  "minimum": 0,
                  "maximum": 159
                },
                "ssbDuration": {
                  "$ref": "#/components/schemas/SsbDuration"
                },
                "nrSectorCarrierRef": {

```

```

        "type": "array",
        "items": {
          "$ref": "genericNrm.json#/components/schemas/Dn"
        }
      },
      "bwpRef": {
        "type": "array",
        "items": {
          "$ref": "genericNrm.json#/components/schemas/Dn"
        }
      },
      "nrFrequencyRef": {
        "$ref": "genericNrm.json#/components/schemas/Dn"
      }
    }
  ]
},
{
  "$ref": "genericNrm.json#/components/schemas/ManagedFunction-ContainingObjects"
}
]
},
"NrSectorCarrier": {
  "allof": [
    {
      "$ref": "genericNrm.json#/components/schemas/Top-Attributes"
    },
    {
      "type": "object",
      "properties": {
        "attributes": {
          "allof": [
            {
              "$ref": "genericNrm.json#/components/schemas/ManagedFunction-Attributes"
            },
            {
              "type": "object",
              "properties": {
                "txDirection": {
                  "$ref": "#/components/schemas/TxDirection"
                },
                "configuredMaxTxPower": {
                  "type": "integer"
                },
                "arfcnDL": {
                  "type": "integer"
                },
                "arfcnUL": {
                  "type": "integer"
                },
                "bSChannelBwDL": {
                  "type": "integer"
                },
                "bSChannelBwUL": {
                  "type": "integer"
                },
                "sectorEquipmentFunctionRef": {
                  "$ref": "genericNrm.json#/components/schemas/Dn"
                }
              }
            }
          ]
        }
      }
    }
  ]
},
{
  "$ref": "genericNrm.json#/components/schemas/ManagedFunction-ContainingObjects"
}
]
},
"Bwp": {
  "allof": [
    {
      "$ref": "genericNrm.json#/components/schemas/Top-Attributes"
    }
  ]
},

```

```

    {
      "type": "object",
      "properties": {
        "attributes": {
          "allOf": [
            {
              "$ref": "genericNrm.json#/components/schemas/ManagedFunction-Attributes"
            },
            {
              "type": "object",
              "properties": {
                "bwpContext": {
                  "$ref": "#/components/schemas/BwpContext"
                },
                "isInitialBwp": {
                  "$ref": "#/components/schemas/IsInitialBwp"
                },
                "subCarrierSpacing": {
                  "type": "integer"
                },
                "cyclicPrefix": {
                  "$ref": "#/components/schemas/CyclicPrefix"
                },
                "startRB": {
                  "type": "integer"
                },
                "numberOfRBs": {
                  "type": "integer"
                }
              }
            }
          ]
        }
      }
    },
    {
      "$ref": "genericNrm.json#/components/schemas/ManagedFunction-ContainingObjects"
    }
  ],
},

```

```

"CommonBeamformingFunction": {
  "allOf": [
    {
      "$ref": "genericNrm.json#/components/schemas/Top-Attributes"
    },
    {
      "type": "object",
      "properties": {
        "attributes": {
          "allOf": [
            {
              "type": "object"
            }
          ]
        }
      }
    }
  ],
},
],
},

```

```

"Beam": {
  "allOf": [
    {
      "$ref": "genericNrm.json#/components/schemas/Top-Attributes"
    },
    {
      "type": "object",
      "properties": {
        "attributes": {
          "allOf": [
            {
              "type": "object",
              "properties": {

```



```

    }
  },
  "EP_F1U": {
    "type": "array",
    "items": {
      "$ref": "#/components/schemas/EP_F1U"
    }
  }
}
]
},
"ExternalGnbCuCpFunction": {
  "allOf": [
    {
      "$ref": "genericNrm.json#/components/schemas/Top-Attributes"
    },
    {
      "type": "object",
      "properties": {
        "attributes": {
          "allOf": [
            {
              "$ref": "genericNrm.json#/components/schemas/ManagedFunction-Attributes"
            },
            {
              "type": "object",
              "properties": {
                "gnbId": {
                  "$ref": "#/components/schemas/GnbId"
                },
                "gnbIdLength": {
                  "$ref": "#/components/schemas/GnbIdLength"
                },
                "plmnId": {
                  "$ref": "#/components/schemas/PlmnId"
                }
              }
            }
          ]
        }
      }
    }
  ],
  "$ref": "genericNrm.json#/components/schemas/ManagedFunction-ContainingObjects"
},
{
  "type": "object",
  "properties": {
    "ExternalNrCellCu": {
      "type": "array",
      "items": {
        "$ref": "#/components/schemas/ExternalNrCellCu"
      }
    },
    "EP_F1C": {
      "type": "array",
      "items": {
        "$ref": "#/components/schemas/EP_F1C"
      }
    },
    "EP_E1": {
      "type": "array",
      "items": {
        "$ref": "#/components/schemas/EP_E1"
      }
    },
    "EP_XnC": {
      "type": "array",
      "items": {
        "$ref": "#/components/schemas/EP_XnC"
      }
    }
  }
}
]
},
"ExternalGnbCuUpFunction": {

```

```

"allOf": [
  {
    "$ref": "genericNrm.json#/components/schemas/Top-Attributes"
  },
  {
    "type": "object",
    "properties": {
      "attributes": {
        "allOf": [
          {
            "$ref": "genericNrm.json#/components/schemas/ManagedFunction-Attributes"
          },
          {
            "type": "object",
            "properties": {
              "gnbId": {
                "$ref": "#/components/schemas/GnbId"
              },
              "gnbIdLength": {
                "$ref": "#/components/schemas/GnbIdLength"
              }
            }
          }
        ]
      }
    }
  }
],
{
  "$ref": "genericNrm.json#/components/schemas/ManagedFunction-ContainingObjects"
},
{
  "type": "object",
  "properties": {
    "EP_E1": {
      "type": "array",
      "items": {
        "$ref": "#/components/schemas/EP_E1"
      }
    },
    "EP_F1U": {
      "type": "array",
      "items": {
        "$ref": "#/components/schemas/EP_F1U"
      }
    },
    "EP_XnU": {
      "type": "array",
      "items": {
        "$ref": "#/components/schemas/EP_XnU"
      }
    }
  }
}
],
"ExternalAmfFunction": {
  "allOf": [
    {
      "$ref": "genericNrm.json#/components/schemas/Top-Attributes"
    },
    {
      "type": "object",
      "properties": {
        "attributes": {
          "allOf": [
            {
              "$ref": "genericNrm.json#/components/schemas/ManagedFunction-Attributes"
            }
          ]
        }
      }
    }
  ]
},
{
  "$ref": "genericNrm.json#/components/schemas/ManagedFunction-ContainingObjects"
},
{
  "type": "object",
  "properties": {

```

```

        "EP_NgC": {
          "type": "array",
          "items": {
            "$ref": "#/components/schemas/EP_NgC"
          }
        }
      ]
    },
    "ExternalUpfFunction": {
      "allOf": [
        {
          "$ref": "genericNrm.json#/components/schemas/Top-Attributes"
        },
        {
          "type": "object",
          "properties": {
            "attributes": {
              "allOf": [
                {
                  "$ref": "genericNrm.json#/components/schemas/ManagedFunction-Attributes"
                }
              ]
            }
          }
        },
        {
          "$ref": "genericNrm.json#/components/schemas/ManagedFunction-ContainingObjects"
        },
        {
          "type": "object",
          "properties": {
            "EP_NgU": {
              "type": "array",
              "items": {
                "$ref": "#/components/schemas/EP_NgU"
              }
            }
          }
        }
      ]
    },
    "ExternalNrCellCu": {
      "allOf": [
        {
          "$ref": "genericNrm.json#/components/schemas/Top-Attributes"
        },
        {
          "type": "object",
          "properties": {
            "attributes": {
              "allOf": [
                {
                  "$ref": "genericNrm.json#/components/schemas/ManagedFunction-Attributes"
                },
                {
                  "type": "object",
                  "properties": {
                    "cellLocalId": {
                      "type": "integer"
                    },
                    "nrPci": {
                      "$ref": "#/components/schemas/NrPci"
                    },
                    "plmnIdList": {
                      "$ref": "#/components/schemas/PlmnIdList"
                    },
                    "nrFrequencyRef": {
                      "$ref": "genericNrm.json#/components/schemas/Dn"
                    }
                  }
                }
              ]
            }
          }
        }
      ]
    }
  },
  {

```

```

    "$ref": "genericNrm.json#/components/schemas/ManagedFunction-ContainingObjects"
  }
],
},
"NRCCellRelation": {
  "allOf": [
    {
      "$ref": "genericNrm.json#/components/schemas/Top-Attributes"
    },
    {
      "type": "object",
      "properties": {
        "attributes": {
          "allOf": [
            {
              "$ref": "genericNrm.json#/components/schemas/ManagedFunction-Attributes"
            },
            {
              "type": "object",
              "properties": {
                "nRTCI": {
                  "type": "integer"
                },
                "cellIndividualOffset": {
                  "$ref": "#/components/schemas/CellIndividualOffset"
                },
                "adjacentNRCellRef": {
                  "$ref": "genericNrm.json#/components/schemas/Dn"
                },
                "nRFrequencyRef": {
                  "$ref": "genericNrm.json#/components/schemas/Dn"
                }
              }
            }
          ]
        }
      }
    }
  ]
},
{
  "$ref": "genericNrm.json#/components/schemas/ManagedFunction-ContainingObjects"
}
],
},
"NRFreqRelation": {
  "allOf": [
    {
      "$ref": "genericNrm.json#/components/schemas/Top-Attributes"
    },
    {
      "type": "object",
      "properties": {
        "attributes": {
          "allOf": [
            {
              "type": "object",
              "properties": {
                "offsetMO": {
                  "$ref": "#/components/schemas/QOffsetRangeList"
                },
                "blackListEntry": {
                  "type": "array",
                  "items": {
                    "type": "integer",
                    "minimum": 0,
                    "maximum": 1007
                  }
                },
                "blackListEntryIdleMode": {
                  "type": "integer"
                }
              }
            },
            {
              "type": "integer"
            }
          ]
        },
        "cellReselectionPriority": {
          "type": "integer"
        },
        "cellReselectionSubPriority": {
          "type": "number",
          "minimum": 0.2,
          "maximum": 0.8,
          "multipleOf": 0.2
        }
      }
    }
  ]
}

```

```

    },
    "pMax": {
      "type": "integer",
      "minimum": -30,
      "maximum": 33
    },
    "qOffsetFreq": {
      "$ref": "#/components/schemas/QOffsetFreq"
    },
    "qQualMin": {
      "type": "number"
    },
    "qRxLevMin": {
      "type": "integer",
      "minimum": -140,
      "maximum": -44
    },
    "threshXHighP": {
      "type": "integer",
      "minimum": 0,
      "maximum": 62
    },
    "threshXHighQ": {
      "type": "integer",
      "minimum": 0,
      "maximum": 31
    },
    "threshXLowP": {
      "type": "integer",
      "minimum": 0,
      "maximum": 62
    },
    "threshXLowQ": {
      "type": "integer",
      "minimum": 0,
      "maximum": 31
    },
    "tReselectionNr": {
      "type": "integer",
      "minimum": 0,
      "maximum": 7
    },
    "tReselectionNRSfHigh": {
      "$ref": "#/components/schemas/TReselectionNRSf"
    },
    "tReselectionNRSfMedium": {
      "$ref": "#/components/schemas/TReselectionNRSf"
    },
    "nRFrequencyRef": {
      "$ref": "genericNrm.json#/components/schemas/Dn"
    }
  }
}
]
}
},
{
  "$ref": "genericNrm.json#/components/schemas/ManagedFunction-ContainingObjects"
}
],
"NRFrequency": {
  "allOf": [
    {
      "$ref": "genericNrm.json#/components/schemas/Top-Attributes"
    },
    {
      "type": "object",
      "properties": {
        "attributes": {
          "allOf": [
            {
              "type": "object",
              "properties": {
                "absoluteFrequencySSB": {
                  "type": "integer",
                  "minimum": 0,

```



```

    }
  ]
}
},
{
  "$ref": "genericNrm.json#/components/schemas/ManagedFunction-ContainingObjects"
}
]
},
"EUtranCellRelation": {
  "allOf": [
    {
      "$ref": "genericNrm.json#/components/schemas/Top-Attributes"
    },
    {
      "type": "object",
      "properties": {
        "attributes": {
          "allOf": [
            {
              "type": "object",
              "properties": {
                "adjacentEUtranCellRef": {
                  "$ref": "genericNrm.json#/components/schemas/Dn"
                }
              }
            }
          ]
        }
      }
    }
  ]
},
}
],
},
"EUtranFreqRelation": {
  "allOf": [
    {
      "$ref": "genericNrm.json#/components/schemas/Top-Attributes"
    },
    {
      "type": "object",
      "properties": {
        "cellIndividualOffset": {
          "$ref": "#/components/schemas/CellIndividualOffset"
        },
        "blackListEntry": {
          "type": "array",
          "items": {
            "type": "integer",
            "minimum": 0,
            "maximum": 1007
          }
        },
        "blackListEntryIdleMode": {
          "type": "integer"
        },
        "cellReselectionPriority": {
          "type": "integer"
        },
        "cellReselectionSubPriority": {
          "type": "number",
          "minimum": 0.2,
          "maximum": 0.8,
          "multipleOf": 0.2
        },
        "pMax": {
          "type": "integer",
          "minimum": -30,
          "maximum": 33
        },
        "qOffsetFreq": {
          "$ref": "#/components/schemas/QOffsetFreq"
        },
        "qQualMin": {
          "type": "number"
        },
        "qRxLevMin": {

```



```

        "type": "integer",
        "minimum": -140,
        "maximum": -44
      },
      "threshXHighP": {
        "type": "integer",
        "minimum": 0,
        "maximum": 62
      },
      "threshXHighQ": {
        "type": "integer",
        "minimum": 0,
        "maximum": 31
      },
      "threshXLowP": {
        "type": "integer",
        "minimum": 0,
        "maximum": 62
      },
      "threshXLowQ": {
        "type": "integer",
        "minimum": 0,
        "maximum": 31
      },
      "tReselectionEutran": {
        "type": "integer",
        "minimum": 0,
        "maximum": 7
      },
      "tReselectionNRSfHigh": {
        "$ref": "#/components/schemas/TReselectionNRSf"
      },
      "tReselectionNRSfMedium": {
        "$ref": "#/components/schemas/TReselectionNRSf"
      },
      "attributes": {
        "allOf": [
          {
            "$ref": "genericNrm.json#/components/schemas/ManagedFunction-Attributes"
          },
          {
            "type": "object",
            "properties": {
              "eUTranFrequencyRef": {
                "$ref": "genericNrm.json#/components/schemas/Dn"
              }
            }
          }
        ]
      }
    },
    {
      "$ref": "genericNrm.json#/components/schemas/ManagedFunction-ContainingObjects"
    }
  ],
  "EUTranFrequency": {
    "allOf": [
      {
        "$ref": "genericNrm.json#/components/schemas/Top-Attributes"
      },
      {
        "type": "object",
        "properties": {
          "attributes": {
            "allOf": [
              {
                "$ref": "genericNrm.json#/components/schemas/ManagedFunction-Attributes"
              },
              {
                "type": "object",
                "properties": {
                  "earfcnDL": {
                    "type": "integer",
                    "minimum": 0,
                    "maximum": 262143
                  }
                }
              }
            ]
          }
        }
      }
    ]
  },

```

```

        "multiBandInfoListEutra": {
            "type": "integer",
            "minimum": 1,
            "maximum": 256
        }
    },
    ],
},
"ManagedElement-Single": {
    "allOf": [
        {
            "$ref": "genericNrm.json#/components/schemas/Top-Attributes"
        },
        {
            "type": "object",
            "properties": {
                "attributes": {
                    "allOf": [
                        {
                            "$ref": "genericNrm.json#/components/schemas/ManagedElement-Attributes"
                        }
                    ]
                }
            }
        },
        {
            "$ref": "genericNrm.json#/components/schemas/ManagedElement-ContainingObjects"
        },
        {
            "type": "object",
            "properties": {
                "GnbDuFunction": {
                    "type": "array",
                    "items": {
                        "$ref": "#/components/schemas/GnbDuFunction"
                    }
                },
                "GnbCuCpFunction": {
                    "type": "array",
                    "items": {
                        "$ref": "#/components/schemas/GnbCuCpFunction"
                    }
                },
                "GnbCuUpFunction": {
                    "type": "array",
                    "items": {
                        "$ref": "#/components/schemas/GnbCuUpFunction"
                    }
                }
            }
        }
    ]
},
"ManagedElement-Multiple": {
    "type": "array",
    "items": {
        "$ref": "#/components/schemas/ManagedElement-Single"
    }
},
"SubNetwork-Single": {
    "allOf": [
        {
            "$ref": "genericNrm.json#/components/schemas/Top-Attributes"
        },
        {
            "type": "object",
            "properties": {
                "attributes": {
                    "allOf": [
                        {
                            "$ref": "genericNrm.json#/components/schemas/SubNetwork-Attributes"
                        }
                    ]
                }
            }
        }
    ]
},
}

```

```

    "$ref": "genericNrm.json#/components/schemas/SubNetwork-ContainingObjects"
  },
  {
    "type": "object",
    "properties": {
      "SubNetwork": {
        "$ref": "#/components/schemas/SubNetwork-Multiple"
      },
      "ManagedElement": {
        "$ref": "#/components/schemas/ManagedElement-Multiple"
      },
      "ExternalGnbCuCpFunction": {
        "type": "array",
        "items": {
          "$ref": "#/components/schemas/ExternalGnbCuCpFunction"
        }
      },
      "ExternalENBFunction": {
        "type": "array",
        "items": {
          "$ref": "#/components/schemas/ExternalENBFunction"
        }
      },
      "NRFrequency": {
        "type": "array",
        "items": {
          "$ref": "#/components/schemas/NRFrequency"
        }
      },
      "EUTranFrequency": {
        "type": "array",
        "items": {
          "$ref": "#/components/schemas/EUTranFrequency"
        }
      }
    }
  }
]
},
"SubNetwork-Multiple": {
  "type": "array",
  "items": {
    "$ref": "#/components/schemas/SubNetwork-Single"
  }
},
"EP_RP": {
  "allof": [
    {
      "$ref": "genericNrm.json#/components/schemas/Top-Attributes"
    },
    {
      "type": "object",
      "properties": {
        "attributes": {
          "type": "object",
          "properties": {
            "userLabel": {
              "type": "string"
            },
            "farEndEntity": {
              "type": "string"
            },
            "localAddress": {
              "$ref": "#/components/schemas/LocalAddress"
            },
            "remoteAddress": {
              "$ref": "#/components/schemas/RemoteAddress"
            }
          }
        }
      }
    }
  ]
},
"EP_E1": {
  "$ref": "#/components/schemas/EP_RP"
},
"EP_XnC": {

```

```
    "$ref": "#/components/schemas/EP_RP"
  },
  "EP_XnU": {
    "$ref": "#/components/schemas/EP_RP"
  },
  "EP_NgC": {
    "$ref": "#/components/schemas/EP_RP"
  },
  "EP_NgU": {
    "$ref": "#/components/schemas/EP_RP"
  },
  "EP_F1C": {
    "$ref": "#/components/schemas/EP_RP"
  },
  "EP_F1U": {
    "$ref": "#/components/schemas/EP_RP"
  },
  "EP_S1U": {
    "$ref": "#/components/schemas/EP_RP"
  },
  "EP_X2C": {
    "$ref": "#/components/schemas/EP_RP"
  },
  "EP_X2U": {
    "$ref": "#/components/schemas/EP_RP"
  }
}
}
```

Annex E (normative): YANG definitions for NR NRM

E.1 General

This annex contains the YANG definitions for the NR and NG-RAN NRM, in accordance with NR and NG-RAN NRM information model definitions specified in clause 4.

E.2 Void

E.3 Void

E.4 Void

E.5 Modules

This is the list of YANG modules for NR and NG-RAN NRM.

```
_3gpp-nr-nrm-beam.yang
_3gpp-nr-nrm-bwp.yang
_3gpp-nr-nrm-commonbeamformingfunction.yang
_3gpp-nr-nrm-ep.yang
_3gpp-nr-nrm-eutrancellrelation.yang
_3gpp-nr-nrm-eutranetwork.yang
_3gpp-nr-nrm-eutranfreqrelation.yang
_3gpp-nr-nrm-eutranfrequency.yang
_3gpp-nr-nrm-externalamffunction.yang
_3gpp-nr-nrm-externalenbfunction.yang
_3gpp-nr-nrm-externaleutrancell.yang
_3gpp-nr-nrm-externalgnbcucpfunction.yang
_3gpp-nr-nrm-externalgnbcuupfunction.yang
_3gpp-nr-nrm-externalgnbdufunction.yang
_3gpp-nr-nrm-externalnrcellcu.yang
_3gpp-nr-nrm-externalservinggwfunction.yang
_3gpp-nr-nrm-externalupffunction.yang
_3gpp-nr-nrm-gnbcucpfunction.yang
_3gpp-nr-nrm-gnbcuupfunction.yang
_3gpp-nr-nrm-gnbdufunction.yang
_3gpp-nr-nrm-nrcellcu.yang
_3gpp-nr-nrm-nrcelldu.yang
_3gpp-nr-nrm-nrcellrelation.yang
_3gpp-nr-nrm-nrfreqrelation.yang
_3gpp-nr-nrm-nrfrequency.yang
_3gpp-nr-nrm-nrnetwork.yang
_3gpp-nr-nrm-nrsectorcarrier.yang
```

These are the YANG modules for NR and NG-RAN NRM.

```
module _3gpp-nr-nrm-beam {
  yang-version 1.1;
  namespace "urn:3gpp:sa5:_3gpp-nr-nrm-nrnetwork-beam";
  prefix "beam3gpp";

  import _3gpp-common-yang-types { prefix types3gpp; }
  import _3gpp-nr-nrm-commonbeamformingfunction { prefix combeamformfunc3gpp; }
  import _3gpp-common-top { prefix top3gpp; }
```

```

organization "3GPP SA5";
description "Defines the YANG mapping of the Beam Information
  Object Class (IOC) that is part of the NR Network Resource Model (NRM).";
reference "3GPP TS 28.541 5G Network Resource Model (NRM)";

revision 2019-XX-XX {
  description "Initial revision";
  reference "Based on
    3GPP TS 28.541 V15.X.XX";
}

typedef BeamType {
  type enumeration {
    enum SSB-BEAM;
  }
}

grouping BeamGrp {
  description "Represents the Beam IOC.";
  reference "3GPP TS 28.541";
  uses mf3gpp:ManagedFunctionGrp;

  leaf beamIndex {
    description "Index of the beam.";
    mandatory true;
    type int32;
  }

  leaf beamType {
    description "The type of the beam.";
    mandatory false;
    type BeamType;
  }

  leaf beamAzimuth {
    description "The azimuth of a beam transmission, which means the horizontal beamforming
  pointing angle (beam peak direction) in the (Phi)  $\phi$ -axis in 1/10th degree resolution. The pointing
  angle is the direction equal to the geometric centre of the half-power contour of the beam relative
  to the reference plane. Zero degree implies explicit antenna bearing (boresight). Positive angle
  implies clockwise from the antenna bearing.";
    reference "3GPP TS 38.104, TS 38.901, TS 28.662";
    mandatory false;
    type int32 { range "-1800..1800"; }
    units 0.1 degree;
  }

  leaf beamTilt {
    description "The tilt of a beam transmission, which means the vertical beamforming pointing
  angle (beam peak direction) in the (Theta)  $\theta$ -axis in 1/10th degree resolution.
  The pointing angle is the direction equal to the geometric centre of the half-power contour of the
  beam relative to the reference plane. Positive value implies downtilt.";
    reference "3GPP TS 38.104, TS 38.901, TS 28.662";
    mandatory false;
    type int32 { range "-900..900"; }
    units 0.1 degree;
  }

  leaf beamHorizWidth {
    description " The Horizontal beamWidth of a beam transmission, which means the horizontal
  beamforming half-power (3dB down) beamwidth in the (Phi)  $\phi$ -axis in 1/10th degree resolution.";
    reference "3GPP TS 38.104, TS 38.901";
    mandatory false;
    type int32 { range "0..3599"; }
    units 0.1 degree;
  }

  leaf beamVertWidth {
    description " The Vertical beamWidth of a beam transmission, which means the vertical
  beamforming half-power (3dB down) beamwidth in the (Theta)  $\theta$ -axis in 1/10th degree resolution.";
    reference "3GPP TS 38.104, TS 38.901";
    mandatory false;
    type int32 { range "0..1800"; }
    units 0.1 degree;
  }
}

```

```

augment "/me3gpp:ManagedElement/combeamformfunc3gpp:CommonBeamformingFunction" {
    list Beam {
        description "Represents the per-Beam information required for, e.g. beam performance
management utilizing measurements generated in the RAN. Can have spatial attributes of
horizontal/azimuth (ie: Phi  $\phi$ -axis) and vertical/tilt (ie: Theta  $\theta$ -axis) beam pointing direction and
beam width attributes.";
        reference "3GPP TS 28.541";
        key id;
        uses top3gpp:Top_Grp;
        container attributes {
            uses BeamGrp;
        }
    }
}

```

```

module _3gpp-nr-nrm-bwp {
    yang-version 1.1;
    namespace "urn:3gpp:sa5:_3gpp-nr-nrm-bwp";
    prefix "bwp3gpp";

    import _3gpp-common-managed-element { prefix me3gpp; }
    import _3gpp-common-managed-function { prefix mf3gpp; }
    import _3gpp-common-top { prefix top3gpp; }
    import _3gpp-nr-nrm-gnbdufunction { prefix gnbdu3gpp; }

    organization "3GPP SA5";
    description "Defines the YANG mapping of the BWP Information Object Class
(IOC) that is part of the NR Network Resource Model (NRM).";
    reference "3GPP TS 28.541 5G Network Resource Model (NRM)";

    revision 2019-06-17 {
        description "Initial revision";
        reference "Based on
3GPP TS 28.541 V15.X.XX";
    }

    typedef CyclicPrefix {
        type enumeration {
            enum NORMAL;
            enum EXTENDED;
        }
    }

    typedef BwpContext {
        type enumeration {
            enum DL;
            enum UL;
            enum SUL;
        }
    }

    typedef IsInitialBwp {
        type enumeration {
            enum INITIAL;
            enum OTHER;
        }
    }

    grouping BWPGrp {
        description "Represents the BWP IOC.";
        reference "3GPP TS 28.541";
        uses mf3gpp:ManagedFunctionGrp;

        leaf bwpContext {
            description "Identifies whether the object is used for downlink, uplink
or supplementary uplink.";
            mandatory true;
            type BwpContext;
        }

        leaf isInitialBwp {
            description "Identifies whether the object is used for initial or other
BWP.";
            mandatory true;
        }
    }
}

```

```

    type IsInitialBwp;
  }

  leaf subCarrierSpacing {
    description "Subcarrier spacing configuration for a BWP.";
    reference "3GPP TS 38.104";
    mandatory true;
    type uint32 { range "5 | 30 | 60 | 120"; }
    units kHz;
  }

  leaf cyclicPrefix {
    description "Cyclic prefix, which may be normal or extended.";
    reference "3GPP TS 38.211";
    mandatory true;
    type CyclicPrefix;
  }

  leaf startRB {
    description "Offset in common resource blocks to common resource block 0
      for the applicable subcarrier spacing for a BWP.";
    reference "N_BWP_start in 3GPP TS 38.211";
    mandatory true;
    type uint32;
  }

  leaf numberOfRBs {
    description "Number of physical resource blocks for a BWP.";
    reference "N_BWP_size in 3GPP TS 38.211";
    mandatory true;
    type uint32;
  }
}

augment "/me3gpp:ManagedElement/gnbdu3gpp:GNBDUFunction" {

  list BWP {
    description "Represents a bandwidth part (BWP).";
    key id;
    uses top3gpp:Top_Grp;
    container attributes {
      uses BWPGrp;
    }
  }
}

module _3gpp-nr-nrm-commonbeamformingfunction {
  yang-version 1.1;
  namespace "urn:3gpp:sa5:_3gpp-nr-nrm-nrnetwork-commonbeamformingfunction";
  prefix "combeamformfunc3gpp";

  import _3gpp-common-yang-types { prefix types3gpp; }
  import _3gpp-nr-nrm-nrsectorcarrier { prefix nrsectcarr3gpp; }
  import _3gpp-common-top { prefix top3gpp; }

  organization "3GPP SA5";
  description "Defines the YANG mapping of the CommonBeamformingFuntion Information
    Object Class (IOC) that is part of the NR Network Resource Model (NRM).";
  reference "3GPP TS 28.541 5G Network Resource Model (NRM)";

  revision 2019-XX-XX {
    description "Initial revision";
    reference "Based on
      3GPP TS 28.541 V15.X.XX";
  }

  grouping CommonBeamformingFunctionGrp {
    description "Represents the CommonBeamformingFunction IOC.";
    reference "3GPP TS 28.541";
    uses mf3gpp:ManagedFunctionGrp;
  }

  augment "/me3gpp:ManagedElement/nrsectcarr3gpp:NRSectorCarrier" {

```



```
list CommonBeamformingFunction {
  description "Represents common beamforming functionality (eg: SSB beams) for the
NRSectorCarrier.";
  reference "3GPP TS 28.541";
  key id;
  uses top3gpp:Top_Grp;
  container attributes {
    uses CommonBeamformingFunctionGrp;
  }
}
}
```

```
module _3gpp-nr-nrm-ep {
  yang-version 1.1;
  namespace "urn:3gpp:sa5:_3gpp-nr-nrm-ep";
  prefix "ep3gpp";

  import _3gpp-common-ep-rp { prefix eprp3gpp; }
  import _3gpp-common-managed-element { prefix me3gpp; }
  import _3gpp-common-top { prefix top3gpp; }
  import _3gpp-nr-nrm-gnbcucpfunction { prefix gnbcucp3gpp; }
  import _3gpp-nr-nrm-gnbcuupfunction { prefix gnbcuup3gpp; }
  import _3gpp-nr-nrm-gnbdufunction { prefix gnbdu3gpp; }

  organization "3GPP SA5";
  description "Defines the YANG mapping of the NR related endpoint
  Information Object Classes (IOCs) that are part of the NR Network
  Resource Model (NRM).";
  reference "3GPP TS 28.541 5G Network Resource Model (NRM)";

  revision 2019-06-17 {
    description "Initial revision";
    reference "Based on
    3GPP TS 28.541 V15.X.XX";
  }

  grouping EP_ElGrp {
    description "Represents the EP_El IOC.";
    reference "3GPP TS 28.541, 3GPP TS 38.401";
    uses eprp3gpp:EP_Common;
  }

  grouping EP_FlCGrp {
    description "Represents the EP_FlC IOC.";
    reference "3GPP TS 28.541, 3GPP TS 38.470";
    uses eprp3gpp:EP_Common;
  }

  grouping EP_FlUGrp {
    description "Represents the EP_FlU IOC.";
    reference "3GPP TS 28.541, 3GPP TS 38.470";
    uses eprp3gpp:EP_Common;
  }

  grouping EP_XnCGrp {
    description "Represents the EP_XnC IOC.";
    reference "3GPP TS 28.541, 3GPP TS 38.420";
    uses eprp3gpp:EP_Common;
  }

  grouping EP_XnUGrp {
    description "Represents the EP_XnU IOC.";
    reference "3GPP TS 28.541, 3GPP TS 38.420";
    uses eprp3gpp:EP_Common;
  }

  grouping EP_NgCGrp {
    description "Represents the EP_NgC IOC.";
    reference "3GPP TS 28.541, 3GPP TS 38.470";
    uses eprp3gpp:EP_Common;
  }
}
```

```
grouping EP_NgUGrp {
  description "Represents the EP_NgU IOC.";
  reference "3GPP TS 28.541, 3GPP TS 38.470";
  uses eprp3gpp:EP_Common;
}

grouping EP_X2CGrp {
  description "Represents the EP_X2C IOC.";
  reference "3GPP TS 28.541, 3GPP TS 36.423";
  uses eprp3gpp:EP_Common;
}

grouping EP_X2UGrp {
  description "Represents the EP_X2U IOC.";
  reference "3GPP TS 28.541, 3GPP TS 36.425";
  uses eprp3gpp:EP_Common;
}

grouping EP_S1UGrp {
  description "Represents the EP_S1U IOC.";
  reference "3GPP TS 28.541, 3GPP TS 36.410";
  uses eprp3gpp:EP_Common;
}

augment "/me3gpp:ManagedElement/gnbcucp3gpp:GNBCUCPFunction" {

  list EP_E1 {
    description "Represents the local end point of the logical link,
      supporting E1 interface between gNB-CU-CP and gNB-CU-UP.";
    reference "3GPP TS 28.541, 3GPP TS 38.401";
    key id;
    uses top3gpp:Top_Grp;
    container attributes {
      uses EP_E1Grp;
    }
  }

  list EP_F1C {
    description "Represents the local end point of the control plane
      interface (F1-C) between the DU and CU or CU-CP.";
    reference "3GPP TS 28.541, 3GPP TS 38.470";
    key id;
    uses top3gpp:Top_Grp;
    container attributes {
      uses EP_F1CGrp;
    }
  }

  list EP_NgC {
    description "Represents the local end point of the control plane
      interface (NG-C) between the gNB and NG-Core entity.";
    reference "3GPP TS 28.541, 3GPP TS 38.470";
    key id;
    uses top3gpp:Top_Grp;
    container attributes {
      uses EP_NgCGrp;
    }
  }

  list EP_XnC {
    description "Represents the local gNB node end point of the logical
      link, supporting Xn application protocols, to a neighbour gNB node.";
    reference "3GPP TS 28.541, 3GPP TS 38.420";
    key id;
    uses top3gpp:Top_Grp;
    container attributes {
      uses EP_XnCGrp;
    }
  }

  list EP_X2C {
    description "Represents the local end point of the logical link,
      supporting X2-C application protocols used in EN-DC, to a neighbour
      eNB or en-gNB node.";
    reference "3GPP TS 28.541, 3GPP TS 36.423";
    key id;
    uses top3gpp:Top_Grp;
    container attributes {
```

```
    uses EP_X2CGrp;
  }
}

augment "/me3gpp:ManagedElement/gnbcuup3gpp:GNBCUUPFunction" {

  list EP_E1 {
    description "Represents the local end point of the logical link,
      supporting E1 interface between gNB-CU-CP and gNB-CU-UP.";
    reference "3GPP TS 28.541, 3GPP TS 38.401";
    key id;
    uses top3gpp:Top_Grp;
    container attributes {
      uses EP_E1Grp;
    }
  }

  list EP_F1U {
    description "Represents the local end point of the user plane
      interface (F1-U) between the DU and CU or CU-UP.";
    reference "3GPP TS 28.541, 3GPP TS 38.470";
    key id;
    uses top3gpp:Top_Grp;
    container attributes {
      uses EP_F1UGrp;
    }
  }

  list EP_NgU {
    description "Represents the local end point of the NG user plane
      (NG-U) interface between the gNB and the UPF.";
    reference "3GPP TS 28.541, 3GPP TS 38.470";
    key id;
    uses top3gpp:Top_Grp;
    container attributes {
      uses EP_NgUGrp;
    }
  }

  list EP_XnU {
    description "Represents the one end-point of a logical link supporting
      the Xn user plane (Xn-U) interface. The Xn-U interface provides
      non-guaranteed delivery of user plane PDUs between two NG-RAN nodes.";
    reference "3GPP TS 28.541, 3GPP TS 38.420";
    key id;
    uses top3gpp:Top_Grp;
    container attributes {
      uses EP_XnUGrp;
    }
  }

  list EP_X2U {
    description "Represents the local end-point of a logical link supporting
      the X2 user plane (X2-U) interface used in EN-DC.";
    reference "3GPP TS 28.541, 3GPP TS 36.425";
    key id;
    uses top3gpp:Top_Grp;
    container attributes {
      uses EP_X2UGrp;
    }
  }

  list EP_S1U {
    description "Represents the local end point of the logical link,
      supporting S1-U interface towards a S-GW node.";
    reference "3GPP TS 28.541, 3GPP TS 36.410";
    key id;
    uses top3gpp:Top_Grp;
    container attributes {
      uses EP_S1UGrp;
    }
  }
}

augment "/me3gpp:ManagedElement/gnbdu3gpp:GNBDUFunction" {

  list EP_F1C {
```

```

        description "Represents the local end point of the control plane
            interface (F1-C) between the DU and CU or CU-CP.";
        reference "3GPP TS 28.541, 3GPP TS 38.470";
        key id;
        uses top3gpp:Top_Grp;
        container attributes {
            uses EP_F1CGrp;
        }
    }

list EP_F1U {
    description "Represents the local end point of the user plane
        interface (F1-U) between the DU and CU or CU-UP.";
    reference "3GPP TS 28.541, 3GPP TS 38.470";
    key id;
    uses top3gpp:Top_Grp;
    container attributes {
        uses EP_F1UGrp;
    }
}
}
}

module _3gpp-nr-nrm-eutranCellrelation {
    yang-version 1.1;
    namespace "urn:3gpp:sa5:_3gpp-nr-nrm-eutranCellrelation";
    prefix "eutranCellrel3gpp";

    import _3gpp-common-yang-types { prefix types3gpp; }
    import _3gpp-common-managed-function { prefix mf3gpp; }
    import _3gpp-common-managed-element { prefix me3gpp; }
    import _3gpp-nr-nrm-gnbcucpfunction { prefix gnbcucp3gpp; }
    import _3gpp-nr-nrm-nrcellcu { prefix nrcellcu3gpp; }
    import _3gpp-common-top { prefix top3gpp; }

    organization "3GPP SA5";
    description "Defines the YANG mapping of the EUTranCellRelation Information
        Object Class (IOC) that is part of the NR Network Resource Model (NRM).";
    reference "3GPP TS 28.541 5G Network Resource Model (NRM)";

    revision 2019-06-17 {
        description "Initial revision";
        reference "Based on
            3GPP TS 28.541 V15.X.XX";
    }

    typedef ActionAllowed {
        type enumeration {
            enum YES;
            enum NO;
        }
    }

    typedef EnergySavingCoverage {
        type enumeration {
            enum YES;
            enum NO;
            enum PARTIAL;
        }
    }

    grouping EUTranCellRelationGrp {
        description "Represents the EUTranCellRelation IOC.";
        reference "3GPP TS 28.541, EUTranRelation in 3GPP TS 28.658";
        uses mf3gpp:ManagedFunctionGrp;

        leaf tCI {
            description "Target Cell Identifier. Consists of E-UTRAN Cell Global
                Identifier (ECGI) and Physical Cell Identifier (PCI) of the target
                cell. Identifies the target cell from the perspective of the parent
                cell instance.";
            mandatory true;
            type uint64;
        }

        leaf isRemoveAllowed {
            description "Indicates if the subject EUTranCellRelation can be removed
                (deleted) or not. If YES, the subject EUTranCellRelation instance can

```

```
    be removed (deleted). If NO, the subject EUTranCellRelation instance
    shall not be removed (deleted) by any entity but an IRPManager.";
    mandatory true;
    type ActionAllowed;
}

leaf isHOAllowed {
    description "Indicates if handover is allowed or prohibited. If YES,
    handover is allowed from source cell to target cell. Source cell is
    represented by the parent cell instance. Target cell is the adjacent
    cell referenced by this EUTranCellRelation instance. If NO, handover
    shall not be allowed.";
    mandatory true;
    type ActionAllowed;
}

leaf isICICInformationSendAllowed {
    description "Indicates if ICIC (Inter Cell Interference Coordination)
    load information message sending is allowed or prohibited. If YES,
    ICIC load information message sending is allowed from source cell to
    target cell. Source cell is represented by the parent cell instance.
    Target cell is the adjacent cell referenced by this EUTranCellRelation
    instance. If NO, ICIC load information message sending shall not be
    allowed.";
    reference "3GPP TS 36.423";
    mandatory true;
    type ActionAllowed;
}

leaf isLBAllowed {
    description "Indicates if load balancing is allowed or prohibited from
    source cell to target cell. If YES, load balancing is allowed from
    source cell to target cell. Source cell is represented by the parent
    cell instance. Target cell is the adjacent cell referenced by this
    EUTranCellRelation instance. If NO, load balancing shall be prohibited
    from source cell to target cell.";
    mandatory true;
    type ActionAllowed;
}

leaf isESCoveredBy {
    description "Indicates whether the adjacent cell according to this
    planning provides no, partial or full coverage for the parent cell
    instance. Adjacent cells with this attribute equal to YES are
    recommended to be considered as candidate cells to take over the
    coverage when the original cell is about to be transferred to energy
    saving state. The entirety of adjacent cells with this property equal
    to PARTIAL are recommended to be considered as entirety of candidate
    cells to take over the coverage when the original cell is about to be
    transferred to energy saving state.";
    mandatory true;
    type EnergySavingCoverage;
}

leaf qOffset {
    description "Offset applicable to a specific neighbouring cell used for
    evaluating the cell as a candidate for cell re-selection. Corresponds
    to parameter q-OffsetCell broadcast in SIB4 for intra-frequency cells
    and in SIB5 for inter-frequency cells. Used for Mobility Robustness
    Optimization.";
    reference "3GPP TS 36.331";
    mandatory true;
    type types3gpp:QOffsetRange;
}

leaf cellIndividualOffset {
    description "Offset applicable to a neighbouring cell. It is used for
    evaluating the neighbouring cell for handover in connected mode. Used
    by the HandOver parameter Optimization (HOO) function or Load
    Balancing Optimization (LBO) function.";
    reference "3GPP TS 36.331";
    config false;
    type types3gpp:QOffsetRange;
}

leaf adjacentCell {
    description "Reference to an EUTranCellFDD/TDD or
    ExternalEUTranCellFDD/TDD instance.";
```

```

        mandatory true;
        type types3gpp:DistinguishedName;
    }
}

augment /me3gpp:ManagedElement/gnbcucp3gpp:GNBCUCPFFunction/nrcellcu3gpp:NRCellCU {

    list EUtranCellRelation {
        description "Represents a relation between an NR cell and an E-UTRAN cell.";
        reference "3GPP TS 28.541";
        key id;
        uses top3gpp:Top_Grp;
        container attributes {
            uses EUtranCellRelationGrp;
        }
    }
}

module _3gpp-nr-nrm-eutranetwork {
    yang-version 1.1;
    namespace "urn:3gpp:sa5:_3gpp-nr-nrm-eutranetwork";
    prefix "eutranet3gpp";

    import _3gpp-common-subnetwork { prefix subnet3gpp; }
    import _3gpp-common-top { prefix top3gpp; }

    organization "3GPP SA5";
    description "Defines the YANG mapping of the EUtraNetwork Information Object
        Class (IOC) that is part of the NR Network Resource Model (NRM).";
    reference "3GPP TS 28.541 5G Network Resource Model (NRM)";

    revision 2019-06-17 {
        description "Initial revision";
        reference "Based on
            3GPP TS 28.541 V15.X.XX";
    }

    feature ExternalsUnderEUtraNetwork {
        description "Classes representing external entities like EUtranFrequency,
            ExternalENBFunction are contained under a EUtraNetwork list/class.";
    }

    grouping EUtraNetworkGrp {
        description "Represents the EUtraNetwork IOC.";
        reference "3GPP TS 28.541";
        uses subnet3gpp:SubNetworkGrp;
    }

    list EUtraNetwork {
        description "A subnetwork containing gNB external E-UTRAN entities.";
        reference "3GPP TS 28.541";
        key id;
        uses top3gpp:Top_Grp;
        container attributes {
            uses EUtraNetworkGrp;
            leaf-list parents {
                description "Reference to all containg EUtraNetwork instances
                    in strict order from the root EUtraNetwork down to the immediate
                    parent EUtraNetwork.
                    If EUtraNetworks form a containment hierarchy this is
                    modeled using references between the child EUtraNetwork and the parent
                    EUtraNetworks.
                    This reference MUST NOT be present for the top level EUtraNetwork and
                    MUST be present for other EUtraNetworks.";
                type leafref {
                    path "../../../../EUtraNetwork/id";
                }
            }
        }

        leaf-list containedChildren{
            description "Reference to all directly contained EUtraNetwork instances.
                If EUtraNetworks form a containment hierarchy this is
                modeled using references between the child EUtraNetwork and the parent
                EUtraNetwork.";
            type leafref {
                path "../../../../EUtraNetwork/id";
            }
        }
    }
}

```

```

    }
  }
}

module _3gpp-nr-nrm-eutranfreqrelation {
  yang-version 1.1;
  namespace "urn:3gpp:sa5:_3gpp-nr-nrm-eutranfreqrelation";
  prefix "eutranfreqrel3gpp";

  import _3gpp-common-yang-types { prefix types3gpp; }
  import _3gpp-common-managed-function { prefix mf3gpp; }
  import _3gpp-common-managed-element { prefix me3gpp; }
  import _3gpp-common-top { prefix top3gpp; }
  import _3gpp-nr-nrm-gnbcucpfunction { prefix gnbcucp3gpp; }
  import _3gpp-nr-nrm-nrcellcu { prefix nrcellcu3gpp; }

  organization "3GPP SA5";
  description "Defines the YANG mapping of the EUTranFreqRelation Information
    Object Class (IOC) that is part of the NR Network Resource Model (NRM).";
  reference "3GPP TS 28.541 5G Network Resource Model (NRM)";

  revision 2019-06-17 {
    description "Initial revision";
    reference "Based on
      3GPP TS 28.541 V15.X.XX";
  }

  grouping EUTranFreqRelationGrp {
    description "Represents the EUTranFreqRelation IOC.";
    reference "3GPP TS 28.541";
    uses mf3gpp:ManagedFunctionGrp;

    leaf cellIndividualOffset {
      description "Offset applicable to a neighbouring cell. Used for
        evaluating the neighbouring cell for handover in connected mode.
        Used by the HandOver parameter Optimization (HOO) function or
        Load Balancing Optimization (LBO) function.";
      reference "cellIndividualOffset in MeasObjectEUTRA in 3GPP TS 38.331";
      default 0;
      type types3gpp:QOffsetRange;
    }

    leaf-list blackListEntry {
      description "A list of Physical Cell Identities (PCIs) that are
        blacklisted in E-UTRAN measurements.";
      reference "3GPP TS 38.331";
      min-elements 0;
      type uint16 { range "0..1007"; }
    }

    leaf-list blackListEntryIdleMode {
      description "A list of Physical Cell Identities (PCIs) that are
        blacklisted in SIB4 and SIB5.";
      min-elements 0;
      type uint16 { range "0..1007"; }
    }

    leaf cellReselectionPriority {
      description "The absolute priority of the carrier frequency used by the
        cell reselection procedure. Value 0 means lowest priority. The value
        must not already used by other RAT, i.e. equal priorities between RATs
        are not supported. The UE behaviour when no value is entered is
        specified in subclause 5.2.4.1 of 3GPP TS 38.304.";
      reference "CellReselectionPriority in 3GPP TS 38.331, priority in
        3GPP TS 38.304";
      mandatory true;
      type int32 { range "0..7"; }
    }

    leaf cellReselectionSubPriority {
      description "Indicates a fractional value to be added to the value of
        cellReselectionPriority to obtain the absolute priority of the
        concerned carrier frequency for E-UTRA and NR.";
      reference "3GPP TS 38.331";
      type uint8 { range "2 | 4 | 6 | 8"; }
      units "0.1";
    }
  }
}

```

```
leaf pMax {
  description "Used for calculation of the parameter Pcompensation
    (defined in 3GPP TS 38.304), at cell reselection to a cell.";
  reference "PEMAX in 3GPP TS 38.101-1";
  mandatory true;
  type int32 { range "-30..33"; }
  units dBm;
}

leaf qOffsetFreq {
  description "The frequency specific offset applied when evaluating
    candidates for cell reselection.";
  type int32;
  default 0;
}

leaf qQualMin {
  description "Indicates the minimum required quality level in the cell.
    Value 0 means that it is not sent and UE applies in such case the
    (default) value of negative infinity for Qqualmin. Sent in SIB3 or
    SIB5.";
  reference "qQualMin in TS 38.304";
  mandatory true;
  type int32 { range "-34..-3 | 0"; }
  units dB;
}

leaf qRxLevMin {
  description "Indicates the required minimum received Reference Symbol
    Received Power (RSRP) level in the (E-UTRA) frequency for cell
    reselection. Broadcast in SIB3 or SIB5, depending on whether the
    related frequency is intra- or inter-frequency. Resolution is 2.";
  reference "Qrxlevmin in 3GPP TS 38.304";
  mandatory true;
  type int32 { range "-140..-44"; }
  units dBm;
}

leaf threshXHighP {
  description "Specifies the Srxlev threshold used by the UE when
    reselecting towards a higher priority RAT/frequency than the current
    serving frequency. Each frequency of NR and E-UTRAN might have a
    specific threshold. Resolution is 2.";
  reference "ThreshX, HighP in 3GPP TS 38.304";
  mandatory true;
  type int32 { range "0..62"; }
  units dB;
}

leaf threshXHighQ {
  description "Specifies the Squal threshold used by the UE when
    reselecting towards a higher priority RAT/frequency than the current
    serving frequency. Each frequency of NR and E-UTRAN might have a
    specific threshold.";
  reference "ThreshX, HighQ in 3GPP TS 38.304";
  mandatory true;
  type int32 { range "0..31"; }
  units dB;
}

leaf threshXLowP {
  description "Specifies the Srxlev threshold used by the UE when
    reselecting towards a lower priority RAT/frequency than the current
    serving frequency. Each frequency of NR and E-UTRAN might have a
    specific threshold. Resolution is 2.";
  reference "ThreshX, LowP in 3GPP TS 38.304";
  mandatory true;
  type int32 { range "0..62"; }
  units dB;
}

leaf threshXLowQ {
  description "Specifies the Squal threshold used by the UE when
    reselecting towards a lower priority RAT/frequency than the current
    serving frequency. Each frequency of NR and E-UTRAN might have a
    specific threshold.";
  reference "ThreshX, LowQ in 3GPP TS 38.304";
```



```

    mandatory false;
    type int32 { range "0..31"; }
    units dB;
  }

  leaf tReselectionEutra {
    description "Cell reselection timer for intra frequency E-UTRA cell
      reselection. May be used for Mobility Robustness Optimization.";
    reference "t-ReselectionEUTRA in 3GPP TS 36.331 and in 3GPP TS 23.207";
    mandatory true;
    type uint8 { range "0..7"; }
    units s;
  }

  leaf tReselectionEutraSfHigh {
    description "The attribute tReselectionEutra (parameter TreselectionEUTRA
      in 3GPP TS 38.304) multiplied with this scaling factor if the UE is in
      high mobility state.";
    reference "Speed dependent ScalingFactor for TreselectionEUTRA for high
      mobility state in 3GPP TS 38.304";
    mandatory true;
    type uint8 { range "25 | 50 | 75 | 100"; }
    units %;
  }

  leaf tReselectionEutraSfMedium {
    description "The attribute tReselectionEutra (parameter TreselectionEUTRA
      in 3GPP TS 38.304) multiplied with this scaling factor if the UE is in
      medium mobility state.";
    reference "Speed dependent ScalingFactor for TreselectionEUTRA for medium
      mobility state in 3GPP TS 38.304";
    mandatory true;
    type uint8 { range "25 | 50 | 75 | 100"; }
    units %;
  }

  leaf eUtranFrequencyRef {
    description "Reference to a corresponding EUtranFrequency instance.";
    mandatory true;
    type types3gpp:DistinguishedName;
  }
}

augment /me3gpp:ManagedElement/gnbcucp3gpp:GNBCUCPFunction/nrcellcu3gpp:NRCellCU {

  list EUtranFreqRelation {
    description "Represents a frequency relation between an NR cell and an
      E-UTRAN cell.";
    reference "3GPP TS 28.541";
    key id;
    uses top3gpp:Top_Grp;
    container attributes {
      uses EUtranFreqRelationGrp;
    }
  }
}

module _3gpp-nr-nrm-eutranfrequency {
  yang-version 1.1;
  namespace "urn:3gpp:sa5:_3gpp-nr-nrm-eutranfrequency";
  prefix "eutranetutranfreq3gpp";

  import _3gpp-common-managed-function { prefix mf3gpp; }
  import _3gpp-nr-nrm-eutranetwork { prefix eutranet3gpp; }
  import _3gpp-common-subnetwork { prefix subnet3gpp; }
  import _3gpp-common-top { prefix top3gpp; }

  organization "3GPP SA5";
  description "Defines the YANG mapping of the EUtranFrequency Information
    Object Class (IOC), that is part of the NR Network Resource Model (NRM).";
  reference "3GPP TS 28.541 5G Network Resource Model (NRM),
    3GPP TS 28.658 (E-UTRAN) Network Resource Model (NRM)";

  revision 2019-06-17 {
    description "Initial revision";
    reference "Based on
      3GPP TS 28.541 V15.X.XX";
  }
}

```

```

    3GPP TS 28.658 V15.X.XX";
}

grouping EUTranFrequencyGrp {
  description "Represents the EUTranFrequency IOC.";
  reference "3GPP TS 28.541";
  uses mf3gpp:ManagedFunctionGrp;

  leaf earfcnDL {
    description "Specifies the channel number for the central DL frequency.";
    reference "3GPP TS 36.101";
    mandatory true;
    type uint32 { range "0..262143"; }
  }

  leaf-list multiBandInfoListEutra {
    description "List of additional frequency bands the frequency belongs to.";
    config false;
    min-elements 0;
    type uint16 { range "1..256"; }
  }
}

grouping EUTranFrequencyWrapper {
  list EUTranFrequency {
    description "Represents certain E-UTRAN frequency properties.";
    reference "3GPP TS 28.658";
    key id;
    uses top3gpp:Top_Grp;
    container attributes {
      uses EUTranFrequencyGrp;
    }
  }
}

augment "/subnet3gpp:SubNetwork" {
  if-feature subnet3gpp:ExternalsUnderSubNetwork ;
  uses EUTranFrequencyWrapper ;
}

augment "/eutranet3gpp:EUTraNetwork" {
  if-feature eutranet3gpp:ExternalsUnderEUTraNetwork;
  uses EUTranFrequencyWrapper ;
}
}

module _3gpp-nr-nrm-externalamffunction {
  yang-version 1.1;
  namespace "urn:3gpp:sa5:_3gpp-nr-nrm-externalamffunction";
  prefix "extamf3gpp";

  import _3gpp-common-managed-function { prefix mf3gpp; }
  import _3gpp-common-subnetwork { prefix subnet3gpp; }
  import _3gpp-nr-nrm-nrnetwork { prefix nrnet3gpp; }
  import _3gpp-common-top { prefix top3gpp; }
  import _3gpp-common-yang-types { prefix types3gpp; }

  organization "3GPP SA5";
  description "Defines the YANG mapping of the ExternalAMFFunction Information
  Object Class (IOC) that is part of the NR Network Resource Model (NRM).";
  reference "3GPP TS 28.541 5G Network Resource Model (NRM)";

  revision 2019-06-17 {
    description "Initial revision";
    reference "Based on
    3GPP TS 28.541 V15.X.XX";
  }

  grouping ExternalAMFFunctionGrp {
    description "Represents the ExternalAMFFunction IOC.";
    reference "3GPP TS 28.541";
    uses mf3gpp:ManagedFunctionGrp;

    list pLMNIdList {
      description "List of at most six entries of PLMN Identifiers, but at least
      one (the primary PLMN Id).
      The PLMN Identifier is composed of a Mobile Country Code (MCC) and a
      Mobile Network Code (MNC).";
    }
  }
}

```

```

        min-elements 1;
        max-elements 6;
        key "mcc mnc";
        uses types3gpp:PLMNId;
    }

    container aMFIIdentifier {
        presence true;
        description "An AMF identifier, comprising an AMF Region ID, an AMF Set ID and an AMF
Pointer.";
        uses types3gpp:AmfIdentifier;
    }
}

grouping ExternalAMFFunctionWrapper {
    list ExternalAMFFunction {
        description "Represents the properties, known by the management
function, of a AMFFunction managed by another management
function.";
        reference "3GPP TS 28.541";
        key id;
        uses top3gpp:Top_Grp;
        container attributes {
            uses ExternalAMFFunctionGrp;
        }
    }
}

augment "/subnet3gpp:SubNetwork" {
    if-feature subnet3gpp:ExternalsUnderSubNetwork ;
    uses ExternalAMFFunctionWrapper;
}

augment "/nrnet3gpp:NRNetwork" {
    if-feature nrnet3gpp:ExternalsUnderNRNetwork;
    uses ExternalAMFFunctionWrapper;
}
}

}module _3gpp-nr-nrm-externalenbfunction {
    yang-version 1.1;
    namespace "urn:3gpp:sa5:_3gpp-nr-nrm-externalenbfunction";
    prefix "extenb3gpp";

    import _3gpp-common-managed-function { prefix mf3gpp; }
    import _3gpp-nr-nrm-eutranetwork { prefix eutranet3gpp; }
    import _3gpp-common-subnetwork { prefix subnet3gpp; }
    import _3gpp-common-top { prefix top3gpp; }

    organization "3GPP SA5";
    description "Defines the YANG mapping of the ExternalENBFunction
Information Object Class (IOC) that is part of the NR Network Resource
Model (NRM).";
    reference "3GPP TS 28.541 5G Network Resource Model (NRM),
3GPP TS 28.658 (E-UTRAN) Network Resource Model (NRM)";

    revision 2019-06-17 {
        description "Initial revision";
        reference "Based on
3GPP TS 28.541 V15.X.XX
3GPP TS 28.658 V15.X.XX";
    }

    grouping ExternalENBFunctionGrp {
        description "Represents the ExternalENBFunction IOC.";
        reference "3GPP TS 28.658";
        uses mf3gpp:ManagedFunctionGrp;

        leaf eNBID {
            description "Unambiguously identifies an eNodeB within a PLMN.";
            reference "3GPP TS 36.413, 3GPP TS 36.300";
            mandatory true;
            type int32 { range "0..268435455"; } // Representing 28 bit eNB ID.
                                                    // 18, 20 and 21 bit eNB IDs also
                                                    // allowed.
        }
    }
}
}

```

```

grouping ExternalENBFunctionWrapper {
  list ExternalENBFunction {
    description "Represents an external eNB functionality.";
    reference "3GPP TS 28.658";
    key id;
    uses top3gpp:Top_Grp;
    container attributes {
      uses ExternalENBFunctionGrp;
    }
  }
}

augment "/subnet3gpp:SubNetwork" {
  if-feature subnet3gpp:ExternalsUnderSubNetwork ;
  uses ExternalENBFunctionWrapper;
}

augment "/eutranet3gpp:EUTraNetwork" {
  if-feature eutranet3gpp:ExternalsUnderEUTraNetwork;
  uses ExternalENBFunctionWrapper;
}

}

}

module _3gpp-nr-nrm-externaleutranCell {
  yang-version 1.1;
  namespace "urn:3gpp:sa5:_3gpp-nr-nrm-externaleutranCell";
  prefix "exteutranCell3gpp";

  import _3gpp-common-yang-types { prefix types3gpp; }
  import _3gpp-common-managed-function { prefix mf3gpp; }
  import _3gpp-common-subnetwork { prefix subnet3gpp; }
  import _3gpp-nr-nrm-eutranetwork { prefix eutranet3gpp; }
  import _3gpp-nr-nrm-externalenbfunction { prefix extenb3gpp; }
  import _3gpp-common-top { prefix top3gpp; }

  organization "3GPP SA5";
  description "Defines the YANG mapping of the ExternalEUTranCellFDD and
    ExternalEUTranCellTDD Information Object Classes (IOCs) that are part
    of the NR Network Resource Model (NRM).";
  reference "3GPP TS 28.541 5G Network Resource Model (NRM),
    3GPP TS 28.658 (E-UTRAN) Network Resource Model (NRM)";

  revision 2019-06-17 {
    description "Initial revision";
    reference "Based on
      3GPP TS 28.541 V15.X.XX
      3GPP TS 28.658 V15.X.XX";
  }

  grouping ExternalEUTranGenericCellGrp {
    description "Represents the ExternalEUTranGenericCell IOC.";
    reference "3GPP TS 28.658";
    uses mf3gpp:ManagedFunctionGrp;

    leaf pci {
      description "The Physical Cell Identity (PCI) of the cell (for
        NM-Centralized, EM-Centralized and Distributed PCI assignment cases).
        In the case of NM-Centralized PCI assignment, see 3GPP TS 36.300.";
      reference "3GPP TS 36.211";
      mandatory true;
      type int32 { range "0..503"; }
    }

    list plmnIdList {
      description "List of unique identities for PLMNs. A cell can broadcast
        up to 6 PLMN IDs. This is to support the case that one cell can be
        used by up to 6 operator's core networks. The PLMN(s) included in this
        list will use the same single tracking area code (TAC) and the same
        Cell Identity (cellLocalId) for sharing the radio access network
        resources. One member of plmnIdList is the primary PLMN ID. A PLMN ID
        included in this list cannot be included in the cellAccessInfoList.
        The PLMN ID is composed of a Mobile Country Code (MCC) and a Mobile
        Network Code (MNC).";
      reference "3GPP TS 36.300, 3GPP TS 36.331, 3GPP TS 23.003";
      key "mcc mnc";
      min-elements 1;
      max-elements 6;
      uses types3gpp:PLMNId;
    }
  }
}

```

```

    }

    leaf cellLocalId {
      description "Unambiguously identifies a cell within an eNodeB.";
      reference "NCI defined in 3GPP TS 38.300";
      type int32 {range "0..255"; }
    }

    leaf eNBId {
      description "Unambiguously identifies an eNodeB within a PLMN.";
      reference "3GPP TS 36.413, 3GPP TS 36.300";
      mandatory true;
      type int32 { range "0..268435455"; } // Representing 28 bit eNB ID.
                                          // 18, 20 and 21 bit eNB IDs also
                                          // allowed.
    }
  }
}

grouping ExternalEUTranCellFDDGrp {
  description "Represents the ExternalEUTranCellFDD IOC.";
  reference "3GPP TS 28.658";
  uses ExternalEUTranGenericCellGrp;

  leaf earfcnDL {
    description "The channel number for the central DL frequency.";
    reference "3GPP TS 36.101";
    mandatory true;
    type int32 { range "0..17999 | 46590..262143"; }
  }

  leaf earfcnUL {
    description "The channel number for the central UL frequency. Value 0
      means that the UL channel number is N/A for the DL-only bands.";
    reference "3GPP TS 36.101";
    mandatory true;
    type int32 { range "0 | 18000..35999 | 46590..262143"; }
  }
}

grouping ExternalEUTranCellTDDGrp {
  description "Represents the ExternalEUTranCellTDD IOC.";
  reference "3GPP TS 28.658";
  uses ExternalEUTranGenericCellGrp;

  leaf earfcn {
    description "The frequency number for the central frequency.";
    reference "3GPP TS 36.104";
    mandatory true;
    type int32 { range "36000..262143"; }
  }
}

grouping ExternalEUTranCellFDDWrapper {
  list ExternalEUTranCellFDD {
    description "Represents the common properties of external E-UTRAN FDD
      cell provided by eNB or NG-RAN FDD cell provided by ng-eNB.";
    reference "3GPP TS 28.658";
    key id;
    uses top3gpp:Top_Grp;
    container attributes {
      uses ExternalEUTranCellFDDGrp;
    }
  }
}

grouping ExternalEUTranCellTDDWrapper {
  list ExternalEUTranCellTDD {
    description "Represents the common properties of external E-UTRAN cell
      TDD provided by eNB or NG-RAN TDD cell provided by ng-eNB.";
    reference "3GPP TS 28.658";
    key id;
    uses top3gpp:Top_Grp;
    container attributes {
      uses ExternalEUTranCellTDDGrp;
    }
  }
}

```

```

augment "/subnet3gpp:SubNetwork/externb3gpp:ExternalENBFunction" {
  if-feature subnet3gpp:ExternalsUnderSubNetwork;
  uses ExternalEUTranCellFDDWrapper;
}

augment "/eutranet3gpp:EUTraNetwork/externb3gpp:ExternalENBFunction" {
  if-feature eutranet3gpp:ExternalsUnderEUTraNetwork;
  uses ExternalEUTranCellFDDWrapper;
}

augment "/subnet3gpp:SubNetwork/externb3gpp:ExternalENBFunction" {
  if-feature subnet3gpp:ExternalsUnderSubNetwork;
  uses ExternalEUTranCellTDDWrapper;
}

augment "/eutranet3gpp:EUTraNetwork/externb3gpp:ExternalENBFunction" {
  if-feature eutranet3gpp:ExternalsUnderEUTraNetwork;
  uses ExternalEUTranCellTDDWrapper;
}
}

}module _3gpp-nr-nrm-externalgnbcucpfunction {
  yang-version 1.1;
  namespace "urn:3gpp:sa5:_3gpp-nr-nrm-externalgnbcucpfunction";
  prefix "extgnbcucp3gpp";

  import _3gpp-common-yang-types { prefix types3gpp; }
  import _3gpp-common-managed-function { prefix mf3gpp; }
  import _3gpp-nr-nrm-nrnetwork { prefix nrnet3gpp; }
  import _3gpp-common-subnetwork { prefix subnet3gpp; }
  import _3gpp-common-top { prefix top3gpp; }

  organization "3GPP SA5";
  description "Defines the YANG mapping of the ExternalGNBCUCPFunction
  Information Object Class (IOC), that is part of the NR Network Resource
  Model (NRM).";
  reference "3GPP TS 28.541 5G Network Resource Model (NRM)";

  revision 2019-06-17 {
    description "Initial revision";
    reference "Based on
    3GPP TS 28.541 V15.X.XX";
  }

  grouping ExternalGNBCUCPFunctionGrp {
    description "Represents the ExternalGNBCUCPFunction IOC.";
    reference "3GPP TS 28.541";
    uses mf3gpp:ManagedFunctionGrp;

    leaf gNBID {
      description "Identifies a gNB within a PLMN.";
      reference "gNB Identifier (gNB ID) in 3GPP TS 38.300, Global gNB ID
      in 3GPP TS 38.413";
      mandatory true;
      type int64 { range "0..4294967295"; }
    }

    leaf gNBIDLength {
      description "Indicates the number of bits for encoding the gNB ID.";
      reference "gNB ID in 3GPP TS 38.300, Global gNB ID in 3GPP TS 38.413";
      mandatory true;
      type int32 { range "22..32"; }
    }

    list pLMNID {
      description "Specifies the PLMN identifier to be used as part of the
      global RAN node identity.";
      key "mcc mnc";
      min-elements 1;
      max-elements 1;
      uses types3gpp:PLMNID;
    }
  }

  grouping ExternalGNBCUCPFunctionWrapper {
    list ExternalGNBCUCPFunction {
      description "Represents the properties, known by the management function,
      of a GNBCUCPFunction managed by another management function.";
    }
  }
}

```

```

        reference "3GPP TS 28.541";
        key id;
        uses top3gpp:Top_Grp;
        container attributes {
            uses ExternalGNBCUCPFFunctionGrp;
        }
    }
}

augment "/subnet3gpp:SubNetwork" {
    if-feature subnet3gpp:ExternalsUnderSubNetwork ;
    uses ExternalGNBCUCPFFunctionWrapper;
}

augment "/nrnet3gpp:NRNetwork" {
    if-feature nrnet3gpp:ExternalsUnderNRNetwork;
    uses ExternalGNBCUCPFFunctionWrapper;
}
}

module _3gpp-nr-nrm-externalgnbcuupfunction {
    yang-version 1.1;
    namespace "urn:3gpp:sa5:_3gpp-nr-nrm-externalgnbcuupfunction";
    prefix "extgnbcuup3gpp";

    import _3gpp-common-managed-function { prefix mf3gpp; }
    import _3gpp-nr-nrm-nrnetwork { prefix nrnet3gpp; }
    import _3gpp-common-subnetwork { prefix subnet3gpp; }
    import _3gpp-common-top { prefix top3gpp; }

    organization "3GPP SA5";
    description "Defines the YANG mapping of the ExternalGNBCUUPFunction
        Information Object Class (IOC), that is part of the NR Network
        Resource Model (NRM).";
    reference "3GPP TS 28.541 5G Network Resource Model (NRM)";

    revision 2019-06-17 {
        description "Initial revision";
        reference "Based on
            3GPP TS 28.541 V15.X.XX";
    }

    grouping ExternalGNBCUUPFunctionGrp {
        description "Resets the ExternalGNBCUUPFunction IOC.";
        reference "3GPP TS 28.541";
        uses mf3gpp:ManagedFunctionGrp;

        leaf gNBId {
            description "Identifies a gNB within a PLMN.";
            reference "gNB Identifier (gNB ID) in 3GPP TS 38.300, Global gNB ID
                in 3GPP TS 38.413";
            mandatory true;
            type int64 { range "0..4294967295"; }
        }

        leaf gNBIdLength {
            description "Indicates the number of bits for encoding the gNB ID.";
            reference "gNB ID in 3GPP TS 38.300, Global gNB ID in 3GPP TS 38.413";
            mandatory true;
            type int32 { range "22..32"; }
        }
    }

    grouping ExternalGNBCUUPFunctionWrapper {
        list ExternalGNBCUUPFunction {
            description "Represents the properties, known by the management function,
                of a GNBCUUPFunction managed by another management function.";
            reference "3GPP TS 28.541";
            key id;
            uses top3gpp:Top_Grp;
            container attributes {
                uses ExternalGNBCUUPFunctionGrp;
            }
        }
    }
}

augment "/subnet3gpp:SubNetwork" {
    if-feature subnet3gpp:ExternalsUnderSubNetwork ;

```

```

    uses ExternalGNBCUUPFunctionWrapper;
  }

  augment "/nrnet3gpp:NRNetwork" {
    if-feature nrnet3gpp:ExternalsUnderNRNetwork;
    uses ExternalGNBCUUPFunctionWrapper;
  }
}

module _3gpp-nr-nrm-externalgnbdufunction {
  yang-version 1.1;
  namespace "urn:3gpp:sa5:_3gpp-nr-nrm-externalgnbdufunction";
  prefix "extgnbdu3gpp";

  import _3gpp-common-yang-types { prefix types3gpp; }
  import _3gpp-common-managed-function { prefix mf3gpp; }
  import _3gpp-nr-nrm-nrnetwork { prefix nrnet3gpp; }
  import _3gpp-common-subnetwork { prefix subnet3gpp; }
  import _3gpp-common-top { prefix top3gpp; }

  organization "3GPP SA5";
  description "Defines the YANG mapping of the ExternalGNBDUFunction
    Information Object Class (IOC) that is part of the NR Network Resource
    Model (NRM).";
  reference "3GPP TS 28.541 5G Network Resource Model (NRM)";

  revision 2019-06-17 {
    description "Initial revision";
    reference "Based on
      3GPP TS 28.541 V15.X.XX";
  }

  grouping ExternalGNBDUFunctionGrp {
    description "Represents the ExternalGNBDUFunction IOC.";
    reference "3GPP TS 28.541";
    uses mf3gpp:ManagedFunctionGrp;

    leaf gNBId {
      description "Identifies a gNB within a PLMN.";
      reference "gNB Identifier (gNB ID) in 3GPP TS 38.300, Global gNB ID
        in 3GPP TS 38.413";
      mandatory true;
      type int64 { range "0..4294967295"; }
    }

    leaf gNBIdLength {
      description "Indicates the number of bits for encoding the gNB ID.";
      reference "gNB ID in 3GPP TS 38.300, Global gNB ID in 3GPP TS 38.413";
      mandatory true;
      type int32 { range "22..32"; }
    }

    list pLMNId {
      description "Specifies the PLMN identifier to be used as part of the
        global RAN node identity.";
      key "mcc mnc";
      min-elements 1;
      max-elements 1;
      uses types3gpp:PLMNId;
    }
  }

  grouping ExternalGNBDUFunctionWrapper {
    list ExternalGNBDUFunction {
      description "Represents the properties, known by the management function,
        of a GNBDUFunction managed by another management function.";
      reference "3GPP TS 28.541";
      key id;
      uses top3gpp:Top_Grp;
      container attributes {
        uses ExternalGNBDUFunctionGrp;
      }
    }
  }

  augment "/subnet3gpp:SubNetwork" {
    if-feature subnet3gpp:ExternalsUnderSubNetwork;
    uses ExternalGNBDUFunctionWrapper;
  }
}

```



```

}

augment "/nrnet3gpp:NRNetwork" {
  if-feature nrnet3gpp:ExternalsUnderNRNetwork;
  uses ExternalGNBDUFunctionWrapper;
}

module _3gpp-nr-nrm-externalnrcellcu {
  yang-version 1.1;
  namespace "urn:3gpp:sa5:_3gpp-nr-nrm-externalnrcellcu";
  prefix "extnrcellcu3gpp";

  import _3gpp-common-yang-types { prefix types3gpp; }
  import _3gpp-common-managed-function { prefix mf3gpp; }
  import _3gpp-nr-nrm-nrnetwork { prefix nrnet3gpp; }
  import _3gpp-common-subnetwork { prefix subnet3gpp; }
  import _3gpp-nr-nrm-externalgnbcucpfunction { prefix extgnbcucp3gpp; }
  import _3gpp-common-top { prefix top3gpp; }

  organization "3GPP SA5";
  description "Defines the YANG mapping of the ExternalNRCellCU Information
    Object Class (IOC), that is part of the NR Network Resource Model (NRM).";
  reference "3GPP TS 28.541 5G Network Resource Model (NRM)";

  revision 2019-06-17 {
    description "Initial revision";
    reference "Based on
      3GPP TS 28.541 V15.X.XX";
  }

  grouping ExternalNRCellCUGrp {
    description "Represents the ExternalNRCellCU IOC.";
    reference "3GPP TS 28.541";
    uses mf3gpp:ManagedFunctionGrp;

    leaf cellLocalId {
      description "Identifies an NR cell of a gNB. Together with corresponding
        gNB ID it forms the NR Cell Identifier (NCI).";
      reference "NCI in 3GPP TS 38.300";
      mandatory true;
      type int32 {range "0..16383"; }
    }

    leaf nRPCI {
      description "The Physical Cell Identity (PCI) of the NR cell.";
      reference "3GPP TS 36.211";
      mandatory true;
      type int32 { range "0..1007"; }
    }

    list pLMNIdList {
      description "Defines which PLMNs that are assumed to be served by the
        NR cell in another gNB CU-CP. This list is either updated by the
        managed element itself (e.g. due to ANR, signalling over Xn, etc.) or
        by consumer over the standard interface.";
      key "mcc mnc";
      min-elements 1;
      max-elements 12;
      uses types3gpp:PLMNId;
    }

    leaf nRFrequencyRef {
      description "Reference to corresponding NRFrequency instance.";
      mandatory true;
      type types3gpp:DistinguishedName;
    }
  }

  grouping ExternalNRCellCUWrapper {
    list ExternalNRCellCU {
      description "Represents the properties of an NRCellCU controlled by
        another Management Service Provider.";
      reference "3GPP TS 28.541";
      key id;
      uses top3gpp:Top_Grp;
      container attributes {
        uses ExternalNRCellCUGrp;
      }
    }
  }
}

```

```

    }
  }
}

augment "/subnet3gpp:SubNetwork/extgnbcucp3gpp:ExternalGNBCUCPFunction" {
  if-feature subnet3gpp:ExternalsUnderSubNetwork ;
  uses ExternalNRCellCUWrapper;
}

augment "/nrnet3gpp:NRNetwork/extgnbcucp3gpp:ExternalGNBCUCPFunction" {
  if-feature nrnet3gpp:ExternalsUnderNRNetwork;
  uses ExternalNRCellCUWrapper;
}
}

module _3gpp-nr-nrm-externalservinggwfunction {
  yang-version 1.1;
  namespace "urn:3gpp:sa5:_3gpp-nr-nrm-externalservinggwfunction";
  prefix "extservgw3gpp";

  import _3gpp-common-managed-function { prefix mf3gpp; }
  import _3gpp-common-subnetwork { prefix subnet3gpp; }
  import _3gpp-nr-nrm-eutranetwork { prefix eutranet3gpp; }
  import _3gpp-common-top { prefix top3gpp; }

  organization "3GPP SA5";
  description "Defines the YANG mapping of the ExternalServingGWFunction
    Information Object Class (IOC) that is part of the NR Network Resource
    Model (NRM).";
  reference "3GPP TS 28.541 5G Network Resource Model (NRM)";

  revision 2019-06-17 {
    description "Initial revision";
    reference "Based on
      3GPP TS 28.541 V15.X.XX";
  }

  grouping ExternalServingGWFunctionGrp {
    description "Represents the ExternalServingGWFunction IOC.";
    reference "3GPP TS 28.541";
    uses mf3gpp:ManagedFunctionGrp;
  }

  grouping ExternalServingGWFunctionWrapper {
    list ExternalServingGWFunction {
      description "Represents the properties, known by the management
        function, of a ServingGWFunction managed by another management
        function.";
      reference "3GPP TS 28.658";
      key id;
      uses top3gpp:Top_Grp;
      container attributes {
        uses ExternalServingGWFunctionGrp;
      }
    }
  }

  augment "/subnet3gpp:SubNetwork" {
    if-feature subnet3gpp:ExternalsUnderSubNetwork ;
    uses ExternalServingGWFunctionWrapper;
  }

  augment "/eutranet3gpp:EUltraNetwork" {
    if-feature eutranet3gpp:ExternalsUnderEUltraNetwork;
    uses ExternalServingGWFunctionWrapper;
  }
}

module _3gpp-nr-nrm-externalupffunction {
  yang-version 1.1;
  namespace "urn:3gpp:sa5:_3gpp-nr-nrm-externalupffunction";
  prefix "extupf3gpp";

  import _3gpp-common-managed-function { prefix mf3gpp; }
  import _3gpp-common-subnetwork { prefix subnet3gpp; }
  import _3gpp-nr-nrm-nrnetwork { prefix nrnet3gpp; }
  import _3gpp-common-top { prefix top3gpp; }

```

```

organization "3GPP SA5";
description "Defines the YANG mapping of the ExternalUPFFunction Information
  Object Class (IOC) that is part of the NR Network Resource Model (NRM).";
reference "3GPP TS 28.541 5G Network Resource Model (NRM)";

revision 2019-06-17 {
  description "Initial revision";
  reference "Based on
    3GPP TS 28.541 V15.X.XX";
}

grouping ExternalUPFFunctionGrp {
  description "Represents the ExternalUPFFunction IOC.";
  reference "3GPP TS 28.541";
  uses mf3gpp:ManagedFunctionGrp;
}

grouping ExternalUPFFunctionWrapper {
  list ExternalUPFFunction {
    description "Represents the properties, known by the management
      function, of a UPFFunction managed by another management
      function.";
    reference "3GPP TS 28.541";
    key id;
    uses top3gpp:Top_Grp;
    container attributes {
      uses ExternalUPFFunctionGrp;
    }
  }
}

augment "/subnet3gpp:SubNetwork" {
  if-feature subnet3gpp:ExternalsUnderSubNetwork ;
  uses ExternalUPFFunctionWrapper;
}

augment "/nrnet3gpp:NRNetwork" {
  if-feature nrnet3gpp:ExternalsUnderNRNetwork;
  uses ExternalUPFFunctionWrapper;
}

}

module _3gpp-nr-nrm-gnbcucpfunction {
  yang-version 1.1;
  namespace "urn:3gpp:sa5:_3gpp-nr-nrm-gnbcucpfunction";
  prefix "gnbcucp3gpp";

  import _3gpp-common-yang-types { prefix types3gpp; }
  import _3gpp-common-managed-function { prefix mf3gpp; }
  import _3gpp-common-managed-element { prefix me3gpp; }
  import _3gpp-common-top { prefix top3gpp; }

  organization "3GPP SA5";
  description "Defines the YANG mapping of the GNBCUCPFunction Information
    Object Class (IOC) that is part of the NR Network Resource Model (NRM).";
  reference "3GPP TS 28.541 5G Network Resource Model (NRM)";

  revision 2019-06-17 {
    description "Initial revision";
    reference "Based on
      3GPP TS 28.541 V15.X.XX";
  }

  grouping GNBCUCPFunctionGrp {
    description "Represents the GNBCUCPFunction IOC.";
    reference "3GPP TS 28.541";
    uses mf3gpp:ManagedFunctionGrp;

    leaf gNBID {
      description "Identifies a gNB within a PLMN. The gNB Identifier (gNB ID)
        is part of the NR Cell Identifier (NCI) of the gNB cells.";
      reference "gNB ID in 3GPP TS 38.300, Global gNB ID in 3GPP TS 38.413";
      mandatory true;
      type int64 { range "0..4294967295"; }
    }

    leaf gNBIDLength {
      description "Indicates the number of bits for encoding the gNB ID.";
    }
  }
}

```

```

    reference "gNB ID in 3GPP TS 38.300, Global gNB ID in 3GPP TS 38.413";
    mandatory true;
    type int32 { range "22..32"; }
  }

  leaf gNBCUName {
    description "Identifies the Central Unit of an gNB.";
    reference "3GPP TS 38.473";
    mandatory true;
    type string { length "1..150"; }
  }

  list pLMNId {
    description "The PLMN identifier to be used as part of the global RAN
      node identity.";
    key "mcc mnc";
    min-elements 1;
    max-elements 1;
    uses types3gpp:PLMNId;
  }
}

augment "/me3gpp:ManagedElement" {

  list GNBCUCPFunction {
    description "Represents the logical function CU-CP of gNB and en-gNB.";
    reference "3GPP TS 28.541";
    key id;
    uses top3gpp:Top_Grp;
    container attributes {
      uses GNBCUCPFunctionGrp;
    }
  }
}

module _3gpp-nr-nrm-gnbcuupfunction {
  yang-version 1.1;
  namespace "urn:3gpp:sa5:_3gpp-nr-nrm-gnbcuupfunction";
  prefix "gnbcuup3gpp";

  import _3gpp-common-yang-types { prefix types3gpp; }
  import _3gpp-common-managed-function { prefix mf3gpp; }
  import _3gpp-common-managed-element { prefix me3gpp; }
  import _3gpp-common-top { prefix top3gpp; }

  organization "3GPP SA5";
  description "Defines the YANG mapping of the GNBCUUPFunction Information
    Object Class (IOC) that is part of the NR Network Resource Model (NRM).";
  reference "3GPP TS 28.541 5G Network Resource Model (NRM)";

  revision 2019-08-21 {
    description "Initial revision";
    reference "Based on
      3GPP TS 28.541 V15.X.XX";
  }

  grouping GNBCUUPFunctionGrp {
    description "Represents the GNBCUUPFunction IOC.";
    reference "3GPP TS 28.541";
    uses mf3gpp:ManagedFunctionGrp;

    leaf gNBCUUPId {
      type uint64 {
        range "0..68719476735" ;
      }
      config false;
      mandatory true;
      description "Identifies the gNB-CU-UP at least within a gNB-CU-CP";
      reference "'gNB-CU-UP ID' in subclause 9.3.1.15 of 3GPP TS 38.463";
    }

    leaf gNBId {
      type int64 { range "0..4294967295"; }
      mandatory true;
      description "Identifies a gNB within a PLMN. The gNB Identifier (gNB ID)
        is part of the NR Cell Identifier (NCI) of the gNB cells.";
      reference "gNB ID in 3GPP TS 38.300, Global gNB ID in 3GPP TS 38.413";
    }
  }
}

```

```

    }

    leaf gNBIdLength {
      type int32 { range "22..32"; }
      mandatory true;
      description "Indicates the number of bits for encoding the gNB ID.";
      reference "gNB ID in 3GPP TS 38.300, Global gNB ID in 3GPP TS 38.413";
    }

    list pLMNIdList {
      key "mcc mnc";
      min-elements 1;
      max-elements 12;
      description "A list of PLMN identifiers. Defines from which set of PLMNs
        an UE must have as its serving PLMN to be allowed to use the
        gNB CU-UP.";
      uses types3gpp:PLMNId;
    }
  }

  augment "/me3gpp:ManagedElement" {

    list GNBCUUPFunction {
      key id;
      description "Represents the logical function CU-UP of gNB or en-gNB.";
      reference "3GPP TS 28.541";
      uses top3gpp:Top_Grp;
      container attributes {
        uses GNBCUUPFunctionGrp;
      }
    }
  }
}

module _3gpp-nr-nrm-gnbdufunction {
  yang-version 1.1;
  namespace "urn:3gpp:sa5:_3gpp-nr-nrm-gnbdufunction";
  prefix "gnbdu3gpp";

  import _3gpp-common-managed-function { prefix mf3gpp; }
  import _3gpp-common-managed-element { prefix me3gpp; }
  import _3gpp-common-top { prefix top3gpp; }

  organization "3GPP SA5";
  description "Defines the YANG mapping of the GNBFunction Information
    Object Class (IOC) that is part of the NR Network Resource Model (NRM).";
  reference "3GPP TS 28.541 5G Network Resource Model (NRM)";

  revision 2019-08-21 {
    description "Initial revision.";
    reference "Based on
      3GPP TS 28.541 V15.X.XX";
  }

  grouping GNBFunctionGrp {
    description "Represents the GNBFunction IOC.";
    reference "3GPP TS 28.541";
    uses mf3gpp:ManagedFunctionGrp;

    leaf gNBId {
      type int64 { range "0..4294967295"; }
      mandatory true;
      description "Identifies a gNB within a PLMN. The gNB Identifier (gNB ID)
        is part of the NR Cell Identifier (NCI) of the gNB cells.";
      reference "gNB ID in 3GPP TS 38.300, Global gNB ID in 3GPP TS 38.413";
    }

    leaf gNBIdLength {
      type int32 { range "22..32"; }
      mandatory true;
      description "Indicates the number of bits for encoding the gNB ID.";
      reference "gNB ID in 3GPP TS 38.300, Global gNB ID in 3GPP TS 38.413";
    }

    leaf gNBUID {
      type int64 { range "0..68719476735"; }
      mandatory true;
      description "Uniquely identifies the DU at least within a gNB.";
    }
  }
}

```

```

    reference "3GPP TS 38.473";
  }

  leaf gNBDUName {
    type string { length "1..150"; }
    mandatory true;
    description "Identifies the Distributed Unit of an NR node";
    reference "3GPP TS 38.473";
  }
}

augment "/me3gpp:ManagedElement" {

  list GNBDUFunction {
    key id;
    description "Represents the logical function DU of gNB or en-gNB.";
    reference "3GPP TS 28.541";
    uses top3gpp:Top_Grp;
    container attributes {
      uses GNBDUFunctionGrp;
    }
  }
}

module _3gpp-nr-nrm-nrcellcu {
  yang-version 1.1;
  namespace "urn:3gpp:sa5:_3gpp-nr-nrm-nrcellcu";
  prefix "nrcellcu3gpp";

  import _3gpp-common-yang-types { prefix types3gpp; }
  import _3gpp-common-managed-function { prefix mf3gpp; }
  import _3gpp-common-managed-element { prefix me3gpp; }
  import _3gpp-nr-nrm-gnbcucpfunction { prefix gnbcucp3gpp; }
  import _3gpp-common-top { prefix top3gpp; }

  organization "3GPP SA5";
  description "Defines the YANG mapping of the NRCellCU Information Object
    Class (IOC) that is part of the NR Network Resource Model (NRM).";
  reference "3GPP TS 28.541 5G Network Resource Model (NRM)";

  revision 2019-06-17 {
    description "Initial revision";
    reference "Based on
      3GPP TS 28.541 V15.X.XX";
  }

  typedef quotaType {
    type enumeration {
      enum STRICT;
      enum FLOAT;
    }
  }

  grouping RRMPolicyRatio1 {
    description "Represents properties of RRMPolicyRatio1.";

    leaf groupId {
      description "Uniquely identifies one sNSSAIIList group inside an
        NRCellCU instance.";
      type uint32;
    }

    leaf-list sNSSAIIList {
      description "List of S-NSSAIs the managed object is supporting. NSSAI is
        a set of supported S-NSSAIs. An S-NSSAI is comprised of an
        SST (Slice/Service type) and an optional SD (Slice Differentiator)
        field.";
      reference "3GPP TS 23.003";
      type types3gpp:SNssai;
    }

    leaf rRRMPolicyRatio {
      description "Percentage of PRBs to be allocated to the corresponding
        S-NSSAIs, in average over time. The sum of the values for
        rRRMPolicyRatio described in rRRMPolicyRatio1List shall be less or
        equal to 100.";
      type uint8 { range "0..100"; }
    }
  }
}

```

```

    units %;
  }
}

grouping RRMPolicyRatio2 {
  description "Represents properties of RRMPolicyRatio2. The RRM policy
    setting the ratios for the split of the radio resources between the
    supported S-NSSAI lists, in average over time.";

  leaf groupId {
    description "Uniquely identifies one sNSSAIIList group inside an
      NRCellCU instance.";
    type uint32;
  }

  leaf-list sNSSAIIList {
    description "List of S-NSSAIs the managed object is supporting. NSSAI
      is a set of supported S-NSSAI(s). An S-NSSAI is comprised of an
      SST (Slice/Service type) and an optional SD (Slice Differentiator)
      field.";
    reference "3GPP TS 23.003";
    type types3gpp:SNssai;
  }

  leaf quotaType {
    description "The type of the quota which allows to allocate resources as
      strictly usable for defined slice(s) (strict quota) or allows that
      resources to be used by other slice(s) when defined slice(s) do not
      need them (float quota).";
    type quotaType;
  }

  leaf rRMPolicyMaxRatio {
    description "The RRM policy setting the maximum percentage of radio
      resources to be allocated to the corresponding S-NSSAI list. This
      quota can be strict or float quota. Strict quota means resources are
      not allowed for other sNSSAIs even when they are not used by the
      defined sNSSAIIList. Float quota resources can be used by other sNSSAIs
      when the defined sNSSAIIList do not need them. Value 0 indicates that
      there is no maximum limit.";
    type uint8 { range "0..100"; }
    units %;
  }

  leaf rRMPolicyMarginMaxRatio {
    description "Maximum quota margin ratio is applicable when maximum quota
      policy ratio is of type "float quota". It defines the resource quota
      within maximum quota to reserve buffers for new resource requirements
      for the specified S-NSSAI list. With the margin ratio, unused resources
      of the maximum resource quota can be allocated to other S-NSSAIs when
      the free resources are more than resource amount indicated by the
      margin. The margin resource quota can only be used for the specific
      S-NSSAI list. Value 0 indicates that no margin is used.";
    type uint8 { range "0..100"; }
    units %;
  }

  leaf rRMPolicyMinRatio {
    description "The RRM policy setting the minimum percentage of radio
      resources to be allocated to the corresponding S-NSSAI list. This
      quota can be strict or float quota. Strict quota means resources are
      not allowed for other sNSSAIs even when they are not used by the
      defined sNSSAIIList. Float quota resources can be used by other sNSSAIs
      when the defined sNSSAIIList do not need them. Value 0 indicates that
      there is no minimum limit.";
    type uint8 { range "0..100"; }
    units %;
  }

  leaf rRMPolicyMarginMinRatio {
    description "Minimum quota margin ratio is applicable when minimum quota
      policy ratio is of type "float quota". It defines the resource quota
      within minimum quota to reserve buffers for new resource requirements
      for the specified S-NSSAI list. With the margin ratio, unused resources
      of the minimum resource quota can be allocated to other S-NSSAIs when
      the free resources are more than resource amount indicated by the
      margin. The margin resource quota can only be used for the specific
      S-NSSAI list. Value 0 indicates that no margin is used. Value 0

```

```

        indicates that there is no minimum limit.";
        type uint8 { range "0..100"; }
        units %;
    }
}

grouping NRCellCUGrp {
    description "Represents the NRCellCU IOC.";
    reference "3GPP TS 28.541";
    uses mf3gpp:ManagedFunctionGrp;

    leaf cellLocalId {
        description "Identifies an NR cell of a gNB. Together with corresponding
            gNB ID it forms the NR Cell Identifier (NCI).";
        mandatory true;
        type int32 { range "0..16383"; }
    }

    list pLMNIdList {
        description "Defines which PLMNs that can be served by the NR cell.";
        // Note: Whether this attribute can be writable depends on the implementation.
        key "mcc mnc";
        min-elements 1;
        max-elements 12;
        uses types3gpp:PLMNId;
    }

    leaf-list sNSSAIDList {
        description "List of S-NSSAIs the cell is capable of supporting. An
            S-NSSAI is comprised of an SST (Slice/Service Type) and an optional
            SD (Slice Differentiator) field.";
        reference "3GPP TS 23.003";
        min-elements 0;
        type types3gpp:SNssai;
    }

    leaf rRMPolicyType {
        description "Type of RRM policy. The value 0 denotes use of the
            rRMPolicy. The value 1 denotes use of the rRMPolicyRatio1List.
            The value 2 denotes use of the rRMPolicyRatio2.";
        mandatory true;
        type uint16 { range "0..65535"; }
    }

    leaf rRMPolicy {
        description "RRM policy which includes guidance for split of radio
            resources between multiple slices the cell supports.";
        mandatory true;
        type string;
    }

    list rRMPolicyRatio1List {
        description "List of RRMPolicyRatio1. Used for setting the ratio for the
            split of the radio resources (i.e. PRBs) between the supported S-NSSAI
            lists.";
        key groupId;
        min-elements 1;
        uses RRMPolicyRatio1;
    }

    list rRMPolicyRatio2 {
        description "List of RRMPolicyRatio2. Used for setting the ratio for the
            split of the radio resources between the S-NSSAI lists for radio
            resources (e.g. RRC connected users, PDCP resource, etc.), in average
            time.";
        key groupId;
        min-elements 1;
        uses RRMPolicyRatio2;
    }

    leaf nRFrequencyRef {
        description "Reference to corresponding NRFrequency instance.";
        config false;
        type types3gpp:DistinguishedName;
    }
}

augment "/me3gpp:ManagedElement/gnbcucp3gpp:GNBCUCPFunction" {

```



```

list NRCellCU {
  description "Represents the information required by CU that is
    responsible for the management of inter-cell mobility and neighbour
    relations via ANR.";
  reference "3GPP TS 28.541";
  key id;
  uses top3gpp:Top_Grp;
  container attributes {
    uses NRCellCUGrp;
  }
}
}
}

module _3gpp-nr-nrm-nrcelldu {
  yang-version 1.1;
  namespace "urn:3gpp:sa5:_3gpp-nr-nrm-nrcelldu";
  prefix "nrcelldu3gpp";

  import _3gpp-common-yang-types { prefix types3gpp; }
  import _3gpp-common-managed-function { prefix mf3gpp; }
  import _3gpp-common-managed-element { prefix me3gpp; }
  import _3gpp-common-top { prefix top3gpp; }
  import _3gpp-nr-nrm-gnbdufunction { prefix gnbdu3gpp; }

  organization "3GPP SA5";
  description "Defines the YANG mapping of the NRCellDU Information Object
    Class (IOC) that is part of the NR Network Resource Model (NRM).";
  reference "3GPP TS 28.541 5G Network Resource Model (NRM)";

  revision 2019-06-17 {
    description "Initial revision";
    reference "Based on
      3GPP TS 28.541 V15.X.XX";
  }

  grouping NRCellDUGrp {
    description "Represents the NRCellDU IOC.";
    reference "3GPP TS 28.541";
    uses mf3gpp:ManagedFunctionGrp;

    leaf cellLocalId {
      description "Identifies an NR cell of a gNB. Together with the
        corresponding gNB identifier in forms the NR Cell Identity (NCI).";
      reference "NCI in 3GPP TS 38.300";
      mandatory true;
      type int32 { range "0..16383"; }
    }

    leaf operationalState {
      description "Operational state of the NRCellDU instance. Indicates
        whether the resource is installed and partially or fully operable
        (ENABLED) or the resource is not installed or not operable
        (DISABLED).";
      config false;
      type types3gpp:OperationalState;
    }

    leaf administrativeState {
      description "Administrative state of the NRCellDU. Indicates the
        permission to use or prohibition against using the cell, imposed
        through the OAM services.";
      mandatory true;
      type types3gpp:AdministrativeState;
    }

    leaf cellState {
      description "Cell state of the NRCellDU instance. Indicates whether the
        cell is not currently in use (IDLE), or currently in use but not
        configured to carry traffic (INACTIVE), or currently in use and is
        configured to carry traffic (ACTIVE).";
      config false;
      type types3gpp:CellState;
    }
  }

  list pLMNidList {
    description "Defines which PLMNs that can be served by the NR cell. The

```

```
    first entry of the list is the PLMN used to construct the nCGI for the
    NR cell.";
    key "mcc mnc";
    min-elements 1;
    max-elements 12;
    uses types3gpp:PLMNid;
}

leaf-list sNSSAIIList {
    description "List of S-NSSAIs the NR cell is supporting. NSSAI is a set
    of supported S-NSSAI(s), and an S-NSSAI is comprised of a SST
    (Slice/Service type) and an optional SD (Slice Differentiator) field.";
    reference "3GPP TS 23.003";
    min-elements 0;
    type types3gpp:SNssai;
}

leaf nRPCI {
    description "The Physical Cell Identity (PCI) of the NR cell.";
    reference "3GPP TS 36.211";
    mandatory true;
    type int32 { range "0..1007"; }
}

leaf nRTAC {
    description "The common 5GS Tracking Area Code for the PLMNs.";
    reference "3GPP TS 23.003, 3GPP TS 38.473";
    mandatory true;
    type types3gpp:Tac;
}

leaf arfcnDL {
    description "NR Absolute Radio Frequency Channel Number (NR-ARFCN) for
    downlink.";
    reference "3GPP TS 38.104";
    mandatory true;
    type int32;
}

leaf arfcnUL {
    description "NR Absolute Radio Frequency Channel Number (NR-ARFCN) for
    uplink.";
    reference "3GPP TS 38.104";
    mandatory true;
    type int32;
}

leaf arfcnSUL {
    description "NR Absolute Radio Frequency Channel Number (NR-ARFCN) for
    supplementary uplink.";
    reference "3GPP TS 38.104";
    mandatory true;
    type int32;
}

leaf bSChannelBwDL {
    description "Base station channel bandwidth for downlink.";
    reference "3GPP TS 38.104";
    mandatory true;
    type int32;
    units MHz;
}

leaf bSChannelBwUL {
    description "Base station channel bandwidth for uplink.";
    reference "3GPP TS 38.104";
    mandatory false;
    type int32;
    units MHz;
}

leaf bSChannelBwSUL {
    description "Base station channel bandwidth for supplementary uplink.";
    reference "3GPP TS 38.104";
    mandatory false;
    type int32;
    units MHz;
}
```

```

leaf ssbFrequency {
  description "Indicates cell defining SSB frequency domain position.
  Frequency (in terms of NR-ARFCN) of the cell defining SSB transmission.
  The frequency identifies the position of resource element RE=#0
  (subcarrier #0) of resource block RB#10 of the SS block. The frequency
  must be positioned on the NR global frequency raster, as defined in
  3GPP TS 38.101-1, and within bSChannelBwDL.";
  mandatory true;
  type int32 { range "0..3279165"; }
}

leaf ssbPeriodicity {
  description "Indicates cell defined SSB periodicity. The SSB periodicity
  is used for the rate matching purpose.";
  mandatory true;
  type int32 { range "5 | 10 | 20 | 40 | 80 | 160"; }
  units "subframes (ms)";
}

leaf ssbSubCarrierSpacing {
  description "Subcarrier spacing of SSB. Only the values 15 kHz or 30 kHz
  (< 6 GHz), 120 kHz or 240 kHz (> 6 GHz) are applicable.";
  reference "3GPP TS 38.211";
  mandatory true;
  type int32 { range "15 | 30 | 120 | 240"; }
  units kHz;
}

leaf ssbOffset {
  description "Indicates cell defining SSB time domain position. Defined
  as the offset of the measurement window, in which to receive SS/PBCH
  blocks, where allowed values depend on the ssbPeriodicity
  (ssbOffset < ssbPeriodicity).";
  mandatory true;
  type int32 { range "0..159"; }
  units "subframes (ms)";
}

leaf ssbDuration {
  description "Duration of the measurement window in which to receive
  SS/PBCH blocks.";
  reference "3GPP TS 38.213";
  mandatory true;
  type int32 { range "1..5"; }
  units "subframes (ms)";
}

leaf-list nRSectorCarrierRef {
  description "Reference to corresponding NRSectorCarrier instance.";
  min-elements 1;
  type types3gpp:DistinguishedName;
}

leaf-list bWPRef {
  description "Reference to corresponding BWP instance.";
  min-elements 0;
  type types3gpp:DistinguishedName;
}

leaf-list nRFrequencyRef {
  description "Reference to corresponding NRFrequency instance.";
  min-elements 0;
  type types3gpp:DistinguishedName;
}
}

augment "/me3gpp:ManagedElement/gnbdu3gpp:GNBDUFunction" {
  list NRCellDU {
    description "Represents the information of a cell known by DU.";
    reference "3GPP TS 28.541";
    key id;
    uses top3gpp:Top_Grp;
    container attributes {
      uses NRCellDUGrp;
    }
  }
}

```

```

    }
}

module _3gpp-nr-nrm-nrcellrelation {
  yang-version 1.1;
  namespace "urn:3gpp:sa5:_3gpp-nr-nrm-nrcellrelation";
  prefix "nrcellrel3gpp";

  import _3gpp-common-yang-types { prefix types3gpp; }
  import _3gpp-common-managed-function { prefix mf3gpp; }
  import _3gpp-common-managed-element { prefix me3gpp; }
  import _3gpp-common-top { prefix top3gpp; }
  import _3gpp-nr-nrm-gnbcucpfunction { prefix gnbcucp3gpp; }
  import _3gpp-nr-nrm-nrcellcu { prefix nrcellcu3gpp; }

  organization "3GPP SA5";
  description "Defines the YANG mapping of the NRCellRelation Information
  Object Class (IOC) that is part of the NR Network Resource Model (NRM).";
  reference "3GPP TS 28.541 5G Network Resource Model (NRM)";

  revision 2019-06-17 {
    description "Initial revision";
    reference "Based on
    3GPP TS 28.541 V15.X.XX";
  }
  revision 2020-04-23 {
    reference "CR0282" ;
  }

  grouping NRCellRelationGrp {
    description "Represents the NRCellRelation IOC.";
    reference "3GPP TS 28.541";

    leaf nRTCI {
      description "Target NR Cell Identifier. It consists of NR Cell
      Identifier (NCI) and Physical Cell Identifier of the target NR cell
      (nRPCI).";
      type uint64;
    }

    container cellIndividualOffset {
      description "A set of offset values for the neighbour cell. Used when
      UE is in connected mode. Defined for rsrpOffsetSSB, rsrqOffsetSSB,
      sinrOffsetSSB, rsrpOffsetCSI-RS, rsrqOffsetCSI-RS and
      sinrOffsetCSI-RS.";
      reference "cellIndividualOffset in MeasObjectNR in 3GPP TS 38.331";

      leaf rsrpOffsetSsb {
        description "Offset value of rsrpOffsetSSB.";
        default 0;
        type types3gpp:QOffsetRange;
      }

      leaf rsrqOffsetSsb{
        description "Offset value of rsrqOffsetSSB.";
        default 0;
        type types3gpp:QOffsetRange;
      }

      leaf sinrOffsetSsb {
        description "Offset value of sinrOffsetSSB.";
        default 0;
        type types3gpp:QOffsetRange;
      }

      leaf rsrpOffsetCsiRs{
        description "Offset value of rsrpOffsetCSI-RS.";
        default 0;
        type types3gpp:QOffsetRange;
      }

      leaf rsrqOffsetCsiRs {
        description "Offset value of rsrqOffsetCSI-RS.";
        default 0;
        type types3gpp:QOffsetRange;
      }

      leaf sinrOffsetCsiRs {

```

```

        description "Offset value of sinrOffsetCSI-RS.";
        default 0;
        type types3gpp:QOffsetRange;
    }
}

leaf nRFreqRelationRef {
    description "Reference to a corresponding NRFrequency instance.";
    mandatory true;
    type types3gpp:DistinguishedName;
}

leaf adjacentNRCellRef {
    description "Reference to an adjacent NR cell (NRCellCU or
        ExternalNRCellCU).";
    mandatory true;
    type types3gpp:DistinguishedName;
}
}

augment /me3gpp:ManagedElement/gnbcucp3gpp:GNBCUCPFunction/nrcellcu3gpp:NRCellCU {

    list NRCellRelation {
        description "Represents a neighbour cell relation from a source cell
            to a target cell, where the target cell is an NRCellCU or
            ExternalNRCellCU instance.";
        reference "3GPP TS 28.541";
        key id;
        uses top3gpp:Top_Grp;
        container attributes {
            uses NRCellRelationGrp;
        }
    }
}

}

module _3gpp-nr-nrm-nrfreqrelation {
    yang-version 1.1;
    namespace "urn:3gpp:sa5:_3gpp-nr-nrm-nrfreqrelation";
    prefix "nrfreqrel3gpp";

    import _3gpp-common-yang-types { prefix types3gpp; }
    import _3gpp-common-managed-function { prefix mf3gpp; }
    import _3gpp-common-managed-element { prefix me3gpp; }
    import _3gpp-common-top { prefix top3gpp; }
    import _3gpp-nr-nrm-gnbcucpfunction { prefix gnbcucp3gpp; }
    import _3gpp-nr-nrm-nrcellcu { prefix nrcellcu3gpp; }

    organization "3GPP SA5";
    description "Defines the YANG mapping of the NRFreqRelation Information
        Object Class (IOC) that is part of the NR Network Resource Model (NRM).";
    reference "3GPP TS 28.541 5G Network Resource Model (NRM)";

    revision 2020-04-23 {
        reference "CR0282";
    }

    revision 2019-06-17 {
        description "Initial revision";
        reference "Based on
            3GPP TS 28.541 V15.X.XX";
    }

    grouping NRFreqRelationGrp {
        description "Represents the NRFreqRelation IOC.";
        reference "3GPP TS 28.541";

        container offsetMO {
            description "A set of offset values applicable to all measured cells
                with reference signal(s) indicated in corresponding MeasObjectNR. It
                is used to indicate a cell, beam or measurement object specific offset
                to be applied when evaluating candidates for cell re-selection or when
                evaluating triggering conditions for measurement reporting. It is
                defined for rsrpOffsetSSB, rsrqOffsetSSB, sinrOffsetSSB,
                rsrpOffsetCSI-RS, rsrqOffsetCSI-RS and sinrOffsetCSI-RS.";
            reference "offsetMO in MeasObjectNR in 3GPP TS 38.331";

            leaf rsrpOffsetSsb {
                description "Offset value of rsrpOffsetSSB.";
            }
        }
    }
}

```

```

    default 0;
    type types3gpp:QOffsetRange;
  }

  leaf rsrqOffsetSsb {
    description "Offset value of rsrqOffsetSSB.";
    default 0;
    type types3gpp:QOffsetRange;
  }

  leaf sinrOffsetSsb {
    description "Offset value of sinrOffsetSSB.";
    default 0;
    type types3gpp:QOffsetRange;
  }

  leaf rsrpOffsetCsiRs {
    description "Offset value of rsrpOffsetCSI-RS.";
    default 0;
    type types3gpp:QOffsetRange;
  }

  leaf rsrqOffsetCsiRs {
    description "Offset value of rsrqOffsetCSI-RS.";
    default 0;
    type types3gpp:QOffsetRange;
  }

  leaf sinrOffsetCsiRs {
    description "Offset value of sinrOffsetCSI-RS.";
    default 0;
    type types3gpp:QOffsetRange;
  }
}

leaf-list blacklistEntry {
  description "A list of Physical Cell Identities (PCIs) that are
  blacklisted in NR measurements.";
  reference "3GPP TS 38.331";
  min-elements 0;
  type uint16 { range "0..1007"; }
}

leaf-list blacklistEntryIdleMode {
  description "A list of Physical Cell Identities (PCIs) that are
  blacklisted in SIB4 and SIB5.";
  min-elements 0;
  type uint16 { range "0..1007"; }
}

leaf cellReselectionPriority {
  description "The absolute priority of the carrier frequency used by the
  cell reselection procedure. Value 0 means lowest priority. The value
  must not already used by other RAT, i.e. equal priorities between RATs
  are not supported. The UE behaviour when no value is entered is
  specified in subclause 5.2.4.1 of 3GPP TS 38.304.";
  reference "CellReselectionPriority in 3GPP TS 38.331, priority in
  3GPP TS 38.304";
  type uint32;
  default 0;
}

leaf cellReselectionSubPriority {
  description "Indicates a fractional value to be added to the value of
  cellReselectionPriority to obtain the absolute priority of the
  concerned carrier frequency for E-UTRA and NR.";
  reference "3GPP TS 38.331";
  type uint8 { range "2 | 4 | 6 | 8"; }
  units "0.1";
}

leaf pMax {
  description "Used for calculation of the parameter Pcompensation
  (defined in 3GPP TS 38.304), at cell reselection to a cell.";
  reference "PEMAX in 3GPP TS 38.101-1";
  mandatory false;
  type int32 { range "-30..33"; }
  units dBm;
}

```

```
}  
  
leaf qOffsetFreq {  
  description "The frequency specific offset applied when evaluating  
    candidates for cell reselection.";  
  mandatory false;  
  type types3gpp:QOffsetRange;  
  default 0;  
}  
  
leaf qQualMin {  
  description "Indicates the minimum required quality level in the cell.  
    Value 0 means that it is not sent and UE applies in such case the  
    (default) value of negative infinity for Qqualmin. Sent in SIB3 or  
    SIB5.";  
  reference "3GPP TS 38.304";  
  type int32 { range "-34..-3 | 0"; }  
  units dB;  
  default 0;  
}  
  
leaf qRxLevMin {  
  description "Indicates the required minimum received Reference Symbol  
    Received Power (RSRP) level in the NR frequency for cell reselection.  
    Broadcast in SIB3 or SIB5, depending on whether the related frequency  
    is intra- or inter-frequency. Resolution is 2.";  
  reference "3GPP TS 38.304";  
  mandatory true;  
  type int32 { range "-140..-44"; }  
  units dBm;  
}  
  
leaf threshXHighP {  
  description "Specifies the Srxlev threshold used by the UE when  
    reselecting towards a higher priority RAT/frequency than the current  
    serving frequency. Each frequency of NR and E-UTRAN might have a  
    specific threshold. Resolution is 2.";  
  reference "ThreshX, HighP in 3GPP TS 38.304";  
  mandatory true;  
  type int32 { range "0..62"; }  
  units dB;  
}  
  
leaf threshXHighQ {  
  description "Specifies the Squal threshold used by the UE when  
    reselecting towards a higher priority RAT/frequency than the current  
    serving frequency. Each frequency of NR and E-UTRAN might have a  
    specific threshold.";  
  reference "ThreshX, HighQ in 3GPP TS 38.304";  
  mandatory true;  
  type int32 { range "0..31"; }  
  units dB;  
}  
  
leaf threshXLowP {  
  description "Specifies the Srxlev threshold used by the UE when  
    reselecting towards a lower priority RAT/frequency than the current  
    serving frequency. Each frequency of NR and E-UTRAN might have a  
    specific threshold. Resolution is 2.";  
  reference "ThreshX, LowP in 3GPP TS 38.304";  
  mandatory true;  
  type int32 { range "0..62"; }  
  units dB;  
}  
  
leaf threshXLowQ {  
  description "Specifies the Squal threshold used by the UE when  
    reselecting towards a lower priority RAT/frequency than the current  
    serving frequency. Each frequency of NR and E-UTRAN might have a  
    specific threshold.";  
  reference "ThreshX, LowQ in 3GPP TS 38.304";  
  mandatory true;  
  type int32 { range "0..31"; }  
  units dB;  
}  
  
leaf tReselectionNR {  
  description "Cell reselection timer for NR.";
```

```

    reference "TreseselectionRAT for NR in 3GPP TS 38.331";
    mandatory true;
    type int32 { range "0..7"; }
    units s;
}

leaf tReseselectionNRSfHigh {
    description "The attribute tReseselectionNr (parameter TreseselectionNR in
        3GPP TS 38.304) is multiplied with this scaling factor if the UE is
        in high mobility state.";
    reference "Speed dependent ScalingFactor for TreseselectionNR for high
        mobility state in 3GPP TS 38.304";
    mandatory true;
    type uint8 { range "25 | 50 | 75 | 100"; }
    units %;
}

leaf tReseselectionNRSfMedium {
    description "The attribute tReseselectionNr (parameter TreseselectionNR in
        3GPP TS 38.304) multiplied with this scaling factor if the UE is in
        medium mobility state.";
    reference "Speed dependent ScalingFactor for TreseselectionNR for medium
        mobility state in 3GPP TS 38.304";
    mandatory true;
    type uint8 { range "25 | 50 | 75 | 100"; }
    units %;
}

leaf nRFrequencyRef {
    description "Reference to a corresponding NRFrequency instance.";
    mandatory true;
    type types3gpp:DistinguishedName;
}
}

augment /me3gpp:ManagedElement/gnbcucp3gpp:GNBCUCPFunction/nrcellcu3gpp:NRCellCU {

    list NRFreqRelation {
        description "Together with the target NRFrequency, it represents the
            frequency properties applicable to the referencing NRFreqRelation.";
        reference "3GPP TS 28.541";
        key id;
        uses top3gpp:Top_Grp;
        container attributes {
            uses NRFreqRelationGrp;
        }
    }
}

module _3gpp-nr-nrm-nrfrequency {
    yang-version 1.1;
    namespace "urn:3gpp:sa5:_3gpp-nr-nrm-nrnetwork-nrfrequency";
    prefix "nrfreq3gpp";

    import _3gpp-common-managed-function { prefix mf3gpp; }
    import _3gpp-nr-nrm-nrnetwork { prefix nrnet3gpp; }
    import _3gpp-common-subnetwork { prefix subnet3gpp; }
    import _3gpp-common-top { prefix top3gpp; }

    organization "3GPP SA5";
    description "Defines the YANG mapping of the NRFrequency Information Object
        Class (IOC) that is part of the NR Network Resource Model (NRM).";
    reference "3GPP TS 28.541 5G Network Resource Model (NRM)";

    revision 2019-06-17 {
        description "Initial revision";
        reference "Based on
            3GPP TS 28.541 V15.X.XX";
    }

    grouping NRFrequencyGrp {
        description "Represents the NRFrequency IOC.";
        reference "3GPP TS 28.541";
        uses mf3gpp:ManagedFunctionGrp;

        leaf absoluteFrequencySSB {
            description "The absolute frequency applicable for a downlink NR carrier

```



```

        frequency associated with the SSB, in terms of NR-ARFCN.";
        mandatory true;
        type uint32 { range "0.. 3279165"; }
    }

    leaf sSSSubCarrierSpacing {
        description "Sub-carrier spacing of the SSB.";
        mandatory true;
        type uint8 { range "15 | 30 | 60 | 120"; }
        units "kHz";
    }

    leaf-list multiFrequencyBandListNR {
        description "List of additional frequency bands the frequency belongs to.
        The list is automatically set by the gNB.";
        config false;
        min-elements 0;
        type uint16 { range "1..256"; }
    }
}

grouping NRFrequencyWrapper {
    list NRFrequency {
        description "Represents certain NR frequency properties.";
        reference "3GPP TS 28.541";
        key id;
        uses top3gpp:Top_Grp;
        container attributes {
            uses NRFrequencyGrp;
        }
    }
}

augment "/subnet3gpp:SubNetwork" {
    if-feature subnet3gpp:ExternalsUnderSubNetwork ;
    uses NRFrequencyWrapper;
}

augment "/nrnet3gpp:NRNetwork" {
    if-feature nrnet3gpp:ExternalsUnderNRNetwork;
    uses NRFrequencyWrapper;
}
}

module _3gpp-nr-nrm-nrnetwork {
    yang-version 1.1;
    namespace "urn:3gpp:sa5:_3gpp-nr-nrm-nrnetwork";
    prefix "nrnet3gpp";

    import _3gpp-common-subnetwork { prefix subnet3gpp; }
    import _3gpp-common-top { prefix top3gpp; }

    organization "3GPP SA5";
    description "Defines the YANG mapping of the NRNetwork Information Object
    Class (IOC) that is part of the NR Network Resource Model (NRM).";
    reference "3GPP TS 28.541 5G Network Resource Model (NRM)";

    revision 2019-06-17 {
        description "Initial revision";
        reference "Based on
        3GPP TS 28.541 V15.X.XX";
    }

    feature ExternalsUnderNRNetwork {
        description "Classes representing external entities like NRFrequency,
        ExternalGNBCUCPFunction, ExternalGNBDUFunction
        are contained under a NRNetwork list/class.";
    }

    grouping NRNetworkGrp {
        description "Represents the NRNetwork IOC.";
        reference "3GPP TS 28.541";
        uses subnet3gpp:SubNetworkGrp;
    }

    list NRNetwork {
        description "A subnetwork containing gNB external NR entities.";
        reference "3GPP TS 28.541";
    }
}

```

```

    key id;
    uses top3gpp:Top_Grp;
    container attributes {
        uses NRNetworkGrp;
    }
}

module _3gpp-nr-nrm-nrsectorcarrier {
    yang-version 1.1;
    namespace "urn:3gpp:sa5:_3gpp-nr-nrm-nrnetwork-nrsectorcarrier";
    prefix "nrsectcarr3gpp";

    import _3gpp-common-yang-types { prefix types3gpp; }
    import _3gpp-common-managed-function { prefix mf3gpp; }
    import _3gpp-common-managed-element { prefix me3gpp; }
    import _3gpp-nr-nrm-gnbdufunction { prefix gnbdu3gpp; }
    import _3gpp-common-top { prefix top3gpp; }

    organization "3GPP SA5";
    description "Defines the YANG mapping of the NRSectorCarrier Information
        Object Class (IOC) that is part of the NR Network Resource Model (NRM).";
    reference "3GPP TS 28.541 5G Network Resource Model (NRM)";

    revision 2019-06-17 {
        description "Initial revision";
        reference "Based on
            3GPP TS 28.541 V15.X.XX";
    }

    grouping NRSectorCarrierGrp {
        description "Represents the NRSectorCarrier IOC.";
        reference "3GPP TS 28.541";
        uses mf3gpp:ManagedFunctionGrp;

        leaf txDirection {
            description "Indicates if the transmission direction is downlink,
                uplink, or both downlink and uplink.";
            mandatory true;
            type types3gpp:TxDirection;
        }

        leaf configuredMaxTxPower {
            description "Maximum possible transmisssion power for all downlink
                channels, used simultaneously in a sector-carrier, added together.";
            mandatory true;
            type int32;
            units mW;
        }

        leaf arfcnDL {
            description "NR Absolute Radio Frequency Channel Number (NR-ARFCN)
                for downlink.";
            reference "3GPP TS 38.104";
            mandatory true;
            type int32 { range "0..3279165"; }
        }

        leaf arfcnUL {
            description "NR Absolute Radio Frequency Channel Number (NR-ARFCN)
                for uplink.";
            reference "3GPP TS 38.104";
            mandatory true;
            type int32 { range "0..3279165"; }
        }

        leaf bSChannelBwDL {
            description "Base station channel bandwitdth for downlink.";
            reference "3GPP TS 38.104";
            mandatory true;
            type int32 { range "5 | 10 | 15 | 20 | 30 | 40 | 50 | 60 | 70 | 80 |
                90 | 100"; }
            units MHz;
        }

        leaf bSChannelBwUL {
            description "Base station channel bandwitdth for uplink.";
            reference "3GPP TS 38.104";
        }
    }
}

```

```

    mandatory true;
    type int32 { range "5 | 10 | 15 | 20 | 30 | 40 | 50 | 60 | 70 | 80 |
      90 | 100"; }
    units MHz;
  }

  leaf sectorEquipmentFunctionRef {
    description "Reference to corresponding SectorEquipmentFunction
      instance.";
    reference "3GPP TS 23.622";
    mandatory true;
    type types3gpp:DistinguishedName;
  }
}

augment "/me3gpp:ManagedElement/gnbdu3gpp:GNBDUFunction" {

  list NRSectorCarrier {
    description "Represents the resources of each transmission point
      included in the cell.";
    reference "3GPP TS 28.541";
    key id;
    uses top3gpp:Top_Grp;
    container attributes {
      uses NRSectorCarrierGrp;
    }
  }
}
}
}

```

E.6 Graphical representation

See the H.6 for the YANG module tree diagram for NR and NG-RAN NRM.

E.7 Mount information

At the mountpoint "children-of-SubNetwork" in the YANG module `_3gpp-common-subnetwork`, the following YANG modules may be mounted if the class `ManagedElement` and the underlying hierarchy is contained under a `SubNetwork`.

See [47] that describes the mechanism that adds the schema trees defined by a set of YANG modules onto a mount point defined in the schema tree in another YANG module.

```

_3gpp-common-ep-rp.yang
_3gpp-common-managed-element.yang
_3gpp-common-managed-function.yang
_3gpp-common-measurements.yang
_3gpp-common-subnetwork.yang
_3gpp-common-top.yang
_3gpp-common-yang-extensions.yang
_3gpp-common-yang-types.yang
_3gpp-nr-nrm-bwp.yang
_3gpp-nr-nrm-ep.yang
_3gpp-nr-nrm-eutrancellrelation.yang
_3gpp-nr-nrm-gnbcucpfunction.yang
_3gpp-nr-nrm-gnbcuupfunction.yang
_3gpp-nr-nrm-gnbdufunction.yang
_3gpp-nr-nrm-nrcellcu.yang
_3gpp-nr-nrm-nrcelldu.yang
_3gpp-nr-nrm-nrcellrelation.yang
_3gpp-nr-nrm-nrfreqrelation.yang
_3gpp-nr-nrm-nrfrequency.yang
_3gpp-nr-nrm-nrnetwork.yang
_3gpp-nr-nrm-nrsectorcarrier.yang
_3gpp-nr-nrm-beam.yang
_3gpp-nr-nrm-commonbeamformingfunction.yang
ietf-inet-types.yang
ietf-yang-types@2013-07-15.yang

```

If the above files are mounted the yang files described in clause H.7 shall also be mounted.

Annex F (normative): XML definitions for 5GC NRM

F.1 General

This annex contains the XML definitions for the 5GC NRM specified in clause 5, in accordance with 5G NRM Information Model definitions specified in clause 4.

F.2 Architectural features

The overall architectural feature of 5GC NRM information model is specified in clause 4, this clause specifies features that are specific to the Schema definitions.

The XML definitions of the present document specify the schema for a configuration content, which can be included in a configuration file for Bulk configuration management operations.

F.3 Mapping

F.3.1 General mapping

An IOC maps to an XML element of the same name as the IOC's name in the Information Model. An IOC attribute maps to a sub-element of the corresponding IOC's XML element, and the name of this sub-element is the same as the attribute's name in the Information Model.

F.3.2 Information Object Class (IOC) mapping

The mapping is not present in the current version of the present document.

F.4 Solution Set definitions

F.4.1 XML definition structure

The overall description of the file format of configuration data XML files is provided by 3GPP TS 32.616 [33].

The present document defines the NRM-specific XML schema `ngcNrm.xsd` for the 5GC NRM Information Model defined in clause 4.

XML schema `ngcNrm.xsd` explicitly declares NRM-specific XML element types for the related NRM.

The definition of those NRM-specific XML element types complies with the generic mapping rules defined in 3GPP TS 32.616 [33].

F.4.2 Graphical representation

The graphical representation is not present in the current version of the present document.

F.4.3 XML schema "`ngcNrm.xsd`"

```
<?xml version="1.0" encoding="UTF-8"?>
```

```

<!--
 3GPP TS 28.541 5GC Network Resource Model
 XML schema definition
 ngcNrm.xsd
-->

<schema
  targetNamespace="http://www.3gpp.org/ftp/specs/archive/28_series/28.541#ngcNrm"
  elementFormDefault="qualified"
  attributeFormDefault="unqualified"
  xmlns="http://www.w3.org/2001/XMLSchema"
  xmlns:xn="http://www.3gpp.org/ftp/specs/archive/28_series/28.623#genericNrm"
  xmlns:nn="http://www.3gpp.org/ftp/specs/archive/28_series/28.541#nrNrm"
  xmlns:en="http://www.3gpp.org/ftp/specs/archive/28_series/28.659#eutranNrm"
  xmlns:ngc="http://www.3gpp.org/ftp/specs/archive/28_series/28.541#ngcNrm"
>

<import namespace="http://www.3gpp.org/ftp/specs/archive/28_series/28.623#genericNrm"/>
<import namespace="http://www.3gpp.org/ftp/specs/archive/28_series/28.659#eutranNrm"/>
<import namespace="http://www.3gpp.org/ftp/specs/archive/28_series/28.541#nrNrm"/>

<!--NGC NRM IM class associated XML elements -->
<complexType name="AmfIdentifier">
  <sequence>
    <element name="amfRegionId" type="ngc:AmfRegionId"/>
    <element name="amfSetId" type="ngc:AmfSetId"/>
    <element name="amfPointer" type="ngc:AmfPointer"/>
  </sequence>
</complexType>
<simpleType name="AmfRegionId">
  <restriction base="integer">
    <maxInclusive value="255"/>
    <!-- The AMF Region ID is 8-bitslength, defined in 23.003 -->
  </restriction>
</simpleType>
<simpleType name="AmfSetId">
  <restriction base="integer">
    <maxInclusive value="1023"/>
    <!-- The AMF Region ID is 10-bits length, defined in 23.003 -->
  </restriction>
</simpleType>
<simpleType name="AmfPointer">
  <restriction base="integer">
    <maxInclusive value="63"/>
    <!-- The AMF Pointer is 6-bits length, defined in 23.003 -->
  </restriction>
</simpleType>
<complexType name="NrTACLList">
  <sequence>
    <element name="tac" type="nn:NrTac" minOccurs="0" maxOccurs="unbounded"/>
  </sequence>
</complexType>
<complexType name="NFProfileList">
  <sequence>
    <element name="nfProfile" type="ngc:NfProfile"/>
  </sequence>
</complexType>
<complexType name="NfProfile">
  <sequence>
    <element name="nfInstanceId" type="string"/>
    <!-- nfInstanceId is uuid of NF instance -->
    <element name="nfType" type="ngc:NfType"/>
    <element name="nfStatus" type="ngc:NfStatus"/>
    <element name="plmn" type="en:PLMNId"/>
    <element name="nfType" type="ngc:NfType"/>
    <element name="sNssais" type="ngc:SnsaiList"/>
    <element name="fqdn" type="string"/>
    <element name="interPlmnFqdn" type="string"/>
    <element name="fqdn" type="string"/>
    <element name="ipv4Addresses" type="string"/>
    <element name="ipv6Addresses" type="string"/>
    <element name="ipv6Prefixes" type="string"/>
    <element name="capacity" type="string"/>
    <element name="udrInfo" type="ngc:UdrInfo"/>
    <element name="amfInfo" type="ngc:AmfInfo"/>
    <element name="smfInfo" type="ngc:SmfInfo"/>
    <element name="upfInfo" type="ngc:UpfInfo"/>
    <element name="nfServices" type="ngc:NfServices"/>
  </sequence>

```

```

    </sequence>
  </complexType>
<complexType name="NfServices">
  <sequence>
    <element name="serviceInstanceId" type="string"/>
    <element name="serviceName" type="string"/>
    <element name="version" type="string"/>
    <element name="schema" type="string"/>
    <element name="fqdn" type="string"/>
    <element name="interPlmnFqdn" type="string"/>
      <element name="ipEndpoints" type="ngc:IpEndpoints"/>
      <element name="apiPrefix" type="string"/>
    <element name="defaultNotificationSubscriptions" type="ngc:DefaultNotificationSubscriptions"/>
      <element name="allowedPlmns" type="en:PLMNIdList"/>
      <element name="allowedNfTypes" type="ngc:NfTypeList"/>
    <element name="allowedNssais" type="ngc:Nssai"/>
      <element name="capacity" type="string"/>
      <element name="supportedFeatures" type="string"/>
    </sequence>
  </complexType>
<simpleType name="NfType">
  <restriction base="string">
    <!-- NF name is defined in TS 23.501 -->
    <enumeration value="NRF"/>
    <enumeration value="UDM"/>
    <enumeration value="AMF"/>
    <enumeration value="SMF"/>
    <enumeration value="AUSF"/>
    <enumeration value="NEF"/>
    <enumeration value="PCF"/>
    <enumeration value="SMSF"/>
    <enumeration value="NSSF"/>
    <enumeration value="UDR"/>
    <enumeration value="LMF"/>
    <enumeration value="GMLC"/>
    <enumeration value="5GEIR"/>
    <enumeration value="SEPP"/>
    <enumeration value="UPF"/>
    <enumeration value="N3IWF"/>
    <enumeration value="AF"/>
    <enumeration value="UDSF"/>
    <enumeration value="DN"/>
  </restriction>
</simpleType>
<complexType name="NfTypeList">
  <sequence>
    <element name="NfType" type="ngc:NfType"/>
  </sequence>
</complexType>
<complexType name="LocalEndPoint">
  <sequence>
    <element name="ipv4Address" type="string"/>
    <element name="ipv6Address" type="string"/>
    <element name="ipv6Prefix" type="string"/>
    <element name="vlanId" type="integer"/>
  </sequence>
</complexType>
<complexType name="RemoteEndPoint">
  <sequence>
    <element name="ipv4Address" type="string"/>
    <element name="ipv6Address" type="string"/>
    <element name="ipv6Prefix" type="string"/>
  </sequence>
</complexType>
<complexType name="UdrInfo">
  <sequence>
    <element name="supiRange" type="ngc:SupiRange"/>
  </sequence>
</complexType>
<complexType name="SupiRange">
  <sequence>
    <element name="start" type="string"/>
    <element name="end" type="string"/>
    <element name="pattern" type="string"/>
  </sequence>
</complexType>
<complexType name="AmfInfo">
  <sequence>

```

```

    <element name="amfSetId" type="ngc:AmfSetId"/>
  </sequence>
</complexType>
<complexType name="SmfInfo">
  <sequence>
    <element name="dnn" type="string"/>
  </sequence>
</complexType>
<complexType name="UpfInfo">
  <sequence>
    <element name="snssaiUpfInfo" type="ngc:SnssaiUpfInfo"/>
  </sequence>
</complexType>
<complexType name="SnssaiUpfInfo">
  <sequence>
    <element name="sNssai" type="ngc:SNssai"/>
    <element name="dnnUpfInfoList" type="ngc:DnnUpfInfoList"/>
  </sequence>
</complexType>
<complexType name="DnnUpfInfoList">
  <sequence>
    <element name="dnn" type="string"/>
  </sequence>
</complexType>
<complexType name="DefaultNotificationSubscription">
  <sequence>
    <element name="notificationType" type="ngc:NotificationType"/>
    <element name="callbackUri" type="string"/>
    <element name="n1MessageClass" type="string"/>
    <element name="n2InformationClass" type="string"/>
  </sequence>
</complexType>
<simpleType name="NotificationType">
  <restriction base="string">
    <enumeration value="N1_MESSAGES"/>
    <enumeration value="N2_INFORMATION"/>
    <enumeration value="LOCATION_NOTIFICATION"/>
  </restriction>
</simpleType>
<simpleType name="TransportProtocol">
  <restriction base="string">
    <enumeration value="TCP"/>
  </restriction>
</simpleType>
<simpleType name="NfStatus">
  <restriction base="string">
    <enumeration value="REGISTERED"/>
    <enumeration value="SUSPENDED"/>
  </restriction>
</simpleType>
<complexType name="NfRegistrationData">
  <sequence>
    <element name="heartBeatTimer" type="integer"/>
    <element name="nfProfile" type="ngc:NfProfile"/>
  </sequence>
</complexType>
<complexType name="NSILdList">
  <sequence>
    <element name="nSIId" type="string"/>
    <!-- NSI Id is defined in TS 29.531 -->
  </sequence>
</complexType>
<complexType name="SnssaiList">
  <sequence>
    <element name="sNssai" type="ngc:SNssai"/>
  </sequence>
</complexType>
<complexType name="SNssai">
  <sequence>
    <element name="sst" type="ngc:Sst" minOccurs="0"/>
    <element name="sd" type="ngc:Sd"/>
  </sequence>
</complexType>
<simpleType name="Sst">
  <restriction base="integer">
    <maxInclusive value="255"/>
    <!-- SST is 1-octets length and defined in TS 23.003 -->
  </restriction>

```

```

</simpleType>
<simpleType name="Sd">
  <restriction base="integer">
    <maxInclusive value="65535"/>
    <!-- SST is 2-octets length and defined in TS 23.003 -->
  </restriction>
</simpleType>
<complexType name="SBIServiceList">
  <sequence>
    <element name="nfServices" type="ngc:NfServices"/>
  </sequence>
</complexType>
<simpleType name="WeightFactor">
  <restriction base="integer">
  </restriction>
</simpleType>

<element name="AMFFunction" substitutionGroup="xn:ManagedElementOptionallyContainedNrmClass">
  <complexType>
    <complexContent>
      <extension base="xn:NrmClass">
        <sequence>
          <element name="attributes">
            <complexType>
              <all>
                <element name="userLabel" type="string"/>
                <element name="vnfParametersList" type="xn:vnfParametersListType" minOccurs="0"/>
                <element name="pLMNidList" type="en:PLMNidList"/>
                <element name="aMFIdentifier" type="ngc:aMFIdentifier"/>
                <element name="sBIFqdn" type="string"/>
                <element name="sBIServceList" type="ngc:SBIServiceList"/>
                <element name="weightFactor" type="ngc:WeightFactor"/>
                <element name="snssaiList" type="ngc:SnssaiList" minOccurs="0"/>
                <element name="aMFSet" type="xn:dn" minOccurs="0"/>
                <element name="priority" type="integer" minOccurs="0"/>
                <element name="measurements" type="xn:MeasurementTypesAndGPsList"
minOccurs="0"/>
              </all>
            </complexType>
          </element>
          <choice minOccurs="0" maxOccurs="unbounded">
            <element ref="ngc:EP_N2"/>
            <element ref="ngc:EP_N8"/>
            <element ref="ngc:EP_N11"/>
            <element ref="ngc:EP_N12"/>
            <element ref="ngc:EP_N14"/>
            <element ref="ngc:EP_N15"/>
            <element ref="ngc:EP_N17"/>
            <element ref="ngc:EP_N22"/>
            <element ref="ngc:EP_N26"/>
            <element ref="ngc:EP_N20"/>
            <element ref="ngc:EP_NLS"/>
            <element ref="ngc:EP_NLG"/>
            <element ref="ngc:EP_SBI_X"/>
            <element ref="xn:VsDataContainer"/>
            <element ref="xn:MeasurementControl"/>
          </choice>
        </sequence>
      </extension>
    </complexContent>
  </complexType>
</element>

<element name="SMFFunction" substitutionGroup="xn:ManagedElementOptionallyContainedNrmClass">
  <complexType>
    <complexContent>
      <extension base="xn:NrmClass">
        <sequence>
          <element name="attributes">
            <complexType>
              <all>
                <element name="userLabel" type="string"/>
                <element name="vnfParametersList" type="xn:vnfParametersListType" minOccurs="0"/>
                <element name="pLMNidList" type="en:PLMNidList"/>
                <element name="nRTACList" type="ngc:NrTACList"/>
                <element name="sBIFqdn" type="string"/>
                <element name="sBIServceList" type="ngc:SBIServiceList"/>
                <element name="snssaiList" type="ngc:SnssaiList" minOccurs="0"/>
                <element name="priority" type="integer" minOccurs="0"/>
              </all>
            </complexType>
          </element>
        </sequence>
      </extension>
    </complexContent>
  </complexType>
</element>

```



```

        <element name="measurements" type="xn:MeasurementTypesAndGPsList"
minOccurs="0"/>
    </all>
  </complexType>
</element>
<choice minOccurs="0" maxOccurs="unbounded">
  <element ref="ngc:EP_N4"/>
  <element ref="ngc:EP_N10"/>
  <element ref="ngc:EP_N11"/>
  <element ref="ngc:EP_N7"/>
  <element ref="ngc:EP_N16"/>
  <element ref="ngc:EP_S5C"/>
  <element ref="ngc:EP_SBI_X"/>
  <element ref="xn:VsDataContainer"/>
  <element ref="xn:MeasurementControl"/>
</choice>
</sequence>
</extension>
</complexContent>
</complexType>
</element>

<element name="UPFFFunction" substitutionGroup="xn:ManagedElementOptionallyContainedNrmClass">
  <complexType>
    <complexContent>
      <extension base="xn:NrmClass">
        <sequence>
          <element name="attributes">
            <complexType>
              <all>
                <element name="userLabel" type="string"/>
                <element name="vnfParametersList" type="xn:vnfParametersListType" minOccurs="0"/>
                <element name="pLMNidList" type="en:PLMNidList"/>
                <element name="nRTACList" type="ngc:NrTACList"/>
                <element name="snssaiList" type="ngc:SnssaiList" minOccurs="0"/>
                <element name="priority" type="integer" minOccurs="0"/>
                <element name="measurements" type="xn:MeasurementTypesAndGPsList"
minOccurs="0"/>
              </all>
            </complexType>
          </element>
        </sequence>
      </extension>
    </complexContent>
  </complexType>
</element>

<element name="N3IWFFunction" substitutionGroup="xn:ManagedElementOptionallyContainedNrmClass">
  <complexType>
    <complexContent>
      <extension base="xn:NrmClass">
        <sequence>
          <element name="attributes">
            <complexType>
              <all>
                <element name="userLabel" type="string"/>
                <element name="vnfParametersList" type="xn:vnfParametersListType" minOccurs="0"/>
                <element name="pLMNidList" type="en:PLMNidList"/>
                <element name="priority" type="integer" minOccurs="0"/>
                <element name="measurements" type="xn:MeasurementTypesAndGPsList"
minOccurs="0"/>
              </all>
            </complexType>
          </element>
        </sequence>
      </extension>
    </complexContent>
  </complexType>
</element>

<choice minOccurs="0" maxOccurs="unbounded">
  <element ref="ngc:EP_N4"/>
  <element ref="ngc:EP_N3"/>
  <element ref="ngc:EP_N9"/>
  <element ref="ngc:EP_S5U"/>
  <element ref="ngc:EP_SBI_X"/>
  <element ref="ngc:EP_N6"/>
  <element ref="xn:VsDataContainer"/>
  <element ref="xn:MeasurementControl"/>
</choice>
</sequence>
</extension>
</complexContent>
</complexType>
</element>

<element name="N3IWFFunction" substitutionGroup="xn:ManagedElementOptionallyContainedNrmClass">
  <complexType>
    <complexContent>
      <extension base="xn:NrmClass">
        <sequence>
          <element name="attributes">
            <complexType>
              <all>
                <element name="userLabel" type="string"/>
                <element name="vnfParametersList" type="xn:vnfParametersListType" minOccurs="0"/>
                <element name="pLMNidList" type="en:PLMNidList"/>
                <element name="priority" type="integer" minOccurs="0"/>
                <element name="measurements" type="xn:MeasurementTypesAndGPsList"
minOccurs="0"/>
              </all>
            </complexType>
          </element>
        </sequence>
      </extension>
    </complexContent>
  </complexType>
</element>

<choice minOccurs="0" maxOccurs="unbounded">
  <element ref="ngc:EP_N2"/>
  <element ref="ngc:EP_N3"/>
  <element ref="xn:VsDataContainer"/>

```

```

        <element ref="xn:MeasurementControl"/>
    </choice>
</sequence>
</extension>
</complexContent>
</complexType>
</element>

<element name="PCFFFunction" substitutionGroup="xn:ManagedElementOptionallyContainedNrmClass">
  <complexType>
    <complexContent>
      <extension base="xn:NrmClass">
        <sequence>
          <element name="attributes">
            <complexType>
              <all>
                <element name="userLabel" type="string"/>
                <element name="vnfParametersList" type="xn:vnfParametersListType" minOccurs="0"/>
                <element name="pLMNidList" type="en:PLMNidList" />
                <element name="sBIFqdn" type="string" />
                <element name="sBIServivceList" type="ngc:SBIServiceList"/>
                <element name="snssaiList" type="ngc:SnssaiList" minOccurs="0"/>
                <element name="priority" type="integer" minOccurs="0"/>
                <element name="measurements" type="xn:MeasurementTypesAndGPsList"
minOccurs="0"/>
              </all>
            </complexType>
          </element>
          <choice minOccurs="0" maxOccurs="unbounded">
            <element ref="ngc:EP_N7"/>
            <element ref="ngc:EP_N15"/>
            <element ref="ngc:EP_N16"/>
            <element ref="ngc:EP_N5"/>
            <element ref="ngc:EP_Rx"/>
            <element ref="ngc:EP_SBI_X"/>
            <element ref="xn:VsDataContainer"/>
            <element ref="xn:MeasurementControl"/>
          </choice>
        </sequence>
      </extension>
    </complexContent>
  </complexType>
</element>

<element name="AUSFFFunction" substitutionGroup="xn:ManagedElementOptionallyContainedNrmClass">
  <complexType>
    <complexContent>
      <extension base="xn:NrmClass">
        <sequence>
          <element name="attributes">
            <complexType>
              <all>
                <element name="userLabel" type="string"/>
                <element name="vnfParametersList" type="xn:vnfParametersListType" minOccurs="0"/>
                <element name="pLMNidList" type="en:PLMNidList"/>
                <element name="sBIFqdn" type="string"/>
                <element name="sBIServivceList" type="ngc:SBIServiceList"/>
                <element name="snssaiList" type="ngc:SnssaiList" minOccurs="0"/>
                <element name="priority" type="integer" minOccurs="0"/>
                <element name="measurements" type="xn:MeasurementTypesAndGPsList" minOccurs="0"/>
              </all>
            </complexType>
          </element>
          <choice minOccurs="0" maxOccurs="unbounded">
            <element ref="ngc:EP_N12"/>
            <element ref="ngc:EP_N13"/>
            <element ref="ngc:EP_SBI_X"/>
            <element ref="xn:VsDataContainer"/>
            <element ref="xn:MeasurementControl"/>
          </choice>
        </sequence>
      </extension>
    </complexContent>
  </complexType>
</element>

<element name="UDMFFunction" substitutionGroup="xn:ManagedElementOptionallyContainedNrmClass">

```

```

<complexType>
  <complexContent>
    <extension base="xn:NrmClass">
      <sequence>
        <element name="attributes">
          <complexType>
            <all>
              <element name="userLabel" type="string"/>
              <element name="vnfParametersList" type="xn:vnfParametersListType" minOccurs="0"/>
              <element name="pLMNIdList" type="en:PLMNIdList"/>
              <element name="sBIFqdn" type="string"/>
              <element name="sBISerivceList" type="ngc:SBIServiceList"/>
              <element name="snssaiList" type="ngc:SnssaiList" minOccurs="0"/>
              <element name="priority" type="integer" minOccurs="0"/>
              <element name="measurements" type="xn:MeasurementTypesAndGPsList" minOccurs="0"/>
            </all>
          </complexType>
        </element>
        <choice minOccurs="0" maxOccurs="unbounded">
          <element ref="ngc:EP_N8"/>
          <element ref="ngc:EP_N10"/>
          <element ref="ngc:EP_N13"/>
          <element ref="ngc:EP_SBI_X"/>
          <element ref="xn:VsDataContainer"/>
          <element ref="xn:MeasurementControl"/>
        </choice>
      </sequence>
    </extension>
  </complexContent>
</complexType>
</element>
<element name="UDRFfunction" substitutionGroup="xn:ManagedElementOptionallyContainedNrmClass">
  <complexType>
    <complexContent>
      <extension base="xn:NrmClass">
        <sequence>
          <element name="attributes">
            <complexType>
              <all>
                <element name="userLabel" type="string"/>
                <element name="vnfParametersList" type="xn:vnfParametersListType" minOccurs="0"/>
                <element name="pLMNIdList" type="en:PLMNIdList"/>
                <element name="sBIFqdn" type="string"/>
                <element name="sBISerivceList" type="ngc:SBIServiceList"/>
                <element name="snssaiList" type="ngc:SnssaiList" minOccurs="0"/>
                <element name="priority" type="integer" minOccurs="0"/>
                <element name="measurements" type="xn:MeasurementTypesAndGPsList" minOccurs="0"/>
              </all>
            </complexType>
          </element>
          <choice minOccurs="0" maxOccurs="unbounded">
            <element ref="ngc:EP_SBI_X"/>
            <element ref="xn:VsDataContainer"/>
            <element ref="xn:MeasurementControl"/>
          </choice>
        </sequence>
      </extension>
    </complexContent>
  </complexType>
</element>
<element name="UDSFfunction" substitutionGroup="xn:ManagedElementOptionallyContainedNrmClass">
  <complexType>
    <complexContent>
      <extension base="xn:NrmClass">
        <sequence>
          <element name="attributes">
            <complexType>
              <all>
                <element name="userLabel" type="string"/>
                <element name="vnfParametersList" type="xn:vnfParametersListType" minOccurs="0"/>
                <element name="pLMNIdList" type="en:PLMNIdList"/>
                <element name="sBIFqdn" type="string"/>
                <element name="sBISerivceList" type="ngc:SBIServiceList"/>
                <element name="snssaiList" type="ngc:SnssaiList" minOccurs="0"/>
                <element name="priority" type="integer" minOccurs="0"/>
                <element name="measurements" type="xn:MeasurementTypesAndGPsList" minOccurs="0"/>
              </all>
            </complexType>
          </element>
        </sequence>
      </extension>
    </complexContent>
  </complexType>
</element>

```

```

    </element>
    <choice minOccurs="0" maxOccurs="unbounded">
      <element ref="ngc:EP_SBI_X"/>
      <element ref="xn:VsDataContainer"/>
      <element ref="xn:MeasurementControl"/>
    </choice>
  </sequence>
</extension>
</complexContent>
</complexType>
</element>

<element name="NRFFFunction" substitutionGroup="xn:ManagedElementOptionallyContainedNrmClass">
  <complexType>
    <complexContent>
      <extension base="xn:NrmClass">
        <sequence>
          <element name="attributes">
            <complexType>
              <all>
                <element name="userLabel" type="string"/>
                <element name="vnfParametersList" type="xn:vnfParametersListType" minOccurs="0"/>
                <element name="pLMNIdList" type="en:PLMNIdList"/>
                <element name="sBIFqdn" type="string"/>
                <element name="nSIIdList" type="ngc:NSIIdList" minOccurs="0"/>
                <element name="nFPProfileList" type="ngc:NFPProfileList" minOccurs="0"/>
                <element name="snssaiList" type="ngc:SnssaiList" minOccurs="0"/>
                <element name="priority" type="integer" minOccurs="0"/>
                <element name="measurements" type="xn:MeasurementTypesAndGPsList" minOccurs="0"/>
              </all>
            </complexType>
          </element>
          <choice minOccurs="0" maxOccurs="unbounded">
            <element ref="ngc:EP_N27"/>
            <element ref="ngc:EP_SBI_X"/>
            <element ref="xn:VsDataContainer"/>
            <element ref="xn:MeasurementControl"/>
          </choice>
        </sequence>
      </extension>
    </complexContent>
  </complexType>
</element>

<element name="NSSFFFunction" substitutionGroup="xn:ManagedElementOptionallyContainedNrmClass">
  <complexType>
    <complexContent>
      <extension base="xn:NrmClass">
        <sequence>
          <element name="attributes">
            <complexType>
              <all>
                <element name="userLabel" type="string"/>
                <element name="vnfParametersList" type="xn:vnfParametersListType" minOccurs="0"/>
                <element name="pLMNIdList" type="en:PLMNIdList"/>
                <element name="sBIFqdn" type="string"/>
                <element name="nSIIdList" type="ngc:NSIIdList"/>
                <element name="snssaiList" type="ngc:SnssaiList" minOccurs="0"/>
                <element name="priority" type="integer" minOccurs="0"/>
                <element name="measurements" type="xn:MeasurementTypesAndGPsList" minOccurs="0"/>
              </all>
            </complexType>
          </element>
          <choice minOccurs="0" maxOccurs="unbounded">
            <element ref="ngc:EP_N27"/>
            <element ref="ngc:EP_N31"/>
            <element ref="ngc:EP_SBI_X"/>
            <element ref="xn:VsDataContainer"/>
            <element ref="xn:MeasurementControl"/>
          </choice>
        </sequence>
      </extension>
    </complexContent>
  </complexType>
</element>

<element name="SMSFunction" substitutionGroup="xn:ManagedElementOptionallyContainedNrmClass">
  <complexType>

```

```

<complexContent>
  <extension base="xn:NrmClass">
    <sequence>
      <element name="attributes">
        <complexType>
          <all>
            <element name="userLabel" type="string"/>
            <element name="vnfParametersList" type="xn:vnfParametersListType" minOccurs="0"/>
            <element name="pLMNIdList" type="en:PLMNIdList"/>
            <element name="sBIFqdn" type="string"/>
            <element name="sBIServivceList" type="ngc:SBIServiceList"/>
            <element name="priority" type="integer" minOccurs="0"/>
            <element name="measurements" type="xn:MeasurementTypesAndGPsList" minOccurs="0"/>
          </all>
        </complexType>
      </element>
      <choice minOccurs="0" maxOccurs="unbounded">
        <element ref="ngc:EP_N20"/>
        <element ref="ngc:EP_N21"/>
        <element ref="ngc:EP_MAP_SMSC"/>
        <element ref="xn:VsDataContainer"/>
        <element ref="xn:MeasurementControl"/>
      </choice>
    </sequence>
  </extension>
</complexContent>
</complexType>
</element>
<element name="LMFFunction" substitutionGroup="xn:ManagedElementOptionallyContainedNrmClass">
  <complexType>
    <complexContent>
      <extension base="xn:NrmClass">
        <sequence>
          <element name="attributes">
            <complexType>
              <all>
                <element name="userLabel" type="string"/>
                <element name="vnfParametersList" type="xn:vnfParametersListType" minOccurs="0"/>
                <element name="pLMNIdList" type="en:PLMNIdList"/>
                <element name="priority" type="integer" minOccurs="0"/>
                <element name="measurements" type="xn:MeasurementTypesAndGPsList" minOccurs="0"/>
              </all>
            </complexType>
          </element>
          <choice minOccurs="0" maxOccurs="unbounded">
            <element ref="ngc:EP_NLS"/>
            <element ref="xn:VsDataContainer"/>
            <element ref="xn:MeasurementControl"/>
          </choice>
        </sequence>
      </extension>
    </complexContent>
  </complexType>
</element>
<element name="NGEIRFunction" substitutionGroup="xn:ManagedElementOptionallyContainedNrmClass">
  <complexType>
    <complexContent>
      <extension base="xn:NrmClass">
        <sequence>
          <element name="attributes">
            <complexType>
              <all>
                <element name="userLabel" type="string"/>
                <element name="vnfParametersList" type="xn:vnfParametersListType" minOccurs="0"/>
                <element name="pLMNIdList" type="en:PLMNIdList"/>
                <element name="sBIFqdn" type="string"/>
                <element name="sBIServivceList" type="ngc:SBIServiceList"/>
                <element name="snssaiList" type="ngc:SnssaiList" minOccurs="0"/>
                <element name="priority" type="integer" minOccurs="0"/>
                <element name="measurements" type="xn:MeasurementTypesAndGPsList" minOccurs="0"/>
              </all>
            </complexType>
          </element>
          <choice minOccurs="0" maxOccurs="unbounded">
            <element ref="ngc:EP_N17"/>
            <element ref="xn:VsDataContainer"/>
            <element ref="xn:MeasurementControl"/>
          </choice>
        </sequence>
      </extension>
    </complexContent>
  </complexType>
</element>

```

```

    </choice>
  </sequence>
</extension>
</complexContent>
</complexType>
</element>

<element name="SEPPFunction" substitutionGroup="xn:ManagedElementOptionallyContainedNrmClass">
  <complexType>
    <complexContent>
      <extension base="xn:NrmClass">
        <sequence>
          <element name="attributes">
            <complexType>
              <all>
                <element name="userLabel" type="string"/>
                <element name="vnfParametersList" type="xn:vnfParametersListType" minOccurs="0"/>
                <element name="pLMNidList" type="en:PLMNidList"/>
                <element name="priority" type="integer" minOccurs="0"/>
                <element name="measurements" type="xn:MeasurementTypesAndGPsList" minOccurs="0"/>
              </all>
            </complexType>
          </element>
          <choice minOccurs="0" maxOccurs="unbounded">
            <element ref="ngc:EP_N32"/>
            <element ref="ngc:EP_SBI_IPX"/>
            <element ref="xn:VsDataContainer"/>
            <element ref="xn:MeasurementControl"/>
          </choice>
        </sequence>
      </extension>
    </complexContent>
  </complexType>
</element>

<element name="NWDAFFunction" substitutionGroup="xn:ManagedElementOptionallyContainedNrmClass">
  <complexType>
    <complexContent>
      <extension base="xn:NrmClass">
        <sequence>
          <element name="attributes">
            <complexType>
              <all>
                <element name="userLabel" type="string"/>
                <element name="vnfParametersList" type="xn:vnfParametersListType" minOccurs="0"/>
                <element name="pLMNidList" type="en:PLMNidList"/>
                <element name="sBIFqdn" type="string"/>
                <element name="sBISerivceList" type="ngc:SBIServiceList"/>
                <element name="snssaiList" type="ngc:SnssaiList" minOccurs="0"/>
                <element name="priority" type="integer" minOccurs="0"/>
                <element name="measurements" type="xn:MeasurementTypesAndGPsList" minOccurs="0"/>
              </all>
            </complexType>
          </element>
          <choice minOccurs="0" maxOccurs="unbounded">
            <element ref="ngc:EP_SBI_X"/>
            <element ref="xn:VsDataContainer"/>
            <element ref="xn:MeasurementControl"/>
          </choice>
        </sequence>
      </extension>
    </complexContent>
  </complexType>
</element>

<element name="EP_N2">
  <complexType>
    <complexContent>
      <extension base="xn:NrmClass">
        <sequence>
          <element name="attributes" minOccurs="0">
            <complexType>
              <all>
                <!-- Inherited attributes from EP_RP -->
                <element name="farEndEntity" type="xn:dn" minOccurs="0"/>
                <element name="userLabel" type="string" minOccurs="0"/>
                <!-- End of inherited attributes from EP_RP -->
                <element name="localAddress" type="ngc:LocalEndPoint" minOccurs="0"/>
                <element name="remoteAddress" type="ngc:RemoteEndPoint" minOccurs="0"/>
              </all>
            </complexType>
          </element>
        </sequence>
      </extension>
    </complexContent>
  </complexType>
</element>

```

```

    </all>
  </complexType>
</element>
<choice minOccurs="0" maxOccurs="unbounded">
  <element ref="xn:VsDataContainer" />
</choice>
</sequence>
</extension>
</complexContent>
</complexType>
</element>

<element name="EP_N3">
  <complexType>
    <complexContent>
      <extension base="xn:NrmClass">
        <sequence>
          <element name="attributes" minOccurs="0">
            <complexType>
              <all>
                <!-- Inherited attributes from EP_RP -->
                <element name="farEndEntity" type="xn:dn" minOccurs="0"/>
                <element name="userLabel" type="string" minOccurs="0"/>
                <!-- End of inherited attributes from EP_RP -->
                <element name="localAddress" type="ngc:LocalEndPoint" minOccurs="0"/>
                <element name="remoteAddress" type="ngc:RemoteEndPoint" minOccurs="0"/>
              </all>
            </complexType>
          </element>
          <choice minOccurs="0" maxOccurs="unbounded">
            <element ref="xn:VsDataContainer" />
          </choice>
        </sequence>
      </extension>
    </complexContent>
  </complexType>
</element>

<element name="EP_N4">
  <complexType>
    <complexContent>
      <extension base="xn:NrmClass">
        <sequence>
          <element name="attributes" minOccurs="0">
            <complexType>
              <all>
                <!-- Inherited attributes from EP_RP -->
                <element name="farEndEntity" type="xn:dn" minOccurs="0"/>
                <element name="userLabel" type="string" minOccurs="0"/>
                <!-- End of inherited attributes from EP_RP -->
                <element name="localAddress" type="ngc:LocalEndPoint" minOccurs="0"/>
                <element name="remoteAddress" type="ngc:RemoteEndPoint" minOccurs="0"/>
              </all>
            </complexType>
          </element>
          <choice minOccurs="0" maxOccurs="unbounded">
            <element ref="xn:VsDataContainer" />
          </choice>
        </sequence>
      </extension>
    </complexContent>
  </complexType>
</element>

<element name="EP_N5">
  <complexType>
    <complexContent>
      <extension base="xn:NrmClass">
        <sequence>
          <element name="attributes" minOccurs="0">
            <complexType>
              <all>
                <!-- Inherited attributes from EP_RP -->
                <element name="farEndEntity" type="xn:dn" minOccurs="0"/>
                <element name="userLabel" type="string" minOccurs="0"/>
                <!-- End of inherited attributes from EP_RP -->
                <element name="localAddress" type="ngc:LocalEndPoint" minOccurs="0"/>
                <element name="remoteAddress" type="ngc:RemoteEndPoint" minOccurs="0"/>
              </all>
            </complexType>
          </element>
          <choice minOccurs="0" maxOccurs="unbounded">
            <element ref="xn:VsDataContainer" />
          </choice>
        </sequence>
      </extension>
    </complexContent>
  </complexType>
</element>

```

```

        </complexType>
      </element>
      <choice minOccurs="0" maxOccurs="unbounded">
        <element ref="xn:VsDataContainer"/>
      </choice>
    </sequence>
  </extension>
</complexContent>
</complexType>
</element>

<element name="EP_N6">
  <complexType>
    <complexContent>
      <extension base="xn:NrmClass">
        <sequence>
          <element name="attributes" minOccurs="0">
            <complexType>
              <all>
                <!-- Inherited attributes from EP_RP -->
                <element name="farEndEntity" type="xn:dn" minOccurs="0"/>
                <element name="userLabel" type="string" minOccurs="0"/>
                <!-- End of inherited attributes from EP_RP -->
                <element name="localAddress" type="ngc:LocalEndPoint" minOccurs="0"/>
                <element name="remoteAddress" type="ngc:RemoteEndPoint" minOccurs="0"/>
              </all>
            </complexType>
          </element>
          <choice minOccurs="0" maxOccurs="unbounded">
            <element ref="xn:VsDataContainer"/>
          </choice>
        </sequence>
      </extension>
    </complexContent>
  </complexType>
</element>

<element name="EP_N7">
  <complexType>
    <complexContent>
      <extension base="xn:NrmClass">
        <sequence>
          <element name="attributes" minOccurs="0">
            <complexType>
              <all>
                <!-- Inherited attributes from EP_RP -->
                <element name="farEndEntity" type="xn:dn" minOccurs="0"/>
                <element name="userLabel" type="string" minOccurs="0"/>
                <!-- End of inherited attributes from EP_RP -->
                <element name="localAddress" type="ngc:LocalEndPoint" minOccurs="0"/>
                <element name="remoteAddress" type="ngc:RemoteEndPoint" minOccurs="0"/>
              </all>
            </complexType>
          </element>
          <choice minOccurs="0" maxOccurs="unbounded">
            <element ref="xn:VsDataContainer"/>
          </choice>
        </sequence>
      </extension>
    </complexContent>
  </complexType>
</element>

<element name="EP_N8">
  <complexType>
    <complexContent>
      <extension base="xn:NrmClass">
        <sequence>
          <element name="attributes" minOccurs="0">
            <complexType>
              <all>
                <!-- Inherited attributes from EP_RP -->
                <element name="farEndEntity" type="xn:dn" minOccurs="0"/>
                <element name="userLabel" type="string" minOccurs="0"/>
                <!-- End of inherited attributes from EP_RP -->
                <element name="localAddress" type="ngc:LocalEndPoint" minOccurs="0"/>
                <element name="remoteAddress" type="ngc:RemoteEndPoint" minOccurs="0"/>
              </all>
            </complexType>
          </element>
          <choice minOccurs="0" maxOccurs="unbounded">
            <element ref="xn:VsDataContainer"/>
          </choice>
        </sequence>
      </extension>
    </complexContent>
  </complexType>
</element>

```



```

        </complexType>
      </element>
      <choice minOccurs="0" maxOccurs="unbounded">
        <element ref="xn:VsDataContainer"/>
      </choice>
    </sequence>
  </extension>
</complexContent>
</complexType>
</element>

<element name="EP_N9">
  <complexType>
    <complexContent>
      <extension base="xn:NrmClass">
        <sequence>
          <element name="attributes" minOccurs="0">
            <complexType>
              <all>
                <!-- Inherited attributes from EP_RP -->
                <element name="farEndEntity" type="xn:dn" minOccurs="0"/>
                <element name="userLabel" type="string" minOccurs="0"/>
                <!-- End of inherited attributes from EP_RP -->
                <element name="localAddress" type="ngc:LocalEndPoint" minOccurs="0"/>
                <element name="remoteAddress" type="ngc:RemoteEndPoint" minOccurs="0"/>
              </all>
            </complexType>
          </element>
          <choice minOccurs="0" maxOccurs="unbounded">
            <element ref="xn:VsDataContainer"/>
          </choice>
        </sequence>
      </extension>
    </complexContent>
  </complexType>
</element>

<element name="EP_N10">
  <complexType>
    <complexContent>
      <extension base="xn:NrmClass">
        <sequence>
          <element name="attributes" minOccurs="0">
            <complexType>
              <all>
                <!-- Inherited attributes from EP_RP -->
                <element name="farEndEntity" type="xn:dn" minOccurs="0"/>
                <element name="userLabel" type="string" minOccurs="0"/>
                <!-- End of inherited attributes from EP_RP -->
                <element name="localAddress" type="ngc:LocalEndPoint" minOccurs="0"/>
                <element name="remoteAddress" type="ngc:RemoteEndPoint" minOccurs="0"/>
              </all>
            </complexType>
          </element>
          <choice minOccurs="0" maxOccurs="unbounded">
            <element ref="xn:VsDataContainer"/>
          </choice>
        </sequence>
      </extension>
    </complexContent>
  </complexType>
</element>

<element name="EP_N11">
  <complexType>
    <complexContent>
      <extension base="xn:NrmClass">
        <sequence>
          <element name="attributes" minOccurs="0">
            <complexType>
              <all>
                <!-- Inherited attributes from EP_RP -->
                <element name="farEndEntity" type="xn:dn" minOccurs="0"/>
                <element name="userLabel" type="string" minOccurs="0"/>
                <!-- End of inherited attributes from EP_RP -->
                <element name="localAddress" type="ngc:LocalEndPoint" minOccurs="0"/>
                <element name="remoteAddress" type="ngc:RemoteEndPoint" minOccurs="0"/>
              </all>
            </complexType>
          </element>
          <choice minOccurs="0" maxOccurs="unbounded">
            <element ref="xn:VsDataContainer"/>
          </choice>
        </sequence>
      </extension>
    </complexContent>
  </complexType>
</element>

```

```

        </complexType>
      </element>
      <choice minOccurs="0" maxOccurs="unbounded">
        <element ref="xn:VsDataContainer"/>
      </choice>
    </sequence>
  </extension>
</complexContent>
</complexType>
</element>

<element name="EP_N12">
  <complexType>
    <complexContent>
      <extension base="xn:NrmClass">
        <sequence>
          <element name="attributes" minOccurs="0">
            <complexType>
              <all>
                <!-- Inherited attributes from EP_RP -->
                <element name="farEndEntity" type="xn:dn" minOccurs="0"/>
                <element name="userLabel" type="string" minOccurs="0"/>
                <!-- End of inherited attributes from EP_RP -->
                <element name="localAddress" type="ngc:ILocalEndPoint" minOccurs="0"/>
                <element name="remoteAddress" type="ngc:RemoteEndPoint" minOccurs="0"/>
              </all>
            </complexType>
          </element>
          <choice minOccurs="0" maxOccurs="unbounded">
            <element ref="xn:VsDataContainer"/>
          </choice>
        </sequence>
      </extension>
    </complexContent>
  </complexType>
</element>

<element name="EP_N13">
  <complexType>
    <complexContent>
      <extension base="xn:NrmClass">
        <sequence>
          <element name="attributes" minOccurs="0">
            <complexType>
              <all>
                <!-- Inherited attributes from EP_RP -->
                <element name="farEndEntity" type="xn:dn" minOccurs="0"/>
                <element name="userLabel" type="string" minOccurs="0"/>
                <!-- End of inherited attributes from EP_RP -->
                <element name="localAddress" type="ngc:LocalEndPoint" minOccurs="0"/>
                <element name="remoteAddress" type="ngc:RemoteEndPoint" minOccurs="0"/>
              </all>
            </complexType>
          </element>
          <choice minOccurs="0" maxOccurs="unbounded">
            <element ref="xn:VsDataContainer"/>
          </choice>
        </sequence>
      </extension>
    </complexContent>
  </complexType>
</element>

<element name="EP_N14">
  <complexType>
    <complexContent>
      <extension base="xn:NrmClass">
        <sequence>
          <element name="attributes" minOccurs="0">
            <complexType>
              <all>
                <!-- Inherited attributes from EP_RP -->
                <element name="farEndEntity" type="xn:dn" minOccurs="0"/>
                <element name="userLabel" type="string" minOccurs="0"/>
                <!-- End of inherited attributes from EP_RP -->
                <element name="localAddress" type="ngc:LocalEndPoint" minOccurs="0"/>
                <element name="remoteAddress" type="ngc:RemoteEndPoint" minOccurs="0"/>
              </all>
            </complexType>
          </element>
          <choice minOccurs="0" maxOccurs="unbounded">
            <element ref="xn:VsDataContainer"/>
          </choice>
        </sequence>
      </extension>
    </complexContent>
  </complexType>
</element>

```

```

        </complexType>
      </element>
      <choice minOccurs="0" maxOccurs="unbounded">
        <element ref="xn:VsDataContainer"/>
      </choice>
    </sequence>
  </extension>
</complexContent>
</complexType>
</element>

<element name="EP_N15">
  <complexType>
    <complexContent>
      <extension base="xn:NrmClass">
        <sequence>
          <element name="attributes" minOccurs="0">
            <complexType>
              <all>
                <!-- Inherited attributes from EP_RP -->
                <element name="farEndEntity" type="xn:dn" minOccurs="0"/>
                <element name="userLabel" type="string" minOccurs="0"/>
                <!-- End of inherited attributes from EP_RP -->
                <element name="localAddress" type="ngc:LocalEndPoint" minOccurs="0"/>
                <element name="remoteAddress" type="ngc:RemoteEndPoint" minOccurs="0"/>
              </all>
            </complexType>
          </element>
          <choice minOccurs="0" maxOccurs="unbounded">
            <element ref="xn:VsDataContainer"/>
          </choice>
        </sequence>
      </extension>
    </complexContent>
  </complexType>
</element>

<element name="EP_N16">
  <complexType>
    <complexContent>
      <extension base="xn:NrmClass">
        <sequence>
          <element name="attributes" minOccurs="0">
            <complexType>
              <all>
                <!-- Inherited attributes from EP_RP -->
                <element name="farEndEntity" type="xn:dn" minOccurs="0"/>
                <element name="userLabel" type="string" minOccurs="0"/>
                <!-- End of inherited attributes from EP_RP -->
                <element name="localAddress" type="ngc:LocalEndPoint" minOccurs="0"/>
                <element name="remoteAddress" type="ngc:RemoteEndPoint" minOccurs="0"/>
              </all>
            </complexType>
          </element>
          <choice minOccurs="0" maxOccurs="unbounded">
            <element ref="xn:VsDataContainer"/>
          </choice>
        </sequence>
      </extension>
    </complexContent>
  </complexType>
</element>

<element name="EP_N17">
  <complexType>
    <complexContent>
      <extension base="xn:NrmClass">
        <sequence>
          <element name="attributes" minOccurs="0">
            <complexType>
              <all>
                <!-- Inherited attributes from EP_RP -->
                <element name="farEndEntity" type="xn:dn" minOccurs="0"/>
                <element name="userLabel" type="string" minOccurs="0"/>
                <!-- End of inherited attributes from EP_RP -->
                <element name="localAddress" type="ngc:LocalEndPoint" minOccurs="0"/>
                <element name="remoteAddress" type="ngc:RemoteEndPoint" minOccurs="0"/>
              </all>
            </complexType>
          </element>
          <choice minOccurs="0" maxOccurs="unbounded">
            <element ref="xn:VsDataContainer"/>
          </choice>
        </sequence>
      </extension>
    </complexContent>
  </complexType>
</element>

```

```

        </complexType>
      </element>
      <choice minOccurs="0" maxOccurs="unbounded">
        <element ref="xn:VsDataContainer"/>
      </choice>
    </sequence>
  </extension>
</complexContent>
</complexType>
</element>

<element name="EP_N20">
  <complexType>
    <complexContent>
      <extension base="xn:NrmClass">
        <sequence>
          <element name="attributes" minOccurs="0">
            <complexType>
              <all>
                <!-- Inherited attributes from EP_RP -->
                <element name="farEndEntity" type="xn:dn" minOccurs="0"/>
                <element name="userLabel" type="string" minOccurs="0"/>
                <!-- End of inherited attributes from EP_RP -->
                <element name="localAddress" type="ngc:LocalEndPoint" minOccurs="0"/>
                <element name="remoteAddress" type="ngc:RemoteEndPoint" minOccurs="0"/>
              </all>
            </complexType>
          </element>
          <choice minOccurs="0" maxOccurs="unbounded">
            <element ref="xn:VsDataContainer"/>
          </choice>
        </sequence>
      </extension>
    </complexContent>
  </complexType>
</element>

<element name="EP_N21">
  <complexType>
    <complexContent>
      <extension base="xn:NrmClass">
        <sequence>
          <element name="attributes" minOccurs="0">
            <complexType>
              <all>
                <!-- Inherited attributes from EP_RP -->
                <element name="farEndEntity" type="xn:dn" minOccurs="0"/>
                <element name="userLabel" type="string" minOccurs="0"/>
                <!-- End of inherited attributes from EP_RP -->
                <element name="localAddress" type="ngc:LocalEndPoint" minOccurs="0"/>
                <element name="remoteAddress" type="ngc:RemoteEndPoint" minOccurs="0"/>
              </all>
            </complexType>
          </element>
          <choice minOccurs="0" maxOccurs="unbounded">
            <element ref="xn:VsDataContainer"/>
          </choice>
        </sequence>
      </extension>
    </complexContent>
  </complexType>
</element>

<element name="EP_N22">
  <complexType>
    <complexContent>
      <extension base="xn:NrmClass">
        <sequence>
          <element name="attributes" minOccurs="0">
            <complexType>
              <all>
                <!-- Inherited attributes from EP_RP -->
                <element name="farEndEntity" type="xn:dn" minOccurs="0"/>
                <element name="userLabel" type="string" minOccurs="0"/>
                <!-- End of inherited attributes from EP_RP -->
                <element name="localAddress" type="ngc:LocalEndPoint" minOccurs="0"/>
                <element name="remoteAddress" type="ngc:RemoteEndPoint" minOccurs="0"/>
              </all>
            </complexType>
          </element>
          <choice minOccurs="0" maxOccurs="unbounded">
            <element ref="xn:VsDataContainer"/>
          </choice>
        </sequence>
      </extension>
    </complexContent>
  </complexType>
</element>

```

```

        </complexType>
      </element>
      <choice minOccurs="0" maxOccurs="unbounded">
        <element ref="xn:VsDataContainer"/>
      </choice>
    </sequence>
  </extension>
</complexContent>
</complexType>
</element>

<element name="EP_N26">
  <complexType>
    <complexContent>
      <extension base="xn:NrmClass">
        <sequence>
          <element name="attributes" minOccurs="0">
            <complexType>
              <all>
                <!-- Inherited attributes from EP_RP -->
                <element name="farEndEntity" type="xn:dn" minOccurs="0"/>
                <element name="userLabel" type="string" minOccurs="0"/>
                <!-- End of inherited attributes from EP_RP -->
                <element name="localAddress" type="ngc:LocalEndPoint" minOccurs="0"/>
                <element name="remoteAddress" type="ngc:RemoteEndPoint" minOccurs="0"/>
              </all>
            </complexType>
          </element>
          <choice minOccurs="0" maxOccurs="unbounded">
            <element ref="xn:VsDataContainer"/>
          </choice>
        </sequence>
      </extension>
    </complexContent>
  </complexType>
</element>

<element name="EP_N27">
  <complexType>
    <complexContent>
      <extension base="xn:NrmClass">
        <sequence>
          <element name="attributes" minOccurs="0">
            <complexType>
              <all>
                <!-- Inherited attributes from EP_RP -->
                <element name="farEndEntity" type="xn:dn" minOccurs="0"/>
                <element name="userLabel" type="string" minOccurs="0"/>
                <!-- End of inherited attributes from EP_RP -->
                <element name="localAddress" type="ngc:LocalEndPoint" minOccurs="0"/>
                <element name="remoteAddress" type="ngc:RemoteEndPoint" minOccurs="0"/>
              </all>
            </complexType>
          </element>
          <choice minOccurs="0" maxOccurs="unbounded">
            <element ref="xn:VsDataContainer"/>
          </choice>
        </sequence>
      </extension>
    </complexContent>
  </complexType>
</element>

<element name="EP_N31">
  <complexType>
    <complexContent>
      <extension base="xn:NrmClass">
        <sequence>
          <element name="attributes" minOccurs="0">
            <complexType>
              <all>
                <!-- Inherited attributes from EP_RP -->
                <element name="farEndEntity" type="xn:dn" minOccurs="0"/>
                <element name="userLabel" type="string" minOccurs="0"/>
                <!-- End of inherited attributes from EP_RP -->
                <element name="localAddress" type="ngc:LocalEndPoint" minOccurs="0"/>
                <element name="remoteAddress" type="ngc:RemoteEndPoint" minOccurs="0"/>
              </all>
            </complexType>
          </element>
          <choice minOccurs="0" maxOccurs="unbounded">
            <element ref="xn:VsDataContainer"/>
          </choice>
        </sequence>
      </extension>
    </complexContent>
  </complexType>
</element>

```

```

        </complexType>
      </element>
      <choice minOccurs="0" maxOccurs="unbounded">
        <element ref="xn:VsDataContainer" />
      </choice>
    </sequence>
  </extension>
</complexContent>
</complexType>
</element>

<element name="EP_N32">
  <complexType>
    <complexContent>
      <extension base="xn:NrmClass">
        <sequence>
          <element name="attributes" minOccurs="0">
            <complexType>
              <all>
                <!-- Inherited attributes from EP_RP -->
                <element name="farEndEntity" type="xn:dn" minOccurs="0"/>
                <element name="userLabel" type="string" minOccurs="0"/>
                <!-- End of inherited attributes from EP_RP -->
                <element name="localAddress" type="ngc:LocalEndPoint" minOccurs="0"/>
                <element name="remoteAddress" type="ngc:RemoteEndPoint" minOccurs="0"/>
              </all>
            </complexType>
          </element>
          <choice minOccurs="0" maxOccurs="unbounded">
            <element ref="xn:VsDataContainer" />
          </choice>
        </sequence>
      </extension>
    </complexContent>
  </complexType>
</element>

<element name="EP_SBI_X">
  <complexType>
    <complexContent>
      <extension base="xn:NrmClass">
        <sequence>
          <element name="attributes" minOccurs="0">
            <complexType>
              <all>
                <!-- Inherited attributes from EP_RP -->
                <element name="farEndEntity" type="xn:dn" minOccurs="0"/>
                <element name="userLabel" type="string" minOccurs="0"/>
                <!-- End of inherited attributes from EP_RP -->
                <element name="localAddress" type="ngc:LocalEndPoint" minOccurs="0"/>
                <element name="remoteAddress" type="ngc:RemoteEndPoint" minOccurs="0"/>
              </all>
            </complexType>
          </element>
          <choice minOccurs="0" maxOccurs="unbounded">
            <element ref="xn:VsDataContainer" />
          </choice>
        </sequence>
      </extension>
    </complexContent>
  </complexType>
</element>

<element name="EP_SBI_IPX">
  <complexType>
    <complexContent>
      <extension base="xn:NrmClass">
        <sequence>
          <element name="attributes" minOccurs="0">
            <complexType>
              <all>
                <!-- Inherited attributes from EP_RP -->
                <element name="farEndEntity" type="xn:dn" minOccurs="0"/>
                <element name="userLabel" type="string" minOccurs="0"/>
                <!-- End of inherited attributes from EP_RP -->
                <element name="localAddress" type="ngc:LocalEndPoint" minOccurs="0"/>
                <element name="remoteAddress" type="ngc:RemoteEndPoint" minOccurs="0"/>
              </all>
            </complexType>
          </element>
          <choice minOccurs="0" maxOccurs="unbounded">
            <element ref="xn:VsDataContainer" />
          </choice>
        </sequence>
      </extension>
    </complexContent>
  </complexType>
</element>

```

```

        </complexType>
      </element>
      <choice minOccurs="0" maxOccurs="unbounded">
        <element ref="xn:VsDataContainer"/>
      </choice>
    </sequence>
  </extension>
</complexContent>
</complexType>
</element>

<element name="EP_S5C">
  <complexType>
    <complexContent>
      <extension base="xn:NrmClass">
        <sequence>
          <element name="attributes" minOccurs="0">
            <complexType>
              <all>
                <!-- Inherited attributes from EP_RP -->
                <element name="farEndEntity" type="xn:dn" minOccurs="0"/>
                <element name="userLabel" type="string" minOccurs="0"/>
                <!-- End of inherited attributes from EP_RP -->
                <element name="localAddress" type="ngc:LocalEndPoint" minOccurs="0"/>
                <element name="remoteAddress" type="ngc:RemoteEndPoint" minOccurs="0"/>
              </all>
            </complexType>
          </element>
          <choice minOccurs="0" maxOccurs="unbounded">
            <element ref="xn:VsDataContainer"/>
          </choice>
        </sequence>
      </extension>
    </complexContent>
  </complexType>
</element>

<element name="EP_S5U">
  <complexType>
    <complexContent>
      <extension base="xn:NrmClass">
        <sequence>
          <element name="attributes" minOccurs="0">
            <complexType>
              <all>
                <!-- Inherited attributes from EP_RP -->
                <element name="farEndEntity" type="xn:dn" minOccurs="0"/>
                <element name="userLabel" type="string" minOccurs="0"/>
                <!-- End of inherited attributes from EP_RP -->
                <element name="localAddress" type="ngc:LocalEndPoint" minOccurs="0"/>
                <element name="remoteAddress" type="ngc:RemoteEndPoint" minOccurs="0"/>
              </all>
            </complexType>
          </element>
          <choice minOccurs="0" maxOccurs="unbounded">
            <element ref="xn:VsDataContainer"/>
          </choice>
        </sequence>
      </extension>
    </complexContent>
  </complexType>
</element>

<element name="EP_Rx">
  <complexType>
    <complexContent>
      <extension base="xn:NrmClass">
        <sequence>
          <element name="attributes" minOccurs="0">
            <complexType>
              <all>
                <!-- Inherited attributes from EP_RP -->
                <element name="farEndEntity" type="xn:dn" minOccurs="0"/>
                <element name="userLabel" type="string" minOccurs="0"/>
                <!-- End of inherited attributes from EP_RP -->
                <element name="localAddress" type="ngc:LocalEndPoint" minOccurs="0"/>
                <element name="remoteAddress" type="ngc:RemoteEndPoint" minOccurs="0"/>
              </all>
            </complexType>
          </element>
          <choice minOccurs="0" maxOccurs="unbounded">
            <element ref="xn:VsDataContainer"/>
          </choice>
        </sequence>
      </extension>
    </complexContent>
  </complexType>
</element>

```

```

    </all>
  </complexType>
</element>
<choice minOccurs="0" maxOccurs="unbounded">
  <element ref="xn:VsDataContainer" />
</choice>
</sequence>
</extension>
</complexContent>
</complexType>
</element>

<element name="EP_MAP_SMSC">
  <complexType>
    <complexContent>
      <extension base="xn:NrmClass">
        <sequence>
          <element name="attributes" minOccurs="0">
            <complexType>
              <all>
                <!-- Inherited attributes from EP_RP -->
                <element name="farEndEntity" type="xn:dn" minOccurs="0"/>
                <element name="userLabel" type="string" minOccurs="0"/>
                <!-- End of inherited attributes from EP_RP -->
                <element name="localAddress" type="ngc:LocalEndPoint" minOccurs="0"/>
                <element name="remoteAddress" type="ngc:RemoteEndPoint" minOccurs="0"/>
              </all>
            </complexType>
          </element>
          <choice minOccurs="0" maxOccurs="unbounded">
            <element ref="xn:VsDataContainer" />
          </choice>
        </sequence>
      </extension>
    </complexContent>
  </complexType>
</element>

<element name="EP-NLS">
  <complexType>
    <complexContent>
      <extension base="xn:NrmClass">
        <sequence>
          <element name="attributes" minOccurs="0">
            <complexType>
              <all>
                <!-- Inherited attributes from EP_RP -->
                <element name="farEndEntity" type="xn:dn" minOccurs="0"/>
                <element name="userLabel" type="string" minOccurs="0"/>
                <!-- End of inherited attributes from EP_RP -->
                <element name="localAddress" type="ngc:LocalEndPoint" minOccurs="0"/>
                <element name="remoteAddress" type="ngc:RemoteEndPoint" minOccurs="0"/>
              </all>
            </complexType>
          </element>
          <choice minOccurs="0" maxOccurs="unbounded">
            <element ref="xn:VsDataContainer" />
          </choice>
        </sequence>
      </extension>
    </complexContent>
  </complexType>
</element>

<element name="EP_NLG">
  <complexType>
    <complexContent>
      <extension base="xn:NrmClass">
        <sequence>
          <element name="attributes" minOccurs="0">
            <complexType>
              <all>
                <!-- Inherited attributes from EP_RP -->
                <element name="farEndEntity" type="xn:dn" minOccurs="0"/>
                <element name="userLabel" type="string" minOccurs="0"/>
                <!-- End of inherited attributes from EP_RP -->
                <element name="localAddress" type="ngc:LocalEndPoint" minOccurs="0"/>
                <element name="remoteAddress" type="ngc:RemoteEndPoint" minOccurs="0"/>
              </all>
            </complexType>
          </element>
          <choice minOccurs="0" maxOccurs="unbounded">
            <element ref="xn:VsDataContainer" />
          </choice>
        </sequence>
      </extension>
    </complexContent>
  </complexType>
</element>

```



```
</all>
</complexType>
</element>
<choice minOccurs="0" maxOccurs="unbounded">
  <element ref="xn:VsDataContainer" />
</choice>
</sequence>
</extension>
</complexContent>
</complexType>
</element>
</schema>
```

Annex G (normative): JSON definitions for 5GC NRM

G.1 General

This annex contains the JSON definitions for the 5GC NRM, in accordance with 5GC NRM information model definitions specified in clause 5.

G.2 Architectural features

The overall architectural feature of 5GC NRM information model is specified in clause 5, this annex specifies features that are specific to the Schema definitions.

G.3 Mapping

Refer to TS 32.160 [46].

G.4 Solution Set definitions

G.4.1 JSON definition structure

JSON is used as resource representations format carried in the HTTP request and HTTP response message bodies. The properties (key-value pairs) on an object are defined using the properties keyword.

G.4.2 Graphical representation

None.

G.4.3 JSON schema "ngcNrm.json"

```
{
  "openapi": "3.0.1",
  "info": {
    "title": "3GPP 5GC NRM",
    "version": "15.3.0",
    "description": "OAS 3.0.1 specification compatible schema for 3GPP 5GC NRM"
  },
  "paths": {},
  "components": {
    "schemas": {
      "AmfIdentifier": {
        "type": "object",
        "description": "AmfIdentifier comprise of amfRegionId, amfSetId and amfPointer",
        "properties": {
          "amfRegionId": {
            "$ref": "#/components/schemas/AmfRegionId"
          },
          "amfSetId": {
            "$ref": "#/components/schemas/AmfSetId"
          },
          "amfPointer": {
            "$ref": "#/components/schemas/AmfPointer"
          }
        }
      }
    }
  }
},
```

```

"AmfRegionId": {
  "type": "integer",
  "description": "AmfRegionId is defined in TS 23.003",
  "maximum": 255
},
"AmfSetId": {
  "type": "string",
  "description": "AmfSetId is defined in TS 23.003",
  "maximum": 1023
},
"AmfPointer": {
  "type": "integer",
  "description": "AmfPointer is defined in TS 23.003",
  "maximum": 63
},
"IpEndPoint": {
  "type": "object",
  "properties": {
    "ipv4Address": {
      "$ref": "genericNrm.json#/components/schemas/Ipv4Addr"
    },
    "ipv6Address": {
      "$ref": "genericNrm.json#/components/schemas/Ipv6Addr"
    },
    "ipv6Prefix": {
      "$ref": "genericNrm.json#/components/schemas/Ipv6Prefix"
    },
    "transport": {
      "$ref": "genericNrm.json#/components/schemas/TransportProtocol"
    },
    "port": {
      "type": "integer"
    }
  }
},
"NFProfileList": {
  "type": "array",
  "description": "List of NF profile",
  "items": {
    "$ref": "#/components/schemas/NFProfile"
  }
},
"NFProfile": {
  "type": "object",
  "description": "NF profile stored in NRF, defined in TS 29.510",
  "properties": {
    "nFInstanceId": {
      "type": "string",
      "description": "uuid of NF instance"
    },
    "nFType": {
      "$ref": "#/components/schemas/NFType"
    },
    "nFStatus": {
      "$ref": "#/components/schemas/NFStatus"
    },
    "plmn": {
      "$ref": "nrNrm.json#/components/schemas/PlmnId"
    },
    "sNssais": {
      "$ref": "nrNrm.json#/components/schemas/Snssai"
    },
    "fqdn": {
      "$ref": "#/components/schemas/Fqdn"
    },
    "interPlmnFqdn": {
      "$ref": "#/components/schemas/Fqdn"
    },
    "nfServices": {
      "type": "array",
      "items": {
        "$ref": "#/components/schemas/NFService"
      }
    }
  }
},
"NFService": {
  "type": "object",

```

```

"description": "NF Service is defined in TS 29.510",
"properties": {
  "serviceInstanceId": {
    "type": "string"
  },
  "serviceName": {
    "type": "string"
  },
  "version": {
    "type": "string"
  },
  "schema": {
    "type": "string"
  },
  "fqdn": {
    "$ref": "#/components/schemas/Fqdn"
  },
  "interPlmnFqdn": {
    "$ref": "#/components/schemas/Fqdn"
  },
  "ipEndPoints": {
    "type": "array",
    "items": {
      "$ref": "#/components/schemas/IpEndPoint"
    }
  },
  "apiPrefix": {
    "type": "string"
  },
  "allowedPlmns": {
    "$ref": "nrNrm.json#/components/schemas/PlmnId"
  },
  "allowedNfTypes": {
    "type": "array",
    "items": {
      "$ref": "#/components/schemas/NFType"
    }
  },
  "allowedNssais": {
    "type": "array",
    "items": {
      "$ref": "nrNrm.json#/components/schemas/Snssai"
    }
  }
},
},
"NFType": {
  "type": "string",
  "description": "NF name defined in TS 23.501",
  "enum": [
    "NRF",
    "UDM",
    "AMF",
    "SMF",
    "AUSF",
    "NEF",
    "PCF",
    "SMSE",
    "NSSF",
    "UDR",
    "LMF",
    "GMLC",
    "5G_EIR",
    "SEPP",
    "UPF",
    "N3IWF",
    "AF",
    "UDSF",
    "DN"
  ]
},
},
"Fqdn": {
  "type": "string"
},
},
"UdrInfo": {
  "type": "object",
  "properties": {
    "supiRanges": {

```

```

        "type": "array",
        "items": {
          "$ref": "#/components/schemas/SupiRange"
        }
      },
    },
    "SupiRange": {
      "type": "object",
      "properties": {
        "start": {
          "type": "string"
        },
        "end": {
          "type": "string"
        },
        "pattern": {
          "type": "string"
        }
      }
    },
  },
  "NFStatus": {
    "type": "string",
    "description": "any of enumerated value",
    "enum": [
      "REGISTERED",
      "SUSPENDED"
    ]
  },
  "NFRegistrationData": {
    "type": "object",
    "properties": {
      "heartBeatTimer": {
        "type": "integer"
      },
      "nfProfile": {
        "$ref": "#/components/schemas/NFProfile"
      }
    }
  },
  "NSIIDList": {
    "type": "array",
    "items": {
      "$ref": "#/components/schemas/NSIID"
    }
  },
  "NSIID": {
    "type": "string",
    "description": "NSI Id is defined in TS 29.531"
  },
  "NrCellId": {
    "type": "string"
  },
  "SBIFqdn": {
    "$ref": "#/components/schemas/Fqdn"
  },
  "SBIServiceList": {
    "type": "array",
    "items": {
      "$ref": "#/components/schemas/NFService"
    }
  },
  "TACList": {
    "type": "array",
    "items": {
      "$ref": "nrNrm.json#/components/schemas/NrTac"
    }
  },
  "WeightFactor": {
    "type": "integer"
  },
  "AmfFunction": {
    "allOf": [
      {
        "$ref": "genericNrm.json#/components/schemas/Top-Attributes"
      },
      {
        "type": "object",

```

```

"properties": {
  "attributes": {
    "allOf": [
      {
        "$ref": "genericNrm.json#/components/schemas/ManagedFunction-Attributes"
      },
      {
        "type": "object",
        "properties": {
          "plmnIdList": {
            "$ref": "nrNrm.json#/components/schemas/PlmnIdList"
          },
          "amfIdentifier": {
            "$ref": "#/components/schemas/AmfIdentifier"
          },
          "sBIFqdn": {
            "type": "string"
          },
          "sBIServiceList": {
            "$ref": "#/components/schemas/SBIServiceList"
          },
          "weightFactor": {
            "$ref": "#/components/schemas/WeightFactor"
          },
          "snssaiList": {
            "$ref": "nrNrm.json#/components/schemas/SnssaiList"
          },
          "amfSet": {
            "$ref": "genericNrm.json#/components/schemas/Dn"
          }
        }
      }
    ]
  }
},
{
  "$ref": "genericNrm.json#/components/schemas/ManagedFunction-ContainingObjects"
},
{
  "type": "object",
  "properties": {
    "EP_N2": {
      "$ref": "#/components/schemas/EP_N2"
    },
    "EP_N8": {
      "$ref": "#/components/schemas/EP_N8"
    },
    "EP_N11": {
      "$ref": "#/components/schemas/EP_N11"
    },
    "EP_N12": {
      "$ref": "#/components/schemas/EP_N12"
    },
    "EP_N14": {
      "$ref": "#/components/schemas/EP_N14"
    },
    "EP_N15": {
      "$ref": "#/components/schemas/EP_N15"
    },
    "EP_N17": {
      "$ref": "#/components/schemas/EP_N17"
    },
    "EP_N20": {
      "$ref": "#/components/schemas/EP_N20"
    },
    "EP_N22": {
      "$ref": "#/components/schemas/EP_N22"
    },
    "EP_N26": {
      "$ref": "#/components/schemas/EP_N26"
    },
    "EP_NLS": {
      "$ref": "#/components/schemas/EP_NLS"
    },
    "EP_NLG": {
      "$ref": "#/components/schemas/EP_NLG"
    }
  }
}

```

```

    }
  ]
},
"AmfSet": {
  "allOf": [
    {
      "$ref": "genericNrm.json#/components/schemas/Top-Attributes"
    },
    {
      "type": "object",
      "properties": {
        "attributes": {
          "allOf": [
            {
              "$ref": "genericNrm.json#/components/schemas/ManagedFunction-Attributes"
            },
            {
              "type": "object",
              "properties": {
                "plmnIdList": {
                  "$ref": "nrNrm.json#/components/schemas/PlmnIdList"
                },
                "nRTACList": {
                  "$ref": "#/components/schemas/TACList"
                },
                "amfSetId": {
                  "$ref": "#/components/schemas/AmfSetId"
                },
                "snssaiList": {
                  "$ref": "nrNrm.json#/components/schemas/SnssaiList"
                }
              }
            }
          ]
        }
      }
    }
  ]
},
"AmfRegion": {
  "allOf": [
    {
      "$ref": "genericNrm.json#/components/schemas/Top-Attributes"
    },
    {
      "type": "object",
      "properties": {
        "attributes": {
          "allOf": [
            {
              "$ref": "genericNrm.json#/components/schemas/ManagedFunction-Attributes"
            },
            {
              "type": "object",
              "properties": {
                "plmnIdList": {
                  "$ref": "nrNrm.json#/components/schemas/PlmnIdList"
                },
                "nRTACList": {
                  "$ref": "#/components/schemas/TACList"
                },
                "amfRegionId": {
                  "$ref": "#/components/schemas/AmfRegionId"
                },
                "snssaiList": {
                  "$ref": "nrNrm.json#/components/schemas/SnssaiList"
                }
              }
            }
          ]
        }
      }
    }
  ]
},
"SmfFunction": {
  "allOf": [

```

```

    {
      "$ref": "genericNrm.json#/components/schemas/Top-Attributes"
    },
    {
      "type": "object",
      "properties": {
        "attributes": {
          "allOf": [
            {
              "$ref": "genericNrm.json#/components/schemas/ManagedFunction-Attributes"
            },
            {
              "type": "object",
              "properties": {
                "plmnIdList": {
                  "$ref": "nrNrm.json#/components/schemas/PlmnIdList"
                },
                "nRTACList": {
                  "$ref": "#/components/schemas/TACList"
                },
                "sBIFqdn": {
                  "type": "string"
                },
                "sBIServiceList": {
                  "$ref": "#/components/schemas/SBIServiceList"
                },
                "snssaiList": {
                  "$ref": "nrNrm.json#/components/schemas/SnssaiList"
                }
              }
            }
          ]
        }
      }
    }
  ],
  {
    "$ref": "genericNrm.json#/components/schemas/ManagedFunction-ContainingObjects"
  },
  {
    "type": "object",
    "properties": {
      "EP_N4": {
        "$ref": "#/components/schemas/EP_N4"
      },
      "EP_N7": {
        "$ref": "#/components/schemas/EP_N7"
      },
      "EP_N10": {
        "$ref": "#/components/schemas/EP_N10"
      },
      "EP_N11": {
        "$ref": "#/components/schemas/EP_N11"
      },
      "EP_N16": {
        "$ref": "#/components/schemas/EP_N16"
      },
      "EP_S5C": {
        "$ref": "#/components/schemas/EP_S5C"
      }
    }
  }
],
  "UpfFunction": {
    "allOf": [
      {
        "$ref": "genericNrm.json#/components/schemas/Top-Attributes"
      },
      {
        "type": "object",
        "properties": {
          "attributes": {
            "allOf": [
              {
                "$ref": "genericNrm.json#/components/schemas/ManagedFunction-Attributes"
              },
              {
                "type": "object",

```



```

        "properties": {
          "plmnIdList": {
            "$ref": "nrNrm.json#/components/schemas/PlmnIdList"
          },
          "nRTACList": {
            "$ref": "#/components/schemas/TACList"
          },
          "snssaiList": {
            "$ref": "nrNrm.json#/components/schemas/SnssaiList"
          }
        }
      }
    ]
  },
  {
    "$ref": "genericNrm.json#/components/schemas/ManagedFunction-ContainingObjects"
  },
  {
    "type": "object",
    "properties": {
      "EP_N3": {
        "$ref": "#/components/schemas/EP_N3"
      },
      "EP_N4": {
        "$ref": "#/components/schemas/EP_N4"
      },
      "EP_N6": {
        "$ref": "#/components/schemas/EP_N6"
      },
      "EP_N9": {
        "$ref": "#/components/schemas/EP_N9"
      },
      "EP_S5U": {
        "$ref": "#/components/schemas/EP_S5U"
      }
    }
  }
]
},
"N3iwfFunction": {
  "allOf": [
    {
      "$ref": "genericNrm.json#/components/schemas/Top-Attributes"
    },
    {
      "type": "object",
      "properties": {
        "attributes": {
          "allOf": [
            {
              "$ref": "genericNrm.json#/components/schemas/ManagedFunction-Attributes"
            },
            {
              "type": "object",
              "properties": {
                "plmnIdList": {
                  "$ref": "nrNrm.json#/components/schemas/PlmnIdList"
                }
              }
            }
          ]
        }
      }
    }
  ]
}
},
{
  "$ref": "genericNrm.json#/components/schemas/ManagedFunction-ContainingObjects"
},
{
  "type": "object",
  "properties": {
    "EP_N3": {
      "$ref": "#/components/schemas/EP_N3"
    },
    "EP_N4": {
      "$ref": "#/components/schemas/EP_N4"
    }
  }
}
}

```

```

    }
  ]
},
"PcfFunction": {
  "allOf": [
    {
      "$ref": "genericNrm.json#/components/schemas/Top-Attributes"
    },
    {
      "type": "object",
      "properties": {
        "attributes": {
          "allOf": [
            {
              "$ref": "genericNrm.json#/components/schemas/ManagedFunction-Attributes"
            },
            {
              "type": "object",
              "properties": {
                "plmnIdList": {
                  "$ref": "nrNrm.json#/components/schemas/PlmnIdList"
                },
                "sBIFqdn": {
                  "type": "string"
                },
                "sBIServiceList": {
                  "$ref": "#/components/schemas/SBIServiceList"
                },
                "snssaiList": {
                  "$ref": "nrNrm.json#/components/schemas/SnssaiList"
                }
              }
            }
          ]
        }
      }
    }
  ],
  {
    "$ref": "genericNrm.json#/components/schemas/ManagedFunction-ContainingObjects"
  },
  {
    "type": "object",
    "properties": {
      "EP_N5": {
        "$ref": "#/components/schemas/EP_N5"
      },
      "EP_N7": {
        "$ref": "#/components/schemas/EP_N7"
      },
      "EP_N15": {
        "$ref": "#/components/schemas/EP_N15"
      },
      "EP_N16": {
        "$ref": "#/components/schemas/EP_N16"
      },
      "EP_Rx": {
        "$ref": "#/components/schemas/EP_Rx"
      }
    }
  }
]
},
"AusfFunction": {
  "allOf": [
    {
      "$ref": "genericNrm.json#/components/schemas/Top-Attributes"
    },
    {
      "type": "object",
      "properties": {
        "attributes": {
          "allOf": [
            {
              "$ref": "genericNrm.json#/components/schemas/ManagedFunction-Attributes"
            },
            {
              "type": "object",

```

```

        "properties": {
          "plmnIdList": {
            "$ref": "nrNrm.json#/components/schemas/PlmnIdList"
          },
          "sBIFqdn": {
            "type": "string"
          },
          "sBIServiceList": {
            "$ref": "#/components/schemas/SBIServiceList"
          },
          "snssaiList": {
            "$ref": "nrNrm.json#/components/schemas/SnssaiList"
          }
        }
      }
    ]
  },
  {
    "$ref": "genericNrm.json#/components/schemas/ManagedFunction-ContainingObjects"
  },
  {
    "type": "object",
    "properties": {
      "EP_N12": {
        "$ref": "#/components/schemas/EP_N12"
      },
      "EP_N13": {
        "$ref": "#/components/schemas/EP_N13"
      }
    }
  }
]
},
"UdmFunction": {
  "allOf": [
    {
      "$ref": "genericNrm.json#/components/schemas/Top-Attributes"
    },
    {
      "type": "object",
      "properties": {
        "attributes": {
          "allOf": [
            {
              "$ref": "genericNrm.json#/components/schemas/ManagedFunction-Attributes"
            },
            {
              "type": "object",
              "properties": {
                "plmnIdList": {
                  "$ref": "nrNrm.json#/components/schemas/PlmnIdList"
                },
                "sBIFqdn": {
                  "type": "string"
                },
                "sBIServiceList": {
                  "$ref": "#/components/schemas/SBIServiceList"
                },
                "snssaiList": {
                  "$ref": "nrNrm.json#/components/schemas/SnssaiList"
                }
              }
            }
          ]
        }
      }
    }
  ]
},
{
  "$ref": "genericNrm.json#/components/schemas/ManagedFunction-ContainingObjects"
},
{
  "type": "object",
  "properties": {
    "EP_N8": {
      "$ref": "#/components/schemas/EP_N8"
    }
  },

```

```

        "EP_N10": {
          "$ref": "#/components/schemas/EP_N10"
        },
        "EP_N13": {
          "$ref": "#/components/schemas/EP_N13"
        }
      ]
    },
    "UdrFunction": {
      "allOf": [
        {
          "$ref": "genericNrm.json#/components/schemas/Top-Attributes"
        },
        {
          "type": "object",
          "properties": {
            "attributes": {
              "allOf": [
                {
                  "$ref": "genericNrm.json#/components/schemas/ManagedFunction-Attributes"
                },
                {
                  "type": "object",
                  "properties": {
                    "plmnIdList": {
                      "$ref": "nrNrm.json#/components/schemas/PlmnIdList"
                    },
                    "sBIFqdn": {
                      "type": "string"
                    },
                    "sBIServiceList": {
                      "$ref": "#/components/schemas/SBIServiceList"
                    },
                    "snssaiList": {
                      "$ref": "nrNrm.json#/components/schemas/SnssaiList"
                    }
                  }
                }
              ]
            }
          }
        }
      ]
    },
    "UdsfFunction": {
      "allOf": [
        {
          "$ref": "genericNrm.json#/components/schemas/Top-Attributes"
        },
        {
          "type": "object",
          "properties": {
            "attributes": {
              "allOf": [
                {
                  "$ref": "genericNrm.json#/components/schemas/ManagedFunction-Attributes"
                },
                {
                  "type": "object",
                  "properties": {
                    "plmnIdList": {
                      "$ref": "nrNrm.json#/components/schemas/PlmnIdList"
                    },
                    "sBIFqdn": {
                      "type": "string"
                    },
                    "sBIServiceList": {
                      "$ref": "#/components/schemas/SBIServiceList"
                    },
                    "snssaiList": {
                      "$ref": "nrNrm.json#/components/schemas/SnssaiList"
                    }
                  }
                }
              ]
            }
          }
        }
      ]
    }
  }
}

```

```

    }
  ]
},
"NrfFunction": {
  "allOf": [
    {
      "$ref": "genericNrm.json#/components/schemas/Top-Attributes"
    },
    {
      "type": "object",
      "properties": {
        "attributes": {
          "allOf": [
            {
              "$ref": "genericNrm.json#/components/schemas/ManagedFunction-Attributes"
            },
            {
              "type": "object",
              "properties": {
                "plmnIdList": {
                  "$ref": "nrNrm.json#/components/schemas/PlmnIdList"
                },
                "sBIFqdn": {
                  "type": "string"
                },
                "nSIIdList": {
                  "$ref": "#/components/schemas/NSIIdList"
                },
                "nFProfileList": {
                  "$ref": "#/components/schemas/NFProfileList"
                },
                "snsaiList": {
                  "$ref": "nrNrm.json#/components/schemas/SnsaiList"
                }
              }
            }
          ]
        }
      }
    }
  ],
  "$ref": "genericNrm.json#/components/schemas/ManagedFunction-ContainingObjects"
},
{
  "type": "object",
  "properties": {
    "EP_N27": {
      "$ref": "#/components/schemas/EP_N27"
    }
  }
}
]
},
"NssfFunction": {
  "allOf": [
    {
      "$ref": "genericNrm.json#/components/schemas/Top-Attributes"
    },
    {
      "type": "object",
      "properties": {
        "attributes": {
          "allOf": [
            {
              "$ref": "genericNrm.json#/components/schemas/ManagedFunction-Attributes"
            },
            {
              "type": "object",
              "properties": {
                "plmnIdList": {
                  "$ref": "nrNrm.json#/components/schemas/PlmnIdList"
                },
                "sBIFqdn": {
                  "type": "string"
                },
                "nSIIdList": {
                  "$ref": "#/components/schemas/NSIIdList"
                }
              }
            }
          ]
        }
      }
    }
  ]
}
}

```

```

    },
    "nFProfileList": {
      "$ref": "#/components/schemas/NFProfileList"
    },
    "snssaiList": {
      "$ref": "nrNrm.json#/components/schemas/SnssaiList"
    }
  }
}
]
},
{
  "$ref": "genericNrm.json#/components/schemas/ManagedFunction-ContainingObjects"
},
{
  "type": "object",
  "properties": {
    "EP_N22": {
      "$ref": "#/components/schemas/EP_N22"
    },
    "EP_N31": {
      "$ref": "#/components/schemas/EP_N31"
    }
  }
}
]
},
"SmsfFunction": {
  "allOf": [
    {
      "$ref": "genericNrm.json#/components/schemas/Top-Attributes"
    },
    {
      "type": "object",
      "properties": {
        "attributes": {
          "allOf": [
            {
              "$ref": "genericNrm.json#/components/schemas/ManagedFunction-Attributes"
            },
            {
              "type": "object",
              "properties": {
                "plmnIdList": {
                  "$ref": "nrNrm.json#/components/schemas/PlmnIdList"
                },
                "sBIFqdn": {
                  "type": "string"
                },
                "sBIServiceList": {
                  "$ref": "#/components/schemas/SBIServiceList"
                }
              }
            }
          ]
        }
      }
    }
  ]
},
{
  "$ref": "genericNrm.json#/components/schemas/ManagedFunction-ContainingObjects"
},
{
  "type": "object",
  "properties": {
    "EP_N20": {
      "$ref": "#/components/schemas/EP_N20"
    },
    "EP_N21": {
      "$ref": "#/components/schemas/EP_N21"
    },
    "EP_MAP_SMSC": {
      "$ref": "#/components/schemas/EP_MAP_SMSC"
    }
  }
}
]

```

```

    },
    "LmfFunction": {
      "allOf": [
        {
          "$ref": "genericNrm.json#/components/schemas/Top-Attributes"
        },
        {
          "type": "object",
          "properties": {
            "attributes": {
              "allOf": [
                {
                  "$ref": "genericNrm.json#/components/schemas/ManagedFunction-Attributes"
                },
                {
                  "type": "object",
                  "properties": {
                    "plmnIdList": {
                      "$ref": "nrNrm.json#/components/schemas/PlmnIdList"
                    }
                  }
                }
              ]
            }
          }
        }
      ],
      "$ref": "genericNrm.json#/components/schemas/ManagedFunction-ContainingObjects"
    },
    {
      "type": "object",
      "properties": {
        "EP_NLS": {
          "$ref": "#/components/schemas/EP_NLS"
        }
      }
    }
  ]
},
"NgeirFunction": {
  "allOf": [
    {
      "$ref": "genericNrm.json#/components/schemas/Top-Attributes"
    },
    {
      "type": "object",
      "properties": {
        "attributes": {
          "allOf": [
            {
              "$ref": "genericNrm.json#/components/schemas/ManagedFunction-Attributes"
            },
            {
              "type": "object",
              "properties": {
                "plmnIdList": {
                  "$ref": "nrNrm.json#/components/schemas/PlmnIdList"
                },
                "sBIFqdn": {
                  "type": "string"
                },
                "sBIServiceList": {
                  "$ref": "#/components/schemas/SBIServiceList"
                },
                "snssaiList": {
                  "$ref": "nrNrm.json#/components/schemas/SnssaiList"
                }
              }
            }
          ]
        }
      }
    }
  ],
  "$ref": "genericNrm.json#/components/schemas/ManagedFunction-ContainingObjects"
},
{
  "type": "object",

```

```

        "properties": {
          "EP_N17": {
            "$ref": "#/components/schemas/EP_N17"
          }
        }
      }
    ],
  },
  "SeppFunction": {
    "allOf": [
      {
        "$ref": "genericNrm.json#/components/schemas/Top-Attributes"
      },
      {
        "type": "object",
        "properties": {
          "attributes": {
            "allOf": [
              {
                "$ref": "genericNrm.json#/components/schemas/ManagedFunction-Attributes"
              },
              {
                "type": "object",
                "properties": {
                  "plmnIdList": {
                    "$ref": "nrNrm.json#/components/schemas/PlmnIdList"
                  }
                }
              }
            ]
          }
        }
      }
    ]
  },
  {
    "$ref": "genericNrm.json#/components/schemas/ManagedFunction-ContainingObjects"
  },
  {
    "type": "object",
    "properties": {
      "EP_N32": {
        "$ref": "#/components/schemas/EP_N32"
      }
    }
  }
]
},
"NwdafFunction": {
  "allOf": [
    {
      "$ref": "genericNrm.json#/components/schemas/Top-Attributes"
    },
    {
      "type": "object",
      "properties": {
        "attributes": {
          "allOf": [
            {
              "$ref": "genericNrm.json#/components/schemas/ManagedFunction-Attributes"
            },
            {
              "type": "object",
              "properties": {
                "plmnIdList": {
                  "$ref": "nrNrm.json#/components/schemas/PlmnIdList"
                },
                "sBIFqdn": {
                  "type": "string"
                },
                "sBIServiceList": {
                  "$ref": "#/components/schemas/SBIServiceList"
                },
                "snssaiList": {
                  "$ref": "nrNrm.json#/components/schemas/SnssaiList"
                }
              }
            }
          ]
        }
      }
    ]
  }
}

```



```

    }
  ]
},
"ExternalAmfFunction": {
  "allOf": [
    {
      "$ref": "genericNrm.json#/components/schemas/Top-Attributes"
    },
    {
      "type": "object",
      "properties": {
        "attributes": {
          "allOf": [
            {
              "$ref": "genericNrm.json#/components/schemas/ManagedFunction-Attributes"
            },
            {
              "type": "object",
              "properties": {
                "plmnIdList": {
                  "$ref": "nrNrm.json#/components/schemas/PlmnIdList"
                },
                "amfIdentifier": {
                  "$ref": "#/components/schemas/AmfIdentifier"
                }
              }
            }
          ]
        }
      }
    }
  ]
},
"ExternalNrfFunction": {
  "allOf": [
    {
      "$ref": "genericNrm.json#/components/schemas/Top-Attributes"
    },
    {
      "type": "object",
      "properties": {
        "attributes": {
          "allOf": [
            {
              "$ref": "genericNrm.json#/components/schemas/ManagedFunction-Attributes"
            },
            {
              "type": "object",
              "properties": {
                "plmnIdList": {
                  "$ref": "nrNrm.json#/components/schemas/PlmnIdList"
                }
              }
            }
          ]
        }
      }
    }
  ]
},
"ExternalNssfFunction": {
  "allOf": [
    {
      "$ref": "genericNrm.json#/components/schemas/Top-Attributes"
    },
    {
      "type": "object",
      "properties": {
        "attributes": {
          "allOf": [
            {
              "$ref": "genericNrm.json#/components/schemas/ManagedFunction-Attributes"
            },
            {
              "type": "object",
              "properties": {
                "plmnIdList": {

```

```

        "$ref": "nrNrm.json#/components/schemas/PlmnIdList"
      }
    }
  ]
}
},
"ManagedElement-Single": {
  "allOf": [
    {
      "$ref": "genericNrm.json#/components/schemas/Top-Attributes"
    },
    {
      "type": "object",
      "properties": {
        "attributes": {
          "allOf": [
            {
              "$ref": "genericNrm.json#/components/schemas/ManagedElement-Attributes"
            },
            {
              "type": "object",
              "properties": {}
            }
          ]
        }
      }
    }
  ],
  "$ref": "genericNrm.json#/components/schemas/ManagedElement-ContainingObjects"
},
{
  "type": "object",
  "properties": {
    "AmfFunction": {
      "type": "array",
      "items": {
        "$ref": "#/components/schemas/AmfFunction"
      }
    },
    "SmfFunction": {
      "type": "array",
      "items": {
        "$ref": "#/components/schemas/SmfFunction"
      }
    },
    "UpfFunction": {
      "type": "array",
      "items": {
        "$ref": "#/components/schemas/UpfFunction"
      }
    },
    "N3iwfFunction": {
      "type": "array",
      "items": {
        "$ref": "#/components/schemas/N3iwfFunction"
      }
    },
    "PcfFunction": {
      "type": "array",
      "items": {
        "$ref": "#/components/schemas/PcfFunction"
      }
    },
    "AusfFunction": {
      "type": "array",
      "items": {
        "$ref": "#/components/schemas/AusfFunction"
      }
    },
    "UdmFunction": {
      "type": "array",
      "items": {
        "$ref": "#/components/schemas/UdmFunction"
      }
    }
  }
}

```

```

    },
    "UdrFunction": {
      "type": "array",
      "items": {
        "$ref": "#/components/schemas/UdrFunction"
      }
    },
    "UdsfFunction": {
      "type": "array",
      "items": {
        "$ref": "#/components/schemas/UdsfFunction"
      }
    },
    "NrfFunction": {
      "type": "array",
      "items": {
        "$ref": "#/components/schemas/NrfFunction"
      }
    },
    "NssfFunction": {
      "type": "array",
      "items": {
        "$ref": "#/components/schemas/NssfFunction"
      }
    },
    "SmsfFunction": {
      "type": "array",
      "items": {
        "$ref": "#/components/schemas/SmsfFunction"
      }
    },
    "LmfFunction": {
      "type": "array",
      "items": {
        "$ref": "#/components/schemas/LmfFunction"
      }
    },
    "NgeirFunction": {
      "type": "array",
      "items": {
        "$ref": "#/components/schemas/NgeirFunction"
      }
    },
    "SeppFunction": {
      "type": "array",
      "items": {
        "$ref": "#/components/schemas/SeppFunction"
      }
    },
    "NwdafFunction": {
      "type": "array",
      "items": {
        "$ref": "#/components/schemas/NwdafFunction"
      }
    }
  }
}
]
},
"ManagedElement-Multiple": {
  "type": "array",
  "items": {
    "$ref": "#/components/schemas/ManagedElement-Single"
  }
},
"SubNetwork-Single": {
  "allOf": [
    {
      "$ref": "genericNrm.json#/components/schemas/Top-Attributes"
    },
    {
      "type": "object",
      "properties": {
        "attributes": {
          "allOf": [
            {
              "$ref": "genericNrm.json#/components/schemas/SubNetwork-Attributes"
            }
          ]
        }
      }
    }
  ]
}

```

```

        {
          "type": "object",
          "properties": {}
        }
      ]
    }
  },
  {
    "$ref": "genericNrm.json#/components/schemas/SubNetwork-ContainingObjects"
  },
  {
    "type": "object",
    "properties": {
      "SubNetwork": {
        "$ref": "#/components/schemas/SubNetwork-Multiple"
      },
      "ManagedElement": {
        "$ref": "#/components/schemas/ManagedElement-Multiple"
      },
      "ExternalAmfFunction": {
        "type": "array",
        "items": {
          "$ref": "#/components/schemas/ExternalAmfFunction"
        }
      },
      "ExternalNrfFunction": {
        "type": "array",
        "items": {
          "$ref": "#/components/schemas/ExternalNrfFunction"
        }
      },
      "ExternalNssfFunction": {
        "type": "array",
        "items": {
          "$ref": "#/components/schemas/ExternalNssfFunction"
        }
      },
      "AmfSet": {
        "type": "array",
        "items": {
          "$ref": "#/components/schemas/AmfSet"
        }
      },
      "AmfRegion": {
        "type": "array",
        "items": {
          "$ref": "#/components/schemas/AmfRegion"
        }
      }
    }
  }
]
},
"SubNetwork-Multiple": {
  "type": "array",
  "items": {
    "$ref": "#/components/schemas/SubNetwork-Single"
  }
},
"EP_N2": {
  "$ref": "nrNrm.json#/components/schemas/EP_RP"
},
"EP_N3": {
  "$ref": "nrNrm.json#/components/schemas/EP_RP"
},
"EP_N4": {
  "$ref": "nrNrm.json#/components/schemas/EP_RP"
},
"EP_N5": {
  "$ref": "nrNrm.json#/components/schemas/EP_RP"
},
"EP_N6": {
  "$ref": "nrNrm.json#/components/schemas/EP_RP"
},
"EP_N7": {
  "$ref": "nrNrm.json#/components/schemas/EP_RP"
},
},

```

```

"EP_N8": {
  "$ref": "nrNrm.json#/components/schemas/EP_RP"
},
"EP_N9": {
  "$ref": "nrNrm.json#/components/schemas/EP_RP"
},
"EP_N10": {
  "$ref": "nrNrm.json#/components/schemas/EP_RP"
},
"EP_N11": {
  "$ref": "nrNrm.json#/components/schemas/EP_RP"
},
"EP_N12": {
  "$ref": "nrNrm.json#/components/schemas/EP_RP"
},
"EP_N13": {
  "$ref": "nrNrm.json#/components/schemas/EP_RP"
},
"EP_N14": {
  "$ref": "nrNrm.json#/components/schemas/EP_RP"
},
"EP_N15": {
  "$ref": "nrNrm.json#/components/schemas/EP_RP"
},
"EP_N16": {
  "$ref": "nrNrm.json#/components/schemas/EP_RP"
},
"EP_N17": {
  "$ref": "nrNrm.json#/components/schemas/EP_RP"
},
"EP_N20": {
  "$ref": "nrNrm.json#/components/schemas/EP_RP"
},
"EP_N21": {
  "$ref": "nrNrm.json#/components/schemas/EP_RP"
},
"EP_N22": {
  "$ref": "nrNrm.json#/components/schemas/EP_RP"
},
"EP_N26": {
  "$ref": "nrNrm.json#/components/schemas/EP_RP"
},
"EP_N27": {
  "$ref": "nrNrm.json#/components/schemas/EP_RP"
},
"EP_N31": {
  "$ref": "nrNrm.json#/components/schemas/EP_RP"
},
"EP_N32": {
  "$ref": "nrNrm.json#/components/schemas/EP_RP"
},
"EP_SBI_X": {
  "$ref": "nrNrm.json#/components/schemas/EP_RP"
},
"EP_SBI_IPX": {
  "$ref": "nrNrm.json#/components/schemas/EP_RP"
},
"EP_S5C": {
  "$ref": "nrNrm.json#/components/schemas/EP_RP"
},
"EP_S5U": {
  "$ref": "nrNrm.json#/components/schemas/EP_RP"
},
"EP_Rx": {
  "$ref": "nrNrm.json#/components/schemas/EP_RP"
},
"EP_MAP_SMSC": {
  "$ref": "nrNrm.json#/components/schemas/EP_RP"
},
"EP_NLS": {
  "$ref": "nrNrm.json#/components/schemas/EP_RP"
},
"EP_NLG": {
  "$ref": "nrNrm.json#/components/schemas/EP_RP"
}
}
}
}

```

Annex H (normative): YANG definitions for 5GC

H.1 General

This annex contains the YANG definitions for the 5GC NRM, in accordance with 5GC information model definitions specified in clause 4.

H.2 Void

H.3 Void

H.4 Void

H.5 Modules

This is the list of YANG modules for 5GC NRM.

```
_3gpp-5gc-nrm-affunction.yang
_3gpp-5gc-nrm-amffunction.yang
_3gpp-5gc-nrm-amfregion.yang
_3gpp-5gc-nrm-amfset.yang
_3gpp-5gc-nrm-ausffunction.yang
_3gpp-5gc-nrm-dnffunction.yang
_3gpp-5gc-nrm-ep.yang
_3gpp-5gc-nrm-externalamffunction.yang
_3gpp-5gc-nrm-externalnrffunction.yang
_3gpp-5gc-nrm-externalnssffunction.yang
_3gpp-5gc-nrm-lmffunction.yang
_3gpp-5gc-nrm-n3iwffunction.yang
_3gpp-5gc-nrm-nfprofile.yang
_3gpp-5gc-nrm-nfservice.yang
_3gpp-5gc-nrm-ngeirfunction.yang
_3gpp-5gc-nrm-nrffunction.yang
_3gpp-5gc-nrm-nssffunction.yang
_3gpp-5gc-nrm-nwdaffunction.yang
_3gpp-5gc-nrm-pcffunction.yang
_3gpp-5gc-nrm-seppfunction.yang
_3gpp-5gc-nrm-smffunction.yang
_3gpp-5gc-nrm-smsffunction.yang
_3gpp-5gc-nrm-udmfunction.yang
_3gpp-5gc-nrm-udrfunction.yang
_3gpp-5gc-nrm-udsffunction.yang
_3gpp-5gc-nrm-upffunction.yang
```

These are the YANG modules for 5GC NRM.

```
module _3gpp-5gc-nrm-affunction {
  yang-version 1.1;

  namespace urn:3gpp:sa5:_3gpp-5gc-nrm-affunction;
  prefix af3gpp;

  import _3gpp-common-managed-function { prefix mf3gpp; }
  import _3gpp-common-managed-element { prefix me3gpp; }
  import _3gpp-common-top { prefix top3gpp; }

  organization "3gpp SA5";
  description "This IOC is defined only to describe the IOCs representing
    its interaction interface with 5GC (i.e. EP_Rx and EP_N5).";
```

```

        It has no attributes defined.";
reference "3GPP TS 28.541";

revision 2019-05-15 {
  description "initial revision";
  reference "Based on
    3GPP TS 28.541 V15.X.XX";
}

grouping AFFunctionGrp {
  uses mf3gpp:ManagedFunctionGrp;
}

augment "/me3gpp:ManagedElement" {
  list AFFunction {
    description "5G Core AF Function";
    reference "3GPP TS 28.541";
    key id;
    uses top3gpp:Top_Grp;
    container attributes {
      uses AFFunctionGrp;
    }
  }
}
}

module _3gpp-5gc-nrm-amffunction {
  yang-version 1.1;
  namespace urn:3gpp:sa5:_3gpp-5gc-nrm-amffunction;
  prefix amf3gpp;

  import _3gpp-common-managed-function { prefix mf3gpp; }
  import _3gpp-common-managed-element { prefix me3gpp; }
  import _3gpp-common-yang-types { prefix types3gpp; }
  import ietf-inet-types { prefix inet; }
  import _3gpp-common-top { prefix top3gpp; }

  description "AMFFunction derived from basic ManagedFunction.";

  revision 2019-05-31 {
    description "Ericsson refactoring.";
    reference "Based on
      3GPP TS 28.541 V15.X.XX";
  }

  revision 2018-08-07 {
    description "Initial revision";
  }

  grouping AMFFunctionGrp {
    uses mf3gpp:ManagedFunctionGrp;

    list pLMNIdList {
      min-elements 1;
      description "A list of PLMN identifiers (Mobile Country Code and Mobile Network Code).";
      key "mcc mnc";
      uses types3gpp:PLMNId;
    }

    container aMFIdentifier {
      presence true;
      description "An AMF identifier, comprising an AMF Region ID, an AMF Set ID and an AMF
Pointer.";
      uses types3gpp:AmfIdentifier;
    }

    leaf sBIFQDN {
      description "The FQDN of the registered NF instance in the service-based interface.";
      type inet:domain-name;
    }

    leaf-list sBIServiceList {
      description "All supported NF services registered on the service-based interface.";
      min-elements 1;
      config false;
      type string;
    }
  }
}

```

```

leaf weightFactor {
  description "Set according to the capacity of local node (AMF) relative to
  other nodes in the same type, to achieve load balancing among a set of
  same type of network functions.";
  type uint16;
}

leaf-list sNSSAICollection {
  min-elements 0; // conditionally mandatory if network slicing feature is supported
  description "List of S-NSSAIs the managed object is capable of supporting.
  (Single Network Slice Selection Assistance Information)
  An S-NSSAI has an SST (Slice/Service type) and an optional SD
  (Slice Differentiator) field.";
  reference "3GPP TS 23.003";
  type types3gpp:SNssai;
}

augment "/me3gpp:ManagedElement" {
  list AMFFunction {
    description "5G Core AMF Function";
    reference "3GPP TS 28.541";
    key id;
    uses top3gpp:Top_Grp;
    container attributes {
      uses AMFFunctionGrp;
    }
  }
}

module _3gpp-5gc-nrm-amfregion {
  yang-version 1.1;
  namespace urn:3gpp:sa5:_3gpp-5gc-nrm-amfregion;
  prefix amfr3gpp;

  import _3gpp-common-yang-types { prefix types3gpp; }
  import _3gpp-common-subnetwork { prefix subnet3gpp; }
  import _3gpp-common-top { prefix top3gpp; }
  import _3gpp-common-managed-function { prefix mf3gpp; }

  description "This IOC represents the AMF Region which consists one or multiple AMF Sets.";

  revision 2019-06-11 {
    description "Ericsson refactoring.";
    reference "Based on
    3GPP TS 28.541 V15.X.XX";
  }

  grouping AMFRegionGrp {
    uses mf3gpp:ManagedFunctionGrp;

    list pLMNIdList {
      description "List of at most six entries of PLMN Identifiers, but at least one (the primary
      PLMN Id).
      The PLMN Identifier is composed of a Mobile Country Code (MCC) and a Mobile
      Network Code (MNC).";
      min-elements 1;
      max-elements 6;
      key "mcc mnc";
      uses types3gpp:PLMNId;
    }

    leaf-list nRTACList {
      description "List of Tracking Area Codes (legacy TAC or extended TAC)
      where the represented management function is serving.";
      reference "TS 38.413 clause 9.3.3.10";
      min-elements 1;
      config false;
      type types3gpp:Tac;
    }

    leaf-list sNSSAICollection {
      description "List of S-NSSAIs the managed object is capable of supporting.
      (Single Network Slice Selection Assistance Information)
      An S-NSSAI has an SST (Slice/Service type) and an optional SD
      (Slice Differentiator) field.";

```



```

        //conditional support only if the network slicing feature is supported.
        reference "3GPP TS 23.003";
        type types3gpp:SNssai;
    }

    leaf aMFRegionId {
        description "Represents the AMF Region ID, which identifies the region.";
        mandatory true;
        type types3gpp:AmfRegionId;
    }

    leaf-list aMFSet {
        description "The AMFSet that the AFMRegion is associated with.";
        min-elements 1;
        type instance-identifier;
    }
}

augment "/subnet3gpp:SubNetwork" {
    list AMFRegion {
        description "5G Core AMFRegion IOC";
        reference "3GPP TS 28.541";
        key id;
        uses top3gpp:Top_Grp;
        container attributes {
            uses AMFRegionGrp;
        }
    }
}

module _3gpp-5gc-nrm-amfset {
    yang-version 1.1;
    namespace urn:3gpp:sa5:_3gpp-5gc-nrm-amfset;
    prefix amfset3gpp;

    import _3gpp-common-yang-types { prefix types3gpp; }
    import _3gpp-common-subnetwork { prefix subnet3gpp; }
    import _3gpp-common-top { prefix top3gpp; }
    import _3gpp-common-managed-function { prefix mf3gpp; }

    description "This IOC represents the AMF Set which consists of some AMFs that serve a given area
    and Network Slice.";

    revision 2019-06-11 {
        description "Ericsson refactoring.";
        reference "Based on
        3GPP TS 28.541 V15.X.XX";
    }

    grouping AMFSetGrp {
        uses mf3gpp:ManagedFunctionGrp;

        list pLMNIdList {
            description "List of at most six entries of PLMN Identifiers, but at least one (the primary
            PLMN Id).
            The PLMN Identifier is composed of a Mobile Country Code (MCC) and a Mobile
            Network Code (MNC).";

            min-elements 1;
            max-elements 6;
            key "mcc mnc";
            uses types3gpp:PLMNId;
        }

        leaf-list nRTACList {
            description "List of Tracking Area Codes (legacy TAC or extended TAC)
            where the represented management function is serving.";
            reference "TS 38.413 clause 9.3.3.10";
            min-elements 1;
            config false;
            type types3gpp:Tac;
        }

        leaf-list sNSSAList {
            description "List of S-NSSAIs the managed object is capable of supporting.
            (Single Network Slice Selection Assistance Information)
            An S-NSSAI has an SST (Slice/Service type) and an optional SD

```

```

        (Slice Differentiator) field.";
        //conditional support only if the network slicing feature is supported.
        reference "3GPP TS 23.003";
        type types3gpp:SNssai;
    }

    leaf aMFRegion {
        description "The AMFRegion that the AFMSet is associated with.";
        type instance-identifier;
    }

    leaf-list aMFSetMemberList {
        description "List of DNSs of AMFFunction instances of the AMFSet.";
        min-elements 1;
        max-elements 1;
        type types3gpp:DistinguishedName;
    }
}

augment "/subnet3gpp:SubNetwork" {
    list AMFSet {
        description "5G Core AMFSet IOC";
        reference "3GPP TS 28.541";
        key id;
        uses top3gpp:Top_Grp;
        container attributes {
            uses AMFSetGrp;
        }
    }
}

module _3gpp-5gc-nrm-ausffunction {
    yang-version 1.1;

    namespace urn:3gpp:sa5:_3gpp-5gc-nrm-ausffunction;
    prefix ausf3gpp;

    import _3gpp-common-managed-function { prefix mf3gpp; }
    import _3gpp-common-managed-element { prefix me3gpp; }
    import ietf-inet-types { prefix inet; }
    import _3gpp-common-yang-types { prefix types3gpp; }
    import _3gpp-common-top { prefix top3gpp; }

    organization "3gpp SA5";
    description "This IOC represents the AUSF function in 5GC. For more information about the AUSF,
    see 3GPP TS 23.501.";
    reference "3GPP TS 28.541";

    revision 2019-05-22 {
        description "initial revision";
        reference "Based on
        3GPP TS 28.541 V15.X.XX";
    }

    grouping AUSFFuntionGrp {
        uses mf3gpp:ManagedFunctionGrp;

        list pLMNidList {
            description "List of at most six entries of PLMN Identifiers, but at least one (the primary
            PLMN Id).
            The PLMN Identifier is composed of a Mobile Country Code (MCC) and a Mobile
            Network Code (MNC).";

            min-elements 1;
            max-elements 6;
            key "mcc mnc";
            uses types3gpp:PLMNid;
        }

        leaf sBIFQDN {
            description "The FQDN of the registered NF instance in the service-based interface.";
            type inet:domain-name;
        }

        leaf-list sBIServiceList {
            description "All supported NF services registered on the service-based interface.";
            config false;
        }
    }
}

```

```

    type string;
  }

  leaf-list sNSSAList {
    description "List of S-NSSAIs the managed object is capable of supporting.
      (Single Network Slice Selection Assistance Information)
      An S-NSSAI has an SST (Slice/Service type) and an optional SD
      (Slice Differentiator) field.";
    //optional support
    reference "3GPP TS 23.003";
    type types3gpp:SNssai;
  }
}

augment "/me3gpp:ManagedElement" {
  list AUSFFunction {
    description "5G Core AUSF Function";
    reference "3GPP TS 28.541";
    key id;
    uses top3gpp:Top_Grp;
    container attributes {
      uses AUSFFuntionGrp;
    }
  }
}

module _3gpp-5gc-nrm-dnfunction {
  yang-version 1.1;

  namespace urn:3gpp:sa5_3gpp-5gc-nrm-dnfunction;
  prefix dn3gpp;

  import _3gpp-common-managed-function { prefix mf3gpp; }
  import _3gpp-common-managed-element { prefix me3gpp; }
  import _3gpp-common-top { prefix top3gpp; }

  organization "3gpp SA5";
  description "This IOC is defined only to describe the IOCs representing
    Data Network (DN) interaction interface with 5GC (i.e. EP_N6).
    It has no attributes defined.";
  reference "3GPP TS 28.541";

  revision 2019-05-15 {
    description "initial revision";
    reference "Based on
      3GPP TS 28.541 V15.X.XX";
  }

  grouping DNFunctionGrp {
    uses mf3gpp:ManagedFunctionGrp;
  }

  augment "/me3gpp:ManagedElement" {
    list DNFunction {
      description "5G Core DN Function";
      reference "3GPP TS 28.541";
      key id;
      uses top3gpp:Top_Grp;
      container attributes {
        uses DNFunctionGrp;
      }
    }
  }
}

module _3gpp-5gc-nrm-ep {
  yang-version 1.1;
  namespace "urn:3gpp:tsg:sa5:nrm:_3gpp-5gc-nrm-ep";
  prefix "cep3gpp";

  import _3gpp-common-ep-rp { prefix eprp3gpp; }
  import _3gpp-common-managed-element { prefix me3gpp; }
  import _3gpp-5gc-nrm-affunction { prefix af3gpp; }
  import _3gpp-5gc-nrm-amffunction { prefix amf3gpp; }
  import _3gpp-5gc-nrm-ausffunction { prefix ausf3gpp; }
  import _3gpp-5gc-nrm-dnfunction { prefix dn3gpp; }
  import _3gpp-5gc-nrm-lmffunction { prefix lmf3gpp; }

```

```
import _3gpp-5gc-nrm-n3iwffunction { prefix n3iwf3gpp; }
import _3gpp-5gc-nrm-ngeirfunction { prefix ngeir3gpp; }
import _3gpp-5gc-nrm-nrffunction { prefix nrf3gpp; }
import _3gpp-5gc-nrm-nssffunction { prefix nssf3gpp; }
import _3gpp-5gc-nrm-nwdaffunction { prefix nwdaf3gpp; }
import _3gpp-5gc-nrm-pcfunction { prefix pcf3gpp; }
import _3gpp-5gc-nrm-seppfunction { prefix sepp3gpp; }
import _3gpp-5gc-nrm-smfunction { prefix smf3gpp; }
import _3gpp-5gc-nrm-smsfunction { prefix smsf3gpp; }
import _3gpp-5gc-nrm-udmfunction { prefix udm3gpp; }
import _3gpp-5gc-nrm-udrfunction { prefix udr3gpp; }
import _3gpp-5gc-nrm-udsffunction { prefix udsf3gpp; }
import _3gpp-5gc-nrm-upfunction { prefix upf3gpp; }
import _3gpp-common-top { prefix top3gpp; }

organization "3GPP SA5";
description "Defines the YANG mapping of the 5GC related endpoint
            Information Object Classes (IOCs) that are part of the 5G Core
            Network Resource Model.";
reference "3GPP TS 28.541";

revision 2019-05-31 {
  description "Ericsson refactoring.";
  reference "Based on
            3GPP TS 28.541 V15.X.XX";
}

revision 2018-07-31 {
  description "Initial revision";
}

grouping EP_N2Grp {
  uses eprp3gpp:EP_Common;
}

grouping EP_N3Grp {
  uses eprp3gpp:EP_Common;
}

grouping EP_N4Grp {
  uses eprp3gpp:EP_Common;
}

grouping EP_N5Grp {
  uses eprp3gpp:EP_Common;
}

grouping EP_N6Grp {
  uses eprp3gpp:EP_Common;
}

grouping EP_N7Grp {
  uses eprp3gpp:EP_Common;
}

grouping EP_N8Grp {
  uses eprp3gpp:EP_Common;
}

grouping EP_N9Grp {
  uses eprp3gpp:EP_Common;
}

grouping EP_N10Grp {
  uses eprp3gpp:EP_Common;
}

grouping EP_N11Grp {
  uses eprp3gpp:EP_Common;
}

grouping EP_N12Grp {
  uses eprp3gpp:EP_Common;
}

grouping EP_N13Grp {
  uses eprp3gpp:EP_Common;
}
```

```
grouping EP_N14Grp {
  uses eprp3gpp:EP_Common;
}

grouping EP_N15Grp {
  uses eprp3gpp:EP_Common;
}

grouping EP_N16Grp {
  uses eprp3gpp:EP_Common;
}

grouping EP_N17Grp {
  uses eprp3gpp:EP_Common;
}

grouping EP_N20Grp {
  uses eprp3gpp:EP_Common;
}

grouping EP_N21Grp {
  uses eprp3gpp:EP_Common;
}

grouping EP_N22Grp {
  uses eprp3gpp:EP_Common;
}

grouping EP_N26Grp {
  uses eprp3gpp:EP_Common;
}

grouping EP_N27Grp {
  uses eprp3gpp:EP_Common;
}

grouping EP_N31Grp {
  uses eprp3gpp:EP_Common;
}

grouping EP_N32Grp {
  uses eprp3gpp:EP_Common;
}

grouping EP_S5CGrp {
  uses eprp3gpp:EP_Common;
}

grouping EP_S5UGrp {
  uses eprp3gpp:EP_Common;
}

grouping EP_RxGrp {
  uses eprp3gpp:EP_Common;
}

grouping EP_MAP_SMSCGrp {
  uses eprp3gpp:EP_Common;
}

grouping EP_NLSGrp {
  uses eprp3gpp:EP_Common;
}

grouping EP_NLGGrp {
  uses eprp3gpp:EP_Common;
}

grouping EP_SBI_XGrp {
  uses eprp3gpp:EP_Common;
  leaf-list sBIService {
    min-elements 1;
    config false;
    type string;
  }
}
```

```
grouping EP_SBI_IPXGrp {
  uses eprp3gpp:EP_Common;
  leaf-list sBIService {
    min-elements 1;
    config false;
    type string;
  }
}

augment "/me3gpp:ManagedElement/af3gpp:AFFunction" {
  list EP_N6 {
    description "Represents the EP_N6 IOC.";
    key id;
    uses top3gpp:Top_Grp;
    container attributes {
      uses EP_N6Grp;
    }
  }

  list EP_Rx {
    description "Represents the EP_Rx IOC.";
    key id;
    uses top3gpp:Top_Grp;
    container attributes {
      uses EP_RxGrp;
    }
  }
}

augment "/me3gpp:ManagedElement/amf3gpp:AMFFunction" {
  list EP_N2 {
    description "Represents the EP_N2 IOC.";
    key id;
    uses top3gpp:Top_Grp;
    container attributes {
      uses EP_N2Grp;
    }
  }

  list EP_N8 {
    description "Represents the EP_N8 IOC.";
    key id;
    uses top3gpp:Top_Grp;
    container attributes {
      uses EP_N8Grp;
    }
  }

  list EP_N11 {
    description "Represents the EP_N11 IOC.";
    key id;
    uses top3gpp:Top_Grp;
    container attributes {
      uses EP_N11Grp;
    }
  }

  list EP_N12 {
    description "Represents the EP_N12 IOC.";
    key id;
    uses top3gpp:Top_Grp;
    container attributes {
      uses EP_N12Grp;
    }
  }

  list EP_N14 {
    description "Represents the EP_N14 IOC.";
    key id;
    uses top3gpp:Top_Grp;
    container attributes {
      uses EP_N14Grp;
    }
  }

  list EP_N15 {
    description "Represents the EP_N15 IOC.";
    key id;
  }
}
```

```
    uses top3gpp:Top_Grp;
    container attributes {
      uses EP_N15Grp;
    }
  }

list EP_N17 {
  description "Represents the EP_N17 IOC.";
  key id;
  uses top3gpp:Top_Grp;
  container attributes {
    uses EP_N17Grp;
  }
}

list EP_N20 {
  description "Represents the EP_N20 IOC.";
  key id;
  uses top3gpp:Top_Grp;
  container attributes {
    uses EP_N20Grp;
  }
}

list EP_N22 {
  description "Represents the EP_N22 IOC.";
  key id;
  uses top3gpp:Top_Grp;
  container attributes {
    uses EP_N22Grp;
  }
}

list EP_N26 {
  description "Represents the EP_N26 IOC.";
  key id;
  uses top3gpp:Top_Grp;
  container attributes {
    uses EP_N26Grp;
  }
}

list EP_NLS {
  description "Represents the EP_NLS IOC.";
  key id;
  uses top3gpp:Top_Grp;
  container attributes {
    uses EP_NLSGrp;
  }
}

list EP_NLG {
  description "Represents the EP_NLG IOC.";
  key id;
  uses top3gpp:Top_Grp;
  container attributes {
    uses EP_NLGGrp;
  }
}

list EP_SBI_X {
  description "Used for the services consumed by the control plane function.
    Far entity and remoteAddress are required for this endpoint.";
  key id;
  uses top3gpp:Top_Grp;
  container attributes {
    uses EP_SBI_XGrp;
  }
}
}

augment "/me3gpp:ManagedElement/ausf3gpp:AUSFFunction" {
  list EP_N12 {
    description "Represents the EP_N12 IOC.";
    key id;
    uses top3gpp:Top_Grp;
    container attributes {
      uses EP_N12Grp;
    }
  }
}
```

```
    }
  }

  list EP_N13 {
    description "Represents the EP_N13 IOC.";
    key id;
    uses top3gpp:Top_Grp;
    container attributes {
      uses EP_N13Grp;
    }
  }

  list EP_SBI_X {
    description "Used for the services consumed by the control plane function.
      Far entity and remoteAddress are required for this endpoint.";
    key id;
    uses top3gpp:Top_Grp;
    container attributes {
      uses EP_SBI_XGrp;
    }
  }
}

augment "/me3gpp:ManagedElement/dn3gpp:DNFunction" {
  list EP_N6 {
    description "Represents the EP_N6 IOC.";
    key id;
    uses top3gpp:Top_Grp;
    container attributes {
      uses EP_N6Grp;
    }
  }
}

augment "/me3gpp:ManagedElement/lmf3gpp:LMFFunction" {
  list EP_NLS {
    description "Represents the EP_NLS IOC.";
    key id;
    uses top3gpp:Top_Grp;
    container attributes {
      uses EP_NLSGrp;
    }
  }
}

augment "/me3gpp:ManagedElement/n3iwf3gpp:N3IWFFunction" {
  list EP_N2 {
    description "Represents the EP_N2 IOC.";
    key id;
    uses top3gpp:Top_Grp;
    container attributes {
      uses EP_N2Grp;
    }
  }

  list EP_N3 {
    description "Represents the EP_N3 IOC.";
    key id;
    uses top3gpp:Top_Grp;
    container attributes {
      uses EP_N3Grp;
    }
  }
}

augment "/me3gpp:ManagedElement/ngair3gpp:NGAIRFunction" {
  list EP_N17 {
    description "Represents the EP_N17 IOC.";
    key id;
    uses top3gpp:Top_Grp;
    container attributes {
      uses EP_N17Grp;
    }
  }
}

augment "/me3gpp:ManagedElement/nrf3gpp:NRFFunction" {
  list EP_N27 {
```



```

    description "Represents the EP_N27 IOC.";
    key id;
    uses top3gpp:Top_Grp;
    container attributes {
        uses EP_N26Grp;
    }
}

list EP_SBI_X {
    description "Used for the services consumed by the control plane function.
        Far entity and remoteAddress are required for this endpoint.";
    key id;
    uses top3gpp:Top_Grp;
    container attributes {
        uses EP_SBI_XGrp;
    }
}
}

augment "/me3gpp:ManagedElement/nssf3gpp:NSSFFunction" {
    list EP_N22 {
        description "Represents the EP_N22 IOC.";
        key id;
        uses top3gpp:Top_Grp;
        container attributes {
            uses EP_N22Grp;
        }
    }

    list EP_N31 {
        description "Represents the EP_N31 IOC.";
        key id;
        uses top3gpp:Top_Grp;
        container attributes {
            uses EP_N31Grp;
        }
    }

    list EP_SBI_X {
        description "Used for the services consumed by the control plane function.
            Far entity and remoteAddress are required for this endpoint.";
        key id;
        uses top3gpp:Top_Grp;
        container attributes {
            uses EP_SBI_XGrp;
        }
    }
}

augment "/me3gpp:ManagedElement/nwdaf3gpp:NWDAFFunction" {
    list EP_SBI_X {
        description "Used for the services consumed by the control plane function.
            Far entity and remoteAddress are required for this endpoint.";
        key id;
        uses top3gpp:Top_Grp;
        container attributes {
            uses EP_SBI_XGrp;
        }
    }
}

augment "/me3gpp:ManagedElement/pcf3gpp:PCFFunction" {
    list EP_N5 {
        description "Represents the EP_N5 IOC.";
        key id;
        uses top3gpp:Top_Grp;
        container attributes {
            uses EP_N5Grp;
        }
    }

    list EP_N7 {
        description "Represents the EP_N7 IOC.";
        key id;
        uses top3gpp:Top_Grp;
        container attributes {
            uses EP_N7Grp;
        }
    }
}

```

```
    }

    list EP_N15 {
      description "Represents the EP_N15 IOC.";
      key id;
      uses top3gpp:Top_Grp;
      container attributes {
        uses EP_N15Grp;
      }
    }

    list EP_N16 {
      description "Represents the EP_N16 IOC.";
      key id;
      uses top3gpp:Top_Grp;
      container attributes {
        uses EP_N16Grp;
      }
    }

    list EP_Rx {
      description "Represents the EP_Rx IOC.";
      key id;
      uses top3gpp:Top_Grp;
      container attributes {
        uses EP_RxGrp;
      }
    }

    list EP_SBI_X {
      description "Used for the services consumed by the contol plane function.
        Far entity and remoteAddress are required for this endpoint.";
      key id;
      uses top3gpp:Top_Grp;
      container attributes {
        uses EP_SBI_XGrp;
      }
    }
  }

augment "/me3gpp:ManagedElement/sepp3gpp:SEPPFunction" {
  list EP_N32 {
    description "Represents the EP_N32 IOC.";
    key id;
    uses top3gpp:Top_Grp;
    container attributes {
      uses EP_N32Grp;
    }
  }

  list EP_SBI_IPX {
    description "Used for the SEPP services consumed by the contol plane function.
      Far entity and remoteAddress are required for this endpoint.";
    key id;
    uses top3gpp:Top_Grp;
    container attributes {
      uses EP_SBI_IPXGrp;
    }
  }
}

augment "/me3gpp:ManagedElement/smsf3gpp:SMSFFunction" {
  list EP_N20 {
    description "Represents the EP_20 IOC.";
    key id;
    uses top3gpp:Top_Grp;
    container attributes {
      uses EP_N20Grp;
    }
  }

  list EP_N21 {
    description "Represents the EP_N21 IOC.";
    key id;
    uses top3gpp:Top_Grp;
    container attributes {
      uses EP_N21Grp;
    }
  }
}
```

```

    }

    list EP_MAP_SMSC {
      description "Represents the EP_MAP_SMSC IOC.";
      key id;
      uses top3gpp:Top_Grp;
      container attributes {
        uses EP_MAP_SMSCGrp;
      }
    }
  }
}

augment "/me3gpp:ManagedElement/smf3gpp:SMFFunction" {
  list EP_N4 {
    description "Represents the EP_N4 IOC.";
    key id;
    uses top3gpp:Top_Grp;
    container attributes {
      uses EP_N4Grp;
    }
  }

  list EP_N7 {
    description "Represents the EP_N7 IOC.";
    key id;
    uses top3gpp:Top_Grp;
    container attributes {
      uses EP_N7Grp;
    }
  }

  list EP_N10 {
    description "Represents the EP_N10 IOC.";
    key id;
    uses top3gpp:Top_Grp;
    container attributes {
      uses EP_N10Grp;
    }
  }

  list EP_N11 {
    description "Represents the EP_N11 IOC.";
    key id;
    uses top3gpp:Top_Grp;
    container attributes {
      uses EP_N11Grp;
    }
  }

  list EP_N16 {
    description "Represents the EP_N16 IOC.";
    key id;
    uses top3gpp:Top_Grp;
    container attributes {
      uses EP_N16Grp;
    }
  }

  list EP_S5C {
    description "Represents the EP_S5C IOC.";
    key id;
    uses top3gpp:Top_Grp;
    container attributes {
      uses EP_S5CGrp;
    }
  }

  list EP_SBI_X {
    description "Used for the services consumed by the contol plane function.
      Far entity and remoteAddress are required for this endpoint.";
    key id;
    uses top3gpp:Top_Grp;
    container attributes {
      uses EP_SBI_XGrp;
    }
  }
}

```

```

augment "/me3gpp:ManagedElement/udm3gpp:UDMFunction" {
  list EP_N8 {
    description "Represents the EP_N8 IOC.";
    key id;
    uses top3gpp:Top_Grp;
    container attributes {
      uses EP_N8Grp;
    }
  }

  list EP_N10 {
    description "Represents the EP_N10 IOC.";
    key id;
    uses top3gpp:Top_Grp;
    container attributes {
      uses EP_N10Grp;
    }
  }

  list EP_N13 {
    description "Represents the EP_N13 IOC.";
    key id;
    uses top3gpp:Top_Grp;
    container attributes {
      uses EP_N13Grp;
    }
  }

  list EP_SBI_X {
    description "Used for the services consumed by the control plane function.
      Far entity and remoteAddress are required for this endpoint.";
    key id;
    uses top3gpp:Top_Grp;
    container attributes {
      uses EP_SBI_XGrp;
    }
  }
}

augment "/me3gpp:ManagedElement/udr3gpp:UDRFunction" {
  list EP_SBI_X {
    description "Used for the services consumed by the control plane function.
      Far entity and remoteAddress are required for this endpoint.";
    key id;
    uses top3gpp:Top_Grp;
    container attributes {
      uses EP_SBI_XGrp;
    }
  }
}

augment "/me3gpp:ManagedElement/udsf3gpp:UDSFFunction" {
  list EP_SBI_X {
    description "Used for the services consumed by the control plane function.
      Far entity and remoteAddress are required for this endpoint.";
    key id;
    uses top3gpp:Top_Grp;
    container attributes {
      uses EP_SBI_XGrp;
    }
  }
}

augment "/me3gpp:ManagedElement/upf3gpp:UPFFunction" {
  list EP_N4 {
    description "Represents the EP_N4 IOC.";
    key id;
    uses top3gpp:Top_Grp;
    container attributes {
      uses EP_N4Grp;
    }
  }

  list EP_N3 {
    description "Represents the EP_N3 IOC.";
    key id;
    uses top3gpp:Top_Grp;
    container attributes {

```

```

        uses EP_N3Grp;
    }
}

list EP_N9 {
    description "Represents the EP_N9 IOC.";
    key id;
    uses top3gpp:Top_Grp;
    container attributes {
        uses EP_N9Grp;
    }
}

list EP_S5U {
    description "Represents the EP_S5U IOC.";
    key id;
    uses top3gpp:Top_Grp;
    container attributes {
        uses EP_S5UGrp;
    }
}

list EP_SBI_X {
    description "Used for the services consumed by the control plane function.
                Far entity and remoteAddress are required for this endpoint.";
    key id;
    uses top3gpp:Top_Grp;
    container attributes {
        uses EP_SBI_XGrp;
    }
}

list EP_N6 {
    description "Represents the EP_N6 IOC.";
    key id;
    uses top3gpp:Top_Grp;
    container attributes {
        uses EP_N6Grp;
    }
}
}
}

module _3gpp-5gc-nrm-externalnrffunction {
    yang-version 1.1;
    namespace urn:3gpp:sa5:_3gpp-5gc-nrm-externalnrffunction;
    prefix extnrf3gpp;

    import _3gpp-common-yang-types { prefix types3gpp; }
    import _3gpp-common-subnetwork { prefix subnet3gpp; }
    import _3gpp-common-top { prefix top3gpp; }
    import _3gpp-common-managed-function { prefix mf3gpp; }

    description "This IOC represents external NRF function controlled by another management domain.";

    revision 2019-06-11 {
        description "Ericsson refactoring.";
        reference "Based on
                3GPP TS 28.541 V15.X.XX";
    }

    grouping ExternalNRFFunctionGrp {
        uses mf3gpp:ManagedFunctionGrp;

        list pLMNIdList {
            description "List of at most six entries of PLMN Identifiers, but at least one (the primary
                PLMN Id).
                The PLMN Identifier is composed of a Mobile Country Code (MCC) and a Mobile
                Network Code (MNC).";
            min-elements 1;
            max-elements 6;
            key "mcc mnc";
            uses types3gpp:PLMNId;
        }
    }

    augment "/subnet3gpp:SubNetwork" {
        list ExternalNRFFunction {

```

```

        description "5G Core External NRF Function";
        reference "3GPP TS 28.541";
        key id;
        uses top3gpp:Top_Grp;
        container attributes {
            uses ExternalNRFFunctionGrp;
        }
    }
}

module _3gpp-5gc-nrm-externalnssffunction {
    yang-version 1.1;
    namespace urn:3gpp:sa5:_3gpp-5gc-nrm-externalnssffunction;
    prefix extnssf3gpp;

    import _3gpp-common-yang-types { prefix types3gpp; }
    import _3gpp-common-subnetwork { prefix subnet3gpp; }
    import _3gpp-common-top { prefix top3gpp; }
    import _3gpp-common-managed-function { prefix mf3gpp; }

    description "This IOC represents external NSSF function controlled by another management domain.";

    revision 2019-06-11 {
        description "Ericsson refactoring.";
        reference "Based on
            3GPP TS 28.541 V15.X.XX";
    }

    grouping ExternalNSSFFunctionGrp {
        uses mf3gpp:ManagedFunctionGrp;

        list pLMNidList {
            description "List of at most six entries of PLMN Identifiers, but at least one (the primary
                PLMN Id).
                The PLMN Identifier is composed of a Mobile Country Code (MCC) and a Mobile
                Network Code (MNC).";
            min-elements 1;
            max-elements 6;
            key "mcc mnc";
            uses types3gpp:PLMNid;
        }
    }

    augment "/subnet3gpp:SubNetwork" {
        list ExternalNSSFFunction {
            description "5G Core External NSSF Function";
            reference "3GPP TS 28.541";
            key id;
            uses top3gpp:Top_Grp;
            container attributes {
                uses ExternalNSSFFunctionGrp;
            }
        }
    }
}

module _3gpp-5gc-nrm-lmffunction {
    yang-version 1.1;

    namespace urn:3gpp:sa5:_3gpp-5gc-nrm-lmffunction;
    prefix lmf3gpp;

    import _3gpp-common-managed-function { prefix mf3gpp; }
    import _3gpp-common-managed-element { prefix me3gpp; }
    import _3gpp-common-yang-types { prefix types3gpp; }
    import _3gpp-common-top { prefix top3gpp; }

    organization "3gpp SA5";
    description "This IOC represents the LMF function defined in 3GPP TS 23.501.";
    reference "3GPP TS 28.541";

    revision 2019-05-15 {
        description "initial revision";
        reference "Based on
            3GPP TS 28.541 V15.X.XX";
    }
}

```

```

grouping LMFFunctionGrp {
    uses mf3gpp:ManagedFunctionGrp;

    list pLMNIdList {
        description "List of at most six entries of PLMN Identifiers, but at least one (the primary
        PLMN Id).
                The PLMN Identifier is composed of a Mobile Country Code (MCC) and a Mobile
        Network Code (MNC).";

        min-elements 1;
        max-elements 6;
        key "mcc mnc";
        uses types3gpp:PLMNId;
    }
}

augment "/me3gpp:ManagedElement" {
    list LMFFunction {
        description "5G Core LMF Function";
        reference "3GPP TS 28.541";
        key id;
        uses top3gpp:Top_Grp;
        container attributes {
            uses LMFFunctionGrp;
        }
    }
}
}

module _3gpp-5gc-nrm-n3iwffunction {
    yang-version 1.1;

    namespace urn:3gpp:sa5:_3gpp-5gc-nrm-n3iwffunction;
    prefix n3iwf3gpp;

    import _3gpp-common-managed-function { prefix mf3gpp; }
    import _3gpp-common-managed-element { prefix me3gpp; }
    import _3gpp-common-yang-types { prefix types3gpp; }
    import _3gpp-common-top { prefix top3gpp; }

    organization "3gpp SA5";
    description "This IOC represents the N3IWF function which is used to enable non-3GPP
    access networks connected to the 5GC. For more information about the N3IWF, see 3GPP
    TS 23.501.";
    reference "3GPP TS 28.541";

    revision 2019-05-22 {
        description "initial revision";
        reference "Based on
        3GPP TS 28.541 V15.X.XX";
    }

    grouping N3IWFFunctionGrp {
        uses mf3gpp:ManagedFunctionGrp;

        list pLMNIdList {
            description "List of at most six entries of PLMN Identifiers, but at least one (the primary
            PLMN Id).
                    The PLMN Identifier is composed of a Mobile Country Code (MCC) and a Mobile
            Network Code (MNC).";

            min-elements 1;
            max-elements 6;
            key "mcc mnc";
            uses types3gpp:PLMNId;
        }
    }

    augment "/me3gpp:ManagedElement" {
        list N3IWFFunction {
            description "5G Core N3IWF Function";
            reference "3GPP TS 28.541";
            key id;
            uses top3gpp:Top_Grp;
            container attributes {
                uses N3IWFFunctionGrp;
            }
        }
    }
}

```

```

}
}
module _3gpp-5gc-nrm-nfprofile {
  yang-version 1.1;

  namespace urn:3gpp:sa5:_3gpp-5gc-nrm-nfprofile;
  prefix nfp3gpp;

  import _3gpp-common-yang-types { prefix types3gpp; }
  import ietf-inet-types { prefix inet; }
  import ietf-yang-types { prefix yang; }
  import _3gpp-5gc-nrm-nfservice { prefix nfs3gpp; }

  organization "3gpp SA5";
  description "NF profile class.";
  reference "3GPP TS 29.510";

  revision 2019-06-17 {
    description "initial revision";
    reference "Based on
      3GPP TS 29.510 V15.X.XX";
  }

  grouping NFProfileGrp {
    leaf nfInstanceID {
      description "String uniquely identifying a NF instance.";
      mandatory true;
      type string;
    }

    leaf nfType {
      description "Type of Network Function.";
      mandatory true;
      type types3gpp:NfType;
    }

    leaf nfStatus {
      description "Status of the NF Instance.";
      mandatory true;
      type NFStatus;
    }

    leaf heartBeatTimer {
      description "Time in seconds expected between 2 consecutive heart-beat messages from
        an NF Instance to the NRF. It may be included in the registration request.
        When present in the request it shall contain the heartbeat time proposed by the
        NF service consumer.";
      //conditional support
      type uint16;
    }

    list plmnList {
      description "PLMN(s) of the Network Function.
        This IE shall be present if this information is available for the NF.
        If not provided, PLMN ID(s) of the PLMN of the NRF are assumed for the NF.";
      //conditional support
      min-elements 1;
      key "mcc mnc";
      uses types3gpp:PLMNId;
    }

    list sNssais { //is the key unique
      description "S-NSSAIs of the Network Function. If not provided, the NF can serve any S-NSSAI.
        When present this IE represents the list of S-NSSAIs supported in all the PLMNs
        listed in the plmnList IE.";
      min-elements 1;
      //optional support
      key "sst sd";
      uses Snssai;
    }

    list perPlmnSnssaiList {
      description "This IE may be included when the list of S-NSSAIs supported by the NF for each
        PLMN it is supporting is different.
        When present, this IE shall include the S-NSSAIs supported by the Network
        Function

```



```

        for each PLMN supported by the Network Function. When present, this IE shall
override sNssais IE.";
    min-elements 1;
    //optional support
    key idx; //no obvious leaf to use as a key
    leaf idx { type uint32; }
    uses PlmnSnsai;
}

leaf-list nsiList {
    description "NSI identities of the Network Function.
        If not provided, the NF can serve any NSI.";
    //optional support
    min-elements 1;
    type string;
}

leaf fqdn {
    description "FQDN of the Network Function. For AMF, the FQDN registered with the NRF
        shall be that of the AMF Name.";
    //conditional support
    type inet:domain-name;
}

leaf interPlmnFqdn {
    description "If the NF needs to be discoverable by other NFs in a different PLMN,
        then an FQDN that is used for inter-PLMN routing is specified.";
    //conditional support
    type inet:domain-name;
}

leaf-list ipv4Addresses {
    description "IPv4 address(es) of the Network Function.";
    min-elements 1;
    //conditional support
    type inet:ipv4-address;
}

leaf-list ipv6Addresses {
    description "IPv6 address(es) of the Network Function.";
    min-elements 1;
    //conditional support
    type inet:ipv6-address;
}

list allowedPlmns {
    description "PLMNs allowed to access the NF instance.
        If not provided, any PLMN is allowed to access the NF.";

    min-elements 1;
    //optional support
    key "mcc mnc";
    uses types3gpp:PLMNid;
}

leaf-list allowedNfTypes {
    description "Type of the NFs allowed to access the NF instance.
        If not provided, any NF type is allowed to access the NF.";
    min-elements 1;
    //optional support
    type types3gpp:NfType;
}

leaf-list allowedNfDomains {
    description "Pattern representing the NF domain names allowed to access the NF instance.
        If not provided, any NF domain is allowed to access the NF.";
    min-elements 1;
    //optional support
    type string;
}

list allowedNssais { //is the key unique
    description "S-NSSAI of the allowed slices to access the NF instance.
        If not provided, any slice is allowed to access the NF.";
    min-elements 1;
    //optional support
    key "sst sd";
    uses Snsai;
}

```

```

    }

    leaf priority {
      description "Priority (relative to other NFs of the same type) in the range of 0-65535, to be
used for NF selection;
        lower values indicate a higher priority. If priority is also present in the
nfServiceList parameters,
        those will have precedence over this value. The NRF may overwrite the received
priority value when exposing
        an NFProfile with the Nnrf_NFDiscovery service.";
      //optional support
      type uint16;
    }

    leaf capacity {
      description "Static capacity information in the range of 0-65535, expressed as a weight
relative to other NF instances of the same type; if capacity is also present
in the nfServiceList parameters, those will have precedence over this value.";
      //optional support
      type uint16;
    }

    leaf load {
      description "Dynamic load information, ranged from 0 to 100, indicates the current load
percentage of the NF.";
      //optional support
      type types3gpp:Load;
    }

    leaf locality {
      description "Operator defined information about the location of the NF instance (e.g.
geographic location, data center).";
      //optional support
      type string;
    }

    grouping udrInfo {
      //optional support

      leaf groupId {
        description "Identity of the UDR group that is served by the UDR instance.
        If not provided, the UDR instance does not pertain to any UDR group.";
        //optional support
        type string;
      }

      list supiRanges {
        description "List of ranges of SUPI's whose profile data is available in the UDR instance.";
        key "start end pattern";
        min-elements 1;
        //optional support
        uses SupiRange;
      }

      list gpsiRanges {
        description "List of ranges of GPSIs whose profile data is available in the UDR instance.";
        key "start end pattern";
        min-elements 1;
        //optional support
        uses IdentityRange;
      }

      list externalGroupIdentifiersRanges {
        description "List of ranges of external groups whose profile data is available in the UDR
instance.";
        key "start end pattern";
        min-elements 1;
        //optional support
        uses IdentityRange;
      }

      leaf-list supportedDataSets {
        description "List of supported data sets in the UDR instance.
        If not provided, the UDR supports all data sets.";
        min-elements 1;
        //optional support
        type DataSetId;
      }
    }
  }

```

```

}

grouping udmInfo {
  //optional support

  leaf groupId {
    description "Identity of the UDM group that is served by the UDM instance.
      If not provided, the UDM instance does not pertain to any UDM group.";
    //optional support
    type string;
  }

  list supiRanges {
    description "List of ranges of SUPI's whose profile data is available in the UDM instance.";
    key "start end pattern";
    min-elements 1;
    //optional support
    uses SupiRange;
  }

  list gpsiRanges {
    description "List of ranges of GPSIs whose profile data is available in the UDM instance.";
    key "start end pattern";
    min-elements 1;
    //optional support
    uses IdentityRange;
  }

  list externalGroupIdentifiersRanges {
    description "List of ranges of external groups whose profile data is available in the UDM
instance.";
    key "start end pattern";
    min-elements 1;
    //optional support
    uses IdentityRange;
  }

  leaf-list routingIndicators {
    description "List of Routing Indicator information that allows to route network signalling
with SUCI
      to the UDM instance. If not provided, the UDM can serve any Routing Indicator.
      Pattern: '^[0-9]{1,4}$'.";
    //optional support
    min-elements 1;
    type string;
  }
}

grouping ausfInfo {
  //optional support

  leaf groupId {
    description "Identity of the AUSF group. If not provided, the AUSF instance does not pertain
to any AUSF group.";
    //optional support
    type string;
  }

  list supiRanges {
    description "List of ranges of SUPIs that can be served by the AUSF instance. If not
provided, the AUSF can serve any SUPI.";
    key "start end pattern";
    min-elements 1;
    //optional support
    uses SupiRange;
  }

  leaf-list routingIndicators {
    description "List of Routing Indicator information that allows to route network signalling
with SUCI
      to the AUSF instance. If not provided, the AUSF can serve any Routing
Indicator.
      Pattern: '^[0-9]{1,4}$'.";
    //optional support
    min-elements 1;
    type string;
  }
}

```

```
grouping amfInfo {
  //optional support

  leaf amfRegionId {
    description "AMF region identifier";
    type string;
  }

  leaf amfSetId {
    description "AMF set identifier";
    type string;
  }

  list guamiList {
    description "List of supported GUAMIs.";

    key idx; //no obvious leaf to use as a key
    leaf idx { type uint32; }

    min-elements 1;
    uses Guami;
  }

  list taiList {
    description "The list of TAIs the AMF can serve. It may contain the non-3GPP access TAI.
    The absence of this attribute and the taiRangeList attribute indicate that
    the AMF can be selected for any TAI in the serving network.";

    key idx; //no obvious leaf to use as a key
    leaf idx { type uint32; }

    //optional support
    min-elements 1;
    uses Tai;
  }

  list taiRangeList {
    description "The range of TAIs the AMF can serve. The absence of this attribute and the
    taiList attribute indicate that the AMF can be selected for any TAI in the serving
    network.";
    //optional support
    min-elements 1;
    key idx; //no obvious leaf to use as a key
    leaf idx { type uint32; }
    uses TaiRange;
  }

  list backupInfoAmfFailure {
    description "List of GUAMIs for which the AMF acts as a backup for AMF failure.";

    key idx; //no obvious leaf to use as a key
    leaf idx { type uint32; }

    //optional support
    min-elements 1;
    uses Guami;
  }

  list backupInfoAmfRemoval {
    description "List of GUAMIs for which the AMF acts as a backup for planned AMF removal.";

    key idx; //no obvious leaf to use as a key
    leaf idx { type uint32; }

    //optional support
    min-elements 1;
    uses Guami;
  }

  list n2InterfaceAmfInfo {
    description "N2 interface information of the AMF. This information needs not be sent in NF
    Discovery responses. It may be used by the NRF to update the DNS for AMF discovery by the 5G Access
    Network.";
    //optional support
```

```

    max-elements 1;
    key idx; //no obvious leaf to use as a key
    leaf idx { type uint32; }
    uses N2InterfaceAmfInfo;
  }
}

grouping smfInfo {
  //optional support

  list sNssaiSmfInfoList {
    description "List of parameters supported by the SMF per S-NSSAI.";
    min-elements 1;
    key idx; //no obvious leaf to use as a key
    leaf idx { type uint32; }
    uses sNssaiSmfInfoItem;
  }

  list taiList {
    description "The list of TAIs the SMF can serve. It may contain the non-3GPP access TAI.
      The absence of this attribute and the taiRangeList attribute indicate that
      the SMF can be selected for any TAI in the serving network.";

    key idx; //no obvious leaf to use as a key
    leaf idx { type uint32; }

    //optional support
    min-elements 1;
    uses Tai;
  }

  list taiRangeList {
    description "The range of TAIs the SMF can serve. The absence of this attribute and the
taiList
network.";
    attribute indicate that the SMF can be selected for any TAI in the serving
    //optional support
    min-elements 1;
    key idx; //no obvious leaf to use as a key
    leaf idx { type uint32; }
    uses TaiRange;
  }

  leaf pgwFqdn {
    description "The FQDN of the PGW if the SMF is a combined SMF/PGW-C.";
    //optional support
    type inet:domain-name;
  }

  leaf-list accessType {
    description "If included, this IE shall contain the access type (3GPP_ACCESS and/or
NON_3GPP_ACCESS) supported by the SMF.
      If not included, it shall be assumed the both access types are supported.";

    //conditional support
    min-elements 1;
    max-elements 2;
    type AccessType;
  }
}

grouping upfInfo {
  //optional support

  list sNssaiUpfInfoList {
    description "List of parameters supported by the UPF per S-NSSAI.";
    min-elements 1;
    key idx; //no obvious leaf to use as a key
    leaf idx { type uint32; }
    uses SnsaiUpfInfoItem;
  }

  leaf-list smfServingArea {
    description "The SMF service area(s) the UPF can serve.
      If not provided, the UPF can serve any SMF service area.";

    //optional support
    min-elements 1;

```

```

    type string;
  }

  list interfaceUpfInfo {
    description "List of User Plane interfaces configured on the UPF. When this IE is provided
in the NF Discovery response,
the NF Service Consumer (e.g. SMF) may use this information for UPF
selection.";

    key idx; //no obvious leaf to use as a key
    leaf idx { type uint32; }

    //optional support
    min-elements 1;
    uses InterfaceUpfInfoItem;
  }

  leaf iwkEpsInd {
    description "Indicates whether interworking with EPS is supported by the UPF.
true: Supported
false (default): Not Supported";

    //optional support
    type boolean;
  }

  leaf-list pduSessionTypes {
    description "List of PDU session type(s) supported by the UPF. The absence of this attribute
indicates that the UPF can be selected
for any PDU session type.";

    //optional support
    min-elements 1;
    type PduSessionType;
  }
}

grouping pcfInfo {
  //optional support

  leaf-list dnnList {
    description "DNNs supported by the PCF.
If not provided, the PCF can serve any DNN.";

    //optional support
    min-elements 1;
    type string;
  }

  list supiRanges {
    description "List of ranges of SUPIs that can be served by the PCF instance. If not
provided, the PCF can serve any SUPI.";
    key "start end pattern";
    min-elements 1;
    //optional support
    uses SupiRange;
  }

  leaf rxDiamHost {
    description "This IE shall be present if the PCF supports Rx interface.
When present, this IE shall indicate the Diameter host of the Rx interface for
the PCF.
Pattern: '^([A-Za-z0-9]+(-[A-Za-z0-9]+).)+[a-z]{2,}$'.";

    //conditional support
    type string;
  }

  leaf rxDiamRealm {
    description "This IE shall be present if the PCF supports Rx interface.
When present, this IE shall indicate the Diameter realm of the Rx interface for
the PCF.
Pattern: '^([A-Za-z0-9]+(-[A-Za-z0-9]+).)+[a-z]{2,}$'.";

    //conditional support
    type string;
  }
}

```

```

grouping bsfInfo {
  //optional support

  list ipv4AddressRanges {
    description "List of ranges of IPv4 addresses handled by BSF.
                If not provided, the BSF can serve any IPv4 address.";
    //optional support
    key "start end";
    uses types3gpp:Ipv4AddressRange;
  }

  leaf-list dnnList {
    description "List of DNNs handled by the BSF
                If not provided, the BSF can serve any DNN.";

    //optional support
    min-elements 1;
    type string;
  }

  leaf-list ipDomainList {
    description "List of IPv4 address domains, as described in subclause 6.2 of 3GPP TS 29.513,
                handled by the BSF.
                If not provided, the BSF can serve any IP domain.";
    //optional support
    min-elements 1;
    type string;
  }

  list ipv6PrefixRanges {
    description "List of ranges of IPv6 prefixes handled by the BSF.
                If not provided, the BSF can serve any IPv6 prefix.";
    //optional support
    key "start end";
    uses types3gpp:Ipv6PrefixRange;
  }
}

grouping chfInfo {
  //optional support

  list supiRangeList {
    description "List of ranges of SUPIs that can be served by the CHF instance. If not
    provided, the CHF can serve any SUPI.";
    key "start end pattern";
    min-elements 1;
    //optional support
    uses SupiRange;
  }

  list gpsiRangeList {
    description "List of ranges of GPSI that can be served by the CHF instance. If not provided,
    the CHF can serve any GPSI.";
    key "start end pattern";
    min-elements 1;
    //optional support
    uses IdentityRange;
  }

  list plmnRangeList {
    description "List of ranges of PLMNs (including the PLMN IDs of the CHF instance) that can
    be served by the CHF instance.
                If not provided, the CHF can serve any PLMN.";

    min-elements 1;
    //optional support
    key "mcc mnc";
    uses types3gpp:PLMNId;
  }
}

grouping nrfInfoGrp {
  //optional support

  list servedUdrInfo {
    description "This attribute contains all the udrInfo attributes locally configured in the
    NRF or the NRF received during NF registration.";
  }
}

```

```
//optional support

key nfInstanceID;
leaf nfInstanceID {
  description "String uniquely identifying a NF instance.";
  type string;
}

min-elements 1;
uses udrInfo;
}

list servedUdmInfo {
  description "This attribute contains all the udmInfo attributes locally configured in the
NRF or the NRF received during NF registration.";
  //optional support

  key nfInstanceID;
  leaf nfInstanceID {
    description "String uniquely identifying a NF instance.";
    type string;
  }

  min-elements 1;
  uses udmInfo;
}

list servedAusfInfo {
  description "This attribute contains all the ausfInfo attributes locally configured in the
NRF or the NRF received during NF registration.";
  //optional support

  key nfInstanceID;
  leaf nfInstanceID {
    description "String uniquely identifying a NF instance.";
    type string;
  }

  min-elements 1;
  uses ausfInfo;
}

list servedAmfInfo {
  description "This attribute contains all the amfInfo attributes locally configured in the
NRF or the NRF received during NF registration.";
  //optional support

  key nfInstanceID;
  leaf nfInstanceID {
    description "String uniquely identifying a NF instance.";
    type string;
  }

  min-elements 1;
  uses amfInfo;
}

list servedSmfInfo {
  description "This attribute contains all the smfInfo attributes locally configured in the
NRF or the NRF received during NF registration.";
  //optional support

  key nfInstanceID;
  leaf nfInstanceID {
    description "String uniquely identifying a NF instance.";
    type string;
  }

  min-elements 1;
  uses smfInfo;
}

list servedUpfInfo {
  description "This attribute contains all the upfInfo attributes locally configured in the
NRF or the NRF received during NF registration.";
  //optional support

  key nfInstanceID;
```



```

    leaf nfInstanceID {
      description "String uniquely identifying a NF instance.";
      type string;
    }

    min-elements 1;
    uses upfInfo;
  }

  list servedPcfInfo {
    description "This attribute contains all the pcfInfo attributes locally configured in the NRF
or the NRF received during NF registration.";
    //optional support

    key nfInstanceID;
    leaf nfInstanceID {
      description "String uniquely identifying a NF instance.";
      type string;
    }

    min-elements 1;
    uses pcfInfo;
  }

  list servedBsfInfo {
    description "This attribute contains all the bsfInfo attributes locally configured in the NRF
or the NRF received during NF registration.";
    //optional support

    key nfInstanceID;
    leaf nfInstanceID {
      description "String uniquely identifying a NF instance.";
      type string;
    }

    min-elements 1;
    uses bsfInfo;
  }

  list servedChfInfo {
    description "This attribute contains all the bsfInfo attributes locally configured in the
NRF or the NRF received during NF registration.";
    //optional support

    key nfInstanceID;
    leaf nfInstanceID {
      description "String uniquely identifying a NF instance.";
      type string;
    }

    min-elements 1;
    uses chfInfo;
  }
}

list nrfInfo {
  key idx; //no obvious leaf to use as a key
  leaf idx { type uint32; }
  max-elements 1;
  uses nrfInfoGrp;
}

leaf customInfo {
  description "Specific data for custom Network Functions.";
  type string;
}

leaf recoveryTime {
  description "Timestamp when the NF was (re)started.";
  //optional support
  type yang:date-and-time;
}

leaf nfServicePersistence {
  description "If present, and set to true, it indicates that the different service instances of
a same NF Service in this NF instance,
      supporting a same API version, are capable to persist their resource state in
shared storage and therefore these resources

```

are available after a new NF service instance supporting the same API version is selected by a NF Service Consumer (see 3GPP TS 23.527).

Otherwise, it indicates that the NF Service Instances of a same NF Service are not capable to share resource state inside the NF Instance.";

```

    //optional support
    type boolean;
}

list nfServices {
    description "List of NF Service Instances. It shall include the services produced by the NF
that can be discovered by other NFs.";
    key serviceInstanceID;
    //optional support
    min-elements 1;
    uses nfs3gpp:NFServiceGrp;
}

leaf nfProfileChangesSupportInd {
    description "NF Profile Changes Support Indicator. This IE may be present in the NFRegister or
NFUpdate (NF Profile Complete Replacement) request and shall be absent in the response.
        true: the NF Service Consumer supports receiving NF Profile Changes in the
response.
        false (default): the NF Service Consumer does not support receiving NF Profile
Changes in the response.";
    //optional support
    type boolean;
}

leaf nfProfileChangesInd {
    description "NF Profile Changes Indicator. This IE shall be absent in the request to the NRF
and may be included by the NRF in NFRegister or NFUpdate (NF Profile Complete Replacement) response.
        true: the NF Profile contains NF Profile changes.
        false (default): complete NF Profile.";
    //optional support
    type boolean;
}

list defaultNotificationSubscriptions {
    description "Notification endpoints for different notification types.";
    key notificationType;
    //optional support
    min-elements 1;
    uses types3gpp:DefaultNotificationSubscription;
}

}

typedef NFStatus {
    type enumeration {
        enum REGISTERED;
        enum SUSPENDED;
    }
}

typedef DataSetId {
    type enumeration {
        enum SUBSCRIPTION;
        enum POLICY;
        enum EXPOSURE;
        enum APPLICATION;
    }
}

grouping SupiRange {
    leaf start {
        description "First value identifying the start of a SUPI range. To be used when the range of
SUPI's can be represented as a numeric range (e.g., IMSI ranges).";
        type string {
            pattern '[0-9]+';
        }
    }

    leaf end {
        description "Last value identifying the end of a SUPI range. To be used when the range of
SUPI's can be represented as a numeric range (e.g. IMSI ranges).";
        type string {

```

```

        pattern '^[0-9]+$';
    }
}

leaf pattern {
    description "Pattern representing the set of SUPI's belonging to this range.
    A SUPI value is considered part of the range if and only if the SUPI string fully
matches the regular expression.";
    type string;
}

grouping IdentityRange {
    leaf start {
        description "First value identifying the start of an identity range. To be used when the range
of identities can be represented as a numeric range (e.g., MSISDN ranges).";
        type string {
            pattern '^[0-9]+$';
        }
    }

    leaf end {
        description "Last value identifying the end of an identity range. To be used when the range of
identities can be represented as a numeric range (e.g. MSISDN ranges).";
        type string {
            pattern '^[0-9]+$';
        }
    }

    leaf pattern {
        description "Pattern representing the set of identities belonging to this range.
An identity value is considered part of the range if and only if the identity
string fully matches the regular expression.";
        type string;
    }
}

grouping TacRange {
    leaf start {
        description "First value identifying the start of a TAC range, to be used when the range of
TAC's can be represented as a hexadecimal range (e.g., TAC ranges).";
        type string {
            pattern '^[A-Fa-f0-9]{4}|[A-Fa-f0-9]{6}$';
        }
    }

    leaf end {
        description "Last value identifying the end of a TAC range, to be used when the range of TAC's
can be represented as a hexadecimal range (e.g. TAC ranges).";
        type string {
            pattern '^[A-Fa-f0-9]{4}|[A-Fa-f0-9]{6}$';
        }
    }

    leaf pattern {
        description "Pattern representing the set of TAC's belonging to this range.";
        type string;
    }
}

grouping SnssaiUpfInfoItem {
    list sNssai { //is the key unique
        description "Supported S-NSSAI.";
        min-elements 1;
        max-elements 1;
        key "sst sd";
        uses Snssai;
    }

    list dnnUpfInfoList {
        description "List of parameters supported by the UPF per DNN.";
        min-elements 1;
        key dnn;
        uses DnnUpfInfoItem;
    }
}

grouping DnnUpfInfoItem {

```

```

leaf dnn {
  description "String representing a Data Network.";
  mandatory true;
  type string;
}

leaf-list dnaiList {
  description "List of Data network access identifiers supported by the UPF for this DNN.
for any DNAI.";
  The absence of this attribute indicates that the UPF can be selected for this DNN
  min-elements 1;
  type string; //dnai is the type but its only a string with desc: DNAI (Data network access
identifier), is this needed as its own typedef or string is ok
}

leaf-list pduSessionTypes {
  description "List of PDU session type(s) supported by the UPF for a specific DNN.";
  min-elements 1;
  type PduSessionType;
}

grouping Snssai {
  leaf sst {
    description "Unsigned integer, within the range 0 to 255, representing the Slice/Service Type.
services.";
    It indicates the expected Network Slice behaviour in terms of features and
    mandatory true;
    type uint32;
  }

  leaf sd {
    description "3-octet string, representing the Slice Differentiator, in hexadecimal
representation.";
    //optional
    type string {
      pattern '^[A-Fa-f0-9]{6}$';
    }
  }

  reference "3GPP TS 29.571";
}

typedef PduSessionType {
  type enumeration {
    enum IPV4;
    enum IPV6;
    enum IPV4V6;
    enum UNSTRUCTURED;
    enum ETHERNET;
  }
}

grouping Guami {
  list plmnId {
    description "PLMN Identity.";
    min-elements 1;
    max-elements 1;
    key "mcc mnc";
    uses types3gpp:PLMNId;
  }

  list amfId {
    description "AMF Identity.";
    min-elements 1;
    max-elements 1;
    key "amfRegionId amfSetId amfPointer";
    uses types3gpp:AmfIdentifier;
  }
}

grouping Tai {
  list plmnId {
    description "PLMN Identity.";
    min-elements 1;
    max-elements 1;
    key "mcc mnc";
    uses types3gpp:PLMNId;
  }
}

```

```

    }

    leaf tac { type types3gpp:Tac; }
}

grouping InterfaceUpfInfoItem {
    leaf interfaceType {
        description "User Plane interface type.";
        mandatory true;
        type UPIInterfaceType;
    }

    ///At least one of the addressing parameters (ipv4address, ipv6address or endpointFqdn) shall be
    included in the InterfaceUpfInfoItem.
    choice address {
        case ipv4EndpointAddresses {
            leaf-list ipv4EndpointAddresses {
                description "Available endpoint IPv4 address(es) of the User Plane interface.";
                //conditional support
                min-elements 1;
                type inet:ipv4-address;
            }
        }

        case ipv6EndpointAddresses {
            leaf-list ipv6EndpointAddresses {
                description "Available endpoint IPv6 address(es) of the User Plane interface.";
                //conditional support
                min-elements 1;
                type inet:ipv6-address;
            }
        }

        case endpointFqdn {
            leaf endpointFqdn {
                description "FQDN of available endpoint of the User Plane interface.";
                //conditional support
                type inet:domain-name;
            }
        }
    }

    leaf networkInstance {
        description "Network Instance associated to the User Plane interface.";
        //optional support
        type string;
    }
}

typedef UPIInterfaceType {
    type enumeration {
        enum N3;
        enum N6;
        enum N9;
    }
}

grouping TaiRange {
    list plmnId {
        description "PLMN ID related to the TacRange.";
        min-elements 1;
        max-elements 1;
        key "mcc mnc";
        uses types3gpp:PLMNId;
    }

    list tacRangeList { //is this key unique
        description "The range of the TACs.";
        min-elements 1;
        key "start end";
        uses TacRange;
    }
}

typedef AccessType {
    type enumeration {
        enum 3GPP_ACCESS;
        enum NON_3GPP_ACCESS;
    }
}

```

```

    }
  }

  grouping N2InterfaceAmfInfo {
    //At least one of the addressing parameters (ipv4address or ipv6address) shall be included.
    choice address {
      case ipv4EndpointAddress {
        leaf-list ipv4EndpointAddress {
          description "Available AMF endpoint IPv4 address(es) for N2.";
          //conditional support
          min-elements 1;
          type inet:ipv4-address;
        }
      }

      case ipv6EndpointAddress {
        leaf-list ipv6EndpointAddress {
          description "Available AMF endpoint IPv6 address(es) for N2.";
          //conditional support
          min-elements 1;
          type inet:ipv6-address;
        }
      }
    }

    leaf amfName {
      description "AMF name.";
      type string;
    }
  }

  grouping sNssaiSmfInfoItem {
    list sNssai { //is the key unique
      description "Supported S-NSSAI.";
      min-elements 1;
      max-elements 1;
      key "sst sd";
      uses Snssai;
    }

    list dnnSmfInfoList { //is the key unique
      description "List of parameters supported by the SMF per DNN.";
      min-elements 1;
      key dnn;
      uses DnnSmfInfoItem;
    }
  }

  grouping DnnSmfInfoItem {
    leaf dnn {
      description "Supported DNN.";
      mandatory true;
      type string;
    }
  }

  grouping PlmnSnssai {
    list plmnId {
      description "PLMN ID for which list of supported S-NSSAI(s) is provided.";
      min-elements 1;
      max-elements 1;
      key "mcc mnc";
      uses types3gpp:PLMNId;
    }

    list sNssaiList { //is the key unique
      description "The specific list of S-NSSAIs supported by the given PLMN.";
      min-elements 1;
      key "sst sd";
      uses Snssai;
    }
  }
}

module _3gpp-5gc-nrm-nfservice {
  yang-version 1.1;

  namespace urn:3gpp:sa5:_3gpp-5gc-nrm-nfservice;

```

```

prefix nfs3gpp;

import _3gpp-common-yang-types { prefix types3gpp; }
import ietf-yang-types { prefix yang; }
import ietf-inet-types { prefix inet; }

organization "3gpp SA5";
description "NF service class.";
reference "3GPP TS 29.510";

revision 2019-06-17 {
  description "initial revision";
  reference "Based on
    3GPP TS 29.510 V15.X.XX";
}

grouping NFServiceGrp {
  leaf serviceInstanceID {
    description "Unique ID of the service instance within a given NF Instance.";
    mandatory true;
    type string;
  }

  leaf serviceName {
    description "Name of the service instance (e.g. 'nudm-sdm').";
    mandatory true;
    type ServiceName;
  }

  list versions { //check in review if key is ok (unique)
    description "API versions supported by the NF Service and if available, the corresponding
retirement date of the NF Service.";
    min-elements 1;
    key "apiVersionInUri apiFullVersion";
    uses NFServiceVersion;
  }

  leaf scheme {
    description "URI scheme (e.g. 'http', 'https').";
    mandatory true;
    type UriScheme;
  }

  leaf nfServiceStatus {
    description "Status of the NF Service Instance.";
    mandatory true;
    type NFServiceStatus;
  }

  leaf fqdn {
    description "FQDN of the NF Service Instance.";
    //optional support
    type inet:domain-name;
  }

  leaf interPlmnFqdn {
    description "If the NF service needs to be discoverable by other NFs in a different PLMN,
then an FQDN that is used for inter PLMN routing.";
    //optional support
    type inet:domain-name;
  }

  list ipEndPoints {
    description "IP address(es) and port information of the Network Function (including IPv4
and/or IPv6 address)
where the service is listening for incoming service requests.";
    //optional support

    key idx;
    leaf idx {
      type string;
    }
    min-elements 1;
    uses ipEndPoint;
  }

  leaf apiPrefix {

```

```
        description "Optional path segment(s) used to construct the {apiRoot} variable of the
different API URIs.";
        //optional support
        type string;
    }

    list defaultNotificationSubscriptions {
        description "Notification endpoints for different notification types.";
        key notificationType;
        //optional support
        min-elements 1;
        uses types3gpp:DefaultNotificationSubscription;
    }

    list allowedPlmns {
        description "PLMNs allowed to access the service instance.
The absence of this attribute indicates that any PLMN is allowed to access the
service instance.";

        min-elements 1;
        //optional support
        key "mcc mnc";
        uses types3gpp:PLMNId;
    }

    leaf-list allowedNfTypes {
        description "Type of the NFs allowed to access the service instance.
The absence of this attribute indicates that any NF type is allowed to access the
service instance.";

        min-elements 1;
        //optional support
        type types3gpp:NfType;
    }

    leaf-list allowedNfDomains {
        description "Pattern representing the NF domain names allowed to access the service
instance.";
        //optional support
        min-elements 1;
        type string;
    }

    leaf-list allowedNssais {
        description "S-NSSAI of the allowed slices to access the service instance.
The absence of this attribute indicates that any slice is allowed to access the
service instance.";
        min-elements 1;
        //optional support
        type types3gpp:SNssai;
    }

    leaf priority {
        description "Priority (relative to other services of the same type) in the range of 0-65535,
to be used for NF Service selection; lower values indicate a higher priority.";
        //optional support
        type uint16;
    }

    leaf capacity {
        description "Static capacity information in the range of 0-65535, expressed as a weight
relative to other services of the same type.";
        //optional support
        type uint16;
    }

    leaf load {
        description "Dynamic load information, ranged from 0 to 100, indicates the current load
percentage of the NF Service.";
        //optional support
        type types3gpp:Load;
    }

    leaf recoveryTime {
        description "Timestamp when the NF was (re)started.";
        //optional support
        type yang:date-and-time;
    }
}
```



```
list chfServiceInfo { //is the key unique
  description "Specific data for a CHF service instance.";
  //optional support
  max-elements 1;
  key "primaryChfServiceInstance secondaryChfServiceInstance";
  uses ChfServiceInfo;
}

leaf supportedFeatures {
  description "Supported Features of the NF Service instance.";
  //optional support
  type SupportedFeatures;
}

typedef SupportedFeatures {
  type string {
    pattern '[A-Za-f0-9]*';
  }
}

grouping ipEndPoint {
  choice address {
    leaf ipv4Address {
      type inet:ipv4-address;
    }

    leaf ipv6Address {
      type inet:ipv6-address;
    }

    leaf ipv6Prefix {
      type inet:ipv6-prefix;
    }
  }

  leaf transport {
    type TransportProtocol;
  }

  leaf port {
    type uint16;
  }
}

typedef TransportProtocol {
  type enumeration {
    enum TCP;
    enum STCP;
    enum UDP;
  }
}

grouping NFServiceVersion {
  leaf apiVersionInUri {
    mandatory true;
    type string;
  }

  leaf apiFullVersion {
    mandatory true;
    type string;
  }

  leaf expiry {
    //optional to support
    type yang:date-and-time;
  }
}

typedef ServiceName {
  type enumeration {
    enum NNRF_NFM;
    enum NNRF_DISC;
    enum NUDM_SDM;
    enum NUDM_UECM;
    enum NUDM_UEAU;
  }
}
```

```

enum NUDM_EE;
enum NUDM_PP;
enum NAMF_COMM;
enum NAMF_EVTS;
enum NAMF_MT;
enum NAMF_LOC;
enum NSMF_PDUSESSION;
enum NSMF_EVENT-EXPOSURE;
enum NAUSF_AUTH;
enum NAUSF_SORPROTECTION;
enum NNEF_PFDMANAGEMENT;
enum NPCF_AM-POLICY-CONTROL;
enum NPCF_SMPOLICYCONTROL;
enum NPCF_POLICYAUTHORIZATION;
enum NPCF_BDTPOLICYCONTROL;
enum NPCF_EVENTEXPOSURE;
enum NPCF_UE_POLICY_CONTROL;
enum NSMSF_SMS;
enum NSSF_NSSELECTION;
enum NSSF_NSSAI-AVAILABILITY;
enum NUDR_DR;
enum NLMF_LOC;
enum N5G_EIR_EIC;
enum NBSF_MANAGEMENT;
enum NCHF_SPENDINGLIMITCONTROL;
enum NCHF_CONVERGEDCHARGING;
enum NNWDAF_EVENTSSUBSCRIPTION;
enum NNWDAF_ANALYTICSINFO;
}
}

typedef UriScheme {
  type enumeration {
    enum HTTP;
    enum HTTPS;
  }
}

typedef NFServiceStatus {
  type enumeration {
    enum REGISTERED;
    enum SUSPENDED;
    enum UNDISCOVERABLE;
  }
}

grouping ChfServiceInfo {
  leaf primaryChfServiceInstance {
    description "Shall be present if the CHF service instance serves as a secondary CHF instance
of another primary CHF service instance.";
    //conditional to support
    type string;
  }

  leaf secondaryChfServiceInstance {
    description "Shall be present if the CHF service instance serves as a primary CHF instance of
another secondary CHF service instance.";
    //conditional to support
    type string;
  }
}
}

module _3gpp-5gc-nrm-ngeirfunction {
  yang-version 1.1;

  namespace urn:3gpp:sa5:_3gpp-5gc-nrm-ngeirfunction;
  prefix ngeir3gpp;

  import _3gpp-common-managed-function { prefix mf3gpp; }
  import _3gpp-common-managed-element { prefix me3gpp; }
  import ietf-inet-types { prefix inet; }
  import _3gpp-common-yang-types { prefix types3gpp; }
  import _3gpp-common-top { prefix top3gpp; }

  organization "3gpp SA5";
  description "This IOC represents the 5G-EIR function in 5GC. For more information about the 5G-
EIR, see 3GPP TS 23.501.";

```

```

reference "3GPP TS 28.541";

revision 2019-05-15 {
  description "initial revision";
  reference "Based on
    3GPP TS 28.541 V15.X.XX";
}

grouping NGEIRFunctionGrp {
  uses mf3gpp:ManagedFunctionGrp;

  list pLMNIdList {
    description "List of at most six entries of PLMN Identifiers, but at least one (the primary
      PLMN Id).
      The PLMN Identifier is composed of a Mobile Country Code (MCC) and a Mobile
      Network Code (MNC).";

    min-elements 1;
    max-elements 6;
    key "mcc mnc";
    uses types3gpp:PLMNId;
  }

  leaf sBIFQDN {
    description "The FQDN of the registered NF instance in the service-based interface.";
    type inet:domain-name;
  }

  leaf-list sBIServiceList {
    description "All supported NF services registered on the service-based interface.";
    config false;
    type string;
  }

  leaf-list sNSSAIList {
    description "List of S-NSSAIs the managed object is capable of supporting.
      (Single Network Slice Selection Assistance Information)
      An S-NSSAI has an SST (Slice/Service type) and an optional SD
      (Slice Differentiator) field.";
    //optional support
    reference "3GPP TS 23.003";
    type types3gpp:SNssai;
  }
}

augment "/me3gpp:ManagedElement" {
  list NGEIRFunction {
    description "5G Core NGEIR Function";
    reference "3GPP TS 28.541";
    key id;
    uses top3gpp:Top_Grp;
    container attributes {
      uses NGEIRFunctionGrp;
    }
  }
}

module _3gpp-5gc-nrm-nrffunction {
  yang-version 1.1;

  namespace urn:3gpp:sa5:_3gpp-5gc-nrm-nrffunction;
  prefix nrf3gpp;

  import _3gpp-common-managed-function { prefix mf3gpp; }
  import _3gpp-common-managed-element { prefix me3gpp; }
  import ietf-inet-types { prefix inet; }
  import _3gpp-common-yang-types { prefix types3gpp; }
  import _3gpp-5gc-nrm-nfprofile { prefix nfp3gpp; }
  import _3gpp-common-top { prefix top3gpp; }

  organization "3gpp SA5";
  description "This IOC represents the NRF function in 5GC.
    For more information about the NRF, see 3GPP TS 23.501 [2].";
  reference "3GPP TS 28.541";

  revision 2019-05-15 {
    description "initial revision";
  }
}

```

```

    reference "Based on
      3GPP TS 28.541 V15.X.XX";
  }

  grouping NRFFunctionGrp {
    uses mf3gpp:ManagedFunctionGrp;

    list pLMNIdList {
      description "List of at most six entries of PLMN Identifiers, but at least one (the primary
        PLMN Id).
          The PLMN Identifier is composed of a Mobile Country Code (MCC) and a Mobile
        Network Code (MNC).";

      min-elements 1;
      max-elements 6;
      key "mcc mnc";
      uses types3gpp:PLMNId;
    }

    leaf sBIFQDN {
      description "The FQDN of the registered NF instance in the service-based interface.";
      type inet:domain-name;
    }

    leaf-list nSIIDListWrap {
      description "Set of NSI Ids. The NSI ID represents the Network Slice Instance Identifier.";
      //optional support
      type types3gpp:NsiId;
    }

    leaf-list sNSSAIList {
      description "List of S-NSSAIs the managed object is capable of supporting.
        (Single Network Slice Selection Assistance Information)
        An S-NSSAI has an SST (Slice/Service type) and an optional SD
        (Slice Differentiator) field.";
      //optional support
      reference "3GPP TS 23.003";
      type types3gpp:SNssai;
    }

    list nFProfileList {
      description "Set of NFPProfile(s) to be registered in the NRF instance.";
      //optional support
      key nfInstanceID;
      uses nfp3gpp:NFPProfileGrp;
    }
  }

  augment "/me3gpp:ManagedElement" {
    list NRFFunction {
      description "5G Core NRF Function";
      reference "3GPP TS 28.541";
      key id;
      uses top3gpp:Top_Grp;
      container attributes {
        uses NRFFunctionGrp;
      }
    }
  }
}

module _3gpp-5gc-nrm-nssffunction {
  yang-version 1.1;

  namespace urn:3gpp:sa5:_3gpp-5gc-nrm-nssffunction;
  prefix nssf3gpp;

  import _3gpp-common-managed-function { prefix mf3gpp; }
  import _3gpp-common-managed-element { prefix me3gpp; }
  import ietf-inet-types { prefix inet; }
  import _3gpp-common-yang-types { prefix types3gpp; }
  import _3gpp-common-top { prefix top3gpp; }

  organization "3gpp SA5";
  description "This IOC represents the NSSF function in 5GC. For more information about the NSSF,
    see 3GPP TS 23.501.";
  reference "3GPP TS 28.541";
}

```

```

revision 2019-05-15 {
  description "initial revision";
  reference "Based on
    3GPP TS 28.541 V15.X.XX";
}

grouping NSSFFunctionGrp {
  uses mf3gpp:ManagedFunctionGrp;

  list pLMNidList {
    description "List of at most six entries of PLMN Identifiers, but at least one (the primary
      PLMN Id).
      The PLMN Identifier is composed of a Mobile Country Code (MCC) and a Mobile
      Network Code (MNC).";

    min-elements 1;
    max-elements 6;
    key "mcc mnc";
    uses types3gpp:PLMNid;
  }

  leaf sBIFQDN {
    description "The FQDN of the registered NF instance in the service-based interface.";
    type inet:domain-name;
  }

  leaf-list sNSSAIList {
    description "List of S-NSSAIs the managed object is capable of supporting.
      (Single Network Slice Selection Assistance Information)
      An S-NSSAI has an SST (Slice/Service type) and an optional SD
      (Slice Differentiator) field.";

    reference "3GPP TS 23.003";
    type types3gpp:SNssai;
  }

  leaf-list nSIIdListWrap {
    description "Set of NSI Ids. The NSI ID represents the Network Slice Instance Identifier.";
    //optional support
    type types3gpp:NsiId;
  }
}

augment "/me3gpp:ManagedElement" {
  list NSSFFunction {
    description "5G Core NSSF Function";
    reference "3GPP TS 28.541";
    key id;
    uses top3gpp:Top_Grp;
    container attributes {
      uses NSSFFunctionGrp;
    }
  }
}

module _3gpp-5gc-nrm-nwdafunction {
  yang-version 1.1;

  namespace urn:3gpp:sa5:_3gpp-5gc-nrm-nwdafunction;
  prefix nwdaf3gpp;

  import _3gpp-common-managed-function { prefix mf3gpp; }
  import _3gpp-common-managed-element { prefix me3gpp; }
  import ietf-inet-types { prefix inet; }
  import _3gpp-common-yang-types { prefix types3gpp; }
  import _3gpp-common-top { prefix top3gpp; }

  organization "3gpp SA5";
  description "This IOC represents the NWDAF function in 5GC. For more information about the NWDAF,
    see 3GPP TS 23.501.";
  reference "3GPP TS 28.541";

  revision 2019-05-15 {
    description "initial revision";
    reference "Based on
      3GPP TS 28.541 V15.X.XX";
  }
}

```

```

grouping NWDAFFunctionGrp {
  uses mf3gpp:ManagedFunctionGrp;

  list pLMNIdList {
    description "List of at most six entries of PLMN Identifiers, but at least one (the primary
    PLMN Id).
                The PLMN Identifier is composed of a Mobile Country Code (MCC) and a Mobile
    Network Code (MNC).";

    min-elements 1;
    max-elements 6;
    key "mcc mnc";
    uses types3gpp:PLMNId;
  }

  leaf sBIFQDN {
    description "The FQDN of the registered NF instance in the service-based interface.";
    type inet:domain-name;
  }

  leaf-list sBIServiceList {
    description "All supported NF services registered on the service-based interface.";
    config false;
    type string;
  }

  leaf-list sNSSAIIList {
    description "List of S-NSSAIs the managed object is capable of supporting.
                (Single Network Slice Selection Assistance Information)
                An S-NSSAI has an SST (Slice/Service type) and an optional SD
                (Slice Differentiator) field.";

    //optional support
    reference "3GPP TS 23.003";
    type types3gpp:SNssai;
  }
}

augment "/me3gpp:ManagedElement" {
  list NWDAFFunction {
    description "5G Core NWDAF Function";
    reference "3GPP TS 28.541";
    key id;
    uses top3gpp:Top_Grp;
    container attributes {
      uses NWDAFFunctionGrp;
    }
  }
}

module _3gpp-5gc-nrm-pcfunction {
  yang-version 1.1;

  namespace urn:3gpp:sa5:_3gpp-5gc-nrm-pcfunction;
  prefix pcf3gpp;

  import _3gpp-common-managed-function { prefix mf3gpp; }
  import _3gpp-common-managed-element { prefix me3gpp; }
  import ietf-inet-types { prefix inet; }
  import _3gpp-common-yang-types { prefix types3gpp; }
  import _3gpp-common-top { prefix top3gpp; }

  organization "3gpp SA5";
  description "This IOC represents the PCF function in 5GC. For more information about the PCF, see
  3GPP TS 23.501.";
  reference "3GPP TS 28.541";

  revision 2019-05-22 {
    description "initial revision";
    reference "Based on
    3GPP TS 28.541 V15.X.XX";
  }

  grouping PCFFuntionGrp {
    uses mf3gpp:ManagedFunctionGrp;

    list pLMNIdList {

```

description "List of at most six entries of PLMN Identifiers, but at least one (the primary PLMN Id).

The PLMN Identifier is composed of a Mobile Country Code (MCC) and a Mobile Network Code (MNC).";

```

    min-elements 1;
    max-elements 6;
    key "mcc mnc";
    uses types3gpp:PLMNId;
}

leaf sBIFQDN {
    description "The FQDN of the registered NF instance in the service-based interface.";
    type inet:domain-name;
}

leaf-list sBIServiceList {
    description "All supported NF services registered on the service-based interface.";
    config false;
    type string;
}

leaf-list sNSSAIList {
    description "List of S-NSSAIs the managed object is capable of supporting.
        (Single Network Slice Selection Assistance Information)
        An S-NSSAI has an SST (Slice/Service type) and an optional SD
        (Slice Differentiator) field.";
    //optional support
    reference "3GPP TS 23.003";
    type types3gpp:SNssai;
}
}

augment "/me3gpp:ManagedElement" {
    list PCFFunction {
        description "5G Core PCF Function";
        reference "3GPP TS 28.541";
        key id;
        uses top3gpp:Top_Grp;
        container attributes {
            uses PCFFuntionGrp;
        }
    }
}
}

module _3gpp-5gc-nrm-seppfunction {
    yang-version 1.1;

    namespace urn:3gpp:sa5:_3gpp-5gc-nrm-seppfunction;
    prefix sepp3gpp;

    import _3gpp-common-managed-function { prefix mf3gpp; }
    import _3gpp-common-managed-element { prefix me3gpp; }
    import _3gpp-common-yang-types { prefix types3gpp; }
    import _3gpp-common-top { prefix top3gpp; }

    organization "3gpp SA5";
    description "This IOC represents the SEPP function which support message filtering
        and policing on inter-PLMN control plane interface. For more information about the
        SEPP, see 3GPP TS 23.501.";
    reference "3GPP TS 28.541";

    revision 2019-05-15 {
        description "initial revision";
        reference "Based on
            3GPP TS 28.541 V15.X.XX";
    }

    grouping SEPPFunctionGrp {
        uses mf3gpp:ManagedFunctionGrp;

        list pLMNIdList {
            description "List of at most six entries of PLMN Identifiers, but at least one (the primary
                PLMN Id).
                The PLMN Identifier is composed of a Mobile Country Code (MCC) and a Mobile
                Network Code (MNC).";

```

```

    min-elements 1;
    max-elements 6;
    key "mcc mnc";
    uses types3gpp:PLMNId;
  }
}

augment "/me3gpp:ManagedElement" {
  list SEPPFunction {
    description "5G Core SEPP Function";
    reference "3GPP TS 28.541";
    key id;
    uses top3gpp:Top_Grp;
    container attributes {
      uses SEPPFunctionGrp;
    }
  }
}

module _3gpp-5gc-nrm-smffunction {
  yang-version 1.1;
  namespace urn:3gpp:sa5:_3gpp-5gc-nrm-smffunction;
  prefix smf3gpp;

  import _3gpp-common-managed-function { prefix mf3gpp; }
  import _3gpp-common-managed-element { prefix me3gpp; }
  import _3gpp-common-yang-types { prefix types3gpp; }
  import ietf-inet-types { prefix inet; }
  import _3gpp-common-top { prefix top3gpp; }

  description "SMFFunction derived from basic ManagedFunction.";

  revision 2019-05-31 {
    description "Ericsson refactoring.";
    reference "Based on
      3GPP TS 28.541 V15.X.XX";
  }

  revision 2018-08-07 {
    description "Initial revision";
  }

  grouping SMFFunctionGrp {
    uses mf3gpp:ManagedFunctionGrp;

    list pLMNIdList {
      min-elements 1;
      description "A list of PLMN identifiers (Mobile Country Code and Mobile Network Code).";
      key "mcc mnc";
      uses types3gpp:PLMNId;
    }

    leaf-list nRTACList {
      description "List of Tracking Area Codes (legacy TAC or extended TAC)
        where the represented management function is serving.";
      reference "TS 38.413 clause 9.3.3.10";
      min-elements 1;
      config false;
      type types3gpp:Tac;
    }

    leaf sBIFQDN {
      description "The FQDN of the registered NF instance in the service-based interface.";
      type inet:domain-name;
    }

    leaf-list sBIServiceList {
      description "All supported NF services registered on the service-based interface.";
      min-elements 1;
      config false;
      type string;
    }

    leaf-list sNSSAIList {
      min-elements 0;
      description "List of S-NSSAIs the managed object is capable of supporting.
        (Single Network Slice Selection Assistance Information)";
    }
  }
}

```



```

        An S-NSSAI has an SST (Slice/Service type) and an optional SD
        (Slice Differentiator) field.";
    reference "3GPP TS 23.003";
    type types3gpp:SNssai;
}
}

augment "/me3gpp:ManagedElement" {
    list SMFFunction {
        description "5G Core SMF Function";
        reference "3GPP TS 28.541";
        key id;
        uses top3gpp:Top_Grp;
        container attributes {
            uses SMFFunctionGrp;
        }
    }
}

module _3gpp-5gc-nrm-smsffunction {
    yang-version 1.1;

    namespace urn:3gpp:sa5:_3gpp-5gc-nrm-smsffunction;
    prefix smsf3gpp;

    import _3gpp-common-managed-function { prefix mf3gpp; }
    import _3gpp-common-managed-element { prefix me3gpp; }
    import ietf-inet-types { prefix inet; }
    import _3gpp-common-yang-types { prefix types3gpp; }
    import _3gpp-common-top { prefix top3gpp; }

    organization "3gpp SA5";
    description "This IOC represents the SMSF function defined in 3GPP TS 23.501.";
    reference "3GPP TS 28.541";

    revision 2019-05-15 {
        description "initial revision";
        reference "Based on
            3GPP TS 28.541 V15.X.XX";
    }

    grouping SMSFFunctionGrp {
        uses mf3gpp:ManagedFunctionGrp;

        list pLMNidList {
            description "List of at most six entries of PLMN Identifiers, but at least one (the primary
                PLMN Id).
                The PLMN Identifier is composed of a Mobile Country Code (MCC) and a Mobile
                Network Code (MNC).";
            min-elements 1;
            max-elements 6;
            key "mcc mnc";
            uses types3gpp:PLMNid;
        }

        leaf sBIFQDN {
            description "The FQDN of the registered NF instance in the service-based interface.";
            type inet:domain-name;
        }

        leaf-list sBIServiceList {
            description "All supported NF services registered on the service-based interface.";
            config false;
            type string;
        }
    }

    augment "/me3gpp:ManagedElement" {
        list SMSFFunction {
            description "5G Core SMSF Function";
            reference "3GPP TS 28.541";
            key id;
            uses top3gpp:Top_Grp;
            container attributes {
                uses SMSFFunctionGrp;
            }
        }
    }
}

```

```

    }
  }
}

module _3gpp-5gc-nrm-udmfunction {
  yang-version 1.1;

  namespace urn:3gpp:sa5:_3gpp-5gc-nrm-udmfunction;
  prefix udm3gpp;

  import _3gpp-common-managed-function { prefix mf3gpp; }
  import _3gpp-common-managed-element { prefix me3gpp; }
  import ietf-inet-types { prefix inet; }
  import _3gpp-common-yang-types { prefix types3gpp; }
  import _3gpp-common-top { prefix top3gpp; }

  organization "3gpp SA5";
  description "This IOC represents the UDM function in 5GC. For more information about the UDM, see
3GPP TS 23.501.";
  reference "3GPP TS 28.541";

  revision 2019-05-22 {
    description "initial revision";
    reference "Based on
      3GPP TS 28.541 V15.X.XX";
  }

  grouping UDMFunctionGrp {
    uses mf3gpp:ManagedFunctionGrp;

    list pLMNIdList {
      description "List of at most six entries of PLMN Identifiers, but at least one (the primary
PLMN Id).
      The PLMN Identifier is composed of a Mobile Country Code (MCC) and a Mobile
Network Code (MNC).";

      min-elements 1;
      max-elements 6;
      key "mcc mnc";
      uses types3gpp:PLMNId;
    }

    leaf sBIFQDN {
      description "The FQDN of the registered NF instance in the service-based interface.";
      type inet:domain-name;
    }

    leaf-list sBIServiceList {
      description "All supported NF services registered on the service-based interface.";
      config false;
      type string;
    }

    leaf-list sNSSAIDList {
      description "List of S-NSSAIs the managed object is capable of supporting.
      (Single Network Slice Selection Assistance Information)
      An S-NSSAI has an SST (Slice/Service type) and an optional SD
      (Slice Differentiator) field.";
      //optional support
      reference "3GPP TS 23.003";
      type types3gpp:SNssai;
    }
  }

  augment "/me3gpp:ManagedElement" {
    list UDMFunction {
      description "5G Core UDM Function";
      reference "3GPP TS 28.541";
      key id;
      uses top3gpp:Top_Grp;
      container attributes {
        uses UDMFunctionGrp;
      }
    }
  }
}

module _3gpp-5gc-nrm-udrfuction {

```

```

yang-version 1.1;

namespace urn:3gpp:sa5:_3gpp-5gc-nrm-udrfunfunction;
prefix udr3gpp;

import _3gpp-common-managed-function { prefix mf3gpp; }
import _3gpp-common-managed-element { prefix me3gpp; }
import ietf-inet-types { prefix inet; }
import _3gpp-common-yang-types { prefix types3gpp; }
import _3gpp-common-top { prefix top3gpp; }

organization "3gpp SA5";
description "This IOC represents the UDR function in 5GC. For more information about the UDR, see
3GPP TS 23.501.";
reference "3GPP TS 28.541";

revision 2019-05-22 {
  description "initial revision";
  reference "Based on
    3GPP TS 28.541 V15.X.XX";
}

grouping UDRFuntionGrp {
  uses mf3gpp:ManagedFunctionGrp;

  list pLMNidList {
    description "List of at most six entries of PLMN Identifiers, but at least one (the primary
    PLMN Id).
      The PLMN Identifier is composed of a Mobile Country Code (MCC) and a Mobile
    Network Code (MNC).";
    min-elements 1;
    max-elements 6;
    key "mcc mnc";
    uses types3gpp:PLMNid;
  }

  leaf sBIFQDN {
    description "The FQDN of the registered NF instance in the service-based interface.";
    type inet:domain-name;
  }

  leaf-list sBIServiceList {
    description "All supported NF services registered on the service-based interface.";
    config false;
    type string;
  }

  leaf-list sNSSAIList {
    description "List of S-NSSAIs the managed object is capable of supporting.
      (Single Network Slice Selection Assistance Information)
      An S-NSSAI has an SST (Slice/Service type) and an optional SD
      (Slice Differentiator) field.";
    //optional support
    reference "3GPP TS 23.003";
    type types3gpp:SNssai;
  }
}

augment "/me3gpp:ManagedElement" {
  list UDRFunction {
    description "5G Core UDR Function";
    reference "3GPP TS 28.541";
    key id;
    uses top3gpp:Top_Grp;
    container attributes {
      uses UDRFuntionGrp;
    }
  }
}

module _3gpp-5gc-nrm-udsffunfunction {
  yang-version 1.1;

  namespace urn:3gpp:sa5:_3gpp-5gc-nrm-udsffunfunction;
  prefix udsf3gpp;

```

```

import _3gpp-common-managed-function { prefix mf3gpp; }
import _3gpp-common-managed-element { prefix me3gpp; }
import ietf-inet-types { prefix inet; }
import _3gpp-common-yang-types { prefix types3gpp; }
import _3gpp-common-top { prefix top3gpp; }

organization "3gpp SA5";
description "This IOC represents the UDSF function which can be interacted with any other 5GC NF
defined in 3GPP TS 23.501.";
reference "3GPP TS 28.541";

revision 2019-05-22 {
  description "initial revision";
  reference "Based on
    3GPP TS 28.541 V15.X.XX";
}

grouping UDSFFuntionGrp {
  uses mf3gpp:ManagedFunctionGrp;

  list pLMNIdList {
    description "List of at most six entries of PLMN Identifiers, but at least one (the primary
PLMN Id).
        The PLMN Identifier is composed of a Mobile Country Code (MCC) and a Mobile
Network Code (MNC).";

    min-elements 1;
    max-elements 6;
    key "mcc mnc";
    uses types3gpp:PLMNId;
  }

  leaf sBIFQDN {
    description "The FQDN of the registered NF instance in the service-based interface.";
    type inet:domain-name;
  }

  leaf-list sBIServiceList {
    description "All supported NF services registered on the service-based interface.";
    config false;
    type string;
  }

  leaf-list sNSSAIList {
    description "List of S-NSSAIs the managed object is capable of supporting.
        (Single Network Slice Selection Assistance Information)
        An S-NSSAI has an SST (Slice/Service type) and an optional SD
        (Slice Differentiator) field.";
    //optional support
    reference "3GPP TS 23.003";
    type types3gpp:SNssai;
  }
}

augment "/me3gpp:ManagedElement" {
  list UDSFFuntion {
    description "5G Core UDSF Function";
    reference "3GPP TS 28.541";
    key id;
    uses top3gpp:Top_Grp;
    container attributes {
      uses UDSFFuntionGrp;
    }
  }
}

module _3gpp-5gc-nrm-upffunction {
  yang-version 1.1;
  namespace urn:3gpp:sa5:_3gpp-5gc-nrm-upffunction;
  prefix upf3gpp;

  import _3gpp-common-managed-function { prefix mf3gpp; }
  import _3gpp-common-managed-element { prefix me3gpp; }
  import _3gpp-common-yang-types { prefix types3gpp; }
  import _3gpp-common-top { prefix top3gpp; }

  description "UPFFuntion derived from basic ManagedFunction.";
}

```

```

revision 2019-05-31 {
  description "Ericsson refactoring.";
  reference "Based on
    3GPP TS 28.541 V15.X.XX";
}

revision 2018-08-07 {
  description "Initial revision";
}

grouping UPFFunctionGrp {
  uses mf3gpp:ManagedFunctionGrp;

  list pLMNIdList {
    description "A list of PLMN identifiers (Mobile Country Code and Mobile Network Code).";
    min-elements 1;
    key "mcc mnc";
    uses types3gpp:PLMNId;
  }

  leaf-list nRTACList {
    description "List of Tracking Area Codes (legacy TAC or extended TAC)
      where the represented management function is serving.";
    reference "TS 38.413 clause 9.3.3.10";
    min-elements 1;
    config false;
    type types3gpp:Tac;
  }

  leaf-list sNSSAIList {
    description "List of S-NSSAIs the managed object is capable of supporting.
      (Single Network Slice Selection Assistance Information)
      An S-NSSAI has an SST (Slice/Service type) and an optional SD
      (Slice Differentiator) field.";
    min-elements 0;
    reference "3GPP TS 23.003";
    type types3gpp:SNssai;
  }
}

augment "/me3gpp:ManagedElement" {
  list UPFFunction {
    description "5G Core UPF Function";
    reference "3GPP TS 28.541";
    key id;
    uses top3gpp:Top_Grp;
    container attributes {
      uses UPFFunctionGrp;
    }
  }
}
}

```

H.6 Graphical representation

This is the YANG module tree diagram for 5GC, NR and NG-RAN NRM. Its syntax is defined in [45].

```

module: _3gpp-common-managed-element
  +--rw ManagedElement* [id]
    +--rw id string
    +--rw attributes
      | +--rw dnPrefix? types3gpp:DistinguishedName
      | +--rw userLabel? string
      | +--ro locationName? string
      | +--ro managedBy* types3gpp:DistinguishedName
      | +--ro managedElementTypeList* string
      | +--ro supportedMeasurementsGPs* [measurementType] {MeasurementsUnderManagedElement}?
      | | +--ro measurementType string
      | | +--ro supportedGPs* uint32
      | +--ro vendorName? string
      | +--rw userDefinedState? string
      | +--ro swVersion? string
      | +--rw priorityLabel uint32
    +--rw MeasurementControl* [id] {MeasurementsUnderManagedElement}?
      | +--rw id string

```

```

+--rw attributes
|   +--rw pMAdministrativeState?          types3gpp:AdministrativeState
|   +--ro pMOperationalState             types3gpp:OperationalState
|   +--rw defaultFileLocation?           string
|   +--rw defaultFileBasedGP             uint32
|   +--rw defaultFileReportingPeriod     uint32
|   +--rw defaultStreamTarget?           string {StreamingSupported}?
|   +--rw defaultStreamBasedGP           uint32 {StreamingSupported}?
+--rw MeasurementReader* [id]
|   +--rw id                             string
|   +--rw attributes
|   |   +--rw measurementTypes*          string
|   |   +--rw managedObjectDNsBasic*    types3gpp:DistinguishedName
|   |   +--rw managedObjectDNs*        types3gpp:DistinguishedName
|   |   +--rw fileLocation?             string
|   |   +--rw fileBasedGP               uint32
|   |   +--rw fileReportingPeriod       uint32
|   |   +--rw streamTarget?             string
|   |   +--rw streamBasedGP             uint32
+--rw gnbdu3gpp:GNBDUFunction* [id]
|   +--rw gnbdu3gpp:id                  string
|   +--rw gnbdu3gpp:attributes
|   |   +--rw gnbdu3gpp:userLabel?      string
|   |   +--rw gnbdu3gpp:vnfParametersList!
|   |   |   +--rw gnbdu3gpp:vnfInstanceId    string
|   |   |   +--rw gnbdu3gpp:vnfdId?        string
|   |   |   +--rw gnbdu3gpp:flavourId?     string
|   |   |   +--rw gnbdu3gpp:autoScalable   boolean
|   |   +--rw gnbdu3gpp:peeParametersList!
|   |   |   +--rw gnbdu3gpp:siteIdentification    string
|   |   |   +--rw gnbdu3gpp:siteLatitude?        decimal64
|   |   |   +--rw gnbdu3gpp:siteLongitude?       decimal64
|   |   |   +--rw gnbdu3gpp:siteDescription      string
|   |   |   +--rw gnbdu3gpp:equipmentType       string
|   |   |   +--rw gnbdu3gpp:environmentType     string
|   |   |   +--rw gnbdu3gpp:powerInterface      string
|   |   +--rw gnbdu3gpp:priorityLabel          uint32
|   |   +--rw gnbdu3gpp:gNBId                  int64
|   |   +--rw gnbdu3gpp:gNBIdLength           int32
|   |   +--rw gnbdu3gpp:gNBDUId              int64
|   |   +--rw gnbdu3gpp:gNBDUName             string
+--rw nrsectcarr3gpp:NRSectorCarrier* [id]
|   +--rw nrsectcarr3gpp:id                  string
|   +--rw nrsectcarr3gpp:attributes
|   |   +--rw nrsectcarr3gpp:userLabel?      string
|   |   +--rw nrsectcarr3gpp:vnfParametersList!
|   |   |   +--rw nrsectcarr3gpp:vnfInstanceId    string
|   |   |   +--rw nrsectcarr3gpp:vnfdId?        string
|   |   |   +--rw nrsectcarr3gpp:flavourId?     string
|   |   |   +--rw nrsectcarr3gpp:autoScalable   boolean
|   |   +--rw nrsectcarr3gpp:peeParametersList!
|   |   |   +--rw nrsectcarr3gpp:siteIdentification    string
|   |   |   +--rw nrsectcarr3gpp:siteLatitude?        decimal64
|   |   |   +--rw nrsectcarr3gpp:siteLongitude?       decimal64
|   |   |   +--rw nrsectcarr3gpp:siteDescription      string
|   |   |   +--rw nrsectcarr3gpp:equipmentType       string
|   |   |   +--rw nrsectcarr3gpp:environmentType     string
|   |   |   +--rw nrsectcarr3gpp:powerInterface      string
|   |   +--rw nrsectcarr3gpp:priorityLabel          uint32
|   |   +--rw nrsectcarr3gpp:txDirection            types3gpp:TxDirection
|   |   +--rw nrsectcarr3gpp:configuredMaxTxPower   int32
|   |   +--rw nrsectcarr3gpp:arfcnDL                int32
|   |   +--rw nrsectcarr3gpp:arfcnUL                int32
|   |   +--rw nrsectcarr3gpp:bSChannelBwDL          int32
|   |   +--rw nrsectcarr3gpp:bSChannelBwUL          int32
|   |   +--rw nrsectcarr3gpp:sectorEquipmentFunctionRef    types3gpp:DistinguishedName
+--rw bwp3gpp:BWP* [id]
|   +--rw bwp3gpp:id                      string
|   +--rw bwp3gpp:attributes
|   |   +--rw bwp3gpp:userLabel?          string
|   |   +--rw bwp3gpp:vnfParametersList!
|   |   |   +--rw bwp3gpp:vnfInstanceId    string
|   |   |   +--rw bwp3gpp:vnfdId?        string
|   |   |   +--rw bwp3gpp:flavourId?     string
|   |   |   +--rw bwp3gpp:autoScalable   boolean
|   |   +--rw bwp3gpp:peeParametersList!
|   |   |   +--rw bwp3gpp:siteIdentification    string
|   |   |   +--rw bwp3gpp:siteLatitude?        decimal64

```

```

    +---rw bwp3gpp:siteLongitude?      decimal64
    +---rw bwp3gpp:siteDescription     string
    +---rw bwp3gpp:equipmentType      string
    +---rw bwp3gpp:environmentType     string
    +---rw bwp3gpp:powerInterface     string
+---rw bwp3gpp:priorityLabel          uint32
+---rw bwp3gpp:bwpContext             BwpContext
+---rw bwp3gpp:isInitialBwp          IsInitialBwp
+---rw bwp3gpp:subCarrierSpacing     uint32
+---rw bwp3gpp:cyclicPrefix          CyclicPrefix
+---rw bwp3gpp:startRB               uint32
+---rw bwp3gpp:numberOfRBs          uint32
+---rw nrcelldu3gpp:NRCellDU* [id]
  +---rw nrcelldu3gpp:id              string
  +---rw nrcelldu3gpp:attributes
    +---rw nrcelldu3gpp:userLabel?    string
    +---rw nrcelldu3gpp:vnfParametersList!
      +---rw nrcelldu3gpp:vnfInstanceId  string
      +---rw nrcelldu3gpp:vnfdId?      string
      +---rw nrcelldu3gpp:flavourId?   string
      +---rw nrcelldu3gpp:autoScalable  boolean
    +---rw nrcelldu3gpp:peeParametersList!
      +---rw nrcelldu3gpp:siteIdentification  string
      +---rw nrcelldu3gpp:siteLatitude?      decimal64
      +---rw nrcelldu3gpp:siteLongitude?     decimal64
      +---rw nrcelldu3gpp:siteDescription    string
      +---rw nrcelldu3gpp:equipmentType     string
      +---rw nrcelldu3gpp:environmentType   string
      +---rw nrcelldu3gpp:powerInterface    string
    +---rw nrcelldu3gpp:priorityLabel        uint32
    +---rw nrcelldu3gpp:cellLocalId         int32
    +---ro nrcelldu3gpp:operationalState?    types3gpp:OperationalState
    +---rw nrcelldu3gpp:administrativeState  types3gpp:AdministrativeState
    +---ro nrcelldu3gpp:cellState?          types3gpp:CellState
    +---rw nrcelldu3gpp:pLMNidList* [mcc mnc]
      +---rw nrcelldu3gpp:mcc  Mcc
      +---rw nrcelldu3gpp:mnc  Mnc
    +---rw nrcelldu3gpp:sNSSAList*          types3gpp:SNssai
    +---rw nrcelldu3gpp:nRPCI              int32
    +---rw nrcelldu3gpp:nRTAC              types3gpp:Tac
    +---rw nrcelldu3gpp:arfcnDL            int32
    +---rw nrcelldu3gpp:arfcnUL            int32
    +---rw nrcelldu3gpp:arfcnSUL           int32
    +---rw nrcelldu3gpp:bSChannelBwDL      int32
    +---rw nrcelldu3gpp:bSChannelBwUL?     int32
    +---rw nrcelldu3gpp:bSChannelBwSUL?    int32
    +---rw nrcelldu3gpp:ssbFrequency        int32
    +---rw nrcelldu3gpp:ssbPeriodicity     int32
    +---rw nrcelldu3gpp:ssbSubCarrierSpacing int32
    +---rw nrcelldu3gpp:ssbOffset          int32
    +---rw nrcelldu3gpp:ssbDuration         int32
    +---rw nrcelldu3gpp:nRSectorCarrierRef* types3gpp:DistinguishedName
    +---rw nrcelldu3gpp:bWPRef*            types3gpp:DistinguishedName
    +---rw nrcelldu3gpp:nRFrequencyRef*    types3gpp:DistinguishedName
+---rw ep3gpp:EP_FL1C* [id]
  +---rw ep3gpp:id              string
  +---rw ep3gpp:attributes
    +---rw ep3gpp:userLabel?    string
    +---ro ep3gpp:farEndEntity?  types3gpp:DistinguishedName
    +---ro ep3gpp:supportedMeasurementsGPs* [measurementType]
      +---ro ep3gpp:measurementType  string
      +---ro ep3gpp:supportedGPs*    uint32
    +---rw ep3gpp:localAddress* [ipAddress vlanId]
      +---rw ep3gpp:ipAddress  inet:ip-address
      +---rw ep3gpp:vlanId    uint16
    +---rw ep3gpp:remoteAddress  inet:ip-address
+---rw ep3gpp:EP_FL1U* [id]
  +---rw ep3gpp:id              string
  +---rw ep3gpp:attributes
    +---rw ep3gpp:userLabel?    string
    +---ro ep3gpp:farEndEntity?  types3gpp:DistinguishedName
    +---ro ep3gpp:supportedMeasurementsGPs* [measurementType]
      +---ro ep3gpp:measurementType  string
      +---ro ep3gpp:supportedGPs*    uint32
    +---rw ep3gpp:localAddress* [ipAddress vlanId]
      +---rw ep3gpp:ipAddress  inet:ip-address
      +---rw ep3gpp:vlanId    uint16
    +---rw ep3gpp:remoteAddress  inet:ip-address

```

```

+--rw pcf3gpp:PCFFunction* [id]
|   +--rw pcf3gpp:id          string
|   +--rw pcf3gpp:attributes
|   |   +--rw pcf3gpp:userLabel?      string
|   |   +--rw pcf3gpp:vnfParametersList!
|   |   |   +--rw pcf3gpp:vnfInstanceId      string
|   |   |   +--rw pcf3gpp:vnfId?          string
|   |   |   +--rw pcf3gpp:flavourId?      string
|   |   |   +--rw pcf3gpp:autoScalable    boolean
|   |   +--rw pcf3gpp:peeParametersList!
|   |   |   +--rw pcf3gpp:siteIdentification      string
|   |   |   +--rw pcf3gpp:siteLatitude?         decimal64
|   |   |   +--rw pcf3gpp:siteLongitude?        decimal64
|   |   |   +--rw pcf3gpp:siteDescription       string
|   |   |   +--rw pcf3gpp:equipmentType        string
|   |   |   +--rw pcf3gpp:environmentType      string
|   |   |   +--rw pcf3gpp:powerInterface       string
|   |   +--rw pcf3gpp:priorityLabel            uint32
|   |   +--rw pcf3gpp:pLMNIDList* [mcc mnc]
|   |   |   +--rw pcf3gpp:mcc      Mcc
|   |   |   +--rw pcf3gpp:mnc      Mnc
|   |   +--rw pcf3gpp:sBIFQDN?          inet:domain-name
|   |   +--ro pcf3gpp:sBIServiceList*   string
|   |   +--rw pcf3gpp:sNSSAIIList*      types3gpp:SNssai
|   +--rw cep3gpp:EP_N5* [id]
|   |   +--rw cep3gpp:id          string
|   |   +--rw cep3gpp:attributes
|   |   |   +--rw cep3gpp:userLabel?      string
|   |   |   +--ro cep3gpp:farEndEntity?    types3gpp:DistinguishedName
|   |   |   +--ro cep3gpp:supportedMeasurementsGPs* [measurementType]
|   |   |   |   +--ro cep3gpp:measurementType      string
|   |   |   |   +--ro cep3gpp:supportedGPs*        uint32
|   |   |   +--rw cep3gpp:localAddress* [ipAddress vlanId]
|   |   |   |   +--rw cep3gpp:ipAddress      inet:ip-address
|   |   |   |   +--rw cep3gpp:vlanId        uint16
|   |   |   +--rw cep3gpp:remoteAddress      inet:ip-address
|   |   +--rw cep3gpp:EP_N7* [id]
|   |   |   +--rw cep3gpp:id          string
|   |   |   +--rw cep3gpp:attributes
|   |   |   |   +--rw cep3gpp:userLabel?      string
|   |   |   |   +--ro cep3gpp:farEndEntity?    types3gpp:DistinguishedName
|   |   |   |   +--ro cep3gpp:supportedMeasurementsGPs* [measurementType]
|   |   |   |   |   +--ro cep3gpp:measurementType      string
|   |   |   |   |   +--ro cep3gpp:supportedGPs*        uint32
|   |   |   |   +--rw cep3gpp:localAddress* [ipAddress vlanId]
|   |   |   |   |   +--rw cep3gpp:ipAddress      inet:ip-address
|   |   |   |   |   +--rw cep3gpp:vlanId        uint16
|   |   |   |   +--rw cep3gpp:remoteAddress      inet:ip-address
|   |   +--rw cep3gpp:EP_N15* [id]
|   |   |   +--rw cep3gpp:id          string
|   |   |   +--rw cep3gpp:attributes
|   |   |   |   +--rw cep3gpp:userLabel?      string
|   |   |   |   +--ro cep3gpp:farEndEntity?    types3gpp:DistinguishedName
|   |   |   |   +--ro cep3gpp:supportedMeasurementsGPs* [measurementType]
|   |   |   |   |   +--ro cep3gpp:measurementType      string
|   |   |   |   |   +--ro cep3gpp:supportedGPs*        uint32
|   |   |   |   +--rw cep3gpp:localAddress* [ipAddress vlanId]
|   |   |   |   |   +--rw cep3gpp:ipAddress      inet:ip-address
|   |   |   |   |   +--rw cep3gpp:vlanId        uint16
|   |   |   |   +--rw cep3gpp:remoteAddress      inet:ip-address
|   |   +--rw cep3gpp:EP_N16* [id]
|   |   |   +--rw cep3gpp:id          string
|   |   |   +--rw cep3gpp:attributes
|   |   |   |   +--rw cep3gpp:userLabel?      string
|   |   |   |   +--ro cep3gpp:farEndEntity?    types3gpp:DistinguishedName
|   |   |   |   +--ro cep3gpp:supportedMeasurementsGPs* [measurementType]
|   |   |   |   |   +--ro cep3gpp:measurementType      string
|   |   |   |   |   +--ro cep3gpp:supportedGPs*        uint32
|   |   |   |   +--rw cep3gpp:localAddress* [ipAddress vlanId]
|   |   |   |   |   +--rw cep3gpp:ipAddress      inet:ip-address
|   |   |   |   |   +--rw cep3gpp:vlanId        uint16
|   |   |   |   +--rw cep3gpp:remoteAddress      inet:ip-address
|   |   +--rw cep3gpp:EP_Rx* [id]
|   |   |   +--rw cep3gpp:id          string
|   |   |   +--rw cep3gpp:attributes
|   |   |   |   +--rw cep3gpp:userLabel?      string
|   |   |   |   +--ro cep3gpp:farEndEntity?    types3gpp:DistinguishedName
|   |   |   |   +--ro cep3gpp:supportedMeasurementsGPs* [measurementType]

```



```

| | | +--ro cep3gpp:measurementType string
| | | +--ro cep3gpp:supportedGPs* uint32
+--rw cep3gpp:localAddress* [ipAddress vlanId]
| | | +--rw cep3gpp:ipAddress inet:ip-address
| | | +--rw cep3gpp:vlanId uint16
| | | +--rw cep3gpp:remoteAddress inet:ip-address
+--rw cep3gpp:EP_SBI_X* [id]
+--rw cep3gpp:id string
+--rw cep3gpp:attributes
| | | +--rw cep3gpp:userLabel? string
| | | +--ro cep3gpp:farEndEntity? types3gpp:DistinguishedName
| | | +--ro cep3gpp:supportedMeasurementsGPs* [measurementType]
| | | | +--ro cep3gpp:measurementType string
| | | | +--ro cep3gpp:supportedGPs* uint32
+--rw cep3gpp:localAddress* [ipAddress vlanId]
| | | +--rw cep3gpp:ipAddress inet:ip-address
| | | +--rw cep3gpp:vlanId uint16
| | | +--rw cep3gpp:remoteAddress inet:ip-address
+--ro cep3gpp:sBIService* string
+--rw af3gpp:AFFunction* [id]
+--rw af3gpp:id string
+--rw af3gpp:attributes
| | | +--rw af3gpp:userLabel? string
+--rw af3gpp:vnfParametersList!
| | | +--rw af3gpp:vnfInstanceId string
| | | +--rw af3gpp:vnfdId? string
| | | +--rw af3gpp:flavourId? string
| | | +--rw af3gpp:autoScalable boolean
+--rw af3gpp:peeParametersList!
| | | +--rw af3gpp:siteIdentification string
| | | +--rw af3gpp:siteLatitude? decimal64
| | | +--rw af3gpp:siteLongitude? decimal64
| | | +--rw af3gpp:siteDescription string
| | | +--rw af3gpp:equipmentType string
| | | +--rw af3gpp:environmentType string
| | | +--rw af3gpp:powerInterface string
+--rw af3gpp:priorityLabel uint32
+--rw cep3gpp:EP_N6* [id]
+--rw cep3gpp:id string
+--rw cep3gpp:attributes
| | | +--rw cep3gpp:userLabel? string
| | | +--ro cep3gpp:farEndEntity? types3gpp:DistinguishedName
+--ro cep3gpp:supportedMeasurementsGPs* [measurementType]
| | | +--ro cep3gpp:measurementType string
| | | +--ro cep3gpp:supportedGPs* uint32
+--rw cep3gpp:localAddress* [ipAddress vlanId]
| | | +--rw cep3gpp:ipAddress inet:ip-address
| | | +--rw cep3gpp:vlanId uint16
+--rw cep3gpp:remoteAddress inet:ip-address
+--rw cep3gpp:EP_Rx* [id]
+--rw cep3gpp:id string
+--rw cep3gpp:attributes
| | | +--rw cep3gpp:userLabel? string
| | | +--ro cep3gpp:farEndEntity? types3gpp:DistinguishedName
+--ro cep3gpp:supportedMeasurementsGPs* [measurementType]
| | | +--ro cep3gpp:measurementType string
| | | +--ro cep3gpp:supportedGPs* uint32
+--rw cep3gpp:localAddress* [ipAddress vlanId]
| | | +--rw cep3gpp:ipAddress inet:ip-address
| | | +--rw cep3gpp:vlanId uint16
+--rw cep3gpp:remoteAddress inet:ip-address
+--rw udm3gpp:UDMFunction* [id]
+--rw udm3gpp:id string
+--rw udm3gpp:attributes
| | | +--rw udm3gpp:userLabel? string
+--rw udm3gpp:vnfParametersList!
| | | +--rw udm3gpp:vnfInstanceId string
| | | +--rw udm3gpp:vnfdId? string
| | | +--rw udm3gpp:flavourId? string
| | | +--rw udm3gpp:autoScalable boolean
+--rw udm3gpp:peeParametersList!
| | | +--rw udm3gpp:siteIdentification string
| | | +--rw udm3gpp:siteLatitude? decimal64
| | | +--rw udm3gpp:siteLongitude? decimal64
| | | +--rw udm3gpp:siteDescription string
| | | +--rw udm3gpp:equipmentType string
| | | +--rw udm3gpp:environmentType string
| | | +--rw udm3gpp:powerInterface string

```

```

|--rw udm3gpp:priorityLabel          uint32
|--rw udm3gpp:pLMNidList* [mcc mnc]
|   |--rw udm3gpp:mcc      Mcc
|   |--rw udm3gpp:mnc      Mnc
|--rw udm3gpp:sBIFQDN?              inet:domain-name
|--ro udm3gpp:sBIServiceList*       string
|--rw udm3gpp:sNSSAIList*           types3gpp:SNssai
+--rw cep3gpp:EP_N8* [id]
|   |--rw cep3gpp:id              string
|   +--rw cep3gpp:attributes
|   |   |--rw cep3gpp:userLabel?      string
|   |   +--ro cep3gpp:farEndEntity?   types3gpp:DistinguishedName
|   |   +--ro cep3gpp:supportedMeasurementsGPs* [measurementType]
|   |   |   |--ro cep3gpp:measurementType  string
|   |   |   |--ro cep3gpp:supportedGPs*    uint32
|   |   +--rw cep3gpp:localAddress* [ipAddress vlanId]
|   |   |   |--rw cep3gpp:ipAddress      inet:ip-address
|   |   |   |--rw cep3gpp:vlanId        uint16
|   |   +--rw cep3gpp:remoteAddress     inet:ip-address
+--rw cep3gpp:EP_N10* [id]
|   |--rw cep3gpp:id              string
|   +--rw cep3gpp:attributes
|   |   |--rw cep3gpp:userLabel?      string
|   |   +--ro cep3gpp:farEndEntity?   types3gpp:DistinguishedName
|   |   +--ro cep3gpp:supportedMeasurementsGPs* [measurementType]
|   |   |   |--ro cep3gpp:measurementType  string
|   |   |   |--ro cep3gpp:supportedGPs*    uint32
|   |   +--rw cep3gpp:localAddress* [ipAddress vlanId]
|   |   |   |--rw cep3gpp:ipAddress      inet:ip-address
|   |   |   |--rw cep3gpp:vlanId        uint16
|   |   +--rw cep3gpp:remoteAddress     inet:ip-address
+--rw cep3gpp:EP_N13* [id]
|   |--rw cep3gpp:id              string
|   +--rw cep3gpp:attributes
|   |   |--rw cep3gpp:userLabel?      string
|   |   +--ro cep3gpp:farEndEntity?   types3gpp:DistinguishedName
|   |   +--ro cep3gpp:supportedMeasurementsGPs* [measurementType]
|   |   |   |--ro cep3gpp:measurementType  string
|   |   |   |--ro cep3gpp:supportedGPs*    uint32
|   |   +--rw cep3gpp:localAddress* [ipAddress vlanId]
|   |   |   |--rw cep3gpp:ipAddress      inet:ip-address
|   |   |   |--rw cep3gpp:vlanId        uint16
|   |   +--rw cep3gpp:remoteAddress     inet:ip-address
+--rw cep3gpp:EP_SBI_X* [id]
|   |--rw cep3gpp:id              string
|   +--rw cep3gpp:attributes
|   |   |--rw cep3gpp:userLabel?      string
|   |   +--ro cep3gpp:farEndEntity?   types3gpp:DistinguishedName
|   |   +--ro cep3gpp:supportedMeasurementsGPs* [measurementType]
|   |   |   |--ro cep3gpp:measurementType  string
|   |   |   |--ro cep3gpp:supportedGPs*    uint32
|   |   +--rw cep3gpp:localAddress* [ipAddress vlanId]
|   |   |   |--rw cep3gpp:ipAddress      inet:ip-address
|   |   |   |--rw cep3gpp:vlanId        uint16
|   |   +--rw cep3gpp:remoteAddress     inet:ip-address
|   +--ro cep3gpp:sBIService*        string
+--rw udr3gpp:UDRFunction* [id]
|--rw udr3gpp:id              string
+--rw udr3gpp:attributes
|   |--rw udr3gpp:userLabel?      string
|   +--rw udr3gpp:vnfParametersList!
|   |   |--rw udr3gpp:vnfInstanceId  string
|   |   |--rw udr3gpp:vnfdId?       string
|   |   |--rw udr3gpp:flavourId?    string
|   |   |--rw udr3gpp:autoScalable  boolean
|   +--rw udr3gpp:peeParametersList!
|   |   |--rw udr3gpp:siteIdentification  string
|   |   |--rw udr3gpp:siteLatitude?      decimal64
|   |   |--rw udr3gpp:siteLongitude?     decimal64
|   |   |--rw udr3gpp:siteDescription    string
|   |   |--rw udr3gpp:equipmentType     string
|   |   |--rw udr3gpp:environmentType    string
|   |   |--rw udr3gpp:powerInterface     string
|   +--rw udr3gpp:priorityLabel          uint32
|   +--rw udr3gpp:pLMNidList* [mcc mnc]
|   |   |--rw udr3gpp:mcc      Mcc
|   |   |--rw udr3gpp:mnc      Mnc
|   +--rw udr3gpp:sBIFQDN?              inet:domain-name

```

```

| | +--ro udr3gpp:sBIServiceList*      string
| | +--rw udr3gpp:sNSSAIIList*        types3gpp:SNssai
+--rw cep3gpp:EP_SBI_X* [id]
+--rw cep3gpp:id                      string
+--rw cep3gpp:attributes
| +--rw cep3gpp:userLabel?           string
| +--ro cep3gpp:farEndEntity?        types3gpp:DistinguishedName
| +--ro cep3gpp:supportedMeasurementsGPs* [measurementType]
| | +--ro cep3gpp:measurementType    string
| | +--ro cep3gpp:supportedGPs*      uint32
+--rw cep3gpp:localAddress* [ipAddress vlanId]
| +--rw cep3gpp:ipAddress            inet:ip-address
| +--rw cep3gpp:vlanId              uint16
| +--rw cep3gpp:remoteAddress        inet:ip-address
+--ro cep3gpp:sBIService*           string
+--rw smf3gpp:SMFFunction* [id]
+--rw smf3gpp:id                      string
+--rw smf3gpp:attributes
| +--rw smf3gpp:userLabel?           string
+--rw smf3gpp:vnfParametersList!
| +--rw smf3gpp:vnfInstanceId        string
| +--rw smf3gpp:vnfId?              string
| +--rw smf3gpp:flavourId?          string
| +--rw smf3gpp:autoScalable         boolean
+--rw smf3gpp:peeParametersList!
| +--rw smf3gpp:siteIdentification   string
| +--rw smf3gpp:siteLatitude?        decimal64
| +--rw smf3gpp:siteLongitude?       decimal64
| +--rw smf3gpp:siteDescription      string
| +--rw smf3gpp:equipmentType        string
| +--rw smf3gpp:environmentType      string
| +--rw smf3gpp:powerInterface       string
+--rw smf3gpp:priorityLabel          uint32
+--rw smf3gpp:pLMNIdList* [mcc mnc]
| +--rw smf3gpp:mcc                 Mcc
| +--rw smf3gpp:mnc                 Mnc
+--ro smf3gpp:nRTACList*             types3gpp:Tac
+--rw smf3gpp:sBIFQDN?              inet:domain-name
+--ro smf3gpp:sBIServiceList*       string
+--rw smf3gpp:sNSSAIIList*          types3gpp:SNssai
+--rw cep3gpp:EP_N4* [id]
+--rw cep3gpp:id                      string
+--rw cep3gpp:attributes
| +--rw cep3gpp:userLabel?           string
| +--ro cep3gpp:farEndEntity?        types3gpp:DistinguishedName
| +--ro cep3gpp:supportedMeasurementsGPs* [measurementType]
| | +--ro cep3gpp:measurementType    string
| | +--ro cep3gpp:supportedGPs*      uint32
+--rw cep3gpp:localAddress* [ipAddress vlanId]
| +--rw cep3gpp:ipAddress            inet:ip-address
| +--rw cep3gpp:vlanId              uint16
| +--rw cep3gpp:remoteAddress        inet:ip-address
+--rw cep3gpp:EP_N7* [id]
+--rw cep3gpp:id                      string
+--rw cep3gpp:attributes
| +--rw cep3gpp:userLabel?           string
| +--ro cep3gpp:farEndEntity?        types3gpp:DistinguishedName
| +--ro cep3gpp:supportedMeasurementsGPs* [measurementType]
| | +--ro cep3gpp:measurementType    string
| | +--ro cep3gpp:supportedGPs*      uint32
+--rw cep3gpp:localAddress* [ipAddress vlanId]
| +--rw cep3gpp:ipAddress            inet:ip-address
| +--rw cep3gpp:vlanId              uint16
| +--rw cep3gpp:remoteAddress        inet:ip-address
+--rw cep3gpp:EP_N10* [id]
+--rw cep3gpp:id                      string
+--rw cep3gpp:attributes
| +--rw cep3gpp:userLabel?           string
| +--ro cep3gpp:farEndEntity?        types3gpp:DistinguishedName
| +--ro cep3gpp:supportedMeasurementsGPs* [measurementType]
| | +--ro cep3gpp:measurementType    string
| | +--ro cep3gpp:supportedGPs*      uint32
+--rw cep3gpp:localAddress* [ipAddress vlanId]
| +--rw cep3gpp:ipAddress            inet:ip-address
| +--rw cep3gpp:vlanId              uint16
| +--rw cep3gpp:remoteAddress        inet:ip-address
+--rw cep3gpp:EP_N11* [id]
| +--rw cep3gpp:id                  string

```

```

|--rw cep3gpp:attributes
  +--rw cep3gpp:userLabel?          string
  +--ro cep3gpp:farEndEntity?       types3gpp:DistinguishedName
  +--ro cep3gpp:supportedMeasurementsGPs* [measurementType]
  |   +--ro cep3gpp:measurementType  string
  |   +--ro cep3gpp:supportedGPs*    uint32
  +--rw cep3gpp:localAddress* [ipAddress vlanId]
  |   +--rw cep3gpp:ipAddress        inet:ip-address
  |   +--rw cep3gpp:vlanId          uint16
  +--rw cep3gpp:remoteAddress       inet:ip-address
+--rw cep3gpp:EP_N16* [id]
  +--rw cep3gpp:id                  string
  +--rw cep3gpp:attributes
    +--rw cep3gpp:userLabel?        string
    +--ro cep3gpp:farEndEntity?      types3gpp:DistinguishedName
    +--ro cep3gpp:supportedMeasurementsGPs* [measurementType]
    |   +--ro cep3gpp:measurementType  string
    |   +--ro cep3gpp:supportedGPs*    uint32
    +--rw cep3gpp:localAddress* [ipAddress vlanId]
    |   +--rw cep3gpp:ipAddress        inet:ip-address
    |   +--rw cep3gpp:vlanId          uint16
    +--rw cep3gpp:remoteAddress     inet:ip-address
+--rw cep3gpp:EP_S5C* [id]
  +--rw cep3gpp:id                  string
  +--rw cep3gpp:attributes
    +--rw cep3gpp:userLabel?        string
    +--ro cep3gpp:farEndEntity?      types3gpp:DistinguishedName
    +--ro cep3gpp:supportedMeasurementsGPs* [measurementType]
    |   +--ro cep3gpp:measurementType  string
    |   +--ro cep3gpp:supportedGPs*    uint32
    +--rw cep3gpp:localAddress* [ipAddress vlanId]
    |   +--rw cep3gpp:ipAddress        inet:ip-address
    |   +--rw cep3gpp:vlanId          uint16
    +--rw cep3gpp:remoteAddress     inet:ip-address
+--rw cep3gpp:EP_SBI_X* [id]
  +--rw cep3gpp:id                  string
  +--rw cep3gpp:attributes
    +--rw cep3gpp:userLabel?        string
    +--ro cep3gpp:farEndEntity?      types3gpp:DistinguishedName
    +--ro cep3gpp:supportedMeasurementsGPs* [measurementType]
    |   +--ro cep3gpp:measurementType  string
    |   +--ro cep3gpp:supportedGPs*    uint32
    +--rw cep3gpp:localAddress* [ipAddress vlanId]
    |   +--rw cep3gpp:ipAddress        inet:ip-address
    |   +--rw cep3gpp:vlanId          uint16
    +--rw cep3gpp:remoteAddress     inet:ip-address
    +--ro cep3gpp:sBIService*        string
+--rw ngeir3gpp:NGEIRFunction* [id]
  +--rw ngeir3gpp:id                string
  +--rw ngeir3gpp:attributes
    +--rw ngeir3gpp:userLabel?       string
    +--rw ngeir3gpp:vnfParametersList!
    |   +--rw ngeir3gpp:vnfInstanceId  string
    |   +--rw ngeir3gpp:vnfId?        string
    |   +--rw ngeir3gpp:flavourId?    string
    |   +--rw ngeir3gpp:autoScalable  boolean
    +--rw ngeir3gpp:peeParametersList!
    |   +--rw ngeir3gpp:siteIdentification  string
    |   +--rw ngeir3gpp:siteLatitude?      decimal64
    |   +--rw ngeir3gpp:siteLongitude?     decimal64
    |   +--rw ngeir3gpp:siteDescription    string
    |   +--rw ngeir3gpp:equipmentType     string
    |   +--rw ngeir3gpp:environmentType   string
    |   +--rw ngeir3gpp:powerInterface    string
    +--rw ngeir3gpp:priorityLabel         uint32
  +--rw ngeir3gpp:pLMNIdList* [mcc mnc]
  |   +--rw ngeir3gpp:mcc      Mcc
  |   +--rw ngeir3gpp:mnc      Mnc
  +--rw ngeir3gpp:sBIFQDN?          inet:domain-name
  +--ro ngeir3gpp:sBIServiceList*   string
  +--rw ngeir3gpp:sNSSAIIList*      types3gpp:SNssai
+--rw cep3gpp:EP_N17* [id]
  +--rw cep3gpp:id                  string
  +--rw cep3gpp:attributes
    +--rw cep3gpp:userLabel?        string
    +--ro cep3gpp:farEndEntity?      types3gpp:DistinguishedName
    +--ro cep3gpp:supportedMeasurementsGPs* [measurementType]
    |   +--ro cep3gpp:measurementType  string

```

```

    |   +--ro cep3gpp:supportedGPs*      uint32
+--rw cep3gpp:localAddress* [ipAddress vlanId]
    |   +--rw cep3gpp:ipAddress      inet:ip-address
    |   +--rw cep3gpp:vlanId        uint16
    |   +--rw cep3gpp:remoteAddress  inet:ip-address
+--rw gnbucup3gpp:GNBCUCPFunction* [id]
    +--rw gnbucup3gpp:id              string
+--rw gnbucup3gpp:attributes
    +--rw gnbucup3gpp:userLabel?     string
+--rw gnbucup3gpp:vnfParametersList!
    |   +--rw gnbucup3gpp:vnfInstanceId string
    |   +--rw gnbucup3gpp:vnfdId?     string
    |   +--rw gnbucup3gpp:flavourId?  string
    |   +--rw gnbucup3gpp:autoScalable boolean
+--rw gnbucup3gpp:peeParametersList!
    |   +--rw gnbucup3gpp:siteIdentification string
    |   +--rw gnbucup3gpp:siteLatitude?     decimal64
    |   +--rw gnbucup3gpp:siteLongitude?    decimal64
    |   +--rw gnbucup3gpp:siteDescription   string
    |   +--rw gnbucup3gpp:equipmentType    string
    |   +--rw gnbucup3gpp:environmentType  string
    |   +--rw gnbucup3gpp:powerInterface   string
+--rw gnbucup3gpp:priorityLabel      uint32
+--rw gnbucup3gpp:gNBId              int64
+--rw gnbucup3gpp:gNBIdLength        int32
+--rw gnbucup3gpp:gNBCUName          string
+--rw gnbucup3gpp:pLMNid* [mcc mnc]
    +--rw gnbucup3gpp:mcc            Mcc
    +--rw gnbucup3gpp:mnc            Mnc
+--rw nrcellcu3gpp:NRCellCU* [id]
    +--rw nrcellcu3gpp:id              string
+--rw nrcellcu3gpp:attributes
    +--rw nrcellcu3gpp:userLabel?     string
+--rw nrcellcu3gpp:vnfParametersList!
    |   +--rw nrcellcu3gpp:vnfInstanceId string
    |   +--rw nrcellcu3gpp:vnfdId?     string
    |   +--rw nrcellcu3gpp:flavourId?  string
    |   +--rw nrcellcu3gpp:autoScalable boolean
+--rw nrcellcu3gpp:peeParametersList!
    |   +--rw nrcellcu3gpp:siteIdentification string
    |   +--rw nrcellcu3gpp:siteLatitude?     decimal64
    |   +--rw nrcellcu3gpp:siteLongitude?    decimal64
    |   +--rw nrcellcu3gpp:siteDescription   string
    |   +--rw nrcellcu3gpp:equipmentType    string
    |   +--rw nrcellcu3gpp:environmentType  string
    |   +--rw nrcellcu3gpp:powerInterface   string
+--rw nrcellcu3gpp:priorityLabel      uint32
+--rw nrcellcu3gpp:cellLocalId        int32
+--rw nrcellcu3gpp:pLMNidList* [mcc mnc]
    |   +--rw nrcellcu3gpp:mcc            Mcc
    |   +--rw nrcellcu3gpp:mnc            Mnc
+--rw nrcellcu3gpp:sNSSAIList*        types3gpp:SNssai
+--rw nrcellcu3gpp:rRMPolicyType      uint16
+--rw nrcellcu3gpp:rRMPolicy          string
+--rw nrcellcu3gpp:rRMPolicyRatioList* [groupId]
    |   +--rw nrcellcu3gpp:groupId        uint32
    |   +--rw nrcellcu3gpp:sNSSAIList*    types3gpp:SNssai
    |   +--rw nrcellcu3gpp:rRRMPolicyRatio? uint8
+--rw nrcellcu3gpp:rRMPolicyRatio2* [groupId]
    |   +--rw nrcellcu3gpp:groupId        uint32
    |   +--rw nrcellcu3gpp:sNSSAIList*    types3gpp:SNssai
    |   +--rw nrcellcu3gpp:quotaType?     quotaType
    |   +--rw nrcellcu3gpp:rRMPolicyMaxRatio? uint8
    |   +--rw nrcellcu3gpp:rRMPolicyMarginMaxRatio? uint8
    |   +--rw nrcellcu3gpp:rRMPolicyMinRatio? uint8
    |   +--rw nrcellcu3gpp:rRMPolicyMarginMinRatio? uint8
+--ro nrcellcu3gpp:nRFrequencyRef?    types3gpp:DistinguishedName
+--rw eutranfreqrel3gpp:EUTranFreqRelation* [id]
    +--rw eutranfreqrel3gpp:id          string
+--rw eutranfreqrel3gpp:attributes
    +--rw eutranfreqrel3gpp:userLabel?   string
+--rw eutranfreqrel3gpp:vnfParametersList!
    |   +--rw eutranfreqrel3gpp:vnfInstanceId string
    |   +--rw eutranfreqrel3gpp:vnfdId?     string
    |   +--rw eutranfreqrel3gpp:flavourId?  string
    |   +--rw eutranfreqrel3gpp:autoScalable boolean
+--rw eutranfreqrel3gpp:peeParametersList!
    |   +--rw eutranfreqrel3gpp:siteIdentification string

```

```

|   |--rw eutranfreqrel3gpp:siteLatitude?        decimal64
|   |--rw eutranfreqrel3gpp:siteLongitude?       decimal64
|   |--rw eutranfreqrel3gpp:siteDescription      string
|   |--rw eutranfreqrel3gpp:equipmentType       string
|   |--rw eutranfreqrel3gpp:environmentType     string
|   |--rw eutranfreqrel3gpp:powerInterface      string
|--rw eutranfreqrel3gpp:priorityLabel           uint32
|--rw eutranfreqrel3gpp:cellIndividualOffset?   types3gpp:QOffsetRange
|--rw eutranfreqrel3gpp:blackListEntry*         uint16
|--rw eutranfreqrel3gpp:blackListEntryIdleMode* uint16
|--rw eutranfreqrel3gpp:cellReselectionPriority int32
|--rw eutranfreqrel3gpp:cellReselectionSubPriority? uint8
|--rw eutranfreqrel3gpp:pMax                    int32
|--rw eutranfreqrel3gpp:qOffsetFreq?           int32
|--rw eutranfreqrel3gpp:qQualMin              int32
|--rw eutranfreqrel3gpp:qRxLevMin             int32
|--rw eutranfreqrel3gpp:threshXHighP          int32
|--rw eutranfreqrel3gpp:threshXHighQ          int32
|--rw eutranfreqrel3gpp:threshXLowP           int32
|--rw eutranfreqrel3gpp:threshXLowQ           int32
|--rw eutranfreqrel3gpp:tReselectionEutra     uint8
|--rw eutranfreqrel3gpp:tReselectionEutraSfHigh uint8
|--rw eutranfreqrel3gpp:tReselectionEutraSfMedium uint8
|--rw eutranfreqrel3gpp:eUtranFrequencyRef    types3gpp:DistinguishedName
+--rw eutrancellrel3gpp:EUtranCellRelation* [id]
|   |--rw eutrancellrel3gpp:id                 string
|   |--rw eutrancellrel3gpp:attributes
|   |--rw eutrancellrel3gpp:userLabel?         string
|   |--rw eutrancellrel3gpp:vnfParametersList!
|   |   |--rw eutrancellrel3gpp:vnfInstanceId   string
|   |   |--rw eutrancellrel3gpp:vnfdId?       string
|   |   |--rw eutrancellrel3gpp:flavourId?    string
|   |   |--rw eutrancellrel3gpp:autoScalable   boolean
|   |--rw eutrancellrel3gpp:peeParametersList!
|   |   |--rw eutrancellrel3gpp:siteIdentification string
|   |   |--rw eutrancellrel3gpp:siteLatitude?   decimal64
|   |   |--rw eutrancellrel3gpp:siteLongitude?   decimal64
|   |   |--rw eutrancellrel3gpp:siteDescription string
|   |   |--rw eutrancellrel3gpp:equipmentType   string
|   |   |--rw eutrancellrel3gpp:environmentType string
|   |   |--rw eutrancellrel3gpp:powerInterface  string
|   |--rw eutrancellrel3gpp:priorityLabel       uint32
|   |--rw eutrancellrel3gpp:tCI                 uint64
|   |--rw eutrancellrel3gpp:isRemoveAllowed     ActionAllowed
|   |--rw eutrancellrel3gpp:isSHOAllowed        ActionAllowed
|   |--rw eutrancellrel3gpp:isICICInformationSendAllowed ActionAllowed
|   |--rw eutrancellrel3gpp:isLBAAllowed        ActionAllowed
|   |--rw eutrancellrel3gpp:isESCoveredBy       EnergySavingCoverage
|   |--rw eutrancellrel3gpp:qOffset            types3gpp:QOffsetRange
|   |--ro eutrancellrel3gpp:cellIndividualOffset? types3gpp:QOffsetRange
|   |--rw eutrancellrel3gpp:adjacentCell       types3gpp:DistinguishedName
+--rw nrcellrel3gpp:NRCellRelation* [id]
|   |--rw nrcellrel3gpp:id                     string
|   |--rw nrcellrel3gpp:attributes
|   |--rw nrcellrel3gpp:userLabel?             string
|   |--rw nrcellrel3gpp:vnfParametersList!
|   |   |--rw nrcellrel3gpp:vnfInstanceId     string
|   |   |--rw nrcellrel3gpp:vnfdId?         string
|   |   |--rw nrcellrel3gpp:flavourId?      string
|   |   |--rw nrcellrel3gpp:autoScalable     boolean
|   |--rw nrcellrel3gpp:peeParametersList!
|   |   |--rw nrcellrel3gpp:siteIdentification string
|   |   |--rw nrcellrel3gpp:siteLatitude?     decimal64
|   |   |--rw nrcellrel3gpp:siteLongitude?     decimal64
|   |   |--rw nrcellrel3gpp:siteDescription   string
|   |   |--rw nrcellrel3gpp:equipmentType     string
|   |   |--rw nrcellrel3gpp:environmentType   string
|   |   |--rw nrcellrel3gpp:powerInterface    string
|   |--rw nrcellrel3gpp:priorityLabel         uint32
|   |--rw nrcellrel3gpp:nRTCI?                uint64
|   |--rw nrcellrel3gpp:cellIndividualOffset
|   |   |--rw nrcellrel3gpp:rsrpOffsetSsb?    types3gpp:QOffsetRange
|   |   |--rw nrcellrel3gpp:rsrqOffsetSsb?    types3gpp:QOffsetRange
|   |   |--rw nrcellrel3gpp:sinrOffsetSsb?    types3gpp:QOffsetRange
|   |   |--rw nrcellrel3gpp:rsrpOffsetCsiRs?  types3gpp:QOffsetRange
|   |   |--rw nrcellrel3gpp:rsrqOffsetCsiRs?  types3gpp:QOffsetRange
|   |   |--rw nrcellrel3gpp:sinrOffsetCsiRs?  types3gpp:QOffsetRange
|   |--rw nrcellrel3gpp:nRFreqRelationRef     types3gpp:DistinguishedName

```

```

|   +--rw nrcellrel3gpp:adjacentNRCellRef          types3gpp:DistinguishedName
+--rw nrfreqrel3gpp:NRFreqRelation* [id]
+--rw nrfreqrel3gpp:id                          string
+--rw nrfreqrel3gpp:attributes
+--rw nrfreqrel3gpp:userLabel?                  string
+--rw nrfreqrel3gpp:vnfParametersList!
|   +--rw nrfreqrel3gpp:vnfInstanceId            string
|   +--rw nrfreqrel3gpp:vnfId?                   string
|   +--rw nrfreqrel3gpp:flavourId?              string
|   +--rw nrfreqrel3gpp:autoScalable             boolean
+--rw nrfreqrel3gpp:peeParametersList!
|   +--rw nrfreqrel3gpp:siteIdentification       string
|   +--rw nrfreqrel3gpp:siteLatitude?           decimal64
|   +--rw nrfreqrel3gpp:siteLongitude?          decimal64
|   +--rw nrfreqrel3gpp:siteDescription         string
|   +--rw nrfreqrel3gpp:equipmentType           string
|   +--rw nrfreqrel3gpp:environmentType         string
|   +--rw nrfreqrel3gpp:powerInterface          string
+--rw nrfreqrel3gpp:priorityLabel                uint32
+--rw nrfreqrel3gpp:offsetMO
|   +--rw nrfreqrel3gpp:rsrpOffsetSsb?          types3gpp:QOffsetRange
|   +--rw nrfreqrel3gpp:rsrqOffsetSsb?          types3gpp:QOffsetRange
|   +--rw nrfreqrel3gpp:sinrOffsetSsb?          types3gpp:QOffsetRange
|   +--rw nrfreqrel3gpp:rsrpOffsetCsiRs?        types3gpp:QOffsetRange
|   +--rw nrfreqrel3gpp:rsrqOffsetCsiRs?        types3gpp:QOffsetRange
|   +--rw nrfreqrel3gpp:sinrOffsetCsiRs?        types3gpp:QOffsetRange
+--rw nrfreqrel3gpp:blackListEntry*             uint16
+--rw nrfreqrel3gpp:blackListEntryIdleMode*    uint16
+--rw nrfreqrel3gpp:cellReselectionPriority?    uint32
+--rw nrfreqrel3gpp:cellReselectionSubPriority? uint8
+--rw nrfreqrel3gpp:pMax?                       int32
+--rw nrfreqrel3gpp:qOffsetFreq?                types3gpp:QOffsetRange
+--rw nrfreqrel3gpp:qQualMin?                   int32
+--rw nrfreqrel3gpp:qRxLevMin                   int32
+--rw nrfreqrel3gpp:threshXHighP                int32
+--rw nrfreqrel3gpp:threshXHighQ               int32
+--rw nrfreqrel3gpp:threshXLowP                 int32
+--rw nrfreqrel3gpp:threshXLowQ                int32
+--rw nrfreqrel3gpp:tReselectionNR              int32
+--rw nrfreqrel3gpp:tReselectionNRSfHigh       uint8
+--rw nrfreqrel3gpp:tReselectionNRSfMedium     uint8
+--rw nrfreqrel3gpp:nRFrequencyRef              types3gpp:DistinguishedName
+--rw ep3gpp:EP_E1* [id]
|   +--rw ep3gpp:id                          string
+--rw ep3gpp:attributes
|   +--rw ep3gpp:userLabel?                  string
|   +--ro ep3gpp:farEndEntity?                types3gpp:DistinguishedName
+--ro ep3gpp:supportedMeasurementsGPs* [measurementType]
|   +--ro ep3gpp:measurementType            string
|   +--ro ep3gpp:supportedGPs*              uint32
+--rw ep3gpp:localAddress* [ipAddress vlanId]
|   +--rw ep3gpp:ipAddress                  inet:ip-address
|   +--rw ep3gpp:vlanId                    uint16
+--rw ep3gpp:remoteAddress                    inet:ip-address
+--rw ep3gpp:EP_FL1C* [id]
|   +--rw ep3gpp:id                          string
+--rw ep3gpp:attributes
|   +--rw ep3gpp:userLabel?                  string
|   +--ro ep3gpp:farEndEntity?                types3gpp:DistinguishedName
+--ro ep3gpp:supportedMeasurementsGPs* [measurementType]
|   +--ro ep3gpp:measurementType            string
|   +--ro ep3gpp:supportedGPs*              uint32
+--rw ep3gpp:localAddress* [ipAddress vlanId]
|   +--rw ep3gpp:ipAddress                  inet:ip-address
|   +--rw ep3gpp:vlanId                    uint16
+--rw ep3gpp:remoteAddress                    inet:ip-address
+--rw ep3gpp:EP_NgC* [id]
|   +--rw ep3gpp:id                          string
+--rw ep3gpp:attributes
|   +--rw ep3gpp:userLabel?                  string
|   +--ro ep3gpp:farEndEntity?                types3gpp:DistinguishedName
+--ro ep3gpp:supportedMeasurementsGPs* [measurementType]
|   +--ro ep3gpp:measurementType            string
|   +--ro ep3gpp:supportedGPs*              uint32
+--rw ep3gpp:localAddress* [ipAddress vlanId]
|   +--rw ep3gpp:ipAddress                  inet:ip-address
|   +--rw ep3gpp:vlanId                    uint16
+--rw ep3gpp:remoteAddress                    inet:ip-address

```

```

+--rw ep3gpp:EP_XnC* [id]
|   +--rw ep3gpp:id          string
|   +--rw ep3gpp:attributes
|   |   +--rw ep3gpp:userLabel?          string
|   |   +--ro ep3gpp:farEndEntity?      types3gpp:DistinguishedName
|   |   +--ro ep3gpp:supportedMeasurementsGPs* [measurementType]
|   |   |   +--ro ep3gpp:measurementType  string
|   |   |   +--ro ep3gpp:supportedGPs*    uint32
|   |   +--rw ep3gpp:localAddress* [ipAddress vlanId]
|   |   |   +--rw ep3gpp:ipAddress      inet:ip-address
|   |   |   +--rw ep3gpp:vlanId        uint16
|   |   +--rw ep3gpp:remoteAddress      inet:ip-address
+--rw ep3gpp:EP_X2C* [id]
|   +--rw ep3gpp:id          string
|   +--rw ep3gpp:attributes
|   |   +--rw ep3gpp:userLabel?          string
|   |   +--ro ep3gpp:farEndEntity?      types3gpp:DistinguishedName
|   |   +--ro ep3gpp:supportedMeasurementsGPs* [measurementType]
|   |   |   +--ro ep3gpp:measurementType  string
|   |   |   +--ro ep3gpp:supportedGPs*    uint32
|   |   +--rw ep3gpp:localAddress* [ipAddress vlanId]
|   |   |   +--rw ep3gpp:ipAddress      inet:ip-address
|   |   |   +--rw ep3gpp:vlanId        uint16
|   |   +--rw ep3gpp:remoteAddress      inet:ip-address
+--rw sepp3gpp:SEPPFunction* [id]
|   +--rw sepp3gpp:id          string
|   +--rw sepp3gpp:attributes
|   |   +--rw sepp3gpp:userLabel?          string
|   |   +--rw sepp3gpp:vnfParametersList!
|   |   |   +--rw sepp3gpp:vnfInstanceId  string
|   |   |   +--rw sepp3gpp:vnfdId?       string
|   |   |   +--rw sepp3gpp:flavourId?    string
|   |   |   +--rw sepp3gpp:autoScalable  boolean
|   |   +--rw sepp3gpp:peeParametersList!
|   |   |   +--rw sepp3gpp:siteIdentification  string
|   |   |   +--rw sepp3gpp:siteLatitude?      decimal64
|   |   |   +--rw sepp3gpp:siteLongitude?     decimal64
|   |   |   +--rw sepp3gpp:siteDescription    string
|   |   |   +--rw sepp3gpp:equipmentType     string
|   |   |   +--rw sepp3gpp:environmentType   string
|   |   |   +--rw sepp3gpp:powerInterface    string
|   |   +--rw sepp3gpp:priorityLabel          uint32
|   |   +--rw sepp3gpp:pLMNidList* [mcc mnc]
|   |   |   +--rw sepp3gpp:mcc  Mcc
|   |   |   +--rw sepp3gpp:mnc  Mnc
+--rw cep3gpp:EP_N32* [id]
|   +--rw cep3gpp:id          string
|   +--rw cep3gpp:attributes
|   |   +--rw cep3gpp:userLabel?          string
|   |   +--ro cep3gpp:farEndEntity?      types3gpp:DistinguishedName
|   |   +--ro cep3gpp:supportedMeasurementsGPs* [measurementType]
|   |   |   +--ro cep3gpp:measurementType  string
|   |   |   +--ro cep3gpp:supportedGPs*    uint32
|   |   +--rw cep3gpp:localAddress* [ipAddress vlanId]
|   |   |   +--rw cep3gpp:ipAddress      inet:ip-address
|   |   |   +--rw cep3gpp:vlanId        uint16
|   |   +--rw cep3gpp:remoteAddress      inet:ip-address
+--rw cep3gpp:EP_SBI_IPX* [id]
|   +--rw cep3gpp:id          string
|   +--rw cep3gpp:attributes
|   |   +--rw cep3gpp:userLabel?          string
|   |   +--ro cep3gpp:farEndEntity?      types3gpp:DistinguishedName
|   |   +--ro cep3gpp:supportedMeasurementsGPs* [measurementType]
|   |   |   +--ro cep3gpp:measurementType  string
|   |   |   +--ro cep3gpp:supportedGPs*    uint32
|   |   +--rw cep3gpp:localAddress* [ipAddress vlanId]
|   |   |   +--rw cep3gpp:ipAddress      inet:ip-address
|   |   |   +--rw cep3gpp:vlanId        uint16
|   |   +--rw cep3gpp:remoteAddress      inet:ip-address
|   |   +--ro cep3gpp:sBIService*        string
+--rw gnbcuup3gpp:GNBCUUPFunction* [id]
|   +--rw gnbcuup3gpp:id          string
|   +--rw gnbcuup3gpp:attributes
|   |   +--rw gnbcuup3gpp:userLabel?          string
|   |   +--rw gnbcuup3gpp:vnfParametersList!
|   |   |   +--rw gnbcuup3gpp:vnfInstanceId  string
|   |   |   +--rw gnbcuup3gpp:vnfdId?       string
|   |   |   +--rw gnbcuup3gpp:flavourId?    string

```



```

| | +--rw gnbcuup3gpp:autoScalable    boolean
+--rw gnbcuup3gpp:peeParametersList!
| | +--rw gnbcuup3gpp:siteIdentification    string
| | +--rw gnbcuup3gpp:siteLatitude?       decimal64
| | +--rw gnbcuup3gpp:siteLongitude?      decimal64
| | +--rw gnbcuup3gpp:siteDescription     string
| | +--rw gnbcuup3gpp:equipmentType      string
| | +--rw gnbcuup3gpp:environmentType    string
| | +--rw gnbcuup3gpp:powerInterface     string
+--rw gnbcuup3gpp:priorityLabel          uint32
+--rw gnbcuup3gpp:gNBID                  int64
+--rw gnbcuup3gpp:gNBIDLength            int32
+--rw gnbcuup3gpp:pLMNIDList* [mcc mnc]
| | +--rw gnbcuup3gpp:mcc      Mcc
| | +--rw gnbcuup3gpp:mnc      Mnc
+--rw ep3gpp:EP_E1* [id]
| | +--rw ep3gpp:id            string
| | +--rw ep3gpp:attributes
| | | +--rw ep3gpp:userLabel?      string
| | | +--ro ep3gpp:farEndEntity?   types3gpp:DistinguishedName
| | | +--ro ep3gpp:supportedMeasurementsGPs* [measurementType]
| | | | +--ro ep3gpp:measurementType    string
| | | | +--ro ep3gpp:supportedGPs*      uint32
| | | +--rw ep3gpp:localAddress* [ipAddress vlanId]
| | | | +--rw ep3gpp:ipAddress    inet:ip-address
| | | | +--rw ep3gpp:vlanId      uint16
| | | +--rw ep3gpp:remoteAddress    inet:ip-address
+--rw ep3gpp:EP_FLU* [id]
| | +--rw ep3gpp:id            string
| | +--rw ep3gpp:attributes
| | | +--rw ep3gpp:userLabel?      string
| | | +--ro ep3gpp:farEndEntity?   types3gpp:DistinguishedName
| | | +--ro ep3gpp:supportedMeasurementsGPs* [measurementType]
| | | | +--ro ep3gpp:measurementType    string
| | | | +--ro ep3gpp:supportedGPs*      uint32
| | | +--rw ep3gpp:localAddress* [ipAddress vlanId]
| | | | +--rw ep3gpp:ipAddress    inet:ip-address
| | | | +--rw ep3gpp:vlanId      uint16
| | | +--rw ep3gpp:remoteAddress    inet:ip-address
+--rw ep3gpp:EP_NgU* [id]
| | +--rw ep3gpp:id            string
| | +--rw ep3gpp:attributes
| | | +--rw ep3gpp:userLabel?      string
| | | +--ro ep3gpp:farEndEntity?   types3gpp:DistinguishedName
| | | +--ro ep3gpp:supportedMeasurementsGPs* [measurementType]
| | | | +--ro ep3gpp:measurementType    string
| | | | +--ro ep3gpp:supportedGPs*      uint32
| | | +--rw ep3gpp:localAddress* [ipAddress vlanId]
| | | | +--rw ep3gpp:ipAddress    inet:ip-address
| | | | +--rw ep3gpp:vlanId      uint16
| | | +--rw ep3gpp:remoteAddress    inet:ip-address
+--rw ep3gpp:EP_XnU* [id]
| | +--rw ep3gpp:id            string
| | +--rw ep3gpp:attributes
| | | +--rw ep3gpp:userLabel?      string
| | | +--ro ep3gpp:farEndEntity?   types3gpp:DistinguishedName
| | | +--ro ep3gpp:supportedMeasurementsGPs* [measurementType]
| | | | +--ro ep3gpp:measurementType    string
| | | | +--ro ep3gpp:supportedGPs*      uint32
| | | +--rw ep3gpp:localAddress* [ipAddress vlanId]
| | | | +--rw ep3gpp:ipAddress    inet:ip-address
| | | | +--rw ep3gpp:vlanId      uint16
| | | +--rw ep3gpp:remoteAddress    inet:ip-address
+--rw ep3gpp:EP_X2U* [id]
| | +--rw ep3gpp:id            string
| | +--rw ep3gpp:attributes
| | | +--rw ep3gpp:userLabel?      string
| | | +--ro ep3gpp:farEndEntity?   types3gpp:DistinguishedName
| | | +--ro ep3gpp:supportedMeasurementsGPs* [measurementType]
| | | | +--ro ep3gpp:measurementType    string
| | | | +--ro ep3gpp:supportedGPs*      uint32
| | | +--rw ep3gpp:localAddress* [ipAddress vlanId]
| | | | +--rw ep3gpp:ipAddress    inet:ip-address
| | | | +--rw ep3gpp:vlanId      uint16
| | | +--rw ep3gpp:remoteAddress    inet:ip-address
+--rw ep3gpp:EP_S1U* [id]
| | +--rw ep3gpp:id            string
| | +--rw ep3gpp:attributes

```

```

    +--rw ep3gpp:userLabel?                string
    +--ro ep3gpp:farEndEntity?             types3gpp:DistinguishedName
    +--ro ep3gpp:supportedMeasurementsGPs* [measurementType]
    |   +--ro ep3gpp:measurementType      string
    |   +--ro ep3gpp:supportedGPs*       uint32
    +--rw ep3gpp:localAddress* [ipAddress vlanId]
    |   +--rw ep3gpp:ipAddress            inet:ip-address
    |   +--rw ep3gpp:vlanId              uint16
    +--rw ep3gpp:remoteAddress             inet:ip-address
+--rw nwdaf3gpp:NWDAFFunction* [id]
  +--rw nwdaf3gpp:id                     string
  +--rw nwdaf3gpp:attributes
  |   +--rw nwdaf3gpp:userLabel?         string
  |   +--rw nwdaf3gpp:vnfParametersList!
  |   |   +--rw nwdaf3gpp:vnfInstanceId  string
  |   |   +--rw nwdaf3gpp:vnfdId?       string
  |   |   +--rw nwdaf3gpp:flavourId?    string
  |   |   +--rw nwdaf3gpp:autoScalable  boolean
  |   +--rw nwdaf3gpp:peeParametersList!
  |   |   +--rw nwdaf3gpp:siteIdentification  string
  |   |   +--rw nwdaf3gpp:siteLatitude?      decimal64
  |   |   +--rw nwdaf3gpp:siteLongitude?     decimal64
  |   |   +--rw nwdaf3gpp:siteDescription    string
  |   |   +--rw nwdaf3gpp:equipmentType     string
  |   |   +--rw nwdaf3gpp:environmentType   string
  |   |   +--rw nwdaf3gpp:powerInterface    string
  |   +--rw nwdaf3gpp:priorityLabel         uint32
  |   +--rw nwdaf3gpp:pLMNIdList* [mcc mnc]
  |   |   +--rw nwdaf3gpp:mcc      Mcc
  |   |   +--rw nwdaf3gpp:mnc      Mnc
  |   +--rw nwdaf3gpp:sBIFQDN?           inet:domain-name
  |   +--ro nwdaf3gpp:sBIServiceList*    string
  |   +--rw nwdaf3gpp:sNSSAIIList*       types3gpp:SNssai
+--rw cep3gpp:EP_SBI_X* [id]
  +--rw cep3gpp:id                       string
  +--rw cep3gpp:attributes
  |   +--rw cep3gpp:userLabel?            string
  |   +--ro cep3gpp:farEndEntity?         types3gpp:DistinguishedName
  |   +--ro cep3gpp:supportedMeasurementsGPs* [measurementType]
  |   |   +--ro cep3gpp:measurementType  string
  |   |   +--ro cep3gpp:supportedGPs*    uint32
  |   +--rw cep3gpp:localAddress* [ipAddress vlanId]
  |   |   +--rw cep3gpp:ipAddress        inet:ip-address
  |   |   +--rw cep3gpp:vlanId          uint16
  |   +--rw cep3gpp:remoteAddress         inet:ip-address
  |   +--ro cep3gpp:sBIService*          string
+--rw smsf3gpp:SMSFFunction* [id]
  +--rw smsf3gpp:id                     string
  +--rw smsf3gpp:attributes
  |   +--rw smsf3gpp:userLabel?         string
  |   +--rw smsf3gpp:vnfParametersList!
  |   |   +--rw smsf3gpp:vnfInstanceId  string
  |   |   +--rw smsf3gpp:vnfdId?       string
  |   |   +--rw smsf3gpp:flavourId?    string
  |   |   +--rw smsf3gpp:autoScalable  boolean
  |   +--rw smsf3gpp:peeParametersList!
  |   |   +--rw smsf3gpp:siteIdentification  string
  |   |   +--rw smsf3gpp:siteLatitude?      decimal64
  |   |   +--rw smsf3gpp:siteLongitude?     decimal64
  |   |   +--rw smsf3gpp:siteDescription    string
  |   |   +--rw smsf3gpp:equipmentType     string
  |   |   +--rw smsf3gpp:environmentType   string
  |   |   +--rw smsf3gpp:powerInterface    string
  |   +--rw smsf3gpp:priorityLabel         uint32
  |   +--rw smsf3gpp:pLMNIdList* [mcc mnc]
  |   |   +--rw smsf3gpp:mcc      Mcc
  |   |   +--rw smsf3gpp:mnc      Mnc
  |   +--rw smsf3gpp:sBIFQDN?           inet:domain-name
  |   +--ro smsf3gpp:sBIServiceList*    string
+--rw cep3gpp:EP_N20* [id]
  +--rw cep3gpp:id                       string
  +--rw cep3gpp:attributes
  |   +--rw cep3gpp:userLabel?            string
  |   +--ro cep3gpp:farEndEntity?         types3gpp:DistinguishedName
  |   +--ro cep3gpp:supportedMeasurementsGPs* [measurementType]
  |   |   +--ro cep3gpp:measurementType  string
  |   |   +--ro cep3gpp:supportedGPs*    uint32
  |   +--rw cep3gpp:localAddress* [ipAddress vlanId]

```

```

| | | +--rw cep3gpp:ipAddress      inet:ip-address
| | | +--rw cep3gpp:vlanId        uint16
| | | +--rw cep3gpp:remoteAddress  inet:ip-address
+--rw cep3gpp:EP_N21* [id]
| +--rw cep3gpp:id                string
| +--rw cep3gpp:attributes
| | +--rw cep3gpp:userLabel?      string
| | +--ro cep3gpp:farEndEntity?   types3gpp:DistinguishedName
| | +--ro cep3gpp:supportedMeasurementsGPs* [measurementType]
| | | +--ro cep3gpp:measurementType  string
| | | +--ro cep3gpp:supportedGPs*   uint32
| | +--rw cep3gpp:localAddress* [ipAddress vlanId]
| | | +--rw cep3gpp:ipAddress      inet:ip-address
| | | +--rw cep3gpp:vlanId        uint16
| | +--rw cep3gpp:remoteAddress  inet:ip-address
+--rw cep3gpp:EP_MAP_SMSC* [id]
| +--rw cep3gpp:id                string
| +--rw cep3gpp:attributes
| | +--rw cep3gpp:userLabel?      string
| | +--ro cep3gpp:farEndEntity?   types3gpp:DistinguishedName
| | +--ro cep3gpp:supportedMeasurementsGPs* [measurementType]
| | | +--ro cep3gpp:measurementType  string
| | | +--ro cep3gpp:supportedGPs*   uint32
| | +--rw cep3gpp:localAddress* [ipAddress vlanId]
| | | +--rw cep3gpp:ipAddress      inet:ip-address
| | | +--rw cep3gpp:vlanId        uint16
| | +--rw cep3gpp:remoteAddress  inet:ip-address
+--rw udsf3gpp:UDSFFunction* [id]
| +--rw udsf3gpp:id                string
| +--rw udsf3gpp:attributes
| | +--rw udsf3gpp:userLabel?      string
| | +--rw udsf3gpp:vnfParametersList!
| | | +--rw udsf3gpp:vnfInstanceId  string
| | | +--rw udsf3gpp:vnfdId?       string
| | | +--rw udsf3gpp:flavourId?    string
| | | +--rw udsf3gpp:autoScalable  boolean
| | +--rw udsf3gpp:peeParametersList!
| | | +--rw udsf3gpp:siteIdentification  string
| | | +--rw udsf3gpp:siteLatitude?     decimal64
| | | +--rw udsf3gpp:siteLongitude?    decimal64
| | | +--rw udsf3gpp:siteDescription   string
| | | +--rw udsf3gpp:equipmentType     string
| | | +--rw udsf3gpp:environmentType  string
| | | +--rw udsf3gpp:powerInterface   string
| | +--rw udsf3gpp:priorityLabel      uint32
| | +--rw udsf3gpp:pLMNIdList* [mcc mnc]
| | | +--rw udsf3gpp:mcc             Mcc
| | | +--rw udsf3gpp:mnc             Mnc
| | +--rw udsf3gpp:sBIFQDN?          inet:domain-name
| | +--ro udsf3gpp:sBIServiceList*   string
| | +--rw udsf3gpp:sNSSAList*        types3gpp:SNssai
+--rw cep3gpp:EP_SBI_X* [id]
| +--rw cep3gpp:id                string
| +--rw cep3gpp:attributes
| | +--rw cep3gpp:userLabel?      string
| | +--ro cep3gpp:farEndEntity?   types3gpp:DistinguishedName
| | +--ro cep3gpp:supportedMeasurementsGPs* [measurementType]
| | | +--ro cep3gpp:measurementType  string
| | | +--ro cep3gpp:supportedGPs*   uint32
| | +--rw cep3gpp:localAddress* [ipAddress vlanId]
| | | +--rw cep3gpp:ipAddress      inet:ip-address
| | | +--rw cep3gpp:vlanId        uint16
| | +--rw cep3gpp:remoteAddress  inet:ip-address
| | +--ro cep3gpp:sBIService*      string
+--rw dn3gpp:DNFunction* [id]
| +--rw dn3gpp:id                string
| +--rw dn3gpp:attributes
| | +--rw dn3gpp:userLabel?      string
| | +--rw dn3gpp:vnfParametersList!
| | | +--rw dn3gpp:vnfInstanceId  string
| | | +--rw dn3gpp:vnfdId?       string
| | | +--rw dn3gpp:flavourId?    string
| | | +--rw dn3gpp:autoScalable  boolean
| | +--rw dn3gpp:peeParametersList!
| | | +--rw dn3gpp:siteIdentification  string
| | | +--rw dn3gpp:siteLatitude?     decimal64
| | | +--rw dn3gpp:siteLongitude?    decimal64
| | | +--rw dn3gpp:siteDescription   string

```

```

| | +--rw dn3gpp:equipmentType      string
| | +--rw dn3gpp:environmentType   string
| | +--rw dn3gpp:powerInterface    string
| +--rw dn3gpp:priorityLabel      uint32
+--rw cep3gpp:EP_N6* [id]
  +--rw cep3gpp:id                 string
  +--rw cep3gpp:attributes
    +--rw cep3gpp:userLabel?       string
    +--ro cep3gpp:farEndEntity?    types3gpp:DistinguishedName
    +--ro cep3gpp:supportedMeasurementsGPs* [measurementType]
      +--ro cep3gpp:measurementType string
      +--ro cep3gpp:supportedGPs*   uint32
    +--rw cep3gpp:localAddress* [ipAddress vlanId]
      +--rw cep3gpp:ipAddress      inet:ip-address
      +--rw cep3gpp:vlanId        uint16
    +--rw cep3gpp:remoteAddress    inet:ip-address
+--rw nssf3gpp:NSSFFunction* [id]
  +--rw nssf3gpp:id               string
  +--rw nssf3gpp:attributes
    +--rw nssf3gpp:userLabel?     string
    +--rw nssf3gpp:vnfParametersList!
      +--rw nssf3gpp:vnfInstanceId string
      +--rw nssf3gpp:vnfId?       string
      +--rw nssf3gpp:flavourId?   string
      +--rw nssf3gpp:autoScalable boolean
    +--rw nssf3gpp:peeParametersList!
      +--rw nssf3gpp:siteIdentification string
      +--rw nssf3gpp:siteLatitude?     decimal64
      +--rw nssf3gpp:siteLongitude?    decimal64
      +--rw nssf3gpp:siteDescription  string
      +--rw nssf3gpp:equipmentType    string
      +--rw nssf3gpp:environmentType  string
      +--rw nssf3gpp:powerInterface   string
    +--rw nssf3gpp:priorityLabel     uint32
    +--rw nssf3gpp:pLMNIdList* [mcc mnc]
      +--rw nssf3gpp:mcc             Mcc
      +--rw nssf3gpp:mnc             Mnc
    +--rw nssf3gpp:sBIFQDN?          inet:domain-name
    +--rw nssf3gpp:sNSSAList*        types3gpp:SNssai
    +--rw nssf3gpp:nSIIIdListWrap*   types3gpp:NsiId
+--rw cep3gpp:EP_N22* [id]
  +--rw cep3gpp:id                 string
  +--rw cep3gpp:attributes
    +--rw cep3gpp:userLabel?       string
    +--ro cep3gpp:farEndEntity?    types3gpp:DistinguishedName
    +--ro cep3gpp:supportedMeasurementsGPs* [measurementType]
      +--ro cep3gpp:measurementType string
      +--ro cep3gpp:supportedGPs*   uint32
    +--rw cep3gpp:localAddress* [ipAddress vlanId]
      +--rw cep3gpp:ipAddress      inet:ip-address
      +--rw cep3gpp:vlanId        uint16
    +--rw cep3gpp:remoteAddress    inet:ip-address
+--rw cep3gpp:EP_N31* [id]
  +--rw cep3gpp:id                 string
  +--rw cep3gpp:attributes
    +--rw cep3gpp:userLabel?       string
    +--ro cep3gpp:farEndEntity?    types3gpp:DistinguishedName
    +--ro cep3gpp:supportedMeasurementsGPs* [measurementType]
      +--ro cep3gpp:measurementType string
      +--ro cep3gpp:supportedGPs*   uint32
    +--rw cep3gpp:localAddress* [ipAddress vlanId]
      +--rw cep3gpp:ipAddress      inet:ip-address
      +--rw cep3gpp:vlanId        uint16
    +--rw cep3gpp:remoteAddress    inet:ip-address
+--rw cep3gpp:EP_SBI_X* [id]
  +--rw cep3gpp:id                 string
  +--rw cep3gpp:attributes
    +--rw cep3gpp:userLabel?       string
    +--ro cep3gpp:farEndEntity?    types3gpp:DistinguishedName
    +--ro cep3gpp:supportedMeasurementsGPs* [measurementType]
      +--ro cep3gpp:measurementType string
      +--ro cep3gpp:supportedGPs*   uint32
    +--rw cep3gpp:localAddress* [ipAddress vlanId]
      +--rw cep3gpp:ipAddress      inet:ip-address
      +--rw cep3gpp:vlanId        uint16
    +--rw cep3gpp:remoteAddress    inet:ip-address
    +--ro cep3gpp:sBIService*      string
+--rw ausf3gpp:AUSFFunction* [id]

```

```

+--rw ausf3gpp:id string
+--rw ausf3gpp:attributes
+--rw ausf3gpp:userLabel? string
+--rw ausf3gpp:vnfParametersList!
| +--rw ausf3gpp:vnfInstanceId string
| +--rw ausf3gpp:vnfdId? string
| +--rw ausf3gpp:flavourId? string
| +--rw ausf3gpp:autoScalable boolean
+--rw ausf3gpp:peeParametersList!
| +--rw ausf3gpp:siteIdentification string
| +--rw ausf3gpp:siteLatitude? decimal64
| +--rw ausf3gpp:siteLongitude? decimal64
| +--rw ausf3gpp:siteDescription string
| +--rw ausf3gpp:equipmentType string
| +--rw ausf3gpp:environmentType string
| +--rw ausf3gpp:powerInterface string
+--rw ausf3gpp:priorityLabel uint32
+--rw ausf3gpp:pLMNidList* [mcc mnc]
| +--rw ausf3gpp:mcc Mcc
| +--rw ausf3gpp:mnc Mnc
+--rw ausf3gpp:sBIFQDN? inet:domain-name
+--ro ausf3gpp:sBIServiceList* string
+--rw ausf3gpp:sNSSAList* types3gpp:SNssai
+--rw cep3gpp:EP_N12* [id]
+--rw cep3gpp:id string
+--rw cep3gpp:attributes
+--rw cep3gpp:userLabel? string
+--ro cep3gpp:farEndEntity? types3gpp:DistinguishedName
+--ro cep3gpp:supportedMeasurementsGPs* [measurementType]
| +--ro cep3gpp:measurementType string
| +--ro cep3gpp:supportedGPs* uint32
+--rw cep3gpp:localAddress* [ipAddress vlanId]
| +--rw cep3gpp:ipAddress inet:ip-address
| +--rw cep3gpp:vlanId uint16
+--rw cep3gpp:remoteAddress inet:ip-address
+--rw cep3gpp:EP_N13* [id]
+--rw cep3gpp:id string
+--rw cep3gpp:attributes
+--rw cep3gpp:userLabel? string
+--ro cep3gpp:farEndEntity? types3gpp:DistinguishedName
+--ro cep3gpp:supportedMeasurementsGPs* [measurementType]
| +--ro cep3gpp:measurementType string
| +--ro cep3gpp:supportedGPs* uint32
+--rw cep3gpp:localAddress* [ipAddress vlanId]
| +--rw cep3gpp:ipAddress inet:ip-address
| +--rw cep3gpp:vlanId uint16
+--rw cep3gpp:remoteAddress inet:ip-address
+--rw cep3gpp:EP_SBI_X* [id]
+--rw cep3gpp:id string
+--rw cep3gpp:attributes
+--rw cep3gpp:userLabel? string
+--ro cep3gpp:farEndEntity? types3gpp:DistinguishedName
+--ro cep3gpp:supportedMeasurementsGPs* [measurementType]
| +--ro cep3gpp:measurementType string
| +--ro cep3gpp:supportedGPs* uint32
+--rw cep3gpp:localAddress* [ipAddress vlanId]
| +--rw cep3gpp:ipAddress inet:ip-address
| +--rw cep3gpp:vlanId uint16
+--rw cep3gpp:remoteAddress inet:ip-address
+--ro cep3gpp:sBIService* string
+--rw upf3gpp:UPFFunction* [id]
+--rw upf3gpp:id string
+--rw upf3gpp:attributes
+--rw upf3gpp:userLabel? string
+--rw upf3gpp:vnfParametersList!
| +--rw upf3gpp:vnfInstanceId string
| +--rw upf3gpp:vnfdId? string
| +--rw upf3gpp:flavourId? string
| +--rw upf3gpp:autoScalable boolean
+--rw upf3gpp:peeParametersList!
| +--rw upf3gpp:siteIdentification string
| +--rw upf3gpp:siteLatitude? decimal64
| +--rw upf3gpp:siteLongitude? decimal64
| +--rw upf3gpp:siteDescription string
| +--rw upf3gpp:equipmentType string
| +--rw upf3gpp:environmentType string
| +--rw upf3gpp:powerInterface string
+--rw upf3gpp:priorityLabel uint32

```

```

|--rw upf3gpp:pLMNidList* [mcc mnc]
| |--rw upf3gpp:mcc Mcc
| |--rw upf3gpp:mnc Mnc
|--ro upf3gpp:nRTACList* types3gpp:Tac
|--rw upf3gpp:sNSSAList* types3gpp:SNssai
+--rw cep3gpp:EP_N4* [id]
|--rw cep3gpp:id string
+--rw cep3gpp:attributes
| |--rw cep3gpp:userLabel? string
| |--ro cep3gpp:farEndEntity? types3gpp:DistinguishedName
| |--ro cep3gpp:supportedMeasurementsGPs* [measurementType]
| | |--ro cep3gpp:measurementType string
| | |--ro cep3gpp:supportedGPs* uint32
| |--rw cep3gpp:localAddress* [ipAddress vlanId]
| | |--rw cep3gpp:ipAddress inet:ip-address
| | |--rw cep3gpp:vlanId uint16
| |--rw cep3gpp:remoteAddress inet:ip-address
+--rw cep3gpp:EP_N3* [id]
|--rw cep3gpp:id string
+--rw cep3gpp:attributes
| |--rw cep3gpp:userLabel? string
| |--ro cep3gpp:farEndEntity? types3gpp:DistinguishedName
| |--ro cep3gpp:supportedMeasurementsGPs* [measurementType]
| | |--ro cep3gpp:measurementType string
| | |--ro cep3gpp:supportedGPs* uint32
| |--rw cep3gpp:localAddress* [ipAddress vlanId]
| | |--rw cep3gpp:ipAddress inet:ip-address
| | |--rw cep3gpp:vlanId uint16
| |--rw cep3gpp:remoteAddress inet:ip-address
+--rw cep3gpp:EP_N9* [id]
|--rw cep3gpp:id string
+--rw cep3gpp:attributes
| |--rw cep3gpp:userLabel? string
| |--ro cep3gpp:farEndEntity? types3gpp:DistinguishedName
| |--ro cep3gpp:supportedMeasurementsGPs* [measurementType]
| | |--ro cep3gpp:measurementType string
| | |--ro cep3gpp:supportedGPs* uint32
| |--rw cep3gpp:localAddress* [ipAddress vlanId]
| | |--rw cep3gpp:ipAddress inet:ip-address
| | |--rw cep3gpp:vlanId uint16
| |--rw cep3gpp:remoteAddress inet:ip-address
+--rw cep3gpp:EP_S5U* [id]
|--rw cep3gpp:id string
+--rw cep3gpp:attributes
| |--rw cep3gpp:userLabel? string
| |--ro cep3gpp:farEndEntity? types3gpp:DistinguishedName
| |--ro cep3gpp:supportedMeasurementsGPs* [measurementType]
| | |--ro cep3gpp:measurementType string
| | |--ro cep3gpp:supportedGPs* uint32
| |--rw cep3gpp:localAddress* [ipAddress vlanId]
| | |--rw cep3gpp:ipAddress inet:ip-address
| | |--rw cep3gpp:vlanId uint16
| |--rw cep3gpp:remoteAddress inet:ip-address
+--rw cep3gpp:EP_SBI_X* [id]
|--rw cep3gpp:id string
+--rw cep3gpp:attributes
| |--rw cep3gpp:userLabel? string
| |--ro cep3gpp:farEndEntity? types3gpp:DistinguishedName
| |--ro cep3gpp:supportedMeasurementsGPs* [measurementType]
| | |--ro cep3gpp:measurementType string
| | |--ro cep3gpp:supportedGPs* uint32
| |--rw cep3gpp:localAddress* [ipAddress vlanId]
| | |--rw cep3gpp:ipAddress inet:ip-address
| | |--rw cep3gpp:vlanId uint16
| |--rw cep3gpp:remoteAddress inet:ip-address
| |--ro cep3gpp:sBIService* string
+--rw cep3gpp:EP_N6* [id]
|--rw cep3gpp:id string
+--rw cep3gpp:attributes
| |--rw cep3gpp:userLabel? string
| |--ro cep3gpp:farEndEntity? types3gpp:DistinguishedName
| |--ro cep3gpp:supportedMeasurementsGPs* [measurementType]
| | |--ro cep3gpp:measurementType string
| | |--ro cep3gpp:supportedGPs* uint32
| |--rw cep3gpp:localAddress* [ipAddress vlanId]
| | |--rw cep3gpp:ipAddress inet:ip-address
| | |--rw cep3gpp:vlanId uint16
| |--rw cep3gpp:remoteAddress inet:ip-address

```

```

+--rw lmf3gpp:LMFFunction* [id]
+--rw lmf3gpp:id string
+--rw lmf3gpp:attributes
| +--rw lmf3gpp:userLabel? string
| +--rw lmf3gpp:vnfParametersList!
| | +--rw lmf3gpp:vnfInstanceId string
| | +--rw lmf3gpp:vnfId? string
| | +--rw lmf3gpp:flavourId? string
| | +--rw lmf3gpp:autoScalable boolean
+--rw lmf3gpp:peeParametersList!
| +--rw lmf3gpp:siteIdentification string
| +--rw lmf3gpp:siteLatitude? decimal64
| +--rw lmf3gpp:siteLongitude? decimal64
| +--rw lmf3gpp:siteDescription string
| +--rw lmf3gpp:equipmentType string
| +--rw lmf3gpp:environmentType string
| +--rw lmf3gpp:powerInterface string
+--rw lmf3gpp:priorityLabel uint32
+--rw lmf3gpp:pLMNIdList* [mcc mnc]
| +--rw lmf3gpp:mcc Mcc
| +--rw lmf3gpp:mnc Mnc
+--rw cep3gpp:EP_NLS* [id]
+--rw cep3gpp:id string
+--rw cep3gpp:attributes
| +--rw cep3gpp:userLabel? string
| +--ro cep3gpp:farEndEntity? types3gpp:DistinguishedName
| +--ro cep3gpp:supportedMeasurementsGPs* [measurementType]
| | +--ro cep3gpp:measurementType string
| | +--ro cep3gpp:supportedGPs* uint32
+--rw cep3gpp:localAddress* [ipAddress vlanId]
| +--rw cep3gpp:ipAddress inet:ip-address
| +--rw cep3gpp:vlanId uint16
+--rw cep3gpp:remoteAddress inet:ip-address
+--rw amf3gpp:AMFFunction* [id]
+--rw amf3gpp:id string
+--rw amf3gpp:attributes
| +--rw amf3gpp:userLabel? string
| +--rw amf3gpp:vnfParametersList!
| | +--rw amf3gpp:vnfInstanceId string
| | +--rw amf3gpp:vnfId? string
| | +--rw amf3gpp:flavourId? string
| | +--rw amf3gpp:autoScalable boolean
+--rw amf3gpp:peeParametersList!
| +--rw amf3gpp:siteIdentification string
| +--rw amf3gpp:siteLatitude? decimal64
| +--rw amf3gpp:siteLongitude? decimal64
| +--rw amf3gpp:siteDescription string
| +--rw amf3gpp:equipmentType string
| +--rw amf3gpp:environmentType string
| +--rw amf3gpp:powerInterface string
+--rw amf3gpp:priorityLabel uint32
+--rw amf3gpp:pLMNIdList* [mcc mnc]
| +--rw amf3gpp:mcc Mcc
| +--rw amf3gpp:mnc Mnc
+--rw amf3gpp:amfIdentifier!
| +--rw amf3gpp:amfRegionId? AmfRegionId
| +--rw amf3gpp:amfSetId? AmfSetId
| +--rw amf3gpp:amfPointer? AmfPointer
+--rw amf3gpp:sBIFQDN? inet:domain-name
+--ro amf3gpp:sBIServiceList* string
+--rw amf3gpp:weightFactor? uint16
+--rw amf3gpp:sNSSAList* types3gpp:SNssai
+--rw cep3gpp:EP_N2* [id]
+--rw cep3gpp:id string
+--rw cep3gpp:attributes
| +--rw cep3gpp:userLabel? string
| +--ro cep3gpp:farEndEntity? types3gpp:DistinguishedName
| +--ro cep3gpp:supportedMeasurementsGPs* [measurementType]
| | +--ro cep3gpp:measurementType string
| | +--ro cep3gpp:supportedGPs* uint32
+--rw cep3gpp:localAddress* [ipAddress vlanId]
| +--rw cep3gpp:ipAddress inet:ip-address
| +--rw cep3gpp:vlanId uint16
+--rw cep3gpp:remoteAddress inet:ip-address
+--rw cep3gpp:EP_N8* [id]
+--rw cep3gpp:id string
+--rw cep3gpp:attributes
| +--rw cep3gpp:userLabel? string

```

```

+--ro cep3gpp:farEndEntity?          types3gpp:DistinguishedName
+--ro cep3gpp:supportedMeasurementsGPs* [measurementType]
|   +--ro cep3gpp:measurementType  string
|   +--ro cep3gpp:supportedGPs*    uint32
+--rw cep3gpp:localAddress* [ipAddress vlanId]
|   +--rw cep3gpp:ipAddress         inet:ip-address
|   +--rw cep3gpp:vlanId           uint16
+--rw cep3gpp:remoteAddress          inet:ip-address
+--rw cep3gpp:EP_N11* [id]
|   +--rw cep3gpp:id                string
+--rw cep3gpp:attributes
|   +--rw cep3gpp:userLabel?        string
+--ro cep3gpp:farEndEntity?          types3gpp:DistinguishedName
+--ro cep3gpp:supportedMeasurementsGPs* [measurementType]
|   +--ro cep3gpp:measurementType  string
|   +--ro cep3gpp:supportedGPs*    uint32
+--rw cep3gpp:localAddress* [ipAddress vlanId]
|   +--rw cep3gpp:ipAddress         inet:ip-address
|   +--rw cep3gpp:vlanId           uint16
+--rw cep3gpp:remoteAddress          inet:ip-address
+--rw cep3gpp:EP_N12* [id]
|   +--rw cep3gpp:id                string
+--rw cep3gpp:attributes
|   +--rw cep3gpp:userLabel?        string
+--ro cep3gpp:farEndEntity?          types3gpp:DistinguishedName
+--ro cep3gpp:supportedMeasurementsGPs* [measurementType]
|   +--ro cep3gpp:measurementType  string
|   +--ro cep3gpp:supportedGPs*    uint32
+--rw cep3gpp:localAddress* [ipAddress vlanId]
|   +--rw cep3gpp:ipAddress         inet:ip-address
|   +--rw cep3gpp:vlanId           uint16
+--rw cep3gpp:remoteAddress          inet:ip-address
+--rw cep3gpp:EP_N14* [id]
|   +--rw cep3gpp:id                string
+--rw cep3gpp:attributes
|   +--rw cep3gpp:userLabel?        string
+--ro cep3gpp:farEndEntity?          types3gpp:DistinguishedName
+--ro cep3gpp:supportedMeasurementsGPs* [measurementType]
|   +--ro cep3gpp:measurementType  string
|   +--ro cep3gpp:supportedGPs*    uint32
+--rw cep3gpp:localAddress* [ipAddress vlanId]
|   +--rw cep3gpp:ipAddress         inet:ip-address
|   +--rw cep3gpp:vlanId           uint16
+--rw cep3gpp:remoteAddress          inet:ip-address
+--rw cep3gpp:EP_N15* [id]
|   +--rw cep3gpp:id                string
+--rw cep3gpp:attributes
|   +--rw cep3gpp:userLabel?        string
+--ro cep3gpp:farEndEntity?          types3gpp:DistinguishedName
+--ro cep3gpp:supportedMeasurementsGPs* [measurementType]
|   +--ro cep3gpp:measurementType  string
|   +--ro cep3gpp:supportedGPs*    uint32
+--rw cep3gpp:localAddress* [ipAddress vlanId]
|   +--rw cep3gpp:ipAddress         inet:ip-address
|   +--rw cep3gpp:vlanId           uint16
+--rw cep3gpp:remoteAddress          inet:ip-address
+--rw cep3gpp:EP_N17* [id]
|   +--rw cep3gpp:id                string
+--rw cep3gpp:attributes
|   +--rw cep3gpp:userLabel?        string
+--ro cep3gpp:farEndEntity?          types3gpp:DistinguishedName
+--ro cep3gpp:supportedMeasurementsGPs* [measurementType]
|   +--ro cep3gpp:measurementType  string
|   +--ro cep3gpp:supportedGPs*    uint32
+--rw cep3gpp:localAddress* [ipAddress vlanId]
|   +--rw cep3gpp:ipAddress         inet:ip-address
|   +--rw cep3gpp:vlanId           uint16
+--rw cep3gpp:remoteAddress          inet:ip-address
+--rw cep3gpp:EP_N20* [id]
|   +--rw cep3gpp:id                string
+--rw cep3gpp:attributes
|   +--rw cep3gpp:userLabel?        string
+--ro cep3gpp:farEndEntity?          types3gpp:DistinguishedName
+--ro cep3gpp:supportedMeasurementsGPs* [measurementType]
|   +--ro cep3gpp:measurementType  string
|   +--ro cep3gpp:supportedGPs*    uint32
+--rw cep3gpp:localAddress* [ipAddress vlanId]
|   +--rw cep3gpp:ipAddress         inet:ip-address

```



```

| | | +--rw cep3gpp:vlanId          uint16
| | | +--rw cep3gpp:remoteAddress    inet:ip-address
+--rw cep3gpp:EP_N22* [id]
| | | +--rw cep3gpp:id              string
| | | +--rw cep3gpp:attributes
| | | | +--rw cep3gpp:userLabel?    string
| | | | +--ro cep3gpp:farEndEntity? types3gpp:DistinguishedName
| | | | +--ro cep3gpp:supportedMeasurementsGPs* [measurementType]
| | | | | +--ro cep3gpp:measurementType string
| | | | | +--ro cep3gpp:supportedGPs*   uint32
| | | | +--rw cep3gpp:localAddress* [ipAddress vlanId]
| | | | | +--rw cep3gpp:ipAddress    inet:ip-address
| | | | | +--rw cep3gpp:vlanId      uint16
| | | | +--rw cep3gpp:remoteAddress    inet:ip-address
+--rw cep3gpp:EP_N26* [id]
| | | +--rw cep3gpp:id              string
| | | +--rw cep3gpp:attributes
| | | | +--rw cep3gpp:userLabel?    string
| | | | +--ro cep3gpp:farEndEntity? types3gpp:DistinguishedName
| | | | +--ro cep3gpp:supportedMeasurementsGPs* [measurementType]
| | | | | +--ro cep3gpp:measurementType string
| | | | | +--ro cep3gpp:supportedGPs*   uint32
| | | | +--rw cep3gpp:localAddress* [ipAddress vlanId]
| | | | | +--rw cep3gpp:ipAddress    inet:ip-address
| | | | | +--rw cep3gpp:vlanId      uint16
| | | | +--rw cep3gpp:remoteAddress    inet:ip-address
+--rw cep3gpp:EP_NLS* [id]
| | | +--rw cep3gpp:id              string
| | | +--rw cep3gpp:attributes
| | | | +--rw cep3gpp:userLabel?    string
| | | | +--ro cep3gpp:farEndEntity? types3gpp:DistinguishedName
| | | | +--ro cep3gpp:supportedMeasurementsGPs* [measurementType]
| | | | | +--ro cep3gpp:measurementType string
| | | | | +--ro cep3gpp:supportedGPs*   uint32
| | | | +--rw cep3gpp:localAddress* [ipAddress vlanId]
| | | | | +--rw cep3gpp:ipAddress    inet:ip-address
| | | | | +--rw cep3gpp:vlanId      uint16
| | | | +--rw cep3gpp:remoteAddress    inet:ip-address
+--rw cep3gpp:EP_NLG* [id]
| | | +--rw cep3gpp:id              string
| | | +--rw cep3gpp:attributes
| | | | +--rw cep3gpp:userLabel?    string
| | | | +--ro cep3gpp:farEndEntity? types3gpp:DistinguishedName
| | | | +--ro cep3gpp:supportedMeasurementsGPs* [measurementType]
| | | | | +--ro cep3gpp:measurementType string
| | | | | +--ro cep3gpp:supportedGPs*   uint32
| | | | +--rw cep3gpp:localAddress* [ipAddress vlanId]
| | | | | +--rw cep3gpp:ipAddress    inet:ip-address
| | | | | +--rw cep3gpp:vlanId      uint16
| | | | +--rw cep3gpp:remoteAddress    inet:ip-address
+--rw cep3gpp:EP_SBI_X* [id]
| | | +--rw cep3gpp:id              string
| | | +--rw cep3gpp:attributes
| | | | +--rw cep3gpp:userLabel?    string
| | | | +--ro cep3gpp:farEndEntity? types3gpp:DistinguishedName
| | | | +--ro cep3gpp:supportedMeasurementsGPs* [measurementType]
| | | | | +--ro cep3gpp:measurementType string
| | | | | +--ro cep3gpp:supportedGPs*   uint32
| | | | +--rw cep3gpp:localAddress* [ipAddress vlanId]
| | | | | +--rw cep3gpp:ipAddress    inet:ip-address
| | | | | +--rw cep3gpp:vlanId      uint16
| | | | +--rw cep3gpp:remoteAddress    inet:ip-address
| | | | +--ro cep3gpp:sBIService*     string
+--rw nrf3gpp:NRFFunction* [id]
| | | +--rw nrf3gpp:id              string
| | | +--rw nrf3gpp:attributes
| | | | +--rw nrf3gpp:userLabel?    string
| | | | +--rw nrf3gpp:vnfParametersList!
| | | | | +--rw nrf3gpp:vnfInstanceId string
| | | | | +--rw nrf3gpp:vnfId?       string
| | | | | +--rw nrf3gpp:flavourId?   string
| | | | | +--rw nrf3gpp:autoScalable boolean
| | | | +--rw nrf3gpp:peeParametersList!
| | | | | +--rw nrf3gpp:siteIdentification string
| | | | | +--rw nrf3gpp:siteLatitude?   decimal64
| | | | | +--rw nrf3gpp:siteLongitude?  decimal64
| | | | | +--rw nrf3gpp:siteDescription string
| | | | | +--rw nrf3gpp:equipmentType   string

```

```

| +--rw nrf3gpp:environmentType      string
| +--rw nrf3gpp:powerInterface       string
+--rw nrf3gpp:priorityLabel          uint32
+--rw nrf3gpp:pLMNidList* [mcc mnc]
| +--rw nrf3gpp:mcc      Mcc
| +--rw nrf3gpp:mnc      Mnc
+--rw nrf3gpp:sBIFQDN?              inet:domain-name
+--rw nrf3gpp:nSIIidListWrap*       types3gpp:NsiId
+--rw nrf3gpp:sNSSAIIList*          types3gpp:SNssai
+--rw nrf3gpp:nFProfileList* [nfInstanceID]
| +--rw nrf3gpp:nfInstanceID        string
| +--rw nrf3gpp:nfType               types3gpp:NfType
| +--rw nrf3gpp:nfStatus             NFStatus
| +--rw nrf3gpp:heartBeatTimer?     uint16
+--rw nrf3gpp:plmnList* [mcc mnc]
| +--rw nrf3gpp:mcc      Mcc
| +--rw nrf3gpp:mnc      Mnc
+--rw nrf3gpp:sNssais* [sst sd]
| +--rw nrf3gpp:sst      uint32
| +--rw nrf3gpp:sd       string
+--rw nrf3gpp:perPlmnSnssaiList* [idx]
| +--rw nrf3gpp:idx      uint32
| +--rw nrf3gpp:plmnId* [mcc mnc]
| | +--rw nrf3gpp:mcc      Mcc
| | +--rw nrf3gpp:mnc      Mnc
| +--rw nrf3gpp:sNssaiList* [sst sd]
| | +--rw nrf3gpp:sst      uint32
| | +--rw nrf3gpp:sd       string
+--rw nrf3gpp:nsiList*              string
+--rw nrf3gpp:fqdn?                 inet:domain-name
+--rw nrf3gpp:interPlmnFqdn?       inet:domain-name
+--rw nrf3gpp:ipv4Addresses*        inet:ipv4-address
+--rw nrf3gpp:ipv6Addresses*        inet:ipv6-address
+--rw nrf3gpp:allowedPlmns* [mcc mnc]
| +--rw nrf3gpp:mcc      Mcc
| +--rw nrf3gpp:mnc      Mnc
+--rw nrf3gpp:allowedNfTypes*       types3gpp:NfType
+--rw nrf3gpp:allowedNfDomains*     string
+--rw nrf3gpp:allowedNssais* [sst sd]
| +--rw nrf3gpp:sst      uint32
| +--rw nrf3gpp:sd       string
+--rw nrf3gpp:priority?             uint16
+--rw nrf3gpp:capacity?             uint16
+--rw nrf3gpp:load?                 types3gpp:Load
+--rw nrf3gpp:locality?             string
+--rw nrf3gpp:nrfInfo* [idx]
| +--rw nrf3gpp:idx      uint32
| +--rw nrf3gpp:servedUdrInfo* [nfInstanceID]
| | +--rw nrf3gpp:nfInstanceID        string
| | +--rw nrf3gpp:groupId?            string
| | +--rw nrf3gpp:supiRanges* [start end pattern]
| | | +--rw nrf3gpp:start             string
| | | +--rw nrf3gpp:end               string
| | | +--rw nrf3gpp:pattern           string
| | +--rw nrf3gpp:gpsiRanges* [start end pattern]
| | | +--rw nrf3gpp:start             string
| | | +--rw nrf3gpp:end               string
| | | +--rw nrf3gpp:pattern           string
| | +--rw nrf3gpp:externalGroupIdentifiersRanges* [start end pattern]
| | | +--rw nrf3gpp:start             string
| | | +--rw nrf3gpp:end               string
| | | +--rw nrf3gpp:pattern           string
| +--rw nrf3gpp:supportedDataSets*   DataSetId
+--rw nrf3gpp:servedUdmInfo* [nfInstanceID]
| +--rw nrf3gpp:nfInstanceID        string
| +--rw nrf3gpp:groupId?            string
| +--rw nrf3gpp:supiRanges* [start end pattern]
| | +--rw nrf3gpp:start             string
| | +--rw nrf3gpp:end               string
| | +--rw nrf3gpp:pattern           string
| +--rw nrf3gpp:gpsiRanges* [start end pattern]
| | +--rw nrf3gpp:start             string
| | +--rw nrf3gpp:end               string
| | +--rw nrf3gpp:pattern           string
| +--rw nrf3gpp:externalGroupIdentifiersRanges* [start end pattern]
| | +--rw nrf3gpp:start             string
| | +--rw nrf3gpp:end               string
| | +--rw nrf3gpp:pattern           string

```

```

|   +--rw nrf3gpp:routingIndicators*          string
+--rw nrf3gpp:servedAusfInfo* [nfInstanceID]
|   +--rw nrf3gpp:nfInstanceID              string
|   +--rw nrf3gpp:groupId?                  string
|   +--rw nrf3gpp:supiRanges* [start end pattern]
|   |   +--rw nrf3gpp:start                  string
|   |   +--rw nrf3gpp:end                    string
|   |   +--rw nrf3gpp:pattern                string
|   +--rw nrf3gpp:routingIndicators*        string
+--rw nrf3gpp:servedAmfInfo* [nfInstanceID]
|   +--rw nrf3gpp:nfInstanceID              string
|   +--rw nrf3gpp:amfRegionId?              string
|   +--rw nrf3gpp:amfSetId?                 string
|   +--rw nrf3gpp:guamiList* [idx]
|   |   +--rw nrf3gpp:idx                    uint32
|   |   +--rw nrf3gpp:plmnId* [mcc mnc]
|   |   |   +--rw nrf3gpp:mcc                Mcc
|   |   |   +--rw nrf3gpp:mnc                Mnc
|   |   +--rw nrf3gpp:amfId* [amfRegionId amfSetId amfPointer]
|   |   |   +--rw nrf3gpp:amfRegionId        AmfRegionId
|   |   |   +--rw nrf3gpp:amfSetId            AmfSetId
|   |   |   +--rw nrf3gpp:amfPointer          AmfPointer
|   +--rw nrf3gpp:taiList* [idx]
|   |   +--rw nrf3gpp:idx                    uint32
|   |   +--rw nrf3gpp:plmnId* [mcc mnc]
|   |   |   +--rw nrf3gpp:mcc                Mcc
|   |   |   +--rw nrf3gpp:mnc                Mnc
|   |   +--rw nrf3gpp:tac?                  types3gpp:Tac
|   +--rw nrf3gpp:taiRangeList* [idx]
|   |   +--rw nrf3gpp:idx                    uint32
|   |   +--rw nrf3gpp:plmnId* [mcc mnc]
|   |   |   +--rw nrf3gpp:mcc                Mcc
|   |   |   +--rw nrf3gpp:mnc                Mnc
|   |   +--rw nrf3gpp:tacRangeList* [start end]
|   |   |   +--rw nrf3gpp:start              string
|   |   |   +--rw nrf3gpp:end                string
|   |   |   +--rw nrf3gpp:pattern?          string
|   +--rw nrf3gpp:backupInfoAmfFailure* [idx]
|   |   +--rw nrf3gpp:idx                    uint32
|   |   +--rw nrf3gpp:plmnId* [mcc mnc]
|   |   |   +--rw nrf3gpp:mcc                Mcc
|   |   |   +--rw nrf3gpp:mnc                Mnc
|   |   +--rw nrf3gpp:amfId* [amfRegionId amfSetId amfPointer]
|   |   |   +--rw nrf3gpp:amfRegionId        AmfRegionId
|   |   |   +--rw nrf3gpp:amfSetId            AmfSetId
|   |   |   +--rw nrf3gpp:amfPointer          AmfPointer
|   +--rw nrf3gpp:backupInfoAmfRemoval* [idx]
|   |   +--rw nrf3gpp:idx                    uint32
|   |   +--rw nrf3gpp:plmnId* [mcc mnc]
|   |   |   +--rw nrf3gpp:mcc                Mcc
|   |   |   +--rw nrf3gpp:mnc                Mnc
|   |   +--rw nrf3gpp:amfId* [amfRegionId amfSetId amfPointer]
|   |   |   +--rw nrf3gpp:amfRegionId        AmfRegionId
|   |   |   +--rw nrf3gpp:amfSetId            AmfSetId
|   |   |   +--rw nrf3gpp:amfPointer          AmfPointer
|   +--rw nrf3gpp:n2InterfaceAmfInfo* [idx]
|   |   +--rw nrf3gpp:idx                    uint32
|   |   +--rw (nrf3gpp:address)?
|   |   |   +--:(nrf3gpp:ipv4EndpointAddress)
|   |   |   |   +--rw nrf3gpp:ipv4EndpointAddress*  inet:ipv4-address
|   |   |   +--:(nrf3gpp:ipv6EndpointAddress)
|   |   |   |   +--rw nrf3gpp:ipv6EndpointAddress*  inet:ipv6-address
|   |   +--rw nrf3gpp:amfName?              string
+--rw nrf3gpp:servedSmfInfo* [nfInstanceID]
|   +--rw nrf3gpp:nfInstanceID              string
|   +--rw nrf3gpp:sNssaiSmfInfoList* [idx]
|   |   +--rw nrf3gpp:idx                    uint32
|   |   +--rw nrf3gpp:sNssai* [sst sd]
|   |   |   +--rw nrf3gpp:sst                uint32
|   |   |   +--rw nrf3gpp:sd                string
|   |   +--rw nrf3gpp:dnnSmfInfoList* [dnn]
|   |   |   +--rw nrf3gpp:dnn                string
|   +--rw nrf3gpp:taiList* [idx]
|   |   +--rw nrf3gpp:idx                    uint32
|   |   +--rw nrf3gpp:plmnId* [mcc mnc]
|   |   |   +--rw nrf3gpp:mcc                Mcc
|   |   |   +--rw nrf3gpp:mnc                Mnc
|   +--rw nrf3gpp:tac?                      types3gpp:Tac

```

```

+--rw nrf3gpp:taiRangeList* [idx]
|   +--rw nrf3gpp:idx                               uint32
+--rw nrf3gpp:plmnId* [mcc mnc]
|   +--rw nrf3gpp:mcc                               Mcc
|   +--rw nrf3gpp:mnc                               Mnc
+--rw nrf3gpp:tacRangeList* [start end]
|   +--rw nrf3gpp:start                             string
|   +--rw nrf3gpp:end                               string
|   +--rw nrf3gpp:pattern?                          string
+--rw nrf3gpp:pgwFqdn?                              inet:domain-name
+--rw nrf3gpp:accessType*                            AccessType
+--rw nrf3gpp:servedUpfInfo* [nfInstanceID]
|   +--rw nrf3gpp:nfInstanceID                      string
+--rw nrf3gpp:sNssaiUpfInfoList* [idx]
|   +--rw nrf3gpp:idx                               uint32
|   +--rw nrf3gpp:sNssai* [sst sd]
|   |   +--rw nrf3gpp:sst                           uint32
|   |   +--rw nrf3gpp:sd                           string
+--rw nrf3gpp:dnnUpfInfoList* [dnn]
|   +--rw nrf3gpp:dnn                               string
|   +--rw nrf3gpp:dnaiList*                         string
|   +--rw nrf3gpp:pduSessionTypes*                 PduSessionType
+--rw nrf3gpp:smfServingArea*                       string
+--rw nrf3gpp:interfaceUpfInfo* [idx]
|   +--rw nrf3gpp:idx                               uint32
|   +--rw nrf3gpp:interfaceType                     UPInterfaceType
|   +--rw (nrf3gpp:address)?
|   |   +--:(nrf3gpp:ipv4EndpointAddresses)
|   |   |   +--rw nrf3gpp:ipv4EndpointAddresses*   inet:ipv4-address
|   |   +--:(nrf3gpp:ipv6EndpointAddresses)
|   |   |   +--rw nrf3gpp:ipv6EndpointAddresses*   inet:ipv6-address
|   |   +--:(nrf3gpp:endpointFqdn)
|   |   |   +--rw nrf3gpp:endpointFqdn?            inet:domain-name
|   |   +--rw nrf3gpp:networkInstance?             string
+--rw nrf3gpp:iwkEpsInd?                            boolean
+--rw nrf3gpp:pduSessionTypes*                      PduSessionType
+--rw nrf3gpp:servedPcfInfo* [nfInstanceID]
|   +--rw nrf3gpp:nfInstanceID                      string
+--rw nrf3gpp:dnnList*                              string
+--rw nrf3gpp:supiRanges* [start end pattern]
|   +--rw nrf3gpp:start                             string
|   +--rw nrf3gpp:end                               string
|   +--rw nrf3gpp:pattern                          string
+--rw nrf3gpp:rxDiamHost?                           string
+--rw nrf3gpp:rxDiamRealm?                          string
+--rw nrf3gpp:servedBsfInfo* [nfInstanceID]
|   +--rw nrf3gpp:nfInstanceID                      string
+--rw nrf3gpp:ipv4AddressRanges* [start end]
|   +--rw nrf3gpp:start                             inet:ipv4-address
|   +--rw nrf3gpp:end                               inet:ipv4-address
+--rw nrf3gpp:dnnList*                              string
+--rw nrf3gpp:ipDomainList*                         string
+--rw nrf3gpp:ipv6PrefixRanges* [start end]
|   +--rw nrf3gpp:start                             inet:ipv6-prefix
|   +--rw nrf3gpp:end                               inet:ipv6-prefix
+--rw nrf3gpp:servedChfInfo* [nfInstanceID]
|   +--rw nrf3gpp:nfInstanceID                      string
+--rw nrf3gpp:supiRangeList* [start end pattern]
|   +--rw nrf3gpp:start                             string
|   +--rw nrf3gpp:end                               string
|   +--rw nrf3gpp:pattern                          string
+--rw nrf3gpp:gsiRangeList* [start end pattern]
|   +--rw nrf3gpp:start                             string
|   +--rw nrf3gpp:end                               string
|   +--rw nrf3gpp:pattern                          string
+--rw nrf3gpp:plmnRangeList* [mcc mnc]
|   +--rw nrf3gpp:mcc                               Mcc
|   +--rw nrf3gpp:mnc                               Mnc
+--rw nrf3gpp:customInfo?                            string
+--rw nrf3gpp:recoveryTime?                          yang:date-and-time
+--rw nrf3gpp:nfServicePersistence?                 boolean
+--rw nrf3gpp:nfServices* [serviceInstanceID]
|   +--rw nrf3gpp:serviceInstanceID                 string
|   +--rw nrf3gpp:serviceName                       ServiceName
+--rw nrf3gpp:versions* [apiVersionInUri apiFullVersion]
|   +--rw nrf3gpp:apiVersionInUri                  string
|   +--rw nrf3gpp:apiFullVersion                   string
+--rw nrf3gpp:expiry?                                yang:date-and-time

```

```

    +--rw nrf3gpp:scheme                               UriScheme
    +--rw nrf3gpp:nfServiceStatus                     NFServiceStatus
    +--rw nrf3gpp:fqdn?                               inet:domain-name
    +--rw nrf3gpp:interPlmnFqdn?                     inet:domain-name
    +--rw nrf3gpp:ipEndPoints* [idx]
      | +--rw nrf3gpp:idx                               string
      | +--rw (nrf3gpp:address)?
      | | +--:(nrf3gpp:ipv4Address)
      | | | +--rw nrf3gpp:ipv4Address?               inet:ipv4-address
      | | +--:(nrf3gpp:ipv6Address)
      | | | +--rw nrf3gpp:ipv6Address?               inet:ipv6-address
      | | +--:(nrf3gpp:ipv6Prefix)
      | | | +--rw nrf3gpp:ipv6Prefix?                 inet:ipv6-prefix
      | +--rw nrf3gpp:transport?                       TransportProtocol
      +--rw nrf3gpp:port?                               uint16
    +--rw nrf3gpp:apiPrefix?                           string
    +--rw nrf3gpp:defaultNotificationSubscriptions* [notificationType]
      | +--rw nrf3gpp:notificationType                 NotificationType
      | +--rw nrf3gpp:callbackUri?                     inet:uri
      | +--rw nrf3gpp:n1MessageClass?                 N1MessageClass
      | +--rw nrf3gpp:n2InformationClass?              N2InformationClass
    +--rw nrf3gpp:allowedPlmns* [mcc mnc]
      | +--rw nrf3gpp:mcc                               Mcc
      | +--rw nrf3gpp:mnc                               Mnc
    +--rw nrf3gpp:allowedNfTypes*                       types3gpp:NfType
    +--rw nrf3gpp:allowedNfDomains*                     string
    +--rw nrf3gpp:allowedNssais*                       types3gpp:SNssai
    +--rw nrf3gpp:priority?                             uint16
    +--rw nrf3gpp:capacity?                             uint16
    +--rw nrf3gpp:load?                                 types3gpp:Load
    +--rw nrf3gpp:recoveryTime?                         yang:date-and-time
    +--rw nrf3gpp:chfServiceInfo* [primaryChfServiceInstance
secondaryChfServiceInstance]
      | +--rw nrf3gpp:primaryChfServiceInstance         string
      | +--rw nrf3gpp:secondaryChfServiceInstance       string
      | +--rw nrf3gpp:supportedFeatures?                 SupportedFeatures
    +--rw nrf3gpp:nfProfileChangesSupportInd?           boolean
    +--rw nrf3gpp:nfProfileChangesInd?                 boolean
    +--rw nrf3gpp:defaultNotificationSubscriptions* [notificationType]
      | +--rw nrf3gpp:notificationType                 NotificationType
      | +--rw nrf3gpp:callbackUri?                     inet:uri
      | +--rw nrf3gpp:n1MessageClass?                 N1MessageClass
      | +--rw nrf3gpp:n2InformationClass?              N2InformationClass
+--rw cep3gpp:EP_N27* [id]
  +--rw cep3gpp:id                               string
  +--rw cep3gpp:attributes
    +--rw cep3gpp:userLabel?                       string
    +--ro cep3gpp:farEndEntity?                     types3gpp:DistinguishedName
    +--ro cep3gpp:supportedMeasurementsGPs* [measurementType]
      | +--ro cep3gpp:measurementType                 string
      | +--ro cep3gpp:supportedGPs*                   uint32
    +--rw cep3gpp:localAddress* [ipAddress vlanId]
      | +--rw cep3gpp:ipAddress                       inet:ip-address
      | +--rw cep3gpp:vlanId                           uint16
      +--rw cep3gpp:remoteAddress                     inet:ip-address
+--rw cep3gpp:EP_SBI_X* [id]
  +--rw cep3gpp:id                               string
  +--rw cep3gpp:attributes
    +--rw cep3gpp:userLabel?                       string
    +--ro cep3gpp:farEndEntity?                     types3gpp:DistinguishedName
    +--ro cep3gpp:supportedMeasurementsGPs* [measurementType]
      | +--ro cep3gpp:measurementType                 string
      | +--ro cep3gpp:supportedGPs*                   uint32
    +--rw cep3gpp:localAddress* [ipAddress vlanId]
      | +--rw cep3gpp:ipAddress                       inet:ip-address
      | +--rw cep3gpp:vlanId                           uint16
      +--rw cep3gpp:remoteAddress                     inet:ip-address
    +--ro cep3gpp:sBIService*                         string
+--rw n3iwf3gpp:N3IWFFunction* [id]
  +--rw n3iwf3gpp:id                               string
  +--rw n3iwf3gpp:attributes
    +--rw n3iwf3gpp:userLabel?                       string
    +--rw n3iwf3gpp:vnfParametersList!
      | +--rw n3iwf3gpp:vnfInstanceId                 string
      | +--rw n3iwf3gpp:vnfId?                         string
      | +--rw n3iwf3gpp:flavourId?                     string
      | +--rw n3iwf3gpp:autoScalable                   boolean
    +--rw n3iwf3gpp:peeParametersList!

```

```

| | +--rw n3iwf3gpp:siteIdentification      string
| | +--rw n3iwf3gpp:siteLatitude?         decimal64
| | +--rw n3iwf3gpp:siteLongitude?       decimal64
| | +--rw n3iwf3gpp:siteDescription      string
| | +--rw n3iwf3gpp:equipmentType        string
| | +--rw n3iwf3gpp:environmentType      string
| | +--rw n3iwf3gpp:powerInterface        string
+--rw n3iwf3gpp:priorityLabel             uint32
+--rw n3iwf3gpp:pLMNIdList* [mcc mnc]
| | +--rw n3iwf3gpp:mcc                   Mcc
| | +--rw n3iwf3gpp:mnc                   Mnc
+--rw cep3gpp:EP_N2* [id]
| | +--rw cep3gpp:id                       string
| | +--rw cep3gpp:attributes
| | | +--rw cep3gpp:userLabel?             string
| | | +--ro cep3gpp:farEndEntity?          types3gpp:DistinguishedName
| | | +--ro cep3gpp:supportedMeasurementsGPs* [measurementType]
| | | | +--ro cep3gpp:measurementType      string
| | | | +--ro cep3gpp:supportedGPs*        uint32
| | | +--rw cep3gpp:localAddress* [ipAddress vlanId]
| | | | +--rw cep3gpp:ipAddress            inet:ip-address
| | | | +--rw cep3gpp:vlanId              uint16
| | | +--rw cep3gpp:remoteAddress          inet:ip-address
+--rw cep3gpp:EP_N3* [id]
| | +--rw cep3gpp:id                       string
| | +--rw cep3gpp:attributes
| | | +--rw cep3gpp:userLabel?             string
| | | +--ro cep3gpp:farEndEntity?          types3gpp:DistinguishedName
| | | +--ro cep3gpp:supportedMeasurementsGPs* [measurementType]
| | | | +--ro cep3gpp:measurementType      string
| | | | +--ro cep3gpp:supportedGPs*        uint32
| | | +--rw cep3gpp:localAddress* [ipAddress vlanId]
| | | | +--rw cep3gpp:ipAddress            inet:ip-address
| | | | +--rw cep3gpp:vlanId              uint16
| | | +--rw cep3gpp:remoteAddress          inet:ip-address
module: _3gpp-common-subnetwork
+--rw SubNetwork* [id]
| | +--rw id                               string
| | +--rw attributes
| | | +--rw dnPrefix?                      types3gpp:DistinguishedName
| | | +--rw userLabel?                    string
| | | +--rw userDefinedNetworkType?       string
| | | +--ro supportedMeasurementsGPs* [measurementType]
| | | | +--ro measurementType              string
| | | | +--ro supportedGPs*                uint32
| | | +--rw setOfMcc*                      types3gpp:Mcc
| | | +--rw priorityLabel                  uint32
| | | +--rw parents*                       -> ../../../../SubNetwork/id
| | | +--rw containedChildren*             -> ../../../../SubNetwork/id
+--rw MeasurementControl* [id] {MeasurementsUnderSubNetwork}?
| | +--rw id                               string
| | +--rw attributes
| | | +--rw pMAdministrativeState?         types3gpp:AdministrativeState
| | | +--ro pMOperationalState            types3gpp:OperationalState
| | | +--rw defaultFileLocation?          string
| | | +--rw defaultFileBasedGP            uint32
| | | +--rw defaultFileReportingPeriod    uint32
| | | +--rw defaultStreamTarget?          string {StreamingSupported}?
| | | +--rw defaultStreamBasedGP         uint32 {StreamingSupported}?
+--rw MeasurementReader* [id]
| | +--rw id                               string
| | +--rw attributes
| | | +--rw measurementTypes*              string
| | | +--rw managedObjectDNsBasic*        types3gpp:DistinguishedName
| | | +--rw managedObjectDNs*             types3gpp:DistinguishedName
| | | +--rw fileLocation?                  string
| | | +--rw fileBasedGP                    uint32
| | | +--rw fileReportingPeriod            uint32
| | | +--rw streamTarget?                  string
| | | +--rw streamBasedGP                  uint32
+--rw extservgw3gpp:ExternalServingGWFunction* [id] {subnet3gpp:ExternalsUnderSubNetwork}?
| | +--rw extservgw3gpp:id                 string
| | +--rw extservgw3gpp:attributes
| | | +--rw extservgw3gpp:userLabel?       string
| | | +--rw extservgw3gpp:vnfParametersList!
| | | | +--rw extservgw3gpp:vnfInstanceId string
| | | | +--rw extservgw3gpp:vnfdId?       string
| | | | +--rw extservgw3gpp:flavourId?    string

```

```

|   +--rw extservgw3gpp:autoScalable      boolean
+--rw extservgw3gpp:peeParametersList!
|   +--rw extservgw3gpp:siteIdentification  string
|   +--rw extservgw3gpp:siteLatitude?     decimal64
|   +--rw extservgw3gpp:siteLongitude?    decimal64
|   +--rw extservgw3gpp:siteDescription   string
|   +--rw extservgw3gpp:equipmentType     string
|   +--rw extservgw3gpp:environmentType   string
|   +--rw extservgw3gpp:powerInterface    string
|   +--rw extservgw3gpp:priorityLabel     uint32
+--rw extenb3gpp:ExternalENBFunction* [id] {subnet3gpp:ExternalsUnderSubNetwork}?
+--rw extenb3gpp:id                       string
+--rw extenb3gpp:attributes
|   +--rw extenb3gpp:userLabel?           string
+--rw extenb3gpp:vnfParametersList!
|   +--rw extenb3gpp:vnfInstanceId        string
|   +--rw extenb3gpp:vnfdId?            string
|   +--rw extenb3gpp:flavourId?         string
|   +--rw extenb3gpp:autoScalable       boolean
+--rw extenb3gpp:peeParametersList!
|   +--rw extenb3gpp:siteIdentification  string
|   +--rw extenb3gpp:siteLatitude?     decimal64
|   +--rw extenb3gpp:siteLongitude?    decimal64
|   +--rw extenb3gpp:siteDescription   string
|   +--rw extenb3gpp:equipmentType     string
|   +--rw extenb3gpp:environmentType   string
|   +--rw extenb3gpp:powerInterface    string
+--rw extenb3gpp:priorityLabel          uint32
+--rw extenb3gpp:eNBId                  int32
+--rw exteutrancell3gpp:ExternalEUTranCellFDD* [id] {subnet3gpp:ExternalsUnderSubNetwork}?
+--rw exteutrancell3gpp:id              string
+--rw exteutrancell3gpp:attributes
|   +--rw exteutrancell3gpp:userLabel?   string
+--rw exteutrancell3gpp:vnfParametersList!
|   +--rw exteutrancell3gpp:vnfInstanceId  string
|   +--rw exteutrancell3gpp:vnfdId?      string
|   +--rw exteutrancell3gpp:flavourId?   string
|   +--rw exteutrancell3gpp:autoScalable  boolean
+--rw exteutrancell3gpp:peeParametersList!
|   +--rw exteutrancell3gpp:siteIdentification  string
|   +--rw exteutrancell3gpp:siteLatitude?     decimal64
|   +--rw exteutrancell3gpp:siteLongitude?    decimal64
|   +--rw exteutrancell3gpp:siteDescription   string
|   +--rw exteutrancell3gpp:equipmentType     string
|   +--rw exteutrancell3gpp:environmentType   string
|   +--rw exteutrancell3gpp:powerInterface    string
+--rw exteutrancell3gpp:priorityLabel          uint32
+--rw exteutrancell3gpp:pci                    int32
+--rw exteutrancell3gpp:plmnIdList* [mcc mnc]
|   +--rw exteutrancell3gpp:mcc      Mcc
|   +--rw exteutrancell3gpp:mnc      Mnc
+--rw exteutrancell3gpp:cellLocalId?        int32
+--rw exteutrancell3gpp:eNBId                int32
+--rw exteutrancell3gpp:earfcnDL             int32
+--rw exteutrancell3gpp:earfcnUL            int32
+--rw exteutrancell3gpp:ExternalEUTranCellTDD* [id] {subnet3gpp:ExternalsUnderSubNetwork}?
+--rw exteutrancell3gpp:id                  string
+--rw exteutrancell3gpp:attributes
|   +--rw exteutrancell3gpp:userLabel?      string
+--rw exteutrancell3gpp:vnfParametersList!
|   +--rw exteutrancell3gpp:vnfInstanceId  string
|   +--rw exteutrancell3gpp:vnfdId?      string
|   +--rw exteutrancell3gpp:flavourId?   string
|   +--rw exteutrancell3gpp:autoScalable  boolean
+--rw exteutrancell3gpp:peeParametersList!
|   +--rw exteutrancell3gpp:siteIdentification  string
|   +--rw exteutrancell3gpp:siteLatitude?     decimal64
|   +--rw exteutrancell3gpp:siteLongitude?    decimal64
|   +--rw exteutrancell3gpp:siteDescription   string
|   +--rw exteutrancell3gpp:equipmentType     string
|   +--rw exteutrancell3gpp:environmentType   string
|   +--rw exteutrancell3gpp:powerInterface    string
+--rw exteutrancell3gpp:priorityLabel          uint32
+--rw exteutrancell3gpp:pci                    int32
+--rw exteutrancell3gpp:plmnIdList* [mcc mnc]
|   +--rw exteutrancell3gpp:mcc      Mcc
|   +--rw exteutrancell3gpp:mnc      Mnc
+--rw exteutrancell3gpp:cellLocalId?        int32

```

```

    +--rw exteutralcell3gpp:eNBId          int32
    +--rw exteutralcell3gpp:earfcn        int32
+--rw amfset3gpp:AMFSet* [id]
  +--rw amfset3gpp:id                     string
  +--rw amfset3gpp:attributes
    +--rw amfset3gpp:userLabel?          string
    +--rw amfset3gpp:vnfParametersList!
      +--rw amfset3gpp:vnfInstanceId     string
      +--rw amfset3gpp:vnfdId?          string
      +--rw amfset3gpp:flavourId?       string
      +--rw amfset3gpp:autoScalable     boolean
    +--rw amfset3gpp:peeParametersList!
      +--rw amfset3gpp:siteIdentification string
      +--rw amfset3gpp:siteLatitude?     decimal64
      +--rw amfset3gpp:siteLongitude?    decimal64
      +--rw amfset3gpp:siteDescription   string
      +--rw amfset3gpp:equipmentType     string
      +--rw amfset3gpp:environmentType   string
      +--rw amfset3gpp:powerInterface    string
    +--rw amfset3gpp:priorityLabel       uint32
  +--rw amfset3gpp:pLMNidList* [mcc mnc]
    +--rw amfset3gpp:mcc                 Mcc
    +--rw amfset3gpp:mnc                 Mnc
  +--ro amfset3gpp:nRTACList*            types3gpp:Tac
  +--rw amfset3gpp:sNSSAList*            types3gpp:SNssai
  +--rw amfset3gpp:aMFRegion?            instance-identifier
  +--rw amfset3gpp:aMFSetMemberList*     types3gpp:DistinguishedName
+--rw extgnbcucp3gpp:ExternalGNBCUCPFunction* [id] {subnet3gpp:ExternalsUnderSubNetwork}?
  +--rw extgnbcucp3gpp:id                string
  +--rw extgnbcucp3gpp:attributes
    +--rw extgnbcucp3gpp:userLabel?      string
    +--rw extgnbcucp3gpp:vnfParametersList!
      +--rw extgnbcucp3gpp:vnfInstanceId string
      +--rw extgnbcucp3gpp:vnfdId?      string
      +--rw extgnbcucp3gpp:flavourId?   string
      +--rw extgnbcucp3gpp:autoScalable  boolean
    +--rw extgnbcucp3gpp:peeParametersList!
      +--rw extgnbcucp3gpp:siteIdentification string
      +--rw extgnbcucp3gpp:siteLatitude?     decimal64
      +--rw extgnbcucp3gpp:siteLongitude?    decimal64
      +--rw extgnbcucp3gpp:siteDescription   string
      +--rw extgnbcucp3gpp:equipmentType     string
      +--rw extgnbcucp3gpp:environmentType   string
      +--rw extgnbcucp3gpp:powerInterface    string
    +--rw extgnbcucp3gpp:priorityLabel       uint32
  +--rw extgnbcucp3gpp:gNBId              int64
  +--rw extgnbcucp3gpp:gNBIdLength        int32
  +--rw extgnbcucp3gpp:pLMNidList* [mcc mnc]
    +--rw extgnbcucp3gpp:mcc                 Mcc
    +--rw extgnbcucp3gpp:mnc                 Mnc
+--rw extnrCellcu3gpp:ExternalNRCellCU* [id] {subnet3gpp:ExternalsUnderSubNetwork}?
  +--rw extnrCellcu3gpp:id                string
  +--rw extnrCellcu3gpp:attributes
    +--rw extnrCellcu3gpp:userLabel?      string
    +--rw extnrCellcu3gpp:vnfParametersList!
      +--rw extnrCellcu3gpp:vnfInstanceId string
      +--rw extnrCellcu3gpp:vnfdId?      string
      +--rw extnrCellcu3gpp:flavourId?   string
      +--rw extnrCellcu3gpp:autoScalable  boolean
    +--rw extnrCellcu3gpp:peeParametersList!
      +--rw extnrCellcu3gpp:siteIdentification string
      +--rw extnrCellcu3gpp:siteLatitude?     decimal64
      +--rw extnrCellcu3gpp:siteLongitude?    decimal64
      +--rw extnrCellcu3gpp:siteDescription   string
      +--rw extnrCellcu3gpp:equipmentType     string
      +--rw extnrCellcu3gpp:environmentType   string
      +--rw extnrCellcu3gpp:powerInterface    string
    +--rw extnrCellcu3gpp:priorityLabel       uint32
  +--rw extnrCellcu3gpp:cellLocalId        int32
  +--rw extnrCellcu3gpp:nRPCI              int32
  +--rw extnrCellcu3gpp:pLMNidList* [mcc mnc]
    +--rw extnrCellcu3gpp:mcc                 Mcc
    +--rw extnrCellcu3gpp:mnc                 Mnc
  +--rw extnrCellcu3gpp:nRFrequencyRef     types3gpp:DistinguishedName
+--rw extnssf3gpp:ExternalNSSFFFunction* [id]
  +--rw extnssf3gpp:id                    string
  +--rw extnssf3gpp:attributes
    +--rw extnssf3gpp:userLabel?          string

```



```

+--rw extnssf3gpp:vnfParametersList!
|   +--rw extnssf3gpp:vnfInstanceId      string
|   +--rw extnssf3gpp:vnfdId?           string
|   +--rw extnssf3gpp:flavourId?        string
|   +--rw extnssf3gpp:autoScalable       boolean
+--rw extnssf3gpp:peeParametersList!
|   +--rw extnssf3gpp:siteIdentification  string
|   +--rw extnssf3gpp:siteLatitude?       decimal64
|   +--rw extnssf3gpp:siteLongitude?     decimal64
|   +--rw extnssf3gpp:siteDescription    string
|   +--rw extnssf3gpp:equipmentType      string
|   +--rw extnssf3gpp:environmentType    string
|   +--rw extnssf3gpp:powerInterface     string
+--rw extnssf3gpp:priorityLabel          uint32
+--rw extnssf3gpp:pLMNIdList* [mcc mnc]
|   +--rw extnssf3gpp:mcc      Mcc
|   +--rw extnssf3gpp:mnc      Mnc
+--rw extgnbcuup3gpp:ExternalGNBCUUPFunction* [id] {subnet3gpp:ExternalsUnderSubNetwork}?
+--rw extgnbcuup3gpp:id          string
+--rw extgnbcuup3gpp:attributes
|   +--rw extgnbcuup3gpp:userLabel?      string
+--rw extgnbcuup3gpp:vnfParametersList!
|   +--rw extgnbcuup3gpp:vnfInstanceId    string
|   +--rw extgnbcuup3gpp:vnfdId?         string
|   +--rw extgnbcuup3gpp:flavourId?      string
|   +--rw extgnbcuup3gpp:autoScalable     boolean
+--rw extgnbcuup3gpp:peeParametersList!
|   +--rw extgnbcuup3gpp:siteIdentification  string
|   +--rw extgnbcuup3gpp:siteLatitude?       decimal64
|   +--rw extgnbcuup3gpp:siteLongitude?     decimal64
|   +--rw extgnbcuup3gpp:siteDescription    string
|   +--rw extgnbcuup3gpp:equipmentType      string
|   +--rw extgnbcuup3gpp:environmentType    string
|   +--rw extgnbcuup3gpp:powerInterface     string
+--rw extgnbcuup3gpp:priorityLabel          uint32
+--rw extgnbcuup3gpp:gNBId                 int64
+--rw extgnbcuup3gpp:gNBIdLength          int32
+--rw extnrf3gpp:ExternalNRFFFunction* [id]
+--rw extnrf3gpp:id          string
+--rw extnrf3gpp:attributes
|   +--rw extnrf3gpp:userLabel?      string
+--rw extnrf3gpp:vnfParametersList!
|   +--rw extnrf3gpp:vnfInstanceId    string
|   +--rw extnrf3gpp:vnfdId?         string
|   +--rw extnrf3gpp:flavourId?      string
|   +--rw extnrf3gpp:autoScalable     boolean
+--rw extnrf3gpp:peeParametersList!
|   +--rw extnrf3gpp:siteIdentification  string
|   +--rw extnrf3gpp:siteLatitude?       decimal64
|   +--rw extnrf3gpp:siteLongitude?     decimal64
|   +--rw extnrf3gpp:siteDescription    string
|   +--rw extnrf3gpp:equipmentType      string
|   +--rw extnrf3gpp:environmentType    string
|   +--rw extnrf3gpp:powerInterface     string
+--rw extnrf3gpp:priorityLabel          uint32
+--rw extnrf3gpp:pLMNIdList* [mcc mnc]
|   +--rw extnrf3gpp:mcc      Mcc
|   +--rw extnrf3gpp:mnc      Mnc
+--rw amfr3gpp:AMFRegion* [id]
+--rw amfr3gpp:id          string
+--rw amfr3gpp:attributes
|   +--rw amfr3gpp:userLabel?      string
+--rw amfr3gpp:vnfParametersList!
|   +--rw amfr3gpp:vnfInstanceId    string
|   +--rw amfr3gpp:vnfdId?         string
|   +--rw amfr3gpp:flavourId?      string
|   +--rw amfr3gpp:autoScalable     boolean
+--rw amfr3gpp:peeParametersList!
|   +--rw amfr3gpp:siteIdentification  string
|   +--rw amfr3gpp:siteLatitude?       decimal64
|   +--rw amfr3gpp:siteLongitude?     decimal64
|   +--rw amfr3gpp:siteDescription    string
|   +--rw amfr3gpp:equipmentType      string
|   +--rw amfr3gpp:environmentType    string
|   +--rw amfr3gpp:powerInterface     string
+--rw amfr3gpp:priorityLabel          uint32
+--rw amfr3gpp:pLMNIdList* [mcc mnc]
|   +--rw amfr3gpp:mcc      Mcc

```

```

|   | +--rw amfr3gpp:mnc      Mnc
+--ro amfr3gpp:nRTACList*      types3gpp:Tac
+--rw amfr3gpp:sNSSAList*     types3gpp:SNssai
+--rw amfr3gpp:amfRegionId    types3gpp:AmfRegionId
+--rw amfr3gpp:amfSet*       instance-identifier
+--rw extupf3gpp:ExternalUPFFunction* [id] {subnet3gpp:ExternalsUnderSubNetwork}?
+--rw extupf3gpp:id          string
+--rw extupf3gpp:attributes
+--rw extupf3gpp:userLabel?   string
+--rw extupf3gpp:vnfParametersList!
|   | +--rw extupf3gpp:vnfInstanceId    string
|   | +--rw extupf3gpp:vnfdId?        string
|   | +--rw extupf3gpp:flavourId?     string
|   | +--rw extupf3gpp:autoScalable   boolean
+--rw extupf3gpp:peeParametersList!
|   | +--rw extupf3gpp:siteIdentification    string
|   | +--rw extupf3gpp:siteLatitude?        decimal64
|   | +--rw extupf3gpp:siteLongitude?       decimal64
|   | +--rw extupf3gpp:siteDescription      string
|   | +--rw extupf3gpp:equipmentType        string
|   | +--rw extupf3gpp:environmentType     string
|   | +--rw extupf3gpp:powerInterface      string
+--rw extupf3gpp:priorityLabel            uint32
+--rw nrfreq3gpp:NRFrequency* [id] {subnet3gpp:ExternalsUnderSubNetwork}?
+--rw nrfreq3gpp:id          string
+--rw nrfreq3gpp:attributes
+--rw nrfreq3gpp:userLabel?   string
+--rw nrfreq3gpp:vnfParametersList!
|   | +--rw nrfreq3gpp:vnfInstanceId    string
|   | +--rw nrfreq3gpp:vnfdId?        string
|   | +--rw nrfreq3gpp:flavourId?     string
|   | +--rw nrfreq3gpp:autoScalable   boolean
+--rw nrfreq3gpp:peeParametersList!
|   | +--rw nrfreq3gpp:siteIdentification    string
|   | +--rw nrfreq3gpp:siteLatitude?        decimal64
|   | +--rw nrfreq3gpp:siteLongitude?       decimal64
|   | +--rw nrfreq3gpp:siteDescription      string
|   | +--rw nrfreq3gpp:equipmentType        string
|   | +--rw nrfreq3gpp:environmentType     string
|   | +--rw nrfreq3gpp:powerInterface      string
+--rw nrfreq3gpp:priorityLabel            uint32
+--rw nrfreq3gpp:absoluteFrequencySSB     uint32
+--rw nrfreq3gpp:sBSSubCarrierSpacing    uint8
+--ro nrfreq3gpp:multiFrequencyBandListNR* uint16
+--rw eutraneteutranfreq3gpp:EUTranFrequency* [id] {subnet3gpp:ExternalsUnderSubNetwork}?
+--rw eutraneteutranfreq3gpp:id          string
+--rw eutraneteutranfreq3gpp:attributes
+--rw eutraneteutranfreq3gpp:userLabel?   string
+--rw eutraneteutranfreq3gpp:vnfParametersList!
|   | +--rw eutraneteutranfreq3gpp:vnfInstanceId    string
|   | +--rw eutraneteutranfreq3gpp:vnfdId?        string
|   | +--rw eutraneteutranfreq3gpp:flavourId?     string
|   | +--rw eutraneteutranfreq3gpp:autoScalable   boolean
+--rw eutraneteutranfreq3gpp:peeParametersList!
|   | +--rw eutraneteutranfreq3gpp:siteIdentification    string
|   | +--rw eutraneteutranfreq3gpp:siteLatitude?        decimal64
|   | +--rw eutraneteutranfreq3gpp:siteLongitude?       decimal64
|   | +--rw eutraneteutranfreq3gpp:siteDescription      string
|   | +--rw eutraneteutranfreq3gpp:equipmentType        string
|   | +--rw eutraneteutranfreq3gpp:environmentType     string
|   | +--rw eutraneteutranfreq3gpp:powerInterface      string
+--rw eutraneteutranfreq3gpp:priorityLabel            uint32
+--rw eutraneteutranfreq3gpp:earfcnDL                uint32
+--ro eutraneteutranfreq3gpp:multiBandInfoListEutra* uint16
+--rw extamf3gpp:ExternalAMFFunction* [id] {subnet3gpp:ExternalsUnderSubNetwork}?
+--rw extamf3gpp:id          string
+--rw extamf3gpp:attributes
+--rw extamf3gpp:userLabel?   string
+--rw extamf3gpp:vnfParametersList!
|   | +--rw extamf3gpp:vnfInstanceId    string
|   | +--rw extamf3gpp:vnfdId?        string
|   | +--rw extamf3gpp:flavourId?     string
|   | +--rw extamf3gpp:autoScalable   boolean
+--rw extamf3gpp:peeParametersList!
|   | +--rw extamf3gpp:siteIdentification    string
|   | +--rw extamf3gpp:siteLatitude?        decimal64
|   | +--rw extamf3gpp:siteLongitude?       decimal64
|   | +--rw extamf3gpp:siteDescription      string

```

```

    | | +--rw extamf3gpp:equipmentType      string
    | | +--rw extamf3gpp:environmentType  string
    | | +--rw extamf3gpp:powerInterface   string
+--rw extamf3gpp:priorityLabel           uint32
+--rw extamf3gpp:pLMNIdList* [mcc mnc]
    | | +--rw extamf3gpp:mcc             Mcc
    | | +--rw extamf3gpp:mnc             Mnc
+--rw extamf3gpp:aMFIIdentifier!
    | | +--rw extamf3gpp:amfRegionId?   AmfRegionId
    | | +--rw extamf3gpp:amfSetId?     AmfSetId
    | | +--rw extamf3gpp:amfPointer?   AmfPointer
+--rw extgnbdu3gpp:ExternalGNBDFunction* [id] {subnet3gpp:ExternalsUnderSubNetwork}?
+--rw extgnbdu3gpp:id                    string
+--rw extgnbdu3gpp:attributes
    | | +--rw extgnbdu3gpp:userLabel?   string
+--rw extgnbdu3gpp:vnfParametersList!
    | | +--rw extgnbdu3gpp:vnfInstanceId string
    | | +--rw extgnbdu3gpp:vnfdId?     string
    | | +--rw extgnbdu3gpp:flavourId?  string
    | | +--rw extgnbdu3gpp:autoScalable boolean
+--rw extgnbdu3gpp:peeParametersList!
    | | +--rw extgnbdu3gpp:siteIdentification string
    | | +--rw extgnbdu3gpp:siteLatitude?    decimal64
    | | +--rw extgnbdu3gpp:siteLongitude?   decimal64
    | | +--rw extgnbdu3gpp:siteDescription  string
    | | +--rw extgnbdu3gpp:equipmentType   string
    | | +--rw extgnbdu3gpp:environmentType string
    | | +--rw extgnbdu3gpp:powerInterface  string
+--rw extgnbdu3gpp:priorityLabel         uint32
+--rw extgnbdu3gpp:gNBId                 int64
+--rw extgnbdu3gpp:gNBIdLength           int32
+--rw extgnbdu3gpp:pLMNId* [mcc mnc]
    | | +--rw extgnbdu3gpp:mcc         Mcc
    | | +--rw extgnbdu3gpp:mnc         Mnc
module: _3gpp-nr-nrm-eutranetwork
+--rw EUtraNetwork* [id]
+--rw id                                  string
+--rw attributes
    | | +--rw dnPrefix?                 types3gpp:DistinguishedName
    | | +--rw userLabel?                string
    | | +--rw userDefinedNetworkType?   string
    | | +--ro supportedMeasurementsGPs* [measurementType]
    | | | +--ro measurementType         string
    | | | +--ro supportedGPs*           uint32
    | | +--rw setOfMcc*                  types3gpp:Mcc
    | | +--rw priorityLabel              uint32
    | | +--rw parents*                   -> ../../../../EUtraNetwork/id
    | | +--rw containedChildren*         -> ../../../../EUtraNetwork/id
+--rw extservgw3gpp:ExternalServingGWFunction* [id] {eutranet3gpp:ExternalsUnderEUtraNetwork}?
+--rw extservgw3gpp:id                  string
+--rw extservgw3gpp:attributes
    | | +--rw extservgw3gpp:userLabel?   string
+--rw extservgw3gpp:vnfParametersList!
    | | +--rw extservgw3gpp:vnfInstanceId string
    | | +--rw extservgw3gpp:vnfdId?     string
    | | +--rw extservgw3gpp:flavourId?  string
    | | +--rw extservgw3gpp:autoScalable boolean
+--rw extservgw3gpp:peeParametersList!
    | | +--rw extservgw3gpp:siteIdentification string
    | | +--rw extservgw3gpp:siteLatitude?    decimal64
    | | +--rw extservgw3gpp:siteLongitude?   decimal64
    | | +--rw extservgw3gpp:siteDescription  string
    | | +--rw extservgw3gpp:equipmentType   string
    | | +--rw extservgw3gpp:environmentType string
    | | +--rw extservgw3gpp:powerInterface  string
+--rw extservgw3gpp:priorityLabel         uint32
+--rw extenb3gpp:ExternalENBFunction* [id] {eutranet3gpp:ExternalsUnderEUtraNetwork}?
+--rw extenb3gpp:id                      string
+--rw extenb3gpp:attributes
    | | +--rw extenb3gpp:userLabel?       string
+--rw extenb3gpp:vnfParametersList!
    | | +--rw extenb3gpp:vnfInstanceId   string
    | | +--rw extenb3gpp:vnfdId?        string
    | | +--rw extenb3gpp:flavourId?     string
    | | +--rw extenb3gpp:autoScalable   boolean
+--rw extenb3gpp:peeParametersList!
    | | +--rw extenb3gpp:siteIdentification string
    | | +--rw extenb3gpp:siteLatitude?    decimal64

```

```

+--rw extenb3gpp:siteLongitude?      decimal64
+--rw extenb3gpp:siteDescription     string
+--rw extenb3gpp:equipmentType       string
+--rw extenb3gpp:environmentType     string
+--rw extenb3gpp:powerInterface      string
+--rw extenb3gpp:priorityLabel        uint32
+--rw extenb3gpp:eNBId                int32
+--rw exteutranCell3gpp:ExternalEUTranCellFDD* [id]
{eutranet3gpp:ExternalsUnderEUTraNetwork}?
+--rw exteutranCell3gpp:id            string
+--rw exteutranCell3gpp:attributes
+--rw exteutranCell3gpp:userLabel?    string
+--rw exteutranCell3gpp:vnfParametersList!
| +--rw exteutranCell3gpp:vnfInstanceId    string
| +--rw exteutranCell3gpp:vnfdId?        string
| +--rw exteutranCell3gpp:flavourId?     string
| +--rw exteutranCell3gpp:autoScalable   boolean
+--rw exteutranCell3gpp:peeParametersList!
| +--rw exteutranCell3gpp:siteIdentification    string
| +--rw exteutranCell3gpp:siteLatitude?        decimal64
| +--rw exteutranCell3gpp:siteLongitude?       decimal64
| +--rw exteutranCell3gpp:siteDescription      string
| +--rw exteutranCell3gpp:equipmentType        string
| +--rw exteutranCell3gpp:environmentType     string
| +--rw exteutranCell3gpp:powerInterface      string
+--rw exteutranCell3gpp:priorityLabel        uint32
+--rw exteutranCell3gpp:pci                  int32
+--rw exteutranCell3gpp:plmnIdList* [mcc mnc]
| +--rw exteutranCell3gpp:mcc    Mcc
| +--rw exteutranCell3gpp:mnc    Mnc
+--rw exteutranCell3gpp:cellLocalId?        int32
+--rw exteutranCell3gpp:eNBId                int32
+--rw exteutranCell3gpp:earfcnDL            int32
+--rw exteutranCell3gpp:earfcnUL            int32
+--rw exteutranCell3gpp:ExternalEUTranCellTDD* [id]
{eutranet3gpp:ExternalsUnderEUTraNetwork}?
+--rw exteutranCell3gpp:id            string
+--rw exteutranCell3gpp:attributes
+--rw exteutranCell3gpp:userLabel?    string
+--rw exteutranCell3gpp:vnfParametersList!
| +--rw exteutranCell3gpp:vnfInstanceId    string
| +--rw exteutranCell3gpp:vnfdId?        string
| +--rw exteutranCell3gpp:flavourId?     string
| +--rw exteutranCell3gpp:autoScalable   boolean
+--rw exteutranCell3gpp:peeParametersList!
| +--rw exteutranCell3gpp:siteIdentification    string
| +--rw exteutranCell3gpp:siteLatitude?        decimal64
| +--rw exteutranCell3gpp:siteLongitude?       decimal64
| +--rw exteutranCell3gpp:siteDescription      string
| +--rw exteutranCell3gpp:equipmentType        string
| +--rw exteutranCell3gpp:environmentType     string
| +--rw exteutranCell3gpp:powerInterface      string
+--rw exteutranCell3gpp:priorityLabel        uint32
+--rw exteutranCell3gpp:pci                  int32
+--rw exteutranCell3gpp:plmnIdList* [mcc mnc]
| +--rw exteutranCell3gpp:mcc    Mcc
| +--rw exteutranCell3gpp:mnc    Mnc
+--rw exteutranCell3gpp:cellLocalId?        int32
+--rw exteutranCell3gpp:eNBId                int32
+--rw exteutranCell3gpp:earfcn                int32
+--rw eutranetEUTranFreq3gpp:EUTranFrequency* [id] {eutranet3gpp:ExternalsUnderEUTraNetwork}?
+--rw eutranetEUTranFreq3gpp:id            string
+--rw eutranetEUTranFreq3gpp:attributes
+--rw eutranetEUTranFreq3gpp:userLabel?    string
+--rw eutranetEUTranFreq3gpp:vnfParametersList!
| +--rw eutranetEUTranFreq3gpp:vnfInstanceId    string
| +--rw eutranetEUTranFreq3gpp:vnfdId?        string
| +--rw eutranetEUTranFreq3gpp:flavourId?     string
| +--rw eutranetEUTranFreq3gpp:autoScalable   boolean
+--rw eutranetEUTranFreq3gpp:peeParametersList!
| +--rw eutranetEUTranFreq3gpp:siteIdentification    string
| +--rw eutranetEUTranFreq3gpp:siteLatitude?        decimal64
| +--rw eutranetEUTranFreq3gpp:siteLongitude?       decimal64
| +--rw eutranetEUTranFreq3gpp:siteDescription      string
| +--rw eutranetEUTranFreq3gpp:equipmentType        string
| +--rw eutranetEUTranFreq3gpp:environmentType     string
| +--rw eutranetEUTranFreq3gpp:powerInterface      string
+--rw eutranetEUTranFreq3gpp:priorityLabel        uint32

```

```

    +--rw eutraneteutranfreq3gpp:earfcnDL                uint32
    +--ro eutraneteutranfreq3gpp:multiBandInfoListEutra*  uint16
module: _3gpp-nr-nrm-nrnetwork
+--rw NRNetwork* [id]
  +--rw id                                             string
  +--rw attributes
    +--rw dnPrefix?                                   types3gpp:DistinguishedName
    +--rw userLabel?                                  string
    +--rw userDefinedNetworkType?                    string
    +--ro supportedMeasurementsGPs* [measurementType]
    | +--ro measurementType                          string
    | +--ro supportedGPs*                            uint32
    +--rw setOfMcc*                                   types3gpp:Mcc
    +--rw priorityLabel                               uint32
+--rw extgnbcucp3gpp:ExternalGNBCUCPFunction* [id] {nrnet3gpp:ExternalsUnderNRNetwork}?
  +--rw extgnbcucp3gpp:id                             string
  +--rw extgnbcucp3gpp:attributes
    +--rw extgnbcucp3gpp:userLabel?                  string
    +--rw extgnbcucp3gpp:vnfParametersList!
    | +--rw extgnbcucp3gpp:vnfInstanceId             string
    | +--rw extgnbcucp3gpp:vnfdId?                  string
    | +--rw extgnbcucp3gpp:flavourId?               string
    | +--rw extgnbcucp3gpp:autoScalable              boolean
    +--rw extgnbcucp3gpp:peeParametersList!
    | +--rw extgnbcucp3gpp:siteIdentification        string
    | +--rw extgnbcucp3gpp:siteLatitude?             decimal64
    | +--rw extgnbcucp3gpp:siteLongitude?           decimal64
    | +--rw extgnbcucp3gpp:siteDescription          string
    | +--rw extgnbcucp3gpp:equipmentType            string
    | +--rw extgnbcucp3gpp:environmentType          string
    | +--rw extgnbcucp3gpp:powerInterface           string
    +--rw extgnbcucp3gpp:priorityLabel               uint32
    +--rw extgnbcucp3gpp:gNBId                       int64
    +--rw extgnbcucp3gpp:gNBIdLength                int32
    +--rw extgnbcucp3gpp:pLMNId* [mcc mnc]
    | +--rw extgnbcucp3gpp:mcc                      Mcc
    | +--rw extgnbcucp3gpp:mnc                      Mnc
+--rw extnrcellcu3gpp:ExternalNRCellCU* [id] {nrnet3gpp:ExternalsUnderNRNetwork}?
  +--rw extnrcellcu3gpp:id                           string
  +--rw extnrcellcu3gpp:attributes
    +--rw extnrcellcu3gpp:userLabel?                 string
    +--rw extnrcellcu3gpp:vnfParametersList!
    | +--rw extnrcellcu3gpp:vnfInstanceId           string
    | +--rw extnrcellcu3gpp:vnfdId?                string
    | +--rw extnrcellcu3gpp:flavourId?             string
    | +--rw extnrcellcu3gpp:autoScalable            boolean
    +--rw extnrcellcu3gpp:peeParametersList!
    | +--rw extnrcellcu3gpp:siteIdentification      string
    | +--rw extnrcellcu3gpp:siteLatitude?           decimal64
    | +--rw extnrcellcu3gpp:siteLongitude?         decimal64
    | +--rw extnrcellcu3gpp:siteDescription        string
    | +--rw extnrcellcu3gpp:equipmentType          string
    | +--rw extnrcellcu3gpp:environmentType        string
    | +--rw extnrcellcu3gpp:powerInterface         string
    +--rw extnrcellcu3gpp:priorityLabel             uint32
    +--rw extnrcellcu3gpp:cellLocalId              int32
    +--rw extnrcellcu3gpp:nRPCI                     int32
    +--rw extnrcellcu3gpp:pLMNIdList* [mcc mnc]
    | +--rw extnrcellcu3gpp:mcc                    Mcc
    | +--rw extnrcellcu3gpp:mnc                    Mnc
    +--rw extnrcellcu3gpp:nRFrequencyRef            types3gpp:DistinguishedName
+--rw extgnbcuup3gpp:ExternalGNBCUUPFunction* [id] {nrnet3gpp:ExternalsUnderNRNetwork}?
  +--rw extgnbcuup3gpp:id                             string
  +--rw extgnbcuup3gpp:attributes
    +--rw extgnbcuup3gpp:userLabel?                  string
    +--rw extgnbcuup3gpp:vnfParametersList!
    | +--rw extgnbcuup3gpp:vnfInstanceId           string
    | +--rw extgnbcuup3gpp:vnfdId?                string
    | +--rw extgnbcuup3gpp:flavourId?             string
    | +--rw extgnbcuup3gpp:autoScalable            boolean
    +--rw extgnbcuup3gpp:peeParametersList!
    | +--rw extgnbcuup3gpp:siteIdentification      string
    | +--rw extgnbcuup3gpp:siteLatitude?           decimal64
    | +--rw extgnbcuup3gpp:siteLongitude?         decimal64
    | +--rw extgnbcuup3gpp:siteDescription        string
    | +--rw extgnbcuup3gpp:equipmentType          string
    | +--rw extgnbcuup3gpp:environmentType        string
    | +--rw extgnbcuup3gpp:powerInterface         string

```

```

|--rw extgnbcuup3gpp:priorityLabel      uint32
|--rw extgnbcuup3gpp:gNBId             int64
|--rw extgnbcuup3gpp:gNBIdLength      int32
+--rw extupf3gpp:ExternalUPFunction* [id] {nrnet3gpp:ExternalsUnderNRNetwork}?
  +--rw extupf3gpp:id                   string
  +--rw extupf3gpp:attributes
    +--rw extupf3gpp:userLabel?         string
    +--rw extupf3gpp:vnfParametersList!
      +--rw extupf3gpp:vnfInstanceId    string
      +--rw extupf3gpp:vnfdId?         string
      +--rw extupf3gpp:flavourId?     string
      +--rw extupf3gpp:autoScalable    boolean
    +--rw extupf3gpp:peeParametersList!
      +--rw extupf3gpp:siteIdentification string
      +--rw extupf3gpp:siteLatitude?    decimal64
      +--rw extupf3gpp:siteLongitude?  decimal64
      +--rw extupf3gpp:siteDescription string
      +--rw extupf3gpp:equipmentType   string
      +--rw extupf3gpp:environmentType string
      +--rw extupf3gpp:powerInterface  string
    +--rw extupf3gpp:priorityLabel      uint32
+--rw nrfreq3gpp:NRFfrequency* [id] {nrnet3gpp:ExternalsUnderNRNetwork}?
  +--rw nrfreq3gpp:id                 string
  +--rw nrfreq3gpp:attributes
    +--rw nrfreq3gpp:userLabel?       string
    +--rw nrfreq3gpp:vnfParametersList!
      +--rw nrfreq3gpp:vnfInstanceId  string
      +--rw nrfreq3gpp:vnfdId?       string
      +--rw nrfreq3gpp:flavourId?    string
      +--rw nrfreq3gpp:autoScalable   boolean
    +--rw nrfreq3gpp:peeParametersList!
      +--rw nrfreq3gpp:siteIdentification string
      +--rw nrfreq3gpp:siteLatitude?    decimal64
      +--rw nrfreq3gpp:siteLongitude?  decimal64
      +--rw nrfreq3gpp:siteDescription string
      +--rw nrfreq3gpp:equipmentType   string
      +--rw nrfreq3gpp:environmentType string
      +--rw nrfreq3gpp:powerInterface  string
    +--rw nrfreq3gpp:priorityLabel      uint32
    +--rw nrfreq3gpp:absoluteFrequencySSB uint32
    +--rw nrfreq3gpp:sSSSubCarrierSpacing uint8
    +--ro nrfreq3gpp:multiFrequencyBandListNR* uint16
+--rw extamf3gpp:ExternalAMFunction* [id] {nrnet3gpp:ExternalsUnderNRNetwork}?
  +--rw extamf3gpp:id                 string
  +--rw extamf3gpp:attributes
    +--rw extamf3gpp:userLabel?       string
    +--rw extamf3gpp:vnfParametersList!
      +--rw extamf3gpp:vnfInstanceId  string
      +--rw extamf3gpp:vnfdId?       string
      +--rw extamf3gpp:flavourId?    string
      +--rw extamf3gpp:autoScalable   boolean
    +--rw extamf3gpp:peeParametersList!
      +--rw extamf3gpp:siteIdentification string
      +--rw extamf3gpp:siteLatitude?    decimal64
      +--rw extamf3gpp:siteLongitude?  decimal64
      +--rw extamf3gpp:siteDescription string
      +--rw extamf3gpp:equipmentType   string
      +--rw extamf3gpp:environmentType string
      +--rw extamf3gpp:powerInterface  string
    +--rw extamf3gpp:priorityLabel      uint32
    +--rw extamf3gpp:pLMNIdList* [mcc mnc]
      +--rw extamf3gpp:mcc            Mcc
      +--rw extamf3gpp:mnc            Mnc
    +--rw extamf3gpp:aMFIdentifier!
      +--rw extamf3gpp:amfRegionId?   AmfRegionId
      +--rw extamf3gpp:amfSetId?     AmfSetId
      +--rw extamf3gpp:amfPointer?   AmfPointer
+--rw extgnbdu3gpp:ExternalGNBDUFunction* [id] {nrnet3gpp:ExternalsUnderNRNetwork}?
  +--rw extgnbdu3gpp:id               string
  +--rw extgnbdu3gpp:attributes
    +--rw extgnbdu3gpp:userLabel?     string
    +--rw extgnbdu3gpp:vnfParametersList!
      +--rw extgnbdu3gpp:vnfInstanceId string
      +--rw extgnbdu3gpp:vnfdId?     string
      +--rw extgnbdu3gpp:flavourId?  string
      +--rw extgnbdu3gpp:autoScalable boolean
    +--rw extgnbdu3gpp:peeParametersList!
      +--rw extgnbdu3gpp:siteIdentification string

```

```

| +--rw extgnbdu3gpp:siteLatitude?          decimal64
| +--rw extgnbdu3gpp:siteLongitude?        decimal64
| +--rw extgnbdu3gpp:siteDescription       string
| +--rw extgnbdu3gpp:equipmentType        string
| +--rw extgnbdu3gpp:environmentType      string
| +--rw extgnbdu3gpp:powerInterface       string
+--rw extgnbdu3gpp:priorityLabel          uint32
+--rw extgnbdu3gpp:gNBId                  int64
+--rw extgnbdu3gpp:gNBIdLength            int32
+--rw extgnbdu3gpp:pLMNId* [mcc mnc]
    +--rw extgnbdu3gpp:mcc                Mcc
    +--rw extgnbdu3gpp:mnc                Mnc
module: ietf-yang-schema-mount
+--ro schema-mounts
+--ro namespace* [prefix]
| +--ro prefix      yang:yang-identifier
| +--ro uri?       inet:uri
+--ro mount-point* [module label]
+--ro module       yang:yang-identifier
+--ro label        yang:yang-identifier
+--ro config?     boolean
+--ro (schema-ref)
+--:(inline)
| +--ro inline!
+--:(shared-schema)
+--ro shared-schema!
+--ro parent-reference* yang:xpath1.0

```

H.7 Mount information

```

_3gpp-5gc-nrm-afffunction.yang
_3gpp-5gc-nrm-amfffunction.yang
_3gpp-5gc-nrm-amfregion.yang
_3gpp-5gc-nrm-amfset.yang
_3gpp-5gc-nrm-ausfffunction.yang
_3gpp-5gc-nrm-dnfffunction.yang
_3gpp-5gc-nrm-ep.yang
_3gpp-5gc-nrm-externalnrfffunction.yang
_3gpp-5gc-nrm-externalnssfffunction.yang
_3gpp-5gc-nrm-lmfffunction.yang
_3gpp-5gc-nrm-n3iwfffunction.yang
_3gpp-5gc-nrm-nfprofile.yang
_3gpp-5gc-nrm-nfservice.yang
_3gpp-5gc-nrm-ngeirfunction.yang
_3gpp-5gc-nrm-nrfffunction.yang
_3gpp-5gc-nrm-nssfffunction.yang
_3gpp-5gc-nrm-nwdafffunction.yang
_3gpp-5gc-nrm-pcfffunction.yang
_3gpp-5gc-nrm-seppfunction.yang
_3gpp-5gc-nrm-smfffunction.yang
_3gpp-5gc-nrm-smsfffunction.yang
_3gpp-5gc-nrm-udmfffunction.yang
_3gpp-5gc-nrm-udrfffunction.yang
_3gpp-5gc-nrm-udsfffunction.yang
_3gpp-5gc-nrm-upfffunction.yang

```

If the above files are mounted the yang files described in clause E.7 must also be mounted .

Annex I (normative): XML definitions for network slice

I.1 General

This annex contains the XML definitions for the network slice NRM, in accordance with network slice NRM Information Model definitions specified in clause 6.

I.2 Architectural features

The overall architectural feature of network slice information model is specified in clause 6, this clause specifies features that are specific to the Schema definitions.

The XML definitions of the present document specify the schema for a configuration content, which can be included in a configuration file for Bulk configuration management operations.

I.3 Mapping

I.3.1 General mapping

An IOC maps to an XML element of the same name as the IOC's name in the Information Model. An IOC attribute maps to a sub-element of the corresponding IOC's XML element, and the name of this sub-element is the same as the attribute's name in the Information Model.

I.3.2 Information Object Class (IOC) mapping

The mapping is not present in the current version of the present document.

I.4 Solution Set (SS) definitions

I.4.1 XML definition structure

The overall description of the file format of configuration data XML files is provided by 3GPP TS 32.616 [33].

This annex defines the NRM-specific XML schema `sliceNrm.xsd` for the network slice Information Model defined in clause 6.

XML schema `sliceNrm.xsd` explicitly declares NRM-specific XML element types for the related NRM.

The definition of those NRM-specific XML element types complies with the generic mapping rules defined in 3GPP TS 32.616 [33].

I.4.2 Graphical representation

The graphical representation is not present in the current version of the present document.

I.4.3 XML schema "`sliceNrm.xsd`"

```
<?xml version="1.0" encoding="UTF-8"?>
```



```

<!--
3GPP TS 28.541 network slice Network Resource Model
XML schema definition
sliceNrm.xsd
-->
<schema xmlns="http://www.w3.org/2001/XMLSchema"
xmlns:xn="http://www.3gpp.org/ftp/specs/archive/28_series/28.623#genericNrm"
xmlns:sl="http://www.3gpp.org/ftp/specs/archive/28_series/28.541#sliceNrm"
xmlns:nn="http://www.3gpp.org/ftp/specs/archive/28_series/28.541#nrNrm"
xmlns:ngc="http://www.3gpp.org/ftp/specs/archive/28_series/28.541#ngcNrm"
xmlns:en="http://www.3gpp.org/ftp/specs/archive/28_series/28.659#eutranNrm"
xmlns:sm="http://www.3gpp.org/ftp/specs/archive/28_series/28.626#stateManagementIRP"
targetNamespace="http://www.3gpp.org/ftp/specs/archive/28_series/28.541#sliceNrm"
elementFormDefault="qualified">
  <import namespace="http://www.3gpp.org/ftp/specs/archive/28_series/28.623#genericNrm"/>
  <import namespace="http://www.3gpp.org/ftp/specs/archive/28_series/28.541#nrNrm"/>
  <import namespace="http://www.3gpp.org/ftp/specs/archive/28_series/28.541#ngcNrm"/>
  <import namespace="http://www.3gpp.org/ftp/specs/archive/28_series/28.659#eutranNrm"/>
  <import namespace="http://www.3gpp.org/ftp/specs/archive/28_series/28.626#stateManagementIRP"/>

  <simpleType name="MobilityLevel">
    <restriction base="string">
      <enumeration value="STATIONARY"/>
      <enumeration value="NOMADIC"/>
      <enumeration value="RESTRICTED MOBILITY"/>
      <enumeration value="FULLY MOBILITY"/>
    </restriction>
  </simpleType>
  <simpleType name="SharingLevel">
    <restriction base="string">
      <enumeration value="SHARED"/>
      <enumeration value="NON-SHARED"/>
    </restriction>
  </simpleType>

  <complexType name="PerfReq">
    <!-- Refer to definitions in TS 22.261-->
    <sequence>
      <choice minOccurs="0" maxOccurs="1">
        <element name="perfReqEMBB" type="sl:PerfReqEmbb"/>
        <element name="perfReqUrllc" type="sl:PerfReqUrllc"/>
      </choice>
    </sequence>
  </complexType>
  <complexType name="PerfReqEmbb">
    <sequence>
      <element name="expDataRateDL" type="integer" minOccurs="0"/>
      <element name="expDataRateUL" type="integer" minOccurs="0"/>
      <element name="areaTrafficCapDL" type="integer" minOccurs="0"/>
      <element name="areaTrafficCapUL" type="integer" minOccurs="0"/>
      <element name="userDensity" type="integer" minOccurs="0"/>
      <element name="activityFactor" type="integer" minOccurs="0"/>
      <element name="uESpeed" type="integer" minOccurs="0"/>
      <element name="coverage" type="string" minOccurs="0"/>
    </sequence>
  </complexType>
  <complexType name="PerfReqUrllc">
    <sequence>
      <element name="e2eKlatency" type="integer" minOccurs="0"/>
      <element name="jitter" type="integer" minOccurs="0"/>
      <element name="survivalTime" type="integer" minOccurs="0"/>
      <element name="cSAvailability" type="float" minOccurs="0"/>
      <element name="reliability" type="float" minOccurs="0"/>
      <element name="expDataRate" type="integer" minOccurs="0"/>
      <element name="payloadSize" type="integer" minOccurs="0"/>
      <element name="trafficDensity" type="string" minOccurs="0"/>
      <element name="connDensity" type="float" minOccurs="0"/>
      <element name="serviceDimension" type="string" minOccurs="0"/>
    </sequence>
  </complexType>
  <complexType name="ServiceProfile">
    <sequence>
      <element name="serviceProfileId" type="string"/>
      <element name="sNSSAIIList" type="ngc:SnsaiList"/>
      <element name="pLMNIdList" type="en:PLMNIdList"/>
      <element name="perfReq" type="sl:PerfReq"/>
      <element name="maxNumberOfUEs" type="long" minOccurs="0"/>
      <element name="coverageAreaTAList" type="ngc:NrTACList" minOccurs="0"/>
    </sequence>
  </complexType>

```

```

    <element name="latency" type="integer" minOccurs="0"/>
    <element name="uEMobilityLevel" type="integer" minOccurs="0"/>
    <element name="resourceSharingLevel" type="integer" minOccurs="0"/>
    <element name="sst" type="ngc:Sst"/>
    <element name="availability" type="float" minOccurs="0"/>
  </sequence>
</complexType>
<complexType name="ServiceProfileList">
  <sequence>
    <element name="serviceProfile" type="sl:ServiceProfile"/>
  </sequence>
</complexType>

<complexType name="SliceProfile">
  <sequence>
    <element name="sliceProfileId" type="string"/>
    <element name="sNSSAList" type="ngc:SnssaiList"/>
    <element name="pLMNIdList" type="en:PLMNIdList"/>
    <element name="perfReq" type="sl:PerfReq"/>
    <element name="maxNumberOfUEs" type="long" minOccurs="0"/>
    <element name="coverageAreaTAList" type="ngc:NrTACList" minOccurs="0"/>
    <element name="latency" type="integer" minOccurs="0"/>
    <element name="uEMobilityLevel" type="sl:MobilityLevel" minOccurs="0"/>
    <element name="resourceSharingLevel" type="integer" minOccurs="0"/>
  </sequence>
</complexType>
<complexType name="SliceProfileList">
  <sequence>
    <element name="sliceProfile" type="sl:SliceProfile"/>
  </sequence>
</complexType>
<complexType name="NsInfo">
  <!-- Refer to definitions in subclause 8.3.3.2.2 of ETSI NFV IFA013 -->
  <sequence>
    <element name="nsInstanceId" type="string"/>
    <element name="nsName" type="string"/>
    <element name="description" type="string"/>
  </sequence>
</complexType>

<element name="NetworkSlice" substitutionGroup="xn:SubNetworkOptionallyContainedNrmClass">
  <complexType>
    <complexContent>
      <extension base="xn:NrmClass">
        <sequence>
          <element name="attributes">
            <complexType>
              <all>
                <!-- Inherited attributes from SubNetwork -->
                <element name="dnPrefix" type="string" minOccurs="0"/>
                <element name="userLabel" type="string"/>
                <element name="userDefinedNetworkType" type="string"/>
                <element name="setOfMcc" type="string" minOccurs="0"/>
                <element name="measurements" type="xn:MeasurementTypesAndGPsList" minOccurs="0"/>
                <!-- End of inherited attributes from SubNetwork -->
                <element name="operationalState" type="sm:operationalStateType"/>
                <element name="administrativeState" type="sm:administrativeStateType"/>
                <element name="serviceProfileList" type="sl:ServiceProfileList"/>
                <element name="networkSliceSubnetRef" type="xn:dn"/>
              </all>
            </complexType>
          </element>
          <choice minOccurs="0" maxOccurs="unbounded">
            <element ref="xn:MeasurementControl"/>
          </choice>
        </sequence>
      </extension>
    </complexContent>
  </complexType>
</element>
<element name="NetworkSliceSubnet" substitutionGroup="xn:SubNetworkOptionallyContainedNrmClass">
  <complexType>
    <complexContent>
      <extension base="xn:NrmClass">
        <sequence>
          <element name="attributes">

```

```
<complexType>
  <all>
    <!-- Inherited attributes from SubNetwork -->
    <element name="dnPrefix" type="string" minOccurs="0"/>
    <element name="userLabel" type="string"/>
    <element name="userDefinedNetworkType" type="string"/>
    <element name="setOfMcc" type="string" minOccurs="0"/>
    <element name="measurements" type="xn:MeasurementTypesAndGPsList" minOccurs="0"/>
    <!-- End of inherited attributes from SubNetwork -->

    <element name="operationalState" type="sm:operationalStateType"/>
    <element name="administrativeState" type="sm:administrativeStateType"/>
    <element name="nsInfo" type="sl:NsInfo" minOccurs="0"/>
    <element name="sliceProfileList" type="sl:SliceProfileList"/>
    <element name="managedFunctionRef" type="xn:dndlist"/>
    <element name="networkSliceSubnetRef" type="xn:dndlist"/>
  </all>
</complexType>
</element>
<choice minOccurs="0" maxOccurs="unbounded">
  <element ref="xn:MeasurementControl"/>
</choice>
</sequence>
</extension>
</complexContent>
</complexType>
</element>
</schema>
```

Annex J (normative): JSON definitions for network slice

J.1 General

This annex contains the JSON definitions for the network slice NRM, in accordance with network slice NRM Information Model definitions specified in clause 6.

J.2 Architectural features

The overall architectural feature of network slice information model is specified in clause 6, this clause specifies features that are specific to the Schema definitions.

J.3 Mapping

Refer to TS 32.160 [46].

J.4 Solution Set (SS) definitions

J.4.1 JSON definition structure

JSON is used as resource representations format carried in the HTTP request and HTTP response message bodies. The properties (key-value pairs) on an object are defined using the properties keyword.

J.4.2 Graphical representation

None.

J.4.3 JSON schema "sliceNrm.json"

```
{
  "openapi": "3.0.1",
  "info": {
    "title": "3GPP Network Slice NRM",
    "version": "15.3.0",
    "description": "OAS 3.0.1 specification compatible schema for 3GPP Network Slice NRM"
  },
  "paths": {},
  "components": {
    "schemas": {
      "MobilityLevel": {
        "type": "string",
        "enum": [
          "STATIONARY",
          "NOMADIC",
          "RESTRICTED MOBILITY",
          "FULLY MOBILITY"
        ]
      },
      "SharingLevel": {
        "type": "string",
        "enum": [
          "SHARED",
          "NON-SHARED"
        ]
      }
    }
  }
}
```

```

    ],
    "PerfReq": {
      "type": "object",
      "properties": {
        "perfReqEmbb": {
          "$ref": "#/components/schemas/PerfReqEmbb"
        },
        "perfReqUrl1c": {
          "$ref": "#/components/schemas/PerfReqUrl1c"
        }
      }
    },
    "PerfReqEmbb": {
      "type": "object",
      "properties": {
        "expDataRateDL": {
          "type": "number"
        },
        "expDataRateUL": {
          "type": "number"
        },
        "areaTrafficCapDL": {
          "type": "number"
        },
        "areaTrafficCapUL": {
          "type": "number"
        },
        "userDensity": {
          "type": "number"
        },
        "activityFactor": {
          "type": "number"
        },
        "uESpeed": {
          "type": "number"
        },
        "coverage": {
          "type": "string"
        }
      }
    },
    "PerfReqUrl1c": {
      "type": "object",
      "properties": {
        "e2eLatency": {
          "type": "number"
        },
        "jitter": {
          "type": "number"
        },
        "survivalTime": {
          "type": "number"
        },
        "areaTrafficCapUL": {
          "type": "number"
        },
        "cSAvailability": {
          "type": "number"
        },
        "reliability": {
          "type": "number"
        },
        "expDataRate": {
          "type": "number"
        },
        "payloadSize": {
          "type": "number"
        },
        "trafficDensity": {
          "type": "string"
        },
        "connDensity": {
          "type": "number"
        },
        "serviceDimension": {
          "type": "string"
        }
      }
    }
  }

```

```

    },
    "NsInfo": {
      "type": "object",
      "properties": {
        "nsInstanceId": {
          "type": "string"
        },
        "nsName": {
          "type": "string"
        }
      }
    },
  },
  "NetworkSlice": {
    "allOf": [
      {
        "$ref": "genericNrm.json#/components/schemas/Top-Attributes"
      },
      {
        "type": "object",
        "properties": {
          "attributes": {
            "allOf": [
              {
                "$ref": "genericNrm.json#/components/schemas/SubNetwork-Attributes"
              },
              {
                "type": "object",
                "properties": {}
              },
              {
                "type": "object",
                "properties": {
                  "networkSliceSubnetRef": {
                    "$ref": "genericNrm.json#/components/schemas/Dn"
                  },
                  "operationalState": {
                    "$ref": "genericNrm.json#/components/schemas/OperationalState"
                  },
                  "administrativeState": {
                    "$ref": "genericNrm.json#/components/schemas/AdministrativeState"
                  },
                  "serviceProfileList": {
                    "$ref": "#/components/schemas/ServiceProfileList"
                  }
                }
              }
            ]
          }
        }
      }
    ]
  },
  "NetworkSliceSubnet": {
    "allOf": [
      {
        "$ref": "genericNrm.json#/components/schemas/Top-Attributes"
      },
      {
        "type": "object",
        "properties": {
          "attributes": {
            "allOf": [
              {
                "$ref": "genericNrm.json#/components/schemas/SubNetwork-Attributes"
              },
              {
                "type": "object",
                "properties": {}
              },
              {
                "type": "object",
                "properties": {
                  "managedFunctionRefList": {
                    "$ref": "genericNrm.json#/components/schemas/DnList"
                  },
                  "networkSliceSubnetRefList": {
                    "$ref": "genericNrm.json#/components/schemas/DnList"
                  }
                }
              }
            ]
          }
        }
      }
    ]
  }
}

```

```

    },
    "operationalState": {
      "$ref": "genericNrm.json#/components/schemas/OperationalState"
    },
    "administrativeState": {
      "$ref": "genericNrm.json#/components/schemas/AdministrativeState"
    },
    "nsInfo": {
      "$ref": "#/components/schemas/NsInfo"
    },
    "sliceProfileList": {
      "$ref": "#/components/schemas/SliceProfileList"
    }
  }
}
]
},
"ServiceProfile": {
  "type": "object",
  "properties": {
    "serviceProfileId": {
      "type": "string"
    },
    "snssaiList": {
      "$ref": "nrNrm.json#/components/schemas/SnssaiList"
    },
    "plmnIdList": {
      "$ref": "nrNrm.json#/components/schemas/PlmnIdList"
    },
    "perfReq": {
      "$ref": "#/components/schemas/PerfReq"
    },
    "maxNumberOfUEs": {
      "type": "number"
    },
    "coverageAreaTAList": {
      "$ref": "ngcNrm.json#/components/schemas/TACList"
    },
    "latency": {
      "type": "number"
    },
    "uEMobilityLevel": {
      "$ref": "#/components/schemas/MobilityLevel"
    },
    "sst": {
      "$ref": "nrNrm.json#/components/schemas/Sst"
    },
    "resourceSharingLevel": {
      "$ref": "#/components/schemas/SharingLevel"
    },
    "availability": {
      "type": "number"
    }
  }
},
"ServiceProfileList": {
  "type": "array",
  "items": {
    "$ref": "#/components/schemas/ServiceProfile"
  }
},
"SliceProfile": {
  "type": "object",
  "properties": {
    "sliceProfileId": {
      "type": "string"
    },
    "snssaiList": {
      "$ref": "nrNrm.json#/components/schemas/SnssaiList"
    },
    "plmnIdList": {
      "$ref": "nrNrm.json#/components/schemas/PlmnIdList"
    },
    "perfReq": {

```

```
    "$ref": "#/components/schemas/PerfReq"
  },
  "maxNumberOfUEs": {
    "type": "number"
  },
  "coverageAreaTAList": {
    "$ref": "ngcNrm.json#/components/schemas/TACLList"
  },
  "latency": {
    "type": "number"
  },
  "uEMobilityLevel": {
    "$ref": "#/components/schemas/MobilityLevel"
  },
  "resourceSharingLevel": {
    "$ref": "#/components/schemas/SharingLevel"
  }
}
},
"SliceProfileList": {
  "type": "array",
  "items": {
    "$ref": "#/components/schemas/SliceProfile"
  }
}
}
}
```

Annex K (normative):
Void

Annex L (informative): Change history

Change history							
Date	Meeting	TDoc	CR	Rev	Cat	Subject/Comment	New version
2018-09	SA#81					Upgrade to change control version	15.0.0
2018-09	SA#81					EdiHelp review	15.0.1
2018-12	SA#82	SP-181046	0001	1	F	Fix issues raised by EditHelp	15.1.0
2018-12	SA#82	SP-181046	0002	2	F	Update NR Stage 2 definition to align with TS 37.340 for MR-DC	15.1.0
2018-12	SA#82	SP-181046	0003	1	F	Update NRM Stage 2 definition to align with TS 23.501 for 5G architecture	15.1.0
2018-12	SA#82	SP-181046	0005	1	F	Update Stage 3 XML definition of NR to align with Stage 2 content	15.1.0
2018-12	SA#82	SP-181046	0006	1	F	Update Stage 3 JSON definition of NR to align with Stage 2 content	15.1.0
2018-12	SA#82	SP-181046	0007	1	F	Update Stage 3 YANG definition of NR to align with Stage 2 content	15.1.0
2018-12	SA#82	SP-181046	0008	1	F	Update Stage 3 XML definition of 5GC to align with Stage 2 content	15.1.0
2018-12	SA#82	SP-181046	0009	1	F	Update Stage 3 JSON definition of 5GC to align with Stage 2 content	15.1.0
2018-12	SA#82	SP-181046	0011	1	F	Update stage 3 XML definition of NS to align with Stage 2 content	15.1.0
2018-12	SA#82	SP-181046	0012	1	F	Update Stage 3 JSON definition of NS to align with Stage 2 content	15.1.0
2018-12	SA#82	SP-181046	0013	1	F	Update stage 3 YANG definition of NS to align with Stage 2 content	15.1.0
2018-12	SA#82	SP-181046	0014	1	F	Correct the term sNSSAList and nRTACList	15.1.0
2018-12	SA#82	SP-181046	0015	1	F	Update the inheritance hierarchy figure for NR NRM to include BWP IOC and NRSectorCarrier IOC	15.1.0
2018-12	SA#82	SP-181046	0016	1	F	Change the term nCGI to nCI	15.1.0
2018-12	SA#82	SP-181046	0019	1	F	Align properties of cell state	15.1.0
2018-12	SA#82	SP-181046	0021	1	F	Add missing attribute definition and condition	15.1.0
2018-12	SA#82	SP-181047	0022	1	F	Add missing detail definition for attribute	15.1.0
2018-12	SA#82	SP-181047	0023	1	F	Adding missing attribute, and correction of reference	15.1.0
2018-12	SA#82	SP-181043	0025	-	F	Remove NSSF from the abbreviations	15.1.0
2018-12	SA#82	SP-181046	0027	-	F	Replace symbol for network slice state management	15.1.0
2018-12	SA#82	SP-181046	0031	1	F	Remove the ExternalENBFunction definition	15.1.0
2018-12	SA#82	SP-181046	0033	1	F	Align the management of external function and cell with TS 28.658	15.1.0
2018-12	SA#82	SP-181156	0034	1	F	Update NR NRM with Cell Relation	15.1.0
2018-12	SA#82	SP-181156	0038	3	F	RRM Policy enhancements	15.1.0
2018-12	SA#82	SP-181156	0039	1	F	Fix containment issue in YANG definition	15.1.0
2018-12	SA#82	SP-181156	0040	-	F	Implement minor corrections	15.1.0
2018-12	SA#82	SP-181042	0041	-	F	Update Stage 3 NRM for RRM Policy enhancements	15.1.0
2019-03	SA#83	SP-190121	0043	1	F	Align NR attributes definition related to SSB with corresponding NG-RAN IE definition	15.2.0
2019-03	SA#83	SP-190121	0044	1	F	Correct the use of nCI and PLMN	15.2.0
2019-03	SA#83	SP-190121	0045	-	F	Remove duplicate definition for ExternalNRCellICU	15.2.0
2019-03	SA#83	SP-190121	0046	2	F	Correct class diagram for view on external entities	15.2.0
2019-03	SA#83	SP-190121	0047	1	F	Correct the definition for resourceSharingLevel	15.2.0
2019-03	SA#83	SP-190121	0048	1	F	Correction of references	15.2.0
2019-03	SA#83	SP-190121	0052	1	F	Align the term mFIdList and constituentNSSIIdList	15.2.0
2019-03	SA#83	SP-190121	0053	1	F	Correct the definition of nSSIId	15.2.0
2019-03	SA#83	SP-190121	0054	1	F	Add missing attribute constraint for class definition of NSSFFunction	15.2.0
2019-03	SA#83	SP-190121	0055	1	F	Correct attribute constraints for RRMpolicy related attributes in NRCellICU	15.2.0
2019-03	SA#83	SP-190121	0057	-	F	Correct cardinality of End Point (EP) to target	15.2.0
2019-03	SA#83	SP-190121	0058	-	F	Correct Import table	15.2.0
2019-03	SA#83	SP-190121	0059	-	F	Remove ExternalNRCellICU.pLMNIdList	15.2.0
2019-03	SA#83	SP-190121	0060	-	F	Use 'bS' (not 'bs') to prefix all BS (base station) attributes	15.2.0
2019-03	SA#83	SP-190121	0061	1	F	Correction of State attributes descriptions	15.2.0

2019-03	SA#83	SP-190121	0062	-	F	Update 5G JSON Solution Set to align with generic NRM	15.2.0
2019-03	SA#83	SP-190121	0063	1	F	Update YANG Solution Set to align with Stage 2 definition	15.2.0
2019-03	SA#83	SP-190121	0064	1	F	Update Information Service to fix Network Slice modeling issue	15.2.0
2019-03	SA#83	SP-190121	0065	1	F	Update Solution Set to fix Network Slice modeling issue	15.2.0
2019-03	SA#83	SP-190121	0066	1	F	Add availability in service profile of network slice resource model	15.2.0
2019-03	SA#83	SP-190121	0068	1	F	Add sST attribute to ServiceProfile	15.2.0
2019-03	SA#83	SP-190121	0069	1	F	Update to sST attribute stage 3	15.2.0
2019-06	SA#84	SP-190374	0082	-	F	Remove attribute availabilityStatus in NRCellDU IOC	15.3.0
2019-06	SA#84	SP-190374	0084	1	F	Correct the definition for nsInfo	15.3.0
2019-06	SA#84	SP-190374	0087	1	F	Update Information Service of NR to fix unclear Note issue	15.3.0
2019-06	SA#84	SP-190374	0094	-	F	Correct definition of configuredMaxTxPower	15.3.0
2019-06	SA#84	SP-190374	0103	-	F	Fix the implementation errors	15.3.0
2019-06	SA#84	SP-190374	0104	2	F	Correct the use of plmnIdList	15.3.0
2019-09	SA#85	SP-190743	0086	2	F	Add missing (NR) cell and frequency relation	15.4.0
2019-09	SA#85	SP-190743	0093	2	F	Correct UML diagram and role-attribute of slice NRM	15.4.0
2019-09	SA#85	SP-190743	0095	2	F	Correct use of Proxy class	15.4.0
2019-09	SA#85	SP-190743	0106	1	F	Correct description for NR deployment scenario	15.4.0
2019-09	SA#85	SP-190743	0108	1	F	Correct NR NRM model to be applicable for all NG-RAN architecture	15.4.0
2019-09	SA#85	SP-190743	0110	1	F	Correct style of enumeration literals	15.4.0
2019-09	SA#85	SP-190743	0113	4	F	Add YANG solution	15.4.0
2019-09	SA#85	SP-190743	0117	3	F	Generate JSON definition for NR NRM based on new style guideline	15.4.0
2019-09	SA#85	SP-190743	0118	3	F	generate JSON definition for Slice NRM based on new style guideline	15.4.0
2019-09	SA#85	SP-190743	0120	1	F	Clarification of sNSSAList attribute	15.4.0
2019-09	SA#85	SP-190743	0122	1	F	Remove pLMNId from GNBDUFunction	15.4.0
2019-09	SA#85	SP-190743	0125	2	F	Update class definition with inheritance information	15.4.0
2019-09	SA#85	SP-190743	0127	1	F	Correct description of NRCellICU and NRCellDU to be applicable for all deployment scenarios	15.4.0
2019-09	SA#85	SP-190743	0129	1	F	Correct XML solution set for NR	15.4.0
2019-09	SA#85	SP-190743	0131	-	F	Correct XML solution set for Network slice	15.4.0
2019-09	SA#85	SP-190743	0137	1	F	Add missing YANG mount info	15.4.0
2019-09	SA#85	SP-190744	0147	1	F	generate JSON definition for 5GC NRM based on new style guideline	15.4.0
2019-09	SA#85	SP-190744	0148	1	F	Fix NR NRM to add missed ID info	15.4.0
2019-09	SA#85	SP-190744	0151	-	F	Align XML Solution Set for 5GC	15.4.0
2019-09	SA#85	SP-190744	0153	-	F	Correct ETSI NFV reference	15.4.0
2019-12	SA#86	SP-191173	0051	14	F	Add stage 2 NRM Info Model definitions for beam managed object classes	15.5.0
2019-12	SA#86	SP-191173	0155	2	F	Correct Import table	15.5.0
2019-12	SA#86	SP-191173	0160	1	F	Correct NR TAC attribute property	15.5.0
2019-12	SA#86	SP-191173	0171	-	F	Correction of the duplicated IOC NSSFFunction in diagram	15.5.0
2019-12	SA#86	SP-191173	0173	-	F	Correction of the wrong IOC names in transport view diagram	15.5.0
2019-12	SA#86	SP-191173	0193	3	F	Correction of the wrong IOC names in transport view diagram	15.5.0
2019-12	SA#86	SP-191173	0196	-	F	Remove Network Slicing YANG SS	15.5.0
2019-12	SA#86	SP-191173	0206	1	F	Update definition of attributes related to RRMPolicy	15.5.0
2020-06	SA#88-e	SP-200491	0280	1	F	Update on NRCellDU	15.6.0
2020-06	SA#88-e	SP-200491	0282	1	F	Update Clause 4.2.1.2 Inheritance UML diagram	15.6.0
2020-06	SA#88-e	SP-200486	0304	1	F	Correction of references	15.6.0
2020-06	SA#88-e	SP-200491	0313	-	F	Clarify definition of configuredMaxTxPower in NRSectorCarrier	15.6.0
2020-09	SA#89e	SP-200730	0324	-	F	Correct on frequency related IOC	15.7.0
2021-03	SA#91e	SP-210154	0433	1	F	Correct the NF name in definition of EP_NgU	15.8.0
2021-03	SA#91e	SP-210154	0465	1	F	Correction to NSI and NSSI state management	15.8.0

History

Document history		
V15.0.1	October 2018	Publication
V15.1.0	April 2019	Publication
V15.2.0	May 2019	Publication
V15.3.0	June 2019	Publication
V15.4.0	October 2019	Publication
V15.5.0	January 2020	Publication
V15.6.0	August 2020	Publication
V15.7.0	November 2020	Publication
V15.8.0	April 2021	Publication