

ETSI TS 129 165 V8.12.0 (2013-04)



Technical Specification

**Digital cellular telecommunications system (Phase 2+);
Universal Mobile Telecommunications System (UMTS);
LTE;
Inter-IMS Network to Network Interface (NNI)
(3GPP TS 29.165 version 8.12.0 Release 8)**



Reference

RTS/TSGC-0329165v8c0

Keywords

GSM,LTE,UMTS

ETSI

650 Route des Lucioles
F-06921 Sophia Antipolis Cedex - FRANCE

Tel.: +33 4 92 94 42 00 Fax: +33 4 93 65 47 16

Siret N° 348 623 562 00017 - NAF 742 C
Association à but non lucratif enregistrée à la
Sous-Préfecture de Grasse (06) N° 7803/88

Important notice

Individual copies of the present document can be downloaded from:

<http://www.etsi.org>

The present document may be made available in more than one electronic version or in print. In any case of existing or perceived difference in contents between such versions, the reference version is the Portable Document Format (PDF). In case of dispute, the reference shall be the printing on ETSI printers of the PDF version kept on a specific network drive within ETSI Secretariat.

Users of the present document should be aware that the document may be subject to revision or change of status. Information on the current status of this and other ETSI documents is available at

<http://portal.etsi.org/tb/status/status.asp>

If you find errors in the present document, please send your comment to one of the following services:

http://portal.etsi.org/chaicor/ETSI_support.asp

Copyright Notification

No part may be reproduced except as authorized by written permission.
The copyright and the foregoing restriction extend to reproduction in all media.

© European Telecommunications Standards Institute 2013.
All rights reserved.

DECT™, **PLUGTESTS™**, **UMTS™** and the ETSI logo are Trade Marks of ETSI registered for the benefit of its Members.
3GPP™ and **LTE™** are Trade Marks of ETSI registered for the benefit of its Members and of the 3GPP Organizational Partners.
GSM® and the GSM logo are Trade Marks registered and owned by the GSM Association.

Intellectual Property Rights

IPRs essential or potentially essential to the present document may have been declared to ETSI. The information pertaining to these essential IPRs, if any, is publicly available for **ETSI members and non-members**, and can be found in ETSI SR 000 314: *"Intellectual Property Rights (IPRs); Essential, or potentially Essential, IPRs notified to ETSI in respect of ETSI standards"*, which is available from the ETSI Secretariat. Latest updates are available on the ETSI Web server (<http://ipr.etsi.org>).

Pursuant to the ETSI IPR Policy, no investigation, including IPR searches, has been carried out by ETSI. No guarantee can be given as to the existence of other IPRs not referenced in ETSI SR 000 314 (or the updates on the ETSI Web server) which are, or may be, or may become, essential to the present document.

Foreword

This Technical Specification (TS) has been produced by ETSI 3rd Generation Partnership Project (3GPP).

The present document may refer to technical specifications or reports using their 3GPP identities, UMTS identities or GSM identities. These should be interpreted as being references to the corresponding ETSI deliverables.

The cross reference between GSM, UMTS, 3GPP and ETSI identities can be found under <http://webapp.etsi.org/key/queryform.asp>.

Contents

Intellectual Property Rights	2
Foreword.....	2
Foreword.....	4
1 Scope	5
2 References	5
3 Definitions, symbols and abbreviations	6
3.1 Definitions	7
3.2 Symbols.....	7
3.3 Abbreviations	7
4 Overview	8
5 Reference model for interconnection between IM CN subsystems	8
5.1 General	8
5.2 Functionalities performed by entities at the edge of the network	9
5.2.1 Interconnection Border Control Function (IBCF).....	9
5.2.2 Transition Gateway (TrGW).....	9
6 Control plane interconnection	10
6.1 Definition of Inter-IMS Network to Network Interconnection.....	10
6.1.1 SIP methods and headers	10
6.1.1.1 General	10
6.1.1.2 SIP methods	10
6.1.1.3 SIP headers.....	11
6.1.1.3.0 General	11
6.1.1.3.1 Trust and not trust domain.....	11
6.1.1.3.2 Derivation of applicable SIP headers from TS 24.229	12
6.1.1.3.3 Applicability of SIP headers on a roaming II-NNI.....	13
6.1.1.3.4 Applicability of SIP headers on a non-roaming II-NNI.....	13
6.1.1.4 Notations of the codes	13
6.1.1.5 Modes of signalling.....	14
6.1.2 SDP protocol.....	14
6.1.2.1 General	14
6.2 Control Plane Transport	14
6.2.1 General.....	14
7 User plane Interconnection.....	14
7.1 Media and Codec.....	14
7.2 User Plane Transport.....	14
8 Numbering, Naming and Addressing	15
9 IP Version.....	15
10 Security.....	16
11 Charging	16
12 Supplementary services associated with the IMS multimedia telephony communication service.....	16
12.1 General	16
12.2 Malicious Communication IDentification (MCID)	16
Annex A (informative): Summary of SIP headers fields.....	17
Annex B: Change history	20
History	21

Foreword

This Technical Specification has been produced by the 3rd Generation Partnership Project (3GPP).

The contents of the present document are subject to continuing work within the TSG and may change following formal TSG approval. Should the TSG modify the contents of the present document, it will be re-released by the TSG with an identifying change of release date and an increase in version number as follows:

Version x.y.z

where:

- x the first digit:
 - 1 presented to TSG for information;
 - 2 presented to TSG for approval;
 - 3 or greater indicates TSG approved document under change control.
- y the second digit is incremented for all changes of substance, i.e. technical enhancements, corrections, updates, etc.
- z the third digit is incremented when editorial only changes have been incorporated in the document.

1 Scope

The objective of this document is to address the Inter-IMS Network to Network Interface (II-NNI) consisting of Ici and Izi reference points between IMS networks in order to support end-to-end service interoperability.

The present document will address the issues related to control plane signalling (3GPP usage of SIP and SDP protocols, required SIP headers) as well as other interconnecting aspects like security, numbering/naming/addressing and user plane issues as transport protocol, media and codecs actually covered in a widespread set of 3GPP specifications. A profiling of the Inter-IMS Network to Network Interface (II-NNI) is also provided.

Charging aspects will be addressed as far as SIP signalling is concerned.

2 References

The following documents contain provisions which, through reference in this text, constitute provisions of the present document.

- References are either specific (identified by date of publication, edition number, version number, etc.) or non-specific.
- For a specific reference, subsequent revisions do not apply.
- For a non-specific reference, the latest version applies. In the case of a reference to a 3GPP document (including a GSM document), a non-specific reference implicitly refers to the latest version of that document *in the same Release as the present document*.

- [1] 3GPP TR 21.905: "Vocabulary for 3GPP Specifications".
- [2] IETF RFC 791: "Internet Protocol".
- [3] 3GPP TS 23.002: "Network architecture".
- [4] 3GPP TS 23.228: "IP Multimedia Subsystem (IMS); Stage 2".
- [5] 3GPP TS 24.229: "Internet Protocol (IP) multimedia call control protocol based on Session Initiation Protocol (SIP) and Session Description Protocol (SDP); Stage 3".
- [6] 3GPP TR 24.930: "Signalling flows for the session setup in the IP Multimedia core network Subsystem (IMS) based on Session Initiation Protocol (SIP) and Session Description Protocol (SDP); Stage 3".
- [7] IETF RFC 2460: "Internet Protocol, Version 6 (IPv6) Specification".
- [8] 3GPP TS 29.162: 'Interworking between the IM CN subsystem and IP networks'.
- [9] 3GPP TS 22.228: "Service requirements for the IP multimedia core network subsystem".
- [10] 3GPP TS 33.210: "3G security; Network Domain Security (NDS); IP network layer security".
- [11] 3GPP TS 26.114: "IP Multimedia Subsystem (IMS); Multimedia Telephony; Media handling and interaction".
- [12] ETSI TS 181 005 1.1.1: "Telecommunications and Internet converged Services and Protocols for Advanced Networking (TISPAN); Services and Capabilities Requirements".
- [13] IETF RFC 3261: "SIP: Session Initiation Protocol".
- [14] IETF RFC 3966: "The tel URI for Telephone Numbers".
- [15] IETF RFC 3860: "Common Profile for Instant Messaging (CPIM)".
- [16] IETF RFC 3859: "Common Profile for Presence (CPP)".

- [17] IETF RFC 4975: "The Message Session Relay Protocol (MSRP)".
- [18] IETF RFC 3262: "Reliability of provisional responses in Session Initiation Protocol (SIP)".
- [19] IETF RFC 3428: "Session Initiation Protocol (SIP) Extension for Instant Messaging".
- [20] IETF RFC 3265: "Session Initiation Protocol (SIP) Specific Event Notification".
- [21] IETF RFC 3903: "An Event State Publication Extension to the Session Initiation Protocol (SIP)".
- [22] IETF RFC 3515: "The Session Initiation Protocol (SIP) REFER method".
- [23] IETF RFC 3311: "The Session Initiation Protocol (SIP) UPDATE method".
- [24] IETF RFC 3455: "Private Header (P-Header) Extensions to the Session Initiation Protocol (SIP) for the 3rd-Generation Partnership Project (3GPP)".
- [25] IETF RFC 4244: "An Extension to the Session Initiation Protocol (SIP) for Request History Information".
- [26] Void
- [27] IETF RFC 4168: "The Stream Control Transmission Protocol (SCTP) as a Transport for the Session Initiation Protocol (SIP)".
- [28] IETF RFC 6086: "Session Initiation Protocol (SIP) INFO Method and Package Framework".
- [29] 3GPP TS 32.260: "Telecommunication management; Charging management; IP Multimedia Subsystem (IMS) charging".
- [30] 3GPP TS 22.173: "IP Multimedia Core Network Subsystem (IMS); Multimedia Telephony Service and supplementary services; Stage 1".
- [31] 3GPP TS 24.173: "IMS multimedia telephony communication service and supplementary services; Stage 3".
- [32] 3GPP TS 24.616: "Malicious Communication Identification (MCID) using IP Multimedia (IM) Core Network (CN) subsystem".
- [33] 3GPP TS 23.003: "Numbering, addressing and identification".
- [34] 3GPP TS 23.292: "IP Multimedia Subsystem (IMS) Centralized Services; Stage 2".
- [35] 3GPP TS 24.292: "IP Multimedia Core Network subsystem Centralized Services; Stage 3".
- [36] IETF RFC 3550: "RTP: A Transport Protocol for Real-Time Applications".
- [37] IETF RFC 768: "User Datagram Protocol".
- [38] IETF RFC 3551: "RTP Profile for Audio and Video Conferences with Minimal Control".
- [39] IETF RFC 3556: "Session Description Protocol (SDP) Bandwidth Modifiers for RTP Control Protocol (RTCP) Bandwidth".
- [40] IETF RFC 4585: "Extended RTP Profile for Real-time Transport Control Protocol (RTCP)-Based Feedback (RTP/AVPF)".
- [41] IETF RFC 793: "Transmission Control Protocol".

3 Definitions, symbols and abbreviations

3.1 Definitions

For the purposes of the present document, the terms and definitions given in 3GPP TR 21.905 [1] and the following apply. A term defined in the present document takes precedence over the definition of the same term, if any, in 3GPP TR 21.905 [1].

example: text used to clarify abstract rules by applying them literally.

IM CN subsystem: (IP Multimedia CN subsystem) comprises of all CN elements for the provision of IP multimedia applications over IP multimedia sessions, as specified in 3GPP TS 22.228 [9].

IP multimedia session: as specified in 3GPP TS 22.228 [9] an IP multimedia session is a set of multimedia senders and receivers and the data streams flowing from senders to receivers. IP multimedia sessions are supported by the IP multimedia CN Subsystem and are enabled by IP connectivity bearers (e.g. GPRS as a bearer). A user can invoke concurrent IP multimedia sessions.

non-roaming II-NNI: the II-NNI between IMS home networks.

roaming II-NNI: the II-NNI between a visited IMS network and the IMS home network.

For the purposes of the present document, the following terms and definitions given in 3GPP TS 23.292 [34] apply:

MSC Server enhanced for ICS

3.2 Symbols

For the purposes of the present document, the following symbols apply:

Ici	Reference Point between an IBCF and another IBCF or I-CSCF belonging to a different IM CN subsystem network
Izi	Reference Point between a TrGW and another TrGW or media handling node belonging to a different IM CN subsystem network
Mi	Reference Point between a BGCF and CSCF
Mm	Reference Point between a CSCF/BGCF/IMS ALG and an IP multimedia network.
Mw	Reference Point between a CSCF and another CSCF
Mx	Reference Point between a CSCF/BGCF/MSC Server enhanced for ICS and IBCF

3.3 Abbreviations

For the purposes of the present document, the abbreviations given in 3GPP TR 21.905 [1] and the following apply. An abbreviation defined in the present document takes precedence over the definition of the same abbreviation, if any, in 3GPP TR 21.905 [1].

B2BUA	Back 2 Back User Agent
BGCF	Break out Gateway Control Function
IBCF	Interconnection Border Control Function
ICS	IMS Centralized Services
I-CSCF	Interrogating CSCF
II-NNI	Inter-IMS Network to Network Interface
IM	Instant Messaging
IMS-ALG	IMS Application Level Gateway
MCID	Malicious Call IDentification
MRFC	Media Resource Function Controller
MSRP	Message Session Relay Protocol
NA(P)T-PT	Network Address (Port-Multiplexing) Translation-Protocol Translation
NNI	Network to Network Interface

OCB	Outgoing Communication Barring
P-CSCF	Proxy CSCF
PRES	Presence
TrGW	Transition Gateway

4 Overview

Interconnection between two different IM CN subsystems shall be guaranteed in order to support end-to-end service interoperability. For this purpose, Inter-IMS Network to Network Interface (II-NNI) between two IM CN subsystem networks is adopted, according to the assumptions coming from 3GPP TS 23.002 [3] and 3GPP TS 23.228 [4].

Aiming to support the delivery of IMS services between two separated IM CN subsystems, protocol interconnection has to occur:

- at a control plane level, in order that IMS procedures can be supported. In this case the adopted reference point is the Ici;
- at a user plane level, where media streams are exchanged over the Izi reference point.

The management of IP multimedia sessions is acted by using SIP. The transport mechanism for both SIP session signalling and media transport is IPv4 (IETF RFC 791 [2]) or IPv6 (IETF RFC 2460 [7]). The 3GPP profile of SIP defining the usage of SIP within the IM CN subsystem is specified in 3GPP TS 24.229 [5]. Example call flows are provided in 3GPP TR 24.930 [6].

The general interconnection model is shown in Figure 4.1.

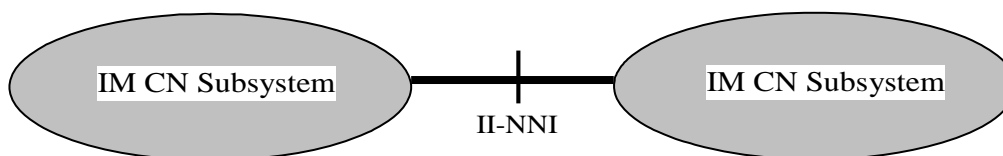

Figure 4.1: Interconnection Model for IM CN Subsystems

The possible functional entities involved in the signalling plane interconnection (IBCF, I-CSCF, P-CSCF, BGCF and MSC Server enhanced for ICS) and in the user plane interconnection (TrGW) are specified in 3GPP TS 24.229 [5], in 3GPP TS 29.292 [35] and in 3GPP TS 29.162 [8].

IP Version interworking is described within 3GPP TS 29.162 [8].

5 Reference model for interconnection between IM CN subsystems

5.1 General

Figure 5.1 illustrates the architecture diagram given in 3GPP TS 23.228 [4] showing the Inter-IMS Network to Network Interface (II-NNI) between two IM CN subsystem networks.

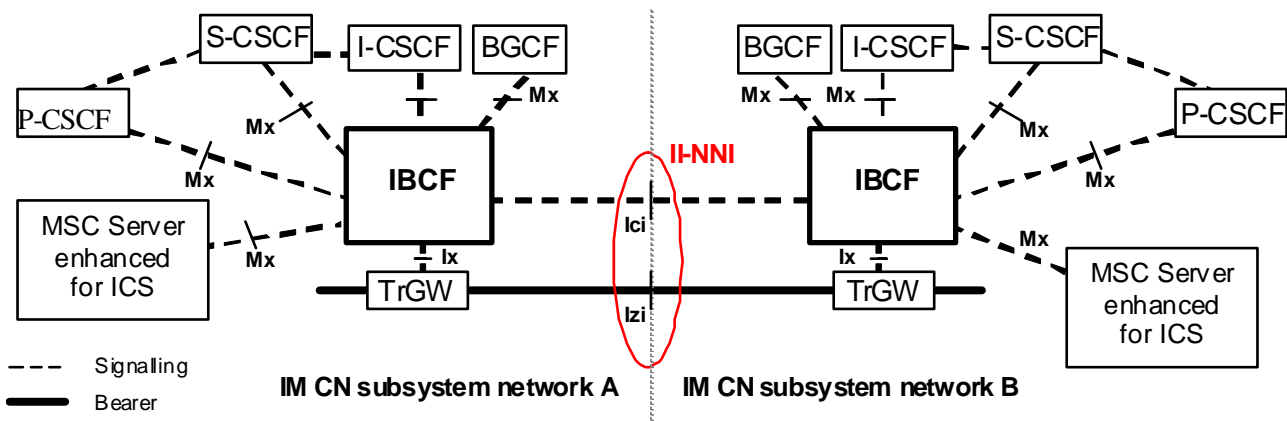

Figure 5.1.1: Inter-IMS Network to Network Interface between two IM CN subsystem networks

The protocols over the two reference points Ici and Izi make up the Inter-IMS Network to Network Interface.

The Ici reference point allows IBCFs to communicate with each other in order to provide the communication and forwarding of SIP signalling messaging between IM CN subsystem networks. The Izi reference point allows TrGWs to forward media streams between IM CN subsystem networks.

IMS roaming performed by using I2-NNI is considered, when the IBCFs are inserted at the network borders.

Whenever the Inter-IMS Network to Network Interface is used to interconnect two IM CN subsystem networks belonging to different security domains, security procedures apply as described in 3GPP TS 33.210 [10].

5.2 Functionalities performed by entities at the edge of the network

5.2.1 Interconnection Border Control Function (IBCF)

An IBCF provides application specific functions at the SIP/SDP protocol layer in order to perform interconnection between IM CN subsystem networks by using Ici reference point. According to 3GPP TS 23.228 [4], IBCF can act both as an entry point and as an exit point for a network.

The functionalities of IBCF are indicated in the 3GPP TS 23.228 [4] and specified in 3GPP TS 24.229 [5]: they include:

- network topology hiding;
- application level gateway (for instance enabling communication between IPv6 and IPv4 SIP applications, or between a SIP application in a private IP address space and a SIP application outside this address space);
- controlling transport plane functions;
- controlling media plane adaptations;
- screening of SIP signalling information;
- selecting the appropriate signalling interconnect;
- generation of charging data records;

Based on local configuration, the IBCF performs transit routing functions [5].

The IBCF acts as a B2BUA when it performs IMS-ALG functionality.

5.2.2 Transition Gateway (TrGW)

According to 3GPP TS 23.002 [3], the TrGW is located at the network borders within the media path and is controlled by an IBCF. Forwarding of media streams between IM CN subsystem networks is applied over Izi reference point.

The TrGW provides functions like network address/port translation and IPv4/IPv6 protocol translation. NAT-PT binds addresses in IPv6 network with addresses in IPv4 network and vice versa to provide transparent routing between the two IP domains without requiring any changes to end points. NA(P)T-PT provides additional translation of transport identifier (TCP and UDP port numbers). The approach is similar to that one described also in 3GPP TS 29.162 [8].

Further details are described in 3GPP TS 23.228 [4].

6 Control plane interconnection

6.1 Definition of Inter-IMS Network to Network Interconnection

6.1.1 SIP methods and headers

6.1.1.1 General

The functional entity closest to the border of an IMS network towards an Inter-IMS Network to Network Interconnection (see reference model in Clause 5) shall provide the capabilities specified for that network element in Annex A.2 of TS 24.229 [5] with modifications as described in the following sub-clauses.

6.1.1.2 SIP methods

3GPP TS 24.229 [5] defines the methods allowing an IBCF to interconnect to an IBCF placed in another IM CN subsystem.

The following SIP methods are supported on the II-NNI as defined in table 6.1.

The following table is based on Table A.5 and Table A.163 of TS 24.229 [5] and endorsed for this document:

Table 6.1: Supported SIP methods

Item	Method	Ref.	II-NNI	
			Sending	Receiving
1	ACK request	[13]	m	m
2	BYE request	[13]	m	m
3	BYE response	[13]	m	m
4	CANCEL request	[13]	m	m
5	CANCEL response	[13]	m	m
5A	INFO request	[28]	o	o
5B	INFO response	[28]	o	o
8	INVITE request	[13]	m	m
9	INVITE response	[13]	m	m
9A	MESSAGE request	[19]	o	o
9B	MESSAGE response	[19]	o	o
10	NOTIFY request	[20]	c1	c1
11	NOTIFY response	[20]	c1	c1
12	OPTIONS request	[13]	m	m
13	OPTIONS response	[13]	m	m
14	PRACK request	[18]	m	m
15	PRACK response	[18]	m	m
15A	PUBLISH request	[21]	c1	c1
15B	PUBLISH response	[21]	c1	c1
16	REFER request	[22]	o	o
17	REFER response	[22]	o	o
18	REGISTER request	[13]	c2	c2
19	REGISTER response	[13]	c2	c2
20	SUBSCRIBE request	[20]	c1	c1
21	SUBSCRIBE response	[20]	c1	c1
22	UPDATE request	[23]	m	m
23	UPDATE response	[23]	m	m
c1:	In case of roaming scenario, the support of the method is m, else o.			
c2:	In case of roaming scenario, the support of the method is m, else n/a.			
NOTE:	In the above table, m, o and c and n/a have the meanings indicated in Table 6.3			

6.1.1.3 SIP headers

6.1.1.3.0 General

The IBCF shall provide the capabilities to manage and modify SIP headers according to section 5.10 and Annex A of TS 24.229 [5] with modifications as described in the following sub-clauses.

6.1.1.3.1 Trust and not trust domain

In case there is a trust relationship between the two IM CN subsystems connected by II-NNI, the IBCF acting as contact point applies the procedures described in the section 4.4 of TS 24.229 [5], before forwarding the SIP signalling to the next IBCF.

In case there is not a trust relationship between the two IM CN subsystems connected by II-NNI, the IBCF acting as exit point applies the procedures described in the section 5.10.2 of TS 24.229 [5] before forwarding the SIP signalling to the IBCF acting as entry point. The IBCF acting as an entry point applies the procedures described in the section 5.10.3 of TS 24.229 [5].

TS 24.229 [5] provide procedures for handling SIP headers based on trust domain. These procedures may be utilized on a per header basis to realize overall trust as well as per service level screening of headers. Trust relationships and trust domains may be defined by inter-operator agreements for individual services and/or individual SIP headers.

The management of the SIP headers (if present) over II-NNI in case of a presence or not of a trust relationship between the two interconnected IM subsystems is wrapped up in the following table.

Table 6.2: Management of SIP headers over II-NNI in presence or not of a trust relationship

Item	Header	Trust domain	Not trust domain
1	P-Asserted-Identity	As specified in 3GPP TS 24.229 [5], clause 4.4	As specified in 3GPP TS 24.229 [5], clause 5.10
2	P-Access-Network-Info	As specified in 3GPP TS 24.229 [5], clause 4.4	As specified in 3GPP TS 24.229 [5], clause 5.10
3	Resource-Priority	As specified in 3GPP TS 24.229 [5], clause 4.4	As specified in 3GPP TS 24.229 [5], clause 4.4
4	History-Info	As specified in 3GPP TS 24.229 [5], clause 4.4	As specified in Clause 4.3.3 of RFC 4244 [25]
5	P-Asserted-Service	As specified in 3GPP TS 24.229 [5], clause 4.4 (NOTE 3)	As specified in 3GPP TS 24.229 [5], clause 4.4. (NOTE 3)
6	P-Charging-Vector (see RFC 3455 [24])	As specified in 3GPP TS 24.229 [5], clause 5.10	As specified in 3GPP TS 24.229 [5], clause 5.10
7	P-Charging-Function-Addresses (see RFC 3455 [24])	As specified in 3GPP TS 24.229 [5], clause 5.10	As specified in 3GPP TS 24.229 [5], clause 5.10
8	P-Profile-Key (NOTE 2)	As specified in 3GPP TS 24.229 [5], clause 4.4	As specified in 3GPP TS 24.229 [5], clause 4.4
9	P-Private-Network-Indication (NOTE 1)	As specified in 3GPP TS 24.229 [5], clause 4.4	As specified in 3GPP TS 24.229 [5], clause 4.4
10	P-Served-User (NOTE 1, NOTE 2)	As specified in 3GPP TS 24.229 [5], clause 4.4	As specified in 3GPP TS 24.229 [5], clause 4.4
NOTE 1: For a roaming II-NNI between a home IMS and a visited IMS, a trust relationship with respect to this header is required.			
NOTE 2: This header is only applicable on an II-NNI between a home IMS and a visited IMS.			
NOTE 3: In addition, value-dependent operator policies may be applied.			

6.1.1.3.2 Derivation of applicable SIP headers from TS 24.229

For any method in Table 6.1, the SIP headers applicable on the II-NNI are detailed in the corresponding method tables for the UA role and proxy role sending behaviour in Annex A of 3GPP TS 24.229 [5]. Unless other information is specified in the normative part of the present specification, the applicability of headers at the II-NNI can be derived for each method from the corresponding tables in Annex A of 3GPP TS 24.229 [5] as follows:

- All headers not present in the corresponding tables in Annex A of 3GPP TS 24.229 or marked as "n/a" in both the "RFC status" and "profile status" columns for the UA role and proxy role sending behaviour of that tables are not applicable at the II-NNI.

Note: Operators could choose to apply headers for new SIP extensions on an II-NNI based on bilateral agreements, but this is outside the scope of the present specification.

- All headers which are marked as "o" in at least one of the "RFC status" or the "profile status" profile columns for the sending behaviour in the corresponding UA role and proxy role tables in Annex A of 3GPP TS 24.229 and as "n/a" or "o" in the other such columns are applicable at II-NNI based on bilateral agreement between operators.
- All headers which are marked as "m" in at least one of the "RFC status" or the "profile status" columns for the sending behaviour in the corresponding UA role or proxy role table in Annex A of 3GPP TS 24.229 and as "n/a", "o", or "m" in the other such columns are applicable at the II-NNI.
- If conditions are specified, they are also applicable at the II-NNI and the above rules are applicable to the "n/a", "o" and "m" values within the conditions.

Note: In the above rules, the RFC profile columns are taken into account in order to enable interworking with non-3GPP networks,

An informative summary of SIP headers to be used over the II-NNI is proposed in Annex A.

6.1.1.3.3 Applicability of SIP headers on a roaming II-NNI

The following SIP headers are only applicable on a roaming II-NNI:

- Authentication-Info
- Authorization
- P-Associated-URI
- P-Called-Party-ID
- P-Preferred-Service
- P-Profile-Key
- P-Served-User
- P-Visited-Network-ID
- Path
- Proxy-Authentication
- Proxy-Authorization
- Service-Route
- WWW-Authenticate

6.1.1.3.4 Applicability of SIP headers on a non-roaming II-NNI

Void

6.1.1.4 Notations of the codes

In the table 6.1 the status codes m, o, c, i and n/a have the following meanings:

Table 6.3: Key to notation codes for SIP messages

Notation code	Notation name	Sending side	Receiving side
m	mandatory	The message shall be supported at II-NNI. Supporting sending a SIP message at the II-NNI means that this message shall be sent over the II-NNI if received from the serving network. It does not imply that network elements inside the serving network or user equipment connected to this network shall support this message.	Supporting receiving a SIP message at the II-NNI means that this message shall be forwarded to the serving network unless the operator's policy is applied as defined in subclause 5.10.1 of 3GPP TS 24.229 [5]. It does not imply that network elements inside the served network or user equipment connected to this network are supporting this message.
o	optional	The message may or may not be supported at II-NNI. The support of the message is provided based on bilateral agreement between the operators.	Same as for sending side.
n/a	not applicable	It is impossible to use/support the message.	It is impossible to use/support the message. This element will be discarded by the IBCF.
c <integer>	conditional	The requirement on the message ("m", "o" or "n/a") depends on the support of other optional or conditional items. <integer> is the identifier of the conditional expression.	Same as for sending side.

6.1.1.5 Modes of signalling

Overlap signalling may be used if agreement exists between operators to use overlap and which method to be used , otherwise enbloc shall be used at the NNI.

6.1.2 SDP protocol

6.1.2.1 General

The functional entity closest to the border of an IMS network towards an Inter-IMS Network to Network Interconnection (see reference model in Clause 5) shall provide the capabilities specified for that network element in Annex A.3 of TS 24.229 [5].

6.2 Control Plane Transport

6.2.1 General

The control plane transport of the IMS Inter-Operator Service Interconnection Interface shall comply with Clause 4.2A of TS 24.229 [5].

Support of SCTP as specified in RFC 4168 [27] is optional for an IBCF connected by II-NNI. Nevertheless this option is favourable if the operators would like to improve reliability over the ICI.

7 User plane Interconnection

7.1 Media and Codec

For "end-to-end" media session involving the II-NNI, the SIP/SDP codec negotiation procedure can be applied between IM CN subsystems using different media codecs. It is possible that the end-to-end codec negotiation could fail because no common codec could be supported by the UEs, in particular for voice services.

To enhance interoperability, the IBCF, the MRFC, or other IMS network entities can interfere with the end-to-end codec negotiation to offer additional codec(s) available via transcoding, or to remove codecs. The IBCF can configure an attached TrGW to transcode, and the MRFC can configure an attached MRFP to transcode.

Codecs applicable at the NNI may be a subject of interworking agreements.

NOTE: Possible codecs which could be used at the II-NNI are described in 3GPP TS 26.114 [11] and ETSI TS 181 005 [12].

However, to avoid that transcoding is performed several times, applicable codecs at the NNI should be restricted as little as possible.

NOTE: Transcoding can be performed in an IMS network serving an SDP offerer or in an IMS network serving an SDP answerer. To avoid that transcoding is performed multiple times, inter-operator agreements can clarify if it is preferred that IMS network serving an SDP offerer or IMS network serving an SDP answerer modify an SDP offer to offer transcoding.

If the IBCF performs media transcoding control, it shall apply the related procedures in 3GPP TS 24.229 [5].

7.2 User Plane Transport

The user plane transport of the IMS Inter-Operator Service Interconnection Interface may use the protocols listed in Table 7.2.1. The used protocols to transport media are negotiated by means of SDP offer/answer.

Table 7.2.1: Supported transport-level RFCs to be described in SIP/SDP messages

Item	RFC	Title	Support
1	IETF RFC 3550 [36]	RTP: A Transport Protocol for Real-Time Applications	Mandatory
2	IETF RFC 768 [37]	User Datagram Protocol	Mandatory
3	IETF RFC 3551 [38]	RTP Profile for Audio and Video Conferences with Minimal Control	Mandatory
4	IETF RFC 3556 [39]	Session Description Protocol (SDP) Bandwidth Modifiers for RTP Control Protocol (RTCP) Bandwidth	Mandatory
5	IETF RFC 4585 [40]	Extended RTP Profile for Real-time Transport Control Protocol (RTCP) - Based Feedback (RTP/AVPF)	Optional (NOTE 1)
6	IETF RFC 793 [41]	Transmission Control Protocol	Optional (NOTE 2)
NOTE 1: used by MTSI, as indicated in 3GPP TS 26.114 [11]			
NOTE 2: used for MSRP service			

8 Numbering, Naming and Addressing

The following URI formats in SIP messages may be applied at the Ici as standardized in 3GPP TS 24.229 [5]:

- SIP URI defined in IETF RFC 3261 [13];
- tel URI defined in IETF RFC 3966 [14];
- IM URI defined in IETF RFC 3860 [15];
- PRES URI defined in IETF RFC 3859 [16].

Moreover, in case of MSRP sessions passing through the II-NNI, the MSRP URI may be also used at the Ici in the SDP exchange, following the formats defined in IETF RFC 4975 [17].

According to TS 24.229, the IBCF acting as an exit or entry point in the IMS network supports these URI formats.

These URI formats shall be supported at the II-NNI. Other URI formats may be supported over the II-NNI depending on the operators' policies.

A global number as defined in IETF RFC 3966 [14] shall be used in a tel-URI or in the user portion of a SIP URI with the user=phone parameter when conveyed via a non-roaming interface in the Request-URI and in the P-Asserted-Identity header, except when agreement exists between the operators to also allow other kinds of numbers.

NOTE 1: In a SIP URI the user portion of the Request-URI represents a telephone number only if the SIP URI includes user=phone parameter.

NOTE 2: Agreements can exist between operators to allow non-global numbers (e.g. national service numbers, business trunking numbers, or private numbers) at a non-roaming II-NNI. A SIP URI with such a number, user=phone, and a phone context agreed between the operators can then be used.

NOTE 3: 3GPP TS 24.229 [5] allows to restrict the number within a SIP Request-URI with user=phone at a non-roaming II-NNI to be a global number (i.e. E.164 in international format) via an appropriate Application Server. Suitable configuration by the operator is needed to achieve the desired modification of the format.

NOTE 4: The allowed phone number formats in the P-Asserted-Identity header field of a served user are configured by the operator. According to 3GPP TS 23.003 [33], international E.164 format is used within a P-Asserted-Identity header field.

NOTE 5: The global number format usage within a SIP Request-URI with user=phone at a non-roaming II-NNI allows the terminating network to find the called subscriber, via HSS interrogation, without any further number translation and thus improves the success of the interconnection between IMS Operators.

9 IP Version

The network elements interconnected by means of the II-NNI may support IPv4 only, IPv6 only or both.

The support of one or both of the IP versions is an operator option and should be based on bilateral agreement.

In case IPv4 and IPv6 networks are interconnected, the involved IBCFs and TrGWs shall apply the IP version interworking procedures as indicated in 3GPP TS 29.162 [8].

10 Security

The supported security mechanisms for IP signalling transport over II-NNI interfaces are described in 3GPP TS 33.210 [10].

11 Charging

The accounting information to be supported over the Ici is described in 3GPP TS 32.260 [29]. It shall be configurable by the operator to use or not the accounting mechanisms provided by the IBCF.

12 Supplementary services associated with the IMS multimedia telephony communication service

12.1 General

In order to assure the end-to-end service interoperability through the Inter-IMS Network to Network Interface (II-NNI), the associated supplementary services of the multimedia telephony communication service may be supported on the II-NNI between the two IMS networks.

The MMTel communication service is identified by means of the media feature tag +g.3gpp.icsi-ref set to "urn:urn-7:3gpp-service.ims.icsi.mmtel". The media feature tag can appear in the Contact header field, the Accept-Contact header field and the P-Asserted-Service header field.

The support of each associated supplementary service is based on agreement between operators.

If a supplementary service is supported, the related procedures from the 3GPP TS 22.173 [30], the protocol details from the 3GPP TS 24.173 [31] and specifications referenced in the later specification shall be applied with the requirements in the relevant subclause following restrictions due to the crossing of the II- NNI.

12.2 Malicious Communication Identification (MCID)

Service specific requirements in accordance with 3GPP TS 24.616 [33] shall be supported over the II-NNI.

The INFO request and the 200 (OK) response to the INFO request containing the application/vnd.etsi.mcid+xml body defined in 3GPP TS 24.616 [33] may be supported at the II-NNI.

If a network terminating the dialog supports MCID, the terminating network shall only deliver the MCID request in the mcid+xml body, as specified in the 3GPP TS 24.616 [32], if an agreement to use the MCID supplementary service according to the 3GPP TS 24.616 [32] exists with the network originating the dialog and if the INVITE request received by the terminating network does not contain the information of the originating party.

NOTE: The IBCF and the AS in the terminating network interact to deliver the MCID request only if an agreement to use the MCID supplementary service exists, as specified in 3GPP TS 24.616 [32] and 3GPP TS 24.229 [5].

The originating network and the terminating network shall have a bilateral agreement to support transportation of the minimum information specified in subclause 4.5.2.5.0 of the 3GPP TS 24.616 [33] between the networks.

Annex A (informative): Summary of SIP headers fields

A summary of the SIP headers to be used in case of interconnection by using II-NNI is proposed in table A.1.

The starting point is the sending behaviour described for proxy and UA roles in annex A of 3GPP TS 24.229 [5]. In case of misalignment between table A.1 and the behaviour described in 3GPP TS 24.229 [5], the behaviour in 3GPP TS 24.229 [5] has the precedence. In case a header is not described in table A.1 and it is described in [5], description in 3GPP TS 24.229 [5] is applicable over II-NNI.

The notation of the codes used for the SIP headers listed in table A.1 has a different meaning to the one proposed for the SIP messages. The definition of these terms is provided in table A.2.

Table A.1: Supported headers

Item	Header	Ref.	II-NNI
1	Accept	[5]	m
2	Accept-Contact	[5]	m
3	Accept-Encoding	[5]	m
4	Accept-Language	[5]	m
5	Alert-Info	[5]	o
6	Allow	[5]	m
7	Allow-Events	[5]	m
8	Authentication-Info	[5]	m on roaming II-NNI, else n/a
9	Authorization	[5]	m on roaming II-NNI, else n/a
9a	Answer-Mode	[5]	o
10	Call-ID	[5]	m
11	Call-Info	[5]	m
12	Contact	[5]	m
13	Content-Disposition	[5]	m
14	Content-Encoding	[5]	m
15	Content-Language	[5]	m
16	Content-Length	[5]	m
17	Content-Type	[5]	m
18	Cseq	[5]	m
19	Date	[5]	m
20	Error-Info	[5]	o
21	Expires	[5]	m
22	Event	[5]	m
23	From	[5]	m
24	Geolocation	[5]	m
25	History-Info	sub-clause 6.1.1.3.1	m in case of a trust relationship between the interconnected networks, else n/a
25a	Info-Package	[5]	o
26	In-Reply-To	[5]	o
27	Join	[5]	o
27a	Max-Breadth	[5]	n/a
28	Max-Forwards	[5]	m
29	Min-Expires	[5]	m
30	MIME-Version	[5]	m
31	Min-SE	[5]	m
32	Organization	[5]	m
33	P-Access-Network-Info	sub-clause 6.1.1.3.1	m in case of a trust relationship between the interconnected networks, else n/a
33a	P-Answer-state	[5]	o
34	P-Asserted-Identity	sub-clause 6.1.1.3.1	m in case of a trust relationship between the interconnected networks, else n/a
35	P-Asserted-Service	sub-clause 6.1.1.3.1	m in case of a trust relationship between the interconnected networks, else n/a
35a	P-Associated-URI	[5]	m on roaming II-NNI, else n/a
36	P-Called-Party-ID	[5]	m on roaming II-NNI, else n/a
37	P-Charging-Function-Addresses	[5]	n/a
38	P-Charging-Vector	sub-clause 6.1.1.3.1	m
39	P-Early-Media	[5]	m
40	P-Media-Authorization	[5]	n/a
41	P-Preferred-Identity	[5]	n/a
42	P-Preferred-Service	[5]	m on roaming II-NNI, else n/a
43	P-Private-Network-Indication	sub-clause 6.1.1.3.1	m on roaming II-NNI, else o
44	P-Profile-Key	sub-clause 6.1.1.3.1	o on roaming II-NNI, else n/a
45	P-Served-User	sub-clause 6.1.1.3.1	m on roaming II-NNI, else n/a
46	P-User-Database	[5]	n/a
47	P-Visited-Network-ID	[5]	m on roaming II-NNI, else n/a
47a	Path	[5]	m on roaming II-NNI, else n/a

Item	Header	Ref.	II-NNI
48	Priority	[5]	o
48a	Priv-Answer-Mode	[5]	o
49	Privacy	[5]	m
50	Proxy-Authenticate	[5]	m on roaming II-NNI, else n/a
51	Proxy-Authorization	[5]	m on roaming II-NNI, else n/a
52	Proxy-Require	[5]	m
53	Reason	[5]	o
54	Record-Route	[5]	m
54a	Recv-Info	[5]	o
55	Referred-By	[5]	m
55a	Refer-Sub	[5]	m in the case the REFER request is supported, else n/a
55b	Refer-To	[5]	m in the case the REFER request is supported, else n/a
56	Reject-Contact	[5]	m
57	Replaces	[5]	o
58	Reply-To	[5]	o
59	Request-Disposition	[5]	m
60	Require	[5]	m
61	Resource-Priority	sub-clause 6.1.1.3.1	o
61a	Retry-After	[5]	o
62	Route	[5]	m
63	Security-Client	[5]	n/a
64	Security-Verify	[5]	n/a
65	Server	[5]	o
65a	Service-Route	[5]	m on roaming II-NNI, else n/a
66	Session-Expires	[5]	m
67	Subject	[5]	o
68	Supported	[5]	m
69	Timestamp	[5]	m
70	To	[5]	m
71	Trigger-Consent	[5]	m
72	User-Agent	[5]	m
73	User-to-User	[5]	o
74	Via	[5]	m
75	Warning	[5]	o
76	WWW-Authenticate	[5]	m on roaming II-NNI, else n/a

Table A.2: Key to notation codes for SIP headers

Notation code	Meaning
m	The SIP header is applicable at II-NNI. Supporting sending a SIP header at the II-NNI means that this header is passed through the IBCF. It does not imply that network elements inside the networks support this header, where 3GPP TS 24.229 [5] is applied. If specified in 3GPP TS 24.229, an IBCF modifies the SIP header.
o	The applicability of SIP header at II-NNI depends on bilateral agreement between the operators.
n/a	It is impossible to use the SIP header at the II-NNI. This header could be discarded by the IBCF.

Annex B: Change history

Change history							
Date	TSG #	TSG Doc.	CR	Rev	Subject/Comment	Old	New
4/05/2008					TS Skeleton (C3-080779)	-	0.0.0
07/07/2008					Added agreed text of C3-080991, C3-081158 and C3-081208	0.0.0	0.1.0
28/08/2008					Added agreed text of C3-081282 and C3-081672	0.1.0	0.2.0
01/09/2008					Version 1.0.0 created for presentation to TSG by MCC	0.2.0	1.0.0
17/10/2008					Added agreed text of C3-081721 and C3-082105	1.0.0	1.1.0
20/11/2008					Added agreed text of C3-082303, C3-082446, C3-082447 and C3-082611	1.0.0	1.2.0
26/11/2008					v 2.0.0 was produced by MCC for Approval in CT#42	1.2.0	2.0.0
13/12/2008	TSG#42				V 8.0.0 was produced by MCC	2.0.0	8.0.0
03/2008	TSG#43	CP-090087	002	3	Charging requirements on II-NNI	8.0.0	8.1.0
03/2008	TSG#43	CP-090087	004	1	Modification of the REFER method status	8.0.0	8.1.0
03/2008	TSG#43	CP-090087	007	2	NNI header tables	8.0.0	8.1.0
05/2009	TSG#44	CP-090341	008	4	Use of E.164 number at the II-NNI	8.1.0	8.2.0
05/2009	TSG#44	CP-090341	009	4	Correction to SIP headers table	8.1.0	8.2.0
09/2009	TSG#45	CP-090576	010	7	MCID interaction at the NNI	8.2.0	8.3.0
09/2009	TSG#45	CP-090576	017	1	Removal of left-over text from TS drafting phase and update of a reference	8.2.0	8.3.0
09/2009	TSG#45	CP-090576	018	2	Applicability of SIP headers for roaming II-NNI	8.2.0	8.3.0
09/2009	TSG#45	CP-090576	019	1	Application level gateway usage to enable communication from private IP address space	8.2.0	8.3.0
09/2009	TSG#45	CP-090576	020	3	Codecs at the NNI	8.2.0	8.3.0
12/2009	TSG#45	CP-090844	023		Aligning references to P-Asserted-Service	8.3.0	8.4.0
12/2009	TSG#45	CP-090844	025		Annex A header updated with Answer-Mode, Priv-Answer-Mode and P-Answer-State	8.3.0	8.4.0
12/2009	TSG#45	CP-090844	048	3	Annex A header updated	8.3.0	8.4.0
03/2010	TSG#47	CP-100077	050	2	Format of Request URI	8.4.0	8.5.0
03/2010	TSG#47	CP-100077	054	2	MSC Server enhanced for ICS missing in architecture	8.4.0	8.5.0
09/2010	TSG#49	CP-100545	097	1	Removing unnecessary normative text	8.5.0	8.6.0
09/2010	TSG#49	CP-100545	107	3	MCID and identity information transfer clarification	8.5.0	8.6.0
12/2010	TSG#50	CP-100775	119		Release version added to ETSI specification	8.6.0	8.7.0
12/2010	TSG#50	CP-100775	124	2	Correcting errors in SIP method subclause	8.6.0	8.7.0
12/2010	TSG#50	CP-100775	131	1	IBCF and URI formats	8.6.0	8.7.0
12/2010	TSG#50	CP-100775	134		Roaming and non-roaming definition added	8.6.0	8.7.0
12/2010	TSG#50	CP-100775	138	2	Refer-Sub and Refer-To missing in annex A	8.6.0	8.7.0
03/2011	TSG#51	CP-110107	170	1	Correcting header table in annex A	8.7.0	8.8.0
03/2011	TSG#51	CP-110107	176		Adding MMTel feature tag in clause 12	8.7.0	8.8.0
03/2011	TSG#51				Editorial changes made by MCC	8.8.0	8.8.1
06/2011	TSG#52	CP-110401	267	1	SIP headers alignment in II-NNI	8.8.1	8.9.0
12/2011	TSG#54	CP-110824	306		Aligning the references with Supported transport-level RFCs	8.9.0	8.10.0
12/2011	TSG#54	CP-110824	331		Reference to the wrong RFC	8.9.0	8.10.0
06/2012	TSG#56	CP-120332	421	2	The description of notation code for SIP message	8.10.0	8.11.0
03/2013	TSG#59	CP-130061	505	1	IMS debug removal of feature	8.11.0	8.12.0

History

Document history		
V8.0.0	February 2009	Publication
V8.1.0	April 2009	Publication
V8.2.0	June 2009	Publication
V8.3.0	October 2009	Publication
V8.4.0	January 2010	Publication
V8.5.0	April 2010	Publication
V8.6.0	October 2010	Publication
V8.7.0	January 2011	Publication
V8.8.1	April 2011	Publication
V8.9.0	June 2011	Publication
V8.10.0	January 2012	Publication
V8.11.0	July 2012	Publication
V8.12.0	April 2013	Publication