

ETSI TS 129 165 V11.4.0 (2012-10)



Technical Specification

**Digital cellular telecommunications system (Phase 2+);
Universal Mobile Telecommunications System (UMTS);
LTE;
Inter-IMS Network to Network Interface (NNI)
(3GPP TS 29.165 version 11.4.0 Release 11)**



Reference

RTS/TSGC-0329165vb40

Keywords

GSM,LTE,UMTS

ETSI

650 Route des Lucioles
F-06921 Sophia Antipolis Cedex - FRANCE

Tel.: +33 4 92 94 42 00 Fax: +33 4 93 65 47 16

Siret N° 348 623 562 00017 - NAF 742 C
Association à but non lucratif enregistrée à la
Sous-Préfecture de Grasse (06) N° 7803/88

Important notice

Individual copies of the present document can be downloaded from:

<http://www.etsi.org>

The present document may be made available in more than one electronic version or in print. In any case of existing or perceived difference in contents between such versions, the reference version is the Portable Document Format (PDF). In case of dispute, the reference shall be the printing on ETSI printers of the PDF version kept on a specific network drive within ETSI Secretariat.

Users of the present document should be aware that the document may be subject to revision or change of status. Information on the current status of this and other ETSI documents is available at

<http://portal.etsi.org/tb/status/status.asp>

If you find errors in the present document, please send your comment to one of the following services:

http://portal.etsi.org/chaicor/ETSI_support.asp

Copyright Notification

No part may be reproduced except as authorized by written permission.
The copyright and the foregoing restriction extend to reproduction in all media.

© European Telecommunications Standards Institute 2012.
All rights reserved.

DECT™, **PLUGTESTS™**, **UMTS™** and the ETSI logo are Trade Marks of ETSI registered for the benefit of its Members.
3GPP™ and **LTE™** are Trade Marks of ETSI registered for the benefit of its Members and of the 3GPP Organizational Partners.
GSM® and the GSM logo are Trade Marks registered and owned by the GSM Association.

Intellectual Property Rights

IPRs essential or potentially essential to the present document may have been declared to ETSI. The information pertaining to these essential IPRs, if any, is publicly available for **ETSI members and non-members**, and can be found in ETSI SR 000 314: *"Intellectual Property Rights (IPRs); Essential, or potentially Essential, IPRs notified to ETSI in respect of ETSI standards"*, which is available from the ETSI Secretariat. Latest updates are available on the ETSI Web server (<http://ipr.etsi.org>).

Pursuant to the ETSI IPR Policy, no investigation, including IPR searches, has been carried out by ETSI. No guarantee can be given as to the existence of other IPRs not referenced in ETSI SR 000 314 (or the updates on the ETSI Web server) which are, or may be, or may become, essential to the present document.

Foreword

This Technical Specification (TS) has been produced by ETSI 3rd Generation Partnership Project (3GPP).

The present document may refer to technical specifications or reports using their 3GPP identities, UMTS identities or GSM identities. These should be interpreted as being references to the corresponding ETSI deliverables.

The cross reference between GSM, UMTS, 3GPP and ETSI identities can be found under <http://webapp.etsi.org/key/queryform.asp>.

Contents

| | |
|--|------------------------------------|
| Intellectual Property Rights | 2 |
| Foreword..... | 2 |
| Foreword..... | 6 |
| 1 Scope | 7 |
| 2 References | 7 |
| 3 Definitions, symbols and abbreviations | 14 |
| 3.1 Definitions | 14 |
| 3.2 Symbols..... | 14 |
| 3.3 Abbreviations | 15 |
| 4 Overview | 16 |
| 5 Reference model for interconnection between IM CN subsystems | 16 |
| 5.1 General | 16 |
| 5.2 Functionalities performed by entities at the edge of the network | 17 |
| 5.2.1 Interconnection Border Control Function (IBCF)..... | 17 |
| 5.2.2 Transition Gateway (TrGW)..... | 18 |
| 6 Control plane interconnection | 18 |
| 6.1 Definition of Inter-IMS Network to Network Interconnection..... | 18 |
| 6.1.1 SIP methods and header fields..... | 18 |
| 6.1.1.1 General | 18 |
| 6.1.1.2 SIP methods | 18 |
| 6.1.1.3 SIP header fields | 19 |
| 6.1.1.3.0 | General 19 |
| 6.1.1.3.1 | Trust and no trust relationship 19 |
| 6.1.1.3.2 Derivation of applicable SIP header fields from 3GPP TS 24.229 [5]..... | 20 |
| 6.1.1.3.3 Applicability of SIP header fields on a roaming II-NNI..... | 21 |
| 6.1.1.3.4 Applicability of SIP header fields on a non-roaming II-NNI | 21 |
| 6.1.1.4 Notations of the codes..... | 21 |
| 6.1.1.5 Modes of signalling..... | 22 |
| 6.1.2 SDP protocol..... | 22 |
| 6.1.2.1 General | 22 |
| 6.1.3 Major capabilities | 22 |
| 6.1.4 SIP message bodies..... | 27 |
| 6.2 Control Plane Transport | 28 |
| 6.2.1 General..... | 28 |
| 6.3 SIP timers | 29 |
| 7 User plane Interconnection..... | 30 |
| 7.1 Media and Codec..... | 30 |
| 7.2 User Plane Transport..... | 31 |
| 8 Numbering, Naming and Addressing | 31 |
| 8.1 Numbering, Naming and Addressing for SIP message | 31 |
| 8.2 Numbering, Naming and Addressing for SDP | 32 |
| 9 IP Version..... | 32 |
| 10 Security..... | 33 |
| 11 Charging | 33 |
| 12 Supplementary services associated with the IMS multimedia telephony communication service..... | 33 |
| 12.1 General | 33 |
| 12.2 Malicious Communication IDentification (MCID)..... | 33 |
| 12.3 Originating Identification Presentation (OIP) and Originating Identification Restriction (OIR)..... | 34 |

| | | |
|---------|---|----|
| 12.4 | Terminating Identification Presentation (TIP) and Terminating Identification Restriction (TIR) | 34 |
| 12.5 | Anonymous Communication Rejection (ACR)..... | 34 |
| 12.6 | Communication DIVersion (CDIV) | 35 |
| 12.7 | Communication Waiting (CW) | 35 |
| 12.8 | Communication HOLD (HOLD) | 35 |
| 12.9 | Message Waiting Indication (MWI)..... | 36 |
| 12.10 | Communication Barring (CB) | 36 |
| 12.10.1 | Incoming Communication Barring (ICB) | 36 |
| 12.10.2 | Outgoing Communication Barring (OCB)..... | 36 |
| 12.11 | Completion of Communications to Busy Subscriber (CCBS)..... | 36 |
| 12.12 | Completion of Communications by No Reply (CCNR)..... | 37 |
| 12.13 | Explicit Communication Transfer (ECT) | 37 |
| 12.14 | Customized Alerting Tone (CAT)..... | 38 |
| 12.15 | Customized Ringing Signal (CRS)..... | 38 |
| 12.16 | Closed User Group (CUG) | 38 |
| 12.17 | Personal Network Management (PNM) | 39 |
| 12.18 | Three-Party (3PTY)..... | 39 |
| 12.19 | Conference (CONF) | 39 |
| 12.20 | Flexible Alerting (FA)..... | 40 |
| 12.21 | Announcements..... | 40 |
| 12.21.1 | General..... | 40 |
| 12.21.2 | Providing announcements during the establishment of a communication session..... | 40 |
| 12.21.3 | Providing announcements during an established communication session..... | 40 |
| 12.21.4 | Providing announcements when communication request is rejected..... | 41 |
| 12.22 | Advice of Charge (AOC) | 41 |
| 12.23 | Completion of Communications on Not Logged-in (CCNL)..... | 41 |
| 12.24 | Unstructured Supplementary Service Data (USSD)..... | 42 |
| 13 | Interoperability of IMS Centralized Services (ICS) over II-NNI..... | 42 |
| 13.1 | General | 42 |
| 13.2 | IMS Centralized Services (ICS) | 42 |
| 14 | Interoperability of IMS Service Continuity over II-NNI | 43 |
| 14.1 | General | 43 |
| 14.2 | PS to CS Single Radio Voice Call Continuity (SRVCC) and Single Radio Video Call Continuity (vSRVCC) | 43 |
| 14.2.1 | Basic PS to CS SRVCC | 43 |
| 14.2.2 | PS to CS SRVCC for calls in alerting phase..... | 43 |
| 14.2.3 | Using the ATCF based architecture | 44 |
| 14.3 | Inter UE Transfer (IUT) | 44 |
| 14.4 | PS to CS SRVCC with the MSC server assisted mid-call feature..... | 44 |
| 14.5 | CS to PS Single Radio Voice Call Continuity (SRVCC) | 45 |
| 14.5.1 | Basic CS to PS SRVCC..... | 45 |
| 14.5.2 | CS to PS SRVCC for calls in alerting phase | 45 |
| 14.5.3 | CS to PS SRVCC with the assisted mid-call feature | 45 |
| 15 | Presence service | 46 |
| 15.0 | General | 46 |
| 15.1 | Subscription of presence information..... | 46 |
| 15.2 | Watcher subscribing to Presence List..... | 46 |
| 15.3 | Subscription to Watcher Information | 47 |
| 15.4 | Subscription to state changes in XML documents | 47 |
| 15.5 | Presence enhancements specified in Open Mobile Alliance (OMA) Release 1.1 | 47 |
| 15.5.1 | General..... | 47 |
| 15.5.2 | OMA subscription of presence information..... | 47 |
| 15.5.3 | OMA watcher subscribing to Presence List..... | 47 |
| 15.5.4 | OMA subscription to Watcher Information | 48 |
| 15.6 | Presence enhancements specified in Open Mobile Alliance (OMA) Release 2.0 | 48 |
| 15.6.1 | General..... | 48 |
| 15.6.2 | OMA subscription of presence information..... | 48 |
| 15.6.3 | OMA watcher subscribing to Presence List..... | 48 |
| 15.6.4 | OMA subscription to Watcher Information | 49 |
| 15.6.5 | Subscription to state changes in XML documents | 49 |

| | | |
|---|--|------------|
| 15.6.6 | Void | 49 |
| 15.6.7 | Void | 49 |
| 16 | Messaging service | 49 |
| 16.1 | General | 49 |
| 16.2 | Page-mode messaging | 50 |
| 16.4 | Session-mode messaging | 50 |
| 16.5 | Session-mode messaging conferences | 50 |
| 17 | Optimal Media Routing | 50 |
| 17.1 | General | 50 |
| 17.2 | OMR related SDP attributes | 51 |
| 17.3 | IP realm names | 51 |
| 18 | Inter-UE transfer (IUT) | 51 |
| 18.1 | General | 51 |
| 18.2 | IUT without establishment of a collaborative session | 51 |
| 18.3 | IUT using a collaborative session | 51 |
| 18.3.1 | Collaborative session of participants of the same subscription | 51 |
| 18.3.2 | Establishment of a collaborative session during session setup | 52 |
| 18.3.3 | Assignment and transfer of control of a collaborative session | 52 |
| 18.3.4 | Collaborative session of participants of different subscriptions | 53 |
| 18.4 | Session replication / media replication | 53 |
| 18.4.1 | Pull mode | 53 |
| 18.4.2 | Push mode | 53 |
| 19 | Roaming Architecture for Voice over IMS with Local Breakout | 54 |
| 20 | Delivery of Media Resource Broker address information | 54 |
| 21 | Overload control | 54 |
| Annex A (informative): Summary of SIP header fields | | 55 |
| Annex B (informative): Dynamic view of SIP header fields within SIP messages | | 59 |
| B.1 | Scope | 59 |
| B.2 | Methodology | 59 |
| B.3 | ACK method | 61 |
| B.4 | BYE method | 62 |
| B.5 | CANCEL method | 64 |
| B.6 | INFO method | 65 |
| B.7 | INVITE method | 69 |
| B.8 | MESSAGE method | 75 |
| B.9 | NOTIFY method | 79 |
| B.10 | OPTIONS method | 83 |
| B.11 | PRACK method | 87 |
| B.12 | PUBLISH method | 89 |
| B.13 | REFER method | 93 |
| B.14 | REGISTER method | 97 |
| B.15 | SUBSCRIBE method | 100 |
| B.16 | UPDATE method | 105 |
| Annex C (informative): The list of option items for II-NNI | | 108 |
| C.1 | Scope | 108 |
| C.2 | Format of option item table | 108 |
| C.3 | Option item table | 108 |
| C.3.0 | Supported II-NNI traversal scenarios | 108 |
| C.3.1 | Option item table common to roaming and non-roaming II-NNI | 109 |
| C.3.2 | Option item table specific to roaming II-NNI | 113 |
| C.3.3 | Option item table specific to non-roaming II-NNI and loopback traversal scenario | 115 |
| Annex D: Change history | | 118 |
| History | | 126 |

Foreword

This Technical Specification has been produced by the 3rd Generation Partnership Project (3GPP).

The contents of the present document are subject to continuing work within the TSG and may change following formal TSG approval. Should the TSG modify the contents of the present document, it will be re-released by the TSG with an identifying change of release date and an increase in version number as follows:

Version x.y.z

where:

- x the first digit:
 - 1 presented to TSG for information;
 - 2 presented to TSG for approval;
 - 3 or greater indicates TSG approved document under change control.
- y the second digit is incremented for all changes of substance, i.e. technical enhancements, corrections, updates, etc.
- z the third digit is incremented when editorial only changes have been incorporated in the document.

1 Scope

The objective of this document is to address the Inter-IMS Network to Network Interface (II-NNI) consisting of Ici and Izi reference points between IMS networks in order to support end-to-end service interoperability.

The present document will address the issues related to control plane signalling (3GPP usage of SIP and SDP protocols, required SIP header fields) as well as other interconnecting aspects like security, numbering/naming/addressing and user plane issues as transport protocol, media and codecs actually covered in a widespread set of 3GPP specifications. A profiling of the Inter-IMS Network to Network Interface (II-NNI) is also provided.

Charging aspects will be addressed as far as SIP signalling is concerned.

SIP signalling traversing the NNI between a CSCF and an AS or MRB, e.g. for media control or Voice Interworking with Enterprise IP-PBX, and SIP signalling traversing the NNI on the Mr interface between the CSCF and the MRFC, or on the Mr' interface between the AS and MRFC, or on the Rc interface between AS and MRB is not considered in the present release of this specification.

2 References

The following documents contain provisions which, through reference in this text, constitute provisions of the present document.

- References are either specific (identified by date of publication, edition number, version number, etc.) or non-specific.
- For a specific reference, subsequent revisions do not apply.
- For a non-specific reference, the latest version applies. In the case of a reference to a 3GPP document (including a GSM document), a non-specific reference implicitly refers to the latest version of that document in the same Release as the present document.

- [1] 3GPP TR 21.905: "Vocabulary for 3GPP Specifications".
- [2] IETF RFC 791: "Internet Protocol".
- [3] 3GPP TS 23.002: "Network architecture".
- [4] 3GPP TS 23.228: "IP Multimedia Subsystem (IMS); Stage 2".
- [5] 3GPP TS 24.229: "Internet Protocol (IP) multimedia call control protocol based on Session Initiation Protocol (SIP) and Session Description Protocol (SDP); Stage 3".
- [6] 3GPP TR 24.930: "Signalling flows for the session setup in the IP Multimedia core network Subsystem (IMS) based on Session Initiation Protocol (SIP) and Session Description Protocol (SDP); Stage 3".
- [7] IETF RFC 2460: "Internet Protocol, Version 6 (IPv6) Specification".
- [8] 3GPP TS 29.162: "Interworking between the IM CN subsystem and IP networks".
- [9] 3GPP TS 22.228: "Service requirements for the IP multimedia core network subsystem".
- [10] 3GPP TS 33.210: "3G security; Network Domain Security (NDS); IP network layer security".
- [11] 3GPP TS 26.114: "IP Multimedia Subsystem (IMS); Multimedia Telephony; Media handling and interaction".
- [12] ETSI TS 181 005 1.1.1: "Telecommunications and Internet converged Services and Protocols for Advanced Networking (TISPAN); Services and Capabilities Requirements".

- [13] IETF RFC 3261: "SIP: Session Initiation Protocol".
- [14] IETF RFC 3966: "The tel URI for Telephone Numbers".
- [15] IETF RFC 3860: "Common Profile for Instant Messaging (CPIM)".
- [16] IETF RFC 3859: "Common Profile for Presence (CPP)".
- [17] IETF RFC 4975: "The Message Session Relay Protocol (MSRP)".
- [18] IETF RFC 3262: "Reliability of provisional responses in Session Initiation Protocol (SIP)".
- [19] IETF RFC 3428: "Session Initiation Protocol (SIP) Extension for Instant Messaging".
- [20] IETF RFC 3265: "Session Initiation Protocol (SIP) Specific Event Notification".
- [21] IETF RFC 3903: "An Event State Publication Extension to the Session Initiation Protocol (SIP)".
- [22] IETF RFC 3515: "The Session Initiation Protocol (SIP) REFER method".
- [23] IETF RFC 3311: "The Session Initiation Protocol (SIP) UPDATE method".
- [24] IETF RFC 3455: "Private Header (P-Header) Extensions to the Session Initiation Protocol (SIP) for the 3rd-Generation Partnership Project (3GPP)".
- [25] IETF RFC 4244: "An Extension to the Session Initiation Protocol (SIP) for Request History Information".
- [26] IETF RFC 6050: "A Session Initiation Protocol (SIP) Extension for the Identification of Services".
- [27] IETF RFC 4168: "The Stream Control Transmission Protocol (SCTP) as a Transport for the Session Initiation Protocol (SIP)".
- [28] Void.
- [29] 3GPP TS 32.260: "Telecommunication management; Charging management; IP Multimedia Subsystem (IMS) charging".
- [30] 3GPP TS 22.173: "IP Multimedia Core Network Subsystem (IMS); Multimedia Telephony Service and supplementary services; Stage 1".
- [31] 3GPP TS 24.173: "IMS multimedia telephony communication service and supplementary services; Stage 3".
- [32] 3GPP TS 24.607: "Originating Identification Presentation (OIP) and Originating Identification Restriction (OIR) using IP Multimedia (IM); Core Network (CN) subsystem".
- [33] 3GPP TS 24.616: "Malicious Communication Identification (MCID) using IP Multimedia (IM) Core Network (CN) subsystem".
- [34] IETF RFC 3323: "A Privacy Mechanism for the Session Initiation Protocol (SIP)".
- [35] 3GPP TS 23.003: "Numbering, addressing and identification".
- [36] 3GPP TS 24.610: "Communication HOLD (HOLD) using IP Multimedia (IM) Core Network (CN) subsystem".
- [37] 3GPP TS 24.615: "Communication Waiting (CW) using IP Multimedia (IM) Core Network (CN) subsystem".
- [38] 3GPP TS 24.628: "Common Basic Communication procedures using IP Multimedia (IM) Core Network (CN) subsystem".
- [39] IETF RFC 6086: "Session Initiation Protocol (SIP) INFO Method and Package Framework".
- [40] IETF RFC 3312: "Integration of resource management and Session Initiation Protocol (SIP)".
- [41] IETF RFC 4032: "Update to the Session Initiation Protocol (SIP) Preconditions Framework".

- [42] IETF RFC 3313: "Private Session Initiation Protocol (SIP) Extensions for Media Authorization".
- [43] IETF RFC 3327: "Session Initiation Protocol Extension Header Field for Registering Non-Adjacent Contacts".
- [44] IETF RFC 3325: "Private Extensions to the Session Initiation Protocol (SIP) for Network Asserted Identity within Trusted Networks".
- [45] IETF RFC 3608: "Session Initiation Protocol (SIP) Extension Header Field for Service Route Discovery During Registration".
- [46] IETF RFC 3486: "Compressing the Session Initiation Protocol (SIP)".
- [47] IETF RFC 3329: "Security Mechanism Agreement for the Session Initiation Protocol (SIP)".
- [48] IETF RFC 3326: "The Reason Header Field for the Session Initiation Protocol (SIP)".
- [49] IETF RFC 6432: "Carrying Q.850 Codes in Reason Header Fields in SIP (Session Initiation Protocol) Responses".
- [50] IETF RFC 3581: "An Extension to the Session Initiation Protocol (SIP) for Symmetric Response Routing".
- [51] IETF RFC 3841: "Caller Preferences for the Session Initiation Protocol (SIP)".
- [52] IETF RFC 4028: "Session Timers in the Session Initiation Protocol (SIP)".
- [53] IETF RFC 3892: "The Session Initiation Protocol (SIP) Referred-By Mechanism".
- [54] IETF RFC 3891: "The Session Initiation Protocol (SIP) 'Replaces' Header".
- [55] IETF RFC 3911: "The Session Initiation Protocol (SIP) 'Join' Header".
- [56] IETF RFC 3840: "Indicating User Agent Capabilities in the Session Initiation Protocol (SIP)".
- [57] IETF RFC 5079: "Rejecting Anonymous Requests in the Session Initiation Protocol (SIP)".
- [58] IETF RFC 4458: "Session Initiation Protocol (SIP) URIs for Applications such as Voicemail and Interactive Voice Response (IVR)".
- [59] IETF RFC 4320: "Actions Addressing Identified Issues with the Session Initiation Protocol's (SIP) Non-INVITE Transaction".
- [60] IETF RFC 4457: "The Session Initiation Protocol (SIP) P-User-Database Private-Header (P-header)".
- [61] IETF RFC 5031: "A Uniform Resource Name (URN) for Emergency and Other Well-Known Services".
- [62] IETF RFC 5627: "Obtaining and Using Globally Routable User Agent (UA) URIs (GRUU) in the Session Initiation Protocol (SIP)".
- [63] Void.
- [64] IETF RFC 5002: "The Session Initiation Protocol (SIP) P-Profile-Key Private Header (P-Header)".
- [65] IETF RFC 5626: "Managing Client-Initiated Connections in the Session Initiation Protocol (SIP)".
- [66] IETF RFC 5768: "Indicating Support for Interactive Connectivity Establishment (ICE) in the Session Initiation Protocol (SIP)".
- [67] IETF RFC 5365: "Multiple-Recipient MESSAGE Requests in the Session Initiation Protocol (SIP)".
- [68] IETF RFC 6442: "Location Conveyance for the Session Initiation Protocol".
- [69] IETF RFC 5368: "Referring to Multiple Resources in the Session Initiation Protocol (SIP)".

- [70] IETF RFC 5366: "Conference Establishment Using Request-Contained Lists in the Session Initiation Protocol (SIP)".
- [71] IETF RFC 5367: "Subscriptions to Request-Contained Resource Lists in the Session Initiation Protocol (SIP)".
- [72] IETF RFC 4967: "Dial String Parameter for the Session Initiation Protocol Uniform Resource Identifier".
- [73] IETF RFC 4964: "The P-Answer-State Header Extension to the Session Initiation Protocol for the Open Mobile Alliance Push to Talk over Cellular".
- [74] IETF RFC 5009: "Private Header (P-Header) Extension to the Session Initiation Protocol (SIP) for Authorization of Early Media".
- [75] IETF RFC 4694: "Number Portability Parameters for the 'tel' URI".
- [76] Void.
- [77] IETF RFC 4411: "Extending the Session Initiation Protocol (SIP) Reason Header for Preemption Events".
- [78] IETF RFC 4412: "Communications Resource Priority for the Session Initiation Protocol (SIP)".
- [79] IETF RFC 5393: "Addressing an Amplification Vulnerability in Session Initiation Protocol (SIP) Forking Proxies".
- [80] IETF RFC 5049: "Applying Signaling Compression (SigComp) to the Session Initiation Protocol (SIP)".
- [81] IETF RFC 5688: "A Session Initiation Protocol (SIP) Media Feature Tag for MIME Application Sub-Types".
- [82] IETF RFC 5360: "A Framework for Consent-Based Communications in the Session Initiation Protocol (SIP)".
- [83] draft-ietf-cuss-sip-uu-06 (May 2012): "A Mechanism for Transporting User to User Call Control Information in SIP".

Editor's note: The above document cannot be formally referenced until it is published as an RFC.

- [83A] draft-ietf-cuss-sip-uu-isdn-04 (May 2012): "Interworking ISDN Call Control User Information with SIP".

Editor's note: The above document cannot be formally referenced until it is published as an RFC.

- [84] draft-vanelburg-dispatch-private-network-ind-01 (June 2010): "The Session Initiation Protocol (SIP) P-Private-Network-Indication Private-Header (P-Header)".

Editor's note: The above document cannot be formally referenced until it is published as an RFC.

- [85] IETF RFC 5502: "The SIP P-Served-User Private-Header (P-Header) for the 3GPP IP Multimedia (IM) Core Network (CN) Subsystem".
- [86] Void.
- [87] draft-dawes-sipping-debug-04 (February 2011): "Session Initiation Protocol (SIP) Header parameter for Debugging".

Editor's note: The above document cannot be formally referenced until it is published as an RFC.

- [88] IETF RFC 6228: "Response Code for Indication of Terminated Dialog".
- [89] IETF RFC 5621: "Message Body Handling in the Session Initiation Protocol (SIP)".
- [90] IETF RFC 6223: "Indication of support for keep-alive".

- [91] IETF RFC 5552: "SIP Interface to VoiceXML Media Services".
- [92] IETF RFC 3862: "Common Presence and Instant Messaging (CPIM): Message Format".
- [93] IETF RFC 5438: "Instant Message Disposition Notification".
- [94] IETF RFC 5373: "Requesting Answering Modes for the Session Initiation Protocol (SIP)".
- [95] Void.
- [96] IETF RFC 3959: "The Early Session Disposition Type for the Session Initiation Protocol (SIP)".
- [97] Void.
- [98] 3GPP TS 24.183: "Customized Ringing Signal (CRS) using IP Multimedia (IM) Core Network (CN) subsystem".
- [99] 3GPP TS 24.259: "Personal Network Management (PNM) using IP Multimedia (IM) Core Network (CN) subsystem".
- [100] 3GPP TS 24.238: "Session Initiation Protocol (SIP) based user configuration".
- [101] 3GPP TS 24.239: "Flexible Alerting (FA) using IP Multimedia (IM) Core Network (CN) subsystem".
- [102] Void.
- [103] 3GPP TS 24.654: "Closed User Group (CUG) using IP Multimedia (IM) Core Network (CN) subsystem".
- [104] Void.
- [105] 3GPP TS 24.605: "Conference (CONF) using IP Multimedia (IM) Core Network (CN) subsystem".
- [106] 3GPP TS 24.147: "Conferencing using the IP Multimedia (IM) Core Network (CN) subsystem".
- [107] Void.
- [108] Void.
- [109] 3GPP TS 24.642: "Completion of Communications to Busy Subscriber (CCBS) Completion of Communications by No Reply (CCNR) using IP Multimedia (IM) Core Network (CN) subsystem".
- [110] Void.
- [111] Void.
- [112] 3GPP TS 24.606: "Message Waiting Indication (MWI) using IP Multimedia (IM) Core Network (CN) subsystem".
- [113] 3GPP TS 24.608: "Terminating Identification Presentation (TIP) and Terminating Identification Restriction (TIR) using IP Multimedia (IM); Core Network (CN) subsystem".
- [114] 3GPP TS 24.611: "Communication Barring (CB) using IP Multimedia (IM); Core Network (CN) subsystem".
- [115] Void.
- [116] 3GPP TS 24.629: "Explicit Communication Transfer (ECT) using IP Multimedia (IM) Core Network (CN) subsystem".
- [117] 3GPP TS 24.604: "Communication DIVersion (CDIV) using IP Multimedia (IM) Core Network (CN) subsystem".
- [118] Void.

- [119] Void.
- [120] 3GPP TS 23.292: "IP Multimedia Subsystem (IMS) Centralized Services; Stage 2".
- [121] 3GPP TS 24.292: "IP Multimedia Core Network subsystem Centralized Services (ICS); Stage 3".
- [122] 3GPP TS 24.647: "Advice Of Charge (AOC) using IP Multimedia (IM) Core Network (CN) subsystem".
- [123] Void.
- [124] draft-kaplan-dispatch-session-id-00 (December 2009): "A Session Identifier for the Session Initiation Protocol (SIP)".

Editor's note: The above document cannot be formally referenced until it is published as an RFC.

- [125] IETF RFC 6026: "Correct Transaction Handling for 2xx Responses to Session Initiation Protocol (SIP) INVITE Requests".
 - [126] IETF RFC 5658: "Addressing Record-Route issues in the Session Initiation Protocol (SIP)".
 - [127] IETF RFC 5954: "Essential correction for IPv6 ABNF and URI comparison in RFC3261".
 - [128] Void.
 - [129] 3GPP TS 24.182: "IP Multimedia Subsystem (IMS) Customized Alerting Tones (CAT)".
 - [130] 3GPP TS 29.292: "Interworking between the IP Multimedia (IM) Core Network (CN) subsystem and MSC Server for IMS Centralized Services (ICS)".
 - [131] 3GPP TS 24.237: "IP Multimedia (IM) Core Network (CN) subsystem; IP Multimedia Subsystem (IMS) Service Continuity".
- [132] 3GPP TS 24.141: "Presence service using the IP Multimedia (IM) Core Network (CN) subsystem".
- [133] draft-ietf-sip-session-policy-framework-10 (February 2011): "A Framework for Session Initiation Protocol (SIP) Session Policies".

Editor's note: The above document cannot be formally referenced until it is published as an RFC.

- [134] IETF RFC 5875: "An Extensible Markup Language (XML) Configuration Access Protocol (XCAP) Diff Event Package".
- [135] IETF RFC 4488: "Suppression of Session Initiation Protocol (SIP) REFER Method Implicit Subscription".
 - [136] draft-ietf-salud-alert-info-urns-06 (April 2012): "Alert-Info URNs for the Session Initiation Protocol (SIP)".

Editor's note: The above document cannot be formally referenced until it is published as an RFC.

- [137] draft-dawes-dispatch-mediasec-parameter-04 (August 2011): "Capability Exchange for Media Plane Security".

Editor's note: The above document cannot be formally referenced until it is published as an RFC.

- [138] OMA-TS-Presence_SIMPLE-V2_0-20101202 "Presence SIMPLE Specification".
- [139] 3GPP TS 24.247: "Messaging service using the IP Multimedia (IM) Core Network (CN) subsystem".
- [140] IETF RFC 4538: "Request Authorization through Dialog Identification in the Session Initiation Protocol (SIP)".
- [141] IETF RFC 5318: "The Session Initiation Protocol (SIP) P-Refused-URI-List Private-Header (P-Header)".

- [142] OMA-TS-Presence_SIMPLE-V1_1-20100225 "Presence SIMPLE Specification".
- [143] draft-ietf-sipcore-proxy-feature-05 (August 2012): "Mechanism to indicate support of features and capabilities in the Session Initiation Protocol (SIP)".

Editor's note: The above document cannot be formally referenced until it is published as an RFC.

- [144] IETF RFC 5839: "An Extension to Session Initiation Protocol (SIP) Events for Conditional Event Notification".
- [145] Void.
- [146] IETF RFC 3264: "An Offer/Answer Model with the Session Description Protocol (SDP)".
- [147] IETF RFC 4566: "SDP: Session Description Protocol".
- [148] 3GPP TS 29.079: "Optimal Media Routeing within the IP Multimedia Subsystem; Stage 3".
- [149] 3GPP TS 24.337: "IP Multimedia Subsystem (IMS) inter-UE transfer".
- [150] IETF RFC 3960: "Early Media and Ringing Tone Generation in the Session Initiation Protocol (SIP)".
- [151] IETF RFC 3550: "RTP: A Transport Protocol for Real-Time Applications".
- [152] IETF RFC 768: "User Datagram Protocol".
- [153] IETF RFC 3551: "RTP Profile for Audio and Video Conferences with Minimal Control".
- [154] IETF RFC 3556: "Session Description Protocol (SDP) Bandwidth Modifiers for RTP Control Protocol (RTCP) Bandwidth".
- [155] IETF RFC 4585: "Extended RTP Profile for Real-time Transport Control Protocol (RTCP)-Based Feedback (RTP/AVPF)".
- [156] IETF RFC 793: "Transmission Control Protocol".
- [157] IETF RFC 4733: "RTP Payload for DTMF Digits, Telephony Tones, and Telephony Signals".
- [158] IETF RFC 4916: "Connected Identity in the Session Initiation Protocol (SIP)".
- [159] 3GPP TS 23.237: "IP Multimedia Subsystem (IMS) Service Continuity".
- [160] IETF RFC 6140: "Registration for Multiple Phone Numbers in the Session Initiation Protocol (SIP)".
- [161] IETF RFC 6230: "Media Control Channel Framework".
- [162] IETF RFC 4145: "TCP-Based Media Transport in the Session Description Protocol (SDP)".
- [163] 3GPP TS 24.390: "Unstructured Supplementary Service Data (USSD)".
- [164] IETF RFC 6357 (August 2011): "Design Considerations for Session Initiation Protocol (SIP) Overload Control".
- [165] draft-ietf-soc-overload-control-09 (July 2012): "Session Initiation Protocol (SIP) Overload Control".

Editor's note: The above document cannot be formally referenced until it is published as an RFC.

- [166] draft-ietf-soc-overload-rate-control-02.txt (June 2012): "Session Initiation Protocol (SIP) Rate Control".

Editor's note: The above document cannot be formally referenced until it is published as an RFC.

- [167] draft-ietf-soc-load-control-event-package-04 (July 2012): "A Session Initiation Protocol (SIP) Load Control Event Package".

Editor's note: The above document cannot be formally referenced until it is published as an RFC.

3 Definitions, symbols and abbreviations

3.1 Definitions

For the purposes of the present document, the terms and definitions given in 3GPP TR 21.905 [1] and the following apply. A term defined in the present document takes precedence over the definition of the same term, if any, in 3GPP TR 21.905 [1].

example: text used to clarify abstract rules by applying them literally.

IM CN subsystem: (IP Multimedia CN subsystem) comprises of all CN elements for the provision of IP multimedia applications over IP multimedia sessions, as specified in 3GPP TS 22.228 [9].

IP multimedia session: as specified in 3GPP TS 22.228 [9] an IP multimedia session is a set of multimedia senders and receivers and the data streams flowing from senders to receivers. IP multimedia sessions are supported by the IP multimedia CN Subsystem and are enabled by IP connectivity bearers (e.g. GPRS as a bearer). A user can invoke concurrent IP multimedia sessions.

non-roaming II-NNI: the II-NNI between IMS home networks, or, if the Roaming Architecture for Voice over IMS with Local Breakout is used, alternatively the II-NNI between the caller's visited network and the callee's home network.

roaming II-NNI: the II-NNI between a visited IMS network and the IMS home network; for the Roaming Architecture for Voice over IMS with Local Breakout, the loopback traversal scenario is excluded.

loopback traversal scenario: for the Roaming Architecture for Voice over IMS with Local Breakout, the scenario where the II-NNI between the caller's home network and the caller's visited network is being traversed by an initial INVITE request from the caller's home network to the caller's visited network or any subsequent SIP message within the same dialogue on the same call leg.

home-to-visited request on roaming II-NNI: SIP request being sent from the callee's home network to the callee's visited network.

visited-to-home request on roaming II-NNI: SIP request being sent from the caller's visited network to the caller's home network.

home-to-visited response on roaming II-NNI: SIP response being sent from the callee's home network to the callee's visited network.

visited-to-home response on roaming II-NNI: SIP response being sent from the caller's visited network to the caller's home network.

For the purposes of the present document, the following terms and definitions given in 3GPP TS 23.292 [120] apply:

MSC Server enhanced for ICS

For the purposes of the present document, the following terms and definitions given in 3GPP TS 23.237 [159] apply:

MSC server enhanced for SRVCC

3.2 Symbols

For the purposes of the present document, the following symbols apply:

| | |
|-----|---|
| I2 | Reference point between the MSC Server enhanced for ICS and the home IMS |
| Ici | Reference Point between an IBCF and another IBCF belonging to a different IM CN subsystem network |
| Izi | Reference Point between a TrGW and another TrGW or media handling node belonging to a different IM CN subsystem network |
| Mi | Reference Point between a BGCF and CSCF |

| | |
|----|---|
| Mm | Reference Point between a CSCF/BGCF/IMS ALG and an IP multimedia network |
| Mw | Reference Point between a CSCF and another CSCF |
| Mx | Reference Point between a CSCF/BGCF/MSC Server enhanced for ICS/ MSC Server enhanced for SRVCC and IBCF |

3.3 Abbreviations

For the purposes of the present document, the abbreviations given in 3GPP TR 21.905 [1] and the following apply. An abbreviation defined in the present document takes precedence over the definition of the same abbreviation, if any, in 3GPP TR 21.905 [1].

| | |
|-----------|--|
| ACR | Anonymous Communication Rejection |
| AS | Application Server |
| ATCF | Access Transfer Control Function |
| B2BUA | Back 2 Back User Agent |
| BGCF | Breakout Gateway Control Function |
| CAT | Customized Alerting Tone |
| CB | Communication Barring |
| CCBS | Completion of Communications to Busy Subscriber |
| CCNR | Communication Completion on No Reply |
| CDIV | Communication Diversion |
| CDIVN | Communication Diversion Notification |
| CRS | Customized Ringing Signal |
| ECT | Explicit Communication Transfer |
| FA | Flexible Alerting |
| HOLD | Communication HOLD |
| CW | Communication Waiting |
| IBCF | Interconnection Border Control Function |
| ICB | Incoming Communication Barring |
| ICS | IMS Centralized Services |
| I-CSCF | Interrogating CSCF |
| IPXS | Advanced IP Interconnection of Services |
| II-NNI | Inter-IMS Network to Network Interface |
| IM | Instant Messaging |
| IMS-ALG | IMS Application Level Gateway |
| IUT | Inter UE Transfer |
| MCID | Malicious Communication IDentification |
| MRB | Media Resource Broker |
| MRFC | Media Resource Function Controller |
| MRFP | Multimedia Resource Function Processor |
| MSRP | Message Session Relay Protocol |
| MWI | Message Waiting Indication |
| NA(P)T-PT | Network Address (Port-Multiplexing) Translation-Protocol Translation |
| NNI | Network to Network Interface |
| OCB | Outgoing Communication Barring |
| OIP | Originating Identification Presentation |
| OIR | Originating Identification Restriction |
| OMA | Open Mobile Alliance |
| OMR | Optimal Media Routeing |
| P-CSCF | Proxy CSCF |
| PNM | Personal Network Management |
| PRES | Presence |
| SRVCC | Single Radio Voice Call Continuity |
| TIP | Terminating Identification Presentation |
| TIR | Terminating Identification Restriction |
| TRF | Transit and Roaming Function |
| TrGW | Transition Gateway |
| vSRVCC | Single Radio Video Call Continuity |

4 Overview

Interconnection between two different IM CN subsystems shall be guaranteed in order to support end-to-end service interoperability. For this purpose, Inter-IMS Network to Network Interface (II-NNI) between two IM CN subsystem networks is adopted, according to the assumptions coming from 3GPP TS 23.002 [3] and 3GPP TS 23.228 [4].

NOTE: The end-to-end service interoperability within one IM CN subsystem over the Mi, Mm, Mw and I2 reference points not passing over the Mx reference point as defined in 3GPP TS 23.228 [4] is outside the scope of this document.

Aiming to support the delivery of IMS services between two separated IM CN subsystems, protocol interconnection has to occur:

- at a control plane level, in order that IMS procedures can be supported. In this case the adopted reference point is the Ici; and
- at a user plane level, where media streams are exchanged over the Izi reference point.

IP multimedia sessions are managed by SIP. The transport mechanism for both SIP session signalling and media transport is IPv4 (IETF RFC 791 [2]) or IPv6 (IETF RFC 2460 [7]). The 3GPP profile of SIP defining the usage of SIP within the IM CN subsystem is specified in 3GPP TS 24.229 [5]. Example call flows are provided in 3GPP TR 24.930 [6].

The general interconnection model is shown in Figure 4.1.

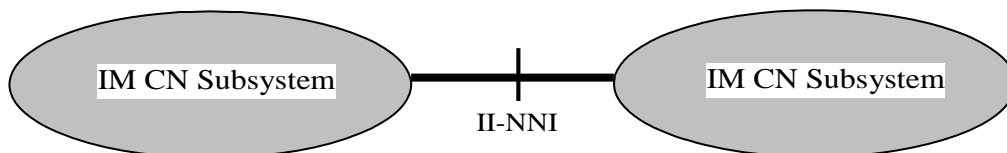

Figure 4.1: Interconnection Model for IM CN subsystems

The possible functional entities involved in the signalling plane interconnection (IBCF, I-CSCF, P-CSCF, ATCF, S-CSCF, BGCF, MSC Server enhanced for ICS and MSC server enhanced for SRVCC) and in the user plane interconnection (TrGW) are specified in 3GPP TS 24.229 [5], in 3GPP TS 24.292 [121], 3GPP TS 29.292 [130] 3GPP TS 29.162 [8] and in 3GPP TS 24.237[131].

IP Version interworking is described within 3GPP TS 29.162 [8].

5 Reference model for interconnection between IM CN subsystems

5.1 General

Figure 5.1 illustrates the architecture diagram given in 3GPP TS 23.228 [4] showing the Inter-IMS Network to Network Interface (II-NNI) between two IM CN subsystem networks.

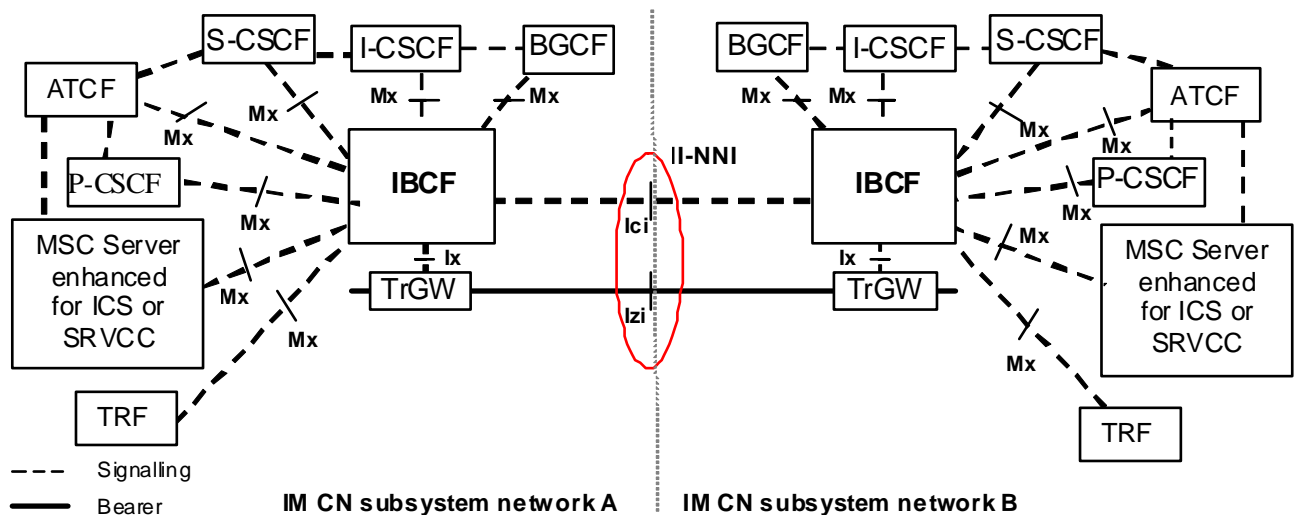

NOTE: The TRF can reside in a stand-alone entity or can be combined with another functional entity.

Figure 5.1.1: Inter-IMS Network to Network Interface between two IM CN subsystem networks

The protocols over the two reference points Ici and Izi make up the Inter-IMS Network to Network Interface.

The Ici reference point allows IBCFs to communicate with each other in order to provide the communication and forwarding of SIP signalling messaging between IM CN subsystem networks. The Izi reference point allows TrGWs to forward media streams between IM CN subsystem networks.

IMS roaming performed by using II-NNI is considered, when the IBCFs are inserted at the network borders. The applicability of roaming scenario by using II-NNI is based on agreement between the operators.

Whenever the Inter-IMS Network to Network Interface is used to interconnect two IM CN subsystem networks belonging to different security domains, security procedures apply as described in 3GPP TS 33.210 [10].

When advanced IP interconnection of services (IPXS) is provided by a transit network interconnecting two IM CN subsystem networks, interfaces on both sides of the transit network are within the scope of this document.

5.2 Functionalities performed by entities at the edge of the network

5.2.1 Interconnection Border Control Function (IBCF)

An IBCF provides application specific functions at the SIP/SDP protocol layer in order to perform interconnection between IM CN subsystem networks by using Ici reference point. According to 3GPP TS 23.228 [4], IBCF can act both as an entry point and as an exit point for a network.

The functionalities of IBCF are indicated in the 3GPP TS 23.228 [4] and specified in 3GPP TS 24.229 [5]. They include:

- network topology hiding;
- application level gateway (for instance enabling communication between IPv6 and IPv4 SIP applications, or between a SIP application in a private IP address space and a SIP application outside this address space);
- controlling transport plane functions;
- controlling media plane adaptations;
- screening of SIP signalling information;
- selecting the appropriate signalling interconnect;

- generation of charging data records;
- privacy protection; and
- inclusion of a transit IOI when acting as an entry point for a transit network.

Based on local configuration, the IBCF performs transit routing functions as specified in 3GPP TS 24.229 [5].

The IBCF acts as a B2BUA when it performs IMS-ALG functionality.

5.2.2 Transition Gateway (TrGW)

According to 3GPP TS 23.002 [3], the TrGW is located at the network borders within the media path and is controlled by an IBCF. Forwarding of media streams between IM CN subsystem networks is applied over Izi reference point.

The TrGW provides functions like network address/port translation and IPv4/IPv6 protocol translation. NAT-PT binds addresses in IPv6 network with addresses in IPv4 network and vice versa to provide transparent routing between the two IP domains without requiring any changes to end points. NA(P)T-PT provides additional translation of transport identifier (TCP and UDP port numbers). The approach is similar to that one described also in 3GPP TS 29.162 [8].

Further details are described in 3GPP TS 23.228 [4].

6 Control plane interconnection

6.1 Definition of Inter-IMS Network to Network Interconnection

6.1.1 SIP methods and header fields

6.1.1.1 General

The functional entity closest to the border of an II-NNI (see reference model in clause 5) shall provide the capabilities specified for that network element in subclause A.2 of 3GPP TS 24.229 [5] with modifications as described in the following subclauses.

6.1.1.2 SIP methods

3GPP TS 24.229 [5] defines the methods allowing an IBCF to interconnect to an IBCF placed in another IM CN subsystem.

The following SIP methods are supported on the II-NNI as defined in table 6.1.

The following table is based on table A.5 and table A.163 of 3GPP TS 24.229 [5] and endorsed for this document:

Table 6.1: Supported SIP methods

| Item | Method | Ref. | II-NNI | |
|-------|---|--------------------|---------|-----------|
| | | | Sending | Receiving |
| 1 | ACK request | IETF RFC 3261 [13] | m | m |
| 2 | BYE request | IETF RFC 3261 [13] | m | m |
| 3 | BYE response | IETF RFC 3261 [13] | m | m |
| 4 | CANCEL request | IETF RFC 3261 [13] | m | m |
| 5 | CANCEL response | IETF RFC 3261 [13] | m | m |
| 5A | INFO request | IETF RFC 6086 [39] | o | o |
| 5B | INFO response | IETF RFC 6086 [39] | o | o |
| 8 | INVITE request | IETF RFC 3261 [13] | m | m |
| 9 | INVITE response | IETF RFC 3261 [13] | m | m |
| 9A | MESSAGE request | IETF RFC 3428 [19] | o | o |
| 9B | MESSAGE response | IETF RFC 3428 [19] | o | o |
| 10 | NOTIFY request | IETF RFC 3265 [20] | c1 | c1 |
| 11 | NOTIFY response | IETF RFC 3265 [20] | c1 | c1 |
| 12 | OPTIONS request | IETF RFC 3261 [13] | m | m |
| 13 | OPTIONS response | IETF RFC 3261 [13] | m | m |
| 14 | PRACK request | IETF RFC 3262 [18] | m | m |
| 15 | PRACK response | IETF RFC 3262 [18] | m | m |
| 15A | PUBLISH request | IETF RFC 3903 [21] | c1 | c1 |
| 15B | PUBLISH response | IETF RFC 3903 [21] | c1 | c1 |
| 16 | REFER request | IETF RFC 3515 [22] | o | o |
| 17 | REFER response | IETF RFC 3515 [22] | o | o |
| 18 | REGISTER request | IETF RFC 3261 [13] | c2 | c2 |
| 19 | REGISTER response | IETF RFC 3261 [13] | c2 | c2 |
| 20 | SUBSCRIBE request | IETF RFC 3265 [20] | c1 | c1 |
| 21 | SUBSCRIBE response | IETF RFC 3265 [20] | c1 | c1 |
| 22 | UPDATE request | IETF RFC 3311 [23] | m | m |
| 23 | UPDATE response | IETF RFC 3311 [23] | m | m |
| c1: | In case of roaming II-NNI, the support of the method is m, else o. | | | |
| c2: | In case of roaming II-NNI, the support of the method is m, else n/a. | | | |
| NOTE: | In the above table, m, o and c and n/a have the meanings indicated in table 6.3 | | | |

6.1.1.3 SIP header fields

6.1.1.3.0 General

The IBCF shall provide the capabilities to manage and modify SIP header fields according to subclause 5.10 and annex A of 3GPP TS 24.229 [5] with modifications as described in the following subclauses.

6.1.1.3.1 Trust and no trust relationship

The IBCF acting as exit point applies the procedures described in subclause 5.10.2 of 3GPP TS 24.229 [5] before forwarding the SIP signalling to the IBCF acting as entry point. The IBCF acting as entry point applies the procedures described in subclause 5.10.3 of 3GPP TS 24.229 [5].

Additionally, in case there is no trust relationship between the two IM CN subsystems connected by II-NNI, the IBCF acting as exit point applies the procedures described in subclause 4.4 of 3GPP TS 24.229 [5], before forwarding the SIP signalling to the next IBCF acting as an entry point. The IBCF acting as an entry point applies the procedures described in subclause 5.10.3 of 3GPP TS 24.229 [5].

These procedures may be utilized on a per header field basis to realize overall trust as well as per service level screening of header fields. Trust relationships and trust domains may be defined by inter-operator agreements for individual services and/or individual SIP header fields.

The management of the SIP header fields (if present) over II-NNI in case of a presence or not of a trust relationship between the two interconnected IM CN subsystems is wrapped up in the following table.

Table 6.2: Management of SIP header fields over II-NNI in presence or not of a trust relationship

| Item | Header field | Reference | Trust relationship | Not trust relationship |
|--|--|---|--|---|
| 1 | P-Asserted-Identity | IETF RFC 3325 [44] | As specified in 3GPP TS 24.229 [5], subclause 4.4 (NOTE 5) | As specified in 3GPP TS 24.229 [5], subclause 4.4 (NOTE 5) |
| 2 | P-Access-Network-Info | IETF RFC 3455 [24] | As specified in 3GPP TS 24.229 [5], subclause 4.4 | As specified in 3GPP TS 24.229 [5], subclause 4.4 |
| 3 | Resource-Priority | IETF RFC 4412 [78] | As specified in 3GPP TS 24.229 [5], subclause 4.4 | As specified in 3GPP TS 24.229 [5], subclause 4.4 |
| 4 | History-Info | IETF RFC 4244 [25] | As specified in 3GPP TS 24.229 [5], subclause 4.4 | As specified in subclause 4.3.3 of RFC 4244 [25] and in 3GPP TS 24.229 [5], subclause 4.4 |
| 5 | P-Asserted-Service | IETF RFC 6050 [26] | As specified in 3GPP TS 24.229 [5], subclause 4.4 (NOTE 3) | As specified in 3GPP TS 24.229 [5], subclause 4.4 (NOTE 3) |
| 6 | P-Charging-Vector | IETF RFC 3455 [24] | As specified in 3GPP TS 24.229 [5], subclause 5.10 | As specified in 3GPP TS 24.229 [5], subclause 5.10 |
| 7 | P-Charging-Function-Addresses (NOTE 4) | IETF RFC 3455 [24] | As specified in 3GPP TS 24.229 [5], subclause 5.10 | As specified in 3GPP TS 24.229 [5], subclause 5.10 |
| 8 | P-Profile-Key (NOTE 2) | IETF RFC 5002 [64] | As specified in 3GPP TS 24.229 [5], subclause 4.4 | As specified in 3GPP TS 24.229 [5], subclause 4.4 |
| 9 | P-Private-Network-Indication (NOTE 1) | draft-vanelburg-dispatch-private-network-ind [84] | As specified in 3GPP TS 24.229 [5], subclause 4.4 | As specified in 3GPP TS 24.229 [5], subclause 4.4 |
| 10 | P-Served-User (NOTE 1, NOTE 2) | IETF RFC 5502 [85] | As specified in 3GPP TS 24.229 [5], subclause 4.4 | As specified in 3GPP TS 24.229 [5], subclause 4.4 |
| 11 | Reason (in a response) | IETF RFC 6432 [49] | As specified in 3GPP TS 24.229 [5], subclause 4.4 | As specified in 3GPP TS 24.229 [5], subclause 4.4 |
| 12 | P-Early-Media | IETF RFC 5009 [74] | As specified in 3GPP TS 24.229 [5], subclause 4.4 | As specified in 3GPP TS 24.229 [5], subclause 4.4 |
| 13 | Feature-Caps | draft-ietf-sipcore-proxy-feature [143] | As specified in 3GPP TS 24.229 [5], subclause 4.4 | As specified in 3GPP TS 24.229 [5], subclause 4.4 |
| <p>NOTE 1: For a roaming II-NNI, a trust relationship with respect to this header field is required.</p> <p>NOTE 2: This header field is only applicable on a roaming II-NNI.</p> <p>NOTE 3: In addition, value-dependent operator policies may be applied.</p> <p>NOTE 4: This header field is not applicable at II-NNI.</p> <p>NOTE 5: The handling of the URI parameters "cpc" and "oli", defined in 3GPP TS 24.229 [5] subclause 7.2A.12, is specified in 3GPP TS 24.229 [5], subclause 4.4.</p> | | | | |

6.1.1.3.2 Derivation of applicable SIP header fields from 3GPP TS 24.229 [5]

For any method in table 6.1, the SIP header fields applicable on the II-NNI are detailed in the corresponding method tables for the UA role and proxy role sending behaviour in annex A of 3GPP TS 24.229 [5]. Unless other information is specified in the normative part of the present specification, the applicability of header fields at the II-NNI can be derived for each method from the corresponding tables in annex A of 3GPP TS 24.229 [5] as follows:

- All header fields not present in the corresponding tables in annex A of 3GPP TS 24.229 or marked as "n/a" in both the "RFC status" and "profile status" columns for the UA role and proxy role sending behaviour of that tables are not applicable at the II-NNI.

NOTE 1: Operators could choose to apply header fields for other SIP extensions on an II-NNI based on bilateral agreements, but this is outside the scope of the present specification.

- All header fields which are marked as "o" in at least one of the "RFC status" or the "profile status" profile columns for the sending behaviour in the corresponding UA role and proxy role tables in annex A of 3GPP TS

24.229 [5] and as "n/a" or "o" in the other such columns are applicable at II-NNI based on bilateral agreement between operators.

- All header fields which are marked as "m" in at least one of the "RFC status" or the "profile status" columns for the sending behaviour in the corresponding UA role or proxy role table in annex A of 3GPP TS 24.229 [5] and as "n/a", "o", or "m" in the other such columns are applicable at the II-NNI.
- If conditions are specified, they are also applicable at the II-NNI and the above rules are applicable to the "n/a", "o" and "m" values within the conditions.

NOTE 2: In the above rules, the RFC profile columns are taken into account in order to enable interworking with non-3GPP networks,

An informative summary of SIP header fields to be used over the II-NNI is proposed in annex A.

6.1.1.3.3 Applicability of SIP header fields on a roaming II-NNI

The following SIP header fields are only applicable on a roaming II-NNI:

- Authentication-Info
- Authorization
- P-Associated-URI
- P-Called-Party-ID
- P-Preferred-Service
- P-Profile-Key
- P-Served-User
- P-Visited-Network-ID
- Path
- Proxy-Authenticate
- Proxy-Authorization
- Service-Route
- WWW-Authenticate

6.1.1.3.4 Applicability of SIP header fields on a non-roaming II-NNI

The following SIP header fields are only applicable on a non-roaming II-NNI or for the loopback traversal scenario:

- P-Refused-URI-List

6.1.1.4 Notations of the codes

In the table 6.1 the status codes "m", "o", "c" and "n/a" have the following meanings:

Table 6.3: Key to notation codes for SIP messages

| Notation code | Notation name | Sending side | Receiving side |
|----------------|----------------|--|---|
| m | mandatory | The message shall be supported at II-NNI. Supporting sending a SIP message at the II-NNI means that this message shall be sent over the II-NNI if received from the serving network. It does not imply that network elements inside the serving network or user equipment connected to this network shall support this message. | Supporting receiving a SIP message at the II-NNI means that this message shall be forwarded to the serving network unless the operator's policy is applied as defined in subclause 5.10.1 of 3GPP TS 24.229 [5]. It does not imply that network elements inside the served network or user equipment connected to this network are supporting this message. |
| o | optional | The message may or may not be supported at II-NNI. The support of the message is provided based on bilateral agreement between the operators. | Same as for sending side. |
| n/a | not applicable | It is impossible to use/support the message. | It is impossible to use/support the message. This message will be discarded by the IBCF. |
| c <integer> | conditional | The requirement on the message ("m", "o" or "n/a") depends on the support of other optional or conditional items. <integer> is the identifier of the conditional expression. | Same as for sending side. |

6.1.1.5 Modes of signalling

Overlap signalling may be used if agreement exists between operators to use overlap and which method to be used, otherwise enbloc shall be used at the II-NNI.

6.1.2 SDP protocol

6.1.2.1 General

The functional entity closest to the border of an II-NNI (see reference model in clause 5) shall provide the capabilities specified for that network element in subclause A.3 of 3GPP TS 24.229 [5].

The SDP bodies shall be encoded as described in IETF RFC 3261 [13] and in IETF RFC 4566 [147].

The offer/answer model with the SDP as defined in IETF RFC 3264 [146] shall be applied.

The procedures and the SDP rules as defined in IETF RFC 4145 [162] may be applied if media streams with TCP is used.

6.1.3 Major capabilities

This subclause contains the major capabilities to be supported over the II-NNI.

The table 6.1.3.1 specifies which capabilities are applicable for II-NNI. The profile status codes within table 6.1.3.1 are defined in table 6.1.3.2.

For the "Basic SIP" capabilities part of table 6.1.3.1, the last column "Profile status over II-NNI" specifies the general status of applicability of the IETF RFC 3261 [13] main mechanisms described in the 2nd column "Capability over the Ici".

For the "Extensions to basic SIP" capabilities part, the last column "Profile status over II-NNI" specifies the general status of applicability of the RFC referenced in the 2nd column "Capability over the Ici".

If necessary, the applicability of RFCs at the II-NNI level is further detailed in the present Technical Specification.

The columns "Reference item in 3GPP TS 24.229 [5] for the profile status" provide informative references for comparison purposes into the UA and Proxy role major capabilities tables in 3GPP TS 24.229 [5], where the capabilities are defined via additional references.

Table 6.1.3.1: Major capabilities over II-NNI

| Item | Capability over the ICI | Reference item in 3GPP TS 24.229 [5] for the profile status | | Profile status over II-NNI |
|------|---|---|--|----------------------------|
| | | UA Role (NOTE 1) | Proxy role (NOTE 2) | |
| | Basic SIP (IETF RFC 3261 [13]) | | | |
| 1 | registrations | 1, 2, 2A | - | c2 |
| 2 | initiating a session | 2B, 2C, 3, 4 | - | m |
| 3 | terminating a session | 5 | 3 | m |
| 4 | General proxy behaviour | - | 4, 5, 14, 15, 19F | n/a |
| 5 | Managing several responses due to forking | 9,10 | 6 | m |
| 6 | support of indication of TLS connections in the Record-Route header | - | 7, 8 | n/a |
| 7 | Support of authentication | 7, 8, 8A | 8A | c2 |
| 8 | Timestamped requests (Timestamp header field) | 6 | - | m |
| 9 | Presence of date in requests and responses (Date header field) | 11 | 9 | m |
| 10 | Presence of alerting information data (Alert-info header field) | 12 | 10 | o |
| 11 | Support and handling of the Require header field for REGISTER and other requests or responses for methods other than REGISTER | - | 11, 12, 13 | m |
| 12 | Support and reading of the Supported and Unsupported header fields | - | 16, 17, 18 | m |
| 13 | Support of the Error-Info header field in 3xx - 6xx responses | - | 19 | o |
| 14 | Support and handling of the Organization header field | - | 19A, 19B | m |
| 15 | Support and handling of the Call-Info header field | - | 19C, 19D | m |
| 16 | Support of the Contact header field in 3xx response | - | 19E | m |
| 16A | Proxy reading the contents of a body or including a body in a request or response | | 19F | n/a |
| | Extensions to basic SIP | | | |
| 16B | 3GPP TS 24.237 [131]: proxy modifying the content of a body | n/a | 19G | n/a |
| 17 | IETF RFC 6086[39]: SIP INFO method and package framework | 13 | 20 | o |
| 17A | IETF RFC 6086 [39]: legacy INFO usage | 13A | 20A | o |
| 18 | IETF RFC 3262 [18]: reliability of provisional responses in SIP (PRACK method) | 14 | 21 | m |
| 19 | IETF RFC 3515 [22]: the SIP REFER method | 15 | 22 | o |
| 20 | IETF RFC 3312 [40] and RFC 4032 [41]: integration of resource management and SIP (Preconditions framework) | 16 | 23 | o |
| 21 | IETF RFC 3311 [23]: the SIP UPDATE method | 17 | 24 | m |
| 22 | IETF RFC 3313 [42]: SIP extensions for media authorization (P-Media-Authorization header field) | 19 | 26 | n/a |
| 23 | IETF RFC 3265 [20]: SIP specific event notification (SUBSCRIBE/NOTIFY methods) | 20, 21, 22, 23 | 27, 28 | c1 |
| 24 | IETF RFC 3327 [43]: session initiation protocol extension header field for registering non-adjacent contacts (Path header field) | 24 | 29 | c2 |
| 25 | IETF RFC 3325 [44]: private extensions to the Session Initiation Protocol (SIP) for network asserted identity within trusted networks | 25 | 30 | c4 |
| 26 | IETF RFC 3325 [44]: the P-Preferred-Identity header field extension | - | - | n/a |
| 27 | IETF RFC 3325 [44]: the P-Asserted-Identity header field extension | - | - | c4 |
| 28 | IETF RFC 3323 [34]: a privacy mechanism for the Session Initiation Protocol (SIP) (Privacy header field) | 26, 26A, 26B, 26C, 26D, 26E, 26F, 26G, 26H | 31, 31A, 31B, 31C, 31D, 31E, 31F, 31G, 31H | m |
| 29 | IETF RFC 3428 [19]: a messaging mechanism for the Session Initiation Protocol (SIP) (MESSAGE method) | 27 | 33 | o |
| 30 | IETF RFC 3608 [45]: session initiation protocol extension header field for service route discovery during registration | 28 | 32 | c2 |

| | | | | |
|-----|---|----------------------------------|----------------------------------|-----|
| | (Service-Route header field) | | | |
| 31 | IETF RFC 3486 [46]: compressing the session initiation protocol | 29 | 34 | n/a |
| 32 | IETF RFC 3455 [24]: private header extensions to the session initiation protocol for the 3 rd -Generation Partnership Project (3GPP) | 30 | 35 | o |
| 32A | IETF RFC 3325 [44]: act as first entity within the trust domain for asserted identity | 30A | 30A | n/a |
| 32B | IETF RFC 3325 [44]: act as entity within trust network that can route outside the trust network | 30B | 30B | n/a |
| 32C | IETF RFC 3325: act as entity passing on identity transparently independent of trust domain | 30C | 30C | n/a |
| 33 | IETF RFC 3455 [24]: the P-Associated-URI header field extension | 31 | 36 | c2 |
| 34 | IETF RFC 3455 [24]: the P-Called-Party-ID header field extension | 32 | 37 | c2 |
| 35 | IETF RFC 3455 [24]: the P-Visited-Network-ID header field extension | 33 | 38, 39 | c2 |
| 36 | IETF RFC 3455 [24]: the P-Access-Network-Info header field extension | 34 | 41, 42, 43 | c4 |
| 37 | IETF RFC 3455 [24]: the P-Charging-Function-Addresses header field extension | 35 | 44, 44A | n/a |
| 38 | IETF RFC 3455 [24]: the P-Charging-Vector header field extension | 36 | 45, 46 | c1 |
| 39 | IETF RFC 3329 [47]: security mechanism agreement for the session initiation protocol | 37 | 47 | n/a |
| 39A | draft-dawes-dispatch-mediasec-parameter-03 [137]: Capability Exchange for Media Plane Security | 37A | 47A | n/a |
| 40 | IETF RFC 3326 [48]: the Reason header field for the session initiation protocol | 38 | 48 | o |
| 41 | IETF RFC 6432 [49]: carrying Q.850 codes in reason header fields in SIP (Session Initiation Protocol) responses | 38A | 48A | c4 |
| 42 | IETF RFC 3581 [50]: an extension to the session initiation protocol for symmetric response routing | 39 | 49 | o |
| 43 | IETF RFC 3841 [51]: caller preferences for the session initiation protocol (Accept-Contact, Reject-Contact and Request-Disposition header fields) | 40, 40A, 40B, 40C, 40D, 40E, 40F | 50, 50A, 50B, 50C, 50D, 50E, 50F | m |
| 44 | IETF RFC 3903 [21]: an event state publication extension to the session initiation protocol (PUBLISH method) | 41 | 51 | c1 |
| 45 | IETF RFC 4028 [52]: SIP session timer (Session-Expires and Min-SE headers) | 42 | 52 | m |
| 46 | IETF RFC 3892 [53]: the SIP Referred-By mechanism | 43 | 53 | m |
| 47 | IETF RFC 3891 [54]: the Session Initiation Protocol (SIP) "Replaces" header | 44 | 54 | o |
| 48 | IETF RFC 3911 [55]: the Session Initiation Protocol (SIP) "Join" header | 45 | 55 | o |
| 49 | IETF RFC 3840 [56]: the callee capabilities | 46 | 56 | o |
| 50 | IETF RFC 4244 [25]: an extension to the session initiation protocol for request history information (History-Info header field) | 47 | 57 | o |
| 51 | IETF RFC 5079 [57]: Rejecting anonymous requests in the session initiation protocol | 48 | 58 | o |
| 52 | IETF RFC 4458 [58]: session initiation protocol URIs for applications such as voicemail and interactive voice response (NOTE 3) | 49 | 59 | o |
| 53 | IETF RFC 4320 [59]: Session Initiation Protocol's (SIP) non-INVITE transactions | 50 | 61 | m |
| 54 | IETF RFC 4457 [60]: the P-User-Database private header field extension | 51 | 60 | n/a |
| 55 | IETF RFC 5031 [61]: A Uniform Resource Name (URN) for Emergency and Other Well-Known Services | 52 | 62 | n/a |
| 56 | IETF RFC 5627 [62]: obtaining and using GRUUs in the Session Initiation Protocol (SIP) | 53 | 63 | c1 |
| 57 | Void | | | |
| 58 | IETF RFC 4168 [27]: the Stream Control Transmission Protocol (SCTP) as a Transport for the Session Initiation | 55 | 65 | o |

| | Protocol (SIP) | | | |
|-----|--|--------------|--------------|-------------------|
| 59 | IETF RFC 5002 [64]: the SIP P-Profile-Key private header field extension | 56 | 66, 66A, 66B | c3 |
| 60 | IETF RFC 5626 [65]: managing client initiated connections in SIP | 57 | 67 | c1 |
| 61 | IETF RFC 5768 [66]: indicating support for interactive connectivity establishment in SIP | 58 | 68 | n/a |
| 62 | IETF RFC 5365 [67]: multiple-recipient MESSAGE requests in the session initiation protocol | 59 | 69 | o if 29, else n/a |
| 63 | IETF RFC 6442 [68]: Location conveyance for the Session Initiation Protocol | 60 | 70, 70A, 70B | m |
| 64 | IETF RFC 5368 [69]: referring to multiple resources in the session initiation protocol | 61 | 71 | o if 19, else n/a |
| 65 | IETF RFC 5366 [70]: conference establishment using request-contained lists in the session initiation protocol | 62 | 72 | o |
| 66 | IETF RFC 5367 [71]: subscriptions to request-contained resource lists in the session initiation protocol | 63 | 73 | o if 23, else n/a |
| 67 | IETF RFC 4967 [72]: dialstring parameter for the session initiation protocol uniform resource identifier | 64 | 74 | c2 |
| 68 | IETF RFC 4964 [73]: the P-Answer-State header extension to the session initiation protocol for the open mobile alliance push to talk over cellular | 65 | 75 | o |
| 69 | IETF RFC 5009 [74]: the SIP P-Early-Media private header field extension for authorization of early media | 66 | 76 | c4 |
| 70 | IETF RFC 4694 [75]: number portability parameters for the 'tel' URI | 67, 67A, 67B | 77, 77A, 77B | o |
| 72 | IETF RFC 4411 [77]: extending the session initiation protocol Reason header for preemption events | 69 | 79 | o |
| 73 | IETF RFC 4412 [78]: communications resource priority for the session initiation protocol (Resource-Priority header field) | 70, 70A, 70B | 80, 80A, 80B | o |
| 74 | IETF RFC 5393 [79]: addressing an amplification vulnerability in session initiation protocol forking proxies | 71 | 81 | m |
| 75 | IETF RFC 5049 [80]: the remote application identification of applying signalling compression to SIP | 72 | 82 | n/a |
| 76 | IETF RFC 5688 [81]: a session initiation protocol media feature tag for MIME application sub-types | 73 | 83 | c1 |
| 77 | IETF RFC 6050 [26]: Identification of communication services in the session initiation protocol | 74 | 84, 84A | o |
| 78 | IETF RFC 5360 [82]: a framework for consent-based communications in SIP | 75, 75A, 75B | 85 | o |
| 79 | draft-ietf-cuss-sip-uu [83]: a mechanism for transporting user to user call control information in SIP | 76 | 86 | c1 |
| 79A | draft-ietf-cuss-sip-uu-isdn [83A]: Interworking ISDN Call Control User Information with SIP | 76A | n/a | c1 |
| 80 | draft-vanelburg-dispatch-private-network-ind-01 [84]: The SIP P-Private-Network-Indication private-header (P-Header) | 77 | 87 | c1 |
| 81 | IETF RFC 5502 [85]: the SIP P-Served-User private header | 78 | 88 | c2 |
| 83 | draft-dawes-sipping-debug-04 [87]: the P-Debug-ID header extension | 80 | 90 | o |
| 84 | IETF RFC 6228 [88]: the 199 (Early Dialog Terminated) response code | 81 | 91 | m |
| 85 | IETF RFC 5621 [89]: message body handling in SIP | 82 | 92 | m |
| 86 | IETF RFC 6223 [90]: indication of support for keep-alive | 83 | 93 | o |
| 87 | IETF RFC 5552 [91]: SIP Interface to VoiceXML Media Services | 84 | 94 | n/a |
| 88 | IETF RFC 3862 [92]: common presence and instant messaging (CPIM): message format | 85 | 95 | o |
| 89 | IETF RFC 5438 [93]: instant message disposition notification | 86 | 96 | o |
| 90 | IETF RFC 5373 [94]: requesting answering modes for SIP (Answer-Mode and Priv-Answer-Mode header fields) | 87 | 97, 97A | o |
| 91 | Void | | | |
| 92 | IETF RFC 3959 [96]: the early session disposition type for SIP | 89 | 99 | o |
| 93 | IETF RFC 4244 [25]: delivery of Request-URI targets to user agents | 90 | 100 | n/a |
| 94 | draft-kaplan-dispatch-session-id-00 [124]: A Session Identifier for the Session Initiation Protocol (SIP) | 91 | 101 | o |

| | | | | |
|--|---|------|------|-------------------|
| 95 | IETF RFC 6026 [125]: correct transaction handling for 200 responses to Session Initiation Protocol INVITE requests | 92 | 102 | m |
| 96 | IETF RFC 5658 [126]: addressing Record-Route issues in the Session Initiation Protocol (SIP) | 93 | 103 | o |
| 97 | IETF RFC 5954 [127]: essential correction for IPv6 ABNF and URI comparison in IETF RFC 3261 [13] | 94 | 104 | m |
| 98 | IETF RFC 4488 [135]: suppression of session initiation protocol REFER method implicit subscription | 95 | 105 | m if 19, else n/a |
| 99 | draft-ietf-salud-alert-info-urns [136]: Alert-Info URNs for the Session Initiation Protocol | 96 | 106 | o |
| 100 | Subclause 3.1 of 3GPP TS 24.229: multiple registrations | 97 | 107 | c2 |
| 101 | IETF RFC 5318 [141]: the SIP P-Refused-URI-List private-header | 98 | 108 | c5 |
| 102 | IETF RFC 4538 [140]: request authorization through dialog Identification in the session initiation protocol (Target-Dialog header field) | 99 | 109 | o |
| 103 | draft-ietf-sipcore-proxy-feature [143]: Mechanism to indicate support of features and capabilities in the Session Initiation Protocol (SIP) | 100 | 110 | o |
| 104 | IETF RFC 6140: registration of bulk number contacts | 101 | 111 | c2 |
| 105 | IETF RFC 6230: media control channel framework | 102 | 112 | o |
| 106 | RFC 6357 [164] SIP overload control | 104 | 114 | o |
| 107 | draft-ietf-soc-overload-control [165] feedback control | 104A | 114A | o |
| 108 | draft-ietf-soc-load-control-event-package [167] distribution of load filters | 104B | 114B | n/a |
| c1: m in case of roaming II-NNI, else o c2: m in case of roaming II-NNI, else n/a c3: o in case of roaming II-NNI, else n/a c4: m in case of trust relationship between the interconnected networks, else n/a c5: o in case of non-roaming II-NNI and loopback traversal scenario, else n/a NOTE 1: The item numbering corresponds to the one provided in table A.4 in [5]. NOTE 2: The item numbering corresponds to the one provided in table A.162 in [5]. NOTE 3: A common URI namespace is required to apply this feature on the II-NNI. | | | | |

Table 6.1.3.2: Key to notation codes for major capabilities

| Notation code | Notation name | Explanation |
|----------------|----------------|---|
| m | mandatory | The capability shall be supported at II-NNI. SIP message relating to this capability shall be sent over the II-NNI if received from the serving network, unless they also make use of other unsupported capabilities. SIP headers or other information elements relating to this capability shall be passed over the II-NNI if received from the sending side. This does not imply that network elements inside the serving network or served network or user equipment connected to these networks shall support this capability. |
| o | optional | The capability may or may not be supported at II-NNI. The support of the capability is provided based on bilateral agreement between the operators. |
| n/a | not applicable | It is impossible to use/support the capability at the II-NNI. |
| c <integer> | conditional | The support of the capability ("m", "o" or "n/a") depends on the support of other optional or conditional items. <integer> is the identifier of the conditional expression. |

6.1.4 SIP message bodies

The MIME type "application/sdp" and multipart message bodies shall be supported over the II-NNI. Other MIME types may be supported over the II-NNI based on agreement between operators.

NOTE 1: Some MIME types in SIP requests and responses are listed in annex A of 3GPP TS 24.229 [5].

NOTE 2: The multipart message bodies are used for carrying two or more message body types as described in IETF RFC 5621 [89].

NOTE 3: The IBCF can provide the capabilities to examine the length of a SIP message body and take an appropriate action (e.g. reject the request, remove the body) as specified in subclause 5.10.6.3 of 3GPP TS 24.229 [5].

Table 6.1.3.2: List of MIME bodies

| Item | MIME body name | Used in |
|------|---|---|
| 1 | application/3gpp-ims+xml | 3GPP TS 24.229 [5] |
| 2 | application/comm-div-info+xml | subclause 12.6 |
| 3 | message/cpim | 3GPP TS 24.229 [5] |
| 4 | message/imdn+xml | 3GPP TS 24.229 [5] |
| 5 | application/im-iscomposing+xml | subclause 16.2 |
| 6 | multipart/mixed | subclause 15.1, subclause 15.4, subclause 15.6.2, subclause 15.6.3, subclause 15.6.4, subclause 18.3.3 |
| 7 | multipart/related | subclause 15.1, subclause 15.2, subclause 15.6.5 |
| 8 | application/pidf+xml | subclause 15.1 |
| 9 | application/pidf-diff+xml | subclause 15.1 |
| 10 | application/resource-lists+xml | subclause 12.19, subclause 15.1, subclause 15.6.3, subclause 16.5 |
| 11 | application/rlmi+xml | subclause 15.2, subclause 15.6.5 |
| 12 | application/sdp | 3GPP TS 24.229 [5] |
| 13 | application/simple-filter+xml | subclause 15.1, subclause 15.6.4 |
| 14 | application/simple-message-summary+xml | subclause 12.9 |
| 15 | message/sipfrag | subclause 12.13, subclause 18.2, subclause 18.3.1 |
| 16 | application/vnd.3gpp.access-transfer-events+xml | subclause 14.5.3 |
| 17 | application/vnd.3gpp.cw+xml | subclause 12.7 |
| 18 | application/vnd.3gpp.iut+xml | subclause 18.3.2, subclause 18.3.3 |
| 19 | application/vnd.3gpp.mid-call+xml | subclause 14.4 |
| 20 | application/vnd.3gpp.replication+xml | subclause 18.4.1, subclause 18.4.2 |
| 21 | application/vnd.3gpp.sms | 3GPP TS 24.229 [5] |
| 22 | application/vnd.3gpp.srvcc-ext+xml | subclause 14.5.1 |
| 23 | application/vnd.3gpp.srvcc-info+xml | subclause 14.2.3 |
| 24 | application/vnd.3gpp.state-and-event-info+xml | subclause 14.2.2, subclause 14.4 |
| 25 | application/vnd.3gpp.ussd | subclause 12.x |
| 26 | application/vnd.etsi.aoc+xml | subclause 12.22 |
| 27 | application/vnd.etsi.cug+xml | subclause 12.16 |
| 28 | application/vnd.etsi.mcid+xml | subclause 12.2 |
| 29 | application/vnd.etsi.pstn+xml | 3GPP TS 24.229 [5] |
| 30 | application/vnd.oma.suppnot+xml | subclause 15.6.2, subclause 15.6.3 |
| 31 | application/watcherinfo+xml | subclause 15.3 |
| 32 | application/xcap-diff+xml | subclause 15.4, subclause 15.6.5 |
| 33 | application/x-session-info | 3GPP TS 24.229 [5] |

6.2 Control Plane Transport

6.2.1 General

The control plane transport of the II-NNI shall comply with subclause 4.2A of 3GPP TS 24.229 [5].

Support of SCTP as specified in IETF RFC 4168 [27] is optional for an IBCF connected by II-NNI. Nevertheless this option is favourable if the operators would like to improve reliability over the ICI.

6.3 SIP timers

Table 6.3.1 shows values of SIP timers that should be supported at II-NNI. It contains the following items:

- the first column, titled "SIP Timer", shows the timer names as defined in IETF RFC 3261 [13];
- the second column reflects the timer meaning as defined in IETF RFC 3261 [13];
- the third column reflects the reference to the proper section in the IETF RFC 3261 [13] and in 3GPP TS 24.229 [5] and
- the final column lists the values recommended for the functional entities closest to the border of an II-NNI (see reference model in clause 5).

Table 6.3.1 reports information from 3GPP TS 24.229 [5], table 7.7.1. Values between IM CN subsystem elements shown in the second column in 3GPP TS 24.229 [5], table 7.7.1 are applicable for the II-NNI and are reported in the fourth column of table 6.3.1. If there are any differences between table 6.3.1 and 3GPP TS 24.229 [5], table 7.7.1, the information within 3GPP TS 24.229 [5], table 7.7.1 is applicable.

Table 6.3.1: SIP timers at II-NNI

| SIP Timer | Meaning | Reference | Recommended values |
|-----------|--|--|-----------------------------|
| T1 | RTT estimate | [13] subclause 17.1.1.1 [5] table 7.7.1 | 500ms default (see NOTE) |
| T2 | The maximum retransmit interval for non-INVITE requests and INVITE responses | [13] subclause 17.1.2.2 [5] table 7.7.1 | 4s (see NOTE) |
| T4 | Maximum duration a message will remain in the network | [13] subclause 17.1.2.2 [5] table 7.7.1 | 5s (see NOTE) |
| Timer A | INVITE request retransmit interval, for UDP only | [13] subclause 17.1.1.2 [5] table 7.7.1 | initially T1 |
| Timer B | INVITE transaction timeout timer | [13] subclause 17.1.1.2 [5] table 7.7.1 | 64*T1 |
| Timer C | proxy INVITE transaction timeout | [13] subclause 16.6 [5] table 7.7.1 | > 3min |
| Timer D | Wait time for response retransmits | [13] subclause 17.1.1.2 [5] table 7.7.1 | > 32s for UDP |
| | | [13] subclause 17.1.1.2 [5] table 7.7.1 | 0s for TCP/SCTP |
| Timer E | non-INVITE request retransmit interval, UDP only | [13] subclause 17.1.2.2 [5] table 7.7.1 | initially T1 |
| Timer F | non-INVITE transaction timeout timer | [13] subclause 17.1.2.2 [5] table 7.7.1 | 64*T1 |
| Timer G | INVITE response retransmit interval | [13] subclause 17.2.1 [5] table 7.7.1 | initially T1 |
| Timer H | Wait time for ACK receipt. | [13] subclause 17.2.1 [5] table 7.7.1 | 64*T1 |
| Timer I | Wait time for ACK retransmits | [13] subclause 17.2.1 [5] table 7.7.1 | T4 for UDP |
| | | [13] subclause 17.2.1 [5] table 7.7.1 | 0s for TCP/SCTP |
| Timer J | Wait time for non-INVITE request retransmits | [13] subclause 17.2.2 [5] table 7.7.1 | 64*T1 for UDP |
| | | [13] subclause 17.2.2 [5] table 7.7.1 | 0s for TCP/SCTP |
| Timer K | Wait time for response retransmits | [13] subclause 17.1.2.2 [5] table 7.7.1 | T4 for UDP |
| | | [13] subclause 17.1.2.2 [5] table 7.7.1 | 0s for TCP/SCTP |
| NOTE: | As a network option, SIP T1 Timer's value can be extended, along with the necessary modifications of T2 and T4 Timers' values, to take into account the specificities of the supported services when the MRFC and the controlling AS are under the control of the same operator and the controlling AS knows, based on local configuration, that the MRFC implements a longer value of SIP T1 Timer. | | |

7 User plane Interconnection

7.1 Media and Codec

For "end-to-end" media session involving the II-NNI, the SIP/SDP codec negotiation procedure can be applied between IM CN subsystems using different media codecs. It is possible that the end-to-end codec negotiation could fail because no common codec could be supported by the UEs, in particular for voice services.

To enhance interoperability, the IBCF, the MRFC, or other IMS network entities can interfere with the end-to-end codec negotiation to offer additional codec(s) available via transcoding, or to remove codecs. The IBCF can configure an attached TrGW to transcode, and the MRFC can configure an attached MRFP to transcode.

Codecs applicable at the II-NNI may be a subject of interworking agreements.

NOTE 1: Possible codecs which could be used at the II-NNI are described in 3GPP TS 26.114 [11] and ETSI TS 181 005 [12].

NOTE 2: As described in 3GPP TS 24.229 [5], the IETF RFC 4733 [157] is used to encode DTMF events and a payload type number associated with the MIME subtype "telephone-event" is included in a SDP message.

However, to avoid that transcoding is performed several times, applicable codecs at the II-NNI should be restricted as little as possible.

NOTE 3: Transcoding can be performed in an IMS network serving an SDP offerer or in an IMS network serving an SDP answerer. To avoid that transcoding is performed multiple times, inter-operator agreements can clarify if it is preferred that IMS network serving an SDP offerer or IMS network serving an SDP answerer modify an SDP offer to offer transcoding.

If the IBCF performs media transcoding control, the IBCF shall apply the related procedures in 3GPP TS 24.229 [5].

7.2 User Plane Transport

The user plane transport of the II-NNI may use the protocols listed in table 7.2.1. Protocols that use UDP, RTP or TCP as the underlying transport protocol may be used based on agreements between operators. The used protocols to transport media are negotiated by means of SDP offer/answer.

Table 7.2.1: Supported transport-level RFCs to be described in SIP/SDP messages

| Item | RFC | Title | Support |
|------|---------------------|--|-------------------|
| 1 | IETF RFC 3550 [151] | RTP: A Transport Protocol for Real-Time Applications | Mandatory |
| 2 | IETF RFC 768 [152] | User Datagram Protocol | Mandatory |
| 3 | IETF RFC 3551 [153] | RTP Profile for Audio and Video Conferences with Minimal Control | Mandatory |
| 4 | IETF RFC 3556 [154] | Session Description Protocol (SDP) Bandwidth Modifiers for RTP Control Protocol (RTCP) Bandwidth | Mandatory |
| 5 | IETF RFC 4585 [155] | Extended RTP Profile for Real-time Transport Control Protocol (RTCP) - Based Feedback (RTP/AVPF) | Optional (NOTE 1) |
| 6 | IETF RFC 793 [156] | Transmission Control Protocol | Optional (NOTE 2) |

NOTE 1: used by MTSI, as indicated in 3GPP TS 26.114 [11].
NOTE 2: used for MSRP service.

8 Numbering, Naming and Addressing

8.1 Numbering, Naming and Addressing for SIP message

The following URI formats in SIP messages may be applied at the ICI as standardized in 3GPP TS 24.229 [5]:

- SIP URI defined in IETF RFC 3261 [13];
- tel URI defined in IETF RFC 3966 [14];
- IM URI defined in IETF RFC 3860 [15];
- PRES URI defined in IETF RFC 3859 [16].

According to 3GPP TS 24.229 [5], the IBCF acting as an exit or entry point in the IMS network supports these URI formats. These URI formats shall be supported at the roaming II-NNI. The SIP URI format shall be supported at the non-roaming II-NNI and for the loopback traversal scenario. The tel URI, IM URI and PRES URI formats may be supported at the non-roaming II-NNI and for the loopback traversal scenario based on agreement between operators. Other URI formats may be supported over the II-NNI depending on the operator agreements.

A global number as defined in IETF RFC 3966 [14] shall be used in a tel URI or in the user portion of a SIP URI with the user=phone parameter when conveyed via a non-roaming II-NNI or for the loopback traversal scenario in the Request-URI and in the P-Asserted-Identity header field, except when agreement exists between the operators to also allow other kinds of numbers.

NOTE 1: In a SIP URI the user portion of the Request-URI represents a telephone number only if the SIP URI includes the user=phone parameter.

NOTE 2: Agreements can exist between operators to allow non-global number (e.g. national service numbers, business trunking numbers, or private numbers) at a non-roaming II-NNI or for the loopback traversal scenario. A SIP URI with such a number, a user=phone parameter, and a phone-context parameter agreed between the operators can then be used.

NOTE 3: 3GPP TS 24.229 [5] allows to restrict the number within a SIP Request-URI with user=phone parameter at a non-roaming II-NNI or for the loopback traversal scenario to be a global number (i.e. E.164 in international format) via an appropriate Application Server. Suitable configuration by the operator is needed to achieve the desired modification of the format.

NOTE 4: The allowed phone number formats in the P-Asserted-Identity header field of a served user are configured by the operator. According to 3GPP TS 23.003 [35], international E.164 format is used within a P-Asserted-Identity header field.

NOTE 5: The global number format usage within a SIP Request-URI with the user=phone parameter at a non-roaming II-NNI or for the loopback traversal scenario allows the terminating network to find the called subscriber, via HSS interrogation, without any further number translation and thus improves the success of the interconnection between IMS operators.

The optional "oli" and "cpc" tel URI parameters associated with a tel URI or a SIP URI with user=phone are described in 3GPP TS 24.229 [5] and can be part of the P-Asserted-Identity header field. Depending on operator agreements, those URI parameters may be supported at the non-roaming II-NNI or for the loopback traversal scenario.

The "sos" SIP URI parameter associated with a URI in the Contact header field of a REGISTER request or 200 OK response to REGISTER request is described in 3GPP TS 24.229 [5]. The "sos" SIP URI parameter shall be supported at the roaming II-NNI.

The "sos" SIP URI parameter associated with the Request-URI for all dialogs and standalone SIP requests described in subclause 5.2.10.3 of 3GPP TS 24.229 [5] and shall be supported at the roaming II-NNI.

The "rn" and "npdi" number portability parameters for the tel URI and the SIP URI with user=phone as described within IETF RFC 4694 [75] can be part of the Request-URI. Depending on operator agreements these parameters may be exchanged over the non-roaming II-NNI or for the loopback traversal scenario.

NOTE 6: The "rn" and "npdi" parameters can be used to address the entry point of the terminating operator depending on national rules for number portability.

The "isub" tel URI parameter for the tel URI and the SIP URI with user=phone as described within IETF RFC 3966 [14] can be part of the Request-URI, To header field and P-Asserted-Identity header field. Depending on operator agreements, this URI parameter may be exchanged over the II-NNI.

8.2 Numbering, Naming and Addressing for SDP

The following URI format in the SDP exchange may be applied at the Ici as standardized in 3GPP TS 24.229 [5]:

- MSRP URI for a session of instant messages defined in IETF RFC 4975 [17].

This URI format shall be supported at the roaming II-NNI and may be supported at the non-roaming II-NNI and for the loopback traversal scenario based on agreement between operators. Other URI formats may be supported over the II-NNI depending on the operators' agreements.

9 IP Version

The network elements interconnected by means of the II-NNI may support IPv4 only, IPv6 only or both.

The support of one or both of the IP versions is an operator option and should be based on bilateral agreement.

In case IPv4 and IPv6 networks are interconnected, the involved IBCFs and TrGWs shall apply the IP version interworking procedures as indicated in 3GPP TS 29.162 [8].

10 Security

The supported security mechanisms for IP signalling transport over II-NNI interfaces are described in 3GPP TS 33.210 [10].

11 Charging

The accounting information to be supported over the Ici is described in 3GPP TS 32.260 [29]. It shall be configurable by the operator to use or not the accounting mechanisms provided by the IBCF.

12 Supplementary services associated with the IMS multimedia telephony communication service

12.1 General

In order to assure the end-to-end service interoperability through the Inter-IMS Network to Network Interface (II-NNI), the associated supplementary services of the multimedia telephony communication service may be supported on the II-NNI between the two IMS networks.

The MMTel communication service is identified by means of the media feature tag "g.3gpp.icsi-ref" (specified in 3GPP TS 24.229 [5] subclause 7.2A.8) or the feature capability indicator "g.3gpp.icsi-ref" (specified in 3GPP TS 24.229 [5] subclause 7.9A.2) set to "urn:urn-7:3gpp-service.ims.icsi.mmtel". The media feature tag can appear in the Contact header field, the Accept-Contact header field and the P-Asserted-Service header field and the feature capability indicator can appear in the Feature-Caps header field.

The support of each associated supplementary service is based on agreement between operators.

If a supplementary service is supported, the related procedures from the 3GPP TS 22.173 [30], the protocol details from the 3GPP TS 24.173 [31] and specifications referenced in the 3GPP TS 24.173 [31] shall be applied with the requirements in the relevant subclause below due to the crossing of the II-NNI.

A classification of the importance of supplementary services applicable over the II-NNI is available in the informative annex Db of 3GPP TS 22.173 [30].

NOTE: Agreeing on interworking of entire class of services according to this classification can simplify the cooperation between interconnecting networks but remains optional.

12.2 Malicious Communication IDentification (MCID)

Service specific requirements in accordance with 3GPP TS 24.616 [33] shall be supported over the II-NNI.

The P-Asserted-Identity header field shall be supported at the II-NNI.

The INFO request and the 200 (OK) response to the INFO request containing the "application/vnd.etsi.mcid+xml" MIME body defined in 3GPP TS 24.616 [33] may be supported at the II-NNI.

If a network terminating the dialog supports MCID, the terminating network shall only deliver the MCID request in the "application/vnd.etsi.mcid+xml" MIME body, as specified in the 3GPP TS 24.616 [33], if an agreement to use the MCID supplementary service according to the 3GPP TS 24.616 [33] exists with the network originating the dialog and if the INVITE request received by the terminating network does not contain the information of the originating party.

NOTE: The IBCF and the AS in the terminating network interact to deliver the MCID request only if an agreement to use the MCID supplementary service exists, as specified in 3GPP TS 24.616 [33] and 3GPP TS 24.229 [5].

The originating network and the terminating network shall have a bilateral agreement to support transportation of the minimum information specified in subclause 4.5.2.5.0 of the 3GPP TS 24.616 [33] between the networks.

12.3 Originating Identification Presentation (OIP) and Originating Identification Restriction (OIR)

Service specific requirements in accordance with 3GPP TS 24.607 [32] shall be supported over the II-NNI.

The P-Asserted-Identity header field and the Privacy header field with values "id", "user", "none", "header" and "critical" shall be supported at the II-NNI.

NOTE 1: P-Asserted-Identity header fields are intended for end-to-end operation. Removal of such header fields will impact the intended end-to-end operation between the end users. Where a trust relationship exists on the P-Asserted-Identity header field between the two IMS networks, this header field cannot be altered when passing through the II-NNI according to 3GPP TS 24.229 [5]. Where no trust relationship exists on the P-Asserted-Identity header field between the two IMS networks, the IBCF determines whether to remove the P-Asserted-Identity header field according to procedures described in 3GPP TS 24.229 [5] subclause 4.4.2 referencing IETF RFC 3325 [44] and local policy rules for using additional screening capabilities as defined in 3GPP TS 24.229 [5] subclause 5.10.6.

NOTE 2: Where a trust relationship exists with the remote domain the From header field will be passed transparently by the IBCF. If a request is received by the terminating network and the application of the OIR service is required with the value "user" for the Privacy header field then the From header field will be anonymised in accordance with IETF RFC 3323 [34] by the terminating network. Where no trust relationship exists with the remote domain, the From header field can be, based on local policy rules, anonymised by the IBCF of the originating network prior passing through the II-NNI using screening capabilities defined in 3GPP TS 24.229 [5] subclause 5.10.6 and subclause 5.10.8.

SIP based user configuration as described in 3GPP TS 24.238 [100] shall be supported at the roaming II-NNI.

12.4 Terminating Identification Presentation (TIP) and Terminating Identification Restriction (TIR)

Service specific requirements in accordance with 3GPP TS 24.608 [113] shall be supported over the II-NNI.

The P-Asserted-Identity header field and the Privacy header field with values "id", "user", "none", "header" and "critical" shall be supported at the II-NNI.

NOTE: P-Asserted-Identity header fields are intended for end-to-end operation. Removal of such header fields will impact the intended end-to-end operation between the end users. Where a trust relationship exists on the P-Asserted-Identity header field between the two IMS networks, this header field will be passed transparently through the II-NNI according to 3GPP TS 24.229 [5]. Where no trust relationship exists on the P-Asserted-Identity header field between the two IMS networks, the IBCF determines whether to remove the P-Asserted-Identity header field according to procedures described in 3GPP TS 24.229 [5] clause 4.4.2, referencing IETF RFC 3325 [44] and local policy rules for using additional screening capabilities as defined in 3GPP TS 24.229 [5] subclause 5.10.6.

The option tag "from-change" defined in IETF RFC 4916 [158], in the Supported header field should be supported at II-NNI.

12.5 Anonymous Communication Rejection (ACR)

Service specific requirements in accordance with 3GPP TS 24.611 [114] shall be supported over the II-NNI.

The P-Asserted-Identity header field and the Privacy header field shall be supported at the II-NNI.

Procedures as described in subclause 12.21.2 are used to provide announcements.

The response code 433 (Anonymity Disallowed) shall be supported at the II-NNI.

SIP based user configuration as described in 3GPP TS 24.238 [100] shall be supported at the roaming II-NNI.

12.6 Communication DIVersion (CDIV)

Service specific requirements in accordance with 3GPP TS 24.604 [117] shall be supported over the II-NNI.

NOTE 1: The support of the Diversion header field not adopted in 3GPP TS 24.604 requires bilateral agreement between the operators.

Procedures as described in subclause 12.21.2 are used to provide announcements.

The Privacy header field with value "history" shall be supported at the II-NNI.

The History-Info header field as described by 3GPP TS 24.604 [117] and the Cause-Codes as defined by the IETF RFC 4458 [58] shall be supported over the II-NNI.

NOTE 2: The networks can have an internal limit in the number of allowed diversions, as described in 3GPP TS 24.604 [117], subclause 4.5.2.6.1. To ensure efficiency of this control operators can indicate in their bilateral agreements their own number of allowed communication diversions, the parameter that is used for counting, and the network behavior when the internal limit is reached.

The response code 181 (Call Is Being Forwarded) shall be supported at the II-NNI.

The SUBSCRIBE requests and the NOTIFY request with the event package name "comm-div-info" in the Event header field and the "application/comm-div-info+xml" MIME body as specified in IETF RFC 3265 [20] and 3GPP TS 24.229 [5] shall be supported at the roaming II-NNI if CDIVN is provided.

The MESSAGE request procedure as specified in IETF RFC 3428 [19] and 3GPP TS 24.229 [5] should be supported at the roaming II-NNI if CDIVN is provided.

NOTE 3: The content of the MESSAGE request is operator specific.

SIP based user configuration as described in 3GPP TS 24.238 [100] shall be supported at the roaming II-NNI.

NOTE 4: The CDIVN supplementary service does not apply at the roaming II-NNI between the MSC Server enhanced for ICS/MSC Server enhanced for SRVCC and the IMS network where the communication is anchored.

12.7 Communication Waiting (CW)

Service specific requirements in accordance with 3GPP TS 24.615 [37] shall be supported over the II-NNI.

The "application/vnd.3gpp.cw+xml" MIME body defined in 3GPP TS 24.615 [37] in the INVITE request shall be supported at the roaming II-NNI.

The Alert-Info header field set to "urn:alert:service:call-waiting" in a 180 (Ringing) response shall be supported at the II-NNI.

As a network option, in case of expiry of the CW timer, the response code 480 (Temporarily Unavailable) including a Reason header field set to cause 19 shall be supported at the non-roaming II-NNI and for the loopback traversal scenario.

Procedures as described in subclause 12.21.2 are used to provide announcements.

12.8 Communication HOLD (HOLD)

Service specific requirements in accordance with 3GPP TS 24.610 [36] shall be supported over the II-NNI.

NOTE: The support of an alternative method not adopted in 3GPP TS 24.610 requires bilateral agreement between the operators and is outside the scope of the present document.

Procedures as described in subclause 12.21.3 are used to provide announcements.

12.9 Message Waiting Indication (MWI)

Service specific requirements in accordance with 3GPP TS 24.606 [112] shall be supported over the II-NNI.

The event package name "message-summary" in the Event header field according to IETF RFC 3265 [20] and 3GPP TS 24.229 [5] in the SUBSCRIBE request shall be supported at the roaming II-NNI.

The "application/simple-message-summary+xml" MIME body described in 3GPP TS 24.606 [112] in the NOTIFY request shall be supported at the roaming II-NNI.

12.10 Communication Barring (CB)

12.10.1 Incoming Communication Barring (ICB)

Service specific requirements in accordance with 3GPP TS 24.611 [114] shall be supported over the II-NNI.

Procedures as described in subclause 12.21.2 are used to provide announcements.

The response code 603 (Decline) including a Reason header field as described in 3GPP TS 24.611 [114] shall be supported at the II-NNI.

A Reason header field as described in 3GPP TS 24.611 [114] included in the BYE request shall be supported at the II-NNI.

SIP based user configuration as described in 3GPP TS 24.238 [100] shall be supported at the roaming II-NNI.

If the option IIFC (Inhibition of Incoming Forwarded Calls) is supported the transparency of information related to communication diversion (see subclause 12.6) shall be supported at II-NNI.

12.10.2 Outgoing Communication Barring (OCB)

Service specific requirements in accordance with 3GPP TS 24.611 [114] shall be supported over the II-NNI.

Procedures as described in subclause 12.21.2 are used to provide announcements.

The response code 603 (Decline) including a Reason header field as described in 3GPP TS 24.611 [114] shall be supported at the roaming II-NNI.

SIP based user configuration as described in 3GPP TS 24.238 [100] shall be supported at the roaming II-NNI.

12.11 Completion of Communications to Busy Subscriber (CCBS)

Service specific requirements in accordance with 3GPP TS 24.642 [109] shall be supported over the II-NNI.

The response code 486 (Busy Here) containing a Call-Info header field with a "purpose" header field parameter set to "call-completion" and the m parameter set to "BS" shall be supported at the non-roaming II-NNI and for the loopback traversal scenario.

For invoking and revoking of the CCBS supplementary service, announcement procedures shall be used to provide announcements and inband-interaction procedures as described in subclause 12.21.2 shall be supported at the roaming II-NNI.

The response code 199 (Early Dialog Terminated) shall be supported at the roaming II-NNI.

Basic call procedures and in case of a call-completion recall initiated by a REFER request, normal REFER method handling procedures according to 3GPP TS 24.229 [5] shall be supported at the roaming II-NNI.

As a network option the special REFER request handling procedures according to 3GPP TS 24.628 [38] should be supported at the roaming II-NNI.

NOTE 1: 3rd party call control procedures can be used when the REFER request is not supported at the II-NNI.

NOTE 2: A REFER request can be rejected by IBCF based on operator policy as specified by 3GPP TS 24.229 [5].

The SUBSCRIBE and NOTIFY methods according to IETF RFC 3265 [20] and 3GPP TS 24.229 [5] containing the event package name "call-completion" in the Event header field and the Call-Info header field with a purpose parameter set to 'call-completion' and the m parameter set to "BS" shall be supported at the non-roaming II-NNI and for the loopback traversal scenario.

The Request-URI with the "m" SIP URI parameter with a value set to "BS" and the Call-Info header field with a purpose parameter set to 'call-completion' and the "m" parameter set to "BS" in the INVITE method shall be supported at the non-roaming II-NNI and for the loopback traversal scenario.

The Date header field in the 486 (Busy Here) response to the INVITE request shall be supported at the roaming II-NNI.

SIP based user configuration as described in 3GPP TS 24.238 [100] shall be supported at the roaming II-NNI.

12.12 Completion of Communications by No Reply (CCNR)

Service specific requirements in accordance with 3GPP TS 24.642 [109] shall be supported over the II-NNI.

The response code 180 (Ringing) containing a Call-Info header field with a purpose parameter set to 'call-completion' and the m parameter set to "NR" shall be supported at the non-roaming II-NNI and for the loopback traversal scenario.

For invoking and revoking of the CCNR supplementary service, announcement procedures shall be used to provide announcements and inband-interaction procedures as described in subclause 12.21.2 shall be supported at the roaming II-NNI.

The response code 199 (Early Dialog Terminated) shall be supported at the roaming II-NNI.

Basic call procedures and in case of a call-completion recall initiated by a REFER request, normal REFER method handling procedures according to 3GPP TS 24.229 [5] shall be supported at the roaming II-NNI.

As a network option the special REFER request handling procedures according to 3GPP TS 24.628 [38] should be supported at the roaming II-NNI.

NOTE 1: 3rd party call control procedures can be used when the REFER request is not supported at the II-NNI.

NOTE 2: A REFER request can be rejected by IBCF based on operator policy as specified by 3GPP TS 24.229 [5].

The SUBSCRIBE and NOTIFY methods according to IETF RFC 3265 [20] and 3GPP TS 24.229 [5] containing the event package name "call-completion" in the Event header field and the Call-Info header field with a purpose parameter set to 'call-completion' and the m parameter set to "NR" shall be supported at the non-roaming II-NNI and for the loopback traversal scenario.

The Request-URI with the "m" SIP URI parameter with a value set to "NR" and the Call-Info header field with a purpose parameter set to 'call-completion' and the "m" parameter set to "NR" in the INVITE method shall be supported at the non-roaming II-NNI and for the loopback traversal scenario.

The Date header field in the 480 (Temporarily Unavailable) response to the INVITE request shall be supported at the roaming II-NNI.

SIP based user configuration as described in 3GPP TS 24.238 [100] shall be supported at the roaming II-NNI.

12.13 Explicit Communication Transfer (ECT)

Service specific requirements in accordance with 3GPP TS 24.629 [116] shall be supported over the II-NNI.

The REFER method, the Referred-By header field and the Replaces header field as specified in 3GPP TS 24.629 [116] and the NOTIFY method containing an "application/sipfrag" MIME body shall be supported at the II-NNI for call transfer without third party call control.

The REFER method, the Referred-By header field and the Replaces header field as specified in 3GPP TS 24.629 [116] and the NOTIFY method containing an "application/sipfrag" MIME body shall be supported at the roaming II-NNI for call transfer with third party call control.

The Refer-To URI header parameter in the REFER request containing the Require header field set to "replaces" shall be supported at the roaming II-NNI.

The Replaces header field in the INVITE request shall be supported at the non-roaming II-NNI and for the loopback traversal scenario.

12.14 Customized Alerting Tone (CAT)

Service specific requirements in accordance with 3GPP TS 24.182 [129] shall be supported over the II-NNI.

The P-Early-Media header field in as described in 3GPP TS 24.182 [129] shall be supported at the II-NNI.

The response code 183 (Session Progress) including a P-Early-Media header field shall be supported over the II-NNI.

The response code 199 (Early Dialog Terminated) shall be supported over the II-NNI.

The Supported header field and the Require header field with "early-session" option-tag may be supported at the II-NNI.

An "application/sdp" MIME body with the Content-Disposition set to "early-session" as specified in IETF RFC 3959 [96] may be supported at II-NNI.

The SIP INFO mechanism for DTMF transport, as defined in 3GPP TS 24.229 [5] may be supported at the II-NNI.

NOTE 1: For telephone-event based DTMF transport, the DTMF digits are sent as media and not visible in the control plane.

NOTE 2: Multiple methods for DTMF transport are defined in 3GPP TS 24.182 [129].

SIP based user configuration as described in 3GPP TS 24.238 [100] shall be supported at the roaming II-NNI.

12.15 Customized Ringing Signal (CRS)

Service specific requirements in accordance with 3GPP TS 24.183 [98] shall be supported over the II-NNI.

An Alert-Info header field in the initial INVITE request containing an URI followed by a URN "urn:alert:service:crs" shall be supported at the II-NNI.

A SDP "a=content" attribute with a "g.3gpp.crs" value in the PRACK request or the re-INVITE request may be supported at the II-NNI.

The Supported header field and the Require header field with "early-session" option-tag may be supported at the II-NNI.

An "application/sdp" MIME body with the Content-Disposition header field set to "early-session" as specified in IETF RFC 3959 [96] may be supported at II-NNI.

The SIP INFO mechanism for DTMF transport, as defined in 3GPP TS 24.229 [5] may be supported at the II-NNI.

NOTE: For telephone-event based DTMF transport, the DTMF digits are sent as media and not visible in the control plane.

SIP based user configuration as described in 3GPP TS 24.238 [100] shall be supported at the roaming II-NNI.

12.16 Closed User Group (CUG)

Service specific requirements in accordance with 3GPP TS 24.654 [103] shall be supported over the II-NNI.

The "application/vnd.etsi.cug+xml" MIME body as specified 3GPP TS 24.654 [103] shall be supported in INVITE requests at the II-NNI.

NOTE: If no agreement between the originating network and the terminating network exists to support the CUG supplementary service the INVITE request is rejected as described in IETF RFC 5621 [89] when the "handling" parameter in the Content-Disposition of the " application/vnd.etsi.cug+xml" MIME body is set to "required".

The 403 (Forbidden) response, the 603 (Decline) response and the 500 (Server Internal Error) response shall be supported at II-NNI.

SIP based user configuration as described in 3GPP TS 24.238 [100] shall be supported at the roaming II-NNI.

12.17 Personal Network Management (PNM)

Service specific requirements in accordance with 3GPP TS 24.259 [99] shall be supported over the II-NNI.

A g.3gpp.iari_ref feature tag with the value urn:urn-7:3gpp-application.ims.iari.pnm-controller in the Contact header field of the REGISTER request shall be supported at the roaming II-NNI.

A g.3gpp.iari_ref feature tag with the value urn:urn-7:3gpp-application.ims.iari.pnm-controller in the Accept-Contact header field shall be supported at the II-NNI.

The History-Info header field shall be supported at II-NNI.

A "histinfo" option tag as described by 3GPP TS 24.259 [99] in the Supported header field shall be supported at II-NNI.

12.18 Three-Party (3PTY)

Service specific requirements in accordance with 3GPP TS 24.605 [105] shall be supported over the II-NNI.

NOTE 1: The requirements below can be relaxed by bilateral agreements between operators.

The requirements for the 3PTY supplementary service are the same as for the CONF supplementary service specified in subclause 12.19 with the following additional requirement:

- If a REFER request is supported at the II-NNI, a Replaces header field in the header portion of the SIP URI of the Refer-to header field of the REFER request shall also be supported at II-NNI.

NOTE 2: Subclause 12.19 describes the conditions for the support of the REFER request.

12.19 Conference (CONF)

Service specific requirements in accordance with 3GPP TS 24.605 [105] shall be supported over the II-NNI.

NOTE 1: The requirements below can be relaxed by bilateral agreements between operators.

The REFER request shall be supported at the roaming II-NNI in the direction from visited to home network. Based on inter-operator agreement, the REFER request may be supported at the non-roaming II-NNI, at for the loopback traversal scenario, and at the roaming II-NNI in the direction from home network to visited network.

NOTE 2: If the REFER request is not supported at the non-roaming II-NNI, at for the loopback traversal scenario, or at the roaming II-NNI in the direction from home network to visited network, an attempt of an UE to send the REFER directly to peers to invite them to a conference without involvement of the conference focus can fail over such an II-NNI. However such failures can also occur if a peer is located in a circuit switched network, or if a peer does not support the REFER method. An operator can avoid such failures by configuring an AS to convert the REFER to an INVITE, as detailed in 3GPP TS 24.628 [38]. Information on security risks associated with the REFER request is provided within the "security consideration" of IETF RFC 3515 [22].

NOTE 3: A REFER request can be rejected by IBCF based on operator policy as specified by 3GPP TS 24.229 [5].

The application/resource-lists+xml MIME body shall be supported at the roaming II-NNI.

The Referred-By header field in the INVITE request shall be supported at the II-NNI.

The "isfocus" feature parameter indicated in Contact header field of the INVITE request and in the 200 (OK) response shall be supported at the II-NNI.

The SUBSCRIBE request including the "conference" event package name in the Event header field and the NOTIFY request procedures according to 3GPP TS 24.147 [106] shall be supported at the II-NNI.

NOTE 4: The subscription to "conference event" package does not apply at the roaming II-NNI between the MSC Server enhanced for ICS/MSC Server enhanced for SRVCC and the IMS network where the communication is anchored.

The Allow-Events header field with the value "conference" shall be supported at the roaming II-NNI and may be supported at the non-roaming II-NNI and for the loopback traversal scenario.

12.20 Flexible Alerting (FA)

Service specific requirements in accordance with 3GPP TS 24.239 [101] shall be supported over the II-NNI.

The 486 (Busy Here) response code shall be supported at the II-NNI.

SIP based user configuration as described in 3GPP TS 24.238 [100] shall be supported at the roaming II-NNI.

12.21 Announcements

12.21.1 General

Announcements may be provided during the establishment of a communication session or during an established communication session. Both of them shall be managed over the II-NNI.

12.21.2 Providing announcements during the establishment of a communication session

Procedures as described in 3GPP TS 24.628 [38] are used to provide announcements.

The P-Early-Media header field authorizing early media as defined in IETF RFC 5009 [74] during the establishment of a communication shall be supported at the II-NNI.

The Alert-Info header field in the 180 (Ringing) response to the INVITE request during the establishment of a communication, should be supported at the II-NNI.

NOTE: The IBCF can decide to remove the Alert-Info header field if required by local policy.

12.21.3 Providing announcements during an established communication session

Procedures as described in 3GPP TS 24.628 [38] are used to provide announcements.

In case of provision of an announcement to a user over the II-NNI during an established communication, the Call-Info header field in a re-INVITE request should be supported at the II-NNI.

NOTE 1: An alternative method to provide announcements is to use the existing media stream.

NOTE 2: The IBCF can decide to remove the Call-Info header field if required by local policy.

12.21.4 Providing announcements when communication request is rejected

Procedures as described in 3GPP TS 24.628 [38] are used to provide announcements when a communication request is rejected.

There are three methods defined in 3GPP TS 24.628 [38] to provide the announcement:

- 1) sending an announcement as an early media;
- 2) return an Error-Info header field; and
- 3) accept the communication request and then provide the announcement.

NOTE 1: The II-NNI requirements for accepting the communication request and then provide the announcement is not within the scope of this subclause.

The P-Early-Media header field authorizing early media as defined in IETF RFC 5009 [74] and the Reason header field with the proper cause value shall be supported at the II-NNI.

NOTE 2: There are 2 methods to use early media for sending the announcement in-band. First method is the gateway model defined by IETF RFC 3960 [150], second method is described in 3GPP TS 24.628 [38] annex D.

The Error-Info header field in the 3xx, 4xx, 5xx or 6xx response to the INVITE request when rejecting the communication request, should be supported at the II-NNI.

NOTE 3: The IBCF can decide to remove the Error-Info header field if required by local policy.

12.22 Advice of Charge (AOC)

Service specific requirements in accordance with 3GPP TS 24.647 [122] shall be supported over the II-NNI.

The Accept header field with "application/vnd.etsi.aoc+xml" shall be supported at the roaming II-NNI.

The INVITE method containing an "application/vnd.etsi.aoc+xml" MIME body shall be supported at the roaming II-NNI.

1xx provisional responses and the 200 (OK) response to the initial INVITE request containing an "application/vnd.etsi.aoc+xml" MIME body shall be supported at the roaming II-NNI.

The INFO method containing an application/vnd.etsi.aoc+xml MIME body shall be supported at the roaming II-NNI.

The response code 504 (Server Time-out) shall be supported at the II-NNI.

A Reason header field with a reason value with the protocol set to "SIP" and the cause set to "504" and a reason value with the protocol set to "Q.850" and the cause set to "31" in the BYE method shall be supported at the II-NNI.

An "application/vnd.etsi.aoc+xml" MIME body in the BYE request or the final response to the BYE request shall be supported over the roaming II-NNI.

12.23 Completion of Communications on Not Logged-in (CCNL)

Service specific requirements in accordance with 3GPP TS 24.642 [109] shall be supported over the II-NNI.

The response code 480 (Temporarily unavailable) containing a Call-Info header field with a purpose parameter set to 'call-completion' and the m parameter set to "NL" shall be supported at the non-roaming II-NNI and for the loopback traversal scenario.

For invoking and revoking of the CCNL supplementary service, announcement procedures shall be used to provide announcements and inband-interaction procedures as described in subclause 12.21.2 shall be supported at the roaming II-NNI.

The response code 199 (Early Dialog Terminated) shall be supported at the roaming II-NNI.

Basic call procedures and in case of a call-completion recall initiated by a REFER request, normal REFER method handling procedures according to 3GPP TS 24.229 [5] shall be supported at the roaming II-NNI.

As a network option the special REFER request handling procedures according to 3GPP TS 24.628 [38] should be supported at the roaming II-NNI.

NOTE: 3rd party call control procedures can be used when the REFER request is not supported at the II-NNI.

The SUBSCRIBE and NOTIFY methods according to IETF RFC 3265 [20] and 3GPP TS 24.229 [5] containing the event package name "call-completion" in the Event header field and the Call-Info header field with a purpose parameter set to 'call-completion' and the m parameter set to "NL" shall be supported at the non-roaming II-NNI and for the loopback traversal scenario.

The Request-URI with the "m" SIP URI parameter with a value set to "NL" and the Call-Info header field with a purpose parameter set to 'call-completion' and the "m" parameter set to "NL" in the INVITE method shall be supported at the non-roaming II-NNI and for the loopback traversal scenario.

The Date header field in the 480 (Temporarily Unavailable) response to the INVITE request shall be supported at the roaming II-NNI.

SIP based user configuration as described in 3GPP TS 24.238 [100] shall be supported at the roaming II-NNI.

12.24 Unstructured Supplementary Service Data (USSD)

Service specific requirements in accordance with 3GPP TS 24.390 [163] shall be supported over the II-NNI.

The Recv-Info header field containing the "g.3gpp.ussd" info package name and the "application/vnd.3gpp.ussd" MIME body as described in annex B of 3GPP TS 24.390 [163] in the INVITE request shall be supported at the roaming II-NNI.

The Recv-Info header field containing the "g.3gpp.ussd" info package name in the 200 (OK) response to the INVITE request shall be supported at the roaming II-NNI.

The INFO request containing "application/vnd.3gpp.ussd" MIME body and the Info-Package header field containing the "g.3gpp.ussd" info package name shall be supported at the roaming II-NNI.

The "application/vnd.3gpp.ussd" MIME body in the BYE request shall be supported at the roaming II-NNI.

13 Interoperability of IMS Centralized Services (ICS) over II-NNI

13.1 General

In order to assure the end-to-end service interoperability through the Inter-IMS Network to Network Interface (II-NNI), the associated service of the IMS Centralized Services (ICS) may be supported on the II-NNI between two IMS networks. The support of ICS is based on agreement between operators.

If ICS is supported, the related procedures from the 3GPP TS 24.292 [121] and 3GPP TS 29.292 [130] shall be applied with the requirements in the subclause 13.2 due to the crossing of the II-NNI.

13.2 IMS Centralized Services (ICS)

Service specific requirements in accordance with 3GPP TS 24.292 [121] and 3GPP TS 29.292 [130] shall be supported over the II-NNI.

The "g.3gpp.ics" media feature tag in the Contact header field as specified in subclause annex B of 3GPP TS 24.292 [121] shall be supported at the roaming II-NNI.

The "g.3gpp.accesstype" media feature tag in the Contact header field as specified in subclause annex B of 3GPP TS 24.292 [121] shall be supported at the roaming II-NNI.

An Accept-Contact header field and a Reject-Contact header field including the media feature tag "g.3gpp.accesstype" and the media feature tag "g.3gpp.ics" in any combination in the INVITE request shall be supported at the roaming II-NNI.

The Target-Dialog header field in the INVITE request shall be supported at the roaming II-NNI.

The P-Early-Media header field from the MSC Server shall be supported on the roaming II-NNI.

The Reason header field with Q.850 cause values in the CANCEL request, the BYE request and in 4xx responses and 6xx responses to the INVITE request shall be supported at the roaming II-NNI.

Procedures as described in subclause 14.4 are used to provide MSC server assisted mid-call features.

14 Interoperability of IMS Service Continuity over II-NNI

14.1 General

In order to assure the end-to-end service interoperability through the Inter-IMS Network to Network Interface (II-NNI), the associated services of the IMS Service Continuity may be supported on the II-NNI between two IMS networks. The support of each service is based on agreement between operators.

If a service is supported, the related procedures from the 3GPP TS 24.237 [131] shall be applied with the requirements in the relevant subclause below due to the crossing of the II-NNI.

14.2 PS to CS Single Radio Voice Call Continuity (SRVCC) and Single Radio Video Call Continuity (vSRVCC)

14.2.1 Basic PS to CS SRVCC

Service specific requirements in accordance with 3GPP TS 24.237 [131] shall be supported over the roaming II-NNI.

Media type "video" in SDP m-lines may be supported at the roaming II-NNI. Related SDP can appear in SDP offer answer exchanges within SIP INVITE dialogues at the roaming II-NNI, and in responses to SIP OPTIONS requests at the roaming II-NNI. If media type "video" is supported within SIP INVITE dialogues at the roaming II-NNI, it shall also be supported within responses to SIP OPTIONS requests at the roaming II-NNI.

The "+g.3gpp.srvcc" header field parameter (specified in 3GPP TS 24.237 [131] annex C) in the Feature-Caps header field of the INVITE request and of 1xx or 2xx responses should be supported at the roaming II-NNI.

The Reason header field containing protocol "SIP" and reason parameter "cause" with value "487" in the re-INVITE request shall be supported at the roaming II-NNI.

The Reason header field containing a SIP 503 (Service Unavailable) response in the SIP BYE request shall be supported at the roaming II-NNI.

Procedures as described in subclause 14.4 are used to provide MSC server assisted mid-call features.

14.2.2 PS to CS SRVCC for calls in alerting phase

The requirements for the PS to CS transfer for alerting calls are the same as in subclause 14. 2.1 with the following additional requirement:

The "g.3gpp.srvcc-alerting" media feature tag (described in 3GPP TS 24.237 [131] annex C) in a Contact header field of the INVITE request and of the 180 (Ringing) response shall be supported at the roaming II-NNI.

The "+g.3gpp.srvcc-alerting" header field parameter (described in 3GPP TS 24.237 [131] annex C) included in a Feature-Caps header field as described in draft-ietf-sipcore-proxy-feature [143] of a SIP INVITE request or 180 (Ringing) response shall be supported at the roaming II-NNI.

The Target-Dialog header field in the INVITE request shall be supported at the roaming II-NNI.

An INFO request containing the Info-Package header field as specified in IETF RFC 6086 [39] with "3gpp.state-and-event" info package name and an "application/vnd.3gpp.state-and-event-info+xml" XML body shall be supported at the roaming II-NNI.

14.2.3 Using the ATCF based architecture

The requirements for the ATCF based architecture is the same as in subclause 14.2.1 with the following additional requirement:

The "+g.3gpp.atcf", the "+g.3gpp.atcf-mgmt-uri" and the "+g.3gpp.atcf-path" header field parameters (specified in 3GPP TS 24.237 [131] annex C) in the Feature-Caps header field of the REGISTER request as described in draft-ietf-sipcore-proxy-feature [143] shall be supported at the roaming II-NNI.

A MESSAGE request containing the "application/vnd.3gpp.srvcc-info+xml" MIME body as defined in annex D of 3GPP TS 24.237 [131] shall be supported at the roaming II-NNI.

The Target-Dialog header field in the INVITE request shall be supported at the roaming II-NNI.

14.3 Inter UE Transfer (IUT)

IUT is described in clause 18.

14.4 PS to CS SRVCC with the MSC server assisted mid-call feature

The requirements for the PS to CS SRVCC with the MSC server assisted mid-call feature are the same as in subclause 14.2.1 with the following additional requirement:

The Contact header field of the REGISTER request and the 200 (OK) response containing "g.3gpp.mid-call" media feature tag as described in annex C of 3GPP 24.237 [131] shall be supported at the roaming II-NNI.

The Feature-Cap header field of the REGISTER request and the 200 (OK) response containing "+g.3gpp.mid-call" header field parameter specified in annex C of 3GPP TS 24.237 [131] shall be supported at the roaming II-NNI.

The media feature tag "g.3gpp.accesstype" in the Contact header field of the REGISTER request shall be supported at roaming II-NNI.

A Contact header field of the INVITE request and the 200 (OK) response containing "g.3gpp.mid-call" media feature tag as described in annex C of 3GPP 24.237 [131] shall be supported at the roaming II-NNI.

The Recv-Info header field containing the "g.3gpp.mid-call" package name in the INVITE request as specified in annex D of 3GPP 24.237 [131] shall be supported at the roaming II-NNI.

An Accept header field in the INVITE request containing the MIME type "application/vnd.3gpp.mid-call+xml" as specified in subclause D.1 of 3GPP TS 24.237 [131] shall be supported at the roaming II-NNI.

The "application/vnd.3gpp.mid-call+xml" MIME body described in subclause D.1.3 of 3GPP TS 24.237 [131] in the INVITE request shall be supported at the roaming II-NNI.

The SUBSCRIBE request containing a "g.3gpp.mid-call" media feature tag in the Contact header field shall be supported at the roaming II-NNI.

NOTE 2: The "g.3gpp.mid-call" media feature tag in the Contact header field of the SUBSCRIBE request may appear if the CONF supplementary service is supported at roaming II-NNI as described in subclause 12.9.

An INFO request containing the Info-Package header field as specified in IETF RFC 6086 [39] with "3gpp.state-and-event" info package name and an "application/vnd.3gpp.state-and-event-info+xml" XML body shall be supported at the roaming II-NNI.

A REFER request sent inside an existing SIP dialog containing the "application/vnd.3gpp.mid-call+xml" MIME body specified in the subclause D.1.3 of 3GPP TS 24.237 [131] shall be supported at the roaming II-NNI.

The Contact header field of the REFER request and 2xx response to the request containing "g.3gpp.mid-call" media feature tag as described in annex C of 3GPP 24.237 [131] shall be supported at the roaming II-NNI.

The Target-Dialog header field in the INVITE request shall be supported at the roaming II-NNI.

The communication HOLD supplementary service as specified in subclause 12.8 for the roaming II-NNI shall be supported.

14.5 CS to PS Single Radio Voice Call Continuity (SRVCC)

14.5.1 Basic CS to PS SRVCC

Service specific requirements in accordance with 3GPP TS 24.237 [131] shall be supported over the roaming II-NNI.

Requirements for the ATCF based architecture at II-NNI as described in subclause 14.4 shall be supported at the roaming II-NNI.

Requirements for IMS Centralized Services (ICS) at II-NNI as described in clause 13 shall be supported at the roaming II-NNI.

The g.3gpp.cs2ps-srvcc and "g.3gpp.path" media feature tags in the Contact header field of the REGISTER request shall be supported at the roaming II-NNI.

The Feature-Caps header field with the "g.3gpp.cs2ps-srvcc" feature capability indicator in the REGISTER request shall be supported at the roaming II-NNI.

The MESSAGE request containing the Accept-Contact header field with the "g.3gpp.path" media feature tag and the "application/vnd.srvcc-ext+xml" MIME body shall be supported at the roaming II-NNI.

14.5.2 CS to PS SRVCC for calls in alerting phase

The requirements for the CS to PS SRVCC for calls in alerting phase are the same as in subclause 14.5.1 with the following additional requirement:

The "g.3gpp.cs2ps-srvcc-alerting" media feature tag in the Contact header field of the REGISTER request shall be supported at the roaming II-NNI.

The REFER request sent inside an existing SIP dialog with the Refer-Sub header field and the "application/vnd.3gpp.state-and-event-info+xml" MIME body shall be supported at the roaming II-NNI.

The INFO request with the Info-Package header field containing the "g.3gpp.state-and-event" package name and the "application/vnd.3gpp.state-and-event-info+xml" MIME body shall be supported at the roaming II-NNI.

14.5.3 CS to PS SRVCC with the assisted mid-call feature

The requirements for the CS to PS SRVCC with the assisted mid-call feature are the same as in subclause 14.5.1 with the following additional requirement:

The "application/vnd.3gpp.access-transfer-events+xml" MIME body in the REFER request shall be supported at the roaming II-NNI.

15 Presence service

15.0 General

In order to assure the end-to-end service interoperability through the Inter-IMS Network to Network Interface (II-NNI), the associated functions of the Presence service may be supported on the II-NNI between two IMS networks. The support of each function is based on agreement between operators.

If a function is supported, the related procedures from the 3GPP TS 24.141 [132] shall be applied with the requirements in the relevant subclause below due to the crossing of the II-NNI.

15.1 Subscription of presence information

Service specific requirements in accordance with 3GPP TS 24.141 [132] shall be supported over the II-NNI.

A PUBLISH request identifying the Presentity using a SIP URI, a tel URI or a PRES URI and the Event header field with the value "presence" and containing an "application/pidf+xml" MIME body shall be supported at the roaming II-NNI.

Additionally to the above and in any combination, a "multipart/related" content type and an "application/pidf-diff+xml" MIME body can be included in the PUBLISH request and shall be supported at the roaming II-NNI.

A SUBSCRIBE request with a Request-URI containing a SIP URI, a TEL URI or a pres URI, the Event header field set to "presence" and Accept header fields with values "application/pidf+xml" and "multipart/related" shall be supported at the II-NNI.

Additionally to the above an "application/simple-filter+xml" MIME body can appear in the SUBSCRIBE request and shall be supported at the II-NNI.

Additionally to the above and in any combination a "multipart/mixed" content type and an "application/resource-lists" MIME body can appear in the SUBSCRIBE request and shall be supported at the roaming II-NNI.

A NOTIFY request including an Event header field with the value "presence" and an "application/pidf" MIME body shall be supported at the II-NNI.

NOTE: The NOTIFY request can contain substantial amount of data and TCP is expected to be used as the transport protocol.

The Allow-Events header field with the value "presence" shall be supported at the roaming II-NNI and may be supported at the non-roaming II-NNI.

15.2 Watcher subscribing to Presence List

Service specific requirements in accordance with 3GPP TS 24.141 [132] shall be supported over the II-NNI.

The requirements for the watcher subscribing to the Presence List are the same as subscribing to presence information as specified in subclause 15.1 with the following additional requirement:

- The SUBSCRIBE request containing a Supported header field with the value "eventlist" shall also be supported at the roaming II-NNI;
- The SUBSCRIBE request containing a Accept header field with the value "application/rlmi+xml" shall be supported at the roaming II-NNI;
- A response code 200 (OK) to the SUBSCRIBE request containing the Require header field with the value "eventlist" shall be supported at the roaming II-NNI; and,
- A NOTIFY message containing the "multipart/related" content type and an "application/rlmi+xml" MIME body shall be supported at the roaming II-NNI.

NOTE: The NOTIFY request can contain substantial amount of data and TCP is expected to be used as the transport protocol.

15.3 Subscription to Watcher Information

Service specific requirements in accordance with 3GPP TS 24.141 [132] shall be supported over the II-NNI.

A SUBSCRIBE request containing an Event header field with the value "presence.wininfo" and an Accept header field with value "application/watcherinfo+xml" shall be supported at the roaming II-NNI.

A NOTIFY request containing the Event header field with the value "presence.wininfo" and an "application/watcherinfo" MIME body shall be supported at the roaming II-NNI.

NOTE: The NOTIFY request can contain substantial amount of data and TCP is expected to be used as the transport protocol.

The Allow-Events header field with the value "presence.wininfo" shall be supported at the roaming II-NNI and may be supported at the non-roaming II-NNI.

15.4 Subscription to state changes in XML documents

Service specific requirements in accordance with 3GPP TS 24.141 [132] shall be supported over the II-NNI.

A SUBSCRIBE request containing the Event header field with the value "xcap-diff" and parameters specified in IETF RFC 5875 [134] shall be supported at the roaming II-NNI.

A NOTIFY request containing the Event header field with the value "xcap-diff", the multipart/mixed content type and any MIME body shall be supported at the roaming II-NNI.

NOTE: The NOTIFY request can contain substantial amount of data and TCP is expected to be the transport protocol.

The Allow-Events header field with the value "xcap-diff" shall be supported at the roaming II-NNI and may be supported at the non-roaming II-NNI.

For backward compatible reasons the Event header field with the value "ua-profile" should be supported at the roaming II-NNI.

15.5 Presence enhancements specified in Open Mobile Alliance (OMA) Release 1.1

15.5.1 General

In order to assure the end-to-end service interoperability through the Inter-IMS Network to Network Interface (II-NNI), the associated functions of the OMA Presence service may be supported on the II-NNI between two IMS networks. The support of each function is based on agreement between operators.

If a function of the OMA Presence Release 1.1 is supported, the related procedures from the OMA-TS-Presence_SIMPLE-V1_1 [142] shall be applied with the requirements in the relevant subclause below due to the crossing of the II-NNI.

15.5.2 OMA subscription of presence information

The requirements for the OMA subscription of presence information are the same as subclause 15.1.

15.5.3 OMA watcher subscribing to Presence List

The requirements for the OMA watcher subscribing to Presence List are the same as subclause 15.2.

15.5.4 OMA subscription to Watcher Information

The requirements for the OMA subscription to Watcher Information are the same as subclause 15.3

15.6 Presence enhancements specified in Open Mobile Alliance (OMA) Release 2.0

15.6.1 General

In order to assure the end-to-end service interoperability through the Inter-IMS Network to Network Interface (II-NNI), the associated functions of the OMA Presence service may be supported on the II-NNI between two IMS networks. The support of each function is based on agreement between operators.

If a function of the OMA Presence Release 2.0 is supported, the related procedures from the OMA-TS-Presence_SIMPLE-V2_0 [138] shall be applied with the requirements in the relevant subclause below due to the crossing of the II-NNI.

15.6.2 OMA subscription of presence information

The requirements for the OMA subscription of presence information are the same as subclause 15.5.2 with the following additional requirement:

- A Policy-Contact header field in the 488 (Not Acceptable Here) response in PUBLISH request shall be supported at the II-NNI.
- An Allow header field containing the value "REFER" in a PUBLISH request shall be supported at the II-NNI.
- A Policy-Contact header field in a 488 (Not Acceptable Here) response to a PUBLISH request shall be supported at the II-NNI.
- A Suppress-If-Match header field in a SUBSCRIBE request shall be supported at the II-NNI.
- An Accept-Encoding header field containing the value "gzip" in a SUBSCRIBE request shall be supported at the II-NNI.
- An "application/vnd.oma.sppnot+xml" MIME body in a SUBSCRIBE request shall be supported at the II-NNI.
- A Content-Encoding header field containing the value "gzip" in a NOTIFY request shall be supported at the II-NNI.
- A "multipart/mixed" content type in a SUBSCRIBE request shall be supported at the II-NNI.
- A Refer-To header field with the value "method=PUBLISH?event=presence", a Refer-Sub header field and a SIP-If-Match header field in a REFER request shall be supported at the II-NNI.

15.6.3 OMA watcher subscribing to Presence List

The requirements for the OMA watcher subscribing to Presence List are the same as subclause 15.5.3 with the following additional requirements;

- A Suppress-If-Match header field in a SUBSCRIBE request shall be supported at the II-NNI.
- An Accept-Encoding header field containing the value "gzip" in a SUBSCRIBE request shall be supported at the II-NNI.
- A body containing an "application/vnd.oma.sppnot+xml" content type in a SUBSCRIBE request shall be supported at the II-NNI.
- A body containing an "application/resource-lists+xml" content type in a SUBSCRIBE request shall be supported at the II-NNI.

- A "multipart/mixed" content type in a SUBSCRIBE request shall be supported at the II-NNI.
- A NOTIFY request with a Content-Encoding header field containing the value "gzip" shall be supported at the II-NNI.

15.6.4 OMA subscription to Watcher Information

The requirements for the OMA subscription to Watcher Information are the same as subclause 15.5.4 with the following additional requirement:

- Indicating support for "multipart/mixed" and "application/simple-filter+xml" in the Accept header field of the SUBSCRIBE request shall be supported at the II-NNI.
- Multiple "application/simple-filter+xml" MIME bodies in the NOTIFY request shall be supported at the II-NNI.
- A Suppress-If-Match header field in a SUBSCRIBE request shall be supported at the II-NNI.
- An Accept-Encoding header field containing the value "gzip" in the SUBSCRIBE request shall be supported at the II-NNI.
- A body with multiple content of the multipart/mixed content type in a NOTIFY request shall be supported at the II-NNI.
- A Content-Encoding header field with the value "gzip" in a NOTIFY request shall be supported at the II-NNI.
- A Refer-To header field with the value "method=SUBSCRIBE?Event=presence.winfo" and a Refer-Sub header field in a REFER request sent to a Watcher Information Subscriber shall be supported at the II-NNI.

15.6.5 Subscription to state changes in XML documents

The requirements for the OMA watcher subscribing to Presence List are the same as subclause 15.4 with the following additional requirements:

- An Accept header field indicating the support for "application/xcap-diff+xml", "application/rlmi+xml" and "multipart/related" in a SUBSCRIBE request shall be supported at the II-NNI.
- An Accept-Encoding header field with the value "gzip" in a SUBSCRIBE request shall be supported at the II-NNI.
- A Content-Encoding header field containing the value "gzip" in a NOTIFY request shall be supported at the II-NNI.
- Multiple "multipart/related" MIME bodies in a NOTIFY request shall be supported at the II-NNI.
- An "application/rlmi+xml" MIME bodies in a NOTIFY request shall be supported at the II-NNI.

15.6.6 Void

15.6.7 Void

16 Messaging service

16.1 General

In order to assure the end-to-end service interoperability through the Inter-IMS Network to Network Interface (II-NNI), the associated function of the messaging service may be supported on the II-NNI between two IMS networks.

If a function is supported, the related procedures from the 3GPP TS 24.247 [139] shall be applied with the requirements in the relevant subclause below due to the crossing of the II-NNI.

16.2 Page-mode messaging

Service specific requirements in accordance with clause 5 of 3GPP TS 24.247 [139] shall be supported over the II-NNI.

A MESSAGE request containing the "application/recipient-list" MIME body specified in IETF RFC 5365 [67], a Required header field with the 'recipient-list-message' option-tag; and a body carrying payload shall be supported at the roaming II-NNI.

A MESSAGE request containing:

- a body that carrying payload; or
- the "application/im-iscomposing+xml" MIME body.

shall be supported at the II-NNI.

The response code 415 (Unsupported Media Type) and the response code 202 (Accepted) shall be supported at the II-NNI.

16.4 Session-mode messaging

Service specific requirements in accordance with clause 6 of 3GPP TS 24.247 [139] shall be supported over the II-NNI.

No restrictions at the II-NNI identified.

16.5 Session-mode messaging conferences

Service specific requirements in accordance with clause 7 of 3GPP TS 24.247 [139] shall be supported over the II-NNI.

The "application/resource-lists+xml" MIME body included in the INVITE request shall be supported at the roaming II-NNI.

The media feature tag "isfocus" in the Contact header field of the INVITE request and responses to the INVITE request shall be supported at the II-NNI.

The SUBSCRIBE request including the "conference" event package name in the Event header field and the NOTIFY request procedures according to 3GPP TS 24.147 [106] shall be supported at the II-NNI.

The REFER request containing a Referred-By header field and NOTIFY requests procedures according to 3GPP TS 24.147 [106] shall be supported at the II-NNI.

The REFER request containing the BYE method URI parameter in the Refer-To header shall be supported at the II-NNI.

The Referred-By header field in the INVITE request shall be supported at the II-NNI.

The Allow-Events header field with the value "conference" shall be supported at the roaming II-NNI and may be supported at the non-roaming II-NNI.

17 Optimal Media Routeing

17.1 General

Based on inter-operator agreement, the Optimal Media Routeing (OMR) procedures may be supported over the II-NNI,

If OMR procedures are supported, the procedures in 3GPP TS 29.079 [148] shall be applied and the capabilities below shall be provided at the II-NNI.

17.2 OMR related SDP attributes

The "visited-realm", "secondary-realm", "omr-codecs", "omr-m-att", "omr-s-att", "omr-m-bw", "omr-s-bw", "omr-s-cksum", and "omr-m-cksum" SDP attributes defined in 3GPP TS 24.229 [5] shall be supported at the II-NNI.

17.3 IP realm names

Operators need to agree on unique names for IP realms (as defined in 3GPP TS 29.079 [148]) used in their own and interconnecting networks to avoid a collision of IP realm names. Operators may choose to share an IP realm, and shall then also assign a single unique name to that realm. As defined in 3GPP TS 24.229 [5], a public IPv4 or IPv6 address reachable from the open internet is associated with the special realm "IN".

18 Inter-UE transfer (IUT)

18.1 General

Inter-UE transfer may be supported over the II-NNI. The IUT consist of several functional blocks, as described in the subclauses below. The support of each of these functional blocks is based on agreement between operators.

If a function is supported, the related procedures from the 3GPP TS 24.337 [149] shall be applied with the requirements in the relevant subclause below.

18.2 IUT without establishment of a collaborative session

Service specific requirements in accordance with 3GPP TS 24.337 [149] shall be supported over the II-NNI.

The REFER request shall be supported at the roaming II-NNI.

The Refer-To header field containing a body parameter including a Replaces header field and the Require header field set to "replaces" shall be supported at the roaming II-NNI.

The Refer-To header field containing a body parameter including a Target-Dialog header field and the Require header field set to "tdialog" shall be supported at the roaming II-NNI.

The Refer-To header field containing a body parameter including an Accept-Contact header field with the "g.3gpp.icsi-ref" media feature tag and a P-Preferred-Service header field set to the IMS communication service identifier shall be supported at the roaming II-NNI.

The Contact header field of the REFER request containing a public GRUU or temporary GRUU as specified in 3GPP TS 24.229 [5] shall be supported at the roaming II-NNI.

The "g.3gpp.icsi-ref" media feature tag in the Accept-Contact header field of the REFER request shall be supported at the roaming II-NNI.

NOTIFY requests containing a "sipfrag" MIME body as specified in IETF RFC 3515 [22] shall be supported at the roaming II-NNI.

18.3 IUT using a collaborative session

18.3.1 Collaborative session of participants of the same subscription

This subclause describes the requirements at the II-NNI for an ongoing session. Service specific requirements in accordance with 3GPP TS 24.337 [149] shall be supported over the II-NNI.

The "g.3gpp.iut-controller" media feature tag in the Accept-Contact header field in the REGISTER request shall be supported.

A REFER request sent outside an existing dialog shall be supported at the roaming II-NNI with the following additional requirements:

- The Refer-To header field containing a body parameter including a MIME sdp body and no method parameter, the method parameter set to "INVITE" or "BYE" shall be supported at the roaming II-NNI.
- The Accept header field containing the MIME type "message/sipfrag" in the REFER request shall be supported at the roaming II-NNI.
- The Target-Dialog header field in the REFER request shall be supported at the roaming II-NNI.
- The Contact header field in the REFER request containing the "g.3gpp.iut-controller" media feature tag as described in annex B of 3GPP TS 24.337 [149] shall be supported at the roaming II-NNI.
- The Contact header field in the REFER request containing the "g.3gpp.current-iut-controller" media feature tag as described in annex B of 3GPP TS 24.337 [149] shall be supported at the roaming II-NNI.
- The "g.3gpp.iut-controller" media feature tag in the Accept-Contact header field shall be supported at the roaming II-NNI.
- The Referred-By header field shall be supported at the roaming II-NNI at the roaming II-NNI.

The NOTIFY request containing a "sipfrag" MIME body as specified in IETF RFC 3515 [22] shall be supported at the roaming II-NNI.

Initial INVITE requests and re-INVITE requests as follows:

- The Referred-By header field included in initial INVITE requests and re-INVITE requests shall be supported at the roaming II-NNI;
- The "g.3gpp.iut-controller" media feature tag as described in annex B of 3GPP TS 24.337 [149] in the Contact header field shall be supported at the roaming II-NNI.

The "g.3gpp.iut-controller" media feature tag in SIP responses to the INVITE request shall be supported at the roaming II-NNI.

The SUBSCRIBE request including the Event header field with the "dialog" event package; and including the Accept-Contact header field with the "g.3gpp.iut-focus" media feature shall be supported at the roaming II-NNI.

The "dialog-info+xml" MIME body in NOTIFY requests shall be supported at the roaming II-NNI.

18.3.2 Establishment of a collaborative session during session setup

Service specific requirements in accordance with 3GPP TS 24.337 [149] shall be supported over the II-NNI.

The Accept header field containing the MIME type "application/vnd.3gpp.iut+xml" in initial INVITE requests shall be supported at the roaming II-NNI.

A SIP 300 (Multiple Choices) response a Content-Type header field containing the MIME type "application/vnd.3gpp.iut+xml" and an "application/vnd.3gpp.iut+xml" MIME body shall be supported at the roaming II-NNI.

18.3.3 Assignment and transfer of control of a collaborative session

Service specific requirements in accordance with 3GPP TS 24.337 [149] shall be supported over the II-NNI.

The g.3gpp.current-iut-controller in the Contact header of the SIP 200 (OK) response to INVITE request shall be supported at the roaming II-NNI.

A "multipart/mixed" MIME body containing the "application/vnd.3gpp.iut+xml" and the "application/sdp" MIME bodies in the INVITE request shall be supported at the roaming II-NNI.

18.3.4 Collaborative session of participants of different subscriptions

Service specific requirements in accordance with 3GPP TS 24.337 [149] shall be supported over the II-NNI.

In addition to the requirements in subclause 18.3.1, 18.3.2 or 18.3.3 the following applies:

- The "g.3gpp.iut-focus" media feature tag (specified in 3GPP TS 24.337 [149] annex B) in the Contact header field shall be supported at the non-roaming II-NNI and for the loopback traversal scenario.
- The "+g.3gpp.iut-focus" header field parameter (specified in 3GPP TS 24.337 [149] annex B) in the Feature-Caps header field as described in draft-ietf-sipcore-proxy-feature [143] shall be supported at the non-roaming II-NNI and for the loopback traversal scenario.

18.4 Session replication / media replication

18.4.1 Pull mode

Service specific requirements in accordance with 3GPP TS 24.337 [149] shall be supported over the II-NNI.

The Target-Dialog header field and the Accept-Contact header field containing the "g.3gpp.iut-focus" media feature tag of the INVITE request shall be supported at the roaming II-NNI.

A REFER request including:

- the method parameter set to "MESSAGE" in the Refer-To header field;
- the In-Reply-To header field;
- the Target-Dialog header field;
- the Require header field populated with the option tag value "tdialog"; and
- the "application/vnd.3gpp.replication+xml" MIME body,

shall be supported at the roaming II-NNI.

A MESSAGE request the In-Reply-To header field and the "application/vnd.3gpp.replication+xml" MIME body shall be supported at the roaming II-NNI.

18.4.2 Push mode

Service specific requirements in accordance with 3GPP TS 24.337 [149] shall be supported over the II-NNI.

A REFER request including:

- the Accept-Contact header field containing the "g.3gpp.iut-focus" media feature tag with explicit and require tags;
- the Target-Dialog header field; and
- the Refer-To header field containing the Accept-Contact header field, the P-Preferred-Service header field and the "application/sdp" body,

shall be supported at the roaming II-NNI.

The "application/vnd.3gpp.replication+xml" MIME body of the SIP REFER request shall be supported at the roaming II-NNI.

19 Roaming Architecture for Voice over IMS with Local Breakout

Based on inter-operator agreement, the roaming architecture for voice over IMS with local breakout procedure may be supported over the II-NNI.

If the roaming architecture for voice over IMS with local breakout procedure is supported, the procedures in 3GPP TS 24.229 [5] shall be applied and the capabilities below shall be provided at the II-NNI.

The "+g.3gpp.trf" header field parameter (defined in 3GPP TS 24.229 [5] subclause 7.9A.3) with a TRF address included in a Feature-Caps header field as described in draft-ietf-sipcore-proxy-feature [143] in the initial INVITE request shall be supported at the roaming II-NNI.

The "+g.3gpp.loopback" header field parameter (defined in 3GPP TS 24.229 [5] subclause 7.9A.4) included in the Feature-Caps header field as described in draft-ietf-sipcore-proxy-feature [143] in the initial SIP INVITE request shall be supported for the loopback traversal scenario.

The procedures in clause 17 shall be supported at the II-NNI.

20 Delivery of Media Resource Broker address information

Based on inter-operator agreement, the procedure to deliver MRB address information may be supported over the roaming II-NNI.

NOTE: Subsequent interaction between home network MRB and visited network MRB is outside the scope of this document.

If the procedure to enable optimised allocation of media resources is supported, the procedures in 3GPP TS 24.229 [5] shall be applied and the capabilities below shall be provided at the roaming II-NNI.

The "g.3gpp.mrb" feature capability indicator (defined in 3GPP TS 24.229 [5] subclause 7.9A.6) with the MRB address included in the Feature-Caps header field as described in draft-ietf-sipcore-proxy-feature [143] in the initial INVITE request shall be supported at the roaming II-NNI.

21 Overload control

Based on inter-operator agreement, overload control may be supported over the II-NNI.

If the overload control is supported, the procedures in 3GPP TS 24.229 [5] shall be applied and the capabilities below shall be provided at the II-NNI.

The overload control defines a feedback based mechanism and a load filter mechanism but only the feedback based mechanism is supported on the II-NNI.

The feedback based mechanism, defined in draft-ietf-soc-overload-control [165], requires no additional support at the II-NNI as it is supported using header field parameters within existing header fields supported at the II-NNI. An algorithm will need to be selected. draft-ietf-soc-overload-control [165] also defines the default algorithm for usage of the feedback based mechanism in the IM CN subsystem. Additional algorithms are either already defined, e.g. the rate-based scheme defined in draft-ietf-soc-overload-rate-control [166], or can also be defined in the future.

Editor's note: [WI: IOC-CT, CR#0470] For overload control using the load filter mechanism, it needs to be determined if it should be supported at the II-NNI.

Annex A (informative): Summary of SIP header fields

A summary of the SIP header fields to be used in case of interconnection by using II-NNI is proposed in table A.1.

The starting point is the sending behaviour described for proxy and UA roles in annex A of 3GPP TS 24.229 [5]:

- In case of misalignment between table A.1 and the behaviour described in 3GPP TS 24.229 [5], the behaviour in 3GPP TS 24.229 [5] has the precedence.
- In case a header field is not described in table A.1 and it is described in 3GPP TS 24.229 [5], the description in 3GPP TS 24.229 [5] is applicable over II-NNI.
- If a header field is not described in 3GPP TS 24.229 [5], the description in table A.1 is applicable over II-NNI.

The notation of the codes used for the SIP headers listed in table A.1 has a different meaning to the one proposed for the SIP messages. The definition of these terms is provided in table A.2.

Table A.1: Supported header fields

| Item | Header field | Ref. | II-NNI |
|------|-----------------------------------|--|--|
| 1 | Accept | [5] | m |
| 2 | Accept-Contact | [5] | m |
| 3 | Accept-Encoding | [5] | m |
| 4 | Accept-Language | [5] | m |
| 4a | Accept-Resource-Priority | [5] | o |
| 5 | Alert-Info | [5] | o |
| 6 | Allow | [5] | m |
| 7 | Allow-Events | [5] | m on roaming II-NNI, else o |
| 8 | Authentication-Info | [5] | m on roaming II-NNI, else n/a |
| 9 | Authorization | [5] | m on roaming II-NNI, else n/a |
| 9a | Answer-Mode | [5] | o |
| 10 | Call-ID | [5] | m |
| 11 | Call-Info | [5] | m |
| 12 | Contact | [5] | m |
| 13 | Content-Disposition | [5] | m |
| 14 | Content-Encoding | [5] | m |
| 15 | Content-Language | [5] | m |
| 16 | Content-Length | [5] | m |
| 17 | Content-Type | [5] | m |
| 18 | CSeq | [5] | m |
| 19 | Date | [5] | m |
| 20 | Error-Info | [5] | o |
| 21 | Expires | [5] | m |
| 21a | Flow-Timer | [5] | m on roaming II-NNI, else o |
| 21b | Feature-Caps | [5] | o |
| 22 | Event | [5] | m |
| 23 | From | [5] | m |
| 24 | Geolocation | [5] | m |
| 24a | Geolocation-Error | [5] | m |
| 24b | Geolocation-Routing | [5] | m |
| 25 | History-Info | subclause 6.1.1.3.1 (table 6.2, item 4) | o |
| 25a | Info-Package | [5] | o |
| 26 | In-Reply-To | [5] | o |
| 27 | Join | [5] | o |
| 27a | Max-Breadth | [5] | m |
| 28 | Max-Forwards | [5] | m |
| 29 | Min-Expires | [5] | m |
| 30 | MIME-Version | [5] | m |
| 31 | Min-SE | [5] | m |
| 32 | Organization | [5] | m |
| 33 | P-Access-Network-Info | subclause 6.1.1.3.1 (table 6.2, item 2) | m in case of a trust relationship between the interconnected networks, else n/a |
| 33a | P-Answer-state | [5] | o |
| 34 | P-Asserted-Identity | subclause 6.1.1.3.1 (table 6.2, item 1) | m in case of a trust relationship between the interconnected networks, else n/a |
| 35 | P-Asserted-Service | subclause 6.1.1.3.1 (table 6.2, item 5) | o |
| 35a | P-Associated-URI | [5] | m on roaming II-NNI, else n/a |
| 36 | P-Called-Party-ID | [5] | m on roaming II-NNI, else n/a |
| 37 | P-Charging-Function- Addresses | subclause 6.1.1.3.1 (table 6.2, item 7) | n/a |

| Item | Header field | Ref. | II-NNI |
|------|------------------------------|--|---|
| 38 | P-Charging-Vector | subclause 6.1.1.3.1 (table 6.2, item 6) | m on roaming II-NNI, else o |
| 38a | P-Debug-Id | [5] | o |
| 39 | P-Early-Media | subclause 6.1.1.3.1 (table 6.2, item 12) | m in case of a trust relationship between the interconnected networks, else n/a |
| 40 | P-Media-Authorization | [5] | n/a |
| 41 | P-Preferred-Identity | [5] | n/a |
| 42 | P-Preferred-Service | [5] | m on roaming II-NNI, else n/a |
| 43 | P-Private-Network-Indication | subclause 6.1.1.3.1 (table 6.2, item 9) | m on roaming II-NNI, else o |
| 44 | P-Profile-Key | subclause 6.1.1.3.1 (table 6.2, item 8) | o on roaming II-NNI, else n/a |
| 44a | P-Refused-URI-List | [5] | o on non-roaming II-NNI and for the loopback traversal scenario else n/a |
| 45 | P-Served-User | subclause 6.1.1.3.1 (table 6.2, item 10) | m on roaming II-NNI, else n/a |
| 46 | P-User-Database | [5] | n/a |
| 47 | P-Visited-Network-ID | [5] | m on roaming II-NNI, else n/a |
| 47a | Path | [5] | m on roaming II-NNI, else n/a |
| 47b | Permission-Missing | [5] | o |
| 47c | Policy-Contact | [133] and subclause 15.6.2 | o |
| 48 | Priority | [5] | o |
| 48a | Priv-Answer-Mode | [5] | o |
| 49 | Privacy | [5] | m |
| 50 | Proxy-Authenticate | [5] | m on roaming II-NNI, else n/a |
| 51 | Proxy-Authorization | [5] | m on roaming II-NNI, else n/a |
| 52 | Proxy-Require | [5] | m |
| 52a | RAck | [5] | m |
| 53 | Reason | [5] and subclause 6.1.1.3.1 (table 6.2, item 11) | o when in a request. When in a response, m in case of a trust relationship between the interconnected networks, else n/a |
| 54 | Record-Route | [5] | m |
| 54a | Recv-Info | [5] | o |
| 55 | Referred-By | [5] | m |
| 55a | Refer-Sub | [5] | m in the case the REFER request is supported, else n/a |
| 55b | Refer-To | [5] | m in the case the REFER request is supported, else n/a |
| 56 | Reject-Contact | [5] | m |
| 57 | Replaces | [5] | o |
| 58 | Reply-To | [5] | o |
| 59 | Request-Disposition | [5] | m |
| 60 | Require | [5] | m |
| 61 | Resource-Priority | subclause 6.1.1.3.1 (table 6.2, item 3) | o |
| 61a | Retry-After | [5] | o |
| 62 | Route | [5] | m |
| 62a | RSeq | [5] | m |
| 63 | Security-Client | [5] | n/a |
| 63a | Security-Server | [5] | n/a |

| Item | Header field | Ref. | II-NNI |
|------|--------------------|----------------------------|--|
| 64 | Security-Verify | [5] | n/a |
| 65 | Server | [5] | o |
| 65a | Service-Route | [5] | m on roaming II-NNI, else n/a |
| 65b | Session-ID | [5] | o |
| 66 | Session-Expires | [5] | m |
| 66a | SIP-ETag | [5] | m in the case the PUBLISH request is supported, else n/a |
| 66b | SIP-If-Match | [5] | m in the case the PUBLISH request is supported, else n/a |
| 67 | Subject | [5] | o |
| 67a | Subscription-State | [5] | m in the case the NOTIFY request is supported, else n/a |
| 67b | Suppress-If-Match | [144] and subclause 15.6.4 | o |
| 68 | Supported | [5] | m |
| 68a | Target-Dialog | [5] | o |
| 69 | Timestamp | [5] | m |
| 70 | To | [5] | m |
| 71 | Trigger-Consent | [5] | m |
| 71a | Unsupported | [5] | m |
| 72 | User-Agent | [5] | m |
| 73 | User-to-User | [5] | o |
| 74 | Via | [5] | m |
| 75 | Warning | [5] | o |
| 76 | WWW-Authenticate | [5] | m on roaming II-NNI, else n/a |

Table A.2: Key to notation codes for SIP header fields

| Notation code | Meaning |
|---------------|---|
| m | The SIP header field is applicable at II-NNI. Supporting a SIP header field at the II-NNI means that this header field is passed through the IBCF. It does not imply that network elements inside the serving and served networks or user equipment connected to these networks shall support this header field, where 3GPP TS 24.229 [5] is applied. If specified in 3GPP TS 24.229, the IBCF modifies the SIP header field. |
| o | The applicability of SIP header field at II-NNI depends on bilateral agreement between the operators. |
| n/a | It is impossible to use the SIP header field at the II-NNI. This header field could be discarded by the IBCF. |

Annex B (informative): Dynamic view of SIP header fields within SIP messages

B.1 Scope

This annex provides the applicability of SIP header fields in SIP messages over II-NNI by using the methodology of a so-called "dynamic view", as used in IETF RFC 3261 [13] and other SIP related RFCs. This methodology documents the presence of SIP header fields in SIP messages over the II-NNI and also takes into account dynamic conditions, for instance the presence of a SIP header field in a SIP request message as condition for the SIP header field in the corresponding SIP response message.

Specific information about the applicability of SIP header fields in SIP messages in a dynamic view is also provided for cases where an MMTel supplementary service is supported over the II-NNI between operators.

The applicability of SIP header fields described in this annex is based on the procedures described in 3GPP TS 24.229 [5] and the list of SIP header fields in annex A of 3GPP TS 24.229 [5].

B.2 Methodology

The meaning of the notation codes used in the tables in subsequent clauses is as follows:

In the "RFC status" column, the notation codes defined in IETF RFC 3261 [13] clause 20 are applied.

In the "II-NNI condition" column the notation codes defined in table B.2.1 are used. If a capability of a SIP header field is specified as either optional or conditional in table 6.1.3.1, then "II-NNI condition" of the SIP header field is described with conditional expression.

In each request-related table, each "Item" number for a SIP header field inherits that of annex A of 3GPP TS 24.229 [5].

In each response-related table, the SIP status code for which the header field is applicable is described in the "SIP status code" column. The notation codes for the "where" column as defined in IETF RFC 3261 [13] clause 20 are applied. The notation code "r" in "SIP status code" column corresponds to any SIP status code which is described in annex A of 3GPP TS 24.229 [5] for the corresponding method. Any SIP header field not listed in a table is not applicable for the corresponding SIP message.

Table B.2.1: Key to notation codes for SIP header fields in dynamic view for II-NNI

| Notation code (NOTE1) | Meaning |
|--|--|
| dc | The SIP header field is required to be present in a SIP message over II-NNI according to the procedures specified in other specifications e.g. 3GPP TS 24.229 [5]. |
| Dm | The SIP header field shall be always present in a SIP message over II-NNI, and if received, it must be handled according to 3GPP TS 24.229 [5]. |
| Dm* | The SIP header field should be present in a SIP message over II-NNI, but the IMS network need to be prepared to receive a SIP message without that header field. |
| do | The SIP header field can be present in a SIP message over II-NNI, and if received, it must be handled according to 3GPP TS 24.229 [5]. (NOTE 2) |
| dt | The header field should be present in a SIP message over II-NNI, but the IMS network need to be prepared to receive a SIP message without that header field. If TCP is used as a transport, then the header field must be present in a SIP message. |
| d* | The SIP header field is required to be present in a SIP message if the message body is not empty. |
| dn/a | The SIP header field is shall not be present in a SIP message over II-NNI. (NOTE 3) |
| dc<integer> | The condition for the presence of the SIP header field. <integer> is the identifier of the condition. This notation code is applied only in each request-related or response-related table. |
| NOTE 1: The meaning of the notation codes is same as in IETF RFC 3261 [13] clause 20 and "d" is used to emphasise the dynamic view. | |
| NOTE 2: If specified by local policy rules, the IBCF acting as entry point may omit or modify any received SIP header fields prior to forwarding SIP messages as specified in 3GPP TS 24.229 [5] subclause 5.10.6.2. | |
| NOTE 3: The SIP header field can be removed at the IBCF acting as exit point by using screening functionality defined in 3GPP TS 24.229 [5] subclause 5.10.6.2. | |

B.3 ACK method

Table B.3.1: Supported header fields within the ACK request

| Item | Header field | Ref. | RFC status | II-NNI condition |
|-------|--|-------|------------|------------------------------------|
| 1 | Accept-Contact | [51] | o | do |
| 2 | Allow-Events | [20] | o | IF table 6.1.3.1/23 THEN do (NOTE) |
| 3 | Authorization | [13] | o | IF table 6.1.3.1/7 THEN do (NOTE) |
| 4 | Call-ID | [13] | m | dm |
| 6 | Content-Disposition | [13] | o | do |
| 7 | Content-Encoding | [13] | o | do |
| 8 | Content-Language | [13] | o | do |
| 9 | Content-Length | [13] | t | dt |
| 10 | Content-Type | [13] | * | d* |
| 11 | CSeq | [13] | m | dm |
| 12 | Date | [13] | o | do |
| 13 | From | [13] | m | dm |
| 13B | Max-Breadth | [79] | o | do |
| 14 | Max-Forwards | [13] | m | dm |
| 15 | MIME-Version | [13] | o | do |
| 15A | P-Debug-ID | [87] | o | IF table 6.1.3.1/83 THEN do (NOTE) |
| 15B | Privacy | [34] | o | do |
| 16 | Proxy-Authorization | [13] | o | IF table 6.1.3.1/7 THEN do (NOTE) |
| 17 | Proxy-Require | [13] | n/a | dn/a |
| 17A | Reason | [48] | o | IF table 6.1.3.1/40 THEN do (NOTE) |
| 17B | Recv-Info | [39] | n/a | dn/a |
| 17C | Reject-Contact | [51] | o | do |
| 17D | Request-Disposition | [51] | o | do |
| 18 | Require | [13] | n/a | dn/a |
| 18A | Resource-Priority | [78] | o | IF table 6.1.3.1/73 THEN do (NOTE) |
| 19 | Route | [13] | c | dc |
| 19A | Session-ID | [124] | m | IF table 6.1.3.1/94 THEN dm (NOTE) |
| 20 | Timestamp | [13] | o | do |
| 21 | To | [13] | m | dm |
| 22 | User-Agent | [13] | o | do |
| 23 | Via | [13] | m | dm |
| NOTE: | If the capability specified in table 6.1.3.1 is not supported over the II-NNI, the IBCF in the receiving network can omit or modify the SIP header fields in the received SIP message prior to forwarding the SIP message as specified in 3GPP TS 24.229 [5] subclause 5.10.6.2. | | | |

B.4 BYE method

Table B.4.1: Supported header fields within the BYE request

| Item | Header field | Ref. | RFC status | II-NNI condition |
|-------|--|-------|------------|---|
| 1 | Accept | [13] | o | IF dc1 (AOC: subclause 12.22) THEN dm ELSE do |
| 1A | Accept-Contact | [51] | o | do |
| 2 | Accept-Encoding | [13] | o | do |
| 3 | Accept-Language | [13] | o | do |
| 3A | Allow | [13] | o | do |
| 4 | Allow-Events | [20] | o | IF table 6.1.3.1/23 THEN do (NOTE) |
| 5 | Authorization | [13] | o | IF table 6.1.3.1/7 THEN do (NOTE) |
| 6 | Call-ID | [13] | m | dm |
| 7 | Content-Disposition | [13] | o | IF dc2 (AOC: subclause 12.22) THEN dm ELSE do |
| 8 | Content-Encoding | [13] | o | do |
| 9 | Content-Language | [13] | o | do |
| 10 | Content-Length | [13] | t | dt |
| 11 | Content-Type | [13] | * | d* |
| 12 | CSeq | [13] | m | dm |
| 13 | Date | [13] | o | do |
| 14 | From | [13] | m | dm |
| 14A | Geolocation | [68] | o | do |
| 14AA | Geolocation-Routing | [68] | o | do |
| 14B | Max-Breadth | [79] | o | do |
| 15 | Max-Forwards | [13] | m | dm |
| 16 | MIME-Version | [13] | o | do |
| 16A | P-Access-Network-Info | [24] | o | IF table 6.1.3.1/36 THEN do (NOTE) |
| 16B | P-Asserted-Identity | [44] | o | IF table 6.1.3.1/27 THEN do (NOTE) |
| 16C | P-Charging-Function-Addresses | [24] | o | dn/a |
| 16D | P-Charging-Vector | [24] | o | dn/a |
| 16E | P-Debug-ID | [87] | o | IF table 6.1.3.1/83 THEN do (NOTE) |
| 16F | P-Preferred-Identity | [44] | o | dn/a |
| 16G | Privacy | [34] | o | do |
| 17 | Proxy-Authorization | [13] | o | IF table 6.1.3.1/7 THEN do (NOTE) |
| 18 | Proxy-Require | [13] | o | do |
| 18A | Reason | [48] | o | IF dc3 (ICB: subclause 12.10.1) THEN dm ELSE IF table 6.1.3.1/40 THEN do (NOTE) |
| 19 | Record-Route | [13] | o | do |
| 19A | Referred-By | [53] | o | do |
| 19B | Reject-Contact | [51] | o | do |
| 19C | Request-Disposition | [51] | o | do |
| 20 | Require | [13] | c | dc |
| 20A | Resource-Priority | [78] | o | IF table 6.1.3.1/73 THEN do (NOTE) |
| 21 | Route | [13] | c | dc |
| 21A | Security-Client | [47] | o | dn/a |
| 21B | Security-Verify | [47] | o | dn/a |
| 21C | Session-ID | [124] | m | IF table 6.1.3.1/94 THEN dm (NOTE) |
| 22 | Supported | [13] | o | do |
| 23 | Timestamp | [13] | o | do |
| 24 | To | [13] | m | dm |
| 25 | User-Agent | [13] | o | do |
| 25A | User-to-User | [83] | o | IF table 6.1.3.1/79 THEN do (NOTE) |
| 26 | Via | [13] | m | dm |
| dc1: | request invoked due to AOC AND visited-to-home request on roaming II-NNI | | | |
| dc2: | request invoked due to AOC AND home-to-visited request on roaming II-NNI | | | |
| dc3: | request invoked due to "dynamic ICB" on a confirmed status | | | |
| NOTE: | If the capability specified in table 6.1.3.1 is not supported over the II-NNI, the IBCF in the receiving network can omit or modify the SIP header fields in the received SIP message prior to forwarding the SIP message as specified in 3GPP TS 24.229 [5] subclause 5.10.6.2. | | | |

Table B.4.2: Supported header fields within the BYE response

| Item | Header field | SIP status code | Ref. | RFC status | II-NNI condition |
|------|-------------------------------|--|------|------------|---|
| 1 | Accept | 415 | [13] | c | dc |
| 2 | Accept-Encoding | 415 | [13] | c | dc |
| 3 | Accept-Language | 415 | [13] | c | dc |
| 4 | Accept-Resource-Priority | 2xx 417 | [78] | o | IF table 6.1.3.1/73 THEN do (NOTE 2) |
| 5 | Allow | 2xx | [13] | o | do |
| | | 405 | | m | dm |
| | | others | | o | do |
| 6 | Allow-Events | 2xx | [20] | o | IF table 6.1.3.1/23 THEN do (NOTE 2) |
| 7 | Authentication-Info | 2xx | [13] | o | IF table 6.1.3.1/7 THEN do (NOTE 2) |
| 8 | Call-ID | 100 others | [13] | m | dm |
| 9 | Contact | 3xx 485 | [13] | o | do |
| 10 | Content-Disposition | r | [13] | o | IF dc1 (AOC: subclause 12.22) THEN dm ELSE do |
| 11 | Content-Encoding | r | [13] | o | do |
| 12 | Content-Language | r | [13] | o | do |
| 13 | Content-Length | 100 others | [13] | t | dt |
| 14 | Content-Type | r | [13] | * | d* |
| 15 | CSeq | 100 others | [13] | m | dm |
| 16 | Date | 100 others | [13] | o | do |
| 17 | Error-Info | 3xx-6xx | [13] | o | IF table 6.1.3.1/13 THEN do (NOTE 2) |
| 18 | From | 100 others | [13] | m | dm |
| 19 | Geolocation-Error | 424 | [68] | m | dm |
| | | others | | o | do |
| 20 | MIME-version | r | [13] | o | do |
| 21 | P-Access-Network-Info | r | [24] | o | IF table 6.1.3.1/36 THEN do (NOTE 2) |
| 22 | P-Asserted-Identity | r | [44] | o | IF table 6.1.3.1/27 THEN do (NOTE 2) |
| 23 | P-Charging-Function-Addresses | r | [24] | o | dn/a |
| 24 | P-Charging-Vector | r | [24] | o | dn/a |
| 25 | P-Debug-ID | 100 others | [87] | o | IF table 6.1.3.1/83 THEN do (NOTE 2) |
| 26 | P-Preferred-Identity | r | [44] | o | dn/a |
| 27 | Privacy | r | [34] | o | do |
| 28 | Proxy-Authenticate | 401 (NOTE 1) | [13] | o | do |
| | | 407 (NOTE 1) | | m | dm |
| 29 | Record-Route | 2xx | [13] | o | do |
| 30 | Require | r | [13] | c | dc |
| 31 | Retry-After | 404 413 480 486 500 503 600 603 | [13] | o | do |
| 32 | Security-Server | 2xx | [47] | n/a | dn/a |
| | | 421 | | o | dn/a |
| | | 494 | | | |

| Item | Header field | SIP status code | Ref. | RFC status | II-NNI condition |
|--|------------------|-----------------|-------|------------|--------------------------------------|
| 33 | Server | r | [13] | o | do |
| 34 | Session-ID | r | [124] | m | IF table 6.1.3.1/94 THEN dm (NOTE 2) |
| 35 | Supported | 2xx | [13] | o | do |
| 36 | Timestamp | r | [13] | o | do |
| 37 | To | 100 others | [13] | m | dm |
| 38 | Unsupported | 420 | [13] | m | dm |
| 39 | User-Agent | r | [13] | o | do |
| 40 | User-to-User | r | [83] | o | IF table 6.1.3.1/79 THEN do (NOTE 2) |
| 41 | Via | 100 others | [13] | m | dm |
| 42 | Warning | r | [13] | o | do |
| 43 | WWW-Authenticate | 401 (NOTE 1) | [13] | m | dm |
| | | 407 (NOTE 1) | | o | do |
| dc1: 200 (OK) response invoked due to AOC AND home-to-visited response on roaming II-NNI | | | | | |
| NOTE 1: The SIP status code is only applicable over the roaming II-NNI. | | | | | |
| NOTE 2: If the capability specified in table 6.1.3.1 is not supported over the II-NNI, the IBCF in the receiving network can omit or modify the SIP header fields in the received SIP message prior to forwarding the SIP message as specified in 3GPP TS 24.229 [5] subclause 5.10.6.2. | | | | | |

B.5 CANCEL method

Table B.5.1: Supported header fields within the CANCEL request

| Item | Header field | Ref. | RFC status | II-NNI condition |
|--|---------------------|-------|------------|---|
| 1 | Accept-Contact | [51] | o | do |
| 5 | Authorization | [13] | o | IF table 6.1.3.1/7 THEN do (NOTE) |
| 6 | Call-ID | [13] | m | dm |
| 8 | Content-Length | [13] | t | dt |
| 9 | CSeq | [13] | m | dm |
| 10 | Date | [13] | o | do |
| 11 | From | [13] | m | dm |
| 11A | Max-Breadth | [79] | o | do |
| 12 | Max-Forwards | [13] | m | dm |
| 13 | P-Debug-ID | [87] | o | IF table 6.1.3.1/83 THEN do (NOTE) |
| 14 | Privacy | [34] | o | do |
| 15 | Reason | [48] | o | IF dc1 (CW: subclause 12.7) THEN dm ELSE IF table 6.1.3.1/40 THEN do (NOTE) |
| 16 | Record-Route | [13] | o | do |
| 17 | Reject-Contact | [51] | o | do |
| 17A | Request-Disposition | [51] | o | do |
| 17B | Resource-Priority | [78] | o | IF table 6.1.3.1/73 THEN do (NOTE) |
| 18 | Route | [13] | c | Dc |
| 18A | Session-ID | [124] | m | IF table 6.1.3.1/94 THEN dm (NOTE) |
| 19 | Supported | [13] | o | do |
| 20 | Timestamp | [13] | o | do |
| 21 | To | [13] | m | dm |
| 22 | User-Agent | [13] | o | do |
| 23 | Via | [13] | m | dm |
| dc1: request invoked due to CW at the expiry of the "CW timer" | | | | |
| NOTE: If the capability specified in table 6.1.3.1 is not supported over the II-NNI, the IBCF in the receiving network can omit or modify the SIP header fields in the received SIP message prior to forwarding the SIP message as specified in 3GPP TS 24.229 [5] subclause 5.10.6.2. | | | | |

Table B.5.2: Supported header fields within the CANCEL response

| Item | Header field | SIP status code | Ref. | RFC status | II-NNI condition |
|-------|--|--|-------|------------|------------------------------------|
| 1 | Accept-Resource-Priority | 2xx 417 | [78] | o | IF table 6.1.3.1/73 THEN do (NOTE) |
| 2 | Call-ID | r | [13] | m | dm |
| 3 | Content-Length | r | [13] | t | dt |
| 4 | CSeq | r | [13] | m | dm |
| 5 | Date | r | [13] | o | do |
| 6 | Error-Info | 3xx-6xx | [13] | o | IF table 6.1.3.1/13 THEN do (NOTE) |
| 7 | From | r | [13] | m | dm |
| 8 | P-Debug-ID | r | [87] | o | IF table 6.1.3.1/83 THEN do (NOTE) |
| 9 | Privacy | r | [34] | o | do |
| 10 | Record-Route | 2xx | [13] | o | do |
| 11 | Retry-After | 404 413 480 486 500 503 600 603 | [13] | o | do |
| 12 | Session-ID | r | [124] | m | IF table 6.1.3.1/94 THEN dm (NOTE) |
| 13 | Supported | 2xx | [13] | o | do |
| 14 | Timestamp | r | [13] | o | do |
| 15 | To | r | [13] | m | dm |
| 16 | User-Agent | r | [13] | o | do |
| 17 | Via | r | [13] | m | dm |
| 18 | Warning | r | [13] | o | do |
| NOTE: | If the capability specified in table 6.1.3.1 is not supported over the II-NNI, the IBCF in the receiving network can omit or modify the SIP header fields in the received SIP message prior to forwarding the SIP message as specified in 3GPP TS 24.229 [5] subclause 5.10.6.2. | | | | |

B.6 INFO method

As described in table 6.1, the support of INFO method over the II-NNI is based on bilateral agreement between the operators.

Table B.6.1: Supported header fields within the INFO request

| Item | Header field | Ref. | RFC status | II-NNI condition |
|--|-------------------------------|------------|------------|---|
| 1 | Accept | [13], [39] | o | do |
| 2 | Accept-Encoding | [13], [39] | o | do |
| 3 | Accept-Language | [13], [39] | o | do |
| 4 | Allow | [13], [39] | o | do |
| 5 | Allow-Events | [20] | o | IF table 6.1.3.1/23 THEN do (NOTE) |
| 6 | Authorization | [13], [39] | o | IF table 6.1.3.1/7 THEN do (NOTE) |
| 7 | Call-ID | [13], [39] | m | dm |
| 7A | Call-Info | [13], [39] | o | do |
| 9 | Content-Disposition | [13], [39] | o | IF dc1 (AOC: subclause 12.22) THEN dm ELSE do |
| 10 | Content-Encoding | [13], [39] | o | do |
| 11 | Content-Language | [13], [39] | o | do |
| 12 | Content-Length | [13], [39] | o | do |
| 13 | Content-Type | [13], [39] | * | d* |
| 14 | CSeq | [13], [39] | m | dm |
| 15 | Date | [13], [39] | o | do |
| 16 | From | [13], [39] | m | dm |
| 17 | Geolocation | [68] | o | do |
| 17A | Geolocation-Routing | [68] | o | do |
| 18 | Info-Package | [39] | m* | IF table 6.1.3.1/17 THEN do (NOTE) |
| 19 | Max-Breadth | [79], [39] | n/a | dn/a |
| 20 | Max-Forwards | [13], [39] | o | do |
| 21 | MIME-Version | [13], [39] | o | do |
| 22 | P-Access-Network-Info | [24] | o | IF table 6.1.3.1/36 THEN do (NOTE) |
| 23 | P-Charging-Function-Addresses | [24] | o | dn/a |
| 24 | P-Charging-Vector | [24] | o | IF table 6.1.3.1/38 THEN do (NOTE) |
| 25 | P-Debug-ID | [87] | o | IF table 6.1.3.1/83 THEN do (NOTE) |
| 26 | Privacy | [34], [39] | o | do |
| 27 | Proxy-Authorization | [13], [39] | o | IF table 6.1.3.1/7 THEN do (NOTE) |
| 28 | Proxy-Require | [13], [39] | o | do |
| 29 | Reason | [48], [39] | o | IF table 6.1.3.1/40 THEN do (NOTE) |
| 30 | Record-Route | [13], [39] | o | do |
| 31 | Referred-By | [53], [39] | o | do |
| 33 | Request-Disposition | [51], [39] | o | do |
| 34 | Require | [13], [39] | o | do |
| 35 | Resource-Priority | [78], [39] | o | IF table 6.1.3.1/73 THEN do (NOTE) |
| 36 | Route | [13], [39] | o | do |
| 37 | Security-Client | [47], [39] | o | dn/a |
| 38 | Security-Verify | [47], [39] | o | dn/a |
| 38A | Session-ID | [124] | m | IF table 6.1.3.1/94 THEN dm (NOTE) |
| 39 | Subject | [13], [39] | o | do |
| 40 | Supported | [13], [39] | o | do |
| 41 | Timestamp | [13], [39] | o | do |
| 42 | To | [13], [39] | m | dm |
| 43 | User-Agent | [13], [39] | o | do |
| 44 | Via | [13], [39] | m | dm |
| dc1: request invoked due to AOC AND home-to-visited request on roaming II-NNI | | | | |
| NOTE: If the capability specified in table 6.1.3.1 is not supported over the II-NNI, the IBCF in the receiving network can omit or modify the SIP header fields in the received SIP message prior to forwarding the SIP message as specified in 3GPP TS 24.229 [5] subclause 5.10.6.2. | | | | |

Table B.6.2: Supported header fields within the INFO response

| Item | Header field | SIP status code | Ref. | RFC status | II-NNI condition |
|------|-------------------------------|-----------------|------------|------------|--------------------------------------|
| 1 | Accept | 2xx 415 | [13], [39] | o | do |
| 2 | Accept-Encoding | 2xx | [13], [39] | o | do |
| | | 415 | | c | dc |
| 3 | Accept-Language | 2xx 415 | [13], [39] | o | do |
| 4 | Accept-Resource-Priority | 2xx 417 | [78], [39] | o | IF table 6.1.3.1/73 THEN do (NOTE 2) |
| 5 | Allow | 405 | [13], [39] | m | dm |
| | | others | | o | do |
| 6 | Allow-Events | 2xx | [20] | o | IF table 6.1.3.1/23 THEN do (NOTE 2) |
| 7 | Authentication-Info | 2xx | [13], [39] | o | IF table 6.1.3.1/7 THEN do (NOTE 2) |
| 8 | Call-ID | 100 | [13], [39] | m | dm |
| | | others | | | |
| 9 | Call-Info | r | [13], [39] | o | do |
| 10 | Content-Disposition | r | [13], [39] | o | do |
| 11 | Content-Encoding | r | [13], [39] | o | do |
| 12 | Content-Language | r | [13], [39] | o | do |
| 13 | Content-Length | 100 | [13], [39] | o | do |
| | | others | | | |
| 14 | Content-Type | r | [13], [39] | * | d* |
| 15 | CSeq | 100 | [13], [39] | m | dm |
| | | others | | | |
| 16 | Date | 100 | [13], [39] | o | do |
| | | others | | | |
| 17 | Error-Info | 3xx-6xx | [13], [39] | o | IF table 6.1.3.1/13 THEN do (NOTE 2) |
| 18 | From | 100 | [13], [39] | m | dm |
| | | others | | | |
| 19 | Geolocation-Error | 424 | [68], [39] | m | dm |
| | | others | | o | do |
| 20 | MIME-version | r | [13], [39] | o | do |
| 21 | Organization | r | [13], [39] | n/a | dn/a |
| 22 | P-Access-Network-Info | r | [24] | o | IF table 6.1.3.1/36 THEN do (NOTE 2) |
| 23 | P-Charging-Function-Addresses | r | [24] | o | dn/a |
| 24 | P-Charging-Vector | r | [24] | o | IF table 6.1.3.1/38 THEN do (NOTE 2) |
| 25 | P-Debug-ID | 100 others | [87] | o | IF table 6.1.3.1/83 THEN do (NOTE 2) |
| 26 | Privacy | r | [34], [39] | o | do |
| 27 | Proxy-Authenticate | 401 (NOTE 1) | [13], [39] | o | do |
| 28 | Require | r | [13], [39] | o | do |
| 29 | Retry-After | 404 | [13], [39] | o | do |
| | | 413 | | | |
| | | 480 | | | |
| | | 486 | | | |
| | | 500 | | | |
| | | 503 | | | |
| | | 600 603 | | | |
| 30 | Security-Server | 2xx | [47], [39] | n/a | dn/a |
| | | 421 | | o | dn/a |
| | | 494 | | | |
| 31 | Server | r | [13], [39] | o | do |
| 32 | Session-ID | r | [124] | m | IF table 6.1.3.1/94 THEN dm (NOTE 2) |
| 33 | Supported | 2xx | [13], [39] | o | do |

| Item | Header field | SIP status code | Ref. | RFC status | II-NNI condition |
|------|------------------|-----------------|------------|------------|------------------|
| 34 | Timestamp | r | [13], [39] | o | do |
| 35 | To | 100 others | [13], [39] | m | dm |
| 36 | Unsupported | 420 | [13], [39] | o | do |
| 37 | User-Agent | r | [13], [39] | o | do |
| 38 | Via | 100 others | [13], [39] | m | dm |
| 39 | Warning | r | [13], [39] | o | do |
| 40 | WWW-Authenticate | 401 (NOTE 1) | [13], [39] | m | dm |

NOTE 1: The SIP status code is only applicable over the roaming II-NNI.

NOTE 2: If the capability specified in table 6.1.3.1 is not supported over the II-NNI, the IBCF in the receiving network can omit or modify the SIP header fields in the received SIP message prior to forwarding the SIP message as specified in 3GPP TS 24.229 [5] subclause 5.10.6.2.

B.7 INVITE method

Table B.7.1: Supported header fields within the INVITE request

| Item | Header field | Ref. | RFC status | II-NNI condition |
|------|-------------------------------|-------|------------|---|
| 1 | Accept | [13] | o | IF dc1 (AOC: subclause 12.22) THEN dm ELSE do |
| 1A | Accept-Contact | [51] | o | IF dc2 (PNM: subclause 12.17) THEN dm ELSE do |
| 2 | Accept-Encoding | [13] | o | do |
| 3 | Accept-Language | [13] | o | do |
| 4 | Alert-Info | [13] | o | IF dc3 (CRS: subclause 12.15) THEN dm ELSE IF table 6.1.3.1/10 THEN do (NOTE 3) |
| 5 | Allow | [13] | o | do |
| 6 | Allow-Events | [20] | o | IF table 6.1.3.1/23 THEN do (NOTE 3) |
| 7 | Answer-Mode | [94] | o | IF table 6.1.3.1/90 THEN do (NOTE 3) |
| 8 | Authorization | [13] | o | IF table 6.1.3.1/7 THEN do (NOTE 3) |
| 9 | Call-ID | [13] | m | dm |
| 10 | Call-Info | [13] | o | IF dc4 (CCBS/CCNR/CCNL: subclause 12.11/12.12/12.23) OR dc5 (announcements: subclause 12.21) THEN dm ELSE do |
| 11 | Contact | [13] | m | dm |
| 12 | Content-Disposition | [13] | o | IF dc6 (AOC: subclause 12.22) THEN dm ELSE do |
| 13 | Content-Encoding | [13] | o | do |
| 14 | Content-Language | [13] | o | do |
| 15 | Content-Length | [13] | t | dt |
| 16 | Content-Type | [13] | * | d* |
| 17 | CSeq | [13] | m | dm |
| 18 | Date | [13] | o | do |
| 19 | Expires | [13] | o | do |
| 19A | Feature-Caps | [143] | o | IF table 6.1.3.1/103 THEN do (NOTE 3) |
| 20 | From | [13] | m | dm |
| 20A | Geolocation | [68] | o | do |
| 20AA | Geolocation-Routing | [68] | o | do |
| 20B | History-Info | [25] | o | IF dc7 (CDIV: subclause 12.6) OR dc2 (PNM: subclause 12.17) THEN dm ELSE IF table 6.1.3.1/50 THEN do (NOTE 1, NOTE 3) |
| 21 | In-Reply-To | [13] | o | do |
| 21A | Join | [55] | o | IF table 6.1.3.1/48 THEN do (NOTE 3) |
| 21B | Max-Breadth | [79] | o | do |
| 22 | Max-Forwards | [13] | m | dm |
| 23 | MIME-Version | [13] | o | do |
| 23A | Min-SE | [52] | o | do |
| 24 | Organization | [13] | o | do |
| 24A | P-Access-Network-Info | [24] | o | IF table 6.1.3.1/36 THEN do (NOTE 3) |
| 24B | P-Asserted-Identity | [44] | o | IF table 6.1.3.1/27 AND initial request THEN dm (NOTE 2, NOTE 3) |
| 24C | P-Asserted-Service | [26] | o | IF (non-roaming II-NNI OR loopback traversal scenario OR home-to-visited request on roaming II-NNI) AND table 6.1.3.1/77 AND initial request THEN do (NOTE 3) |
| 24D | P-Called-Party-ID | [24] | o | IF home-to-visited request on roaming II-NNI AND table 6.1.3.1/34 THEN do (NOTE 3) |
| 24E | P-Charging-Function-Addresses | [24] | o | dn/a |
| 24F | P-Charging-Vector | [24] | o | IF table 6.1.3.1/38 THEN do (NOTE 3) |
| 24G | P-Debug-ID | [87] | o | IF table 6.1.3.1/83 THEN do (NOTE 3) |
| 24H | P-Early-Media | [74] | o | IF table 6.1.3.1/69 THEN do (NOTE 3) |
| 25 | P-Media-Authorization | [42] | o | dn/a |
| 25A | P-Preferred-Identity | [44] | o | dn/a |
| 25B | P-Preferred-Service | [26] | o | IF visited-to-home request on roaming II-NNI AND table 6.1.3.1/77 AND initial request THEN |

| Item | Header field | Ref. | RFC status | II-NNI condition |
|-------|---|-------|------------|---|
| | | | | do (NOTE 3) |
| 25C | P-Private-Network-Indication | [84] | o | IF table 6.1.3.1/80 THEN do (NOTE 3) |
| 25D | P-Profile-Key | [64] | o | IF table 6.1.3.1/59 AND initial request THEN do (NOTE 3) |
| 25E | P-Served-User | [85] | o | IF visited-to-home request on roaming II-NNI AND initial request being sent from "privileged sender" THEN dm (NOTE 3) |
| 25F | P-User-Database | [60] | o | dn/a |
| 25G | P-Visited-Network-ID | [24] | o | dn/a |
| 26 | Priority | [13] | o | do |
| 26A | Privacy | [34] | o | IF dc8 (OIP/OIR: subclause 12.3) THEN dm ELSE do |
| 26B | Priv-Answer-Mode | [94] | o | IF table 6.1.3.1/90 THEN do (NOTE 3) |
| 27 | Proxy-Authorization | [13] | o | IF table 6.1.3.1/7 THEN do (NOTE 3) |
| 28 | Proxy-Require | [13] | o | do |
| 28A | Reason | [48] | o | IF table 6.1.3.1/40 AND subsequent request THEN do (NOTE 3) |
| 29 | Record-Route | [13] | o | do |
| 29A | Recv-Info | [39] | m | IF table 6.1.3.1/17 THEN dm (NOTE 3) |
| 30 | Referred-By | [53] | o | IF dc9 (ECT: subclause 12.13) OR dc10 (CONF: subclause 12.19) THEN dm ELSE do |
| 31 | Reject-Contact | [51] | o | do |
| 31A | Replaces | [54] | o | IF dc11 (ECT: subclause 12.13) OR dc12 (CONF: subclause 12.19) THEN dm ELSE IF table 6.1.3.1/47 THEN do (NOTE 3) |
| 31B | Reply-To | [13] | o | do |
| 31C | Request-Disposition | [51] | o | do |
| 32 | Require | [13] | c | IF dc11 (ECT: subclause 12.13) THEN dm ELSE dc |
| 32A | Resource-Priority | [78] | o | IF table 6.1.3.1/73 THEN do (NOTE 3) |
| 33 | Route | [13] | c | dc |
| 33A | Security-Client | [47] | o | dn/a |
| 33B | Security-Verify | [47] | o | dn/a |
| 33D | Session-Expires | [52] | o | do |
| 33E | Session-ID | [124] | m | IF table 6.1.3.1/94 THEN dm (NOTE 3) |
| 34 | Subject | [13] | o | do |
| 35 | Supported | [13] | m* | IF dc2 (PNM: subclause 12.17) THEN dm ELSE dm* |
| 35A | Target-Dialog | [140] | o | IF table 6.1.3.1/102 THEN do (NOTE 3) |
| 36 | Timestamp | [13] | o | do |
| 37 | To | [13] | m | dm |
| 37A | Trigger-Consent | [82] | o | IF table 6.1.3.1/78 THEN do (NOTE 3) |
| 38 | User-Agent | [13] | o | do |
| 38A | User-to-User | [83] | o | IF table 6.1.3.1/79 THEN do (NOTE 3) |
| 39 | Via | [13] | m | dm |
| dc1: | request invoked due to AOC AND visited-to-home request on roaming II-NNI | | | |
| dc2: | initial request invoked due to PNM in case of ("PN UE redirection" OR "PN access control") AND (non-roaming II-NNI OR loopback traversal scenario OR home-to-visited request on roaming II-NNI) | | | |
| dc3: | initial request invoked due to CRS AND (non-roaming II-NNI OR loopback traversal scenario OR home-to-visited request on roaming II-NNI) | | | |
| dc4: | initial request invoked due to CCBS/CCNR/CCNL AND "CC call" request AND (non-roaming II-NNI OR loopback traversal scenario OR home-to-visited request on roaming II-NNI) | | | |
| dc5: | subsequent request invoked due to announcements using the Call-info header field AND (non-roaming II-NNI OR loopback traversal scenario OR home-to-visited request on roaming II-NNI) | | | |
| dc6: | request invoked due to AOC AND home-to-visited request on roaming II-NNI | | | |
| dc7: | initial request towards the network serving "the diverted-to user" AND CFU/CFB/CFNR/CFNRc/CD/CFNL AND (non-roaming II-NNI OR loopback traversal scenario OR home-to-visited request on roaming II-NNI) | | | |
| dc8: | (initial request invoked due to OIP/OIR AND "override the default setting" in temporary mode AND visited-to-home request on roaming II-NNI) OR (initial request invoked due to OIP/OIR AND "presentation of the public user identity is restricted" AND (non-roaming II-NNI OR loopback traversal scenario OR home-to-visited request on roaming II-NNI)) | | | |
| dc9: | initial request invoked due to ECT AND (non-roaming II-NNI OR loopback traversal scenario OR home-to-visited request on roaming II-NNI) | | | |
| dc10: | (initial request from "conference participant" receiving REFER request with Referred-By header field AND (visited-to-home request on roaming II-NNI OR non-roaming II-NNI OR loopback traversal scenario)) OR | | | |

| Item | Header field | Ref. | RFC status | II-NNI condition |
|---------|---|------|------------|------------------|
| dc11: | (initial request from "conference focus" receiving REFER request AND (non-roaming II-NNI OR loopback traversal scenario OR home-to-visited request on roaming II-NNI)) "Consultative transfer" due to ECT AND (non-roaming II-NNI OR loopback traversal scenario OR home-to-visited request on roaming II-NNI) | | | |
| dc12: | initial request from "conference focus" receiving REFER request with Replaces header field escaped in Refer-To header field AND (non-roaming II-NNI OR loopback traversal scenario OR home-to-visited request on roaming II-NNI) | | | |
| NOTE 1: | The Privacy header field can be escaped in the header field for CDIV. | | | |
| NOTE 2: | The header field is not included in some exceptional cases. (e.g. when an incoming call from a circuit-switched network has not included the required information to be mapped into the header field) | | | |
| NOTE 3: | If the capability specified in table 6.1.3.1 is not supported over the II-NNI, the IBCF in the receiving network can omit or modify the SIP header fields in the received SIP message prior to forwarding the SIP message as specified in 3GPP TS 24.229 [5] subclause 5.10.6.2. | | | |

Table B.7.2: Supported header fields within the INVITE response

| Item | Header field | SIP status code | Ref. | RFC status | II-NNI condition |
|------|--------------------------|-----------------|-------|------------|---|
| 1 | Accept | 2xx | [13] | o | do |
| | | 415 | | c | dc |
| 2 | Accept-Encoding | 2xx | [13] | o | do |
| | | 415 | | c | dc |
| 3 | Accept-Language | 2xx | [13] | o | do |
| | | 415 | | c | dc |
| 4 | Accept-Resource-Priority | 2xx 417 | [78] | o | IF table 6.1.3.1/73 THEN do (NOTE 3) |
| 5 | Alert-Info | 180 | [13] | o | IF dc1 (CW: subclause 12.7) OR dc2 (announcements: subclause 12.21) THEN dm ELSE IF table 6.1.3.1/10 THEN do (NOTE 3) |
| 6 | Allow | 2xx | [13] | m* | dm* |
| | | 405 | | m | dm |
| | | others | | o | do |
| 7 | Allow-Events | 2xx | [20] | o | IF table 6.1.3.1/23 THEN do (NOTE 3) |
| 8 | Answer-Mode | 2xx | [94] | o | IF table 6.1.3.1/90 THEN do (NOTE 3) |
| 9 | Authentication-Info | 2xx | [13] | o | IF table 6.1.3.1/7 THEN do (NOTE 3) |
| 10 | Call-ID | r | [13] | m | dm |
| 11 | Call-Info | r | [13] | o | IF dc3 (CCBS: subclause 12.11) OR dc4 (CCNR: subclause 12.12) OR dc5 (CCNL: subclause 12.23) THEN dm ELSE do |
| 12 | Contact | 18x 199 | [13] | o | do |
| | | 2xx | | m | dm |
| | | 3xx 485 | | o | do |
| 13 | Content-Disposition | r | [13] | o | IF dc6 (AOC: subclause 12.22) THEN dm ELSE do |
| 14 | Content-Encoding | r | [13] | o | do |
| 15 | Content-Language | r | [13] | o | do |
| 16 | Content-Length | 100 others | [13] | t | dt |
| 17 | Content-Type | r | [13] | * | IF dc7 (CCBS: subclause 12.11) OR dc8 (CCNR/CCNL: subclause 12.12/12.23) THEN dm ELSE d* |
| 18 | CSeq | 100 others | [13] | m | dm |
| 19 | Date | 100 others | [13] | o | IF dc7 (CCBS: subclause 12.11) OR dc8 (CCNR/CCNL: subclause 12.12/12.23) THEN dm ELSE do |
| 20 | Error-Info | 3xx-6xx | [13] | o | IF dc9 (announcements: subclause 12.21) THEN dm ELSE IF table 6.1.3.1/13 THEN do (NOTE 3) |
| 21 | Expires | r | [13] | o | do |
| 21A | Feature-Caps | 18x 2xx | [143] | o | IF table 6.1.3.1/103 THEN do (NOTE 3) |
| 22 | From | 100 others | [13] | m | dm |
| 23 | Geolocation-Error | 424 | [68] | m | dm |
| | | others | | o | do |
| 24 | History-Info | r | [25] | o | IF dc10 (CDIV: subclause 12.6) THEN dm ELSE IF table 6.1.3.1/50 THEN do (NOTE 2, NOTE 3) |
| 25 | MIME-version | r | [13] | o | do |

| Item | Header field | SIP status code | Ref. | RFC status | II-NNI condition |
|------|-------------------------------|--|-------|------------|--|
| 26 | Min-SE | 422 | [52] | m | dm |
| 27 | Organization | r | [13] | o | do |
| 28 | P-Access-Network-Info | r | [24] | o | IF table 6.1.3.1/36 THEN do (NOTE 3) |
| 29 | P-Answer-State | 18x 2xx | [73] | o | IF table 6.1.3.1/68 THEN do (NOTE 3) |
| 30 | P-Asserted-Identity | r | [44] | o | IF dc11 (TIP/TIR: subclause 12.4) THEN dm ELSE IF table 6.1.3.1/27 AND response to initial request THEN do (NOTE 3) |
| 31 | P-Charging-Function-Addresses | r | [24] | o | dn/a |
| 32 | P-Charging-Vector | r | [24] | o | IF dc12 (CONF: subclause 12.19) THEN dm ELSE IF table 6.1.3.1/38 THEN do (NOTE 3) |
| 33 | P-Debug-ID | 100 others | [87] | o | IF table 6.1.3.1/83 THEN do (NOTE 3) |
| 34 | P-Early-Media | 18x | [74] | o | IF dc13 (CAT: subclause 12.14) OR dc14 (announcements: subclause 12.21) THEN dm ELSE IF table 6.1.3.1/69 THEN do (NOTE 3) |
| 35 | P-Media-Authorization | 18x 2xx | [42] | o | dn/a |
| 36 | P-Preferred-Identity | r | [44] | o | dn/a |
| 36A | P-Refused-URI-List | 403 | [141] | o | IF (non-roaming II-NNI OR loopback traversal scenario) AND table 6.1.3.1/101 THEN do (NOTE 3) |
| 37 | Permission-Missing | 470 | [82] | o | IF table 6.1.3.1/78 THEN do (NOTE 3) |
| 38 | Privacy | r | [34] | o | IF dc15 (TIP/TIR: subclause 12.4) THEN dm ELSE do |
| 39 | Priv-Answer-Mode | 2xx | [94] | o | IF table 6.1.3.1/90 THEN do (NOTE 3) |
| 40 | Proxy-Authenticate | 401 (NOTE 1) | [13] | o | do |
| | | 407 (NOTE 1) | | m | dm |
| 41 | Reason | 18x 199 3xx-6xx | [48] | o | IF dc16 (CW: subclause 12.7) OR dc17 (ICB: subclause 12.10.1) OR dc18 (announcements: subclause 12.21) THEN dm ELSE IF table 6.1.3.1/40 THEN do (NOTE 3) |
| 42 | Record-Route | 18x 199 2xx | [13] | o | do |
| 43 | Recv-Info | 18x 199 2xx | [39] | c | IF table 6.1.3.1/17 THEN dc (NOTE 3) |
| 44 | Reply-To | r | [13] | o | do |
| 45 | Require | r | [13] | c | IF dc19 (CAT: subclause 12.14) THEN dm ELSE dc |
| 46 | Retry-After | 404 413 480 486 500 503 600 603 | [13] | o | do |
| 47 | RSeq | 18x 199 | [18] | o | do |
| 48 | Security-Server | 421 494 | [47] | o | dn/a |
| 49 | Server | r | [13] | o | do |

| Item | Header field | SIP status code | Ref. | RFC status | II-NNI condition |
|---------|--|-----------------|-------|------------|--|
| 50 | Session-Expires | 2xx | [52] | o | do |
| 51 | Session-ID | r | [124] | m | IF table 6.1.3.1/94 THEN dm (NOTE 3) |
| 52 | Supported | 2xx | [13] | m* | dm* |
| 53 | Timestamp | r | [13] | o | do |
| 54 | To | 100 others | [13] | m | dm |
| 55 | Unsupported | 420 | [13] | m | dm |
| 56 | User-Agent | r | [13] | o | do |
| 57 | User-to-User | r | [83] | o | IF table 6.1.3.1/79 THEN do (NOTE 3) |
| 58 | Via | 100 others | [13] | m | dm |
| 59 | Warning | r | [13] | o | IF dc20 (CDIV: subclause 12.6) THEN dm ELSE do |
| 60 | WWW-Authenticate | 401 (NOTE 1) | [13] | m | dm |
| | | 407 (NOTE 1) | | o | do |
| dc1: | response invoked due to CW AND (non-roaming II-NNI OR loopback traversal scenario OR home-to-visited response on roaming II-NNI) | | | | |
| dc2: | response to initial request invoked due to announcements using the Alert-Info header field AND (non-roaming II-NNI OR loopback traversal scenario OR home-to-visited response on roaming II-NNI) | | | | |
| dc3: | 486 (Busy Here) response invoked due to CCBS AND (non-roaming II-NNI OR loopback traversal scenario OR home-to-visited response on roaming II-NNI) | | | | |
| dc4: | 180 (Ringing) response invoked due to CCNR AND (non-roaming II-NNI OR loopback traversal scenario) | | | | |
| dc5: | 480 (Temporarily Unavailable) response invoked due to CCNL AND (non-roaming II-NNI OR loopback traversal scenario OR home-to-visited response on roaming II-NNI) | | | | |
| dc6: | 1xx/200 (OK) response invoked due to AOC AND home-to-visited response on roaming II-NNI | | | | |
| dc7: | 486 (Busy Here) response invoked due to CCBS AND home-to-visited response on roaming II-NNI | | | | |
| dc8: | 480 (Temporarily Unavailable) response invoked due to CCNR/CCNL AND home-to-visited response on roaming II-NNI | | | | |
| dc9: | response to initial request invoked due to announcements using the Error-Info header field AND (non-roaming II-NNI OR loopback traversal scenario OR home-to-visited response on roaming II-NNI) | | | | |
| dc10: | 180 (Ringing)/181 (Call Is Being Forwarded)/200 (OK) response to initial request AND CFU/CFB/CFNR/CFNRc/CD/CFNL AND (non-roaming II-NNI OR loopback traversal scenario OR home-to-visited response on roaming II-NNI) | | | | |
| dc11: | (TIP/TIR AND 2xx response to initial request AND (visited-to-home response on roaming II-NNI OR non-roaming II-NNI OR loopback traversal scenario)) OR (TIP/TIR AND response to initial request AND "presentation is allowed" AND home-to-visited response on roaming II-NNI) | | | | |
| dc12: | first response from "conference focus" to initial request AND (non-roaming II-NNI OR loopback traversal scenario OR home-to-visited response on roaming II-NNI) | | | | |
| dc13: | reliable response to initial request invoked due to CAT using "forking model" AND (non-roaming II-NNI OR loopback traversal scenario OR home-to-visited response on roaming II-NNI) | | | | |
| dc14: | 183 (Session Progress) response to initial request invoked due to announcements authorizing early media AND (non-roaming II-NNI OR loopback traversal scenario OR home-to-visited response on roaming II-NNI) | | | | |
| dc15: | (TIP/TIR AND non-100 response to initial request AND "override the default setting" in temporary mode AND visited-to-home response on roaming II-NNI) OR (TIP/TIR AND 2xx response to initial request AND "presentation of the network asserted identity is restricted" AND (non-roaming II-NNI OR loopback traversal scenario OR home-to-visited response on roaming II-NNI)) | | | | |
| dc16: | 480 (Temporarily Unavailable) response invoked due to CW at the expiry of the "CW timer" | | | | |
| dc17: | 603 (Decline) response invoked due to "dynamic ICB" on an early dialog | | | | |
| dc18: | 183 (Session Progress) response to initial request invoked due to announcements authorizing early media when rejecting a communication request AND (non-roaming II-NNI OR loopback traversal scenario OR home-to-visited response on roaming II-NNI) | | | | |
| dc19: | first 18x response to initial request invoked due to CAT using "early session model" AND (non-roaming II-NNI OR loopback traversal scenario OR home-to-visited response on roaming II-NNI) | | | | |
| dc20: | 480 (Temporarily Unavailable)/486 (Busy Here) response to initial request AND CFU/CFB/CFNR/CFNRc/CD/CFNL in case "maximum number of diversions" exceeds AND (non-roaming II-NNI OR loopback traversal scenario OR home-to-visited response on roaming II-NNI) | | | | |
| NOTE 1: | The SIP status code is only applicable over the roaming II-NNI. | | | | |
| NOTE 2: | The Privacy header field can be escaped in the header field for CDIV. | | | | |
| NOTE 3: | If the capability specified in table 6.1.3.1 is not supported over the II-NNI, the IBCF in the receiving network can omit or modify the SIP header fields in the received SIP message prior to forwarding the SIP message as specified in 3GPP TS 24.229 [5] subclause 5.10.6.2. | | | | |

B.8 MESSAGE method

As described in table 6.1, the support of MESSAGE method over the II-NNI is based on bilateral agreement between the operators.

Table B.8.1: Supported header fields within the MESSAGE request

| Item | Header field | Ref. | RFC status | II-NNI condition |
|------|-----------------------------------|------------|------------|--|
| 1 | Accept-Contact | [51] | o | IF dc1 (PNM: subclause 12.17) THEN dm ELSE do |
| 1A | Allow | [13], [19] | o | do |
| 2 | Allow-Events | [20] | o | IF table 6.1.3.1/23 THEN do (NOTE) |
| 3 | Authorization | [13], [19] | o | IF table 6.1.3.1/7 THEN do (NOTE) |
| 4 | Call-ID | [13], [19] | m | dm |
| 5 | Call-Info | [13], [19] | o | do |
| 6 | Content-Disposition | [13], [19] | o | do |
| 7 | Content-Encoding | [13], [19] | o | do |
| 8 | Content-Language | [13], [19] | o | do |
| 9 | Content-Length | [13], [19] | t | dt |
| 10 | Content-Type | [13], [19] | * | d* |
| 11 | CSeq | [13], [19] | m | dm |
| 12 | Date | [13], [19] | o | do |
| 13 | Expires | [13], [19] | o | do |
| 13A | Feature-Caps | [143] | o | IF table 6.1.3.1/103 AND request outside an existing dialog THEN do (NOTE) |
| 14 | From | [13], [19] | m | dm |
| 14A | Geolocation | [68] | o | do |
| 14AA | Geolocation-Routing | [68] | o | do |
| 14B | History-Info | [25] | o | IF dc1 (PNM: subclause 12.17) THEN dm ELSE IF table 6.1.3.1/50 THEN do (NOTE) |
| 15 | In-Reply-To | [13], [19] | o | do |
| 15A | Max-Breadth | [79] | o | do |
| 16 | Max-Forwards | [13], [19] | m | dm |
| 17 | MIME-Version | [13] | o | do |
| 18 | Organization | [13], [19] | o | do |
| 18A | P-Access-Network-Info | [24] | o | IF table 6.1.3.1/36 THEN do (NOTE) |
| 18B | P-Asserted-Identity | [44] | o | IF table 6.1.3.1/27 AND request outside an existing dialog THEN dm (NOTE) |
| 18C | P-Asserted-Service | [26] | o | IF (non-roaming II-NNI OR home-to-visited request on roaming II-NNI) AND table 6.1.3.1/77 AND request outside an existing dialog THEN do (NOTE) |
| 18D | P-Called-Party-ID | [24] | o | IF home-to-visited request on roaming II-NNI AND table 6.1.3.1/34 THEN do (NOTE) |
| 18E | P-Charging-Function- Addresses | [24] | o | dn/a |
| 18F | P-Charging-Vector | [24] | o | IF table 6.1.3.1/38 THEN do (NOTE) |
| 18G | P-Debug-ID | [87] | o | IF table 6.1.3.1/83 THEN do (NOTE) |
| 18H | P-Preferred-Identity | [44] | o | dn/a |
| 18I | P-Preferred-Service | [26] | o | IF visited-to-home request on roaming II-NNI AND table 6.1.3.1/77 AND request outside an existing dialog THEN do (NOTE) |
| 18J | P-Private-Network-Indication | [84] | o | IF table 6.1.3.1/80 THEN do (NOTE) |
| 18K | P-Profile-Key | [64] | o | IF table 6.1.3.1/59 AND request outside an existing dialog THEN do (NOTE) |
| 18L | P-Served-User | [85] | o | IF visited-to-home request on roaming II-NNI AND request outside an existing dialog being sent from "privileged sender" THEN dm (NOTE) |
| 18M | P-User-Database | [60] | o | dn/a |
| 18N | P-Visited-Network-ID | [24] | o | dn/a |
| 19 | Priority | [13], [19] | o | do |
| 19A | Privacy | [34] | o | IF dc2 (OIP/OIR: subclause 12.3) THEN dm ELSE do |
| 20 | Proxy-Authorization | [13], [19] | o | IF table 6.1.3.1/7 THEN do (NOTE) |
| 21 | Proxy-Require | [13], [19] | o | do |
| 21A | Reason | [48] | o | IF table 6.1.3.1/40 AND request inside an existing dialog THEN do (NOTE) |
| 22 | Record-Route | [13], [19] | n/a | dn/a |
| 22A | Referred-By | [53] | o | do |
| 23 | Reject-Contact | [51] | o | do |

| Item | Header field | Ref. | RFC status | II-NNI condition |
|-------|--|------------|------------|--|
| 23A | Reply-To | [13], [19] | o | do |
| 23B | Request-Disposition | [51] | o | do |
| 24 | Require | [13], [19] | c | dc |
| 24A | Resource-Priority | [78] | o | IF table 6.1.3.1/73 THEN do (NOTE) |
| 25 | Route | [13], [19] | c | dc |
| 25A | Security-Client | [47] | o | dn/a |
| 25B | Security-Verify | [47] | o | dn/a |
| 25C | Session-ID | [124] | m | IF table 6.1.3.1/94 THEN dm (NOTE) |
| 26 | Subject | [13], [19] | o | do |
| 27 | Supported | [13] | o | IF dc1 (PNM: subclause 12.17) THEN dm ELSE do |
| 28 | Timestamp | [13], [19] | o | do |
| 29 | To | [13], [19] | m | dm |
| 29A | Trigger-Consent | [82] | o | IF table 6.1.3.1/78 THEN do (NOTE) |
| 30 | User-Agent | [13], [19] | o | do |
| 31 | Via | [13], [19] | m | dm |
| dc1: | request outside an existing dialog invoked due to PNM in case of ("PN UE redirection" OR "PN access control") AND (non-roaming II-NNI OR home-to-visited request on roaming II-NNI) | | | |
| dc2: | (request outside an existing dialog invoked due to OIP/OIR AND "override the default setting" in temporary mode AND visited-to-home request on roaming II-NNI) OR (request outside an existing dialog invoked due to OIP/OIR AND "presentation of the public user identity is restricted" AND (non-roaming II-NNI OR home-to-visited request on roaming II-NNI)) | | | |
| NOTE: | If the capability specified in table 6.1.3.1 is not supported over the II-NNI, the IBCF in the receiving network can omit or modify the SIP header fields in the received SIP message prior to forwarding the SIP message as specified in 3GPP TS 24.229 [5] subclause 5.10.6.2. | | | |

Table B.8.2: Supported header fields within the MESSAGE response

| Item | Header field | SIP status code | Ref. | RFC status | II-NNI condition |
|------|-------------------------------|-----------------|------------|------------|---|
| 1 | Accept | 415 | [13], [19] | m* | dm* |
| 2 | Accept-Encoding | 415 | [13], [19] | m* | dm* |
| 3 | Accept-Language | 415 | [13], [19] | m* | dm* |
| 4 | Accept-Resource-Priority | 2xx 417 | [78] | o | IF table 6.1.3.1/73 THEN do (NOTE 2) |
| 5 | Allow | 2xx | [13], [19] | o | do |
| | | 405 | | m | dm |
| | | others | | o | do |
| 6 | Allow-Events | 2xx | [20] | o | IF table 6.1.3.1/23 THEN do (NOTE 2) |
| 7 | Authentication-Info | 2xx | [13], [19] | o | IF table 6.1.3.1/7 THEN do (NOTE 2) |
| 8 | Call-ID | 100 others | [13], [19] | m | dm |
| 9 | Call-Info | r | [13], [19] | o | do |
| 10 | Contact | 3xx 485 | [13], [19] | o | do |
| 11 | Content-Disposition | r | [13], [19] | o | do |
| 12 | Content-Encoding | r | [13], [19] | o | do |
| 13 | Content-Language | r | [13], [19] | o | do |
| 14 | Content-Length | 100 others | [13], [19] | t | dt |
| 15 | Content-Type | r | [13], [19] | * | d* |
| 16 | CSeq | 100 others | [13], [19] | m | dm |
| 17 | Date | 100 others | [13], [19] | o | do |
| 18 | Error-Info | 3xx-6xx | [13], [19] | o | IF table 6.1.3.1/13 THEN do (NOTE 2) |
| 19 | Expires | r | [13], [19] | o | do |
| 19A | Feature-Caps | 2xx | [143] | o | IF table 6.1.3.1/103 AND response to request outside an existing dialog THEN do (NOTE 2) |
| 20 | From | 100 others | [13], [19] | m | dm |
| 21 | Geolocation-Error | 424 | [68] | m | dm |
| | | others | | o | do |
| 22 | History-Info | r | [25] | o | IF table 6.1.3.1/50 THEN do (NOTE 2) |
| 23 | MIME-version | r | [13] | o | do |
| 24 | Organization | r | [13], [19] | o | do |
| 25 | P-Access-Network-Info | r | [24] | o | IF table 6.1.3.1/36 THEN do (NOTE 2) |
| 26 | P-Asserted-Identity | r | [44] | o | IF dc1 (TIP/TIR: subclause 12.4) THEN dm ELSE IF table 6.1.3.1/27 AND response to request outside an existing dialog THEN do (NOTE 2) |
| 27 | P-Charging-Function-Addresses | r | [24] | o | dn/a |
| 28 | P-Charging-Vector | r | [24] | o | IF table 6.1.3.1/38 THEN do (NOTE 2) |
| 29 | P-Debug-ID | 100 others | [87] | o | IF table 6.1.3.1/83 THEN do (NOTE 2) |
| 30 | P-Preferred-Identity | r | [44] | o | dn/a |
| 31 | Permission-Missing | 470 | [82] | o | IF table 6.1.3.1/78 THEN do (NOTE 2) |
| 32 | Privacy | r | [34] | o | IF dc2(TIP/TIR: subclause 12.4) THEN dm ELSE do |
| 33 | Proxy-Authenticate | 401 (NOTE 1) | [13], [19] | o | do |
| | | 407 (NOTE 1) | | m | dm |

| Item | Header field | SIP status code | Ref. | RFC status | II-NNI condition |
|--|---|--|------------|------------|---|
| 34 | Record-Route | 2xx | [13], [19] | n/a | dn/a |
| 35 | Reply-To | r | [13], [19] | o | do |
| 36 | Require | r | [13], [19] | c | dc |
| 37 | Retry-After | 404 413 480 486 500 503 600 603 | [13], [19] | o | do |
| 38 | Security-Server | 2xx | [47] | n/a | dn/a |
| | | 421 494 | | o | dn/a |
| 39 | Server | r | [13], [19] | o | do |
| 40 | Session-ID | r | [124] | m | IF table 6.1.3.1/94 THEN dm (NOTE 2) |
| 41 | Supported | 2xx | [13] | o | do |
| 42 | Timestamp | r | [13], [19] | o | do |
| 43 | To | 100 others | [13], [19] | m | dm |
| 44 | Unsupported | 420 | [13], [19] | o | do |
| 45 | User-Agent | r | [13], [19] | o | do |
| 46 | Via | 100 others | [13], [19] | m | dm |
| 47 | Warning | r | [13], [19] | o | do |
| 48 | WWW-Authenticate | 401 (NOTE 1) | [13], [19] | m | dm |
| | | 407 (NOTE 1) | | o | do |
| dc1: | (TIP/TIR AND 2xx response to request outside an existing dialog AND (visited-to-home response on roaming II-NNI OR non-roaming II-NNI)) OR (TIP/TIR AND response to request outside an existing dialog AND "presentation is allowed" AND home-to-visited response on roaming II-NNI) | | | | |
| dc2: | (TIP/TIR AND non-100 response to request outside an existing dialog AND "override the default setting" in temporary mode AND visited-to-home response on roaming II-NNI) OR (TIP/TIR AND 2xx response to request outside an existing dialog AND "presentation of the network asserted identity is restricted" AND (non-roaming II-NNI OR home-to-visited response on roaming II-NNI)) | | | | |
| NOTE 1: The SIP status code is only applicable over the roaming II-NNI. | | | | | |
| NOTE 2: If the capability specified in table 6.1.3.1 is not supported over the II-NNI, the IBCF in the receiving network can omit or modify the SIP header fields in the received SIP message prior to forwarding the SIP message as specified in 3GPP TS 24.229 [5] subclause 5.10.6.2. | | | | | |

B.9 NOTIFY method

As described in table 6.1, the support of NOTIFY method over the non-roaming II-NNI is based on bilateral agreement between the operators.

Table B.9.1: Supported header fields within the NOTIFY request

| Item | Header field | Ref. | RFC status | II-NNI condition |
|-------|--|------------|------------|-------------------------------------|
| 1 | Accept | [13], [20] | o | do |
| 1A | Accept-Contact | [51] | o | do |
| 2 | Accept-Encoding | [13], [20] | o | do |
| 3 | Accept-Language | [13], [20] | o | do |
| 3A | Allow | [13], [20] | o | do |
| 4 | Allow-Events | [20] | o | do |
| 5 | Authorization | [13], [20] | o | IF table 6.1.3.1/7 THEN do (NOTE) |
| 6 | Call-ID | [13], [20] | m | dm |
| 6A | Call-Info | [13] | o | do |
| 6B | Contact | [13], [20] | m | dm |
| 7 | Content-Disposition | [13], [20] | o | do |
| 8 | Content-Encoding | [13], [20] | o | do |
| 9 | Content-Language | [13], [20] | o | do |
| 10 | Content-Length | [13], [20] | t | dt |
| 11 | Content-Type | [13], [20] | * | d* |
| 12 | CSeq | [13], [20] | m | dm |
| 13 | Date | [13], [20] | o | do |
| 14 | Event | [20] | m | dm |
| 14A | Feature-Caps | [143] | o | IF table 6.1.3.1/103 THEN do (NOTE) |
| 15 | From | [13], [20] | m | dm |
| 15A | Geolocation | [68] | o | do |
| 15AA | Geolocation-Routing | [68] | o | do |
| 15B | History-Info | [25] | o | IF table 6.1.3.1/50 THEN do (NOTE) |
| 15C | Max-Breadth | [79] | o | do |
| 16 | Max-Forwards | [13], [20] | m | dm |
| 17 | MIME-Version | [13], [20] | o | do |
| 17A | P-Access-Network-Info | [24] | o | IF table 6.1.3.1/36 THEN do (NOTE) |
| 17B | P-Asserted-Identity | [44] | o | IF table 6.1.3.1/27 THEN do (NOTE) |
| 17C | P-Charging-Function-Addresses | [24] | o | dn/a |
| 17D | P-Charging-Vector | [24] | o | dn/a |
| 17E | P-Debug-ID | [87] | o | IF table 6.1.3.1/83 THEN do (NOTE) |
| 17F | P-Preferred-Identity | [44] | o | dn/a |
| 17G | Privacy | [34] | o | do |
| 18 | Proxy-Authorization | [13], [20] | o | IF table 6.1.3.1/7 THEN do (NOTE) |
| 19 | Proxy-Require | [13], [20] | o | do |
| 19A | Reason | [48] | o | IF table 6.1.3.1/40 THEN do (NOTE) |
| 20 | Record-Route | [13], [20] | o | do |
| 20A | Referred-By | [53] | o | do |
| 20B | Reject-Contact | [51] | o | do |
| 20C | Request-Disposition | [51] | o | do |
| 21 | Require | [13], [20] | o | do |
| 22 | Route | [13], [20] | c | dc |
| 22A | Resource-Priority | [78] | o | IF table 6.1.3.1/73 THEN do (NOTE) |
| 22B | Security-Client | [47] | o | dn/a |
| 22C | Security-Verify | [47] | o | dn/a |
| 22D | Session-ID | [124] | m | IF table 6.1.3.1/94 THEN dm (NOTE) |
| 23 | Subscription-State | [20] | m | dm |
| 24 | Supported | [13], [20] | o | do |
| 25 | Timestamp | [13], [20] | o | do |
| 26 | To | [13], [20] | m | dm |
| 27 | User-Agent | [13], [20] | o | do |
| 28 | Via | [13], [20] | m | dm |
| 29 | Warning | [13], [20] | o | do |
| NOTE: | If the capability specified in table 6.1.3.1 is not supported over the II-NNI, the IBCF in the receiving network can omit or modify the SIP header fields in the received SIP message prior to forwarding the SIP message as specified in 3GPP TS 24.229 [5] subclause 5.10.6.2. | | | |

Table B.9.2: Supported header fields within the NOTIFY response

| Item | Header field | SIP status code | Ref. | RFC status | II-NNI condition |
|------|-------------------------------|--|------------|------------|---------------------------------------|
| 1 | Accept | 415 | [13], [20] | o | do |
| 2 | Accept-Encoding | 415 | [13], [20] | o | do |
| 3 | Accept-Language | 415 | [13], [20] | o | do |
| 4 | Accept-Resource-Priority | 2xx 417 | [78] | o | IF table 6.1.3.1/73 THEN do (NOTE 2) |
| 5 | Allow | 405 | [13], [20] | m | dm |
| | | others | | o | do |
| 6 | Allow-Events | 2xx | [20] | o | do |
| | | 489 | | m | dm |
| 7 | Authentication-Info | 2xx | [13], [20] | o | IF table 6.1.3.1/7 THEN do (NOTE 2) |
| 8 | Call-ID | 100 others | [13], [20] | m | dm |
| 9 | Contact | 2xx | [13], [20] | o | do |
| | | 3xx | | m | dm |
| | | 485 | | o | do |
| 10 | Content-Disposition | r | [13], [20] | o | do |
| 11 | Content-Encoding | r | [13], [20] | o | do |
| 12 | Content-Language | r | [13], [20] | o | do |
| 13 | Content-Length | 100 others | [13], [20] | t | dt |
| 14 | Content-Type | r | [13], [20] | * | d* |
| 15 | CSeq | 100 others | [13], [20] | m | dm |
| 16 | Date | 100 others | [13], [20] | o | do |
| 17 | Error-Info | 3xx-6xx | [13], [20] | o | IF table 6.1.3.1/13 THEN do (NOTE 2) |
| 17A | Feature-Caps | 2xx | [143] | o | IF table 6.1.3.1/103 THEN do (NOTE 2) |
| 18 | From | 100 others | [13], [20] | m | dm |
| 19 | Geolocation-Error | 424 | [68] | m | dm |
| | | others | | o | do |
| 20 | MIME-version | r | [13], [20] | o | do |
| 21 | P-Access-Network-Info | r | [24] | o | IF table 6.1.3.1/36 THEN do (NOTE 2) |
| 22 | P-Asserted-Identity | r | [44] | o | IF table 6.1.3.1/27 THEN do (NOTE 2) |
| 23 | P-Charging-Function-Addresses | r | [24] | o | dn/a |
| 24 | P-Charging-Vector | r | [24] | o | dn/a |
| 25 | P-Debug-ID | 100 others | [87] | o | IF table 6.1.3.1/83 THEN do (NOTE 2) |
| 26 | P-Preferred-Identity | r | [44] | o | dn/a |
| 27 | Privacy | r | [34] | o | do |
| 28 | Proxy-Authenticate | 401 (NOTE 1) | [13], [20] | o | do |
| | | 407 (NOTE 1) | | m | dm |
| 29 | Record-Route | 2xx | [13], [20] | o | do |
| 30 | Require | r | [13], [20] | o | do |
| 31 | Retry-After | 404 413 480 486 500 503 600 603 | [13], [20] | o | do |
| 32 | Security-Server | 2xx | [47] | n/a | dn/a |

| Item | Header field | SIP status code | Ref. | RFC status | II-NNI condition |
|--|------------------|-----------------|------------|------------|---|
| | | 421 494 | | o | dn/a |
| 33 | Server | r | [13], [20] | o | do |
| 34 | Session-ID | r | [124] | m | IF table 6.1.3.1/94 THEN dm (NOTE 2) |
| 35 | Supported | 2xx | [13], [20] | o | do |
| 36 | Timestamp | r | [13], [20] | o | do |
| 37 | To | 100 others | [13], [20] | m | dm |
| 38 | Unsupported | 420 | [13], [20] | o | do |
| 39 | User-Agent | r | [13], [20] | o | do |
| 40 | Via | 100 others | [13], [20] | m | dm |
| 41 | Warning | r | [13], [20] | o | do |
| 42 | WWW-Authenticate | 401 (NOTE 1) | [13], [20] | m | dm |
| | | 407 (NOTE 1) | | o | do |
| NOTE 1: The SIP status code is only applicable over the roaming II-NNI. | | | | | |
| NOTE 2: If the capability specified in table 6.1.3.1 is not supported over the II-NNI, the IBCF in the receiving network can omit or modify the SIP header fields in the received SIP message prior to forwarding the SIP message as specified in 3GPP TS 24.229 [5] subclause 5.10.6.2. | | | | | |

B.10 OPTIONS method

Table B.10.1: Supported header fields within the OPTIONS request

| Item | Header field | Ref. | RFC status | II-NNI condition |
|------|-----------------------------------|-------|------------|--|
| 1 | Accept | [13] | m* | dm* |
| 1A | Accept-Contact | [51] | o | IF dc1 (PNM: subclause 12.17) THEN dm ELSE do |
| 2 | Accept-Encoding | [13] | o | do |
| 3 | Accept-Language | [13] | o | do |
| 3A | Allow | [13] | o | do |
| 4 | Allow-Events | [20] | o | IF table 6.1.3.1/23 THEN do (NOTE) |
| 5 | Authorization | [13] | o | IF table 6.1.3.1/7 THEN do (NOTE) |
| 6 | Call-ID | [13] | m | dm |
| 7 | Call-Info | [13] | o | do |
| 8 | Contact | [13] | o | do |
| 9 | Content-Disposition | [13] | o | do |
| 10 | Content-Encoding | [13] | o | do |
| 11 | Content-Language | [13] | o | do |
| 12 | Content-Length | [13] | t | dt |
| 13 | Content-Type | [13] | * | d* |
| 14 | CSeq | [13] | m | dm |
| 15 | Date | [13] | o | do |
| 15A | Feature-Caps | [143] | o | IF table 6.1.3.1/103 AND request outside an existing dialog THEN do (NOTE) |
| 16 | From | [13] | m | dm |
| 16A | Geolocation | [68] | o | do |
| 16AA | Geolocation-Routing | [68] | o | do |
| 16B | History-Info | [25] | o | IF (dc1 (PNM: subclause 12.17) THEN dm ELSE IF table 6.1.3.1/50 THEN do (NOTE) |
| 16C | Max-Breadth | [79] | o | do |
| 17 | Max-Forwards | [13] | m | dm |
| 18 | MIME-Version | [13] | o | do |
| 19 | Organization | [13] | o | do |
| 19A | P-Access-Network-Info | [24] | o | IF table 6.1.3.1/36 THEN do (NOTE) |
| 19B | P-Asserted-Identity | [44] | o | IF table 6.1.3.1/27 AND request outside an existing dialog THEN dm (NOTE) |
| 19C | P-Asserted-Service | [26] | o | IF (non-roaming II-NNI OR home-to-visited request on roaming II-NNI) AND table 6.1.3.1/77 AND request outside an existing dialog THEN do (NOTE) |
| 19D | P-Called-Party-ID | [24] | o | IF home-to-visited request on roaming II-NNI AND table 6.1.3.1/34 THEN do (NOTE) |
| 19E | P-Charging-Function- Addresses | [24] | o | dn/a |
| 19F | P-Charging-Vector | [24] | o | IF table 6.1.3.1/38 THEN do (NOTE) |
| 19G | P-Debug-ID | [87] | o | IF table 6.1.3.1/83 THEN do (NOTE) |
| 19H | P-Preferred-Identity | [44] | o | dn/a |
| 19I | P-Preferred-Service | [26] | o | IF visited-to-home request on roaming II-NNI AND table 6.1.3.1/77 AND request outside an existing dialog THEN do (NOTE) |
| 19J | P-Private-Network-Indication | [84] | o | IF table 6.1.3.1/80 THEN do (NOTE) |
| 19K | P-Profile-Key | [64] | o | IF table 6.1.3.1/59 AND request outside an existing dialog THEN do (NOTE) |
| 19L | P-Served-User | [85] | o | IF visited-to-home request on roaming II-NNI AND request outside an existing dialog being sent from "privileged sender" THEN dm (NOTE) |
| 19M | P-User-Database | [60] | o | dn/a |
| 19N | P-Visited-Network-ID | [24] | o | dn/a |
| 19O | Privacy | [34] | o | IF dc2 (OIP/OIR: subclause 12.3) THEN dm ELSE do |
| 20 | Proxy-Authorization | [13] | o | IF table 6.1.3.1/7 THEN do (NOTE) |
| 21 | Proxy-Require | [13] | o | do |
| 21A | Reason | [48] | o | IF table 6.1.3.1/40 AND request inside an |

| Item | Header field | Ref. | RFC status | II-NNI condition |
|-------|--|-------|------------|--|
| | | | | existing dialog THEN do (NOTE) |
| 22 | Record-Route | [13] | o | do |
| 22A | Recv-Info | [39] | n/a | dn/a |
| 22B | Referred-By | [53] | o | do |
| 22C | Reject-Contact | [51] | o | do |
| 22D | Request-Disposition | [51] | o | do |
| 23 | Require | [13] | c | dc |
| 23A | Resource-Priority | [78] | o | IF table 6.1.3.1/73 THEN do (NOTE) |
| 24 | Route | [13] | c | dc |
| 24A | Security-Client | [47] | o | dn/a |
| 24B | Security-Verify | [47] | o | dn/a |
| 24C | Session-ID | [124] | m | IF table 6.1.3.1/94 THEN dm (NOTE) |
| 25 | Supported | [13] | o | IF dc1 (PNM: subclause 12.17) THEN dm ELSE do |
| 26 | Timestamp | [13] | o | do |
| 27 | To | [13] | m | dm |
| 28 | User-Agent | [13] | o | do |
| 29 | Via | [13] | m | dm |
| dc1: | request outside an existing dialog invoked due to PNM in case of ("PN UE redirection" OR "PN access control") AND (non-roaming II-NNI OR home-to-visited request on roaming II-NNI) | | | |
| dc2: | (request outside an existing dialog invoked due to OIP/OIR AND "override the default setting" in temporary mode AND visited-to-home request on roaming II-NNI) OR (request outside an existing dialog invoked due to OIP/OIR AND "presentation of the public user identity is restricted" AND (non-roaming II-NNI OR home-to-visited request on roaming II-NNI)) | | | |
| NOTE: | If the capability specified in table 6.1.3.1 is not supported over the II-NNI, the IBCF in the receiving network can omit or modify the SIP header fields in the received SIP message prior to forwarding the SIP message as specified in 3GPP TS 24.229 [5] subclause 5.10.6.2. | | | |

Table B.10.2: Supported header fields within the OPTIONS response

| Item | Header field | SIP status code | Ref. | RFC status | II-NNI condition |
|------|-------------------------------|-------------------|-------|------------|---|
| 1 | Accept | 2xx | [13] | m* | dm* |
| | | 415 | | c | dc |
| 2 | Accept-Encoding | 2xx | [13] | m* | dm* |
| | | 415 | | c | dc |
| 3 | Accept-Language | 2xx | [13] | m* | dm* |
| | | 415 | | c | dc |
| 4 | Accept-Resource-Priority | 2xx 417 | [78] | o | IF table 6.1.3.1/73 THEN do (NOTE 2) |
| 5 | Allow | 2xx | [13] | m* | dm* |
| | | 405 | | m | dm |
| | | others | | o | do |
| 6 | Allow-Events | 2xx | [20] | o | IF table 6.1.3.1/23 THEN do (NOTE 2) |
| 7 | Authentication-Info | 2xx | [13] | o | IF table 6.1.3.1/7 THEN do (NOTE 2) |
| 8 | Call-ID | 100 others | [13] | m | dm |
| 9 | Call-Info | r | [13] | o | do |
| 10 | Contact | 2xx 3xx 485 | [13] | o | do |
| 11 | Content-Disposition | r | [13] | o | do |
| 12 | Content-Encoding | r | [13] | o | do |
| 13 | Content-Language | r | [13] | o | do |
| 14 | Content-Length | 100 others | [13] | t | dt |
| 15 | Content-Type | r | [13] | * | d* |
| 16 | CSeq | 100 others | [13] | m | dm |
| 17 | Date | 100 others | [13] | o | do |
| 18 | Error-Info | 3xx-6xx | [13] | o | IF table 6.1.3.1/13 THEN do (NOTE 2) |
| 18A | Feature-Caps | 2xx | [143] | o | IF table 6.1.3.1/103 AND response to request outside an existing dialog THEN do (NOTE 2) |
| 19 | From | 100 others | [13] | m | dm |
| 20 | Geolocation-Error | 424 | [68] | m | dm |
| | | others | | o | do |
| 21 | History-Info | r | [25] | o | IF table 6.1.3.1/50 THEN do (NOTE 2) |
| 22 | MIME-version | r | [13] | o | do |
| 23 | Organization | r | [13] | o | do |
| 24 | P-Access-Network-Info | r | [24] | o | IF table 6.1.3.1/36 THEN do (NOTE 2) |
| 25 | P-Asserted-Identity | r | [44] | o | IF dc1 (TIP/TIR: subclause 12.4) THEN dm ELSE IF table 6.1.3.1/27 AND response to request outside an existing dialog THEN do (NOTE 2) |
| 26 | P-Charging-Function-Addresses | r | [24] | o | dn/a |
| 27 | P-Charging-Vector | r | [24] | o | IF table 6.1.3.1/38 THEN do (NOTE 2) |
| 28 | P-Debug-ID | 100 others | [87] | o | IF table 6.1.3.1/83 THEN do (NOTE 2) |
| 29 | P-Preferred-Identity | r | [44] | o | dn/a |
| 30 | Privacy | r | [34] | o | IF dc2 (TIP/TIR: subclause 12.4) THEN dm ELSE do |
| 31 | Proxy-Authenticate | 401 (NOTE 1) | [13] | o | do |
| | | 407 | | m | dm |

| Item | Header field | SIP status code | Ref. | RFC status | II-NNI condition |
|---------|---|--|-------|------------|---|
| | | (NOTE 1) | | | |
| 32 | Record-Route | 2xx | [13] | o | do |
| 33 | Recv-Info | 2xx others | [39] | n/a | dn/a |
| 34 | Require | r | [13] | c | dc |
| 35 | Retry-After | 404 413 480 486 500 503 600 603 | [13] | o | do |
| 36 | Security-Server | 2xx | [47] | n/a | dn/a |
| | | 421 | | o | dn/a |
| | | 494 | | | |
| 37 | Server | r | [13] | o | do |
| 38 | Session-ID | r | [124] | m | IF table 6.1.3.1/94 THEN dm (NOTE 2) |
| 39 | Supported | 2xx | [13] | m* | dm* |
| 40 | Timestamp | r | [13] | o | do |
| 41 | To | 100 others | [13] | m | dm |
| 42 | Unsupported | 420 | [13] | m | dm |
| 43 | User-Agent | r | [13] | o | do |
| 44 | Via | 100 others | [13] | m | dm |
| 45 | Warning | r | [13] | o | do |
| 46 | WWW-Authenticate | 401 (NOTE 1) | [13] | m | dm |
| | | 407 (NOTE 1) | | o | do |
| dc1: | (TIP/TIR AND 2xx response to request outside an existing dialog AND (visited-to-home response on roaming II-NNI OR non-roaming II-NNI)) OR (TIP/TIR AND response to request outside an existing dialog AND "presentation is allowed" AND home-to-visited response on roaming II-NNI) | | | | |
| dc2: | (TIP/TIR AND non-100 response to request outside an existing dialog AND "override the default setting" in temporary mode AND visited-to-home response on roaming II-NNI) OR (TIP/TIR AND 2xx response to request outside an existing dialog AND "presentation of the network asserted identity is restricted" AND (non-roaming II-NNI OR home-to-visited response on roaming II-NNI)) | | | | |
| NOTE 1: | The SIP status code is only applicable over the roaming II-NNI. | | | | |
| NOTE 2: | If the capability specified in table 6.1.3.1 is not supported over the II-NNI, the IBCF in the receiving network can omit or modify the SIP header fields in the received SIP message prior to forwarding the SIP message as specified in 3GPP TS 24.229 [5] subclause 5.10.6.2. | | | | |

B.11 PRACK method

Table B.11.1: Supported header fields within the PRACK request

| Item | Header field | Ref. | RFC status | II-NNI condition |
|-------|--|------------|------------|---|
| 1 | Accept | [13], [18] | o | do |
| 1A | Accept-Contact | [51] | o | do |
| 2 | Accept-Encoding | [13], [18] | o | do |
| 3 | Accept-Language | [13], [18] | o | do |
| 3A | Allow | [13], [18] | o | do |
| 4 | Allow-Events | [20] | o | IF table 6.1.3.1/23 THEN do (NOTE) |
| 5 | Authorization | [13], [18] | o | IF table 6.1.3.1/7 THEN do (NOTE) |
| 6 | Call-ID | [13], [18] | m | dm |
| 7 | Content-Disposition | [13], [18] | o | do |
| 8 | Content-Encoding | [13], [18] | o | do |
| 9 | Content-Language | [13], [18] | o | do |
| 10 | Content-Length | [13], [18] | t | dt |
| 11 | Content-Type | [13], [18] | * | d* |
| 12 | CSeq | [13], [18] | m | dm |
| 13 | Date | [13], [18] | o | do |
| 14 | From | [13], [18] | m | dm |
| 14A | Max-Breadth | [79] | o | do |
| 15 | Max-Forwards | [13], [18] | m | dm |
| 16 | MIME-Version | [13], [18] | o | do |
| 16A | P-Access-Network-Info | [24] | o | IF table 6.1.3.1/36 THEN do (NOTE) |
| 16B | P-Charging-Function-Addresses | [24] | o | dn/a |
| 16C | P-Charging-Vector | [24] | o | dn/a |
| 16D | P-Debug-ID | [87] | o | IF table 6.1.3.1/83 THEN do (NOTE) |
| 16E | P-Early-Media | [74] | o | IF dc1 (CAT: subclause 12.14) THEN dm ELSE IF table 6.1.3.1/69 THEN do (NOTE) |
| 16F | Privacy | [34] | o | do |
| 17 | Proxy-Authorization | [13], [18] | o | IF table 6.1.3.1/7 THEN do (NOTE) |
| 18 | Proxy-Require | [13], [18] | o | do |
| 19 | RAck | [18] | m | dm |
| 19A | Reason | [48] | o | IF table 6.1.3.1/40 THEN do (NOTE) |
| 20 | Record-Route | [13], [18] | o | do |
| 20A | Recv-Info | [39] | o | IF table 6.1.3.1/17 THEN do (NOTE) |
| 20B | Referred-By | [53] | o | do |
| 20C | Reject-Contact | [51] | o | do |
| 20D | Request-Disposition | [51] | o | do |
| 21 | Require | [13], [18] | c | dc |
| 21A | Resource-Priority | [78] | o | IF table 6.1.3.1/73 THEN do (NOTE) |
| 22 | Route | [13], [18] | c | dc |
| 22A | Session-ID | [124] | m | IF table 6.1.3.1/94 THEN dm (NOTE) |
| 23 | Supported | [13], [18] | o | do |
| 24 | Timestamp | [13], [18] | o | do |
| 25 | To | [13], [18] | m | dm |
| 26 | User-Agent | [13], [18] | o | do |
| 27 | Via | [13], [18] | m | dm |
| dc1: | request invoked due to CAT to first 18x response with P-Early-Media header field cancelling "CAT service" provided by terminating AS AND (non-roaming II-NNI OR loopback traversal scenario OR home-to-visited request on roaming II-NNI) | | | |
| NOTE: | If the capability specified in table 6.1.3.1 is not supported over the II-NNI, the IBCF in the receiving network can omit or modify the SIP header fields in the received SIP message prior to forwarding the SIP message as specified in 3GPP TS 24.229 [5] subclause 5.10.6.2. | | | |

Table B.11.2: Supported header fields within the PRACK response

| Item | Header field | SIP status code | Ref. | RFC status | II-NNI condition |
|------|-------------------------------|--|------------|------------|--------------------------------------|
| 1 | Accept | 415 | [13], [18] | c | dc |
| 2 | Accept-Encoding | 415 | [13], [18] | c | dc |
| 3 | Accept-Language | 415 | [13], [18] | c | dc |
| 4 | Accept-Resource-Priority | 2xx 417 | [78] | o | IF table 6.1.3.1/73 THEN do (NOTE 2) |
| 5 | Allow | 2xx | [13], [18] | o | do |
| | | 405 | | m | dm |
| | | others | | o | do |
| 6 | Allow-Events | 2xx | [20] | o | IF table 6.1.3.1/23 THEN do (NOTE 2) |
| 7 | Authentication-Info | 2xx | [13], [18] | o | IF table 6.1.3.1/7 THEN do (NOTE 2) |
| 8 | Call-ID | 100 r | [13], [18] | m | dm |
| 9 | Contact | 3xx 485 | [13], [18] | o | do |
| 10 | Content-Disposition | r | [13], [18] | o | do |
| 11 | Content-Encoding | r | [13], [18] | o | do |
| 12 | Content-Language | r | [13], [18] | o | do |
| 13 | Content-Length | 100 others | [13], [18] | t | dt |
| 14 | Content-Type | r | [13], [18] | * | d* |
| 15 | CSeq | 100 others | [13], [18] | m | dm |
| 16 | Date | 100 others | [13], [18] | o | do |
| 17 | Error-Info | 3xx-6xx | [13], [18] | o | IF table 6.1.3.1/13 THEN do (NOTE 2) |
| 18 | From | 100 others | [13], [18] | m | dm |
| 19 | MIME-version | r | [13], [18] | o | do |
| 20 | P-Access-Network-Info | r | [24] | o | IF table 6.1.3.1/36 THEN do (NOTE 2) |
| 21 | P-Charging-Function-Addresses | r | [24] | o | dn/a |
| 22 | P-Charging-Vector | r | [24] | o | dn/a |
| 23 | P-Debug-ID | 100 others | [87] | o | IF table 6.1.3.1/83 THEN do (NOTE 2) |
| 24 | P-Early-Media | 2xx | [74] | o | IF table 6.1.3.1/69 THEN do (NOTE 2) |
| | | others | | n/a | dn/a |
| 25 | Privacy | r | [34] | o | do |
| 26 | Proxy-Authenticate | 401 (NOTE 1) | [13], [18] | o | do |
| | | 407 (NOTE 1) | | m | dm |
| 27 | Record-Route | 2xx | [13], [18] | o | do |
| 28 | Recv-Info | 2xx | [39] | c | IF table 6.1.3.1/17 THEN dc (NOTE 2) |
| | | others | | o | IF table 6.1.3.1/17 THEN do (NOTE 2) |
| 29 | Require | r | [13], [18] | c | dc |
| 30 | Retry-After | 404 413 480 486 500 503 600 603 | [13], [18] | o | do |
| 31 | Security-Server | 421 494 | [47] | n/a | dn/a |

| Item | Header field | SIP status code | Ref. | RFC status | II-NNI condition |
|--|------------------|-----------------|------------|------------|--------------------------------------|
| 32 | Server | r | [13], [18] | o | do |
| 33 | Session-ID | r | [124] | m | IF table 6.1.3.1/94 THEN dm (NOTE 2) |
| 34 | Supported | 2xx | [13], [18] | o | do |
| 35 | Timestamp | r | [13], [18] | o | do |
| 36 | To | 100 others | [13], [18] | m | dm |
| 37 | Unsupported | 420 | [13], [18] | m | dm |
| 38 | User-Agent | r | [13], [18] | o | do |
| 39 | Via | 100 others | [13], [18] | m | dm |
| 40 | Warning | r | [13], [18] | o | do |
| 41 | WWW-Authenticate | 401 (NOTE 1) | [13], [18] | m | dm |
| | | 407 (NOTE 1) | | o | do |
| NOTE 1: The SIP status code is only applicable over the roaming II-NNI. | | | | | |
| NOTE 2: If the capability specified in table 6.1.3.1 is not supported over the II-NNI, the IBCF in the receiving network can omit or modify the SIP header fields in the received SIP message prior to forwarding the SIP message as specified in 3GPP TS 24.229 [5] subclause 5.10.6.2. | | | | | |

B.12 PUBLISH method

As described in table 6.1, the support of PUBLISH method over the non-roaming II-NNI is based on bilateral agreement between the operators.

Table B.12.1: Supported header fields within the PUBLISH request

| Item | Header field | Ref. | RFC status | II-NNI condition |
|------|-------------------------------|------------|------------|---|
| 1 | Accept-Contact | [51] | o | IF dc1 (PNM: subclause 12.17) THEN dm ELSE do |
| 2 | Allow | [13], [21] | o | do |
| 3 | Allow-Events | [20] | o | IF table 6.1.3.1/23 THEN do (NOTE) |
| 4 | Authorization | [13], [21] | o | IF table 6.1.3.1/7 THEN do (NOTE) |
| 5 | Call-ID | [13], [21] | m | dm |
| 6 | Call-Info | [13], [21] | o | IF dc2 (CCBS/CCNR/CCNL: subclause 12.11/12.12/12.23) THEN dm ELSE do |
| 6A | Contact | [13], [21] | n/a | dn/a |
| 7 | Content-Disposition | [13], [21] | o | do |
| 8 | Content-Encoding | [13], [21] | o | do |
| 9 | Content-Language | [13], [21] | o | do |
| 10 | Content-Length | [13], [21] | t | dt |
| 11 | Content-Type | [13], [21] | * | d* |
| 12 | CSeq | [13], [12] | m | dm |
| 13 | Date | [13], [21] | o | do |
| 14 | Event | [20] | m | dm |
| 15 | Expires | [13], [21] | o | IF dc2 (CCBS/CCNR/CCNL: subclause 12.11/12.12/12.23) THEN dm ELSE do |
| 15A | Feature-Caps | [143] | o | IF table 6.1.3.1/103 AND request outside an existing dialog THEN do |
| 16 | From | [13], [21] | m | dm |
| 16A | Geolocation | [68] | o | do |
| 16AA | Geolocation-Routing | [68] | o | do |
| 16B | History-Info | [25] | o | IF dc1 (PNM: subclause 12.17) THEN dm ELSE IF table 6.1.3.1/50 THEN do (NOTE) |
| 17 | In-Reply-To | [13], [21] | n/a | dn/a |
| 17A | Max-Breadth | [79] | o | do |
| 18 | Max-Forwards | [13], [21] | m | dm |
| 19 | MIME-Version | [13], [21] | o | do |
| 20 | Organization | [13], [21] | o | do |
| 21 | P-Access-Network-Info | [24] | o | IF table 6.1.3.1/36 THEN do (NOTE) |
| 22 | P-Asserted-Identity | [44] | o | IF dc2 (CCBS/CCNR/CCNL: subclause 12.11/12.12/12.23) OR table 6.1.3.1/27 AND request outside an existing dialog THEN dm (NOTE) |
| 22A | P-Asserted-Service | [26] | o | IF (non-roaming II-NNI OR home-to-visited request on roaming II-NNI) AND table 6.1.3.1/77 AND request outside an existing dialog THEN do (NOTE) |
| 23 | P-Called-Party-ID | [24] | o | IF home-to-visited request on roaming II-NNI AND table 6.1.3.1/34 THEN do (NOTE) |
| 24 | P-Charging-Function-Addresses | [24] | o | dn/a |
| 25 | P-Charging-Vector | [24] | o | IF table 6.1.3.1/38 THEN do (NOTE) |
| 25A | P-Debug-ID | [87] | o | IF table 6.1.3.1/83 THEN do (NOTE) |
| 26 | P-Preferred-Identity | [44] | o | dn/a |
| 26A | P-Preferred-Service | [26] | o | IF visited-to-home request on roaming II-NNI AND table 6.1.3.1/77 AND request outside an existing dialog THEN do (NOTE) |
| 26B | P-Private-Network-Indication | [84] | o | IF table 6.1.3.1/80 THEN do (NOTE) |
| 26C | P-Profile-Key | [64] | o | IF table 6.1.3.1/59 AND request outside an existing dialog THEN do (NOTE) |
| 26D | P-Served-User | [85] | o | IF visited-to-home request on roaming II-NNI AND request outside an existing dialog being sent from "privileged sender" THEN dm (NOTE) |
| 26E | P-User-Database | [60] | o | dn/a |
| 27 | P-Visited-Network-ID | [24] | o | dn/a |
| 28 | Priority | [13], [21] | o | do |
| 29 | Privacy | [34] | o | IF dc3 (OIP/OIR: subclause 12.3) THEN dm |

| Item | Header field | Ref. | RFC status | II-NNI condition |
|-------|--|------------|------------|--|
| | | | | ELSE do |
| 30 | Proxy-Authorization | [13], [21] | o | IF table 6.1.3.1/7 THEN do (NOTE) |
| 31 | Proxy-Require | [13], [21] | o | do |
| 32 | Reason | [48] | o | IF table 6.1.3.1/40 AND request inside an existing dialog THEN do (NOTE) |
| 33 | Reject-Contact | [39] | o | do |
| 33A | Referred-By | [53] | o | do |
| 34 | Request-Disposition | [54] | o | do |
| 35 | Reply-To | [13], [21] | n/a | dn/a |
| 36 | Require | [13], [21] | o | do |
| 36A | Resource-Priority | [78] | o | IF table 6.1.3.1/73 THEN do (NOTE) |
| 37 | Route | [13], [21] | c | dc |
| 38 | Security-Client | [47] | o | dn/a |
| 39 | Security-Verify | [47] | o | dn/a |
| 39A | Session-ID | [124] | m | IF table 6.1.3.1/94 THEN dm (NOTE) |
| 40 | SIP-If-Match | [21] | o | do |
| 41 | Subject | [13], [21] | o | do |
| 42 | Supported | [13], [21] | o | IF dc1 (PNM: subclause 12.17) THEN dm ELSE do |
| 43 | Timestamp | [13], [21] | o | do |
| 44 | To | [13], [21] | m | dm |
| 45 | User-Agent | [13], [21] | o | do |
| 46 | Via | [13], [21] | m | dm |
| dc1: | request outside an existing dialog invoked due to PNM in case of ("PN UE redirection" OR "PN access control") AND (non-roaming II-NNI OR home-to-visited request on roaming II-NNI) | | | |
| dc2: | (request inside an existing dialog invoked due to CCBS/CCNR/CCNL suspending the "CC request" AND (non-roaming II-NNI OR loopback traversal scenario) OR (request inside an existing dialog invoked due to CCBS/CCNR/CCNL resuming the "CC request" AND (non-roaming II-NNI OR loopback traversal scenario)) | | | |
| dc3: | (request outside an existing dialog invoked due to OIP/OIR AND "override the default setting" in temporary mode AND visited-to-home request on roaming II-NNI) OR (request outside an existing dialog invoked due to OIP/OIR AND "presentation of the public user identity is restricted" AND (non-roaming II-NNI OR home-to-visited request on roaming II-NNI)) | | | |
| NOTE: | If the capability specified in table 6.1.3.1 is not supported over the II-NNI, the IBCF in the receiving network can omit or modify the SIP header fields in the received SIP message prior to forwarding the SIP message as specified in 3GPP TS 24.229 [5] subclause 5.10.6.2. | | | |

Table B.12.2: Supported header fields within the PUBLISH response

| Item | Header field | SIP status code | Ref. | RFC status | II-NNI condition |
|------|-------------------------------|-----------------|------------|------------|---|
| 1 | Accept | 415 | [13], [21] | m* | dm* |
| 2 | Accept-Encoding | 415 | [13], [21] | m* | dm* |
| 3 | Accept-Language | 415 | [13], [21] | m* | dm* |
| 4 | Accept-Resource-Priority | 2xx 417 | [78] | o | IF table 6.1.3.1/73 THEN do (NOTE 2) |
| 5 | Allow | 405 | [13], [21] | m | dm |
| | | r | | o | do |
| 6 | Allow-Events | 2xx | [20] | o | IF table 6.1.3.1/23 THEN do (NOTE 2) |
| | | 489 | | m | dm |
| 7 | Authentication-Info | 2xx | [13], [21] | o | IF table 6.1.3.1/7 THEN do (NOTE 2) |
| 8 | Call-ID | 100 others | [13], [21] | m | dm |
| 9 | Call-Info | r | [13], [21] | o | do |
| 10 | Contact | 3xx 485 | [13], [21] | o | do |
| 11 | Content-Disposition | r | [13], [21] | o | do |
| 12 | Content-Encoding | r | [13], [21] | o | do |
| 13 | Content-Language | r | [13], [21] | o | do |
| 14 | Content-Length | 100 others | [13], [21] | t | dt |
| 15 | Content-Type | r | [13], [21] | * | d* |
| 16 | CSeq | 100 others | [13], [21] | m | dm |
| 17 | Date | 100 others | [13], [21] | o | do |
| 18 | Error-Info | 3xx-6xx | [13], [21] | o | IF table 6.1.3.1/13 THEN do (NOTE 2) |
| 19 | Expires | 2xx | [13], [21] | m | dm |
| | | r | | o | do |
| 19A | Feature-Caps | 200 | [143] | o | IF table 6.1.3.1/103 AND response to request outside an existing dialog THEN do |
| 20 | From | 100 others | [13], [21] | m | dm |
| 21 | Geolocation-Error | 424 | [68] | m | dm |
| | | others | | o | do |
| 22 | History-Info | r | [25] | o | IF table 6.1.3.1/50 THEN do (NOTE 2) |
| 23 | MIME-version | r | [13], [21] | o | do |
| 24 | Min-Expires | 423 | [13], [21] | m | dm |
| 25 | Organization | r | [13], [21] | o | do |
| 26 | P-Access-Network-Info | r | [24] | o | IF table 6.1.3.1/36 THEN do (NOTE 2) |
| 27 | P-Asserted-Identity | r | [44] | o | IF dc1 (TIP/TIR: subclause 12.4) THEN dm ELSE IF table 6.1.3.1/27 AND response to request outside an existing dialog THEN do (NOTE 2) |
| 28 | P-Charging-Function-Addresses | r | [24] | o | dn/a |
| 29 | P-Charging-Vector | r | [24] | o | IF table 6.1.3.1/38 THEN do (NOTE 2) |
| 30 | P-Debug-ID | 100 others | [87] | o | IF table 6.1.3.1/83 THEN do (NOTE 2) |
| 31 | P-Preferred-Identity | r | [44] | o | dn/a |
| 32 | Privacy | r | [34] | o | IF dc2 (TIP/TIR: subclause 12.4) THEN dm ELSE do |
| 33 | Proxy-Authenticate | 401 (NOTE 1) | [13], [21] | o | do |
| | | 407 (NOTE 1) | | m | dm |

| Item | Header field | SIP status code | Ref. | RFC status | II-NNI condition |
|--|---|--|------------|------------|---|
| 34 | Require | r | [13], [21] | o | do |
| 35 | Retry-After | 404 413 480 486 500 503 600 603 | [13], [21] | o | do |
| 36 | Security-Server | 2xx | [47] | n/a | dn/a |
| | | 421 494 | | o | dn/a |
| 37 | Server | r | [13], [21] | o | do |
| 38 | Session-ID | r | [124] | m | IF table 6.1.3.1/94 THEN dm (NOTE 2) |
| 39 | SIP-Etag | 2xx | [21] | m | dm |
| 40 | Supported | 2xx | [13], [21] | o | do |
| 41 | Timestamp | r | [13], [21] | o | do |
| 42 | To | 100 others | [13], [21] | m | dm |
| 43 | Unsupported | 420 | [13], [21] | o | do |
| 44 | User-Agent | r | [13], [21] | o | do |
| 45 | Via | 100 others | [13], [21] | m | dm |
| 46 | Warning | r | [13], [21] | o | do |
| 47 | WWW-Authenticate | 401 (NOTE 1) | [13], [21] | m | dm |
| | | 407 (NOTE 1) | | o | do |
| dc1: | (TIP/TIR AND 2xx response to request outside an existing dialog AND (visited-to-home response on roaming II-NNI OR non-roaming II-NNI)) OR (TIP/TIR AND response to request outside an existing dialog AND "presentation is allowed" AND home-to-visited response on roaming II-NNI) | | | | |
| dc2: | (TIP/TIR AND non-100 response to request outside an existing dialog AND "override the default setting" in temporary mode AND visited-to-home response on roaming II-NNI) OR (TIP/TIR AND 2xx response to request outside an existing dialog AND "presentation of the network asserted identity is restricted" AND (non-roaming II-NNI OR home-to-visited response on roaming II-NNI)) | | | | |
| NOTE 1: The SIP status code is only applicable over the roaming II-NNI. | | | | | |
| NOTE 2: If the capability specified in table 6.1.3.1 is not supported over the II-NNI, the IBCF in the receiving network can omit or modify the SIP header fields in the received SIP message prior to forwarding the SIP message as specified in 3GPP TS 24.229 [5] subclause 5.10.6.2. | | | | | |

B.13 REFER method

As described in table 6.1, the support of REFER method over the II-NNI is based on bilateral agreement between the operators.

Table B.13.1: Supported header fields within the REFER request

| Item | Header field | Ref. | RFC status | II-NNI condition |
|------|-------------------------------|------------|------------|--|
| 0A | Accept | [13], [22] | o | do |
| 0B | Accept-Contact | [51] | o | IF dc1 (PNM: subclause 12.17) THEN dm ELSE do |
| 0C | Accept-Encoding | [13], [22] | o | do |
| 1 | Accept-Language | [13], [22] | o | do |
| 1A | Allow | [13], [22] | o | do |
| 2 | Allow-Events | [20] | o | IF table 6.1.3.1/23 THEN do (NOTE) |
| 3 | Authorization | [13], [22] | o | IF table 6.1.3.1/7 THEN do (NOTE) |
| 4 | Call-ID | [13], [22] | m | dm |
| 5 | Contact | [13], [22] | m | dm |
| 5A | Content-Disposition | [13], [22] | o | do |
| 5B | Content-Encoding | [13], [22] | o | do |
| 5C | Content-Language | [13], [22] | o | do |
| 6 | Content-Length | [13], [22] | o | do |
| 7 | Content-Type | [13], [22] | * | d* |
| 8 | CSeq | [13], [22] | m | dm |
| 9 | Date | [13], [22] | o | do |
| 10 | Expires | [13], [22] | o | do |
| 10A | Feature-Caps | [143] | o | IF table 6.1.3.1/103 AND request outside an existing dialog THEN do (NOTE) |
| 11 | From | [13], [22] | m | dm |
| 11A | Geolocation | [68] | o | do |
| 11AA | Geolocation-Routing | [68] | o | do |
| 11B | History-Info | [25] | o | IF dc1 (PNM: subclause 12.17) THEN dm ELSE IF table 6.1.3.1/50 AND request outside an existing dialog THEN do (NOTE) |
| 11C | Max-Breadth | [79] | o | do |
| 12 | Max-Forwards | [13], [22] | m | dm |
| 13 | MIME-Version | [13], [22] | o | do |
| 14 | Organization | [13], [22] | o | do |
| 14A | P-Access-Network-Info | [24] | o | IF table 6.1.3.1/36 THEN do (NOTE) |
| 14B | P-Asserted-Identity | [44] | o | IF table 6.1.3.1/27 AND request outside an existing dialog THEN dm (NOTE) |
| 14C | P-Asserted-Service | [26] | o | IF (non-roaming II-NNI OR home-to-visited request on roaming II-NNI) AND table 6.1.3.1/77 AND request outside an existing dialog THEN do (NOTE) |
| 14D | P-Called-Party-ID | [24] | o | IF home-to-visited request on roaming II-NNI AND table 6.1.3.1/34 THEN do (NOTE) |
| 14E | P-Charging-Function-Addresses | [24] | o | dn/a |
| 14F | P-Charging-Vector | [24] | o | IF table 6.1.3.1/38 THEN do (NOTE) |
| 14G | P-Debug-ID | [87] | o | IF table 6.1.3.1/83 THEN do (NOTE) |
| 14H | P-Preferred-Identity | [44] | o | dn/a |
| 14I | P-Preferred-Service | [26] | o | IF visited-to-home request on roaming II-NNI AND table 6.1.3.1/77 AND request outside an existing dialog THEN do (NOTE) |
| 14J | P-Private-Network-Indication | [84] | o | IF table 6.1.3.1/80 THEN do (NOTE) |
| 14K | P-Profile-Key | [64] | o | IF table 6.1.3.1/59 AND request outside an existing dialog THEN do (NOTE) |
| 14L | P-Served-User | [85] | o | IF visited-to-home request on roaming II-NNI AND request outside an existing dialog being sent from "privileged sender" THEN dm (NOTE) |
| 14M | P-User-Database | [60] | o | dn/a |
| 14N | P-Visited-Network-ID | [24] | o | dn/a |
| 14O | Privacy | [34] | o | IF dc2 (OIP/OIR: subclause 12.3) OR dc3 (ECT: subclause 12.13) THEN dm ELSE do |
| 15 | Proxy-Authorization | [13], [22] | o | IF table 6.1.3.1/7 THEN do (NOTE) |
| 16 | Proxy-Require | [13], [22] | o | do |
| 16A | Reason | [48] | o | IF table 6.1.3.1/40 AND request inside an existing dialog THEN do (NOTE) |

| Item | Header field | Ref. | RFC status | II-NNI condition |
|-------|--|------------|------------|---|
| 17 | Record-Route | [13], [22] | o | do |
| 17A | Refer-Sub | [135] | o | do |
| 18 | Refer-To | [22] | dm | dm |
| 18A | Referred-By | [53] | o | IF dc4 (ECT: subclause 12.13) THEN dm ELSE do |
| 18B | Reject-Contact | [51] | o | do |
| 18C | Request-Disposition | [51] | o | do |
| 19 | Require | [13], [22] | c | dc |
| 19A | Resource-Priority | [78] | o | IF table 6.1.3.1/73 THEN do (NOTE) |
| 20 | Route | [13], [22] | c | dc |
| 20A | Security-Client | [47] | o | dn/a |
| 20B | Security-Verify | [47] | o | dn/a |
| 20C | Session-ID | [124] | m | IF table 6.1.3.1/94 THEN dm (NOTE) |
| 21 | Supported | [13], [22] | o | IF dc1 (PNM: subclause 12.17) THEN dm ELSE do |
| 21A | Target-Dialog | [140] | o | IF table 6.1.3.1/102 THEN do (NOTE) |
| 22 | Timestamp | [13], [22] | o | do |
| 23 | To | [13], [22] | m | dm |
| 23A | Trigger-Consent | [82] | o | IF table 6.1.3.1/78 THEN do (NOTE) |
| 24 | User-Agent | [13], [22] | o | do |
| 25 | Via | [13], [22] | m | dm |
| dc1: | request outside an existing dialog invoked due to PNM in case of ("PN UE redirection" OR "PN access control") AND (non-roaming II-NNI OR home-to-visited request on roaming II-NNI) | | | |
| dc2: | (request outside an existing dialog invoked due to OIP/OIR AND "override the default setting" in temporary mode AND visited-to-home request on roaming II-NNI) OR (request outside an existing dialog invoked due to OIP/OIR AND "presentation of the public user identity is restricted" AND (non-roaming II-NNI OR home-to-visited request on roaming II-NNI)) | | | |
| dc3: | request inside an existing dialog invoked due to ECT including Referred-By header field with privacy requested in the "original communication" | | | |
| dc4: | request inside an existing dialog invoked due to ECT AND (non-roaming II-NNI OR loopback traversal scenario OR home-to-visited request on roaming II-NNI) | | | |
| NOTE: | If the capability specified in table 6.1.3.1 is not supported over the II-NNI, the IBCF in the receiving network can omit or modify the SIP header fields in the received SIP message prior to forwarding the SIP message as specified in 3GPP TS 24.229 [5] subclause 5.10.6.2. | | | |

Table B.13.2: Supported header fields within the REFER response

| Item | Header field | SIP status code | Ref. | RFC status | II-NNI condition |
|------|-------------------------------|-----------------|------------|------------|---|
| 1 | Accept | 415 | [13], [22] | c | dc |
| 2 | Accept-Encoding | 415 | [13], [22] | c | dc |
| 3 | Accept-Language | 415 | [13], [22] | c | dc |
| 4 | Accept-Resource-Priority | 2xx 417 | [78] | o | IF table 6.1.3.1/73 THEN do (NOTE 2) |
| 5 | Allow | 405 | [13], [22] | m | dm |
| | | others | | o | do |
| 6 | Allow-Events | 2xx | [20] | o | IF table 6.1.3.1/23 THEN do (NOTE 2) |
| 7 | Authentication-Info | 2xx | [13], [22] | o | IF table 6.1.3.1/7 THEN do (NOTE 2) |
| 8 | Call-ID | 100 others | [13], [22] | m | dm |
| 9 | Contact | 1xx | [13], [22] | n/a | dn/a |
| | | 2xx | | m | dm |
| | | 3xx-6xx | | o | do |
| 10 | Content-Disposition | r | [13], [22] | o | do |
| 11 | Content-Encoding | r | [13], [22] | o | do |
| 12 | Content-Language | r | [13], [22] | o | do |
| 13 | Content-Length | 100 others | [13], [22] | t | dt |
| 14 | Content-Type | r | [13], [22] | * | d* |
| 15 | CSeq | 100 others | [13], [22] | m | dm |
| 16 | Date | 100 others | [13], [22] | o | do |
| 17 | Error-Info | 3xx-6xx | [13], [22] | o | IF table 6.1.3.1/13 THEN do (NOTE 2) |
| 17A | Feature-Caps | 2xx | [143] | o | IF table 6.1.3.1/103 AND response to request outside an existing dialog THEN do (NOTE 2) |
| 18 | From | 100 others | [13], [22] | m | dm |
| 19 | Geolocation-Error | 424 | [68] | m | dm |
| | | others | | o | do |
| 20 | History-Info | r | [25] | o | IF table 6.1.3.1/50 THEN do (NOTE 2) |
| 21 | MIME-version | r | [13], [22] | o | do |
| 22 | Organization | r | [13], [22] | o | do |
| 23 | P-Access-Network-Info | r | [24] | o | IF table 6.1.3.1/36 THEN do (NOTE 2) |
| 24 | P-Asserted-Identity | r | [44] | o | IF dc1 (TIP/TIR: subclause 12.4) THEN dm ELSE IF table 6.1.3.1/27 AND response to request outside an existing dialog THEN do (NOTE 2) |
| 25 | P-Charging-Function-Addresses | r | [24] | o | dn/a |
| 26 | P-Charging-Vector | r | [24] | o | IF dc2 (CONF: subclause 12.19) THEN dm ELSE IF table 6.1.3.1/38 THEN do (NOTE 2) |
| 27 | P-Debug-ID | 100 others | [87] | o | IF table 6.1.3.1/83 THEN do (NOTE 2) |
| 28 | P-Preferred-Identity | r | [44] | o | dn/a |
| 29 | Permission-Missing | 470 | [82] | o | IF table 6.1.3.1/78 THEN do (NOTE 2) |
| 30 | Privacy | r | [34] | o | IF dc3 (TIP/TIR: subclause 12.4) THEN dm ELSE do |
| 31 | Proxy-Authenticate | 401 (NOTE) | [13], [22] | o | do |
| | | 407 (NOTE) | | m | dm |
| 32 | Record-Route | 2xx | [13], [22] | o | do |

| Item | Header field | SIP status code | Ref. | RFC status | II-NNI condition |
|---------|---|--|------------|------------|--------------------------------------|
| 33 | Refer-Sub | 2xx | [135] | o | IF table 6.1.3.1/83 THEN do (NOTE 2) |
| 34 | Require | r | [13], [22] | c | dc |
| 35 | Retry-After | 404 413 480 486 500 503 600 603 | [13], [22] | o | do |
| 36 | Security-Server | 2xx | [47] | n/a | dn/a |
| | | 421 494 | | o | dn/a |
| 37 | Server | r | [13], [22] | o | do |
| 38 | Session-ID | r | [124] | m | IF table 6.1.3.1/94 THEN dm (NOTE 2) |
| 39 | Supported | 2xx | [13], [22] | o | do |
| 40 | Timestamp | r | [13], [22] | o | do |
| 41 | To | 100 others | [13], [22] | m | dm |
| 42 | Unsupported | 420 | [13], [22] | o | do |
| 43 | User-Agent | r | [13], [22] | o | do |
| 44 | Via | 100 others | [13], [22] | m | dm |
| 45 | Warning | r | [13], [22] | o | do |
| 46 | WWW-Authenticate | 401 (NOTE 1) | [13], [22] | m | dm |
| | | 407 (NOTE 1) | | o | do |
| dc1: | (TIP/TIR AND 2xx response to request outside an existing dialog AND (visited-to-home response on roaming II-NNI OR non-roaming II-NNI)) OR (TIP/TIR AND response to request outside an existing dialog AND "presentation is allowed" AND home-to-visited response on roaming II-NNI) | | | | |
| dc2: | first response from "conference focus" to request outside an existing dialog AND (non-roaming II-NNI OR home-to-visited response on roaming II-NNI) | | | | |
| dc3: | (TIP/TIR AND non-100 response to request outside an existing dialog AND "override the default setting" in temporary mode AND visited-to-home response on roaming II-NNI) OR (TIP/TIR AND 2xx response to request outside an existing dialog AND "presentation of the network asserted identity is restricted" AND (non-roaming II-NNI OR home-to-visited response on roaming II-NNI)) | | | | |
| NOTE 1: | The SIP status code is only applicable over the roaming II-NNI. | | | | |
| NOTE 2: | If the capability specified in table 6.1.3.1 is not supported over the II-NNI, the IBCF in the receiving network can omit or modify the SIP header fields in the received SIP message prior to forwarding the SIP message as specified in 3GPP TS 24.229 [5] subclause 5.10.6.2. | | | | |

B.14 REGISTER method

As described in table 6.1, the REGISTER method is supported only over the roaming II-NNI.

Table B.14.1: Supported header fields within the REGISTER request

| Item | Header field | Ref. | RFC status | II-NNI condition |
|-------|--|-------|------------|--|
| 1 | Accept | [13] | o | do |
| 2 | Accept-Encoding | [13] | o | do |
| 3 | Accept-Language | [13] | o | do |
| 3A | Allow | [13] | o | do |
| 4 | Allow-Events | [20] | o | IF table 6.1.3.1/23 THEN do (NOTE) |
| 5 | Authorization | [13] | o | IF using IMS AKA OR using SIP digest THEN dm ELSE do |
| 6 | Call-ID | [13] | m | dm |
| 7 | Call-Info | [13] | o | do |
| 8 | Contact | [13] | o | dm |
| 9 | Content-Disposition | [13] | o | do |
| 10 | Content-Encoding | [13] | o | do |
| 11 | Content-Language | [13] | o | do |
| 12 | Content-Length | [13] | t | dt |
| 13 | Content-Type | [13] | * | d* |
| 14 | CSeq | [13] | m | dm |
| 15 | Date | [13] | o | do |
| 16 | Expires | [13] | o | do |
| 16A | Feature-Caps | [143] | o | IF table 6.1.3.1/103 THEN do (NOTE) |
| 17 | From | [13] | m | dm |
| 17A | Geolocation | [68] | o | do |
| 17AA | Geolocation-Routing | [68] | o | do |
| 17B | History-Info | [25] | o | IF table 6.1.3.1/50 THEN do (NOTE) |
| 17C | Max-Breadth | [79] | o | do |
| 18 | Max-Forwards | [13] | m | dm |
| 19 | MIME-Version | [13] | o | do |
| 20 | Organization | [13] | o | do |
| 20A | P-Access-Network-Info | [24] | o | IF table 6.1.3.1/36 THEN do (NOTE) |
| 20B | P-Charging-Function-Addresses | [24] | o | dn/a |
| 20C | P-Charging-Vector | [24] | o | dm |
| 20D | P-Debug-ID | [87] | o | IF table 6.1.3.1/83 THEN do (NOTE) |
| 20E | P-User-Database | [60] | o | dn/a |
| 20F | P-Visited-Network-ID | [24] | o | dm |
| 20G | Path | [43] | o | dm |
| 20H | Privacy | [34] | o | dn/a |
| 21 | Proxy-Authorization | [13] | o | do |
| 22 | Proxy-Require | [13] | o | do |
| 22A | Reason | [48] | o | IF table 6.1.3.1/40 THEN do (NOTE) |
| 22B | Recv-Info | [39] | o | IF table 6.1.3.1/17 THEN do (NOTE) |
| 22C | Referred-By | [53] | o | do |
| 22D | Request-Disposition | [51] | o | do |
| 23 | Require | [13] | c | dm |
| 23A | Resource-Priority | [78] | o | IF table 6.1.3.1/73 THEN do (NOTE) |
| 24 | Route | [13] | c | dc |
| 24A | Security-Client | [47] | o | dn/a |
| 24B | Security-Verify | [47] | o | dn/a |
| 24C | Session-ID | [124] | m | IF table 6.1.3.1/94 THEN dm (NOTE) |
| 25 | Supported | [13] | o | dm |
| 26 | Timestamp | [13] | o | do |
| 27 | To | [13] | m | dm |
| 28 | User-Agent | [13] | o | do |
| 29 | Via | [13] | m | dm |
| NOTE: | If the capability specified in table 6.1.3.1 is not supported over the II-NNI, the IBCF in the receiving network can omit or modify the SIP header fields in the received SIP message prior to forwarding the SIP message as specified in 3GPP TS 24.229 [5] subclause 5.10.6.2. | | | |

Table B.14.2: Supported header fields within the REGISTER response

| Item | Header field | SIP status code | Ref. | RFC status | II-NNI condition |
|------|-------------------------------|-----------------|-------|------------|-------------------------------------|
| 1 | Accept | 2xx | [13] | o | do |
| | | 415 | | c | dc |
| 2 | Accept-Encoding | 2xx | [13] | o | do |
| | | 415 | | c | dc |
| 3 | Accept-Language | 2xx | [13] | o | do |
| | | 415 | | c | dc |
| 4 | Accept-Resource-Priority | 2xx 417 | [78] | o | IF table 6.1.3.1/73 THEN do (NOTE) |
| 5 | Allow | 2xx | [13] | o | do |
| | | 405 | | m | dm |
| | | others | | o | do |
| 6 | Allow-Events | 2xx | [20] | o | IF table 6.1.3.1/23 THEN do (NOTE) |
| 7 | Authentication-Info | 2xx | [13] | o | do |
| 8 | Call-ID | 100 | [13] | m | dm |
| | | others | | | |
| 9 | Call-Info | r | [13] | o | do |
| 10 | Contact | 2xx | [13] | o | dm |
| | | 3xx | | o | do |
| | | 485 | | | |
| 11 | Content-Disposition | r | [13] | o | do |
| 12 | Content-Encoding | r | [13] | o | do |
| 13 | Content-Language | r | [13] | o | do |
| 14 | Content-Length | 100 | [13] | t | dt |
| | | others | | | |
| 15 | Content-Type | r | [13] | * | d* |
| 16 | CSeq | 100 | [13] | m | dm |
| | | others | | | |
| 17 | Date | 100 | [13] | o | do |
| | | others | | | |
| 18 | Error-Info | 3xx-6xx | [13] | o | IF table 6.1.3.1/13 THEN do (NOTE) |
| 18A | Feature-Caps | 2xx | [143] | o | IF table 6.1.3.1/103 THEN do (NOTE) |
| 19 | Flow-Timer | 2xx | [65] | o | do |
| 20 | From | 100 | [13] | m | dm |
| | | others | | | |
| 21 | Geolocation-Error | 424 | [68] | m | dm |
| | | others | | o | do |
| 22 | History-Info | r | [25] | o | IF table 6.1.3.1/50 THEN do (NOTE) |
| 23 | MIME-version | r | [13] | o | do |
| 24 | Min-Expires | 423 | [13] | m | dm |
| 25 | Organization | r | [13] | o | do |
| 26 | P-Access-Network-Info | r | [24] | o | IF table 6.1.3.1/36 THEN do (NOTE) |
| 27 | P-Associated-URI | 2xx | [24] | o | dm |
| 28 | P-Charging-Function-Addresses | r | [24] | o | dn/a |
| 29 | P-Charging-Vector | r | [24] | o | dm |
| 30 | P-Debug-ID | r | [87] | o | IF table 6.1.3.1/83 THEN do (NOTE) |
| 31 | Path | 2xx | [43] | o | dm |
| 32 | Privacy | r | [34] | o | do |
| 33 | Proxy-Authenticate | 401 | [13] | o | do |
| | | 407 | | m | dm |
| 34 | Require | r | [13] | c | dc |
| 35 | Retry-After | 404 | [13] | o | do |
| | | 413 | | | |
| | | 480 | | | |
| | | 486 | | | |
| | | 500 | | | |
| | | 503 | | | |
| | | 600 | | | |
| 603 | | | | | |
| 36 | Security-Server | 2xx | [47] | n/a | dn/a |
| | | 401 | | | |

| Item | Header field | SIP status code | Ref. | RFC status | II-NNI condition |
|--|------------------|-----------------|-------|------------|------------------------------------|
| | | 421 494 | | o | dn/a |
| 37 | Server | r | [13] | o | do |
| 38 | Service-Route | 2xx | [45] | o | dm |
| 39 | Session-ID | r | [124] | m | IF table 6.1.3.1/94 THEN dm (NOTE) |
| 40 | Supported | 2xx | [13] | o | do |
| 41 | Timestamp | r | [13] | o | do |
| 42 | To | 100 others | [13] | m | dm |
| 43 | Unsupported | 420 | [13] | m | dm |
| 44 | User-Agent | r | [13] | o | do |
| 45 | Via | 100 others | [13] | m | dm |
| 46 | Warning | r | [13] | o | do |
| 47 | WWW-Authenticate | 401 | [13] | m | dm |
| | | 407 | | o | do |
| NOTE: If the capability specified in table 6.1.3.1 is not supported over the II-NNI, the IBCF in the receiving network can omit or modify the SIP header fields in the received SIP message prior to forwarding the SIP message as specified in 3GPP TS 24.229 [5] subclause 5.10.6.2. | | | | | |

B.15 SUBSCRIBE method

As described in table 6.1, the support of SUBSCRIBE method over the non-roaming II-NNI is based on bilateral agreement between the operators.

Table B.15.1: Supported header fields within the SUBSCRIBE request

| Item | Header field | Ref. | RFC status | II-NNI condition |
|------|-------------------------------|------------|------------|---|
| 1 | Accept | [13], [20] | o | do |
| 1A | Accept-Contact | [51] | o | IF dc1 (PNM: subclause 12.17) THEN dm ELSE do |
| 2 | Accept-Encoding | [13], [20] | o | do |
| 3 | Accept-Language | [13], [20] | o | do |
| 3A | Allow | [13], [20] | o | do |
| 4 | Allow-Events | [20] | o | do |
| 5 | Authorization | [13], [20] | o | IF table 6.1.3.1/7 THEN do (NOTE) |
| 6 | Call-ID | [13], [20] | m | dm |
| 6A | Call-Info | [13], [20] | o | IF dc2 (CCBS/CCNR/CCNL: subclause 12.11/12.12/12.23) THEN dm ELSE dn/a |
| 6B | Contact | [13], [20] | m | dm |
| 7 | Content-Disposition | [13], [20] | o | do |
| 8 | Content-Encoding | [13], [20] | o | do |
| 9 | Content-Language | [13], [20] | o | do |
| 10 | Content-Length | [13], [20] | t | dt |
| 11 | Content-Type | [13], [20] | * | d* |
| 12 | CSeq | [13], [20] | m | dm |
| 13 | Date | [13], [20] | o | do |
| 14 | Event | [20] | m | dm |
| 15 | Expires | [13], [20] | o | IF dc2 (CCBS/CCNR/CCNL: subclause 12.11/12.12/12.23) OR using reg event package THEN dm ELSE do |
| 15A | Feature-Caps | [143] | o | IF table 6.1.3.1/103 THEN do (NOTE) |
| 16 | From | [13], [20] | m | dm |
| 16A | Geolocation | [68] | o | do |
| 16AA | Geolocation-Routing | [68] | o | do |
| 16B | History-Info | [25] | o | IF dc1 (PNM: subclause 12.17) THEN dm ELSE IF table 6.1.3.1/50 AND initial request THEN do (NOTE) |
| 16C | Max-Breadth | [79] | o | dn/a |
| 17 | Max-Forwards | [13], [20] | m | dm |
| 18 | MIME-Version | [13], [20] | o | do |
| 18A | Organization | [13], [20] | o | do |
| 18B | P-Access-Network-Info | [24] | o | IF table 6.1.3.1/36 THEN do (NOTE) |
| 18C | P-Asserted-Identity | [44] | o | IF dc2 (CCBS/CCNR/CCNL: subclause 12.11/12.12/12.23) OR table 6.1.3.1/27 AND initial request THEN dm (NOTE) |
| 18D | P-Asserted-Service | [26] | o | IF (non-roaming II-NNI OR home-to-visited request on roaming II-NNI) AND table 6.1.3.1/77 AND initial request THEN do (NOTE) |
| 18E | P-Called-Party-ID | [24] | o | IF home-to-visited request on roaming II-NNI AND table 6.1.3.1/34 THEN do (NOTE) |
| 18F | P-Charging-Function-Addresses | [24] | o | dn/a |
| 18G | P-Charging-Vector | [24] | o | IF table 6.1.3.1/38 THEN do (NOTE) |
| 18H | P-Debug-ID | [87] | o | IF table 6.1.3.1/83 THEN do (NOTE) |
| 18I | P-Preferred-Identity | [44] | o | dn/a |
| 18J | P-Preferred-Service | [26] | o | IF visited-to-home request on roaming II-NNI AND table 6.1.3.1/77 AND initial request THEN do (NOTE) |
| 18K | P-Private-Network-Indication | [84] | o | IF table 6.1.3.1/80 THEN do (NOTE) |
| 18L | P-Profile-Key | [64] | o | IF table 6.1.3.1/59 AND initial request THEN do (NOTE) |
| 18M | P-Served-User | [85] | o | IF visited-to-home request on roaming II-NNI AND initial request being sent from "privileged sender" THEN dm (NOTE) |
| 18N | P-User-Database | [60] | o | dn/a |
| 18O | P-Visited-Network-ID | [24] | o | dn/a |
| 18P | Privacy | [34] | o | IF dc3 (OIP/OIR: subclause 12.3) THEN dm |

| Item | Header field | Ref. | RFC status | II-NNI condition |
|-------|--|------------|------------|---|
| | | | | ELSE do |
| 19 | Proxy-Authorization | [13], [20] | o | IF table 6.1.3.1/7 THEN do (NOTE) |
| 20 | Proxy-Require | [13], [20] | o | do |
| 20A | Reason | [48] | o | IF table 6.1.3.1/40 AND subsequent request THEN do (NOTE) |
| 21 | Record-Route | [13], [20] | o | do |
| 21A | Referred-By | [53] | o | do |
| 21B | Reject-Contact | [51] | o | do |
| 21C | Request-Disposition | [51] | o | do |
| 22 | Require | [13], [20] | o | do |
| 22A | Resource-Priority | [78] | o | IF table 6.1.3.1/73 THEN do (NOTE) |
| 23 | Route | [13], [20] | c | dc |
| 23A | Security-Client | [47] | o | dn/a |
| 23B | Security-Verify | [47] | o | dn/a |
| 23E | Session-ID | [124] | m | IF table 6.1.3.1/94 THEN dm (NOTE) |
| 24 | Supported | [13], [20] | o | IF dc1 (PNM: subclause 12.17) THEN dm ELSE do |
| 24A | Target-Dialog | [140] | o | IF table 6.1.3.1/102 THEN do (NOTE) |
| 25 | Timestamp | [13], [20] | o | do |
| 26 | To | [13], [20] | m | dm |
| 26A | Trigger-Consent | [82] | o | IF table 6.1.3.1/78 THEN do (NOTE) |
| 27 | User-Agent | [13], [20] | o | do |
| 28 | Via | [13], [20] | m | dm |
| dc1: | initial request invoked due to PNM in case of ("PN UE redirection" OR "PN access control") AND (non-roaming II-NNI OR home-to-visited request on roaming II-NNI) | | | |
| dc2: | ("CC invocation request" due to CCBS/CCNR/CCNL AND non-roaming II-NNI) OR ("CC revocation request" due to CCBS/CCNR/CCNL AND non-roaming II-NNI) | | | |
| dc3: | (initial request invoked due to OIP/OIR AND "override the default setting" in temporary mode AND visited-to-home request on roaming II-NNI) OR (initial request invoked due to OIP/OIR AND "presentation of the public user identity is restricted" AND (non-roaming II-NNI OR home-to-visited request on roaming II-NNI)) | | | |
| NOTE: | If the capability specified in table 6.1.3.1 is not supported over the II-NNI, the IBCF in the receiving network can omit or modify the SIP header fields in the received SIP message prior to forwarding the SIP message as specified in 3GPP TS 24.229 [5] subclause 5.10.6.2. | | | |

Table B.15.2: Supported header fields within the SUBSCRIBE response

| Item | Header field | SIP status code | Ref. | RFC status | II-NNI condition |
|------|-------------------------------|-----------------|------------|------------|--|
| 1 | Accept | 415 | [13], [20] | o | do |
| 2 | Accept-Encoding | 415 | [13], [20] | o | do |
| 3 | Accept-Language | 415 | [13], [20] | o | do |
| 4 | Accept-Resource-Priority | 2xx 417 | [78] | o | IF table 6.1.3.1/73 THEN do (NOTE 2) |
| 5 | Allow | 405 | [13], [20] | m | dm |
| | | others | | o | do |
| 6 | Allow-Events | 2xx | [20] | o | do |
| | | 489 | | m | dm |
| 7 | Authentication-Info | 2xx | [13], [20] | o | IF table 6.1.3.1/7 THEN do (NOTE 2) |
| 8 | Call-ID | 100 r | [13], [20] | m | dm |
| 8A | Call-Info | r | [13], [20] | o | do |
| 9 | Contact | 2xx | [13], [20] | m | dm |
| | | 3xx | | | |
| | | 485 | | o | do |
| 10 | Content-Disposition | r | [13], [20] | o | do |
| 11 | Content-Encoding | r | [13], [20] | o | do |
| 12 | Content-Language | r | [13], [20] | o | do |
| 13 | Content-Length | 100 others | [13], [20] | t | dt |
| 14 | Content-Type | r | [13], [20] | * | d* |
| 15 | CSeq | 100 others | [13], [20] | m | dm |
| 16 | Date | 100 others | [13], [20] | o | do |
| 17 | Error-Info | 3xx-6xx | [13], [20] | o | IF table 6.1.3.1/13 THEN do (NOTE 2) |
| 18 | Expires | 2xx | [13], [20] | m | dm |
| 18A | Feature-Caps | 2xx | [143] | o | IF table 6.1.3.1/103 THEN do (NOTE 2) |
| 19 | From | 100 others | [13], [20] | m | dm |
| 20 | Geolocation-Error | 424 | [68] | m | dm |
| | | others | | o | do |
| 21 | History-Info | r | [25] | o | IF table 6.1.3.1/50 THEN do (NOTE 2) |
| 22 | MIME-version | r | [13], [20] | o | do |
| 23 | Min-Expires | 423 | [13], [20] | m | dm |
| 24 | Organization | r | [13], [20] | o | do |
| 25 | P-Access-Network-Info | r | [24] | o | IF table 6.1.3.1/36 THEN do (NOTE 2) |
| 26 | P-Asserted-Identity | r | [44] | o | IF dc1 (TIP/TIR: subclause 12.4) THEN dm ELSE IF table 6.1.3.1/27 AND response to initial request THEN do (NOTE 2) |
| 27 | P-Charging-Function-Addresses | r | [24] | o | dn/a |
| 28 | P-Charging-Vector | r | [24] | o | IF table 6.1.3.1/38 THEN do (NOTE 2) |
| 29 | P-Debug-ID | 100 others | [87] | o | IF table 6.1.3.1/83 THEN do (NOTE 2) |
| 30 | P-Preferred-Identity | r | [44] | o | dn/a |
| 31 | Permission-Missing | 470 | [82] | o | IF table 6.1.3.1/78 THEN do (NOTE 2) |
| 32 | Privacy | r | [34] | o | IF dc2 (TIP/TIR: subclause 12.4) THEN dm ELSE do |
| 33 | Proxy-Authenticate | 401 (NOTE 1) | [13], [20] | o | do |
| | | 407 (NOTE 1) | | m | dm |

| Item | Header field | SIP status code | Ref. | RFC status | II-NNI condition |
|--|---|--|------------|------------|---|
| 34 | Record-Route | 2xx | [13], [20] | o | do |
| 35 | Require | r | [13], [20] | o | do |
| 36 | Retry-After | 404 413 480 486 500 503 600 603 | [13], [20] | o | do |
| 37 | Security-Server | 2xx | [47] | n/a | dn/a |
| | | 421 494 | | o | dn/a |
| 38 | Server | 415 others | [13], [20] | o | do |
| 39 | Session-ID | r | [124] | m | IF table 6.1.3.1/94 THEN dm (NOTE 2) |
| 40 | Supported | 2xx | [13], [20] | o | do |
| 41 | Timestamp | r | [13], [20] | o | do |
| 42 | To | 100 others | [13], [20] | m | dm |
| 43 | Unsupported | 420 | [13], [20] | o | do |
| 44 | User-Agent | r | [13], [20] | o | do |
| 45 | Via | 100 others | [13], [20] | m | dm |
| 46 | Warning | r | [13], [20] | o | do |
| 47 | WWW-Authenticate | 401 (NOTE 1) | [13], [20] | m | dm |
| | | 407 (NOTE 1) | | o | do |
| dc1: | (TIP/TIR AND 2xx response to initial request AND (visited-to-home response on roaming II-NNI OR non-roaming II-NNI)) OR (TIP/TIR AND response to initial request AND "presentation is allowed" AND home-to-visited response on roaming II-NNI) | | | | |
| dc2: | (TIP/TIR AND non-100 response to initial request AND "override the default setting" in temporary mode AND visited-to-home response on roaming II-NNI) OR (TIP/TIR AND 2xx response to initial request AND "presentation of the network asserted identity is restricted" AND (non-roaming II-NNI OR home-to-visited response on roaming II-NNI)) | | | | |
| NOTE 1: The SIP status code is only applicable over the roaming II-NNI. | | | | | |
| NOTE 2: If the capability specified in table 6.1.3.1 is not supported over the II-NNI, the IBCF in the receiving network can omit or modify the SIP header fields in the received SIP message prior to forwarding the SIP message as specified in 3GPP TS 24.229 [5] subclause 5.10.6.2. | | | | | |

B.16 UPDATE method

Table B.16.1: Supported header fields within the UPDATE request

| Item | Header field | Ref. | RFC status | II-NNI condition |
|-------|--|------------|------------|-------------------------------------|
| 1 | Accept | [13], [23] | o | do |
| 1A | Accept-Contact | [51] | o | do |
| 2 | Accept-Encoding | [13], [23] | o | do |
| 3 | Accept-Language | [13], [23] | o | do |
| 4 | Allow | [13], [23] | o | do |
| 5 | Allow-Events | [20] | n/a | dn/a |
| 6 | Authorization | [13], [23] | o | IF table 6.1.3.1/7 THEN do (NOTE) |
| 7 | Call-ID | [13], [23] | m | dm |
| 8 | Call-Info | [13], [23] | o | do |
| 9 | Contact | [13], [23] | m | dm |
| 10 | Content-Disposition | [13], [23] | o | do |
| 11 | Content-Encoding | [13], [23] | o | do |
| 12 | Content-Language | [13], [23] | o | do |
| 13 | Content-Length | [13], [23] | t | dt |
| 14 | Content-Type | [13], [23] | * | d* |
| 15 | CSeq | [13], [23] | m | dm |
| 16 | Date | [13], [23] | o | do |
| 16A | Feature-Caps | [143] | o | IF table 6.1.3.1/103 THEN do (NOTE) |
| 17 | From | [13], [23] | m | dm |
| 17A | Geolocation | [68] | o | do |
| 17AA | Geolocation-Routing | [68] | o | do |
| 17B | Max-Breadth | [79] | o | dn/a |
| 18 | Max-Forwards | [13], [23] | m | dm |
| 19 | MIME-Version | [13], [23] | o | do |
| 19A | Min-SE | [52] | o | do |
| 20 | Organization | [13], [23] | o | do |
| 20A | P-Access-Network-Info | [24] | o | IF table 6.1.3.1/36 THEN do (NOTE) |
| 20B | P-Charging-Function-Addresses | [24] | o | dn/a |
| 20C | P-Charging-Vector | [24] | o | IF table 6.1.3.1/38 THEN do (NOTE) |
| 20D | P-Debug-ID | [87] | o | IF table 6.1.3.1/83 THEN do (NOTE) |
| 20E | P-Early-Media | [74] | o | IF table 6.1.3.1/69 THEN do (NOTE) |
| 20F | Privacy | [34] | o | do |
| 21 | Proxy-Authorization | [13], [23] | o | IF table 6.1.3.1/7 THEN do (NOTE) |
| 22 | Proxy-Require | [13], [23] | o | do |
| 22A | Reason | [48] | o | IF table 6.1.3.1/40 THEN do (NOTE) |
| 23 | Record-Route | [13], [23] | o | do |
| 23A | Recv-Info | [39] | o | IF table 6.1.3.1/17 THEN do (NOTE) |
| 23B | Referred-By | [53] | o | do |
| 23C | Reject-Contact | [51] | o | do |
| 23D | Request-Disposition | [51] | o | do |
| 24 | Require | [13], [23] | c | dc |
| 24A | Resource-Priority | [78] | o | IF table 6.1.3.1/73 THEN do (NOTE) |
| 25 | Route | [13], [23] | c | dc |
| 25A | Security-Client | [47] | o | dn/a |
| 25B | Security-Verify | [47] | o | dn/a |
| 25C | Session-Expires | [52] | o | do |
| 25D | Session-ID | [124] | m | IF table 6.1.3.1/94 THEN dm (NOTE) |
| 26 | Supported | [13], [23] | o | do |
| 27 | Timestamp | [13], [23] | o | do |
| 28 | To | [13], [23] | m | dm |
| 29 | User-Agent | [13], [23] | o | do |
| 30 | Via | [13], [23] | m | dm |
| NOTE: | If the capability specified in table 6.1.3.1 is not supported over the II-NNI, the IBCF in the receiving network can omit or modify the SIP header fields in the received SIP message prior to forwarding the SIP message as specified in 3GPP TS 24.229 [5] subclause 5.10.6.2. | | | |

Table B.16.2: Supported header fields within the UPDATE response

| Item | Header field | SIP status code | Ref. | RFC status | II-NNI condition |
|------|-------------------------------|-----------------|------------|------------|---------------------------------------|
| 1 | Accept | 2xx | [13], [23] | o | do |
| | | 415 | | c | dc |
| 2 | Accept-Encoding | 2xx | [13], [23] | o | do |
| | | 415 | | c | dc |
| 3 | Accept-Language | 2xx | [13], [23] | o | do |
| | | 415 | | c | dc |
| 4 | Accept-Resource-Priority | 2xx 417 | [78] | o | IF table 6.1.3.1/73 THEN do (NOTE 2) |
| 5 | Allow | 2xx | [13], [23] | o | do |
| | | 405 | | m | dm |
| | | others | | o | do |
| 6 | Allow-Events | 2xx | [20] | n/a | dn/a |
| 7 | Authentication-Info | 2xx | [13], [23] | o | IF table 6.1.3.1/7 THEN do (NOTE 2) |
| 8 | Call-ID | 100 others | [13], [23] | m | dm |
| 9 | Call-Info | r | [13], [23] | o | do |
| 10 | Contact | 2xx | [13], [23] | m | dm |
| | | 3xx | | o | do |
| | | 485 | | | |
| | | others | | o | do |
| 11 | Content-Disposition | r | [13], [23] | o | do |
| 12 | Content-Encoding | r | [13], [23] | o | do |
| 13 | Content-Language | r | [13], [23] | o | do |
| 14 | Content-Length | 100 others | [13], [23] | t | dt |
| 15 | Content-Type | r | [13], [23] | * | d* |
| 16 | CSeq | 100 | [13], [23] | m | dm |
| | | others | | | |
| 17 | Date | 100 others | [13], [23] | o | do |
| 18 | Error-Info | 3xx-6xx | [13], [23] | o | IF table 6.1.3.1/13 THEN do (NOTE 2) |
| 18A | Feature-Caps | 2xx | [143] | o | IF table 6.1.3.1/103 THEN do (NOTE 2) |
| 19 | From | 100 | [13], [23] | m | dm |
| | | others | | | |
| 20 | Geolocation-Error | 424 | [68] | m | dm |
| | | others | | o | do |
| 21 | MIME-version | r | [13], [23] | o | do |
| 22 | Min-SE | 422 | [52] | m | dm |
| 23 | Organization | r | [13], [23] | o | do |
| 24 | P-Access-Network-Info | r | [24] | o | IF table 6.1.3.1/36 THEN do (NOTE 2) |
| 25 | P-Charging-Function-Addresses | r | [24] | o | dn/a |
| 26 | P-Charging-Vector | r | [24] | o | IF table 6.1.3.1/38 THEN do (NOTE 2) |
| 27 | P-Debug-ID | 100 others | [87] | o | IF table 6.1.3.1/83 THEN do (NOTE 2) |
| 28 | P-Early-Media | 2xx | [74] | o | IF table 6.1.3.1/69 THEN do (NOTE 2) |
| 29 | Privacy | r | [34] | o | do |
| 30 | Proxy-Authenticate | 401 (NOTE 1) | [13], [23] | o | do |
| | | 407 (NOTE 1) | | m | dm |
| 31 | Recv-Info | 2xx | [39] | c | IF table 6.1.3.1/17 THEN dc (NOTE 2) |
| | | others | | o | IF table 6.1.3.1/17 THEN do (NOTE 2) |
| 32 | Require | r | [13], [23] | c | dc |

| Item | Header field | SIP status code | Ref. | RFC status | II-NNI condition |
|--|------------------|--|------------|------------|---|
| 33 | Retry-After | 404 413 480 486 500 503 600 603 | [13], [23] | o | do |
| 34 | Security-Server | 421 494 | [47] | o | dn/a |
| 35 | Server | r | [13], [23] | o | do |
| 36 | Session-Expires | 2xx | [52] | o | do |
| 37 | Session-ID | r | [124] | m | IF table 6.1.3.1/94 THEN dm (NOTE 2) |
| 38 | Supported | 2xx | [13], [23] | o | do |
| 39 | Timestamp | r | [13], [23] | o | do |
| 40 | To | 100 others | [13], [23] | m | dm |
| 41 | Unsupported | 420 | [13], [23] | m | dm |
| 42 | User-Agent | r | [13], [23] | o | do |
| 43 | Via | 100 others | [13], [23] | m | dm |
| 44 | Warning | r | [13], [23] | o | do |
| 45 | WWW-Authenticate | 401 (NOTE 1) | [13], [23] | m | dm |
| | | 407 (NOTE 1) | | o | do |
| NOTE 1: The SIP status code is only applicable over the roaming II-NNI. | | | | | |
| NOTE 2: If the capability specified in table 6.1.3.1 is not supported over the II-NNI, the IBCF in the receiving network can omit or modify the SIP header fields in the received SIP message prior to forwarding the SIP message as specified in 3GPP TS 24.229 [5] subclause 5.10.6.2. | | | | | |

Annex C (informative): The list of option items for II-NNI

C.1 Scope

This annex provides a list of items that are recommended to be selected by inter-operator agreements for the interconnection between IMS operators using the II-NNI. The items in this annex have an influence on the service interconnection.

For the purposes of this annex, these items are called "option items". The option items are extracted from the present document other than this annex, and are categorized from the aspect of service provisioning by IMS operators.

If an option item is used based on inter-operator agreements, then relating capabilities described in the references are used over the II-NNI. In case of misalignment between the normative part of the present document and this annex, the normative part of the present document takes precedence.

C.2 Format of option item table

The format of option item table used in the subsequent subclauses is as follows:

- The 2nd column "Option item" shows the option item.
- The 3rd column "References" shows the relevant clauses of the present document for each option item.
- The 4th column "Applicability at the II-NNI" shows the selectable patterns for each option item.
- The 5th column "Details for operator choice" shows the details for the inter-operator agreements in case the corresponding pattern is chosen.

C.3 Option item table

C.3.0 Supported II-NNI traversal scenarios

Table C.3.0.1: Supported II-NNI traversal scenarios

| No. | Option item | References | Applicability at the II-NNI | Details for operator choice |
|-----|----------------------------|------------------------------|-----------------------------|---|
| 1 | Roaming II-NNI support | entire present specification | Yes | a. Option items in subclauses C.3.1 and C.3.2. b. Applicability of "Roaming Architecture for Voice over IMS with Local Breakout" (Clause 19). c. If "Roaming Architecture for Voice over IMS with Local Breakout" is applicable: + option items in subclause C.3.3; and + the default TRF address to use when not included in the g.3gpp.trf media feature tag. |
| | | | No | |
| 2 | Non-roaming II-NNI support | entire present specification | Yes | Option items in subclauses C.3.1 and C.3.3. |
| | | | No | |

C.3.1 Option item table common to roaming and non-roaming II-NNI

This subclause describes the option item tables common to the roaming II-NNI, the loopback traversal scenario, and the non-roaming II-NNI.

Table C.3.1.1: SIP method (Common)

| No. | Option item | References | Applicability at the II-NNI | Details for operator choice |
|-----|----------------|------------------------------|-----------------------------|--|
| 1 | INFO method | table 6.1/5A table 6.1/5B | Yes | Info package name to use. |
| | | | No | |
| 2 | MESSAGE method | table 6.1/9A table 6.1/9B | Yes | Inside or outside existing dialog, and content of MESSAGE request. |
| | | | No | |
| 3 | REFER method | table 6.1/16 table 6.1/17 | Yes | Inside or outside existing dialog. |
| | | | No | |

Table C.3.1.1A: SIP overload control

| No. | Option item | References | Applicability at the II-NNI | Details for operator choice |
|-----|----------------------|-------------------|-----------------------------|--|
| 1 | SIP overload control | Table 6.1.3.1/mmm | Yes | mechanisms to be used |
| | | | No | |
| 2 | feedback control | Table 6.1.3.1/nnn | Yes | algorithm to be used if not default (see subclause 21) |
| | | | No | |

Table C.3.1.2: Negotiation of resource reservation

| No. | Option item | References | Applicability at the II-NNI | Details for operator choice |
|-----|--|------------------|-----------------------------|-----------------------------|
| 1 | Negotiation of resource reservation (precondition) | table 6.1.3.1/20 | Yes | |
| | | | No | |

Table C.3.1.2A: Periodic refresh of SIP sessions

| No. | Option item | References | Applicability at the II-NNI | Details for operator choice |
|-----|---------------------------|------------------|-----------------------------|--|
| 1 | SIP session timer (timer) | table 6.1.3.1/45 | Yes | Use conditions. (Possible restriction on range of times and whether SIP session timer is applied in all sessions.) |

Table C.3.1.3: Replacing of SIP dialogs

| No. | Option item | References | Applicability at the II-NNI | Details for operator choice |
|-----|-------------------------------------|------------------|-----------------------------|-----------------------------|
| 1 | Replacing of SIP dialogs (replaces) | table 6.1.3.1/47 | Yes | |
| | | | No | |

Table C.3.1.4: Session participation

| No. | Option item | References | Applicability at the II-NNI | Details for operator choice |
|-----|------------------------------|------------------|-----------------------------|-----------------------------|
| 1 | Session participation (join) | table 6.1.3.1/48 | Yes | |
| | | | No | |

Table C.3.1.5: Conveying capabilities of UE

| No. | Option item | References | Applicability at the II-NNI | Details for operator choice |
|-----|------------------------------|------------------|-----------------------------|-----------------------------|
| 1 | Conveying capabilities of UE | table 6.1.3.1/49 | Yes | |
| | | | No | |

Table C.3.1.6: Asserting the service of authenticated users

| No. | Option item | References | Applicability at the II-NNI | Details for operator choice |
|-----|---|------------------|-----------------------------|-----------------------------------|
| 1 | Managing the indication of the asserted service (P-Asserted-Service header field) | table 6.1.3.1/77 | Yes | Service identifier values to use. |
| | | | No | |

Table C.3.1.7: Mode of signalling

| No. | Option item | References | Applicability at the II-NNI | Details for operator choice | |
|-----|--------------------|-------------------|-----------------------------|-----------------------------|--|
| 1 | Overlap signalling | subclause 6.1.1.5 | In-dialog method | Yes | |
| | | | Multiple-INVITE method | No | |
| | | | | Yes | |
| | | | No | | |

Table C.3.1.7A: SIP message bodies

| No. | Option item | References | Applicability at the II-NNI | Details for operator choice |
|-----|-------------|-----------------|-----------------------------|-----------------------------|
| 1 | MIME type | subclause 6.1.4 | Yes | MIME types to use. |

Table C.3.1.7B: SIP message body size

| No. | Option item | References | Applicability at the II-NNI | Details for operator choice |
|-----|--|-----------------|-----------------------------|-----------------------------|
| 1 | Limitation on maximum length of a SIP message body | subclause 6.1.4 | Yes | Maximum length accepted |
| | | | No | |

Table C.3.1.8: Control Plane Transport

| No. | Option item | References | Applicability at the II-NNI | Details for operator choice |
|-----|-------------|---------------|-----------------------------|---|
| 1 | TCP | subclause 6.2 | Yes | Use conditions. (e.g. port number to accept, number of simultaneous connections in case of reuse of the existing connections) |
| | | | No | |
| 2 | UDP | subclause 6.2 | Yes | Use conditions. (e.g. port number to accept) |
| | | | No | |
| 3 | SCTP | subclause 6.2 | Yes | Use conditions. (e.g. port number to accept) |
| | | | No | |

Table C.3.1.9: User Plane Transport, Media, and codec

| No. | Option item | References | Applicability at the II-NNI | Details for operator choice |
|-----|-------------------------------|---------------|-----------------------------|--|
| 1 | Speech media (m=audio) | subclause 7.1 | Yes | Names of speech codecs to use. |
| 2 | Video media (m=video) | subclause 7.1 | Yes | Names of video codecs to use. |
| | | | No | |
| 3 | Other media | subclause 7.1 | Yes | Media type (m=line of SDP) to use. (e.g. application, image, message) |
| | | | No | |
| 4 | RTP/AVPF | subclause 7.2 | Yes | Media type (m=line of SDP) that uses the protocol. |
| | | | No | |
| 5 | Transmission Control Protocol | subclause 7.2 | Yes | Media type (m=line of SDP) that uses the protocol. |
| | | | No | |
| 6 | Other user plane protocols | subclause 7.2 | Yes | Protocols to use (e.g. udptl, TCP/MSRP) and media types (m=line of SDP) that describe the protocols. |
| | | | No | |

Table C.3.1.10: Dual Tone Multi Frequency (DTMF)

| No. | Option item | References | Applicability at the II-NNI | Details for operator choice | |
|-----|----------------|--|-----------------------------|-----------------------------|--|
| 1 | DTMF transport | "telephone-event" based DTMF transport The SIP INFO mechanism | subclause 7.1 | Yes | |
| | | | table 6.1/5A | No | |
| | | | table 6.1/5B | Yes | |
| | | | subclause 12.14 | No | |
| | | subclause 12.15 | | | |

Table C.3.1.10A: Numbering, Naming and Addressing (Common)

| No. | Option item | References | Applicability at the II-NNI | Details for operator choice |
|-----|-------------------------------|---------------|-----------------------------|-----------------------------|
| 1 | Subaddress ("isub" parameter) | subclause 8.1 | Yes | |
| | | | No | |

Table C.3.1.11: IP Version

| No. | Option item | References | Applicability at the II-NNI | Details for operator choice |
|-----|-------------|------------|-----------------------------|--|
| 1 | IPv4 | clause 9 | Yes | Use conditions. (e.g. for control plane, for user plane) |
| | | | No | |
| 2 | IPv6 | clause 9 | Yes | Use conditions. (e.g. for control plane, for user plane) |
| | | | No | |

Table C.3.1.12: Supplementary services (Common)

| No. | Option item | | References | Applicability at the II-NNI | Details for operator choice | |
|-----|--|--|-------------------|-----------------------------|--|-----------------------------------|
| 1 | Malicious Communication Identification (MCID) | | subclause 12.2 | Yes | Minimum information exchanged over the II-NNI. | |
| | | | | No | | |
| 2 | Originating Identification Presentation (OIP) and Originating Identification Restriction (OIR) | | subclause 12.3 | Yes | | |
| | | | | No | | |
| 3 | Terminating Identification Presentation (TIP) and Terminating Identification Restriction (TIR) | | subclause 12.4 | Yes | | |
| | | | | No | | |
| 4 | Anonymous Communication Rejection (ACR) | | subclause 12.5 | Yes | | |
| | | | | No | | |
| 5 | Communication DIVersion (CDIV) excluding Communication Diversion Notification (CDIVN) | | subclause 12.6 | Yes | | |
| | | | | No | | |
| 6 | Communication Waiting (CW) | | subclause 12.7 | Yes | | |
| | | | | No | | |
| 7 | Communication HOLD (HOLD) | | subclause 12.8 | Yes | | |
| | | | | No | | |
| 8 | Message Waiting Indication (MWI) | | subclause 12.9 | Yes | | |
| | | | | No | | |
| 9 | Incoming Communication Barring (ICB) | | subclause 12.10.1 | Yes | | |
| | | | | No | | |
| 9A | Outgoing Communication Barring (OCB) | | subclause 12.10.2 | Yes | | |
| | | | | No | | |
| 10 | Completion of Communications to Busy Subscriber (CCBS) | | subclause 12.11 | Yes | | |
| | | | | No | | |
| 11 | Completion of Communications by No Reply (CCNR) | | subclause 12.12 | Yes | | |
| | | | | No | | |
| 12 | Explicit Communication Transfer (ECT) | | subclause 12.13 | Yes | | |
| | | | | No | | |
| 13 | Customized Alerting Tone (CAT) | | subclause 12.14 | Yes | CAT model to use. (Gateway model, forking model and early session model) | |
| | | | | No | | |
| 14 | Customized Ringing Signal (CRS) | | subclause 12.15 | Yes | | |
| | | | | No | | |
| 15 | Closed User Group (CUG) | | subclause 12.16 | Yes | | |
| | | | | No | | |
| 16 | Personal Network Management (PNM) | | subclause 12.17 | Yes | | |
| | | | | No | | |
| 17 | Three-Party (3PTY) | | subclause 12.18 | Yes | | |
| | | | | No | | |
| 18 | Conference (CONF) | | subclause 12.19 | Yes | | |
| | | | | No | | |
| 19 | Flexible Alerting (FA) | | subclause 12.20 | Yes | | |
| | | | | No | | |
| 20 | Announcements | During the establishment of a session | subclause 12.21.2 | Yes | Methods for sending announcement. | |
| | | | | No | | |
| | | During an established communication session | subclause 12.21.3 | | Yes | Methods for sending announcement. |
| | | | | | No | |
| | | Providing announcements when communication request is rejected | subclause 12.21.4 | | Yes | Methods for sending announcement. |
| | | | | | No | |
| 21 | Advice of Charge (AOC) | | subclause 12.22 | Yes | | |
| | | | | No | | |
| 22 | Completion of Communications on | | subclause 12.23 | Yes | | |

| No. | Option item | | References | Applicability at the II-NNI | Details for operator choice |
|-----|---|------------------------------------|---------------------------------------|-----------------------------|---|
| | Not Logged-in (CCNL) | | | No | |
| 23 | Presence service | | clause 15 | Yes | Presence services to use (3GPP TS 24.141 [132], OMA 1.1 [142] or OMA 2.0 [138]) |
| | | | | No | |
| 24 | Messaging service | Page-mode messaging | subclause 16.2 | Yes | |
| | | | | No | |
| | | Session-mode messaging | subclause 16.4 | Yes | |
| | | | | No | |
| | | Session-mode messaging conferences | subclause 16.5 | Yes | |
| | | | | No | |
| 25 | Other additional service using other SIP extensions | | subclause 6.1.1.3.2 subclause 12.6 | Yes | The SIP extensions to use and the service that uses the extensions. |
| | | | | No | |

Table C.3.1.13: Additional functions (Common)

| No. | Option item | | References | Applicability at the II-NNI | Details for operator choice |
|--|---------------------------|--|-----------------|-----------------------------|--|
| 1 | Optimal Media Routeing | | clause 17 | Yes | |
| | | | | No | |
| 2 | Applying forking (NOTE 1) | | table 6.1.3.1/5 | Yes | Usage of Request-Disposition header field with value "no-fork". (NOTE 3) |
| | | | | No (NOTE 2) | |
| NOTE 1: Support of handling of forked responses and of the SIP Request-Disposition header field, is mandated on the II-NNI. | | | | | |
| NOTE 2: In case the operator interconnects with IMS non-compliant networks, and wishes to use the II-NNI anyway, then the operators might want to negotiate if the forking procedures are applicable. | | | | | |
| NOTE 3: The Request-Disposition header field with value "no-fork" can be used to suppress that forking occurs. However, a peer operator might require the usage of forking e.g. to implement certain services. | | | | | |

Table C.3.1.14: SDP lines

| No. | Option item | | References | Applicability at the II-NNI | Details for operator choice |
|-----|-------------|--|-----------------|-----------------------------|---|
| 1 | m=line | | subclause 6.1.2 | Yes | Used static RTP payload type numbers. |
| 2 | b=line | | subclause 6.1.2 | Yes | Used bandwidth modifier types. |
| 3 | a=line | | subclause 6.1.2 | Yes | Used attributes. For the "rtptime" attribute, used "encoding names". |

C.3.2 Option item table specific to roaming II-NNI

This subclause describes the option item tables specific to roaming II-NNI.

Table C.3.2.1: Mechanism for authentication

| No. | Option item | References | Applicability at the II-NNI | Details for operator choice |
|-----|---|-----------------|-----------------------------|-----------------------------|
| 1 | IMS AKA plus Ipsec ESP | table 6.1.3.1/7 | Yes | |
| | | | No | |
| 2 | SIP digest plus check of IP association | table 6.1.3.1/7 | Yes | |
| | | | No | |
| 3 | SIP digest plus Proxy Authentication | table 6.1.3.1/7 | Yes | |
| | | | No | |
| 4 | SIP digest with TLS | table 6.1.3.1/7 | Yes | |
| | | | No | |

Table C.3.2.2: The key of service profile for HSS query

| No. | Option item | References | Applicability at the II-NNI | Details for operator choice |
|-----|---|------------------|-----------------------------|-----------------------------|
| 1 | The key of service profile for HSS query (P-Profile-Key header field) | table 6.1.3.1/59 | Yes | |
| | | | No | |

Table C.3.2.3: Numbering, Naming and Addressing (roaming II-NNI)

| No. | Option item | References | Applicability at the II-NNI | Details for operator choice |
|-----|--|------------------|-----------------------------|-----------------------------|
| 1 | Dial string ("user=dialstring " parameter) | table 6.1.3.1/67 | Yes | |
| | | | No | |

Table C.3.2.4: Supplementary services (roaming II-NNI)

| No. | Option item | References | Applicability at the II-NNI | Details for operator choice |
|-----|--|-----------------|-----------------------------|-----------------------------|
| 1 | Communication Diversion Notification (CDIVN) | subclause 12.6 | Yes | |
| | | | No | |
| 2 | Unstructured Supplementary Service Data | subclause 12.24 | Yes | |
| | | | No | |

Table C.3.2.5: Access transfer services (roaming II-NNI)

| No. | Option item | References | Applicability at the II-NNI | Details for operator choice |
|-----|---|----------------|-----------------------------|--|
| 1 | IMS Centralized Services (ICS) | clause 13 | Yes | |
| | | | No | |
| 2 | PS to CS Single Radio Voice Call Continuity (SRVCC) | clause 14 | Yes | Additional use conditions (PS to CS SRVCC for calls in alerting phase, support of ATCF architecture and PS to CS SRVCC with the MSC server assisted mid-call feature). |
| | | | No | |
| 3 | Single Radio Video Call Continuity (vSRVCC) | clause 14 | Yes | Additional use condition (transfer in alerting phase). |
| | | | No | |
| 4 | Inter UE Transfer (IUT) | clause 18 | Yes | |
| | | | No | |
| 5 | CS to PS Single Radio Voice Call Continuity (SRVCC) | subclause 14.5 | Yes | Additional use conditions (support of CS to PS SRVCC for calls in alerting phase and support of CS to PS SRVCC with the assisted mid-call feature). |
| | | | No | |

C.3.3 Option item table specific to non-roaming II-NNI and loopback traversal scenario

This subclause describes the option item tables specific to the non-roaming II-NNI and the loopback traversal scenario .

Table C.3.3.1: SIP method (non-roaming II-NNI and loopback traversal scenario)

| No. | Option item | References | Applicability at the II-NNI | Details for operator choice |
|-----|------------------|--------------------------------|-----------------------------|-----------------------------|
| 1 | NOTIFY method | table 6.1/10 table 6.1/11 | Yes | Event package name to use. |
| | | | No | |
| 2 | SUBSCRIBE method | table 6.1/20 table 6.1/21 | Yes | Event package name to use. |
| | | | No | |
| 3 | PUBLISH method | table 6.1/15A table 6.1/15B | Yes | Event package name to use. |
| | | | No | |

Table C.3.3.2: Charging

| No. | Option item | References | Applicability at the II-NNI | Details for operator choice |
|-----|---|------------------|-----------------------------|--|
| 1 | Inter-carrier charging information (P-Charging-Vector header field) | table 6.1.3.1/38 | Yes | Header parameter to use and use conditions for inter-carrier charging. |
| | | | No | |

Table C.3.3.3: Globally Routable User Agent URIs

| No. | Option item | References | Applicability at the II-NNI | Details for operator choice |
|-----|--|------------------|-----------------------------|-----------------------------|
| 1 | Globally Routable User Agent URIs (gruu) | table 6.1.3.1/56 | Yes | |
| | | | No | |

Table C.3.3.4: Media feature tags

| No. | Option item | References | Applicability at the II-NNI | Details for operator choice |
|-----|--------------------|---|-----------------------------|-------------------------------------|
| 1 | Media feature tags | table 6.1.3.1/76 clause 12 clause 13 clause 14 clause 16 clause 18 | Yes | Names of media feature tags to use. |
| | | | No | |

Table C.3.3.5: ISDN interworking

| No. | Option item | References | Applicability at the II-NNI | Details for operator choice |
|-----|--|------------------|-----------------------------|-----------------------------|
| 1 | User to User Call Control Information in SIP for ISDN Interworking (uui) | table 6.1.3.1/79 | Yes | |
| | | | No | |

Table C.3.3.6: Corporate network

| No. | Option item | References | Applicability at the II-NNI | Details for operator choice |
|-----|---|------------------|-----------------------------|-----------------------------|
| 1 | Private network traffic (P-Private-Network-Indication header field) | table 6.1.3.1/80 | Yes | |
| | | | No | |

Table C.3.3.7: Numbering, Naming and Addressing (non-roaming II-NNI and loopback traversal scenario)

| No. | Option item | References | Applicability at the II-NNI | Details for operator choice |
|-----|---|---------------|-----------------------------|--|
| 0 | SIP URI | subclause 8.1 | Yes | Any non-global numbers that are allowed in addition to global numbers. Domain name(s) and/or IP address(es) of hostportion to accept. |
| 0A | tel URI | subclause 8.1 | Yes | Any non-global numbers that are allowed in addition to global numbers. Applicability of the URI in P-Asserted-Identity header field and/or Request-URI. |
| | | | No | |
| 0B | IM URI | subclause 8.1 | Yes | |
| | | | No | |
| 0C | PRES URI | subclause 8.1 | Yes | |
| | | | No | |
| 1 | Number Portability Routing Number ("rn" and "npdi" parameter) | subclause 8.1 | Yes | |
| | | | No | |
| 2 | Calling Party's Category ("cpc" parameter) | subclause 8.1 | Yes | cpc-values to use. |
| | | | No | |
| 3 | Originating Line Information ("oli" parameter) | subclause 8.1 | Yes | oli-values to use. |
| | | | No | |

Table C.3.3.8: Additional functions (non-roaming II-NNI and loopback traversal scenario)

| No. | Option item | References | Applicability at the II-NNI | Details for operator choice |
|-----|---|------------------------------|-----------------------------|-----------------------------|
| 1 | Support of out-of-dialog OPTIONS method | table 6.1/12 table 6.1/13 | Yes | The purpose of the method. |
| | | | No | |

Annex D: Change history

| Change history | | | | | | | |
|----------------|--------|-----------|-----|-----|--|-------|-------|
| Date | TSG # | TSG Doc. | CR | Rev | Subject/Comment | Old | New |
| 4/05/2008 | | | | | TS Skeleton (C3-080779) | - | 0.0.0 |
| 07/07/2008 | | | | | Added agreed text of C3-080991, C3-081158 and C3-081208 | 0.0.0 | 0.1.0 |
| 28/08/2008 | | | | | Added agreed text of C3-081282 and C3-081672 | 0.1.0 | 0.2.0 |
| 01/09/2008 | | | | | Version 1.0.0 created for presentation to TSG by MCC | 0.2.0 | 1.0.0 |
| 17/10/2008 | | | | | Added agreed text of C3-081721 and C3-082105 | 1.0.0 | 1.1.0 |
| 20/11/2008 | | | | | Added agreed text of C3-082303, C3-082446, C3-082447 and C3-082611 | 1.0.0 | 1.2.0 |
| 26/11/2008 | | | | | v 2.0.0 was produced by MCC for Approval in CT#42 | 1.2.0 | 2.0.0 |
| 13/12/2008 | TSG#42 | | | | V 8.0.0 was produced by MCC | 2.0.0 | 8.0.0 |
| 03/2008 | TSG#43 | CP-090087 | 002 | 3 | Charging requirements on II-NNI | 8.0.0 | 8.1.0 |
| 03/2008 | TSG#43 | CP-090087 | 004 | 1 | Modification of the REFER method status | 8.0.0 | 8.1.0 |
| 03/2008 | TSG#43 | CP-090087 | 007 | 2 | NNI header tables | 8.0.0 | 8.1.0 |
| 05/2009 | TSG#44 | CP-090341 | 008 | 4 | Use of E.164 number at the II-NNI | 8.1.0 | 8.2.0 |
| 05/2009 | TSG#44 | CP-090341 | 009 | 4 | Correction to SIP headers table | 8.1.0 | 8.2.0 |
| 09/2009 | TSG#45 | CP-090576 | 017 | 1 | Removal of left-over text from TS drafting phase and update of a reference | 8.2.0 | 8.3.0 |
| 09/2009 | TSG#45 | CP-090576 | 018 | 2 | Applicability of SIP headers for roaming II-NNI | 8.2.0 | 8.3.0 |
| 09/2009 | TSG#45 | CP-090576 | 019 | 1 | Application level gateway usage to enable communication from private IP address space | 8.2.0 | 8.3.0 |
| 09/2009 | TSG#45 | CP-090576 | 020 | 3 | Codecs at the NNI | 8.2.0 | 8.3.0 |
| 09/2009 | TSG#45 | CP-090584 | 011 | 4 | Major capabilities on II-NNI | 8.3.0 | 9.0.0 |
| 09/2009 | TSG#45 | CP-090584 | 013 | 4 | Management of SIP headers over II-NNI in presence of trust or no trusted relationship (V1) | 8.3.0 | 9.0.0 |
| 09/2009 | TSG#45 | CP-090584 | 015 | 4 | Requirements for the end-to-end interoperability of supplementary services | 8.3.0 | 9.0.0 |
| 09/2009 | TSG#45 | CP-090584 | 016 | 3 | Deletion of the note about the normalization of phone numbers | 8.3.0 | 9.0.0 |
| 12/2009 | TSG#46 | CP-090854 | 021 | 5 | Requirements for HOLD service over II-NNI | 9.0.0 | 9.1.0 |
| 12/2009 | TSG#46 | CP-090854 | 022 | 5 | Requirements for CW service over II-NNI | 9.0.0 | 9.1.0 |
| 12/2009 | TSG#46 | CP-090844 | 024 | 3 | Aligning references to P-Asserted-Service | 9.0.0 | 9.1.0 |
| 12/2009 | TSG#46 | CP-090844 | 026 | | Annex A header updated with Answer-Mode, Priv-Answer-Mode and P-Answer-State | 9.0.0 | 9.1.0 |
| 12/2009 | TSG#46 | CP-090854 | 031 | 6 | Filling of the table about major capabilities on II-NNI | 9.0.0 | 9.1.0 |
| 12/2009 | TSG#46 | CP-090854 | 032 | 1 | Customized Ringing Signal (CRS) modification | 9.0.0 | 9.1.0 |
| 12/2009 | TSG#46 | CP-090854 | 033 | 2 | Completing the Personal Network Management (PNM) supplementary service | 9.0.0 | 9.1.0 |
| 12/2009 | TSG#46 | CP-090854 | 034 | 1 | Aligning existing supplementary services | 9.0.0 | 9.1.0 |

| | | | | | | | |
|---------|--------|-----------|-----|---|--|-------|-------|
| 12/2009 | TSG#46 | CP-090854 | 035 | 1 | Completing the Flexible Alerting (FA) supplementary service | 9.0.0 | 9.1.0 |
| 12/2009 | TSG#46 | CP-090854 | 036 | 1 | Completing the Closed User Group (CUG) supplementary service | 9.0.0 | 9.1.0 |
| 12/2009 | TSG#46 | CP-090854 | 037 | 3 | Completing the Three-Party (3PTY) and Conference (CONF) supplementary services | 9.0.0 | 9.1.0 |
| 12/2009 | TSG#46 | CP-090854 | 038 | 3 | Completing the Anonymous Communication Rejection (ACR) supplementary service | 9.0.0 | 9.1.0 |
| 12/2009 | TSG#46 | CP-090854 | 039 | 3 | Completing Completion of Communications to Busy Subscriber (CCBS) and Completion of Communications by No Reply (CCNR) supplementary services | 9.0.0 | 9.1.0 |
| 12/2009 | TSG#46 | CP-090854 | 040 | | Completing Message Waiting Indication (MWI) supplementary service | 9.0.0 | 9.1.0 |
| 12/2009 | TSG#46 | CP-090854 | 041 | 1 | Completing the Terminating Identification Presentation (TIP) and Terminating Identification Restriction (TIR) needs to be completed. | 9.0.0 | 9.1.0 |
| 12/2009 | TSG#46 | CP-090854 | 042 | 3 | Completing the Communication Barring (CB) supplementary service | 9.0.0 | 9.1.0 |
| 12/2009 | TSG#46 | CP-090854 | 043 | 2 | Completing Explicit Communication Transfer (ECT) | 9.0.0 | 9.1.0 |
| 12/2009 | TSG#46 | CP-090854 | 044 | 3 | Completing Communication DIVersion (CDIV) supplementary services | 9.0.0 | 9.1.0 |
| 12/2009 | TSG#46 | CP-090854 | 046 | 2 | Deletion of an editors note on OIR service | 9.0.0 | 9.1.0 |
| 12/2009 | TSG#46 | CP-090844 | 047 | 3 | Annex A header updated | 9.0.0 | 9.1.0 |
| 03/2010 | TSG#47 | CP-100077 | 051 | 2 | Format of Request URI | 9.1.0 | 9.2.0 |
| 03/2010 | TSG#47 | CP-100077 | 055 | 2 | MSC Server enhanced for ICS missing in architecture | 9.1.0 | 9.2.0 |
| 03/2010 | TSG#47 | CP-100087 | 058 | | AOC added to supplementary services | 9.1.0 | 9.2.0 |
| 03/2010 | TSG#47 | CP-100087 | 059 | | CPC and OLI IETF reference update | 9.1.0 | 9.2.0 |
| 03/2010 | TSG#47 | CP-100087 | 060 | 3 | CPC and OLI and trust domain | 9.1.0 | 9.2.0 |
| 03/2010 | TSG#47 | CP-100087 | 061 | 1 | Modifying CUG interactions | 9.1.0 | 9.2.0 |
| 03/2010 | TSG#47 | CP-100087 | 062 | | Correcting minor errors | 9.1.0 | 9.2.0 |
| 03/2010 | TSG#47 | CP-100087 | 063 | 4 | Updating Major Capability according to latest 24.229 | 9.1.0 | 9.2.0 |
| 03/2010 | TSG#47 | CP-100087 | 064 | 1 | Major Capabilities revision 2 | 9.1.0 | 9.2.0 |
| 03/2010 | TSG#47 | CP-100087 | 067 | 1 | Table 6.2 update | 9.1.0 | 9.2.0 |
| 03/2010 | TSG#47 | CP-100087 | 068 | 1 | Modification of OIP/OIR paragraph description (R9 29.165) | 9.1.0 | 9.2.0 |
| 03/2010 | TSG#47 | CP-100087 | 071 | 1 | References numbers update (R9 29.165) | 9.1.0 | 9.2.0 |
| 06/2010 | TSG#48 | CP-100319 | 073 | 1 | The Session-ID added to annex A | 9.2.0 | 9.3.0 |
| 06/2010 | TSG#48 | CP-100319 | 077 | 2 | Correcting incorrect interface name | 9.2.0 | 9.3.0 |
| 06/2010 | TSG#48 | CP-100319 | 079 | 2 | Supported URI formats also based on operator agreements | 9.2.0 | 9.3.0 |
| 06/2010 | TSG#48 | CP-100319 | 080 | 2 | Customized Alerting Tone (CAT) | 9.2.0 | 9.3.0 |
| 06/2010 | TSG#48 | CP-100319 | 081 | 2 | Customized Ringing Signal (CRS) | 9.2.0 | 9.3.0 |
| 06/2010 | TSG#48 | CP-100319 | 082 | 1 | Correcting miscellaneous errors | 9.2.0 | 9.3.0 |
| 06/2010 | TSG#48 | CP-100319 | 084 | 2 | Applicability of 'critical' privacy value | 9.2.0 | 9.3.0 |
| 06/2010 | TSG#48 | CP-100319 | 085 | | Making Alert-Info not mandatory | 9.2.0 | 9.3.0 |
| 06/2010 | TSG#48 | CP-100319 | 086 | 1 | Draft-johnston-sipping-cc-uii reference updated to new version | 9.2.0 | 9.3.0 |

| | | | | | | | |
|---------|--------|-----------|-----|---|--|--------|--------|
| 06/2010 | TSG#48 | CP-100319 | 087 | 2 | Correcting references for removal of P-Asserted-Identity | 9.2.0 | 9.3.0 |
| 06/2010 | TSG#48 | CP-100319 | 091 | 2 | Correction of Mayor Capabilities | 9.2.0 | 9.3.0 |
| 06/2010 | TSG#48 | CP-100319 | 093 | 2 | Usage of 'Refer' for conferencing and 3PTY | 9.2.0 | 9.3.0 |
| 06/2010 | TSG#48 | CP-100325 | 083 | 4 | ICS, SRVCC, IUT and MSC Server mid-call assisted feature interoperability | 9.3.0 | 10.0.0 |
| 09/2010 | TSG#49 | CP-100614 | 094 | 1 | Presence service at II-NNI | 10.0.0 | 10.1.0 |
| 09/2010 | TSG#49 | CP-100553 | 096 | 2 | Support of REFER checked by entry IBCF | 10.0.0 | 10.1.0 |
| 09/2010 | TSG#49 | CP-100545 | 099 | 2 | Removing unnecessary normative text | 10.0.0 | 10.1.0 |
| 09/2010 | TSG#49 | CP-100553 | 101 | 1 | CCBS and CCNR and the m-parameter | 10.0.0 | 10.1.0 |
| 09/2010 | TSG#49 | CP-100559 | 102 | 2 | CCNL support in the II-NNI | 10.0.0 | 10.1.0 |
| 09/2010 | TSG#49 | CP-100553 | 104 | 1 | Correcting references | 10.0.0 | 10.1.0 |
| 09/2010 | TSG#49 | CP-100553 | 106 | | Adding missing 'history' privacy value to CDIV | 10.0.0 | 10.1.0 |
| 09/2010 | TSG#49 | CP-100553 | 109 | 3 | MCID and identity information transfer clarification | 10.0.0 | 10.1.0 |
| 09/2010 | TSG#49 | CP-100553 | 111 | 2 | Correcting name of the Authenticate header field and the applicability over II-NNI | 10.0.0 | 10.1.0 |
| 09/2010 | TSG#49 | CP-100553 | 113 | 2 | Aligning Major Capabilities Table with 24.229 | 10.0.0 | 10.1.0 |
| 09/2010 | TSG#49 | CP-100614 | 114 | 2 | SRVCC additions and reference to subclause 14.2 | 10.0.0 | 10.1.0 |
| 12/2010 | TSG#50 | CP-100781 | 118 | 2 | Aligning annex A with Major Capabilities Table | 10.1.0 | 10.2.0 |
| 12/2010 | TSG#50 | CP-100775 | 121 | | Release version added to ETSI specification | 10.1.0 | 10.2.0 |
| 12/2010 | TSG#50 | CP-100785 | 123 | | Privacy protection in IBCF | 10.1.0 | 10.2.0 |
| 12/2010 | TSG#50 | CP-100775 | 126 | | Correcting errors in SIP method subclause | 10.1.0 | 10.2.0 |
| 12/2010 | TSG#50 | CP-100781 | 128 | | Duplications of rows in Major capability table | 10.1.0 | 10.2.0 |
| 12/2010 | TSG#50 | CP-100785 | 129 | 1 | Editorial corrections | 10.1.0 | 10.2.0 |
| 12/2010 | TSG#50 | CP-100785 | 130 | | Missing reference to 24.229 in major capability table | 10.1.0 | 10.2.0 |
| 12/2010 | TSG#50 | CP-100775 | 133 | 1 | IBCF and URI formats | 10.1.0 | 10.2.0 |
| 12/2010 | TSG#50 | CP-100775 | 136 | 1 | Roaming and non-roaming definition added | 10.1.0 | 10.2.0 |
| 12/2010 | TSG#50 | CP-100886 | 137 | 3 | Clarification of relevance of restrictions over II-NNI | 10.1.0 | 10.2.0 |
| 12/2010 | TSG#50 | CP-100775 | 140 | 2 | Refer-Sub and Refer-To missing in annex A | 10.1.0 | 10.2.0 |
| 12/2010 | TSG#50 | CP-100781 | 142 | 2 | Supplementary services corrections | 10.1.0 | 10.2.0 |
| 12/2010 | TSG#50 | CP-100785 | 143 | 2 | OMA presence additions to 3GPP | 10.1.0 | 10.2.0 |
| 12/2010 | TSG#50 | CP-100785 | 144 | 1 | Instant messaging | 10.1.0 | 10.2.0 |
| 12/2010 | TSG#50 | CP-100785 | 145 | 3 | adding references to table 6.2 | 10.1.0 | 10.2.0 |
| 12/2010 | TSG#50 | CP-100785 | 146 | 1 | Editors change of major capability n98 | 10.1.0 | 10.2.0 |
| 12/2010 | TSG#50 | CP-100785 | 147 | 2 | ICB | 10.1.0 | 10.2.0 |
| 12/2010 | TSG#50 | CP-100785 | 148 | 2 | Service OIP/OIR, TIP/TIR | 10.1.0 | 10.2.0 |
| 12/2010 | TSG#50 | CP-100781 | 149 | 1 | MCID and ACR | 10.1.0 | 10.2.0 |
| 12/2010 | TSG#50 | CP-100785 | 150 | 1 | Clarifications of operator option items | 10.1.0 | 10.2.0 |
| 03/2011 | TSG#51 | CP-110113 | 156 | | Correction on Major Capabilities over II-NNI | 10.2.0 | 10.3.0 |

| | | | | | | | |
|---------|--------|-----------|-----|---|---|--------|--------|
| 03/2011 | TSG#51 | CP-110113 | 158 | 1 | Addition of the Target-Dialog header field to the table of major capabilities and Annex A | 10.2.0 | 10.3.0 |
| 03/2011 | TSG#51 | CP-110113 | 160 | 2 | Correcting major capabilities related to trust domain | 10.2.0 | 10.3.0 |
| 03/2011 | TSG#51 | CP-110116 | 161 | 1 | RFC 5318 in the Major capability table | 10.2.0 | 10.3.0 |
| 03/2011 | TSG#51 | CP-110116 | 162 | 2 | Updating OMA presence requirements | 10.2.0 | 10.3.0 |
| 03/2011 | TSG#51 | CP-110113 | 164 | 3 | Reference clause updates | 10.2.0 | 10.3.0 |
| 03/2011 | TSG#51 | CP-110116 | 165 | | Introduction of ATCF | 10.2.0 | 10.3.0 |
| 03/2011 | TSG#51 | CP-110116 | 166 | 2 | Interoperability of IMS Service Continuity over II-NNI updates | 10.2.0 | 10.3.0 |
| 03/2011 | TSG#51 | CP-110113 | 168 | 2 | Updates of the Major capability table | 10.2.0 | 10.3.0 |
| 03/2011 | TSG#51 | CP-110116 | 169 | 3 | Adding new header fields Annex A | 10.2.0 | 10.3.0 |
| 03/2011 | TSG#51 | CP-110107 | 172 | 1 | Correcting header table in annex A | 10.2.0 | 10.3.0 |
| 03/2011 | TSG#51 | CP-110113 | 174 | | Reference update: RFC 6086 | 10.2.0 | 10.3.0 |
| 03/2011 | TSG#51 | CP-110116 | 175 | 1 | Reference points Mi, Mm, Mw and I2 | 10.2.0 | 10.3.0 |
| 03/2011 | TSG#51 | CP-110107 | 178 | | Adding MMTel feature tag in clause 12 | 10.2.0 | 10.3.0 |
| 03/2011 | TSG#51 | CP-110116 | 179 | | Minor corrections to 3GPP TS 29.165 | 10.2.0 | 10.3.0 |
| 03/2011 | TSG#51 | CP-110116 | 180 | | Alignment with 23.228 Ici reference point | 10.2.0 | 10.3.0 |
| 03/2011 | TSG#51 | CP-110116 | 181 | 1 | Miscellaneous error corrections to 3GPP TS 29.165 | 10.2.0 | 10.3.0 |
| 03/2011 | TSG#51 | CP-110129 | 182 | 5 | New annex for dynamic view of SIP messages | 10.2.0 | 10.3.0 |
| 03/2011 | TSG#51 | CP-110129 | 183 | 3 | Summary of notation codes in dynamic view (ACK method) | 10.2.0 | 10.3.0 |
| 03/2011 | TSG#51 | CP-110129 | 184 | 5 | Summary of notation codes in dynamic view (BYE method) | 10.2.0 | 10.3.0 |
| 03/2011 | TSG#51 | CP-110129 | 185 | 3 | Summary of notation codes in dynamic view (CANCEL method) | 10.2.0 | 10.3.0 |
| 03/2011 | TSG#51 | CP-110129 | 186 | 5 | Summary of notation codes in dynamic view (INVITE method) | 10.2.0 | 10.3.0 |
| 03/2011 | TSG#51 | CP-110129 | 187 | 5 | Summary of notation codes in dynamic view (MESSAGE method) | 10.2.0 | 10.3.0 |
| 03/2011 | TSG#51 | CP-110129 | 188 | 5 | Summary of notation codes in dynamic view (OPTIONS method) | 10.2.0 | 10.3.0 |
| 03/2011 | TSG#51 | CP-110129 | 189 | 5 | Summary of notation codes in dynamic view (PRACK method) | 10.2.0 | 10.3.0 |
| 03/2011 | TSG#51 | CP-110129 | 190 | 5 | Summary of notation codes in dynamic view (PUBLISH method) | 10.2.0 | 10.3.0 |
| 03/2011 | TSG#51 | CP-110129 | 191 | 3 | Summary of notation codes in dynamic view (REGISTER method) | 10.2.0 | 10.3.0 |
| 03/2011 | TSG#51 | CP-110129 | 192 | 5 | Summary of notation codes in dynamic view (UPDATE method) | 10.2.0 | 10.3.0 |
| 03/2011 | TSG#51 | CP-110113 | 194 | 4 | Alignment of INFO support for DTMF transport with TS 24.182 | 10.2.0 | 10.3.0 |
| 03/2011 | TSG#51 | CP-110116 | 197 | 2 | Addition of normative references for in band DTMF and SDP messages | 10.2.0 | 10.3.0 |
| 03/2011 | TSG#51 | CP-110113 | 199 | 1 | Correcting the management of SIP header field relating to trust relationship | 10.2.0 | 10.3.0 |
| 03/2011 | TSG#51 | CP-110116 | 206 | 1 | Correcting related to references | 10.2.0 | 10.3.0 |
| 03/2011 | TSG#51 | CP-110113 | 212 | 1 | Updating references in TS29.165 | 10.2.0 | 10.3.0 |
| 03/2011 | TSG#51 | CP-110116 | 213 | | Minor correction on reference in table 6.2 of TS 29.165 | 10.2.0 | 10.3.0 |
| 03/2011 | TSG#51 | CP-110116 | 214 | 1 | Updating references in TS29.16 release 10 | 10.2.0 | 10.3.0 |
| 03/2011 | TSG#51 | CP-110113 | 217 | 3 | Removal av draft-patel-dispatch-cpc-oli-parameter from references | 10.2.0 | 10.3.0 |
| 03/2011 | TSG#51 | CP-110113 | 219 | 1 | Removal of draft-patel-ecrit-sos-parameter | 10.2.0 | 10.3.0 |

| | | | | | | | |
|---------|--------|-----------|-----|---|---|--------|--------|
| 03/2011 | TSG#51 | CP-110129 | 224 | 2 | Summary of notation codes in dynamic view (INFO method) | 10.2.0 | 10.3.0 |
| 03/2011 | TSG#51 | CP-110129 | 225 | 2 | Summary of notation codes in dynamic view (NOTIFY method) | 10.2.0 | 10.3.0 |
| 03/2011 | TSG#51 | CP-110129 | 226 | 2 | Summary of notation codes in dynamic view (REFER method) | 10.2.0 | 10.3.0 |
| 03/2011 | TSG#51 | CP-110129 | 227 | 2 | Summary of notation codes in dynamic view (SUBSCRIBE method) | 10.2.0 | 10.3.0 |
| 03/2011 | TSG#51 | CP-110117 | 228 | 2 | OMR | 10.2.0 | 10.3.0 |
| 03/2011 | TSG#51 | CP-110116 | 234 | | Unification of the words and phrases in clause 12 | 10.2.0 | 10.3.0 |
| 03/2011 | TSG#51 | | | | Editorial changes made by MCC | 10.3.0 | 10.3.1 |
| 06/2011 | TSG#52 | CP-110403 | 238 | 2 | Reference section updates (II-NNI) | 10.3.1 | 10.4.0 |
| 06/2011 | TSG#52 | CP-110415 | 240 | 2 | CPC/OLI and trust domain | 10.3.1 | 10.4.0 |
| 06/2011 | TSG#52 | CP-110523 | 241 | 2 | Completing SRVCC by removing one EN | 10.3.1 | 10.4.0 |
| 06/2011 | TSG#52 | CP-110407 | 242 | | Completing MSC assisted mid call | 10.3.1 | 10.4.0 |
| 06/2011 | TSG#52 | CP-110407 | 243 | 2 | Completing and restructuring IUT | 10.3.1 | 10.4.0 |
| 06/2011 | TSG#52 | CP-110407 | 244 | | Reference section updates (II-NNI2) | 10.3.1 | 10.4.0 |
| 06/2011 | TSG#52 | CP-110419 | 245 | 1 | Modification of the terminology related to roaming II-NNI | 10.3.1 | 10.4.0 |
| 06/2011 | TSG#52 | CP-110419 | 246 | 2 | The addition of an notation code for SIP header fields in dynamic view for II-NNI | 10.3.1 | 10.4.0 |
| 06/2011 | TSG#52 | CP-110419 | 247 | 1 | The addition of the conditions for the presence of SIP header fields in SIP messages for supplementary services | 10.3.1 | 10.4.0 |
| 06/2011 | TSG#52 | CP-110403 | 263 | 1 | Allow-Event header field (II-NNI) | 10.3.1 | 10.4.0 |
| 06/2011 | TSG#52 | CP-110407 | 264 | 1 | Allow-Event header field (II-NNI2) | 10.3.1 | 10.4.0 |
| 06/2011 | TSG#52 | CP-110403 | 266 | | Max-Breadth header field correction | 10.3.1 | 10.4.0 |
| 06/2011 | TSG#52 | CP-110401 | 269 | 1 | SIP headers alignment in II-NNI | 10.3.1 | 10.4.0 |
| 06/2011 | TSG#52 | CP-110406 | 271 | 1 | Removal of dial around indicator | 10.3.1 | 10.4.0 |
| 06/2011 | TSG#52 | CP-110403 | 276 | 1 | Forking definition on II-NNI | 10.3.1 | 10.4.0 |
| 06/2011 | TSG#52 | CP-110407 | 279 | 1 | Services at II-NNI R10 | 10.3.1 | 10.4.0 |
| 09/2011 | TSG#53 | CP-110621 | 282 | | CDIV History-Info header field correction | 10.4.0 | 10.5.0 |
| 09/2011 | TSG#53 | CP-110621 | 284 | 1 | P-Served-User correction in annex b | 10.4.0 | 10.5.0 |
| 09/2011 | TSG#53 | CP-110612 | 286 | | Date header field missing in CCBS and CCNR | 10.4.0 | 10.5.0 |
| 09/2011 | TSG#53 | CP-110615 | 287 | | Date header field missing in CCNL | 10.4.0 | 10.5.0 |
| 09/2011 | TSG#53 | CP-110612 | 289 | | Support of replaces missing in ECT | 10.4.0 | 10.5.0 |
| 09/2011 | TSG#53 | CP-110612 | 291 | 1 | Error-Info missing in announcements | 10.4.0 | 10.5.0 |
| 09/2011 | TSG#53 | CP-110616 | 293 | | ICS error corrections | 10.4.0 | 10.5.0 |
| 09/2011 | TSG#53 | CP-110616 | 294 | | SRVCC Target-Dialog corrections | 10.4.0 | 10.5.0 |
| 09/2011 | TSG#53 | CP-110616 | 297 | 1 | Reference section update (II-NNI2) | 10.4.0 | 10.5.0 |
| 09/2011 | TSG#53 | CP-110619 | 298 | 1 | Table error corrections | 10.4.0 | 10.5.0 |
| 09/2011 | TSG#53 | CP-110621 | 299 | | Correction on descriptions related to CONF in Dynamic View. | 10.4.0 | 10.5.0 |
| 09/2011 | TSG#53 | CP-110621 | 300 | | Minor correction on REFER request in Dynamic View | 10.4.0 | 10.5.0 |
| 09/2011 | TSG#53 | CP-110625 | 283 | | Editorial corrections on SIP header field name | 10.5.0 | 11.0.0 |

| | | | | | | | |
|---------|--------|-----------|-----|---|---|--------|--------|
| 09/2011 | TSG#53 | CP-110625 | 292 | 1 | Minor error correction in major capabilities table | 10.5.0 | 11.0.0 |
| 09/2011 | TSG#53 | CP-110624 | 303 | 2 | Interoperability on vSRVCC | 10.5.0 | 11.0.0 |
| 12/2011 | TSG#54 | CP-110841 | 301 | 5 | The list of option items for II-NNI | 11.0.0 | 11.1.0 |
| 12/2011 | TSG#54 | CP-110837 | 305 | | Adding SIP header fields to dynamic view tables | 11.0.0 | 11.1.0 |
| 12/2011 | TSG#54 | CP-110824 | 309 | | Aligning the references with Supported transport-level RFCs | 11.0.0 | 11.1.0 |
| 12/2011 | TSG#54 | CP-110833 | 311 | 1 | Correcting the references | 11.0.0 | 11.1.0 |
| 12/2011 | TSG#54 | CP-110837 | 313 | | Minor correction on PUBLISH request in Dynamic View | 11.0.0 | 11.1.0 |
| 12/2011 | TSG#54 | CP-110829 | 316 | 1 | Reference updates | 11.0.0 | 11.1.0 |
| 12/2011 | TSG#54 | CP-110833 | 318 | 1 | MSC server enhanced for SRVCC | 11.0.0 | 11.1.0 |
| 12/2011 | TSG#54 | CP-110829 | 321 | 1 | Reference to wrong RFC for INFO method | 11.0.0 | 11.1.0 |
| 12/2011 | TSG#54 | CP-110833 | 323 | 5 | Indication of features supported by proxy | 11.0.0 | 11.1.0 |
| 12/2011 | TSG#54 | CP-110833 | 325 | 2 | SRVCC updates | 11.0.0 | 11.1.0 |
| 12/2011 | TSG#54 | CP-110833 | 327 | | Removal of draft-ietf-sip-session-policy-framework | 11.0.0 | 11.1.0 |
| 12/2011 | TSG#54 | CP-110842 | 328 | 1 | Editorial corrections and alignments | 11.0.0 | 11.1.0 |
| 12/2011 | TSG#54 | CP-110833 | 330 | 3 | 'ua-profile' replaced with 'xcap-diff' | 11.0.0 | 11.1.0 |
| 12/2011 | TSG#54 | CP-110829 | 334 | 2 | Reference update: Reason header in SIP responses | 11.0.0 | 11.1.0 |
| 12/2011 | TSG#54 | CP-110840 | 335 | 2 | Interoperability on vSRVCC | 11.0.0 | 11.1.0 |
| 12/2011 | TSG#54 | CP-110837 | 340 | 1 | Correction on dynamic view of SIP message | 11.0.0 | 11.1.0 |
| 12/2011 | TSG#54 | CP-110829 | 348 | 2 | RFC4694 passing of rn parameter | 11.0.0 | 11.1.0 |
| 03/2012 | TSG#55 | CP-120206 | 343 | 5 | Updating of UUS references | 11.1.0 | 11.2.0 |
| 03/2012 | TSG#55 | CP-120067 | 350 | | Missing correction for SIP message in dynamic view tables | 11.1.0 | 11.2.0 |
| 03/2012 | TSG#55 | CP-120060 | 353 | 1 | Clarification on URI formats in SIP message | 11.1.0 | 11.2.0 |
| 03/2012 | TSG#55 | CP-120071 | 354 | 2 | Addition of SIP session timer to option item table over II-NNI | 11.1.0 | 11.2.0 |
| 03/2012 | TSG#55 | CP-120071 | 364 | 2 | Addition of option items related to URI for II-NNI | 11.1.0 | 11,2,0 |
| 03/2012 | TSG#55 | CP-120071 | 365 | 2 | Addition of option item related to user plane transport protocol for II-NNI | 11.1.0 | 11,2,0 |
| 03/2012 | TSG#55 | CP-120064 | 367 | 1 | Indication of features supported by proxy updates | 11.1.0 | 11.2.0 |
| 03/2012 | TSG#55 | CP-120060 | 370 | 3 | IETF draft update – Location Conveyance | 11.1.0 | 11.2.0 |
| 03/2012 | TSG#55 | CP-120060 | 373 | | Removing draft-rosenberg-sipcore-target-uri-delivery | 11.1.0 | 11.2.0 |
| 03/2012 | TSG#55 | CP-120072 | 376 | | ICSI in the Feature-Caps header field | 11.1.0 | 11.2.0 |
| 03/2012 | TSG#55 | CP-120064 | 378 | 1 | SRVCC updates and corrections | 11.1.0 | 11.2.0 |
| 03/2012 | TSG#55 | CP-120076 | 379 | | Correcting editorial errors in Dynamic View | 11.1.0 | 11.2.0 |
| 03/2012 | TSG#55 | CP-120071 | 382 | | Providing announcements when communication request is rejected | 11.1.0 | 11,2,0 |
| 03/2012 | TSG#55 | CP-120071 | 383 | 3 | Clarifications of the presence service option items | 11.1.0 | 11.2.0 |
| 03/2012 | TSG#55 | CP-120071 | 384 | 1 | Access transfer services option items | 11.1.0 | 11.2.0 |
| 03/2012 | TSG#55 | CP-120064 | 386 | 1 | Clarification of user plane transport with operator agreement | 11.1.0 | 11.2.0 |
| 03/2012 | TSG#55 | CP-120069 | 387 | 2 | Addition of SIP timers table for II-NNI | 11.1.0 | 11.2.0 |
| 03/2012 | TSG#55 | CP-120060 | 390 | 2 | CDIV limitation 29.165r11 | 11.1.0 | 11.2.0 |

| | | | | | | | |
|---------|--------|-----------|-----|---|---|--------|--------|
| 06/2012 | TSG#56 | CP-120348 | 359 | 7 | Addition of services using OPTIONS method to option item table | 11.2.0 | 11.3.0 |
| 06/2012 | TSG#56 | CP-120340 | 393 | 1 | Reference update: draft-salud-alert-info-urns | 11.2.0 | 11.3.0 |
| 06/2012 | TSG#56 | CP-120349 | 395 | | Updating the title of draft-kaplan-dispatch-session-id | 11.2.0 | 11.3.0 |
| 06/2012 | TSG#56 | CP-120349 | 396 | | Update of IBCF function list | 11.2.0 | 11.3.0 |
| 06/2012 | TSG#56 | CP-120349 | 397 | 1 | Major capability updates | 11.2.0 | 11.3.0 |
| 06/2012 | TSG#56 | CP-120355 | 398 | 2 | Roaming Architecture for Voice over IMS with Local Breakout | 11.2.0 | 11.3.0 |
| 06/2012 | TSG#56 | CP-120348 | 402 | | Clarification of a using model for CAT service over II-NNI | 11.2.0 | 11.3.0 |
| 06/2012 | TSG#56 | CP-120342 | 404 | 3 | Clarification on SIP message bodies over II-NNI | 11.2.0 | 11.3.0 |
| 06/2012 | TSG#56 | CP-120348 | 405 | 1 | Fixing the option items related to control plane transport over II-NNI | 11.2.0 | 11.3.0 |
| 06/2012 | TSG#56 | CP-120340 | 408 | 2 | Usage of isub parameter over II-NNI | 11.2.0 | 11.3.0 |
| 06/2012 | TSG#56 | CP-120348 | 409 | 1 | Addition of option item related isub parameter over II-NNI | 11.2.0 | 11.3.0 |
| 06/2012 | TSG#56 | CP-120348 | 411 | 2 | Unification of description for option item table related to services | 11.2.0 | 11.3.0 |
| 06/2012 | TSG#56 | CP-120342 | 415 | | The sos URI parameter in Request-URIs | 11.2.0 | 11.3.0 |
| 06/2012 | TSG#56 | CP-120348 | 416 | 2 | Addition of option items related to SDP lines for II-NNI | 11.2.0 | 11.3.0 |
| 06/2012 | TSG#56 | CP-120340 | 419 | | Updating of UUS references | 11.2.0 | 11.3.0 |
| 06/2012 | TSG#56 | CP-120348 | 420 | 4 | forking option over II-NNI | 11.2.0 | 11.3.0 |
| 06/2012 | TSG#56 | CP-120332 | 424 | 2 | The description of notation code for SIP message | 11.2.0 | 11.3.0 |
| 09/2012 | TSG#57 | CP-120525 | 425 | 1 | Removal of editor's note in Annex C | 11.3.0 | 11.4.0 |
| 09/2012 | TSG#57 | CP-120519 | 427 | 1 | P-Refused-URI-List header field | 11.3.0 | 11.4.0 |
| 09/2012 | TSG#57 | CP-120518 | 430 | | Correction on the description of "g.3gpp.crs" | 11.3.0 | 11.4.0 |
| 09/2012 | TSG#57 | CP-120518 | 433 | | Correction on the description of "application/vnd.etsi.mcid+xml" MIME body | 11.3.0 | 11.4.0 |
| 09/2012 | TSG#57 | CP-120519 | 434 | 1 | Correcting minor errors | 11.3.0 | 11.4.0 |
| 09/2012 | TSG#57 | CP-120525 | 435 | 2 | Managing the maximum length of a SIP message body | 11.3.0 | 11.4.0 |
| 09/2012 | TSG#57 | CP-120519 | 437 | 1 | Clarification on the SDP rules for transporting media streams with TCP | 11.3.0 | 11.4.0 |
| 09/2012 | TSG#57 | CP-120518 | 440 | 1 | Correcting reference | 11.3.0 | 11.4.0 |
| 09/2012 | TSG#57 | CP-120535 | 441 | 2 | Loopback NNI | 11.3.0 | 11.4.0 |
| 09/2012 | TSG#57 | CP-120535 | 442 | 3 | Roaming Option Item | 11.3.0 | 11.4.0 |
| 09/2012 | TSG#57 | CP-120535 | 443 | 3 | Adding TRF into reference architecture | 11.3.0 | 11.4.0 |
| 09/2012 | TSG#57 | CP-120531 | 444 | 2 | Media control related SIP signalling traversing the II- NNI is not considered | 11.3.0 | 11.4.0 |
| 09/2012 | TSG#57 | CP-120522 | 445 | | Minor Corrections | 11.3.0 | 11.4.0 |
| 09/2012 | TSG#57 | CP-120519 | 450 | 1 | draft-ietf-sipcore-proxy-feature: reference update and technical changes | 11.3.0 | 11.4.0 |
| 09/2012 | TSG#57 | CP-120531 | 451 | 1 | Optimised allocation of media resources | 11.3.0 | 11.4.0 |
| 09/2012 | TSG#57 | CP-120519 | 453 | | Feature-Caps added to trust domain - CT CR CORRELATION NEEDED | 11.3.0 | 11.4.0 |
| 09/2012 | TSG#57 | CP-120524 | 454 | 3 | Unstructured Supplementary Service Data (USSD) | 11.3.0 | 11.4.0 |
| 09/2012 | TSG#57 | CP-120536 | 455 | 3 | Adding MIME body table and removing an EN - CT CR | 11.3.0 | 11.4.0 |

| | | | | | CORRELATION NEEDED | | |
|---------|--------|-----------|-----|---|---|--------|--------|
| 09/2012 | TSG#57 | CP-120530 | 456 | 4 | CS to PS access transfer | 11.3.0 | 11.4.0 |
| 09/2012 | TSG#57 | CP-120526 | 457 | 1 | Editorial corrections | 11.3.0 | 11.4.0 |
| 09/2012 | TSG#57 | CP-120519 | 459 | 1 | IUT reference update | 11.3.0 | 11.4.0 |
| 09/2012 | TSG#57 | CP-120519 | 461 | 1 | MIME body name update | 11.3.0 | 11.4.0 |
| 09/2012 | TSG#57 | CP-120519 | 463 | | CDIV corrections | 11.3.0 | 11.4.0 |
| 09/2012 | TSG#57 | CP-120519 | 465 | 1 | Missing the Event header in MWI | 11.3.0 | 11.4.0 |
| 09/2012 | TSG#57 | CP-120519 | 467 | | Event header field missing in CC services | 11.3.0 | 11.4.0 |
| 09/2012 | TSG#57 | CP-120614 | 470 | 3 | Support of overload control | 11.3.0 | 11.4.0 |
| 09/2012 | TSG#57 | CP-120532 | 472 | 2 | Add IPXS to architecture | 11.3.0 | 11.4.0 |

History

| Document history | | |
|-------------------------|--------------|-------------|
| V11.4.0 | October 2012 | Publication |
| | | |
| | | |
| | | |
| | | |