



**Digital cellular telecommunications system (Phase 2+) (GSM);  
Universal Mobile Telecommunications System (UMTS);  
LTE;  
Location Services (LCS);  
LCS Application Protocol (LCS-AP)  
between the Mobile Management Entity (MME)  
and Evolved Serving Mobile Location Centre (E-SMLC);  
SLs interface  
(3GPP TS 29.171 version 15.3.0 Release 15)**



---

Reference

RTS/TSGC-0429171vf30

---

Keywords

GSM,LTE,UMTS

**ETSI**

650 Route des Lucioles  
F-06921 Sophia Antipolis Cedex - FRANCE

Tel.: +33 4 92 94 42 00 Fax: +33 4 93 65 47 16

Siret N° 348 623 562 00017 - NAF 742 C  
Association à but non lucratif enregistrée à la  
Sous-Préfecture de Grasse (06) N° 7803/88

---

**Important notice**

The present document can be downloaded from:

<http://www.etsi.org/standards-search>

The present document may be made available in electronic versions and/or in print. The content of any electronic and/or print versions of the present document shall not be modified without the prior written authorization of ETSI. In case of any existing or perceived difference in contents between such versions and/or in print, the prevailing version of an ETSI deliverable is the one made publicly available in PDF format at [www.etsi.org/deliver](http://www.etsi.org/deliver).

Users of the present document should be aware that the document may be subject to revision or change of status.

Information on the current status of this and other ETSI documents is available at

<https://portal.etsi.org/TB/ETSIDeliverableStatus.aspx>

If you find errors in the present document, please send your comment to one of the following services:

<https://portal.etsi.org/People/CommiteeSupportStaff.aspx>

---

**Copyright Notification**

No part may be reproduced or utilized in any form or by any means, electronic or mechanical, including photocopying and microfilm except as authorized by written permission of ETSI.

The content of the PDF version shall not be modified without the written authorization of ETSI.

The copyright and the foregoing restriction extend to reproduction in all media.

© ETSI 2019.

All rights reserved.

**DECT™**, **PLUGTESTS™**, **UMTS™** and the ETSI logo are trademarks of ETSI registered for the benefit of its Members.

**3GPP™** and **LTE™** are trademarks of ETSI registered for the benefit of its Members and of the 3GPP Organizational Partners.

**oneM2M™** logo is a trademark of ETSI registered for the benefit of its Members and of the oneM2M Partners.

**GSM®** and the GSM logo are trademarks registered and owned by the GSM Association.

---

## Intellectual Property Rights

### Essential patents

IPRs essential or potentially essential to normative deliverables may have been declared to ETSI. The information pertaining to these essential IPRs, if any, is publicly available for **ETSI members and non-members**, and can be found in ETSI SR 000 314: "*Intellectual Property Rights (IPRs); Essential, or potentially Essential, IPRs notified to ETSI in respect of ETSI standards*", which is available from the ETSI Secretariat. Latest updates are available on the ETSI Web server (<https://ipr.etsi.org/>).

Pursuant to the ETSI IPR Policy, no investigation, including IPR searches, has been carried out by ETSI. No guarantee can be given as to the existence of other IPRs not referenced in ETSI SR 000 314 (or the updates on the ETSI Web server) which are, or may be, or may become, essential to the present document.

### Trademarks

The present document may include trademarks and/or tradenames which are asserted and/or registered by their owners. ETSI claims no ownership of these except for any which are indicated as being the property of ETSI, and conveys no right to use or reproduce any trademark and/or tradename. Mention of those trademarks in the present document does not constitute an endorsement by ETSI of products, services or organizations associated with those trademarks.

---

## Legal Notice

This Technical Specification (TS) has been produced by ETSI 3rd Generation Partnership Project (3GPP).

The present document may refer to technical specifications or reports using their 3GPP identities. These shall be interpreted as being references to the corresponding ETSI deliverables.

The cross reference between 3GPP and ETSI identities can be found under <http://webapp.etsi.org/key/queryform.asp>.

---

## Modal verbs terminology

In the present document "**shall**", "**shall not**", "**should**", "**should not**", "**may**", "**need not**", "**will**", "**will not**", "**can**" and "**cannot**" are to be interpreted as described in clause 3.2 of the [ETSI Drafting Rules](#) (Verbal forms for the expression of provisions).

"**must**" and "**must not**" are **NOT** allowed in ETSI deliverables except when used in direct citation.

# Contents

Intellectual Property Rights .....	2
Legal Notice .....	2
Modal verbs terminology.....	2
Foreword.....	6
1 Scope .....	7
2 References .....	7
3 Definitions and abbreviations.....	8
3.1 Definitions .....	8
3.2 Abbreviations .....	8
4 Functional Overview .....	8
4.1 General .....	8
5 LCS-AP Message Transport.....	9
5.1 General .....	9
5.2 Protocol Layering.....	9
5.3 Usage of SCTP Associations.....	10
6 LCS-AP Procedures .....	10
6.1 General .....	10
6.2 Procedures Applicable to LCS-AP.....	10
6.2.1 Location Service Request .....	10
6.2.1.1 General .....	10
6.2.1.2 Successful Operation.....	10
6.2.1.3 Unsuccessful Operation .....	12
6.2.2 Location Information Exchange .....	12
6.2.2.1 Connection Oriented Information Transfer.....	12
6.2.2.1.1 General .....	12
6.2.2.1.2 Successful Operation .....	13
6.2.2.1.3 Abnormal Conditions .....	13
6.2.2.2 Connectionless Information Transfer.....	13
6.2.2.2.1 General .....	13
6.2.2.2.2 Successful Operation .....	14
6.2.2.2.3 Unsuccessful Operation.....	14
6.2.2.2.4 Abnormal Conditions .....	14
6.2.3 Ciphering Keys Delivery .....	15
6.2.3.1 General .....	15
6.2.3.2 Successful Operation.....	15
6.2.3.3 Unsuccessful Operation .....	15
6.3 Exception Procedures.....	15
6.3.1 Location Abort.....	15
6.3.1.1 General .....	15
6.3.1.2 Normal Operation .....	16
6.3.1.3 Abnormal Conditions .....	16
6.3.2 Reset .....	16
6.3.2.1 General .....	16
6.3.2.2 Normal Operation .....	16
6.3.2.3 Abnormal Conditions .....	17
6.4 Error Handling.....	17
6.4.1 Abnormal Conditions.....	17
6.4.2 Overload .....	17
7 LCS-AP Messages and Message Formats.....	18
7.1 General .....	18
7.2 Message Formats.....	18
7.3 LCS-AP Messages.....	18

7.3.1	LCS-AP Location Request message .....	18
7.3.2	LCS-AP Location Response message .....	19
7.3.3	LCS-AP Location Abort Request message .....	20
7.3.4	LCS-AP Connection Oriented Information message .....	20
7.3.5	LCS-AP Connectionless Information message .....	20
7.3.6	LCS-AP Reset Request message .....	21
7.3.7	LCS-AP Reset Acknowledge message .....	21
7.3.8	LCS-AP Ciphering Key Data message .....	21
7.3.9	LCS-AP Ciphering Key Data Result message .....	21
7.4	Information Elements .....	22
7.4.1	General .....	22
7.4.2	Message Type .....	22
7.4.3	Location Type .....	22
7.4.4	E-CGI .....	22
7.4.5	LCS Client Type .....	23
7.4.6	LCS Priority .....	23
7.4.7	LCS QoS .....	23
7.4.8	UE Positioning Capability .....	24
7.4.9	Include Velocity .....	24
7.4.10	IMSI .....	24
7.4.11	IMEI .....	25
7.4.12	Geographic Area .....	26
7.4.13	Positioning Data .....	28
7.4.14	Velocity Estimate .....	32
7.4.15	Accuracy Fulfilment Indicator .....	32
7.4.16	LCS Cause .....	33
7.4.17	Payload Type .....	34
7.4.18	APDU .....	34
7.4.19	Network Element .....	34
7.4.20	Return Error Request .....	34
7.4.21	Return Error Cause .....	34
7.4.22	Altitude and direction .....	35
7.4.23	Geographical Coordinates .....	35
7.4.24	Uncertainty Ellipse .....	36
7.4.25	Horizontal Speed and Bearing .....	36
7.4.26	Vertical Velocity .....	36
7.4.27	PLMN Identity .....	37
7.4.28	Correlation ID .....	37
7.4.29	eNB ID .....	38
7.4.30	LCS Service Type ID .....	38
7.4.31	Cell Portion ID .....	38
7.4.32	Civic Address .....	38
7.4.33	Barometric Pressure .....	39
7.4.34	RAT Type .....	39
7.4.35	Coverage Level .....	39
7.4.36	Ciphering Data .....	39
7.4.37	Ciphering Data Ack .....	40
7.4.38	Ciphering Data Error Report .....	40
7.4.39	Ciphering Data Set .....	40
7.4.40	Ciphering Data Error Report Contents .....	44
7.4.41	High Accuracy Geographical Coordinates .....	44
7.4.42	High Accuracy Uncertainty Ellipse .....	45
7.4.43	High Accuracy Altitude .....	45
7.5	Message and information element abstract syntax .....	45
7.5.1	General .....	45
7.5.2	Usage of protocol extension mechanism for non-standard use .....	46
7.5.3	Elementary procedure definitions .....	46
7.5.4	PDU definitions .....	48
7.5.5	Information element definitions .....	53
7.5.6	Common definitions .....	61
7.5.7	Constant definitions .....	62
7.5.8	Container Definitions .....	63

7.5.9 Message transfer syntax .....64

7.6 Handling of unknown, unforeseen and erroneous protocol data .....65

8 LCS-AP Timers .....65

8.1 General .....65

8.2 Timers of LCS-AP.....65

**Annex A (informative): Change history .....66**

History .....67

---

# Foreword

This Technical Specification has been produced by the 3<sup>rd</sup> Generation Partnership Project (3GPP).

The contents of the present document are subject to continuing work within the TSG and may change following formal TSG approval. Should the TSG modify the contents of the present document, it will be re-released by the TSG with an identifying change of release date and an increase in version number as follows:

Version x.y.z

where:

- x the first digit:
  - 1 presented to TSG for information;
  - 2 presented to TSG for approval;
  - 3 or greater indicates TSG approved document under change control.
- y the second digit is incremented for all changes of substance, i.e. technical enhancements, corrections, updates, etc.
- z the third digit is incremented when editorial only changes have been incorporated in the document.

---

# 1 Scope

The present document specifies the procedures and information coding for LCS Application Protocol (LCS-AP) that is needed to support the location services in E-UTRAN. The LCS-AP message set is applicable to the SLs interface between the E-SMLC and the MME. LCS-AP is developed in accordance to the general principles stated in 3GPP TS 23.271 [3].

---

# 2 References

The following documents contain provisions which, through reference in this text, constitute provisions of the present document.

- References are either specific (identified by date of publication, edition number, version number, etc.) or non-specific.
- For a specific reference, subsequent revisions do not apply.
- For a non-specific reference, the latest version applies. In the case of a reference to a 3GPP document (including a GSM document), a non-specific reference implicitly refers to the latest version of that document *in the same Release as the present document*.

- [1] 3GPP TR 21.905: "Vocabulary for 3GPP Specifications".
- [2] 3GPP TS 36.305: "Stage 2 functional specification of User Equipment (UE) positioning in E-UTRAN".
- [3] 3GPP TS 23.271: "Functional stage 2 description of Location Services (LCS)".
- [4] IETF RFC 4960: "Stream Control Transmission Protocol".
- [5] TIA/EIA/IS-J-STD-036 (2000): "Wireless Enhanced Emergency Services".
- [6] 3GPP TS 23.032: "Universal Geographical Area Description (GAD)".
- [7] 3GPP TS 36.413: "S1 Application Protocol (S1AP)".
- [8] ITU-T Recommendation X.680 (07/2002): "Information Technology - Abstract Syntax Notation One (ASN.1): Specification of basic notation".
- [9] ITU-T Recommendation X.681 (07/2002): "Information Technology - Abstract Syntax Notation One (ASN.1): Information object specification".
- [10] 3GPP TS 22.071: "Location Services (LCS); Service Description; Stage1".
- [11] 3GPP TS 23.003: "Numbering, addressing and identification".
- [12] ITU-T Recommendation X.691 (07/2002): "Information Technology - ASN.1 encoding rules - Specification of Packed Encoding Rules (PER)".
- [13] IETF RFC 4119: "A Presence-based GEOPRIV Location Object Format".
- [14] IETF RFC 5139: "Revised Civic Location Format for Presence Information Data Format Location Object".
- [15] IETF RFC 6848: "Specifying Civic Address Extensions in the Presence Information Data Format Location Object (PIDF-LO)".
- [16] IETF RFC 5905: "Network Time Protocol Version 4: Protocol and Algorithms Specification".
- [17] 3GPP TS 24.301: "Non-Access-Stratum (NAS) protocol for Evolved Packet System (EPS); Stage 3".



---

## 3 Definitions and abbreviations

### 3.1 Definitions

For the purposes of the present document, the terms and definitions given in TR 21.905 [1] and the following apply. A term defined in the present document takes precedence over the definition of the same term, if any, in TR 21.905 [1].

**Elementary Procedure:** LCS-AP protocol consists of Elementary Procedures (EPs). An LCS-AP Elementary Procedure is a unit of interaction between the MME and the E-SMLC. An EP consists of an initiating message and possibly a response message. Two kinds of EPs are used:

- **Class 1:** Elementary Procedures with response (success or failure),
- **Class 2:** Elementary Procedures without response.

### 3.2 Abbreviations

For the purposes of the present document, the abbreviations given in TR 21.905 [1] and the following apply. An abbreviation defined in the present document takes precedence over the definition of the same abbreviation, if any, in TR 21.905 [1].

CID	Cell-ID (positioning method)
E-CID	Enhanced Cell-ID (positioning method)
E-SMLC	Enhanced Serving Mobile Location Centre
E-UTRAN	Evolved Universal Terrestrial Radio Access Network
GNSS	Global Navigation Satellite System
GPS	Global Positioning System
LCS	LoCation Services
LCS-AP	LCS Application Protocol
LPP	LTE Positioning Protocol
LPPa	LTE Positioning Protocol Annex
LTE	Long Term Evolution
MBS	Metropolitan Beacon System
MO-LR	Mobile Originated Location Request
MT-LR	Mobile Terminated Location Request
NI-LR	Network Induced Location Request
MME	Mobility Management Entity
OTDOA	Observed Time Difference Of Arrival
PDU	Protocol Data Unit
SCTP	Stream Control Transmission Protocol
SET	SUPL Enabled Terminal
SLP	SUPL Location Platform
SUPL	Secure User Plane Location
TA	Timing Advanced
UE	User Equipment
U-TDOA	Uplink Time Difference Of Arrival

---

## 4 Functional Overview

### 4.1 General

Figure 4.1-1 below shows the architecture applicable to the positioning of a UE with E-UTRAN access. The SLs interface is used to convey LCS-AP messages and parameters between the MME to the E-SMLC. It is also used for tunnelling LTE Positioning Protocols (LPP between the E-SMLC and the target UE, LPPa between the E-SMLC and the eNB), which are transparent to the MME as described in 3GPP TS 36.305 [2].

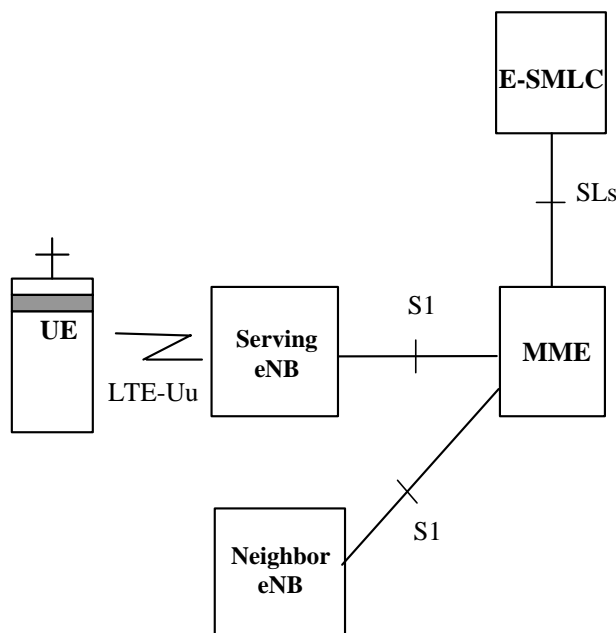

Figure 4.1-1 Positioning Interfaces in E-UTRAN

## 5 LCS-AP Message Transport

### 5.1 General

The LCS-AP is a logical interface between the MME and the E-SMLC. This clause specifies the standards for signaling transport to be used across LCS-AP.

### 5.2 Protocol Layering

Figure 5.2-1 below shows the protocol layering used to support the transfer of LCS-AP PDUs between an E-SMLC and a MME. The LTE Positioning Protocols (LPP and LPPa) can be carried in LCS-AP messages which are transparent to the MME.

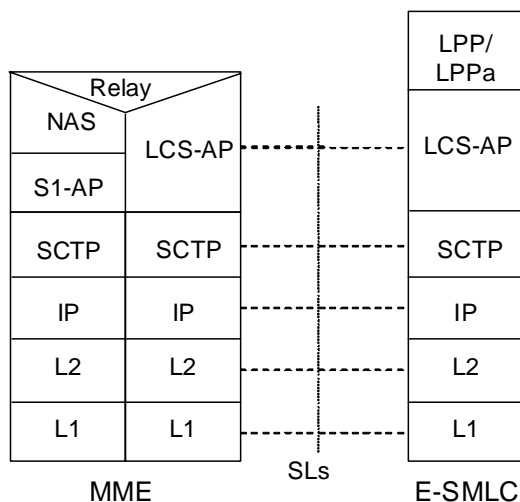

Figure 5.2-1 Protocol Layering for LCS-AP

## 5.3 Usage of SCTP Associations

SCTP (see IETF RFC 4960 [4]) shall be supported as the transport layer of LCS-AP messages.

Semi-permanent SCTP associations shall be established between MME and E-SMLC, i.e. the SCTP associations shall remain up under normal circumstances.

Local multi-homing should be supported. Remote multi-homing shall be supported.

Multiple local SCTP endpoints may be supported. Multiple remote SCTP endpoints shall be supported. When multiple local or remote SCTP endpoints are configured, several simultaneous SCTP associations shall be supported between MME and E-SMLC.

The MME shall establish the SCTP association. Since under normal operation there should always be an SCTP association established between an MME and an E-SMLC, if the E-SMLC needs to initiate a message towards an MME it shall do so over an existing SCTP association already established with that MME.

When an entity detects that an SCTP association has been lost, all resources for transactions open on that association shall be released.

The registered port number for LCS-AP is 9082. The registered payload protocol identifier for LCS-AP is 29.

---

## 6 LCS-AP Procedures

### 6.1 General

The LCS-AP interface can be divided into the following procedures:

- Location service request procedure
- Location information exchange procedure

The E-UTRAN positioning capabilities are intended to be forward compatible to other access types and other position methods, in an effort to reduce the amount of additional positioning support needed in the future.

### 6.2 Procedures Applicable to LCS-AP

#### 6.2.1 Location Service Request

##### 6.2.1.1 General

The purpose of the location service request procedure is to obtain the location estimate for a target UE in E-UTRAN.

##### 6.2.1.2 Successful Operation

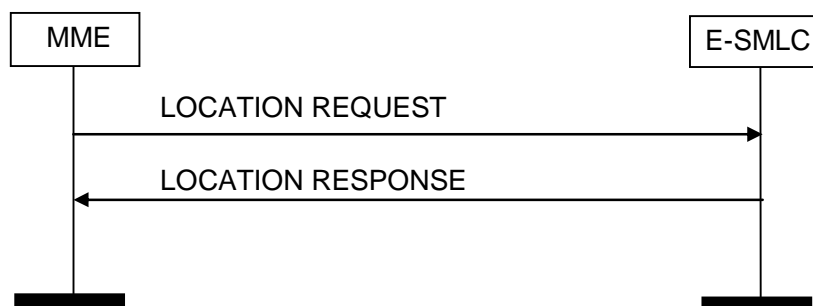

Figure 6.2.1.2-1 Location Service Request Procedure, Successful Operation

The initiator (MME) of the location service request procedure sends a LCS-AP Location Request message to the E-SMLC associated with the current or last known serving cell for the target UE and starts the timer T3x01. The message contains the following mandatory (M), conditional (C) and optional (O) information, where conditional parameters are required if available.

- Correlation ID (M)
- Location Type (M)
- Cell Identifier (M)
- LCS Client Type (C)
- LCS Priority (C)
- LCS Service Type ID (C)
- LCS QoS (C)
- UE Positioning Capability (O)
- Include Velocity (O)
- IMSI of target UE (O)
- IMEI of target UE (O)
- APDU (O)
- RAT Type (O)
- Coverage Level (O)

The Correlation ID is assigned by the MME and enables association of the location response with the location request when more than one location service request procedure is ongoing for the UE with the same E-SMLC.

The Location Type IE indicates the type of Location Information being requested. The following types are supported:

- Current geographic location estimate
- Location assistance data for the target UE
- Last known location estimate

If the location estimate is requested, the E-SMLC performs positioning procedure on the target UE using a particular position method or a combination of more than one positioning method based on the UE capability. If UE capability is unknown, the E-SMLC may request UE position capability through LPP as defined in 3GPP TS 36.305 [2].

Alternatively, if assistance data was requested, the E-SMLC may provide positioning assistance data to the UE. The E-SMLC may invoke the following LCS-AP procedures to get assistance data:

- Connection Oriented Information Transfer
- Connectionless Information Transfer

Otherwise, if a last known location estimate is requested, the E-SMLC obtains a geographic location estimate using only the information provided in the LCS-AP Location Request message. The E-SMLC shall not attempt to obtain location information for the target UE from either the E-UTRAN or the target UE (e.g. because the UE may not be currently reachable).

If a location estimate or a last known location estimate was requested and was subsequently obtained, the E-SMLC shall return a LCS-AP Location Response to the initiator of the location request using the same SCTP association as the location request. This message contains the following mandatory (M), conditional (C) and optional parameters (O).

- Correlation ID (M)

- Location Estimate (M).
- Accuracy Fulfilment Indicator (O).
- Velocity estimate (C).
- Positioning Data (C).
- E-UTRAN Cell Identifier (O).
- Cell Portion ID (O).
- Civic Address (O).
- Barometric Pressure (O).

If assistance data was instead requested for an UE and the E-SMLC was able successfully to transfer this to the UE, the E-SMLC shall return a LCS-AP Location Response to the initiator of the location request (MME). This message shall contain no parameters. The absence of a LCS Cause parameter in this case implies that the transfer was successful.

If the MME receives the LCS-AP Location Response for corresponding request message, the MME shall stop the timer T3x01.

### 6.2.1.3 Unsuccessful Operation

If the E-SMLC is unable to obtain any of the location information requested or if requested LCS assistance data could not be transferred, the E-SMLC shall return a LCS-AP Location Response to the initiator of the Location Request carrying the following parameters:

- Correlation ID (M)
- LCS Cause (M)
- Positioning Data (O)

The E-SMLC shall use the same SCTP association for the Location Response as was used for the request.

If the MME receives the LCS-AP Location Response for corresponding request message, the MME shall stop the timer T3x01.

On the expiry of the timer T3x01, the MME shall abort the procedure, release any resources allocated for this location request procedure and notify the node that triggered the Location Request about the error.

## 6.2.2 Location Information Exchange

### 6.2.2.1 Connection Oriented Information Transfer

#### 6.2.2.1.1 General

The Connection Oriented Information transfer procedure enables two-way transfer of LPP and LPPa messages between an E-SMLC and a MME. The procedure is only valid while a location request procedure for the target UE is ongoing. This procedure makes use of the same SCTP association as the location request procedure for the particular target UE.

### 6.2.2.1.2 Successful Operation

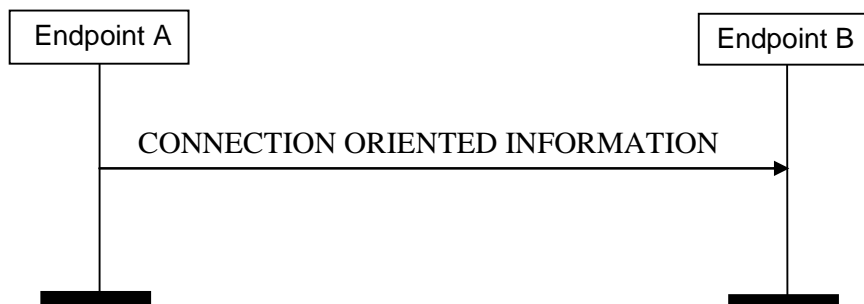

**Figure 6.2.2.1.2-1 Connection Oriented Information, Successful Operation**

The initiator of the procedure (E-SMLC or MME) with a LPP or LPPa message to transfer concerning a particular target UE sends a LCS-AP Connection Oriented Information message to a recipient carrying the following parameters:

- Correlation ID (M)
- Payload Type (M)
- APDU (M);

The Correlation ID in this message is the Correlation ID used for the Location Request. It shall be present for a message transfer from the E-SMLC to the MME and for a message transfer from the MME to the E-SMLC.

The Payload Type shall be present to indicate the type of the APDU. The supported information types are LPP and LPPa.

The APDU shall contain an LPP APDU when communicating between the E-SMLC and the target UE or an LPPa APDU when communicating between the E-SMLC and serving eNB. The MME shall forward this to the serving eNB for the target UE.

If the intended recipient is the E-SMLC for a target UE, the message is terminated in the E-SMLC. The E-SMLC shall then perform interpretation of the APDU.

### 6.2.2.1.3 Abnormal Conditions

At an intermediate entity, if a received LCS-AP Connection Oriented Information message contains unrecognized information or if the message cannot be sent on, the message shall be discarded.

## 6.2.2.2 Connectionless Information Transfer

### 6.2.2.2.1 General

The Connectionless Information transfer procedure enables two-way transfer of LPPa messages between an E-SMLC and a MME when there is no existing signalling connection association. This procedure can be used to query eNBs for the information not related to a UE connection, such as Timing information on the eNB.

## 6.2.2.2.2 Successful Operation

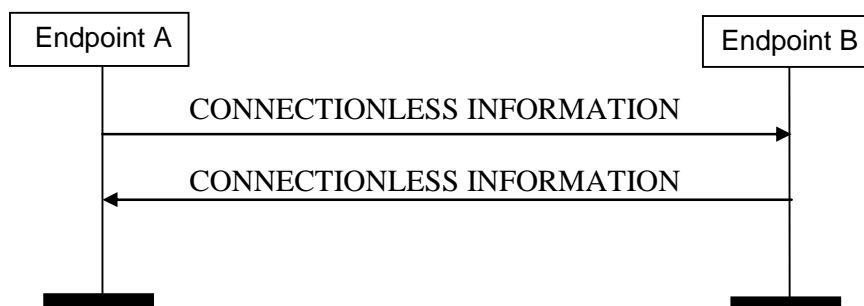

**Figure 6.2.2.2-1 Connectionless Information Procedure, Successful Operation**

The initiator of the procedure (either E-SMLC or MME) sends a LCS-AP Connectionless Information message to a recipient carrying the following parameters:

- Source Entity (M)
- Destination Entity (M)
- APDU (M)
- Return Error Request (O)

The source entity identifies the sender. The recipient entity identifies the final destination. The APDU contains a LPPa APDU to be transferred. The Return Error Request may be included to request notification in the event of unsuccessful transfer and indicate the type of notification needed. If the recipient entity is not the final destination, the recipient shall transfer the LCS-AP Connectionless Information message to either the final destination or an intermediate entity capable of forward it to the final destination.

## 6.2.2.2.3 Unsuccessful Operation

If the message cannot be transferred by an intermediate entity or destination entity and the Return Error Request is not included, the message shall be discarded. If the Return Error Request is included, the intermediate or destination entity shall, depending on the Return Error Request type, send a LCS-AP Connectionless Information message to, or towards, the original source containing the following parameters:

- Source Entity (M)
- Destination Entity (M)
- APDU (M)
- Return Error Cause (M)

The Source entity shall indicate the Destination Entity in the original received message. The Destination Entity shall indicate the Source Entity in the original message. The Return Error cause shall indicate the reason for unsuccessful transfer. The APDU shall contain any originally received APDU.

If a received LCS-AP Connectionless Information message containing a Return Error Cause cannot be transferred by an intermediate entity, it shall be discarded with no return error message.

## 6.2.2.2.4 Abnormal Conditions

At an intermediate entity, if a received LCS-AP Connectionless Information message contains unrecognized or invalid information, the message shall be discarded.

At the recipient entity, if a received LCS-AP Connectionless Information message contains invalid or unrecognized information as defined for LCS-AP, the message shall be discarded.

## 6.2.3 Cipherring Keys Delivery

### 6.2.3.1 General

The purpose of the cipherring keys delivery procedure is to enable the E-SMLC to send cipherring keys for broadcast assistance data to the MME so that the MME can then distribute the cipherring keys to suitably subscribed UEs.

### 6.2.3.2 Successful Operation

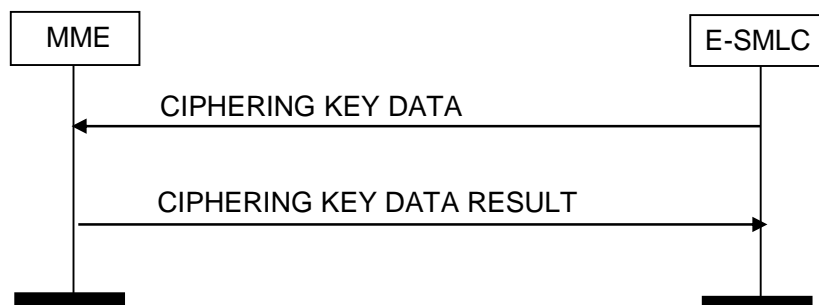

**Figure 6.2.3.2-1 Cipherring Keys Delivery Procedure, Successful Operation**

The initiator (E-SMLC) of the cipherring keys delivery procedure sends a Cipherring Key Data message to the MME and starts the timer T3x03. The message contains the following mandatory (M) information:

- Cipherring Data (M):

If the MME is able to successfully store all cipherring data sets included in the Cipherring Key Data message, the MME sends a Cipherring Key Data Result message. The message contains the following mandatory (M) information:

- Cipherring Data Ack (M)

If the E-SMLC receives the Cipherring Key Data Result message, the E-SMLC shall stop the timer T3x03.

### 6.2.3.3 Unsuccessful Operation

If the MME is unable to successfully store one or more cipherring data sets included in the Cipherring Key Data message, the MME shall return a Cipherring Key Data Result message carrying the following mandatory (M) information:

- Cipherring Data Error Report (M)

If the E-SMLC receives the Cipherring Key Data Result message, the E-SMLC shall stop the timer T3x03.

On the expiry of the timer T3x03, the E-SMLC shall abort the procedure and release any resources allocated for this cipherring keys delivery procedure.

## 6.3 Exception Procedures

### 6.3.1 Location Abort

#### 6.3.1.1 General

The purpose of the Location Abort procedure is to cancel an ongoing positioning attempt or the request for assistance data. This message can be sent from the MME to the E-SMLC. This procedure makes use of the same SCTP association as the location request procedure for the particular target UE.



### 6.3.1.2 Normal Operation

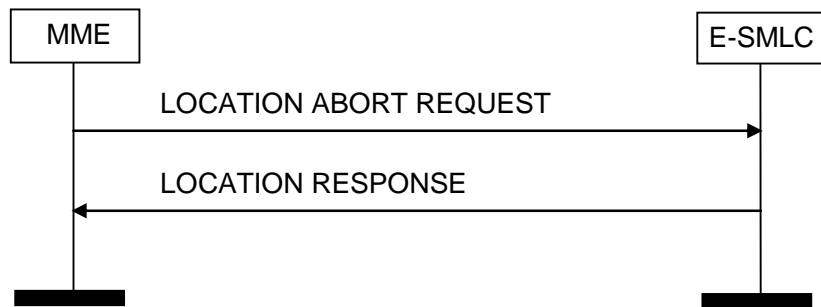

**Figure 6.3.1.2-1 Location Abort Procedure, Normal Operation**

The MME sends a LCS-AP Location Abort Request message to the E-SMLC across the SLs interface. The message contains a LCS Cause parameter indicating the reason of cancellation.

On receipt of this message, the E-SMLC shall stop the positioning transactions of the target UE and may release any resources previously allocated. The E-SMLC shall return a LCS-AP Location Response message containing the LCS Cause received in Location Abort Request and, optionally, positioning data. The E-SMLC may also optionally include in this response any "best-effort" location estimate that it has already determined prior to receiving the LCS-AP Location Abort Request.

### 6.3.1.3 Abnormal Conditions

At the recipient entity, if no ongoing location transaction for the target UE is found, the recipient entity shall discard the received LCS-AP Location Abort Request message with no return error message.

## 6.3.2 Reset

### 6.3.2.1 General

The Reset procedure is an optional procedure applicable to the LCS-AP. It enables an E-SMLC or a MME that has undergone a failure with loss of location service transactions to indicate this to a partner entity. The recipient entity can then release its own connection and transaction resources. The Reset procedure may not be applicable when only a limited part of an E-SMLC or a MME has suffered a failure, since error recovery procedures specific to individual connections and transactions may then be used. The Reset procedure applies to all transactions initiated on a single SCTP association.

### 6.3.2.2 Normal Operation

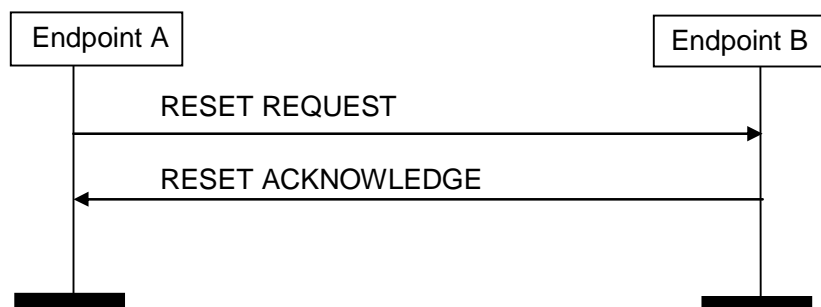

**Figure 6.3.2.2-1 Reset Procedure, Normal Operation**

In the event of a failure at an E-SMLC or a MME that results in the loss of location service transactions, a LCS-AP Reset Request message may be sent to the partner entity across the SLs interface. The message contains a LCS Cause parameter indicating the reason for the reset. The sending entity shall ensure that all information on location service transactions for the SCTP association on which the Reset Request was sent is reinitialized to indicate no existing transactions.

On receiving a LCS-AP Reset Request message, the recipient entity (E-SMLC or MME) shall clear all references and state information for the location service transactions on the SCTP association on which the Reset Request was received and shall release any associated resources. The recipient entity shall then return a LCS-AP Reset Acknowledge message using the same SCTP association as the Reset Request.

If the initiating entity (E-SMLC or MME) received the LCS-AP Reset Acknowledge message, it shall stop the timer T3x02.

### 6.3.2.3 Abnormal Conditions

On the first expiry of the timer T3x02, the Source entity (E-SMLC or MME) shall resend the LCS-AP Reset Request message and shall reset and restart timer T3x02. This retransmission is repeated a maximum of "n" times, where "n" is an O&M administered parameter. Following "n" unsuccessful reset attempts, the procedure shall be terminated and maintenance shall be informed.

## 6.4 Error Handling

### 6.4.1 Abnormal Conditions

If an ongoing location request is pre-empted at the initiator by an inter-eNB handover and MME relocation, or if the main signalling link to the target UE is released by the MME, or if a main signalling link failure indicated by the serving eNodeB persists for more than a certain timeout interval or if there is a timeout waiting for the positioning response, or any other abnormal conditions for which the positioning procedure cannot be maintained, the MME shall send a LCS-AP Location Abort message to the E-SMLC to terminate the positioning procedure.

For Intra-MME handovers, the location session between the MME and E-SMLC is not affected. Application layer impacts on these handovers are handled by higher protocol layers.

If the E-SMLC cannot proceed with positioning due to some protocol violation or error condition (e.g. inter-eNB handover), it shall return a LCS-AP Location Response message to the initiator containing a LCS cause and, optionally, positioning data.

### 6.4.2 Overload

If an E-SMLC is in overload condition, it may reject a LCS-AP Location Request by returning a LCS-AP Location Response containing a LCS Cause parameter indicating congestion. The initiator of the location requests (i.e. MME) may reduce the frequency of later location requests until rejection due to overload has ceased. In reducing the frequency of location service requests, the MME shall reduce lower priority requests, to zero if necessary, before reducing the frequency of higher priority requests. An E-SMLC shall similarly reject location requests of a lower priority, to zero if necessary, due to overload before rejecting location requests of a higher priority. An E-SMLC in overload condition may optionally employ the following procedures to alleviate overload:

- a) Allow higher priority location service requests to pre-empt lower priority requests for which location service procedures are already in progress.
- b) Abort lower priority location service requests already in progress.
- c) Reduce the supported QoS for lower priority requests for a location estimate – e.g. by reducing accuracy or increasing response time.
- d) Employ UE based positioning methods, where supported by the target UE and the E-SMLC, rather than UE assisted or network based methods (except TA).

The priority of a location request shall be defined according to the value in the LCS Priority parameter. If this parameter is absent in a LCS-AP Location Request, the lowest priority shall be assumed.

---

## 7 LCS-AP Messages and Message Formats

### 7.1 General

This clause describes the structure of the messages and information elements required for the LCS-AP messages.

### 7.2 Message Formats

LCS-AP ASN.1 definition conforms to ITU-T Recommendations ITU-T Recommendation X.680 (07/2002) [8] and ITU-T Recommendation X.681 (07/2002) [9]. The ASN.1 definition specifies the structure and content of LCS-AP messages. The LCS-AP messages may contain any IEs specified in the object set definitions for that message without the order or number of occurrence being restricted by ASN.1. However, for this version of the standard, a sending entity shall construct a LCS-AP message according to the PDU definitions module and with the following additional rules (Note that in the following IE means an IE in the object set with an explicit id. If one IE needed to appear more than once in one object set, then the different occurrences have different IE ids):

- IEs shall be ordered (in an IE container) in the order they appear in object set definitions.
- Object set definitions specify how many times IEs may appear. An IE shall appear exactly once if the presence field in an object has value "mandatory". An IE may appear at most once if the presence field in an object has value "optional" or "conditional". If in a tabular format there is multiplicity specified for an IE (i.e. an IE list) then in the corresponding ASN.1 definition the list definition is separated into two parts. The first part defines an IE container list where the list elements reside. The second part defines list elements. The IE container list appears as an IE of its own. For this version of the standard an IE container list may contain only one kind of list elements.

If a LCS-AP message that is not constructed as defined above is received, this shall be considered as Abstract Syntax Error, and the message shall be handled as defined for Abstract Syntax error.

For the handling of unknown, unforeseen and erroneous protocol data, please refer to 3GPP TS 36.413 [7].

### 7.3 LCS-AP Messages

The following attributes are used for the tabular description of the messages and information elements: Presence, Range Criticality and Assigned Criticality. Their definition and use can be found in 3GPP TS 36.413 [7].

#### 7.3.1 LCS-AP Location Request message

This message is sent by the MME to request a location estimate for a target UE and contains sufficient information to enable location according to the required QoS using any positioning method supported. The message is also used to request LCS assistance data transfer to an UE.

Direction: MME → E-SMLC

Table 7.3.1-1: Location Request message contents

IE/Group Name	Presence	Range	IE type and reference	Semantics description	Criticality	Assigned Criticality
Message Type	M		7.4.2		YES	reject
Correlation ID	M		7.4.28		YES	reject
Location Type	M		7.4.3		YES	reject
E-UTRAN Cell Identifier	M		E-CGI / 7.4.4		YES	ignore
LCS Client Type	O		7.4.5		YES	reject
LCS Priority	O		7.4.6		YES	reject
LCS QoS	O		7.4.7		YES	reject
LCS Service Type ID	O		7.4.30		YES	ignore
UE Positioning Capability	O		7.4.8		YES	reject
Include Velocity	O		7.4.9		YES	reject
IMSI	O		7.4.10		YES	ignore
IMEI	O		7.4.11		YES	ignore
Multiple APDUs		0..3				
APDU	M		7.4.18		YES	reject
RAT Type	O		7.4.34		YES	ignore
Coverage Level	O		7.4.35		YES	ignore

NOTE: The IMSI should be sent preferably if known. The IMEI may be sent if the IMSI is not known, or in addition to the IMSI for the purpose of allowing correlation between the two identities.

### 7.3.2 LCS-AP Location Response message

This message is sent in response to a LCS-AP Location Request to return a successful location estimate for a target UE or to indicate some failure in obtaining this. The message is also sent in response to a LCS-AP Location Request to return an indication that LCS assistance data has been successfully delivered to an UE.

Direction: E-SMLC → MME

Table 7.3.2-1: Location Response message contents

IE/Group Name	Presence	Range	IE type and reference	Semantics description	Criticality	Assigned Criticality
Message Type	M		7.4.2		YES	reject
Correlation ID	M		7.4.28		YES	reject
Location Estimate	O		Geographic Area / 7.4.12		YES	reject
Positioning Data	O		7.4.13		YES	reject
Velocity Estimate	O		7.4.14		YES	reject
Accuracy Fulfilment Indicator	O		7.4.15		YES	reject
LCS Cause	O		7.4.16		YES	ignore
E-UTRAN Cell Identifier	O		E-CGI / 7.4.4		YES	ignore
Cell Portion ID	O		7.4.31		YES	ignore
Civic Address	O		7.4.32		YES	ignore
Barometric Pressure	O		7.4.33		YES	ignore

### 7.3.3 LCS-AP Location Abort Request message

This message is sent by the MME to abort the positioning attempt or the request for assistance data.

Direction: MME → E-SMLC

**Table 7.3.3-1: Location Abort Request message contents**

IE/Group Name	Presence	Range	IE type and reference	Semantics description	Criticality	Assigned Criticality
Message Type	M		7.4.2		YES	reject
Correlation ID	M		7.4.28		YES	reject
LCS Cause	M		7.4.16		YES	ignore

### 7.3.4 LCS-AP Connection Oriented Information message

This message is sent in association with an existing signalling connection between an E-SMLC and another entity to transfer information between the E-SMLC and other entity belonging to a higher level protocol.

Direction: E-SMLC → MME or MME → E-SMLC

**Table 7.3.4-1: Connection Oriented Information message contents**

IE/Group Name	Presence	Range	IE type and reference	Semantics description	Criticality	Assigned Criticality
Message Type	M		7.4.2		YES	reject
Correlation ID	M		7.4.28		YES	reject
Payload Type	M		7.4.17		YES	reject
APDU	M		7.4.18		YES	reject

### 7.3.5 LCS-AP Connectionless Information message

This message conveys signalling information associated with a higher protocol level between an E-SMLC and another entity when there is no existing signalling connection association.

Direction: E-SMLC → MME or MME → E-SMLC

**Table 7.3.5-1: Connectionless Information message contents**

IE/Group Name	Presence	Range	IE type and reference	Semantics description	Criticality	Assigned Criticality
Message Type	M		7.4.2		YES	reject
Source Identity	M		Network Element / 7.4.19		YES	reject
Destination Identity	M		Network Element / 7.4.19		YES	reject
APDU	M		7.4.18		YES	reject
Return Error Request	O		7.4.20		YES	reject
Return Error Cause	O		7.4.21		YES	ignore

### 7.3.6 LCS-AP Reset Request message

This message is sent to indicate a failure in the sending entity with loss of location service transactions that were established or were being established.

Direction: E-SMLC → MME or MME → E-SMLC

**Table 7.3.6-1: Reset Request message contents**

IE/Group Name	Presence	Range	IE type and reference	Semantics description	Criticality	Assigned Criticality
Message Type	M		7.4.2		YES	reject
LCS Cause	M		7.4.16		YES	ignore

### 7.3.7 LCS-AP Reset Acknowledge message

This message is sent in response to a LCS-AP Reset message to indicate that references and resources associated with location service transactions towards the entity sending the LCS-AP Reset have been released.

Direction: E-SMLC → MME or MME → E-SMLC

**Table 7.3.7-1: Reset Acknowledge message contents**

IE/Group Name	Presence	Range	IE type and reference	Semantics description	Criticality	Assigned Criticality
Message Type	M		7.4.2		YES	reject

### 7.3.8 LCS-AP Ciphering Key Data message

This message is used by the E-SMLC to send ciphering keys for broadcast assistance data to the MME.

Direction: E-SMLC → MME

**Table 7.3.8-1: Ciphering Key Data message contents**

IE/Group Name	Presence	Range	IE type and reference	Semantics description	Criticality	Assigned Criticality
Message Type	M		7.4.2		YES	reject
Ciphering Data	M		7.4.36		YES	reject

### 7.3.9 LCS-AP Ciphering Key Data Result message

This message is used by the MME to indicate to the E-SMLC whether the MME was able to successfully store the ciphering data sets received from the E-SMLC in a Ciphering Data Key message.

Direction: MME → E-SMLC

**Table 7.3.9-1: Ciphering Key Data Result message contents**

IE/Group Name	Presence	Range	IE type and reference	Semantics description	Criticality	Assigned Criticality
Message Type	M		7.4.2		YES	reject
Ciphering Data Ack	C		7.4.37		YES	reject
Ciphering Data Error Report	C		7.4.38		YES	reject

## 7.4 Information Elements

### 7.4.1 General

When specifying information elements which are to be represented by bit strings, if not otherwise specifically stated in the semantics description of the concerned IE or elsewhere, the following principle applies with regards to the ordering of bits:

- The first bit (leftmost bit) contains the most significant bit (MSB)
- The last bit (rightmost bit) contains the least significant bit (LSB)
- When importing bit strings from other specifications, the first bit of the bit string contains the first bit of the concerned information

### 7.4.2 Message Type

The *Message Type* IE uniquely identifies the message being sent. It is mandatory for all messages.

**Table 7.4.2-1: Message Type**

IE/Group Name	Presence	Range	IE type and reference	Semantics description
Procedure Code	M		INTEGER (0..255)	"0" = LCS-AP LOCATION SERVICE REQUEST "1" = LCS-AP CONNECTION ORIENTED INFORMATION TRANSFER "2" = LCS-AP CONNECTIONLESS INFORMATION TRANSFER "3" = LCS-AP LOCATION ABORT "4" = LCS-AP RESET "5" = LCS-AP CIPHERING KEY DATA
Type of Message	M		ENUMERATED (Initiating Message, Successful Outcome, Unsuccessful Outcome, ...)	

### 7.4.3 Location Type

This parameter defines the type of location information being requested.

**Table 7.4.3-1: Location Type**

IE/Group Name	Presence	Range	IE type and reference	Semantics description
Location Type	M		ENUMERATED (geographic location, assistance information, ..., last known location)	

### 7.4.4 E-CGI

This parameter gives the current cell location of the target UE or the last known cell location for the case when the Location Type IE is set to last known location. The E-UTRAN Cell Global Identifier (ECGI) is used to globally identify a cell.

Table 7.4.4-1: ECGI

IE/Group Name	Presence	Range	IE type and reference	Semantics description
PLMN Identity	M		7.4.27	
Cell Identity	M		BIT STRING (28)	The leftmost bits of the Cell Identity correspond to the eNB ID (defined in 7.4.19).

## 7.4.5 LCS Client Type

This parameter defines the type of the originating LCS Client. It shall be included if the Location Type indicates a request for a location estimate and may be included in other cases to assist an SMLC to appropriately prioritize a location request.

Table 7.4.5-1: LCS Client Type

IE/Group Name	Presence	Range	IE type and reference	Semantics description
Client Type	M		ENUMERATED (Emergency Services, Value Added Services, PLMN Operator Services, Lawful Intercept Services, PLMN Operator - broadcast services, PLMN Operator - O&M, PLMN Operator - anonymous statistics, PLMN Operator - Target MS service support, ...)	Identifies the category of LCS client.

## 7.4.6 LCS Priority

This parameter defines the priority of the location request.

Table 7.4.6-1: LCS Priority

IE/Group Name	Presence	Range	IE type and reference	Semantics description
LCS Priority	M		OCTET STRING (SIZE(1))	0= highest priority 1= normal priority all other values treated as 1 For details, refer to 3GPP TS 22.071 [10].

## 7.4.7 LCS QoS

This parameter provides the required Quality of Service for the LCS Request. Quality of Service may include horizontal accuracy, vertical accuracy and allowed response time.



Table 7.4.7-1: LCS QoS

IE/Group Name	Presence	Range	IE type and reference	Semantics description
Horizontal Accuracy	O		INTEGER(0..127)	bit 8 = 0 bits 7-1 = 7 bit Uncertainty Code defined in 3GPP TS 23.032 [6]. The horizontal location error should be less than the error indicated by the uncertainty code with 67% confidence.
Vertical Requested	O		ENUMERATED(VERTICAL Coordinate Is Not Requested (0), VERTICAL Coordinate Is Requested (1) )	Default value if this IE is not present is: VERTICAL Coordinate Is Not Requested (0).
Vertical Accuracy	O		INTEGER(0..127)	bit 8 = 0 bits 7-1 = 7 bit Vertical Uncertainty Code defined in 3GPP TS 23.032 [6]. The vertical location error should be less than the error indicated by the uncertainty code with 67% confidence. If the vertical requested IE is not present or present with a value of 0, then this vertical accuracy will be ignored, if present.
Response Time	O		ENUMERATED (Low Delay(0), Delay Tolerant (1), ...)	For details, refer to 3GPP TS 22.071 [10].

## 7.4.8 UE Positioning Capability

This parameter provides information about the LCS capabilities of the target UE.

Table 7.4.8-1: UE Positioning Capability

IE/Group Name	Presence	Range	IE Type and Reference	Semantics Description	Criticality	Assigned Criticality
LPP Support	M		BOOLEAN	Defines if the UE supports LPP or not. TRUE means supported.	–	

## 7.4.9 Include Velocity

This parameter indicates if the Velocity of the target UE is requested in the Location Response.

Table 7.4.9-1: Include Velocity

IE/Group Name	Presence	Range	IE type and reference	Semantics description
Velocity Indicator	O		ENUMERATED (requested, not requested, ...)	Specify if Velocity of UE is requested.

## 7.4.10 IMSI

This parameter identifies the IMSI of the target UE.

**Table 7.4.10-1: IMSI**

<b>IE/Group Name</b>	<b>Presence</b>	<b>Range</b>	<b>IE type and reference</b>	<b>Semantics description</b>
IMSI	M		OCTET STRING (SIZE (3..8))	The number of decimal digits shall be from 6 to 15 starting with the digits from the PLMN identity. It is encoded with TBCD String, two digits per octet.

## 7.4.11 IMEI

This parameter identifies the IMEI of the target UE.

**Table 7.4.11-1: IMEI**

<b>IE/Group Name</b>	<b>Presence</b>	<b>Range</b>	<b>IE type and reference</b>	<b>Semantics description</b>
IMEI	M		OCTET STRING (SIZE (8))	Refers to International Mobile Station Equipment Identity and Software Version Number (SVN) defined in TS 3GPP TS 23.003 [11].  This IE is 16 digits encoded with TBCD String, two digits per octet.  If the SVN is not present the last octet shall contain the digit 0 as filler. If present the SVN shall be included in the last octet.

## 7.4.12 Geographic Area

This parameter provides a location estimate for the target UE in the case of a successful location attempt.

**Table 7.4.12-1: Geographic Area**

IE/Group Name	Presence	Range	IE type and reference	Semantics description
CHOICE <i>Geographical Area</i>				
> <i>Point</i>				Ellipsoid point
>>Geographical Coordinates	M		7.4.23	
> <i>Point With Uncertainty</i>				Ellipsoid point with uncertainty circle
>>Geographical Coordinates	M		7.4.23	
>>Uncertainty Code	M		INTEGER (0..127)	The uncertainty "r" expressed in meters is derived from the "Uncertainty Code" k by $r = 10x(1.1^{k-1})$
> <i>Ellipsoid point with uncertainty Ellipse</i>				
>>Geographical Coordinates	M		7.4.23	
>>Uncertainty Ellipse	M		7.4.24	
>>Confidence	M		INTEGER (0..100)	In percentage
> <i>Polygon</i>				List of Ellipsoid points
>>Polygon Point		1..<maxnoofPoints>		The minimum number of points allowed is 3.
>>>Geographical Coordinates	M		7.4.23	
> <i>Ellipsoid point with altitude</i>				
>>Geographical Coordinates	M		7.4.23	
>>Altitude and direction	M		7.4.22	
> <i>Ellipsoid point with altitude and uncertainty Ellipsoid</i>				
>>Geographical Coordinates	M		7.4.23	
>>Altitude and direction	M		7.4.22	
>>Uncertainty Ellipse	M		7.4.24	
>>Uncertainty Altitude	M		INTEGER (0..127)	The uncertainty altitude "h" expressed in metres is derived from the "Uncertainty Altitude" k, by: $h=45x(1.025^{k-1})$
>>Confidence	M		INTEGER (0..100)	In percentage
> <i>Ellipsoid Arc</i>				
>>Geographical Coordinates	M		7.4.23	
>>Inner radius	M		INTEGER (0..2 <sup>16</sup> -1)	The relation between the value (N) and the radius (r) in meters it describes is $5N \leq r < 5(N+1)$ , except for $N=2^{16}-1$ for which the range is extended to include all greater values of (r).
>>Uncertainty radius	M		INTEGER (0..127)	The uncertainty "r" is derived from the "Uncertainty radius" k by $r = 10x(1.1^{k-1})$
>>Offset angle	M		INTEGER (0..179)	The relation between the value (N) and the angle (a) in degrees it describes is $2N \leq a < 2(N+1)$

IE/Group Name	Presence	Range	IE type and reference	Semantics description
>>Included angle	M		INTEGER (0..179)	The relation between the value (N) and the angle (a) in degrees it describes is $2N < a \leq 2(N+1)$
>>Confidence	M		INTEGER (0..100)	
>High Accuracy Ellipsoid point with uncertainty Ellipse				
>>High Accuracy Geographical Coordinates	M		7.4.41	
>>High Accuracy Uncertainty Ellipse	M		7.4.42	
>>Confidence	M		INTEGER (0..100)	In percentage
>High Accuracy Ellipsoid point with altitude and uncertainty Ellipsoid				
>>High Accuracy Geographical Coordinates	M		7.4.41	
>>High Accuracy Altitude	M		7.4.43	
>>High Accuracy Uncertainty Ellipse	M		7.4.42	
>>Confidence	M		INTEGER (0..100)	In percentage
>>High Accuracy Uncertainty Altitude	M		INTEGER (0..127)	The uncertainty altitude "h" expressed in metres is derived from the "Uncertainty Altitude" k, by: $h=0.3 \times (1.02^k - 1)$
>>Vertical Confidence	M		INTEGER (0..100)	In percentage

Table 7.4.12-2: Range bound

Range bound	Explanation
maxnoofPoints	Maximum no. of points in polygon. Value is 15.

## 7.4.13 Positioning Data

This parameter provides additional information for the positioning attempt from the E-SMLC.

Table 7.4.13-1: Positioning Data

IE/Group Name	Presence	Range	IE type and reference	Semantics description
<b>Position Data</b>	M			
>Positioning Data Set	O			

<p>&gt;&gt;Positioning Method and Usage</p>		<p>1..&lt;maxSet&gt;</p>	<p>OCTET STRING (1)</p>	<p>Coding of positioning method (bits 8-4):                      00000 Cell ID                      00001 Reserved                      00010 E-CID                      00011 Reserved                      00100 OTDOA                      00101 Reserved                      00110 Reserved                      00111 Reserved                      01000 U-TDOA                      01001 Reserved                      01010 Reserved                      01011 Reserved                      01100 to 01111 reserved for other location technologies                      10000 to 11111 reserved for network specific positioning methods</p> <p>Coding of usage (bits 3-1):                      000 Attempted unsuccessfully due to failure or interruption - not used.                      001 Attempted successfully: results not used to generate location - not used.                      010 Attempted successfully: results used to verify but not generate location - not used.                      011 Attempted successfully: results used to generate location.                      100 Attempted successfully: case where UE supports multiple mobile based positioning methods and the actual method or methods used by the UE cannot be determined.</p>
<p>&gt;GNSS Positioning Data Set</p>	<p>0</p>			

<p>&gt;&gt;GNSS Positioning Method and Usage</p>	<p>O</p>	<p>1..&lt;maxGNSSSet&gt;</p>	<p>OCTET STRING (1)</p>	<p>Coding of Method (Bits 8-7) :                      00 : UE-Based                      01 : UE-Assisted                      10 : Conventional                      11 : Reserved</p> <p>Coding of GNSS ID (Bits 6-4) :                      000 : GPS                      001 : Galileo                      010 : SBAS                      011 : Modernized GPS                      100 : QZSS                      101 : GLONASS                      other values reserved</p> <p>Coding of usage (bits 3-1):</p> <p>000 Attempted unsuccessfully due to failure or interruption                      001 Attempted successfully: results not used to generate location                      010 Attempted successfully: results used to verify but not generate location                      011 Attempted successfully: results used to generate location                      100 Attempted successfully: case where UE supports multiple mobile based positioning methods and the actual method or methods used by the UE cannot be determined.</p>
<p>&gt;Additional Positioning Data Set</p>	<p>O</p>			

<p>&gt;&gt;Additional Positioning Method and Usage</p>		<p>1 to &lt;maxAddPosSet&gt;</p>	<p>OCTET STRING (SIZE(1))</p>	<p>Coding of positioning method (bits 8-7):                      00 UE-Based;                      01 UE-Assisted;                      10 Standalone;                      11 Reserved.</p> <p>Coding of Additional Positioning ID (bits 6-4):                      000 Barometric Pressure;                      001 WLAN;                      010 Bluetooth;                      011 MBS;                      other values reserved.</p> <p>Coding of usage (bits 3-1):</p> <p>000 Attempted unsuccessfully due to failure or interruption                      001 Attempted successfully: results not used to generate location                      010 Attempted successfully: results used to verify but not generate location                      011 Attempted successfully: results used to generate location                      100 Attempted successfully: case where UE supports multiple mobile based positioning methods and the actual method or methods used by the UE cannot be determined.</p>
--	--	----------------------------------	-------------------------------	--

**Table 7.4.13-2: Range bound**

Range bound	Explanation
maxSet	Maximum size of the data set. Value is 9.
maxGNSSSet	Maximum size of the data. Value is 9.
maxAddPosSet	Maximum size of the data Value is 8.



## 7.4.14 Velocity Estimate

This parameter provides the velocity estimate for the target UE.

**Table 7.4.14-1: Velocity Estimate**

IE/Group Name	Presence	Range	IE type and reference	Semantics description
<i>Choice Velocity Estimate</i>				
>Horizontal Velocity				Horizontal speed and bearing (the direction of travel).
>>Horizontal Speed and Bearing	M		7.4.25	
>Horizontal with Vertical Velocity				Horizontal speed and bearing (the direction of travel) as well as vertical speed and the direction (upward or downward)
>>Horizontal Speed and Bearing	M		7.4.25	
>>Vertical Velocity	M		7.4.26	
>Horizontal Velocity with Uncertainty				Horizontal speed, bearing (the direction of travel), and the uncertainty of the reported speed.
>>Horizontal Speed and Bearing	M		7.4.25	
>>Uncertainty Speed	M		INTEGER (0..255)	Uncertainty speed is encoded in increments of 1 kilometer per hour using an 8 bit binary coded number (N). The value of N gives the uncertainty speed except for N=255 which indicates that the uncertainty is not specified
>Horizontal with Vertical Velocity and Uncertainty				Horizontal speed and bearing (the direction of travel) as well as vertical speed and the direction (upward or downward) and the uncertainty of the reported speed.
>>Horizontal Speed and Bearing	M		7.4.25	
>>Vertical Velocity	M		7.4.26	
>>Horizontal Uncertainty Speed	M		INTEGER (0..255)	Horizontal Uncertainty Speed is encoded in increments of 1 kilometer per hour using an 8 bit binary coded number (N). The value of N gives the uncertainty speed except for N=255 which indicates that the uncertainty is not specified
>>Vertical Uncertainty Speed	M		INTEGER (0..255)	Vertical Uncertainty Speed is encoded in increments of 1 kilometer per hour using an 8 bit binary coded number (N). The value of N gives the uncertainty speed except for N=255 which indicates that the uncertainty is not specified

## 7.4.15 Accuracy Fulfilment Indicator

This parameter whether the returned position estimate satisfies the requested accuracy or not.

Table 7.4.15-1: Accuracy Fulfilment Indicator

IE/Group Name	Presence	Range	IE type and reference	Semantics description
Accuracy Fulfilment Indicator	O		ENUMERATED (requested accuracy fulfilled, requested accuracy not fulfilled, ...)	Indicates if the requested accuracy is fulfilled or not.

## 7.4.16 LCS Cause

The LCS Cause is included if and only if a requested location estimate was not successfully obtained (e.g. location estimate not available), requested LCS assistance data was not successfully transferred to the UE or location-related data has been lost. The parameter provides the reason for the failure.

Table 7.4.16-1: LCS Cause

IE/Group Name	Presence	Range	IE Type and Reference	Semantics Description
<i>CHOICE Cause Group</i>				
<i>&gt;Radio Network Layer</i>				
>>Radio Network Layer Cause	M		ENUMERATED ( Unspecified ...)	
<i>&gt;Transport Layer</i>				
>>Transport Layer Cause	M		ENUMERATED (Transport Resource Unavailable, Unspecified, ...)	
<i>&gt;Protocol</i>				
>>Protocol Cause	M		ENUMERATED (Transfer Syntax Error, Abstract Syntax Error (Reject), Abstract Syntax Error (Ignore and Notify), Message not Compatible with Receiver State, Semantic Error, Unspecified, Abstract Syntax Error (Falsely Constructed Message), ...)	
<i>&gt;Misc</i>				
>>Misc Cause	M		ENUMERATED (Processing Overload, Hardware Failure, O&M Intervention, Unspecified, .... Ciphering Key Data Lost)	

## 7.4.17 Payload Type

This parameter indicates the type of APDU included in LCS-AP Connected Oriented Information message. The supported information types are LPP and LPPa.

**Table 7.4.17-1: Payload Type**

IE/Group Name	Presence	Range	IE type and reference	Semantics description
Payload Type	M		ENUMERATED (LPP, LPPa, ...)	

## 7.4.18 APDU

This parameter contains an embedded APDU. For information transfer between an E-SMLC and an eNB this shall be an LPPa APDU. For information transfer between an E-SMLC and a target UE, this shall be an LPP APDU.

**Table 7.4.18-1: APDU**

IE/Group Name	Presence	Range	IE type and reference	Semantics description
APDU	M		OCTET STRING	This IE contains a message whose content and encoding are defined according to the Payload Type.

## 7.4.19 Network Element

This parameter identifies the source or destination of the message. The network element is identified by association with either an eNB ID or the identity of an E-SMLC.

**Table 7.4.19-1: Network Element**

IE/Group Name	Presence	Range	IE type and reference	Semantics description
CHOICE <i>Network Element</i>	M			
>Global eNB ID				The global identity of the eNB
>>PLMN Identity			7.4.27	
>>eNB ID			7.4.29	
>E-SMLC Identity			INTEGER (0..255)	The identity of the E-SMLC (an index to identify an specific E-SMLC among all the available E-SMLCs in the network)

## 7.4.20 Return Error Request

This parameter may be included to request an error response if LCS-AP message cannot be delivered successfully to its final destination. This parameter shall not be included if the Return Error cause is present.

**Table 7.4.20-1: Return Error Type**

IE/Group Name	Presence	Range	IE type and reference	Semantics description
Return Error Type	M		ENUMERATED ( Yes, No )	

## 7.4.21 Return Error Cause

This parameter indicates an error response for a LCS-AP connectionless information message that could not be delivered to its final destination. The APDU should be present and the same as the APDU in the original undelivered

message. The source and destination identities shall be included and the same as the destination and source identities, respectively, in the original undelivered message.

**Table 7.4.21-1: Return Error Cause**

IE/Group Name	Presence	Range	IE type and reference	Semantics description
Return Error Cause	M		ENUMERATED (systemfailure, protocolerror, destinationunkown, destinationunreachable, congestion,...)	

## 7.4.22 Altitude and direction

**Table 7.4.22-1: Altitude and direction**

IE/Group Name	Presence	Range	IE type and reference	Semantics description
Direction of Altitude	M		ENUMERATED (Height, Depth)	
Altitude	M		INTEGER (0..2 <sup>15</sup> -1)	The relation between the value (N) and the altitude (a) in meters it describes is $N \leq a < N+1$ , except for $N=2^{15}-1$ for which the range is extended to include all greater values of (a).

## 7.4.23 Geographical Coordinates

This IE contains the geographical coordinates.

**Table 7.4.23-1: Geographical Coordinates**

IE/Group Name	Presence	Range	IE type and reference	Semantics description
Latitude Sign	M		ENUMERATED (North, South)	
Degrees Of Latitude	M		INTEGER (0..2 <sup>23</sup> -1)	The IE value (N) is derived by this formula: $N \leq 2^{23} \times X / 90 < N+1$ X being the latitude in degree (0°.. 90°)
Degrees Of Longitude	M		INTEGER (-2 <sup>23</sup> ..2 <sup>23</sup> -1)	The IE value (N) is derived by this formula: $N \leq 2^{24} \times X / 360 < N+1$ X being the longitude in degree (-180°..+180°)

## 7.4.24 Uncertainty Ellipse

This IE contains the uncertainty ellipse of a geographical area.

**Table 7.4.24-1: Uncertainty Ellipse**

IE/Group Name	Presence	Range	IE type and reference	Semantics description
Uncertainty semi-major	M		INTEGER (0..127)	The uncertainty "r" is derived from the "uncertainty code" k by $r = 10 \times (1.1^{k-1})$
Uncertainty semi-minor	M		INTEGER (0..127)	The uncertainty "r" is derived from the "uncertainty code" k by $r = 10 \times (1.1^{k-1})$
Orientation of major axis	M		INTEGER (0..89)	The relation between the IE value (N) and the angle (a) in degrees it describes is $2N \leq a < 2(N+1)$

## 7.4.25 Horizontal Speed and Bearing

This IE contains the two components of horizontal velocity: speed and bearing

**Table 7.4.25-1: Horizontal Speed and Bearing**

IE/Group Name	Presence	Range	IE type and reference	Semantics description
Bearing	M		INTEGER (0..359)	The direction of movement is given in degrees where '0' represents North, '90' represents East, etc.
Horizontal Speed	M		INTEGER (0.. $2^{11}-1$ )	The relationship between (N) and the horizontal speed (h) in kilometers per hour it describes is: $N \leq h < N + 0.5$ (N=0) $N - 0.5 \leq h < N + 0.5$ (0 < N < $2^{11}-1$ ) $N - 0.5 \leq h$ (N = $2^{11}-1$ )

## 7.4.26 Vertical Velocity

This IE contains the two components of vertical velocity: speed and direction

**Table 7.4.26-1: Vertical Velocity**

IE/Group Name	Presence	Range	IE type and reference	Semantics description
Vertical Speed	M		INTEGER (0.. $2^8-1$ )	The relationship between (N) and the vertical speed (v) in kilometers per hour it describes is: $N \leq v < N + 0.5$ (N = 0) $N - 0.5 \leq v < N + 0.5$ (0 < N < $2^8-1$ ) $N - 0.5 \leq v$ (N = $2^8-1$ )
Vertical Speed Direction			ENUMERATED (upward, downward)	

## 7.4.27 PLMN Identity

This information element indicates the PLMN Identity.

**Table 7.4.27-1: PLMN Identity**

IE/Group Name	Presence	Range	IE type and reference	Semantics description
PLMN identity	M		OCTET STRING (SIZE (3))	<ul style="list-style-type: none"> <li>- digits 0 to 9, encoded 0000 to 1001,</li> <li>- 1111 used as filler digit, two digits per octet,</li> <li>- bits 4 to 1 of octet n encoding digit 2n-1</li> <li>- bits 8 to 5 of octet n encoding digit 2n</li> </ul> <p>-The Selected PLMN identity consists of 3 digits from MCC followed by either</p> <ul style="list-style-type: none"> <li>-a filler digit plus 2 digits from MNC (in case of 2 digit MNC) or</li> <li>-3 digits from MNC (in case of a 3 digit MNC).</li> </ul>

## 7.4.28 Correlation ID

This IE indicates a specific location session. It is used in order to correlate request/response and an ongoing location session.

**Table 7.4.28-1: Correlation ID**

IE/Group Name	Presence	Range	IE type and reference	Semantics description
Correlation ID	M		OCTET STRING (SIZE (4))	The identifier of a location session in E-UTRAN. It should be unique for all concurrently active location sessions in a particular MME.

## 7.4.29 eNB ID

This information element is used to identify an eNB.

**Table 7.4.29-1: eNB ID**

IE/Group Name	Presence	Range	IE type and reference	Semantics description
CHOICE <i>eNB ID</i>				
>Macro <i>eNB ID</i>	M		BIT STRING (20)	Equal to the 20 leftmost bits of the <i>Cell Identity</i> IE contained in the <i>E-UTRAN CGI</i> IE (see clause 7.4.4) of each cell served by the eNB
>Home <i>eNB ID</i>	M		BIT STRING (28)	Equal to the <i>Cell Identity</i> IE contained in the <i>E-UTRAN CGI</i> IE (see clause 7.4.4) of the cell served by the eNB
>Short Macro <i>eNB ID</i>	M		BIT STRING (18)	Equal to the 18 leftmost bits of the <i>Cell Identity</i> IE contained in the <i>E-UTRAN CGI</i> IE (see clause 7.4.4) of each cell served by the eNB
>Long Macro <i>eNB ID</i>	M		BIT STRING (21)	Equal to the 21 leftmost bits of the <i>Cell Identity</i> IE contained in the <i>E-UTRAN CGI</i> IE (see clause 7.4.4) of each cell served by the eNB

## 7.4.30 LCS Service Type ID

This parameter defines the service type ID for the location request.

**Table 7.4.30-1: LCS Service Type ID**

IE/Group Name	Presence	Range	IE type and reference	Semantics description
LCS Service Type ID	O		INTEGER(0..127)	Identifies the type of service requested. The meaning of the different service types is defined in 3GPP TS 22.071 [10].

## 7.4.31 Cell Portion ID

This parameter gives the current Cell Portion location of the target UE. The Cell Portion ID is the unique identifier for a cell portion within a cell.

**Table 7.4.31-1: Cell Portion**

IE/Group Name	Presence	Range	IE type and reference	Semantics description
Cell Portion ID	M		INTEGER(0..255,..., 256..4095)	

## 7.4.32 Civic Address

This information element contains a location estimate for the target UE expressed as a Civic address.

Table 7.4.32-1: Civic Address

IE/Group Name	Presence	Range	IE type and reference	Semantics description
Civic Address	O		OCTET STRING	This IE contains a UTF-8 encoded PIDF-LO XML document as defined in IETF RFC 4119 [13]. The document shall only contain a civic address using the namespaces "urn:ietf:params:xml:ns:pidf:geopriv10:civicAddr" per IETF RFC 5139 [14] and "urn:ietf:params:xml:ns:pidf:geopriv10:civicAddr:ext" per IETF RFC 6848 [15].

### 7.4.33 Barometric Pressure

This information element contains the barometric pressure measurement as reported by the target UE.

Table 7.4.33-1: Barometric Pressure

IE/Group Name	Presence	Range	IE type and reference	Semantics description
Barometric Pressure	O		INTEGER (30000..115000)	This IE specifies the measured uncompensated atmospheric pressure in units of Pascal (Pa).

### 7.4.34 RAT Type

This parameter provides the serving RAT type for the target UE or the last known serving RAT type for the case when the Location Type IE is set to last known location.

Table 7.4.34-1: RAT Type

IE/Group Name	Presence	Range	IE type and reference	Semantics description
RAT Type	O		ENUMERATED (lte-wb, nb-iot, lte-m, ...)	This IE provides the serving RAT type.

### 7.4.35 Coverage Level

This parameter defines the type of coverage level being requested.

Table 7.4.35-1: Coverage Level

IE/Group Name	Presence	Range	IE type and reference	Semantics description
Coverage Level	O		ENUMERATED (Extended Coverage, ...)	

### 7.4.36 Ciphering Data

This parameter contains the ciphering data sets sent by the E-SMLC to the MME.

Table 7.4.36-1: Ciphering Data

IE/Group Name	Presence	Range	IE type and reference	Semantics description
<b>Ciphering Data</b>	M			
>Ciphering Data Set	M	1..<maxCiphe rSet>	7.4.39	



Table 7.4.36-2: Range bound

Range bound	Explanation
maxCipherSet	Maximum size of the data set. Value is 16

## 7.4.37 Cipherng Data Ack

This parameter contains the cipherng data acknowledgement information sent by the MME to the E-SMLC.

Table 7.4.37-1: Cipherng Data Ack

IE/Group Name	Presence	Range	IE type and reference	Semantics description
<b>Cipherng Data Ack</b>	M			This IE contains the list of cipherng set IDs for which the MME is sending an acknowledgement
>Cipherng Set ID	M	1..<maxCipherSet>	INTEGER (0..65535)	

Table 7.4.37-2: Range bound

Range bound	Explanation
maxCipherSet	Maximum size of the data set. Value is 16

## 7.4.38 Cipherng Data Error Report

This parameter contains a list of cipherng data sets with the associated outcome of storage attempt at the MME.

Table 7.4.38-1: Cipherng Data Error Report

IE/Group Name	Presence	Range	IE type and reference	Semantics description
<b>Cipherng Data Error Report</b>	M			
>Cipherng Data Error Report Contents	M	1..<maxCipherSet>	7.4.40	

Table 7.4.38-2: Range bound

Range bound	Explanation
maxCipherSet	Maximum size of the data set. Value is 16

## 7.4.39 Cipherng Data Set

This parameter contains a cipherng data set sent by the E-SMLC to the MME.

Table 7.4.39-1: Cipherng Data Set

IE/Group Name	Presence	Range	IE type and reference	Semantics description
<b>Cipherng Data Set</b>	M			
>Cipherng Set ID	M		INTEGER (0..65535)	

>Ciphering Key	M		OCTET STRING (SIZE(16))	
>c0	M		BIT STRING (SIZE (1..128))	

<p>&gt;SIB Types</p>	<p>M</p>		<p>OCTET STRING (SIZE(4))</p>	<p>This IE contains a bitmap indicating the positioning SIB types for which the ciphering data set is applicable:</p> <ul style="list-style-type: none"> <li>-- a bit set to 0 indicates that the ciphering data set is not applicable to the corresponding positioning SIB type</li> <li>- a bit set to 1 indicates that the ciphering data set is applicable to the corresponding positioning SIB type</li> </ul> <p>The mapping of the bits to the positioning SIB types is as follows:</p> <ul style="list-style-type: none"> <li>-- bit 8 in the first octet maps to positioning SIB Type 1-1</li> <li>-- bit 7 in the first octet maps to positioning SIB Type 1-2</li> <li>-- bit 6 in the first octet maps to positioning SIB Type 1-3</li> <li>-- bit 5 in the first octet maps to positioning SIB Type 1-4</li> <li>-- bit 4 in the first octet maps to positioning SIB Type 1-5</li> <li>-- bit 3 in the first octet maps to positioning SIB Type 1-6</li> <li>-- bit 2 in the first octet maps to positioning SIB Type 1-7</li> <li>-- bit 1 in the first octet maps to positioning SIB Type 2-1</li> <li>-- bit 8 in the second octet maps to positioning SIB Type 2-2</li> <li>-- bit 7 in the second octet maps to positioning SIB Type 2-3</li> <li>-- bit 6 in the second octet maps to positioning SIB Type 2-4</li> <li>-- bit 5 in the second octet maps to positioning SIB Type 2-5</li> <li>-- bit 4 in the second octet maps to positioning SIB Type 2-6</li> <li>-- bit 3 in the second octet maps to</li> </ul>
----------------------	----------	--	-------------------------------	--

				<p>positioning SIB Type 2-7</p> <ul style="list-style-type: none"> <li>-- bit 2 in the second octet maps to positioning SIB Type 2-8</li> <li>-- bit 1 in the second octet maps to positioning SIB Type 2-9</li> </ul> <ul style="list-style-type: none"> <li>-- bit 8 in the third octet maps to positioning SIB Type 2-10</li> <li>-- bit 7 in the third octet maps to positioning SIB Type 2-11</li> <li>-- bit 6 in the third octet maps to positioning SIB Type 2-12</li> <li>-- bit 5 in the third octet maps to positioning SIB Type 2-13</li> <li>-- bit 4 in the third octet maps to positioning SIB Type 2-14</li> <li>-- bit 3 in the third octet maps to positioning SIB Type 2-15</li> <li>-- bit 2 in the third octet maps to positioning SIB Type 2-16</li> <li>-- bit 1 in the third octet maps to positioning SIB Type 2-17</li> </ul> <ul style="list-style-type: none"> <li>-- bit 8 in the fourth octet maps to positioning SIB Type 2-18</li> <li>-- bit 7 in the fourth octet maps to positioning SIB Type 2-19</li> <li>-- bit 6 in the fourth octet maps to positioning SIB Type 3-1</li> </ul> <p>Bits 5 to 1 in the fourth octets are spare and shall be coded as zero.</p>
>Validity Start time	M		OCTET STRING (SIZE(4))	This IE contains the UTC time when the ciphering data set becomes valid, encoded in the same format as the first four octets of the 64-bit timestamp format as defined in clause 6 of IETF RFC 5905 [16].
>Validity Duration	M		INTEGER (0..65535)	In minutes

>TAIs List	O		OCTET STRING (SIZE (7..97))	<p>This IE contains the TAIs of the tracking areas for which the ciphering data set is applicable. It is encoded as octets 2 to n of the Tracking area identity list IE specified in clause 9.9.3.33 of 3GPP TS 24.301 [17].</p> <p>If this IE is omitted, the ciphering data set is valid in the entire PLMN.</p>
------------	---	--	-----------------------------	--

### 7.4.40 Ciphering Data Error Report Contents

This parameter contains a ciphering data set ID with the associated outcome of storage attempt at the MME.

**Table 7.4.40-1: Ciphering Data Error Report Contents**

IE/Group Name	Presence	Range	IE type and reference	Semantics description
<b>Ciphering Data Error Report Contents</b>	M			
>Ciphering Set ID	M		INTEGER (0..65535)	This IE contains the list of ciphering set IDs for which the MME is sending an acknowledgement
>Storage outcome	M		ENUMERATED ( Successful, Failed )	

### 7.4.41 High Accuracy Geographical Coordinates

This IE contains the high accuracy geographical coordinates.

**Table 7.4.41-1: High Accuracy Geographical Coordinates**

IE/Group Name	Presence	Range	IE type and reference	Semantics description
High Accuracy Degrees Of Latitude	M		INTEGER ( $-2^{31}..2^{31}-1$ )	The IE value (N) is derived by this formula: $N = 2^{31} X / 90$ X being the latitude in degree (-90°.. +90°)
High Accuracy Degrees Of Longitude	M		INTEGER ( $-2^{31}..2^{31}-1$ )	The IE value (N) is derived by this formula: $N = 2^{31} X / 180$ X being the longitude in degree (-180°..+180°)

## 7.4.42 High Accuracy Uncertainty Ellipse

This IE contains the high accuracy uncertainty ellipse of a geographical area.

**Table 7.4.42-1: High Accuracy Uncertainty Ellipse**

IE/Group Name	Presence	Range	IE type and reference	Semantics description
High Accuracy Uncertainty semi-major	M		INTEGER (0..127)	The uncertainty "r" is derived from the "uncertainty code" k by $r = 0.3 \times (1.02^k - 1)$
High Accuracy Uncertainty semi-minor	M		INTEGER (0..127)	The uncertainty "r" is derived from the "uncertainty code" k by $r = 0.3 \times (1.02^k - 1)$
Orientation of major axis	M		INTEGER (0..179)	Angle in degrees between the major axis and north

## 7.4.43 High Accuracy Altitude

**Table 7.44.3-1: High Accuracy Altitude**

IE/Group Name	Presence	Range	IE type and reference	Semantics description
High Accuracy Altitude	M		INTEGER (-64000..128000)	The relation between the IE value (N) and the altitude a (in metres) it encodes is described by the following equation: $a = N \times 2^{-7}$

## 7.5 Message and information element abstract syntax

### 7.5.1 General

LCS-AP ASN.1 definition conforms to [8] and [9].

The ASN.1 definition specifies the structure and content of LCS-AP messages. LCS-AP messages can contain any IEs specified in the object set definitions for that message without the order or number of occurrence being restricted by ASN.1. However, for this version of the standard, a sending entity shall construct a LCS-AP message according to the PDU definitions module and with the following additional rules (Note that in the following IE means an IE in the object set with an explicit id. If one IE needed to appear more than once in one object set, then the different occurrences have different IE ids):

- IEs shall be ordered (in an IE container) in the order they appear in object set definitions.
- Object set definitions specify how many times IEs may appear. An IE shall appear exactly once if the presence field in an object has value "mandatory". An IE may appear at most once if the presence field in an object has value "optional" or "conditional". If in a tabular format there is multiplicity specified for an IE (i.e. an IE list) then in the corresponding ASN.1 definition the list definition is separated into two parts. The first part defines an IE container list where the list elements reside. The second part defines list elements. The IE container list appears as an IE of its own. For this version of the standard an IE container list may contain only one kind of list elements.

If a LCS-AP message that is not constructed as defined above is received, this shall be considered as Abstract Syntax Error, and the message shall be handled as defined for Abstract Syntax error in clause 10 of [7].

## 7.5.2 Usage of protocol extension mechanism for non-standard use

The protocol extension mechanism for non-standard use may be used:

- for special operator- (and/or vendor) specific features considered not to be part of the basic functionality, i.e. the functionality required for a complete and high-quality specification in order to guarantee multi-vendor interoperability.
- by vendors for research purposes, e.g. to implement and evaluate new algorithms/features before such features are proposed for standardisation.

The extension mechanism shall not be used for basic functionality. Such functionality shall be standardised.

## 7.5.3 Elementary procedure definitions

```
-- *****
--
-- Elementary Procedure definitions
--
-- *****

LCS-AP-PDU-Descriptions {
itu-t (0) identified-organization (4) etsi (0) mobileDomain (0)
eps-Access (21) modules (3) lcs-AP (4) version1 (1) lcs-AP-PDU-Descriptions (0)}

DEFINITIONS AUTOMATIC TAGS ::=

BEGIN

-- *****
--
-- IE parameter types from other modules.
--
-- *****

IMPORTS
    Criticality,
    ProcedureCode
FROM LCS-AP-CommonDataTypes

    Location-Request,
    Location-Response,
    Location-Abort-Request,
    Connection-Oriented-Information,
    Connectionless-Information,
    Reset-Request,
    Reset-Acknowledge,
    Ciphering-Key-Data,
    Ciphering-Key-Data-Result
FROM LCS-AP-PDU-Contents

    id-Location-Service-Request,
    id-Connection-Oriented-Information-Transfer,
    id-Connectionless-Information-Transfer,
    id-Location-Abort,
    id-Reset,
    id-Ciphering-Key-Data-Delivery
FROM LCS-AP-Constants;

-- *****
--
-- Interface Elementary Procedure Class
--
-- *****

LCS-AP-ELEMENTARY-PROCEDURE ::= CLASS {
    &InitiatingMessage
    &SuccessfulOutcome          OPTIONAL,
    &UnsuccessfulOutcome        OPTIONAL,
    &procedureCode              ProcedureCode UNIQUE,
    &criticality                 Criticality DEFAULT ignore
}
WITH SYNTAX {
```

```

INITIATING MESSAGE &InitiatingMessage
[SUCCESSFUL OUTCOME &SuccessfulOutcome]
[UNSUCCESSFUL OUTCOME &UnsuccessfulOutcome]
PROCEDURE CODE &procedureCode
[CRITICALITY &criticality]
}

-- *****
--
-- Interface PDU Definition
--
-- *****

LCS-AP-PDU ::= CHOICE {
    initiatingMessage InitiatingMessage,
    successfulOutcome SuccessfulOutcome,
    unsuccessfulOutcome UnsuccessfulOutcome,
    ...
}

InitiatingMessage ::= SEQUENCE {
    procedureCode LCS-AP-ELEMENTARY-PROCEDURE.&procedureCode ({LCS-AP-ELEMENTARY-PROCEDURES}),
    criticality LCS-AP-ELEMENTARY-PROCEDURE.&criticality ({LCS-AP-ELEMENTARY-PROCEDURES}{@procedureCode}),
    value LCS-AP-ELEMENTARY-PROCEDURE.&InitiatingMessage ({LCS-AP-ELEMENTARY-PROCEDURES}{@procedureCode})
}

SuccessfulOutcome ::= SEQUENCE {
    procedureCode LCS-AP-ELEMENTARY-PROCEDURE.&procedureCode ({LCS-AP-ELEMENTARY-PROCEDURES}),
    criticality LCS-AP-ELEMENTARY-PROCEDURE.&criticality ({LCS-AP-ELEMENTARY-PROCEDURES}{@procedureCode}),
    value LCS-AP-ELEMENTARY-PROCEDURE.&SuccessfulOutcome ({LCS-AP-ELEMENTARY-PROCEDURES}{@procedureCode})
}

UnsuccessfulOutcome ::= SEQUENCE {
    procedureCode LCS-AP-ELEMENTARY-PROCEDURE.&procedureCode ({LCS-AP-ELEMENTARY-PROCEDURES}),
    criticality LCS-AP-ELEMENTARY-PROCEDURE.&criticality ({LCS-AP-ELEMENTARY-PROCEDURES}{@procedureCode}),
    value LCS-AP-ELEMENTARY-PROCEDURE.&UnsuccessfulOutcome ({LCS-AP-ELEMENTARY-PROCEDURES}{@procedureCode})
}

-- *****
--
-- Interface Elementary Procedure List
--
-- *****

LCS-AP-ELEMENTARY-PROCEDURES LCS-AP-ELEMENTARY-PROCEDURE ::= {
    LCS-AP-ELEMENTARY-PROCEDURES-CLASS-1 |
    LCS-AP-ELEMENTARY-PROCEDURES-CLASS-2 ,
    ...
}

LCS-AP-ELEMENTARY-PROCEDURES-CLASS-1 LCS-AP-ELEMENTARY-PROCEDURE ::= {
    location-Service-Request |
    connectionless-Information-Transfer |
    location-Abort |
    reset |
    ciphering-Key-Data-Delivery ,
    ...
}

LCS-AP-ELEMENTARY-PROCEDURES-CLASS-2 LCS-AP-ELEMENTARY-PROCEDURE ::= {
    connection-Oriented-Information-Transfer ,
    ...
}

-- *****
--
-- Interface Elementary Procedures
--
-- *****

```



```

location-Service-Request LCS-AP-ELEMENTARY-PROCEDURE ::= {
    INITIATING MESSAGE Location-Request
    SUCCESSFUL OUTCOME Location-Response
    UNSUCCESSFUL OUTCOME Location-Response
    PROCEDURE CODE      id-Location-Service-Request
    CRITICALITY         reject
}

connection-Oriented-Information-Transfer LCS-AP-ELEMENTARY-PROCEDURE ::= {
    INITIATING MESSAGE Connection-Oriented-Information
    PROCEDURE CODE      id-Connection-Oriented-Information-Transfer
    CRITICALITY         reject
}

connectionless-Information-Transfer LCS-AP-ELEMENTARY-PROCEDURE ::= {
    INITIATING MESSAGE Connectionless-Information
    UNSUCCESSFUL OUTCOME Connectionless-Information
    PROCEDURE CODE      id-Connectionless-Information-Transfer
    CRITICALITY         reject
}

location-Abort LCS-AP-ELEMENTARY-PROCEDURE ::= {
    INITIATING MESSAGE Location-Abort-Request
    SUCCESSFUL OUTCOME Location-Response
    PROCEDURE CODE      id-Location-Abort
    CRITICALITY         reject
}

reset LCS-AP-ELEMENTARY-PROCEDURE ::= {
    INITIATING MESSAGE Reset-Request
    SUCCESSFUL OUTCOME Reset-Acknowledge
    PROCEDURE CODE      id-Reset
    CRITICALITY         reject
}

ciphering-Key-Data-Delivery LCS-AP-ELEMENTARY-PROCEDURE ::= {
    INITIATING MESSAGE Ciphering-Key-Data
    SUCCESSFUL OUTCOME Ciphering-Key-Data-Result
    UNSUCCESSFUL OUTCOME Ciphering-Key-Data-Result
    PROCEDURE CODE      id-Ciphering-Key-Data-Delivery
    CRITICALITY         reject
}

END

```

## 7.5.4 PDU definitions

```

-- *****
--
-- PDU definitions for LCS-AP.
--
-- *****

LCS-AP-PDU-Contents {
itu-t (0) identified-organization (4) etsi (0) mobileDomain (0)
eps-Access (21) modules (3) lcs-AP (4) version1 (1) lcs-AP-PDU-Contents (1)}

DEFINITIONS AUTOMATIC TAGS ::=

BEGIN

-- *****
--
-- IE parameter types from other modules.
--
-- *****

IMPORTS

    APDU,
    Accuracy-Fulfillment-Indicator,
    Barometric-Pressure,
    Cell-Portion-ID,
    Ciphering-Data,
    Ciphering-Data-Ack,

```

```

Ciphering-Data-Error-Report,
Civic-Address,
Correlation-ID,
Coverage-Level,
E-CGI,
Geographical-Area,
IMSI,
IMEI,
Include-Velocity,
LCS-Cause,
LCS-Client-Type,
LCS-Service-Type-ID,
LCS-Priority,
LCS-QoS,
Location-Type,
MultipleAPDUs,
Network-Element,
Payload-Type,
Positioning-Data,
RAT-Type,
Return-Error-Type,
Return-Error-Cause,
UE-Positioning-Capability,
Velocity-Estimate
FROM LCS-AP-IES

```

```

ProtocolExtensionContainer{},
ProtocolIE-Container{},
LCS-AP-PROTOCOL-EXTENSION,
LCS-AP-PROTOCOL-IES
FROM LCS-AP-Containers

```

```

id-Accuracy-Fulfillment-Indicator,
id-APDU,
id-Barometric-Pressure,
id-Cell-Portion-ID,
id-Ciphering-Data,
id-Ciphering-Data-Ack,
id-Ciphering-Data-Error-Report,
id-Civic-Address,
id-Correlation-ID,
id-Coverage-Level,
id-Destination-ID,
id-E-UTRAN-Cell-Identifier,
id-Include-Velocity,
id-IMEI,
id-IMSI,
id-LCS-Client-Type,
id-LCS-Priority,
id-LCS-QOS,
id-LCS-Cause,
id-LCS-Service-Type-ID,
id-Location-Estimate,
id-Location-Type,
id-MultipleAPDUs,
id-Payload-Type,
id-Positioning-Data,
id-RAT-Type,
id-Return-Error-Request,
id-Return-Error-Cause,
id-Source-Identity,
id-UE-Positioning-Capability,
id-Velocity-Estimate
FROM LCS-AP-Constants;

```

```

-- *****
--
-- Location-Request
--
-- *****

```

```

Location-Request ::= SEQUENCE {
    protocolIEs      ProtocolIE-Container      { { Location-Request-IEs } },
    protocolExtensions ProtocolExtensionContainer { { Location-Request-Extensions } } OPTIONAL,
    ...
}

```

```

Location-Request-IEs LCS-AP-PROTOCOL-IES ::= {
  { ID id-Correlation-ID          CRITICALITY reject  TYPE Correlation-ID          PRESENCE mandatory } |
  { ID id-Location-Type          CRITICALITY reject  TYPE Location-Type          PRESENCE mandatory } |
  { ID id-E-UTRAN-Cell-Identifier CRITICALITY ignore TYPE E-CGI                PRESENCE mandatory } |
  { ID id-LCS-Client-Type        CRITICALITY reject  TYPE LCS-Client-Type        PRESENCE optional   }
}
|
  { ID id-LCS-Priority          CRITICALITY reject  TYPE LCS-Priority          PRESENCE optional   } |
  { ID id-LCS-QoS              CRITICALITY reject  TYPE LCS-QoS              PRESENCE optional   } |
  { ID id-UE-Positioning-Capability CRITICALITY reject  TYPE UE-Positioning-Capability PRESENCE optional   }
optional } |
  { ID id-Include-Velocity      CRITICALITY reject  TYPE Include-Velocity      PRESENCE optional   }
optional } |
  { ID id-IMSI                 CRITICALITY ignore  TYPE IMSI                 PRESENCE optional   } |
  { ID id-IMEI                 CRITICALITY ignore  TYPE IMEI                 PRESENCE optional   } |
  { ID id-MultipleAPDUs        CRITICALITY reject  TYPE MultipleAPDUs        PRESENCE optional   } |
  { ID id-RAT-Type            CRITICALITY ignore  TYPE RAT-Type            PRESENCE optional   } |
  { ID id-Coverage-Level       CRITICALITY ignore  TYPE Coverage-Level       PRESENCE optional   },
  ...
}

```

```

Location-Request-Extensions LCS-AP-PROTOCOL-EXTENSION ::= {
  { ID id-LCS-Service-Type-ID    CRITICALITY ignore  EXTENSION LCS-Service-Type-ID    PRESENCE optional   },
  ...
}

```

```

-- *****
--
-- Location-Response
--
-- *****

```

```

Location-Response ::= SEQUENCE {
  protocolIEs      ProtocolIE-Container      { {Location-Response-IEs} },
  protocolExtensions ProtocolExtensionContainer { {Location-Response-Extensions} } OPTIONAL,
  ...
}

```

```

Location-Response-IEs LCS-AP-PROTOCOL-IES ::= {
  { ID id-Correlation-ID          CRITICALITY reject  TYPE Correlation-ID          PRESENCE mandatory } |
  { ID id-Location-Estimate      CRITICALITY reject  TYPE Geographical-Area      PRESENCE optional } |
  { ID id-Positioning-Data      CRITICALITY reject  TYPE Positioning-Data      PRESENCE optional } |
  { ID id-Velocity-Estimate      CRITICALITY reject  TYPE Velocity-Estimate      PRESENCE optional } |
  { ID id-Accuracy-Fulfillment-Indicator CRITICALITY reject  TYPE Accuracy-Fulfillment-Indicator PRESENCE optional } |
  { ID id-LCS-Cause              CRITICALITY ignore  TYPE LCS-Cause              PRESENCE optional }
,
  ...
}

```

```

Location-Response-Extensions LCS-AP-PROTOCOL-EXTENSION ::= {
  { ID id-E-UTRAN-Cell-Identifier CRITICALITY ignore  EXTENSION E-CGI PRESENCE optional } |
  { ID id-Cell-Portion-ID        CRITICALITY ignore  EXTENSION Cell-Portion-ID        PRESENCE optional } |
  { ID id-Civic-Address          CRITICALITY ignore  EXTENSION Civic-Address          PRESENCE optional } |
  { ID id-Barometric-Pressure    CRITICALITY ignore  EXTENSION Barometric-Pressure    PRESENCE optional }
,
  ...
}

```

```

-- *****
--
-- Location-Abort
--
-- *****

```

```

Location-Abort-Request ::= SEQUENCE {
  protocolIEs      ProtocolIE-Container      { {Location-Abort-Request-IEs} },
  protocolExtensions ProtocolExtensionContainer { {Location-Abort-Request-Extensions} } OPTIONAL,
  ...
}

```

```

Location-Abort-Request-IEs LCS-AP-PROTOCOL-IES ::= {
  { ID id-Correlation-ID          CRITICALITY reject  TYPE Correlation-ID PRESENCE mandatory } |
  { ID id-LCS-Cause              CRITICALITY ignore   TYPE LCS-Cause      PRESENCE mandatory } ,
  ...
}

Location-Abort-Request-Extensions LCS-AP-PROTOCOL-EXTENSION ::= {
  ...
}

-- *****
--
-- Connection-Oriented-Information
--
-- *****

Connection-Oriented-Information ::= SEQUENCE {
  protocolIEs      ProtocolIE-Container      { {Connection-Oriented-Information-IEs} },
  protocolExtensions ProtocolExtensionContainer { {Connection-Oriented-Information-Extensions} }
OPTIONAL,
  ...
}

Connection-Oriented-Information-IEs LCS-AP-PROTOCOL-IES ::= {
  { ID id-Correlation-ID  CRITICALITY reject  TYPE Correlation-ID      PRESENCE optional } |
  { ID id-Payload-Type    CRITICALITY reject  TYPE Payload-Type          PRESENCE optional } |
  { ID id-APDU            CRITICALITY reject  TYPE APDU                  PRESENCE optional } ,
  ...
}

Connection-Oriented-Information-Extensions LCS-AP-PROTOCOL-EXTENSION ::= {
  ...
}

-- *****
--
-- Connectionless-Information
--
-- *****

Connectionless-Information ::= SEQUENCE {
  protocolIEs      ProtocolIE-Container      { {Connectionless-Information-IEs} },
  protocolExtensions ProtocolExtensionContainer { {Connectionless-Information-Extensions} }
OPTIONAL,
  ...
}

Connectionless-Information-IEs LCS-AP-PROTOCOL-IES ::= {
  { ID id-Source-Identity  CRITICALITY reject  TYPE Network-Element      PRESENCE mandatory } |
  { ID id-Destination-ID   CRITICALITY reject  TYPE Network-Element      PRESENCE mandatory } |
  { ID id-APDU             CRITICALITY reject  TYPE APDU                 PRESENCE mandatory } |
  { ID id-Return-Error-Request CRITICALITY reject  TYPE Return-Error-Type    PRESENCE optional }
|
  { ID id-Return-Error-Cause CRITICALITY ignore  TYPE Return-Error-Cause   PRESENCE optional } ,
  ...
}

Connectionless-Information-Extensions LCS-AP-PROTOCOL-EXTENSION ::= {
  ...
}

-- *****
--
-- Reset-Request
--
-- *****

Reset-Request ::= SEQUENCE {
  protocolIEs      ProtocolIE-Container      { {Reset-Request-IEs} },
  protocolExtensions ProtocolExtensionContainer { {Reset-Request-Extensions} } OPTIONAL,
  ...
}

Reset-Request-IEs LCS-AP-PROTOCOL-IES ::= {
  { ID id-LCS-Cause        CRITICALITY ignore  TYPE LCS-Cause            PRESENCE mandatory } ,
  ...
}

```

```

}

Reset-Request-Extensions LCS-AP-PROTOCOL-EXTENSION ::= {
  ...
}

-- *****
--
-- Reset-Acknowledge
--
-- *****

Reset-Acknowledge ::= SEQUENCE {
  protocolIEs ProtocolIE-Container { { Reset-Acknowledge-IEs } },
  protocolExtensions ProtocolExtensionContainer { { Reset-Acknowledge-Extensions } } OPTIONAL,
  ...
}

Reset-Acknowledge-IEs LCS-AP-PROTOCOL-IES ::= {
  ...
}

Reset-Acknowledge-Extensions LCS-AP-PROTOCOL-EXTENSION ::= {
  ...
}

-- *****
--
-- Ciphering-Key-Data
--
-- *****

Ciphering-Key-Data ::= SEQUENCE {
  protocolIEs ProtocolIE-Container { { Ciphering-Key-Data-IEs } },
  protocolExtensions ProtocolExtensionContainer { { Ciphering-Key-Data-Extensions } } OPTIONAL,
  ...
}

Ciphering-Key-Data-IEs LCS-AP-PROTOCOL-IES ::= {
  { ID id-Ciphering-Data CRITICALITY reject TYPE Ciphering-Data PRESENCE mandatory } ,
  ...
}

Ciphering-Key-Data-Extensions LCS-AP-PROTOCOL-EXTENSION ::= {
  ...
}

-- *****
--
-- Ciphering-Key-Data-Result
--
-- *****

Ciphering-Key-Data-Result ::= SEQUENCE {
  protocolIEs ProtocolIE-Container { { Ciphering-Key-Data-Result-IEs } },
  protocolExtensions ProtocolExtensionContainer { { Ciphering-Key-Data-Result-Extensions } }
OPTIONAL,
  ...
}

Ciphering-Key-Data-Result-IEs LCS-AP-PROTOCOL-IES ::= {
  { ID id-Ciphering-Data-Ack CRITICALITY reject TYPE Ciphering-Data-Ack PRESENCE conditional
} |
  { ID id-Ciphering-Data-Error-Report CRITICALITY reject TYPE Ciphering-Data-Error-Report
  PRESENCE conditional } ,
  ...
}

Ciphering-Key-Data-Result-Extensions LCS-AP-PROTOCOL-EXTENSION ::= {
  ...
}

```

END

## 7.5.5 Information element definitions

```

-- *****
--
-- Information Element Definitions
--
-- *****

LCS-AP-IEs {
itu-t (0) identified-organization (4) etsi (0) mobileDomain (0)
eps-Access (21) modules (3) lcs-AP (4) version1 (1) lcs-AP-IEs (2)}

DEFINITIONS AUTOMATIC TAGS ::=

BEGIN

IMPORTS

    max-No-Of-Points,
    max-Set,
    max-GNSS-Set,
    max-Add-Pos-Set,
    max-Cipher-Set
FROM LCS-AP-Constants

    Criticality,
    ProcedureCode,
    TriggeringMessage,
    ProtocolIE-ID
FROM LCS-AP-CommonDataTypes

    ProtocolExtensionContainer{ },
    LCS-AP-PROTOCOL-EXTENSION
FROM LCS-AP-Containers;

-- A

APDU ::= OCTET STRING

Accuracy-Fulfillment-Indicator ::= ENUMERATED {
    requested-accuracy-fulfilled,
    requested-accuracy-not-fulfilled,
    ...
}

Additional-PositioningDataSet ::= SEQUENCE(SIZE(1..max-Add-Pos-Set)) OF Additional-
PositioningMethodAndUsage

Additional-PositioningMethodAndUsage ::= OCTET STRING (SIZE(1))

Altitude ::= INTEGER (0..65535)
-- The valid value for this IE is 0 to 32767.
-- Reception of value greater than 32767 shall be mapped to the value 32767.

Altitude-And-Direction ::= SEQUENCE {
    direction-Of-Altitude Direction-Of-Altitude,
    altitude Altitude,
    ...
}

Angle ::= INTEGER (0..179)

-- B

Barometric-Pressure ::= INTEGER (30000..115000)

Bearing ::= INTEGER (0..359)

```

```

-- C

C0 ::= BIT STRING (SIZE (1..128))

CellIdentity ::= BIT STRING (SIZE (28))

Cell-Portion-ID ::= INTEGER (0..255,..., 256..4095)

Ciphering-Data ::= SEQUENCE(SIZE(1..max-Cipher-Set)) OF Ciphering-Data-Set

Ciphering-Data-Ack ::= SEQUENCE(SIZE(1..max-Cipher-Set)) OF Ciphering-Set-ID

Ciphering-Data-Error-Report ::= SEQUENCE(SIZE(1..max-Cipher-Set)) OF Ciphering-Data-Error-Report-
Contents

Ciphering-Data-Set ::= SEQUENCE {
  ciphering-Set-ID Ciphering-Set-ID,
  ciphering-Key Ciphering-Key,
  c0 C0,
  sib-Types SIB-Types,
  validity-Start-Time Validity-Start-Time,
  validity-Duration Validity-Duration,
  tais-List TAIs-List,
  ...
}

Ciphering-Data-Error-Report-Contents ::= SEQUENCE {
  ciphering-Set-ID Ciphering-Set-ID,
  storage-Outcome Storage-Outcome,
  ...
}

Ciphering-Set-ID ::= INTEGER (0..65535)

Ciphering-Key ::= OCTET STRING (SIZE (16))

Civic-Address ::= OCTET STRING

Confidence ::= INTEGER (0..100)

Correlation-ID ::= OCTET STRING (SIZE (4))

-- D

DegreesLatitude ::= INTEGER (0..8388607) -- 23 bit field

DegreesLongitude ::= INTEGER (-8388608..8388607) -- 24 bit field

Direction-Of-Altitude ::= ENUMERATED {
  height,
  depth
}

-- E

E-CGI ::= SEQUENCE {
  pLMNidentity PLMN-ID,
  cell-ID CellIdentity,
  iE-Extensions ProtocolExtensionContainer { { E-CGI-ExtIEs } } OPTIONAL,
  ...}

E-CGI-ExtIEs LCS-AP-PROTOCOL-EXTENSION ::= {
  ...
}

Coverage-Level ::= ENUMERATED {
  extendedcoverage,
  ...
}

Ellipsoid-Point-With-Uncertainty-Ellipse ::= SEQUENCE {
  geographical-Coordinates Geographical-Coordinates,
  uncertainty-Ellipse Uncertainty-Ellipse,
  confidence Confidence,
}

```

```

    iE-Extensions      ProtocolExtensionContainer { { Ellipsoid-Point-With-Uncertainty-Ellipse-
ExtIEs} } OPTIONAL,
    ...}

```

```

Ellipsoid-Point-With-Uncertainty-Ellipse-ExtIEs LCS-AP-PROTOCOL-EXTENSION ::= {
    ...
}

```

```

Ellipsoid-Point-With-Altitude ::= SEQUENCE {
    geographical-Coordinates      Geographical-Coordinates,
    altitude-And-Direction        Altitude-And-Direction,
    iE-Extensions      ProtocolExtensionContainer { { Ellipsoid-Point-With-Altitude-ExtIEs} }
OPTIONAL,
    ...}

```

```

Ellipsoid-Point-With-Altitude-ExtIEs LCS-AP-PROTOCOL-EXTENSION ::= {
    ...
}

```

```

Ellipsoid-Point-With-Altitude-And-Uncertainty-Ellipsoid ::= SEQUENCE {
    geographical-Coordinates      Geographical-Coordinates,
    altitude-And-Direction        Altitude-And-Direction,
    uncertainty-Ellipse           Uncertainty-Ellipse,
    uncertainty-Altitude         Uncertainty-Altitude,
    confidence                    Confidence,
    iE-Extensions      ProtocolExtensionContainer { { Ellipsoid-Point-With-Altitude-And-
Uncertainty-Ellipsoid-ExtIEs} } OPTIONAL,
    ...}

```

```

Ellipsoid-Point-With-Altitude-And-Uncertainty-Ellipsoid-ExtIEs LCS-AP-PROTOCOL-EXTENSION ::= {
    ...
}

```

```

Ellipsoid-Arc ::= SEQUENCE {
    geographical-Coordinates      Geographical-Coordinates,
    inner-Radius                 Inner-Radius,
    uncertainty-Radius           Uncertainty-Code,
    offset-Angle                 Angle,
    included-Angle               Angle,
    confidence                    Confidence,
    iE-Extensions      ProtocolExtensionContainer { { Ellipsoid-Arc-ExtIEs} } OPTIONAL,
    ...
}

```

```

Ellipsoid-Arc-ExtIEs LCS-AP-PROTOCOL-EXTENSION ::= {
    ...
}

```

```

ENB-ID ::= CHOICE {
    macro-eNB-ID      Macro-eNB-ID,
    home-eNB-ID      Home-eNB-ID,
    ...,
    short-macro-eNB-ID      Short-Macro-eNB-ID,
    long-macro-eNB-ID      Long-Macro-eNB-ID
}

```

```

E-SMLC-ID ::= INTEGER (0..255)

```

```

-- F
-- G

```

```

Geographical-Area ::= CHOICE {
    point                Point,
    point-With-Uncertainty      Point-With-Uncertainty,
    ellipsoidPoint-With-Uncertainty-Ellipse      Ellipsoid-Point-With-Uncertainty-Ellipse,
    polygon              Polygon,
    ellipsoid-Point-With-Altitude      Ellipsoid-Point-With-Altitude,
    ellipsoid-Point-With-Altitude-And-Uncertainty-Ellipsoid      Ellipsoid-Point-With-Altitude-And-
Uncertainty-Ellipsoid,
    ellipsoid-Arc                Ellipsoid-Arc,
    ...,
}

```



```

    high-Accuracy-Ellipsoid-Point-With-Uncertainty-Ellipse High-Accuracy-Ellipsoid-Point-With-
    Uncertainty-Ellipse,
    high-Accuracy-Ellipsoid-Point-With-Altitude-And-Uncertainty-Ellipsoid High-Accuracy-Ellipsoid-
    Point-With-Altitude-And-Uncertainty-Ellipsoid
}

Geographical-Coordinates ::= SEQUENCE {
    latitudeSign LatitudeSign,
    degreesLatitude DegreesLatitude,
    degreesLongitude DegreesLongitude,
    iE-Extensions ProtocolExtensionContainer { {Geographical-Coordinates-ExtIEs} } OPTIONAL,
    ...
}

Geographical-Coordinates-ExtIEs LCS-AP-PROTOCOL-EXTENSION ::= {
    ...
}

Global-eNB-ID ::= SEQUENCE {
    pLMN-ID PLMN-ID,
    eNB-ID ENB-ID
}

GNSS-Positioning-Method-And-Usage ::= OCTET STRING (SIZE (1))

GNSS-Positioning-Data-Set ::= SEQUENCE (SIZE (1..max-GNSS-Set)) OF GNSS-Positioning-Method-And-Usage

-- H

High-Accuracy-Altitude ::= INTEGER (-64000..128000)

High-Accuracy-DegreesLatitude ::= INTEGER(-2147483648..2147483647)

High-Accuracy-DegreesLongitude ::= INTEGER(-2147483648..2147483647)

High-Accuracy-Ellipsoid-Point-With-Uncertainty-Ellipse ::= SEQUENCE {
    high-Accuracy-Geographical-Coordinates High-Accuracy-Geographical-Coordinates,
    high-Accuracy-Uncertainty-Ellipse High-Accuracy-Uncertainty-Ellipse,
    confidence Confidence,
    iE-Extensions ProtocolExtensionContainer { { High-Accuracy-Ellipsoid-Point-With-
    Uncertainty-Ellipse-ExtIEs} } OPTIONAL,
    ...}

High-Accuracy-Ellipsoid-Point-With-Uncertainty-Ellipse-ExtIEs LCS-AP-PROTOCOL-EXTENSION ::= {
    ...
}

High-Accuracy-Ellipsoid-Point-With-Altitude-And-Uncertainty-Ellipsoid ::= SEQUENCE {
    high-Accuracy-Geographical-Coordinates High-Accuracy-Geographical-Coordinates,
    high-Accuracy-Altitude High-Accuracy-Altitude,
    high-Accuracy-Uncertainty-Ellipse High-Accuracy-Uncertainty-Ellipse,
    confidence Confidence,
    high-Accuracy-Uncertainty-Altitude Uncertainty-Altitude,
    vertical-Confidence Confidence,
    iE-Extensions ProtocolExtensionContainer { { High-Accuracy-Ellipsoid-Point-With-Altitude-
    And-Uncertainty-Ellipsoid-ExtIEs} } OPTIONAL,
    ...}

High-Accuracy-Ellipsoid-Point-With-Altitude-And-Uncertainty-Ellipsoid-ExtIEs LCS-AP-PROTOCOL-
EXTENSION ::= {
    ...
}

High-Accuracy-Geographical-Coordinates ::= SEQUENCE {
    high-Accuracy-DegreesLatitude High-Accuracy-DegreesLatitude,
    high-Accuracy-DegreesLongitude High-Accuracy-DegreesLongitude,
    iE-Extensions ProtocolExtensionContainer { { High-Accuracy-Geographical-Coordinates-
    ExtIEs} } OPTIONAL,
    ...
}

```

```

High-Accuracy-Geographical-Coordinates-ExtIEs LCS-AP-PROTOCOL-EXTENSION ::= {
  ...
}

High-Accuracy-Uncertainty-Ellipse ::= SEQUENCE {
  high-Accuracy-Uncertainty-SemiMajor Uncertainty-Code,
  high-Accuracy-Uncertainty-SemiMinor Uncertainty-Code,
  orientation-Major-Axis INTEGER (0..179)
}

Home-eNB-ID ::= BIT STRING (SIZE (28))

Horizontal-Accuracy ::= INTEGER (0..127)

Horizontal-Speed-And-Bearing ::= SEQUENCE {
  bearing INTEGER (0..359),
  horizontal-Speed INTEGER (0..2047)
}

Horizontal-Velocity ::= SEQUENCE {
  horizontal-Speed-And-Bearing Horizontal-Speed-And-Bearing,
  iE-Extensions ProtocolExtensionContainer { { Horizontal-Velocity-ExtIEs} } OPTIONAL,
  ...
}

Horizontal-Velocity-ExtIEs LCS-AP-PROTOCOL-EXTENSION ::= {
  ...
}

Horizontal-With-Vertical-Velocity ::= SEQUENCE {
  horizontal-Speed-And-Bearing Horizontal-Speed-And-Bearing,
  vertical-Velocity Vertical-Velocity,
  iE-Extensions ProtocolExtensionContainer { { Horizontal-With-Vertical-Velocity-ExtIEs} } OPTIONAL,
  ...
}

Horizontal-With-Vertical-Velocity-ExtIEs LCS-AP-PROTOCOL-EXTENSION ::= {
  ...
}

Horizontal-Velocity-With-Uncertainty ::= SEQUENCE {
  horizontal-Speed-And-Bearing Horizontal-Speed-And-Bearing,
  uncertainty-Speed INTEGER (0..255),
  iE-Extensions ProtocolExtensionContainer { { Horizontal-Velocity-With-Uncertainty-ExtIEs} } OPTIONAL,
  ...
}

Horizontal-Velocity-With-Uncertainty-ExtIEs LCS-AP-PROTOCOL-EXTENSION ::= {
  ...
}

Horizontal-With-Vertical-Velocity-And-Uncertainty ::= SEQUENCE {
  horizontal-Speed-And-Bearing Horizontal-Speed-And-Bearing,
  vertical-Velocity Vertical-Velocity,
  horizontal-Uncertainty-Speed INTEGER (0..255),
  vertical-Uncertainty-Speed INTEGER (0..255),
  iE-Extensions ProtocolExtensionContainer { { Horizontal-With-Vertical-Velocity-And-Uncertainty-ExtIEs} } OPTIONAL,
  ...
}

Horizontal-With-Vertical-Velocity-And-Uncertainty-ExtIEs LCS-AP-PROTOCOL-EXTENSION ::= {
  ...
}

-- I

IMSI ::= OCTET STRING (SIZE (3..8))

```

```
IMEI ::= OCTET STRING (SIZE (8))

Include-Velocity ::= ENUMERATED {
    requested,
    not-Requested,
    ...
}

Inner-Radius ::= INTEGER (0..65535) -- 16 bit field

-- J
-- K
-- L

LatitudeSign ::= ENUMERATED {
    north,
    south
}

Location-Type ::= ENUMERATED {
    geographic-Information,
    assistance-Information,
    ...,
    last-known-location
}

LCS-Cause ::= CHOICE {
    radio-Network-Layer Radio-Network-Layer-Cause,
    transport-Layer Transport-Layer-Cause,
    protocol Protocol-Cause,
    misc Misc-Cause
}

LCS-Client-Type ::= ENUMERATED {
    emergency-Services,
    value-Added-Services,
    pLMN-Operator-Services,
    lawful-Intercept-Services,
    pLMN-Operator-broadcast-Services,
    pLMN-Operator-OM,
    pLMN-Operator-Anonymous-Statistics,
    pLMN-Operator-Target-MS-Service-Support,
    ...
}

LCS-Priority ::= OCTET STRING (SIZE (1))

LCS-QoS ::= SEQUENCE {
    horizontal-Accuracy Horizontal-Accuracy OPTIONAL,
    vertical-Requested Vertical-Requested OPTIONAL,
    vertical-Accuracy Vertical-Accuracy OPTIONAL,
    response-Time Response-Time OPTIONAL,
    ...
}

LCS-Service-Type-ID ::= INTEGER (0..127)

Long-Macro-eNB-ID ::= BIT STRING (SIZE (21))

-- M

Macro-eNB-ID ::= BIT STRING (SIZE (20))

Message-Identifier ::= BIT STRING (SIZE (16))

Misc-Cause ::= ENUMERATED {
    processing-Overload,
    hardware-Failure,
    o-And-M-Intervention,
    unspecified,
}
```

```

...
    ciphering-key-data-lost
}

MultipleAPDUs ::= SEQUENCE (SIZE (1.. 3)) OF APDU

-- N

Network-Element ::= CHOICE {
    global-eNB-ID      Global-eNB-ID,
    e-SMLC-ID         E-SMLC-ID
}

-- O

Orientation-Major-Axis ::= INTEGER (0..89)

-- P

Payload-Type ::= ENUMERATED {
    lPP,
    lPPa,
    ...
}

PLMN-ID ::= TBCD-STRING

Point ::= SEQUENCE {
    geographical-Coordinates Geographical-Coordinates,
    iE-Extensions           ProtocolExtensionContainer { {Point-ExtIEs} } OPTIONAL,
    ...
}

Point-ExtIEs LCS-AP-PROTOCOL-EXTENSION ::= {
    ...
}

Point-With-Uncertainty ::= SEQUENCE {
    geographical-Coordinates Geographical-Coordinates,
    uncertainty-Code         Uncertainty-Code,
    iE-Extensions           ProtocolExtensionContainer { {Point-With-Uncertainty-ExtIEs} } OPTIONAL,
    ...
}

Point-With-Uncertainty-ExtIEs LCS-AP-PROTOCOL-EXTENSION ::= {
    ...
}

Polygon ::= SEQUENCE (SIZE (1..max-No-Of-Points)) OF Polygon-Point

Polygon-Point ::= SEQUENCE {
    geographical-Coordinates Geographical-Coordinates,
    iE-Extensions           ProtocolExtensionContainer { {Polygon-Point-ExtIEs} } OPTIONAL,
    ...
}

Polygon-Point-ExtIEs LCS-AP-PROTOCOL-EXTENSION ::= {
    ...
}

Positioning-Data ::= SEQUENCE {
    positioning-Data-Set      Positioning-Data-Set OPTIONAL,
    gNSS-Positioning-Data-Set GNSS-Positioning-Data-Set OPTIONAL,
    iE-Extensions           ProtocolExtensionContainer { {Positioning-Data-ExtIEs} } OPTIONAL,
    ...
}

Positioning-Data-ExtIEs LCS-AP-PROTOCOL-EXTENSION ::= {
    { ID id-Additional-PositioningDataSet      CRITICALITY ignore EXTENSION Additional-
    PositioningDataSet      PRESENCE optional },
    ...
}

Positioning-Data-Set ::= SEQUENCE (SIZE (1..max-Set)) OF Positioning-Method-And-Usage

```

```
Positioning-Method-And-Usage ::= OCTET STRING (SIZE (1))

Protocol-Cause ::= ENUMERATED {
transfer-Syntax-Error,
abstract-Syntax-Error-Reject,
abstract-Syntax-Error-Ignore-And-Notify,
message-Not-Compatible-With-Receiver-State,
semantic-Error,
unspecified,
abstract-Syntax-Error,
...
}

-- Q
-- R

Radio-Network-Layer-Cause ::= ENUMERATED {
unspecified,
...
}

RAT-Type ::= ENUMERATED {
lte-wb,
nb-iot,
...,
lte-m
}

Response-Time ::= ENUMERATED {
low-Delay(0),
delay-Tolerant(1),
...
}

Return-Error-Type ::= ENUMERATED {
yes,
no
}

Return-Error-Cause ::= ENUMERATED {
system-Failure,
protocol-Error,
destination-Unknown,
destination-Unreachable,
congestion,
...
}

-- S

Short-Macro-eNB-ID ::= BIT STRING (SIZE (18))

SIB-Types ::= OCTET STRING (SIZE (4))

Storage-Outcome ::= ENUMERATED {
successful,
failed
}

-- T

TAIs-List ::= OCTET STRING (SIZE (7..97))

TBCD-STRING ::= OCTET STRING (SIZE (3))

Transport-Layer-Cause ::= ENUMERATED {
transport-Resource-Unavailable,
unspecified,
...
}

-- U

Uncertainty-Altitude ::= INTEGER (0..127)

Uncertainty-Code ::= INTEGER (0..127)

Uncertainty-Ellipse ::= SEQUENCE {
```

```

    uncertainty-SemiMajor    Uncertainty-Code,
    uncertainty-SemiMinor    Uncertainty-Code,
    orientation-Major-Axis    Orientation-Major-Axis
}

UE-Positioning-Capability ::= SEQUENCE {
    LPP                BOOLEAN,
    ...
}

-- V

Validity-Duration ::= INTEGER (0..65535)

Validity-Start-Time ::= OCTET STRING (SIZE (4))

Velocity-Estimate ::= CHOICE {
    horizontal-Velocity                Horizontal-Velocity,
    horizontal-With-Vertical-Velocity    Horizontal-With-Vertical-Velocity,
    horizontal-Velocity-With-Uncertainty    Horizontal-Velocity-With-Uncertainty,
    horizontal-With-Vertical-Velocity-And-Uncertainty    Horizontal-With-Vertical-Velocity-And-
        Uncertainty,
    ...
}

Vertical-Requested ::= ENUMERATED {
    vertical-coordinate-Is-Not-Requested(0),
    vertical-coordinate-Is-Requested(1)
}

Vertical-Accuracy ::= INTEGER (0..127)

Vertical-Velocity ::= SEQUENCE {
    vertical-Speed                INTEGER (0..255),
    vertical-Speed-Direction        Vertical-Speed-Direction
}

Vertical-Speed-Direction ::= ENUMERATED {
    upward,
    downward
}

-- W
-- X
-- Y

END

```

## 7.5.6 Common definitions

```

-- *****
--
-- Common definitions
--
-- *****

LCS-AP-CommonDataTypes {
itu-t (0) identified-organization (4) etsi (0) mobileDomain (0)
eps-Access (21) modules (3) lcs-AP (4) version1 (1) lcs-AP-CommonDataTypes (3)}

DEFINITIONS AUTOMATIC TAGS ::=

BEGIN

Criticality ::= ENUMERATED { reject, ignore, notify }

Presence ::= ENUMERATED { optional, conditional, mandatory }

ProcedureCode ::= INTEGER (0..255)

ProtocolExtensionID ::= INTEGER (0..65535)

ProtocolIE-ID ::= INTEGER (0..65535)

TriggeringMessage ::= ENUMERATED {initiating-message, successful-outcome, unsuccessful-outcome,
outcome}

```

END

## 7.5.7 Constant definitions

```

-- *****
--
-- Constant definitions
--
-- *****

LCS-AP-Constants {
itu-t (0) identified-organization (4) etsi (0) mobileDomain (0)
eps-Access (21) modules (3) lcs-AP (4) version1 (1) lcs-AP-Constants (4)}

DEFINITIONS AUTOMATIC TAGS ::=

BEGIN

-- *****
--
-- Elementary Procedures
--
-- *****

id-Location-Service-Request          INTEGER ::= 0
id-Connection-Oriented-Information-Transfer INTEGER ::= 1
id-Connectionless-Information-Transfer  INTEGER ::= 2
id-Location-Abort                    INTEGER ::= 3
id-Reset                              INTEGER ::= 4
id-Ciphering-Key-Data-Delivery         INTEGER ::= 5

-- *****
--
-- IEs
--
-- *****

id-Accuracy-Fulfillment-Indicator  INTEGER ::= 0
id-APDU                             INTEGER ::= 1
id-Correlation-ID                   INTEGER ::= 2
id-Destination-ID                   INTEGER ::= 3
id-E-UTRAN-Cell-Identifier           INTEGER ::= 4
id-Include-Velocity                 INTEGER ::= 5
id-IMEI                              INTEGER ::= 6
id-IMSI                              INTEGER ::= 7
id-LCS-Client-Type                  INTEGER ::= 8
id-LCS-Priority                      INTEGER ::= 9
id-LCS-QOS                           INTEGER ::= 10
id-LCS-Cause                         INTEGER ::= 11
id-Location-Estimate                INTEGER ::= 12
id-Location-Type                    INTEGER ::= 13
id-MultipleAPDUs                    INTEGER ::= 14
id-Payload-Type                      INTEGER ::= 15
id-Positioning-Data                 INTEGER ::= 16
id-Return-Error-Request              INTEGER ::= 17
id-Return-Error-Cause               INTEGER ::= 18
id-Source-Identity                  INTEGER ::= 19
id-UE-Positioning-Capability         INTEGER ::= 20
id-Velocity-Estimate                INTEGER ::= 21
id-LCS-Service-Type-ID              INTEGER ::= 22
id-Cell-Portion-ID                  INTEGER ::= 23
id-Civic-Address                    INTEGER ::= 24
id-Barometric-Pressure              INTEGER ::= 25
id-Additional-PositioningDataSet     INTEGER ::= 26
id-RAT-Type                          INTEGER ::= 27
id-Ciphering-Data                   INTEGER ::= 28
id-Ciphering-Data-Ack               INTEGER ::= 29
id-Ciphering-Data-Error-Report      INTEGER ::= 30
id-Coverage-Level                   INTEGER ::= 31

```

```

-- *****
--
-- Extension constants
--
-- *****
--
-- *****
--
-- Lists
--
-- *****

max-No-Of-Points      INTEGER ::= 15
max-Set               INTEGER ::= 9
max-GNSS-Set         INTEGER ::= 9
max-Add-Pos-Set      INTEGER ::= 8
max-Cipher-Set       INTEGER ::= 16

maxProtocolExtensions INTEGER ::= 65535
maxProtocolIEs       INTEGER ::= 65535

END

```

## 7.5.8 Container Definitions

```

-- *****
--
-- Container definitions
--
-- *****

LCS-AP-Containers {
itu-t (0) identified-organization (4) etsi (0) mobileDomain (0)
eps-Access (21) modules (3) lcs-AP (4) version1 (1) lcs-AP-Containers (5)}

DEFINITIONS AUTOMATIC TAGS ::=

BEGIN

-- *****
--
-- IE parameter types from other modules.
--
-- *****

IMPORTS
    Criticality,
    Presence,
    ProtocolExtensionID,
    ProtocolIE-ID
FROM LCS-AP-CommonDataTypes

    maxProtocolExtensions,
    maxProtocolIEs
FROM LCS-AP-Constants;

-- *****
--
-- Class Definition for Protocol IEs
--
-- *****

LCS-AP-PROTOCOL-IES ::= CLASS {
    &id      ProtocolIE-ID    UNIQUE,
    &criticality    Criticality DEFAULT ignore,
    &Value,
    &presence    Presence
}
WITH SYNTAX {
    ID          &id
    CRITICALITY    &criticality
    TYPE          &Value
    PRESENCE      &presence
}

```



```

-- *****
--
-- Class Definition for Protocol Extensions
--
-- *****

LCS-AP-PROTOCOL-EXTENSION ::= CLASS {
    &id      ProtocolExtensionID UNIQUE,
    &criticality Criticality      DEFAULT ignore,
    &Extension,
    &presence Presence
}
WITH SYNTAX {
    ID          &id
    CRITICALITY &criticality
    EXTENSION   &Extension
    PRESENCE    &presence
}

-- *****
--
-- Container for Protocol IES
--
-- *****

ProtocolIE-Container {LCS-AP-PROTOCOL-IES : IESSetParam} ::=
    SEQUENCE (SIZE (0..maxProtocolIEs)) OF
    ProtocolIE-Field {{IESSetParam}}

ProtocolIE-Field {LCS-AP-PROTOCOL-IES : IESSetParam} ::= SEQUENCE {
    id          LCS-AP-PROTOCOL-IES.&id      ({IESSetParam}),
    criticality LCS-AP-PROTOCOL-IES.&criticality  ({IESSetParam}{@id}),
    value       LCS-AP-PROTOCOL-IES.&Value   ({IESSetParam}{@id})
}

-- *****
--
-- Container Lists for Protocol IE Containers
--
-- *****

ProtocolIE-ContainerList {INTEGER : lowerBound, INTEGER : upperBound, LCS-AP-PROTOCOL-IES :
IESSetParam} ::=
    SEQUENCE (SIZE (lowerBound..upperBound)) OF
    ProtocolIE-Container {{IESSetParam}}

-- *****
--
-- Container for Protocol Extensions
--
-- *****

ProtocolExtensionContainer {LCS-AP-PROTOCOL-EXTENSION : ExtensionSetParam} ::=
    SEQUENCE (SIZE (1..maxProtocolExtensions)) OF
    ProtocolExtensionField {{ExtensionSetParam}}

ProtocolExtensionField {LCS-AP-PROTOCOL-EXTENSION : ExtensionSetParam} ::= SEQUENCE {
    id          LCS-AP-PROTOCOL-EXTENSION.&id      ({ExtensionSetParam}),
    criticality LCS-AP-PROTOCOL-EXTENSION.&criticality  ({ExtensionSetParam}{@id}),
    extensionValue LCS-AP-PROTOCOL-EXTENSION.&Extension  ({ExtensionSetParam}{@id})
}

END

```

## 7.5.9 Message transfer syntax

LCS-AP shall use the ASN.1 Basic Packed Encoding Rules (BASIC-PER) Aligned Variant as transfer syntax as specified in ITU-T Recommendation X.691 [12].

## 7.6 Handling of unknown, unforeseen and erroneous protocol data

Clause 10 of 3GPP TS 36.413 [7] is applicable for the purposes of the present document.

---

## 8 LCS-AP Timers

### 8.1 General

The description of timers in the following tables should be considered a brief summary.

### 8.2 Timers of LCS-AP

**Table 8.2.1: LCS-AP timers**

TIMER NUM.	TIMER VALUE	CAUSE OF START	NORMAL STOP	ON EXPIRY
T3x01	This value can be operator configurable, based on the received QoS response time.	A Location Request procedure started in the MME.	Location Response message is received	MME shall send Abort message to E-SMLC and return error to the requesting entity
T3x02	3 seconds	A Reset message is sent	Reset Acknowledge message is received	Retransmission of the Reset message
T3x03	This value can be operator configurable	A Ciphering Keys Delivery procedure started in the E-SMLC	Ciphering Key Data Result message is received	E-SMLC shall abort the procedure and release any resources allocated for the procedure

## Annex A (informative): Change history

Date	TSG #	TSG Doc.	CR	Rev	Subject/Comment	New
2010-03	CP-47	CP-100054			3GPP TS presented for approval in CT#47	9.0.0
2010-06	CP-48	CP-100286	0001		Correction to Positioning Data Element	9.1.0
			0003		Correction to Cell ID Category	
2010-06	CP-48	CP-100417	0002	3	Provide Service Type ID to E-SMLC	10.0.0
2010-09	CP-49	CP-100463	0006	1	Define message transfer syntax in LCS-AP Add LCS-AP port identifier, payload protocol identifier and Elementary Procedure number	10.1.0
2011-03	CP-51	CP-110054	0014	2	Fix mismatches between technical description and ASN.1 coding	10.2.0
2011-06	CP-52	CP-110365	0016	1	Protocol Layering for LCS-AP	10.3.0
2011-09	CP-53	CP-110579	0020	1	Polygon encoding correction	11.0.0
2012-03	CP-55	CP-120038	0021	2	Use of multiple SCTP associations between MME and E-SMLC	11.1.0
2012-12	CP-58	CP-120880	0023	1	Mandatory Correlation ID in Connection Oriented Information	11.2.0
2013-06	CP-60	CP-130287	0024	1	APDU in Connection Oriented Information message	11.3.0
2013-12	CP-62	CP-130631	0025	1	Adding E-SMLC provided Cell info and Cell Portion	12.0.0
2014-06	CP-64	CP-140269	0026	-	Value range of Cell-Portion-ID	12.1.0
2015-09	CP-69	CP-150441	0027	1	Clarification on the MME behaviour upon expiration of timer T3x01	13.0.0
2015-12	CP-70	CP-150740	0033	-	ASN.1 Corrections	13.1.0
2015-12	CP-70	CP-150766	0029	2	Indoor Positioning support in LCS-AP	13.1.0
2016-03	CP/71	CP-160024	0034	-	Implementation Error in CR#29	13.2.0
2016-12	CT#74	CP-160668	0035	1	Consistency for UE-Based positioning method in LPP	14.0.0
2016-12	CT#74	CP-160668	0036	1	Cell Portion ID Extension	14.0.0
2017-06	CT#76	CP-171030	0037	3	Enhancements to Location Services for CIoT	14.1.0
2017-06	CT#76	CP-171030	0038	1	Location service message size adaptation according to coverage level	14.1.0
2017-06	CT#76	CP-171025	0039	2	LCS-AP corrections	14.1.0
2017-12	CT#78	CP-173020	0042	-	Introduction of New types of eNB ID	14.2.0
2018-06	CT#80	CP-181124	0043	1	Ciphering keys delivery to support broadcast of ciphered assistance data in E-UTRAN	15.0.0
2018-09	CT#81	CP-182077	0045	-	Update of SIB Types information in Ciphering Data Set	15.1.0
2019-03	CT#83	CP-190034	0046	1	LTE-M RAT Type	15.2.0
2019-09	CT#85	CP-192095	0047	-	Ciphering key lost	15.3.0
2019-09	CT#85	CP-192095	0050	1	Correction of ASN.1 errors	15.3.0
2019-09	CT#85	CP-192095	0051	1	Addition of High Accuracy location estimates	15.3.0
2019-09	CT#85	CP-192093	0053	1	Correction on Coverage Level	15.3.0

---

## History

<b>Document history</b>		
V15.0.0	July 2018	Publication
V15.1.0	September 2018	Publication
V15.2.0	July 2019	Publication
V15.3.0	September 2019	Publication