

ETSI TS 129 201 V17.0.0 (2022-05)



**Universal Mobile Telecommunications System (UMTS);
LTE;
Representational State Transfer (REST)
reference point between Application Function (AF)
and Protocol Converter (PC)
(3GPP TS 29.201 version 17.0.0 Release 17)**



Reference

RTS/TSGC-0329201vh00

Keywords

LTE,UMTS

ETSI

650 Route des Lucioles
F-06921 Sophia Antipolis Cedex - FRANCE

Tel.: +33 4 92 94 42 00 Fax: +33 4 93 65 47 16

Siret N° 348 623 562 00017 - APE 7112B
Association à but non lucratif enregistrée à la
Sous-Préfecture de Grasse (06) N° w061004871

Important notice

The present document can be downloaded from:

<http://www.etsi.org/standards-search>

The present document may be made available in electronic versions and/or in print. The content of any electronic and/or print versions of the present document shall not be modified without the prior written authorization of ETSI. In case of any existing or perceived difference in contents between such versions and/or in print, the prevailing version of an ETSI deliverable is the one made publicly available in PDF format at www.etsi.org/deliver.

Users of the present document should be aware that the document may be subject to revision or change of status.

Information on the current status of this and other ETSI documents is available at

<https://portal.etsi.org/TB/ETSIDeliverableStatus.aspx>

If you find errors in the present document, please send your comment to one of the following services:

<https://portal.etsi.org/People/CommitteeSupportStaff.aspx>

If you find a security vulnerability in the present document, please report it through our
Coordinated Vulnerability Disclosure Program:

<https://www.etsi.org/standards/coordinated-vulnerability-disclosure>

Notice of disclaimer & limitation of liability

The information provided in the present deliverable is directed solely to professionals who have the appropriate degree of experience to understand and interpret its content in accordance with generally accepted engineering or other professional standard and applicable regulations.

No recommendation as to products and services or vendors is made or should be implied.

No representation or warranty is made that this deliverable is technically accurate or sufficient or conforms to any law and/or governmental rule and/or regulation and further, no representation or warranty is made of merchantability or fitness for any particular purpose or against infringement of intellectual property rights.

In no event shall ETSI be held liable for loss of profits or any other incidental or consequential damages.

Any software contained in this deliverable is provided "AS IS" with no warranties, express or implied, including but not limited to, the warranties of merchantability, fitness for a particular purpose and non-infringement of intellectual property rights and ETSI shall not be held liable in any event for any damages whatsoever (including, without limitation, damages for loss of profits, business interruption, loss of information, or any other pecuniary loss) arising out of or related to the use of or inability to use the software.

Copyright Notification

No part may be reproduced or utilized in any form or by any means, electronic or mechanical, including photocopying and microfilm except as authorized by written permission of ETSI.

The content of the PDF version shall not be modified without the written authorization of ETSI.

The copyright and the foregoing restriction extend to reproduction in all media.

© ETSI 2022.
All rights reserved.

Intellectual Property Rights

Essential patents

IPRs essential or potentially essential to normative deliverables may have been declared to ETSI. The declarations pertaining to these essential IPRs, if any, are publicly available for **ETSI members and non-members**, and can be found in ETSI SR 000 314: "*Intellectual Property Rights (IPRs); Essential, or potentially Essential, IPRs notified to ETSI in respect of ETSI standards*", which is available from the ETSI Secretariat. Latest updates are available on the ETSI Web server (<https://ipr.etsi.org/>).

Pursuant to the ETSI Directives including the ETSI IPR Policy, no investigation regarding the essentiality of IPRs, including IPR searches, has been carried out by ETSI. No guarantee can be given as to the existence of other IPRs not referenced in ETSI SR 000 314 (or the updates on the ETSI Web server) which are, or may be, or may become, essential to the present document.

Trademarks

The present document may include trademarks and/or tradenames which are asserted and/or registered by their owners. ETSI claims no ownership of these except for any which are indicated as being the property of ETSI, and conveys no right to use or reproduce any trademark and/or tradename. Mention of those trademarks in the present document does not constitute an endorsement by ETSI of products, services or organizations associated with those trademarks.

DECT™, **PLUGTESTS™**, **UMTS™** and the ETSI logo are trademarks of ETSI registered for the benefit of its Members. **3GPP™** and **LTE™** are trademarks of ETSI registered for the benefit of its Members and of the 3GPP Organizational Partners. **oneM2M™** logo is a trademark of ETSI registered for the benefit of its Members and of the oneM2M Partners. **GSM®** and the GSM logo are trademarks registered and owned by the GSM Association.

Legal Notice

This Technical Specification (TS) has been produced by ETSI 3rd Generation Partnership Project (3GPP).

The present document may refer to technical specifications or reports using their 3GPP identities. These shall be interpreted as being references to the corresponding ETSI deliverables.

The cross reference between 3GPP and ETSI identities can be found under <http://webapp.etsi.org/key/queryform.asp>.

Modal verbs terminology

In the present document "**shall**", "**shall not**", "**should**", "**should not**", "**may**", "**need not**", "**will**", "**will not**", "**can**" and "**cannot**" are to be interpreted as described in clause 3.2 of the [ETSI Drafting Rules](#) (Verbal forms for the expression of provisions).

"**must**" and "**must not**" are **NOT** allowed in ETSI deliverables except when used in direct citation.

Contents

Intellectual Property Rights	2
Legal Notice	2
Modal verbs terminology.....	2
Foreword.....	5
1 Scope	6
2 References	6
3 Definitions and abbreviations.....	7
3.1 Definitions	7
3.2 Abbreviations	7
4 Representational State Transfer (REST) reference point based on Protocol Converter (PC) architecture	8
4.1 Overview	8
4.2 Reference model.....	8
4.3 Functional elements.....	9
4.3.1 Application function	9
4.3.2 Protocol converter.....	9
4.4 Location of the PC within the PLMN.....	9
4.4.1 General.....	9
4.4.2 Protocol converter located in the PLMN but outside of the PCRF realm	9
4.4.3 Protocol converter located in the PCRF realm.....	10
4.5 PCC Procedures over the RESTful reference point.....	10
4.5.1 General.....	10
4.5.2 Initial Provisioning of Session Information	11
4.5.3 Modification of Session Information	12
4.5.4 AF Session Termination	13
4.5.5 Gate Related Procedures	13
4.5.6 Subscription to Notification of Signalling Path Status	13
4.5.7 Traffic Plane Events.....	13
5 Protocol	14
5.1 Introduction	14
5.2 Transport layer	14
5.3 Application delivery layer	14
5.3.1 Methods	15
5.3.2 Void	16
5.3.3 Resources and URI design	16
5.3.4 HTTP request/response dialogues.....	16
5.3.5 AF Session ID.....	18
5.4 Specific application communication	18
5.4.0 General.....	18
5.4.1 Content type XML.....	18
5.4.1.1 XML schema.....	18
5.4.1.2 Data types and mapping between XML elements	18
5.4.1.3 Mapping between Diameter AVPs and XML elements and groups.....	19
5.5 PC discovery	22
6 Routing.....	22
6.1 PC located in the PLMN but outside of the PCRF realm	22
6.2 PC located in the PCRF realm.....	22
7 Secure communication	23
Annex A (informative): Call Flows	24
A.1 General	24

A.2	AF session establishment	24
A.3	AF Session Modification Initiated by AF	24
A.4	AF Session Termination.....	25
A.5	Gate Related Procedures	25
A.6	Subscription to Notification of Signalling Path Status.....	26
A.7	Notification of Traffic Plane Events	26
A.7.1	Traffic plane event reporting	27
A.7.2	Service data flow deactivation when all service data flows are affected.....	27
A.7.3	IP-CAN Session Termination.....	28
Annex B (normative):	XML Schema.....	30
B.1	XML elements and groups	30
B.2	Diameter message representation.....	33
Annex C (informative):	Change history	37
History		38

Foreword

This Technical Specification has been produced by the 3rd Generation Partnership Project (3GPP).

The contents of the present document are subject to continuing work within the TSG and may change following formal TSG approval. Should the TSG modify the contents of the present document, it will be re-released by the TSG with an identifying change of release date and an increase in version number as follows:

Version x.y.z

where:

- x the first digit:
 - 1 presented to TSG for information;
 - 2 presented to TSG for approval;
 - 3 or greater indicates TSG approved document under change control.
- y the second digit is incremented for all changes of substance, i.e. technical enhancements, corrections, updates, etc.
- z the third digit is incremented when editorial only changes have been incorporated in the document.

1 Scope

The present document describes the Representational State Transfer (REST) reference point, which is used to exchange application level session information between the Protocol Converter (PC) and the Application Function (AF). REST shall be used as an architectural style as appropriate.

2 References

The following documents contain provisions which, through reference in this text, constitute provisions of the present document.

- References are either specific (identified by date of publication, edition number, version number, etc.) or non-specific.
- For a specific reference, subsequent revisions do not apply.
- For a non-specific reference, the latest version applies. In the case of a reference to a 3GPP document (including a GSM document), a non-specific reference implicitly refers to the latest version of that document *in the same Release as the present document*.

- [1] 3GPP TR 21.905: "Vocabulary for 3GPP Specifications".
- [2] 3GPP TR 29.817: "Study on XML based access of AF to the PCRF".
- [3] 3GPP TS 29.213: "Policy and Charging Control signalling flows and Quality of Service (QoS) parameter mapping".
- [4] 3GPP TS 29.214: "Policy and Charging Control over Rx reference point".
- [5] 3GPP TS 23.203: "Policy and Charging Control architecture".
- [6] Void.
- [7] Void.
- [8] IETF RFC 793: "Transmission Control Protocol".
- [9] Void.
- [10] IETF RFC 3986: "Uniform Resource Identifier (URI): Generic Syntax".
- [11] IETF RFC 1035: "Domain Names – Implementation and Specification".
- [12] IETF RFC 2131: "Dynamic Host Configuration Protocol".
- [13] 3GPP TS 33.310: "Network Domain Security (NDS); Authentication Framework (AF)".
- [14] IETF RFC 2818: "HTTP Over TLS".
- [15] IETF RFC 1786: "Uniform Resource Locators (URL)".
- [16] Void.
- [17] IETF RFC 6733: "Diameter Base Protocol".
- [18] IETF RFC 7230: "Hypertext Transfer Protocol (HTTP/1.1): Message Syntax and Routing".
- [19] IETF RFC 7231: "Hypertext Transfer Protocol (HTTP/1.1): Semantics and Content".
- [20] IETF RFC 7232: "Hypertext Transfer Protocol (HTTP/1.1): Conditional Requests".
- [21] IETF RFC 7233: "Hypertext Transfer Protocol (HTTP/1.1): Range Requests".
- [22] IETF RFC 7234: "Hypertext Transfer Protocol (HTTP/1.1): Caching".

[23] IETF RFC 7235: "Hypertext Transfer Protocol (HTTP/1.1): Authentication".

3 Definitions and abbreviations

3.1 Definitions

For the purposes of the present document, the terms and definitions given in 3GPP TR 21.905 [1] and the following apply. A term defined in the present document takes precedence over the definition of the same term, if any, in 3GPP TR 21.905 [1].

Application Function (AF): element offering application(s) that use IP bearer resources.

Protocol Converter (PC): element that converts the RESTful/XML based Rx reference point to the Diameter based Rx reference point.

Representation: is a view of a resource state, it is encoded in one or more transferable formats, such as XML, JSON, plain text or other formats.

RESTful HTTP: is an architectural style consisting of a coordinated set of architectural constraints applied to components, connectors, and data elements, within a distributed hypermedia system applied to the development of web services.

REST-Rx: term that is used to indicate the Rx interface based on RESTful HTTP between the AF and the PC.

3.2 Abbreviations

For the purposes of the present document, the abbreviations given in 3GPP TR 21.905 [1] and the following apply. An abbreviation defined in the present document takes precedence over the definition of the same abbreviation, if any, in 3GPP TR 21.905 [1].

AAA	Authentication, Authorization, Accounting
AF	Application Function
API	Application Programming Interface
BBERF	Bearer Binding and Event Reporting Function
DHCP	Dynamic Host Configuration Protocol
DNS	Domain Name System
DRA	Diameter Routing Agent
DRMP	Diameter Routing Message Priority
DSCP	Differentiated Services Code Point
HTTP	HyperText Transfer Protocol
HTTPS	Hypertext Transfer Protocol Secure
IP-CAN	IP Connectivity Access Network
PC	Protocol Converter
PCC	Policy and Charging Control
PCEF	Policy and Charging Enforcement Function
PCRF	Policy and Charging Rules Function
PDN	Packet Data Network
PLMN	Public Land Mobile Network
QoS	Quality of Service
REST	Representational State Transfer
SPR	Subscription Profile Repository
UDR	User Data Repository
URI	Uniform Resource Identifier
URL	Uniform Resource Locator
UE	User Equipment
XML	Extensible Markup Language

4 Representational State Transfer (REST) reference point based on Protocol Converter (PC) architecture

4.1 Overview

The Representational State Transfer (REST) reference point resides between the AF and the Protocol Converter (PC). The PC converts application level information received from the AF to Diameter session information and communicates with the PCRF via the Diameter based Rx reference point (3GPP TS 29.214 [4]).

4.2 Reference model

The Rx reference point, which is based on Diameter, is defined between the PCRF and the AF in 3GPP TS 29.214 [4]. If the AF supports RESTful HTTP and XML a Protocol Converter (PC) is needed. In this specification the interface between the AF and the PC is named REST-Rx. The REST-Rx interface shall be used in non-IMS scenarios only.

The PC converts the information, received over the REST-Rx interface, into information that can be used on the Diameter based Rx interface in order to get an access to the PCC architecture and vice versa. The PC manages RESTful resources, which are an integral part of the REST-Rx interface. As defined in the stage 2 specifications (3GPP TS 23.203 [5]), information from the AF is part of the input used by the PCRF for Policy and Charging Control (PCC) decisions. Signalling flows are specified in Annex A.

The overall PCC architecture is depicted in subclause 3a of 3GPP TS 29.213[3].

The relationships between the different functional entities involved are depicted in figure 4.2.1.

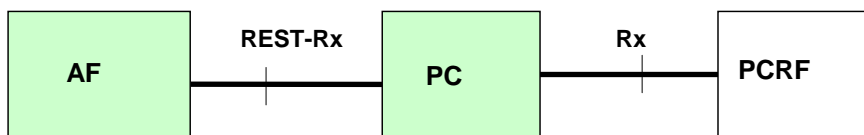

Figure 4.2.1: The REST-Rx reference model

NOTE: The PCRF and PC are both together either located in the VPLMN or HPLMN. The AF is either in the same PLMN as the PC, or it is in a third part network attached to that PLMN.

Figure 4.2.2: Void

Figure 4.2.3: Void

Figure 4.2.4: Void

Figure 4.2.5: Void

Figure 4.2.6: Void

4.3 Functional elements

4.3.1 Application function

The AF is an element offering applications that require the Policy and Charging Control of traffic plane resources (e.g. UMTS PS domain/GPRS domain resources). The AF shall use the Rx reference point to provide session information to the PCRF.

NOTE: The AFs may be deployed by the same operator offering the IP-CAN or may be provided by external third party service provider.

4.3.2 Protocol converter

If the AF only supports RESTful HTTP and XML a protocol converter is needed between the AF and the PCRF.

The Protocol converter (PC) is an element converting information carried over RESTful HTTP and XML to information carried over Diameter in order to get an access to the PCC architecture.

4.4 Location of the PC within the PLMN

4.4.1 General

The protocol converter can be located:

- (1) In the PLMN but outside of the PCRF realm;
- (2) In the PCRF realm.

There is only one logical protocol converter in both above cases.

4.4.2 Protocol converter located in the PLMN but outside of the PCRF realm

In this scenario the protocol converter is in the PLMN but outside of the PCRF realm, as shown in figure 4.4.2.1.

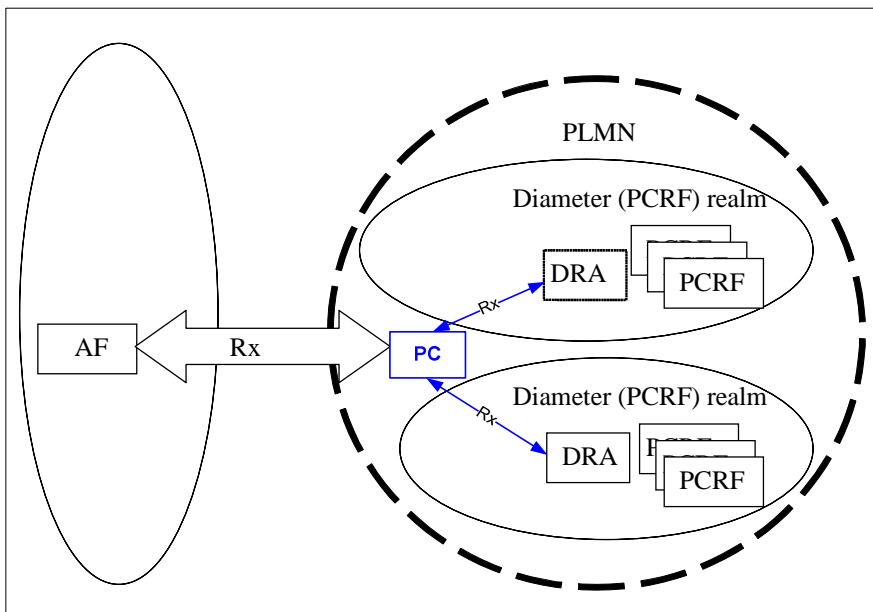

NOTE: A DRA is needed if more than one PCRF is present in a Diameter (PCRF) realm.

Figure 4.4.2.1: Protocol converter placed within PLMN but outside of the Diameter (PCRF) realm

4.4.3 Protocol converter located in the PCRF realm

In this scenario the protocol converter is in the PCRF realm, as shown in figure 4.4.3.1.

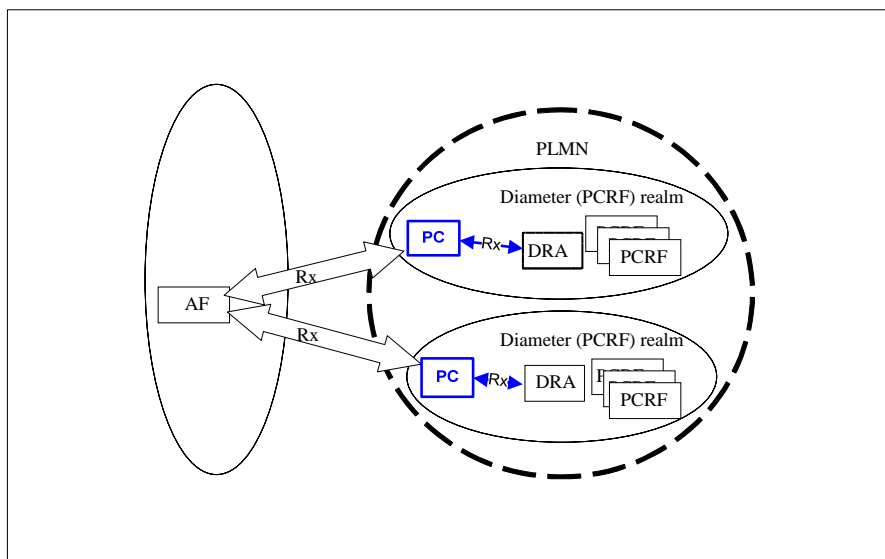

Figure 4.4.3.1: Protocol converter placed within the Diameter (PCRF) realm

NOTE: A DRA is needed if more than one PCRF is present in a Diameter (PCRF) realm.

4.5 PCC Procedures over the RESTful reference point

4.5.1 General

PCC procedures which can be operated at the REST-Rx interface are described in the following subclauses.

4.5.2 Initial Provisioning of Session Information

When a new AF session is being established and media information for this AF session is available at the AF and the related media require PCC supervision, the AF shall open a RESTful Rx session with the PC for the AF session using an HTTP POST message that addresses the resource responsible for resource creation, unless an Rx session has already been established for the AF session. If the RESTful Rx session already exists for the AF session, the AF uses the existing RESTful Rx session and shall use the HTTP PUT message including the AF Session ID in the path element to address the existing resource. The AF shall provide the full IP address of the UE using either UEIP element or UEIPv6 element, and the corresponding Service Information within MCD group(s). The AF shall not include circuit-switched bearer related media in the service information sent to the PC. The AF shall indicate to the PC as part of the MCD element whether the media IP flow(s) should be enabled or disabled with the FlowStatus element.

The AF may include the AFAppId element into the AF session establishment representation in order to indicate the particular service that the AF session belongs to. This element can be provided at both AF session level, and media component description level. When provided at both levels, the AFAppId element provided within the MCD group will have precedence.

The AF may include the AFChargingId element into the AF session establishment representation for charging correlation purposes. The AF may also include the SpecificAction element to request notification for certain user plane events, e.g. bearer termination.

The AF may include the SvcURN element in order to indicate that the new AF session relates to emergency traffic.

The AF may include the MPSId element in order to indicate that the new AF session relates to an MPS session.

If the AF provides service information that has been fully negotiated, the AF may include the SvcInfoStatus element set to FINAL_SERVICE_INFORMATION as specified in 3GPP TS 29.214 [4].

The AF may additionally provide preliminary service information not fully negotiated yet at an earlier stage. To do so, the AF shall include the SvcInfoStatus element with the value set to PRELIMINARY_SERVICE_INFORMATION as specified in 3GPP TS 29.214 [4].

For sponsored data connectivity and if SponsoredConnectivity is supported, the AF shall provide the application service provider identity and the sponsor identity to the PCRF via the PC by including the ASPI element and the SponsId element in the SpConnData group in the AF session establishment representation. Additionally if SponsorChange is supported the AF shall provide an indication whether to enable or not enable sponsored data connectivity to the PCRF by including the SponsAct element set to the applicable value.

NOTE 1: The relationship between AF and sponsor is out of scope of this specification. A single AF can serve multiple sponsors.

To support the usage monitoring of sponsored data connectivity, the AF may also include the GSU group in the SpConnData group and the SpecificAction element set to the value USAGE_REPORT as specified in 3GPP TS 29.214 [4] to request notification when the usage threshold has been reached.

NOTE 2: If the AF is in the user plane, the AF can handle the usage monitoring and therefore it is not required to provide a usage threshold to the PCRF as part of the sponsored data connectivity information.

If the PCRF includes the Retry-Interval AVP within the AA-Answer command to the PC, the PC shall provide the same value of retry interval in the RetryInterval element in the AF session establishment representation. The AF shall not send the same service information to the PCRF (via the PC) again (for the same IP-CAN session) until the retry interval has elapsed.

To allow the PCRF and PCEF to perform PCC rule authorization and bearer binding for the described service IP flows, the AF may supply both source and destination IP addresses and port numbers within the FlowDesc element, if such information is available.

The AF may specify the TTC element for the described service data flows together with the FlowDesc element.

NOTE 3: The TTC element can be useful when another packet filter attribute is needed to differentiate between flows. For example, (when EPS bearers are used for group communication services) flows encapsulated and encrypted by a tunneling protocol and thus having their IP five-tuple attributes obscured can be differentiated by the Type of Service (or Traffic Class) value of the outer header.

NOTE 4: The use of TTC element by the AF assumes that no DSCP re-marking is applied from the application to the PGW.

The AF may specify the ResPrio element at request level in the AF session establishment representation in order to assign a priority to the AF session as well as specify the ResPrio element at the media component description level to assign a priority to the IP flow. The presence of the ResPrio in both levels does not constitute a conflict as they each represent different types of priority. Specifically the ResPrio at the AF session establishment representation level provides the relative priority for a session while the ResPrio at the media component description level provides the relative priority for an IP flow within a session. If the ResPrio element is not specified the requested priority is DEFAULT (0) as specified in 3GPP TS 29.214 [4].

The AF may request notifications of specific IP-CAN session events through the usage of the SpecificAction element in the AF session establishment representation. The HTTP POST message, which is used to establishment of a new session, shall include the notification URL in the representation.

The AF may include the ReqType element set to INITIAL_REQUEST as specified in 3GPP TS 29.214 [4].

To allow the PCRF to derive the PCC rules for the background data transfer according to the transfer policy stored in the SPR, the AF may supply the reference id of transfer policy in the RefId element.

When the PC receives the SuppFeatures element from the AF, it shall only include in the corresponding Diameter Supported-Features AVP sent to the PCRF the intersection of the AF advertised features and the features supported by the PC.

The behaviour when the AF does not receive the HTTP 201 CREATED response, or when it arrives after the internal timer waiting for it has expired, is out of scope of this specification and based on operator policy.

4.5.3 Modification of Session Information

The AF may modify the session information at any time (e.g. due to an AF session modification or internal AF trigger) by sending an HTTP PUT message to PC including the AF session ID as an URL address and the MCD group(s) with the updated Service Information in the HTTP body. The AF shall send an AF session modification request representation to the PCRF via the PC, only after the previous AF session modification request has been acknowledged.

If the AF provides service information that has been fully negotiated, the AF may include the SvcInfoStatus element set to FINAL_SERVICE_INFORMATION as specified in 3GPP TS 29.214 [4].

The AF may additionally provide preliminary service information not fully negotiated yet at an earlier stage. To do so, the AF shall include the SvcInfoStatus element with the value set to PRELIMINARY_SERVICE_INFORMATION as specified in 3GPP TS 29.214 [4].

The AF may include the ReqType element set to UPDATE_REQUEST as specified in 3GPP TS 29.214 [4] in the AF SESSION MODIFICATION REQUEST.

The AF may include the MPSId element in order to indicate that the modified AF session relates to an MPS session.

For sponsored data connectivity and if Sponsored Connectivity is supported, the AF shall provide the application service provider identity and the sponsor identity to the PCRF via the PC by including the ASPIId element and the SponsId element in the SpConnData group in the AF session modification representation.

If SponsorChange is supported and the AF requests to enable sponsored data connectivity the AF shall provide the application service provider identity, the sponsor identity and an indication to enable sponsored data connectivity to the PCRF via the PC by including ASPIId element, the SponsId element and the SponsAct element set to the value ENABLE_SPONSORING (1) in the SpConnData group in the AF session modification representation.

If the AF requests to disable sponsored data connectivity the AF shall provide an indication to disable sponsored data connectivity to the PCRF via the PC by including the SponsAct element set to the value DISABLE_SPONSORING (0) in the SpConnData group in the AF session modification representation.

To support the usage monitoring of sponsored data connectivity, the AF may also include the GSU group in the SpConnData group in the AF session modification representation.

NOTE: If the AF is in the user plane, the AF can handle the usage monitoring and therefore it is not required to provide a usage threshold to the PCRF via the PC as part of the sponsored data connectivity information.

To allow the PCRF to derive the PCC rules for the background data transfer according to the transfer policy stored in the SPR, the AF may supply the reference id of transfer policy in the RefId element.

If the PCRF includes the Retry-Interval AVP within the AA-Answer command to the PC, the PC shall provide the same value of retry interval in the RetryInterval element in the AF session modification representation. The AF shall not send the same service information to the PCRF (via the PC) again (for the same IP-CAN session) until the retry interval has elapsed.

4.5.4 AF Session Termination

When an AF session is terminated, the AF shall send an HTTP DELETE message including the AF Session ID as an URL address to the PC.

If the AF requires access network information at this step, the AF shall include the ReqAccInfo element within the AF session termination representation, indicating the required information.

4.5.5 Gate Related Procedures

Depending on the application, in the Service Information provision, the AF may instruct the PCRF via the PC by sending an HTTP PUT message when the IP flow(s) are to be enabled or disabled to pass through the IP-CAN. The AF does this by sending the gate status request message representation containing the MCD group(s) that contains the flow status information (in the FlowStatus element) for the flows to be enabled or disabled.

The behaviour when the AF does not receive the gate status response from the PC, or when it arrives after the internal timer waiting for it has expired, or when it arrives with an indication different than SUCCESS, are outside the scope of this specification and based on operator policy.

4.5.6 Subscription to Notification of Signalling Path Status

An AF may subscribe to notifications of the status of the AF signalling transmission path. To do so, the AF shall send an HTTP POST message to establish an AF session with the PC (as per sub-clause 5.3.4). The HTTP POST message shall provide a URL which shall be used as a notification URL by the PC. The AF shall provide the UE's IP address (using either the UEIP element or the UEIPv6 element) and the SpecificAction element requesting the subscription to "INDICATION_OF_LOSS_OF BEARER" and/or "INDICATION_OF_RELEASE_OF BEARER" in the representation. The AF shall additionally provide an MCD group including a single MSC group with the FlowUsage element set to the value "AF_SIGNALLING" within the representation. The MCD group shall contain the MCN element set to "0".

If the AF Session is only used for subscription to Notification of Signalling Path Status, the AF may cancel the subscription to notifications of the status of the AF Signalling transmission path. In that case, the AF shall send an HTTP DELETE message to the PC, which shall be acknowledged with an HTTP 200 OK response.

NOTE: The Rx session created for the AF signalling can also be used when the AF requests notifications of IP-CAN type change and/or when the AF provisions AF Signalling Flow Information.

4.5.7 Traffic Plane Events

If the PC receives a Diameter RAR command for traffic plane events reporting as defined in subclause 4.4.6 of 3GPP TS 29.214 [4], the PC includes the content translated from the RAR command as a representation into an HTTP PUT message to indicate to the AF the traffic plane events. After the PC receives the HTTP 200 OK response from the AF, the PC converts the representation of the response to a Diameter RAA command and sends the Diameter RAA command to the PCRF as specified in 3GPP TS 29.214 [4].

If the PC receives a Diameter ASR command for IP-CAN session termination as defined in subclause 4.4.6.1 and 4.4.6.2 of 3GPP TS 29.214 [4], the PC includes the content translated from the ASR command as a representation into an HTTP PUT message to indicate to the AF the IP-CAN session termination. After the PC receives the HTTP response from the AF and the response includes a representation of an ASA, the PC converts the the representation of the response to a Diameter ASA command and sends the Diameter ASA command to the PCRF as specified in 3GPP TS 29.214 [4]. The AF initiates the session termination procedure as defined in subclause 4.5.4.

NOTE: The definition of error cases are out of scope of the present specification.

5 Protocol

5.1 Introduction

The following layers of the protocol stack for the Rx reference point between AF and PC are described in sub-clauses:

- TCP as defined in IETF RFC 793 [8] provides the communication service at the transport layer.
- An optional communication security layer can be added between the transport and the application delivery layer (see clause 7).
- The application delivery layer provides the transport of the specific application communication data using HTTP/1.1 as defined in IETF RFC 7230 [18], IETF RFC 7231 [19], IETF RFC 7232 [20], IETF RFC 7233 [21], IETF RFC 7234 [22] and IETF RFC 7235 [23].
- The specific application communication layer constitutes the transport of the XML documents. The XML schema describes the data structure, which is accepted by the Rx software applications.

Figure 5.1.1 illustrates the protocol stack of the RESTful Rx reference point.

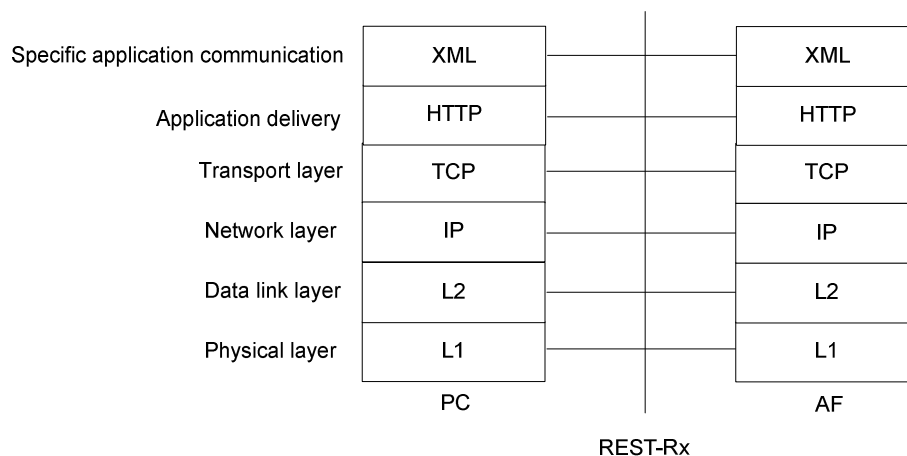

Figure 5.1.1: Protocol stack of the RESTful Rx reference point

5.2 Transport layer

HTTP is layered over TCP, which provides a reliable transport.

PC and the AF act as HTTP client and HTTP server both. As a result the PC and the AF establish a TCP connection for each direction. This permits bidirectional communication.

AF and PC shall use persistent connections. If the AF or PC has not already initiated a persistent TCP connection at the time sending an HTTP message, AF or PC shall initiate a TCP connection before sending the HTTP message; otherwise the AF or PC shall use the persistent connection.

5.3 Application delivery layer

The application delivery layer shall use RESTful HTTP.

The application delivery layer provides the following services:

- session establishment including creation of resources, which are addressable in the path element of an URL, and setup of notification URLs
- session modification, termination and gate related procedures by HTTP request/response dialogs
- subscription to notifications
- notification dialog by HTTP request/response messages
- transport of the specific application communication included in the HTTP message body

Creation of resources shall be a part of the AF session establishment. The AF session ID shall be assigned by the PC and shall be used to identify the session resource at the PC. This also sets-up the notification URL, which shall be used to address the resource for notifications from the PC to the AF.

NOTE: The AF session ID is allocated by the PC. In the session dialogue the AF session ID will be used to address a resource. If it is allocated by the PC, the client will be informed about the AF session ID within the HTTP response 201 Created. This means that the session related URI (see sub-clause 5.3.4 ...sessions/afsessionid) is dynamically discovered and not defined by the client.

The AF session ID is defined in subclause 5.3.5.

The Rx application requires that the PC can notify the AF about traffic plane events. The AF normally acts as the HTTP client, but the requirement for notifications result in a reversal role of the client and server. Therefore, PC and AF may act as HTTP client and HTTP server both.

If the AF establishes an AF session (i.e. initiates the initial provisioning of session information), the AF shall send an HTTP POST message to the PC including all session information required. The AF shall include the URL, which shall be used by the PC when the PC will report traffic plane events corresponding to the AF session. The PC shall allocate a new AF session ID for the AF session and shall establish an Rx Diameter session with a new Rx Diameter session ID. The PC shall keep the mapping between the AF session ID and the URL and the mapping between the AF session ID and the Rx Diameter session ID. The PC shall send an HTTP 201 CREATED response to the AF including the allocated AF session ID once it receives a response from the PCRF.

If the AF modifies an AF session (i.e. initiates modification of session information), the AF shall send an HTTP PUT message, which includes the AF session ID as a path element of the URI. The PC shall send an HTTP 200 OK response to the AF after update of the corresponding Rx Diameter session.

If the AF terminates an AF session, the AF shall send an HTTP DELETE message including the AF session ID as a path element of the URI. The PC shall send an HTTP 200 OK response to the AF after termination of the corresponding Rx Diameter session.

If the AF initializes a gate related procedure, the AF shall send an HTTP PUT to the PC including all information required. The PC shall send an HTTP response to the AF after update of the corresponding Rx Diameter session.

If the AF subscribes to notifications of the status of the signalling transmission path, the AF shall send an HTTP POST to the PC including event information for the subscription. The subscription to notifications is performed as a separate session. The PC shall send an HTTP 201 CREATED response to the AF after update of the corresponding Rx Diameter session.

When the PC reports traffic plane events corresponding to the AF session, the PC shall send an HTTP PUT to the AF using the notification URL. The request includes the AF session ID as a path element of the notification URL. The AF may use the information for appropriate actions and will send an HTTP 200 OK response to the PC.

Every HTTP message contains the specific communication information required for this case in its body.

Annex A provides call flows for all procedures.

5.3.1 Methods

Methods indicate to the server what action has to be performed. Every HTTP request message has a method. The following HTTP methods as defined in IETF RFC 7231 [19] can be used:

- POST: Used to create a resource state. The URI defines the address responsible for the creation of the resource.

- PUT: Used to modify a resource state. The URI defines the resource which will be modified.
- DELETE: Used to delete a resource state.

Every HTTP request results in a response message that comes back with a status code and further information in its body, if required. The AF waits for this response before initiating a further request for the same AF session.

5.3.2 Void

5.3.3 Resources and URI design

REST claims that the session state is held by the client or it is transferred into a resource state by the server, in order to allow a stateless communication. The concept of the resource state avoids the transfer of the complete resource state to the client. Therefore, resources shall be an integral part of the REST-Rx interface. Resources are identifiable and have state representation.

NOTE 1: Stateless communication reduces the coupling of client and server. E.g., two requests that follow each other may not be processed by the same server instance.

NOTE 2: Resources may have one or more representations. JSON may be another representation (3GPP TR 29.817 [2]). It is possible to use different representations of resources for different requirements. In this release XML will be used as a representation only.

Resources shall be identified by URIs. The URI design shall be based on the structure defined in IETF RFC 3986 [10]:

```
scheme ":" hier-part [ "?" query ] [ "#" fragment ]
  hier-part = "/" authority path-abempty
            / path-absolute
            / path-rootless
            / path-empty
```

The URI design for the REST-Rx interface shall be based on the characteristics and requirements of the reference point between AF and PC and shall have a hierarchical structure.

The scheme may be HTTP or HTTPS for the REST-Rx interface. Within a scheme the definition of names shall follow the rules of HTTP URIs. Host and port are the main parts of the authority. The path element identifies the resources. The URIs, which are allowed on the REST-Rx interface and build out of the obligatory parts, shall have the structure:

Scheme://Host/Mainapplication/Mainresources

The obligatory parts have the meaning:

- Scheme: The application delivery layer protocol HTTP or HTTPS.
- Host: This part of the URI represents the server address including the port.
- Main application: The application which shall be accessed by the request. This release shall only provide the Rx application.

NOTE 3: The main application level makes possible defining different applications as resources at the same entity. This release only provides the Rx application.

- Main resources: Sessions are the core concepts of the REST-Rx interface and can be defined as the main resources by URIs. Main resources may be split into sub-resources further (e.g. individual sessions may be identified by AF session IDs).

The URI addressing of the main resource sessions can look like:

- <http://pcserver/rxapplication/sessions>

5.3.4 HTTP request/response dialogues

The HTTP request/response dialogue may consist out of different dialogues providing the functionalities for session establishment, modification, termination, gate related procedures, subscription to notifications and notifications. These

dialogues shall include the required content translated from the Diameter messages as defined in 3GPP TS 29.214 [4] and represented by the specific application communication language as defined in sub-clause 5.4. Sessions are addressed as resources in the path of the URI.

The HTTP request message, which is related to a session establishment procedure, shall use the POST method and shall include the notification URL in addition to the required content of an AAR message XML representation. The message addresses a resource, which is responsible for resource creation and session establishment, and has the general structure:

```
HTTP POST https://pcserver/rxapplication/sessions
  <Settings>
    <NotificationBaseURL>https://afresponsehost/path</NotificationBaseURL>
  </Settings>
  <AA-Request>
    <xs:annotation>
      <xs:documentation>=====</xs:documentation>
      <xs:documentation>Rx specific information</xs:documentation>
      <xs:documentation>=====</xs:documentation>
    </xs:annotation>
  </AA-Request>
```

This HTTP POST message instructs the PC to create a resource state with a notification URL and to establish an AF session between the PC and the PCRF. An AAA message, received by the PC, will result in a 201 Created response, which shall include the required content to be translated from the Diameter AAA answer message as a representation of the AAA message. The response message shall include one resource in the Location header field, which represents the AF session ID and will be used as a resource address by the AF.

The HTTP request message, which is related to a session with an AF session ID, shall have the general structure:

```
HTTP METHOD https://pcserver/rxapplication/sessions/afsessionid
  <RxMessage> <!-- The actual element sent is the xml document is one of :
    AA-Request, ST-Request, RA-Request or AS-Request -->
    <xs:annotation>
      <xs:documentation>=====</xs:documentation>
      <xs:documentation>Rx specific information</xs:documentation>
      <xs:documentation>=====</xs:documentation>
    </xs:annotation>
  </RxMessage>
```

It is answered by an HTTP response message that includes the correct content translated from a Diameter answer message as a representation as defined in Annex B.2. The HTTP response message shall have the general structure:

```
HTTP STATUS_CODE REASON_PHRASE
  <RxMessage> <!-- The actual element sent is the xml document is one of :
    AA-Answer, ST- Answer, RA-Request or AS-Request -->
    <xs:annotation>
      <xs:documentation>=====</xs:documentation>
      <xs:documentation>Rx specific answer messages </xs:documentation>
      <xs:documentation>=====</xs:documentation>
    </xs:annotation>
  </RxMessage>
```

The definition of sessions as resources makes it possible to use HTTP methods to retrieve information about the sessions and control their state.

Table 5.3.4.1: Rx methods and their result

Method	Result
POST .../sessions	Creates a resource for a session and initiates an AF session establishment procedure
PUT ...sessions/afsessionid	Modifies a session/resource state or initiates a gate related procedure. "afsessionid" is the AF session resource id that was previously created by the PC and returned in the Location header within the answer to the POST message.
PUT ...<notificationbaseurl>/<afsessionid>	Notifies the AF about traffic plane events associated with an AF session. The "notificationbaseurl" is set to the received NotificationBaseURL value in the original POST message that created the corresponding AF session resource. The "afsessionid" is the AF session resource id that was previously created by the PC and returned in the Location header within the answer to the POST message.
DELETE ...sessions/<afsessionid>	Deletes a session/resource state. The "afsessionid" is the AF session resource id that was previously created by the PC and returned within the answer to the POST message.

5.3.5 AF Session ID

The Diameter session between the PC and PCRF is mapped to a resource on the REST-Rx interface. The AF uses the AF session ID allocated by the PC, in the path element of an HTTP method to address the PC resource, which is used as an address for events corresponding to a particular activity. When the PC reports traffic plane events corresponding to the AF session, the PC adds the AF session ID as a path element to the notification URL.

The syntax of the Session ID defined for IETF RFC 6733 [17] can be mapped to the AF Session ID. The format of the AF session ID shall follow the implementation-specific syntax standardized for path elements of URLs [15]. The delimiter ";", which is used in the Diameter Session ID definition, need not be percent-encoded since there will be no conflict with a reserved character of the URI component.

NOTE: Characters in the reserved set are protected from normalization and are therefore safe to be used by scheme-specific and producer-specific algorithms for delimiting data subcomponents within a URI [15].

5.4 Specific application communication

5.4.0 General

Specific application communication represents the presentation of application data structures by transforming data into the form that the application accepts. It establishes the context between application-layer entities.

Note: This release only supports the content type XML.

5.4.1 Content type XML

The content type of the RESTful HTTP message shall be XML.

5.4.1.1 XML schema

The XML schema is given in annex B.

5.4.1.2 Data types and mapping between XML elements

The mapping between the Diameter value types or other parameter types used in this specification and the XML simple types is defined in table 5.4.1.2.1.

Table 5.4.1.2.1: Mapping between Diameter AVPs, other types and XML types

Diameter Value Type or other type	XML Simple Type	Remark
Enumerated	unsignedInt, integer	In XML enumerations constrain the value space to a specified set of values defined in TS 29.214 [4]. Integer or unsignedInt is selected as the XML type.
IPFilterRule	string	The Diameter IPFilterRule is derived from OctetString. The IPFilterRule uses the ASCII charset.
OctetString	hexBinary	OctetStrings contain arbitrary data of variable length. They are used to process arrays of byte values. The data type is not limited to string values but can store any byte based data type (including binary data).
Time	unsignedLong	The time format is derived from the OctetString AVP Base Format. The string must contain four octets, in the same format as the first four bytes of the NTP timestamp format. The 64-bit timestamp format is used on the REST-Rx interface. It includes a 32-bit unsigned seconds field spanning 136 years and a 32-bit fraction field resolving 232 picoseconds.
Unsigned32	unsignedInt	
Unsigned64	unsignedLong	
UTF8String	string	The UTF8String is derived from the OctetString the base format.
Binary data	hexBinary	hexBinary represents arbitrary hex-encoded binary data.
Integer (used as enumeration indication)	unsignedInt	The unsigned integer can be used as enumeration value.

NOTE: AVPs which are defined in 3GPP TS 29.214 [4] but not defined in the XML schema (see Annex B.1) as representations of AVPs cannot be supported on the specific application communication layer of the REST-Rx interface respectively cannot be supported for the Diameter message representation (see Annex B.2).

5.4.1.3 Mapping between Diameter AVPs and XML elements and groups

The mapping between the Diameter AVP names and XML element and group names is defined in table 5.4.1.3.1.

Table 5.4.1.3.1: Mapping between Diameter AVPs and XML elements or groups

Diameter AVP [4]	REST-Rx abbreviation	Type
3GPP-MS-TimeZone	MSTimeZone	Complex element
3GPP-SGSN-MCC-MNC	SgsnMccMnc	Complex element
3GPP-User-Location-Info	ULI	Complex element
AN-GW-Address	ANGWAddr	Simple element
AN-Trusted	ANTrusted	Simple element
Abort-Cause	AbortCause	Simple element
Acceptable-Service-Info	AcceptableSvcInfo	Group
Access-Network-Charging-Address	ANCAddr	Simple element
Access-Network-Charging-Identifier	ANCID	Group
Access-Network-Charging-Identifier-Value	ANCIDVal	Simple element
AF-Application-Identifier	AFAppId	Simple element
AF-Charging-Identifier	AFChargingId	Simple element
Application-Service-Provider-Identity	ASPIId	Simple element
Called-Station-ID	APN	Simple element
CC-Input-Octets	CCIO	Simple element
CC-Output-Octets	CCOO	Simple element
CC-Total-Octets	CCTO	Simple element
Codec-Data	CodecData	Simple element
DRMP	DiaPri	Simple element
Experimental-Result	ExperiRes	Group
Experimental-Result-Code	ExperiResCode	Simple element
Extended-Max-Requested-BW-DL	ExtMaxBwDL	Simple element
Extended-Max-Requested-BW-UL	ExtMaxBwUL	Simple element
Extended-Min-Requested-BW-DL	ExtMinBwDL	Simple element
Extended-Min-Requested-BW-UL	ExtMinBwUL	Simple element
Feature-List	FeatList	Simple element
Feature-List-ID	FeatListId	Simple element
Final-Unit-Action	FinUnitAct	Simple element
Flow-Description	FlowDesc	Simple element
Flow-Number	FlowNum	Simple element
Flow-Status	FlowStatus	Simple element
Flow-Usage	FlowUsage	Simple element
Flows	Flows	Group
Framed-IP-Address	UEIP	Simple element
Framed-IPv6-Prefix	UEIPv6	Simple element
Granted-Service-Unit	GSU	Group
IP-CAN-Type	IPCANType	Simple element
IP-Domain-ID	IPDomainId	Simple element
Max-Requested-Bandwidth-DL	MaxBwDL	Simple element
Max-Requested-Bandwidth-UL	MaxBwUL	Simple element
Media-Component-Number	MCN	Simple element
Media-Component-Description	MCD	Group
Media-Sub-Component	MSC	Group
Media-Type	MediaType	Simple element
Min-Requested-Bandwidth-DL	MinBwDL	Simple element
Min-Requested-Bandwidth-UL	MinBwUL	Simple element
MPS-Identifier	MPSId	Simple element
NetLoc-Access-Support	NETLocAccSupp	Simple element
Origin-State-ID	OrigStateId	Simple element
RAN-NAS-Release-Cause	RANNASRelCause	Complex element
RAT-Type	RATType	Simple element
Reference-Id	RefId	Simple element
Required-Access-Info	ReqAcclInfo	Simple element
Reservation-Priority	ResPrio	Simple element
Result-Code	ResCode	Simple element
Retry-Interval	RetryInterval	Simple element
RR-Bandwidth	RRBw	Simple element
RS-Bandwidth	RSBw	Simple element
Rx-Request-Type	ReqType	Simple element
Service-Info-Status	SvcInfoStatus	Simple element
Service-URN	SvcURN	Simple element
Specific-Action	SpecificAction	Simple element
Sponsoring-Action	SponsAct	Simple element

Sponsor-Identity	SponsId	Simple element
Sponsored-Connectivity-Data	SpConnData	Group
Subscription-ID	SubId	Group
Subscription-ID-Data	SubIdVal	Simple element
Subscription-ID-Type	SubIdType	Simple element
Supported-Features	SuppFeatures	Group
TCP-Source-Port	TCPsrcPort	Simple element
Termination-Cause	TermCause	Simple element
TWAN-Identifier	TWANId	Simple element
ToS-Traffic-Class	TTC	Simple element
UDP-Source-Port	UDPSrcPort	Simple element
UE-Local-IP-Address	UELocalIP	Simple element
Used-Service-Unit	USU	Group
User-Location-Info-Time	ULITime	Simple element
Vendor-ID	VenID	Simple element

NOTE 1: Diameter AVPs which are listed in 3GPP TS 29.214 [4] but not listed in table 5.4.1.3.1 will not be supported on the specific application communication layer of the REST-Rx interface.

NOTE 2: When the Diameter message transports the Result Code AVP or an Experimental Result Code AVP, for example, the PC need not inspect these AVPs and need not map these AVPs to HTTP status codes. The AVPs shall be included into HTTP commands as representations and will be transported between the endpoints (PCRF and AF), which are responsible to take this information into account.

5.5 PC discovery

The Dynamic Host Configuration Protocol (DHCP) [12] and Domain Name System (DNS) [11] interfaces are typically not included in architecture diagrams or described as reference points. For the PC discovery, DHCP and DNS interactions can take place between the AF and the PC. If the AF does not have PC address information (i.e. provided by preconfiguration or other protocol configuration options), DHCP and DNS queries can be carried out before the creation of resources by the AF. The input parameters could be the UE IP address, User identity, IP domain Id and PDN Id.

6 Routing

6.1 PC located in the PLMN but outside of the PCRF realm

The AF may have following parameters: UE IP address (i.e. IPv4 or IPv6 address), PDN information, user identity and domain Identity.

The AF may use above parameters to construct the HTTP request URL to the protocol converter.

The above available parameters shall also be included in the AF session establishment requests to the protocol converter.

For the routing between the protocol converter and PCRF, if the PC can extract the realm information from the user identification and/or other information from the AF, the PC can send the Diameter message to the correct PCRF realm. Otherwise, if the PC can't extract the realm information from the user identification and/or other information from the AF, the PC may use pre-configured information to find the PCRF realm. The parameters provided by the PC may include the UE's IPv4 address, the UE's IPv6 address, PDN information, user identity and domain identity.

NOTE: The DRA procedure for the PC to find the PCRF is defined in subclause 7.3.2 of 3GPP TS 29.213 [3].

6.2 PC located in the PCRF realm

The AF may have following parameters: UE IP address (i.e. IPv4 or IPv6 address), PDN information, user identity and domain Identity.

The AF may use above parameters to construct the HTTP request URL to the protocol converter.

The above available parameters shall also be included in the AF session establishment requests to the protocol converter.

For the routing between the protocol converter and PCRF, the protocol converter shall provide the PCRF or the DRA of the PCRF realm with the parameters translated from the HTTP request. The parameters provided by the PC may include the UE's IPv4 address, the UE's IPv6 address, PDN information, user identity and domain identity.

NOTE: The DRA procedure for the PC to find the PCRF is defined in subclause 7.3.2 of 3GPP TS 29.213 [3].

7 Secure communication

3GPP TS 33.310 [13] provides a highly scalable entity authentication framework for 3GPP network nodes.

The unsecured HTTP protocol may be combined with TLS [14] in order to provide confidentiality and integrity protection. HTTP/TLS is differentiated from HTTP URIs by using the "HTTPS" scheme in place of the "HTTP" scheme. Mutual authentication shall be enabled in TLS for authenticating and allowing only an authorized 3rd party AF to access the PC

NOTE: In case a client knows the application level protocol (HTTP) and the format of the representation (XML), it is able to communicate with every resource around the world, for which a representation is retrievable in this format. Since HTTP and XML are extensively used in the internet community it is highly desirable to use the option for secure communication.

Annex A (informative): Call Flows

A.1 General

This annex describes the procedures which use the two TCP connections to implement the interactions between the AF and the PC. The AF in the annex A.2, A.3, A.4, A.5 and A.6 uses one TCP connection initiated by the AF to send the HTTP request message and the PC in the annex A.7 uses one TCP connection initiated by the PC to send the HTTP request message.

A.2 AF session establishment

This sub-clause describes the signalling flow for the AF session establishment procedure through the PC.

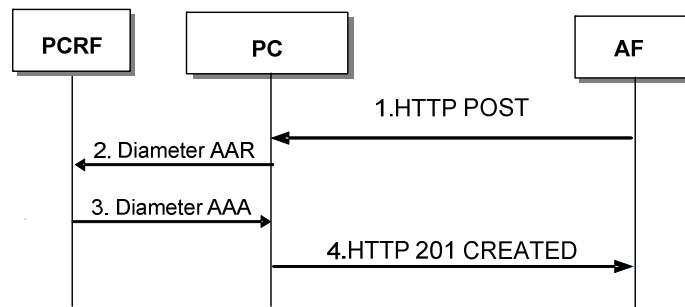

Figure A.2.1: Initial AF session request

1. The AF sends the HTTP POST to the PC to initiate the creation of a resource state, to inform the PC about the notification URL and to initiate an AF session establishment including the parameters defined in sub-clause 4.5.2.
2. The PC converts the request to a Diameter AAR command. The PC provides the Service Information to the PCRF by sending a Diameter AAR command as specified in 3GPP TS 29.214 [4] for a new Rx Diameter session.
3. The PCRF sends a Diameter AAA command to the PC as specified in 3GPP TS 29.214 [4].
4. The PC converts the required content of the Diameter AAA command and provides it in the HTTP 201 CREATED response to the AF including the parameters defined in sub-clause 4.5.2. The response message includes one resource in the Location header field, which represent the AF session ID.

A.3 AF Session Modification Initiated by AF

This sub-clause describes the signalling flow for the AF session modification procedure through PC.

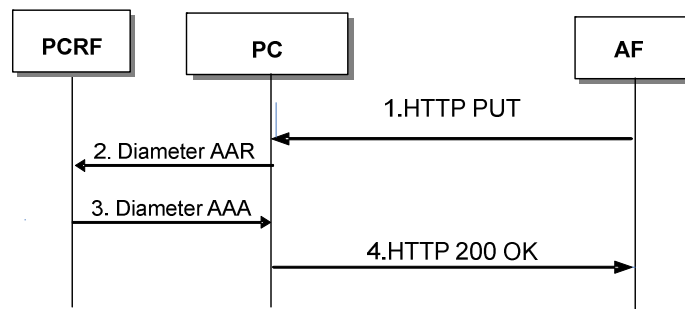

Figure A.3.1: AF session modification initiated by AF

1. The AF sends the HTTP PUT to the PC to initiate the AF session modification procedure including the parameters defined in sub-clause 4.5.3.
2. The PC converts the AF session modification request to a Diameter AAR command and sends the Diameter AAR command to the PCRF as specified in 3GPP TS 29.214 [4].
3. The PCRF sends a Diameter AAA command to the PC as specified in 3GPP TS 29.214 [4].
4. The PC converts the required content of the Diameter AAA command and provides it in the HTTP 200 OK to the AF including the parameters defined in sub-clause 4.5.3.

A.4 AF Session Termination

This sub-clause describes the signalling flow for the AF session termination procedures through PC.

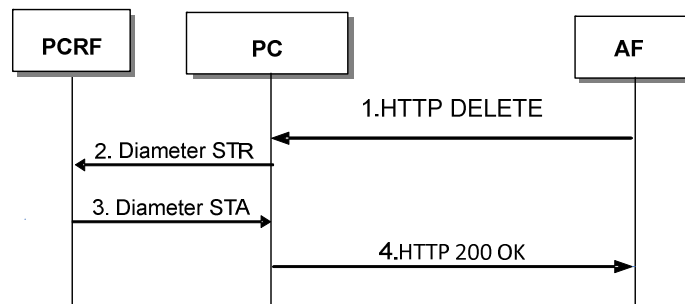

Figure A.4.1: AF session termination Procedures

1. The AF sends the HTTP DELETE to the PC to initiate the AF session termination procedure including the parameters defined in sub-clause 4.5.4.
2. The PC converts the AF session termination request to a Diameter STR command and sends the Diameter STR command to the PCRF as specified in 3GPP TS 29.214 [4].
3. The PCRF sends a Diameter STA command to the PC as specified in 3GPP TS 29.214 [4].
4. The PC converts the Diameter STA command and provides the HTTP 200 OK to the AF including the parameters defined in sub-clause 4.5.4.

A.5 Gate Related Procedures

This sub-clause describes the signalling flow for the gate related procedures through PC.

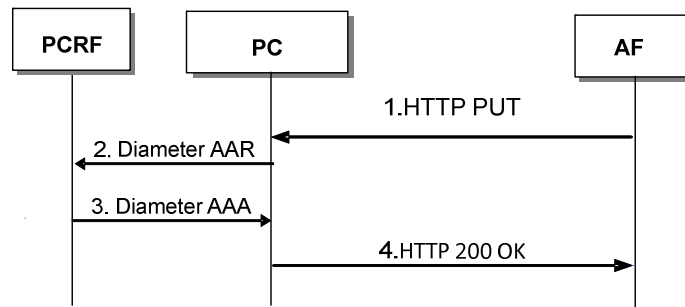

Figure A.5.1: Gate Related Procedures

1. The AF sends the HTTP PUT to the PC to indicate gate status including the parameters defined in sub-clause 4.5.5.
2. The PC converts the gate status request to Diameter AAR command and sends the Diameter AAR command to the PCRF as specified in 3GPP TS 29.214 [4].
3. The PCRF sends a Diameter AAA command to the PC as specified in 3GPP TS 29.214 [4].
4. The PC converts the Diameter AAA command and provides the HTTP 200 OK to the AF including the parameters defined in sub-clause 4.5.5.

A.6 Subscription to Notification of Signalling Path Status

This sub-clause describes the signalling flow for the subscription to notification of signalling path status through PC.

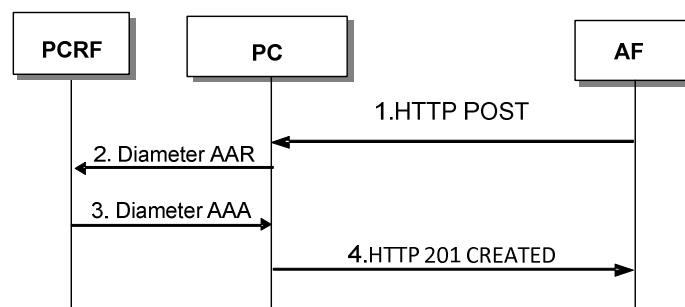

Figure A.6.1: Subscription to Notification of Signalling Path Status

1. The AF sends the HTTP POST to the PC to subscribe to notification of signalling path status including the parameters defined in sub-clause 4.5.6.
2. The PC converts the subscription request to Diameter AAR command and sends the Diameter AAR command to the PCRF as specified in 3GPP TS 29.214 [4].
3. The PCRF sends a Diameter AAA command to the PC as specified in 3GPP TS 29.214 [4].
4. The PC converts the Diameter AAA command and provides the HTTP 201 CREATED to the AF including the parameters defined in sub-clause 4.5.6.

A.7 Notification of Traffic Plane Events

This sub-clause describes the signalling flow for the notification of traffic plane events through the PC.

A.7.1 Traffic plane event reporting

This subclause describes the signalling flow for traffic plane event reporting through the PC.

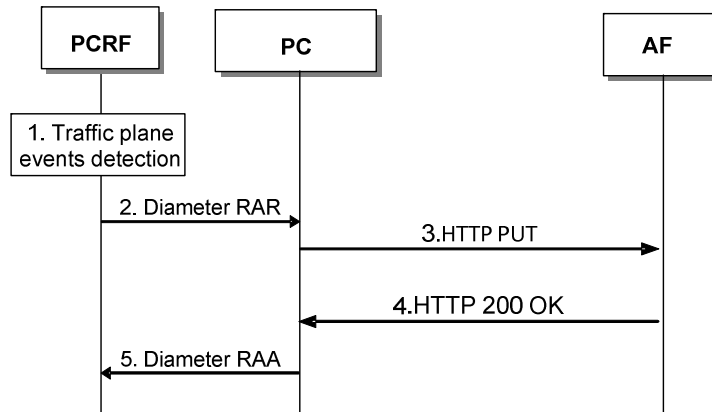

Figure A.7.1.1: Traffic plane events reporting

1. The PCRF detects the occurrence of the traffic plane events.
2. When the traffic plane events occur, the PCRF notifies the corresponding events to the PC via a Diameter RAR command as specified in 3GPP TS 29.214 [4].
3. The PC converts the Diameter RAR command to HTTP PUT to indicate the traffic plane events including the parameters defined in sub-clause 4.5.7.
4. The AF sends the HTTP 200 OK to the PC including the parameters defined in sub-clause 4.5.7.
5. The PC converts the HTTP 200 OK to Diameter RAA command and sends the Diameter RAA command to the PCRF as specified in 3GPP TS 29.214 [4].

NOTE: The signalling for traffic plane event reporting, when all service data flows within the AF session are affected, is described in subclause A.7.2.

A.7.2 Service data flow deactivation when all service data flows are affected

This subclause describes the signalling flow when all the service data flows within the AF session are affected through the PC.

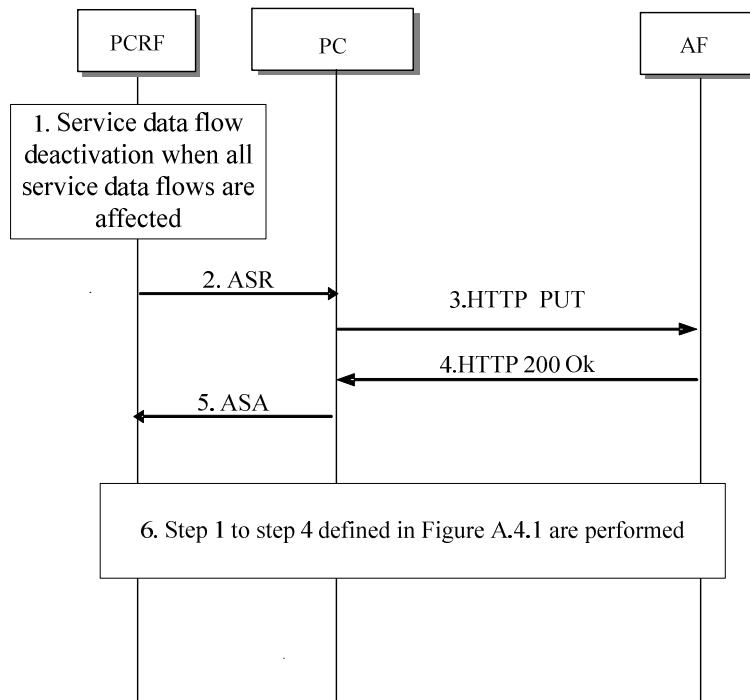

Figure A.7.2.1: Service data flow deactivation when all service data flows are affected

1. The PCRF detects that all service data flows are terminated within the AF session.
2. The PCRF sends the ASR command to the PC;
3. The PC converts the Diameter ASR command to HTTP PUT including the parameters defined in subclause 4.5.7.
4. The AF sends the HTTP 200 OK to the PC including the parameters defined in subclause 4.5.7.
5. The PC converts the HTTP 200 OK to Diameter ASA command including the parameters defined in subclause 4.5.7.
6. Step 1 to step 4 defined in Figure A.4.1 are performed.

A.7.3 IP-CAN Session Termination

This subclause describes the signalling flow for the IP-CAN session termination through the PC.

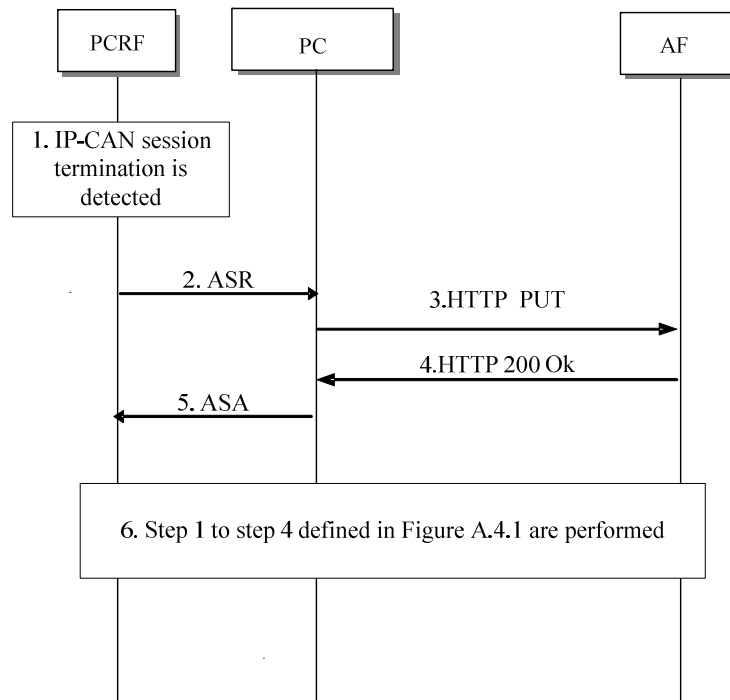

Figure A.7.3.1: IP-CAN Session Termination

1. The PCRF detects the IP-CAN session is terminated and determines the AF session needs to be terminated.
2. The PCRF sends the ASR command to the PC;
3. The PC converts the Diameter ASR command to HTTP PUT to indicate the IP-CAN session termination including the parameters defined in subclause 4.5.7.
4. The AF sends the HTTP 200 OK to the PC including the parameters defined in subclause 4.5.7.
5. The PC converts the HTTP 200 OK to Diameter ASA command including the parameters defined in subclause 4.5.7.
6. Step 1 to step 4 defined in Figure A.4.1 are performed.

Annex B (normative): XML Schema

B.1 XML elements and groups

This annex defines the XML structure of simple elements and groups, which shall be used as HTTP message content (see subclause B.2). The structure is based on the AVP definition in 3GPP TS 29.214 [4].

```

<xs:annotation>
  <xs:documentation>=====</xs:documentation>
  <xs:documentation>Definition of Elements</xs:documentation>
  <xs:documentation>=====</xs:documentation>
</xs:annotation>
<xs:element name="MSTimeZone" type="TypeMSTimeZone" />
<xs:element name="SgsnMccMnc" type="TypeSgsnMccMnc" />
<xs:element name="ULI" type="TypeULI" />
<xs:element name="TCPSrcPort" type="xs:unsignedInt" />
<xs:element name="UDPSrcPort" type="xs:unsignedInt" />
<xs:element name="ANTrusted" type="xs:unsignedInt" />
<xs:element name="AbortCause" type="xs:unsignedInt" />
<xs:element name="ANCAddr" type="xs:hexBinary" />
<xs:element name="ANGWAddr" type="xs:hexBinary" />
<xs:element name="ANCIDVal" type="xs:hexBinary" />
<xs:element name="VenID" type="xs:unsignedInt" />
<xs:element name="ExperiResCode" type="xs:unsignedInt" />
<xs:element name="IPCANType" type="xs:unsignedInt" />
<xs:element name="MPSId" type="xs:string" />
<xs:element name="NetLocAccSupp" type="xs:unsignedInt" />
<xs:element name="RANNASRelCause" type="TypeRANNASRelCause" />
<xs:element name="RATType" type="xs:unsignedInt" />
<xs:element name="RefId" type="xs:string" />
<xs:element name="ResCode" type="xs:unsignedInt" />
<xs:element name="RetryInterval" type="xs:unsignedInt" />
<xs:element name="TermCause" type="xs:unsignedInt" />
<xs:element name="TWANId" type="xs:hexBinary" />
<xs:element name="TTC" type="xs:unsignedInt" />
<xs:element name="ULITime" type="xs:unsignedLong" />
<xs:element name="FinUnitAct" type="xs:unsignedInt" />
<xs:element name="IPDomainId" type="xs:string" />
<xs:element name="AFAppId" type="xs:string" />
<xs:element name="FlowNum" type="xs:unsignedInt" />
<xs:element name="FlowDesc" type="xs:string" />
<xs:element name="FlowStatus" type="xs:unsignedInt" />
<xs:element name="FlowUsage" type="xs:unsignedInt" />
<xs:element name="MaxBwUL" type="xs:unsignedInt" />
<xs:element name="MaxBwDL" type="xs:unsignedInt" />
<xs:element name="MinBwDL" type="xs:unsignedInt" />
<xs:element name="MinBwUL" type="xs:unsignedInt" />
<xs:element name="ExtMaxBwUL" type="xs:unsignedInt" />
<xs:element name="ExtMaxBwDL" type="xs:unsignedInt" />
<xs:element name="ExtMinBwDL" type="xs:unsignedInt" />
<xs:element name="ExtMinBwUL" type="xs:unsignedInt" />
<xs:element name="MediaType" type="xs:integer" />
<xs:element name="DiaPri" type="xs:unsignedInt" />
<xs:element name="ResPrio" type="xs:unsignedInt" />
<xs:element name="RSBw" type="xs:unsignedInt" />
<xs:element name="RRBw" type="xs:unsignedInt" />
<xs:element name="SvcInfoStatus" type="xs:unsignedInt" />
<xs:element name="AFChargingId" type="xs:hexBinary" />
<xs:element name="SpecificAction" type="xs:unsignedInt" />
<xs:element name="MCN" type="xs:unsignedInt" />
<xs:element name="CodecData" type="xs:string" />
<xs:element name="SubIdType" type="xs:unsignedInt" />
<xs:element name="SubIdVal" type="xs:string" />
<xs:element name="FeatListId" type="xs:unsignedInt" />
<xs:element name="FeatList" type="xs:unsignedInt" />
<xs:element name="UEIP" type="xs:hexBinary" />
<xs:element name="UEIPv6" type="xs:hexBinary" />
<xs:element name="UELocalIP" type="xs:hexBinary" />
<xs:element name="APN" type="xs:string" />
<xs:element name="SvcURN" type="xs:string" />
<xs:element name="SponsId" type="xs:string" />

```

```

<xs:element name="ASPID" type="xs:string" />
<xs:element name="SponsAct" type="xs:unsignedInt" />
<xs:element name="CCTO" type="xs:unsignedLong" />
<xs:element name="CCIO" type="xs:unsignedLong" />
<xs:element name="CCOO" type="xs:unsignedLong" />
<xs:element name="ReqType" type="xs:unsignedInt" />
<xs:element name="ReqAccInfo" type="xs:unsignedInt" />
<xs:element name="OrigStateId" type="xs:unsignedInt" />
<xs:element name="Settings" type="TypeSettings" />
<xs:annotation>
  <xs:documentation>===== </xs:documentation>
  <xs:documentation>Definition of Complex Types</xs:documentation>
  <xs:documentation>===== </xs:documentation>
</xs:annotation>
<xs:element name="TimeZoneOffset" type="xs:integer" />
<xs:element name="DST" type="xs:integer" />
<xs:element name="MCCdigits" type="xs:string" />
<xs:element name="MNCdigits" type="xs:string" />
<xs:element name="GeoLocType" type="xs:unsignedInt" />
<xs:element name="GeoLoc" type="xs:hexBinary" />
<xs:element name="ProtocolType" type="xs:unsignedInt" />
<xs:element name="CauseType" type="xs:unsignedInt" />
<xs:element name="CauseValue" type="xs:hexBinary" />
<xs:element name="NotificationBaseURL" type="xs:anyURI" />
<xs:complexType name="TypeMSTimeZone" >
  <xs:sequence>
    <xs:element ref="TimeZoneOffset" />
    <xs:element ref="DST" />
    <xs:any minOccurs="0" />
  </xs:sequence>
</xs:complexType>
<xs:complexType name="TypeSgsnMccMnc" >
  <xs:sequence>
    <xs:element ref="MCCdigits" />
    <xs:element ref="MNCdigits" />
    <xs:any minOccurs="0" />
  </xs:sequence>
</xs:complexType>
<xs:complexType name="TypeULI" >
  <xs:sequence>
    <xs:element ref="GeoLocType" />
    <xs:element ref="GeoLoc" />
    <xs:any minOccurs="0" />
  </xs:sequence>
</xs:complexType>
<xs:complexType name="TypeRANNASRelCause">
  <xs:sequence>
    <xs:element ref="ProtocolType" />
    <xs:element ref="CauseType" />
    <xs:element ref="CauseValue" />
    <xs:any minOccurs="0" />
  </xs:sequence>
</xs:complexType>
<xs:complexType name="TypeSettings" >
  <xs:sequence>
    <xs:element ref="NotificationBaseURL" />
    <xs:any minOccurs="0" />
  </xs:sequence>
</xs:complexType>
<xs:annotation>
  <xs:documentation>===== </xs:documentation>
  <xs:documentation>Definition of Groups</xs:documentation>
  <xs:documentation>===== </xs:documentation>
</xs:annotation>
<xs:group name="ANCID">
  <xs:sequence>
    <xs:element ref="ANCIDVal" />
    <xs:element minOccurs="0" maxOccurs="unbounded" name="Flows">
      <xs:complexType>
        <xs:group ref="Flows" />
      </xs:complexType>
    </xs:element>
    <xs:any minOccurs="0" />
  </xs:sequence>
</xs:group>
<xs:group name="ExperiRes">
  <xs:sequence>
    <xs:element ref="VenID" />

```



```

    <xs:element ref="ExperiResCode" />
    <xs:any minOccurs="0"/>
  </xs:sequence>
</xs:group>
<xs:group name="Flows">
  <xs:sequence>
    <xs:element ref="MCN" />
    <xs:element minOccurs="0" maxOccurs="unbounded" ref="FlowNum" />
    <xs:element minOccurs="0" ref="FinUnitAct" />
    <xs:any minOccurs="0"/>
  </xs:sequence>
</xs:group>
<xs:group name="MCD">
  <xs:sequence>
    <xs:element ref="MCN" />
    <xs:element minOccurs="0" ref="AFAppId" />
    <xs:element minOccurs="0" ref="MediaType" />
    <xs:element minOccurs="0" ref="MaxBwDL" />
    <xs:element minOccurs="0" ref="MaxBwUL" />
    <xs:element minOccurs="0" ref="MinBwDL" />
    <xs:element minOccurs="0" ref="MinBwUL" />
    <xs:element minOccurs="0" ref="ExtMaxBwDL" />
    <xs:element minOccurs="0" ref="ExtMaxBwUL" />
    <xs:element minOccurs="0" ref="ExtMinBwDL" />
    <xs:element minOccurs="0" ref="ExtMinBwUL" />
    <xs:element minOccurs="0" ref="FlowStatus" />
    <xs:element minOccurs="0" ref="ResPrio" />
    <xs:element minOccurs="0" ref="RSBw" />
    <xs:element minOccurs="0" ref="RRBw" />
    <xs:element minOccurs="0" maxOccurs="2" ref="CodecData" />
    <xs:element minOccurs="0" maxOccurs="unbounded" name="MSC">
      <xs:complexType>
        <xs:group ref="MSC" />
      </xs:complexType>
    </xs:element>
    <xs:any minOccurs="0"/>
  </xs:sequence>
</xs:group>
<xs:group name="MSC">
  <xs:sequence>
    <xs:element ref="FlowNum" />
    <xs:element minOccurs="0" maxOccurs="2" ref="FlowDesc" />
    <xs:element minOccurs="0" ref="FlowStatus" />
    <xs:element minOccurs="0" ref="FlowUsage" />
    <xs:element minOccurs="0" ref="MaxBwUL" />
    <xs:element minOccurs="0" ref="MaxBwDL" />
    <xs:element minOccurs="0" ref="ExtMaxBwDL" />
    <xs:element minOccurs="0" ref="ExtMaxBwUL" />
    <xs:element minOccurs="0" ref="TTC" />
    <xs:any minOccurs="0"/>
  </xs:sequence>
</xs:group>
<xs:group name="SubId">
  <xs:sequence>
    <xs:element ref="SubIdType" />
    <xs:element ref="SubIdVal" />
    <xs:any minOccurs="0"/>
  </xs:sequence>
</xs:group>
<xs:group name="SuppFeatures">
  <xs:sequence>
    <xs:element ref="FeatListId" />
    <xs:element ref="FeatList" />
    <xs:any minOccurs="0"/>
  </xs:sequence>
</xs:group>
<xs:group name="SpConnData">
  <xs:sequence>
    <xs:element minOccurs="0" ref="SponsId" />
    <xs:element minOccurs="0" ref="ASPID" />
    <xs:element minOccurs="0" ref="SponsAct" />
    <xs:element minOccurs="0" name="GSU">
      <xs:complexType>
        <xs:group ref="GSU" />
      </xs:complexType>
    </xs:element>
    <xs:element minOccurs="0" name="USU">
      <xs:complexType>

```

```

        <xs:group ref="USU" />
      </xs:complexType>
    </xs:element>
    <xs:any minOccurs="0" />
  </xs:sequence>
</xs:group>
<xs:group name="GSU">
  <xs:sequence>
    <xs:element minOccurs="0" ref="CCTO" />
    <xs:element minOccurs="0" ref="CCIO" />
    <xs:element minOccurs="0" ref="CCOO" />
    <xs:any minOccurs="0" />
  </xs:sequence>
</xs:group>
<xs:group name="USU">
  <xs:sequence>
    <xs:element minOccurs="0" ref="CCTO" />
    <xs:element minOccurs="0" ref="CCIO" />
    <xs:element minOccurs="0" ref="CCOO" />
    <xs:any minOccurs="0" />
  </xs:sequence>
</xs:group>
<xs:group name="AcceptableSvcInfo">
  <xs:sequence>
    <xs:element minOccurs="0" maxOccurs="1" ref="MaxBwDL" />
    <xs:element minOccurs="0" maxOccurs="1" ref="MaxBwUL" />
    <xs:element minOccurs="0" maxOccurs="1" ref="ExtMaxBwDL" />
    <xs:element minOccurs="0" maxOccurs="1" ref="ExtMaxBwUL" />
    <xs:element minOccurs="0" maxOccurs="unbounded" name="MCD">
      <xs:complexType>
        <xs:group ref="MCD" />
      </xs:complexType>
    </xs:element>
    <xs:any minOccurs="0" />
  </xs:sequence>
</xs:group>

```

B.2 Diameter message representation

This annex defines the XML structure of Diameter message representations, which shall be transported as content of HTTP methods. The structure is based on the message definition in 3GPP TS 29.214 [4] and the definition of the XML elements and groups (see subclause B.1).

```

<xs:annotation>
  <xs:documentation>=====</xs:documentation>
  <xs:documentation>Definition of Diameter message representation</xs:documentation>
  <xs:documentation>=====</xs:documentation>
</xs:annotation>
<xs:annotation>
  <xs:documentation>=====</xs:documentation>
  <xs:documentation>AA-Request Representation</xs:documentation>
  <xs:documentation>=====</xs:documentation>
</xs:annotation>
<xs:element name="AA-Request">
  <xs:complexType>
    <xs:sequence>
      <xs:element minOccurs="0" ref="DiaPri" />
      <xs:element minOccurs="0" ref="IPDomainId" />
      <xs:element minOccurs="0" ref="AFAppId" />
      <xs:element minOccurs="0" maxOccurs="unbounded" name="MCD">
        <xs:complexType>
          <xs:group ref="MCD" />
        </xs:complexType>
      </xs:element>
      <xs:element minOccurs="0" ref="SvcInfoStatus" />
      <xs:element minOccurs="0" ref="AFChargingId" />
      <xs:element minOccurs="0" maxOccurs="unbounded" ref="SpecificAction" />
      <xs:element minOccurs="0" maxOccurs="unbounded" name="SubId">
        <xs:complexType>
          <xs:group ref="SubId" />
        </xs:complexType>
      </xs:element>
      <xs:element minOccurs="0" maxOccurs="unbounded" name="SuppFeatures">
        <xs:complexType>

```

```

    <xs:group ref="SuppFeatures" />
  </xs:complexType>
</xs:element>
<xs:element minOccurs="0" ref="ResPrio" />
<xs:element minOccurs="0" ref="UEIP" />
<xs:element minOccurs="0" ref="UEIPv6" />
<xs:element minOccurs="0" ref="APN" />
<xs:element minOccurs="0" ref="SvcURN" />
<xs:element minOccurs="0" name="SpConnData">
  <xs:complexType>
    <xs:group ref="SpConnData" />
  </xs:complexType>
</xs:element>
<xs:element minOccurs="0" ref="MPSId" />
<xs:element minOccurs="0" ref="ReqType" />
<xs:element minOccurs="0" ref="RefId" />
<xs:element minOccurs="0" maxOccurs="unbounded" ref="ReqAccInfo" />
<xs:element minOccurs="0" ref="OrigStateId" />
</xs:sequence>
</xs:complexType>
</xs:element>
<xs:annotation>
  <xs:documentation>===== </xs:documentation>
  <xs:documentation>AA-Answer Representation </xs:documentation>
  <xs:documentation>===== </xs:documentation>
</xs:annotation>
<xs:element name="AA-Answer">
  <xs:complexType>
    <xs:sequence>
      <xs:element minOccurs="0" ref="ResCode" />
      <xs:element minOccurs="0" name="ExperiRes">
        <xs:complexType>
          <xs:group ref="ExperiRes" />
        </xs:complexType>
      </xs:element>
      <xs:element minOccurs="0" maxOccurs="unbounded" name="ANCID">
        <xs:complexType>
          <xs:group ref="ANCID" />
        </xs:complexType>
      </xs:element>
      <xs:element minOccurs="0" ref="ANCAAddr" />
      <xs:element minOccurs="0" name="AcceptableSvcInfo">
        <xs:complexType>
          <xs:group ref="AcceptableSvcInfo" />
        </xs:complexType>
      </xs:element>
      <xs:element minOccurs="0" ref="IPCANType" />
      <xs:element minOccurs="0" ref="NetLocAccSupp" />
      <xs:element minOccurs="0" ref="RATType" />
      <xs:element minOccurs="0" ref="ANTrusted" />
      <xs:element minOccurs="0" ref="ANGWAddr" />
      <xs:element minOccurs="0" maxOccurs="unbounded" name="Flows">
        <xs:complexType>
          <xs:group ref="Flows" />
        </xs:complexType>
      </xs:element>
      <xs:element minOccurs="0" maxOccurs="unbounded" name="SuppFeatures">
        <xs:complexType>
          <xs:group ref="SuppFeatures" />
        </xs:complexType>
      </xs:element>
      <xs:element minOccurs="0" ref="RetryInterval" />
      <xs:any minOccurs="0"/>
    </xs:sequence>
  </xs:complexType>
</xs:element>
<xs:annotation>
  <xs:documentation>===== </xs:documentation>
  <xs:documentation>RA-Request Representation </xs:documentation>
  <xs:documentation>===== </xs:documentation>
</xs:annotation>
<xs:element name="RA-Request">
  <xs:complexType>
    <xs:sequence>
      <xs:element minOccurs="0" maxOccurs="unbounded" ref="SpecificAction" />
      <xs:element minOccurs="0" maxOccurs="unbounded" name="ANCID">
        <xs:complexType>
          <xs:group ref="ANCID" />
        </xs:complexType>
      </xs:element>
    </xs:sequence>
  </xs:complexType>
</xs:element>

```

```

    </xs:complexType>
  </xs:element>
  <xs:element minOccurs="0" ref="ANCAddr" />
  <xs:element minOccurs="0" maxOccurs="unbounded" name="Flows">
    <xs:complexType>
      <xs:group ref="Flows" />
    </xs:complexType>
  </xs:element>
  <xs:element minOccurs="0" maxOccurs="unbounded" name="SubId">
    <xs:complexType>
      <xs:group ref="SubId" />
    </xs:complexType>
  </xs:element>
  <xs:element minOccurs="0" ref="AbortCause" />
  <xs:element minOccurs="0" ref="IPCANType" />
  <xs:element minOccurs="0" ref="NetLocAccSupp" />
  <xs:element minOccurs="0" ref="RATType" />
  <xs:element minOccurs="0" ref="ANTrusted" />
  <xs:element minOccurs="0" name="SpConnData">
  <xs:element minOccurs="0" ref="ANGWAddr" />
  <xs:element minOccurs="0" ref="TCPsrcPort" />
  <xs:element minOccurs="0" ref="UDPSrcPort" />
    <xs:complexType>
      <xs:group ref="SpConnData" />
    </xs:complexType>
  </xs:element>
  <xs:element minOccurs="0" ref="ULI" />
  <xs:element minOccurs="0" ref="ULITime" />
  <xs:element minOccurs="0" ref="MSTimeZone" />
  <xs:element minOccurs="0" ref="UELocalIP" />
  <xs:element minOccurs="0" maxOccurs="unbounded" ref="RANNASRelCause" />
  <xs:element minOccurs="0" ref="SgsnMccMnc" />
  <xs:element minOccurs="0" ref="TWANId" />
  <xs:any minOccurs="0" />
</xs:sequence>
</xs:complexType>
</xs:element>
<xs:annotation>
  <xs:documentation>===== </xs:documentation>
  <xs:documentation>RA-Answer Representation</xs:documentation>
  <xs:documentation>===== </xs:documentation>
</xs:annotation>
<xs:element name="RA-Answer">
  <xs:complexType>
    <xs:sequence>
      <xs:element minOccurs="0" ref="DiaPri" />
      <xs:element minOccurs="0" ref="ResCode" />
      <xs:element minOccurs="0" name="ExperiRes">
        <xs:complexType>
          <xs:group ref="ExperiRes" />
        </xs:complexType>
      </xs:element>
      <xs:element minOccurs="0" maxOccurs="unbounded" name="MCD">
        <xs:complexType>
          <xs:group ref="MCD" />
        </xs:complexType>
      </xs:element>
      <xs:element minOccurs="0" ref="SvcURN" />
      <xs:any minOccurs="0" />
    </xs:sequence>
  </xs:complexType>
</xs:element>
<xs:annotation>
  <xs:documentation>===== </xs:documentation>
  <xs:documentation>ST-Request Representation</xs:documentation>
  <xs:documentation>===== </xs:documentation>
</xs:annotation>
<xs:element name="ST-Request">
  <xs:complexType>
    <xs:sequence>
      <xs:element minOccurs="0" ref="DiaPri" />
      <xs:element minOccurs="0" ref="TermCause" />
      <xs:element minOccurs="0" maxOccurs="unbounded" ref="ReqAccInfo" />
      <xs:any minOccurs="0" />
    </xs:sequence>
  </xs:complexType>
</xs:element>
<xs:annotation>

```

```

<xs:documentation>=====</xs:documentation>
<xs:documentation>ST-Answer Representation</xs:documentation>
<xs:documentation>=====</xs:documentation>
</xs:annotation>
<xs:element name="ST-Answer">
  <xs:complexType>
    <xs:sequence>
      <xs:element minOccurs="0" ref="ResCode" />
      <xs:element minOccurs="0" name="SpConnData">
        <xs:complexType>
          <xs:group ref="SpConnData" />
        </xs:complexType>
      </xs:element>
      <xs:element minOccurs="0" ref="ULI" />
      <xs:element minOccurs="0" ref="ULITime" />
      <xs:element minOccurs="0" ref="MSTimeZone" />
      <xs:element minOccurs="0" ref="UELocalIP" />
      <xs:element minOccurs="0" maxOccurs="unbounded" ref="RANNASRelCause" />
      <xs:element minOccurs="0" ref="SgsnMccMnc" />
      <xs:element minOccurs="0" ref="TWANId" />
      <xs:element minOccurs="0" ref="NetLocAccSupp" />
      <xs:element minOccurs="0" ref="TCPSrcPort" />
      <xs:element minOccurs="0" ref="UDPSrcPort" />
      <xs:any minOccurs="0"/>
    </xs:sequence>
  </xs:complexType>
</xs:element>
<xs:annotation>
  <xs:documentation>=====</xs:documentation>
  <xs:documentation>AS-Request Representation</xs:documentation>
  <xs:documentation>=====</xs:documentation>
</xs:annotation>
<xs:element name="AS-Request">
  <xs:complexType>
    <xs:sequence>
      <xs:element ref="AbortCause" />
      <xs:any minOccurs="0"/>
    </xs:sequence>
  </xs:complexType>
</xs:element>
<xs:annotation>
  <xs:documentation>=====</xs:documentation>
  <xs:documentation>AS-Answer Representation</xs:documentation>
  <xs:documentation>=====</xs:documentation>
</xs:annotation>
<xs:element name="AS-Answer">
  <xs:complexType>
    <xs:sequence>
      <xs:element minOccurs="0" ref="DiaPri" />
      <xs:element minOccurs="0" ref="ResCode" />
      <xs:any minOccurs="0"/>
    </xs:sequence>
  </xs:complexType>
</xs:element>

```

NOTE: Rx message content which is defined in 3GPP TS 29.214 [4] but not defined in this XML schema as representation of the message content cannot be supported on the specific application communication layer of the REST-Rx interface as HTTP message content.

Annex C (informative): Change history

Change history							
Date	TSG #	TSG Doc.	CR	Rev	Subject/Comment	Old	New
2015-03	CT#67	CP-150125	0019	-	Adapt PCC architecture diagrams to include Np reference point	12.2.0	13.0.0
2015-03	CT#67	CP-150125	0020	1	Mitigating RAN user plane congestion over Rest Rx	12.2.0	13.0.0
2015-06	CT#68	CP-150363	0026	1	Add the TTC element to the Restful Rx	13.0.0	13.1.0
2015-09	CT#69	CP-150473	0028	2	Introduction of the Acceptable-Service-Info AVP as an XML group	13.1.0	13.2.0
2015-09	CT#69	CP-150473	0030	1	Correction of XML elements, complex types, groups and message representations	13.1.0	13.2.0
2015-09	CT#70	CP-150797	0032	1	Update the PCC architecture figures in 29.201	13.2.0	13.3.0

Change history							
Date	TSG #	TSG Doc.	CR	Rev	Cat	Subject/Comment	New
2016-03	CT#71	CP-160103	0034	2	A	Capability of REST-Rx	13.4.0
2016-03	CT#71	CP-160095	0035	1	B	REST-Rx enhancement for Change of chargeable party	13.4.0
2016-03	CT#71	CP-160095	0036	2	B	Rx impact for background data transfer	13.4.0
2016-03	CT#71	CP-160104	0037	1	B	REST-Rx enhancement for NetLoc-Untrusted-WLAN	13.4.0
2016-03	CT#71	CP-160101	0038	1	B	Include the AN-Trusted element	13.4.0
2016-03	CT#71	CP-160093	0039	1	B	DRMP over REST Interface	13.4.0
2016-06	CT#72	CP-160265	0040	-	F	Correction of command name for REST-Rx session termination	13.5.0
2016-12	CT#74	CP-160614	0041	1	F	Delete the reference of IETF draft-ietf-dime-drmp-03	13.6.0
2016-12	CT#74	CP-160629	0042	1	F	Addition of UDPTCP port and ePDG address over Rest-Rx	13.6.0
2016-12	CT#74	CP-160616	0043	3	F	Diameter base protocol specification update	14.0.0
2017-09	CT#77	CP-172038	0048	1	B	Extension of QoS values	15.0.0
2020-07	SA#88e	-	-	-	-	Update to Rel-16 version (MCC)	16.0.0
2021-12	CT#94e	CP-213220	0049	-	B	Reference update for HTTP/1.1 protocol	17.0.0

History

Document history		
V17.0.0	May 2022	Publication